

Oracle® Solaris Modular Debugger Guide

Beta

Copyright © 1999, 2010, Oracle and/or its affiliates. All rights reserved.

This software and related documentation are provided under a license agreement containing restrictions on use and disclosure and are protected by intellectual property laws. Except as expressly permitted in your license agreement or allowed by law, you may not use, copy, reproduce, translate, broadcast, modify, license, transmit, distribute, exhibit, perform, publish, or display any part, in any form, or by any means. Reverse engineering, disassembly, or decompilation of this software, unless required by law for interoperability, is prohibited.

The information contained herein is subject to change without notice and is not warranted to be error-free. If you find any errors, please report them to us in writing.

If this is software or related software documentation that is delivered to the U.S. Government or anyone licensing it on behalf of the U.S. Government, the following notice is applicable:

U.S. GOVERNMENT RIGHTS Programs, software, databases, and related documentation and technical data delivered to U.S. Government customers are "commercial computer software" or "commercial technical data" pursuant to the applicable Federal Acquisition Regulation and agency-specific supplemental regulations. As such, the use, duplication, disclosure, modification, and adaptation shall be subject to the restrictions and license terms set forth in the applicable Government contract, and, to the extent applicable by the terms of the Government contract, the additional rights set forth in FAR 52.227-19, Commercial Computer Software License (December 2007). Oracle America, Inc., 500 Oracle Parkway, Redwood City, CA 94065.

This software or hardware is developed for general use in a variety of information management applications. It is not developed or intended for use in any inherently dangerous applications, including applications which may create a risk of personal injury. If you use this software or hardware in dangerous applications, then you shall be responsible to take all appropriate fail-safe, backup, redundancy, and other measures to ensure its safe use. Oracle Corporation and its affiliates disclaim any liability for any damages caused by use of this software or hardware in dangerous applications.

Oracle and Java are registered trademarks of Oracle and/or its affiliates. Other names may be trademarks of their respective owners.

AMD, Opteron, the AMD logo, and the AMD Opteron logo are trademarks or registered trademarks of Advanced Micro Devices. Intel and Intel Xeon are trademarks or registered trademarks of Intel Corporation. All SPARC trademarks are used under license and are trademarks or registered trademarks of SPARC International, Inc. UNIX is a registered trademark licensed through X/Open Company, Ltd.

This software or hardware and documentation may provide access to or information on content, products, and services from third parties. Oracle Corporation and its affiliates are not responsible for and expressly disclaim all warranties of any kind with respect to third-party content, products, and services. Oracle Corporation and its affiliates will not be responsible for any loss, costs, or damages incurred due to your access to or use of third-party content, products, or services.

Copyright © 1999, 2010, Oracle et/ou ses affiliés. Tous droits réservés.

Ce logiciel et la documentation qui l'accompagne sont protégés par les lois sur la propriété intellectuelle. Ils sont concédés sous licence et soumis à des restrictions d'utilisation et de divulgation. Sauf disposition de votre contrat de licence ou de la loi, vous ne pouvez pas copier, reproduire, traduire, diffuser, modifier, breveter, transmettre, distribuer, exposer, exécuter, publier ou afficher le logiciel, même partiellement, sous quelque forme et par quelque procédé que ce soit. Par ailleurs, il est interdit de procéder à toute ingénierie inverse du logiciel, de le désassembler ou de le décompiler, excepté à des fins d'interopérabilité avec des logiciels tiers ou tel que prescrit par la loi.

Les informations fournies dans ce document sont susceptibles de modification sans préavis. Par ailleurs, Oracle Corporation ne garantit pas qu'elles soient exemptes d'erreurs et vous invite, le cas échéant, à lui en faire part par écrit.

Si ce logiciel, ou la documentation qui l'accompagne, est concédé sous licence au Gouvernement des Etats-Unis, ou à toute entité qui délivre la licence de ce logiciel ou l'utilise pour le compte du Gouvernement des Etats-Unis, la notice suivante s'applique :

U.S. GOVERNMENT RIGHTS Programs, software, databases, and related documentation and technical data delivered to U.S. Government customers are "commercial computer software" or "commercial technical data" pursuant to the applicable Federal Acquisition Regulation and agency-specific supplemental regulations. As such, the use, duplication, disclosure, modification, and adaptation shall be subject to the restrictions and license terms set forth in the applicable Government contract, and, to the extent applicable by the terms of the Government contract, the additional rights set forth in FAR 52.227-19, Commercial Computer Software License (December 2007). Oracle America, Inc., 500 Oracle Parkway, Redwood City, CA 94065.

Ce logiciel ou matériel a été développé pour un usage général dans le cadre d'applications de gestion des informations. Ce logiciel ou matériel n'est destiné à être utilisé dans des applications à risque, notamment dans des applications pouvant causer des dommages corporels. Si vous utilisez ce logiciel ou matériel dans le cadre d'applications dangereuses, il est de votre responsabilité de prendre toutes les mesures de secours, de sauvegarde, de redondance et autres mesures nécessaires à son utilisation dans des conditions optimales de sécurité. Oracle Corporation et ses affiliés déclinent toute responsabilité quant aux dommages causés par l'utilisation de ce logiciel ou matériel pour ce type d'applications.

Oracle et Java sont des marques déposées d'Oracle Corporation et/ou de ses affiliés. Tout autre nom mentionné peut correspondre à des marques appartenant à d'autres propriétaires qu'Oracle.

AMD, Opteron, le logo AMD et le logo AMD Opteron sont des marques ou des marques déposées d'Advanced Micro Devices. Intel et Intel Xeon sont des marques ou des marques déposées d'Intel Corporation. Toutes les marques SPARC sont utilisées sous licence et sont des marques ou des marques déposées de SPARC International, Inc. UNIX est une marque déposée concédée sous licence par X/Open Company, Ltd.

Contents

Preface	9
1 Modular Debugger Overview	15
Introduction	15
MDB Features	16
Using MDB	17
Future Enhancements	17
2 Debugger Concepts	19
Building Blocks	19
Modularity	21
3 MDB Language Syntax	23
Syntax	23
Commands	25
Comments	26
Arithmetic Expansion	26
Unary Operators	27
Binary Operators	27
Quoting	28
Shell Escapes	28
Variables	28
Symbol Name Resolution	29
Symbol Tables	30
Symbol Name Scoping	30
Scoping Within User-Level Applications and Shared Libraries	31
Scoping Within the Kernel	31

Dcmd and Walker Name Resolution	34
Dcmd Pipelines	34
Formatting Dcmds	35
4 Using MDB Commands Interactively	39
Command Reentry	39
Inline Editing	39
Keyboard Shortcuts	41
Output Pager	41
Signal Handling	41
5 Built-In Commands	43
Built-In Dcmds	43
6 Execution Control	59
Execution Control	59
Event Callbacks	60
Thread Support	60
Built-in Dcmds	61
Interaction with exec	67
Interaction with Job Control	68
Process Attach and Release	68
7 Kernel Execution Control	69
Booting, Loading, and Unloading	69
Terminal Handling	71
Debugger Entry	71
Processor-Specific Features	71
8 Kernel Debugging Modules	73
Generic Kernel Debugging Support (genunix)	73
Kernel Memory Allocator	73
File Systems	77
Virtual Memory	77

CPU Structures and the Kernel Dispatcher	78
Device Drivers and DDI Framework	79
STREAMS	81
Networking	83
Files, Processes, and Threads	84
Synchronization Primitives	86
Cyclics	87
Task Queues	87
Error Queues	88
System Configuration	88
Interprocess Communication Debugging Support (ipc)	88
Interprocess Communication Dcmds	88
Interprocess Communication Walkers	89
Loopback File System Debugging Support (lofs)	90
Loopback File System Dcmds	90
Loopback File System Walkers	90
Internet Protocol Module Debugging Support (ip)	90
Internet Protocol Dcmds	90
Internet Protocol Walkers	91
Kernel Runtime Link Editor Debugging Support (krtld)	91
Kernel Runtime Link Editor Dcmds	91
Kernel Runtime Link Editor Walkers	91
USB Framework Debugging Support (uhci)	91
USB Host Controller Dcmds	91
USB Host Controller Walkers	92
USB Framework Debugging Support (usba)	92
USB Framework Dcmds	92
USB Framework Walkers	92
x86: x86 Platform Debugging Support (unix)	93
x86 Platform Dcmds	93
x86 Platform Walkers	93
SPARC: sun4u Platform Debugging Support (unix)	93
sun4u Platform Dcmds	93
sun4u Platform Walkers	94

9 Debugging With the Kernel Memory Allocator	95
Getting Started: Creating a Sample Crash Dump	95
Setting <code>kmem_flags</code>	95
Forcing a Crash Dump	96
Saving a Crash Dump	97
Starting MDB	98
Allocator Basics	98
Buffer States	98
Transactions	98
Sleeping and Non-Sleeping Allocations	99
Kernel Memory Caches	99
Kernel Memory Caches	100
Detecting Memory Corruption	102
Freed Buffer Checking: <code>0xdeadbeef</code>	103
Redzone: <code>0xfeedface</code>	103
Uninitialized Data: <code>0xbaddcafe</code>	106
Associating Panic Messages With Failures	106
Memory Allocation Logging	107
Buftag Data Integrity	107
The <code>bufctl</code> Pointer	108
Advanced Memory Analysis	109
Finding Memory Leaks	109
Finding References to Data	110
Finding Corrupt Buffers With <code>::kmem_verify</code>	111
Allocator Logging Facility	112
10 Module Programming API	115
Debugger Module Linkage	115
<code>_mdb_init()</code>	115
<code>_mdb_fini()</code>	116
Dcmd Definitions	116
Walker Definitions	118
API Functions	121
<code>mdb_pwalk()</code>	121
<code>mdb_walk()</code>	121

<code>mdb_pwalk_dcmd()</code>	122
<code>mdb_walk_dcmd()</code>	122
<code>mdb_call_dcmd()</code>	122
<code>mdb_layered_walk()</code>	122
<code>mdb_add_walker()</code>	123
<code>mdb_remove_walker()</code>	123
<code>mdb_vread()</code> and <code>mdb_vwrite()</code>	124
<code>mdb_fread()</code> and <code>mdb_fwrite()</code>	124
<code>mdb_pread()</code> and <code>mdb_pwrite()</code>	124
<code>mdb_readstr()</code>	124
<code>mdb_writestr()</code>	125
<code>mdb_readsym()</code>	125
<code>mdb_writesym()</code>	125
<code>mdb_readvar()</code> and <code>mdb_writevar()</code>	126
<code>mdb_lookup_by_name()</code> and <code>mdb_lookup_by_obj()</code>	126
<code>mdb_lookup_by_addr()</code>	127
<code>mdb_getopts()</code>	127
<code>mdb_strtoul()</code>	129
<code>mdb_alloc()</code> , <code>mdb_zalloc()</code> and <code>mdb_free()</code>	130
<code>mdb_printf()</code>	130
<code>mdb_snprintf()</code>	135
<code>mdb_warn()</code>	135
<code>mdb_flush()</code>	135
<code>mdb_nhconvert()</code>	136
<code>mdb_dumpptr()</code> and <code>mdb_dump64()</code>	136
<code>mdb_one_bit()</code>	137
<code>mdb_inval_bits()</code>	138
<code>mdb_inc_indent()</code> and <code>mdb_dec_indent()</code>	138
<code>mdb_eval()</code>	138
<code>mdb_set_dot()</code> and <code>mdb_get_dot()</code>	139
<code>mdb_get_pipe()</code>	139
<code>mdb_set_pipe()</code>	139
<code>mdb_get_xdata()</code>	140
Additional Functions	140

A	MDB Options	141
	Summary of MDB Command-Line Options	141
	Operands	145
	Exit Status	146
	Environment Variables	146
B	Notes	147
	Warnings	147
	Use of the Error Recovery Mechanism	147
	Use of the Debugger to Modify the Live Operating System	147
	Use of kmdb to Stop the Live Operating System	147
	Notes	148
	Limitations on Examining Process Core Files	148
	Limitations on Examining Crash Dump Files	148
	Relationship Between 32-bit and 64-bit Debugger	148
	Limitations on Memory Available to kmdb	148
	Developer Information	149
C	Transition From adb and kadb	151
	Command-Line Options	151
	Syntax	151
	Watchpoint Length Specifier	152
	Address Map Modifier	152
	Output	153
	Deferred Breakpoints	153
	x86: I/O Port Access	153
D	Transition From crash	155
	Command-Line Options	155
	Input in MDB	155
	Crash Functions and MDB Dcmds	156
	Index	159

Preface

The Modular Debugger (MDB) is a highly extensible, general purpose debugging tool for the Oracle Solaris operating system. The *Oracle Solaris Modular Debugger Guide* describes how to use MDB to debug complex software systems, with a particular emphasis on the facilities available for debugging the Oracle Solaris kernel and associated device drivers and modules. This guide also includes a complete reference for and discussion of the MDB language syntax, debugger features, and MDB module programming API.

Note – This Oracle Solaris release supports systems that use the SPARC and x86 families of processor architectures. The supported systems appear in the [Solaris OS: Hardware Compatibility Lists \(http://www.sun.com/bigadmin/hcl\)](http://www.sun.com/bigadmin/hcl). This document cites any implementation differences between the platform types.

In this document these x86 related terms mean the following:

- “x86” refers to the larger family of 64-bit and 32-bit x86 compatible products.
- “x64” relates specifically to 64-bit x86 compatible CPUs.
- “32-bit x86” points out specific 32-bit information about x86 based systems.

For supported systems, see the *Oracle Solaris OS: Hardware Compatibility Lists*.

Who Should Use This Book

If you were a detective and were investigating at the scene of a crime, you might interview the witnesses and ask them to describe what happened and who they saw. However, if there were no witnesses or these descriptions proved insufficient, you might consider collecting fingerprints and forensic evidence that could be examined for DNA to help solve the case. Often, software program failures divide into analogous categories: problems that can be solved with source-level debugging tools, and problems that require low-level debugging facilities, examination of core files, and knowledge of assembly language to diagnose and correct. MDB facilitates analysis of this second class of problems.

MDB is most useful when you are programming a complex low-level software system such as an operating system. The MDB debugging framework allows you to construct your own custom

analysis tools to aid in the diagnosis of these low-level problems. MDB also provides a powerful set of built-in commands that enable you to analyze the state of your program at the assembly language level.

Before You Read This Book

If you are not familiar with assembly language programming and debugging, “[Related Books and Papers](#)” on page 11 provides references to materials that you might find useful.

You should disassemble various functions of interest in the programs you will be debugging in order to familiarize yourself with the relationship between your program's source code and the corresponding assembly language code. If you are planning to use MDB for debugging Oracle Solaris kernel software, read carefully [Chapter 8, “Kernel Debugging Modules,”](#) and [Chapter 9, “Debugging With the Kernel Memory Allocator.”](#) These chapters provide more detailed information on the MDB commands and facilities provided for debugging the kernel software.

How This Book Is Organized

[Chapter 1, “Modular Debugger Overview,”](#) provides an overview of the debugger.

[Chapter 2, “Debugger Concepts,”](#) describes the MDB architecture and explains the terminology for the debugger concepts used throughout this book.

[Chapter 3, “MDB Language Syntax,”](#) describes the syntax, operators and evaluation rules for the MDB language.

[Chapter 4, “Using MDB Commands Interactively,”](#) describes the MDB interactive command-line editing facilities and output pager.

[Chapter 5, “Built-In Commands,”](#) describes the set of built-in debugger commands that are always available.

[Chapter 6, “Execution Control,”](#) describes the MDB facilities for controlling the execution of live running programs. This chapter is intended for application developers and device driver developers. Execution control features might also be useful for system administrators.

[Chapter 7, “Kernel Execution Control,”](#) describes the MDB facilities for controlling the execution of the live operating system kernel that are specific to `kmdb`. This chapter is intended for operating system kernel developers and device driver developers.

[Chapter 8, “Kernel Debugging Modules,”](#) describes the set of loadable debugger commands that are provided for debugging the Oracle Solaris kernel. This chapter is intended for users who intend to examine kernel crash dumps and for kernel software developers.

Chapter 9, “Debugging With the Kernel Memory Allocator,” describes the debugging features of the Oracle Solaris kernel memory allocator and the MDB commands provided to take advantage of these features. This chapter is intended for advanced programmers and kernel software developers.

Chapter 10, “Module Programming API,” describes the facilities for writing loadable debugger modules. This chapter is intended for advanced programmers and software developers who intend to develop custom debugging support for MDB.

Appendix A, “MDB Options,” provides a reference for MDB command-line options.

Appendix B, “Notes,” provides warnings and notes about using the debugger.

Appendix C, “Transition From `adb` and `kadb`,” provides a reference for `adb` commands and their MDB equivalents. The `adb` command is implemented by `mdb`.

Appendix D, “Transition From `crash`,” provides a reference for `crash` commands and their MDB equivalents. The `crash` command is no longer present in the Oracle Solaris OS.

Related Books and Papers

The following books and papers are recommended and related to the tasks that you need to perform:

- Uresh Vahalia; *UNIX Internals: The New Frontiers*; Prentice Hall; 2010; ISBN 978-0130210340
- Richard McDougall, Jim Mauro; *Solaris Internals: Solaris 10 and OpenSolaris Kernel Architecture*; Prentice Hall; 2006; ISBN 978-0131482098
- Richard McDougall, Jim Mauro, Brendan Gregg; *Solaris Performance and Tools: DTrace and MDB Techniques for Solaris 10 and OpenSolaris*; Prentice Hall; 2006; ISBN 978-0131568198
- David L. Weaver (editor); *OpenSPARC Internals*; Lulu.com; 2008; ISBN 978-0557019748
- SPARC International; *The SPARC Architecture Manual*, Version 9; Prentice Hall; 1993; ISBN 978-0130992277
- *AMD64 Architecture Programmer's Manual*; Advanced Micro Devices; 2006; available at <http://developer.amd.com/>
- Intel Corporation; *Pentium Pro Family Developer's Manual*; McGraw-Hill Companies; 1996; ISBN 978-1555122607
- Jeff Bonwick, Jonathan Adams; *Magazines and Vmem: Extending the Slab Allocator to Many CPUs and Arbitrary Resources*; Proceedings of the 2001 USENIX Annual Technical Conference; 2001; available at http://www.usenix.org/publications/library/proceedings/usenix01/full_papers/bonwick/bonwick_html/

- Jeff Bonwick; *The Slab Allocator: An Object-Caching Kernel Memory Allocator*; Proceedings of the Summer 1994 Usenix Conference; 1994; available at <http://www.usenix.org/publications/Library/proceedings/bos94/bonwick.html>
- *SPARC Assembly Language Reference Manual*
- *x86 Assembly Language Reference Manual*
- *Writing Device Drivers*
- *STREAMS Programming Guide*
- *Linker and Libraries Guide*

Third-party URLs are referenced in this document and provide additional, related information.

Note – Oracle is not responsible for the availability of third-party web sites mentioned in this document. Oracle does not endorse and is not responsible or liable for any content, advertising, products, or other materials that are available on or through such sites or resources. Oracle will not be responsible or liable for any actual or alleged damage or loss caused or alleged to be caused by or in connection with use of or reliance on any such content, goods, or services that are available on or through such sites or resources.

Documentation, Support, and Training

See the following web sites for additional resources:

- [Documentation \(http://docs.sun.com\)](http://docs.sun.com)
- [Support \(http://www.oracle.com/us/support/systems/index.html\)](http://www.oracle.com/us/support/systems/index.html)
- [Training \(http://education.oracle.com\)](http://education.oracle.com) – Click the Sun link in the left navigation bar.

Oracle Software Resources

Oracle Technology Network (<http://www.oracle.com/technetwork/index.html>) offers a range of resources related to Oracle software:

- Discuss technical problems and solutions on the [Discussion Forums \(http://forums.oracle.com\)](http://forums.oracle.com).
- Get hands-on step-by-step tutorials with [Oracle By Example \(http://www.oracle.com/technetwork/tutorials/index.html\)](http://www.oracle.com/technetwork/tutorials/index.html).
- Download [Sample Code \(http://www.oracle.com/technology/sample_code/index.html\)](http://www.oracle.com/technology/sample_code/index.html).

Typographic Conventions

The following table describes the typographic conventions that are used in this book.

TABLE P-1 Typographic Conventions

Typeface	Meaning	Example
AaBbCc123	The names of commands, files, and directories, and onscreen computer output	Edit your <code>.login</code> file. Use <code>ls -a</code> to list all files. <code>machine_name%</code> you have mail.
AaBbCc123	What you type, contrasted with onscreen computer output	<code>machine_name%</code> su Password:
<i>aabbcc123</i>	Placeholder: replace with a real name or value	The command to remove a file is <i>rm filename</i> .
<i>AaBbCc123</i>	Book titles, new terms, and terms to be emphasized	Read Chapter 6 in the <i>User's Guide</i> . <i>A cache</i> is a copy that is stored locally. Do <i>not</i> save the file. Note: Some emphasized items appear bold online.

Shell Prompts in Command Examples

The following table shows the default UNIX system prompt and superuser prompt for shells that are included in the Oracle Solaris OS. Note that the default system prompt that is displayed in command examples varies, depending on the Oracle Solaris release.

TABLE P-2 Shell Prompts

Shell	Prompt
Bash shell, Korn shell, and Bourne shell	\$
Bash shell, Korn shell, and Bourne shell for superuser	#
C shell	<code>machine_name%</code>
C shell for superuser	<code>machine_name#</code>

Modular Debugger Overview

The Modular Debugger (MDB) is a general purpose debugging tool for the Oracle Solaris OS whose primary feature is its extensibility. This book describes how to use MDB to debug complex software systems, with a particular emphasis on the facilities available for debugging the Oracle Solaris kernel and associated device drivers and modules. The book also includes a complete reference for and discussion of the MDB language syntax, debugger features, and MDB Module Programming API.

Introduction

Debugging is the process of analyzing the execution and state of a software program in order to remove defects. Traditional debugging tools provide facilities for execution control so that programmers can execute programs in a controlled environment and display the current state of program data or evaluate expressions in the source language used to develop the program. Unfortunately, these techniques are often inappropriate for debugging complex software systems.

The following examples describe complex software systems that MDB is well suited to examine and debug:

- An operating system, where bugs might not be reproducible and program state is massive and distributed
- Programs that are highly optimized or have had their debug information removed
- Programs that are themselves low-level debugging tools
- Customer situations where the developer can only access post-mortem information

MDB provides a completely customizable environment for debugging these programs and scenarios, including a dynamic module facility that you can use to implement your own debugging commands to perform program-specific analysis. Each MDB module can be used to examine the program in several different contexts, including live and post-mortem. The Oracle Solaris OS includes a set of MDB modules that help you debug the kernel and related device

drivers and kernel modules. Third-party developers might want to develop and deliver their own debugging modules for supervisor or user software.

MDB Features

MDB provides an extensive collection of features for analyzing the Oracle Solaris kernel and other target programs.

The following examples show some of the tasks you can do with MDB:

- Perform post-mortem analysis of kernel crash dumps and user process core dumps. MDB includes a collection of debugger modules that facilitate sophisticated analysis of kernel and process state, in addition to standard data display and formatting capabilities.

These debugger modules enable you to formulate complex queries to investigate kernel and process state in the following ways:

- Locate all the memory allocated by a particular thread
- Print a visual picture of a kernel STREAM
- Determine what type of structure a particular address refers to
- Locate leaked memory blocks in the kernel
- Analyze memory to locate stack traces
- Use a first-class programming API to implement your own debugger commands and analysis tools without having to recompile or modify MDB. In MDB, debugging support is implemented as a set of loadable modules (shared libraries that the debugger can open with the `dlopen(3C)` function), each of which provides a set of commands that extends the capabilities of MDB. MDB provides an API of core services, such as the ability to read and write memory and access symbol table information. MDB provides a framework for you to implement debugging support for your own drivers and modules. Your command and tools can then be made available for everyone to use.
- Learn to use MDB if you are already familiar with the legacy debugging tools `adb` and `crash`. MDB provides backward compatibility with these existing debugging solutions. The MDB language is a superset of the `adb` language. All existing `adb` macros and commands work within MDB. Thus, developers who use `adb` can immediately use MDB without knowing any MDB-specific commands. MDB also provides commands that surpass the functionality available from the `crash` utility.
- Benefit from enhanced usability features.

MDB provides many usability features, including the following:

- Command-line editing
- Command history
- Built-in output pager
- Syntax error checking and handling
- Online help

- Interactive session logging

Using MDB

MDB is available on Oracle Solaris systems as two commands that share common features: `mdb` and `kmdb`. You can use the `mdb` command interactively or in scripts to debug live user processes, user process core files, kernel crash dumps, the live operating system, object files, and other files. You can use the `kmdb` command to debug the live operating system kernel and device drivers when you also need to control and halt the execution of the kernel. To start `mdb`, use the `mdb` command as described in the [mdb\(1\)](#) man page. To start `kmdb`, boot the system as described in the [kmdb\(1\)](#) man page, or execute the `mdb` command with the `-K` option.

Future Enhancements

MDB provides a stable foundation for developing advanced post-mortem analysis tools. You can use MDB to debug existing software programs, and you can develop your own modules to improve your ability to debug your own Oracle Solaris drivers and applications.

Debugger Concepts

This chapter discusses the significant features of MDB and the benefits derived from this architecture.

Building Blocks

The **target** is the program being inspected by the debugger.

MDB provides support for the following types of targets:

- User processes
- User process core files
- Live operating system without kernel execution control (through `/dev/kmem` and `/dev/ksyms`)
- Live operating system with kernel execution control (through the `kmdb(1)` command)
- Operating system crash dumps
- User process images recorded inside an operating system crash dump
- ELF object files
- Raw data files

Each target exports a standard set of properties, including one or more address spaces, one or more symbol tables, a set of load objects, and a set of threads. [Figure 2-1](#) shows an overview of the MDB architecture, including two of the built-in targets and a pair of sample modules.

A debugger command, or **dcmd** (pronounced *dee-command*) in MDB terminology, is a routine in the debugger that can access any of the properties of the current target. MDB parses commands from standard input, then executes the corresponding dcmds. Each dcmd can also accept a list of string or numerical arguments, as shown in [“Syntax” on page 23](#). MDB contains a set of built-in dcmds that are always available. These built-in dcmds are described in

Chapter 5, “Built-In Commands.” You can also extend the capabilities of MDB by writing dcmds using a programming API provided with MDB.

A **walker** is a set of routines that describe how to walk, or iterate, through the elements of a particular program data structure. A walker encapsulates the data structure's implementation from dcmds and from MDB. You can use walkers interactively, or you can use walkers as primitives to build other dcmds or walkers. As with dcmds, you can extend MDB by implementing additional walkers as part of a debugger module.

A debugger module, or **dmod** (pronounced *dee-mod*), is a dynamically loaded library that contains a set of dcmds and walkers. During initialization, MDB attempts to load dmods corresponding to the load objects present in the target. You can subsequently load or unload dmods at any time while running MDB. MDB provides a set of standard dmods for debugging the Oracle Solaris kernel.

A **macro file** is a text file that contains a set of commands to execute. Macro files are typically used to automate the process of displaying a simple data structure. MDB provides complete backward compatibility for the execution of macro files written for adb. The set of macro files provided with the Oracle Solaris installation can therefore be used with either tool.

FIGURE 2-1 MDB architecture

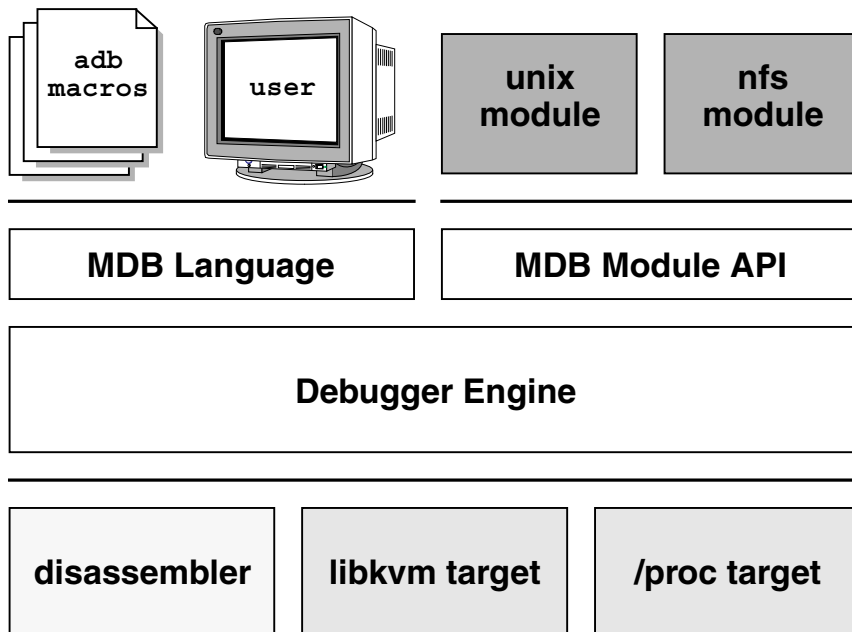

Modularity

The benefit of MDB's modular architecture extends beyond the ability to load a module containing additional debugger commands. The MDB architecture defines clear interface boundaries between each of the layers shown in [Figure 2–1](#). Macro files execute commands written in the MDB or `adb` language. Dcmds and walkers in debugger modules are written using the MDB Module API. The MDB Module API is the basis of an application binary interface that allows the debugger and its modules to evolve independently.

The MDB name space of walkers and dcmds also defines a second set of layers between debugging code. These layers maximize code sharing and limit the amount of code that must be modified as the target program evolves. For example, one of the primary data structures in the Oracle Solaris kernel is the list of `proc_t` structures that represent active processes in the system. The `::ps` dcmd must iterate over this list in order to produce its output. However, the code to iterate over the list is not in the `::ps` dcmd. The code to iterate over the list of `proc_t` structures is encapsulated in the `genunix` module's `proc` walker.

MDB provides both `::ps` and `::ptree` dcmds, but neither of these dcmds has any knowledge of how `proc_t` structures are accessed in the kernel. Instead, these dcmds invoke the `proc` walker programmatically and format the set of returned structures appropriately. If the data structure used for `proc_t` structures ever changed, MDB could provide a new `proc` walker, and none of the dependent dcmds would need to change. The `proc` walker can also be accessed interactively using the `::walk` dcmd in order to create novel commands as you work during a debugging session.

In addition to facilitating layering and code sharing, the MDB Module API provides dcmds and walkers with a single stable interface for accessing various properties of the underlying target. The same API functions are used to access information from user process or kernel targets, simplifying the task of developing new debugging facilities.

In addition, you can use a custom MDB module to perform debugging tasks in a variety of contexts. For example, you might want to develop an MDB module for a user program you are developing. Once you have done so, you can use this module when MDB examines a live process executing your program, a core dump of your program, or even a kernel crash dump taken on a system where your program was executing.

The Module API provides facilities for accessing the following target properties:

Address Spaces	The module API provides facilities for reading and writing data from the target's virtual address space. Functions for reading and writing using physical addresses are also provided for kernel debugging modules.
Symbol Tables	The module API provides access to the static and dynamic symbol tables of the target's primary executable file, its

runtime link-editor, and a set of load objects. Load objects are shared libraries in a user process or loadable modules in the Oracle Solaris kernel.

External Data

The module API provides a facility for retrieving a collection of named external data buffers associated with the target. For example, MDB provides programmatic access to the `proc(4)` structures associated with a user process or user core file target.

In addition, you can use built-in MDB `dcmds` to access information about target memory mappings, load objects, register values, and control the execution of user process targets.

MDB Language Syntax

This chapter describes the MDB language syntax, operators, and rules for command and symbol name resolution.

- “Syntax” on page 23
- “Commands” on page 25
- “Comments” on page 26
- “Arithmetic Expansion” on page 26
- “Quoting” on page 28
- “Shell Escapes” on page 28
- “Variables” on page 28
- “Symbol Name Resolution” on page 29
- “Dcmd and Walker Name Resolution” on page 34
- “Dcmd Pipelines” on page 34
- “Formatting Dcmds” on page 35

Syntax

MDB processes commands from standard input. If standard input is a terminal, MDB provides terminal editing capabilities. MDB can also process commands from macro files and from dcmd pipelines.

The MDB language syntax defines the following behavior:

1. Compute the value of an expression. This value typically is a memory address in the target. The current address location is referred to as **dot**. Use the dot or period character (.) to reference the value of the current address.
2. Apply a dcmd to the computed address.

A **metacharacter** is a newline, space, or tab character, or one of the following characters:

[] | ! / \ ? = > \$: ;

A **blank** is a space or tab character.

A **word** is a sequence of characters separated by one or more non-quoted metacharacters.

An **expression** is a sequence of words that is evaluated to compute a 64-bit unsigned integer value. The words are evaluated using the rules described in [“Arithmetic Expansion” on page 26](#).

An **identifier** is a sequence of letters, digits, underscores, periods, or back quotation marks. An identifier begins with a letter, underscore, or period. Identifiers are used as the names of symbols, variables, dcmds, and walkers. Commands are delimited by a newline or semicolon (;).

A **dcmd** is denoted by one of the following words or metacharacters:

/ \ ? = > \$character :character ::identifier

Dcmds named by metacharacters or prefixed by a single dollar sign (\$) or colon character (:) are provided as built-in **operators**. These dcmds implement complete compatibility with the command set of the legacy `adb(1)` utility. After a dcmd has been parsed, the /, \, ?, =, >, \$, and : characters are no longer recognized as metacharacters until the termination of the argument list.

A **simple-command** is a dcmd followed by a sequence of zero or more blank-separated words. The words are passed as arguments to the invoked dcmd, except as specified under [“Arithmetic Expansion” on page 26](#) and [“Quoting” on page 28](#).

Each dcmd returns an exit status value that indicates one of the following occurred:

- The dcmd succeeded.
- The dcmd failed.
- The dcmd was invoked with invalid arguments.

A **pipeline** is a sequence of one or more simple-commands, each separated by the vertical bar or pipe character (|). After the pipeline has been parsed, each dcmd is invoked in order from left to right. The output of each dcmd is processed and stored as described in [“Dcmd Pipelines” on page 34](#). After the first dcmd in the pipeline is complete, its processed output is used as input for the second dcmd in the pipeline. When the second dcmd is complete, its output is used as input for the third dcmd in the pipeline, and so on. If any dcmd does not return a successful exit status, the pipeline is aborted.

Commands

A **command** is one of the following:

pipeline [! word ...] [;]

A simple-command or pipeline can be optionally followed by the exclamation point or bang character (!), indicating that the debugger should open a [pipe\(2\)](#). The standard output of the last dcmd in the MDB pipeline is sent to an external process created by executing \$SHELL -c followed by the string formed by concatenating the words after the ! character. For more details, refer to “[Shell Escapes](#)” on page 28.

expression pipeline [! word ...] [;]

A simple-command or pipeline can be prefixed with an expression. Before execution of the pipeline, any occurrence of the dot or period character (.) in the pipeline is set to the value of the expression.

expression1 , expression2 pipeline [! word ...] [;]

A simple-command or pipeline can be prefixed with two expressions. The value of the first expression is the new value of dot. The value of the second expression is a repeat count for the first dcmd in the pipeline. The first dcmd in the pipeline is executed *expression2* times before the next dcmd in the pipeline is executed. The repeat count applies only to the first dcmd in the pipeline.

, expression pipeline [! word ...] [;]

If the first expression is omitted, dot is not modified. The value of the second expression (the expression after the comma character) is used exactly the same way as *expression2* above.

expression [! word ...] [;]

A command can consist of only an arithmetic expression. The value of the expression is the new value of dot. The previous dcmd pipeline is re-executed using the new value of dot.

expression1 , expression2 [! word ...] [;]

A command can consist of only a dot expression and repeat count expression. The value of *expression1* is the new value of dot. The previous dcmd pipeline is re-executed *expression2* times using the new value of dot.

, expression [! word ...] [;]

If the first expression is omitted, dot is not modified. The value of the second expression (the expression after the comma character) is used exactly the same way as *expression2* above.

! word ... [;]

If the command begins with the ! character, no dcmds are executed. The debugger executes \$SHELL -c followed by the string formed by concatenating the words after the ! character.

Comments

A word that begins with two forward slash characters (`//`) causes that word and all the subsequent characters up to a newline to be ignored.

Arithmetic Expansion

Arithmetic expansion is performed to determine the value of an expression. MDB commands can be preceded by expressions that represent a start address or a repeat count. Arithmetic expansion can also be performed to compute a numeric argument for a `dcmd`. An expression can appear in an argument list enclosed in square brackets preceded by a dollar sign (`[$expr]`). In this case, the expression is replaced by its arithmetic value.

Expressions can contain any of the following special words:

<i>integer</i>	The specified integer value. Integer values can be prefixed with <code>0i</code> or <code>0I</code> to indicate binary values, <code>0o</code> or <code>0O</code> to indicate octal values, <code>0t</code> or <code>0T</code> to indicate decimal values, and <code>0x</code> or <code>0X</code> to indicate hexadecimal values (the default).
<code>0[tT][0-9]+.[0-9]+</code>	The specified decimal floating point value, converted to its IEEE double-precision floating point representation.
<code>'ccccccc'</code>	The integer value computed by converting each character to a byte equal to its ASCII value. Up to eight characters can be specified in a character constant. Characters are packed into the integer in reverse order (right-to-left), beginning at the least significant byte.
<code><identifier</code>	The value of the variable named by <i>identifier</i> .
<i>identifier</i>	The value of the symbol named by <i>identifier</i> .
<i>(expression)</i>	The value of <i>expression</i> .
<code>.</code>	The value of dot.
<code>&</code>	The most recent value of dot used to execute a <code>dcmd</code> .
<code>+</code>	The value of dot incremented by the current increment.
<code>^</code>	The value of dot decremented by the current increment.

The increment is a global variable that stores the total bytes read by the last formatting `dcmd`. For more information on the increment, refer to the discussion of “[Formatting Dcmds](#)” on [page 35](#).

Unary Operators

Unary operators are right associative and have higher precedence than binary operators. The unary operators are:

<i>#expression</i>	Logical negation
<i>~expression</i>	Bitwise complement
<i>-expression</i>	Integer negation
<i>%expression</i>	Value of a pointer-sized quantity at the object file location corresponding to virtual address <i>expression</i> in the target's virtual address space
<i>%[csil]/expression</i>	Value of a char-sized, short-sized, int-sized, or long-sized quantity at the object file location corresponding to virtual address <i>expression</i> in the target's virtual address space
<i>%[1248]/expression</i>	Value of a one-byte, two-byte, four-byte, or eight-byte quantity at the object file location corresponding to virtual address <i>expression</i> in the target's virtual address space
<i>*expression</i>	Value of a pointer-sized quantity at virtual address <i>expression</i> in the target's virtual address space
<i>*/[csil]/expression</i>	Value of a char-sized, short-sized, int-sized, or long-sized quantity at virtual address <i>expression</i> in the target's virtual address space
<i>*/[1248]/expression</i>	Value of a one-byte, two-byte, four-byte, or eight-byte quantity at virtual address <i>expression</i> in the target's virtual address space

Binary Operators

Binary operators are left associative and have lower precedence than unary operators. The binary operators, in order of precedence from highest to lowest, are:

*	Integer multiplication
%	Integer division
#	Left-hand side rounded up to next multiple of right-hand side
+	Integer addition
-	Integer subtraction
<<	Bitwise shift left
>>	Bitwise shift right

==	Logical equality
!=	Logical inequality
&	Bitwise AND
^	Bitwise exclusive OR
	Bitwise inclusive OR

Quoting

Each metacharacter described in “Syntax” on page 23 terminates a word unless the metacharacter is quoted. Characters can be quoted by enclosing them in a pair of single quotation marks (') or double quotation marks ("). Quoting characters forces MDB to interpret each character as itself without any special significance. A single quotation mark cannot appear inside single quotation marks. Inside double quotation marks, MDB recognizes the C programming language character escape sequences.

Shell Escapes

The ! character can be used to create a pipeline between an MDB command and the user's shell. Shell escapes are available only when using mdb and not when using kmdb. If the \$SHELL environment variable is set, MDB will fork and exec this \$SHELL program for shell escapes. If \$SHELL is not set, /bin/sh is used. The shell is invoked with the -c option followed by a string formed by concatenating the words after the ! character.

The ! character takes precedence over all other metacharacters, except semicolon (;) and newline. After a shell escape is detected, the remaining characters up to the next semicolon or newline are passed “as is” to the shell. The output of shell commands cannot be piped to MDB dcmds. The output of commands executed by a shell escape is sent directly to the terminal, not to MDB.

Variables

A **variable** is a variable name, a corresponding integer value, and a set of attributes. A variable name is a sequence of letters, digits, underscores, or periods. Use the > dcmd or :: typeset dcmd to assign a value to a variable. Use the :: typeset dcmd to manipulate the attributes of a variable. Each variable's value is represented as a 64-bit unsigned integer. A variable can have one or more of the following attributes: read-only (cannot be modified by the user), persistent (cannot be unset by the user), and tagged (user-defined indicator).

The following variables are defined as persistent:

0	Most recent value printed using the /, \, ?, or = dcmd.
9	Most recent count used with the \$< dcmd.
b	Virtual address of the base of the data section.
cpuid	The CPU identifier corresponding to the CPU on which kmdb is currently executing.
d	Size of the data section in bytes.
e	Virtual address of the entry point.
hits	The count of the number of times the matched software event specifier has been matched. See “Event Callbacks” on page 60 .
m	Initial bytes (magic number) of the target's primary object file, or zero if no object file has been read yet.
t	Size of the text section in bytes.
thread	The thread identifier of the current representative thread. The value of the identifier depends on the threading model used by the current target. See “Thread Support” on page 60 .

In addition, the MDB kernel and process targets export the current values of the representative thread's register set as named variables. The names of these variables depend on the target's platform and instruction set architecture.

Symbol Name Resolution

As explained in [“Syntax” on page 23](#), a symbol identifier in an expression evaluates to the value of that symbol. The value typically denotes the virtual address of the storage associated with the symbol in the target's virtual address space.

Tip – In the case of a naming conflict between a symbol and a hexadecimal integer value, MDB attempts to evaluate an ambiguous token as a symbol first, before evaluating it as an integer value. For example, the token `f` can refer to the decimal integer value 15 specified in hexadecimal (the default base), or `f` can refer to a global variable in the symbol table of the target. To avoid ambiguity, use an explicit `0x` or `0X` prefix to specify an integer value.

Symbol Tables

A target can support multiple symbol tables. The following examples are some of the symbol tables that a target can support:

- Primary executable symbol table
- Primary dynamic symbol table
- Runtime link-editor symbol table
- Standard and dynamic symbol tables for each of a number of load objects (such as shared libraries in a user process, or kernel modules in the Oracle Solaris kernel)

The target typically searches the symbol tables of the primary executable first, then one or more of the other symbol tables. Note that ELF symbol tables contain only entries for external, global, and static symbols. Automatic symbols do not appear in the symbol tables processed by MDB.

Additionally, MDB provides a private user-defined symbol table that is searched prior to any of the target symbol tables. The private symbol table is initially empty. Use the `::nmadd` and `::nmde1` dcmts to manipulate the private symbol table.

Use the `::nm -P` dcmt to display the contents of the private symbol table. The private symbol table enables you to create symbol definitions for program functions or data that were either missing from the original program or stripped out. These definitions are then used whenever MDB converts a symbolic name to an address, or converts an address to the nearest symbol.

Symbol Name Scoping

A target can support multiple symbol tables, and each symbol table can include symbols from multiple object files. Therefore, different symbols with the same name can exist. When two different symbols have the same name, use the symbol-name scoping operator to obtain the value of the desired symbol. The symbol-name scoping operator is the back quotation mark (`'`).

Use one of the following three forms to specify the scope used to resolve a symbol name:

*object'*name
*file'*name
*object'**file'*name

The *object* identifier refers to the name of a load object. The *file* identifier refers to the base name of a source file that has a symbol of type `STT_FILE` in the specified object's symbol table. Interpretation of the *object* identifier depends on the target type. A target can be a process target or a kernel target.

Scoping Within User-Level Applications and Shared Libraries

The MDB **process target** expects *object* to specify the name of the executable or of a loaded shared library.

Object Identifier

The *object* identifier can take any of the following four forms:

- Exact match (that is, a full path name): `/usr/lib/libc.so.1`
- Exact basename match: `libc.so.1`
- Initial basename match up to a period or dot character (.) suffix: `libc.so` or `libc`
- Literal string `a.out`, which is accepted as an alias for the executable

Link Map Identifier

The process target also accepts any of the four forms described above preceded by an optional link-map id (`lmid`). The `lmid` prefix is specified by an initial `LM` followed by the link-map id in hexadecimal followed by an additional back quotation mark (`'`). For example, the following symbol name evaluates to the value of the `_init` symbol in the `libc.so.1` library that is loaded on link-map 0 (`LM_ID_BASE`):

```
LM0'libc.so.1'_init
```

The link-map specifier might be necessary to resolve symbol naming conflicts if the same library is loaded on more than one link map. For more information on link maps, refer to the [Linker and Libraries Guide](#) and the `dlopen(3C)` man page. Link-map identifiers are displayed when symbols are printed according to the setting of the `showlmid` option, as described in “[Summary of MDB Command-Line Options](#)” on page 141.

Scoping Within the Kernel

The MDB **kernel target** expects *object* to specify the base name of a loaded kernel module. For example, the following symbol name evaluates to the value of the `_init` symbol in the `specfs` kernel module:

```
specfs'_init
```

Kernel Debug Information

MDB uses CTF debug information to read and display structures correctly. CTF (Compact C Type Format) is a reduced form of debug information similar to DWARF and stab. CTF describes types (structures, unions, and typedefs, for example) and function prototypes. Oracle Solaris kernel binaries embed CTF data as an ELF section (`.SUNW_ctf`).

As much as possible, CTF data is stored in one place to minimize duplication of common types. Other occurrences of each type reference the one unique definition. When a kernel update is released, existing CTF structure definitions must be preserved because some kernel modules might not be updated and might still be using the old definitions. When a kernel update is released but not all modules are updated, the CTF definitions are held in the module in which they are defined. When you use MDB to examine a crash dump, you might see a message that the structure you want to examine does not exist, or you might see an indication that the structure has changed. If the structure definition has changed, the data might look corrupt, for example. If you encounter either of these conditions, use the scoping operator to specify the module where the structure is defined.

Using the Scoping Operator With a Kernel Module

The `genunix` module contains many common types. The `ip` module also contains types that are used by many kernel modules but that are not found in `genunix`. Therefore, you might need to use scoping with the `ip` module more often than with other kernel modules.

Notice the use of the scoping operator with the `ip` module in the second versions of the following examples.

EXAMPLE 3-1 Failed To Find Member of Structure

```
> ::print -at conn_t conn_udp
mdb: failed to find member conn_udp of conn_t: no such member of structure or union
>
> ::print -at ip!conn_t conn_udp
30 struct udp_s *conn_udp
>
```

EXAMPLE 3-2 Data Looks Wrong: The Structure Definition Might Have Changed

```
> 0x300b038cc38::print queue_t q_ptr | ::print -at conn_t
{
  3021e581780 kmutex_t conn_lock = {
    3021e581780 void *[1] _opaque = [ 0 ]
  }
  3021e581788 uint32_t conn_ref = 0x3
  3021e58178c uint_t conn_state_flags = 0
  3021e581790 ire_t *conn_ire_cache = 0x600b102f598
  3021e581798 uint32_t conn_flags = 0x49000001
  3021e58179c unsigned conn_on_sq = 0
  3021e58179c unsigned conn_dontroute = 0
  3021e58179c unsigned conn_loopback = 0
}
```

EXAMPLE 3-2 Data Looks Wrong: The Structure Definition Might Have Changed (Continued)

```

3021e58179c unsigned conn_broadcast = 0
3021e58179c unsigned conn_reuseaddr = 1
3021e58179c unsigned conn_multicast_loop = 0
3021e58179c unsigned conn_multi_router = 0
3021e58179c unsigned conn_draining = 0
3021e58179d unsigned conn_did_putbq = 0
3021e58179d unsigned conn_unspec_src = 0
3021e58179d unsigned conn_policy_cached = 0
3021e58179d unsigned conn_in_enforce_policy = 0
3021e58179d unsigned conn_out_enforce_policy = 0
3021e58179d unsigned conn_af_isv6 = 0
3021e58179d unsigned conn_pkt_isv6 = 0
3021e58179d unsigned conn_ipv6_rcvpcinfo = 0
3021e58179e unsigned conn_ipv6_rcvphoplmit = 0
3021e58179e unsigned conn_ipv6_rcvhopopts = 0
3021e58179e unsigned conn_ipv6_rcvdstopts = 0
3021e58179e unsigned conn_ipv6_rcvrthdr = 0
3021e58179e unsigned conn_ipv6_rcvrtdstopts = 0
3021e58179e unsigned conn_ipv6_v6only = 0
3021e58179e unsigned conn_ipv6_rcvtclass = 0
3021e58179e unsigned conn_ipv6_rcvpathmtu = 0
3021e58179f unsigned conn_pathmtu_valid = 0
3021e58179f unsigned conn_ipv6_dontfrag = 0
3021e58179f unsigned conn_fully_bound = 1
3021e58179f unsigned conn_recvif = 0
3021e58179f unsigned conn_recvlla = 0
3021e58179f unsigned conn_mdt_ok = 0
3021e58179f unsigned pad_to_bit_31 = 0
3021e5817a0 tcp_t *conn_tcp = 0
3021e5817a8 squeue_t *conn_sqp = 0x3021e581980
3021e5817b0 edesc_rpf conn_recv = 0
3021e5817b8 void *conn_pad1 = 0x600b082ba40 // Should have 0's in this field. Data looks
3021e5817c0 ill_t *conn_xmit_if_ill = tcp_input // wrong starting from the conn_pad1 field.
3021e5817c8 ill_t *conn_nofailover_ill = 0
3021e5817d0 ipsec_latch_t *conn_latch = 0
3021e5817d8 ill_t *conn_outgoing_ill = 0
3021e5817e0 edesc_spf conn_send = 0
3021e5817e8 queue_t *conn_rq = 0
3021e5817f0 queue_t *conn_wq = ip_output
3021e5817f8 dev_t conn_dev = 0
...
}

> 0x300b038cc38::print queue_t q_ptr | ::print -at ip'conn_t
{
....
3021e5817c8 void *conn_pad1 = 0 // Now the data looks correct from here on.
3021e5817d0 ill_t *conn_xmit_if_ill = 0
3021e5817d8 ill_t *conn_nofailover_ill = 0
3021e5817e0 ipsec_latch_t *conn_latch = 0
3021e5817e8 ill_t *conn_outgoing_ill = 0
3021e5817f0 edesc_spf conn_send = ip_output
3021e5817f8 queue_t *conn_rq = 0
3021e581800 queue_t *conn_wq = 0

```

EXAMPLE 3-2 Data Looks Wrong: The Structure Definition Might Have Changed (Continued)

```
3021e581808 dev_t conn_dev = 0x1d2b
...
}
```

Dcmd and Walker Name Resolution

As described earlier, each MDB dmod provides a set of dcmds and walkers. Dcmds and walkers are tracked in two distinct, global namespaces. MDB also keeps track of a dcmd and walker namespace associated with each dmod. Identically named dcmds or walkers within a given dmod are not allowed. A dmod with this type of naming conflict will fail to load.

Name conflicts between dcmds or walkers from different dmods are allowed in the global namespace. In the case of a conflict, the first dcmd or walker with that particular name to be loaded is given precedence in the global namespace. Alternate definitions are kept in a list in load order.

Use the backquote character (`) in a dcmd or walker name as a scoping operator to select an alternate definition. For example, if dmods `m1` and `m2` each provide a dcmd `d`, and `m1` is loaded prior to `m2`, then you can use the scoping operator as shown below to specify the dcmd you want:

```
::d      Executes m1's definition of d
::m1'd   Executes m1's definition of d
::m2'd   Executes m2's definition of d
```

If module `m1` is unloaded, the next dcmd on the global definition list (`m2'd`) is promoted to global visibility. Use the `::which` dcmd to determine the current definition of a dcmd or walker. Use the `::which -v` dcmd to display the global definition list.

Dcmd Pipelines

Use the vertical bar (`|`) operator to pipeline dcmds. The purpose of a pipeline is to pass values from one dcmd or walker to another. The values passed usually are virtual addresses. Pipeline stages might be used to map a pointer from one type of data structure to a pointer to a corresponding data structure, to sort a list of addresses, or to select the addresses of structures with certain properties.

MDB executes each dcmd in the pipeline in order from left to right. The left-most dcmd is executed using the current value of dot, or using the value specified by an explicit expression at

the start of the command. A pipe operator (`|`) causes MDB to create a shared buffer between the output of the dcmd to its left and the MDB parser, and an empty list of values.

As the dcmd executes, its standard output is placed in the pipe and then consumed and evaluated by the parser, as if MDB were reading this data from standard input. Each line must consist of an arithmetic expression terminated by a newline or semicolon (`;`). The value of the expression is appended to the list of values associated with the pipe. If a syntax error is detected, the pipeline is aborted.

When the dcmd to the left of a `|` operator completes, the list of values associated with the pipe is then used to invoke the dcmd to the right of the `|` operator. For each value in the list, dot is set to this value, and the right-hand dcmd is executed. Only the output of the rightmost dcmd in the pipeline is written to standard output. If any dcmd in the pipeline produces output to standard error, these messages are written directly to standard error and are not processed as part of the pipeline.

Formatting Dcmds

The `/`, `\`, `?`, and `=` metacharacters are used to denote the special output formatting dcmds. Each of these dcmds accepts an argument list consisting of one or more format characters, repeat counts, or quoted strings. A format character is one of the ASCII characters described below.

Format characters are used to read and format data from the target. A repeat count is a positive integer preceding the format character that is always interpreted in base 10 (decimal). A repeat count can also be specified as an expression enclosed in square brackets preceded by a dollar sign (`[$expr]`). A string argument must be enclosed in double quotation marks ("`str`"). No blanks are necessary between format arguments.

The formatting dcmds are:

- `/` Display data from the target's virtual address space starting at the virtual address specified by dot.
- `\` Display data from the target's physical address space starting at the physical address specified by dot.
- `?` Display data from the target's primary object file starting at the object file location corresponding to the virtual address specified by dot.
- `=` Display the value of dot in each of the specified data formats. The `=` dcmd is useful for converting between bases and performing arithmetic.

In addition to dot, MDB keeps track of another global value called the **increment**. The increment represents the distance between dot and the address following all the data read by the last formatting dcmd.

For example, let dot equal address *addr*, where *addr* displays as a 4-byte integer. After a formatting dcmd is executed with dot equal to *addr*, the increment is set to 4. The plus (+) operator, described in “[Arithmetic Expansion](#)” on page 26, would now evaluate to the value *A+4*, and could be used to reset dot to the address of the next data object for a subsequent dcmd.

Most format characters increase the value of the increment by the number of bytes corresponding to the size of the data format. The number of bytes in various data formats are shown below. Use the `::formats dcmd` to display the list of format characters from within MDB.

The format characters are:

- + Increment dot by the count (variable size)
- Decrement dot by the count (variable size)
- B Hexadecimal int (1 byte)
- C Character using C character notation (1 byte)
- D Decimal signed int (4 bytes)
- E Decimal unsigned long long (8 bytes)
- F Double (8 bytes)
- G Octal unsigned long long (8 bytes)
- H Swap bytes and shorts (4 bytes)
- I Address and disassembled instruction (variable size)
- J Hexadecimal long long (8 bytes)
- K Hexadecimal uintptr_t (4 or 8 bytes)
- N Newline
- O Octal unsigned int (4 bytes)
- P Symbol (4 or 8 bytes)
- Q Octal signed int (4 bytes)
- R Binary int (8 bytes)
- S String using C string notation (variable size)
- T Horizontal tab
- U Decimal unsigned int (4 bytes)
- V Decimal unsigned int (1 byte)
- W Default radix unsigned int (4 bytes)

X	Hexadecimal int (4 bytes)
Y	Decoded time32_t (4 bytes)
Z	Hexadecimal long long (8 bytes)
^	Decrement dot by increment * count (variable size)
a	Dot as symbol+offset
b	Octal unsigned int (1 byte)
c	Character (1 byte)
d	Decimal signed short (2 bytes)
e	Decimal signed long long (8 bytes)
f	Float (4 bytes)
g	Octal signed long long (8 bytes)
h	Swap bytes (2 bytes)
i	Disassembled instruction (variable size)
n	Newline
o	Octal unsigned short (2 bytes)
p	Symbol (4 or 8 bytes)
q	Octal signed short (2 bytes)
r	Whitespace
s	Raw string (variable size)
t	Horizontal tab
u	Decimal unsigned short (2 bytes)
v	Decimal signed int (1 byte)
w	Default radix unsigned short (2 bytes)
x	Hexadecimal short (2 bytes)
y	Decoded time64_t (8 bytes)

You can also use the /, \, and ? formatting dcmds to write to the target's virtual address space, physical address space, or object file. First, specify one of the following modifiers as the first format character, and then specify a list of words. The words in the list are either immediate values or expressions enclosed in square brackets preceded by a dollar sign ($\$[expr]$).

The write modifiers are:

- v Write the lowest byte of the value of each expression to the target beginning at the location specified by dot
- w Write the lowest 2 bytes of the value of each expression to the target beginning at the location specified by dot
- W Write the lowest 4 bytes of the value of each expression to the target beginning at the location specified by dot
- Z Write the complete 8 bytes of the value of each expression to the target beginning at the location specified by dot

You can also use the `/`, `\`, and `?` formatting dcmds to search for a particular integer value in the target's virtual address space, physical address space, and object file, respectively. First specify one of the following modifiers as the first format character, and then specify a value and optional mask. The value and mask are each either immediate values or expressions enclosed in square brackets preceded by a dollar sign.

If only a value is specified, MDB reads integers of the appropriate size and stops at the address that contains the matching value. If a value `V` and mask `M` are specified, MDB reads integers of the appropriate size and stops at the address that contains a value `X` where $(X \& M) == V$. At the completion of the dcmd, dot is updated to the address of the match. If no match is found, dot is left at the last address that was read.

The search modifiers are:

- l Search for the specified 2-byte value
- L Search for the specified 4-byte value
- M Search for the specified 8-byte value

For both user and kernel targets, an address space is typically composed of a set of discontinuous segments. It is not legal to read from an address that does not have a corresponding segment. If a search reaches a segment boundary without finding a match, the search aborts when the read past the end of the segment boundary fails.

Using MDB Commands Interactively

This chapter describes the MDB interactive command line editing and history functions, the output pager, and debugger signal handling.

Command Reentry

The text of the last HISTSIZE (default 128) commands entered from a terminal device is saved in memory. The inline editing facility provides key mappings for searching and fetching elements from the history list.

Inline Editing

If standard input is a terminal device, MDB provides some simple emacs-style facilities for editing the command line. The search, previous, and next commands in edit mode provide access to the history list. Only strings, not patterns, are matched when searching. In the list below, the notation for control characters is the caret character (^) followed by a character shown in uppercase. The notation for escape sequences is M- followed by a character. For example, M-f (pronounced *meta-eff*) is entered by pressing the ESC keyboard key followed by the f key, or by pressing the Meta key followed by the f key on keyboards that support a Meta key. A command line is committed and executed using RETURN or NEWLINE. The edit commands are:

^F	Move cursor forward (right) one character.
M-f	Move cursor forward one word.
^B	Move cursor backward (left) one character.
M-b	Move cursor backward one word.
^A	Move cursor to start of line.
^E	Move cursor to end of line.

<code>^D</code>	Delete current character, if the current line is not empty. If the current line is empty, <code>^D</code> denotes EOF and the debugger will exit.
<code>M-^H</code>	(Meta-backspace) Delete previous word.
<code>^K</code>	Delete from the cursor to the end of the line.
<code>^L</code>	Reprint the current line.
<code>^T</code>	Transpose the current character with the next character.
<code>^N</code>	Fetch the next command from the history. Each time <code>^N</code> is entered, the next command forward in time is retrieved.
<code>^P</code>	Fetch the previous command from the history. Each time <code>^P</code> is entered, the next command backward in time is retrieved.
<code>^R[string]</code>	Search backward in the history for a previous command line containing <i>string</i> . The string should be terminated by a RETURN or NEWLINE. If <i>string</i> is omitted, the previous history element containing the most recent string is retrieved.

The editing mode also interprets the following user-defined sequences as editing commands. User-defined sequences can be read or modified using the `stty(1)` command.

<code>erase</code>	User-defined erase character (usually <code>^H</code> or <code>^?</code>). Delete previous character.
<code>intr</code>	User-defined interrupt character (usually <code>^C</code>). Abort the current command and print a new prompt.
<code>kill</code>	User-defined kill character (usually <code>^U</code>). Kill the entire current command line.
<code>quit</code>	User-defined quit character (usually <code>^\<code></code></code>). Quit the debugger.
<code>suspend</code>	User-defined suspend character (usually <code>^Z</code>). Suspend the debugger.
<code>werase</code>	User-defined word erase character (usually <code>^W</code>). Erase the preceding word.

On keyboards that support an extended keypad with arrow keys, `mdb` interprets these keystrokes as editing commands:

Up arrow	Fetch the previous command from the history (same as <code>^P</code>).
Down arrow	Fetch the next command from the history (same as <code>^N</code>).
Left arrow	Move cursor backward one character (same as <code>^B</code>).
Right arrow	Move cursor forward one character (same as <code>^F</code>).

Keyboard Shortcuts

MDB provides a set of keyboard shortcuts that bind individual keystrokes to common MDB commands when the keystroke listed in the table below is typed as the first character following the MDB prompt. The keyboard shortcuts are:

- [Execute the command `::step over`.
-] Execute the command `::step`.

Output Pager

MDB provides a built-in output pager. The output pager is enabled if the debugger's standard output is a terminal device. Each time a command is executed, `mdb` pauses after each screenful of output is written and displays a pager prompt:

```
>> More [<space>, <cr>, q, n, c, a] ?
```

The following key sequences are recognized by the pager:

SPACE	Display the next screenful of output.
a, A	Abort the current top-level command and return to the prompt.
c, C	Continue displaying output without pausing at each screenful, until the current top-level command is complete.
n, N, NEWLINE, RETURN	Display the next line of output.
q, Q, ^C, ^\	Quit (abort) the current <code>dcmd</code> only.

Signal Handling

MDB ignores the PIPE and QUIT signals. The INT signal aborts the command that is currently executing. The debugger intercepts and provides special handling for the ILL, TRAP, EMT, FPE, BUS, and SEGV signals. If any of these signals is generated asynchronously (delivered from another process using the `kill(2)` call), MDB restores the signal to its default disposition and dumps core. However, if any of these signals is generated synchronously by the debugger process itself and a `dmod` from an externally loaded `dmod` is currently executing, and standard input is a terminal, MDB will provide a menu of choices allowing the user to force a core dump, quit without producing a core dump, stop for attach by a debugger, or attempt to resume. The resume option will abort all active commands and unload the `dmod` whose `dcmd` was active at the time the fault occurred. It can then be subsequently re-loaded by the user. The resume

option provides limited protection against buggy dcmds. Refer to [“Warnings” on page 147](#), Use of the Error Recovery Mechanism, for information about the risks associated with the resume option.

Built-In Commands

MDB provides a set of built-in dcmds that are always defined. Some of these dcmds are applicable only to certain targets: if a dcmd is not applicable to the current target, it fails and prints a message indicating “command is not supported by current target”.

In many cases, MDB provides a mnemonic equivalent (`::identifier`) for the legacy `adb(1)` dcmd names. For example, `::quit` is provided as the equivalent of `$q`. Programmers who are experienced with `adb(1)` or who appreciate brevity or arcana might prefer the `$` or `:` forms of the built-ins. Programmers who are new to MDB might prefer the more verbose `::` form. The built-ins are shown in alphabetical order. If a `$` or `:` form has a `::identifier` equivalent, it is shown under the `::identifier` form.

Built-In Dcmds

`> variable-name`

`> /modifier/ variable-name`

Assign the value of dot to the specified named variable. Some variables are read-only and cannot be modified. If the `>` is followed by a modifier character surrounded by `//`, then the value is modified as part of the assignment. The modifier characters are:

- `c` Unsigned char quantity (1-byte)
- `s` Unsigned short quantity (2-byte)
- `i` Unsigned int quantity (4-byte)
- `l` Unsigned long quantity (4-byte in 32-bit, 8-byte in 64-bit)

Notice that these operators do not perform a cast; they instead fetch the specified number of low-order bytes (on little-endian architectures) or high-order bytes (big-endian architectures). These modifiers are provided for backward compatibility; the MDB `*/modifier/` and `%/modifier/` syntax should be used instead.

\$< *macro-name*

Read and execute commands from the specified macro file. The file name can be given as an absolute or relative path. If the file name is a simple name (that is, if it does not contain a '/'), MDB searches for it in the macro file include path. If another macro file is currently being processed, this file is closed and replaced with the new file.

\$<< *macro-name*

Read and execute commands from the specified macro file (as with \$<), but do not close the current open macro file.

\$?

Print the process-ID and current signal of the target if it is a user process or core file, and then print the general register set of the representative thread.

[*address*] \$C [*count*]

Print a C stack backtrace, including stack frame pointer information. If the dcmd is preceded by an explicit *address*, a backtrace beginning at this virtual memory address is displayed. Otherwise, the stack of the representative thread is displayed. If an optional count value is given as an argument, no more than *count* arguments are displayed for each stack frame in the output.

64-bit SPARC only – The biased frame pointer value (that is, the virtual address minus 0x7ff) should be used as the address when requesting a stack trace.

[*base*] \$d

Get or set the default output radix. If the dcmd is preceded by an explicit expression, the default output radix is set to the given *base*; otherwise, the current radix is printed in base 10 (decimal). The default radix is base 16 (hexadecimal).

\$e

Print a list of all known external (global) symbols of type object or function, the value of the symbol, and the first 4 (32-bit mdb) or 8 (64-bit mdb) bytes stored at this location in the target's virtual address space. The `::nm` dcmd provides more flexible options for displaying symbol tables.

\$P *prompt-string*

Set the prompt to the specified *prompt-string*. The default prompt is '>'. The prompt can also be set using `::set -P` or the `-P` command-line option.

\$M

In `kmdb` only, list the macro files that are cached by `kmdb` for use with the `$<` dcmd.

***distance* \$s**

Get or set the symbol matching *distance* for address-to-symbol-name conversions. The symbol matching distance modes are discussed along with the `-s` command-line option in [Appendix A, “MDB Options.”](#) The symbol matching distance can also be modified using the `::set -s` option. If no distance is specified, the current setting is displayed.

\$v

Print a list of the named variables that have non-zero values. The `::vars` dcmd provides other options for listing variables.

width \$w

Set the output page *width* to the specified value. Typically, this command is not necessary, as MDB queries the terminal for its width and handles resize events.

\$W

Reopen the target for writing, as if MDB had been executed with the `-w` option on the command line. Write mode can also be enabled with the `::set -w` option.

`::array type count`

Print the address of each element of an array. The type of the array elements should be specified as the first argument, *type*, and the number of elements to be computed should be specified as the second argument, *count*. The output of `::array` can be pipelined to the `::print` dcmd to print the elements of an array data structure.

Note – This dcmd may only be used with objects that contain compressed symbolic debugging information designed for use with `mdb`. This information is currently only available for certain Oracle Solaris kernel modules. The SUNWzlib decompression software must be installed in order to process the symbolic debugging information.

`[pid] ::attach [core | pid]`

`[pid] :A [core | pid]`

If the user process target is active, attach to and debug the specified process-ID or *core* file.

The *core* file path name should be specified as a string argument. The process-ID can be specified as the string argument, or as the value of the expression preceding the dcmd. Recall that the default base is hexadecimal, so decimal PIDs obtained using `pgrep(1)` or `ps(1)` should be preceded with “`0t`” when specified as expressions.

`::branches [-v]`

Display the most recent branches taken by the current CPU. This dcmd is currently only available when using `kmdb` on x86 systems where the appropriate processor-specific feature is enabled. The number and type of branches that can be displayed is determined by the processor architecture. If the `-v` option is present, the instructions prior to each branch are displayed.

`::cat filename ...`

Concatenate and display files. Each file name can be specified as a relative or absolute path name. The file contents will print to standard output, but will not pass through the output pager. This dcmd is intended to be used with the `|` operator; the programmer can initiate a pipeline using a list of addresses stored in an external file.

`address ::context`

`address $p`

Context switch to the specified process. A context switch operation is valid only when using the kernel target. The process context is specified using the *address* of its *proc* structure in the kernel's virtual address space. The special context address *0* is used to denote the context of the kernel itself. MDB can only perform a context switch when examining a crash dump if the dump contains the physical memory pages of the specified user process (as opposed to just kernel pages). The kernel crash dump facility can be configured to dump all pages or the pages of the current user process using *dumpadm(1M)*. The `::status` dcmd can be used to display the contents of the current crash dump.

When the user requests a context switch from the kernel target, MDB constructs a new target representing the specified user process. After the switch occurs, the new target interposes its dcmds at the global level: thus the `/` dcmd can now format and display data from the virtual address space of the user process, the `::mappings` dcmd can display the mappings in the address space of the user process, and so on. The kernel target can be restored by executing `0::context`.

`::cpuregs [-c cpuid]`

Display the current general-purpose register set for the current CPU or the specified *cpuid*. This command is only available when using *kldb*.

`::cpustack [-c cpuid]`

Display a C stack backtrace for the thread executing on the current CPU or the specified *cpuid*. This command is only available when using *kldb*.

`::dcmds`

List the available dcmds and print a brief description for each one.

`[address] ::dis [-abfw] [-n count] [address]`

Disassemble starting at or around the *address* specified by the final argument, or the current value of dot. If the address matches the start of a known function, the entire function is disassembled. Otherwise, a “window” of instructions before and after the specified address is printed in order to provide context. By default, instructions are read from the target's virtual address space; if the `-f` option is present, instructions are read from the target's object file instead. The `-f` option is enabled by default if the debugger is not currently attached to a live process, core file, or crash dump. The `-w` option can be used to force window-mode, even if the address is the start of a known function. The size of the window defaults to ten instructions; use the `-n` option to explicitly specify the number of instructions. If the `-a` option is present, addresses are printed as numeric values rather than symbolically. The `-b` option displays both address and symbol names of the disassembled code.

`::disasms`

List the available disassembler modes. When a target is initialized, MDB attempts to select the appropriate disassembler mode. The user can change the mode to any of the modes listed using the `::dismode` dcmd.

`::dismode [mode]`

`$V [mode]`

Get or set the disassembler mode. If no argument is specified, print the current disassembler mode. If a *mode* argument is specified, switch the disassembler to the specified mode. The list of available disassemblers can be displayed using the `::disasms` dcmd.

`::dmods [-l] [module-name]`

List the loaded debugger modules. If the `-l` option is specified, the list of the dcmds and walkers associated with each dmod is printed below its name. The output can be restricted to a particular dmod by specifying its name as an additional argument.

`[address] ::dump [-eqrstuv] [-f|-p] [-g bytes] [-w paragraphs]`

Print a hexadecimal and ASCII memory dump of the 16-byte aligned region of virtual memory containing the address specified by dot. If a repeat count is specified for `::dump`, this is interpreted as a number of bytes to dump rather than a number of iterations. The `::dump` dcmd also recognizes the following options:

- e Adjust for endianness. The `-e` option assumes 4-byte words; the `-g` option can be used to change the default word size.
- f Read data from the object file location corresponding to the given virtual address instead of from the target's virtual address space. The `-f` option is enabled by default if the debugger is not currently attached to a live process, core file, or crash dump.
- g *group* Display bytes in groups of bytes. The default *group* size is 4 bytes. The *group* size must be a power of two that divides the line width
- p Interpret *address* as a physical address location in the target's address space instead of a virtual address.
- q Do not print an ASCII decoding of the data.
- r Number lines relative to the start address instead of with the explicit address of each line. This option implies the `-u` option.
- s Elide repeated lines.
- t Only read from and display the contents of the specified addresses, instead of reading and printing entire lines.
- u Unalign output instead of aligning the output at a paragraph boundary.
- w *paragraphs* Display paragraphs 16-byte paragraphs per line. The default number of paragraphs is one. The maximum value accepted for `-w` is 16.

`::echo [string | value ...]`

Print the arguments separated by blanks and terminated by a NEWLINE to standard output. Expressions enclosed in `$()` will be evaluated to a value and printed in the default base.

`::eval command`

Evaluate and execute the specified string as a command. If the command contains metacharacters or white space, it should be enclosed in double or single quotes.

`::files [object]`

`$f`

Print a list of the known source files (symbols of type `STT_FILE` present in the various target symbol tables). If an *object* name is specified, the output is restricted to file symbols present in the corresponding object file.

`[address] ::findsym [-g] [address | symbol ...]`

Search instruction text for instructions that refer to the specified symbols or addresses. The search list should consist of one or more addresses or symbol names specified as an address preceding the dcmd or one or more symbol names or expressions following the dcmd. If the `-g` option is specified, the search is restricted to instruction text that is part of a globally visible function in the target's symbol table.

Note – SPARC only. The `::findsym` dcmd is only available when debugging a target that uses the SPARC instruction set architecture.

`::formats`

List the available output format characters for use with the `/`, `\`, `?`, and `=` formatting dcmds. The formats and their use is described in “[Formatting Dcmds](#)” on page 35.

`[thread] ::fpregs [-dqs]`

`[thread] $x, $X, $y, $Y`

Print the floating-point register set of the representative thread. If a thread is specified, the floating point registers of that thread are displayed. The thread expression should be one of the thread identifiers described under “[Thread Support](#)” on page 60.

Note – SPARC only. The `-d`, `-q`, and `-s` options can be used to display the floating point registers as a collection of double-precision (`-d`), quad-precision (`-q`), or single-precision (`-s`) floating point values.

`::grep command`

Evaluate the specified command string, then print the old value of dot if the new value of dot is non-zero. If the *command* contains white space or metacharacters, it must be quoted. The `::grep` dcmd can be used in pipelines to filter a list of addresses.

`::help [dcmd-name]`

With no arguments, the `::help` dcmd prints a brief overview of the help facilities available in MDB. If a *dcmd-name* is specified, MDB prints a usage summary for that dcmd.

`[address [, len]] ::in [-L len]`

Read and display *len* bytes from the I/O port specified by *address*. The value of the `-L` option, if present, takes precedence over the repeat count specified on the left-hand side. The *len* must be 1, 2, or 4 bytes and the port address must be aligned according to the length. This command is only available when using `kmdb` on x86 systems.

```
[ address ] :: list type member [ variable-name ]
```

Walk through the elements of a linked list data structure and print the address of each element in the list. The address of the first element in the list can be specified using an optional *address*; otherwise the list is assumed to start at the current value of dot. The *type* parameter must name a C struct or union type and is used to describe the type of the list elements so that MDB can read in objects of the appropriate size. The *member* parameter is used to name the member of *type* that contains a pointer to the next list element. The `::list` dcmd will continue iterating until a NULL pointer is encountered, the first element is reached again (a circular list), or an error occurs while reading an element. If the optional *variable-name* is specified, the specified variable will be assigned the value returned at each step of the walk when MDB invokes the next stage of a pipeline.

Note – This dcmd may only be used with objects that contain compressed symbolic debugging information designed for use with `mdb`. This information is currently only available for certain Oracle Solaris kernel modules. The SUNWzlib decompression software must be installed in order to process the symbolic debugging information.

```
:: load [ -s ] module-name
```

Load the specified dmod. The module name can be given as an absolute or relative path. If *module-name* is a simple name (that is, does not contain a '/'), MDB searches for it in the module library path. Modules with conflicting names cannot be loaded; the existing module must be unloaded first. If the `-s` option is present, MDB will remain silent and not issue any error messages if the module is not found or could not be loaded.

```
:: log [ -d | [ -e ] filename ]
$> [ filename ]
```

Enable or disable the output log. MDB provides an interactive logging facility where both the input commands and standard output can be logged to a file while still interacting with the user. The `-e` option enables logging to the specified file, or re-enables logging to the previous log file if no file name is given. The `-d` option disables logging. If the `$>` dcmd is used, logging is enabled if a file name argument is specified; otherwise, logging is disabled. If the specified log file already exists, MDB appends any new log output to the file.

```
:: map command
```

Map the value of dot to a corresponding value using the *command* specified as a string argument, then print the new value of dot. If the command contains white space or metacharacters, it must be quoted. The `::map` dcmd can be used in pipelines to transform the list of addresses into a new list of addresses.

```
[ address ] :: mappings [ name ]
[ address ] $m [ name ]
```

Print a list of each mapping in the target's virtual address space, including the address, size, and description of each mapping. If the dcmd is preceded by an *address*, MDB shows only the mapping that contains the given address. If a string *name* argument is given, MDB shows only the mapping that matched the description.

[*address*] : : nm [-DPdghnopuvx] [-t *types*] [-f *format*] [*object*]

Print the symbol tables associated with the current target. If an optional *address* preceding the dcmd is specified, only the symbol table entry for the symbol corresponding to address is displayed. If an *object* name is specified, only the symbol table for this load object is displayed. The : : nm dcmd also recognizes the following options:

- D Prints .dynam (dynamic symbol table) instead of .symtab.
- P Prints the private symbol table instead of .symtab.
- d Prints value and size fields in decimal.
- f *format* [,*format*...] Print only the specified symbol information. The valid format argument strings are:
 - ndx symbol table index
 - val symbol table
 - size size in bytes
 - type symbol type
 - bind binding
 - oth other
 - shndx section index
 - name symbol name
 - ctype C type for symbol (if known)
 - obj object which defines symbol
- g Prints only global symbols.
- h Suppresses the header line.
- n Sorts symbols by name.
- o Prints value and size fields in octal.
- p Prints symbols as a series of : : nmadd commands. This option can be used with -P to produce a macro file that can be subsequently read into the debugger with \$<.
- t *type* [,*type*...] Prints only symbols of the specified types. The valid type argument strings are:
 - noty STT_NOTYPE
 - objt STT_OBJECT
 - func STT_FUNC

sect	STT_SECTION
file	STT_FILE
comm	STT_COMMON
tls	STT_TLS
regi	STT_SPARC_REGISTER
-u	Prints only undefined symbols.
-v	Sorts symbols by value.
-x	Prints value and size fields in hexadecimal.

value :: nmadd [-fo] [-e end] [-s size] *name*

Add the specified symbol *name* to the private symbol table. MDB provides a private, configurable symbol table that can be used to interpose on the target's symbol table, as described in [“Symbol Name Resolution” on page 29](#). The ::nmadd dcmd also recognizes the following options:

- e Set the size of the symbol to *end - value*.
- f Set the type of the symbol to STT_FUNC.
- o Set the type of the symbol to STT_OBJECT.
- s Set the size of the symbol to *size*.

::nmde1 *name*

Delete the specified symbol *name* from the private symbol table.

::objects [-v]

Print a map of the target's virtual address space, showing only those mappings that correspond to the primary mapping (usually the text section) of each of the known load objects. If the -v option is present, the command displays the version of each object if version information is known. If no version information is known, a version of Unknown will be displayed in the output.

::offsetof *type member*

Print the offset of the specified member of the specified type. The type should be the name of a C structure. The offset is printed in bytes, unless the member is a bit-field in which case the offset may be printed in bits. The output is always suffixed with the appropriate units for clarity. The type name may use the backquote (`) scoping operator described in [“Symbol Name Resolution” on page 29](#).

Note – This dcmd may only be used with objects that contain compressed symbolic debugging information designed for use with mdb. This information is currently only available for certain Oracle Solaris kernel modules. The SUNWzlib decompression software must be installed in order to process the symbolic debugging information.

[*address* [, *len*]] ::out [-L *len*]

Write the specified *value* to the I/O port specified by *address*. The value of the -L option, if present, takes precedence over the repeat count specified on the left-hand side. The *len* must be 1, 2, or 4 bytes and the port address must be aligned according to the length. This command is only available when using kmdb on x86 systems.

[*address*] ::print [-aCdiLptx] [-c *lim*] [-l *lim*] [*type* [*member*|*offset* ...]]

Print the data structure at the specified virtual *address* using the given *type* information. The *type* parameter may name a C struct, union, enum, fundamental integer type, or a pointer to any of these types. If the type name contains whitespace (for example, struct foo), it must be enclosed in single quotation marks or double quotation marks. The type name can use the backquote (`) scoping operator described under “[Symbol Name Resolution](#)” on page 29. If the type is a structured type, the ::print dcmd recursively prints each member of the struct or union. If the *type* argument is not present and a static or global STT_OBJECT symbol matches the address, ::print infers the appropriate type automatically.

The type argument can be followed by an optional list of *member* or *offset* expressions, in which case only those members and submembers of the specified *type* are displayed. Members can be specified using C syntax that includes the array index operator ([]), the structure member operator (->), and the structure pointer operator (.). Offsets can be specified using the MDB arithmetic expansion syntax (\$[]). After displaying the data structure, ::print increments dot by the size of *type* in bytes.

Note – The ::print dcmd may only be used with objects that contain compressed symbolic debugging information designed for use with MDB. This information is only available at present in certain Oracle Solaris kernel modules and user libraries. The SUNWzlib decompression software must be installed in order to process the symbolic debugging information.

If the -a option is present, the address of each member is displayed. If the -i option is present, the expression on the left-hand side is interpreted as an immediate value to be displayed using the specified type. If the -p option is present, ::print interprets address as a physical memory address instead of a virtual memory address. If the -t option is present, the type of each member is displayed. If the -d or -x options are present, all integers are displayed in decimal (-d) or hexadecimal (-x); by default a heuristic is used to determine if the value should be displayed in decimal or hexadecimal. The number of characters in a character array that will be read and displayed as a string can be limited with the -c option. If

the `-C` option is present, no limit is enforced. The number of elements in a standard array that will be read and displayed can be limited with the `-l` option. If the `-L` option is present, no limit is enforced and all array elements are shown. The default values for `-c` and `-l` can be modified using `::set` or the `-o` command-line option as described in [Appendix A, “MDB Options.”](#)

```
::quit [ -u ]
```

```
$q [ -u ]
```

Quit the debugger. When using `kmdb` only, the `-u` option causes the debugger to resume execution of the operating system and unload the debugger. The `-u` option cannot be used if `kmdb` was loaded at boot. If the `-u` option is not present, `::quit` causes `kmdb` to exit to the firmware (on SPARC systems) or causes the system to reboot (on x86 systems).

```
[ thread ] ::regs
```

```
[ thread ] $r
```

Print the general-purpose register set of the representative thread. If a thread is specified, the general purpose register set of that thread is displayed. The thread expression should be one of the thread identifiers described under [“Thread Support” on page 60.](#)

```
::release [ -a ]
```

```
:R [ -a ]
```

Release the previously attached process or core file. If the `-a` option is present, the process is released and left stopped and abandoned. It can subsequently be continued by `prun(1)` or it can be resumed by applying MDB or another debugger. By default, a released process is forcibly terminated if it was created by MDB using `::run`, or it is released and set running if it was attached to by MDB using the `-p` option or using the `::attach` or `:A dcmds`.

```
::set [ -wF ] [ +/-o option ] [ -s distance ] [ -I path ] [ -L path ] [ -P prompt ]
```

Get or set miscellaneous debugger properties. If no options are specified, the current set of debugger properties is displayed. The `::set` dcmd recognizes the following options:

- F Forcibly take over the next user process that `::attach` is applied to, as if `kmdb` had been executed with the `-F` option on the command line.
- I Set the default path for locating macro files. The path argument can contain any of the special tokens described for the `-I` command-line option in [Appendix A, “MDB Options.”](#)
- L Set the default path for locating debugger modules. The path argument can contain any of the special tokens described for the `-I` command-line option in [Appendix A, “MDB Options.”](#)
- o Enable the specified debugger option. If the `+o` form is used, the option is disabled. The option strings are described along with the `-o` command-line option in [Appendix A, “MDB Options.”](#)
- P Set the command prompt to the specified prompt string.

- s Set the symbol matching distance to the specified distance. Refer to the description of the -s command-line option in [Appendix A, “MDB Options,”](#) for more information.
- w Re-open the target for writing, as if mdb had been executed with the -w option on the command line.

::showrev [-pv]

Display revision information for the hardware and software corresponding the current target. If no options are specified, general system information is displayed. If the -p option is present, information for each load object that is part of a patch is displayed. If the -v option is present, information for each load object is displayed. Load objects without version information will be omitted from the output for the -p option. Load objects without version information will report Unknown in the output of the -v option.

::sizeof *type*

Print the size of the specified type in bytes. The *type* parameter may name a C struct, union, enum, fundamental integer type, or a pointer to any of these types. The type name may use the backquote (`) scoping operator described in [“Symbol Name Resolution” on page 29](#).

Note – This dcmd may only be used with objects that contain compressed symbolic debugging information designed for use with mdb. This information is currently only available for certain Oracle Solaris kernel modules. The SUNWzlib decompression software must be installed in order to process the symbolic debugging information.

[*address*] ::stack [*count*]

[*address*] \$c [*count*]

Print a C stack back trace. If the dcmd is preceded by an explicit *address*, a back trace beginning at this virtual memory address is displayed. Otherwise, the stack of the representative thread is displayed. If an optional count value is given as an argument, no more than *count* arguments are displayed for each stack frame in the output.

64-bit SPARC only – The biased frame pointer value (that is, the virtual address minus 0x7ff) should be used as the address when requesting a stack trace.

[*address*] ::stackinfo [-h|-a]

Display kthread_t stack usage.

Shows the real utilization of the kernel stack if the /etc/system kmem_stackinfo tunable (an unsigned integer) is nonzero at kthread creation time. For example:

THREAD	STACK	SIZE	CUR	MAX	CMD/LWPID
ffffff014f5f2c20	ffffff0004153000	4f00	4%	43%	init/1

The current stack size utilization for this kthread is 4% of its maximum size. The stack size utilization for this kthread has been up to 43% of its maximum size. Stack size is 4f00 bytes.

The MAX value can be shown as n/a (not available) in the following cases:

- For the very first kthread (sched/1)
- If `kmem_stackinfo` was zero at kthread creation time
- If the kthread has not yet run

The `-a` option shows `TS_FREE` kthreads (interrupt kthreads). The `-h` option shows history (dead kthreads that used their kernel stack the most).

If the `/etc/system kmem_stackinfo` tunable is nonzero, then the DTrace probe `sdt:genunix:stkinfo_end:stack-usage` is activated for dead kthreads as follows:

<code>arg0</code>	<code>kthread_t *</code>	A dead kthread
<code>arg1</code>	<code>size_t</code>	The kernel stack size of the dead kthread
<code>arg2</code>	<code>size_t</code>	A percentage that is the maximum use of the kernel stack for this dead kthread

If the `/etc/system kmem_stackinfo` tunable is nonzero, then the performance of creating and deleting kthreads is decreased.

`::status`

Print a summary of information related to the current target.

`cpuid ::switch`

`cpuid :x`

When using `kmdb` only, switch to the CPU indicated by the specified `cpuid` and use this CPU's current register state as the representative for debugging.

`::term`

Print the name of the terminal type that MDB is using to perform any terminal-dependent input and output operations, such as command-line editing.

`thread ::tls symbol`

Print the address of the storage for the specified thread-local storage (TLS) symbol in the context of the specified thread. The thread expression should be one of the thread identifiers described under [“Thread Support” on page 60](#). The symbol name may use any of the scoping operators described under [“Symbol Name Resolution” on page 29](#).

`::typeset [+/-t] variable-name ...`

Set attributes for named variables. If one or more variable names are specified, they are defined and set to the value of dot. If the `-t` option is present, the user-defined tag associated with each variable is set. If the `+t` option is present, the tag is cleared. If no variable names are specified, the list of variables and their values is printed.

`::unload module-name`

Unload the specified dmod. The list of active dmods can be printed using the `::dmods` dcmd. Built-in modules cannot be unloaded. Modules that are busy (that is, provide dcmds that are currently executing) cannot be unloaded.

`::unset variable-name ...`

Unset (remove) the specified variables from the list of defined variables. Some variables are exported by MDB are marked as persistent, and cannot be unset by the user.

`::vars [-npt]`

Print a listing of named variables. If the `-n` option is present, the output is restricted to variables that currently have non-zero values. If the `-p` option is present, the variables are printed in a form suitable for re-processing by the debugger using the `$<` dcmd. This option can be used to record the variables to a macro file, then restore these values later. If the `-t` option is present, only the tagged variables are printed. Variables can be tagged using the `-t` option of the `::typeset` dcmd.

`::version`

Print the debugger version number.

`address ::vtop [-a as]`

Print the physical address mapping for the specified virtual address, if possible. The `::vtop` dcmd is only available when examining a kernel target, or when examining a user process inside a kernel crash dump (after a `::context` dcmd has been issued).

When examining a kernel target from the kernel context, the `-a` option can be used to specify the address (*as*) of an alternate address space structure that should be used for the virtual to physical translation. By default, the kernel's address space is used for translation. This option is available for active address spaces even when the dump content only contains kernel pages.

`[address] ::walk walker-name [variable-name]`

Walk through the elements of a data structure using the specified walker. The available walkers can be listed using the `::walkers` dcmd. Some walkers operate on a global data structure and do not require a starting address. For example, walk the list of proc structures in the kernel. Other walkers operate on a specific data structure whose address must be specified explicitly. For example, given a pointer to an address space, walk the list of segments.

When used interactively, the `::walk` dcmd will print the address of each element of the data structure in the default base. The dcmd can also be used to provide a list of addresses for a pipeline. The walker name can use the backquote “`” scoping operator described in [“Dcmd and Walker Name Resolution” on page 34](#). If the optional *variable-name* is specified, the specified variable will be assigned the value returned at each step of the walk when MDB invokes the next stage of the pipeline.

`::walkers`

List the available walkers and print a brief description for each one.

: :whence [-v] *name* ...

: :which [-v] *name* ...

Print the dmod that exports the specified dcmds and walkers. These dcmds can be used to determine which dmod is currently providing the global definition of the given dcmd or walker. Refer to [“Dcmd and Walker Name Resolution” on page 34](#) for more information on global name resolution. The -v option causes the dcmd to print the alternate definitions of each dcmd and walker in order of precedence.

: :xdata

List the external data buffers exported by the current target. External data buffers represent information associated with the target that cannot be accessed through standard target facilities (that is, an address space, symbol table, or register set). These buffers can be consumed by dcmds; for more information, refer to [“mdb_get_xdata\(\)” on page 140](#).

Execution Control

MDB provides facilities for controlling and tracing the execution of live running programs, including both user applications and the live operating system kernel and device drivers. You can use the `mdb` command to control user processes that are already running, or create new processes under the control of the debugger. You can boot or load `kmdb` to control the execution of the operating system kernel itself, or debug a device driver. This chapter describes the built-in `dcmds` that can be used to control target execution. These commands can be used in either `mdb` or `kmdb`, except as noted in the descriptions. Additional topics relating only to execution control in `kmdb` are discussed in [Chapter 7, “Kernel Execution Control.”](#)

Execution Control

MDB provides a simple model of execution control: a target process can be started from within the debugger using `::run`, or MDB can attach to an existing process using `::attach`, or the `-p` command-line option (see [Chapter 5, “Built-In Commands”](#)). Alternately, the kernel can be booted using `kmdb` or `kmdb` can be loaded afterward. In either case, a list of traced *software events* can be specified by the user. Each time a traced event occurs in the target program, all threads in the target stop, the thread that triggered the event is chosen as the representative thread, and control returns to the debugger. Once the target program is set running, control can be asynchronously returned to the debugger by typing the user-defined interrupt character (typically Control-C).

A *software event* is a state transition in the target program that is observed by the debugger. For example, the debugger may observe the transition of a program counter register to a value of interest (a breakpoint) or the delivery of a particular signal.

A *software event specifier* is a description of a class of software events that is used by the debugger to instrument the target program in order to observe these events. The `::events` `dcmd` is used to list the software event specifiers. A set of standard properties is associated with each event specifier, as described under `::events` in [“Built-in Dcmds” on page 61.](#)

The debugger can observe a variety of different software events, including breakpoints, watchpoints, signals, machine faults, and system calls. New specifiers can be created using `::bp`, `::fltbp`, `::sigbp`, `::sysbp`, or `::wp`. Each specifier has an associated callback (an MDB command string to execute as if it had been typed at the command prompt) and a set of properties, as described under `::events` in “Built-in Dcmds” on page 61. Any number of specifiers for the same event may be created, each with different callbacks and properties. The current list of traced events and the properties of the corresponding event specifiers can be displayed using the `::events dcmd`. The event specifier properties are defined as part of the description of the `::events` and `::evset` dcmds, in “Built-in Dcmds” on page 61.

The execution control built-in dcmds, described in “Built-in Dcmds” on page 61, are always available, but will issue an error message indicating they are not supported if applied to a target that does not support execution control.

Event Callbacks

The `::evset` dcmd and event tracing dcmds allow you to associate an event callback (using the `-c` option) with each event specifier. The event callbacks are strings that represent MDB commands to execute when the corresponding event occurs in the target. These commands are executed as if they had been typed at the command prompt. Prior to executing each callback, the `dot` variable is set to the value of the representative thread's program counter and the `hits` variable is set to the number of times this specifier has been matched, including the current match.

If the event callbacks themselves contain one or more commands to continue the target (for example, `::cont` or `::step`), these commands do *not* immediately continue the target and wait for it to stop again. Instead, inside of an event callback, the continue dcmds note that a continue operation is now pending, and then return immediately. Therefore, if multiple dcmds are included in an event callback, the `step` or `continue` dcmd should be the last command specified. Following the execution of *all* event callbacks, the target will immediately resume execution if *all* matching event callbacks requested a continue. If conflicting continue operations are requested, the operation with the highest precedence determines what type of continue will occur. The order of precedence from highest to lowest is: `step`, `step-over (next)`, `step-out`, `continue`.

Thread Support

MDB provides facilities to examine the stacks and registers of each thread associated with the target. The persistent `thread` variable contains the current representative thread identifier. The format of the thread identifier depends on the target. The `::regs` and `::fpregs` dcmds can be used to examine the register set of the representative thread, or of another thread if its register set is currently available. In addition, the register set of the representative thread is exported as a set of named variables. The user can modify the value of one or more registers by applying the `>` dcmd to the corresponding named variable.

The MDB kernel target exports the virtual address of the corresponding internal thread structure as the identifier for a given thread. This address corresponds to the `kthread_t` data structure in the operating system source code. When using `kmdb`, the CPU identifier for the CPU running `kmdb` is stored in the `cpuid` variable.

The MDB process target provides proper support for examination of multi-threaded user processes that use the native `lwp_*` interfaces, `/usr/lib/libthread.so`, or `/usr/lib/libpthread.so`. When debugging a live user process, MDB will detect if a single threaded process dlopens or closes `libthread` and will automatically adjust its view of the threading model on-the-fly. The process target thread identifiers will correspond to either the `lwpid_t`, `thread_t`, or `pthread_t` of the representative, depending on the threading model used by the application.

If MDB is debugging a user process target and the target makes use of compiler-supported thread-local storage, MDB will automatically evaluate symbol names referring to thread-local storage to the address of the storage corresponding to the current representative thread. The `::tls` built-in dcmd can be used to display the value of the symbol for threads other than the representative thread.

Built-in Dcmds

```
[ addr ] :: bp [+/-dDestT] [-c cmd] [-n count] sym ...
addr :b [cmd ... ]
```

Set a breakpoint at the specified locations. The `::bp` dcmd sets a breakpoint at each address or symbol specified, including an optional address specified by an explicit expression preceding the dcmd, and each string or immediate value following the dcmd. The arguments may either be symbol names or immediate values denoting a particular virtual address of interest. If a symbol name is specified, it may refer to a symbol that cannot yet be evaluated in the target process: that is, it may consist of an object name and function name in a load object that has not yet been opened. In this case, the breakpoint is deferred and it will not be active in the target until an object matching the given name is loaded. The breakpoint will be automatically enabled when the load object is opened. Breakpoints on symbols defined in a shared library should always be set using a symbol name and not using an address expression, as the address may refer to the corresponding Procedure Linkage Table (PLT) entry instead of the actual symbol definition. Breakpoints set on PLT entries may be overwritten by the run-time link-editor when the PLT entry is subsequently resolved to the actual symbol definition. The `-d`, `-D`, `-e`, `-s`, `-t`, `-T`, `-c`, and `-n` options have the same meaning as they do for the `::evset` dcmd, as described later in this section. If the `:b` form of the dcmd is used, a breakpoint is only set at the virtual address specified by the expression preceding the dcmd. The arguments following the `:b` dcmd are concatenated together to form the callback string. If this string contains meta-characters, it must be quoted.

```
function :: call [ arg ... ]
```

When using `kmdb` only, call the specified *function* defined in the operating system kernel. The *function* expression must match the address of a defined function in a symbol table of one of

the known kernel modules. If expression arguments are specified, these arguments are passed by value. If string arguments are specified, these arguments are passed by reference.

Note – The `::call` command should be used only with extreme caution and should never be applied to a production system. The operating system kernel will not resume execution in order to execute the specified function. Therefore, the function being called must not utilize arbitrary kernel services and must not block for any reason. You must be fully aware of the side-effects of any function you call using this command.

`::cont [SIG]`

`:c [SIG]`

Suspend the debugger, continue the target program, and wait for it to terminate or stop following a software event of interest. If the target is already running because the debugger was attached to a running program with the `-o nostop` option enabled, this dcmd simply waits for the target to terminate or stop after an event of interest. If an optional signal name or number is specified as an argument (see the [signal\(3HEAD\)](#) man page), the signal is immediately delivered to the target as part of resuming its execution. If the SIGINT signal is traced, control may be asynchronously returned to the debugger by typing the user-defined interrupt character (usually `^C`). This SIGINT signal will be automatically cleared and will not be observed by the target the next time it is continued. If no target program is currently running, `::cont` will start a new program running as if by `::run`.

`addr ::delete [id | all]`

`addr :d [id | all]`

Delete the event specifiers with the given *id* number. The *id* number argument is interpreted in decimal by default. If an optional address is specified preceding the dcmd, all event specifiers that are associated with the given virtual address are deleted (for example, all breakpoints or watchpoints affecting that address). If the special argument `all` is given, all event specifiers are deleted, except those that are marked sticky (T flag). The `::events` dcmd displays the current list of event specifiers.

`::events [-av]`

`$b [-av]`

Display the list of software event specifiers. Each event specifier is assigned a unique ID number that can be used to delete or modify it at a later time. The debugger may also have its own internal events enabled for tracing; these will only be displayed if the `-a` option is present. If the `-v` option is present, a more verbose display including the reason for any specifier inactivity will be shown. The following `::events` dcmd shows example output:

```
> ::events
  ID S TA HT LM Description                               Action
  -----
[ 1 ] - T  1  0 stop on SIGINT                             -
[ 2 ] - T  0  0 stop on SIGQUIT                           -
[ 3 ] - T  0  0 stop on SIGILL                             -
...

```

```
[ 11] - T  0  0 stop on SIGXCPU           -
[ 12] - T  0  0 stop on SIGXFSZ          -
[ 13] -   2  0 stop at libc'printf      ::echo printf
>
```

The following discussion explains the meaning of each column. A summary of this information is available using `::help events`.

ID	The event specifier identifier. The identifier will be shown in square brackets [] if the specifier is enabled, in parentheses () if the specifier is disabled, or in angle brackets < > if the target program is currently stopped on an event that matches the given specifier.
S	The event specifier state. The state will be one of the following symbols: <ul style="list-style-type: none"> - The event specifier is idle. When no target program is running, all specifiers are idle. When the target program is running, a specifier may be idle if it cannot be evaluated (such as a deferred breakpoint in a shared object that is not yet loaded). + The event specifier is active. When the target is continued, events of this type will be detected by the debugger. * The event specifier is armed. This state means that the target is currently running with instrumentation for this type of event. This state is only visible if the debugger is attached to a running program with the <code>-o nostop</code> option. ! The event specifier was not armed due to an operating system error. The <code>::events -v</code> option can be used to display more information about the reason the instrumentation failed.
TA	The Temporary, Sticky, and Automatic event specifier properties. One or more of the following symbols may be shown: <ul style="list-style-type: none"> t The event specifier is temporary, and will be deleted the next time the target stops, regardless of whether it is matched. T The event specifier is sticky, and will not be deleted by <code>::delete all</code> or <code>::z</code>. The specifier can be deleted by explicitly specifying its id number to <code>::delete</code>. d The event specifier will be automatically disabled when the hit count is equal to the hit limit. D The event specifier will be automatically deleted when the hit count is equal to the hit limit. s The target will automatically stop when the hit count is equal to the hit limit.

HT	The current hit count. This column displays the number of times the corresponding software event has occurred in the target since the creation of this event specifier.
LM	The current hit limit. This column displays the limit on the hit count at which the auto-disable, auto-delete, or auto-stop behavior will take effect. These behaviors can be configured using the <code>::evset dcmd</code> .
Description	A description of the type of software event that is matched by the given specifier.
Action	The callback string to execute when the corresponding software event occurs. This callback is executed as if it had been typed at the command prompt.

`id ::evset [+/-dDestT] [-c cmd] [-n count] id ...`

Modify the properties of one or more software event specifiers. The properties are set for each specifier identified by the optional expression preceding the dcmd and an optional list of arguments following the dcmd. The argument list is interpreted as a list of decimal integers, unless an explicit radix is specified. The `::evset dcmd` recognizes the following options:

- d Disable the event specifier when the hit count reaches the hit limit. If the +d form of the option is given, this behavior is disabled. Once an event specifier is disabled, the debugger will remove any corresponding instrumentation and will ignore the corresponding software events until the specifier is subsequently re-enabled. If the -n option is not present, the specifier is disabled immediately.
- D Delete the event specifier when the hit count reaches the hit limit. If the +D form of the option is given, this behavior is disabled. The -D option takes precedence over the -d option. The hit limit can be configured using the -n option.
- e Enable the event specifier. If the +e form of the option is given, the specifier is disabled.
- s Stop the target program when the hit count reaches the hit limit. If the +s form of the option is given, this behavior is disabled. The -s behavior tells the debugger to act as if `::cont` were issued following each execution of the specifier's callback, except for the Nth execution, where N is the current value of the specifier's hit limit. The -s option takes precedence over both the -D option and the -d option.
- t Mark the event specifier as temporary. Temporary specifiers are automatically deleted the next time the target stops, regardless of whether it stopped as the result of a software event corresponding to the given specifier. If the +t form of the option is given, the temporary marker is removed. The -t option takes precedence over the -T option.
- T Mark the event specifier as sticky. Sticky specifiers will not be deleted by `::delete all` or `::z`. They can be deleted by specifying the corresponding specifier ID as an

- explicit argument to `::delete`. If the `+T` form of the option is given, the sticky property is removed. The default set of event specifiers are all initially marked sticky.
- c Execute the specified *cmd* string each time the corresponding software event occurs in the target program. The current callback string can be displayed using `::events`.
 - n Set the current value of the hit limit to *count*. If no hit limit is currently set and the `-n` option does not accompany `-s` or `-D`, the hit limit will be set to one.

A summary of this information is available using `::help evset`.

flt `::fltp [+/-dDestT] [-c cmd] [-n count] flt ...`

Trace the specified machine faults. The faults are identified using an optional fault number preceding the dcmd, or a list of fault names or numbers (see `<sys/fault.h>`) following the dcmd. The `-d`, `-D`, `-e`, `-s`, `-t`, `-T`, `-c`, and `-n` options have the same meaning as they do for the `::evset` dcmd. The `::fltp` command applies to user process debugging only.

signal `::i`

If the target is a live user process, ignore the specified signal and allow it to be delivered transparently to the target. All event specifiers that are tracing delivery of the specified signal will be deleted from the list of traced events. By default, the set of ignored signals is initialized to the complement of the set of signals that cause a process to dump core by default (see the `signal(3HEAD)` man page), except for `SIGINT`, which is traced by default. The `::i` command applies to user process debugging only.

`::i`

Display the list of signals that are ignored by the debugger and will be handled directly by the target. More information on traced signals can be obtained using the `::events` dcmd. The `::i` command applies to user process debugging only.

`::kill`

`::k`

Forcibly terminate the target if it is a live user process. The target will also be forcibly terminated when the debugger exits if it was created by the debugger using `::run`. The `::kill` command applies to user process debugging only.

`::l`

Print the LWPID of the representative thread, if the target is a user process.

`::L`

Print the LWPIDs of each LWP in the target, if the target is a user process.

`::next [SIG]`

`::e [SIG]`

Step the target program one instruction, but step over subroutine calls. If an optional signal name or number (see `signal(3HEAD)` man page) is specified as an argument, the signal is immediately delivered to the target as part of resuming its execution. If no target program is currently running, `::next` will start a new program running as if by `::run` and stop at the first instruction.

`:: run [args ...]`

`: r [args ...]`

Start a new target program running with the specified arguments and attach to it. The arguments are not interpreted by the shell. If the debugger is already examining a live running program, it will first detach from this program as if by `:: release`.

`[signal] :: sigbp [+/-dDestT] [-c cmd] [-n count] SIG ...`

`[signal] :t [+/-dDestT] [-c cmd] [-n count] SIG ...`

Trace delivery of the specified signals. The signals are identified using an optional signal number preceding the dcmd, or a list of signal names or numbers (see `signal(3HEAD)`) following the dcmd. The `-d`, `-D`, `-e`, `-s`, `-t`, `-T`, `-c`, and `-n` options have the same meaning as they do for the `:: evset` dcmd. Initially, the set of signals that cause the process to dump core by default (see `signal(3HEAD)`) and `SIGINT` are traced. The `:: sigbp` command applies to user process debugging only.

`:: step [branch | over | out] [SIG]`

`:s SIG`

`:u SIG`

Step the target program one instruction. If an optional signal name or number (see the `signal(3HEAD)` man page) is specified as an argument and the target is a user process, the signal is immediately delivered to the target as part of resuming its execution. If the optional branch argument is specified, the target program will continue until the next instruction that branches the control flow of the processor. The `:: step branch` feature is only available when using `kmdb` on x86 systems with appropriate processor-specific features enabled. If the optional over argument is specified, `:: step` will step over subroutine calls. The `:: step over` argument is the same as the `:: next` dcmd. If the optional out argument is specified, the target program will continue until the representative thread returns from the current function. If no target program is currently running, `:: step over` will start a new program running as if by `:: run` and stop at the first instruction. The `:s` dcmd is the same as `:: step`. The `:u` dcmd is the same as `:: step out`.

`[syscall] :: sysbp [+/-dDestT] [-io] [-c cmd] [-n count] syscall ...`

Trace entry to or exit from the specified system calls. The system calls are identified using an optional system call number preceding the dcmd, or a list of system call names or numbers (see `<sys/syscall.h>`) following the dcmd. If the `-i` option is specified (the default), the event specifiers trigger on entry into the kernel for each system call. If the `-o` option is specified, the event specifiers trigger on exit out from the kernel. The `-d`, `-D`, `-e`, `-s`, `-t`, `-T`, `-c`, and `-n` options have the same meaning as they do for the `:: evset` dcmd. The `:: sysbp` command applies to user process debugging only.

`addr [,len] :: wp [+/-dDestT] [-rwx] [-ip] [-c cmd] [-n count]`

`addr [,len] :a [cmd...]`

`addr [,len] :p [cmd...]`

`addr [,len] :w [cmd...]`

Set a watchpoint at the specified address. The length in bytes of the watched region may be set by specifying an optional repeat count preceding the dcmd. If no length is explicitly set, the default is one byte. The `:: wp` dcmd allows the watchpoint to be configured to trigger on

any combination of read (-r option), write (-w option), or execute (-x option) access. The -d, -D, -e, -s, -t, -T, -c, and -n options have the same meaning as they do for the ::evset dcmd. When using kmdb on x86 systems only, the -i option can be used to indicate that a watchpoint should be set on the address of an I/O port. When using kmdb only, the -p option can be used to indicate that the specified address should be interpreted as a physical address. The :a dcmd sets a read access watchpoint at the specified address. The :p dcmd sets an execute access watchpoint at the specified address. The :w dcmd sets a write access watchpoint at the specified address. The arguments following the :a, :p, and :w dcmds are concatenated together to form the callback string. If this string contains meta-characters, it must be quoted.

:z

Delete all event specifiers from the list of traced software events. Event specifiers can also be deleted using ::delete.

Interaction with exec

When a controlled user process performs a successful exec(2), the behavior of the debugger is controlled by the ::set -o follow_exec_mode option, as described in [“Summary of MDB Command-Line Options” on page 141](#). If the debugger and victim process have the same data model, then the stop and follow modes determine whether MDB automatically continues the target or returns to the debugger prompt following the exec. If the debugger and victim process have a different data model, then the follow behavior causes MDB to automatically re-exec the MDB binary with the appropriate data model and reattach to the process, still stopped on return from the exec. Not all debugger state is preserved across this re-exec.

If a 32-bit victim process execs a 64-bit program, then stop will return to the command prompt, but the debugger will no longer be able to examine the process because it is now using the 64-bit data model. To resume debugging, execute the ::release -a dcmd, quit MDB, and then execute mdb -p *pid* to re-attach the 64-bit debugger to the process.

If a 64-bit victim process execs a 32-bit program, then stop will return to the command prompt, but the debugger will only provide limited capabilities for examining the new process. All built-in dcmds will work as advertised, but loadable dcmds will not since they do not perform data model conversion of structures. The user should release and reattach the debugger to the process as described above in order to restore full debugging capabilities.

Interaction with Job Control

If the debugger is attached to a user process that is stopped by job control (that is, it stopped in response to SIGTSTP, SIGTTIN, or SIGTTOU), the process may not be able to be set running again when it is continued by a `continue` dcmd. If the victim process is a member of the same session (that is, it shares the same controlling terminal as MDB), MDB will attempt to bring the associated process group to the foreground and continue the process with SIGCONT to resume it from job control stop. When MDB is detached from such a process, it will restore the process group to the background before exiting. If the victim process is not a member of the same session, MDB cannot safely bring the process group to the foreground, so it will continue the process with respect to the debugger but the process will remain stopped by job control. MDB will print a warning in this case, and the user must issue a `fg` command from the appropriate shell in order to resume the process.

Process Attach and Release

When MDB attaches to a running user process, the process is stopped and remains stopped until one of the `continue` dcmds is applied, or the debugger quits. If the `-o nostop` option is enabled prior to attaching the debugger to a process with `-p` or prior to issuing an `::attach` or `:A` command, MDB will attach to the process but not stop it. While the process is still running, it may be inspected as usual (albeit with inconsistent results) and breakpoints or other tracing flags may be enabled. If the `:c` or `::cont` dcmds are executed while the process is running, the debugger will wait for the process to stop. If no traced software events occur, the user can send an interrupt (^C) after `:c` or `::cont` to force the process to stop and return control to the debugger.

MDB releases the current running process (if any) when the `:R`, `::release`, `:r`, `::run`, `$q`, or `::quit` dcmds are executed, or when the debugger terminates as the result of an EOF or signal. If the process was originally created by the debugger using `:r` or `::run`, it will be forcibly terminated as if by SIGKILL when it is released. If the process was already running prior to attaching MDB to it, it will be set running again when it is released. A process may be released and left stopped and abandoned using the `::release -a` option.

Kernel Execution Control

This chapter describes the MDB features for execution control of the live operating system kernel available when running `kldb`. `kldb` is a version of MDB specifically designed for kernel execution control and live kernel debugging. Using `kldb`, the kernel can be controlled and observed in much the same way that a user process can be controlled and observed using `mdb`. The kernel execution control functionality includes instruction-level control of kernel threads executing on each CPU, enabling developers to single-step the kernel and inspect data structures in real time.

Both `mdb` and `kldb` share the same user interface. All of the execution control functionality described in [Chapter 6, “Execution Control,”](#) is available in `kldb`, and is identical to the set of commands used to control user processes. The commands used to inspect kernel state, described in [Chapter 3, “MDB Language Syntax,”](#) and [Chapter 5, “Built-In Commands,”](#) are also available when using `kldb`. Finally, the commands specific to the Oracle Solaris kernel implementation, described in [Chapter 8, “Kernel Debugging Modules,”](#) are available unless otherwise noted. This chapter describes the remaining features that are specific to `kldb`.

Booting, Loading, and Unloading

To facilitate the debugging of kernel startup, `kldb` can be loaded during the earliest stages of the boot process, before control has passed from the kernel runtime linker (`krtld`) to the kernel. `kldb` may be loaded at boot using the `-k` boot flag, the `kldb` boot file, or the `kadb` boot file (for compatibility). If `kldb` is loaded at boot, the debugger cannot be unloaded until the system subsequently reboots. Some functionality will not be immediately available during the earliest stages of boot. In particular, debugging modules will not be loaded until the kernel module subsystem has initialized. Processor-specific functionality will not be enabled until the kernel has completed the processor identification process.

If you boot your system using the `-k` option, `kldb` will automatically load during the boot process. You can use the `-d` boot option to request a debugger breakpoint prior to starting the

kernel. This feature works with the default kernel as well as alternate kernels. For example, to boot a SPARC system with `kmdb` and request immediate entry to the debugger, type any of the following commands:

```
ok boot -kd
ok boot kmdb -d
ok boot kadb -d
```

To boot an x86 system in the same manner, type any of the following commands:

```
Select (b)oot or (i)nterpreter: b -kd
Select (b)oot or (i)nterpreter: b kmdb -d
Select (b)oot or (i)nterpreter: b kadb -d
```

To boot a SPARC system with `kmdb` and load an alternate 64-bit kernel, type the following command:

```
ok boot kernel.test/sparcv9/unix -k
```

To boot an x86 system with `kmdb` and load an alternate 64-bit kernel, type the following command:

```
Select (b)oot or (i)nterpreter: b kernel.test/amd64/unix -k
```

If the boot file is set to the string `kmdb` or `kadb` and you want to boot an alternate kernel, use the `-D` option to specify the name of the kernel to boot. To boot a SPARC system in this manner, type the following command:

```
ok boot kmdb -D kernel.test/sparcv9/unix
```

To boot a 32-bit x86 system in this manner, type the following command:

```
Select (b) or (i)nterpreter: b kmdb -D kernel.test/unix
```

To boot a 64-bit x86 system in this manner, type the following command:

```
Select (b) or (i)nterpreter: b kmdb -D kernel.test/amd64/unix
```

To debug a system that has already booted, use the `mdb -K` option to load `kmdb` and stop kernel execution. When the debugger is loaded using this method, it can be subsequently unloaded. You can unload `kmdb` when you are done debugging by specifying the `-u` option to the `::quit` dcmd. Alternatively, you can resume execution of the operating system using the command `mdb -U`.

Terminal Handling

`kldb` always uses the system console for interaction.

`kldb` determines the appropriate terminal type according to the following rules:

- If the system being debugged uses an attached keyboard and monitor for its console and the debugger is loaded at boot, the terminal type will be determined automatically based upon the platform architecture and console terminal settings.
- If the system being debugged uses a serial console and the debugger is loaded at boot, a default terminal type of `vt100` will be assumed.
- If the debugger is loaded by running `mdb -K` on the console, the value of the `$TERM` environment variable will be used as the terminal type.
- If the debugger is loaded by running `mdb -K` on a terminal that is not the console, the debugger will use the terminal type that has been configured for use with the system console login prompt.

You can use the `::term` dcmd from within `kldb` to display the terminal type.

Debugger Entry

The operating system kernel will implicitly stop executing and enter `kldb` when a breakpoint is reached or according to the other execution control settings described in [Chapter 6, “Execution Control.”](#) You can use the `mdb -K` option or an appropriate keyboard break sequence to request explicit entry to `kldb`. On a SPARC system console, use the `STOP-A` key sequence to send a break and enter `kldb`. On an x86 system console, use the `F1-A` key sequence to send a break and enter `kldb`. You can use the `kbd` command to customize the escape sequence on your Oracle Solaris system. To enter `kldb` on a system with a serial console, use the appropriate serial console command to send a break sequence.

Processor-Specific Features

Some `kldb` functionality is specific to an individual processor architecture. For example, various x86 processors support a hardware branch tracing capability that is not found on some other processor architectures. Access to processor-specific features is provided through processor-specific dcmds that are only present on systems that support them. The availability of processor-specific support will be indicated in the output of the `::status` dcmd. The debugger relies upon the kernel to determine the processor type. Therefore, even though the debugger may provide features for a given processor architecture, this support will not be exposed until the kernel has progressed to the point where processor identification has completed.

Kernel Debugging Modules

This chapter describes the debugger modules, dcmds, and walkers provided to debug the Oracle Solaris kernel. Each kernel debugger module is named after the corresponding kernel module, so that it will be loaded automatically by MDB. The facilities described here reflect the current kernel implementation. In general, the kernel debugging facilities described in this chapter are meaningful only in the context of the corresponding kernel subsystem implementation. See [“Related Books and Papers” on page 11](#) for a list of references that provide more information about the Oracle Solaris kernel implementation.

Note – MDB exposes kernel implementation details that are subject to change at any time. This guide reflects the Oracle Solaris kernel implementation as of the date of publication of this guide. Information provided in this guide about modules, dcmds, walkers, and their output formats and arguments might not be correct or applicable to past or future Oracle Solaris releases.

Generic Kernel Debugging Support (genunix)

Kernel Memory Allocator

This section discusses the dcmds and walkers used to debug problems identified by the Oracle Solaris kernel memory allocator and to examine memory and memory usage. The dcmds and walkers described here are discussed in more detail in [Chapter 9, “Debugging With the Kernel Memory Allocator.”](#)

Kernel Memory Allocator Dcmds

thread : :allocdby

Given the address of a kernel thread, print a list of memory allocations it has performed in reverse chronological order.

bufctl :: bufctl [-a *address*] [-c *caller*] [-e *earliest*] [-l *latest*] [-t *thread*]

Print a summary of the *bufctl* information for the specified *bufctl address*. If one or more options are present, the *bufctl* information is printed only if it matches the criteria defined by the option arguments; in this way, the *dcmd* can be used as a filter for input from a pipeline. The *-a* option indicates that the *bufctl*'s corresponding buffer address must equal the specified address. The *-c* option indicates that a program counter value from the specified caller must be present in the *bufctl*'s saved stack trace. The *-e* option indicates that the *bufctl*'s timestamp must be greater than or equal to the specified earliest timestamp. The *-l* option indicates that the *bufctl*'s timestamp must be less than or equal to the specified latest timestamp. The *-t* option indicates that the *bufctl*'s thread pointer must be equal to the specified thread address.

[*address*] :: findleaks [-v]

The *::findleaks* *dcmd* provides powerful and efficient detection of memory leaks in kernel crash dumps where the full set of *kmem* debug features has been enabled. The first execution of *::findleaks* processes the dump for memory leaks (this can take a few minutes), then coalesces the leaks by the allocation stack trace. The *findleaks* report shows a *bufctl* address and the topmost stack frame for each memory leak that was identified.

If the *-v* option is specified, the *dcmd* prints more verbose messages as it executes. If an explicit address is specified prior to the *dcmd*, the report is filtered and only leaks whose allocation stack traces contain the specified function address are displayed.

thread :: freedby

Given the address of a kernel thread, print a list of memory frees it has performed, in reverse chronological order.

value :: kgrep

Search the kernel address space for pointer-aligned addresses that contain the specified pointer-sized value. The list of addresses that contain matching values is then printed. Unlike *MDB*'s built-in search operators, *::kgrep* searches every segment of the kernel's address space and searches across discontinuous segment boundaries. On large kernels, *::kgrep* can take a considerable amount of time to execute.

::kmalog [slab | fail]

Display events in a kernel memory allocator transaction log. Events are displayed in time-reverse order, with the most recent event displayed first. For each event, *::kmalog* displays the time relative to the most recent event in T-minus notation (for example, T-0.000151879), the *bufctl*, the buffer address, the *kmem* cache name, and the stack trace at the time of the event. Without arguments, *::kmalog* displays the *kmem* transaction log, which is present only if *KMF_AUDIT* is set in *kmem_flags*. *::kmalog fail* displays the allocation failure log, which is always present; this can be useful in debugging drivers that don't cope with allocation failure correctly. *::kmalog slab* displays the slab create log, which is always present. *::kmalog slab* can be useful when searching for memory leaks.

- `:: kmastat`
 Display the list of kernel memory allocator caches and virtual memory arenas, along with corresponding statistics.
- `:: kmausers [-ef] [cache ...]`
 Print information about the medium and large users of the kernel memory allocator that have current memory allocations. The output consists of one entry for each unique stack trace specifying the total amount of memory and number of allocations that was made with that stack trace. This dcmd requires that the `KMF_AUDIT` flag is set in `kmem_flags`.
- If one or more cache names (for example, `kmem_alloc_256`) are specified, the scan of memory usage is restricted to those caches. By default all caches are included. If the `-e` option is used, the small users of the allocator are included. The small users are allocations that total less than 1024 bytes of memory or for which there are less than 10 allocations with the same stack trace. If the `-f` option is used, the stack traces are printed for each individual allocation.
- `[address] :: kmem_cache`
 Format and display the `kmem_cache` structure stored at the specified address, or the complete set of active `kmem_cache` structures.
- `:: kmem_log`
 Display the complete set of `kmem` transaction logs, sorted in reverse chronological order. This dcmd uses a more concise tabular output format than `:: kma log`.
- `[address] :: kmem_verify`
 Verify the integrity of the `kmem_cache` structure stored at the specified address, or the complete set of active `kmem_cache` structures. If an explicit cache address is specified, the dcmd displays more verbose information regarding errors; otherwise, a summary report is displayed. The `:: kmem_verify` dcmd is discussed in more detail in [“Kernel Memory Caches” on page 100](#).
- `[address] :: vmem`
 Format and display the `vmem` structure stored at the specified address, or the complete set of active `vmem` structures. This structure is defined in `<sys/vmem_impl.h>`.
- `address :: vmem_seg`
 Format and display the `vmem_seg` structure stored at the specified address. This structure is defined in `<sys/vmem_impl.h>`.
- `address :: whatis [-abv]`
 Report information about the specified address. In particular, `:: whatis` will attempt to determine if the address is a pointer to a `kmem`-managed buffer or another type of special memory region, such as a thread stack, and report its findings. If the `-a` option is present, the dcmd reports all matches instead of just the first match to its queries. If the `-b` option is present, the dcmd also attempts to determine if the address is referred to by a known `kmem` buffer. If the `-v` option is present, the dcmd reports its progress as it searches various kernel data structures.

Kernel Memory Allocator Walkers

<code>allocdb</code>	Given the address of a <code>kthread_t</code> structure as a starting point, iterate over the set of <code>bufctl</code> structures corresponding to memory allocations performed by this kernel thread.
<code>bufctl</code>	Given the address of a <code>kmem_cache_t</code> structure as a starting point, iterate over the set of allocated <code>bufctls</code> associated with this cache.
<code>freectl</code>	Given the address of a <code>kmem_cache_t</code> structure as a starting point, iterate over the set of free <code>bufctls</code> associated with this cache.
<code>freedby</code>	Given the address of a <code>kthread_t</code> structure as a starting point, iterate over the set of <code>bufctl</code> structures corresponding to memory deallocations performed by this kernel thread.
<code>freemem</code>	Given the address of a <code>kmem_cache_t</code> structure as a starting point, iterate over the set of free buffers associated with this cache.
<code>kmem</code>	Given the address of a <code>kmem_cache_t</code> structure as a starting point, iterate over the set of allocated buffers associated with this cache.
<code>kmem_cache</code>	Iterate over the active set of <code>kmem_cache_t</code> structures. This structure is defined in <code><sys/kmem_impl.h></code> .
<code>kmem_cpu_cache</code>	Given the address of a <code>kmem_cache_t</code> structure as a starting point, iterate over the per-CPU <code>kmem_cpu_cache_t</code> structures associated with this cache. This structure is defined in <code><sys/kmem_impl.h></code> .
<code>kmem_slab</code>	Given the address of a <code>kmem_cache_t</code> structure as a starting point, iterate over the set of associated <code>kmem_slab_t</code> structures. This structure is defined in <code><sys/kmem_impl.h></code> .
<code>kmem_log</code>	Iterate over the set of <code>bufctls</code> stored in the <code>kmem</code> allocator transaction log.
<code>leak</code>	Given the address of a <code>bufctl</code> structure, iterate over the set of <code>bufctl</code> structures corresponding to leaked memory buffers with similar allocation stack traces. The <code>::findleaks dcmd</code> must be applied to locate memory leaks before the leak walker can be used.
<code>leakbuf</code>	Given the address of a <code>bufctl</code> structure, iterate over the set of buffer addresses corresponding to leaked memory buffers with similar allocation stack traces. The <code>::findleaks dcmd</code> must be applied to locate memory leaks before the <code>leakbuf</code> walker can be used.

File Systems

The MDB file systems debugging support includes a built-in facility to convert vnode pointers to the corresponding file system path name. This conversion is performed using the Directory Name Lookup Cache (DNLC); because the cache does not hold all active vnodes, some vnodes might not be able to be converted to path names and “??” is displayed instead of a name.

File Systems Dcmds

<code>:: fsinfo</code>	Display a table of mounted file systems, including the <code>vfs_t</code> address, ops vector, and mount point of each file system.
<code>:: lminfo</code>	Display a table of vnodes with active network locks registered with the lock manager. The pathname corresponding to each vnode is shown.
<code>address :: vnode2path [-v]</code>	Display the pathname corresponding to the given vnode address. If the <code>-v</code> option is specified, the dcmd prints a more verbose display, including the vnode pointer of each intermediate path component.

File Systems Walkers

`buf` Iterate over the set of active block I/O transfer structures (`buf_t` structures). The `buf` structure is defined in `<sys/buf.h>` and is described in more detail in [buf\(9S\)](#).

Virtual Memory

This section describes the debugging support for the kernel virtual memory subsystem.

Virtual Memory Dcmds

<code>address :: addr2smap [offset]</code>	Print the <code>smap</code> structure address that corresponds to the given address in the kernel's segmap address space segment.
<code>as :: as2proc</code>	Display the <code>proc_t</code> address for the process corresponding to the <code>as_t</code> address <code>as</code> .
<code>[address] :: memlist [-aiv]</code>	Display the specified <code>memlist</code> structure or one of the well-known <code>memlist</code> structures. If no <code>memlist</code> address and options are present or if the <code>-i</code> option is present, the <code>memlist</code> representing physically installed memory is displayed. If the <code>-a</code> option is present, the <code>memlist</code> representing available physical memory is displayed. If the <code>-v</code> option is present, the <code>memlist</code> representing available virtual memory is displayed.

<code>::memstat</code>	Display a system-wide memory usage summary. The amount and percentage of system memory consumed by different classes of pages (kernel, anonymous memory, executables and libraries, page cache, and free lists) are displayed, along with the total amount of system memory.
<code>[address] ::page</code>	Display the properties of the specified <code>page_t</code> . If no <code>page_t</code> address is specified, the <code>dcmd</code> displays the properties of all system pages.
<code>seg ::seg</code>	Format and display the specified address space segment (<code>seg_t</code> address).
<code>[address] ::swapinfo</code>	Display information on all active <code>swapinfo</code> structures or about the specified struct <code>swapinfo</code> . The <code>vnode</code> , filename, and statistics for each structure are displayed.
<code>vnode ::vnode2smmap[<i>offset</i>]</code>	Print the <code>smmap</code> structure address that corresponds to the given <code>vnode_t</code> address and offset.

Virtual Memory Walkers

<code>anon</code>	Given the address of an <code>anon_map</code> structure as a starting point, iterate over the set of related <code>anon</code> structures. The <code>anon</code> map implementation is defined in <code><vm/anon.h></code> .
<code>memlist</code>	Iterate over the spans of the specified <code>memlist</code> structure. This walker can be used in conjunction with the <code>::memlist</code> <code>dcmd</code> to display each span.
<code>page</code>	Iterate over all system <code>page</code> structures. If an explicit address is specified for the walk, this is taken to be the address of a <code>vnode</code> and the walker iterates over only those pages associated with the <code>vnode</code> .
<code>seg</code>	Given the address of an <code>as_t</code> structure as a starting point, iterate over the set of address space segments (<code>seg</code> structures) associated with the specified address space. The <code>seg</code> structure is defined in <code><vm/seg.h></code> .
<code>swapinfo</code>	Iterate over the list of active <code>swapinfo</code> structures. This walker may be used in conjunction with the <code>::swapinfo</code> <code>dcmd</code> .

CPU Structures and the Kernel Dispatcher

This section describes the facilities for examining the state of the CPU structures and the kernel dispatcher.

CPU and Dispatcher Dcmds

- `::callout` Display the callout table. The function, argument, and expiration time for each callout is displayed.
- `::class` Display the scheduling class table.
- `[cpuid] ::cpuinfo [-v]` Display a table of the threads currently executing on each CPU. If an optional CPU ID number or CPU structure address is specified prior to the dcmd name, only the information for the specified CPU is displayed. If the `-v` option is present, `::cpuinfo` also displays the runnable threads waiting to execute on each CPU as well as the active interrupt threads.

CPU and Dispatcher Walkers

- `cpu` Iterate over the set of kernel CPU structures. The `cpu_t` structure is defined in `<sys/cpuvar.h>`.

Device Drivers and DDI Framework

This section describes dcmds and walkers that are useful for kernel developers as well as third-party device driver developers.

Device Driver Dcmds

- `address ::binding_hash_entry`
Given the address of a kernel name-to-major number binding hash table entry (struct `bind`), display the node binding name, major number, and pointer to the next element.
- `::devbindings device-name`
Display the list of all instances of the named driver. The output consists of an entry for each instance, beginning with the pointer to the struct `dev_info` (viewable with `$<devinfo` or `::devinfo`), the driver name, the instance number, and the driver and system properties associated with that instance.
- `address ::devinfo [-q]`
Print the system and driver properties associated with a `devinfo` node. If the `-q` option is specified, only a quick summary of the device node is shown.
- `address ::devinfo2driver`
Print the name of the driver (if any) associated with the `devinfo` node.
- `[address] ::devnames [-v]`
Display the kernel's `devnames` table along with the `dn_head` pointer, which points at the driver instance list. If the `-v` flag is specified, additional information stored at each entry in the `devnames` table is displayed.

[*devinfo*] : : prtconf [-cpv]

Display the kernel device tree starting at the device node specified by *devinfo*. If *devinfo* is not provided, the root of the device tree is assumed by default. If the -c option is specified, only children of the given device node are displayed. If the -p option is specified, only ancestors of the given device node are displayed. If -v is specified, the properties associated with each node are displayed.

[*major-num*] : : major2name [*major-num*]

Display the driver name corresponding to the specified major number. The major number can be specified as an expression preceding the dcmd or as a command-line argument.

[*address*] : : modctl2devinfo

Print all of the device nodes that correspond to the specified modctl address.

: : name2major *driver-name*

Given a device driver name, display its major number.

[*address*] : : softstate [*instance-number*]

Given a softstate state pointer (see `ddi_soft_state_init(9F)`) and a device instance number, display the soft state for that instance.

Device Driver Walkers

binding_hash	Given the address of an array of kernel binding hash table entries (struct bind**), walk all entries in the hash table and return the address of each struct bind.
devinfo	First, iterate over the parents of the given devinfo and return them in order of seniority from most to least senior. Second, return the given devinfo itself. Third, iterate over the children of the given devinfo in order of seniority from most to least senior. The dev_info struct is defined in <sys/ddi_impldefs.h>.
devinfo_children	First, return the given devinfo, then iterate over the children of the given devinfo in order of seniority from most to least senior. The dev_info struct is defined in <sys/ddi_impldefs.h>.
devinfo_parents	Iterate over the parents of the given devinfo in order of seniority from most to least senior, and then return the given devinfo. The dev_info struct is defined in <sys/ddi_impldefs.h>.
devi_next	Iterate over the siblings of the given devinfo. The dev_info struct is defined in <sys/ddi_impldefs.h>.
devnames	Iterate over the entries in the devnames array. This structure is defined in <sys/autoconf.h>.
softstate	Given a softstate pointer (see <code>ddi_soft_state_init(9F)</code>) display all non-NULL pointers to driver state structures.

`softstate_all` Given a `softstate` pointer (see `ddi_soft_state_init(9F)`) display all pointers to driver state structures. Note that the pointers for unused instances will be `NULL`.

STREAMS

This section describes `dcmds` and `walkers` that are useful for kernel developers as well as developers of third-party `STREAMS` modules and drivers.

STREAMS Dcmds

`address::mblk2dblk`

Given the address of an `mblk_t`, print the address of the corresponding `dblk_t`.

`[address]::mblk_verify`

Verify the integrity of one or more message blocks. If an explicit message block address is specified, the integrity of this message block is checked. If no address is specified, the integrity of all active message blocks are checked. This `dcmd` produces output for any invalid message block state that is detected.

`address::queue [-v] [-f flag] [-F flag] [-s syncq]`

Filter and display the specified `queue_t` data structure. With no options, various properties of the `queue_t` are shown. If the `-v` option is present, the queue flags are decoded in greater detail. If the `-f`, `-F`, or `-m` options are present, the queue is displayed only if it matches the criteria defined by the arguments to these options; in this way, the `dcmd` can be used as a filter for input from a pipeline. The `-f` option indicates that the specified flag (one of the `Q` flag names from `<sys/stream.h>`) must be present in the queue flags. The `-F` option indicates that the specified flag must be absent from the queue flags. The `-m` option indicates that the module name associated with the queue must match the specified `modname`. The `-s` option indicates that the `syncq_t` associated with the queue must match the specified `syncq_t` address.

`address::q2syncq`

Given the address of a `queue_t`, print the address of the corresponding `syncq_t` data structure.

`address::q2otherq`

Given the address of a `queue_t`, print the address of the peer read or write queue structure.

`address::q2rdq`

Given the address of a `queue_t`, print the address of the corresponding read queue.

`address::q2wrq`

Given the address of a `queue_t`, print the address of the corresponding write queue.

[*address*] :: stream

Display a visual picture of a kernel STREAM data structure, given the address of the `stdata_t` structure representing the STREAM head. The read and write queue pointers, byte count, and flags for each module are shown, and in some cases additional information for the specific queue is shown in the margin.

address :: syncq [-v] [-f *flag*] [-F *flag*] [-t *type*] [-T *type*]

Filter and display the specified `syncq_t` data structure. With no options, various properties of the `syncq_t` are shown. If the `-v` option is present, the `syncq` flags are decoded in greater detail. If the `-f`, `-F`, `-t`, or `-T` options are present, the `syncq` is displayed only if it matches the criteria defined by the arguments to these options; in this way, the `dcmd` can be used as a filter for input from a pipeline. The `-f` option indicates that the specified flag (one of the `SQ_` flag names from `<sys/strsubr.h>`) must be present in the `syncq` flags. The `-F` option indicates that the specified flag must be absent from the `syncq` flags. The `-t` option indicates that the specified type (one of the `SQ_CI` or `SQ_CO` type names from `<sys/strsubr.h>`) must be present in the `syncq` type bits. The `-T` option indicates that the specified type must be absent from the `syncq` type bits.

address :: syncq2q

Given the address of a `syncq_t`, print the address of the corresponding `queue_t` data structure.

STREAMS Walkers

- `b_cont` Given the address of an `mblk_t`, iterate over the set of associated message structures by following the `b_cont` pointer. The `b_cont` pointer is used to link a given message block to the next associated message block that is the continuation of the same message. The message block is described in more detail in `msgb(9S)`.
- `b_next` Given the address of an `mblk_t`, iterate over the set of associated message structures by following the `b_next` pointer. The `b_next` pointer is used to link a given message block to the next associated message block on a given queue. The message block is described in more detail in `msgb(9S)`.
- `qlink` Given the address of a `queue_t` structure, walk the list of related queues using the `q_link` pointer. This structure is defined in `<sys/stream.h>`.
- `qnext` Given the address of a `queue_t` structure, walk the list of related queues using the `q_next` pointer. This structure is defined in `<sys/stream.h>`.
- `readq` Given the address of an `stdata_t` structure, walk the list of read-side queue structures.
- `writeq` Given the address of an `stdata_t` structure, walk the list of write-side queue structures.

Networking

The following dcmds and walkers are provided to help debug the core kernel networking stack protocols.

Networking Dcmds

address : :mi [-p] [-d | -m]

Given the address of a kernel MI_O, filter and display the MI_O or its payload. If the -p option is specified, then the address of the corresponding payload of the MI_O is displayed, otherwise the MI_O itself is displayed. Specifying filter -d or -m enables the dcmd to filter device or module MI_O objects respectively.

: :netstat [-av] [-f inet | inet6 | unix] [-P tcp | udp]

Show network statistics and active connections. If the -a option is present, the state of all sockets is displayed. If the -v option is present, more verbose output is displayed. If the -f option is present, only connections associated with the specified address family are displayed. If the -P option is present, only connections associated with the specified protocols are displayed.

[*address*] : :sonode [-f inet | inet6 | unix | id] [-t stream | dgram | raw | id] [-p id]

Filters and displays sonode objects. If no address is given, then the list of AF_UNIX sockets is displayed, otherwise only the specified sonode is displayed. If the -f option is present, then only sockets of the given family will be output. If the -t option is present, then only sonodes of the given type will be output. If the -p option is present, then only sockets of the given protocol will be displayed.

[*address*] : :tcpb [-av] [-P v4 | v6]

Filters and displays tcpb objects. If no address is specified, all connections are walked, otherwise only the specified tcpb is filtered/displayed. Specifying -a filters for only active connections and -P can be used to filter for TCP IPv4 or IPv6 connections. The tcpb dcmd is intelligent about filtering TCP connections, and if a IPv6 TCP connection is in a state that would still facilitate a IPv4 connection, the -P filter considers the connection as both IPv4 and IPv6 in much the same way that : :netstat does. If the dcmd is not being used as a filter and the -v option is specified, then the output of the dcmd will be verbose.

Networking Walkers

- ar Given the address of an ar, this walker walks all ar objects from the given ar to the final ar. If no address is specified, all ar objects are walked.
- icmp Given the address of an icmp, this walker walks all icmp objects from the given icmp to the final icmp. If no address is specified, all icmp objects are walked.
- ill Given the address of an interface link layer structure (ill), this walker walks all ill objects from the given ill to the final. If no address is specified, all ill objects are walked.

ipc	Given the address of an ipc, this walker walks all ipc objects from the given ipc to the final ipc. If no address is specified, all ipc objects are walked.
mi	Given the address of a MI_O, walk all the MI_O's in this MI.
sonode	Given the address of a AF_UNIX sonode, walk the associated list of AF_UNIX sonodes beginning with the given sonode. If no address is specified, this walker walks the list of all AF_UNIX sockets.
tcpb	Given the address of a tcpb, this walker walks all TCP connections from the given tcpb to the final TCP connection. If no address is specified, all tcpb objects are walked.
udp	Given the address of a udp, this walker walks all udp objects from the given udp to the final udp. If no address is specified, all udp objects are walked.

Files, Processes, and Threads

This section describes dcmds and walkers used to format and examine various fundamental file, process, and thread structures in the Oracle Solaris kernel.

Files, Processes, and Threads Dcmds

process :: fd *fd-num*

Print the `file_t` address corresponding to the file descriptor *fd-num* associated with the specified process. The process is specified using the virtual address of its `proc_t` structure.

thread :: findstack [*command*]

Print the stack trace associated with the given kernel thread, identified by the virtual address of its `kthread_t` structure. The dcmd employs several different algorithms to locate the appropriate stack backtrace. If an optional command string is specified, the dot variable is reset to the frame pointer address of the topmost stack frame, and the specified command is evaluated as if it had been typed at the command line. The default command string is “<. \$C0”; that is, print a stack trace including frame pointers but no arguments.

:: pgrep [-x] [-n|-o] *regexp*

Display process information for processes whose name matches the *regexp* regular expression pattern. The :: pgrep dcmd is similar to the `pgrep(1)` command. The :: pgrep dcmd is used to pattern match against all processes. When the -n option is used, display only the newest process that matches the pattern. When the -o option is used, display only the oldest process that matches the pattern. When the -x option is used, display only those processes whose names are exactly the same as the search pattern.

In `kmdb(1)`, the *regexp* used with :: pgrep must be a plain alpha-numeric text string.

pid : : pid2proc

Print the `proc_t` address corresponding to the specified PID. Recall that MDB's default base is hexadecimal, so decimal PIDs obtained using `pgrep(1)` or `ps(1)` should be prefixed with `0t`.

process : : pmap [-q]

Print the memory map of the process indicated by the given process address. The `dcmd` displays output using a format similar to `pmap(1)`. If the `-q` option is present, the `dcmd` displays an abbreviated form of its output that requires less processing time.

[*address*] : : ps [-fltTP]

Print a summary of the information related to the specified process, or all active system processes, similar to `ps(1)`. If the `-f` option is specified, the full command name and initial arguments are printed. If the `-l` option is specified, the LWPs associated with each process are printed. If the `-t` option is specified, the kernel threads associated with each process LWP are printed. If the `-T` option is specified, the task ID associated with each process is displayed. If the `-P` option is specified, the project ID associated with each process is displayed.

: : ptree

Print a process tree, with child processes indented from their respective parent processes. The `dcmd` displays output using a format similar to `ptree(1)`.

address : : task

Print a list of the active kernel task structures and their associated ID numbers and attributes. The process task ID is described in more detail in `settaskid(2)`.

[*address*] : : thread [-bdfimps]

Display properties of the specified kernel `kthread_t` structure. If no `kthread_t` address is specified, the properties of all kernel threads are displayed. The `dcmd` options are used to control which output columns are shown. If no options are present, the `-i` option is enabled by default. If the `-b` option is present, information relating to the thread's turnstile and blocking synchronization object is shown. If the `-d` option is present, the thread's dispatcher priority, binding, and last dispatch time is shown. If the `-f` option is present, threads whose state is `TS_FREE` are elided from the output. If the `-i` option is present (the default), thread state, flags, priority, and interrupt information is shown. If the `-m` option is present, all of the other output options are merged together on to a single output line. If the `-p` option is present, the thread's process, LWP, and credential pointers are displayed. If the `-s` option is present, the thread's signal queue and masks of pending and held signals are shown.

vnode : : whereopen

Given a `vnode_t` address, print the `proc_t` addresses of all processes that have this `vnode` currently open in their file table.

Files, Processes, and Threads Walkers

file Given the address of a `proc_t` structure as a starting point, iterate over the set of open files (`file_t` structures) associated with the specified process. The `file_t` structure is defined in `<sys/file.h>`.

proc	Iterate over the active process (<code>proc_t</code>) structures. This structure is defined in <code><sys/proc.h></code> .
task	Given a task pointer, iterate over the list of <code>proc_t</code> structures for processes that are members of the given task.
thread	Iterate over a set of kernel thread (<code>kthread_t</code>) structures. If the global walk is invoked, all kernel threads are returned by the walker. If a local walk is invoked using a <code>proc_t</code> address as the starting point, the set of threads associated with the specified process is returned. The <code>kthread_t</code> structure is defined in <code><sys/thread.h></code> .

Synchronization Primitives

This section describes dcmds and walkers used to examine particular kernel synchronization primitives. The semantics of each primitive are discussed in the corresponding (9f) section of the manual pages.

Synchronization Primitives Dcmds

<code>rwlock :: rwlock</code>	Given the address of a readers-writers lock (see rwlock(9F)), display the current state of the lock and the list of waiting threads.
<code>address :: sobj2ts</code>	Convert the address of a synchronization object to the address of the corresponding turnstile and print the turnstile address.
<code>[address] :: turnstile</code>	Display the properties of the specified <code>turnstile_t</code> . If no <code>turnstile_t</code> address is specified, the dcmd displays the properties of all turnstiles.
<code>[address] :: wchaninfo [-v]</code>	Given the address of a condition variable (see condvar(9F)) or semaphore (see semaphore(9F)), display the current number of waiters on this object. If no explicit address is specified, display all such objects that have waiting threads. If the <code>-v</code> option is specified, display the list of threads that are blocked on each object.

Synchronization Primitives Walkers

blocked	Given the address of a synchronization object (such as a mutex(9F) or rwlock(9F)), iterate over the list of blocked kernel threads.
wchan	Given the address of a condition variable (see condvar(9F)) or semaphore (see semaphore(9F)), iterate over the list of blocked kernel threads.

Cyclics

The cyclic subsystem is a low-level kernel subsystem that provides high resolution, per-CPU interval timer facilities to other kernel services and programming interfaces.

Cyclics Dcmds

- `::cycinfo [-vV]` Display the cyclic subsystem per-CPU state for each CPU. If the `-v` option is present, a more verbose display is shown. If the `-V` option is present, an even more verbose display than `-v` is shown.
- `address ::cyclic` Format and display the `cyclic_t` at the specified address.
- `::cyccover` Display cyclic subsystem code coverage information. This information is available only in a DEBUG kernel.
- `::cyctrace` Display cyclic subsystem trace information. This information is available only in a DEBUG kernel.

Cyclics Walkers

- `cyccpu` Iterate over the per-CPU `cyc_cpu_t` structures. This structure is defined in `<sys/cyclic_impl.h>`.
- `cyctrace` Iterate over the cyclic trace buffer structures. This information is only available in a DEBUG kernel.

Task Queues

The task queue subsystem provides general-purpose asynchronous task scheduling for a variety of clients in the kernel.

Task Queues Dcmds

- `address ::taskq_entry` Print the contents of the specified struct `taskq_entry`.

Task Queues Walkers

- `taskq_entry` Given the address of a `taskq` structure, iterate over the list of `taskq_entry` structures.

Error Queues

The error queue subsystem provides general-purpose asynchronous error event processing for platform-specific error handling code.

Error Queues Dcmds

[*address*] :: errorq Display a summary of information relating to the specified error queue. If no address is given, display information relating to all system error queues. The address, name, queue length, and data element size for each queue are displayed, along with various queue statistics.

Error Queues Walkers

errorq Walk the list of system error queues and return the address of each individual error queue.

errorq_data Given the address of an error queue, return the address of each pending error event data buffer.

System Configuration

This section describes dcmds that can be used to examine system configuration data.

System Configuration Dcmds

:: system Display the contents of the system(4) configuration file at the time the kernel parsed the file during system initialization.

Interprocess Communication Debugging Support (ipc)

The ipc module provides debugging support for the implementation of the message queue, semaphore, and shared memory interprocess communication primitives.

Interprocess Communication Dcmds

:: ipc [-l] Display a listing of system-wide IPC identifiers, corresponding to known message queues, semaphores, and shared memory segments. If the -l option is specified, a longer listing of information is shown.

<code>address ::msg [-l] [-t type]</code>	Display the properties of the specified message queue element (struct <code>msg</code>). If the <code>-l</code> option is present, the raw contents of the message are displayed in hexadecimal and ASCII. If the <code>-t</code> option is present, it can be used to filter the output and only display messages of the specified type. This can be useful when piping the output of the <code>msgqueue</code> walker to <code>::msg</code> .
<code>id ::msqid [-k]</code>	Convert the specified message queue IPC identifier to a pointer to the corresponding kernel implementation structure and print the address of this kernel structure. If the <code>-k</code> option is present, the <code>id</code> is instead interpreted as a message queue key to match (see <code>msgget(2)</code>).
<code>[address] ::msqid_ds [-l]</code>	Print the specified <code>msqid_ds</code> structure or a table of the active <code>msqid_ds</code> structures (message queue identifiers). If the <code>-l</code> option is specified, a longer listing of information is displayed.
<code>id ::semid [-k]</code>	Convert the specified semaphore IPC identifier to a pointer to the corresponding kernel implementation structure and print the address of this kernel structure. If the <code>-k</code> option is present, the <code>id</code> is instead interpreted as a semaphore key to match (see <code>semget(2)</code>).
<code>[address] ::semid_ds [-l]</code>	Print the specified <code>semid_ds</code> structure or a table of the active <code>semid_ds</code> structures (semaphore identifiers). If the <code>-l</code> option is specified, a longer listing of information is displayed.
<code>id ::shmid [-k]</code>	Convert the specified shared memory IPC identifier to a pointer to the corresponding kernel implementation structure and print the address of this kernel structure. If the <code>-k</code> option is present, the <code>id</code> is instead interpreted as a shared memory key to match (see <code>shmget(2)</code>).
<code>[address] ::shmid_ds [-l]</code>	Print the specified <code>shmid_ds</code> structure or a table of the active <code>shmid_ds</code> structures (shared memory segment identifiers). If the <code>-l</code> option is specified, a longer listing of information is displayed.

Interprocess Communication Walkers

<code>msg</code>	Walk the active <code>msqid_ds</code> structures corresponding to message queue identifiers. This structure is defined in <code><sys/msg.h></code> .
<code>msgqueue</code>	Iterate over the message structures that are currently enqueued on the specified message queue.

sem	Walk the active <code>semid_ds</code> structures corresponding to semaphore identifiers. This structure is defined in <code><sys/sem.h></code> .
shm	Walk the active <code>shmid_ds</code> structures corresponding to shared memory segment identifiers. This structure is defined in <code><sys/shm.h></code> .

Loopback File System Debugging Support (lofs)

The `lofs` module provides debugging support for the `lofs(7FS)` file system.

Loopback File System Dcmds

<code>[address] :: lnode</code>	Print the specified <code>lnode_t</code> , or a table of the active <code>lnode_t</code> structures in the kernel.
<code>address :: lnode2dev</code>	Print the <code>dev_t</code> (<code>vfs_dev</code>) for the underlying loopback mounted filesystem corresponding to the given <code>lnode_t</code> address.
<code>address :: lnode2rdev</code>	Print the <code>dev_t</code> (<code>li_rdev</code>) for the underlying loopback mounted file system corresponding to the given <code>lnode_t</code> address.

Loopback File System Walkers

<code>lnode</code>	Walk the active <code>lnode_t</code> structures in the kernel. This structure is defined in <code><sys/fs/lofs_node.h></code> .
--------------------	---

Internet Protocol Module Debugging Support (ip)

The `ip` module provides debugging support for the `ip(7P)` driver.

Internet Protocol Dcmds

<code>[address] :: ire [-q]</code>	Print the specified <code>ire_t</code> , or a table of the active <code>ire_t</code> structures in the kernel. If the <code>-q</code> flag is specified, the send and receive queue pointers are printed instead of the source and destination addresses.
--------------------------------------	---

Internet Protocol Walkers

`ire` Walk the active `ire` (Internet Route Entry) structures in the kernel. This structure is defined in `<inet/ip.h>`.

Kernel Runtime Link Editor Debugging Support (krtld)

This section describes the debugging support for the kernel runtime link editor, which is responsible for loading kernel modules and drivers.

Kernel Runtime Link Editor Dcmds

`[address] :: modctl` Print the specified `modctl`, or a table of the active `modctl` structures in the kernel.

`address :: modhdrs` Given the address of a `modctl` structure, print the module's ELF executable header and section headers.

`:: modinfo` Print information about the active kernel modules, similar to the output of the `/usr/sbin/modinfo` command.

Kernel Runtime Link Editor Walkers

`modctl` Walk the list of active `modctl` structures in the kernel. This structure is defined in `<sys/modctl.h>`.

USB Framework Debugging Support (uhci)

The `uchi` module provides debugging support for the host controller interface portion of the Universal Serial Bus (USB) framework.

USB Host Controller Dcmds

`address :: uhci_qh [-bd]` Given the address of a USB UHCI controller Queue Head (QH) structure, print the contents of the structure. If the `-b` option is present iterate over the `link_ptr` chain, printing all QHs found. If the `-d` option is present, iterate over the `element_ptr` chain, printing all TDs found.

address :: uhci_td [-d] Given the address of a USB UHCI controller Transaction Descriptor (TD) structure, print the contents of the structure. Note this only works for Control and Interrupt TDs. If the -d option is present, iterate over the element_ptr chain, printing all TDs found.

USB Host Controller Walkers

uhci_qh Given the address of a USB UHCI controller Queue Head (QH) structure, iterate over the list of such structures.

uhci_td Given the address of a USB UHCI controller Queue Head Descriptor (TD) structure, iterate over the list of such structures.

USB Framework Debugging Support (usba)

The usba module provides debugging support for the platform-independent Universal Serial Bus (USB) framework.

USB Framework Dcmds

::usba_debug_buf Print the USB debugging information buffer.

::usba_clear_debug_buf Empty the USB debugging information buffer.

[*address*] ::usba_device [-pv] Given the address of a usba_device structure, print summary information. If no address is supplied, this dcmd walks the global list of usba_device structures. If the -p option is present, also list information for all open pipes on this device. If the -v option is present, list verbose information for each device.

address ::usb_pipe_handle Given the address of a USB pipe handle structure (struct usb_ph_impl), print summary information for this handle.

USB Framework Walkers

usba_list_entry Given the address of a usba_list_entry structure, iterate over the chain of such structures.

`usba_device` Walk the global list of `usba_device_t` structures.

`usb_pipe_handle` Given a `usba_device_t` address, walk USB pipe handles.

x86: x86 Platform Debugging Support (unix)

These dcmts and walkers are specific to x86 platforms.

x86 Platform Dcmds

`[cpuid | address] :: ttrace [-x]`

Display trap trace records in reverse chronological order. The trap trace facility is available only in DEBUG kernels. If an explicit dot value is specified, this is interpreted as either a CPU ID number or a trap trace record address, depending on the precise value. If a CPU ID is specified, the output is restricted to the buffer from that CPU. If a record address is specified, only that record is formatted. If the `-x` option is specified, the complete raw record is displayed.

x86 Platform Walkers

`ttrace` Walk the list of trap trace record addresses in reverse chronological order. The trap trace facility is available only in DEBUG kernels.

SPARC: sun4u Platform Debugging Support (unix)

These dcmts and walkers are specific to the SPARC sun4u platform.

sun4u Platform Dcmds

`[address] :: softint` Display the soft interrupt vector structure at the specified address, or display all the active soft interrupt vectors. The pending count, PIL, argument, and handler function for each structure is displayed.

`:: ttctl` Display trap trace control records. The trap trace facility is available only in DEBUG kernels.

`[cpuid] :: ttrace [-x]` Display trap trace records in reverse chronological order. The trap trace facility is available only in DEBUG kernels. If an explicit dot value is specified, this is interpreted as a CPU ID number, and the

	output is restricted to the buffer from that CPU. If the <code>-x</code> option is specified, the complete raw record is displayed.
<code>[address] ::xc_mbox</code>	Display the cross-call mailbox at the specified address, or format all the cross-call mailboxes that have pending requests.
<code>::xctrace</code>	Format and display cross-call trace records in reverse chronological order that are related to CPU cross-call activity. The cross-call trace facility is available only in DEBUG kernels.

sun4u Platform Walkers

<code>softint</code>	Iterate over the soft interrupt vector table entries.
<code>ttrace</code>	Iterate over the trap trace record addresses in reverse chronological order. The trap trace facility is only available in DEBUG kernels.
<code>xc_mbox</code>	Iterate over the mailboxes used for CPU handshake and cross-call (x-call) requests.

Debugging With the Kernel Memory Allocator

The Oracle Solaris kernel memory (kmem) allocator provides a powerful set of debugging features that can facilitate analysis of a kernel crash dump. This chapter discusses these debugging features, and the MDB `dcmds` and `walkers` designed specifically for the allocator. Bonwick (see “[Related Books and Papers](#)” on page 11) provides an overview of the principles of the allocator itself. Refer to the header file `<sys/kmem_impl.h>` for the definitions of allocator data structures. The kmem debugging features can be enabled on a production system to enhance problem analysis, or on development systems to aid in debugging kernel software and device drivers.

Note – MDB exposes kernel implementation details that are subject to change at any time. This guide reflects the Oracle Solaris kernel implementation as of the date of publication of this guide. Information provided in this guide about the kernel memory allocator might not be correct or applicable to past or future Oracle Solaris releases.

Getting Started: Creating a Sample Crash Dump

This section shows you how to obtain a sample crash dump, and how to invoke MDB in order to examine it.

Setting `kmem_flags`

The kernel memory allocator contains many advanced debugging features, but these are not enabled by default because they can cause performance degradation. In order to follow the examples in this guide, you should turn on these features. You should enable these features only on a test system, as they can cause performance degradation or expose latent problems.

The allocator's debugging functionality is controlled by the `kmem_flags` tunable. To get started, make sure `kmem_flags` is set properly:

```
# mdb -k
> kmem_flags/X
kmem_flags:
kmem_flags:      f
```

If `kmem_flags` is not set to `f`, you should add the following line to the `/etc/system` file:

```
set kmem_flags=0xf
```

The reboot the system. When the system reboots, confirm that `kmem_flags` is set to `f`. Remember to remove your `/etc/system` modifications before returning this system to production use.

Forcing a Crash Dump

The next step is to make sure crash dumps are properly configured. First, confirm that `dumpadm` is configured to save kernel crash dumps and that `savecore` is enabled. See [dumpadm\(1M\)](#) for more information on crash dump parameters.

```
# dumpadm
          Dump content: kernel pages
          Dump device: /dev/dsk/c0t0d0s1 (swap)
Savecore directory: /var/crash/testsystem
Savecore enabled: yes
Save compressed: on
```

Next, reboot the system using the `-d` flag to [reboot\(1M\)](#), which forces the kernel to panic and save a crash dump.

```
# reboot -d
Sep 28 17:51:18 testsystem reboot: rebooted by root

panic[cpu0]/thread=70aacde0: forced crash dump initiated at user request

401fbb10 genunix:uadmin+55c (1, 1, 0, 6d700000, 5, 0)
  %l0-7: 00000000 00000000 00000000 00000000 00000000 00000000 00000000
        00000000
...
```

When the system reboots, `savecore` runs automatically to preserve the crash dump in a file. When finished, a message is printed on the system console:

```
Sep 17 10:47:23 testsystem savecore: Decompress the crash dump with
Sep 17 10:47:23 testsystem 'savecore -vf /var/crash/testsystem/vmdump.0'
```

If the message does not appear right away, check to whether `savecore(1M)` is still running:

```
$ pgrep savecore
864
$ cd /var/crash/testsystem
$ ls
bounds    vmdump.0
```

The `vmdump.n` file is a compressed version of `vmcore.n` plus `unix.n`.

If your dump directory contains no dump files, then that partition might be out of space. You can free up space and run `savecore(1M)` manually as root to subsequently save the dump.

If your dump directory contains multiple crash dumps, the one you just created is the `unix.n` and `vmcore.n` pair or `vmdump.n` file with the most recent modification time.

Saving a Crash Dump

When the system panics, or when you enter `reboot -d`, the following kinds of messages appear on the console:

```
Sep 17 10:47:23 testsystem savecore: Decompress the crash dump with
Sep 17 10:47:23 testsystem 'savecore -vf /var/crash/testsystem/vmdump.0'
```

Enter the following command:

```
root@testsystem # savecore -vf /var/crash/testsystem/vmdump.0
savecore: System dump time: Thu Sep 17 10:43:20 2009

savecore: saving system crash dump in /var/crash/testsystem/{unix,vmcore}.0
Constructing namelist /var/crash/testsystem/unix.0
Constructing corefile /var/crash/testsystem/vmcore.0
  1:29 100% done: 825215 of 825215 pages saved
 1:30 dump decompress is done
```

Now you can use `mdb`:

```
root@testsystem# mdb /var/crash/testsystem/{unix,vmcore}.0
Loading modules: [ unix genunix specfs dtrace zfs scsi_vhci sd mpt px mac ldc sockfs
ip hook neti sctp arp usba stmf qlc fctl nca lofs idm logindmux ptm ufs md cpc spps
random smbsrv nfs crypto mdesc nsctl sdbc sv rdc fcp fcip ii nsmb ]
>
```

You can copy the `vmdump.n` file to another system for analysis. You can use `savecore(1M)` either locally or remotely to uncompress the dump file.

Use the `dumpadm(1M)` command to control the particular paths of the dump device and the `savecore` directory.

You can use the `file(1)` command to quickly examine files in the directory:

```
$ cd /var/crash/testsystem
$ file *
bounds:          ascii text
unix.0:          ELF 64-bit MSB executable SPARCv9 Version 1, UltraSPARC3 Extensions
Required, statically linked, not stripped, no debugging information available
vmcore.0:        SunOS 5.11 Generic 64-bit SPARC crash dump from 'testsystem'
vmdump.0:        SunOS 5.11 Generic 64-bit SPARC compressed crash dump from 'testsystem'
```

Starting MDB

Now, run `mdb` on the crash dump you created, and check its status:

```
$ mdb unix.1 vmcore.1
Loading modules: [ unix krtld genunix ip nfs ipc ]
> ::status
debugging crash dump vmcore.1 (32-bit) from testsystem
operating system: 5.10 Generic (sun4u)
panic message: forced crash dump initiated at user request
```

In the examples presented in this guide, a crash dump from a 32-bit kernel is used. All of the techniques presented here are applicable to a 64-bit kernel, and care has been taken to distinguish pointers (sized differently on 32- and 64-bit systems) from fixed-sized quantities, which are invariant with respect to the kernel data model.

An UltraSPARC workstation was used to generate the example presented. Your results can vary depending on the architecture and model of system you use.

Allocator Basics

The kernel memory allocator's job is to parcel out regions of virtual memory to other kernel subsystems (these are commonly called *clients*). This section explains the basics of the allocator's operation and introduces some terms used later in this guide.

Buffer States

The functional domain of the kernel memory allocator is the set of *buffers* of virtual memory that make up the kernel heap. These buffers are grouped together into sets of uniform size and purpose, known as *caches*. Each cache contains a set of buffers. Some of these buffers are currently *free*, which means that they have not yet been allocated to any client of the allocator. The remaining buffers are *allocated*, which means that a pointer to that buffer has been provided to a client of the allocator. If no client of the allocator holds a pointer to an allocated buffer, this buffer is said to be *leaked*, because it cannot be freed. Leaked buffers indicate incorrect code that is wasting kernel resources.

Transactions

A *kmem transaction* is a transition on a buffer between the allocated and free states. The allocator can verify that the state of a buffer is valid as part of each transaction. Additionally, the allocator has facilities for logging transactions for post-mortem examination.

Sleeping and Non-Sleeping Allocations

Unlike the Standard C Library's `malloc(3C)` function, the kernel memory allocator can block (or *sleep*), waiting until enough virtual memory is available to satisfy the client's request. This is controlled by the `flag` parameter to `kmem_alloc(9F)`. A call to `kmem_alloc(9F)` which has the `KM_SLEEP` flag set can never fail; it will block forever waiting for resources to become available.

Kernel Memory Caches

The kernel memory allocator divides the memory it manages into a set of *caches*. All allocations are supplied from these caches, which are represented by the `kmem_cache_t` data structure. Each cache has a fixed *buffer size*, which represents the maximum allocation size satisfied by that cache. Each cache has a string name indicating the type of data it manages.

Some kernel memory caches are special purpose and are initialized to allocate only a particular kind of data structure. An example of this is the “`thread_cache`,” which allocates only structures of type `kthread_t`. Memory from these caches is allocated to clients by the `kmem_cache_alloc()` function and freed by the `kmem_cache_free()` function.

Note – `kmem_cache_alloc()` and `kmem_cache_free()` are not public DDI interfaces. Do NOT write code that relies on them, because they are subject to change or removal in future releases of Oracle Solaris.

Caches whose name begins with “`kmem_alloc_`” implement the kernel's general memory allocation scheme. These caches provide memory to clients of `kmem_alloc(9F)` and `kmem_zalloc(9F)`. Each of these caches satisfies requests whose size is between the buffer size of that cache and the buffer size of the next smallest cache. For example, the kernel has `kmem_alloc_8` and `kmem_alloc_16` caches. In this case, the `kmem_alloc_16` cache handles all client requests for 9-16 bytes of memory. Remember that the size of each buffer in the `kmem_alloc_16` cache is 16 bytes, regardless of the size of the client request. In a 14 byte request, two bytes of the resulting buffer are unused, since the request is satisfied from the `kmem_alloc_16` cache.

The last set of caches are those used internally by the kernel memory allocator for its own bookkeeping. These include those caches whose names start with “`kmem_magazine_`” or “`kmem_va_`”, the `kmem_slab_cache`, the `kmem_bufctl_cache` and others.

Kernel Memory Caches

This section explains how to find and examine kernel memory caches. You can learn about the various `kmem` caches on the system by issuing the `::kmastat` command.

```
> ::kmastat
cache
name          buf    buf    buf    memory    alloc alloc
              size in use total  in use    succeed fail
-----
kmem_magazine_1      8     24   1020     8192      24    0
kmem_magazine_3     16    141    510     8192     141    0
kmem_magazine_7     32     96    255     8192     96    0
...
kmem_alloc_8         8   3614   3751    90112   9834113  0
kmem_alloc_16        16  2781   3072    98304   8278603  0
kmem_alloc_24         24   517    612    24576   680537  0
kmem_alloc_32         32   398    510    24576   903214  0
kmem_alloc_40         40   482    584    32768   672089  0
...
thread_cache        368    107    126    49152   669881  0
lwp_cache           576    107    117    73728     182    0
turnstile_cache     36    149    292    16384   670506  0
cred_cache          96     6     73     8192   2677787  0
...
```

If you run `::kmasat` you get a feel for what a “normal” system looks like. This will help you to spot excessively large caches on systems that are leaking memory. The results of `::kmasat` will vary depending on the system you are running on, how many processes are running, and so forth.

Another way to list the various `kmem` caches is with the `::kmem_cache` command:

```
> ::kmem_cache
ADDR      NAME          FLAG  CFLAG  BUFSIZE  BUFTOTL
70036028  kmem_magazine_1  0020  0e0000    8      1020
700362a8  kmem_magazine_3  0020  0e0000   16       510
70036528  kmem_magazine_7  0020  0e0000   32       255
...
70039428  kmem_alloc_8     020f  000000    8      3751
700396a8  kmem_alloc_16    020f  000000   16      3072
70039928  kmem_alloc_24    020f  000000   24       612
70039ba8  kmem_alloc_32    020f  000000   32       510
7003a028  kmem_alloc_40    020f  000000   40       584
...
```

This command is useful because it maps cache names to addresses, and provides the debugging flags for each cache in the `FLAG` column. It is important to understand that the allocator's selection of debugging features is derived on a per-cache basis from this set of flags. These are set in conjunction with the global `kmem_flags` variable at cache creation time. Setting `kmem_flags` while the system is running has no effect on the debugging behavior, except for subsequently created caches (which is rare after boot-up).

Next, walk the list of `kmem` caches directly using MDB's `kmem_cache` walker:

```
> ::walk kmem_cache
70036028
700362a8
70036528
700367a8
...
```

This produces a list of pointers that correspond to each kmem cache in the kernel. To find out about a specific cache, apply the `kmem_cache` macro:

```
> 0x70039928$<kmem_cache
0x70039928: lock
0x70039928: owner/waiters
0
0x70039930: flags freelist offset
20f 707c86a0 24
0x7003993c: global_alloc global_free alloc_fail
523 0 0
0x70039948: hash_shift hash_mask hash_table
5 1ff 70444858
0x70039954: nullslab
0x70039954: cache base next
70039928 0 702d5de0
0x70039960: prev head tail
707c86a0 0 0
0x7003996c: refcnt chunks
-1 0
0x70039974: constructor destructor reclaim
0 0 0
0x70039980: private arena cflags
0 104444f8 0
0x70039994: bufsize align chunksize
24 8 40
0x700399a0: slabsize color maxcolor
8192 24 32
0x700399ac: slab_create slab_destroy buftotal
3 0 612
0x700399b8: bufmax rescale lookup_depth
612 1 0
0x700399c4: kstat next prev
702c8608 70039ba8 700396a8
0x700399d0: name kmem_alloc_24
0x700399f0: bufctl_cache magazine_cache magazine_size
70037ba8 700367a8 15
...
```

Important fields for debugging include 'bufsize', 'flags' and 'name'. The name of the `kmem_cache` (in this case “`kmem_alloc_24`”) indicates its purpose in the system. Bufsize indicates the size of each buffer in this cache; in this case, the cache is used for allocations of size 24 and smaller.

'flags' indicates what debugging features are turned on for this cache. You can find the debugging flags listed in `<sys/kmem_impl.h>`. In this case 'flags' is `0x20f`, which is `KMF_AUDIT | KMF_DEADBEEF | KMF_REDZONE | KMF_CONTENTS | KMF_HASH`. This document explains each of the debugging features in subsequent sections.

When you are interested in looking at buffers in a particular cache, you can walk the allocated and freed buffers in that cache directly:

```
> 0x70039928::walk kmem
704ba010
702ba008
704ba038
702ba030
...

> 0x70039928::walk freemem
70a9ae50
70a9ae28
704bb730
704bb2f8
...
```

MDB provides a shortcut to supplying the cache address to the kmem walker: a specific walker is provided for each kmem cache, and its name is the same as the name of the cache. For example:

```
> ::walk kmem_alloc_24
704ba010
702ba008
704ba038
702ba030
...

> ::walk thread_cache
70b38080
70aac060
705c4020
70aac1e0
...
```

Now you know how to iterate over the kernel memory allocator's internal data structures and examine the most important members of the `kmem_cache` data structure.

Detecting Memory Corruption

One of the primary debugging facilities of the allocator is that it includes algorithms to recognize data corruption quickly. When corruption is detected, the allocator immediately panics the system. This section describes how the allocator recognizes data corruption. You must understand this to be able to debug these problems.

Memory abuse typically falls into one of the following categories:

- Writing past the end of a buffer
- Accessing uninitialized data
- Continuing to use a freed buffer
- Corrupting kernel memory

Keep these problems in mind as you read the next three sections. They will help you to understand the allocator's design, and enable you to diagnose problems more efficiently.

Freed Buffer Checking: 0xdeadbeef

When the `KMF_DEADBEEF (0x2)` bit is set in the flags field of a `kmem_cache`, the allocator tries to make memory corruption easy to detect by writing a special pattern into all freed buffers. This pattern is `0xdeadbeef`. Since a typical region of memory contains both allocated and freed memory, sections of each kind of block will be interspersed. The following example is from the `kmem_alloc_24` cache:

```

0x70a9add8:  deadbeef      deadbeef
0x70a9ade0:  deadbeef      deadbeef
0x70a9ade8:  deadbeef      deadbeef
0x70a9adf0:  feedface      feedface
0x70a9adf8:  70ae3260      8440c68e
0x70a9ae00:  5             4ef83
0x70a9ae08:  0             0
0x70a9ae10:  1             bddcafe
0x70a9ae18:  feedface      139d
0x70a9ae20:  70ae3200      d1bfaed
0x70a9ae28:  deadbeef      deadbeef
0x70a9ae30:  deadbeef      deadbeef
0x70a9ae38:  deadbeef      deadbeef
0x70a9ae40:  feedface      feedface
0x70a9ae48:  70ae31a0      8440c54e

```

The buffers at `0x70a9add8` and `0x70a9ae28` are filled with `0xdeadbeefdeadbeef`, which shows that these buffers are free. The buffer *redzones* are filled with `0xfeedfacefeedface`, which indicates they are untouched (no buffer overrun has occurred). See the following section for an explanation of redzones. At `0x70a9ae00` an allocated buffer is located between the two free buffers.

Redzone: 0xfeedface

Note the pattern `0xfeedface` in the buffer shown in the previous section. This pattern is known as the *redzone* indicator. This pattern enables the allocator (and a programmer debugging a problem) to determine whether the boundaries of a buffer have been violated. Following the redzone is some additional information. The content of that data depends on other factors (see “[Memory Allocation Logging](#)” on page 107). The redzone and its suffix are collectively called the *buftag* region. [Figure 9–1](#) summarizes this information.

FIGURE 9–1 The Redzone

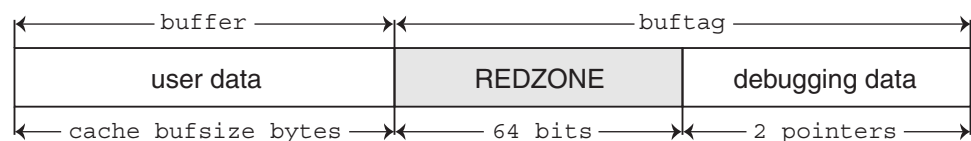

The buftag is appended to each buffer in a cache when any of the KMF_AUDIT, KMF_DEADBEEF, or KMF_REDZONE flags is set in that buffer's cache. The content of the buftag depends on whether KMF_AUDIT is set.

Decomposing the memory region presented above into distinct buffers is now simple:

```

0x70a9add8:  deadbeef      deadbeef  \
0x70a9ade0:  deadbeef      deadbeef  +- User Data (free)
0x70a9ade8:  deadbeef      deadbeef  /
0x70a9adf0:  feedface      feedface  -- REDZONE
0x70a9adf8:  70ae3260     8440c68e  -- Debugging Data

0x70a9ae00:  5             4ef83     \
0x70a9ae08:  0             0         +- User Data (allocated)
0x70a9ae10:  1             bddcafe   /
0x70a9ae18:  feedface      139d     -- REDZONE
0x70a9ae20:  70ae3200     d1bfaed   -- Debugging Data

0x70a9ae28:  deadbeef      deadbeef  \
0x70a9ae30:  deadbeef      deadbeef  +- User Data (free)
0x70a9ae38:  deadbeef      deadbeef  /
0x70a9ae40:  feedface      feedface  -- REDZONE
0x70a9ae48:  70ae31a0     8440c54e  -- Debugging Data
    
```

The buffers at 0x70a9add8 and 0x70a9ae28 are filled with 0xdeadbeefdeadbeef, which shows that these buffers are free. The buffer redzones are filled with 0xfeedfacefeedface, which indicates they are untouched (no buffer overrun has occurred).

0xbddcafe Buffer is allocated but uninitialized (see “[Uninitialized Data: 0xbddcafe](#)” on [page 106](#)).

0xdeadbeef Buffer is free.

0xfeedface Buffer limits were respected (no overflow).

In the allocated buffer beginning at 0x70a9ae00, the situation is different. Recall from “[Allocator Basics](#)” on [page 98](#) that there are two allocation types:

1. The client requested memory using `kmem_cache_alloc(9F)`, in which case the size of the requested buffer is equal to the `bufsize` of the cache.
2. The client requested memory using `kmem_alloc(9F)`, in which case the size of the requested buffer is less than or equal to the `bufsize` of the cache. For example, a request for 20 bytes will be fulfilled from the `kmem_alloc_24` cache. The allocator enforces the buffer boundary by placing a marker, the *redzone byte*, immediately following the client data:

```

0x70a9ae00:  5             4ef83     \
0x70a9ae08:  0             0         +- User Data (allocated)
0x70a9ae10:  1             bddcafe   /
0x70a9ae18:  feedface      139d     -- REDZONE
0x70a9ae20:  70ae3200     d1bfaed   -- Debugging Data
    
```

The `0xfedface` value at `0x70a9ae18` is followed by a 32-bit word containing what seems to be a random value. This number is actually an encoded representation of the size of the buffer. To decode this number and find the size of the allocated buffer, use the formula:

$$\text{size} = \text{redzone_value} / 251$$

So, in this example,

$$\text{size} = 0x139d / 251 = 20 \text{ bytes.}$$

This indicates that the buffer requested was of size 20 bytes. The allocator performs this decoding operation and finds that the redzone byte should be at offset 20. The redzone byte is the hex pattern `0xbb`, which is present at `0x729084e4` (`0x729084d0 + 0x14`) as expected.

FIGURE 9-2 Sample `kmem_alloc(9F)` Buffer

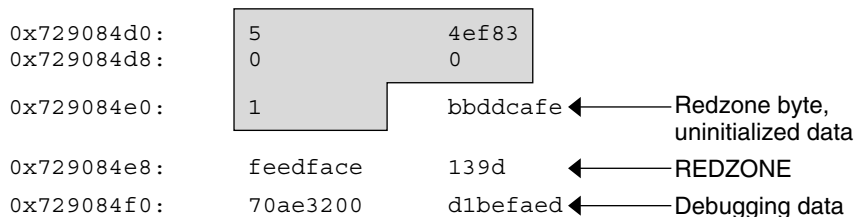

Valid User Data

Figure 9-3 shows the general form of this memory layout.

FIGURE 9-3 Redzone Byte

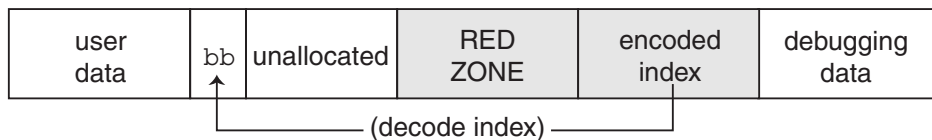

If the allocation size is the same as the `bufsize` of the cache, the redzone byte overwrites the first byte of the redzone itself, as shown in Figure 9-4.

FIGURE 9-4 Redzone Byte at the Beginning of the Redzone

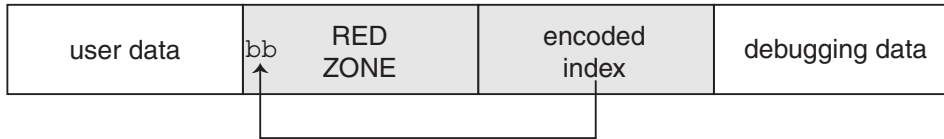

This overwriting results in the first 32-bit word of the redzone being `0xbbbedface`, or `0xfeedfabb` depending on the endianness of the hardware on which the system is running.

Note – Why is the allocation size encoded this way? To encode the size, the allocator uses the formula $(251 * \text{size} + 1)$. When the size decode occurs, the integer division discards the remainder of '+1'. However, the addition of 1 is valuable because the allocator can check whether the size is valid by testing whether $(\text{size} \% 251 == 1)$. In this way, the allocator defends against corruption of the redzone byte index.

Uninitialized Data: `0xbaddcafe`

You might be wondering what the suspicious `0xbaddcafe` at address `0x729084d4` was *before* the redzone byte got placed over the first byte in the word. It was `0xbaddcafe`. When the `KMF_DEADBEEF` flag is set in the cache, allocated but *uninitialized* memory is filled with the `0xbaddcafe` pattern. When the allocator performs an allocation, it loops across the words of the buffer and verifies that each word contains `0xdeadbeef`, then fills that word with `0xbaddcafe`.

A system can panic with a message such as:

```
panic[cpu1]/thread=e1979420: BAD TRAP: type=e (Page Fault)
rp=ef641e88 addr=baddcafe occurred in module "unix" due to an
illegal access to a user address
```

In this case, the address that caused the fault was `0xbaddcafe`: the panicking thread has accessed some data that was never initialized.

Associating Panic Messages With Failures

The kernel memory allocator emits panic messages corresponding to the failure modes described earlier. For example, a system can panic with a message such as:

```
kernel memory allocator: buffer modified after being freed
modification occurred at offset 0x30
```

The allocator was able to detect this case because it tried to validate that the buffer in question was filled with `0xdeadbeef`. At offset `0x30`, this condition was not met. Since this condition indicates memory corruption, the allocator panicked the system.

Another example failure message is:

```
kernel memory allocator: redzone violation: write past end of buffer
```

The allocator was able to detect this case because it tried to validate that the redzone byte (`0xbb`) was in the location it determined from the redzone size encoding. It failed to find the signature byte in the correct location. Since this indicates memory corruption, the allocator panicked the system. Other allocator panic messages are discussed later.

Memory Allocation Logging

This section explains the logging features of the kernel memory allocator and how you can employ them to debug system crashes.

Buftag Data Integrity

As explained earlier, the second half of each buftag contains extra information about the corresponding buffer. Some of this data is debugging information, and some is data private to the allocator. While this auxiliary data can take several different forms, it is collectively known as “Buffer Control” or *bufctl* data.

However, the allocator needs to know whether a buffer's *bufctl* pointer is valid, since this pointer might also have been corrupted by malfunctioning code. The allocator confirms the integrity of its auxiliary pointer by storing the pointer *and* an encoded version of that pointer, and then cross-checking the two versions.

As shown in [Figure 9–5](#), these pointers are the *bcp* (buffer control pointer) and *bxstat* (buffer control XOR status). The allocator arranges *bcp* and *bxstat* so that the expression *bcp XOR bxstat* equals a well-known value.

FIGURE 9–5 Extra Debugging Data in the Buftag

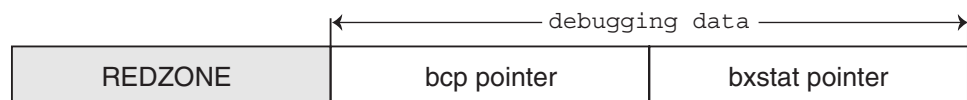

In the event that one or both of these pointers becomes corrupted, the allocator can easily detect such corruption and panic the system. When a buffer is *allocated*, `bcp XOR bxstat = 0xa110c8ed` (“allocated”). When a buffer is free, `bcp XOR bxstat = 0xf4eef4ee` (“freefree”).

Note – You might find it helpful to re-examine the example provided in [“Freed Buffer Checking: 0xdeadbeef” on page 103](#), in order to confirm that the `buftag` pointers shown there are consistent.

In the event that the allocator finds a corrupt `buftag`, it panics the system and produces a message similar to the following:

```
kernel memory allocator: boundary tag corrupted
  bcp ^ bxstat = 0xffeef4ee, should be f4eef4ee
```

Remember, if `bcp` is corrupt, it is still possible to retrieve its value by taking the value of `bxstat XOR 0xf4eef4ee` or `bxstat XOR 0xa110c8ed`, depending on whether the buffer is allocated or free.

The `bufctl` Pointer

The buffer control (`bufctl`) pointer contained in the `buftag` region can have different meanings, depending on the cache's `kmem_flags`. The behavior toggled by the `KMF_AUDIT` flag is of particular interest: when the `KMF_AUDIT` flag is *not* set, the kernel memory allocator allocates a `kmem_bufctl_t` structure for each buffer. This structure contains some minimal accounting information about each buffer. When the `KMF_AUDIT` flag *is* set, the allocator instead allocates a `kmem_bufctl_audit_t`, an extended version of the `kmem_bufctl_t`.

This section presumes the `KMF_AUDIT` flag is set. For caches that do not have this bit set, the amount of available debugging information is reduced.

The `kmem_bufctl_audit_t` (`bufctl_audit` for short) contains additional information about the last transaction that occurred on this buffer. The following example shows how to apply the `bufctl_audit` macro to examine an audit record. The buffer shown is the example buffer used in [“Detecting Memory Corruption” on page 102](#):

```
> 0x70a9ae00,5/KKn
0x70a9ae00:  5          4ef83
                0          0
                1          bddcafe
                feedface  139d
                70ae3200  d1bfaed
```

Using the techniques presented above, it is easy to see that `0x70ae3200` points to the `bufctl_audit` record: it is the first pointer following the redzone. To examine the `bufctl_audit` record it points to, apply the `bufctl_audit` macro:

```
> 0x70ae3200$<bufctl_audit
0x70ae3200:  next_          addr          slab
              70378000      70a9ae00      707c86a0
0x70ae320c:  cache          timestamp     thread
              70039928      e1bd0e26afe   70aac4e0
0x70ae321c:  lastlog        contents      stackdepth
              7011c7c0      7018a0b0      4
0x70ae3228:
              kmem_zalloc+0x30
              pid_assign+8
              getproc+0x68
              cfork+0x60
```

The 'addr' field is the address of the buffer corresponding to this `bufctl_audit` record. This is the original address: `0x70a9ae00`. The 'cache' field points at the `kmem_cache` that allocated this buffer. You can use the `::kmem_cache` dcmd to examine it as follows:

```
> 0x70039928::kmem_cache
ADDR      NAME          FLAG  CFLAG  BUFSIZE  BUFTOTL
70039928  kmem_alloc_24  020f  000000  24       612
```

The 'timestamp' field represents the time this transaction occurred. This time is expressed in the same manner as `gethrtime(3C)`.

'thread' is a pointer to the thread that performed the last transaction on this buffer. The 'lastlog' and 'contents' pointers point to locations in the allocator's *transaction logs*. These logs are discussed in detail in “[Allocator Logging Facility](#)” on page 112.

Typically, the most useful piece of information provided by `bufctl_audit` is the stack trace recorded at the point at which the transaction took place. In this case, the transaction was an allocation called as part of executing `fork(2)`.

Advanced Memory Analysis

This section describes facilities for performing advanced memory analysis, including locating memory leaks and sources of data corruption.

Finding Memory Leaks

The `::findleaks` dcmd provides powerful and efficient detection of memory leaks in kernel crash dumps where the full set of `kmem` debug features has been enabled. The first execution of `::findleaks` processes the dump for memory leaks (this can take a few minutes), and then

coalesces the leaks by the allocation stack trace. The findleaks report shows a bufctl address and the topmost stack frame for each memory leak that was identified:

```
> ::findleaks
CACHE    LEAKED    BUFCTL  CALLER
70039ba8    1 703746c0 pm_autoconfig+0x708
70039ba8    1 703748a0 pm_autoconfig+0x708
7003a028    1 70d3b1a0 sigaddq+0x108
7003c7a8    1 70515200 pm_ioctl+0x187c
-----
Total      4 buffers, 376 bytes
```

Using the bufctl pointers, you can obtain the complete stack backtrace of the allocation by applying the bufctl_audit macro:

```
> 70d3b1a0$<bufctl_audit
0x70d3b1a0:    next          addr          slab
              70a049c0     70d03b28     70bb7480
0x70d3b1ac:    cache         timestamp     thread
              7003a028     13f7cf63b3   70b38380
0x70d3b1bc:    lastlog      contents      stackdepth
              700d6e60     0             5
0x70d3b1c8:
              kmem_alloc+0x30
              sigaddq+0x108
              sigsendproc+0x210
              sigqkill+0x90
              kill+0x28
```

The programmer can usually use the bufctl_audit information and the allocation stack trace to quickly track down the code path that leaks the given buffer.

Finding References to Data

When trying to diagnose a memory corruption problem, you should know what other kernel entities hold a copy of a particular pointer. This is important because it can reveal which thread accessed a data structure after it was freed. It can also make it easier to understand what kernel entities are sharing knowledge of a particular (valid) data item. The ::what is and ::kgrep dcmds can be used to answer these questions. You can apply ::what is to a value of interest:

```
> 0x705d8640::what is
705d8640 is 705d8640+0, allocated from streams_mblk
```

In this case, 0x705d8640 is revealed to be a pointer to a STREAMS mblk structure. To see the entire allocation tree, use ::what is -a instead:

```
> 0x705d8640::what is -a
705d8640 is 705d8640+0, allocated from streams_mblk
705d8640 is 705d8000+640, allocated from kmem_va_8192
705d8640 is 705d8000+640 from kmem_default vmem arena
```

```
705d8640 is 705d2000+2640 from kmem_va vmem arena
705d8640 is 705d2000+2640 from heap vmem arena
```

This reveals that the allocation also appears in the `kmem_va_8192` cache. The `kmem_va_8192` cache is a `kmem` cache that is fronting the `kmem_va` `vmem` arena. It also shows the full stack of `vmem` allocations.

The complete list of `kmem` caches and `vmem` arenas is displayed by the `::kmasstat` dcmd. You can use `::kgrep` to locate other kernel addresses that contain a pointer to this `mblk`. This illustrates the hierarchical nature of memory allocations in the system; in general, you can determine the type of object referred to by the given address from the name of the most specific `kmem` cache.

```
> 0x705d8640::kgrep
400a3720
70580d24
7069d7f0
706a37ec
706add34
```

and investigate them by applying `::what is` again:

```
> 400a3720::what is
400a3720 is in thread 7095b240's stack

> 706add34::what is
706add34 is 706add20+14, allocated from streams_dblk_120
```

Here one pointer is located on the stack of a known kernel thread, and another is the `mblk` pointer inside of the corresponding `STREAMS` `dblk` structure.

Finding Corrupt Buffers With `::kmem_verify`

MDB's `::kmem_verify` dcmd implements most of the same checks that the `kmem` allocator does at runtime. `::kmem_verify` can be invoked in order to scan every `kmem` cache with appropriate `kmem_flags`, or to examine a particular cache.

Here is an example of using `::kmem_verify` to isolate a problem:

```
> ::kmem_verify
Cache Name                Addr      Cache Integrity
kmem_alloc_8              70039428 clean
kmem_alloc_16             700396a8 clean
kmem_alloc_24             70039928 1 corrupt buffer
kmem_alloc_32             70039ba8 clean
kmem_alloc_40             7003a028 clean
kmem_alloc_48             7003a2a8 clean
...
```

It is easy to see here that the `kmem_alloc_24` cache contains what `::kmem_verify` believes to be a problem. With an explicit cache argument, the `::kmem_verify dcmd` provides more detailed information about the problem:

```
> 70039928::kmem_verify
Summary for cache 'kmem_alloc_24'
  buffer 702babc0 (free) seems corrupted, at 702babc0
```

The next step is to examine the buffer which `::kmem_verify` believes to be corrupt:

```
> 0x702babc0,5/KKn
0x702babc0:  0          deadbeef
              deadbeef          deadbeef
              deadbeef          deadbeef
              feedface          feedface
              703785a0          84d9714e
```

The reason that `::kmem_verify` flagged this buffer is now clear: The first word in the buffer (at `0x702babc0`) should probably be filled with the `0xdeadbeef` pattern, not with a `0`. At this point, examining the `bufctl_audit` for this buffer might yield clues about what code recently wrote to the buffer, indicating where and when it was freed.

Another useful technique in this situation is to use `::kgrep` to search the address space for references to address `0x702babc0`, in order to discover what threads or data structures are still holding references to this freed data.

Allocator Logging Facility

When `KMF_AUDIT` is set for a cache, the kernel memory allocator maintains a log that records the recent history of its activity. This *transaction log* records `bufctl_audit` records. If the `KMF_AUDIT` and the `KMF_CONTENTS` flags are both set, the allocator generates a *contents log* that records portions of the actual contents of allocated and freed buffers. The structure and use of the contents log is outside the scope of this document. The transaction log is discussed in this section.

MDB provides several facilities for displaying the transaction log. The simplest is `::walk kmem_log`, which prints out the transaction in the log as a series of `bufctl_audit_t` pointers:

```
> ::walk kmem_log
70128340
701282e0
70128280
70128220
701281c0
...
> 70128340$<bufctl_audit
0x70128340:  next          addr          slab
              70ac1d40          70bc4ea8          70bb7c00
```



```

0x7012834c:    cache          timestamp      thread
              70039428     e1bd7abe721   70aacde0
0x7012835c:    lastlog        contents       stackdepth
              701282e0     7018f340     4
0x70128368:
              kmem_cache_free+0x24
              nfs3_sync+0x3c
              vfs_sync+0x84
              sysync+4

```

A more elegant way to view the entire transaction log is by using the `::kmem_log` command:

```

> ::kmem_log
CPU ADDR      BUFADDR      TIMESTAMP    THREAD
0 70128340 70bc4ea8     e1bd7abe721 70aacde0
0 701282e0 70bc4ea8     e1bd7aa86fa 70aacde0
0 70128280 70bc4ea8     e1bd7aa27dd 70aacde0
0 70128220 70bc4ea8     e1bd7a98a6e 70aacde0
0 701281c0 70d03738     e1bd7a8e3e0 70aacde0
...
0 70127140 70cf78a0     e1bd78035ad 70aacde0
0 701270e0 709cf6c0     e1bd6d2573a 40033e60
0 70127080 70cedf20     e1bd6d1e984 40033e60
0 70127020 70b09578     e1bd5fc1791 40033e60
0 70126fc0 70cf78a0     e1bd5fb6b5a 40033e60
0 70126f60 705ed388     e1bd5fb080d 40033e60
0 70126f00 705ed388     e1bd551ff73 70aacde0
...

```

The output of `::kmem_log` is sorted in descending order by timestamp. The ADDR column is the `bufctl_audit` structure corresponding to that transaction; BUFADDR points to the actual buffer.

These figures represent *transactions* on buffers (both allocations and frees). When a particular buffer is corrupted, it can be helpful to locate that buffer in the transaction log, then determine in which other transactions the transacting thread was involved. This can help to assemble a picture of the sequence of events that occurred prior to and after the allocation (or free) of a buffer.

You can employ the `::bufctl` command to filter the output of walking the transaction log. The `::bufctl -a` command filters the buffers in the transaction log by buffer address. This example filters on buffer `0x70b09578`:

```

> ::walk kmem_log | ::bufctl -a 0x70b09578
ADDR      BUFADDR      TIMESTAMP    THREAD    CALLER
70127020 70b09578     e1bd5fc1791 40033e60  biodone+0x108
70126e40 70b09578     e1bd55062da 70aacde0  pageio_setup+0x268
70126de0 70b09578     e1bd52b2317 40033e60  biodone+0x108
70126c00 70b09578     e1bd497ee8e 70aacde0  pageio_setup+0x268
70120480 70b09578     e1bd21c5e2a 70aacde0  elfexec+0x9f0
70120060 70b09578     e1bd20f5ab5 70aacde0  getelfhead+0x100
7011ef20 70b09578     e1bd1e9a1dd 70aacde0  ufs_getpage_miss+0x354
7011d720 70b09578     e1bd1170dc4 70aacde0  pageio_setup+0x268
70117d80 70b09578     e1bcff6ff27 70bc2480  elfexec+0x9f0

```

```
70117960 70b09578 e1bcfea4a9f 70bc2480 getelfhead+0x100
...
```

This example illustrates that a particular buffer can be used in numerous transactions.

Note – Remember that the kmem transaction log is an incomplete record of the transactions made by the kernel memory allocator. Older entries in the log are evicted as needed in order to keep the size of the log constant.

The `::allocdb` and `::freedby` dcmls provide a convenient way to summarize transactions associated with a particular thread. Here is an example of listing the recent allocations performed by thread `0x70aacde0`:

```
> 0x70aacde0::allocdb
BUFCTL      TIMESTAMP CALLER
70d4d8c0    e1edb14511a allocb+0x88
70d4e8a0    e1edb142472 dblk_constructor+0xc
70d4a240    e1edb13dd4f allocb+0x88
70d4e840    e1edb13aeec dblk_constructor+0xc
70d4d860    e1ed8344071 allocb+0x88
70d4e7e0    e1ed8342536 dblk_constructor+0xc
70d4a1e0    e1ed82b3a3c allocb+0x88
70a53f80    e1ed82b0b91 dblk_constructor+0xc
70d4d800    e1e9b663b92 allocb+0x88
```

By examining `bufctl_audit` records, you can understand the recent activities of a particular thread.

Module Programming API

This chapter describes the structures and functions contained in the MDB debugger module API. The header file `<sys/mdb_modapi.h>` contains prototypes for these functions, and the `SUNWmdbdm` package provides source code for an example module in the directory `/usr/demo/mdb`.

Debugger Module Linkage

`_mdb_init()`

```
const mdb_modinfo_t *_mdb_init(void);
```

Each debugger module is required to provide, for linkage and identification purposes, a function named `_mdb_init()`. This function returns a pointer to a persistent (that is, not declared as an automatic variable) `mdb_modinfo_t` structure, as defined in `<sys/mdb_modapi.h>`:

```
typedef struct mdb_modinfo {  
    ushort_t mi_dvers;           /* Debugger API version number */  
    const mdb_dcmd_t *mi_dcmds; /* NULL-terminated list of dcmds */  
    const mdb_walker_t *mi_walkers; /* NULL-terminated list of walks */  
} mdb_modinfo_t;
```

The `mi_dvers` member is used to identify the API version number, and should always be set to `MDB_API_VERSION`. The current version number is therefore compiled into each debugger module, allowing the debugger to identify and verify the application binary interface used by the module. The debugger does not load modules that are compiled for an API version that is more recent than the debugger itself.

The `mi_dcmds` and `mi_walkers` members, if not `NULL`, point to arrays of `dcmd` and `walker` definition structures, respectively. Each array must be terminated by a `NULL` element. These `dcmds` and `walkers` are installed and registered with the debugger as part of the module loading

process. The debugger will refuse to load the module if one or more dcmds or walkers are defined improperly or if they have conflicting or invalid names. Dcmd and walker names are prohibited from containing characters that have special meaning to the debugger, such as quotation marks and parentheses.

The module can also execute code in `_mdb_init()` using the module API to determine if it is appropriate to load. For example, a module can only be appropriate for a particular target if certain symbols are present. If these symbols are not found, the module can return NULL from the `_mdb_init()` function. In this case, the debugger will refuse to load the module and an appropriate error message is printed.

`_mdb_fini()`

```
void _mdb_fini(void);
```

If the module performs certain tasks prior to unloading, such as freeing persistent memory previously allocated with `mdb_alloc()`, it can declare a function named `_mdb_fini()` for this purpose. This function is not required by the debugger. If declared, it is called once prior to unloading the module. Modules are unloaded when the user requests that the debugger terminate or when the user explicitly unloads a module using the `::unload` built-in dcmd.

Dcmd Definitions

```
int dcmd(uintptr_t addr, uint_t flags, int argc, const mdb_arg_t *argv);
```

A dcmd is implemented with a function similar to the `dcmd()` declaration. This function receives four arguments and returns an integer status. The function arguments are:

addr Current address, also called dot. At the start of the dcmd, this address corresponds to the value of the dot “.” variable in the debugger.

flags Integer containing the logical OR of one or more of the following flags:

DCMD_ADDRSPEC	An explicit address was specified to the left of <code>::dcmd</code> .
DCMD_LOOP	The dcmd was invoked in a loop using the <code>,count</code> syntax, or the dcmd was invoked in a loop by a pipeline.
DCMD_LOOPFIRST	This invocation of the dcmd function corresponds to the first loop or pipeline invocation.
DCMD_PIPE	The dcmd was invoked with input from a pipeline.
DCMD_PIPE_OUT	The dcmd was invoked with output set to a pipeline.

As a convenience, the `DCMD_HDRSPEC()` macro is provided to allow a `dcmd` to test its flags to determine if it should print a header line (that is, it was not invoked as part of a loop, or it was invoked as the first iteration of a loop or pipeline).

`argc` Number of arguments in the `argv` array.

`argv` Array of arguments specified to the right of `: : dcmd` on the command line. These arguments can be either strings or integer values.

The `dcmd` function is expected to return one of the following integer values, defined in `<sys/mdb_modapi.h>`.

`DCMD_OK` The `dcmd` completed successfully.

`DCMD_ERR` The `dcmd` failed for some reason.

`DCMD_USAGE` The `dcmd` failed because invalid arguments were specified. When this value is returned, the `dcmd` usage message (described below) prints automatically.

`DCMD_NEXT` The next `dcmd` definition (if one is present) is automatically invoked with the same arguments.

`DCMD_ABORT` The `dcmd` failed, and the current loop or pipeline should be aborted. This is like `DCMD_ERR`, but indicates that no further progress is possible in the current loop or pipe.

Each `dcmd` consists of a function defined according to the example `dcmd()` prototype, and a corresponding `mdb_dcmd_t` structure, as defined in `<sys/mdb_modapi.h>`. This structure consists of the following fields:

`const char *dc_name` The string name of the `dcmd`, without the leading `“: :”`. The name cannot contain any of the MDB meta-characters, such as `$` or `’`.

`const char *dc_usage` An optional usage string for the `dcmd`, to be printed when the `dcmd` returns `DCMD_USAGE`. For example, if the `dcmd` accepts options `-a` and `-b`, `dc_usage` might be specified as `“[-ab]”`. If the `dcmd` accepts no arguments, `dc_usage` can be set to `NULL`. If the usage string begins with `“: :”`, this is shorthand for indicating that the `dcmd` requires an explicit address (that is, it requires `DCMD_ADDRSPEC` to be set in its flags parameter). If the usage string begins with `“?”`, this indicates that the `dcmd` optionally accepts an address. These hints modify the usage message accordingly.

`const char *dc_descr` A mandatory description string, briefly explaining the purpose of the `dcmd`. This string should consist of only a single line of text.

`mdb_dcmd_f *dc_funcp` A pointer to the function that will be called to execute the `dcmd`.

`void (*dc_help)(void)` An optional function pointer to a help function for the `dcmd`. If this pointer is not `NULL`, this function will be called when the user executes `::help dcmd`. This function can use `mdb_printf()` to display further information or examples.

Walker Definitions

```
int walk_init(mdb_walk_state_t *wsp);
int walk_step(mdb_walk_state_t *wsp);
void walk_fini(mdb_walk_state_t *wsp);
```

A walker is composed of three functions, `init`, `step`, and `fini`, which are defined according to the example prototypes above. A walker is invoked by the debugger when one of the walk functions (such as `mdb_walk()`) is called, or when the user executes the `::walk` built-in `dcmd`. When the walk begins, MDB calls the walker's `init` function, passing it the address of a new `mdb_walk_state_t` structure, as defined in `<sys/mdb_modapi.h>`:

```
typedef struct mdb_walk_state {
    mdb_walk_cb_t walk_callback; /* Callback to issue */
    void *walk_cbdata;          /* Callback private data */
    uintptr_t walk_addr;        /* Current address */
    void *walk_data;            /* Walk private data */
    void *walk_arg;             /* Walk private argument */
    void *walk_layer;           /* Data from underlying layer */
} mdb_walk_state_t;
```

A separate `mdb_walk_state_t` is created for each walk, so that multiple instances of the same walker can be active simultaneously. The state structure contains the callback the walker should invoke at each step (`walk_callback`), and the private data for the callback (`walk_cbdata`), as specified to `mdb_walk()`, for example. The `walk_cbdata` pointer is opaque to the walker: it must not modify or dereference this value, nor can it assume it is a pointer to valid memory.

The starting address for the walk is stored in `walk_addr`. This is either `NULL` if `mdb_walk()` was called, or the address parameter specified to `mdb_pwalk()`. If the `::walk` built-in was used, `walk_addr` will be non-`NULL` if an explicit address was specified on the left-hand side of `::walk`. A walk with a starting address of `NULL` is referred to as *global*. A walk with an explicit non-`NULL` starting address is referred to as *local*.

The `walk_data` and `walk_arg` fields are provided for use as private storage for the walker. Complex walkers might need to allocate an auxiliary state structure and set `walk_data` to point to this structure. Each time a walk is initiated, `walk_arg` is initialized to the value of the `walk_init_arg` member of the corresponding walker's `mdb_walker_t` structure.

In some cases, it is useful to have several walkers share the same `init`, `step`, and `fini` routines. For example, the MDB `genunix` module provides walkers for each kernel memory cache. These

share the same `init`, `step`, and `fini` functions, and use the `walk_init_arg` member of the `mdb_walker_t` to specify the address of the appropriate cache as the `walk_arg`.

If the walker calls `mdb_layered_walk()` to instantiate an underlying layer, then the underlying layer will reset `walk_addr` and `walk_layer` prior to each call to the walker's step function. The underlying layer sets `walk_addr` to the target virtual address of the underlying object, and set `walk_layer` to point to the walker's local copy of the underlying object. For more information on layered walks, refer to the discussion of `mdb_layered_walk()` below.

The walker `init` and `step` functions are expected to return one of the following status values:

<code>WALK_NEXT</code>	Proceed to the next step. When the walk <code>init</code> function returns <code>WALK_NEXT</code> , MDB invokes the walk <code>step</code> function. When the walk <code>step</code> function returns <code>WALK_NEXT</code> , this indicates that MDB should call the <code>step</code> function again.
<code>WALK_DONE</code>	The walk has completed successfully. <code>WALK_DONE</code> can be returned by either the <code>step</code> function to indicate that the walk is complete, or by the <code>init</code> function to indicate that no steps are needed (for example, if the given data structure is empty).
<code>WALK_ERR</code>	The walk has terminated due to an error. If <code>WALK_ERR</code> is returned by the <code>init</code> function, <code>mdb_walk()</code> (or any of its counterparts) returns <code>-1</code> to indicate that the walker failed to initialize. If <code>WALK_ERR</code> is returned by the <code>step</code> function, the walk terminates but <code>mdb_walk()</code> returns success.

The `walk_callback` is also expected to return one of the values above. Therefore, the walk `step` function's job is to determine the address of the next object, read in a local copy of this object, call the `walk_callback` function, then return its status. The `step` function can also return `WALK_DONE` or `WALK_ERR` without invoking the callback if the walk is complete or if an error occurred.

The walker itself is defined using the `mdb_walker_t` structure, defined in :

```
typedef struct mdb_walker {
    const char *walk_name;           /* Walk type name */
    const char *walk_descr;         /* Walk description */
    int (*walk_init)(mdb_walk_state_t *); /* Walk constructor */
    int (*walk_step)(mdb_walk_state_t *); /* Walk iterator */
    void (*walk_fini)(mdb_walk_state_t *); /* Walk destructor */
    void *walk_init_arg;           /* Constructor argument */
} mdb_walker_t;
```

The `walk_name` and `walk_descr` fields should be initialized to point to strings containing the name and a brief description of the walker, respectively. A walker is required to have a non-NULL name and description, and the name cannot contain any of the MDB meta-characters. The description string is printed by the `::walkers` and `::dmods` built-in `dcmds`.

The `walk_init`, `walk_step`, and `walk_fini` members refer to the walk functions themselves, as described earlier. The `walk_init` and `walk_fini` members can be set to `NULL` to indicate that no special initialization or cleanup actions need to be taken. The `walk_step` member cannot be set to `NULL`. The `walk_init_arg` member is used to initialize the `walk_arg` member of each new `mdb_walk_state_t` created for the given walker, as described earlier. Figure 10–1 shows a flowchart for the algorithm of a typical walker.

FIGURE 10–1 Sample Walker

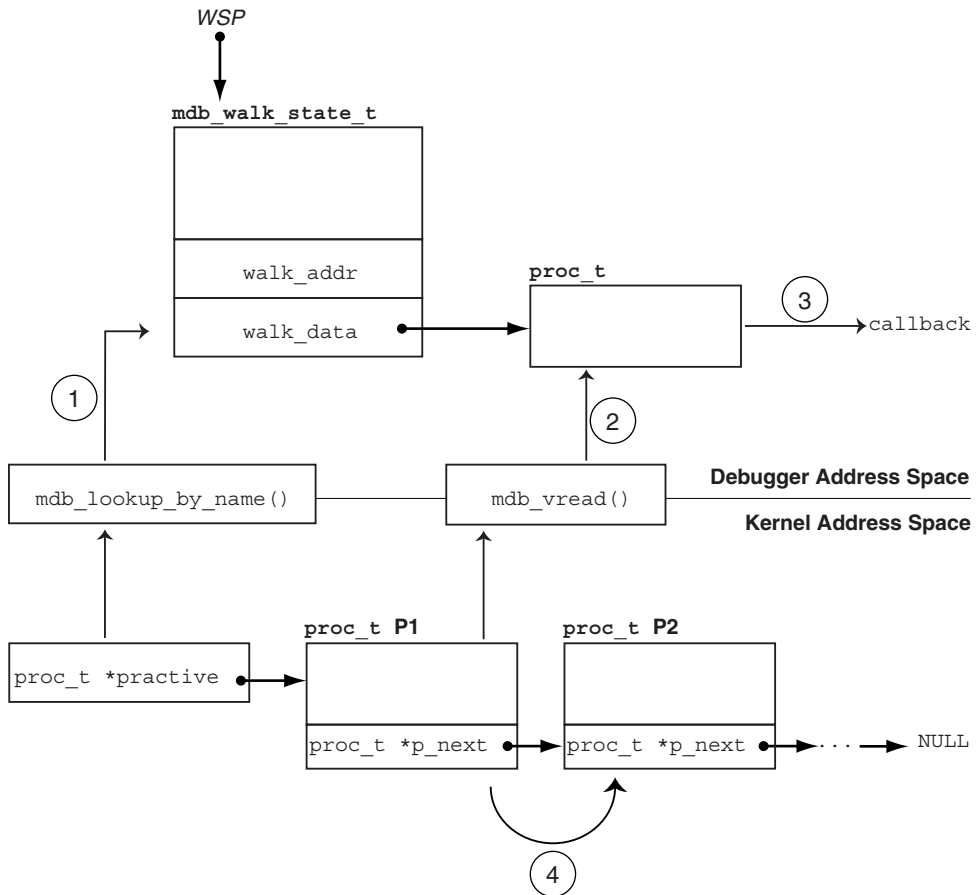

The walker is designed to iterate over the list of `proc_t` structures in the kernel. The head of the list is stored in the global `practive` variable, and each element's `p_next` pointer points to the next `proc_t` in the list. The list is terminated with a `NULL` pointer. In the walker's `init` routine, the `practive` symbol is located using `mdb_lookup_by_name()` step (1), and its value is copied into the `mdb_walk_state_t` pointed to by `wsp`.

In the walker's step function, the next `proc_t` structure in the list is copied into the debugger's address space using `mdb_vread()` step (2), the callback function is invoked with a pointer to this local copy, step (3), and then the `mdb_walk_state_t` is updated with the address of the `proc_t` structure for the next iteration. This update corresponds to following the pointer, step (4), to the next element in the list.

These steps demonstrate the structure of a typical walker: the `init` routine locates the global information for a particular data structure, the `step` function reads in a local copy of the next data item and passes it to the callback function, and the address of the next element is read. Finally, when the walk terminates, the `fini` function frees any private storage.

API Functions

`mdb_pwalk()`

```
int mdb_pwalk(const char *name, mdb_walk_cb_t func, void *data,
              uintptr_t addr);
```

Initiate a local walk starting at `addr` using the walker specified by `name`, and invoke the callback function `func` at each step. If `addr` is `NULL`, a global walk is performed (that is, the `mdb_pwalk()` invocation is equivalent to the identical call to `mdb_walk()` without the trailing `addr` parameter). This function returns 0 for success, or -1 for error. The `mdb_pwalk()` function fails if the walker itself returns a fatal error, or if the specified walker name is not known to the debugger. The walker name may be scoped using the backquote (‘) operator if there are naming conflicts. The `data` parameter is an opaque argument that has meaning only to the caller; it is passed back to `func` at each step of the walk.

`mdb_walk()`

```
int mdb_walk(const char *name, mdb_walk_cb_t func, void *data);
```

Initiate a global walk using the walker specified by `name`, and invoke the callback function `func` at each step. This function returns 0 for success, or -1 for error. The `mdb_walk()` function fails if the walker itself returns a fatal error, or if the specified walker name is not known to the debugger. The walker name can be scoped using the backquote (‘) operator if there are naming conflicts. The `data` parameter is an opaque argument that has meaning only to the caller; it is passed back to `func` at each step of the walk.

mdb_pwalk_dcmd()

```
int mdb_pwalk_dcmd(const char *wname, const char *dcname, int argc,
                  const mdb_arg_t *argv, uintptr_t addr);
```

Initiate a local walk starting at *addr* using the walker specified by *wname*, and invoke the dcmd specified by *dcname* with the specified *argc* and *argv* at each step. This function returns 0 for success, or -1 for error. The function fails if the walker itself returns a fatal error, if the specified walker name or dcmd name is not known to the debugger, or if the dcmd itself returns DCMD_ABORT or DCMD_USAGE to the walker. The walker name and dcmd name can each be scoped using the backquote (‘) operator if there are naming conflicts. When invoked from `mdb_pwalk_dcmd()`, the dcmd will have the DCMD_LOOP and DCMD_ADDRSPEC bits set in its flags parameter, and the first call will have DCMD_LOOPFIRST set.

mdb_walk_dcmd()

```
int mdb_walk_dcmd(const char *wname, const char *dcname, int argc,
                  const mdb_arg_t *argv);
```

Initiate a global walk using the walker specified by *wname*, and invoke the dcmd specified by *dcname* with the specified *argc* and *argv* at each step. This function returns 0 for success, or -1 for error. The function fails if the walker itself returns a fatal error, if the specified walker name or dcmd name is not known to the debugger, or if the dcmd itself returns DCMD_ABORT or DCMD_USAGE to the walker. The walker name and dcmd name can each be scoped using the backquote (‘) operator if there are naming conflicts. When invoked from `mdb_walk_dcmd()`, the dcmd will have the DCMD_LOOP and DCMD_ADDRSPEC bits set in its flags parameter, and the first call will have DCMD_LOOPFIRST set.

mdb_call_dcmd()

```
int mdb_call_dcmd(const char *name, uintptr_t addr, uint_t flags,
                  int argc, const mdb_arg_t *argv);
```

Invoke the specified dcmd name with the given parameters. The dot variable is reset to *addr*, and *addr*, *flags*, *argc*, and *argv* are passed to the dcmd. The function returns 0 for success, or -1 for error. The function fails if the dcmd returns DCMD_ERR, DCMD_ABORT, or DCMD_USAGE, or if the specified dcmd name is not known to the debugger. The dcmd name can be scoped using the backquote (‘) operator if there are naming conflicts.

mdb_layered_walk()

```
int mdb_layered_walk(const char *name, mdb_walk_state_t *wsp);
```

Layer the walk denoted by *wsp* on top of a walk initiated using the specified walker *name*. The name can be scoped using the backquote (‘) operator if there are naming conflicts. Layered walks can be used, for example, to facilitate constructing walkers for data structures that are embedded in other data structures.

For example, suppose that each CPU structure in the kernel contains a pointer to an embedded structure. To write a walker for the embedded structure type, you could replicate the code to iterate over CPU structures and dereference the appropriate member of each CPU structure, or you could layer the embedded structure's walker on top of the existing CPU walker.

The `mdb_layered_walk()` function is used from within a walker's init routine to add a new layer to the current walk. The underlying layer is initialized as part of the call to `mdb_layered_walk()`. The calling walk routine passes in a pointer to its current walk state; this state is used to construct the layered walk. Each layered walk is cleaned up after the caller's walk fini function is called. If more than one layer is added to a walk, the caller's walk step function will step through each element returned by the first layer, then the second layer, and so forth.

The `mdb_layered_walk()` function returns 0 for success, or -1 for error. The function fails if the specified walker name is not known to the debugger, if the *wsp* pointer is not a valid, active walk state pointer, if the layered walker itself fails to initialize, or if the caller attempts to layer the walker on top of itself.

mdb_add_walker()

```
int mdb_add_walker(const mdb_walker_t *w);
```

Register a new walker with the debugger. The walker is added to the module's namespace, and to the debugger's global namespace according to the name resolution rules described in [“Dcmd and Walker Name Resolution” on page 34](#). This function returns 0 for success, or -1 for error if the given walker name is already registered by this module, or if the walker structure *w* is improperly constructed. The information in the `mdb_walker_t w` is copied to internal debugger structures, so the caller can reuse or free this structure after the call to `mdb_add_walker()`.

mdb_remove_walker()

```
int mdb_remove_walker(const char *name);
```

Remove the walker with the specified *name*. This function returns 0 for success, or -1 for error. The walker is removed from the current module's namespace. The function fails if the walker name is unknown, or is registered only in another module's namespace. The `mdb_remove_walker()` function can be used to remove walkers that were added dynamically using `mdb_add_walker()`, or walkers that were added statically as part of the module's linkage

structure. The scoping operator cannot be used in the walker name; it is not legal for the caller of `mdb_remove_walker()` to attempt to remove a walker exported by a different module.

mdb_vread() and mdb_vwrite()

```
ssize_t mdb_vread(void *buf, size_t nbytes, uintptr_t addr);
ssize_t mdb_vwrite(const void *buf, size_t nbytes, uintptr_t addr);
```

These functions provide the ability to read and write data from a given target virtual address, specified by the *addr* parameter. The `mdb_vread()` function returns *nbytes* for success, or -1 for error; if a read is truncated because only a portion of the data can be read from the specified address, -1 is returned. The `mdb_vwrite()` function returns the number of bytes actually written upon success; -1 is returned upon error.

mdb_fread() and mdb_fwrite()

```
ssize_t mdb_fread(void *buf, size_t nbytes, uintptr_t addr);
ssize_t mdb_fwrite(const void *buf, size_t nbytes, uintptr_t addr);
```

These functions provide the ability to read and write data from the object file location corresponding to the given target virtual address, specified by the *addr* parameter. The `mdb_fread()` function returns *nbytes* for success, or -1 for error; if a read is truncated because only a portion of the data can be read from the specified address, -1 is returned. The `mdb_fwrite()` function returns the number of bytes actually written upon success; -1 is returned upon error.

mdb_pread() and mdb_pwrite()

```
ssize_t mdb_pread(void *buf, size_t nbytes, uint64_t addr);
ssize_t mdb_pwrite(const void *buf, size_t nbytes, uint64_t addr);
```

These functions provide the ability to read and write data from a given target physical address, specified by the *addr* parameter. The `mdb_pread()` function returns *nbytes* for success, or -1 for error; if a read is truncated because only a portion of the data can be read from the specified address, -1 is returned. The `mdb_pwrite()` function returns the number of bytes actually written upon success; -1 is returned upon error.

mdb_readstr()

```
ssize_t mdb_readstr(char *s, size_t nbytes, uintptr_t addr);
```

The `mdb_readstr()` function reads a null-terminated C string beginning at the target virtual address *addr* into the buffer addressed by *s*. The size of the buffer is specified by *nbytes*. If the string is longer than can fit in the buffer, the string is truncated to the buffer size and a null byte is stored at `s[nbytes - 1]`. The length of the string stored in *s* (not including the terminating null byte) is returned upon success; otherwise -1 is returned to indicate an error.

`mdb_writestr()`

```
ssize_t mdb_writestr(const char *s, uintptr_t addr);
```

The `mdb_writestr()` function writes a null-terminated C string from *s* (including the trailing null byte) to the target's virtual address space at the address specified by *addr*. The number of bytes written (not including the terminating null byte) is returned upon success; otherwise, -1 is returned to indicate an error.

`mdb_readsym()`

```
ssize_t mdb_readsym(void *buf, size_t nbytes, const char *name);
```

`mdb_readsym()` is similar to `mdb_vread()`, except that the virtual address at which reading begins is obtained from the value of the symbol specified by *name*. If no symbol by that name is found or a read error occurs, -1 is returned; otherwise *nbytes* is returned for success.

The caller can first look up the symbol separately if it is necessary to distinguish between symbol lookup failure and read failure. The primary executable's symbol table is used for the symbol lookup; if the symbol resides in another symbol table, you must first apply `mdb_lookup_by_obj()`, then `mdb_vread()`.

`mdb_writesym()`

```
ssize_t mdb_writesym(const void *buf, size_t nbytes, const char *name);
```

`mdb_writesym()` is identical to `mdb_vwrite()`, except that the virtual address at which writing begins is obtained from the value of the symbol specified by *name*. If no symbol by that name is found, -1 is returned. Otherwise, the number of bytes successfully written is returned on success, and -1 is returned on error. The primary executable's symbol table is used for the symbol lookup; if the symbol resides in another symbol table, you must first apply `mdb_lookup_by_obj()`, then `mdb_vwrite()`.

mdb_readvar() and mdb_writevar()

```
ssize_t mdb_readvar(void *buf, const char *name);
ssize_t mdb_writevar(const void *buf, const char *name);
```

`mdb_readvar()` is similar to `mdb_vread()`, except that the virtual address at which reading begins and the number of bytes to read are obtained from the value and size of the symbol specified by *name*. If no symbol by that name is found, -1 is returned. The symbol size (the number of bytes read) is returned on success; -1 is returned on error. This is useful for reading well-known variables whose sizes are fixed. For example:

```
int hz; /* system clock rate */
mdb_readvar(&hz, "hz");
```

The caller can first look up the symbol separately if it is necessary to distinguish between symbol lookup failure and read failure. The caller must also carefully check the definition of the symbol of interest in order to make sure that the local declaration is the exact same type as the target's definition. For example, if the caller declares an `int`, and the symbol of interest is actually a `long`, and the debugger is examining a 64-bit kernel target, `mdb_readvar()` copies back 8 bytes to the caller's buffer, corrupting the 4 bytes following the storage for the `int`.

`mdb_writevar()` is identical to `mdb_vwrite()`, except that the virtual address at which writing begins and the number of bytes to write are obtained from the value and size of the symbol specified by name. If no symbol by that name is found, -1 is returned. Otherwise, the number of bytes successfully written is returned on success, and -1 is returned on error.

For both functions, the primary executable's symbol table is used for the symbol lookup; if the symbol resides in another symbol table, you must first apply `mdb_lookup_by_obj()`, then `mdb_vread()` or `mdb_vwrite()`.

mdb_lookup_by_name() and mdb_lookup_by_obj()

```
int mdb_lookup_by_name(const char *name, GElf_Sym *sym);
int mdb_lookup_by_obj(const char *object, const char *name, GElf_Sym *sym);
```

Look up the specified symbol name and copy the ELF symbol information into the `GElf_Sym` pointed to by *sym*. If the symbol is found, the function returns 0; otherwise, -1 is returned. The *name* parameter specifies the symbol name. The *object* parameter tells the debugger where to look for the symbol. For the `mdb_lookup_by_name()` function, the object file defaults to `MDB_OBJ_EXEC`. For `mdb_lookup_by_obj()`, the object name should be one of the following:

<code>MDB_OBJ_EXEC</code>	Look in the executable's symbol table (<code>.symtab</code> section). For kernel crash dumps, this corresponds to the symbol table from the <code>unix.X</code> file or from <code>/dev/ksyms</code> .
---------------------------	---

<code>MDB_OBJ_RTLD</code>	Look in the runtime link-editor's symbol table. For kernel crash dumps, this corresponds to the symbol table for the <code>krtld</code> module.
<code>MDB_OBJ EVERY</code>	Look in all known symbol tables. For kernel crash dumps, this includes the <code>.symtab</code> and <code>.dynsym</code> sections from the <code>unix.X</code> file or <code>/dev/ksyms</code> , as well as per-module symbol tables if these have been processed.
<code>object</code>	If the name of a particular load object is explicitly specified, the search is restricted to the symbol table of this object. The object can be named according to the naming convention for load objects described in “Symbol Name Resolution” on page 29 .

`mdb_lookup_by_addr()`

```
int mdb_lookup_by_addr(uintptr_t addr, uint_t flag, char *buf,
                      size_t len, GElf_Sym *sym);
```

Locate the symbol corresponding to the specified address and copy the ELF symbol information into the `GElf_Sym` pointed to by `sym` and the symbol name into the character array addressed by `buf`. If a corresponding symbol is found, the function returns 0; otherwise -1 is returned.

The flag parameter specifies the lookup mode and should be one of the following:

<code>MDB_SYM_FUZZY</code>	Allow fuzzy matching to take place, based on the current symbol distance setting. The symbol distance can be controlled using the <code>::set -s</code> built-in. If an explicit symbol distance has been set (absolute mode), the address can match a symbol if the distance from the symbol's value to the address does not exceed the absolute symbol distance. If smart mode is enabled (symbol distance = 0), then the address can match the symbol if it is in the range [symbol value, symbol value + symbol size).
<code>MDB_SYM_EXACT</code>	Disallow fuzzy matching. The symbol can match only the address if the symbol value exactly equals the specified address.

If a symbol match occurs, the name of the symbol is copied into the `buf` supplied by the caller. The `len` parameter specifies the length of this buffer in bytes. The caller's `buf` should be at least of size `MDB_SYM_NAMLEN` bytes. The debugger copies the name to this buffer and appends a trailing null byte. If the name length exceeds the length of the buffer, the name is truncated but always includes a trailing null byte.

`mdb_getopts()`

```
int mdb_getopts(int argc, const mdb_arg_t *argv, ...);
```

Parse and process options and option arguments from the specified argument array (*argv*). The *argc* parameter denotes the length of the argument array. This function processes each argument in order, and stops and returns the array index of the first argument that could not be processed. If all arguments are processed successfully, *argc* is returned.

Following the *argc* and *argv* parameters, the `mdb_getopts()` function accepts a variable list of arguments describing the options that are expected to appear in the *argv* array. Each option is described by an option letter (char argument), an option type (`uint_t` argument), and one or two additional arguments, as shown in the table below. The list of option arguments is terminated with a NULL argument. The type should be one of one of the following:

<code>MDB_OPT_SETBITS</code>	<p>The option will OR the specified bits into a flag word. The option is described by these parameters:</p> <p><code>char c, uint_t type, uint_t bits, uint_t *p</code></p> <p>If type is <code>MDB_OPT_SETBITS</code> and option <i>c</i> is detected in the <i>argv</i> list, the debugger will OR bits into the integer referenced by pointer <i>p</i>.</p>
<code>MDB_OPT_CLRBITS</code>	<p>The option clears the specified bits from a flag word. The option is described by these parameters:</p> <p><code>char c, uint_t type, uint_t bits, uint_t *p</code></p> <p>If type is <code>MDB_OPT_CLRBITS</code> and option <i>c</i> is detected in the <i>argv</i> list, the debugger clears bits from the integer referenced by pointer <i>p</i>.</p>
<code>MDB_OPT_STR</code>	<p>The option accepts a string argument. The option is described by these parameters:</p> <p><code>char c, uint_t type, const char **p</code></p> <p>If type is <code>MDB_OPT_STR</code> and option <i>c</i> is detected in the <i>argv</i> list, the debugger stores a pointer to the string argument following <i>c</i> in the pointer referenced by <i>p</i>.</p>
<code>MDB_OPT_UINTPTR</code>	<p>The option accepts a <code>uintptr_t</code> argument. The option is described by these parameters:</p> <p><code>char c, uint_t type, uintptr_t *p</code></p> <p>If type is <code>MDB_OPT_UINTPTR</code> and option <i>c</i> is detected in the <i>argv</i> list, the debugger stores the integer argument following <i>c</i> in the <code>uintptr_t</code> referenced by <i>p</i>.</p>

MDB_OPT_UINTPTR_SET

The option accepts a `uintptr_t` argument. The option is described by these parameters:

```
char c, uint_t type, boolean_t *flag, uintptr_t *p
```

If type is `MDB_OPT_UINTPTR_SET` and option *c* is detected in the *argv* list, the debugger stores the value '1' (TRUE) into the `boolean_t` referenced by *flag*, and the integer argument following *c* in the `uintptr_t` referenced by *p*.

MDB_OPT_UINT64

The option accepts a `uint64_t` argument. The option is described by these parameters:

```
char c, uint_t type, uint64_t *p
```

If type is `MDB_OPT_UINT64` and option *c* is detected in the *argv* list, the debugger stores the integer argument following *c* in the `uint64_t` referenced by *p*.

For example, the following source code:

```
int
dcmd(uintptr_t addr, uint_t flags, int argc, const mdb_arg_t *argv)
{
    uint_t opt_v = FALSE;
    const char *opt_s = NULL;

    if (mdb_getopts(argc, argv,
        'v', MDB_OPT_SETBITS, TRUE, &opt_v,
        's', MDB_OPT_STR, &opt_s, NULL) != argc)
        return (DCMD_USAGE);

    /* ... */
}
```

demonstrates how `mdb_getopts()` might be used in a `dcmd` to accept a boolean option “-v” that sets the `opt_v` variable to TRUE, and an option “-s” that accepts a string argument that is stored in the `opt_s` variable. The `mdb_getopts()` function also automatically issues warning messages if it detects an invalid option letter or missing option argument before returning to the caller. The storage for argument strings and the *argv* array is automatically garbage-collected by the debugger upon completion of the `dcmd`.

mdb_strtoul()

```
u_longlong_t mdb_strtoul(const char *s);
```

Convert the specified string *s* to an unsigned long long representation. This function is intended for use in processing and converting string arguments in situations where

`mdb_getopts()` is not appropriate. If the string argument cannot be converted to a valid integer representation, the function fails by printing an appropriate error message and aborting the `dcmd`. Therefore, error checking code is not required. The string can be prefixed with any of the valid base specifiers (0i, 0l, 0o, 0O, 0t, 0T, 0x, or 0X); otherwise, it is interpreted using the default base. The function will fail and abort the `dcmd` if any of the characters in `s` are not appropriate for the base, or if integer overflow occurs.

`mdb_alloc()`, `mdb_zalloc()` and `mdb_free()`

```
void *mdb_alloc(size_t size, uint_t flags);
void *mdb_zalloc(size_t size, uint_t flags);
void mdb_free(void *buf, size_t size);
```

`mdb_alloc()` allocates `size` bytes of debugger memory and returns a pointer to the allocated memory. The allocated memory is at least double-word aligned, so it can hold any C data structure. No greater alignment can be assumed. The `flags` parameter should be the bitwise OR of one or more of the following values:

<code>UM_NOSLEEP</code>	If sufficient memory to fulfill the request is not immediately available, return NULL to indicate failure. The caller must check for NULL and handle this case appropriately.
<code>UM_SLEEP</code>	If sufficient memory to fulfill the request is not immediately available, sleep until such time as the request can be fulfilled. As a result, <code>UM_SLEEP</code> allocations are guaranteed to succeed. The caller need not check for a NULL return value.
<code>UM_GC</code>	Garbage-collect allocation automatically at the end of this debugger command. The caller should not subsequently call <code>mdb_free()</code> on this block, as the debugger will take care of deallocation automatically. All memory allocation from within a <code>dcmd</code> must use <code>UM_GC</code> so that if the <code>dcmd</code> is interrupted by the user, the debugger can garbage-collect the memory.

`mdb_zalloc()` is like `mdb_alloc()`, but the allocated memory is filled with zeroes before returning it to the caller. No guarantees are made about the initial contents of memory returned by `mdb_alloc()`. `mdb_free()` is used to free previously allocated memory (unless it was allocated `UM_GC`). The buffer address and size must exactly match the original allocation. It is not legal to free only a portion of an allocation with `mdb_free()`. It is not legal to free an allocation more than once. An allocation of zero bytes always returns NULL; freeing a NULL pointer with size zero always succeeds.

`mdb_printf()`

```
void mdb_printf(const char *format, ...);
```

Print formatted output using the specified format string and arguments. Module writers should use `mdb_printf()` for all output, except for warning and error messages. This function automatically triggers the built-in output pager when appropriate. The `mdb_printf()` function is similar to `printf(3C)`, with certain exceptions: the `%C`, `%S`, and `%ws` specifiers for wide character strings are not supported, the `%f` floating-point format is not supported, the `%e`, `%E`, `%g`, and `%G` specifiers for alternative double formats produce only a single style of output, and precision specifications of the form `%.n` are not supported. The list of specifiers that are supported follows:

Flag Specifiers

- `%#` If the `#` sign is found in the format string, this selects the alternate form of the given format. Not all formats have an alternate form; the alternate form is different depending on the format. Refer to the format descriptions below for details on the alternate format.
- `%+` When printing signed values, always display the sign (prefix with either `'+'` or `'-'`). Without `%+`, positive values have no sign prefix, and negative values have a `'-'` prefix prepended to them.
- `%-` Left-justify the output within the specified field width. If the width of the output is less than the specified field width, the output will be padded with blanks on the right-hand side. Without `%-`, values are right-justified by default.
- `%0` Zero-fill the output field if the output is right-justified and the width of the output is less than the specified field width. Without `%0`, right-justified values are prepended with blanks in order to fill the field.

Field Width Specifiers

- `%n` Field width is set to the specified decimal value.
- `%?` Field width is set to the maximum width of a hexadecimal pointer value. This is 8 in an ILP32 environment, and 16 in an LP64 environment.
- `%*` Field width is set to the value specified at the current position in the argument list. This value is assumed to be an `int`. Note that in the 64-bit compilation environment, it may be necessary to cast `long` values to `int`.

Integer Specifiers

- `%h` Integer value to be printed is a `short`.
- `%l` Integer value to be printed is a `long`.
- `%ll` Integer value to be printed is a `long long`.

Terminal Attribute Specifiers

If standard output for the debugger is a terminal, and terminal attributes can be obtained by the terminfo database, the following terminal escape constructs can be used:

- `%<n>` Enable the terminal attribute corresponding to *n*. Only a single attribute can be enabled with each instance of `%<>`.
- `%</n>` Disable the terminal attribute corresponding to *n*. Note that in the case of reverse video, dim text, and bold text, the terminal codes to disable these attributes might be identical. Therefore, it might not be possible to disable these attributes independently of one another.

If no terminal information is available, each terminal attribute construct is ignored by `mdb_printf()`. For more information on terminal attributes, see [terminfo\(4\)](#). The available terminfo attributes are:

- `a` Alternate character set
- `b` Bold text
- `d` Dim text
- `r` Reverse video
- `s` Best standout capability
- `u` Underlining

Format Specifiers

- `%%` The '%' symbol is printed.
- `%a` Prints an address in symbolic form. The minimum size of the value associated with `%a` is a `uintptr_t`; specifying `%la` is not necessary. If address-to-symbol conversion is on, the debugger will attempt to convert the address to a symbol name followed by an offset in the current output radix and print this string; otherwise, the value is printed in the default output radix. If `##a` is used, the alternate format adds a ':' suffix to the output.
- `%A` This format is identical to `%a`, except when an address cannot be converted to a symbol name plus an offset, nothing is printed. If `##A` is used, the alternate format prints a '?' when address conversion fails.
- `%b` Decode and print a bit field in symbolic form. This specifier expects two consecutive arguments: the bit field value (`int` for `%b`, `long` for `%lb`, and so forth), and a pointer to an array of `mdb_bitmask_t` structures:

```
typedef struct mdb_bitmask {
    const char *bm_name;      /* String name to print */
    u_longlong_t bm_mask;    /* Mask for bits */
}
```

```

        u_longlong_t bm_bits;        /* Result for value & mask */
    } mdb_bitmask_t;

```

The array should be terminated by a structure whose `bm_name` field is set to `NULL`. When `%b` is used, the debugger reads the value argument, then iterates through each `mdb_bitmask` structure checking to see if:

```
(value & bitmask->bm_mask) == bitmask->bm_bits
```

If this expression is true, the `bm_name` string is printed. Each string printed is separated by a comma. The following example shows how `%b` can be used to decode the `t_flag` field in a `kthread_t`:

```

const mdb_bitmask_t t_flag_bits[] = {
    { "T_INTR_THREAD", T_INTR_THREAD, T_INTR_THREAD },
    { "T_WAKEABLE", T_WAKEABLE, T_WAKEABLE },
    { "T_TOMASK", T_TOMASK, T_TOMASK },
    { "T_TALLOCSTK", T_TALLOCSTK, T_TALLOCSTK },
    /* ... */
    { NULL, 0, 0 }
};

void
thr_dump(kthread_t *t)
{
    mdb_printf("t_flag = <hb>\n", t->t_flag, t_flag_bits);
    /* ... */
}

```

If `t_flag` was set to `0x000a`, the function would print:

```
t_flag = <T_WAKEABLE,T_TALLOCSTK>
```

If `%b` is specified, the union of all bits that were not matched by an element in the bitmask array is printed as a hexadecimal value following the decoded names.

- `%c` Print the specified integer as an ASCII character.
- `%d` Print the specified integer as a signed decimal value. Same as `%i`. If `%#d` is specified, the alternate format prefixes the value with `'0t'`.
- `%e` Print the specified double in the floating-point format `[+/-]d. dddddde[+/-]dd`, where there is one digit before the radix character, seven digits of precision, and at least two digits following the exponent.
- `%E` Print the specified double using the same rules as `%e`, except that the exponent character will be `'E'` instead of `'e'`.
- `%g` Print the specified double in the same floating-point format as `%e`, but with sixteen digits of precision. If `%lg` is specified, the argument is expected to be of type `long double` (quad-precision floating-point value).

<code>%G</code>	Print the specified double using the same rules as <code>%g</code> , except that the exponent character will be 'E' instead of 'e'.
<code>%i</code>	Print the specified integer as a signed decimal value. Same as <code>%d</code> . If <code>%#i</code> is specified, the alternate format prefixes the value with <code>'0t'</code> .
<code>%I</code>	Print the specified 32-bit unsigned integer as an Internet IPv4 address in dotted-decimal format (for example, the hexadecimal value <code>0xffffffff</code> would print as <code>255.255.255.255</code>).
<code>%m</code>	Print a margin of whitespace. If no field is specified, the default output margin width is used; otherwise, the field width determines the number of characters of white space that are printed.
<code>%o</code>	Print the specified integer as an unsigned octal value. If <code>%#o</code> is used, the alternate format prefixes the output with <code>'0'</code> .
<code>%p</code>	Print the specified pointer (<code>void *</code>) as a hexadecimal value.
<code>%q</code>	Print the specified integer as a signed octal value. If <code>%#o</code> is used, the alternate format prefixes the output with <code>'0'</code> .
<code>%r</code>	Print the specified integer as an unsigned value in the current output radix. The user can change the output radix using the <code>\$d</code> dcmd. If <code>%#r</code> is specified, the alternate format prefixes the value with the appropriate base prefix: <code>'0i'</code> for binary, <code>'0o'</code> for octal, <code>'0t'</code> for decimal, or <code>'0x'</code> for hexadecimal.
<code>%R</code>	Print the specified integer as a signed value in the current output radix. If <code>%#R</code> is specified, the alternate format prefixes the value with the appropriate base prefix.
<code>%s</code>	Print the specified string (<code>char *</code>). If the string pointer is NULL, the string <code>'<NULL>'</code> is printed.
<code>%t</code>	Advance one or more tab stops. If no width is specified, output advances to the next tab stop; otherwise the field width determines how many tab stops are advanced.
<code>%T</code>	Advance the output column to the next multiple of the field width. If no field width is specified, no action is taken. If the current output column is not a multiple of the field width, white space is added to advance the output column.
<code>%u</code>	Print the specified integer as an unsigned decimal value. If <code>%#u</code> is specified, the alternate format prefixes the value with <code>'0t'</code> .
<code>%x</code>	Print the specified integer as a hexadecimal value. The characters a-f are used as the digits for the values 10-15. If <code>%#x</code> is specified, the alternate format prefixes the value with <code>'0x'</code> .
<code>%X</code>	Print the specified integer as a hexadecimal value. The characters A-F are used as the digits for the values 10-15. If <code>%#X</code> is specified, the alternate format prefixes the value with <code>'0X'</code> .

`%Y` The specified `time_t` is printed as the string 'year month day HH:MM:SS'.

`mdb_snprintf()`

```
size_t mdb_snprintf(char *buf, size_t len, const char *format, ...);
```

Construct a formatted string based on the specified format string and arguments, and store the resulting string into the specified *buf*. The `mdb_snprintf()` function accepts the same format specifiers and arguments as the `mdb_printf()` function. The *len* parameter specifies the size of *buf* in bytes. No more than *len* - 1 formatted bytes are placed in *buf*; `mdb_snprintf()` always terminates *buf* with a null byte. The function returns the number of bytes required for the complete formatted string, not including the terminating null byte. If the *buf* parameter is NULL and *len* is set to zero, the function will not store any characters to *buf* and returns the number of bytes required for the complete formatted string; this technique can be used to determine the appropriate size of a buffer for dynamic memory allocation.

`mdb_warn()`

```
void mdb_warn(const char *format, ...);
```

Print an error or warning message to standard error. The `mdb_warn()` function accepts a format string and variable argument list that can contain any of the specifiers documented for `mdb_printf()`. However, the output of `mdb_warn()` is sent to standard error, which is not buffered and is not sent through the output pager or processed as part of a `dcmd` pipeline. All error messages are automatically prefixed with the string "mdb:".

In addition, if the *format* parameter does not contain a newline (`\n`) character, the format string is implicitly suffixed with the string ":%s\n", where `%s` is replaced by the error message string corresponding to the last error recorded by a module API function. For example, the following source code:

```
if (mdb_lookup_by_name("no_such_symbol", &sym) == -1)
    mdb_warn("lookup_by_name failed");
```

produces this output:

```
mdb: lookup_by_name failed: unknown symbol name
```

`mdb_flush()`

```
void mdb_flush(void);
```

Flush all currently buffered output. Normally, `mdb's` standard output is line-buffered; output generated using `mdb_printf()` is not flushed to the terminal (or other standard output destination) until a newline is encountered, or at the end of the current `cmd`. However, in some situations you might want to explicitly flush standard output prior to printing a newline; `mdb_flush()` can be used for this purpose.

mdb_nhconvert()

```
void mdb_nhconvert(void *dst, const void *src, size_t nbytes);
```

Convert a sequence of `nbytes` bytes stored at the address specified by `src` from network byte order to host byte order and store the result at the address specified by `dst`. The `src` and `dst` parameters may be the same, in which case the object is converted in place. This function may be used to convert from host order to network order or from network order to host order, since the conversion is the same in either case.

mdb_dumpptr() and mdb_dump64()

```
int mdb_dumpptr(uintptr_t addr, size_t nbytes, uint_t flags,  
               mdb_dumpptr_cb_t func, void *data);  
int mdb_dump64(uint64_t addr, uint64_t nbytes, uint_t flags,  
               mdb_dump64_cb_t func, void *data);
```

These functions can be used to generate formatted hexadecimal and ASCII data dumps that are printed to standard output. Each function accepts an `addr` parameter specifying the starting location, a `nbytes` parameter specifying the number of bytes to display, a set of flags described below, a `func` callback function to use to read the data to display, and a `data` parameter that is passed to each invocation of the callback `func` as its last argument. The functions are identical in every regard except that `mdb_dumpptr` uses `uintptr_t` for its address parameters and `mdb_dump64` uses `uint64_t`. This distinction is useful when combining `mdb_dump64` with `mdb_pread`, for example. The built-in `::dump` `cmd` uses these functions to perform its data display.

The flags parameter should be the bitwise OR of one or more of the following values:

<code>MDB_DUMP_RELATIVE</code>	Number lines relative to the start address instead of with the explicit address of each line.
<code>MDB_DUMP_ALIGN</code>	Align the output at a paragraph boundary.
<code>MDB_DUMP_PEDANT</code>	Display full-width addresses instead of truncating the address to fit the output in 80 columns.
<code>MDB_DUMP_ASCII</code>	Display ASCII values next to the hexadecimal data.
<code>MDB_DUMP_HEADER</code>	Display a header line about the data.

<code>MDB_DUMP_TRIM</code>	Only read from and display the contents of the specified addresses, instead of reading and printing entire lines.
<code>MDB_DUMP_SQUISH</code>	Elide repeated lines by placing a “*” on a line that is a repeat of the previous line.
<code>MDB_DUMP_NEWDOT</code>	Update the value of dot to the address beyond the last address read by the function.
<code>MDB_DUMP_ENDIAN</code>	Adjust for endianness. This option assumes that the word size is equal to the current group size, specified by <code>MDB_DUMP_GROUP()</code> . This option will always turn off alignment, headers, and ASCII display to avoid confusing output. If <code>MDB_DUMP_TRIM</code> is set with <code>MDB_DUMP_ENDIAN</code> , the number of bytes dumped will be rounded down to the nearest word size bytes.
<code>MDB_DUMP_WIDTH(<i>width</i>)</code>	Increase the number of 16-byte paragraphs per line that are displayed. The default value of <i>width</i> is one, and the maximum value is 16.
<code>MDB_DUMP_GROUP(<i>group</i>)</code>	Set the byte group size to <i>group</i> . The default <i>group</i> size is four bytes. The <i>group</i> size must be a power of two that divides the line width.

`mdb_one_bit()`

```
const char *mdb_one_bit(int width, int bit, int on);
```

The `mdb_one_bit()` function can be used to print a graphical representation of a bit field in which a single bit of interest is turned on or off. This function is useful for creating verbose displays of bit fields similar to the output from `snoop(1M) -v`. For example, the following source code:

```
#define FLAG_BUSY      0x1

uint_t flags;

/* ... */

mdb_printf("%s = BUSY\n", mdb_one_bit(8, 0, flags & FLAG_BUSY));
```

produces this output:

```
.... ...1 = BUSY
```

Each bit in the bit field is printed as a period (.), with each 4-bit sequence separated by a white space. The bit of interest is printed as 1 or 0, depending on the setting of the *on* parameter. The total *width* of the bit field in bits is specified by the *width* parameter, and the bit position of the

bit of interest is specified by the *bit* parameter. Bits are numbered starting from zero. The function returns a pointer to an appropriately sized, null-terminated string containing the formatted bit representation. The string is automatically garbage-collected upon completion of the current dcmd.

mdb_inval_bits()

```
const char *mdb_inval_bits(int width, int start, int stop);
```

The `mdb_inval_bits()` function is used, along with `mdb_one_bit()`, to print a graphical representation of a bit field. This function marks a sequence of bits as invalid or reserved by displaying an 'x' at the appropriate bit location. Each bit in the bit field is represented as a period (.), except for those bits in the range of bit positions specified by the start and stop parameters. Bits are numbered starting from zero. For example, the following source code:

```
mdb_printf("%s = reserved\n", mdb_inval_bits(8, 7, 7));
```

produces this output:

```
x... .... = reserved
```

The function returns a pointer to an appropriately sized, null-terminated string containing the formatted bit representation. The string is automatically garbage-collected upon completion of the current dcmd.

mdb_inc_indent() and mdb_dec_indent()

```
ulong_t mdb_inc_indent(ulong_t n);  
ulong_t mdb_dec_indent(ulong_t n);
```

These functions increment and decrement the numbers of columns that MDB will auto-indent with white space before printing a line of output. The size of the delta is specified by *n*, a number of columns. Each function returns the previous absolute value of the indent. Attempts to decrement the indent below zero have no effect. Following a call to either function, subsequent calls to `mdb_printf()` are indented appropriately. If the dcmd completes or is forcibly terminated by the user, the indent is restored automatically to its default setting by the debugger.

mdb_eval()

```
int mdb_eval(const char *s);
```

Evaluate and execute the specified command string *s*, as if it had been read from standard input by the debugger. This function returns 0 for success, or -1 for error. `mdb_eval()` fails if the command string contains a syntax error, or if the command string executed by `mdb_eval()` is forcibly aborted by the user using the pager or by issuing an interrupt.

mdb_set_dot() and mdb_get_dot()

```
void mdb_set_dot(uintmax_t dot);
uintmax_t mdb_get_dot(void);
```

Set or get the current value of dot (the “.” variable). Module developers might want to reposition dot so that, for example, it refers to the address following the last address read by the dcmd.

mdb_get_pipe()

```
void mdb_get_pipe(mdb_pipe_t *p);
```

Retrieve the contents of the pipeline input buffer for the current dcmd. The `mdb_get_pipe()` function is intended to be used by dcmds that want to consume the complete set of pipe input and execute only once, instead of being invoked repeatedly by the debugger for each pipe input element. Once `mdb_get_pipe()` is invoked, the dcmd will not be invoked again by the debugger as part of the current command. This can be used, for example, to construct a dcmd that sorts a set of input values.

The pipe contents are placed in an array that is garbage-collected upon termination of the dcmd, and the array pointer is stored in `p->pipe_data`. The length of the array is placed in `p->pipe_len`. If the dcmd was not executed on the right-hand side of a pipeline (that is, the `DCMD_PIPE` flag was not set in its `flags` parameter), `p->pipe_data` is set to `NULL` and `p->pipe_len` is set to zero.

mdb_set_pipe()

```
void mdb_set_pipe(const mdb_pipe_t *p);
```

Set the pipeline output buffer to the contents described by the pipe structure *p*. The pipe values are placed in the array `p->pipe_data`, and the length of the array is stored in `p->pipe_len`. The debugger makes its own copy of this information, so the caller must remember to free `p->pipe_data` if necessary. If the pipeline output buffer was previously non-empty, its contents are replaced by the new array. If the dcmd was not executed on the left side of a pipeline (that is, the `DCMD_PIPE_OUT` flag was not set in its `flags` parameter), this function has no effect.

mdb_get_xdata()

```
ssize_t mdb_get_xdata(const char *name, void *buf, size_t nbytes);
```

Read the contents of the target external data buffer specified by name into the buffer specified by *buf*. The size of *buf* is specified by the *nbytes* parameter; no more than *nbytes* will be copied to the caller's buffer. The total number of bytes read will be returned upon success; -1 will be returned upon error. If the caller wants to determine the size of a particular named buffer, *buf* should be specified as NULL and *nbytes* should be specified as zero. In this case, `mdb_get_xdata()` will return the total size of the buffer in bytes but no data will be read. External data buffers provide module writers access to target data that is not otherwise accessible through the module API. The set of named buffers exported by the current target can be viewed using the `::xdata` built-in dcmd.

Additional Functions

Additionally, module writers can use the following [string\(3C\)](#) and [bstring\(3C\)](#) functions. They are guaranteed to have the same semantics as the functions described in the corresponding Oracle Solaris man page.

<code>strcat()</code>	<code>strcpy()</code>	<code>strncpy()</code>
<code>strchr()</code>	<code>strrchr()</code>	<code>strcmp()</code>
<code>strncmp()</code>	<code>strcasecmp()</code>	<code>strncasecmp()</code>
<code>strlen()</code>	<code>bcmp()</code>	<code>bcopy()</code>
<code>bzero()</code>	<code>bsearch()</code>	<code>qsort()</code>

MDB Options

This appendix provides a reference for MDB command-line options.

Summary of MDB Command-Line Options

```
mdb [ -fkmwyAFMS ] [ +o option ] [ -p pid ] [ -s distance ]  
    [ -I path ] [ -L path ] [ -P prompt ] [ -R root ]  
    [ -V dis-version ] [ object [ core ] | core | suffix ]
```

The following options are supported:

- A Disables automatic loading of `mdb` modules. By default, `mdb` attempts to load debugger modules corresponding to the active shared libraries in a user process or core file, or to the loaded kernel modules in the live operating system or an operating system crash dump.
- F Forcibly takes over the specified user process, if necessary. By default, `mdb` refuses to attach to a user process that is already under the control of another debugging tool, such as `truss(1)`. With the `-F` option, `mdb` attaches to these processes anyway. This can produce unexpected interactions between `mdb` and the other tools attempting to control the process.
- f Force raw file debugging mode. By default, `mdb` attempts to infer whether the object and core file operands refer to a user executable and core dump or to a pair of operating system crash dump files. If the file type cannot be inferred, the debugger will default to examining the files as plain binary data. The `-f` option forces `mdb` to interpret the arguments as a set of raw files to examine
- I Sets default path for locating macro files. Macro files are read using the `$<` or `$<<` dcmds. The path is a sequence of directory names delimited by colon (`:`) characters. The `-I include path` and `-L library path` (see below) can also contain any of the following tokens:

- `%i` Expands to the current instruction set architecture (ISA) name: `sparc`, `sparcv9`, `i386`, or `amd64`.
- `%o` Expands to the old value of the path being modified. This is useful for appending or prepending directories to an existing path.
- `%p` Expands to the current platform string (either `uname -i` or the platform string stored in the process core file or crash dump).
- `%r` Expands to the path name of the root directory. An alternate root directory can be specified using the `-R` option. If no `-R` option is present, the root directory is derived dynamically from the path to the `mdb` executable itself. For example, if `/bin/mdb` is executed, the root directory is `.`. If `/net/hostname/bin/mdb` were executed, the root directory would be derived as `/net/hostname`.
- `%t` Expands to the name of the current target. This is either the literal string `'proc'` (a user process or user process core file), or `'kvm'` (a kernel crash dump or the live operating system).

The default include path for 32-bit `mdb`

```
is:%r/usr/platform/%p/lib/adb:%r/usr/lib/adb
```

The default include path for 64-bit `mdb`

```
is:%r/usr/platform/%p/lib/adb/%i:%r/usr/lib/adb/%i
```

- `-k` Forces kernel debugging mode. By default, `mdb` attempts to infer whether the object and core file operands refer to a user executable and core dump, or to a pair of operating system crash dump files. The `-k` option forces `mdb` to assume these files are operating system crash dump files. If no object or core operand is specified, but the `-k` option is specified, `mdb` defaults to an object file of `/dev/ksyms` and a core file of `/dev/kmem`. Access to `/dev/kmem` is restricted to group `sys`.
- `-K` Load `kmdb`, stop the live running operating system kernel, and proceed to the `kmdb` debugger prompt. This option should only be used on the system console, as the subsequent `kmdb` prompt will appear on the system console.
- `-L` Sets default path for locating debugger modules. Modules are loaded automatically on startup or by using the `::load dcmd`. The path is a sequence of directory names delimited by colon (`:`) characters. The `-L` library path can also contain any of the tokens shown for `-I` above.
- `-m` Disables demand-loading of kernel module symbols. By default, `mdb` processes the list of loaded kernel modules and performs demand loading of per-module symbol tables. If the `-m` option is specified, `mdb` does not attempt to process the kernel module list or provide per-module symbol tables. As a result, `mdb` modules corresponding to active kernel modules are not loaded on startup.

- M** Preloads all kernel module symbols. By default, `mdb` performs demand-loading for kernel module symbols: the complete symbol table for a module is read when an address in that module's text or data section is referenced. With the `-M` option, `mdb` loads the complete symbol table of all kernel modules during startup.
- o option** Enables the specified debugger option. If the `+o` form of the option is used, the specified option is disabled. Unless noted below, each option is off by default. `mdb` recognizes the following option arguments:
- adb**
Enable stricter `adb(1)` compatibility. The prompt is set to the empty string and many `mdb` features, such as the output pager, are disabled.
- array_mem_limit=limit**
Set the default limit on the number of array members that `::print` will display. If *limit* is the special token `none`, all array members will be displayed by default.
- array_str_limit=limit**
Set the default limit on the number of characters that `::print` will attempt to display as an ASCII string when printing a `char` array. If *limit* is the special token `none`, the entire `char` array will be displayed as a `string` by default.
- follow_exec_mode=mode**
Set the debugger behavior for following an `exec(2)` system call. The mode should be one of the following named constants:
- ask** If `stdout` is a terminal device, the debugger stops after the `exec()` system call returns and then prompts the user to decide whether to follow the `exec` or stop. If `stdout` is not a terminal device, the `ask` mode defaults to stop.
- follow** The debugger follows the `exec` by automatically continuing the target process and resetting all of its mappings and symbol tables based on the new executable. The follow behavior is discussed in more detail under “[Interaction with exec](#)” on page 67.
- stop** The debugger stops after the `exec()` system call returns. The stop behavior is discussed in more detail under “[Interaction with exec](#)” on page 67.
- follow_fork_mode=mode**
Set the debugger behavior for following a `fork(2)`, `fork1(2)`, or `vfork(2)` system call. The mode should be one of the following named constants:
- ask** If `stdout` is a terminal device, the debugger stops after the `fork()` system call has returned and then prompts the user to decide whether to follow the parent or child. If `stdout` is not a terminal device, the `ask` mode defaults to parent.

- parent** The debugger follows the parent process, and detaches from the child process and sets the child process running.
- child** The debugger follows the child process, and detaches from the parent process and sets the parent process running.
- ignoreeof**
The debugger does not exit when an EOF sequence (^D) is entered at the terminal. The `::quit dcmd` must be used to quit.
- nostop**
Do not stop a user process when attaching to it when the `-p` option is specified or when the `::attach` or `::A dcmds` are applied. The nostop behavior is described in more detail under [“Process Attach and Release” on page 68](#).
- pager**
The output pager is enabled (default).
- repeatlast**
If a NEWLINE is entered as the complete command at the terminal, `mdb` repeats the previous command with the current value of dot. This option is implied by `-o adb`.
- showlmid**
MDB provides support for symbol naming and identification in user applications that make use of link maps other than `LM_ID_BASE` and `LM_ID_LDSO`, as described in [“Symbol Name Resolution” on page 29](#). Symbols on link maps other than `LM_ID_BASE` or `LM_ID_LDSO` will be shown as `LMlmid‘library’symbol`, where `lmid` is the link-map ID in the default output radix (16). The user may optionally configure MDB to show the link-map ID scope of all symbols and objects, including those associated with `LM_ID_BASE` and `LM_ID_LDSO`, by enabling the `showlmid` option. Built-in dcmds that deal with object file names will display link-map IDs according to the value of `showlmid` above, including `::nm`, `::mappings`, `$m`, and `::objects`.
- p *pid*** Attaches to and stops the specified process id. `mdb` uses the `/proc/pid/object/a.out` file as the executable file path name.
- P** Sets the command prompt. The default prompt is `'>'`.
- R** Sets root directory for path name expansion. By default, the root directory is derived from the path name of the `mdb` executable itself. The root directory is substituted in place of the `%r` token during path name expansion.
- s *distance*** Sets the symbol matching distance for address-to-symbol-name conversions to the specified *distance*. By default, `mdb` sets the distance to zero, which enables a smart-matching mode. Each ELF symbol table entry includes a value `V` and size `S`, representing the size of the function or data object in bytes. In smart mode, `mdb` matches an address `A` with the given symbol if `A` is in the range `[V, V + S)`. If any

- non-zero distance is specified, the same algorithm is used, but `S` in the given expression is always the specified absolute distance and the symbol size is ignored.
- S Suppresses processing of the user's `~/ .mddbrc` file. By default, `mdb` reads and processes the macro file `.mddbrc` if one is present in the user's home directory, as defined by `$HOME`. If the `-S` option is present, this file is not read.
 - u Forces user debugging mode. By default, `mdb` attempts to infer whether the object and core file operands refer to a user executable and core dump, or to a pair of operating system crash dump files. The `-u` option forces `mdb` to assume these files are not operating system crash dump files.
 - U Unload `kmdb` if it is loaded. You should unload `kmdb` when it is not in use to release the memory used by the kernel debugger back to the free memory available to the operating system.
 - V Sets disassembler version. By default, `mdb` attempts to infer the appropriate disassembler version for the debug target. The disassembler can be set explicitly using the `-V` option. The `:disasms dcmd` lists the available disassembler versions.
 - w Opens the specified object and core files for writing.
 - y Sends explicit terminal initialization sequences for tty mode. Some terminals require explicit initialization sequences to switch into a tty mode. Without this initialization sequence, terminal features such as standout mode might not be available to `mdb`.

Operands

The following operands are supported:

- object Specifies an ELF format object file to examine. `mdb` provides the ability to examine and edit ELF format executables (`ET_EXEC`), ELF dynamic library files (`ET_DYN`), ELF relocatable object files (`ET_REL`), and operating system `unix.X` symbol table files.
- core Specifies an ELF process core file (`ET_CORE`), or an operating system crash dump `vmcore.X` file. If an ELF core file operand is provided without a corresponding object file, `mdb` will attempt to infer the name of the executable file that produced the core using several different algorithms. If no executable is found, `mdb` will still execute, but some symbol information may be unavailable.
- suffix Specifies the numeric suffix that represents a pair of operating system crash dump files. For example, if the suffix is `3`, then `mdb` should examine the files `unix.3` and `vmcore.3`. If these files do not exist, but `vmdump.3` does exist, then a message displays telling you to first run the following command to uncompress the dump file.

```
# savecore -f vmdump.3
```

The string of digits is not interpreted as a suffix if an actual file of the same name is present in the current directory.

Exit Status

The following exit values are returned:

- 0 Debugger completed execution successfully.
- 1 A fatal error occurred.
- 2 Invalid command line options were specified.

Environment Variables

The following environment variables are supported:

- HISTSIZE** This variable is used to determine the maximum length of the command history list. If this variable is not present, the default length is 128.
- HOME** This variable is used to determine the pathname of the user's home directory, where a `.mdbc` file may reside. If this variable is not present, no `.mdbc` processing will occur.
- SHELL** This variable is used to determine the pathname of the shell used to process shell escapes requested using the `!` meta-character. If this variable is not present, `/bin/sh` is used.

Notes

Warnings

The following warning information applies to the use of MDB.

Use of the Error Recovery Mechanism

The debugger and its dmods execute in the same address space, and thus it is quite possible that a buggy dmod can cause MDB to dump core or otherwise misbehave. The MDB resume capability, described in [“Signal Handling” on page 41](#), provides a limited recovery mechanism for these situations. However, it is not possible for MDB to know definitively whether the dmod in question has corrupted only its own state, or the debugger's global state. Therefore a resume operation cannot be guaranteed to be safe, or to prevent a subsequent crash of the debugger. The safest course of action following a resume is to save any important debug information, and then quit and restart the debugger.

Use of the Debugger to Modify the Live Operating System

The use of the debugger to modify (that is, write to) the address space of live running operating system is extremely dangerous, and may result in a system panic in the event the user damages a kernel data structure.

Use of kmdb to Stop the Live Operating System

The use of kmdb to stop the live operating system using `mdb -K` or by setting a breakpoint in the live operating system is intended for use by developers and not on production systems. When

the operating system kernel is stopped by `kmdb`, operating system services and networking are not executing, and other systems on the network that depend upon the target system will not be able to contact the target system.

Notes

Limitations on Examining Process Core Files

MDB does not provide support for examining process core files that were generated by a release of the Oracle Solaris operating system preceding Solaris 2.6. If a core file from one operating system release is examined on a different operating system release, the run-time link-editor debugging interface (`librtld_db`) may not be able to initialize. In this case, symbol information for shared libraries will not be available. Furthermore, since shared mappings are not present in user core files, the text section and read-only data of shared libraries may not match the data that was present in the process at the time it dumped core. Core files from Oracle Solaris x86 systems may not be examined on Oracle Solaris SPARC systems, and vice-versa.

Limitations on Examining Crash Dump Files

Crash dumps from Solaris 7 and earlier releases may only be examined with the aid of the `libkvm` from the corresponding operating system release. If a crash dump from one operating system release is examined using the `dmods` from a different operating system release, changes in the kernel implementation may prevent some `dcmds` or `walkers` from working properly. MDB will issue a warning message if it detects this condition. Crash dumps from Oracle Solaris x86 systems may not be examined on Oracle Solaris SPARC systems, and vice-versa.

Relationship Between 32-bit and 64-bit Debugger

MDB provides support for debugging both 32-bit and 64-bit programs. Once it has examined the target and determined its data model, MDB will automatically re-execute the `mdb` binary that has the same data model as the target, if necessary. This approach simplifies the task of writing debugger modules, because the modules that are loaded will use the same data model as the primary target. Only the 64-bit debugger may be used to debug 64-bit target programs. The 64-bit debugger can only be used on a system that is running the 64-bit operating environment.

Limitations on Memory Available to `kmdb`

The memory available to `kmdb` is allocated when the debugger is loaded, and cannot be expanded after that point in time. If debugger commands attempt to allocate more memory

than is available, they will not be able to execute. The debugger will attempt to gracefully recover from low memory situations, but may be forced to terminate the system under dire circumstances. System memory constraints are especially acute on x86 platforms that use the 32-bit operating system kernel.

Developer Information

The `mdb(1)` man page provides a detailed description of built-in `mdb` features for easy developer reference. The header file `<sys/mdb_modapi.h>` contains prototypes for the functions in the MDB Module API, and the `SUNWmdbdm` package provides source code for an example module in the directory `/usr/demo/mdb`.

Transition From adb and kadb

The transition from using the legacy `adb(1)` utility to using `mdb(1)` is relatively simple: MDB provides evolutionary compatibility for the `adb` syntax, built-in commands, and command-line options. MDB attempts to provide compatibility for all existing `adb(1)` features, but it is not bug-for-bug compatible with `adb(1)`. This appendix briefly discusses several features of `adb(1)` that are not precisely emulated by `mdb(1)` in order to guide users to the new functionality

Command-Line Options

MDB provides a superset of the command-line options recognized by `adb(1)`. All the `adb(1)` options are supported and have the same meaning as before. The `/usr/bin/adb` pathname is delivered as a link that invokes `mdb(1)`, and automatically enables enhanced `adb(1)` compatibility mode. Executing the `/usr/bin/adb` link is equivalent to executing `mdb` with the `-o adb` option, or executing `: : set -o adb` once the debugger has started.

Syntax

The MDB language adheres to the same syntax as the `adb(1)` language, in order to provide compatibility for legacy macros and script files. New MDB `dcmds` use the extended form `: : name`, in order to distinguish them from legacy commands that are prefixed with either `:` or `$`. Expressions can also be evaluated on the right-hand side of a `dcmd` name by enclosing them in square brackets preceded by a dollar sign (`$()`). Similar to `adb(1)`, an input line that begins with an exclamation mark (`!`) indicates that the command line should be executed by the user's shell. In MDB, a debugger command may also be suffixed with an exclamation mark to indicate that its output should be piped to the shell command following the exclamation mark.

In `adb(1)`, binary operators are left associative and have lower precedence than unary operators. Binary operators are evaluated in strict left-to-right order on the input line. In MDB, binary operators are left associative and have lower precedence than unary operators, but the binary operators operate in order of precedence according to the table in “Binary Operators” on

page 27. The operators conform to the order of precedence in ANSI C. Legacy `adb(1)` macro files that do not explicitly parenthesize ambiguous expressions may need to be updated to work with MDB. For example, in `adb` the following command evaluates to the integer value nine:

```
$ echo "4-1*3=X" | adb
9
```

In MDB, as in ANSI C, operator `*` has higher precedence than `-` and therefore the result is the integer value one:

```
$ echo "4-1*3=X" | mdb
1
```

Watchpoint Length Specifier

The watchpoint length specifier syntax recognized by MDB is different from the syntax described in `adb(1)`. In particular, the `adb` watchpoint commands `:w`, `:a`, and `:p` allow an integer length in bytes to be inserted between the colon and the command character. In MDB, the count should be specified following the initial address as a repeat count. Stated simply, these `adb(1)` commands:

```
123:456w
123:456a
123:456p
```

are specified in MDB as

```
123,456:w
123,456:a
123,456:p
```

The MDB `:wp` `dcmd` provides more complete facilities for creating user process watchpoints. Similarly, the legacy `kadb` length modifier command `$l` is not supported. Therefore, the watchpoint size should be specified to each `:wp` command used in `kmdb`.

Address Map Modifier

The `adb(1)` commands to modify segments of the virtual address map and object file map are not present in MDB. Specifically, the `/m`, `/*m`, `?m`, and `?*m` format specifiers are not recognized or supported by MDB. These specifiers were used to manually modify the valid addressable range of the current object and core files. MDB properly recognizes the addressable range of such files automatically, and updates the ranges when a live process is being debugged, so these commands are no longer necessary.

Output

The precise text output form of some commands is different in MDB. Macro files are formatted using the same basic rules, but shell scripts that depend on the precise character-by-character output of certain commands may need to change. Users who have shell scripts that parse the output of `adb` commands will need to revalidate and update such scripts as part of the transition to MDB.

Deferred Breakpoints

The legacy `kadb` utility supported a syntax for deferred breakpoints that was incompatible with the existing `adb` syntax. These deferred breakpoints were specified using the syntax `module#symbol:b` in `kadb`. To set a deferred breakpoint in `kmdb`, use the MDB `::bp` `dcmd` as described in [Chapter 6, “Execution Control.”](#)

x86: I/O Port Access

The legacy `kadb` utility provided access to I/O ports on x86 systems using the `:i` and `:o` commands. These commands are not supported in `mdb` or `kmdb`. Access to I/O ports on x86 systems is provided by the `::in` and `::out` commands.

Transition From `crash`

The transition from using the legacy `crash` utility to using `mdb(1)` is relatively simple: MDB provides most of the “canned” `crash` commands. The additional extensibility and interactive features of MDB allow the programmer to explore aspects of the system not examined by the current set of commands. This appendix briefly discusses several features of `crash` and provides pointers to equivalent MDB functionality.

Command-Line Options

The `crash -d`, `-n`, and `-w` command-line options are not supported by `mdb`. The `crash` dump file and name list (symbol table file) are specified as arguments to `mdb` in the order of name list, `crash` dump file. To examine the live kernel, the `mdb -k` option should be specified with no additional arguments. Users who want to redirect the output of `mdb` to a file or other output destination, should either employ the appropriate shell redirection operator following the `mdb` invocation on the command line, or use the `::log` built-in `dcmd`.

Input in MDB

In general, input in MDB is similar to `crash`, except that function names (in MDB, `dcmd` names) are prefixed with `::`. Some MDB `dcmds` accept a leading expression argument that precedes the `dcmd` name. Like `crash`, string options can follow the `dcmd` name. If a `!` character follows a function invocation, MDB will also create a pipeline to the specified shell pipeline. All immediate values specified in MDB are interpreted in hexadecimal by default. The radix specifiers for immediate values are different in `crash` and MDB as shown in [Table D-1](#).

TABLE D-1 Radix Specifiers

<code>crash</code>	<code>mdb</code>	Radix
0x	0x	hexadecimal (base 16)

TABLE D-1 Radix Specifiers (Continued)

crash	mdb	Radix
0d	0t	decimal (base 10)
0b	0i	binary (base 2)

Many crash commands accepted slot numbers or slot ranges as input arguments. The Oracle Solaris operating system is no longer structured in terms of slots, so MDB dcmds do not provide support for slot-number processing.

Crash Functions and MDB Dcmds

crash function	mdb dcmd	Comments
?	::dcmds	List available functions.
!command	!command	Escape to the shell and execute command.
base	=	In mdb, the = format character can be used to convert the left-hand expression value to any of the known formats. Formats for octal, decimal, and hexadecimal are provided.
callout	::callout	Print the callout table.
class	::class	Print scheduling classes.
cpu	::cpuinfo	Print information about the threads dispatched on the system CPUs. If the contents of a particular CPU structure are needed, the user should apply the \$<cpu macro to the CPU address in mdb.
help	::help	Print a description of the named dcmd, or general help information.
kfp	::regs	The mdb ::regs dcmd displays the complete kernel register set, including the current stack frame pointer. The \$C dcmd can be used to display a stack backtrace including frame pointers.
kmalog	::kmalog	Display events in kernel memory allocator transaction log.
kmastat	::kmastat	Print kernel memory allocator transaction log.
kmausers	::kmausers	Print information about the medium and large users of the kernel memory allocator that have current memory allocations.
mount	::fsinfo	Print information about mounted file systems.
nm	::nm	Print symbol type and value information.
od	::dump	Print a formatted memory dump of a given region. In mdb, ::dump displays a mixed ASCII and hexadecimal display of the region.

crash function	mdb dcmd	Comments
proc	::ps	Print a table of the active processes.
quit	::quit	Quit the debugger.
rd	::dump	Print a formatted memory dump of a given region. In mdb, ::dump displays a mixed ASCII and hexadecimal display of the region.
redirect	::log	In mdb, output for input and output can be globally redirected to a log file using ::log.
search	::kgrep	In mdb, the ::kgrep dcmd can be used to search the kernel's address space for a particular value. The pattern match built-in dcmds can also be used to search the physical, virtual, or object files address spaces for patterns.
stack	::stack	The current stack trace can be obtained using ::stack. The stack trace of a particular kernel thread can be determined using the ::findstack dcmd. A memory dump of the current stack can be obtained using the / or ::dump dcmds and the current stack pointer. The \$<stackregs macro can be applied to a stack pointer to obtain the per-frame saved register values.
status	::status	Display status information about the system or dump being examined by the debugger.
stream	::stream	The mdb ::stream dcmd can be used to format and display the structure of a particular kernel STREAM. If the list of active STREAM structures is needed, the user should execute ::walk stream_head_cache in mdb and pipe the resulting addresses to an appropriate formatting dcmd or macro.
strstat	::kmastat	The ::kmastat dcmd displays a superset of the information reported by the strstat function.
trace	::stack	The current stack trace can be obtained using ::stack. The stack trace of a particular kernel thread can be determined using the ::findstack dcmd. A memory dump of the current stack can be obtained using the / or ::dump dcmds and the current stack pointer. The \$<stackregs macro can be applied to a stack pointer to obtain the per-frame saved register values.
var	\$<v	Print the tunable system parameters in the global var structure.
vfs	::fsinfo	Print information about mounted file systems.
vtop	::vtop	Print the physical address translation of the given virtual address.

Index

Numbers and Symbols

0xbaddcafe, 106
0xdeadbeef, 103
0xfeedface, 103

A

arithmetic expansion, definition, 26–28
arrow keys, 40

B

bcp, 107
blank, definition, 24
bufctl, 107, 108
buftag, 103
bxstat, 107

C

command
 definition, 25
 shell escapes, 28
command reentry, 39
comment, definition, 26
Configuration
 dcmds
 ::system, 88
contents log, 112

CPUs and the Dispatcher

dcmds
 ::callout, 79
 ::class, 79
 ::cpuinfo, 79

Walkers

cpu, 79

crash(1M), 155

Cyclics

dcmds
 ::cyccover, 87
 ::cycinfo, 87
 ::cyclic, 87
 ::cyctrace, 87

Walkers

cyccpu, 87
cyctrace, 87

D

dcmd
 built-in operators, 24
 definition, 19
 metacharacters, 24
 name resolution, 34
DCMD_ABORT, 117
DCMD_ADDRSPEC, 116
DCMD_ERR, 117
DCMD_LOOP, 116
DCMD_LOOPFIRST, 116
DCMD_NEXT, 117

DCMD_OK, 117
DCMD_PIPE, 116
DCMD_PIPE_OUT, 116
DCMD_USAGE, 117
dcmds
 \$<, 44
 \$?, 44
 \$>, 49
 \$<<, 44
 \$c, 54
 \$C, 44
 \$d, 44
 \$e, 44
 \$f, 47
 \$m, 49
 \$P, 44
 \$p, 45
 \$q, 53
 \$r, 53
 \$s, 44
 \$v, 45
 \$V, 46
 \$w, 45
 \$W, 45
 \$x, 48
 \$X, 48
 \$y, 48
 \$Y, 48
 :A, 45
 ::addr2smap, 77
 ::memlist, 77
 ::memstat, 77
 ::page, 78
 ::allocdby, 73, 114
 ::as2proc, 77
 ::attach, 45
 ::bufctl, 74, 113
 ::callout, 79
 ::cat, 45
 ::class, 79
 ::context, 45
 ::cpuinfo, 79
 ::cyccover, 87
 ::cycinfo, 87

dcmds (*Continued*)
 ::cyclic, 87
 ::cyctrace, 87
 ::dcmds, 46
 ::binding_hash_entry, 79
 ::devbindings, 79
 ::devinfo, 79
 ::devinfo2driver, 79
 ::devnames, 79
 ::dis, 46
 ::disasms, 46
 ::dismode, 46
 ::dmods, 47
 ::dump, 47
 ::echo, 47
 ::eval, 47
 ::fd, 84
 ::mi, 83
 ::netstat, 83
 ::sonode, 83
 ::tcpb, 83
 ::files, 47
 ::findleaks, 74, 109
 ::findstack, 84
 ::pgrep, 84
 ::formats, 48
 formats, 36
 formatting, 35–38
 ::fpregs, 48
 ::freedby, 74, 114
 ::fsinfo, 77
 ::grep, 48
 ::help, 48
 ::errorq, 88
 ::ipcs, 88
 ::msg, 89
 ::msqid, 89
 ::system, 88
 ::taskq_entry, 87
 ::ire, 90
 ::kgrep, 74, 110
 ::kmalog, 74
 ::kmastat, 74, 100
 ::kmausers, 75

dcmds (*Continued*)

- ::kmem_cache, 75,100
- ::kmem_log, 75,113
- ::kmem_verify, 75,111
- ::lminfo, 77
- ::lnode, 90
- ::lnode2dev, 90
- ::lnode2rdev, 90
- ::load, 49
- ::log, 49
- ::major2name, 80
- ::map, 49
- ::mappings, 49
- ::modctl, 91
- ::modctl2devinfo, 80
- ::modhdrs, 91
- ::modinfo, 91
- ::msqid_ds, 89
- ::semid, 89
- ::name2major, 80
- ::nm, 49
- ::nmadd, 51
- ::nmdel, 51
- ::objects, 51
- ::pid2proc, 84
- ::pmap, 85
- ::prtconf, 79
- ::ps, 85
- ::ptree, 85
- ::task, 85
- ::thread, 85
- ::q2otherq, 81
- ::q2rdq, 81
- ::q2syncq, 81
- ::q2wrq, 81
- ::queue, 81
- ::quit, 53
- :R, 53
- ::regs, 53
- ::release, 53
- ::rwlock, 86
- ::sobj2ts, 86
- ::turnstile, 86
- ::seg, 78

dcmds (*Continued*)

- ::swapinfo, 78
- ::semid_ds, 89
- ::shmid, 89
- ::set, 53
- ::shmid_ds, 89
- ::softint, 93
- ::softstate, 60
- ::stack, 54
- ::stackinfo, 54
- ::status, 55
- ::stream, 81
- ::syncq, 82
- ::syncq2q, 82
- ::ttctl, 93
- ::ttrace, 93
- ::uhci_qh, 91
- ::uhci_td, 92
- ::usba_clear_debug_buf, 92
- ::usba_debug_buf, 92
- ::usba_device, 92
- ::usb_pipe_handle, 92
- ::typeset, 55
- ::unload, 55
- ::unset, 56
- ::vars, 56
- ::version, 56
- ::vmem, 75
- ::vmem_seg, 75
- ::vnode2path, 77
- ::vnode2smap, 78
- ::vtop, 56
- ::walk, 56
- ::walkers, 56
- ::wchaninfo, 86
- ::whatis, 75,110
- ::whence, 56
- ::whereopen, 85
- ::which, 56
- which, 34
- ::xc_mbox, 94
- ::xctrace, 94
- ::xdata, 57,140
- /dev/kmem, 142

/dev/ksyms, 142

Device Drivers and DDI Framework

dcmds

::binding_hash_entry, 79

::devbindings, 79

::devinfo, 79

::devinfo2driver, 79

::devnames, 79

::major2name, 80

::modctl2devinfo, 80

::name2major, 80

::prtconf, 79

::softstate, 80

Walkers

binding_hash, 80

devi_next, 80

devinfo, 80

devinfo_children, 80

devinfo_parents, 80

devnames, 80

softstate, 80

softstate_all, 80

Directory Name Lookup Cache (DNLC), 77

dmod, definition, 20

dot address, definition, 23

dumpadm, 96, 97

E

editing commands, 39

Error Queues

dcmds

::errorq, 88

Walkers

errorq, 88

errorq_data, 88

expression

components, 26

definition, 24

evaluation, 26–28

F

field width specifiers, 131

File Systems

dcmds

::fsinfo, 77

::lminfo, 77

::vnode2path, 77

Walkers

buf, 77

Files, Processes, and Threads

dcmds

::fd, 84

::findstack, 84

::pgrep, 84

::pid2proc, 84

::pmap, 85

::ps, 85

::ptree, 85

::task, 85

::thread, 85

::whereopen, 85

Walkers

file, 85

proc, 85

thread, 86

flag specifiers, 131

format characters, 36

search modifiers, 38

write modifiers, 37

format specifiers, 132–135

formats dcmd, 36

I

identifier, definition, 24

increment, definition, 35

inline editing, 39

integer specifiers, 131

Internet Protocol Module Debugging Support (ip)

dcmds

::ire, 90

Walkers

ire, 91

Interprocess Communication Debugging Support (ipc)

dcmds

- ::ipcs, 88
- ::msg, 89
- ::msqid, 89
- ::msqid_ds, 89
- ::semid, 89
- ::semid_ds, 89
- ::shmid, 89
- ::shmid_ds, 89

Walkers

- msg, 89
- msgqueue, 89
- sem, 89
- shm, 90

K

Kernel Debugging Modules, 73–94

Kernel Memory Allocator

dcmds

- ::allocdby, 73
- ::bufctl, 74
- ::findleaks, 74
- ::freedby, 74
- ::kgrep, 74
- ::kmalog, 74
- ::kmastat, 74
- ::kmausers, 75
- ::kmem_cache, 75
- ::kmem_log, 75
- ::kmem_verify, 75
- ::vmem, 75
- ::vmem_seg, 75
- ::whatis, 75

Walkers

- allocdby, 76
- bufctl, 76
- freectl, 76
- freedby, 76
- freemem, 76
- kmem, 76
- kmem_cache, 76
- kmem_cpu_cache, 76

Kernel Memory Allocator, Walkers (*Continued*)

- kmem_log, 76
- kmem_slab, 76

Kernel Runtime Link Editor Debugging Support

dcmds

- ::modctl, 91

Kernel Runtime Link Editor Debugging Support

(krtld)

dcmds

- ::modhdrs, 91
- ::modinfo, 91

Walkers

- modctl, 91

keyboard shortcuts, 41

- kmem_alloc(), 99, 104
- kmem_bufctl_audit_t, 108
- kmem_bufctl_t, 108
- kmem_cache_alloc(), 99, 104
- kmem_cache_free(), 99
- kmem_cache_t, 99
- kmem_flags, 95
- kmem_zalloc(), 99

L

Loopback File System Debugging Support

dcmds

- ::lnode, 90

Loopback File System Debugging Support (lofs)

dcmds

- ::lnode2dev, 90
- ::lnode2rdev, 90

Walkers

- lnode, 90

M

macro file, definition, 20

Macros

- bufctl_audit, 109, 110
- kmem_cache, 101
- mdb_add_walker(), 123
- mdb_alloc(), 130

- MDB_API_VERSION, 115
 - mdb_bitmask_t, 132
 - mdb_call_dcmd(), 122
 - mdb_dcmd_t, 117
 - mdb_dec_indent(), 138
 - MDB_DUMP_ALIGN, 136
 - MDB_DUMP_ASCII, 136
 - MDB_DUMP_ENDIAN, 137
 - MDB_DUMP_GROUP, 137
 - MDB_DUMP_HEADER, 136
 - MDB_DUMP_NEWDOT, 137
 - MDB_DUMP_PEDANT, 136
 - MDB_DUMP_RELATIVE, 136
 - MDB_DUMP_SQUISH, 137
 - MDB_DUMP_TRIM, 137
 - MDB_DUMP_WIDTH, 137
 - mdb_dump64(), 136
 - mdb_dumpptr(), 136
 - mdb_eval(), 139
 - _mdb_fini(), 116
 - mdb_flush(), 136
 - mdb_fread(), 124
 - mdb_free(), 130
 - mdb_fwrite(), 124
 - mdb_get_dot(), 139
 - mdb_get_pipe(), 139
 - mdb_get_xdata(), 140
 - mdb_getopts(), 128
 - mdb_inc_indent(), 138
 - _mdb_init(), 115
 - mdb_inval_bits(), 138
 - mdb_layered_walk(), 123
 - mdb_lookup_by_addr(), 127
 - mdb_lookup_by_name(), 126
 - mdb_lookup_by_obj(), 126
 - mdb_modinfo_t, 115
 - mdb_nhconvert(), 136
 - MDB_OBJ EVERY, 127
 - MDB_OBJ EXEC, 126
 - MDB_OBJ RTLD, 127
 - mdb_one_bit(), 137
 - MDB_OPT_CLRBITS, 128
 - MDB_OPT_SETBITS, 128
 - MDB_OPT_STR, 128
 - MDB_OPT_UINT64, 129
 - MDB_OPT_UINTPTR, 128
 - mdb_pread(), 124
 - mdb_printf(), 131
 - mdb_pwalk(), 121
 - mdb_pwalk_dcmd(), 122
 - mdb_pwrite(), 124
 - mdb_readstr(), 125
 - mdb_readsym(), 125
 - mdb_readvar(), 126
 - mdb_remove_walker(), 123
 - mdb_set_dot(), 139
 - mdb_snprintf(), 135
 - mdb_strtoll(), 129
 - MDB_SYM_EXACT, 127
 - MDB_SYM_FUZZY, 127
 - mdb_vread(), 124
 - mdb_vwrite(), 124
 - mdb_walk(), 121
 - mdb_walk_dcmd(), 122
 - mdb_walk_state_t, 118
 - mdb_walker_t, 119
 - mdb_warn(), 135
 - mdb_writestr(), 125
 - mdb_writesym(), 125
 - mdb_writevar(), 126
 - mdb_zalloc(), 130
 - .mdbrc, 145
 - memory corruption, 102
 - metacharacter, definition, 23
 - metacharacters
 - dcmds, 24
 - quoting, 28
- N**
- Networking
 - dcmds
 - ::mi, 83
 - ::netstat, 83
 - ::sonode, 83
 - ::tcpb, 83
 - Walkers
 - ar, 83

Networking, Walkers (*Continued*)

- icmp, 83
- ill, 83
- ipc, 83
- mi, 84
- sonode, 84
- tcpb, 84
- udp, 84

O

- operators
 - binary, 27
 - unary, 27
- output pager, 41

P

- pipeline, definition, 24
- pipelines, 34–35
- Platform Debugging Support
 - dcmds
 - ::softint, 93
 - ::ttctl, 93
 - ::ttrace, 93
 - ::xc_mbox, 94
 - ::xctrace, 94
 - Walkers
 - softint, 94
 - ttrace, 93, 94
 - xc_mbox, 94

Q

- quoting characters, 28

R

- reboot, 96
- redzone, 103
- redzone byte, 104

- resolving symbol names, 29–34

S

- scoping operator, 30, 34
- shell escapes, 28
- signal handling, 41
- simple-command, definition, 24
- stack bias, 54
- step command, 41
- step over command, 41

STREAMS

dcmds

- ::q2otherq, 81
- ::q2rdq, 81
- ::q2syncq, 81
- ::q2wrq, 81
- ::queue, 81
- ::stream, 81
- ::syncq, 82
- ::syncq2q, 82

Walkers

- qlink, 82
- qnext, 82
- readq, 82
- writeq, 82

- string functions, 140

symbol names

- resolving, 29–34
- scope, 30

- symbol tables, 29–34

Synchronization Primitives

dcmds

- ::rwlock, 86
- ::sobj2ts, 86
- ::turnstile, 86
- ::wchaninfo, 86

Walkers

- blocked, 86
- wchan, 86

- syntax, symbol name resolution, 29–34

T

target, definition, 19–20
Task Queues
 dcmds
 ::taskq_entry, 87
 Walkers
 taskq_entry, 87
terminal attribute specifiers, 132
transaction log, 112

U

UM_GC, 130
UM_NOSLEEP, 130
UM_SLEEP, 130
Uninitialized Data, 106
USB Framework Debugging Support (uhci)
 dcmds
 ::uhci_qh, 91
 ::uhci_td, 92
 Walkers
 uhci_qh, 92
 uhci_td, 92
USB Framework Debugging Support (usba)
 dcmds
 ::usba_clear_debug_buf, 92
 ::usba_debug_buf, 92
 ::usba_device, 92
 ::usb_pipe_handle, 92
 Walkers
 usb_pipe_handle, 93
 usba_device, 92
 usba_list_entry, 92

V

variable, definition, 28–29
Virtual Memory
 dcmds
 ::addr2smap, 77
 ::memlist, 77
 ::memstat, 77
 ::page, 78

Virtual Memory, dcmds (*Continued*)

 ::as2proc, 77
 ::seg, 78
 ::swapinfo, 78
 ::vnode2smap, 78

Walkers

 anon, 78
 memlist, 78
 page, 78
 seg, 78
 swapinfo, 78

W

WALK_DONE, 119
WALK_ERR, 119
WALK_NEXT, 119
walker
 definition, 20
 name resolution, 34
Walkers
 allocdby, 76
 anon, 78
 ar, 83
 binding_hash, 80
 blocked, 86
 buf, 77
 bufctl, 76
 cpu, 79
 cyccpu, 87
 cyctrace, 87
 devi_next, 80
 devinfo, 80
 devinfo_children, 80
 devinfo_parents, 80
 devnames, 80
 errorq, 88
 errorq_data, 88
 file, 85
 freectl, 76
 freedby, 76
 freemem, 76, 101
 icmp, 83
 ill, 83

Walkers (Continued)

ipc, 83
ire, 91
kmem, 76, 101
kmem_cache, 76, 100
kmem_cpu_cache, 76
kmem_log, 76, 112
kmem_slab, 76
lnode, 90
memlist, 78
mi, 84
modctl, 91
msg, 89
msgqueue, 89
page, 78
proc, 85
qlink, 82
qnext, 82
readq, 82
seg, 78
sem, 89
shm, 90
softint, 94
softstate, 80
softstate_all, 80
sonode, 84
swapinfo, 78
taskq_entry, 87
tcpb, 84
thread, 86
ttrace, 93, 94
udp, 84
uhci_qh, 92
uhci_td, 92
usb_pipe_handle, 93
usba_device, 92
usba_list_entry, 92
wchan, 86
writeq, 82
xc_mbox, 94
which dcmd, 34
word, definition, 24

