

Oracle® Crystal Ball Enterprise Performance Management

*Oracle® Crystal Ball Enterprise Performance Management for Oracle Hyperion
Enterprise Planning Suite*

Integration Guide

Release 11.1.2.2

ORACLE®

**ENTERPRISE PERFORMANCE
MANAGEMENT SYSTEM**

Crystal Ball EPM Integration Guide, 11.1.2.2

Copyright © 1988, 2012, Oracle and/or its affiliates. All rights reserved.

Authors: EPM Information Development Team

Oracle and Java are registered trademarks of Oracle and/or its affiliates. Other names may be trademarks of their respective owners.

This software and related documentation are provided under a license agreement containing restrictions on use and disclosure and are protected by intellectual property laws. Except as expressly permitted in your license agreement or allowed by law, you may not use, copy, reproduce, translate, broadcast, modify, license, transmit, distribute, exhibit, perform, publish, or display any part, in any form, or by any means. Reverse engineering, disassembly, or decompilation of this software, unless required by law for interoperability, is prohibited.

The information contained herein is subject to change without notice and is not warranted to be error-free. If you find any errors, please report them to us in writing.

If this is software or related documentation that is delivered to the U.S. Government or anyone licensing it on behalf of the U.S. Government, the following notice is applicable:

U.S. GOVERNMENT RIGHTS:

Programs, software, databases, and related documentation and technical data delivered to U.S. Government customers are "commercial computer software" or "commercial technical data" pursuant to the applicable Federal Acquisition Regulation and agency-specific supplemental regulations. As such, the use, duplication, disclosure, modification, and adaptation shall be subject to the restrictions and license terms set forth in the applicable Government contract, and, to the extent applicable by the terms of the Government contract, the additional rights set forth in FAR 52.227-19, Commercial Computer Software License (December 2007). Oracle America, Inc., 500 Oracle Parkway, Redwood City, CA 94065.

This software or hardware is developed for general use in a variety of information management applications. It is not developed or intended for use in any inherently dangerous applications, including applications that may create a risk of personal injury. If you use this software or hardware in dangerous applications, then you shall be responsible to take all appropriate fail-safe, backup, redundancy, and other measures to ensure its safe use. Oracle Corporation and its affiliates disclaim any liability for any damages caused by use of this software or hardware in dangerous applications.

This software or hardware and documentation may provide access to or information on content, products, and services from third parties. Oracle Corporation and its affiliates are not responsible for and expressly disclaim all warranties of any kind with respect to third-party content, products, and services. Oracle Corporation and its affiliates will not be responsible for any loss, costs, or damages incurred due to your access to or use of third-party content, products, or services.

Contents

Documentation Accessibility	5
Chapter 1. Welcome	7
Introduction	7
What You Will Need	8
How This Guide Is Organized	8
Getting Help	8
Crystal Ball EPM Documentation Set	9
Learning Crystal Ball EPM	9
Chapter 2. Overview	11
About Crystal Ball EPM	11
About Smart View	12
About Strategic Finance	12
Crystal Ball EPM and Accessibility	13
Chapter 3. Using the Crystal Ball Enterprise Performance Management Connector	15
About the Crystal Ball Enterprise Performance Management Connector	15
Compatible Applications	16
Important Guidelines for Use	16
Starting Crystal Ball EPM with Microsoft Excel and Smart View	17
Using the Crystal Ball Enterprise Performance Management Connector	18
Crystal Ball Enterprise Performance Management Connector Example	19
Chapter 4. Using the Crystal Ball Strategic Finance Connector	21
Introduction	21
Running Crystal Ball EPM and the Strategic Finance Setup Wizard	21
Starting Crystal Ball EPM	22
Running the Strategic Finance Setup Wizard	22
Strategic Finance Integration Example	23
Chapter 5. Using Crystal Ball EPM Models in Smart View	29
About Using Crystal Ball EPM Models in Smart View	29

Managing Crystal Ball Files in the Central Repository	30
Accessing Data From Other EPM Applications Within Smart View	30
Smart View Data Linking Example	31
Index	35

Documentation Accessibility

For information about Oracle's commitment to accessibility, visit the Oracle Accessibility Program website at <http://www.oracle.com/pls/topic/lookup?ctx=acc&id=docacc>.

Access to Oracle Support

Oracle customers have access to electronic support through My Oracle Support. For information, visit <http://www.oracle.com/pls/topic/lookup?ctx=acc&id=info> or visit <http://www.oracle.com/pls/topic/lookup?ctx=acc&id=trs> if you are hearing impaired.



Welcome

In This Chapter

Introduction.....	7
What You Will Need.....	8
How This Guide Is Organized.....	8
Getting Help.....	8
Crystal Ball EPM Documentation Set.....	9
Learning Crystal Ball EPM.....	9

Introduction

Oracle Crystal Ball Enterprise Performance Management (Crystal Ball EPM) is a graphically-oriented forecasting and risk analysis application that helps reduce the uncertainty of decision-making. Unlike other versions of Oracle Crystal Ball, Crystal Ball EPM includes integration with the following Oracle Enterprise Performance Management System applications:

- Oracle Essbase and Oracle Hyperion Planning, using the Crystal Ball Enterprise Performance Management Connector and Oracle Hyperion Smart View for Office.
- Oracle Hyperion Strategic Finance, using the Crystal Ball Strategic Finance Connector.

You can use these connectors to run simulations on application data using the applications' own business rules or other logic.

You can also use Crystal Ball EPM within Smart View to build models based on any data that can be entered into Smart View directly or loaded from applications that are compatible with Smart View.

Through a technique known as Monte Carlo simulation, Crystal Ball EPM forecasts the entire range of results possible for a given situation. It also shows you confidence levels, so you will know the likelihood of any specific event taking place.

Crystal Ball EPM is easy to learn and use. Unlike other forecasting and risk analysis programs, you do not have to learn unfamiliar formats or special modeling languages. You do not need highly advanced statistical or computer knowledge to use Crystal Ball EPM to its full potential. All you need is a basic working knowledge of your personal computer and Crystal Ball EPM, and familiarity with either Strategic Finance or Smart View and one of these compatible products: Essbase or Planning. In fact, if you use the procedures described in [Chapter 5, “Using Crystal Ball EPM Models in Smart View,”](#) you can work with virtually any EPM System product that can have data loaded into a Smart View worksheet.

This Integration Guide explains how to use Crystal Ball EPM with other EPM System products. For basic information about adding Crystal Ball assumptions, decision variables, and forecasts to projects and worksheets, see the *Oracle Crystal Ball User's Guide*.

What You Will Need

Crystal Ball EPM runs on several versions of Microsoft Windows and Microsoft Excel. For a complete list of required hardware and software, see the *Oracle Crystal Ball Installation and Licensing Guide*.

How This Guide Is Organized

This Guide includes the following additional chapters:

- [Chapter 2, “Overview”](#)—Describes Crystal Ball EPM and compatible Oracle applications.
- [Chapter 3, “Using the Crystal Ball Enterprise Performance Management Connector”](#)—Describes how to define Crystal Ball assumptions, decision variables, and forecasts in Essbase or Planning ad-hoc queries and forms in Smart View, and then run simulations directly on underlying data.
- [Chapter 4, “Using the Crystal Ball Strategic Finance Connector”](#)—Describes how Crystal Ball EPM works with Strategic Finance to allow Monte Carlo analysis of selected accounts from a given Strategic Finance entity.
- [Chapter 5, “Using Crystal Ball EPM Models in Smart View”](#)—Describes how Crystal Ball EPM works within the Smart View spreadsheet interface to share data between compatible applications and Crystal Ball EPM.

For information about how to use all the Oracle Crystal Ball features, see the *Oracle Crystal Ball User's Guide* and online help.

Getting Help

As you work in Crystal Ball EPM, you can display online help in a variety of ways:

- Click **Help** in a dialog or wizard panel.
- Click  in the Crystal Ball EPM toolbar in Microsoft Excel.
- In the Microsoft Excel menu bar, select **Help**, then **Crystal Ball**, and then **Crystal Ball Help**.
- In the **Distribution Gallery** and other dialogs, press **F1**.

In Microsoft Excel 2007 or later, click **Help** at the end of the Crystal Ball EPM ribbon. If you press **F1** in Microsoft Excel 2007 or later, Microsoft Excel help opens unless you are viewing the Distribution Gallery or another Crystal Ball EPM dialog.

- To view a table of contents for Crystal Ball EPM help, click **Contents** at the top of the help window.

Crystal Ball EPM Documentation Set

The extensive Crystal Ball documentation set is installed in HTML format with Crystal Ball EPM.

- To view a list of available documentation, select **Start**, then **All Programs**, then **Oracle Crystal Ball**, and then **Documentation**. In Microsoft Excel 2007 or later, you can also select **Resources**, then **Crystal Ball Documentation** in the **Help** group on the Crystal Ball ribbon. In Crystal Ball running on Microsoft Excel 2003, select **Help**, then **Crystal Ball**, and then **Crystal Ball Documentation**.

Documentation is installed in the Docs folder below the main Crystal Ball EPM installation folder (by default, C:\Program Files\Oracle\Crystal Ball).

Crystal Ball EPM documentation in PDF format is available at:

<http://www.oracle.com/technology/documentation/epm.html>

Learning Crystal Ball EPM

Oracle offers a variety of resources to help you learn and use Crystal Ball products. For information about Crystal Ball EPM technical support, training, and other services, see:

<http://www.oracle.com/crystalball>

2

Overview

In This Chapter

About Crystal Ball EPM	11
About Smart View	12
About Strategic Finance	12
Crystal Ball EPM and Accessibility	13

About Crystal Ball EPM

EPM applications, such as Planning, have two inherent limitations when it comes to analysis:

- You can only change a small view or slice of the data at one time. As a result, exploring all of the possible scenarios and outcomes is next to impossible; you cannot realistically determine the amount of risk that is affecting your business or organization.
- “What-if” analysis, such as exploring the best or worst case scenarios, always results in a single view of the business and does not include the likelihood of achieving any particular outcome. While single views may tell you what is *possible*, they do not tell you what is *probable*.

Crystal Ball EPM overcomes these limitations:

- You can describe ranges of possible values for the uncertain factors and drivers in your application. Everything you know about each factor or driver is expressed at once. For example, you can define a key “Cost of Goods Sold” ratio as being any value between 70% and 80%, instead of using a single-point estimate of 75%. Crystal Ball EPM then uses this information as input to a simulation.
- Using a process called Monte Carlo simulation, Crystal Ball EPM generates hundreds, if not thousands, of realistic scenarios for your business. It then forecasts the entire range of possible outcomes and the likelihood of achieving each of them. With this information, you can answer questions like “What are the chances of exceeding our expense target?” or “How likely are we to achieve this level of profitability?”. You’ll no longer have to make decisions like this without realistic data to back them up.

To summarize, Crystal Ball EPM is an analytical tool that helps planners, analysts, forecasters, and others make intelligent decisions by performing simulations on EPM applications. The forecasts that result from these simulations help quantify areas of risk so decision-makers can have as much information as possible to support their decisions.

The basic process for using Crystal Ball EPM is to:

1. Open a view of data to analyze.
2. Define cells of the data view as Crystal Ball data cells (assumptions, forecasts, or decision variables)
3. Run a simulation on it.
4. Analyze the results.

While Monte Carlo simulation is easy to understand and straightforward, you should become familiar with the basic concepts and features of Crystal Ball EPM before using it with EPM applications. The best way to quickly familiarize yourself with Crystal Ball EPM is to read the introductory material and work through the tutorials in the *Oracle Crystal Ball User's Guide*.

Note: Crystal Ball EPM and related products are the only Crystal Ball products that support integration with the EPM System components described here.

Users with an application-specific license may not be able to run Crystal Ball example models and the tutorials in Crystal Ball documentation.

About Smart View

Smart View is a Microsoft Office add-in that uses a Microsoft Excel spreadsheet interface to access data in a variety of Oracle Enterprise Performance Management System products.

You can load Essbase ad-hoc queries or Planning forms into Smart View, and then use Crystal Ball EPM to define assumptions, decision variables, and forecasts and run Crystal Ball simulations directly on the underlying data. This technique uses the Crystal Ball Enterprise Performance management connector, described in [Chapter 3, “Using the Crystal Ball Enterprise Performance Management Connector.”](#)

You can also use the Smart View Connection Manager (the Data Source Manager) to store Crystal Ball EPM models within a central repository. Then, you can load them into Smart View, access data from other compatible applications within the repository, and—using cell references populate the Crystal Ball models with current EPM data for further analysis. This technique is described in [Chapter 5, “Using Crystal Ball EPM Models in Smart View.”](#)

About Strategic Finance

Strategic Finance integrates and consolidates financial forecast models among several stakeholder groups within an organization. Strategic Finance reduces time and planning costs while assuring accurate analytics. It is ideal for merger and acquisition analysis, strategic planning, equity analysis, deal underwriting, and portfolio analysis.

If you have Strategic Finance, you can use the Strategic Finance Setup wizard included in Crystal Ball EPM to create a worksheet containing accounts selected from a particular Strategic Finance entity and scenario. Then, you can define the worksheet as a Crystal Ball model and run Monte

Carlo simulations to determine the probability of achieving particular outcomes. For more information, see [Chapter 4, “Using the Crystal Ball Strategic Finance Connector”](#).

Crystal Ball EPM and Accessibility

Crystal Ball EPM has been carefully designed for accessibility by people with a variety of physical impairments. For details, see the *Oracle Crystal Ball User's Guide*.

3

Using the Crystal Ball Enterprise Performance Management Connector

In This Chapter

- About the Crystal Ball Enterprise Performance Management Connector15
- Starting Crystal Ball EPM with Microsoft Excel and Smart View17
- Using the Crystal Ball Enterprise Performance Management Connector.....18
- Crystal Ball Enterprise Performance Management Connector Example.....19

About the Crystal Ball Enterprise Performance Management Connector

The Crystal Ball Enterprise Performance Management Connector is a feature included in Crystal Ball EPM, starting with version 11.1.1.3.00. If you have installed and licensed Crystal Ball EPM version 11.1.1.3.00 or later and have a compatible version of Smart View, you can use the Crystal Ball Enterprise Performance Management Connector with Smart View to define Crystal Ball data cells directly in worksheets of a compatible application. Then, you can use Crystal Ball EPM to run a simulation against the application using a selected calculation script or default set of business rules. Figure 1 shows how Crystal Ball EPM shares data with an EPM application such as Essbase or Planning using the Crystal Ball Enterprise Performance Management Connector and Smart View.

Figure 1 Interactions Among Crystal Ball EPM (CB), Smart View, and a Compatible EPM Application

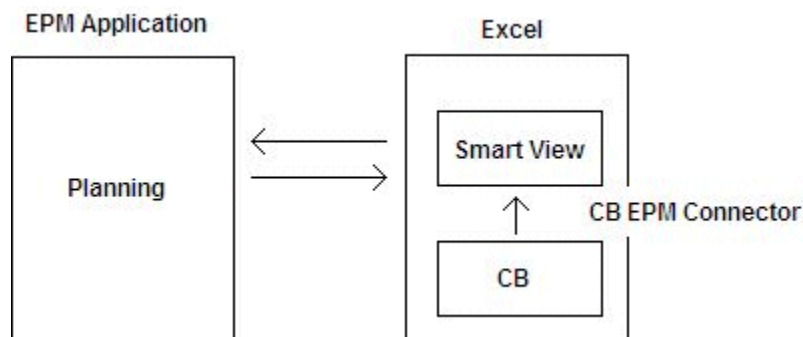

Related sections:

- “Compatible Applications” on page 16
- “Important Guidelines for Use” on page 16

- [“Starting Crystal Ball EPM with Microsoft Excel and Smart View” on page 17](#)
- [“Using the Crystal Ball Enterprise Performance Management Connector” on page 18](#)
- [“Crystal Ball Enterprise Performance Management Connector Example” on page 19](#)

Compatible Applications

The procedures described in this chapter are designed to work in the following combinations of Crystal Ball EPM and Smart View. See the *Oracle Crystal Ball Installation and Licensing Guide* and appropriate Smart View documentation for additional information about compatible software and hardware platform requirements.

- Crystal Ball EPM version 11.1.1.3.00 running against Smart View version 11.1.1.3.00
- Crystal Ball EPM version 11.1.2.x running against Smart View version 11.1.1.3.00
- Crystal Ball EPM version 11.1.2.x running against Smart View version 11.1.2.x

Note: 64-bit versions of Crystal Ball EPM are not compatible with 32-bit versions of Smart View and related EPM products such as Essbase, Planning, and Strategic Finance.

The current version of Crystal Ball Enterprise Performance Management Connector is supported for Essbase ad-hoc queries and Planning forms running in Smart View.

Important Guidelines for Use

Caution! The Crystal Ball Enterprise Performance Management Connector submits data from Smart View directly to the underlying EPM application's database. The data is submitted from Smart View during each Crystal Ball EPM trial and is then restored at the end of the simulation. Working with a copy of your production data is highly recommended. Avoid running a simulation on data when other users could be modifying it.

The following guidelines are important to follow as you work with the Crystal Ball Enterprise Performance Management Connector:

- The Crystal Ball Enterprise Performance Management Connector works on only one workbook at a time.
- The connector supports Crystal Ball EPM forecasting with Predictor. However, tools under the More Tools menu command or ribbon group, such as Data Analysis and Batch Fit, are not currently supported.
- For best results, work in a scenario that contains an updated copy of the database. What If scenarios are frequently created for this purpose. Avoid working directly with production data.

- Always refresh the data source before all add, delete, and get commands in the Smart View Data Source Manager.
- Before attempting to add Crystal Ball data to a query or form, be sure you understand the view and what you are updating. You can test this manually. Change data and submit it manually. If you want to include a calculation script in the model, you can run it manually as well. When updates occur as expected, you can define Crystal Ball assumptions and forecasts in place of the manual updates.
- Be sure you fully understand the functionality of any calculation scripts and are aware of how they may affect the ability to simulate editable values in the data view.
- You can pivot views and add to them. However, it is best to make changes before you add Crystal Ball data. If you change views with existing Crystal Ball data, select **Define**, and then **Select** to synchronize the Crystal Ball cell colors. Data synchronization occurs when you run a simulation.
- If two simulations run simultaneously against the same database, unexpected results can occur. Likewise, it is not acceptable to run one simulation using different EPM applications, for example Smart View and Strategic Finance.
- If the view has duplicate members defined as assumptions—for example, you show data for January through March twice—only the values from the last occurrence will be submitted. Avoid defining duplicate data as Crystal Ball data cells.
- Crystal Ball Enterprise Performance Management Connector supports the following Crystal Ball EPM commands: **Define Assumption**, **Define Decision Variable**, **Define Forecast**, **Simulation Start/Continue/Single Step**, and—in OptQuest—**Start/Continue**. You can also perform a **Reset**.
- If you copy a Smart View sheet within the same workbook, Smart View objects, including Crystal Ball data cells (assumptions, decision variables, and forecasts) are no longer connected to their data sources. The worksheet must be manually reconnected.
- If you have a license for Oracle Crystal Ball Decision Optimizer as well as Crystal Ball EPM, simulations in Smart View run at Normal speed, although Extreme speed is the default with your license. This is also true if you are using Crystal Ball EPM and Decision Optimizer with Strategic Finance, as described in [Chapter 4, “Using the Crystal Ball Strategic Finance Connector.”](#)

Starting Crystal Ball EPM with Microsoft Excel and Smart View

Note: These instructions assume that you are using a compatible version of Smart View and that Smart View is set to load automatically and is enabled as a Microsoft Excel add-in when you start Microsoft Excel (the default configuration).

Begin by installing Crystal Ball EPM using the instructions in the current *Oracle Crystal Ball Installation and Licensing Guide*.

Then, to start Crystal Ball EPM with Microsoft Excel and Smart View, select **Start**, then **All Programs**, then **Oracle Crystal Ball**, and then **Crystal Ball**.

By default, in Microsoft Excel 2007 or later, Smart View and Crystal Ball are displayed as tab labels above the Microsoft Excel ribbon.

Note: If you are using Microsoft Excel 2003, it opens with a Smart View menu and three Crystal Ball EPM menus: Define, Run, and Analyze. The Crystal Ball EPM toolbar also opens.

If Microsoft Excel is already running, a new instance opens when you start Crystal Ball.

- To start Crystal Ball automatically each time you start Microsoft Excel:
 - 1 Select **Start**, then **All Programs**, then **Oracle Crystal Ball**, and then **Application Manager**.
 - 2 Select **When starting Microsoft Excel, automatically launch Crystal Ball** and click **OK**.

Using the Crystal Ball Enterprise Performance Management Connector

- To use the Crystal Ball Enterprise Performance Management Connector:
 - 1 Start Crystal Ball EPM following the instructions in [“Starting Crystal Ball EPM with Microsoft Excel and Smart View” on page 17](#).
 - 2 In Microsoft Excel 2007 or later, select **More Tools**, then **Integration Tools**, and then **Enterprise Performance Management** from the **Tools** group in the **Crystal Ball** ribbon. In Microsoft Excel 2003, select **Run**, then **More Tools**, then **Integration Tools**, and then **Enterprise Performance Management**.
 - 3 In the **Enterprise Performance Management – Preferences** dialog, click **Options**.
 - 4 Select **Enable Smart View integration** and **Preserve Crystal Ball highlighting**.
 - 5 **Optional:** Click **Calculations** and select a calculation script.
 - 6 Within Smart View, select **Hyperion**, and then **Options**.
 - 7 From the **Display** tab, select **UI Colors**, **Use Microsoft Excel Formatting**, and **Retain Numeric Formatting**, and then click **OK**.
 - 8 Within Smart View, connect to a data source and open an Essbase ad-hoc analysis query or a Planning form as usual (as described in the documentation for Smart View and Essbase or Planning).
 - 9 Arrange the view to suit your analysis, and then use the Crystal Ball toolbar and menus to create Crystal Ball assumptions, forecasts, and decision variables if required. See the *Oracle Crystal Ball User's Guide*.
 - 10 Use the Crystal Ball toolbar and menus to run a simulation or time-series forecast.
 - 11 View the resulting charts and tables to analyze the results as described in the *Oracle Crystal Ball User's Guide* and related documentation for OptQuest and Predictor.

For an example, see “Crystal Ball Enterprise Performance Management Connector Example” on page 19.

For related sections, see “About the Crystal Ball Enterprise Performance Management Connector” on page 15.

Crystal Ball Enterprise Performance Management Connector Example

Figure 2 shows a Smart View worksheet with monthly sales figures for four sales regions. The figures are loaded from Essbase. Crystal Ball assumptions have been defined for the monthly figures. Crystal Ball forecasts have been defined for the quarterly and yearly totals. This worksheet includes no formulas. Totals come from Essbase business rules.

Figure 2 Smart View Worksheet with Essbase Data

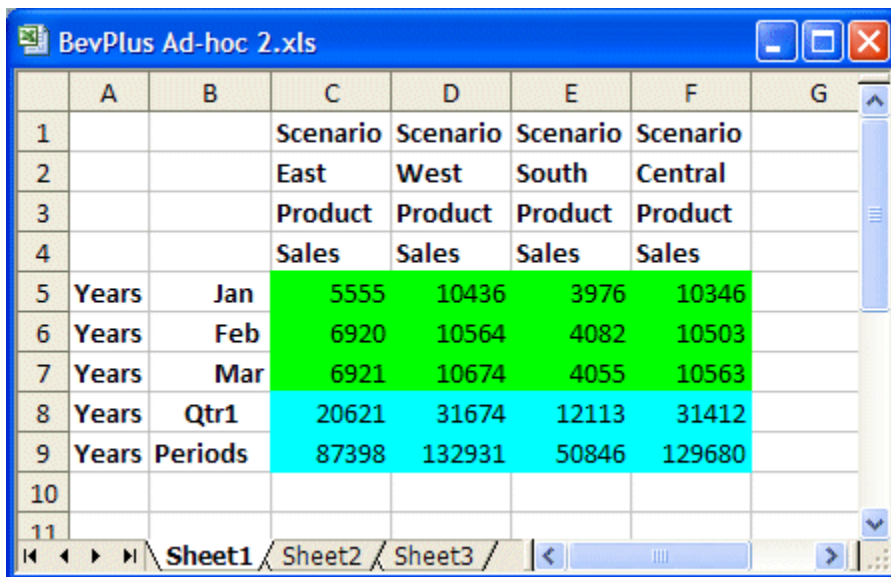

	A	B	C	D	E	F	G
1			Scenario	Scenario	Scenario	Scenario	
2			East	West	South	Central	
3			Product	Product	Product	Product	
4			Sales	Sales	Sales	Sales	
5	Years	Jan	5555	10436	3976	10346	
6	Years	Feb	6920	10564	4082	10503	
7	Years	Mar	6921	10674	4055	10563	
8	Years	Qtr1	20621	31674	12113	31412	
9	Years	Periods	87398	132931	50846	129680	
10							
11							

At the beginning of the simulation, Crystal Ball EPM temporarily stores current data values for all assumption cells. Then, while the simulation is running, Crystal Ball EPM generates values for the assumption cells and submits them to Essbase. The values returned in the forecast cells are saved for analysis and reporting. These can be viewed and analyzed as described in “Smart View Data Linking Example” on page 31.

When the simulation ends, Crystal Ball EPM restores the original values in the worksheet to Essbase. “Smart View Data Linking Example” on page 31.

4

Using the Crystal Ball Strategic Finance Connector

In This Chapter

Introduction.....	21
Running Crystal Ball EPM and the Strategic Finance Setup Wizard.....	21
Strategic Finance Integration Example.....	23

Introduction

This chapter describes how to use Crystal Ball EPM and the Strategic Finance Setup wizard to analyze Strategic Finance data. This functionality is not available with other versions of Crystal Ball.

Figure 3 shows how Crystal Ball EPM shares data with Strategic Finance using the Crystal Ball Strategic Finance Connector.

Figure 3 Interactions Among Crystal Ball EPM (CB) and Strategic Finance using the Crystal Ball Strategic Finance Connector

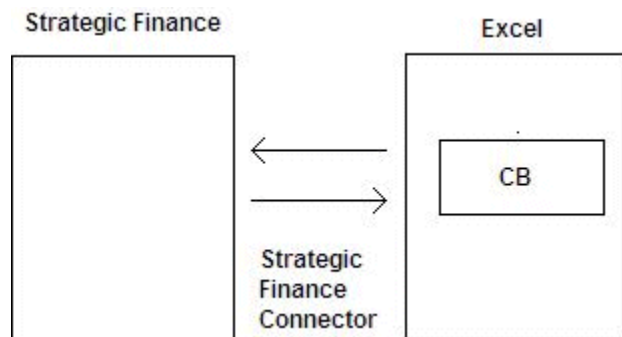

Running Crystal Ball EPM and the Strategic Finance Setup Wizard

Begin by installing Crystal Ball EPM version 11.1.1.1.00 or later using the instructions in the current *Oracle Crystal Ball Installation and Licensing Guide*. Follow the instructions to activate a license that is valid for Crystal Ball EPM. A supported version of Microsoft Excel must also be installed on your computer. You also need a compatible version of Smart View, as described in “Compatible Applications” on page 16, and a version of Strategic Finance that is compatible

with that version of Smart View. For additional compatibility information, see the Smart View and Strategic Finance documentation.

Note: 64-bit versions of Crystal Ball EPM are not compatible with 32-bit versions of Smart View and related EPM products such as Essbase, Planning, and Strategic Finance. For additional compatibility information, see “Compatible Applications” on page 16.

Users with an application-specific license may require an active connection to Strategic Finance to run Crystal Ball models.

Starting Crystal Ball EPM

► To start Crystal Ball EPM, select **Start**, then **All Programs**, then **Oracle Crystal Ball**, and then **Crystal Ball**.

Microsoft Excel 2007 or later contains a single Crystal Ball ribbon that contains all the commands. Microsoft Excel 2003 opens with three Crystal Ball EPM menus: **Define**, **Run**, and **Analyze**. The Crystal Ball EPM toolbar also opens.

Note:

If Microsoft Excel is already running, a new instance opens when you start Crystal Ball EPM.

► To start Crystal Ball EPM automatically each time you start Microsoft Excel:

- 1 Select **Start**, then **All Programs**, then **Oracle Crystal Ball**, and then **Application Manager**.
- 2 Select **When starting Microsoft Excel, automatically launch Crystal Ball**.
- 3 Click **OK**.

Running the Strategic Finance Setup Wizard

► To start and use the Strategic Finance Setup wizard from within Crystal Ball EPM:

- 1 In Microsoft Excel 2007 or later, select **More Tools**, then **Integration Tools**, and then **Strategic Finance** from the **Tools** group in the **Crystal Ball** ribbon. In Microsoft Excel 2003, select **Run**, then **More Tools**, then **Integration Tools**, and then **Strategic Finance**.

The Strategic Finance Setup wizard opens.

- 2 Complete the settings on each panel of the wizard to select an entity, a scenario, time periods, input assumptions, and output forecasts.
- 3 When settings are complete, click **Finish**.

A Strategic Finance worksheet opens with the Crystal Ball toolbar. You can define Crystal Ball assumptions and forecasts, and then run simulations against the data.

Note: The Crystal Ball Strategic Finance Connector supports Crystal Ball EPM forecasting with Predictor. However, tools under the More Tools menu command or ribbon group, such as Data Analysis and Batch Fit, are not currently supported.

As you work, you can click **Help** to display context-sensitive help for each wizard panel. On the **Summary** panel, you can select **Guide me through creating assumptions and forecasts** to display guide-card help that describes the main Crystal Ball EPM procedures. You can click **Help** in any Crystal Ball EPM dialog for more information, or select **Help**, then **Crystal Ball**, and then **Crystal Ball Help**. See the *Oracle Crystal Ball User's Guide* for detailed instructions.

For an example, see “[Strategic Finance Integration Example](#)” on page 23.

Strategic Finance Integration Example

Suppose you have a Strategic Finance entity with revenue and cost accounts projected out for a number of years beyond 2008. You can choose several accounts and years and estimate the probability of earning certain net incomes in a particular year. In this case, you want to analyze Unit Volume, Product Price, and Cost of Goods Sold for the years 2008, 2009, and 2010. You want to determine the probability of obtaining several ranges of net income.

► To perform these estimates:

- 1 Start Crystal Ball EPM and run the Strategic Finance Setup wizard (“[Running the Strategic Finance Setup Wizard](#)” on page 22).

If this is the first time you run the wizard, the **Welcome** panel opens ([Figure 4](#)).

Figure 4 Welcome Panel, Strategic Finance Setup Wizard

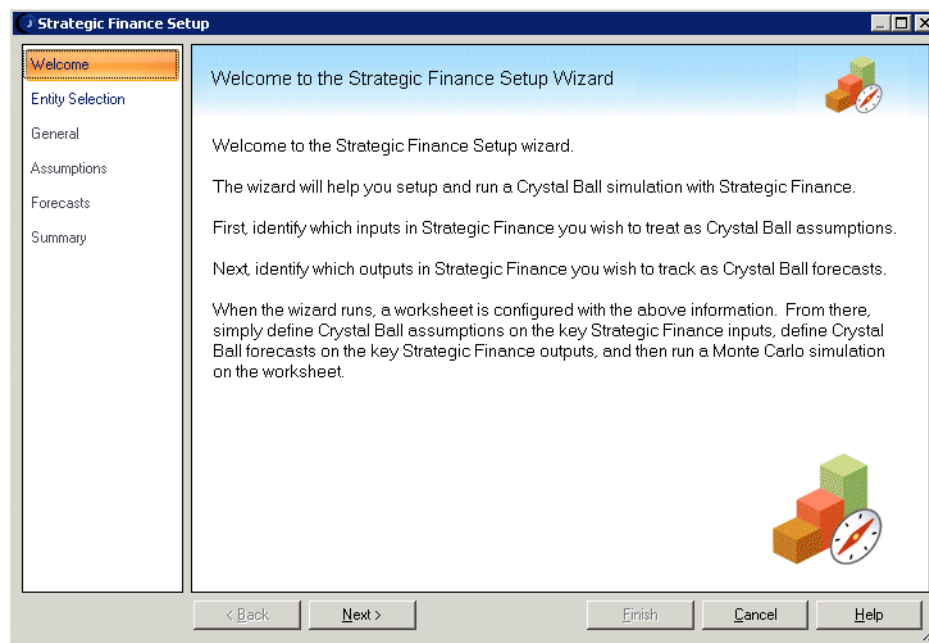

- 2 **Optional:** If the **Welcome** panel opens, click **Next** to display the **Entity Selection** panel, complete its settings, and then click **Next** to move to the next panel.

For this example, you make the following settings:

- On the **Entity Selection** panel, you can select a Strategic Finance entity, either on a local disk or a server. You select `sample.alc` on your computer.
 - On the **General** panel, you select the Base scenario and the years 2008, 2009, and 2010.
 - On the **Assumptions** panel, you can select input assumptions, variables you can't control. You select two accounts related to revenue, Unit Volume and Product Price, and one cost account, Cost of Goods Sold.
 - On the **Forecasts** panel, you select Net Income as the output forecast to investigate.
- 3 Click **Finish** to produce the Strategic Finance Worksheet (**Figure 5**). It shows the selected entity, scenario, and accounts.

Figure 5 Strategic Finance Worksheet

Strategic Finance Worksheet			
(For best results, do not modify the structure of this worksheet)			
Description:			
Entity:	C:\Hyperion\StrategicFinance\Client\Sample.alc		
Scenario:	Base		
Units:	Millions of Dollars		
Store folder:	C:\Documents and Settings\Administrator\My Documents		
Assumptions (Strategic Finance inputs)			
	2008	2009	2010
300.00.000: Unit Volume	7	6	5
305.00.000: Product Price	36.6	39.25	40
1040.00.000: Cost of Goods Sold	74	72.5	72
Forecasts (Strategic Finance outputs)			
	2008	2009	2010
1750.00.000: Net Income	254.1163	160.0534	168.1336

- 4 You decide to define all the cells in the Assumptions group as Crystal Ball EPM assumptions using the normal distribution and default mean and standard deviation.

The mean is the original cell value and the standard deviation is a tenth of that value.

Note: Although this example uses the normal distribution, you may want to select another distribution that is more appropriate for your data, or use the triangular distribution since it suits a variety of situations.

- 5 Because you are only interested in Net Income for the year 2010, you select cell E19 and define it as a Crystal Ball EPM forecast.

This works because it is related to at least some of the assumption cells.

The Crystal Ball EPM data cells are now defined. The assumption cells are green and the forecast cell is blue (Figure 6).

Note: If you are unable to distinguish these two colors, you can use the Crystal Ball EPM cell preferences to change the colors or use patterns instead. For details, see the *Oracle Crystal Ball User's Guide*.

Figure 6 Strategic Finance Worksheet with Crystal Ball Data Cells

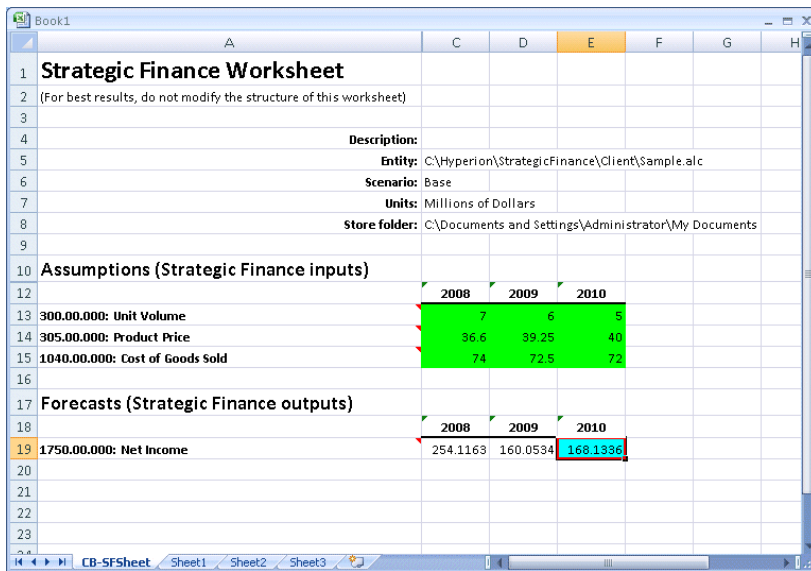

6 Now you can run a simulation against the model.

You run 500 trials. A forecast chart is displayed for 2010 Net Income (Figure 7).

Figure 7 Crystal Ball Forecast Chart for 2010 Net Income

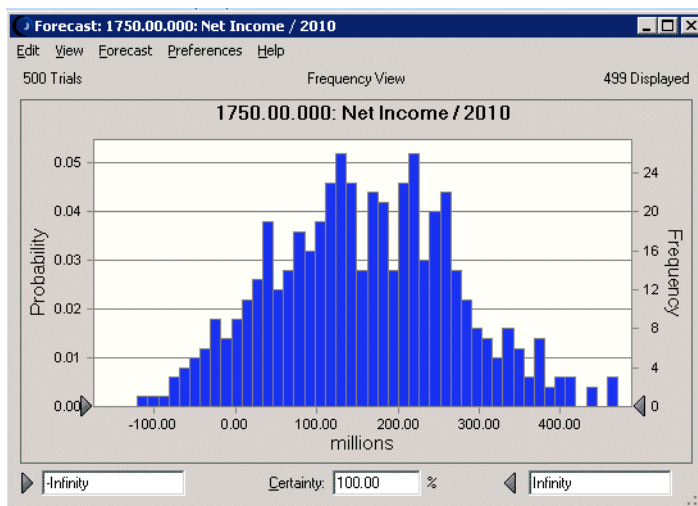

7 You type different values into the forecast chart to explore the probability of different events occurring.

As illustrated in the following steps, when you type values into the certainty minimum, certainty maximum, and the certainty value text boxes, you can determine the probability of achieving a value between the certainty minimum and maximum.

8 You learn the answers to several questions.

The probability of breaking even, achieving Net Income greater than 0, is about 92 percent (Figure 8).

Figure 8 Forecast Chart for 2010 Net Income Greater than \$0

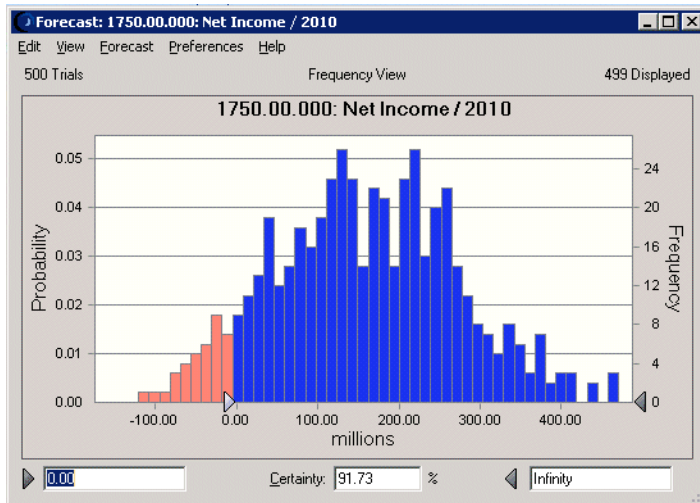

The probability of earning Net Income between about 78 and 237 million dollars is about 50% (Figure 9).

Figure 9 Forecast Chart for the Middle 50% of 2010 Net Income

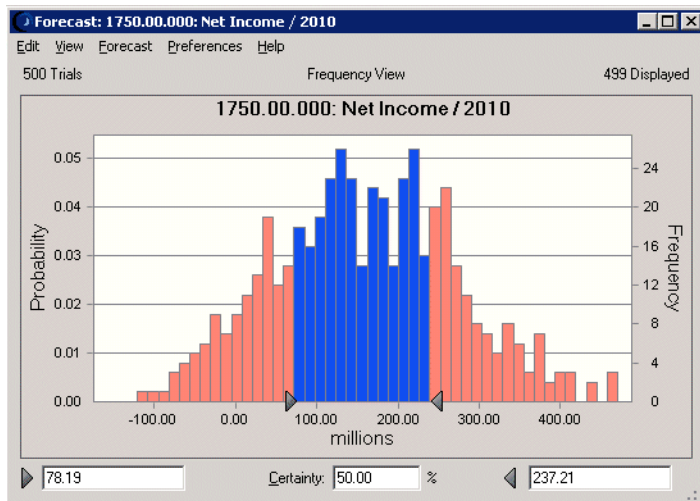

You determine that the probability of earning Net Income greater than 200 million dollars is just under 38% (Figure 10).

Figure 10 Forecast Chart for 2010 Net Income Greater than \$200 Million

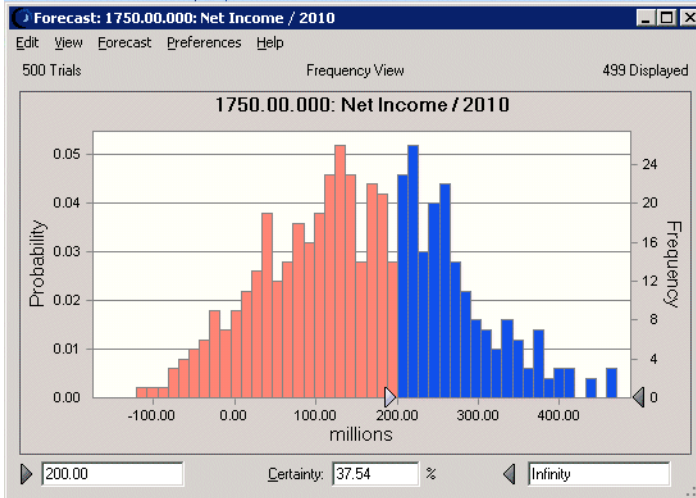

Finally, you generate a sensitivity chart of all defined assumptions against the 2010 Net Income forecast (Figure 11). You see that 2010 Cost of Goods is responsible for over 98% of the variance in 2010 Net Income. You decide to focus efforts on reducing those costs.

Figure 11 Sensitivity Chart for 2010 Net Income

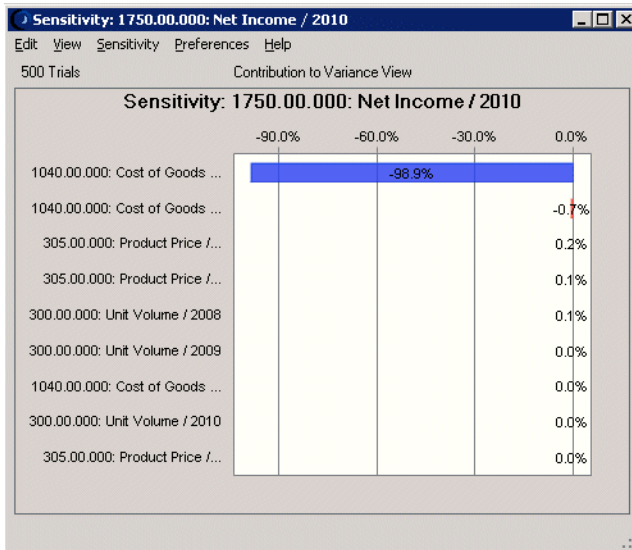

9 You close the Strategic Finance Worksheet and all the charts.

The next time you want to review the worksheet or charts, you can simply open Strategic Finance and select **Analysis**, then **What If Analysis**, and then **Crystal Ball**. You can then select **Models** to open a worksheet and **Results** to open the charts for further analysis of the simulation results. Each time you use the wizard to set up an Crystal Ball model and then run a simulation against that model, the results and the model are stored for future use.

5

Using Crystal Ball EPM Models in Smart View

In This Chapter

About Using Crystal Ball EPM Models in Smart View	29
Managing Crystal Ball Files in the Central Repository	30
Accessing Data From Other EPM Applications Within Smart View	30
Smart View Data Linking Example	31

About Using Crystal Ball EPM Models in Smart View

A Crystal Ball EPM model is built in a spreadsheet and contains not only Crystal Ball data cells but all the underlying formulas that connect the assumptions, forecasts, and optional decision variable cells that drive the model. With Crystal Ball EPM, you can build models within Smart View, and then reference data from other applications that are compatible with Smart View.

Previous chapters in this Integration Guide explain how to use the Crystal Ball EPM connectors to run Crystal Ball simulations on Essbase, Planning, and Oracle Hyperion Strategic Finance data. The procedures and processes described previously differ from those described in this chapter because they rely on logic within the EPM application, while the modeling process described in this chapter is self-contained; all analytical logic resides within Crystal Ball EPM. This chapter describes how to use Crystal Ball EPM with Smart View and other applications that are compatible with it to share data through standard Microsoft Excel processes, and then analyze the data using Crystal Ball EPM methodology. This Smart View-compatible functionality is not available with other versions of Crystal Ball.

You can use Crystal Ball EPM within Smart View to:

- Create and modify Crystal Ball EPM models
- Reference data from Smart View-compatible applications within those models
- Add and delete files within the central repository

Note: Users with an application-specific license may require an active connection to Smart View to run Crystal Ball models.

Getting Started

To begin using Crystal Ball EPM within Smart View, start Crystal Ball EPM following the instructions in [“Starting Crystal Ball EPM with Microsoft Excel and Smart View”](#) on page 17.

Crystal Ball EPM opens an instance of Smart View within Microsoft Excel, if Smart View is installed.

You can create, open, and modify Crystal Ball models within Smart View as described in the *Oracle Crystal Ball User's Guide*. Even if you intend to add them to the central repository, save them locally to your hard drive or a network space.

[“Managing Crystal Ball Files in the Central Repository” on page 30](#) describes how to manage Crystal Ball EPM files in the central repository.

Note: Starting with Crystal Ball EPM Release 11.1.1.3.00, you can run Crystal Ball simulations directly on Essbase or Planning data loaded into Smart View. See [Chapter 3, “Using the Crystal Ball Enterprise Performance Management Connector.”](#)

Managing Crystal Ball Files in the Central Repository

From within Smart View, you can connect to the Crystal Ball folder in the central repository. Once there, you can add, open, and delete Crystal Ball files.

► To use Crystal Ball EPM files within Smart View:

1 Connect to **Simulation & Forecasting Workbooks** following the instructions in the Smart View user documentation.

If necessary, obtain the correct Crystal Ball URL and Folder settings from the Enterprise Performance Management System administrator.

2 When you are properly connected to the Crystal Ball data source, the Crystal Ball data folder opens.

With appropriate rights, you can add and delete files within that folder.

3 To ensure that you are viewing the current contents of the folder, refresh the file list.

After you connect to the Crystal Ball data source, you can follow the instructions in the Oracle Hyperion Reporting and Analysis Framework user documentation to add, open, modify, and delete files created with Crystal Ball EPM within Smart View and Microsoft Excel.

Note: You must save new or modified files locally to your hard drive or a network space before saving them to the repository.

Accessing Data From Other EPM Applications Within Smart View

If you can open an application and view its data within Smart View, you can use that data in a Crystal Ball model.

► To share data with Crystal Ball:

- 1 Follow the instructions in the *Smart View* documentation to connect to a service that is compatible with Smart View (Oracle Business Intelligence Enterprise Edition or Oracle Hyperion Financial Management, for example).
- 2 Open or create a file within Smart View. Modify the view as wanted.
- 3 Within Crystal Ball EPM, build a model that references cells within the other application's data view.
- 4 Run the Crystal Ball simulation and analyze it.

When you refresh data in the other application's view, the referenced cells will also update in Oracle Crystal Ball.

Smart View Data Linking Example

Suppose you have estimated sales data from a compatible application, Oracle BI EE, within Oracle Hyperion Smart View for Office on Sheet 1, as shown in [Figure 12](#). You want to know the probability of earning first quarter sales revenue between 36 and 40 million dollars.

Note: In this example, Oracle BI EE and Crystal Ball EPM data are entered on two different sheets of the same workbook. This is not a requirement; they could be in separate workbooks or even on the same worksheet.

Figure 12 Estimated Quarterly Sales Figures

	A	B	C	D	E	F
1						
2		Estimated Quarterly Sales in Millions				
3						
4						
5		Q1	Q2	Q3	Q4	
6	Region 1	12.185	13.542	11.897	14.972	
7	Region 2	15.231	16.928	14.871	18.715	
8	Region 3	11.576	12.865	11.302	14.223	
9						

You can create Crystal Ball data on Sheet 2 with worst-case and best-case estimates for the three regions to estimate sales for Q1 of the following year. These estimates are made with formulas that include cell references to the Oracle BI EE data on Sheet 1. The most likely column is empty for now ([Figure 13](#)).

Figure 13 Worst-case, Best-case, and Most Likely Estimates for Q1

	A	B	C	D	E	F
1						
2			Q1			
3			Worst Case	Most Likely	Best Case	
4		Region 1	9.992		13.647	
5		Region 2	12.490		17.059	
6		Region 3	9.492		12.965	
7						

Now, suppose you create Crystal Ball EPM assumptions in cells D4, D5, and D6. You create these using triangular distributions with cell references to columns C and E of Sheet 2 for the

Minimum and Maximum parameters and a reference to the Q1 estimate in Oracle Business Intelligence Enterprise Edition on Sheet 1 for the Likeliest parameter value (Figure 14).

Figure 14 Crystal Ball Assumption, Defined with Cell References

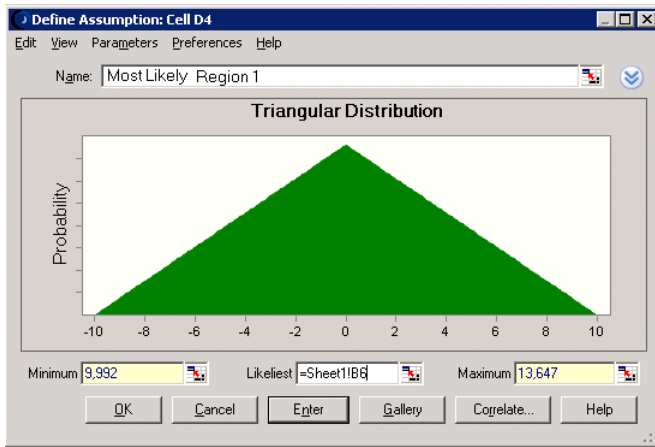

In addition to these assumptions, you create a quarterly forecast in cell D8. Its formula is the sum of cells D4 through D6.

When you run the simulation, all the cell references are used as parameters for the triangular distributions defined in cells D4 through D6. With cell preferences set to show the mean of the distribution for each assumption, Sheet 2 with Oracle Crystal Ball Enterprise Performance Management data opens as shown in Figure 15.

Figure 15 Crystal Ball EPM Model with Simulation Data Means

	A	B	C	D	E	F
1						
2			Q1			
3			Worst Case	Most Likely	Best Case	
4		Region 1	9.992	11.941	13.647	
5		Region 2	12.490	14.927	17.059	
6		Region 3	9.492	11.344	12.965	
7						
8		Most likely quarterly total		38.212		
9						

A forecast chart is generated for the forecast defined in cell D8 (Figure 16). It shows that the certainty, or probability, of sales revenue between 36 and 40 million dollars in the first quarter is 83.15%.

Figure 16 First Quarter Revenue Forecast

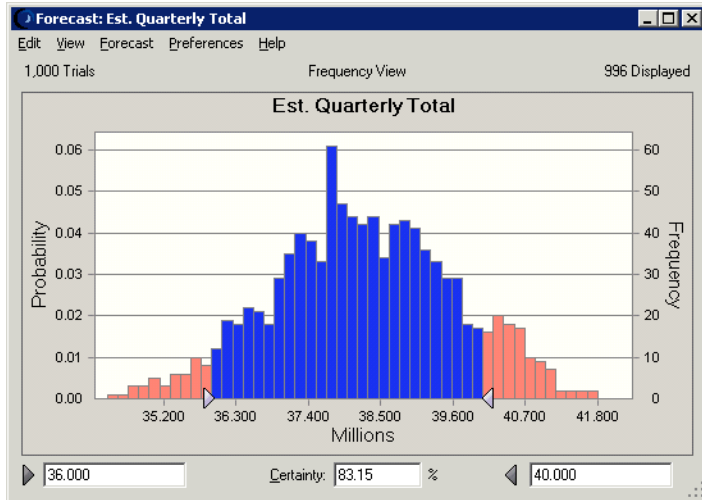

For a more direct way to perform similar forecasts with Oracle Essbase or Oracle Hyperion Planning, see [Chapter 3, “Using the Crystal Ball Enterprise Performance Management Connector.”](#)

Index

A

accessibility features, 13

C

cautions, 16

compatible applications, 16

contents, 8

Crystal Ball

 system requirements, 8

Crystal Ball documentation, 9

Crystal Ball Enterprise Performance Management

 Connector example, 19

Crystal Ball EPM

 introduction, 7

 starting, 17

Crystal Ball, benefits, 11

D

data from other applications, 30

documentation, 9

E

Enterprise Performance Management connector, 15

Enterprise Performance Management connector, 16

example

 Crystal Ball Enterprise Performance Management
 Connector, 19

 Smart View data linking, 31

 Strategic Finance integration, 23

F

files

 managing in Smart View, 30

G

guidelines, 16

H

help, online, 8

I

integration example

 Smart View, 19, 31

 Strategic Finance, 23

introduction

 Smart View, 12

 Strategic Finance, 12

M

managing files, 30

manual contents, 8

O

online help, 8

R

requirements, system, 8

risk analysis, 11

rules, 16

S

sharing data, 30

Smart View

 introduction, 12

 starting Crystal Ball EPM, 17

Smart View integration example, 19, 31

starting Crystal Ball EPM, 17

starting the Strategic Finance Setup wizard, 21

Strategic Finance

introduction, [12](#)

Strategic Finance integration example, [23](#)

Strategic Finance Setup wizard

starting, [21](#)

support, technical, [9](#)

system requirements, [8](#)

T

technical support, [9](#)

W

warnings, [16](#)