

SeeBeyond ICAN Suite

Batch eWay Intelligent Adapter User's Guide

Release 5.0.5



The information contained in this document is subject to change and is updated periodically to reflect changes to the applicable software. Although every effort has been made to ensure the accuracy of this document, SeeBeyond Technology Corporation (SeeBeyond) assumes no responsibility for any errors that may appear herein. The software described in this document is furnished under a License Agreement and may be used or copied only in accordance with the terms of such License Agreement. Printing, copying, or reproducing this document in any fashion is prohibited except in accordance with the License Agreement. The contents of this document are designated as being confidential and proprietary; are considered to be trade secrets of SeeBeyond; and may be used only in accordance with the License Agreement, as protected and enforceable by law. SeeBeyond assumes no responsibility for the use or reliability of its software on platforms that are not supported by SeeBeyond.

SeeBeyond, e*Gate, e*Way, and e*Xchange are the registered trademarks of SeeBeyond Technology Corporation in the United States and/or select foreign countries. The SeeBeyond logo, SeeBeyond Integrated Composite Application Network Suite, eGate, eWay, eInsight, eVision, eXchange, eView, eIndex, eTL, ePortal, eBAM, and e*Insight are trademarks of SeeBeyond Technology Corporation. The absence of a trademark from this list does not constitute a waiver of SeeBeyond Technology Corporation's intellectual property rights concerning that trademark. This document may contain references to other company, brand, and product names. These company, brand, and product names are used herein for identification purposes only and may be the trademarks of their respective owners.

© 2004 by SeeBeyond Technology Corporation. All Rights Reserved. This work is protected as an unpublished work under the copyright laws.

This work is confidential and proprietary information of SeeBeyond and must be maintained in strict confidence.

Version 20040930093036.

Contents

Chapter 1

Introducing the Batch eWay	11
About the Batch eWay Intelligent Adapter	11
Batch eWay OTDs	11
What's in This Document	12
Organization of Information	12
Scope of the Document	12
Intended Audience	12
Writing Conventions	13
SeeBeyond Web Site	13
SeeBeyond Documentation Feedback	13
	13

Chapter 2

Installing the Batch eWay	14
Supported Operating Systems	14
WebLogic and WebSphere Application Server Support	15
System Requirements	15
Installing the Batch eWay	15
Installing the Batch eWay on an eGate Supported System	15
Installing the Batch eWay on an eGate supported system	16
After Installation	16

Chapter 3

Configuring the Batch eWay	17
Creating and Configuring the Batch eWay	17
Selecting Batch as the External Application	18
Creating Custom Properties for a Batch eWay	19
Using the Properties Editor	19
Batch eWay Properties	21
BatchFTP eWay Connectivity Map Properties	21
Pre Transfer	22

Contents

Pre Directory Name	22
Pre Directory Name Is Pattern	23
Pre File Name	23
Pre File Name Is Pattern	23
Pre Transfer Command	24
SOCKS	25
Socks Enabled	25
Socks Version	26
FTP	27
Command Connection Timeout	27
Data Connection Timeout	27
Directory Listing Style	28
Mode	29
Use PASV	29
FTP Raw Commands	30
Post Transfer Raw Commands	30
Pre Transfer Raw Commands	31
Sequence Numbering	32
Max Sequence Number	32
Starting Sequence Number	33
Post Transfer	34
Post Directory Name	34
Post Directory Name Is Pattern	35
Post File Name	35
Post File Name Is Pattern	35
Post Transfer Command	36
Target Location	37
Append	37
Target Directory Name	38
Target Directory Name Is Pattern	38
Target File Name	38
Target File Name Is Pattern	39
SSH Tunneling	40
Additional SSH-supporting Software	40
Port-forwarding Configuration	40
SSH Channel Established	41
SSH Command Line	41
SSH Tunneling Enabled	43
BatchFTP eWay Environment Explorer Properties	44
SOCKS	44
Socks Host Name	45
Socks Password	45
Socks Server Port	45
Socks User Name	45
FTP	46
Host Name	46
Password	47
Server Port	47
User Name	47
SSH Tunneling	48
SSH Listen Host	48
SSH Listen Port	49
SSH Password	49

SSH User Name	49
BatchLocalFile Connectivity Map Properties	51
Pre Transfer	51
Pre Directory Name	52
Pre Directory Name Is Pattern	52
Pre File Name	52
Pre File Name Is Pattern	53
Pre Transfer Command	53
Sequence Numbering	54
Max Sequence Number	54
Starting Sequence Number	54
Post Transfer	55
Post Directory Name	55
Post Directory Name Is Pattern	56
Post File Name	56
Post File Name Is Pattern	57
Post Transfer Command	57
General Settings	58
Resume Reading Enabled	58
Target Location	59
Append	59
Target Directory Name	59
Target Directory Name Is Pattern	60
Target File Name	60
Target File Name Is Pattern	60
BatchRecord Connectivity Map Properties	61
General Settings	61
Parse or Create Mode	61
Record	62
Delimiter on Last Record	62
Record Delimiter	62
Record Size	63
Record Type	63
BatchInbound Connectivity Map Properties	64
Settings	64
Directory Name	64
File Name	65
File Name is Pattern	65
Schedule Interval	65
Using FTP Heuristics	66
FTP Heuristics: eWay Operation	66
Platform or File Type Selection	66
Modifying the FTP Heuristics	67
FTP Heuristics Configuration Parameters	68
Commands Supported by FTP Server	69
Header Lines To Skip	69
Header Indication Regex Expression	69
Trailer Lines To Skip	70
Trailer Indication Regex Expression	70
Directory Indication Regex Expression	70
File Link Real Data Available	71

File Link Indication Regex Expression	71
File Link Symbol Regex Expression	71
List Line Format	72
Valid File Line Minimum Position	72
File Name Is Last Entity	73
File Name Position	73
File Name Length	73
File Extension Position	74
File Extension Length	74
File Size Verifiable	74
File Size Position	75
File Size Length	75
Special Envelope For Absolute Path Name	75
Listing Directory Yields Absolute Path Names	76
Absolute Path Name Delimiter Set	76
Change Directory Before Listing	77
Directory Name Requires Terminator	77
FTP Configuration Requirements for AS400 UNIX	77
Dynamic Configuration	78
Alerting and Logging	80
Logging Categories for the Batch eWay	80

Chapter 4

Understanding Batch eWay OTDs	81
Overview of the Batch OTDs	81
Types of Batch eWay OTDs	82
OTD Components	82
OTD for FTP Operations	82
OTD Structure and Operation	83
Configuration Node	83
Client and Provider Nodes	83
BatchFTP OTD Node Functions	83
Using the BatchFTP OTD	84
Handling Type Conversions	85
Essential BatchFTP OTD Methods	86
Sequence Numbering	86
Additional FTP File Transfer Commands	87
OTD for Local File	87
OTD Structure and Operation	87
Configuration Node	87
Client Node	87
BatchLocalFile OTD Node Functions	88
Using the BatchLocalFile OTD	89
Advantages of Using the OTD	89
Pre/post File Transfer Commands	89
Essential BatchLocalFile OTD Methods	92
Resume Reading Feature	92
Data Stream-adapter Provider	94

Sequence Numbering	94
Handling Type Conversions	95
Recommended Practice	95
Example 1: Parsing a Large File	95
Example 2: Slow, Complex Query	95
OTD Limitations	95
OTD for Batch Record Processing	96
OTD Structure and Operation	96
Record-processing OTD Node Functions	96
Using the Record-processing OTD	97
Using get() and put()	98
Choosing the Parse or Create Mode	98
Creating a Payload	98
Parsing a Payload	99
Parser Interface	99
Use With Data Streaming	100
OTD for Batch Input (Trigger) File	100
OTD Structure and Operation	100
Using Regular Expressions	100
Regular Expressions: Overview	101
Entering Regular Expressions	102
Regular Expressions and the eWay	102
Rules for Directory Regular Expressions	102
Basic Directory Regular Expression Rules	102
Directory Regular Expression Examples	103
Using Special Characters	104
Types of Name Expansion	104
Resolving Names	105
Date/time Format Syntax	105

Chapter 5

Additional Features	108
Streaming Data Between Components	108
Introduction to Data Streaming	108
Overcoming Large-file Limitations	109
Using Data Streaming	109
Data-streaming Operation	109
Data Streaming Versus Payload Data Transfer	110
Data Streaming Setups	110
Consuming-stream Adapters	110
Stream-adapter Interfaces	111
Inbound Transfers	111
Outbound Transfers	111
SOCKS FTP Support	112
SOCKS	112
SOCKS: Overview	112
SOCKS and the Batch eWay	113

SSH Tunneling Support	114
SSH Tunneling: Overview	114
Additional Software Requirements	114
SSH Tunneling and the Batch eWay	115
Ensuring Secure FTP Data Transfers	117

Chapter 6

Using the Batch eWay With eInsight	118
eInsight Engine and eGate Components	118
Batch eWay With eInsight	119
Considerations	119
The Batch eWay eInsight Sample Projects	120
Sample data files	120
Importing a Sample Project	120
The Batch_BP_FTPIIn Sample Project	121
Create a Project	121
Creating the BP_FTPIIn Business Process	121
Configuring the Modeling Elements	123
Create a Connectivity Map	125
Select the External Applications	125
Populate the Connectivity Map	125
Binding the Project Components	126
Creating an Environment	127
Configuring the eWay Properties	128
Configuring the File eWay Properties	129
Configuring the BatchFTP eWay Properties	129
Creating and Activating the Deployment Profile	130
Running the Project	131
The Batch_BP_LFIIn Sample Project	132
Create a Project	132
Creating the BP_LFIIn Business Process	132
Configuring the Modeling Elements	134
Create a Connectivity Map	136
Select the External Applications	136
Populate the Connectivity Map	136
Binding the Project Components	137
Configuring the eWay Properties	137
Configuring the File eWay Properties	138
Configuring the BatchLocalFile eWay Properties	138
Creating an Environment	138
Creating and Activating the Deployment Profile	139
Running the Project	139
The Batch_BP_LFOOut Sample Project	140
Create a Project	140
Creating the BP_LFOOut Business Process	140
Configuring the Modeling Elements	142

Create a Connectivity Map	144
Select the External Applications	144
Populate the Connectivity Map	144
Binding the Project Components	145
Configuring the eWays	145
Configuring the File eWays	145
Configuring the BatchLocalFile eWay	146
Creating an Environment	146
Creating and Activating the Deployment Profile	146
Running the Project	147

Chapter 7

Implementing a Batch eWay Project 148

Batch eWay Components	148
Considerations	149
Importing a Sample Project	149
The Batch eWay Sample Projects	149
Sample data files	150
The Batch_FTPIIn_LFOOut_Sample Project	150
Create a Project	150
Creating a Connectivity Map	151
Selecting the External Applications	151
Populating the Connectivity Map	152
Creating Collaboration Definitions	152
Create the jcd_FTPIInLFOOut Collaboration	153
Using the Collaboration Editor (Java)	154
Create the jcd_FTPIInLFOOut Collaboration Business Rules	154
Creating Collaboration Bindings	158
Creating an Environment	159
Configuring the eWays Properties	160
Configuring the File eWay Properties	161
Configuring the BatchLocalFile eWay Properties	161
Configuring the BatchFTP eWay Properties	162
Creating and Activating the Deployment Profile	163
Running the Project	163
The Batch_RecParseStream_Sample Project	165
Create a Project	165
Create a Connectivity Map	165
Select the External Applications	165
Populate the Connectivity Map	166
Creating a Collaboration Definition	166
Using the Collaboration Editor (Java)	167
Binding the Project Components	171
Creating an Environment	172
Configuring the eWay Properties	173
Configuring the File eWay Properties	173
Configuring the BatchLocalFile eWay Properties	173
Creating and Activating the Deployment Profile	173

Running the Project	174
The BatchInbound_Sample Project	175
Create a Project	175
Create a Connectivity Map	175
Select the External Applications	175
Populate the Connectivity Map	176
Creating a Collaboration Definition	176
Using the Collaboration Editor (Java)	177
Binding the Project Components	180
Creating an Environment	181
Configuring the eWay Properties	182
Configuring the File eWay Properties	182
Configuring the BatchLocalFile eWay Properties	182
Creating and Activating the Deployment Profile	182
Running the Project	183

Chapter 8

Using eWay Java Classes and Methods **184**

Batch eWay Classes and Methods: Overview	184
Batch eWay Java Classes	184
Batch eWay Javadoc	185

Index **186**

Introducing the Batch eWay

This chapter provides a brief overview of the Batch eWay, and presents an outline of the information provided in this user's guide.

What's in This Chapter

- [About the Batch eWay Intelligent Adapter](#) on page 11
- [What's in This Document](#) on page 12
- [SeeBeyond Web Site](#) on page 13

1.1 About the Batch eWay Intelligent Adapter

All eWays provide a communication bridge between the eGate environment and one or more external systems.

The Batch eWay Intelligent Adapter, referred to as the Batch eWay throughout this document, performs a variety of FTP and FTP-related operations (depending on your specific needs, network environment, record-processing, file transfer, and external system requirements). The Batch eWay enables eGate to use an FTP connection to exchange data with other network hosts for the purpose of receiving and delivering objects stored in files.

1.1.1 Batch eWay OTDs

The Batch eWay provides Object Type Definitions (OTDs) that enable the creation of file transfer operations using FTP.

The Batch eWay includes four specific OTDs:

- **BatchFTP:** The FTP OTD connects to external FTP servers.
- **BatchLocalFile:** The local file OTD picks up or puts data files to local file systems.
- **BatchRecord:** The record-processing OTD extracts records out of files, parses files into specific records, and defines the content of files as records.
- **BatchInbound:** The inbound OTD receives a file, renames the file with GUID file name, and triggers the Business Process or Collaboration.

Note: The Batch eWay supports standard FTP according to RFC-959.

1.2 What's in This Document

This section provides a brief outline of this user's guide.

1.2.1. Organization of Information

This book includes the following chapters:

- **Chapter 1 "Introducing the Batch eWay"** provides an overview of the Batch eWay Intelligent Adapter.
- **Chapter 2 "Installing the Batch eWay"** provides the supported operating systems and system requirements for the Batch eWay. It also includes directions for installing the eWay and accessing the accompanying documentation and sample projects.
- **Chapter 3 "Configuring the Batch eWay"** describes the process of configuring the Batch eWay to run in your environment.
- **Chapter 4 "Understanding Batch eWay OTDs"** provides an overview of the Object Type Definitions (OTDs) available with the Batch eWay.
- **Chapter 5 "Additional Features"** provides information on the Data Streaming, SSH Tunneling, and SOCKS features of the Batch eWay:
- **Chapter 6 "Using the Batch eWay With eInsight"** describes how to use the Batch eWay with the ICAN Suite's eInsight Business Process Manager and the Web Services interface.
- **Chapter 7 "Implementing a Batch eWay Project"** describes the features and functionality of the Batch eWay using the eGate Integrator and the Collaboration Editor (Java).
- **Chapter 8 "Using eWay Java Classes and Methods"** describes the Batch eWay's Java classes and provides directions for accessing the eWay's Javadoc.

1.2.2. Scope of the Document

This user's guide provides a description of the Batch eWay Intelligent Adapter. It includes directions for installing the eWay, configuring the eWay properties, and implementing the eWay's sample projects. This document is also intended as a reference guide, listing available properties, functions, and considerations. For a reference of available Batch eWay Java methods, see the associated Javadoc.

1.2.3 Intended Audience

This guide is intended for experienced computer users who have the responsibility of helping to set up and maintain a fully functioning ICAN Suite system. This person must also understand any operating systems on which the ICAN Suite will be installed and must be thoroughly familiar with Windows-style GUI operations.

1.2.4 Writing Conventions

The following writing conventions are observed throughout this document.

Table 1 Writing Conventions

Text	Convention	Example
Button, file, icon, parameter, variable, method, menu, and object names.	Bold text	<ul style="list-style-type: none">▪ Click OK to save and close.▪ From the File menu, select Exit.▪ Select the logicalhost.exe file.▪ Enter the timeout value.▪ Use the getClassName() method.▪ Configure the Inbound File eWay.
Command line arguments and code samples	Fixed font. Variables are shown in <i>bold italic</i> .	bootstrap -p <i>password</i>
Hypertext links	Blue text	http://www.seebeyond.com

1.3 SeeBeyond Web Site

The SeeBeyond Web site is your best source for up-to-the-minute product news and technical support information. The site's URL is:

<http://www.seebeyond.com>

SeeBeyond Documentation Feedback

We appreciate your feedback. Please send any comments or suggestions regarding this document to:

docfeedback@seebeyond.com

1.4

Installing the Batch eWay

This chapter contains installation information for the Batch eWay.

What's in This Chapter

- [Supported Operating Systems](#) on page 14
- [System Requirements](#) on page 15
- [Installing the Batch eWay](#) on page 15

2.1 Supported Operating Systems

The Batch eWay is available on the following operating systems:

- Windows 2000, Windows XP, and Windows Server 2003
- HP NonStop Server G06.22
- HP Tru64 V5.1A
- HP-UX 11.0, 11i (PA-RISC), and 11i V2.0 (11.23)
- IBM AIX 5.1L and 5.2
- Red Hat Enterprise Linux AS 2.1 (Intel x86)
- Sun Solaris 8 and 9
- Suse Linux Enterprise Server 8 (Intel x86)
- Japanese Windows 2000, Windows XP, and Windows Server 2003
- Japanese HP-UX 11.0, 11i (PA-RISC), and 11i V2.0 (11.23)
- Japanese IBM AIX 5.1L and 5.2
- Japanese Sun Solaris 8 and 9
- Korean Windows 2000, Windows XP, and Windows Server 2003
- Korean HP-UX 11.0, 11i (PA-RISC), and 11i V2.0 (11.23)
- Korean IBM AIX 5.1L and 5.2
- Korean Sun Solaris 8 and 9

WebLogic and WebSphere Application Server Support

- In addition to the operating systems listed above, this eWay is also supported on WebSphere™ and WebLogic™ application servers. This is limited to outbound mode using Java Collaborations. For additional information see the *eGate Integrator User's Guide*.

2.2 System Requirements

- The system requirements for the Batch eWay are the same as those for the eGate Integrator. For more information, refer to the *SeeBeyond ICAN Suite Installation Guide*. It is also helpful to review the *Readme.txt* for any additional requirements prior to installation. The *Readme.txt* is located on the installation CD-ROM.
- In addition, the `JAVA_HOME` variable must be set to the location of the JDK.
- To enable Web Services, you must install and configure the SeeBeyond ICAN Suite eInsight Business Process Manager.

2.3 Installing the Batch eWay

During the eGate Integrator installation process, the Enterprise Manager, a web-based application, is used to select and upload eWays (eWay.sar files) from the eGate installation CD-ROM to the Repository.

When the Repository is running on a UNIX operating system, eGate and the eWays are installed using the Enterprise Manager from a computer running Windows, connected to the Repository server.

2.3.1 Installing the Batch eWay on an eGate Supported System

The Batch eWay is installed during the installation of the eGate Integrator. The eGate installation process includes the following operations:

- Install the eGate Repository
- Upload products to the Repository
- Download components (such as the SeeBeyond Enterprise Designer and Logical Host)

Follow the instructions for installing the eGate Integrator in the *SeeBeyond ICAN Suite Installation Guide*, and include the following steps:

- 1 During the procedures for uploading files to the eGate Repository using the Enterprise Manager, after uploading the **eGate.sar** file, select and upload the following files:
 - ♦ **BatcheWay.sar** (to install the Batch eWay)

- ♦ **FileeWay.sar** (to install the File eWay, used in the sample project)
 - ♦ **BatcheWayDocs.sar** (to download the Batch eWay User's Guide, Javadoc, and Sample Projects)
- 2 Continue installing the eGate Integrator as instructed in the *SeeBeyond ICAN Suite Installation Guide*

Installing the Batch eWay on an eGate supported system

The ICAN Suite installation process includes the following operations:

- Install the eGate Repository
- Upload products to the Repository
- Download components (including the eGate Enterprise Designer and Logical Host)

Follow the directions for installing the ICAN Suite in the *SeeBeyond ICAN Suite Installation Guide*. After you have installed eGate and any other purchased core products, do the following:

- 1 From the Enterprise Manager's **ADMIN** tab, browse to the **Add-ons** directory and select the **ProductsManifest.xml**, and click **Submit**. The available Add-on product list is now displayed.
- 2 Browse to and select the following files located in the **Add-ons** directory:
 - ♦ **FileeWay.sar** (to install the File eWay, used in the sample project)
 - ♦ **BatcheWay.sar** (to install the Batch eWay)
- 3 Click **upload now** to upload the selected products.
- 4 Click on the Manifest File field's **Browse** option, browse to the Add-ons > **Documentation** directory, select the **ProductsManifest.xml**, and click **Submit**. The available Add-ons documentation list is now displayed.
- 5 Select and upload the following file:
 - ♦ **BatcheWayDocs.sar** (to upload the e-Mail eWay User's Guide, Javadoc, Readme, and sample projects to the Enterprise Manager).
- 6 Click **upload now** to upload the selected product.
- 7 Continue installing the eGate Integrator as instructed in the *SeeBeyond ICAN Suite Installation Guide*.

2.3.2. After Installation

Once the eWay is installed and configured, it must then be incorporated into a project before it can perform its intended functions. See the *eGate Integrator User's Guide* for more information on incorporating the eWay into an eGate project.

Configuring the Batch eWay

This chapter explains how to configure the Batch eWay properties.

What's in This Chapter

- [Creating and Configuring the Batch eWay](#) on page 17
- [Using the Properties Editor](#) on page 19
- [Batch eWay Properties](#) on page 21
- [Using FTP Heuristics](#) on page 66
- [Dynamic Configuration](#) on page 78
- [Alerting and Logging](#) on page 80

3.1 Creating and Configuring the Batch eWay

All eWays contain a set of parameters with properties unique to that eWay type. After the eWays are established and a Batch External System is created in the project's Environment, the eWay parameters can be modified for your specific system. The Batch eWay contains Properties templates for the following applications:

- **BatchFTP** — two properties templates, accessed from the Connectivity Map and Environment Explorer tree.
- **BatchLocalFile**
- **BatchRecord**
- **BatchInbound**

All Batch eWays contain properties that are accessed from the **Connectivity Map**. These properties most commonly apply to a specific eWay, and may vary from other eWays (of the same type) in the project.

The BatchFTP eWay also contains properties that must be accessed and configured from the **Environment Explorer tree**. These parameters are commonly global, applying to all eWays (of this same type) in the project.

The properties for the BatchFTP eWay must be set in both locations. BatchLocalFile and BatchRecord properties are only accessed and modified from the Connectivity Map.

3.1.1 Selecting Batch as the External Application

To create a Batch eWay, you must first create a Batch External Application in your Connectivity Map. Batch eWays are located between a Batch External Application and a Service. Services are containers for Collaborations, Business Processes, eTL processes, and so forth.

To create the Batch External Application

- 1 From the Connectivity Map toolbar, click the **External Applications** icon.
- 2 Select a **Batch External Application** from the menu (see Figure 1). The selected Batch External Application icon appears on the Connectivity Map toolbar.

Figure 1 External Applications Selection Menu

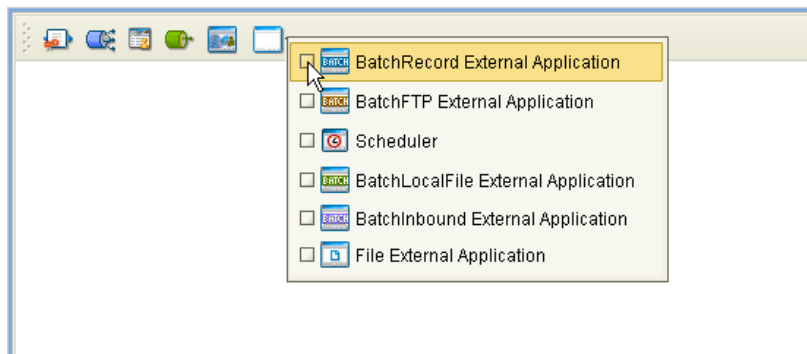

- 3 Drag the new **Batch External Application** from the toolbar onto the Connectivity Map canvas. This represents an external Batch system.

From the Connectivity Map, you can associate (bind) the External Application with the Service to establish an eWay (see Figure 2).

Figure 2 eWay Location.

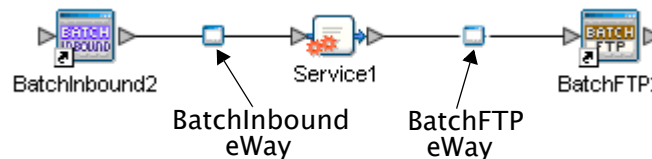

When Batch is selected as the External Application, it automatically applies the default Batch eWay properties, provided by the OTD, to the eWay that connects it to the Service. These properties can then be modified for your specific system, using the **Properties Editor**.

3.1.2 Creating Custom Properties for a Batch eWay

A project's eWay properties can be modified after the eWays are established in the Connectivity Map and the Environment is created.

Modifying the Batch eWay (Connectivity Map) Properties

- 1 From the Connectivity Map, double click the eWay icon, located in the link between the associated External Application and the Service.
- 2 The eWay **Properties Editor** opens to the eWay Batch Connectivity Map parameters. Make any necessary modifications and click **OK** to save the settings.

Modifying the Batch eWay (Environment Explorer) Properties

- 1 From the Environment Explorer tree, right-click the Batch external system. Select **Properties** from the shortcut menu. The **Properties Editor** appears.
- 2 Make any necessary modifications to the Environment parameters of the Batch eWays, and click **OK** to save the settings.

3.1.3. Using the Properties Editor

The Batch eWay properties are modified using the Batch eWay Properties Editor.

To modify the default eWay configuration properties

- 1 Open the Properties Editor for a Batch eWay (see [Creating Custom Properties for a Batch eWay](#) on page 19).
- 2 From the upper-right pane of the Properties Editor, select a subdirectory of the configuration directory. The properties contained in that subdirectory are now displayed in the Properties pane of the Properties Editor. For example, clicking on the **Pre Transfer** subdirectory displays the editable parameters in the right pane, as shown in [Figure 3 on page 20](#).

Figure 3 Batch eWay Properties Editor

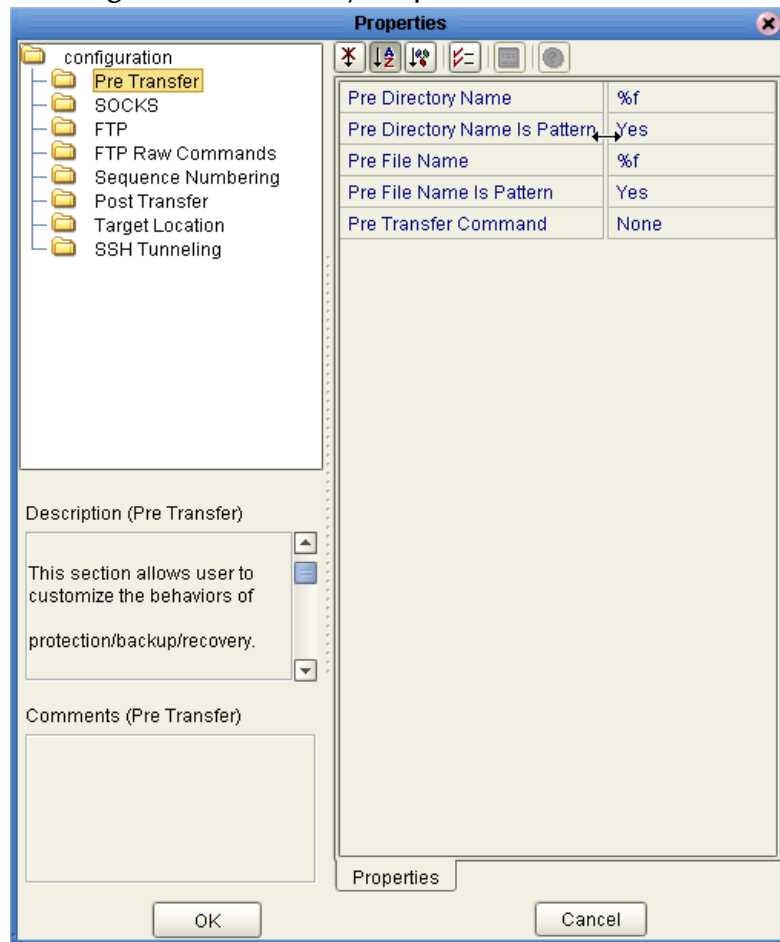

- 3 Click on any property field to make it editable. For example, click on the **class** parameter to edit the class value. If a parameter's value is true/false or multiple choice, the field reveals a submenu of property options.
- 4 Click on the ellipsis (. . .) in the properties field to open a separate configuration dialog box. This is helpful for large values that cannot be fully displayed in the parameter's property field. Enter the property value in the dialog box and click **OK**. The value is now displayed in the parameter's property field.
- 5 A description of each parameter is displayed in the **Description** box when that parameter is selected, providing an explanation of any required settings or options.
- 6 The **Comments** box, located below the Description box, provides an area for recording notes and information regarding the currently selected parameter. This is saved for future referral.
- 7 After modifying the configuration properties, click **OK** to close the Properties Editor and save your current changes.
- 8 After modifying the configuration properties, click **OK** to close the Properties Editor and save the changes.

3.2 Batch eWay Properties

The Batch eWay's Properties are organized as follows:

[BatchFTP eWay Connectivity Map Properties](#) on page 21

[BatchFTP eWay Environment Explorer Properties](#) on page 44

[BatchLocalFile Connectivity Map Properties](#) on page 51

[BatchRecord Connectivity Map Properties](#) on page 61

[BatchInbound Connectivity Map Properties](#) on page 64

Note: *Creating customized individual OTD configuration settings can override default eWay OTD configuration settings.*

3.3 BatchFTP eWay Connectivity Map Properties

This section describes the configuration parameters for the **BatchFTP OTD**, accessed from the Connectivity Map.

The BatchFTP Connectivity Map properties include the following sections:

- [Pre Transfer](#) on page 22
- [SOCKS](#) on page 25
- [FTP](#) on page 27
- [SSH Tunneling](#) on page 40

Caution: *Several of these configuration options allow you to use regular expressions. This advanced feature is useful but must be used carefully. An improperly formed regular expression can cause the creation of undesired data or even the loss of data. You must have a clear understanding of regular-expression syntax and construction before attempting to use this feature. It is recommended that you test such configurations thoroughly before moving them to production.*

3.3.1 Pre Transfer

Pre-transfer operations are those performed before the file transfer. The Pre Transfer section contains the top level parameters displayed in Figure 4.

Figure 4 BatchFTP Properties - Pre-Transfer section

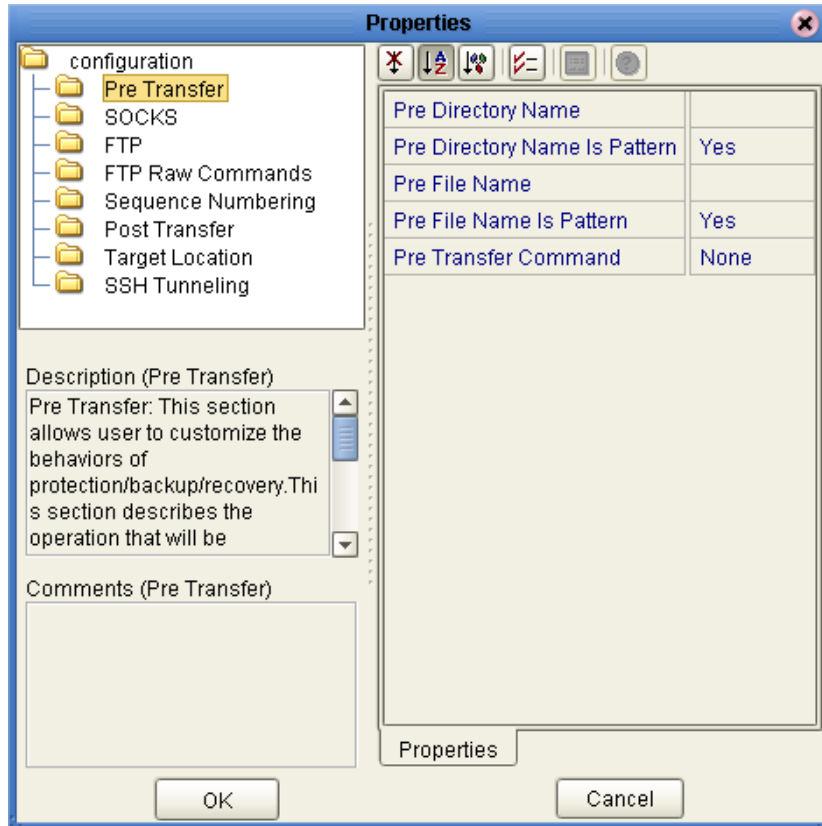

Note: For more information on this feature, see [Pre/post File Transfer Commands](#) on page 89.

Pre Directory Name

Description

Specifies the directory on the external system in which a file is renamed or copied. The absolute directory name is expected.

For an outbound transfer (publishing), the directory is created if it does not already exist. This setting is only for the **Rename** or **Copy** operations of **Pre Transfer Command** parameter.

Special characters are allowed. For example, the pattern %f indicates the original working directory name. The expansion of any special characters is carried out each time this parameter is used. See [Using Special Characters](#) on page 104 for details on using these characters.

Required Values

A valid directory name and path location on the target system; special characters are allowed.

Pre Directory Name Is Pattern

Description

Specifies whether the pattern entered for the directory is interpreted literally (if **No**) or as a name expansion (if **Yes**), as follows:

- If you choose **No**, it is assumed that the name entered represents what you want as an exact match. No pattern matching of any kind is done.
- If you choose **Yes**, the value you enter is assumed to be a pattern for name expansion.

Required Values

Yes or **No**; the default is **Yes**.

Pre File Name

Description

Specifies the file name on the external system, to which a file is renamed or copied. The value represents the base file name instead of the full file name. This setting is only for the **Rename** or **Copy** operations of **Pre Transfer Command** parameter.

Special characters are allowed, for example, the pattern %f means the original working file name. The expansion of any special characters is carried out each time this parameter is used. See [“Using Special Characters” on page 104](#) for details on using these characters.

Required Values

A valid file name on the target system; special characters are allowed.

Pre File Name Is Pattern

Description

Specifies whether the pattern entered for the file name is interpreted literally (if **No**) or as a name expansion (if **Yes**), as follows:

- If you choose **No**, it is assumed that the name entered represents what you want as an exact match. No pattern matching of any kind is done.
- If you choose **Yes**, the value you enter is assumed to be a pattern for name expansion.

Required Values

Yes or **No**; the default is **Yes**.

Pre Transfer Command

Description

Allows you to execute a desired action directly before the actual file transfer. For an inbound transfer, the file can be made unavailable to other clients polling the target system with the same directory and file pattern or name. For an outbound transfer, you can perform an automatic backup or clean-up of the existing files.

The options are:

- **Rename:** Rename the target file for protection or recovery.
- **Copy:** Copy the target file for backup or recovery.
- **None:** Do nothing.

Note: *The **Copy** option could slow system performance, especially if you are copying a large file.*

To gain proper protection, backup, or recovery, you must choose the appropriate setting that serves your purpose. For example, to recover from failures on an outbound appending transfer, use the **Copy** setting.

Caution: *When you are using **Rename**, if the destination file exists, different FTP servers can behave differently. For example, on some UNIX FTP servers, the destination file is overwritten without question. That is, no error or warning message is given. On other FTP servers, a Windows XP server for example, the system generates an error that results in exceptions being thrown in the called OTD method.*

Be sure you are familiar with the native behavior of the corresponding FTP server. If you are in doubt, try the action at the command prompt. If the action displays an error message, it is likely to result in an exceptions being thrown in the Collaboration.

Required Values

Rename, Copy, or None. The default is **None**.

3.3.2 SOCKS

The **SOCKS** section contains the top level parameters displayed in Figure 5.

Figure 5 BatchFTP Properties - SOCKS section

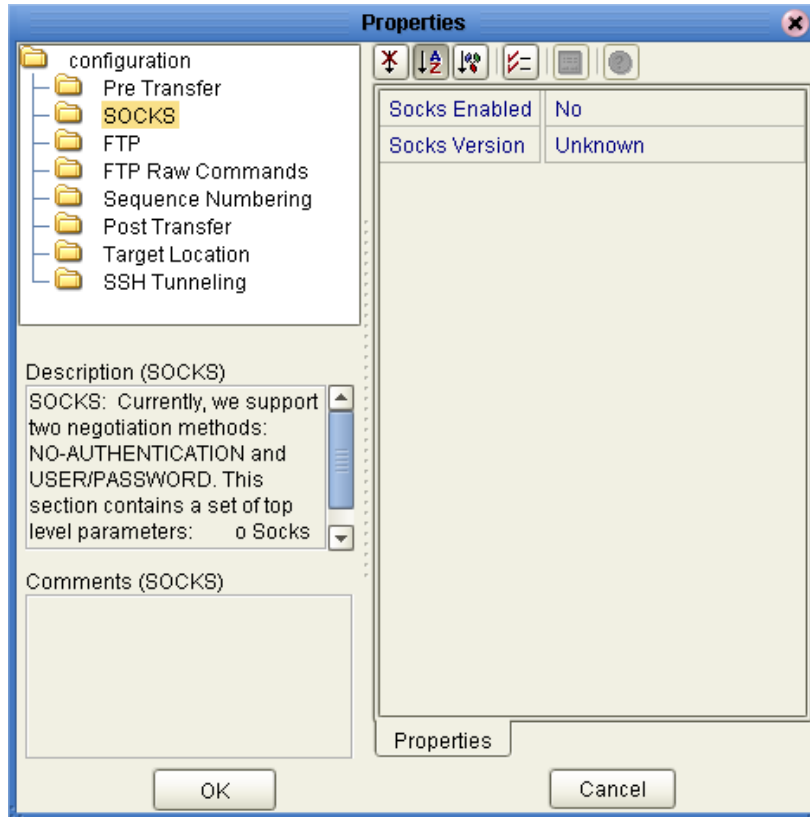

For more information on SOCKS, see [“SOCKS” on page 112](#).

Socks Enabled

Description

Specifies whether the FTP command connection goes through a SOCKS server.

If you choose **No**, the eWay does not connect to a SOCKS server. In this case, all other parameters under the **SOCKS** section are ignored.

Note: *If this parameter is set to **Yes**, the host name under the **FTP** configuration could fail to resolve some names, such as **localhost** or **127.0.0.1** correctly. Use real IP or machine names to represent the hosts. See [“Host Name” on page 46](#) for more details.*

Required Values

Yes or **No**; the default is **No**.

Socks Version

Description

Specifies the SOCKS server version. If you choose **Unknown**, the eWay detects the actual version for you.

***Note:** For the best performance, specify the version number, 4 or 5.*

Required Values

Version 4 or 5, or **Unknown** (the default).

3.3.3 FTP

The FTP section contains the top level parameters displayed in Figure 6.

Figure 6 BatchFTP Properties - FTP section

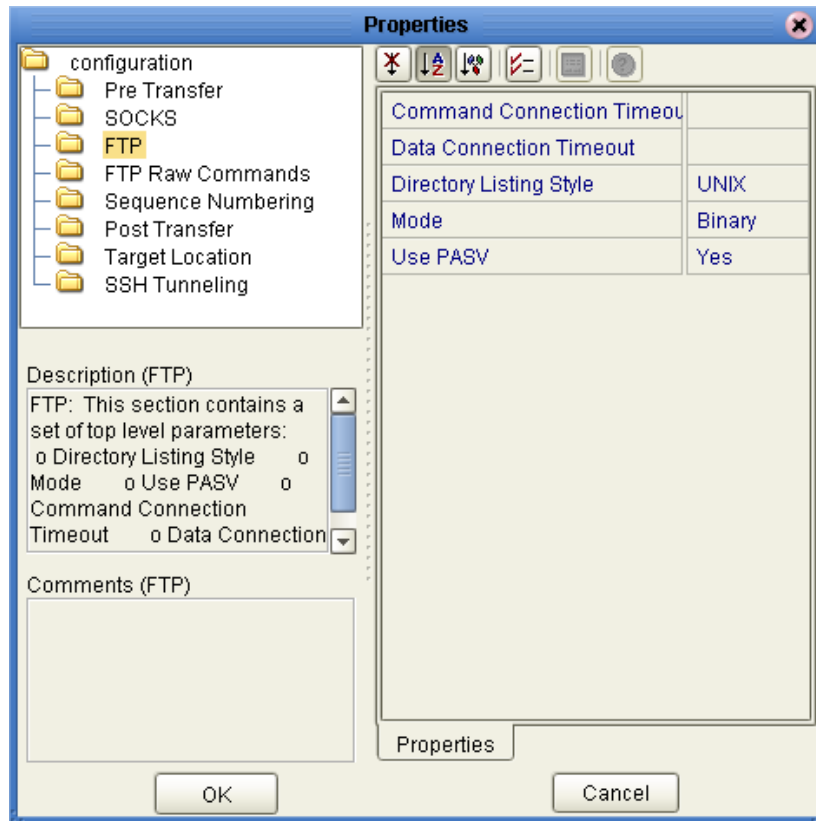

Command Connection Timeout

Description

Allows you to set the timeout of the FTP command/control connection socket. Normally, the larger the file you are transferring, the higher this value must be. Of course, the quality of the network connection also affects this setting.

The value is in milliseconds. A timeout of zero is interpreted as an infinite timeout.

Required Values

An integer from 0 to 2147483647. The default is 0.

Data Connection Timeout

Description

Allows you to set the timeout of the FTP data connection socket. Normally, a slow or busy network connection requires a higher timeout setting.

The value is in milliseconds. A timeout of zero is interpreted as an infinite timeout.

For setting the timeout of the command/control connection socket, see the parameter **Command Connection Timeout**.

Required Values

An integer from **0** to **2147483647**. The default is **45000**.

Directory Listing Style

Description

Specifies the system that reflects the remote host. This parameter is used to determine the format in which the **LIST** command returns file-listing information.

Required Values

One of the following values:

- UNIX
- AS400
- AS400-UNIX
- HCLFTPD 6.0.1.3
- HCLFTPD 5.1
- MPE
- MSFTPD 2.0
- MSP PDS (Fujitsu)
- MSP PS (Fujitsu)
- MVS GDG (Generation Data Group)
- MVS PDS (Partitioned Data Sets)
- MVS Sequential
- Netware 4.11
- Windows NT 3.5
- Windows NT 4.0
- User Defined
- VM/ESA
- VMS
- VOS3 PDS (Hitachi)
- VOS3 PS (Hitachi)
- VOSK (Hitachi)

Additional platforms and properties defined by the user, if applicable

Note: For more information, see [“Using FTP Heuristics” on page 66](#).

Mode

Description

Specifies the mode used to transfer data to or from the FTP server, using the **Ascii**, **Binary**, or **Ebcdic** mode.

Required Values

Ascii, **Binary**, or **Ebcdic**; the default is **Binary**.

Note: If you choose *Ebcdic*, make sure that:

- ◆ Your FTP server supports the EBCDIC mode.
- ◆ You are processing EBCDIC data.

Use PASV

Description

Allows you to prompt the eWay to enter either the passive or active mode.

Normally, when you connect to an FTP site, the site establishes the data connection to your computer. However, some FTP sites allow passive transfers, meaning that your computer establishes the data connection.

By default, the passive mode is used. It is recommended that you use this mode for transfers to and from FTP sites that support it.

The passive mode can be required in the following situations:

- For users on networks behind some types of router-based firewalls
- For users on networks behind a gateway requiring passive transfers
- If transfers are erratic
- If data-channel errors are prevalent in your environment

Required Values

Yes or **No**; the default is **Yes**.

3.3.4 FTP Raw Commands

FTP raw commands are commands that are sent directly to the FTP server. The **FTP Raw Commands** section contains the top level parameters displayed in Figure 7.

Figure 7 BatchFTP Properties - FTP Raw Commands section

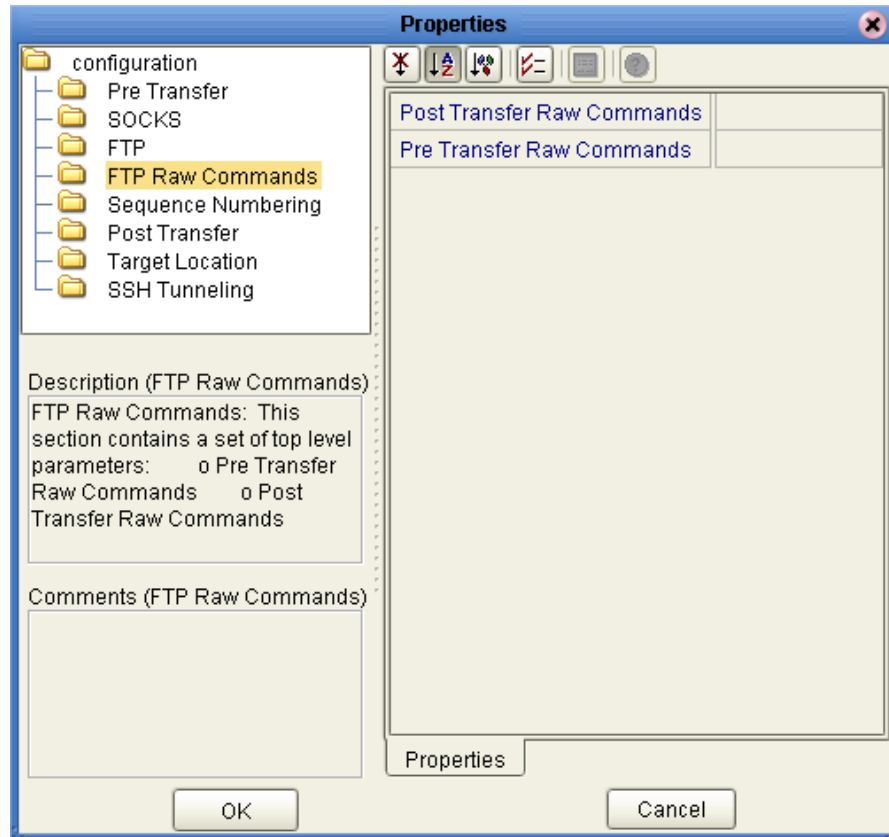

Post Transfer Raw Commands

Description

Specifies the FTP raw commands to be used directly after the file-transfer command, for example, some SITE commands.

Use a ; (semi-colon) to separate the command set, for example,

```
SITE RECFM=FB;SITE LRECL=50;SITE BLOCKSIZE=32750;SITE  
TRACKS;SITE PRI=5;SITE SEC=5
```

These commands are sent one by one, in the sequence they are listed.

Caution: *Certain combinations of post-transfer raw commands can cause the loss of data if there is a failure on the FTP server. For example, if the inbound post-transfer command is **Delete**, and your post-transfer raw commands fail, the deleted file is not recoverable.*

Required Values

One or more valid FTP raw commands.

Note: *These commands are sent to the FTP server directly and are not interpreted by the eWay in any way.*

Pre Transfer Raw Commands

Description

Specifies the FTP raw commands to be used directly before the file-transfer command, for example, some SITE commands.

Use a ; (semi-colon) to separate the command set, for example,

```
SITE RECFM=FB;SITE LRECL=50;SITE BLOCKSIZE=32750;SITE  
TRACKS;SITE PRI=5;SITE SEC=5
```

These commands are sent one by one, in the sequence they are listed.

Required Values

One or more valid FTP raw commands.

Note: *These commands are sent to the FTP server directly and are not interpreted by the eWay in any way.*

3.3.5 Sequence Numbering

The **Sequence Numbering** section contains the top level parameters displayed in Figure 8.

Figure 8 BatchFTP Properties - Sequence Numbering section

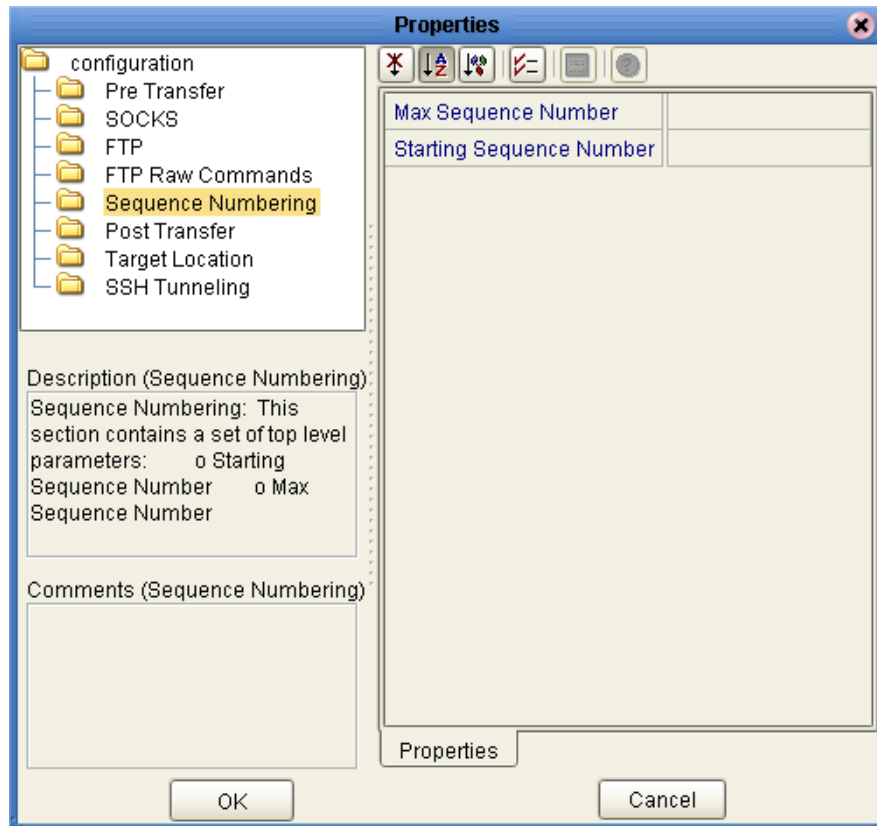

Max Sequence Number

Description

Use this parameter when you have set up the target directory or file name to contain a sequence number. It tells the eWay that when this value (the **Max Sequence Number**) is reached, to reset the sequence number to the **Starting Sequence Number** value.

This parameter is used for the name pattern %#.

Required Values

An integer from **1** to **2147483647**. The value of **Max Sequence Number** *must* be greater than that of **Starting Sequence Number**. The default value is **999999**.

Starting Sequence Number

Description

Use this parameter when you have set up the target directory or file name to contain a sequence number. It tells the eWay which value to start with in the absence of a sequence number from the previous run.

This parameter is used for the name pattern %#.

When the **Max Sequence Number** value is reached, the sequence number rolls over to the **Starting Sequence Number** value.

Required Values

An integer from 0 to 2147483647. The value of the **Starting Sequence Number** *must* be less than the **Max Sequence Number** value. The default value is 1.

3.3.6 Post Transfer

Post-transfer operations are those performed after the file transfer. The **Post Transfer** section contains the top level parameters displayed in Figure 9.

Figure 9 BatchFTP Properties - Post-Transfer section

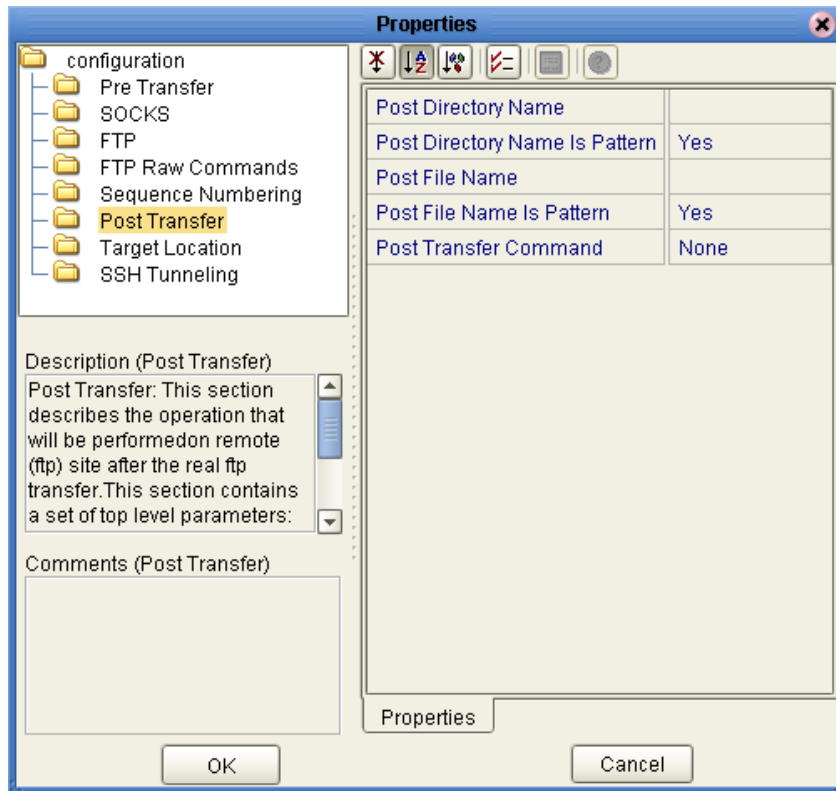

Note: For more information on this feature, see [“Pre/post File Transfer Commands” on page 89](#).

Post Directory Name

Description

Specifies the directory on the external system in which a file is renamed. The absolute directory name is expected.

For an outbound transfer (publishing), the directory is created if it does not already exist. This setting is only for the **Rename** operation of the **Post Transfer Command** parameter.

Special characters are allowed, for example, the pattern %f means the original working directory name. The expansion of any special characters is carried out each time this parameter is used. See [“Using Special Characters” on page 104](#) for details on using these characters.

Required Values

A valid directory name and path location on the target system; special characters are allowed.

Post Directory Name Is Pattern

Description

Specifies whether the pattern entered for the directory is interpreted literally (if **No**) or as a name expansion (if **Yes**), as follows:

- If you choose **No**, it is assumed that the name entered represents what you want as an exact match. No pattern matching of any kind is done.
- If you choose **Yes**, the value you enter is assumed to be a pattern for name expansion.

Required Values

Yes or **No**; the default is **Yes**.

Post File Name

Description

Specifies the file name on an external system to which a file is renamed. The value represents the base file name instead of the full file name.

This setting is only for **Rename** operation of **Post Transfer Command** parameter.

Special characters are allowed. For example, the pattern **%f** indicates the original working file name. The expansion of any special characters is carried out each time this parameter is used. See [“Using Special Characters” on page 104](#) for details on using these characters.

Required Values

A valid file name on the target system; special characters are allowed.

Post File Name Is Pattern

Description

Specifies whether the pattern entered for the file name is interpreted literally (if **No**) or as a name expansion (if **Yes**), as follows:

- If you choose **No**, it is assumed that the name entered represents what you want as an exact match. No pattern matching of any kind is done.
- If you choose **Yes**, the value you enter is assumed to be a pattern for name expansion.

Required Values

Yes or **No**; the default is **Yes**.

Post Transfer Command

Description

Allows you to execute a desired action directly after the actual file transfer or during the “commit” phase.

For an inbound transfer, you can mark the transferred file as “consumed” by making an automatic backup (**Rename**) or by destroying it permanently (**Delete**). For an outbound transfer, you can make the transferred file available to other clients by renaming it.

The options are:

- **Rename:** Rename the transferred file.
- **Delete:** Delete the transferred file (inbound transfers only).
- **None:** Do nothing.

Caution: *When you are using **Rename**, if the destination file exists, different FTP servers can behave differently. For example, on some UNIX FTP servers, the destination file is overwritten without question. That is, no error or warning message is given. On other FTP servers, a Windows XP server for example, the system generates an error that results in exceptions being thrown in the called OTD method.*

Be sure you are familiar with the native behavior of the corresponding FTP server. If you are in doubt, try the action at the command prompt. If the action displays an error message, it is likely to result in an exceptions being thrown in the Collaboration.

Required Values

Rename, Delete, or None; the default is **None**.

3.3.7 Target Location

The Target Location section allows you to configure the parameters for the **Target Location** (remote location) of the FTP directories and files. The **Target Location** section contains the top level parameters displayed in Figure 10.

Figure 10 BatchFTP Properties - Target Location section

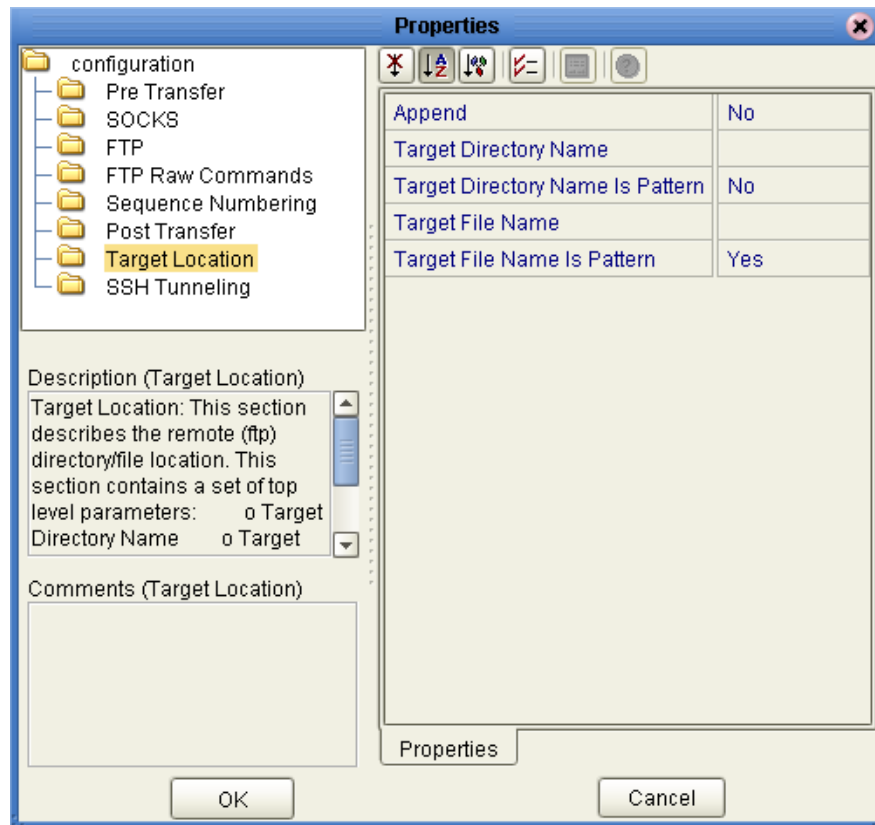

Append

Description

Specifies whether to overwrite or append the data to the existing file. Use this parameter for outbound FTP transfers only. Choose the appropriate setting as follows:

- If you select **Yes** and the target file already exists, the data is appended to the existing file.
- If you select **No**, the eWay overwrites the existing file on the remote system.
- If a file with the same name does not exist, both **Yes** and **No** create a new file on the external host.

Required Values

Yes or **No**; the default is **No**.

Target Directory Name

Description

Specifies the directory on the external system from which files are retrieved or where they are sent. The absolute directory name is preferred, otherwise, this path is relative to the home directory where you are when you log on to the FTP server.

For outbound FTP operations (publishing), the directory is created if it does not already exist.

Required Values

A valid directory name/path location on the target external system.

Target Directory Name Is Pattern

Description

Specifies whether the pattern entered for the directory is interpreted literally (if **No**) or as a regular expression or name expansion (if **Yes**), as follows:

- If you choose **No**, it is assumed that the name entered represents what you want as an exact match. No pattern matching of any kind is done.
- If you choose **Yes**, the value you enter is assumed to be a regular expression (when doing inbound) or name expansion (when doing an outbound FTP to the file system).

Note: Target directory names are resolved relative to the home directory of the user unless an absolute path is given.

Required Values

Yes or **No**; the default is **No**.

Target File Name

Description

Specifies the name of the remote FTP file to be retrieved or sent. This parameter can specify the exact file name or a regular-expression pattern. For outbound data (publishing), the file is created if it does not already exist. This parameter represents the base file name instead of the full file name.

For MVS GDG systems, the target file name can be the version of the data set, for example:

- Target directory name = 'STC.SAMPLE.GDGSET'
- Target file name = (0) to indicate the current version

Required Values

A valid file name or a regular expression or name expansion file name.

Target File Name Is Pattern

Description

Specifies whether the pattern entered for the file name is interpreted literally (if **No**) or as a regular expression or name expansion (if **Yes**), as follows:

- If you choose **No**, it is assumed that the name entered represents what you want as an exact match. No pattern matching of any kind is done.
- If you choose **Yes**, the value you enter is assumed to be a regular expression (when doing inbound) or name expansion (when doing an outbound FTP to the file system).

Required Values

Yes or **No**; the default is **Yes**.

3.3.8 SSH Tunneling

This section provides a brief explanation of how the BatchFTP OTD supports Secure Shell (SSH) tunneling, and information on configuring the **SSH Tunneling** secure FTP properties (accessed from the Connectivity Map). The **SSH Tunneling** section contains the top level parameters displayed in Figure 11.

Figure 11 BatchFTP Properties - TSSH Tunneling section

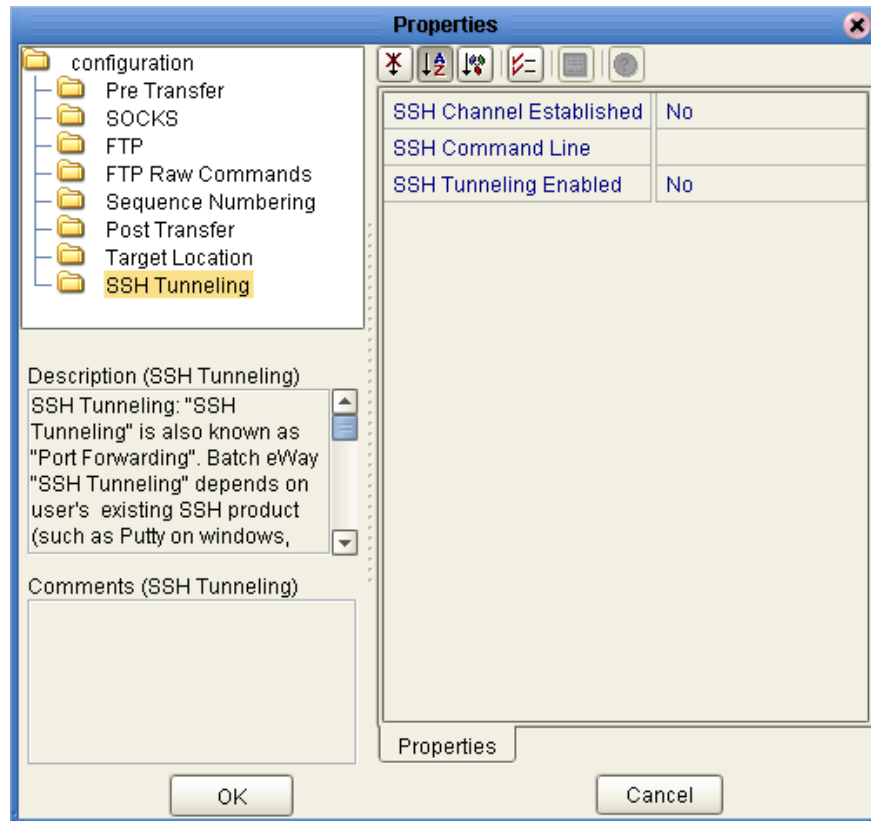

Additional SSH-supporting Software

The eWay's SSH tunneling (also known as port forwarding) feature utilizes additional existing SSH-supporting software applications, for example, Plink on Windows or OpenSSH on UNIX (see [Additional Software Requirements](#) on page 114

For different SSH client implementations, the command syntax and environment configuration may vary. See your SSH-supporting application's user guide for details.

Port-forwarding Configuration

SSH tunneling provides secure FTP command connections. This mechanism is based on an existing SSH port-forwarding configuration. You must configure SSH port forwarding on the *SSH listen host* before you configure the supporting eWay Connection.

For example, on the eGate client host **localhost**, you can issue a command, such as:

```
ssh -L 4567:apple:21 -o BatchMode=yes apple
```

Under the eWay's configuration for the previous example, you must specify:

- **localhost** for the Environment parameter **SSH Listen Host**
- **4567** for the Environment parameter **SSH Listen Port**

In this case, the eWay connects to the FTP server **apple:21** through an SSH tunnel. For more information on SSH tunneling, see ["SSH Tunneling Support" on page 114](#).

It is possible to use SOCKS and SSH tunneling at the same time. However, this practice is not recommended.

SSH Channel Established

Description

Specifies whether the eWay needs to launch an SSH subprocess.

Selecting **No** means the SSH channel has not yet been established. The eWay spawns a subprocess internally then establishes the channel on your behalf.

If you select **No**, you must set the following parameters:

- **SSH Command Line**
- **SSH Listen Port** (Environment property)

If you select **No**, setting the following parameters is optional:

- **SSH User Name** (Environment property)
- **SSH Password** (Environment property)

Selecting **Yes** means an SSH channel has already been established. That is, the channel has already been started outside the eWay, and the eWay does not need to establish it. For example, you could have issued a command outside of eGate, or you could know that another Batch eWay instance has already established the channel by the time this eWay runs.

If you select **Yes**, you must set the following parameters:

- **SSH Listen Host** (Environment property)
- **SSH Listen Port** (Environment property)

Required Values

Yes or **No**; the default is **No**.

SSH Command Line

Description

Specifies the command line used to establish an SSH channel. This parameter is required only when you set the **SSH Channel Established** parameter to **No**.

This entry must be the complete, correct command line required by the additional software application you are using to support SSH tunneling. This command line is executed as it is, so you must be sure that it:

- Contains all the necessary arguments
- Is correct in syntax
- Is compliant with your SSH-environment

To verify these requirements, test this command line manually outside of eGate to make sure it works correctly. Execute the command line from the shell and ensure that it does not prompt for any additional user input. If it does, continue to add whatever additional parameters are required until it no longer prompts for additional input, then use that command line in the eWay's configuration.

You can specify any other options that are based on your SSH-environment. However, if you do so, you must still be sure this command line is correct and complete. For example, port forwarding could be specified using the following command-line option:

```
-L ListenPort:FtpServerHost:FtpServerPort
```

In the previous example, *ListenPort* must be the same value as that given for the parameter **SSH Listen Port**. The value given for *FtpServerHost* overwrites the parameter setting for **Host Name** under the **FTP** parameters. The value given for *FtpServerPort* overwrites the parameter setting for **Server Port** under the **FTP** parameters. All other settings under the **FTP** parameters operate for the specified FTP server: **FtpServerHost:FtpServerPort**.

If the SSH channel established by an SSH command line must be shared by other Batch eWay instances located on different eGate client hosts, you must configure SSH port forwarding to allow non-local connections from other hosts. For some SSH clients, you can use the option **-g**.

Note: You also can specify port forwarding in your SSH configuration file.

The command-line syntax can differ, depending on the type of SSH client implementation you are using. See your SSH-tunneling support software user documentation for details.

Examples

```
ssh -L 3456:ftp.sun.com:21 -o BatchMode=yes apple
ssh -L 4567:apple:21 -o BatchMode=yes apple
ssh -L 5678:orange:21 -o BatchMode=yes apple
ssh -L 6789:orange:21 -g -o BatchMode=yes apple
plink -L 4567:apple:21 apple
plink -L 5678:orange:21 apple
plink -L 6789:orange:21 -g apple
```

Required Values

A valid SSH command line.

SSH Tunneling Enabled

Description

Specifies whether the FTP command connection is secured through an SSH tunnel.

If you choose **No**, all other parameters in this section are ignored.

Note: *If you want to use the SSH port-forwarding feature, you may need to reconfigure your FTP server, depending on what kind of server you are using and how it is currently configured. See your SSH documentation for more information.*

Required Values

Yes or No; the default is **No**.

3.4 BatchFTP eWay Environment Explorer Properties

This section describes the configuration properties for the **BatchFTP OTD** accessed from the Environment Explorer tree.

The BatchFTP Environment Explorer properties include the following sections:

- **SOCKS** on page 44
- **FTP** on page 46
- **SSH Tunneling** on page 48

Caution: Several of these configuration options allow you to use regular expressions. This advanced feature is useful but must be used carefully. An improperly formed regular expression can cause the creation of undesired data or even the loss of data. You must have a clear understanding of regular-expression syntax and construction before attempting to use this feature. It is recommended that you test such configurations thoroughly before moving them to production.

3.4.1 SOCKS

This section provides information for configuring the **SOCKS** properties (accessed from the Environment Explorer). The eWay supports the negotiation methods, **No-authentication** and **User/password**. The **SOCKS** section contains the top level parameters displayed in Figure 12.

For more information on SOCKS, see **“SOCKS” on page 112**.

Figure 12 BatchFTP Properties - SOCKS section

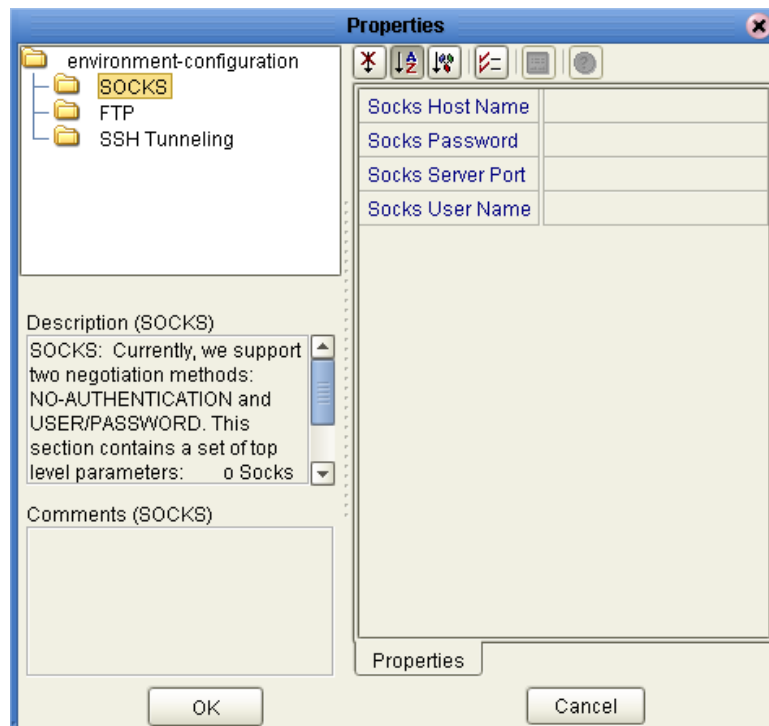

Socks Host Name

Description

Specifies the SOCKS server (host) name. If you are communicating with a SOCKS server enter the SOCKS server name in this parameter.

Required Values

The name of the SOCKS server.

Socks Password

Description

Specifies the password to use (together with the user name specified under the **Socks User Name** parameter) for authentication with a SOCKS5 server, if necessary. This parameter is used for the user/password negotiation method.

Note: The corresponding Java accessors are `getSocksPassword()`, `setSocksPassword(java.lang.String p)` and `setSocksEncryptedPassword(java.lang.String p)`.

Required Values

A valid SOCKS5 password.

Socks Server Port

Description

Specifies the port number to use on the SOCKS server, when connecting to it.

Required Values

An integer from 1 to 65,535; the default is 1080.

Socks User Name

Description

Specifies the user name to use (together with the password specified under the **Socks Password** parameter) for authentication with a SOCKS5 server, if necessary. This parameter is used for the user/password negotiation method.

Required Values

A valid SOCKS5 user name.

3.4.2 FTP

This section provides information for configuring the **FTP** properties (accessed from the Environment Explorer). The **FTP** section contains the top level parameters displayed in Figure 13.

Figure 13 BatchFTP Properties - FTP section

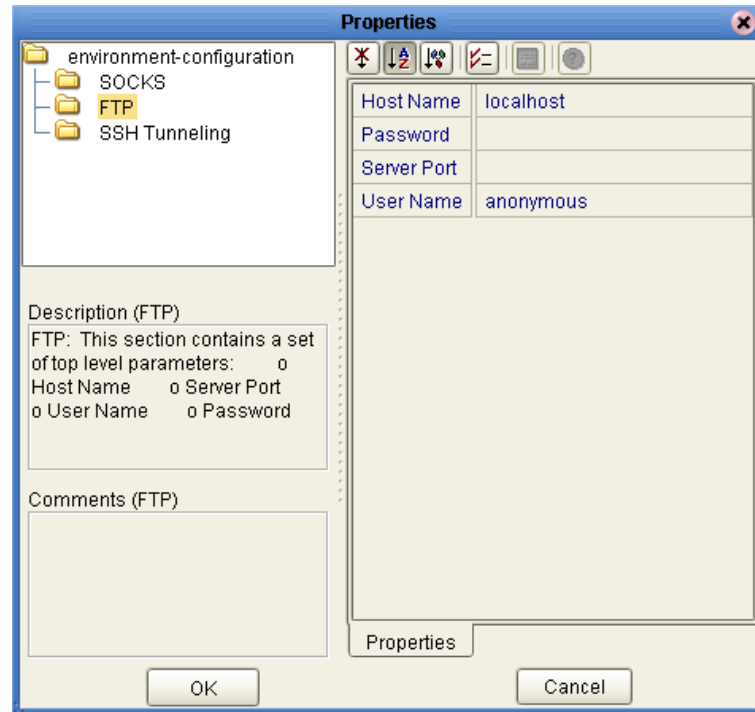

Host Name

Description

Specifies the name of the external system that the eWay connects to.

If the parameter **SSH Tunneling Enabled** under the **SSH Tunneling** configuration settings is set to **Yes**, the parameters **Host Name** and **Server Port**, under the **FTP** settings, are ignored. In this case, the FTP host name is determined by an SSH option, according to the following model:

```
ssh -L ListenPort:FtpServerHost:FtpServerPort SSHServer
```

In the previous example, the FTP feature communicates with the FTP server *FtpServerHost:FtpServerPort* using an existing SSH tunnel. See [“SSH Tunneling” on page 40](#) for details.

If the parameter **Socks Enabled** under the **SOCKS** configuration parameters is set to **Yes**, the host name under the **FTP** configuration could fail to resolve some names, for example, **localhost** or **127.0.0.1** correctly. Use real IP or machine names to represent the hosts. See [“SOCKS” on page 25](#) for details.

Required Values

A valid host name.

Password

Description

If a password is required to log on to an external system, enter the password that corresponds to the user name.

The corresponding Java accessor methods are **getPassword()**, **setPassword()**, and **setEncryptedPassword()**.

Required Values

A valid password.

Server Port

Description

Specifies the port number to use on the FTP server when connecting to it.

If the parameter **SSH Tunneling Enabled** under the **SSH Tunneling** configuration is set to **Yes**, the parameters **Host Name** and **Server Port** under the **FTP** configuration are ignored. In this case, the FTP server port number is determined by an SSH option, according to the following model:

```
ssh -L ListenPort:FtpServerHost:FtpServerPort SSHServer
```

In the previous example, the FTP feature communicates with the FTP server *FtpServerHost:FtpServerPort* using an existing SSH tunnel. See [“SSH Tunneling” on page 40](#) for details.

Required Values

A valid server port number.

User Name

Description

Specifies the user name used to log onto the external system, when required.

Required Values

A user name that provides access to the external system.

3.4.3 SSH Tunneling

This section provides information for configuring the **SSH Tunneling** properties (accessed from the Environment Explorer). The **SSH Tunneling** section contains the top level parameters displayed in Figure 14.

Figure 14 BatchFTP Properties - SSH Tunneling section

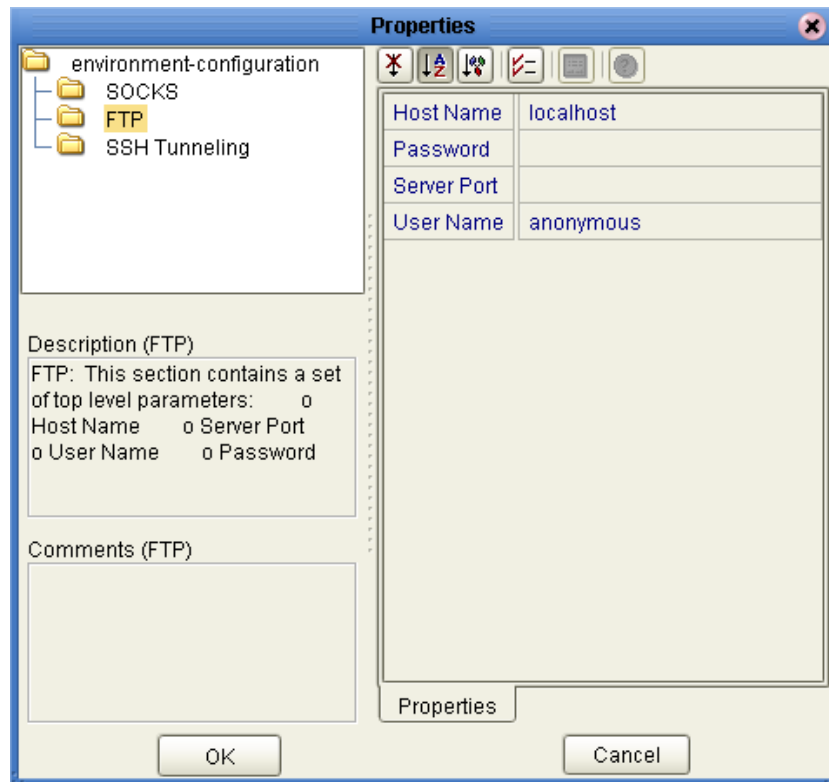

SSH Listen Host

Description

Specifies the name of the host where the SSH support software runs, and the host it listens to.

This parameter is required only when you set the **SSH Channel Established** parameter to **Yes**. If you choose **No**, the **Listen Host** is always **localhost** because the SSH support software is always started from the local host. For optimum security, it is recommended that you use **localhost** as your choice. The connection to the corresponding port number on this host is forwarded to the FTP server through an SSH-secure channel.

On this listen host, the SSH support software must be configured and started with the port-forwarding option. The FTP command connection is forwarded through the secure tunnel. The corresponding SSH command uses the following model:

```
ssh -L ListenPort:FtpServerHost:FtpServerPort -o BatchMode=yes  
SSHServer
```

For example, on an SSH listen host, you could issue a command, such as:

```
ssh -L 4567:apple:21 -o BatchMode=yes apple or ssh -L 5678:orange:  
21 -o BatchMode=yes apple
```

If this host name is not **localhost**, the data transport between the local host and the SSH listen host is not secure. Also, your SSH support software must be configured to allow connections to other hosts (for some SSH applications, you can use an option **-g**).

Regardless, the transport between the SSH listen host and the FTP server is still secure.

Required Values

A valid SSH listen host name; the default is **localhost**.

SSH Listen Port

Description

Specifies the port number that the SSH-tunneling support software uses to check for incoming connections. This port number can be any unused port number on the SSH listen host.

The connection to this port is forwarded to the FTP server through an SSH-secure channel. This parameter is required and it must be exactly same as the *ListenPort* value in the SSH command you issue either inside or outside the eGate system. The corresponding SSH command line uses the following model:

```
ssh -L ListenPort:FtpServerHost:FtpServerPort -o BatchMode=yes  
SSHServer Required Values
```

Required Values

An integer from 1 to 65535; the default is 4567.

SSH Password

Description

Specifies an SSH password corresponding to the user name entered under **SSH User Name**. This parameter can be required only when the setting for the **SSH Channel Established** parameter is **No**. For more information, see **SSH User Name**.

Required Values

A valid SSH password.

SSH User Name

Description

Specifies an SSH user name. This parameter can be required when the setting for the **SSH Channel Established** parameter is **No**.

This parameter is required only if the SSH support software is started from within the eWay (refer to the corresponding SSH command line). Even then, it is only required if your SSH implementation executes in an interactive way that requires you to enter a user name. Again, this requirement depends on how you specify the SSH command line and how your SSH environment is configured.

Required Values

A valid SSH user name.

3.5 BatchLocalFile Connectivity Map Properties

This section explains the configuration parameters for the **BatchLocalFile OTD**, accessed from the Connectivity Map (there are no Environment properties for BatchLocalFile).

The BatchLocalFile properties include the following sections:

- **Pre Transfer** on page 51
- **Sequence Numbering** on page 54
- **Post Transfer** on page 55
- **General Settings** on page 58
- **Target Location** on page 59

Caution: *Several of these configuration options allow regular expressions to be used. This advanced feature is useful but must be used carefully. An improperly formed regular expression can cause undesired data, or loss of data. You must have a clear understanding of regular-expression syntax and construction before attempting to use this feature. It is recommended that you test such configurations thoroughly before moving them to production.*

3.5.1 Pre Transfer

This section provides information about configuring the **Pre Transfer** parameters. Pre-transfer operations are those performed before the data transfer. The **Pre Transfer** section contains the top level parameters displayed in Figure 15.

Figure 15 BatchLocalFile Properties - Pre Transfer section

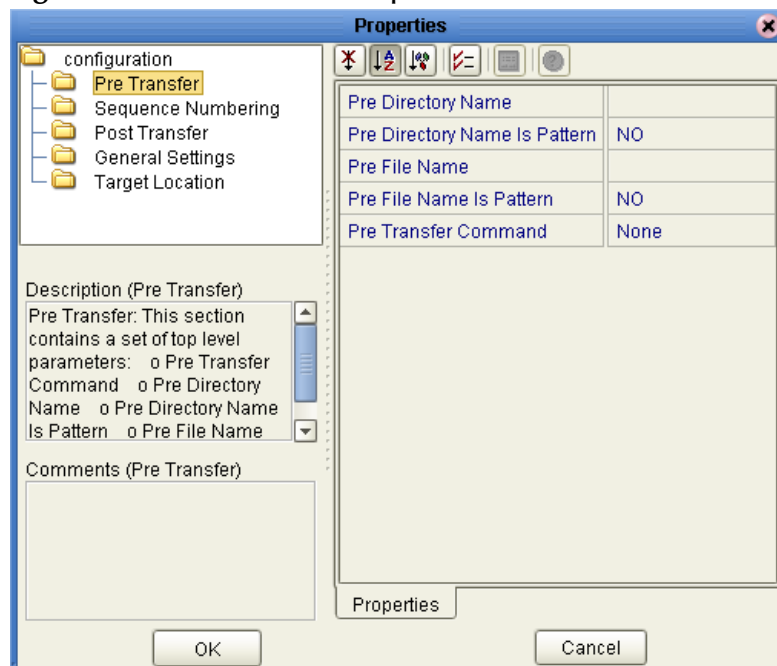

Note: For more information on this feature, see [“Pre/post File Transfer Commands” on page 89](#).

Pre Directory Name

Description

Specifies either the name of the directory that the remote file is renamed to (**Rename**), or the directory it is moved to (**Move**), depending on the value set in the parameter **Pre Transfer Command**.

Special characters are allowed. The expansion of any special characters are carried out each time this parameter is used.

If you are entering a path name, use the forward slash (/) instead of the back slash (\) because the eWay interprets the back slash as a special character and not a path separator. For example, use **c:/temp/dir** for a path location, *not* **c:\temp\dir**.

Required Values

One of the following values:

- A valid file name or a regular-expression file name
- A valid directory name and path location or the regular-expression directory name and path location on the local system

Pre Directory Name Is Pattern

Description

Specifies the meaning of the **Pre Directory Name** parameter as follows:

- **Yes** means that the **Pre Transfer Name** (file or directory) represents a pattern to be used as a regular expression for pattern matching on inbound transfers or name expansion on outbound transfers.
- **No** means that the **Pre Transfer Name** (file or directory) represents the exact directory name to be used for the transfer. No pattern matching of any kind is performed.

Required Values

Yes or **No**; the default is **Yes**.

Pre File Name

Description

Specifies either the name of the file that the remote file is renamed to (**Rename**), or the directory it is moved to (**Move**), depending on the value set in the parameter **Pre Transfer Command**.

Special characters are allowed. The expansion of any special characters are carried out each time this parameter is used.

If you are entering a path name, use the forward slash (/) instead of the back slash (\) because the eWay interprets the back slash as a special character and not a path separator. For example, use **c:/temp/dir** for a path location, *not* **c:\temp\dir**.

Required Values

One of the following values:

- A valid file name or a regular-expression file name
- A valid directory name and path location or the regular-expression directory name and path location on the local system

Pre File Name Is Pattern

Description

Specifies the meaning of the **Pre File Name** parameter as follows:

- **Yes** means that the **Pre File Name** (file or directory) represents a pattern to be used as a regular expression for pattern matching on inbound transfers or name expansion on outbound transfers.
- **No** means that the **Pre File Name** (file or directory) represents the exact directory name to be used for the transfer. No pattern matching of any kind is performed.

Required Values

Yes or **No**; the default is **Yes**.

Pre Transfer Command

Description

Allows you to determine the action executed directly before the actual file transfer.

In the case of an inbound file transfer, you can make the file unavailable to other clients polling the target system via the same directory and file pattern or name. In the case of an outbound transfer, you can make an automatic backup of the existing file.

Your options are:

- **Rename**: Rename the target file.
- **Move**: Move the target file to another directory.
- **None**: Do nothing.

Caution: *Rename and Move overwrite the file or directory specified by the **Pre Transfer Name** parameter, if either or both have been entered.*

Required Values

Rename, **Move**, or **None**; the default is **None**.

3.5.2 Sequence Numbering

The Sequence Numbering section contains the top level parameters displayed in Figure 16.

Figure 16 BatchLocalFile Properties - Sequence Numbering section

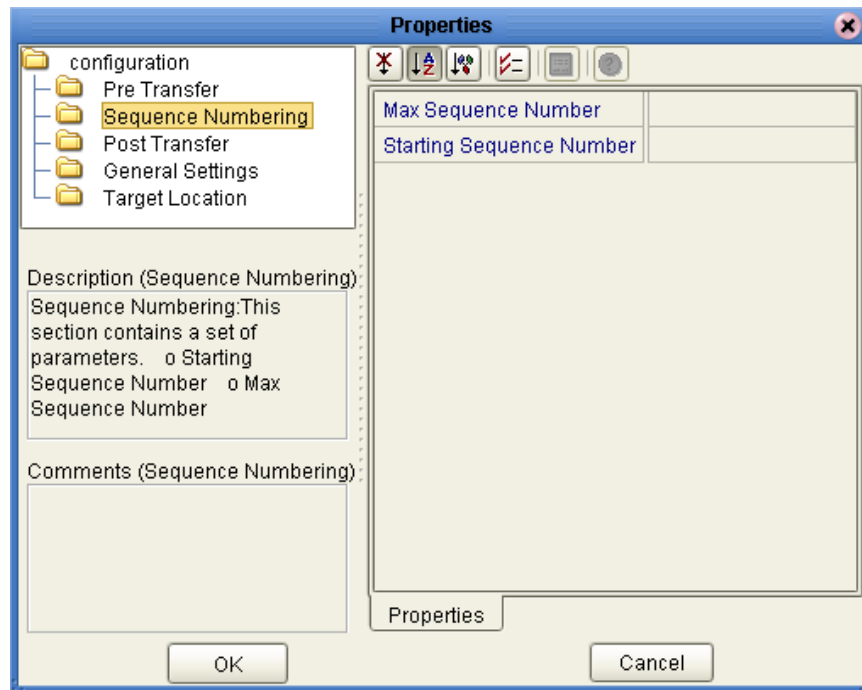

Max Sequence Number

Description

Use this parameter when you have set up the target file name to contain a sequence number. It tells the eWay that when this value (the **Max Sequence Number**) is reached, to reset the sequence number to the **Starting Sequence Number** value.

This parameter is used for the name pattern %#.

Required Values

An integer from 1 to 2147483647. The value of **Max Sequence Number** *must* be greater than that of **Starting Sequence Number**. The default value is 999999.

Starting Sequence Number

Description

Use this parameter when you have set up the target file name to contain a sequence number. It tells the eWay which value to start with in the absence of a sequence number from a previous run.

Also, when the **Max Sequence Number** value is reached, the sequence number rolls over to the **Starting Sequence Number** value.

This parameter is used for the name pattern %#.

Required Values

An integer from 0 to 2147483647. The value of the **Starting Sequence Number** *must* be less than the **Max Sequence Number**. The default value is 1.

3.5.3 Post Transfer

Post-transfer operations are those performed after the data transfer. The **Post Transfer** section contains the top level parameters displayed in Figure 17.

Figure 17 BatchLocalFile Properties - Post Transfer section

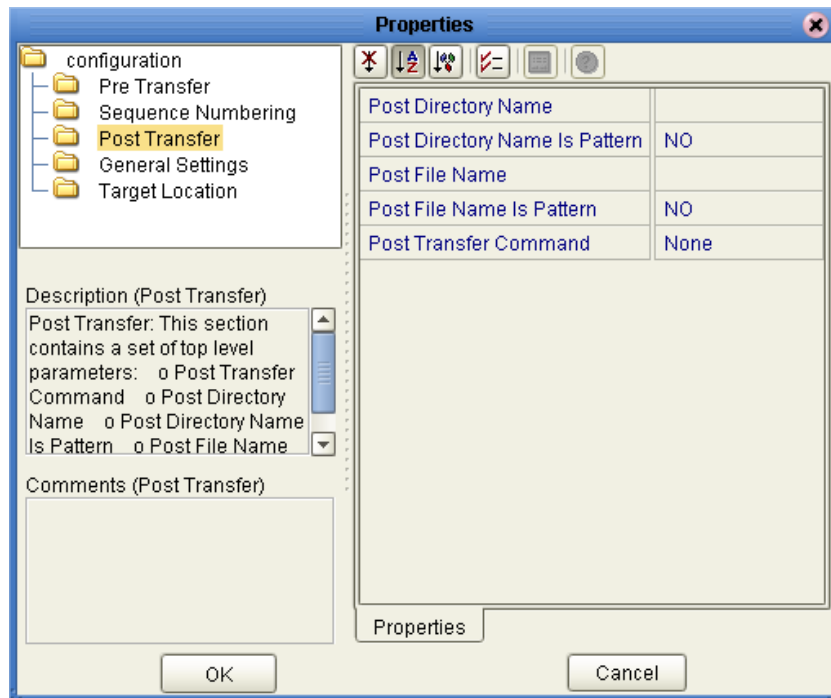

Post Directory Name

Description

Specifies either the name of the file that the transferred file is renamed to (**Rename**) or the directory it is moved to (**Move**), depending on the setting in the parameter **Post Transfer Command**.

Special characters are allowed. The expansion of any special characters are carried out each time this parameter is used.

If you are entering a path name, use the forward slash (/) instead of the back slash (\) because the eWay interprets the back slash as a special character and not a path separator. For example, use **c:/temp/dir** for a path location, *not* **c:\temp\dir**.

Required Values

One of the following values:

- A valid file name or a regular-expression file name.
- A valid directory name and path location or the regular-expression directory name and path location on the local system.

Post Directory Name Is Pattern

Description

Specifies the meaning of the **Post Transfer Name** parameter as follows:

- **Yes** means that the **Post Transfer Name** (file or directory) represents a pattern to be used for name expansion.
- **No** means that the **Post Transfer Name** represents the exact file or directory name to be used for the transfer. No pattern matching of any kind is performed.

Required Values

Yes or **No**; the default is **Yes**.

Post File Name

Description

Specifies either the name of the file that the transferred file is renamed to (**Rename**) or the directory it is moved to (**Move**), depending on the setting in the parameter **Post Transfer Command**.

Special characters are allowed. The expansion of any special characters are carried out each time this parameter is used.

If you are entering a path name, use the forward slash (/) instead of the back slash (\) because the eWay interprets the back slash as a special character and not a path separator. For example, use **c:/temp/dir** for a path location, *not* **c:\temp\dir**.

Required Values

One of the following values:

- A valid file name or a regular-expression file name.
- A valid directory name and path location or the regular-expression directory name and path location on the local system.

Post File Name Is Pattern

Description

Specifies the meaning of the **Post Transfer Name** parameter as follows:

- **Yes** means that the **Post Transfer Name** (file or directory) represents a pattern to be used for name expansion.
- **No** means that the **Post Transfer Name** represents the exact file or directory name to be used for the transfer. No pattern matching of any kind is performed.

Required Values

Yes or **No**; the default is **Yes**.

Post Transfer Command

Description

Allows you to execute a desired action directly after the actual file transfer. For an inbound transfer, you can mark the transferred file as “consumed” by making an automatic backup (**Rename** or **Move**) or by destroying it permanently (**Delete**). For an outbound transfer, you can make the transferred file available to other clients by renaming or moving it.

The options are:

- **Rename**: Rename the transferred file.
- **Move**: Move the target file to another directory.
- **Delete**: Delete the transferred file (inbound transfers only).
- **None**: Do nothing.

The **Rename** and **Move** settings overwrite the file specified under the **Pre Transfer Name** parameter, if one is specified.

3.5.4 General Settings

The **General Settings** section contains the top level parameters displayed in Figure 18.

Figure 18 BatchLocalFile Properties - General Settings section

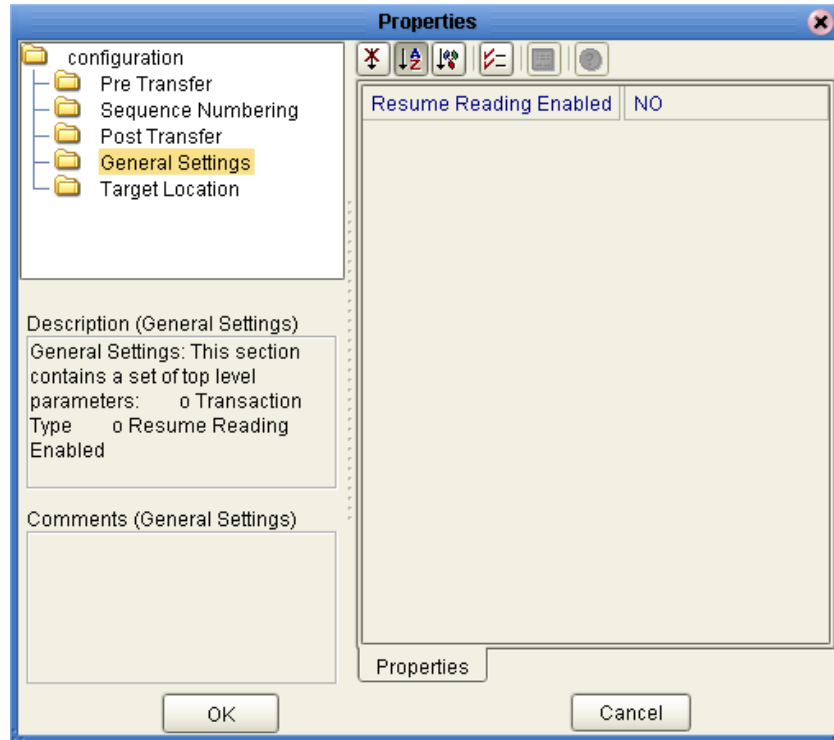

Resume Reading Enabled

Description

Specifies whether the OTD handles the Resume Reading feature as follows:

- **Yes:** Enables the OTD to store any state information necessary to resume reading from the current file in a subsequent execution of the Collaboration Rule.
- **No:** Means the file is considered “consumed” even if the streaming consumer did *not* read until the end of file.

Required Values

Yes or No; the default is **No**.

3.5.5 Target Location

The **Target Location** section contains the top level parameters displayed in Figure 19.

Figure 19 BatchLocalFile Properties - Target Location section

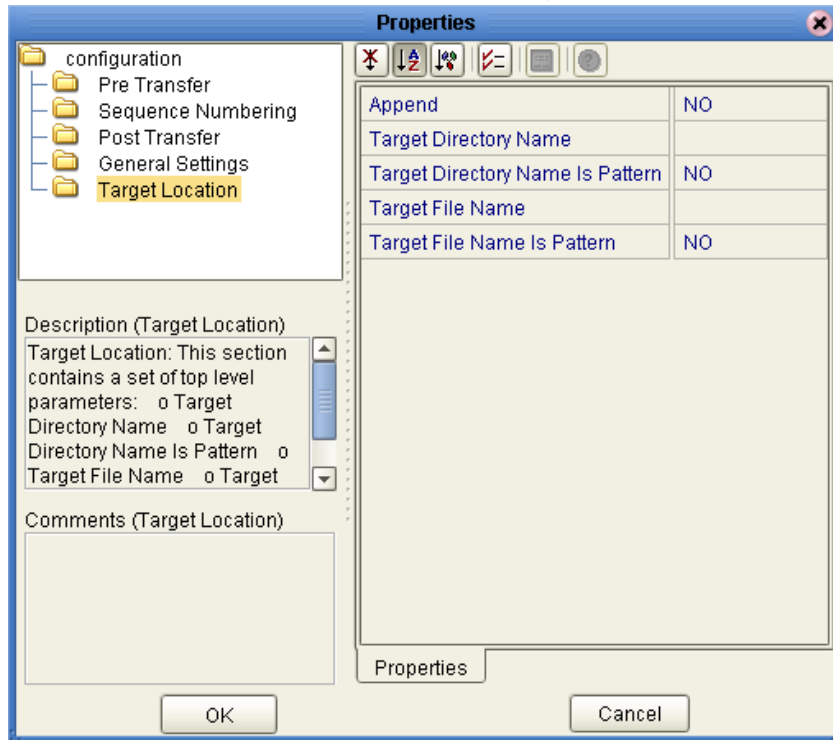

Append

Description

Specifies whether to overwrite or append the data to the existing file. Use this parameter for outbound file transfers only. Choose the appropriate setting as follows:

- If you select **Yes** and the target file already exists, the data is appended to the existing file.
- If you select **No**, the eWay overwrites the existing file on the remote system.
- If a file with the same name does not exist, both **Yes** and **No** create a new file on the external host.

Required Values

Yes or **No**; the default is **No**.

Target Directory Name

Description

Specifies the directory on the local system from which files are retrieved or where they are sent. This parameter can specify the exact directory path or a regular-expression pattern. For an outbound transfer, the directory is created if it does not already exist.

Required Values

A valid directory name and path location or the regular-expression pattern directory name and path location on the local system.

Target Directory Name Is Pattern

Description

Specifies the meaning of the **Target Directory Name** parameter as follows:

- **Yes** means that the **Target Directory Name** represents a pattern to be used as a regular expression for pattern matching on inbound transfers or name expansion on outbound transfers.
- **No** means that the **Target Directory Name** represents the exact directory name to be used for the transfer. No pattern matching of any kind is performed.

Note: Target directory names are resolved relative to the home directory of the user unless an absolute path is given.

Required Values

Yes or **No**; the default is **No**.

Target File Name

Description

Specifies the name of the file on the local system either to be retrieved or sent. This parameter can specify the exact file name or a regular-expression pattern. For outbound data (publishing), the file is created if it does not already exist. This parameter represents the base file name instead of the full file name.

Required Values

A valid file name or a regular-expression file name.

Target File Name Is Pattern

Description

Specifies the meaning of the **Target File Name** parameter as follows:

- **Yes** means that the **Target File Name** represents a pattern to be used as a regular expression for pattern matching on inbound transfers or name expansion on outbound transfers.
- **No** means that the **Target File Name** represents the exact file name to be used for the transfer. No pattern matching of any kind is performed.

Required Values

Yes or **No**; the default is **Yes**.

3.6 BatchRecord Connectivity Map Properties

This section explains the properties for the record-processing **BatchRecordOTD**. The BatchRecord properties include the following sections:

- **General Settings** on page 61
- **Record** on page 62

3.6.1 General Settings

The **General Settings** section contains the top level parameters displayed in Figure 20.

Figure 20 BatchRecord Properties - General Settings section

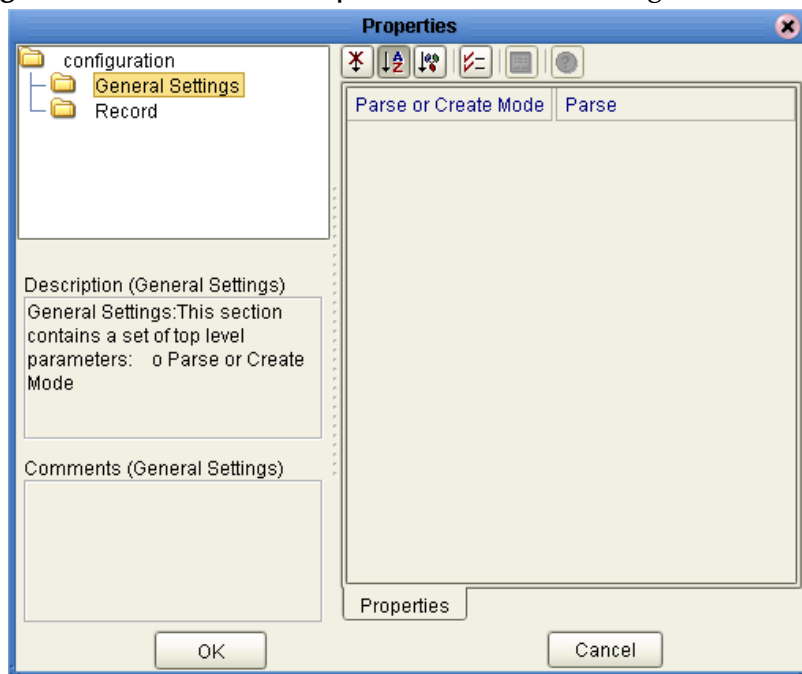

Parse or Create Mode

Description

Specifies how this eWay Connection for the record-processing OTD is used. Set this parameter as follows:

- To use the OTD for parsing an inbound payload, choose **Parse**.
- To use the OTD for creating an outbound payload, choose **Create**.

An instance of the OTD can be used for parsing an inbound payload (only) or for creating an outbound payload (only). A single OTD cannot be used for both purposes at the same time in the same Collaboration.

Required Values

Create or Parse; the default is **Parse**.

3.6.2 Record

This section allows you to configure the **Record** parameters, specifying the record characteristics you want the eWay to recognize. The **Record** section contains the top level parameters displayed in Figure 21.

Figure 21 BatchRecord Properties - Record section

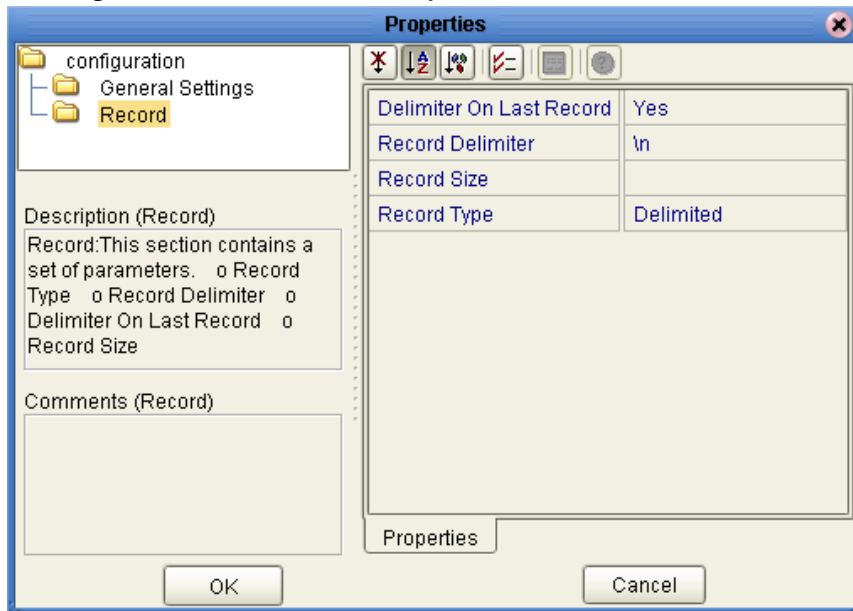

Delimiter on Last Record

Description

Allows you to supply the delimiter to be used with the final record. Use this parameter only when the **Record Type** is set to **Delimited**.

Some message formats insist that the final message in a record set has no trailing delimiter. However, in most cases, you can safely leave this parameter set to **Yes**.

Required Values

No or **Yes** (the default).

Record Delimiter

Description

Specifies the delimiter to be used for records. Use this parameter when the **Record Type** is set to **Delimited**.

The value entered is interpreted as a sequence of one or more bytes. If there are multiple bytes in the delimiter, each must be separated by a comma.

Note: When using character delimiters with DBCS data, use single byte character(s), or the equivalent hex values that do not coincide with either byte of the double byte character.

You can enter the delimiters in the following formats:

- **ASCII Characters:** The eWay supports all ASCII characters.
 - ♦ Example: *,*,* (records separated by ***)
 - ♦ Example: | (records separated by a |)
- **Escaped ASCII:** The eWay supports \r, \n, \t, and \f.
 - ♦ Example: \r,\n (records separated by CR NL)
 - ♦ Example: \n (records separated by NL only)
- **Hex:** The eWay supports 0x00 to 0x7E
 - ♦ Example: \0x0D,\0x0A (records separated by CR NL)
- **Octal:** The eWay supports 000 to 0177.
 - ♦ Example: \015,\012 (same as \0x0D,\0x0A)

Note: When using escaped ASCII, Hex, or Octal, the “\” character is required.

Required Values

A valid data record delimiter.

Record Size

Description

Specifies a number indicating the record size (byte count). Use this parameter when the **Record Type** is set to **Fixed**, and a number indicating length must be supplied.

Required Values

A number from 1 to 2,147,483,647 indicating the record size (byte count).

Record Type

Description

Specifies the format of the records in the data payload in the Collaboration.

Each payload contains zero or more records. Using this and related parameters, you can pass records individually to another component within eGate. Available options:

- **Delimited:** The records are separated by the delimiter specified under the Record Delimiter parameter.
- **Fixed:** The records are all of a given size; the size of each record is specified by the Record Size parameter.
- **Single Record:** If the payload is to be processed “as-is,” select this option.
- **User Defined:** This option is not supported.

Required Values

Delimited (the default), **Fixed**, or **Single Record**.

3.7 BatchInbound Connectivity Map Properties

This section explains the configuration parameters for the **BatchInbound** eWay (OTD), accessed from the Connectivity Map (there are no Environment properties for BatchInbound).

The BatchInbound properties include the following sections:

- **Settings** on page 64

3.7.1 Settings

The **Settings** section contains the top level parameters displayed in Figure 22.

Figure 22 BatchInbound Properties - Settings section

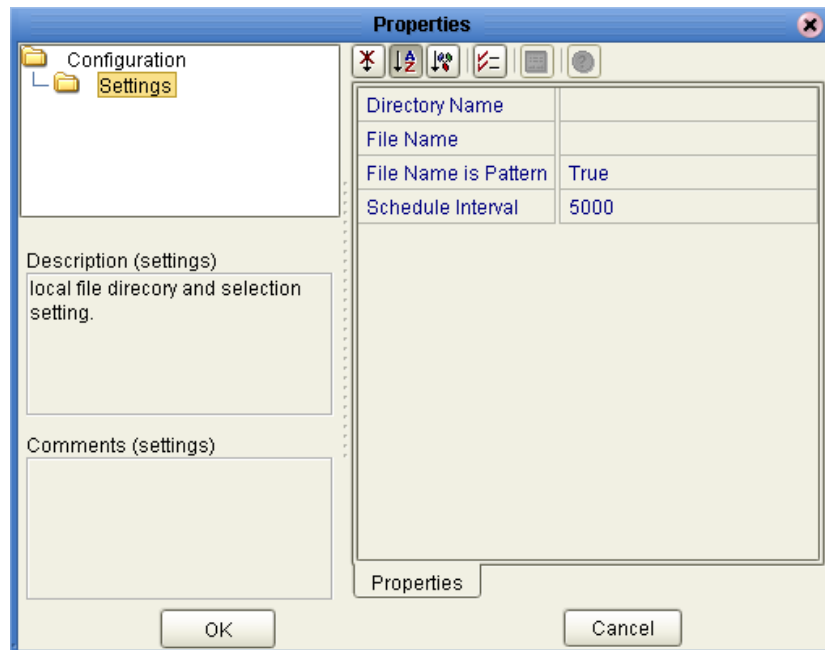

Directory Name

Description

Specifies the input directory name and path (absolute path): for example C:\Temp. It indicates the directory that the BatchInbound eWay polls and from which it transfers input data files.

Required Values

The absolute path (location and name) of the input directory.

File Name

Description

Specifies the input data filename used to select the appropriate input files. This parameter is used in conjunction with **File Name is Pattern**, which specifies whether the value is the exact file name or a regular expression-pattern.

Required Values

A valid **exact file name** (if File Name is Pattern is **False**), or a **regular expression-pattern** (if File Name is Pattern is **True**). For more information on regular expressions see [Using Regular Expressions](#) on page 100.

File Name is Pattern

Description

Specifies the meaning of the **File Name** parameter as follows:

- **True** means that the **File Name** represents a pattern to be used as a **regular expression** for pattern matching on inbound file transfers: for example `\AMessage(\d){1,3}.txt`. For more information on using regular expressions see [Using Regular Expressions](#) on page 100.
- **False** means that the **File Name** represents the exact file name to be used for the transfer. No pattern matching of any kind is performed.

Required Values

True or **False**. The default is **True**.

Schedule Interval

Description

Specifies the polling interval, or number of seconds between each poll of the input directory by the eWay for input files.

Required Values

A number indicating the length of time in Milliseconds between eWay polls of the directory. The configured default is 5000 (or 5 seconds).

3.8 Using FTP Heuristics

This section provides a general explanation of how the FTP Heuristics feature of the eWay operates, as well as some basic information on how to use it. It also explains the FTP Heuristics configuration parameters for the eWay.

FTP Heuristics: eWay Operation

The FTP Heuristics are a set of parameters that the eWay uses to interact with external FTP daemons on a platform-specific level. The primary functions of FTP Heuristics are to create and parse both path and file names in the style required by the external systems' platform (operating system).

Platform or File Type Selection

The platform is selected from the eWay Properties Editor. To select the specific platform for the eWay do the following:

- 1 From the Connectivity Map, double-click the BatchFTP eWay. The FTPBatch eWay Properties Editor appears.
- 2 From the left pane, under the configuration tree, select **FTP**. The **FTP** parameters are now displayed in the Properties pane.
- 3 Click the **Directory Listing Style** field and select a system platform from the drop-down box. The properties for that platform, listed in the FtpHeuristics.cfg file, are now applied to the Directory Listing Style parameter.

The eWay's FTP Heuristics support the following platform types:

- UNIX
- AS400
- AS400-UNIX
- HCLFTPD 6.0.1.3
- HCLFTPD 5.1
- MPE
- MSFTPD 2.0
- MSP PDS (Fujitsu)
- MSP PS (Fujitsu)
- MVS GDG (Generation Data Group)
- MVS PDS (Partitioned Data Sets)
- MVS Sequential
- Netware 4.11
- Windows NT 3.5
- Windows NT 4.0

- User Defined
- VM/ESA
- VMS
- VOS3 PDS (Hitachi)
- VOS3 PS (Hitachi)
- VOSK (Hitachi)
- Additional platforms and properties defined by the user, if applicable

Note: When using FTP with an **AS400 UNIX** system some specific FTP configuration settings are required (see [FTP Configuration Requirements for AS400 UNIX](#) on page 77).

The FTP Heuristic methods used for communication with **MVS Sequential**, **MVS GDG**, and **MVS PDS** for the Batch eWay are designed for FTP servers (at the mainframe) that use the **IBM IP** stack.

Therefore, when you use FTP to an **MVS Sequential**, **MVS GDG**, or **MVS PDS** file system on a mainframe computer, you need to make sure that the FTP server is using an **IBM IP** stack. If any other IP stack is in place, the FTP Heuristic features will not work or may require modification.

A **User Defined** platform type is provided in the FtpHeuristics.cfg file which allows the user to modify the properties for an unlisted platform (see [Modifying the FTP Heuristics](#) on page 67).

Additional platforms types may also be added to the FtpHeuristics.cfg file by copying and pasting the User Defined properties (or any of the other platform properties sections), providing a unique name, and modifying the properties for that specific platform. The new platform option is then available to the **Directory Listing Style** parameter (see [Directory Listing Style](#) on page 28).

The following systems support Japanese mainframes:

- MSP PDS (Partitioned Data Sets)
- MSP PS (Physical Sequential)
- VOS3 PDS (Partition Data Sets)
- VOS3 PS (Physical Sequential)
- VOSK

3.8.1 Modifying the FTP Heuristics

The FTP Heuristics properties are configured by modifying the FtpHeuristics.cfg file for a specific system. To open and modify the FtpHeuristics.cfg file do the following:

- 1 From the directory <ican50 directory>\repository\data\files\eWay\BatchFTP extract **batchadapter.rar** to a temporary directory using a zip program such as WinZip™.

- 2 From the temporary file, extract the **hostupdate.jar** file in the same manner that you extracted the .rar file in step 1.
- 3 From the extracted files, open the **configs\FtpHeuristics\FtpHeuristics.cfg** file using any text editor program such as Notepad™.
- 4 Modify the FTP Heuristics properties as needed for your specific system.
- 5 Save and repackage the updated files, replacing the FtpHeuristics.cfg file and zipping up the hostupdate.jar and batchadapter.rar files.

The updated FtpHeuristics.cfg file is global for all logical hosts deployed from the repository.

3.8.2 FTP Heuristics Configuration Parameters

This section describes the configuration parameters for the **Batch FTP Heuristics** located in the **FtpHeuristics.cfg** file. The Batch FTP Heuristics configuration file (FtpHeuristics.cfg) contains the full set of parameters for each of the platforms listed under **Platform or File Type Selection** on page 66.

The FTP Heuristics configuration parameters are as follows:

- **Commands Supported by FTP Server** on page 69
- **Header Lines To Skip** on page 69
- **Header Indication Regex Expression** on page 69
- **Trailer Lines To Skip** on page 70
- **Trailer Indication Regex Expression** on page 70
- **Directory Indication Regex Expression** on page 70
- **File Link Real Data Available** on page 71
- **File Link Indication Regex Expression** on page 71
- **File Link Symbol Regex Expression** on page 71
- **List Line Format** on page 72
- **Valid File Line Minimum Position** on page 72
- **File Name Is Last Entity** on page 73
- **File Name Position** on page 73
- **File Name Length** on page 73
- **File Extension Position** on page 74
- **File Extension Length** on page 74
- **File Size Verifiable** on page 74
- **File Size Position** on page 75
- **File Size Length** on page 75
- **Special Envelope For Absolute Path Name** on page 75

- [Listing Directory Yields Absolute Path Names](#) on page 76
- [Absolute Path Name Delimiter Set](#) on page 76
- [Change Directory Before Listing](#) on page 77
- [Directory Name Requires Terminator](#) on page 77

Commands Supported by FTP Server

Description

Specifies the commands that the FTP server on the given host supports.

Required Values

One or more FTP commands as selected from the list.

Header Lines To Skip

Description

Specifies the number of beginning lines from a **LIST** command to be considered as a potential header (subject to the **Header Indication Regex Expression** configuration parameter, discussed below) and skipped.

Required Values

A non-negative integer. Enter zero if there are no headers.

Additional Information

In the example below, the line “total 6” comprises a one-line header.

```
total 6
-rw-r----- 1 ed      usr      110 Apr 15 13:43 AAA
-rw-r--r--  1 ed      usr      110 Apr 15 13:33 aaa
```

Header Indication Regex Expression

Description

Specifies a regular expression used to help identify lines which comprise the header in the output of a **LIST** command. All the declared lines of the header (see **Header Lines To Skip**, above) must match the regular expression.

Required Values

A regular expression. The default varies based on the FTP server’s operating system. If there is no reliable way of identifying the header lines in the **LIST** command’s output, leave this parameter undefined.

Additional Information

The regular expression “`^ *total`” indicates that each line in the header starts with “total,” possibly preceded by blanks, for example:

```
total 6
-rw-r----- 1 ed      usr      110 Apr 15 13:43 AAA
-rw-r--r--  1 ed      usr      110 Apr 15 13:33 aaa
```

If the regular expression is undefined, then the header is solely determined by the value of the configuration parameter **Header Lines To Skip**.

Trailer Lines To Skip

Definition

Specifies the number of ending lines from a **LIST** command that are to be considered as a potential Trailer (subject to the **Trailer Indication Regex Expression**) and skipped.

Required Values

A non-negative integer. Enter zero if there are no trailers.

Trailer Indication Regex Expression

Definition

Specifies the regular expression used to help identify lines which comprise the trailer in the output of a **LIST** command. All the declared lines of the trailer (see **Trailer Lines To Skip**) must match the regular expression.

Required Values

A regular expression. If there is no reliable way of identifying the trailer lines in the **LIST** output, then leave this parameter undefined.

Additional Information

If the regular expression is undefined, then the header is determined solely by the value of the **Trailer Lines To Skip** configuration parameter.

Directory Indication Regex Expression

Definition

Specifies a regular expression used to identify external directories in the output of a **LIST** command. Directories cannot be retrieved and must be filtered out of the file list.

Required Values

A regular expression. If there is no reliable way of identifying the trailer lines in the **LIST** output, then leave this parameter undefined.

Additional Information

The regular expression “`^ *d`” specifies that a directory is indicated by a line starting with the lowercase ‘d,’ possibly preceded by blanks, for example:

```
drwxr-xr-x  2 ed   usr   2048 Apr 17 17:43 public_html
```

File Link Real Data Available

Definition

Specifies whether a file may be a file link (a pointer to a file) on those operating systems whereon an FTP server will return the data for the real file as opposed to the content of the link itself.

Required Values

Yes or No.

File Link Indication Regex Expression

Definition

Specifies a regular expression that identifies external file links in the output of a **LIST** command. File links are pointers to the real file and usually have some visual symbol, such as `->`, mixed in with the file name in the output of the **LIST** command. Only the link name is desired within the returned list.

Required Values

A regular expression. If there is no reliable way of identifying a file link within a **LIST** output, then leave this parameter undefined.

Additional Information

The regular expression “`^ *l`” specifies that a file link is indicated by a line starting with the lowercase “l,” preceded possibly by blanks, for example:

```
lrwxr-xr-x  2 ed   usr   2048 Apr 17 17:43 p -> public_html
```

File Link Symbol Regex Expression

Definition

Specifies a regular expression that parses the external file link name in the output of a **LIST** command. Only the link name is required for the file list to be returned.

Required Values

A regular expression. If there is no reliable way of identifying a file link within a **LIST** output, then leave this parameter undefined.

Additional Information

The regular expression “`[] ->[]`” defines that a file link symbol is represented by an arrow surrounded by spaces (“ `->` ”). When parsed, only the file name to the right of the symbol is used.

In the following example, only the **public_html** would be used, not the “p” character:

```
lrwxrwxrwx 2 ed      usr  4 Apr 17 17:43 p -> public_html
```

List Line Format

Definition

Specifies whether fields in each line are blank delimited or fixed, that is, whether information always appears at certain columns.

Required Values

Blank Delimited or Fixed.

Additional Information

Even though some lines appear to be blank delimited, be wary of certain fields continuing their maximum value when juxtaposed with the next field without any separating blank. In such a case, we recommend you declare the line as “Fixed,” for example:

```
-rw-r--r-- 1 ed      usr      110 Apr 15 13:33 aaa
^^^^^^^^^^  ^  ^^      ^^^
              1      2 3      4      5 6 7 8 9
```

Valid File Line Minimum Position

Definition

Specifies the minimum number of positions (inclusive) a listing line must have in order to be considered as a possible valid file name line.

Required Values

For a **Fixed** list line format, enter a value equal to the number of columns, counting the first column at the far left as column 1. For a **Blank Delimited** list line format, enter a value equal to the number of fields, counting the first field on the far left as field 1.

For either case, if no minimum can be determined, set this value to zero (0).

Additional Information

For example, in the **Blank Delimited** line below, the minimum number of fields is 9:

```
-rw-r--r-- 1 ed      usr      110 Apr 15 13:33 aaa
^^^^^^^^^^  ^  ^^      ^^^
              1      2 3      4      5 6 7 8 9
                                           File Name
```

Note: *The URL FTP Proxy will fail on ascertaining file names that have leading blanks, trailing blanks, or both.*

File Name Is Last Entity

Definition

Specifies whether the file name is the last entity on each line. This allows the file name to have imbedded blanks (however, leading or trailing blanks are not supported).

Required Values

Yes or No.

File Name Position

Definition

Specifies the starting position (inclusive) of a file name.

Required Values

For **Fixed** list line format, enter the column number, counting the first column on the far left as column 1. For **Blank Delimited** list line format, enter the field number, counting the first field on the extreme left as field 1.

Additional Information

For **Blank Delimited** List Line Format only, if the file name has imbedded blanks, then it can span over several fields, for example:

```
-rw-r--r--  1 ed      usr      110 Apr 15 13:33 aaa
^^^^^^^^^^  ^  ^^    ^^^
           1      2  3      4          5  6  7      8      9
                                           File Name
```

File Name Length

Definition

Represents the maximum width of a file name; valid only for **Fixed** list line format.

Required Values

- **An Integer:** Positive lengths imply that the file name is right-justified within the maximum field width, and thus leading-blanks are discarded.
- **Negative Lengths:** That is, compared to the absolute length, imply that the file name is left-justified and trailing-blanks are discarded.
- **Zero (0) Value Length:** If the file name is at the end of a file listing line, this value implies that the file name field extends to the end of the line.

Note: For **Blank Delimited** list line format, this value is usually zero (0). However, if the **File Name Length** parameter is supplied even though a **Blank Delimited** list line format is specified, this implies that if the file name field exceeds the given length, then the rest of the **List Line** data occurs on the following line.

File Extension Position

Definition

Specifies the left-most position of the file extension for those operating systems that present the file name extension separated from the main file name.

Required Values

For **Fixed** list line format, enter the column number, counting the first column at the extreme left as column 1. For **Blank Delimited** list line format, enter the field number, counting the first field at the far left as field 1. If there is no file extension (as on UNIX systems) set the value to zero (0).

File Extension Length

Definition

Specifies the maximum width of the file extension; valid only for **Fixed** list line format.

Required Values

- **An Integer**
- **Positive Lengths:** Imply that the file extension is right-justified within the maximum field width and therefore leading-blanks are discarded.
- **Negative Lengths:** Imply that the file extension is left-justified and trailing-blanks are discarded (the absolute length is used).
- **Value of Zero (0):** *Always* for the **Blank Delimited** list line format.

File Size Verifiable

Definition

Specifies whether the file size is verifiable, significant, and accurate within a directory listing.

Required Values

Yes or **No**. The **File Size Stability Check** configurable parameter must also be enabled.

Additional Information

Even if the file size field of a listing line is not significant (that is, it is there but only represents an approximate value), the value of this parameter must be **No**. However, the file size location must still be declared in the **File Size Position** parameter below to assist determining which line of listing represents a valid file name, for example:

```
-rw-r--r--  1 ed      usr          110 Apr 15 13:33 aaa
              ^^^
              File Size
```

Note: *Use of this parameter does not guarantee that the file is actually stable. As this feature is intended only for backward compatibility with previous FTP implementations, we do not recommend that you rely on this functionality for critical data.*

File Size Position

Definition

Specifies the left-most position in the listing line that represents the size of the file. Even though for some operating systems the value shown might not truly reflect the file size, this position is still important in ascertaining that the line contains a valid file name.

Required Values

A non-negative integer. For **Fixed** list line format, the position value is the column number (starting with one (1) on the far left). For **Blank Delimited**, this value represents the field number (starting with one (1) on the far left). If the **LIST** line does not have a size field, set this parameter to zero (0).

Example

```

-rw-r--r--  1 ed      usr      110 Apr 15 13:33 aaa
^^^^^^^^^^  ^  ^^    ^^^      ^^^  ^^^  ^^^  ^^^  ^^^
           1      2 3      4           5  6  7   8   9
                                     File
                                       Size

```

The following text represents valid number representations of file sizes:

```
1234 or 1,234,567 or -12345 or +12345 or ' 1234 ' or 12/34 or
1,234/56
```

The following text represents invalid number representations of file sizes (the ^ indicates where the error occurs):

```
'12 34' or 123,45,678 or 123-456-789 or --123 or 123-
^          ^          ^          ^          ^
or 12345678901 or any number > 4294967295 or < -2147483647
^ (too large)
or 123.45 or 12AB34 or 0x45 or ,123,456 or 12//34
^          ^          ^          ^          ^
or /123 or 123/ or 12,3/45
^          ^          ^
```

File Size Length

Definition

Specifies the maximum width (number of columns) of the file size field, only valid for **Fixed** List Line Format.

Required Values

A non-negative integer. For **Blank Delimited** list line format, set this value to zero (0).

Special Envelope For Absolute Path Name

Definition

Specifies special enveloping characters required to surround an absolute path name (for example, single quotes are used in MVS). Only use a single quote at the start of the directory name.

Required Values

A pair of enveloping characters. Even if the leading and trailing character is identical, enter it twice.

If no enveloping characters are required for an operating system, leave this parameter undefined.

Note: On UNIX, this parameter is always undefined.

Listing Directory Yields Absolute Path Names

Definition

Specifies whether, when the **DIR** command is used on a directory name, the resulting file names are absolute.

Required Values

Yes or No.

Note: On UNIX, this character is always set to No.

Absolute Path Name Delimiter Set

Definition

Specifies any absolute path requiring certain delimiters to separate directory names (or their equivalent) from each other and from the file name.

Required Values

Enter the delimiters for the absolute path, starting from the left, for:

- Initial (left-most) directory delimiter
- Intermediate directory delimiters
- Initial (left-most) file name delimiter
- Optionally, the ending (right-most) file name delimiter

Wherever there is no specific delimiter, use “\0” (backslash zero) to act as a placeholder. Delimiters that are backslashes need to be escaped with another backslash (see Table 2).

Table 2 Delimiters and Path Naming by Platform

OS	Path Name Format	Delimiter Set				
		1	2	3	4	Enter
UNIX	/dir1/dir2/file.ext	/	/	/		///
Windows	C:\dir1\dir2\file.ext	\\	\\	\\		\\\\\\
VMS	disk1:[dir1.dir2]file.ext;1	[.]	;	[.];
MVS PDS	dir1.dir2(member)	\0	.	()	\0.)

Table 2 Delimiters and Path Naming by Platform (Continued)

OS	Path Name Format	Delimiter Set				
		1	2	3	4	Enter
MVS Sequential	dir1.dir2.filename	\0	.	.		\0..
MVS GDG	dir1.dir2.file(version#) (see Note)	\0	.	.		\0..
AS400	dir1/file.ext	\0	/	.		\0/.

Note: Where version # = 0 for current, +1 for new, -1 (-2, -3, etc.) for previous generations.

Change Directory Before Listing

Definition

Determines whether a change directory (**cd**) command needs to be done before issuing the **DIR** command to get a listing of files under the desired directory.

Required Values

Yes or No.

Note: The current Batch eWay implementation does not rely on this parameter.

Directory Name Requires Terminator

Definition

Determines whether a directory name that is not followed immediately by a file name requires the ending directory delimiter as a terminator (for example, as on VMS).

Required Values

Yes or No.

3.9 FTP Configuration Requirements for AS400 UNIX

Note: When using FTP with an AS400 UNIX system, the following FTP configuration settings are required:

- ◆ FTP - Use PASV: **No** (see [Use PASV](#) on page 29)
- ◆ FTP Raw Commands - Pre Transfer Raw Commands: **site namefmt 1** (see [Pre Transfer Raw Commands](#) on page 31)

3.10 Dynamic Configuration

The BatchFTP OTD supports automatic connection during initialization. Automatic connection requires the following properties to be set in the eWay's configuration.

Environment Explorer properties:

- Host Name
- Server Port
- User Name
- Password

Connectivity Map properties:

- Target Directory Name
- Target Directory Name is Pattern (Yes or No)
- Target File Name
- Target File Name is Pattern (Yes or No)

These parameters must be set to valid values prior to using the BatchFTP OTD, so that the eWay can initialize successfully. After the initialization is successful, the parameters can be reconfigured from within the Collaboration Rule.

Dynamic configuration allows the user to change configuration settings (based on the data input or Collaboration Rule logic) on the fly. Changes are made to the Collaboration using the Collaboration Editor. Make any necessary changes to the configuration settings and perform the **put** or **get**. The project disconnects, reconnects with the new configuration settings, and performs the transfer.

Dynamic Configuration Sample

The following sample code demonstrates how to dynamically configure the eWay and perform a simple file transfer.

1 From BatchLocalFile:

- Set the TargetDirectoryName

```
//@map:Copy "InDir" to TargetDirectoryName  
BatchLocalFile_1.getConfiguration().setTargetDirectoryName( "InDir" );
```

2 From BatchFTP:

- Disconnect the eWay

```
//@map:Client.disconnect  
BatchFTP_1.getClient().disconnect();
```

- Set the TargetDirectoryName

```
//@map:Copy "OutDir" to TargetDirectoryName  
BatchFTP_1.getConfiguration().setTargetDirectoryName( "OutDir" );
```

- Set the HostName

```
//@map:Copy "myftphostname" to HostName  
BatchFTP_1.getClient().setHostName( "myftphostname" );
```

- Connect the eWay

```
//@map:Client.connect  
BatchFTP_1.getClient().connect();
```

3 Perform a simple file transfer:

- Get a local file

```
//@map:  
BatchLocalFile_1.getClient().get();
```

- Assign the Payload

```
//@map:Copy Payload to Payload  
BatchFTP_1.getClient().setPayload(BatchLocalFile_1.getClient().getPay  
load() );
```

- Put a file on the FTP server

```
//@map:Client.put  
BatchFTP_1.getClient().put();
```

To view the Collaboration Editor's Java Source Editor, click the **Advance mode** or **Source Code mode** icon, available on the Collaboration Editor toolbar.

3.11 Alerting and Logging

eGate provides an alerting and logging feature. This allows monitoring of messages, and captures any adverse messages in order of severity based on configured severity level.

Logging Categories for the Batch eWay

The following logging categories apply to the Batch eWay. The level of logging for each category can be modified from the Enterprise Manager's Monitor.

- Batch eWay
- eWay management framework
- eWay resource adapter framework
- eWay hostadapter
- eWay hostadapter resource adapter

For information on enabling or modifying the level of logging for the each logging category, see the *eGate Integrator System Administration Guide*.

Note: *The alerts/status notifications for the Batch eWay are currently limited to Started, Running, Stopping, and Stopped.*

Understanding Batch eWay OTDs

This chapter provides an overview of the Object Type Definitions (OTDs) available with the Batch eWay. The OTDs include fields that contain methods, properties, and their application.

What's in This Chapter

- [Overview of the Batch OTDs](#) on page 81
- [OTD for FTP Operations](#) on page 82
- [OTD for Local File](#) on page 87
- [OTD for Batch Record Processing](#) on page 96
- [OTD for Batch Input \(Trigger\) File](#) on page 100
- [Using Regular Expressions](#) on page 100
- [Using Special Characters](#) on page 104

4.1 Overview of the Batch OTDs

An OTD contains a set of rules that define an object. The object encodes data as it travels through eGate. OTDs are used as the basis for creating Collaboration Definitions for a project.

Each OTD acts as a template with a unique set of features of the eWay. The Batch eWay OTD template is not customizable and cannot be edited.

The four parts of an OTD are:

- **Element:** An element is the highest level in the OTD tree. The element is the basic container that holds the other parts of the OTD. The element can contain fields and methods.
- **Field:** Fields are used to represent data. A field can contain data in any of the following formats: string, boolean, int, double, or float.
- **Method:** Method nodes represent actual Java methods.
- **Parameter:** Parameter nodes represent the Java methods' parameters.

A high-level view of the OTD folder structure shows methods and attributes you can use in creating Business Rules that invoke FTP, batch record, or local file data exchange.

4.1.1 Types of Batch eWay OTDs

Table 3 shows the specialized OTDs available with the eWay.

Table 3 Batch eWay OTDs

OTD Name	Description
BatchFTP	Provides FTP access to remote systems.
BatchLocalFile	Provides easy access to local file systems.
BatchRecord	Allows the eWay to parse or create (or both) payloads of records in specified formats.
BatchInbound	Polls for input file, renames the file to a GUID, and triggers the Business Process or Collaboration.

This chapter explains each of these OTDs and how to use them with the eWay.

4.1.2 OTD Components

Each of the OTDs is made up of the following components:

- **OTD Operation:** The OTD is used in a Collaboration Rule to operate with eWays.
- **Definition and eGate Enterprise Designer:** An **eWay Properties Sheet** is available, providing a central location in which you can define the eWay’s properties.
- **eWay:** An eWay provides access to the information necessary to interface with a specified external application.

All OTDs must be configured and administered using the Enterprise Designer.

Note: For complete information on how to use the Enterprise Designer and the eWay Properties Sheet, see the *eGate Integrator User’s Guide*.

Client Components

Any client components relevant to these OTDs have their own requirements. See the client system’s documentation for details.

4.2 OTD for FTP Operations

The Batch eWay includes an OTD that allows you to perform FTP data-transfer functions, the BatchFTP OTD.

The combination of this OTD, working with a specific eWay with its own set of configurable parameters, defines the characteristics of the external interface. Using the BatchFTP OTD and one or more eWays, you can create the Collaboration Rules to make the Batch eWay behave in specific ways.

Note: Create Collaboration Rules using the eGate Enterprise Designer's Collaboration Rules Editor. For more information on this feature, see the *eGate Integrator User's Guide*.

The BatchFTP OTD enables the eGate system to exchange data with other network hosts for the purpose of receiving and delivering objects stored in files. The BatchFTP OTD data uses a byte array. You must also use a byte array for the payload copy, specifically for binary transfers.

Caution: It is recommended to use a byte array in all cases. Failure to do so can cause loss of data.

4.2.1 OTD Structure and Operation

The BatchFTP OTD contains three top-level nodes, Configuration, Client, and Provider. Each is described in the sections to follow. You can expand these nodes in the OTD Editor to reveal additional sub-nodes.

Configuration Node

Each field sub-node in the **Configuration** node of the OTD corresponds to one of the eWay's FTP configuration parameters.

Client and Provider Nodes

This OTD includes two additional top-level nodes, the **Client** and **Provider**. These nodes implement their respective functionality interfaces in the eWay.

- The *client interface* represents how the functionality of the provider is actually used.
- The *provider interface* represents all the general FTP operations that can be performed in the OTD.

These operations are the FTP services provided to those who want to use them to create their own implementation.

4.2.2 BatchFTP OTD Node Functions

The following list provides an explanation of each node in the BatchFTP OTD, including primary functions:

- **BatchFTPOTD:** Represents the OTD's root node.
- **Configuration:** Each field sub-node within this node corresponds to an eWay configuration parameter and contains settings information. See [OTD for FTP Operations](#) on page 82 for details on these parameters and settings.

Note: This OTD has configuration parameters that can be regular expressions. See [Using Regular Expressions](#) on page 100 for details.

- **Client:** This node contains the following sub-nodes, which implement the eWay's client interface in the OTD (**FtpFileClient**):
 - ♦ **Payload:** An in-memory buffer that contains the payload or message data you want to transfer by FTP, in the form of a byte array.
 - ♦ **UserProperties:** Only used if you have provided a user-defined implementation of the **FtpFileClient** interface (see [Chapter 5](#) for details); in such cases, the node represents the properties specified in the configuration.
 - ♦ **InputStreamAdapter** and **OutputStreamAdapter:** Allow you to use and control the OTD's data-streaming features; see [Streaming Data Between Components](#) on page 108 for details.

Note: You can transfer data using the **Payload** node or by using data streaming (**InputStreamAdapter** and **OutputStreamAdapter** nodes), but you cannot use both methods in the same OTD.

- ♦ **ResolvedNamesForGet** and **ResolvedNamesForPut:** Allow you to get the real file or directory name used during a transfer and perform an operation with it. For example, you could do a file transfer, with **get()** or **put()**, using the real name. You are able to retrieve the real file or directory name, even if these names have been expressed using regular expressions or special characters.

These nodes contain sub-nodes allowing you to resolve file and directory names for target destinations, as well as names for pre- and post-transfer commands (see [Pre/post File Transfer Commands](#) on page 89 for details).

Note: See [Resolving Names](#) on page 105 for more information on these nodes; see [Using Regular Expressions](#) on page 100 for more information on regular expressions.

- ♦ **get(), put(), reset(), connect(), disconnect(), and isConnected():** See [Essential BatchFTP OTD Methods](#) on page 86.
- **Provider:** The sub-nodes contained in this node are methods that implement the eWay's provider interface in this OTD (**FtpFileProvider**). These methods allow you to do the general FTP operations that can be performed using the OTD.

4.2.3 Using the BatchFTP OTD

The BatchFTP OTD nodes allow you to configure specific eWay configuration parameters for the Collaboration controlling the FTP process. Once you have set the configuration parameters as desired, you do not have to define the same parameters in each corresponding eWay component that uses this Collaboration.

Handling Type Conversions

The **Payload** node in the BatchFTP OTD is predefined as a byte array (**byte[]**). This definition allows the eWay to handle both binary and character data.

For example, you could be using another OTD (such as an OTD from another eWay or a user-defined OTD) where the “data” node has been defined as a string (**java.lang.String**). If you were to drag and drop that string to the BatchFTP OTD’s **Payload** node, the eGate Collaboration Rules Editor can do an automatic type conversion and create code similar to that shown in the next example.

You must use care with this feature. While it works in many situations, there can be occasions when the default encoding causes errors in the translation.

Code Conversion and Generation

For example, in a string-to-byte array conversion (or vice versa), the generated Java code could be:

```
getoutput().setPayload(STCTypeConverter.toByteArray  
    (getinput().getBlob()));
```

or

```
getinput().setBlob(STCTypeConverter.toString  
    (getoutput().getPayload()));
```

If you define the blob data as a byte array, no type conversion is necessary. When there is a conversion, the Collaboration Rules Editor uses the Java Virtual Machine (JVM) default encoding to do the conversion to code, as shown in the previous examples.

Note: For more information on the BatchFTP OTD’s node structure, see [BatchFTP OTD Node Functions](#) on page 83.

Type Conversion Troubleshooting

As explained previously, the default encoding and translation works for many situations. There are cases, however (for example, binary data such as a **.zip** file), when the encoding could cause errors in the translation. Depending on the data character set and JVM default encoding, you *must* choose the appropriate encoding. In most cases, using the encoding string “ISO-8859-1” is the best choice.

To use this encoding, you can modify the code manually by adding the encoding string. Taking the previous examples, the resulting code using “ISO-8859-1” is:

```
getoutput().setPayload(STCTypeConverter.toByteArray  
    (getinput().getBlob(), "ISO-8859-1"));
```

or

```
getinput().setBlob(STCTypeConverter.toString  
    (getoutput().getPayload(), "ISO-8859-1"));
```

Using this string solves this type conversion problem. For more information, see the appropriate JVM encoding reference manuals.

Essential BatchFTP OTD Methods

In addition to the field elements, the BatchFTP OTD's **Client** node contains methods that extend the client interface functionality of the eWay. These methods are essential to the proper use of the OTD and require some additional explanation. They are:

- **get()**: Retrieves a file from the remote FTP server then stores its contents as a data payload. The method retrieves the first matching file based on the **Target Directory Name** and **Target File Name** parameters and stores the contents as a data payload (a byte array). It then performs any **Post Transfer Command**.

Note: After this method call, you can get the payload's contents via the method `getPayload()`.

If no qualified file is available for retrieving, you get the exception containing `java.io.FTPFileException` as a nested exception.

- **put()**: Places the payload data on the FTP server, that is, it performs an append or put action from the **Payload** node to the remote FTP server and performs any **Post Transfer Command**.

If no qualified file is available for sending, you get the exception containing `java.io.FTPFileException` as a nested exception.

Note: When you are using the eWay's data-streaming feature, the `get()` and `put()` methods operate differently. See [Streaming Data Between Components](#) on page 108 for details on this operation.

- **reset()**: Allows you to return the **Client** node to its state immediately after the previous initialization.

Note: The `reset()` method is available in both BatchFTP and BatchLocalFile OTDs. It must be called when the OTD has to be reused for another transfer during the same execution of `executeBusinessRules()` (for example, when you are using the Dynamic Configuration feature). The `reset()` method resets the content of the **Client** node without resetting the whole OTD. If you attempt another transfer without calling `reset()` first, the system throws an exception and makes an entry in the eWay's error log file.

- **restoreConfigValues()**: Allows you to restore the configuration parameter defaults to the related eWay configuration.
- **connect()**, **disconnect()**, and **isConnected()**: Perform connection-related operations with respect to the FTP server.

Sequence Numbering

The sequence numbering feature allows you to set up the FTP target directory or file name to contain a sequence number. You can set the starting and maximum sequence numbers using the eWay configuration parameters for the OTD.

This parameter is used for the name pattern `%#`.

Starting Sequence Number

This parameter tells the eWay which value to start with in the absence of a sequence number from the previous run.

When the maximum sequence number is reached, the sequence number rolls over to the starting sequence number.

Maximum Sequence Number

This parameter tells the eWay when this value (the maximum sequence number) is reached, to reset the sequence number to the starting sequence number.

Note: *Keep in mind that the maximum sequence number **must** be greater than the starting sequence number.*

This feature is also available with the **BatchLocalFile OTD**. For more information on these configuration parameters, see [Sequence Numbering](#) on page 32.

Additional FTP File Transfer Commands

The BatchFTP OTD also allows you to enter commands to be executed directly before and after the file transfer operation. See [Pre/post File Transfer Commands](#) on page 89 for details.

4.3 OTD for Local File

The BatchLocalFile OTD provides access to files on your local system. While file access is not always necessary in eGate, it makes sense for the Batch eWay to have this feature because file processing is one of its core functions.

Additional BatchLocalFile features include regular expressions for accessing files and a sequence-numbering scheme for creating files. This section provides information about these features.

4.3.1 OTD Structure and Operation

Configuration Node

As in the BatchFTP OTD, each field sub-node under the **Configuration** node in the BatchLocalFile OTD corresponds to one of the eWay's configuration parameters for that OTD. See [BatchLocalFile Connectivity Map Properties](#) on page 51 for details.

Client Node

This OTD includes an additional top-level node, the **Client**. This node implements its respective functionality interface in the eWay.

The *client interface* represents how the functionality of the OTD is actually used. This functionality includes the basic operations and features of the OTD. The client interface provides the OTD's the file services those who want to use them.

4.3.2 BatchLocalFile OTD Node Functions

The following list explains the nodes in the BatchLocalFile OTD, including primary functions:

- **Configuration:** The field sub-nodes within this node corresponds to an eWay configuration parameter and contains the corresponding settings information. See [BatchLocalFile Connectivity Map Properties](#) on page 51 for details on these parameters and settings.

Note: This OTD has configuration parameters that can be regular expressions. See [Using Regular Expressions](#) on page 100 for details.

- **Client:** The following sub-nodes, contained in this node, implement the eWay's client interface in the OTD (**LocalFileClient**):
 - ♦ **ResolvedNamesToGet** and **ResolvedNamesToPut:** Allow you to get the real file or directory name used during a transfer and perform an operation with it. For example, you could do a local file transfer, with **get()** or **put()**, using the real name. You are able to retrieve the real file or directory name, even if these names have been expressed using regular expressions or special characters.

Note: See [Using Regular Expressions](#) on page 100 and [Using Special Characters](#) on page 104 for more information on these features.

- ♦ **InputStreamAdapter** and **OutputStreamAdapter:** Allow you to use and control the OTD's data-streaming features; see [Streaming Data Between Components](#) on page 108 for details.

These nodes contain sub-nodes allowing you to resolve file and directory names for target destinations, as well as names for pre- and post-transfer commands (see [Pre/post File Transfer Commands](#) on page 89 for details).

- ♦ **Payload:** An in-memory buffer that contains the payload or message data you want to transfer by local file, in the form of a byte array.

Caution: It is a good idea to use a byte array in all cases. Failure to do so can cause loss of data.

- ♦ **get()**, **put()**, and **reset()**: See [Essential BatchLocalFile OTD Methods](#) on page 92.
- ♦ **ResumeReadingInProgress:** This node allows you to resume a data-streaming file transfer operation that was interrupted for whatever reason. These transfers occur piece by piece and usually involve large files. This feature allows you to resume at the same point where the transfer left off when it stopped.

Note: You can transfer data using the **Payload** node or by using data streaming (**InputStreamAdapter** and **OutputStreamAdapter** nodes), but you cannot use both methods in the same OTD.

4.3.3 Using the BatchLocalFile OTD

This section explains how to use the BatchLocalFile OTD's features.

Note: There is no particular order for the calls that can be made on the BatchLocalFile OTD. The only required call is **reset()** after a transfer, if it is used for more than one transfer per Collaboration Rules execution. An example of this usage is a dynamic batch order with multiple files to be transferred.

*If you are using a Java Collaboration to generate multiple files with sequence numbers using the BatchLocalFile interface, you must call the **reset()** method to indicate the end of one file and the start of the next one.*

Advantages of Using the OTD

Using the BatchLocalFile OTD to read records from a local file has the following advantages:

- **Data Streaming:** Allows your system to stream data directly to and from a local file system when used together with the BatchFTP OTD or the record-processing OTD. This feature minimizes the required RAM when large files are read, because the entire file is never loaded in memory.
- **Resume Reading:** Allows your system to read large files in a number of subsequent Business Rule executions, when you are using data streaming. This operation is achieved by persisting information about the current successful file read operation and resuming the next read operation from that last stored position.

Note: For more information on the Resume Reading feature, see [Resume Reading Feature](#) on page 92..

Pre/post File Transfer Commands

The eWay has features that allow you to execute desired actions directly before or after the actual file transfer. You can enter these settings at the eWay configuration parameters or in the Configuration node of the desired OTD.

These features are available with both the BatchLocalFile OTD and the BatchFTP OTD.

Caution: When you are using **Rename**, if the destination file exists, different FTP servers can behave differently. For example, on some UNIX FTP servers, the destination file is overwritten without question. That is, no error or warning message is given. On other FTP servers, a Windows XP server for example, the system generates an error that results in exceptions being thrown in the called OTD method.

Be sure you are familiar with the native behavior of the corresponding FTP server. If you are in doubt, try the action at the command prompt. If the action displays an error message, it is likely to result in the throwing of an exception in the Collaboration.

Pre Commands

For an inbound transfer, the file can be made unavailable to other clients polling the target system with the same directory and file pattern or name (**Rename**). For an outbound transfer, you can perform an automatic backup of the existing file (**Copy**).

Your pre-transfer options are:

- **Rename:** Rename the target file for protection or recovery; you must provide a desired directory and file name.
- **Copy:** Copy the target file for backup or recovery; you must enter a desired directory and file name.
- **None:** Do nothing.

Note: The directory is created if it does not already exist.

To gain proper protection, backup, or recovery, you must choose the appropriate setting that serves your purpose. For example, to recover from failures on an outbound appending transfer, use the **Copy** setting. When specifying file and directory names you can use regular expressions, special characters, or both.

Post Commands

For an inbound transfer, you can mark the transferred file as “consumed” by making an automatic backup (**Rename**) or by destroying it permanently (**Delete**). For an outbound transfer, you can make the transferred file available to other clients by renaming it. When specifying file and directory names you can use regular expressions, special characters, or both.

Your post-transfer options are:

- **Rename:** Rename the transferred file; you must provide a desired directory and file name.
- **Delete:** Delete the transferred file (inbound transfers only).
- **None:** Do nothing.

Note: For an outbound transfer (publishing), the directory is created if it does not already exist.

Figure 23 shows a diagram of how the different pre- and post-file-transfer commands operate in carrying out **get()** and **put()** method calls.

Figure 23 Pre- and Post-transfer Processes

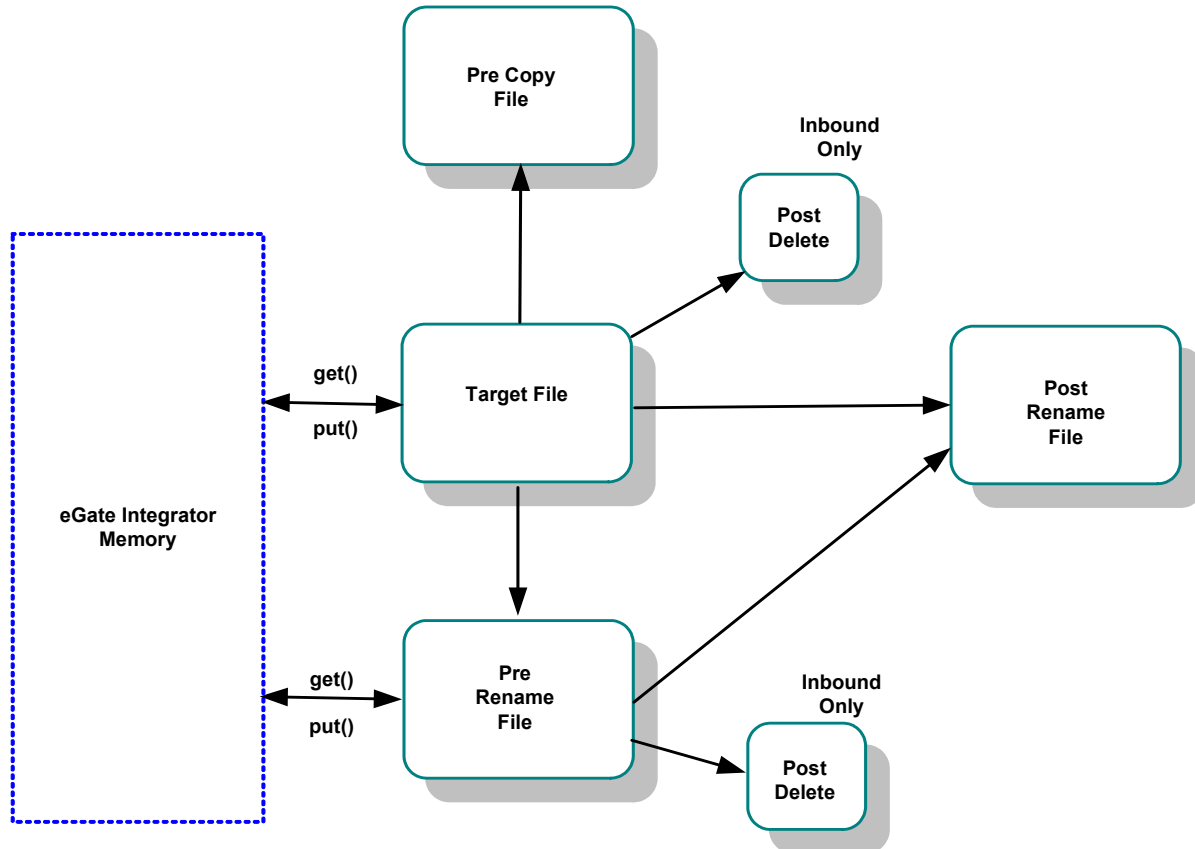

For information on the eWay configuration parameters for these commands, see:

BatchFTP OTD

- **Pre Transfer** on page 22
- **Post Transfer** on page 34

BatchLocalFile OTD

- **Pre Transfer** on page 22
- **Post Transfer** on page 34

Essential BatchLocalFile OTD Methods

In addition to the field elements, the BatchLocalFile OTD's **Client** node contains methods that extend the client interface functionality of the eWay. These methods are essential to the proper use of the OTD. These methods include:

- **get():** Retrieves a local file then stores its contents as a data payload. The method retrieves the first matching file based on the **Target Directory Name** and **Target File Name** parameters and stores the contents as a data payload (a byte array). It then performs any **Post Transfer Command**.

Note: After this method call, you can get the payload's contents via the method **getPayload()**.

- **put():** Stores the data payload (as a byte array) to a file. It then performs any **Post Transfer Command**.

Note: Before using this method call, you must set the file contents using the method **setPayload()**.

The method throws an exception (**LocalFileException**) if there is a problem.

- **reset():** Allows you to return the **Client** node to its state immediately after the previous initialization.

Note: The **reset()** method is available in both BatchFTP and BatchLocalFile OTDs. It must be called when the OTD has to be reused for another transfer during the same execution of **executeBusinessRules()** (for example, when you are using the Dynamic Configuration feature). The **reset()** method resets the content of the **Client** node without resetting the whole OTD.

Resume Reading Feature

The purpose of this feature is to allow the system to read large files in parts instead of processing the whole file at once. Resume Reading allows your system to read files in a number of subsequent Business Rule executions, when you are using data streaming.

General Operation

The Resume Reading feature's operation is achieved by keeping persistent information about the current successful file read operation, breaking, then resuming the next read operation from that last stored break position. As a result, the current file is read in parts, and the beginning and end of each part is determined by a predefined *break condition*.

You determine the break condition through the definition of your Business Rules. Since the Resume Reading feature operates based on reading one part of a file at a time per Business Rule, these rules must determine the break. Each Business Rule executes reading a part of the file, breaks, then passes to the next rule, which reads the next part up to the break, and so on, until the entire file is read.

A break condition can be any type of stopping point you determine in your Collaboration Rules. For example, this condition could be a fixed number of records, a delimiter, or reaching a specific character string.

The **Client** node in the OTD has a read-only property (**ResumeReadingInProgress** node) indicating whether there is a resume-reading operation in progress. This node is for informational purposes only. Also, the Resume Reading feature is available in the data-streaming mode only.

The feature has no special operational requirements besides setting the eWay configuration option. The eWay configuration has an option to enable or disable this feature. This option is also accessible at run time.

Note: *If this feature is enabled, the eWay always checks first for a resume-reading operation in progress. If this feature is not in progress, the eWay determines the next file based on the eWay configuration settings.*

Step-by-step Operation

Figure 24 shows a diagram of how the Resume Reading feature operates along with pre- and post-file-transfer commands. In this example, the Collaboration executes the same Business Rule four times. Each execution causes the Collaboration to read another section of the file. When the Collaboration reads the final records, it executes the Post-Transfer commands

Figure 24 Resume Reading Operation

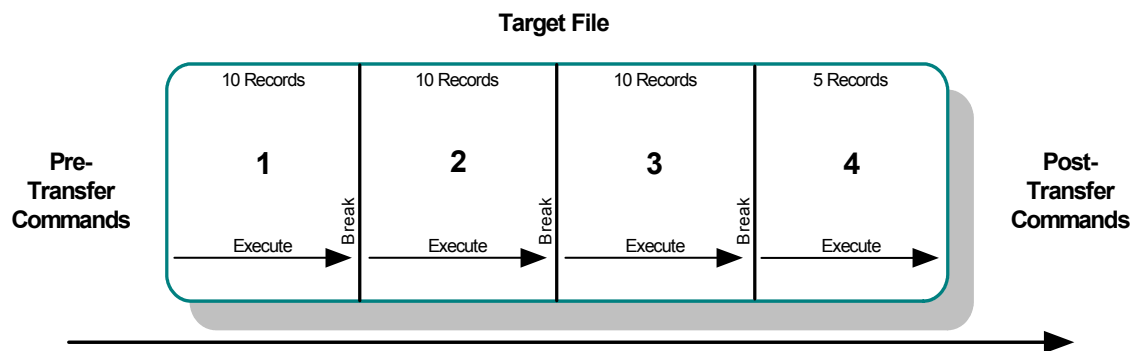

In this example, the reading happens in the following steps:

- 1 The eWay starts reading the file then reaches a break condition after a partial data read (the end of **Part 1**), the eWay's pre-transfer commands have already been executed. The resume-reading state is stored, and no post-transfer commands are executed. The eWay is waiting for the next execution of the Business Rule.
- 2 The resume-reading operation is in progress but still attains only partial data reads. The eWay reads from one break condition to the next (**Part 2** and **Part 3** in the figure) The resume-reading state is stored in each case, and the eWay executes the Business Rule once per each part.

- 3 The resume-reading operation is in progress and completes its data read during the final execution of the Business Rule (**Part 4**). The eWay reads from a break condition to the end of a file. No resume-reading state is stored, and any post-transfer commands are then executed.

In all of the previous steps, the Business Rule is executed repeatedly, and the current read position in the file changes on each execution. If the file is smaller than **Part 1** in the figure, the eWay does not reach a break condition. The operation is normal, and no resume-reading state is stored. The pre- and post-transfer commands are executed.

Operation Without Resume Reading Enabled

If the Resume Reading feature is not enabled:

- **Data-read Stop Then Restart:** Any unread data at the end of the file is ignored.
- **Resume Reading in Progress:** If there is a resume-reading operation in progress from a previous execution, an error is generated, and an exception is thrown.

***Note:** If there is a resume-reading operation in progress it cannot be interrupted and must be completed. The `executeBusinessRules()` method must be called enough times to fully consume the file. In other words, do not discontinue processing the file before it has been completely consumed.*

To Avoid Storing a Resume Reading State

Sometimes a partial data-stream read is necessary even when the Resume Reading feature is enabled. For example, there could be some application logic on top of the record parsers, which might abandon the rest of the file because of a corrupted record and close the file successfully after reading only part of the file's content.

In this case, you must set the `LocalFileOTD.Configuration.ResumeReading` node to **False** before calling `finish()`. This setting tells the BatchLocalFile OTD to complete the operation without storing a resume-reading state. You can set up the Collaboration Rule to then send notifications or take other measures, as desired.

Data Stream-adapter Provider

You can use the BatchLocalFile OTD to implement the eWay's data streaming feature. This feature is also available with the FTP and record-processing OTDs. However, the BatchLocalFile OTD is a data stream-adapter provider, while the other two OTDs are only consumers. See [Streaming Data Between Components](#) on page 108 for details on how to use the OTD's data streaming feature.

Sequence Numbering

Sequence numbering for the BatchLocalFile OTD operates similar to sequence numbering for the BatchFTP OTD. See [Sequence Numbering](#) on page 86 for details.

Generating Multiple Files with Sequence Numbering

When using a Java Collaboration to generate multiple files that have sequence numbering using the BatchLocalFile interface, `reset()` must be called to signify the end of one file and the start of the next.

Handling Type Conversions

This feature in this OTD operates in the same way as type conversion for the BatchFTP OTD. See [Handling Type Conversions](#) on page 85 for details.

4.3.4 Recommended Practice

It is recommended that Collaboration Rules use the record-processing OTD together with the BatchLocalFile OTD to parse records or construct payloads. This usage is a better practice than the use of only the BatchFTP OTD.

Example 1: Parsing a Large File

For example, you have set up a Collaboration Rule to parse a large file and submit the records to a database or a JMS IQ Manager. If something goes wrong during the parsing process, the whole file needs to be transmitted again from the FTP server.

In contrast, streaming from a local file system can avoid later FTP transfers of the same file in case of error. This approach has the advantage of allowing you to use data streaming and the Resume Reading feature with large files (see [Streaming Data Between Components](#) on page 108 and [Resume Reading Feature](#) on page 92).

Example 2: Slow, Complex Query

Another scenario could be a case where a slow, complex SQL query is used to retrieve a number of records. The Collaboration Rule packs them into a **Payload** node using the record-processing OTD then sends them via FTP to an external system. If the FTP transfer fails, the SQL query must be executed again.

In contrast, if the data payload has been stored locally with the BatchLocalFile OTD, the FTP transfer can be repeated without the need to re-execute the SQL query. In such cases, you can also use data streaming and local-file appending.

In both cases, the use of a data-streaming link can significantly reduce the memory requirements compared to the in-memory data-payload transfer used with the BatchFTP OTD.

4.3.5 OTD Limitations

The BatchLocalFile OTD supports mapped drives and NFS mounted drives. It does not, however, support the mapping of the drives. That is, the drive must already be mapped or mounted. The eWay itself does not perform any mapping or mounting.

The OTD supports Universal Reference Identifiers (URIs) but the scheme must be left off as follows:

\\drive\directory\file_name

4.4 OTD for Batch Record Processing

The Batch eWay's record-processing OTD allows you to *parse* (extract) *records* from an incoming *payload* (payload data) or to create an outgoing payload consisting of records. Understanding the operation of this OTD and how to use it requires an explanation of some of these terms.

The word *payload* here refers to an in-memory buffer, that is, a sequence of bytes or a stream. Also, *records* in this context are not records in the database sense. Instead, a record simply means a sequence of bytes with a known and simple structure, for example, fixed-length or delimited records.

For example, each of the following types of records can be parsed or created by this OTD:

- A large data file that contains a number of SAP IDocs, each with 1024 bytes in length.
- A data file that contains a large number of X12 purchase orders, each terminated by a special sequence of bytes.

The record-processing OTD can handle records in the following formats:

- **Fixed length:** Each record in the payload is exactly the same size.
- **Delimited:** Each record is followed by a specific sequence of bytes, for example, CR,LF.
- **Single:** The entire payload is the record.

Note: *When using character delimiters with DBCS data, use single byte character(s) or equivalent hex values with hex values that do not coincide with either byte of the double byte character.*

4.4.1 OTD Structure and Operation

Each field node in the **Configuration** node in the OTD corresponds to one of the eWay's record-processing configuration parameters.

4.4.2 Record-processing OTD Node Functions

The following list explains these primary nodes in the record-processing OTD, including their functions:

- **BatchRecord:** Represents the OTD's root node.
- **Configuration:** Each sub-node within this node corresponds to an eWay configuration parameter and contains the corresponding settings information, except for the **Parse or Create** parameter. See [BatchRecord Connectivity Map Properties](#) on page 61 for details.

Note: For the record-processing OTD, these configuration nodes are read-only. They are provided only for the purpose of accessing and checking the configuration information at run time.

- **Record:** A properties node that represents either:
 - ♦ The current record just retrieved via the **get()** method, if the call succeeded
 - ♦ The current record to be added to the data payload when **put()** is called
- **Payload:** The in-memory buffer containing the data payload byte array you are parsing or creating.

Caution: It is a good idea to use a byte array in all cases. Failure to do so can cause loss of data.

- **InputStreamAdapter** and **OutputStreamAdapter:** Allow you to use and control the data-streaming features of the OTD. For details on their operation, see [Streaming Data Between Components](#) on page 108.

Note: You can transfer data using the **Payload** node or by using data streaming (**InputStreamAdapter** and **OutputStreamAdapter** nodes), but you cannot use both methods in the same OTD.

- **put():** Adds whatever is currently in the **Record** node to the data payload. The method returns **true** if the call is successful.
- **get():** Retrieves the next record from the data payload (or stream), and it populates the **Record** node with the record retrieved. The method returns **true** if the call is successful.
- **finish():** Allows you to indicate a successful completion of either a parse or create loop for both **put()** and **get()**.

Note: Use **reset()** to indicate any errors and allow the OTD to clean up any unneeded internal data structures.

4.4.3 Using the Record-processing OTD

This OTD has the following basic uses:

- **Parsing a payload:** When the payload comes from an external system
- **Creating a payload:** Before sending the payload to an external system

A single instance of the OTD is not designed to be used for both purposes at the same time in the same Collaboration. To enforce this restriction, there is a setting under the eWay's General Settings parameters called **Parse or Create Mode**, for which you can select *either Parse or Create*.

Using `get()` and `put()`

The `get()` and `put()` methods are the heart of the OTD's functionality. If you call either method, the record retrieved or added is assumed to be of the type specified in the eWay configuration, for example, fixed-length or delimited.

The `get()` method can throw an exception, but generally this action only happens when there is a severe failure. One such failure is an attempt to call `get()` before the payload data (or stream if you are streaming) has been set. However, the best practice is to code the Collaboration to check the return value from a `get()` call. A return of `true` means a successful get operation; a `false` means the opposite.

Choosing the Parse or Create Mode

The eWay checks to ensure that the proper calls are made according to your mode setting. For example, calling `put()` in a parse-mode environment would cause the eWay to throw an exception with an appropriate error message explaining why. Calling `get()` in the create mode would also result in an error.

The eWay requires these restrictions because:

- If you are processing an inbound payload, you are calling `get()` to extract records from the payload (parsing). In this situation it makes little sense to call `put()`. Doing so at this point would alter the payload while you are trying to extract records from it. Calling `put()` would overwrite the payload and destroy the data you are trying to obtain.
- Conversely, when you are creating a payload by calling `put()`, you have no need to extract or parse data at this point. Therefore, you cannot call `get()`.

As a result, you can place the OTD on the source or destination side of a given Collaboration, as desired, and use the OTD for either parsing or creating a payload. However, you cannot parse and create at the same time. Implement your OTD in a Collaboration using the eGate Collaboration Rules Editor.

Creating a Payload

When you want the payload data sent to an external system, you can place the OTD on the outbound side of the Collaboration interfacing with that system. Successive calls to `put()` build up the payload data in the format defined in the eWay configuration.

Once all the records have been added to the payload, you can drag and drop the payload onto the node or nodes that represent the Collaboration's outbound destination. Also, you can set an output stream as the payload's destination (see [Chapter 5](#) for details on payload streaming).

When you are building a data payload, you must take into account the type and format of the data you are sending. The eWay allows you to use the following formats:

Single Record

This type of payload represents a single record to be sent. Each successive call to `put()` has the effect of growing the payload by the size of the data being put, and the payload is one contiguous stream of bytes.

Fixed-size Records

This type of payload is made up of records, with each being exactly the same size. An attempt to **put()** a record that is not of the size specified causes an exception to be thrown.

Delimited Records

This type of payload is made up of records that have a delimiter at the end. Each record can be a different size. Do not add any delimiters to this data type when it is passed to **put()**. The delimiters are added automatically by the eWay.

User Defined

In this type of payload, the semantics are fully controlled by your own implementation.

Parsing a Payload

To represent payload data inbound from an external system, you drag and drop the data onto the payload node in the OTD (in the Collaboration Rules Editor). In addition, you can specify an input stream as a source (see [Chapter 5](#) for details on payload streaming).

Extracting Records

Either way, each successive call to **get()** extracts the next record from the payload. The type of record extracted depends on the parameters you set in the eWay's configuration, for example, fixed size or delimited.

You must design the parsing Collaboration with instructions on what to do with each record extracted. Normally, the record can be sent to another Collaboration where a custom OTD describes the record format and carries on further processing.

Fully Consuming a Payload

It is possible to fully consume a payload. That is, after a number of successive calls to **get()**, you can retrieve all the records in the payload. After this point, successive calls to **get()** return the Boolean **false**. You must design the business rules in the subject Collaboration to take this possibility into account.

Parser Interface

The functionality underlying the record-processing component is described in the parser interface (**BatchRecordParser**). This interface is defined in the **com.stc.eways.batchext** package.

If you want to write your own record-parsing implementation, you can either implement this interface from scratch or derive it from one of our implementations changing only the method or methods you need to change.

Use With Data Streaming

If you are using the record-processing OTD with data streaming, you must be careful not to overwrite the output files. If the OTD is continually streaming to a BatchLocalFile OTD that uses the same output file name, the OTD can write over files on the output side.

To avoid this problem, you must use either file sequence numbering or change the output file names in the Collaboration Rules. Sequence numbering allows the BatchLocalFile OTD to distinguish individual files by adding a sequence number to them. If you use target file names, post-transfer file names, or both, you can change the name of the output file to a different file name.

For more information on how to use these features, see:

- [Sequence Numbering](#) on page 94
- [Pre/post File Transfer Commands](#) on page 89

4.5 OTD for Batch Input (Trigger) File

Polls for input file, renames the file to a GUID, and triggers the Business Process or Collaboration.

The Batch eWay's **BatchInbound** OTD acts similar to the inbound File eWay, in that it regularly polls an input directory for inbound target files. But unlike the File eWay, when a file with the appropriate name is received by the BatchInbound eWay, the target file is immediately locked so no other process can access it, and renamed to the form: **GUID.original_filename** to ensure that the file is not over-written and is only sent once. A GUID (Globally Unique Identifier) provides a unique, formatted string that represents a 128-bit value.

The BatchInbound OTD does not read the file, but renames the file in such a way that it provides the name of the file that triggers the Business Process or Collaboration

4.5.1 OTD Structure and Operation

The BatchInbound OTD contains one top-level node, **BatchAppconnMessage**, with three fields, **GUIDFileName**, **OriginalFileName**, and **PathDirName**. These nodes provide the external input directory, original file name, and the GUID file name.

4.6 Using Regular Expressions

A regular expression is a character string in which some characters provide special meaning in regard to matching patterns. This section explains some basic guidelines on how to use regular expressions with the Batch eWay.

4.6.1 Regular Expressions: Overview

Regular expressions allow you to specify wildcard patterns for the file name and directory name.

Note: *The full scope of regular expressions is not covered here. For a good explanation of regular expressions, see the book “**sed and awk**” by Dale Dougherty and Arnold Robbins (published by O’Reilly).*

The BatchLocalFile, BatchFTP OTD’s, and BatchInbound configurations allow you to use regular expressions, for example, if you want to access all files with the same extension. For more information on available characters and supported syntax when using regular expressions with the eWay, see the following Web site:

<http://www.cacas.org/java/gnu/regexp/syntax.html>

Regular expressions operate with the BatchLocalFile, BatchInbound, BatchFTP OTDs as follows:

- The directory/file names can be defined as either:
 - ♦ Actual file names (everywhere)
 - ♦ Name patterns (all names for put operations and pre/post transfer names for get operations)
 - ♦ Regular expressions (target names for get operations)
- The difference between the regular expressions and name patterns is:
 - ♦ Regular expressions are used to match existing names on the FTP server or the local file system.
 - ♦ Name patterns are used to create names by replacing the special characters in the pattern.

Note: *For more information on name patterns, using special characters, see [Using Special Characters](#) on page 104.*

You can specify an extension, for example, `.*\.dat$`. Then, each time the `get()` method is called, the eWay gets the next file with a `.dat` extension. The eWay then retrieves each file into the OTD’s **Payload** node and updates the working file-name attribute with the name of the file currently being accessed.

For another example, you can use the file-matching the pattern `data\.00[1-9]` to get the files `data.001`, then `data.002`, and so on. Note that in each case the “.” is escaped, which is consistent with regular-expression syntax. It also matches to `xyzdata.001` and `xyz.data.001`, because it does not exclude anything before “data”. To make “data” the exact start of the matching pattern you must use `^data\.00[1-9]` or `\A data\.00[1-9]`.

Caution: *The use of regular expressions is an advanced feature and must be implemented carefully. An improperly formed regular expression can cause undesired data or even the loss of data. You must have a clear understanding of regular-expression syntax and construction before attempting to use this feature. It is recommended that you test such configurations thoroughly before moving them to production.*

Entering Regular Expressions

You can enter a regular expression for the FTP or local file name in a variety of ways, for example, `**.dat$` or `^xyz.**.dat$`. The first case indicates all files with an extension of `.dat`. The second case indicates all file names with an extension of `.dat` whose names start with `xyz`.

Another example could be `file[0-9]\.dat`. This expression specifies `file0.dat`, `file1.dat`, `file2.dat`, and so on, through `file9.dat`. This will also match `xyz.file0.dat`, `xyz.file1.dat`, and so on. This type of expression will not exclude anything in front of “file”. To exclude any characters before “file” (to make “file” the exact beginning) use `^file[0-9].dat` or `\Afile[0-9].dat`.

These types of regular expression patterns can be used for a get operation.

Regular Expressions and the eWay

You must exercise great care when using regular expressions. This tool can give the new, inexperienced user problems.

Note that there is a **File Name Is Pattern** or **Directory Name Is Pattern** configuration parameter in the eWay configuration interface, after every parameter where you can choose whether to enter a regular expression. This feature allows you to specify that the pattern entered is a regular expression or just a static text entry to be interpreted literally.

***Important:** Regular expressions resolve even with a partial match to the file name. The resolution process searches for what the file name contains instead of what the file name is.*

4.6.2 Rules for Directory Regular Expressions

There are special considerations you must take into account when you are using regular expressions for directories. This section explains the general rules and guidelines for using directory regular expressions with the Batch eWay. It also provides some examples.

Basic Directory Regular Expression Rules

The following are the general rules for directory regular expressions:

- The directory root, the drive name, and directory separators must be expressed exclusively. That is, do not express any of these elements as a regular expression. Only folder names are expected to appear as regular expressions.
- A regular expression must not span over the directory separators. So, if you use a regular expression between two directory separators, it must be one whole expression.
- Escape all directory separators in a directory pattern if the separator conflicts with a regular expression special character (that is, ' * [] () | + { } : . ^ \$? \ "). The back slash (\) is the special character used to escape other special characters in regular expressions. For Windows platforms, the directory separator is the back slash, so it must be escaped as \ \ .
- For the Windows Universal Naming Convention (UNC), the directory root (including the computer name and the shared root folder name) must be expressed exclusively. That is, do not express the computer name and shared root folder as a regular expression.
- Different platforms require different regular expression patterns, for example:
 - ♦ With Windows platforms, use the following pattern:
`drive:\\regexp1\\regexp2\\regexp3 ...`
 - ♦ With UNIX platforms, including mounted directories, use the following pattern:
`/regexp1/regexp2/regexp3 ...`
 - ♦ With Windows UNC platforms, use the following pattern:
`\\\\machineName\\shared_folder\\regexp1\\regexp2\\regexp3 ...`

Directory Regular Expression Examples

Several examples of directory regular expression usage follow:

Windows Examples

```
c:\\eGate$\\^client\\collab\\D\\ ...
```

The expression `\\D` means any non-digit character.

```
d:\\a.b\\c.d\\e.f\\g.h\\[0-9]\\ ...
```

The symbol `."` means any character

UNIX Examples

```
/abc\\d\\def\\ghi/ ...
```

The expression `\\d` means any digit character.

```
/^PRE[0-9]{5}\\dat$/ ...
```

This expression means to begin with **PRE** followed by a five-digit number and use a `.dat` extension. The symbol `\\.` means to interpret the real character (a period) instead of any character. Therefore, **PRE12345.dat** does match, but **PRE123456dat** does not.

Windows UNC Example

```
\\\\My_Machine\\public\\xyz$\\^abc
```

The prefix for Windows UNC platforms is \\ . After escaping, it becomes \\\\ .

4.7 Using Special Characters

The Batch eWay allows you to use *special characters* to symbolize often-used information in a short-hand way. You can use these character combinations to specify place holders for this information. Using these symbols, you can quickly convey date/time, number, and file-name information.

Special characters are utilities the eWay uses for file-name expansion. The general rules for their use are:

- Use % to indicate the special character that needs to be expanded.
- Use %% to indicate the escaped character %; for example, **abc%%d** means **abc%d**, and the **%d** is not expanded again.

Note: For information on regular expressions, see [Using Regular Expressions](#) on page 100.

For example, for a put operation, a pattern such as **file%#.dat** can be used. This pattern uses the sequence number setting in the configuration, and each put creates successive files named **file1.dat**, **file2.dat**, and so on.

4.7.1 Types of Name Expansion

The eWay provides the following types of name expansion:

Date/Time stamp

- Uses the format %[GyMdhHmsSEDFwWakKz], for example, **abc%y%y%y%y** means **abc2001** (see [Table 4 on page 105](#) for more information).

Sequence number

- Uses the format %#, %5#, for example, **abc%#** means **abc1**, **abc2**, **abc3**, and so on; for another example, **abc%5#** (zero-padded) means **abc00001**, **abc00002**, **abc00003**, ..., **abc00010**, ..., **abc00100**, and so on.

Working-file name

- Uses the format %f; normally, it is used for pre- or post-file-transfer commands (see [Pre/post File Transfer Commands](#) on page 89), for example, **%f.abc** means **working_filename.abc**.

The sequence of expansion operates in the reverse order of the previous list, that is, first the file name is expanded, then the sequence number, and finally the time stamp.

Additional Examples

- **abc.%y%y%y%y%y%M%M%d%d.%h%h%m%m%s%s%S%S** means **abc.20011112.162532678**
- **abc%#.def%#** means **abc2.def3**
- **%f.%#** means **xxxxx.4, xxxxx.5, ...**

Where xxxxx is the working-file name.

4.7.2 Resolving Names

Typically, the pre/post names with patterns are resolved during **get()** and **put()** method calls. But sometimes, in using Collaboration Rules, the eWay has to get the resolved names before the actual **get()** or **put()** call.

In such cases, you can get the resolved names in this way through the **ResolvedNamesForGet** and **ResolvedNamesForPut** nodes in the BatchFTP OTD, for example:

getResolvedNamesForPut().getTargetFileName()

The previous code yields **file1** based on the pattern **file%#**. In this usage, the OTD nodes can be used to make the desired method call.

Note: See **BatchFTP OTD Node Functions** on page 83 for more information on BatchFTP OTD nodes.

4.7.3 Date/time Format Syntax

The eWay uses the Java simple default date and time format syntax (U.S. locale). To specify these formats for name expansion, you must use a time pattern string.

Note: The eWay uses the Java standard for date/time stamps from the Java class **java.text.SimpleDateFormat**. Some of these formats can differ from the list given here, depending on the Java SDK version you are using.

In these patterns, all ASCII letters are reserved as pattern letters. See Table 4 for a complete list.

Table 4 Time Pattern Strings and Meanings

Symbol	Meaning	Presentation	Example
%G	Era designator	Text	AD
%y	Year	Number	1996
%M	Month in year	Text and number	July & 07
%d	Day in month	Number	10
%h	Hour in a.m./p.m. (1 through12)	Number	12
%H	Hour in day (0 through 23)	Number	0

Table 4 Time Pattern Strings and Meanings (Continued)

Symbol	Meaning	Presentation	Example
%m	Minute in hour	Number	30
%s	Second in minute	Number	55
%S	Millisecond	Number	978
%E	Day in week	Text	Tuesday
%D	Day in year	Number	189
%F	Day of week in month	Number	2 (second Wednesday in July)
%w	Week in year	Number	27
%W	Week in month	Number	2
%a	Marker for a.m./p.m.	Text	PM
%k	Hour in day (1 through 24)	Number	24
%K	Hour in a.m./p.m. (0 through 1)	Number	0
%z	Time zone	Text	Pacific Standard Time

The general rules for date/time formats are:

- **Text:** The count of pattern letters determines the format as follows:
 - ♦ For four or more pattern letters, use the full form.
 - ♦ For fewer than four, use the short or abbreviated form if one exists.
- **Number:** The minimum number of digits as follows:
 - ♦ Shorter numbers are zero-padded to this amount.
 - ♦ The year is handled differently; that is, if the count of “y” is two, the year is truncated to two digits.
- **Text and number:** For three or more pattern letters, use text; otherwise use a number.
- **Quotes and delimiters:** Use these symbols as follows:
 - ♦ Enclose literal text you want rendered within single quotes.
 - ♦ Use double quotes to mean single quotes.
 - ♦ Use commas for delimiters.

Examples

Table 5 shows some examples using the U.S. locale.

Table 5 U.S. Locale Date/time Patterns

Format Pattern	Result
yyyy.MM.dd, G, 'at' hh:mm:ss, z	1996.07.10 AD at 15:08:56 PDT
E, M, dd, 'yy	Wednesday, July 10, '96
h:mm, a	12:08 PM
h, 'o'clock' a, z	12 o'clock PM., Pacific Daylight Time
K:mm a, z	0:00 p.m., PST
yyyyy.M.dd, G, hh:mm, a	1996.July.10 AD 12:08 PM

Additional Features

This chapter explains additional features of the Batch eWay, including Data Streaming, SOCKS, SSH Tunneling, and Ensuring Secure FTP Data Transfers.

What's in This Chapter

- [Streaming Data Between Components](#) on page 108
- [SOCKS FTP Support](#) on page 112
- [SSH Tunneling Support](#) on page 114
- [Ensuring Secure FTP Data Transfers](#) on page 117

5.1 Streaming Data Between Components

Components in the Batch eWay implement a feature for *data streaming*. This chapter explains data streaming, how it works, and how to use it with the eWay and eGate Integrator.

5.1.1 Introduction to Data Streaming

Data streaming provides a means for interconnecting any two components of the eWay by means of a *data stream channel*. This channel provides an alternate way of transferring the data between the Batch eWay components. Streaming is available between BatchLocalFile and BatchFTP, or BatchLocalFile and BatchRecord.

Each OTD component in the eWay has a **Payload** node. This node represents the in-memory data and is used when the data is known to be relatively small in size or has already been loaded into memory. The node can represent, for example, the buffer in the record-processing OTD, as it is being built or parsed, or the contents of a file read into memory.

Instead of moving the data all at once between components in eGate's memory, you can use a *data-stream channel* to provide for streaming the data between them a little at a time, outside of eGate.

Data streaming was designed primarily to handle large files, but you can use it for smaller data sizes as well.

You will use the eGate Enterprise Designer's Collaboration Rules Editor to set up data-streaming operations. The rest of this section explains the data streaming feature and how to set it up.

Note: *Payload-based and streaming-based transfers are mutually exclusive. You can use one or the other but not both for the same data.*

5.1.2 Overcoming Large-file Limitations

The primary advantage of using data streaming is that it helps to overcome the limitations of dealing with large files. For example, if you have a 1-gigabyte file that contains a large number of records, you need a large amount of resources to load the payload into memory just to parse it.

Streaming allows you to read from the file, little by little, using a data-streaming mechanism. This way, you do not need to load the file into the eGate system's memory. Using streaming is not as fast as using in-memory operations, but it is far less resource-intensive.

5.1.3 Using Data Streaming

Each data-streaming transfer involves two OTDs in a Collaboration as follows:

- One provides the *stream adapter*.
- The other consumes the stream adapter to perform the data transfer.

Caution: *Implementing `InputStream` must support `skip()` with negative numbers as an argument.*

This section explains how the two data-streaming OTDs operate to effect the transfer of data.

Data-streaming Operation

Each of the OTDs in the Batch eWay exposes stream adapter nodes that enable any OTD to participate in data-streaming transfers. The nodes are named **InputStreamAdapter** and **OutputStreamAdapter**. You can associate the stream adapters by using the drag-and-drop features of the eGate Enterprise Designer.

The **InputStreamAdapter** (highlighted) and **OutputStreamAdapter** nodes in the OTD are used for data streaming. This feature operates as follows:

- **Stream-adapter consumers:** The FTP and the record-processing OTDs can only *consume* stream adapters. Therefore, their stream-adapter nodes are *write-only*. Their node values can be *set* (modified).
- **Stream-adapter provider:** The local file OTD can only *provide* stream adapters, so its stream-adapter nodes are *read-only*. Its node value can only be *retrieved*.

The local file OTD is always the stream provider, and the FTP and record-processing OTDs are the consumers.

Note: For an explanation of the eWay's different types of OTDs, see [Chapter 4](#).

Data Streaming Versus Payload Data Transfer

Use of the **InputStreamAdapter** and **OutputStreamAdapter** nodes is an alternative to using the **Payload** node as follows:

- Use these stream adapter nodes to transfer data if you want data streaming.
- Use the **Payload** node for a data transfer *without* data streaming (payload data transfer).

All operations that, in payload data transfer, *read* from the **Payload** node require the **InputStreamAdapter** node when you are setting up data streaming. Using the same logic, all operations that, in payload data transfer, *write* to the **Payload** node require **OutputStreamAdapter** node for data streaming.

Do *not* confuse the stream adapter nodes with the **get()** and **put()** methods on the OTDs. For example, the BatchFTP OTD's client interface **get()** method *writes* to the **Payload** node during a payload transfer, so it requires an **OutputStreamAdapter** node to write to for data streaming. In contrast, the record-processing OTD's **get()** method *reads* from the **Payload** node during a payload transfer, so for data streaming, **get()** requires an input stream adapter to read from.

Data Streaming Setups

The eWay provides four basic data-streaming setups, allowing you to transfer data:

- From a local file system to a record-processing setup (uses **InputStreamAdapter** node in OTD)
- From a record-processing setup to a local file system (uses **OutputStreamAdapter** node in OTD)
- From a local file system to a remote FTP server (uses **InputStreamAdapter** node in OTD)
- From a remote FTP server to a local file system (uses **OutputStreamAdapter** node in OTD)

Consuming-stream Adapters

This section explains how to use consuming-stream adapters.

To obtain a stream

- Use the **requestXXStream()** method to obtain the corresponding **XX** stream.

To use a stream

- Perform the transfer using the methods provided by the stream.

To dispose of a stream

- Release any references to the stream.
- Release the stream (**XX**) using the **releaseXXStream()** method. Some of the OTDs support post-transfer commands. The **Success** parameter indicates whether these commands are executed. Do not close the stream.

5.1.4 Stream-adapter Interfaces

This section provides the Batch eWay's OTD stream-adapter Java interfaces. This information is only for advanced users familiar with Java programming, who want to provide custom OTD implementations for stream-adapter consumers or providers.

Inbound Transfers

The following Java programming-language interface provides support for inbound transfers from an external system:

```
public interface com.stc.eways.common.eway.streaming.  
    InputStreamAdapter {  
    public java.io.InputStream requestInputStream() throws  
        StreamingException;  
    public void releaseInputStream(boolean success) throws  
        StreamingException;  
}
```

Outbound Transfers

The following Java interface provides support for outbound transfers to an external system:

```
public interface com.stc.eways.common.eway.streaming.  
    OutputStreamAdapter {  
    public java.io.OutputStream requestOutputStream() throws  
        StreamingException;  
    public void releaseOutputStream(boolean success) throws  
        StreamingException;  
}
```

5.2 SOCKS FTP Support

This section explains the SOCKS FTP features available for the Batch eWay.

5.2.1 SOCKS

SOCKS is an Internet Engineering Task Force (IETF) -approved standard (RFC 1928) generic, proxy protocol for TCP/IP-based network applications. This simple protocol supports a flexible framework for developing secure communications. SOCKS accomplish this by easily integrating other security technologies.

Note: *The eWay only supports SOCKS protocols that conform to this IETF standard.*

There are two versions of the SOCKS protocol.

- **SOCKSv4** (version 4), that provides the following functions:
 - ♦ requests connections
 - ♦ Setup proxy clientss
 - ♦ transmits application data
- **SOCKSv5** (version 5) that includes all the functionality of version 4 and also provides authentication

Both the SOCKSv4 and SOCKSv5 protocols are supported by the Batch eWay. To enable support, the following properties must be specified in the Batch eWay Properties Sheet:

- SOCKS server name
- SOCKS server port number
- User name
- Encrypted password

Details of these configuration parameters are provided under **“SOCKS Configuration Properties” on page 113**.

Note: *In the Collaboration Rules, make sure you set the SOCKS version number to 4, 5, or -1 (unknown). Do not set this value to any other number.*

SOCKS: Overview

SOCKS embodies two components, the **SOCKS Server** (implemented at the application layer), and the **SOCKS Client** (implemented between the application and transport layers).

In essence, the purpose of the SOCKS protocol is to allow a host on one side of a SOCKS Server to interact with a host on the other side of the Server, subject to authentication, without passing IP packets directly between the two.

SOCKS Proxy Server

The SOCKS proxy server connects to the application server on behalf of the application client, and functionality relays data between the client and an application server. From the application server's perspective, the SOCKS proxy is the client.

SOCKS and the Batch eWay

Negotiation Methods

The BatchFTP eWay supports the following methods used to define the negotiation phase of authentication between the Socks Client and Server:

- No-authentication (no authentication required)
- User/password (user name and password)

SOCKS Configuration Properties

The Batch eWay contains a number of properties used to configure SOCKS with the BatchFTP eWay. These properties are configured using the BatchFTP Properties Sheet accessed from the Connectivity Map and the Environment Explorer.

Socks Enabled

Specifies whether the FTP command connection goes through a SOCKS server. A value of **No** indicates that the eWay is not connecting to a SOCKS server. In this case, all other parameters under the **SOCKS** section are ignored.

Socks Host Name

Specifies the SOCKS host name. When you are communicating with a SOCKS server, enter the SOCKS server name in this parameter.

Socks Server Port

Specifies the port number of the SOCKS server.

Socks Version

Specifies the SOCKS server version. A value of **4** or **5** for SOCKSv4 or SOCKSv5 provides the best performance, but the default value **Unknown** can if the version is in question.

Socks User Name

Specifies the user name that matches the associated password used for authentication with a SOCKS5 server. This parameter is applied when user/password negotiation method is used.

Socks Password

Specifies the password to use along with the user name for authentication with a SOCKS5 server. This parameter is applied when user/password negotiation method is used.

For information on the BatchFTP configuration properties, see [BatchFTP eWay Connectivity Map Properties](#) on page 21, and [BatchFTP eWay Environment Explorer Properties](#) on page 44.

5.3 SSH Tunneling Support

This section explains the Batch eWay's Secure Shell (SSH) tunneling features. SSH tunneling is also called SSH port forwarding.

SSH Tunneling: Overview

Developed by SSH Communications Security Ltd., Secure Shell (SSH) is a program that allows a computer to log onto another computer over a network to move files over the network and execute commands. SSH is intended as a replacement for **rlogin**, **rsh**, **rcp**, and **rdist**.

SSH provides strong authentication and secure communications over non-secure channels. SSH protects a network from attacks such as IP and DNS spoofing, IP source routing, and interception of plaintext passwords and authentication data. If an attacker manages to take over a network, he can only force SSH to disconnect. The content and the connection are secure when encryption is enabled.

When you are using the SSH **slogin** (instead of **rlogin**), the entire logged-on session, including the transmission of the password, is encrypted. As a result, it is almost impossible for an outsider to collect passwords.

Note: *For improved security, the number of times the eWay can log on during a single session is limited because, during a disconnect, the SSH tunnel is not closed. This method of operation allows you to establish another connection without logging on.*

For more information on SSH and how to use it, see the following Web site:

<http://www.openssh.com>

Additional Software Requirements

The eWay makes use of additional software applications. The eWay also supports either of the following applications for SSH tunneling:

- **OpenSSH:** an encryption and authentication tool for UNIX. For more information go to:

<http://www.openssh.org>

- **Plink.exe:** Plink is a Win32-only command-line interface to the PuTTY Telnet/SSH client. For more information visit:

<http://www.chiark.greenend.org.uk/~sgtatham/putty>

In either case, the you are responsible for downloading, installing, and properly configuring the necessary software. You must refer to the appropriate software provider for support and documentation.

SSH Tunneling and the Batch eWay

To use SSH tunneling to provide for secure logon IDs and passwords, the BatchFTP eWay uses the additional SSH-tunneling software (see [Additional Software Requirements](#) on page 114).

Enabling SSH Tunneling

To enable SSH tunneling, select **Yes** under the **SSH Tunneling Enabled** parameter in the eWay Connection configuration (see [“SSH Tunneling Configuration Parameters” on page 116](#)). You can use the SSH-tunneling software in either of the following ways:

- By using an existing SSH channel where a secure connection has already been established
- By internally launching an SSH process for the eWay's use

Using an Existing Channel

To use an existing channel, select **Yes** under the **SSH Channel Established** parameter in the configuration. The eWay then operates under the assumption that you have already established the SSH channel using the additional software. Once you set this parameter to **Yes**, the eWay automatically uses that channel.

Using an Internal Channel

If you choose **No**, under the **SSH Channel Established** parameter, the eWay launches a process within eGate to establish a channel. In this case, you must specify, under the **SSH Command Line** parameter, a full and correct command-line statement for your SSH-tunneling application and environment.

Note: You can obtain this information from the SSH-tunneling application's configuration. See the application's documentation for details.

You must enter a correct and complete command-line statement. That is, all necessary command line parameters must be provided so that the SSH-tunneling software can run correctly without requiring further interaction.

Check the accuracy of this information by executing the command line from the shell. If the software prompts for more information, add the required information to the command line and try again. Continue this process until the software starts and operates properly without additional action.

Note: You may need to launch the application at least once from the shell before using it in the eWay. This requirement depends on the SSH-tunneling application and platform. Some applications prompt for trust-related information on the first attempt, to connect to a remote host.

Port-forwarding Configuration

Through SSH tunneling, the FTP command connection is protected. This mechanism is based on an existing SSH port-forwarding configuration. You must configure SSH port forwarding on the *SSH listen host* before you configure the supporting eWay Connection.

For example, on the eGate client host **localhost**, you can issue a command, such as:

```
ssh -L 4567:atlas:21 -o BatchMode=yes atlas
```

Under the eWay's configuration for the previous example, you must specify:

- **localhost** for the parameter **SSH Listen Host**
- **4567** for the parameter **SSH Listen Port**

In this case, the eWay connects to the FTP server **atlas:21** through an SSH tunnel.

SSH Tunneling Configuration Parameters

This section lists the SSH tunneling parameters you must set to configure the eWay Connection. For more information, see "[SSH Tunneling Configuration Parameters](#)" on page 116.

SSH Tunneling Enabled

Specifies whether the FTP command connection is secured through an SSH tunnel.

- ♦ **No** indicates that all other parameters in this section are ignored.

SSH Channel Established

Specifies whether the eWay needs to launch an SSH subprocess.

- ♦ **No** indicates that there is no existing SSH channel for an FTP transfer.
- ♦ **Yes** indicates that an SSH channel has been established, so it is not necessary for the eWay to spawn an SSH subprocess. If you select **Yes**, the following parameters are required:
 - ♦ **SSH Listen Host**
 - ♦ **SSH Listen Port**

SSH Command Line

Specifies the command line used to establish an SSH channel. This parameter is required only when you set the **SSH Channel Established** parameter to **No**.

The command-line syntax can be different, depending on the specific SSH client implementation. See your SSH-tunneling support software user's guides for details.

SSH Listen Host

Specifies the host name where the SSH support software runs, as well as the host it listens to.

This parameter is required only when you set the **SSH Channel Established** parameter to **Yes**. If you choose **No**, the **Listen Host** is always **localhost** because the SSH support software is always started from the local host.

SSH Listen Port

Specifies the port number that the SSH-tunneling support software uses to check for incoming connections. This port number can be any unused port number on the SSH listen host.

SSH User Name

Specifies an SSH user name. This parameter can be required when the setting for the **SSH Channel Established** parameter is **No**.

SSH Password

Specifies an SSH password corresponding to the user name entered under **SSH User Name**. This parameter can be required only when the setting for the **SSH Channel Established** parameter is **No**. For more information, see **SSH User Name**.

5.4 Ensuring Secure FTP Data Transfers

The Batch eWay encrypts the command channel of FTP utilizing SSH. To encrypt data, the user can encrypt the file prior to sending it, using their preferred method or that of the receiver. The received file can then be decrypted by the recipient.

Using the Batch eWay With eInsight

This chapter describes how to use the Batch eWay with ICAN Suite's eInsight Business Process Manager and its engine's Web Services interface.

Note: You must have the *eInsight.sar* file installed to use the Web Services interface.

What's in This Chapter

- [eInsight Engine and eGate Components](#) on page 118
- [Batch eWay With eInsight](#) on page 119
- [The Batch eWay eInsight Sample Projects](#) on page 120

6.1 eInsight Engine and eGate Components

You can deploy an eGate component as an Activity in an eInsight Business Process. Once you associate the desired component with an Activity, eInsight invokes it using a Web Services interface. eGate components that can interface with eInsight in this include the following:

- Java Messaging Service (JMS)
- Object Type Definitions (OTDs)
- eWays
- Collaborations

Using the eGate Enterprise Designer and eInsight, you can add an Activity to a Business Process, then associate that Activity with an eGate component, for example, an eWay. Then, when eInsight runs the Business Process, it automatically invokes that component via its Web Services interface.

See the *eInsight Business Process Manager User's Guide* for details.

6.2 Batch eWay With eInsight

You can associate an eInsight Business Process Activity with eGate during the system design phase. To make this association, select the desired operator under the eWay in the Enterprise Explorer and drag it onto the eInsight Business Process canvas.

For Business Process operations, the Batch eWay has the following operators available under the for Batch configuration nodes:

BatchLocalFile

- read
- write

BatchFTP

- get
- put

BatchInbound

- receive

BatchRecord

Not Applicable

The operator automatically changes to an Activity with an icon identifying the component that is the basis for the Activity.

At run time, the eInsight engine invokes each step in the order defined in the Business Process. Using the engine's Web Services interface, the Activity invokes the Batch eWay.

6.3 Considerations

The following items must be considered when implementing a Batch eWay project:

- When using FTP with an **AS400 UNIX** system, the following FTP configuration settings are required:
 - ♦ FTP - Use PASV: **No** (see [Use PASV](#) on page 29)
 - ♦ FTP Raw Commands - Pre Transfer Raw Commands: **site namefmt 1** (see [Pre Transfer Raw Commands](#) on page 31)

6.4 The Batch eWay eInsight Sample Projects

The following sample projects demonstrate how eInsight Business Processes are used with the Batch eWay:

- [The Batch_BP_FTPIIn Sample Project](#) on page 121, that includes the BatchFTP eWay.
- [The Batch_BP_LFIIn Sample Project](#) on page 132, that includes the BatchLocalFile eWay.
- [The Batch_BP_LFOOut Sample Project](#) on page 140, that includes the BatchLocalFile eWay.

Sample data files

Sample data files for the Batch eWay projects are included with the samples. See `Input_Files_Readme.txt` included with the sample data files for more information.

6.5 Importing a Sample Project

Sample eWay projects are included as part of the installation CD-ROM package. To import a sample eWay project to the Enterprise Designer, do the following:

The sample files are first uploaded with the Batch eWay's documentation .sar file (**BatcheWayDocs.sar**) and downloaded from the Enterprise Manager's Documentation tab. Extract the samples from the Enterprise Manager to a local file.

- 1 Save all unsaved work before importing a project.
- 2 From the Enterprise Designer's Project Explorer pane, right-click the Repository and select **Import** from the shortcut menu. The **Import Manager** appears.
- 3 Browse to the directory that contains the sample project zip file. Select the sample file (for example, **Batch_BP_FTPIIn.zip**) and click **Import**. After the sample project is successfully imported, click **Close**.
- 4 Before an imported sample project can be run you must do the following:
 - ♦ Create an **Environment** (see [Creating an Environment](#) on page 127)
 - ♦ Configure the eWay Properties for your specific system (see [Creating and Configuring the Batch eWay](#) on page 17)
 - ♦ Create a **Deployment Profile** (see [Creating and Activating the Deployment Profile](#) on page 130)

6.6 The Batch_BP_FTPIIn Sample Project

The **Batch_BP_FTPIIn_Sample** project demonstrates the following:

The eGate Scheduler prompts the BatchFTP eWay to pick up a file from an external directory. The data is converted from bytes to text and published to the File eWay. The File eWay then publishes the data file to an external directory.

The following pages provide step by step directions for manually creating the **Batch_BP_FTPIIn_Sample** project.

6.6.1. Create a Project

The first step is to create a new project in the SeeBeyond Enterprise Designer.

- 1 Start the Enterprise Designer.
- 2 From the Enterprise Explorer's Project Explorer tab, right-click the Repository and select **New Project** (see [Figure 25 on page 121](#)). A new project (Project1) appears on the Project Explorer tree.

Figure 25 Enterprise Explorer - New Project

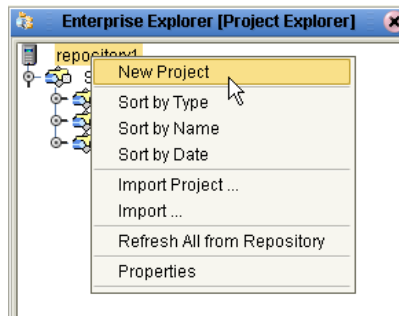

- 3 Click twice on **Project1** and rename the project (for this sample, **Batch_BP_FTPIIn_Sample**).

6.6.2 Creating the BP_FTPIIn Business Process

Creating the Business Process Flow

- 1 From the Enterprise Designer's Project Explorer tree, right-click **Batch_BP_FTPIIn_Sample**, and select **New > Business Process** from the shortcut menu. The eInsight Business Process Designer appears and **BusinessProcess1** is added to the Project Explorer tree. Rename the Business Process to **BP_FTPIIn**.
- 2 From the Project Explorer tree, expand the **SeeBeyond > eGate > Scheduler, eWays > BatchWay > BatchFTP**, and **File > FileClient** nodes to expose the available Business Process elements.

- 3 Populate the eInsight Business Process Designer's modeling canvas with the following elements from the Project Explorer tree, as displayed in [Figure 26 on page 122](#):
 - ♦ **start**, under SeeBeyond > eGate > Scheduler
 - ♦ **get**, under SeeBeyond > eWays > BatcheWay > BatchFTP
 - ♦ **write**, under SeeBeyond > eWays > File > FileClient

Figure 26 eInsight Business Process Designer - Populate the Canvas

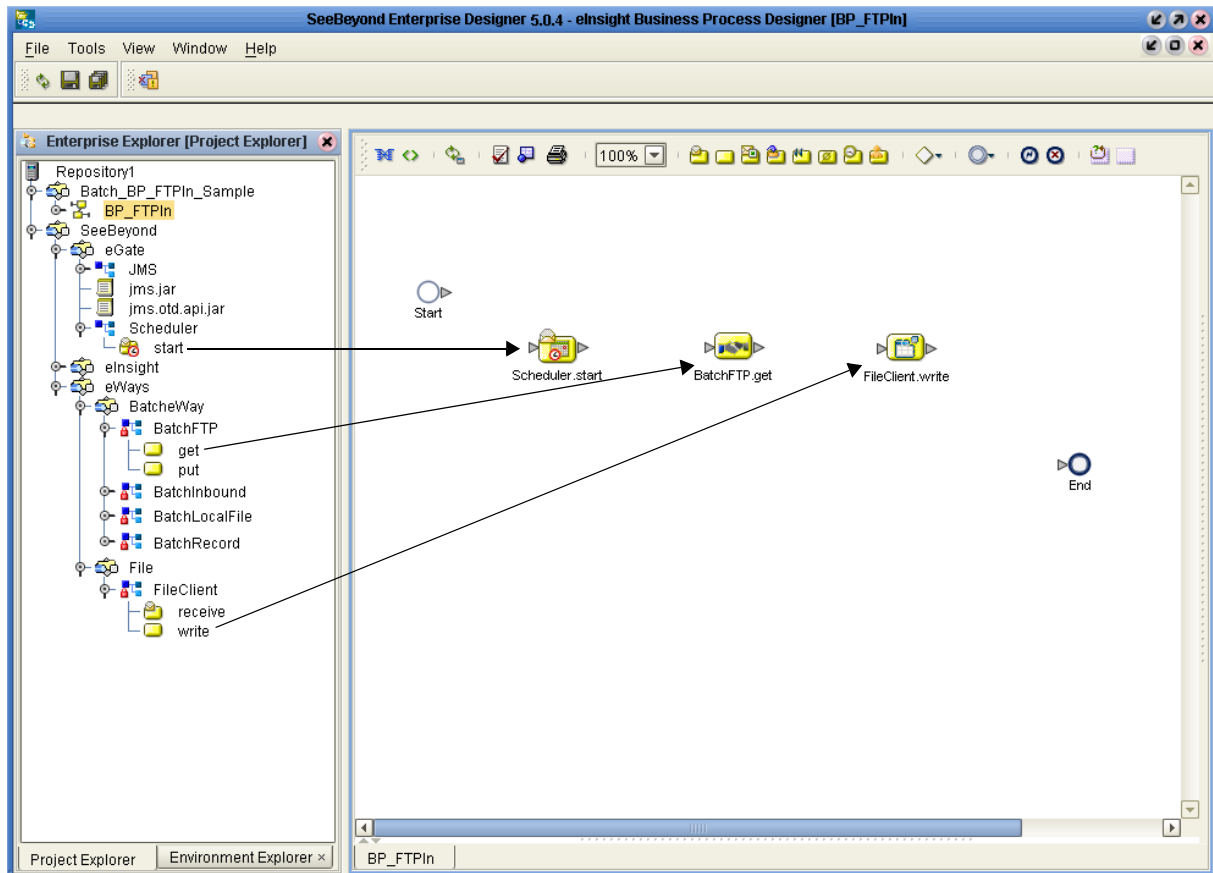

- 4 Link the modeling elements by clicking on the element's connector and dragging the cursor to the next element's connector, making the following links as displayed in [Figure 27 on page 123](#).
 - ♦ Start -> Scheduler.start
 - ♦ Scheduler.start -> BatchFTP.get
 - ♦ BatchFTP.get -> FileClient.write
 - ♦ FileClient.write -> End

Figure 27 eInsight Business Process Designer - Link the Modeling Elements

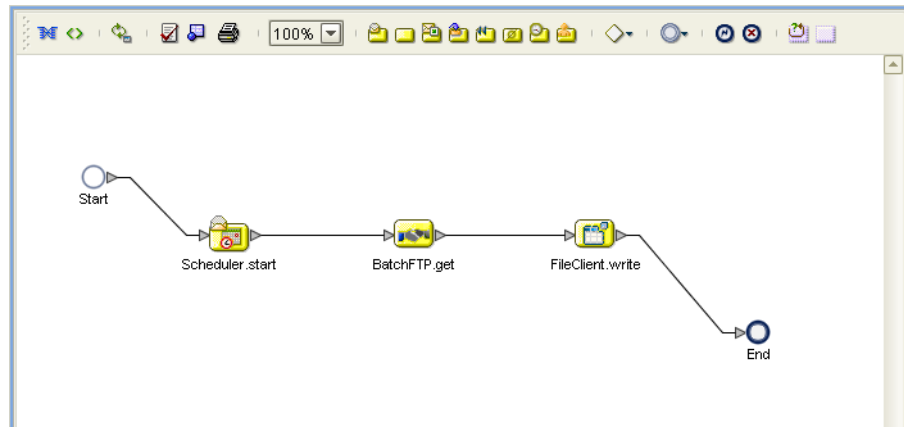

Configuring the Modeling Elements

Business Rules, created between the Business Process elements, define the relationship between the input and output Attributes of the elements.

- 1 Right-click the link between the **BatchFTP.get** and **FileClient.write** Activities and select **Add Business Rule** from the shortcut menu as displayed in Figure 28.

Figure 28 eInsight Business Process Designer - Adding Business Rules

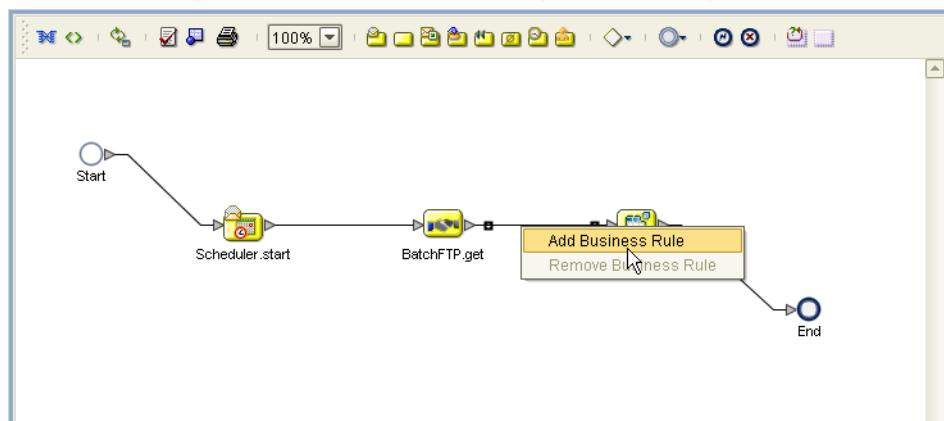

- 2 From the eInsight Business Process Designer toolbar, click the **Map Business Process Attributes** button. The Business Rule Designer appears at the bottom of the eInsight Business Process Designer.
- 3 Click on the **Business Rule** icon in the link between **BatchFTP.get** and **FileClient.write** to display the Business Rule Output and Input Attributes in the Business Rule Designer. These Attributes can now be modified.
- 4 From the Business Rule Designer toolbar, click the Method Palette icon (see [Figure 29 on page 124](#)). The Method Palette appears. From the **String** tab of the Method Palette, select **bytes to text** and click **Close**. The **bytes to text** icon is added to the toolbar.

- From the Business Rule Designer toolbar, drag and drop the **bytes to text** icon onto the Business Rule Designer canvas. The **bytes to text** method box appears (see Figure 29).

Figure 29 eInsight Business Rule Designer

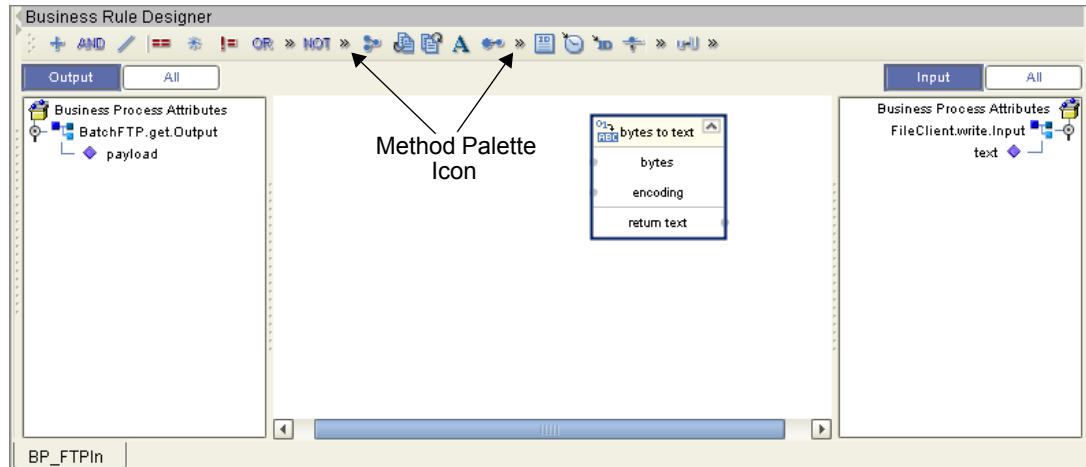

- Map **payload**, under **BatchFTP.get.Output** in the Output pane of the Business Rule Designer, to the **bytes** input node of the **bytes to text** method box. This is done by clicking on **payload** and dragging the cursor to the **bytes** input node of the **bytes to text** method box.
- Map the **return text** output node of the **bytes to text** method box to **text**, under **FileClient.write.input** in the Input pane of the Business Rule Designer. The Business Process Designer (see Figure 30).

Figure 30 eInsight Business Rule Designer

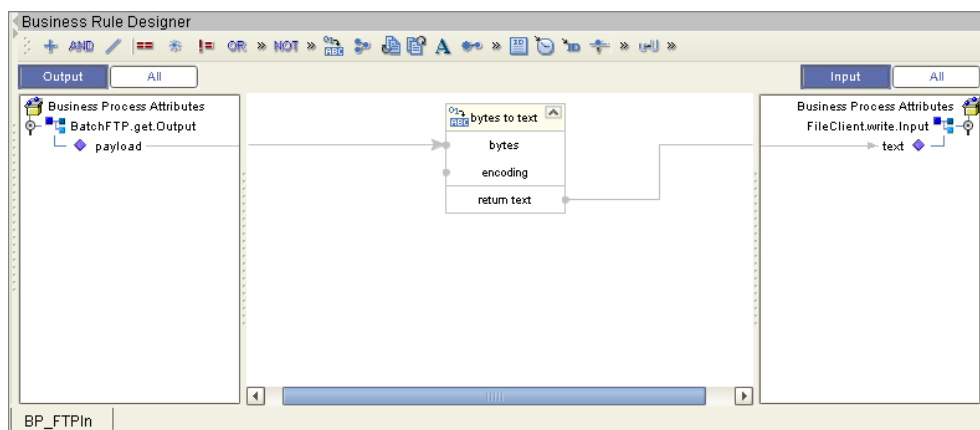

- From the Business Process Designer toolbar, click the **Synchronize Graphical Model and Business Process Code** icon to synchronize the graphical interface to the Business Process code.
- Click the Enterprise Designer's **Save All** icon to save your current changes.

6.6.3 Create a Connectivity Map

The Connectivity Map provides a canvas for assembling and configuring a project's components.

- 1 In Enterprise Explorer's Project Explorer, right-click the **Batch_BP_FTPIIn_Sample** project and select **New > New Connectivity Map** from the shortcut menu.
- 2 The New Connectivity Map appears and a node for the Connectivity Map is added to the Project Explorer tree labeled **CMap1**. Rename the Connectivity Map to **CM_Batch_BP_FTPIIn**.

The icons in the toolbar represent the available components used to populate the Connectivity Map canvas.

Select the External Applications

When creating a Connectivity Map, the eWays are associated with External Systems. For example, to establish a connection to BatchFTP eWay, you must first select BatchFTP as an External System to use in your Connectivity Map.

To create the External Applications used by the Batch_BP_FTPIIn_Sample project do the following:

- 1 Click the **External Application** icon on the Connectivity Map toolbar (see Figure 31).

Figure 31 Connectivity Map - External Applications

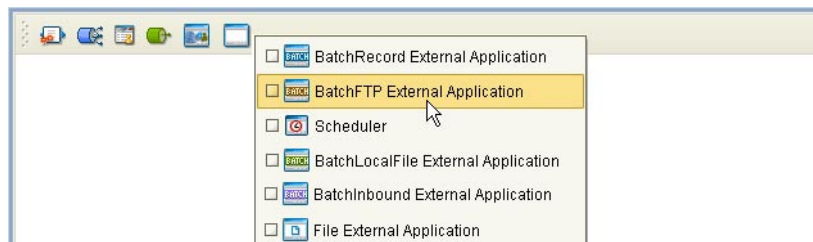

- 2 Select the applications needed for your project (for this sample, **Scheduler**, **File External Application**, and **BatchFTP External Application**). Icons representing the selected applications are added to the Connectivity Map toolbar.

Populate the Connectivity Map

Add the project components to the Connectivity Map by dragging the icons from the toolbar to the canvas.

- 1 Drag the following components onto the Connectivity Map canvas as displayed in [Figure 32 on page 126](#):
 - ♦ **Scheduler**
 - ♦ **Service** (A service is a container for Collaborations, Business Processes, eTL processes, and so forth)
 - ♦ **BatchFTP External Application**

◆ **File External Application**

- 2 From the Connectivity Map, rename the **File1** application to **FileOut**, and rename the **Service1** container to **BP_FTP_In**.

Figure 32 Connectivity Map with Components

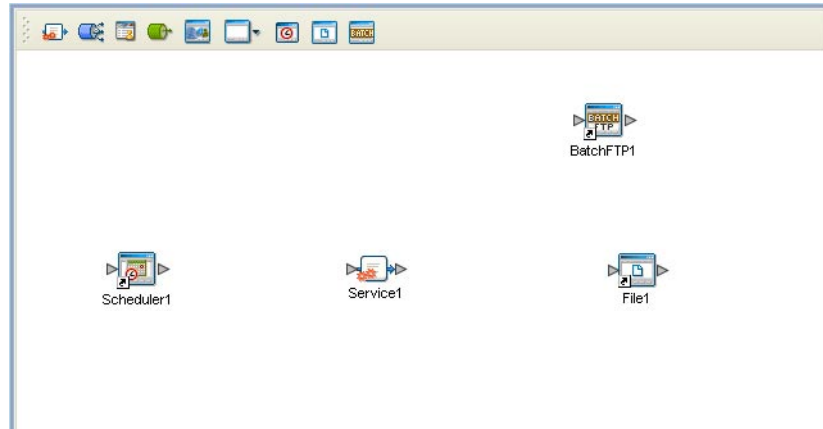

- 3 Click the **Save All** icon to save your current changes.

6.6.4. Binding the Project Components

After the Business Processes have been completed, the components are associated and the bindings are created using the Connectivity Map.

- 1 From the Project Explorer, double-click the Connectivity Map, **CM_Batch_BP_FTPIIn**, to display the Connectivity Map canvas.
- 2 Drag and drop the **BP_FTPIIn** Business Process from the Project Explorer to the **BP_FTPIIn** service (see Figure 33).

Figure 33 Connectivity Map - Binding the Components

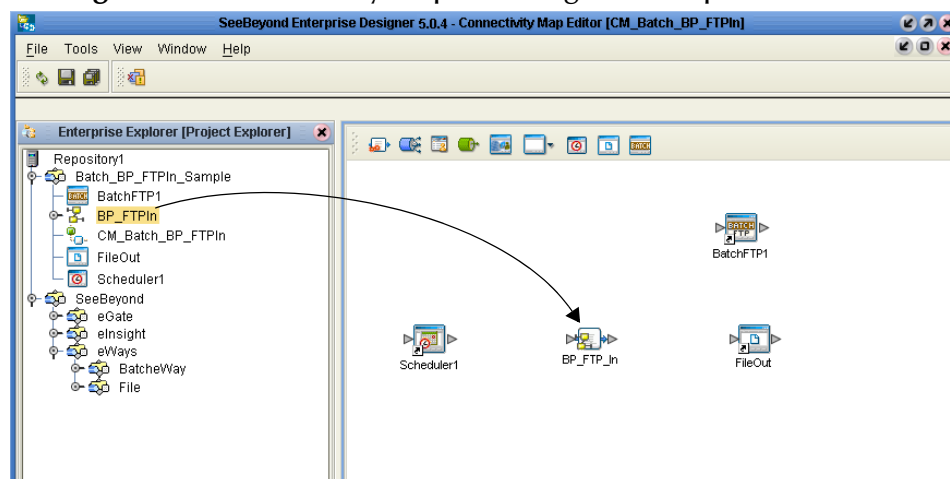

- 3 Double-click the **BP_FTPIIn** service. The **BP_FTPIIn** binding box appears with the **BP_FTPIIn** Rule.

- 4 From the **BP_FTP_In** binding box, map **SchedulerStart** (under Implemented Services) to the **Scheduler1** application.
- 5 From the **BP_FTP_In** binding box, map **BatchFTPReceiver** (under Invoked Services) to the **BatchFTP1** External Application.
- 6 From the **BP_FTP_In** binding box, map **FileReceiver** to **FileOut** (see Figure 34).

Figure 34 Connectivity Map - Binding the Components

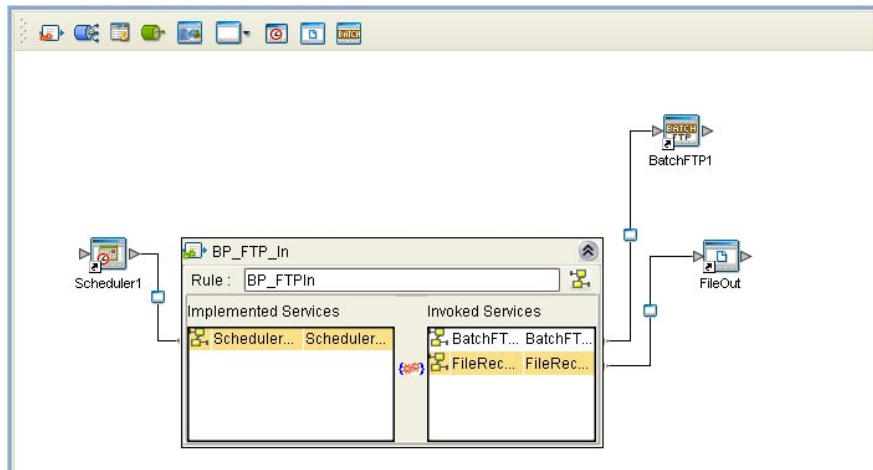

- 7 Minimize the **BP_FTP_In** binding box by clicking the chevrons in the upper-right corner and save your current changes.

6.6.5. Creating an Environment

Environments include the external systems, Logical Hosts, integration servers and JMS IQ Managers used by a project and contain the configuration information for these components. Environments are created using the Enterprise Designer's Environment Explorer and Environment Editor.

- 1 From the Enterprise Designer's Enterprise Explorer, click the **Environment Explorer** tab.
- 2 Right-click the Repository and select **New Environment**. A new Environment is added to the Environment Explorer tree.
- 3 Rename the new Environment to **ENV_Batch_BP_FTPIIn**.
- 4 From the Project Explorer tree, right-click **ENV_Batch_BP_FTPIIn** and select **New BatchFTP External System**. Name the External System **BatchFTPExtSys**. Click **OK**. The **BatchFTPExtSys** window is added to the Environment Editor.
- 5 From the Project Explorer tree, right-click **ENV_Batch_BP_FTPIIn** and select **New File External System**. Name this External System **FileExtSysOut** and select **Outbound File eWay** as the External System Type. The **FileExtSysOut** window is added to the Environment Editor.
- 6 From the Project Explorer tree, right-click **ENV_Batch_BP_FTPIIn** and select **New Scheduler**. Name the External System **Scheduler**. Click **OK**. The **Scheduler** window is added to the Environment Editor.

- 7 From the Project Explorer tree, right-click **ENV_Batch_BP_FTPIn** and select **New Logical Host**. The **LogicalHost1** box is added to the Environment and **LogicalHost1** is added to the Environment Editor tree.
- 8 From the Environment Explorer tree, right-click **LogicalHost1** and select **New SeeBeyond Integration Server**. A new Integration Server (**IntegrationSvr1**) is added to the Environment Explorer tree under LogicalHost1.
- 9 Save changes to the Repository. The Environment Explorer and Environment Editor now appear as displayed in Figure 35.

Figure 35 Environment Editor

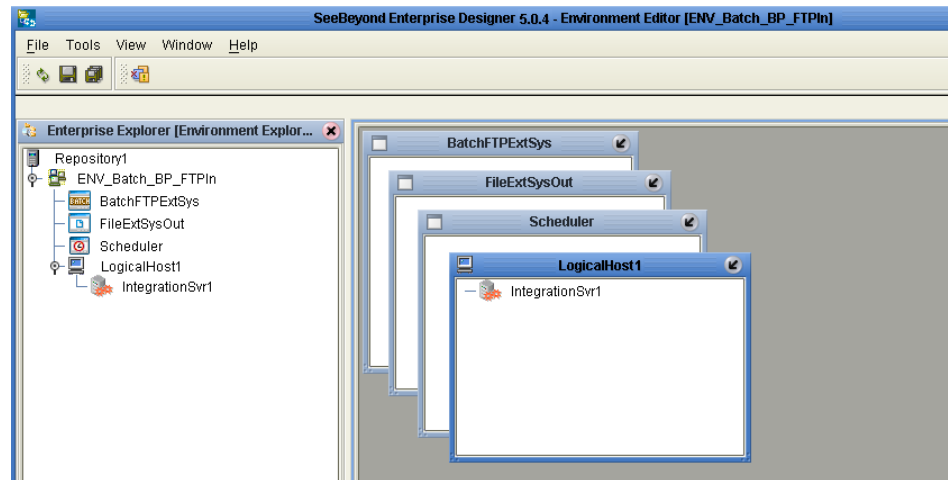

6.6.6. Configuring the eWay Properties

The Batch_BP_FTPIn_Sample project contains two eWays, each represented in the Connectivity Map as a node between an External Application and a service. eWays facilitate communication and movement of data between the external applications and the eGate system (see Figure 36).

Figure 36 eWay Configurations

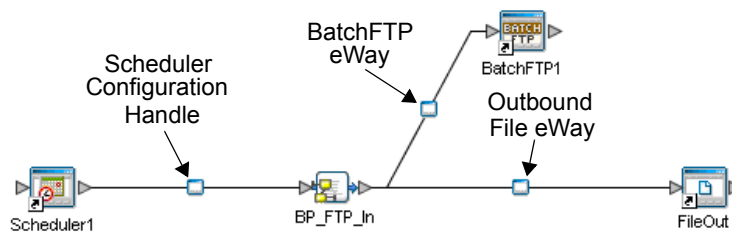

The File eWay configuration parameters are configured from the Connectivity Map. The BatchFTP eWay configuration parameters are set from both the Project Explorer's Connectivity Map and the Environment Explorer tree. To configure the eWays do the following:

Configuring the File eWay Properties

- 1 Double-click the **Outbound File eWay**, select **Outbound File eWay** in the Templates dialog box and click **OK**.
- 2 The Properties Sheet opens to the Outbound File eWay properties. Modify the properties for your system, including the settings for the **Outbound File eWay** in Table 6, and click **OK**. The properties are saved for the eWay.

Table 6 Outbound File eWay Settings

Outbound File eWay Properties	
Directory	C:/temp
Output file name	output%d.dat

Configuring the BatchFTP eWay Properties

The BatchFTP eWay configuration parameters must be set in both the Project Explorer and Environment Explorer. For more information on the BatchFTP eWay properties and the Properties Sheet, see [Creating and Configuring the Batch eWay](#) on page 17 or see the *eGate Integrator User's Guide*.

For the Batch_BP_FTPIIn_Sample project, do the following:

Modifying the BatchFTP eWay Connectivity Map Properties

- 1 From the Connectivity Map, double-click the **BatchFTP** eWay. The Properties Sheet opens to the BatchFTP eWay Connectivity Map properties.
- 2 Modify the **BatchFTP** eWay properties for your system, including the settings in Table 7, and click **OK**.

Table 7 BatchFTP Connectivity Map eWay Settings

BatchFTP eWay Connectivity Map Properties	
Target Location Set as directed, otherwise use the default settings	
Target Directory Name	The directory (absolute path) on the external system from which files will be retrieved or sent.
Target File Name	Retrieved file name

Modifying the BatchFTP eWay Environment Explorer Properties

- 1 From the **Environment Explorer** tree, right-click the BatchFTP External System (**BatchFTPExtSys** in this sample), and select **Properties**. The Properties Sheet opens to the BatchFTP eWay Environment properties.
- 2 Modify the BatchFTP eWay Environment properties for your system, including the settings in Table 8, and click **OK**.

Table 8 BatchFTP Environment Explorer eWay Settings

BatchFTP eWay Environment Explorer Properties	
FTP Set as directed, otherwise use the default settings.	
Host Name	<i>The name of the external system that the eWay connects to.</i>
Password	<i>Password required to log into the external system</i>
Server Port	<i>Port number to use to connect to the FTP server</i>
User Name	<i>User ID used to login to the external system</i>

6.6.7 Creating and Activating the Deployment Profile

A Deployment Profile is used to assign Business Processes and message destinations to the integration server and JMS IQ Manager. Deployment Profiles are created using the Deployment Editor.

- 1 From the Enterprise Explorer’s Project Explorer, right-click the project (**Batch_BP_FTPIIn_Sample**) and select **New > Deployment Profile**.
- 2 Enter a name for the Deployment Profile (for this sample **DP_Batch_BP_FTPIIn**). Make sure that the selected Environment is **ENV_Batch_BP_FTPIIn**. Click **OK**.
- 3 From the left pane of the Deployment Editor, drag **BP_FTP_In -> FileOut** (External Application) to the **FileExtSysOut** window.
- 4 From the left pane of the Deployment Editor, drag the **BP_FTP_In -> BatchFTP1** (External Application) to the **BatchFTPExtSys** window.
- 5 Drag **Scheduler1 -> BP_FTP_In** (Application) to the **Scheduler** window.
- 6 From the left pane of the Deployment Editor, drag **BP_FTP_In** (Business Process) to **IntegrationSvr1** in the **LogicalHost1** window (see Figure 37).

Figure 37 Deployment Profile

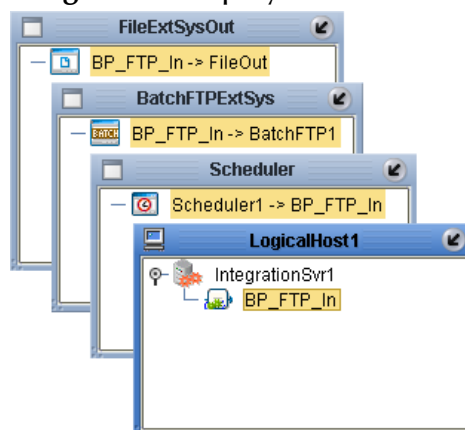

- 7 Click **Activate**. When activation succeeds, save the changes to the Repository.

6.6.8. Running the Project

The following directions assume that the Enterprise Designer was downloaded to C:\ican50. If this is not the case, replace that location in the following directions with the appropriate location.

- 1 From the Enterprise Manager Downloads tab, download **Logical Host - for win32**.
- 2 Extract the file to the **ican50\logicalhost1** directory. You must specify the **logicalhost1** directory for it to be created.
- 3 Navigate to **C:\ican50\logicalhost1\logicalhost\bootstrap\config** directory and open the **logical-host.properties** file using Notepad™.
- 4 Enter the following information in the appropriate fields:
 - ♦ Logical Host root directory: **ican50\logicalhost1\logicalhost**
 - ♦ Repository URL: **http://localhost:port number/repository name**
 - ♦ Repository user name and password: *Your user name and password*
 - ♦ Logical Host Environment name: **ENV_Batch_BP_FTPIIn**
 - ♦ Logical Host name: **logicalhost1**

Save your changes to **logical-host.properties** and close the file.

- 5 Run the **bootstrap.bat** file in the **ican50\logicalhost1\logicalhost\bootstrap\bin** directory.
- 6 Copy the sample input data file to the input directory.

For more information on running a project that utilizes eInsight from the SeeBeyond Enterprise Designer see the *eInsight Business Process Manager User's Guide* and the *eGate Integrator User's Guide*.

6.7 The Batch_BP_LFIn Sample Project

The **Batch_BP_LFIn** project demonstrates the following: The eGate Scheduler prompts the BatchLocalFile eWay to pick up a file from an external directory. The data is converted from bytes to text and published to the File eWay. The File eWay then publishes the data file to an external directory.

The following pages provide step by step directions for manually creating the Batch_BP_LFIn sample project components.

To create the **Batch_BP_LFIn** project do the following:

6.7.1. Create a Project

The first step is to create and name a new project in eGate Enterprise Designer.

- 1 Start the Enterprise Designer.
- 2 From the Enterprise Explorer's Project Explorer tab, select your Repository on the Project Explorer tree, right-click the Repository and select **New Project**. A new project appears on the Project Explorer tree.
- 3 Click twice on **Project1** and rename the project (for this sample, **Batch_BP_LFIn_Sample**).

6.7.2 Creating the BP_LFIn Business Process

Creating the Business Process Flow

- 1 From the Enterprise Designer's Project Explorer tree, right-click **Batch_BP_LFIn_Sample**, and select **New > Business Process** from the shortcut menu. The eInsight Business Process Designer appears and **BusinessProcess1** is added to the Project Explorer tree. Rename the Business Process to **BP_LFIn**.
- 2 Populate the eInsight Business Process Designer's modeling canvas with the following elements from the Project Explorer tree, as displayed in [Figure 38 on page 133](#):
 - ♦ **start**, under SeeBeyond > eGate > Scheduler
 - ♦ **read**, under SeeBeyond > eWays > BatcheWay > BatchLocalFile
 - ♦ **write**, under SeeBeyond > eWays > FileClient

Figure 38 eInsight Business Process Designer - Populate the Canvas

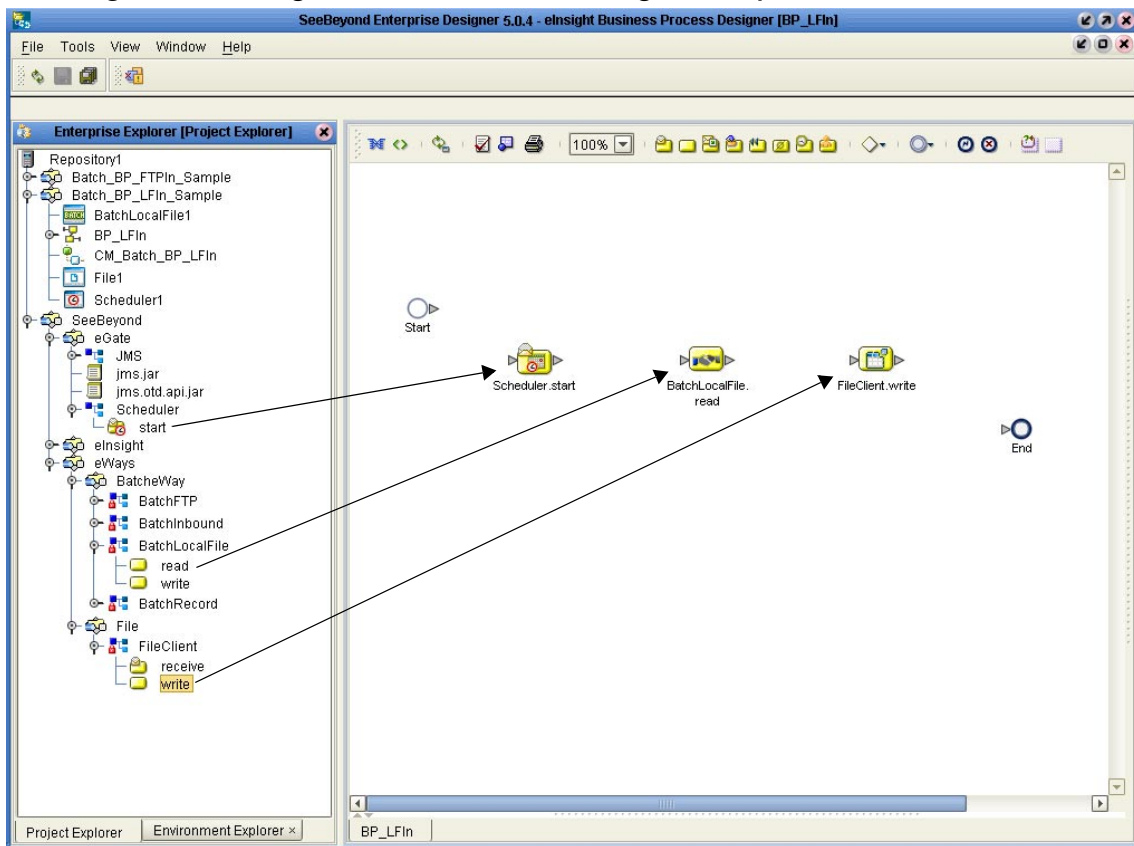

3 Link the modeling elements by clicking on the element's connector and dragging the cursor to the next element's connector, making the following links as displayed in [Figure 39 on page 134](#).

- ◆ Start -> Scheduler.start
- ◆ Scheduler.start -> BatchLocalFile.read
- ◆ BatchLocalFile.read -> FileClient.write
- ◆ FileClient.write -> End

Figure 39 eInsight Business Process Designer - Link the Modeling Elements

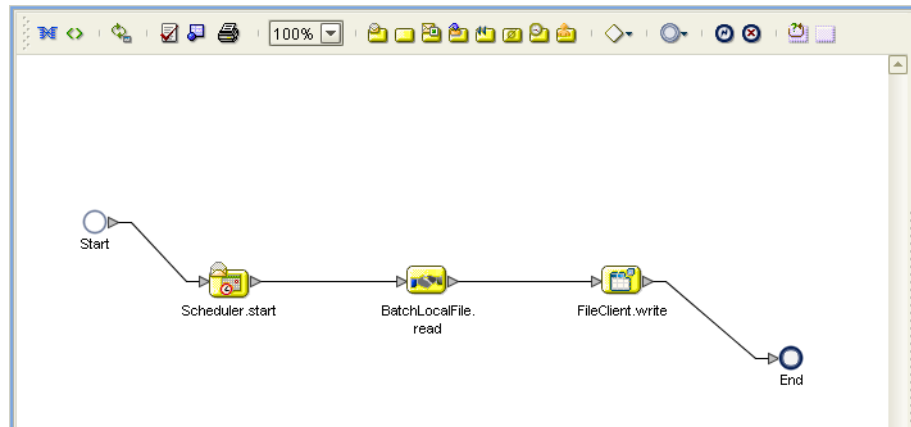

Configuring the Modeling Elements

Business Rules, created between the Business Process elements, define the relationship between the input and output Attributes of the elements.

- 1 Right-click the link between the **BatchLocalFile.read** and **FileClient.write** Activities and select **Add Business Rule** from the shortcut menu (see Figure 40).

Figure 40 eInsight Business Process Designer - Adding Business Rules

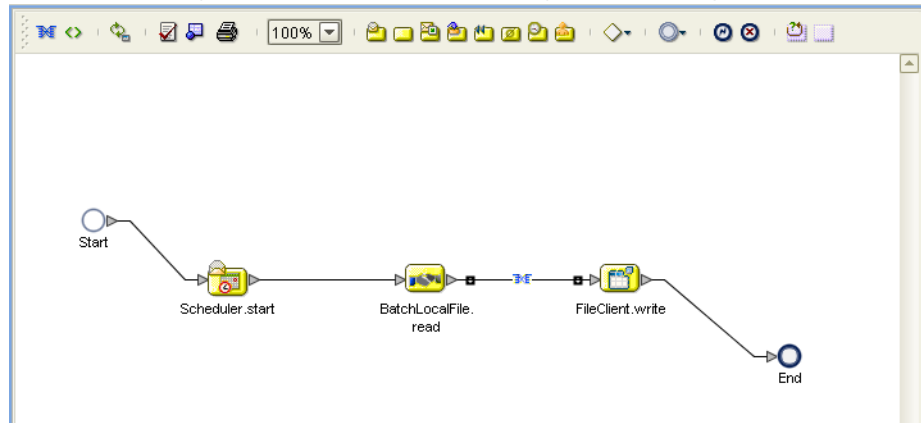

- 2 From the eInsight Business Process Designer toolbar, click the **Map Business Process Attributes** button. The Business Rule Designer appears at the bottom of the eInsight Business Process Designer.
- 3 Click on the **Business Rule** icon in the link between **BatchLocalFile.read** and **FileClient.write** to display the Business Process Output and Input Attributes in the Business Rule Designer. These Attributes can now be modified.
- 4 From the Business Rule Designer toolbar, click the Method Palette icon. The Method Palette appears. From the **String** tab of the Method Palette, select **bytes to text** and click **Close**. The **bytes to text** icon is added to the toolbar.
- 5 From the Business Rule Designer toolbar, drag and drop the **bytes to text** icon onto the Business Rule Designer canvas. The **bytes to text** method box appears (see [Figure 41 on page 135](#)).

Figure 41 eInsight Business Rule Designer

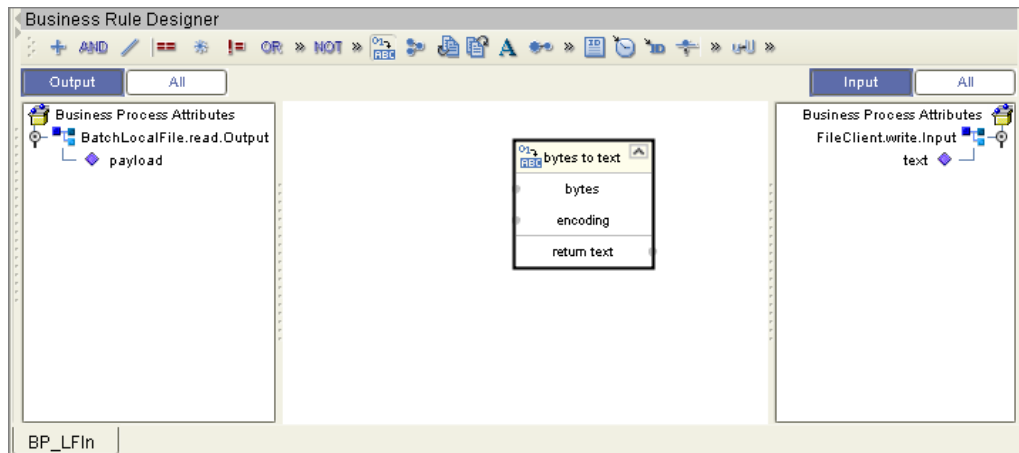

- 6 Map **payload**, under `BatchLocalFile.read.Output` in the Output pane of the Business Rule Designer, to the **bytes** input node of the **bytes to text** method box. This is done by clicking on **payload** and dragging the cursor to the **bytes** input node of the **bytes to text** method box.
- 7 Map the **return text** output node of the **bytes to text** method box, to **text** under `FileClient.write.input` in the Input pane of the Business Rule Designer (see Figure 42).

Figure 42 eInsight Business Rule Designer

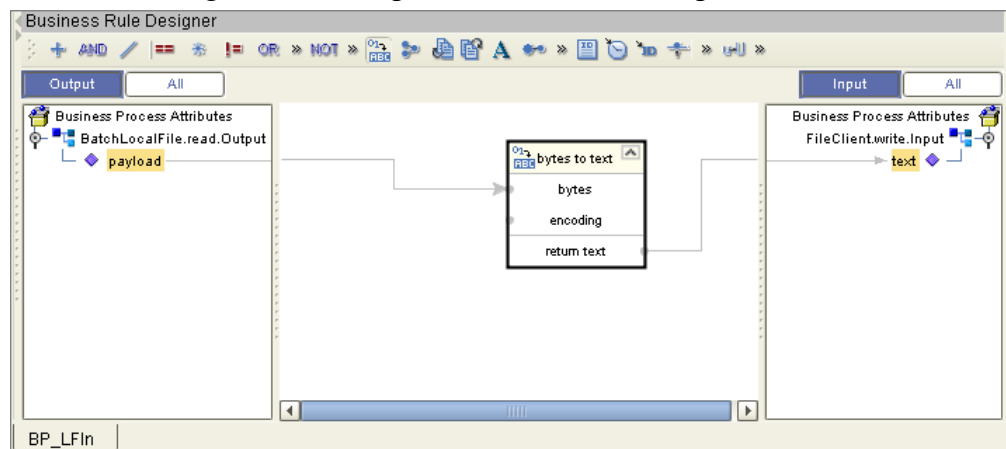

- 8 When the Business Process is complete, from the Business Process Designer toolbar, click the **Synchronize Graphical Model and Business Process Code** icon to synchronize the graphical interface to the Business Process code.
- 9 Click the Enterprise Designer's **Save All** icon to save your current changes.

6.7.3 Create a Connectivity Map

The Connectivity Map provides a canvas for configuring a project's components.

- 1 In Enterprise Explorer's Project Explorer, right-click the new project (**Batch_BP_LFIn_Sample**) and select **New > New Connectivity Map** from the shortcut menu.
- 2 The New Connectivity Map appears and a node for the Connectivity Map is added under the project on the Project Explorer tree labeled **CMap1**. Rename the Connectivity Map **CM_Batch_BP_LFIn**.

Select the External Applications

- 1 Click the **External Application** icon on the Connectivity Map toolbar,
- 2 Select the applications needed for your project (for this sample, **Scheduler**, **BatchLocalFile External Application** and **File External Application**). Icons representing the selected applications are added to the Connectivity Map toolbar.

Populate the Connectivity Map

Add the project components to the Connectivity Map by dragging the icons from the toolbar to the canvas.

- 1 For the **Batch_BP_LFIn_Sample** project, drag the following components onto the Connectivity Map canvas as displayed in Figure 43:
 - ♦ Scheduler
 - ♦ Service
 - ♦ BatchLocalFile External System
 - ♦ File External System

Figure 43 CM_Batch_BP_LFIn Connectivity Map with Components

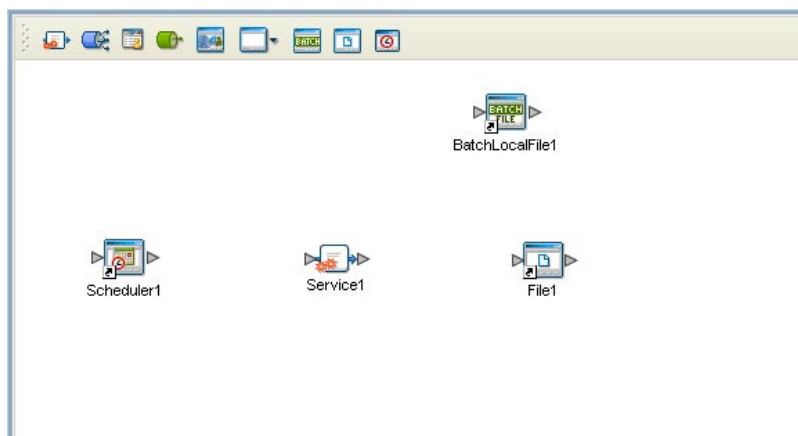

- 2 Rename **File1** to **FileOut1** by clicking the external application's name once and clicking it again. Enter the new name.
- 3 Rename **BatchLocalFile1** to **BatchLocalFileIn1**.

- 4 Rename **Service1** to **BP_LFIn1**.
- 5 Save your current changes to the Repository.

6.7.4. Binding the Project Components

The components are associated and the bindings are created in the Connectivity Map.

- 1 From the Project Explorer, double-click the Connectivity Map **CM_Batch_BP_LFIn**. The Enterprise Designer canvas now displays the **CM_Batch_BP_LFIn** Connectivity Map.
- 2 Drag and drop the **BP_LFIn** Business Process from the Project Explorer onto **BP_LFIn1** in the **CM_Batch_BP_LFIn** Connectivity Map.
- 3 Double-click **BP_LFIn1**. The **BP_LFIn1** binding dialog box appears.
- 4 From the **BP_LFIn1** binding box, map **SchedulerStart** (under Implemented Services) to the **Scheduler** application.
- 5 From the **BP_LFIn1** binding box, map the **BatchLocalFileReceiver** (under Invoked Services) to the **BatchLocalFileIn1** External Application.
- 6 From the **BP_LFIn1** binding box, map the **FileReceiver** (under Invoked Services) to the **FileOut1** External Application.
- 7 Minimize the **BP_LFIn1** binding box. The Connectivity Map now appears similar to the Connectivity Map displayed in Figure 44.

Figure 44 Connectivity Map - Connecting the Project's Components

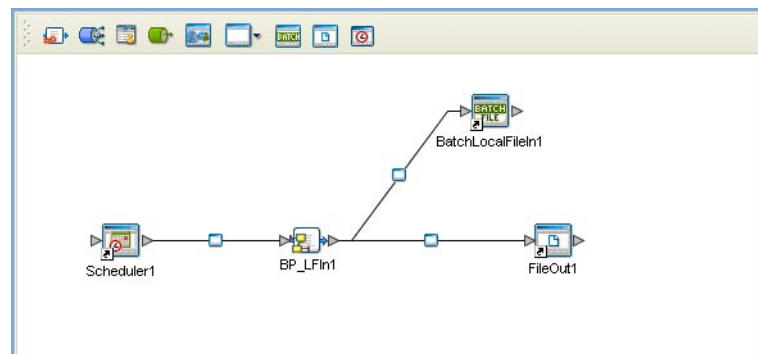

- 8 Save the current changes to your Repository.

6.7.5. Configuring the eWay Properties

The Batch_BP_LFIn_Sample project uses two eWays, each represented in the Connectivity Map as a node between an External Application and a Collaboration.

The File eWay configuration parameters are configured from the Connectivity Map. The BatchLocalFile eWay unlike the BatchFTP eWay, is only configured from the Project Explorer's Connectivity Map, and not from the Environment Explorer. To configure the eWays do the following:

Configuring the File eWay Properties

- 1 Double-click the **Outbound File eWay** and select **Outbound File eWay** in the Templates dialog box and click **OK**.
- 2 The Properties Sheet opens to the Outbound File eWay configuration. Modify the properties for your system.

Configuring the BatchLocalFile eWay Properties

The BatchLocalFile eWay properties are set from the Project Explorer's Connectivity Map. For more information on the BatchLocalFile eWay properties and the Properties Sheet, see [Creating and Configuring the Batch eWay](#) on page 17 or see the *eGate Integrator User's Guide*.

For the Batch_BP_LFIn_Sample project, do the following:

Modifying the BatchLocalFile eWay Connectivity Map Properties

- 1 From the **Connectivity Map**, double-click the **BatchLocalFile** eWay. The Properties Sheet opens to the BatchLocalFile eWay properties.
- 2 Modify the BatchLocalFile eWay Connectivity Map properties for your system.

6.7.6. Creating an Environment

Environments include the external systems, Logical Hosts, integration servers and JMS IQ Managers used by a project and contain the configuration information for these components.

- 1 From the Enterprise Designer's Enterprise Explorer, click the **Environment Explorer** tab.
- 2 Right-click the Repository and select **New Environment**. A new Environment is added to the Environment Explorer tree.
- 3 Rename the new Environment to **ENV_Batch_BP_LFIn**.
- 4 Right-click **ENV_Batch_BP_LFIn** and select **New BatchLocalFile External System**. Name the External System **BatchLocalFileExtSys**. Click **OK**. The **BatchLFExtSys** window is added to the Environment Editor.
- 5 Right-click **ENV_Batch_BP_LFIn** and select **New File External System**. Name this External System **FileExtSysOut** and select **Outbound File eWay** as the External System Type. The **FileExtSysOut** window is added to the Environment Editor.
- 6 Right-click **ENV_Batch_BP_LFIn** and select **New Scheduler**. Name the External System **Scheduler**. Click **OK**. The **Scheduler** window is added to the Environment Editor.
- 7 Right-click **ENV_Batch_BP_LFIn** and select **New Logical Host**. Enter **Localhost2** in the **Logical Host Name** field. Select **SeeBeyond JMS IQ Manager** as the System JMS Type. The **Localhost2** window is added to the Environment Editor.

- 8 From the Environment Explorer tree, right-click **Localhost2** and select **New SeeBeyond Integration Server**. A new Integration Server (**IntegrationSvr1**) is added to the Environment Explorer tree under Localhost2.
- 9 Save your current changes to the Repository.

6.7.7 Creating and Activating the Deployment Profile

A Deployment Profile is used to assign Collaborations and message destinations to the integration server and JMS IQ Manager. Deployment profiles are created using the Deployment Editor.

- 1 From the Enterprise Explorer's Project Explorer, right-click the project (**Batch_BP_LFIn_Sample**) and select **New > Deployment Profile**.
- 2 Enter a name for the Deployment Profile (for this sample **DP_Batch_BP_LFIn**). Make sure that the selected Environment is **ENV_Batch_BP_LFIn**. Click **OK**.
- 3 From the left pane of the Deployment Editor, drag **BP_LFIN1** -> **FileOut1** (External Application) to the **FileExtSysOut** window.
- 4 From the left pane of the Deployment Editor, drag the **BP_LFIN1** -> **BatchLocalFileIn1** (External Application) to the **BatchLocalFileExtSys** window.
- 5 Drag **Scheduler1** -> **BP_LFIN1** (Application) to the **Scheduler** window.
- 6 From the left pane of the Deployment Editor, drag **BP_LFIN1** (Business Process) to **IntegrationSvr1** in the **Localhost2** window.
- 7 Click **Activate**. When activation succeeds, save the changes to the Repository.

6.7.8. Running the Project

The following directions assume that the Enterprise Designer was downloaded to C:\ican50. If this is not the case, replace that location in the following directions with the appropriate location.

- 1 From the Enterprise Manager Downloads tab, click on **Local Host - for win32**.
- 2 Extract the file to the **ican50\logicalhost2** directory. You must specify the **logicalhost2** directory for it to be created.
- 3 Navigate to **C:\ican50\logicalhost2\logicalhost\bootstrap\config** directory and open the **logical-host.properties** file using Notepad™.
- 4 Enter the following information in the appropriate fields:
 - ♦ Logical Host root directory: **ican50\logicalhost2\logicalhost**
 - ♦ Repository URL: **http://localhost:port number/repository name**
 - ♦ Repository user name and password: **Your user name and password**
 - ♦ Logical Host Environment name: **ENV_Batch_BP_LFIn**
 - ♦ Logical Host name: **logicalhost2**

Save your changes to **logical-host.properties** and close the file.

- 5 Run the **bootstrap.bat** file in the **ican50\logicalhost2\logicalhost\bootstrap\bin** directory.
- 6 Copy the sample input data file to the input directory.

6.8 The Batch_BP_LFOut Sample Project

The **Batch_BP_LFOut** project demonstrates the following:

- The File eWay picks up a file from an external directory and publishes the data to the BatchLocalFile eWay.
- The data is converted from text to bytes.
- The payload node of the BatchLocalFile eWay publishes the converted file to a target directory with the same name as the file content.

The following pages provide step by step directions for manually creating the **Batch_BP_LFOut** sample project components.

To create the **Batch_BP_LFOut** project do the following:

6.8.1. Create a Project

The first step is to create and name a new project in eGate Enterprise Designer.

- 1 Start the Enterprise Designer.
- 2 From the Enterprise Explorer's Project Explorer tab, select your Repository on the Project Explorer tree, right-click the Repository and select **New Project**. A new project appears on the Project Explorer tree.
- 3 Click twice on **Project1** and rename the project (for this sample, **Batch_BP_LFOut_Sample**).

6.8.2 Creating the BP_LFOut Business Process

Creating the Business Process Flow

- 1 From the Enterprise Designer's Project Explorer tree, right-click **Batch_BP_LFOut_Sample**, and select **New > Business Process** from the shortcut menu. The eInsight Business Process Designer appears and **BusinessProcess1** is added to the Project Explorer tree. Rename the Business Process to **BP_LFOut**.
- 2 Populate the eInsight Business Process Designer's modeling canvas with the following elements from the Project Explorer tree, as displayed in [Figure 38 on page 133](#):
 - ♦ **receive**, under SeeBeyond > eWays > FileClient
 - ♦ **write**, under SeeBeyond > eWays > BatcheWay > BatchLocalFile

Figure 45 eInsight Business Process Designer - Populate the Canvas

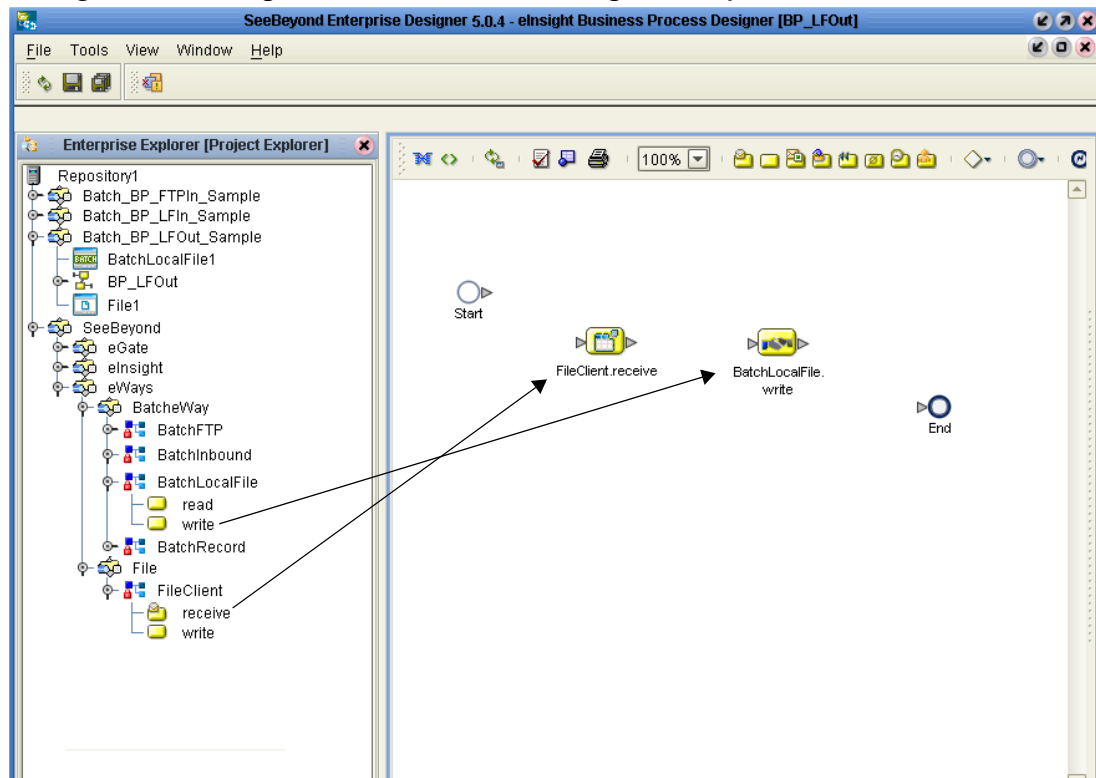

3 Link the modeling elements by clicking on the element's connector and dragging the cursor to the next element's connector, making the following links as displayed in Figure 46.

- ◆ Start -> FileClient.receive
- ◆ FileClient.receive -> BatchLocalFile.write
- ◆ BatchLocalFile.write -> End

Figure 46 eInsight Business Process Designer - Link the Modeling Elements

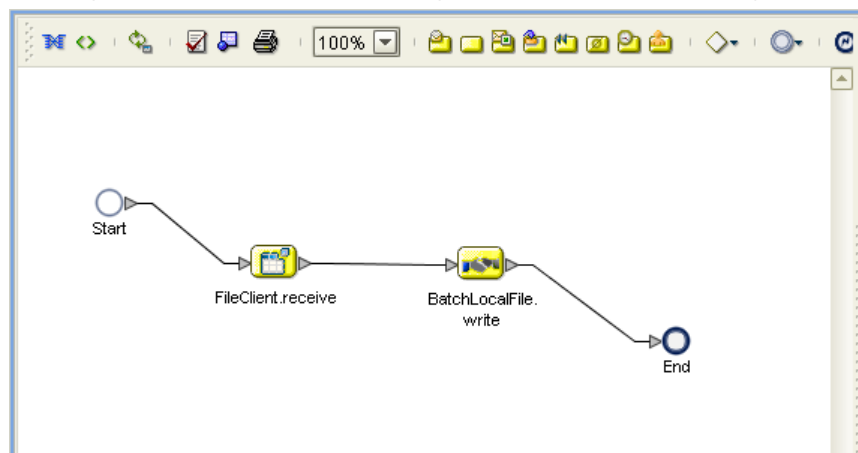

Configuring the Modeling Elements

Business Rules, created between the Business Process elements, define the relationship between the input and output attributes of the elements.

- 1 Right-click the link between the **FileClient.receive** and **BatchLocalFile.write** Activities and select **Add Business Rule** from the shortcut menu (see Figure 47).

Figure 47 eInsight Business Process Designer - Adding Business Rules

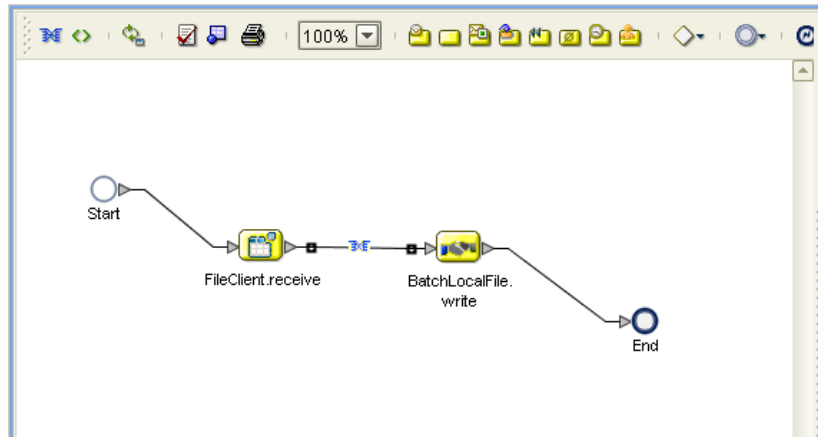

- 2 From the eInsight Business Process Designer toolbar, click the **Map Business Process Attributes** button. The Business Rule Designer appears at the bottom of the eInsight Business Process Designer.
- 3 Click on the **Business Rule** icon in the link between **FileClient.receive** and **BatchLocalFile.write** to display the Business Rule Output and Input Attributes in the Business Rule Designer. These Attributes can now be modified.
- 4 From the Business Rule Designer toolbar, click the Method Palette icon. The Method Palette appears. From the **String** tab of the Method Palette, select **text to bytes** and click **Close**. The **text to bytes** icon is added to the toolbar.
- 5 From the Business Rule Designer toolbar, drag and drop the **text to bytes** icon onto the Business Rule Designer canvas. The **bytes to text** method box appears (see Figure 48).

Figure 48 eInsight Business Rule Designer

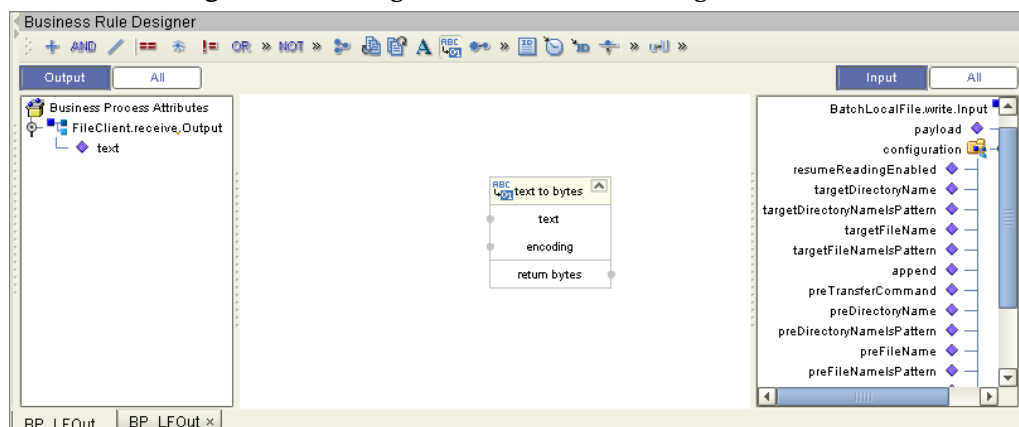

- 6 Map **text**, under FileClient.receive.Output in the Output pane of the Business Rule Designer, to the **text** input node of the **text to bytes** method box. This is done by clicking on **text** and dragging the cursor to the **text** input node of the **text to bytes** method box.
- 7 Map the **return bytes** output node of the **text to bytes** method box, to bytes to under BatchLocalFile.write.input in the Input pane of the Business Rule Designer. The Business Process Designer (see Figure 49).

Figure 49 eInsight Business Rule Designer

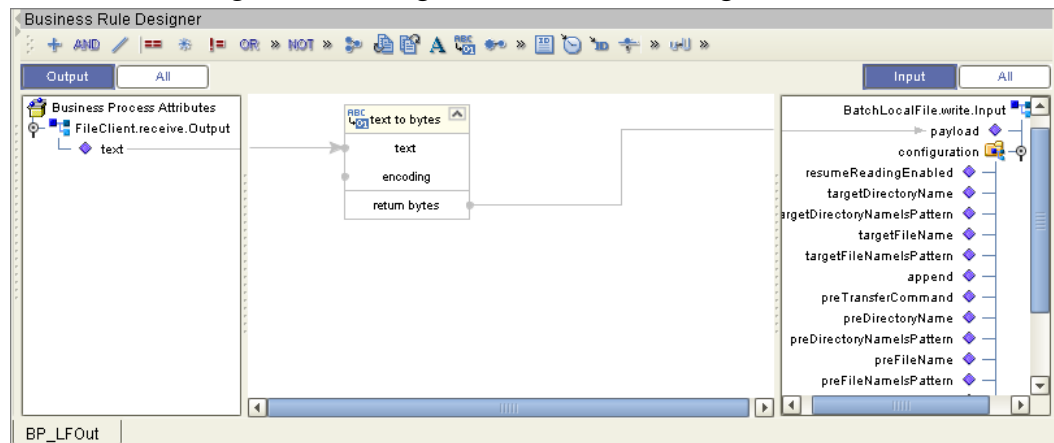

- 8 Map **text**, under FileClient.receive.Output in the Output pane of the Business Rule Designer, to **targetFileName** under Configuration > BatchLocalFile.write.input in the Input pane of the Business Rule Designer (see Figure 50).

Figure 50 eInsight Business Rule Designer

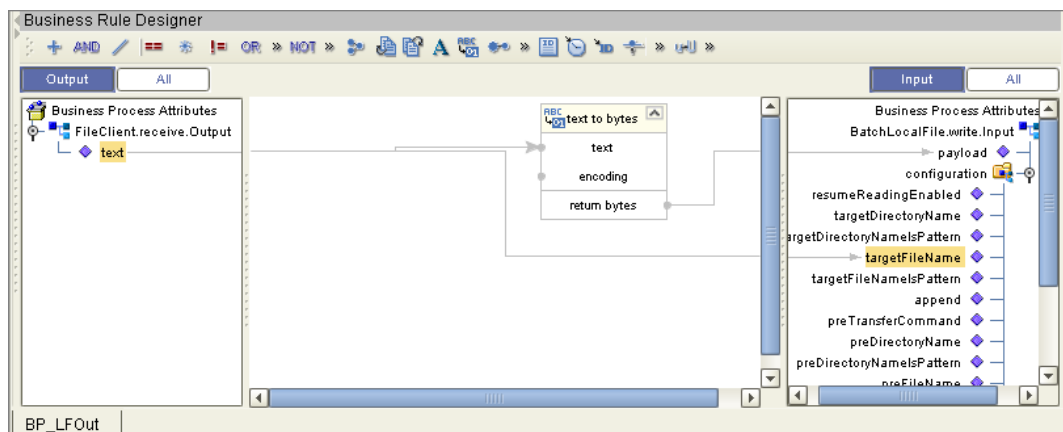

- 9 When the Business Process is complete, from the Business Process Designer toolbar, click the **Synchronize Graphical Model and Business Process Code** icon to synchronize the graphical interface to the Business Process code.
- 10 Click the Enterprise Designer's **Save All** icon to your current changes.

6.8.3 Create a Connectivity Map

The Connectivity Map provides a canvas for configuring a project's components.

- 1 In Enterprise Explorer's Project Explorer, right-click the new project (**Batch_BP_LFOut_Sample**) and select **New > New Connectivity Map** from the shortcut menu.
- 2 The New Connectivity Map appears and a node for the Connectivity Map is added under the project on the Project Explorer tree labeled **CMap1**. Rename the Connectivity Map **CM_Batch_BP_LFOut**.

Select the External Applications

- 1 Click the **External Application** icon on the Connectivity Map toolbar,
- 2 Select the applications needed for your project (for this sample, **BatchLocalFile External Application** and **File External Application**). Icons representing the selected applications are added to the Connectivity Map toolbar.

Populate the Connectivity Map

Add the project components to the Connectivity Map by dragging the icons from the toolbar to the canvas.

- 1 For the Batch_BP_LFIn_Sample project, drag the following components onto the Connectivity Map canvas as displayed in Figure 51:
 - ◆ File External System
 - ◆ Service
 - ◆ BatchLocalFile External System

Figure 51 CM_Batch_BP_LFIn Connectivity Map with Components

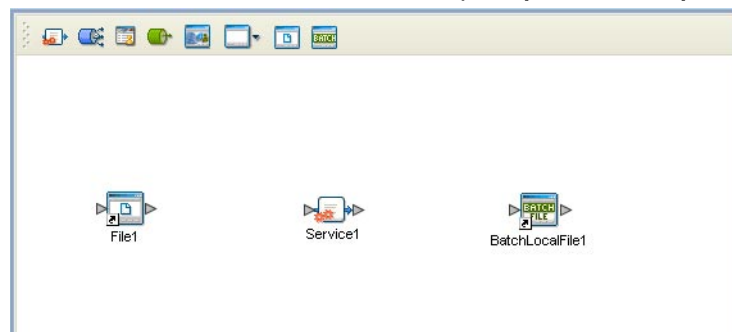

- 2 Rename **File1** to **FileIn1** by clicking the external application's name once and clicking it again. Enter the new name.
- 3 Rename **BatchLocalFile1** to **BatchLocalFileOut1**.
- 4 Rename **Service1** to **BP_LFOut1**.
- 5 Save your current changes to the Repository.

6.8.4. Binding the Project Components

Components are associated and the bindings are created in the Connectivity Map.

- 1 From the Project Explorer, double-click the Connectivity Map **CM_Batch_BP_LFOut**. The Enterprise Designer canvas now displays the **CM_Batch_BP_LFOut** Connectivity Map.
- 2 Drag and drop the **BP_LFOut** Business Process from the Project Explorer onto **BP_LFOut1** in the **CM_Batch_BP_LFOut** Connectivity Map.
- 3 Double-click **BP_LFOut1**. The **BP_LFOut1** binding dialog box appears.
- 4 From the **BP_LFOut1** binding box, map **FileSender** (under Implemented Services) to the **FileIn1** External Application.
- 5 From the **BP_LFOut1** binding box, map the **BatchLocalFileReceiver** (under Invoked Services) to the **BatchLocalFileOut1** External Application.
- 6 Minimize the **BP_LFOut1** binding box. The Connectivity Map now appears as displayed in Figure 52.

Figure 52 Connectivity Map - Connecting the Project's Components

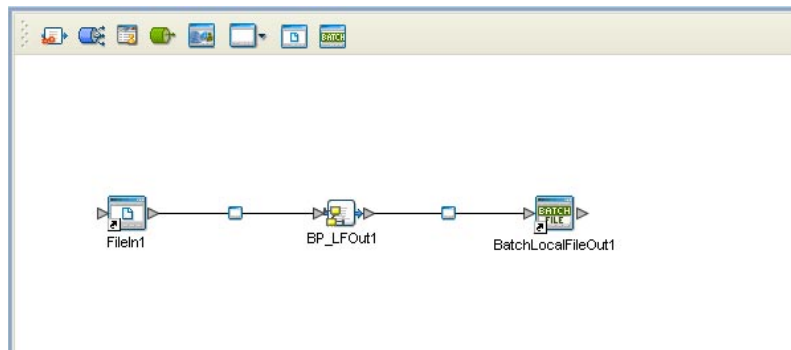

- 7 Save the current changes to your Repository.

6.8.5. Configuring the eWays

The Batch_BP_LFOut_Sample project uses two eWays, each represented in the Connectivity Map as a node between an External Application and a Service.

The File eWay properties are configured from the Connectivity Map. The BatchLocalFile eWay, unlike the BatchFTP eWay, is only configured from the Project Explorer's Connectivity Map, and not from the Environment Explorer. To configure the eWays, do the following:

Configuring the File eWays

- 1 Double-click the **Inbound File eWay** and select **Inbound File eWay** in the Templates dialog box and click **OK**.
- 2 The Properties Sheet opens to the Inbound File eWay properties. Modify the properties for your system.

Configuring the BatchLocalFile eWay

The BatchLocalFile eWay properties are set from the Project Explorer's Connectivity Map. For more information on the BatchLocalFile eWay properties and the Properties Sheet, see [Creating and Configuring the Batch eWay](#) on page 17 or see the *eGate Integrator User's Guide*.

For the Batch_BP_LFOut_Sample project, do the following:

Modifying the BatchLocalFile eWay Connectivity Map Properties

- 1 From the **Connectivity Map**, double-click the **BatchLocalFile** eWay. The Properties Sheet opens to the BatchLocalFile eWay properties.
- 2 Modify the BatchLocalFile eWay properties for your system.

6.8.6. Creating an Environment

Environments include the external systems, Logical Hosts, integration servers and JMS IQ Managers used by a project and contain the configuration information for these components.

- 1 From the Enterprise Designer's Enterprise Explorer, click the **Environment Explorer** tab.
- 2 Right-click the Repository and select **New Environment**. A new Environment is added to the Environment Explorer tree.
- 3 Rename the new Environment to **ENV_Batch_BP_LFOut**.
- 4 Right-click **ENV_Batch_BP_LFOut** and select **New BatchLocalFile External System**. Name the External System **BatchLocalFileExtSys**. Click **OK**. The **BatchLFExtSys** window is added to the Environment Editor.
- 5 Right-click **ENV_Batch_BP_LFOut** and select **New File External System**. Name this External System **FileExtSysIn** and select **Inbound File eWay** as the External System Type. The **FileExtSysIn** window is added to the Environment Editor.
- 6 Right-click **ENV_Batch_BP_LFOut** and select **New Logical Host**. The **LogicalHost1** box is added to the Environment and **LogicalHost1** is added to the Environment Editor tree.
- 7 From the Environment Explorer tree, right-click **LogicalHost1** and select **New SeeBeyond Integration Server**. A new Integration Server (**IntegrationSvr1**) is added to the Environment Explorer tree under **LogicalHost3**.
- 8 Save your current changes to the Repository.

6.8.7 Creating and Activating the Deployment Profile

A Deployment Profile is used to assign Collaborations and message destinations to the integration server and JMS IQ Manager. Deployment profiles are created using the Deployment Editor.

- 1 From the Enterprise Explorer's Project Explorer, right-click the project (**Batch_BP_LFOut_Sample**) and select **New > Deployment Profile**.

- 2 Enter a name for the Deployment Profile (for this sample **DP_Batch_BP_LFOut**). Make sure that the selected Environment is **ENV_Batch_BP_LFOut**. Click **OK**.
- 3 From the left pane of the Deployment Editor, drag **FileIn1** -> **BP_LEFOut1** (External Application) to the **FileExtSysIn** window.
- 4 From the left pane of the Deployment Editor, drag the **BP_LFOut1** -> **BatchLocalFileOut1** (External Application) to the **BatchLocalFileExtSys** window.
- 5 From the left pane of the Deployment Editor, drag **BP_LFOut1** (Business Process) to **IntegrationSvr1** in the **LogicalHost1** window.
- 6 Click **Activate**. When activation succeeds, save the changes to the Repository.

6.8.8. Running the Project

Note: For the *Batch_BP_LFOut_Sample*, make sure that the file content and target directory name are the same, including spaces, carriage returns, and so forth.

The following directions assume that the Enterprise Designer was downloaded to C:\ican50. If this is not the case, replace that location in the following directions with the appropriate location.

- 1 From the Enterprise Manager Downloads tab, download **Logical Host - for win32**.
 - 2 Extract the file to the **ican50\logicalhost3** directory. You must specify the **logicalhost3** directory for it to be created.
 - 3 Navigate to **C:\ican50\logicalhost3\logicalhost\bootstrap\config** directory and open the **logical-host.properties** file using Notepad™.
 - 4 Enter the following information in the appropriate fields:
 - ♦ Logical Host root directory: **ican50\logicalhost3\logicalhost**
 - ♦ Repository URL: **http://localhost:port number/repository name**
 - ♦ Repository user name and password: *Your user name and password*
 - ♦ Logical Host Environment name: **ENV_Batch_BP_LFOut**
 - ♦ Logical Host name: **logicalhost3**
- Save your changes to **logical-host.properties** and close the file.
- 5 Run the **bootstrap.bat** file in the **ican50\logicalhost3\logicalhost\bootstrap\bin** directory.
 - 6 Copy the sample input data file to the input directory.

Implementing a Batch eWay Project

This chapter provides an introduction to the Batch eWay components used in a Collaboration based project. This chapter assumes that you are already familiar with ICAN concepts and that you understand how to create a project using the SeeBeyond Enterprise Designer.

This chapter presents two sample Batch eWay projects created using the same procedures as the sample end-to-end project provided in the *eGate Integrator Tutorial*.

For a complete explanation of ICAN terminology and concepts, see the *eGate Integrator User's Guide*.

What's in This Chapter

- [Batch eWay Components](#) on page 148
- [Importing a Sample Project](#) on page 149
- [The Batch eWay Sample Projects](#) on page 149

7.1 Batch eWay Components

eWay components that are unique to the Batch eWay include the following:

Batch eWay Configuration Files

The properties files for the Batch eWay contain the parameters used to connect with a specific external system. These properties are set using the Properties Sheet. For more information about the Batch eWay properties files and the Properties Sheet see [Creating and Configuring the Batch eWay](#) on page 17.

Batch eWay OTDs

Object Type Definitions (OTDs) map input and output message segments at the field level. The Batch eWay has the following four OTDs:

- **BatchRecord OTD**
- **BatchFTP OTD**
- **BatchLocalFile OTD**
- **BatchInbound OTD**

For information on the Batch eWay OTDs, see [Overview of the Batch OTDs](#) on page 81.

7.2 Considerations

The following items must be considered when implementing a Batch eWay project:

- When using FTP with an **AS400 UNIX** system, the following FTP configuration settings are required:
 - ♦ FTP - Use PASV: **No** (see [Use PASV](#) on page 29)
 - ♦ FTP Raw Commands - Pre Transfer Raw Commands: **site namefmt 1** (see [Pre Transfer Raw Commands](#) on page 31)

7.3 Importing a Sample Project

Sample eWay projects are included as part of the installation CD-ROM package. To import a sample eWay project to the Enterprise Designer do the following:

The sample files are first uploaded with the Batch eWay's documentation .sar file (**BatcheWayDocs.sar**) and downloaded from the Enterprise Manager's Documentation tab. Extract the samples from the Enterprise Manager to a local file.

- 1 Save all unsaved work before importing a project.
- 2 From the Enterprise Designer's Project Explorer pane, right-click the Repository and select **Import** from the shortcut menu. The **Import Manager** appears.
- 3 Browse to the directory that contains the sample project zip file. Select the sample file (for example, **BatchSample1.zip**) and click **Import**. After the sample project is successfully imported, click **Close**.
- 4 Before an imported sample project can be run you must do the following:
 - ♦ Create an **Environment** (see [Creating an Environment](#) on page 159)
 - ♦ Configure the eWays for your specific system (see [Configuring the eWays Properties](#) on page 160)
 - ♦ Create a **Deployment Profile** (see [Creating and Activating the Deployment Profile](#) on page 163)

7.4 The Batch eWay Sample Projects

This chapter provides step by step directions for three sample Batch eWay projects.

- [The Batch_FTPIIn_LFOOut_Sample Project](#) on page 150,
- [The Batch_RecParseStream_Sample Project](#) on page 165
- [The BatchInbound_Sample Project](#) on page 175

Sample data files

Sample data files for the Batch eWay projects are included with the samples. See `Input_Files_Readme.txt` included with the sample data files for more information.

7.5 The Batch_FTPIn_LFOut_Sample Project

The `Batch_FTPIn_LFOut_Sample` project demonstrates how the Batch eWay uses a File eWay to locate and select a file from a local directory. The BatchFTP eWay brings data in and the Collaboration combines the data and writes it to a local file.

The Collaboration (Java) invokes the Batch FTP eWay to get the payload file, populates the payload with data, and then puts the data into a local file. To accomplish this, the Collaboration has three Business Rules that convert incompatible data types by doing the following:

- Unmarshaling data from a String
- Converting String data to byte array
- Populating a payload with the converted data and writing it to a local file

Figure 53 shows the data flow of the Batch eWay sample project.

Figure 53 Batch eWay Sample Project

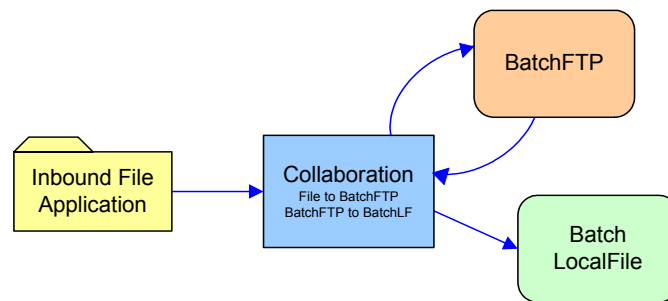

7.5.1. Create a Project

The first step is to create a new project in the SeeBeyond Enterprise Designer.

- 1 Start the Enterprise Designer.
- 2 From the Enterprise Explorer's Project Explorer tab, right-click the Repository and select **New Project** (see Figure 54). A new project (Project1) appears on the Project Explorer tree.

Figure 54 Enterprise Explorer - New Project

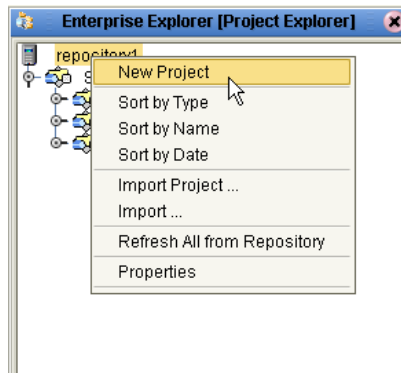

- 3 Rename the project (for this sample, **Batch_FTPInLFOut_Sample**).

7.5.2 Creating a Connectivity Map

A Connectivity Map provides a canvas for assembling and configuring a project's components.

- 1 In the Enterprise Explorer's Project Explorer, right-click **Batch_FTPInLFOut_Sample** and select **New > Connectivity Map** from the shortcut menu.
- 2 The new Connectivity Map appears and adds a node on the Project Explorer tree labeled **CMap1**.

Selecting the External Applications

In the Connectivity Map, eWays are associated with External Applications. For example, to establish a connection to an external FTP server, you must first select BatchFTP as an External System to use in the Connectivity Map (see Figure 55).

Figure 55 Connectivity Map - External Applications

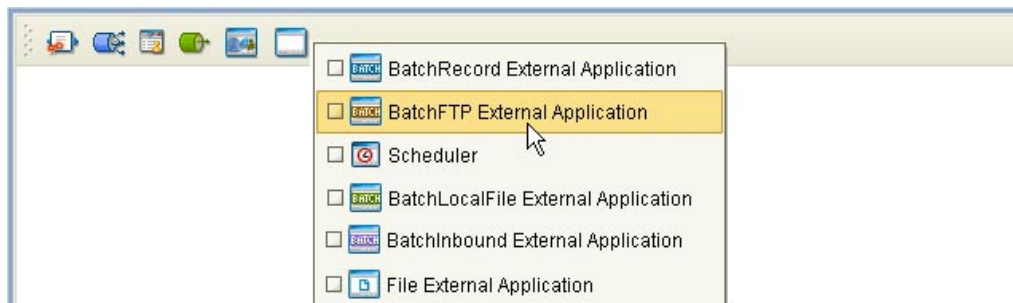

- 1 Click the **External Application** icon on the Connectivity Map toolbar.
- 2 Select the External Applications for your project. For this sample, select **File External Application**, **BatchFTP External Application**, and **BatchLocalFile External Application**. This adds icons representing the **File** and **BatchFTP** and **BatchLocalFile** External Application icons to the Connectivity Map toolbar.

7.5.3 Populating the Connectivity Map

Add the project components to the Connectivity Map by dragging the icons from the Connectivity Map toolbar to the canvas.

- 1 For the **Batch_FTPInLFOOut_Sample** sample, drag and drop the following components onto the Connectivity Map canvas as displayed in **Figure 56** on page 152:
 - ◆ File External Application
 - ◆ Service (container for the Collaboration)
 - ◆ BatchLocalFile External Application
 - ◆ BatchFTP External Application

Figure 56 Batch_FTPInLFOOut_Sample Connectivity Map

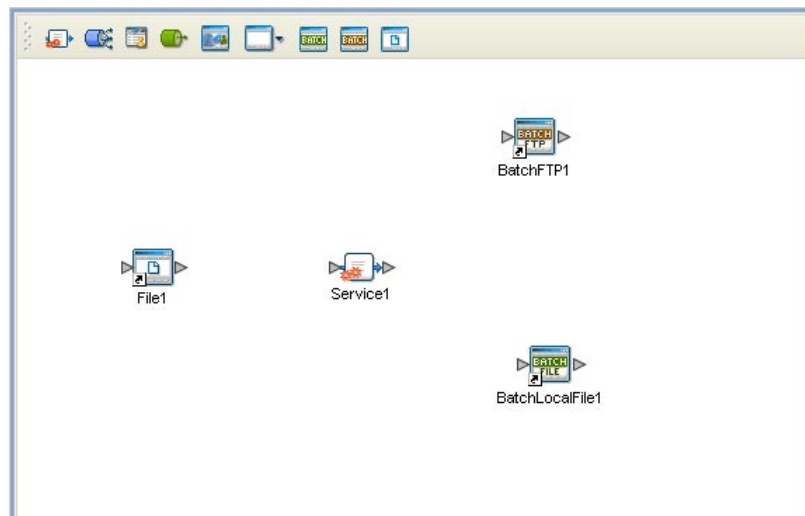

- 2 Rename the items in the Connectivity Map by right-clicking the item, selecting Rename from the shortcut menu, and typing the new name in. Rename the items as follows:
 - ◆ **File1** to **FileIn1**
 - ◆ **BatchFTP1** to **BatchFTPIn1**
 - ◆ **BatchLocalFile1** to **BatchLocalFileOut1**
 - ◆ **Service1** to **CollabFTPInLFOOut**

7.5.4 Creating Collaboration Definitions

The next step in the sample project is to create the **jcd_FTPInLFOOut** Collaboration Definition. A Collaboration Definition contains Business Rules that define the processing and transport of data between eGate components.

The Collaboration Definition Wizard (Java) is used to create the Java Collaboration Definitions. Once a Collaboration is created, the Collaboration Editor is used to create the Business Rules of the Collaboration.

Create the jcd_FTPInLFOut Collaboration

The `jcd_FTPInLFOut` Collaboration defines how data is transferred between the FileIn application, the Inbound BatchFTP application and the Outbound BatchLocalFile.

- 1 From the Project Explorer, right-click **Batch_FTPInLFOut_Sample** and select **New > Collaboration Definition (Java)** from the shortcut menu. The **Collaboration Definition Wizard (Java)** appears.
- 2 Enter a Collaboration Definition name (for this sample `jcd_FTPInLFOut`) and click **Next**.
- 3 For Step 2 of the Wizard, double-click **SeeBeyond > eWays > File > FileClient > receive**. The File Name field now displays `receive`. Click **Next**.
- 4 For Step 3 of the Wizard, from the Select OTDs selection window, double-click **SeeBeyond > eWays > BatcheWay > BatchFTP**. The **BatchFtp** OTD is added to the Selected OTDs field.
- 5 From the Select OTDs selection window, double-click **BatchLocalFile** (SeeBeyond > eWays > BatcheWay > BatchLocalFile). The **BatchLocalFile** OTD is added to the Selected OTDs field (see [Figure 57](#) on page 153).

Figure 57 Collaboration Definition Wizard (Java) - `jcd_FTPInLFOut` - Select OTDs

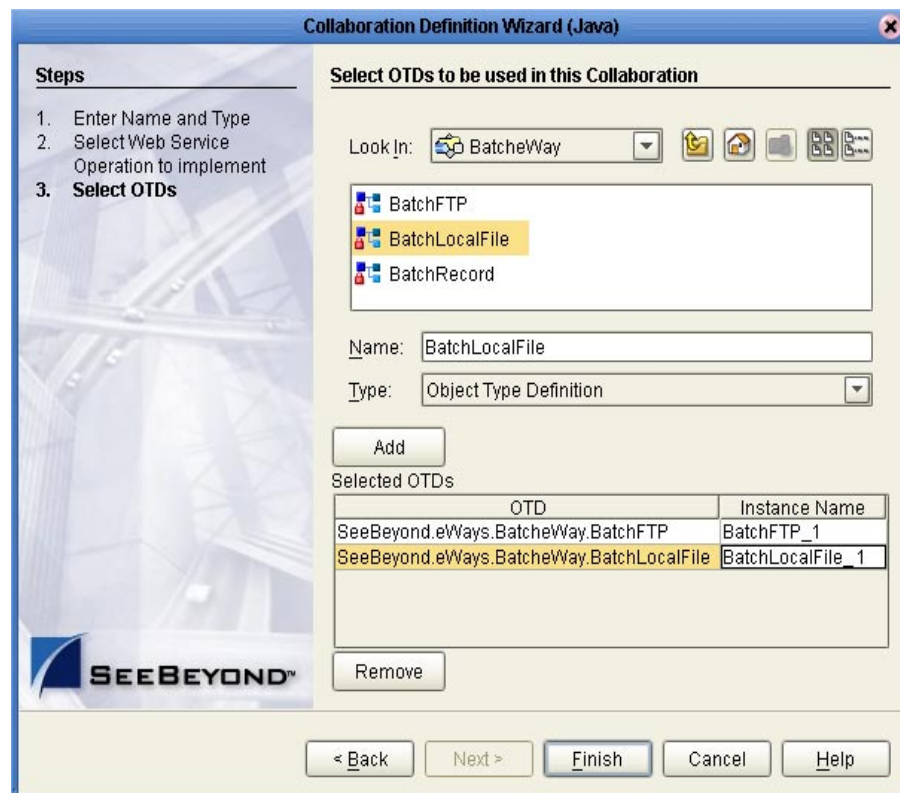

- 6 Click **Finish**. The new `jcd_FTPInLFOut` Collaboration appears in the Project Explorer tree.

7.5.5 Using the Collaboration Editor (Java)

The `Batch_FTPInLFOut_Sample` project uses the `jcd_FTPInLFOut` Collaboration created in the previous section. To complete the Collaboration, use the Collaboration Editor (Java) to create the Business Rules.

Create the `jcd_FTPInLFOut` Collaboration Business Rules

Be careful to open all nodes specified in the directions to connect the correct items. The `jcd_FTPInLFOut` Collaboration contains the Business Rule displayed in [Figure 58](#) on page 154.

Figure 58 `jcd_Passthru` Business Rules

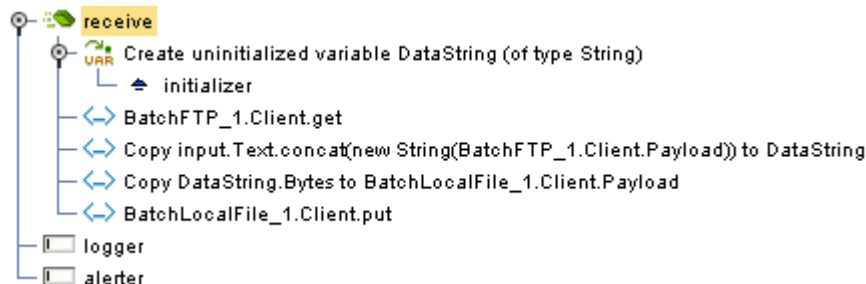

To create the `jcd_Passthru` Collaboration Business Rules, do the following:

- 1 From the Project Explorer tree, double-click `jcd_Passthru`. The Collaboration Editor (Java) opens to the `jcd_Passthru` Collaboration.
- 2 To create comments for the Business Rules, from the Business Rules toolbar, click the **comment** icon. The **Enter a Comment** dialog box appears. Enter the comment and click **OK**. The comment is placed on the Business Rules tree under the last selected item. Once the Comment is created, it can be moved by clicking the comment and dragging it up or down the Business Rules tree to a new location.
- 3 To create the **Create uninitialized variable DataString (of type String)** variable rule do the following:
 - A Right-click **DataString** in the left pane of the Business Rules Designer, and select **Create new Variable of this type** from the shortcut menu. The Create a Variable dialog box appears.
 - B Enter **DataString** as the Variable Name and click **OK**.
- 4 To create the **BatchFTP_1.Client.get** rule do the following:
 - A Click **rule** on the Business Rules toolbar to add a new rule in the Business Rules pane.
 - B Right-click **Client** under the **BatchFTP_1** node in the left pane of the Business Rules Designer, and click **Select a method to call** from the shortcut menu. The **method selection** window appears.
 - C Select **get()** from the method selection window. The get method box appears in the Business Rules Designer canvas (see [Figure 59](#)).

Figure 59 Collaboration Editor (Java) - Business Rules Designer

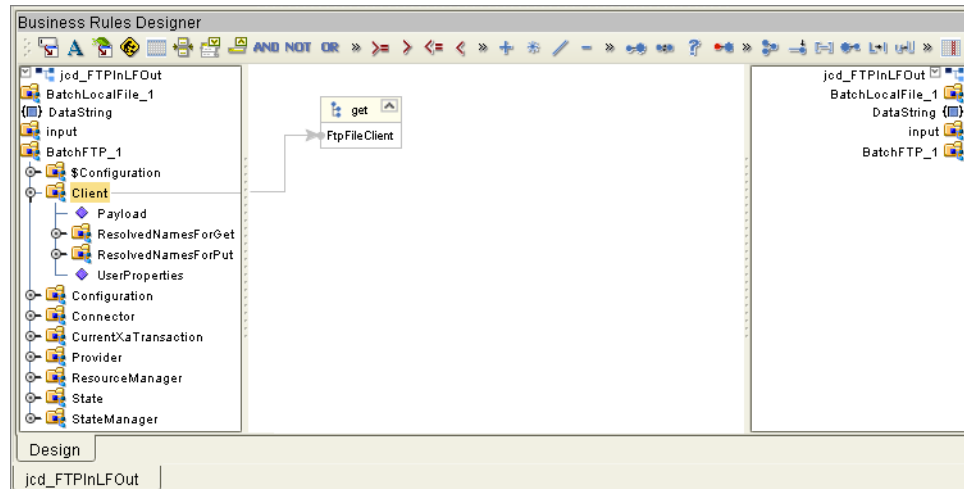

- 5 To create the **Copy input.Text.concat(new String(BatchFTP_1.Client.Payload)) to DataString** rule do the following:
 - A From the Business Rules Designer toolbar, drag the **concat** icon to the Business Rules Designer canvas. The **concat** method box appears.
 - B Map **Text** under **input** in the left pane of the Business Rules Designer, to the **String** input node of the **concat** method box.
 - C Map the **result (String)** output node of the **concat** method box to **DataString** in the right pane of the Business Rules Designer.
 - D From the Business Rules Designer toolbar, click the **Call New Constructor** icon. The **Call New Constructor** dialog box appears. Select **String** in the **All Classes** window, select **java.lang.String(byte[] bytes)** in the **Constructors** window, and click **OK**. The **java.lang.String** method box appears in the Business Rules Designer canvas.
 - E Map **Payload** under **BatchFTP_1 > Client** in the left pane of the Business Rules Designer, to the **bytes (byte[])** input node of the **java.lang.String** method box.
 - F Map the **result (String)** output node of the **java.lang.String** method box to the **str (String)** input node of the **concat** method box (see [Figure 60](#) on page 156).

Figure 60 Collaboration Editor (Java) - Business Rules Designer

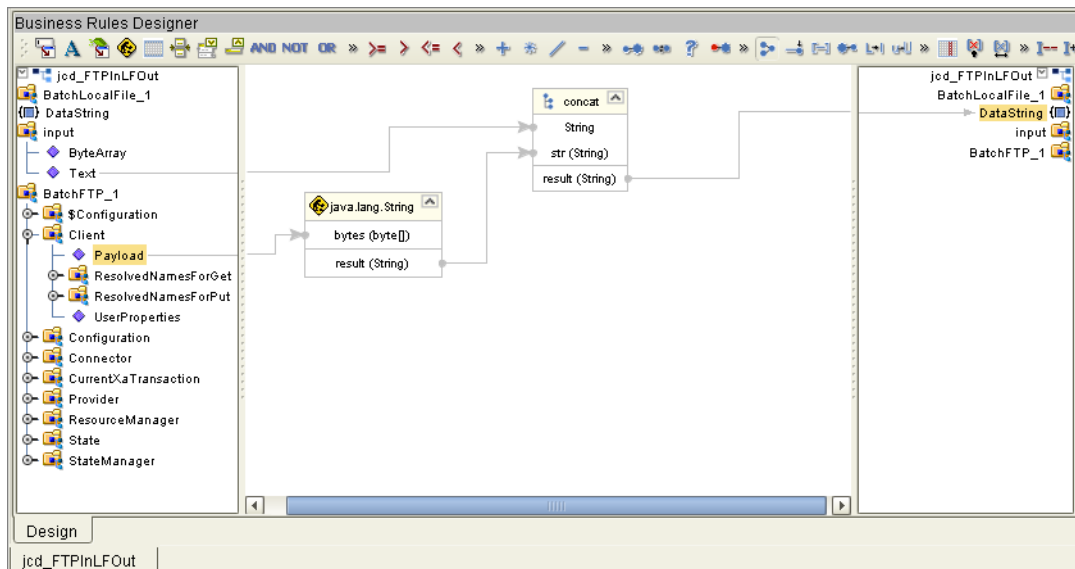

6 To create the **Copy DataString.Bytes to BatchLocalFile_1.Client.Payload** rule do the following:

- A Click **rule** on the Business Rules toolbar to add a new rule in the Business Rules pane.
- B Right-click **DataString** in the left pane of the Business Rules Designer and click **Select a method to call** from the shortcut menu. Select **getBytes()** from the method selection window. The **getBytes** method box appears.

Note: For eGate 5.0.4, the **getBytes()** method may not be available from the method selection window. To create this method, click the **Call Java Method** icon on the Business Rules Designer toolbar. From the **Call Method** dialog box, select **String** as the value for **All Classes**, select **getBytes()** as the **Methods** value, and click **OK**. The **getBytes** method box appears. Map **DataString** in the left pane of the Business Rules Designer, to the **String** input node of the **getBytes** method box.

- C Map the **result (byte[])** output node of the **getBytes** method box, to **Payload** under **BatchLocalFile_1 > Client** in the right pane of the Business Rules Designer. The Editor now appears as displayed in **Figure 61** on page 157.

Figure 61 Collaboration Editor (Java) - Business Rules Designer

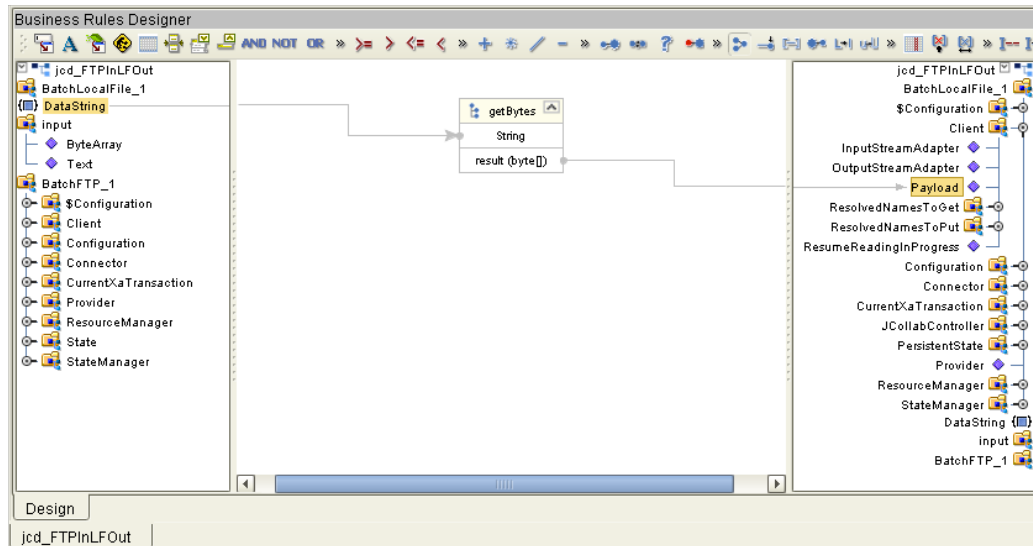

- 7 To create the **BatchLocalFile_1.Client.put** rule do the following:
 - A Click **rule** on the Business Rules toolbar to add a new rule in the Business Rules pane.
 - B .Right-click **Client** under the **BatchLocalFile_1** node in the left pane of the Business Rules Designer, and click **Select a method to call** from the shortcut menu. The **method selection** window appears.
- 8 Select **put()** from the method selection window. The get method box appears in the Business Rules Designer canvas (see Figure 62).

Figure 62 Collaboration Editor (Java) - Creating Business Rules

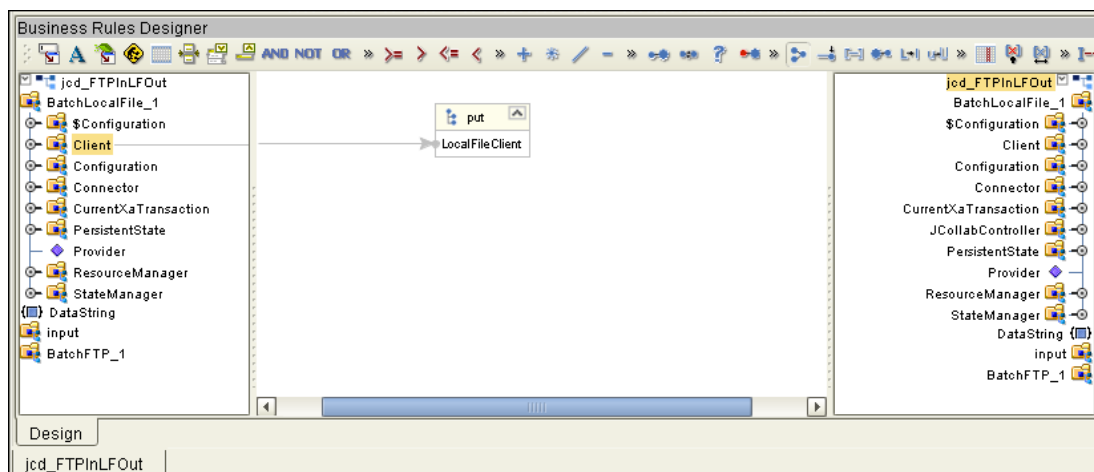

- 9 From the editor's toolbar, click **Validate** to check the Collaboration for errors.
- 10 Save your current changes to the Repository.

Note: See the *eGate Integrator User's Guide* for more information on editing Collaborations.

7.5.6 Creating Collaboration Bindings

After the Collaboration is complete, associate the components and create Collaboration Bindings by connecting the components in the Connectivity Map.

Create the Collaboration Bindings

- 1 From the Project Explorer, double-click the Connectivity Map **CMap1**.
- 2 Drag and drop the **jcd_FTPInLFOut** Collaboration from the Project Explorer onto **Collaboration1**. If the Collaboration is successfully associated the “gears” icon changes from red to green.
- 3 From the Project Explorer, drag and drop the **jcd_FTPInLFOut** Collaboration, onto **CollabFTPInLFOut** in the connectivity Map canvas (see Figure 63).

Figure 63 Connectivity Map - Binding the Project components

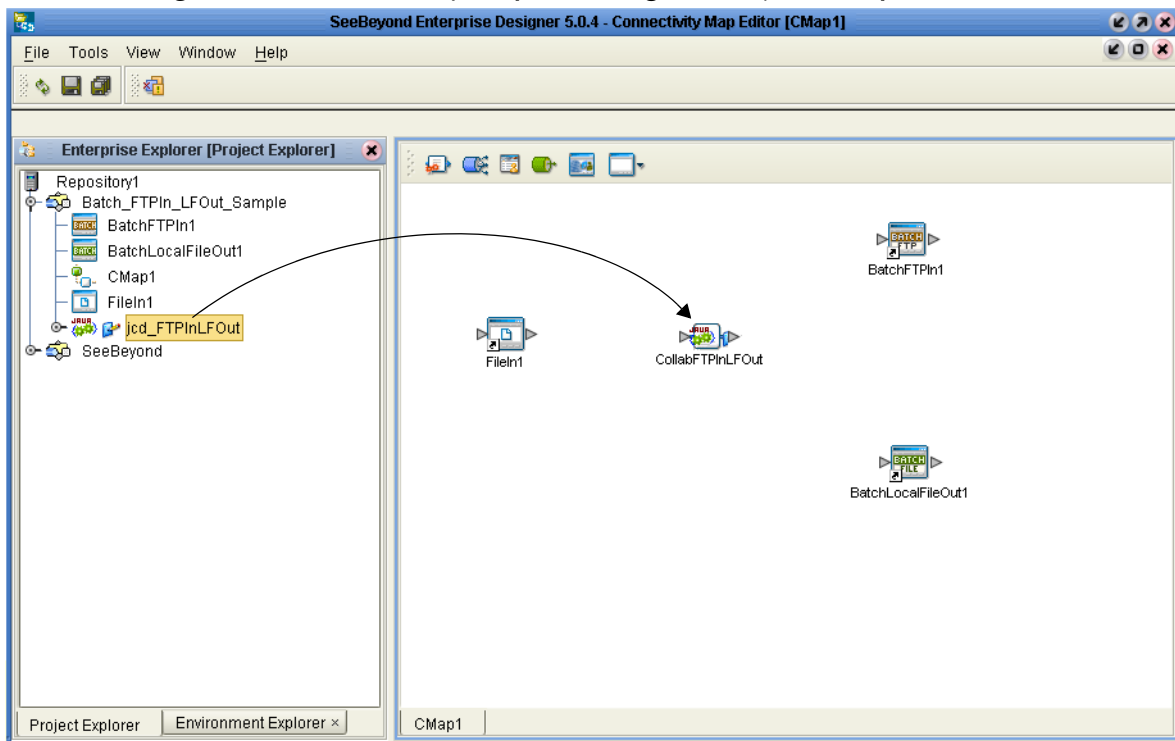

- 4 From the connectivity Map, double-click **CollabFTPInLFOut**. The **CollabFTPInLFOut** binding dialog box opens with **jcd_FTPInLFOut** as the rule.
- 5 From the Connectivity Map, map **FileClient input** under Implemented Services in the **CollabFTPInLFOut** binding dialog box, to **FileIn1**.
- 6 Map **BatchFTP** under Invoked Services in the **CollabFTPInLFOut** binding dialog box, to **BatchFTPIn1**.
- 7 Map **BatchLocalFileOut1** under Invoked Services in the **CollabFTPInLFOut** binding dialog box, to **BatchLocalFileOut1** (see Figure 64).

Figure 64 Connectivity Map - Binding the Project components

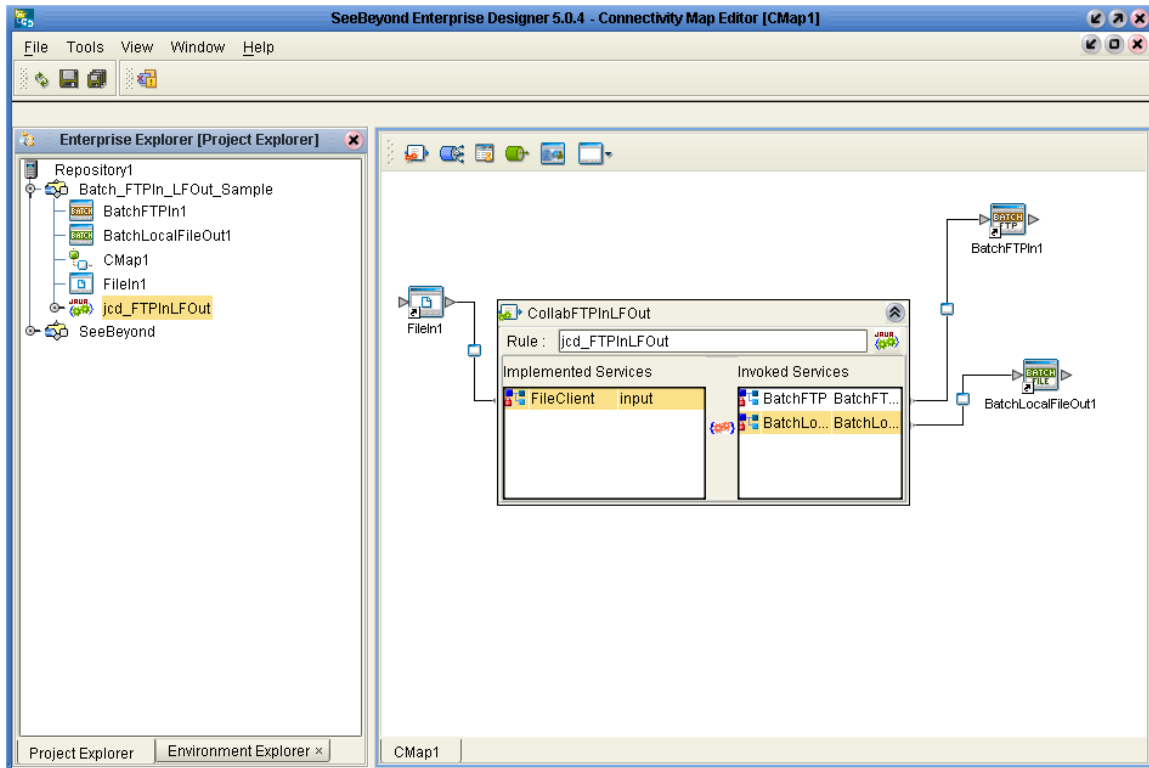

- 8 Minimize the **CollabFTPInLFOut** binding dialog box and save your changes to the Repository.

7.5.7. Creating an Environment

Environments include the external systems, Logical Hosts, integration servers and message servers used by a project and contain the configuration information for these components. Environments are created using the Enterprise Designer's Environment Explorer and Environment Editor.

- 1 From the Enterprise Designer's Enterprise Explorer, click the **Environment Explorer** tab.
- 2 Right-click the Repository and select **New Environment**. A new Environment is added to the Environment Explorer tree.
- 3 Rename the new Environment to **ENV_Batch_FTPInLFOut**.
- 4 From the Project Explorer tree, right-click **ENV_Batch_FTPInLFOut** and select **New File External System**. Name this External System **FileExtSysIn** and select **Inbound File eWay** as the External System Type. The **FileExtSysIn** window is added to the Environment Editor.
- 5 From the Project Explorer tree, right-click **ENV_Batch_FTPInLFOut** and select **New BatchFTP External System**. Name the External System **BatchFTPExtSys**. Click **OK**. The **BatchFTPExtSys** window is added to the Environment Editor.

- 6 From the Project Explorer tree, right-click **ENV_Batch_FTPInLFOut** and select **New BatchLocalFile External System**. Name the External System **BatchLocalFileExtSys**. Click **OK**. The **BatchLocalFileExtSys** window is added to the Environment Editor.
- 7 From the Project Explorer tree, right-click **ENV_Batch_FTPInLFOut** and select **New Logical Host**. The **LogicalHost1** box is added to the Environment and **LogicalHost1** is added to the Environment Editor tree.
- 8 From the Environment Explorer tree, right-click **LogicalHost1** and select **New SeeBeyond Integration Server**. A new Integration Server (**IntegrationSvr1**) is added to the Environment Explorer tree under **LogicalHost1**.
- 9 Save changes to the Repository. The Environment Explorer and Environment Editor now appear as displayed in Figure 65.

Figure 65 Environment Editor

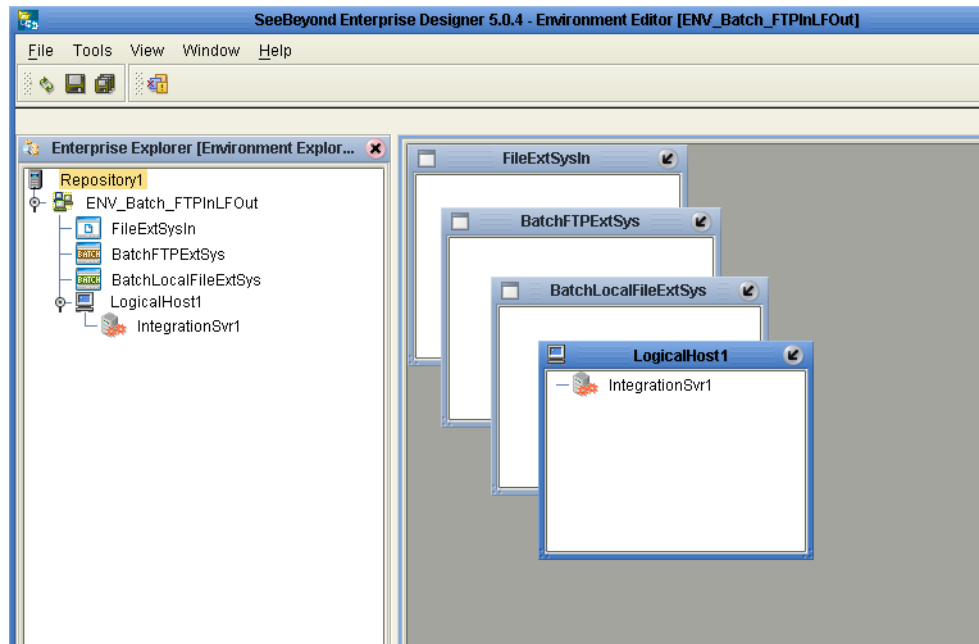

7.5.8. Configuring the eWays Properties

The **ENV_Batch_FTPInLFOut_Sample** project contains three eWays, each represented in the Connectivity Map as a node between an External Application and a Collaboration. The eWays facilitate communication and movement of data between the external applications and the eGate system (see [Figure 66](#) on page 161).

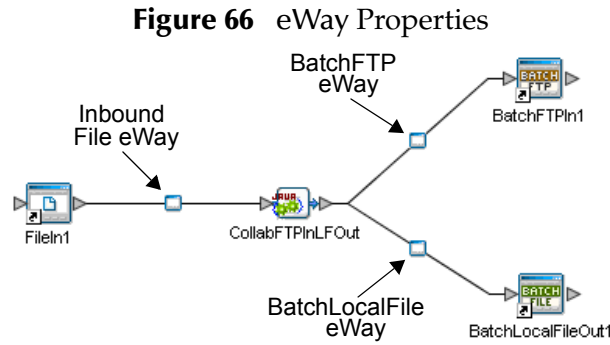

The **File eWay** and the **BatchLocalFile eWay** properties are accessed and set from the Connectivity Map. The **BatchFTP eWay** properties must be set from both the Project Explorer’s Connectivity Map and the Environment Explorer tree. To configure the eWays do the following:

Configuring the File eWay Properties

- 1 Double-click the **Inbound File eWay**, select **Inbound File eWay** in the Templates dialog box and click **OK**.
- 2 The Properties Sheet opens to the Inbound File eWay properties. Modify the properties for your system, including the settings for the **Inbound File eWay** in Table 9, and click **OK**. The properties are saved for the eWay.

Table 9 Inbound File eWay Properties

Inbound File eWay Properties	
Directory	C:/temp
Output file name	output%d.dat

Configuring the BatchLocalFile eWay Properties

- 1 Double-click the **BatchLocalFile eWay**. The Properties Sheet opens to the Outbound File eWay properties.
- 2 Modify the properties for your system, including the settings in Table 10, and click **OK**. The properties are saved for the eWay.

Table 10 BatchLocalFile eWay Settings

BatchLocalFile eWay Properties	
Append	No
Target Directory Name	The directory on the file system where files are retrieved or sent.
Target Directory Name is Pattern	No
Target File Name	The name of the file to be retrieved or sent.
Target File Name is Pattern	No

Configuring the BatchFTP eWay Properties

The BatchFTP eWay properties must be set in both Connectivity Map and Environment Explorer. For more information on the BatchFTP eWay properties and the Properties Sheet, see [Creating and Configuring the Batch eWay](#) on page 17 or see the *eGate Integrator User's Guide*.

Modifying the BatchFTP eWay Connectivity Map Properties

- 1 From the Connectivity Map, double-click the **BatchFTP** eWay. The Properties Sheet opens to the BatchFTP eWay Connectivity Map properties.
- 2 Modify the **BatchFTP** eWay (Project Explorer) configuration for your system, including the settings in Table 11, and click **OK**.

Table 11 BatchFTP eWay Connectivity Map Properties

BatchFTP eWay Connectivity Map Properties	
Target Location Set as directed, otherwise use the default settings	
Target Directory Name	The directory on the external system (absolute path) from which files are retrieved or sent
Target File Name	The FTP remote file name which is retrieved from or sent to

Modifying the BatchFTP eWay (Environment Explorer) Properties

- 1 From the **Environment Explorer** tree, right-click the BatchFTP External System (**BatchFTPExtSys** in this sample), and select **Properties**. The Properties Sheet opens to the BatchFTP eWay environment-configuration properties.
- 2 Modify the BatchFTP eWay environment-configuration properties for your system, including the settings in Table 12, and click **OK**.

Table 12 BatchFTP eWay Environment Explorer Properties

BatchFTP eWay Environment-Configuration Parameters	
FTP Set as directed, otherwise use the default settings.	
Host Name	<i>The name of the external system to which the eWay connects</i>
Password	<i>Password required to log into the external system</i>
Server Port	<i>Port number to use to connect to the FTP server</i>
User Name	<i>User ID used to login to the external system</i>

7.5.9 Creating and Activating the Deployment Profile

A Deployment Profile is used to assign Collaborations and message destinations to the integration server and message server. Deployment profiles are created using the Deployment Editor.

- 1 From the Enterprise Explorer's Project Explorer, right-click the project and select **New > Deployment Profile**.
- 2 Enter a name for the Deployment Profile (for this sample **DP_Batch_FTPInLFOut**). Make sure that the selected Environment is **ENV_Batch_FTPInLFOut**. Click **OK**.
- 3 From the left pane of the Deployment Editor, drag the **FileIn1 -> CollabFTPInLFOut** (External Application) to the **FileExtSysOut** window.
- 4 From the left pane of the Deployment Editor, drag the **CollabFTPInLFOut -> Batch_FTPIn** (External Application) to the **BatchFTPExtSys** window.
- 5 From the left pane of the Deployment Editor, drag the **CollabFTPInLFOut -> Batch_LocalFileOut** (External Application) to the **BatchLocalFileExtSys** window.
- 6 From the left pane of the Deployment Editor, drag **CollabFTPInLFOut** (Collaboration) to **IntegrationSvr1** in the **LogicalHost1** window (see Figure 67).

Figure 67 Deployment Profile

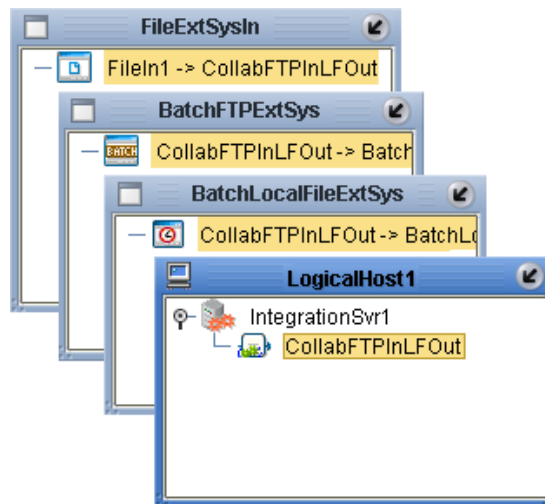

- 7 Click **Activate**. When activation succeeds, save your current changes to the Repository.

7.5.10. Running the Project

The following directions assume that the Enterprise Designer was downloaded to C:\ican50. If this is not the case, replace that location in the following directions with the appropriate location.

- 1 From the Enterprise Manager Downloads tab, click on **Logical Host - for win32**.
- 2 Extract the file to the **ican50\logicalhost4** directory. You must specify the **logicalhost4** directory for it to be created.

- 3 Navigate to **C:\ican50\logicalhost4\logicalhost\bootstrap\config** directory and open the **logical-host.properties** file using Notepad™.
- 4 Enter the following information in the appropriate fields:
 - ♦ Logical Host root directory: **ican50\logicalhost4\logicalhost**
 - ♦ Repository URL: **http://localhost:port number/repository name**
 - ♦ Repository user name and password: *Your user name and password*
 - ♦ Logical Host Environment name: **ENV_Batch_FTPInLFOut**
 - ♦ Logical Host name: **logicalhost4**

Save your changes to **logical-host.properties** and close the file.

- 5 Run the **bootstrap.bat** file in the **ican50\logicalhost4\logicalhost\bootstrap\bin** directory.
- 6 Copy the sample input data file to the input directory.

For more information on running a project that utilizes eInsight from the SeeBeyond Enterprise Designer see the *eInsight Business Process Manager User's Guide* and the *eGate Integrator User's Guide*.

7.6 The Batch_RecParseStream_Sample Project

The **Batch_RecParseStream_Sample** project demonstrates the following: The eGate Scheduler prompts the BatchLocalFile eWay to pick up a file from an external directory. The data is converted from bytes to text and published to the file eWay. The File eWay then publishes the data file to an external directory.

The following pages provide step by step directions for manually creating the **Batch_RecParseStream_Sample** project components.

To create the sample project do the following:

7.6.1. Create a Project

The first step is to create and name a new project in eGate Enterprise Designer.

- 1 Start the Enterprise Designer.
- 2 From the Enterprise Explorer's Project Explorer tab, select your Repository on the Project Explorer tree, right-click the Repository and select **New Project**. A new project appears on the Project Explorer tree.
- 3 Click twice on **Project1** and rename the project (for this sample, **Batch_RecParseStream_Sample**).

7.6.2 Create a Connectivity Map

The Connectivity Map provides a canvas for configuring a project's components.

- 1 In Enterprise Explorer's Project Explorer, right-click the new project (**Batch_RecParseStream_Sample**) and select **New > Connectivity Map** from the shortcut menu.
- 2 The New Connectivity Map appears and a node for the Connectivity Map is added under the project on the Project Explorer tree labeled **CMap1**. Rename the Connectivity Map **CM_RecParseStream_Sample**.

Select the External Applications

- 1 Click the **External Application** icon on the Connectivity Map toolbar,
- 2 Select the following applications for your project:
 - ♦ (2) File External Application
 - ♦ BatchLocalFile External System
 - ♦ BatchRecord External System
- 3 Icons representing the selected applications are added to the Connectivity Map toolbar.

Populate the Connectivity Map

Add the project components to the Connectivity Map by dragging the icons from the toolbar to the canvas.

- 1 For the Batch_RecParseStream_Sample project, drag the following components onto the Connectivity Map canvas, and name each as displayed in Figure 68:
 - ♦ (2) File External Application - **FileIn1**, **FileOut1**
 - ♦ Service - **Service1**
 - ♦ BatchLocalFile External System - **BatchLocalFileIn1**
 - ♦ BatchRecord External System - **BatchRecordParse1**

Figure 68 CM_RecParseStream_Sample Connectivity Map with Components

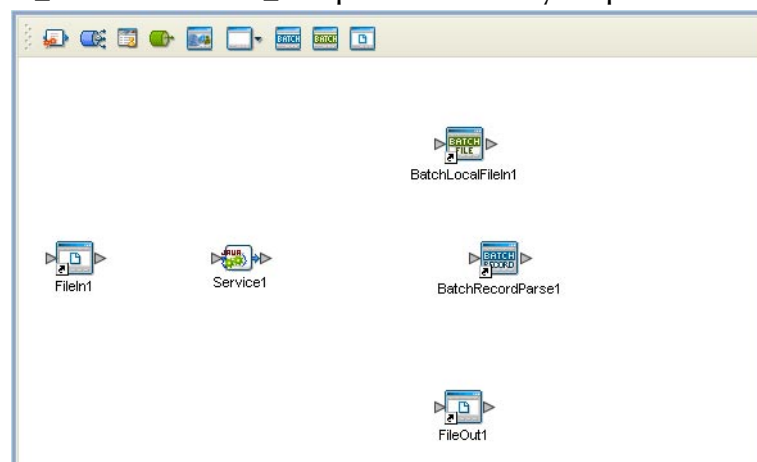

- 2 Save your current changes to the Repository.

7.6.3. Creating a Collaboration Definition

The next step in the sample is to create a Java Collaboration using the Collaboration Definition Wizard (Java). Once a Collaboration Definition has been created, the Business Rules of the Collaboration are written using the Collaboration Editor.

The jcd_RecParse_Stream Collaboration

- 1 From the Project Explorer, right-click the **Batch_RecParseStream_Sample** project and select **New > Collaboration Definition (Java)** from the shortcut menu. The **Collaboration Definition Wizard (Java)** appears.
- 2 Enter a Collaboration Definition name (for this sample **jcd_RecParse_Stream**) and click **Next**.
- 3 For Step 2 of the Wizard, from the Web Services Interfaces selection window, double-click **SeeBeyond > eWays > File > FileClient > receive**. The File Name field now displays **receive**. Click **Next**.
- 4 For Step 3 of the Wizard, from the Select OTDs selection window, double-click **SeeBeyond > eWays > BatcheWay > BatchLocalFile**. The **LocalFile** OTD is added to the Selected OTDs field.

- From the Select OTDs selection window, double-click **SeeBeyond > eWays > BatcheWay > BatchRecord**. The **BatchRecord** OTD is added to the Selected OTDs field.
- Click the **Up One Level** button to return to the Repository directory. Double-click **SeeBeyond > eWays > File > FileClient**. The **FileClient** OTD is added to the Selected OTDs field.

Figure 69 Collaboration Definition Wizard (Java) - Select OTDs

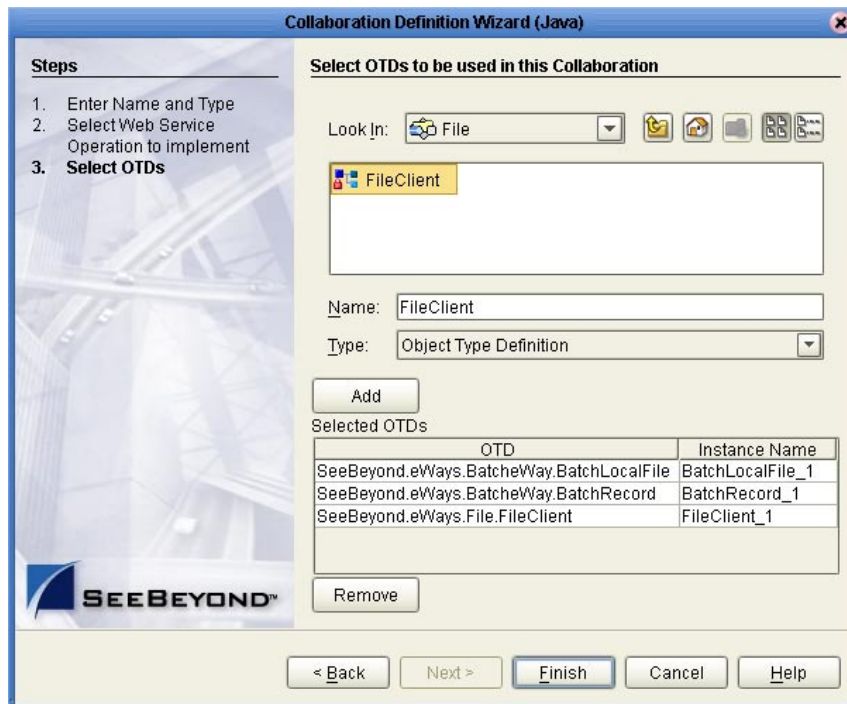

- Click **Finish**. The Collaboration Editor (Java) opens to the new Collaboration in the right pane of the Enterprise Designer.

7.6.4. Using the Collaboration Editor (Java)

The **Batch_FTPInLFOut_Sample** project uses the **jcd_FTPInLFOut** Collaboration created in the previous section. To complete the Collaboration, use the Collaboration Editor to create the Business Rules.

Create the **jcd_RecParse_Stream** Collaboration Business Rules

Be careful to open all nodes specified in the directions to connect the correct items. The **jcd_RecParse_Stream** Collaboration contains the Business Rule displayed in **Figure 70** on page 168.

Figure 70 jjcd_RecParse_Stream Business Rules

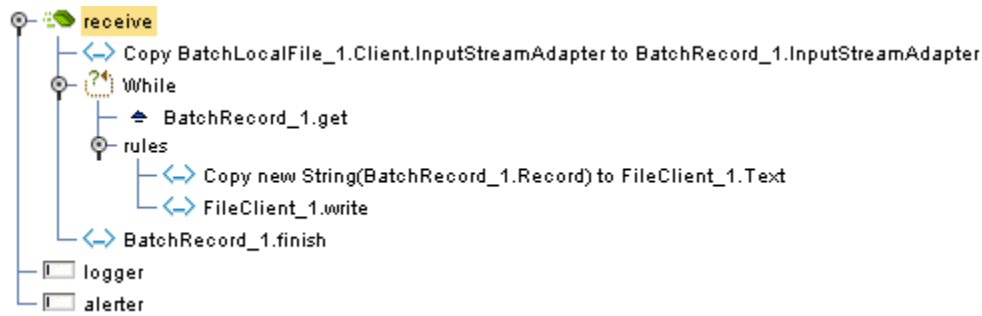

To create the `jjcd_RecParse_Stream` Collaboration Business Rules, do the following:

- 1 From the Project Explorer tree, double-click `jjcd_RecParse_Stream`. The Collaboration Editor (Java) opens to the `jjcd_RecParse_Stream` Collaboration.
- 2 To create comments for the Business Rules, from the Business Rules toolbar, click the **comment** icon. The **Enter a Comment** dialog box appears. Enter the comment and click **OK**. The comment is placed on the Business Rules tree under the last selected item. Once the Comment is created, it can be moved by clicking the comment and dragging it up or down the Business Rules tree to a new location.
- 3 To create the **Copy BatchLocalFile_1.Client.InputStreamAdapter to BatchRecord_1.InputStreamAdapter** rule do the following:
 - C Map **InputStreamAdapter** under **BatchLocalFile_1 > Client** in the left pane of the Business Rules Designer, to **InputStreamAdapter** under **BatchRecord_1** in the right pane of the Business Rules Designer. This is done by clicking on and dragging **InputStreamAdapter** to the destination **InputStreamAdapter**, and releasing the cursor.
- 4 To create the **while** statement do the following:
 - A Click **while** on the Business Rules toolbar to add a new while statement in the Business Rules pane.
 - B Select the Condition under the while statement (this appears as an up-arrow under the while statement) in the Business Rules pane. Right-click **BatchRecord_1** in the left pane of the Business Rules Designer, and click **Select a method to call** from the shortcut menu. The **method selection** window appears.
 - C Select **get()** from the method selection window. The **get** method box appears in the Business Rules Designer canvas (see Figure 71).

Figure 71 Collaboration Editor (Java) - Business Rules

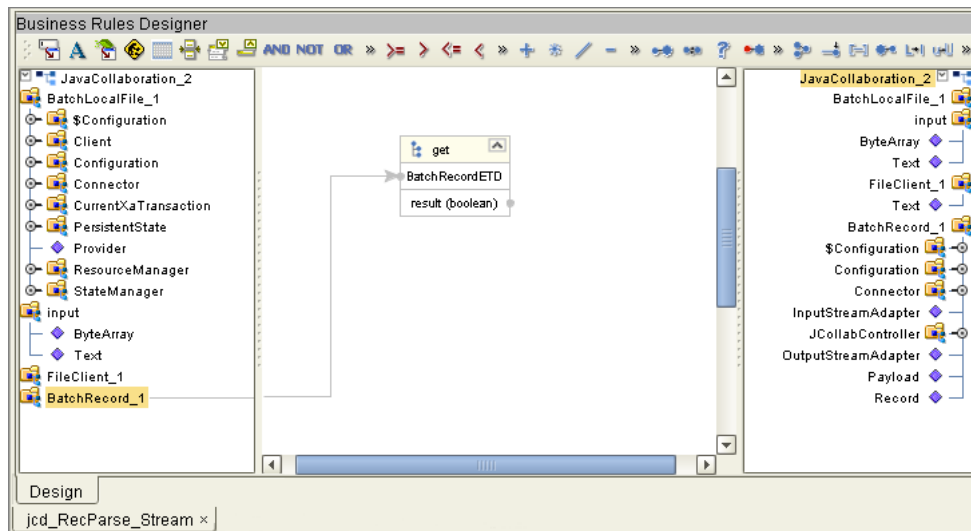

- 5 To create the **Copy new String(BatchRecord_1.Record) to FileClient_1.Text** rule under the **while** statement do the following:
 - A Select the first rule (**Copy new java.lang.String(Record) to Text**) under the **while** statement in the Business Rules pane.
 - B From the Business Rules Designer toolbar, click on the **Call New Constructor** icon. The **Call New Constructor** dialog box appears. Select **String** from the **All Classes** box and **java.lang.String(byte[] bytes)** from the Constructors box. Click **OK**. The **java.lang.String** method box appears in the Business Rules Designer canvas.
 - C Map **Record**, under **BatchRecord_1** in the left pane of the Business Rules Designer, to the **bytes (byte[])** input node of the **java.lang.String** method box.
 - D Map the result (String) output node of the **java.lang.String** method box, to **Text** under **FileClient_1** in the right pane of the Business Rules Designer (see Figure 72).

Figure 72 Collaboration Editor (Java) - Business Rules

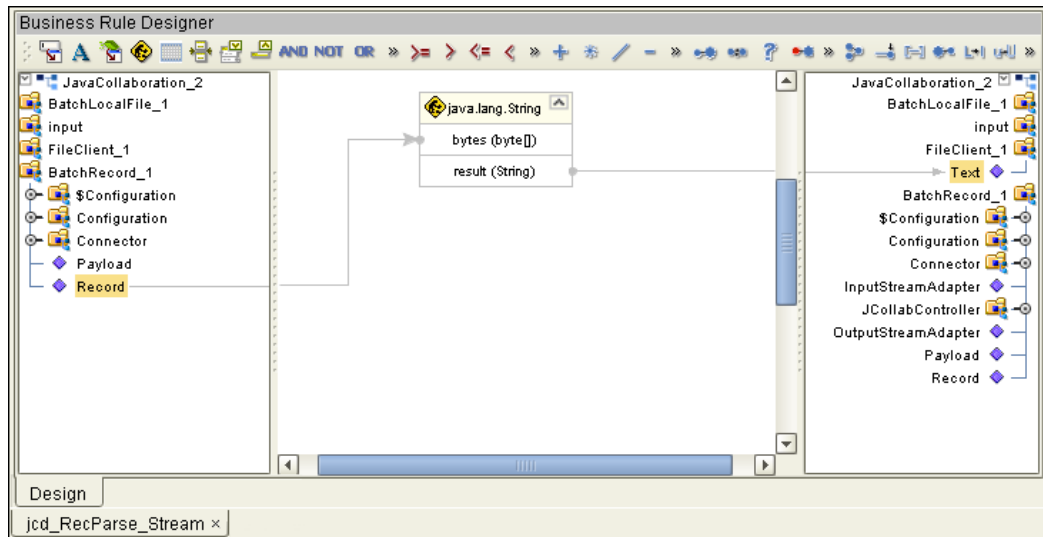

- 6 To create the **FileClient_1.write** rule under the **while** statement do the following:
 - A Select the rules node in the Business Rules pane, and from the Business Rules toolbar, click the rule icon. A new rule is added to the Business Rules tree under the while statement.
 - B Right-click FileClient_1 in the left pane of the Business Rules Designer, and click **Select a method to call** from the shortcut menu. The **method selection** window appears.
 - C Select **write()** from the method selection window. The write method box appears in the Business Rules Designer canvas (see Figure 73).

Figure 73 Collaboration Editor (Java) - Business Rules

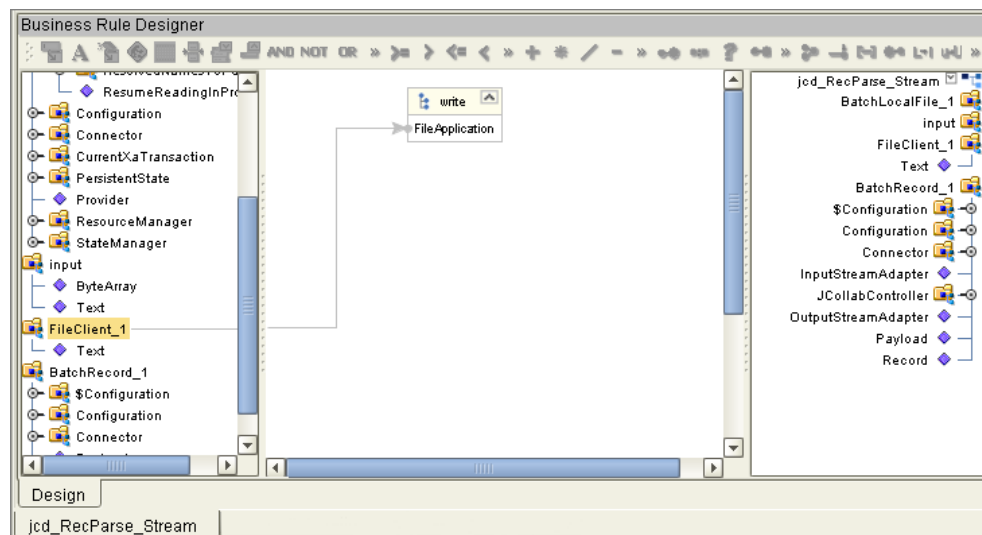

- 7 To create the **BatchRecord_1.finish** rule do the following:

- A Click **rule** on the Business Rules toolbar to add a new rule in the Business Rules pane.
 - B Right-click **BatchRecord_1** in the left pane of the Business Rules Designer, and click **Select a method to call** from the shortcut menu. The **method selection** window appears.
 - C Select **finish()** from the method selection window. The **finish** method box appears in the Business Rules Designer canvas
- 8 From the editor's toolbar, click **Validate** to check the Collaboration for errors.
 - 9 Save your changes to the Repository.

For more information on how to create Business Rules using the Collaboration Editor see the *eGate Integrator User's Guide*.

7.6.5. Binding the Project Components

The components are associated and the bindings are created in the Connectivity Map.

- 1 From the Project Explorer, double-click the Connectivity Map **CM_RecParseStream_Sample**. The Enterprise Designer canvas now displays the **CM_RecParseStream_Sample** Connectivity Map.
- 2 Drag and drop the **jcd_RecParse_Stream** Collaboration from the Project Explorer tree onto **Service1** in the **CM_RecParseStream_Sample** Connectivity Map.
- 3 Double-click **Service1**. The **Service1** binding dialog box appears with **jcd_RecParse_Stream** as the rule.
- 4 From the **Service1** binding box, map **FileClient input** (under Implemented Services) to the **FileIn1** application.
- 5 From the **Service1** binding box, map the **BatchLocalFile** (under Invoked Services) to the **BatchLocalFileIn1** External Application.
- 6 From the **Service1** binding box, map the **BatchRecord** (under Invoked Services) to the **BatchRecordParse1** External Application.
- 7 From the **Service1** binding box, map the **FileClient** (under Invoked Services) to the **FileOut1** External Application.
- 8 Minimize the **Service1** binding box. The Connectivity Map now appears as displayed in Figure 74.

Figure 74 Connectivity Map - Connecting the Project's Components

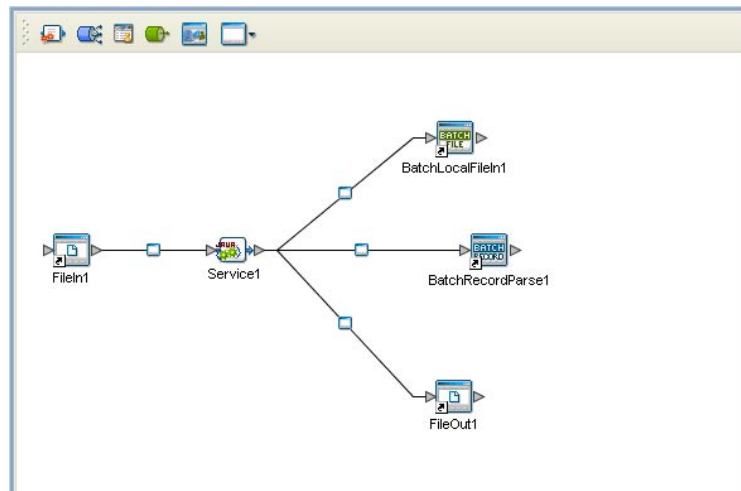

- 9 Save your current changes to your Repository.

7.6.6. Creating an Environment

Environments include the external systems, Logical Hosts, integration servers and message servers used by a project and contain the configuration information for these components.

- 1 From the Enterprise Designer's Enterprise Explorer, click the **Environment Explorer** tab.
- 2 Right-click the Repository and select **New Environment**. A new Environment is added to the Environment Explorer tree.
- 3 Rename the new Environment to **ENV_Batch_RecParseStream**.
- 4 Right-click **ENV_Batch_RecParseStream** and select **New File External System**. Name this External System **FileExtSysIn** and select **Inbound File eWay** as the External System Type. The **FileExtSysIn** window is added to the Environment Editor.
- 5 Right-click **ENV_Batch_RecParseStream** and select **New File External System**. Name this External System **FileExtSysOut** and select **Outbound File eWay** as the External System Type. The **FileExtSysOut** window is added to the Environment Editor.
- 6 Right-click **ENV_Batch_RecParseStream** and select **New BatchLocalFile External System**. Name the External System **BatchLocalFileExtSys**. Click **OK**. The **BatchLocalFileExtSys** window is added to the Environment Editor.
- 7 Right-click **ENV_Batch_RecParseStream** and select **New BatchRecord External System**. Name the External System **BatchRecordExtSys**. Click **OK**. The **BatchRecordExtSys** window is added to the Environment Editor.
- 8 Right-click **ENV_Batch_RecParseStream** and select **New Logical Host**. The **LogicalHost1** box is added to the Environment and **LogicalHost1** is added to the Environment Editor tree.

- 9 From the Environment Explorer tree, right-click **LogicalHost1** and select **New SeeBeyond Integration Server**. A new Integration Server (**IntegrationSvr1**) is added to the Environment Explorer tree under Localhost4.
- 10 Save your current changes to the Repository.

7.6.7. Configuring the eWay Properties

The **Batch_RecParseStream_Sample** project uses three eWays, each represented in the Connectivity Map as a node between an External Application and a Service.

The **File**, **BatchLocalFile**, and **BatchRecord** eWay properties are configured from the Connectivity Map. To configure the eWays do the following:

Configuring the File eWay Properties

- 1 Double-click the **Outbound File eWay** and select **Outbound File eWay** in the Templates dialog box and click **OK**.
- 2 The Properties Sheet opens to the Outbound File eWay properties. Modify the configuration for your system.

Configuring the BatchLocalFile eWay Properties

The **BatchLocalFile** and **BatchRecord** eWay properties are set from the Project Explorer's Connectivity Map. For more information on the **BatchLocalFile** eWay properties and the Properties Sheet, see [Creating and Configuring the Batch eWay](#) on page 17.

For the **Batch_RecParseStream_Sample** project, do the following:

Modifying the BatchLocalFile and BatchRecord eWay (Project Explorer) Properties

- 1 From the **Connectivity Map**, double-click the eWay. The Properties Sheet opens to the eWay Connectivity Map properties.
- 2 Modify the eWay properties for your system.
- 3 Save the current changes to your Repository.

7.6.8 Creating and Activating the Deployment Profile

A Deployment Profile is used to assign Collaborations and message destinations to the integration server and message server. Deployment profiles are created using the Deployment Editor.

- 1 From the Enterprise Explorer's Project Explorer, right-click the project (**Batch_RecParseStream_Sample**) and select **New > Deployment Profile**.
- 2 Enter a name for the Deployment Profile (for this sample **DP_Batch_RecParseStream**). Make sure that the selected Environment is **ENV_Batch_RecParseStream**. Click **OK**.
- 3 From the left pane of the Deployment Editor, drag the **FileIn1 -> Service1** (External Application) to the **FileExtSysIn** window.

- 4 From the left pane of the Deployment Editor, drag **Service1** -> **FileOut1** (External Application) to the **FileExtSysOut** window.
- 5 From the left pane of the Deployment Editor, drag the **Service1** -> **BatchLocalFileIn1** (External Application) to the **BatchLocalFileExtSys** window.
- 6 From the left pane of the Deployment Editor, drag the **Service1** -> **BatchRecordParse1** (External Application) to the **BatchRecordExtSys** window.
- 7 From the left pane of the Deployment Editor, drag **Service1** (Collaboration) to **IntegrationSvr1** in the **LogicalHost1** window.
- 8 Click **Activate**. When activation succeeds, save Your current changes to the Repository.

7.6.9. Running the Project

The following directions assume that the Enterprise Designer was downloaded to C:\ican50. If this is not the case, replace that location in the following directions with the appropriate location.

- 1 From the Enterprise Manager Downloads tab, click on **Logical Host - for win32**.
- 2 Extract the file to the **ican50\logicalhost5** directory. You must specify the **logicalhost5** directory for it to be created.
- 3 Navigate to **C:\ican50\logicalhost5\logicalhost\bootstrap\config** directory and open the **logical-host.properties** file using Notepad™.
- 4 Enter the following information in the appropriate fields:
 - ♦ Logical Host root directory: **ican50\logicalhost5\logicalhost**
 - ♦ Repository URL: **http://localhost:port number/repository name**
 - ♦ Repository user name and password: *Your user name and password*
 - ♦ Logical Host Environment name: **ENV_Batch_RecParseStream**
 - ♦ Logical Host name: **logicalhost5**

Save your changes to **logical-host.properties** and close the file.

- 5 Run the **bootstrap.bat** file in the **ican50\logicalhost5\logicalhost\bootstrap\bin** directory.
- 6 Copy the sample input data file to the input directory.

7.7 The BatchInbound_Sample Project

The **BatchInbound_Sample** project demonstrates the following:

- 1 The BatchInbound eWay polls the input directory periodically. When it sees a specified file, it renames the file with a GUID file name, and triggers the Collaboration.
- 2 The BatchLocalfileIn eWay gets the file with the GUID file name.
- 3 The files contents is copied from BatchLocalfileIn payload to the FileOut payload.
- 4 The FileOut eWay writes the payload to an output file.

The following pages provide step by step directions for manually creating the **BatchInbound_Sample** project components.

7.7.1. Create a Project

The first step is to create and name a new project in eGate Enterprise Designer.

- 1 Start the Enterprise Designer.
- 2 From the Enterprise Explorer's Project Explorer tab, select your Repository on the Project Explorer tree, right-click the Repository and select **New Project**. A new project appears on the Project Explorer tree.
- 3 Rename the project (for this sample, **BatchInbound_Sample**).

7.7.2 Create a Connectivity Map

The Connectivity Map provides a canvas for configuring a project's components.

- 1 In Enterprise Explorer's Project Explorer, right-click the new project (**BatchInbound_Sample**) and select **New > Connectivity Map** from the shortcut menu.
- 2 The New Connectivity Map appears and a node for the Connectivity Map is added under the project, on the Project Explorer tree, labeled **CMap1**. Rename the Connectivity Map **CMap_BatchInbound**.

Select the External Applications

- 1 Click the **External Application** icon on the Connectivity Map toolbar,
- 2 Select the following applications for your project:
 - ♦ BatchInbound External Application
 - ♦ BatchLocalFile External System
 - ♦ File External System

- 3 Icons representing the selected applications are added to the Connectivity Map toolbar.

Populate the Connectivity Map

Add the project components to the Connectivity Map by dragging the icons from the toolbar to the canvas.

- 1 For the BatchInbound_Sample project, drag the following components onto the Connectivity Map canvas, and name each as displayed in Figure 68:
 - ◆ BatchInbound External Application (rename to **BatchInbound**)
 - ◆ Service (rename to **ServiceBatchInbound**)
 - ◆ BatchLocalFile External System (rename to **BatchLocalFileIn**)
 - ◆ File External Application (rename to **Fileout**)

Figure 75 CMap_BatchInbound Connectivity Map with Components

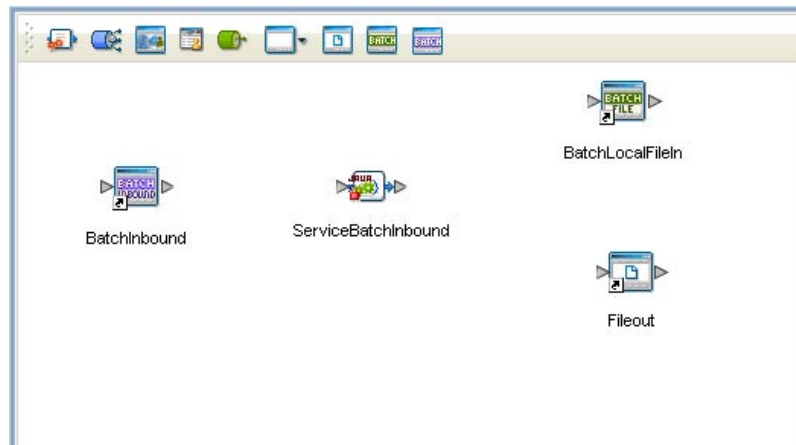

- 2 Save your current changes to the Repository.

7.7.3. Creating a Collaboration Definition

The next step in the sample is to create a Java Collaboration using the Collaboration Definition Wizard (Java). Once a Collaboration Definition has been created, the Business Rules of the Collaboration are written using the Collaboration Editor.

The CollabBatchInbound Collaboration

- 1 From the Project Explorer, right-click the **BatchInbound_Sample** project and select **New > Collaboration Definition (Java)** from the shortcut menu. The **Collaboration Definition Wizard (Java)** appears.
- 2 Enter a Collaboration Definition name (for this sample **CollabBatchInbound**) and click **Next**.
- 3 For Step 2 of the Wizard, from the Web Services Interfaces selection window, double-click **SeeBeyond > eWays > BatcheWay > BatchInbound > receive**. The Name field now displays **receive**. Click **Next**.

- 4 For Step 3 of the Wizard, from the Select OTDs selection window, double-click **SeeBeyond > eWays > BatcheWay > BatchLocalFile**. The **BatchLocalFile.LocalFile** OTD is added to the Selected OTDs field. Double-click the **BatchLocalFile_1** Instance Name and rename the instance to **BatchLocalFile_In**.
- 5 Click the **Up One Level** button to return to the Repository directory. Double-click **SeeBeyond > eWays > File > FileClient**. The **FileClient** OTD is added to the Selected OTDs field. Double-click the **FileClient_1** Instance Name and rename the instance to **FileClient_Out**.

Figure 76 Collaboration Definition Wizard (Java) - Select OTDs

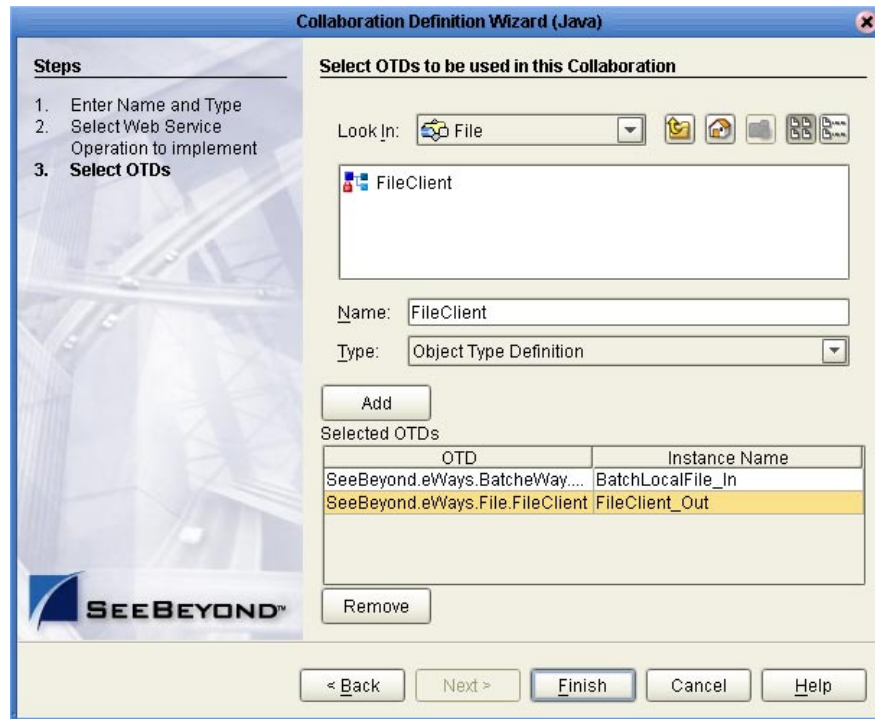

- 6 Click **Finish**. The Collaboration Editor (Java) opens to the new Collaboration in the right pane of the Enterprise Designer.

7.7.4. Using the Collaboration Editor (Java)

The **BatchInbound_Sample** project uses the **CollabBatchInbound** Collaboration created in the previous section. To complete the Collaboration, use the Collaboration Editor to create the Business Rules.

Create the CollabBatchInbound Collaboration Business Rules

Be careful to open all nodes specified in the directions to connect the correct items. The **CollabBatchInbound** Collaboration contains the Business Rule displayed in [Figure 77](#) on page 178.

Figure 77 CollabBatchInbound Business Rules

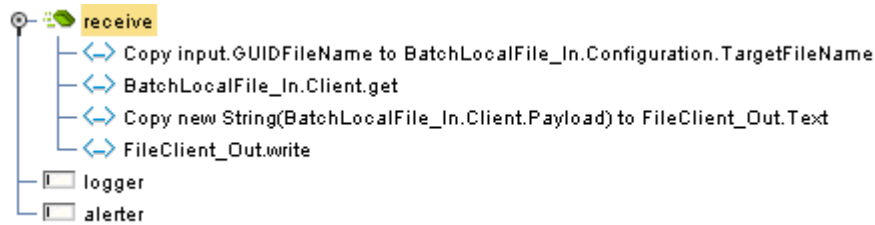

To create the **CollabBatchInbound** Collaboration Business Rules, do the following:

- 1 From the Project Explorer tree, double-click **CollabBatchInbound**. The Collaboration Editor (Java) opens to the **CollabBatchInbound** Collaboration.
- 2 To create comments for the Business Rules, from the Business Rules toolbar, click the **comment** icon. The **Enter a Comment** dialog box appears. Enter the comment and click **OK**. The comment is placed on the Business Rules tree under the last selected item. Once the Comment is created, it can be moved by clicking the comment and dragging it up or down the Business Rules tree to a new location.
- 3 To create the **Copy input.GUIDFileName to BatchLocalFile_In.Configuration.TargetFileName** Business Rule, do the following:
 - A Map **GUIDFileName** under **BatchAppconnMessage > input** in the left pane of the Business Rules Designer, to **TargetFileName** under **Configuration > BatchLocalFile_In** in the right pane of the Business Rules Designer. To do this, click on **GUIDFileName** in the left pane of the Business Rules Designer, and drag the cursor to **TargetFileName** in the right pane of the Business Rules Designer, and release the cursor (see [Figure 78](#) on page 178).

Figure 78 Collaboration Editor (Java) - Business Rules

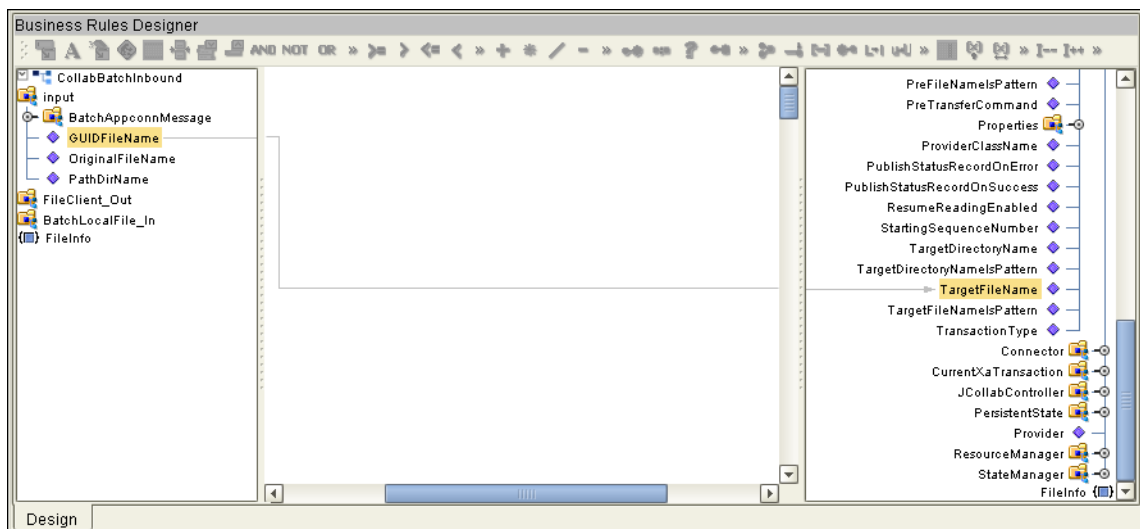

- 4 To create the **BatchLocalFile_In.Client.get** rule, do the following:
 - A Click **rule** on the Business Rules toolbar to add a new rule in the Business Rules pane.

- B Right-click **Client** under **BatchLocalFile_In** in the left pane of the Business Rules Designer, and click **Select a method to call** from the shortcut menu. The **method selection** window appears.
- C Select **get()** from the method selection window. The **get** method box appears in the Business Rules Designer canvas as displayed in Figure 79.

Figure 79 Collaboration Editor (Java) - Business Rules

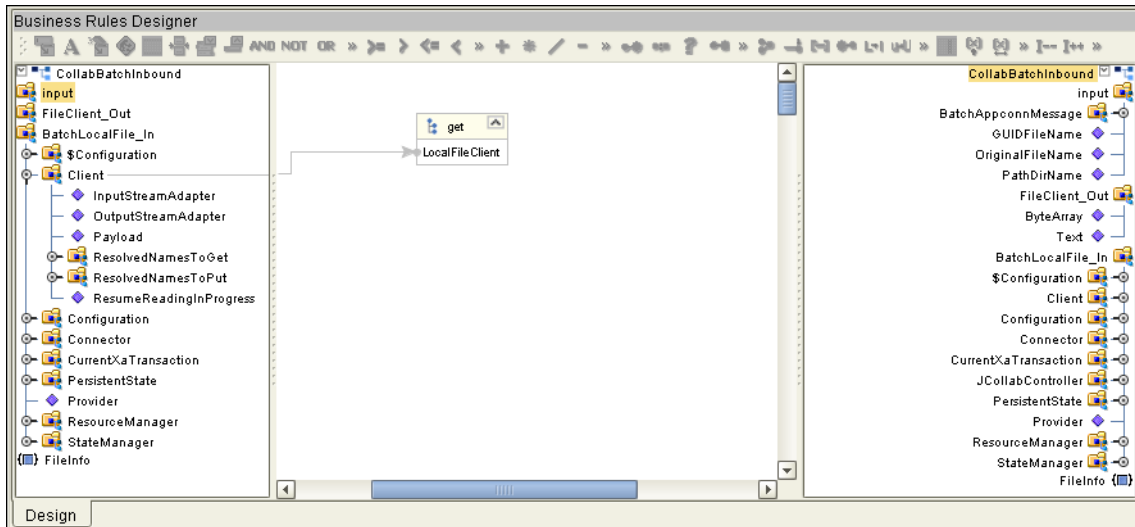

- 5 To create the **Copy new String(BatchLocalFile_In.Client.Payload) to FileClient_Out.Text** rule do the following:
 - A Click **rule** on the Business Rules toolbar to add a new rule in the Business Rules pane.
 - B Map **Payload** under **Client > BatchAppconnMessage** in the left pane of the Business Rules Designer, to **ByteArray** under **FileClient_Out** in the right pane of the Business Rules Designer (see Figure 80).

Figure 80 Collaboration Editor (Java) - Business Rules

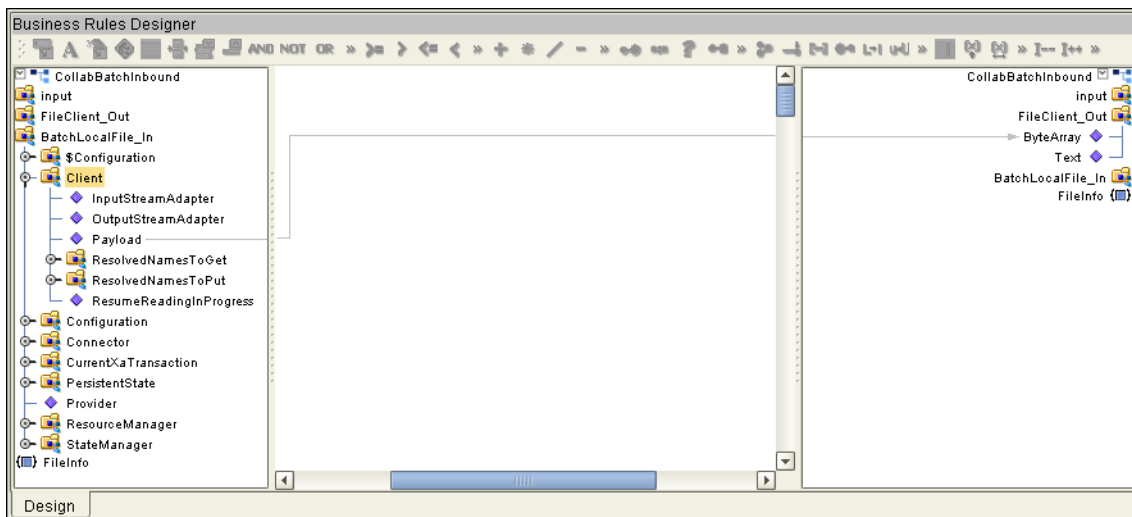

- 6 To create the **FileClient_Out.write** rule do the following:
 - A Click **rule** on the Business Rules toolbar to add a new rule in the Business Rules pane.
 - B Right-click **FileClient** in the left pane of the Business Rules Designer, and click **Select a method to call** from the shortcut menu. The **method selection** window appears.
 - C Select **writeBytes()** from the method selection window. The **writeBytes** method box appears in the Business Rules Designer canvas as displayed in Figure 81.

Figure 81 Collaboration Editor (Java) - Business Rules

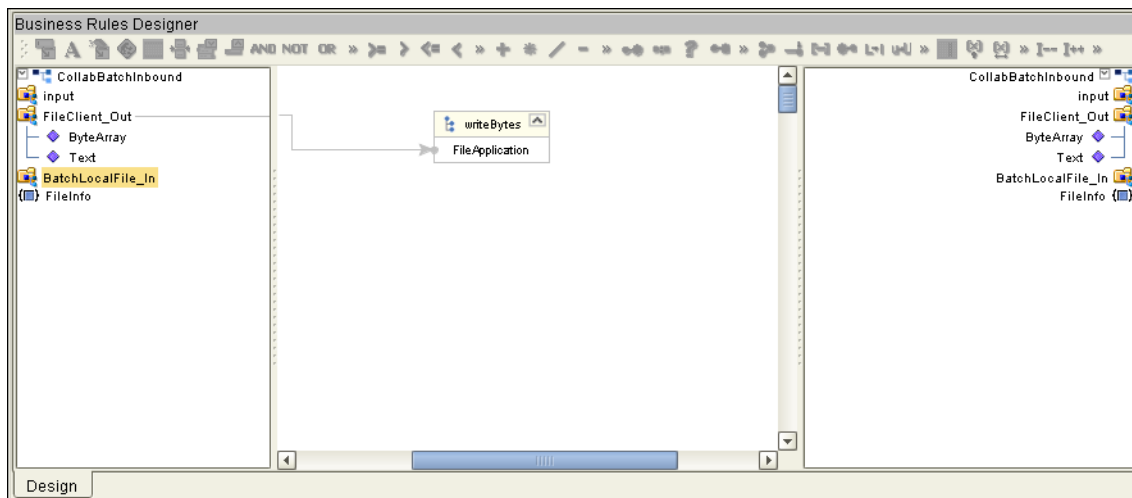

- 7 From the editor's toolbar, click **Validate** to check the Collaboration for errors.
- 8 Save your changes to the Repository.

For more information on how to create Business Rules using the Collaboration Editor see the *eGate Integrator User's Guide*.

7.7.5. Binding the Project Components

The components are associated and the bindings are created in the Connectivity Map.

- 1 From the Project Explorer, double-click the Connectivity Map **CMap_BatchInbound** to display the Connectivity Map in the Enterprise Designer.
- 2 Drag and drop the **CollabBatchInbound** Collaboration from the Project Explorer tree onto the **ServiceBatchInbound** service in the Connectivity Map.
- 3 Double-click **ServiceBatchInbound**. The **ServiceBatchInbound** binding dialog box appears with **CollabBatchInbound** as the rule.
- 4 From the **ServiceBatchInbound** binding box, map **BatchInbound input** (under Implemented Services) to the **BatchInbound** application.
- 5 From the **ServiceBatchInbound** binding box, map the **BatchLocalFile** (under Invoked Services) to the **BatchLocalFileIn** External Application.

- 6 From the **ServiceBatchInbound** binding box, map the **FileClient** (under Invoked Services) to the **Fileout** External Application (see [Figure 82](#) on page 181).

Figure 82 Connectivity Map - Connecting the Project's Components

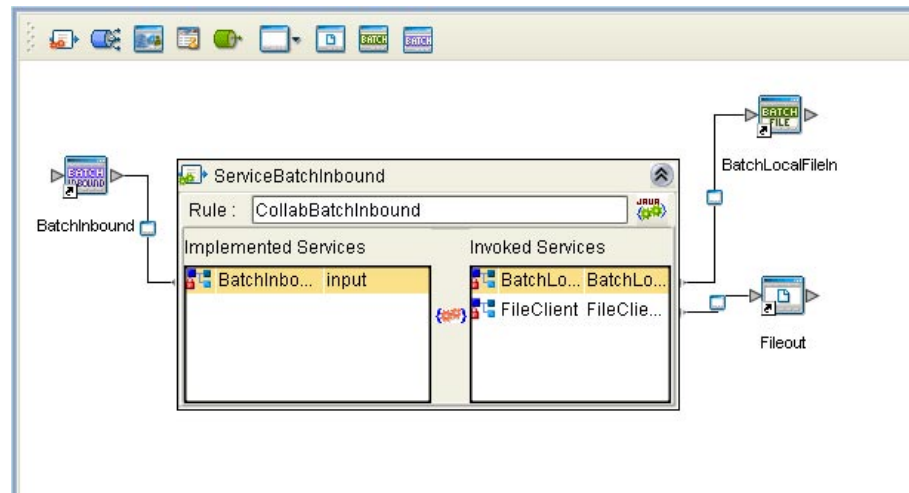

- 7 Minimize the **ServiceBatchInbound** binding box.
- 8 Save your current changes to your Repository.

7.7.6. Creating an Environment

Environments include the external systems, Logical Hosts, integration servers and message servers used by a project and contain the configuration information for these components.

- 1 From the Enterprise Designer's Enterprise Explorer, click the **Environment Explorer** tab.
- 2 Right-click the Repository and select **New Environment**. A new Environment is added to the Environment Explorer tree.
- 3 Rename the new Environment to **Env_BatchInbound**.
- 4 Right-click **Env_BatchInbound** and select **New BatchInbound External System**. Name this External System **BatchInboundExtSysIn**. The **BatchInboundExtSysIn** window is added to the Environment Editor.
- 5 Right-click **Env_BatchInbound** and select **New File External System**. Name this External System **FileExtSysOut** and select **Outbound File eWay** as the External System Type. The **FileExtSysOut** window is added to the Environment Editor.
- 6 Right-click **Env_BatchInbound** and select **New BatchLocalFile External System**. Name the External System **BatchLocalFileExtSys**. Click **OK**. The **BatchLocalFileExtSys** window is added to the Environment Editor.
- 7 Right-click **Env_BatchInbound** and select **New Logical Host**. The **LogicalHost1 box** is added to the Environment and **LogicalHost1** is added to the Environment Editor tree.

- 8 From the Environment Explorer tree, right-click **LogicalHost1** and select **New SeeBeyond Integration Server**. A new Integration Server (**IntegrationSvr1**) is added to the Environment Explorer tree under Localhost4.
- 9 Save your current changes to the Repository.

7.7.7. Configuring the eWay Properties

The **BatchInbound_Sample** project uses three eWays, each represented in the Connectivity Map as a node between an External Application and a Service.

The **BatchInbound**, **BatchLocalFile**, and **File** eWay properties are configured from the Connectivity Map. To configure the eWays do the following:

Configuring the File eWay Properties

The File eWay properties are set from the Project Explorer's Connectivity Map.

- 1 Double-click the **Outbound File eWay** and select **Outbound File eWay** in the Templates dialog box and click **OK**.
- 2 The Properties Sheet opens to the Outbound File eWay properties. Modify the configuration for your system.

Configuring the BatchLocalFile eWay Properties

The BatchLocalFile and BatchInbound eWay properties are set from the Project Explorer's Connectivity Map. For more information on the eWay properties and the Properties Sheet, see [Creating and Configuring the Batch eWay](#) on page 17.

- 1 From the **Connectivity Map**, double-click the eWay. The Properties Sheet opens to the eWay Connectivity Map properties.
- 2 Modify the eWay properties for your system.
- 3 Save the current changes to your Repository.

7.7.8 Creating and Activating the Deployment Profile

A Deployment Profile is used to assign Collaborations and message destinations to the integration server and message server. Deployment profiles are created using the Deployment Editor.

- 1 From the Enterprise Explorer's Project Explorer, right-click the project (**BatchInbound_Sample**) and select **New > Deployment Profile**.
- 2 Enter a name for the Deployment Profile (for this sample **DP_BatchInbound**). Make sure that the selected Environment is **Env_BatchInbound**. Click **OK**.
- 3 From the left pane of the Deployment Editor, drag **ServiceBatchInbound -> FileOut** (External Application) to the **FileExtSysOut** window.
- 4 From the left pane of the Deployment Editor, drag the **BatchInbound -> ServiceBatchInbound** (External Application) to the **BatchInboundExtSys** window.

- 5 From the left pane of the Deployment Editor, drag the **ServiceBatchInbound -> BatchLocalFileIn** (External Application) to the **BatchLocalFileExtSys** window.
- 6 From the left pane of the Deployment Editor, drag **ServiceBatchInbound** (Collaboration) to **IntegrationSvr1** in the **LogicalHost1** window.
- 7 Click **Activate**. When activation succeeds, save Your current changes to the Repository.

7.7.9. Running the Project

The following directions assume that the Enterprise Designer was downloaded to C:\ican50. If this is not the case, replace that location in the following directions with the appropriate location.

- 1 From the Enterprise Manager Downloads tab, click on **Logical Host - for win32**.
 - 2 Extract the file to the **ican50\logicalhost6** directory. You must specify the **logicalhost6** directory for it to be created.
 - 3 Navigate to **C:\ican50\logicalhost6\logicalhost\bootstrap\config** directory and open the **logical-host.properties** file using a text editor.
 - 4 Enter the following information in the appropriate fields:
 - ♦ Logical Host root directory: **ican50\logicalhost6\logicalhost**
 - ♦ Repository URL: **http://localhost:port number/repository name**
 - ♦ Repository user name and password: *Your user name and password*
 - ♦ Logical Host Environment name: **ENV_BatchInbound**
 - ♦ Logical Host name: **logicalhost6**
- Save your changes to **logical-host.properties** and close the file.
- 5 Run the **bootstrap.bat** file in the **ican50\logicalhost6\logicalhost\bootstrap\bin** directory.
 - 6 Copy the sample input data file to the input directory.

Using eWay Java Classes and Methods

This chapter provides an overview of the Java classes and methods contained in the Batch eWay. These methods are used to extend the functionality of the eWay.

What's in This Chapter

- [Batch eWay Java Classes](#) on page 184
- [Batch eWay Javadoc](#) on page 185

8.1 Batch eWay Classes and Methods: Overview

Java methods allow you to set information in the Batch eWay Object Type Definitions (OTDs), as well as get information from them.

The nature of this data transfer depends on the configuration parameters you set for the eWay in the eGate Enterprise Designer. For more information, see [Chapter 3](#).

***Note:** For more information on the Batch eWay OTD structures, their nodes, and attributes, see [Chapter 4](#).*

8.1.1 Batch eWay Java Classes

Java methods are organized into related classes. The methods for the Batch eWay are organized into the following Java classes:

- **BatchException**
- **BatchRecordConfiguration**
- **BatchRecordOTD**
- **BatchRecordParser**
- **BatchOTD**
- **FtpFileClient**
- **FtpFileConfiguration**
- **FtpFileException**
- **FtpFileProvider**

- **FtpHeuristics**
- **InputStreamAdapter**
- **LocalFileClient**
- **LocalFileConfiguration**
- **LocalFileOTD**
- **LocalFileException**
- **NestedException**
- **OutputStreamAdapter**
- **StreamingException**

8.1.2 Batch eWay Javadoc

The Javadoc is uploaded with the eWay's documentation file (**BatcheWayDocs.sar**) and downloaded from the Documentation tab of the Enterprise Manager. To access the full Javadoc, extract the Javadoc to an easily accessible folder, and double click the **index.html** file.

Index

A

alerting and logging 69
 Append parameter 29, 47
 automatic connection 67

B

Batch eWay With eInsight
 web services 70
 Batch input (trigger) file 156
 BatchInbound 156
 BatchInbound properties
 Directory Name 54
 File Name 54
 File Name is Pattern 54
 Schedule Interval 54
 BatchRecordOTD configuration parameters 49, 53
 book 164

C

Class parameter 50
 Command Connection Timeout parameter 23
 configuration parameters, eWay 66
 configuration settings
 changing of the fly 67
 Connector Configuration, BatchRecordOTD 50

D

Data Connection Timeout parameter 23
 data streaming
 consuming-stream adapters 166
 four basic setups 166
 overcoming large-file limitations 165
 overview 164
 stream-adapter interfaces 167
 use and operation 165
 Delimiter on Last Record parameter 51
 Directory Listing Style parameter 23
 Dynamic Configuration 67

E

eWays
 creating 16

F

file transfer commands, pre and post 145
 FTP
 configuration
 FtpOTD 23, 37
 FtpOTD 23
 heuristics
 file type selection 55
 overview 55
 platform selection 55
 OTD
 essential methods 142
 node functions 139
 overview 138
 sequence numbering 142
 type conversions 141
 Raw Commands Configuration
 FtpOTD 25
 FtpOTD configuration parameters 19

G

General Settings Configuration, BatchRecordOTD 49
 General Settings Configuration, LocalFileOTD 46
 GUID
 file name 156

H

Host Name parameter 38

I

index
 book 164

J

Java methods and classes
 overview 173
 Javadoc 174

L

local file OTD
 data stream-adapter provider 150
 essential methods 148

- node functions 144
- overview 143
- pre/post file transfer commands 145
- resume reading feature 148
- usage 145

LocalFileOTD configuration parameters 41

logging

- enabling and modifying 69
- levels and categories 69

M

- Max Sequence Number parameter 26, 43
- Mode parameter 24
- MVS Generation Data Group (GDG) 55
- MVS Partition Data Sets (PDS) 55
- MVS Sequential 55

O

OTD

- BatchFTP 139
- BatchInbound 156
- BatchLocalFile 143
- BatchRecord 152

OTDs, eWay

- components 138
- types 138

P

- Parse or Create Mode parameter 49
- Password parameter 38
- Post Directory Name Is Pattern parameter 27
- Post Directory Name parameter 27
- Post File Name Is Pattern parameter 28
- Post File Name parameter 28
- Post Transfer Command parameter 28, 46
- Post Transfer Configuration, FtpOTD 27
- Post Transfer Configuration, LocalFileOTD 44
- Post Transfer Name Is Pattern parameter 45, 46
- Post Transfer Name parameter 44, 45
- Post Transfer Raw Commands parameter 25
- Pre Directory Name Is Pattern parameter 20
- Pre Directory Name parameter 20
- Pre File Name Is Pattern parameter 21
- Pre File Name parameter 20
- Pre Transfer Command parameter 21, 43
- Pre Transfer Configuration, FtpOTD 19
- Pre Transfer Configuration, LocalFileOTD 41
- Pre Transfer Name Is Pattern parameter 42, 43
- Pre Transfer Name parameter 41, 42
- Pre Transfer Raw Commands parameter 25

Property.Tag parameter 50

R

- Record Configuration, BatchRecordOTD 50
- Record Delimiter parameter 51
- Record Size parameter 52
- Record Type parameter 52
- record-processing OTD
 - creating a payload 154
 - get() and put() 154
 - overview 152
 - parse or create mode 154
 - parser interface 156
 - parsing a payload 155
 - usage 154
- regular expressions
 - examples 159
 - examples of directories/platforms 159
 - overview 157
 - rules for directory usage 158
 - using 157
- Resume Reading Enabled parameter 46

S

- sequence numbering 142
- Sequence Numbering Configuration, FtpOTD 26
- Sequence Numbering Configuration, LocalFileOTD 43
- Server Port parameter 38
- SOCKS Configuration, FtpOTD 22, 36
- Socks Enabled parameter 22
- Socks Password parameter 37
- Socks Server Port parameter 37
- SOCKS support
 - general information 168
 - overview 167
- Socks User Name parameter 37
- Socks Version parameter 22
- SOCKS, configuration parameters overview 169
- special characters
 - date/time format syntax 161
 - overview 160
 - resolving names 161
 - types of name expansion 160
- SSH Channel Established parameter 32
- SSH Command Line parameter 32
- SSH Listen Host parameter 34, 39
- SSH Listen Port parameter 34, 40
- SSH Password parameter 35, 40
- SSH tunneling
 - 171
 - enabling with Batch eWay 170

Index

overview 169

SSH Tunneling Configuration, FtpOTD 31, 39

SSH Tunneling Enabled parameter 35

SSH tunneling, configuration parameters overview
171

SSH User Name parameter 40

Starting Sequence Number parameter 26, 44

T

Target Directory Name Is Pattern parameter 30, 48

Target Directory Name parameter 30, 47

Target File Name Is Pattern parameter 31, 48, 54

Target File Name parameter 30, 48

Target Location Configuration, FtpOTD 29

Target Location Configuration, LocalFileOTD 47

Type parameter 50

U

Use PASV parameter 24

User Class Configuration, BatchRecordOTD 52

User Class parameter 52

User Name parameter 24, 39

User Properties parameter 53

W

Web Services interface 70

WebLogic 12

WebSphere 12