

SPARCserver™ 1000 System Disk Drive Installation Manual



Warning – Procedures in this manual must be performed by qualified, service-trained maintenance providers.

Please refer to the section entitled “Notes, Cautions, and Warnings” in the Preface of this manual.



Sun Microsystems Computer Company
A Sun Microsystems, Inc. Business
2550 Garcia Avenue
Mountain View, CA 94043 U.S.A.
415 960-1300 FAX 415 969-9131

Part No.: 801-7670-11
Revision 01, July 1995

© 1995 Sun Microsystems, Inc. 2550 Garcia Avenue, Mountain View, California 94043-1100 U.S.A.

All rights reserved. This product or document is protected by copyright and distributed under licenses restricting its use, copying, distribution and decompilation. No part of this product or document may be reproduced in any form by any means without prior written authorization of Sun and its licensors, if any.

Portions of this product may be derived from the UNIX® system and from the Berkeley 4.3 BSD system, licensed from the University of California. Third-party software, including font technology in this product, is protected by copyright and licensed from Sun's Suppliers.

RESTRICTED RIGHTS LEGEND: Use, duplication, or disclosure by the government is subject to restrictions as set forth in subparagraph (c)(1)(ii) of the Rights in Technical Data and Computer Software clause at DFARS 252.227-7013 and FAR 52.227-19.

The product described in this manual may be protected by one or more U.S. patents, foreign patents, or pending applications.

TRADEMARKS

Sun, Sun Microsystems, the Sun logo, AnswerBook, OpenBoot, and Solaris are trademarks or registered trademarks of Sun Microsystems, Inc. in the United States and may be protected as trademarks in other countries. UNIX is a registered trademark in the United States and other countries, exclusively licensed through X/Open Company, Ltd. OPEN LOOK is a registered trademark of Novell, Inc. PostScript and Display PostScript are trademarks of Adobe Systems, Inc. All other product, service, or company names mentioned herein are claimed as trademarks and trade names by their respective companies.

All SPARC trademarks, including the SCD Compliant Logo, are trademarks or registered trademarks of SPARC International, Inc. in the United States and may be protected as trademarks in other countries. SPARCcenter, SPARCcluster, SPARCcompiler, SPARCdesign, SPARC811, SPARCengine, SPARCprinter, SPARCserver, SPARCstation, SPARCstorage, SPARCworks, microSPARC, microSPARC-II, and UltraSPARC are licensed exclusively to Sun Microsystems, Inc. Products bearing SPARC trademarks are based upon an architecture developed by Sun Microsystems, Inc.

The OPEN LOOK™ and Sun™ Graphical User Interfaces were developed by Sun Microsystems, Inc. for its users and licensees. Sun acknowledges the pioneering efforts of Xerox in researching and developing the concept of visual or graphical user interfaces for the computer industry. Sun holds a non-exclusive license from Xerox to the Xerox Graphical User Interface, which license also covers Sun's licensees who implement OPEN LOOK GUI's and otherwise comply with Sun's written license agreements.

X Window System is a trademark of X Consortium, Inc.

THIS PUBLICATION IS PROVIDED "AS IS" WITHOUT WARRANTY OF ANY KIND, EITHER EXPRESS OR IMPLIED, INCLUDING, BUT NOT LIMITED TO, THE IMPLIED WARRANTIES OF MERCHANTABILITY, FITNESS FOR A PARTICULAR PURPOSE, OR NON-INFRINGEMENT.

THIS PUBLICATION COULD INCLUDE TECHNICAL INACCURACIES OR TYPOGRAPHICAL ERRORS. CHANGES ARE PERIODICALLY ADDED TO THE INFORMATION HEREIN, THESE CHANGES WILL BE INCORPORATED IN NEW EDITIONS OF THE PUBLICATION. SUN MICROSYSTEMS, INC. MAY MAKE IMPROVEMENTS AND/OR CHANGES IN THE PRODUCT(S) AND/OR THE PROGRAMS(S) DESCRIBED IN THIS PUBLICATION AT ANY TIME.



Please
Recycle



Adobe PostScript

Contents

Preface.....	ix
1. Preparing for Installation	1-1
Types of Disk Drive Units.....	1-1
Safety Precautions	1-2
Tools Required	1-3
Unpacking and Inspecting the Disk Drive Unit.....	1-3
Setting SCSI Target Addresses on the Drives.....	1-5
2. Installing Drives in the SCSI Tray.....	2-1
Disassembling the SPARCserver 1000 System.....	2-1
Switching Off System Power	2-1
Removing the Front Cover	2-2
Removing the Electromagnetic Interference (EMI) Shield ..	2-3
Removing the SCSI Tray.....	2-4
Installing the Disk Drive Unit	2-5
Reassembling the System	2-6

Installing the SCSI Tray	2-6
Checking Connections.	2-7
Installing the EMI Shield	2-7
Attaching the Front Cover	2-7
Verifying Disk Drive Installation	2-7
A. Removing a Disk Drive From the Bracket	A-1

Figures

Figure 1-1	Disk Drive Unit with Drive Controller Card Face Down	1-3
Figure 1-2	Disk Drive Unit Assembly	1-4
Figure 1-3	SCSI Tray of the SPARCserver 1000 system	1-5
Figure 1-4	Conner 1.05 Gbyte Disk Drive SCSI Target Address Jumpers	1-6
Figure 1-5	Seagate 1.05 Gbyte Disk Drive SCSI Target Address Jumpers	1-7
Figure 1-6	Seagate 2.1 Gbyte Disk Drive SCSI Target Address Jumpers .	1-7
Figure 1-7	IBM 2.1 Gbyte Disk Drive SCSI Target Address Jumpers	1-8
Figure 2-1	Removing the Front Cover	2-2
Figure 2-2	Removing the EMI Shield	2-3
Figure 2-3	Removing the SCSI Tray	2-4
Figure 2-4	Inserting the Disk Drive Unit into the Rear of the SCSI Tray .	2-5
Figure 2-5	Power and Data Cable Connections	2-6
Figure A-1	Removing the Disk Drive from the Bracket	A-2

Tables

Table 1-1	Safety Precautions	1-2
Table 1-2	Device Addressing for the SCSI Tray	1-5

Preface

This manual provides installation and removal procedures for the disk drive unit (two SCSI disk drives attached to the disk drive bracket) for the SPARCserver™ 1000 system.

Using UNIX Commands

This manual does not include specific software commands or procedures. Instead, it names software tasks and refers you to operating system documentation or the handbook that was shipped with your new hardware.

The type of information for which you might need to use references includes:

- Shutting down the system
- Booting the system
- Configuring devices

You can find descriptions of commands and procedures in the following documents:

- *Solaris Handbook for SMCC Peripherals* that corresponds to your software environment
- On-line *AnswerBook™* documentation that comes with the Solaris™ 2.x software environment
- Other software documentation that you received with your system

Related Documents

Refer to the following manuals for more information:

- *SPARCserver 1000 System Installation Manual*, (part no. 801-2893-xx).
- *SPARCserver 1000 System Service Manual*, (part no. 801-2895-xx).
- *SPARCserver Boot PROM User's Guide*, (part no. 800-4852-xx).
- *SPARCserver 1000 POST User's Guide* (part no. 801-2916-xx).

Typographic Conventions

The following table describes the typographic changes used in this book.

Table P-1 Typographic Conventions

Typeface or Symbol	Meaning	Example
AaBbCc123	The names of commands, files, and directories; on-screen computer output	Edit your <code>.login</code> file. Use <code>ls -a</code> to list all files. <code>machine_name%</code> You have mail.
AaBbCc123	What you type, contrasted with on-screen computer output	<code>machine_name%</code> su Password:
<i>AaBbCc123</i>	Command-line placeholder: replace with a real name or value	To delete a file, type <code>rm filename</code> .
<i>AaBbCc123</i>	Book titles, new words or terms, or words to be emphasized	Read Chapter 6 in the <i>User's Guide</i> . These are called <i>class</i> options. You <i>must</i> be root to do this.

Shell Prompts in Command Examples

The following table shows the default system prompt and superuser prompt for the C shell, Bourne shell, and Korn shell.

Table P-2 Shell Prompts

Shell	Prompt
C shell	machine_name%
C shell superuser	machine_name#
Bourne shell and Korn shell	\$
Bourne shell and Korn shell superuser	#

Notes, Cautions, and Warnings



Warning – This equipment contains lethal voltage. Accidental contact can result in serious injury or death.



Caution – Improper handling by unqualified personnel can cause serious damage to this equipment. Unqualified personnel who tamper with this equipment may be held liable for any resultant damage to the equipment.

Individuals who remove any outer panels to access this equipment must observe all safety precautions and ensure compliance with skill level requirements, certification, and all applicable local and national laws.

Procedures contained in this document must be performed by qualified service-trained maintenance providers.

Note – Before you begin, carefully read each of the procedures in this manual. If you have not performed similar operations on comparable equipment, *do not attempt* to perform these procedures.

Preparing for Installation



This chapter describes:

- Which types of disk drive units you can install in your system
- What tools you need for the installation
- What safety precautions you must observe
- How to unpack and inspect the new disk drive unit
- How to set SCSI addresses on the disk drives

Note – Make sure you perform the tasks described in this chapter before proceeding with the installation.

Types of Disk Drive Units

The procedures in this manual can be used to install the following:

- Disk drive unit with two 2.1 Gbyte disk drives
- Disk drive unit with two 1.05 Gbyte disk drives

Note – Unless otherwise specified, illustrations in this manual show a typical disk drive unit. Your disk drives may look different.

Safety Precautions



Caution – Use the electrostatic discharge (ESD) kit provided when working on the SPARCserver 1000 system.

Table 1-1 Safety Precautions

Item	Problem	Precaution
Alternating Current (AC) cord	ESD can damage the system components	The AC power cord from the server must only be connected to a grounded electrical outlet. The power cord provides a ground path for the cabinet.
Wrist strap or foot strap	ESD can damage the system components	Wear a conductive wrist strap or foot strap when you handle printed circuit boards. The conductive strap discharges static electricity (which could damage the sensitive electrical components) safely to ground.
ESD mat	ESD can damage the system components	Use the ESD kit provided when working on a printed circuit board. When used with a wrist strap or foot strap, the mat provides ESD protection and cushions the PC board to prevent breakage of any small parts that may be mounted on the bottom of the board.
Printed circuit (PC) board	ESD can damage the system components	Wear a conductive wrist or foot strap when you handle printed circuit boards, and handle a (PC) board only by the edges. Store the board in an antistatic bag.
Disk drives	ESD can damage the system components	Handle the disk drive by the edges only; be careful with the PC controller board that attaches to the disk drive. Store the disk drive in an antistatic bag.
Cover panels	System damage, overheating, and regulatory compliance	Install all cover panels after performing any service work on the system. The panels keep out foreign objects to prevent physical damage to internal parts and overheating. Also, some panels are required for regulatory compliance.
Filler panels	System damage and overheating	Install filler panels in all unused card cage slots. Unused, open slots severely reduce the cooling capability of the system and can lead to equipment damage.

Tools Required

- Antistatic mat and wrist strap
- #2 Phillips screwdriver

Unpacking and Inspecting the Disk Drive Unit

- 1. Inspect the shipping container upon receipt of the disk drives, and look for evidence of damage.**
If the carrier's agent is not present when the container is opened, and the contents are found to be damaged, keep all contents and packing materials for the agent's inspection.
- 2. If there is no evidence of damage, carefully remove the package containing the disk drive unit from the shipping container.**
Save the carton and the packing material for possible later use.

Note – Always transport the disk drive unit in the antistatic bag from the original packaging.

- 3. Attach the antistatic wrist strap to yourself and the power supply of your system, and place the antistatic mat on a flat surface.**
- 4. Remove the disk drive unit from the protective packaging and place it on the antistatic mat with the disk drives face down and the bracket face up.**
See Figure 1-1.

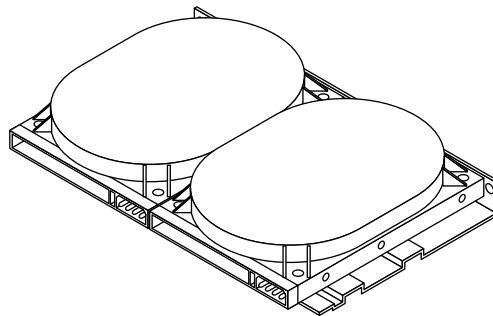

Figure 1-1 Disk Drive Unit with Drive Controller Card Face Down

5. Inspect the disk drive unit for damage.

If you find any damaged components, contact your service representative.

6. Make sure the screws that secure the disk drives to the bracket are tight.

See Figure 1-2.

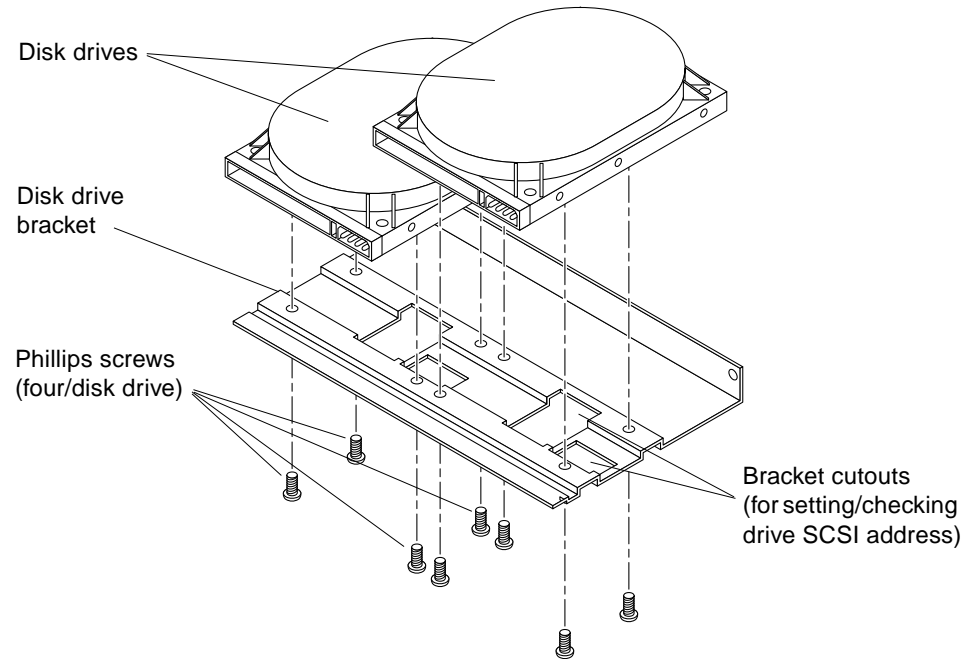

Figure 1-2 Disk Drive Unit Assembly

Setting SCSI Target Addresses on the Drives

The disk drive unit is installed in the SCSI tray of the SPARCserver 1000 system. The SCSI tray supports up to six SCSI devices: one CD-ROM drive, one tape drive, and up to four disk drives. See Figure 1-3.

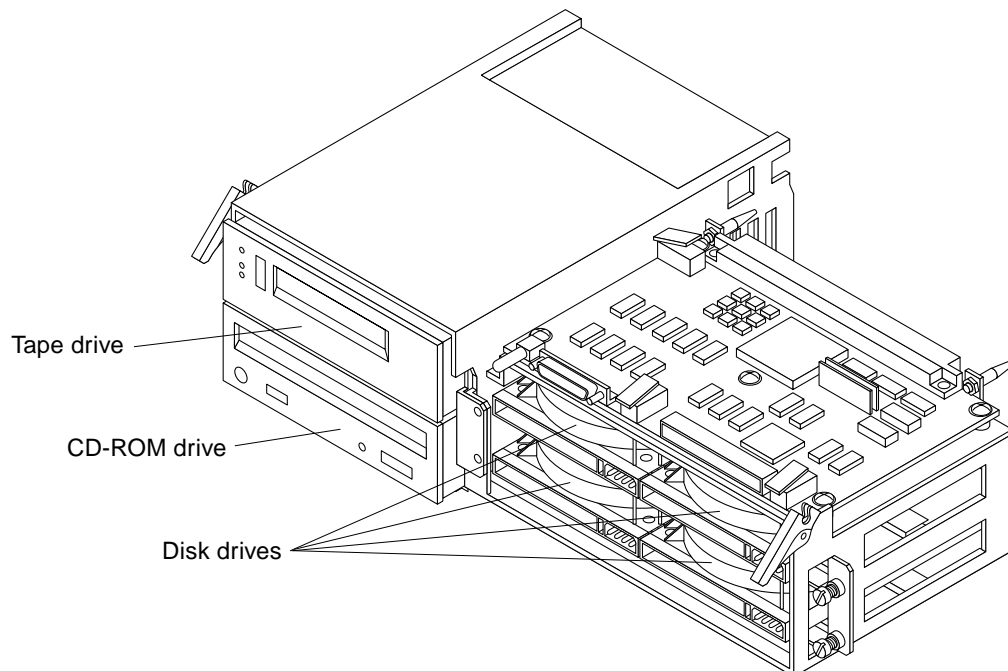

Figure 1-3 SCSI Tray of the SPARCserver 1000 system

Table 1-2 shows the physical arrangement of the SCSI tray and the target addresses of each drive as you view the tray from the front. Note that each disk drive has a unique SCSI target address.

Table 1-2 Device Addressing for the SCSI Tray

SCSI Device (Address)	SCSI Device (Address)	
Tape Drive (5)	Disk Drive (1)	Disk Drive (0)
CD-ROM (6)	Disk Drive (3)	Disk Drive (2)

Before you install the disk drive unit in the SCSI tray, make sure the SCSI target address jumpers on the disk drives are set correctly. The locations for these jumpers depend on the manufacturer of the drive:

- Conner 1.05 Gbyte disk drive is shown in Figure 1-4.
- Seagate 1.05 Gbyte disk drive is shown in Figure 1-5.
- Seagate 2.1 Gbyte disk drive is shown in Figure 1-6.
- IBM 2.1 Gbyte disk drive is shown in Figure 1-7.

Set the SCSI target address jumpers based on the location of the drives in the SCSI tray, as indicated in Table 1-2.

Note – You may need to remove the bracket that holds the disk drive unit together in order to access the jumper pins and set the SCSI target address. To remove the bracket, see Appendix A.

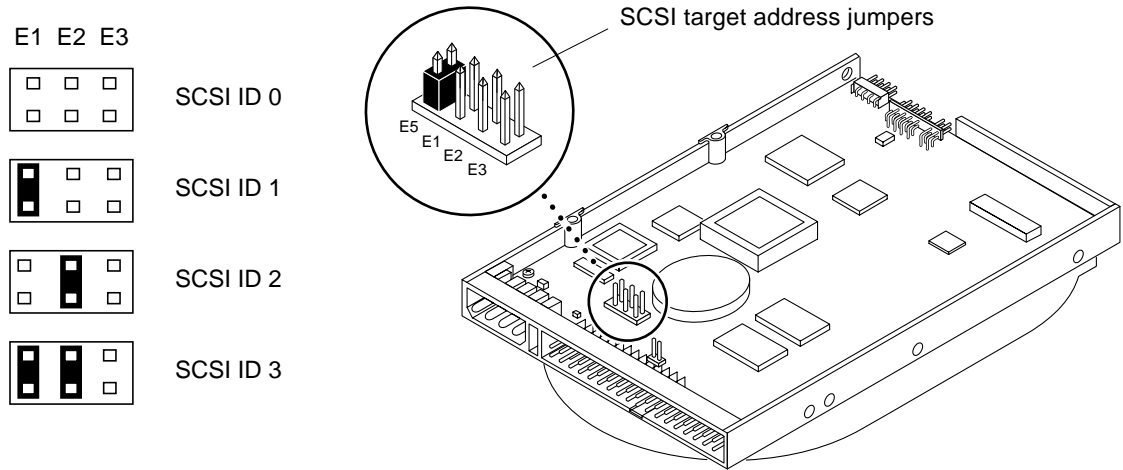

Figure 1-4 Conner 1.05 Gbyte Disk Drive SCSI Target Address Jumpers

Note – On the Conner 1.05 Gbyte drive, E5 should remain jumpered.

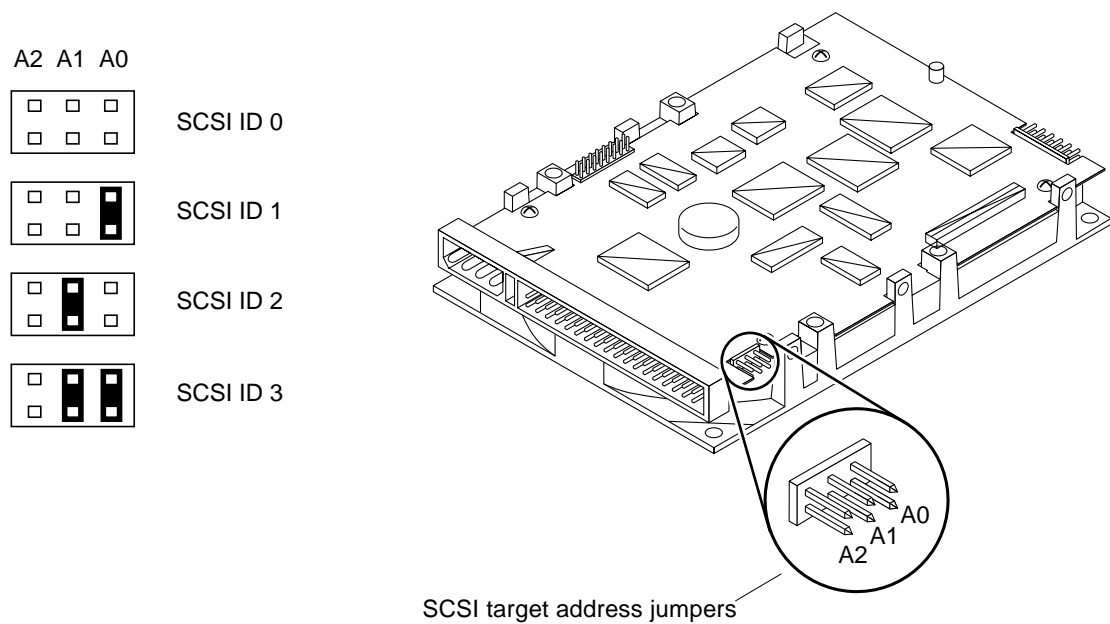

Figure 1-5 Seagate 1.05 Gbyte Disk Drive SCSI Target Address Jumpers

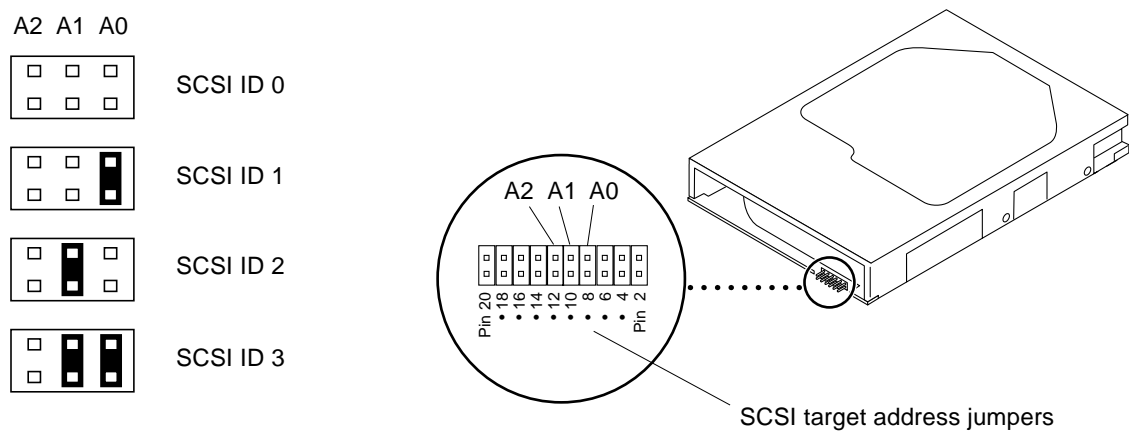

Figure 1-6 Seagate 2.1 Gbyte Disk Drive SCSI Target Address Jumpers

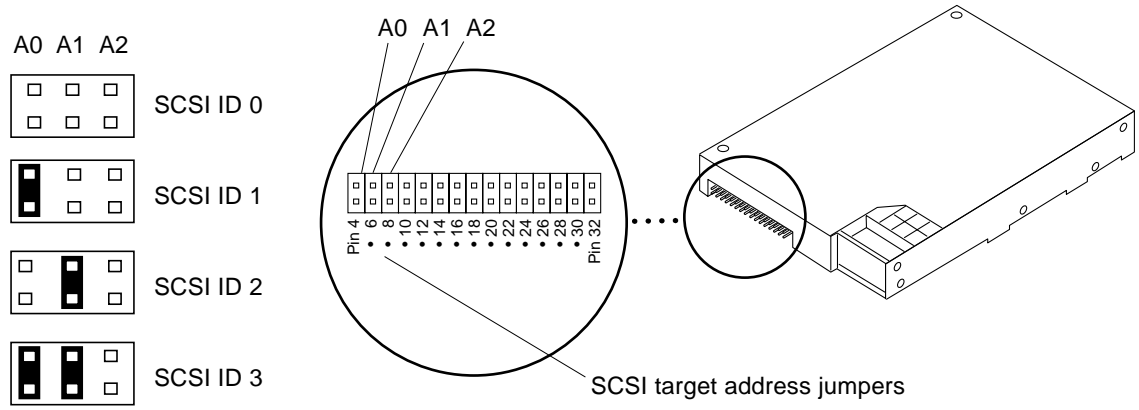

Figure 1-7 IBM 2.1 Gbyte Disk Drive SCSI Target Address Jumpers

Installing Drives in the SCSI Tray



This chapter describes how the disk drive unit must be installed in the SCSI tray of the SPARCserver 1000 system.

Disassembling the SPARCserver 1000 System

Switching Off System Power

1. Halt the operating system.

Refer to the *Solaris Handbook for SMCC Peripherals* that came with your system.

2. Turn off the power to the system.

Refer to the *SPARCserver 1000 System Installation Manual* (part no. 801-2893-xx) for instructions.

Removing the Front Cover

- 1. Remove the key from the keyswitch.**
- 2. Unlock the latch that secures the cover to the server.**
With your fingers, push in the latch located on the bottom of the cover. See Figure 2-1.
- 3. Lift and raise the cover upward so it can disengage from the keepers at the top of the chassis.**

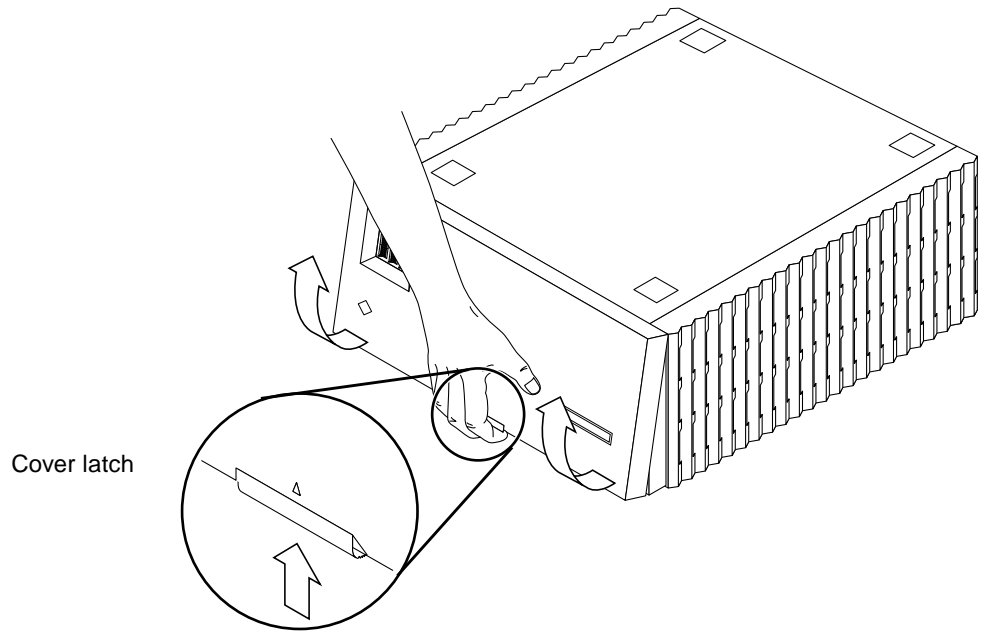

Figure 2-1 Removing the Front Cover

Removing the Electromagnetic Interference (EMI) Shield

1. Loosen the six captive screws of the shield.
2. Move the shield forward, toward you, to disengage it from the chassis.
See Figure 2-2.

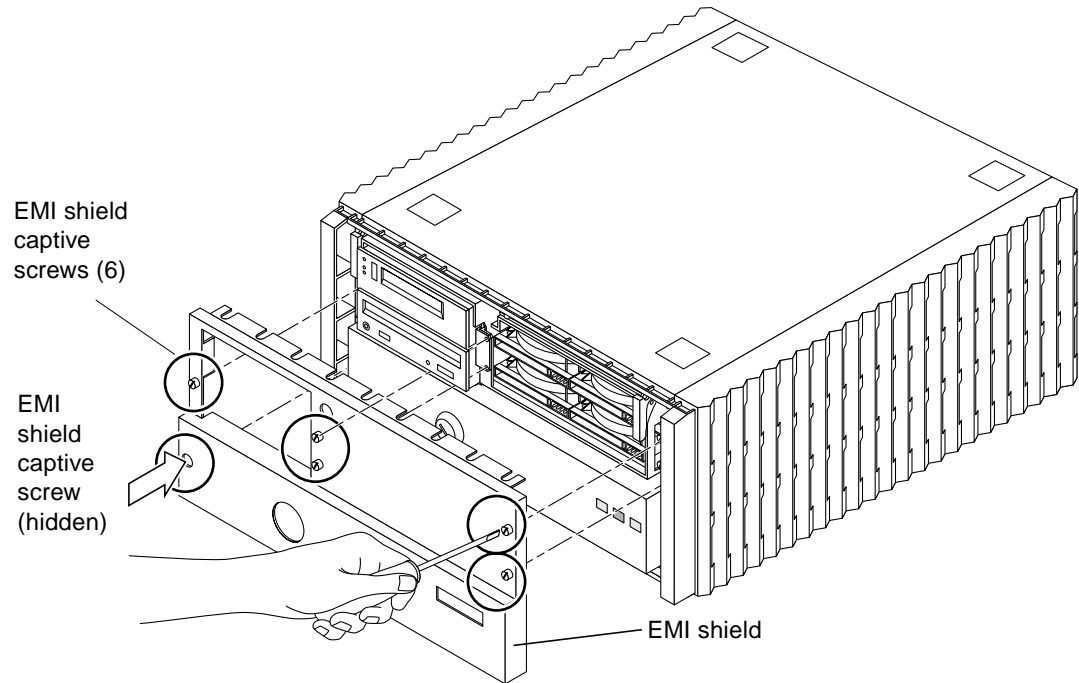

Figure 2-2 Removing the EMI Shield

Removing the SCSI Tray

1. Loosen the four captive screws that secure the SCSI tray to the SPARCserver 1000 system.

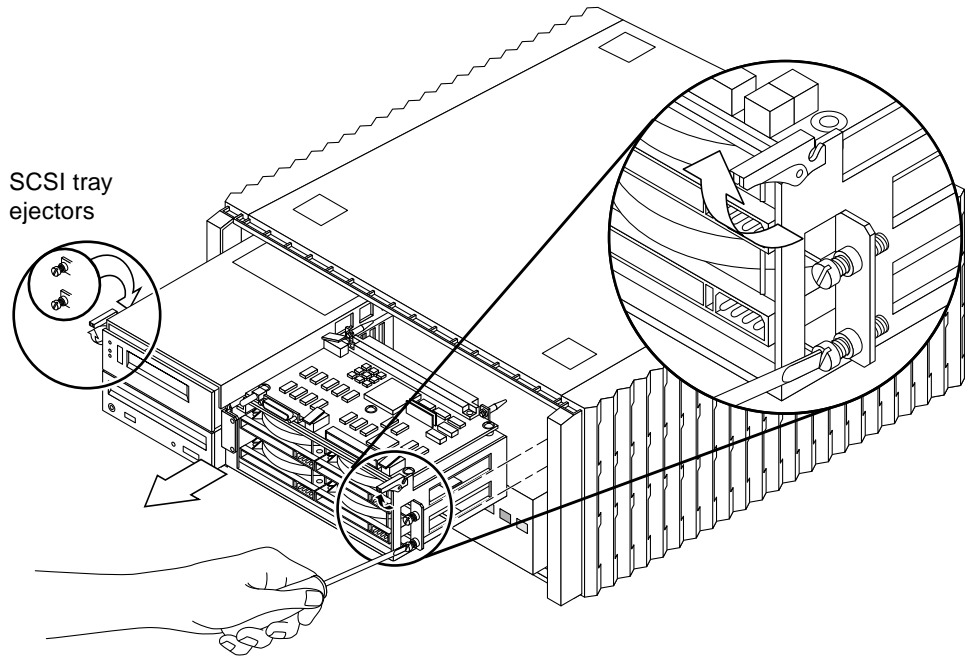

Figure 2-3 Removing the SCSI Tray

2. Release the SCSI tray from the SPARCserver 1000 system. See Figure 2-3.
 - a. Rotate the ejectors towards you until you feel the SCSI tray connector disconnect from the backplane connector.
 - b. Place your hands under the SCSI tray, and slide it out carefully.



Warning - The SCSI tray is heavy. Be sure you have a good grip on the tray before removing it from the SPARCserver 1000 system card cage.

3. Place the SCSI tray on the ESD mat.

Installing the Disk Drive Unit

1. **Face the rear of the SCSI tray, and insert the disk drive unit into the tray.**
See Figure 2-4.

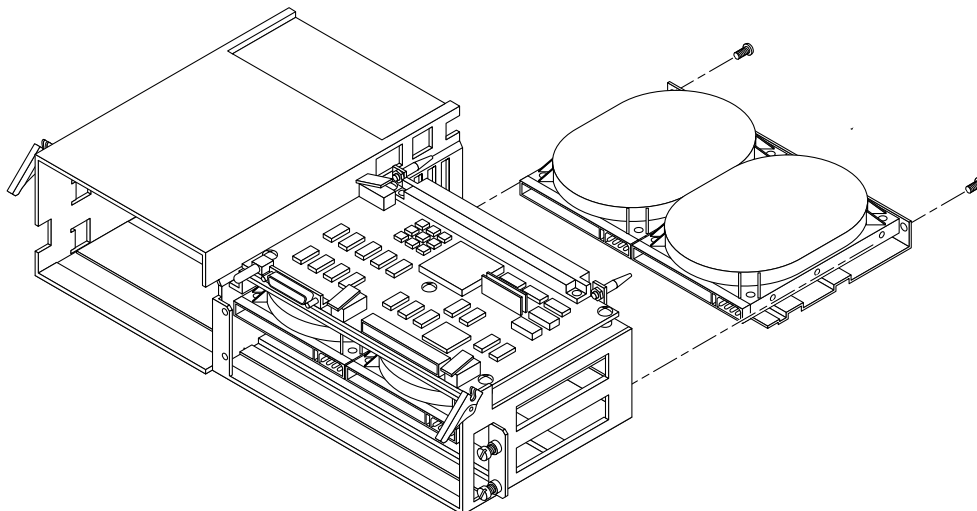

Figure 2-4 Inserting the Disk Drive Unit into the Rear of the SCSI Tray

2. **Secure the disk drive unit to the tray.**
Use the two #2 Phillips screws that came with the unit. See Figure 2-4.
3. **Attach the power and data connectors to the two disk drives.**
See Figure 2-5.



Caution – Do not force the cable connectors into the connectors on the drive—you may damage them.

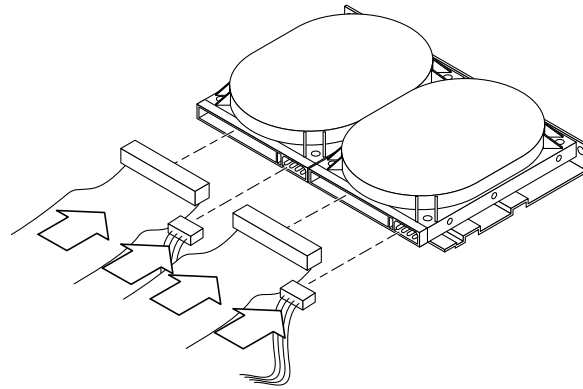

Figure 2-5 Power and Data Cable Connections

Reassembling the System

Installing the SCSI Tray

1. Grasp the tray on either side, lift it, and place it in the opening to the SPARCserver 1000 system.
2. Slide the SCSI tray into the SPARCserver 1000 system.
Keep the ejector tabs up until their hooks slide into place. See Figure 2-3.
3. Place your thumbs on the ejector tabs and use equal pressure when you close the ejector tabs.
As you close the ejector tabs, you will feel a slight resistance as the backplane connector seats in the SCSI tray connector.



Caution – *Do not force* the SCSI tray into the backplane — you may damage the backplane connectors.

4. Tighten the four captive screws to secure the SCSI tray to the SPARCserver 1000 system.

Checking Connections

1. **Verify that the extraction levers for the SCSI tray are fully closed.**
2. **Check that all cables are connected and secure.**
Cables or connections you did not install or change may have come loose during the installation.

Installing the EMI Shield

1. **Line up the EMI shield with the housing.**
2. **Slip the EMI shield on, tighten each screw one full turn, then tighten them again fully.**

Attaching the Front Cover

1. **Place the top of the cover on the front of the SPARCserver 1000 system and swing the bottom into place while pressing the release latch.**
2. **Return the key to the keyswitch.**

Verifying Disk Drive Installation

1. **Turn on the power to the monitor.**
Refer to the chapter that discusses powering the server on and off in the *SPARCserver 1000 System Installation Manual* (part no. 801-2893-xx).

If the system does not have a monitor, refer to the *SPARCserver 1000 System Service Manual* (part no. 801-2895-xx) for information on attaching an RS-232C terminal.
2. **Turn the key switch on the front panel of the SPARCserver 1000 system to the 1 position.**
The system will boot.
3. **Refer to the *Solaris Handbook for SMCC Peripherals* that came with your SPARCserver 1000 system for the appropriate command to display the OpenBoot™ prompt (ok).**

4. At the `ok` prompt, type:

```
ok probe-scsi-all
```

The OpenBoot `probe-scsi-all` command checks all available SCSI devices on the host SCSI bus. Watch the monitor and verify that it displays the newly-added SCSI tray disk drives.

Note – If the SPARCserver 1000 system does not recognize one or more disk drives (new or old), contact your service representative.

5. When the system displays the `ok` prompt, type:

```
ok boot -r
```

When the system finishes booting, it displays the login prompt (`hostname%`). At this point, log in and continue operation.

Removing a Disk Drive From the Bracket



Caution – Use the ESD kit provided with your disk drive unit for this procedure.

- 1. Attach the antistatic strap to your wrist and to a ground point (the bare metal of the card cage, for instance).**
- 2. Place the disk drive unit on the antistatic mat, with the retaining screws facing up.**
- 3. Remove the four screws for the selected disk drive. See Figure A-1.**

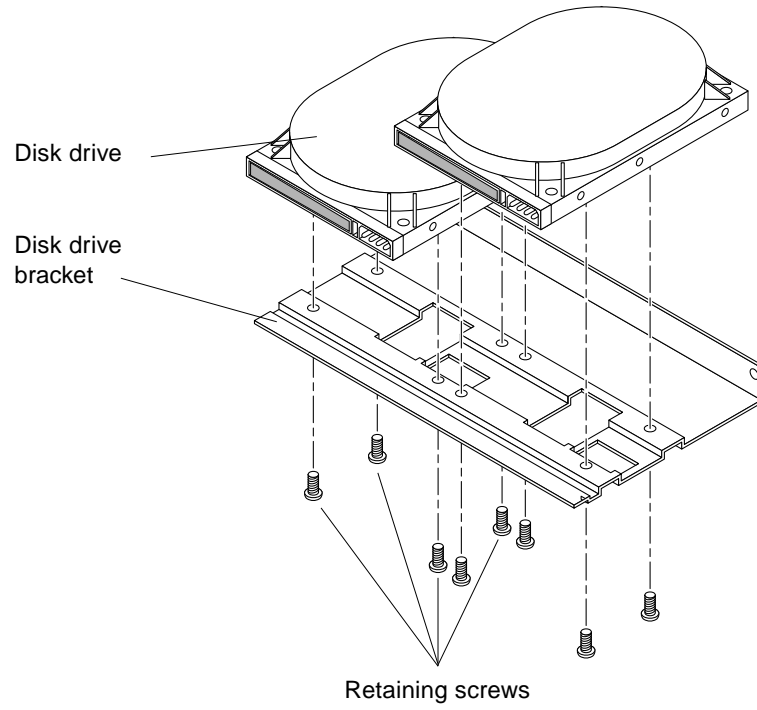

Figure A-1 Removing the Disk Drive from the Bracket

Revision History

Revision	Date	Comments
801-7670-10	May 1994	First Customer Ship
801-7670-11	July 1995	First Customer Ship

Reader Comments

We welcome your comments and suggestions to help improve this manual. Please let us know what you think about the *SPARCserver 1000 System Disk Drive Installation Manual*, part number 801-7670-11.

- The procedures were well documented.

Strongly Agree	Agree	Disagree	Strongly Disagree	Not Applicable
<input type="checkbox"/>	<input type="checkbox"/>	<input type="checkbox"/>	<input type="checkbox"/>	<input type="checkbox"/>

Comments _____

- The tasks were easy to follow.

Strongly Agree	Agree	Disagree	Strongly Disagree	Not Applicable
<input type="checkbox"/>	<input type="checkbox"/>	<input type="checkbox"/>	<input type="checkbox"/>	<input type="checkbox"/>

Comments _____

- The illustrations were clear.

Strongly Agree	Agree	Disagree	Strongly Disagree	Not Applicable
<input type="checkbox"/>	<input type="checkbox"/>	<input type="checkbox"/>	<input type="checkbox"/>	<input type="checkbox"/>

Comments _____

- The information was complete and easy to find.

Strongly Agree	Agree	Disagree	Strongly Disagree	Not Applicable
<input type="checkbox"/>	<input type="checkbox"/>	<input type="checkbox"/>	<input type="checkbox"/>	<input type="checkbox"/>

Comments _____

- Do you have additional comments about the *SPARCserver 1000 System Disk Drive Installation Manual*?

Name: _____

Title: _____

Company: _____

Address: _____

Telephone: _____

Email address: _____

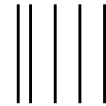

NO POSTAGE
NECESSARY
IF MAILED
IN THE
UNITED STATES

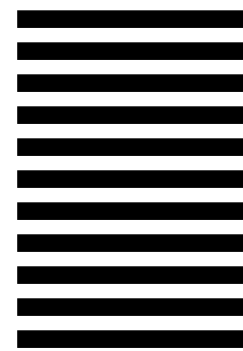

BUSINESS REPLY MAIL
FIRST CLASS MAIL PERMIT NO. 1 MOUNTAIN VIEW, CA

POSTAGE WILL BE PAID BY ADDRESSEE



SUN MICROSYSTEMS, INC.
Attn: Manager, Hardware Publications
MS MPK 14-101
2550 Garcia Avenue
Mt. View, CA 94043-9850

