



# **Solaris Volume Manager Administration Guide**



Sun Microsystems, Inc.  
4150 Network Circle  
Santa Clara, CA 95054  
U.S.A.

Part No: 819-2789-01  
June 2006

Copyright 2006 Sun Microsystems, Inc. 4150 Network Circle, Santa Clara, CA 95054 U.S.A. All rights reserved.

This product or document is protected by copyright and distributed under licenses restricting its use, copying, distribution, and decompilation. No part of this product or document may be reproduced in any form by any means without prior written authorization of Sun and its licensors, if any. Third-party software, including font technology, is copyrighted and licensed from Sun suppliers.

Parts of the product may be derived from Berkeley BSD systems, licensed from the University of California. UNIX is a registered trademark in the U.S. and other countries, exclusively licensed through X/Open Company, Ltd.

Sun, Sun Microsystems, the Sun logo, docs.sun.com, AnswerBook, AnswerBook2, and Solaris are trademarks or registered trademarks of Sun Microsystems, Inc. in the U.S. and other countries. All SPARC trademarks are used under license and are trademarks or registered trademarks of SPARC International, Inc. in the U.S. and other countries. Products bearing SPARC trademarks are based upon an architecture developed by Sun Microsystems, Inc.

The OPEN LOOK and Sun™ Graphical User Interface was developed by Sun Microsystems, Inc. for its users and licensees. Sun acknowledges the pioneering efforts of Xerox in researching and developing the concept of visual or graphical user interfaces for the computer industry. Sun holds a non-exclusive license from Xerox to the Xerox Graphical User Interface, which license also covers Sun's licensees who implement OPEN LOOK GUIs and otherwise comply with Sun's written license agreements.

U.S. Government Rights – Commercial software. Government users are subject to the Sun Microsystems, Inc. standard license agreement and applicable provisions of the FAR and its supplements.

DOCUMENTATION IS PROVIDED "AS IS" AND ALL EXPRESS OR IMPLIED CONDITIONS, REPRESENTATIONS AND WARRANTIES, INCLUDING ANY IMPLIED WARRANTY OF MERCHANTABILITY, FITNESS FOR A PARTICULAR PURPOSE OR NON-INFRINGEMENT, ARE DISCLAIMED, EXCEPT TO THE EXTENT THAT SUCH DISCLAIMERS ARE HELD TO BE LEGALLY INVALID.

---

Copyright 2006 Sun Microsystems, Inc. 4150 Network Circle, Santa Clara, CA 95054 U.S.A. Tous droits réservés.

Ce produit ou document est protégé par un copyright et distribué avec des licences qui en restreignent l'utilisation, la copie, la distribution, et la décompilation. Aucune partie de ce produit ou document ne peut être reproduite sous aucune forme, par quelque moyen que ce soit, sans l'autorisation préalable et écrite de Sun et de ses bailleurs de licence, s'il y en a. Le logiciel détenu par des tiers, et qui comprend la technologie relative aux polices de caractères, est protégé par un copyright et licencié par des fournisseurs de Sun.

Des parties de ce produit pourront être dérivées du système Berkeley BSD licenciés par l'Université de Californie. UNIX est une marque déposée aux Etats-Unis et dans d'autres pays et licenciée exclusivement par X/Open Company, Ltd.

Sun, Sun Microsystems, le logo Sun, docs.sun.com, AnswerBook, AnswerBook2, et Solaris sont des marques de fabrique ou des marques déposées, de Sun Microsystems, Inc. aux Etats-Unis et dans d'autres pays. Toutes les marques SPARC sont utilisées sous licence et sont des marques de fabrique ou des marques déposées de SPARC International, Inc. aux Etats-Unis et dans d'autres pays. Les produits portant les marques SPARC sont basés sur une architecture développée par Sun Microsystems, Inc.

L'interface d'utilisation graphique OPEN LOOK et Sun a été développée par Sun Microsystems, Inc. pour ses utilisateurs et licenciés. Sun reconnaît les efforts de pionniers de Xerox pour la recherche et le développement du concept des interfaces d'utilisation visuelle ou graphique pour l'industrie de l'informatique. Sun détient une licence non exclusive de Xerox sur l'interface d'utilisation graphique Xerox, cette licence couvrant également les licenciés de Sun qui mettent en place l'interface d'utilisation graphique OPEN LOOK et qui en outre se conforment aux licences écrites de Sun.

CETTE PUBLICATION EST FOURNIE "EN L'ETAT" ET AUCUNE GARANTIE, EXPRESSE OU IMPLICITE, N'EST ACCORDEE, Y COMPRIS DES GARANTIES CONCERNANT LA VALEUR MARCHANDE, L'APTITUDE DE LA PUBLICATION A REpondre A UNE UTILISATION PARTICULIERE, OU LE FAIT QU'ELLE NE SOIT PAS CONTREFAISANTE DE PRODUIT DE TIERS. CE DENI DE GARANTIE NE S'APPLIQUERAIT PAS, DANS LA MESURE OU IL SERAIT TENU JURIDIQUEMENT NUL ET NON AVENU.

# Contents

---

<b>Preface</b> .....	17
<b>1 Getting Started With Solaris Volume Manager</b> .....	21
Solaris Volume Manager Roadmap—What’s New .....	22
Solaris Volume Manager Roadmap—Storage Capacity .....	22
Solaris Volume Manager Roadmap—Availability .....	23
Solaris Volume Manager Roadmap—I/O Performance .....	24
Solaris Volume Manager Roadmap—Administration .....	24
Solaris Volume Manager Roadmap—Troubleshooting .....	25
<b>2 Storage Management Concepts</b> .....	27
Introduction to Storage Management .....	27
Storage Hardware .....	27
RAID Levels .....	28
Configuration Planning Guidelines .....	29
Choosing Storage .....	29
General Performance Guidelines .....	30
Random I/O and Sequential I/O Optimization .....	31
Random I/O .....	31
Sequential Access I/O .....	32
<b>3 Solaris Volume Manager Overview</b> .....	33
What’s New in Solaris Volume Manager .....	33
Support for Descriptive Names .....	33
Introduction to Solaris Volume Manager .....	34
How Solaris Volume Manager Manages Storage .....	34
How to Administer Solaris Volume Manager .....	35
▼ How to Access the Solaris Volume Manager Graphical User Interface (GUI) .....	36

Solaris Volume Manager Requirements .....	36
Overview of Solaris Volume Manager Components .....	37
Overview of Volumes .....	37
State Database and State Database Replicas .....	42
Hot Spare Pools .....	42
Disk Sets .....	43
Solaris Volume Manager Configuration Guidelines .....	43
General Guidelines .....	43
File System Guidelines .....	43
Overview of Creating Solaris Volume Manager Components .....	44
Prerequisites for Creating Solaris Volume Manager Components .....	44
Overview of Multi-Terabyte Support in Solaris Volume Manager .....	44
Large Volume Support Limitations .....	45
Using Large Volumes .....	45
Upgrading to Solaris Volume Manager .....	46
<b>4 Solaris Volume Manager for Sun Cluster (Overview) .....</b>	<b>49</b>
Introduction to Solaris Volume Manager for Sun Cluster .....	49
Prerequisite: Required Software Components for Multi-Owner Disk Set Functionality .....	50
Multi-Owner Disk Set Concepts .....	51
Tasks Associated With Multi-Owner Disk Sets .....	52
Solaris Volume Manager for Sun Cluster Configuration .....	53
RAID-1 (Mirror) Volumes in Multi-Owner Disk Sets .....	54
Mirror Ownership With Multi-Owner Disk Sets .....	54
Data Management and Recovery Processes .....	55
<b>5 Configuring and Using Solaris Volume Manager (Scenario) .....</b>	<b>57</b>
Scenario Background Information .....	57
Hardware Configuration .....	57
Initial Physical Storage Configuration .....	58
Final Solaris Volume Manager Configuration .....	58
<b>6 State Database (Overview) .....</b>	<b>61</b>
About the Solaris Volume Manager State Database and Replicas .....	61
Understanding the Majority Consensus Algorithm .....	62
Administering State Database Replicas .....	63

Handling State Database Replica Errors .....	64
Scenario—State Database Replicas .....	65
<b>7 State Database (Tasks) .....</b>	<b>67</b>
State Database Replicas (Task Map) .....	67
Creating State Database Replicas .....	68
▼ How to Create State Database Replicas .....	68
Maintaining State Database Replicas .....	70
▼ How to Check the Status of State Database Replicas .....	70
▼ How to Delete State Database Replicas .....	71
<b>8 RAID-0 (Stripe and Concatenation) Volumes (Overview) .....</b>	<b>73</b>
Overview of RAID-0 Volumes .....	73
RAID-0 (Stripe) Volume .....	74
RAID-0 (Concatenation) Volume .....	76
RAID-0 (Concatenated Stripe) Volume .....	77
Background Information for Creating RAID-0 Volumes .....	80
RAID-0 Volume Requirements .....	80
RAID-0 Volume Guidelines .....	80
Scenario—RAID-0 Volumes .....	81
<b>9 RAID-0 (Stripe and Concatenation) Volumes (Tasks) .....</b>	<b>83</b>
RAID-0 Volumes (Task Map) .....	83
Creating RAID-0 (Stripe) Volumes .....	84
▼ How to Create a RAID-0 (Stripe) Volume .....	84
Creating RAID-0 (Concatenation) Volumes .....	85
▼ How to Create a RAID-0 (Concatenation) Volume .....	85
Expanding Storage Capacity .....	87
▼ How to Expand Storage Capacity for Existing Data .....	87
▼ How to Expand an Existing RAID-0 Volume .....	88
Removing a RAID-0 Volume .....	90
▼ How to Remove a RAID-0 Volume .....	90
<b>10 RAID-1 (Mirror) Volumes (Overview) .....</b>	<b>93</b>
Overview of RAID-1 (Mirror) Volumes .....	93

Overview of Submirrors .....	93
Scenario—RAID-1 (Mirror) Volume .....	94
Providing RAID-1+0 and RAID-0+1 .....	95
RAID-1 Volume (Mirror) Resynchronization .....	96
Full Resynchronization .....	96
Optimized Resynchronization .....	96
Partial Resynchronization .....	97
Canceling and Resuming Resynchronization With the <code>metasync</code> Command .....	97
Creating and Maintaining RAID-1 Volumes .....	97
Configuration Guidelines for RAID-1 Volumes .....	97
Performance Guidelines for RAID-1 Volumes .....	99
About RAID-1 Volume Options .....	99
Understanding Submirror Status to Determine Maintenance Actions .....	101
The Affect of Booting Into Single-User Mode on RAID-1 Volumes .....	102
Scenario—RAID-1 Volumes (Mirrors) .....	103
<b>11 RAID-1 (Mirror) Volumes (Tasks) .....</b>	<b>105</b>
RAID-1 Volumes (Task Map) .....	105
Creating a RAID-1 Volume .....	107
▼ How to Create a RAID-1 Volume From Unused Slices .....	107
▼ How to Create a RAID-1 Volume From a File System .....	109
▼ SPARC: How to Create a RAID-1 Volume From the root (/) File System .....	113
▼ x86: How to Create a RAID-1 Volume From the root (/) File System .....	117
Understanding Boot Time Warnings When Mirroring the root (/) File System .....	122
Working With Submirrors .....	122
▼ How to Attach a Submirror .....	122
▼ How to Detach a Submirror .....	124
▼ How to Place a Submirror Offline and Online .....	124
▼ How to Enable a Slice in a Submirror .....	125
Maintaining RAID-1 Volumes .....	126
▼ How to View the Status of Mirrors and Submirrors .....	126
▼ How to Change RAID-1 Volume Options .....	128
▼ How to Expand a RAID-1 Volume .....	129
▼ How to Cancel a Volume Resynchronization Process .....	130
▼ How to Resume a Volume Resynchronization Process .....	133
Responding to RAID-1 Volume Component Failures .....	135

▼ How to Replace a Slice in a Submirror .....	135
▼ How to Replace a Submirror .....	136
Removing RAID-1 Volumes (Unmirroring) .....	138
▼ How to Unmirror a File System .....	138
▼ How to Unmirror a File System That Cannot Be Unmounted .....	140
Backing Up Data on a RAID-1 Volume .....	143
▼ How to Perform an Online Backup of a RAID-1 Volume .....	143
<b>12 Soft Partitions (Overview) .....</b>	<b>147</b>
Overview of Soft Partitions .....	147
Configuration Guidelines for Soft Partitions .....	148
Scenario—Soft Partitions .....	148
<b>13 Soft Partitions (Tasks) .....</b>	<b>149</b>
Soft Partitions (Task Map) .....	149
Creating Soft Partitions .....	150
▼ How to Create a Soft Partition .....	150
Maintaining Soft Partitions .....	151
▼ How to Check the Status of a Soft Partition .....	151
▼ How to Expand a Soft Partition .....	152
▼ How to Remove a Soft Partition .....	153
<b>14 RAID-5 Volumes (Overview) .....</b>	<b>155</b>
Overview of RAID-5 Volumes .....	155
Example—RAID-5 Volume .....	156
Example—Concatenated (Expanded) RAID-5 Volume .....	157
Background Information for Creating RAID-5 Volumes .....	158
Requirements for RAID-5 Volumes .....	158
Guidelines for RAID-5 Volumes .....	158
Overview of Checking Status of RAID-5 Volumes .....	159
Overview of Replacing and Enabling Slices in RAID-5 Volumes .....	161
Scenario—RAID-5 Volumes .....	161
<b>15 RAID-5 Volumes (Tasks) .....</b>	<b>163</b>
RAID-5 Volumes (Task Map) .....	163

Creating RAID-5 Volumes .....	164
▼ How to Create a RAID-5 Volume .....	164
Maintaining RAID-5 Volumes .....	165
▼ How to Check the Status of a RAID-5 Volume .....	165
▼ How to Expand a RAID-5 Volume .....	166
▼ How to Enable a Component in a RAID-5 Volume .....	167
▼ How to Replace a Component in a RAID-5 Volume .....	168
<b>16 Hot Spare Pools (Overview) .....</b>	<b>171</b>
Overview of Hot Spares and Hot Spare Pools .....	171
Hot Spares .....	172
Hot Spare Pools .....	172
How Hot Spares Work .....	172
Hot Spare Pool States .....	173
Example—Hot Spare Pool .....	173
Scenario—Hot Spares .....	174
<b>17 Hot Spare Pools (Tasks) .....</b>	<b>175</b>
Hot Spare Pools (Task Map) .....	175
Creating a Hot Spare Pool .....	176
▼ How to Create a Hot Spare Pool .....	176
▼ How to Add Additional Slices to a Hot Spare Pool .....	177
Associating a Hot Spare Pool With Volumes .....	178
▼ How to Associate a Hot Spare Pool With a Volume .....	178
▼ How to Change the Associated Hot Spare Pool .....	179
Maintaining Hot Spare Pools .....	181
▼ How to Check the Status of Hot Spares and Hot Spare Pools .....	181
▼ How to Replace a Hot Spare in a Hot Spare Pool .....	182
▼ How to Delete a Hot Spare From a Hot Spare Pool .....	183
▼ How to Enable a Hot Spare .....	184
<b>18 Disk Sets (Overview) .....</b>	<b>185</b>
What's New in Disk Sets .....	185
Enhanced Output With the <code>metaimport</code> Command .....	185
Introduction to Disk Sets .....	186
Types of Disk Sets .....	186



Local Disk Sets .....	186
Named Disk Sets .....	187
Solaris Volume Manager Disk Set Administration .....	188
Reserving a Disk Set .....	189
Releasing a Disk Set .....	190
Importing a Disk Set .....	190
Automatic Disk Partitioning .....	191
Disk Set Name Requirements .....	193
Example—Two Shared Disk Sets .....	193
Guidelines for Working With Disk Sets .....	194
Asynchronous Shared Storage in Disk Sets .....	195
Scenario—Disk Sets .....	195
<b>19 Disk Sets (Tasks) .....</b>	<b>197</b>
Disk Sets (Task Map) .....	197
Creating Disk Sets .....	198
▼ How to Create a Disk Set .....	198
Expanding Disk Sets .....	200
▼ How to Add Disks to a Disk Set .....	200
▼ How to Add Another Host to a Disk Set .....	201
▼ How to Create Solaris Volume Manager Components in a Disk Set .....	202
Maintaining Disk Sets .....	204
▼ How to Check the Status of a Disk Set .....	204
▼ How to Delete Disks From a Disk Set .....	204
▼ How to Take a Disk Set .....	205
▼ How to Release a Disk Set .....	207
▼ How to Delete a Host or Disk Set .....	208
Importing Disk Sets .....	210
▼ How to Print a Report on Disk Sets Available for Import .....	210
▼ How to Import a Disk Set From One System to Another System .....	213
<b>20 Maintaining Solaris Volume Manager (Tasks) .....</b>	<b>215</b>
Solaris Volume Manager Maintenance (Task Map) .....	215
Viewing the Solaris Volume Manager Configuration .....	216
▼ How to View the Solaris Volume Manager Volume Configuration .....	216
Where To Go From Here .....	220

---

Renaming Volumes .....	220
Background Information for Renaming Volumes .....	220
Exchanging Volume Names .....	221
▼ How to Rename a Volume .....	221
Working With Configuration Files .....	223
▼ How to Create Configuration Files .....	223
▼ How to Initialize Solaris Volume Manager From a Configuration File .....	223
Changing Solaris Volume Manager Default Values .....	225
Expanding a File System Using the <code>growfs</code> Command .....	225
Background Information for Expanding Slices and Volumes .....	226
▼ How to Expand a File System .....	227
Overview of Replacing and Enabling Components in RAID-1 and RAID-5 Volumes .....	228
Enabling a Component .....	228
Replacing a Component With Another Available Component .....	229
Maintenance and Last Erred States .....	229
Background Information for Replacing and Enabling Components in RAID-1 and RAID-5 Volumes .....	230
<b>21 Best Practices for Solaris Volume Manager .....</b>	<b>233</b>
Deploying Small Servers .....	233
Using Solaris Volume Manager With Networked Storage Devices .....	235
<b>22 Top-Down Volume Creation (Overview) .....</b>	<b>237</b>
Overview of Top-Down Volume Creation .....	237
Top-Down Volume Creation Implementation With Disk Sets .....	238
Top-Down Volume Creation Processes .....	238
Determining Which Disks Are Available for Top-Down Volume Creation .....	240
<b>23 Top-Down Volume Creation (Tasks) .....</b>	<b>241</b>
Top-Down Volume Creation (Task Map) .....	241
Prerequisites for Top-Down Volume Creation .....	242
Creating Volumes Automatically .....	243
Analyzing Volume Creation by Specifying Output Verbosity .....	243
▼ How to Create RAID-1 (mirror) Volumes Using the <code>metassist</code> Command .....	243
Working With File-Based Data Using the <code>metassist</code> Command .....	246
Creating a Command File (Shell Script) Using the <code>metassist</code> Command .....	246

▼ How to Create a Command File (Shell Script) Using the <code>metassist</code> Command .....	247
Creating a Volume With a Saved Shell Script Created by the <code>metassist</code> Command .....	251
▼ How to Execute a Saved <code>metassist</code> Command Shell Script .....	251
Creating a Volume Configuration File With the <code>metassist</code> Command .....	252
▼ How to Create a Volume Configuration File Using the <code>metassist</code> Command .....	252
Changing the Default Behavior of the <code>metassist</code> Command .....	254
Changing the Volume Defaults File .....	254
<b>24 Monitoring and Error Reporting (Tasks) .....</b>	<b>257</b>
Solaris Volume Manager Monitoring and Reporting (Task Map) .....	257
Configuring the <code>mdmonitord</code> Command for Periodic Error Checking .....	258
▼ How to Configure the <code>mdmonitord</code> Command for Periodic Error Checking .....	258
Solaris Volume Manager SNMP Agents Overview .....	259
Configuring the Solaris Volume Manager SNMP Agents .....	259
▼ How to Configure the Solaris Volume Manager SNMP Agents .....	260
Limitations of the Solaris Volume Manager SNMP Agent .....	262
Monitoring Solaris Volume Manager With a <code>cron</code> Job .....	262
▼ How to Automate Checking for Errors in Volumes .....	262
<b>25 Troubleshooting Solaris Volume Manager (Tasks) .....</b>	<b>273</b>
Troubleshooting Solaris Volume Manager (Task Map) .....	273
Overview of Troubleshooting the System .....	274
Prerequisites for Troubleshooting the System .....	274
General Guidelines for Troubleshooting Solaris Volume Manager .....	275
General Troubleshooting Approach .....	275
Replacing Disks .....	276
▼ How to Replace a Failed Disk .....	276
Recovering From Disk Movement Problems .....	278
Disk Movement and Device ID Overview .....	278
Resolving Unnamed Devices Error Message .....	278
Device ID Discrepancies After Upgrading to the Solaris 10 Release .....	279
Recovering From Boot Problems .....	281
Background Information for Boot Problems .....	281
How to Recover From Improper <code>/etc/vfstab</code> Entries .....	282
▼ Recovering the root (/) RAID-1 (Mirror) Volume .....	282
▼ How to Recover From a Boot Device Failure .....	284

Recovering From State Database Replica Failures .....	288
▼ How to Recover From Insufficient State Database Replicas .....	288
Recovering From Soft Partition Problems .....	291
▼ How to Recover Configuration Data for a Soft Partition .....	291
Recovering Storage From a Different System .....	293
▼ How to Recover Storage From a Local Disk Set .....	293
Recovering Storage From a Known Disk Set .....	298
▼ How to Print a Report on Disk Sets Available for Import .....	298
▼ How to Import a Disk Set From One System to Another System .....	299
Recovering From Disk Set Problems .....	300
What to Do When You Cannot Take Ownership of A Disk Set .....	300
▼ How to Purge a Disk Set .....	300
Performing Mounted Filesystem Backups Using the <code>ufsdump</code> Command .....	301
▼ How to Perform a Backup of a Mounted Filesystem Located on a RAID-1 Volume .....	302
Performing System Recovery .....	303
▼ How to Recover a System Using a Solaris Volume Manager Configuration .....	303
<b>A Important Solaris Volume Manager Files .....</b>	<b>305</b>
System Files and Startup Files .....	305
Manually Configured Files .....	306
Overview of the <code>md.tab</code> File .....	306
<b>B Solaris Volume Manager Quick Reference .....</b>	<b>309</b>
Command-Line Reference .....	309
<b>C Solaris Volume Manager CIM/WBEM API .....</b>	<b>311</b>
Managing Solaris Volume Manager .....	311
<b>Index .....</b>	<b>313</b>

# Tables

---

TABLE 2-1	Comparison of Types of Storage .....	29
TABLE 2-2	Optimizing Redundant Storage .....	30
TABLE 3-1	Summary of Solaris Volume Manager Features .....	37
TABLE 3-2	Classes of Volumes .....	38
TABLE 10-1	RAID-1 Volume Read Policies .....	100
TABLE 10-2	RAID-1 Volume Write Policies .....	100
TABLE 10-3	Submirror States .....	101
TABLE 10-4	Submirror Slice States .....	102
TABLE 14-1	RAID-5 Volume States .....	160
TABLE 14-2	RAID-5 Slice States .....	160
TABLE 16-1	Hot Spare Pool States (Command Line) .....	173
TABLE 18-1	Example Volume Names for Disk Sets .....	193
TABLE 25-1	Common Boot Problems With Solaris Volume Manager .....	281
TABLE B-1	Solaris Volume Manager Commands .....	309



# Figures

---

FIGURE 3-1	View of the Enhanced Storage Tool (Solaris Volume Manager) in the Solaris Management Console .....	35
FIGURE 3-2	Relationship Among a Volume, Physical Disks, and Slices .....	39
FIGURE 4-1	Sample Cluster Configuration .....	50
FIGURE 5-1	Basic Hardware Diagram Storage Scenario .....	58
FIGURE 8-1	RAID-0 (Stripe) Volume Example .....	76
FIGURE 8-2	RAID-0 (Concatenation) Volume Example .....	77
FIGURE 8-3	RAID-0 (Concatenated Stripe) Volume Example .....	79
FIGURE 10-1	RAID-1 (Mirror) Example .....	94
FIGURE 10-2	RAID-1+0 Example .....	95
FIGURE 14-1	RAID-5 Volume Example .....	156
FIGURE 14-2	Expanded RAID-5 Volume Example .....	157
FIGURE 16-1	Hot Spare Pool Example .....	174
FIGURE 18-1	Disk Sets Example .....	194
FIGURE 21-1	Small System Configuration .....	234
FIGURE 22-1	Processing Options for Top-Down Volume Creation .....	239





# Preface

---

The *Solaris Volume Manager Administration Guide* explains how to use Solaris™ Volume Manager to manage your system's storage needs. Solaris Volume Manager enables you to create, modify, and use RAID-0 (concatenation and stripe) volumes, RAID-1 (mirror) volumes,

---

**Note** – This Solaris release supports systems that use the SPARC® and x86 families of processor architectures: UltraSPARC®, SPARC64, AMD64, Pentium, and Xeon EM64T. The supported systems appear in the *Solaris 10 Hardware Compatibility List* at <http://www.sun.com/bigadmin/hcl>. This document cites any implementation differences between the platform types.

In this document these x86 related terms mean the following:

- x86 refers to the larger family of 64-bit and 32-bit x86 compatible products.
- x64 points out specific 64-bit information about AMD64 or EM64T systems.
- 32-bit x86 points out specific 32-bit information about x86 based systems.

For supported systems, see the *Solaris 10 Hardware Compatibility List*.

---

## Who Should Use This Book

System and storage administrators can use this book to identify:

- Tasks supported by Solaris Volume Manager
- Ways to use Solaris Volume Manager to provide more reliable and accessible data

## How This Book Is Organized

The *Solaris Volume Manager Administration Guide* includes the following information:

**Chapter 1** provides a detailed “roadmap” to the concepts and tasks described in this book. Use this chapter as a navigational aid to the book's content.

**Chapter 2** provides an introduction to general storage management concepts for those readers who are new to this technology.

**Chapter 3** describes Solaris Volume Manager. This chapter introduces essential product-related concepts and explains how to access Solaris Volume Manager tools.

[Chapter 4](#) provides an introduction to multi-owner disk sets. Multi-owner disk sets enhance the use of Solaris Volume Manager in a Sun™ Cluster environment.

[Chapter 5](#) provides the storage configuration scenario used throughout this book. This scenario is intended to help you understand the Solaris Volume Manager product.

[Chapter 6](#) describes concepts related to state databases and state database replicas.

[Chapter 7](#) explains how to perform tasks related to state databases and state database replicas.

[Chapter 8](#) describes concepts related to RAID-0 (stripe and concatenation) volumes.

[Chapter 9](#) explains how to perform tasks related to RAID-0 (stripe and concatenation) volumes.

[Chapter 10](#) describes concepts related to RAID-1 (mirror) volumes.

[Chapter 11](#) explains how to perform tasks related to RAID-1 (mirror) volumes.

[Chapter 12](#) describes concepts related to Solaris Volume Manager's soft partitioning feature.

[Chapter 13](#) explains how to perform tasks related to soft partitioning.

[Chapter 14](#) describes concepts related to RAID-5 volumes.

[Chapter 15](#) explains how to perform tasks related to RAID-5 volumes.

[Chapter 16](#) describes concepts related to hot spares and hot spare pools.

[Chapter 17](#) explains how to perform tasks related to hot spares and hot spare pools.

[Chapter 18](#) describes concepts related to disk sets.

[Chapter 19](#) explains how to perform tasks related to disk sets.

[Chapter 20](#) explains some general maintenance tasks that are not related to a specific Solaris Volume Manager component.

[Chapter 21](#) provides some “best practices” information about configuring and using Solaris Volume Manager.

[Chapter 23](#) describes concepts of and tasks related to the Solaris Volume Manager top-down volume creation feature.

[Chapter 24](#) provides concepts and instructions for using the Solaris Volume Manager SNMP agent and for other error-checking approaches.

[Chapter 25](#) provides information about troubleshooting and solving common problems in the Solaris Volume Manager environment.

[Appendix A](#) lists important Solaris Volume Manager files.

[Appendix B](#) provides tables that summarize commands and other helpful information.

[Appendix C](#) provides a brief introduction to the CIM/WBEM API that allows open Solaris Volume Manager management from WBEM-compliant management tools.

## Related Books

Solaris Volume Manager is one of several system administration tools available for the Solaris operating system. Information about overall system administration features and functions, as well as related tools are provided in the following:

- *System Administration Guide: Basic Administration*
- *System Administration Guide: Advanced Administration*
- *System Administration Guide: Devices and File Systems*

## Documentation, Support, and Training

Sun Function	URL	Description
Documentation	<a href="http://www.sun.com/documentation/">http://www.sun.com/documentation/</a>	Download PDF and HTML documents, and order printed documents
Support and Training	<a href="http://www.sun.com/supporttraining/">http://www.sun.com/supporttraining/</a>	Obtain technical support, download patches, and learn about Sun courses

## Typographic Conventions

The following table describes the typographic changes that are used in this book.

TABLE P-1 Typographic Conventions

Typeface or Symbol	Meaning	Example
AaBbCc123	The names of commands, files, and directories, and onscreen computer output	Edit your <code>.login</code> file. Use <code>ls -a</code> to list all files. <code>machine_name% you have mail.</code>
<b>AaBbCc123</b>	What you type, contrasted with onscreen computer output	<code>machine_name% su</code> Password:

TABLE P-1 Typographic Conventions (Continued)

Typeface or Symbol	Meaning	Example
<i>AaBbCc123</i>	Command-line placeholder: replace with a real name or value	The command to remove a file is <code>rm filename</code> .
<b><i>AaBbCc123</i></b>	Book titles, new terms, and terms to be emphasized	Read Chapter 6 in the <i>User's Guide</i> . Perform a <i>patch analysis</i> . Do <i>not</i> save the file. [Note that some emphasized items appear bold online.]

## Shell Prompts in Command Examples

The following table shows the default system prompt and superuser prompt for the C shell, Bourne shell, and Korn shell.

TABLE P-2 Shell Prompts

Shell	Prompt
C shell prompt	machine_name%
C shell superuser prompt	machine_name#
Bourne shell and Korn shell prompt	\$
Bourne shell and Korn shell superuser prompt	#

# Getting Started With Solaris Volume Manager

---

The *Solaris Volume Manager Administration Guide* describes how to set up and maintain systems using Solaris Volume Manager to manage storage for high availability, flexibility, and reliability.

This chapter serves as a high-level guide to find information for certain Solaris Volume Manager tasks, such as setting up storage capacity. This chapter does not address all the tasks that you will need to use Solaris Volume Manager. Instead, this chapter provides an overview of new features and an easy way to find procedures describing common tasks associated with Solaris Volume Manager concepts.

This chapter includes the following roadmaps:

- “Solaris Volume Manager Roadmap—What’s New” on page 22
- “Solaris Volume Manager Roadmap—Storage Capacity” on page 22
- “Solaris Volume Manager Roadmap—Availability” on page 23
- “Solaris Volume Manager Roadmap—I/O Performance” on page 24
- “Solaris Volume Manager Roadmap—Administration” on page 24
- “Solaris Volume Manager Roadmap—Troubleshooting” on page 25



**Caution** – If you do not use Solaris Volume Manager correctly, you can destroy data. Solaris Volume Manager provides a powerful way to reliably manage your disks and data on them. However, you should always maintain backups of your data, particularly before you modify an active Solaris Volume Manager configuration.

---

## Solaris Volume Manager Roadmap—What's New

Task	Description	For Instructions
Manage storage in which one or more components is greater than 1 TB	Use physical logical unit numbers (LUNs) that are greater than 1 TB in size, or create logical volumes that are greater than 1 TB.	<a href="#">“Overview of Multi-Terabyte Support in Solaris Volume Manager” on page 44</a>
Import a disk set from one system to another	Use the <code>metaimport</code> command to import disk sets, even disk sets created on different systems. This command uses expanded device ID support to automatically track disk movement within named disk sets.	<a href="#">“Importing a Disk Set” on page 190</a> <a href="#">“Asynchronous Shared Storage in Disk Sets” on page 195</a>
Create and manage multi-owner disk sets	Use the <code>metaset -M</code> to administer multi-owner disk sets in a Sun Cluster environment.	<a href="#">“Tasks Associated With Multi-Owner Disk Sets” on page 52</a>

## Solaris Volume Manager Roadmap—Storage Capacity

Task	Description	For Instructions
Set up storage	Create storage that spans slices by creating a RAID-0 or a RAID-5 volume. The RAID-0 or RAID-5 volume can then be used for a file system or any application, such as a database, that accesses the raw device.	<a href="#">“How to Create a RAID-0 (Stripe) Volume” on page 84</a> <a href="#">“How to Create a RAID-0 (Concatenation) Volume” on page 85</a> <a href="#">“How to Create a RAID-1 Volume From Unused Slices” on page 107</a> <a href="#">“How to Create a RAID-1 Volume From a File System” on page 109</a> <a href="#">“How to Create a RAID-5 Volume” on page 164</a>
Expand an existing file system	Increase the capacity of an existing file system by creating a RAID-0 (concatenation) volume, then adding additional slices to that volume.	<a href="#">“How to Expand Storage Capacity for Existing Data” on page 87</a>

Task	Description	For Instructions
Expand an existing RAID-0 (concatenation or stripe) volume	Expand an existing RAID-0 volume by concatenating additional slices to it.	<a href="#">“How to Expand an Existing RAID-0 Volume” on page 88</a>
Expand a RAID-5 volume	Expand the capacity of a RAID-5 volume by concatenating additional slices to it.	<a href="#">“How to Expand a RAID-5 Volume” on page 166</a>
Increase the size of a UFS file system on an expanded volume	Expand a file system by using the <code>growfs</code> command to expand the size of a UFS while it is mounted and without disrupting access to the data.	<a href="#">“How to Expand a File System” on page 227</a>
Subdivide slices or logical volumes into smaller partitions, breaking the 8-slice hard partition limit	Subdivide logical volumes or slices by using soft partitions.	<a href="#">“How to Create a Soft Partition” on page 150</a>
Create a file system	Create a file system on a RAID-0 (stripe or concatenation), RAID-1 (mirror), RAID-5, or on a soft partition.	Chapter 18, “Creating UFS, TMPFS, and LOFS File Systems (Tasks),” in <i>System Administration Guide: Devices and File Systems</i>

## Solaris Volume Manager Roadmap—Availability

Task	Description	For Instructions
Maximize data availability	Use Solaris Volume Manager’s mirroring feature to maintain multiple copies of your data. You can create a RAID-1 volume from unused slices in preparation for data, or you can mirror an existing file system, including root ( <code>/</code> ) and <code>/usr</code> .	<a href="#">“How to Create a RAID-1 Volume From Unused Slices” on page 107</a> <a href="#">“How to Create a RAID-1 Volume From a File System” on page 109</a>
Add data availability with minimum hardware cost	Increase data availability with a minimum of hardware by using Solaris Volume Manager’s RAID-5 volumes.	<a href="#">“How to Create a RAID-5 Volume” on page 164</a>

Task	Description	For Instructions
Increase data availability for an existing RAID-1 or RAID-5 volume	Increase data availability for a RAID-1 or a RAID-5 volume, by creating a hot spare pool then associating it with the submirrors of a RAID-1 volume, or a RAID-5 volume.	<a href="#">“Creating a Hot Spare Pool” on page 176</a> <a href="#">“Associating a Hot Spare Pool With Volumes” on page 178</a>

## Solaris Volume Manager Roadmap—I/O Performance

Task	Description	For Instructions
Tune RAID-1 volume readandwrite policies	Specify the read and write policies for a RAID-1 volume to improve I/O performance for a given configuration.	<a href="#">“RAID-1 Volume Read-and-Write Policies” on page 100</a> <a href="#">“How to Change RAID-1 Volume Options” on page 128</a>
Optimize device performance	Create RAID-0 (stripe) volumes to optimize I/O performance of devices that make up the stripe. The interlace value can be optimized for random or sequential access.	<a href="#">“Creating RAID-0 (Stripe) Volumes” on page 84</a>
Maintain device performance within a RAID-0 (stripe)	Expand a stripe or concatenation that has run out of space by concatenating a new component to it. A concatenation of stripes is better for I/O performance than a concatenation of slices.	<a href="#">“Expanding Storage Capacity” on page 87</a>

## Solaris Volume Manager Roadmap—Administration

Task	Description	For Instructions
Graphically administer your volume management configuration	Use the Solaris Management Console graphical user interface (GUI) to administer your volume management configuration.	Online help from within Solaris Volume Manager (Enhanced Storage) node of the Solaris Management Console application



Task	Description	For Instructions
Graphically administer slices and file systems	Use the Solaris Management Console GUI to administer your disks and file systems, performing such tasks as partitioning disks and constructing UFS file systems.	Online help from within the Solaris Management Console application
Optimize Solaris Volume Manager	Solaris Volume Manager performance is dependent on a well-designed configuration. Once created, the configuration needs monitoring and tuning.	<a href="#">“Solaris Volume Manager Configuration Guidelines” on page 43</a> <a href="#">“Working With Configuration Files” on page 223</a>
Plan for future expansion	Because file systems tend to run out of space, you can plan for future growth by putting a file system into a concatenation.	<a href="#">“Creating RAID-0 (Concatenation) Volumes” on page 85</a> <a href="#">“Expanding Storage Capacity” on page 87</a>

## Solaris Volume Manager Roadmap—Troubleshooting

Task	Description	For Instructions
Replace a failing slice	If a disk fails, you must replace the slices used in your Solaris Volume Manager configuration. In the case of RAID-0 volume, you have to use a new slice, delete and re-create the volume, then restore data from a backup. Slices in RAID-1 and RAID-5 volumes can be replaced and resynchronized without loss of data.	<a href="#">“Responding to RAID-1 Volume Component Failures” on page 135</a> <a href="#">“How to Replace a Component in a RAID-5 Volume” on page 168</a>
Recover from boot problems	Special problems can arise when booting the system, due to a hardware problem or operator error.	<a href="#">“How to Recover From Improper /etc/vfstab Entries” on page 282</a> <a href="#">“How to Recover From Insufficient State Database Replicas” on page 288</a> <a href="#">“How to Recover From a Boot Device Failure” on page 284</a>



# Storage Management Concepts

---

This chapter provides a brief introduction to some common storage management concepts.

This chapter contains the following information:

- “Introduction to Storage Management” on page 27
- “Configuration Planning Guidelines” on page 29
- “General Performance Guidelines” on page 30
- “Random I/O and Sequential I/O Optimization” on page 31

## Introduction to Storage Management

How you choose to manage your storage determines how you control the devices that store the active data on your system. To be useful, active data must be available and remain persistent even after unexpected events, such as a hardware or software failure.

### Storage Hardware

There are many different devices on which data can be stored. The selection of devices to best meet your storage needs depends primarily on three factors:

- Performance
- Availability
- Cost

You can use Solaris Volume Manager to help manage the trade-offs in performance, availability, and cost. You can often mitigate many of the trade-offs with Solaris Volume Manager.

Solaris Volume Manager works well with any supported storage on any system that runs the Solaris operating system.

## RAID Levels

RAID is an acronym for Redundant Array of Inexpensive (or Independent) Disks. RAID refers to a set of disks, called an array or a *volume*, that appears to the user as a single large disk drive. Depending on the configuration, this array provides improved reliability, response time, or storage capacity.

Technically, there are six RAID levels, 0-5. Each level refers to a method of distributing data while ensuring data redundancy. (RAID Level 0 does not provide data redundancy, but is usually included as a RAID classification anyway. RAID Level 0 provides the basis for the majority of RAID configurations in use.) Very few storage environments support RAID Levels 2, 3, and 4, so those environments are not described here.

Solaris Volume Manager supports the following RAID levels:

- **RAID LEVEL 0** – Although stripes and concatenations do not provide redundancy, these volumes are often referred to as RAID-0. Basically, data are spread across relatively small, equally-sized fragments that are allocated alternately and evenly across multiple physical disks. Any single drive failure can cause data loss. RAID-0 offers a high data transfer rate and high I/O throughput, but suffers lower reliability and lower availability than a single disk.
- **RAID Level 1** – Mirroring uses equal amounts of disk capacity to store data and a copy (mirror) of the data. Data is duplicated, or mirrored, over two or more physical disks. Data can be read from both drives simultaneously, meaning that either drive can service any request, which provides improved performance. If one physical disk fails, you can continue to use the mirror with no loss in performance or loss of data.

Solaris Volume Manager supports both RAID-0+1 and (transparently) RAID-1+0 mirroring, depending on the underlying volumes. See [“Providing RAID-1+0 and RAID-0+1” on page 95](#) for details.

- **RAID Level 5** – RAID-5 uses striping to spread the data over the disks in an array. RAID-5 also records parity information to provide some data redundancy. A RAID-5 volume can withstand the failure of an underlying device without failing. If a RAID-5 volume is used in conjunction with hot spares, the volume can withstand multiple failures without failing. A RAID-5 volume will have a substantial performance degradation when operating with a failed device.

In the RAID-5 model, every device has one area that contains a parity stripe and other areas that contain data. The parity is spread over all of the disks in the array, which reduces the write time. Write time is reduced because writes do not have to wait until a dedicated parity disk can accept the data.

# Configuration Planning Guidelines

When you are planning your storage management configuration, keep in mind that for any given configuration, there are trade-offs in *performance*, *availability*, and *hardware costs*. You might need to experiment with the different variables to determine what works best for your configuration.

This section provides guidelines for working with the following types of volumes:

- RAID-0 (concatenation and stripe) volumes
- RAID-1 (mirror) volumes
- RAID-5 volumes
- Soft partitions
- File systems that are constructed on Solaris Volume Manager volumes

## Choosing Storage

Before you implement your storage management approach, you need to decide what kinds of storage devices to use. This set of guidelines compares the various types of storage to help you choose. Additional sets of guidelines apply to specific types of storage as implemented in Solaris Volume Manager. See specific chapters about each volume type for details.

---

**Note** – The types of storage that are listed here are not mutually exclusive. You can use these volumes in combination to meet multiple goals. For example, you could first create a RAID-1 volume for redundancy. Next, you could create soft partitions on that RAID-1 volume to increase the possible number of discrete file systems.

---

The following table provides a comparison between the features available for each type of storage.

TABLE 2-1 Comparison of Types of Storage

Requirements	RAID-0 (Concatenation)	RAID-0 (Stripe)	RAID-1 (Mirror)	RAID-5	Soft Partitions
Redundant data	No	No	Yes	Yes	No
Improved read performance	No	Yes	Depends on underlying device	Yes	No
Improved write performance	No	Yes	No	No	No
More than 8 slices per device	No	No	No	No	Yes
Larger available storage space	Yes	Yes	No	Yes	No

The following table outlines the trade-offs in write operations, random reads, and hardware costs between RAID-1 and RAID-5 volumes.

TABLE 2-2 Optimizing Redundant Storage

	RAID-1 (Mirror)	RAID-5
Write operations	Faster	Slower
Random read	Faster	Slower
Hardware cost	Higher	Lower

The following list summarizes the information outlined in the tables:

- RAID-0 volumes (stripes and concatenations) and soft partitions do not provide any redundancy of data.
- Concatenation works well for small random I/O operations.
- Striping performs well for large sequential I/O operations and for random I/O operations.
- Mirroring might improve read performance, but write performance is always degraded in mirrors.
- Because of the read-modify-write nature of RAID-5 volumes, volumes with over 20 percent writes should not be RAID-5. If redundancy is required, consider mirroring.
- RAID-5 writes cannot be as fast as mirrored writes, which in turn cannot be as fast as unprotected writes.
- Soft partitions are useful for managing very large storage devices.

---

**Note** – In addition to these generic storage options, see “[Hot Spare Pools](#)” on page 42 for more information about using Solaris Volume Manager to support redundant devices.

---

## General Performance Guidelines

When you design your storage configuration, consider the following performance guidelines:

- Striping generally has the best performance, but striping offers no data redundancy. For write-intensive applications, RAID-1 volumes generally have better performance than RAID-5 volumes.
- RAID-1 and RAID-5 volumes both increase data availability, but both types of volumes generally have lower performance for write operations. Mirroring does improve random read performance.
- RAID-5 volumes have a lower hardware cost than RAID-1 volumes, while RAID-0 volumes have no additional hardware cost.

- Both stripes and RAID-5 volumes distribute data across multiple disk drives and help balance the I/O load.
- Identify the most frequently accessed data, and increase access bandwidth to that data with mirroring or striping.
- Use available performance monitoring capabilities and generic tools such as the `iostat` command to identify the most frequently accessed data. Once identified, the access bandwidth to this data can be increased using striping, RAID-1 volumes or RAID-5 volumes.
- The performance of soft partitions can degrade when the soft partition size is changed multiple times.
- RAID-5 volume performance is lower than stripe performance for write operations. This performance penalty results from the multiple I/O operations required to calculate and store the RAID-5 volume parity.
- For raw random I/O reads, the stripe and the RAID-5 volume are comparable. Both the stripe and RAID-5 volumes split the data across multiple disks. RAID-5 volume parity calculations are not a factor in reads except after a slice failure.
- For raw random I/O writes, the stripe is superior to RAID-5 volumes.

For configuration guidelines specific to Solaris Volume Manager, see [“Solaris Volume Manager Configuration Guidelines” on page 43](#).

## Random I/O and Sequential I/O Optimization

This section explains strategies for optimizing your configuration.

If you do not know if sequential I/O or random I/O predominates on the Solaris Volume Manager volumes you are creating, do not implement these performance tuning tips. These tips can degrade performance if the tips are improperly implemented.

The following optimization suggestions assume that you are optimizing a RAID-0 volume. In general, you would want to optimize a RAID-0 volume, then mirror that volume to provide both optimal performance and data redundancy.

### Random I/O

In a random I/O environment, such as an environment used for databases and general-purpose file servers, all disks should spend equal amounts of time servicing I/O requests.

For example, assume that you have 40 Gbytes of storage for a database application. If you stripe across four 10 Gbyte disk spindles, and if the I/O is random and evenly dispersed across the volume, then each of the disks will be equally busy, which generally improves performance.

The target for maximum random I/O performance on a disk is 35 percent or lower usage, as reported by the `iostat` command. Disk use in excess of 65 percent on a typical basis is a problem. Disk use in

excess of 90 percent is a significant problem. The solution to having disk use values that are too high is to create a new RAID-0 volume with more disks (spindles).

---

**Note** – Simply attaching additional disks to an existing volume cannot improve performance. You must create a new volume with the ideal parameters to optimize performance.

---

The interlace size of the stripe does not matter because you just want to spread the data across all the disks. Any interlace value greater than the typical I/O request will suffice.

## Sequential Access I/O

You can optimize the performance of your configuration in a sequential I/O environment, such as DBMS servers that are dominated by full table scans and NFS servers in very data-intensive environments. To take advantage of a sequential I/O environment, set the interlace value low relative to the size of the typical I/O request.

For example, assume a typical I/O request size of 256 Kbytes and striping across 4 spindles. A good choice for the stripe unit size in this example would be:

$$256 \text{ Kbytes} / 4 = 64 \text{ Kbytes, or smaller}$$

This strategy ensures that the typical I/O request is spread across multiple disk spindles, thus increasing the sequential bandwidth.

---

**Note** – Seek time and rotation time are practically zero in the sequential I/O environment. When you optimize sequential I/O, the internal transfer rate of a disk is most important.

---

In sequential applications, the typical I/O size is usually large, meaning more than 128 Kbytes or even more than 1 Mbyte. Assume an application with a typical I/O request size of 2 Mbytes and assume striping across 4 disk spindles, thus:

$$2048 \text{ Kbytes} / 4 = 512 \text{ Kbytes}$$

So, a good choice for the interlace size would be 256–512 Kbytes.



# Solaris Volume Manager Overview

---

This chapter explains the overall structure of Solaris Volume Manager. This chapter contains the following information:

- “What’s New in Solaris Volume Manager” on page 33
- “Introduction to Solaris Volume Manager” on page 34
- “Solaris Volume Manager Requirements” on page 36
- “Overview of Solaris Volume Manager Components” on page 37
- “Solaris Volume Manager Configuration Guidelines” on page 43
- “Overview of Creating Solaris Volume Manager Components” on page 44
- “Overview of Multi-Terabyte Support in Solaris Volume Manager” on page 44
- “Upgrading to Solaris Volume Manager” on page 46

## What’s New in Solaris Volume Manager

This section describes new features for working with Solaris Volume Manager in this Solaris release.

For a complete listing of new Solaris features and a description of Solaris releases, see *What’s New in Solaris Express*.

## Support for Descriptive Names

**Solaris Express 4/06:** Solaris Volume Manager has been enhanced to include the use of descriptive names for both volumes and hot spare pools. System administrators can now name volumes and hot spare pools by using any name that follows the naming guidelines.

A new option has been added to the `metastat` command to assist in identifying volumes and hot spare pools with descriptive names. The `metastat -D` command lists all of the volumes and hot spare pools with descriptive names. This information is useful if it becomes necessary to move your storage to a previous release of the Solaris OS that does not support the use of descriptive names.

For more information, see “Volume Names” on page 40.

# Introduction to Solaris Volume Manager

Solaris Volume Manager is a software product that lets you manage large numbers of disks and the data on those disks. Although there are many ways to use Solaris Volume Manager, most tasks include the following:

- Increasing storage capacity
- Increasing data availability
- Easing administration of large storage devices

In some instances, Solaris Volume Manager can also improve I/O performance.

For information on the types of disks supported in the Solaris operating system, see Chapter 11, “Managing Disks (Overview),” in *System Administration Guide: Devices and File Systems*.

## How Solaris Volume Manager Manages Storage

Solaris Volume Manager uses virtual disks to manage physical disks and their associated data. In Solaris Volume Manager, a virtual disk is called a *volume*. For historical reasons, some command-line utilities also refer to a volume as a *metadevice*.

From the perspective of an application or a file system, a volume is functionally identical to a physical disk. Solaris Volume Manager converts I/O requests directed at a volume into I/O requests to the underlying member disks.

Solaris Volume Manager volumes are built from disk slices or from other Solaris Volume Manager volumes. An easy way to build volumes is to use the graphical user interface (GUI) that is built into the Solaris Management Console. The Enhanced Storage tool within the Solaris Management Console presents you with a view of all the existing volumes. By following the steps in wizards, you can easily build any kind of Solaris Volume Manager volume or component. You can also build and modify volumes by using Solaris Volume Manager command-line utilities.

For example, if you need more storage capacity as a single volume, you could use Solaris Volume Manager to make the system treat a collection of slices as one larger volume. After you create a volume from these slices, you can immediately begin using the volume just as you would use any “real” slice or device.

For a more detailed discussion of volumes, see [“Overview of Volumes” on page 37](#).

Solaris Volume Manager can increase the reliability and availability of data by using RAID-1 (mirror) volumes and RAID-5 volumes. Solaris Volume Manager hot spares can provide another level of data availability for mirrors and RAID-5 volumes.

Once you have set up your configuration, you can use the Enhanced Storage tool within the Solaris Management Console to report on its operation.

# How to Administer Solaris Volume Manager

Use either of these methods to administer Solaris Volume Manager:

- Solaris Management Console – This tool provides a GUI to administer volume management functions. Use the Enhanced Storage tool within the Solaris Management Console. See [Figure 3–1](#) for an example of the Enhanced Storage tool. This interface provides a graphical view of Solaris Volume Manager components, including volumes, hot spare pools, and state database replicas. This interface offers wizard-based manipulation of Solaris Volume Manager components, enabling you to quickly configure your disks or change an existing configuration.
- The command line – You can use several commands to perform volume management functions. The Solaris Volume Manager core commands begin with `met`, for example the `metainit` and `metastat` commands. For a list of Solaris Volume Manager commands, see [Appendix B](#).

**Note** – Do not attempt to administer Solaris Volume Manager with the command line and the GUI at the same time. Conflicting changes could be made to the configuration, and its behavior would be unpredictable. You can use both tools to administer Solaris Volume Manager, but not concurrently.

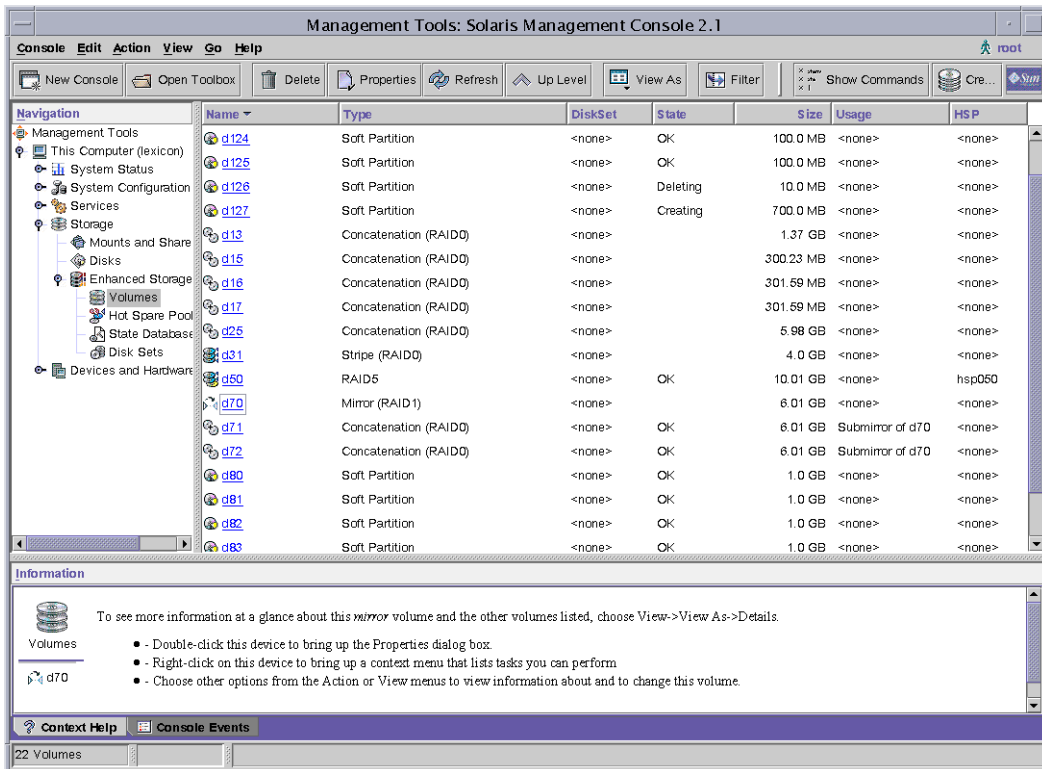

FIGURE 3–1 View of the Enhanced Storage Tool (Solaris Volume Manager) in the Solaris Management Console

## ▼ How to Access the Solaris Volume Manager Graphical User Interface (GUI)

The Solaris Volume Manager GUI (Enhanced Storage) is part of the Solaris Management Console. To access the GUI, use the following instructions:

- 1 **Start the Solaris Management Console on the host system by using the following command:**  

```
% /usr/sbin/smc
```
- 2 **Double-click This Computer in the Navigation pane.**
- 3 **Double-click Storage in the Navigation pane.**
- 4 **Double-click Enhanced Storage in the Navigation pane to load the Solaris Volume Manager tools.**
- 5 **If prompted to log in, log in as root or as a user who has equivalent access.**
- 6 **Double-click the appropriate icon to manage volumes, hot spare pools, state database replicas, and disk sets.**

---

**Tip** – All tools in the Solaris Management Console display information in the bottom section of the console window or at the left side of a wizard panel. Choose Help at any time to find additional information about performing tasks in this interface.

---

## Solaris Volume Manager Requirements

Solaris Volume Manager requirements include the following:

- You must have root privilege to administer Solaris Volume Manager. Equivalent privileges granted through the User Profile feature in the Solaris Management Console allow administration through the Solaris Management Console. However, only the root user can use the Solaris Volume Manager command-line interface.
- Before you can create volumes with Solaris Volume Manager, state database replicas must exist on the Solaris Volume Manager system. A state database replica contains configuration and status information for all volumes, hot spares, and disk sets. At least three replicas should exist, and the replicas should be placed on different controllers and different disks for maximum reliability. See [“About the Solaris Volume Manager State Database and Replicas”](#) on page 61 for more information about state database replicas. See [“Creating State Database Replicas”](#) on page 68 for instructions on how to create state database replicas.

# Overview of Solaris Volume Manager Components

The five basic types of components that you create with Solaris Volume Manager are volumes, soft partitions, disk sets, state database replicas, and hot spare pools. The following table gives an overview of these Solaris Volume Manager features.

TABLE 3-1 Summary of Solaris Volume Manager Features

Solaris Volume Manager Feature	Definition	Purpose	For More Information
<ul style="list-style-type: none"> <li>■ RAID-0 volume (stripe, concatenation, concatenated stripe)</li> <li>■ RAID-1 (mirror) volume</li> <li>■ RAID-5 volume</li> </ul>	A group of physical slices that appear to the system as a single, logical device	To increase storage capacity, performance, or data availability.	<a href="#">“Overview of Volumes” on page 37</a>
Soft partition	A subdivision of physical slices or logical volumes to provide smaller, more manageable storage units	To improve manageability of large storage volumes.	<a href="#">Chapter 12</a>
State database (state database replicas)	A database that contains configuration and status information for all volumes, hot spares, and disk sets. Solaris Volume Manager cannot operate until you have created the state database replicas.	To store information about the state of your Solaris Volume Manager configuration	<a href="#">“State Database and State Database Replicas” on page 42</a>
Hot spare pool	A collection of slices (hot spares) reserved. These slices are automatically substituted when either a submirror or RAID-5 volume component fails.	To increase data availability for RAID-1 and RAID-5 volumes.	<a href="#">“Hot Spare Pools” on page 42</a>
Disk set	A set of shared disk drives in a separate namespace that contains volumes and hot spares and that can be shared non-concurrently by multiple hosts	To provide data redundancy and data availability and to provide a separate namespace for easier administration.	<a href="#">“Disk Sets” on page 43</a>

## Overview of Volumes

A *volume* is a group of physical slices that appears to the system as a single, logical device. Volumes are actually pseudo, or virtual, devices in standard UNIX® terms.

---

**Note** – Historically, the Solstice DiskSuite™ product referred to these logical devices as metadevices. However, for simplicity and standardization, this book refers to these devices as volumes.

---

## Classes of Volumes

You create a volume as a RAID-0 (concatenation or stripe) volume, a RAID-1 (mirror) volume, a RAID-5 volume, .

You can use either the Enhanced Storage tool within the Solaris Management Console or the command-line utilities to create and administer volumes.

The following table summarizes the classes of volumes.

**TABLE 3-2** Classes of Volumes

Volume	Description
RAID-0 (stripe or concatenation)	Can be used directly, or as the basic building block for mirrors. RAID-0 volumes do not directly provide data redundancy.
RAID-1 (mirror)	Replicates data by maintaining multiple copies. A RAID-1 volume is composed of one or more RAID-0 volumes that are called submirrors.
RAID-5	Replicates data by using parity information. In the case of disk failure, the missing data can be regenerated by using available data and the parity information. A RAID-5 volume is generally composed of slices. One slice's worth of space is allocated to parity information, but the parity is distributed across all slices in the RAID-5 volume.
Soft partition	Divides a slice or logical volume into one or more smaller, extensible volumes.

## How Volumes Are Used

You use volumes to increase storage capacity, performance, and data availability. In some instances, volumes can also increase I/O performance. Functionally, volumes behave the same way as slices. Because volumes look like slices, the volumes are transparent to end users, applications, and file systems. As with physical devices, volumes are accessed through block or raw device names. The volume name changes, depending on whether the block or raw device is used. See [“Volume Names” on page 40](#) for details about volume names.

You can use most file system commands, including `mkfs`, `mount`, `umount`, `ufsdump`, `ufsrestore`, and others, on volumes. You cannot use the `format` command, however. You can read, write, and copy files to and from a volume, as long as the volume contains a mounted file system.

## Example—Volume That Consists of Two Slices

[Figure 3-2](#) shows a volume that contains two slices, one slice from Disk A and one slice from Disk B. An application or UFS treats the volume as if it were one physical disk. Adding more slices to the volume increases its storage capacity.

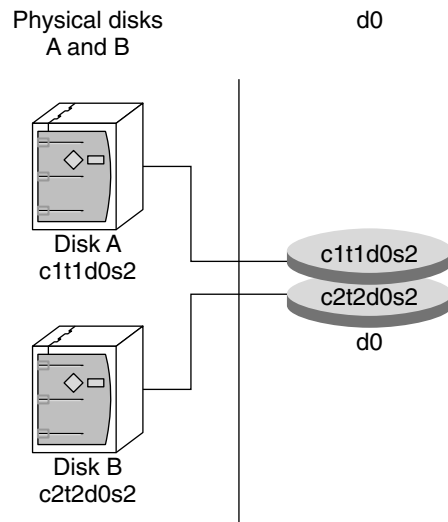

FIGURE 3-2 Relationship Among a Volume, Physical Disks, and Slices

## Volume and Disk Space Expansion Using the `growfs` Command

Solaris Volume Manager enables you to expand a volume by adding additional slices. You can use either the Enhanced Storage tool within the Solaris Management Console or the command-line interface to add a slice to an existing volume.

You can expand a mounted or unmounted UFS file system that is contained within a volume without having to halt or back up your system. Nevertheless, backing up your data is always a good idea. After you expand the volume, use the `growfs` command to grow the file system.

---

**Note** – After a file system has been expanded, the file system cannot be reduced in size. The inability to reduce the size of a file system is a UFS limitation. Similarly, after a Solaris Volume Manager partition has been increased in size, it cannot be reduced.

---

Applications and databases that use the raw volume must have their own method to “grow” the added space so that applications can recognize it. Solaris Volume Manager does not provide this capability.

You can expand the disk space in volumes in the following ways:

- Adding one or more slices to a RAID-0 volume
- Adding one or more slices to all submirrors of a RAID-1 volume
- Adding one or more slices to a RAID-5 volume
- Expanding a soft partition with additional space from the underlying component

The `growfs` command expands a UFS file system without loss of service or data. However, write access to the volume is suspended while the `growfs` command is running. You can expand the file system to the size of the slice or the volume that contains the file system.

The file system can be expanded to use only part of the additional disk space by using the `-s size` option to the `growfs` command.

---

**Note** – When you expand a mirror, space is added to the mirror’s underlying submirrors. The `growfs` command is then run on the RAID-1 volume. The general rule is that space is added to the underlying devices, and the `growfs` command is run on the top-level device.

---

## Volume Names

As with physical slices, volumes have logical names that appear in the file system. Logical volume names have entries in the `/dev/md/dsk` directory for block devices and the `/dev/md/rdsk` directory for raw devices. Instead of specifying the full volume name, such as `/dev/md/dsk/volume-name`, you can often use an abbreviated volume name, such as `d1`, with any `meta*` command. You can generally rename a volume, as long as the volume is not currently being used and the new name is not being used by another volume. For more information, see [“Exchanging Volume Names” on page 221](#).

Originally, volume names had to begin with the letter “d” followed by a number (for example, `d0`). This format is still acceptable. The following are examples of volume names that use the “d\*” naming construct:

<code>/dev/md/dsk/d0</code>	Block volume <code>d0</code>
<code>/dev/md/dsk/d1</code>	Block volume <code>d1</code>
<code>/dev/md/rdsk/d126</code>	Raw volume <code>d126</code>
<code>/dev/md/rdsk/d127</code>	Raw volume <code>d127</code>

Beginning with the Solaris Express 4/06 release, Solaris Volume Manager has been enhanced to include the use of descriptive names for naming volumes and hot spare pools. A *descriptive name* for a volume is a name that can be composed of a combination of the following:

- Alphanumeric characters
- “-” (a dash)
- “\_” (an underscore)
- “.” (a period)

Descriptive names must begin with a letter. The words “all” and “none” are reserved and cannot be used as names for volumes or hot spare pools. You also cannot use only a “.” (period) or “..” (two periods) as the entire name. Finally, you cannot create a descriptive name that looks like a physical disk name, such as `c0t0d0s0`. As noted previously, you can also continue to use the “d\*” naming convention. The following are examples of descriptive volume names:

`account_stripe_1`



```
mirror.3
d100
d-100
```

When descriptive names are used in disk sets, each descriptive name must be unique within that disk set. Hot spare pools and volumes within the same disk set cannot have the same name. However, you can reuse names within different disk sets. For example, if you have two disk sets, one disk set called `admins` and one disk set called `managers`, you can create a volume named `employee_files` in each disk set.

The functionality of the Solaris Volume Manager commands that are used to administer volumes with descriptive names remains unchanged. You can substitute a descriptive name in any `meta*` command where you previously used the “`d*`” format. For example, to create a single-stripe volume of one slice with the name `employee_files`, you would type the following command at the command line:

```
# metainit employee_files 1 1 c0t1d0s4
```

If you create volumes and hot spare pools using descriptive names and then later determine that you need to use Solaris Volume Manager under previous releases of the Solaris OS, you must remove the components that are defined with descriptive names. To determine if the Solaris Volume Manager configuration on your system contains descriptive names, you can use the `-D` option of the `metastat` command. The `metastat -D` command lists volumes and hot spare pools that were created using descriptive names. These components must be removed from the Solaris Volume Manager configuration before the remaining configuration can be used with a release prior to the Solaris Express 4/06 release. If these components are not removed, the Solaris Volume Manager in these prior Solaris releases does not start. For more information about the `-D` option, see the `metastat(1M)` man page. For information about removing components from a configuration, see [“Removing RAID-1 Volumes \(Unmirroring\)” on page 138](#) and [“Removing a RAID-0 Volume” on page 90](#).

## Volume Name Guidelines

The use of a standard for your volume names can simplify administration and enable you at a glance to identify the volume type. Here are a few suggestions:

- Use ranges for each type of volume. For example, assign numbers 0–20 for RAID-1 volumes, 21–40 for RAID-0 volumes, and so on.
- Use a naming relationship for mirrors. For example, name mirrors with a number that ends in zero (0), and submirrors that end in one (1), two (2), and so on. For example, you might name mirrors as follows: mirror `d10`, submirrors `d11` and `d12`; mirror `d20`, submirrors `d21`, `d22`, `d23`, and `d24`. In an example using descriptive names, you could use a naming relationship such as `employee_mirror1` for a mirror with `employee_sub1` and `employee_sub2` comprising the submirrors.
- Use a naming method that maps the slice number and disk number to volume numbers.

## State Database and State Database Replicas

The *state database* is a database that stores information about the state of your Solaris Volume Manager configuration. The state database records and tracks changes made to your configuration. Solaris Volume Manager automatically updates the state database when a configuration or state change occurs. Creating a new volume is an example of a configuration change. A submirror failure is an example of a state change.

The state database is actually a collection of multiple, replicated database copies. Each copy, referred to as a *state database replica*, ensures that the data in the database is always valid. Multiple copies of the state database protect against data loss from single points-of-failure. The state database tracks the location and status of all known state database replicas.

Solaris Volume Manager cannot operate until you have created the state database and its state database replicas. A Solaris Volume Manager configuration must have an operating state database.

When you set up your configuration, you can locate the state database replicas on either of the following:

- On dedicated slices
- On slices that will later become part of volumes

Solaris Volume Manager recognizes when a slice contains a state database replica, and automatically skips over the replica if the slice is used in a volume. The part of a slice reserved for the state database replica should not be used for any other purpose.

You can keep more than one copy of a state database on one slice. However, you might make the system more vulnerable to a single point-of-failure by doing so.

The Solaris operating system continues to function correctly if all state database replicas are deleted. However, the system loses all Solaris Volume Manager configuration data if a reboot occurs with no existing state database replicas on disk.

## Hot Spare Pools

A *hot spare pool* is a collection of slices (*hot spares*) reserved by Solaris Volume Manager to be automatically substituted for failed components. These hot spares can be used in either a submirror or RAID-5 volume. Hot spares provide increased data availability for RAID-1 and RAID-5 volumes. You can create a hot spare pool with either the Enhanced Storage tool within the Solaris Management Console or the command-line interface.

When component errors occur, Solaris Volume Manager checks for the first available hot spare whose size is equal to or greater than the size of the failed component. If found, Solaris Volume Manager automatically replaces the component and resynchronizes the data. If a slice of adequate size is not found in the list of hot spares, the submirror or RAID-5 volume is considered to have failed. For more information, see [Chapter 16](#).

## Disk Sets

A disk set is a set of physical storage volumes that contain logical volumes and hot spares. Volumes and hot spare pools must be built on drives from within that disk set. Once you have created a volume within the disk set, you can use the volume just as you would a physical slice.

A disk set provides data availability in a clustered environment. If one host fails, another host can take over the failed host's disk set. (This type of configuration is known as a *failover configuration*.) Additionally, disk sets can be used to help manage the Solaris Volume Manager namespace, and to provide ready access to network-attached storage devices.

For more information, see [Chapter 18](#).

# Solaris Volume Manager Configuration Guidelines

A poorly designed Solaris Volume Manager configuration can degrade performance. This section offers tips for achieving good performance from Solaris Volume Manager. For information on storage configuration performance guidelines, see “[General Performance Guidelines](#)” on page 30.

## General Guidelines

- **Disk and controllers** – Place drives in a volume on separate drive paths, or for SCSI drives, separate host adapters. An I/O load distributed over several controllers improves volume performance and availability.
- **System files** – Never edit or remove the `/etc/lvm/mddb.cf` or `/etc/lvm/md.cf` files. Make sure these files are backed up regularly.
- **Volume Integrity** – If a slice is defined as a volume, do not use the underlying slice for any other purpose, including using the slice as a dump device.
- **Information about disks and partitions** – Keep a copy of output from the `prtvtoc` and `metastat -p` commands in case you need to reformat a bad disk or recreate your Solaris Volume Manager configuration.

## File System Guidelines

Do not mount file systems on a volume's underlying slice. If a slice is used for a volume of any kind, you must not mount that slice as a file system. If possible, unmount any physical device that you intend to use as a volume before you activate the volume.

## Overview of Creating Solaris Volume Manager Components

When you create a Solaris Volume Manager component, you assign physical slices to a logical Solaris Volume Manager name, such as `d0`. The Solaris Volume Manager components that you can create include the following:

- State database replicas
- Volumes (RAID-0 (stripes, concatenations), RAID-1 (mirrors), RAID-5, )
- Hot spare pools
- Disk sets

---

**Note** – For suggestions on how to name volumes, see [“Volume Names” on page 40](#).

---

## Prerequisites for Creating Solaris Volume Manager Components

The prerequisites for creating Solaris Volume Manager components are as follows:

- Create initial state database replicas. If you have not done so, see [“Creating State Database Replicas” on page 68](#).
- Identify slices that are available for use by Solaris Volume Manager. If necessary, use the `format` command, the `fmt hard` command, or the Solaris Management Console to repartition existing disks.
- Make sure you have root privilege.
- Have a current backup of all data.
- If you are using the GUI, start the Solaris Management Console and navigate to the Solaris Volume Manager feature. For information, see [“How to Access the Solaris Volume Manager Graphical User Interface \(GUI\)” on page 36](#).

## Overview of Multi-Terabyte Support in Solaris Volume Manager

Starting with the Solaris 9 4/03 release, Solaris Volume Manager supports storage devices and logical volumes greater than 1 terabyte (Tbyte) on systems running a 64-bit kernel.

---

**Note** – Use `isainfo -v` to determine if your system is running a 64-bit kernel. If the string “64-bit” appears, you are running a 64-bit kernel.

---

Solaris Volume Manager allows you to do the following:

- Create, modify, and delete logical volumes built on or from logical storage units (LUNs) greater than 1 Tbyte in size.
- Create, modify, and delete logical volumes that exceed 1 Tbyte in size.

Support for large volumes is automatic. If a device greater than 1 Tbyte is created, Solaris Volume Manager configures it appropriately and without user intervention.

## Large Volume Support Limitations

Solaris Volume Manager only supports large volumes (greater than 1 Tbyte) on the Solaris 9 4/03 or later release when running a 64-bit kernel. Running a system with large volumes under 32-bit kernel on previous Solaris 9 releases will affect Solaris Volume Manager functionality. Specifically, note the following:

- If a system with large volumes is rebooted under a 32-bit Solaris 9 4/03 or later kernel, the large volumes will be visible through `metastat` output, but they cannot be accessed, modified or deleted. In addition, new large volumes cannot be created. Any volumes or file systems on a large volume will also be unavailable.
- If a system with large volumes is rebooted under a Solaris release prior to Solaris 9 4/03, Solaris Volume Manager will not start. All large volumes must be removed before Solaris Volume Manager will run under another version of the Solaris platform.



---

**Caution** – Do not create large volumes if you expect to run the Solaris software with a 32-bit kernel or if you expect to use a version of the Solaris OS prior to the Solaris 9 4/03 release.

---

## Using Large Volumes

All Solaris Volume Manager commands work with large volumes. No syntax differences or special tasks are required to take advantage of large volume support. Thus, system administrators who are familiar with Solaris Volume Manager can immediately work with Solaris Volume Manager large volumes.

---

**Tip** – If you create large volumes, then later determine that you need to use Solaris Volume Manager under previous releases of Solaris or that you need to run under the 32-bit Solaris 9 4/03 or later kernel, you will need to remove the large volumes. Use the `metaclear` command under the 64-bit kernel to remove the large volumes from your Solaris Volume Manager configuration before rebooting under previous Solaris release or under a 32-bit kernel.

---

## Upgrading to Solaris Volume Manager

Solaris Volume Manager fully supports seamless upgrade from Solstice DiskSuite versions 4.1, 4.2, and 4.2.1. Make sure that all volumes are in Okay state (not “Needs Maintenance” or “Last Erred”) and that no hot spares are in use. You do not need to do anything else special to Solaris Volume Manager for the upgrade to work—it is not necessary to change the configuration or break down the root mirror. When you upgrade your system, the Solstice DiskSuite configuration will be brought forward and will be accessible after upgrade through Solaris Volume Manager tools.

The Solaris 10 OS introduced the Service Management Facility (SMF), which provides an infrastructure that augments the traditional UNIX start-up scripts, `init` run levels, and configuration files. When upgrading from a previous version of the Solaris OS, verify that the SMF services associated with Solaris Volume Manager are online. If the SMF services are not online, you might encounter problems when administering Solaris Volume Manager.

To check the SMF services associated with Solaris Volume Manager, use the following form of the `svcs` command:

```
# svcs -a |egrep "md|meta"
disabled      12:05:45  svc:/network/rpc/mdcomm:default
disabled      12:05:45  svc:/network/rpc/metamed:default
disabled      12:05:45  svc:/network/rpc/metamh:default
online        12:05:39  svc:/system/metainit:default
online        12:05:46  svc:/network/rpc/meta:default
online        12:05:48  svc:/system/fmd:default
online        12:05:51  svc:/system/mdmonitor:default
```

If the Solaris Volume Manager configuration consists of a local set only, then these services should be online:

```
svc:/system/metainit
svc:/network/rpc/meta
svc:/system/mdmonitor
```

If the Solaris Volume Manager configuration includes disk sets, then these additional services should be online:

```
svc:/network/rpc/metamed
svc:/network/rpc/metamh
```

If the Solaris Volume Manager includes multi-node disk sets, then this service should be online in addition to the other services already mentioned:

```
svc:/network/rpc/mdcomm
```

For more information on SMF, see Chapter 14, “Managing Services (Overview),” in *System Administration Guide: Basic Administration*.





# Solaris Volume Manager for Sun Cluster (Overview)

---

This chapter provides an overview of Solaris Volume Manager for Sun Cluster.

This chapter includes the following information:

- “Introduction to Solaris Volume Manager for Sun Cluster” on page 49
- “Multi-Owner Disk Set Concepts” on page 51
- “Solaris Volume Manager for Sun Cluster Configuration” on page 53
- “RAID-1 (Mirror) Volumes in Multi-Owner Disk Sets” on page 54

## Introduction to Solaris Volume Manager for Sun Cluster

Starting with the Solaris 9 9/04 release, Solaris Volume Manager can manage storage in a Sun Cluster environment using multi-owner disk sets. *Multi-owner disk sets* allow multiple nodes to share ownership of a disk set and to simultaneously write to the shared disks. Previously, shared disk sets were visible from all participating hosts in the disk set, but only one host could access it at a time. Multi-owner disk sets work with Sun Cluster and with applications such as Oracle Real Application Clusters.

Multi-owner disk sets and Solaris Volume Manager shared disk sets can coexist on the same node. However, moving disk sets between the two configurations is not supported.

---

**Note** – Solaris Volume Manager for Sun Cluster device id support for multi-owner disk sets is not available. Therefore, importing multi-owner disk sets from one system to another is not supported at this time.

---

Solaris Volume Manager for Sun Cluster creates the same components that you can create with Solaris Volume Manager, including stripes, concatenations, mirrors, soft partitions, and hot spares. Solaris Volume Manager for Sun Cluster does not support RAID-5 volumes and transactional volumes.

The following figure shows the association between the software and the shared storage in a typical cluster configuration.

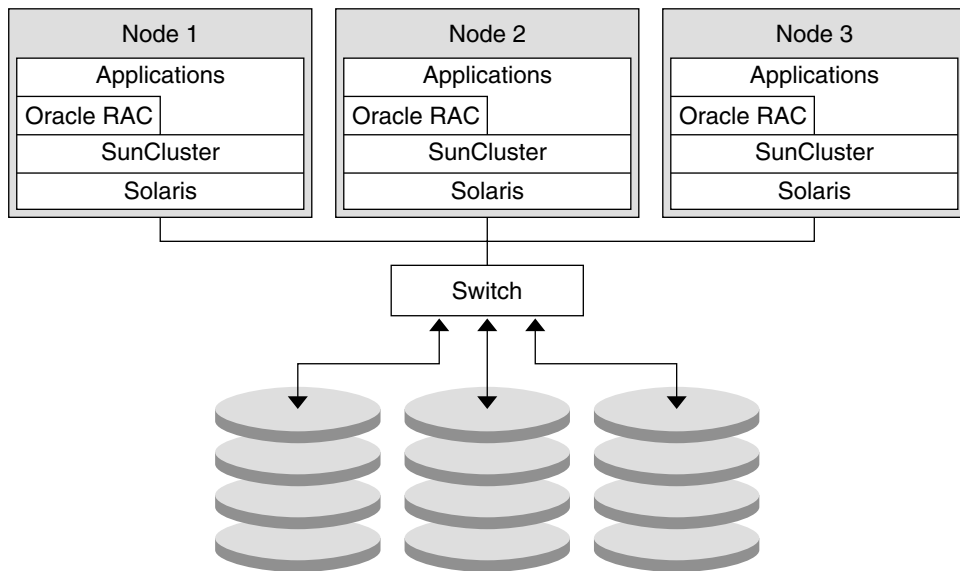

FIGURE 4-1 Sample Cluster Configuration

Each node has local storage as well as at least one path to shared storage. The multi-owner disk sets in the cluster are managed by Solaris Volume Manager for Sun Cluster, which is part of the Solaris Operating System (Solaris OS).

## Prerequisite: Required Software Components for Multi-Owner Disk Set Functionality

To use Solaris Volume Manager for Sun Cluster, the following software must be installed in addition to the Solaris OS:

- Sun Cluster initial cluster framework
- Sun Cluster Support for Oracle Real Application Clusters software
- Oracle Real Application Clusters software

---

**Note** – For information on setting up Sun Cluster and Oracle Real Application Clusters software, see *Sun Cluster Software Installation Guide for Solaris OS* and *Sun Cluster Data Service for Oracle RAC Guide for Solaris OS*.

---

## Multi-Owner Disk Set Concepts

The storage managed by Solaris Volume Manager for Sun Cluster is grouped into multi-owner disk sets. Multi-owner disk sets allow multiple nodes to share ownership of a disk set and to simultaneously write to the shared disks. An instance of an application such as Oracle Real Application Clusters runs on each node in the cluster, so multi-owner disk sets provide scalability. Since each instance of the application directly accesses the shared storage, multi-owner disk sets also enhance the performance of the application.

---

**Note** – Multi-owner disk set functionality is enabled only in a Sun Cluster environment. *Nodes* are the physical machines that are part of a Sun Cluster system.

---

Each multi-owner disk set is associated with a list of nodes. These nodes share ownership of the disk set. The following `metaset -s disk-set` command shows the output for a multi-owner disk set.

```
# metaset -s blue
```

```
Multi-owner Set name = blue, Set number = 1, Master = nodeone
```

Host	Owner	Member
nodeone	multi-owner	Yes
nodetwo	multi-owner	Yes

```
Drive   Dbase
```

```
d9      Yes
```

```
d13     Yes
```

This output shows `nodeone` and `nodetwo` in the list of nodes that share ownership of the disk set. Additionally, `nodeone` is designated as the *master node*.

Each multi-owner disk set has a master node. After a disk set is created, the node that adds the first disk to the disk set becomes the master node of the disk set. The master node creates, deletes, and updates the state database replicas in the disk set.

---

**Note** – For more information on state database replicas, see [Chapter 6](#).

---

Solaris Volume Manager for Sun Cluster can support disk sets with different, yet overlapping, node lists. Because each disk set has a master node, multiple masters can exist simultaneously on the same cluster.

The following output from the `metaset` command shows that `nodeone` becomes the master node when the first disk is added to the disk set.

```

nodeone# metaset -s red
Multi-owner Set name = red, Set number = 1, Master =

Host          Owner          Member
nodeone              Yes
nodetwo           Yes
nodeone# metaset -s red -a /dev/did/dsk/d9
nodeone# metaset -s red

Multi-owner Set name = red, Set number = 1, Master = nodeone

Host          Owner          Member
nodeone      multi-owner    Yes
nodetwo      multi-owner    Yes

Drive   Dbase
d9      Yes

```

Solaris Volume Manager for Sun Cluster can support disk sets with different, yet overlapping, node lists. Because each disk set has a master node, multiple masters can exist simultaneously on the same cluster.

## Tasks Associated With Multi-Owner Disk Sets



**Caution** – Before configuring multi-owner disk sets, you must have the following software installed, in addition to the Solaris OS:

- Sun Cluster initial cluster framework
- Sun Cluster Support for Oracle Real Application Clusters software
- Oracle Real Application Clusters software

For information on setting up Sun Cluster and Oracle Real Application Clusters software, see *Sun Cluster Software Installation Guide for Solaris OS* and *Sun Cluster Data Service for Oracle RAC Guide for Solaris OS*.

Solaris Volume Manager for Sun Cluster generally uses the same set of Solaris Volume Manager commands to perform tasks associated with disk sets. Some command options unique to multi-owner disk sets have been added to the `metaset` command. For example, the task to create a multi-owner disk set requires the `-M` to the `metaset` command. The following output shows you how to create a multi-owner disk set using the `metaset -s diskset-name -a -M -h hostname` command.

```

# metaset -s red -a -M -h nodeone
# metaset
Multi-owner Set name = red, Set number = 1, Master =

```

Host	Owner	Member
nodeone		Yes

In addition, some of the `metaset` command options, such as the commands to take and release disk sets, are not used with multi-owner disk sets. For more information, see the `metaset(1M)` man page.

Another example of how tasks differ in a Sun Cluster environment occurs when working with disks. Sun Cluster assigns each disk a unique device ID (DID) number. Rather than using the `cntrdn` format to identify a disk, use the Sun Cluster DID path name, `/dev/did/dsk/dN`. The variable `N` is the device number assigned by Sun Cluster.

The following output shows you how to add a disk to a multi-owner disk set using the `metaset -s diskset-name -a disk-name` command and the Sun Cluster DID path name to identify the disk.

```
nodeone# metaset -s red
Multi-owner Set name = red
Multi-owner Set name = red, Set number = 1, Master =

Host          Owner          Member
nodeone              Yes
nodetwo              Yes
nodeone# metaset -s red -a /dev/did/dsk/d13
nodeone# metaset -s red
Multi-owner Set name = red, Set number = 1, Master = nodeone

Host          Owner          Member
nodeone      multi-owner  Yes
```

Drive Dbase

d13 Yes

For information on creating multi-owner disk sets for the Oracle Real Application Clusters, see “Creating a Multi-Owner Disk Set in Solaris Volume Manager for Sun Cluster for the Oracle RAC Database” in *Sun Cluster Data Service for Oracle RAC Guide for Solaris OS*.

For tasks that are associated with disk sets, see [Chapter 19](#).

## Solaris Volume Manager for Sun Cluster Configuration

Solaris Volume Manager for Sun Cluster supports the following configuration:

- Solaris Volume Manager for Sun Cluster supports up to 32 disk sets. These disk sets can include any combination of multi-owner disk sets, shared disk sets, and the local disk set.

---

**Note** – For more information on different types of disk sets, see “Types of Disk Sets” on page 186.

---

- Each multi-owner disk set supports a maximum of 8192 volumes per disk set.
- The default size for a state database replica is 16 Mbytes. The minimum size is 16 Mbytes. The maximum size is 256 Mbytes.

Many of the extension properties for Sun Cluster Support for Oracle Real Application Clusters specify timeouts for steps in reconfiguration processes. For further information about setting timeouts, refer to “Tuning Sun Cluster Support for Oracle RAC” in *Sun Cluster Data Service for Oracle RAC Guide for Solaris OS*.

## RAID-1 (Mirror) Volumes in Multi-Owner Disk Sets

A RAID-1 volume, or mirror, created in a multi-owner disk set functions identically to a RAID-1 volume in a Solaris Volume Manager shared disk set. However, RAID-1 volumes in multi-owner disk sets have some additional features.

### Mirror Ownership With Multi-Owner Disk Sets

The concept of mirror ownership is unique to multi-owner disk sets. Unlike a RAID-1 volume in a Solaris Volume Manager shared disk set, a RAID-1 volume in a multi-owner disk set usually has an owner associated with it. The ownership of the mirror volume is chosen by the volume manager. The owner of the volume is one of the nodes designated in the node list for the disk set. Only the owner of the RAID-1 volume can write to the volume. If a non-owner node wants to write to the volume, the ownership switches to the node doing the write operation. The following output from the `metastat -s diskset-name` command shows `nodeone` as the owner of the RAID-1 volume, `d24`.

```
# metastat -s red
red/d24: Mirror
  Submirror 0: red/d20
    State: Okay
  Submirror 1: red/d21
    State: Okay
  Pass: 1
  Read option: roundrobin (default)
  Write option: parallel (default)
  Resync option: optimizedresync
  Owner: nodeone
  Size: 825930 blocks (403 MB)
```

## Data Management and Recovery Processes

As with RAID-1 volumes in Solaris Volume Manager, RAID-1 volumes in Solaris Volume Manager for Sun Cluster perform operations to ensure consistent data. Solaris Volume Manager for Sun Cluster provides RAID-1 volumes with two options for data management and recovery.

### Optimized Resynchronization for Solaris Volume Manager for Sun Cluster

Optimized resynchronization in Solaris Volume Manager for Sun Cluster functions identically to optimized resynchronization in Solaris Volume Manager. However, in a multi-owner disk set, a RAID-1 volume with the resynchronization option set to optimized resynchronization always has a mirror owner. The following output from the `metastat -s diskset-name` command shows the resynchronization option set to `optimizedresync` (for optimized resynchronization).

```
# metastat -s red
red/d24: Mirror
  Submirror 0: red/d20
    State: Okay
  Submirror 1: red/d21
    State: Okay
  Pass: 1
  Read option: roundrobin (default)
  Write option: parallel (default)
  Resync option: optimizedresync
  Owner: nodeone
  Size: 825930 blocks (403 MB)
```

For more information on optimized resynchronization, see [“Optimized Resynchronization”](#) on page 96.

### Application-Based Recovery and Directed Mirror Reads

To optimize data recovery in Solaris Volume Manager for Sun Cluster, applications such as Oracle Real Application Clusters require the ability to manage and control the recovery of data. Enabling an application to control the recovery improves the performance of the recovery. The `ioctl`s `DKIOGETVOLCAP`, `DKIOSETVOLCAP`, and `DKIODMR` provide support for an application’s data management recovery in a cluster environment. These `ioctl`s provide an application with the following capabilities:

- Application Based Recovery (ABR)—Allows the application to control the recovery of data on mirrored volumes
- Directed Mirror Reads—Allows the application to direct reads to specific submirrors and to determine the state of the data

For more information on the `ioctl`s used with application-based data management recovery, see the `dkio(7I)` man page.

A RAID-1 volume with the resynchronization option set to application-based recovery only has a mirror owner during the application-based recovery process. The following output from the `metastat -s diskset-name` command shows a RAID-1 volume in a normal state. The resynchronization option is set to application-based recovery. There is no mirror owner.

```
# metastat -s red
red/d24: Mirror
  Submirror 0: red/d20
    State: Okay
  Submirror 1: red/d21
    State: Okay
  Pass: 1
  Read option: roundrobin (default)
  Write option: parallel (default)
  Resync option: application based
  Owner: None
  Size: 825930 blocks (403 MB)
```



# Configuring and Using Solaris Volume Manager (Scenario)

---

Throughout the *Solaris Volume Manager Administration Guide*, the examples generally relate to a single storage configuration, whenever that is possible. This chapter describes the scenario used in the examples. The chapter provides details about the initial storage configuration that is used in subsequent chapters.

This chapter contains the following information:

- “Scenario Background Information” on page 57
- “Final Solaris Volume Manager Configuration” on page 58

## Scenario Background Information

Throughout this book, the scenarios and many of the examples relate to a single configuration. Although this configuration is small (to simplify the documentation), the concepts scale to much larger storage environments.

## Hardware Configuration

The hardware system is configured as follows:

- There are three physically separate controllers (c0 – IDE, c1 – SCSI, and c2 – SCSI).
- Each SCSI controller connects to a MultiPack that contains six internal 9-Gbyte disks (c1t1 through c1t6 and c2t1 through c2t6). This creates a mirror configuration.
- Each controller/terminator pair (cntn) has 8.49 Gbytes of usable storage space.
- Storage space on the root (/) drive c0t0d0 is split into six partitions.

An alternative way to understand this configuration is shown in the following diagram.

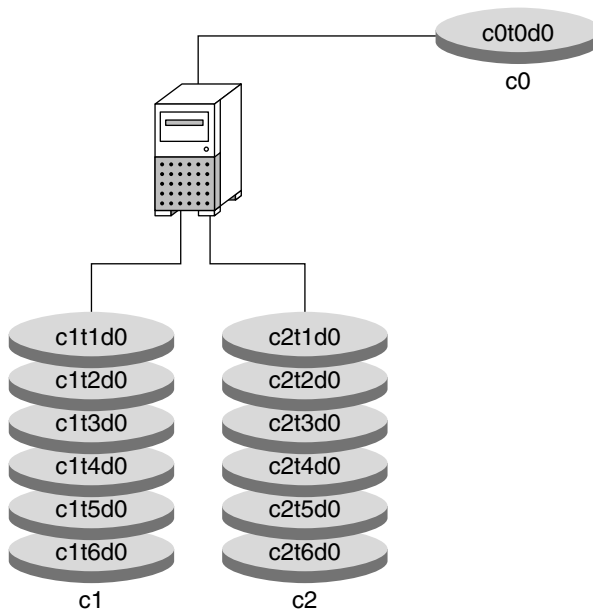

FIGURE 5-1 Basic Hardware Diagram Storage Scenario

## Initial Physical Storage Configuration

Here is the storage configuration before Solaris Volume Manager is configured:

- The SCSI controller/terminator pairs (`cntn`) have approximately 20 Gbytes of storage space.
- Storage space on each disk (for example, `c1t1d0`) is split into seven partitions (`cntnd0s0` through `cntnd0s6`).

To partition a disk, follow the procedures explained in “Formatting a Disk” in *System Administration Guide: Devices and File Systems*.

## Final Solaris Volume Manager Configuration

Throughout this book, specific scenarios are provided with specific tasks. However, so that you can better understand the examples throughout the book, the final configuration is approximately as follows, as displayed by the `metastat -p` command:

```
[root@lexicon:~]$ metastat -p
d50 -r c1t4d0s5 c1t5d0s5 c2t4d0s5 c2t5d0s5 c1t1d0s5 c2t1d0s5 -k -i 32b
d1 1 1 c1t2d0s3
d2 1 1 c2t2d0s3
```

```

d12 1 1 c1t1d0s0
d13 1 1 c2t1d0s0
d16 1 1 c1t1d0s1
d17 1 1 c2t1d0s1
d25 2 2 c1t1d0s3 c2t1d0s3 -i 32b \
      1 c0t0d0s3
d31 1 2 c1t4d0s4 c2t4d0s4 -i 8192b
d80 -p d70 -o 1 -b 2097152
d81 -p d70 -o 2097154 -b 2097152
d82 -p d70 -o 4194307 -b 2097152
d83 -p d70 -o 6291460 -b 2097152
d84 -p d70 -o 8388613 -b 2097152
d85 -p d70 -o 10485766 -b 2097152
d70 -m d71 d72 1
d71 3 1 c1t3d0s3 \
      1 c1t3d0s4 \
      1 c1t3d0s5
d72 3 1 c2t3d0s3 \
      1 c2t3d0s4 \
      1 c2t3d0s5
d123 -p c1t3d0s6 -o 1 -b 204800
d124 -p c1t3d0s6 -o 204802 -b 204800
d125 -p c1t3d0s6 -o 409603 -b 204800
d126 -p c1t3d0s7 -o 3592 -b 20480
d127 -p c2t3d0s7 -o 3592 -b 1433600
hsp010
hsp014 c1t2d0s1 c2t2d0s1
hsp050 c1t2d0s5 c2t2d0s5
hsp070 c1t2d0s4 c2t2d0s4

```

See the `metastat(1M)` command for more information on the `-p` option.



## State Database (Overview)

---

This chapter provides conceptual information about state database replicas. For information about performing related tasks, see [Chapter 7](#).

This chapter contains the following information:

- “About the Solaris Volume Manager State Database and Replicas” on page 61
- “Understanding the Majority Consensus Algorithm” on page 62
- “Handling State Database Replica Errors” on page 64
- “Scenario—State Database Replicas” on page 65

### About the Solaris Volume Manager State Database and Replicas

The Solaris Volume Manager state database contains configuration and status information for all volumes, hot spares, and disk sets. Solaris Volume Manager maintains multiple copies (replicas) of the state database to provide redundancy and to prevent the database from being corrupted during a system crash (at most, only one database copy will be corrupted).

The state database replicas ensure that the data in the state database is always valid. When the state database is updated, each state database replica is also updated. The updates occur one at a time (to protect against corrupting all updates if the system crashes).

If your system loses a state database replica, Solaris Volume Manager must figure out which state database replicas still contain valid data. Solaris Volume Manager determines this information by using a *majority consensus algorithm*. This algorithm requires that a majority (half + 1) of the state database replicas be available and in agreement before any of them are considered valid. Because of the requirements of the majority consensus algorithm, you must create at least three state database replicas when you set up your disk configuration. A consensus can be reached as long as at least two of the three state database replicas are available.

During booting, Solaris Volume Manager ignores corrupted state database replicas. In some cases, Solaris Volume Manager tries to rewrite state database replicas that are corrupted. Otherwise, they

are ignored until you repair them. If a state database replica becomes corrupted because its underlying slice encountered an error, you need to repair or replace the slice and then enable the replica.



---

**Caution** – Do not place state database replicas on fabric-attached storage, SANs, or other storage that is not directly attached to the system. You might not be able to boot Solaris Volume Manager. Replicas must be on storage devices that are available at the same point in the boot process as traditional SCSI or IDE drives.

---

If all state database replicas are lost, you could, in theory, lose all data that is stored on your Solaris Volume Manager volumes. For this reason, it is good practice to create enough state database replicas on separate drives and across controllers to prevent catastrophic failure. It is also wise to save your initial Solaris Volume Manager configuration information, as well as your disk partition information.

See [Chapter 7](#) for information on adding additional state database replicas to the system. See [“Recovering From State Database Replica Failures” on page 288](#) for information on recovering when state database replicas are lost.

State database replicas are also used for RAID-1 volume resynchronization regions. Too few state database replicas relative to the number of mirrors might cause replica I/O to impact RAID-1 volume performance. That is, if you have a large number of mirrors, make sure that you have at least two state database replicas per RAID-1 volume, up to the maximum of 50 replicas per disk set.

By default each state database replica for volumes, the local set and for disk sets occupies 4 Mbytes (8192 disk sectors) of disk storage. The default size of a state database replica for a multi-owner disk set is 16 Mbytes.

Replicas can be stored on the following devices:

- A dedicated local disk partition
- A local partition that will be part of a volume
- A local partition that will be part of a UFS logging device

Replicas cannot be stored on the root (`/`), `swap`, or `/usr` slices. Nor can replicas be stored on slices that contain existing file systems or data. After the replicas have been stored, volumes or file systems can be placed on the same slice.

## Understanding the Majority Consensus Algorithm

An inherent problem with replicated databases is that it can be difficult to determine which database has valid and correct data. To solve this problem, Solaris Volume Manager uses a majority consensus algorithm. This algorithm requires that a majority of the database replicas agree with each other before any of them are declared valid. This algorithm requires the presence of at least three initial replicas, which you create. A consensus can then be reached as long as at least two of the three replicas are available. If only one replica exists and the system crashes, it is possible that all volume configuration data will be lost.

To protect data, Solaris Volume Manager does not function unless half of all state database replicas are available. The algorithm, therefore, ensures against corrupt data.

The majority consensus algorithm provides the following:

- The system continues to run if at least half of the state database replicas are available.
- The system panics if fewer than half of the state database replicas are available.
- The system cannot reboot into multiuser mode unless a majority ( $\text{half} + 1$ ) of the total number of state database replicas is available.

If insufficient state database replicas are available, you must boot into single-user mode and delete enough of the corrupted or missing replicas to achieve a quorum. See [“How to Recover From Insufficient State Database Replicas”](#) on page 288.

---

**Note** – When the total number of state database replicas is an odd number, Solaris Volume Manager computes the majority by dividing the number in half, rounding down to the nearest integer, then adding 1 (one). For example, on a system with seven replicas, the majority would be four (seven divided by two is three and one-half, rounded down is three, plus one is four).

---

## Administering State Database Replicas

- By default, the size of a state database replica is 4 Mbytes or 8192 blocks. You should create state database replicas on a dedicated slice with at least 4 Mbytes per replica. Because your disk slices might not be that small, you might want to resize a slice to hold the state database replica. For information about resizing a slice, see Chapter 12, “Administering Disks (Tasks),” in *System Administration Guide: Devices and File Systems*.
- To avoid single points-of-failure, distribute state database replicas across slices, drives, and controllers. You want a majority of replicas to survive a single component failure. If you lose a replica (for example, due to a device failure), problems might occur with running Solaris Volume Manager or when rebooting the system. Solaris Volume Manager requires at least half of the replicas to be available to run, but a majority ( $\text{half} + 1$ ) to reboot into multiuser mode.  
A minimum of 3 state database replicas are recommended, up to a maximum of 50 replicas per Solaris Volume Manager disk set. The following guidelines are recommended:
  - For a system with only a single drive: put all three replicas on one slice.
  - For a system with two to four drives: put two replicas on each drive.
  - For a system with five or more drives: put one replica on each drive.
- If multiple controllers exist, replicas should be distributed as evenly as possible across all controllers. This strategy provides redundancy in case a controller fails and also helps balance the load. If multiple disks exist on a controller, at least two of the disks on each controller should store a replica.

- If necessary, you could create state database replicas on a slice that will be used as part of a RAID-0, RAID-1, or RAID-5 volume. You must create the replicas before you add the slice to the volume. Solaris Volume Manager reserves the beginning of the slice for the state database replica.

When a state database replica is placed on a slice that becomes part of a volume, the capacity of the volume is reduced by the space that is occupied by the replica. The space used by a replica is rounded up to the next cylinder boundary. This space is skipped by the volume.

- RAID-1 volumes are used for small-sized random I/O (as in for a database). For best performance, have at least two extra replicas per RAID-1 volume on slices (and preferably on separate disks and controllers) that are unconnected to the RAID-1 volume.
- You cannot create state database replicas on existing file systems, or the root (/), /usr, and swap file systems. If necessary, you can create a new slice (provided a slice name is available) by allocating space from swap. Then, put the state database replicas on that new slice.
- You can create state database replicas on slices that are not in use.
- You can add additional state database replicas to the system at any time. The additional state database replicas help ensure Solaris Volume Manager availability.



---

**Caution** – If you upgraded from the Solstice DiskSuite product to Solaris Volume Manager and you have state database replicas sharing slices with file systems or logical volumes (as opposed to on separate slices), do not delete the existing replicas and replace them with new replicas in the same location.

The default state database replica size in Solaris Volume Manager is 8192 blocks, while the default size in the Solstice DiskSuite product is 1034 blocks. Use caution if you delete a default-sized state database replica created in the Solstice DiskSuite product, and then add a new default-sized replica with Solaris Volume Manager. You will overwrite the first 7158 blocks of any file system that occupies the rest of the shared slice, thus destroying the data.

---

## Handling State Database Replica Errors

If a state database replica fails, the system continues to run if at least half of the remaining replicas are available. The system panics when fewer than half of the replicas are available.

The system can enter reboot multiuser mode when at least one more than half of the replicas are available. If fewer than a majority of replicas are available, you must reboot into single-user mode and delete the unavailable replicas (by using the `metadb` command).

For example, assume you have four replicas. The system continues to run as long as two replicas (half the total number) are available. However, to reboot the system, three replicas (half the total + 1) must be available.

In a two-disk configuration, you should always create at least two replicas on each disk. For example, assume you have a configuration with two disks, and you only create three replicas (two replicas on



---

the first disk and one replica on the second disk). If the disk with two replicas fails, the system panics because the remaining disk only has one replica. This is less than half the total number of replicas.

---

**Note** – If you create two replicas on each disk in a two-disk configuration, Solaris Volume Manager still functions if one disk fails. But because you must have one more than half of the total replicas available for the system to reboot, you cannot reboot.

---

If a slice that contains a state database replica fails, the rest of your configuration should remain in operation. Solaris Volume Manager finds a valid state database during boot (as long as at least half +1 valid state database replicas are available).

When you manually repair or enable state database replicas, Solaris Volume Manager updates them with valid data.

## Scenario—State Database Replicas

State database replicas provide redundant data about the overall Solaris Volume Manager configuration. The following example, is based on the sample system in the scenario provided in [Chapter 5](#). This example describes how state database replicas can be distributed to provide adequate redundancy.

The sample system has one internal IDE controller and drive, plus two SCSI controllers. Each SCSI controller has six disks attached. With three controllers, the system can be configured to avoid any single point-of-failure. Any system with only two controllers cannot avoid a single point-of-failure relative to Solaris Volume Manager. By distributing replicas evenly across all three controllers and across at least one disk on each controller (across two disks, if possible), the system can withstand any single hardware failure.

In a minimal configuration, you could put a single state database replica on slice 7 of the root disk, then an additional replica on slice 7 of one disk on each of the other two controllers. To help protect against the admittedly remote possibility of media failure, add another replica to the root disk and then two replicas on two different disks on each controller, for a total of six replicas, provides more than adequate security.

To provide even more security, add 12 additional replicas spread evenly across the 6 disks on each side of the two mirrors. This configuration results in a total of 18 replicas with 2 on the root disk and 8 on each of the SCSI controllers, distributed across the disks on each controller.



## State Database (Tasks)

---

This chapter provides information about performing tasks that are associated with Solaris Volume Manager’s state database replicas. For information about the concepts involved in these tasks, see [Chapter 6](#).

### State Database Replicas (Task Map)

The following task map identifies the procedures that are needed to manage Solaris Volume Manager state database replicas.

Task	Description	For Instructions
Create state database replicas	Use the Solaris Volume Manager GUI or the <code>metadb -a</code> command to create state database replicas.	<a href="#">“How to Create State Database Replicas” on page 68</a>
Check the status of state database replicas	Use the Solaris Volume Manager GUI or the <code>metadb</code> command to check the status of existing replicas.	<a href="#">“How to Check the Status of State Database Replicas” on page 70</a>
Delete state database replicas	Use the Solaris Volume Manager GUI or the <code>metadb -d</code> command to delete state database replicas.	<a href="#">“How to Delete State Database Replicas” on page 71</a>

# Creating State Database Replicas



**Caution** – If you upgraded from the Solstice DiskSuite product to Solaris Volume Manager and you have state database replicas sharing slices with file systems or logical volumes (as opposed to on separate slices), do not delete existing replicas and replace them with new default replicas in the same location.

The default state database replica size in Solaris Volume Manager is 8192 blocks, while the default size in the Solstice DiskSuite product is 1034 blocks. Use caution if you delete a default-sized state database replica created in the Solstice DiskSuite product, and then add a new default-sized replica with Solaris Volume Manager. You will overwrite the first 7158 blocks of any file system that occupies the rest of the shared slice, thus destroying the data.



**Caution** – Do not place state database replicas on fabric-attached storage, SANs, or other storage that is not directly attached to the system. You might not be able to boot Solaris Volume Manager. Replicas must be on storage devices that are available at the same point in the boot process as traditional SCSI or IDE drives.

## ▼ How to Create State Database Replicas

**Before You Begin** Check “Prerequisites for Creating Solaris Volume Manager Components” on page 44.

**1 Become superuser.**

**2 To create state database replicas, use one of the following methods:**

- From the Enhanced Storage tool within the Solaris Management Console, open the State Database Replicas node. Choose Action⇒Create Replicas and follow the onscreen instructions. For more information, see the online help.
- Use the following form of the `metadb` command. See the `metadb(1M)`.

```
# metadb -a -c number -l length-of-replica -f ctds-of-slice
```

-a Specifies to add or create a state database replica.

-f Specifies to force the operation, even if no replicas exist. Use the -f to force the creation of the initial replicas.

-c *number* Specifies the number of replicas to add to the specified slice.

-l *length-of-replica* Specifies the size of the new replicas, in blocks. The default size is 8192. This size should be appropriate for virtually all configurations, including those configurations with thousands of logical volumes.

*ctds-of-slice* Specifies the name of the component that will hold the replica.

---

**Note** – The `metadb` command entered on the command line without options reports the status of all state database replicas.

---

### Example 7-1 Creating the First State Database Replica

```
# metadb -a -f c0t0d0s7
# metadb
      flags          first blk    block count
...
  a      u           16             8192        /dev/dsk/c0t0d0s7
```

You must use the `-f` option along with the `-a` option to create the first state database replica. The `-a` option adds state database replicas to the system. The `-f` option forces the creation of the first replica (and may be omitted when you add supplemental replicas to the system).

### Example 7-2 Adding Two State Database Replicas to the Same Slice

```
# metadb -a -c 2 c1t3d0s1
# metadb
      flags          first blk    block count
...
  a      u           16             8192        /dev/dsk/c1t3d0s1
  a      u           8208            8192        /dev/dsk/c1t3d0s1
```

The `-a` option adds state database replicas to the system. The `-c 2` option places two replicas on the specified slice. The `metadb` command checks that the replicas are active, as indicated by the `a` flag in the `metadb` command output.

### Example 7-3 Adding State Database Replicas of a Specific Size

If you are replacing existing state database replicas, you might need to specify a replica size. Particularly if you have existing state database replicas (on a system upgraded from the Solstice DiskSuite product, perhaps) that share a slice with a file system, you must replace existing replicas with other replicas of the same size or add new replicas in a different location.

```
# metadb -a -c 3 -l 1034 c0t0d0s7
# metadb
      flags          first blk    block count
...
  a      u           16             1034        /dev/dsk/c0t0d0s7
  a      u          1050            1034        /dev/dsk/c0t0d0s7
  a      u          2084            1034        /dev/dsk/c0t0d0s7
```

The `-a` option adds state database replicas to the system. The `-l` option specifies the length in blocks of the replica to add.

## Maintaining State Database Replicas

### ▼ How to Check the Status of State Database Replicas

- 1 Become superuser.
- 2 To check the status of state database replicas, use one of the following methods:
  - From the Enhanced Storage tool within the Solaris Management Console, open the State Database Replicas node to view all existing state database replicas. For more information, see the online help.
  - Use the `metadb` command to view the status of state database replicas. Add the `-i` option to display an explanation of the status flags, as shown in the following example. See the `metadb(1M)`.

#### Example 7-4 Checking the Status of All State Database Replicas

```
# metadb -i
      flags          first blk      block count      /dev/dsk/c0t0d0s7
a m p luo          16             8192
a p luo            8208           8192
a p luo            16400          8192
a p luo            16             8192
W p l              16             8192
a p luo            16             8192
a p luo            8208           8192
a p luo            16400          8192
r - replica does not have device relocation information
o - replica active prior to last mddb configuration change
u - replica is up to date
l - locator for this replica was read successfully
c - replica's location was in /etc/lvm/mddb.cf
p - replica's location was patched in kernel
m - replica is master, this is replica selected as input
W - replica has device write errors
a - replica is active, commits are occurring to this replica
M - replica had problem with master blocks
D - replica had problem with data blocks
F - replica had format problems
```

S - replica is too small to hold current data base  
 R - replica had device read errors

A legend of all the flags follows the status. The characters in front of the device name represent the status. Uppercase letters indicate a problem status. Lowercase letters indicate an “Okay” status.

## ▼ How to Delete State Database Replicas

You might need to delete state database replicas to maintain your Solaris Volume Manager configuration. For example, if you will be replacing disk drives, you want to delete the state database replicas before you remove the drives. Otherwise Solaris Volume Manager will report them as having errors.

### 1 Become superuser.

### 2 To remove state database replicas, use one of the following methods:

- From the Enhanced Storage tool within the Solaris Management Console, open the State Database Replicas node to view all existing state database replicas. Select replicas to delete, then choose Edit⇒Delete to remove them. For more information, see the online help.
- Use the following form of the `metadb` command:

```
# metadb -d -f ctds-of-slice
-d           Specifies to delete a state database replica.
-f           Specifies to force the operation, even if no replicas exist.
ctds-of-slice Specifies the name of the component that contains the replica.
```

Note that you need to specify each slice from which you want to remove the state database replica. See the `metadb(1M)` man page for more information.

### Example 7-5 Deleting State Database Replicas

```
# metadb -d -f c0t0d0s7
```

This example shows the last replica being deleted from a slice.

You must add the `-f` option to force the deletion of the last replica on the system.





## RAID-0 (Stripe and Concatenation) Volumes (Overview)

---

This chapter describes RAID-0 (both stripe and concatenation) volumes that are available in Solaris Volume Manager. For information about related tasks, see [Chapter 9](#).

This chapter provides the following information:

- “Overview of RAID-0 Volumes” on page 73
- “Background Information for Creating RAID-0 Volumes” on page 80
- “Scenario—RAID-0 Volumes” on page 81

### Overview of RAID-0 Volumes

RAID-0 volumes, are composed of slices or soft partitions. These volumes enable you to expand disk storage capacity. They can be used either directly or as the building blocks for RAID-1 (mirror) volumes, and soft partitions. There are three kinds of RAID-0 volumes:

- Stripe volumes
- Concatenation volumes
- Concatenated stripe volumes

---

**Note** – A *component* refers to any devices, from slices to soft partitions, used in another logical volume.

---

A stripe volume spreads data equally across all components in the volume, while a concatenation volume writes data to the first available component until it is full, then moves to the next available component. A concatenated stripe volume is simply a stripe volume that has been expanded from its original configuration by adding additional components.

RAID-0 volumes allow you to quickly and simply expand disk storage capacity. The drawback is that these volumes do not provide any data redundancy, unlike RAID-1 or RAID-5 volumes. If a single component fails on a RAID-0 volume, data is lost.

For sequential I/O operations on a stripe volume, Solaris Volume Manager reads all the blocks in a segment of blocks (called an *interlace*) on the first component, then all the blocks in a segment of blocks on the second component, and so forth.

For sequential I/O operations on a concatenation volume, Solaris Volume Manager reads all the blocks on the first component, then all the blocks of the second component, and so forth.

On both a concatenation volume and a stripe volume, all I/O operations occurs in parallel.

You can use a RAID-0 volume that contains a single slice for any file system.

You can use a RAID-0 volume that contains multiple components for any file system except the following:

- root (/)
- /usr
- swap
- /var
- /opt
- Any file system that is accessed during an operating system upgrade or installation

---

**Note** – When you mirror root (/), /usr, swap, /var, or /opt, you put the file system into a one-way concatenation or stripe (a concatenation of a single slice) that acts as a submirror. This one-way concatenation is mirrored by another submirror, which must also be a concatenation.

---

## RAID-0 (Stripe) Volume

A RAID-0 (stripe) volume is a volume that arranges data across one or more components. Striping alternates equally-sized segments of data across two or more components, forming one logical storage unit. These segments are interleaved round-robin so that the combined space is made alternately from each component, in effect, shuffled like a deck of cards.

---

**Note** – To increase the capacity of a stripe volume, you need to build a concatenated stripe volume. See “RAID-0 (Concatenated Stripe) Volume” on page 77.

---

Striping enables multiple controllers to access data at the same time, which is also called *parallel access*. Parallel access can increase I/O throughput because all disks in the volume are busy most of the time servicing I/O requests.

An existing file system cannot be converted directly to a stripe. To place an existing file system on a stripe volume, you must back up the file system, create the volume, then restore the file system to the stripe volume.

---

## Interlace Values for a RAID-0 (Stripe) Volume

An interlace is the size, in Kbytes, Mbytes, or blocks, of the logical data segments on a stripe volume. Depending on the application, different interlace values can increase performance for your configuration. The performance increase comes from having several disk arms managing I/O requests. When the I/O request is larger than the interlace size, you might get better performance.

---

**Note** – RAID-5 volumes also use an interlace value. See “[Overview of RAID-5 Volumes](#)” on page 155 for more information.

---

When you create a stripe volume, you can set the interlace value or use the Solaris Volume Manager default interlace value of 512 Kbytes. Once you have created the stripe volume, you cannot change the interlace value. However, you could back up the data on it, delete the stripe volume, create a new stripe volume with a new interlace value, and then restore the data.

## Scenario—RAID-0 (Stripe) Volume

[Figure 8-1](#) shows a stripe volume that is built from three components (slices). It also illustrates how data is written onto the volume components according to the interlace size and using the round-robin technique.

When Solaris Volume Manager writes data onto the components of a stripe volume, it writes data blocks of the interlace width to Disk A (interlace 1), Disk B (interlace 2), and Disk C (interlace 3). Solaris Volume Manager then repeats the pattern writing to Disk A (interlace 4), Disk B (interlace 5), Disk C (interlace 6), and so forth.

The interlace value sets the size of each time data is written to a slice. The total capacity of the stripe volume equals the number of components multiplied by the size of the smallest component. (If each slice in the following example were 2 Gbytes, the volume would equal 6 Gbytes.)

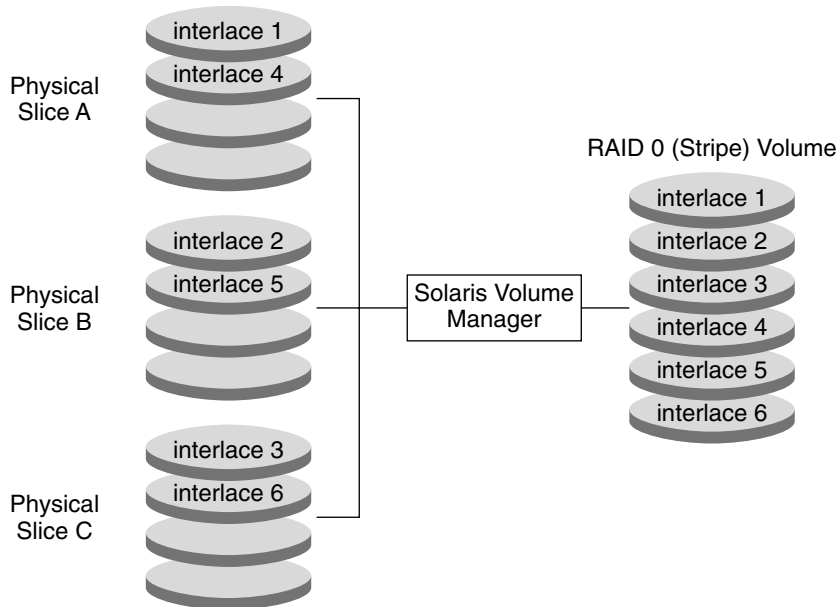

FIGURE 8-1 RAID-0 (Stripe) Volume Example

## RAID-0 (Concatenation) Volume

A RAID-0 (concatenation) volume is a volume whose data is organized serially and adjacently across components, forming one logical storage unit.

Use a concatenation volume to get more storage capacity by combining the capacities of several components. You can add more components to the concatenation volume as the demand for storage grows.

A concatenation volume enables you to dynamically expand storage capacity and file system sizes online. A concatenation volume allows you to add components even if the other components are currently active.

A concatenation volume can also expand any active and mounted UFS file system without having to bring down the system. In general, the total capacity of a concatenation volume is equal to the total size of all the components in the volume. If a concatenation volume contains a slice with a state database replica, the total capacity of the volume is the sum of the components minus the space that is reserved for the replica.

You can also create a concatenation volume from a single component. Later, when you need more storage, you can add more components to the volume.

**Note** – You must use a concatenation volume to encapsulate root (/), swap, /usr, /opt, or /var when mirroring these file systems.

## Scenario—RAID-0 (Concatenation) Volume

Figure 8–2 illustrates a concatenation volume that is built from three components (slices). It also illustrates how data is written onto the volume components according to the interlace size and onto each slice sequentially.

The data blocks are written sequentially across the components, beginning with Slice A. You can envision Slice A as containing logical data blocks 1 through 4. Disk B would contain logical data blocks 5 through 8. Drive C would contain logical data blocks 9 through 12. The total capacity of volume would be the combined capacities of the three slices. If each slice were 2 Gbytes, the volume would have an overall capacity of 6 Gbytes.

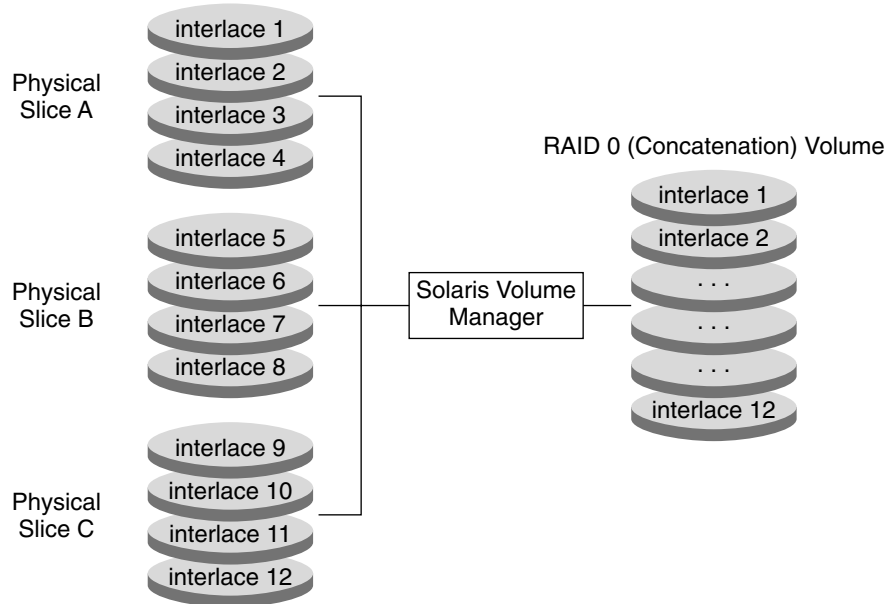

FIGURE 8–2 RAID-0 (Concatenation) Volume Example

## RAID-0 (Concatenated Stripe) Volume

A RAID-0 (concatenated stripe) volume is a stripe that has been expanded by adding additional components (stripes).

To set the interlace value for a concatenated stripe volume, at the stripe level, use either the Enhanced Storage tool within the Solaris Management Console, or the `metattach -i` command. Each stripe

within the concatenated stripe volume can have its own interlace value. When you create a concatenated stripe volume from scratch, if you do not specify an interlace value for a particular stripe, it inherits the interlace value from the previous stripe added to the volume.

### **Example—RAID-0 (Concatenated Stripe) Volume**

Figure 8-3 illustrates a concatenated stripe volume that is a concatenation of three stripes.

The first stripe consists of three slices, Slice A through C, with an interlace value of 512 Kbytes. The second stripe consists of two slices, Slice D and E, and uses an interlace value of 1024 Kbytes. The last stripe consists of two slices, Slice F and G. Because no interlace value is specified for the third stripe, it inherits the value from the stripe that was added before it, which in this case is 1024 Kbytes. Sequential data blocks are added to the first stripe until that stripe has no more space. Data blocks are then added to the second stripe. When this stripe has no more space, data blocks are added to the third stripe. Within each stripe, the data blocks are interleaved according to the specified interlace value.

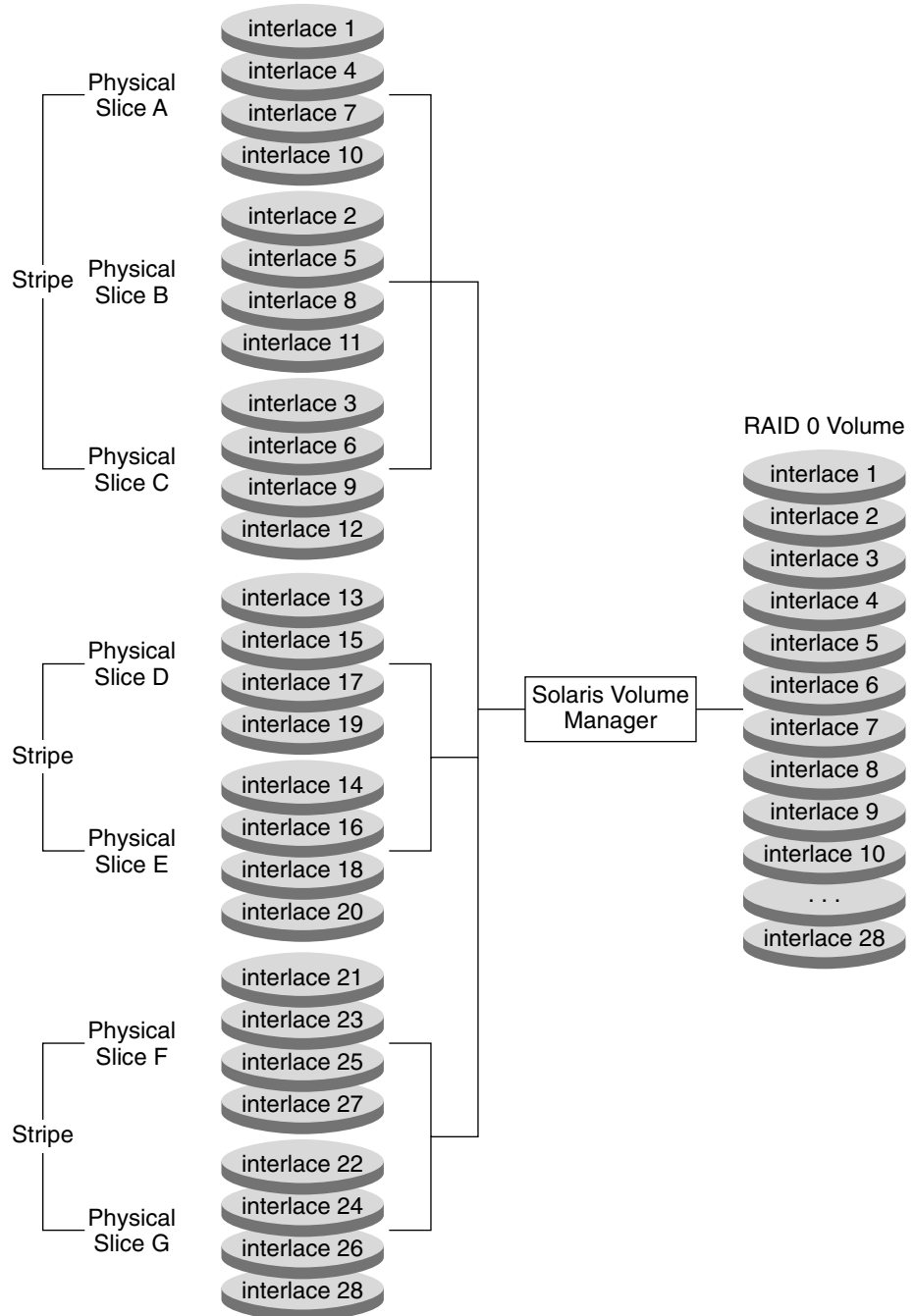

FIGURE 8-3 RAID-0 (Concatenated Stripe) Volume Example

# Background Information for Creating RAID-0 Volumes

## RAID-0 Volume Requirements

When you are working with RAID-0 volumes, consider the following:

- Use components that are each on different controllers to increase the number of simultaneous reads and writes that can be performed.
- Do not create a stripe from an existing file system or data. Doing so will destroy data. Instead, use a concatenation. (You can create a stripe from existing data, but you must dump and restore the data to the volume.)
- Use disk components of the same size for stripes. Striping components of different sizes results in wasted disk space.
- Set up a stripe's interlace value to better match the I/O requests made by the system or applications.
- Because a stripe or concatenation does not contain replicated data, when such a volume has a component failure, you must replace the component, recreate the stripe or concatenation, and restore data from a backup.
- When you recreate a stripe or concatenation, use a replacement component that has at least the same size as the failed component.

## RAID-0 Volume Guidelines

- Concatenation uses less CPU cycles than striping and performs well for small random I/O and for even I/O distribution.
- When possible, distribute the components of a stripe or concatenation across different controllers and busses. Using stripes that are each on different controllers increases the number of simultaneous reads and writes that can be performed.
- If a stripe is defined on a failing controller and another controller is available on the system, you can “move” the stripe to the new controller by moving the disks to the controller and redefining the stripe.
- Number of stripes: Another way of looking at striping is to first determine the performance requirements. For example, you might need 10.4 Mbytes/sec performance for a selected application, and each disk might deliver approximately 4 Mbyte/sec. Based on this formula, then determine how many disk spindles you need to stripe across:

$$10.4 \text{ Mbyte/sec} / 4 \text{ Mbyte/sec} = 2.6$$

Therefore, you need three disks capable of performing I/O operations in parallel.



## Scenario—RAID-0 Volumes

RAID-0 volumes provide the fundamental building blocks for creating more complex storage configurations or for building mirrors. The following example, drawing on the scenario explained in [Chapter 5](#), describes how RAID-0 volumes can provide larger storage spaces and allow you to construct a mirror of existing file systems, including root (/).

The sample system in the scenario has a collection of relatively small (9 Gbyte) disks, but specific applications would likely require larger storage spaces. To create larger spaces (and improve performance), you can create a stripe that spans multiple disks. For example, each one of the following disks, `c1t1d0`, `c1t2d0`, `c1t3d0`, `c2t1d0`, `c2t2d0`, and `c2t3d0`, could be formatted with a slice `0` that spans the entire disk. Then, a stripe including all three of the disks from one controller could provide approximately 27 Gbytes of storage and allow faster access. The second stripe, from the second controller, could be used for redundancy, as described in [Chapter 11](#) and specifically in the “[Scenario—RAID-1 Volumes \(Mirrors\)](#)” on page 103.



# RAID-0 (Stripe and Concatenation) Volumes (Tasks)

---

This chapter contains information about tasks that are related to RAID-0 volumes. For information about related concepts, see [Chapter 8](#).

## RAID-0 Volumes (Task Map)

The following task map identifies the procedures that are needed to manage Solaris Volume Manager RAID-0 volumes.

Task	Description	For Instructions
Create RAID-0 (stripe) volumes	Use the Solaris Volume Manager GUI or the <code>metainit</code> command to create a new volume.	<a href="#">“How to Create a RAID-0 (Stripe) Volume” on page 84</a>
Create RAID-0 (concatenation) volumes	Use the Solaris Volume Manager GUI or the <code>metainit</code> command to create a new volume.	<a href="#">“How to Create a RAID-0 (Concatenation) Volume” on page 85</a>
Expand storage space	Use the Solaris Volume Manager GUI or the <code>metainit</code> command to expand an existing file system.	<a href="#">“How to Expand Storage Capacity for Existing Data” on page 87</a>
Expand an existing RAID-0 volume	Use the Solaris Volume Manager GUI or the <code>metattach</code> command to expand an existing volume.	<a href="#">“How to Expand an Existing RAID-0 Volume” on page 88</a>
Remove a RAID-0 volume	Use the Solaris Volume Manager GUI or the <code>metaclear</code> command to delete a volume.	<a href="#">“How to Remove a RAID-0 Volume” on page 90</a>

## Creating RAID-0 (Stripe) Volumes



**Caution** – Do not create a stripe from an existing file system or data. Doing so destroys data. To create a stripe from existing data, you must back up the data, create the stripe volume, and then restore the data to the volume.



**Caution** – Do not create volumes larger than 1Tbyte if you expect to run the Solaris software with a 32-bit kernel. Additionally, do not create volumes larger than 1Tbyte if you expect to use a version of the Solaris OS prior to the Solaris 9 4/03 release. See [“Overview of Multi-Terabyte Support in Solaris Volume Manager” on page 44](#) for more information about large volume support in Solaris Volume Manager.

### ▼ How to Create a RAID-0 (Stripe) Volume

**Before You Begin** Check [“Prerequisites for Creating Solaris Volume Manager Components” on page 44](#) and [“Background Information for Creating RAID-0 Volumes” on page 80](#).

#### ► To create a stripe volume, use one of the following methods:

- From the Enhanced Storage tool within the Solaris Management Console, open the Volumes node. Choose Action⇒Create Volume, then follow the instructions in the wizard. For more information, see the online help.
- Use the following form of the `metainit` command:

```
# metainit volume-name number-of-stripes
    components-per-stripe
    component-names
    [ -i interlace]
```

*volume-name* Specifies the name of the volume to create. For information on naming volumes, see [“Volume Names” on page 40](#).

*number-of-stripes* Specifies the number of stripes to create.

*components-per-stripe* Specifies the number of components each stripe should have.

*component-names* Specifies the names of the components that are used. If more than one component is used, separate each component with a space.

*-i interlace* Specifies the interlace width to use for the stripe. The interlace width is a value, followed by either ‘k’ for kilobytes, ‘m’ for megabytes, or ‘b’ for blocks. The interlace specified cannot be less than 16 blocks, or greater than 100 megabytes. The default interlace width is 512 kilobytes.

See the following examples and the `metainit(1M)` man page for more information.

**Example 9-1** Creating a RAID-0 (Stripe) Volume of Three Slices

```
# metainit d20 1 3 c0t1d0s2 c0t2d0s2 c0t3d0s2
d20: Concat/Stripe is setup
```

This example shows the stripe, d20, consists of a single stripe (the number 1). The stripe is composed of three slices (the number 3). Because no interlace value is specified, the stripe uses the default of 512 Kbytes. The system confirms that the volume has been set up.

**Example 9-2** Creating a RAID-0 (Stripe) Volume of Two Slices With a 32-Kbyte Interlace Value

```
# metainit d10 1 2 c0t1d0s2 c0t2d0s2 -i 32k
d10: Concat/Stripe is setup
```

This example shows the stripe, d10, consists of a single stripe (the number 1). The stripe is composed of two slices (the number 2). The `-i` option sets the interlace value to 32 Kbytes. (The interlace value cannot be less than 8 Kbytes, nor greater than 100 Mbytes.) The system verifies that the volume has been set up.

**See Also** To prepare the newly created stripe for a file system, see Chapter 18, “Creating UFS, TMPFS, and LOFS File Systems (Tasks),” in *System Administration Guide: Devices and File Systems*. Some applications, such as a database, do not use a file system. These applications instead use the raw device. The application must have its own way of accessing the raw device.

## Creating RAID-0 (Concatenation) Volumes

### ▼ How to Create a RAID-0 (Concatenation) Volume



**Caution** – Do not create volumes larger than 1 Tbyte if you expect to run the Solaris software with a 32-bit kernel. Additionally, do not create volumes larger than 1 Tbyte if you expect to use a version of the Solaris OS prior to the Solaris 9 4/03 release. See “[Overview of Multi-Terabyte Support in Solaris Volume Manager](#)” on page 44 for more information about multi-terabyte volumes in Solaris Volume Manager.

**Before You Begin** Check “[Prerequisites for Creating Solaris Volume Manager Components](#)” on page 44 and “[Background Information for Creating RAID-0 Volumes](#)” on page 80.

- ▶ **To create a concatenation volume, use one of the following methods:**

- From the Enhanced Storage tool within the Solaris Management Console, open the Volumes node. Choose Action⇒Create Volume, then follow the instructions in the wizard. For more information, see the online help.
- Use the following form of the `metainit` command:

```
# metainit volume-name number-of-stripes
components-per-stripe
component-names
```

*volume-name* Specifies the name of the volume to create.

*number-of-stripes* Specifies the number of stripes to create.

*components-per-concatenation* Specifies the number of components each concatenation should have.

*component-names* Specifies the names of the components that are used. If more than one component is used, separate each component with a space.

For more information, see the following examples and the `metainit(1M)` man page.

### Example 9-3 Creating a Concatenation of One Slice

```
# metainit d25 1 1 c0t1d0s2
d25: Concat/Stripe is setup
```

This example shows the creation of a concatenation, `d25`. This concatenation consists of one stripe (the first number 1) composed of a single slice (the second number 1 in front of the slice). The system verifies that the volume has been set up.

The example shows a concatenation that can safely encapsulate existing data.

### Example 9-4 Creating a Concatenation of Four Slices

```
# metainit d40 4 1 c0t1d0s2 1 c0t2d0s2 1 c0t2d0s3 1 c0t2d1s3
d40: Concat/Stripe is setup
```

This example shows the creation of a concatenation, `d40`. The concatenation consists of four stripes (the number 4), each composed of a single slice (the number 1 in front of each slice). The system verifies that the volume has been set up.

**See Also** To prepare the newly created concatenation for a file system, see Chapter 18, “Creating UFS, TMPFS, and LOFS File Systems (Tasks),” in *System Administration Guide: Devices and File Systems*.

# Expanding Storage Capacity

To add storage capacity to a file system, create a concatenation volume. To add storage capacity to an existing stripe, create a concatenated stripe volume.

## ▼ How to Expand Storage Capacity for Existing Data



**Caution** – Do not create volumes larger than 1Tbyte if you expect to run the Solaris software with a 32-bit kernel. Additionally, do not create volumes larger than 1 Tbyte if you expect to use a version of the Solaris OS prior to the Solaris 9 4/03 release. See “[Overview of Multi-Terabyte Support in Solaris Volume Manager](#)” on page 44 for more information about multi-terabyte volume support in Solaris Volume Manager.

**Before You Begin** Check “[Prerequisites for Creating Solaris Volume Manager Components](#)” on page 44 and “[Background Information for Creating RAID-0 Volumes](#)” on page 80.

### 1 Unmount the file system.

```
# umount /filesystem
```

### 2 To create a concatenation, use one of the following methods:

- From the Enhanced Storage tool within the Solaris Management Console, open the Volumes node. Choose Action⇒Create Volume, then follow the instructions in the wizard. For more information, see the online help.
- Use the following form of the `metainit` command:

```
# metainit volume-name number-of-stripes
    components-per-stripe
    component-names
```

*volume-name* Specifies is the name of the volume to create.

*number-of-stripes* Specifies the number of stripes to create.

*components-per-stripe* Specifies the number of components each stripe should have.

*component-names* Specifies the names of the components that are used. If more than one component is used, separate each component with a space.

For more information, see the `metainit(1M)` man page.

### 3 Edit the `/etc/vfstab` file so that the file system references the name of the concatenation.

#### 4 Remount the file system.

```
# mount /filesystem
```

### Example 9-5 Expanding a File System by Creating a Concatenation

```
# umount /docs
# metainit d25 2 1 c0t1d0s2 1 c0t2d0s2
d25: Concat/Stripe is setup
  (Edit the /etc/vfstab file so that the file system references the volume d25 instead of slice c0t1d0s2)
# mount /docs
```

This example shows the creation of a concatenation, d25, out of two slices, /dev/dsk/c0t1d0s2 (which contains a file system mounted on /docs) and /dev/dsk/c0t2d0s2. The file system must first be unmounted. Note that the first slice in the `metainit` command must be the slice that contains the file system. If not, you will corrupt your data.

Next, the entry for the file system in the `/etc/vfstab` file is changed (or entered for the first time) to reference the concatenation. For example, initially, the following line appears in the `/etc/vfstab` file:

```
/dev/dsk/c0t1d0s2 /dev/rdisk/c0t1d0s2 /docs ufs 2 yes -
```

This line should be changed to the following:

```
/dev/md/dsk/d25 /dev/md/rdisk/d25 /docs ufs 2 yes -
```

Finally, the file system is remounted.

**See Also** For a UFS file system, run the `growfs` command on the concatenation. See [“How to Expand a File System” on page 227](#).

Some applications, such as a database, do not use a file system. An application such as a database uses the raw concatenation and must have its own way of recognizing the concatenation, or of growing the added space.

## ▼ How to Expand an Existing RAID-0 Volume

A concatenated stripe enables you to expand an existing stripe. For example, if a stripe has run out of storage capacity, you convert it into a concatenated stripe. Doing so allows you to expand your storage capacity without having to back up and restore data.

This procedure assumes that you are adding an additional stripe to an existing stripe.





**Caution** – Do not create volumes larger than 1Tbyte if you expect to run the Solaris software with a 32-bit kernel. Additionally, do not create volumes larger than 1 Tbyte if you expect to use a version of the Solaris OS prior to the Solaris 9 4/03 release. See [“Overview of Multi-Terabyte Support in Solaris Volume Manager” on page 44](#) for more information about multi-terabyte support in Solaris Volume Manager.

**Before You Begin** Check [“Prerequisites for Creating Solaris Volume Manager Components” on page 44](#) and [“Background Information for Creating RAID-0 Volumes” on page 80](#).

► **To create a concatenated stripe, use one of the following methods:**

- From the Enhanced Storage tool within the Solaris Management Console, open the Volumes node. Choose Action⇒Create Volume, then follow the instructions in the wizard. For more information, see the online help.
- To concatenate existing stripes from the command line, use the following form of the `metattach` command:

```
# metattach volume-name component-names
```

*volume-name* Specifies the name of the volume to expand.

*component-names* Specifies the names of the components that are used. If more than one component is used, separate each component with a space.

See the `metattach(1M)` man page for more information.

**Example 9–6** Creating a Concatenated Stripe by Attaching a Single Slice

```
# metattach d2 c1t2d0s2
d2: components are attached
```

This example illustrates how to attach a slice to an existing stripe, `d2`. The system confirms that the slice is attached.

**Example 9–7** Creating a Concatenated Stripe by Adding Several Slices

```
# metattach d25 c1t2d0s2 c1t2d1s2 c1t2d3s2
d25: components are attached
```

This example takes an existing three-way stripe, `d25`, and concatenates another three-way stripe to it. Because no interlace value is given for the attached slices, the stripes inherit the interlace value configured for `d25`. The system verifies that the volume has been set up.

**See Also** For a UFS file system, run the `growfs` command on the volume. See “How to Expand a File System” on page 227.

Some applications, such as a database, do not use a file system. An application such as a database uses the raw volume and must have its own way of recognizing the volume, or of growing the added space.

To prepare a newly created concatenated stripe for a file system, see Chapter 18, “Creating UFS, TMPFS, and LOFS File Systems (Tasks),” in *System Administration Guide: Devices and File Systems*.

## Removing a RAID-0 Volume

### ▼ How to Remove a RAID-0 Volume

**1 Make sure that you have a current backup of all data and that you have root privilege.**

**2 Make sure that you no longer need the volume.**

If you delete a stripe or concatenation and reuse the slices that were part of the deleted volume, all data on the volume is deleted from the system.

**3 Unmount the file system, if needed.**

```
# umount /filesystem
```

**4 To remove a volume, use one of the following methods:**

- From the Enhanced Storage tool within the Solaris Management Console, open the Volumes node. Choose Edit⇒Delete, then follow the onscreen instructions. For more information, see the online help.
- Use the following format of the `metaclear` command to delete the volume:

```
metaclear volume-name
```

See the following example and the `metaclear(1M)` man page for more information.

#### Example 9–8 Removing a Concatenation

```
# umount d8
# metaclear d8
d8: Concat/Stripe is cleared
   (Edit the /etc/vfstab file)
```

This example illustrates removing the concatenation, `d8`, that also contains a mounted file system. The file system must be unmounted before the volume can be removed. The system displays a

confirmation message that the concatenation is removed. If an entry in the `/etc/vfstab` file exists for this volume, delete that entry. You do not want to confuse the system by asking it to mount a file system on a nonexistent volume.



## RAID-1 (Mirror) Volumes (Overview)

---

This chapter explains essential Solaris Volume Manager concepts related to mirrors and submirrors. For information about performing related tasks, see [Chapter 11](#).

This chapter contains the following information:

- “Overview of RAID-1 (Mirror) Volumes” on page 93
- “RAID-1 Volume (Mirror) Resynchronization” on page 96
- “Creating and Maintaining RAID-1 Volumes” on page 97
- “The Affect of Booting Into Single-User Mode on RAID-1 Volumes” on page 102
- “Scenario—RAID-1 Volumes (Mirrors)” on page 103

### Overview of RAID-1 (Mirror) Volumes

A RAID-1 volume, or *mirror*, is a volume that maintains identical copies of the data in RAID-0 (stripe or concatenation) volumes. The RAID-0 volumes that are mirrored are called *submirrors*. Mirroring requires an investment in disks. You need at least twice as much disk space as the amount of data you have to mirror. Because Solaris Volume Manager must write to all submirrors, mirroring can also increase the amount of time it takes for write requests to be written to disk.

After you configure a mirror, the mirror can be used just like a physical slice.

You can mirror any file system, including existing file systems. These file systems root (*/*), swap, and */usr*. You can also use a mirror for any application, such as a database.

---

**Tip** – Use Solaris Volume Manager’s hot spare feature with mirrors to keep data safe and available. For information on hot spares, see [Chapter 16](#) and [Chapter 17](#).

---

### Overview of Submirrors

A mirror is composed of one or more RAID-0 volumes (stripes or concatenations) called submirrors.

A mirror can consist of up to four submirrors. However, two-way mirrors usually provide sufficient data redundancy for most applications and are less expensive in terms of disk drive costs. A third submirror enables you to make online backups without losing data redundancy while one submirror is offline for the backup.

If you take a submirror “offline,” the mirror stops reading and writing to the submirror. At this point, you could access the submirror itself, for example, to perform a backup. However, the submirror is in a read-only state. While a submirror is offline, Solaris Volume Manager keeps track of all writes to the mirror. When the submirror is brought back online, only the portions of the mirror that were written while the submirror was offline (the *resynchronization regions*) are resynchronized. Submirrors can also be taken offline to troubleshoot or repair physical devices that have errors.

Submirrors can be attached or be detached from a mirror at any time, though at least one submirror must remain attached at all times.

Normally, you create a mirror with only a single submirror. Then, you attach a second submirror after you create the mirror.

## Scenario—RAID-1 (Mirror) Volume

Figure 10-1 illustrates a mirror, d20. The mirror is made of two volumes (submirrors) d21 and d22.

Solaris Volume Manager makes duplicate copies of the data on multiple physical disks, and presents one virtual disk to the application, d20 in the example. All disk writes are duplicated. Disk reads come from one of the underlying submirrors. The total capacity of mirror d20 is the size of the smallest of the submirrors (if they are not of equal size).

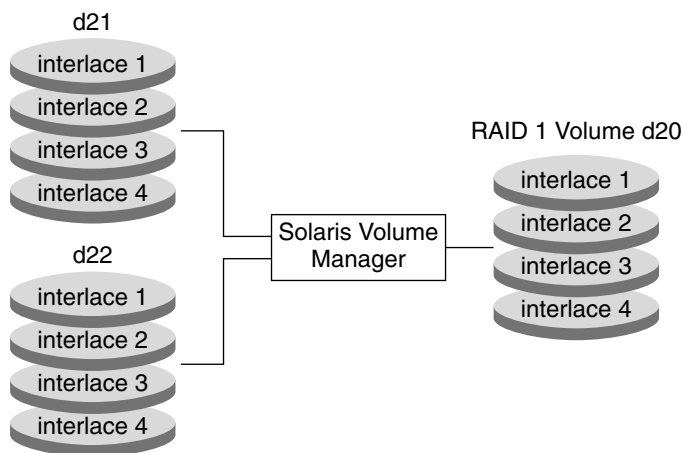

FIGURE 10-1 RAID-1 (Mirror) Example

## Providing RAID-1+0 and RAID-0+1

Solaris Volume Manager supports both RAID-1+0 and RAID-0+1 redundancy. RAID-1+0 redundancy constitutes a configuration of mirrors that are then striped. RAID-0+1 redundancy constitutes a configuration of stripes that are then mirrored. The Solaris Volume Manager interface makes it appear that all RAID-1 devices are strictly RAID-0+1. However, Solaris Volume Manager recognizes the underlying components and mirrors each individually, when possible.

**Note** – Solaris Volume Manager cannot always provide RAID-1+0 functionality. However, where both submirrors are identical to each other and are composed of disk slices (and not soft partitions), RAID-1+0 is possible.

Consider a RAID-0+1 implementation with a two-way mirror that consists of three striped slices. Without Solaris Volume Manager, a single slice failure could fail one side of the mirror. Assuming that no hot spares are in use, a second slice failure would fail the mirror. Using Solaris Volume Manager, up to three slices could potentially fail without failing the mirror. The mirror does not fail because each of the three striped slices are individually mirrored to their counterparts on the other half of the mirror.

Figure 10–2 illustrates how a RAID-1 volume can experience the loss of a slice, yet the RAID-1+0 implementation prevents data loss.

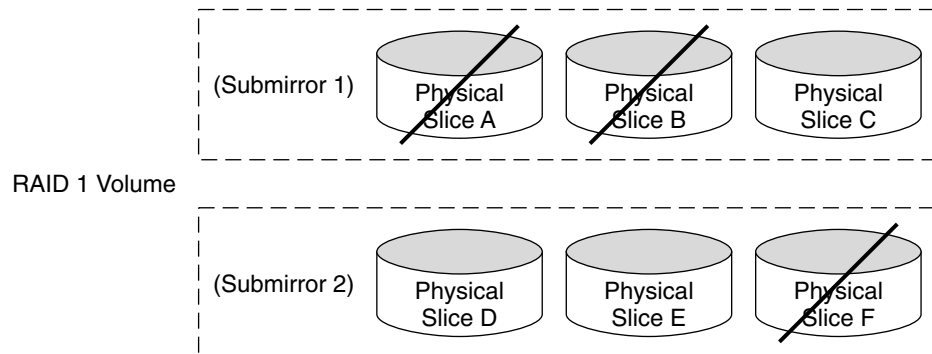

FIGURE 10-2 RAID-1+0 Example

The RAID-1 volume consists of two submirrors. Each of the submirrors consist of three identical physical disks that have the same interlace value. A failure of three disks, A, B, and F, is tolerated. The entire logical block range of the mirror is still contained on at least one good disk. All of the volume's data is available.

However, if disks A and D fail, a portion of the mirror's data is no longer available on any disk. Access to these logical blocks fail. However, access to portions of the mirror where data is available still succeed. Under this situation, the mirror acts like a single disk that has developed bad blocks. The damaged portions are unavailable, but the remaining portions are available.

## RAID-1 Volume (Mirror) Resynchronization

RAID-1 volume (mirror) resynchronization is the process of copying data from one submirror to another submirror when one of the following occurs:

- Submirrors fail
- The system crashes
- A submirror has been taken offline and brought back online
- A new submirror has been added

While the resynchronization takes place, the mirror remains readable and writable by users.

A mirror resynchronization ensures proper mirror operation by maintaining all submirrors with identical data, with the exception of writes in progress.

---

**Note** – A mirror resynchronization should not be bypassed. You do not need to manually initiate a mirror resynchronization. This process occurs automatically.

---

## Full Resynchronization

When a new submirror is attached (added) to a mirror, all the data from another submirror in the mirror is automatically written to the newly attached submirror. Once the mirror resynchronization is done, the new submirror is readable. A submirror remains attached to a mirror until it is detached.

If the system crashes while a resynchronization is in progress, the resynchronization is restarted when the system finishes rebooting.

## Optimized Resynchronization

During a reboot following a system failure, or when a submirror that was offline is brought back online, Solaris Volume Manager performs an *optimized mirror resynchronization*. The metadisk driver tracks submirror regions. This functionality enables the metadisk driver to know which submirror regions might be out-of-sync after a failure. An optimized mirror resynchronization is performed only on the out-of-sync regions. You can specify the order in which mirrors are resynchronized during reboot. You can omit a mirror resynchronization by setting submirror pass numbers to zero. For tasks associated with changing a pass number, see [Example 11-15](#).



---

**Caution** – A pass number of zero should only be used on mirrors that are mounted as read-only.

---



## Partial Resynchronization

Following the replacement of a slice within a submirror, Solaris Volume Manager performs a *partial mirror resynchronization* of data. Solaris Volume Manager copies the data from the remaining good slices of another submirror to the replaced slice.

## Canceling and Resuming Resynchronization With the `metasync` Command

The resynchronization process affects both the performance of a system, as well as the user's ability to perform tasks. For example, resynchronizations impact the I/O performance and the response time of a system. Additionally, during a resynchronization process, a disk set cannot be released from a host. In another example, if a volume is attached by mistake, the volume cannot be released until the resynchronization has completed. Because of situations such as these, allowing a resynchronization process to complete is not always advantageous.

The `metasync -c volume` command cancels the resynchronization process on a given volume. The following functionality is associated with canceling resynchronization processes:

- Canceled resynchronization processes are logged by using the `syslog` utility
- After a reboot, any canceled resynchronization process is resumed from the point that it stopped
- When a disk set is taken, any canceled resynchronization process within that disk set resumes automatically from the point of the cancellation

A canceled resynchronization process can be resumed manually from the point that it stopped by issuing the `metasync volume` command.

For the tasks associated with canceling and resuming resynchronization processes using the `metasync` command, see [“How to Cancel a Volume Resynchronization Process”](#) on page 130 and [“How to Resume a Volume Resynchronization Process”](#) on page 133.

## Creating and Maintaining RAID-1 Volumes

This section provides guidelines can assist you in creating mirrors. This section also provides performance guidelines for the mirrors that you create.

### Configuration Guidelines for RAID-1 Volumes

- Before you create a mirror, create the RAID-0 (stripe or concatenation) volumes that comprise the mirror.
- When creating a mirror, first create a one-way mirror, then attach a second submirror. This strategy starts a resynchronization operation. This strategy also ensures that data is not corrupted. You can also create a one-way mirror for use as a future two-way or multi-way mirror.

- You can create a two-way mirror, three-way mirror, or four-way mirror from a one-way mirror with a single command. You can speed the creation process by creating all submirrors with a single command. Use this process only if you are not mirroring existing data and if you are comfortable destroying the data on all of the submirrors.
- You can create a RAID-1 volume from an existing file system that is built on a slice. Only the single slice may be included in the primary RAID-0 volume (submirror). If you are mirroring root or other system-critical file systems, all submirrors must consist of only a single slice.
- Use the `swap -l` command to check for all swap devices. Each slice that is specified as `swap` must be mirrored independently from the remaining swap slices.
- The Enhanced Storage tool within the Solaris Management Console does not support unmirroring `/`, `/opt`, `/usr`, or `swap`. In fact, the tool does not support unmirroring any file system that cannot be unmounted while the system is running. Instead, use the command-line procedure for these file systems.
- Use submirrors of the same size. Submirrors of different sizes result in unused disk space.
- Use only similarly configured submirrors within a mirror. In particular, if you create a mirror with an unlabeled submirror, you cannot attach any submirrors that contain disk labels.
- You can have a mirrored file system in which the first submirror attached does not start on cylinder 0. All additional submirrors you attach must also not start on cylinder 0. If you attempt to attach a submirror starting in this situation, the following error message displays:

```
can't attach labeled submirror to an unlabeled mirror
```

Either all submirrors intended for use within a specific mirror must start on cylinder 0, or all of the submirrors must *not* start on cylinder 0.

Starting cylinders do not have to be the same across all submirrors. However, all submirrors must either include or not include cylinder 0.

- You can improve a mirror's performance by adding additional state database replicas before you create the mirror. As a general rule, add two additional replicas for each mirror you add to the system. Solaris Volume Manager uses these additional replicas to store the dirty region log (DRL), which is used to provide optimized resynchronization. By providing adequate numbers of replicas, you can minimize I/O impact on RAID-1 volume performance. Using at least two replicas on the same disks or controllers as the mirror that the replicas log also helps to improve overall performance.
- Only mount the mirror device directly. Do not try to mount a submirror directly, unless the submirror is offline and mounted read-only. Do not mount a slice that is part of a submirror. This process could destroy data and crash the system.

## Performance Guidelines for RAID-1 Volumes

- Keep the slices of different submirrors on different disks and controllers. Data protection is diminished considerably if slices of two or more submirrors of the same mirror are on the same disk. Likewise, organize submirrors across separate controllers, because controllers and associated cables tend to fail more often than disks. This practice also improves mirror performance.
- Use the same type of disks and controllers in a single mirror. Particularly in old SCSI storage devices, different models or different brands of disks or controllers can have widely varying performance. If disks and controller that have the different performance levels are used in a single mirror, performance can degrade significantly.
- Mirroring might improve read performance, but write performance is always degraded. Mirroring improves read performance only in threaded or asynchronous I/O situations. A single thread reading from the volume does not provide a performance gain.
- You can experiment with the mirror read policies can improve performance. For example, the default read mode is to alternate reads in a round-robin fashion among the disks. This policy is the default because round-robin tends to work best for UFS multiuser, multiprocessor activity. In some cases, the geometric read option improves performance by minimizing head motion and access time. This option is most effective when:
  - There is only one slice per disk
  - Only one process at a time is using the slice or file system
  - I/O patterns are highly sequential or when all accesses are read
- You can attach a submirror to a mirror without interrupting service. You attach submirrors to mirrors to create two-way, three-way, and four-way mirrors.
- When you place a submirror offline, you prevent the mirror from reading from and writing to the submirror. However, you preserve the submirror's logical association to the mirror. While the submirror is offline, Solaris Volume Manager keeps track of all writes to the mirror. The writes are written to the submirror when it is brought back online. By performing an optimized resynchronization, Solaris Volume Manager only has to resynchronize data that has changed, not the entire submirror. When you detach a submirror, you sever its logical association to the mirror. Typically, you place a submirror offline to perform maintenance. You detach a submirror to remove it.

## About RAID-1 Volume Options

The following options are available to optimize mirror performance:

- Mirror read policy
- Mirror write policy
- The order in which mirrors are resynchronized (pass number)

You can define mirror options when you initially create the mirror. You can also change mirror options after a mirror has been set up and is running. For tasks related to changing these options, see [“How to Change RAID-1 Volume Options”](#) on page 128.

## RAID-1 Volume Read-and-Write Policies

Solaris Volume Manager enables different read-and-write policies to be configured for a RAID-1 volume. Properly set read-and-write policies can improve performance for a given configuration.

TABLE 10-1 RAID-1 Volume Read Policies

Read Policy	Description
Round-Robin (Default)	Attempts to balance the load across the submirrors. All reads are made in a round-robin order (one after another) from all submirrors in a mirror.
Geometric	Enables reads to be divided among submirrors on the basis of a logical disk block address. For example, with a two-way submirror, the disk space on the mirror is divided into two equally-sized logical address ranges. Reads from one submirror are restricted to one half of the logical range. Reads from the other submirror are restricted to the other half. The geometric read policy effectively reduces the seek time that is necessary for reads. The performance gained by this read policy depends on the system I/O load and the access patterns of the applications.
First	Directs all reads to the first submirror. This policy should be used only when the device or devices that comprise the first submirror are substantially faster than the devices of the second submirror.

TABLE 10-2 RAID-1 Volume Write Policies

Write Policy	Description
Parallel (Default)	Performs writes to a mirror that are replicated and dispatched to all of the submirrors simultaneously.
Serial	Performs writes to submirrors serially (that is, the first submirror write completes before the second submirror write is started). This policy specifies that writes to one submirror must be completed before the next submirror write is initiated. This policy is provided in case a submirror becomes unreadable, for example, due to a power failure.

## Pass Number

The pass number, a number in the range 0–9, determines the order in which a particular mirror is resynchronized during a system reboot. The default pass number is 1. The lower pass numbers are resynchronized first. If zero is used, the mirror resynchronization is skipped. A pass number of zero should be used only for mirrors that are mounted as read-only. Mirrors with the same pass number are resynchronized at the same time.

## Understanding Submirror Status to Determine Maintenance Actions

The `metastat` command of Solaris Volume Manager reports status information on RAID 1 volumes and submirrors. The status information helps you to determine if maintenance action is required on a RAID-1 volume. The following table explains submirror states shown when you run the `metastat` command on a RAID-1 volume.

TABLE 10-3 Submirror States

State	Meaning
Okay	The submirror has no errors and is functioning correctly.
Resyncing	The submirror is actively being resynchronized. An error has occurred and has been corrected, the submirror has just been brought back online, or a new submirror has been added.
Resync canceled	The resynchronization process on the submirror has been canceled using the <code>metasync</code> command.
Needs Maintenance	A slice (or slices) in the submirror has encountered an I/O error or an open error. All reads and writes to and from this slice in the submirror have been discontinued.

Additionally, for each slice in a submirror, the `metastat` command shows the following:

Device	Indicates the device name of the slice in the stripe
Start Block	Indicates the block on which the slice begins
Dbase	Indicates if the slice contains a state database replica
State	Indicates the state of the slice
Hot Spare	Indicates that a slice is being used as a hot spare for a failed slice

The submirror state only provides general information on the status of the submirror. The slice state is perhaps the most important information to review when you are troubleshooting mirror errors. If the submirror reports a “Needs Maintenance” state, you must refer to the slice state for more information.

You take a different recovery action depending on if the slice is in the “Maintenance” state or in the “Last Erred” state. If you only have slices in the “Maintenance” state, they can be repaired in any order. If you have slices both in the “Maintenance” state and in the “Last Erred” state, you must fix the slices in the “Maintenance” state first. Once the slices in the “Maintenance” state have been fixed, then fix the slices in the “Last Erred” state. For more information, see [“Overview of Replacing and Enabling Components in RAID-1 and RAID-5 Volumes”](#) on page 228.

The following table explains the slice states for submirrors and possible actions to take.

TABLE 10-4 Submirror Slice States

State	Meaning	Action
Okay	The slice has no errors and is functioning correctly.	None.
Resyncing	The slice is actively being resynchronized. An error has occurred and been corrected, the submirror has just been brought back online, or a new submirror has been added.	If desired, monitor the submirror status until the resynchronization is done.
Maintenance	The slice has encountered an I/O error or an open error. All reads and writes to and from this component have been discontinued.	Enable or replace the failed slice. See <a href="#">“How to Enable a Slice in a Submirror”</a> on page 125, or <a href="#">“How to Replace a Slice in a Submirror”</a> on page 135. The <code>metastat</code> command will show an invoke recovery message with the appropriate action to take with the <code>metareplace</code> command. You can also use the <code>metareplace -e</code> command.
Last Erred	The slice has encountered an I/O error or an open error. However, the data is not replicated elsewhere due to another slice failure. I/O is still performed on the slice. If I/O errors result, the mirror I/O fails.	First, enable or replace slices in the “Maintenance” state. See <a href="#">“How to Enable a Slice in a Submirror”</a> on page 125, or <a href="#">“How to Replace a Slice in a Submirror”</a> on page 135. Usually, this error results in some data loss, so validate the mirror after it is fixed. For a file system, use the <code>fsck</code> command, then check the data. An application or database must have its own method of validating the device.

## The Affect of Booting Into Single-User Mode on RAID-1 Volumes

Sometimes, you may need to boot a system with mirrors for root (`/`), `/usr`, and swap, the so-called “boot” file systems, into single-user mode (by using the `boot -s` command). In this case, these mirrors and possibly all mirrors on the system will appear in the “Needing Maintenance” state when viewed with the `metastat` command. Furthermore, if writes occur to these slices, the `metastat` command shows an increase in dirty regions on the mirrors.

This situation appears to be potentially dangerous. However, the `metasync -r` command, which normally runs during boot to resynchronize mirrors, is interrupted when the system is booted into single-user mode. Once the system is rebooted, the `metasync -r` command will run and resynchronize all mirrors.

If this situation is a concern, you can run the `metasync -r` command manually.

## Scenario—RAID-1 Volumes (Mirrors)

RAID-1 volumes provide a means of constructing redundant volumes. Thus, when a partial or complete failure of one of the underlying RAID-0 volumes occurs, there is no data loss or interruption of access to the file systems. The following example, drawing on the scenario explained in [Chapter 5](#) and continued in [“Scenario—RAID-0 Volumes” on page 81](#), describes how RAID-1 volumes can provide redundant storage.

As described in [“Scenario—RAID-0 Volumes” on page 81](#), the sample system has two RAID-0 volumes. Each volume is approximately 27 Gbytes in size and spans three disks. By creating a RAID-1 volume to mirror these two RAID-0 volumes, a fully redundant storage space can provide resilient data storage.

Within this RAID-1 volume, the failure of either disk controller does not interrupt access to the volume. Similarly, failure of up to three individual disks might be tolerated without access interruption.

To provide additional protection against problems that could interrupt access, use hot spares, as described in [Chapter 16](#). Specifically, see [“How Hot Spares Work” on page 172](#).





# RAID-1 (Mirror) Volumes (Tasks)

---

This chapter explains how to perform Solaris Volume Manager tasks that are related to RAID-1 volumes. For information about related concepts, see [Chapter 10](#).

## RAID-1 Volumes (Task Map)

The following task map identifies the procedures that are needed to manage Solaris Volume Manager RAID-1 volumes.

Task	Description	For Instructions
Create a mirror from unused slices	Use the Solaris Volume Manager GUI or the <code>metainit</code> command to create a mirror from unused slices.	<a href="#">“How to Create a RAID-1 Volume From Unused Slices” on page 107</a>
Create a mirror from an existing file system	Use the Solaris Volume Manager GUI or the <code>metainit</code> command to create a mirror from an existing file system.	<a href="#">“How to Create a RAID-1 Volume From a File System” on page 109</a>
Create a mirror from the root (/) file system	Use the Solaris Volume Manager GUI or the <code>metainit</code> command to create a mirror from the root (/) file system.	<a href="#">“SPARC: How to Create a RAID-1 Volume From the root (/) File System” on page 113</a> <a href="#">“x86: How to Create a RAID-1 Volume From the root (/) File System” on page 117</a>
Attach a submirror	Use the Solaris Volume Manager GUI or the <code>metattach</code> command to attach a submirror.	<a href="#">“How to Attach a Submirror” on page 122</a>
Detach a submirror	Use the Solaris Volume Manager GUI or the <code>metadetach</code> command to detach the submirror.	<a href="#">“How to Detach a Submirror” on page 124</a>

Task	Description	For Instructions
Place a submirror online or take a submirror offline	Use the Solaris Volume Manager GUI or the <code>metaonline</code> command to put a submirror online. Use the Solaris Volume Manager GUI or the <code>metaoffline</code> command to take a submirror offline.	<a href="#">“How to Place a Submirror Offline and Online” on page 124</a>
Enable a slice within a submirror	Use the Solaris Volume Manager GUI or the <code>metareplace</code> command to enable a slice in a submirror.	<a href="#">“How to Enable a Slice in a Submirror” on page 125</a>
Check mirror status	Use the Solaris Volume Manager GUI or the <code>metastat</code> command to check the status of RAID-1 volumes.	<a href="#">“How to View the Status of Mirrors and Submirrors” on page 126</a>
Change mirror options	Use the Solaris Volume Manager GUI or the <code>metaparam</code> command to change the options for a specific RAID-1 volume.	<a href="#">“How to Change RAID-1 Volume Options” on page 128</a>
Expand a mirror	Use the Solaris Volume Manager GUI or the <code>metattach</code> command to expand the capacity of a mirror.	<a href="#">“How to Expand a RAID-1 Volume” on page 129</a>
Replace a slice within a submirror	Use the Solaris Volume Manager GUI or the <code>metareplace</code> command to replace a slice in a submirror.	<a href="#">“How to Replace a Slice in a Submirror” on page 135</a>
Replace a submirror	Use the Solaris Volume Manager GUI or the <code>metattach</code> command to replace a submirror.	<a href="#">“How to Replace a Submirror” on page 136</a>
Remove a mirror (unmirror)	Use the Solaris Volume Manager GUI, the <code>metadetach</code> command, or the <code>metaclear</code> command to unmirror a file system.	<a href="#">“How to Unmirror a File System” on page 138</a>
Remove a mirror (unmirror) of a file system that cannot be unmounted	Use the Solaris Volume Manager GUI, the <code>metadetach</code> command, or the <code>metaclear</code> command to unmirror a file system that cannot be unmounted.	<a href="#">“How to Unmirror a File System That Cannot Be Unmounted” on page 140</a>
Use a mirror to perform backups	Use the Solaris Volume Manager GUI, the <code>metaonline</code> command, or the <code>metaoffline</code> commands to perform backups with mirrors.	<a href="#">“How to Perform an Online Backup of a RAID-1 Volume” on page 143</a>
Cancel or resume the resynchronization process on a mirror	Use the <code>metasync</code> command to cancel and resume the resynchronization process on a mirror	<a href="#">“How to Cancel a Volume Resynchronization Process” on page 130</a>  <a href="#">“How to Resume a Volume Resynchronization Process” on page 133</a>

# Creating a RAID-1 Volume

## ▼ How to Create a RAID-1 Volume From Unused Slices

This procedure shows you how to create a two-way mirror. If you want to create a three-way mirror or a four-way mirror, use the same procedure.

**Before You Begin** Check “Prerequisites for Creating Solaris Volume Manager Components” on page 44 and “Creating and Maintaining RAID-1 Volumes” on page 97.

### 1 Create two stripes or concatenations. These components become the submirrors.

See “How to Create a RAID-0 (Stripe) Volume” on page 84 or “How to Create a RAID-0 (Concatenation) Volume” on page 85.

### 2 To create the mirror, use one of the following methods:

- From the Enhanced Storage tool within the Solaris Management Console, open the Volumes node, then choose Action⇒Create Volume and follow the onscreen instructions. For more information, see the online help.
- Use the following form of the `metainit` command to create a one-way mirror:

```
# metainit volume-name -m submirror-name
volume-name      Specifies the name of the volume to create
-m               Specifies to create a mirror
submirror-name   Specifies the name of the component that will be the first submirror in the
                 mirror
```

See the following examples and the `metainit(1M)` man page for more information.

### 3 To add the second submirror, use one of the following methods:

- From the Enhanced Storage tool within the Solaris Management Console, open the Volumes node, then choose the mirror you want to modify. Choose Action⇒Properties, then the Submirrors. Follow the onscreen instructions to attach the submirror. For more information, see the online help.
- Use the following form of the `metattach` command:

```
# metattach volume-name submirror-name
volume-name      Specifies the name of the RAID-1 volume on which to add the submirror
submirror-name   Specifies the name of the component that will be the second submirror
                 attached to the mirror
```

See the following examples and the `metattach(1M)` man page for more information.

### Example 11-1 Creating a Two-Way Mirror

```
# metainit d51 1 1 c0t0d0s2
d51: Concat/Stripe is setup
# metainit d52 1 1 c1t0d0s2
d52: Concat/Stripe is setup
# metainit d50 -m d51
d50: Mirror is setup
# metattach d50 d52
d50: Submirror d52 is attached
```

This example shows you how to create the two-way mirror, `d50`. The `metainit` command creates two submirrors (`d51` and `d52`), which are RAID-0 volumes. The `metainit -m` command creates the one-way mirror from the `d51` RAID-0 volume. The `metattach` command attaches `d52`, creating a two-way mirror and causing a resynchronization. Any data on the attached submirror is overwritten by the other submirror during the resynchronization.

### Example 11-2 Creating a Two-Way Mirror Without Resynchronization

```
# metainit d51 1 1 c0t0d0s2
d51: Concat/Stripe is setup
# metainit d52 1 1 c1t0d0s2
d52: Concat/Stripe is setup
# metainit d50 -m d51 d52
metainit: d50: WARNING: This form of metainit is not recommended.
The submirrors may not have the same data.
Please see ERRORS in metainit(1M) for additional information.
d50: Mirror is setup
```

This example shows the creation a two-way mirror, `d50`. The `metainit` command creates two submirrors (`d51` and `d52`), which are RAID-0 volumes. The `metainit -m` command is then run with both submirrors to create the mirror. When you create a mirror using the `metainit` command rather than the `metattach` command, no resynchronization operations occur. As a result, data could become corrupted when Solaris Volume Manager assumes that both sides of the mirror are identical and can be used interchangeably.

**See Also** To prepare a newly created mirror for a file system, see Chapter 18, “Creating UFS, TMPFS, and LOFS File Systems (Tasks),” in *System Administration Guide: Devices and File Systems*. Some applications, such as a database, do not use a file system. These applications instead use the raw device. The application must have its own way of accessing the raw device.

## ▼ How to Create a RAID-1 Volume From a File System

Use this procedure to mirror an existing file system. If the file system can be unmounted, the entire procedure can be completed without a reboot. For file systems that cannot be unmounted, such as `/usr` and `/swap`, the system must be rebooted to complete the procedure.

When creating a RAID-1 volume from an existing file system built on a slice, only the single slice may be included in the primary RAID-0 volume (submirror). If you are mirroring system-critical file systems, all submirrors must consist of only a single slice.

For the procedures associated with mirroring the root (`/`) file system, see [“SPARC: How to Create a RAID-1 Volume From the root \(`/`\) File System”](#) on page 113 and [“x86: How to Create a RAID-1 Volume From the root \(`/`\) File System”](#) on page 117.

In the example used in this procedure, the existing slice is `c1t0d0s0`. The second slice, `c1t1d0s0`, is available for the second half of the mirror. The submirrors are `d1` and `d2`, respectively, and the mirror is `d0`.



---

**Caution** – Be sure to create a one-way mirror with the `metainit` command then attach the additional submirrors with the `metatatch` command. When the `metatatch` command is not used, no resynchronization operations occur. As a result, data could become corrupted when Solaris Volume Manager assumes that both sides of the mirror are identical and can be used interchangeably.

---

**Before You Begin** Check [“Prerequisites for Creating Solaris Volume Manager Components”](#) on page 44 and [“Creating and Maintaining RAID-1 Volumes”](#) on page 97.

**1 Identify the slice that contains the existing file system to be mirrored** This example uses the slice `c1t0d0s0`.

**2 Create a new RAID-0 volume on the slice from the previous step by using one of the following methods:**

- From the Enhanced Storage tool within the Solaris Management Console, open the Volumes node, then choose Action⇒Create Volume. Follow the onscreen instructions. For more information, see the online help.
- Use the following form of the `metainit` command:

```
# metainit -f volume-name number-of-stripes components-per-stripe component-name
```

`-f` Forces the command to continue. You must use this option when the slice contains a mounted file system.

`volume-name` Specifies the name of the volume to create. For information on naming volumes, see [“Volume Names”](#) on page 40.

`number-of-stripes` Specifies the number of stripes to create.

<i>components-per-stripe</i>	Specifies the number of components each stripe should have.
<i>component-names</i>	Specifies the names of the components that are used. This example uses the root slice, <code>c0t0d0s0</code> .

**3 Create a second RAID-0 volume (concatenation) on an unused slice (`c1t1d0s0` in this example) to act as the second submirror. The second submirror must be the same size as the original submirror or larger. Use one of the following methods:**

- From the Enhanced Storage tool within the Solaris Management Console, open the Volumes node, then choose Action->Create Volume and follow the instructions on screen. For more information, see the online help.
- Use the following form of the `metainit` command.

```
# metainit volume-name number-of-stripes components-per-stripe component-name
```

---

**Note** – See Step 2 for an explanation of the options.

---

**4 Create a one-way mirror by using one of the following methods:**

- From the Enhanced Storage tool within the Solaris Management Console, open the Volumes node, then choose Action⇒Create Volume. Follow the onscreen instructions. For more information, see the online help.
- Use the following form of the `metainit` command.

```
# metainit volume-name -m submirror-name
```

*volume-name* Specifies the name of the volume to create.

`-m` Specifies to create a mirror.

*submirror-name* Specifies the name of the component that will be the first submirror in the mirror. In this example, it is the RAID-0 volume that contains the root slice.

See the `metainit(1M)` man page for more information.



---

**Caution** – When you create a mirror from an existing file system, you must follow the next two steps precisely to avoid data corruption.

---

**5 Edit the `/etc/vfstab` file so that the file system mount instructions refer to the mirror, not to the block device. For more information about the `/etc/vfstab` file, see “Mounting File Systems” in *System Administration Guide: Devices and File Systems*.**

For example, if the `/etc/vfstab` file contains the following entry for the file system:

```
/dev/dsk/slice /dev/rdisk/slice /var ufs 2 yes -
```

Change the entry to read as follows:

```
/dev/md/dsk/mirror-name /dev/md/rdisk/mirror-name /var ufs 2 yes -
```

## 6 Remount your newly mirrored file system according to one of the following procedures:

- If you are mirroring a file system that can be unmounted, then unmount and remount the file system.

```
# umount /filesystem
# mount /filesystem
```

- If you are mirroring a file system that cannot be unmounted, then reboot your system.

```
# reboot
```

## 7 Use the following form of the `metattach` command to attach the second submirror.

```
# metattach volume-name submirror-name
```

*volume-name* Specifies the name of the RAID-1 volume on which to add the submirror

*submirror-name* Specifies the name of the component that will be the second submirror attached to the mirror

See the `metattach(1M)` man page for more information.

### Example 11-3 Creating a Two-Way Mirror From a File System That Can Be Unmounted

```
# metainit -f d1 1 1 c1t0d0s0
d1: Concat/Stripe is setup
# metainit d2 1 1 c1t1d0s0
d2: Concat/Stripe is setup
# metainit d0 -m d1
d0: Mirror is setup
# umount /master
    (Edit the /etc/vfstab file so that the file system references the mirror)
# mount /master
# metattach d0 d2
d0: Submirror d2 is attached
```

In this example, the `-f` option forces the creation of the first concatenation, `d1`, which contains the mounted file system `/master` on `/dev/dsk/c1t0d0s0`. The second concatenation, `d2`, is created from `/dev/dsk/c1t1d0s0`. This slice must be the same size as, or larger than the size of `d1`.) The `metainit` command with the `-m` option creates the one-way mirror, `d0`, from `d1`.

Next, the entry for the file system should be changed in the `/etc/vfstab` file to reference the mirror. The following line in the `/etc/vfstab` file initially appears as follows:

```
/dev/dsk/c1t0d0s0 /dev/rdisk/c1t0d0s0 /var ufs 2 yes -
```

The entry is changed to the following:

```
/dev/md/dsk/d0 /dev/md/rdisk/d0 /var ufs 2 yes -
```

Finally, the file system is remounted and submirror d2 is attached to the mirror, causing a mirror resynchronization. The system confirms that the RAID-0 and RAID-1 volumes are set up, and that submirror d2 is attached.

#### Example 11-4 Creating a Two-way Mirror From a File System That Cannot Be Unmounted

```
# metainit -f d12 1 1 c0t3d0s6
d12: Concat/Stripe is setup
# metainit d22 1 1 c1t0d0s6
d22: Concat/Stripe is setup
# metainit d2 -m d12
d2: Mirror is setup
    (Edit the /etc/vfstab file so that /usr references the mirror)
# reboot
...
# metattach d2 d22
d2: Submirror d22 is attached
```

This example creates a two-way mirror using a slice containing the `/usr` file system. The `-f` option forces the creation of the first concatenation, `d12`, which contains the mounted file system `/usr` on `/dev/dsk/c0t3d0s6`. The second concatenation, `d22`, is created from `/dev/dsk/c1t0d0s6`. This slice must be the same size as, or larger than the size of `d12`. The `metainit` command with the `-m` option creates the one-way mirror `d2` using the concatenation that contains the `/usr` file system. Next, the `/etc/vfstab` file must be edited to change the entry for `/usr` to reference the mirror.

The `/etc/vfstab` file contains the following entry for the `/usr` file system:

```
/dev/dsk/c0t3d0s6 /dev/rdisk/c0t3d0s6 /usr ufs 1 yes -
```

Change the entry to read as follows:

```
/dev/md/dsk/d2 /dev/md/rdisk/d2 /usr ufs 1 yes -
```

After a reboot, the second submirror `d22` is attached to the mirror, causing a mirror resynchronization.

#### Example 11-5 Creating a Mirror From the `/swap` Space

```
# metainit -f d11 1 1 c0t0d0s1
d11: Concat/Stripe is setup
# metainit d21 1 1 c1t0d0s1
```



```

d21: Concat/Stripe is setup
# metainit d1 -m d11
d1: Mirror is setup
    (Edit the /etc/vfstab file so that swap references the mirror)
# reboot
...
# metattach d1 d21
d1: Submirror d21 is attached

```

In this example, the `-f` option forces the creation of the first concatenation, `d11`, which contains the mounted file system `swap` on `/dev/dsk/c0t0d0s1`. The second concatenation, `d21`, is created from `/dev/dsk/c1t0d0s1`. This slice must be the same size as, or larger than the size of `d11`. The `metainit` command with the `-m` option creates the one-way mirror `d1` using the concatenation that contains `swap`. Next, if there is an entry for `swap` in the `/etc/vfstab` file, it must be edited to reference the mirror.

The `/etc/vfstab` file contains the following entry for the swap space:

```
/dev/dsk/c0t0d0s1 - - swap - no -
```

Change the entry to read as follows:

```
/dev/md/dsk/d1 - - swap - no -
```

After a reboot, the second submirror `d21` is attached to the mirror, causing a mirror resynchronization.

To save the crash dump when you have mirrored the swap space, use the `dumpadm` command to configure the dump device as a volume. For instance, if the swap device is named `/dev/md/dsk/d2`, use the `dumpadm` command to set this device as the dump device.

## ▼ SPARC: How to Create a RAID-1 Volume From the root (/) File System

The process for mirroring the root (`/`) file system on a SPARC platform is similar to mirroring any other file system that you cannot unmount. The procedure differs in that the `metaroot` command is run instead of manually editing the `/etc/vfstab` file. Mirroring the root (`/`) file system also requires recording the path to the alternate boot device. This device reboots the system if the submirror fails.

In the example used in this procedure, the existing slice is `c1t0d0s0`. The second slice, `c1t1d0s0`, is available for the second half of the mirror. The submirrors are `d1` and `d2`, respectively, and the mirror is `d0`.



---

**Caution** – Be sure to create a one-way mirror with the `metainit` command then attach the additional submirrors with the `metattach` command. When the `metattach` command is not used, no resynchronization operations occur. As a result, data could become corrupted when Solaris Volume Manager assumes that both sides of the mirror are identical and can be used interchangeably.

---

**Before You Begin** Check “Prerequisites for Creating Solaris Volume Manager Components” on page 44 and “Creating and Maintaining RAID-1 Volumes” on page 97.

**1 Identify the slice that contains the existing root (/) file system to be mirrored. This example uses the slice `c1t0d0s0`.**

**2 Create a new RAID-0 volume on the slice from the previous step by using one of the following methods. Only the single slice can be included in the RAID-0 volume.**

- From the Enhanced Storage tool within the Solaris Management Console, open the Volumes node, then choose Action⇒Create Volume. Follow the onscreen instructions. For more information, see the online help.
- Use the following form of the `metainit` command:

```
# metainit -f volume-name number-of-stripes components-per-stripe component-name
```

`-f` Forces the command to continue. You must use this option when the slice contains a mounted file system.

`volume-name` Specifies the name of the volume to create. For information on naming volumes, see “Volume Names” on page 40.

`number-of-stripes` Specifies the number of stripes to create.

`components-per-stripe` Specifies the number of components each stripe should have.

`component-names` Specifies the names of the components that are used. This example uses the root slice, `c0t0d0s0`.

**3 Create a second RAID-0 volume on an unused slice (`c1t1d0s0` in this example) to act as the second submirror. The secondary submirror must be the same size as the original submirror, or larger. Use one of the following methods:**

- From the Enhanced Storage tool within the Solaris Management Console, open the Volumes node, then choose Action->Create Volume and follow the instructions on screen. For more information, see the online help.
- Use the following form of the `metainit` command.

```
# metainit volume-name number-of-stripes components-per-stripe component-name
```

---

**Note** – See Step 2 for and explanation of the options.

---

#### 4 Create a one-way mirror by using one of the following methods:

- From the Enhanced Storage tool within the Solaris Management Console, open the Volumes node, then choose Action⇒Create Volume. Follow the onscreen instructions. For more information, see the online help.
- Use the following form of the `metainit` command.

```
# metainit volume-name -m submirror-name
```

*volume-name* Specifies the name of the volume to create.

`-m` Specifies to create a mirror.

*submirror-name* Specifies the name of the component that will be the first submirror in the mirror. In this example, it is the RAID-0 volume that contains the root slice.

#### 5 Remount your newly mirrored file system. Run the `metaroot volume-name` command, replacing *volume-name* with the name of the mirror you have created. Then, reboot your system.

```
# metaroot volume-name
# reboot
```

For more information, see the `metaroot(1M)` man page.

#### 6 Use the following form of the `metattach` command to attach the second submirror.

```
# metattach volume-name submirror-name
```

*volume-name* Specifies the name of the RAID-1 volume on which to add the submirror

*submirror-name* Specifies the name of the component that will be the second submirror attached to the mirror

See the `metattach(1M)` man page for more information.

#### 7 Record the alternate boot path.

- a. Determine the path to the alternate root device. Use the `ls -l` command on the slice that is being attached as the second submirror to the root (/) file system mirror.

```
# ls -l /dev/dsk/c1t1d0s0
lrwxrwxrwx 1 root root 55 Mar 5 12:54 /dev/rdisk/c1t1d0s0 -> \
../../devices/sbus@1,f8000000/esp@1,200000/sd@3,0:a
```

- b. Record the string that follows the `/devices` directory:

```
/sbus@1,f8000000/esp@1,200000/sd@3,0:a.
```

---

**Note** – Because the system might not be available, this information should also be written down somewhere other than on the system. See [“Recovering From Boot Problems” on page 281](#) for details on booting from the alternate boot device.

---

- c. **Edit the string to change the major name (sd, in this case) to disk, resulting in /sbus@1,f8000000/esp@1,200000/disk@3,0:a. If the system uses an IDE bus, the original full path might look like**

```
$ ls -l /dev/dsk/c1t1d0s0
lrwxrwxrwx 1 root root 38 Mar 13 15:03 /dev/dsk/c0t0d0s0 -> \
../../../../devices/pci@1f,0/ide@d/dad@0,0:a
```

After changing the major name dad to disk, you would have /pci@1f,0/ide@d/disk@0,0:a

- d. **Use the OpenBoot™ PROM nvalias command to define a “backup root” device alias for the secondary root (/) file system mirror. For example:**

```
ok nvalias backup_root /sbus@1,f8000000/esp@1,200000/disk@3,0:a
```

- e. **Redefine the boot-device alias to reference both the primary and secondary submirrors, in the order in which you want them to be used, and store the configuration.**

```
ok printenv boot-device
boot-device =          disk net
ok setenv boot-device disk backup_root net
boot-device =          disk backup_root net
ok nvstore
```

---

**Note** – In the event that the primary submirror fails, the system would automatically boot to the second submirror. Or, if you boot manually, rather than using autoboot, you would enter:

```
ok boot backup_root
```

---

### Example 11–6 SPARC: Creating a Mirror From the root (/) File System

```
# metainit -f d1 1 1 c0t0d0s0
d1: Concat/Stripe is setup
# metainit d2 1 1 c0t1d0s0
d2: Concat/Stripe is setup
# metainit d0 -m d1
d0: Mirror is setup
# metaroot d0
# lockfs -fa
# reboot
...
# metattach d0 d2
```

```

d0: Submirror d2 is attached
# ls -l /dev/dsk/c0t1d0s0
lrwxrwxrwx  1 root    root          88 Feb  8 15:51 /dev/rdisk/c1t3d0s0 ->
../../../../devices/pci@1f,0/pci@1,1/ide@3/dad@0,0:a
# init 0
.
.
.
ok nvalias backup_root /pci@1f,0/pci@1,1/ide@3/disk@0,0:a
ok setenv boot-device disk backup_root net
ok nvstore

```

In this example, the `-f` option forces the creation of the first RAID-0 volume, `d1`, which contains the mounted root (`/`) file system on `/dev/dsk/c0t0d0s0`. The second concatenation, `d2`, is created from `/dev/dsk/c0t1d0s0`. This slice must be the same size as, or larger than the size of `d1`. The `metainit` command with the `-m` option creates the one-way mirror `d0` using the concatenation that contains root (`/`).

Next, the `metaroot` command edits the `/etc/vfstab` and `/etc/system` files so that the system can be booted with the root (`/`) file system on a volume. It is a good idea to run the `lockfs -fa` command before rebooting. For more information, see the `lockfs(1M)` man page.

Do not attach the second submirror before the system is rebooted. You must reboot after running the `metaroot` command and before attaching the second submirror.

After a reboot, the submirror `d2` is attached to the mirror, causing a mirror resynchronization. The system confirms that the concatenations and the mirror are set up, and that submirror `d2` is attached.

The `ls -l` command is run on the root raw device to determine the path to the alternate root device in case the system might later need to be booted from it.

## ▼ x86: How to Create a RAID-1 Volume From the root (`/`) File System

The process for mirroring the root (`/`) file system on an x86 based system is similar to mirroring root on a SPARC system. However, on x86 based systems, the BIOS and `fdisk` partitioning add an additional layer of complexity.

In the example used in the procedures, the existing slice is `c1t0d0s0`. The second slice, `c1t1d0s0`, is available for the second half of the mirror. The submirrors are `d1` and `d2`, respectively, and the mirror is `d0`.

**Before You Begin** Before implementing any of the procedures, check “Prerequisites for Creating Solaris Volume Manager Components” on page 44 and “Creating and Maintaining RAID-1 Volumes” on page 97.

## 1 Verify that the ordering for the BIOS boot device can be configured to allow the system to boot off of the second disk in the mirror.

Before the kernel is started, the system is controlled by the read-only-memory (ROM) Basic Input/Output System (BIOS), which is the firmware interface on an x86 based system. The BIOS is analogous to the boot PROM on a SPARC based system. Some of the BIOS's tasks are as follows:

- Perform startup functions.
- Detect the correct device from which to boot the system.
- Load the master boot record from that device to allow the system to self-boot.

You can usually configure the BIOS to select the order of devices to probe for the boot record. Additionally, most modern BIOS implementations allow you to configure your devices so that the failover to the secondary submirror is automatic. If your system's BIOS does not have this feature and the primary submirror fails, you need to access the BIOS during system boot to reconfigure the system to boot from the secondary root slice. Consult the user's guide for your BIOS for instructions on how to configure settings in your BIOS

Before setting up a root mirror, check the BIOS on your system to verify that you can boot off of more than one disk. Some device drivers are configured to only see one disk on the system.

## 2 Verify that the `fdisk` partitions are configured to support root mirroring.

The existence of a separate x86 boot partition presents a problem when mirroring the root (`/`) file system. Because it exists outside of the Solaris `fdisk` partition, the x86 boot partition cannot be mirrored by Solaris Volume Manager. Additionally, because only one copy of the x86 boot partition exists, it represents a single point of failure.

The GRUB-based installation program of the Solaris 10 1/06 software and subsequent releases no longer automatically creates an x86 boot partition. However, if the x86 already exists in the system, the installation program preserves that partition by default.

To determine if your system has a separate x86 boot partition, check the `/etc/vfstab` file. The x86 boot partition exists if the file contains an entry similar to the following:

```
/dev/dsk/c2t1d0p0:boot - /boot pcfs - no -
```

To use the Solaris Volume Manager to mirror the root (`/`) file system, the file system must use the single Solaris `fdisk` partition. Therefore, if the x86 boot partition already exists in the system, delete this partition with the `fdisk` command and then reinstall the Solaris software. When you reinstall, the boot partition is no longer recreated.

---

**Note** – Solaris Volume Manager can only mirror slices within the Solaris `fdisk` partition. If you have multiple `fdisk` partitions, you need to use another approach to protect the data outside of the Solaris `fdisk` partition.

---

### 3 Make the secondary submirror bootable with a master boot program.

#### a. Specify the master boot program.

```
# fdisk -b /usr/lib/fs/ufs/mboot /dev/rdisk/c1t1d0p0
```

The following screen appears:

```

Total disk size is 31035 cylinders
Cylinder size is 1146 (512 byte) blocks

          Cylinders
Partition  Status  Type          Start  End  Length  %
=====  =====  =====
          1      Active  Solaris       1 31034 31034 100

```

SELECT ONE OF THE FOLLOWING:

1. Create a partition
2. Specify the active partition
3. Delete a partition
4. Change between Solaris and Solaris2 Partition IDs
5. Exit (update disk configuration and exit)
6. Cancel (exit without updating disk configuration)

Enter Selection:

#### b. Choose number 5 from the menu, and press return.

### 4 Make the secondary disk bootable.

```
# /sbin/installgrub /boot/grub/stage1 /boot/grub/stage2 /dev/rdisk/c1t1d0s0
```

For more information about `installgrub`, refer to the `installgrub(1M)` man page.

### 5 Identify the slice that contains the existing root (/) file system to be mirrored.

This example uses the slice `c1t0d0s0`.

### 6 Create a new RAID-0 volume on the slice from the previous step.

Only the single slice can be included in the RAID-0 volume. Use one of the following methods:

- From the Enhanced Storage tool within the Solaris Management Console, open the Volumes node, then choose Action⇒Create Volume. Follow the onscreen instructions. For more information, see the online help.
- Use the following form of the `metainit` command:

```
# metainit -f volume-name number-of-stripes components-per-stripe component-name
```

- f	Forces the command to continue. You must use this option when the slice contains a mounted file system.
<i>volume-name</i>	Specifies the name of the volume to create. For information on naming volumes, see “Volume Names” on page 40.
<i>number-of-stripes</i>	Specifies the number of stripes to create.
<i>components-per-stripe</i>	Specifies the number of components each stripe should have.
<i>component-names</i>	Specifies the names of the components that are used. This example uses the root slice, <code>c0t0d0s0</code> .

**7 Create a second RAID-0 volume (c1t1d0s0 in this example) on an unused slice to act as the second submirror.**

---

**Note** – The secondary submirror must be the same size as the original submirror, or larger. Also, the slice you use as the second submirror must have a slice tag of “root” and the root slice must be slice 0.

For information on configuring the slice tag field, see the `format(1M)` man page.

---

Use either of the following methods:

- From the Enhanced Storage tool within the Solaris Management Console, open the Volumes node, then choose Action->Create Volume and follow the instructions on screen. For more information, see the online help.
- Use the following form of the `metainit` command.

```
# metainit volume-name number-of-stripes components-per-stripes component-names
```

---

**Note** – See Step 6 for an explanation of the options.

---

**8 Create a one-way mirror by using one of the following methods:**

- From the Enhanced Storage tool within the Solaris Management Console, open the Volumes node, then choose Action=>Create Volume. Follow the onscreen instructions. For more information, see the online help.
- Use the following form of the `metainit` command.

```
# metainit volume-name -m submirror-name
```

*volume-name* Specifies the name of the volume to create.

-m Specifies to create a mirror.

*submirror-name* Specifies the name of the component that will be the first submirror in the mirror. In this example, it is the RAID-0 volume that contains the root slice.



**9 Remount your newly mirrored file system, then reboot the system.**

```
# metaroot volume-name
# reboot
```

For more information, see the `metaroot(1M)` man page.

**10 Attach the second submirror.**

```
# metattach volume-name submirror-name
```

*volume-name* Specifies the name of the RAID-1 volume on which to add the submirror.

*submirror-name* Specifies the name of the component that will be the second submirror attached to the mirror.

See the `metattach(1M)` man page for more information.

**11 Define the alternative boot path in the `menu.lst` file.**

To enable the system to boot off of the disk that holds the secondary submirror, configure the system to see the disk as the alternate boot device. In the current example, `c1t1d0s0`, the alternative path is on the first slice of the first fdisk partition on the second disk. Thus, you would edit the `menu.lst` with the following entry:

```
title alternate boot
  root (hd1,0,a)
  kernel /boot/multiboot
  module /boot/x86.miniroot-safe
```

---

**Note** – To properly edit entries in `menu.lst`, you must be familiar with disk-naming conventions in GRUB. For details, see Chapter 11, “GRUB Based Booting (Tasks),” in *System Administration Guide: Basic Administration*

---

After you have completed editing the `menu.lst` file, the system is set to failover to the second disk. If the primary disk fails, disk numbering changes so that the system boots from the secondary disk.



**Caution** – On certain cases, the automatic disk-renumbering feature of the BIOS might affect recovery from an unavailable primary disk. When disk renumbering forces the system to boot from the secondary disk, the primary disk’s boot archive becomes stale. If the same primary disk becomes available later and you boot the system, the disk numbering switches again to use the default primary disk for the system boot. However, at this stage, the primary disk’s boot archive remains stale. Consequently, the system might not boot at all. Therefore make sure that in such cases, you select the correct entry from the GRUB menu to boot the system from the valid boot archive. After the system completes the boot up process, perform the normal `metadevice` maintenance which synchronizes both primary and secondary disks and restores the valid boot archive to the primary disk.

---

## Understanding Boot Time Warnings When Mirroring the root (/) File System

After you mirror your root (/) file system, error messages will be displayed in the console and logged in the system log that is defined in the `/etc/syslog.conf` file. These error messages do not indicate a problem. These messages are displayed for each device type that you are not currently using, because an unused module cannot be force loaded. The error messages are similar to the following:

```
Jul 13 10:17:42 ifr genunix: [ID 370176 kern.warning] WARNING: forcload of
misc/md_trans failed
Jul 13 10:17:42 ifr genunix: [ID 370176 kern.warning] WARNING: forcload of
misc/md_raid failed
Jul 13 10:17:42 ifr genunix: [ID 370176 kern.warning] WARNING: forcload of
misc/md_hotspares failed
```

You can safely disregard these error messages.

## Working With Submirrors

### ▼ How to Attach a Submirror

---

**Note** – An error message stating “can’t attach labeled submirror to an unlabeled mirror” indicates that you unsuccessfully attempted to attach a RAID-0 volume to a mirror. A labeled volume (submirror) is a volume whose first component starts at cylinder 0, while an unlabeled volume’s first component starts at cylinder 1. To prevent the labeled submirror’s label from being corrupted, Solaris Volume Manager does not allow labeled submirrors to be attached to unlabeled mirrors.

---

**Before You Begin** Read [“Creating and Maintaining RAID-1 Volumes”](#) on page 97.

**1 Identify the component (concatenation or stripe) to be used as a submirror.**

The component must be the same size as, or larger than the existing submirror in the mirror. If you have not yet created a volume to be a submirror, see [“Creating RAID-0 \(Stripe\) Volumes”](#) on page 84 or [“Creating RAID-0 \(Concatenation\) Volumes”](#) on page 85.

**2 Make sure that you have root privilege and that you have a current backup of all data.**

**3 Verify that the status of the mirror you want to work with is in an “Okay” state using the `metastat` command.**

```
# metastat mirror
```

#### 4 Use one of the following methods to attach a submirror.

- From the Enhanced Storage tool within the Solaris Management Console, open the Volumes node. Choose the mirror. Then, choose Action⇒Properties and click the Submirror tab. Follow the onscreen instructions. For more information, see the online help.
- Use the `metattach mirror submirror` command.

```
# metattach mirror submirror
```

See the `metattach(1M)` man page for more information.

#### 5 View the status of the mirror using the `metastat` command.

```
# metastat mirror
```

### Example 11-7 Attaching a Submirror

```
# metastat d30
d30: mirror
    Submirror 0: d60
    State: Okay
...
# metattach d30 d70
d30: submirror d70 is attached
# metastat d30
d30: mirror
    Submirror 0: d60
    State: Okay
    Submirror 1: d70
    State: Resyncing
    Resync in progress: 41 % done
    Pass: 1
    Read option: roundrobin (default)
    Write option: parallel (default)
    Size: 2006130 blocks
...
```

This example shows the attaching of a submirror, `d70`, to a one-way mirror, `d30`. You create a two-way mirror when you attach the submirror to the mirror. The mirror `d30` initially consists of submirror `d60`. The submirror `d70` is a RAID-0 volume. You verify that the status of the mirror is “Okay” with the `metastat` command, then attach the submirror. When the `metattach` command is run, the new submirror is resynchronized with the existing mirror. When you attach an additional submirror to the mirror, the system displays a message. To verify that the mirror is resynchronizing, use the `metastat` command.

## ▼ How to Detach a Submirror

**Before You Begin** Read “Creating and Maintaining RAID-1 Volumes” on page 97.

- 1 **Make sure that you have root privilege. Make sure that you have a current backup of all data.**
- 2 **Verify that the status of the mirror you want to work with is in an “Okay” state using the `metastat` command.**
- 3 **Use one of the following methods to detach a submirror.**
  - From the Enhanced Storage tool within the Solaris Management Console, open the Volumes node. Choose the mirror. Then, choose Action⇒Properties and click the Submirror tab. Follow the onscreen instructions. For more information, see the online help.
  - Use the `metadetach` command to detach a submirror from a mirror.

```
# metadetach mirror submirror
```

See the `metadetach(1M)` man page for more information.

### Example 11–8 Detaching a Submirror

```
# metastat
d5: mirror
   Submirror 0: d50
...
# metadetach d5 d50
d5: submirror d50 is detached
```

In this example, mirror `d5` has a submirror, `d50`. You detach the submirror with the `metadetach` command. The underlying slices from `d50` can be reused elsewhere. After the submirror is detached from the mirror, the system displays a confirmation message.

## ▼ How to Place a Submirror Offline and Online

The `metaonline` command can only be used when a submirror was taken offline by the `metaoffline` command. After the `metaonline` command runs, Solaris Volume Manager automatically begins resynchronizing the submirror with the mirror.

---

**Note** – The `metaoffline` command’s capabilities are similar to the capabilities offered by the `metadetach` command. However, the `metaoffline` command does not sever the logical association between the submirror and the mirror.

---

**Before You Begin** Read [“Creating and Maintaining RAID-1 Volumes”](#) on page 97.

- 1 **Make sure that you have root privilege and that you have a current backup of all data.**
- 2 **Use one of the following methods to place a submirror online or offline.**
  - From the Enhanced Storage tool within the Solaris Management Console, open the Volumes node. Choose the mirror. Then, choose Action⇒Properties and click the Submirror tab. Follow the onscreen instructions . For more information, see the online help.
  - Use the `metaoffline` command to a submirror offline.
 

```
# metaoffline mirror submirror
```

See the `metaoffline(1M)` man page for more information.
  - Use the `metaonline` command to place a submirror online.
 

```
# metaonline mirror submirror
```

See the `metaonline(1M)` man page for more information.

#### Example 11–9 Placing a Submirror Offline

```
# metaoffline d10 d11
d10: submirror d11 is offlined
```

In this example, submirror d11 is taken offline from mirror d10. Reads continue to be made from the other submirror. The mirror is out of sync as soon as the first write is made. This inconsistency is corrected when the offlined submirror is brought back online.

#### Example 11–10 Placing a Submirror Online

```
# metaonline d10 d11d10: submirror d11 is onlined
```

In this example, submirror d11 is brought back online in mirror d10.

## ▼ How to Enable a Slice in a Submirror

**Before You Begin** Read [“Overview of Replacing and Enabling Components in RAID-1 and RAID-5 Volumes”](#) on page 228 and [“Creating and Maintaining RAID-1 Volumes”](#) on page 97.

- 1 **Make sure that you have root privilege and that you have a current backup of all data.**
- 2 **Use one of the following methods to enable a slice in a submirror.**

- From the Enhanced Storage tool within the Solaris Management Console, open the Volumes node. Choose the mirror. Then, choose Action⇒Properties and click the Submirror tab. Follow the onscreen instructions. For more information, see the online help.
- Use the `metareplace` command to enable a failed slice in a submirror.

```
# metareplace -e mirror failed-slice
```

The `metareplace` command automatically starts a resynchronization to synchronize the repaired or replaced slice with the rest of the mirror.

See the `metareplace(1M)` man page for more information.

### Example 11-11 Enabling a Slice in a Submirror

```
# metareplace -e d11 c1t4d0s7
d11: device c1t4d0s7 is enabled
```

In this example, the mirror `d11` has a submirror that contains slice, `c1t4d0s7`, which had a soft error. The `metareplace` command with the `-e` option enables the failed slice.

If a physical disk is defective, you can replace it with another available disk (and its slices) on the system as documented in “[How to Replace a Slice in a Submirror](#)” on page 135. Alternatively, you can repair or replace the disk, format it, and then run the `metareplace` command with the `-e` option as shown in this example.

## Maintaining RAID-1 Volumes

### ▼ How to View the Status of Mirrors and Submirrors

**Before You Begin** For an overview of the status information associated with RAID-1 volumes and submirrors, see “[Understanding Submirror Status to Determine Maintenance Actions](#)” on page 101.

#### ► Use one of the following methods to check mirror or submirror status.

- From the Enhanced Storage tool within the Solaris Management Console, open the Volumes node. Choose the mirror. Then, choose Action⇒Properties. Follow the onscreen instructions. For more information, see the online help.
- Run the `metastat` command on the mirror to view the status of each submirror.

```
# metastat mirror
```

See “[How to Change RAID-1 Volume Options](#)” on page 128 to change a mirror’s pass number, read option, or write option.

See `metastat(1M)` for more information about checking device status.

### Example 11-12 Checking Status of RAID-1 Volumes

Here is sample output from the `metastat` command. Use `metastat` command without a mirror name to display all the status of all mirrors.

```
# metastatd70: Mirror
  Submirror 0: d71
    State: Okay
  Pass: 1
  Read option: roundrobin (default)
  Write option: parallel (default)
  Size: 12593637 blocks

d71: Submirror of d70
  State: Okay
  Size: 12593637 blocks
  Stripe 0:
    Device          Start Block  Dbase State      Reloc Hot Spare
    c1t3d0s3         0           No  Okay        Yes
  Stripe 1:
    Device          Start Block  Dbase State      Reloc Hot Spare
    c1t3d0s4         0           No  Okay        Yes
  Stripe 2:
    Device          Start Block  Dbase State      Reloc Hot Spare
    c1t3d0s5         0           No  Okay        Yes

d0: Mirror
  Submirror 0: d1
    State: Okay
  Submirror 1: d2
    State: Okay
  Pass: 1
  Read option: roundrobin (default)
  Write option: parallel (default)
  Size: 5600 blocks

d1: Submirror of d0
  State: Okay
  Size: 5600 blocks
  Stripe 0:
    Device          Start Block  Dbase State      Hot Spare
    c0t2d0s7         0           No  Okay

...
```

Use the `metastat` command with a mirror name argument to display output for a specific mirror.

```

metastat d70
d70: Mirror
  Submirror 0: d71
    State: Okay
    Pass: 1
    Read option: roundrobin (default)
    Write option: parallel (default)
    Size: 12593637 blocks

d71: Submirror of d70
  State: Okay
  Size: 12593637 blocks
  Stripe 0:
    Device          Start Block  Dbase State      Reloc Hot Spare
    c1t3d0s3         0           No  Okay        Yes
  Stripe 1:
    Device          Start Block  Dbase State      Reloc Hot Spare
    c1t3d0s4         0           No  Okay        Yes
  Stripe 2:
    Device          Start Block  Dbase State      Reloc Hot Spare
    c1t3d0s5         0           No  Okay        Yes

```

For each submirror in the mirror, the `metastat` command shows the status, an “invoke” line if there is an error, the assigned hot spare pool (if any), the size in blocks, and information about each slice in the submirror.

## ▼ How to Change RAID-1 Volume Options

**Before You Begin** Check “[About RAID-1 Volume Options](#)” on page 99.

- 1 **Make sure that you have root privilege and that you have a current backup of all data.**
- 2 **Use one of the following methods to change the RAID-1 options.**
  - From the Enhanced Storage tool within the Solaris Management Console, open the Volumes node. Choose the mirror. Then, choose Action⇒Properties. Follow the onscreen instructions. For more information, see the online help.
  - Use the `metaparam` command to display and change a mirror’s options.

```
# metaparam [mirror options] mirror
```

See “[About RAID-1 Volume Options](#)” on page 99 for a description of mirror options. Also, see the `metaparam(1M)` man page.



**Example 11-13** Changing a RAID-1 Volume's Read Policy

```
# metaparam -r geometric d30
# metaparam d30
d30: mirror current parameters are:
    Pass: 1
    Read option: geometric (-g)
    Write option: parallel (default)
```

In this example, the `-r` option changes a mirror's read policy to `geometric`.

**Example 11-14** Changing a RAID-1 Volume's Write Policy

```
# metaparam -w serial d40
# metaparam d40
d40: mirror current parameters are:
    Pass: 1
    Read option: roundrobin (default)
    Write option: serial (-S)
```

In this example, the `-w` option changes a mirror's write policy to `serial`.

**Example 11-15** Changing a RAID-1 Volume's Pass Number

```
# metaparam -p 5 d50
# metaparam d50
d50: mirror current parameters are:
    Pass: 5
    Read option: roundrobin (default)
    Write option: parallel (default)
```

In this example, the `-p` option changes a mirror's pass number to 5.

## ▼ How to Expand a RAID-1 Volume

**Before You Begin** Read [“Creating and Maintaining RAID-1 Volumes” on page 97](#).

- 1 **Make sure that you have root privilege and that you have a current backup of all data.**
- 2 **Use one of the following methods to expand a mirror.**
  - From the Enhanced Storage tool within the Solaris Management Console, open the Volumes node. Choose the mirror. Then, choose Action->Properties and click the Submirror tab. Follow the onscreen instructions. For more information, see the online help.
  - Use the `metattach` command to attach additional slices to each submirror.

```
# metattach submirror slice
```

Each submirror in a mirror must be expanded. See the `metattach(1M)` man page for more information.

- 3 Use the `metattach` command to cause the mirror to recompute its size based on the size of the submirror.

```
# metattach mirror
```

### Example 11–16 Expanding a Two-Way Mirror That Contains a Mounted File System

```
# metastat
d8: Mirror
  Submirror 0: d9
    State: Okay
  Submirror 1: d10
    State: Okay
...
# metattach d9 c0t2d0s5
d9: component is attached
# metattach d10 c0t3d0s5
d10: component is attached
# metattach d8
```

This example shows how to expand a mirrored, mounted file system by concatenating two disk drives to the mirror’s two submirrors. The mirror is named `d8` and contains two submirrors named `d9` and `d10`.

**See Also** For a UFS, run the `growfs(1M)` command on the mirror volume. See [“How to Expand a File System” on page 227](#).

An application, such as a database, that uses the raw volume must have its own way of expanding the added storage.

## ▼ How to Cancel a Volume Resynchronization Process

- 1 Assume the Primary Administrator role, or become superuser.

The Primary Administrator role includes the Primary Administrator profile. To create the role and assign the role to a user, see Chapter 2, “Working With the Solaris Management Console (Tasks),” in *System Administration Guide: Basic Administration*.

- 2 Use the `metastat` command to view the status of the RAID-1 volume and associated submirrors.

```
# metastat mirror-name
```

or

```
metastat -a
```

- 3 Use the `metasync -c volume` command to cancel the resynchronization process.

### Example 11-17 Canceling a Volume Resynchronization Process

The following example illustrates how to cancel the resynchronization process on a volume that is part of the disk set `blue`. Notice that the submirrors are in the “Resync cancelled” state after running the `metasync` command.

```
# metastat -a
```

```
blue/d10: Mirror
  Submirror 0: blue/d1
    State: Resyncing
  Submirror 1: blue/d2
    State: Okay
  Resync in progress: 0 % done
  Pass: 1
  Read option: roundrobin (default)
  Write option: parallel (default)
  Size: 10485760 blocks (5.0 GB)

blue/d1: Submirror of blue/d10
  State: Resyncing
  Size: 10485760 blocks (5.0 GB)
  Stripe 0:
    Device                Start Block  Dbase      State Reloc
  Hot Spare
    /dev/dsk/c3t50020F230000FA57d0s0      0      No      Okay   Yes

blue/d2: Submirror of blue/d10
  State: Okay
  Size: 10485760 blocks (5.0 GB)
  Stripe 0:
    Device                Start Block  Dbase      State Reloc
  Hot Spare
    /dev/dsk/c3t50020F230000FA57d0s1      0      No      Okay   Yes
```

```
Device Relocation Information:
Device                               Reloc Device ID
/dev/dsk/c3t50020F230000FA57d0     Yes   id1,ssd@n60020f200000fa574033661f000c641
4
```

```
# metasync -s blue -c d10
Mar 1 12:46:18 SunSystem1 md_mirror: WARNING: md: blue/d10: Resync cancelled
```

```
# metastat -a
```

```
blue/d10: Mirror
  Submirror 0: blue/d1
    State: Resync cancelled
  Submirror 1: blue/d2
    State: Okay
  Resync cancelled: 3 % done
  Pass: 1
  Read option: roundrobin (default)
  Write option: parallel (default)
  Size: 10485760 blocks (5.0 GB)
```

```
blue/d1: Submirror of blue/d10
  State: Resync cancelled
  Invoke: metasync blue/d10
  Size: 10485760 blocks (5.0 GB)
  Stripe 0:
    Device                               Start Block  Dbase      State Reloc
  Hot Spare
    /dev/dsk/c3t50020F230000FA57d0s0     0           No         Okay   Yes
```

```
blue/d2: Submirror of blue/d10
  State: Okay
  Size: 10485760 blocks (5.0 GB)
  Stripe 0:
    Device                               Start Block  Dbase      State Reloc
  Hot Spare
    /dev/dsk/c3t50020F230000FA57d0s1     0           No         Okay   Yes
```

```
Device Relocation Information:
Device                               Reloc Device ID
/dev/dsk/c3t50020F230000FA57d0     Yes   id1,ssd@n60020f200000fa574033661f000c641
4
```

## ▼ How to Resume a Volume Resynchronization Process

### 1 Assume the Primary Administrator role, or become superuser.

The Primary Administrator role includes the Primary Administrator profile. To create the role and assign the role to a user, see Chapter 2, “Working With the Solaris Management Console (Tasks),” in *System Administration Guide: Basic Administration*.

### 2 Use the `metastat` command to view the status of the RAID-1 volume and associated submirrors.

```
# metastat mirror-name
```

or

```
metastat -a
```

### 3 Use the `metasync volume` command to resume the resynchronization process.

```
# metasync volume
```

#### Example 11–18 Resuming a Volume Resynchronization Process

The following example illustrates how to resume the resynchronization process on a volume that is part of the disk set `blue`. Notice that the submirrors are in the “Resync cancelled” state before running the `metasync` command. Once the `metasync` command is issued, the resynchronization process resumes.

```
# metastat -a

blue/d10: Mirror
  Submirror 0: blue/d1
    State: Resync cancelled
  Submirror 1: blue/d2
    State: Okay
  Resync cancelled: 3 % done
  Pass: 1
  Read option: roundrobin (default)
  Write option: parallel (default)
  Size: 10485760 blocks (5.0 GB)

blue/d1: Submirror of blue/d10
  State: Resync cancelled
  Invoke: metasync blue/d10
  Size: 10485760 blocks (5.0 GB)
  Stripe 0:
    Device                Start Block  Dbase      State Reloc
  Hot Spare
    /dev/dsk/c3t50020F230000FA57d0s0      0      No        Okay   Yes
```

```
blue/d2: Submirror of blue/d10
  State: Okay
  Size: 10485760 blocks (5.0 GB)
  Stripe 0:
    Device                               Start Block  Dbase        State Reloc
Hot Spare
  /dev/dsk/c3t50020F230000FA57d0s1      0           No           Okay   Yes
```

Device Relocation Information:

```
Device                               Reloc  Device ID
/dev/dsk/c3t50020F230000FA57d0      Yes    id1,ssd@n60020f200000fa574033661f000c641
4
```

```
# metasync -s blue d10
# metastat -a
```

```
blue/d10: Mirror
  Submirror 0: blue/d1
    State: Resyncing
  Submirror 1: blue/d2
    State: Okay
  Resync in progress: 3 % done
  Pass: 1
  Read option: roundrobin (default)
  Write option: parallel (default)
  Size: 10485760 blocks (5.0 GB)
```

```
blue/d1: Submirror of blue/d10
  State: Resyncing
  Size: 10485760 blocks (5.0 GB)
  Stripe 0:
    Device                               Start Block  Dbase        State Reloc
Hot Spare
  /dev/dsk/c3t50020F230000FA57d0s0      0           No           Okay   Yes
```

```
blue/d2: Submirror of blue/d10
  State: Okay
  Size: 10485760 blocks (5.0 GB)
  Stripe 0:
    Device                               Start Block  Dbase        State Reloc
Hot Spare
```

```
/dev/dsk/c3t50020F230000FA57d0s1      0      No      Okay      Yes
```

#### Device Relocation Information:

```
Device      Reloc  Device ID
/dev/dsk/c3t50020F230000FA57d0  Yes    id1,ssd@n60020f200000fa574033661f000c641
4
```

## Responding to RAID-1 Volume Component Failures

### ▼ How to Replace a Slice in a Submirror

**Before You Begin** Read “Overview of Replacing and Enabling Components in RAID-1 and RAID-5 Volumes” on page 228 and “Creating and Maintaining RAID-1 Volumes” on page 97.

- 1 **Make sure that you have root privilege and that you have a current backup of all data.**
- 2 **Use the `metastat` command to view the status of the RAID-1 volume and associated submirrors.**  
# `metastat mirror-name`
- 3 **Use one of the following methods to replace a slice in a submirror.**
  - From the Enhanced Storage tool within the Solaris Management Console, open the Volumes node. Choose the mirror. Then, choose Action⇒Properties and click the Submirror tab. Follow the onscreen instructions. For more information, see the online help.
  - Use the following form of the `metareplace` command to replace a slice in a submirror:

```
# metareplace mirror-name component-name
```

- *mirror-name* is the name of the volume to create.
- *component-name* specifies the name of the component to replace.

*mirror-name*            Specifies the name of the volume to create

*component-name*       Specifies the name of the component to replace

See the following examples and the `metainit(1M)` man page for more information.

#### Example 11-19 Replacing a Failed Slice in a Mirror

The following example illustrates how to replace a failed slice when the system is not configured to use hot spare pools for the automatic replacement of failed disks. See [Chapter 16](#) for more information about using hot spare pools.

```
# metastat d6
d6: Mirror
  Submirror 0: d16
    State: Okay
  Submirror 1: d26
    State: Needs maintenance
...
d26: Submirror of d6
  State: Needs maintenance
  Invoke: metareplace d6 c0t2d0s2 <new device>
...
# metareplace d6 c0t2d0s2 c0t2d2s2
d6: device c0t2d0s2 is replaced with c0t2d2s2
```

The `metastat` command confirms that mirror `d6` has a submirror, `d26`, with a slice in the “Needs maintenance” state. The `metareplace` command replaces the slice as specified in the “Invoke” line of the `metastat` output with another available slice on the system. The system confirms that the slice is replaced, and starts resynchronizing the submirror.

## ▼ How to Replace a Submirror

**Before You Begin** Read “[Overview of Replacing and Enabling Components in RAID-1 and RAID-5 Volumes](#)” on page 228 and “[Creating and Maintaining RAID-1 Volumes](#)” on page 97.

- 1 **Make sure that you have root privilege and that you have a current backup of all data.**
- 2 **Use the `metastat` command to view the status of the RAID-1 volume and associated submirrors.**

```
# metastat mirror-name
```

- 3 **Use one of the following methods to replace a submirror.**

- From the Enhanced Storage tool within the Solaris Management Console, open the Volumes node. Choose the mirror. Then, choose Action⇒Properties and click the Submirror tab. Follow the onscreen instructions. For more information, see the online help.
- Use the `metadetach`, `metaclear`, `metatinit`, and `metattach` commands to replace an entire submirror.
  - a. Use the `metadetach` command to the failed submirror from the mirror.

```
# metadetach -f mirror-name submirror
-f                Forces the detach to occur
mirror-name     Specifies the name of the mirror
submirror       Specifies the submirror to detach
```



- b. Use the `metaclear` command to delete the submirror.

```
# metaclear -f submirror
-f           Forces the deletion of the submirror to occur
submirror   Specifies the submirror to delete
```

- c. Use the `metainit` command to create a new submirror.

```
# metainit volume-name number-of-stripes components-per-stripe component-name
volume-name   Specifies the name of the volume to create. For information on
              naming volumes, see “Volume Names” on page 40.
number-of-stripes Specifies the number of stripes to create.
components-per-stripe Specifies the number of components each stripe should have.
component-names Specifies the names of the components that are used. This example
              uses the root slice, c0t0d0s0.
```

- d. Use the `metattach` command to attach the new submirror.

```
# metattach mirror submirror
```

### Example 11–20 Replacing a Submirror in a Mirror

The following example illustrates how to replace a submirror in an active mirror.

```
# metastat d20
d20: Mirror
  Submirror 0: d21
  State: Okay
  Submirror 1: d22
  State: Needs maintenance
...
# metadetach -f d20 d22
d20: submirror d22 is detached
# metaclear -f d22
d22: Concat/Stripe is cleared
# metainit d22 2 1 c1t0d0s2 1 c1t0d1s2
d22: Concat/Stripe is setup
# metattach d20 d22
d20: components are attached
```

In this example, the `metastat` command confirms that the two-way mirror, `d20`, has a submirror, `d22`, in the “Needs maintenance” state. In this case, the entire submirror needs to be cleared and recreated. The `metadetach` command detaches the failed submirror from the mirror by using the `-f` option, which forces the detachment to occur. The `metaclear` command clears the submirror. The

`metainit` command recreates submirror, `d22`, with new slices. Finally, the `metattach` command attaches the rebuilt submirror. A mirror resynchronization begins automatically.

The specific configuration of the new volume, `d22`, depends on the component you are replacing. A concatenation, as shown here, can sufficiently replace a concatenation. However, a concatenation would not be an ideal replacement for a stripe because it could impact performance.

You temporarily lose the capability for data redundancy while the mirror is a one-way mirror.

## Removing RAID-1 Volumes (Unmirroring)

### ▼ How to Unmirror a File System

Use this procedure to unmirror a file system that can be unmounted while the system is running. To unmirror `root (/)`, `/var`, `/usr`, or `swap`, or any other file system that cannot be unmounted while the system is running, see [“How to Unmirror a File System That Cannot Be Unmounted”](#) on page 140.

**Before You Begin** Read [“Creating and Maintaining RAID-1 Volumes”](#) on page 97.

**1 Make sure that you have root privilege and that you have a current backup of all data.**

**2 Verify that at least one submirror is in the Okay state.**

```
# metastat mirror
```

**3 Unmount the file system.**

```
# umount /file-system
```

**4 Detach the submirror that will continue to be used for the file system.**

```
# metadetach mirror submirror
```

For more information, see the `metadetach(1M)` man page.

**5 Clear the mirror and remaining subcomponents.**

```
# metaclear -r mirror
```

For more information, see the `metaclear(1M)` man page.

**6 Edit the `/etc/vfstab` file to use the component detached in [Step 4](#), if necessary.**

**7 Remount the file system.**

```
# mount /file-system
```

**Example 11-21** Unmirroring the /opt File System

```

# metastat d4
d4: Mirror
  Submirror 0: d2
    State: Okay
  Submirror 1: d3
    State: Okay
  Pass: 1
  Read option: roundrobin (default)
  Write option: parallel (default)
  Size: 2100735 blocks (1.0 GB)

d2: Submirror of d4
  State: Okay
  Size: 2100735 blocks (1.0 GB)
  Stripe 0:
    Device      Start Block  Dbase      State Reloc Hot Spare
    c0t0d0s0      0      No         Okay      Yes

d3: Submirror of d4
  State: Okay
  Size: 2100735 blocks (1.0 GB)
  Stripe 0:
    Device      Start Block  Dbase      State Reloc Hot Spare
    c1t0d0s0      0      No         Okay      Yes

...
# umount /opt
# metadetach d4 d2
d4: submirror d2 is detached
# metaclear -r d4
d4: Mirror is cleared
d3: Concat/Stripe is cleared
    (Edit the /etc/vfstab file so that the entry for /opt is changed from d4 to the underlying slice or volume)
# mount /opt

```

In this example, the /opt file system is composed of a two-way mirror, d4. The submirrors of the mirror are d2 and d3. The submirrors are composed of slices /dev/dsk/c0t0d0s0 and /dev/dsk/c1t0d0s0. The `metastat` command verifies that at least one submirror is in the “Okay” state. (A mirror with no submirrors in the “Okay” state must be repaired first.) The file system is unmounted. Then, submirror d2 is detached. The `metaclear -r` command deletes the mirror and the other submirror, d3.

Next, the entry for /opt in the /etc/vfstab file is changed to reference the underlying slice.

In this example the /etc/vfstab file contains the following entry for the /opt file system:

```
/dev/md/dsk/d4 /dev/md/rdisk/d4 /opt ufs 2 yes -
```

Change the entry to read as follows:

```
/dev/md/dsk/d2 /dev/md/rdisk/d2 /opt ufs 2 yes -
```

By using the submirror name, you can continue to have the file system mounted on a volume. Finally, the `/opt` file system is remounted.

By using `d2` instead of `d4` in the `/etc/vfstab` file, you have unmirrored the mirror. Because `d2` consists of a single slice, you can mount the file system on the slice name (`/dev/dsk/c0t0d0s0`) if you do not want the device to support a volume.

## ▼ How to Unmirror a File System That Cannot Be Unmounted

Use this task to unmirror file systems, including `/`, `/usr`, `/opt`, and `swap`, that cannot be unmounted during normal system operation.

- 1 **Make sure that you have root privilege and that you have a current backup of all data.**

- 2 **Verify that at least one submirror is in the Okay state.**

```
# metastat mirror
```

- 3 **Detach the submirror that will continue to be used for the file system.**

```
# metadetach mirror submirror
```

For more information, see the `metadetach(1M)` man page.

- 4 **Use one of the following commands, depending the file system you want to unmirror:**

- For the `/usr`, `/opt`, or `swap` file systems, change the file system entry in the `/etc/vfstab` file to use a non-Solaris Volume Manager device (slice).
- For the `/` file system *only*: run the `metaroot` command.

```
# metaroot rootslice
```

For more information, see the `metaroot(1M)` man page.

- 5 **Reboot the system.**

```
# reboot
```

- 6 **Clear the remaining mirror and submirrors.**

```
# metaclear -r mirror
```

For more information, see the `metaclear(1M)` man page.

### Example 11-22 Unmirroring the root (/) File System

```
# metastat d0
d0: Mirror
  Submirror 0: d10
    State: Okay
  Submirror 1: d20
    State: Okay
  Pass: 1
  Read option: roundrobin (default)
  Write option: parallel (default)
  Size: 2100735 blocks (1.0 GB)

d10: Submirror of d0
  State: Okay
  Size: 2100735 blocks (1.0 GB)
  Stripe 0:
    Device      Start Block  Dbase      State Reloc Hot Spare
    c0t3d0s0          0    No        Okay   Yes

d20: Submirror of d0
  State: Okay
  Size: 2100735 blocks (1.0 GB)
  Stripe 0:
    Device      Start Block  Dbase      State Reloc Hot Spare
    c1t3d0s0          0    No        Okay   Yes

# metadetach d0 d20
d0: submirror d20 is detached
# metaroot /dev/dsk/c0t3d0s0
# reboot
...
# metaclear -r d0
d0: Mirror is cleared
d10: Concat/Stripe is cleared
# metaclear d20
d20: Concat/Stripe is cleared
```

In this example, the root (/) file system is a two-way mirror, `d0`. The submirrors of the mirror are `d10` and `d20`. The submirrors are composed of slices `/dev/dsk/c0t3d0s0` and `/dev/dsk/c1t3d0s0`. The `metastat` command verifies that at least one submirror is in the “Okay” state. (A mirror with no submirrors in the “Okay” state must be repaired first.) Submirror `d20` is detached to make `d0` a one-way mirror.

The *rootslice* is the slice containing the root (/) file system. The `metaroot` command is run, using the *rootslice* from which the system is going to boot. This command edits the `/etc/system` and `/etc/vfstab` files. The command removes information that specifies mirroring of the root (/) file system.

After rebooting the system, the `metaclear -r` command deletes the mirror and the other submirror, `d10`. The last `metaclear` command clears submirror `d20`.

### Example 11–23 Unmirroring the swap File System

```
# metastat d1
d1: Mirror
   Submirror 0: d11
       State: Okay
   Submirror 1: d21
       State: Okay
...
# metadetach d1 d21
d1: submirror d21 is detached
   (Edit the /etc/vfstab file to change the entry for swap from metadvice to slice name)
# reboot
...
# metaclear -r d1
d1: Mirror is cleared
d11: Concat/Stripe is cleared
# metaclear d21
d21: Concat/stripes is cleared
```

In this example, the swap file system is made of a two-way mirror, `d1`. The submirrors of the mirror are `d11` and `d21`. The submirrors are composed of slices `/dev/dsk/c0t3d0s1` and `/dev/dsk/c1t3d0s1`. The `metastat` command verifies that at least one submirror is in the “Okay” state. (A mirror with no submirrors in the “Okay” state must be repaired first.) Submirror `d21` is detached to make `d1` a one-way mirror. Next, the `/etc/vfstab` file is edited to change the entry for swap to reference the slice that is in submirror `d21`.

In this example, the `/etc/vfstab` file contains the following entry for the swap file system:

```
/dev/md/dsk/d4 /dev/md/rdisk/d4 /opt ufs 2 yes -
/dev/md/dsk/d1 - - swap - no -
```

Change the entry to read as follows:

```
/dev/dsk/c0t3d0s1 - - swap - no -
```

After rebooting the system, the `metaclear -r` command deletes the mirror and the other submirror, `d11`. The final `metaclear` command clears submirror `d21`.

## Backing Up Data on a RAID-1 Volume

Solaris Volume Manager is not meant to be a “backup product.” Solaris Volume Manager does provide a means for backing up mirrored data without causing any of the following to occur:

- Unmounting the mirror
- Taking the entire mirror offline
- Halting the system
- Denying users access to data

Solaris Volume Manager backs up mirrored data by first taking one of the submirrors offline. During the backup, mirroring is temporarily unavailable. As soon as the backup is complete, the submirror is then placed back online and resynchronized.

---

**Note** – The UFS Snapshots feature provides an alternative way to backup a system without taking the file system offline. You can perform the backup without detaching the submirror and incurring the performance penalty of resynchronizing the mirror later. Before performing a backup using the UFS Snapshots feature, make sure you have enough space available on your UFS file system. For more information, see Chapter 26, “Using UFS Snapshots (Tasks),” in *System Administration Guide: Devices and File Systems*.

---

### ▼ How to Perform an Online Backup of a RAID-1 Volume

You can use this procedure on any file system except the root (/) file system. Be aware that this type of backup creates a “snapshot” of an active file system. Depending on how the file system is being used when it is write-locked, some files on the backup might not correspond to the actual files on disk.

The following limitations apply to this procedure:

- If you use this procedure on a two-way mirror, be aware that data redundancy is lost while one submirror is offline for backup. A multi-way mirror does not have this problem.
- There is some overhead on the system when the reattached submirror is resynchronized after the backup is complete.

The high-level steps in this procedure are as follows:

- Write-locking the file system (UFS only). Do not lock root (/).
- Flushing all data from cache to disk.
- Using the `metadetach` command to take one submirror off of the mirror
- Unlocking the file system
- Using the `fsck` command to check the file system on the detached submirror
- Backing up the data on the detached submirror
- Using the `metaattach` command to place the detached submirror back in the mirror

---

**Note** – If you use these procedures regularly, put them into a script for ease of use.

---

**Tip** – The safer approach to this process is to attach a third or fourth submirror to the mirror, allow it to resynchronize, and use it for the backup. This technique ensures that data redundancy is maintained at all times.

---

**1 Verify that the mirror is in the “Okay” state.**

A mirror that is in the “Maintenance” state should be repaired first.

```
# metastat mirror
```

**2 Flush data and UFS logging data from cache to disk and write-lock the file system.**

```
# /usr/sbin/lockfs -w mount-point
```

Only a UFS volume needs to be write-locked. If the volume is set up as a raw device for database management software or some other application, running the `lockfs` command is not necessary. You might, however, want to run the appropriate vendor-supplied utility to flush any buffers and lock access.



**Caution** – Do not write-lock the root (`/`) file system. Write-locking the root (`/`) file system causes the system to hang. If you are backing up your root (`/`) file system, skip this step.

---

**3 Detach one submirror from the mirror.**

```
# metadetach mirror submirror
```

*mirror*            Is the volume name of the mirror.

*submirror*        Is the volume name of the submirror (volume) being detached.

Reads continue to be made from the other submirror. The mirror is out of sync as soon as the first write is made. This inconsistency is corrected when the detached submirror is reattached in [Step 7](#).

**4 Unlock the file system and allow writes to continue.**

```
# /usr/sbin/lockfs -u mount-point
```

You might need to perform necessary unlocking procedures based on vendor-dependent utilities used in [Step 2](#).

**5 Use the `fscck` command to check the file system on the detached submirror. This step ensures a clean backup occurs.**

```
# fscck /dev/md/rdisk/name
```



**6 Perform a backup of the offlined submirror.**

Use the `ufsdump` command or your usual backup utility. For information on performing the backup using the `ufsdump` command, see “Performing Mounted Filesystem Backups Using the `ufsdump` Command” on page 301.

---

**Note** – To ensure a proper backup, use the *raw* volume name, such as `/dev/md/rdisk/d4`. Using the raw volume name access to storage that is greater than 2 Gbytes.

---

**7 Attach the submirror.**

```
# metattach mirror submirror
```

Solaris Volume Manager automatically begins resynchronizing the submirror with the mirror.

**Example 11–24 Performing an Online Backup of a RAID-1 Volume**

This example uses a mirror, `d1`. The mirror consists of submirrors `d2`, `d3` and `d4`. The submirror `d3` is detached and backed up while submirrors `d2` and `d4` stay online. The file system on the mirror is `/home1`.

```
# metastat d1
d1: Mirror
  Submirror 0: d2
    State: Okay
  Submirror 1: d3
    State: Okay
  Submirror 1: d4
    State: Okay
...

# /usr/sbin/lockfs -w /home1
# metadetach d1 d3
# /usr/sbin/lockfs -u /home1
# /usr/sbin/fsck /dev/md/rdisk/d3
  (Perform backup using /dev/md/rdisk/d3)
# metattach d1 d3
```



## Soft Partitions (Overview)

---

This chapter provides information about Solaris Volume Manager soft partitions. For information about related tasks, see [Chapter 13](#).

This chapter contains the following information:

- “[Overview of Soft Partitions](#)” on page 147
- “[Configuration Guidelines for Soft Partitions](#)” on page 148

### Overview of Soft Partitions

As the storage capacity of disks has increased, disk arrays present larger logical devices to Solaris systems. In order to create more manageable file systems or partition sizes, users might need to subdivide disks or logical volumes into more than eight partitions. Solaris Volume Manager’s soft partition feature addresses this need.

Solaris Volume Manager can support up to 8192 logical volumes per disk set. This number includes the local, or unspecified, disk set. Solaris Volume Manager configures volumes dynamically as they are needed.

You can use soft partitions to divide a disk slice or logical volume into as many partitions as needed. You must provide a name for each division, or *soft partition*, just like you do for other storage volumes, such as stripes or mirrors. A soft partition, once named, can be accessed by applications, including file systems, as long as the soft partition is not included in another volume. Once included in a volume, the soft partition should no longer be directly accessed.

Soft partitions can be placed directly above a disk slice, or on top of a mirror, stripe, or RAID-5 volume. A soft partition may not be both above and below other volumes. For example, a soft partition built on a stripe with a mirror built on the soft partition is not allowed.

A soft partition appears to file systems and other applications as a single contiguous logical volume. However, the soft partition actually comprises a series of *extents* that could be located at arbitrary

locations on the underlying media. In addition to the soft partitions, extent headers (also called *system recovery data areas*) on disk record information about the soft partitions to facilitate recovery in the event of a catastrophic system failure.

## Configuration Guidelines for Soft Partitions

- Slices that are used for soft partitions cannot be used for other purposes.
- When you partition a disk and build file systems on the resulting slices, you cannot later extend a slice without modifying or destroying the disk format. Soft partitions behave differently. You can extend a soft partition up to the amount of space on the underlying device without moving or destroying data on other soft partitions.
- While it is technically possible to manually place extents of soft partitions at arbitrary locations on disk, you should allow the system to place them automatically. For an example of an extent that has been manually placed, see the output of the `metastat` command in [“Viewing the Solaris Volume Manager Configuration” on page 216](#).
- You can build soft partitions on any slice. However, creating a single slice that occupies the entire disk and then creating soft partitions on that slice is the most efficient way to use soft partitions at the disk level.
- The maximum size of a soft partition is limited to the size of the slice or logical volume on which it is built. Because of this limitation, you should build a volume on top of your disk slices, then build soft partitions on top of the volume. This strategy allows you to add components to the volume later, and then expand the soft partitions as needed.
- For maximum flexibility and high availability, build RAID-1 (mirror) or RAID-5 volumes on disk slices, then create soft partitions on the mirror or RAID-5 volume.

## Scenario—Soft Partitions

Soft partitions provide tools with which to subdivide larger storage spaces into more manageable spaces. For example, in other scenarios ([“Scenario—RAID-1 Volumes \(Mirrors\)” on page 103](#) or [“Scenario—RAID-5 Volumes” on page 161](#)), large storage aggregations provided redundant storage of many gigabytes. However, many possible scenarios would not initially, require so much space. Soft partitions allow you to subdivide that storage space into more manageable partitions. Each of those partitions can have a complete file system. For example, you could create 1000 soft partitions on top of a RAID-1 or RAID-5 volume so that each of your users can have a home directory on a separate file system. If a user needs more space, you could simply expand the soft partition.

## Soft Partitions (Tasks)

---

This chapter provides information about performing tasks that are associated with Solaris Volume Manager soft partitions. For conceptual information regarding soft partitions, see [Chapter 12](#).

### Soft Partitions (Task Map)

The following task map identifies the procedures that are needed to manage Solaris Volume Manager soft partitions.

Task	Description	For Instructions
Create soft partitions	Use the Solaris Volume Manager GUI or the <code>metainit</code> command to create soft partitions.	<a href="#">“How to Create a Soft Partition” on page 150</a>
Check the status of soft partitions	Use the Solaris Volume Manager GUI or the <code>metastat</code> command to check the status of soft partitions.	<a href="#">“How to Check the Status of a Soft Partition” on page 151</a>
Expand soft partitions	Use the Solaris Volume Manager GUI or the <code>metattach</code> command to expand soft partitions.	<a href="#">“How to Expand a Soft Partition” on page 152</a>
Remove soft partitions	Use the Solaris Volume Manager GUI or the <code>metaclear</code> command to remove soft partitions.	<a href="#">“How to Remove a Soft Partition” on page 153</a>

# Creating Soft Partitions

## ▼ How to Create a Soft Partition

**Before You Begin** Check the “[Configuration Guidelines for Soft Partitions](#)” on page 148.

► **Use one of the following methods to create a soft partition:**

- From the Enhanced Storage tool within the Solaris Management Console, open the Volumes node. Choose Action⇒Create Volume. Then, follow the instructions in the wizard. For more information, see the online help.
- To create a soft partition, use the following form of the `metainit` command:

```
# metainit [-s diskset] soft-partition -p [-e] component size
```

<code>-sdiskset</code>	Specifies which disk set is being used. If <code>-s</code> is not specified, the local (default) disk set is used.
<code>-p</code>	Specifies that a soft partition be configured.
<code>-e</code>	Specifies that the entire disk should be reformatted. Formatting the disk provides a slice 0, which takes most of the disk. Formatting the disk also provides a slice 7 of a minimum of 4 Mbytes in size. Slice 7 contains a state database replica.
<i>soft-partition</i>	Specifies the name of the soft partition. The name is of the form <i>dnnn</i> , where <i>nnn</i> is a number in a range between 0 and 8192.
<i>component</i>	Specifies the disk, slice, or logical volume from which to create the soft partition. <i>All existing data on the component is destroyed</i> because the soft partition headers are written at the beginning of the component.
<i>size</i>	Specifies the size of the soft partition. The size is specified as a number followed by one of the following: <ul style="list-style-type: none"> <li>▪ M or m for megabytes</li> <li>▪ G or g for gigabytes</li> <li>▪ T or t for terabytes</li> <li>▪ B or b for blocks (sectors)</li> </ul>

See the following examples and the `metainit(1M)` man page for more information.

### Example 13–1 Creating a Soft Partition

In the following example, a 4-Gbyte soft partition called `d20` is created on `c1t3d0s2`.

```
# metainit d20 -p c1t3d0s2 4g
```

**Example 13–2** Taking a Whole Disk for Soft Partitions

The following example creates a soft partition and formats disk `c1t2d0`. This action destroys any data on that disk and creates a new soft partition on slice 0.

```
# metainit d7 -p -e c1t2d0 1G
```

## Maintaining Soft Partitions

Maintaining soft partitions is no different from maintaining other logical volumes.

### ▼ How to Check the Status of a Soft Partition

**Before You Begin** Read the “[Configuration Guidelines for Soft Partitions](#)” on page 148.

► **Use one of the following methods to check the status of a soft partition:**

- From the Enhanced Storage tool within the Solaris Management Console, open the Volumes node. Choose the soft partition that you want to monitor. Then, choose Action⇒Properties. Follow the onscreen instructions. For more information, see the online help.
- To view the existing configuration, use the following form of the `metastat` command:

```
# metastat soft-partition
```

*soft-partition* Specifies the name of the partition you want to check.

**Example 13–3** Checking the Status of a Soft Partition

In the following example, the status of soft partition `d1` is checked. This soft partition includes two extents and is built on the RAID-1 volume `d100`.

```
# metastat d1
d1: soft partition
   component: d100
   state: OKAY
   size: 42674285 blocks
        Extent          Start Block          Block Count
        0                10234                40674285
        1                89377263             2000000
d100: Mirror
     Submirror 0: d10
     State: OKAY
     Read option: roundrobin (default)
     Write option: parallel (default)
```

Size: 426742857 blocks

d10: Submirror of d100

State: OKAY

Hot spare pool: hsp002

Size: 426742857 blocks

Stripe 0: (interlace: 32 blocks)

Device	Start Block	Dbase	State	Hot Spare
c3t3d0s0	0	No	Okay	

## ▼ How to Expand a Soft Partition

When no other logical volumes have been built on a soft partition, you can add space to the soft partition. Free space is located and used to extend the partition. Existing data is not moved.

---

**Note** – If a soft partition has been used to create another volume (for example, if it is a component of a RAID-0 volume), the soft partition cannot be expanded. In most cases, the same objective (providing more space for the device that contains the soft partition) can be achieved by concatenating other volumes onto the containing device. See “[Expanding Storage Capacity](#)” on page 87 for more information.

---

**Before You Begin** Read the “[Configuration Guidelines for Soft Partitions](#)” on page 148.

► **Use one of the following methods to expand a soft partition:**

- From the Enhanced Storage tool within the Solaris Management Console, open the Volumes node. Choose the soft partition that you want to expand, then choose Action⇒Properties. Follow the onscreen instructions. For more information, see the online help.
- To add space to a soft partition, use the following form of the `metattach` command:

```
# metattach [-s diskset] soft-partition size
```

*diskset* Specifies the name of the disk set in which the soft partition exists.

*soft-partition* Specifies the name of an existing soft partition.

*size* Specifies the amount of storage space to add.

### Example 13–4 Expanding a Soft Partition

The following example shows how to attach space to a soft partition. The file system is then expanded using the `growfs` command while the soft partition is online and mounted.



```
# mount /dev/md/dsk/d20 /home2
# metattach d20 10g
# growfs -M /home2 /dev/md/rdisk/d20
```

For more information on the `growfs` command, see “Expanding a File System Using the `growfs` Command” on page 225.

## ▼ How to Remove a Soft Partition

**Before You Begin** Read the “Configuration Guidelines for Soft Partitions” on page 148.

### ► Use one of the following methods to delete a soft partition:

- From the Enhanced Storage tool within the Solaris Management Console, open the Volumes node. Choose the soft partition that you want to delete. Then choose Action⇒Properties. Follow the onscreen instructions. For more information, see the online help.
- To delete a soft partition, use one of the following forms of the `metaclear` command:

```
# metaclear [-s diskset] component
# metaclear [-s diskset] -r soft-partition
# metaclear [-s diskset] -p component
```

*diskset* Specifies the disk set in which the soft partition exists.

*soft-partition* Specifies the soft partition to delete.

-r Specifies to recursively delete logical volumes, but not volumes on which others depend.

-p Specifies to purge all soft partitions on the specified component, except those soft partitions that are open.

*component* Specifies the component from which to clear all of the soft partitions.

### Example 13–5 Removing a Soft Partition

This example shows how to delete all soft partitions on `c1t4d2s0`.

```
# metaclear -p c1t4d2s0
```



## RAID-5 Volumes (Overview)

---

This chapter provides conceptual information about Solaris Volume Manager's RAID-5 volumes. For information about performing related tasks, see [Chapter 15](#).

This chapter contains the following:

- “Overview of RAID-5 Volumes” on page 155
- “Background Information for Creating RAID-5 Volumes” on page 158
- “Overview of Checking Status of RAID-5 Volumes” on page 159
- “Overview of Replacing and Enabling Slices in RAID-5 Volumes” on page 161
- “Scenario—RAID-5 Volumes” on page 161

### Overview of RAID-5 Volumes

RAID level 5 is similar to striping, but with parity data distributed across all components (disk or logical volume). If a component fails, the data on the failed component can be rebuilt from the distributed data and parity information on the other components. In Solaris Volume Manager, a *RAID-5 volume* is a volume that supports RAID level 5.

A RAID-5 volume uses storage capacity equivalent to one component in the volume to store redundant information (parity). This parity information contains information about user data stored on the remainder of the RAID-5 volume's components. That is, if you have three components, the equivalent of one component is used for the parity information. If you have five components, then the equivalent of one component is used for parity information. The parity information is distributed across all components in the volume. Similar to a mirror, a RAID-5 volume increases data availability, but with a minimum of cost in terms of hardware and only a moderate penalty for write operations. However, you cannot use a RAID-5 volume for the root (*/*), */usr*, and swap file systems, or for other existing file systems.

Solaris Volume Manager automatically resynchronizes a RAID-5 volume when you replace an existing component. Solaris Volume Manager also resynchronizes RAID-5 volumes during rebooting if a system failure or panic took place.

## Example—RAID-5 Volume

Figure 14-1 illustrates a RAID-5 volume that consists of four disks (components).

The first three data segments are written to Component A (interlace 1), Component B (interlace 2), and Component C (interlace 3). The next data segment that is written is a parity segment. This parity segment is written to Component D (P 1-3). This segment consists of an exclusive OR of the first three segments of data. The next three data segments are written to Component A (interlace 4), Component B (interlace 5), and Component D (interlace 6). Then, another parity segment is written to Component C (P 4-6).

This pattern of writing data and parity segments results in both data and parity being spread across all disks in the RAID-5 volume. Each drive can be read independently. The parity protects against a single disk failure. If each disk in this example were 2 Gbytes, the total capacity of the RAID-5 volume would be 6 Gbytes. One drive's worth of space is allocated to parity.

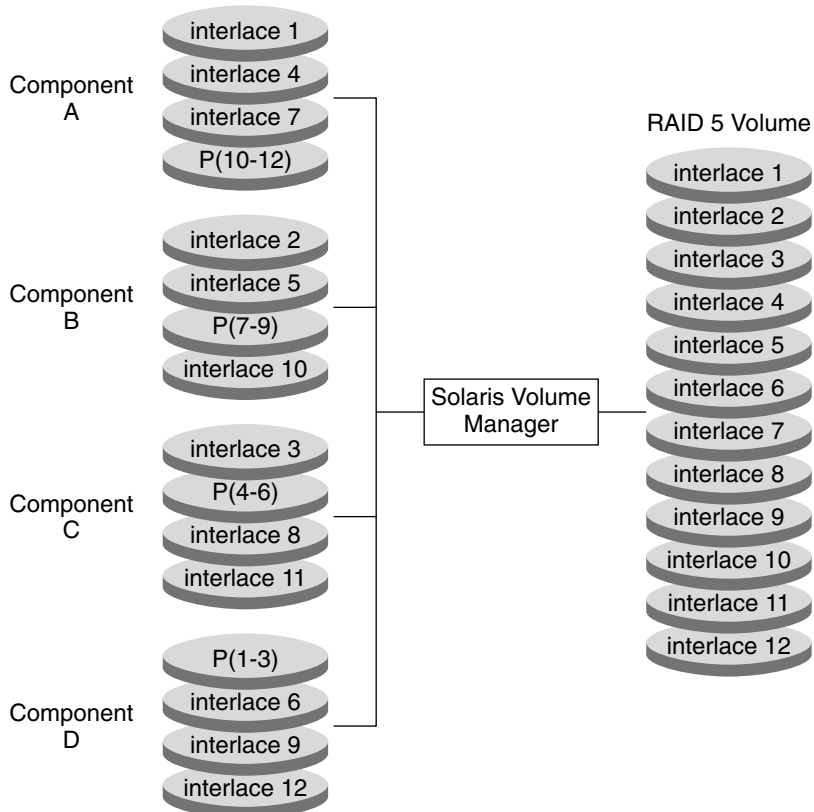

FIGURE 14-1 RAID-5 Volume Example

## Example—Concatenated (Expanded) RAID-5 Volume

The following figure shows an example of an RAID-5 volume that initially consisted of four disks (components). A fifth disk has been dynamically concatenated to the volume to expand the RAID-5 volume.

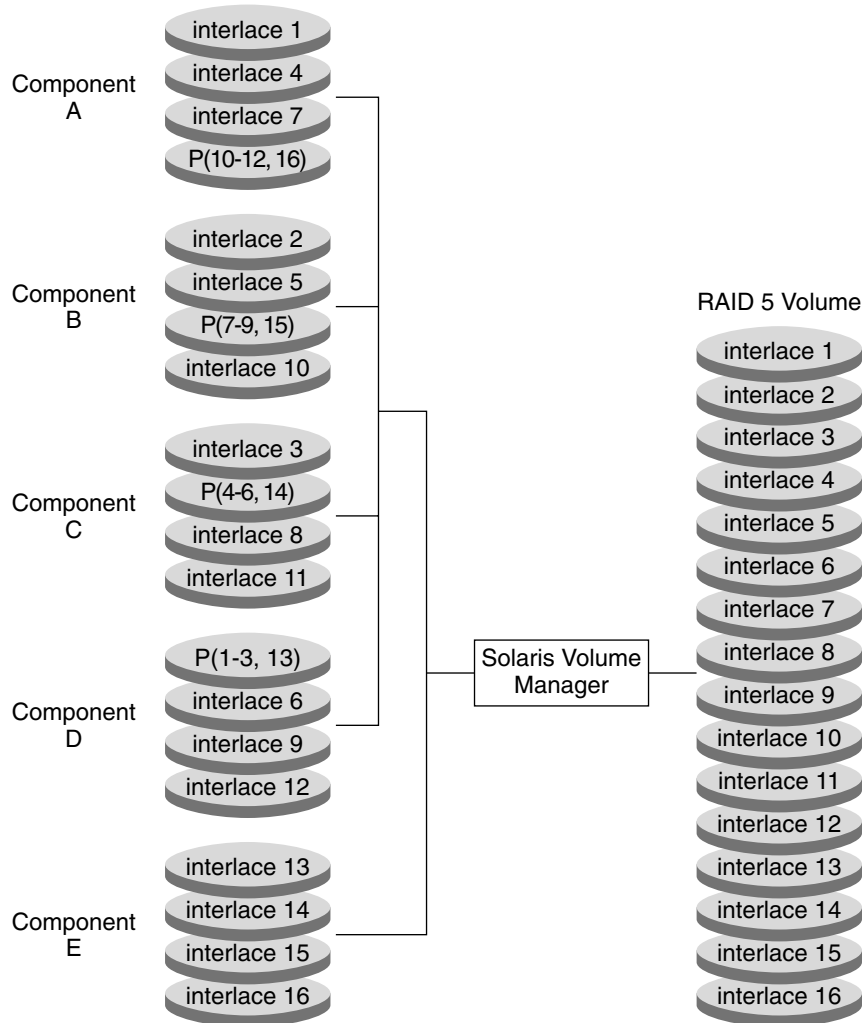

FIGURE 14-2 Expanded RAID-5 Volume Example

The parity areas are allocated when the initial RAID-5 volume is created. One component's worth of space is allocated to parity, although the actual parity blocks are distributed across all of the original components to distribute I/O. When additional components are concatenated to the RAID-5

volume, the additional space is devoted entirely to data. No new parity blocks are allocated. The data on the concatenated component is, however, included in the parity calculations, so the data is protected against single device failures.

Concatenated RAID-5 volumes are not suited for long-term use. Use a concatenated RAID-5 volume until it is possible to reconfigure a larger RAID-5 volume. Then, copy the data to the larger volume.

---

**Note** – When you add a new component to a RAID-5 volume, Solaris Volume Manager “zeros” all the blocks in that component. This process ensures that the parity protects the new data. As data is written to the additional space, Solaris Volume Manager includes the data in the parity calculations.

---

## Background Information for Creating RAID-5 Volumes

When you work with RAID-5 volumes, consider the [“Requirements for RAID-5 Volumes” on page 158](#) and [“Guidelines for RAID-5 Volumes” on page 158](#). Many striping guidelines also apply to RAID-5 volume configurations. See [“RAID-0 Volume Requirements” on page 80](#).

### Requirements for RAID-5 Volumes

- A RAID-5 volume must consist of at least three components. The more components a RAID-5 volume contains, however, the longer read and write operations take when a component fails.
- RAID-5 volumes cannot be striped, concatenated, or mirrored.
- Do not create a RAID-5 volume from a component that contains an existing file system. Doing so will erase the data during the RAID-5 initialization process.
- When you create a RAID-5 volume, you can define the interlace value. If not specified, the interlace value defaults to 512 Kbytes. This value is reasonable for most applications.
- A RAID-5 volume (with no hot spares) can only handle a single component failure.
- When you create RAID-5 volumes, use components across separate controllers. Controllers and associated cables tend to fail more often than disks.
- Use components of the same size. Creating a RAID-5 volume with components of different sizes results in unused disk space.

### Guidelines for RAID-5 Volumes

- Because of the complexity of parity calculations, volumes with greater than about 20 percent writes should probably not be RAID-5 volumes. If data redundancy on a write-heavy volume is needed, consider mirroring.
- If the different components in a RAID-5 volume reside on different controllers and the accesses to the volume are primarily large sequential accesses, then setting the interlace value to 32 Kbytes might improve performance.

- You can expand a RAID-5 volume by concatenating additional components to the volume. Concatenating a new component to an existing RAID-5 volume decreases the overall performance of the volume because the data on concatenations is sequential. Data is not striped across all components. The original components of the volume have data and parity striped across all components. This striping is lost for the concatenated component. However, the data is still recoverable from errors because the parity is used during the component I/O. The resulting RAID-5 volume continues to handle a single component failure.

Concatenated components also differ in the sense that they do not have parity striped on any of the regions. Thus, the entire contents of the component are available for data.

Any performance enhancements for large or sequential writes are lost when components are concatenated.

- You can create a RAID-5 volume without having to “zero out” the data blocks. To do so, do one of the following:
  - Use the `metainit` command with the `-k` option. The `-k` option recreates the RAID-5 volume without initializing it, and sets the disk blocks to the “Okay” state. This option is potentially dangerous, as any errors that exist on disk blocks within the volume will cause unpredictable behavior from Solaris Volume Manager, including the possibility of fabricated data.
  - Initialize the device and restore data from tape. See the `metainit(1M)` man page for more information.

## Overview of Checking Status of RAID-5 Volumes

You can check the status of RAID-5 volumes by looking at the volume states and the slice states for the volume. The slice state provides the most specific information when you are troubleshooting RAID-5 volume errors. The RAID-5 volume state only provides general status information, such as “Okay” or “Maintenance.”

If the RAID-5 volume state reports a “Maintenance” state, refer to the slice state. The slice state specifically reports if the slice is in the “Maintenance” state or the “Last Erred” state. You take a different recovery action depending on if the the slice is in the “Maintenance” state or the “Last Erred” state. If you only have a slice in the “Maintenance” state, it can be repaired without loss of data. If you have a slice in the “Maintenance” state and a slice in the “Last Erred” state, data has probably been corrupted. You must fix the slice in the “Maintenance” state first, then fix the “Last Erred” slice.

The following table explains RAID-5 volume states.

TABLE 14-1 RAID-5 Volume States

State	Meaning
Initializing	Slices are in the process of having all disk blocks zeroed. This process is necessary due to the nature of RAID-5 volumes with respect to data and parity interlace striping.  Once the state changes to “Okay,” the initialization process is complete and you are able to open the device. Until then, applications receive error messages.
Okay	The device is ready for use and is currently free from errors.
Maintenance	A slice has been marked as failed due to I/O or open errors. These errors were encountered during a read or write operation.

The following table explains the slice states for a RAID-5 volume and possible actions to take.

TABLE 14-2 RAID-5 Slice States

State	Meaning	Action
Initializing	Slices are in the process of having all disk blocks zeroed. This process is necessary due to the nature of RAID-5 volumes with respect to data and parity interlace striping.	Normally, none. If an I/O error occurs during this process, the device goes into the “Maintenance” state. If the initialization fails, the volume is in the “Initialization Failed” state, and the slice is in the “Maintenance” state. If this happens, clear the volume and recreate it.
Okay	The device is ready for use and is currently free from errors.	None. Slices can be added or replaced, if necessary.
Resyncing	The slice is actively being resynchronized. An error has occurred and been corrected, a slice has been enabled, or a slice has been added.	If desired, monitor the RAID-5 volume status until the resynchronization is done.
Maintenance	A single slice has been marked as failed due to I/O or open errors. These errors were encountered during a read or write operation.	Enable or replace the failed slice. See “ <a href="#">How to Enable a Component in a RAID-5 Volume</a> ” on page 167, or “ <a href="#">How to Replace a Component in a RAID-5 Volume</a> ” on page 168. The <code>metastat</code> command will show an <code>invoke</code> recovery message with the appropriate action to take with the <code>metareplace</code> command.



TABLE 14-2 RAID-5 Slice States (Continued)

State	Meaning	Action
Maintenance/Last Erred	Multiple slices have encountered errors. The state of the failed slices is either “Maintenance” or “Last Erred.” In this state, no I/O is attempted on the slice that is in the “Maintenance” state. However, I/O is attempted on the slice marked “Last Erred” with the outcome being the overall status of the I/O request.	Enable or replace the failed slices. See “How to Enable a Component in a RAID-5 Volume” on page 167, or “How to Replace a Component in a RAID-5 Volume” on page 168. The <code>metastat</code> command will show an <code>invoke recovery</code> message with the appropriate action to take with the <code>metareplace</code> command. This command must be run with the <code>-f</code> flag. This state indicates that data might be fabricated due to multiple failed slices.

## Overview of Replacing and Enabling Slices in RAID-5 Volumes

Solaris Volume Manager has the capability to *replace* and *enable* components within mirrors and RAID-5 volumes. The issues and requirements for doing so are the same for mirrors and RAID-5 volumes. For more information, see “Overview of Replacing and Enabling Components in RAID-1 and RAID-5 Volumes” on page 228.

## Scenario—RAID-5 Volumes

RAID-5 volumes allow you to have redundant storage without the overhead of RAID-1 volumes, which require two times the total storage space to provide data redundancy. By setting up a RAID-5 volume, you can provide redundant storage of greater capacity than you could achieve with a RAID-1 volume on the same set of disk components. In addition, with the help of hot spares (see Chapter 16 and specifically “How Hot Spares Work” on page 172), you can achieve nearly the same level of safety. The drawbacks are increased write time and markedly impaired performance in the event of a component failure. However, those tradeoffs might be insignificant for many situations. The following example, drawing on the sample scenario explained in Chapter 5, describes how RAID-5 volumes can provide extra storage capacity.

Other scenarios for RAID-0 and RAID-1 volumes used 6 slices (`c1t1d0`, `c1t2d0`, `c1t3d0`, `c2t1d0`, `c2t2d0`, `c2t3d0`) on 6 disks, spread over 2 controllers, to provide 27 Gbytes of redundant storage. By using the same slices in a RAID-5 configuration, 45 Gbytes of storage is available. Also, the configuration can withstand a single component failure without data loss or access interruption. By adding hot spares to the configuration, the RAID-5 volume can withstand additional component failures. The most significant drawback to this approach is that a controller failure would result in data loss to this RAID-5 volume, while it would not with the RAID-1 volume described in “Scenario—RAID-1 Volumes (Mirrors)” on page 103.



## RAID-5 Volumes (Tasks)

---

This chapter provides information about performing Solaris Volume Manager tasks that are associated with RAID-5 volumes. For information about the concepts involved in these tasks, see [Chapter 14](#).

### RAID-5 Volumes (Task Map)

The following task map identifies the procedures that are needed to manage Solaris Volume Manager's 5 volumes.

Task	Description	For Instructions
Create RAID-5 volumes	Use the Solaris Volume Manager GUI or the <code>metainit</code> command to create RAID-5 volumes.	<a href="#">“How to Create a RAID-5 Volume” on page 164</a>
Check the status of RAID-5 volumes	Use the Solaris Volume Manager GUI or the <code>metastat</code> command to check the status of RAID-5 volumes.	<a href="#">“How to Check the Status of a RAID-5 Volume” on page 165</a>
Expand a RAID-5 volume	Use the Solaris Volume Manager GUI or the <code>metattach</code> command to expand RAID-5 volumes.	<a href="#">“How to Expand a RAID-5 Volume” on page 166</a>
Enable a slice in a RAID-5 volume	Use the Solaris Volume Manager GUI or the <code>metareplace</code> command to enable slices in RAID-5 volumes.	<a href="#">“How to Enable a Component in a RAID-5 Volume” on page 167</a>
Replace a slice in a RAID-5 volume	Use the Solaris Volume Manager GUI or the <code>metareplace</code> command to replace slices in RAID-5 volumes.	<a href="#">“How to Replace a Component in a RAID-5 Volume” on page 168</a>

# Creating RAID-5 Volumes



**Caution** – Do not create volumes larger than 1 Tbyte if you expect to run the Solaris software with a 32-bit kernel or if you expect to use a version of the Solaris OS prior to the Solaris 9 4/03 release. See “[Overview of Multi-Terabyte Support in Solaris Volume Manager](#)” on page 44 for more information about large volume support in Solaris Volume Manager.

## ▼ How to Create a RAID-5 Volume

**Before You Begin** Check “[Prerequisites for Creating Solaris Volume Manager Components](#)” on page 44 and “[Background Information for Creating RAID-5 Volumes](#)” on page 158.

► **To create a RAID-5 volume, use one of the following methods:**

- From the Enhanced Storage tool within the Solaris Management Console, open the Volumes node. Choose Action⇒Create Volume. Then, follow the steps in the wizard. For more information, see the online help.
- Use the following form of the `metainit` command:

```
# metainit volume-name -r component component component -i interlace-value
```

*volume-name* Specifies the name of the volume to create.

`-r` Specifies to create a RAID-5 volume.

*component* Specifies a slice or soft partition to include in the RAID-5 volume. At least 3 components are required.

`-i` Specifies an interlace value.

For more information, see the `metainit(1M)` man page.

### Example 15–1 Creating a RAID-5 Volume of Three Slices

In this example, the RAID-5 volume `d45` is created with the `-r` option from 3 slices. Because no interlace value is specified, `d45` uses the default of 512 Kbytes. The system verifies that the RAID-5 volume has been set up and begins initializing the volume.

You must wait for the initialization to finish before you can use the RAID-5 volume.

```
# metainit d45 -r c2t3d0s2 c3t0d0s2 c4t0d0s2
d45: RAID is setup
```

**See Also** To prepare the newly created RAID-5 volume for a file system, see Chapter 18, “Creating UFS, TMPFS, and LOFS File Systems (Tasks),” in *System Administration Guide: Devices and File Systems*.

Some applications, such as a database, do not use a file system. These applications instead use the raw volume. The application must have its own way of recognizing the volume.

To associate a hot spare pool with a RAID-5 volume, see [“How to Associate a Hot Spare Pool With a Volume” on page 178](#).

## Maintaining RAID-5 Volumes

### ▼ How to Check the Status of a RAID-5 Volume

When checking status of RAID-5 volumes, you need to check both the RAID-5 state and the slice state to fully understand the state of the volume and the possibility of data loss if the volumes are not in an Okay state. See [“Overview of Checking Status of RAID-5 Volumes” on page 159](#) for details.

---

**Note** – RAID-5 volume initialization or resynchronization cannot be interrupted.

---

#### ► To check the status of a RAID-5 volume, use one of the following methods:

- From the Enhanced Storage tool within the Solaris Management Console, open the Volumes node and view the status of the volumes. Choose a volume. Then, choose Action⇒Properties to see more detailed information. For more information, see the online help.
- Use the `metastat` command to display the status of a RAID-5 volume.

```
# metastat [-s diskset] [volume]
```

*-s diskset*      Specifies the name of the disk set on which to perform the command.

*volume*          Specifies the volume to display.

For each slice in the RAID-5 volume, the `metastat` command shows the following:

Device            Specifies the device name of the slice in the stripe.

Start Block      Specifies the block on which the slice begins.

Dbase            Specifies whether the slice contains a state database replica

State             Specifies the state of the slice.

Hot Spare        Specifies whether the slice is being used to hot spare a failed slice

#### Example 15–2 Viewing RAID-5 Volume Status

The following example shows RAID-5 volume output from the `metastat` command.

```
# metastat d10
d10: RAID
  State: Okay
  Interlace: 32 blocks
  Size: 10080 blocks
Original device:
  Size: 10496 blocks
  Device          Start Block  Dbase State      Hot Spare
  c0t0d0s1        330         No   Okay
  c1t2d0s1        330         No   Okay
  c2t3d0s1        330         No   Okay
```

The `metastat` command output identifies the volume as a RAID-5 volume. This information is indicated by the “RAID” notation after the volume name. For each slice in the RAID-5 volume, the output shows the following:

- The name of the slice in the stripe.
- The block on which the slice begins.
- An indicator that none of these slices contain a state database replica.
- The state of the slices. In this example all slices are in the “Okay” state.
- If a slice is a hot spare replacement for a failed slice.

## ▼ How to Expand a RAID-5 Volume

In general, attaching components is a short-term solution to a RAID-5 volume that is running out of space. For performance reasons, it is best to have a “pure” RAID-5 volume. If you must expand an existing RAID-5 volume to gain extra storage space, use this procedure.



**Caution** – Do not create volumes larger than 1 Tbyte if you expect to run the Solaris software with a 32-bit kernel or if you expect to use a version of the Solaris OS prior to the Solaris 9 4/03 release. See [“Overview of Multi-Terabyte Support in Solaris Volume Manager”](#) on page 44 for more information about multiterabyte volume support in Solaris Volume Manager.

**Before You Begin** Read [“Background Information for Creating RAID-5 Volumes”](#) on page 158.

- 1 **Make sure that you have a current backup of all data and that you have superuser access.**
- 2 **To attach additional components to a RAID-5 volume, use one of the following methods:**
  - From the Enhanced Storage tool within the Solaris Management Console, open the Volumes node, then open the RAID-5 volume. Choose the Components pane. Then, choose Attach Component. Follow the onscreen instructions. For more information, see the online help.

- Use the following form of the `metattach` command:

```
# metattach volume-name name-of-component-to-add
```

*volume-name* Specifies the name of the RAID-5 volume to expand.

*name-of-component-to-add* Specifies the name of the component to attach to the RAID-5 volume.

See the `metattach(1M)` man page for more information.

### Example 15–3 Adding a Component to a RAID-5 Volume

The following example shows the addition of slice `c2t1d0s2` to an existing RAID-5 volume, `d2`.

```
# metattach d2 c2t1d0s2
d2: column is attached
```

**See Also** For a UFS file system, run the `growfs` command on the RAID-5 volume. See [“Volume and Disk Space Expansion Using the `growfs` Command” on page 39](#).

Some applications, such as a database, do not use a file system. These applications instead use the raw volume. In these cases, the application must have its own way of growing the added space.

## ▼ How to Enable a Component in a RAID-5 Volume

If a disk drive is defective, you can replace it with another available disk (and its slices) on the system as documented in [“How to Replace a Component in a RAID-5 Volume” on page 168](#). Alternatively, you can repair the disk, label it, and run the `metareplace` command with the `-e` option to re-enable the disk.

**1 Make sure that you have a current backup of all data and that you have superuser access.**

**2 To enable a failed component in a RAID-5 volume, use one of the following methods:**

- From the Enhanced Storage tool within the Solaris Management Console, open the Volumes node, then open the RAID-5 volume. Choose the Components pane. Then, choose the failed component. Click Enable Component. Follow the onscreen instructions. For more information, see the online help.
- Use the following form of the `metareplace` command:

```
# metareplace -e volume-name component-name
```

`-e` Specifies to place the failed component into an available state and to perform a resynchronization on the failed component.

*volume-name* Specifies the name of the volume containing the failed component.

*component-name* Specifies the name of the failed component.

The `metareplace` command automatically starts resynchronizing the new component with the rest of the RAID-5 volume.

#### Example 15-4 Enabling a Component in a RAID-5 Volume

In the following example, the RAID-5 volume `d20` has a slice, `c2t0d0s2`, which had a soft error. The `metareplace` command with the `-e` option enables the slice.

```
# metareplace -e d20 c2t0d0s2
```

## ▼ How to Replace a Component in a RAID-5 Volume

This task replaces a failed slice of a RAID-5 volume in which only one slice has failed.



**Caution** – Replacing a failed slice when multiple slices are in error might cause data to be fabricated. In this instance, the integrity of the data in this instance would be questionable.

You can use the `metareplace` command on non-failed devices to change a disk slice or other component. This procedure can be useful for tuning the performance of RAID-5 volumes.

- 1 **Make sure that you have a current backup of all data and that you have superuser access.**
- 2 **Use one of the following methods to determine which slice of the RAID-5 volume needs to be replaced:**
  - From the Enhanced Storage tool within the Solaris Management Console, open the Volumes node. Then open the RAID-5 volume. Choose the Components pane. View the status of the individual components. For more information, see the online help.
  - Use the `metastat` command.

```
# metastat volume
```

*volume* Specifies the name of the RAID-5 volume.

Look for the keyword phrase “Needs Maintenance” to identify the state of the RAID-5 volume. Look for the keyword “Maintenance” to identify the failed slice.

- 3 **Use one of the following methods to replace the failed slice with another slice:**



- From the Enhanced Storage tool within the Solaris Management Console, open the Volumes node. Then open the RAID-5 volume. Choose the Components pane. Choose the failed component. Click Replace Component and follow the onscreen instructions. For more information, see the online help.
- Use the following form of the `metareplace` command:

```
# metareplace volume-name failed-component new-component
```

- `volume-name` is the name of the RAID-5 volume with a failed component.
- `failed-component` specifies the name of the component to replace.
- `new-component` specifies the name of the component to add to the volume in place of the failed component.

See the `metareplace(1M)` man page for more information.

#### 4 To verify the status of the replacement slice, use one of the methods described in [Step 2](#).

The state of the replaced slice should be “Resyncing” or “Okay.”

### Example 15–5 Replacing a RAID-5 Component

```
# metastat d1
d1: RAID
State: Needs Maintenance
  Invoke: metareplace d1 c0t14d0s6 <new device>
  Interlace: 32 blocks
  Size: 8087040 blocks
Original device:
  Size: 8087520 blocks
  Device          Start Block  Dbase State      Hot Spare
  c0t9d0s6         330         No   Okay
  c0t13d0s6        330         No   Okay
  c0t10d0s6        330         No   Okay
  c0t11d0s6        330         No   Okay
  c0t12d0s6        330         No   Okay
  c0t14d0s6        330         No   Maintenance

# metareplace d1 c0t14d0s6 c0t4d0s6
d1: device c0t14d0s6 is replaced with c0t4d0s6
# metastat d1
d1: RAID
  State: Resyncing
  Resync in progress: 98% done
  Interlace: 32 blocks
  Size: 8087040 blocks
Original device:
  Size: 8087520 blocks
```

Device	Start Block	Dbase	State	Hot Spare
c0t9d0s6	330	No	Okay	
c0t13d0s6	330	No	Okay	
c0t10d0s6	330	No	Okay	
c0t11d0s6	330	No	Okay	
c0t12d0s6	330	No	Okay	
c0t4d0s6	330	No	Resyncing	

In this example, the `metastat` command displays the failed slice in the RAID-5 volume, d1. After locating an available slice, the `metareplace` command is run, specifying the failed slice first, then the replacement slice.

If no other slices are available, run the `metareplace` command with the `-e` option to attempt to recover from possible soft errors by resynchronizing the failed device. For more information on this procedure, see [“How to Enable a Component in a RAID-5 Volume” on page 167](#). If multiple errors exist, the slice in the “Maintenance” state must first be replaced or enabled. Then the slice in the “Last Erred” state can be repaired. After running the `metareplace` command, you can use the `metastat` command to monitor the progress of the resynchronization. During the replacement, the state of the volume and the new slice is “Resyncing.” You can continue to use the volume while it is in this state.

## Hot Spare Pools (Overview)

---

This chapter explains how Solaris Volume Manager uses hot spare pools. For information about performing related tasks, see [Chapter 17](#).

This chapter contains the following information:

- “Overview of Hot Spares and Hot Spare Pools” on page 171
- “Scenario—Hot Spares” on page 174

### Overview of Hot Spares and Hot Spare Pools

A *hot spare pool* is collection of slices (*hot spares*) that Solaris Volume Manager uses to provide increased data availability for RAID-1 (mirror) and RAID-5 volumes. In a slice failure occurs, in either a submirror or a RAID-5 volume, Solaris Volume Manager automatically substitutes the hot spare for the failed slice.

---

**Note** – Hot spares do not apply to RAID-0 volumes or one-way mirrors. For automatic substitution to work, redundant data must be available.

---

A hot spare cannot be used to hold data or state database replicas while it is idle. A hot spare must remain ready for immediate use a slice failure occurs in the volume with which it is associated. To use hot spares, you must invest in additional disks beyond those disks that the system actually requires to function.

Solaris Volume Manager enables you to dynamically add, delete, replace, and enable hot spares within hot spare pools. You can use either the Solaris Management Console or the command-line utilities to administer hot spares and hot spare pools. See [Chapter 17](#) for details on these tasks.

## Hot Spares

A hot spare is a slice (not a volume) that is functional and available, but not in use. A hot spare is reserved, meaning that it stands ready to substitute for a failed slice in a submirror or RAID-5 volume.

Hot spares provide protection from hardware failure. Slices from RAID-1 and RAID-5 volumes are automatically replaced by hot spares when they fail. The hot spares are resynchronized available for use in the volume. The hot spare can be used temporarily until the failed submirror or RAID-5 volume slice can either be fixed or replaced.

You create hot spares within hot spare pools. Individual hot spares can be included in one or more hot spare pools. For example, you might have two submirrors and two hot spares. The hot spares can be arranged as two hot spare pools, with each pool having the two hot spares in a different order of preference. This strategy enables you to specify which hot spare is used first. This strategy also improves availability by having more hot spares available.

A submirror or RAID-5 volume can use only a hot spare whose size is equal to or greater than the size of the failed slice in the submirror or RAID-5 volume. If, for example, you have a submirror made of 1-Gbyte drives, a hot spare for the submirror must be 1 Gbyte or greater.

## Hot Spare Pools

A hot spare pool is an ordered list (collection) of hot spares.

You can place hot spares into one or more hot spare pools to get the most flexibility and protection from the fewest slices. You could put a single slice designated for use as a hot spare into multiple hot spare pools, with each hot spare pool having different slices and characteristics. Then, you could assign a hot spare pool to any number of submirror volumes or RAID-5 volumes.

---

**Note** – You can assign a single hot spare pool to multiple submirrors or RAID-5 volumes. However, a submirror or a RAID-5 volume can be associated with only one hot spare pool.

---

## How Hot Spares Work

When I/O errors occur, Solaris Volume Manager searches the hot spare pool for a hot spare based on the order in which hot spares were added to the hot spare pool. Solaris Volume Manager checks the hot spare pool for the first available hot spare whose size is equal to or greater than the size of the slice that is being replaced. The first hot spare found by Solaris Volume Manager that is large enough is used as a replacement. Solaris Volume Manager changes the hot spare's status to "In-Use" and automatically resynchronizes the data if necessary. The order of hot spares in the hot spare pool is not changed when a replacement occurs.

In the case of a mirror, the hot spare is resynchronized with data from a functional submirror. In the case of a RAID-5 volume, the hot spare is resynchronized with the other slices in the volume. If a slice of adequate size is not found in the list of hot spares, the submirror or RAID-5 volume that failed goes into a failed state and the hot spares remain unused. In the case of the submirror, the submirror no longer replicates the data completely. In the case of the RAID-5 volume, data redundancy is no longer available.

---

**Tip** – When you add hot spares to a hot spare pool, add them from smallest to largest in size. This strategy avoids potentially wasting “large” hot spares as replacements for small slices.

---

When a slice experiences an I/O error, the failed slice is placed in the “Broken” state. To fix this condition, first repair or replace the failed slice. Then, bring the slice back to the “Available” state by using the Enhanced Storage tool within the Solaris Management Console. Or, use the `metahs -e` command.

A submirror or RAID-5 volume uses a hot spare in place of a failed slice until that failed slice is enabled or replaced. The hot spare is then marked “Available” in the hot spare pool. This hot spare is again ready for use.

## Hot Spare Pool States

The following table explains hot spare pool states and possible actions to take.

TABLE 16–1 Hot Spare Pool States (Command Line)

State	Meaning	Action
Available	The hot spares in the hot spare pool are running and ready to accept data. The hot spares are not currently being written to or read from.	None.
In-Use	This hot spare pool includes hot spares that are being used to replace failed slices in a redundant volume.	Diagnose how the hot spares are being used. Then, repair the slice in the volume for which the hot spare is being used.
Broken	A problem exists with a hot spare or hot spare pool. However, there is no immediate danger of losing data. This status is also displayed if all the hot spares are in use.	Diagnose how the hot spares are being used or why they are broken. You can add more hot spares to the hot spare pool, if desired.

## Example—Hot Spare Pool

Figure 16–1 illustrates a hot spare pool that is associated with submirrors `d11` and `d12` in mirror `d1`. If a slice in either submirror were to fail, a hot spare would automatically be substituted for the failed slice. The hot spare pool itself is associated with each submirror volume, not the mirror. The hot spare pool could also be associated with other submirrors or RAID-5 volumes, if desired.

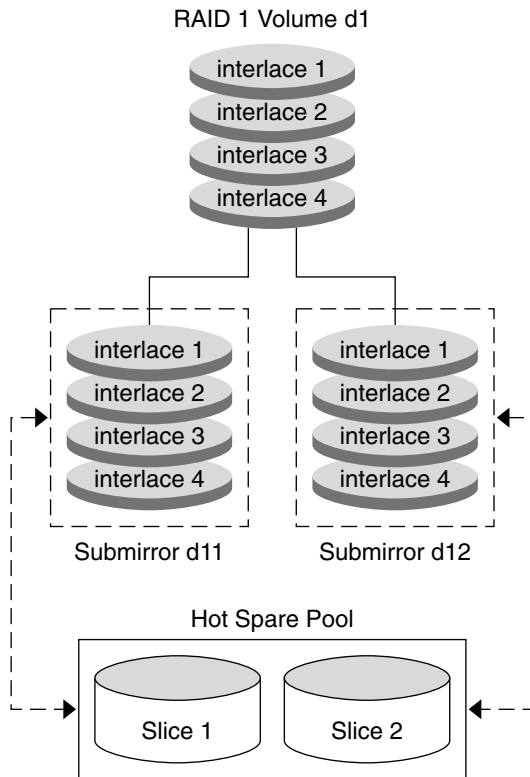

FIGURE 16-1 Hot Spare Pool Example

## Scenario—Hot Spares

Hot spares provide extra protection for redundant volumes (RAID-1 and RAID-5) to help guard against data loss. By associating hot spares with the underlying slices that comprise your RAID-0 submirrors or RAID-5 configuration, you can have the system automatically replace failed slices with working slices from the hot spare pool. Those slices that were swapped into use are updated with the information they should have. The slices then can continue to function just like the original slices. You can replace the failed slices at your convenience.

# Hot Spare Pools (Tasks)

---

This chapter explains how to work with Solaris Volume Manager’s hot spares and hot spare pools. For information about related concepts, see [Chapter 16](#).

## Hot Spare Pools (Task Map)

The following task map identifies the procedures that are needed to manage Solaris Volume Manager hot spare pools.

Task	Description	For Instructions
Create a hot spare pool	Use the Solaris Volume Manager GUI or the <code>metainit</code> command to create a hot spare pool.	<a href="#">“How to Create a Hot Spare Pool” on page 176</a>
Add slices to a hot spare pool	Use the Solaris Volume Manager GUI or the <code>metahs</code> command to add slices to a hot spare pool.	<a href="#">“How to Add Additional Slices to a Hot Spare Pool” on page 177</a>
Associate a hot spare pool with a volume	Use the Solaris Volume Manager GUI or the <code>metaparam</code> command to associate a hot spare pool with a volume.	<a href="#">“How to Associate a Hot Spare Pool With a Volume” on page 178</a>
Change which hot spare pool is associated with a volume	Use the Solaris Volume Manager GUI or the <code>metaparam</code> command to change which hot spare pool is associated with a volume.	<a href="#">“How to Change the Associated Hot Spare Pool” on page 179</a>
Check the status of hot spares and hot spare pools	Use the Solaris Volume Manager GUI, the <code>metastat</code> command, or <code>metahs -i</code> command to check the status of a hot spare or hot spare pool.	<a href="#">“How to Check the Status of Hot Spares and Hot Spare Pools” on page 181</a>

Task	Description	For Instructions
Replace a hot spare in a hot spare pool	Use the Solaris Volume Manager GUI or the <code>metahs</code> command to replace a hot spare in a hot spare pool.	<a href="#">“How to Replace a Hot Spare in a Hot Spare Pool” on page 182</a>
Delete a hot spare from a hot spare pool	Use the Solaris Volume Manager GUI or the <code>metahs</code> command to delete a hot spare from a hot spare pool.	<a href="#">“How to Delete a Hot Spare From a Hot Spare Pool” on page 183</a>
Enable a hot spare	Use the Solaris Volume Manager GUI or the <code>metahs</code> command to enable a hot spare in a hot spare pool.	<a href="#">“How to Enable a Hot Spare” on page 184</a>

## Creating a Hot Spare Pool

### ▼ How to Create a Hot Spare Pool



**Caution** – Do not create volumes or hot spares larger than 1 Tbyte if you expect to run the Solaris software with a 32-bit kernel or if you expect to use a version of the Solaris OS prior to the Solaris 9 4/03 release. See [“Overview of Multi-Terabyte Support in Solaris Volume Manager” on page 44](#) for more information about multiterabyte volume support in Solaris Volume Manager.



**Caution** – Solaris Volume Manager does not warn you if you create a hot spare that is not large enough. If the hot spare is not equal to, or larger than, the volume to which it is attached, the hot spare will not work.

**Before You Begin** Check [“Prerequisites for Creating Solaris Volume Manager Components” on page 44](#).

**1 Become superuser.**

**2 To create a hot spare pool, use one of the following methods:**

- From the Enhanced Storage tool within the Solaris Management Console, open the Hot Spare Pools node. Then, choose Action⇒Create Hot Spare Pool. For more information, see the online help.
- Use the following form of the `metainit` command:

```
# metainit hot-spare-pool-name ctds-for-slice
```

*hot-spare-pool-name* Specifies the name of the hot spare pool.

*ctds-for-slice* Specifies the slice being added to the hot spare pool. The option is repeated for each slice being added to the hot spare pool.



See the `metainit(1M)` man page for more information.

---

**Note** – The `metahs` command can also be used to create hot spare pools.

---

### Example 17–1 Creating a Hot Spare Pool

```
# metainit hsp001 c2t2d0s2 c3t2d0s2
hsp001: Hotspare pool is setup
```

In this example, the hot spare pool `hsp001` contains two disks as the hot spares. The system confirms that the hot spare pool has been set up.

**See Also** To add more hot spares to the hot spare pool, see “[How to Add Additional Slices to a Hot Spare Pool](#)” on page 177. After you create the hot spare pool, you need to associate it with a submirror or RAID-5 volume. See “[How to Associate a Hot Spare Pool With a Volume](#)” on page 178.

## ▼ How to Add Additional Slices to a Hot Spare Pool

**Before You Begin** Check “[Prerequisites for Creating Solaris Volume Manager Components](#)” on page 44.

- 1 **Become superuser.**
- 2 **To add a slice to an existing hot spare pool, use one of the following methods:**
  - From the Enhanced Storage tool within the Solaris Management Console, open the Hot Spare Pools node. Choose the hot spare pool you want to change. Choose Action⇒Properties. Then, choose the Hot Spares panel. For more information, see the online help.
  - Use one of the following forms of the `metahs` command:

```
# metahs -a hot-spare-pool-name slice-to-add
```

```
# metahs -a -all hot-spare-pool-name slice-to-add
```

`-a hot-spare-pool-name` Specifies to add the slice to the specified hot spare pool.

`-a all` Specifies to add the slice to all hot spare pools.

`slice-to-add` Specifies the slice to add to the hot spare pool.

See the `metahs(1M)` man page for more information.

---

**Note** – You can add a hot spare to one or more hot spare pools. When you add a hot spare to a hot spare pool, the hot spare is added to the end of the list of slices in the hot spare pool.

---

**Example 17-2 Adding a Hot Spare Slice to One Hot Spare Pool**

In this example, the `-a` option adds the slice `/dev/dsk/c3t0d0s2` to hot spare pool `hsp001`. The system verifies that the slice has been added to the hot spare pool.

```
# metahs -a hsp001 /dev/dsk/c3t0d0s2
hsp001: Hotspare is added
```

**Example 17-3 Adding a Hot Spare Slice to All Hot Spare Pools**

In this example, the `-a` option used with `all` adds the slice `/dev/dsk/c3t0d0s2` to all hot spare pools configured on the system. The system verifies that the slice has been added to all hot spare pools.

```
# metahs -a -all /dev/dsk/c3t0d0s2
hsp001: Hotspare is added
hsp002: Hotspare is added
hsp003: Hotspare is added
```

## Associating a Hot Spare Pool With Volumes

### ▼ How to Associate a Hot Spare Pool With a Volume

**Before You Begin** Check [“Prerequisites for Creating Solaris Volume Manager Components”](#) on page 44.

- 1 **Become superuser.**
- 2 **To associate a hot spare pool with a RAID-5 volume or submirror, use one of the following methods:**
  - From the Enhanced Storage tool within the Solaris Management Console, open the Volumes and choose a volume. Choose Action⇒Properties. Then, choose the Hot Spare Pool panel. Finally, choose Attach HSP. For more information, see the online help.
  - Use the following form of the `metaparam` command:

```
# metaparam -h hot-spare-pool component
```

`-h` Specifies to modify the named hot spare pool.

`hot-spare-pool` Specifies the name of the hot spare pool.

`component` Specifies the name of the submirror or RAID-5 volume to which the hot spare pool is being associated.

See the `metaparam(1M)` man page for more information.

**Example 17-4** Associating a Hot Spare Pool With Submirrors

In the following example, the `-h` option associates a hot spare pool, `hsp100`, with two submirrors, `d10` and `d11`, of mirror, `d0`. The `metastat` command shows that the hot spare pool is associated with the submirrors.

```
# metaparam -h hsp100 d10
# metaparam -h hsp100 d11
# metastat d0
d0: Mirror
    Submirror 0: d10
        State: Okay
    Submirror 1: d11
        State: Okay
...

d10: Submirror of d0
    State: Okay
    Hot spare pool: hsp100
...

d11: Submirror of d0
    State: Okay
    Hot spare pool: hsp100
...
```

**Example 17-5** Associating a Hot Spare Pool With a RAID-5 Volume

In the following example, the `-h` option associates a hot spare, `hsp001`, with a RAID-5 volume, `d10`. The `metastat` command shows that the hot spare pool is associated with the RAID-5 volume.

```
# metaparam -h hsp001 d10
# metastat d10
d10: RAID
    State: Okay
    Hot spare pool: hsp001
...
```

## ▼ How to Change the Associated Hot Spare Pool

**Before You Begin** Check “Prerequisites for Creating Solaris Volume Manager Components” on page 44.

- 1 Become superuser.

## 2 To change a volume's associated hot spare pool, use one of the following methods:

- From the Enhanced Storage tool within the Solaris Management Console, open the Volumes node and choose the volume. Choose Action⇒Properties. Then choose the Hot Spare Pool panel. Detach the unwanted hot spare pool and attach the new hot spare pool by following the onscreen instructions. For more information, see the online help.
- Use the following form of the `metaparam` command:

```
# metaparam -h hot-spare-pool-name RAID5-volume-or-submirror-name
```

```
-h                Specifies to modify the hot spare pool named.
```

```
hot-spare-pool  Specifies the name of the new hot spare pool, or the special keyword none to remove hot spare pool associations.
```

```
component      Specifies the name of the submirror or RAID-5 volume to which the hot spare pool is being attached.
```

See the `metaparam(1M)` man page for more information.

### Example 17-6 Changing the Hot Spare Pool Association

In the following example, the hot spare pool, `hsp001`, is initially associated with a RAID-5 volume, `d4`. The hot spare pool association for the volume is then changed to `hsp002`. The `metastat` command shows the hot spare pool association before and after this change.

```
# metastat d4
d4: RAID
    State: Okay
    Hot spare pool: hsp001
...
# metaparam -h hsp002 d4
# metastat d4
d4: RAID
    State: Okay
    Hot spare pool: hsp002
...
```

### Example 17-7 Removing a Volume's Hot Spare Pool Association

In the following example, the hot spare pool, `hsp001`, is initially associated with a RAID-5 volume, `d4`. The hot spare pool association is then changed to `none`, which indicates that no hot spare pool should be associated with this volume. The `metastat` command shows the hot spare pool association before and after this change.

```
# metastat d4
d4: RAID
```

```

    State: Okay
    Hot spare pool: hsp001
...
# metaparam -h none d4
# metastat d4
d4: RAID
    State: Okay
    Hot spare pool:
...

```

## Maintaining Hot Spare Pools

The following sections show how to perform maintenance tasks on hot spare pools.

### ▼ How to Check the Status of Hot Spares and Hot Spare Pools

#### ► To view the status of a hot spare pool and its hot spares, use one of the following methods:

- From the Enhanced Storage tool within the Solaris Management Console, open the Hot Spare Pools node and select a hot spare pool. Choose Action⇒Properties to view detailed status information. For more information, see the online help.
- Run the following form of the `metastat` command:

```
# metastat hot-spare-pool-name
```

#### Example 17-8 Viewing the Status of a Hot Spare Pool

The following example shows sample output from the `metastat` command on a hot spare pool.

```

# metastat hsp001
hsp001: 1 hot spare
        c1t3d0s2           Available       16800 blocks

```

The `metahs` command can also be used to check the status of a hot spare pool.

For information on the hot spare pool states and the possible actions to take, see [“Hot Spare Pool States” on page 173](#).

## ▼ How to Replace a Hot Spare in a Hot Spare Pool

### 1 Become superuser.

### 2 Verify whether the hot spare is currently being used by using one of the following methods:

- From the Enhanced Storage tool within the Solaris Management Console, open the Hot Spare Pools node and select a hot spare pool. Choose Action⇒Properties. Then choose the Hot Spares panel. Follow the onscreen instructions. For more information, see the online help.
- Use the following form of the `metastat` command to view the status of the hot spare pool:

```
# metastat hot-spare-pool-name
```

For more information, see the `metastat(1M)` man page.

### 3 To replace the hot spare, use one of the following methods:

- From the Enhanced Storage tool within the Solaris Management Console, open the Hot Spare Pools node and select a hot spare pool. Choose Action⇒Properties. Then choose the Hot Spares panel. Follow the onscreen instructions. For more information, see the online help.
- Use the following form of the `metahs` command:

```
# metahs -r hot-spare-pool-name current-hot-spare replacement-hot-spare
```

`-r` Specifies to replace disks in the named hot spare pool.

`hot-spare-pool-name` Specifies the name of the hot spare pool. You can also use the special keyword `all` to change all hot spare pool associations.

`current-hot-spare` Specifies the name of the current hot spare that will be replaced.

`replacement-hot-spare` Specifies the name of the slice that will replace the current hot spare in the named hot spare pool.

For more information, see the `metahs(1M)` man page.

### Example 17-9 Replacing a Hot Spare in One Hot Spare Pool

In the following example, the `metastat` command shows that the hot spare is not in use. The `metahs -r` command replaces the hot spare, `/dev/dsk/c0t2d0s2`, with the hot spare, `/dev/dsk/c3t1d0s2`, in the hot spare pool, `hsp003`.

```
# metastat hsp003
hsp003: 1 hot spare
        c0t2d0s2                Broken        5600 blocks
# metahs -r hsp003 c0t2d0s2 c3t1d0s2
hsp003: Hotspare c0t2d0s2 is replaced with c3t1d0s2
```

**Example 17-10** Replacing a Hot Spare in All Associated Hot Spare Pools

In the following example, the keyword `all` replaces the hot spare, `/dev/dsk/c1t0d0s2`, with the hot spare, `/dev/dsk/c3t1d0s2`, in all its associated hot spare pools.

```
# metahs -r all c1t0d0s2 c3t1d0s2
hsp001: Hotspare c1t0d0s2 is replaced with c3t1d0s2
hsp002: Hotspare c1t0d0s2 is replaced with c3t1d0s2
hsp003: Hotspare c1t0d0s2 is replaced with c3t1d0s2
```

## ▼ How to Delete a Hot Spare From a Hot Spare Pool

### 1 Become superuser.

### 2 Verify whether the hot spare is currently being used by using one of the following methods:

- From the Enhanced Storage tool within the Solaris Management Console, open the Hot Spare Pools node and select a hot spare pool. Choose Action⇒Properties. Then choose the Hot Spares panel. Follow the onscreen instructions. For more information, see the online help.
- Use the following form of the `metastat` command to view the status of the hot spare pool:

```
# metastat hot-spare-pool-name
```

See the `metastat(1M)` man page.

### 3 To delete the hot spare, use one of the following methods:

- From the Enhanced Storage tool within the Solaris Management Console, open the Hot Spare Pools node and select a hot spare pool. Choose Action⇒Properties. Then choose the Hot Spares panel. Follow the onscreen instructions. For more information, see the online help.
- Use the following form of the `metahs` command:

```
# metahs -d hot-spare-pool-name current-hot-spare
```

`-d` Specifies to delete a hot spare from the named hot spare pool.

`hot-spare-pool` Specifies the name of the hot spare pool. You can also use the special keyword `all` to delete the hot spare from all hot spare pools.

`current-hot-spare` Specifies the name of the current hot spare that will be deleted.

For more information, see the `metahs(1M)` man page.

**Example 17-11** Deleting a Hot Spare from One Hot Spare Pool

In the following example, the `metastat` command shows that the hot spare is not in use. The `metahs -d` command deletes the hot spare, `/dev/dsk/c0t2d0s2`, in the hot spare pool, `hsp003`.

```
# metastat hsp003
hsp003: 1 hot spare
          c0t2d0s2          Broken          5600 blocks
# metahs -d hsp003 c0t2d0s2
```

## ▼ How to Enable a Hot Spare

1 Become superuser.

2 To return a hot spare to the “available” state, use one of the following methods:

- From the Enhanced Storage tool within the Solaris Management Console, open the Hot Spare Pools node and select a hot spare pool. Choose Action⇒Properties. Then, choose the Hot Spares panel. Follow the onscreen instructions. For more information, see the online help.
- Use the following form of the `metahs` command:

```
# metahs -e hot-spare-slice
-e          Specifies to enable a hot spare.
hot-spare-slice Specifies the name of the slice to enable.
```

For more information, see the `metahs(1M)` man page.

**Example 17-12** Enabling a Hot Spare

In the following example, the `metahs` command places the hot spare, `/dev/dsk/c0t0d0s2` in the “Available” state after it has been repaired. It is unnecessary to specify a hot spare pool.

```
# metahs -e c0t0d0s2
```



## Disk Sets (Overview)

---

This chapter provides conceptual information about disk sets. For information about performing related tasks, see [Chapter 19](#).

This chapter includes the following information:

- “What’s New in Disk Sets” on page 185
- “Introduction to Disk Sets” on page 186
- “Solaris Volume Manager Disk Set Administration” on page 188
- “Guidelines for Working With Disk Sets” on page 194
- “Asynchronous Shared Storage in Disk Sets” on page 195
- “Scenario—Disk Sets” on page 195

### What’s New in Disk Sets

This section describes new disk set features in this Solaris release.

For a complete listing of new Solaris features and a description of Solaris releases, see *What’s New in Solaris Express*.

### Enhanced Output With the `metainport` Command

**Solaris Express 6/06:** The `metainport` command has been enhanced to allow you to import partial disk sets. A partial disk set is a disk set that has at least one disk that is not available. With this enhancement, a partial disk set can still be imported provided one disk with a `metadb` is present in the set.

This new functionality is associated with enhancements in the `metainport -r` command. The command’s output now includes the following information:

Time stamp	The time the disk set is created is displayed.
Unavailable disks	If a disk has become unresponsive or might have been removed from the system, the disk is labeled unavailable.

Disk conflicts	If a disk is listed as belonging to more than one disk set, the disk is marked as in conflict.
Import recommendation	If disk conflicts exist, <code>metaimport</code> recommends which disk set to import with the disk in conflict.

The information generated by `metaimport -r` helps reduce the risk of data corruption when importing disk sets. In cases of disk conflicts, `metaimport` imports only the most recent disk set that is created with the disk in conflict. If a user imports a disk set with time conflicts contrary to the recommendation, the attempt is blocked.

The `metaimport -rv` command now contains more information in the output. This information allows the user to see the basic structure of the volumes that are available for import.

Finally, you can import the recommended partial disk set by using the following syntax:

```
metaimport -s setname -f diskname
```

For examples of the output of the `metaimport -r` and `metaimport -rv` commands, see [“How to Print a Report on Disk Sets Available for Import” on page 210](#).

## Introduction to Disk Sets

A disk set is a set of physical storage volumes that contain logical volumes and hot spares. Volumes and hot spare pools must be built on drives from within that disk set. Once you have created a volume within the disk set, you can use the volume just as you would use a physical slice. You can use the volume to create and to mount a file system and to store data.

---

**Note** – Disk sets are supported on both SPARC and x86 based platforms.

---

## Types of Disk Sets

This section discusses the different types of disk sets available in Solaris Volume Manager.

### Local Disk Sets

Each host has a local disk set. The local disk set consists of all of the disks on a host that are not in a named disk set. A local disk set belongs exclusively to a specific host. The local disk set contains the state database for that specific host’s configuration. Volumes and hot spare pools in the local disk set consist only of drives from within the local disk set.

---

## Named Disk Sets

In addition to local disk sets, hosts can participate in named disk sets. A named disk set is any disk set that is not in the local disk set. You can implement the following types of named disk sets to manage volumes, depending on the configuration of your system.

### Shared Disk Sets

A *shared disk set* can be shared by multiple hosts. Although a shared disk set is visible from all the participating hosts, only the owner of the disk set can access it. Each host can control a shared disk set, but only one host can control it at a time. Additionally, shared disk sets provide a distinct namespace within which the volume is managed.

A shared disk set supports data redundancy and data availability. If one host fails, another host can take over the failed host's disk set (this type of configuration is known as a *failover configuration*).

---

**Note** – Shared disk sets are intended, in part, for use with Sun Cluster, Solstice HA (High Availability), or another supported third-party HA framework. Solaris Volume Manager by itself does not provide all the functionality necessary to implement a failover configuration.

---

Although each host can control the set of disks, only one host can control it at a time.

### Autotake Disk Sets

Before the autotake feature became available in the Solaris 9 4/04 release, Solaris Volume Manager did not support the automatic mounting of file systems on disk sets through the `/etc/vfstab` file. Solaris Volume Manager required the system administrator to manually issue a disk set take command by using the `metaset -s setname -t` command before the file systems on the disk set could be accessed.

With the autotake feature, you can set a disk set to be automatically accessed at boot time by using the `metaset -s setname -A enable` command. The autotake feature makes it possible for you to define at boot the mount options for a file system in the `/etc/vfstab` file. This feature allows you to define the mount options in the `/etc/vfstab` file for file systems on volumes in the enabled disk set.

Only single-host disk sets support the autotake feature. The autotake feature requires that the disk set is not shared with any other systems. A disk set that is shared cannot be set to use the autotake feature, and the `metaset -A` command will fail. However, after other hosts are removed from the disk set, it may then be set to autotake. Similarly, an autotake disk set cannot have other hosts added to it. If the autotake feature is disabled, additional hosts can then be added to the disk set.

---

**Note** – In a Sun Cluster environment, the autotake feature is disabled. Sun Cluster handles the take and release of a disk set.

---

For more information on the autotake feature see the `-A` option of the `metaset(1M)` command.

## Multi-Owner Disk Sets

Named disk sets created in a Sun Cluster environment are called multi-owner disk sets. Multi-owner disk sets allow multiple nodes to share the ownership of the disk sets and to simultaneously access the shared disks. All disks and volumes in a multi-owner disk set can be directly accessed by all the nodes in a cluster. Each multi-owner disk set contains a list of hosts that have been added to the disk set. Consequently, each multi-owner disk set within a cluster configuration can have a different (and sometimes overlapping) set of hosts.

Each multi-owner disk set has a master node. The function of the master node is to manage and update the state database replica changes. Since there is a master node per disk set, multiple masters can exist simultaneously. There are two ways that the master is chosen. The first way is that a node becomes the master if it is the first node to add a disk to the disk set. The second way is when a master node panics and fails. The node with the lowest node id becomes the master node.

Multi-owner disk set functionality is enabled only in a Sun Cluster environment to manage multi-owner disk set storage. The Solaris Volume Manager for Sun Cluster feature works with releases of Sun Cluster beginning with the Sun Cluster 10/04 software collection and with applications like Oracle Real Applications Clusters. For more information on Solaris Volume Manager for Sun Cluster, see Chapter 4, *Solaris Volume Manager for Sun Cluster (Overview)*.

Before you can configure multi-owner disk sets, the following software must be installed in addition to the Solaris OS:

- Sun Cluster initial cluster framework
- Sun Cluster Support for Oracle Real Application Clusters software
- Oracle Real Application Clusters software

---

**Note** – For information on setting up Sun Cluster and Oracle Real Application Clusters software, see *Sun Cluster Software Installation Guide for Solaris OS* and *Sun Cluster Data Service for Oracle RAC Guide for Solaris OS*.

---

## Solaris Volume Manager Disk Set Administration

Unlike local disk set administration, you do not need to manually create or delete disk set state databases. Solaris Volume Manager places one state database replica (on slice 7) on each disk across all disks in the disk set, up to a maximum of 50 total replicas in the disk set.

When you add disks to a disk set, Solaris Volume Manager automatically creates the state database replicas on the disk set. When a disk is accepted into a disk set, Solaris Volume Manager might repartition the disk so that the state database replica for the disk set can be placed on the disk (see “Automatic Disk Partitioning” on page 191).

A file system that resides on a volume in a disk set normally is not mounted automatically at boot time with the `/etc/vfstab` file. The necessary Solaris Volume Manager RPC daemons (`rpc.metad`

and `rpc.metamhd`) do not start early enough in the boot process to permit this. Additionally, the ownership of a disk set is lost during a reboot. Do not disable the Solaris Volume Manager RPC daemons in the `/etc/inetd.conf` file. They are configured to start by default. These daemons must remain enabled to allow Solaris Volume Manager to use its full functionality.

When the `autotake` feature is enabled using the `-A` option of the `metaset` command, the disk set is automatically taken at boot time. Under these circumstances, a file system that resides on a volume in a disk set can be automatically mounted with the `/etc/vfstab` file. To enable an automatic take during the boot process, the disk set must be associated with only a single host, and must have the `autotake` feature enabled. A disk set can be enabled either during or after disk set creation. For more information on the `autotake` feature, see “[Autotake Disk Sets](#)” on page 187.

---

**Note** – Although disk sets are supported in single-host configurations, they are often not appropriate for “local” (not dual-connected) use. Two common exceptions are the use of disk sets to provide a more manageable namespace for logical volumes, and to more easily manage storage on a Storage Area Network (SAN) fabric (see “[Scenario—Disk Sets](#)” on page 195).

---

Disk sets can be created and configured by using the Solaris Volume Manager command-line interface (the `metaset` command) or the Enhanced Storage tool within the Solaris Management Console.

After disks are added to a disk set, the disk set can be *reserved* (or *taken*) and *released* by hosts in the disk set. When a disk set is reserved by a host, the other host in the disk set cannot access the data on the disks in the disk set. To perform maintenance on a disk set, a host must be the owner of the disk set or have reserved the disk set. A host takes implicit ownership of the disk set by putting the first disk into the set.

Disk sets, including disk sets created on a different system, can be imported into existing Solaris Volume Manager configurations using the `metaimport` command.

## Reserving a Disk Set

Before a host can use the disks in a disk set, the host must reserve the disk set. There are two methods of reserving a disk set:

- **Safely** - When you safely reserve a disk set, Solaris Volume Manager attempts to take the disk set, and the other host attempts to release the disk set. The release (and therefore the reservation) might fail.
- **Forcibly** - When you forcibly reserve a disk set, Solaris Volume Manager reserves the disk set whether or not another host currently has the set reserved. This method is generally used when a host in the disk set is down or not communicating. All disks within the disk set are taken over. The state database is read in on the host performing the reservation and the shared volumes configured in the disk set become accessible. If the other host had the disk set reserved at this point, it would panic due to reservation loss.

Normally, two hosts in a disk set cooperate with each other to ensure that the disks in a disk set are reserved by only one host at a time. A normal situation is defined as both hosts being up and communicating with each other.

---

**Note** – If a disk has been determined unexpectedly not to be reserved (perhaps because another host using the disk set forcibly took the disk), the host will panic. This behavior helps to minimize data loss which would occur if two hosts were to simultaneously access the same disk.

---

For more information about taking or reserving a disk set, see [“How to Take a Disk Set” on page 205](#).

## Releasing a Disk Set

Releasing a disk set can be useful when you perform maintenance on the physical disks in the disk set. When a disk set is released, it cannot be accessed by the host. If both hosts in a disk set release the set, neither host in the disk set can access the disks in the disk set.

For more information about releasing a disk set, see [“How to Release a Disk Set” on page 207](#).

## Importing a Disk Set

Beginning with the Solaris 9 9/04 release, the `metaimport` command enables you to import disk sets, including replicated disk sets, into existing Solaris Volume Manager configurations that have device ID support in the disk set. You can also use the `metaimport` command to report on disk sets that are available for import.

Replicated disk sets are created using remote replication software. In order for a replicated disk set to be imported with the `metaimport` command, the slice containing the state database replica for each disk in the disk set must also be replicated onto the same slice of the replicated disk set. This corresponds to slice 7 for non-EFI disks and slice 6 for EFI disks. Before replicating a disk set, make sure that the disk configurations of the data to be replicated and of the remote site match. This step ensures that both the state database replica and the data are replicated accurately.

The `metaimport` command also does not import a disk in a disk set if the disk does not contain a volume or a state database replica. This scenario occurs if a volume or a state database replica have not been added to a disk or have been deleted from a disk. In this case, when you import the disk set to another system, you would find that the disk is missing from the disk set. For example, maximum of 50 state database replicas are allowed per Solaris Volume Manager disk set. If you have 60 disks in a disk set, the 10 disks that do not contain a state database replica must contain a volume in order to be imported with the disk set.

For tasks associated with importing a disk set, see [“Importing Disk Sets” on page 210](#).

---

**Note** – In a Sun Cluster environment, the `metaimport` command is not available.

---

## Automatic Disk Partitioning

When you add a new disk to a disk set, Solaris Volume Manager checks the disk format. If necessary, Solaris Volume Manager repartitions the disk to ensure that the disk has an appropriately configured slice 7 with adequate space for a state database replica. The precise size of slice 7 depends on the disk geometry. However, the size will be no less than 4 Mbytes, and probably closer to 6 Mbytes (depending on where the cylinder boundaries lie).

By default, Solaris Volume Manager places one state database replica on slice 7. You can increase the default size of slice 7 or decrease the size of the state database replica in order to fit more than one state database replica onto the slice.

---

**Note** – The minimal size for slice 7 will likely change in the future, based on a variety of factors, including the size of the state database replica and information to be stored in the state database replica. The default size for a state database replica in a multi-owner disk set is 16 Mbytes.

---

For use in disk sets, disks must have a slice 7 that meets these criteria:

- Starts at sector 0
- Includes enough space for a disk label and state database replicas
- Cannot be mounted
- Does not overlap with any other slices, including slice 2

If the existing partition table does not meet these criteria, Solaris Volume Manager repartitions the disk. A small portion of each drive is reserved in slice 7 for use by Solaris Volume Manager. The remainder of the space on each drive is placed into slice 0. Any existing data on the disks is lost by repartitioning.

---

**Tip** – After you add a drive to a disk set, you may repartition it as necessary, with the exception that slice 7 is not altered in any way.

---

The following output from the `prtvtoc` command shows a disk before it is added to a disk set.

```
[root@lexicon:apps]$ prtvtoc /dev/rdisk/clt6d0s0
* /dev/rdisk/clt6d0s0 partition map
*
* Dimensions:
*   512 bytes/sector
*   133 sectors/track
*   27 tracks/cylinder
*   3591 sectors/cylinder
```

```

*   4926 cylinders
*   4924 accessible cylinders
*
* Flags:
*   1: unmountable
*  10: read-only
*
*
* Partition  Tag  Flags      First   Sector   Last
* Partition  Tag  Flags      Sector  Count    Sector  Mount Directory
*   0         2   00         0     4111695  4111694
*   1         3   01      4111695  1235304  5346998
*   2         5   01         0  17682084 17682083
*   3         0   00      5346999  4197879  9544877
*   4         0   00      9544878  4197879 13742756
*   5         0   00     13742757 3939327 17682083

```

The above output shows that the disk does not contain a slice 7. Therefore, when the disk is added to a disk set, Solaris Volume Manager repartitions the disk. The following output from the `prtvtoc` command shows the disk after it is added to a disk set.

```

[root@lexicon:apps]$ prtvtoc /dev/rdisk/clt6d0s0
* /dev/rdisk/clt6d0s0 partition map
*
* Dimensions:
*   512 bytes/sector
*   133 sectors/track
*   27 tracks/cylinder
*  3591 sectors/cylinder
*   4926 cylinders
*   4924 accessible cylinders
*
* Flags:
*   1: unmountable
*  10: read-only
*
*
* Partition  Tag  Flags      First   Sector   Last
* Partition  Tag  Flags      Sector  Count    Sector  Mount Directory
*   0         0   00      10773 17671311 17682083
*   7   0  01     0  10773  10772
[root@lexicon:apps]$

```

The output shows that the disk has been repartitioned to include a slice 7 that starts at cylinder 0 and that has sufficient space for the state database replica. If disks you add to a disk set each have an acceptable slice 7, they are not reformatted.



---

**Note** – If you have disk sets that you upgraded from Solstice DiskSuite software, the default state database replica size on those sets is 1034 blocks, not the 8192 block size from Solaris Volume Manager. Also, slice 7 on the disks that were added under Solstice DiskSuite software are correspondingly smaller than slice 7 on disks that were added under Solaris Volume Manager.

---

## Disk Set Name Requirements

Disk set volume names are similar to other Solaris Volume Manager component names. However, the disk set name is included as part of the name. For example, volume path names include the disk set name after `/dev/md/` and before the actual volume name in the path.

The following table shows some example disk set volume names.

**TABLE 18-1** Example Volume Names for Disk Sets

<code>/dev/md/blue/dsk/d0</code>	Block volume d0 in disk set blue
<code>/dev/md/blue/dsk/d1</code>	Block volume d1 in disk set blue
<code>/dev/md/blue/rdisk/d126</code>	Raw volume d126 in disk set blue
<code>/dev/md/blue/rdisk/d127</code>	Raw volume d127 in disk set blue

Similarly, hot spare pools have the disk set name as part of the hot spare name.

## Example—Two Shared Disk Sets

Figure 18-1 shows an example configuration that uses two disk sets.

In this configuration, Host A and Host B share the disk sets red and blue. They each have their own local disk set, which is not shared. If Host A fails, Host B can take over control of Host A's shared disk set, the disk set red. Likewise, if Host B fails, Host A can take control of Host B's shared disk set, the disk set blue.

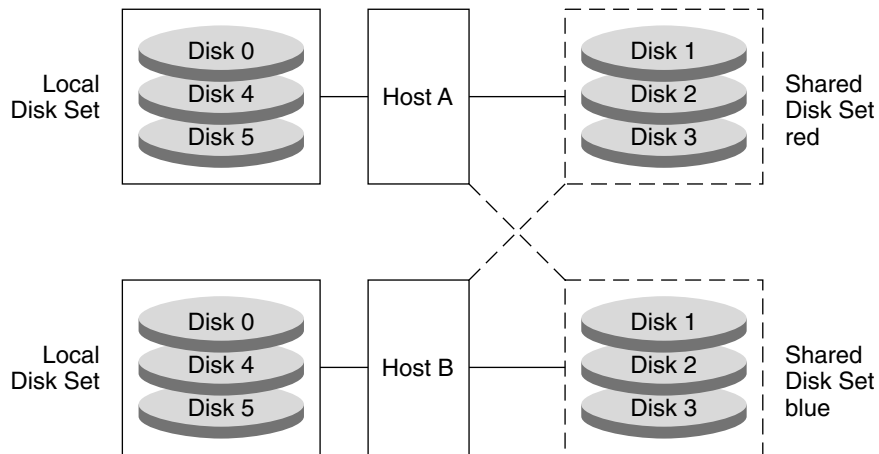

FIGURE 18-1 Disk Sets Example

## Guidelines for Working With Disk Sets

When working with disk sets, consider the following guidelines:

- Solaris Volume Manager must be configured on each host that will be connected to the disk set.
- Each host must have its local state database set up before you can create disk sets.
- The sequence of steps for creating a disk set and creating the volumes for that disk set is to, first, create the disk set. Then, add the disks to the disk set. Finally, create the volumes in the disk set.
- To create and work with a disk set in a clustering environment, root must be a member of Group 14. Alternatively, the `.rhosts` file on each host must contain an entry for the other host names associated with the disk set.

---

**Note** – This step is not necessary in a SunCluster 3.x environment.

---

- To perform maintenance on a disk set, a host must be the owner of the disk set or have reserved the disk set. A host takes implicit ownership of the disk set by putting the first drives into the disk set.
- You cannot add a drive to a disk set that is in use for a file system, database or any other application. Before you add a drive, make sure that it is not currently being used.
- Do not add to a disk set a drive containing existing data that you want to preserve. The process of adding the disk to the disk set repartitions the disk and destroys existing data.
- Unlike local volume administration, it is not necessary to manually create or delete state database replicas on the disk set. Solaris Volume Manager tries to balance a reasonable number of state database replicas across all drives in a disk set.

- When drives are added to a disk set, Solaris Volume Manager rebalances the state database replicas across the remaining drives. Later, if necessary, you can change the replica layout with the `metadb` command.

## Asynchronous Shared Storage in Disk Sets

In previous versions of Solaris Volume Manager, all of the disks that you planned to share between hosts in the disk set had to be connected to each host. They also had to have the exact same path, driver, and name on each host. Specifically, a shared disk drive had to be seen by both hosts in the same location (`/dev/rdisk/c#t#d#`). In addition, the shared disks had to use the same driver name (`ssd`).

In the current Solaris OS release, systems that have different views of commonly accessible storage can nonconcurrently share access to a disk set. With the introduction of device ID support for disk sets, Solaris Volume Manager automatically tracks disk movement within named disk sets.

---

**Note** – Device ID support for disk sets is not supported in a Sun Cluster environment.

---

When you upgrade to the latest Solaris OS, you need to take the disk set once in order to enable disk tracking. For more information on taking a disk set, see [“How to Take a Disk Set” on page 205](#).

If the autotake feature is not enabled, you have to take each disk set manually. If this feature is enabled, this step is done automatically when the system is rebooted. For more information on the autotake feature, see [“Autotake Disk Sets” on page 187](#).

This expanded device ID support also enables you to import disk sets, even disk sets that were created on different systems. For more information on importing disk sets, see [“Importing a Disk Set” on page 190](#).

## Scenario—Disk Sets

The following example, drawing on the sample system shown in [Chapter 5](#), describes how disk sets should be used to manage storage that resides on a SAN (Storage Area Network) fabric.

Assume that the sample system has an additional controller that connects to a fiber switch and SAN storage. Storage on the SAN fabric is unavailable to the system as early in the boot process as other devices, such as SCSI and IDE disks. In addition, Solaris Volume Manager would report logical volumes on the fabric as unavailable at boot. However, by adding the storage to a disk set, and then using the disk set tools to manage the storage, this problem with boot time availability is avoided. Also, the fabric-attached storage can be easily managed within a separate, disk set-controlled, namespace from the local storage.



# Disk Sets (Tasks)

---

This chapter provides information about performing tasks that are associated with disk sets. For information about the concepts that are involved in these tasks, see [Chapter 18](#).

## Disk Sets (Task Map)

The following task map identifies the procedures that are needed to manage Solaris Volume Manager disk sets and Solaris Volume Manager for Sun Cluster multi-owner disk sets. All commands work for both types of disk sets except where noted. The Solaris Volume Manager GUI is not available for tasks associated with multi-owner disk sets.

Task	Description	For Instructions
Create a disk set	Use the Solaris Volume Manager GUI or the <code>metaset</code> command to create a disk set.  Use the <code>metaset -M</code> command to create a multi-owner disk set.	<a href="#">“How to Create a Disk Set” on page 198</a>
Add disks to a disk set	Use the Solaris Volume Manager GUI or the <code>metaset</code> command to add disks to a disk set.	<a href="#">“How to Add Disks to a Disk Set” on page 200</a>
Add a host to a disk set	Use the Solaris Volume Manager GUI or the <code>metaset</code> command to add a host to a disk set.	<a href="#">“How to Add Another Host to a Disk Set” on page 201</a>
Create Solaris Volume Manager volumes in a disk set	Use the Solaris Volume Manager GUI or the <code>metainit</code> command to create volumes in a disk set.	<a href="#">“How to Create Solaris Volume Manager Components in a Disk Set” on page 202</a>
Check the status of a disk set	Use the Solaris Volume Manager GUI, or use the <code>metaset</code> command to check the status of a disk set.	<a href="#">“How to Check the Status of a Disk Set” on page 204</a>

Task	Description	For Instructions
Remove disks from a disk set	Use the Solaris Volume Manager GUI or the <code>metaset</code> command to remove disks from a disk set.	<a href="#">“How to Delete Disks From a Disk Set” on page 204</a>
Take a disk set	Use the Solaris Volume Manager GUI or the <code>metaset</code> command to take a disk set.	<a href="#">“How to Take a Disk Set” on page 205</a>
Release a disk set	Use the Solaris Volume Manager GUI or the <code>metaset</code> command to release a disk set.	<a href="#">“How to Release a Disk Set” on page 207</a>
Delete a host from a disk set	Use the Solaris Volume Manager GUI or the <code>metaset</code> command to delete hosts from a disk set.	<a href="#">“How to Delete a Host or Disk Set” on page 208</a>
Delete a disk set	Use the Solaris Volume Manager GUI or the <code>metaset</code> command to delete the last host from a disk set, thus deleting the disk set.	<a href="#">“How to Delete a Host or Disk Set” on page 208</a>
Import a disk set	Use the <code>metaimport</code> command to run reports on disk sets to determine which disk sets can be imported and to import disk sets from one system to another.	<a href="#">“Importing Disk Sets” on page 210</a>

## Creating Disk Sets

### ▼ How to Create a Disk Set

**Before You Begin** Check [“Guidelines for Working With Disk Sets” on page 194](#).

#### 1 To create a disk set, use one of the following methods:

- From the Enhanced Storage tool within the Solaris Management Console, open the Disk Sets node. Choose Action⇒Create Disk Set. Then, follow the instructions in the wizard. For more information, see the online help.
- To create a disk set from scratch from the command line, use the following form of the `metaset` command:

```
# metaset -s diskset-name -a -h -M hostname
```

-s *diskset-name* Specifies the name of a disk set on which the `metaset` command will work.

-a Adds hosts to the named disk set. Solaris Volume Manager supports up to four hosts per disk set.

-M Specifies that the disk set being created is a multi-owner disk set.

`-h hostname` Specifies one or more hosts to be added to a disk set. Adding the first host creates the set. The second host can be added later. However, the second host is not accepted if all the disks within the set cannot be found on the specified *hostname*. *hostname* is the same name found in the `/etc/nodename` file.

See the `metaset(1M)` man page for more information.

## 2 Check the status of the new disk set.

```
# metaset
```

### Example 19-1 Creating a Disk Set

In the following example, you create a shared disk set called `blue`, from the host `host1`. The `metaset` command shows the status. At this point, the disk set has no owner. The host that adds disks to the set becomes the owner by default.

```
# metaset -s blue -a -h host1
# metaset
Set name = blue, Set number = 1

Host                Owner
host1
```

### Example 19-2 Creating a Multi-Owner Disk Set

In the following example, you create a multi-owner disk set called `red`. The first line of the output from the `metaset` command displays “Multi-owner,” indicating that the disk set is a multi-owner disk set.

```
# metaset -s red -a -M -h nodeone
# metaset -s red
Multi-owner Set name = red, Set number = 1, Master =

Host                Owner                Member
nodeone
```

# Expanding Disk Sets

## ▼ How to Add Disks to a Disk Set



---

**Caution** – Do not add disks larger than 1Tbyte to disk sets if you expect to run the Solaris software with a 32-bit kernel or if you expect to use a version of the Solaris OS prior to the Solaris 9 4/03 release. See “[Overview of Multi-Terabyte Support in Solaris Volume Manager](#)” on page 44 for more information about multi-terabyte volume support in Solaris Volume Manager.

---

Only disks that meet the following conditions can be added to a disk set:

- The disk must not be in use in a volume or hot spare pool.
- The disk must not contain a state database replica.
- The disk must not be currently mounted, swapped on, or otherwise opened for use by an application.

**Before You Begin** Check “[Guidelines for Working With Disk Sets](#)” on page 194.

### 1 To add disks to a disk set, use one of the following methods:

- From the Enhanced Storage tool within the Solaris Management Console, open the Disk Sets node. Select the disk set that you want to modify. Then click the right mouse button and choose Properties. Select the Disks tab. Click Add Disk. Then follow the instructions in the wizard. For more information, see the online help.
- To add disks to a disk set from the command line, use the following form of the `metaset` command:

```
# metaset -s diskset-name -a disk-name
```

-s *diskset-name* Specifies the name of a disk set on which the `metaset` command will work.

-a Adds disks to the named disk set.

*disk-name* Specifies the disks to add to the disk set. disk names are in the form `cxt:dx`.  
N The “sx” slice identifiers are not included when adding a disk to a disk set.

See the `metaset(1M)` man page for more information.

The first host to add a disk to a disk set becomes the owner of the disk set.



---

**Caution** – Do not add a disk with data to a disk set. The process of adding a disk with data to a disk set might repartition the disk, destroying the data.

---



**2 Verify the status of the disk set and disks.**

```
# metaset
```

**Example 19-3 Adding a Disk to a Disk Set**

```
# metaset -s blue -a c1t6d0
# metaset
Set name = blue, Set number = 1
```

Host	Owner
host1	Yes

Drive	Dbase
c1t6d0	Yes

In this example, the host name is host1. The shared disk set is blue. Only the disk, c1t6d0, has been added to the disk set blue.

Optionally, you could add multiple disks at once by listing each disk on the command line. For example, you could use the following command to add two disks to the disk set simultaneously:

```
# metaset -s blue -a c1t6d0 c2t6d0
```

**▼ How to Add Another Host to a Disk Set**

This procedure explains how to add another host to an existing disk set that only has one host. Solaris Volume Manager supports up to four hosts per disk set.

**Before You Begin** Check “[Guidelines for Working With Disk Sets](#)” on page 194.

**1 To add a host to a disk set, use one of the following methods:**

- From the Enhanced Storage tool within the Solaris Management Console, open the Disk Sets node and choose the disk set you want to modify. Select the disk set you want to modify. Then click the right mouse button, and choose Properties. Select the Hosts tab. Click Add Host. Then follow the instructions in the wizard. For more information, see the online help.
- To add hosts to a disk set from the command line, use the following form of the `metaset` command:

```
# metaset -s diskset-name -a -h hostname
-s diskset-name    Specifies the name of a disk set on which to add the host.
-a                  Adds the host to the named disk set.
```

`-h hostname` Specifies one or more host names to be added to the disk set. Adding the first host creates the disk set. The host name is the same name found in the `/etc/nodename` file.

See the `metaset(1M)` man page for more information.

## 2 Verify that the host has been added to the disk set.

```
# metaset
```

### Example 19-4 Adding Another Host to a Disk Set

```
# metaset -s blue -a -h host2
# metaset
Set name = blue, Set number = 1

Host                Owner
  host1              Yes
  host2

Drive              Dbase
  c1t6d0             Yes
  c2t6d0             Yes
```

This example shows the addition of the host, `host2`, to the disk set, `blue`.

## ▼ How to Create Solaris Volume Manager Components in a Disk Set

After you create a disk set, you can create volumes and hot spare pools using the disks you added to the disk set. You can use either the Enhanced Storage tool within the Solaris Management Console or the command-line utilities.

### ► To create volumes or other Solaris Volume Manager components within a disk set, use one of the following methods:

- From the Enhanced Storage tool within the Solaris Management Console, open the Volumes, State Database Replicas, or Hot Spare Pools node. Choose **Action** ⇒ **Create**. Then follow the instructions in the wizard. For more information, see the online help.
- Use the same command line utilities with the same basic syntax to create volumes, state database replicas, or hot spare pools. However, add `-s disk-set` immediately after the command for every command.

```
# command -s disk-set
```

**Example 19-5** Creating Solaris Volume Manager Volumes in a Disk Set

The following example shows the creation of a mirror, `d10`, in the disk set, `blue`. The mirror consists of submirrors (RAID-0 volumes), `d11` and `d12`.

```
# metainit -s blue d11 1 1 c1t6d0s0
blue/d11: Concat/Stripe is setup
# metainit -s blue d12 1 1 c2t6d0s0
blue/d12: Concat/Stripe is setup
# metainit -s blue d10 -m d11
blue/d10: Mirror is setup
# metattach -s blue d10 d12
blue/d10: submirror blue/d12 is attached

# metastat -s blue
blue/d10: Mirror
  Submirror 0: blue/d11
    State: Okay
  Submirror 1: blue/d12
    State: Resyncing
  Resync in progress: 0 % done
  Pass: 1
  Read option: roundrobin (default)
  Write option: parallel (default)
  Size: 17674902 blocks

blue/d11: Submirror of blue/d10
  State: Okay
  Size: 17674902 blocks
  Stripe 0:
    Device                Start Block  Dbase State      Reloc  Hot Spare
    c1t6d0s0                0           No  Okay

blue/d12: Submirror of blue/d10
  State: Resyncing
  Size: 17674902 blocks
  Stripe 0:
    Device                Start Block  Dbase State      Reloc  Hot Spare
    c2t6d0s0                0           No  Okay
```

# Maintaining Disk Sets

## ▼ How to Check the Status of a Disk Set

### ► Use one of the following methods to check the status of a disk set.

- From the Enhanced Storage tool within the Solaris Management Console, open the Disk Sets node. Click the right mouse button on the Disk Set you want to monitor. Then choose Properties from the menu. For more information, see the online help.
- Use the following form of the `metaset` command to view disk set status.

```
# metaset -s diskset-name
```

See the `metaset(1M)` man page for more information.

---

**Note** – Disk set ownership is only shown on the owning host.

---

### Example 19–6 Checking the Status of a Specified Disk Set

The following example shows the `metaset` command with the `-s` option followed by the name of the disk set, `blue`. The output from this command displays status information for that disk set. The output indicates that `host1` is the disk set owner. The `metaset` command also displays the disks in the disk set.

```
red# metaset -s blue
```

```
Set name = blue, Set number = 1
```

Host	Owner
host1	Yes

Drive	Dbase
c1t6d0	Yes
c2t6d0	Yes

The `metaset` command by itself displays the status of all disk sets.

## ▼ How to Delete Disks From a Disk Set

### 1 To delete a disk from a disk set, use one of the following methods:

- From the Enhanced Storage tool within the Solaris Management Console, open the Disk Sets node. Click the right mouse on the Disk Set that you want to release. Then choose Properties from the menu. Click the Disks tab. Follow the instructions in the online help.
- Use the following form of the `metaset` command to delete a disk from a disk set.

```
# metaset -s diskset-name -d disk-name
```

`-s diskset-name` Specifies the name of a disk set on which to delete the disk.

`-d disk-name` Specifies the disks to delete from the disk set. Disk names are in the form `cxtxdx`. The “sx” slice identifiers are not included when deleting a disk from a disk set.

See the `metaset(1M)` man page for more information.

## 2 Verify that the disk has been deleted from the disk.

```
# metaset -s diskset-name
```

---

**Note** – To delete a disk set, you must first delete all the disks from the disk set.

---

### Example 19–7 Deleting a Disk from a Disk Set

The following example shows the deletion of the disk, `c1t6d0` from the disk set, `blue`.

```
host1# metaset -s blue -d c1t6d0
host1# metaset -s blue
```

```
Set name = blue, Set number = 1
```

Host	Owner
host1	
host2	

Drive	Dbase
c2t6d0	Yes

## ▼ How to Take a Disk Set

---

**Note** – This option is not available for multi-owner disk sets.

---

- ▶ Use one of the following methods to take a disk set:

- From the Enhanced Storage tool within the Solaris Management Console, open the Disk Sets node. Click the right mouse on the disk set you want to take. Then, then choose Take Ownership from the menu. For more information, see the online help.
- Use the following form of the `metaset` command.

```
# metaset -s diskset-name -t -f
```

-s *diskset-name* Specifies the name of a disk set to take.

-t Specifies to take the disk set.

-f Specifies to take the disk set forcibly.

See the `metaset(1M)` man page for more information.

Only one host at a time can own a disk set. When one host in a disk set takes the disk set, the other host in the disk set cannot access data on the disks in the disk set.

The default behavior of the `metaset` command is to allow your host to take the disk set only if a release is possible on the host that has ownership of the disk set. Use the `-f` option to forcibly take the disk set. This option takes the disk set whether or not another host currently has the set. Use this method when a host in the disk set is down or not communicating. If the other host had the disk set taken at this point, it would panic when it attempts to perform an I/O operation on the disk set.

---

**Note** – Disk set ownership is only shown on the owning host.

---

### Example 19–8 Taking a Disk Set

In the following example, the host, `host1`, communicates with the host, `host2`. This communication ensures that the host `host2` has released the disk set before the host, `host1`, attempts to take the disk set.

```
host1# metaset
...
Set name = blue, Set number = 1

Host                Owner
  host1
  host2
...
host1# metaset -s blue -t
host2# metaset
...
Set name = blue, Set number = 1

Host                Owner
  host1                Yes
```

```
host2
...
```

If `host2` owned the disk set, `blue`, the “Owner” column in the preceding output would still have been blank. The `metaset` command only shows whether the host issuing the command owns the disk set.

### Example 19–9 Taking a Disk Set Forcibly

In the following example, the host that is taking the disk set does not communicate with the other host. Instead, the `-f` option allows the disks in the disk set to be forcibly taken without warning. If the other host had owned the disk set, that host would panic when it attempted an I/O operation on the disk set.

```
# metaset -s blue -t -f
```

## ▼ How to Release a Disk Set

Releasing a disk set is useful when you perform maintenance on the physical disks in the disk set. When a disk set is released, it cannot be accessed by the host. If both hosts in a disk set release the set, neither host in the disk set can access directly the volumes or hot spare pools that are defined in the disk set. However, if both hosts release the disk set, the hosts can access the disks directly through their `c*t*d*` names.

---

**Note** – This option is not available for multi-owner disk sets.

---

**Before You Begin** Check “[Guidelines for Working With Disk Sets](#)” on page 194.

### 1 Use one of the following methods to release a disk set:

- From the Enhanced Storage tool within the Solaris Management Console, open the Disk Sets node. Click the right mouse on the disk set that you want to release. Then choose Release Ownership from the menu. For more information, see the online help.
- To release ownership of the disk set, use the following form of the `metaset` command:

```
# metaset -s diskset-name -r
```

```
-s diskset-name    Specifies the name of a disk set on which the metaset command will work.
```

```
-r                Releases ownership of a disk set. The reservation of all the disks within the
                  disk set is removed. The volumes within the disk set are no longer accessible.
```

See the `metaset(1M)` man page for more information.

---

**Note** – Disk set ownership is only shown on the owning host.

---

## 2 Verify that the disk set has been released on this host.

```
# metaset
```

### Example 19–10 Releasing a Disk Set

The following example shows the release of the disk set, `blue`. Note that there is no owner of the disk set. Viewing status from the host `host1` could be misleading. A host can only determine if it does or does not own a disk set. For example, if the host, `host2`, were to take ownership of the disk set, the ownership would not appear from the host, `host1`. Only the host, `host2`, would display that `host2` has ownership of the disk set.

```
host1# metaset -s blue -r
host1# metaset -s blue

Set name = blue, Set number = 1
```

Host	Owner
host1	
host2	

Drive	Dbase
c1t6d0	Yes
c2t6d0	Yes

## ▼ How to Delete a Host or Disk Set

Deleting a disk set requires that the disk set contains no disks and that no other hosts are attached to the disk set. Deleting the last host destroys the disk set.

### 1 Use one of the following methods to delete a host from a disk set, or to delete a disk set:

- From the Enhanced Storage tool within the Solaris Management Console, open the Disk Sets node. Click the right mouse on the disk set you want to release, then choose `Delete` from the menu. Follow the instructions in the online help.
- To delete the host use the following form of the `metaset` command.

```
metaset -s diskset-name -d -h hostname
```

-s *diskset-name* Specifies the name of a disk set on which the `metaset` command will work.

-d Deletes a host from a disk set.



`-h hostname` Specifies the name of the host to delete.

Use the same form of the preceding `metaset` command to delete a disk set. Deleting a disk set requires that the disk set contains no disks and that no other hosts own the disk set. Deleting the last host destroys the disk set.

See the `metaset(1M)` man page for more information.

- 2 **Verify that the host has been deleted from the disk set by using the `metaset` command. Note that only the current (owning) host is shown. Other hosts have been deleted.**

```
# metaset -s disk-set
```

### Example 19–11 Deleting a Host From a Disk Set

The following example shows the deletion of the host, `host2` from the disk set, `blue`.

```
# metaset -s blue
Set name = blue, Set number = 1
```

Host	Owner
host1	Yes
..host2	

Drive	Dbase
c1t2d0	Yes
c1t3d0	Yes
c1t4d0	Yes
c1t5d0	Yes
c1t6d0	Yes
c2t1d0	Yes

```
# metaset -s blue -d -h host2
```

```
# metaset -s blue
Set name = blue, Set number = 1
```

Host	Owner
host1	Yes

Drive	Dbase
c1t2d0	Yes
c1t3d0	Yes
c1t4d0	Yes
c1t5d0	Yes
c1t6d0	Yes
c2t1d0	Yes

**Example 19–12** Deleting the Last Host from a Disk Set

The following example shows the deletion of the last host from the disk set, `blue`.

```
host1# metaset -s blue -d -h host1
host1# metaset -s blue

metaset: host: setname "blue": no such set
```

## Importing Disk Sets

importing a disk set

The `metaimport` command allows you to import disk sets from one system to another.

### ▼ How to Print a Report on Disk Sets Available for Import

- 1 Become superuser.
- 2 Obtain a report on disk sets available for import.

```
# metaimport -r -v
```

- r Provides a report of the unconfigured disk sets available for import on the system.
- v Provides detailed information about the state database (`metadb`) replica location and status on the disks of unconfigured disk sets available for import on the system.

**Example 19–13** Reporting on Disk Sets Available for Import

The following examples show how to print a report on disk sets available for import. The output from the `metaimport` command distinguishes between regular disk sets and replicated disk sets.

```
# metaimport -r
Disksets eligible for import:

1) Found replicated diskset containing disks :
   c1t2d0
   c1t3d0
   Creation time:      Tue May 3 14:27:29 2006
For more information about this set:
   metaimport -r -v c1t2d0
To import this set:
   metaimport -s <newsetname> c1t2d0
```

```
2) Found replicated diskset containing disks :
   c1t12d0
   c1t9d0
```

```
   Creation time:      Tue May 3 14:30:00 2006
```

```
For more information about this set:
```

```
  metaimport -r -v c1t12d0
```

```
To import this set:
```

```
  metaimport -s <newsetname> c1t12d0
```

```
Number of disksets eligible for import: 2
```

```
# metaimport -r -v c1t2d0
```

```
Disksets eligible for import:
```

```
1) Found regular diskset containing disks:
```

```
  c1t2d0
```

```
  c1t3d0
```

```
  Metadatabase information:
```

flags		first blk	block count	
a	u	16	8192	/dev/dsk/c1t2d0s7
a	u	16	8192	/dev/dsk/c1t3d0s7

```
  Metadevice information:
```

```
  Creation time:      Tue May 23 13:05:39 2006
```

```
  Last modified time: Tue May 23 13:05:39 2006
```

```
  To import this diskset:
```

```
    metaimport -s <newsetname> c1t2d0
```

The following output of `metaimport -r` reports the following conditions in the system's disk set configuration.

- A partial disk set in which one or more disks are unavailable
- Disk conflicts where the disk is detected in more than one disk set
- A replicated disk set
- The recommended disk set to import

---

**Note** – A disk can also be reported as unavailable and in conflict at the same time.

---

```
# metaimport -r
```

```
Disksets eligible for import:
```

```
1) Found partial regular diskset containing disks:
```

```
  c1t2d0 (CONFLICT)
```

```
c3t50020F230000FA57d0 (UNAVAIL)
c3t50020F230000FA57d1 (UNAVAIL)
  (UNAVAIL) WARNING: This disk is unavailable on this system.
  Import may corrupt data in the diskset.
```

```
  (CONFLICT) WARNING: This disk has been reused
in another diskset or system c onfiguration.
  Import may corrupt data in the diskset.
```

```
Creation time:      Tue May 23 13:05:39 2006
For more information about this diskset:
  metaimport -r -v c1t2d0
To import this diskset:
  metaimport -f -s <newsetname> c1t2d0
```

2) Found regular diskset containing disks:

```
c1t2d0 (CONFLICT)
c1t3d0
c1t4d0
```

```
  (CONFLICT) WARNING: This disk has been reused
in another diskset or system c onfiguration.
  Import may corrupt data in the diskset.
```

```
Creation time:      Tue May 23 13:04:57 2006
For more information about this diskset:
  metaimport -r -v c1t3d0
To import this diskset:
  metaimport -f -s <newsetname> c1t3d0
```

3) Found replicated diskset containing disks:

```
c3t50020F23000100F7d13
c3t50020F23000100F7d15
c3t50020F23000100F7d14
```

```
Creation time:      Thu May 25 14:56:13 2006
For more information about this diskset:
  metaimport -r -v c3t50020F23000100F7d13
To import this diskset:
  metaimport -s <newsetname> c3t50020F23000100F7d13
```

Number of disksets eligible for import: 3

Warning: The following disks have been detected in more than one set.  
Import recommendation based upon set creation time.

```
Proceed with the import with caution.
c1t2d0 - must import with set created at : Tue May 23 13:05:39 2006
#
```

Importing a disk set is blocked if the disk set has disk conflicts. The preceding example recommends that c1t2d0 be imported with the set created at 13:05:39 on Tuesday, May 23. If you import a different disk set instead, the following message is displayed:

```
# metaimport -f -s <setname> c1t3d0

Importing regular diskset containing disks:
c1t2d0 (CONFLICT)
c1t3d0
c1t4d0

(CONFLICT) WARNING: This disk has been reused in another diskset
or system configuration.
Import may corrupt data in the diskset.

Creation time:      Tue May 23 13:04:57 2006

Warning: The following disks have been detected in more than one set.
Import recommendation based upon set creation time.
Proceed with the import with caution.
c1t2d0 - must import with set created at : Tue May 23 13:05:39 2006
To import this set, c1t2d0 must be removed from the system
#
```

## ▼ How to Import a Disk Set From One System to Another System

- 1 Become superuser.
- 2 Verify that a disk set is available for import.

```
# metaimport -r -v
```

- 3 Import an available disk set.

```
# metaimport -s diskset-name disk-name
```

- s *diskset-name* Specifies the name of the disk set being created.

*disk-name* Identifies a disk (c#t#d#) containing a state database replica from the disk set being imported.

**4 Verify that the disk set has been imported.**

```
# metaset -s diskset-name
```

**Example 19-14 Importing a Disk Set**

The following example shows how to import a disk set.

```
# metainport -s red c1t2d0
Drives in diskset including disk c1t2d0:
  c1t2d0
  c1t3d0
  c1t8d0
# metaset -s red
```

Set name = red, Set number = 1

Host	Owner
host1	Yes

Drive	Dbase
c1t2d0	Yes
c1t3d0	Yes
c1t8d0	Yes

# Maintaining Solaris Volume Manager (Tasks)

---

This chapter provides information about performing general storage administration maintenance tasks with Solaris Volume Manager.

This is a list of the information in this chapter:

- “Solaris Volume Manager Maintenance (Task Map)” on page 215
- “Viewing the Solaris Volume Manager Configuration” on page 216
- “Renaming Volumes” on page 220
- “Working With Configuration Files” on page 223
- “Changing Solaris Volume Manager Default Values” on page 225
- “Expanding a File System Using the `growfs` Command” on page 225
- “Overview of Replacing and Enabling Components in RAID-1 and RAID-5 Volumes” on page 228

## Solaris Volume Manager Maintenance (Task Map)

The following task map identifies the procedures that are needed to maintain Solaris Volume Manager.

Task	Description	For Instructions
View the Solaris Volume Manager configuration	Use the Solaris Volume Manager GUI or the <code>metastat</code> command to view the system configuration.	“How to View the Solaris Volume Manager Volume Configuration” on page 216
Rename a volume	Use the Solaris Volume Manager GUI or the <code>metarename</code> command to rename a volume.	“How to Rename a Volume” on page 221
Create configuration files	Use the <code>metastat -p</code> command and the <code>metadb</code> command to create configuration files.	“How to Create Configuration Files” on page 223

Task	Description	For Instructions
Initialize Solaris Volume Manager from configuration files	Use the <code>metainit</code> command to initialize Solaris Volume Manager from configuration files.	<a href="#">“How to Initialize Solaris Volume Manager From a Configuration File” on page 223</a>
Expand a file system	Use the <code>growfs</code> command to expand a file system.	<a href="#">“How to Expand a File System” on page 227</a>
Enable components	Use the Solaris Volume Manager GUI or the <code>metareplace</code> command to enable components.	<a href="#">“Enabling a Component” on page 228</a>
Replace components	Use the Solaris Volume Manager GUI or the <code>metareplace</code> command to replace components.	<a href="#">“Replacing a Component With Another Available Component” on page 229</a>

## Viewing the Solaris Volume Manager Configuration

---

**Tip** – The `metastat` command does not sort output. Pipe the output of the `metastat -p` command to the `sort` or `grep` commands for a more manageable listing of your configuration.

---

### ▼ How to View the Solaris Volume Manager Volume Configuration

#### ► To view the volume configuration, use one of the following methods:

- From the Enhanced Storage tool within the Solaris Management Console, open the Volumes node. For more information, see the online help.
- Use the following form of the `metastat` command:

```
# metastat -p -i component-name
```

`-p` Specifies to show output in a condensed summary. This output is suitable for use in creating the `md.tab` file.

`-i` Specifies to verify that RAID-1 (mirror) volumes, RAID-5 volumes, and hot spares can be accessed.

`component-name` Specifies the name of the volume to view. If no volume name is specified, a complete list of components is displayed.

#### **Example 20-1** Viewing the Solaris Volume Manager Volume Configuration

The following example illustrates output from the `metastat` command.



# **metastat**

d50: RAID

State: Okay

Interlace: 32 blocks

Size: 20985804 blocks

Original device:

Size: 20987680 blocks

Device	Start Block	Dbase	State	Reloc	Hot Spare
c1t4d0s5	330	No	Okay	Yes	
c1t5d0s5	330	No	Okay	Yes	
c2t4d0s5	330	No	Okay	Yes	
c2t5d0s5	330	No	Okay	Yes	
c1t1d0s5	330	No	Okay	Yes	
c2t1d0s5	330	No	Okay	Yes	

d1: Concat/Stripe

Size: 4197879 blocks

Stripe 0:

Device	Start Block	Dbase	Reloc
c1t2d0s3	0	No	Yes

d2: Concat/Stripe

Size: 4197879 blocks

Stripe 0:

Device	Start Block	Dbase	Reloc
c1t2d0s3	0	No	Yes

d80: Soft Partition

Device: d70

State: Okay

Size: 2097152 blocks

Extent	Start Block	Block count
0	1	2097152

d81: Soft Partition

Device: d70

State: Okay

Size: 2097152 blocks

Extent	Start Block	Block count
0	2097154	2097152

d70: Mirror

Submirror 0: d71

State: Okay

Submirror 1: d72

State: Okay

Pass: 1  
 Read option: roundrobin (default)  
 Write option: parallel (default)  
 Size: 12593637 blocks

## d71: Submirror of d70

State: Okay  
 Size: 12593637 blocks  
 Stripe 0:

Device	Start Block	Dbase	State	Reloc	Hot Spare
c1t3d0s3	0	No	Okay	Yes	

## Stripe 1:

Device	Start Block	Dbase	State	Reloc	Hot Spare
c1t3d0s4	0	No	Okay	Yes	

## Stripe 2:

Device	Start Block	Dbase	State	Reloc	Hot Spare
c1t3d0s5	0	No	Okay	Yes	

## d72: Submirror of d70

State: Okay  
 Size: 12593637 blocks  
 Stripe 0:

Device	Start Block	Dbase	State	Reloc	Hot Spare
c2t3d0s3	0	No	Okay	Yes	

## Stripe 1:

Device	Start Block	Dbase	State	Reloc	Hot Spare
c2t3d0s4	0	No	Okay	Yes	

## Stripe 2:

Device	Start Block	Dbase	State	Reloc	Hot Spare
c2t3d0s5	0	No	Okay	Yes	

hsp010: is empty

## hsp014: 2 hot spares

Device	Status	Length	Reloc
c1t2d0s1	Available	617652 blocks	Yes
c2t2d0s1	Available	617652 blocks	Yes

## hsp050: 2 hot spares

Device	Status	Length	Reloc
c1t2d0s5	Available	4197879 blocks	Yes
c2t2d0s5	Available	4197879 blocks	Yes

## hsp070: 2 hot spares

Device	Status	Length	Reloc
c1t2d0s4	Available	4197879 blocks	Yes

```

c2t2d0s4          Available      4197879 blocks Yes

```

Device Relocation Information:

Device	Reloc	Device ID
c1t2d0	Yes	id1,sd@SSEAGATE_ST39204LCSUN9.0G3BV0N1S200002103AF29
c2t2d0	Yes	id1,sd@SSEAGATE_ST39204LCSUN9.0G3BV0P64Z00002105Q6J7
c1t1d0	Yes	id1,sd@SSEAGATE_ST39204LCSUN9.0G3BV0N1EM00002104NP2J
c2t1d0	Yes	id1,sd@SSEAGATE_ST39204LCSUN9.0G3BV0N93J000071040L3S
c0t0d0	Yes	id1,dad@s53554e575f4154415f5f53543339313430412525415933

## Example 20-2 Viewing a Multi-Terabyte Solaris Volume Manager Volume

The following example illustrates output from the `metastat` command for a multi-terabyte storage volume (11 Tbytes).

```

# metastat d0
d0: Concat/Stripe
  Size: 25074708480 blocks (11 TB)
  Stripe 0: (interlace: 32 blocks)
    Device      Start Block  Dbase  Reloc
    c27t8d3s0      0           No     Yes
    c4t7d0s0      12288        No     Yes
  Stripe 1: (interlace: 32 blocks)
    Device      Start Block  Dbase  Reloc
    c13t2d1s0      16384        No     Yes
    c13t4d1s0      16384        No     Yes
    c13t6d1s0      16384        No     Yes
    c13t8d1s0      16384        No     Yes
    c16t3d0s0      16384        No     Yes
    c16t5d0s0      16384        No     Yes
    c16t7d0s0      16384        No     Yes
    c20t4d1s0      16384        No     Yes
    c20t6d1s0      16384        No     Yes
    c20t8d1s0      16384        No     Yes
    c9t1d0s0       16384        No     Yes
    c9t3d0s0       16384        No     Yes
    c9t5d0s0       16384        No     Yes
    c9t7d0s0       16384        No     Yes
  Stripe 2: (interlace: 32 blocks)
    Device      Start Block  Dbase  Reloc
    c27t8d2s0      16384        No     Yes
    c4t7d1s0       16384        No     Yes
  Stripe 3: (interlace: 32 blocks)
    Device      Start Block  Dbase  Reloc
    c10t7d0s0      32768        No     Yes
    c11t5d0s0      32768        No     Yes

```

c12t2d1s0	32768	No	Yes
c14t1d0s0	32768	No	Yes
c15t8d1s0	32768	No	Yes
c17t3d0s0	32768	No	Yes
c18t6d1s0	32768	No	Yes
c19t4d1s0	32768	No	Yes
c1t5d0s0	32768	No	Yes
c2t6d1s0	32768	No	Yes
c3t4d1s0	32768	No	Yes
c5t2d1s0	32768	No	Yes
c6t1d0s0	32768	No	Yes
c8t3d0s0	32768	No	Yes

## Where To Go From Here

For more information, see the `metastat(1M)` man page.

# Renaming Volumes

## Background Information for Renaming Volumes

Solaris Volume Manager enables you to rename most types of volumes at any time, subject to some constraints. You can use either the Enhanced Storage tool within the Solaris Management Console or the command line (the `metarename(1M)` command) to rename volumes.

Renaming volumes or switching volume names is an administrative convenience for the management of volume names. For example, you could arrange all file system mount points in a desired numeric range. You might rename volumes to maintain a naming scheme for your logical volumes or to allow a transactional volume to use the same name as the name of the underlying volume.

---

**Note** – Transactional volumes are no longer valid in Solaris Volume Manager. You can rename transactional volumes to replace them.

---

Before you rename a volume, make sure that it is not currently in use. For a file system, make sure that it is not mounted or being used as swap. Other applications that use the raw device, such as a database, should have their own way of stopping access to the data.

Specific considerations for renaming volumes include the following:

- You can rename any volume except the following:

- Soft partitions
  - Volumes on which soft partitions are directly built
  - Volumes that are being used as log devices
  - Hot spare pools
- You can rename volumes within a disk set. However, you cannot rename volumes to move them from one disk set to another disk set.

## Exchanging Volume Names

Using the `meta rename` command with the `-x` option exchanges the names of volumes that have a parent-child relationship. For more information, see [“How to Rename a Volume” on page 221](#) and the `meta rename(1M)` man page. The name of an existing volume is exchanged with one of its subcomponents. For example, this type of exchange can occur between a mirror and one of its submirrors. The `meta rename -x` command can make it easier to mirror or unmirror an existing volume.

---

**Note** – You must use the command line to exchange volume names. This functionality is currently unavailable in the Solaris Volume Manager GUI. However, you can rename a volume with either the command line or the GUI.

---

Consider the following guidelines when you want to rename a volume:

- You cannot rename a volume that is currently in use. This restriction includes volumes that are used as mounted file systems, as swap, or as active storage for applications or databases. Thus, before you use the `meta rename` command, stop all access to the volume that is being renamed. For example, unmount a mounted file system.
- You cannot exchange volumes in a failed state.
- You cannot exchange volumes that are using a hot spare replacement.
- An exchange can only take place between volumes with a direct parent-child relationship.
- You cannot exchange (or rename) a log device. The workaround is to detach the log device and attach another log device of the desired name.
- Only volumes can be exchanged. You cannot exchange slices or hot spares.

## ▼ How to Rename a Volume

**Before You Begin** Check the volume name requirements ([“Volume Names” on page 40](#)), and [“Background Information for Renaming Volumes” on page 220](#).

### 1 Unmount the file system that uses the volume.

```
# umount /filesystem
```

**2 To rename the volume, use one of the following methods:**

- From the Enhanced Storage tool within the Solaris Management Console, open the Volumes. Select the volume you want to rename. Click the right mouse on the icon. Choose the Properties option. Then, follow the onscreen instructions. For more information, see the online help.
- Use the following form of the `metarename` command:

```
# metarename old-volume-name new-volume-name
```

*old-volume-name* Specifies the name of the existing volume.

*new-volume-name* Specifies the new name for the existing volume.

See the `metarename(1M)` man page for more information.

**3 Edit the `/etc/vfstab` file to refer to the new volume name, if necessary.****4 Remount the file system.**

```
# mount /filesystem
```

**Example 20-3 Renaming a Volume Used for a File System**

In the following example, the volume, `d10`, is renamed to `d100`.

```
# umount /home
# metarename d10 d100
d10: has been renamed to d100
    (Edit the /etc/vfstab file so that the file system references the new volume)
# mount /home
```

Because `d10` contains a mounted file system, the file system must be unmounted before the volume can be renamed. If the volume is used for a file system with an entry in the `/etc/vfstab` file, the entry must be changed to reference the new volume name.

For example, if the `/etc/vfstab` file contains the following entry for the file system:

```
/dev/md/dsk/d10 /dev/md/rdisk/d10 /docs home 2 yes -
```

Change the entry to read as follows:

```
/dev/md/dsk/d100 /dev/md/rdisk/d100 /docs home 2 yes -
```

Then, remount the file system.

If you have an existing mirror or transactional volume, you can use the `metarename -x` command to remove the mirror or transactional volume and keep data on the underlying volume. For a transactional volume, as long as the master device is a volume (either a RAID-0, RAID-1, or RAID-5 volume), you can keep data on that volume.

## Working With Configuration Files

Solaris Volume Manager configuration files contain basic Solaris Volume Manager information, as well as most of the data that is necessary to reconstruct a configuration. The following procedures illustrate how to work with these files.

### ▼ How to Create Configuration Files

- ▶ **Once you have defined all appropriate parameters for the Solaris Volume Manager environment, use the `metastat -p` command to create the `/etc/lvm/md.tab` file.**

```
# metastat -p > /etc/lvm/md.tab
```

This file contains all parameters for use by the `metainit` command and `metabs` command. Use this file if you need to set up several similar environments or if you need to recreate the configuration after a system failure.

For more information about the `md.tab` file, see “[Overview of the `md.tab` File](#)” on page 306 and the `md.tab(4)` man page.

### ▼ How to Initialize Solaris Volume Manager From a Configuration File



**Caution** – Use this procedure in the following circumstances:

- If you have experienced a complete loss of your Solaris Volume Manager configuration
- If you have no configuration yet, and you want to create a configuration from a saved configuration file

On occasion, your system loses the information maintained in the state database. For example, this loss might occur if the system was rebooted after all of the state database replicas were deleted. As long as no volumes were created after the state database was lost, you can use the `md.cf` or `md.tab` files to recover your Solaris Volume Manager configuration.

---

**Note** – The `md.cf` file does not maintain information on active hot spares. Thus, if hot spares were in use when the Solaris Volume Manager configuration was lost, those volumes that were using active hot spares are likely corrupted.

---

For more information about these files, see the `md.cf(4)` and the `md.tab(4)` man pages.

**1 Create state database replicas.**

See “[Creating State Database Replicas](#)” on page 68 for more information.

**2 Create or update the `/etc/lvm/md.tab` file.**

- If you are attempting to recover the last known Solaris Volume Manager configuration, copy the `md.cf` file into the `/etc/lvm/md.tab` file.
- If you are creating a new Solaris Volume Manager configuration based on a copy of the `md.tab` file that have you preserved, copy the preserved file into the `/etc/lvm/md.tab` file.

**3 Edit the “new” `/etc/lvm/md.tab` file and do the following:**

- If you are creating a new configuration or recovering a configuration after a crash, configure the mirrors as one-way mirrors. For example:

```
d80 -m d81 1
d81 1 1 c1t6d0s3
```

If the submirrors of a mirror are not the same size, be sure to use the smallest submirror for this one-way mirror. Otherwise, data could be lost.

- If you are recovering an existing configuration and Solaris Volume Manager was cleanly stopped, leave the mirror configuration as multi-way mirrors. For example:

```
d70 -m d71 d72 1
d71 1 1 c1t6d0s2
d72 1 1 c1t5d0s0
```

- Specify RAID-5 volumes with the `-k` option, to prevent reinitialization of the device. For example:

```
d45 -r c1t3d0s5 c1t3d0s3 c1t3d0s4 -k -i 32b
```

See the `metainit(1M)` man page for more information.

**4 Check the syntax of the `/etc/lvm/md.tab` file entries without committing changes by using one of the following forms of the `metainit` command:**

```
# metainit -n md.tab-entry
```

```
# metainit -n -a
```



The `metainit` command does not maintain a hypothetical state of the devices that might have been created while running with the `-n`, so creating volumes that rely on other, nonexistent volumes will result in errors with the `-n` even though the command may succeed without the `-n` option.

- `-n` Specifies not to actually create the devices. Use this option to verify that the results are as you expected.
- `md.tab-entry` Specifies the name of the component to initialize.
- `-a` Specifies to check all components.

**5 If no problems were apparent from the previous step, recreate the volumes and hot spare pools from the `md.tab` file:**

```
# metainit -a
```

- `-a` Specifies to activate the entries in the `/etc/lvm/md.tab` file.

**6 As needed, make the one-way mirrors into multi-way mirrors by using the `metattach` command.**

```
# mettach mirror submirror
```

**7 Validate the data on the volumes to confirm that the configuration has been reconstructed accurately.**

```
# metastat
```

## Changing Solaris Volume Manager Default Values

With the Solaris 10 release, Solaris Volume Manager has been enhanced to configure volumes dynamically. You no longer need to edit the `nmd` and the `md_nsets` parameters in the `/kernel/drv/md.conf` file. New volumes are dynamically created, as needed.

The maximum Solaris Volume Manager configuration values remain unchanged:

- The maximum number of volumes that is supported is 8192.
- The maximum number of disk sets supported is 32.

## Expanding a File System Using the `growfs` Command

After a volume that contains a UFS file system is expanded (meaning that more space is added), you also need to expand the file system in order to recognize the added space. You must manually expand the file system with the `growfs` command. The `growfs` command expands the file system, even while the file system is mounted. However, write access to the file system is not possible while the `growfs` command is running.

An application, such as a database, that uses the raw device must have its own method to incorporate the added space. Solaris Volume Manager does not provide this capability.

The `growfs` command “write-locks” a mounted file system as it expands the file system. The length of time the file system is write-locked can be shortened by expanding the file system in stages. For instance, to expand a 1-Gbyte file system to 2 Gbytes, the file system can be grown in 16 Mbyte stages by using the `-s` option. This option specifies the total size of the new file system at each stage.

During the expansion, the file system is not available for write access because of the write-lock feature. Write accesses are transparently suspended and are restarted when the `growfs` command unlocks the file system. Read accesses are not affected. However, access times are not kept while the lock is in effect.

## Background Information for Expanding Slices and Volumes

---

**Note** – Solaris Volume Manager volumes can be expanded. However, volumes cannot be reduced in size.

---

- A volume can be expanded whether it is used for a file system, application, or database. You can expand RAID-0 (stripe and concatenation) volumes, RAID-1 (mirror) volumes, and RAID-5 volumes and soft partitions.
- You can concatenate a volume that contains an existing file system while the file system is in use. As long as the file system is a UFS file system, the file system can be expanded (with the `growfs` command) to fill the larger space. You can expand the file system without interrupting read access to the data.
- Once a file system is expanded, it cannot be reduced in size, due to constraints in the UFS file system.
- Applications and databases that use the raw device must have their own method to expand the added space so that they can recognize it. Solaris Volume Manager does not provide this capability.
- When a component is added to a RAID-5 volume, it becomes a concatenation to the volume. The new component does not contain parity information. However, data on the new component is protected by the overall parity calculation that takes place for the volume.
- You can expand a log device by adding additional components. You do not need to run the `growfs` command, as Solaris Volume Manager automatically recognizes the additional space on reboot.
- Soft partitions can be expanded by adding space from the underlying volume or slice. All other volumes can be expanded by adding slices.

## ▼ How to Expand a File System

**Before You Begin** Check “Prerequisites for Creating Solaris Volume Manager Components” on page 44.

### 1 Review the disk space associated with a file system.

```
# df -hk
```

See the `df(1M)` man page for more information.

### 2 Expand a UFS file system on a logical volume.

```
# growfs -M /mount-point /dev/md/rdisk/volume-name
```

`-M/mount-point` Specifies the mount point for the file system to be expanded.

`/dev/md/rdisk/volume-name` Specifies the name of the volume on which you want to expand.

See the following example and the `growfs(1M)` man page for more information.

#### Example 20–4 Expanding a File System

In the following example, a new slice is added to a volume, `d10`, which contains the mounted file system, `/home2`. The `growfs` command specifies the mount point with the `-M` option to be `/home2`, which is expanded onto the raw volume `/dev/md/rdisk/d10`. The file system will span the entire volume when the `growfs` command is complete. You can use the `df -hk` command before and after expanding the file system to verify the total disk capacity.

```
# df -hk
Filesystem          kbytes   used   avail capacity  Mounted on
...
/dev/md/dsk/d10     69047   65426      0   100%    /home2
...
# growfs -M /home2 /dev/md/rdisk/d10
/dev/md/rdisk/d10:      295200 sectors in 240 cylinders of 15 tracks, 82 sectors
      144.1MB in 15 cyl groups (16 c/g, 9.61MB/g, 4608 i/g)
super-block backups (for fsck -F ufs -o b=#) at:
   32, 19808, 39584, 59360, 79136, 98912, 118688, 138464, 158240, 178016, 197792,
   217568, 237344, 257120, 276896,
# df -hk
Filesystem          kbytes   used   avail capacity  Mounted on
...
/dev/md/dsk/d10     138703   65426   59407    53%    /home2
...

```

For mirror volumes, always run the `growfs` command on the top-level volume. Do not run the command on a submirror or master device, even though space is added to the submirror or master device.

# Overview of Replacing and Enabling Components in RAID-1 and RAID-5 Volumes

Solaris Volume Manager can *replace* and *enable* components within RAID-1 (mirror) and RAID-5 volumes.

In Solaris Volume Manager terminology, *replacing* a component is a way to substitute an available component on the system for a selected component in a submirror or RAID-5 volume. You can think of this process as logical replacement, as opposed to physically replacing the component. For more information see “[Replacing a Component With Another Available Component](#)” on page 229.

*Enabling* a component means to “activate” or substitute a component with itself (that is, the component name is the same). For more information, see “[Enabling a Component](#)” on page 228.

---

**Note** – When recovering from disk errors, scan `/var/adm/messages` to see what kind of errors occurred. If the errors are transitory and the disks themselves do not have problems, try enabling the failed components. You can also use the `format` command to test a disk.

---

## Enabling a Component

You can enable a component when any of the following conditions exist:

- Solaris Volume Manager cannot access the physical drive. This problem might occur, for example, due to a power loss, or a loose drive cable. In this case, Solaris Volume Manager puts the components in the “Maintenance” state. You need to make sure that the drive is accessible (restore power, reattach cables, and so on), and then enable the components in the volumes.
- You suspect that a physical drive is having transitory problems that are not disk-related. You might be able to fix a component in the “Maintenance” state by simply enabling it. If enabling the component does not fix the problem, then you need to do one of the following:
  - Physically replace the disk drive and enable the component
  - Replace the component with another available component on the system

When you physically replace a disk, be sure to partition the disk like the replaced disk to ensure adequate space on each used component.

---

**Note** – Always check for state database replicas and hot spares on the disk that is being replaced. Any state database replica in an erred state should be deleted before you replace the disk. Then, after you enable the component, recreate the state database replicas using the same size. You should treat hot spares in the same manner.

---

## Replacing a Component With Another Available Component

You use the `metareplace` command when you replace or swap an existing component with a different component that is available and not in use on the system.

You can use this command when any of the following conditions exist:

- A disk drive has problems, and you do not have a replacement drive. However, you do have available components elsewhere on the system.  
You might want to use this strategy when a replacement is absolutely necessary, but you do not want to shut down the system.
- You see soft errors on the physical disks.  
Physical disks might report soft errors even though Solaris Volume Manager shows the mirror/submirror or RAID-5 volume in the “Okay” state. Replacing the component in question with another available component enables you to perform preventative maintenance and potentially prevent hard errors from occurring.
- You want to do performance tuning.  
One way that you can evaluate components is by using the performance monitoring feature available from the Enhanced Storage tool within the Solaris Management Console. For example, you might see that a particular component in a RAID-5 volume is experiencing a high load average, even though it is in the “Okay” state. To balance the load on the volume, you can replace that component with a component from a disk that is less utilized. You can perform this type of replacement online without interrupting service to the volume.

## Maintenance and Last Erred States

When a component in a RAID-1 or RAID-5 volume experiences errors, Solaris Volume Manager puts the component in the “Maintenance” state. No further reads or writes are performed to a component in the “Maintenance” state.

Sometimes a component goes into a “Last Erred” state. For a RAID-1 volume, this usually occurs with a one-sided mirror. The volume experiences errors. However, there are no redundant components to read from. For a RAID-5 volume this occurs after one component goes into “Maintenance” state, and another component fails. The second component to fail goes into the “Last Erred” state.

When either a RAID-1 volume or a RAID-5 volume has a component in the “Last Erred” state, I/O is still attempted to the component marked “Last Erred.” This I/O attempt occurs because a “Last Erred” component contains the last good copy of data from Solaris Volume Manager’s point of view. With a component in the “Last Erred” state, the volume behaves like a normal device (disk) and returns I/O errors to an application. Usually, at this point, some data has been lost.

The subsequent errors on other components in the same volume are handled differently, depending on the type of volume.

**RAID-1 Volume**      A RAID-1 volume might be able to tolerate many components in the “Maintenance” state and still be read from and written to. If components are in the “Maintenance” state, no data has been lost. You can safely replace or enable the components in any order. If a component is in the “Last Erred” state, you cannot replace it until you first replace the components in the “Maintenance” state. Replacing or enabling a component in the “Last Erred” state usually means that some data has been lost. Be sure to validate the data on the mirror after you repair it.

**RAID-5 Volume**      A RAID-5 volume can tolerate a single component in the “Maintenance” state. You can safely replace a single component in the “Maintenance” state without losing data. If an error on another component occurs, it is put into the “Last Erred” state. At this point, the RAID-5 volume is a read-only device. You need to perform some type of error recovery so that the state of the RAID-5 volume is stable and the possibility of data loss is reduced. If a RAID-5 volume reaches a “Last Erred” state, there is a good chance it has lost data. Be sure to validate the data on the RAID-5 volume after you repair it.

Always replace components in the “Maintenance” state first, followed by those in the “Last Erred” state. After a component is replaced and resynchronized, use the `metastat` command to verify its state. Then, validate the data.

## Background Information for Replacing and Enabling Components in RAID-1 and RAID-5 Volumes

When you replace components in a RAID-1 volume or a RAID-5 volume, follow these guidelines:

- Always replace components in the “Maintenance” state first, followed by those components in the “Last Erred” state.
- After a component is replaced and resynchronized, use the `metastat` command to verify the state of the volume. Then, validate the data. Replacing or enabling a component in the “Last Erred” state usually means that some data has been lost. Be sure to validate the data on the volume after you repair it. For a UFS, run the `fsck` command to validate the “metadata” (the structure of the file system). Then, check the actual user data. (Practically, users will have to examine their files.) A database or other application must have its own way of validating its internal data structure.
- Always check for state database replicas and hot spares when you replace components. Any state database replica in an erred state should be deleted before you replace the physical disk. The state database replica should be added back before you enable the component. The same procedure applies to hot spares.

- During component replacement for a RAID-5 volume, data is recovered in one of two ways. The data is recovered either from a hot spare currently in use or from using the RAID-5 parity, when no hot spare is in use.
- When you replace a component for a RAID-1 volume, Solaris Volume Manager automatically starts resynchronizing the new component with the rest of the volume. When the resynchronization completes, the replaced component becomes readable and writable. If the failed component has been replaced with data from a hot spare, the hot spare is placed in the “Available” state and made available for other hot spare replacements.
- The new component must be large enough to replace the old component.
- As a precaution, back up all data before you replace “Last Erred” devices.





# Best Practices for Solaris Volume Manager

---

This chapter provides general best practices information from a real-world storage scenario using Solaris Volume Manager. In this chapter, you will see a typical configuration, followed by an analysis, followed by a recommended (“Best Practices”) configuration to meet the same needs.

This chapter includes the following information:

- [“Deploying Small Servers” on page 233](#)
- [“Using Solaris Volume Manager With Networked Storage Devices” on page 235](#)

## Deploying Small Servers

Distributed computing environments, often need to deploy similar or identical servers at multiple locations. These environments include ISPs, geographically distributed sales offices, and telecommunication service providers. Servers in a distributed computing environment might provide some of the following services:

- Router or firewall services
- Email services
- DNS caches
- Usenet (Network News) servers
- DHCP services
- Other services best provided at a variety of locations

These small servers have several characteristics in common:

- High-reliability requirements
- High-availability requirements
- Routine hardware and performance requirements

As a starting point, consider a Netra™ server with a single SCSI bus and two internal disks. This off-the-shelf configuration is a good starting point for distributed servers. Solaris Volume Manager could easily be used to mirror some or all of the slices, thus providing redundant storage to help guard against disk failure. See the following figure for an example of this small system configuration.

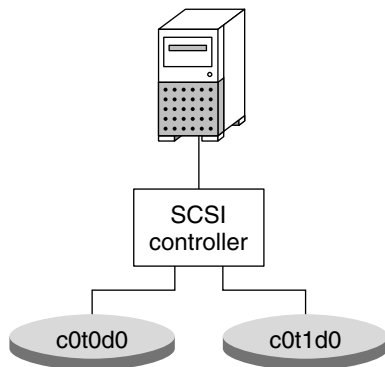

FIGURE 21-1 Small System Configuration

This configuration might include mirrors for the root (`/`), `/usr`, `swap`, `/var`, and `/export` file systems, plus state database replicas (one per disk). As such, a failure of either side of any of the mirrors would not necessarily result in system failure. Also, up to five discrete failures could possibly be tolerated. However, the system is not sufficiently protected against disk or slice failure. A variety of potential failures could result in a complete system failure, requiring operator intervention.

While this configuration does help provide some protection against catastrophic disk failure, it exposes key possible single points of failure:

- The single SCSI controller represents a potential point of failure. If the controller fails, the system is down, pending replacement of the part.
- The two disks do not provide adequate distribution of state database replicas. The majority consensus algorithm requires that half of the state database replicas be available for the system to continue to run. This algorithm also requires half plus one replica for a reboot. So, if one state database replica were on each disk and one disk or the slice that contains the replica failed, the system could not reboot. As a result a mirrored root (`/`) file system would become ineffective. If two or more state database replicas were on each disk, a single slice failure would likely not be problematic. However, a disk failure would still prevent a reboot. If different number of replicas were on each disk, one disk would have more than half and one disk would have fewer than half. If the disk with fewer replicas failed, the system could reboot and continue. However, if the disk with more replicas failed, the system would immediately panic.

A “Best Practices” approach would be to modify the configuration by adding one more controller and one more hard drive. The resulting configuration would be far more resilient.

# Using Solaris Volume Manager With Networked Storage Devices

Solaris Volume Manager works well with networked storage devices, particularly those devices that provide configurable RAID levels and flexible options. Usually, the combination of Solaris Volume Manager and such devices can result in performance and flexibility that is superior to either product alone.

Generally, do not establish Solaris Volume Manager's RAID-5 volumes on any hardware storage devices that provide redundancy (for example, RAID-1 and RAID-5 volumes). Unless you have a very unusual situation, performance suffers. Also, you will gain very little in terms of redundancy or higher availability.

Configuring underlying hardware storage devices with RAID-5 volumes, on the other hand, is very effective. Doing so provides a good foundation for Solaris Volume Manager volumes. Hardware RAID-5 provides additional redundancy for Solaris Volume Manager's RAID-1 volumes, soft partitions, or other volumes.

---

**Note** – Do not configure similar software and hardware devices. For example, do not build software RAID-1 volumes on top of hardware RAID-1 devices. Configuring similar devices in hardware and software results in performance penalties without offsetting any gains in reliability.

---

Solaris Volume Manager's RAID-1 volumes that are built on underlying hardware storage devices are not RAID-1+0. Solaris Volume Manager cannot understand the underlying storage well enough to offer RAID-1+0 capabilities.

Configuring soft partitions on top of Solaris Volume Manager RAID-1 volume, built in turn on a hardware RAID-5 device, is a very flexible and resilient configuration.



## Top-Down Volume Creation (Overview)

---

This chapter provides conceptual information about Solaris Volume Manager *top-down* volume creation.

This chapter contains the following information:

- “Overview of Top-Down Volume Creation” on page 237
- “Top-Down Volume Creation Implementation With Disk Sets” on page 238
- “Top-Down Volume Creation Processes” on page 238
- “Determining Which Disks Are Available for Top-Down Volume Creation” on page 240

For information about performing related tasks, see [Chapter 23](#).

### Overview of Top-Down Volume Creation

Top-down volume creation enables you to automatically create Solaris Volume Manager volume configurations using the `metassist` command. You no longer need to manually go through the process of partitioning disks, creating RAID-0 volumes (as submirrors), creating hot spare pools and hot spares, and finally creating a mirror. Instead, you can issue the `metassist` command to create a volume. Solaris Volume Manager does the rest for you.

The `metassist` command enables you to create Solaris Volume Manager volume configurations with a single command. You can specify volume characteristics in terms of *quality-of-service*. Quality-of-service characteristics means that without specifying the hardware components to be used in a volume, you can use input to the `metassist` command to provide the following:

- Volume size
- Level of redundancy, which refers to the number of copies of the data
- Number of data paths to the volume
- Fault recovery, which indicates whether the volume is associated with a hot spare pool

You can specify the volume by quality-of-service with command-line options or in an input file named on the command line.

In some cases, it is important to more specifically define the volume characteristics or the constraints under which the volumes should be created. In such cases, you can also specify the following characteristics:

- Volume types (for example, a RAID-0 (concatenation) or RAID-0 (stripe) volume).
- Components to use in specific volumes.
- Components that are available or unavailable for use.
- Number of components to use.
- Details specific to the type of volume being created. Details include the stripes, the read policy for mirrors, and similar characteristics.

If you prefer to specify the names, sizes, and components of a volume in more detail, use an input file. Input files include volume request files and volume specification files. For more information on how to use input files, see [“Top-Down Volume Creation Processes” on page 238](#).

Finally, you can constrain the `metassist` command to use (or not use) specific disks or paths.

## Top-Down Volume Creation Implementation With Disk Sets

The `metassist` command uses Solaris Volume Manager disk sets to manage volumes and available disks for top-down volume creation. For any given top-down volume creation process, all the disks used as building blocks must be either in the disk set or available to add to the disk set. You can use the top-down creation process to create volumes in different disk sets. However, the disks and components that are available are constrained by disk set functionality.

## Top-Down Volume Creation Processes

The top-down volume creation process provides flexibility by offering the following processes:

- A fully automated end-to-end process through which you can specify needed constraints and have the necessary volumes created when the command completes
- A more granular process with breakpoints at which you can write to an XML-based file

The following figure shows how the `metassist` command supports end-to-end processing based on command-line input and input files. The figure also shows how the `metassist` command supports partial processing, which allows you to provide file-based data or to check volume characteristics.

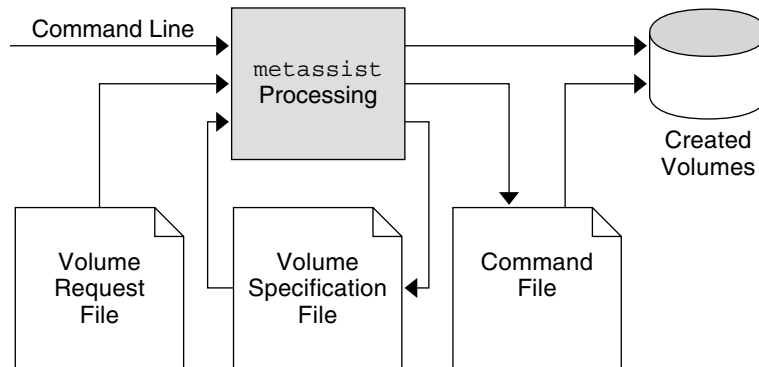

FIGURE 22-1 Processing Options for Top-Down Volume Creation

For an automatic, hands-off approach to volume creation, use the command line to specify the quality-of-service characteristics you require. The `metassist` command automatically creates the requested volumes for you. For example:

```
# metassist create -s storagepool -S 10Gb
```

This command creates a stripe volume of 10 Gbytes in size in the `storagepool` disk set. The command uses available storage that exists in the `storagepool` disk set.

Alternatively, you can use a *volume request file* to define the characteristics of a volume. Then, you can use the `metassist -F request-file` command to create a volume with those characteristics.

You can use the `metassist -d` command to produce a volume specification file. You can use this file to assess the intended implementation and edit the file, if needed. The volume specification file can then be used as input to the `metassist` command to create volumes.

Finally, you can use the `metassist -c` command to create a command file. The *command file* is a shell script that implements the Solaris Volume Manager device configuration specified by the `metassist` command. You can use this file for repeated volume creation and edit the file, as appropriate.

When you use the `metassist` command to create these files, you learn what the `metassist` command does and how it makes decisions. This information can be useful for troubleshooting some of the following:

- Why a volume was created in a certain way
- Why a volume was not created
- What volumes the `metassist` command would create, without actually creating the volumes

## Determining Which Disks Are Available for Top-Down Volume Creation

The `metassist` command checks disks to determine which disks appear to be unused. The command attempts to conservatively determine which disks are available. Any disk or slice that is in use is unavailable for use by the `metassist` command. The `metassist` command checks the following:

- Disks used in other disk sets
- Mounted slices
- Slices with a file system superblock, indicating a mountable file system
- Slices used in other Solaris Volume Manager volumes

Any slices that meet one of these criteria are unavailable for top-down volume creation.



## Top-Down Volume Creation (Tasks)

---

This chapter provides tasks associated with Solaris Volume Manager top-down volume creation using the `metassist` command.

This is a list of the information in this chapter:

- “Top-Down Volume Creation (Task Map)” on page 241
- “Prerequisites for Top-Down Volume Creation” on page 242
- “Creating Volumes Automatically” on page 243
- “Working With File-Based Data Using the `metassist` Command” on page 246
- “Changing the Default Behavior of the `metassist` Command” on page 254

For conceptual information about top-down volume creation, see [Chapter 22](#).

### Top-Down Volume Creation (Task Map)

The following task map identifies the procedures needed to create Solaris Volume Manager volumes using the `metassist` command. This command enables you to specify volumes based on quality-of-service characteristics and to create sets of layered volumes with a single command.

Task	Description	Instructions
Create volumes automatically	Enables you to use the <code>metassist</code> command to create one or more Solaris Volume Manager volumes.  Also, enables you to control the amount of information about the volume creation process that the <code>metassist</code> command provides for troubleshooting or for diagnosing problems.	“Creating Volumes Automatically” on page 243  “Analyzing Volume Creation by Specifying Output Verbosity” on page 243

---

Task	Description	Instructions
Create a command file	Helps you create a shell script with the <code>metassist</code> command to generate the volumes that the command specifies.	<a href="#">“Creating a Volume Configuration File With the <code>metassist</code> Command” on page 252</a>
Create a volume with a shell script	Shows you how to create the Solaris Volume Manager volumes that the <code>metassist</code> command specified with the shell script previously generated by the command.	<a href="#">“Creating a Volume With a Saved Shell Script Created by the <code>metassist</code> Command” on page 251</a>
Create a volume configuration file	Helps you create a volume configuration file, describing the characteristics of the volumes you want to create.	<a href="#">“Creating a Volume Configuration File With the <code>metassist</code> Command” on page 252</a>
Change the volume defaults file	Allows you to set default volume characteristics to customize the behavior of <code>metassist</code> command.	<a href="#">“Changing the Volume Defaults File” on page 254</a>

## Prerequisites for Top-Down Volume Creation

Creating volumes and volume configurations automatically using the `metassist` command requires that you have a functional Solaris Volume Manager configuration. Before you begin, you should have the following:

- Superuser access, or be able to assume an equivalent role-based access control (RBAC) role. See [“Becoming Superuser \(root\) or Assuming a Role” in \*System Administration Guide: Basic Administration\*](#) for more information.
- State database replicas, distributed appropriately for your system. See [“About the Solaris Volume Manager State Database and Replicas” on page 61](#) for more information about state database replicas.
- Available disks for creating volumes. The `metassist` command uses disk sets to help manage storage. Completely unused disks (or an existing disk set) must be available to create new volumes using the `metassist` command. See [“Determining Which Disks Are Available for Top-Down Volume Creation” on page 240](#) for more information about disk availability.

In addition to these minimum requirements, do not disable the Solaris Volume Manager RPC daemons (`rpc.metad`, `rpc.metamhd`, and `rpc.metamedd`) in the `/etc/inetd.conf` file. These daemons are configured to start by default. They must remain enabled to allow Solaris Volume Manager to use shared disk sets.

## Creating Volumes Automatically

The `metassist` command enables you to create Solaris Volume Manager volumes, as well as sets of volumes, based on quality-of-service criteria. The `metassist` command creates volumes for you with one command, rather than the series of commands that Solaris Volume Manager traditionally requires to create volumes.

You can use the `metassist` command to create RAID-1 (mirror) volumes directly. Thus, you do not have to first create the submirrors (concatenations or stripes) that are used as components of the RAID-1 (mirror) volume.

### Analyzing Volume Creation by Specifying Output Verbosity

When you run the `metassist` command, you can specify the level of verbose output. More verbose output can help diagnose problems, such as determining why disks were or were not selected for use in a volume, or to determine why a specific attempted command failed. Less verbose output can reduce the amount of extraneous information that you must review.

When you specify output verbosity, you can learn what the `metassist` command does and how it makes its decisions. This information is useful for troubleshooting some of the following:

- Why a volume was created in a certain way
- Why a volume was not created
- What volumes the `metassist` command would create, without actually creating the volumes

## ▼ How to Create RAID-1 (mirror) Volumes Using the `metassist` Command

**Before You Begin** Check “Prerequisites for Top-Down Volume Creation” on page 242.

### 1 Identify the available storage on which to create the volume.

If you do not explicitly specify storage, Solaris Volume Manager identifies unused storage on the system and uses it, as appropriate. If you choose to specify storage, either broadly (for example, all storage on controller 1) or specifically (for example, use `c1t4d2`, but do not use `c1t4d1`), Solaris Volume Manager uses the storage you specify.

### 2 Use the `metassist` command and the appropriate options for your task.

- To create volumes from the command line, use the following form of the `metassist` command.

```
# metassist create -s diskset-name -f -r redundancy -a device1, device2... -S size -v verbosity
```

`create`

Is the subcommand used to create volumes.

- s *diskset-name* Specifies the name of the disk set to use for the volume.
- f Specifies that the volume be associated with a hot spare.
- r *redundancy* Specifies the level of redundancy (number of data copies) to create.
- a *device1, device2...* Specifies the devices that are available for creating the volume.
- S *size* Specifies the size of the volume to create in KB, MB, GB, or TB, for kilobytes, megabytes, gigabytes, and terabytes, respectively.
- v *verbosity* Specifies how verbose the output should be. Allowable values range from 0 (nearly silent output) to 2 (significant output). The default level is 1 (moderate output).

- To create volumes using an input file to specify volume characteristics, use one of the following forms of the `metassist` command.

```
# metassist create [-v n] [-c] -F config_file
```

```
# metassist create [-v n] [-c | -d] -F request_file
```

-c Specifies to output the command script that would implement the specified or generated volume configuration. The command script is not run, and processing stops at this stage.

-d Specifies to output the volume configuration that satisfies the specified or generated volume request. No command script is generated or executed, and processing stops at this stage.

-F *config\_file* | *request\_file* Specifies the volume request or volume configuration file to process. If *config\_file* or *request\_file* is specified as a dash (-), it is read from standard input. The -d option cannot be specified when input file is a volume configuration file.

A volume configuration file describes detailed configurations of the volumes to be created, while a volume request file provides characteristics for the volumes to be produced. For more information, see `volume-config(4)`, `volume-config(4)` and `volume-request(4)` man pages.

-v *verbosity* Specifies how verbose the output should be. Allowable values range from 0 (nearly silent output) to 2 (significant output). The default level is 1 (moderate output).

See the following examples and the `metassist(1M)` man page for more information.

### 3 Once you have created the volumes, view the new volumes.

```
# metastat -s diskset-name
```

**Example 23-1** Creating a Two-Way Mirror Using the `metassist` Command

The following example shows how to create a two-way mirror, 10 Mbytes in size. The `metassist` command identifies unused disks and creates the best mirror possible using those disks. The `-s myset` argument specifies that the volumes will be created in the `myset` disk set. The disk set is created, if necessary.

```
# metassist create -s myset -r 2 -S 10mb
```

**Example 23-2** Creating a Two-Way Mirror and Hot Spare Using the `metassist` Command

The following example shows how to use the `metassist` command to create a two-way mirror, 10 Mbytes in size, with a hot spare to provide additional fault tolerance. The `-f` option specifies the fault tolerance.

```
# metassist create -s myset -f -r 2 -S 10mb
```

**Example 23-3** Creating a Stripe With a Specific Controller Using the `metassist` Command

The following example shows how to use the `metassist` command to create a stripe using disks available on controller 1. The `-a` option specifies the available controller.

```
# metassist create -s myset -a c1 -S 10mb
```

**Example 23-4** Specifying Output Verbosity From the `metassist` Command

The following example shows how to use the `metassist` command to create a two-way mirror, 10 Mbytes in size, with a hot spare to provide additional fault tolerance. The `-f` option specifies fault tolerance. The final argument (`-v 2`) specifies a verbosity level of two, which is the maximum level and will provide the most information possible about how the `metassist` command worked.

```
# metassist create -s myset -f -r 2 -S 10mb -v 2
```

```
Scanning system physical device configuration...
```

```
These HBA/Controllers are known:.
```

```
c0                /pci@1f,0/pci@1,1/ide@3
c1                /pci@1f,0/pci@1/pci@2/SUNW,isptwo@4
```

```
These disks are known:
```

```
c0t0d0            id1,dad@AST34342A=_____VGD97101
c1t1d0            id1,sd@SSEAGATE_ST39204LCSUN9.0G3BV0L88P000021097XNL
c1t2d0            id1,sd@SSEAGATE_ST39102LCSUN9.0GLJW22867000019171JDF
c1t3d0            id1,sd@SSEAGATE_ST39204LCSUN9.0G3BV0L7RV00007108TG0H
```

```

c1t4d0          id1, sd@SSEAGATE_ST39204LCSUN9.0G3BV0LDFR000021087R1T
c1t5d0          id1, sd@SSEAGATE_ST39204LCSUN9.0G3BV0L0M200002109812L
c1t6d0          id1, sd@SSEAGATE_ST39204LCSUN9.0G3BV0L8K8000021087R0Z
.
.
.
(output truncated)

```

The following example shows how to use the `metassist` command to create a two-way mirror, 10 Mbytes in size, with a hot spare to provide additional fault tolerance. The `-f` option specifies fault tolerance. The final argument (`-v 0`) specifies a verbosity level of zero, which is the minimum level and will provide nearly silent output when the command runs.

```

# metassist create -s myset -f -r 2 -S 10mb -v 0
myset/hsp000: Hotspare pool is setup
myset/hsp000: Hotspare is added
myset/d2: Concat/Stripe is setup
myset/d1: Concat/Stripe is setup
myset/d0: Mirror is setup
myset/d0: submirror myset/d1 is attached

```

### Example 23–5 Creating a Volume Using an Input File

The following example shows how to use the `metassist` command to create a volume using an input file.

```

# metassist create -F request.xml

```

For more information on using input files with the `metassist` command, see [“Working With File-Based Data Using the `metassist` Command” on page 246](#).

## Working With File-Based Data Using the `metassist` Command

The `metassist` command enables you to create files that you can use to evaluate volume characteristics or for actual volume creation.

### Creating a Command File (Shell Script) Using the `metassist` Command

By running the `metassist` command with the `-c` argument, you can generate a Bourne shell script containing the commands that would be used to create the volume configuration. This technique enables you to review the commands before actually creating the volume, or even to modify the script somewhat to meet specific needs.

## ▼ How to Create a Command File (Shell Script) Using the `metassist` Command

**Before You Begin** Check “Prerequisites for Top-Down Volume Creation” on page 242.

### 1 Identify the available storage on which to create the volume.

If you do not explicitly specify storage, Solaris Volume Manager identifies unused storage on the system and uses it, as appropriate. If you choose to specify storage, either broadly (for example, all storage on controller 1) or specifically (for example, use `c1t4d2`, but do not use `c1t4d1`), Solaris Volume Manager uses the storage you specify.

### 2 Use the `metassist` command and the appropriate options for your task.

Use the `-c` option to specify that the volume should not actually be created.

```
# metassist create -s diskset-name -f -r redundancy -a device1, device2... \
-S size -v verbosity [-c]
```

<code>create</code>	Is the subcommand used to create volumes.
<code>-s diskset-name</code>	Specifies the name of the disk set to use for the volume.
<code>-f</code>	Specifies that the volume be associated with a hot spare.
<code>-r redundancy</code>	Specifies the level of redundancy (number of data copies) to create.
<code>-a device1, device2...</code>	Specifies the devices that are available for creating the volume.
<code>-S size</code>	Specifies the size of the volume to create in KB, MB, GB, or TB, for kilobytes, megabytes, gigabytes, and terabytes, respectively.
<code>-v verbosity</code>	Specifies how verbose the output should be. Allowable values range from 0 (nearly silent output) to 2 (significant output). The default level is 1 (moderate output).
<code>-c</code>	Specifies that the volume should not actually be created. Instead, a shell script that can be used to create the specified configuration is sent to standard output.

---

**Note** – The shell script required by the `-c` argument is sent to standard output, while the rest of the output from the `metassist` command goes to standard error. You can redirect the output streams as you choose.

---

See the following examples and the `metassist(1M)` man page for more information.

**Example 23–6** Creating a Command File (Shell Script) Using the `metassist` Command

The following example shows how to use the `metassist` command to create a two-way mirror, 10 Mbytes in size, with a hot spare to provide additional fault tolerance. The `-f` option specifies fault tolerance. The final argument (`-c`) specifies that the volume should not actually be created. Rather, a shell script that could be used to create the specified configuration should be sent to standard output.

```
# metassist create -s myset -f -r 2 -S 10mb -c
(output truncated)
.
.
.
Volume request completed successfully.
#!/bin/sh

#
# Environment
#

# Amend PATH
PATH="/usr/sbin:/usr/bin:$PATH"
export PATH

# Disk set name
diskset='myset'

#
# Functions
#

# Echo (verbose) and exec given command, exit on error
execho () {
    test -n "$verbose" && echo "$@"
    "$@" || exit
}

# Get full /dev/rdisk path of given slice
fullpath () {
    case "$1" in
        /dev/dsk*/dev/did/dsk/*) echo "$1" | sed 's/dsk/rdsk/' ;;
        /*) echo "$1" ;;
        *) echo /dev/rdsk/"$1" ;;
    esac
}

# Run fmthard, ignore partboot error, error if output
fmthard_special () {
```



```

        ignore='Error writing partboot'
        out='fmthard "$@" 2>&1'
        result=$?
        echo "$out" |
        case "$out" in
            *"$ignore"*) grep -v "$ignore"; return 0 ;;
            '') return "$result" ;;
            *) cat; return 1 ;;
        esac >&2
    }

#
# Main
#

# Verify root
if [ "'id | sed 's/^[^()*(\[[^]]*\).*\/\1/'" != root ]
then
    echo "This script must be run as root." >&2
    exit 1;
fi

# Check for verbose option
case "$1" in
    -v) verbose=1 ;;
    *) verbose= ;;
esac

# Does the disk set exist?
if metaset -s "$diskset" >/dev/null 2>&1
then
    # Take control of disk set
    execho metaset -s "$diskset" -t
else
    # Create the disk set
    autotakeargs=
    /usr/sbin/clinfo || autotakeargs='-A enable'
    execho metaset -s "$diskset" $autotakeargs -a -h 'uname -n | cut -f1 -d.'
fi

# Format slices
execho fmthard_special -d 7:0:0:0:0 'fullpath clt3d0s7'
execho fmthard_special -d 7:0:0:0:0 'fullpath clt6d0s7'
execho fmthard_special -d 7:0:0:0:0 'fullpath clt4d0s7'

# Add disks to set
execho metaset -s "$diskset" -a clt3d0

```

```

execho metaset -s "$diskset" -a c1t6d0
execho metaset -s "$diskset" -a c1t4d0

# Format slices
execho fmthard_special -d 0:4:0:10773:17649765 'fullpath c1t3d0s0'
execho fmthard_special -d 0:4:0:10773:17649765 'fullpath c1t6d0s0'
execho fmthard_special -d 0:4:0:10773:17649765 'fullpath c1t4d0s0'
execho fmthard_special -d 1:4:0:17660538:21546 'fullpath c1t3d0s1'
execho fmthard_special -d 1:4:0:17660538:21546 'fullpath c1t4d0s1'
execho fmthard_special -d 1:4:0:17660538:21546 'fullpath c1t6d0s1'

# Does hsp000 exist?
metahs -s "$diskset" -i hsp000 >/dev/null 2>&1 || {
    # Create hsp hsp000
    execho metainit -s "$diskset" hsp000
}

# Add slices to hsp000
execho metahs -s "$diskset" -a hsp000 c1t3d0s1

# Create concat d2
execho metainit -s "$diskset" d2 1 1 c1t4d0s1

# Associate concat d2 with hot spare pool hsp000
execho metaparam -s "$diskset" -h hsp000 d2

# Create concat d1
execho metainit -s "$diskset" d1 1 1 c1t6d0s1

# Associate concat d1 with hot spare pool hsp000
execho metaparam -s "$diskset" -h hsp000 d1

# Create mirror d0
execho metainit -s "$diskset" d0 -m d2 1
execho metattach -s "$diskset" d0 d1
#

```

### Example 23–7 Saving a Command File (Shell Script) Using the `metassist` Command

The following example shows how to use the `metassist` command to create a two-way mirror, 10 Mbytes in size, with a hot spare to provide additional fault tolerance. The `-f` option specifies fault tolerance. The final argument (`-c`) specifies that the volume should not actually be created. Rather, a shell script that could be used to create the specified configuration should be sent to standard output. The end of the command redirects standard output to create the `/tmp/metassist-shell-script.sh` shell script that can later be used to create the specified volume.

```
# metassist create -s myset -f -r 2 -S 10mb -c > \
/tmp/metassist-shell-script.sh
```

## Creating a Volume With a Saved Shell Script Created by the `metassist` Command

After you have created a shell script with the `metassist` command, you can use that script to create the volumes that you specified when the shell script was created.



**Caution** – The command script created by the `metassist` command has significant dependencies on the specific system configuration of the system on which the script was created, at the time the script was created. Using the script on different systems or after any changes to the system configuration can lead to data corruption or loss.

### ▼ How to Execute a Saved `metassist` Command Shell Script

**Before You Begin** Check “Prerequisites for Top-Down Volume Creation” on page 242.

- 1 **Ensure that the system configuration has not changed since the shell script was created, and that you are executing the script on the same system it was created on.**
- 2 **Execute the saved shell script.**  

```
# sh ./metassist-shell-script-name
```
- 3 **View the new volume.**  

```
# metastat -s diskset-name
```

#### Example 23–8 Executing a Saved `metassist` Command Shell Script

The following example shows how to use the `metassist` command to create a volume using a shell script.

```
# sh ./tmp/metassist-shell-script.sh
myset/hsp000: Hotspare pool is setup
myset/hsp000: Hotspare is added
myset/d2: Concat/Stripe is setup
myset/d1: Concat/Stripe is setup
myset/d0: Mirror is setup
myset/d0: submirror myset/d1 is attached
```

## Creating a Volume Configuration File With the `metassist` Command

By running the `metassist` command with the `-d` argument, you can generate an XML-based volume configuration file that specifies the volumes and their components in detail, including all options and relevant information about the volumes. Reviewing this file helps you to understand the configuration that the `metassist` command recommends. Making careful changes to this file can also enable you to fine-tune the configuration, then to use the volume configuration file as input to the `metassist` command to actually create volumes.

### ▼ How to Create a Volume Configuration File Using the `metassist` Command

**Before You Begin** Check “Prerequisites for Top-Down Volume Creation” on page 242.

#### 1 Identify the available storage on which to create the volume.

If you do not explicitly specify storage, Solaris Volume Manager identifies unused storage on the system and uses it, as appropriate. If you choose to specify storage, either broadly (for example, all storage on controller 1) or specifically (for example, use `c1t4d2`, but do not use `c1t4d1`), Solaris Volume Manager uses the storage you specify.

#### 2 Use the `metassist` command and the appropriate options for your task.

Use the `-d` option to specify that the volume should not actually be created. Instead, an XML-based volume configuration file is sent to standard output:

```
# metassist create -s diskset-name -f -r redundancy -a device1, device2... \
  -S size -v verbosity [-d]
```

<code>create</code>	Is the subcommand used to create volumes.
<code>-s diskset-name</code>	Specifies the name of the disk set to use for the volume.
<code>-f</code>	Specifies that the volume be associated with a hot spare.
<code>-r redundancy</code>	Specifies the level of redundancy (number of data copies) to create.
<code>-a device1, device2...</code>	Specifies the devices that are available for creating the volume.
<code>-S size</code>	Specifies the size of the volume to create in KB, MB, GB, or TB, for kilobytes, megabytes, gigabytes, and terabytes, respectively.
<code>-v verbosity</code>	Specifies how verbose the output should be. Allowable values range from 0 (nearly silent output) to 2 (significant output). The default level is 1 (moderate output).
<code>-d</code>	Specifies that the volume should not actually be created.

---

**Note** – The XML-based volume configuration file required by the `-d` argument is sent to standard output. However, the rest of the output from the `metassist` command goes to standard error. You can redirect the output streams as you choose.

---

See the following examples and the `metassist(1M)` man page for more information.

### Example 23–9 Creating a Volume Configuration File Using the `metassist` Command

This example shows how to use the `metassist` command to create a two-way mirror, 10 Mbytes in size, with a hot spare to provide additional fault tolerance. The `-f` option specifies fault tolerance. The final argument (`-d`) specifies that the volume should not actually be created. Rather, a volume configuration file that could eventually be used to create the specified configuration should be sent to standard output.

```
# metassist create -s myset -f -r 2 -S 10mb -d

.(output truncated)
.
.
Volume request completed successfully.
<?xml version="1.0"?>
<!DOCTYPE volume-config SYSTEM "/usr/share/lib/xml/dtd/volume-config.dtd">
<volume-config>
<diskset name="myset"/>
<disk name="clt3d0"/>
<disk name="clt6d0"/>
<disk name="clt4d0"/>
<slice name="clt3d0s7" sizeinblocks="0"/>
<slice name="clt3d0s0" sizeinblocks="17649765" startsector="10773"/>
<slice name="clt6d0s7" sizeinblocks="0"/>
<slice name="clt6d0s0" sizeinblocks="17649765" startsector="10773"/>
<slice name="clt4d0s7" sizeinblocks="0"/>
<slice name="clt4d0s0" sizeinblocks="17649765" startsector="10773"/>
<hsp name="hsp000">
<slice name="clt3d0s1" sizeinblocks="21546" startsector="17660538"/>
</hsp>
<mirror name="d0" read="ROUNDROBIN" write="PARALLEL" passnum="1">
<concat name="d2">
<slice name="clt4d0s1" sizeinblocks="21546" startsector="17660538"/>
<hsp name="hsp000"/>
</concat>
<concat name="d1">
```

```
<slice name="clt6d0s1" sizeinblocks="21546" startsector="17660538"/>
<hsp name="hsp000"/>
</concat>
</mirror>
</volume-config>
#
```

### Example 23–10 Saving a Volume Configuration File Using the `metassist` Command

This example shows how to use the `metassist` command to create a two-way mirror, 10 Mbytes in size, with a hot spare to provide additional fault tolerance. The `-f` option specifies fault tolerance. The final argument (`-d`) specifies that the volume should not actually be created. Rather, a volume configuration file that could eventually be used to create the specified configuration should be sent to standard output. The end of the command redirects standard output to create the `/tmp/metassist-volume-config.xml` volume configuration file that can later be used to create the specified volume.

```
# metassist create -s myset -f -r 2 -S 10mb -d > \
/tmp/metassist-volume-config.xml
```

## Changing the Default Behavior of the `metassist` Command

You can use the volume defaults file (`/etc/defaults/metassist.xml`) to change the default behavior for the `metassist` command. By changing the defaults file, you can explicitly exclude from consideration, or include for consideration, specific disks or controllers. You can also specify requirements for most volume settings used by the `metassist` command.

The format of the `/etc/defaults/metassist.xml` is specified by the `/usr/share/lib/xml/dtd/volume-defaults.dtd` Document Type Definition (DTD). The format is documented in the `volume-defaults(4)` man page.

## Changing the Volume Defaults File

Edit the volume defaults file (`/etc/defaults/metassist.xml`) to specify how the `metassist` command should behave.

---

**Note** – When you edit the file, you must ensure that the file continues to be compliant with the `/usr/share/lib/xml/dtd/volume-defaults.dtd` Document Type Definition (DTD). If the XML file is not compliant with the DTD, the `metassist` command will fail with an error message.

---

**EXAMPLE 23-11** Creating a Volume With Changed Defaults Using the `metassist` Command

Before creating a volume, edit the `/etc/default/metassist.xml` file to specify the default settings that you want to apply to all volumes you will create with the `metassist` command. In this example, the `metassist` command only creates volumes on controller `c1` and, when creating stripes, only creates stripes with exactly four components and an interlace of value `512KB`. These constraints apply to all uses of the `metassist` command until the `/etc/default/metassist.xml` file is changed again.

```
# cat /etc/default/metassist.xml
<!DOCTYPE volume-defaults SYSTEM \
"/usr/share/lib/xml/dtd/volume-defaults.dtd">

<volume-defaults>
<available name="c1" />
<stripe mincomp="4" maxcomp="4" interlace="512KB" ></stripe>
</volume-defaults>

# metassist create -s myset -S 10Gb
```

The `metassist` command creates a 10-Gbyte stripe, using exactly four slices and an interlace value of 512 Kbytes, as specified in the `/etc/default/metassist.xml` file.





## Monitoring and Error Reporting (Tasks)

---

Sometimes Solaris Volume Manager encounters a problem, such as being unable to write to a volume due to physical errors at the slice level. When problems occur, Solaris Volume Manager changes the status of the volume so that system administrators can stay informed. However, unless you regularly check the status in the Solaris Volume Manager GUI through the Solaris Management Console, or by running the `metastat` command, you might not see these status changes promptly.

This chapter provides information about various monitoring tools that are available for Solaris Volume Manager. One tool is the Solaris Volume Manager SNMP agent, which is a subagent of the Solstice Enterprise Agents™ monitoring software. In addition to configuring this tool to report SNMP traps, you can create a shell script to actively monitor many Solaris Volume Manager functions. This shell script could run as a cron job and be valuable in identifying issues before they become problems.

This is a list of the information in this chapter:

- “Solaris Volume Manager Monitoring and Reporting (Task Map)” on page 257
- “Configuring the `mdmonitord` Command for Periodic Error Checking” on page 258
- “Solaris Volume Manager SNMP Agents Overview” on page 259
- “Configuring the Solaris Volume Manager SNMP Agents” on page 259
- “Limitations of the Solaris Volume Manager SNMP Agent” on page 262
- “Monitoring Solaris Volume Manager With a cron Job” on page 262

### Solaris Volume Manager Monitoring and Reporting (Task Map)

The following task map identifies the procedures that are needed to manage error reporting for Solaris Volume Manager.

Task	Description	For Instructions
Configure the <code>mdmonitord</code> daemon to periodically check for errors	Configure the error-checking interval used by the <code>mdmonitord</code> daemon by editing the <code>/lib/svc/method/svc-mdmonitor</code> script.	<a href="#">“Configuring the <code>mdmonitord</code> Command for Periodic Error Checking” on page 258</a>
Configure the Solaris Volume Manager SNMP agent	Edit the configuration files in the <code>/etc/snmp/conf</code> directory so that Solaris Volume Manager will throw traps appropriately, to the correct system.	<a href="#">“Configuring the Solaris Volume Manager SNMP Agents” on page 259</a>
Monitor Solaris Volume Manager with scripts run by the <code>cron</code> command	Create or adapt a script to check for errors, then run the script from the <code>cron</code> command.	<a href="#">“Monitoring Solaris Volume Manager With a <code>cron</code> Job” on page 262</a>

## Configuring the `mdmonitord` Command for Periodic Error Checking

Solaris Volume Manager includes the `/usr/sbin/mdmonitord` daemon. When a disk fails, Solaris Volume Manager detects the failure and generates an error. This error event triggers the `mdmonitord` daemon to perform a check of RAID-1 (mirror) volumes, RAID-5 volumes, and hot spares. However, you can also configure this program to actively check for errors at an interval that you specify.

### ▼ How to Configure the `mdmonitord` Command for Periodic Error Checking

Edit the `/lib/svc/method/svc-mdmonitor` script to add a time interval for periodic checking.

- 1 **Become superuser.**
- 2 **Open the `/lib/svc/method/svc-mdmonitor` script in the editor of your choice. Locate the following section in the script:**

```
$MDMONITORD
error=$?
case $error in
0)      exit 0
        ;;

*)      echo "Could not start $MDMONITORD. Error $error."
        exit 0
```

- 3 Change the line that starts the `mdmonitord` command by adding a `-t` flag and the number of seconds between checks.**

```
$MDMONITORD -t 3600
error=$?
case $error in
0)      exit 0
        ;;

*)      echo "Could not start $MDMONITORD. Error $error."
        exit 0
        ;;
esac
```

- 4 Restart the `mdmonitord` command to activate your changes.**

```
# svcadm restart system/mdmonitor
```

For more information, see the `mdmonitord(1M)` man page.

## Solaris Volume Manager SNMP Agents Overview

The Solaris Volume Manager SNMP trap agents requires the core packages `SUNWlvmr`, and the packages for the `SUNWlvm` and the Solstice Enterprise Agents. These core packages include the following:

- `SUNWmibii`
- `SUNWsacom`
- `SUNWsadmi`
- `SUNWsasnm`

These packages are part of the Solaris operating system. They are normally installed by default unless the package selection was modified at install time or a minimal set of packages was installed. To confirm that these packages are available, use the `pkginfo pkgname` command, as in `pkginfo SUNWsasnm`. After you confirm that all five packages are available, you need to configure the Solaris Volume Manager SNMP agent, as described in the following section.

## Configuring the Solaris Volume Manager SNMP Agents

The Solaris Volume Manager SNMP agents is not enabled by default. Use the following procedure to enable SNMP traps.

Whenever you upgrade your Solaris operating system, you will probably need to edit the `/etc/snmp/conf/enterprises.oid` file and append the line in [Step 6](#) again, then restart the Solaris Enterprise Agents server.

After you have completed this procedure, your system will issue SNMP traps to the host or hosts that you specified. You will need to use an appropriate SNMP monitor, such as Solstice Enterprise Agents software, to view the traps as they are issued.

Set the `mdmonitord` command to probe your system regularly to help ensure that you receive traps if problems arise. See [“Configuring the `mdmonitord` Command for Periodic Error Checking”](#) on page 258. Also, refer to [“Monitoring Solaris Volume Manager With a `cron` Job”](#) on page 262 for additional error-checking options.

## ▼ How to Configure the Solaris Volume Manager SNMP Agents

- 1 **Become superuser.**
- 2 **Move the `/etc/snmp/conf/mdlogd.rsrc`—configuration file to `/etc/snmp/conf/mdlogd.rsrc`.**  

```
# mv /etc/snmp/conf/mdlogd.rsrc- /etc/snmp/conf/mdlogd.rsrc
```
- 3 **Edit the `/etc/snmp/conf/mdlogd.acl` file to specify which hosts should receive SNMP traps. Look in the file for the following:**

```
trap = {
  {
    trap-community = SNMP-trap
    hosts = corsair
    {
      enterprise = "Solaris Volume Manager"
      trap-num = 1, 2, 3
    }
  }
}
```

Change the line that contains `hosts = corsair` to specify the host name that you want to receive Solaris Volume Manager SNMP traps. For example, to send SNMP traps to `lexicon`, you would change the line to `hosts = lexicon`. If you want to include multiple hosts, provide a comma-delimited list of host names, as in `hosts = lexicon, idiom`.

- 4 **Also edit the `/etc/snmp/conf/snmpdx.acl` file to specify which hosts should receive the SNMP traps.**

Find the block that begins with `trap =` and add the same list of hosts that you added in the previous step. This section might be commented out with `#`'s. If so, you must remove the `#` at the beginning of the required lines in this section. Additional lines in the `trap` section are also commented out. However, you can leave those lines alone or delete them for clarity. After uncommenting the required lines and updating the `hosts` line, this section could look similar to the following:

```
#####
# trap parameters #
#####
```

```
trap = {
```

```

{
    trap-community = SNMP-trap
    hosts =lexicon
    {
        enterprise = "sun"
        trap-num = 0, 1, 2-5, 6-16
    }
#
#   {
#       enterprise = "3Com"
#       trap-num = 4
#   }
#   {
#       enterprise = "snmp"
#       trap-num = 0, 2, 5
#   }
# }
# {
#   trap-community = jerry-trap
#   hosts = jerry, nanak, hubble
#   {
#       enterprise = "sun"
#       trap-num = 1, 3
#   }
#   {
#       enterprise = "snmp"
#       trap-num = 1-3
#   }
# }
}

```

---

**Note** – Make sure that you have the same number of opening and closing brackets in the `/etc/snmp/conf/snmpdx.acl` file.

---

- 5 Add a new Solaris Volume Manager section to the `/etc/snmp/conf/snmpdx.acl` file, inside the section you that uncommented in the previous step.**

```

trap-community = SNMP-trap
hosts = lexicon
{
    enterprise = "sun"
    trap-num = 0, 1, 2-5, 6-16
}
{
    enterprise = "Solaris Volume Manager"
    trap-num = 1, 2, 3
}

```

Note that the added four lines are placed immediately after the `enterprise = "sun"` block.

- 6 **Append the following line to the `/etc/snmp/conf/enterprises.oid` file:**

```
"Solaris Volume Manager"                                "1.3.6.1.4.1.42.104"
```
- 7 **Restart the Solstice Enterprise Agents server.**

```
# svcadm restart svc:/application/management/snmpdx
```

## Limitations of the Solaris Volume Manager SNMP Agent

The Solaris Volume Manager SNMP agent does not issue traps for all of the Solaris Volume Manager problems that system administrators need to be aware of. Specifically, the agent issues traps *only* in the following instances:

- A RAID-1 or RAID-5 subcomponent goes into a “Needs Maintenance” state
- A hot spare is swapped into service
- A hot spare starts to resynchronize
- A hot spare completes resynchronization
- A mirror is taken offline
- A disk set is taken by another host and the current host panics

Many problems, such as an unavailable disk with RAID-0 volumes or soft partitions on it, do not result in SNMP traps, even when reads and writes to the device are attempted. SCSI or IDE errors are generally reported in these cases. However, other SNMP agents must issue traps for those errors to be reported to a monitoring console.

## Monitoring Solaris Volume Manager With a cron Job

### ▼ How to Automate Checking for Errors in Volumes

- ▶ **To automatically check your Solaris Volume Manager configuration for errors, create a script that the cron utility can periodically run.**

The following example shows a script that you can adapt and modify for your needs.

---

**Note** – This script serves as a starting point for automating error checking for Solaris Volume Manager. You probably need to modify this script for your own configuration.

---

```
#
#!/bin/ksh
#ident "@(#)metacheck.sh 1.3 96/06/21 SMI"
# ident='%Z%M% %I% %E% SMI'
```

```

#
# Copyright (c) 1999 by Sun Microsystems, Inc.
#
# metacheck
#
# Check on the status of the metadevice configuration.  If there is a problem
# return a non zero exit code.  Depending on options, send email notification.
#
# -h
#   help
# -s setname
#   Specify the set to check.  By default, the 'local' set will be checked.
# -m recipient [recipient...]
#   Send email notification to the specified recipients.  This
#   must be the last argument.  The notification shows up as a short
#   email message with a subject of
#       "Solaris Volume Manager Problem: metacheck.who.nodename.setname"
#   which summarizes the problem(s) and tells how to obtain detailed
#   information.  The "setname" is from the -s option, "who" is from
#   the -w option, and "nodename" is reported by uname(1).
#   Email notification is further affected by the following options:
#       -f   to suppress additional messages after a problem
#           has been found.
#       -d   to control the suppression.
#       -w   to identify who generated the email.
#       -t   to force email even when there is no problem.
# -w who
#   indicate who is running the command.  By default, this is the
#   user-name as reported by id(1M).  This is used when sending
#   email notification (-m).
# -f
#   Enable filtering.  Filtering applies to email notification (-m).
#   Filtering requires root permission.  When sending email notification
#   the file /etc/lvm/metacheck.setname.pending is used to
#   control the filter.  The following matrix specifies the behavior
#   of the filter:
#
#   problem_found   file_exists
#   yes             no           Create file, send notification
#   yes             yes          Resend notification if the current date
#                               (as specified by -d datefmt) is
#                               different than the file date.
#   no              yes          Delete file, send notification
#                               that the problem is resolved.
#   no              no           Send notification if -t specified.
#
# -d datefmt
#   Specify the format of the date for filtering (-f).  This option

```

```
# controls the how often re-notification via email occurs. If the
# current date according to the specified format (strftime(3C)) is
# identical to the date contained in the
# /etc/lvm/metacheck.setname.pending file then the message is
# suppressed. The default date format is "%D", which will send one
# re-notification per day.
# -t
# Test mode. Enable email generation even when there is no problem.
# Used for end-to-end verification of the mechanism and email addresses.
#
#
# These options are designed to allow integration of metacheck
# into crontab. For example, a root crontab entry of:
#
# 0,15,30,45 * * * * /usr/sbin/metacheck -f -w SVMcron \
# -d '%D %h' -m notice@example.com 2148357243.8333033@pager.example.com
#
# would check for problems every 15 minutes, and generate an email to
# notice@example.com (and send to an email pager service) every hour when
# there is a problem. Note the \ prior to the '%' characters for a
# crontab entry. Bounced email would come back to root@nodename.
# The subject line for email generated by the above line would be
# Solaris Volume Manager Problem: metacheck.SVMcron.nodename.local
#

# display a debug line to controlling terminal (works in pipes)
decho()
{
    if [ "$debug" = "yes" ] ; then
        echo "DEBUG: $" < /dev/null > /dev/tty 2>&1
    fi
}

# if string $1 is in $2-* then return $1, else return ""
strstr()
{
    typeset look="$1"
    typeset ret=""

    shift
# decho "strstr LOOK .$look. FIRST .$1."
while [ $# -ne 0 ] ; do
    if [ "$look" = "$1" ] ; then
        ret="$look"
    fi
    shift
done
echo "$ret"
```



```

}

# if string $1 is in $2-* then delete it. return result
strdstr()
{
    typeset    look="$1"
    typeset    ret=""

    shift

#   decho "strdstr LOOK .$look. FIRST .$1."
    while [ $# -ne 0 ] ; do
        if [ "$look" != "$1" ] ; then
            ret="$ret $1"
        fi
    done
    echo "$ret"
}

merge_continued_lines()
{
    awk -e '\
BEGIN { line = "";} \
$NF == "\\\" { \
    $NF = ""; \
    line = line $0; \
    next; \
} \
$NF != "\\\" { \
    if ( line != "" ) { \
        print line $0; \
        line = ""; \
    } else { \
        print $0; \
    } \
}'
}

# trim out stuff not associated with metadevices
find_meta_devices()
{
    typeset    devices=""

#   decho "find_meta_devices .$*."
    while [ $# -ne 0 ] ; do
        case $1 in
            d+([0-9]) )    # metadvice name
                devices="$devices $1"
        esac
    done
}

```

```

        ;;
    esac
    shift
done
echo "$devices"
}

# return the list of top level metadevices
topLevel()
{
    typeset    comp_meta_devices=""
    typeset    top_meta_devices=""
    typeset    devices=""
    typeset    device=""
    typeset    comp=""

    metastat$setarg -p | merge_continued_lines | while read line ; do
    echo "$line"
    devices='find_meta_devices $line'
    set -- $devices
    if [ $# -ne 0 ] ; then
        device=$1
        shift
        # check to see if device already referred to as component
        comp='strstr $device $comp_meta_devices'
        if [ -z $comp ] ; then
            top_meta_devices="$top_meta_devices $device"
        fi
        # add components to component list, remove from top list
        while [ $# -ne 0 ] ; do
            comp=$1
            comp_meta_devices="$comp_meta_devices $comp"
            top_meta_devices='strdstr $comp $top_meta_devices'
            shift
        done

        fi
    done > /dev/null 2>&1
    echo $top_meta_devices
}

#
# - MAIN
#
METAPATH=/usr/sbin
PATH=//usr/bin:$METAPATH
USAGE="usage: metacheck [-s setname] [-h] [[-t] [-f [-d datefmt]] \
    [-w who] -m recipient [recipient...]]"
```

```

datefmt="%D"
debug="no"
filter="no"
mflag="no"
set="local"
setarg=""
testarg="no"
who='id | sed -e 's/^uid=[0-9][0-9]*(// ' -e 's/).*/''

while getopts d:Dfms:tw: flag
do
    case $flag in
        d)    datefmt=$OPTARG;
            ;;
        D)    debug="yes"
            ;;
        f)    filter="yes"
            ;;
        m)    mflag="yes"
            ;;
        s)    set=$OPTARG;
            if [ "$set" != "local" ] ; then
                setarg=" -s $set";
            fi
            ;;
        t)    testarg="yes";
            ;;
        w)    who=$OPTARG;
            ;;
        \?)    echo $USAGE
            exit 1
            ;;
    esac
done

# if mflag specified then everything else part of recipient
shift `expr $OPTIND - 1`
if [ $mflag = "no" ] ; then
    if [ $# -ne 0 ] ; then
        echo $USAGE
        exit 1
    fi
else
    if [ $# -eq 0 ] ; then
        echo $USAGE
        exit 1
    fi
fi

```

```

recipients="$*"

curdate_filter='date +%datefmt'
curdate='date'
node='uname -n'

# establish files
msg_f=/tmp/metacheck.msg.$$
msgs_f=/tmp/metacheck.msgs.$$
metastat_f=/tmp/metacheck.metastat.$$
metadb_f=/tmp/metacheck.metadb.$$
metahs_f=/tmp/metacheck.metahs.$$
pending_f=/etc/lvm/metacheck.$set.pending
files="$metastat_f $metadb_f $metahs_f $msg_f $msgs_f"

rm -f $files > /dev/null 2>&1
trap "rm -f $files > /dev/null 2>&1; exit 1" 1 2 3 15

# Check to see if metadb is capable of running
have_metadb="yes"
metadb$setarg > $metadb_f 2>&1
if [ $? -ne 0 ] ; then
    have_metadb="no"
fi
grep "there are no existing databases" < $metadb_f > /dev/null 2>&1
if [ $? -eq 0 ] ; then
    have_metadb="no"
fi
grep "/dev/md/admin" < $metadb_f > /dev/null 2>&1
if [ $? -eq 0 ] ; then
    have_metadb="no"
fi

# check for problems accessing metadbs
retval=0
if [ "$have_metadb" = "no" ] ; then
    retval=1
    echo "metacheck: metadb problem, can't run '$METAPATH/metadb$setarg'" \
        >> $msgs_f
else
    # snapshot the state
    metadb$setarg 2>&1 | sed -e 'ld' | merge_continued_lines > $metadb_f
    metastat$setarg 2>&1 | merge_continued_lines > $metastat_f
    metahs$setarg -i 2>&1 | merge_continued_lines > $metahs_f

    #
    # Check replicas for problems, capital letters in the flags
    # indicate an error, fields are separated by tabs.

```

```

#
problem='awk < $metadb_f -F\t '{if ($1 ~ /[A-Z]/) print $1;}'
if [ -n "$problem" ] ; then
retval='expr $retval + 64'
echo "\
metacheck: metadb problem, for more detail run:\n\t$METAPATH/metadb$setarg -i" \
    >> $msgs_f
fi

#
# Check the metadevice state
#
problem='awk < $metastat_f -e \
    '/State:/ {if ($2 != "Okay" && $2 != "Resyncing") print $0;}'
if [ -n "$problem" ] ; then
retval='expr $retval + 128'
echo "\
metacheck: metadevice problem, for more detail run:" \
    >> $msgs_f

# refine the message to toplevel metadevices that have a problem
top='toplevel'
set -- $top
while [ $# -ne 0 ] ; do
    device=$1
    problem='metastat $device | awk -e \
        '/State:/ {if ($2 != "Okay" && $2 != "Resyncing") print $0;}'
    if [ -n "$problem" ] ; then
        echo "\t$METAPATH/metastat$setarg $device" >> $msgs_f
        # find out what is mounted on the device
        mp='mount|awk -e '/dev/md/dsk/'$device'[ \t]/{print $1;}'
        if [ -n "$mp" ] ; then
            echo "\t\t$mp mounted on $device" >> $msgs_f
        fi
    fi
    shift
done
fi

#
# Check the hotspares to see if any have been used.
#
problem=""
grep "no hotspare pools found" < $metahs_f > /dev/null 2>&1
if [ $? -ne 0 ] ; then
problem='awk < $metahs_f -e \
    '/blocks/ { if ( $2 != "Available" ) print $0;}'
fi

```

```

        if [ -n "$problem" ] ; then
            retval='expr $retval + 256'
            echo "\
metacheck: hot spare in use, for more detail run:\n\t$METAPATH/metahs$setarg -i" \
                >> $msgs_f
        fi
    fi

# If any errors occurred, then mail the report
if [ $retval -ne 0 ] ; then
    if [ -n "$recipients" ] ; then
        re=""
        if [ -f $pending_f ] && [ "$filter" = "yes" ] ; then
            re="Re: "
            # we have a pending notification, check date to see if we resend
            penddate_filter='cat $pending_f | head -1'
            if [ "$curdate_filter" != "$penddate_filter" ] ; then
                rm -f $pending_f > /dev/null 2>&1
            else
                if [ "$debug" = "yes" ] ; then
                    echo "metacheck: email problem notification still pending"
                    cat $pending_f
                fi
            fi
        fi
        if [ ! -f $pending_f ] ; then
            if [ "$filter" = "yes" ] ; then
                echo "$curdate_filter\n\tDate:$curdate\n\tTo:$recipients" \
                    > $pending_f
            fi
            echo "\
Solaris Volume Manager: $node: metacheck$setarg: Report: $curdate" >> $msg_f
            echo "\
-----" >> $msg_f
            cat $msg_f $msgs_f | mailx -s \
                "${re}Solaris Volume Manager Problem: metacheck.$who.$set.$node" $recipients
        fi
    else
        cat $msgs_f
    fi
else
    # no problems detected,
    if [ -n "$recipients" ] ; then
        # default is to not send any mail, or print anything.
        echo "\
Solaris Volume Manager: $node: metacheck$setarg: Report: $curdate" >> $msg_f
        echo "\
-----" >> $msg_f
    fi

```

```
if [ -f $pending_f ] && [ "$filter" = "yes" ] ; then
# pending filter exists, remove it and send OK
rm -f $pending_f > /dev/null 2>&1
echo "Problem resolved" >> $msg_f
cat $msg_f | mailx -s \
"Re: Solaris Volume Manager Problem: metacheck.$who.$node.$set" $recipients
elif [ "$testarg" = "yes" ] ; then
# for testing, send mail every time even though there is no problem
echo "Messaging test, no problems detected" >> $msg_f
cat $msg_f | mailx -s \
"Solaris Volume Manager Problem: metacheck.$who.$node.$set" $recipients
fi
else
echo "metacheck: Okay"
fi
fi

rm -f $files > /dev/null 2>&1
exit $retval
```

For information on invoking scripts by using the cron utility, see the cron(1M) man page.





# Troubleshooting Solaris Volume Manager (Tasks)

---

This chapter describes how to troubleshoot problems that are related to Solaris Volume Manager. This chapter provides both general troubleshooting guidelines and specific procedures for resolving some known problems.

This chapter includes the following information:

- “Troubleshooting Solaris Volume Manager (Task Map)” on page 273
- “Overview of Troubleshooting the System” on page 274
- “Replacing Disks” on page 276
- “Recovering From Disk Movement Problems” on page 278
- “Device ID Discrepancies After Upgrading to the Solaris 10 Release” on page 279
- “Recovering From Boot Problems” on page 281
- “Recovering From State Database Replica Failures” on page 288
- “Recovering From Soft Partition Problems” on page 291
- “Recovering Storage From a Different System” on page 293
- “Recovering From Disk Set Problems” on page 300
- “Performing Mounted Filesystem Backups Using the `ufsdump` Command” on page 301
- “Performing System Recovery” on page 303

This chapter describes some Solaris Volume Manager problems and their appropriate solution. This chapter is not intended to be all-inclusive, but rather to present common scenarios and recovery procedures.

## Troubleshooting Solaris Volume Manager (Task Map)

The following task map identifies some procedures that are needed to troubleshoot Solaris Volume Manager.

Task	Description	For Instructions
Replace a failed disk	Replace a disk, then update state database replicas and logical volumes on the new disk.	<a href="#">“How to Replace a Failed Disk” on page 276</a>
Recover from disk movement problems	Restore disks to original locations or contact product support.	<a href="#">“Recovering From Disk Movement Problems” on page 278</a>
Recover from improper /etc/vfstab entries	Use the <code>fsck</code> command on the mirror, then edit the <code>/etc/vfstab</code> file so that the system boots correctly.	<a href="#">“How to Recover From Improper /etc/vfstab Entries” on page 282</a>
Recover from a boot device failure	Boot from a different submirror.	<a href="#">“How to Recover From a Boot Device Failure” on page 284</a>
Recover from insufficient state database replicas	Delete unavailable replicas by using the <code>metadb</code> command.	<a href="#">“How to Recover From Insufficient State Database Replicas” on page 288</a>
Recover configuration data for a lost soft partition	Use the <code>metarecover</code> command to recover configuration data for a soft partition.	<a href="#">“How to Recover Configuration Data for a Soft Partition” on page 291</a>
Recover a Solaris Volume Manager configuration from salvaged disks	Attach disks to a new system and have Solaris Volume Manager rebuild the configuration from the existing state database replicas.	<a href="#">“How to Recover Storage From a Local Disk Set” on page 293</a>
Recover storage from a different system	Import storage from known disk sets to a different system.	<a href="#">“Recovering Storage From a Different System” on page 293</a>
Purge an inaccessible disk set.	Use the <code>metaset</code> command to purge knowledge of a disk set that you cannot take or use.	<a href="#">“Recovering From Disk Set Problems” on page 300</a>
Recover a system configuration stored on Solaris Volume Manager volumes.	Use Solaris OS installation media to recover a system configuration stored on Solaris Volume Manager volumes.	<a href="#">“Performing System Recovery” on page 303</a>

## Overview of Troubleshooting the System

### Prerequisites for Troubleshooting the System

To troubleshoot storage management problems that are related to Solaris Volume Manager, you need to do the following:

- Have root privilege
- Have a current backup of all data

---

## General Guidelines for Troubleshooting Solaris Volume Manager

You should have the following information on hand when you troubleshoot Solaris Volume Manager problems:

- Output from the `metadb` command
- Output from the `metastat` command
- Output from the `metastat -p` command
- Backup copy of the `/etc/vfstab` file
- Backup copy of the `/etc/lvm/mddb.cf` file
- Disk partition information from the `prtvtoc` command (SPARC® systems) or the `fdisk` command (x86 based systems)
- The Solaris version on your system
- A list of the Solaris patches that have been installed
- A list of the Solaris Volume Manager patches that have been installed

---

**Tip** – Any time you update your Solaris Volume Manager configuration, or make other storage or operating system-related changes to your system, generate fresh copies of this configuration information. You could also generate this information automatically with a `cron` job.

---

## General Troubleshooting Approach

Although no single procedure enables you to evaluate all problems with Solaris Volume Manager, the following process provides one general approach that might help.

1. Gather information about current the configuration.
2. Review the current status indicators, including the output from the `metastat` and `metadb` commands. This information should indicate which component is faulty.
3. Check the hardware for obvious points of failure:
  - Is everything connected properly?
  - Was there a recent electrical outage?
  - Have there been equipment changes or additions?

# Replacing Disks

This section describes how to replace disks in a Solaris Volume Manager environment.



**Caution** – If you have soft partitions on a failed disk or on volumes that are built on a failed disk, you must put the new disk in the same physical location. Also, use the same `cntndn` number as the disk being replaced.

## ▼ How to Replace a Failed Disk

- 1 **Identify the failed disk to be replaced by examining the `/var/adm/messages` file and the `metastat` command output.**
- 2 **Locate any state database replicas that might have been placed on the failed disk.**

Use the `metadb` command to find the replicas.

The `metadb` command might report errors for the state database replicas that are located on the failed disk. In this example, `c0t1d0` is the problem device.

```
# metadb
  flags      first blk      block count      /dev/dsk/c0t0d0s4
a m   u       16             1034
a     u       1050            1034
a     u       2084            1034
W pc  lu0     16             1034
W pc  lu0     1050            1034
W pc  lu0     2084            1034
```

The output shows three state database replicas on each slice 4 of the local disks, `c0t0d0` and `c0t1d0`. The `W` in the flags field of the `c0t1d0s4` slice indicates that the device has write errors. Three replicas on the `c0t0d0s4` slice are still good.

- 3 **Record the slice name where the state database replicas reside and the number of state database replicas. Then, delete the state database replicas.**

The number of state database replicas is obtained by counting the number of appearances of a slice in the `metadb` command output. In this example, the three state database replicas that exist on `c0t1d0s4` are deleted.

```
# metadb -d c0t1d0s4
```



**Caution** – If, after deleting the bad state database replicas, you are left with three or fewer, [add more state database replicas](#) before continuing. Doing so helps to ensure that configuration information remains intact.

**4 Locate and delete any hot spares on the failed disk.**

Use the `metastat` command to find hot spares. In this example, hot spare pool `hsp000` included `c0t1d0s6`, which is then deleted from the pool.

```
# metahs -d hsp000 c0t1d0s6
hsp000: Hotspare is deleted
```

**5 Replace the failed disk.**

This step might entail using the `cfgadm` command, the `luxadm` command, or other commands as appropriate for your hardware and environment. When performing this step, make sure to follow your hardware's documented procedures to properly manipulate the Solaris state of this disk.

**6 Repartition the new disk.**

Use the `format` command or the `fmthard` command to partition the disk with the same slice information as the failed disk. If you have the `prtvtoc` output from the failed disk, you can format the replacement disk with the `fmthard -s /tmp/failed-disk-prtvtoc-output` command.

**7 If you deleted state database replicas, add the same number back to the appropriate slice.**

In this example, `/dev/dsk/c0t1d0s4` is used.

```
# metadb -a -c 3 c0t1d0s4
```

**8 If any slices on the disk are components of RAID-5 volumes or are components of RAID-0 volumes that are in turn submirrors of RAID-1 volumes, run the `metareplace -e` command for each slice.**

In this example, `/dev/dsk/c0t1d0s4` and mirror `d10` are used.

```
# metareplace -e d10 c0t1d0s4
```

**9 If any soft partitions are built directly on slices on the replaced disk, run the `metarecover -m -p` command on each slice that contains soft partitions. This command regenerates the extent headers on disk.**

In this example, `/dev/dsk/c0t1d0s4` needs to have the soft partition markings on disk regenerated. The slice is scanned and the markings are reapplied, based on the information in the state database replicas.

```
# metarecover c0t1d0s4 -m -p
```

**10 If any soft partitions on the disk are components of RAID-5 volumes or are components of RAID-0 volumes that are submirrors of RAID-1 volumes, run the `metareplace -e` command for each slice.**

In this example, `/dev/dsk/c0t1d0s4` and mirror `d10` are used.

```
# metareplace -e d10 c0t1d0s4
```

**11 If any RAID-0 volumes have soft partitions built on them, run the `metarecover` command for each RAID-0 volume.**

In this example, RAID-0 volume, `d17`, has soft partitions built on it.

```
# metarecover d17 -m -p
```

**12 Replace hot spares that were deleted, and add them to the appropriate hot spare pool or pools.**

In this example, hot spare pool, `hsp000` included `c0t1d0s6`. This slice is added to the hot spare pool.

```
# metahs -a hsp000 c0t1d0s6hsp000: Hotspare is added
```

**13 If soft partitions or nonredundant volumes were affected by the failure, restore data from backups. If only redundant volumes were affected, then validate your data.**

Check the user and application data on all volumes. You might have to run an application-level consistency checker, or use some other method to check the data.

## Recovering From Disk Movement Problems

This section describes how to recover from unexpected problems after moving disks in the Solaris Volume Manager environment.

### Disk Movement and Device ID Overview

Solaris Volume Manager uses device IDs, which are associated with a specific disk, to track all disks that are used in a Solaris Volume Manager configuration. When disks are moved to a different controller or when the SCSI target numbers change, Solaris Volume Manager usually correctly identifies the movement and updates all related Solaris Volume Manager records accordingly. No system administrator intervention is required. In isolated cases, Solaris Volume Manager cannot completely update the records and reports an error on boot.

### Resolving Unnamed Devices Error Message

If you add new hardware or move hardware (for example, you move a string of disks from one controller to another controller), Solaris Volume Manager checks the device IDs that are associated with the disks that moved, and updates the `cntndn` names in internal Solaris Volume Manager records accordingly. If the records cannot be updated, the boot processes that are spawned by the `svc:/system/mdmonitor` service report an error to the console at boot time:

```
Unable to resolve unnamed devices for volume management.  
Please refer to the Solaris Volume Manager documentation,  
Troubleshooting section, at http://docs.sun.com or from  
your local copy.
```

No data loss has occurred, and none will occur as a direct result of this problem. This error message indicates that the Solaris Volume Manager name records have been only partially updated. Output from the `metastat` command shows some of the `cntndn` names that were previously used. The output also shows some of the `cntndn` names that reflect the state after the move.

If you need to update your Solaris Volume Manager configuration while this condition exists, you must use the `cntndn` names that are reported by the `metastat` command when you issue any `meta*` commands.

If this error condition occurs, you can do one of the following to resolve the condition:

- Restore all disks to their original locations. Next, do a reconfiguration reboot, or run (as a single command):

```
/usr/sbin/devfsadm && /usr/sbin/metadevadm -r
```

After these commands complete, the error condition is resolved.

- Contact your support representative for guidance.

---

**Note** – This error condition is quite unlikely to occur. If it does occur, it is most likely to affect Fibre Channel-attached storage.

---

## Device ID Discrepancies After Upgrading to the Solaris 10 Release

Beginning with the Solaris 10 release, device ID output is displayed in a new format. Solaris Volume Manager may display the device ID output in a new or old format depending on when the device id information was added to the state database replica.

Previously, the device ID was displayed as a hexadecimal value. The new format displays the device ID as an ASCII string. In many cases, the change is negligible, as in the following example:

old format:     id1, ssd@w600c0ff0000000007ecd255a9336d00

new format:    id1, ssd@n600c0ff00000000007ecd255a9336d00

In other cases, the change is more noticeable, as in the following example:

old format:     id1, sd@w4849544143484920444b3332454a2d33364  
e4320202020203433334239383939

new format:    id1, ssd@n600c0ff00000000007ecd255a9336d00

When you upgrade to the Solaris 10 release, the format of the device IDs that are associated with existing disk sets that were created in a previous Solaris release are not updated in the Solaris Volume Manager configuration. If you need to revert back to a previous Solaris release, configuration changes made to disk sets after the upgrade might not be available to that release. These configuration changes include:

- Adding a new disk to a disk set that existed before the upgrade
- Creating a new disk set
- Creating state database replicas

These configuration changes can affect all disk sets that you are able to create in Solaris Volume Manager, including the local set. For example, if you implement any of these changes to a disk set created in the Solaris 10 release, you cannot import the disk set to a previous Solaris release. As

another example, you might upgrade one side of a mirrored root to the Solaris 10 release and then make configuration changes to the local set. These changes would not be recognized if you then incorporated the submirror back into the previous Solaris release.

The Solaris 10 OS configuration always displays the new format of the device ID, even in the case of an upgrade. You can display this information using the `prtconf -v` command. Conversely, Solaris Volume Manager displays either the old or the new format. Which format is displayed in Solaris Volume Manager depends on which version of the Solaris OS you were running when you began using the disk. To determine if Solaris Volume Manager is displaying a different, but equivalent, form of the device ID from that of the Solaris OS configuration, compare the output from the `metastat` command with the output from the `prtconf -v` command.

In the following example, the `metastat` command output displays a different, but equivalent, form of the device ID for `c1t6d0` from the `prtconf -v` command output for the same disk.

```
# metastat
```

```
d127: Concat/Stripe
  Size: 17629184 blocks (8.4 GB)
  Stripe 0:
    Device      Start Block  Dbase  Reloc
    c1t6d0s2    32768       Yes    Yes
```

```
Device Relocation Information:
```

```
Device  Reloc  Device ID  c1t6d0  Yes  id1,sd@w4849544143484920444b3332454a2d33364e4320202020203433334239383939
```

```
# prtconf -v
```

```
.(output truncated)
```

```
.
```

```
.
```

```
sd, instance #6
```

```
System properties:
```

```
name='lun' type=int items=1
value=00000000
name='target' type=int items=1
value=00000006
name='class' type=string items=1
value='scsi'
```

```
Driver properties:
```

```
name='pm-components' type=string items=3 dev=none
value='NAME=spindle-motor' + '0=off' + '1=on'
name='pm-hardware-state' type=string items=1 dev=none
value='needs-suspend-resume'
name='ddi-failfast-supported' type=boolean dev=none
name='ddi-kernel-ioctl' type=boolean dev=none
```

```
Hardware properties:
```

```
name='devid' type=string items=1
```



```
value='id1,@THITACHI_DK32EJ-36NC_____433B9899'
```

```
.
.
.
(output truncated)
```

The line containing “instance #6” in the output from the `prtconf -v` command correlates to the disk `c1t6d0` in the output from the `metastat` command. The device id, `id1,@THITACHI_DK32EJ-36NC_____433B9899`, in the output from the `prtconf -v` command correlates to the device id, `id1,sd@w4849544143484920444b3332454a2d33364e43202020203433334239383939`, in the output from the `metastat` command. This difference in output indicates that Solaris Volume Manager is displaying the hexadecimal form of the device ID in the output from the `metastat` command, while the Solaris 10 OS configuration is displaying an ASCII string in the output from the `prtconf` command.

## Recovering From Boot Problems

Because Solaris Volume Manager enables you to mirror the root (`/`), `swap`, and `/usr` directories, special problems can arise when you boot the system. These problems can arise either through hardware failures or operator error. The procedures in this section provide solutions to such potential problems.

The following table describes these problems and points you to the appropriate solution.

**TABLE 25-1** Common Boot Problems With Solaris Volume Manager

Reason for the Boot Problem	For Instructions
The <code>/etc/vfstab</code> file contains incorrect information.	<a href="#">“How to Recover From Improper <code>/etc/vfstab</code> Entries” on page 282</a>
Not enough state database replicas have been defined.	<a href="#">“How to Recover From Insufficient State Database Replicas” on page 288</a>
A boot device (disk) has failed.	<a href="#">“How to Recover From a Boot Device Failure” on page 284</a>

## Background Information for Boot Problems

- If Solaris Volume Manager takes a volume offline due to errors, unmount all file systems on the disk where the failure occurred.

Because each disk slice is independent, multiple file systems can be mounted on a single disk. If the software has encountered a failure, other slices on the same disk will likely experience failures soon. File systems that are mounted directly on disk slices do not have the protection of Solaris Volume Manager error handling. Leaving such file systems mounted can leave you vulnerable to crashing the system and losing data.

- Minimize the amount of time you run with submirrors that are disabled or offline. During resynchronization and online backup intervals, the full protection of mirroring is gone.

## How to Recover From Improper `/etc/vfstab` Entries

If you have made an incorrect entry in the `/etc/vfstab` file, for example, when mirroring the root (`/`) file system, the system appears at first to be booting properly. Then, the system fails. To remedy this situation, you need to edit the `/etc/vfstab` file while in single-user mode.

The high-level steps to recover from improper `/etc/vfstab` file entries are as follows:

1. Booting the system to single-user mode
2. Running the `fsck` command on the mirror volume
3. Remounting file system read-write options enabled
4. Optional: running the `metaroot` command for a root (`/`) mirror
5. Verifying that the `/etc/vfstab` file correctly references the volume for the file system entry
6. Rebooting the system

### ▼ Recovering the root (`/`) RAID-1 (Mirror) Volume

In the following example, the root (`/`) file system is mirrored with a two-way mirror, `d0`. The root (`/`) entry in the `/etc/vfstab` file has somehow reverted back to the original slice of the file system. However, the information in the `/etc/system` file still shows booting to be from the mirror `d0`. The most likely reason is that the `metaroot` command was not used to maintain the `/etc/system` and `/etc/vfstab` files. Another possible reason is that an old copy of the `/etc/vfstab` file was copied back into the current `/etc/vfstab` file.

The incorrect `/etc/vfstab` file looks similar to the following:

```
#device      device      mount      FS      fsck  mount  mount
#to mount    to fsck     point      type    pass  at boot options
#
/dev/dsk/c0t3d0s0 /dev/rdisk/c0t3d0s0 /          ufs     1      no     -
/dev/dsk/c0t3d0s1 -           -          swap    -      no     -
/dev/dsk/c0t3d0s6 /dev/rdisk/c0t3d0s6 /usr      ufs     2      no     -
#
/proc        -           /proc     proc    -      no     -
swap        -           /tmp      tmpfs   -      yes    -
```

Because of the errors, you automatically go into single-user mode when the system is booted:

```
ok boot
...
configuring network interfaces: hme0.
Hostname: host1
mount: /dev/dsk/c0t3d0s0 is not this fstype.
setmnt: Cannot open /etc/mnttab for writing

INIT: Cannot create /var/adm/utmp or /var/adm/utmpx

INIT: failed write of utmpx entry:" "

INIT: failed write of utmpx entry:" "

INIT: SINGLE USER MODE

Type Ctrl-d to proceed with normal startup,
(or give root password for system maintenance): <root-password>
```

At this point, the root (/) and /usr file systems are mounted read-only. Follow these steps:

### 1 Run the `fsck` command on the root (/) mirror.

---

**Note** – Be careful to use the correct volume for the root (/) mirror.

---

```
# fsck /dev/md/rdisk/d0
** /dev/md/rdisk/d0
** Currently Mounted on /
** Phase 1 - Check Blocks and Sizes
** Phase 2 - Check Pathnames
** Phase 3 - Check Connectivity
** Phase 4 - Check Reference Counts
** Phase 5 - Check Cyl groups
2274 files, 11815 used, 10302 free (158 frags, 1268 blocks,
0.7% fragmentation)
```

### 2 Remount the root (/) file system as read/write file system so that you can edit the `/etc/vfstab` file.

```
# mount -o rw,remount /dev/md/dsk/d0 /
mount: warning: cannot lock temp file </etc/.mnt.lock>
```

### 3 Run the `metaroot` command.

```
# metaroot d0
```

This command edits the `/etc/system` and `/etc/vfstab` files to specify that the root (/) file system is now on volume `d0`.

**4 Verify that the `/etc/vfstab` file contains the correct volume entries.**

The root (`/`) entry in the `/etc/vfstab` file should appear as follows so that the entry for the file system correctly references the RAID-1 volume:

```
#device          device          mount   FS      fsck   mount  mount
#to mount       to fsck        point   type    pass  at boot options
#
/dev/md/dsk/d0   /dev/md/rdisk/d0 /        ufs     1      no     -
/dev/dsk/c0t3d0s1 -                -        swap    -      no     -
/dev/dsk/c0t3d0s6 /dev/rdisk/c0t3d0s6 /usr     ufs     2      no     -
#
/proc           -                /proc    proc    -      no     -
swap           -                /tmp     tmpfs   -      yes    -
```

**5 Reboot the system.**

The system returns to normal operation.

**▼ How to Recover From a Boot Device Failure**

If you have a root (`/`) mirror and your boot device fails, you need to set up an alternate boot device.

The high-level steps in this task are as follows:

- Booting from the alternate root (`/`) submirror
- Determining the erred state database replicas and volumes
- Repairing the failed disk
- Restoring state database replicas and volumes to their original state

Initially, when the boot device fails, you'll see a message similar to the following. This message might differ among various architectures.

```
Rebooting with command:
Boot device: /iommu/sbus/dma@f,81000/esp@f,80000/sd@3,0
The selected SCSI device is not responding
Can't open boot device
...
```

When you see this message, note the device. Then, follow these steps:

**1 Boot from another root (`/`) submirror.**

Since only two of the six state database replicas in this example are in error, you can still boot. If this were not the case, you would need to delete the inaccessible state database replicas in single-user mode. This procedure is described in [“How to Recover From Insufficient State Database Replicas” on page 288](#).

When you created the mirror for the root (/) file system, you should have recorded the alternate boot device as part of that procedure. In this example, disk2 is that alternate boot device.

```
ok boot disk2
SunOS Release 5.9 Version s81_51 64-bit
Copyright 1983-2001 Sun Microsystems, Inc. All rights reserved.
Hostname: demo
...
demo console login: root
Password: <root-password>
Dec 16 12:22:09 host1 login: ROOT LOGIN /dev/console
Last login: Wed Dec 12 10:55:16 on console
Sun Microsystems Inc. SunOS 5.9 s81_51 May 2002
...
```

## 2 Determine how many state database replicas have failed by using the `metadb` command.

```
# metadb
      flags      first blk  block count
M      p      unknown   unknown   /dev/dsk/c0t3d0s3
M      p      unknown   unknown   /dev/dsk/c0t3d0s3
a m    p  luo      16      1034     /dev/dsk/c0t2d0s3
a      p  luo     1050     1034     /dev/dsk/c0t2d0s3
a      p  luo      16      1034     /dev/dsk/c0t1d0s3
a      p  luo     1050     1034     /dev/dsk/c0t1d0s3
```

In this example, the system can no longer detect state database replicas on slice `/dev/dsk/c0t3d0s3`, which is part of the failed disk.

## 3 Determine that half of the root (/), swap, and /usr mirrors have failed by using the `metastat` command.

```
# metastat
d0: Mirror
  Submirror 0: d10
    State: Needs maintenance
  Submirror 1: d20
    State: Okay
...

d10: Submirror of d0
  State: Needs maintenance
  Invoke: "metareplace d0 /dev/dsk/c0t3d0s0 <new device>"
  Size: 47628 blocks
  Stripe 0:
    Device          Start Block  Dbase State      Hot Spare
    /dev/dsk/c0t3d0s0      0      No   Maintenance
```

```
d20: Submirror of d0
  State: Okay
  Size: 47628 blocks
```

```
Stripe 0:
Device           Start Block  Dbase State      Hot Spare
/dev/dsk/c0t2d0s0      0      No   Okay

d1: Mirror
  Submirror 0: d11
    State: Needs maintenance
  Submirror 1: d21
    State: Okay
...

d11: Submirror of d1
  State: Needs maintenance
  Invoke: "metareplace d1 /dev/dsk/c0t3d0s1 <new device>"
  Size: 69660 blocks
  Stripe 0:
  Device           Start Block  Dbase State      Hot Spare
/dev/dsk/c0t3d0s1      0      No   Maintenance

d21: Submirror of d1
  State: Okay
  Size: 69660 blocks
  Stripe 0:
  Device           Start Block  Dbase State      Hot Spare
/dev/dsk/c0t2d0s1      0      No   Okay

d2: Mirror
  Submirror 0: d12
    State: Needs maintenance
  Submirror 1: d22
    State: Okay
...

d12: Submirror of d2
  State: Needs maintenance
  Invoke: "metareplace d2 /dev/dsk/c0t3d0s6 <new device>"
  Size: 286740 blocks
  Stripe 0:
  Device           Start Block  Dbase State      Hot Spare
/dev/dsk/c0t3d0s6      0      No   Maintenance

d22: Submirror of d2
  State: Okay
  Size: 286740 blocks
  Stripe 0:
  Device           Start Block  Dbase State      Hot Spare
/dev/dsk/c0t2d0s6      0      No   Okay
```

In this example, the `metastat` command shows that the following submirrors need maintenance:

- Submirror d10, device c0t3d0s0
- Submirror d11, device c0t3d0s1
- Submirror d12, device c0t3d0s6

**4 Halt the system, replace the disk. Use the `format` command or the `fmthard` command, to partition the disk as it was before the failure.**

---

**Tip** – If the new disk is identical to the existing disk (the intact side of the mirror, in this example), quickly format the new disk. To do so, use the `prtvtoc /dev/rdisk/c0t2d0s2 | fmthard -s - /dev/rdisk/c0t3d0s2` command (c0t3d0, in this example).

---

```
# halt
...
Halted
...
ok boot
...
# format /dev/rdisk/c0t3d0s0
```

**5 Reboot the system.**

Note that you must reboot from the other half of the root (/) mirror. You should have recorded the alternate boot device when you created the mirror.

```
# halt
...
ok boot disk2
```

**6 To delete the failed state database replicas and then add them back, use the `metadb` command.**

```
# metadb
      flags          first blk   block count
M      p            unknown    unknown    /dev/dsk/c0t3d0s3
M      p            unknown    unknown    /dev/dsk/c0t3d0s3
a m    p    luo     16          1034      /dev/dsk/c0t2d0s3
a      p    luo     1050       1034      /dev/dsk/c0t2d0s3
a      p    luo     16          1034      /dev/dsk/c0t1d0s3
a      p    luo     1050       1034      /dev/dsk/c0t1d0s3
# metadb -d c0t3d0s3
# metadb -c 2 -a c0t3d0s3
# metadb
      flags          first blk   block count
a m    p    luo     16          1034      /dev/dsk/c0t2d0s3
a      p    luo     1050       1034      /dev/dsk/c0t2d0s3
a      p    luo     16          1034      /dev/dsk/c0t1d0s3
a      p    luo     1050       1034      /dev/dsk/c0t1d0s3
a          u         16          1034      /dev/dsk/c0t3d0s3
a          u         1050       1034      /dev/dsk/c0t3d0s3
```

**7 Re-enable the submirrors by using the `metareplace` command.**

```
# metareplace -e d0 c0t3d0s0  
Device /dev/dsk/c0t3d0s0 is enabled
```

```
# metareplace -e d1 c0t3d0s1  
Device /dev/dsk/c0t3d0s1 is enabled
```

```
# metareplace -e d2 c0t3d0s6  
Device /dev/dsk/c0t3d0s6 is enabled
```

After some time, the resynchronization will complete. You can now return to booting from the original device.

## Recovering From State Database Replica Failures

If the state database replica quorum is not met, for example, due to a drive failure, the system cannot be rebooted into multiuser mode. This situation could follow a panic when Solaris Volume Manager discovers that fewer than half of the state database replicas are available. This situation could also occur if the system is rebooted with exactly half or fewer functional state database replicas. In Solaris Volume Manager terminology, the state database has gone “stale.” This procedure explains how to recover from this problem.

### ▼ How to Recover From Insufficient State Database Replicas

**1 Boot the system.****2 Determine which state database replicas are unavailable.**

```
# metadb -i
```

**3 If one or more disks are known to be unavailable, delete the state database replicas on those disks. Otherwise, delete enough erred state database replicas (W, M, D, F, or R status flags reported by `metadb`) to ensure that a majority of the existing state database replicas are not erred.**

```
# metadb -d disk-slice
```

---

**Tip** – State database replicas with a capitalized status flag are in error. State database replicas with a lowercase status flag are functioning normally.

---

**4 Verify that the replicas have been deleted.**

```
# metadb
```



**5 Reboot the system.**

```
# reboot
```

**6 If necessary, replace the disk, format it appropriately, then add any state database replicas that are needed to the disk.**

Follow the instructions in “Creating State Database Replicas” on page 68.

Once you have a replacement disk, halt the system, replace the failed disk, and once again, reboot the system. Use the `format` command or the `fmthard` command to partition the disk as it was configured before the failure.

**Example 25-1 Recovering From Stale State Database Replicas**

In the following example, a disk that contains seven replicas has gone bad. As a result, the system has only three good replicas. The system panics, then cannot reboot into multiuser mode.

```
panic[cpu0]/thread=70a41e00: md: state database problem

403238a8 md:mddb_commitrec_wrapper+6c (2, 1, 70a66ca0, 40323964, 70a66ca0, 3c)
  %l0-7: 0000000a 00000000 00000001 70bbcce0 70bbcd04 70995400 00000002 00000000
40323908 md:alloc_entry+c4 (70b00844, 1, 9, 0, 403239e4, ff00)
  %l0-7: 70b796a4 00000001 00000000 705064cc 70a66ca0 00000002 00000024 00000000
40323968 md:md_setdevname+2d4 (7003b988, 6, 0, 63, 70a71618, 10)
  %l0-7: 70a71620 00000000 705064cc 70b00844 00000010 00000000 00000000 00000000
403239f8 md:setnm_ioctl+134 (7003b968, 100003, 64, 0, 0, ffbffc00)
  %l0-7: 7003b988 00000000 70a71618 00000000 00000000 000225f0 00000000 00000000
40323a58 md:md_base_ioctl+9b4 (157ffff, 5605, ffbffa3c, 100003, 40323ba8, ff1b5470)
  %l0-7: ff3f2208 ff3f2138 ff3f26a0 00000000 00000000 00000064 ff1396e9 00000000
40323ad0 md:md_admin_ioctl+24 (157ffff, 5605, ffbffa3c, 100003, 40323ba8, 0)
  %l0-7: 00005605 ffbffa3c 00100003 0157ffff 0aa64245 00000000 7efefeff 81010100
40323b48 md:mdioctl+e4 (157ffff, 5605, ffbffa3c, 100003, 7016db60, 40323c7c)
  %l0-7: 0157ffff 00005605 ffbffa3c 00100003 0003ffff 70995598 70995570 0147c800
40323bb0 genunix:ioctl+1dc (3, 5605, ffbffa3c, ffffffff, ffffffff, ffbffa65)
  %l0-7: 0114c57c 70937428 ff3f26a0 00000000 00000001 ff3b10d4 0aa64245 00000000

panic:
stopped at      edd000d8:          ta          %icc,%g0 + 125
Type 'go' to resume

ok boot -s
Resetting ...

Sun Ultra 5/10 UPA/PCI (UltraSPARC-IIi 270MHz), No Keyboard
OpenBoot 3.11, 128 MB memory installed, Serial #9841776.
Ethernet address 8:0:20:96:2c:70, Host ID: 80962c70.
```

```
Rebooting with command: boot -s
Boot device: /pci@1f,0/pci@1,1/ide@3/disk@0,0:a File and args: -s
SunOS Release 5.9 Version s81_39 64-bit
```

```
Copyright 1983-2001 Sun Microsystems, Inc. All rights reserved.
configuring IPv4 interfaces: hme0.
Hostname: dodo
```

```
metainit: dodo: stale databases
```

```
Insufficient metadevice database replicas located.
```

```
Use metadb to delete databases which are broken.
Ignore any "Read-only file system" error messages.
Reboot the system when finished to reload the metadevice database.
After reboot, repair any broken database replicas which were deleted.
```

```
Type control-d to proceed with normal startup,
(or give root password for system maintenance): root-password
single-user privilege assigned to /dev/console.
Entering System Maintenance Mode
```

```
Jun 7 08:57:25 su: 'su root' succeeded for root on /dev/console
Sun Microsystems Inc. SunOS 5.9 s81_39 May 2002
```

```
# metadb -i
```

flags	first blk	block count	
a m p lu	16	8192	/dev/dsk/c0t0d0s7
a p l	8208	8192	/dev/dsk/c0t0d0s7
a p l	16400	8192	/dev/dsk/c0t0d0s7
M p	16	unknown	/dev/dsk/clt1d0s0
M p	8208	unknown	/dev/dsk/clt1d0s0
M p	16400	unknown	/dev/dsk/clt1d0s0
M p	24592	unknown	/dev/dsk/clt1d0s0
M p	32784	unknown	/dev/dsk/clt1d0s0
M p	40976	unknown	/dev/dsk/clt1d0s0
M p	49168	unknown	/dev/dsk/clt1d0s0

```
# metadb -d clt1d0s0
# metadb
```

flags	first blk	block count	
a m p lu	16	8192	/dev/dsk/c0t0d0s7
a p l	8208	8192	/dev/dsk/c0t0d0s7
a p l	16400	8192	/dev/dsk/c0t0d0s7

```
#
```

The system panicked because it could no longer detect state database replicas on slice /dev/dsk/clt1d0s0. This slice is part of the failed disk or is attached to a failed controller. The first metadb -i command identifies the replicas on this slice as having a problem with the master blocks.

When you delete the stale state database replicas, the root (/) file system is read-only. You can ignore the `mddb.cf` error messages that are displayed.

At this point, the system is again functional, although it probably has fewer state database replicas than it should. Any volumes that used part of the failed storage are also either failed, erred, or hot-spaced. Those issues should be addressed promptly.

## Recovering From Soft Partition Problems

This section shows how to recover configuration information for soft partitions. You should only use the following procedure if all of your state database replicas have been lost and you do not have one of the following:

- A current or accurate copy of `metastat -p` output
- A current or accurate copy of the `md.cf` file
- An up-to-date `md.tab` file

### ▼ How to Recover Configuration Data for a Soft Partition

At the beginning of each soft partition extent, a sector is used to mark the beginning of the soft partition extent. These hidden sectors are called *extent headers*. These headers do not appear to the user of the soft partition. If all Solaris Volume Manager configuration data is lost, the disk can be scanned in an attempt to generate the configuration data.

This procedure is a last option to recover lost soft partition configuration information. The `metarecover` command should only be used when you have lost both your `metadb` and `md.cf` files, and your `md.tab` file is lost or out of date.

---

**Note** – This procedure only works to recover soft partition information. This procedure does not assist in recovering from other lost configurations or for recovering configuration information for other Solaris Volume Manager volumes.

---



---

**Note** – If your configuration included other Solaris Volume Manager volumes that were built on top of soft partitions, you should recover the soft partitions before attempting to recover the other volumes.

---

Configuration information about your soft partitions is stored on your devices and in your state database. Since either source could be corrupt, you must indicate to the `metarecover` command which source is reliable.

First, use the `metarecover` command to determine whether the two sources agree. If they do agree, the `metarecover` command cannot be used to make any changes. However, if the `metarecover` command reports an inconsistency, you must examine its output carefully to determine whether the disk or the state database is corrupt. Then, you should use the `metarecover` command to rebuild the configuration based on the appropriate source.

- 1 Read the “[Configuration Guidelines for Soft Partitions](#)” on page 148.
- 2 Review the soft partition recovery information by using the `metarecover` command.

```
# metarecover component -p -d
```

*component* Specifies the *cntrndnsname* of the raw component

-p Specifies to regenerate soft partitions

-d Specifies to scan the physical slice for extent headers of soft partitions

### Example 25–2 Recovering Soft Partitions from On-Disk Extent Headers

```
# metarecover clt1d0s1 -p -d
```

The following soft partitions were found and will be added to your metadvice configuration.

Name	Size	No. of Extents
d10	10240	1
d11	10240	1
d12	10240	1

```
# metarecover clt1d0s1 -p -d
```

The following soft partitions were found and will be added to your metadvice configuration.

Name	Size	No. of Extents
d10	10240	1
d11	10240	1
d12	10240	1

WARNING: You are about to add one or more soft partition metadevices to your metadvice configuration. If there appears to be an error in the soft partition(s) displayed above, do NOT proceed with this recovery operation.

Are you sure you want to do this (yes/no)?**yes**

clt1d0s1: Soft Partitions recovered from device.

```
bash-2.05# metastat
```

d10: Soft Partition

```
Device: clt1d0s1
State: Okay
Size: 10240 blocks
```

Device	Start Block	Dbase Reloc
clt1d0s1	0	No Yes

Extent	Start Block	Block count
0	1	10240

d11: Soft Partition

```
Device: clt1d0s1
State: Okay
Size: 10240 blocks
```

```

Device          Start Block  Dbase Reloc
c1t1d0s1              0      No    Yes

Extent          Start Block          Block count
      0              10242              10240

d12: Soft Partition
Device: c1t1d0s1
State: Okay
Size: 10240 blocks
Device          Start Block  Dbase Reloc
c1t1d0s1              0      No    Yes

Extent          Start Block          Block count
      0              20483              10240

```

In this example, three soft partitions are recovered from disk, after the state database replicas were accidentally deleted.

## Recovering Storage From a Different System

You can recover a Solaris Volume Manager configuration, even onto a different system from the original system.

### ▼ How to Recover Storage From a Local Disk Set

If you experience a system failure, you can attach the storage to a different system and recover the complete configuration from the local disk set. For example, assume you have a system with an external disk pack of six disks in it and a Solaris Volume Manager configuration, including at least one state database replica, on some of those disks. If you have a system failure, you can physically move the disk pack to a new system and enable the new system to recognize the configuration. This procedure describes how to move the disks to another system and recover the configuration from a local disk set.

---

**Note** – This recovery procedure works only with Solaris 9, and later, Solaris Volume Manager volumes.

---

- 1 **Attach the disk or disks that contain the Solaris Volume Manager configuration to a system with no preexisting Solaris Volume Manager configuration.**
- 2 **Do a reconfiguration reboot to ensure that the system recognizes the newly added disks.**

```
# reboot -- -r
```

### 3 Determine the major/minor number for a slice containing a state database replica on the newly added disks.

Use `ls -lL`, and note the two numbers between the group name and the date. These numbers are the major/minor numbers for this slice.

```
# ls -lL /dev/dsk/c1t9d0s7
brw-r----- 1 root    sys      32, 71 Dec  5 10:05 /dev/dsk/c1t9d0s7
```

### 4 If necessary, determine the major name corresponding with the major number by looking up the major number in `/etc/name_to_major`.

```
# grep " 32" /etc/name_to_major sd 32
```

### 5 Update the `/kernel/drv/md.conf` file with the information that instructs Solaris Volume Manager where to find a valid state database replica on the new disks.

For example, in the line that begins with `mddb_bootlist1`, replace the `sd` with the major name you found in step 4. Replace `71` in the example with the minor number you identified in [Step 3](#).

```
#pragma ident "@(#)md.conf 2.2 04/04/02 SMI"
#
# Copyright 2004 Sun Microsystems, Inc. All rights reserved.
# Use is subject to license terms.
#
# The parameters nmd and md_nsets are obsolete. The values for these
# parameters no longer have any meaning.
name="md" parent="pseudo" nmd=128 md_nsets=4;

# Begin MDD database info (do not edit)
mddb_bootlist1="sd:71:16:id0";
# End MDD database info (do not edit)
```

### 6 Reboot to force Solaris Volume Manager to reload your configuration.

You will see messages similar to the following displayed on the console.

```
volume management starting.
Dec  5 10:11:53 host1 metadevadm: Disk movement detected
Dec  5 10:11:53 host1 metadevadm: Updating device names in
Solaris Volume Manager
The system is ready.
```

### 7 Verify your configuration. Use the `metadb` command to verify the status of the state database replicas, and `metastat` command view the status for each volume.

```
# metadb
      flags      first blk      block count
a m p  lu0      16            8192        /dev/dsk/c1t9d0s7
a      lu0      16            8192        /dev/dsk/c1t10d0s7
a      lu0      16            8192        /dev/dsk/c1t11d0s7
a      lu0      16            8192        /dev/dsk/c1t12d0s7
```

```

a      luo      16      8192      /dev/dsk/c1t13d0s7
# metastat
d12: RAID
    State: Okay
    Interlace: 32 blocks
    Size: 125685 blocks
Original device:
    Size: 128576 blocks
    Device          Start Block  Dbase State      Reloc  Hot Spare
    c1t11d0s3        330         No   Okay         Yes
    c1t12d0s3        330         No   Okay         Yes
    c1t13d0s3        330         No   Okay         Yes

d20: Soft Partition
    Device: d10
    State: Okay
    Size: 8192 blocks
    Extent          Start Block      Block count
    0                3592             8192

d21: Soft Partition
    Device: d10
    State: Okay
    Size: 8192 blocks
    Extent          Start Block      Block count
    0                11785            8192

d22: Soft Partition
    Device: d10
    State: Okay
    Size: 8192 blocks
    Extent          Start Block      Block count
    0                19978            8192

d10: Mirror
    Submirror 0: d0
    State: Okay
    Submirror 1: d1
    State: Okay
    Pass: 1
    Read option: roundrobin (default)
    Write option: parallel (default)
    Size: 82593 blocks

d0: Submirror of d10
    State: Okay
    Size: 118503 blocks

```

```

Stripe 0: (interlace: 32 blocks)
  Device          Start Block  Dbase State      Reloc Hot Spare
  c1t9d0s0        0           No   Okay           Yes
  c1t10d0s0       3591        No   Okay           Yes
    
```

d1: Submirror of d10

State: Okay

Size: 82593 blocks

Stripe 0: (interlace: 32 blocks)

```

  Device          Start Block  Dbase State      Reloc Hot Spare
  c1t9d0s1        0           No   Okay           Yes
  c1t10d0s1       0           No   Okay           Yes
    
```

Device Relocation Information:

```

Device      Reloc   Device ID
c1t9d0      Yes    id1,sd@SSEAGATE_ST39103LCSUN9.0GLS3487980000U00907AZ
c1t10d0     Yes    id1,sd@SSEAGATE_ST39103LCSUN9.0GLS3397070000W0090A8Q
c1t11d0     Yes    id1,sd@SSEAGATE_ST39103LCSUN9.0GLS3449660000U00904NZ
c1t12d0     Yes    id1,sd@SSEAGATE_ST39103LCSUN9.0GLS32655400007010H04J
c1t13d0     Yes    id1,sd@SSEAGATE_ST39103LCSUN9.0GLS3461190000701001T0
    
```

#

# metadb

```

      flags          first blk      block count
a m p luo          16           8192      /dev/dsk/c1t9d0s7
a      luo          16           8192      /dev/dsk/c1t10d0s7
a      luo          16           8192      /dev/dsk/c1t11d0s7
a      luo          16           8192      /dev/dsk/c1t12d0s7
a      luo          16           8192      /dev/dsk/c1t13d0s7
    
```

# metastat

d12: RAID

State: Okay

Interlace: 32 blocks

Size: 125685 blocks

Original device:

Size: 128576 blocks

```

  Device          Start Block  Dbase State      Reloc Hot Spare
  c1t11d0s3       330         No   Okay           Yes
  c1t12d0s3       330         No   Okay           Yes
  c1t13d0s3       330         No   Okay           Yes
    
```

d20: Soft Partition

Device: d10

State: Okay

Size: 8192 blocks

```

  Extent          Start Block      Block count
    
```



```

                0                3592                8192

d21: Soft Partition
  Device: d10
  State: Okay
  Size: 8192 blocks
    Extent          Start Block          Block count
      0                11785                8192

d22: Soft Partition
  Device: d10
  State: Okay
  Size: 8192 blocks
    Extent          Start Block          Block count
      0                19978                8192

d10: Mirror
  Submirror 0: d0
    State: Okay
  Submirror 1: d1
    State: Okay
  Pass: 1
  Read option: roundrobin (default)
  Write option: parallel (default)
  Size: 82593 blocks

d0: Submirror of d10
  State: Okay
  Size: 118503 blocks
  Stripe 0: (interlace: 32 blocks)
    Device          Start Block  Dbase State          Reloc  Hot Spare
    c1t9d0s0                0          No   Okay          Yes
    c1t10d0s0            3591          No   Okay          Yes

d1: Submirror of d10
  State: Okay
  Size: 82593 blocks
  Stripe 0: (interlace: 32 blocks)
    Device          Start Block  Dbase State          Reloc  Hot Spare
    c1t9d0s1                0          No   Okay          Yes
    c1t10d0s1            0          No   Okay          Yes

Device Relocation Information:
Device      Reloc  Device ID
c1t9d0      Yes    id1,sd@SSEAGATE_ST39103LCSUN9.0GLS3487980000U00907AZ1

```

```

c1t10d0      Yes      id1,sd@SSEAGATE_ST39103LCSUN9.0GLS3397070000W0090A8Q
c1t11d0      Yes      id1,sd@SSEAGATE_ST39103LCSUN9.0GLS3449660000U00904NZ
c1t12d0      Yes      id1,sd@SSEAGATE_ST39103LCSUN9.0GLS32655400007010H04J
c1t13d0      Yes      id1,sd@SSEAGATE_ST39103LCSUN9.0GLS3461190000701001T0
# metastat -p
d12 -r c1t11d0s3 c1t12d0s3 c1t13d0s3 -k -i 32b
d20 -p d10 -o 3592 -b 8192
d21 -p d10 -o 11785 -b 8192
d22 -p d10 -o 19978 -b 8192
d10 -m d0 d1 1
d0 1 2 c1t9d0s0 c1t10d0s0 -i 32b
d1 1 2 c1t9d0s1 c1t10d0s1 -i 32b
#

```

## Recovering Storage From a Known Disk Set

The introduction of device ID support for disk sets in Solaris Volume Manager allows you to recover storage from known disk sets and to import the disk set to a different system. The `metainport` command allows you to import known disk sets from one system to another system. Both systems must contain existing Solaris Volume Manager configurations that include device ID support. For more information on device ID support, see [“Asynchronous Shared Storage in Disk Sets”](#) on page 195. For more information on the `metainport` command, see the `metainport(1M)` man page.

### ▼ How to Print a Report on Disk Sets Available for Import

- 1 Become superuser.
- 2 Obtain a report on disk sets available for import.

```
# metainport -r -v
```

- r Provides a report of the unconfigured disk sets available for import on the system.
- v Provides detailed information about the state database replica location and status on the disks of unconfigured disk sets available for import on the system.

#### Example 25–3 Reporting on Disk Sets Available for Import

The following examples show how to print a report on disk sets available for import.

```

# metainport -r
Drives in regular diskset including disk c1t2d0:
  c1t2d0
  c1t3d0
More info:
  metainport -r -v c1t2d0

```

```

Import:  metaimport -s <newsetname> c1t2d0
Drives in replicated diskset including disk c1t4d0:
    c1t4d0
    c1t5d0
More info:
    metaimport -r -v c1t4d0
Import:  metaimport -s <newsetname> c1t4d0

```

```

# metaimport -r -v c1t2d0
Import: metaimport -s <newsetname> c1t2d0
Last update: Mon Dec 29 14:13:35 2003
Device      offset      length replica flags
c1t2d0      16          8192    a      u
c1t3d0      16          8192    a      u
c1t8d0      16          8192    a      u

```

## ▼ How to Import a Disk Set From One System to Another System

1 Become superuser.

2 Verify that a disk set is available for import.

```
# metaimport -r -v
```

3 Import an available disk set.

```
# metaimport -s diskset-name drive-name
```

-s *diskset-name* Specifies the name of the disk set being created.

*drive-name* Identifies a disk (c#t#d#) containing a state database replica from the disk set being imported.

4 Verify that the disk set has been imported.

```
# metaset -s diskset-name
```

### Example 25–4 Importing a Disk Set

The following example shows how to import a disk set.

```

# metaimport -s red c1t2d0
Drives in diskset including disk c1t2d0:
    c1t2d0
    c1t3d0
    c1t8d0
# metaset -s red

```

```
Set name = red, Set number = 1
```

```
Host          Owner
  host1       Yes
```

```
Drive  Dbase
```

```
c1t2d0  Yes
```

```
c1t3d0  Yes
```

```
c1t8d0  Yes
```

## Recovering From Disk Set Problems

The following sections detail how to recover from specific disk set related problems.

### What to Do When You Cannot Take Ownership of A Disk Set

In cases in which you cannot take ownership of a disk set from any node (perhaps as a result of a system failure, disk failure, or communication link failure), and therefore cannot delete the disk set record, it is possible to purge the disk set from the Solaris Volume Manager state database replica records on the current host.

Purging the disk set records does not affect the state database information contained in the disk set, so the disk set could later be imported (with the `metainport` command, described at [“Importing Disk Sets” on page 210](#)).

If you need to purge a disk set from a Sun Cluster configuration, use the following procedure, but use the `-C` option instead of the `-P` option you use when no Sun Cluster configuration is present.

#### ▼ How to Purge a Disk Set

##### 1 Attempt to take the disk set with the `metaset` command.

```
# metaset -s setname -t -f
```

This command will attempt to take (`-t`) the disk set named *setname* forcibly (`-f`). If the set can be taken, this command will succeed. If the set is owned by another host when this command runs, the other host will panic to avoid data corruption or loss. If this command succeeds, you can delete the disk set cleanly, without the need to purge the set.

If it is not possible to take the set, you may purge ownership records.

**2 Use the `metaset` command with the `-P` to purge the disk set from the current host.**

```
# metaset -s setname -P
```

This command will purge (`-P`) the disk set named `setname` from the host on which the command is run.

**3 Use the `metaset` command to verify that the set has been purged.**

```
# metaset
```

### Example 25–5 Purging a Disk Set

```
host1# metaset -s red -t -f
metaset: host1: setname "red": no such set
```

```
host2# metaset
```

```
Set name = red, Set number = 1
```

```
Host          Owner
  host2
```

```
Drive  Dbase
```

```
c1t2d0  Yes
```

```
c1t3d0  Yes
```

```
c1t8d0  Yes
```

```
host2# metaset -s red -P
```

```
host2# metaset
```

- See Also**
- [Chapter 18](#), for conceptual information about disk sets.
  - [Chapter 19](#), for information about tasks associated with disk sets.

## Performing Mounted Filesystem Backups Using the `ufsdump` Command

The following procedure describes how to increase the performance of the `ufsdump` command when you use it to backup a mounted filesystem located on a RAID-1 volume.

## ▼ How to Perform a Backup of a Mounted Filesystem Located on a RAID-1 Volume

You can use the `ufsdump` command to backup the files of a mounted filesystem residing on a RAID-1 volume. Set the read policy on the volume to "first" when the backup utility is `ufsdump`. This improves the rate at which the backup is performed.

### 1 Become superuser.

### 2 Run the `metastat` command to make sure the mirror is in the "Okay" state.

```
# metastat d40
d40: Mirror
    Submirror 0: d41
        State: Okay
    Submirror 1: d42
        State: Okay
    Pass: 1
    Read option: roundrobin (default)
    Write option: parallel (default)
    Size: 20484288 blocks (9.8 GB)
```

A mirror that is in the "Maintenance" state should be repaired first.

### 3 Set the read policy on the mirror to "first."

```
# metaparam -r first d40
# metastat d40
d40: Mirror
    Submirror 0: d41
        State: Okay
    Submirror 1: d42
        State: Okay
    Pass: 1
    Read option: first
    Write option: parallel (default)
    Size: 20484288 blocks (9.8 GB)
```

### 4 Perform a backup the filesystem.

```
# ufsdump 0f /dev/backup /opt/test
```

### 5 After the `ufsdump` command is done, set the read policy on the mirror to "roundrobin."

```
# metaparam -r roundrobin d40
# metastat d40
d40: Mirror
    Submirror 0: d41
        State: Okay
```

```
Submirror 1: d42
  State: Okay
  Pass: 1
  Read option: roundrobin
  Write option: parallel (default)
  Size: 20484288 blocks (9.8 GB)
```

## Performing System Recovery

Sometimes it is useful to boot from a Solaris OS install image on DVD or CD media to perform a system recovery. Resetting the root password is one example of when using the install image is useful.

If you are using a Solaris Volume Manager configuration, then you want to mount the Solaris Volume Manager volumes instead of the underlying disks. This step is especially important if the root (/) file system is mirrored. Because Solaris Volume Manager is part of the Solaris OS, mounting the Solaris Volume Manager volumes ensures that any changes are reflected on both sides of the mirror.

Use the following procedure to make the Solaris Volume Manager volumes accessible from a Solaris OS DVD or CD-ROM install image.

### ▼ How to Recover a System Using a Solaris Volume Manager Configuration

Boot your system from the Solaris OS installation DVD or CD media. Perform this procedure from the root prompt of the Solaris miniroot.

- 1 Mount as read only the underlying disk containing the Solaris Volume Manager configuration.**  

```
# mount -o ro /dev/dsk/c0t0d0s0 /a
```
- 2 Copy the md.conf file into /kernel/drv directory.**  

```
# cp /a/kernel/drv/md.conf /kernel/drv/md.conf
```
- 3 Unmount the file system from the miniroot.**  

```
# umount /a
```
- 4 Update the Solaris Volume Manager driver to load the configuration. Ignore any warning messages printed by the update\_drv command.**  

```
# update_drv -f md
```

**5 Configure the system volumes.**

```
# metainit -r
```

**6 If you have RAID-1 volumes in the Solaris Volume Manager configuration, resynchronize them.**

```
# metasync mirror-name
```

**7 Solaris Volume Manager volumes should be accessible using the `mount` command.**

```
# mount /dev/md/dsk/volume-name /a
```

**Example 25-6 Recovering a System Using a Solaris Volume Manager Configuration**

```
# mount -o ro /dev/dsk/c0t0d0s0 /a
# cp /a/kernel/drv/md.conf /kernel/drv/md.conf
# umount /a
# update_drv -f md
Cannot unload module: md
Will be unloaded upon reboot.
Forcing update of md.conf.
devfsadm: mkdir failed for /dev 0xled: Read-only file system
devfsadm: inst_sync failed for /etc/path_to_inst.1359: Read-only file system
devfsadm: WARNING: failed to update /etc/path_to_inst
# metainit -r
# metasync d0
# mount /dev/md/dsk/d0 /a
```



## Important Solaris Volume Manager Files

---

This appendix contains information about Solaris Volume Manager files for reference purposes. This appendix contains the following:

- “System Files and Startup Files” on page 305
- “Manually Configured Files” on page 306

### System Files and Startup Files

This section explains the files that are necessary for Solaris Volume Manager to operate correctly. With the exception of a few specialized configuration changes, you do not need to access or modify these files.

- `/etc/lvm/mddb.cf`



---

**Caution** – Do not edit this file. If you change this file, you could corrupt your Solaris Volume Manager configuration.

---

The `/etc/lvm/mddb.cf` file records the locations of state database replicas. When state database replica locations change, Solaris Volume Manager makes an entry in the `mddb.cf` file that records the locations of all state databases. See the `mddb.cf(4)` man page for more information.

- `/etc/lvm/md.cf`

The `/etc/lvm/md.cf` file contains automatically generated configuration information for the default (unspecified or local) disk set. When you change the Solaris Volume Manager configuration, Solaris Volume Manager automatically updates the `md.cf` file (except for information about hot spares in use). See the `md.cf(4)` man page for more information.



---

**Caution** – Do not edit this file. If you change this file, you could corrupt or be unable to recover your Solaris Volume Manager configuration.

---

If your system loses the information that is maintained in the state database, and as long as no volumes were changed or created in the meantime, you can use the `md.cf` file to recover your configuration. See [“How to Initialize Solaris Volume Manager From a Configuration File” on page 223](#).

- `/kernel/drv/md.conf`

The `md.conf` configuration file is read by Solaris Volume Manager at startup. The `md.conf` file contains the state database replica configuration information. As of Solaris 10, the `nmd` and `md_nsets` parameters are no longer edited manually. Solaris Volume Manager has been enhanced to configure volumes dynamically, as needed.

- `/etc/rcS.d/S35svm.init`

This file configures and starts Solaris Volume Manager at boot and allows administrators to start and stop the daemons.

- `/etc/rc2.d/S95svm.sync`

This file checks the Solaris Volume Manager configuration at boot, starts resynchronization of mirrors if necessary, and starts the active monitoring daemon. (For more information, see `mdmonitord(1M)`.)

## Manually Configured Files

### Overview of the `md.tab` File

The `/etc/lvm/md.tab` file contains Solaris Volume Manager configuration information that can be used to reconstruct your Solaris Volume Manager configuration. Solaris Volume Manager can use this file as input to the command-line utilities `metainit`, `metadb`, and `metahs` to reconstruct a configuration. Volumes, disk sets, and hot spare pools might have entries in this file. See [“How to Create Configuration Files” on page 223](#) for instructions on creating this file (by using the `metastat -p > /etc/lvm/md.tab` command).

---

**Note** – The configuration information in the `/etc/lvm/md.tab` file might differ from the current volumes, hot spares, and state database replicas in use. This file is used manually, by the system administrator, to capture the intended configuration. After you change your Solaris Volume Manager configuration, recreate this file and preserve a backup copy.

---

Once you have created and updated the file, the `metainit`, `metahs`, and `metadb` commands then activate the volumes, hot spare pools, and state database replicas defined in the file.

In the `/etc/lvm/md.tab` file, one complete configuration entry for a single volume appears on each line using the syntax of the `metainit`, `metadb`, and `metahs` commands.

---

**Note** – If you use the `metainit -an` command to simulate initializing all of the volumes in the `md.tab` file, you might see error messages for volumes that have dependencies on other volumes defined in `md.tab`. These error messages occur because Solaris Volume Manager does not maintain state of the volumes that would have been created when running `metainit -an`. Each line is evaluated based on the existing configuration, if a configuration exists. Therefore, even if it appears that the `metainit -an` command would fail, it might succeed without the `-n` option.

---

You then run the `metainit` command with either the `-a` option, to activate all volumes in the `/etc/lvm/md.tab` file, or with the volume name that corresponds to a specific entry in the file.

---

**Note** – Solaris Volume Manager does not write to or store configuration information in the `/etc/lvm/md.tab` file. You must manually edit the file and run the `metainit`, `metahs`, or `metadb` commands to create Solaris Volume Manager components.

---

For more information, see the `md.tab(4)` man page.



# Solaris Volume Manager Quick Reference

---

This appendix provides quick access information about the features and functions available with Solaris Volume Manager.

## Command-Line Reference

Listed here are all the commands that you use to administer Solaris Volume Manager. For more detailed information, see the man pages.

**TABLE B-1** Solaris Volume Manager Commands

Solaris Volume Manager Command	Description	Man page
growfs	Expands a UFS file system in a nondestructive fashion.	growfs(1M)
metaclear	Deletes active volumes and hot spare pools.	metaclear(1M)
metadb	Creates and deletes state database replicas.	metadb(1M)
metadetach	Detaches a volume from a RAID-0 or RAID-1 (mirror) volume, or a log device from a transactional volume.  <b>Note</b> – Transactional volumes are no longer supported.	metadetach(1M)
metadevadm	Checks device ID configuration.	metadevadm(1M)
metahs	Manages hot spares and hot spare pools.	metahs(1M)
metaimport	Import disk sets, including replicated disk sets, into existing Solaris Volume Manager configurations that have device ID support in the disk set.	metaimport(1M)
metainit	Configures volumes.	metainit(1M)
metaoffline	Places submirrors offline.	metaoffline(1M)

**TABLE B-1 Solaris Volume Manager Commands** (Continued)

<b>Solaris Volume Manager Command</b>	<b>Description</b>	<b>Man page</b>
metaonline	Places submirrors online.	metaonline(1M)
metaparam	Modifies volume parameters.	metaparam(1M)
metarecover	Recovers configuration information for soft partitions.	metarecover(1M)
metarename	Renames and exchanges volume names.	metarename(1M)
metareplace	Replaces components in submirrors and RAID-5 volumes.	metareplace(1M)
metaroot	Sets up system files for mirroring the root (/) file system.	metaroot(1M)
metaset	Administers disk sets.	metaset(1M)
metastat	Displays the status of volumes or hot spare pools.	metastat(1M)
metasync	Resynchronizes volumes during reboot.	metasync(1M)
metattach	Attaches a component to a RAID-0 or RAID-1 volume.	metattach(1M)

# Solaris Volume Manager CIM/WBEM API

---

## Managing Solaris Volume Manager

The Solaris Volume Manager CIM/WBEM Application Programming Interface (API) provides a public, standards-based programmatic interface to observe and configure Solaris Volume Manager. This API is based on the Distributed Management Task Force (DMTF) Common Information Model (CIM). For more information about DMTF, see <http://www.dmtf.org>.

CIM defines the data model, referred to as the “schema” which describes the following:

- Attributes of and the operations against Solaris Volume Manager devices
- Relationships among the various Solaris Volume Manager devices
- Relationships among the Solaris Volume Manager devices and other aspects of the operating system, such as file systems

This model is made available through the Solaris Web Based Enterprise Management (WBEM) SDK. The WBEM SDK is a set of Java™ technology-based API's that allow access to system management capabilities that are represented by CIM.

For more information about the CIM/WBEM SDK, see the *Solaris WBEM Developer's Guide*.





# Index

---

## A

- adding a host to a disk set, 201-202
- adding disks to a disk set, 200
- adding hot spares, 178
- administering disk sets, 188-194
- application based recovery, 54-56
- automatic disk partitioning, 191-193
- autotake disk set, 186

## B

- boot problems, 281-288
- booting into single-user mode, 102

## C

- changing default values, 225
- checking status of a disk set, 204
- component, definition of, 73
- concatenated stripe
  - See* RAID-0 (concatenated stripe volume definition)
  - See also* RAID-0 (concatenated stripe) volume
- removing, 90
- concatenation
  - creating, 86
  - definition
    - See also* RAID-0 (concatenation) volume
  - example with three slices, 77
  - expanding, 89
  - expanding UFS file system, 76
  - removing, 90

## concatenation (*Continued*)

- usage, 76
- concatenation volume, *See* RAID-0 (concatenation) volume
- configuration, viewing, 216-220
- configuration file, creating, 223-225
- configuration planning
  - guidelines, 29
  - overview, 29
  - trade-offs, 30
- creating a disk set, 198-199
- creating components in a disk set, 202-203
- creating configuration files, 223-225
- cron command, 262

## D

- deleting a disk set, 208-210
- deleting a host from a disk set, 208-210
- deleting disks from a disk set, 204-205
- device ID, formats of, 279-281
- directed mirror reads, 54-56
- disk set, 186
  - adding disks to, 200
  - adding host to, 201-202
  - administering, 188-194
  - asynchronous shared storage, 195
  - automatic disk partitioning, 191-193
  - autotake, 186
  - checking status, 204
  - creating, 198-199
  - creating components, 202-203
  - definition, 37, 43

**disk set (Continued)**

- deleting a disk set, 208-210
- deleting a host from a disk set, 208-210
- deleting disks, 204-205
- example with two shared disk sets, 193
- guidelines, 194-195
- importing, 190-191
- local, 186
- multi-owner, 186
  - See multi-owner disk set
- named, 186
- naming conventions, 193
- releasing, 190, 207-208
- reserving, 189-190, 207
- scenario, 195
- shared, 186
- taking, 205-207
- usage, 186

**disk sets**

- importing, 210-214
- maximum number supported, 225

DiskSuite Tool, *See* graphical interface

**E**

- enabling a slice in a RAID-5 volume, 168
- enabling a slice in a submirror, 126
- Enhanced Storage, *See* graphical interface
- error checking, 258-259
- errors, checking for using a script, 262-271
- /etc/lvm/md.cf file, 305
- /etc/lvm/mddb.cf file, 305
- /etc/rc2.d/S95lvm.sync file, 306
- /etc/rcS.d/S35lvm.init file, 306
- /etc/vfstab file, 140
  - recovering from improper entries, 282
- exchanging volume names, 221

**F**

- failover configuration, 43
- file system
  - expanding, 225-227
  - expanding by creating a concatenation, 88

**file system (Continued)**

- expansion overview, 39
- guidelines, 43
  - unmirroring, 142
- first read policy, 100
- fmthard command, 287, 289
- format command, 287, 289

**G**

- general performance guidelines, 30
- geometric read policy, 100
- graphical interface, overview, 34
- growfs command, 225-227, 309
- growfs command, 39, 227
- GUI, sample, 35

**H****hot spare**

- adding to a hot spare pool, 178
  - conceptual overview, 172
  - definition, 172
  - enabling, 184
  - how hot spares work with Solaris Volume Manager, 172
  - replacing in a hot spare pool, 183
- hot spare pool, 42
  - adding slices to, 177-178
  - associating, 179
  - associating with a volume, 178-181
  - basic operation, 42
  - changing association, 180
  - changing association of, 179-181
  - checking status, 181-184
  - conceptual overview, 171-174
  - creating, 176-177
  - definition, 37, 42, 172
  - deleting hot spare, 183-184
  - example with mirror, 173
  - maintaining, 181-184
  - replacing hot spare, 182-183
  - states, 173

**I**

I/O, 31  
 importing a disk set, 190-191  
 install program, system recovery, 303-304  
 interfaces, *See* Solaris Volume Manager interfaces  
 interlace, specifying, 85  
 interlace value, 74

**K**

/kernel/drv/md.conf file, 306

**L**

local disk set, 186  
 lockfs command, 144

**M**

majority consensus algorithm, 61  
 master node, 51-53  
 md.cf file, 306  
     recovering a Solaris Volume Manager  
     configuration, 223  
 md.tab file, 224  
     overview, 306-307  
 mdmonitord command, 258-259  
 metaclear command, 309  
 metaclear command, 90, 137, 138, 140-142  
 metadb command, 309  
 metadb command, 71  
 metadb command, replacing a failed disk and, 276  
 metadetach command, 309  
 metadetach command, 124, 137, 138  
 metadevadm command, 309  
     replacing a failed disk and, 276  
 metadvice, *See* volume  
 metahs command, 309  
     adding slices to a hot spare pool, 177-178  
     deleting hot spare, 183-184  
     enabling, 184  
     replacing a failed disk and, 276  
     replacing hot spare, 182-183

metainport command, 190-191, 210-214, 298-300, 309  
 metainit command, 309  
 metainit command, 224  
 metainit command, creating hot spare pool, 176-177  
 metaoffline command, 309  
 metaoffline command, 125  
 metaonline command, 310  
 metaparam command, 310  
 metaparam command, 129  
 metaparam command  
     associating hot spare pool with volume, 178-181  
     changing association of hot spare pool, 179-181  
 metarecover command, 310  
     replacing a failed disk and, 276  
 metarename command, 221, 310  
 metarename command, 222  
 metareplace command, 310  
 metareplace command, 126, 168, 288  
 metareplace command, replacing a failed disk and, 276  
 metaroot command, 310  
 metaset command, 310  
     adding a host to a disk set, 201-202  
     adding disks to a disk set, 200  
     checking status of a disk set, 204  
     creating a disk set, 198-199  
     deleting a disk set, 208-210  
     deleting a host from a disk set, 208-210  
     deleting disks from a disk set, 204-205  
     releasing a disk set, 207-208  
     taking a disk set, 205-207  
 metastat command, 310  
 metastat command, 128, 165  
 metasync command, 310  
 metattach  
     task, 111, 115, 121  
 metattach command, 310  
 metattach command, 89, 123, 130  
     attach RAID-5 component, 167  
     attach submirror, 225  
 mirror  
     *See* RAID-1 Volume  
     *See also* RAID-1 volume  
     and online backup, 143  
     attaching a submirror, 123  
     changing options, 129  
     creating, 107-122

- mirror (*Continued*)
    - definition, 38
    - example with two submirrors, 94-95
    - expanding, 130
    - replacing and enabling components, 161
    - resynchronization, 96,97
      - canceling, 130-132
      - resuming, 133-135
    - sample status output, 127
    - two-way mirror, 245, 248-250, 250-251, 253-254, 254, 255
    - updating the size of, 129-130
  - mirroring
    - file system, 109-113
    - file system that can be unmounted, 111
    - read and write performance, 30
    - root (/), /usr, and swap, 112
    - root file system
      - SPARC, 113-117
      - x86, 117-122
  - multi-owner disk set, 186
    - defined, 49-50
    - device id support, 49-50
    - importing, 49-50
    - master node, 51-53
  - multi-owner disk sets
    - RAID-1 volumes, 54-56
    - tasks, 52-53
- N**
- named disk set, 186
- O**
- Oracle Real Application Clusters, 49-50
- P**
- parallel access, definition of, 74
  - parallel write policy, 100
  - pass number
    - and read-only mirror, 96
  - pass number (*Continued*)
    - defined, 100
  - prtconf command, viewing device IDs, 279-281
- R**
- RAID, levels supported in Solaris Volume Manager, 28
  - RAID-0 (stripe) Volume, example with three slices, 74
  - RAID-0+1, 95
  - RAID-0 volume
    - definition, 73
    - usage, 73
  - RAID-1+0, 95
  - RAID-1 Volume, 93-95
    - booting into single-user mode, 102
  - RAID-1 volume
    - creating, 107-122
    - information for replacing and enabling components, 230-231
    - maintenance vs. last erred, 229-230
  - RAID-1 Volume
    - mirror, 93-95
    - options, 99-100
    - pass number, 100
    - RAID-0+1, 95
    - RAID-1+0, 95
    - read-and-write policies, 100
  - RAID-1 volume
    - replacing and enabling components, 228-231
  - RAID-1 Volume
    - submirror, 93-95
  - RAID-5 volume
    - and interlace, 158
    - checking status of, 165-166
    - creating, 164-165
    - definition, 28, 38
    - enabling a component, 167-168
    - enabling a failed slice, 168
    - example with an expanded device, 157
    - example with four disks, 156
    - expanding, 166-167, 167
    - guidelines, 158
    - information for replacing and enabling components, 230
    - maintenance vs. last erred, 229-230

- RAID-5 volume (*Continued*)
    - overview, 155-158
    - parity calculations, 158
    - parity information, 155, 157
    - replacing a component, 168-170
    - replacing a failed slice, 170
    - replacing and enabling components, 161, 228-231
    - requirements for, 158-159
    - resynchronizing slices, 155
    - slice states, 159-161
    - states, 159-161
    - tasks, 163-164
  - RAID-0 (concatenated stripe) volume
    - example with three stripes, 78
    - interlace value for, 77
  - RAID-0 (concatenation) volume, information for
    - creating, 80
  - RAID-0 (stripe) volume, 74
    - information for creating, 80
  - RAID-0 volume
    - guidelines, 80
    - types of, 73
  - random I/O, 31-32
  - releasing a disk set, 190, 207-208
  - renaming volumes, 220
  - repartitioning a disk, 191-193
  - replica, 42
  - reserving a disk set, 189-190
  - resynchronization
    - canceling, 130-132
    - full, 96
    - optimized, 96
    - partial, 97
    - resuming, 133-135
  - round-robin read policy, 100
- S**
- SCSI disk
    - replacing, 276, 278
  - sequential I/O, 32
  - serial write policy, 100
  - Service Management Facility (SMF), *See* SMF
  - shared disk set, 186
  - simple volume, definition, 38
  - slices, expanding, 88
  - small servers, overview of deploying, 233-234
  - SMF
    - Solaris Volume Manager services, 46-47
    - upgrading Solaris Volume Manager and, 46-47
  - soft partition
    - creating, 150-151
    - deleting, 153
    - recovering configuration for, 291
    - removing, 153
  - soft partitions, 147-148
    - checking status of, 151-153
    - definition, 147
    - expanding, 152-153
    - guidelines, 148
    - locations, 147
    - maintaining, 151-153
    - tasks, 149
  - Solaris Volume Manager
    - See* Solaris Volume Manager
    - configuration guidelines, 43
    - networked storage devices and, 235
    - Oracle Real Applications Clusters and, 49-50
    - recovering the configuration, 223
    - Sun Cluster and, 49-50
  - Solaris Volume Manager elements, overview, 37
  - Solaris Volume Manager for Sun Cluster
    - application based recovery, 54-56
    - configuration, 53-54
    - data management and recovery, 54-56
    - directed mirror reads, 54-56
    - optimized resynchronization, 54-56
    - software components, 50
    - timeouts, 53-54
  - Solaris Volume Manager interfaces
    - command line, 35
    - sample GUI, 35
    - Solaris Management Console, 35
  - state database
    - conceptual overview, 42, 62
    - corrupt, 61
    - definition, 37, 42
  - state database replica
    - criteria for disk set, 191-193
    - size of, 191-193
  - state database replicas, 42

- state database replicas (*Continued*)
  - adding larger replicas, 71
  - basic operation, 61
  - creating multiple on a single slice, 63-64
  - definition, 42
  - errors, 65
  - location, 42, 63-64
  - minimum number, 63-64
  - two-disk configuration, 64-65
  - usage, 61
- status, 204
- stripe
  - creating, 85
  - definition
    - See also* RAID-0 (stripe) volume
  - expanding, 89
  - removing, 90
- stripe volume, *See* RAID-0 (stripe) volume
- striping, definition, 74
- submirror, 93-94
  - See* RAID-1 Volume
  - attaching, 94
  - detaching, 94
  - enabling a failed slice, 126
  - operation while offline, 94
  - replacing a failed slice, 136
  - replacing entire, 138
- Sun Cluster, 49-50
- svc-mdmonitor script, 258-259
- swap, unmirroring, 142
- system files, 305-306
- system recovery from install program, 303-304

## T

- taking a disk set, 205-207
- topdown volume creation
  - defaults, 254-255
  - RAID 1 volume, creating, 243-246
  - shell script, 246-254
  - volume configuration file, 252
- troubleshooting
  - boot problems, 281-288
  - device ID discrepancies, 279-281
  - general guidelines, 275

- troubleshooting (*Continued*)
  - importing a disk set, 298-300
  - improper /etc/vfstab file entries, 282
  - metaimport command, 298-300
  - recovering from disk movement problems, 278
  - replacing a failed disk, 276

## V

- /var/adm/messages file, 228
  - replacing a failed disk, 276
- viewing Solaris Volume Manager configuration, 216-220
- volume
  - conceptual overview, 37
  - definition, 37
  - exchanging name, 221
  - expanding disk space, 39-40
  - renaming, 222
  - types, 38
  - uses, 38
  - using file system commands on, 38
  - virtual disk, 34
- volume name switching, 41
- volumes, maximum number supported, 225