

ORACLE®

PEOPLESOFT

PeopleSoft EPM 9.1: Activity-Based Management

June 2013

ORACLE®

PeopleSoft EPM 9.1: Activity-Based Management
CDSKU epm91pbr3
Copyright © 1999, 2013, Oracle and/or its affiliates. All rights reserved.

Trademark Notice

Oracle and Java are registered trademarks of Oracle and/or its affiliates. Other names may be trademarks of their respective owners.

Intel and Intel Xeon are trademarks or registered trademarks of Intel Corporation. All SPARC trademarks are used under license and are trademarks or registered trademarks of SPARC International, Inc. AMD, Opteron, the AMD logo, and the AMD Opteron logo are trademarks or registered trademarks of Advanced Micro Devices. UNIX is a registered trademark of The Open Group.

License Restrictions Warranty/Consequential Damages Disclaimer

This software and related documentation are provided under a license agreement containing restrictions on use and disclosure and are protected by intellectual property laws. Except as expressly permitted in your license agreement or allowed by law, you may not use, copy, reproduce, translate, broadcast, modify, license, transmit, distribute, exhibit, perform, publish, or display any part, in any form, or by any means. Reverse engineering, disassembly, or decompilation of this software, unless required by law for interoperability, is prohibited.

Warranty Disclaimer

The information contained herein is subject to change without notice and is not warranted to be error-free. If you find any errors, please report them to us in writing.

Restricted Rights Notice

If this is software or related documentation that is delivered to the U.S. Government or anyone licensing it on behalf of the U.S. Government, the following notice is applicable:

U.S. GOVERNMENT END USERS: Oracle programs, including any operating system, integrated software, any programs installed on the hardware, and/or documentation, delivered to U.S. Government end users are "commercial computer software" pursuant to the applicable Federal Acquisition Regulation and agency-specific supplemental regulations. As such, use, duplication, disclosure, modification, and adaptation of the programs, including any operating system, integrated software, any programs installed on the hardware, and/or documentation, shall be subject to license terms and license restrictions applicable to the programs. No other rights are granted to the U.S. Government.

Hazardous Applications Notice

This software or hardware is developed for general use in a variety of information management applications. It is not developed or intended for use in any inherently dangerous applications, including applications that may create a risk of personal injury. If you use this software or hardware in dangerous applications, then you shall be responsible to take all appropriate fail-safe, backup, redundancy, and other measures to ensure its safe use. Oracle Corporation and its affiliates disclaim any liability for any damages caused by use of this software or hardware in dangerous applications.

Third Party Content, Products, and Services Disclaimer

This software or hardware and documentation may provide access to or information on content, products, and services from third parties. Oracle Corporation and its affiliates are not responsible for and expressly disclaim all warranties of any kind with respect to third-party content, products, and services. Oracle Corporation and its affiliates will not be responsible for any loss, costs, or damages incurred due to your access to or use of third-party content, products, or services.

Alpha and Beta Draft Documentation Notice

If this document is in preproduction status:

This documentation is in preproduction status and is intended for demonstration and preliminary use only. It may not be specific to the hardware on which you are using the software. Oracle Corporation and its affiliates are not responsible for and expressly disclaim all warranties of any kind with respect to this documentation and will not be responsible for any loss, costs, or damages incurred due to the use of this documentation.

Contents

Preface	xiii
Understanding the PeopleSoft Online Help and PeopleBooks.....	xiii
PeopleSoft Hosted Documentation.....	xiii
Locally Installed Help.....	xiii
Downloadable PeopleBook PDF Files.....	xiii
Common Help Documentation.....	xiii
Field and Control Definitions.....	xiv
Typographical Conventions.....	xiv
ISO Country and Currency Codes.....	xv
Region and Industry Identifiers.....	xv
Access to Oracle Support.....	xvi
Documentation Accessibility.....	xvi
Using and Managing the PeopleSoft Online Help.....	xvi
PeopleSoft EPM Related Links.....	xvi
Contact Us.....	xvii
Follow Us.....	xvii
Chapter 1: Getting Started with PeopleSoft Activity-Based Management	19
PeopleSoft Activity-Based Management Overview.....	19
PeopleSoft Activity-Based Management Business Processes.....	20
PeopleSoft Activity-Based Management Integrations.....	22
PeopleSoft Activity-Based Management Implementation.....	22
Tools for Building Models.....	22
Chapter 2: Navigating in Activity Based Management	25
Navigating in Activity Based Management.....	25
Pages Used to Navigate in Activity Based Management.....	25
Pages Used to Navigate in Planning and Simulation Center.....	26
Pages Used to Navigate in Real Time Processing Center.....	26
Common Elements Used in Activity-Based Management.....	27
Deferred Processing.....	28
Chapter 3: Understanding Activity-Based Management Models, Modeling Components, and Rate Types	29
Activity-Based Management Modeling Components.....	29
Using Activity-Based Management Models.....	30
Using Rates with Your Activity-Based Management Model.....	30
Actual Rates.....	31
Budgeted Rates.....	31
Capacity Rates.....	32
Frozen Rates.....	35
Combination Rates.....	37
Creating Interunit Models for Shared Services.....	37
Understanding Reciprocal Allocation and Looping.....	38
Understanding Reciprocal Allocation Methods.....	38
Modeling for Manufacturing Purposes.....	41
Modeling for Service-Related Industries.....	41
Modeling with ABPS.....	41
Chapter 4: Using Trees with Activity-Based Management	43
Understanding Trees in Activity-Based Management.....	43

Related Documentation.....	43
Trees and Reporting.....	44
Trees and Activity-Based Management Processing.....	44
Chapter 5: Setting Up Activity-Based Management Models and Scenarios.....	47
Understanding Models.....	47
Model Configuration Steps.....	47
Understanding Object-Oriented Modeling and Scenarios.....	48
Prerequisites.....	48
Setting Up Activity-Based Management Models.....	48
Pages Used to Define Model Properties.....	49
Models Page.....	49
Specifying Roll Up Tree Names.....	51
Run Control Information Page.....	52
Reciprocal Looping Parameters Page.....	53
Copying Activity-Based Management Models.....	54
Page Used to Copy Models.....	55
Model Copy Page.....	55
Chapter 6: Setting Up Attributes, Cost of Capital, Resources, and Ledger Mapping Rules.....	57
Understanding Model Components.....	57
Primary and Secondary Resources.....	57
Attributes for Resources, Activities, and Cost Objects.....	58
Cost of Capital.....	58
Ledger-to-Resource Mapping.....	59
Ledger Mapper Generator.....	59
Setting Up Attributes.....	59
Page Used to Set Up Attributes.....	59
Attributes Page.....	60
Setting Up Cost of Capital.....	60
Page Used to Set Up Cost of Capital.....	60
Cost of Capital Page.....	60
Setting Up Ledger Source.....	61
Pages Used to Set Up Ledger Source.....	61
Understanding Ledger Source Setup.....	61
Ledger Source Page.....	61
Setting Up Resources.....	63
Pages Used to Set Up Resources.....	63
Understanding Resource Setup.....	63
Prerequisites.....	64
Resources Page.....	64
Mapping Ledgers to Resources.....	66
Pages Used to Map Ledgers to Resources.....	67
Prerequisites.....	67
Ledger Map Rule Page.....	68
Ledger to Resource Mapping Page.....	69
Chapter 7: Setting Up Activities.....	71
Understanding Activities.....	71
Understanding Common Activities.....	71
Understanding Dimensionality.....	72
Understanding Consumption Patterns.....	72
Understanding Sustaining Activities.....	73
Defining Activities.....	73

Pages Used to Define Activities.....	73
Common Activities Page.....	74
Activities Page.....	74
Reviewing Your Activity Setup.....	76
Pages Used to Review Your Activity Setup.....	77
Copying Common Activities.....	77
Page Used to Copy Activities.....	77
Common Activity Copy Page.....	77
Chapter 8: Setting Up Cost Objects.....	79
Understanding Cost Objects.....	79
Understanding Cost Object Use.....	79
Understanding Cost Object Groups.....	79
Defining Cost Objects.....	81
Pages Used to Set Up Cost Objects.....	81
Cost Objects Page.....	81
Reviewing Cost Objects.....	83
Pages Used to Review Cost Objects.....	83
Updating Your Model Definition.....	83
Chapter 9: Setting Up Pointers.....	85
Understanding Pointers.....	85
Types of Pointers.....	86
Common Elements Used in Setting Up Pointers.....	86
Prerequisites.....	87
Setting Up Pointers.....	87
Pages Used to Set Up Pointers.....	87
Pointers Page.....	88
Implicit Pointers Page.....	88
Transaction Pointer Page.....	89
Compiling Pointer Metadata.....	90
Creating Drivers.....	90
Using Volume Definitions.....	91
Pages Used to Define Volumes.....	91
Activity Volume Page.....	91
Cost Object Volume Page.....	91
Chapter 10: Setting Up Drivers.....	93
Understanding Drivers.....	93
Interunit Drivers.....	93
Driver Tables.....	93
Driver Attributes.....	94
Driver Class.....	94
Driver Categories.....	94
Driver Methods.....	95
Assigning Driver Sources and Targets.....	96
Driver Target Definition Types.....	97
Prerequisites.....	97
Setting Up Drivers.....	98
Pages Used to Set Up Drivers.....	98
Driver Attribute Page.....	98
Driver Page.....	99
Driver - Rates Page.....	101
Driver - Source Page.....	102

Driver - Target Page.....	102
Setting Up Interunit Drivers.....	103
Pages Used to Set Up Interunit Drivers.....	104
IBU Driver Page.....	104
IBU Driver - Source Page.....	105
IBU Driver - Target Page.....	105
Copying and Deleting Drivers and Interunit Drivers.....	106
Pages Used to Copy and Delete Drivers and Interunit Drivers.....	106
Driver Copy Page.....	107
Driver Copy - Model to Model Page.....	107
Driver Delete Page.....	107
Specifying Model Driver Quantity Options for Combination Models.....	107
Page Used to Specify Model Driver Quantity Options for Combination Models.....	108
Model Driver Qty Option Page.....	108
Using Alternate Methods to Set Up Drivers.....	108
Pages Used to Set Up Drivers Using Alternate Methods.....	109
Driver Quantities 1 Page.....	109
Processing Data Using the Routing Information Engine (AB_RTG).....	109
Reviewing Driver Setup.....	110
Pages Used to Review Driver Setup.....	110
Chapter 11: Generating and Maintaining Models.....	113
Understanding Model Generator and Ledger Mapper Generator.....	113
Prerequisites.....	113
Loading Source Data.....	114
Setting Up Model Generator.....	115
Page Used to Set Up Model Generator.....	115
Model Generation Definition Page.....	115
Setting Up Ledger Mapper Generator.....	117
Page Used to Set Up Ledger Mapper Generator.....	117
Ledger Mapping Creation Page.....	117
Assigning Generation IDs to Your Activity-Based Management Model.....	119
Running Model Generator and Ledger Mapper Generator.....	119
Pages Used to Run Model Generator and Ledger Mapper Generator.....	119
Understanding Delivered Engines.....	119
Run Jobstream Page.....	120
Inquiring about Engine Messages.....	121
Reviewing Model Objects and Ledger Mapping Rules.....	121
Chapter 12: Processing in Real-Time Activity-Based Management.....	123
Understanding Real-Time Activity-Based Management.....	123
Processing in Real-Time Activity-Based Management.....	123
Pages Used in Real-Time Activity-Based Management.....	124
Understanding Real-Time Activity-Based Management.....	125
Real Time ABM Page.....	125
Load Rule Data Page.....	132
Real-Time ABM Graphical Model Page.....	134
ABM Real-Time Interface Table Page.....	136
Real Time ABM Interface Page.....	139
Chapter 13: Processing Batch Models.....	141
Understanding Batch Processing.....	141
Jobstreams and Engines.....	141
Activity-Based Management Tables.....	144

Verifying Model Setup Using Model Navigator.....	146
Pages Used to Verify Your Model Setup.....	146
Understanding How to Verify Model Setup Using Model Navigator.....	146
Model Navigator Page.....	147
Model Navigator - Resources Page.....	147
Model Navigator - Activities Page.....	148
Model Navigator - Cost Objects Page.....	149
Validating Models.....	149
Populating the Activity-Based Management Object Table.....	150
Processing Data Using the Activity-Based Management Engine.....	150
Creating Multidimensional Models Using Data Manager.....	150
Understanding Multidimensional Models Using Data Manager.....	151
Analyzing Profitability Using Profit Manager.....	153
Chapter 14: Reconciling Your Model and Analyzing Engine Output.....	155
Understanding Model Reconciliation.....	155
Prerequisites.....	155
Viewing Charts and Printing Results.....	156
Balancing Your Model.....	156
Using the Reconciliation Engine and Job Total Metadata.....	156
Common Model Balance Errors.....	156
Inquiring on Balances.....	157
Pages Used to Inquire on Balances.....	157
Object Rates Page.....	158
Resources Page.....	158
Activities Page.....	159
Cost Objects Page.....	159
Object Details Page.....	160
Using Object Navigator and Model Analyzer.....	160
Pages Used to Drill into Objects and Models.....	161
Object Navigator Page.....	161
Model Analyzer Page.....	163
Contribution Cost Page.....	163
Using Activity-Based Management Trend and Variance Analysis.....	164
Pages Used to View Trend and Variance Data.....	165
Using the Trend Analysis and Variance Analysis Components.....	166
Trend Analysis Selection Criteria Page.....	166
Trend Analysis Page.....	167
Variance Analysis Selection Criteria Page.....	168
Variance Analysis Page.....	169
Creating and Reviewing OLAP Cubes.....	170
Page Used to Create and View OLAP Cubes.....	171
Running the Create Activity-Based Management Cube Process.....	171
Inquiring on Engine Messages.....	171
OLAP Cube Page.....	171
Using the Activity-Based Management Drillback Engine.....	172
Page Used to Specify Drillback Levels.....	172
Drillback Levels Page.....	172
Running the Activity-Based Management Drillback Engine.....	173
Using PF Ledger Drilldown.....	173
Page Used to Drill Back.....	173
Drilling Back with PF Ledger Drilldown.....	174

Other Activity-Based Management Inquiry Pages.....	174
Pages Used to Review Pointers and Drivers.....	174
Pointer Quantities Page.....	175
Driver Quantities Page.....	175
Driver Rates Page.....	175
Chapter 15: Using Employee Profile.....	177
Understanding the Employee Profile Feature.....	177
Employee Profiles.....	177
Employee Profile and the Operational Warehouse.....	180
Activity Fragmentation.....	180
Setting Up Employee Profiles.....	181
Pages Used to Set Up Employee Profiles.....	181
Understanding Work Groups and Work Profiles.....	182
Understanding the Employee Profile Component.....	182
Prerequisites.....	182
Work Group Page.....	182
Work/Department Profile Page.....	183
Employee Profile Page.....	184
Employee Profile - Work Distribution Page.....	185
Running the Employee Profile Engine.....	186
Inquiring About Engine Messages.....	186
Inquiring About Engine Output.....	186
Completing Employee Profile Processing.....	186
Reviewing Employee Profile Information.....	187
Pages Used to Review Employee Profile Information.....	187
Chapter 16: Using Reciprocal Allocation Looping.....	189
Understanding Reciprocal Allocation Looping.....	189
Setting Up Reciprocal Allocation Looping.....	190
Setting Up Reciprocal Resources and Cost Objects.....	190
Specifying Reciprocal Looping Parameters on the Model Definition.....	190
Processing Your Model and Reviewing Output.....	191
Chapter 17: Using Activity-Based Planning and Simulation (ABPS).....	193
Understanding ABPS.....	193
Planning Activity Types and ABPS Models.....	193
Spending Patterns.....	195
Planning Techniques.....	196
Creating an ABPS Model.....	196
Specifying Planning Information for the Model.....	197
Setting Up Planning and Simulation Criteria.....	197
Pages Used to Set Up Planning and Simulation Criteria.....	197
Budget Constraint Page.....	198
Resource Spending Pattern Page.....	199
Job Code Profile Page.....	200
Running the ABPS Engine.....	201
Inquiring on Engine Messages.....	201
Reviewing and Adjusting ABPS Output.....	201
Pages Used to Review and Adjust ABPS Output.....	202
Employee Details Page.....	203
Employee Details - Hours Assigned Page.....	204
Employee Details - Budget Constraint Page.....	204
Ledger to Resource Data Page.....	205

Ledger to Resource Data - Spending Pattern Page.....	205
Ledger Resource Planning - Budget Constraint Page.....	206
Inquiring on ABPS.....	206
Pages Used to Inquire on ABPS.....	206
Viewing ABPS Employee and Ledger Resource Data.....	207
Job Code to Hire Page.....	207
ABPS Object Volume Data Page.....	207
APBS Ledger to Budget Page.....	207
Chapter 18: Modeling for Service-Related Industries.....	209
Understanding Bill of Services.....	209
Prerequisites.....	209
Using Bill of Services.....	209
Pages Used to Establish Bill of Services.....	210
Bill of Services Page.....	210
Bill of Services - Service Page.....	210
Running the Activity-Based Management Engine.....	211
Adjusting Rates for Activities.....	211
Appendix A: Activity-Based Management Validation Engine Messages.....	213
Activity-Based Management Validation Engine Messages by Message Number.....	213
Appendix B: Manually Entering Values for Testing Purposes.....	217
Manually Entering Values.....	217
Page Used to Enter Testing Values.....	217
Define Interface Values Page.....	217
Appendix C: Manufacturing Integration.....	219
Understanding Manufacturing Integration.....	219
Setting Up Models for Manufacturing.....	219
Running the Routing Information Engine.....	219
Inquiring on Engine Messages.....	220

Preface

Understanding the PeopleSoft Online Help and PeopleBooks

The PeopleSoft Online Help is a website that enables you to view all help content for PeopleSoft Applications and PeopleTools. The help provides standard navigation and full-text searching, as well as context-sensitive online help for PeopleSoft users.

PeopleSoft Hosted Documentation

You access the PeopleSoft Online Help on Oracle's PeopleSoft Hosted Documentation website, which enables you to access the full help website and context-sensitive help directly from an Oracle hosted server. The hosted documentation is updated on a regular schedule, ensuring that you have access to the most current documentation. This reduces the need to view separate documentation posts for application maintenance on My Oracle Support, because that documentation is now incorporated into the hosted website content. The Hosted Documentation website is available in English only.

Locally Installed Help

If your organization has firewall restrictions that prevent you from using the Hosted Documentation website, you can install the PeopleSoft Online Help locally. If you install the help locally, you have more control over which documents users can access and you can include links to your organization's custom documentation on help pages.

In addition, if you locally install the PeopleSoft Online Help, you can use any search engine for full-text searching. Your installation documentation includes instructions about how to set up Oracle Secure Enterprise Search for full-text searching.

See *PeopleTools 8.53 Installation* for your database platform, "Installing PeopleSoft Online Help." If you do not use Secure Enterprise Search, see the documentation for your chosen search engine.

Note: Before users can access the search engine on a locally installed help website, you must enable the Search portlet and link. Click the Help link on any page in the PeopleSoft Online Help for instructions.

Downloadable PeopleBook PDF Files

You can access downloadable PDF versions of the help content in the traditional PeopleBook format. The content in the PeopleBook PDFs is the same as the content in the PeopleSoft Online Help, but it has a different structure and it does not include the interactive navigation features that are available in the online help.

Common Help Documentation

Common help documentation contains information that applies to multiple applications. The two main types of common help are:

- Application Fundamentals

- Using PeopleSoft Applications

Most product lines provide a set of application fundamentals help topics that discuss essential information about the setup and design of your system. This information applies to many or all applications in the PeopleSoft product line. Whether you are implementing a single application, some combination of applications within the product line, or the entire product line, you should be familiar with the contents of the appropriate application fundamentals help. They provide the starting points for fundamental implementation tasks.

In addition, the *PeopleTools: PeopleSoft Applications User's Guide* introduces you to the various elements of the PeopleSoft Pure Internet Architecture. It also explains how to use the navigational hierarchy, components, and pages to perform basic functions as you navigate through the system. While your application or implementation may differ, the topics in this user's guide provide general information about using PeopleSoft Applications.

Field and Control Definitions

PeopleSoft documentation includes definitions for most fields and controls that appear on application pages. These definitions describe how to use a field or control, where populated values come from, the effects of selecting certain values, and so on. If a field or control is not defined, then it either requires no additional explanation or is documented in a common elements section earlier in the documentation. For example, the Date field rarely requires additional explanation and may not be defined in the documentation for some pages.

Typographical Conventions

The following table describes the typographical conventions that are used in the online help.

<i>Typographical Convention</i>	<i>Description</i>
Bold	Highlights PeopleCode function names, business function names, event names, system function names, method names, language constructs, and PeopleCode reserved words that must be included literally in the function call.
<i>Italics</i>	Highlights field values, emphasis, and PeopleSoft or other book-length publication titles. In PeopleCode syntax, italic items are placeholders for arguments that your program must supply. Italics also highlight references to words or letters, as in the following example: Enter the letter <i>O</i> .
Key+Key	Indicates a key combination action. For example, a plus sign (+) between keys means that you must hold down the first key while you press the second key. For Alt+W, hold down the Alt key while you press the W key.
Monospace font	Highlights a PeopleCode program or other code example.
... (ellipses)	Indicate that the preceding item or series can be repeated any number of times in PeopleCode syntax.

Typographical Convention	Description
{ } (curly braces)	Indicate a choice between two options in PeopleCode syntax. Options are separated by a pipe ().
[] (square brackets)	Indicate optional items in PeopleCode syntax.
& (ampersand)	When placed before a parameter in PeopleCode syntax, an ampersand indicates that the parameter is an already instantiated object. Ampersands also precede all PeopleCode variables.
=>	This continuation character has been inserted at the end of a line of code that has been wrapped at the page margin. The code should be viewed or entered as a single, continuous line of code without the continuation character.

ISO Country and Currency Codes

PeopleSoft Online Help topics use International Organization for Standardization (ISO) country and currency codes to identify country-specific information and monetary amounts.

ISO country codes may appear as country identifiers, and ISO currency codes may appear as currency identifiers in your PeopleSoft documentation. Reference to an ISO country code in your documentation does not imply that your application includes every ISO country code. The following example is a country-specific heading: "(FRA) Hiring an Employee."

The PeopleSoft Currency Code table (CURRENCY_CD_TBL) contains sample currency code data. The Currency Code table is based on ISO Standard 4217, "Codes for the representation of currencies," and also relies on ISO country codes in the Country table (COUNTRY_TBL). The navigation to the pages where you maintain currency code and country information depends on which PeopleSoft applications you are using. To access the pages for maintaining the Currency Code and Country tables, consult the online help for your applications for more information.

Region and Industry Identifiers

Information that applies only to a specific region or industry is preceded by a standard identifier in parentheses. This identifier typically appears at the beginning of a section heading, but it may also appear at the beginning of a note or other text.

Example of a region-specific heading: "(Latin America) Setting Up Depreciation"

Region Identifiers

Regions are identified by the region name. The following region identifiers may appear in the PeopleSoft Online Help:

- Asia Pacific
- Europe
- Latin America

- North America

Industry Identifiers

Industries are identified by the industry name or by an abbreviation for that industry. The following industry identifiers may appear in the PeopleSoft Online Help:

- USF (U.S. Federal)
- E&G (Education and Government)

Access to Oracle Support

Oracle customers have access to electronic support through My Oracle Support. For information, visit <http://www.oracle.com/pls/topic/lookup?ctx=acc&id=info> or visit <http://www.oracle.com/pls/topic/lookup?ctx=acc&id=trs> if you are hearing impaired.

Documentation Accessibility

For information about Oracle's commitment to accessibility, visit the Oracle Accessibility Program website at <http://www.oracle.com/pls/topic/lookup?ctx=acc&id=docacc>.

Using and Managing the PeopleSoft Online Help

Click the Help link in the universal navigation header of any page in the PeopleSoft Online Help to see information on the following topics:

- What's new in the PeopleSoft Online Help.
- PeopleSoft Online Help accessibility.
- Accessing, navigating, and searching the PeopleSoft Online Help.
- Managing a locally installed PeopleSoft Online Help website.

PeopleSoft EPM Related Links

[My Oracle Support](#)

[PeopleSoft Information Portal on Oracle.com](#)

[PeopleSoft Training from Oracle University](#)

[PeopleSoft Video Feature Overviews on YouTube](#)

Contact Us

Send us your suggestions Please include release numbers for the PeopleTools and applications that you are using.

Follow Us



Get the latest PeopleSoft updates on [Facebook](#).



Follow PeopleSoft on [Twitter@PeopleSoft_Info](#).

Getting Started with PeopleSoft Activity-Based Management

PeopleSoft Activity-Based Management Overview

Building Activity-Based Management models is an investment that you make to better understand costs and profitability. Strategic analysis, incisive cost and profitability analysis, and reliable decision support are the foundation of critical business decisions that keep you ahead of the competition. Accurate, well-managed costing information can affect pricing of goods and services, budget outlays, profitability analysis, and other business processes.

Activity-Based Management enables managers to analyze the real costs of business processes for better cost and profitability management. Without it, managers are forced into a guessing game to determine where they make money and how much things really cost.

Activity-Based Management was developed in tandem with leading academics and goes beyond traditional accounting methods to deliver tools to support strategic and operational decision making. It provides the business intelligence that you need to answer pressing business questions about your organization's activities, such as:

- What are the costs of serving my customers?
- Which customers, products, or channels are the most profitable?
- Where are the best opportunities to reduce costs?
- In what products or services should we divest or invest?

Activity-Based Management does not arbitrarily allocate costs. It traces overhead based on the cause and effect of business activities. An Activity-Based Management model maintains the relationship of activities to costs. This model is a complete set of rules used to define individual activity-based costing model objects and their relationship to your organization's financial management systems. Activity-Based Management enables you to define models, process them, and then analyze the results to assess your organization's profitability.

The system assigns ledger amounts (from your general ledger, for example) to resources. Resources are the economic elements used in the performance of activities. They can be people, facilities, or any other expenses such as supplies or travel.

Ledger mappers provide a process by which you relate expense data from a ledger to resource objects. Activities consume resources and drive costs to cost objects. Activities are the lowest-level definition of what you do as an organization; they serve as the foundation for measuring activity costs.

Cost objects represent cost information grouped by profitability dimensions such as products, customers, and channels. They are the final result of the activities performed by your organization.

Drivers are the means of assigning monetary amounts from one object to another throughout the model. Resource drivers link expenses as captured in the ledger to the activities performed. Activity drivers distribute the activity costs to cost objects.

Activity-Based Management is part of the Performance Management business process.

PeopleSoft Activity-Based Management Business Processes

Image: Activity-Based Management business process

The following process flow illustrates the Activity-Based Management business processes.

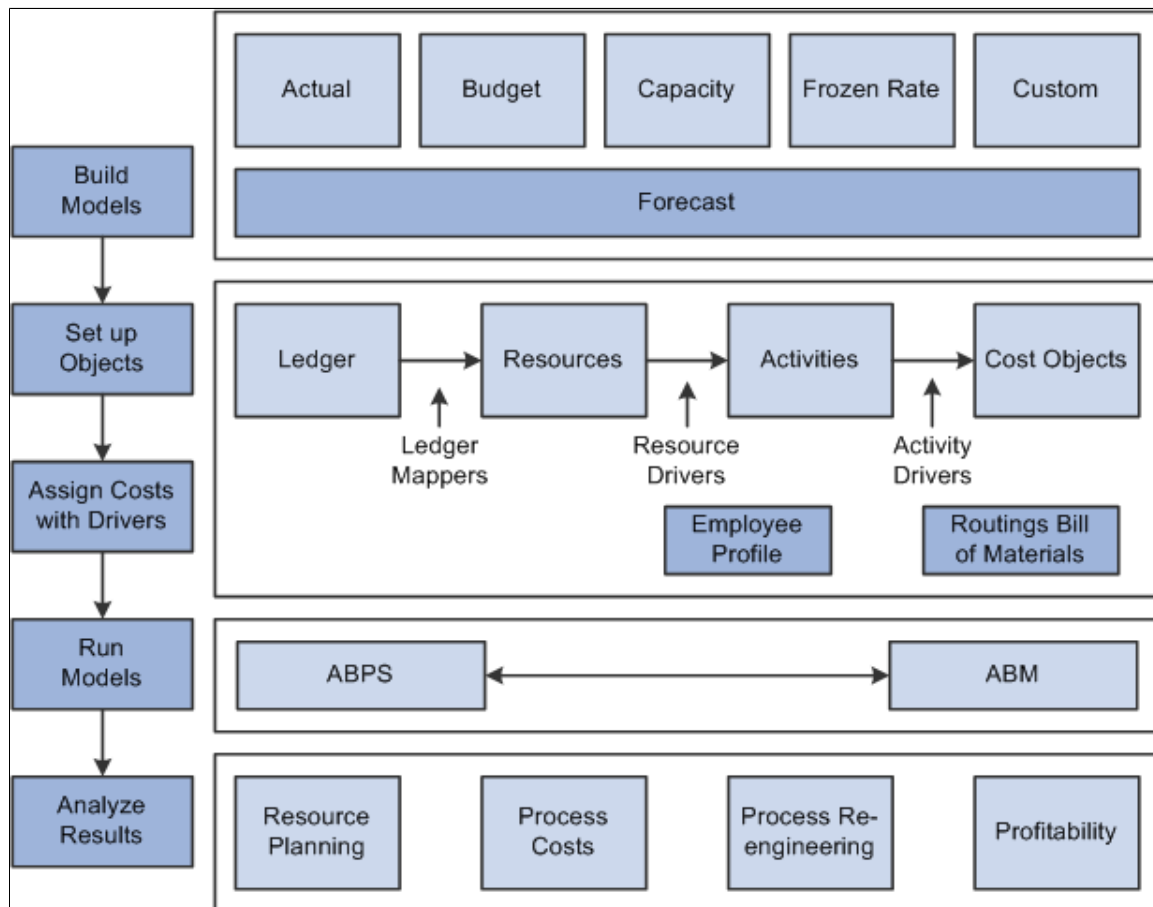

Activity-Based Management is an analytical application that supports the measurement and management of your organization's current costs today and enables you to better plan for the future. It successfully integrates the proven computational power, leading-edge technology, and operational and financial information available with Activity-Based Costing/Management (ABC/M,) and Activity-Based Budgeting (ABB) theories and practices. This combination provides unrivaled strategic cost management and overcomes data integrity, transformation, and repeatability issues that troubled earlier cost management efforts. PeopleSoft Activity-Based Management aligns advanced cost management techniques with multidimensional profitability analysis and reporting and supports business process reengineering efforts. It provides a flexible, object-based solution that can easily adjust to your organization's unique business processes, activities, and data sources.

Activity-Based Management models are highly integrated with operational and financial information. They are flexible and easily adjusted to your organization's unique business processes, activities, and data sources. Activity Based Management can calculate five model types: Budget, Actual, Capacity, Frozen and Combination.

These model options enable you to:

- Calculate variances from actual costs such as spending, volume, and capacity variances.
- Attribute dollar amounts to entities that operate at greater or less than their capacity.
- Maintain a more constant consumption pattern over time.
- Link strategic choices with their operational impact.
- Use a mix of rates, budget, actual, capacity, or frozen as necessary for your organization.
- Perform unlimited 'what if' planning and simulation.

Activity-Based Management offers the following features to follow the general activity-based management business processes:

- Understanding Activity-Based Management models, modeling components, and rate types
- Using trees with Activity-Based Management
- Setting up Activity-Based Management models and scenarios
- Setting up attributes, cost of capital, resources, and ledger mapping rules
- Setting up activities
- Setting up cost objects
- Setting up pointers, implicit pointers, and transaction pointers
- Setting up drivers
- Generating and maintaining models
- Processing in Real-Time Activity-Based Management
- Processing batch models
- Reconciling your model and analyzing engine output
- Using employee profile
- Using reciprocal allocation looping
- Using Activity-Based Planning and Simulation
- Modeling for service-related industries

We discuss these business processes in the business process topics.

PeopleSoft Activity-Based Management Integrations

We discuss integration considerations in the implementation topics.

Supplemental information about third-party application integrations is located on the My Oracle Support web site.

PeopleSoft Activity-Based Management Implementation

PeopleSoft Setup Manager enables you to generate a list of setup tasks for your organization based on the features that you are implementing. The setup tasks include the components that you must set up, listed in the order in which you must enter data into the component tables, and links to the corresponding Peoplesoft documentation.

Other Sources of Information

In the planning phase of your implementation, take advantage of all PeopleSoft sources of information including the installation guides, table-loading sequences, data models, and business process maps.

See the product documentation for *PeopleTools: PeopleSoft Setup Manager*, *PeopleTools: PeopleSoft Component Interfaces*

Tools for Building Models

Activity-Based Management also provides tools that let you quickly create a prototype model using the following engines:

- **Model Generator:** Automates the setup of filter and constraint metadata as well as Activity-Based Management objects, drivers, and pointers.
- **Ledger Mapper Generator:** Automates the setup of the ledger mapping rules for the resources.

The following table lists the model-building steps:

Step	Reference
Set up EPM Foundation.	See "Understanding PeopleSoft EPM Business Rule Setups (<i>PeopleSoft 9.1: Enterprise Performance Management Fundamentals</i>)" and "Understanding EPM Security and Setups (<i>PeopleSoft 9.1: Enterprise Performance Management Fundamentals</i>)".
Set up the Model Generation Definition.	See Setting Up Model Generator .
Set up the Ledger Maps Generation Definition.	See Setting Up Ledger Mapper Generator .
Set up your Activity-Based Management model and specify the Ledger Maps Generation and Model Generation IDs.	See Setting Up Activity-Based Management Models .
Start Activity-Based Management Model Generator.	See Running Model Generator and Ledger Mapper Generator .

Step	Reference
Start the Ledger Mapper Generator.	See <u>Running Model Generator and Ledger Mapper Generator</u> .

Chapter 2

Navigating in Activity Based Management

Navigating in Activity Based Management

Activity Based Management provides custom navigation pages that contain groupings of folders that support a specific business process, task, or user role.

This section discusses how to navigate in:

- ABM center.
- Planning and simulation center.
- Real time processing center.

With powerful features that align advanced cost management techniques with multidimensional profitability analysis and reporting, Activity-Based Management is an analytic application providing the control and flexibility needed to identify and manage direct and indirect costs and profitability within your organization.

Pages Used to Navigate in Activity Based Management

This table lists the Custom Navigation pages that are used to navigate in Activity Based Management

Page Name	Navigation	Usage
ABM Center	Activity Based Management, ABM Center	Access Activity Based Management Center.
Preferences	Click the Preferences link on the ABM Center page.	Define preferences for variance analysis and the ABM page and pagelets.
Define Model	Click the Define Resources link on the ABM Center page.	Set up performance business unit, general ledger business unit, models and scenarios.
Define Resources	Click the Preferences link on the ABM Center page.	Set up resources, trees, and employee profiles.
Assign Costs	Click the Assign Costs link on the ABM Center page.	Set up ledger mapping and assign costs to resources.
Define Activities	Click the Define Model Activities link on the ABM Center page.	Set up activities, trees, activity volumes, and pointers for volumes.
Define Drivers	Click the Define Drivers link on the ABM Center page.	Define drivers and pointers to link objects.

Page Name	Navigation	Usage
Define Cost Objects	Click the Define Cost Objects link on the ABM Center page.	Set up cost objects, trees, cost object volumes, pointers, and bill of service.
Use Model Generator	Click the Use Model Generator link on the ABM Center page.	Automate model creation.
Process ABM	Click the Process ABM link on the ABM Center page.	View ABM model and request real time or batch process.
Analyze Results	Click the Analyze Results link on the ABM Center page.	Get charts and inquiries, and analyze ABM results.

Pages Used to Navigate in Planning and Simulation Center

This table lists the Custom Navigation pages that are used to navigate in Planning and Simulation Center.

Page Name	Navigation	Usage
Planning and Simulation Center	Activity Based Management, Planning and Simulation Center.	Access Planning and Simulation Center.
Planning and Simulation Model	Click the Planning and Simulation Model link on the Planning and Simulation Center page.	Setup activity-based budgeting planning and simulation model.
ABPS Inquiries	Click the ABPS Inquiries link on the Planning and Simulation Center page.	Inquire on the results of the activity-based budgeting planning and simulation model.
ABPS Processing	Click the ABPS Processing link on the Planning and Simulation Center page.	Set up resources, trees, and employee profiles.

Pages Used to Navigate in Real Time Processing Center

This table lists the Custom Navigation pages that are used to navigate in Real Time Processing Center.

Page Name	Navigation	Usage
Real Time Processing Center	Activity Based Management, Real Time Processing Center.	Access Real Time Processing Center to create and run ABM models in real time. You can post data to batch ABM or retrieve data.
Real Time ABM	Click the Real Time ABM link on the Real Time Processing Center page.	Perform real-time activity-based management.
Ledger Sources and Mappings	Click the Ledger Sources and Mappings link on the Real Time Processing Center page.	Define sources and ledger mappings, and assign costs to resources.
Post to Batch	Click the Post to Batch link on the Real Time Processing Center page.	View and edit interface table and run model generation.

Common Elements Used in Activity-Based Management

This section lists common elements used in Activity-Based Management.

SetID	Provides the ID code for a TableSet, which is a group of tables (records) necessary to define your company's structure and processing options.
Effective Date	Establishes the date that the row in the table becomes effective. The effective date determines when you can view and change the information. Pages and batch processes that use the information use the current row.
Status	Indicates whether a row in a table is active or inactive. You cannot select inactive rows on pages or use them for running batch processes.
Description	Enter up to 30 characters of text describing what you are defining.
Run Control ID	Identifies specific run control settings for a process or report.
Program Name	Provides the Enterprise Performance Management program name for which you are running the report or process.
When	Specifies the frequency with which you want to run a process. Values are: <i>Once</i> , <i>Always</i> , or <i>Don't</i> .
Last Run On	Indicates the date that you last ran the report or process.
As Of Date	Indicates the last date for which the report or process includes data.
Model ID	Identifies a model. A model uniquely identifies the type of data that you want to include in a scenario. For example, you might want to review revenue by region—a high-level scope. Or, if you use Activity-Based Management, you might want to review only the activities that relate to a certain product line for certain types of resources—a narrow scope.
Fiscal Year	Specifies the fiscal year for your scenario or process run.
Period	Specifies the accounting period for the object being defined or the process being run.
Job ID	Specifies an instance of an engine.

Deferred Processing

Several Activity-Based Management pages operate in deferred processing mode. Most fields on these pages are not updated or validated until you save the page or refresh it by clicking a button, link, or tab. This delayed processing has various implications for the field values on the page. For example, if a field contains a default value, any value that you enter before the system updates the page overrides the default. Another implication is that the system updates quantity balances or totals only when you save or otherwise refresh the page. See the guidelines for designing pages in the *PeopleTools: PeopleSoft Application Designer Developer's Guide*.

Understanding Activity-Based Management Models, Modeling Components, and Rate Types

Activity-Based Management Modeling Components

Activity-Based Management uses models—complete sets of rules to define individual activity-based costing model objects and their relationship to your organization's financial management system, primarily the general ledger. Models let you specify different business scenarios for comparative analysis. Activity-Based Management lets you define, run, and analyze models to assess your organization's profitability.

Image: Modeling components

Create models in Activity-Based Management by defining the following components.

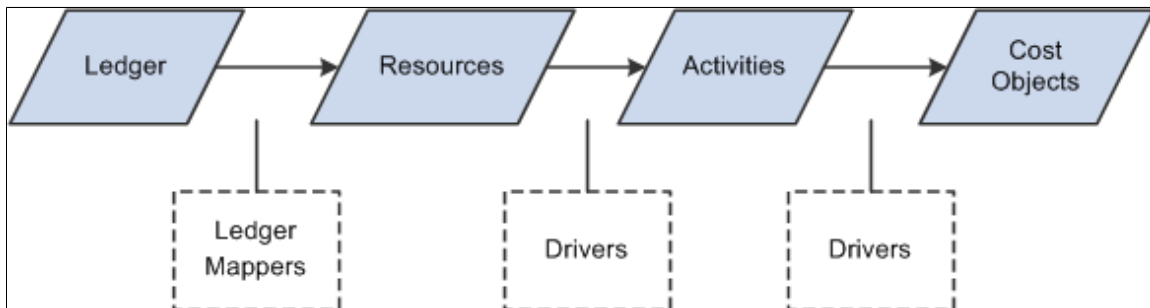

Resources

Resources—such as people, facilities, and costs associated with people and expenses—are the economic elements consumed while performing activities. They are the core elements that let your organization operate.

Activities

Activities consume resources and drive costs to cost objects. The lowest-level definition of what your organization does, activities are the foundation for measuring activity costs.

Cost Objects

Cost objects represent cost information grouped by profitability dimensions—products, customers, and channels. With your model's resources and activities linked to cost objects, which are the final results of the activities performed by your organization, they are often the focal point of profitability analysis.

Ledger Mappers

Ledger mappers relate expense data from your general ledger accounts to resource objects. You can map multiple ledger line item amounts to one or more resource IDs in the following two ways:

- An *actual* amount that represents actual costs of the accounting period results
- A *budgeted* amount that you can use to calculate the capacity rates as well as budgeted model results

Drivers

Drivers—transactional, duration, and intensity—let you assign monetary amounts from one object to another throughout the model (calculated by amount, percentage, spread even, and direct) in different ways depending on assignment type and object type. You can even assign drivers across business units.

Pointers

Pointers specify the location of driver quantities in the Operational Warehouse - Enriched (OWE) tables. Rather than entering and maintaining static driver quantities, pointers let you to extract values from any location in the OWE, and then use these values as driver quantities.

Using Activity-Based Management Models

The foundation of Activity-Based Management is the ability to create models that replicate your organization's business processes so that you can analyze how costs flow through your customers, departments, and channels, thus letting you increase your understanding of the relationships between resources, activities, and cost objects.

To use a model in Activity-Based Management, first define it within the system by selecting a rate type that specifies how Activity-Based Management should calculate the monetary amounts for each object in the model.

Using Rates with Your Activity-Based Management Model

While most activity-based costing systems calculate resource, activity, and cost object results using actual or budgeted historical data, Activity-Based Management offers capacity and frozen rates as well. This section discusses the following rate options for model types:

- Actual
- Budgeted
- Capacity
- Frozen
- Combination

These rate options let you create and run basic, full-absorption models that have the following advantages:

- They calculate variances from actual costs such as spending, volume, and capacity variances.
- They attribute monetary amounts to entities that operate at greater than or less than their capacity.
- They maintain a more constant consumption pattern over multiple time periods.

Actual Rates

Ledger mappers move actual amounts mapped from the general ledger into resource objects of the Activity-Based Management engine, which tracks data related to actual driver quantities:

Image: Calculating actual rates

Calculating actual rates.



The actual rate type assumes that operations are occurring at 100 percent capacity.

A rate represents a monetary amount divided by a driver quantity. To calculate an actual rate, Activity-Based Management applies the following formula to the values captured by the model:

$$(Actual\ Rate) = (Actual\ Monetary\ Amount) / (Actual\ Driver\ Quantity)$$

Note: This rate type can fluctuate temporarily with general ledger fluctuations and does not address capacity.

Budgeted Rates

Ledger mappers move budgeted amounts mapped from the general ledger into resource objects of the Activity-Based Management engine, which tracks data related to budgeted driver quantities:

Image: Calculating budgeted rates

Calculating budgeted rates.



Because a rate represents a monetary amount divided by a driver quantity, Activity-Based Management calculates the budgeted rate by applying the following formula to arbitrary values captured by a model:

$$\text{budgeted rate} = \text{budgeted amount} / \text{budgeted driver quantity}$$

Determining both the actual and budgeted rates let you calculate two variance types:

Variance Type	Calculation
Volume	(budgeted driver quantity - actual driver quantity) x (budgeted rate)

Variance Type	Calculation
Spending	(budgeted rate - actual rate) x (actual driver quantity)

As a result, you can calculate the following two types of variance results:

Favorable variances Costs that are less than those budgeted and are expressed as positive amounts.

Unfavorable variances Costs that are greater than those budgeted and are expressed as negative amounts.

The combined results create the total variance. If you apply the budgeted rate calculated by the Activity-Based Management engine, only those values pass through the remainder of the model versus passing along the actual amount.

Image: Variance calculation for actual and budgeted rates

The following diagram illustrates how the system calculates volume and spending variance.

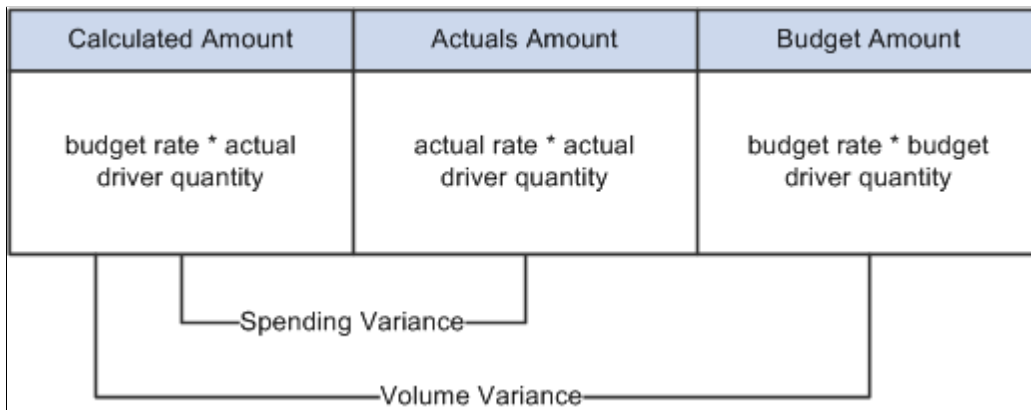

Note: As with the actual rate, the budgeted rate also does not address capacity and is subject to fluctuations based on general ledger fluctuations.

Capacity Rates

Actual and budgeted driver quantities can and do fluctuate over time; likewise, the actual and budgeted rates fluctuate over the same time period. Because decisions made on the basis of these fluctuating rates could be misleading, the concept of capacity rates becomes important.

When entities are not operating at their full capacity and all costs are applied to activities and cost objects, the model fully absorbs the costs and managers are forced to use historical information to make decisions.

Activity-Based Management lets you assign the excess costs to a departmental cost object so that you can track excess capacity. Assigning excess capacity to such an object balances the actual amounts within the model, and the flow of amounts through the objects remains constant:

Image: Calculating capacity rates

Calculating capacity rates.

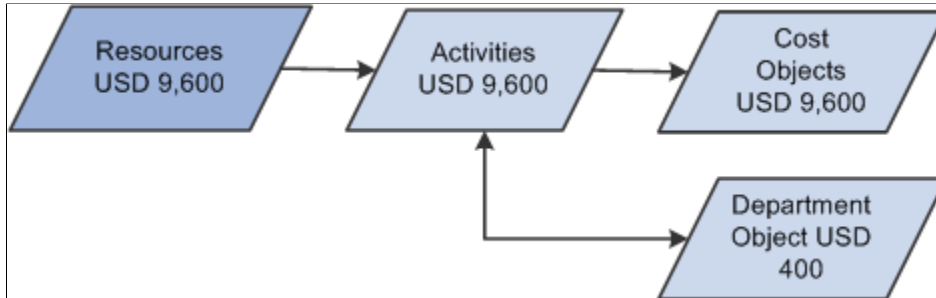

The capacity rate is the result of the budgeted amount divided by the capacity driver quantity:

$$\text{capacity rate} = (\text{budgeted monetary amount}) / (\text{capacity driver quantity})$$

Example of a Capacity Calculation

Suppose that the actual resource cost mapped from the general ledger is 10,000 USD. Our actual driver quantity for activity 1 is 600 units; for activity 2 it is 400 units. In addition, suppose that the budgeted amount for the resource is 9,600 USD, and the capacity volume for the resource is 1,600.

The system calculates a capacity rate by dividing the budget amount value by the capacity volume quantity as follows:

$$9,600 \text{ USD} / 1,600 = 6.00 \text{ USD}$$

Values going to activity 1 and activity 2 are then calculated by multiplying the actual driver quantities by the capacity amount.

$$\text{Activity 1 actual driver quantity} = 600 \times 6 \text{ USD} = 3,600$$

$$\text{Activity 2 actual driver quantity} = 400 \times 6 \text{ USD} = 2,400$$

For the model to balance, the system places the excess amount in the departmental excess capacity cost object. The resource total is 10,000 USD while activities total 6,000 USD. The system places the remaining 4,000 USD in the excess capacity cost object:

Image: Capacity rate calculation example

Example of capacity rate calculation.

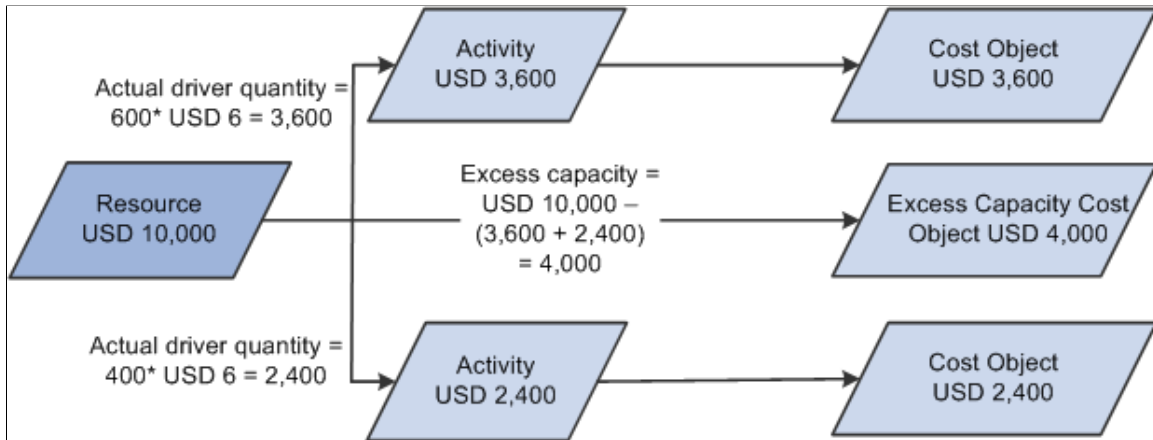

When defining the model, it is important to determine where in the data flow the capacity calculation will occur. You can calculate capacity at either the resource or activity driver level in a single data flow.

It cannot exist in both the resource driver and activity driver levels of a single data flow. A model can consist of several data flows.

Image: Example of an Activity-Based Management model with two data flows

The following diagram illustrates a single model containing two data flows where data flow 1 could have the calculation occur at the resource driver level and data flow 2 could have the calculation occur at the activity driver level.

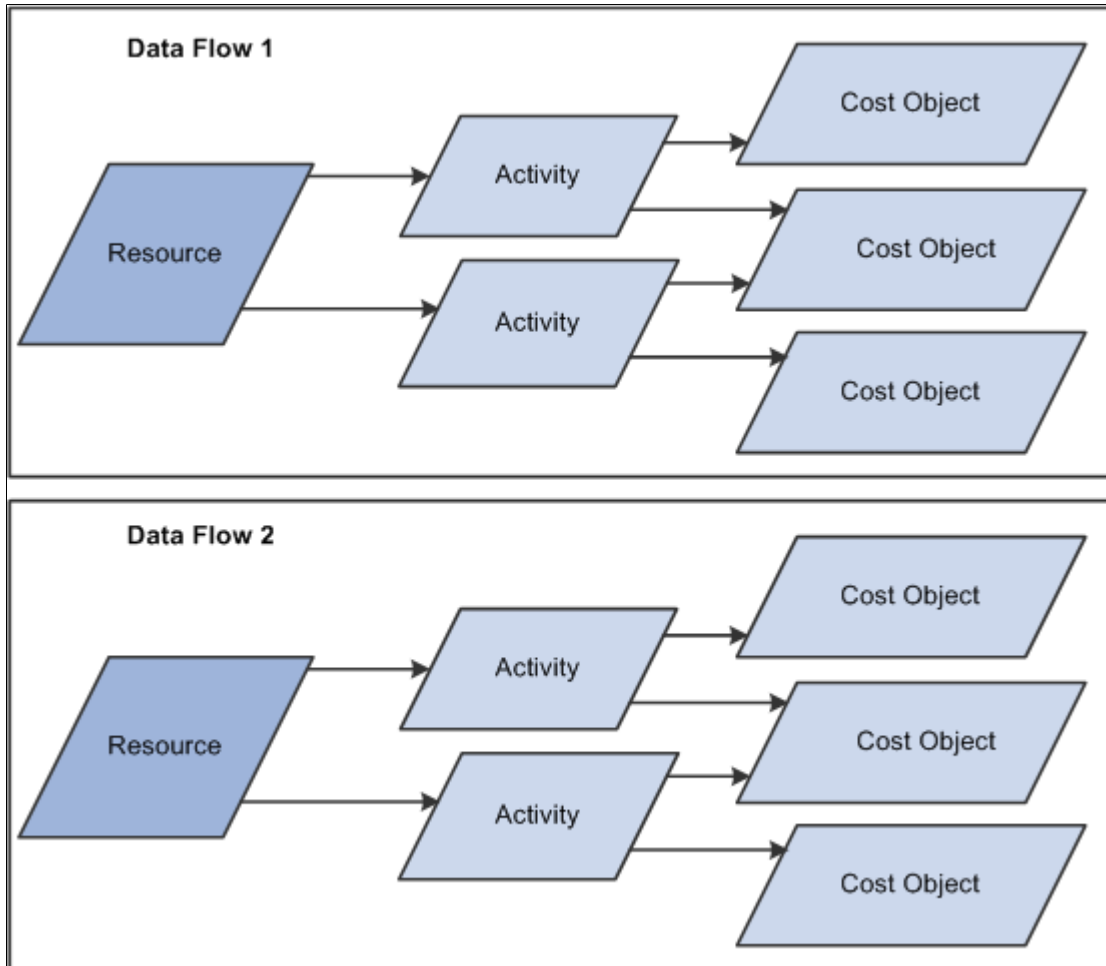

Frozen Rates

A frozen rate is fixed and agreed upon outside the context of the Activity-Based Management model:

Image: Calculating frozen rates

Calculating frozen rates.



Example of a Frozen Rate Calculation

Using a frozen rate lets you calculate variances from actual, budgeted, or capacity values. Because information about the driver quantity is not used to calculate the rate, the variance is not divided between spending and volume:

Image: Frozen rate calculation example

Example of frozen rate calculation.

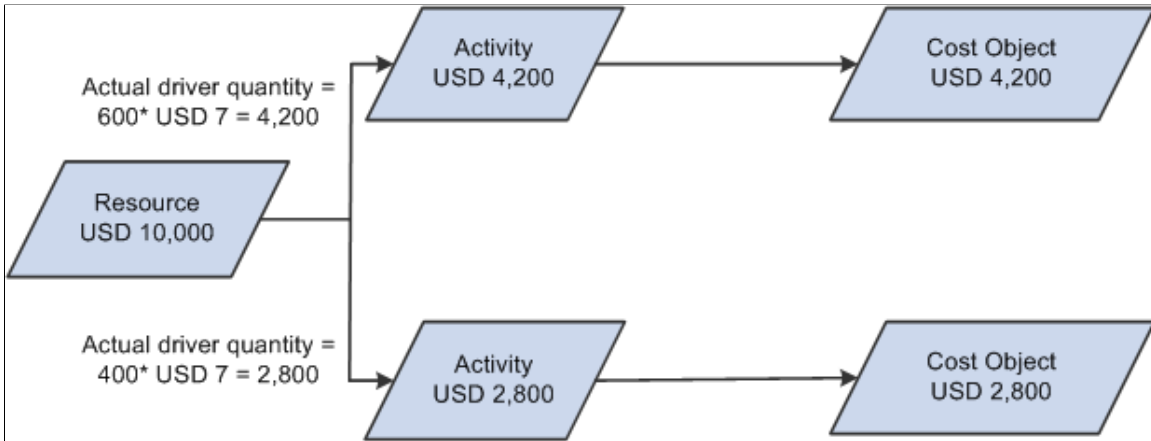

Image: Frozen rate variance calculation

The following diagram shows the variance calculation using a frozen rate.

Calculated Amount	Actuals Amount	Budget Amount
Frozen rate * actual driver quantity	actual rate * actual driver quantity	Since you should not have both budget and frozen rate information for a single driver this will reflect actual rate * actual driver quantity
<div style="border: 1px solid black; width: 200px; margin: 0 auto; padding: 5px;">Frozen Rate Variance</div>		

Combination Rates

Combination rates let you combine a mixture of actual, budgeted, capacity, and frozen rate information. Here's an example of the calculation of data flow for a combination model:

Image: Calculation data flow example for a combination model type

Calculation data flow example for a combination model type.

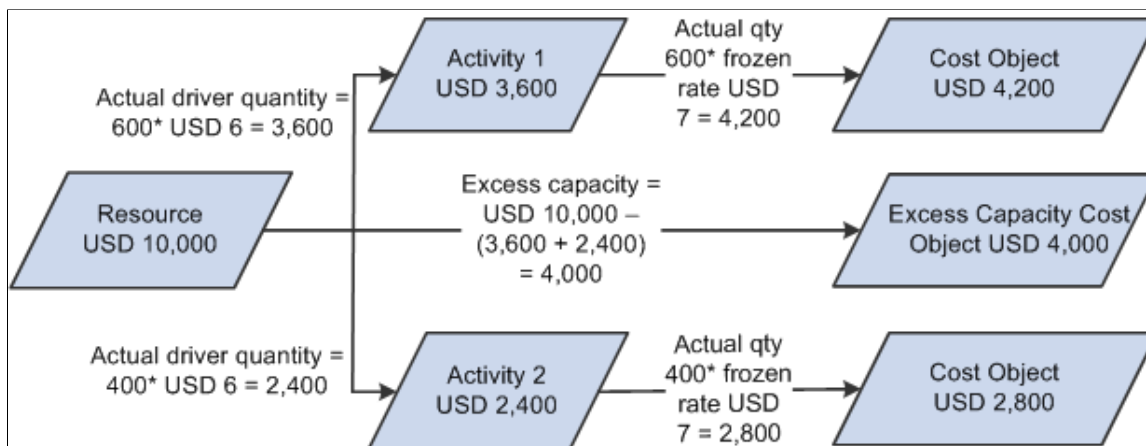

Creating Interunit Models for Shared Services

What happens if you need several models for shared services? For example, suppose that your business unit has two production sites and a central administrative office supporting the two production sites. In traditional activity-based costing, the only way to model this is by making a single, large model for the entire business unit. This makes the scope of the project large and complicated. However, with Activity-Based Management, you can use an interunit, shared-service model to address this business requirement.

Activity-Based Management lets you cost services provided by a shared-services business unit or a shared-services group into a separate model. After you determine these shared-services cost objects, assign those costs to other models within or outside the same business unit.

Perhaps one of the shared services, provided by the example's central administrative office, is the human resources function. Because you need to drive human resources amounts between models, while you're creating a model you make *Hiring Personnel* a cost object. After you finish building your model, run the model and derive a total monthly cost for the Hiring Personnel cost object.

Suppose that, for example, Site A is an older facility and does not require many new hires; in fact, Site A hired only two people last month. Site B, however, is a rapidly growing facility and hired 18 people last month. This disparity could lead you to define an interunit driver that assigns 10 percent of the cost of hiring to Site A and 90 percent to Site B. This type of driver lets you make assignments from the cost object of one business unit and model to the support activities of one or more business units and models.

You can allocate shared-service resource costs to other shared-service resources using the looping method, which can produce more accurate results because the system bases the allocation on the processes that the resource performs. Once the allocation is complete, the cost from the cost object loops to the corresponding resource and continues looping until the percentage difference between the cost resource and the corresponding cost object meets a tolerance limit or exceeds a maximum loop amount.

Once reciprocal allocations are complete, the system sends final costs to a production Activity-Based Management model using the existing inter-business unit (IBU) drivers.

Understanding Reciprocal Allocation and Looping

Reciprocal allocation in Activity-Based Management models lets you allocate shared-service resource costs to other shared resources. Define a single, shared-service model that includes all reciprocal Activity-Based Management objects and activities. Once reciprocal allocations are complete, the system sends final costs to a production Activity-Based Management model using the existing IBU drivers.

Within the shared-service model, define a cost object with the same name as the resource. The system bases the allocation on the processes that the resource performs. Once the allocation is complete, the cost from the cost object *loops* to the corresponding resource and continues looping until the percentage difference between the cost resource and the corresponding cost object meets a tolerance limit or exceeds a maximum loop amount. You can allocate any residual cost remaining after looping is complete because the targets of residual amounts often serve as sources for further allocations.

Understanding Reciprocal Allocation Methods

Activity based costing drives overhead costs from resources to activities and then to the cost objects. Activity based costing can also drive costs directly from resources to cost objects. In scenarios where costs require allocations among resources (reciprocal allocations), activity based costing drives costs to activities only after completing allocations to the resources. For example, IT and HR resources could share costs with each other. Therefore, the actual cost of these resources can be determined only after they complete the allocation of costs to each other.

The following example shares costs between resource 'S' and resource 'T.' In addition, it allocates the resource cost of 'S' to cost objects 'U,' 'V,' and resource 'T' (40%, 40% and 20% respectively) and drives resource cost of 'T' to objects 'V,' 'W,' and resource 'S' (20%, 50% and 30% respectively).

Image: Example reciprocal allocation to share costs

This example illustrates the fields and controls on the Example reciprocal allocation to share costs.

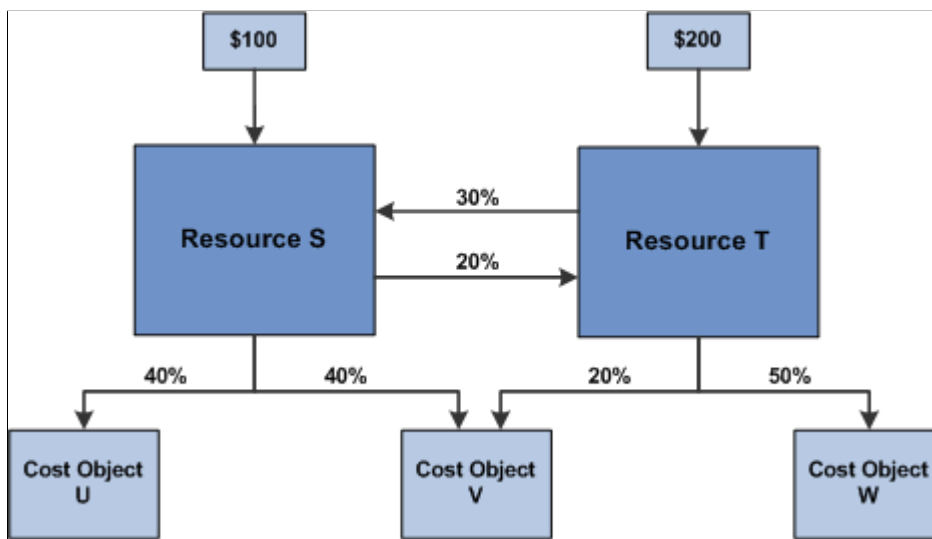

There are two methods of performing a reciprocal allocation:

- Mathematical (simultaneous equation)

- Iterative

These methods are discussed below.

Mathematical Method

The following algebraic equation models our example for simplistic reciprocal allocations:

- $S = 100 + .3T$
- $T = 200 + .2S$

Solving for S and T gives $S = \$170.21$ and $T = \$234.04$.

Image: Mathematical Method

The following steps demonstrate a reciprocal allocation.

Steps	S	T	U	V	W	Sum (U, V, and W)
Starting Amounts	\$100	\$200				
Adjustments	(\$170.21)	(\$234.04)				
Allocate S (\$170.21)		\$34.04	\$68.08	\$68.08	\$0	\$136.17
Allocate T (\$234.04)	\$70.21		\$0	\$46.81	\$117.02	\$163.83
Net Amount	\$0	\$0	\$68.08	\$114.89	\$117.02	\$300.00

Allocate the cost of resource S to objects U, V and resource T (40%, 40% & 20% respectively).

Allocate the cost of resource T to objects V, W and resource S (20%, 50% & 30% respectively).

Iterative Method

With the iterative method, you repeat allocations until the resource amounts for S and T become negligible or zero. This method is most suited for computer applications. When the resource amounts

become negligible (as defined by a tolerance limit attribute), the program exits the iterative allocation loop.

Image: Iterative Method

The following steps demonstrate an iterative allocation.

Steps		S	T	U	V	W	Sum (U, V, and W)
Iteration 1	Starting Amounts	\$100.00	\$200.00				
	Allocate S		\$20.00	\$40.00	\$40.00	\$0.00	\$80.00
	Allocate T	\$60.00		\$0.00	\$40.00	\$100.00	\$140.00
	Total	\$60.00	\$20.00	\$40.00	\$80.00	\$100.00	\$220.00
Iteration 2	Allocate S		\$12.00	\$24.00	\$24.00	\$0.00	\$48.00
	Allocate T	\$6.00		\$0.00	\$4.00	\$10.00	\$14.00
	Total	\$6.00	\$12.00	\$24.00	\$28.00	\$10.00	\$62.00
Iteration 3	Allocate S		\$1.20	\$2.40	\$2.40	\$0.00	\$4.80
	Allocate T	\$3.60		\$0.00	\$2.40	\$6.00	\$8.40
	Total	\$3.60	\$1.20	\$2.40	\$4.80	\$6.00	\$13.20
Iteration 4	Allocate S		\$0.72	\$1.44	\$1.44	\$0.00	\$2.88
	Allocate T	\$0.36		\$0.00	\$0.24	\$0.60	\$0.84
	Total	\$0.36	\$0.72	\$1.44	\$1.68	\$0.60	\$3.72
Iteration 5	Allocate S		\$0.07	\$0.14	\$0.14	\$0.00	\$0.29
	Allocate T	\$0.22		\$0.00	\$0.14	\$0.36	\$0.50
	Total	\$0.22	\$0.07	\$0.14	\$0.29	\$0.36	\$0.79
Iteration 6	Allocate S		\$0.04	\$0.09	\$0.09	\$0.00	\$0.17
	Allocate T	\$0.02		\$0.01	\$0.01	\$0.04	\$0.05
	Total	\$0.02	\$0.04	\$0.10	\$0.10	\$0.04	\$0.22
Iteration 7	Allocate S		\$0.00	\$0.01	\$0.01	\$0.00	\$0.02
	Allocate T	\$0.01		\$0.01	\$0.01	\$0.02	\$0.03
	Total	\$0.01	\$0.00	\$0.02	\$0.02	\$0.02	\$0.05
Iteration 8	Allocate S		\$0.00	\$0.01	\$0.01	\$0.00	\$0.01
	Allocate T	\$0.00		\$0.00	\$0.00	\$0.00	\$0.00
	Total	\$0.00	\$0.00	\$0.01	\$0.01	\$0.00	\$0.01
Net Amount		-	-	\$68.08	\$114.89	\$117.02	\$300.00

Allocate the cost of resource S to objects U, V and resource T (40%, 40% & 20%, respectively).

Allocate the cost of resource T to objects V, W and resource S (20%, 50% & 30%, respectively).

Iteration 1 starts by allocating resource costs of S (\$100) and T (\$200). After allocation, resources S and T have reciprocal allocation amounts of \$60 and \$20 respectively.

After Iteration 2, resources S and T have reciprocal amounts of \$6 and \$12, respectively.

We repeat the allocations until the allocating resource amounts are near zero (which occurs in Iteration 8).

Modeling for Manufacturing Purposes

Activity-Based Management lets you use routing information from manufacturing to set up activity driver information within the system. Activity-Based Management can determine which activity is performed on which cost objects along with the quantifiable measures for that relationship. It uses Bill of Materials (BOM) information from manufacturing and transforms the components within the BOM hierarchy into cost objects in Activity-Based Management. In addition, Activity-Based Management can maintain the BOM structure. This is important because, once the Activity-Based Management calculation is finished, each component contains cost information. The roll-up of these costs using BOM hierarchy results in a total indirect cost of the resources, activities, and cost objects. Then, the indirect cost information calculated from Activity-Based Management output is directed back to the PeopleSoft Cost Management environment.

To set up models for manufacturing purposes, create a combination model and start the Routing Information engine to set up your drivers.

Modeling for Service-Related Industries

Service industries typically offer a wide range of products. Banks, for example, have many types of checking and savings accounts, home mortgages, and car loans. Cable television companies tend to offer many packages such as basic and standard services, premium packages with selections of movie channels, and digital cable channel packages. Each product or service has its own unique characteristics requiring different demands on the providing organization's resources. Essentially, all of the operating costs associated with the products from any service organization are determined by its customers' behavior.

To determine costs for services, Activity-Based Management lets you model for Bill of Services (BOS). BOS is a collection of product and service costs for customers. This collection of costs, which can be a unique combination of standard products and services, lets you create new service packages and, in turn, new business opportunities to serve your customers.

BOS functionality includes the ability to create new and unique combinations of standard services and combine them into a package service. It also includes functionality to apply a standard rate to the new services provided to estimate new business opportunities and costs to serve a customer. Based on data from pre-existing or new package services, you can manipulate the volume, adjust to the correct customer demand for those services, and eventually calculate the resource requirements for the new changes in demand.

Modeling with ABPS

The ABPS feature of Activity-Based Management lets you forecast values for your models. Using ABPS functionality, you can make decisions on resource requirements based on factual data for product demand, resource efficiency, activity efficiency, and activity rate cost.

Related Links

[Understanding ABPS](#)

Chapter 4

Using Trees with Activity-Based Management

Understanding Trees in Activity-Based Management

Trees add a visual layer and hierarchical structure, letting you see where detail items (such as departments and accounts) fit into your organization's structure and letting you navigate to the appropriate level of detail. Use trees to organize and maintain Activity-Based Management objects and dimensions and to simplify reporting needs. Visually establish and change the rules for summarizing detail elements. When the summarization rules change, for example, simply update the tree; the system automatically reflects your revisions everywhere within the tree. You can also use trees to summarize or combine financial results from all segments of your organization.

While you definitely want your financial reporting systems to manage detailed information, their greatest value comes from their ability to consistently summarize huge volumes of information for management reporting. Whether you're an accountant, CFO, tax manager, product manager, or sales manager, chances are that you're only concerned with a portion of your organization's database—a particular level of information. Yet, at the same time, you also have to summarize and look at the big picture. Trees give you the option to easily view information at any level.

There are three main reasons to use PeopleSoft trees with your Activity-Based Management application:

- Reporting.
- Processing.
- Security.

Note: Review the *Enterprise Performance Management Fundamentals 9.1* documentation for details about security.

Related Links

"Understanding EPM Security and Setups (*PeopleSoft 9.1: Enterprise Performance Management Fundamentals*)"

Related Documentation

Consider referring to the documentation in the following table for more information about PeopleSoft Tree Manager including tree terminology, types of trees, and establishing the tree structure as well as information about how trees are used as part of the EPM applications:

Source	Description
<i>PeopleTools: PeopleSoft Tree Manager</i>	This documentation describes how to use PeopleTools Tree Manager to modify, copy, and audit trees, how to create tree branches, and discusses the different types of trees.
<i>Enterprise Performance Management Fundamentals 9.1</i>	This documentation describes how to set up the EPM Foundation for use with your analytic application and provides information on tree metadata and tree utilities such as Super Tree and Tree Compare.

Trees and Reporting

Use reporting trees to:

- Map general ledger amounts into Activity-Based Management resource objects.
- Generate reports from the PF Ledger table that summarizes results for a particular dimension or business unit.

Without a tree, you would have to explicitly specify which departments to include every time you create a report. By using trees, the system can consult the trees to determine which departments or account groupings to include in reports. In addition, trees give you the option to view information at any level.

Trees and Activity-Based Management Processing

Activity-Based Management requires PeopleSoft trees to roll up or summarize the values calculated for your Activity-Based Management objects or models. PeopleSoft delivers Activity-Based Management tree structures with the application to help get you started.

Your Activity-Based Management objects, resources, activities, and cost objects have their values calculated by the Activity-Based Management engine. In many cases, you want to summarize lower-level information for inquiry purposes as well as to meet certain reporting needs. The Activity-Based Management engine references these trees to perform this summarization.

PeopleSoft trees enable model roll-up. If you have multiple models for a single business unit, you can set up these models so that they roll up to higher-level models to ensure complete, comprehensive costing for the entire business unit.

Using PeopleSoft trees, Activity-Based Management assesses costs for each model and assigns costs for each resource, activity, and cost object based on where each resides in the tree and whether each is a target or a source. Sources are the resources, activities, and cost objects that are being assigned to the next level. To be a meaningful part of a tree, every branch must contain at least one source or one parent branch that contains a source. Sources must balance for every resource, activity, and cost object; otherwise, the Activity-Based Management engine generates error messages. Every resource, activity, or cost object that you add to a tree beneath a source is informational only and cannot be used for reporting and costing.

In addition to having sources, trees also have targets. A resource, activity, or cost object can be a target and can receive money. The sum of all targets must balance for every resource, activity, and cost object.

To use trees for model roll-up, create a tree that displays how smaller models should be added together into a bigger model. Thus, all you need to create are the smaller models at the end of the trees. PeopleSoft Tree Manager and Activity-Based Management calculate all of the other models.

For example, suppose that your business unit has two production sites and you decide to independently model these production sites. Create a model for Site A and a model for Site B, and then calculate costs for both sites. You then find that you are also interested in creating a model for the entire business unit. Rather than creating a new model, use model roll-up to combine the two existing models into a larger model. By using trees, Activity-Based Management lets you roll up multiple levels. For example, you can roll up Site A and Site B into a Production Center 1 model. You can then roll up Production Center 1 and 2 into the final business unit model.

Note: Because trees use model information derived from the calculation tables (where primary objects are rolled-up and the results are stored), your views may be skewed and occasionally result in totals that appear too high.

Setting Up Activity-Based Management Models and Scenarios

Understanding Models

A model is a complete set of rules used to define model objects and their relationship to the general ledger. Models let you define how to measure performance within your organization by providing insight to such questions as:

- Which cost object do I want to measure—customers, products, or channels?
- What activities are key to my organization and how do they relate to the cost objects?

You can define, run, and analyze models using Activity-Based Management.

Model Configuration Steps

To configure a Activity-Based Management model:

1. Establish a model under a SetID.

This model is accessible to all business units using that SetID for the Activity-Based Management Models record group.

2. Create a scenario ID under the SetID, and then assign the model ID to the scenario.
3. Associate the scenario ID with a business unit and calendar.

Note: The calendar defined here overrides the calendar defined for the PF business unit, letting you associate quarterly models with a monthly PF business unit, for example.

4. Define the Activity-Based Management model properties.

This documentation discusses only the last of these four steps. For the first three steps, refer to information in the *Enterprise Performance Management Fundamentals 9.1* for details on setting up a model ID and scenario.

See "Defining Models and Scenarios (*PeopleSoft 9.1: Enterprise Performance Management Fundamentals*)".

Image: Model configuration setup procedures

The following diagram illustrates the steps to create a Activity-Based Management model.

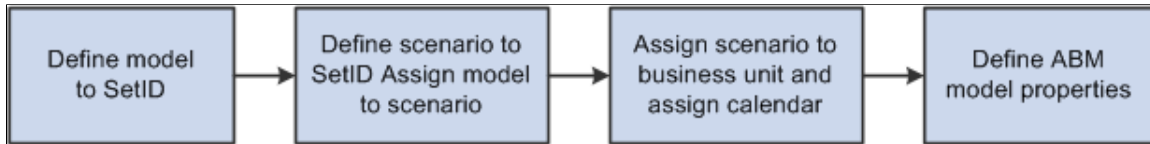

Understanding Object-Oriented Modeling and Scenarios

PeopleSoft Enterprise Performance Management (PeopleSoft EPM) lets you modify a model and view the results of the impact. Employing object-oriented modeling lets you copy the data that must be changed instead of copying an entire model by defining a what-if scenario in the Scenario Manager, a parent model, and a child model.

For example, the parent model could represent your current business operations. This is the model that you want to use as the basis to assess the impact of any changes. The child model could represent these changes.

You can create scenarios for each child and parent combination.

Prerequisites

Before creating your models in Activity-Based Management, you must:

- Complete your EPM Foundation setup.
- Review the Understanding Activity-Based Management Models and Model Types topic.
- Review the Using Trees in Activity-Based Management topic.
- Create a model ID and scenario ID in the EPM Foundation application.
- Assign the model ID to the scenario, and then associate the scenario with a business unit and calendar.

Related Links

[Understanding Trees in Activity-Based Management](#)

Setting Up Activity-Based Management Models

Activity-Based Management model properties let you specify calculations for comparative analysis. Once you create a model ID, assign it to a scenario, and associate it with a PF business unit, define Activity-Based Management properties for the model.

To define Activity-Based Management model properties:

1. On the Models page, specify calculation types and model information.
2. On the Run Control Information page, define the run control information for the model.

Pages Used to Define Model Properties

<i>Page Name</i>	<i>Definition Name</i>	<i>Navigation</i>	<i>Usage</i>
Models	MODEL_TBL1	Activity Based Management, Setup, Model, Models	Specify model properties such as model calculation type and its location within the tree.
Run Control Information	MODEL_TBL3	Activity Based Management, Setup, Model, Models, Run Control Information tab	Specify which processes to run.
Reciprocal Looping Parameters	MODEL_TBL2S	Activity Based Management, Setup, Model, Models, select the Reciprocal Looping Model check box, click Refresh, and then click the Reciprocal Looping Model button.	Specify parameters for reciprocal looping.

Models Page

Use the Models page (MODEL_TBL1) to specify model properties such as model calculation type and its location within the tree.

Navigation

Activity Based Management, Setup, Model, Models

Image: Models page

This example illustrates the fields and controls on the Models page. You can find definitions for the fields and controls later on this page.

The screenshot shows the Oracle Models page with the following configuration:

- Business Unit:** CORP1
- Model ID:** BANK BANK
- Details:**
 - *Effective Date: 01/01/1900
 - *Status: Active
 - *Model Type: Actuals Model
- Model Information:**
 - Rule ID: LEDMAP
 - Sequence#: (empty)
 - Accept Inter Unit Cost
- Model Trees:**
 - Resource: RES_TREE_BANK (Bank Resource tree)
 - Activity: ACT_TREE_BANK (BANK activity tree)
 - Cost Object: CST_TREE_BANK (Bank cost tree)
 - *Resolve Method: Target Resolve Only

To set up the Activity-Based Management model:

1. Select the Model Type:

Actuals Model

Select to analyze past (historical) data to affect the future. Actual models are typically easy to implement and understand but have limitations to their effectiveness (such as the assumption that entities operate at 100 percent of their capacity which compromises driver information if the capacity of the entities is not fully used and, because the actual data is historical, you cannot forecast based on anticipated costs).

Budgeted Model

Select to view the future with budgeting expenses and forecast using anticipated costs. While easy to implement and understand, budget models share the same disadvantages as those based on actual data.

Capacity Model

Select to measure the cost of capacity resources (which is similar to standard costing). The capacity rate is the result of the budgeted amount being divided by the capacity driver quantity. The capacity model lets you assign excess costs to a capacity cost object and balance the actual amounts within the model. You can then track and report on excess capacity.

Combination Model

Select a model that uses both capacity and frozen rates. This is typically used in manufacturing environments.

Frozen Rate Model

Select to use a frozen, manually defined rate that enables calculation of variances from actual, budget, or capacity values. You can define the frozen rate on the Drivers page.

2. In the Model Information group box, select the Ledger Mapper Rule ID to apply to this model that identifies the location of the PeopleSoft EPM general ledger tables for this model.
3. Click View Related Links to add a Ledger Mapper rule or update an existing one.
4. If you are setting up several models with costs flowing from one to the next through interunit drivers, use the Sequence Number field to specify the flow sequence between the models.
5. If you are using shared-services models and you want amounts from other models to be distributed into this model through relationships established by interunit drivers, select Accept Inter Unit Cost.
6. In the Model Trees group box, specify the trees that you want to use for this model:

Resource

Enter the name of the resource tree.

Activity

Enter the name of the activity tree.

Costs Object

Enter the name of the cost object tree.



You can click Cost Object Trees to access the Roll Up Tree Names page, which rolls up data by dimension in each individual tree to the cost-object level that you define in the Costs Object Tree Name field.



Click View Related Links to add or update the Activity-Based Management tree metadata for any of the trees that you specify.

7. Select a Tree Resolve Method to determine the detail of the tree roll-up:

Target Resolve Only

The tree roll-up saves data for each node.

Target to Source Resolve

The tree roll-up saves data only for the nodes defined as a source.

Related Links

[Activity-Based Management Modeling Components](#)

Specifying Roll Up Tree Names

To access the Roll Up Tree Names page, from the Models page — Setup, Model, Models — click Cost Objects Trees.

Specify the Product Tree, Channel Tree, Customer Tree, and Department Tree that you want to roll up to the cost-object level that you define in the Costs Object Tree Name field on the Models page. This

lets you pick any tree to serve as your cost-object tree, including trees brought in from your enterprise resource planning system.

Run Control Information Page

Use the Run Control Information page (MODEL_TBL3) to specify which processes to run.

Navigation

Activity Based Management, Setup, Model, Models, Run Control Information tab

Image: Run Control Information page

This example illustrates the fields and controls on the Run Control Information page. You can find definitions for the fields and controls later on this page.

To set up run control information for the model:

1. Specify how the system accesses information in the ABM Run Info group box.

Get Drill Level 2 information

Select only if you are intending to use the Activity-Based Management Drillback engine to drill back on data.

Use Actual Mapper for Budget

Select to use actual ledger to resource mapping for both actual and budgeted calculations.

Reciprocal Looping Model

Select if this is a reciprocal looping model for allocating shared-service resource costs to other shared-service resources.



After you select the Reciprocal Looping Model check box, click Refresh, and then click the Reciprocal Looping Model

button to access the Reciprocal Looping Parameters page and define looping parameters such as Tolerance Percentage, Minimum Iterations, Maximum Iterations, and Residual Target Model.

2. If you are using the Model Generator or the Ledger Mapper Generator for this model, enter the Model Gen ID (Model Generation ID) or the Ledmap Gen ID (Ledger Maps Generation ID).

You defined these IDs on the Model Generation Definition and Ledger Maps Generation Definition pages.

3. Specify the Activity-Based Management model validation profile that you want performed when you start the Model Validation engine:

Audit Validation	Verifies your model metadata setup.
Complete Validation	Completely validates the model including audits, data integrity, and setup.
Data Integrity Validation	Ensures that the information that you want to model is available and accurate.
Setup Validation	Searches for errors that cause the Activity-Based Management engine to stop processing (such as no filters being available for the pointers to use, activities not matching the drivers, or invalid cost object dimensions).

4. In the Employee Profile Info group box, select the type of calculations for an employee profile:

Recreate Source Data	Select to use the Employee Profile engine (described later) to delete existing resource and resource driver data and recreate it.
Weighted Calculation	Select to include salaries in the employee profile driver calculations.

Planning Info

Use the fields in the Planning Info group box for APBS and display only if you are using a child model. Refer to the ABPS sections of this documentation for more information on these fields.

Related Links

[Setting Up Planning and Simulation Criteria](#)

Reciprocal Looping Parameters Page

Use the Reciprocal Looping Parameters page (MODEL_TBL2S) to specify parameters for reciprocal looping.

Navigation

Activity Based Management, Setup, Model, Models, select the Reciprocal Looping Model check box, click Refresh, and then click the Reciprocal Looping Model button.

Image: Reciprocal Looping Parameters page

This example illustrates the fields and controls on the Reciprocal Looping Parameters page. You can find definitions for the fields and controls later on this page.

The screenshot shows a dialog box titled "Reciprocal Looping Parameters". Inside the dialog, there are four rows of controls:

- Tolerance Percentage:** An empty text input field.
- Minimum Iterations:** A text input field containing the number "1".
- Maximum Iterations:** A text input field containing the number "1".
- Residual Target Model:** An empty text input field with a magnifying glass icon to its right, indicating a search function.

At the bottom of the dialog, there are three buttons: "OK", "Cancel", and "Refresh".

To specify reciprocal looping parameters for a reciprocal looping model:

1. Enter the Tolerance Percentage that the looping object must reach before looping terminates.
This percentage is the difference between the amount of the cost object before and after a loop.
2. Specify the Minimum Iterations and Maximum Iterations to apply to this model.
3. Select the Residual Target Model ID of the model to which the system should allocate any residual cost after the looping.

Copying Activity-Based Management Models

The Activity-Based Management Model Copy feature creates a duplicate of an existing model that includes the ledger mappings and drivers. You must have an established model from which to copy object information. The new model name must be defined within the system for the model copy function to copy the data from the first model into the second. You can modify the duplicate model to create new models.

Page Used to Copy Models

<i>Page Name</i>	<i>Definition Name</i>	<i>Navigation</i>	<i>Usage</i>
Model Copy	MODEL_COPY	Activity Based Management, Setup, Model, Model Copy	Create a duplicate of an existing model that you can modify as you choose to create new models.

Model Copy Page

Use the Model Copy page (MODEL_COPY) to create a duplicate of an existing model that you can modify as you choose to create new models.

Navigation

Activity Based Management, Setup, Model, Model Copy

To copy an Activity-Based Management model:

1. Select the New Model ID for your model, and then click Copy to create a copy of the model.

Note: You must create your model ID and scenario in EPM Foundation before selecting the model in the New Model ID field.

2. Access the Model component, and then make the necessary modifications.

Related Links

[Setting Up Activity-Based Management Models](#)

Chapter 6

Setting Up Attributes, Cost of Capital, Resources, and Ledger Mapping Rules

Understanding Model Components

Objects—resources, activities, and cost objects—are the basic components of the Activity-Based Management model. So that the model provides you with meaningful information, use ledger-to-resource mappers and drivers to assign costs to resources, activities, and cost objects. By assigning these costs, you define how Activity-Based Management processes the model.

This section discusses:

- Primary and secondary resources.
- Attributes for resources, activities, and cost objects.
- Cost of capital.
- Ledger-to-resource mapping.
- Ledger Mapper Generator.

Primary and Secondary Resources

Resources are the required economic elements to perform the activities associated with your business and are consumed in the performance of these activities and thus denote operating costs. In Activity-Based Management, resources are typically regarded as the groupings of one or more source ledger accounts. For example, resources in a manufacturing business might include costs for indirect labor, production support, facility maintenance, and all costs outside of production such as sales and marketing. In a service business, however, resources might include salaries, office rentals, and costs of capital such as information systems, depreciation, real estate taxes, and other associated costs.

You can categorize resources in the following two ways:

- *Primary resources* are consumed directly by activities or cost objects.

An employee, a work group, or direct materials are examples of primary resources.

- *Secondary resources* are consumed by other resources before being assigned to activities.

For example, suppose that you have one account—Repair and Maintenance—but that account supports both your manufacturing and operations departments and thus requires that you split the costs between your manufacturing and operations departments. In this case, Repair and Maintenance is a secondary resource assigned to two primary resources—Manufacturing Repair and Maintenance as well as Operations Repair and Maintenance.

Attributes for Resources, Activities, and Cost Objects

You can categorize resources, activities, and cost objects by first defining attributes for them, and then adding the attributes to them. Adding one or more attributes to an object also gives you greater control over the processes and analyses associated with that object. Grouping resources with similar characteristics enhances your ability to extract and analyze report data.

For example, suppose that you print history books. Your cost objects might be Asian history by author X, Asian history by author Y, European history by author Z, European history by author T, and so on. To know about some attribute related to these books (such as their cover type), you can enter those values as attributes so that you can generate reports to track and analyze them.

Cost of Capital

Many advocates of shareholder value analysis, cash flow return on investment, and economic value added encourage the maximization of profits after including the costs of capital employed. To achieve this, include the cost of the employed capital assets — also known as the *cost of capital* — when you assign operating expenses to activities and cost objects.

Activity-Based Management enables you to determine the cost of capital by correcting the arbitrary allocations of overhead expenses to products as well as the inability to assign indirect costs to activities and the associated profitability dimensions. Activity-Based Management enables you to correct the financial accounting failure of calculating company profits without recognizing the cost of capital as an economic expense. By correcting these areas of potential miscalculation, you can redirect your attention and specific actions to operations where economic losses are incurred. Therefore, you can successfully protect, retain, and expand economically profitable operations.

Traditionally, employed assets and capital are measured at the corporation, division, or business unit level. Using Activity-Based Management, you can measure the cost of capital in more depth (for example, at the activities and cost-objects level).

Image: Cost of capital flow chart

The following diagram illustrates how cost of capital is distributed at the activities and cost-objects level.

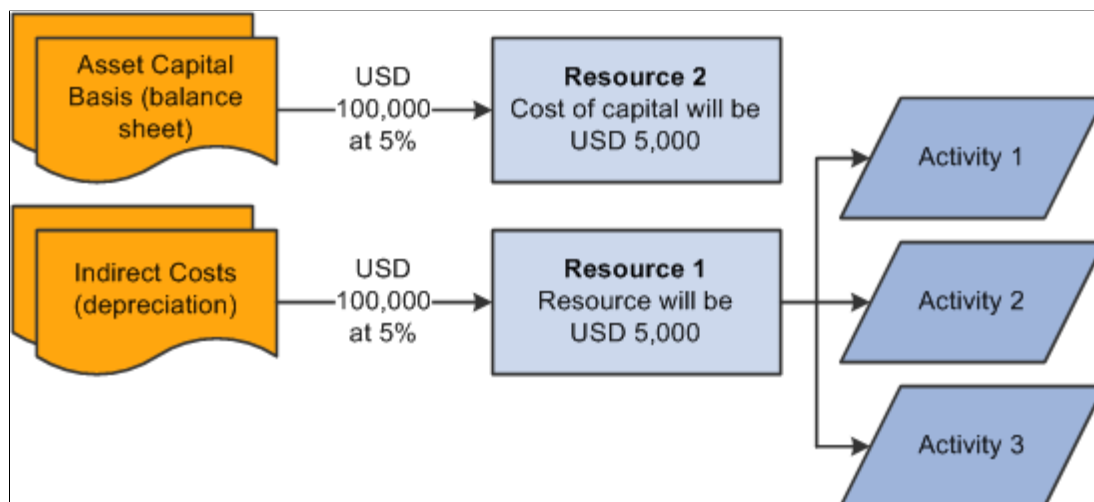

Ledger-to-Resource Mapping

After you define resources, use the ledger-to-resource mapper to assign actual and budgeted monetary amounts from your source ledger to the resources.

Activity-Based Management source ledger-to-resource mapping populates resources in Activity-Based Management with source ledger account items. It can map multiple source ledger line items to a single resource ID. In addition, you can assign many business units to one PeopleSoft EPM business unit. Activity-Based Management source ledger-to-resource mapping processes two amounts—an actual amount that represents actual costs of the accounting period and a budgeted amount used to calculate budgeted model results and compute capacity rate information.

Image: Assigning costs in Activity-Based Management

The following diagram illustrates how Activity-Based Management assigns costs.

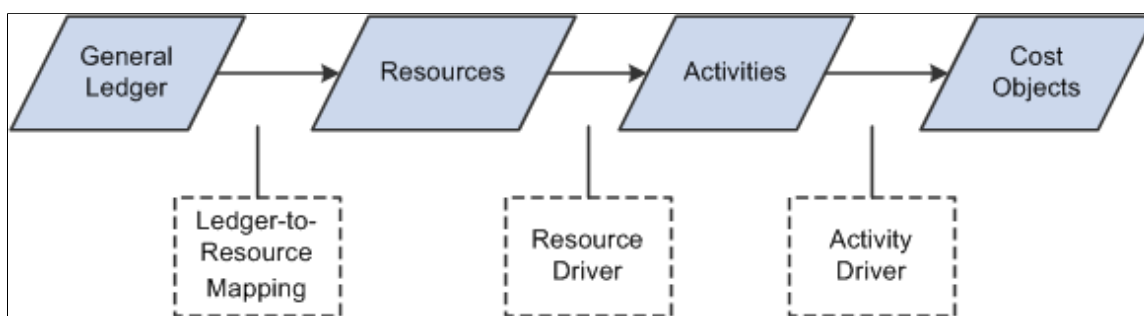

Ledger Mapper Generator

The Ledger Mapper Generator engine (AB_LDMPGEN) automatically generates the ledger mapping rules for Activity-Based Management resources.

Related Links

[Understanding Model Generator and Ledger Mapper Generator](#)

Setting Up Attributes

If you use attributes with resources, first define the attributes, and then define the resources so that you can associate the attributes with their respective resources. You can use the same or different attributes for resources, activities, and cost objects.

This section discusses how to set up attributes.

Page Used to Set Up Attributes

<i>Page Name</i>	<i>Definition Name</i>	<i>Navigation</i>	<i>Usage</i>
Attributes	AB_ATTRIB_TBL1	Activity Based Management, Setup, Attributes, Attributes	Define attributes for resources, activities, and cost objects.

Attributes Page

Use the Attributes page (AB_ATTRIB_TBL1) to define attributes for resources, activities, and cost objects.

Navigation

Activity Based Management, Setup, Attributes, Attributes

Resource Attribute Use, Activity Attribute Use, and Cost Object Attribute Use

Select to designate whether you can use the particular attribute with resources, activities, cost objects, or any combination of these.

Setting Up Cost of Capital

This section discusses how to set up cost of capital percentage.

Page Used to Set Up Cost of Capital

<i>Page Name</i>	<i>Definition Name</i>	<i>Navigation</i>	<i>Usage</i>
Cost of Capital	AB_CST_OF_CAPTL	Activity Based Management, Setup, Resources, Cost of Capital	Set up capital charges for resources that can be assigned to activities and cost objects.

Cost of Capital Page

Use the Cost of Capital page (AB_CST_OF_CAPTL) to set up capital charges for resources that can be assigned to activities and cost objects.

Navigation

Activity Based Management, Setup, Resources, Cost of Capital

Cost of Capital

Enter the numeric percentage amount that the system should use when assigning cost to a resource based on the ledger mapping rule.

Note: The applied formula is:

$$(AMT_FROM_SOURCE_LEDGER) \times (ABC_PERCENTAGE \div 100) \times (AB_COC_PERCENTAGE \div 100)$$

If *AB_COC_PERCENTAGE* is not defined, the default is 1.

Note: Set up cost of capital before setting up resources.

Set up cost of capital at the SetID level to link the cost of capital to resources using the Resource Definition page.

Setting Up Ledger Source

This section provides an overview of ledger source setup and discusses how to set up ledger source IDs.

Pages Used to Set Up Ledger Source

<i>Page Name</i>	<i>Definition Name</i>	<i>Navigation</i>	<i>Usage</i>
Ledger Source	ABM_SOURCE_TBL	Activity Based Management, Setup, Ledger Source, Ledger Source	Identify the datamap containing the source record of information to be mapped and specify the ChartFields to use.

Understanding Ledger Source Setup

Use the Ledger Source page to specify which source (record) datamap and which source-ledger ChartFields (dimensions) you want to map to Activity-Based Management. All ChartFields are available. For example, you may be particularly interested in mapping the sub-account and project-related ChartFields. You can map up to eight ChartFields at a time. (Each ChartField that you select impacts system performance; therefore, select only those ChartFields that you need.) Based on the needs of your implementation, you can even map a null ChartField value.

The combination of the ChartFields that you select must be a *unique key* in the datamap. Those fields should be keys in the primary table or record metadata. If not, the system displays a duplicate row type error when running the ABC engine (for example, if Ledger Source TEST has Ledger, Account, and Operating Unit ChartFields). This means that the datamap for that Ledger Source must have these fields as keys (or the primary table that creates that datamap/tablemap must be grouped by ledger, account, and operating unit) to assure that the key is unique.

Ledger Source Page

Use the Ledger Source page (ABM_SOURCE_TBL) to identify the datamap containing the source record of information to be mapped and specify the ChartFields to use.

Navigation

Activity Based Management, Setup, Ledger Source, Ledger Source

Image: Ledger Source page

This example illustrates the fields and controls on the Ledger Source page. You can find definitions for the fields and controls later on this page.

The screenshot shows a web form titled "Ledger Source". At the top, "Source ID:" is followed by the value "LEDGER". Below this is a section titled "Select ChartFields to use" which contains a list of fields, each with a text input box and a magnifying glass icon to its right. The fields and their values are as follows:

*DataMap Code:	ABM_LEDGER
*Measure:	POSTED_TOTAL_AMT
*BCE Measure:	POSTED_BASE_AMT
Source Unit:	BUSINESS_UNIT_GL
* CHARTFIELD 1:	LEDGER
CHARTFIELD 2:	ACCOUNT
CHARTFIELD 3:	OPERATING_UNIT
CHARTFIELD 4:	DEPTID
CHARTFIELD 5:	PRODUCT
CHARTFIELD 6:	AFFILIATE
CHARTFIELD 7:	STATISTICS_CODE
CHARTFIELD 8:	PROJECT_ID

Source ID Displays the identifier of the selected ledger source (record).

Note: Activity-Based Management can take data from all EPM applications and tables. At a minimum, the source table must include the following fields: Business Unit, Accounting Period, Fiscal Year, Currency Code, and at least one CHARTFIELD and one Measure field.

DataMap Code Enter the code associated with the datamap (table) to be used for the source.

Note: By default, the source datamap is based on PS_LEDGER as the fact table.

Measure Enter the measure field to be used.

If it is the ledger, you can enter the posted total amount.

BCE Measure (base currency equivalent measure) Enter the measure in base currency.

Source Unit Enter the source unit.

CHARTFIELD (1 to 8)

Enter up to eight distinct ChartField dimensions from the source table to use as ChartFields.

Note: The following default ChartField dimensions from the EPM copy of source ledger data are available: LEDGER, ACCOUNT, OPERATING_UNIT, DEPTID, PRODUCT, AFFILIATE, STATISTICS_CODE, and PROJECT_ID.

Note: Only one ChartField configuration is necessary per database; multiple rows on this page are not required.

Setting Up Resources

This section provides an overview of resource setup, lists prerequisites, and discusses how to set up resources.

Pages Used to Set Up Resources

<i>Page Name</i>	<i>Definition Name</i>	<i>Navigation</i>	<i>Usage</i>
Resources	RES_TBL1	Activity Based Management, Setup, Resources, Resources, Resources	Define resources for models to calculate values.
Resource Notes	RES_TBL2	Activity Based Management, Setup, Resources, Resources, Resource Notes	Record setup comments, advice, or notes.
Resource Listing (inquiry)	RES_LIST_VW1	Activity Based Management, Setup, Resources, Resource Listing	Review resources that you set up in the system.
Resource Listing (report)	RUN_RAB_2002	Reports, Activity/Resource Reports, Resource Listing	Run the Resource Listing report.

Understanding Resource Setup

Set up resources using any of the following three methods:

- Use the Resource component to enter resources.
- (Optional) Use PeopleSoft Tree Manager to set up a resource tree.
- (Optional) Define a resource using the Resource component while creating a resource tree.

After you add all of your resources, review detailed resource information on the Resource Listing page or run the Resource Listing report (ABC2002). Both tools provide a listing of resources by SetID and their settings.

Prerequisites

Before you can set up resources, you must do the following:

1. Create a model.
2. If you are using the Employee Profile feature, set up the associated pages, and then start the Employee Profile engine to create the employee, work group, and department resources.
3. If you are using the Cost of Capital feature, set up the associated cost of capital.
4. If you are using attributes with resources, define the attributes using the Attributes page.

Related Links

[Setting Up Cost of Capital](#)

Resources Page

Use the Resources page (RES_TBL1) to define resources for models to calculate values.

Navigation

Activity Based Management, Setup, Resources, Resources, Resources

Image: Resources page

This example illustrates the fields and controls on the Resources page. You can find definitions for the fields and controls later on this page.

The screenshot displays the 'Resources' page with the following details:

- SetID:** SHARE
- Resource ID:** ACCT_MGR
- Resource Details:**
 - *Effective Date: 01/01/1900
 - *Description: Account Manager
 - Owner ID: E1 (Walters, Gary)
 - *Resource Use: Primary
 - *Resource Group: Non people-related cost
 - Spending Pattern ID: LINE (Add Spending Pattern ID)
 - Resource Supplied: Flexible
 - Accounting Class: Non-inventory
- Assignment Type:**
 - Target
 - Source
- Capital Resource Information:**
 - Capital Resource
 - Cost of Capital ID: (Add Cost of Capital ID)
 - Related Resource
 - Resource ID: (View Cost of Capital ID)
- Attributes Table:**

*Attribute ID	Description
(Empty)	(Empty)

Owner ID

(Optional) Enter the unique identifier of the user designated as the owner of the resource.

Resource Use

Select how the resource is consumed. Values are:

Primary: Specifies resources consumed by activities or cost objects.

Secondary: Specifies resources consumed by other resources before being assigned to activities.

Resource Group

Select a resource group composed of resources with similar cost profiles. Values are: *Expense*, *Other*, and *People*.

Spending Pattern ID

If you use the PeopleSoft Activity-Based Planning and Simulation feature, enter the identifier for the desired spending pattern.

View Spending Pattern ID

Click to access the Resource Spending Pattern page in Add mode, where you can define a new spending pattern.

Add Spending Pattern ID

Click to access the Resource Spending Pattern page in Update/Display mode, where you can review an existing spending pattern.

Resource Supplied

Select the resource supplied. Values are:

Committed: Specifies that the resource supply is unalterable in the short term (for example, being unable to change the cost of providing a business location because of a lease structure).

Flexible: Specifies that the resource supply is variable in the short term (for example, a casual labor supply).

Accounting Class

Select an accounting class. Values are:

Inventory: Specifies that the resource is a direct component of the goods or services that you sell (for example, direct materials sold in a manufacturing environment).

Non-inventory: Specifies that the resource is *not* a direct component of the goods and services that you sell (for example, administrative or overhead costs).

Assignment Type

Select Target and Source if the object serves as both the target and source of values assigned to and from other objects.

Deselect Target and Source if the values are not derived from or assigned to this object. You would deselect both check boxes only when working with trees. Some of the objects that you create are higher nodes in the tree (not leaves). Those objects are not going to be targets or sources; you create them to have the intermediate nodes for the tree structure.

Target

Select if the object is the target to which support values are assigned from other objects or sources.

Target objects must be at lower levels in the tree structure than their source objects.

Source	Select if the object is the source of values assigned to other objects or targets. Source objects must be at higher levels in the tree structure than their target objects.
Capital Resource Information	
Capital Resource	Select to assign a cost of capital to this resource, and then enter a Cost of Capital ID.
Cost of Capital ID	Enter the identifier of the cost of capital. This field is available for entry only when you select Capital Resource.
View Cost of Capital ID	Click to access the Resource Spending Pattern page in Add mode, where you can define a new cost of capital item. This option is available only when you select Capital Resource.
Add Cost of Capital ID	Click to access the Cost of Capital page in Update/Display mode, where you can review an existing cost of capital definition. This option is available only when you select Capital Resource.
Related Resource	Select to relate capital resources used by a range of products and let them share drivers such as operating expenses, and then enter a Resource ID.
Resource ID	Enter the identifier of the resource.
	<hr/> Note: Resource ID is available when you select Related Resource. <hr/>

Attributes

Attribute ID If you are using attributes, enter the identifier of the attribute to further categorize the activity.

Related Links

[Setting Up Attributes](#)

Mapping Ledgers to Resources

This section lists prerequisites and discusses how to:

- Set up Activity-Based Management ledger mapping rules.
- Set up ledger-to-resource mapping.

Pages Used to Map Ledgers to Resources

<i>Page Name</i>	<i>Definition Name</i>	<i>Navigation</i>	<i>Usage</i>
Ledger Map Rule	ABM_LEDMAP_RULE	Activity Based Management, Setup, Ledger Source, Ledger Map Rule	Specify the source ledgers to use for actual and budget amounts.
Map Ledger to Tree	ABM_LM_TOPT_TBL	Activity Based Management, Setup, Ledger Source, Ledger Mapping Tree Usage	Set up ledger mapping tree usage for ChartFields.
Ledger Mapping Defaults - Tree and Node Views	ABM_LED_TMPL_TBL1	Activity Based Management, Setup, Ledger Source, Ledger Mapping Defaults, Tree and Node Views	Configure ledger mapping defaults by entering the tree view, tree node, and tree to use for those ChartFields that are identified as using trees.
Ledger Mapping Defaults - Tree View	ABM_LED_TMPL_TBL2	Activity Based Management, Setup, Ledger Source, Ledger Mapping Defaults, Tree View	Select the specific trees to use for mapping.
Ledger to Resource Mapping	ABM_LEDMAP_TBL1	Activity Based Management, Setup, Ledger Source, Ledger to Resource Mapping	Assign costs to resources by using or overriding ledger defaults that you define using the Ledger Mapper Defaults page.

Prerequisites

Before setting up Activity-Based Management ledger-to-resource mapping rules, complete the following business rules setup:

1. Access the Ledger Source page to identify the source of information to be mapped and specify the ChartFields to use.
2. Access the Map Ledger to Tree page, and then select the check boxes next to the ChartFields that you want to associate with the trees.
3. Access the Ledger Mapping Defaults - Tree and Node Views page.

The system displays your changes from the Map Ledger to Tree page. Enter the tree view, tree node, and tree to use for those fields identified as using trees. Specify whether the field accepts all values or tree values and if the field is required.

4. Access the Ledger Mapping Defaults - Tree View page.

The tree names display for the ChartFields that you want to associate with the trees. In the Validation group box, select all check boxes associated with required fields.

Related Links

[Understanding Model Generator and Ledger Mapper Generator](#)

Ledger Map Rule Page

Use the Ledger Map Rule page (ABM_LEDMAP_RULE) to specify the source ledgers to use for actual and budget amounts.

Navigation

Activity Based Management, Setup, Ledger Source, Ledger Map Rule

Image: Ledger Map Rule page

This example illustrates the fields and controls on the Ledger Map Rule page. You can find definitions for the fields and controls later on this page.

Actuals Source ID

Select the identifier of the actuals source.

Note: A source is identified by its datamap and ChartField configuration.

Constraint Code - Actuals

Enter the code associated with the actual constraint to identify where the PeopleSoft EPM constraint definition tables are located for this model such as the datamap, source, and ChartFields to use by the rule for ledger-to-resource mapping.

Note: The constraint code filters values for objects at runtime. Invalid or duplicate constraint codes cause jobstreams to abort.

Note: The constraint used for actual and budget can be (but is not required to be) the same.

Budget Source ID

Select the identifier of the budget source.

Constraint Code - Budget

Enter the code associated with the budget constraint to identify where the PeopleSoft EPM constraint definition tables are located for this model—the datamap, source, and ChartFields to be used by the rule for ledger-to-resource mapping.

Note: The constraint code filters values for objects at runtime. Invalid or duplicate constraint codes cause jobstreams to abort.

Note: The constraint used for budget and actual can be (but is not required to be) the same.

Ledger to Resource Mapping Page

Use the Ledger to Resource Mapping page (ABM_LEDMAP_TBL1) to assign costs to resources by using or overriding ledger defaults that you define using the Ledger Mapper Defaults page.

Navigation

Activity Based Management, Setup, Ledger Source, Ledger to Resource Mapping

Image: Ledger to Resource Mapping page

This example illustrates the fields and controls on the Ledger to Resource Mapping page. You can find definitions for the fields and controls later on this page.

Ledger Mapping

Business Unit: CORP1 Model ID: BANK

Resource ID: ACCT_MGR Account Manager

*Effective Date: 01/31/1999 *Status: Active *Description: Cost to get New Accounts

Mapper Type

*Mapper Type: Actuals

Map Specification

*Source Unit: CORP1 Corporation 1

*Percentage: 20.00

Ledger: ACT All Tree

Account: MANAGERS All Tree

Oper Unit: All Tree

DeptID: MARKETING All Tree

Product: All Tree

Affiliate: All Tree

Stat: All Tree

Project: All Tree

Mapper Type

Select the mapping on which you are currently working. Values are:

Actuals: Specifies that the current mapping represents the actual costs of the accounting period.

Budgeted: Specifies that the current mapping represents the amount used to calculate the capacity rates as well as the budgeted model results.

Source Unit

Enter the source business unit that you want to map to Activity-Based Management.

Percentage

Enter the percentage of cost assigned to the specified resource based on the mapping rule.

<ChartFields>

Note: For example, from a GL source, account 150000 assigns 20 percent of the posted amount to Resource 1.

Displays up to eight editable ledger mapping ChartField settings associated with the model's source. Indicate which ChartField values to use, either all ChartField values, the ChartField values included in a tree node, or a specific ChartField value.

The system hides unused ChartFields.

Note: To configure ChartFields, access the Ledger Source page.

All

Select to use all of the values that are defined for the ChartField.

Tree

Select to use only the ChartField values that are included in the selected tree node.

Note: If *Tree Name not defined* displays, specify the tree name using the Tree and Node Views page.

Note: If you do not select All or Tree for a ChartField, you may enter a specific value, or select one from the prompt list. However, a prompt list appears only if the record metadata for the source ledger has a prompt table defined for that ChartField.

Warning! When mapping activity based costing resources, do not mix tree nodes and direct accounts as this may lead to duplicate mappings that result in engine failure. Use the PeopleTools Tree Manager page to create tree nodes and prevent duplicate mappings.

Chapter 7

Setting Up Activities

Understanding Activities

Activities—the foundation for measuring activity-based cost and profitability—consume resources and represent the processes and procedures within an organization that cause work to be performed by that organization and that consume resources in their performance. For reporting purposes, activities are usually the lowest detail level that you define in Activity-Based Management.

Your decisions about how to define these objects are crucial to obtaining the right type of information from your system. Before you set up these objects, consider the following questions:

- Which activities are central to your organization?
- What resources do these activities consume?
- Which cost objects represent your organization's output?
- What information do you expect to obtain from reports generated by your Activity-Based Management system?

Using one of the many Activity-Based Management activity dictionary templates, identify and define all of your organization's activities in as much detail as your organization requires. Write your activity definitions clearly, and base each one on accurate evaluations of the work actually performed.

There are two types of activities:

- *Primary activities* represent a final result.
- *Secondary activities* depend on another primary activity or represent tasks that are not directly related to the output of your organization.

Understanding Common Activities

Many PeopleSoft applications use the concept of activities. Even though the applications use different terminology, we provide a common table to capture Activity-Based Management, PeopleSoft Projects, PeopleSoft Time and Labor, and PeopleSoft Manufacturing, as well as other manufacturing systems.

Projects

Projects and Activity-Based Management do have activities in common; however, an activity in Activity-Based Management is a standalone chunk of work whereas an activity in Projects is a chunk of work that is a derivative of a project.

Time and Labor

Activities from Projects are already integrated with Time and Labor. Activity-Based Management uses the interface between Projects and Time and Labor to gather information related to the time spent on these activities.

See [Understanding the Employee Profile Feature](#).

Manufacturing

Each task in manufacturing can relate to an Activity-Based Management activity on a one-to-one basis.

Understanding Dimensionality

You can define activities as single dimensional or multidimensional.

Single Dimensional Activities

Single dimensional activities exist in one of four possible dimensions:

- Channel
- Customer
- Department
- Prod/Serv (product or service)

Within PeopleSoft Activity-Based Management, you can only assign single dimensional activities to cost objects that exist in the same dimension to ensure that every activity is related to a customer, product, or channel cost object dimension, thus enabling an accurate measurement of cost.

Multidimensional Activities

Multidimensional activities are a combination of two or more Activity-Based Management dimensions (such as a transaction). Multidimensional activities are associated with multidimensional cost objects and are used in transaction costing.

Understanding Consumption Patterns

The consumption pattern of an activity defines the way in which the activity consumes resources for model validation and reporting purposes. There are three types of consumption patterns:

Unit

Unit-level activities must be performed for every unit of product or service. The quantity of the unit-level activities performed is proportional to production or sales volumes.

For example, a traditional accounting system relies on unit-level cost drivers when using allocation bases such as labor hours, machine hours, units of product, or gross sales amounts when assigning indirect costs to cost objects.

Batch

Batch-level activities must be performed for each batch or setup of work performed. The resources required for these activities are independent of the number of units in the batch.

Administrative

Administrative-level activities are operations of an organization that support an overall dimension but provide no greater information when broken down into any further dimension.

For example, for an activity that randomly checks the quality of a particular product, it would not make sense to further break down the activity into the cost of each product sold to each customer.

Understanding Sustaining Activities

Sustaining activities support the overall dimension or organization.

Product-sustaining activities enable the production of individual products or services. Customer-sustaining activities let an organization serve the needs of and manage an individual customer, but are independent of the volume or mix of the products and services sold to that customer.

You can trace sustaining activities to the product, customer, or service for which the activities are performed, but the quantity of resources used in the product- and customer-sustaining activities is independent of the production and sales volumes and quantity of production batches and customer orders.

Defining Activities

Define activities by:

1. Setting up common activities.
2. Defining your Activity-Based Management activities and properties.

Note: To expand on the delivered activity dictionary, use the Common Activities page. Time and Labor, Manufacturing, and Projects also use the activity dictionary. The Application Messaging feature in PeopleSoft EPM let these products automatically share data.

Pages Used to Define Activities

<i>Page Name</i>	<i>Definition Name</i>	<i>Navigation</i>	<i>Usage</i>
Common Activities	FS_ACTIVITY_TBL1	Activity Based Management, Setup, Activities, Common Activities	Set up the activity dictionary used by Activity-Based Management and several other PeopleSoft applications such as Time and Labor, Manufacturing, and Projects.
Activities	ACT_TBL1	Activity Based Management, Setup, Activities, Activities	Set up activities that your model uses to represent processes or procedures that cause work performance.

Page Name	Definition Name	Navigation	Usage
Activity Description Long	ACT_TBL2S	Click the Group Message button.	Enter additional comments about this activity.
Jobcode Profile	ACT_JOBCODE_TBL	Activity Based Management, Setup, Activities, Jobcode Profile.	Associate job code with the activity.

Common Activities Page

Use the Common Activities page (FS_ACTIVITY_TBL1) to set up the activity dictionary used by Activity-Based Management and several other PeopleSoft applications such as Time and Labor, Manufacturing, and Projects.

Navigation

Activity Based Management, Setup, Activities, Common Activities

To set up common activities:

1. In the Used by group box, select Projects, and then enter a Project Type if PeopleSoft Projects will use this common activity.
2. Select Performance Measurement if EPM uses this common activity.

Note: Consider selecting both check boxes regardless of whether you will actually use the activity with either application because doing so makes the activity more flexible.

To delete the common activity, click the Delete button.

Activities Page

Use the Activities page (ACT_TBL1) to set up activities that your model uses to represent processes or procedures that cause work performance.

Navigation

Activity Based Management, Setup, Activities, Activities

Image: Activities page

This example illustrates the fields and controls on the Activities page. You can find definitions for the fields and controls later on this page.

The screenshot shows the Oracle Activities page for Activity ID A1. The page is titled 'Activities' and 'Jobcode Profile'. The 'SetID' is 'SHARE' and the 'Activity ID' is 'A1'. The 'Effective Date' is '01/01/1900' and the 'Status' is 'Active'. The 'Description' is 'A1 Desc'. The 'Owner ID' is 'E1' with the name 'Walters, Gary'. The 'Activity Use' is 'Primary', 'Consumption Pattern' is 'Unit', and 'Value' is 'Medium Priority'. The 'Assignment Type' section has 'Target' and 'Source' checked, and 'Sustaining' is unchecked. The 'Activity Group Information' section has 'Multi-dimensional' and 'Single Dimensional' radio buttons, with 'Single Dimensional' selected, and a 'Product/Service' dropdown menu. The 'Attributes' section has a table with columns 'Attribute ID' and 'Description'.

To set up activities:

1. Enter a Description for this activity, and then click the Group Message button to enter additional comments about this activity.
2. In the Owner ID field, enter the unique identifier of the user designated as the owner of the resource (for reporting purposes only).
3. Select the type of Activity Use for this activity:

Primary

Select for activities that represent a final result.

Secondary

Select for activities that are dependent on another primary activity, or that represent tasks not directly related to your organization's output.

Note: Selecting this value makes unavailable the Assignment Type and Activity Group Information group boxes unavailable.

4. Select a Consumption Pattern (which classifies activities for reporting purposes and does not affect the calculation of activities by the Activity-Based Management engine).

Administrative

Specifies an activity that supports an overall dimension for the organization.

Batch

Specifies an activity that must be performed for each batch or setup of work performed.

Unit Specifies an activity that must be performed for each unit of product or service—the default.

5. Select a Value (*High, Low, or Medium*) to indicate the level of importance this activity has to your organization.
6. For primary activities, in the Assignment Type group box:

Target Select to assign costs to this activity from a source activity or resource.

Source Select to assign costs from this activity to another activity (if this is a secondary activity) or a target cost object.

Source and Target Select to have the object serve both as the source and the target of values assigned from and to other objects.

(No selection) Deselect both check boxes to neither have values derived from nor assigned to this object.

7. Select Sustaining if this is a product- or customer-sustaining activity.
8. In the Activity Group Information group box, specify whether the activity is Multi-dimensional or Single Dimensional. For a single dimensional activity, select the appropriate dimension for the activity: *Channel, Customer, Department, or Prod/Serv* (product/service).
9. Enter an Attribute ID to further categorize the activity.

Note: ABPS uses the Job Code Profile page to assign capacity to the job code that can do the activity better.

Related Links

[Understanding Model Components](#)

[Understanding Dimensionality](#)

[Understanding Consumption Patterns](#)

[Understanding Sustaining Activities](#)

[Understanding ABPS](#)

Reviewing Your Activity Setup

PeopleSoft Activity-Based Management provides you with two tools to review your activity setup by displaying activities by SetID and their settings:

- The Activity Listing page.
- The Activity Listing report (ABC2005).

Pages Used to Review Your Activity Setup

<i>Page Name</i>	<i>Definition Name</i>	<i>Navigation</i>	<i>Usage</i>
Activity Listing inquiry	ACT_LIST_VW1	Activity Based Management, Setup, Activities, Activity Listing	Review your activity setup by SetID.
Activity Listing report	RUN_RAB_2005	Reports, Activity/Resource Reports, Activity Listing	Run the Activity Listing report (ABC2005).

Copying Common Activities

You can also copy common activities to another SetID using the Common Activity Copy page.

Page Used to Copy Activities

<i>Page Name</i>	<i>Definition Name</i>	<i>Navigation</i>	<i>Usage</i>
Common Activity Copy	AB_FS_ACT_COPY	Activity Based Management, Setup, Activities, Copy Common Activities	Copy common activities from one SetID to another.

Common Activity Copy Page

Use the Common Activity Copy page (AB_FS_ACT_COPY) to copy common activities from one SetID to another.

Navigation

Activity Based Management, Setup, Activities, Copy Common Activities

Select the SetID to which you want to copy the common activities, and then click the Copy button. The system automatically saves a copy of your common activity model.

Chapter 8

Setting Up Cost Objects

Understanding Cost Objects

Cost objects represent cost information about products, customers, and channels. They are the final results of the activities performed by your business—the focal points of costing and profitability analysis.

You already added product, customer, and channel data to your central repository of information—the Operational Warehouse - Enriched (OWE). In addition, you may have defined trees for the customer, product, channel, and department cost object types. Using Activity-Based Management, you can use these trees for the Activity-Based Management engine's cost object roll-up.

Understanding Cost Object Use

A primary cost object is the final customer, product, or channel. This is the object about which you want to derive cost or revenue information. Use a secondary cost object for costing components of a final customer, product, or channel.

Understanding Cost Object Groups

There are three cost object groups:

- Single-dimensional
- Multidimensional
- Sustaining

Understanding Single-Dimensional Cost Objects

A single-dimensional cost object exists in a single Activity-Based Management dimension. Select a single, common dimension for each combination of activities and cost objects. The single-dimensional approach assures that every activity relates to a customer, product, or channel. These are linked through

activity drivers to a corresponding customer, product, channel, or department cost object, letting you accurately measure costs.

Image: Example of single-dimensional cost objects

Single-dimensional costing preserves the cause and effect relationship between activities and cost objects as shown in the following illustration.

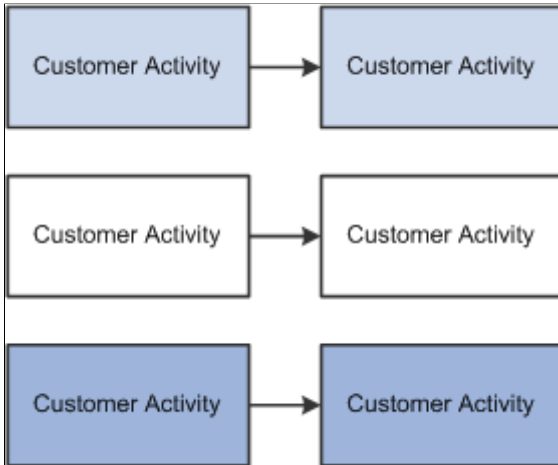

Understanding Multidimensional Cost Objects

A multidimensional cost object — often referred to as *transaction costing* — is a combination of two or more Activity-Based Management dimensions such as those involved in a transaction. Multidimensional cost objects are useful in service-based organizations, such as banks, where costs are not easily defined as belonging to a customer, product, channel, or dimension. Many costs actually represent the point where multiple dimensions intersect. For example, when a customer withdrawals money from a bank's ATM, the specific transaction takes place at the intersection of three dimensions as shown in the following illustration.

Image: Example of a multidimensional cost object

Example of a multidimensional cost object.

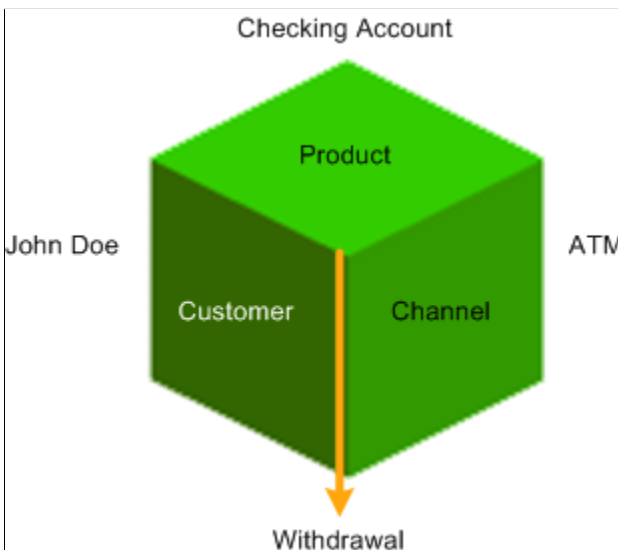

Because you can derive multidimensional cost objects from transaction tables that record customer, product, and channel dimensions, metadata can group certain characteristics together to establish a costing basis. Using metadata to define table and data structures provides flexibility in developing models for your business since doing so lets you create multidimensional cost objects that you can use for costing.

Understanding Sustaining Cost Objects

The cost object supports the overall dimension or organization. Product-sustaining cost objects enable the production of individual products or services. Customer-sustaining cost objects let an organization sell to an individual customer, but are not independent of the volume or mix of the products and services sold and delivered to the customer. You can easily trace sustaining cost objects to the customer, product, or service for which the cost objects are performed. However, the quantity of resources used in the product- and customer-sustaining cost objects are independent of the production and sales volumes and quantity of production batches and customer orders.

Defining Cost Objects

Use the Cost Objects page to set up cost objects.

When adding cost objects using the Cost Objects search page, if you select Integrate Cost Object, you must have already set up the object to which the cost object refers in the Operational Warehouse - Enriched (OWE). For example, if you set up a cost object called *PENCIL*, it must already exist in the Product table (PRODUCT_D00); otherwise, it does not display in the Cost Object ID list.

Pages Used to Set Up Cost Objects

Page Name	Definition Name	Navigation	Usage
Cost Objects	CST_TBL1	Activity Based Management, Setup, Cost Objects, Cost Objects	Set up cost objects for your model.
Cost Object Description Long	CST_TBL2S	Click the Information button on the Cost Objects page.	Enter a long description of the cost object.

Cost Objects Page

Use the Cost Objects page (CST_TBL1) to set up cost objects for your model.

Navigation

Activity Based Management, Setup, Cost Objects, Cost Objects

Enter a SetID, Cost Object Group, Dimension, and Cost Object ID. (If Integrate Cost Object is selected, this cost object must be set up in the OWE).

Image: Cost Objects page

This example illustrates the fields and controls on the Cost Objects page. You can find definitions for the fields and controls later on this page.

The screenshot displays the 'Cost Objects' page with the following details:

- SetID:** SHARE
- Cost Object ID:** MEDIUM_BIZ
- *Effective Date:** 01/01/1900
- *Status:** Active
- *Description:** Medium Business
- *Cost Object Use:** Primary
- Assignment Type:** Target (checked)
- Dimension Usage:** Single Dimensional (selected)
- Attributes Table:**

*Attribute ID	Description
DISCOUNT	

Description

Enter a description of the cost object.



(Optional) Click the Information button to enter a long description of the cost object.

Cost Object Use

Select the cost object use. Values are:

Primary: Select to have the cost object be the final customer, product, or channel (or other object). This represents the object for which you want to derive cost or revenue information.

Secondary: Select to have the cost object be used when you are costing components of a final customer, product, or channel.

For example, if a product consists of two separate components, you may want to treat each as a secondary cost object. To obtain the cost of the total product, assign each secondary cost object to a primary cost object that represents the combined product.

Selecting this value makes the Sustaining and Target check boxes unavailable for entry.

Multi-dimensional

Select to specify that the cost is a combination of two or more dimensions—a customer, a product, or a channel—such as a transaction.

Single Dimensional

Select to specify that the cost object exists in a single dimension —customer, product, or channel.

Note: If you are adding a new single-dimensional cost object using the Cost Objects search page, select the Cost Object Group and Dimension – customer, product/service, channel, or department.

Sustaining

Select if the *Primary* cost object supports the overall business, cannot reasonably be attributed to one or more dimensions, or does not generate revenue.

Target

Select if this *Primary* cost object is a target

Related Links

[Understanding Model Components](#)

Reviewing Cost Objects

Review cost object setup by using the Cost Object Listing inquiry page, that lists the cost objects and settings by SetID or by generating the Cost Object Listing report (ABC2008) that you can either run for all cost objects in a SetID or for just a specific cost object ID.

Pages Used to Review Cost Objects

Page Name	Definition Name	Navigation	Usage
Cost Object Listing inquiry	CST_LIST_VW1	Activity Based Management, Setup, Cost Objects, Cost Object Listing	Review a list of cost objects by SetID.
Cost Object Listing report	RUN_RAB_2008	Activity Based Management, Reports, Cost Object Reports, Cost Object Listing	Generate the Cost Object Listing report (ABC2008).

Updating Your Model Definition

If you use cost object trees for the Activity-Based Management engine's cost object roll-up, update your Activity-Based Management model definition to reflect the object trees that you created. On the Define Model page, click the Cost Object Trees button to select specific trees for each dimension.

Setting Up Pointers

Understanding Pointers

A sustainable Activity-Based Management model must be highly integrated (using pointers, implicit pointers, and transaction pointers) with the operational warehouse-enriched (OWE).

Pointers let you extract values from the operational warehouse-enriched (OWE) tables within the EPM database, and then use those values as driver quantities. By using pointers, you avoid entering static driver quantities that require maintenance. SetID defines and uses pointers. You can identify pointer-resolved quantities by their associated business unit, fiscal year, and accounting period. Activity-Based Management assures that only the correct numeric value is available for extraction. As long as your warehouse is current, your model remains current.

For example, you might define a driver as the number of cases. You assign to a driver the specific quantity that represents the amount of this driver for a given period of time. This driver quantity resides in a table such as the Sales Transactions table. To associate this value with the specific driver, define where the value is located within the OWE. Information that you enter in the setup page for pointers acts as a roadmap for the Activity-Based Management engine to locate the specific data.

Using Filters, Constraints, and Units of Measure

In Activity-Based Management, filters and constraints:

- Help define pointers, implicit pointers, and transaction pointers.
- Help the Activity-Based Management engine process large amounts of data efficiently by defining subsets of the data from the datamap.

Pointers, implicit pointers, and transaction pointers are defined in terms of the constraint. You can optionally incorporate units of measure to ensure that Activity-Based Management only uses driver quantities with the same unit of measure designations.

Using Value Objects

Value objects enhance the power of your filters by letting you enter a constraint string that defines the target field of a filter so that you can share filters in your constraints that use the same datamap. Using value objects also lets you reduce the number of metadata filters that you create and maintain; you don't need to create an individual filter for each pointer because you can create generic filters to reuse for each pointer.

To help understand how value objects work, consider the example of setting up an implicit pointer using a value object. If you use value objects, define just one filter and constraint pair that you can then reuse for one datamap. In the Filter Rules group box of the Selection Criteria page, specify your DataMap Column, and select Obj (object), and then enter `%AB_VAL_OBJ_VAL` in the Value field.

Next, set up the constraint to use the filter that you just defined. In the Filter Code field, enter *FL8* – the code for the filter that you just defined.

Understanding Key Performance Indicators and Pointers

When used with PeopleSoft Enterprise Scorecard, your pointers can use key performance indicators (KPIs) instead of constraints. Use KPIs like constraints; they return a quantity—or quantity and key target object ID—to be used as a measure for a key that is a source object ID.

Types of Pointers

You can create basic pointers, implicit pointers, and transaction pointers.

Basic Pointers

Basic pointers point to driver quantities in OWE tables. They point to an object ID for every target in the driver.

Implicit Pointers

Implicit pointers let you define a table, or a subset of a table, as the target for a driver. For some purposes this is more efficient than defining an object ID for every target in a driver. The table that you define as the target then provides both the object ID and driver quantity of the driver target. You use filters and constraints to define a subset of the table.

Implicit pointers are particularly useful when you need to access a large transaction table. For example, assume you find that the cost of an activity is allocated to customers on the basis of the number of times a customer creates a transaction. An implicit pointer lets you incorporate the table that includes the customer IDs, the associated cost object ID, and transaction quantity data into a driver.

Transaction Pointers

Transaction pointers are even more specific than implicit pointers. Transaction pointers let you define tables (or a subsets of tables) and indicate what columns *within* the tables represent the product, customer, and channel dimensions in a multidimensional object.

Common Elements Used in Setting Up Pointers

Use KPI	Select if you are using KPIs for this pointer.
KPI ID	Select the ID of the KPI that you want to use.
	Click the View Related Links button to either access the KPI Definition component or the Unit of Measure page (UNITS_TBL1).
Constraint Code	Enter the constraint code for this pointer if you are using constraints. The constraint defines what data you want to retrieve from the operational warehouse, and the location of the data. Set up constraints using the Constraints component.

See "Setting Up Constraints (*PeopleSoft 9.1: Enterprise Performance Management Fundamentals*)".



Click the Update button to the right of the Constraint Code field to access the Constraints component.

Value Object Value

Enter a value object to use value objects in the filters used by your pointer's constraint to enhance the power of the filters.

Unit of Measure

Select one, if applicable, to ensure that Activity-Based Management only uses driver quantities with the same unit of measure destinations.

Measure

Select a numeric amount for the unit of measure.



If you defined a new data element or modified an existing one, click the Compile Implicit Pointer button to generate the new SQL.

Prerequisites

Before you can complete the task of setting up your pointers, you must:

- Set up filters, constraints, and datamaps in the EPM Foundation.
- Set up KPI IDs (if you are using KPIs).

Setting Up Pointers

To complete your pointer setup:

1. Access the Pointers page to define basic pointers.
2. Access the Implicit Pointers page to define implicit pointers.
3. Access the Transaction Pointers page to define transaction pointers representing the volume for a transaction.
4. (Optional) Recompile pointer metadata.
5. Create drivers.

Pages Used to Set Up Pointers

Page Name	Definition Name	Navigation	Usage
Pointers	POINTER_TBL1	Activity Based Management, Setup, Pointers to Drivers, Pointers	Specify where driver quantities exist.

Page Name	Definition Name	Navigation	Usage
Implicit Pointers	AB_IMPL_PTR_TBL1	Activity Base Management, Setup, Pointers to Drivers, Implicit Pointers	Specify implicit pointers to driver quantities.
Transaction Pointer	TRN_PTR_TBL1	Activity Based Management, Setup, Pointers to Drivers, Transaction Pointers	Specify transaction pointers to driver quantities.
Transactions	CALC_TRN_VW1	Activity Based Management, Setup, Pointers to Drivers, Transactions	Review transactions.

Pointers Page

Use the Pointers page (POINTER_TBL1) to specify where driver quantities exist.

Navigation

Activity Based Management, Setup, Pointers to Drivers, Pointers

Image: Pointers page

This example illustrates the fields and controls on the Pointers page.

Pointers

SetID: SHARE Pointer ID: V3000

Details Find | View All First 1 of 1 Last

*Effective Date: 01/01/1900 *Status: Active

Quantity Pointer Information

*Description: V3000 Use KPI

KPI ID:

Constraint Code: V3000 V3000

Value Object Value:

Unit of Measure:

Measure: 6 Amount

Implicit Pointers Page

Use the Implicit Pointers page (AB_IMPL_PTR_TBL1) to specify implicit pointers to driver quantities.

Navigation

Activity Base Management, Setup, Pointers to Drivers, Implicit Pointers

Image: Implicit Pointers page

This example illustrates the fields and controls on the Implicit Pointers page. You can find definitions for the fields and controls later on this page.

Dimension

Enter the appropriate dimension to specify the datamap column number that the system uses to obtain a subset of the data.

Inter Unit

Select to use the pointer for inter-business unit cost assignments, and then select the appropriate IBU Business Unit (inter-business unit) and IBU Model ID.

Complexity Flag

Select if the pointer uses a complexity factor for weighted calculation, and then select an ABC Complexity Factor.



Compile Implicit Pointer

Click to generate the new SQL if you defined a new data element or modified an existing one.

Transaction Pointer Page

Use the Transaction Pointer page (TRN_PTR_TBL1) to specify transaction pointers to driver quantities.

Navigation

Activity Based Management, Setup, Pointers to Drivers, Transaction Pointers

Image: Transaction Pointer page

This example illustrates the fields and controls on the Transaction Pointer page. You can find definitions for the fields and controls later on this page.

The screenshot shows the 'Transaction Pointer' configuration page. At the top, it displays 'SetID: CORP1' and 'Transaction ID: A'. Below this is a 'Details' section with a search bar and navigation controls. The main form includes fields for '*Effective Date:' (03/25/2010), '*Status:' (Active), and 'SQL Prefix:'. A 'Quantity Pointer Information' section contains fields for '*Description:', '*Constraint Code:', 'Value Object Value:', '*Measure:', and 'Unit of Measure:'. At the bottom, a 'Dimension' table is shown with columns for 'Dimension', 'Description', and 'Transaction Tbl Dim Name'. The table lists 'ABC Dimension' and has a dropdown menu for 'Transaction Tbl Dim Name'.

ABC Dimension

Displays the dimensions for the selected transaction.

Transaction Tbl Dim Name (transaction table dimension name)

Select at least one transaction table dimension name to identify the column within the transaction table that represents the dimensions that you want to use for this transaction.

Note: Consider defining three table dimensions including a channel ID, a customer ID, and a product ID.



Compile Transaction Pointer

Click to generate the new SQL if you defined a new data element or modified an existing one.

Compiling Pointer Metadata

Consider occasionally recompiling your pointer metadata using the Mass Compile page in *Enterprise Performance Management Fundamentals 9.1* documentation. This would be a good thing to do, for example, if you change any constraints and filters on which your pointers are based.

Creating Drivers

You are now ready to create drivers using either the Drivers or the Inter Unit Drivers component.

See [Understanding Drivers](#).

Using Volume Definitions

There may be times when you must calculate volume costs. Once you supply the system with a volume amount, it uses that value as the denominator in an equation that establishes a metric for a given activity or cost object by pointing to the table location of the required data. For example, to determine the cost of production per unit, and the total cost of units is the numerator, supply a volume amount for the denominator. Activity-Based Management then calculates the cost of processing per unit.

Note: Before adding volume definitions, you must establish your activities, cost objects, and pointers.

Establish volume definitions using pointers for:

- Activities using the Activity Volume page.
- Cost objects using the Cost Object Volume page.

Note: Activity-Based Planning and Simulation (ABPS) uses these pages to calculate the change in volume required to calculate resource spending needs. In ABPS, depending upon the model type, you must define the correct budgeted, capacity, or rate pointer along with the actual pointer.

Pages Used to Define Volumes

<i>Page Name</i>	<i>Definition Name</i>	<i>Navigation</i>	<i>Usage</i>
Activity Volume	ACT_VOL_TBL1	Activity Based Management, Setup, Activities, Activity Volume	Determine the volume that calculates object rates.
Cost Object Volume	CST_VOL_TBL1	Activity Based Management, Setup, Cost Objects, Cost Object Volume	Determine the volume that calculates cost object rates.

Related Links

[Understanding ABPS](#)

Activity Volume Page

Use the Activity Volume page (ACT_VOL_TBL1) to determine the volume that calculates object rates.

Navigation

Activity Based Management, Setup, Activities, Activity Volume

Select an Actuals Pointer ID, Budgeted Pointer ID, Capacity Pointer ID, and Rate Pointer ID to indicate the table location of actuals, budgeted, capacity, and rate information respectively.

Cost Object Volume Page

Use the Cost Object Volume page (CST_VOL_TBL1) to determine the volume that calculates cost object rates.

Navigation

Activity Based Management, Setup, Cost Objects, Cost Object Volume

Select an Actuals Pointer ID, Budgeted Pointer ID, Capacity Pointer ID, and Rate Pointer ID to indicate the table location of actuals, budgeted, capacity, and rate information respectively.

Chapter 10

Setting Up Drivers

Understanding Drivers

Drivers link Activity-Based Management objects and drive costs from one object (such as a source object) to another (such as a target object) according to the method defined in the driver. In Activity-Based Management, you can assign drivers attributes to establish their source and target, and their capacity and rate handling information. You can also assign driver attributes to group drivers with similar characteristics for reporting and data management purposes. Finally, the system uses pointers and implicit pointers to identify the quantitative measures on which drivers are based.

See [Understanding Pointers](#).

When you define drivers, set up two kinds:

- *Resource Drivers* drive resource costs to an activity, cost object, or another resource and link expenses captured in the general ledger to the activities performed.
- *Activity Drivers* drive the activity cost to the cost object or another activity and distribute the activity costs to cost objects such as products, customers, and channels.

Interunit Drivers

Interunit drivers let you distribute costs across business units and establish relationships between the cost objects of one organization and the supporting activities of the other organizations that share business units and models. Interunit drivers are useful in a shared-services business unit or a shared-services model with a corporate type business unit providing services to one or more operating type business units. Interunit drivers can define costs from a cost object in one model or business unit to resources, activities, and cost objects that pertain to other business units and models.

For example, your corporate shared services provide human resources (HR) and information technology (IT) support to the different operating business units such as manufacturing and sales. By establishing interunit drivers, you can assure that these cost objects are driven from the corporate model to the production model (such as from HR to the manufacturing department). Interunit drivers ensure that specific costs get directed from one business unit to another according to the definitions that you create. PeopleSoft provides components for setting up interunit drivers.

Driver Tables

The following table lists the tables in which drivers are stored:

Table Name	Description
Driver Definition (DRIVER_TBL)	Defines driver behavior (such as the assignment method and how capacity is handled).

Table Name	Description
Driver Source (DRIVER_SRC_SEQ)	Defines the input object for the driver.
Driver Target (DRIVER_TAR_SEQ)	Defines the target for the drivers, where the monetary amounts go, and how the driver method is implemented. The pointers defining the driver amounts or volumes are located in this table. Complexity factors are also defined here.

Driver Attributes

Driver attributes group drivers with like characteristics for reporting purposes. For example, suppose that you have two drivers—number of cases of coffee and number of cases of tea. However, for reporting purposes, you are only interested in the total number of cases of product shipped. In this situation, define a *Cases of Product* attribute to be used for each of the two drivers. That way you can report the total number of cases of product used as drivers.

You can also use driver attributes for modeling purposes to group drivers that are modeled the same way.

Note: Before defining your actual drivers, define driver attributes.

Driver Class

The driver class that you assign determines whether the driver is a unit, batch, or sustaining driver. This definition should be the same as the consumption pattern that you defined on the Activities page. Sustaining drivers relate to activities that support activities such as administrative functions, customers, and products.

Related Links

[Defining Activities](#)

[Understanding Consumption Patterns](#)

Driver Categories

Driver categories group drivers with similar characteristics. For each driver that you define, select the driver category. All but the category *Other*, lets you input a pointer to specify capacity information, frozen rate information, and residual objects. You can also add complexity factors for the targets. This section discusses the driver categories that you can assign to the defined, implicit, and interunit drivers.

Note: You do not set up categories or methods for employee profile and routing drivers because the system automatically sets up these types of drivers.

Transactional Drivers

Transactional drivers are based on the occurrence of a particular event. They assume the same quantity of resources is required each time an activity is performed. These are the least expensive drivers to set up and are useful if you are not concerned about the variation in use by a cost object. For example, set up

transactional drivers for such activities as processing purchase orders, receiving products, or scheduling production runs.

Duration Drivers

Duration drivers represent an estimate of the amount of time required to perform a given activity. Use these when a significant variation exists in the amount of activity required for different outputs. These drivers are more expensive to set up due to the time estimates required for each activity. Duration drivers let you use a complexity factor for a weighted index approach if you select Duration Capacity on the Drivers - Rates page.

Intensity Drivers

Intensity drivers take into account the complexity of actions by using a complexity factor for a weighted index approach. The complexity factor is multiplied by the driver quantity to obtain the final driver quantity to be used for cost calculation. This is different from the duration driver because, with duration drivers, the driver quantity is given; whereas, the system obtains the driver quantity for the intensity driver using the following equation:

$$(\text{given driver quantity}) * (\text{complexity factor}) = \text{intensity driver}$$

Use intensity drivers when the resources associated with the activity are expensive and variable. This is the most expensive driver to implement as it directly charges for the resources used each time an activity is performed. It also requires special setup involving quality control staff and special test and gauging equipment.

Other Drivers

The *Other* category lets set up a user-defined driver method.

Driver Methods

The driver method defines the type of driver and dictates the manner in which the system assigns costs. The available methods are dependent on the selected driver category. The following table lists the methods that you can assign to the defined, implicit, and interunit drivers:

<i>Driver Method</i>	<i>Use</i>
Amount	Denotes a driver based on a quantity of resources or activities that are consumed. This is the only method available if you select a driver category of Duration Drivers, Intensity Drivers, or Transactional Drivers. The system locates the amounts using pointers.
Percentage	Denotes that the driver is based on the percentage of a model object consumed. The system locates the amounts using pointers.
Spread Even	Distributes the resource or activity cost evenly over the targets to which this driver is linked.
Direct	Denotes that a model object is assigned entirely to another model object.

Driver Method	Use
Residual Based on Prior Allocation	Denotes that the system allocates any residual cost objects generated by drivers using capacity or frozen rates to the specified target model objects.

Image: Relationships among driver categories and driver methods

The following diagram illustrates the relationship between driver categories and their methods.

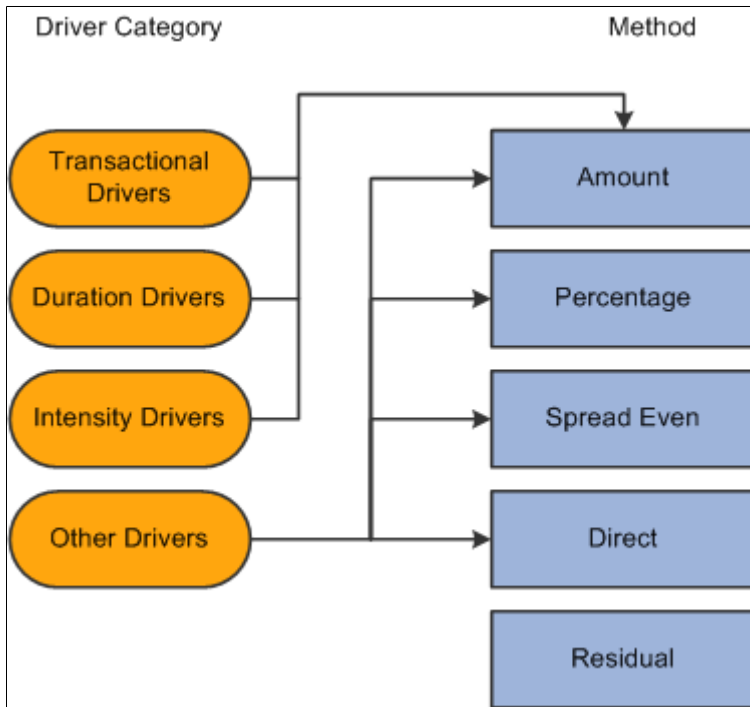

Assigning Driver Sources and Targets

The logic in the Drivers - Source and Drivers - Target pages ensures that you can only select the following valid object combinations:

Source Type	Target Type	Source ID List	Target ID List
Resource	Resource	Secondary resources	Primary resources identified as a target and other secondary resources
Resource	Activity	Primary resources identified as a source	Primary activities identified as a target and other secondary activities
Resource	Cost Object	Primary resources identified as a source	Primary cost objects identified as a target and other secondary cost objects
Activity	Activity	Secondary activities	Primary activities identified as a target and other secondary activities

Source Type	Target Type	Source ID List	Target ID List
Activity	Cost Object	Primary activities identified as a source	Primary cost objects identified as a target and secondary cost objects
Cost Object	Cost Object	Secondary cost objects	Primary cost objects identified as a target and other secondary cost objects

Driver Target Definition Types

When you set up drivers, you can select the driver target definition types that determine how the system retrieves and presents driver quantities. Here are the four available definition types:

Defined

The defined driver option lets you define target objects. You can specify actual and budgeted pointers. Use this definition type if you have actual or budgeted costs.

Implicit

The implicit driver option lets you use a table to define the driver quantities and driver targets using an implicit pointer to point to a particular table. Use this driver to specify specific subsets of costs such as transaction costs.

Employee Survey

The system automatically assigns the Employee Survey option to drivers created using the Employee Profile feature.

Routing Info

The system automatically creates routing information drivers when you run the Routing Information engine. If you use Activity-Based Management within a manufacturing environment, run the Routing Information engine that uses these drivers.

Related Links

[Understanding Manufacturing Integration](#)

[Understanding the Employee Profile Feature](#)

Prerequisites

Before setting up your drivers in Activity-Based Management, you must set up your:

- Model.
- Resources, activities, and cost objects.
- Pointers.

Setting Up Drivers

To set up drivers, complete the following steps:

1. (Optional) Define driver attributes.
2. Set up drivers.
3. Set up driver rates.
4. Specify source model objects for drivers.
5. Specify target model objects for drivers.

Pages Used to Set Up Drivers

<i>Page Name</i>	<i>Definition Name</i>	<i>Navigation</i>	<i>Usage</i>
Driver Attribute	DRIVER_ATTR_TBL1	Activity Based Management, Setup, Drivers, Driver Attributes	Define driver attributes to group drivers with similar characteristics.
Driver	DRIVER_TBL1	Activity Based Management, Setup, Drivers, Driver, Driver	Create the driver and define its most important characteristics.
Driver Description Long	DRIVER_TBL5S	Click the Information button on the Driver page.	Enter a long description for the driver.
Driver - Rates	DRIVER_TBL2	Activity Based Management, Setup, Drivers, Driver, Rates	Define the location of the capacity volume and the excess capacity cost object for the model to use and set up driver rates for capacity and frozen rate models.
Driver - Source	DRIVER_TBL3	Activity Based Management, Setup, Drivers, Driver, Source	Specify the source model cost object for the driver.
Driver - Target	DRIVER_TBL4	Activity Based Management, Setup, Drivers, Driver, Target	Specify the target model objects for the driver.

Driver Attribute Page

Use the Driver Attribute page (DRIVER_ATTR_TBL1) to define driver attributes to group drivers with similar characteristics.

Navigation

Activity Based Management, Setup, Drivers, Driver Attributes

To define driver attributes, enter a description for the attribute.

Driver Page

Use the Driver page (DRIVER_TBL1) to create the driver and define its most important characteristics.

Navigation

Activity Based Management, Setup, Drivers, Driver, Driver

Image: Driver page

This example illustrates the fields and controls on the Driver page. You can find definitions for the fields and controls later on this page.

The screenshot shows the 'Driver' page with the following fields and values:

- Business Unit: CORP1
- Model ID: BANK
- Driver ID: DAACCT_PROCESSING
- Driver Details: Find | View All | First | 1 of 1 | Last
- *Effective Date: 01/31/1999
- *Status: Active
- Driver Quantities Override for this Driver
- *Description: A/ACCT_PROCESSING
- Driver Attribute: [Empty]
- *Driver Class: Unit Driver
- *Driver Category: Duration Drivers
- *Method: Amount
- *Source: Activity
- *Target: Cost Object
- *Target Definition: Implicit Driver

Driver Quantities Override for this Driver

Select if you defined driver quantities for the driver.

Define quantities for drivers using the Driver Quantities pages.

If you define quantities on these pages, the Activity-Based Management engine overrides and does not use the quantities defined in the driver.

Driver Attribute

Select a driver attribute for this driver, if applicable.

Note: This is a report grouping only and has no effect on the calculations. You should have already set up any driver attributes using the Driver Attribute page.

Driver Class

Select a driver class. Values are: *Unit*, *Batch*, and *Sustain* driver.

This definition should be the same as the consumption pattern that you defined using the Activities page. Sustain class drivers relate to activities such as administrative functions, customers, and products.

Note: A warning message displays if the consumption pattern does not correspond, but processing is unaffected.

Driver Category

Select the driver category. Values are:

Duration Drivers: Represent an estimate of the amount of time required to perform a given activity.

Intensity Drivers: Let you use a complexity factor for a weighted index approach. Intensity drivers also take into account the complexity of actions; you can use them instead of duration drivers. In such cases, the complexity factor becomes an estimate of time.

Transactional Drivers: Let you specify frozen rates and are based on the occurrence of a particular event. For example, you could categorize a *Number of Cases driver* as a transactional driver because each case is treated the same—Case 1 is treated the same as Case 100.

Other: Lets you define a driver method category. Click Refresh to activate the Method field.

Note: The first three values automatically assign the *Amount* driver method and activate the Drivers - Rates page.

Method

Select a method to define the type of driver that you are creating. Values are:

Amount: Specifies a driver based on a quantity of resources or activities consumed.

Note: This is the only method available if you select a driver category of *Duration Drivers*, *Intensity Drivers*, or *Transactional Drivers*.

Direct: Specifies that an object is assigned entirely to another object.

Percentage: Specifies a driver based on the percentage of an object that is consumed. For example, employees might spend 20 percent of their work time performing an activity such as painting a wall, another 40 percent performing a second activity such as installing windows, and the remaining 40 percent performing a third activity such as building stairs.

Residual based on prior alloc (residual based on prior allocation): Specifies that the system allocates any residual cost objects generated by drivers using capacity or frozen rates to the specified target model objects.

Spread Even: Assigns the resource or activity evenly over the targets to which this driver is linked.

Source

Select the source from which costs are derived.

Target

Select the target to which costs are assigned.

Target Definition

Select to specify how the system retrieves and presents the driver quantities. Values are:

Defined: If you select this method, you must enter driver targets using the Target page. Depending on the combination that you select, you may also have to enter actual pointers, budgeted pointers, or both to use a table to define the driver quantities.

For example, if you select a spread even method, it is not necessary to define pointers.

Empl Surv (employee survey): Select to create the driver with the Employee Profile feature.

Impl Drv (implicit driver): Select if you use a table to define the driver quantities and use an implicit pointer to point at a particular table.

Rout Info (routing information): Select to automatically create the driver using the Routing engine. You do not need to set up this type of driver.

Related Links

[Understanding Drivers](#)

[Driver - Rates Page](#)

Driver - Rates Page

Use the Driver - Rates page (DRIVER_TBL2) to define the location of the capacity volume and the excess capacity cost object for the model to use and set up driver rates for capacity and frozen rate models.

Navigation

Activity Based Management, Setup, Drivers, Driver, Rates

Capacity Pointer ID and Rate Pointer ID

Specify either a capacity pointer ID or a rate pointer ID from the Pointer table for duration, intensity, or transactional drivers.

If you specify both, the model type that you are running determines which one the system picks up.



[View Related Links](#)

Click to add or update pointers.

Residual Object

Select the cost object that contains the excess capacity. This cost object must be attributed to the department dimension.



[View Related Links](#)

Click to add or update cost objects.

Duration Capacity

Select to indicate that the source is a *fungible* object that can be reused for other purposes.

Note: On the Drivers - Target page, you can enter a Complexity Factor representing time weighting of the driver.

Note: If you populate the two rates on this page after running the model, your results contain three rates because the model calculates an actual and budgeted rate (assuming budgeted data exists) by default, and population of this page adds a capacity or frozen rate. You then have an option of running the model for a second time using whichever rate you choose.

Driver - Source Page

Use the Driver - Source page (DRIVER_TBL3) to specify the source model cost object for the driver.

Navigation

Activity Based Management, Setup, Drivers, Driver, Source

Source Displays the source selected using the Drivers - General page.

Object ID Depending on the source selected using the Drivers - General page, select the available object ID. Values are: *Resource ID*, *Cost Object ID*, or *Activity ID*.

Note: A driver can be related to more than one source model object, but the source model objects must be of the same type.

Driver - Target Page

Use the Driver - Target page (DRIVER_TBL4) to specify the target model objects for the driver.

Navigation

Activity Based Management, Setup, Drivers, Driver, Target

Image: Driver - Target page

This example illustrates the fields and controls on the Driver - Target page. You can find definitions for the fields and controls later on this page.

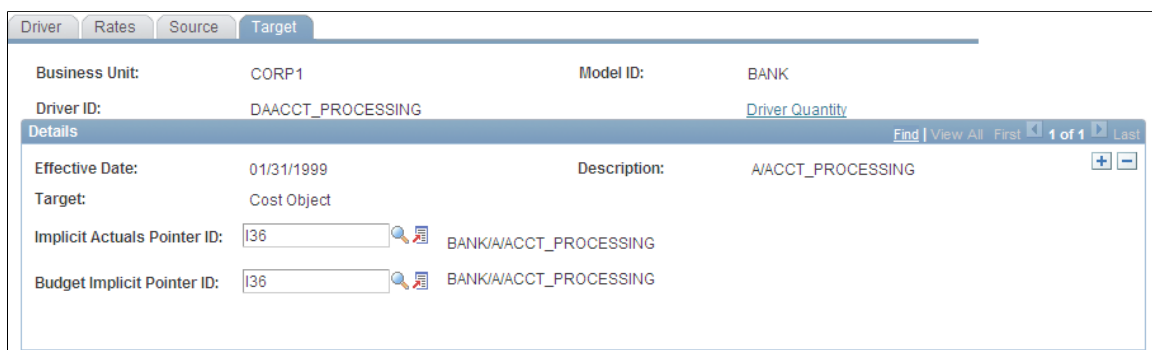

Note: The appearance of this page and its fields varies depending on the target definition setting on the Drivers - General page. It is only active if you select a target definition of *Defined* or *Impl Drv* (implicit driver).

Target

Displays the target selected using the Drivers - General page.

Object ID

If you specified a *Defined* target definition using the Drivers - General page, add one or more object IDs—resource ID, cost object ID, or activity ID. For each object ID that you add, you can specify:

Actuals Pointer ID: Identifies the location of actuals information.

Unit of Measure: Specifies the type of measure for the actuals or budgeted pointer. You can also add or update a unit of measure directly from this page by clicking the View Related Links button next to Unit of Measure. This automatically transfers you to the Unit of Measure page (UNITS_TBL1) in add or update mode.

Budgeted Pointer ID: Identifies the location of the budgeted information.

Complexity Factor: Enter a complexity factor for a weighted index approach. If you select Duration Capacity using the Drivers - Rates page, this field displays with a driver category of *Duration Drivers* or *Intensity Drivers*. Define the driver category using the Drivers - General page.

In cases where the driver has a *Defined* target definition, the driver can have multiple target model objects. You must define each target model object as either a resource, activity, or cost object that conforms to the rules governing these assignments.

If you selected *Residual based on prior alloc* in the Method field on the Drivers - General page, select the object IDs for the target model objects to which the system assigns any residual costs.

Implicit Actuals Pointer ID and Budget Implicit Pointer ID

If you specified a target definition of *Implicit Driver* using the Drivers - General page, for each target model object that you added, you can select an implicit actuals pointer ID or a budget implicit pointer ID.

Setting Up Interunit Drivers

To set up interunit drivers:

1. Define interunit drivers.
2. Define source cost object IDs.
3. Define target model objects.

Pages Used to Set Up Interunit Drivers

Page Name	Definition Name	Navigation	Usage
IBU Driver	IBU_DRV_TBL1	Activity Based Management, Setup, Drivers, IBU Driver, IBU Driver	Define the driver and specify the driver information.
IBU Driver - Source	IBU_DRV_TBL2	Activity Based Management, Setup, Drivers, IBU Driver, Source	Define the cost object IDs that are the source for the driver.
IBU Driver - Target	IBU_DRV_TBL3	Activity Based Management, Setup, Drivers, IBU Driver, Target	Define the target model objects for your interunit drivers.

Related Links

[Interunit Drivers](#)

IBU Driver Page

Use the IBU Driver page (IBU_DRV_TBL1) to define the driver and specify the driver information.

Navigation

Activity Based Management, Setup, Drivers, IBU Driver, IBU Driver

Description

Enter a description for the driver.

Method

Select a method to define the type of driver that you are creating. Values are:

Amount: Specifies a driver based on a quantity consumed.

Direct: Specifies that a cost object is assigned entirely to another object.

Percentage: Specifies a driver based on the percentage of a cost object that is consumed.

Residual based on prior alloc (residual based on prior allocation): Do not select.

Spread Even: Do not select.

Source

Displays *Cost Object* for interunit drivers.

Target

Select a target to specify where to assign your target costs. Values are: *Activity*, *Cost Object*, and *Resource*

Target Definition

Select a target definition to specify how the system retrieves and presents driver quantities. Values are:

Defined: If you select this method, enter driver targets using the Target page. You may also have to enter actual pointers, budgeted pointers, or both to use a table to define the driver quantities.

Empl Surv. (employee survey): Do not select for interunit drivers.

Impl Drv (implicit driver): Select if you use a table to define the driver quantities and use an implicit pointer to point to a particular table.

Rout Info (route information): Do not select for interunit drivers.

IBU Driver - Source Page

Use the IBU Driver - Source page (IBU_DRV_TBL2) to define the cost object IDs that are the source for the driver.

Navigation

Activity Based Management, Setup, Drivers, IBU Driver, Source

Cost Object ID Enter the cost object ID.

Note: An interunit driver can be related to more than one source cost.

IBU Driver - Target Page

Use the IBU Driver - Target page (IBU_DRV_TBL3) to define the target model objects for your interunit drivers.

Navigation

Activity Based Management, Setup, Drivers, IBU Driver, Target

Note: The appearance of this page and its fields varies depending on the target definition setting on the IBU Driver page. It is only active if you select a target definition of *Defined* or *Impl Drv*.

Object ID

If you specify a target definition of *Defined* using the IBU Driver page, add one or more object IDs—resource ID, cost object ID, or activity ID. For each object ID that you add, specify the following:

Inter Business Unit: The inter-business unit for the object that you are adding.

IBU Model ID: Identifies inter business unit model.

Actuals Pointer ID: Identifies the location of the actuals information.

Budgeted Pointer ID: Identifies the location of the budgeted information.

Unit of Measure ID: Identifies the type of measure for the actuals or budgeted pointer. You can also add or update a unit of measure or pointer by clicking the associated View Related Links button.

Note: In the case of a *Defined* target definition, the driver can have multiple target model objects. You must define each target model object as either a resource, activity, or cost object conforming to the rules governing these assignments.

Implicit Actuals Pointer ID and Budget Implicit Pointer ID

If you specify a target definition of *Impl Drv* (implicit driver) using the IBU Driver page, you may select an implicit actuals pointer ID or budget implicit pointer ID. Click the Add/Update button next to the pointer fields.

Copying and Deleting Drivers and Interunit Drivers

Activity-Based Management provides tools that enable you to:

- Copy drivers or interunit drivers.
- Copy drivers to another model ID.
- Delete drivers or interunit drivers.

Pages Used to Copy and Delete Drivers and Interunit Drivers

Page Name	Definition Name	Navigation	Usage
Driver Copy	DRIVER_COPY	Activity Based Management, Setup, Drivers, Driver Copy	Copy an existing driver to create a new driver.
IBU Driver Copy	IBU_DRIVER_COPY	Activity Based Management, Setup, Drivers, IBU Driver Copy	Copy an existing inter-business-unit driver to create a new inter-business-unit driver.
Driver Copy - Model to Model	AB_DRIVER_MOD_COPY	Activity Based Management, Setup, Drivers, Driver Copy Model to Model	Copy an existing driver from one model and use it in another model.
Driver Delete	DRIVER_DELETE	Activity Based Management, Setup, Drivers, Driver Delete	Delete a driver that you no longer use.
IBU Driver Delete	IBU_DRIVER_DELETE	Activity Based Management, Setup, Drivers, IBU Driver Delete	Delete an inter-business-unit driver that you no longer use.

Driver Copy Page

Use the Driver Copy page (DRIVER_COPY) to copy an existing driver to create a new driver.

Navigation

Activity Based Management, Setup, Drivers, Driver Copy

Driver ID Enter the new driver ID.

Copy After you enter the new driver ID, click Copy.

You can now change any settings for this new driver by using the Drivers or IBU Driver component as appropriate.

Driver Copy - Model to Model Page

Use the Driver Copy - Model to Model page (AB_DRIVER_MOD_COPY) to copy an existing driver from one model and use it in another model.

Navigation

Activity Based Management, Setup, Drivers, Driver Copy Model to Model

New Model ID Enter the new model ID.

Copy After you enter the new model ID, click Copy.

Driver Delete Page

Use the Driver Delete page (DRIVER_DELETE) to delete a driver that you no longer use.

Navigation

Activity Based Management, Setup, Drivers, Driver Delete

Current Driver Select to specify that you want to delete the current driver.

In the warning message that displays asking you to confirm that you want to delete the driver, click OK.

Delete Click to delete the current driver.

Specifying Model Driver Quantity Options for Combination Models

Use the Model Driver Qty Option (model driver quantity option) page with combination models to specify which rate type each driver should use to assign costs.

Page Used to Specify Model Driver Quantity Options for Combination Models

<i>Page Name</i>	<i>Definition Name</i>	<i>Navigation</i>	<i>Usage</i>
Model Driver Qty Option (model driver quantity option)	MODEL_TBL2	Activity Based Management, Setup, Model, Model Driver Qty Option	Identify model driver quantity options for combination models.

Model Driver Qty Option Page

Use the Model Driver Qty Option (model driver quantity option) page (MODEL_TBL2) to identify model driver quantity options for combination models.

Navigation

Activity Based Management, Setup, Model, Model Driver Qty Option

Driver ID and Description

Use these columns to view the drivers available to use for the model.

Driver Quantity Type Rate

Select the driver quantity type rate that you want each driver to use to assign costs. Values are:

Actuals: Select to use the actual rate.

Budgeted: Select to use the budgeted rate.

Capacity: Select to use the capacity rate to track and report excess capacity.

Frozen: Represents a fixed or frozen rate agreed upon outside of the context of the Activity-Based Management model.

Using Alternate Methods to Set Up Drivers

Activity-Based Management uses drivers as the basis for sustainable models; therefore, you do not need to set up drivers every time you run the Activity-Based Management engine. Drivers pick up costs from operational warehouse - enriched (OWE) tables and assign them between resources, activities, and cost objects.

Special circumstances occasionally require you to hard code driver values—for example, to prototype some quantities. If you need this functionality, you can use the Driver Quantity pages to hard code the values.

Warning! To avoid using hard-coded values for drivers that may have a negative effect on your models, ensure that you thoroughly understand how using them impacts your system.

Pages Used to Set Up Drivers Using Alternate Methods

<i>Page Name</i>	<i>Definition Name</i>	<i>Navigation</i>	<i>Usage</i>
Driver Quantities 1	DRIVER_QTY_TBL1	Activity Based Management, Setup, Drivers, Driver Quantities, Driver Quantities1	Enter quantities for drivers associated with activities in case you do not have system-generated data.
Driver Quantities 2	DRIVER_QTY_TBL2	Activity Based Management, Setup, Drivers, Driver Quantities, Driver Quantities2	Enter driver quantities according to object ID.

Driver Quantities 1 Page

Use the Driver Quantities 1 page (DRIVER_QTY_TBL1) to enter quantities for drivers associated with activities in case you do not have system-generated data.

Navigation

Activity Based Management, Setup, Drivers, Driver Quantities, Driver Quantities1

Capacity Amount

Enter a capacity amount for a driver using capacity rates.

Frozen Rate

Enter the frozen rate if the driver is using a frozen rate.

Actual Driver Quantity

For each object ID, enter the actual driver quantity.

Note: Select the Driver Quantities 2 tab to enter driver quantities by target object ID.

Budgeted Driver Quantity

For each object ID, enter the budgeted driver quantity.

Note: Select the Driver Quantities 2 tab to enter driver quantities by target object ID.

Warning! This method requires a considerable amount of maintenance and can easily result in long-term sustainability problems for your models if used extensively.

Processing Data Using the Routing Information Engine (AB_RTG)

If you are using a manufacturing model, run the Routing Information engine to establish a relationship between the activity and cost objects to create activity driver information.

Related Links

[Running the Routing Information Engine](#)

Reviewing Driver Setup

Activity-Based Management provides the following tools to review your driver setup:

- Four inquiry pages.
- Six reports.

Pages Used to Review Driver Setup

Page Name	Definition Name	Navigation	Usage
Resource Target Drivers	RES_DRIVER_VW1	Activity Based Management, Setup, Resources, Resource Target Drivers	View information about a resource including the driver IDs that assign costs to the selected resource, the assignment method, driver classification, and driver category.
Activity Target Drivers	ACT_DRIVER_VW1	Activity Based Management, Setup, Activities, Activity Target Drivers	View information about an activity including the driver IDs that assign costs to the selected activity, the assignment method, driver classification, and driver category.
Cost Object Target Drivers	CST_DRIVER_VW1	Activity Based Management, Setup, Cost Objects, Cost Object Target Drivers	View information about a cost object including the driver IDs that assign costs to the selected cost object, the assignment method, driver classification, and driver category.
Driver Listing inquiry	DRIVER_LIST_VW1	Activity Based Management, Setup, Drivers, Driver Listing	View driver information for all drivers assigned to a specific model ID.
Driver Characteristics report	RUN_RAB_2009	Activity Based Management, Reports, Driver Reports, Driver Characteristics	Run the Driver Characteristics report (ABC2009) that lists the characteristics of all drivers entered into the system. Run the report by business unit and limit it to specific drivers if desired.
Driver Pointer report	RUN_RAB_2015	Activity Based Management, Reports, Driver Reports, Driver Pointer	Run the Driver Pointer report (ABC2015) that lists drivers using pointers and identifies the related pointer. Run the report by business unit and limit it to specific drivers if desired. You can also limit it to a specific actuals pointer ID.

Generating and Maintaining Models

Understanding Model Generator and Ledger Mapper Generator

In addition to defining Activity-Based Management models and setting up resources, activities, cost objects, drivers, and pointers for sustainable models, Activity-Based Management also features two engines that let you create reusable, sustainable models. The following table lists the engines that automate model creation to streamline the model building process:

<i>Engine</i>	<i>Usage</i>
Model Generator	Automates the process of setting up your Activity-Based Management model by generating resources, activities, cost objects, and drivers.
Ledger Mapper Generator	Creates your ledger-to-resource mappings.

Once you run these engines and create resources, activities, cost objects, drivers, and ledger-to-resource mappings for your model, you can process your Activity-Based Management model.

You can run Model Generator, Ledger Mapper Generator, or both engines. If you run both, run Model Generator before Ledger Mapper Generator. If you are only running Ledger Mapper Generator, first complete resource setup for the model.

Related Links

[Running Model Generator and Ledger Mapper Generator](#)

Prerequisites

Before you can run Model Generator or Ledger Mapper Generator, you must:

- Create your business model in EPM Foundation.
- Set up the scenario for the model in EPM Foundation.
- Set up the performance (PF) unit scenario definition in EPM Foundation.
- Identify whether you are using trees for ledger mapping on the Ledger Mapping Tree Usage page.
- Set up ledger mapping defaults for all general ledger business units from which you want to map expense data to the Activity-Based Management resources.
- Set up the Ledger Mapping Rule for the SetID of your PF business unit.
- Load the source data into a OWE table.

- Set up metadata for the source data.

Loading Source Data

For Model Generator, you can use a spreadsheet containing your source and target information to load your source data into the system. To load this spreadsheet into the system, you can use your ETL tool.

For Ledger Mapper Generator, you can either use a spreadsheet to load the data into the system or use and adapt your existing general ledger data.

Review the following Ledger Mapper Generator and Model Generator sample spreadsheets:

Image: Sample spreadsheet for Ledger Mapper Generator data

Sample spreadsheet for Ledger Mapper Generator data.

A	B	C	D	E	F	G	H	I	J	K	L	M	N
BUSINESS_UNI	PF_SCENARIO	AB_KEY_ID	ABC_RES_ID	EFFDT	EFF_STA	DESCR	BUSINESS_UN	MAP_GL	MAP_OPER	MAP_DEF	MAP_PRI	ABC_PERCENTAGE	
2	CORP1	BANK	LED	ACCT_MGR	1/1/00	A	Cost to ge	CORP1	MANAGEI	MARKETING			20
3	CORP1	BANK	LED	ATM	1/1/00	A	ATM cost	CORP1	MISC				20
4	CORP1	BANK	LED	INVESTMENT	1/1/00	A	Investment	CORP1	MANAGEI	MARKETING			20
5	CORP1	BANK	LED	PROCESS_MG	1/1/00	A	Processing	CORP1	MANAGEI	DEVELOPMENT			20
6	CORP1	BANK	LED	TELLER	1/1/00	A	Teller Cost	CORP1	OTHER				20
7	CORP1	BANK2	LED	1ACCT_MGR	1/1/00	A	Cost to ge	CORP1	MANAGEI	MARKETING			20
8	CORP1	BANK2	LED	1ATM	1/1/00	A	ATM cost	CORP1	MISC				20
9	CORP1	BANK2	LED	1INVESTMENT	1/1/00	A	Investment	CORP1	MANAGEI	MARKETING			20
10	CORP1	BANK2	LED	1PROCESS_MG	1/1/00	A	Processing	CORP1	MANAGEI	DEVELOPMENT			20
11	CORP1	BANK2	LED	1TELLER	1/1/00	A	Teller Cost	CORP1	OTHER				20
12	CORP1	BANK2	LED	2ACCT_MGR	1/1/00	A	Cost to ge	CORP1	MANAGEI	MARKETING			20
13	CORP1	BANK2	LED	2ATM	1/1/00	A	ATM cost	CORP1	MISC				20
14	CORP1	BANK2	LED	2INVESTMENT	1/1/00	A	Investment	CORP1	MANAGEI	MARKETING			20
15	CORP1	BANK2	LED	2PROCESS_MG	1/1/00	A	Processing	CORP1	MANAGEI	DEVELOPMENT			20
16	CORP1	BANK2	LED	2TELLER	1/1/00	A	Teller Cost	CORP1	OTHER				20
17	CORP1	BANK2	LED	3ACCT_MGR	1/1/00	A	Cost to ge	CORP1	MANAGEI	MARKETING			20
18	CORP1	BANK2	LED	3ATM	1/1/00	A	ATM cost	CORP1	MISC				20
19	CORP1	BANK2	LED	3INVESTMENT	1/1/00	A	Investment	CORP1	MANAGEI	MARKETING			20
20	CORP1	BANK2	LED	3PROCESS_MG	1/1/00	A	Processing	CORP1	MANAGEI	DEVELOPMENT			20
21	CORP1	BANK2	LED	3TELLER	1/1/00	A	Teller Cost	CORP1	OTHER				20
22	CORP1	BANK2	LED	4ACCT_MGR	1/1/00	A	Cost to ge	CORP1	MANAGEI	MARKETING			20
23	CORP1	BANK2	LED	4ATM	1/1/00	A	ATM cost	CORP1	MISC				20

Image: Sample spreadsheet for Model Generator data

Sample spreadsheet for Model Generator data.

A	B	C	D	E	F	G	H	I	J	K	L	M	N	O	P
BUSINESS_UNI	PF_SCENARIO	AB_KEY_ID	ABC_OBJ_FI	ABC_OBJ_TO	II EFFDT	EFF_STA	AB_DESCR_FROM	AB_DESCR_TO	IBU_BUSI	IBU_MOC	ACT_AM	BUO_AM	ABC_CAI	ABC_RATE	AMT
1	CORP1	BANK	AA	HR_ACTS	ACCT_PROCES	1/1/00	A	HR Activities	Accounts Processing		10.000000	10.000000	\$0.00	\$0.00	
2	CORP1	BANK	AA	HR_ACTS	CHECK_PROCE	1/1/00	A	HR Activities	Check Processing		20.000000	20.000000	\$0.00	\$0.00	
3	CORP1	BANK	AA	HR_ACTS	CUST_SUPPORT	1/1/00	A	HR Activities	Customer Support		20.000000	20.000000	\$0.00	\$0.00	
4	CORP1	BANK	AA	HR_ACTS	INVESTMENT_A	1/1/00	A	HR Activities	Investment Activities		10.000000	10.000000	\$0.00	\$0.00	
5	CORP1	BANK	AA	HR_ACTS	STMT_PROCES	1/1/00	A	HR Activities	Statement Processing		20.000000	20.000000	\$0.00	\$0.00	
6	CORP1	BANK	AA	HR_ACTS	TELLER_ACTS	1/1/00	A	HR Activities	Teller Activities		20.000000	20.000000	\$0.00	\$0.00	
7	CORP1	BANK	AA	IT_ACTS	ACCT_PROCES	1/1/00	A	IT Activities	Accounts Processing		10.000000	10.000000	\$0.00	\$0.00	
8	CORP1	BANK	AA	IT_ACTS	CHECK_PROCE	3/1/00	A	IT Activities	Check Processing		20.000000	20.000000	\$0.00	\$0.00	
9	CORP1	BANK	AA	IT_ACTS	CUST_SUPPORT	3/1/00	A	IT Activities	Customer Support		20.000000	20.000000	\$0.00	\$0.00	
10	CORP1	BANK	AA	IT_ACTS	INVESTMENT_A	1/1/00	A	IT Activities	Investment Activities		10.000000	10.000000	\$0.00	\$0.00	
11	CORP1	BANK	AA	IT_ACTS	STMT_PROCES	1/1/00	A	IT Activities	Statement Processing		20.000000	20.000000	\$0.00	\$0.00	
12	CORP1	BANK	AA	IT_ACTS	TELLER_ACTS	1/1/00	A	IT Activities	Teller Activities		20.000000	20.000000	\$0.00	\$0.00	
13	CORP1	BANK	AC	ATM_ACTS	BIG_ACCOUNT	1/1/00	A	ATM Activities	Big Account		20.000000	20.000000	\$0.00	\$0.00	
14	CORP1	BANK	AC	ATM_ACTS	SMALL_ACCOU	1/1/00	A	ATM Activities	Small Account		50.000000	50.000000	\$0.00	\$0.00	
15	CORP1	BANK	AC	CHECK_PRC	BIG_ACCOUNT	1/1/00	A	Check Processing	Big Account		10.000000	10.000000	\$0.00	\$0.00	
16	CORP1	BANK	AC	CHECK_PRC	LARGE_BIZ	1/1/00	A	Check Processing	Large Business		10.000000	10.000000	\$0.00	\$0.00	
17	CORP1	BANK	AC	CHECK_PRC	MEDIUM_BIZ	1/1/00	A	Check Processing	Medium Business		10.000000	10.000000	\$0.00	\$0.00	
18	CORP1	BANK	AC	CHECK_PRC	SMALL_ACCOU	1/1/00	A	Check Processing	Small Account		20.000000	20.000000	\$0.00	\$0.00	
19	CORP1	BANK	AC	CHECK_PRC	SMALL_BIZ	1/1/00	A	Check Processing	Small Business		10.000000	10.000000	\$0.00	\$0.00	
20	CORP1	BANK	AC	CUST_SUPPI	BIG_ACCOUNT	1/1/00	A	Customer Support	Big Account		15.000000	15.000000	\$0.00	\$0.00	
21	CORP1	BANK	AC	CUST_SUPPI	LARGE_BIZ	1/1/00	A	Customer Support	Large Business		15.000000	15.000000	\$0.00	\$0.00	
22	CORP1	BANK	AC	CUST_SUPPI	MEDIUM_BIZ	1/1/00	A	Customer Support	Medium Business		10.000000	10.000000	\$0.00	\$0.00	
23	CORP1	BANK	AC	CUST_SUPPI	SMALL_ACCOU	1/1/00	A	Customer Support	Small Account		30.000000	30.000000	\$0.00	\$0.00	
24	CORP1	BANK	AC	CUST_SUPPI	SMALL_BIZ	1/1/00	A	Customer Support	Small Business		20.000000	20.000000	\$0.00	\$0.00	
25	CORP1	BANK	AC	INVESTMEN	BIG_ACCOUNT	1/1/00	A	Investment Activities	Big Account		10.000000	10.000000	\$0.00	\$0.00	
26	CORP1	BANK	AC	INVESTMEN	LARGE_BIZ	1/1/00	A	Investment Activities	Large Business		10.000000	10.000000	\$0.00	\$0.00	
27	CORP1	BANK	AC	INVESTMEN	MEDIUM_BIZ	1/1/00	A	Investment Activities	Medium Business		10.000000	10.000000	\$0.00	\$0.00	
28	CORP1	BANK	AC	INVESTMEN	SMALL_BIZ	1/1/00	A	Investment Activities	Small Business		10.000000	10.000000	\$0.00	\$0.00	

Setting Up Model Generator

This section discusses how to set up the model generation definition.

Activity-Based Management Model Generator automates the process of setting up the metadata for filters and constraints as well as setting up Activity-Based Management objects, drivers, and the pointers for driver quantities.

Model Generator generates:

- Activity-Based Management resources, activities, and cost objects.
- Drivers, interunit drivers, and constraints and filters for driver quantities.

To accomplish this, Model Generator requires source data that can be loaded into the system from a spreadsheet.

To run Model Generator, set up a model generation ID to specify:

- The location of the source data.
- Source and target setup.
- Driver quantities and rates.
- Any interunit drivers.

Page Used to Set Up Model Generator

<i>Page Name</i>	<i>Definition Name</i>	<i>Navigation</i>	<i>Usage</i>
Model Generation Definition	AB_MODELGEN_TBL1	Activity Based Management, Setup, Model Generator, Model Generation Definition	Set up the model generation definition by defining the model generation ID and parameters. This page lets you build your model one step at a time by defining multiple generator sequences.

Model Generation Definition Page

Use the Model Generation Definition page (AB_MODELGEN_TBL1) to set up the model generation definition by defining the model generation ID and parameters.

This page lets you build your model one step at a time by defining multiple generator sequences.

Navigation

Activity Based Management, Setup, Model Generator, Model Generation Definition

Image: Model Generation Definition page

This example illustrates the fields and controls on the Model Generation Definition page. You can find definitions for the fields and controls later on this page.

The screenshot shows the 'Model Generation Definition' page. At the top, it displays 'SetID: SHARE' and 'Model Generation ID: GEN1'. Below this is a '*Description:' field containing 'gen1'. A 'Model Generation Rules' table is visible, with a search bar and navigation controls. The table lists several fields: '*Load sequence:' (value: 1), '*Description:' (value: Resource to Resource), '*Constraint Code:' (value: RR), '*Source Field Seq:' (value: Interface Key 1), '*Source Desc Field Seq:' (value: Text 1), '*Target Field Seq:' (value: Interface Key 2), '*Target Desc Field Seq:' (value: Text 2), '*Actual Driver Quantity:' (value: Amount), 'Capacity Driver Quantity:', and 'IBU Business Unit:'. On the right side of the table, there are fields for '*Source:' (value: Resource), '*Target:' (value: Resource), 'Budget Quantity:' (value: Amount 2), 'Frozen Rate:', and 'IBU Model ID:'. A legend at the bottom left indicates '* Required Field'.

Load sequence

Enter the sequence of each source and target type mapping that you add.

Note: Load sequence 1 specifies that this is the first step in driving monetary amounts from a source to a target.

Constraint Code

Enter a constraint code to identify the location of the source data.

Source Field Seq (source field sequence)

Select a source field sequence to specify the datamap column sequence number that you want to use for the source.

This is the location of the source information for your model. Specify whether this source is a resource, activity, or cost object.

Source Desc Field Seq (source description field sequence)

Select the location of the description for your source.

Target Field Seq (target field sequence) and Target Desc Field Seq (target description field sequence)

Select the location of your target information on the source data table.

Specify whether this target is a resource, activity, or cost object.

Actual Driver Quantity, Budget Quantity, Capacity Driver Quantity, and Frozen Rate

Select the location of the actual, budgeted, and capacity driver quantity information as well as the frozen rate.

IBU Business Unit and IBU Model ID

If this is an interunit model, select the location of the IBU business unit and IBU model ID.

Setting Up Ledger Mapper Generator

This section discusses how to set up the ledger mapping generation definition.

Activity-Based Management Ledger Mapper Generator lets you create ledger mapping rules automatically by using information loaded into the operational warehouse tables from a spreadsheet or by adapting existing system data from a general ledger. Ledger Mapper Generator generates the mapping rules that determine how general ledger accounts are assigned to existing Activity-Based Management resources. This is an alternate method to manually setting up mapping rules using the Ledger Mapping Rule page.

You can use Ledger Mapper Generator to identify which columns—business unit, general ledger business unit, department, and so on—in the datamap are for resources. Ledger Mapper Generator contains the same flexible mapping capabilities as manually entered maps. As with manually entered maps, you can define whether you are mapping a tree node or a percentage value. Ledger Mapper Generator also accommodates actual and budget maps.

In addition, Ledger Mapper Generator is scalable and sustainable. You can use it on an ongoing basis to update previously generated maps or for adding and deleting maps that you no longer use.

To run Ledger Mapper Generator, first set up a ledger mapping generation definition.

Page Used to Set Up Ledger Mapper Generator

<i>Page Name</i>	<i>Definition Name</i>	<i>Navigation</i>	<i>Usage</i>
Ledger Mapping Creation	AB_LDMPGEN_TBL1	Activity Based Management, Setup, Model Generator, Ledger Mapping Creation	Set up the ledger mapping generation definition by defining the parameters for Ledger Mapper Generator. This page lets you generate mapping rules one step at a time by defining multiple generator sequences.

Ledger Mapping Creation Page

Use the Ledger Mapping Creation page (AB_LDMPGEN_TBL1) to set up the ledger mapping generation definition by defining the parameters for Ledger Mapper Generator.

This page lets you generate mapping rules one step at a time by defining multiple generator sequences.

Navigation

Activity Based Management, Setup, Model Generator, Ledger Mapping Creation

Image: Ledger Mapping Creation page

This example illustrates the fields and controls on the Ledger Mapping Creation page. You can find definitions for the fields and controls later on this page.

Ledger Mapping Creation

SetID: SHARE Ledger Maps Generation ID: LEDGEN

*Description: Ledger Map Generator

Ledger To Resource Mapping Rules Find | View All First 1 of 16 Last

*Load sequence: 1 Status: Active

*Constraint: LED1 Ledger Map Gen -All Chartfield

*Resource: 2 Interface Key 1

Ledmap Desc: 18 Text 1

*Mapper Type: Actuals

Business Unit: 3 Interface Key 2

Percentage Seq: 6 Amount

Chartfield 1:	11	Interface Key 6	<input type="checkbox"/> All	<input type="checkbox"/> Tree
Chartfield 2:	4	Interface Key 3	<input type="checkbox"/> All	<input checked="" type="checkbox"/> Tree
Chartfield 3:	5	Interface Key 4	<input type="checkbox"/> All	<input checked="" type="checkbox"/> Tree
Chartfield 4:	10	Interface Key 5	<input type="checkbox"/> All	<input checked="" type="checkbox"/> Tree
Chartfield 5:	12	Interface Key 7	<input checked="" type="checkbox"/> All	<input type="checkbox"/> Tree
Chartfield 6:	13	Interface Key 8	<input checked="" type="checkbox"/> All	<input type="checkbox"/> Tree
Chartfield 7:	14	Interface Key 9	<input checked="" type="checkbox"/> All	<input type="checkbox"/> Tree
Chartfield 8:	15	Interface Key 10	<input checked="" type="checkbox"/> All	<input type="checkbox"/> Tree

* Required Field

Load Sequence

Enter the sequence of each mapping rule that you add.

Note: Load Sequence 1 specifies that this is the first ledger mapping rule.

Constraint

Enter a constraint code to identify the location of the source data.

This data can be a table generated from spreadsheet data or existing general ledger data in the system.

Resource

Enter a resource field sequence to specify the datamap column sequence number that you want to use for the resource.

Ledmap Des (ledger map description)

Enter the ledger map datamap column sequence number for the ledger map description.

Mapper Type

Select a mapper type. Values are: *Actuals* or *Budgeted*.

Business Unit, Percentage Seq, (Percentage Sequence), and Map Chartfield 1 through 8

Enter the datamap column sequence number to use.

Assigning Generation IDs to Your Activity-Based Management Model

Once you set up your model generation and ledger map generation IDs, you must assign them to the model. To assign the generation ID, you must first select the model ID that you want to use, and then select the Run Control Information tab. Define the appropriate model generation ID, ledger maps generation ID, or both, and then save the page.

See [Models Page](#).

Note: You do not have to run both engines. You can run Model Generator, Ledger Mapper Generator, or both.

Running Model Generator and Ledger Mapper Generator

This section provides an overview of delivered engines and discusses how to:

- Specify run control parameters.
- Inquire about engine messages.

Pages Used to Run Model Generator and Ledger Mapper Generator

<i>Page Name</i>	<i>Definition Name</i>	<i>Navigation</i>	<i>Usage</i>
Run Jobstream	RUN_PF_JOBSTREAM	Activity Based Management, Setup, Processing, Run Jobstream.	Use to run model generator and ledge mapper generator.
Message Header	PF_ENGMSG_HEAD	Activity Based Management, Setup, Processing, Error Messages, Message Header	Use to view error messages.
Message Detail	PF_ENGMSG_LOG	Activity Based Management, Setup, Processing, Error Messages, Message Detail	Use to view error messages.

Understanding Delivered Engines

The following table lists the delivered engines for building models:

<i>Engine Name</i>	<i>Job ID</i>	<i>Usage</i>
Activity-Based Management Model Generator (AB_MODEL_GEN)	AB_MDLGEN	Generates the objects and drivers for a model.
Activity-Based Management Ledger Mapper Generator (AB_LDMPGEN)	AB_LDMPGEN	Generates the ledger-to-resource mappings.

Run Jobstream Page

Use the Run Jobstream page (RUN_PF_JOBSTREAM) to use to run model generator and ledge mapper generator.

Navigation

Activity Based Management, Setup, Processing, Run Jobstream.

Image: Run Jobstream page

This example illustrates the fields and controls on the Run Jobstream page. You can find definitions for the fields and controls later on this page.

The screenshot shows the 'Run Jobstream' page with the following elements:

- User ID:** VP1
- Run Control ID:** Job
- Process Information:**
 - Program Name:** PF_JOBSTREAM
 - When:** Always (dropdown menu)
 - As Of Dated Jobstream**
 - Send Email Notification** (with [Specify Email Parameters](#) link)
 - *Description:** (text input field)
 - *Unit:** CORP1 (with search icon and 'Corporation 1' label)
 - *Scenario ID:** (text input field with search icon)
 - Fiscal Year:** (text input field)
 - Period:** (text input field)
 - *Jobstream ID:** (text input field with search icon)
 - Rerun**
 - Last Run On:** (text input field)
 - As Of Date:** (text input field)
- Navigation Links:** [Report Manager](#), [Process Monitor](#), [View Messages](#), [Clear All Suites](#), [Clear Last Suite](#)
- Run Button:** Run

When

Select the frequency with which you want to run the process. Values are: *Always*, *Don't*, or *Once*.

You most often select *Always*.

As Of Dated Jobstream

Do not select. The Activity-Based Management engines do not use as of date functionality with run controls.

Description, Unit, and Scenario ID

Enter a description and specify the business unit and scenario ID to process.

Fiscal Year and Period

Enter the fiscal year and period to process.

Jobstream ID

Enter the jobstream ID to use.

Rerun

Select if you are processing the same job an additional time using the *identical* parameters and you want the system to re-resolve the tables.

This option may slow down processing if you are assigned to the same record suite assigned the previous time that the engine was run.

Run

Click to start processing.

Inquiring about Engine Messages

You can review messages generated by these jobs by opening the Application Engine message log.

See *PeopleTools: PeopleSoft Process Scheduler*

Reviewing Model Objects and Ledger Mapping Rules

Once you run Model Generator and Ledger Mapper Generator, you can use the following pages to review the objects and mapping rules that you created as well as make any appropriate adjustments:

Page Name	Navigation
Resources	Activity Based Management, Setup, Resources, Resources
Activities	Activity Based Management, Setup, Activities, Activities
Cost Objects	Activity Based Management, Setup, Cost Objects, Cost Objects
Implicit Pointers	Activity Based Management, Setup, Pointers to Drivers, Implicit Pointers
Drivers	Activity Based Management, Setup, Drivers, Driver
Inter Unit Drivers	Activity Based Management, Setup, Drivers, IBU Driver
Ledger Mapper Rule	Activity Based Management, Setup, Resources, Ledger Map Rule

You can also use the Model Navigator component to review your generated model.

Related Links

[Setting Up Resources](#)

[Defining Activities](#)

[Defining Cost Objects](#)

[Implicit Pointers Page](#)

[Setting Up Drivers](#)

[Setting Up Interunit Drivers](#)

Processing in Real-Time Activity-Based Management

Understanding Real-Time Activity-Based Management

You can start working on a Real-Time Activity Based Management model in the following ways:

- Create objects, activities, cost objects, and drivers using Real-Time ABM from scratch without looking at what you have in batch ABM.
- Prepare the data from an existing batch ABM model.
- Create batch resources in Real-Time ABM, but use the assigned (mapped) costs for those resources from the ABM_LEDMAP table.

The Real-Time Activity-Based Management component simplifies the often complex network model cost development process by letting you graphically define the business process, the role of performers that perform these business processes, the standard time to perform one unit of each activity or business process, and other activity details, and then calculate and analyze the Activity-Based Management results immediately instead of waiting for an engine to run.

What-if modeling lets you modify the Activity-Based Management model and reflect business re-engineering almost instantaneously. In other words, you can calculate and analyze Activity-Based Management model results and see the effect of changes to model data in real time. After entering the resources, activities, their association, and then defining how activities consume the resources (driver data), clicking Calculate displays the calculated results. After analyzing these results, you can modify the driver data for what-if planning, delete or insert objects, change driver quantities, or change the volume of activities or cost objects, and then click Calculate again. You can continue doing this until you are satisfied with the results.

Processing in Real-Time Activity-Based Management

This section provides an overview of Real-Time Activity-Based Management and discusses how to:

- Process in real time.
- Open a batch model.
- Display your model graphically.
- Post to batch.
- View and edit the Real-Time ABM interface table.

Pages Used in Real-Time Activity-Based Management

Page Name	Definition Name	Navigation	Usage
Real Time ABM	AB_CALC_ENG_PG	<ul style="list-style-type: none"> Activity Based Management, Setup, Processing, Real Time ABM Activity Based Management, ABM Center, Process ABM, Real Time ABM Activity Based Management, Real Time Processing Center, Real Time ABM 	Perform Real-Time Activity-Based Management processing.
Real-Time ABM Save As	AB_CE_SAVE_AS_PG	Click Save As on the Real Time ABM page.	Saves a copy of buffer data, including results, into a new model.
Load Rule Data	AB_CE_LOAD_RULE_PG	Click Get Batch Model on the Real Time ABM page.	Lets you enter the desired batch model and ledger mapper parameters associated with the batch model that you want to open from the current rule tables.
Real-Time ABM Graphical Model	AB_CE_APPLET_PG	Click Graphical Model on the Real Time ABM page.	Displays the graphical model that read all model rules and results of the scenario associated with the model.
Real-Time ABM Results	AB_CE_RESULTS_PG	Click Calculate on the Real Time ABM page.	Displays the calculated amounts for outbound IBUs.
ABM Real-Time Interface Table	AB_RT_INTERFACE_PG	Click Post to Batch on the Real Time ABM page.	Enter the scenario to which you want to post, move your data to the Real-Time ABM interface table to view or edit it, and start Model Generator.
Ledger Rule	AB_CE_MAPPER_PG	Click Map Ledger Amt (amounts) on the Real Time ABM page.	Lets you enter ledger mapper parameters.
Inbound IBU	AB_INBOUND_PG	Click the View Inbound IBUs link on the Real Time ABM page.	View inbound interunit business units for the displayed model.
Real Time ABM Interface	AB_RT_INTRF_LD_PG	Activity Based Management, Real Time Processing Center, Post to Batch, Real Time ABM Interface	View or edit the Real-Time ABM interface table.

Page Name	Definition Name	Navigation	Usage
Model Generation Definition	AB_MODELGEN_TBL1	Activity Based Management, Real Time Processing Center, Post to Batch, Model Generation Definition	Update the delivered model generation identifier or create a new one.
Run Jobstream	RUN_PF_JOB	Activity Based Management, Real Time Processing Center, Post to Batch, Run Jobstream	Start jobstream process which creates resources, activities, cost objects, and drivers.

Understanding Real-Time Activity-Based Management

PeopleSoft Activity-Based Management provides a centralized home page that groups all of the links related to the Real-Time Activity-Based Management processing activity. This home page has three main sections/folders:

- Real Time ABM page.

You access this page to start working from scratch using a production model as a template or using only the ledger amounts assigned to the resources, go directly to the Real-Time ABM page.

- Ledger Sources and Mappings folder.

To start working on a Real-Time model taking only the ledger amounts assigned to the resources (not a complete production model), first go to the Ledger Sources and Mappings folder that groups the links to the source data that you need to review, set up, or create (if this data is not already set up).

To create this source data, ABM provides an engine called ABM_RT_MAP.

- Post to batch folder.

To send data from Real-TIM ABM to batch ABM, go to Post to Batch folder. You can access from there the page to edit the Real Time Interface table (before posting to batch), and/or the Model Generation definition setup page or the Run Jobstream page to run Model Generator.

Real Time ABM Page

Use the Real Time ABM page (AB_CALC_ENG_PG) to perform Real-Time Activity-Based Management processing.

Navigation

- Activity Based Management, Setup, Processing, Real Time ABM
- Activity Based Management, ABM Center, Process ABM, Real Time ABM
- Activity Based Management, Real Time Processing Center, Real Time ABM

Image: Real Time ABM page (1 of 2)

This example illustrates the fields and controls on the Real Time ABM page (1 of 2). You can find definitions for the fields and controls later on this page.

Model/Scenario

Business Unit:	CORP1	Real-Time Model ID:	RT_TEST
*Description:	<input type="text" value="RT Model example"/>	*Model Type:	<input style="border: 1px solid gray;" type="text" value="Actuals Model"/>

Actions

Show Graphical Model Buttons

Object ID:	<input type="text"/>	Object Type:	<input style="border: 1px solid gray;" type="text"/>
------------	----------------------	--------------	--

All Objects

Setup Objects

Node Amounts F11
Customize | Find | View All | | First 1-8 of 8 Last

	*ABM Object ID	*Description	*Object Type	Use Ledger Map		
1	<input type="text" value="RT_A1"/>	Activity 1	Activity <input style="border: 1px solid gray;" type="text" value="v"/>	<input type="checkbox"/>	<input type="button" value="+"/>	<input type="button" value="-"/>
2	<input type="text" value="RT_A2"/>	Activity 2	Activity <input style="border: 1px solid gray;" type="text" value="v"/>	<input type="checkbox"/>	<input type="button" value="+"/>	<input type="button" value="-"/>
3	<input type="text" value="RT_A3"/>	Activity 3	Activity <input style="border: 1px solid gray;" type="text" value="v"/>	<input type="checkbox"/>	<input type="button" value="+"/>	<input type="button" value="-"/>
4	<input type="text" value="RT_C1"/>	Cost Object 1	Cost Object <input style="border: 1px solid gray;" type="text" value="v"/>	<input type="checkbox"/>	<input type="button" value="+"/>	<input type="button" value="-"/>
5	<input type="text" value="RT_C2"/>	Cost Object 2	Cost Object <input style="border: 1px solid gray;" type="text" value="v"/>	<input type="checkbox"/>	<input type="button" value="+"/>	<input type="button" value="-"/>
6	<input type="text" value="RT_C3"/>	Cost Object 3	Cost Object <input style="border: 1px solid gray;" type="text" value="v"/>	<input type="checkbox"/>	<input type="button" value="+"/>	<input type="button" value="-"/>
7	<input type="text" value="RT_R1"/>	Resource 1	Resource <input style="border: 1px solid gray;" type="text" value="v"/>	<input type="checkbox"/>	<input type="button" value="+"/>	<input type="button" value="-"/>
8	<input type="text" value="RT_R2"/>	Resource 2	Resource <input style="border: 1px solid gray;" type="text" value="v"/>	<input type="checkbox"/>	<input type="button" value="+"/>	<input type="button" value="-"/>

Image: Real Time ABM page (2 of 2)

This example illustrates the fields and controls on the Real Time ABM page (2 of 2). You can find definitions for the fields and controls later on this page.

The screenshot displays two main sections: "Driver Data" and "IBU Driver".

Driver Data Section:

From Object: Object Type: All Drivers

Driver Data Customize | Find | View All | First 1-8 of 8 Last

Driver	Quantities	*Driver Type	*Source	*Object From ID	*Target	*Object To
1		Amount	Activity	RT_A1	Cost Object	RT_C1
2		Percentage	Activity	RT_A2	Cost Object	RT_C2
3		Percentage	Activity	RT_A2	Cost Object	RT_C3
4		Amount	Activity	RT_A1	Cost Object	RT_C2
5		Direct	Resource	RT_R1	Cost Object	RT_C1
6		Spread Even	Resource	RT_R2	Activity	RT_A1
7		Spread Even	Resource	RT_R2	Activity	RT_A2
8		Spread Even	Resource	RT_R2	Activity	RT_A3

From Object: All IBU Drivers [View Inbound IBUs](#)

IBU Driver Section:

IBU Driver Customize | Find | View All | First 1 of 1 Last

IBU Driver	Quantities	Driver Type	Source	*Object From ID	*Target	*Object T
1		<input type="text"/>	Cost Object	<input type="text"/>	<input type="text"/>	<input type="text"/>

Model/Scenario**Business Unit**

Displays the name of the business unit on which you are working.

You can work on any business unit.

Note: If the model already exists, after you specify the Business Unit, Model ID, and Effective Date, Activity-Based Management conforms the grid to the appropriate rules.

Real-Time Model ID

Displays the unique identifier of the Real-Time model on which you are working.

You can work on any model.

Note: If the model already exists, after you specify the Business Unit and Real-Time Model ID, Activity-Based Management conforms the grid to the appropriate rules.

Model Type

Select the type of model to display. Values are:

Act Model (actual model): Select to analyze past (historical) data to affect the future. Actual models are typically easy to implement and understand but have limitations to their effectiveness (such as the assumption that entities operate at 100

percent of their capacity, which compromises driver information if the capacity of the entities is not fully used and, because the actual data is historical. you cannot forecast based on anticipated costs).

Bud Model (budget model): Select to view the future with budgeting expenses and forecast using anticipated costs. While easy to implement and understand, budget models share the same disadvantages as those based on actual data.

Cap Model (capacity model): Select to measure the cost of capacity resources (which is similar to standard costing). The capacity rate is the result of the budgeted amount divided by the capacity driver quantity. The capacity model lets you assign excess costs to a capacity cost object and balance the actual amounts within the model. You can then track and report on excess capacity.

Rate Model (frozen rate model): Select to use a frozen, manually defined rate that enables calculation of variances from actual, budget, or capacity values.

Actions

Save

Click to save buffer data, including results, into the current model.

Save As

Click to save a copy of buffer data, including results, into a new model.

On the Real-Time ABM Save As page that displays, enter the Business Unit, Real-Time Model ID, and a model Description.

Get Batch Model

Click to display the Load Rule Data page where you can enter the desired batch model and ledger mapper parameters associated with the batch model that you want to open from the current rule tables.

This process:

- Reads the model definition and objects, and then populates the Object table with objects from the Resource, Activity, or Cost Object tables.
- Resolves pointers and implicit pointers for normal and IBU drivers when loading the data into Real-Time Activity-Based Management.
- Populates the IBU Driver table.

See [Load Rule Data Page](#).

Graphical Model

Click to start the graphical model that reads all model rules and results of the scenario associated with the model currently

displayed in the grid (if the results are already calculated), and then graphically displays the model as a network diagram.

You can then:

- Add or delete objects such as resources, activities, cost objects.
- Add, delete, or modify object associations.
- Modify driver amounts, object volume, resource cost, or object capacity.
- Recalculate the model, and then analyze the results.

Note: Click Save before clicking Graphical Model.

See [Real-Time ABM Graphical Model Page](#).

Show Graphical Model Buttons

Select to display graphical model buttons when you click Graphical Model.

Calculate

Click to display calculated results after you enter the resources, activities, their associations, and the driver data.

The process reads the object, driver data, and resource cost/ ledger mapping tables, calculates the model, and then writes the results into the buffer for the Calc Detail and Calc Obj tables.

To run Real-Time Activity-Based Management, you do not need to run any engine. You can click Calculate from either the Real Time ABM page (grid) or the graphical model to display results.

Clicking Calculate on the grid lets you view all the calculations for all the objects at the same time. Clicking Calculate on the graphical model, though, assigns the calculated amounts to each of the objects (letting you display those amounts by double-clicking an object or by selecting Show Details).

Post to Batch

Click to display the ABM Real-Time Interface Table page where you can enter the scenario to which you want to post, move your data to the Real-Time ABM interface table to view or edit it, and start Model Generator.

See [ABM Real-Time Interface Table Page](#).

Setup Objects

Use the elements in the Setup Objects group box to set up all of the objects and their attributes.

To search the Object table and populate the Setup Objects grid with specific objects and associated attributes, enter the Object ID, select the specific Object Type — *Activity*, *Cost Obj.* (cost object), or *Resource* — or select All Objects, and then click Get.

Map Ledger Amt (amounts)

Click to access the Ledger Rule page and specify the ledger mapper parameters such as business unit, scenario ID, fiscal year, and period to map existing ledger mapping amounts that you have available in your batch or production environment.

In this case, enter the resources that you want to use. You do not need to enter actual and budget amounts since they are taken from the production environment). Select the Use Ledger Map check box for all the resources for which you want to take the amounts from the production environment, and then click the Map Ledger Amt button to specify the source of the information such as a batch activity-based Management scenario, fiscal year, and period.

The source data exists as a result of running a complete batch model (the PF_ABC engine) or processing the section to assign the ledger amounts to resources (the ABM_RT_MAP engine).

Note: Use the Map Ledger Amt button in conjunction with the Use Ledger Map check box. First enter the resources that you want in the model. Second, select the check box to take the existing amounts from the production environment. Third, once you select all of the resources and check boxes, click the Map Ledger Amt button.

ABM Object ID

Enter the unique identifier of the Activity-Based Management object.

Object Type

Select the type of object to display in the grid (from the Object table). Values are:

Activity: Select to specify how much you spend on each activity and why. (Activities are described by verbs and associated objects such as schedule production, move materials, purchase materials, inspect items, respond to customers, improve products, introduce new products, and so on.)

Cost Obj (cost object): Select to identify your products, services, and customers. You perform activities to design and build for and deliver products and services to customers. Cost objects are the end result of model calculations.

Resource: Select to represent the cost base for the model. A resource comprises a distinct and homogeneous grouping of existing costs that fulfill a similar function or, in the case of people, having a similar work profile. The sum of all resources for a model equals the total cost for an organization within a set time frame.

Actual Amount

Displays the actual amount to define resource costs directly.

Budget Amount

Displays the budget amount to define resource costs directly.

Use Ledger Map

Select to define resource costs using ledger mapping.

Driver Data

Use the elements in the Driver Data group box to set up the driver data for the objects. Driver data specifies how activities consume resources.

To search the Driver Data table and populate the Driver Data grid, enter the name of the specific object used as a From Object, select the specific Object From Type — *Activity*, *Cost Obj.* (cost object), or *Source* — or select All Drivers, and then click Get. (For example, to display all drivers with Teller as their source, in the From Object field, enter *Teller*; and then click Get.)

Driver Type

Select the type of driver.

Amount: Select to specify a driver based on a quantity of resources or activities consumed.

Direct: Select to specify that an object is entirely assigned to another object (100 percent). This represents a special case of percentage.

Percent: Select to specify that the driver is based on the percentage of an object consumed—the percentage change in volume of cost objects and activities or the change in consumption pattern and driver data.

Sprd Even (spread even): Select to distribute the resource or activity cost evenly over the targets to which it has been linked.

Source

Select the source. Values are:

Activity: Specifies in what basis the cost objects are consuming the activities.

Cost Obj. (cost object)

Resource: Specifies the time that resources spend on activities.

Object From ID

Enter the unique identifier where the object is coming from that is consuming the activities.

Target

Select the target—*Activity*, *Cost Obj.* (cost object), or *Resource*.

Note: Select the Driver tab to display Target.

Object To ID

Enter the unique identifier where the object is going.

Note: Select the Driver tab to display Object To ID.

Actual Driver Quantity

Enter the actual driver quantity, which is *always* required.

Note: Select the Quantities tab to display Actual Driver Quantity.

Budgeted Driver Quantity

Enter the budgeted driver quantity if you are working on frozen or capacity budgeted models.

Note: Select the Quantities tab to display Budgeted Driver Quantity.

Rate Driver Quantity

Displays the rate driver quantity.

Capacity Driver Quantity

Display the capacity driver quantity.

IBU Driver

Use the elements in the IBU Driver group box to set up interunit business unit (IBU) drivers or links to some other Real-Time model. An IBU driver displays the same attributes as a normal driver. You can only create outbound IBUs which means that, when you create an IBU driver, the source must always be a cost object. The target can be a resource, activity, or cost object of another model such as the BU plus model.

To search the IBU Driver table and populate the IBU Driver grid with a specific source cost object and select a resource, activity, or cost object target from another model, enter the name of the specific object used as a From Object, or select All Drivers, and then click Get.

All elements *except* View Inbound IBUs, RT IBU, and RT IBU Model ID are described in the earlier Driver Data section.

View Inbound IBUs (interunit business units)

Click to access the Inbound IBU page to view inbound interunit business units for the model that you are linking to if that model is receiving IBUs originated in another model.

Note: You can only create outbound IBUs from a specific model. Outbound IBUs are IBU drivers that push amounts from one model to another.

RT IBU (Real-Time interunit business unit)

Enter a valid Real-Time interunit business unit.

Note: The system does not validate your entry in real time so that you have the flexibility to enter an IBU now that may not yet exist, but will exist in the future.

RT IBU Model ID (Real-Time interunit business unit model identifier)

Enter a valid Real-Time interunit business unit model identifier.

Note: The system does not validate your entry in real time so that you have the flexibility to enter an IBU now that may not yet exist, but will exist in the future.

Load Rule Data Page

Use the Load Rule Data page (AB_CE_LOAD_RULE_PG) to lets you enter the desired batch model and ledger mapper parameters associated with the batch model that you want to open from the current rule tables.

Navigation

Click Get Batch Model on the Real Time ABM page.

Image: Load Rule Data page

This example illustrates the fields and controls on the Load Rule Data page. You can find definitions for the fields and controls later on this page.

The screenshot shows the 'Load Rule Data' page with the following fields and controls:

- Business Unit:** CORP1
- Real-Time Model ID:** RT_TEST
- Batch Model Parameters:**
 - Business Unit:** [Text Field]
 - Scenario ID:** [Text Field]
 - Effective Date:** 03/25/2010 [Calendar Icon]
 - Model ID:** [Text Field]
- Ledger Mapper Parameters:**
 - Fiscal Year:** [Text Field]
 - Period:** [Text Field]
 - Get IBUs

Models receiving IBUs should be imported before getting Models sending IBUs.

Business Unit

Enter the business unit associated with the batch model that you want to open.

Scenario ID

Enter the scenario identifier associated with the batch model that you want to open.

Effective Date

Enter the effective date of the objects that you want to open.

Note: Consider entering an earlier date to ensure that you gain access to all of the data.

Fiscal Year

Enter the four-digit fiscal year—yyyy—associated with the batch model in which you want to specify the desired ledger mapping information to assign costs to your resources.

Period

Enter the accounting period associated with the batch model in which you want to specify the desired ledger mapping information to assign costs to your resources.

Depending upon the calendar used, the account period values are usually 1 through 12 for the months in a year.

Get IBUs (interunit business units)

Select to display the IBU Mapping grid that displays any IBUs associated with the batch model that you want to open and lets you enter valid mappings for those IBUs so that you can reference a Real-Time IBU business unit and IBU model.

The system lets you reference a Real-Time IBU business unit and IBU model that may not yet exist.

Note: Before opening models linked through IBUs — models that send IBUs — first open models that receive IBUs.

Real-Time ABM Graphical Model Page

Use the Real-Time ABM Graphical Model page (AB_CE_APPLET_PG) to displays the graphical model that read all model rules and results of the scenario associated with the model.

Navigation

Click Graphical Model on the Real Time ABM page.

Note: To display the buttons, on the Real Time ABM page, select Show Graphical Model Buttons. Right-click to gain access to the same features as the buttons.

Add Activity	Click to enter an activity ID and description.
Add Cost Object	Click to enter a cost ID and description.
Add Driver	Click to select a source and target node, and then select the driver type—Amount, Direct, Percent, or Spread Even. Also enter the source and target nodes and actual and budget quantities.
Add IBU (interunit business unit)	Click to enter a business unit, model ID, object ID (this will be the IBU target object), and then select the source object —Resource, Activity, or Cost Object.

Note: When you create an IBU, you are creating a driver.

Add Resources	Click to enter a resource ID, description, and actual and budget amount.
Auto Layout	Click to reset the model to the default layout.

Note: The system *does not* save coordinates. In other words, you can drag and drop objects, arrange model objects, and so on, but the system does not save that view.

Calculate	Click to start Real-Time calculations.
Center	Click to position your view of the elements in the center of the display.
Delete Driver	Click this button, and then click the driver in the display that you want to delete.

Delete Node	<p>Note: You can also use this button to delete some <i>legs</i> of an IBU driver; however, if you leave an IBU object without any associated driver (using the graphical model), when you save and return to the Model Definition page, the system does not save the IBU object that you disconnected and, in fact, it disappears when you return to the graphical model to view it.</p> <hr/> <p>Click this button, and then click the node in the display that you want to delete.</p> <hr/> <p>Note: Deleting the node also deletes its object and associated drivers.</p> <hr/>
Description, None, ID	<p>Click Description to display each node's description; click None to hide any description; click ID to display each node's identifier.</p>
Find Node	<p>Click to select an object type—Resource, Activity, or Cost Object. This selection changes the items in the associated drop-down list from which you can select the desired item. Then, click Find Node or Bring Node.</p>
Hide	<p>Click to hide unselected nodes and to display all selected nodes.</p>
Print State	<p>Click to view debugging information using the Java Console.</p> <p>After you click Print State, double-click the blue cup icon on the toolbar to open the Java Console.</p>
Reset	<p>Click to deselect all node selections.</p>
Save	<p>Click to save any changes to the Real-Time model.</p>
Show Details	<p>Select to display selected node IDs, descriptions, and actual, budgeted, and calculated amounts.</p>
Show Driver Amounts	<p>Select to display each driver's numeric value next to the percentage amount.</p>
Toggle Selected	<p>Click to change (swap) your selection from the currently selected nodes to the unselected nodes with each click.</p>
View Affected	<p>Click this button, and then click a node in the display to view the associations, which are displayed as red lines, as well as other nodes that affect the node.</p>
Zoom In	<p>Click to increase the magnification of the display but see less field of view.</p>
Zoom Out	<p>Click to reduce the magnification of the display but see more field of view.</p>

ABM Real-Time Interface Table Page

Use the ABM Real-Time Interface Table page (AB_RT_INTERFACE_PG) to enter the scenario to which you want to post, move your data to the Real-Time ABM interface table to view or edit it, and start Model Generator.

Navigation

Click Post to Batch on the Real Time ABM page.

Scenario ID

Enter the scenario to which you want to post.

Note: To get the data from Real-Time Activity-Based Management, the scenario must have an associated, valid Real-Time Model ID with the correct model generation definition that reads from the Real-Time Activity-Based Management interface table (AB_RT_INTERFACE). Instead, you can use the example Activity-Based Management batch model that uses the RT model generation identifier with the associated RT1 scenario. If the scenario is already used by another Real-Time model ID, the system displays an error message explaining that you cannot post to a scenario used by another Real-Time model ID.

In other words, you can post a Real-Time model ID to several scenarios; however, a specified scenario can receive data from only one Real-Time model ID. If you are reposting data, the system displays a warning message to verify that you want to overwrite the existing data.

Note: Cost objects used in your Real-Time Activity-Based Management model must exist as dimensions. Real-Time Activity-Based Management does not maintain information about cost object dimensions. The delivered metadata equates cost object dimensions with Product.

To post a Real-Time Activity-Based Management model with cost objects not equated to the Product dimension, manually update the delivered model generation identifier or create a new one using the Model Generation Definition page before running the Model Generator.

Post IBUs

Select if the Real-Time model to be posted has interunit business units (IBUs).

Note: Associated IBUs display in the IBU Mapping grid where you can enter a valid mapping for the target Batch Inter Business Unit and Batch IBU Model ID to post an IBU.

Configure RT Interface Rules

Click to configure the Real-Time interface rules by moving your data to the Real-Time ABM interface table which then displays (in the Real-Time Interface Attributes grid) the information loaded into the Real-Time ABM interface table.

You can view or edit the ABM Real-Time Interface Table using the AB_RT_INTERFACE table page *before* starting Model Generator *or* you can *immediately* start Model Generator.

Note: The Configure RT Interface Rules button becomes available *after* you enter a Scenario ID.

Note: Since the ABM Real-Time interface table is not effective dated, the fiscal year and period that you specify in the run control ID does not filter any row. You can use the current date to start Model Generator.

Run Jobstream

Click to start Model Generator.

Note: Real-Time Activity-Based Management posts to batch Activity-Based Management using Model Generator. You can use the delivered model generation identifier (RT) or create your own. Be sure that the dimensions for your cost objects exist before running Model Generator.

See [Understanding Model Generator and Ledger Mapper Generator](#).

IBU Mapping

RT IBU

Displays the Real-Time interunit business unit associated with the scenario ID.

RT IBU Model ID

Displays the interunit business unit model identifier associated with the scenario ID.

Batch Inter Business Unit

Enter a valid batch interunit business unit.

Batch IBU Model ID

Enter a valid batch interunit business unit model identifier.

Note: The system does not validate your Batch Inter Business Unit or Batch IBU Model ID entries in real time so that you have the flexibility to enter these values now that may not yet exist, but will exist in the future.

Real-Time Interface Attributes

Interface Key (1 through 12)

Displays the normal drivers for the model—the data that Model Generator takes to post to batch.

1: Source Object

2: Target Object

3: Source Object Type (*Resource, Activity, or Cost object*)

4: Target Object Type (*Resource, Activity, or Cost object*)

5: IBU Business Unit

6: IBU Model

Note: Interface keys 5 and 6 only display when the driver is an IBU driver.

Amount (1 through 4)

1: Actual Amount

2: Budget Amount

3: Frozen Amount

4: Capacity Amount

Note: Amount fields are available when you select the Amounts tab.

Text (1 through 2)

Displays a description of the source object ID (1) and target object ID (2).

Note: Text fields are available when you select the Amounts tab.

Note: Access the Real Time ABM Interface page (Activity Based Management, Real Time Processing Center, Post to Batch, Real Time ABM Interface) to view much of this same information.

Real-Time ABM-Delivered Metadata

The delivered Real-Time ABM metadata lets you run Model Generator from Real-Time ABM using a Model Generator ID template (RT) that contains all of the related metadata (such as recordset, tablemap, datamap, filters, and constraints) and the Model Generator definition:

Metadata	Metadata Types	Description
Recordset	AB_RT_INTERFACE	
Tablemap	AB_RT_INTF	
Datamap	AB_RT_INTF	
Filters	RT_RR	Real-Time to resource to resource
	RT_RA	Real-Time to resource to activity
	RT_RC	Real-Time to resource to cost object
	RT_AA	Real-Time to activity to activity
	RT_AC	Real-Time to activity to cost object

Metadata	Metadata Types	Description
	RT_CC	Real-Time to cost object to cost object
	RT_CIBUR	Cost object to an interunit business unit resource
	RT_CIBUA	Cost object to an interunit business unit activity
	RT_CIBUC	Cost object to an interunit business unit cost object
Constraints	RT_RR	Real-Time to resource to resource
	RT_RA	Real-Time to resource to activity
	RT_RC	Real-Time to resource to cost object
	RT_AA	Real-Time to activity to activity
	RT_AC	Real-Time to activity to cost object
	RT_CC	Real-Time to cost object to cost object
	RT_CIBUR	Cost object to an interunit business unit resource
	RT_CIBUA	Cost object to an interunit business unit activity
	RT_CIBUC	Cost object to an interunit business unit cost object
Model Generation ID	RT	
RT Model	RT_TEST1	Example of a Real-Time model
EW Model RT/EW Scenario	RT1/ABM Model RT	Scenario RT1 is added to the business unit.
		Cost objects are added as product dimensions
		New Model Generator Jobstream

Real Time ABM Interface Page

Use the Real Time ABM Interface page (AB_RT_INTRF_LD_PG) to view or edit the Real-Time ABM interface table.

Navigation

Activity Based Management, Real Time Processing Center, Post to Batch, Real Time ABM Interface

Image: Real Time ABM Interface page

This example illustrates the fields and controls on the Real Time ABM Interface page. You can find definitions for the fields and controls later on this page.

The screenshot shows the Real Time ABM Interface page with the following sections:

- Model/Scenario:** Business Unit: CORP1, Scenario ID: ACTUAL01, Real-Time Model ID: (empty)
- Key Fields:** A table with columns 'Key Field Name 01' and 'Field Value'. Row 1: ABC_INTFC_KEY_ (dropdown), (empty dropdown), (+) (-)
- Get Search Data:** A button.
- Real Time Interface Values:** A table with columns 'Interface Key 1' through 'Interface Key 6'. Row 1: (empty text boxes)

Key Field Name

Select the primary field by which you want to filter the interface values.

Note: To specify several keys to filter the display, you can add rows containing the different filtering conditions. You can only specify a Key Field Name once; *do not* select it in multiple rows. The different rows act as *where* conditions concatenated with *AND*. If you select the same key field with different values, nothing displays in the grid.

Field Value

Select the value associated with the selected Key Field Name to further filter the display.

Get Search Data

Click to filter the display by your selections.

Interface Key (1 though 12), Amount (through 4), Interface Value 1, and Text (1 and 2)

Enter additional filter criteria by multiple keys, amounts, interface values, and text fields.

Chapter 13

Processing Batch Models

Understanding Batch Processing

Once you complete the necessary setup, you can process your model using engines that validate metadata (or model setup) or that process data for single or multiple dimensions (or ensure that the model is configured correctly within the system).

This section provides overviews of:

- Jobstreams and engines.
- Activity-Based Management tables.
- Batch processing process flow.

Jobstreams and Engines

Jobstreams let multiple users run their own jobs using instances of the same engines at the same time. By sharing temporary tables passed between jobs, jobstreams also speed up processing.

This section discusses:

- Jobstreams.
- Delivered engines.

Jobstreams

Instead of locking up the primary input (fact) tables in the operation warehouse - enriched (OWE), jobstreams use temporary tables for intermediate processing. A set of delivered temporary tables, which are called record suites, use only the relevant data from the main OWE fact tables to run the engines and process the data. This lets the engines in the jobstream run faster while keeping the fact tables open and accessible to other users so they can run the same engines simultaneously. The system assigns the record suites when the first engine runs and releases them when the last engine finishes.

Note: PeopleSoft Enterprise Performance Management (EPM) has predefined engines, engine metadata, jobs, job metadata, jobstreams, and record suites. You can also set up your own jobstreams. To do so, associate each engine with a job ID using the Job Metadata page, and then associate jobs with a jobstream using the Jobstream Setup page. A job must be unique across all jobstreams.

See "Using Balancing and Reconciliation Features (*PeopleSoft 9.1: Enterprise Performance Management Fundamentals*)".

See [Using the Reconciliation Engine and Job Total Metadata](#).

Delivered Engines

PeopleSoft EPM applications use engines to run processes. PeopleSoft delivers engine metadata with the system. This metadata stores information about the various PeopleSoft Application Engine programs used within an engine. The following table lists the delivered PeopleSoft engines and the associated job IDs that you use when processing Activity-Based Management:

Engine Name	Job ID	Description	Usage
RUN_PF_JOBSTREAM	RUN_PF_JOBSTREAM	Activity-Based Management Model and Activity-Based Management Ledger Mapper	Generates the objects and drivers for a model and the ledger-to-resource mapping for a model.
PF_EMP_SURV	EMP	Employee Profile	Generates resources and drivers based on the employee profile information.
AB_RTG	RTG	Routing Information engine	Creates relationships (drivers) for activities and cost objects for manufacturing purposes.
PF_Activity-Based Management_CUBE	AB_CUBE	Activity-Based Management Cube engine	Creates online analytical processing cubes.
AB_DRILLBACK	AB_DRILL	Activity-Based Management Drillback engine	Processes data for multidimensional reporting using a third-party reporting tool.
PF_ABPS	ABPS	ABPS engine	Processes ABPS models.
PF_OBJ_TBL	OBJ_TBL	Populate Activity-Based Management Object Table	Combines the separate object tables into a single table for modeling and reporting. Run this engine any time that you make changes to any objects.
AB_VALIDATE	ABMD	Activity-Based Management Model Validation	Validates resources, activities, cost objects, business rules, and tree structures for the model. You can run it any time after creating the model.
PF_ABC	Activity-Based Management	Activity-Based Management engine	Calculates single dimensional costs for resources, activities, and cost objects.

Engine Name	Job ID	Description	Usage
PF_MERGE	MERGE	Merge engine	Moves engine output from the temporary processing tables to the appropriate final table. This engine is part of EPM Foundation and should be run after all other engines.
ABM_RT_MAP	ABM_RT_MAP	Activity-Based Management mapping	Assign costs and amounts to resources based on the resource-to-ledger mapping rules and saves the output in ABM_LEDMAP_F00. This engine is used when preparing the ledger to resource mapping/amounts from the Real-Time ABM model. See Understanding Real-Time Activity-Based Management .

Note: This list does not include any Data Manager activities discussed in the *Enterprise Warehouse Tools and Administration* documentation.

This document discusses the following engines:

- Model Generator
- Ledger Mapper Generator
- Employee Profile
- Routing Information
- Activity-Based Management Cube
- Activity-Based Management Drillback
- Employee Profile
- ABPS

You can only run the Activity-Based Management Objects engine in a jobstream. It does not have a separate run control page.

Related Links

[Running the ABPS Engine](#)

[Running the Employee Profile Engine](#)

[Using the Reconciliation Engine and Job Total Metadata](#)

[Running Model Generator and Ledger Mapper Generator](#)

[Understanding the Employee Profile Feature](#)

[Understanding ABPS](#)

[Understanding Model Generator and Ledger Mapper Generator](#)

[Understanding Manufacturing Integration](#)

Activity-Based Management Tables

Activity-Based Management has input tables that enable you to enter information into the system for processing and output tables that store processing results.

Image: Key Activity-Based Management tables

The following flow chart illustrates key tables that the system uses during Activity-Based Management, Data Manager, and Profit Manager processing.

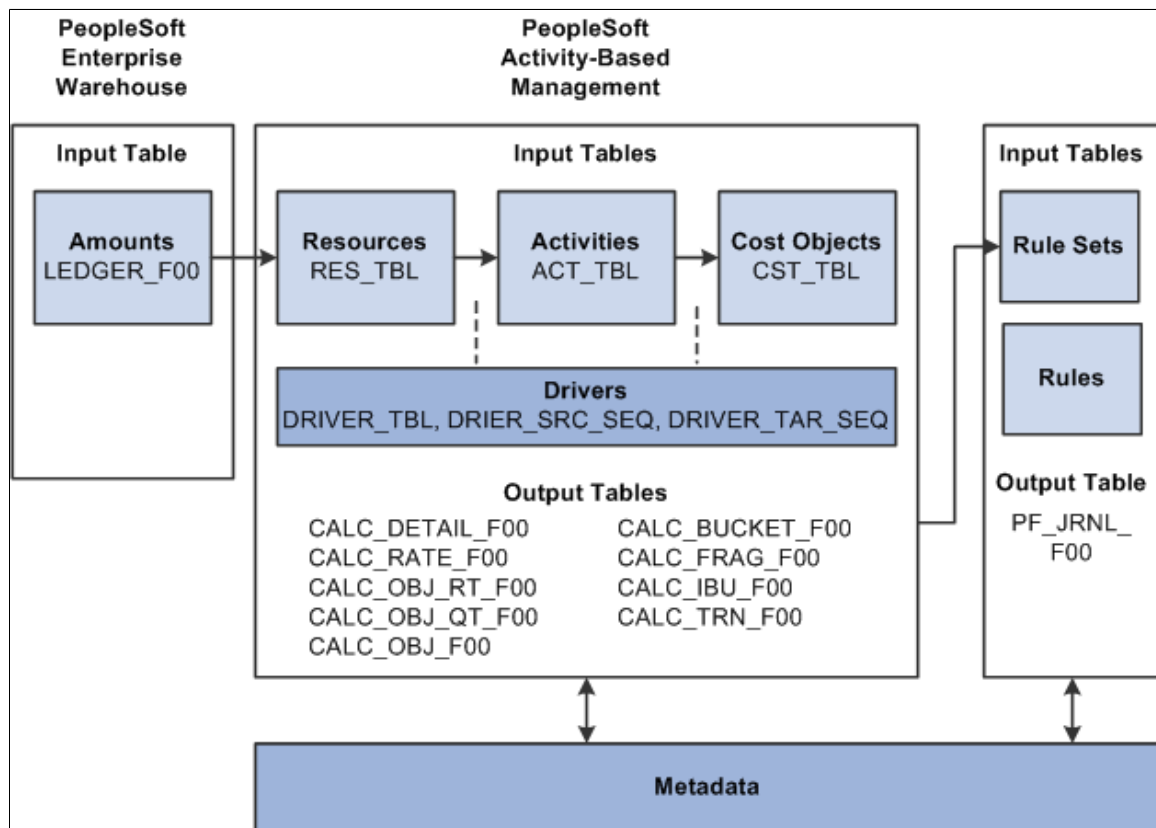

You can select any of the following input tables for ledger mapping information; however, you may choose to use the first two tables more frequently:

- Amounts (LEDGER_F00)
- Optional Budget Amounts (LEDGER_BUDG)
- Resources (RES_TBL)
- Activities (ACT_TBL)
- Cost Objects (CST_TBL)

- Driver (DRIVER_TBL, DRIVER_SRC_SEQ, and DRIVER_TAR_SEQ)

The output tables contain calculation tables. Metadata defines the types of data that the calculation tables store, which affects the calculation tables' output and how Data Manager uses the output for processing. The calculation tables store the output of the Activity-Based Management engine until it is used by other system processes. The system performs calculations in stages, and then stores these calculations in temporary tables; however, the system copies all of the results to the final tables.

The following table lists Activity-Based Management calculation tables:

Table Name	Object ID	Contents
Calculation Objects	CALC_OBJ_F00	Contains calculated cost values for resource, activity, and cost object amount information as processed by the Activity-Based Management engine. Use this table to query amount results for an object.
Calculation Detail	CALC_DETAIL_F00	Contains drillback or direct assignment information. The Drill Level field within the table denotes the type of calculation assignment. Use this table to drill back to the previous object (direct calculation) and obtain information for drilling back to all objects that contribute indirectly to the object (drillback calculation).
Calculation Bucket	CALC_BUCKET_F00	Contains temporary calculation results for resources, activities, and cost objects; therefore, it contains the most amount of detail. The system stores all finalized values in the Calculation Detail table (to be used for other processes).
Calculation Rate	CALC_RATE_F00	Contains driver rates.
Calculation Object Rate	CALC_OBJ_RATE_F00	Contains object rates such as object costs or object-calculated amounts.
Calculation Object Quantity	CALC_OBJ_QTY_F00	Contains object volume and quantity.
Calculation Fragmentation	CALC_FRAG_F00	Contains activity fragmentation data for employee resources.
Calculation Inter-Business Unit	CALC_IBU_F00	Contains cost data from inter-unit drivers.
Calculation Transaction	CALC_TRN_F00	Contains transaction rates.
Inter-Unit Rate	BU_RATE_F00	Contains inter-business unit driver rates.

Related Links

"Defining Data Manager Rules (*PeopleSoft 9.1: Enterprise Performance Management Fundamentals*)"

Verifying Model Setup Using Model Navigator

This section provides an overview of model setup verification using Model Navigator and discusses how to:

- Drill back through model data.
- Review resource attributes.
- Review activity attributes.
- Review cost-object attributes.

Pages Used to Verify Your Model Setup

<i>Page Name</i>	<i>Definition Name</i>	<i>Navigation</i>	<i>Usage</i>
Model Navigator	ABC_DRILL_MODEL1	Activity Based Management, Setup, Model, Model Navigator, Model Navigator	Review your model setup.
Model Navigator - Resources	ABC_DRILL_RES	Activity Based Management, Setup, Model, Model Navigator, Resources	Review the attributes of the resources used in your models.
Model Navigator - Activities	ABC_DRILL_ACT	Activity Based Management, Setup, Model, Model Navigator, Activities	Review the attributes of the activities used in the model.
Model Navigator - Cost Objects	ABC_DRILL_CST	Activity Based Management, Setup, Model, Model Navigator, Cost Objects	Review the attributes of the cost objects used in the model.

Understanding How to Verify Model Setup Using Model Navigator

Use Model Navigator to verify your model setup before running the Activity-Based Management Model Validation engine and Activity-Based Management engines. Model Navigator lets you drill back through resources, activities, and cost objects based on how the you set up the drivers. It uses information from the sources and targets to drill down to the next level.

Note: The Model Navigator - Resources, Model Navigator - Activities, and Model Navigator - Cost Objects pages display only the attributes for the Activity-Based Management objects, not the monetary amounts. (To determine how the system assigns costs throughout the model, use Object Navigator.) You can also use Model Navigator to drill through implicit drivers; however, to use this functionality, first run the Model Validation engine.

Related Links

[Using Object Navigator and Model Analyzer](#)
[Validating Models](#)

Model Navigator Page

Use the Model Navigator page (ABC_DRILL_MODEL1) to review your model setup.

Navigation

Activity Based Management, Setup, Model, Model Navigator, Model Navigator

Object Type

Select *Activity*, *Cost Obj.* (cost object), or *Resource*.

Object ID

Enter the unique identifier of the object.

Get Source(s)

Click to populate the grid with a list of sources for the associated object ID.

Get Target(s)

Click to populate the grid with a list of targets for the associated object ID.



Click the Drill Down button to navigate through the model.



Click the Get Object Data button to navigate to the appropriate setup page for that object. For example, if you click this button while viewing an activity, the Define Activities page displays.



Click the Get Driver Data button to view the driver setup in the Drivers component.

Model Navigator - Resources Page

Use the Model Navigator - Resources page (ABC_DRILL_RES) to review the attributes of the resources used in your models.

Navigation

Activity Based Management, Setup, Model, Model Navigator, Resources

Image: Model Navigator page - Resources tab

This example illustrates the fields and controls on the Model Navigator page - Resources tab. You can find definitions for the fields and controls later on this page.

The screenshot shows the Model Navigator page with the Resources tab selected. The Business Unit is CORP1 and the Model ID is BANK. The Search Criteria section includes several checked boxes: All Resources, All Res Use, All Res Group, All Res Supply As, and All Accounting Class. There are also dropdown menus for Resource Use (Primary), Resource Supplied (Committed), Resource Group (People-related expense), and Accounting Class (Inventory). A 'Get Resources' link is present. Below the search criteria is a table titled 'Resource Details' with columns for Resource ID, Description, Resource Use, Resource Group, Resource Supplied, Accounting Class, Source, and Target. The table contains five rows of data.

Resource ID	Description	Resource Use	Resource Group	Resource Supplied	Accounting Class	Source	Target
ACCT_MGR	Account Manager	Primary	Non people-related cost	Flexible	Non-inventory	<input checked="" type="checkbox"/>	<input checked="" type="checkbox"/>
ATM	ATM Machine	Primary	Non people-related cost	Flexible	Non-inventory	<input checked="" type="checkbox"/>	<input checked="" type="checkbox"/>
INVESTMENT_MGR	Investment Manager	Primary	Non people-related cost	Flexible	Non-inventory	<input checked="" type="checkbox"/>	<input checked="" type="checkbox"/>
PROCESS_MGR	Process Manager	Primary	Non people-related cost	Flexible	Non-inventory	<input checked="" type="checkbox"/>	<input checked="" type="checkbox"/>
TELLER	Teller	Primary	Non people-related cost	Flexible	Non-inventory	<input checked="" type="checkbox"/>	<input checked="" type="checkbox"/>

All Resources

Select All Resources to search for all possible resources that you want to review.

All Res Use (all resource use), All Res Group (all resource groups), All Res Supply As (all resource supply as), and All Accounting Class

Select any combination of check boxes to search for those types of resources that you want to review, and then refine your search further by selecting a value from the associated drop-down lists that display.

For example, selecting the All Res Group check box displays the corresponding Resource Use drop-down list where you can select a specific resource use.

The more check boxes that you select, the more detailed your search.

Get Resources

Click to display your search results.

Related Links

[Setting Up Resources](#)

Model Navigator - Activities Page

Use the Model Navigator - Activities page (ABC_DRILL_ACT) to review the attributes of the activities used in the model.

Navigation

Activity Based Management, Setup, Model, Model Navigator, Activities

This page functions the same as the Model Navigator - Resources page. In the Search Criteria group box, specify the detail of your search by selecting the desired check boxes, and then selecting items for the corresponding drop-down lists. Click Get Activities to display your search results. The Defining Activities section describes the grid columns.

Related Links

[Defining Activities](#)

[Model Navigator - Resources Page](#)

Model Navigator - Cost Objects Page

Use the Model Navigator - Cost Objects page (ABC_DRILL_CST) to review the attributes of the cost objects used in the model.

Navigation

Activity Based Management, Setup, Model, Model Navigator, Cost Objects

This page functions the same as the Model Navigator - Resources page. In the Search Criteria group box, specify the detail of your search by selecting the desired check boxes, and then selecting items for the corresponding drop-down lists. Click Get Cost Objects to display your search results.

Related Links

[Model Navigator - Resources Page](#)

[Defining Cost Objects](#)

Validating Models

To enhance data integrity, run the Activity-Based Management Model Validation engine to find most of the setup problems, data integrity errors, business rule errors, tree errors, and other audit errors. The Model Validation engine lets you display all errors online according to type, severity, and related parameters that identify the cause of the error so that you can correct errors without substantial additional investigation.

See [Activity-Based Management Validation Engine Messages by Message Number](#).

When you run this engine, the system creates a temporary table for error message details. Because you need to merge these details into the final tables, run a single jobstream that runs this engine with the Merge engine to ensure that the system populates the final tables.

When you set up your models using the Models component (MODEL_TBL1), click the Run Control Information tab (MODEL_TBL3) to define the Activity-Based Management Model Validation Profile that you want to use.

Audit Validation

Select to check your model metadata setup.

Complete Validation

Select to run a complete validation for the model including audit, data integrity, and setup.

Data Integrity Validation	Select to ensure that the information that you want to use in the model is available and accurate.
Setup Validation	Select to search for errors that cause the Activity-Based Management engine to stop processing.

Note: You can also audit your metadata before running these engines by running the Audit Utility in the PeopleSoft EPM.

Related Links

[Run Control Information Page](#)

Populating the Activity-Based Management Object Table

The Preprocess Activity-Based Management Objects engine (OBJ_TBL) takes the separate object tables and combines them into one table for reporting and modeling. Run this engine as soon as you set up your objects. Thereafter, run it whenever you make any changes to any of the resources, activities, or cost objects. In addition, run this process before running any reports; otherwise, your reports do not reflect meaningful information.

Run this engine in a jobstream by itself. You cannot combine it with other engines; it must be run separately.

See "Understanding Jobstreams (*PeopleSoft 9.1: Enterprise Performance Management Fundamentals*)".

Processing Data Using the Activity-Based Management Engine

To process single dimensional models, run the Activity-Based Management engine. This engine stores the final output in the calculation tables.

Before running this engine, complete model setup including its resources, activities, cost objects, pointers, drivers, and ledger mappers.

After running this engine, reconcile your model.

See [Understanding Batch Processing](#).

Related Links

[Understanding Model Reconciliation](#)

Creating Multidimensional Models Using Data Manager

This section provides an overview of creating multidimensional models using Data Manager and lists the page to run Data Manager.

Understanding Multidimensional Models Using Data Manager

Although you may have used single-dimensional assignments in your model to preserve cause-and-effect relationships, the Data Manager engine can help you enrich and convert data into a multidimensional format for further analysis. It takes direct costs, indirect costs, and revenue, and calculates data across multiple dimensions—product, customer, channel, and department.

Determining whether to use single-dimensional costing or multidimensional costing requires a precise definition of the business case that you want to address. You must know what questions you want answered. For example, if your organization manufactures beverages, such as coffee and tea, you can use Activity-Based Management to calculate a model based on single-dimensional costing. The output of Activity-Based Management single-dimensional analysis might look something like this:

Cost Object	Type	Cost in USD	Units	Cost per Unit in USD
Southwest Company	Customer	400	n/a	n/a
Central Company	Customer	600	n/a	n/a
New Northern Company	Customer	400	n/a	n/a
Tea	Product	600	60	10/case
Coffee	Product	900	120	7.50/case

With single-dimensional output and information, answers to these questions come easily:

- How much does it cost to make four cases of tea?
- How much is the unit cost of a case of coffee?
- How much does it cost to serve all of our customers?
- How much money could be saved by not doing business with the Central Company?

However, these types of questions are impossible to answer using this single-dimensional output:

- Which customer is the most or least profitable?
- Which product is the most or least profitable?
- Which mix of products is the most or least profitable?

Clearly, more information is required to answer these questions. You need information regarding the revenue from each of the products as well as information regarding the products that each of the customers purchased. Such information could be obtained from your billing system as the following table represents:

Customer	Product	Quantity	Revenue in USD per Case	Total Revenue in USD
Southwest Company	Coffee	50	10	500

Customer	Product	Quantity	Revenue in USD per Case	Total Revenue in USD
Central Company	Coffee	30	10	300
New Northern Company	Coffee	40	10	400
Southwest Company	Tea	10	15	150
Central Company	Tea	20	15	300
New Northern Company	Tea	30	15	450

The data in this example provides information regarding the number of product cases purchased by a customer and the revenues associated with these product cases. You can use the quantities purchased as the basis for assigning the single-dimensional costs.

After you obtain billing information, use that information in conjunction with the single-dimensional information and use both as input for Data Manager. Data Manager lets you integrate the product and customer dimensions effectively. The following table lists an example of possible Data Manager output with all amounts in USD:

Revenues	Product	Southwest Company	Central Company	New Northern Company	Total
	Coffee	500	300	400	1,200
	Tea	150	300	450	900
	Total	650	600	850	2,100
Cost of Sales					
	Coffee	375	225	300	900
	Tea	100	200	300	600
	Total	475	425	600	1,500
Gross Profit		175	175	250	600
Customer Costs		400	600	400	1,400
Net income (or loss)		(225)	(425)	(250)	(800)

The results of this analysis show that the Central Company is the least profitable customer.

Image: Data flow to Data Manager

The following flow chart illustrates how Activity-Based Management and Data Manager use direct and indirect costs and revenue.

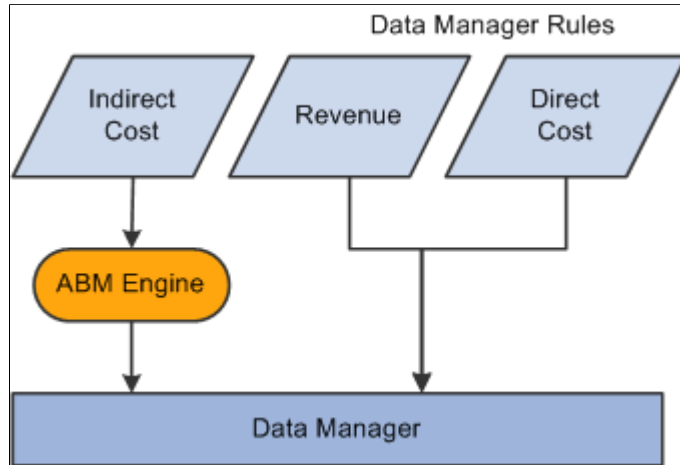

After the system processes data through Data Manager, it is stored in the PF Journal table (PF_JOURNAL_F00).

Note: The Calculation Detail fact table (CALC_DETAIL_F00) and the Calculation Objects fact table (CALC_OBJ_F00) describe the same set of data in different ways. Be careful not to process data redundantly using Data Manager. You should take an *either-or* approach when determining which tables to use when you are assigning costs using Data Manager.

Related Links

"Defining Data Manager Rules (*PeopleSoft 9.1: Enterprise Performance Management Fundamentals*)"

Analyzing Profitability Using Profit Manager

After your model is set up and processed, you can generate profitability reports. To report on profitability, ensure that your data is in the PF Ledger table (PF_LEDGER_F00) where the reporting tools access information. Your data may still be in the PF Journal table, particularly if you ran Data Manager (which stores data in the journal). To get data from the PF Journal table to the PF Ledger table, run Profit Manager, which is the PF Post process.

Note: PeopleSoft EPM considers *model ID* to be the same as *ledger* for reporting purposes. It is important that the engines use the same model ID in those instances when you want the engine results to be reflected in the same profitability report.

Reconciling Your Model and Analyzing Engine Output

Understanding Model Reconciliation

After running the Activity-Based Management engine, to reconcile your model the next steps are:

- Balance your model by balancing your job totals.
- Review your balances to find any errors and discrepancies in your model.
- Correct any errors.
- Rerun the Activity-Based Management engine.
- Analyze your engine output with Activity-Based Management's inquiry, analysis, and reporting tools.

Note: If you use Allocation Manager to set up allocations that use ABM tables, the Allocation Manager Inquiry tool enables you to review allocation audit data from the target to source, and it integrates with the ABM Object Navigator Inquiry tool for full drill-down capability.

See "Allocation Manager (*PeopleSoft 9.1: Enterprise Performance Management Fundamentals*)".

Prerequisites

Before you can use the pages described in this topic to review, reconcile, and analyze your model, you must run the Activity-Based Management and Merge engines. Running these engines reconciles costs from ledgers to resources, as well as resources to activities.

At a different level, you can run Data Manager to balance your job totals. This involves matching amounts moved through your model from the general ledger table (PS_LEDGER_F00) to the PF Ledger table (PS_PF_LEDGER_F00). The latter is the primary table where all data is derived and posted for processing and reporting.

To obtain job totals for balancing, ensure that you:

1. Create and run a jobstream for job totals that includes the following jobs: Employee Profile engine (if you use this option), Activity-Based Management engine, Merge engine, Data Manager engine, and PF Journal Edit engine.
2. Define job total and balance rule metadata.

This process is described in the *PeopleSoft Enterprise Performance Management Fundamentals*.

See "Understanding Jobstreams (*PeopleSoft 9.1: Enterprise Performance Management Fundamentals*)".

See "Using Balancing and Reconciliation Features (*PeopleSoft 9.1: Enterprise Performance Management Fundamentals*)".

Viewing Charts and Printing Results

You must install the EPM charting tool to view the charts used by many of the components.

To use Model Analyzer, you must also select the Applets check box.

Balancing Your Model

Once you run the Activity-Based Management engine, you need to balance your model. Model balancing is a reconciliation process that checks your results against your setup. You will also need to balance your job totals as described previously.

One of the more important aspects of balancing your job totals is examining the setup to assure that the data available for analysis is accurate. We provide a number of inquiry pages that enable you to review your balances. In addition, Object Navigator enables you to drill back from any object to the general ledger ChartFields, and Model Analyzer enables you to view all aspects of your model.

We provide various tools for reconciling your model:

- Reconciliation engine combined with job total metadata.
- Several inquiry pages.

Using the Reconciliation Engine and Job Total Metadata

One method for balancing your model is running the Reconciliation engine together with the job total metadata and balance rules metadata. We provide sample data specifically for this process.

To balance your model, run the Reconciliation engine, then review the results on the Job Totals page by selecting Performance Ledger, Performance Journals, Review Bal/Recon Results.

Related Links

"Using Balancing and Reconciliation Features (*PeopleSoft 9.1: Enterprise Performance Management Fundamentals*)"

[Analyzing Profitability Using Profit Manager](#)

Common Model Balance Errors

Common errors that may cause your model to be out of balance are:

- Improper ledger-to-resource mappings.
- Improper tree setup.

- Improper effective dates.
- Failure to rebuild the SQL after making changes to datamaps, constraints, or implicit pointers.

Inquiring on Balances

PeopleSoft Activity-Based Management features several inquiry pages you can use to check the balances for your model after you run the Activity-Based Management engine and balance your job totals. You use these pages to identify any errors. You can then correct these errors on the appropriate object setup pages and run the Activity-Based Management engine again.

When you balance your model, use the following formula:

$$(\text{sum of the ledger mappers}) = (\text{sum of the primary resources}) = (\text{sum of the primary activities}) = (\text{sum of the primary cost objects})$$

Note: Because Activity-Based Management calculations allow an unlimited number of iterations, or levels, the model will not balance at every level of your calculations.

To use any of the following pages, you first need to balance your job totals as described in the previous sections

Pages Used to Inquire on Balances

<i>Page Name</i>	<i>Definition Name</i>	<i>Navigation</i>	<i>Usage</i>
Object Rates	CALC_OBJ_RT_TBL1	Activity Based Management, Setup, Review Objects, Object Rates	Review the objects amounts, rates, and quantities calculated by the Activity-Based Management engine. This page displays the results of your Activity-Based Management engine for all objects in the model associated with the specified scenario.
Resources	ABIC_OBJ_NAV_RES	Activity Based Management, Setup, Review Objects, Resources	Review the resource details and amounts calculated by the Activity-Based Management engine.
Activities	ABIC_OBJ_NAV_ACT	Activity Based Management, Setup, Review Objects, Activities	Review the activity details and amounts used in your model and calculated by the Activity-Based Management engine.
Cost Objects	ABIC_OBJ_NAV_CST	Activity Based Management, Setup, Review Objects, Cost Objects	Review the cost object details and amounts calculated by the Activity-Based Management engine.

Page Name	Definition Name	Navigation	Usage
Object Details	CALC_DETAIL_TBL1	Activity Based Management, Setup, Review Objects, Object Details	Review the object details and amounts and details of the cost flow of the objects in your model, as calculated by the Activity-Based Management engine.

Related Links

[Prerequisites](#)

Object Rates Page

Use the Object Rates page (CALC_OBJ_RT_TBL1) to review the objects amounts, rates, and quantities calculated by the Activity-Based Management engine.

This page displays the results of your Activity-Based Management engine for all objects in the model associated with the specified scenario.

Navigation

Activity Based Management, Setup, Review Objects, Object Rates

On this page, you can view each Object ID by its Object Type.

The page also lists the Amount, Rate, and Quantity information for each object.

From here you can use the other inquiry pages to begin your reconciliation in smaller steps.

Resources Page

Use the Resources page (ABIC_OBJ_NAV_RES) to review the resource details and amounts calculated by the Activity-Based Management engine.

Navigation

Activity Based Management, Setup, Review Objects, Resources

To review balances for individual resources and identify any errors:

1. Enter the Search Criteria for the resources you want to review. To search on all possible resources, select the All Resources check box. For more detailed searches, select any of the other check boxes: All Res Use (all resource use), All Res Group (all resource group), All Res Supply As (all resource supply as), and All Accounting Class. Selecting any of these check boxes will activate the corresponding search criteria drop-down list box where you can make your search even more detailed. The more check boxes you select, the more detailed your search.
2. Once you have entered your search criteria, click the Get the objects based on the above selected search criteria. link to populate the page with your search results.
3. The grid displays the resources returned by Resource ID.
4. Click the Attributes tab to view the attributes of the resources.

- Click the Go To Object Navigator link to drill down through your objects to the general ledger ChartFields. From here you can also access the Model Analyzer, which enables you to analyze your model graphically.

Related Links

[Resources Page](#)

Activities Page

Use the Activities page (ABIC_OBJ_NAV_ACT) to review the activity details and amounts used in your model and calculated by the Activity-Based Management engine.

Navigation

Activity Based Management, Setup, Review Objects, Activities

This page functions the same way as the previously discussed Resources page.

Related Links

[Resources Page](#)

[Defining Activities](#)

[Using Object Navigator and Model Analyzer](#)

Cost Objects Page

Use the Cost Objects page (ABIC_OBJ_NAV_CST) to review the cost object details and amounts calculated by the Activity-Based Management engine.

Navigation

Activity Based Management, Setup, Review Objects, Cost Objects

Image: Cost Objects page

This example illustrates the fields and controls on the Cost Objects page.

The screenshot shows the 'Cost Objects' page interface. At the top, it displays search criteria: Business Unit: CORP1, Scenario ID: ACTUAL01, Fiscal Year: 1999, and Period: 1. Below this is a 'Search Criteria' section with input fields for Cost Object ID, Cost Object Use, Cost Object Group, and Dimension. To the right, there are checkboxes for 'All Cost Objects', 'All Cst Use', 'All Cst Group', and 'All Dimension'. A 'Go To Object Navigator' link is also present. The main section is titled 'Cost Object Details' and contains a table with columns for Object ID, Description, Amount, Quantity, and Rate. The table lists three objects: C1, C2, and C3.

Object ID	Description	Amount	Quantity	Rate
C1	C1 Desc	112670.707038	2000.000000	56.335354
C2	C2 Desc	112670.707038	2000.000000	56.335354
C3	C3 Desc	291288.888838	2000.000000	145.644444

This page functions the same way as the previously discussed Resources page.

Related Links

[Resources Page](#)

[Defining Cost Objects](#)

[Using Object Navigator and Model Analyzer](#)

Object Details Page

Use the Object Details page (CALC_DETAIL_TBL1) to review the object details and amounts and details of the cost flow of the objects in your model, as calculated by the Activity-Based Management engine.

Navigation

Activity Based Management, Setup, Review Objects, Object Details

To get an idea of the cost flow from one object to another:

1. Enter the Search Criteria for the objects you want to review. To retrieve all objects, click the Get Details link without entering any search criteria.
2. You can also narrow your search by searching for a particular Source Type (*Activity, Bud Ledger* [budget ledger], *Cost Obj* [cost object], *Ledger, Resource*); Target Type (*Activity, Cost Obj, Ledger Map, Resource*); and Drill Level (*Both, Direct, Indirect*). The more options you select, the more specific your search.
3. Click the Get Details link to populate the grid at the bottom of the page with your search results.
4. View the Source and Target information, as well as the Calculated Amount, Actuals Amount, and Budgeted Amount.

Using Object Navigator and Model Analyzer

The Object Navigator enables you to drill from any cost objects, activities, or resources to the general ledger ChartFields mapped to the resources. You can navigate through the various Activity-Based Management objects by using the Activity-Based Management trees or a grid. The Object Navigator also features graphic capabilities. You can view information in the form of a pie chart or bar chart. You also have the option of not displaying any graphics, which enables you to see more of the grid at the bottom of the page.

You can link directly to the Object Navigator from the Resources, Activities, or Cost Objects inquiry pages.

From the Object Navigator, you can also access the Model Analyzer which enables you to view a particular object, model, and any related models graphically. Use this feature to perform detailed analysis of your models.

The Model Analyzer enables you to:

- View an entire model with its resources, activities, and cost objects, as well as their sources and targets.
- Switch between models.

- View all related models for a shared services model setup.
- Focus only on objects of interest by selecting objects only as needed.
- View details of objects in the model
- See how costs flow from one object to another.
- View driver attributes, quantities, and amounts.

PeopleSoft Activity-Based Management also provides an inquiry page for reviewing contribution costs for objects in shared services models. You specify the target model and can view the contribution costs of various objects to that target model. You can also narrow your source to view the costs coming from one particular model.

Pages Used to Drill into Objects and Models

<i>Page Name</i>	<i>Definition Name</i>	<i>Navigation</i>	<i>Usage</i>
Object Navigator	AB_DRILL_TBL1	Activity Based Management, Analysis, Object Navigator	Navigate into your model.
Model Analyzer	AB_MODEL_ANALYZER	Activity-Based Management, Analysis, Model Analyzer	View your model graphically enabling detailed analysis.
Contribution Cost	AB_GET_COST	Activity Based Management Analysis, Contribution Cost	View contribution costs for shared objects.

Object Navigator Page

Use the Object Navigator page (AB_DRILL_TBL1) to navigate into your model.

Navigation

Activity Based Management, Analysis, Object Navigator

Image: Object Navigator page

This example illustrates the fields and controls on the Object Navigator page. You can find definitions for the fields and controls later on this page.

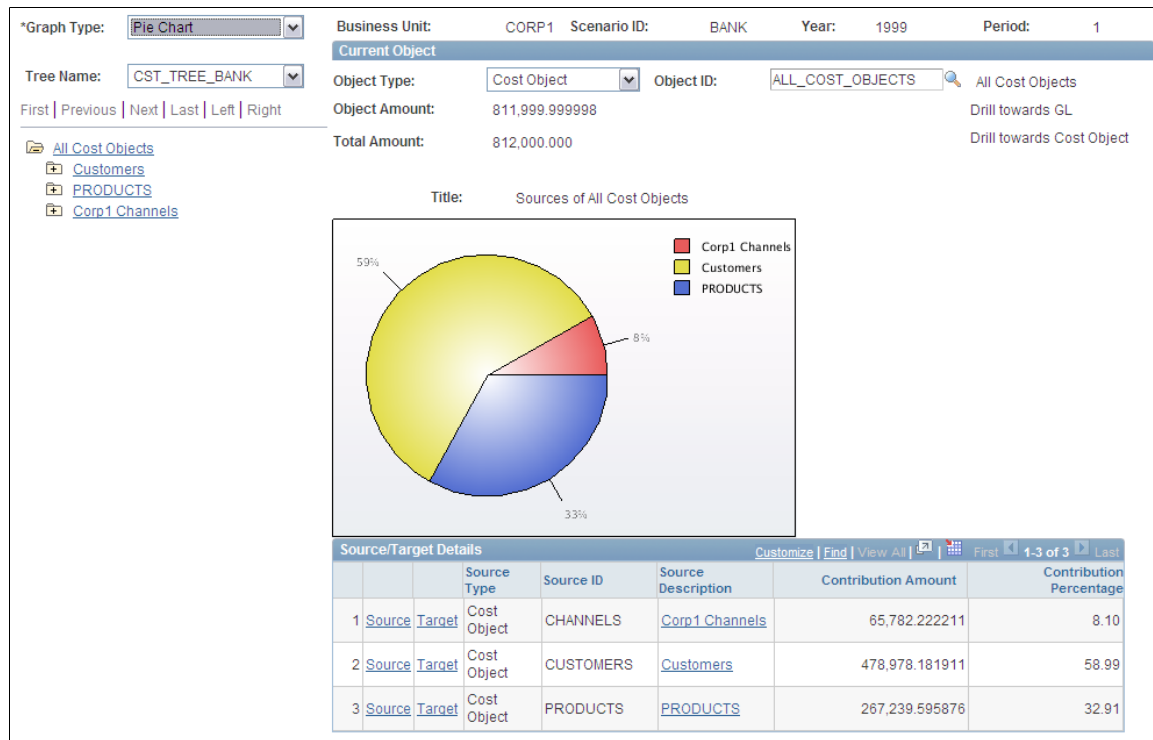

To navigate into your model:

1. On the left of the Object Navigator page you can view a tree control. Above the tree control are fields that you can use to set the chart display on the page and the tree you are viewing. You can change the tree by selecting another Tree Name.

You can navigate into the model by clicking on any of these tree nodes. When you select a node, the page display on the right changes to display the information for that object. You can also select a different Graph Type: *Bar Chart*, *No Graph*, or *Pie Chart*. If you choose *No Graph* there is more room for the grid to display.

2. The Current Object group box to the right of the tree display contains the ID of the current object as well as the Object Amount and Total Contribution Amount. Click the Drill towards GL and Drill towards Cost Object links to drill from the current object to the general ledger or the cost object, respectively.
3. The grid at the bottom of the page shows the details of the objects linked to the current object. You can also use the grid to navigate into the model. Click the Source or Target links to drill to the source or target objects for any of the objects listed. Click a Source Description link to view the inquiry page for that object. For example, if you are viewing a source that is an activity and you click its Source Description link, the system transfers you to the Activities inquiry page for that activity. You can also view the Contribution Amount as well as the Contribution Percentage totals for each object listed.

Model Analyzer Page

Use the Model Analyzer page (AB_MODEL_ANALYZER) to view your model graphically enabling detailed analysis.

Navigation

Activity-Based Management, Analysis, Model Analyzer

Click [This Model](#) or [Related Models](#) to start the graphical model that reads all model rules and results of the scenario associated with the model currently displayed in the grid (if the results are already calculated), and then graphically displays the model as a network diagram.

You can then:

- Add or delete objects such as resources, activities, cost objects.
- Add, delete, or modify object associations.
- Modify driver amounts, object volume, resource cost, or object capacity.
- Recalculate the model, and then analyze the results.

Note: Click Save before clicking Graphical Model.

Note: To access this page, you must select the Applets check box on the Installation Options - Web Services page.

The Model Analyzer provides a full graphic representation of your model results and relationships. Any object you select in the Model Analyzer representation displays in red; objects not selected display in yellow:

Related Links

[Viewing Charts and Printing Results](#)

Contribution Cost Page

Use the Contribution Cost page (AB_GET_COST) to view contribution costs for shared objects.

Navigation

Activity Based Management Analysis, Contribution Cost

Image: Contribution Cost page

This example illustrates the fields and controls on the Contribution Cost page. You can find definitions for the fields and controls later on this page.

The screenshot shows the 'Contribution Cost' page with the following fields and controls:

- Business Unit:** CORP1
- Scenario ID:** ACTUAL01
- Fiscal Year:** 1999
- Period:** 1
- Search Criteria:**
 - Target Type:** Cost Object (dropdown menu)
 - To Object Id:** (text input field)
- Source Criteria:**
 - Business Unit:** CORP1 (text input field)
 - Scenario ID:** ACTUAL01 (text input field)
 - Source Type:** (dropdown menu)
 - From Object Id:** (text input field)
- Get contribution to the target from the source(s) for the chosen criteria.** (link)
- Go To Object Navigator** (link)
- Contribution Cost Details Table:**

Business Unit	Scenario ID	Source Type	Source ID	Description	Contribution Amount
CORP1	ACTUAL01				

Note: To view data on this page, you must select the Get Drill Level 2 Information check box on the Models - Run Control Information page and run the Activity-Based Management Drillback engine.

To review contribution costs:

1. Specify the Target Type for which you want to view data: *Activity*, *Bud Ledger* (budget ledger), *Cost Obj.* (cost object), *Ledger*, or *Resource*. You can also select a specific target type in the adjacent To Object ID field. If you leave these fields blank, the system returns all objects that contribute to this model.
2. In the Source Criteria group box, the Business Unit and Scenario ID default to the business unit and scenario ID you specified on accessing the page. If you do not change these settings, the system returns all the objects that contribute to the model based on the specified Target Type and To Object ID. To view the costs coming from a particular model, enter the business unit and scenario ID for that model. For example, you may only want to view any Human Resources contribution.
3. You can further narrow your search by specifying a Source Type and a From Object ID.
4. After you enter search criteria, click the Get contribution from the target to the source(s) for the chosen criteria. link. The search returns a list of objects based on your search criteria. For each object you can view the Source Type, Source ID, Description, and Contribution Amount.
5. Enter different search criteria to view more data, or click the Go To Object Navigator link to continue reviewing your model.

Using Activity-Based Management Trend and Variance Analysis

Activity-Based Management features two tools enabling you to analyze you model results:

- Activity-Based Management Trend Analysis.

- Activity-Based Management Variance Analysis.

Understanding Activity-Based Management Trend Analysis

Activity-Based Management Trend Analysis enables you to compare trend results from any Activity-Based Management scenario over a specified time frame. Using this feature you can:

- Specify the model criteria to use for the comparison.
- Specify the scenario and the number of periods you want to include in the trend analysis.
- Display Activity-Based Management trees using tree control functionality for the specified model.
- Drill through the tree using the tree control or a grid.
- View details of the Activity-Based Management model in a chart and grid format.

Understanding Activity-Based Management Variance Analysis

Activity-Based Management Variance Analysis enables you to compare results between:

- Two different models from the same or different periods.
- Two different time periods for the same model.
- The actual, budget, and calculated fields for the same model and time period.
- The actual, budget, and calculated fields for a different model and time period.

As with Activity-Based Management Trend Analysis, you can:

- Specify the model criteria to use for the comparison.
- Display Activity-Based Management trees using tree control functionality for the specified model.
- Drill through the model using the tree control or via the grid.
- View details for the variance results in chart and grid format.

Pages Used to View Trend and Variance Data

Page Name	Definition Name	Navigation	Usage
Trend Analysis selection criteria	AB_TREND_SRCH	Activity Based Management Analysis, Trend Analysis	Enter search criteria for the scenario and periods you want to analyze.
Trend Analysis	AB_TREND_MAIN	Click the Do analysis link on the Trend Analysis selection criteria page.	View the trend data based on the selection criteria and drill down into greater detail.
Variance Analysis selection criteria	AB_VAR_SEL_PAGE	Activity Based Management Analysis, Variance Analysis	Enter search criteria for the models, periods, and calculation types you want to compare using this tool.

Page Name	Definition Name	Navigation	Usage
Variance Analysis	AB_VAR_MAIN_PAGE	Click the Do analysis link on the Variance Analysis selection criteria page.	View the variance data based on the selection criteria and drill down into greater detail.

Using the Trend Analysis and Variance Analysis Components

The Trend Analysis and Variance Analysis components are very similar in their structure and behavior.

Entering Selection Criteria

When you first access the components you enter selection criteria to specify which scenario, model, or combination of both, to compare. These pages vary slightly and are described later in this section.

Trend Analysis and Variance Analysis Data Display

Once you have entered your search criteria, select the Do analysis to transfer to the main Trend Analysis or Variance Analysis report page. Each of these pages is laid out as follows.

- On the top left is the tree control. This is based on the tree specified in your search criteria (resource, activity, or cost object).
- To the right of the tree control is a chart display of the results based on the criteria you entered. Above the chart, a summary of your selection criteria displays.
- Below the chart is a grid listing objects based on your selection criteria.

Using the Tree Control

You can use the tree control to drill down through the model. Simply expand or collapse the tree and select any node to navigate to different information. The chart and grid display change based on your selection. The tree displayed is the tree attached to the object type you specify in your selection criteria.

Using the Grid

You can also use the grid at the bottom of the pages to drill down through the model. Select any of the objects listed to drill down a level. For example, if you select a cost object, you will drill down to view the activities for that cost object. The chart display and grid display change based on your selection.

Trend Analysis Selection Criteria Page

Use the Trend Analysis selection criteria page (AB_TREND_SRCH) to enter search criteria for the scenario and periods you want to analyze.

Navigation

Activity Based Management Analysis, Trend Analysis

To analyze trend data:

1. Enter the Number of Periods to Trend. The system will analyze the trend data over this number of periods, enabling you to compare two or many periods.

- Specify the Object Type to use as the starting point for the analysis: *Activity*, *Cost Obj.* (cost object), or *Resource*.
- The Tree Name for the object type you select displays.

Note: You must select an object type that has an attached tree in order to perform a trend analysis.

- Click the Do analysis link to view the data returned based on your selection criteria.
- You can also reset your scenario selection by clicking the Select new base link.

Trend Analysis Page

Use the Trend Analysis page (AB_TREND_MAIN) to view the trend data based on the selection criteria and drill down into greater detail.

Navigation

Click the Do analysis link on the Trend Analysis selection criteria page.

Image: Trend Analysis page

This example illustrates the fields and controls on the Trend Analysis page.

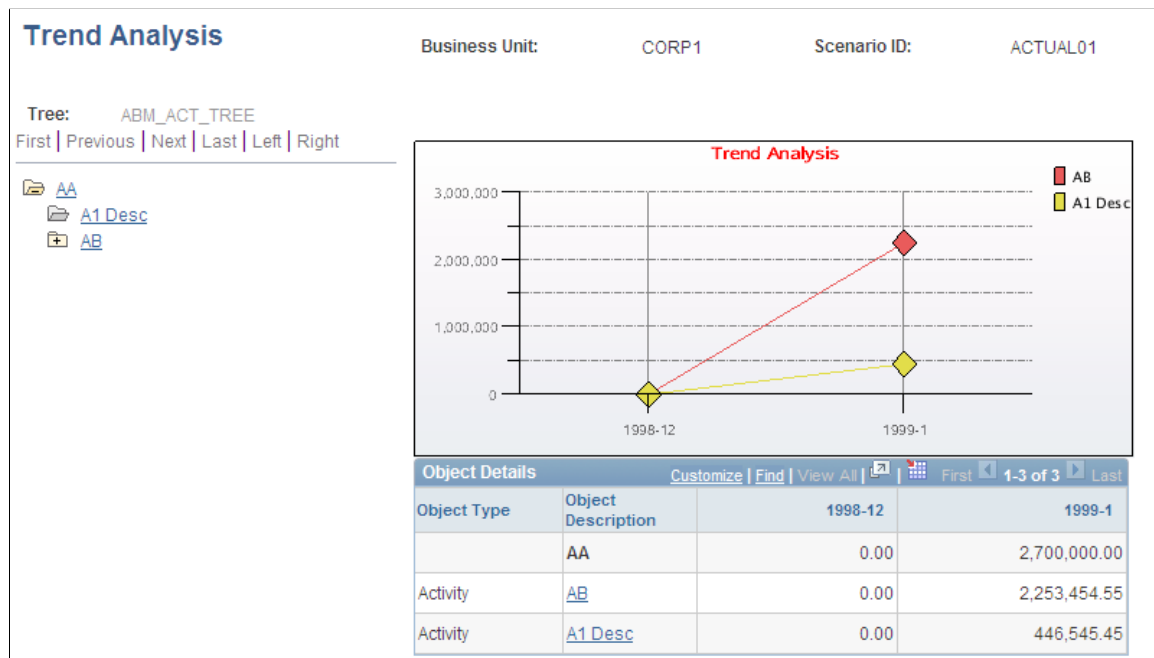

The grid display has the following columns:

- Object Type** The objects currently selected from the tree control or the grid.
- Object Description** Links that you can use to drill down to linked objects. For example, clicking a cost object description enables you to drill down to view the activities that drive that cost object.
- fiscal year-period (such as 1998-12)** These columns display the amount values for the fiscal year and periods specified in your search criteria. For example, if you

chose to run the trend analysis over three periods, four columns display the base column followed by the next three periods. You can directly and easily compare the values in each column and drill down to get more detail.

The chart displays the column amount data in graphic form enabling you to view the trend for the data. The chart display changes based on the objects you're viewing.

To change your selection criteria or enter new criteria, click the Choose scenario link to return to the Trend Analysis selection criteria page.

Variance Analysis Selection Criteria Page

Use the Variance Analysis selection criteria page (AB_VAR_SEL_PAGE) to enter search criteria for the models, periods, and calculation types you want to compare using this tool.

Navigation

Activity Based Management Analysis, Variance Analysis

Image: Variance Analysis selection criteria page

This example illustrates the fields and controls on the Variance Analysis selection criteria page.

Select Compare Scenario		
	Base Scenario	Compare Scenario
Business Unit:	CORP1	CORP1
*Scenario ID:	BANK	BANK
Fiscal Year:	1999	1999
Accounting Period:	1	1
Calculation Column:	Actuals Amount	Actuals Amount
Select Base Scenario Tree		
Object Type:	Cost Object	
Tree Name:	CST_TREE_BANK	

[Do analysis](#) [Select new base](#)

To analyze variance data:

1. The Base Scenario fields display the settings you selected for opening this page. You can change the Calculation Column to include a different calculation type in your analysis: *Actuals*, *Budgeted*, or *Calculated*.
2. In the Compare Scenario column, select the Scenario ID of the model you want to use for the comparison. This can either be the same scenario if you want to compare a different fiscal year and period, or a different calculation type, or an entirely different scenario.

If you are comparing the model amounts, for example (such as actuals versus budgeted, actuals versus calculated, or budgeted versus calculated) specify these settings in the Calculation Column drop-down list box.

- In the Select Base Scenario Tree group box, specify the Object Type that you want to use as the starting point for the analysis: *Activity*, *Cost Obj.* (cost object), or *Resource*. The Tree Name for the object type you select automatically displays.

Note: You must select an object type that has an attached tree in order to perform a variance analysis.

- Click the Do analysis link to view the data based on your selection criteria.
- You can also reset your scenario selection by clicking the Select new base link.

Variance Analysis Page

Use the Variance Analysis page (AB_VAR_MAIN_PAGE) to view the variance data based on the selection criteria and drill down into greater detail.

Navigation

Click the Do analysis link on the Variance Analysis selection criteria page.

Image: Variance Analysis page

This example illustrates the fields and controls on the Variance Analysis page.

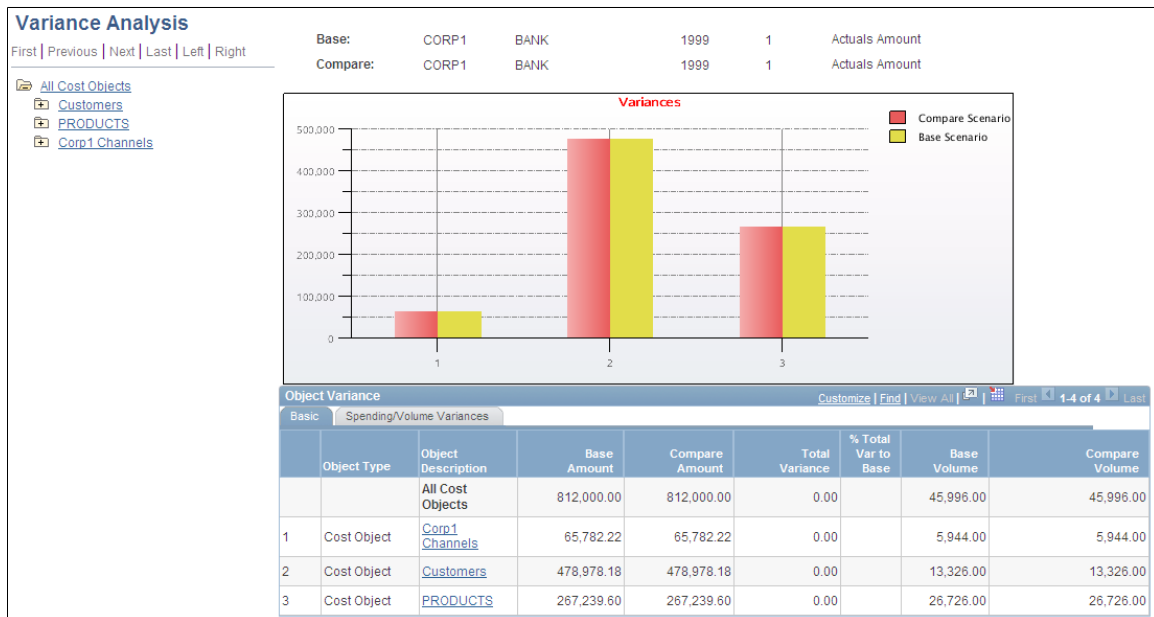

The Object Type column displays the objects currently selected using the tree control or grid. The Object Description column displays descriptions of the objects as links that you can use to drill down to linked objects. For example, clicking on a cost object description enables you to drill down to view the activities that drive this cost object.

For each object listed, the grid displays the Base Amount and the Compare Amount. It also displays the Total Variance as both an amount and a percentage, and you can also view the Base Volume and the Compare Volume.

Click the Spending/Volume Variances tab to view the Spending Variance and Volume Variance both as an amount and percentage.

The following formulas are used to calculate the variance amounts:

Variance Amount	Formula
Total variance	base amount \diamond compare amount
Percent total variance to base	$(\text{total variance} / \text{base amount}) * 100$
Volume variance	$(\text{base volume} \diamond \text{compare volume}) * (\text{base amount} / \text{base volume})$
Percent volume variance to base	$(\text{spending variance} / \text{base amount}) * 100$
Spending variance	$((\text{base amount} / \text{base volume}) \diamond (\text{compare amount} / \text{compare volume})) * \text{compare volume}$
Percent spending variance to base	$(\text{volume variance} / \text{base amount}) * 100$

The chart displays the grid data in graphic form enabling you to view the variance for the data.

To change your selection criteria or enter new criteria, click the Choose scenario link to return to the Variance Analysis selection criteria page.

Related Links

[Trend Analysis Page](#)

Creating and Reviewing OLAP Cubes

With Activity-Based Management you can create an OLAP (online analytical processing) cube for analytical purposes. By creating an OLAP cube with Activity-Based Management data, you can easily see how costs relate to each other. Activity-Based Management cubes are used to see three-dimensional costs; for example, costs going from resources to cost objects through activities.

You typically use cubes after you've run all the Activity-Based Management engines and your model is created and balanced.

Note: As an option, you can use the Object Navigator to view three-dimensional costs one at a time, however, Activity-Based Management cubes show all costs at the same time.

You can create an Activity-Based Management cube and then review your results using the OLAP Cube inquire page.

Page Used to Create and View OLAP Cubes

Page Name	Definition Name	Navigation	Usage
OLAP Cube	CALC_CUBE_TBL1	Activity Based Management, Analysis, Cube Results	Review the results of OLAP cubes. The page lists values at the intersection of primary resources, activities, and cost objects.

Running the Create Activity-Based Management Cube Process

As with all Activity-Based Management engines, you can run the Create Activity-Based Management Cube engine in a jobstream. You can also run it separately by selecting Activity Based Management, Analysis, ABM Cube.

The Create Activity-Based Management Cube engine populates temporary tables. After running this engine, you need to run the Merge engine to transfer the data from the temporary tables to final tables. You can do this by creating a jobstream for both engines, or you can run the engines separately.

Inquiring on Engine Messages

To review messages generated by these jobs, access the Application Engine message log for the relevant process instance and engine ID.

See "Viewing Engine Messages (*PeopleSoft 9.1: Enterprise Performance Management Fundamentals*)".

OLAP Cube Page

Use the OLAP Cube page (CALC_CUBE_TBL1) to review the results of OLAP cubes.

The page lists values at the intersection of primary resources, activities, and cost objects.

Navigation

Activity Based Management, Analysis, Cube Results

Image: OLAP Cube page

This example illustrates the fields and controls on the OLAP Cube page.

OLAP Cube			
Business Unit:	CORP1	Scenario ID:	ACTUAL01
Fiscal Year:	1999	Period:	1
Search Criteria			
Resource ID:	<input type="text" value="E6"/>		E6
Activity ID:	<input type="text"/>		
Cost Object ID:	<input type="text"/>		
Get Cube Details	Total Amount:		300,000.000
Cube Details			
			Customize Find View All First 1-15 of 16 Last
Description	Description	Descr	Calculated Amount
E6	A1 Desc	C1 Desc	12,000.000000
E6	A1 Desc	C2 Desc	12,000.000000
E6	A1 Desc	C3 Desc	36,000.000000
E6	A2 Desc	ch1	18,000.000000

To review the results of the OLAP cube:

1. Enter the Search Criteria for the objects you want to review. To retrieve all objects, click the Get Cube Details link without entering any search criteria.
2. You can also narrow your search by searching for a particular Resource ID, Activity ID, or Cost Object ID. The more options you select, the more specific your search results will be.
3. Click the Get Cube Details link to populate the grid at the bottom of the page with your search results.
4. The Calculated Amount column displays the calculated values at the intersection of resources, activities, and cost objects.

Using the Activity-Based Management Drillback Engine

In addition to using OLAP cubes to get a three-dimensional view of your Activity-Based Management data, you can use the Activity-Based Management Drillback engine to get a multidimensional view for reporting purposes.

To use the Activity-Based Management Drillback engine, you must:

- Specify the drillback levels on the Drillback Levels page.
- Run the Activity-Based Management Drillback Application Engine process.

Note: If you are using the Activity-Based Management Drillback engine you also must select the Get Drill Level 2 Information check box on the Models - Run Control Information page before running the Activity-Based Management engine.

See [Run Control Information Page](#).

Page Used to Specify Drillback Levels

<i>Page Name</i>	<i>Definition Name</i>	<i>Navigation</i>	<i>Usage</i>
Drillback Levels	AB_SEC_LEVEL_TBL1	Activity Based Management, Analysis, Drillback Levels	Name the drillback levels that will display in reports generated after you run the Activity-Based Management Drillback engine.

Drillback Levels Page

Use the Drillback Levels page (AB_SEC_LEVEL_TBL1) to name the drillback levels that will display in reports generated after you run the Activity-Based Management Drillback engine.

Navigation

Activity Based Management, Analysis, Drillback Levels

To name the drillback levels for multidimensional reporting, enter a Drillback Level Name and Description. The description will appear in any reports you generate after running the Activity-Based Management Drillback engine.

Running the Activity-Based Management Drillback Engine

As with all Activity-Based Management engines, you can run the Activity-Based Management Drillback engine in a jobstream. You can also run it separately from the Activity-Based Management Drillback page by selecting Activity Based Management, Analysis, Drillback.

The Activity-Based Management Drillback engine first populates temporary tables. After running this engine, you need to run the Merge engine to transfer the data from the temporary tables to the final table, the Drillback table (AB_DRILL_F00) used to drill back data. You can do this by creating a jobstream for both engines, or you can run the engines separately.

You can review messages generated when you run these jobs, by accessing the Application Engine message log for the specific process instance and engine ID. This component is described in detail in the *PeopleSoft Enterprise Performance Management Fundamentals 9.1* documentation.

Using PF Ledger Drilldown

The PF Ledger Drilldown tool enables you to view Activity-Based Management-specific data that comes from the general ledger.

Ledger Drilldown uses rules you defined in Data Manager to determine which page to automatically navigate towards. That information appears in the Source column on the Drill Details page. Data originating in Activity-Based Management is defined as *Activity-Based Management*.

Note: You can also use Object Navigator to perform these functions, as well as to view graphics.

Page Used to Drill Back

<i>Page Name</i>	<i>Definition Name</i>	<i>Navigation</i>	<i>Usage</i>
Activity-Based Management Ledger Data	AB_DRILL_TBL2	<ul style="list-style-type: none"> Performance Ledger, Performance Journals, Review Ledger Details Click the Get Drill Data button. Click the Get More Drill Back Data button. 	View the criteria you mapped to the Ledger Mapping table (PF_LEDMAP_F00).

Related Links

"Using Ledger Drill Down (*PeopleSoft 9.1: Enterprise Performance Management Fundamentals*)"

Drilling Back with PF Ledger Drilldown

To drill back using Ledger Drilldown:

1. You must have run a jobstream that included the Activity-Based Management engine, Activity-Based Management Drillback engine, and Profit Manager processes, including PF Post and PF Edit.
2. Select Performance Ledger, Performance Journals, Review Ledger Details, and set up the Drill Criteria page (PF_DRILLSRCH_TBL1) with the following criteria in the Drill Criteria group box: business unit, scenario ID, fiscal year, accounting period, and source (be sure to enter *Activity-Based Management* as the source).
3. Click the Get Drill Data button near the upper right on the page. Doing so transfers you to the Drill Details page. You can use this page to drill down through Activity-Based Management calculations to the Ledger table (PF_LEDGER_F00). Here you can choose data from the ledger and drill back to the source for data from PeopleSoft Activity-Based Management.
4. On the Drill Details page, in the left-hand column, click the Get More Drill Back Data button for the line item (object) on which you want to drill back. Doing so immediately populates the next drilldown page, the Activity-Based Management Ledger Data page (AB_DRILL_TBL2), with the appropriate data.

This is a view only page that displays the criteria you mapped to the Ledger Mapping table (PF_LEDMAP_F00).

5. On the Drill Details page the Scenarios tab displays information about the scenario and the dimension, while the Amounts tab displays information about the currency and the amount.

Other Activity-Based Management Inquiry Pages

PeopleSoft Activity-Based Management also provides three pages you can use to review the following:

- Pointer quantities.
- Driver quantities.
- Driver rates.

Pages Used to Review Pointers and Drivers

Page Name	Definition Name	Navigation	Usage
Pointer Quantities	POINTER_QTY_TBL1	Activity Based Management, Setup, Pointers to Drivers, Pointer Quantities	Review which pointer quantities the Activity-Based Management engine used for its calculations.
Driver Quantities	DRIVER_NUM_TBL1	Activity Based Management, Setup, Drivers, Review Driver Quantities	Review which driver quantities the Activity-Based Management engine used for its calculations.

Page Name	Definition Name	Navigation	Usage
Driver Rates	CALC_RATE_TBL1	Activity Based Management, Setup, Drivers, Driver Rates	Review which driver rates the Activity-Based Management engine used for its calculations.

Pointer Quantities Page

Use the Pointer Quantities page (POINTER_QTY_TBL1) to review which pointer quantities the Activity-Based Management engine used for its calculations.

Navigation

Activity Based Management, Setup, Pointers to Drivers, Pointer Quantities

In the Search Criteria group box, you can either choose a particular Pointer ID by selecting from the prompt list, and then click the Get Pointer Details link, or view all pointers by leaving the Pointer ID field blank and clicking the Get Pointer Details link.

The grid then displays a Description and Pointer Quantity for each pointer ID. This is the quantity used by the Activity-Based Management engine.

Driver Quantities Page

Use the Driver Quantities page (DRIVER_NUM_TBL1) to review which driver quantities the Activity-Based Management engine used for its calculations.

Navigation

Activity Based Management, Setup, Drivers, Review Driver Quantities

1. In the Search Criteria group box, you can either choose a particular Driver ID by selecting from the prompt list and clicking the Get Driver Details link, or view all drivers by leaving the Driver ID field blank and then clicking the Get Driver Details link.
2. The grid populates based on your search criteria, displaying for each object a Description and Target. You can also view the Driver Quantity and Percentage. This is the quantity used by the Activity-Based Management engine.
3. Click the Actual/Budgeted tab to view the Actual Driver Quantity, Budgeted Driver Quantity, Rate Driver Quantity, and Capacity Driver Quantity as applicable.

Driver Rates Page

Use the Driver Rates page (CALC_RATE_TBL1) to review which driver rates the Activity-Based Management engine used for its calculations.

Navigation

Activity Based Management, Setup, Drivers, Driver Rates

1. In the Search Criteria group box, you can either choose a particular Driver ID by selecting from the prompt list and clicking the Get Driver Rate link, or view the rates for all drivers by leaving the Driver ID field blank and clicking the Get Driver Rate link.
2. The grid populates based on your search criteria, displaying for each Driver ID a Description, Calculated Rate, and Actual Rate.

Using Employee Profile

Understanding the Employee Profile Feature

Many users of activity-based management applications are primarily interested in the costs of processes, activities, and tasks that are carried out within their organizations. An in-depth understanding of the costs of these processes and activities, and their associated costs, can provide insight, and can also help to answer the following types of questions:

- What type of work do employees spend the most time doing?
- Can non-value-added activities be eliminated?
- Which business processes are most expensive?
- How many full-time equivalents are involved in the purchasing process?
- Should more time be spent doing certain types of activities?

Much of the information that is required to find answers to questions such as these involves collecting information about work activities from individual employees or groups of employees performing similar tasks. This can be a daunting task in large organizations, but the Activity-Based Management Employee Profile feature makes the collection of this information as efficient as possible.

Every employee or group of employees should be able to select activities that they are performing from the delivered activity dictionary. This functionality is either called Employee Survey when it is performed on a continuous basis, or Employee Profile when it is performed as a template over a certain period of time. The system uses these employee activity profiles to drive resources to activities for workforce-related costs in a more precise and documented manner.

To start the process, you must create activities either with the Activity component or with PeopleSoft Tree Manager. You must ensure that any personal employee information has been entered and is available to the system. Next, you associate work performed on activities, such as tasks, with a percentage of time or actual hours worked.

Employee Profiles

The Employee Profile feature enables you to create resources and resource drivers based on information related to employees and the activities those employees perform. The employee information can come from either PeopleSoft Time and Labor or from the Employee Profile module in Activity-Based Management.

Time and labor information is important, because it links people and activities, indirectly forming the basic setup for resource drivers. If you have installed PeopleSoft Time and Labor, the Employee Profile feature derives employee activity information directly from time and labor data. The system uses data migration tools to aggregate the information to the fiscal year and accounting period, providing the most accurate source of employee activity information. If you are using PeopleSoft Time and Labor,

the Employee Profile process associates employees with the activities by creating system-generated, effective-dated resources, drivers, and driver quantities.

If you do not use PeopleSoft Time and Labor or do not use it for all of your employees, you can use the Employee Profile feature delivered with Activity-Based Management to capture activity information. The Employee Profile functionality enables you to define an activity profile for individual employees or to define an activity profile for a group of employees who perform similar activities and who constitute a work group or department. These profiles are defined with an effective date and capture information on the activities that are performed by employees, work groups, or departments. Profiles remain active until they are superseded by a profile with a different effective date. Models using the Employee Profile feature calculate the budgeted hours with the employee profile data. The Employee Profile feature requires that an activity profile exist for each employee of the company whether they are part of a workgroup or whether they are modeled separately. Running the Employee Profile process generates a resource object for each employee, department, and work group. It also generates the resource drivers for each resource to activity reported.

Note: Because employee profiles are effective-dated and are not aggregated into a fiscal year and accounting period, they cannot be used to capture day-to-day employee activity information. If you require this functionality, you must use PeopleSoft Time and Labor.

How the Employee Profile feature works:

- The Employee Profile feature analyzes employee activity first by verifying that the information exists in the employee profile that you have defined.
- Activity-Based Management uses the employee activity information if it is available; otherwise, it searches for the information in the operational warehouse - enriched (OWE) tables.

Either way, the time and labor information is automatically transformed into resource and driver data.

- The Employee Profile engine generates resources and drivers.

Populating Tables for the Employee Profile Feature

If you have installed PeopleSoft Time and Labor, to use the Employee Profile feature you must populate the following tables:

Required Table	ETL Job
JOB_F00	J_F00_PS_JOB
PERSONAL_D00	J_D00_PS_PERSONAL
TIME_LABOR_F00	J_FACT_PS_F_TIME_LABOR_E1

If you are using the Employee Profile module to obtain employee data, you must populate the following tables:

Required Table	ETL Job
JOB_F00	J_F00_PS_JOB

Required Table	ETL Job
JOBCODE_D00	J_D00_PS_JOBCODE
PERSONAL_D00	J_D00_PS_PERSONAL
DEPARTMENT_TBL	J_BASE_PS_DEPARTMENT_TBL
EMPL_SURVEY_TBL	Data is entered online using ABM.
EMPL_SURVEY_SEQ	Data is entered online using ABM.

Note: If you choose to obtain employee survey data using ETL, rather than entering it on an Activity-Based Management Employee Survey page, you must create your own ETL job. If you do not use Activity-Based Management Employee Survey pages to enter data, then you do not need to populate the PERSONAL_D00 table.

If you are not using department activities, you do not need to populate the DEPARTMENT_TBL table.

Employee Profile and the Operational Warehouse

Personal employee information combined with the department and job information creates a maintainable employee profile. The Employee Profile process utilizes this information to create resources and resource drivers for each employee, department, and work group.

Image: Employee profile and operational warehouse tables

The following diagram illustrates the informational relationships.

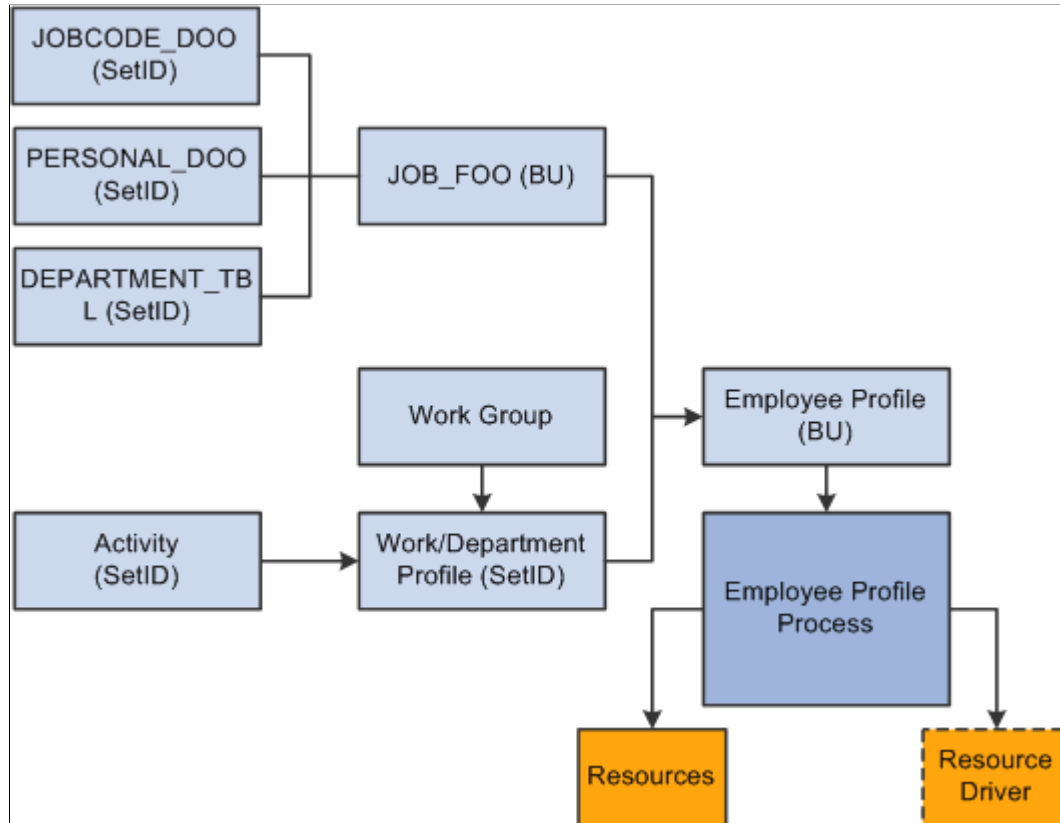

Activity Fragmentation

An important feature of analyzing employee activity is the ability to determine activity fragmentation. Activity fragmentation provides information about the number of employees that are involved in completing a particular activity on either a full-time or part-time basis. It provides managers with a convenient measure that helps them focus their attention on areas within the business that might be made more efficient. The degree to which an activity is divided among the members of an organization can be represented by the activity fragmentation ratio.

With activity fragmentation, the number of full-time equivalents (FTEs) performing the activity is divided by the number of people performing the activity. In general, higher fragmentation ratios indicate efficiency while lower ratios indicate inefficiency.

Here's the formula that the system uses to calculate activity fragmentation: $\text{number of FTEs} / \text{headcount for activity} = \text{fragmentation}$.

This table lists how fragmentation can be used:

Activity	Full-time Equivalents Performing Activity	Number of People Performing Activity	Fragmentation Ratio
Selling products	4	15	0.2557
Performing credit checks	12	24	0.5000
Delivering goods	1	6	0.1667

According to this example, the activity *delivering goods* has the lowest fragmentation ratio. Upon closer examination, it appears that six people are delivering goods that could be performed by one full-time equivalent. While there may be justifiable business reasons for this particular structure, it is easy to see how Activity-Based Management can identify areas that need to be assessed for optimal efficiency.

Use the Employee Profile setup page to define the data elements that are necessary to capture information about activity fragmentation. After running the Activity-Based Management engine, you can view your activity fragmentation information from the inquiry pages.

Setting Up Employee Profiles

This section provides overviews of work groups and work profiles, as well as the Employee Profile component, and discusses how to:

- Set up work groups.
- Define work group and department profiles.
- Update employee profiles.
- Establish the employee activity profile.

Pages Used to Set Up Employee Profiles

Page Name	Definition Name	Navigation	Usage
Work Group	EMPL_WRKGRP_TBL1	Activity Based Management, Setup, Resources, Work Group	Set up work groups.
Work/Department Profile	EMPL_WRKDPT_TBL1	Activity Based Management, Setup, Resources, Work/ Department Profile	Define activities performed by work groups, departments, or both.
Employee Profile	EMPL_SURVEY_TBL1	Activity Based Management, Setup, Resources, Employee Profile, Employee Profile	Define employee profiles.
Employee Profile - Work Distribution	EMPL_SURVEY_TBL2	Activity Based Management, Setup, Resources, Employee Profile, Work Distribution	Set up the activity profile for an employee.

Understanding Work Groups and Work Profiles

A work group is two or more employees sharing the same resource ID. This resource ID is different than the departmental grouping. Each work group can have a unique activity profile that can be associated with it. For example, you may have a work group for database administrators. Employees such as these are charged to a variety of departments, yet they perform the same activities.

Sometimes, adding separate activity profiles for an individual employee is cumbersome, and subsequent rolling up in the organizational structure is not meaningful. For example, an organization might have a large number of accounts payable clerks who essentially perform the same activities.

While you might define separate activity profiles for the individual employees, doing so would probably not add significant value to the model. In this case, the employees can best be represented by a single activity profile. This profile can be designated as a unique work group (or department) to which the individual employees belong. Additionally, you can add common activities into the work group (or department group) setup. After you associate the employee with a workgroup or department, the common activities from the group are populated to the work distribution page of the employee. With those common activities in place, you can easily include their work hours for those activities. At the same time, the employee can also enter specific activities with the corresponding time distribution to their task list. If the employees add activities outside of the work group common activities, these activities are not included in the total work group activities. They are picked up only at the employee-resource level.

Understanding the Employee Profile Component

The Employee Profile component features separate pages for defining the employee data and employee work distribution data ensuring that only manager-level employees can add, define, or modify employee data. Employees can input the actual hours for the activities they perform and managers can correct the actual hours spent by the employees on the Work Distribution page.

Prerequisites

Before setting up an employee profile, define your activities using the Activity component or PeopleSoft Tree Manager.

Load personal data, department data, job code data, and job data into the following OWE tables:

- Personal Dimension (PERSONAL_D00)
- Department (DEPARTMENT_TBL)
- Job Code Dimension (JOB_CODE_D00)
- Job Fact (JOB_F00)

Work Group Page

Use the Work Group page (EMPL_WRKGRP_TBL1) to set up work groups.

Navigation

Activity Based Management, Setup, Resources, Work Group

Enter a description for the work group.

Work/Department Profile Page

Use the Work/Department Profile page (EMPL_WRKDPT_TBL1) to define activities performed by work groups, departments, or both.

Navigation

Activity Based Management, Setup, Resources, Work/Department Profile

Image: Work/Department Profile page

This example illustrates the fields and controls on the Work/Department Profile page. You can find definitions for the fields and controls later on this page.

The screenshot shows the 'Work/Department Profile' page. At the top, it displays 'SetID: SHARE' and 'Group Type: Work Group'. Below that, 'Group Object ID: G2' is shown. A search bar contains 'Find | View All | First | 1 of 1 | Last'. The main form includes:

- *Effective Date: 03/25/2010
- *Status: Active
- *Description: Work Group 2
- *Head Count: 10.00
- Enter Hours

 Below the form is a table with columns: *Activity ID, Description, Actual Work Hours, and Budget Hours. The table contains one row:

*Activity ID	Description	Actual Work Hours	Budget Hours
ACCT_PROCESSING	Accounts Processing	8	10

 The table has a search icon and a refresh button next to the first cell. At the bottom of the table, there are navigation controls: 'Customize | Find | View All | First | 1 of 1 | Last'.

Note: For workgroups, the system prompts from the Work Group table (EMPL_WRKGRP_TBL) and for Departments, the system prompts from the Department table (DEPARTMENT_TBL).

Enter Hours

Select to enter standard hours at the department or work group level.

Doing so activates the Actual Work Hours and Budget Hours columns. If you do not select this check box, you can still input hours at the individual employee level.

Note: After selecting the Enter Hours check box, you must click the Refresh button to display the Actual Work Hours and Budget Hours columns.

Head Count

Enter the head count to indicate the number of people belonging to this work group or department.

The system uses this value when calculating activity fragmentation. Hours entered on this page must represent the exact quantity that you want for your drivers.

Activity ID

Specify each activity ID for this work group or department.

Actual Work Hours

Enter the actual hours for this work group.

Budgeted Hours

Enter the budgeted hours for this work group.

Employee Profile Page

Use the Employee Profile page (EMPL_SURVEY_TBL1) to define employee profiles.

Navigation

Activity Based Management, Setup, Resources, Employee Profile, Employee Profile

Image: Employee Profile page

This example illustrates the fields and controls on the Employee Profile page. You can find definitions for the fields and controls later on this page.

The screenshot shows the 'Employee Profile' page with the following fields and values:

- Business Unit: CORP1
- Empl ID: 1300000
- Empl Rcd#: 0
- Personal Name: Anderson, Jake
- *Effective Date: 03/25/2010
- *Status: Active
- *Head Count: 1.00
- *Base Hours: 176
- *Assign Method: By Hours Worked
- Work Group: (empty)
- Department: 20300 Accounting Group
- Salary: 2624.00

Head Count

The head count for this employee displays and represents the number of employees defined by this record.

A value of *1.00* indicates that the record represents a single employee. The system combines head count entries for a given activity to define the denominator in the activity-fragmentation equation.

Base Hours

Enter the actual base hours to define the FTE of the employee or employees who are defined by the record.

The default is a standard work month of 22 days at 8 hours per day *176* hours. If the actual hours that an employee worked is greater or less than the default value, an employee is considered either more or less than a full-time equivalent. For example, suppose that an employee works 264 actual hours, the system calculates that they represent 1.5 FTE (because $176 * 1.5 = 264$). However, if an employee works only 88 actual hours, the system calculates that they represent 0.5 FTE ($176 * 0.5 = 88$).

Here's the equation used to calculate full-time equivalency:

$$\text{FTE} = \text{actual work hours} / \text{actual base hours}$$

Assign Method	Select the assign method by which the system assigns resources to this activity profile. Values are <i>Hour</i> or <i>Percent</i> .
Work Group	If this employee belongs to a work group, select the work group. The system aggregates the combined activities of individuals attributed to a particular work group to form the activity profile for the work group. You cannot change this work group if you enter hours on the Employee Profile - Work Distribution page.
Department	The field displays the department to which the employee belongs as defined in the general ledger.
Salary	If you have appropriate security access, you can also view the field, and you can change the amount.

Note: You can easily change the denominator used in the equation on an employee-by-employee basis to force the FTE calculation. For example, an employee who works 264 actual hours might really perform the work of one extremely efficient employee who works 176 actual hours. In this case, you may want to adjust the value in the Actual Base Hours field to *264* for the individual who is working longer hours. The system then calculates that this person represents 1.00 FTE, instead of 1.5 FTE.

Employee Profile - Work Distribution Page

Use the Employee Profile - Work Distribution page (EMPL_SURVEY_TBL2) to set up the activity profile for an employee.

Navigation

Activity Based Management, Setup, Resources, Employee Profile, Work Distribution

Employee Work Distribution	Use the group box to specify the activity ID for this employee profile. You can add one or more activities.
Actual Hours	Enter the actual work hours for each activity. This value is the numerator in the equation that calculates full-time equivalency.
Budget Hours	Enter the number of hours budgeted for this employee for this activity in the field.
Percentage and Budget Percentage	As you add activities, the field displays the percentage of the actual hours worked by an employee that have been assigned to each of these activities, and the field displays the percentage of hours budgeted based upon activity fragmentation.
Department Activity, Manual Activity, and WorkGroup Activity	The columns are display only.

Y appears if the entered activity was defined for a department or for a work group on the Work/Department Profile page, or defined manually by the employee.

Running the Employee Profile Engine

You can now run the Employee Profile Application Engine program.

As with all Activity-Based Management engines, you can run this engine in a jobstream. You can also run it separately by accessing the Employee Profile run control page.

The Employee Profile engine creates resources and drivers. It populates temporary tables with this data. After running this engine, run the Merge engine to transfer the data from the temporary tables to the final tables. You can do this by creating a jobstream for both engines, or you can run the engines separately.

Depending on the settings that you defined in the Employee Profile Info (employee profile information) group box on the Model - Run Control Information page, the Employee Profile engine either deletes existing resource and resource driver data and recreates it, or includes salaries in the driver calculations.

Related Links

[Setting Up Resources](#)

Inquiring About Engine Messages

You can review messages generated by these jobs by navigating to the PeopleSoft Application Engine message log for the specific process instance and engine ID that you specify.

See "Viewing Engine Messages (*PeopleSoft 9.1: Enterprise Performance Management Fundamentals*)".

Inquiring About Engine Output

After running the Employee Profile engine you can review the resources and drivers by navigating to the Resources and the Drivers components.

Note: The naming convention for drivers created by the Employee Profile engine is the department or employee number preceded by an *S*. This denotes that it is system-generated.

Completing Employee Profile Processing

Once the Employee Profile engine has run and created resources and drivers, you must complete the following steps to include this new information in the Activity-Based Management model:

1. Define the ledger-to-resource mapping for the resources.
2. Define activity drivers for employee-related resources, if necessary.
3. Run the Activity-Based Management engine.

4. Reconcile your model and rerun the Activity-Based Management engine, as necessary.

Related Links

[Understanding Model Reconciliation](#)

Reviewing Employee Profile Information

Activity-Based Management provides inquiry pages and reports for reviewing your employee profile data once you run the Activity-Based Management engine.

See [Reviewing Driver Setup](#).

Pages Used to Review Employee Profile Information

<i>Page Name</i>	<i>Definition Name</i>	<i>Navigation</i>	<i>Usage</i>
Employee Survey	CALC_EMPLSUR_VW1	Activity Based Management, Reports, Activity/Resource Reports, Employee Survey	Review employee profile calculations by employee.
Fragmentation	CALC_FRAG_VW1	Activity Based Management, Reports, Activity/Resource Reports, Review Fragmentation	Review activity fragmentation.
Resource Listing	RUN_RAB_2002	Activity-Based Management, Reports, Activity/Resource Reports, Resource Listing	Run the Resource Listing report (ABC2002).
Activities Listing	RUN_RAB_2005	Activity Based Management, Reports, Activity/Resource Reports, Activity Listing	Run the Activities Listing report (ABC2005).

Using Reciprocal Allocation Looping

Understanding Reciprocal Allocation Looping

Activity-Based Management's Reciprocal Allocation Looping feature enables you to define cost allocation among resources sharing each other. For example, your organization probably has departments that share costs with each other, in which case you can only determine the actual costs of these resources after they complete their respective allocation of cost to each other.

To use this feature, you define a single, shared-service model that includes all reciprocal Activity-Based Management objects and activities. The resources allocate cost to other resources, which you define as cost objects with the same name as their resource counterparts. The allocation executes based on the processes performed by the resources. Once the allocation is complete, the cost from the cost object loops to its resource counterpart and repeats allocation. The allocation loop continues until the percentage difference of the cost of the resource and its cost object counterpart is within a tolerance limit you define, or until a maximum number of loops have been performed. Any residual cost is then allocated to an Activity-Based Management production model using existing interunit drivers. You are able to allocate any residual cost remaining after the looping is completed because the targets of residual amounts often serve as sources for further allocations. The residual amount is prorated based on interunit assignments. The looping cost never goes back to the resources, it goes to a looping cost object.

Image: Reciprocal Allocation Looping process

The following diagram illustrates the Reciprocal Allocation Looping process.

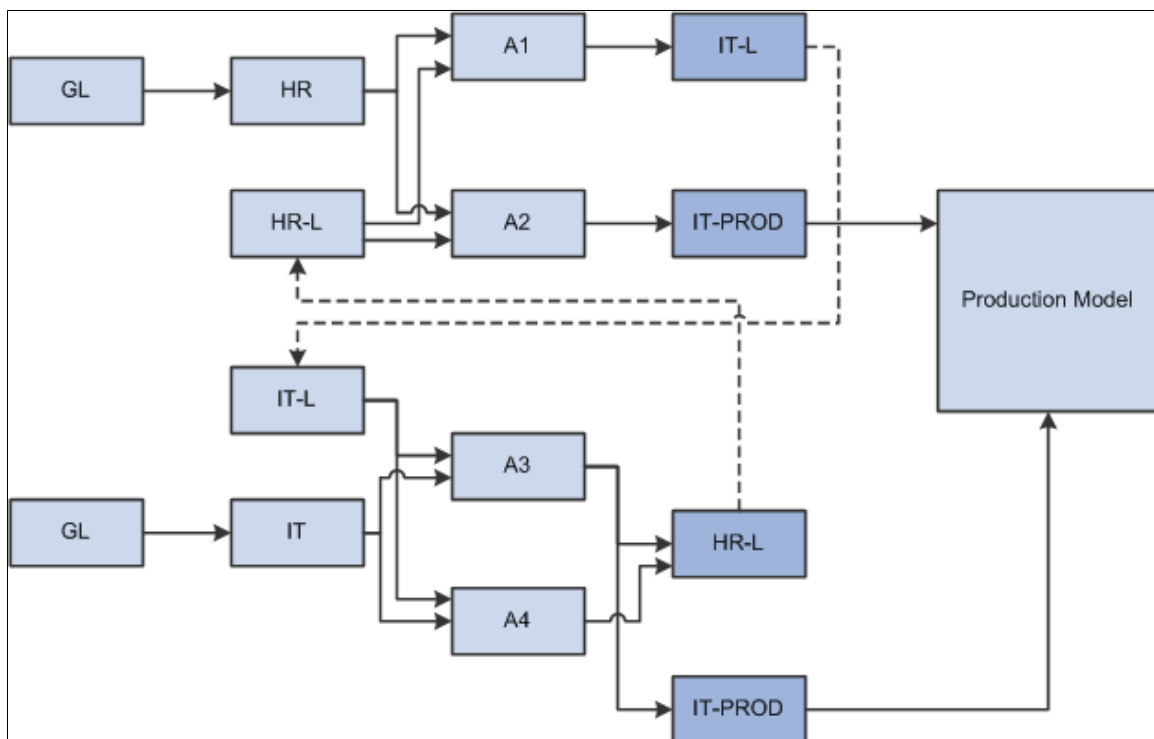

Some important facts to remember with reciprocal allocation looping:

- Objects with identical names to the resources are included in the looping process.
- Looping continues until either a percentage tolerance is reached or the maximum number of loops as defined in the Models component is completed.
- Percentage tolerance values and the number of loops determine the size of the residual value and the processing time.
- Looping assumes 100 percent allocation.
- Residual values use interunit drivers.

Setting Up Reciprocal Allocation Looping

In addition to the steps for setting up a model, you must make sure you complete the following for the Reciprocal Allocation Looping feature:

- Set up reciprocal resources and cost objects.
- Specify reciprocal looping parameters on the model definition.

Setting Up Reciprocal Resources and Cost Objects

To set up the reciprocal resources and cost objects:

1. Select Activity Based Management, Setup, Resources, Resources and add the resources you need for holding the reciprocal cost from the cost objects.
2. Select Activity Based Management, Setup, Cost Objects, Cost Objects and add cost objects with the same name as the reciprocal resource IDs.

Related Links

[Defining Cost Objects](#)

[Resources Page](#)

Specifying Reciprocal Looping Parameters on the Model Definition

To specify reciprocal looping parameters:

1. Select Activity Based Management, Setup, Model, Models, Run Control Information.
2. In the Activity-Based Management Run Info group box, select the Reciprocal Looping Model check box to specify that this model is used for reciprocal looping.

Note: Refresh the page after selecting this check box.

3. Click the Reciprocal Looping Model button in the Activity-Based Management Run Info group box to access the Reciprocal Looping Parameters page on which you can define the looping parameters for this model.

- Specify the following looping parameters:

Tolerance Percentage	The tolerance limit the looping object must reach before looping terminates. This is the difference between the amount of the cost object before and after a loop.
Minimum Iterations	The minimum number of loops to be performed.
Maximum Iterations	The maximum number of loops to be performed.
Residual Target Model	The ID of the model to which the system allocates any residual cost after it performs looping with interunit drivers.

Related Links

[Setting Up Activity-Based Management Models](#)

Processing Your Model and Reviewing Output

Once you have completed the setup of your shared-services model with reciprocal resources and cost objects, activities, pointers, and drivers, you must create a jobstream for running the Activity-Based Management engine and performing the reciprocal looping.

You can review the results of the Activity-Based Management engine run by accessing the Object Rates page, as well as Object Navigator and Model Analyzer.

Related Links

[Reviewing Cost Objects](#)

Using Activity-Based Planning and Simulation (ABPS)

Understanding ABPS

This section provides an overview of ABPS and discusses:

- Planning activity types and ABPS models.
- Spending patterns.
- Planning techniques.

Activity-Based Management features Activity-Based Planning and Simulation (ABPS), a planning and simulation feature that forecasts values for your models. You can use an ABPS model that is based on existing Activity-Based Management values to calculate activity and resource demands, new rates, and cost and activity volumes based on demand forecasts. ABPS converts the new resource demands into new cost requirements at the general ledger item level and uses that for budgeting input.

PeopleSoft ABPS uses spending patterns and data from PeopleSoft Workforce Analytics to calculate the new resource cost for the estimated resource requirement based on the volume forecast. You can use planning techniques with ABPS that enable you to assign the resource costs to activities, cost objects, and calculate the new driver rates and object rates.

Planning Activity Types and ABPS Models

With ABPS you can perform the following three types of planning activities:

- Business restructuring.
- Demand planning.
- Resource planning.

Forecasting using any of these planning activity types is an iterative process. You enter forecast values, run the forecasts, review the results, modify values if necessary, and repeat the process until the results seem reasonable.

Forecasting with ABPS is possible through the use of object-based modeling. The ABPS model must always be the child of an Activity-Based Management parent model with changes made for business planning and forecasting volumes. The original model from which the ABPS model is derived is called the base model.

The ABPS model can have the following changes from the base model:

- Driver changes to represent business planning.

- Volume changes to represent demand planning.
- Budget constraints to represent resource planning.

Business Restructuring

Business restructuring focuses on eliminating unneeded activities by changing the drivers. You create an ABPS model that uses new or changed objects (resources, activities, or cost objects) and drivers. Then you run the Activity-Based Management engine to calculate the new driver and object rates.

Demand Planning

Demand planning focuses on studying the impact of cost object and activity volumes. You can change the cost object or activity volumes in the ABPS model. The ABPS engine then compares these forecasted volumes with actual volumes in the master model to obtain the percentage change. ABPS uses the change in volume to calculate the resource demand and its cost. ABPS directs the resource cost to the general ledger line item to calculate the budget data. The Activity-Based Management engine subsequently directs the new resource cost to the activities and cost objects to calculate the new driver and object rates, and cost object costs.

Resource Planning

Resource planning focuses on resource allocations that create expected results such as driver rates and cost object costs. Resource allocation can be changed either manually or can be the result of an interface with other applications such as PeopleSoft Workforce Analytics. The ABPS model used for resource planning may include costs mapped from general ledger line items and is created according to business unit, model, fiscal year, and accounting period. The Activity-Based Management engine runs this model to calculate new drivers, object rates, and cost object costs.

You set up resource planning on the Resources Definition page. After completing your setup, you can save your work to the Ledger Mapping table (PF_LEDMAP_F00) and use it to assign the costs activities and cost objects.

Resource planning can be done using budget constraints, in which case it will not have manual interaction.

You can perform all three planning types at the same time.

Image: ABPS flow for different forecasting types

The following diagram illustrates the flow for the different PeopleSoft ABPS forecasting types.

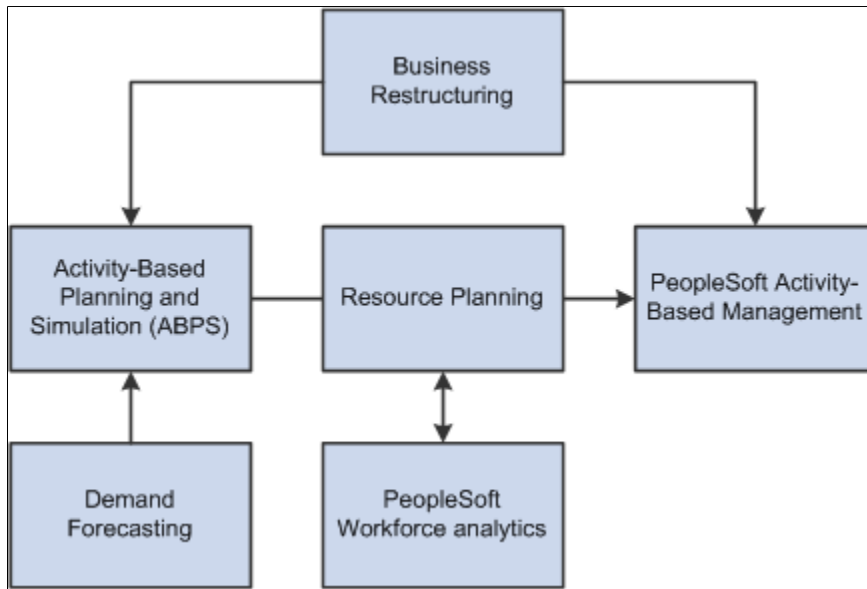

Spending Patterns

Your resources exhibit some sort of spending pattern. It's important that you identify that pattern and associate the resource with that spending pattern within the system.

Use the following criteria as guidelines:

- You can choose from the following patterns: flexible, fixed, and practical capacity.
- If the resource is flexible, then use 100 percent flexible (line method).
- If the resource is committed, but is assigned mostly to unit or batch activities, then use 100 percent practical capacity. This enables an increase in resources if demand increases. There is no need to change resources if demand decreases (unless demand falls to zero percent).
- If the resource is committed, but is not assigned to unit or batch activities, then use zero percent practical capacity. This indicates that there will be no changes in resources unless demand falls to zero.

Image: Example of resource flow through a model

The following diagram illustrates how the ABPS engine calculates resources.

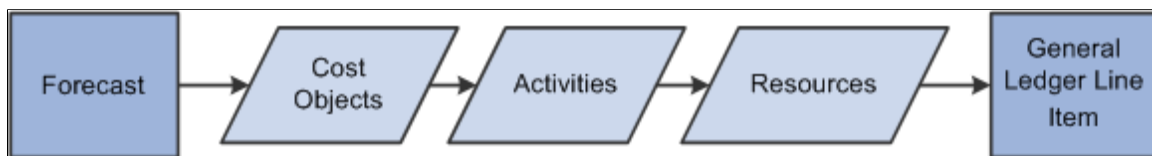

The following table lists the calculations the system uses to move demand forecast costs through the model.

Calculation	Formula
New Resource Cost	Step (new driver quantity * driver rate)
Percent Change in Resource Cost	$((\text{New resource cost} * \text{old resource cost}) / \text{old resource cost})$ ◆ 100
New Unit Volume	Old volume + (old volume * percentage of change)
Percent Change	$((\text{New volume} * \text{old volume}) / \text{old volume})$ ◆ 100
New Driver Quantity	Old quantity + (old quantity * percentage of change)

Planning Techniques

ABPS uses planning techniques for assigning resource costs to activities and cost objects. These planning techniques also calculate the new driver rates and object rates:

There are two available planning techniques:

Fully Loaded Uses calculated rates from the base model to calculate resource cost.

Capacity Adjusted Uses capacity rates to calculate resource cost.

Although planning techniques are used to calculate the resource cost, the final resource budget cost is calculated based on the spending pattern data. If you have not defined a spending pattern, then the cost (as calculated with the planning technique) is used for budgeting. For either technique, set up the model as an actuals model.

Creating an ABPS Model

To create an ABPS model:

1. Set up a base Activity-Based Management model (a parent model) with all its objects and drivers and run the Activity-Based Management engine.
2. Add a child model using the base model you set up as the parent model ID.
3. Create a scenario ID for this model with a *Forecast* scenario type.
4. Link the scenario ID to the business unit.
5. Create a model definition in Activity-Based Management and enter the ABPS planning information for the model.
6. Set up planning and simulation criteria (described in the next section).
7. Run the ABPS engine.

Specifying Planning Information for the Model

To specify ABPS information for the model:

1. Access the Models - Run Control Information page by selecting Activity Based Management, Setup, Model, Models, Run Control Information.
2. In the Planning Info group box, select the Planning Technique to use: *Capacity Adjusted* or *Fully Loaded*.
3. Select the Budget Source that will determine the cost of new resources. You can either specify *General Ledger* or *Workforce Analytics*.

Note: To calculate the cost of full-time equivalent (FTE) employees, the budget source must be *Workforce Analytics*.

4. In the TimeSpan field select the production data you want the Activity-Based Management engine to use when it runs. You set up TimeSpans in PeopleSoft EPM. Click the adjacent button to add or update TimeSpans.
5. You can specify a budget Constraint ID. You define these constraints on the ABPS Budget Constraints page.

Setting Up Planning and Simulation Criteria

You can set up planning and simulation criteria for ABPS by using pointers to forecast data. You can:

- (Optional) Define budget constraints. The budget constraints you define are parameters that you establish from your budget to ensure that the values you obtain fall within your budget. You can either use a budgeted amount or job code information to constrain your results.
- Set up resource spending patterns and assign them to resources.
- Set up job code profiles. ABPS uses job code profiles to find out which resources are needed for activity volume and to choose a job code for additional resource requirements. ABPS chooses the job code that has the maximum number of activities that have an increase in volume with a higher priority and less cost.

You must set up your activities before completing these pages.

Pages Used to Set Up Planning and Simulation Criteria

Page Name	Definition Name	Navigation	Usage
Budget Constraint	AB_CONSTRNT_TBL1	Activity Based Management, Planning and Simulation, Budget Constraint	Define any budget constraints for forecast models.
Resource Spending Pattern	SPEND_PATRN_TBL1	Activity Based Management, Planning and Simulation, Resource Spending Pattern	Define spending patterns that can be associated with resources.

Page Name	Definition Name	Navigation	Usage
Spending Pattern Descr Long (spending pattern description long)	SPEND_PATRN2S	Click the Description button on the Resource Spending Pattern page.	Enter a detailed description of the spending pattern.
Job Code Profile	JOBCODE_PROF_TBL1	Activity Based Management, Planning and Simulation, Jobcode Profile	Establish job code profile priorities.

Budget Constraint Page

Use the Budget Constraint page (AB_CONSTRNT_TBL1) to define any budget constraints for forecast models.

Navigation

Activity Based Management, Planning and Simulation, Budget Constraint

Image: Budget Constraint page

This example illustrates the fields and controls on the Budget Constraint page. You can find definitions for the fields and controls later on this page.

Resource

Enter the to be the constrained resource. You can add or update resources.

Use Amount

Select the check box to activate the Budgeted Amount field in which you enter the amount you want to use to constrain your results. If you do not want to use a budgeted amount, deselect this check box and you can specify job code details.

All Jobcodes

Select the check box if you do not want to constrain the full-time equivalent by job code. Enter the number of people you can add in the Full time Equivalent field.

Steps Needed

In the field for non-people related resources, specify the number of steps that can be added if the spending pattern is step or step practical. You define the spending pattern on the Spending Pattern page.

Full time Equivalent

If you do not select the All Jobcodes check box, you can specify individual job codes and values for them in the grid that displays at the bottom of the page.

Resource

In the second field, select the ID for the constraining resource. You can add or update resources

Note: Add the budget constraint you specified here to the model in the Constraint ID field on the Models - Run Control Information page.

Related Links

[Run Control Information Page](#)

Resource Spending Pattern Page

Use the Resource Spending Pattern page (SPEND_PATRN_TBL1) to define spending patterns that can be associated with resources.

Navigation

Activity Based Management, Planning and Simulation, Resource Spending Pattern

Image: Resource Spending Pattern page

This example illustrates the fields and controls on the Resource Spending Pattern page. You can find definitions for the fields and controls later on this page.

The screenshot shows the 'Resource Spending Pattern' page. At the top, it displays 'SetID: SHARE' and 'Spending Pattern ID: LINE'. Below this is a 'Details' section with a search bar and navigation controls. The main form includes:

- *Effective Date: 01/01/1900
- *Status: Active
- *Description: LINE
- Spending Pattern Information section with radio buttons for:
 - Standard Line (selected)
 - Practical Capacity
 - Step
 - Step Practical
- Slope Percentage: 100
- Width Percentage: [empty]
- Step Percentage: [empty]
- Step Amount: [empty]

 A legend at the bottom left indicates '* Required Field'.



Click to enter a longer description.

Spending Pattern Information

Standard Line	Select if you have a flexible resource where cost increases linearly with capacity.
Practical Capacity	Select if you do not have an increase in cost until capacity is reached, and at which point it then increases linearly.
Step	Select if costs increase in step with respect to capacity width-capacity step cost. You can enter either a Step Percentage or a Step Amount.
Step Practical	Use this option if cost increases in step with capacity after capacity is reached. Selecting this radio button activates the Width Percentage, Step Percentage and Step Amount fields.
Slope Percentage	If you selected either the Line or the Capacity radio button, enter a percentage that denotes the slope you want to apply to this spending pattern.
Width Percentage	If you selected either the Step or the Step Practical radio button, enter a percentage that denotes the width you want to apply to this spending pattern. Width is the capacity of one step to the total existing capacity.
Step Percentage	If you selected either the Step or the Step Practical radio button, enter a percentage that denotes the step you want to apply to this spending pattern. Step percentage is the cost of one step to the total existing cost of the resource.
Step Amount	If you selected either the Step or the Step Practical radio button, enter an amount that denotes the step you want to apply to this spending pattern. Costs increase per step.

Related Links

[Resources Page](#)

Job Code Profile Page

Use the Job Code Profile page (JOB_CODE_PROF_TBL1) to establish job code profile priorities.

Navigation

Activity Based Management, Planning and Simulation, Jobcode Profile

Activity ID Select each that you want to include in this job code profile.

Priority For each ID you add, specify its to represent which activity the job code best performs.

Note: You only need to access this page if you aren't using the Employee Profile engine to populate the Activities - Jobcode Profile page, or you want to override employee profile values.

Note: If you modify a priority on this page, ensure that your changes correspond to those in the activity profile.

Related Links

[Understanding Activities](#)

Running the ABPS Engine

As with all Activity-Based Management engines, you can run the ABPS engine in a jobstream. You can also run it separately by accessing the ABPS page.

The ABPS engine populates temporary tables. After running this engine, you need to run the Merge engine to transfer the data from the temporary tables to the final tables. You can do this by creating a jobstream for both engines, or you can run the engines separately.

Note: Do not select the As Of Dated Jobstream check box on the ABPS run control page, since ABPS does not use as of date functionality.

Inquiring on Engine Messages

You can review messages generated by these jobs by accessing the Application Engine message log for the process instance and engine ID you specify.

See "Viewing Engine Messages (*PeopleSoft 9.1: Enterprise Performance Management Fundamentals*)".

Reviewing and Adjusting ABPS Output

After running the APBS engine to achieve preliminary results, you can review the output using the Employee Resource - Planning and Ledger Resource - Planning components. You can also use these components to adjust values.

Once you are satisfied with the values, rerun the ABPS engine.

Note: These components can also be accessed as inquiry pages, where they have no enterable fields and can be used only to view the information.

Understanding Employee Resource Planning

You can use the Employee Resources - Planning component to adjust employee resource values as necessary. Each of the Employee Resource - Planning pages has a Budgeted Amount field where you can enter the cost of the employee resource for the forecasted model calculated based on any of the following:

- Volume increases.
- Spending patterns.
- Planning techniques.

You can also view the actuals and calculated amounts on these pages. The actuals amount represents the base data and does not change. The calculated amount represents the amount calculated before applying spending patterns, PeopleSoft Workforce Analytics data, and budget constraints. These amounts are fixed. You can use them to compare against the budget amount. If the budgeted amount is lower than the calculated amount, then it's possible that the volume forecasted may not be reached.

Note: To calculate the cost of full-time equivalent (FTE) employees, a budget source of *Workforce Analytics* must be established on the Models - Run Control Information page before running ABPS.

Understanding Ledger Resource Planning

You can use the Ledger Resource - Planning component to adjust ledger resource values.

Each of the Ledger Resource - Planning pages has a Budgeted Amount field. By manipulating the values in the Ledger Mapping page, you can impact how the other pages calculate forecasted values for spending patterns and budget constraints. Adjusting the budgeted amount in this way can affect volume activity and cost objects.

Pages Used to Review and Adjust ABPS Output

Page Name	Definition Name	Navigation	Usage
Employee Details	AB_RES_PLN2	Activity Based Management, Planning and Simulation, Employee Details, Employee Details	View and adjust factors associated with full-time equivalent (FTE) information.
Employee Details - Hours Assigned	AB_RES_PLN3	Activity Based Management, Planning and Simulation, Employee Details, Hours Assigned	Review the values for assigned hours calculated by the ABPS engine.
Employee Details - Budget Constraint	AB_RES_PLN6	Activity Based Management, Planning and Simulation, Employee Details, Budget Constraint	View the budget constraint used to calculate the budgeted amount that is displayed.
Employee Resource Data	AB_RES_PLN2	Activity Based Management, Planning and Simulation, Employee Resource Data, Employee Resource Data	View and adjust factors associated with full-time equivalent (FTE) information.
Employee Resource Data - Hours Assigned	AB_RES_PLN3	Activity Based Management, Planning and Simulation, Employee Resource Data, Hours Assigned	Review the values for assigned hours calculated by the ABPS engine.
Employee Resource Data - Budget Constraint	AB_RES_PLN6	Activity Based Management, Planning and Simulation, Employee Resource Data, Budget Constraint	Review the constraints used to calculate the budgeted amount.

Page Name	Definition Name	Navigation	Usage
Ledger to Resource Data	AB_RES_PLN1	Activity Based Management, Planning and Simulation, Ledger to Resource Data, Ledger to Resource Data	View or adjust the budgeted amounts at the general ledger line item level.
Ledger to Resource Data - Spending Pattern	AB_RES_PLN4	Activity Based Management, Planning and Simulation, Ledger to Resource Data, Spending Pattern	View the spending pattern details for the resource.
Ledger Resource Planning - Budget Constraint	AB_RES_PLN5	Activity Based Management, Planning and Simulation, Ledger to Resource Data, Budget Constraint	Review the constraints used to calculate the budgeted amount.

Employee Details Page

Use the Employee Details page (AB_RES_PLN2) to view and adjust factors associated with full-time equivalent (FTE) information.

Navigation

Activity Based Management, Planning and Simulation, Employee Details, Employee Details

Image: Employee Details page

This example illustrates the fields and controls on the Employee Details page. You can find definitions for the fields and controls later on this page.

Employee Details		Hours Assigned	Budget Constraint				
Business Unit:	CORP1	Scenario ID:	PLAN01				
		Fiscal Year:	1999				
		Period:	3				
Resource:	G1	Workgroup One					
Base Scenario's Actual Amount:	449,288.589503						
Amount needed for changes:	688,579.692272						
Budgeted Amount:	449,288.589500	Resource Cost after FTE calc and budget constraint					
Employee Resource Info							
Customize Find View All 1-3 of 3 First 1-3 of 3 Last							
Job Code	Description	Department	Capacity Amount	Cap per emp for the period	Employee Salary	Full time Equivalent	Excess Capacity
1052	Sr Financial Analyst			171.4286	4945.06		
1053	Financial Analyst		354.2857	171.4286	4932.99		54.6937
1055	Quality Assurance Analyst			171.4286	3581.21		

Base Scenario's Actual Amount

The resource cost from the base model.

Amount needed for changes

The resource cost calculated by ABPS based on forecast data, driver changes, and the planning techniques before applying spending patterns, PeopleSoft Workforce Analytics data, and budget constraints.

Budgeted Amount	The resource costs from the ABPS model based on spending patterns, PeopleSoft Workforce Analytics data, and budget constraints.
Capacity Amount	The capacity of the job code after adding the additional capacity.
Cap per emp for the period (capacity per employee for the period)	The capacity per FTE information added.
Employee Salary	You can adjust the and the Full time Equivalent values. Here is the salary calculation: $\text{salary} = (\text{number of weeks in a period}) \times (\text{standard hours}) \times (\text{hourly rates})$
More	Click the tab to view additional job code information:
Std Hrs Wk (standard hours per week)	The standard number of hours per week associated with the FTE information.
Salary Plan	The salary administration plan from the Job Code Dimension table (JOBCODE_D00).
Grade	The salary grade from the Job Code Dimension table.
Midpoint Pay Rate - Hourly BCE (midpoint pay rate - hourly base currency equivalent)	The midpoint pay rate or hourly base currency amount.

Employee Details - Hours Assigned Page

Use the Employee Details - Hours Assigned page (AB_RES_PLN3) to review the values for assigned hours calculated by the ABPS engine.

Navigation

Activity Based Management, Planning and Simulation, Employee Details, Hours Assigned

Here you view the hours assigned calculated by the ABPS engine, and the fields reflect any adjustments you made on the FTE Requirement page.

On this page you can view the Hours Required for each Activity ID. This is the forecast amount for hours required. You can also view the Hours Assigned to the Activity ID by Job Code.

Employee Details - Budget Constraint Page

Use the Employee Details - Budget Constraint page (AB_RES_PLN6) to view the budget constraint used to calculate the budgeted amount that is displayed.

Navigation

Activity Based Management, Planning and Simulation, Employee Details, Budget Constraint

Here you view the budget constraints used to calculate the budgeted amount.

In the Budget Constraint group box, you can view the Constraint ID. This is the budget constraint that was used by the ABPS Engine.

Ledger to Resource Data Page

Use the Ledger to Resource Data page (AB_RES_PLN1) to view or adjust the budgeted amounts at the general ledger line item level.

Navigation

Activity Based Management, Planning and Simulation, Ledger to Resource Data, Ledger to Resource Data

Base Scenario's Actual Amount	The resource cost from the base model.
Amount needed for changes	The resource cost calculated by ABPS based on forecast data, driver changes, and the planning techniques before applying spending patterns, PeopleSoft Workforce Analytics data, and budget constraints.
Budgeted Amount	The resource costs from the ABPS model based on spending patterns, PeopleSoft Workforce Analytics data, and budget constraints.

The grid at the bottom of the page lists the general ledger line items. For any of these line items, you can change the Posted Base Currency Amount. This is the amount that you can map to the resource from the general ledger line item.

Related Links

[Employee Details Page](#)

Ledger to Resource Data - Spending Pattern Page

Use the Ledger to Resource Data - Spending Pattern page (AB_RES_PLN4) to view the spending pattern details for the resource.

Navigation

Activity Based Management, Planning and Simulation, Ledger to Resource Data, Spending Pattern

Spending Pattern group box	Here you view the spending pattern for details for this resource. The Spending Pattern group box displays the Spending Pattern ID and the Spending Pattern method specified on the Resources Spending Pattern page. Depending on this setting different fields display. For example, if you selected a spending pattern of <i>Step</i> , the Step Amount and Steps Needed fields display. You can adjust the amounts in these fields.
-----------------------------------	--

Related Links

[Resource Spending Pattern Page](#)

Ledger Resource Planning - Budget Constraint Page

Use the Ledger Resource Planning - Budget Constraint page (AB_RES_PLN5) to review the constraints used to calculate the budgeted amount.

Navigation

Activity Based Management, Planning and Simulation, Ledger to Resource Data, Budget Constraint

Budget Constraint group box

Here you assess how values you adjusted on the Ledger Mapping page have affected budget constraints.

In the Budget Constraint group box, you can view the Constraint ID. This is the budget constraint that was used by the ABPS Engine.

Inquiring on ABPS

We provide a number of pages with which you can review the following ABPS output:

- ABPS employee resource data.
- ABPS ledger resource data.
- ABPS job code to hire information.
- ABPS object volume data.
- ABPS ledger to budget details.

Pages Used to Inquire on ABPS

Page Name	Definition Name	Navigation	Usage
Employee Resource Data - Spending Reason	AB_RES_SPND_REAS	Activity Based Management, Planning and Simulation, Employee Resource Data, Spending Reason	View ABPS employee resource data and reasons for resource spending for a specific business unit, scenario ID, fiscal year, accounting period, and resource ID.
Ledger to Resource Data - Spending Reason	AB_RES_SPND_REAS2	Activity Based Management, Planning and Simulation, Ledger to Resource Data, Spending Reason	View ABPS ledger resource data and reasons for resource spending for a specific business unit, scenario ID, fiscal year, accounting period, and resource ID.

Page Name	Definition Name	Navigation	Usage
Job Code to Hire	AB_JOB_CODE_HIRE	Activity Based Management, Planning and Simulation, Jobcode to Hire	View the number of FTEs required per job code and department. This data is shared with PeopleSoft Workforce Analytics.
Vol Change Reason	AB_VOL_CHG_REASON	Activity Based Management, Planning and Simulation, Object Volume Data	Determine why the forecast volume increase cannot be met.
Ledger to Budget	AB_ABPS_LEDGER	Activity Based Management, Planning and Simulation, Ledger to Budget	View the budgeted amount by general ledger line item.

Viewing ABPS Employee and Ledger Resource Data

The first three pages of these components are the same pages as in the Employee Resource - Planning and the Ledger Resource - Planning components described previously. The only differences are that all fields are display only.

The ABPS Employee Resource Data and Ledger Resource Data components also feature a Spending Reason page. On this page you can view the reasons for resource spending, such as the cause of an increased resource demand. Both of these pages display any objects that have changed along with the assigned Base Scenario Volume, Volume Needed, and Budgeted Volume amounts. The Change Type column shows the type of change (*Volume* or *Driver Quantity*) and any changed drivers are listed in the Driver Change column. Clicking any of these drivers transfers you to the Drivers component to review information for that driver.

Note: You must run the ABPS and Activity-Based Management engines prior to using these pages, otherwise data will not be available.

Job Code to Hire Page

Use the Job Code to Hire page to find out how many FTEs are needed by job code and department.

Note: This data is shared with the PeopleSoft Workforce Analytics application.

ABPS Object Volume Data Page

Use the ABPS Object Volume Data page to determine such things as the reason why the forecasted volume increase cannot be met. This page lists by resource whether the Budgeted Amount has been changed. It also lists the Constraint applied to each resource.

APBS Ledger to Budget Page

Use the APBS Ledger to Budget page to inquire on the budgeted amount per the general ledger line item.

Modeling for Service-Related Industries

Understanding Bill of Services

Because many service industries typically offer a wide range of options, Activity-Based Management's Bill of Services functionality enables you to:

- Create new and unique combinations of standard services and combine them into a package service.
- Apply a standard rate to the new services provided in order to estimate new business opportunities and costs to serve a customer.

You can easily manipulate volumes and adjust to customer demands, and calculate the resource requirements for the new changes in demand.

Related Links

[Modeling for Service-Related Industries](#)

Prerequisites

Before you can set up your bill of services pages, you must complete your model setup including:

- Activity-Based Management model definition.
- Resources and ledger-to-resource mapping.
- Activities.
- Activity volumes.
- Cost objects.
- Drivers and pointers.

Note: Activity volumes are necessary to calculate a per unit cost of the activity.

Related Links

[Activity Volume Page](#)

Using Bill of Services

To use the Bill of Services feature:

- Establish the service, product, or both.
- Link the bill of service to cost objects.
- Run the Activity-Based Management engine.
- Adjust the rates for the activities related to bill of service cost objects.

Pages Used to Establish Bill of Services

<i>Page Name</i>	<i>Definition Name</i>	<i>Navigation</i>	<i>Usage</i>
Bill of Services	BOS_TBL1	Activity Based Management, Setup, Bill of Services, Bill of Services	Establish the service, product, or both within Activity-Based Management.
BOS Description Long	BOS_TBL4S	Click the Information button on the Bill of Services page.	Enter a more detailed description of the bill of service you are adding.
Bill of Services - Service	BOS_TBL2	Activity Based Management, Setup, Bill of Services, Bill of Services, Service	Set up the relationship between the Bill of Service and the cost objects.
Bill of Service Activities	BOS_TBL3	Activity Based Management, Setup, Bill of Services, Bill of Services Activities	Define the unit quantity and adjusts the rates for the activities related to the Bill of Service cost objects.

Bill of Services Page

Use the Bill of Services page (BOS_TBL1) to establish the service, product, or both within Activity-Based Management.

Navigation

Activity Based Management, Setup, Bill of Services, Bill of Services

Bill of Services Run Flag

Select to include this Bill of Service when you run the Activity-Based Management engine. Running the engine will then create the Bill of Service activity tables (BOS_ACT_TBL and BOS_ACT_SEQ).

Information

You can enter a longer description for the bill of service you are adding by clicking this button.

Bill of Services - Service Page

Use the Bill of Services - Service page (BOS_TBL2) to set up the relationship between the Bill of Service and the cost objects.

Navigation

Activity Based Management, Setup, Bill of Services, Bill of Services, Service

Cost Object ID

To establish a cost-to-service model, specify the cost objects for this bill of service by entering each Cost Object ID.

Running the Activity-Based Management Engine

Run the Activity-Based Management engine.

This is important because the activity cost data it generates together with the activity volumes defined, enables the engine to calculate the activity rate for each activity performed. This enables you to associate the activities for a given service.

See [Understanding Delivered Engines](#).

Adjusting Rates for Activities

To adjust rates for activities related to cost objects associated with a bill of service, as well as add additional activity such as unit quantity and rate:

1. Access the Bill of Services Activities page for the bill of services ID you want to update or adjust.
2. Specify the Activity ID you want to apply to this bill of services ID.
3. Enter a Unit Quantity and Amount for this particular activity ID.
4. Click the Insert Calc Table (insert calculation table) button to recalculate changes and view the results. The related activities, their quantities, and their calculated rates display.

Appendix A

Activity-Based Management Validation Engine Messages

Activity-Based Management Validation Engine Messages by Message Number

This table lists the Activity-Based Management Validation engine messages. All of these messages are in message set 10623:

<i>Message Number</i>	<i>Message Text</i>	<i>Extended Message Text</i>
14	Inconsistent Consumption Pattern defined for the driver and the target.	Consumption Pattern of the Driver does not match the Consumption Pattern of the Driver's Target.
15	Inconsistent Unit of Measure defined for the Pointers of the Driver.	Inconsistent Unit of Measure defined for the Pointers of the Driver.
16	Invalid Activity and Cost Object Dimensions combination.	Invalid Activity and Cost Object Dimensions combination.
17	Invalid Source and Target Listing.	Invalid Source and Target Listing.
18	More than 1 Target for Direct Assignment Method.	More than 1 Target for Direct Assignment Method.
20	Amount Type Driver allocated more or less than 100 percent.	Amount Type Driver allocated more or less than 100 percent.
21	Object Unassigned.	Object Unassigned.
22	Cost not driven out of primary resource/activity.	Cost not driven out of primary resource/activity.
23	Cost not driven out of secondary resource.	Cost not driven out of secondary resource.
24	Cost not driven out of secondary activity.	Cost not driven out of secondary activity.
25	Cost not driven out of secondary cost object.	Cost not driven out of secondary cost object.
26	Target object used in Implicit Pointer not defined.	Target object used in Implicit Pointer not defined.
27	No data found for Pointer.	No data found for Pointer.

Message Number	Message Text	Extended Message Text
28	No data found for Implicit Pointer.	No data found for Implicit Pointer.
29	Pointer Quantity is zero.	Pointer Quantity is zero.
30	Implicit Pointer Quantity is zero.	Implicit Pointer Quantity is zero.
31	GL Accounts used in Ledger Mapping Rules but not found in GL Ledger.	GL Accounts used in Ledger Mapping Rules but not found in GL Ledger.
32	GL Accounts used in Ledger Mapping Rules but not found in GL Account Table.	GL Accounts used in Ledger Mapping Rules but not found in GL Account Table.
33	Cost Object missing in Product Table.	Cost Object missing in Product Table.
34	Cost Object missing in Customer Table.	Cost Object missing in Customer Table.
35	Cost Object missing in Channel Table.	Cost Object missing in Channel Table.
36	Cost Object missing in Department Table.	Cost Object missing in Department Table.
37	Pointer used in Driver not found.	Pointer used in Driver not found.
38	Implicit Pointer used in Driver not found.	Implicit Pointer used in Driver not found.
39	Constraint used in Pointer/Implicit Pointer not found.	Constraint used in Pointer/Implicit Pointer not found.
44	Tree not defined for the model.	Resource Tree, Activity Tree, Cost Object Tree not defined for the model.
45	Calendar not defined for the model.	Calendar not defined for the model.
46	Tree node specified in ledger mapping rules not found.	Tree node specified in Ledger mapping rules not found in the tree defined in ledger default.
69	2 Drivers exist with the same source and target.	2 Drivers exists with the same source and target. This scenario will cause the Activity-Based Management engine to abort. Please modify the driver setup.
70	Driver causes looping.	Source and Target are points of a loop.
74	Tree node used in ledger mapping has been deleted from the tree.	Please update your ledger mapping with another tree node or delete the ledger mapping itself.
75	Tree node used in ledger mapping has been updated.	Tree node has been moved from one parent to another. Please check to see whether the ledger mapping needs to be updated.

Message Number	Message Text	Extended Message Text
76	Tree node used in ledger mapping has been updated.	Tree node moved from one parent to another. Please check to see whether the ledger mapping needs to be updated.
77	New tree node added to tree.	Please check to see whether this new tree node added needs to be used in the ledger mapping.
178	No cost object exists with same name as resources.	No looping cost objects exists for the reciprocal model. Please setup looping cost objects with same name as looping reciprocal resources.
179	No Ledger Mapping Defined for the resource.	Please define ledger mapping for the resource to bring in expenses into the model.
180	Ledger Mapping defined for looping resource.	Ledger Mapping should be defined for looping resource.
182	Please define tolerance percentage and maximum iteration.	Please define a tolerance percentage that defines the stopping point for the looping. Also define the maximum iteration number which defines the maximum number of times to loop.
183	Please define minimum iteration.	Please define minimum number of times to loop even if the tolerance is reached. It cannot be zero.
184	Please define residual target model.	Please define a residual target model to receive the expenses from the looping reciprocal model.
185	No interunit driver to target model defined.	Please define interunit driver for the cost object to send amount to target model. Also make sure the target object in target model that receives the amount is a resource with same name as cost object sending it.
290	IBU Driver Target Model out of sequence.	You have defined an IBU driver that drives costs from a Model with a higher sequence number to a Model with lower sequence number. Either correct the driver or change the Model sequence number.
291	Value Object Value is missing data for the Pointer, Implicit Pointer or Transaction Pointer.	The filter used by the constraint uses a Value Object and the Value Object Value for a Pointer, Implicit Pointer or Transaction Pointer is missing data.

Manually Entering Values for Testing Purposes

Manually Entering Values

With Activity-Based Management you migrate original transaction tables and their contents from the source systems into the operational warehouse - enriched (OWE). Once you have done this, you make the values in these tables accessible to Activity-Based Management through the use of pointers, implicit pointers, or transaction pointers. Doing so enables you to create sustainable models.

However, we also provide a page that enables you to enter values manually for testing and prototyping purposes.

Note: Remember this page is useful for testing and prototyping models. You should keep its use to a minimum. Use the OWE tables with data from your source systems to build sustainable models.

Page Used to Enter Testing Values

<i>Page Name</i>	<i>Definition Name</i>	<i>Navigation</i>	<i>Usage</i>
Define Interface Values	ABC_INTERFACE_TBL1	Activity Based Management, Setup, Model, Interface Values	Enter transactional values manually.

Define Interface Values Page

Use the Define Interface Values page (ABC_INTERFACE_TBL1) to enter transactional values manually.

Navigation

Activity Based Management, Setup, Model, Interface Values

Image: Interface Values page

This example illustrates the fields and controls on the Interface Values page.

Interface Values

Business Unit:	CORP1	Scenario ID:	ACTUAL01	Actual Scenario
Interface Key 1:	A1A2A3	Interface Key 7:		
Interface Key 2:	A1	Interface Key 8:		
Interface Key 3:		Interface Key 9:		
Interface Key 4:		Interface Key 10:		
Interface Key 5:		Interface Key 11:		
Interface Key 6:		Interface Key 12:		

Effective Date:	<input type="text" value="01/01/1900"/>		Status:	<input type="text" value="Active"/>
-----------------	---	--	---------	-------------------------------------

Value Info	
*Amount:	<input type="text" value="20.000000"/>
Amount 2:	<input type="text" value="100.000000"/>
Amount 3:	<input type="text"/>
Interface Value 1:	<input type="text"/>
Text 1:	<input type="text"/>
Text 2:	<input type="text"/>

To create test and prototype values, specify the appropriate fields for your specific use: Interface Key, Amount, Interface Value, and Text.

Manufacturing Integration

Understanding Manufacturing Integration

Activity-Based Management enables you to use routing information from PeopleSoft Manufacturing to set up activity driver information within the system. Activity-Based Management can determine which activity is performed on which cost object as well as determine the quantifiable measures for that relationship. It uses Bill of Materials (BOM) information from Manufacturing and transforms the components within the BOM hierarchy into cost objects. In addition, Activity-Based Management is able to maintain the BOM structure. This is important because once you have run the Activity-Based Management engine, each component contains cost information. The roll-up of these costs using the BOM hierarchy results in a total indirect cost of the resources, activities, and cost objects. This total indirect cost is then directed back to the Cost Management environment.

Setting Up Models for Manufacturing

To set up models for PeopleSoft Manufacturing purposes, create a model and run the Routing Information engine to set up your activity drivers. You must then build the rest of the model by setting up resources and ledger-to-resource mapping and building resource drivers.

In many manufacturing environments, you use combination models that enable you to choose capacity or fixed rates for your resource drivers. You can have a capacity rate for one resource driver and a fixed rate for another resource driver in the same model.

Related Links

[Setting Up Drivers](#)

Running the Routing Information Engine

The Routing Information engine establishes a relationship between the activity and its associated cost objects and thus creates activity driver information. It establishes drivers between activities and cost objects. These drivers are similar to the drivers established from resources to activities when you run the Employee Profile engine. Once data is received automatically from PeopleSoft Manufacturing, you run the Routing Information engine to populate the Routing Options table (RTG_OPS_F00).

Routing Information is an optional engine that you run prior to running the Activity-Based Management engine. As with all Activity-Based Management engines, you can run the Routing Information engine in a job stream. You can also run it separately by accessing the Routing Information page.

The Routing Information engine populates temporary tables. After running this engine, you must run the Merge engine to transfer the data from the temporary tables to the final tables. You can do this by creating

a job stream for both engines, or you can run both engines separately. You can also create a job stream that includes the Activity-Based Management engine.

Note: The routing engine does not create common activities or dimensions, which may be necessary to create certain objects, such as activities and cost objects. Those required elements must exist in the database before running the Routing Information engine.

Inquiring on Engine Messages

To review messages generated by these jobs, open the Application Engine message log for the specific process instance and engine ID.

See "Viewing Engine Messages (*PeopleSoft 9.1: Enterprise Performance Management Fundamentals*)".