

# *Tekelec 1200/5100 Integrated Application Platform*

---

## **Installation Manual**

910-5681-001 Revision D

September 2010



Copyright 2010 Tekelec. All Rights Reserved. Printed in USA.

Legal Information can be accessed from the Main Menu of the optical disc or on the Tekelec Customer Support web site in the *Legal Information* folder of the *Product Support* tab.

# Table of Contents

<b>Chapter 1: Introduction.....</b>	<b>8</b>
Overview.....	9
Scope and Audience.....	9
Manual Organization.....	9
Related Publications.....	9
Documentation Availability, Packaging, and Updates.....	10
Locate Product Documentation on the Customer Support Site.....	10
Product Packaging and Delivery.....	11
Hardware Repair and Return.....	11
Repair and Return Shipping Instructions.....	13
Customer Care Center.....	14
Contact Information.....	16
Emergency Response.....	17
<b>Chapter 2: Safety and Pre-Installation Requirements.....</b>	<b>18</b>
Safety Information.....	19
General.....	19
Cabinets.....	20
Frames.....	20
Power.....	21
Electrostatic Discharge.....	22
Components.....	23
Safety and Electromagnetic Compatibility.....	23
Generic Site Requirements.....	24
Building Requirements.....	24
Earthquake Resistance.....	24
Elevation.....	24
Fire Protection.....	24
Floor Loading.....	24
HVAC Requirements.....	24
Lighting.....	25
Relative Humidity.....	25
Space Requirements.....	25
Temperature Variation.....	25

**Chapter 3: Hardware Description.....26**

Application Cabinet.....27

- About Zones.....27
- Zone Loading Rules.....30
- Tekelec 1200 Platform Components.....31
- Tekelec 5100 Platform Components.....32

Application Switch.....33

Content Switch.....34

Console Server.....34

Ethernet Switch.....35

Modem Router.....35

Power Distribution Panel (PDP).....35

T1200 Application Server.....36

T5100 Applications Shelf.....36

- Compute Blades.....37
- Ethernet Switch Blade.....38
- Shelf Alarm Display.....38
- Shelf Alarm Panel.....38
- Shelf Manager.....39

**Chapter 4: Cabinet Installation.....40**

Overview.....41

Unpacking the Cabinet.....41

- Required Tools.....41
- Procedure — Receiving Shipping Container for the Cabinet.....42
- Procedure — Unpacking the Container for the Cabinet.....42
- Procedure — Optional Hoist with Crane.....44

Installing the Cabinet.....45

- Precautions.....46
- Marking Floor Layout for Cabinet Installation.....47
- Raised Floor Installation.....48
- Concrete Floor Installation .....52
- Procedure — Cabinet Door Removal.....54

Grounding Information.....56

- Frame Ground Cabling Procedures.....59
- Recommended Tools.....59
- Procedure — Ground Frame.....60
- Procedure — Connect Ground Cable to T1200.....61

Power Requirements in a DC Environment.....61

Procedure — Power Terminations.....	62
PDP Alarm Card.....	63
Cabling Information.....	69
<b>Glossary.....</b>	<b>74</b>

# List of Figures

Figure 1: Zones and their Components.....	27
Figure 2: T5100 Platform DC Configurations (Examples).....	28
Figure 3: Co-mingled Cabinet Configuration (Example).....	29
Figure 4: Example of T1200 Application Cabinet Configuration.....	31
Figure 5: Example of T5100 Application Cabinet Configuration.....	33
Figure 6: Application Switch (front view).....	34
Figure 7: Content Switch (front view).....	34
Figure 8: Console Server.....	34
Figure 9: Ethernet Switch (front view).....	35
Figure 10: Modem Router.....	35
Figure 11: Power Distribution Panel (rear).....	36
Figure 12: T1200 Application Server (rear view) - DC.....	36
Figure 13: T5100 Applications Shelf (front).....	37
Figure 14: Shelf Alarm Display - Front.....	38
Figure 15: Shelf Alarm Panel - Front.....	38
Figure 16: Shelf Manager.....	39
Figure 17: Packed Cabinet Crate.....	41
Figure 18: Draw Latch on Crate.....	42
Figure 19: Integrated Crate Ramp.....	42
Figure 20: Shipping, Detach Dolly Frame.....	43
Figure 21: Dolly Mounting Bolts.....	44
Figure 22: Kick Plates.....	45
Figure 23: Mark Floor Layout.....	47
Figure 24: Raised Floor Anchor.....	49
Figure 25: Earthquake Bracing .....	51
Figure 26: Stack-up Seismic Anchor.....	52
Figure 27: Cabinet Door Hinge Pin.....	54
Figure 28: Prying open hinge spring wire.....	55
Figure 29: Removing pin with rubber hammer.....	55
Figure 30: Main Ground Bus Location .....	56
Figure 31: Door Ground - Bottom .....	57
Figure 32: Door Ground - Top.....	57
Figure 33: Grounded PDP.....	58
Figure 34: Grounded T1200 Application Server .....	58
Figure 35: System Frame Grounding.....	60
Figure 36: Lug Installation.....	63
Figure 37: Unscrewing Alarm Card.....	63

Figure 38: Removing the Alarm Card.....	64
Figure 39: Locating Rails and Socket in Slot.....	64
Figure 40: Insert Alarm Card Carefully.....	65
Figure 41: Alarm Card Front and Side View.....	66
Figure 42: Example of T1200 Cabinet as Shipped.....	69
Figure 43: T1200 cabinet with Pre-installed Components.....	70
Figure 44: Example of T1200 cabinet with Pre-cabled Components.....	70
Figure 45: Power Distribution Panel (PDP) Cabling.....	71
Figure 46: Ethernet Switch Cabling - Front.....	71
Figure 47: Ethernet Switch Cabling - Rear.....	72
Figure 48: T1200 Application Server Cabling.....	72
Figure 49: Cable Management.....	72

# List of Tables

Table 1: Basic RMA Types.....12

Table 2: RMA Reasons for Return.....12

Table 3: Safety Information Icons and Text.....19

Table 4: Table 4-1. Power Cable Conductor Sizes.....62

Table 5: Individual Power Supply Input Monitoring (DIP Switches S2 and S3).....67

Table 6: Alarm Input Monitoring (DIP Switch S4).....68

# Chapter 1

## Introduction

---

### Topics:

- *Overview.....9*
- *Scope and Audience.....9*
- *Manual Organization.....9*
- *Related Publications.....9*
- *Documentation Availability, Packaging, and Updates.....10*
- *Locate Product Documentation on the Customer Support Site.....10*
- *Product Packaging and Delivery.....11*
- *Hardware Repair and Return.....11*
- *Customer Care Center.....14*

This chapter contains general information about manual organization, scope, and audience, related documentation, how to locate customer documentation on the Customer Support site, how to get technical assistance, and RMA requirements.



## Overview

The Tekelec 1200 integrated application platform (T1200 platform) is a complete solution consisting of hardware, operating system, and middleware. The T1200 platform has a modular hardware architecture and allows hardware co-mingling to consolidate product configurations of multiple product families to one common cabinet. Tekelec platform software provides alarm management and configuration of each hardware component. Tekelec platform maintenance covers the T1200 components.

## Scope and Audience

This manual provides safety information, site requirements, hardware diagnostics, replacement procedures for field-replaceable units. Where applicable, hardware component configuration is performed through the product application. Instructions can be found in the administrator section of the respective online-help system, which is provided with the product application on the same or a separate DVD.

This manual is intended for maintenance personnel who must maintain the T1200 platform. For a list of system generated alarms and error messages and their procedures, refer to the Platform Alarm Manual.

## Manual Organization

This manual is organized into the following chapters:

- *Introduction* contains general information about manual organization, scope, and audience, related documentation, how to locate customer documentation on the Customer Support site, how to get technical assistance, and RMA requirements.
- *Safety and Pre-Installation Requirements* provides safety information when handling hardware components, electromagnetic compatibility, and typical site requirements.
- *Hardware Description* provides detailed descriptions of the platform hardware components.
- *Cabinet Installation* contains information describing how to unpack and install the application cabinet..

## Related Publications

This document has the following related publications, which can be found either on the same documentation disc, on the application documentation disc, or on the Customer Support site:

- Tekelec 5100 Integrated Application Platform: System Overview
- T5100 Field Replaceable Unit (FRU) Procedures
- PM&C/T5100 ATCA Platform Troubleshooting Guide

- PM&C/T5100 Initial Installation and Configuration User's Guide
- PM&C Administrator's Manual: Help System PDF

## Documentation Availability, Packaging, and Updates

Tekelec provides documentation with each system and in accordance with contractual agreements. For General Availability (GA) releases, Tekelec publishes a complete EAGLE 5 ISS documentation set. For Limited Availability (LA) releases, Tekelec may publish a documentation subset tailored to specific feature content or hardware requirements. Documentation Bulletins announce a new or updated release.

The Tekelec EAGLE 5 ISS documentation set is released on an optical disc. This format allows for easy searches through all parts of the documentation set.

The electronic file of each manual is also available from the [Tekelec Customer Support](#) site. This site allows for 24-hour access to the most up-to-date documentation, including the latest versions of Feature Notices.

Printed documentation is available for GA releases on request only and with a lead time of six weeks. The printed documentation set includes pocket guides for commands and alarms. Pocket guides may also be ordered separately. Exceptions to printed documentation are:

- Hardware or Installation manuals are printed without the linked attachments found in the electronic version of the manuals.
- The Release Notice is available only on the Customer Support site.

**Note:** Customers may print a reasonable number of each manual for their own use.

Documentation is updated when significant changes are made that affect system operation. Updates resulting from Severity 1 and 2 Problem Reports (PRs) are made to existing manuals. Other changes are included in the documentation for the next scheduled release. Updates are made by re-issuing an electronic file to the customer support site. Customers with printed documentation should contact their Sales Representative for an addendum. Occasionally, changes are communicated first with a Documentation Bulletin to provide customers with an advanced notice of the issue until officially released in the documentation. Documentation Bulletins are posted on the Customer Support site and can be viewed per product and release.

## Locate Product Documentation on the Customer Support Site

Access to Tekelec's Customer Support site is restricted to current Tekelec customers only. This section describes how to log into the Tekelec Customer Support site and locate a document. Viewing the document requires Adobe Acrobat Reader, which can be downloaded at [www.adobe.com](http://www.adobe.com).

1. Log into the [Tekelec Customer Support](#) site.

**Note:** If you have not registered for this new site, click the **Register Here** link. Have your customer number available. The response time for registration requests is 24 to 48 hours.

2. Click the **Product Support** tab.

3. Use the Search field to locate a document by its part number, release number, document name, or document type. The Search field accepts both full and partial entries.
4. Click a subject folder to browse through a list of related files.
5. To download a file to your location, right-click the file name and select **Save Target As**.

## Product Packaging and Delivery



**DANGER:** At least two people are required to safely move and position any frame.

### DANGER

Before opening any shipping container, inspect for evidence of damage during shipment. Report any damage to the carrier for investigation and possible claims. Also report any damage to the Tekelec site supervisor.

Check the packing slips against the equipment specification list for this installation site. Report any discrepancies to Tekelec Production Control at 1-888-673-4827, or if necessary, call 919-460-2150 inside the USA.

Inventory the shipment to make sure that all items listed on the pick list have been received in good condition. Report any discrepancies or damaged equipment by calling 1-888-673-4827.

TEKELEC

Attn: RMA Department

5200 Paramount Parkway

Morrisville, NC 27560

RMA#: <assigned by Tekelec>

## Hardware Repair and Return

Any system components being returned for repair or replacement must be processed through the Tekelec Return Material Authorization (RMA) procedures. A hardware repair is defined as an item returned to Tekelec due to a failure, with the returned item being repaired and returned to the customer. It is essential that serial numbers are recorded correctly. RMAs cannot be created without a valid serial number. All repair and quality information is tracked by serial number. [Table 1: Basic RMA Types](#) lists the basic RMA types. [Table 2: RMA Reasons for Return](#) lists the RMA return reasons.

Table 1: Basic RMA Types

Replacement Type	Description	Turnaround
Priority Advance Replacement	Customer requests the URGENT replacement of a damaged product	Same Day Shipment
Advance Replacement	Customer request the replacement of a damaged product	Shipment Within 3 Business Days
Repair / Return	Customer will return a damaged product for repair	Shipment Within 5 Days After Receipt
Expendable	A damaged part, such as a cable, is replaced, but the Customer does not return the damaged product	Depends on Urgency - Shipment Within 3 Business Days

Table 2: RMA Reasons for Return

Reason for Return	Description
Damaged by Environment	Product damaged by environmental phenomena such as water damage or earthquake.
Damaged in Shipment	Damaged between shipment from Tekelec and receipt at the Customer's installation site.
DOA – Dead on Arrival	Product is not functional when it is first installed at the Customer's location.
Lab Return	Products returned from lab sites.
Product Capture	Defect to be captured by Quality or Engineering (not Product Recall).
Product Deficiency	Anything wrong with the part that doesn't fall into another category.
Product Recall	Products recalled by divisions for the repair of a defect or replacement of defective products.

Reason for Return	Description
Return – No Product Deficiency	Anything returned without the product being defective.

## Repair and Return Shipping Instructions

All returned equipment, assemblies, or subassemblies must be shipped to the Tekelec Repair and Return Facility specified by the [Customer Care Center](#). The item being returned must be shipped in the original carton or in an equivalent container assuring proper static handling procedures and with the freight charges prepaid.

The assigned RMA number must be clearly printed on the “RMA#.” line of the shipping label on the outside of the shipping package. If the RMA number is not placed on the label, the return could be delayed.

### Procedure - RMA

1. Obtain and confirm the following information before contacting the [Customer Care Center](#):

- Your name:
- Company name:
- Call-back number:
- Email address:
- Which product you are calling about?
- Site location:
- CLLI number
- System serial number (NT, CE, LM, DS, etc.):
- Complete software release (e.g., 28.0.1-41.53.0):
- Upgrade forms
  - WI005153
  - WI005154
  - WI005218
  - WI005219
  - WI005220
- Tekelec card type: (e.g., MPL, DSM, etc.):
- Tekelec card part number (870-####-##):
- Associated serial number (102#####):
- Reason for return or replacement (isolated from system):
- Full name of person the replacement card is being shipped to:
- Shipping address:

**Note:** If possible, include associated alarms (UAMs) and a copy of the associated output (capture file).

2. Contact the *Customer Care Center* and request a Return of Material Authorization (RMA).
3. If the item is a like-for-like advance replacement, the *Customer Care Center* arranges for shipment of the replacement item to the customer.
  - a) Wait for the replacement component to arrive.
  - b) Package the defective component in the box of materials you received with your replacement. Use proper static handling procedures.
  - c) Label the outside and inside of the box with your RMA number clearly visible. Place the packing slip from the received replacements on the inside of your box.
  - d) Ship the defective component to the return address listed on the packing slip.
4. If the item is a repair/return, the *Customer Care Center* arranges for shipment of the replacement item to the customer.
  - a) Package the defective component in a suitable package for shipping. Use proper static handling procedures.
  - b) Label the outside and inside of the box with your RMA number clearly visible. Include a packing slip with all the information from *Step 1* along with the RMA number.
  - c) Ship the defective component to the following address:

TEKELEC  
Attn: RMA Department  
5200 Paramount Parkway  
Morrisville, NC 27560  
RMA#: <assigned by Tekelec>
  - d) Wait for the repaired component to arrive.

## Customer Care Center

The Tekelec Customer Care Center is your initial point of contact for all product support needs. A representative takes your call or email, creates a Customer Service Request (CSR) and directs your requests to the Tekelec Technical Assistance Center (TAC). Each CSR includes an individual tracking number. Together with TAC Engineers, the representative will help you resolve your request.

The Customer Care Center is available 24 hours a day, 7 days a week, 365 days a year, and is linked to TAC Engineers around the globe.

Tekelec TAC Engineers are available to provide solutions to your technical questions and issues 7 days a week, 24 hours a day. After a CSR is issued, the TAC Engineer determines the classification of the trouble. If a critical problem exists, emergency procedures are initiated. If the problem is not critical, normal support procedures apply. A primary Technical Engineer is assigned to work on the CSR and provide a solution to the problem. The CSR is closed when the problem is resolved.

Tekelec Technical Assistance Centers are located around the globe in the following locations:

**Tekelec - Global**

Email (All Regions): support@tekelec.com

- **USA and Canada**

Phone:

1-888-FOR-TKLC or 1-888-367-8552 (toll-free, within continental USA and Canada)

1-919-460-2150 (outside continental USA and Canada)

TAC Regional Support Office Hours:

8:00 a.m. through 5:00 p.m. (GMT minus 5 hours), Monday through Friday, excluding holidays

- **Central and Latin America (CALA)**

Phone:

USA access code +1-800-658-5454, then 1-888-FOR-TKLC or 1-888-367-8552 (toll-free)

TAC Regional Support Office Hours (except Brazil):

10:00 a.m. through 7:00 p.m. (GMT minus 6 hours), Monday through Friday, excluding holidays

- **Argentina**

Phone:

0-800-555-5246 (toll-free)

- **Brazil**

Phone:

0-800-891-4341 (toll-free)

TAC Regional Support Office Hours:

8:30 a.m. through 6:30 p.m. (GMT minus 3 hours), Monday through Friday, excluding holidays

- **Chile**

Phone:

1230-020-555-5468

- **Colombia**

Phone:

01-800-912-0537

- **Dominican Republic**

Phone:

1-888-367-8552

- **Mexico**

Phone:

001-888-367-8552

- **Peru**

Phone:

0800-53-087

- **Puerto Rico**

Phone:

1-888-367-8552 (1-888-FOR-TKLC)

- **Venezuela**

Phone:

0800-176-6497

- **Europe, Middle East, and Africa**

Regional Office Hours:

8:30 a.m. through 5:00 p.m. (GMT), Monday through Friday, excluding holidays

- **Signaling**

Phone:

+44 1784 467 804 (within UK)

- **Software Solutions**

Phone:

+33 3 89 33 54 00

- **Asia**

- **India**

Phone:

+91 124 436 8552 or +91 124 436 8553

TAC Regional Support Office Hours:

10:00 a.m. through 7:00 p.m. (GMT plus 5 1/2 hours), Monday through Saturday, excluding holidays

- **Singapore**

Phone:

+65 6796 2288

TAC Regional Support Office Hours:

9:00 a.m. through 6:00 p.m. (GMT plus 8 hours), Monday through Friday, excluding holidays

## Contact Information

**Note:** For issues requiring emergency response, contact the Tekelec Customer Care Center by phone only.

- Tekelec, USA

Phone (US and Canada) +1 888-FOR-TKLC or 888-367-8552



Phone (international) +1 919-460-2150

Fax +1-919-460-2126

Email: support@tekelec.com

- Tekelec, Europe and UK

Phone +44 1784 467 804

Fax +44 1784 477 120

Email: support@tekelec.com

## Emergency Response

In the event of a critical service situation, emergency response is offered by the Tekelec Customer Care Center 24 hours a day, 7 days a week. The emergency response provides immediate coverage, automatic escalation, and other features to ensure that the critical situation is resolved as rapidly as possible.

A critical situation is defined as a problem with the installed equipment that severely affects service, traffic, or maintenance capabilities, and requires immediate corrective action. Critical problems affect service and/or system operation resulting in:

- A total system failure that results in loss of all transaction processing capability
- Significant reduction in system capacity or traffic handling capability
- Loss of the system's ability to perform automatic system reconfiguration
- Inability to restart a processor or the system
- Corruption of system databases that requires service affecting corrective actions
- Loss of access for maintenance or recovery operations
- Loss of the system ability to provide any required critical or major trouble notification

Any other problem severely affecting service, capacity /traffic, billing, and maintenance capabilities may be defined as critical by prior discussion and agreement with the Tekelec Customer Care Center.

# Chapter 2

## Safety and Pre-Installation Requirements

---

**Topics:**

- *Safety Information.....19*
- *Safety and Electromagnetic Compatibility.....23*
- *Generic Site Requirements.....24*

This chapter provides information pertaining to safety, electromagnetic compatibility, and typical site requirements





## Safety Information


### General


The icons and text shown in *Table 3: Safety Information Icons and Text* are used throughout this manual to alert the reader, to assure personnel safety, to minimize service interruptions, and to warn of potential equipment damage.

**Note:** All personnel must be aware of and conform to the safety information provided in each “Safety Information” section of this manual.

**Table 3: Safety Information Icons and Text**

 TOPPLE	<p><b>TOPPLE:</b> (This icon and text indicate the possibility of personnel injury and equipment damage.)</p>
 DANGER	<p><b>DANGER:</b> (This icon and text indicate the possibility of personnel injury.)</p>
 WARNING	<p><b>WARNING:</b> (This icon and text indicate the possibility of equipment damage and personnel injury.)</p>
 CAUTION	<p><b>CAUTION:</b> (This icon and text indicate the possibility of service interruption and personnel injury.)</p>

 **WARNING:** All personnel associated with the installation of these systems must adhere to all safety precautions and use required protection equipment to avoid the possibility of injury, equipment damage, service degradation, or service interruption.

 **WARNING:** This procedure may interrupt service. When possible, perform maintenance during low traffic and database provisioning periods, such as the maintenance window

## Cabinets



**TOPPLE:** Always read and understand instructions thoroughly and completely before working on, moving, raising or lowering the cabinet, any portion of the cabinet, attachments to the cabinet, or equipment.



**TOPPLE:** Never try to unpack any frame from the shipping container without at least two people to steady any movement of the frame and related components. At least two people are required to safely move and position a frame into place.



**TOPPLE:** Never pull out the shelf of a frame that is not anchored properly. Systems with sliding shelves must be securely anchored to the floor and to the overhead cable racks. Extending a shelf without correctly anchoring the frame can cause the frame to topple and endanger personnel and damage equipment.



**DANGER:** Moving a frame requires two people. Injury or damage to internal components due to shock and vibration might occur if not handled properly.



**WARNING:** Before drilling holes in any flooring, verify with facilities personnel that the area is free of gas or water pipes, ventilation plenum, and electrical wiring conduits.



**WARNING:** Finger-tighten nuts on threaded rods inside the frames above the raised floor before finger tightening the nuts below the raised floor.



**CAUTION:** Frame ground. Do not “double lug”: The practice of using one bolt through a lug and the ground bar, and through another lug on the other side of the ground bar, held in place by one nut.

## Frames



**TOPPLE:** Always read and understand instructions thoroughly and completely before working on, moving, raising or lowering the cabinet, any portion of the cabinet, attachments to the cabinet, or equipment.



**TOPPLE:** Never try to unpack any frame from the shipping container without at least two people to steady any movement of the frame and related components. At least two people are required to safely move and position a frame into place.



**TOPPLE:** Never pull out the shelf of a frame that is not anchored properly. Systems with sliding shelves must be securely anchored to the floor and to the overhead cable racks. Extending a shelf without correctly anchoring the frame can cause the frame to topple and endanger personnel and damage equipment.



**TOPPLE:** Frames are required to be attached to over-head ladder-racks before shelves are extended.

TOPPLE



**DANGER:** Moving a frame requires two people. Injury or damage to internal components due to shock and vibration might occur if not handled properly.

DANGER



**WARNING:** Before drilling holes in any flooring, verify with facilities personnel that the area is free of gas or water pipes, ventilation plenum, and electrical wiring conduits.

WARNING



**WARNING:** Finger-tighten nuts on threaded rods inside the frames above the raised floor before finger tightening the nuts below the raised floor.

WARNING



**CAUTION:** Frame ground. Do not “double lug”: The practice of using one bolt through a lug and the ground bar, and through another lug on the other side of the ground bar, held in place by one nut.

CAUTION



**CAUTION:** After the frame has been shipped or moved, remove all cards prior to applying power. Carefully reset cards to avoid possible faulty connections.

CAUTION

## Power



**DANGER:** Strictly observe all grounding requirements to reduce the risk of electric shock.

DANGER



**DANGER:** Do not use or place commercially AC-powered equipment within 7 ft. of –48V equipment. Close proximity can create a shock or current loop that is severely hazardous to personnel and equipment.

DANGER



WARNING

**WARNING:** The intra-building port(s) of the equipment or subassembly is suitable for connection to intra-building or unexposed wiring or cabling only. The intra-building port(s) of the equipment or subassembly **MUST NOT** be metallically connected to interfaces that connect to the Outside Plant (OSP) or its wiring. These interfaces are designed for use as intra-building interfaces only (Type 2 or Type 4 ports as described in GR-1089-CORE, Issue 4) and require isolation from the exposed OSP cabling. The addition of Primary Protectors is not sufficient protection in order to connect these interfaces metallically to OSP wiring.



**WARNING:** Before testing -48VDC power source:

- Ensure that no power is being provided to the system from the -48VDC power source, such as a power board
- Ensure that no circuit cards are installed in the shelves
- Open all circuit breakers in the PDP
- Recheck wiring and connections for proper polarity



**WARNING:** Always install an isolator pad between the frame and ground. Frames are shipped with isolator pads to completely isolate the frames from ground.



**WARNING:** Application servers. Verify that all breakers are set to the OFF (O) position. An application server chassis is redundantly powered from both A and B -48VDC buses. Ensure that both the circuit breaker supplying A power to the chassis and the circuit breaker supplying B power to the chassis are turned OFF by measuring the voltage with a VOM on the cable that connects the chassis to its breakers. Both A and B power LEDs on the front panel of the chassis should be OFF.



**CAUTION:** Redundant systems allow service during normal maintenance. When repairs require a total power disconnect, both input supply sources must be disconnected. This causes service interruption and takes down the systems.



**CAUTION:** This equipment has a connection between the earthed conductor of the DC supply circuit and the earthing conductor.



**CAUTION:** Install equipment in restricted access areas in accordance with articles 110-16, 110-17, and 110-18 of the National Electric Code, ANSI/NFPA 70.



**CAUTION:** Incorporate a readily accessible approved disconnect device in the field wiring.



**CAUTION:** Use only listed closed-loop connectors for connection to the power supply.

## Electrostatic Discharge



**DANGER:** Always wear a wrist strap or other electrostatic protection when handling printed circuit cards and other electrostatic-sensitive devices



**WARNING:** Use an antistatic wrist strap connected to the wrist strap grounding point on the frame when performing these procedures.



**WARNING:** Do not use tie wraps on or above the top traverse arms on a frame. Always trim tie wrap flush and turn the trimmed tie wrap to the rear of the cable. Contact the Site Supervisor for site-specific customer information.



**WARNING:** Do not use tie wraps for optical cables.

## Components



**WARNING:** If components arrive in containers that might have been subjected to extreme temperatures or variations in humidity (such as air transport), allow 6 hours for the components to acclimatize to your site conditions before operating.



**WARNING:** Metal points on Printed Circuit Boards conduct -48VDC and can cause shorts, shocks, and damage if not handled properly.



**CAUTION:** New CPCI cards may have a small plastic cover over the screws or the alignment ejector pins. Remove and discard these plastic covers. If inserting the cards takes an excessive amount of force, check for obstructions. Forcing the card into a slot may damage the ejector handle or pin.



**CAUTION:** Do not impact the faceplate in order to mate the connectors. Any impact to the card's faceplate can damage the faceplate, the pins, or the connectors.

## Safety and Electromagnetic Compatibility

GR-1089-CORE Electromagnetic Compatibility and Electrical Safety - Generic Criteria for Network Telecommunications Equipment, Telcordia Technologies. NEBS Level 3.

GR-63-CORE NEBS Requirements: Physical Protection, Telcordia Technologies Generic Requirements, NEBS Level 3.

UL 60950-1 Information Technology Equipment - Safety - Part 1: General Requirements, Agency Listing

IEC 60950-1 Information Technology Equipment - Safety - Part 1: General Requirements

Safety Directive 2006/95/EC EN 60950-1, Information Technology Equipment - Safety - Part 1: General Requirements

CSA C22.2 No. 60950-1 Information Technology Equipment - Safety - Part 1: General Requirements for Canada

EMC Directive 2004/108/EC Compliance with EU Harmonized Standards EN 55022, I.T.E. Radio disturbance characteristics Limits and Methods of Measurement. Compliance with EN 55024, I.T.E. Immunity characteristics Limits and Methods of Measurement

## Generic Site Requirements

The following specifications are standard telephony industry requirements for equipment installation.

### Building Requirements

The building requirements for this system are standard telephony industry requirements for equipment installation.

The building must provide a clear, uncluttered route between the loading/receiving dock and the planned system location. In order to move the equipment to the proper location, recommended hall clearance is at least 4.5 feet (1.4 meters) wide by 8.5 feet (2.6 meters) tall.

Four foot, (1.2 meter) side aisles should be used to allow maneuvering frames into place and provide ample work space around the equipment.

The room selected for system installation should be large enough so the system frames can be at least 2.5 feet (76 cm) from the walls for front and rear access and at least 12 inches (31 cm) for side access.

### Earthquake Resistance

All Tekelec system configurations are designed to assure that the system remains operational during and after an earthquake, even when the system is located on the upper floors of a zone 4 central office.

### Elevation

Operating: 60 m below sea level at ambient temperature of 30° C to +4000 m above sea level at ambient temperature of 40° C.

### Fire Protection

Local fire protection codes must be satisfied in the equipment room where the system is to be located.

### Floor Loading

It is recommended the floor or raised sub-flooring have a distributed load capacity of no less than 100 pounds per square foot (453 kg/m<sup>2</sup>). The floor loading is determined by using the following equation:  
Total equipment weight/floor area = distributed floor capacity.

### HVAC Requirements

To maintain the required temperature range, Heating, Ventilation, and Air Conditioning (HVAC) equipment should have the capacity to compensate for the site engineering recommendations.



The required HVAC capacity to compensate for a miscellaneous frame varies depending on the customer previously installed equipment. To calculate needed HVAC capacity, determine the wattage of the installed equipment and use the following formula:  $\text{watts} \times 3.413 = \text{BTUs/hr}$ .

## Lighting

Adequate lighting should be provided in the room where the equipment is to be located. Lighting fixtures must be far enough from the equipment and cables to prevent heat damage and to allow safe access to equipment and cables.

## Relative Humidity

- Operating: 5% to 85% non-condensing (maximum absolute humidity of 0.024 kg of water per kg of dry air)
- Short Term Operating: 5% to 90% non-condensing (maximum absolute humidity of 0.024 kg of water per kg of dry air)

## Space Requirements

This system equipment is housed in 7 foot high (44U), 24 inch wide, floor supported, upright frame with top and side panels as well as door.

The number of frames required for an installation is described in the Initial Sales Order for that site. The number of frames is determined by the space required by the module population of the system.

When planning the installation, be sure to take into account spare module storage, modems, terminals, printers, cross connect panels, and all other items that might require space in a system.

## Temperature Variation

Typical environmental conditions are temperature and humidity controlled. With loss of environmental control, the equipment covered in this manual complies with these conditions:

- Operating: 5° C to 40° C (41° F to 104° F)
- Exceptional Operating Limit: -5° C to 50° C (23° F to 122° F) (no more than 96 hours duration at extremes and at elevations less than 1800m)
- Storage: Tested to meet the storage and transportation requirements in Telcordia GR-63-CORE, ETSI EN 300 019-2-2, T2.3

# Chapter 3

## Hardware Description

---

### Topics:

- *Application Cabinet.....27*
- *Application Switch.....33*
- *Content Switch.....34*
- *Console Server.....34*
- *Ethernet Switch.....35*
- *Modem Router.....35*
- *Power Distribution Panel (PDP).....35*
- *T1200 Application Server.....36*
- *T5100 Applications Shelf.....36*

This chapter provides detailed descriptions of the platform hardware components.

## Application Cabinet

The application cabinet used for the T1200 or T5100 application platform is 23 inches wide, 44U (77.0 inches or 1,955.8 mm) high with top and side panels as well as front and rear doors. The rails are set for standard 19-inch(482.6 mm) rack mount equipment and is earthquake zone 4 compliant. The cabinet provides adequate air flow, as well as front and rear access for cabling and FRU replacement. The application cabinet can be configured for AC or DC applications. This manual describes DC configurations.

The application cabinet supports hardware co-mingling, which allows multiple applications that are hosted on separate server clusters to reside in a common cabinet. Each application is hosted on its own set of servers, just as if each application would be placed in separate cabinets. However, there is no management element spanning the applications at this time.

### About Zones

The application cabinet space is divided into zones to better support hardware co-mingling:

- The Power Zone (7U) supports power distribution panels (PDPs)
- The Network Zone (10U) supports Ethernet switches and front-to-rear cable plenum when T5100 application shelves are included.
- Application Zone 1 (6U) supports an application hosted on up to 6 T1200 application servers.
- Application Zone 2 (6U) supports an independent application hosted on up to 6 T1200 application servers, or expansion of a Zone 1 application to a total of 12 T1200 application servers.
- Application Zone 3 (13U) supports an independent application hosted on a T5100 application server, up to 6 T1200 application servers, an expansion of a Zone 2 application to a total of 12 T1200 application servers, or an expansion of a Zone 1 application to a total of 18 T1200 application servers.

**Note:** Applications can span multiple physical zones. An application starting in physical zone 1 may also occupy physical zone 2 and, possibly zone 3, depending on the number of servers the application requires.

The three application zones allow for product simplification to the greatest extent possible. No equipment has to be moved to support a field extension of a second application into the application cabinet. Each application is independent of both the interaction of servers and the networking design.

*Figure 1: Zones and their Components* shows the components that can be loaded in each zone depending on a single T1200 or T5100 configuration, or for a co-mingled cabinet. Exact configurations are based on Customer sales orders and are identified in the Dimensioning Drawings, which are provided with each shipment.

#### **Figure 1: Zones and their Components**

U	Legend	Zones	W D C	Components that can be loaded in each zone
1	Power (7U)		1	PDP(12+1 Aux breaker)
2			2	
3			3	
4			4	1U filler Panel
5			5	PDP(12+1 Aux breaker)
6			6	
7			7	
8	Network (10U)		1	Cable Management
9			2	Ethernet Sw (24 -port)
10			3	Application Sw (48-port)
11			4	Content Switches
12			5	
13			6	
14			7	
15			8	
16			9	Console Server
17			10	
18	Zone 1 (6U)		1	
19			2	
20			3	T1200 Servers
21			4	
22			5	
23			6	
24	Zone 2 (6U)		1	
25			2	
26			3	T1200 Servers
27			4	
28			5	T5100 Shelf
29			6	
30	Zone 3 (13U)		1	
31			2	
32			3	T1200 Servers
33			4	
34			5	T5100 Shelf
35			6	
36			7	Storage Arrays
37			8	
38			9	Modem Routers
39			10	
40			11	
41			12	
42			13	
43	Raised floor cable entry(2U)		1	
44			2	

Figure 2: T5100 Platform DC Configurations (Examples) shows T5100 configurations with one or two T5100 shelves.

Figure 2: T5100 Platform DC Configurations (Examples)





- b. any time 9 or more T1200 pieces are added to a T1200 cabinet co-mingled with an ATCA shelf.
  - c. anytime 14 or more T1200 pieces are specified or zone 2 is populated with servers in a T1200 cabinet.
2. A 3U PDP is populated with breakers based on the strategy defined in the 3U PDP worksheet.
  3. A 1U Filler panel is required above the second 3U PDP for thermal management.
  4. All equipment in the network zone and application zones 1 - 3 are loaded and numbered from top to bottom. Storage arrays are loaded starting at U34 for weight distribution purposes.
  5. The first T5100 shelf is always loaded in zone 3 at bottom of cabinet, a second T5100 shelf is loaded above the first shelf.
  6. A 2U space is reserved at bottom of cabinet to accommodate raised floor power cable entry.

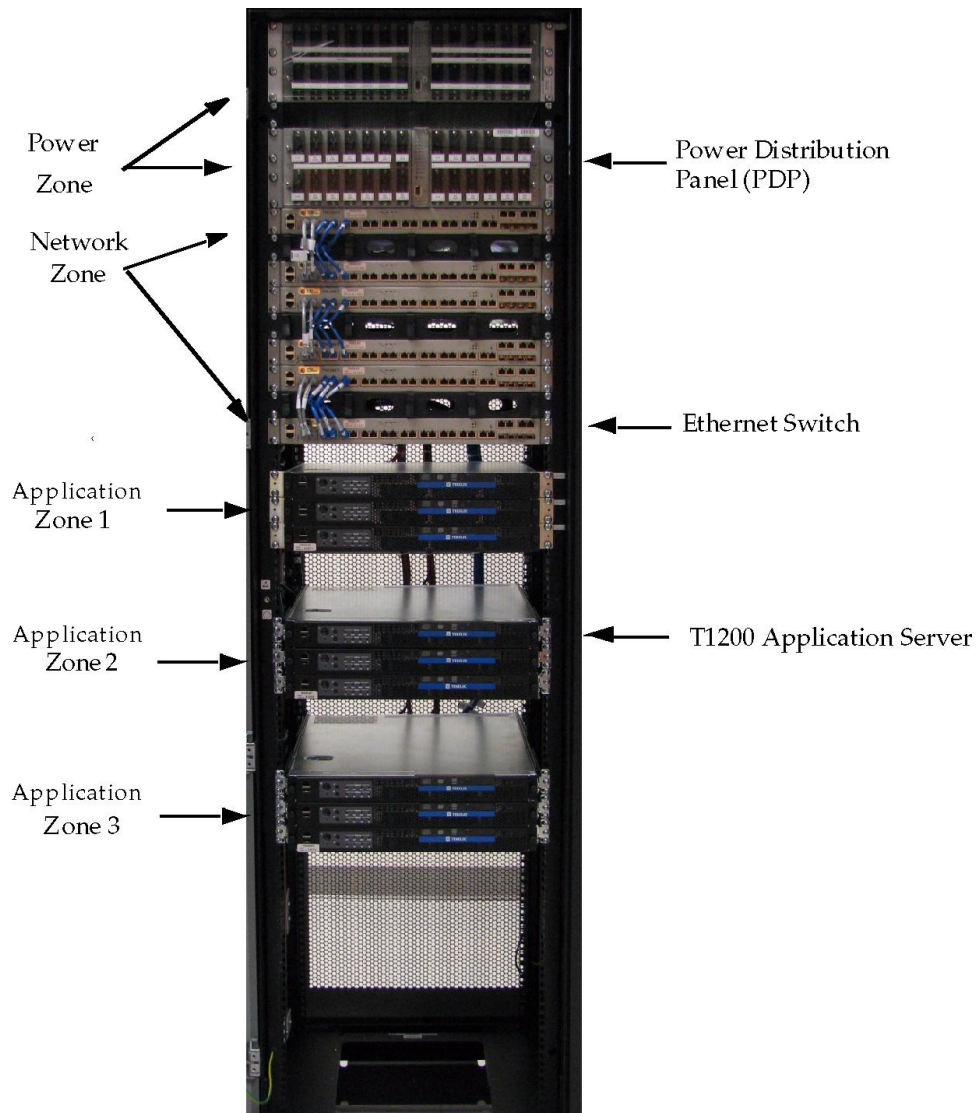
## Tekelec 1200 Platform Components

The cabinet for the Tekelec 1200 (T1200) platform contains these components:

- *Power Distribution Panel (PDP)*
- *Modem Router*
- *Application Switch*
- *Content Switch*
- *Ethernet Switch*
- *T1200 Application Server*

*Figure 4: Example of T1200 Application Cabinet Configuration* shows a T1200 application cabinet with 2 PDPs, 6 Ethernet switches, and 9 T1200 application servers installed.

**Figure 4: Example of T1200 Application Cabinet Configuration**



## Tekelec 5100 Platform Components

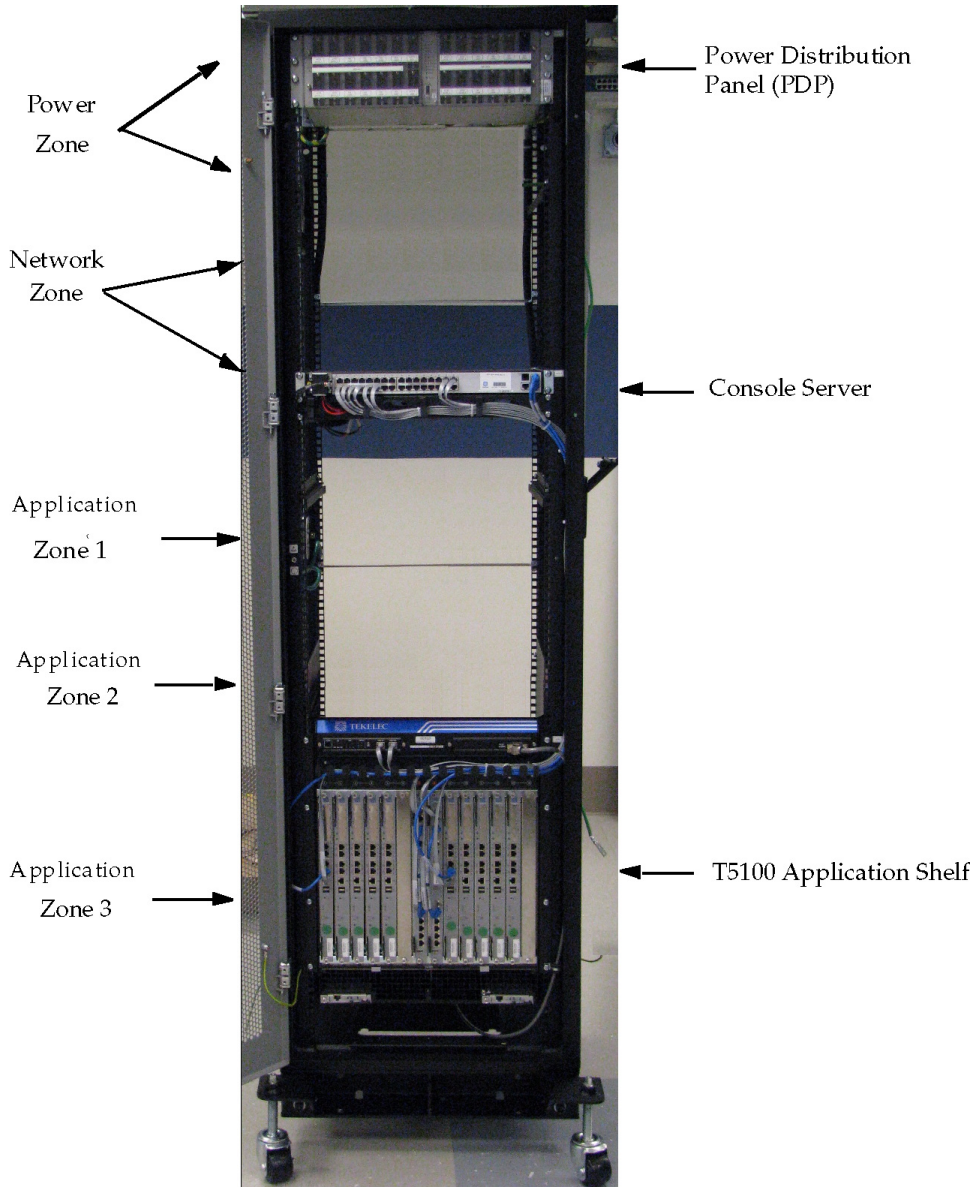
The cabinet for the Tekelec 5100 (T5100) platform contains these components:

- *Power Distribution Panel (PDP)*
- *Console Server*
- *T5100 Applications Shelf*
  - *Compute Blades*
  - *Ethernet Switch Blade*
  - *Shelf Alarm Display*
  - *Shelf Alarm Panel*
  - *Shelf Manager*



*Figure 5: Example of T5100 Application Cabinet Configuration* shows the T5100 application cabinet with a PDP, console server, and T5100 application shelf installed.

**Figure 5: Example of T5100 Application Cabinet Configuration**



## Application Switch

The Application Switch is a wire-speed, low-latency, Layer 2 to 4, 1-rack-unit (1U), fixed-configuration switch for rack-optimized server switching. It has exceptional performance and reliability for low-density, multilayer aggregation of high-performance servers and workstations.

High performance and scalability of intelligent network services is made possible with dedicated specialized resources known as ternary content addressable memory (TCAM). Ample TCAM resources (64,000 entries) enable high feature capacity, providing wire-speed routing and switching performance with concurrent provisioning of services such as quality of service (QoS) and security and helping ensure scalability for today's network requirements with ample room for future growth.

The Application Switch has 48 ports of wire-speed 10/100/1000BASE-T with four alternative wired 1 ports that can accommodate optional 1000BASE-X Small Form-Factor Pluggable (SFP) optics.

**Figure 6: Application Switch (front view)**

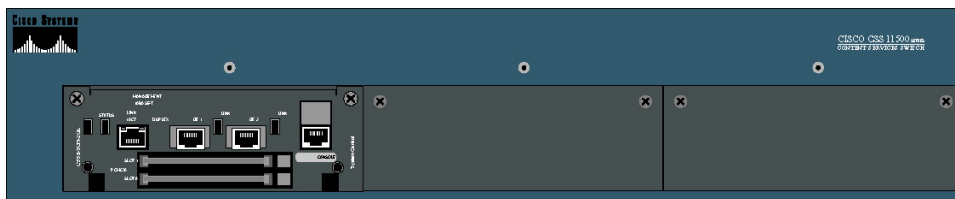


## Content Switch

The Content Switch improves application and site availability and transaction integrity by using Adaptive Session Redundancy (ASR), an industry standard in stateful failover.

The Content Switch delivers flexibility for customizing combinations of ports, performance, and services. The switch scales secured application transaction performance through support of an integrated, high-capacity Secure Sockets Layer (SSL) module. Off-loading SSL onto the network improves the overall performance of the web and application server enabling better application performance.

**Figure 7: Content Switch (front view)**



## Console Server

The console server provides secure console or serial port management. The PM&C application configures the console server with the "Add Frame" and "Add Shelf" operations. The "Add Shelf" operation accesses the console ports of each shelf manager and switch for initial configuration of those components. The console server is also used for FRU activities and disaster recovery operations.

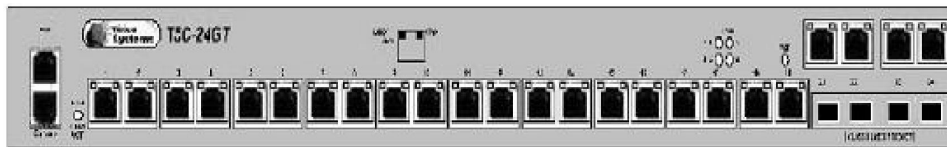
**Figure 8: Console Server**



## Ethernet Switch

The Ethernet Switch is a compact high-performance switch made for demanding networks that require multi-layer service capabilities at wire speed. A high-density architecture enables the Ethernet switch to utilize a large variety of interfaces to transparently switch Layer 2, 3, and 4 network traffic over copper, at 10, 100 or 1000 Mbps speeds and over fiber at 1000 Mbps speed. [Figure 9: Ethernet Switch \(front view\)](#) shows the front view of the switch.

**Figure 9: Ethernet Switch (front view)**



## Modem Router

The Modem Router offers secure, wire-speed delivery of concurrent data, voice, and video services. The modular design of the router provides maximum flexibility for evolving needs. The router incorporates data, security, and voice services in a single system for fast, scalable delivery of crucial business applications.

**Figure 10: Modem Router**

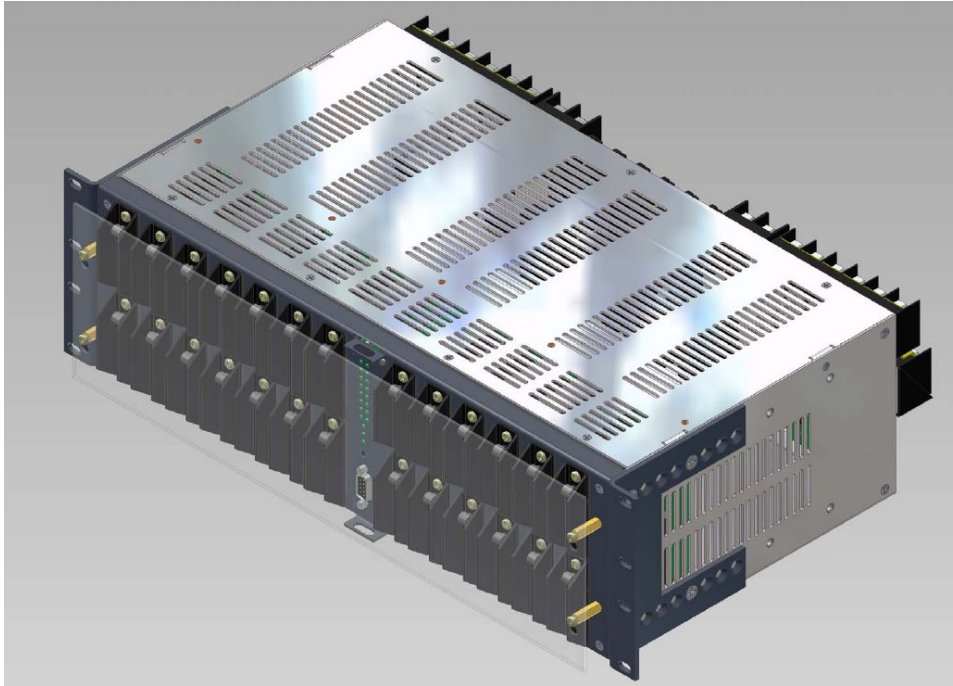


## Power Distribution Panel (PDP)

The Power Distribution Panel (PDP) monitors primary and secondary power sources on a continuous basis. The PDP is a pluggable circuit breaker panel that distributes DC power to the equipment. The

panel accommodates up to 26 IMG-style pluggable breakers, which can be installed or removed in the field. Alarm circuitry is provided to indicate and extend alarm conditions when faults occur.

**Figure 11: Power Distribution Panel (rear)**



## T1200 Application Server

The T1200 application server is an off-the-shelf 1U server to host Tekelec central office applications at a significant performance improvement.

The T1200 application server has high availability. Advanced server management and alarming ensures maximum uptime. Redundant hot-swap power and cooling reduce Mean-Time-To-Repair (MTTR) and increase Mean-Time-Between-Failures (MTBF).

**Figure 12: T1200 Application Server (rear view) - DC**



## T5100 Applications Shelf

The T5100 applications shelf is an integrated designed assembly that includes a shelf alarm display and a shelf alarm panel at the top, two shelf manager modules at the bottom, the 14-slot card cage, a

mid-plane circuit board, integrated redundant fan modules, and redundant power entry modules. See [Figure 13: T5100 Applications Shelf \(front\)](#).

**Figure 13: T5100 Applications Shelf (front)**



## Compute Blades

Each individual compute blade is a single-slot card and performs independently as a full-function server running its own operating system with IP connectivity via the base and fabric Network Interface Cards (NICs). The compute blade provides two USB ports and one serial console interface on the front panel.

Compute blades in the T5100 platform are classified as follows:

- Application server blades (host telecommunications software)
- PM&C server blade

Host the PM&C application for platform configuration and management; Ethernet connection to shelf manager and Ethernet switch)

- the primary PM&C server blade
- the spare server blade, used for PM&C backups and disaster recovery

## Ethernet Switch Blade

Each IEEE 802.3 high-speed Gigabit Ethernet (GigE) switch blades is deployed in pairs, operating in a 1+1 redundant active/active configuration.

There are two physically separate switches within each physical switch blade:

- Base switch, which is assigned platform management responsibilities
- Fabric switch, which is assigned data responsibilities

This configuration ensures not just a logical separation, but the complete, physical separation between platform management packets (base switch) and data packets (fabric switch).

The two switches have a connection between them on each of the switching domains. The switch provides for external Gigabit Ethernet connectivity, in addition to the on-shelf Gigabit Ethernet connection to each blade, over the midplane.

## Shelf Alarm Display

The shelf alarm display indicates Telco faults (MIN, MAJ, CRIT), or FAN TRAY failures along with faults in Shelf Management. The shelf alarm display is hot-swappable.

**Figure 14: Shelf Alarm Display - Front**



## Shelf Alarm Panel

The shelf alarm connects to the PDP and provides power to the shelf alarm display. The shelf alarm panel is hot-swappable and is mounted in the upper, right front corner of the T5100 applications shelf, see [Figure 13: T5100 Applications Shelf \(front\)](#).

[Figure 15: Shelf Alarm Panel - Front](#) shows the front of the shelf alarm panel with the serial port used by the connector.

**Figure 15: Shelf Alarm Panel - Front**



## Shelf Manager

Each T5100 application shelf has two shelf managers for redundancy. The shelf manager controls and monitors compute blades and other hardware components within the shelf. The shelf manager interfaces with the power distribution and shelf alarm display. Shelf managers are deployed in redundant pairs. There are no customer-external interfaces to the shelf manager.

**Figure 16: Shelf Manager**



# Chapter

# 4

## Cabinet Installation

---

### Topics:

- *Overview.....41*
- *Unpacking the Cabinet.....41*
- *Installing the Cabinet.....45*
- *Grounding Information.....56*
- *Power Requirements in a DC Environment.....61*
- *Cabling Information.....69*

This chapter contains information describing how to unpack and install the application cabinet.



## Overview

This chapter describes how to unpack the application cabinet from the crate, prepare a concrete or raised floor for installation, anchor the frame to floor and overhead rack, examine the grounding requirements and the cabling.

## Unpacking the Cabinet

This section describes the steps to unpack the cabinet. Each cabinet is shipped in a wooden crate on a shock pallet. See [Figure 17: Packed Cabinet Crate](#).

**Figure 17: Packed Cabinet Crate**



## Required Tools

- 9/16" Open End Wrench
- 9/16" Socket with Drive Ratchet
- 15/16" Socket with 1/2" Drive Ratchet
- 15/16" Open End Wrench
- 10 mm Allen Wrench
- 19 mm Socket with Drive Ratchet

## Procedure — Receiving Shipping Container for the Cabinet



**DANGER:** At least two people are required to safely move and position the cabinets. Read and understand this procedure completely before continuing.

**DANGER**

1. Before opening any shipping container, inspect it for evidence of damage during shipment.  
Report any damage to the carrier for investigation and possible claims. Also report any damage to the site supervisor.
2. Check the packing slips against the equipment specification list for this installation site.  
Report any discrepancies.

## Procedure — Unpacking the Container for the Cabinet



**DANGER:** At least two people are required to safely move and position the cabinets. Read and understand this procedure completely before continuing.

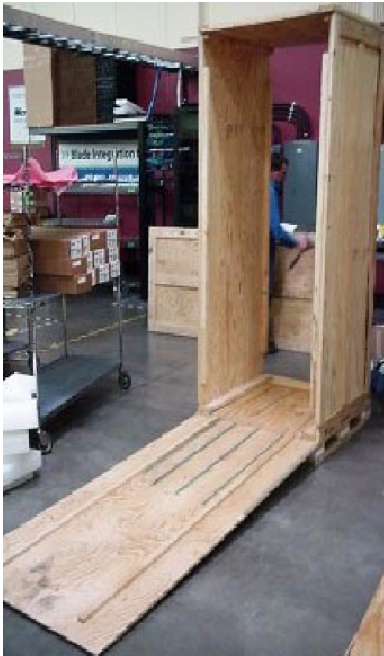
**DANGER**

1. Open crate door with integrated ramp by opening draw latches.  
Use the crate door with integrated ramp to remove the cabinet from the shipping compartment. (See [Figure 19: Integrated Crate Ramp](#)). See [Figure 18: Draw Latch on Crate](#) and [Figure 19: Integrated Crate Ramp](#).

**Figure 18: Draw Latch on Crate**

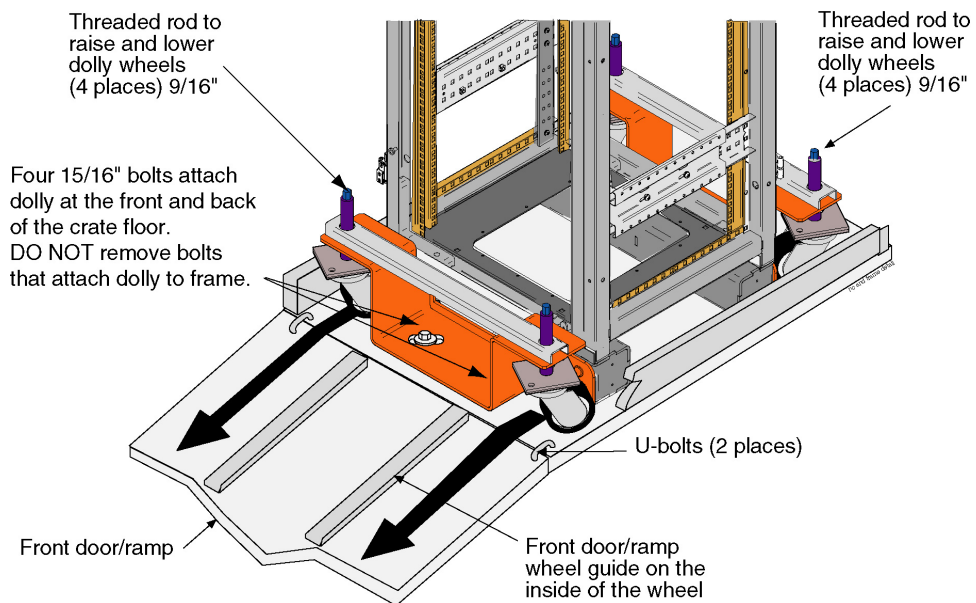


**Figure 19: Integrated Crate Ramp**



2. Place the ramp against the front of the container making sure the angle side is up and slants away from the cabinet in the container.
3. Insert the U-bolts in the holes to secure the ramp support and container together (refer to [Figure 20: Shipping, Detach Dolly Frame](#)).
4. Open the rear door of the shipping container.
5. 6. Use the 15/16" socket wrench with a 15/16" wrench ratchet to unbolt the cabinet from the crate. Refer to [Figure 20: Shipping, Detach Dolly Frame](#).

**Figure 20: Shipping, Detach Dolly Frame**



6. Remove the drag chain if it had not been removed prior to shipment.

- Use the 9/16" open end wrench to turn the threaded rod clockwise to lower the wheels of the dollies and to raise the cabinet and dolly enough to clear the front edge of the shipping container, approximately 1 inch. Refer to *Figure 20: Shipping, Detach Dolly Frame*.

The threaded bolts must be turned at the same time by two people, one in the front and one in the rear to avoid making the cabinet tilt.

- When the cabinet and dollies have been raised enough to clear the angle created by the front ramp, slowly and carefully roll the cabinet out of the shipping container.

Be sure to have two people perform this procedure.



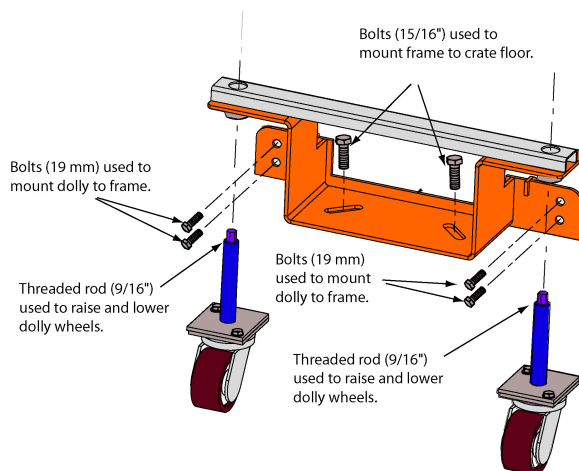
**TOPPLE:** Never try to unpack any frame from the shipping container without at least two people to steady any movement of the frame and related components. At least two people are required to safely move and position a frame into place.

- Move the cabinet to the desired location. At the correct site location, turn the threaded rods counter clockwise to lower the cabinet by raising the wheels of the dolly.

Again two technicians must turn the threaded rods at the same time to avoid tilting.

- Remove the 19 mm bolts, front and rear, that attach the dollies to the cabinet. Refer to

#### Figure 21: Dolly Mounting Bolts



- Inventory the shipment to make sure that all items listed on the pick list have been received in good condition. Report any discrepancies or damaged equipment.
- Do not allow the empty shipping containers to become a safety problem or a fire hazard. Contact the site supervisor for specific instructions for disposal of leftover packaging materials according to local recycling procedures. Follow this procedure when opening all similar shipping containers. Bolts (15/16") used to mount frame to crate floor. Bolts (19 mm) used to mount dolly to frame. Threaded rod (9/16") used to raise and lower dolly wheels.

### Procedure — Optional Hoist with Crane

Another option to unpack the cabinet is to remove the cabinet from the pallet and lower it to the floor using hoisting eyebolts and a crane. Use this method if there is not enough room to open the crate and use the door ramp.



**WARNING:** To avoid physical injury, be sure that properly rated hoisting equipment is used. When hoisting the cabinet, pull straight up slowly on the eyebolts using properly rated hardware attached evenly to the eyebolts to prevent the cabinet from swinging.

Always secure the cabinet during lifting to minimize swing.

1. Remove crate lid.
2. Screw the eyebolts completely into the top of the cabinet.
3. Securely attach the eyebolts to a hoist. The hoist should be positioned so that the four eyebolts evenly support the weight of the cabinet.
4. Use the 15/16" socket wrench with 15/16" drive ratchet to unbolt the cabinet from the crate.
5. Using a crane, carefully lift the cabinet off the pallet and lower the cabinet into its final position over the anchor holes drilled in the floor.

Minor manual adjustments may be necessary to ensure correct alignment of the cabinet to anchor sites.

## Installing the Cabinet

You must bolt the seismic cabinet to a floor using the anchors provided. The following steps are required to install the cabinet.


- *Procedure — How to Mark the Floor Layout*
- *Procedure — Prepare Raised Floor for Anchors*
- *Procedure — Drill Cable Holes*
- *Procedure — Cabinet Anchoring*
- *Procedure — Raised Floor Earthquake Bracing*
- *Procedure — Anchor Cabinet on Concrete Floor*
- Install kick plates (see *Figure 22: Kick Plates*) with 10 mm allen wrench


**Figure 22: Kick Plates**





## Precautions

Observe all safety precautions for avoiding personal injury and equipment damage that are outlined in your local building standards. The procedures in this document contain specific caution and warning information that must be observed while you are performing each procedure.

 **WARNING:** Cabinet installation instructions are provided in this user manual for the convenience of users only. Only qualified and experienced installers should be used. Incorrect methods or installation performed by unqualified personnel may lead to serious personal injury or damage to equipment or property. Installation of the seismic cabinet is the sole responsibility of the customer as well as any liability and injuries caused by this process.

 **WARNING:** An unsecured cabinet is prone to tipping. The cabinet must never be put to use without first being bolted to the floor. Failure to do so can result in product damage and serious personal injury or death.

 **WARNING:** To avoid the risk of injury: Wear safety goggles and hearing protection. Be sure to read and understand the user manual that comes with the drill. Pay particular attention to all safety instructions. Eye protection must always be worn with power tools to avoid injury from flying debris. In addition, hearing protection should be worn to avoid damage to hearing from exposure to high levels of noise during tool operation.

 **WARNING:** All procedures and methods used in the installation of the cabinet must comply with all applicable federal, state, county, and local laws, regulations, ordinances and codes. This includes compliance to all applicable Occupational Safety and Health Administration (OSHA) and Environmental Protection Agency (EPA) regulations when

dealing with hazardous materials and work place hazards. Compliance of these requirements is the responsibility of the installer and the site management.



CAUTION

**CAUTION:** Water seepage: When drilling holes in a basement or below-ground structures, ensure that you do not penetrate through the concrete and into the vapor barrier. If this does occur, groundwater may come up through the anchor hole. It is the customer's responsibility to verify building construction features before the drilling operation begins.

## Marking Floor Layout for Cabinet Installation

Cabinet layout is site specific. The recommended minimum aisle spacing is 3 ft. (91.5 cm) front and rear.



WARNING

**WARNING:** When planning the location of the equipment, avoid positioning the equipment over permanent gas, water, electrical utility lines or conduits.



CAUTION

**CAUTION:** Restricted available workspace: In a raised-floor application, ensure that Cabinets are positioned with enough clearance to allow you to remove tiles.

## Recommended Materials

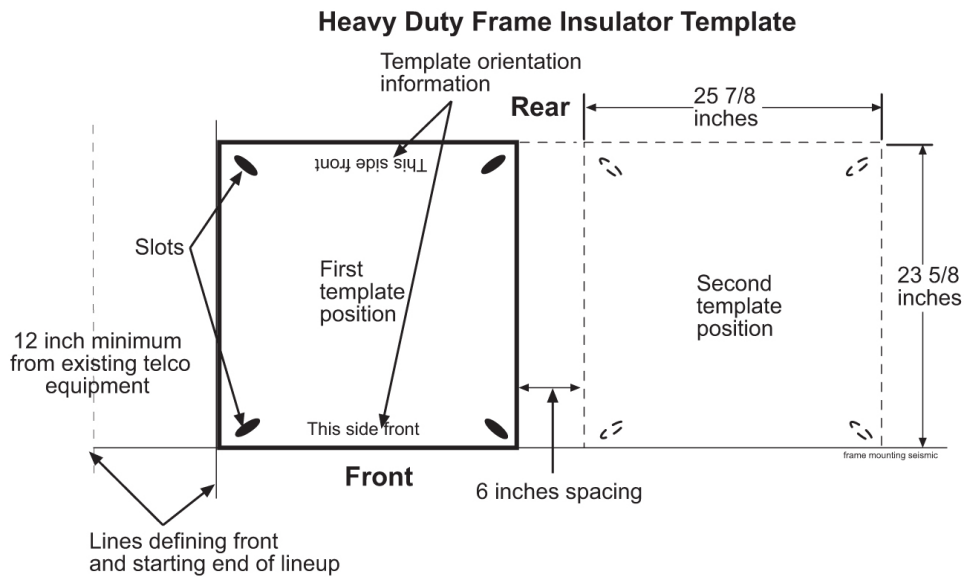
- Safety glasses
- Chalk-line, with chalk
- Fiberglass tape measure
- Felt tip pen
- Isolation sheet (template in Raised Floor Kit) to mount one cabinet

## Procedure — How to Mark the Floor Layout

Use the following procedure to mark the floor layout.

1. Verify with a customer representative that the required area dimensions and equipment location correspond with the marked floor plan.
2. Use the floor plan provided with the engineering site file specifications to mark the front base line and the borders of the cabinet with the chalk line.
3. Align the front of the cabinet template (isolator pad) along the front chalk line. Using a felt tip pen, mark anchor locations in the middle of each oval anchor slot, see [Figure 23: Mark Floor Layout](#).

### Figure 23: Mark Floor Layout



## Raised Floor Installation

Use the procedures in this section to prepare floors for anchoring cabinets on raised flooring. For this type of installation, you must create cable and anchor holes in the raised floor tiles.

The procedure for preparing raised flooring is highly site specific. For more information, refer to the site specific specification as per the Method Of Procedure (MOP) for the particular installation.



**WARNING**

**WARNING:** Before drilling holes in any flooring, verify with facilities personnel that the area will support a loaded cabinet and is free of gas or water pipes, ventilation ducts, electrical wiring conduits, or any other items that may be damaged. If the hole is drilled at an angle the anchor and cabinet will not come together properly. After marking anchor locations, remove the tiles and take them to an approved location for drilling. Do not drill tiles in the equipment area.

## Recommended Tools and Materials

Tekelec tools should be labeled "Property of TEKELEC" with either a press-on Field Tool Identification label or Field Tool Identification wrap.

- Safety glasses
- Ear protectors
- Rotary impact drill
- 18 mm masonry drill-bit
- 1-inch drill-bit (hole saw)
- Fiberglass tape measure
- Extension cord
- Vacuum cleaner (an approved, industrial type, that prevents escaping dust particles that may contaminate electronic equipment)
- Masking tape
- Isolation sheet



- Subfloor marking tool
- Felt tipped marking pen
- File
- Raised Floor Kit

The procedure for preparing raised flooring is highly site specific. For more information, refer to the site specific specification as per the Method Of Procedure (MOP) for the particular installation.



**WARNING:** Before drilling holes in any flooring, verify with facilities personnel that the area will support a loaded cabinet and is free of gas or water pipes, ventilation ducts, electrical wiring conduits, or any other items that may be damaged. If the hole is drilled at an angle the anchor and cabinet will not come together properly. After marking anchor locations, remove the tiles and take them to an approved location for drilling. Do not drill tiles in the equipment area.

### Procedure — Prepare Raised Floor for Anchors

1. On the raised floor mark the corners of the tiles so that the same tile will be returned to the same place when the job is complete. Mark the spot to be drilled, and remove the tiles from the equipment area.
2. Drill a 1-inch (2.54 cm) diameter hole in the tiles corresponding to the marked anchor locations. Use a vacuum cleaner to collect the shavings while drilling.
3. Use a file to remove any sharp edges or protrusions from metal parts if applicable and vacuum.
4. Return to the equipment area and replace the tiles, making sure the holes match, where the cabinet will be installed.
5. Insert the subfloor marking tool into the anchor holes, making sure that the tool is perpendicular with the hole. If the hole is drilled at an angle, the anchor and cabinet will not come together properly. With a hammer, tap the head of the star bit with enough force to mark the concrete floor. Repeat this step for each hole of the cabinet.
6. Remove the floor tiles for access to the concrete floor.
7. Clean out each hole after the drilling is complete.

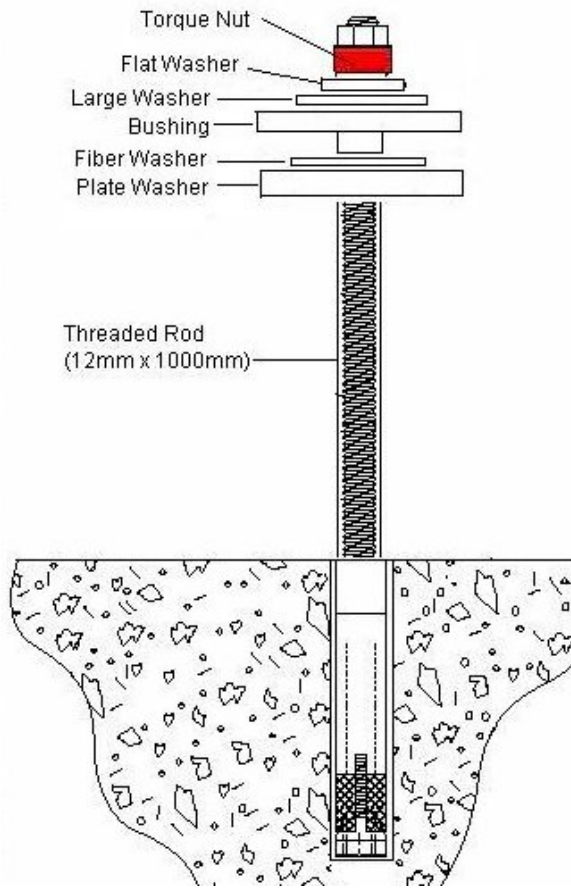
### Procedure — Drill Cable Holes

Mark holes and remove tiles from the equipment area, using a carbide-toothed hole saw of the appropriate diameter. Drill any cable holes required in the raised floor tiles. Replace tiles in the original tiles location.

### Procedure — Cabinet Anchoring

This section describes how to anchor a cabinet on a raised floor. Use [Figure 24: Raised Floor Anchor](#) to identify the parts of the raised floor anchor as you follow the procedure.

#### Figure 24: Raised Floor Anchor



1. If necessary, remove the tiles.
2. Insert the anchor assembly, including the threaded rod, into the hole flush against the floor.
3. Finger-tighten the torque nut. This step will set the cone nut into the anchor.
4. Preload the anchor by tightening the torque nut 1 1/2 turns. (Do not exceed 50ft lbs)
5. Remove the torque nut and remove the anchor rod via the 1/4" protrusion at the top of the rod.
6. Insert 1,000 mm threaded rod into hole and make sure that rod has threaded onto the set anchor.
7. If earthquake bracing is required, perform [Procedure — Raised Floor Earthquake Bracing](#) before continuing with this procedure.

**Note:** Bracing is required in earthquake zones 3 and 4 when installing a cabinet onto a raised floor with a spacing of 1.5 feet or more between the raised floor and the subfloor.

8. Lay the isolator pad on the floor with the holes in the isolator pad aligned over the anchor assemblies.
9. Roll the cabinet (still on the dolly) into position over the isolator pad.



**TOPPLE:** Two people are needed to position the cabinet onto threaded rods.

10. Lower cabinet over rod and level as needed.

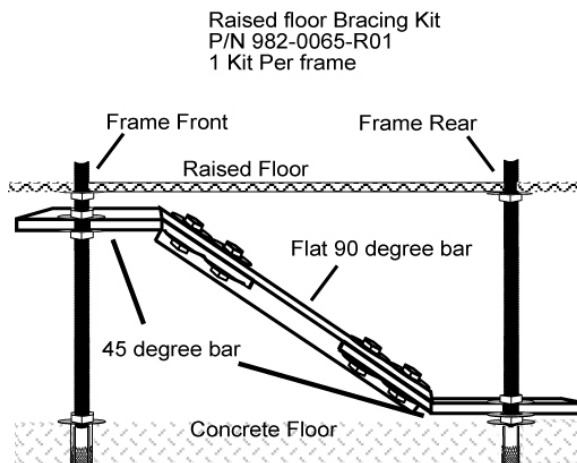
11. Place anchor stack-up parts on rod (see *Figure 24: Raised Floor Anchor*.
  - a) Plate washer
  - b) Fiber washer
  - c) Bushing
  - d) Large washer
  - e) Flat washer
12. Re-thread torque nut onto rod.
13. Tighten torque nut until it separated, approximately 60 ft. lbs.

### Procedure — Raised Floor Earthquake Bracing

This section describes how to install earthquake bracing to a raised floor installation. Bracing is required in earthquake zones 3 and 4 when installing a cabinet onto a raised floor with a spacing of 1.5 feet or more between the raised floor and the subfloor

1. Assemble the Earthquake Brace by securing the 45 degree bar steel pieces to the flat 90 degree bar. Use the Earthquake Brace Kit.

**Figure 25: Earthquake Bracing**



2. On the threaded rod located at the front of the cabinet:
    - a) Install a 5/8" nut onto the rod. The nut will need to be threaded approximately 5 inches from the top of the raised floor.
    - b) Place a helical washer onto the rod.
    - c) Place a flat washer onto the rod.
  3. On the threaded rod located at the back of the cabinet, place a flat washer on the threaded rod so that the washer is sitting on the nut holding the anchor in place.
  4. Place a flat washer on the back threaded rod.
  5. Slide the Earthquake brace onto the threaded rod from the front threaded rod to the back threaded rod. Refer to *Figure 25: Earthquake Bracing* .
- Note:** Do not over adjust as this may cause the tile or cabinet to tilt.
6. On the threaded rod located at the rear of the cabinet:

- a) Place a flat washer onto the rod.
  - b) Place a helical washer onto the rod.
  - c) Install a 5/8 nut onto the rod and secure tightly, but do not overtighten.
7. On the threaded rod located at the front of the cabinet:
    - a) Place a flat washer onto the rod.
    - b) Place a helical washer onto the rod.
    - c) Install a 5/8 nut onto the rod.
  8. Adjust the front rod nuts and washers so that the flat portion of the Earthquake bracing bar attached at the threaded rod is level.
  9. Repeat all the above steps for all additional sets of front and back threaded rods.
  10. Once all Earthquake Bracing is installed, continue with the installation of the cabinet to the raised floor.

## Concrete Floor Installation

Use this procedure to anchor the cabinet directly to a concrete floor. Always get permission from facility personnel before drilling any holes for cabinet installation.



**CAUTION:** All personnel associated with the installation of this system must adhere to all safety precautions and use required protection equipment to avoid the possibility of injury to personnel, service degradation, and/or service interruption.



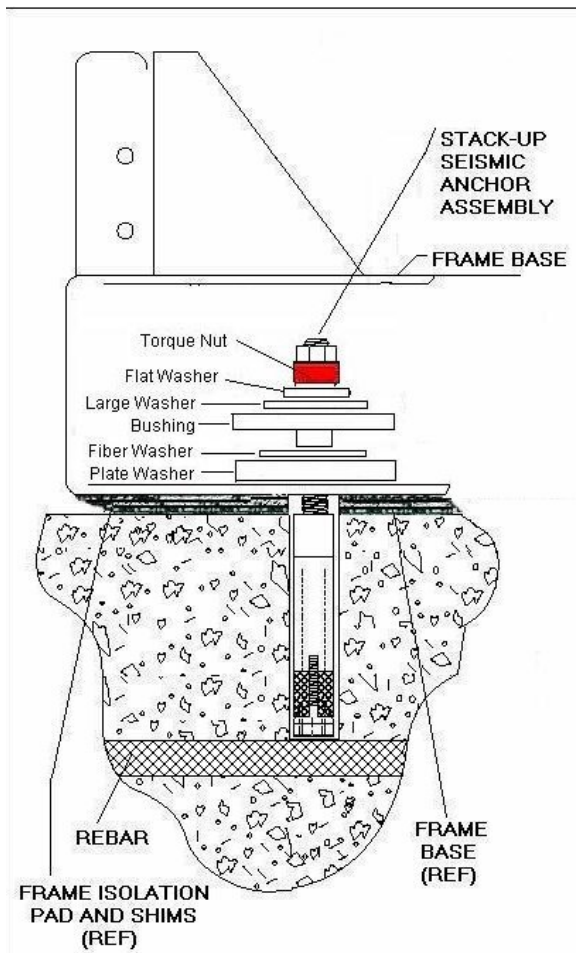
**CAUTION:** This is a redundant system to allow service during normal maintenance. When repairs require a total power disconnect, both input supply sources must be disconnected. Disconnection will cause service interruption and take down the system.



**WARNING:** Before drilling holes in any flooring, verify with facilities personnel that the area is free of gas or water pipes, ventilation and electrical wiring conduits.

Use [Figure 26: Stack-up Seismic Anchor](#) to identify the parts of the raised floor anchor as you follow the procedure.

**Figure 26: Stack-up Seismic Anchor**



### Recommended Tools and Materials

- Safety glasses
- Rotary impact drill
- 18 mm masonry drill-bit
- Extension cord
- Vacuum cleaner (an approved, industrial type, that prevents escaping dust particles that may contaminate electronic equipment)
- Masking tape
- Fiberglass tape measure
- Isolation sheet (in Raised Floor Kit)
- Ear protectors
- Felt tipped marking pen
- Raised Floor Kit

### Procedure — Anchor Cabinet on Concrete Floor

1. At each anchor location marked on the concrete floor, drill a hole that is 11/16 inches (18 mm) in diameter to a depth of 3 1/8 inches (7.9 cm) or 4 inches (10.2 cm) depending on the depth requirements at the site. Use the HEPA vacuum cleaner to collect the dust while drilling holes.

**Note:** The anchor and cabinet will not come together properly if the hole is drilled at an angle other than 90°.

**Note:** If any obstruction is encountered while drilling the hole, fill the unusable hole with liquid concrete. After allowing sufficient time for the liquid concrete to set, drill the hole at another spot within the marked area.

Clean out each hole after drilling is completed.

2. Insert the anchor assembly into the hole until the plate washer is flush against the floor.
3. Finger-tighten the torque nut. This step will set the cone nut into the anchor.
4. Preload the anchor by tightening the torque nut 1 1/2 turns. (Do not exceed 50ft lbs)
5. Remove the torque nut, leave anchor rod in concrete.
6. Lay the isolator pad on the floor with the holes in the isolator pad aligned over the anchor assemblies.
7. Roll the cabinet (still on the dolly) into position over the isolator pad.



**TOPPLE:** Two people are needed to position the cabinet onto threaded rods.

8. Lower cabinet over rod and level as needed.
9. Place anchor stack-up parts on rod (see [Figure 26: Stack-up Seismic Anchor](#)).
  - a) Plate washer
  - b) Fiber washer
  - c) Bushing
  - d) Large washer
  - e) Flat washer
10. Re-thread torque nut onto rod.
11. Tighten torque nut until it separated, approximately 60 ft. lbs.

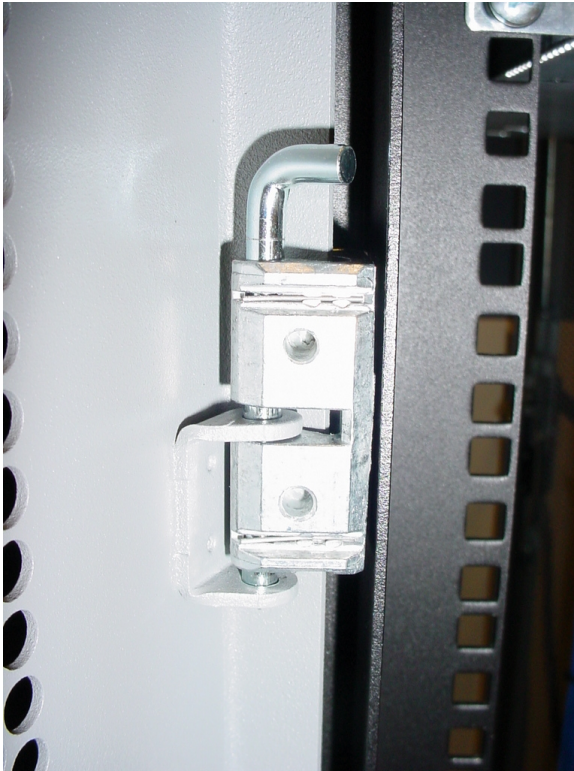
### Procedure — Cabinet Door Removal

Installations with limited space to open the rear cabinet door may choose to remove the rear door prior to installation.

1. Open the cabinet door and locate the door hinges.

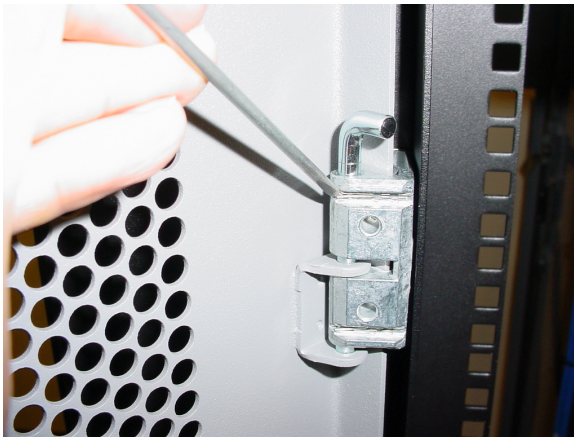
The normal position of the hinge pin is shown in [Figure 27: Cabinet Door Hinge Pin](#).

**Figure 27: Cabinet Door Hinge Pin**



2. Using a thin blade screwdriver, locate and pry the hinge spring wire open as shown in [Figure 28: Prying open hinge spring wire](#).

**Figure 28: Prying open hinge spring wire**



3. Lift pin up while spring wire is pulled away.  
Use a “scratch-free” hammer to force the pin up and free of the hinge. See [Figure 29: Removing pin with rubber hammer](#).

**Figure 29: Removing pin with rubber hammer**



## Grounding Information

This chapter describes how to unpack the application cabinet from the crate, prepare a concrete or raised floor for installation, anchor the frame to floor and overhead rack, examine the grounding requirements and the cabling.

### Safety Precautions



**WARNING:** This is a redundant system to allow service during normal maintenance. When repairs require a total power disconnect, both input supply sources must be disconnected. This will cause service interruption and take down the system.



**WARNING:** Consult with a qualified electrician to ensure proper power and grounding requirements are met.



**CAUTION:** All personnel associated with the installation of this system must adhere to all safety precautions and protection equipment required to avoid the possibility of injury to personnel, service degradation, and/or service interruption.

### Grounding Requirements

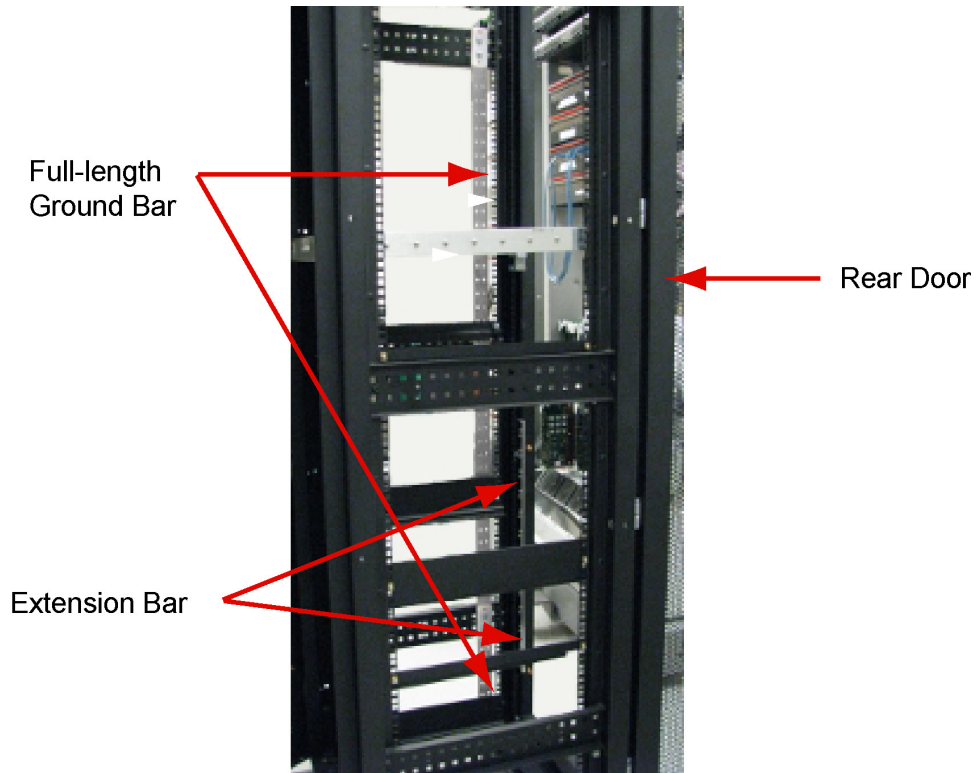
Tekelec systems operate in an isolated bonding network in a central office environment and require a single connection to the central office.

- Main ground bus

The system's ground cable must provide the sole grounding connection between the entire system and the central office ground. The cabinet has a full-length main ground bus bar (per drawing) and an extension bar. The main bus bar allows for bottom-fed and top-fed cabling. The extension ground bar is secured to the cabinet with lugs, screws, and bolts on the right rear door flange. The main bus bar is attached to the right side of the cabinet on the right side of the door.

**Figure 30: Main Ground Bus Location**



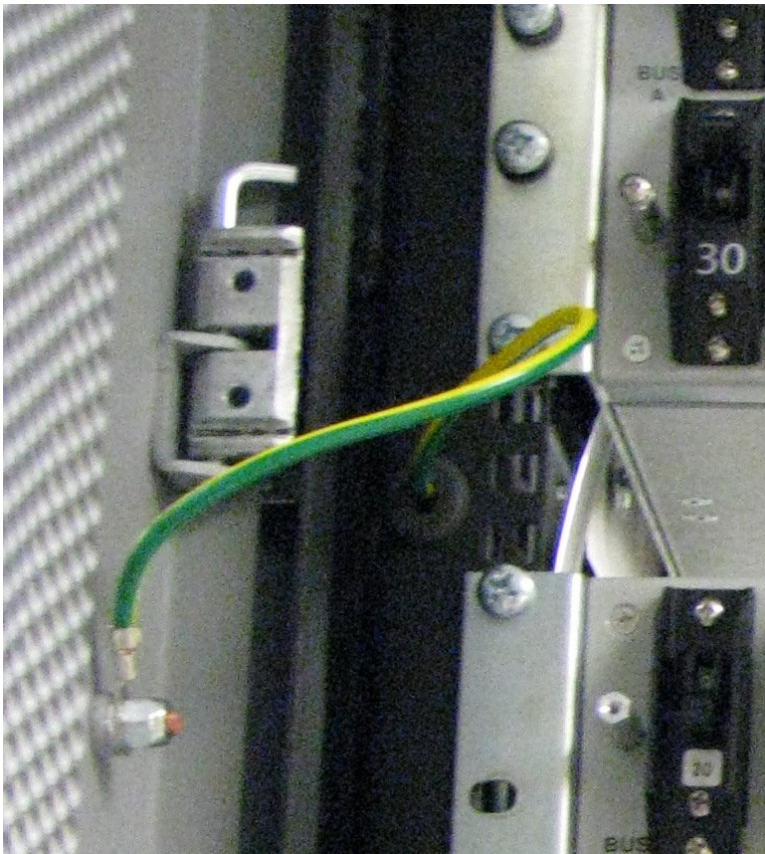


The doors installed are grounded to the main bus through a two-hole lug ground wire and through a screw-down latch. The rear door is grounded at the bottom of the door, the front door is grounded at the top of the door.

**Figure 31: Door Ground - Bottom**



**Figure 32: Door Ground - Top**



The PDP is grounded directly to the main ground bus.

**Figure 33: Grounded PDP**



The T1200 application servers are grounded to the extension bar.

**Figure 34: Grounded T1200 Application Server**



WARNING

**WARNING:** Always install an isolator pad between the cabinet and ground floor. Tekelec cabinets are shipped with isolator pads to isolate the cabinets from the floor. If a non-Tekelec cabinet is used, an isolator pad must be provided.

- Cabinet/chassis ground

The cabinet/chassis ground path provides a low impedance connection for all metal parts of the entire system, including the cabinet, doors, shelves, and end panels. Each cabinet/chassis connection within the system lineup terminates to the cabinet bus bar. The bus bar connects to the Central Office main ground bus by way of Htaps, #6 American Wire Gauge (AWG) to 1/0 cable.

**Note:** The cabinet/chassis ground path does not carry current.

## Frame Ground Cabling Procedures

This section covers these procedures:

- [Procedure — Ground Frame](#)
- [Procedure — Connect Ground Cable to T1200](#)

## Recommended Tools

Tekelec tools should be labeled "Property of TEKELEC" with either a press-on Field Tool Identification label or Field Tool Identification wrap.

- Safety glasses

- Power knife
- Cable cutters
- Cable stripper
- Flush cutters
- Crimping tool with embossing dies (test before using)
- Socket wrench set, 1/4-inch or 3/8-inch drive or open-end wrenches
- Non oxidizing grease

**Note:** It is a requirement that when mating dissimilar metals non oxidizing grease is used between them as a corrosion inhibitor.

- Lacing cord and nylon cable ties
- Heat-shrink gun (hot air blower)
- Torque wrench
- Fiber paper

## Procedure — Ground Frame

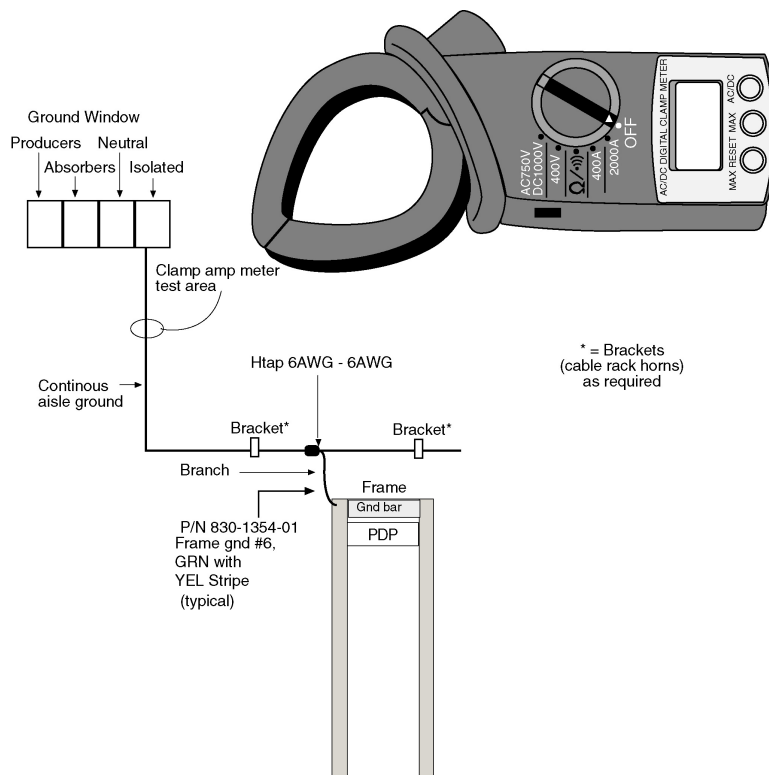
1. Install the continuous ground conductor to the Ground Window. Run the conductor the length of the equipment lineup (see the figure System Frame Grounding).

The separate #6 American Wire Gauge (AWG) cable ground that runs to each frame will allow removal of a frame from the lineup without interrupting the grounding of other frames in the lineup.

2. Install the branch ground conductor to the frame ground cable (P/N 830-1354-01, Cable Assy\_6AWG\_Frame Ground\_GRN with YEL Stripe) pre-attached to the Frame Bus Bar. Use H-tap to connect this cable to the branch ground conductor.

The continuous aisle ground conductor will be H-tapped to the branch (see the figure System Frame Grounding). Torque screws to 45 inch-pounds.

**Figure 35: System Frame Grounding**



3. Secure the cable to the cable brackets with lacing cord.
4. Cables must be labeled, 145P tags should have “TO” and “FROM” location information.  
Example: FROM MGB (Main Ground Bar) TO system ground bar XX Frame..

**Procedure — Connect Ground Cable to T1200**



**CAUTION:** This equipment has a connection between the earthed conductor of the DC supply circuit and the earthing conductor.

Use the lacing cord to secure a “DO NOT DISCONNECT LEAD” tag at each end of the cable, just beyond the lug.

**Note:** Frame Ground: A cable #6 AWG from a frame is H-tapped into another #6 cable or 1/0 cable and also terminates on the “I” (Isolated) section of the ground window.

**Power Requirements in a DC Environment**

A Direct Current (DC) environment must supply 14 60-Amp feeds from the customer’s power source. Each cabinet is divided into A and B power buses, each with seven feeds. If loss of power on one of the buses occurs, the other bus must be able to supply current for the entire cabinet.

**Note:** The nominal voltage is -48VDC, and operating voltage range is -40VDC to -56.7VDC.

**Note:** The DC return terminal is not connected to the equipment frame or the grounding means of the equipment, Isolated DC return (DC-I).

**Note:** If breakers are tripped, they must be switched completely OFF and then ON to reset.

**Note:** The size of the cable is determined by the overall length of the cable run. Refer to the Site File Book.

## Procedure — Power Terminations

All power terminations on the 3U PDP will be #6 awg. Use H-taps for each -48vdc and RTN run to reduce the wire size to the proper gauge required.

Table 4-1 shows the list of required wiring sizes based on the length of the cable run. All cable equipment power ratings are 125A @ -48VDC.

**Table 4: Table 4-1. Power Cable Conductor Sizes**

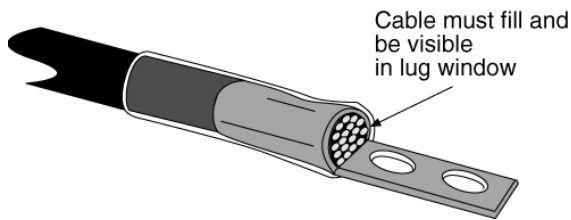
Breaker Size in Amperes	Cable Length	Conductor Size (AWG)
40A	up to 40 ft. (12.2 meters)	#6
	up to 70 ft. (21.3 meters)	#4
	up to 110 ft. (33.5 meters)	#2
	up to 170 ft. (51.8 meters)	1/0
	up to 200 ft. (61 meters)	2/0
	up to 220 ft. (67.1 meters)	4/0
60A	up to 40 ft. (12.2 meters)	#2
	up to 70 ft. (21.3 meters)	1/0
	up to 110 ft. (33.5 meters)	2/0
	up to 170 ft. (51.8 meters)	4/0
	up to 200 ft. (61 meters)	350MCM
	up to 220 ft. (67.1 meters)	350MCM

**Note:** Where the cable leaves the cable rack, the cable must be protected with fiber paper throughout the system.

1. Apply the cable tags, provided with the system, to both ends of the supply and return cables.

2. Ensure that power is off at the central office power distribution board for the circuits being wired. Use a multimeter.
3. Remove the clear plastic cover from the back of the 3U PDP.
4. Run, form, and dress the cable from the power distribution board to the 3U PDP.
5. For the A side and B side, strip the cable ends, slide a one-inch length of clear heat-shrink tubing over and past the portion of stripped cable.

**Figure 36: Lug Installation**



6. Apply non oxidizing grease to the stripped end of the cable, and install the lug. The stripped cable must fill lug completely to the end of the barrel of the lug and be visible in the end window of the lug.
7. Double crimp the lugs onto the cable end using the embossing crimper.
8. Slide the one-inch length of clear tubing from Step 7 over the crimped lug. Apply heat and heat-shrink the one-inch length of clear tubing around the crimped lug.
9. Fasten the lugs of the cables to the respective A-side and B-side power and return on the 3U PDP. Torque to 36 inch-pounds.
10. Verify correct connection with a multimeter by running continuity check.

## PDP Alarm Card

Monitoring of the power input is provided by the alarm card. Three DIP switches on the card allows this monitoring to be turned on or turned off. If the monitoring is not turned off for unconnected inputs, the alarm card detects a loss of input power to these inputs and the corresponding LED for the breakers will be red and an alarm is indicated.

The DIP switches monitor Bus A (S2) and Bus B (S3) individual power inputs. Monitoring of specific alarm cable inputs is provided by switch S4.

### Procedure — Replacing the PDP Alarm Card



**WARNING:** All power sources must be removed from the PDP before reomoving the alarm card assembly. All alarm contacts will signal an alarm state when all power sources are removed or when the alarm card is removed.

1. Observe the safety and ESD precautions in [Safety and Pre-Installation Requirements](#).
2. Remove all power source from the PDP. The removal of the power source will cause an alarm.
3. Remove the top and bottom screws from the alarm card face plate.

**Figure 37: Unscrewing Alarm Card**



4. Hold the card at the top and bottom edge and pull it out straight. The removal of the alarm card will cause another alarm.

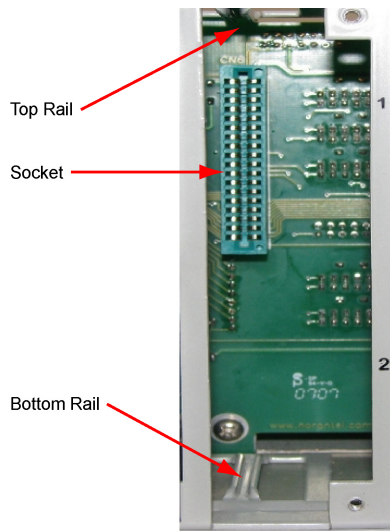
**Figure 38: Removing the Alarm Card**



5. Go to [Procedure — Configuring the PDP Alarm Card](#) to set the monitoring of the PDP Alarm Card.
6. Locate the top and bottom rail as well as the socket in the open alarm card slot.

**Figure 39: Locating Rails and Socket in Slot**





7. Slide the board of the new alarm card into the top and bottom rails of the open slot.
8. Push the card back carefully to match up the card connector with its socket in the slot.

**Figure 40: Insert Alarm Card Carefully**



9. Replace the screws on the face plate
10. Reconnect all power source to the PDP.
11. Verify that all LEDs on the alarm card are green.

### Procedure — Configuring the PDP Alarm Card

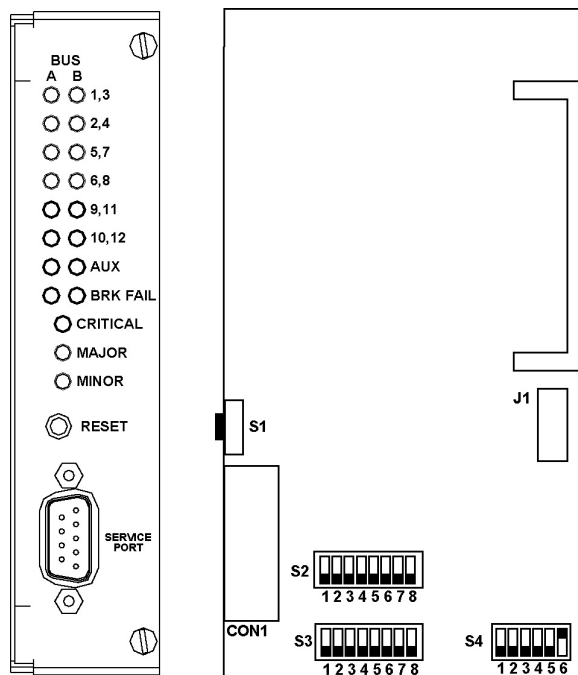
Monitoring of the power input is provided by the alarm card. Three DIP switches on the card allows this monitoring to be turned on or turned off. If the monitoring is not turned off for unconnected inputs, the alarm card detects a loss of input power to these inputs and the corresponding LED for the breakers will be red and an alarm is indicated.

The DIP switches monitor Bus A (S2) and Bus B (S3) individual power inputs. Monitoring of specific alarm cable inputs is provided by switch S4.

This procedure describes how to set the monitoring of the input terminal using a DIP switch on the alarm panel.

1. Observe the safety and ESD precautions in [Safety and Pre-Installation Requirements](#).
2. Remove the alarm card using [Procedure — Replacing the PDP Alarm Card](#).
3. Locate DIP switches S2, S3, and S4. See [Figure 41: Alarm Card Front and Side View](#)

**Figure 41: Alarm Card Front and Side View**



4. Use [Table 5: Individual Power Supply Input Monitoring \(DIP Switches S2 and S3\)](#) to set DIP switch S2 positions 1 through 8 to monitor power supply inputs for BUS A and DIP switch S3 positions 1 through 8 to monitor power supply inputs for BUS B.

**Note:** Factory settings are S4:6 is OFF, all other positions for S2, S3, and S4 are ON.

Table 5: Individual Power Supply Input Monitoring (DIP Switches S2 and S3)

DIP Switch Position 1 - 8	Group	Breaker and LED Position	Setting	Description	
1	A	1 and 3	ON	Input Monitored, LED Enabled.	
			OFF	Input Not Monitored, LED Disabled (OFF).	
2		2 and 4	ON	Input Monitored, LED Enabled.	
			OFF	Input Not Monitored, LED Disabled (OFF).	
3		B	5 and 7	ON	Input Monitored, LED Enabled.
				OFF	Input Not Monitored, LED Disabled (OFF).
4	6 and 8		ON	Input Monitored, LED Enabled.	
			OFF	Input Not Monitored, LED Disabled (OFF).	
5	C		9 and 11	ON	Input Monitored, LED Enabled.
				OFF	Input Not Monitored, LED Disabled (OFF).
6		10 and 12	ON	Input Monitored, LED Enabled.	
			OFF	Input Not Monitored, LED Disabled (OFF).	

DIP Switch Position 1 - 8	Group	Breaker and LED Position	Setting	Description
7	-----	AUX	ON	Input Monitored, LED Enabled.
			OFF	Input Not Monitored, LED Disabled (OFF).
8	-----	-----	ON	Overrides DIP switch positions 1-6 settings. See S4:1-S4:4 settings.
			OFF	Enable DIP switch settings 1-6.

**Note:** LED for the associated supply input and breaker when enabled shall illuminate either:

- GREEN when -48VDC is connected
- RED when -48VDC is not connected

**Note:** When position 8 is set ON, DIP switch settings 1-6 are ignored with 7 active. For example, if alarm inputs are enabled for PAN and PBN, but disabled for PCN, then the BUS input supply monitoring LEDs are enabled for Group A (inputs 1- 4) and Group B (inputs 5-8), but disabled for Group C (inputs 9-12).

5. Use [Table 6: Alarm Input Monitoring \(DIP Switch S4\)](#) to set DIP switch S4 positions 1 through 4 to specify monitoring of alarm cable inputs on a group (A, B, and/or C) basis.

**Note:** Factory settings are S4:6 is OFF, all other positions for S2, S3, and S4 are ON.

**Table 6: Alarm Input Monitoring (DIP Switch S4)**

DIP Switch Position 1 - 6	Alarm Input	Setting	Description
1	PAN	ON	Alarm Input Enabled and Monitored.
		OFF	Alarm Input Disabled and Not Monitored.
2	PBN	ON	Alarm Input Enabled and Monitored.

DIP Switch Position 1 - 6	Alarm Input	Setting	Description
		OFF	Alarm Input Disabled and Not Monitored.
3	PCN	ON	Alarm Input Enabled and Monitored.
		OFF	Alarm Input Disabled and Not Monitored.
4	-----	ON	Use S4:1-S4:3 settings for alarm input monitoring.
		OFF	All alarm cables inputs provide monitoring.
5	-----	ON	Not Used.
		OFF	Not Used, set to ON.
6	-----	ON	Not Used, set to OFF.
		OFF	Not Used.

6. Re install the alarm card using *Procedure — Replacing the PDP Alarm Card*.
7. Reconnect all power sources to the PDP.

## Cabling Information

The application cabinet is shipped pre-configured based on a customer's sales order. Power, ground, and network connections from the Customer site are required.

*Figure 42: Example of T1200 Cabinet as Shipped* shows an example of a T1200 application cabinet with doors and pre-configured before shipping.

**Figure 42: Example of T1200 Cabinet as Shipped**



*Figure 43: T1200 cabinet with Pre-installed Components* shows the same T1200 cabinet with a view of the pre-installed components.

**Figure 43: T1200 cabinet with Pre-installed Components**



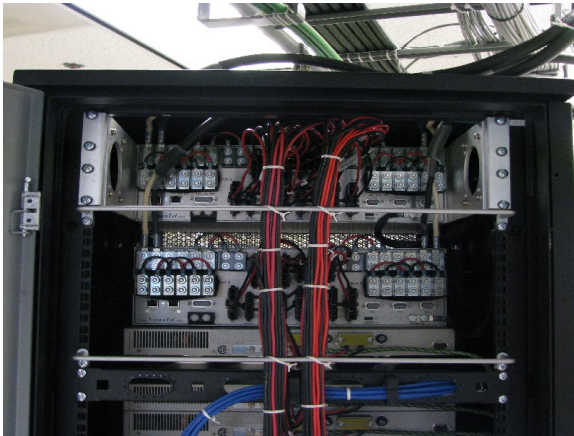
*Figure 44: Example of T1200 cabinet with Pre-cabled Components* shows the same T1200 application cabinet with a view of the pre-cabled components.

**Figure 44: Example of T1200 cabinet with Pre-cabled Components**



Components are connected to one another. Power and network cables are connected to the power distribution panel.

**Figure 45: Power Distribution Panel (PDP) Cabling**



See the site survey and interconnect diagram for information on power and network cable termination.

Breakers in the PDP are installed based on component configuration of the cabinet. For information on how to install or replace a breaker, refer to the Maintenance Manual (T1200) or FRU replacement document.

**Figure 46: Ethernet Switch Cabling - Front**

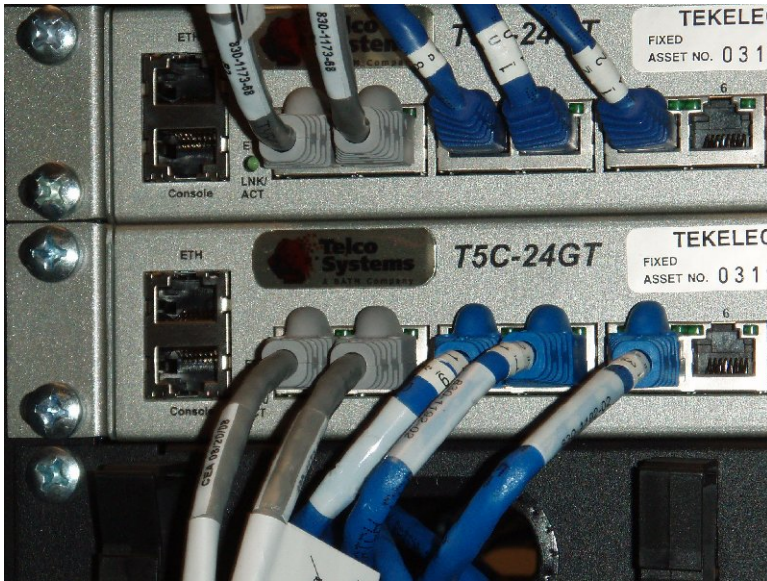


Figure 47: Ethernet Switch Cabling - Rear



Figure 48: T1200 Application Server Cabling

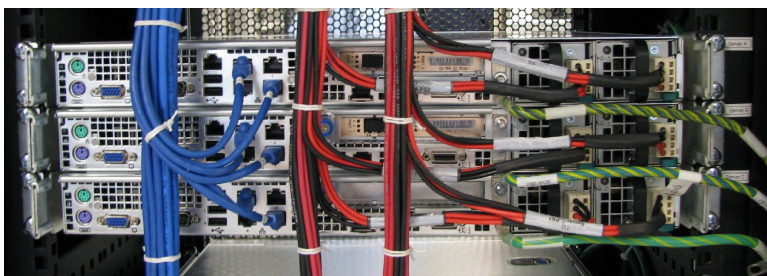
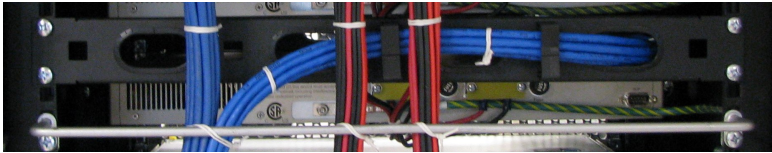


Figure 49: Cable Management





# Glossary

## A

AC	Alternating Current Application Context Authentication Center Area Code
----	--

architecture	Used to conceptually describe the function, interaction, and connectivity of hardware, software, and/or system components within a network.
--------------	---

## B

BTU	British Thermal Unit
-----	----------------------

## D

DC	Direct Current
----	----------------

## M

middleware	A communications layer that allows applications to interact across hardware and network environments.
------------	---

## N

NC	Network Cluster Network Code Not Compliant
NEBS	Network Equipment Building Systems

## P

PDP	Permissive Dialing Period
-----	---------------------------

**P**

Power Distribution Panel

Monitors primary and secondary power sources on a continuous basis.

platform

A platform refers to a framework on which applications may be run.

platform software

Refers to the operating system, firmware, and management software components of a platform. Does not refer to the application software that runs on the platform.

**R**

RMA

Return Material Authorization

**T**

TO

Timing Output

**V**

VOM

Volt Ohm Meter