

Oracle Communications EAGLE Release 46.1 Planning Guide

ORACLE WHITE PAPER | OCTOBER 2015





Table of Contents

List of Terms	5
References	7
Introduction	8
Product Capacities & Benchmark Disclaimers	9
Purpose	9
OC EAGLE Hardware and Equipment Configuration	10
Base System Hardware	14
Maintenance and Administration Subsystem	14
Communication Subsystem	16
Database Application Subsystem	17
Shelves, Frames, Power, and Protection	21
Cables and Adapters	23
OC EAGLE Power	23
Power and Fan Requirements	23
System Timing Considerations	25
Input Clocks for the OC EAGLE	25
Timing Sources	26
High Speed Master Clocking	26
OC EAGLE Site Requirements	26
Space Requirements	26
Lighting	27



Building Requirements	27
Earthquake Resistance	27
Environmental Requirements	27
Operational	28
Transport and Storage	28
Heating Ventilation and Air Condition Requirements	28
Floor Loading	28
Grounding	28
SS7 and IP Signaling Provisioning Rules	30
SS7	30
OC EAGLE “B” Cards	30
OC EAGLE-ATM-B Card	30
OC EAGLE-E1T1-B	32
IP Signaling	33
OC EAGLE-ENET-B	34
Large System Provisioning	36
Greater than 500 link support	37
1 Million TPS	38
Database Services Features	39
Global Title Translation	40
Local Number Portability (LNP) – North America	42
OC EAGLE Provisioning Application Processor (EPAP)	45



SIP Number Portability	51
Combining Multiple Advanced Database Features	52
Gateway Screening	52
GSM MAP Screening (ITU) Enhanced GSM MAP Screening (ANSI/ITU)	53
Peripheral Equipment	53
OC STP LAN Interface	53
SEAS over IP	54
Measurements Platform	54
IP User Interface	55
Remote Upgrade/Download	56
FTP-based Table Retrieve Application	56
Integrated Monitoring (PIC)	57
OC EAGLE Fast Copy configuration rules	58
OC EAGLE OC EAGLE-APP-B IMF Configuration Rules	58
OC EAGLE-OAM SNMP Support	60
Feature Control Requirements	60
Hardware Requirements	60
Software Compatibility	60
Hardware Lifecycle Management	66
Hardware Part Number Mapping	67

Table of Figures

Figure 1 - OC EAGLE Functional Overview.....	10
Figure 2 - OC EAGLE Frames.....	11
Figure 3 - OC EAGLE Control Shelf.....	12
Figure 4 - OC EAGLE Extension Shelf.....	13
Figure 5 - OC EAGLE Based Maintenance and Administration Subsystem Block Diagram.....	15
Figure 6 - HIPR2 Architecture.....	17
Figure 7 - Assembly/Installation Kits.....	22
Figure 8 - OC EAGLE Frames: Floor Plan - Top View.....	23
Figure 9 - 830-1342-05 ATM Adapter.....	31
Figure 10 - 830-1342-06 ATM Adapter.....	32
Figure 11 - E1/T1 Channel Bridging Feature.....	33
Figure 12 - OC EAGLE-ENET-B Adapters (DB-26 to RJ-45).....	36
Figure 13 - LSMS Network.....	44
Figure 14 - EPAP Architecture.....	46
Figure 15 - Diameter S13/S13' EIR Architecture.....	49
Figure 16 - Diameter S13/S13' EIR Card EPAP Interface.....	50
Figure 17 - S13 Card EPAP Interface.....	51
Figure 18 - SIP Card Interface with ExAP.....	52
Figure 19 - SEAS over IP.....	54

Table of Tables

Table 1: OC EAGLE Card Power Consumption Table.....	24
Table 2: OC EAGLE-ENET-B Performance Guidelines.....	35
Table 3: Service Module Throughput/DB Capacity Table.....	41
Table 4: LNP FAK/Hardware Compatibility.....	42
Table 5: ELAP 10.0 SW Compatibility.....	43
Table 6: EPAP Release 15 Compatibility with OC EAGLE-APP-B.....	47
Table 7: EPAP Release 15 Compatibility with T1200.....	47
Table 8: STC Provisioning Table for LSL and ATM HSL.....	59
Table 9: STC Provisioning Table for Sigtran.....	59
Table 10: OC EAGLE Release 46.1 Software Compatibility.....	61
Table 11: EPAP R16 Software Compatibility.....	62
Table 12: FTRA R4.6 Software Compatibility.....	62
Table 13: EMS R46.1 Software Compatibility.....	62
Table 14: OC EAGLE/PIC Compatibility.....	62
Table 15: OC EAGLE/EPAP Compatibility.....	64
Table 16: OC EAGLE/ELAP Compatibility.....	65
Table 17: OC EAGLE / LSMS Compatibility.....	65
Table 18: OC EAGLE/EMS Compatibility.....	65
Table 19: OC EAGLE /FTRA Compatibility.....	66
Table 20: OC EAGLE Lifecycle Milestones.....	67
Table 21: Part Number Mapping.....	67

List of Terms

Acronym	Description
ANSI	American National Standards Institute
ATM	Asynchronous Transfer Mode
ATO	Assemble to Order
DDR	Double Data Rate
DN	Dialed Number
DPC	Destination Point Code
E1	European DS1
OC EAGLE-APP-B	OC EAGLE Application Card – Generation B
OC EAGLE-ATM-B	OC EAGLE ATM (E1/T1) Card – Generation B
OC EAGLE-E1T1-B	OC EAGLE E1/T1 (LSL/SE-HSL/ST-HSL) – Generation B
OC EAGLE-ENET-B	OC EAGLE Ethernet Card – Generation B
OC EAGLE-MASP	OC EAGLE Maintenance and Administration Subsystem Processor Card
OC EAGLE-MCPM-B	OC EAGLE Measurements and Polling Module – Generation B
OC EAGLE-MDAL	OC EAGLE Maintenance Disk and Alarm Card
OC EAGLE-SM8G-B	OC EAGLE Service Module 8G – Generation B
OC EAGLE-TDM	OC EAGLE Terminal Disk Module
EGTT	Enhanced Global Title Translation
EIR	Equipment Identity Register
ELAP	OC EAGLE LNP Application Processor
EPAP	OC EAGLE Provisioning Application Processor
FTRA	FTP-based Table Retrieve Application
GLS	Gateway Loading Services
GPL	General Program Load
GSM	Global System for Mobile Communication
GTT	Global Title Translation
GWS	Gateway Screening
HIPR2	High Speed IMT Packet Router – Generation 2
HLR	Home Location Register
HSL	High Speed Link
IETF	Internet Engineering Task Force
IMEI	International Mobile Equipment Identity
IMF	Integrated Message Feeder



IMSI	International Mobile Station Identifier
IMT	Inter-processor Message Transport
IN	Intelligent Network
INAP	Intelligent Network Application Part
INP	INAP-based Number Portability
IP	Internet Protocol
IPGWx	Internet Protocol Gateway GPL (ANSI or ITU)
IPLIM	IP Link Interface Module
IPLIMx	IPLIM GPL (ANSI or ITU)
IPMR	IP Message Router
IPSG	IP Signaling Gateway
ISUP	ISDN User Part
ITU	International Telecommunications Union
LAN	Local Area Network
LED	Light Emitting Diode
LIM	Link Interface Module
LNP	Local Number Portability
LSL	Low Speed Link
LSMS	Local Service Management System
LTE	Long Term Evolution
MAS	Maintenance and Administration Subsystem
MAP	Mobile Application Part
MG	Media Gateway
MGC	Media Gateway Controller
MNP	Mobile Number Portability
MPS	Multipurpose Server
MSC	Mobile Switching Center
MSISDN	Mobile Subscriber ISDN
MSU	Message Signaling Unit
MTP	Message Transfer Part
M2PA	MTP2 User Peer to Peer Adaptation Layer
M3UA	MTP3 Adaptation Layer
NEBS	Network Equipment Building System
NGN	Next Generation Network
OPC	Origination Point Code



PCI	Peripheral Component Interconnect
PTO	Pick to Order
QoS	Quality of Service
RAM	Random Access Memory
RoHS	Reduction of Hazardous Substances
RTT	Round Trip Time
SCCP	Signaling Connection Control Part
SCP	Service Control Point
SCTP	Service Control Transmission Protocol
SEAS	Signaling Engineering and Administration System
SE-HSL	Synchronous E1 – High Speed Link
SFTP	Secure File Transfer Protocol
SG	Signaling Gateway
SIGTRAN	IETF Signaling Transport
SIP	Session Initiation Protocol
SMS	Short Message Service
SNAM	Signaling Network Activation Manager
SPC	Secondary Point Code
SS7	Signaling System 7
SS7oIP	SS7 over IP
SSH	Secure Shell
SSN	Subsystem Number
SSP	Service Switching Point
STC	Signaling Transport Card
STP	Signaling Transfer Point
T1000	TekServer 1000
T1100	TekServer 2000
T1200	TekServer 3000
TCAP	Transaction Capabilities Application Part
TCP	Transmission Control Protocol
TPS	Transactions per Second

References

- 1 OC EAGLE Release 46.1 Documentation Set – Available at Oracle.com on the Oracle Technology Network (OTN)
- 2 OC EAGLE Hardware Reference – Available at Oracle.com on the Oracle Technology Network (OTN)
- 3 OC EAGLE Installation Guide – Available at Oracle.com on the Oracle Technology Network (OTN)
- 4 SIGTRAN User Guide – Available at Oracle.com on the Oracle Technology Network (OTN)
- 5 OC EAGLE Feature Guide – Available at Oracle.com on the Oracle Technology Network (OTN)
- 6 APP Hardware and Installation Guide – Available at Oracle.com on the Oracle Technology Network (OTN)
- 7 EPAP Administration Manual
- 8 PIC Planning Guide – Available at Oracle.com on the Oracle Technology Network (OTN)
- 9 SIGTRAN User's Guide – Available at Oracle.com on the Oracle Technology Network (OTN)

Introduction

With over 20 years of SS7 signaling, SS7oIP signaling, and network applications experience in the market, Oracle remains proud of its leadership role in the signaling network. Oracle continues to demonstrate its leadership and expand its presence throughout the world in 2015 and beyond with the continued evolution of OC EAGLE and further integration of value-added applications, data acquisition in support of business intelligence applications, and next generation signaling capabilities. The OC EAGLE is a multi-disciplined, high capacity, highly flexible, and highly reliable signaling platform designed to be the heart of the mobile and fixed line networks of today and tomorrow.

The OC EAGLE platform provides the following set of capabilities:

- » Legendary STP and IP signaling capabilities
- » A complete line of fully integrated "OC EAGLE" database and advanced routing applications
- » An integrated platform for the deployment of advanced value-added applications and capabilities
- » Data acquisition for business intelligence applications provided via Oracle Communications Performance Intelligence Center (PIC)

All these capabilities are available within the same footprint of the OC EAGLE STP, and without the need for a "forklift" upgrade for existing OC EAGLE customers.

The features available directly on the OC EAGLE core platform include the following:

- » **STP** - Provides traditional TDM-based SS7 signaling transfer point functionality including OC EAGLE's many connectivity options (E1, T1, ATM-HSL, Synchronous E1 HSL) and routing capabilities (GTT, MTP and Origin-based routing, etc.).
- » **Signaling Gateway** - Provides SS7 over IP signaling including the IETF SIGTRAN protocols (SCTP, M2PA, M3UA, SUA).
- » **LNP** - North American Local Number Portability solution.
- » **INP** - INAP CS-1 based Number Portability solution.
- » **MNP** - GSM Mobile Number Portability solution based on the 3GPP-defined SRF method.
- » **HLR Router** - Provides flexible routing based on individual MSISDN/MDN and/or individual IMSI/MIN subscriber numbers. Allows for virtual HLR and SIM card management solutions.
- » **EIR** - GSM and LTE Equipment Identity Register functionality.
- » **Network Migration** - Solution for networks migrating from one core mobile technology to another (e.g., IS-41 to GSM). Allows subscribers to retain their existing directory number through the migration process.
- » **3G to 4G/IMS Migration** - Solution for networks migrating from one 3G to 4G/IMS core mobile technology

- » **LSMS** - Provides provisioning support for the LNP product. Provides a provisioning connection between the NPAC and Oracle's ELAP for provisioning of North American LNP data into the OC EAGLE system.
- » **EPAP/ELAP** - EPAP provides the provisioning interface for the MNP, HLR Router, INP/AINPQ, EIR, IGM, and Network Migration solutions. ELAP provides the provisioning interface for the North American LNP solution.
- » **EMS** - Optional element management system for use with OC EAGLE deployments.
- » **FTRA** - Optional software package to allow provisioning of OC EAGLE tables via FTP retrieval and script replacement.

The OC EAGLE is a total signaling and services solution package for operators. The package provides tremendous growth capacity and delivers cost-effective, reliable signaling and application services to help the operator generate more revenue with lower operating costs.

Product Capacities & Benchmark Disclaimers

This document is provided for information purposes and should not be relied upon in making a purchasing decision. The contents hereof are subject to change without notice. This document is not warranted to be error-free, nor subject to any other warranties or conditions, whether expressed orally or implied in law; including, implied warranties and conditions of merchantability or fitness for a particular purpose.

This document is not part of a license agreement nor can it be incorporated into any contractual agreement with Oracle Corporation or its subsidiaries or affiliates.

Failure to adhere to these benchmarks does not constitute a breach of Oracle's obligations. We specifically disclaim any liability with respect to this document and no contractual obligations are formed either directly or indirectly by this document. This document may not be reproduced or transmitted in any form or by any means, electronic or mechanical, for any purpose, without our prior written permission.

» Single Node Configuration

Standard configuration includes mated pairs of OC EAGLE's. In very rare circumstances an OC EAGLE may be deployed as a single node (without a mated OC EAGLE). This is not standard industry practice and is not recommended due to potential outage – please consult with Oracle Sales Consultants for input for this scenario. If an OC EAGLE is deployed without a mated pair, the following apply:

- » Oracle does not and will not warrant that the use of a single STP node operates as provided in the specifications to the extent that the specifications anticipate functionality arising out of or related to the implementation or use of a mated pair. Except as expressly stated herein, Oracle expressly disclaims all other warranties, whether express, implied, or statutory, including by not limited to warranties of merchantability, fitness for a particular purpose, or that the single node operates uninterrupted or error free.
- » Oracle shall have no liability whatsoever for any losses arising out of, resulting from, or related to a single node or the use thereof, including but not limited to special, incidental, indirect, punitive, exemplary or consequential damages, including but not limited to lost or damaged data, lost profits, business, revenue, goodwill, or anticipated savings, replacement costs or costs of substitute products.
- » An outage shall be classified as a customer-attributable outage if an outage prevention capability, for example, redundant infrastructure or stand-alone mode, exists that would have prevented the outage condition for the network element and the capability is a generally accepted industry practice, but the customer has chosen not to equip the product with the capability.

Purpose

The purpose of this document is to assist customers in planning for new deployments of the Oracle Communications OC EAGLE and associated products. This document is current for OC EAGLE Release 46.1, EPAP 16, LSMS 13.1, ELAP 10.0, and FTRA 4.5.

Specifically, this document provides an overview of the hardware components for each system and describes the configuration requirements through OC EAGLE Release 46.1 (see Figure 1 - OC EAGLE Functional Overview). Only the hardware provisionable features are described. For detailed descriptions of system functionality, hardware, interfaces, and other features, refer to OC EAGLE Feature Guide – Available at Oracle.com on the Oracle Technology Network (OTN) and the OC EAGLE Release 46.1 Documentation Set – Available at Oracle.com on the Oracle Technology Network (OTN).

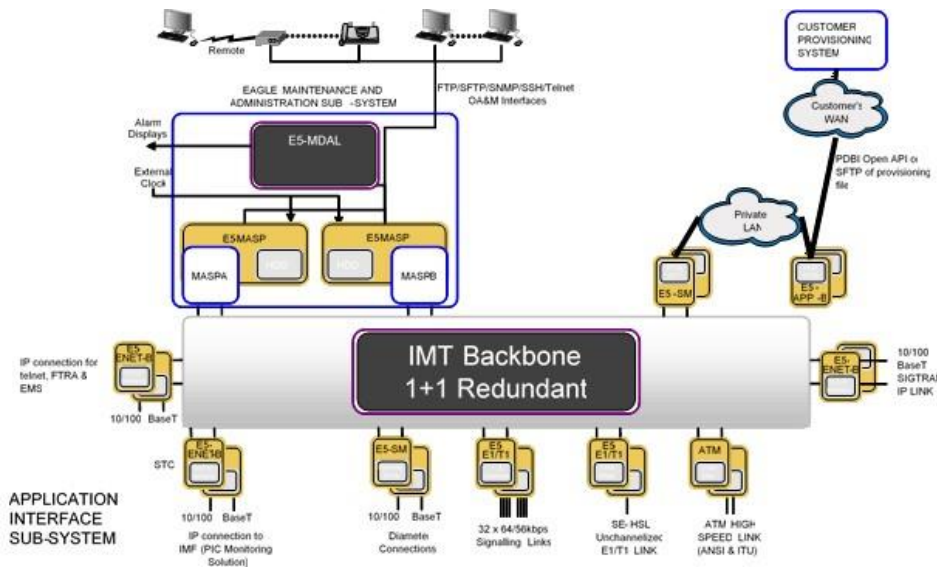

Figure 1 - OC EAGLE Functional Overview

OC EAGLE Hardware and Equipment Configuration

The OC EAGLE is a large-capacity, multi-functional, fully scalable Signaling Transfer Point (STP) that is deployed in mated pair configuration. The OC EAGLE compliance report is for NEBS Level 3 (GR-63-CORE, GR-1089-CORE, Network Equipment-Building Systems). High capacity and scalability allow the OC EAGLE to grow to 2,800 links or 1 million MSUs per second. Due to their critical network function, STPs are deployed in mated pair configurations and each STP is engineered at 40% of capacity (for links, SCCP cards, etc).

The OC EAGLE's modular design makes it easy to build, maintain, and expand an SS7 switching system. Application and interface cards are designed to provide plug-and-play functionality that allows future growth to occur seamlessly. The modular design of the OC EAGLE platform allows you to fully customize and define how your system is configured. Removing and inserting cards on a live system is supported with the OC EAGLE.

The OC EAGLE is comprised of functional subsystems. Each subsystem is responsible for a specific task. These subsystems are depicted in Figure 1 - OC EAGLE Functional Overview.

The OC EAGLE hardware platform (described in OC EAGLE Hardware Reference – Available at Oracle.com on the Oracle Technology Network (OTN)) consists of various frame types (control, extension, miscellaneous) typically

deployed side-by-side in a DC environment. See Figure 2 - OC EAGLE Frames for a view of an OC EAGLE extension frame. Each frame holds shelves or rack-mounted equipment. The shelves hold plug-in modules as shown in Figure 3 - OC EAGLE Control Shelf. High reliability and redundancy maximize system availability. In addition to providing quality products to our customer base, Oracle is committed to ensuring these products are environmentally friendly.

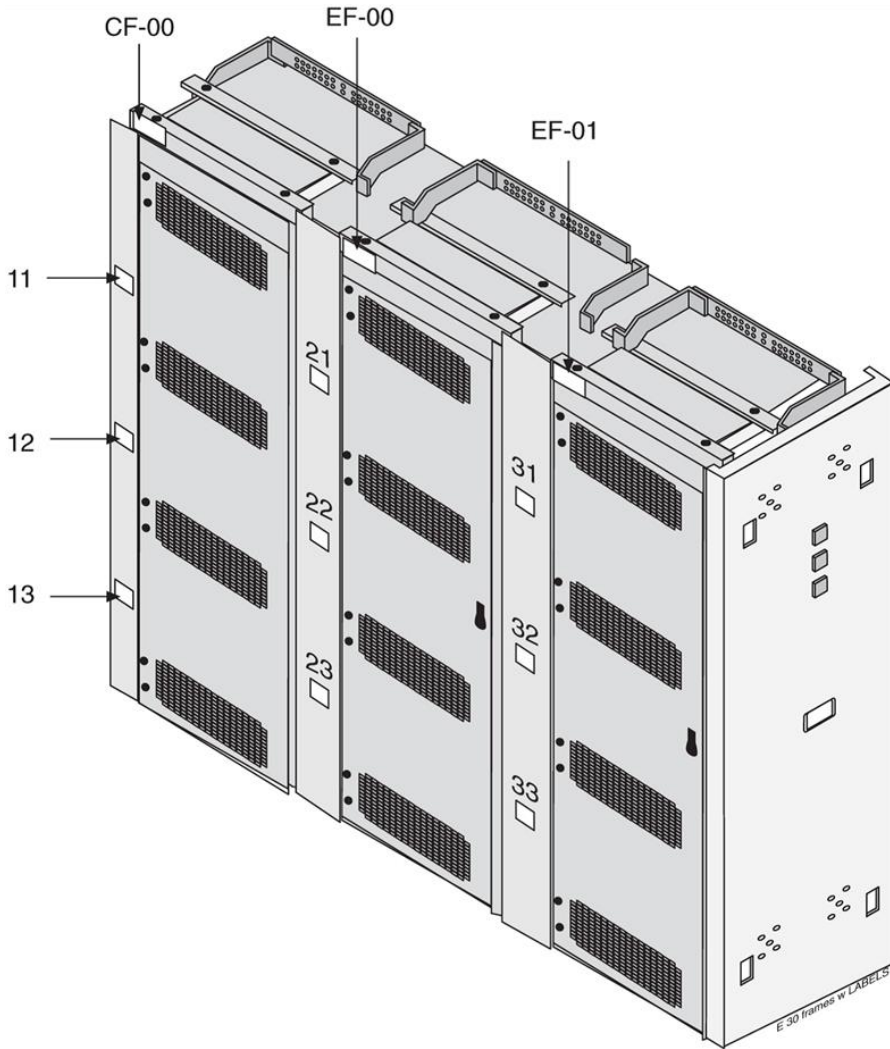

Figure 2 - OC EAGLE Frames

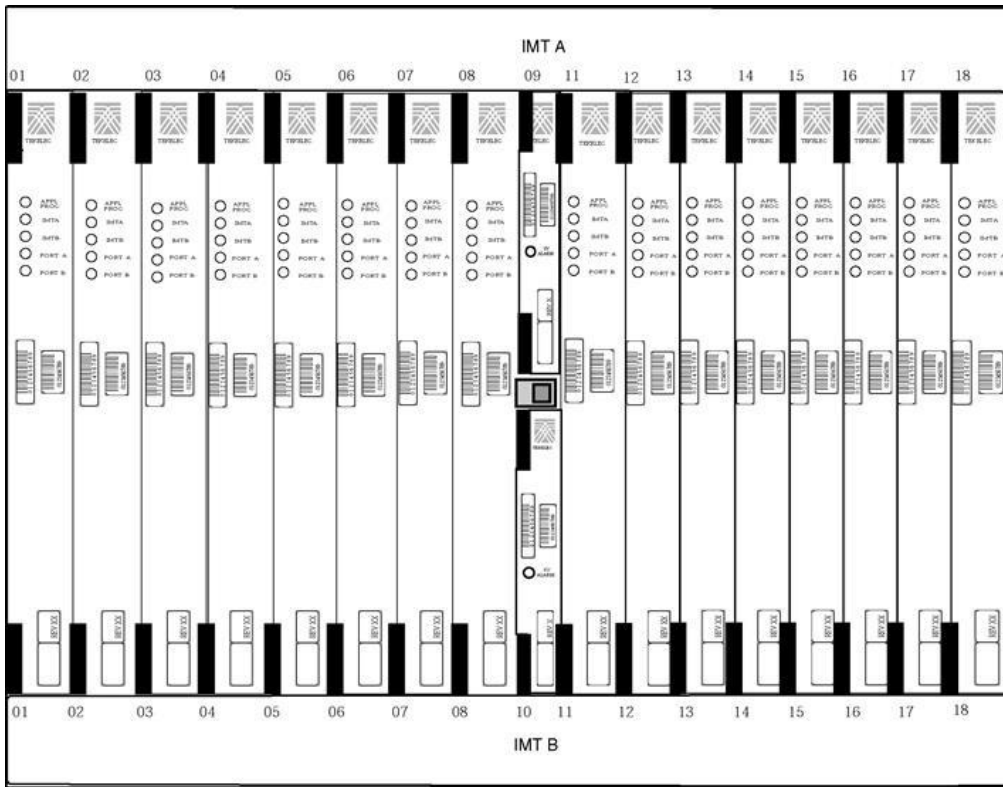



Figure 4 – OC EAGLE Extension Shelf

Oracle is committed to minimizing the use of potentially harmful substances in developing, manufacturing and packaging of Oracle products. Oracle endeavors to comply with all applicable laws and regulations restricting the use of potentially harmful substances in the development, manufacturing and packaging of Oracle products, and governing the use, sourcing, recycling and reporting requirements for raw materials. Oracle requires the removal of potentially harmful substances from its products, and maintains records regarding the raw material content of Oracle products, to the extent required by applicable laws or regulations.

The information provided above is applicable to Oracle's supply chain and related products, packaging and processes, and is intended for planning purposes only. The information may be derived from one or more of the following: product information developed at Oracle; general industry information; and information furnished by third parties, including but not limited to manufacturers and component suppliers in Oracle's supply chain. As a result, the information provided is not intended to be a representation or warranty of any kind, nor is it intended to modify in any way the terms and conditions of any agreement between Oracle and your company, or the rights of either party arising therefrom.

- » WEEE Directive 2012/19/EU: OC EAGLE STP Products include the WEEE label for proper disposal at end of life. Disposal sites are provided by Oracle and a link for *Product Take Back and Recycling* can be found on the first web site listed below.
- » RoHS Directive 2011/65/EU and all amendments and additions: RoHS compliance for OC EAGLE STP Products are described at the finished product and spare part level. The Declaration of Conformity (DoC) for OC EAGLE



STP (available) includes a statement of RoHS compliance. Detailed RoHS Material Declarations for individual marketing product part numbers are available upon request .

For more information about Oracle's sustainability and environmental practices, please see the following URLs:

- » <http://www.oracle.com/us/corporate/citizenship/sustainability/supply-chain/index.html>
- » <http://www.oracle.com/us/corporate/citizenship/sustainability/facilities/index.html>
- » <http://www.oracle.com/us/products/applications/green/ehsms-184396.html>
- » <http://www.oracle.com/us/products/applications/green/harmful-substances-185039.html>

OC EAGLE Frame

- » Small Footprint
 - » Frame Dimension
 - (84" H x 26" W x 22" D)
 - (2.13m H x .66m W x .56m D)
- » Two Main Functional Shelves
 - » Control Shelf
 - Only shelf with dedicated slots (6 for OAM)
 - 10 slots for link and/or service cards
 - » Extension Shelf
 - 16 slots for link and/or service cards
 - » Robust Design
 - Key functions are fully redundant
 - » Highly Scalable and Integrated
 - 1 to 16 shelves per node
 - 256 cards per node
 - » Standards:
 - NEBS GR-78-CORE, GR-63-CORE
 - CE Mark
 - (CB) Test Certificate to IEC 60950-1

Base System Hardware

Maintenance and Administration Subsystem

The Maintenance and Administration Subsystem (MAS) is the central management point for the OC EAGLE. The MAS provides user interface, maintenance communication, peripheral services, alarm processing, system disk interface, and measurements. The OC EAGLE architecture provides

Inter-processor Message Transport (IMT) connectivity directly to the maintenance and administration subsystem. The MAS includes redundancy ensuring continuous management control for the Oracle Communications OC EAGLE. Management and redundancy is provided by use of two separate subsystem processors.

The MAS consists of two separate OC EAGLE Maintenance and Administration Subsystem Processor (OC EAGLE-MASP) cards and an OC EAGLE Maintenance Disk and Alarm (OC EAGLE-MDAL) card - collectively referred to as control cards. The control cards are located in slots 1113 through 1118 of the OC EAGLE Control Shelf.

OC EAGLE-Based Control Cards

The OC EAGLE-based set of OC EAGLE control cards consist of the following cards:

- » One OC EAGLE-based Maintenance Disk and Alarm (OC EAGLE-MDAL) card.
- » Two OC EAGLE-based Maintenance and Administration Subsystem Processors (OC EAGLE-MASP) cards. The OC EAGLE-MASP card is a single dual-slot physical assembly made up of the following two cards.
- » OC EAGLE-based Maintenance Communication Application Processor (OC EAGLE-MCAP) card
- » OC EAGLE-based Terminal Disk Module (OC EAGLE-TDM) card

Note: An OC EAGLE control card is not compatible with a legacy control card. If FTRA is in use and OC EAGLE-OAM cards are deployed, OC EAGLE R41 or higher, and FTRA 4.2 and higher are required.

The OC EAGLE-MASP is a dual-card/dual-slot assembly occupying slots 1113/1114 or 1115/1116 of the control shelf. The OC EAGLE-MDAL is a dual-slot card occupying slots 1117 or 1118 of the control shelf.

The relationship between the control cards is depicted below.

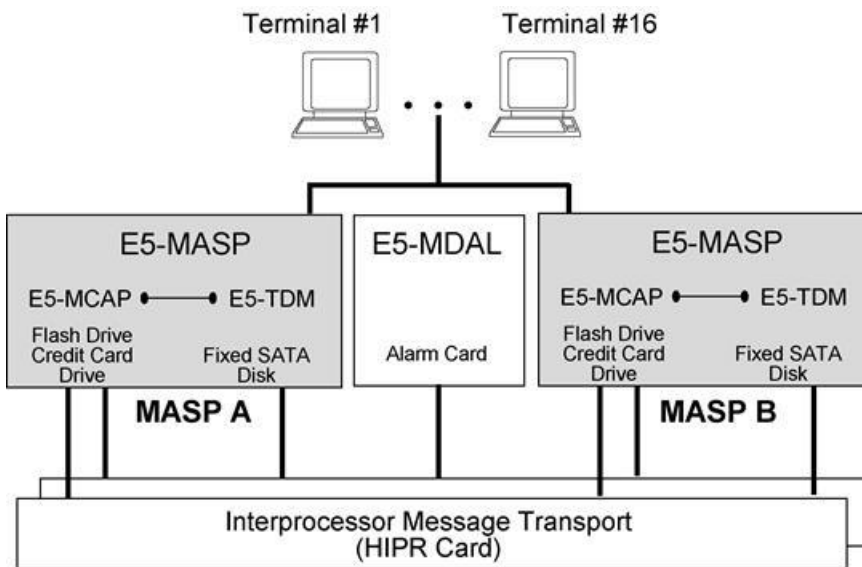

Figure 5 - OC EAGLE Based Maintenance and Administration Subsystem Block Diagram

OC EAGLE Maintenance and Administration Subsystem Processor (OC EAGLE-MASP) Card

The Maintenance and Administration Subsystem Processor (OC EAGLE-MASP) card contains all of the necessary logic to perform both application and communication processing of the data streams provided by the OC EAGLE. The card provides connections to the IMT bus through the backplane and all of the necessary logic to perform both application and communication processing of the data streams through the OC EAGLE. The OC EAGLE-MASP card contains one fixed drive and USB connectors for two removable drives.

The OC EAGLE-MASP consists of the OC EAGLE-MCAP and the OC EAGLE-TDM and provides the following functionality:

- » database administration
- » user access terminals
- » clock distribution and monitoring
- » shelf ID distribution
- » disk storage

» alarm interface

OC EAGLE-MCAP

The OC EAGLE-MCAP card provides increased processor and memory performance over the legacy GPSM-II card. The OC EAGLE-MCAP card is equipped with 4 GB of physical application processor memory. The primary data interface to the OC EAGLE-MCAP is RS-232 interfaces (i.e.: terminals) through the OC EAGLE-TDM.

The OC EAGLE-MCAP card contains one latched USB port for use with removable flash media (“thumb drive”), and one flush-mounted USB port for use with a plug-in “credit card” flash drive. The removable media drive is used to install and back up customer data. The USB thumb drive media is used for upgrades (prior to Release 45 the credit card media is used for upgrade and could be used for disaster recovery).

OC EAGLE-TDM

The OC EAGLE-TDM card contains four major subsystems: the Terminal Processor Subsystem, the System Clock/Control Subsystem, the SATA Subsystem, and a Power Subsystem. These subsystems provide the OC EAGLE with 16 user-accessible terminals, distributes Composite Clocks and High Speed Master clocks throughout the OC EAGLE, distributes Shelf ID to the OC EAGLE, and disk storage for an OC EAGLE-MCAP card. The OC EAGLE-TDM card provides an interface to the OC EAGLE-MDAL card for system alarms.

The OC EAGLE-TDM card contains one fixed solid-state SATA drive that is removable and used to store primary and backup system databases, measurements, and Generic Program Loads (GPLs).

OC EAGLE-MDAL

The OC EAGLE-MDAL card processes alarm requests, provides general purpose relays, and provides fan control. There is only one OC EAGLE-MDAL card in a control card set and it is shared between two OC EAGLE-MASP cards. The OC EAGLE-MDAL card is located in slots 1117 and 1118 of the control shelf.

Critical, major and minor system alarms are provided for up to 6 individual frames. In addition to the 3 system alarms, the OC EAGLE-MDAL card provides the system audible alarm. All alarms are software controlled. The OC EAGLE-MDAL card provides control of fans on a per frame basis. The control logic allows for each fan relay to be set individually. The OC EAGLE-MDAL card does not contain a disk drive.

Communication Subsystem

The Communication Subsystem consists of the Inter-processor Message Transport (IMT) bus, and its interface processors. Two High Speed IMT Packet Router 2 (HIPR2) cards per shelf implement the IMT bus architecture and provide fully redundant internal communication. The IMT is composed of shelf-level redundant 125 Mbps switched connections (HIPR2) and a 1Gbps/2.5Gbps backbone ring connecting all shelves. The Communications Subsystem connects all the OC EAGLE cards together for communications and software downloads from the OAM cards. (The Oracle EAGLE-APP-B cards do not connect to the IMT bus and therefore do not communicate via this subsystem.)

High Speed IMT Packet Router 2 (HIPR2)

The High-speed IMT Packet Router 2 (HIPR) replaces HMUX or HIPR cards. The HIPR2 provides 125 Mbps switched connectivity to each slot instead of the shared 125 Mbps ring architecture implemented by legacy HMUX. HIPR2 supports the 1Gbps backbone ring architecture making it compatible with legacy HMUX and legacy HIPR (note the last release supported for HMUX is 45, and the last release supported for HIPR is 46.0). Each shelf must have the same type of IMT card. Higher IMT throughput (2.5Gbps) is achieved with HIPR2s throughput a node utilizing high rate mode. IMT cabling upgrade may be required to support high rate mode.

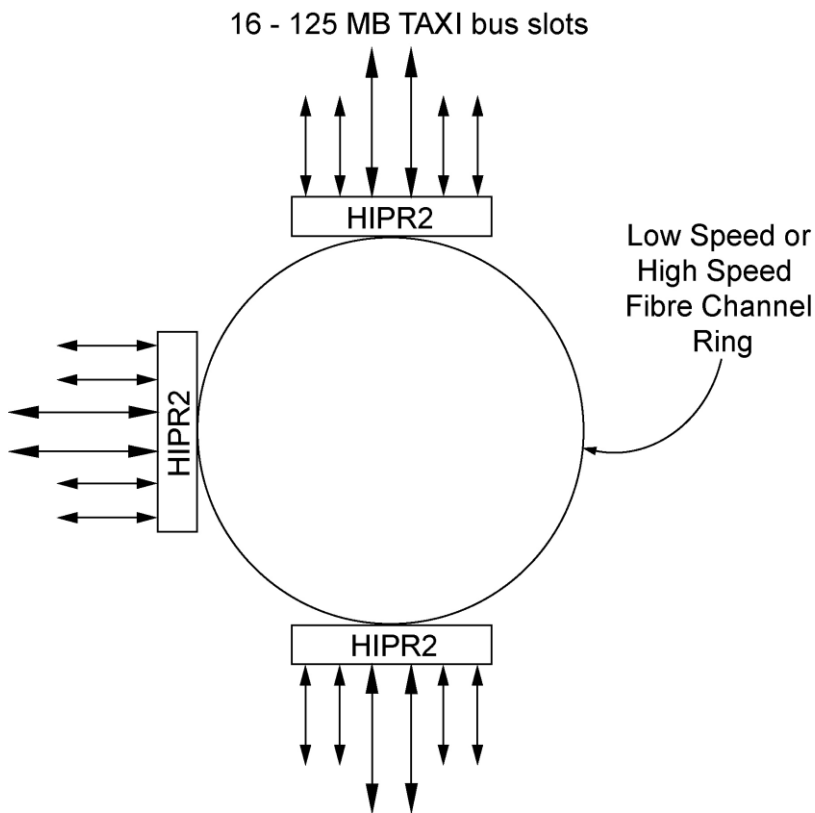

Figure 6 - HIPR2 Architecture

Database Application Subsystem

The Auxiliary Memory Subsystem provides the Service Modules required for optional features provided by the OC EAGLE. The Auxiliary Memory Subsystem consists of one or more of the following card types deployed according to the provisioning rules defined later in this document.

OC EAGLE-SM8G-B

The OC EAGLE-SM8G-B card provides advanced processing power with 8 GB memory configuration for high-capacity GTT and database applications, for example, EPAP and ELAP database features. The OC EAGLE-SM8G-B is a dual slot card designed to operate in an OC EAGLE control or extension shelf. The module must be assigned to available, odd numbered slots.

The OC EAGLE-SM8G-B card provides two IEEE 802.3 Standard compliant, Ethernet interface ports that support TCP/IP connectivity for internal communications. The OC EAGLE-SM8G-B card provides the following for the OC EAGLE system:

- » Support for the SCCP features
- » SS7 traffic exchange between B, C, D links and the IP network
- » Enhanced bulk download

The OC EAGLE-SM8G-B card has the following requirements and dependencies:

- » Requires HIPR or HIPR2 to be active on both IMT buses in the shelf where the OC EAGLE-SM4G/SM8G-B resides.

- » Requires a fan tray assembly for thermal management (890-0001-04).
- » Can replace a DSM or OC EAGLE-SM4G without requiring additional provisioning (note adapter and cabling may be needed).
- » Can interoperate with DSMs or OC EAGLE-SM4G's. Note the last supported release for DSMs is R45.

Note: HIPR in one bus and HIPR2 in the other bus for a shelf is not a supported configuration

OC EAGLE-APP-B Processor Subsystem

MPS

The Multi-Purpose Server (MPS) is a redundant, active/standby processor system (A and B servers) operating on dual slot OC EAGLE-APP-B cards that enables database applications to run at high transactions rates with very high reliability. The MPS provides a variety of high capacity and high speed database processing functions and database support functions to the OC EAGLE.

OC EAGLE Provisioning Application Processor

The OC EAGLE is also capable of assuming database related services typically associated with a Service Control Point (SCP). This allows database services to run at high transaction rates with very high reliability. Currently, the database services that utilize EPAP include A-Port, HLR Router, MNP, IS-41 to GSM Migration, INAP based number portability (INP), GSM Prepaid SMS Intercept, GSM Equipment Identity Register (EIR), and LNP for North America (Local Number Portability).

The following configuration rules apply to OC EAGLE-APP-B (870-3096-01/02) based EPAP:

- » Switches are configured in the lower shelf position of an OC EAGLE frame. In frames including switches, 2 is the maximum quantity of shelves available.
- » EPAP 15 is compatible with OC EAGLE Releases 43, 44, 45, 46.0/46.1. EPAP 16 is compatible with OC EAGLE Releases 46.0/46.1.
- » EPAP 15 can run in parallel for short periods with EPAP 14 and EPAP 13 (to permit the staged migration of customers with many pairs of EPAPs.)
- » Existing T1000 EPAP frames (890-1801-xx) can be retrofitted with Switches and OC EAGLE shelves.
- » Two switches support up to 17 Service Module cards per OC EAGLE (four switches support up to 32 Service Modules).
- » Configurations with switches in a customer supplied frame include following requirements:
 - » The maximum distance supported between OC EAGLE-APP-B cards and switches is 100 ft distance
 - » Customer must supply DC power with isolated ground.
- » Standard "B card" requirements and guidelines apply (key points summarized below):
 - » Fans (890-0001-xx) are required for all OC EAGLE shelves that host "B" series cards (including OC EAGLE-ENET-B, OC EAGLE-ATM-B, OC EAGLE-MCPM-B, OC EAGLE-SM8G-B, OC EAGLE-E1T1-B, OC EAGLE-APP-B). OC EAGLE Fan Filters (551-0032-R01) are included in the BOM of the fan assembly – additional may be ordered separately as required for maintenance.
 - » Air Management cards (870-1824-02) are required to fill the shelf where the Fan units are installed that host "B" series cards
 - » Dual 60A power feeds are recommended for all frames that host B series cards. OC EAGLE frames that host B series cards may require dual 60 Amp power feeds, depending on frame configuration.
- » Distance limitations include 100M maximum cable length between Switches and OC EAGLE Service Modules, and 100 Feet maximum cable length between OC EAGLE-APP-B cards and Switches.
- » OC EAGLE-APP-B cards do not connect to the IMT bus, but they can be deployed in OC EAGLE shelves connected to IMT bus if the frame is in the OC EAGLE line-up (side by side)
- » Other OC EAGLE cards can be used in shelves connected to IMT bus

- » OC EAGLE shelf positions 6200 & 6300 do not connect to IMT bus (existing OC EAGLE shelf limit on IMT bus remains 16)
- » DSM's (870-1984-xx) are not supported for OC EAGLE-APP-B based EPAP.
- » OC EAGLE-SMxG cards and the required adaptors 830-1104-04 (2 per card) must be configured for new installs and when migrating from EPAP 13 with DSM cards.
- » >120M EPAP Record specific rules/notes:
 - » OC EAGLE P/N 893-0398-01 (FAK for 120M DN + 120M IMSI) is required for >120M EPAP capacity along with applicable DB capacity RTU licenses (971-3055-01 per 500K records)
 - » The maximum Service Selector table size supported is 1,000 records when greater than 120M EPAP DB records is implemented.
 - » The following cards are not supported for greater than 120M EPAP records: DSM's (870-1984-xx), EDCM's for SIGTRAN (870-2372-xx), MPL's (870-2061-xx), E1/T1 MIM's (870-2198-xx), and E1 or T1 ATM's (870-2455-xx, 870-1293-xx).
 - » OC EAGLE P/N 893-0217-01 (FAK for HLR ROUTER MAP LAYER ROUTING) can't co-exist with >120M EPAP Record Feature
 - » Migration Services and Installation Materials are required

The following migration options to OC EAGLE-APP-B based EPAP apply:

- » Option 1 – Existing EPAP Frame
 - » Install OC EAGLE-APP-B cards in the existing EPAP Frame along with a new OC EAGLE Shelf, FAP, and new switches.
- » Option 2 – New OC EAGLE shelf
 - » Install OC EAGLE-APP-B cards in a new OC EAGLE Shelf with new switches in existing OC EAGLE Extension frame
- » Option 3 – Existing OC EAGLE shelf
 - » Install OC EAGLE-APP-B cards in existing OC EAGLE Shelf location and mount Switches in existing OC EAGLE frame or customer frame/cabinet
- » Option 4 – Existing OC EAGLE shelf
 - » Install OC EAGLE-APP-B cards in existing OC EAGLE Shelf location and leave Switches in existing EPAP frame
(Only applies to customers migrating from T1200 servers)
- » Option 5 – New installs
- » Option 6 – T1000 EPAP Frame Conversion
 - » EPAP frame conversion to OC EAGLE frame with FAP, 2 new OC EAGLE shelves and switches installed in x300 position.

OC EAGLE LNP Application Processor (ELAP)

The OC EAGLE LNP Application Processor (ELAP) platform provides capacity and performance required to support the ever-growing ported number database. The platform is based on the OC EAGLE OC EAGLE-APP-B card.

- » OC EAGLE-APP-B (870-3096-01/02) based ELAP is available for ELAP 10 – ELAP 10 is compatible with OC EAGLE Release 43, 44, and 45
- » ELAP 10 does not support T1100 based ELAP
- » LSMS 13 requires ELAP 10
- » LSMS 13 does not support T1100 based LSMS
- » Existing T1100 based ELAP frames (890-1843-xx) can be retrofitted with Switches and OC EAGLE shelves.
- » Two switches support up to 18 Service Module cards per OC EAGLE
- » Configurations with switches in a customer supplied frame, include notes:

- » The maximum distance supported between OC EAGLE-APP-B cards and switches is 100 ft distance
- » Customer must supply DC power with isolated ground.
- » A frame with switches can support 2 OC EAGLE shelves (the switches consume other shelf position)
- » Include standard B card note in all quotes (key points summarized below):
 - » Fans (890-0001-xx) are required for all OC EAGLE shelves that host "B" series cards (including OC EAGLE-ENET-B, OC EAGLE-ATM-B, OC EAGLE-MCPM-B, OC EAGLE-SM8G-B, OC EAGLE-E1T1/OC EAGLE-E1T1-B-B, OC EAGLE-APP-B).
 - » Air Management cards (870-1824-02) are required to fill the shelf where the Fan units are installed that host "B" series cards
 - » Dual 60A power feeds are recommended for all frames that host B series cards. OC EAGLE frames that host B series cards may require dual 60 Amp power feeds, depending on frame configuration.
- » Distance limitations include 100M maximum cable length between Switches and OC EAGLE Service Modules, and 100 Feet maximum cable length between OC EAGLE-APP-B cards and Switches.
- » OC EAGLE-APP-B cards do not connect to the IMT bus, but they can be deployed in OC EAGLE shelves connected to IMT bus if the frame is in the OC EAGLE line-up (frames side by side)
 - » Other OC EAGLE cards can be used in shelves connected to IMT bus
 - » OC EAGLE shelf positions 6200 & 6300 do not connect to IMT bus (existing OC EAGLE shelf limit connected to the IMT bus remains 16)
- » DSM's (870-1984-xx) are not supported for OC EAGLE-APP-B based ELAP.
- » Services and Installation Materials are required (quote based on specific installation/migration scenario)
- » OC EAGLE-SMxG cards and the required adaptors 830-1104-04 (2 per card) must be included in the quote for new installs

The following OC EAGLE-APP-B based ELAP migration options apply:

- » Option 1
 - » Install OC EAGLE-APP-B cards in existing ELAP Frame with new OC EAGLE Shelf, FAP, and install new switches
- » Option 2
 - » Install OC EAGLE-APP-B cards in new OC EAGLE Shelf with new switches in existing OC EAGLE Extension frame
- » Option 3
 - » Install OC EAGLE-APP-B cards in existing OC EAGLE Shelf location and mount Switches in existing OC EAGLE frame or customer frame/cabinet
- » Option 4
 - » Install OC EAGLE-APP-B cards in existing OC EAGLE Shelf location and install Switches in existing ELAP frame
- » Option 5
 - » New Installation of standalone frame with only 1 shelf, fan, and switches
- » Option 6
 - » ELAP frame conversion to OC EAGLE frame with FAP, 2 new OC EAGLE shelves and switches installed in x300 position

For ELAP 8.0 or later, the ELAP frame contains two Ethernet switches for communication between the OC EAGLE OC EAGLE-SM4G cards and the T1100s. One switch supports the main OC EAGLE-SM4G network and one switch supports the backup OC EAGLE-SM4G network. The Ethernet switches support full-duplex communications with the OC EAGLE-SM4G cards. The OC EAGLE-SM4G cards require adapters. Data is replicated between the two



servers as well as mirrored on dual hard drives on each server to provide failsafe data integrity. The connection from the ELAP to the LSMS is direct from the ELAP Ethernet ports to the customer's network.

Shelves, Frames, Power, and Protection

The OC EAGLE includes two main shelf types: the Control Shelf and the Extension Shelf. The minimum configuration consists of a Control Frame including a Control Shelf and two Extension Shelves.

Control Shelf and Extension Shelf

The Control Shelf (shown in Figure 3 - OC EAGLE Control Shelf) contains the three MAS plug-in assemblies (two dual-slot OC EAGLE-MASPs, and the dual-slot OC EAGLE-MDAL) in six dedicated slots, plus ten additional slots for provisionable processor modules. The Extension Shelf (shown in Figure 4 – OC EAGLE Extension Shelf) holds up to 16 processor modules. All shelves are equipped with two OC EAGLE HIPR2 cards.

Frames

The OC EAGLE consists of the following frame types:

- » • Control Frame
- » • Extension Frame
- » • Miscellaneous Frame

The Control and Extension frames are assembled in the factory fully configured with shelves, fans, and switches (if required). The frames consist of a Control Frame with 2 shelves/fans, and switches in the bottom shelf position, Control Frame with 3 shelves/fans, Extension Frame with 2 shelves/fans and switches in the bottom shelf position, Extension Frame with 3 shelves/fans, or Extension Frame with 1 shelf/fan (for last frame in the lineup for the 16th OC EAGLE shelf). All frames are 84 inches high x 25 7/8 inches wide x 23 5/8 inches deep (2.13 m x 66 cm x 61 cm). Each OC EAGLE Control and Extension Frame can hold three shelves/fans.

The Control Frame contains the Control Shelf and Extension Shelves. The Control Shelf accommodates the OC EAGLE-OAM cards, HIPR2 cards, and up to ten additional single slot processor modules. The Extension Shelf supports two HIPR2 cards and can accommodate up to 16 single slot processor modules. The OC EAGLE platform's flexible design permits any of the provisionable processor module types to be inserted into any configurable shelf slot, with the exception of the OC EAGLE-SM8G-B (DSM, OC EAGLE-SM4G, and HC-MIM legacy cards) which require two slots starting in an odd numbered slot.

Therefore, a Control Frame can support up to 42 single slot processor modules. When a system requires more than 42 single slot processor modules, up to five Extension Frames can be added to accommodate up to an additional 13 Extension shelves. Extension frames 1 through 4 hold three shelves each, while Extension frame 5 only holds one shelf. A Fuse and Alarm Panel (FAP) located at the top of each frame distributes nominal -48 VDC to all shelves in the frame. The FAP distributes and protects the primary DC power to each shelf mounted in the frame. It also displays critical, major, and minor alarms within the frame. Each control shelf and each extension shelf is protected by 18 fuses.

There are associated assemblies and installation kits for the Legacy and Go Forward frame and shelf configurations as depicted below. ATO refers to Assemble to Order (new frames being manufactured), and PTO is Pick to Order (standalone items boxed and shipped to the field).

Legacy	Go Forward	ATO	PTO	
	X	X		5 Frame Models (the new frame models defined with WWOPS for GF model to simplify configurations and increase velocity) Control frame with 3 shelves and fans Control frame with 2 shelves and fans (switches are not in BOM but will be included via configurator and workbook rules) Extension frame with 3 shelves and fans Extension frame with 2 shelves and fans (switches are not in BOM but will be included via configurator and workbook rules) Extension frame with 1 shelf and fan assembly
	X	X		8 kits for assembly material - Extension orders with Extension frames (includes IMT cables, etc) Replaces 890-0230-xx and 870-3305-01 thru 870-3320-01 in legacy model GF Initials still use 7M p/n equivalents of existing 890-0230-xx and 870-33xx-01. Assembly materials for second frame (first extension frame) for 3 shelves (for factory Assembly) Assembly materials for third frame (second extension frame) for 3 shelves (for factory Assembly) Assembly materials for fourth frame (third extension frame) for 3 shelves (for factory Assembly) Assembly materials for fifth frame (fourth extension frame) for 3 shelves (for factory Assembly) Assembly materials for second frame (first extension frame) for 2 shelves (for factory Assembly) Assembly materials for third frame (second extension frame) for 2 shelves (for factory Assembly) Assembly materials for fourth frame (third extension frame) for 2 shelves (for factory Assembly) Assembly materials for fifth frame (fourth extension frame) for 2 shelves (for factory Assembly) The single extension shelf in frame 6 (extension frame 5) uses 870-3350-15 (ATO w/ frame) or 814-3350-15 (PTO w/o frame) These kits go with the 5 frame models above
	X	X		890-0230-xxMKT IMT, Power, Timing, Alarm cables (for initials) As is for legacy (ie 16 kits) Intra-frame cabling assembled in factory, Inter-frame cabling coiled and placed inside frame
	X	X		870-3305-01MKT thru 870-3320-01MKT (16 kits) (for initials) Assembly materials for control shelf (for factory installation), plus a kit for control shelf plus each extension shelves up to 15. Based on the existing 1268 kits Consists of Fuses, labels, shelf cables Goes with 890-0230-xx above in legacy model
	X	X		15 kits for assembly material for adding extension shelves to an existing node in the field (in scenarios where new frames with shelves are being manufactured). 870-3350-00 thru 870-3350-15
	X	X	X	15 kits for installation material to add extension shelves to an existing node in the field (in scenarios requiring shelves only - ie NOT shelves in new frames). 814-3350-00 thru 814-3350-15
	X	X	X	4 Installation Material kits (raised floor vs concrete) - not installed in factory (boxed and shipped with frame) 3 kits are per frame, 1 is per site (870-3303-01) The p/n's are 870-3300-01 thru 870-3303-01 for ATO (with new frames), and 814-3300-01 thru 814-3303-01 for PTO 870-3300-01MKT Materials for raised floor mounting (for factory installation) 870-3301-01MKT Materials for raised floor brace mounting (for factory installation) 870-3302-01MKT Installation materials for frame (for factory installation) 870-3303-01MKT Start up installation materials (for factory installation) Included via configuration rules
NOTES:	870-33xx-01(MKT) includes boxed installation materials (ie not installed in factory). EG material for bolting equipment to floor. 890-0230-xx includes IMT, power, alarm, and timing cabling			

Figure 7 - Assembly/Installation Kits

The maximum OC EAGLE Control and Extension Frame lineup configuration includes one control frame and five extension frames, which hold one control shelf and up to 15 extension shelves. When the following frames are ordered, they are installed to the left of the Control Frame.

» Miscellaneous Frame

An optional third frame type, the Miscellaneous Frame (MF), can be used to mount customer-provided equipment or a shelf without a backplane for storing spare modules (card cage). Examples of customer-provided equipment accommodated are 75 ohm converters, holdover clock, test equipment, jack panels, spare card shelf, modem shelf, printer and terminal. In some scenarios EAGLE shelves and switches may be provisioned – please contact Oracle Sales Consultants for more information.

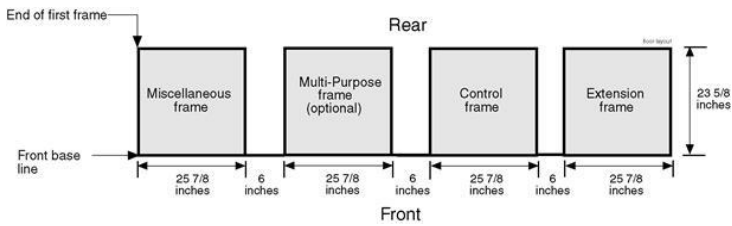

Figure 8 - OC EAGLE Frames: Floor Plan - Top View

Fan Assembly for OC EAGLE Shelves

Fans and Air Management Cards in empty slots are required to dissipate heat when an OC EAGLE card specifies forced air cooling is required. All of the OC EAGLE B cards require fans (and legacy HCMIM).

A fan alarm is displayed when a fan alarm is present in any fan assembly in the OC EAGLE. When a fan alarm is present, indicators on the controller card(s) provide additional detail to isolate the fault. The fan assembly may optionally be used with any OC EAGLE shelf if unusual ambient conditions warrant forced air cooling methods.

Cables and Adapters

Please refer to the OC EAGLE Installation Guide – Available at Oracle.com on the Oracle Technology Network (OTN). Shielded CAT 5 cables are required for Ethernet interfaces.

OC EAGLE Power

The OC EAGLE derives its primary power from nominal -48 VDC central office batteries provided by the customer. Power feeds to all individual modules within each frame are protected by fuses. (All lower voltage power, for logic circuitry, disk devices, and so forth, is derived from on-board power supplies mounted on each module.) To allow for the full population of an OC EAGLE frame, and for the failure of one primary supply, the circuit breakers for each frame should be rated at 60 Amperes (all new installs beginning with OC EAGLE Release 34.0 require two 60 Ampere feeds). The OC EAGLE Installation Guide – Available at Oracle.com on the Oracle Technology Network (OTN) describes grounding requirements for the OC EAGLE.

A wide variety of components are used in the OC EAGLE architecture to provide numerous configurations to meet customers' individual needs. Detailed power calculations should be done for each specific configuration needed. The table below identifies the power consumption of most OC EAGLE modules and can be used for general power planning.

Redundant power feeds provide nominal -48 VDC to each frame. Power protection is provided by fused circuits in the FAP. Power is distributed on two circuits, A and B. If A or B fails, the other circuit picks up the full load of both circuits. New installations of Control and Extension Frames (as of Release 34.0) use 60 amp breakers (see note). Local Alarms for the Frame's Power Distribution System are provided at each frame.

Power and Fan Requirements

Fans are required for all shelves that contain OC EAGLE-ENET-B, OC EAGLE-ATM-B, OC EAGLE-E1/T1-B, OC EAGLE-MCPM-B, OC EAGLE-SM8G-B, HCMIM, or OC EAGLE-APP-B cards. Air management cards are required in empty slots in shelves containing B cards and fans. Due to higher power B cards, dual 60 Ampere power feeds to a frame may be required depending on frame configuration. Contact an Oracle Sales Consultant for additional information.

- » The Frame Power Budget Alarm feature (R35) provides an alarm if the power consumption of cards in a frame nears the frame-level power capacity. The current capacity value can be provisioned in the Frame Power Threshold (FPT) table or a default value of 30 Amperes can be used (30 A through 60 A are values that can be

used). The feature identifies the type of cards in a frame, calculates potential current consumption based on the frame-level population of cards, compares calculated current consumption to the frame-level current capacity figure, and raises alarms based on provisioned thresholds (90%, 95%, and 98%). RTRV STP:DISPLAY=POWER can be used to obtain existing frame card configurations and frame power budget.

Table 1: OC EAGLE Card Power Consumption Table

Component	Power (W)	Part Number
Fan Tray	125	890-0001-XX
MDAL	30	870-0773-XX
OC EAGLE-MDAL	12	870-2900-XX
TDM	34	870-0774-XX
GPSM-II	35	870-2360-XX
OC EAGLE-MASP	58	870-2903-XX
OC EAGLE-ENET	27	870-2212-XX
OC EAGLE-E1T1	25	870-1873-XX
OC EAGLE-ATM	23	870-1872-XX
EDSM-2G (MCPM)	30	870-2372-03 870-2372-07 870- 2372-09 870-2372- 14 870-2372-15
TSM	29	870-1289-XX 870- 1290-XX 870-1291- XX 870-1292-XX
LIM-ATM (E1)	21	870-2455-XX
MPL	35	870-2061-01
OC EAGLE-TSM	26	870-2943-XX
LIM-ATM (T1)	25	870-1293-XX
SS EDCM / STC	29	870-2372-01 870- 2372-08 870-2372- 13
E1/T1 MIM	22	870-2198-XX
HC MIM	75	870-2671-XX
OC EAGLE-IPSM	27	870-2877-XX
DSM	35	870-1984-XX
OC EAGLE-SM4G	51	870-2860-XX
OC EAGLE-ENET-B	34	870-2971-XX
OC EAGLE-ATM-B	34	870-2972-XX
OC EAGLE-E1T1-B	32	870-2970-XX
OC EAGLE-	32	870-3089-XX

MCPM-B		
OC EAGLE-SM8G-B	63	870-2990-XX
HIPR2	18	870-2872-XX
HIPR / HMUX	16	870-1965-XX 870-2574-XX
DCM	26	870-1945-XX
DSM-1G	25	870-2371-XX
EDCM-A	21	870-2508-XX
Telco Switch	120	870-2904-01
OC EAGLE-APP-B	78	870-3096-01

Primary Rules for Power Upgrades:

- 1 If upgrade to 60A FAP is required and 870-1606-01 (3U FAP) or Hendry FAP (870-0243-xx)
 - » 870-2804-01 (1U FAP) - One per frame
 - » 890-0013-02 (Installation Kit) - One per frame
- 2 If 870-2320-01 Rev A thru Rev I (Heavy Duty 3U FAP) or 870-1606-02 Rev A or B (Standard 3U FAP) is existing. Configure a new FAP if 840-0139-01 (control frame FAP upgrade kit) or 840-0139-02 (extension frame FAP upgrade kit) is not existing.
- 3 Control Shelf backplane 850-0330-06 or greater is required for primary/secondary power feeds, and Ethernet port for OC EAGLE-OAM Integrated Measurements or SNMP.
- 4 Oracle Services are required for Power Upgrades
- 5 Existing cabling from OC EAGLE frame to external feed (eg BDFB) must support 60A (new cables may be required)

OC EAGLEs are installed to conform with single-point grounding practices as described in Bellcore/Telcordia TR-NWT-000295, Isolated Ground Planes: Definition and Applications to Telephone Central Offices. Site surveys are conducted to determine the specific grounding arrangement.

System Timing Considerations

When deploying any network element, system-level timing strategies must be considered to ensure that adequate synchronization of clocks throughout the network is achieved. Typically, highly accurate, stratum-3 clock sources are engineered into the network architecture to provide timing references for all network elements. Network elements then derive timing from the stratum-3 timing reference. Some network elements may be used to distribute the timing reference to other elements and thus operate in Master timing modes. Other elements derive timing from the adjacent elements to which they are connected, thus operating in Slave timing modes. Timing modes can be individually defined at a port level within a given network element. For Signal Transfer Points (STPs), the slave timing mode is recommended wherever possible since the signaling network is usually an overlay network to the primary architecture. The OC EAGLE can support both Master and Slave timing modes.

Input Clocks for the OC EAGLE

The OC EAGLE accepts external clock inputs through an external clock interface on the Control Shelf. The interface is terminated on two (for redundancy) DB-15 style connectors. These clocks serve as Primary and Secondary system clock inputs which are then internally distributed by the TDM through the OC EAGLE as clocks A and B. The DB-15 connectors and the appropriate cables can accept up to three distinct types of clock signals, (a) an RS-422 High-Speed



Master Timing clock running at 2.048Mhz or 1.544Mhz, (b) clock reference signals in T1 or E1 formats and (c) a 64KHz composite clock. External timing is used for three purposes, for timing DS0A channels, for the TSC sync feature for PIC message time stamping, and for timing E1/T1 interfaces operating as channelized E1/T1 or ATM-formatted High Speed Links. For DS0A links (used only in North America) the 64KHz composite clock signal is required. TSC sync is supported by the 64KHz composite clock or any high-speed clock reference. For High-Speed Master timing, the supplied signal must be 2.048Mhz or 1.544Mhz to source E1 rate or T1 rate clocks respectively. For these High-speed clock signals, the incoming clock must contain only the clock in an RS-422 compatible format or in standard E1 and T1 formats*; the signal must not contain any signaling or other “payload” data.

Note: E1/T1 inputs are recommended for High Speed clock signals to ensure greater immunity to power fluctuations. If RS-422 is used for the input clock signal, it is recommended that the clock distribution device be included in the OC EAGLE isolated ground plane.

High-Speed clock input is required to support an OC EAGLE serving as the Timing Master in a network. High-Speed clocks are not necessary if OC EAGLE high-speed signaling links (either channelized E1/T1, or ATM-formatted E1 or T1) operate in “line” mode, meaning that each individual link derives timing from its incoming signal.

Both High-speed Master Timing inputs and Composite Clock signals can be simultaneously accommodated by the Control Shelf using the appropriate Oracle cables.

Note: OC EAGLE equipped with a TDM card 870-0774-15 or later and OC EAGLE software Release 31.6 or later can accommodate E1 and T1 formatted clock reference signals in addition to RS-422 signals and can support TSC sync with either the 64KHz composite clock or any high-speed reference.

Timing Sources

External clock inputs as described above are the customer’s responsibility. If the customer’s current network architecture does not provide the proper clock rates and interface formats required by the OC EAGLE, external clock conditioning devices may be required.

High Speed Master Clocking

This feature provides master clocking for the E1 Links (OC EAGLE-E1T1/OC EAGLE-E1T1-B, HC-MIM, LIM-E1, E1/T1 MIM, and LIM-ATM) and for the T1 Links (E1/T1 MIM and LIM-ATM). The OC EAGLE accepts E1 or T1 Master Clock input and provides the master clock for the High Speed Links and E1/T1 Links rather than derive the timing from the received E1 or T1 signal. Refer to section 2.5 for a description of system timing considerations. TDM 870-0774-15 or greater is required.

OC EAGLE Site Requirements

This section contains an overview of site requirements for the installation OC EAGLE. This section includes information on power, environmental, and floor plan requirements relating to that installation. This section covers only those areas unique to OC EAGLE systems and does not cover common telecommunications installation requirements. The system is designed to be installed and operated in a central office environment. Local fire protection codes must be satisfied in the equipment room where the system is to be located. See the OC EAGLE Installation Manual in the customer documentation set for additional site requirement details.

Space Requirements

This system equipment is housed in 7 foot high, 23 inch wide, floor supported, unequal flange upright frames. Separator panels, and end panels add to the width of multiple frame systems.



The floor area taken up by this system is:

- » 1 frame = 30 inches wide by 22 inches deep = 660 square inches (4.6 square feet)
- » 2 frames = 62 inches wide by 22 inches deep = 1364 square inches (9.5 square feet)
- » 3 frames = 94 inches wide by 22 inches deep = 2068 square inches (14.4 square feet)
- » 4 frames = 126 inches wide by 22 inches deep = 2772 square inches (19.3 square feet)
- » 5 frames = 158 inches wide by 22 inches deep = 3476 square inches (24.1 square feet)
- » 6 frames = 190 inches wide by 22 inches deep = 4180 square inches (29 square feet)

The number of frames required for an installation is described in the Sales Order for that site. The number of frames is determined by the space required by the module population of the system and optional items such as MPS and Miscellaneous frames.

When planning the installation, be sure to take into account spare module storage, modems, terminals, printers, cross connect panels, and all other items that might require space in a system.

Each OC EAGLE frame has a 1.57 m² footprint when one half of the maintenance and wiring aisles (in front and back) is included.

- A Frame Depth 0.826 m
- B Main Aisle 1.18 m * 1/2
- C Wire Aisle 0.94 m * 1/2
- D Frame Width 0.836 m

Formula $[A + B/2 + C/2] * D$

Lighting

Adequate lighting should be provided in the room where the equipment is to be located. Lighting fixtures must be far enough from the equipment and cables to prevent heat damage and to allow safe access to equipment and cables.

Building Requirements

The building requirements for this system are standard telephony industry requirements for equipment installation. The building must provide a clear, uncluttered route between the loading/receiving dock and the planned system location. In order to move the equipment to the proper location, recommended hall clearance is at least 4.5 feet (1.4 meters) wide by 8 feet (2.4 meters) tall.

Four foot, (1.2 meter) side aisles should be used to allow maneuvering frames into place and provide ample work space around the equipment. The room selected for system installation should be large enough so the system frames can be at least 2.5 feet (76 cm) from the walls for front and rear access and at least 12 inches (31 cm) for side access.

Earthquake Resistance

All of the configurations are designed to assure the system remains operational during and after an earthquake, even when the system is located on the upper floors of a zone 4 central office.

Environmental Requirements

The environmental conditions for the system must be maintained to the following ambient temperature and humidity specifications:

Operational

- » Normal operating temperature: 41° F to 104° F (5° C to 40° C)
- » Short-term temperature range: 23° F to 122° F (-5° C to 50° C)
- » Maximum rate of temperature change: 15° F, (8° C)/hour
- » Normal operating relative humidity: 5% to 85%
- » Short-term relative humidity: 5% to 90% (not to exceed 0.024 kg of water per kg of dry air)
- » Altitude: 200 feet (60 meters) below to 13,000 feet (3,900 meters) above sea level

Note: Short-term refers to a period of not more than 96 consecutive hours and a total of not more than 15 days in one year.

Note: Ambient refers to conditions at a location 1.5 m (59 in) above the floor and 400 mm (15.8 in) in front of equipment.

Transport and Storage

- » Temperature Range: -40° F to 158° F (-40° C to 70° C)
- » Relative Humidity: not to exceed 95% non-condensing. (Any evidence of condensation violates these requirements.)
- » Rain and Precipitation: Rain protection is required. No exposure to condensed water, dripping water, snow or rain is permitted, such as storage on a (non-weather protected) dock exposed to prevailing weather conditions.
- » Corrosive environment: Salt air and pollution are to be limited to short time durations, such as unloading onto a dock and moving the container out of the corrosive environment.

Heating Ventilation and Air Condition Requirements

To maintain the required temperature range, Heating, Ventilation, and Air Conditioning (HVAC) equipment should have the capacity to compensate for the BTUs/hr for each installed system shelf. The required HVAC capacity to compensate for a miscellaneous frame varies depending on the customer previously installed equipment. To calculate needed HVAC capacity, determine the wattage of the installed equipment and use the following formula: watts x 3.413 = BTUs/hr.

Floor Loading

It is recommended the floor or raised sub-flooring supporting an OC EAGLE control or extension frame have a distributed load capacity of no less than 185 pounds per square foot (932 kg/ m²). The floor loading is determined by using the following equation:

Total equipment weight/floor area = distributed floor capacity

Maximum weight of equipped OC EAGLE Control or Extension frames: 850 lbs (386 kg).

Grounding

The system operates as a digital isolated ground plane system in a central office environment and requires a single connection to the central office ground window. The system ground bars and ground cables must provide the sole grounding connection between the entire system and the central office grounding.

The system uses three types of grounding paths:

- » Battery return
- » Frame/chassis ground
- » Logic ground



Non-oxidizing grease is applied to all lugs terminated on a copper, system ground bar. The power return grounding path is the return path for all nominal -48VDC loads in the system. This path is isolated from other system grounds and connects to the rest of the central office through the nominal -48VDC return connections located on the Fuse and Alarm Panel (FAP) of each frame.

The frame/chassis ground path provides a low impedance connection for all metal parts of the entire system, including the frame, doors, card cages, and end panels. Each frame/chassis connection within a system lineup terminates to the frame and connects to the main ground bar by way of Htaps, #6 American Wire Gauge (AWG) to 1/0 cable.

The logic ground path provides a common voltage reference point between all circuit boards of a system. Each connection terminates to the system ground bar on the control frame. The frame/chassis and logic ground paths are both noncurrent carrying (i.e., less than 0.01 amps) paths.

SS7 and IP Signaling Provisioning Rules

This section provides OC EAGLE provisioning guidelines to support signaling interfaces in Release 46.1. Due to their critical network function, STPs are deployed in mated pair configurations and each STP is engineered at 40% of capacity (for links, SCCP cards, etc). Therefore, these guidelines apply to both members of the pair and result in the symmetry required within signaling networks.

SS7

MTP routing is accomplished by the Link Interface Modules which terminate E1/T1 low speed links, IP Links (SIGTRAN), ATM links, or SE-HSL/ST-HSL links.

For a complete list of supported cards in R46.1, see the OC EAGLE Hardware Reference – Available at Oracle.com on the Oracle Technology Network (OTN).

OC EAGLE “B” Cards

The OC EAGLE B cards include OC EAGLE-ENET-B (870-2971-xx), OC EAGLE-SM8G-B (870-2990-xx), OC EAGLE-APP-B (870-3096-xx), OC EAGLE-ATM-B (870-2972-xx), and OC EAGLE-MCPM-B (870-3089-xx). The following requirements are applicable for the B cards:

- » OC EAGLE fans (890-0001-xx) are required for all OC EAGLE shelves that host OC EAGLE “B” Cards. Air management cards (870-1824) are required in empty slots in shelves equipped with fans and cards that require fans. If existing, legacy OC EAGLE fans (890-1038-xx) must be replaced with 890-0001-xx fans.
- » HIPR (870-2574-xx) or HIPR2 (870-2872-xx) are required in each shelf that a B card resides in.
- » The following cards are not supported in nodes that contain OC EAGLE-ENET-B, OC EAGLE-ATM-B, OC EAGLE-MCPM-B, OC EAGLE-SM8G-B: DSM's (870-1984-xx), DCM's (870-1945-xx), EDCM's (870-2372-xx) used for SLAN or STC functionality, and EDCM-A's (870-2508-xx) used for SLAN or STC functionality.
- » The following cards are not supported in nodes that contain OC EAGLE-APP-B cards: DSM's (870-1984-xx).
- » FAP's 870-1606-02+, 870-2320-xx, and 870-2804-xx support 60A power feeds (upgrade kits must be existing in 870-1606-02+ and 870-2320-xx in order to support 60A feeds).
- » Frames shipped since ~2005 can support 60A feeds and have 60A as installation guideline.
- » Power Guidelines: (90% of the current rating is used in all calculations)
- » If customers have 60A power feeds/FAP, there is sufficient power available.
- » If customers have 30A power feeds/FAP, upgrade to 60A power feeds/FAP is recommended. Frames equipped with 30A power feeds/FAP can support 1 shelf with a fan assembly.
- » If customers have 40A power feeds/FAP, upgrade to 60A power feeds/FAP is recommended. Frames equipped with 40A power feeds/FAP can support 2 shelves with fan assemblies.
- » If customers choose not to upgrade the power feeds/FAP, then;
- » RTRV STP:DISPLAY=POWER can be used to obtain existing frame card configurations and frame power budget.
- » If customer would like Oracle to evaluate existing power at site and provide requirements for specific configurations, a site survey can be ordered. A separate quote can then be generated with required HW and power requirements

OC EAGLE-ATM-B Card

The OC EAGLE-ATM-B card is a single slot card providing 3 ports for ATM over E1 and T1 connectivity for OC EAGLE control and extension shelves. The OC EAGLE-ATM-B card supports both ANSI (Telcordia's GR-2878-CORE, July 1995, CCS Nodes Supporting ATM High Speed Signaling links) and ITU implementations (ITU I.361, I.363, Q.2110, Q.2144, and Q.2210). Only one implementation is supported per card. An OC EAGLE-ATM-B card can be “hot-swapped” with existing OC EAGLE-ATM (870-1872-xx), LIM-ATM card (870-1293-xx), or E1-ATM card

(870-2455-xx), but hot-swapping is limited to one interface for LIM-ATM and E1-ATM cards. Adapters (830-1342-05 or 830-1342-06) can be used to physically connect up to 2 non-adjacent points on the patch panel (or other termination that the OC EAGLE is connected to). If link one is communicating through one cable, and links two and three are communicating through another cable then 830-1342-05 is the applicable adapter. If links one and two are communicating through one cable, and link three is communicating through another cable then 830-1342-06 is the applicable adapter. The additional links (if applicable) and can be provisioned after the OC EAGLE-ATM-B card (and adapter/cabling if applicable) is installed. If more than one link is provisioned, then the card slot is no longer compatible with the LIM-ATM or E1-ATM cards. Inserting one of these cards after provisioning additional links causes the card to auto-inhibit.

The legacy OC EAGLE-ATM card supports 2 HSL prior to R43, and 3 HSL in R43 or greater.

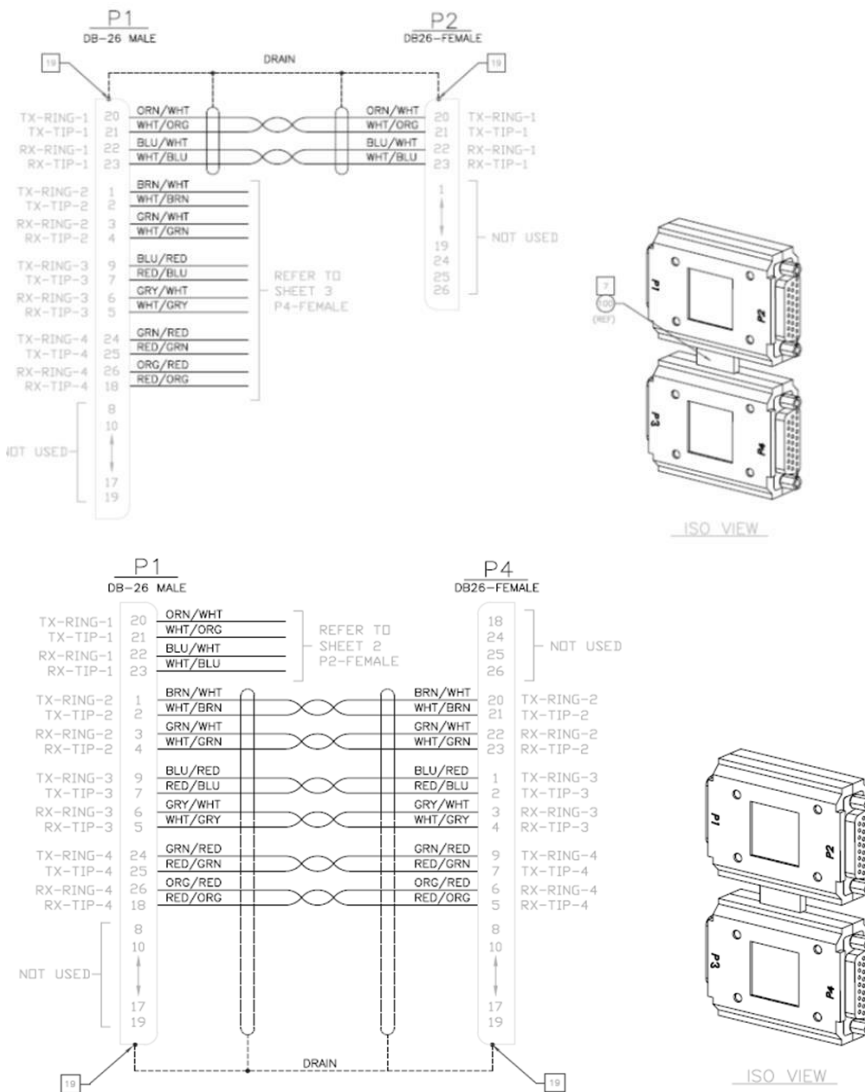

Figure 9 - 830-1342-05 ATM Adapter

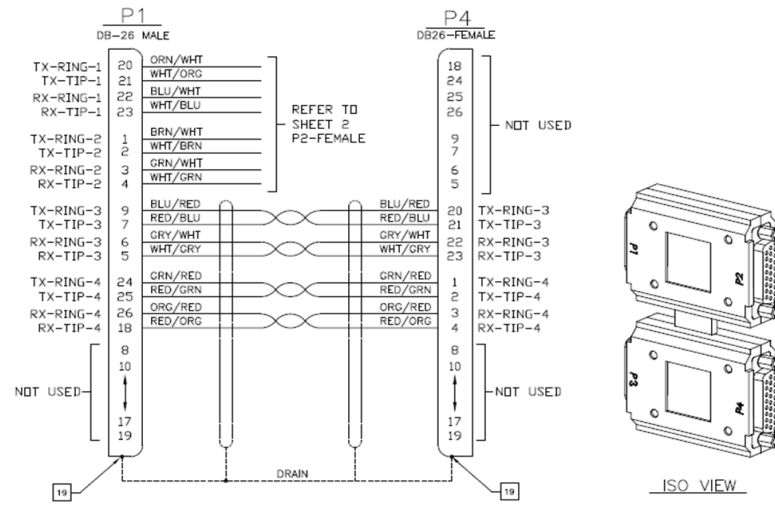
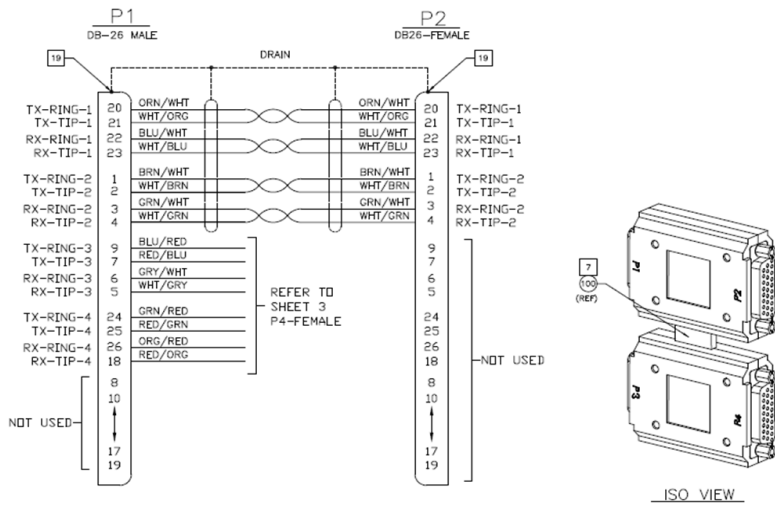

Figure 10 - 830-1342-06 ATM Adapter

OC EAGLE-E1T1-B

The OC EAGLE supports a single slot OC EAGLE-E1T1/OC EAGLE-E1T1-B card that provides low speed link or SE-HSL/ST-HSL connectivity. The card can operate in two modes, channelized E1 or T1, or Synchronous E1 mode for a (Q.703 Annex A) compliant High Speed Link (SE-HSL), or Synchronous T1 High Speed Link (ST-HSL). The OC EAGLE-E1T1/OC EAGLE-E1T1-B card includes 8 ports for terminating E1 or T1 trunks and a processing capacity for up to 32 channels of SS7 traffic from any combination of the 8 ports. Alternatively, the OC EAGLE-E1T1/OC EAGLE-E1T1-B can support 1 SE-HSL or 1 ST-HSL.

OC EAGLE-E1T1/OC EAGLE-E1T1-B cards require HIPR2 (or HIPR) in the shelf in which they reside. OC EAGLE-E1T1-B supports:

- » Release 45.0 - 32 LSL or 1 SE-HSL/ST-HSL
- » Release 46.0+ – 64 LSL or 2 SE-HSL/ST-HSL

Channelized Operation

In channelized mode, the OC EAGLE-E1T1/OC EAGLE-E1T1-B can support either E1 or T1 formats. All 8 ports terminate the same format, i.e., E1 and T1 cannot be terminated on the same card. The links can be comprised of any combination of channels from among the 8 ports. The E1 interface complies with ITU-T Recommendations G.703, G.704, G.705, and G.706. The E1 interface supports either a 75-ohm (with adapter) or 120-ohm termination. The T1 interface complies with ANSI T1.102, T1.403, and T1.408 and supports a 100-ohm termination.

A "channel-bridging" mode is also supported that allows carriers to mix signaling and non-signaling (data or voice) traffic on a trunk and terminate it at the OC EAGLE. When channel-bridging is invoked, adjacent ports are paired and non-signaling traffic received on a port is bridged to the adjacent port and transmitted back to the network. Signaling links are extracted and processed normally.

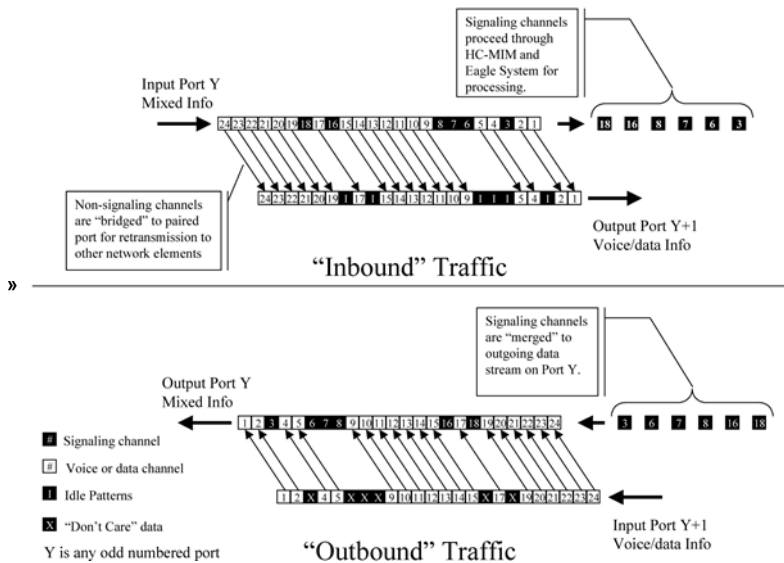

Figure 11 - E1/T1 Channel Bridging Feature

Synchronous E1 – High Speed Link Operation

The SE-HSL or ST-HSL link type is an alternative mode of operation for the OC EAGLE-E1T1/OC EAGLE-E1T1-B card. When provisioned for SE-HSL, the OC EAGLE-E1T1/OC EAGLE-E1T1-B supports ITU Q.703, Annex A compliant format. When provisioned for SE-HSL/ST-HSL operation, channelized operation is not supported on any ports. **Note:** For SE-HSL/ST-HSL operation it is recommended that the layer 3 timing t1-t6 is 500 msec or less

All ports on a single board operate in the same trunk format, E1 or T1. However, it is possible to have a mixture of trunk formats in a node with some OC EAGLE-E1T1/OC EAGLE-E1T1-Bs operating in T1 mode with others operating in E1 mode for gateway node scenarios.

IP Signaling

The OC EAGLE supports IP Signaling for A,B, C, D and E link connectivity with STPs. IP Signaling interfaces provide the SS7/IP transport interface and protocol conversions necessary to support SS7 signaling over IEEE 802.3 Ethernet 100BaseT via the SCTP/IP protocols. These features are based on the OC EAGLE-ENET-B hardware and SIGTRAN Software – IPSG (IP Signaling Gateway), IPLIM (IP Link Interface Module), and the IPGW (IP Gateway). IPSG SW is the preferred SW and provides M2PA or M3UA IETF protocols (note only one protocol is supported per card). IPLIM SW provides M2PA and IPGW SW provides M3UA or SUA. M2PA is typically used to provide IP transport of SS7 MTP packets over B, C, and D Links. M2PA also allows A and E Link connectivity to

SCPs and HLRs. M3UA provides TCAP support over A links to IP network elements such as SCPs or HLRs. SCTP is the IETF transport protocol that is required by M2PA, M3UA, and SUA.

Refer to SIGTRAN User's Guide – Available at Oracle.com on the Oracle Technology Network (OTN) available at Oracle.com on the Oracle Technology Network (OTN) for detailed capabilities and provisioning information for SIGTRAN.

OC EAGLE-ENET-B

The OC EAGLE Ethernet B (OC EAGLE-ENET-B) card is a single slot card that provides up to two Ethernet ports (100 Mbps) for signaling. Two additional ports are available for Fast Copy – an optional feature for interface to Oracle Performance Intelligence Center (PIC) product. As an alternative the OC EAGLE-ENET-B card can be provisioned to support STC, SLAN, IP User Interface, or SEAS over IP functionality. Please refer to Integrated Monitoring (PIC), OC STP LAN, IP User Interface or SEAS over IP for more details.

The OC EAGLE-ENET-B card (or legacy OC EAGLE-ENET-A) supports the following:

- » IPSP - SCTP, M2PA, M3UA
 - » A maximum of each of the following are supported per card:
 - 32 links
 - 32 SCTP associations
 - 16 M3UA links per SCTP association
 - » M3UA and M2PA are supported per card. Each SCTP association supports M2PA or M3UA (but not both).
 - » ANSI and ITU links are supported per card. One association can support both ANSI and ITU.
 - » For M2PA 1 link = 1 SCTP association.
- » IPLIM - SCTP, M2PA
 - » Up to 16 links are supported per card, each link with one SCTP association
 - » 4,000 TUs are supported per card (OC EAGLE-ENET-B card (or legacy OC EAGLE-ENET-A))
- » IPGWY - SCTP, M3UA, SUA
 - » 1 link and up to 50 SCTP associations are supported per card
 - » 4,000 TUs are supported per card (OC EAGLE-ENET-B card (or legacy OC EAGLE-ENET-A))

Transactions, Transaction Units, and TPS

In SS7 signaling, a transaction is typically defined as one MSU transmitted and one MSU received, and assumes a worst-case scenario of that many MSUs both transmitted and received simultaneously per second.

IP signaling capacity is not usually constrained by the IP network (bandwidth), but rather by the processing platform (CPU or memory). The cost of a given transaction varies based upon the feature set triggered by the transaction. Not all MSUs are the same, and not all configurations are the same. Rather than to continue to engineer product capacity for the worst case and thereby penalizing customers who are not using worst-case scenarios, Oracle is providing the Transaction Unit (TU) model to allow customers flexibility in how to use application or card capacity.

Under the TU model, a transaction unit indicates the relative cost of an IP signaling transaction; the base transaction unit is 1.0. Some transactions are more expensive than others in terms of IP signaling card capacity. A transaction that is less expensive than the base has a transaction unit less than 1.0, and a transaction that is more expensive is greater than 1.0. The total transaction units consumed by an MSU are the sum of the base transaction unit value and the additional transaction unit value. Transaction Units per Second (TPS) are then calculated with the total transaction unit value and the Advertised Card capacity.

Refer to SIGTRAN User's Guide – Available at Oracle.com on the Oracle Technology Network (OTN) available at Oracle.com on the Oracle Technology Network (OTN) for detailed capabilities and provisioning information for SIGTRAN.

The OC EAGLE-ENET-B card provisioned as IPSG supports 6,500 Transaction Units (TUs) in standard operating mode. The formula to calculate throughput is $TUs = TPS * TU \text{ factor}$. The TU factor is 1 plus the following TU adjustment factors apply in standard operating mode for IPSG (ie without High Throughput feature).

- » .15 for MSU size greater than 160 byte
- » .135 for >16 IP connections
- » .2 for SCCP Class-1 Sequencing feature
- » .00143 * MSU size for SLAN
- » .00143 * MSU size for MTP routed SCCP Conversion feature
- » .43 for copied traffic for STC based monitoring (ie non Fast Copy)

Up to 9,500 TU per card may be provided if criteria are met and High Throughput feature is enabled (893-0395-01). The TU factors above are still applicable (except MSU size > 120 byte and IP connection > 4 IP links). Additional TU factors with High Throughput feature include RTT > 50ms and M3UA protocol. Operating guidelines are below for support of greater than 6,500 TPS. Refer to SIGTRAN User's Guide – Available at Oracle.com on the Oracle Technology Network (OTN) available at Oracle.com on the Oracle Technology Network (OTN) for detailed capabilities and provisioning information for SIGTRAN.

Table 2: OC EAGLE-ENET-B Performance Guidelines

Transactions/sec (TUs)	6,500 (Base TUs)	7,500	8000	9,500
RTT (current)	<= 120 ms	<= 90 ms	<=70 ms	<=50 ms
Average MSU size (max)	272 byte	160 byte	140 byte	120 byte
Link Quantity (max)	16	12	8	4
Protocol	M2PA, M3UA	Both	Both	M2PA

It is recommended that customers do not mix OC EAGLE-ENET-B and previous generation SIGTRAN cards within a linkset due to differences in performance and N+1 redundancy. If they are mixed within a linkset, the lowest performance card should be assumed for all cards within the linkset.

If Class One Sequencing is enabled, ENET-B should be configured with a minimum of 2 cards

OC EAGLE-ENET-B Adapters

A DB26 Male to Dual RJ-45 adapter 830-1102-xx (Figure 12 - OC EAGLE-ENET-B Adapters (DB-26 to RJ-45)) is required for new card installations of OC EAGLE-ENET-B. Two adapters and two CAT5 ethernet cables are required per OC EAGLE-ENET-B card. The adapters are connected to the backplane and the CAT5 cable is connected from the other side of the adapter to a switch or a patch panel.

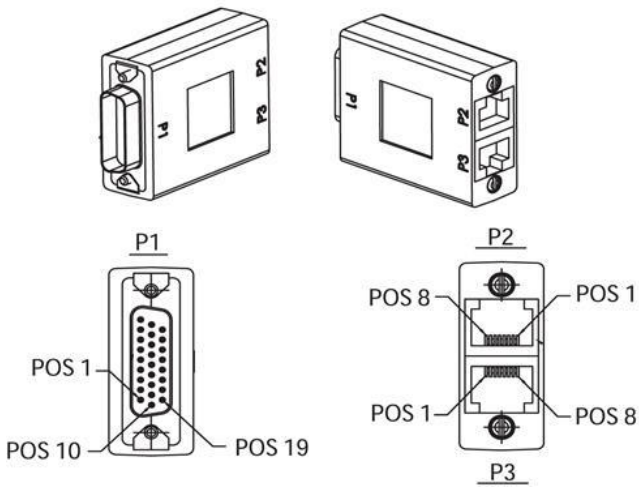
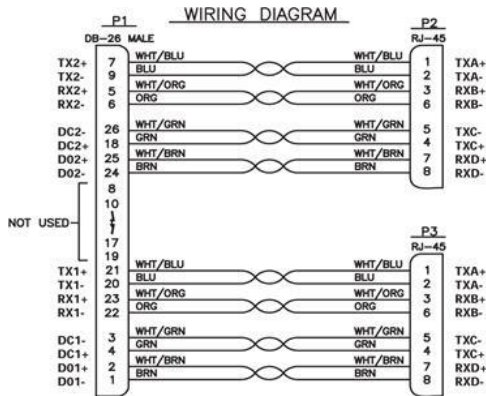

Figure 12 - OC EAGLE-ENET-B Adapters (DB-26 to RJ-45)

Optional Feature Provisioning

This section provides OC EAGLE provisioning guidelines to support optional features that require specific hardware for Release 46.1.

Due to their critical network function, STPs are deployed in mated pair configurations and each STP is engineered at 40% of capacity (for links, SCCP cards, etc). Service Modules follow these guidelines and are also deployed with N + 1 redundancy per node.

Large System Provisioning

The OC EAGLE Large System feature allows greater link capacity and configuration flexibility. The following rules apply for Large System configurations:

- 1 Maximum 2,800 links, any type defined per the following (see rules for provisioning systems with greater than 500 links in this section):
 - » 1 LSL = 1 Link
 - » 1 ATM HSL card = 1 link
 - » 1 SE-HSL/ST-HSL = 1 link
 - » 1 IPLIM = 1 to 16 links (quantity of links equals quantity of associations provisioned)
 - » 1 IPGW = 1 link

- » 1 IPSP = 1 to 32 links
 - » IPSP supports either M2PA or M3UA.
 - » For M2PA, 1 SCTP association = 1 SS7 signaling link.
 - » For M3U, up to 32 signaling links, 16 M3UA links per association, or 32 associations are supported per card (for example a card could be 32 associations with one link each, or 2 associations with 16 links each, or 16 associations with 2 links each, etc).
- 2 Maximum 1 Million TPS (Nodal Transactions per second). See rules for provisioning systems greater than 500K TPS in this section.
- 3 HIPR2 operating in High Rate Mode is required beyond 500K TPS
- 4 High Rate Mode requires high speed IMT cables throughout a node (890-0230-xx, 890-0231-xx, or 830-1344-xx for all shelves).
- 5 FAK's are required beyond 500K TPS (893-0201-01), and beyond 750K TPS (893-0407-01). Nodes being considered for support beyond 750K should be evaluated by an Oracle Sales Consultant to ensure the node does not exceed capacity limitations based on link and/or features planned. Go Forward Pricing structure includes L99411 for each 250K TPS increment.
- 6 Maximum 120 SE-HSL links is supported with FAK 893-0130-16 (R46.0 or greater is required, for prior releases the maximum is 80 SE-HSL links)
- 7 Maximum 112 ST-HSL links is supported (893-0273-15 required)

Greater than 500 link support

Rules for provisioning systems greater than 500 links.

- » Greater than 500 links up to 1,200 links (available pre-R34):
 - » 971-4143-01 SW RTU - One per node
 - » Requires Measurements Platform
- » Greater than 1,200 links up to 1,500 links (available pre-R34):
 - » 893-0059-01 – one per node
 - » Requires >500 Links feature
- » Greater than 1,500 links up to 2,000 links (available R35.1):
 - » One 893-0059-10 (SW FAK) per node
 - » Requires Large System >1200 Links feature.
 - » HIPR cards (870-2574-xx) are required throughout the node.
 - » Cards not supported:
 - LIM-DSO: 870-1009-XX / 870-1485-XX
 - LIM-OCU: 870-1010-XX / 870-1486-XX
 - LIM-V.35: 870-1012-XX / 870-1487-XX
 - LIM-AINF: 870-1014-XX / 870-1488-XX
 - LIM-ILA: 870-1484-01/02
 - LIM-EILA: 870-2049-XX
 - HMUX: 870-1965-XX
 - » Features not supported:
 - SLAN
 - China market
- » Greater than 2,000 links up to 2,800 links:

- » One 893-0059-11 (SW FAK) per node.
- » Requires Large System >1,500 Links feature.
- » Requires OC EAGLE-OAM card set (OC EAGLE-MASP 870-2903-xx and OC EAGLE-MDAL 870-2900-xx).
- » Cards not supported:
 - MPL (870-2061-xx)
 - LIM ATM (E1) (870-2455-xx)
 - LIM ATM (T1) (870-1293-xx)
 - OAM cards (TDM 870-0774-xx, GPSM-II 870-2360-xx, MDAL 870-0773-xx)
 - TSM (870-1289-xx thru 870-1292-xx)
 - E1/T1 MIM (870-2198-xx)
 - LIM E1 (870-1379-xx)
 - SSEDPCM (870-2372-01/08/13) (IPLIMx/IPGWx applications) – SSEDPCM's/EDPCM-A's can be used for STC or SLAN applications
 - ACM (870-1008-xx)
 - DCM (870-1945-xx)
 - DSM (870-1984-xx)
- » Features not supported:
 - Integrated Monitoring

1 Million TPS

The 1M System TPS feature increases the allowed System TPS (SIGTRAN TPS + ATM TPS) to 1 million transactions per second (TPS). This feature adds capacity to users who already have HIPR2 High Rate Mode feature ON and are running with any of the suggested system configuration and traffic pattern.

The maximum allowed System TPS for all SIGTRAN and ATM links and linksets provisioned in the system includes IPGW, IPSP, IPLIM and ATM links and linksets. The maximum allowed System TPS value is 500,000, 750,000 or 1,000,000 depending on the status of the HIPR2 High Rate Mode, MFC, and 1M System TPS features:

- » If the HIPR2 High Rate Mode feature is disabled or turned off, the maximum allowed System TPS is 500,000 (500k).
- » If the HIPR2 High Rate Mode feature is turned on and the 1M System TPS feature is disabled or turned off, the maximum allowed System TPS is 750,000 (750k).
- » If the HIPR2 High Rate Mode feature, the MFC feature, and the 1M System TPS feature are turned on, the maximum allowed System TPS is 1,000,000 (1M).

Provisioned TPS calculation that contributes toward 1M TPS nodal maximum includes:

- » IPLIM TPS – 4K TPS per OC EAGLE-ENET or OC EAGLE-ENET-B
- » IPGW TPS – Sum of IPGW linksets' TPS value using iptps parameter (4K TPS maximum per OC EAGLE-ENET or OC EAGLE-ENET-B)
- » OC EAGLE-ENET IPSP TPS – Minimum (5K, Sum (MAXSLKTPS) from all links on a card
- » OC EAGLE-ENET-B IPSP TPS - Minimum (6.5K, Sum (MAXSLKTPS) from all links on card, OR Minimum (9.5K, Sum (MAXSLKTPS) from all links on card if High Throughput feature is ON
- » ATM TPS - 1,630 TPS/ANSI T1 ATM link, 2,038 TPS/ITU E1 ATM link.

There are 2 applicable IPSP configuration parameters: RSVDSLKTPS and MAXSLKTPS.

RSVDSLKTPS is the amount of reserved TPS for a link, and MAXSLKTPS is the maximum TPS per link.



Reserved TPS is the amount guaranteed that is supported on a link and maximum TPS can be greater than reserved for load-sharing if desired (each card still cannot exceed its maximum of 5K TPS for ENET, 6.5K TPS for ENET-B, 9.5K TPS for ENET-B with High Throughput).

For example, 2 links on an ENET-B card (without High Throughput on) that are reserved at 2,500 TPS each, and max TPS on each link is 5K TPS. One link can operate at 1K TPS and the other link can operate up to 5K TPS (limited by the Max TPS setting). If link one increases to 2K TPS, then link two drops to 4.5K TPS (limited by card capacity of 6.5K TPS).

Example 1 – ENET-B card with one M2PA link that is being engineered for 5K TPS

- » RSVDSLKTPS is 5K TPS, MAXSLKTPS is 5K TPS
- » Value towards nodal 1M TPS capacity is 5K TPS (MAXSLKTPS)

Example 2 – ENET-B card with two M2PA links that are being engineered for 5K TPS (split evenly between the two links)

- » RSVDSLKTPS is 2.5K TPS for each of the two links (to total the 5K TPS), MAXSLKTPS is 5K TPS for each link (to provide load-sharing capability)
- » Value towards nodal 1M TPS is 6.5K TPS – ie Minimum (6.5K, Sum (MAXSLKTPS) from all links on card = 10K = 5K + 5K in this case)

Rules/Limitations

For the 1M System TPS feature, the OC EAGLE has following rules:

- » 893-0407-01 software FAK is required. The feature can be turned on and off.
- » The 1M System TPS feature cannot be turned on unless the HIPR2 High Rate Mode feature is ON and the MFC feature is ON.
- » HIPR2's are required throughout the node for greater than 500K TPS (ie HMUX, HIPR do not support)
- » The HIPR2 High Rate Mode feature cannot be turned off if 1M System TPS feature is turned on.
- » The MFC feature cannot be turned off if 1M System TPS feature is turned on.
- » The OC EAGLE configuration must follow the recommended node configuration, overhead features, and traffic pattern.
- » The HIPR2 High Rate Mode feature cannot be turned off if the OC EAGLE has more than 500,000 System TPS provisioned.
- » The 1M System TPS feature cannot be turned off if the OC EAGLE has more than 750,000 System TPS provisioned.
- » If the OC EAGLE has 1,000,000 System TPS provisioned, the user cannot enter a provisioning command to increase the provisioned System TPS.
- » High rate IMT cables are required (890-0230-xx, 890-0231-xx, or 830-1344-xx). If cable retrofits are required, Oracle Consulting services are required for implementation.

Database Services Features

The OC EAGLE is capable of providing integrated database services typically associated with a SCP or stand-alone application server. The integration of these applications with the core OC EAGLE infrastructure and STP functionality allows database services to run at high transaction rates with very high reliability. OC EAGLE supports the following database services (those features that require ELAP or EPAP are noted):

- » Query-based Number Portability Solutions (Fixed or Mobile)

- » NA LNP - North American Local Number Portability (ELAP)
- » INP - INAP-based Number Portability (EPAP)
- » AINPQ ANSI-41 NP Query
- » Mobile Number Portability Solutions
 - » GSM Mobile Number Portability (EPAP)
 - » ANSI-41 Mobile Number Portability (EPAP)
 - » IS-41-to-GSM Migration (EPAP)
- » Number Portability Solutions for Prepaid/Service Node Access
 - » GSM SRI Query (EPAP)
 - » GSM ATI Query (EPAP)
 - » IDP Relay (EPAP)
 - » IDP Relay for SMS (EPAP)
 - » IDP Screening (EPAP)
- » ISUP-interception-based Routing and Number Portability Solutions
 - » Trigger-less ISUP Number Portability (TINP) (EPAP)
 - » TIF NP – Trigger-less ISUP Framework Number Portability (EPAP)
 - » TIF Number Substitution (EPAP)
- » SMS Number Portability and Routing Solutions
 - » Prepaid SMS Intercept (EPAP)
 - » SMS Number Portability for GSM and IS41 (EPAP)
 - » MO SMS IS41-to-GSM Migration (EPAP)
- » HLR Router (EPAP)
- » V-Flex Voicemail Router (EPAP)
- » Equipment Identity Register (EPAP)
- » Diameter S13/S13' Equipment Identify Register (EPAP)
- » SIP Number Portability (EPAP or ELAP)
- » Supporting Functionalities
 - » SCCP Service Reroute
 - » MTP Messages for SCCP Applications
 - » Multiple Local Subsystems
 - » Additional Subscriber Data (ASD) (EPAP)
 - » Numbering Plan Processor (NPP)
 - » Home SMSC “Match with Digits” Option
 - » TCAP-Segmented SMS Phase 1

The EPAP based features require GTT, the application specific software, along with service modules (quantity N+1) with associated adapters (two 830-1104-04 per card), cables, switches, and OC EAGLE-APP-B cards (quantity 2).

- » The engineered TPS should be cumulative between GTT and the application (eg HLR Router requires GTT TPS + HLR Router TPS).
- » The calculation for service module TPS is determined by information in Table 3: Service Module Throughput/DB Capacity Table. For information regarding EIR and SIP NP please refer to Equipment Identity Register for 2G, 3G, and LTE Networks and SIP Number Portability.

Global Title Translation

OC EAGLE Service Modules with 8GB memory (OC EAGLE-SM8G-B) are provisioned to provide GTT. See the table below for throughput for each application. For reliability, the number of OC EAGLE-SM8G-Bs equipped is “N+1”. In these equations, “N” represents the number of OC EAGLE-SM8G-Bs required for the TPS specified.

GTT is required for all SCCP features including advanced GTT routing features, EPAP based features, and ELAP (for NA Number Portability). Hex Digit support requires OC EAGLE-SM4G or OC EAGLE-SM8G-B.

Table 3: Service Module Throughput/DB Capacity Table

OC EAGLE Release (Planned Availability)	GTT Card TPS (System)	ANSI HLR Router Card TPS (System)	ITU EPAP Application Card TPS (System)	LNP Card TPS (System)	LNP DB Entries	EPAP Application DB Entries
38.0 (2Q08)	5,000 (150K)	5,000 (120K)	3,125 (75K)	1,700 (40K)	192M	96M
39.0 (LA)	5,000 (150K)	5,000 (120K)	3,125 (75K)	5,000 (40K)	384M	96M
40.0 (1Q09)	5,000 (150K)	5,000 (120K)	3,125 (75K)	5,000 (40K)	384M	120M
41.1 (4Q09)	6,800 (210K)	6,800 (163K)	6,800 (163K)	6,800 (54K)	384M	120M
42.0 (4Q10)	6,800 (210K)	6,800 (210K)	6,800 (210K)	6,800 (115K)	384M	120M
44.0 (2Q12)	10,000 (310K)	10,000 (310K)	10,000 (310K)	10,000 (170K)	384M	120M
45.0 (2Q13)	13,600 (421.6K)	13,600 (421.6K)	13,600 (421.6K)	13,600 (231.2K)	384M	120M (DN)+ 120M (IMS)

Table Notes:

Releases with throughput or DB capacity enhancements are highlighted in light gray.

OC EAGLE- SM8G-B is required for 10K TPS/Card (R44 and forward)

13.6K/SM8G- B requires all B cards (or OC EAGLE-E1T1) and HIPR2 throughout the node

T1000/Hub based EPAP Applications are limited to 25 total Service Module cards (24 + 1)

EIR has maximum database entries of 32M

OC EAGLE- SM8G-B throughput for S13/S13’ EIR and SIP NP are described in their respective sections.

The following is the formula for determining the number of service module cards required:

OC EAGLE-SM8G-B Qty = ROUNDUP (TPS/13,600)+ 1. Specific limitations that are noted in the table notes throughput chart may result in less TPS per OC EAGLE-SM8G-B.

Example: If the transaction rate on the OC EAGLE is 50,000 per second, the following calculations would be used to determine “N+1”. Note service modules should provide standard SS7 guidelines (engineered at 40% capacity).

$$\text{OC EAGLE-SM8G-Bs: } \text{ROUNDUP}(50,000 / 13,600) + 1 = 4 + 1 = 5 \text{ OC EAGLE-SM8G-Bs}$$

Baseline GTT Components are service module cards and GTT software.

An OC EAGLE node with current hardware supports up to a total of 32 service module cards. Some applications do not support 32 cards (eg S13/S13' EIR and SIP NP each only support 16 service module cards), but if one of these applications are deployed the remaining cards (up to 32 total) may support other applications.

Local Number Portability (LNP) – North America

The Local Number Portability feature allows subscribers to switch local or wireless carriers and still retain the same phone number. For ELAP 8.0 and later, the 384 Million LNP Records feature supports up to 384 Million telephone numbers (TNs). This feature interacts with the LSMS, which must be release 11.0 or greater for 384M records support. For more than 228 million LNP records, the Measurement Platform feature must be turned on.

The 384 Million LNP Records feature allows up to 13,600 TPS per OC EAGLE-SM8G-B card. The total system OC EAGLE-SM8G cards that are supported is 18 (17 + 1). See Table 3: Service Module Throughput/DB Capacity Table, for details.

The 384 Million LNP Records feature requires OC EAGLE-SM8G-B/SM4G cards (along with the Measurements Platform). See the table below for more details.

- » For ELAP releases 7.0 and earlier, LNP subscriber numbers of less than 192 million can use a mix of DSM and OC EAGLE-SM4G cards; for 204 to 228 million numbers, only DSM cards can be used.
- » For ELAP release 8.0 or greater, 204 to 228 million numbers or more than 240 million numbers require OC EAGLE-SM8G-B (or legacy OC EAGLE-SM4G) cards with adapters (830-1104-04). OC EAGLE-APP-B and switches are also required (T1100 with Switches for legacy installations).

ELAP 10.0 requires OC EAGLE-APP-B cards and switches.

Table 4: LNP FAK/Hardware Compatibility

Quantity FAK Enabled	ELAP 7.0 or earlier	ELAP 8.0+
<= 192M	DSM, OC EAGLE-SM4G, OC EAGLE-SM8G-B with Hubs	OC EAGLE-SM4G, OC EAGLE-SM8G-B with switches
>192M, <= 228M	DSMs with Hubs	OC EAGLE-SM4G, OC EAGLE-SM8G-B with switches
>240M	N/A	OC EAGLE-SM4G, OC EAGLE-SM8G-B with switches

- » With switches, a total of 18 service modules (17 + 1_) can be deployed per OC EAGLE node.
- » With hubs, a total of 25 Service Modules (24 + 1) can be deployed per OC EAGLE node.
- » N is calculated from the expected number of transactions per second.

For reliability, the number of OC EAGLE-SM8G-Bs equipped is “N+1.” In these equations, “N” represents the number of OC EAGLE-SM8G-Bs needed. Thus, N is calculated from the expected number of transactions per second.

The Oracle Local Services Management System (LSMS) supports the LNP feature of the OC EAGLE. The LSMS interfaces with Number Portability Administration Centers (NPACs) and the Element Management Systems (EMS) on the OC EAGLE to provision LNP data.

The LNP baseline components include LNP software, GTT, service module cards (and associated adapters and cables), and OC EAGLE-APP-B cards. For EAGLE and LSMS software compatibility with ELAP, see Table 16: OC EAGLE/ELAP Compatibility and Table 17: OC EAGLE / LSMS Compatibility.

Table 5: ELAP 10.0 SW Compatibility

Release #	Compatibility
OC EAGLE R43	FC
OC EAGLE R44	FC
OC EAGLE R45	FC
LSMS 10	NC
LSMS 11.x	FC
LSMS 12	FC

Local Service Management System (LSMS)

The LSMS provides an interface between the Number Portability Administration Center (NPAC) Service Management System (SMS) and the service provider's Element Management System (EMS). The LSMS maintains a service provider's LNP data.

LNP allows a subscriber to change local service provider, while keeping the same directory number. LNP ensures that subscribers receive the same freedom of choice for local service as they do with long-distance service providers.

The LSMS is composed of hardware and software components that interact to create a secure and reliable LNP system.

LSMS provides a series of network connections to enable it to interact with NPACs, EMSs, and remote consoles. Refer to Figure 13 - LSMS Network. The following sets of network connections can be made to your network:

- » NPAC - Depending on your network configuration, a 100BASE-TX Ethernet interface that typically connects to an external WAN. This interface provides connectivity to one or more remote NPAC sites. These connections are shown going to the NPAC WAN in Figure 13 - LSMS Network.
- » ELAP WAN -- Depending on your network configuration, a 100BASE-TX Ethernet interface that typically connects to your site's secure WAN. This interface provides connectivity to the customer's OC EAGLE sites.
- » Application -- Depending on your network configuration, a 100BASE-TX Ethernet interface that typically connects to your site's internal LAN or secure WAN. This interface provides connectivity for workstations that use the optional IP User Interface. These connections are shown going to the Application WAN in Figure 13 - LSMS Network.

Administration -- Depending on your network configuration, a 100BASE-TX Ethernet interface on an OC EAGLE-APP-B. This interface provides connectivity between the LSMS redundant servers and the remote administration LAN. This interface uses a reserved class IP address (192.168.52.0). These connections are shown going to the

Administration LAN in Figure 13 - LSMS Network.

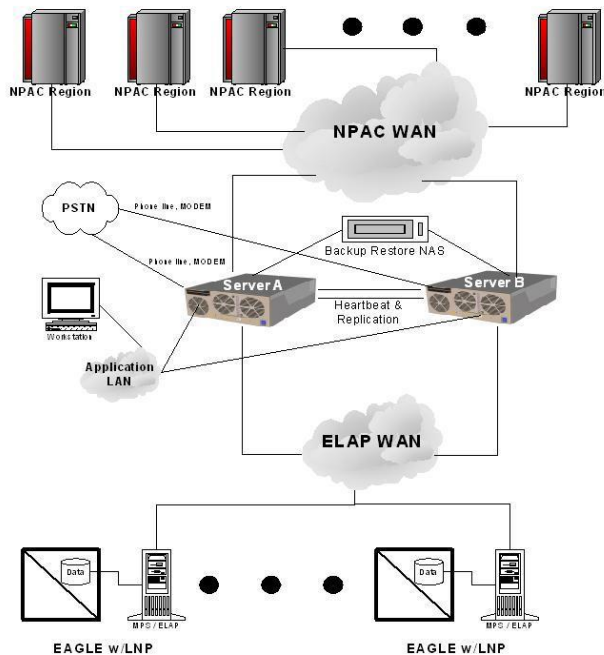

Figure 13 - LSMS Network

LSMS 13 Configuration Rules

- » LSMS 13 requires OC EAGLE-APP-B with 480GB drive (870-3096-02) for LSMS and NAS. LSMS requires a software license (per LSMS OC EAGLE-APP-B)
- » LSMS requires ELAP 10.0 (OC EAGLE-APP-B)
- » DC Power is required for OC EAGLE frame and shelf to house the LSMS/NAS OC EAGLE-APP-Bs.
- » 870-3096-02 (OC EAGLE-APP-B Card) – Qty 3 plus spare per node (2 for LSMS servers, 1 for NAS). Each is dual slot card that resides in an OC EAGLE shelf.
- » LSMS requires an 870-3332-01 installation kit
- » LSMS supports up to 16 LNP nodes.
- » One LSMS is required per network (note additional LSMSs may be configured if network is configured regionally).

In addition to these external interfaces, there are two inter-server 100BASE-TX connections that provide redundant heartbeat monitoring to help with switchover initiation. These are connections on a private LSMS network. If there are conflicts with defaults of IP addresses assigned to these private networks, they may be changed to resolve the conflicts.

Optional Query Server Software Package

The query server is a function hosted on a platform distinct from the LSMS that maintains a copy of the LNP data that resides on the LSMS. This feature provides the software and configuration information required to deploy the query server function. The hardware itself is not part of this feature. Customers may procure their own hardware system based on platform specifications provided by Oracle.

By hosting a copy of the LSMS database on a separate platform, high volume customized queries may be performed with controlled processing impact on the LSMS itself.

The query server system is provisioned from the Oracle LSMS using database replication techniques provided by MySQL.

Note: The platform hosting a query server is to be solely dedicated to the query server function. Using the query server platform for any other processing degrades performance and may potentially conflict with the query server operation and produce unexpected results. The network between the LSMS and query server, and between query server and daisy-chained query server must meet minimum requirements and be configured specifically to accommodate the expected traffic. See your Oracle Sales Consultant for additional details.

OC EAGLE Provisioning Application Processor (EPAP)

The OC EAGLE Provisioning Application Processor (EPAP) platform, coupled with the Provisioning Database Application (PDBA), facilitates and maintains the database required by EPAP-related features.

The EPAP serves two major purposes:

- 1 Accept and store data provisioned by the customer
- 2 Update customer provisioning data and reload databases on the Service Module cards in the OC EAGLE.

EPAP SW/HW compatibilities:

- » EPAP 15 requires T1200/switches or OC EAGLE-APP-B/switches (note EPAP 15 is the last release to support T1200/switches)
- » EPAP 14 or greater requires T1200/switches (ie T1000/hubs are not supported beyond EPAP R13)

EPAP is deployed on 2 OC EAGLE-APP-B cards per OC EAGLE node (of which they can be one provisioning and one non-provisioning, or two non-provisioning). There are a minimum of two provisioning APP-B's running EPAP per network and a maximum of 22 OC EAGLEs served by the two provisioning OC EAGLE APP-Bs.

In EPAP 15 or greater, there is also an option of having a Stand-alone PDB (provisioning DB) for greater performance. In this deployment scenario the first pair of OC EAGLEs in a network includes 3 OC EAGLE-APP-B cards (1 OC EAGLE-APP-B for provisioning, the other 2 OC EAGLE APP-Bs non-provisioning).

During normal operation, information flows through the EPAP and PDBA with no intervention. Each EPAP has a graphical user interface that supports maintenance, debugging, and platform operations.

The EPAP user interface includes a PDBA user interface for configuration and database maintenance. An EPAP system consists of two mated EPAP processors (A and B) installed as part of an OC EAGLE. A set of Service Module cards is part of the OC EAGLE. Each Service Module card stores a copy of the Real Time Database (RTDB).

The main and backup Service Module networks are two high-speed Ethernet links, which connect the Service Module cards and the EPAPs. Another Ethernet link connects the two EPAPs and is identified as the EPAP Sync network.

Figure 14 - EPAP Architecture below shows the network layout and examples of typical IP addresses of the network elements. The shaded portion represents a second OC EAGLE and mated EPAPs deployed as a mated OC EAGLE. The EPAP system maintains the Real Time Database (RTDB) required to provision the OC EAGLE Service Module cards, and maintains redundant copies of both databases on each mated EPAP.

One EPAP runs as the Active EPAP and the other as the Standby EPAP. In normal operation, the Service Module card database is provisioned through the main Service Module network by the Active EPAP. If the Active EPAP fails, the Standby EPAP takes over the role of Active EPAP and continues to provision the database. If the main Service Module network fails completely and connectivity is lost for all OC EAGLE Service Modules cards, the Active EPAP switches to the backup Service Module network to continue provisioning the Service Module cards.

Any failure which has a limited impact on database provisioning does not automatically trigger a switchover to the backup Service Module network. At any given time, only one Active EPAP uses one Service Module network per EPAP system. The Provisioning Multiple EPAPs Support feature provides the capability to connect to a single active provisioning EPAP A that is used to provision up to 22 non-provisioning EPAP systems.

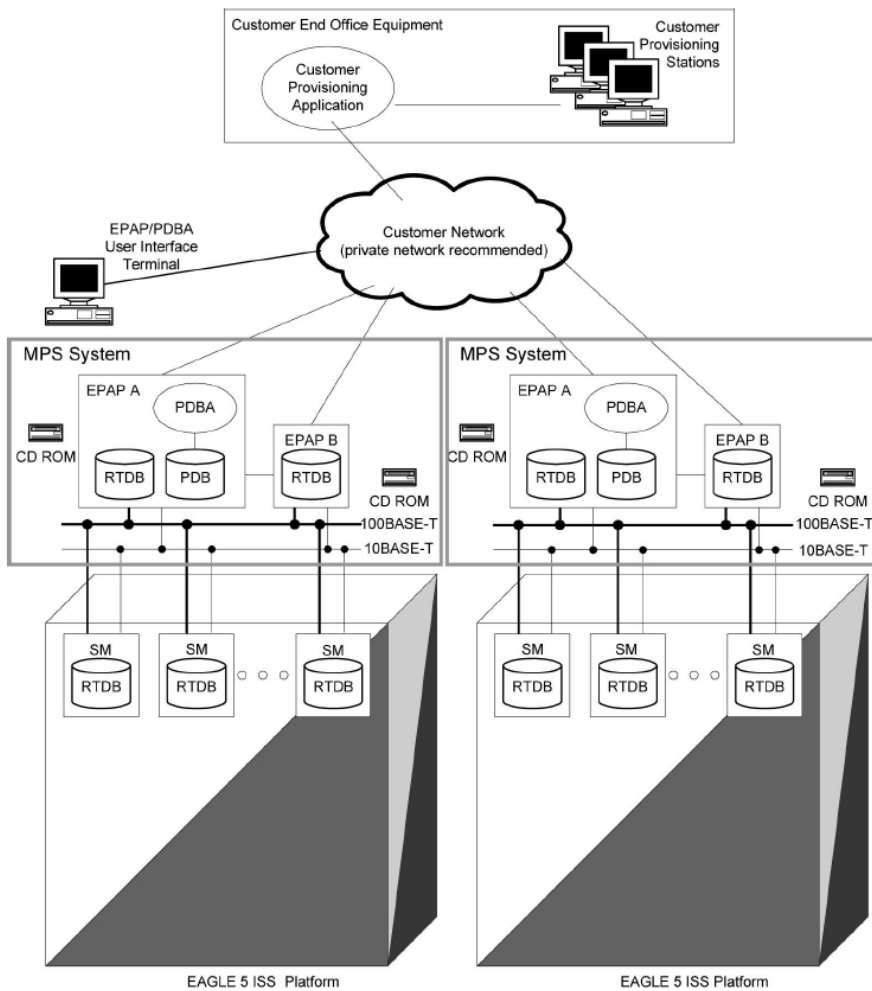

Figure 14 - EPAP Architecture

The following rules apply to all features that require EPAP.

- » EPAP is deployed on OC EAGLE-APP-B cards
- » There are 2 OC EAGLE-APP-B EPAP servers per OC EAGLE, of which they can be 1 provisioning and 1 non-provisioning, or 2 non-provisioning.

- » There are a minimum of 2 provisioning servers per network.
- » There are a maximum of 22 OC EAGLE's supported by 2 provisioning servers.

Table 6: EPAP Release 15 Compatibility with OC EAGLE-APP-B

Product	Release	Compatibility
OC EAGLE	43.0	PC*
	44.0	PC*
	45.0	FC

* Some of the new features introduced in EPAP 15.0 are only available when OC EAGLE is upgraded to Release 45.0

Table 7: EPAP Release 15 Compatibility with T1200

Product	Release	Compatibility
OC EAGLE	43.0	NC*
	44.0	NC*
	45.0	FC

*OC EAGLE must be upgraded to Release 45.0 prior to upgrading EPAP to Release 15.0.

» EPAP 120 Million DN/IMSI Entries

The 120 Million EPAP DN/IMSI Entries feature allows an EPAP-based OC EAGLE user to provision up to 120 million records in the EPAP/RTDB database, utilizing OC EAGLE-SM4G/SM8G-B cards and compacting the database. This database capacity is available for DN-only, IMSI only, or combinations of DN and IMSI entries, as currently supported by EPAP.

This feature also increases the supported DN ranges to 100,000 range entries.

Note: Not all combinations of DN and IMSI add up to 120 million. However, up to 60 Million subscribers are supported assuming a 1:1 ratio of DN and IMSIs.

Note: For legacy T1000 EPAPs hard disks must be 250 GB drives or greater and the file systems must be reconfigured if the database size exceeds 56 million entries. The non-provisioning server's hard disk does not require any changes to support the 120 Million EPAP DN/IMSI Entries feature. (A single active provisioning EPAP A can provision up to 12 non-provisioning EPAP systems).

» 120M DN + 120M IMSI Entries

The 120M DN and 120M IMSIs is implemented via the Split Database feature, or EPAP Data Split feature. The EPAP data is split into DN and IMSI subsets. Each subset of data is loaded on a specific set of OC EAGLE-SM4G or OC EAGLE-SM8G-B cards. Since each set can support 120 million, splitting the data allows a system-wide EPAP data capacity of 240 million.



After the EPAP Data Split feature is turned on, the chg-card command is used to designate OC EAGLE-SM4G and OC EAGLE-SM8G-B cards as either DN or IMSI cards. The DN, DN Block, ASD and Entity data are loaded on the DN card, and the IMSI, IMEI, IMEI block, and Entity data are loaded on the IMSI card.

Feature Control Requirements

- » 893-0398-01 software FAK along with applicable DB capacity RTU licenses (971-3055-01 per 500K records)
- » A temporary FAK cannot be used to enable the feature.
- » The feature cannot be turned off after it is turned on.
- » The EPAP Data Split feature requires EPAP 15 or higher.
- » Message Flow Control must be turned on before the EPAP Data Split feature can be enabled.
- » At least one EPAP-related feature must be turned on before the EPAP Data Split feature can be enabled.
- » OC EAGLE-SM4G or OC EAGLE-SM8G-B service module cards must be present in the system before the feature can be enabled.
- » Two groups of service module cards are required, each configured for N + 1 redundancy. One group for DN, one group for IMSI.
- » The following cards are not supported for this feature: DSM's (870-1984-xx), EDCM's for SIGTRAN (870-2372-xx), MPL's (870-2061-xx), E1/T1 MIM's (870-2198-xx), and E1 or T1 ATM's (870-2455-xx, 870-1293-xx).
- » The maximum Service Selector table size supported is 1,000 records when greater than 120M EPAP DB records is implemented.
- » OC EAGLE P/N 893-0217-01 (FAK for HLR Router MAP Layer Routing) cannot co-exist with this feature

Hardware Requirements

- » OC EAGLE-SM4G or OC EAGLE-SM8G-B cards must be running in the system before the EPAP Data Split feature can be enabled. If a DSM card is running, then the feature cannot be enabled.
- » If a DSM, E1-ATM, E1T1-MIM, LIM-ATM, or MPL card is installed after the EPAP Data Split feature is turned on, then the card auto-inhibits.
- » OC EAGLE-APP-B EPAP cards are required.
- » Equipment Identity Register for 2G, 3G, and LTE Networks

OC EAGLE's EIR solution has supported traditional SS7 networks such as ANSI/ITU MAP for several years. Operators evolving their networks are now faced with interface problems when they want to leverage their existing SCP-based EIR databases. OC EAGLE's Diameter S13/S13' EIR feature was developed to meet EIR requirements for LTE networks and is available in OC EAGLE Release 45.1.

The Diameter S13/S13' feature interface solution stands between OC EAGLE EIR database and MME/SGSN acting as Diameter S13/S13' application gateway. It enhances OC EAGLE's capability to support S13/S13' interface and also provides EIR lookup using OC EAGLE's RTDB.

The rules for OC EAGLE's SS7 EIR are the same as other standard EPAP features (see OC EAGLE Provisioning Application Processor (EPAP)). Note 32M database entries is the maximum for EIR.

The associated rules associated with Diameter S13/S13' EIR include the following:

- » OC EAGLE-SM8G-B cards are required.
- » Each OC EAGLE-SM8G-B supports 8K TPS (3.2K TPS engineered with standard 40% capacity guideline), configured with N+1 redundancy
- » The OC EAGLE-SM8G-B cards used for Diameter S13/S13' EIR are a dedicated group of cards. Other SCCP applications using Service Modules require their own group of Service Module cards.
- » Diameter S13/S13' EIR requires EIR (each with their own pool of service module cards)
- » Up to 16 OC EAGLE-SM8G-B's can be used for Diameter S13/S13' EIR

- » OC EAGLE maximum is 32 Service Module cards per node (cumulative total that is used for Diameter S13/S13' EIR, EIR, SIP NP, or other SCCP applications)
- » An OC EAGLE-SM8G-B card running Diameter S13/S13' EIR supports up to 32 diameter connections.
- » Diameter S13/S13' EIR can co-exist with other EPAP based applications, such as MNP, HLR Router.
- » Up to 32M subscriber records are supported for Diameter S13/S13' EIR
- » Diameter S13/S13' EIR requires EPAP - OC EAGLE-APP-B for new shipments, T1000 or T1200 EPAP are supported for existing EPAP customers
- » Customer provided load balancer may be needed if traffic levels high enough that scalability and load-sharing are needed
- » FAK 893-0424-01 is required.
- » Diameter S13/S13' EIR does not support FTRA for new commands.
- » Diameter S13/S13' EIR does not support OC EAGLEMS for new commands in Release 45.1.

Diameter S13/S13' EIR Diameter Architecture

Diameter S13/S13' EIR architecture consists of:

- » Diameter S13/S13' EIR card does connect to EPAP using port A.
- » Diameter S13/S13' EIR card does connect to diameter signaling network using port B.

The figure below displays the overall system architecture:

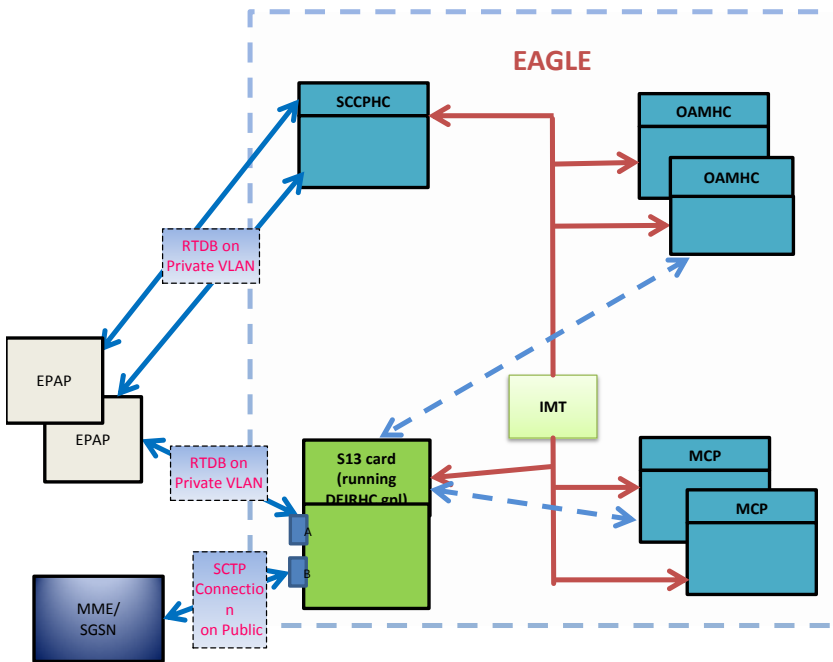

Figure 15 - Diameter S13/S13' EIR Architecture

Diameter S13/S13' EIR EPAP Interface

The SM8G-B card running Diameter S13/S13' EIR connects to EPAP using port A. The RTDB data is downloaded on the card in the same manner as it's done on Service Module cards.

The difference between the EPAP connectivity on a Diameter S13/S13' EIR card and Service Module card running other EPAP applications is that upon failure of Switch-A (between EPAP-A and OC EAGLE) or port A on OC EAGLE's card, SCCP card starts data download via port B/Switch B. Refer to the figure below. However for

Diameter S13/S13' EIR card, the cable must be manually moved to other switch and Diameter S13/S13' EIR card is re-provisioned with other EPAP's address.

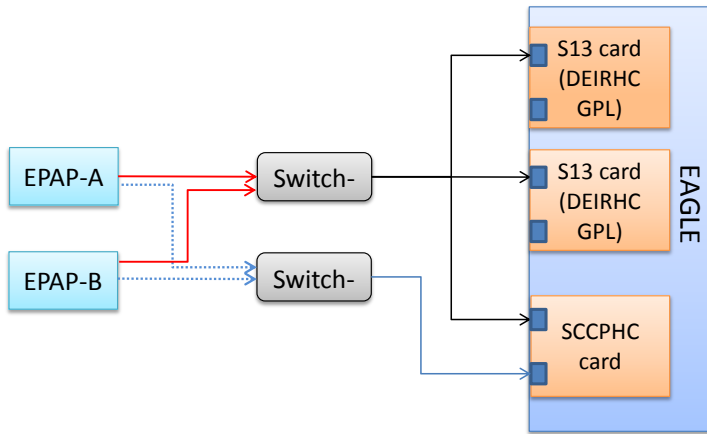

Figure 16 - Diameter S13/S13' EIR Card EPAP Interface

Signaling Network Redundancy

For the signaling network, redundancy actually means scalability/load sharing. Thus a solution for scalability can most likely be used to address redundancy as well. Signaling side redundancy is provided using external load balancer. An external load balancer provides both scalability and load sharing.

OC EAGLE supports multiple Diameter S13/S13' EIR cards. Each card has a separate IP and operates independently. An external load balancer makes connections with all Diameter S13/S13' EIR cards and load-shares the traffic. If one Diameter S13/S13' EIR card goes down then traffic currently being handled by that card is lost. An external load balancer does not use that card for load sharing traffic until the card is ready to handle traffic again. If a connection between a Diameter S13/S13' EIR card and load balancer goes down, the behavior is similar as if the is card down.

Private Network redundancy

A Diameter S13/S13' EIR card is connected to EPAP using a private network. Port A on a Diameter S13/S13' EIR card is reserved for EPAP connection. As per the current approach, there is no EPAP network redundancy. If a connection to EPAP goes down, then the Diameter S13/S13' EIR card continues to operate with the existing EIR database.

The figure below depicts a signaling network side redundancy and private network side redundancy.

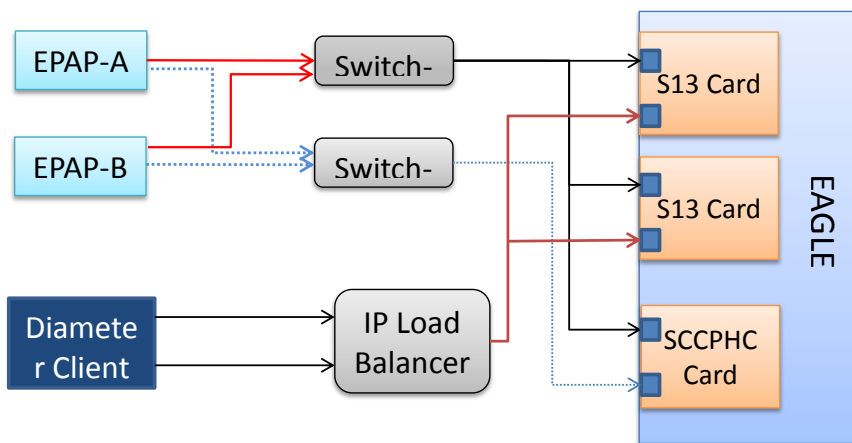

Figure 17 - S13 Card EPAP Interface

SIP Number Portability

The Session Initiation Protocol SIP Number Portability (SIP NP) feature provides SIP-based Number Portability using OC EAGLE's RxDB (RTDB/RIDB). This feature adds an SIP interface to allow SIP NP requests to be received by an OC EAGLE card, processed by the OC EAGLE's RxDB, and a response transmitted back to the requestor.

The SIPHC GPL supporting a SIP stack over TCP/UDP is used and runs on OC EAGLE-SM8G-B hardware. The ON Only Feature Access Key (P/N 893-0406-01) controls SIP-based Number Portability functionality.

» SIP NP Architecture

- » SIPHC GPL for SIP NP solution
- » SIP App runs on OC EAGLE-SM8G-B (configure N+1 based on 1,000 TPS maximum per card in R45, 400 TPS at 40% engineered rate). Configure 4,000 TPS per card in R46 (1,600 TPS at 40% engineered rate).
- » The OC EAGLE-SM8G-B cards used for SIP NP are a dedicated group of cards. Other SCCP applications or other applications using Service Modules (e.g., S13/S13' EIR) require their own group of service module cards.
- » SIP card connects to ExAP using port A
- » SIP card connects to SIP signaling network using port B
- » No RxDB redundancy
- » OC EAGLE-SM8G-B card running SCCPHC GPL continues to function normally
- » External Load Balancer may be required (3rd party equipment to be provided by customer)

The hardware requirements and configuration include these items:

- » SIPHC GPL only runs on OC EAGLE-SM8G-B card.
- » A maximum of 16 SIP cards can be configured per OC EAGLE:
- » Note: An EPAP system can support up to 32 SM cards; 16 of those cards can be SIP cards
- » An ELAP system can support up to 17 cards; 16 of those cards can be SIP cards
- » A combined ELAP/EPAP system can support up to 32 cards; both rules above apply
- » Ethernet Interface A0 is used for ExAP connectivity and B0 is used for signaling network.
- » Requires Measurements Platform

» ExAP Interface

SIP card connects to ExAP using port A. The RxDDB data is downloaded on the SIP card in same manner as on Service Module cards; however, SIP card's cable must be manually moved to other switch and the SIP card re-provisioned with other ExAP's address.

SIP App performs lookup RxDDB using Normalized DN. For RTDB, lookup is performed first on individual entries, and if no match is found, then on range DNs.

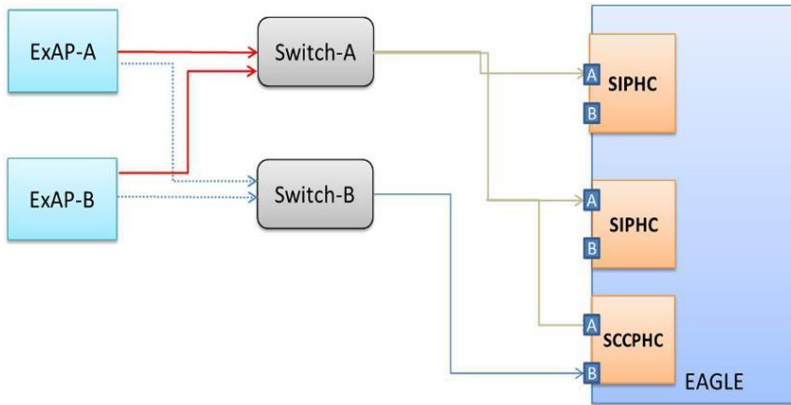

Figure 18 - SIP Card Interface with ExAP

Combining Multiple Advanced Database Features

In the case that multiple Advanced Database Features are deployed on the same node, the following guidelines are used:

- » OC EAGLE-SM8G-B quantity is calculated based on the number of expected total SS7 SSCP TPS, including messages that are processed by MNP, HLR Router, INP and EIR as well as message processed by standard/enhanced GTT. The OC EAGLE-SM8G-B card processes SS7 traffic destined for all Advanced Database features and GTT service).
- » Calculate:
 - # Advanced Database Entries = SUM (MNP MSISDNs + HLR Router IMSIs + (EIR IMEIs or INP DNs))
 - Note: 32 Million IMEIs is supported for EIR
- » Requires two OC EAGLE-APP-Bs running EPAP application, and associated peripheral hardware.
- » Provision GTT or Enhanced Global Title Translation optional software feature modules. If GTT or EGTT is not activated, the system does not allow EIR to be activated. If this is an existing system which already has GTT or EGTT active, this feature is not required.
- » EIR and INP cannot coexist on the same node.
- » Include required software licenses for requested features.

Dual ExAP (Release 45)

These configuration rules are incremental to the ELAP and EPAP configuration rules:

- » SW FAK is required per node (893-0405-01)

Gateway Screening

To provide for the immediate and rapid downloading of gateway screening data to LIMs, the OC EAGLE backs up screening data tables on the OC EAGLE-OAM cards.

- » OC EAGLE-OAM cards, R44.0, and a Feature Access Key (893-0389-01) is required for new implementations
- » Legacy OC EAGLE-TSM cards 870-2943 also support Gateway Screening in the current OC EAGLE release (deployed with two cards)

GSM MAP Screening (ITU) Enhanced GSM MAP Screening (ANSI/ITU)

The GSM MAP screening features allow an extension of the OC EAGLE message screening capabilities beyond the MTP and SCCP levels to the MAP level. Rules for provisioning hardware is the same as GTT. In the event that unusually high-traffic is experienced by a card executing GSM MAP screening, the feature may momentarily be disabled to give precedence to GTT operations. This feature requires GTT and Measurements Platform.

Peripheral Equipment

For Network Management, User Interfaces, or other Peripheral equipment, the OC EAGLE System provides RS-232C interfaces for up to 16 customer provided terminal devices. The OC EAGLE user terminal can be a personal computer (PC) running terminal emulation software. Choose the specific terminal devices appropriate for your OC EAGLE installation. Data transfer speeds are provided between 2,400 and 19,200 bits/second.

OC STP LAN Interface

The OC EAGLE STP LAN interface is implemented through a pool of OC EAGLE-ENET-B cards running the STP LAN application. The OC EAGLE-SLAN card supports all features currently implemented on the DCM card (SSEDCM or EDCM-A assembly). Legacy STP LAN cards (eg OC EAGLE ENET-A or EDCM) and an OC EAGLE-ENET-B card running STP LAN can be “hot-swapped” without re-provisioning the card (the OC EAGLE-ENET-B card requires backplane cable adapters). OC EAGLE-ENET-B STP LAN cards must be provisioned in the same shelf that contains the cards or links being monitored.

OC EAGLE-ENET-Bs are provisioned per STP site based upon the expected number of messages per second to be transferred at .8 erlang per link. Baseline components include STP LAN software, OC EAGLE ENET-B cards, and Gateway Screening feature. For reliability, OC EAGLE-ENET-B cards running STP LAN are provisioned on an “N+1” redundancy basis. The redundant STP LAN card should be the highest capacity card running the application (eg if OC EAGLE ENET-B and legacy EDCM cards are running STP LAN, an OC EAGLE ENET-B should be the “+1” redundant card). A maximum of 2 OC EAGLE-ENET-B STP LAN cards can be provisioned per shelf.

Use the larger number from the following three calculations for N, based on the number of cards in the system and assuming a particular average message size:

- 1 Equation 1, message size = 80 octets:

$$\text{ROUNDUP}\{ \text{LSL}/806 + \text{HSL}/30 + \text{KTPS}/60 + \text{SE-HSL}/26 \}$$
- 2 Equation 2, message size = 140 octets:

$$\text{ROUNDUP}\{ \text{LSL}/820 + \text{HSL}/31 + \text{KTPS}/36 + \text{SE-HSL}/27 \}$$
- 3 Equation 3, message size = 272 octets:

$$\text{ROUNDUP}\{ \text{LSL}/520 + \text{HSL}/15 + \text{KTPS}/12 + \text{SE-HSL}/17 \}$$

Note: The OC EAGLE can support up to 32 OC EAGLE-SLAN cards. Where:

- » LSL = the number of low-speed links in the system
- » HSL = the number of high-speed ATM Links
- » SE-HSL/ST-HSL = the number of high-speed SE-HSL/ST-HSL Links in the system

- » KTPS = the number thousands of packets per second that SIGTRAN cards transfer, e.g.,
- » 2 for 2,000 TPS, 4 for 4,000 TPS, etc

SEAS over IP

The former EOAP platform has been replaced with SEAS over IP interface based on the OC EAGLE-ENET-B card (legacy E5-IPSM 870-2877-xx also supports). The SEAS over IP Feature eliminates the need for an EOAP, thereby saving the customer footprint space and providing an IP interface.

SEAS over IP interfaces to Telcordia's CCS Message Router, hereafter referred to as the IP MR. The IP MR is a stand-alone, self-contained system developed by Telcordia that is designed to provide a centralized mechanism for routing CCS network operations traffic between STPs/SCPs and existing and new OSS's.

The SEAS over IP interface utilizes the SR-5129 protocol. SR-5129 provides a detailed description of Telcordia's implementation of the TCP/IP protocol to be used by the IP MR and Network Elements as an alternative/replacement to the existing UAL/X.25 protocol defined in TA-ST5-000298 (used on the legacy EOAP).

The figure depicts the new architecture for the SEAS over IP feature, which utilizes dual redundant OC EAGLE-IPSM cards, hereafter referred to as OC EAGLE-IPSMs, to provide SR-5129 IP formatted SEAS data to the Telcordia IP MR.

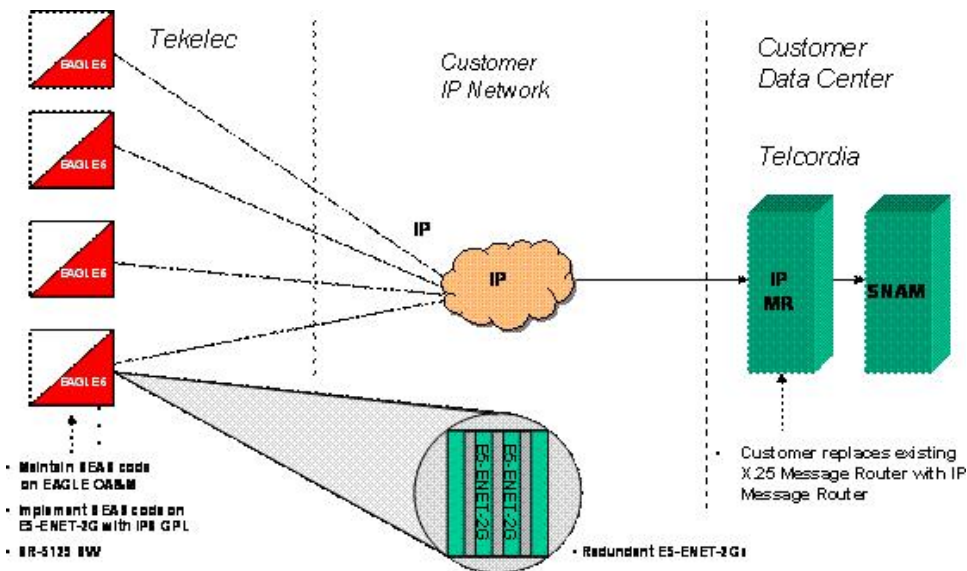

Figure 19 - SEAS over IP

Measurements Platform

The Measurements Platform feature provides a platform on which today's OC EAGLE GR- 82 and database measurements are collected. From this platform, measurements data in comma delimited format is available via a TCP/IP interface, which provides faster measurement retrieval from the OC EAGLE. Core STP (GR-82) and database related measurements are readily available for off-loading to a third party platform via FTP.

Measurements Platform is required for nodes with any of the following:

- » >700 links,

- » LNP 384M (>228M record capacity),
- » GSM MAP Screening,
- » ATINP/PATINP
- » AIQ
- » EGMS
- » VFLEX
- » GTT Actions
- » EIR
- » 15 minute measurements

OC EAGLE-OAM Integrated Measurements provides Measurements Platform capability in nodes up to 1,200 links (2,400 links if 15 Minute Measurements is not in use). This capability requires OC EAGLE-OAM cards – quantity (2) 870-2903-xx OC EAGLE-MASP cards, and 1 870-2900-xx OC EAGLE-MDAL card. A FAK (Feature Access Key) is also required.

Legacy OAM cards do not support Integrated Measurements.

OC EAGLE-OAM Integrated Measurements requires (2) 830-1333-02 backplane adapters (1 per OC EAGLE-MASP) and associated cables.

OC EAGLE-OAM Integrated Measurements requires a control shelf backplane of 850-0330-06 or greater (870-2321-02 or greater, 870-2330-01 or greater, or 870-2377-01 or greater).

The OC EAGLE-MCPM-B is a single slot card that also supports this feature (2 deployed per node for redundancy). This can be used instead of Integrated Measurements in any configuration, and is required for nodes greater than 2,400 links (1,200 links if 15 Minute Measurements is enabled). OC EAGLE-MCPM-B was introduced for large systems in R44

Requires 830-1102-03 (DB-26 to RJ-45).

The following engineering rules apply for output devices:

- » For system < 500 link (see note), use existing terminal and printer guidelines
- » For systems 500 - 700 links (see note) only a dedicated 19200 terminal is recommended, hard copy printer output is NOT guaranteed
- » For systems > 700 links (see note) User Interface serial terminal output is NOT recommended or guaranteed. Print facilities of the COTS software used to manipulate the off-loaded data files should be used.
- » The customer must provide an FTP server to receive the reports provided by this feature.

Note: Links are treated as follows:

- » ATM HSL = 1 link
- » SE-HSL/ST-HSL = 1 link per HSL
- » HC-MIM = 1 link per channelized low speed link (maximum of 64 per HC-MIM card)
- » IPLIM = 1 link per IP link (maximum of 8 per IP LIM card)
- » IPGW = 1 link per IPGW link (maximum of 1 per IPGW card)
- » 1 IPSTG = 1 link per association

IP User Interface



The OC EAGLE-ENET-B card supports the optional IP User Interface feature (legacy OC EAGLE-IPSM cards also supports – MFC is not needed for this application). This feature enhances the MAS features by providing a higher-speed Ethernet connection for OC EAGLE commands and responses. Up to 3 OC EAGLE-ENET-Bs for IPUI can be deployed in a single OC EAGLE node. Each OC EAGLE-ENET-B card supports up to 8 simultaneous users over a 10/100BaseT Ethernet connection (Telnet). The Secure Shell (SSH) protocol is supported for added security. SSH clients and SFTP servers deployed by customers must be OpenSSH Version 2 Compatible. The OC EAGLE also supports 16 RS-232 terminal ports.

Provisioning Rules:

- » Maximum of 3 IPUI cards per node
- » 8 sessions are supported per card
- » Configure one session for each user (simultaneous)
- » EMS requires 2 sessions on one card, plus 2 sessions on another card for redundancy if desired.
- » SEAS over IP consumes 2 sessions
- » FTRA consumes 2 sessions
- » Remote Backup/Download consumes 2 sessions
- » Configure quantity one of 893-4000-01 per node (or L99410) - OC EAGLE_OA&M IP SECURITY ENHANCEMENTS_FEATURE ACCESS KEY_1 DOCUMENT
- » Configure quantity one of 893-0057-01 per node (or L99410) - OC EAGLE_IP USER INTERFACE_FEATURE ACCESS KEY_1 DOCUMENT
- » Configure quantity one of 830-1102-03 adapter per card (plus one Ethernet cable).
- » Requires HIPR2 (or HIPR) configured in shelf in which card resides

Remote Upgrade/Download

The OC EAGLE-ENET-B supports the optional Remote Upgrade Download and Remote Backup features (legacy E5-IPSM 870-2877-xx also supports starting in R39.2). The Remote Upgrade Download feature allows new software to be downloaded to the OC EAGLE from a remote server, using FTP. If the OC EAGLE OA&M IP Security feature is turned on, then Secure FTP is used for data transfer.

The OC EAGLE downloads software via a single TAR file that contains compressed files associated with the software release. The OC EAGLE unpacks and un-compresses all files of a software release and places them on the inactive partition of the OC EAGLE-MASP cards. A remote server must be set up within the customer network to support data transfer to the OC EAGLE.

The Remote Backup feature allows the database to be saved to and restored from a remote server, using FTP. If the OC EAGLE OA&M IP Security feature is turned on, then Secure FTP is used for data backup. For a database backup, the OC EAGLE packs and compresses all files in a TAR file before transferring to a remote server. For a database restore, the OC EAGLE unpacks and uncompresses the files and places the files on the active partition group of the OC EAGLE-MASPs.

FTP-based Table Retrieve Application

The OC EAGLE's FTP Retrieve and Replace Feature enables the FTP-based Table Retrieve Application (FTRA) software package (on a customer's computer) to provide additional capability for table data retrieval. FTRA is used in conjunction with the IP User Interface option (provided by OC EAGLE-ENET-B cards). There are eight terminal ports on each OC EAGLE-ENET-B and up to three OC EAGLE-NET-Bs may be provisioned for FTRA. The FTRA software is compatible with both Unix and Windows platforms, which are supplied by the customer.

Integrated Monitoring (PIC)

The OC EAGLE-ENET-B-based Signaling Transport Card (STC) provides OC EAGLE support for the optional integrated monitoring function, which is used by Oracle's Performance Intelligence Center (PIC). OC EAGLE support is enabled by the OC EAGLEIS Feature Bit and OC EAGLE Hardware is required. The STC card is used to receive all relevant signaling units as forwarded by the OC EAGLE LIM cards. The STC card then forwards these messages via TCP/IP to PIC using private 100MB Ethernet links.

A load-sharing algorithm is utilized to dynamically balance the capacity among the STCs. These STC cards may be distributed across different shelves. N+1 Redundant STC cards must be installed in the OC EAGLE, based on total link capacity. The STC cards connect to two Ethernet NICs installed in each PIC Integrated Message Feeder (IMF). See PIC documentation for further details regarding the PIC functionality.

The OC EAGLE Fast Copy (Fast Copy) feature uses 2 fast copy ports on each ENET-B card to send relevant SIGTRAN data directly to the Integrated Message Feeder (IMF) while bypassing the Inter-Module Transport (IMT) and network stack. This ability allows data from the SIGTRAN network to be monitored in real time without impacting the OC EAGLE IMT bus, thereby eliminating OC EAGLE overhead and reducing the need for STC cards. A minimum of 2 STC cards are required when using Fast Copy to transport configuration and link event data.

Fast Copy architecture uses two separate networks for STC monitoring and Fast Copy monitoring. The Fast Copy feature runs on OC EAGLE-ENET-B cards (or OC EAGLE-ENET) that are running the IPSG application. The Fast Copy mode is a system-wide option. If the mode is set to fast copy, then all cards that are capable of supporting fast copy automatically switch to data acquisition for PIC using fast copy. The system can not combine STC monitoring with fast copy monitoring for SIGTRAN.

Note: A card that can run the Fast Copy interface is referred to as an FC-capable card. After the Fast Copy feature is provisioned on an FC-capable card, the card is referred to as an FC-enabled card.

- » Maximum of 32 STC cards per node
- » Maximum of 3 STC cards per HMUX equipped shelf. No maximum (other than physical slot limitation) with HIPR2 or HIPR (870-2574-xx) equipped shelves.
- » Sufficient STC cards shall be provisioned on the same OC EAGLE Control or Extension shelf as Data Feed links to accommodate the associated Data Feed traffic for SIGTRAN. For all HIPR2 or HIPR equipped shelves, it is recommended (but not necessarily required) to provision STC cards on the same OC EAGLE shelf as Data Feed links to accommodate the associated Data Feed traffic.
- » HIPR2 or HIPR cards are required on the same OC EAGLE Control or Extension shelves which contain SIGTRAN (IPLIM/IPGW) for data feeds.
- » It is RECOMMENDED to provision STC cards on the same OC EAGLE Control or Extension shelves which contain HIPR2 or HIPR cards.
- » Provision STC cards based on the guidelines provided in **Error! Reference source not found.** STC Provisioning tables below. The throughputs listed in this table are for release 35 and greater. Previous OC EAGLE releases are 50% of the listed throughput.
- » Data Feed traffic on an individual control or extension shelf may exceed the STC capacity by 25% of a single STC card capacity. For example, if the calculation for one shelf is 2.25 STC cards, then 2 STCs are sufficient; if the calculation for one shelf is 2.26 STC cards, then 3 STCs are required.
- » STC cards should be provisioned for N+1 redundancy.
- » OC EAGLE SW and HW required (870-0774-10+ (TDM), 870-2360 (GPSM-II), and HMUX (870-1965) or HIPR (870-2574) for all Integrated Data Feed deployments.

- » External clock input is required (composite clock, or high-speed clock via E1/T1). If composite clock is used, then quantity two TDM 870-0774-10 or greater is required. If E1/T1 is used, then quantity two TDM GTI 870-0774-15 or greater is required.
- » For Sigtran dimensioning, determine the node's normal sustainable level of Sigtran traffic in TPS. Calculate the number of required STC cards in accordance with table. Normal sustainable traffic assumes both nodes of a pair are operational (equivalent to 0.4 Erlang for non-IP interfaces). Don't assume maximum Sigtran throughput unless fail-over support is required (equivalent to 0.8 Erlang for non-IP interfaces).
- » For large nodes, defined as nodes with more than 12 shelves, or more than 60 OC EAGLE or HCMIM cards, special consideration must be given to STC dimensioning to ensure IMT performance. Configurations that meet this requirement must be evaluated by Oracle Sales Engineers.
- » Integrated Data Acquisition requires that an external reference clock be provided to the OC EAGLE control shelf. The clock may be in composite clock format, which is common in North America, or in E1/T1 format. The clock source, typically available in any telco Central Office, is the responsibility of the customer.

OC EAGLE Fast Copy configuration rules

- » Requires OC EAGLE-ENET-B (or OC EAGLE-ENET) SIGTRAN cards running IP Signaling Gateway (IPSG) SW (971-0287-xx).
- » The following adapters and cables are required for each OC EAGLE-ENET card. To add Fast Copy to an existing OC EAGLE-ENET-B/ENET SIGTRAN card, two additional Cat5E cables are required per OC EAGLE-ENET card.
- » Requires two (2) 830-1102-xx (DB-26 to 2x RJ45 Adaptors) per OC EAGLE-ENET IPSG SIGTRAN card (default for new shipments). Requires four (4) Cat5E Shielded cables for each OC EAGLE-ENET card (if customer does not supply their own Cat5E cables).
- » If a customer has existing 830-0978-xx cables that they want to reuse, quantity one (1) 830-1343-01 (upper) and one (1) 830-1343-02 (lower) adapters can be used in place of the two 830-1102-xx adapters above. Each 830-1343 adapter has one DB26 connector and one RJ-45 connector. The 830-1343 adapters are typically used when EDCM SIGTRAN cards using 830-0978-xx cables are replaced with OC EAGLE-ENET SIGTRAN cards. Two Cat5E cables must also be supplied for each OC EAGLE-ENET card (if customer does not supply their own Cat5E cables).
- » A minimum of 2 STC cards are required per node (these are OC EAGLE-ENET for new shipments, but if EDCMs are already existing they can be used). The IPSG SIGTRAN cards that are utilizing Fast Copy do not drive the need for additional STC cards.
- » Fast Copy can co-exist with Integrated Monitoring for non-IPSG SIGTRAN links and other link types.
- » Fast Copy Requires OC EAGLE Release 41.0 or greater

OC EAGLE OC EAGLE-APP-B IMF Configuration Rules

This capability allows the use of OC EAGLE OC EAGLE-APP-B cards in an OC EAGLE shelf (vs IMF on third party hardware). OC EAGLE-APP-B IMF is suitable for small and medium IMF configurations (per node). Large configurations are supported with rack mount servers. The OC EAGLE configuration rules are stated below - refer to the PIC Planning Guide for additional information and associated PIC configuration rules.

OC EAGLE-APP-B IMF requires the following:

- » OC EAGLE R43.0 or greater, and PIC 10.1 or greater
- » OC EAGLE-APP-B -02 (one per 50Mbps plus one for redundancy if required) in an OC EAGLE shelf with fan assembly.
- » Up to 4 OC EAGLE-APP-B -02 cards and 19 OC EAGLE cards are supported with one Cisco 4948E-F Switch (805-0592-01PT) per node
- » Up to 6 OC EAGLE-APP-B -02 cards and 38 OC EAGLE cards are supported with two Cisco Switches
- » Up to 6 devices are supported in the bottom shelf position of an OC EAGLE frame (ie switches and/or terminal server 870-2858-03PT) per node

- » Up to 2 switches are supported for IMF
- » Cisco switch requires a Heavy Duty OC EAGLE frame (used since 2001)
- » One Installation Kit (814-0036-01PT or 7108611) is required per application (eg IMF, EPAP, ELAP, Terminal Server)

Table 8: STC Provisioning Table for LSL and ATM HSL

Average MSU Size (Bytes)	Link Type	Erlang	Links per STC ¹	
			EDCM	OC EAGLE-ENET
40 or 80	T1 LSL	0.4	210	525
40 or 80	E1 LSL ²	0.4	184	460
40 or 80	ATM HSL (T1)	0.4	9	22
40 or 80	ATM HSL (E1)	0.4	9	22
40 or 80	T1 LSL	0.8	130	325
40 or 80	E1 LSL ²	0.8	115	287
40 or 80	ATM HSL (T1)	0.8	5	12
40 or 80	ATM HSL (E1)	0.8	5	12
140	T1 LSL	0.4	184	460
140	E1 LSL ²	0.4	161	402
140	ATM HSL (T1)	0.4	10	25
140	ATM HSL (E1)	0.4	8	20
140	T1 LSL	0.8	115	287
140	E1 LSL ²	0.8	100	250
140	ATM HSL (T1)	0.8	6	15
140	ATM HSL (E1)	0.8	5	12

Table 9: STC Provisioning Table for Sigtran

Average MSU Size (Bytes)	Link Type	TPS per STC ¹ (for Data Acquisition)	
		EDCM	OC EAGLE-ENET
40	M2PA	12,600	31,500
40	M3UA	11,500	28,750
40	SUA	6,900	17,250
80	M2PA	8,600	21,500
80	M3UA	7,400	18,500
80	SUA	5,100	12,750

140	M2PA	5,700	14,250
140	M3UA	5,100	12,750
140	SUA	4,000	10,000

Note 1: The EDCM column is calculated based on STC maximum capacity for R35 going forward. Pre-release 35 is half of the above throughput for EDCMs. OC EAGLE-ENET based STC is available in R37.0.

Note 2: SE-HSL (Q.703) is equivalent to 31 LSL's.

Note 3: All link/TPS data in this table is bi-directional (eg 40 byte M2PA traffic requires one STC per 12,600 bi-directional TPS (12,600 receive and 12,600 transmit per STC.))

OC EAGLE-OAM SNMP Support

The OC EAGLE-OAM SNMP Support feature allows the OC EAGLE to communicate directly with a Network Management System (NMS) without requiring an intermediary Element Management System (EMS).

After this feature is enabled and turned on, the SNMP traps for alarms are sent to an NMS or a set of NMSs specified by the ent/chg/rtrv-snmpp-host commands. Configured NMSs can request a resynchronization for all of the existing UAMs. Each provisioned NMS receives a heartbeatTrap at a rate determined by the NMS declaration. The heartbeatTrap indicates to the NMS that the network connection is intact during periods of low UAM/UIM activity.

For each NMS, a host name and IP address must be specified with the ent-snmpp-host command.

Optional parameters allow the SNMP command and trap port numbers to be changed, as well as allow the TRAP community string to be specified for the traps sent to the NMS, and set the heartbeatTrap interval. After a host is provisioned, the optional parameters may be changed with the chg-snmpp-host command. The system-wide SNMP options can be changed with the chg-snmppopts command. The chg-snmppopts command enables the GET and SET community strings to be changed, and enables or disables sending UIM as traps to the NMS.

Feature Control Requirements

- » FAK for Part Number 893-0404-01
- » A temporary FAK cannot be used to enable the feature.
- » The feature can be turned on and off.
- » The SNMP FAK must be enabled before any NMS hosts can be provisioned.

Hardware Requirements

- » OC EAGLE-OAM SNMP requires OC EAGLE-OAM cards – quantity (2) 870-2903-xx OC EAGLE-MASP cards, and 1 870-2900-xx OC EAGLE-MDAL card. A FAK (Feature Access Key) is also required).
- » Legacy OAM cards do not support Integrated Measurements.
- » OC EAGLE-OAM Integrated Measurements requires (2) 830-1333-02 backplane adapters (1 per OC EAGLE-MASP) and associated cables.
- » OC EAGLE-OAM Integrated Measurements requires a control shelf backplane of 850-0330-06 or greater (870-2321-02 or greater, 870-2330-01 or greater, or 870-2377-01 or greater).

Software Compatibility

Below details OC EAGLE software release compatibilities.

Table 10: OC EAGLE Release 46.1 Software Compatibility

Product	Release	Compatibility
ELAP	<9.0	NC
	9.0	NC
	10.0	FC
EPAP	<14.0	NC
	14.0	NC
	15.0	PC
	16.0	PC**
LSMS	<12.0	NC*
	12.0	PC*
	13.0	FC*
OC EAGLE-MS	45.0	PC
	46.0	FC
FTRA	<4.4	NC
	4.4	PC
	4.5	PC
	4.6	FC
ECAP	<41.1	NC
	41.1	PC**
PIC	9.0	PC
	10.0	PC**

FC - Fully Compatible

PC - Partially Compatible-Product combinations are functional but have not undergone complete regression testing. Some feature capabilities may not be fully functional or supported.

NC - Not Compatible

N/A – Not Applicable

** Inherited from ELAP 10 Release Compatibilities.*

*** J7 Point Code format is NOT supported on ECAP 41.1, EPAP 16.0 and PIC 10.0*

Table 11: EPAP R16 Software Compatibility

Product	Release	Compatibility
OC EAGLE	<44.0	NC
	44.0	NC
	45.0	NC
	46.0	FC
OC EAGLE-MS	45.0	N/A
	46.0	FC

Table 12: FTRA R4.6 Software Compatibility

Product	Release	Compatibility
OC EAGLE	<44.0	NC
	44.0	NC
	45.0	NC
	46.0	FC

Table 13: EMS R46.1 Software Compatibility

Product	Release	Compatibility
OC EAGLE	<44.0	NC
	44.0	PC
	45.0 & R45.1	PC
	46.0	FC
EPAP	<16.0	N/A
	16.0	FC
LSMS	<12.0	N/A
	12.0	FC
	13.0	FC

Table 14: OC EAGLE/PIC Compatibility

OC EAGLE Release	Sentinel 11.7.1.106	IAS 2.x (IXP & ICP)	IAS 3.x (IXP & ICP)	IAS 4.x (IXP & ICP)	IAS 6.x (IXP only)	PIC 7.0	PIC 7.1	PIC 7.5 (GA 8/12)	PIC 9.0 (GA 2/13)	PIC 10.0 (GA 8/14)	PIC 10.1 (GA 10/14)
OC EAGLE	Contact customer				Not Supported						



37	service prior to this upgrade									
OC EAGLE 38				Minimum OC EAGLE and PIC release for support of TimeStamp		Not Supported				
OC EAGLE 39.x										
OC EAGLE 40		Not Supported								
OC EAGLE 40.1				Minimum OC EAGLE and PIC release with Fast Copy		Not Supported				
OC EAGLE 41.0			Not Supported				Not Supported			
OC EAGLE 41.1.x				Refer to TSB TN003261	Minimum OC EAGLE and PIC release to support linkset synchronization					
OC EAGLE 42					Minimum OC EAGLE and PIC release for Fast Copy on IPG					Not Supported
OC EAGLE 42.1				Not Supported						
OC EAGLE 43										
OC EAGLE 44							Minimum OC EAGLE and PIC release to support OC EAGLE-ENET B and OC EAGLE-ATM-B cards			
OC										Minimum



EAGLE 45										release to support OC EAGLE-APP-B IMF
OC EAGLE 46.0				Not Supported						Minimum release to support OC EAGLE-E1T1-B card
OC EAGLE 46.1										

Table 15: OC EAGLE/EPAP Compatibility

	EPAP 9	EPAP 10	EPAP 11	EPAP 12	EPAP 12.1	EPAP 13	EPAP 14 (Note 1)	EPAP 15	EPAP 16
OC EAGLE 41.0	Not Supported	Capacity limited to 96M					T1000 not supported	Not Supported	
OC EAGLE 41.1									
OC EAGLE 42									
OC EAGLE 42.1				Not Supported					
OC EAGLE 43 (Note 2)		Not Supported					T1000 not supported	OC EAGLE-APP-B	Not Supported
OC EAGLE 44 (Note 2)			Not Supported						
OC EAGLE 45								T1000 not supported	
OC EAGLE 46.0/46.1			Not Supported					T1200 not supported. J7 point code format is not supported on PIC 10.0	

NOTES:

- 1 T1000 not supported EPAP R14 or forward
- 2 Features 120M DN + 120M IMSI, and EIR IMEI 50K to 100K block extensions not supported
- 3 T1200 not supported EPAP R16 or forward

4 EPAP 16 FC with FTRA 4.5 and NC FTRA 4.4 and before

Table 16: OC EAGLE/ELAP Compatibility

	ELAP 6	ELAP 7	ELAP 8	ELAP 9	ELAP 10
OC EAGLE 41.0	Not supported	Capacity limited to 192M (SM4G) or 228M (DSM)			Not supported
OC EAGLE 41.1					
OC EAGLE 42					
OC EAGLE 42.1		Not supported			
OC EAGLE 43					OC EAGLE-APP-B Only
OC EAGLE 44					
OC EAGLE 45					
OC EAGLE 46.0/46.1		Not supported			

Table 17: OC EAGLE / LSMS Compatibility

	LSMS 9	LSMS 10	LSMS 11	LSMS 11.1	LSMS 12	LSMS 13
OC EAGLE 41.0	Not supported	Capacity limited to 192M(SM4G) or 228M(DSM)				Not supported
OC EAGLE 41.1						
OC EAGLE 42		Not supported				
OC EAGLE 42.1			Not supported			
OC EAGLE 43						OC EAGLE-APP-B only & requires ELAP 10
OC EAGLE 44						
OC EAGLE 45		Not supported				
OC EAGLE 46.0/46.1		Not supported				

Table 18: OC EAGLE/EMS Compatibility

	EMS 41.0	EMS 41.1	EMS 42	EMS 43	EMS 44	OC EAGLE-MS R45	OC EAGLE-MS R46 ¹
OC EAGLE 41.0		Not supported					
OC EAGLE 41.1	Not		Not supported				



OC EAGLE 42	supported	Not supported		Not supported			
OC EAGLE 43		Not supported	Not supported		Not supported		
OC EAGLE 44				Not supported			
OC EAGLE 45							
OC EAGLE 46.0/46.1				Not supported			

Table 19: OC EAGLE /FTRA Compatibility

	FTRA 3	FTRA 4	FTRA 4.1	FTRA 4.2	FTRA 4.3	FTRA 4.4	FTRA 4.5
OC EAGLE 41.0	Not supported		OC EAGLE-OAM cards not supported				Not supported
OC EAGLE 41.1							
OC EAGLE 42		Not supported					
OC EAGLE 42.1							
OC EAGLE 43							
OC EAGLE 44							
OC EAGLE 45			Not supported				
OC EAGLE 46.0/46.1		Not supported					

Hardware Lifecycle Management

Below is a summary of the hardware lifecycle management plan for OC EAGLE and associated products (LSMS, ELAP, EPAP).

Table 20: OC EAGLE Lifecycle Milestones

CATEGORY	EAGLE HW	Part Numbers	LIFECYCLE Milestones			Successor Card
			EOL Announcement	LOD/LSO	Last SW Release Supported*	
CORE Hardware Cards	HIPR	870-2574-xx	Jan, 2010	Jan, 2011	R46.0	OC EAGLE HIPR 2 Card
	E5-TSM	870-2943-xx	July, 2011	July, 2013	2H 2016	OC EAGLE Operations Administration & Maintenance Card Set
	E5-IPSM	870-2877-xx	July, 2012	July, 2013	2H 2016	OC EAGLE Ethernet B Card
	MCPM	870-2372-03/09/14/15	Jan, 2012	Jan, 2013	R45.x	OC EAGLE Operations Administration & Maintenance Card Set / OC EAGLE Measurement Collection & Polling B Card
	IPSM	870-2371-xx	Feb, 2010	Feb, 2009	R44.x	OC EAGLE Ethernet B Card
	TSM (GLS)	870-1289-xx	Jan, 2009	Jan, 2010	R44.x	OC EAGLE Operations Administration & Maintenance Card Set
	HMLUX	870-1965-xx	July, 2007	July, 2008	R45.x	OC EAGLE HIPR 2 Card
LIM Cards	OAM (TDM, MDAL, GPSM-II)	870-0774-xx, 870-0773-xx, 870-2360-xx	July, 2009	July, 2010	R44.x	OC EAGLE Operations Administration & Maintenance Card Set
	E5-ENET	870-2212-xx	July, 2012	July, 2013	1H 2017	OC EAGLE Ethernet B Card
	E5-ATM	870-1872-xx	July, 2012	July, 2013	1H 2017	OC EAGLE Asynchronous Transfer Mode B Card
	E5-E1/T1	870-1873-xx	Sept, 2014	Sep, 2014	1H 2017	OC EAGLE E1T1-B Card
	HC-MIM	870-2671-xx	Jan, 2013	Jan, 2013	1H 2017	OC EAGLE E1T1-B Card
	EDCM (SIGTRAN)	870-2372-01/08/13	July, 2007	Jul, 2008	R44.x	OC EAGLE Ethernet B Card
	ATM E1/T1	870-2455-xx (E1), 870-1293-xx (T1)	July, 2008	July, 2009	R45.x	OC EAGLE Asynchronous Transfer Mode B Card
SCCP/SLAN Cards, ELAP/EPAP Servers	E1/T1 MIM	870-2198-xx	July, 2008	July, 2009	R45.x	OC EAGLE E1T1-B Card
	MPL	870-2061-xx	Jan, 2009	Jan, 2010	R45.x	OC EAGLE E1T1-B Card
	E5-SM4G	870-2860-xx	July, 2012	July, 2013	1H 2017	OC EAGLE Service Module 8 GB B Card
	DSM	870-1984-xx	July, 2007	July, 2008	R45.x	OC EAGLE Service Module 8 GB B Card
	DCM (STC/SLAN)	870-1945-xx	July, 2007	July, 2008	R45.x	OC EAGLE Ethernet B Card
	EDCM-A (STC/SLAN)	870-2508-xx	July, 2007	July, 2008	R45.x	OC EAGLE Ethernet B Card
	EDCM (STC/SLAN)	870-2372-01/08/13	July, 2007	July, 2008	R45.x	OC EAGLE Ethernet B Card
	T1200	805-0291-R03	Jan, 2012	July, 2013	EPAP R15.0	OC EAGLE Application B Card with 300 GB HDD
	T1000 (EPAP)	870-2640-xx	Jan, 2010	July, 2010	R13.0	OC EAGLE Application B Card with 300 GB HDD
	T1100 (ELAP)	870-2754/2807/1893-xx	Jan, 2013	Oct, 2013	R9.0	OC EAGLE Application B Card with 300 GB HDD
T1100 (ECAP)	870-2754/2807/1893-xx	Jan, 2010	Jan, 2011	ECAP R41.1	N/A	
T1100 (LSMS)	870-2754/2807/1893-xx	Jan, 2013	Oct, 2013	R12.0	OC EAGLE Application B Card with 480 GB HDD	

EOL Announcement - End of Life announcement provides notification of last order/ship date.
 LOD/LSO - Last Order Date/Last Ship Date specifies the last dates HW can be ordered/shipped.
 Last SW Release Supported - Specifies the last SW release that the HW will operate.
 EOSL - End of Service Life - HW no longer supported.
 * Identifies last release that HW is compatible. Features may require new HW.

Hardware Part Number Mapping

Part numbers and descriptions are changing with Tekelec's integration into Oracle. Below are the Legacy part numbers/descriptions available, and the Go Forward part numbers/descriptions available.

The Legacy part numbers listed are the same part numbers that were used within Tekelec, except a suffix of MKT and/or PT are added. MKT represents part numbers that are assembled in a frame in the factory before shipping to customer, whereas PT (Pick to Order) are ship-loose items that are not.

Below list does not include installation materials.

Table 21: Part Number Mapping

Legacy Tekelec	Oracle Tekelec Restricted Price List	Oracle Commercial Price List
Part Number/Description	Part Number / Description	Part Number/Description
551-0022-R01 T1000 FAN FILTER 0.5 INCH X 15.4375 INCH X 4.625 INCH QUADRAFOAM 83% ARRESTANCE ROHS	551-0022-R01PT T1000_FAN FILTER_0.5" X 15.4375" X 4.625" QUADRAFOAM_83% ARRESTANCE_ROHS	None - This part is no longer available T1000_FAN FILTER_0.5" X 15.4375" X 4.625" QUADRAFOAM_83% ARRESTANCE_ROHS
551-0022-R02 T1100 FAN FILTER 0.5 INCH X 5.125 INCH X 5.125 INCH QUADRAFOAM 83% ARRESTANCE ROHS	551-0022-R02PT Fan filter: 0.5 inches by 5.125 inches by 5.125 inches	7108608 Fan filter: 0.5 inches by 5.125 inches by 5.125 inches
551-0022-R03 T1100 FAN FILTER 0.5 INCH X 5.125 INCH X 10.000 INCH QUADRAFOAM 83% ARRESTANCE ROHS	551-0022-R03PT Fan filter: 0.5 inches by 5.125 inches by 10.000 inches	7108609 Fan filter: 0.5 inches by 5.125 inches by 10.000 inches
800-0244-R01 HW EQUIPMENT TRAY 11 GAUGE STEEL 21IN X 20IN ROHS 5/6	800-0244-R01PT Equipment tray with 11 gauge steel, 21 inches by 20 inches	7108614 Equipment tray with 11 gauge steel, 21 inches by 20 inches

804-0076-R01 DEC VT520 TERMINAL AND KEYBOARD 100 to 240 VAC ANSI 108 KEYS ROHS 5/6	804-0076-R01PT DEC VT520 terminal and keyboard: 100 to 240 VAC	7108589 DEC VT520 terminal and keyboard: 100 to 240 VAC 7108852 SPARE: DEC VT520 terminal and keyboard: 100 to 240 VAC
804-0982-R01 75 OHM TO 120 OHM CONVERTER 64 TERMINATION CHASSIS ROHS 5/6	804-0982-R01MKT 75 OHM to 120 OHM converter with 64 termination chassis (for factory installation)	7108554 75 OHM to 120 OHM converter with 64 termination chassis (for factory installation)
804-0983-R01 75 OHM TO 120 OHM CONVERTER 4 TERMINATION WIRE-WRAP/WIRE-WRAP MODULE ROHS 5/6	804-0983-R01MKT 75 OHM to 120 OHM converter for wire wrap module (for factory installation)	7108555 75 OHM to 120 OHM converter for wire wrap module (for factory installation)
804-0984-R01 75 OHM TO 120 OHM CONVERTER 4 TERMINATION WIRE-WRAP/BNC MODULE ROHS 5/6	804-0984-R01MKT 75 OHM to 120 OHM converter for wire wrap and BNC module (for factory installation)	7108556 75 OHM to 120 OHM converter for wire wrap and BNC module (for factory installation)
804-1706-R01 T1000/1100 MOUNTING KIT 20 INCH SLIDES W/23 INCH TRAVEL LOCKS ROHS	804-1706-R01MKT Mounting kit for 23-inch cabinets with travel locks (for factory installation)	7108548 Mounting kit for 23-inch cabinets with travel locks (for factory installation)
804-2152-R11 ETHERNET SWITCH DC 24 PORT (10/100/1000) 011 NEBS ROHS 5/6	804-2152-R11PT DC ethernet switch with twenty-four 10/100/1000 Mb/sec ports	7108604 DC ethernet switch with twenty-four 10/100/1000 Mb/sec ports
804-2153-R01 USB 2.0 FLASH MEMORY DRIVE 2 GB 10 MB/S READ/WRITE 94V-0 ROHS 5/6	804-2153-R01MKT USB 2.0 flash memory drive: 2 GB (for factory installation)	7108585 USB 2.0 flash memory drive: 2 GB (for factory installation) 7108888 SPARE: USB 2GB flash memory
804-2153-R01 USB 2.0 FLASH MEMORY DRIVE 2 GB 10 MB/S READ/WRITE 94V-0 ROHS 5/6	804-2153-R01PT USB 2.0 flash memory drive: 2 GB	7108610 USB 2.0 flash memory drive: 2 GB 7108888 SPARE: USB 2GB flash memory
804-2904-01 3UX19 INCH DC PDP WITH ALARMING NEBS	804-2904-01PT 3U DC power distribution panel with alarming for 19-inch cabinet , NEBS compliant	7108595 3U DC power distribution panel with alarming for 19-inch cabinet , NEBS compliant
804-2904-01 3UX19 INCH DC PDP WITH ALARMING NEBS	804-2904-01PT 3U DC power distribution panel with alarming for 19-inch cabinet , NEBS compliant	7108059 3U DC power distribution panel with alarming for 19-inch cabinet , NEBS compliant
804-2904-01 3UX19 INCH DC PDP WITH ALARMING NEBS	804-2904-01MKT 3U DC power distribution panel with alarming for 19-inch cabinet , NEBS compliant (for factory installation)	7108616 3U DC power distribution panel with alarming for 19-inch cabinet , NEBS compliant (for factory installation)
804-2904-01 3UX19 INCH DC PDP WITH ALARMING NEBS	804-2904-01MKT 3U DC power distribution panel with alarming for 19-inch cabinet , NEBS	7108225 3U DC power distribution panel with alarming for 19-inch cabinet , NEBS

	compliant (for factory installation)	compliant (for factory installation)
814-0036-01 ROHS 5/6 KIT OC EAGLE-APP-B SWITCH INSTALLATION	814-0036-01MKT Oracle Communications OC EAGLE application B switch installation kit (for factory installation)	7108493 Oracle Communications OC EAGLE application B switch installation kit (for factory installation)
814-0036-01 ROHS 5/6 KIT OC EAGLE-APP-B SWITCH INSTALLATION	814-0036-01PT Oracle Communications OC EAGLE application B switch installation kit	7108611 Oracle Communications OC EAGLE application B switch installation kit
840-0139-01 3U FAP 48 AMP UPGRADE KIT FOR THE 890-1410-01 CONTROL FRAME	840-0139-01PT 3U fuse and alarm panel upgrade kit for control frame	7108596 3U fuse and alarm panel upgrade kit for control frame
840-0139-02 3U FAP 48 AMP UPGRADE KIT FOR THE 890-1443-01 EXTENSION FRAME	840-0139-02PT 3U fuse and alarm panel upgrade kit for extension frame	7108597 3U fuse and alarm panel upgrade kit for extension frame
870-1824-02 ROHS 5/6 Subassy Single Slot Air Management Module OC EAGLE	870-1824-02PT Single slot air management module	7108291 Single slot air management module 7108890 SPARE: air management module
870-1824-02 ROHS 5/6 SUBASSY SINGLE SLOT AIR MANAGEMENT MODULE OC EAGLE	870-1824-02MKT Single slot air management module (for factory installation)	7108620 Single slot air management module (for factory installation) 7108890 SPARE: air management module
870-1872-02 OC EAGLE ATM CARD 02 ROHS 5/6	870-1872-02PT (Last Order Date: 31-Dec-2014) Oracle Communications OC EAGLE asynchronous transfer mode card	7108557 (Last Order Date: 10-Oct-2014) Oracle Communications OC EAGLE asynchronous transfer mode card 7108891 (Last Order Date: 10-Oct-2014) SPARE: Oracle Communications OC EAGLE Asynchronous Transfer Mode card
870-1872-02 OC EAGLE ATM CARD 02 ROHS 5/6	870-1872-02MKT (Last Order Date: 10-Oct-2014) Oracle Communications OC EAGLE asynchronous transfer mode card (for factory installation)	7108594 (Last Order Date: 10-Oct-2014) Oracle Communications OC EAGLE asynchronous transfer mode card (for factory installation) 7108891 (Last Order Date: 10-Oct-2014) SPARE: Oracle Communications OC EAGLE Asynchronous Transfer Mode card
870-1873-04 OC EAGLE E1/T1 CARD 04 ROHS 5/6	870-1873-04PT Oracle Communications OC EAGLE E1T1 card	7108558 Oracle Communications OC EAGLE E1T1 card 7108892 SPARE: Oracle Communications OC EAGLE E1T1 Card

870-1873-04 OC EAGLE E1/T1 CARD 04 ROHS 5/6	870-1873-04MKT Oracle Communications OC EAGLE E1T1 card (for factory installation)	7108617 Oracle Communications OC EAGLE E1T1 card (for factory installation) 7108892 SPARE: Oracle Communications OC EAGLE E1T1 Card
870-1893-03 T1100 DC SERVER NEBS ROHS 5/6	870-1893-03MKT DC T1100, NEBS compliant (for factory installation)	7108532 DC T1100, NEBS compliant (for factory installation)
870-1893-04 ROHS 5/6 ASSY TEKSERVER II AC XEON ENHANCED NEBS	870-1893-04MKT AC T1100 , NEBS compliant (for factory installation)	7108535 AC T1100 , NEBS compliant (for factory installation)
870-2061-06 ROHS 5/6 SUBASSY MULTIPOINT LIM W/BGA COMM PROCESSOR	870-2061-06PT (Last order date: 30-Nov-2015) Multipoint link interface module with ball grid array communication processor	7108559 (Last order date: 30-Nov-2015) Multipoint link interface module with ball grid array communication processor 7108893 (Last order date: 30-Nov-2015) SPARE: Multipoint link interface module
870-2061-06 ROHS 5/6 SUBASSY MULTIPOINT LIM W/BGA COMM PROCESSOR	870-2061-06MKT (Last order date: 30-Nov-2015) Multipoint link interface module with ball grid array communication processor (for factory installation)	7108592 (Last order date: 30-Nov-2015) Multipoint link interface module with ball grid array communication processor (for factory installation) 7108893 (Last order date: 30-Nov-2015) SPARE: Multipoint link interface module with ball grid array communication processor
870-2212-05 OC EAGLE ENET CARD 05 ROHS 5/6	None - This part is no longer available Oracle Communications OC EAGLE ethernet card	None - This part is no longer available Oracle Communications OC EAGLE ethernet card 7108954 SPARE: Oracle Communications OC EAGLE Ethernet B Card
870-2308-02 T1100 ECAP CABLE ASSEMBLY-ROHS 5/6	870-2308-02MKT Enhanced communication application processor cable assembly (for factory installation)	7108551 Enhanced communication application processor cable assembly (for factory installation)
870-2308-02 T1100 ECAP CABLE ASSEMBLY-ROHS 5/6	870-2308-02PT (Last Order Date: 06-Jan-2015) Enhanced communication application processor cable assembly	7108561 Enhanced communication application processor cable assembly
870-2320-01 SUBASSY SEISMIC FUSE ALARM PANEL (FAP)	870-2320-01PT SUBASSY_SEISMIC FUSE ALARM PANEL (FAP)	None - This part is no longer available SUBASSY_SEISMIC FUSE ALARM PANEL (FAP)
870-2372-03 SUBASSY ENHANCED DATABASE SERVICE MODULE GPSSM-II 2 GB	870-2372-03PT (Last Order Date: 10-Oct-2014) SUBASSY_ENHANCED DATABASE SERVICE MODULE_GPSSM-II_2 GB	None - This part is no longer available SUBASSY_ENHANCED DATABASE SERVICE MODULE_GPSSM-II_2 GB 7108895 (Last Order Date: 10-Oct-2014) SPARE: GPSSM II card

870-2372-15 OC EAGLE MCPM CARD 15 ROHS 5/6	870-2372-15PT Oracle Communications OC EAGLE measurement collection and polling card	7108562 Oracle Communications OC EAGLE measurement collection and polling card 7108896 SPARE: Oracle Communications OC EAGLE Measurement Collection and Polling Card
870-2372-15 OC EAGLE MCPM CARD 15 ROHS 5/6	870-2372-15MKT Oracle Communications OC EAGLE measurement collection and polling card (for factory installation)	7108588 Oracle Communications OC EAGLE measurement collection and polling card (for factory installation) 7108896 SPARE: Oracle Communications OC EAGLE Measurement Collection and Polling Card
870-2377-02 OC EAGLE DC CONTROL SHELF ROHS 5/6	870-2377-02PT DC control shelf	7108563 DC control shelf 7108897 SPARE: Control Shelf
870-2377-02 OC EAGLE DC CONTROL SHELF ROHS 5/6	870-2377-02MKT OC EAGLE_DC_CONTROL SHELF_ROHS 5/6	None - This part is no longer available OC EAGLE_DC_CONTROL SHELF_ROHS 5/6 7108897 SPARE: Control Shelf
870-2378-02 OC EAGLE DC EXTENSION SHELF 02 ROHS 5/6	870-2378-02PT DC extension shelf	7108564 DC extension shelf
870-2378-02 OC EAGLE DC EXTENSION SHELF 02 ROHS 5/6	870-2378-02MKT OC EAGLE_DC_EXTENSION SHELF_02_ROHS 5/6	None - This part is no longer available OC EAGLE_DC_EXTENSION SHELF_02_ROHS 5/6
870-2706-04 T1000/T1100 DUAL PORT ETHERNET PCI (10/100/1000) 04 ROHS 5/6	870-2706-04MKT Dual port ethernet PCIe with twenty-four 10/100/1000 Mb/sec ports (for factory installation)	7108543 Dual port ethernet PCIe with twenty-four 10/100/1000 Mb/sec ports (for factory installation)
870-2708-02 T1000/T1100 QUAD PORT SERIAL PCI RS-232/422/485 ASYNCHRONOUS ROHS 5/6	870-2708-02MKT RS-232/422/485 serial PCIe asynchronous card (for factory installation)	7108544 RS-232/422/485 serial PCIe asynchronous card (for factory installation)
870-2721-06 ROHS 5/6 ASSY HARD DISK DRIVE 500GB T1000	870-2721-06PT (Last Order Date: 10-Mar-2015) One 500 GB HDD and mounting brackets	7108600 (Last Order Date: 10-Mar-2015) One 500 GB HDD and mounting brackets
870-2758-03 CISCO SWITCH DC 24 PORT 1U ROHS 5/6	870-2758-03MKT Cisco Catalyst 2950G 24 E1 DC Switch (for factory installation)	7108536 Cisco Catalyst 2950G 24 E1 DC Switch (for factory installation) 7108906 SPARE: CISCO DC 24-port 1U switch

870-2787-02 T1100 HARD DISK DRIVE 250 GB SATA ROHS 5/6	870-2787-02MKT One 250 GB 7200 rpm 3.5-inch SATA HDD (for factory installation)	7108545 One 250 GB 7200 rpm 3.5-inch SATA HDD (for factory installation)
870-2804-01 ROHS 5/6 ASSY FUSE ALARM PANEL UNI POWER 1U 23 INCH MOUNT 63 AMP 18 GMT FUSES PER SIDE	870-2804-01PT Fuse alarm panel with 1U 23-inch mount with 18 GMT fuses per side	7108598 Fuse alarm panel with 1U 23-inch mount with 18 GMT fuses per side
870-2833-02 T1100 2GB SDRAM DDR2 400 240 PIN ROHS 5/6	870-2833-02MKT One 2 GB DDR2-667 registered DIMM (for factory installation)	7108540 One 2 GB DDR2-667 registered DIMM (for factory installation)
870-2858-03 ROHS 5/6 CONSOLE SERVER 32 PORTS W/MODEM DUAL DC PWR	870-2858-03PT Console server, 32-port with modem, dual DC power	7109471 Console server, 32-port with modem, dual DC power 7108907 SPARE: console server, 32-port w/modem, dual DC power
870-2860-02 OC EAGLE SM4G CARD 02 ROHS 5/6	870-2860-02PT (Last Order Date: 31-Dec- 2014) Oracle Communications OC EAGLE Service Module 4 GB Card	7108565 (Last Order Date: 10-Oct-2014) Oracle Communications OC EAGLE Service Module 4 GB Card
870-2860-02 OC EAGLE SM4G CARD 02 ROHS 5/6	870-2860-02MKT (Last Order Date: 10-Oct- 2014) Oracle Communications OC EAGLE Service Module 4 GB Card (for factory installation)	7108606 (Last Order Date: 10-Oct-2014) Oracle Communications OC EAGLE Service Module 4 GB Card (for factory installation)
870-2872-02 OC EAGLE HIPR2 CARD ROHS 5/6 02	870-2872-02MKT Oracle Communications OC EAGLE HIPR 2 Card A (for factory installation)	7108581 Oracle Communications OC EAGLE HIPR 2 Card A (for factory installation) 7108909 SPARE: Oracle Communications OC EAGLE HIPR 2 Card A
870-2872-02 OC EAGLE HIPR2 CARD ROHS 5/6 02	870-2872-02PT (Last Order Date: 31-Aug- 2015) Oracle Communications OC EAGLE HIPR 2 Card A	7109472 (Last Order Date: 31-Aug-2015) Oracle Communications OC EAGLE HIPR 2 Card A 7108909 SPARE: Oracle Communications OC EAGLE HIPR 2 Card A
870-2900-01 OC EAGLE MDAL CARD ROHS 5/6	870-2900-01PT Oracle Communications OC EAGLE maintenance disk and alarm card	7108568 Oracle Communications OC EAGLE maintenance disk and alarm card 7108912 SPARE: Oracle Communications OC EAGLE Maintenance Disk and Alarm Card

870-2900-01 OC EAGLE MDAL CARD ROHS 5/6	870-2900-01MKT Oracle Communications OC EAGLE maintenance disk and alarm card (for factory installation)	7108586 Oracle Communications OC EAGLE maintenance disk and alarm card (for factory installation) 7108912 SPARE: Oracle Communications OC EAGLE Maintenance Disk and Alarm Card
870-2903-02 OC EAGLE MASP CARD W/ SSD LOCKING ROHS 5/6	870-2903-02PT (Last Order Date: 31-Aug-2015) Oracle Communications OC EAGLE maintenance and administration subsystem processor card with SSD locking	7108569 (Last Order Date: 31-Aug-2015) Oracle Communications OC EAGLE maintenance and administration subsystem processor card with SSD locking 7108913 SPARE: Oracle Communications OC EAGLE Maintenance and Administration Subsystem Processor Card with SSD Locking
870-2903-02 OC EAGLE MASP CARD W/ SSD LOCKING ROHS 5/6	870-2903-02MKT Oracle Communications OC EAGLE maintenance and administration subsystem processor card with SSD locking (for factory installation)	7108584 Oracle Communications OC EAGLE maintenance and administration subsystem processor card with SSD locking (for factory installation) 7108913 SPARE: Oracle Communications OC EAGLE Maintenance and Administration Subsystem Processor Card with SSD Locking
870-2904-01 SWITCH DC 24 PORT 1U ROHS 5/6	870-2904-01MKT 1U DC 24 ports ethernet switch (for factory installation)	7108491 1U DC 24 ports ethernet switch (for factory installation) 7108914 SPARE: 24-port 1U DC switch
870-2904-01 SWITCH DC 24 PORT 1U ROHS 5/6	870-2904-01PT 1U DC 24 ports ethernet switch	7108570 1U DC 24 ports ethernet switch 7108914 SPARE: 24-port 1U DC switch
870-2916-02 ROHS 5/6 ASSY CONSOLE SERVER 16 PORTS W/MODEM DUAL AC PWR	870-2916-02PT AC 16-port console server	7108612 AC 16-port console server 7108915 SPARE: console server, 16-port w/modem, dual AC power
870-2916-02 ROHS 5/6 ASSY CONSOLE SERVER 16 PORTS W/MODEM DUAL AC PWR	870-2916-02PT AC 16-port console server	7108303 AC 16-port console server 7108915 SPARE: console server, 16-port w/modem, dual AC power

870-2943-03 OC EAGLE TSM CARD 03 ROHS 5/6	870-2943-03MKT (Last Order Date: 10-Oct-2014) Oracle Communications OC EAGLE translations services module card (for factory installation)	None - This part is no longer available Oracle Communications OC EAGLE translations services module card (for factory installation) 7108952 (Last Order Date: 10-Oct-2014) SPARE: Oracle Communications OC EAGLE Translations Services Module card
870-2943-03 OC EAGLE TSM CARD 03 ROHS 5/6	870-2943-03PT (Last Order Date: 10-Oct-2014) Oracle Communications OC EAGLE translations services module card	7108571 (Last Order Date: 10-Oct-2014) Oracle Communications OC EAGLE translations services module card 7108952 (Last Order Date: 10-Oct-2014) SPARE: Oracle Communications OC EAGLE Translations Services Module card
870-2970-01 OC EAGLE_E1T1-B_CARD_ROHS	870-2970-01MKT Oracle Communications OC EAGLE E1T1 B card (for factory installation)	7108607 Oracle Communications OC EAGLE E1T1 B card (for factory installation) 7108953 Spare: Oracle Communications OC EAGLE E1T1-B Card
870-2970-01 OC EAGLE E1T1-B CARD ROHS	870-2970-01PT (Last Order Date: 31-Aug-2015) Oracle Communications OC EAGLE E1T1 B card	7108572 (Last Order Date: 31-Aug-2015) Oracle Communications OC EAGLE E1T1 B card 7108953 Spare: Oracle Communications OC EAGLE E1T1-B Card
870-2971-01 OC EAGLE ENET-B CARD ROHS	870-2971-01MKT Oracle Communications OC EAGLE ethernet B card (for factory installation)	7108602 Oracle Communications OC EAGLE ethernet B card (for factory installation) 7108954 SPARE: Oracle Communications OC EAGLE Ethernet B Card
870-2971-01 OC EAGLE ENET-B CARD ROHS	870-2971-01PT (Last Order Date: 31-Aug-2015) Oracle Communications OC EAGLE ethernet B card	7108573 (Last Order Date: 31-Aug-2015) Oracle Communications OC EAGLE ethernet B card 7108954 SPARE: Oracle Communications OC EAGLE Ethernet B Card
870-2972-01 OC EAGLE ATM-B CARD ROHS	870-2972-01MKT Oracle Communications OC EAGLE asynchronous transfer mode B card (for factory installation)	7108593 Oracle Communications OC EAGLE asynchronous transfer mode B card (for factory installation) 7108955 SPARE: Oracle Communications OC EAGLE Asynchronous Transfer Mode B card

870-2972-01 OC EAGLE ATM-B CARD ROHS	870-2972-01PT (Last Order Date: 31-Aug-2015) Oracle Communications OC EAGLE asynchronous transfer mode B card	7108574 (Last Order Date: 31-Aug-2015) Oracle Communications OC EAGLE asynchronous transfer mode B card 7108955 SPARE: Oracle Communications OC EAGLE Asynchronous Transfer Mode B card
870-2990-01 OC EAGLE SM8G-B CARD ROHS	870-2990-01MKT Oracle Communications OC EAGLE service module 8 GB B card (for factory installation)	7108605 Oracle Communications OC EAGLE service module 8 GB B card (for factory installation) 7108956 SPARE: Oracle Communications OC EAGLE Service Module 8 GB B Card
870-2990-01 OC EAGLE SM8G-B CARD ROHS	870-2990-01PT (Last Order Date: 31-Aug-2015) Oracle Communications OC EAGLE Service Module 8 GB B Card	7108575 (Last Order Date: 31-Aug-2015) Oracle Communications OC EAGLE Service Module 8 GB B Card 7108956 SPARE: Oracle Communications OC EAGLE Service Module 8 GB B Card
870-3002-01 ROHS 5/6 KIT CABLE 19 INCH CABINET POWER	870-3002-01MKT Cable kit for 19-inch cabinet (for factory installation)	7108615 Cable kit for 19-inch cabinet (for factory installation)
870-3002-01 ROHS 5/6 KIT CABLE 19 INCH CABINET POWER	870-3002-01MKT Cable kit for 19-inch cabinet (for factory installation)	7108439 Cable kit for 19-inch cabinet (for factory installation)
870-3007-01 OC EAGLE 5 EPAP DC CABINET ASSEMBLY ROHS 5/6	870-3007-01MKT DC OC EAGLE provisioning application processor cabinet (for factory installation)	7108622 DC OC EAGLE provisioning application processor cabinet (for factory installation)
870-3008-01 OC EAGLE 5 ECAP DC CABINET ASSEMBLY ROHS 5/6	870-3008-01MKT DC enhanced communication application processor cabinet (for factory installation)	7108623 DC enhanced communication application processor cabinet (for factory installation)
870-3089-01 OC EAGLE MCPM-B CARD ROHS	870-3089-01MKT Oracle Communications OC EAGLE measurement collection and polling B card (for factory installation)	7108587 Oracle Communications OC EAGLE measurement collection and polling B card (for factory installation) 7108958 SPARE: Oracle Communications OC EAGLE Measurement Collection and Polling B Card
870-3089-01 OC EAGLE MCPM-B CARD ROHS	870-3089-01PT (Last Order Date: 31-Aug-2015) Oracle Communications OC EAGLE measurement collection and polling B card	7108576 (Last Order Date: 31-Aug-2015) Oracle Communications OC EAGLE measurement collection and polling B card 7108958 SPARE: Oracle Communications OC EAGLE Measurement Collection and Polling B Card

870-3096-01 OC EAGLE APP-B CARD ROHS	870-3096-01MKT (Last order date: 30-Nov-2015) Oracle Communications OC EAGLE application B card (for factory installation)	7108619 (Last order date: 30-Nov-2015) Oracle Communications OC EAGLE application B card (for factory installation) 7108959 (Last order date: 30-Nov-2015) SPARE: Oracle Communications OC EAGLE application B card
870-3096-01 OC EAGLE APP-B CARD ROHS	870-3096-01PT (Last order date: 30-Nov-2015) Oracle Communications OC EAGLE Application B Card with 300 GB HDD	7108577 (Last order date: 30-Nov-2015) Oracle Communications OC EAGLE Application B Card with 300 GB HDD 7108959 (Last order date: 30-Nov-2015) SPARE: Oracle Communications OC EAGLE application B card
870-3096-02 OC EAGLE-APP-B	870-3096-02MKT Oracle Communications OC EAGLE Application B Card with 480 GB HDD (for factory installation)	7108618 Oracle Communications OC EAGLE Application B Card with 480 GB HDD (for factory installation) 7108961 SPARE: Oracle Communications OC EAGLE Application B Card with 480 GB HDD
870-3096-02 OC EAGLE-APP-B	870-3096-02PT (Last Order Date: 31-Aug-2015) Oracle Communications OC EAGLE Application B Card with 480 GB HDD	7108578 (Last Order Date: 31-Aug-2015) Oracle Communications OC EAGLE Application B Card with 480 GB HDD 7108961 SPARE: Oracle Communications OC EAGLE Application B Card with 480 GB HDD
890-0001-04 OC EAGLE FAN TRAY WITH MTG TABS ROHS 5/6	890-0001-04PT Fan tray with mounting tabs	7108613 Fan tray with mounting tabs 7108963 SPARE: fan tray
890-0001-04 OC EAGLE FAN TRAY WITH MTG TABS ROHS 5/6	890-0001-04MKT OC EAGLE_FAN TRAY WITH MTG TABS_ROHS 5/6	None - This part is no longer available OC EAGLE_FAN TRAY WITH MTG TABS_ROHS 5/6 7108963 SPARE: fan tray
890-0011-02 T1100 DC FRAME ROHS 5/6	890-0011-02MKT DC frame (for factory installation)	7108624 DC frame (for factory installation)
890-0013-02 ROHS ASSY KIT FOR OC EAGLE 1UFAP INSTALLATION	890-0013-02PT 1U fuse and alarm panel installation assembly kit	7108599 1U fuse and alarm panel installation assembly kit
890-0211-01 ROHS 5/6 FINAL ASSEMBLY IMF T1100 DC 48 PORT SWITCH FRAME ASSY	890-0211-01MKT ROHS 5/6_FINAL ASSEMBLY_IMF_T1100 DC_48 PORT SWITCH_FRAME ASSY	None - This part is no longer available ROHS 5/6_FINAL ASSEMBLY_IMF_T1100 DC_48 PORT SWITCH_FRAME ASSY

890-0230-01 IMT CABLES CTRL SHELF ONLY HIPR2 HIGH RATE MODE ROHS 5/6	890-0230-01MKT IMT CABLES_CTRL SHELF ONLY_HIPR2 HIGH RATE MODE_ROHS 5/6	None - This part is no longer available IMT CABLES_CTRL SHELF ONLY_HIPR2 HIGH RATE MODE_ROHS 5/6
890-0230-02 IMT CABLES CTRL + 1 EXT SHELF HIPR2 HIGH RATE MODE ROHS 5/6	890-0230-02MKT Inter-processor message transmit bus cable kit for 1 control and 1 extension shelf (for factory installation)	7108495 Inter-processor message transmit bus cable kit for 1 control and 1 extension shelf (for factory installation)
890-0230-03 IMT CABLES CTRL + 3 EXT SHELVES HIPR2 HIGH RATE MODE ROHS 5/6	890-0230-03MKT IMT CABLES_CTRL + 3 EXT SHELVES_HIPR2 HIGH RATE MODE_ROHS 5/6	None - This part is no longer available IMT CABLES_CTRL + 3 EXT SHELVES_HIPR2 HIGH RATE MODE_ROHS 5/6
890-0230-04 IMT CABLES CTRL + 5 EXT SHELVES HIPR2 HIGH RATE MODE ROHS 5/6	890-0230-04MKT Inter-processor message transmit bus cable kit for 1 control and 5 extension shelves (for factory installation)	7108499 Inter-processor message transmit bus cable kit for 1 control and 5 extension shelves (for factory installation)
890-0230-05 IMT CABLES CTRL + 2 EXT SHELVES HIPR2 HIGH RATE MODE ROHS 5/6	890-0230-05MKT Inter-processor message transmit bus cable kit for 1 control and 2 extension shelves (for factory installation)	7108496 Inter-processor message transmit bus cable kit for 1 control and 2 extension shelves (for factory installation)
890-0230-06 IMT CABLES CTRL + 8 EXT SHELVES HIPR2 HIGH RATE MODE ROHS 5/6	890-0230-06MKT Inter-processor message transmit bus cable kit for 1 control and 8 extension shelves (for factory installation)	7108501 Inter-processor message transmit bus cable kit for 1 control and 8 extension shelves (for factory installation)
890-0230-07 IMT CABLES CTRL + 9 EXT SHELVES HIPR2 HIGH RATE MODE ROHS 5/6	890-0230-07MKT IMT CABLES_CTRL + 9 EXT SHELVES_HIPR2 HIGH RATE MODE_ROHS 5/6	None - This part is no longer available IMT CABLES_CTRL + 9 EXT SHELVES_HIPR2 HIGH RATE MODE_ROHS 5/6
890-0230-08 IMT CABLES CTRL + 11 EXT SHELVES HIPR2 HIGH RATE MODE ROHS 5/6	890-0230-08MKT Inter-processor message transmit bus cable kit for 1 control and 11 extension shelves (for factory installation)	7108503 Inter-processor message transmit bus cable kit for 1 control and 11 extension shelves (for factory installation)
890-0230-09 IMT CABLES CTRL + 14 EXT SHELVES HIPR2 HIGH RATE MODE ROHS 5/6	890-0230-09MKT Inter-processor message transmit bus cable kit for 1 control and 14 extension shelves (for factory installation)	7108505 Inter-processor message transmit bus cable kit for 1 control and 14 extension shelves (for factory installation)
890-0230-10 IMT CABLES CTRL + 15 EXT SHELVES HIPR2 HIGH RATE MODE ROHS 5/6	890-0230-10MKT Inter-processor message transmit bus cable kit for 1 control and 15 extension shelves (for factory installation)	7108506 Inter-processor message transmit bus cable kit for 1 control and 15 extension shelves (for factory installation)
890-0230-11 IMT CABLES CTRL + 4 EXT SHELVES HIPR2 HIGH RATE MODE ROHS 5/6	890-0230-11MKT Inter-processor message transmit bus cable kit for 1 control and 4 extension shelves (for factory installation)	7108497 Inter-processor message transmit bus cable kit for 1 control and 4 extension shelves (for factory installation)
890-0230-12 IMT CABLES CTRL + 6 EXT SHELVES HIPR2 HIGH RATE MODE ROHS 5/6	890-0230-12MKT IMT CABLES_CTRL + 6 EXT SHELVES_HIPR2 HIGH RATE MODE_ROHS 5/6	None - This part is no longer available IMT CABLES_CTRL + 6 EXT SHELVES_HIPR2 HIGH RATE MODE_ROHS 5/6

890-0230-13 IMT CABLES CTRL + 7 EXT SHELVES HIPR2 HIGH RATE MODE ROHS 5/6	890-0230-13MKT Inter-processor message transmit bus cable kit for 1 control and 7 extension shelves (for factory installation)	7108500 Inter-processor message transmit bus cable kit for 1 control and 7 extension shelves (for factory installation)
890-0230-14 IMT CABLES CTRL + 10 EXT SHELVES HIPR2 HIGH RATE MODE ROHS 5/6	890-0230-14MKT Inter-processor message transmit bus cable kit for 1 control and 10 extension shelves (for factory installation)	7108502 Inter-processor message transmit bus cable kit for 1 control and 10 extension shelves (for factory installation)
890-0230-15 IMT CABLES CTRL + 12 EXT SHELVES HIPR2 HIGH RATE MODE ROHS 5/6	890-0230-15MKT IMT CABLES_CTRL + 12 EXT SHELVES_HIPR2 HIGH RATE MODE_ROHS 5/6	None - This part is no longer available IMT CABLES_CTRL + 12 EXT SHELVES_HIPR2 HIGH RATE MODE_ROHS 5/6
890-0230-16 IMT CABLES CTRL + 13 EXT SHELVES HIPR2 HIGH RATE MODE ROHS 5/6	890-0230-16MKT Inter-processor message transmit bus cable kit for 1 control and 13 extension shelves (for factory installation)	7108504 Inter-processor message transmit bus cable kit for 1 control and 13 extension shelves (for factory installation)
890-0238-01 Assembly materials for second extension frame for 3 shelves (for factory Assembly)	890-0238-01MKT Assembly materials for second extension frame for 3 shelves (for factory Assembly)	7108507 Assembly materials for second extension frame for 3 shelves (for factory Assembly)
890-0238-02 Assembly materials for third extension frame for 3 shelves (for factory Assembly)	890-0238-02MKT Assembly materials for third extension frame for 3 shelves (for factory Assembly)	7108508 Assembly materials for third extension frame for 3 shelves (for factory Assembly)
890-0238-03 Assembly materials for forth extension frame for 3 shelves (for factory Assembly)	890-0238-03MKT Assembly materials for forth extension frame for 3 shelves (for factory Assembly)	7108509 Assembly materials for forth extension frame for 3 shelves (for factory Assembly)
890-0238-04 Assembly materials for fifth extension frame for 3 shelves (for factory Assembly)	890-0238-04MKT Assembly materials for fifth extension frame for 3 shelves (for factory Assembly)	7108510 Assembly materials for fifth extension frame for 3 shelves (for factory Assembly)
890-0238-05 Assembly materials for second frame for 2 shelves (for factory Assembly)	890-0238-05MKT Assembly materials for second frame for 2 shelves (for factory Assembly)	7108511 Assembly materials for second frame for 2 shelves (for factory Assembly)
890-0238-06 Assembly materials for third extension frame for 2 shelves (for factory Assembly)	890-0238-06MKT Assembly materials for third extension frame for 2 shelves (for factory Assembly)	7108512 Assembly materials for third extension frame for 2 shelves (for factory Assembly)
890-0238-07 Assembly materials for forth extension frame for 2 shelves (for factory Assembly)	890-0238-07MKT Assembly materials for forth extension frame for 2 shelves (for factory Assembly)	7108513 Assembly materials for forth extension frame for 2 shelves (for factory Assembly)
890-0238-08 Assembly materials for fifth extension frame for 2 shelves (for factory Assembly)	890-0238-08MKT Assembly materials for fifth extension frame for 2 shelves (for factory Assembly)	7108579 Assembly materials for fifth extension frame for 2 shelves (for factory Assembly)
890-0239-01 Control frame with 3 shelves (for factory installation)	890-0239-01MKT Oracle Communications OC EAGLE Control Frame with 3 Shelves (for factory installation)	7108486 Oracle Communications OC EAGLE Control Frame with 3 Shelves (for factory installation)

890-0240-01 Control frame with 2 shelves (for factory installation)	890-0240-01MKT Oracle Communications OC EAGLE Control Frame with 2 Shelves (for factory installation)	7108487 Oracle Communications OC EAGLE Control Frame with 2 Shelves (for factory installation)
890-0241-01 Extension frame with 3 shelves (for factory installation)	890-0241-01MKT Oracle Communications OC EAGLE Extension Frame with 3 Shelves (for factory installation)	7108488 Oracle Communications OC EAGLE Extension Frame with 3 Shelves (for factory installation)
890-0242-01 Extension frame with 2 shelves (for factory installation)	890-0242-01MKT Oracle Communications OC EAGLE Extension Frame with 2 Shelves (for factory installation)	7108489 Oracle Communications OC EAGLE Extension Frame with 2 Shelves (for factory installation)
890-0243-01 Extension frame with 1 shelf (for factory installation)	890-0243-01MKT Oracle Communications OC EAGLE Extension Frame with 1 Shelf (for factory installation)	7108490 Oracle Communications OC EAGLE Extension Frame with 1 Shelf (for factory installation)
890-1410-03 OC EAGLE DC CONTROL FRAME WITH 1U FAP HEAVY DUTY ROHS 5/6	890-1410-03MKT OC EAGLE_DC_CONTROL FRAME WITH 1U FAP_HEAVY DUTY_ROHS 5/6	None - This part is no longer available OC EAGLE_DC_CONTROL FRAME WITH 1U FAP_HEAVY DUTY_ROHS 5/6
890-1443-03 OC EAGLE DC EXT FRAME WITH 1U FAP HEAVY DUTY ROHS 5/6	890-1443-03MKT OC EAGLE_DC_EXT FRAME WITH 1U FAP_HEAVY DUTY_ROHS 5/6	None - This part is no longer available OC EAGLE_DC_EXT FRAME WITH 1U FAP_HEAVY DUTY_ROHS 5/6
890-1444-03 OC EAGLE DC MIS FRAME WITH 1U FAP HEAVY DUTY ROHS 5/6	890-1444-03MKT Miscellaneous heavy duty DC frame with 1U fuse and alarm panel (for factory installation)	7108552 Miscellaneous heavy duty DC frame with 1U fuse and alarm panel (for factory installation)
890-1445-02 OC EAGLE DC MISC FRAME WITHOUT FAP HEAVY DUTY ROHS 5/6	890-1445-02MKT Miscellaneous heavy duty DC frame without fuse and alarm panel (for factory installation)	7108553 Miscellaneous heavy duty DC frame without fuse and alarm panel (for factory installation)
890-1657-02 OC EAGLE SPARE CARD CAGE HEAVY DUTY FRAME ROHS 5/6	890-1657-02PT Card cage with heavy duty frame	7108580 Card cage with heavy duty frame
890-1657-02 OC EAGLE SPARE CARD CAGE HEAVY DUTY FRAME ROHS 5/6	890-1657-02MKT OC EAGLE_SPARE CARD CAGE_HEAVY DUTY FRAME_ROHS 5/6	None - This part is no longer available OC EAGLE_SPARE CARD CAGE_HEAVY DUTY FRAME_ROHS 5/6
804-0982-R01 75 OHM TO 120 OHM CONVERTER 64 TERMINATION CHASSIS ROHS 5/6	804-0982-R01PT 75 OHM to 120 OHM converter with 64 termination chassis	7110428 75 OHM to 120 OHM converter with 64 termination chassis
804-0983-R01 75 OHM TO 120 OHM CONVERTER 4 TERMINATION WIRE-WRAP/WIRE-WRAP MODULE ROHS 5/6	804-0983-R01PT 75 OHM to 120 OHM converter for wire wrap module	7110427 75 OHM to 120 OHM converter for wire wrap module



804-0984-R01 75 OHM TO 120 OHM CONVERTER 4 TERMINATION WIRE-WRAP/BNC MODULE ROHS 5/6	804-0984-R01PT 75 OHM to 120 OHM converter for wire wrap and BNC module	7110426 75 OHM to 120 OHM converter for wire wrap and BNC module
---	---	--



Oracle Corporation, World Headquarters
500 Oracle Parkway
Redwood Shores, CA 94065, USA

Worldwide Inquiries
Phone: +1.650.506.7000
Fax: +1.650.506.7200



CONNECT WITH US

 blogs.oracle.com/oracle

 facebook.com/oracle

 twitter.com/oracle

 oracle.com

Integrated Cloud Applications & Platform Services

Copyright © 2015, Oracle and/or its affiliates. All rights reserved. This document is provided *for* information purposes only, and the contents hereof are subject to change without notice. This document is not warranted to be error-free, nor subject to any other warranties or conditions, whether expressed orally or implied in law, including implied warranties and conditions of merchantability or fitness for a particular purpose. We specifically disclaim any liability with respect to this document, and no contractual obligations are formed either directly or indirectly by this document. This document may not be reproduced or transmitted in any form or by any means, electronic or mechanical, for any purpose, without our prior written permission.

Oracle and Java are registered trademarks of Oracle and/or its affiliates. Other names may be trademarks of their respective owners.

Intel and Intel Xeon are trademarks or registered trademarks of Intel Corporation. All SPARC trademarks are used under license and are trademarks or registered trademarks of SPARC International, Inc. AMD, Opteron, the AMD logo, and the AMD Opteron logo are trademarks or registered trademarks of Advanced Micro Devices. UNIX is a registered trademark of The Open Group. 0615

Oracle Communications EAGLE 46.1 Planning Guide
October 2015



Oracle is committed to developing practices and products that help protect the environment