

Oracle® Communications EAGLE

SIGTRAN User's Guide

Release 46.6

E93335 Revision 2

December 2018

Copyright © 1993, 2018, Oracle and/or its affiliates. All rights reserved.

This software and related documentation are provided under a license agreement containing restrictions on use and disclosure and are protected by intellectual property laws. Except as expressly permitted in your license agreement or allowed by law, you may not use, copy, reproduce, translate, broadcast, modify, license, transmit, distribute, exhibit, perform, publish, or display any part, in any form, or by any means. Reverse engineering, disassembly, or decompilation of this software, unless required by law for interoperability, is prohibited.

The information contained herein is subject to change without notice and is not warranted to be error-free. If you find any errors, please report them to us in writing.

If this is software or related documentation that is delivered to the U.S. Government or anyone licensing it on behalf of the U.S. Government, then the following notice is applicable:

U.S. GOVERNMENT END USERS: Oracle programs, including any operating system, integrated software, any programs installed on the hardware, and/or documentation, delivered to U.S. Government end users are "commercial computer software" pursuant to the applicable Federal Acquisition Regulation and agency-specific supplemental regulations. As such, use, duplication, disclosure, modification, and adaptation of the programs, including any operating system, integrated software, any programs installed on the hardware, and/or documentation, shall be subject to license terms and license restrictions applicable to the programs. No other rights are granted to the U.S. Government.

This software or hardware is developed for general use in a variety of information management applications. It is not developed or intended for use in any inherently dangerous applications, including applications that may create a risk of personal injury. If you use this software or hardware in dangerous applications, then you shall be responsible to take all appropriate fail-safe, backup, redundancy, and other measures to ensure its safe use. Oracle Corporation and its affiliates disclaim any liability for any damages caused by use of this software or hardware in dangerous applications.

Oracle and Java are registered trademarks of Oracle and/or its affiliates. Other names may be trademarks of their respective owners.

Intel and Intel Xeon are trademarks or registered trademarks of Intel Corporation. All SPARC trademarks are used under license and are trademarks or registered trademarks of SPARC International, Inc. AMD, Opteron, the AMD logo, and the AMD Opteron logo are trademarks or registered trademarks of Advanced Micro Devices. UNIX is a registered trademark of The Open Group.

This software or hardware and documentation may provide access to or information about content, products, and services from third parties. Oracle Corporation and its affiliates are not responsible for and expressly disclaim all warranties of any kind with respect to third-party content, products, and services unless otherwise set forth in an applicable agreement between you and Oracle. Oracle Corporation and its affiliates will not be responsible for any loss, costs, or damages incurred due to your access to or use of third-party content, products, or services, except as set forth in an applicable agreement between you and Oracle.

This documentation is in preproduction status and is intended for demonstration and preliminary use only. It may not be specific to the hardware on which you are using the software. Oracle Corporation and its affiliates are not responsible for and expressly disclaim all warranties of any kind with respect to this documentation and will not be responsible for any loss, costs, or damages incurred due to the use of this documentation.

The information contained in this document is for informational sharing purposes only and should be considered in your capacity as a customer advisory board member or pursuant to your beta trial agreement only. It is not a commitment to deliver any material, code, or functionality, and should not be relied upon in making purchasing decisions. The development, release, and timing of any features or functionality described in this document remains at the sole discretion of Oracle.

This document in any form, software or printed matter, contains proprietary information that is the exclusive property of Oracle. Your access to and use of this confidential material is subject to the terms and conditions of your Oracle Master Agreement, Oracle License and Services Agreement, Oracle PartnerNetwork Agreement, Oracle distribution agreement, or other license agreement which has been executed by you and Oracle and with which you agree to comply. This document and information contained herein may not be disclosed, copied, reproduced, or distributed to anyone outside Oracle without prior written consent of Oracle. This document is not part of your license agreement nor can it be incorporated into any contractual agreement with Oracle or its subsidiaries or affiliates.

Contents

1 Introduction

About This Guide	1-1
Audience	1-1
Updates for this Release.....	1-1
Documentation Admonishments	1-2
Manual organization	1-2
Manual conventions	1-3
My Oracle Support (MOS).....	1-3
Emergency Response.....	1-4
Related Publications	1-4
Customer Training	1-4
Locate Product Documentation on the Oracle Help Center Site	1-4

2 SS7-over-IP Networks

SS7-over-IP Networks Overview.....	2-1
SS7 limitations	2-1
Role of SIGTRAN.....	2-2
SCTP (Stream Control Transmission Protocol)	2-3
M2PA (MTP2 User Peer-to-Peer Adaptation Layer) Protocol	2-4
M3UA (MTP Level 3 User Adaptation Layer) Protocol	2-5
SUA (SCCP User Adaptation) Protocol	2-5
SS7-over-IP signaling transport	2-6
From SS7 Message to IP Packet	2-7
Communication inside the Wide Area Network (WAN)	2-7
Reasons to transition to an SS7-over-IP SIGTRAN network.....	2-8
Cost Effectiveness.....	2-8
Increased capacity	2-9
Integration	2-9
Type of Network Change.....	2-10
Dedicated Network versus Converged IP Network	2-10
Replacement versus Expansion.....	2-10
Diversity	2-11

When to transition to an SS7-over-IP SIGTRAN network	2-11
3 Oracle Communications Solutions	
Overview	3-1
EAGLE.....	3-1
Integrated Application Solutions (IAS)	3-3
Integrated Message Feeder (IMF).....	3-4
4 Transition Planning	
Transition guidelines	4-1
Resolve high-level network design.....	4-1
Collect network information.....	4-2
Analyze data	4-4
Prepare configurations.....	4-5
Implement and test	4-5
Refine timers and parameters.....	4-5
5 Dimensioning	
About bandwidth, throughput, transaction units, and TPS.....	5-1
Transactions versus transaction units and TPS.....	5-1
Scalability	5-1
Link equivalency	5-2
Hardware and software requirements	5-6
System capacity	5-6
Achieving IP Signaling Applications' Advertised Capacity	5-7
Factors Affecting Advertised Capacity	5-7
Base transaction unit.....	5-9
Adjusted transaction unit.....	5-13
How to calculate transaction units per second (TPS).....	5-16
Functionality of Configurable SCTP Buffer Sizes per Association	5-20
System Constraints Affecting Total IP Signaling Capacity	5-21
SIGTRAN Engineering Guidelines	5-26
Calculate the Number of Cards Required.....	5-28
IPGWx Congestion Management Options.....	5-29
Redundancy and Link Engineering	5-30
Unihoming versus Multihoming	5-30
Choosing a Redundancy Method for M2PA Links.....	5-31
Mated Signal Transfer Point Redundancy	5-32
IPGWx mateset	5-32
Signaling Link Selection (SLS) Routing.....	5-33
LAN/WAN Considerations	5-33
Retransmission Concept	5-34
Retransmissions and Destination Status.....	5-34

SCTP Timers	5-35
Configure Congestion Window Minimum (CWMIN) Parameter	5-38

6 Implementation

Hardware requirements.....	6-1
EAGLE	6-1
Integrated Message Feeder (IMF)	6-2
Converting Non-IPSG-M2PA Linksets to IPSG-M2PA Linksets.....	6-2
Converting IPGWx M3UA Application Servers to IPSG-M3UA Linksets.....	6-3
Configuration	6-10
Configure the IPSG Application.....	6-10
Configure the IPSG Application on the Same Card	6-11
Configure the IPLIMx Application	6-12
Configure the IPGWx Application.....	6-13
Refine Timers and Parameters	6-17
Define RTIMES Association Retransmits.....	6-17
Define RTO Parameter.....	6-17
Define RTXTHR Parameter.....	6-17
Measure Jitter	6-18
Refine RTO Parameter	6-18
System Verification	6-19
Verify Network Connectivity.....	6-19
Verify IPLIMx configuration.....	6-20
Verify IPGWx configuration	6-20

7 Troubleshooting

General troubleshooting	7-1
Verify UIMs and UAMs	7-1
Is the card configured correctly?	7-1
Connection does not become established.....	7-2
Connection bounces and is unstable.....	7-3
AS/PC in route key does not become available or ACTIVE (IPGWx only)	7-3
IP destination is not informed of SS7 destination status changes; network management is not working correctly (IPGWx only).....	7-3
Traffic not arriving at IP destination or traffic is lost.....	7-4
Are connection(s) congesting?	7-4
Traffic not load-balanced properly	7-4
Link Level Events	7-5
Association.....	7-5

A Additional Deployment Scenarios

IPSG Deployment Scenario	A-1
IPGW/M3UA deployment scenarios	A-3

B References

Oracle Communications Internal References	B-1
External References.....	B-1

List of Figures

2-1	SIGTRAN Protocols Used by Oracle Communications.....	2-2
2-2	M2PA Network.....	2-4
2-3	SS7-over-IP Network.....	2-6
2-4	Transmitting an SS7 Message using IP.....	2-7
2-5	Communication inside the WAN.....	2-8
2-6	Typical EAGLE SS7-over-IP Deployment.....	2-10
5-1	SIGTRAN: Every IP Link at 0.4 Erlang.....	5-27
5-2	SIGTRAN: Failover at 0.8 Erlang.....	5-27
5-3	SIGTRAN: Every Link at 0.4 Erlang and 800 MSU/s.....	5-27
5-4	EAGLE: Failover at 0.8 Erlang and 1600 MSU/s.....	5-28
5-5	Unihoming versus multihoming.....	5-31
5-6	Mated Signal Transfer Point Redundancy.....	5-32
6-1	IPGWx to IPSP-M3UA Conversion Strategy Example 1.....	6-5
6-2	IPGWx to IPSP-M3UA Conversion Strategy Example 2.....	6-7
6-3	IPGWx to IPSP-M3UA Conversion Strategy Example 2A	6-9
A-1	Example Deployment of IPSP Application.....	A-1
A-2	IPGWx active/standby configuration.....	A-3
A-3	Two-Pair IPGWx for maximum TPS.....	A-4
A-4	Four IPGWx pairs (two SS7IPW pairs and two IPGWI pairs).....	A-5
A-5	Eight IPGWx cards, two mates, three linksets.....	A-6
A-6	Four IPGWx cards, one linkset for end office.....	A-7
A-7	Unsupported deployment scenario: combined linksets (1).....	A-8
A-8	Unsupported deployment scenario: combined linksets (2).....	A-8

List of Tables

1-1	Admonishments.....	1-2
4-1	M2PA and M3UA configuration parameter data.....	4-3
5-1	EAGLE Link Equivalency for IPLIMx/IPGWx.....	5-2
5-2	EAGLE Link Equivalency for IPSG on E5-ENET.....	5-3
5-3	EAGLE Link Equivalency for IPSG on E5-ENET-B (E5-ENET-B when IPSG High Throughput Feature OFF, E5-ENET).....	5-4
5-4	EAGLE Link Equivalency for IPSG on E5-ENET-B (E5-ENET-B IPSG High Throughput Feature ON).....	5-5
5-5	Baseline Configuration Changes for the E5-ENET-B IPSG High Throughput Feature....	5-8
5-6	Base Advertised Capacity for IPSG Cards.....	5-9
5-7	Base Transaction Unit Cost Per MSU SIF Size.....	5-11
5-8	Base Transaction Unit Cost Per MSU SIF Size for IPSG Cards.....	5-12
5-9	Additional IPLIMx/IPGWx Transaction Units for Advanced Configurations.....	5-13
5-10	IPSG Additional Transaction Units for Advanced Configurations (E5-ENET-B when IPSG High Throughput Feature OFF, E5-ENET).....	5-14
5-11	IPSG Additional Transaction Units for Advanced Configurations (E5-ENET-B IPSG High Throughput Feature ON).....	5-15
5-12	Calculating TPS for IPGW and IPLIM Cards.....	5-17
5-13	Calculating TPS for IPSG Cards: E5-ENET-B when IPSG High Throughput Feature OFF, E5-ENET.....	5-18
5-14	Calculating TPS for E5-ENET-B IPSG Cards: E5-ENET-B IPSG High Throughput Feature ON.....	5-19
5-15	SCTP Buffer Space per Connection, Card and Application.....	5-21
5-16	IPLIMx and IPGWx Connectivity Data.....	5-21
5-17	IPSG Connectivity Data.....	5-23
5-18	Guidelines for Maximum Provisionable IPSG Cards.....	5-29
5-19	SCTP Configuration Data Descriptions for Oracle EAGLE.....	5-35
6-1	EAGLE IP Signaling Maximum Capacities by Card and Application.....	6-1

Introduction

This chapter provides a brief description of Oracle Communication's SS7-over-IP using SIGTRAN feature of the EAGLE. It also includes the scope, audience, and organization of this guide; how to find related publications; and how to contact Oracle for assistance.

About This Guide

An SS7-over-IP network consists of a traditional SS7 network that utilizes an IP network. This document describes SS7-over-IP networks that use the Signaling Transport (SIGTRAN) protocol suite as an enabler to access IP networks. IP-enabled or all-IP networks are growing in popularity for both wireline and wireless operators as they promise higher bandwidth at a lower cost, higher efficiency, and access to an exploding number of revenue-generating services. Participation in such services becomes increasingly difficult because of the high bandwidth required and the link restriction imposed by the traditional SS7 network.

A first step to IP success is an SS7-over-IP or SIGTRAN converged network to make reliable signaling over IP possible without replacing the entire network. The goal is to eventually move from the converged TDM/IP network to an all-IP network to take advantage of bandwidth, redundancy, reliability, and access to IP-based functions and applications. Oracle is prepared to take customers through this process at their own pace by offering expertise and tested products that will assist in achieving this goal.

This document examines the reasons for transitioning to an SS7-over-IP (SSoIP) network, the considerations that go into planning and dimensioning, and helpful information for implementing the network. This document does not attempt to provide a beginning-to-end solution for such a transition; contact your Sales Representative to discuss your specific needs.

Audience

This document is written for departments that are affected by the development, sale, or service of SIGTRAN-related products, as well as Oracle customers that require an overview of SS7-over-IP networks, SIGTRAN, and other products that are part of the solution.

Updates for this Release

As of Release 46.6, SLIC cards permit a higher capacity of 12K TPS when the IPSPG High Throughput feature is turned OFF.





Note: If IPSPG High Throughput is turn ON for SLIC hardware, the hardware will not support rates exceeding 12K.

Additional information is contained in various User's Guides in the EAGLE documentation, including *EAGLE Release Notes*, *Command User's Guide*, *Database Administration - IP7 User's Guide*, and *Hardware Reference*.

Documentation Admonishments

Admonishments are icons and text throughout this manual that alert the reader to assure personal safety, to minimize possible service interruptions, and to warn of the potential for equipment damage.

Table 1-1 Admonishments

Icon	Description
 DANGER	Danger: (This icon and text indicate the possibility of <i>personal injury</i> .)
 WARNING	Warning: (This icon and text indicate the possibility of <i>equipment damage</i> .)
 CAUTION	Caution: (This icon and text indicate the possibility of <i>service interruption</i> .)
 TOPPLE	Topple: (This icon and text indicate the possibility of <i>personal injury and equipment damage</i> .)

Manual organization

The manual is organized into these chapters:

- [Introduction](#) provides the purpose of this document, the targeted audience, how the manual is organized, and contact information.
- [SS7-over-IP Networks](#) describes the concept of an SS7-over-IP network and the protocols it uses, the opportunities it provides now and what it means for future directions. This section takes the reader from current TDM limitations, to the role of SIGTRAN, to the reasoning of why and when to transition to an SS7-over-IP network.
- [Oracle Communications Solutions](#) describes how products are a part of the SS7-over-IP solution. This section describes the EAGLE function as a gateway to internet networks; and the Integrated Application Solution (IAS), which provides several network management and performance tools including IP traffic monitoring through the Integrated Message Feeder (IMF).
- [Transition Planning](#) provides a guideline on how to prepare for transition to an SS7-over-IP network.

- **Dimensioning** describes dimensioning issues and calculations required to maximize the efficiency of the new network. This section addresses scalability, redundancy schemes, throughput calculations for both normal and failover mode, LAN/WAN considerations, and retransmission concepts.
- **Implementation** provides hardware information, high-level configuration steps for the IPLIMx, IPGWx, and IPST applications, how to refine timers and parameters after the installation, and high-level system verification steps.
- **Troubleshooting** offers troubleshooting procedures based on symptoms occurring in the network.
- **Additional Deployment Scenarios** provides hardware information, high-level configuration steps for the IPLIMx and IPGWx applications, how to refine timers and parameters after the installation, and high-level system verification steps.
- **References** lists external and internal references used in this manual. Customers requiring access to internal references should contact their Sales Representative to obtain equivalent information. This section also provides the location of customer documentation on the OTN.

Manual conventions

Several conventions are used in this document. While certain acronyms are standard in the telecom industry and are understood by most readers, this document treats network components and feature name as proper names and spells out their names to improve the reading of this document.

For some process descriptions, figures or tables are displayed at the beginning of the process to allow the reader to follow most of the process on the same page. This convention is identified with each process.

Where “end points” are mentioned, the full range is included: Service Switching Points (SSPs), Signaling Control Points (SCPs), Home Locator Registers (HLRs), and Short Message Service Centers (SMSCs).

My Oracle Support (MOS)

MOS (<https://support.oracle.com>) is your initial point of contact for all product support and training needs. A representative at Customer Access Support (CAS) can assist you with MOS registration.

Call the CAS main number at 1-800-223-1711 (toll-free in the US), or call the Oracle Support hotline for your local country from the list at <http://www.oracle.com/us/support/contact/index.html>. When calling, make the selections in the sequence shown below on the Support telephone menu:

1. Select 2 for New Service Request
2. Select 3 for Hardware, Networking and Solaris Operating System Support
3. Select one of the following options:
 - For Technical issues such as creating a new Service Request (SR), Select 1
 - For Non-technical issues such as registration or assistance with MOS, Select 2

You will be connected to a live agent who can assist you with MOS registration and opening a support ticket.

MOS is available 24 hours a day, 7 days a week, 365 days a year.

Emergency Response

In the event of a critical service situation, emergency response is offered by the Customer Access Support (CAS) main number at 1-800-223-1711 (toll-free in the US), or by calling the Oracle Support hotline for your local country from the list at <http://www.oracle.com/us/support/contact/index.html>. The emergency response provides immediate coverage, automatic escalation, and other features to ensure that the critical situation is resolved as rapidly as possible.

A critical situation is defined as a problem with the installed equipment that severely affects service, traffic, or maintenance capabilities, and requires immediate corrective action. Critical situations affect service and/or system operation resulting in one or several of these situations:

- A total system failure that results in loss of all transaction processing capability
- Significant reduction in system capacity or traffic handling capability
- Loss of the system's ability to perform automatic system reconfiguration
- Inability to restart a processor or the system
- Corruption of system databases that requires service affecting corrective actions
- Loss of access for maintenance or recovery operations
- Loss of the system ability to provide any required critical or major trouble notification

Any other problem severely affecting service, capacity/traffic, billing, and maintenance capabilities may be defined as critical by prior discussion and agreement with Oracle.

Related Publications

For information about additional publications related to this document, refer to the Oracle Help Center site. See [Locate Product Documentation on the Oracle Help Center Site](#) for more information on related product publications.

Customer Training

Oracle University offers training for service providers and enterprises. Visit our web site to view, and register for, Oracle Communications training:

<http://education.oracle.com/communication>

To obtain contact phone numbers for countries or regions, visit the Oracle University Education web site:

www.oracle.com/education/contacts

Locate Product Documentation on the Oracle Help Center Site

Oracle Communications customer documentation is available on the web at the Oracle Help Center (OHC) site, <http://docs.oracle.com>. You do not have to register to access these documents. Viewing these files requires Adobe Acrobat Reader, which can be downloaded at <http://www.adobe.com>.

1. Access the Oracle Help Center site at <http://docs.oracle.com>.
2. Click `Industries`.
3. Under the Oracle Communications subheading, click the Oracle Communications documentation link.

The Communications Documentation page appears. Most products covered by these documentation sets will appear under the headings "Network Session Delivery and Control Infrastructure" or "Platforms."

4. Click on your Product and then the Release Number.

A list of the entire documentation set for the selected product and release appears.

5. To download a file to your location, right-click the PDF link, select `Save target as` (or similar command based on your browser), and save to a local folder.

SS7-over-IP Networks

This chapter describes the concept of an SS7-over-IP network and the protocols it uses, the opportunities it provides now, and what it means for future directions. It takes the reader from current TDM limitations, to the role of SIGTRAN, to the reasoning of why and when to transition to an SS7-over-IP network.

SS7-over-IP Networks Overview

An SS7-over-IP network consists of a traditional SS7 network that can integrate IP-enabled or all-IP devices with protocols defined by the **Internet Engineering Task Force (IETF)** standards organization.

SS7-over-IP signaling primarily addresses the transport aspect of SS7. Call-control services and other types of services, therefore, can continue to be offered and deployed without concern for the method of interconnection. The method of service implementation, however, remains dependent on the particular network element chosen to support the service rather than the transport chosen.

This section looks at the limitations of the traditional SS7 network and its network components, the role of SIGTRAN protocols, the purpose of SS7-over-IP networks, the advantages of transitioning to this network, and when it is time to consider transitioning.

SS7 limitations

SS7 is a signaling network (data traffic) protocol used to send and receive signaling messages between Signaling End Points over dedicated signaling links. Operators deploy SS7 services over a dedicated network of 56- or 64-kbps Time Division Multiplexed (TDM) lines, or use high-speed T1 (1.5 Mbps) or E1 (2.048 Mbps) lines. SS7 uses centralized databases and services, achieves reliable connections through network management, and is secure because of its isolation from end users through the dedicated network. SS7 signaling is mature, with standards and a rich feature set, and offers these advantages to both wireline and wireless services.

However, SS7 limitations in scalability, bandwidth, and network availability slow network growth and opportunities to participate in new IP services:

- Scalability is limited by 16-link linksets consisting of 64 kbps transport
 - Up to 16 links may be grouped into one circuit, or linkset. Adjacent network elements, such as Signal Transfer Points (STPs) and Service Control Points (SCPs), may be connected by no more than one linkset. The protocol further recommends that links and linksets are configured to no more than 40% of their maximum capacity, so that the alternate path can carry the full load of messages during failover.
- Bandwidth

A traditional SS7 message size is limited to about 272 octets. E1/T1 links allow the transmission of larger messages, but not without originating, routing, or end points supporting either large messages or message segmentation.

Note: If an E5-ENET-B card running the IPSG application is used and the E5-ENET-B IPSG High Throughput feature is turned on, then the optimal SS7 message size is 120 octets or less. See [Table 5-5](#) for optimal configurations.

A bandwidth of 56 kbps or 64 kbps per link and dedicated links reduce flexibility and increase cost significantly when creating sufficient bandwidth for new service applications. In a TDM network, entire transmission segments must be reserved for each call, even if the TDM connection is idle.

TDM-based SS7 is continuing to evolve, but slowly. Instead, wireline and wireless operators are looking to IP solutions.

Role of SIGTRAN

SIGTRAN is a working group of the IETF, addressing packet-based Public Switched Telephone Network (PSTN) signaling over IP networks. A set of signaling transport protocols has been developed out of the group’s work. For the purposes of this document, the protocols are collectively called the “SIGTRAN” protocols or suite.

The SIGTRAN architecture used by Oracle Communications includes several IETF protocols. [Figure 2-1](#) illustrates their location in the protocol stack:

- **MTP2 User Peer-to-Peer Adaptation Layer (M2PA)** protocol; RFC 4165
- **MTP3 User Adaptation Layer (M3UA)** protocol; RFC 4666
- **SCCP User Adaptation Layer (SUA)** protocol; RFC 3868
- **Stream Control Transmission Protocol (SCTP)** protocol; RFC 4960

Figure 2-1 SIGTRAN Protocols Used by Oracle Communications

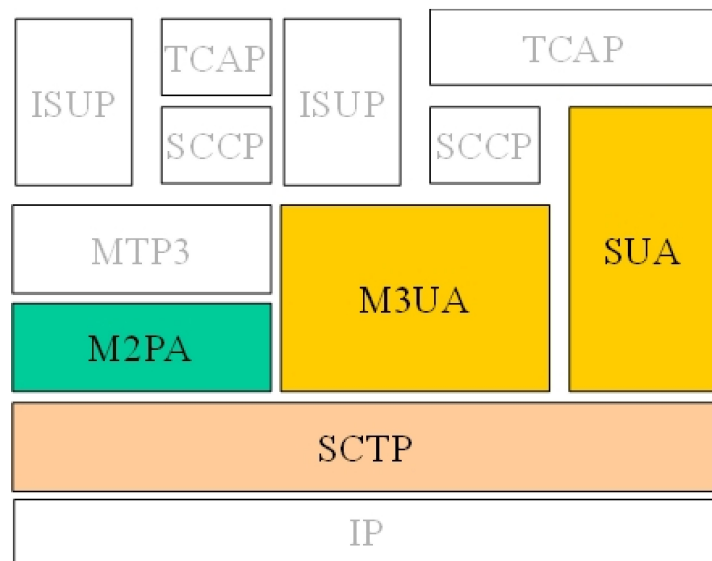

SCTP (Stream Control Transmission Protocol)

SCTP is a new reliable transport protocol that operates on top of a connectionless **packet** network such as IP, and operates at the same layer as TCP. It establishes a connection between two endpoints, called an association, for transmission of user messages. To establish an association between SCTP endpoints, one endpoint provides the other with a list of its **transport addresses** (one or more IP addresses in combination with an SCTP port). These transport addresses identify the addresses that will send and receive SCTP packets. SCTP was developed to eliminate deficiencies in TCP and offers acknowledged, error-free, non-duplicated user data transport.

IP signaling traffic is usually composed of many independent message sequences between many different signaling endpoints. SCTP allows signaling messages to be independently ordered within multiple streams (unidirectional logical channels established from one SCTP end point to another) to ensure in-sequence delivery between associated end points. By transferring independent message sequences in separate SCTP streams, it is less likely that the retransmission of a lost message will affect the timely delivery of other messages in unrelated sequences (called head-of-line blocking). Because TCP does enforce head-of-line blocking, the SIGTRAN Working Group recommends SCTP rather than TCP for the transmission of signaling messages over IP networks.

Security

SCTP provides certain transport-related security features, such as resistance against blind "denial of service" attacks, masquerades, or improper monopolization of services.

SIGTRAN protocols do not define new security mechanisms, as the currently available security protocols provide the necessary mechanisms for secure transmission of SS7 messages over IP networks.

Deviations

The following sections summarize the most important deviations from the IETF RFCs that Oracle has made. Refer to the protocol compliance matrices for details (see [Oracle Communications Internal References](#)). Contact your Sales Representative for access to the information contained in these documents.

SCTP Multiple Streams

There are several architectural issues regarding the use of multiple streams as described in the SCTP protocol. These issues include:

- Synchronization between data streams
- Synchronization from control stream to data streams
- Load-sharing implementation based on Signaling Link Selection (SLS) across streams, either within a connection or across all of the connections in an **Application Server**

Since the underlying SS7 network is connectionless, a stringent requirement for mis-sequenced messages has been set because it is often easier to recover from the loss of a message by a time-out than from one message delivered out-of-sequence. The **Message Transfer Part (MTP)** is able to maintain a high probability of message sequencing. This is ensured by the MTP user, which generates a value for a **Signaling Link Selection (SLS)** field as a parameter for each message. As the message is routed through the network, wherever there is a choice to be made

between alternate routes, the link selection is made based on the SLS value in the message.

- Connection behavior when a stream becomes congested

A lack of consensus on the IETF SIGTRAN mailing list regarding these issues resulted in supporting a maximum of two streams: one control stream and one data stream.

SCTP Timer

Based on experiences in the field, Oracle has deviated from some RFC-recommended timer settings, especially those related to retransmission, to better accommodate signaling networks.

The default mode for the retransmission timer (RMODE) is linear, whereas the RFC-recommended timer setting is exponential. Oracle makes both settings available through configuring an association to use either the Linear (LIN) or the exponential (RFC) method. For more information about both modes and the timer settings, see [SCTP Timers](#).

M2PA (MTP2 User Peer-to-Peer Adaptation Layer) Protocol

M2PA is used primarily to replace B-, C-, and D-links. When used with A-links, M2PA connects to Service Switching Points, Signaling Control Points, Home Locator Registers and other endpoints. M2PA is a direct replacement for channelized TDM circuits because it provides specific controls for assurance of in-sequence delivery of messages. As such, M2PA is used to connect points that pass call-related data that is time-sensitive, such as ISUP calling data.

Congestion procedures conform to those specified by the ANSI/ITU standards. The M2PA protocol can coexist in a linkset with other link types such as low-speed links and ATM high speed links. When using other link types, the throughput will always match the lowest-speed link in the linkset.

Oracle implemented the M2PA protocol through its IPLIMx application. For more information on the IPLIMx application, see [IPLIMx](#), [IPGWx](#) and [IPSG applications](#).

Figure 2-2 M2PA Network

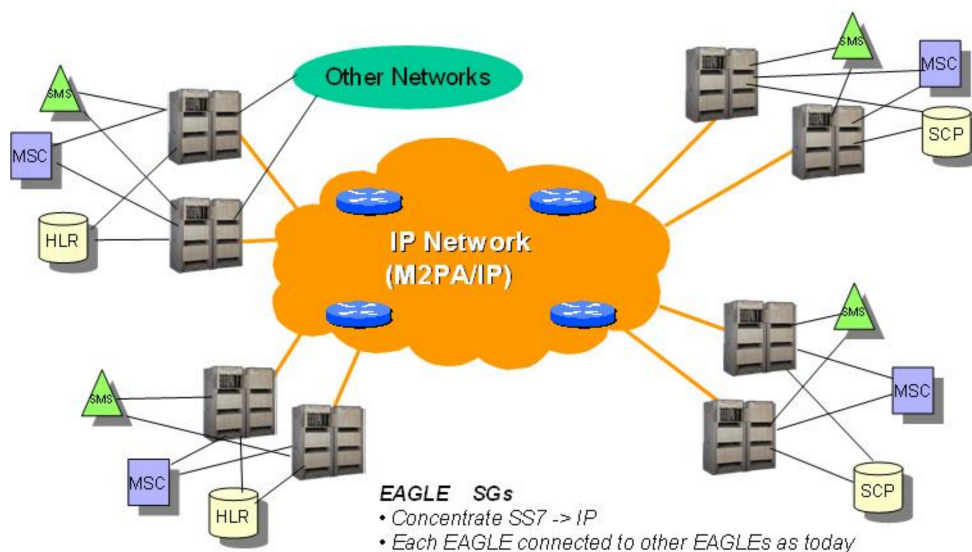

M3UA (MTP Level 3 User Adaptation Layer) Protocol

M3UA seamlessly transports SS7 MTP3 user part signaling messages over IP using SCTP. M3UA-connected IP endpoints do not have to conform to standard SS7 topology, because each M3UA association does not require an SS7 link; there are no 16-link-per-linkset restrictions. Each M3UA-connected IP endpoint can be addressed by an SS7 point code unique from the signaling gateway's point code. Oracle offers two types of topologies for M3UA: IPGWx using routing keys, and IPSP using IPSP-M3UA links.

Note: A-links for nodes requiring in-sequence delivery of messages should be configured on the IPLIMx card using M2PA; M3UA does not have sequence numbers to support lossless changeover/changeback.

A routing key defines a set of IP connections as a network path for a portion of SS7 traffic, and is the IETF Signaling Gateway equivalent of a Signal Transfer Point's SS7 route. Routing keys are supported by the M3UA protocols to partition SS7 traffic using combinations of Destination Point Code (DPC), Origination Point Code (OPC), Service Indicator (SI), Network Indicator (NI), SS7 Subsystem Number (SSN), and/or Circuit Identification Code (CIC) message fields.

Using IPGWx, M3UA-connected IP endpoints do not have to conform to standard SS7 topology, because each M3UA association does not require an SS7 link; there are no 16-link-per-linkset restrictions. Each M3UA-connected IP endpoint can be addressed by an SS7 point code unique from the signaling gateway's point code.

M3UA can also be implemented using IPSP, supporting routing keys in the form of SS7 Routes referencing IPSP M3UA linksets rather than as distinct 'routing key' managed elements. Instead, it performs similarly to the M2PA protocol. Each M3UA association is viewed as a link by the core EAGLE, and each IPSP card can have up to 32 associations/links per card. MTP Origin-Based Routing cannot be used with adjacent point codes.

M3UA does not have a 272-octet Signaling Information Field (SIF) length limit as specified by some SS7 MTP3 variants. Larger information blocks can be accommodated directly by M3UA/SCTP without the need for an upper layer segmentation or re-assembly procedure, as specified by the SCCP and ISUP standards. However, a Signaling Gateway will enforce the maximum 272-octet limit when connected to a SS7 network that does not support the transfer of larger information blocks to the destination.

At the Signaling Gateway, M3UA indicates to remote MTP3 users at IP end points when an SS7 signaling point is reachable or unreachable, or when SS7 network congestion or restrictions occur.

Note: IPGW and IPSP M3UA links cannot be in the same link set at the same time. However, the EAGLE allows IPGW and IPSP-M3UA link sets to have separate routes to the same AS, aiding in cutover.

SUA (SCCP User Adaptation) Protocol

SUA transports any SS7 SCCP signaling messages over IP using SCTP, and is used between a Signaling Gateway and a signaling end point or between signaling end points.

SUA is used to direct queries to the correct IP-based Application Server Process. It replaces the SCCP layer with its own SUA layer and is used when source and destination are both IP.

A Signaling Gateway can determine the “next **hop**” using the Global Title Translations delivered in the Called Party Address of the **Message Signaling Unit (MSU)**.

Note: A-links for nodes requiring in-sequence delivery of messages should be configured on the IPLIMx card using M2PA; SUA does not have sequence numbers to support lossless changeover/changeback. For more information on the IPLIMx application, see [IPLIMx, IPGWx and IPSG applications](#).

Routing keys are supported by the SUA protocol as in M3UA. Routing key parameters include DPC, OPC, SI, and SSN.

IPSG does not support SUA.

SS7-over-IP signaling transport

SIGTRAN protocols connect IP-based or IP-enabled **Media Gateway Controllers (MGCs)**, **Signaling Gateway (SG)**, switches, databases and other Next Generation signaling applications with traditional circuit-switched signaling architecture.

Figure 2-3 SS7-over-IP Network

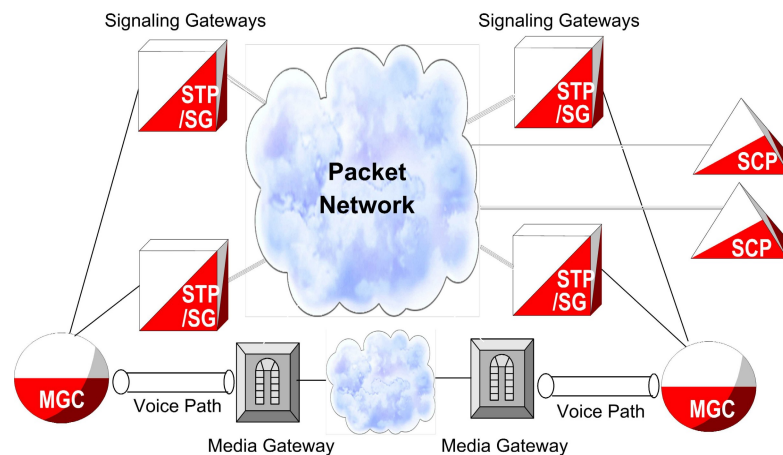

In SS7-over-IP networks, traditional SS7 signals from a telephone company switch are transmitted to a Signaling Gateway, which wraps the signals in an IP packet for transmission over IP to either the next Signaling Gateway or to a MGC, other Service Control Points, or Mobile Switching Centers (MSCs). SIGTRAN protocols define how the SS7 messages can be transported reliably over the IP network; see also [Role of SIGTRAN](#).

The Signaling Gateway has a critical role in the integrated network and is often deployed in groups of two or more to ensure high availability. The Signaling Gateway provides transparent interworking of signaling between TDM and IP networks. The Signaling Gateway may terminate SS7 signaling or translate and relay messages over an IP network to a **Signaling End Point (SEP)** or another Signaling Gateway, which may be separate physical devices or integrated in any combination. For example, the EAGLE can perform the functions of a Signal Transfer Point in addition to those of a Signaling Gateway.

From SS7 Message to IP Packet

The following figure and description show how SS7 messages are encapsulated and sent over an IP network to a host in another network.

Figure 2-4 *Transmitting an SS7 Message using IP*

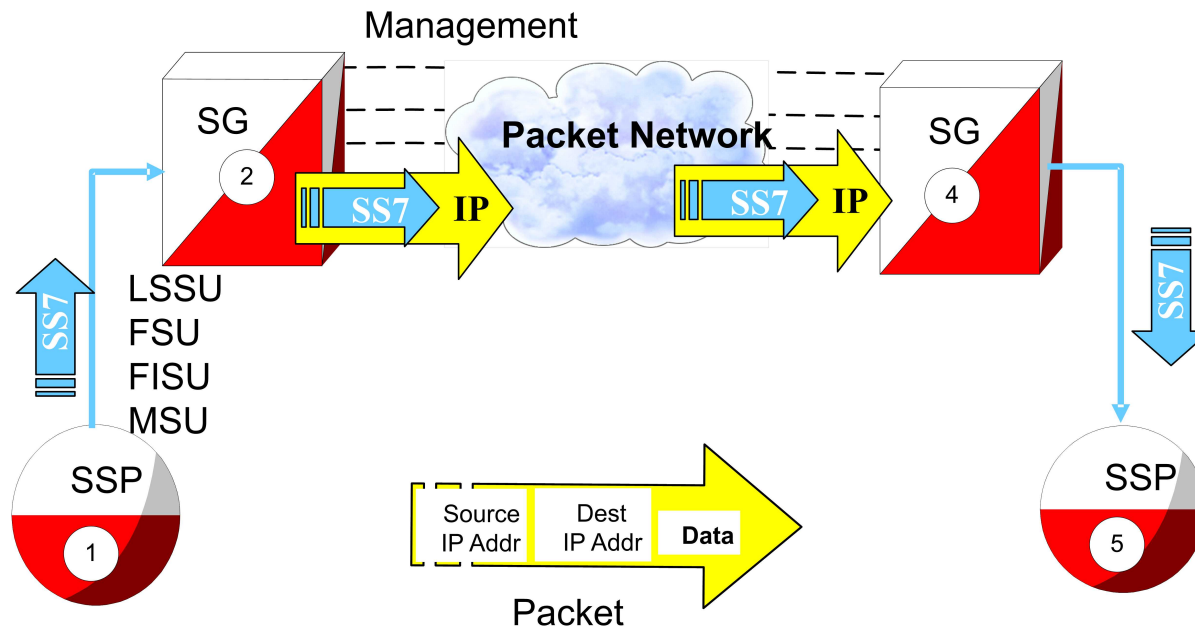

1. A signaling point issues an SS7 message, unaware that there is IP signaling in the network. The message contains Link Status Signaling Units (LSSU), Fill In Signal Units (FISU), Final Signal Units (FSU), and Message Signal Units (MSUs).
2. The Signaling Gateway receives the SS7 packet and encapsulates all necessary SS7 information into the data section of the IP packet. The packet includes the data, source and destination IP addresses.
3. The packet travels across the IP network. The network is unaware that it is delivering SS7 data. There is no need to modify the routers or gateways along the way.
4. The packet is delivered to the Signaling Gateway on the receiving network. The SS7 information is recovered from the IP packet.
5. A well-formed SS7 packet is sent to the destination Signaling Point.

Communication inside the Wide Area Network (WAN)

The following figure and description show the routing inside the Wide Area Network (WAN).

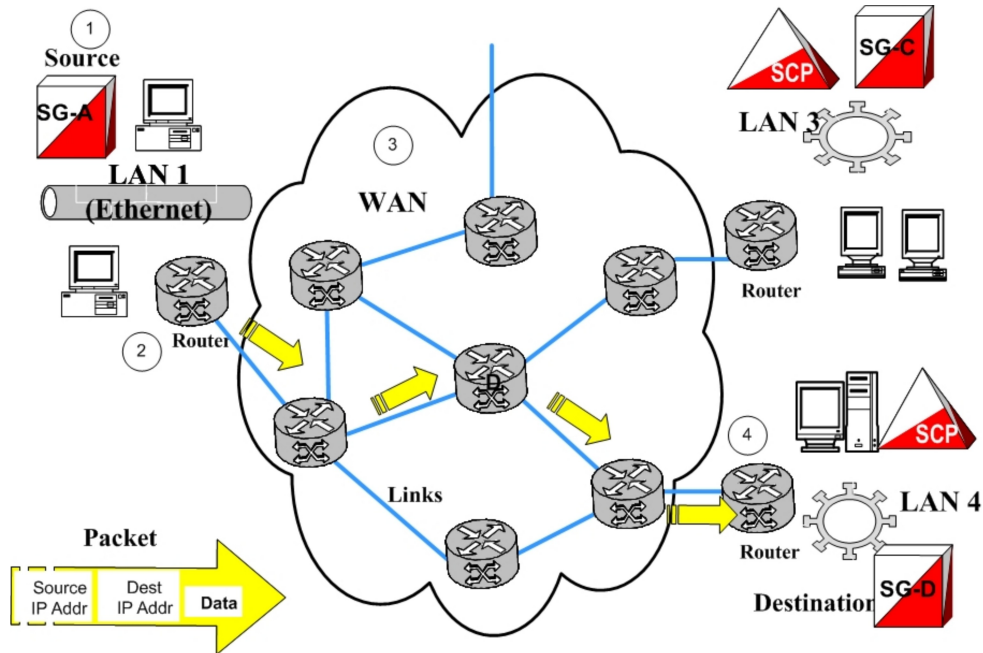
Figure 2-5 Communication inside the WAN

1. The Source Host (Signaling Gateway) builds a packet with a destination IP address.
2. A router on the LAN converts the packet to the WAN protocol and places it on the WAN.
3. Each router on the WAN looks at the destination IP address and determines the port to which it forwards the packet. Each router needs to know only how to get the packet closer to the destination.
4. The final router converts the packet to the local LAN format and delivers it to the Destination Host.

Reasons to transition to an SS7-over-IP SIGTRAN network

There are many reasons for transitioning to an SS7-over-IP network. The resulting network offers improved cost effectiveness, increased capacity that can be further scaled as needed, a high **Quality of Service (QoS)** including redundancy and security, and efficient deployment using existing equipment.

Cost Effectiveness

SS7-over-IP networks lower network capital and operational expenditures. SIGTRAN is based on the IP protocol; these networks use industry standard, off-the-shelf network interfaces, cables, switches, and software. Improvements in technology and reductions in cost found in the general computer industry can be applied readily in signaling applications. As an industry standard, SIGTRAN allows customers to interoperate in a multi-vendor environment.

Replacing long-haul point-to-point SS7 links between network elements with IP connectivity can reduce recurring signaling transport costs and the need for dedicated TDM lines. IP-based network monitoring and **provisioning** improve operation efficiencies.

Increased capacity

SS7-over-IP networks offer increased capacity. The bandwidth overall is greater, both due to inherent capacity and to dynamic bandwidth sharing. Data traffic, including **Short Message Service (SMS)**, can run more efficiently over SIGTRAN. For example, SMS data is saturating some SS7 networks. Using devices such as the EAGLE with its gateway functions, operators can have a **Short Message Service Center** communicate directly to **Home Location Registers (HLR)** and **Mobile Switching Centers (MSCs)** using SIGTRAN.

Flexibility

SIGTRAN uses the packet IP network to define logical connections between devices. Because the network developers, planners, and installers are no longer tied to deploying fixed circuits for signaling, they have the flexibility to define the network as needs and demands change. Flexibility is key in adapting bandwidth on demand; redimensioning the SS7-over-IP network can be done completely through software. With legacy SS7, users are limited to either 56 or 64 kbps links.

There is also flexibility when adding capacity for new IP-based solutions and value-added services; future enhancements are more transparent.

Integration

Enabling a network with IP does not require expensive investments or costly upgrades for existing end nodes; it enables migration to packet-based architecture without adding new point codes or reconfiguring the network.

For M2PA, there are no architectural changes. When using SIGTRAN, SS7 routing translations are the same for TDM or IP linksets.

An SS7-over-IP network is the first step to an all-IP network. [Figure 2-6](#) shows the diversity of solutions that are possible using SIGTRAN protocols. For example, M3UA and SUA support an IP-enabled Short Message Service Center (SMSC) or Home Location Register (HLR). SS7-over-IP solves the throughput limitations that were inherited from the SS7 standards, thus allowing Short Message Service Center, Home Location Register, and other equipment to support heavy SS7 traffic needs.

Figure 2-6 Typical EAGLE SS7-over-IP Deployment

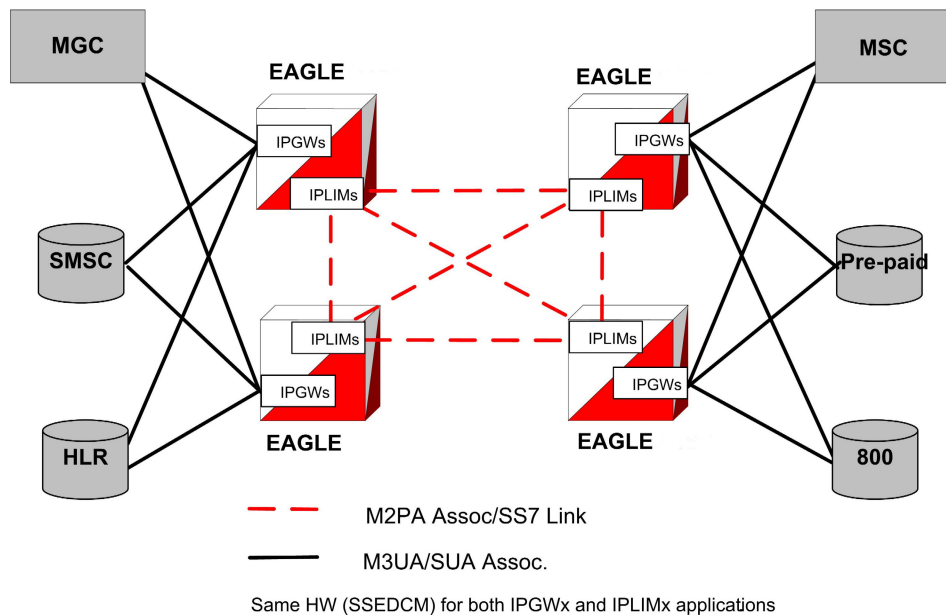

Type of Network Change

When considering a transition, determine the type of change to make. Consider the advantages and disadvantages of a dedicated network versus a converged network. Does the equipment need to be phased out or will new equipment be added? Does the network require additional protection or supplier integration through diversity? All these issues should be considered in the initial planning because of their significant impact on the overall network architecture.

Dedicated Network versus Converged IP Network

While a dedicated IP network offers inherent security and minimal routing, a converged network carrying both voice and data also will satisfy these needs at a lower cost, provided that the QoS attributes such as **Round Trip Time (RTT)**, Packet Loss, and **Jitter** are satisfied. These attributes should always be given the highest priority on the IP network.

Implementing SS7-over-IP on an SS7 system creates a converged IP network that allows quick, cost-effective implementation of IP-based services using existing network elements. The EAGLE, with its Signaling Transfer Point and Signaling Gateway functions, offers a reliable solution for this transition.

Decisions regarding the customization of the IP network are left up to the customer, but Oracle Professional Services can provide recommendations based on their experiences with previous SIGTRAN deployments.

Replacement versus Expansion

When transitioning to an SS7-over-IP network, consider these strategies:

- Replacement of out-phased (end of life) TDM equipment
- Gradual replacement, which means coexistence of the two technologies: there is no need to retire an existing switch if you are deploying purely for additional capacity

- Full accelerated replacement with a short transition period based on cost, efficiency, and fault management. Even if complete transition is desired, it is unrealistic to expect to instantaneously cut over, unless the subscriber base is very small.

There is enormous leverage when one platform provides both TDM and SS7-over-IP. The issue is more than cost savings. A combined platform can support new multimodal voice, data and video services that utilize a combination of IP data with diverse messaging capabilities, location and presence information, voice connections, speech recognition and Intelligent Network control. Of course, not every application requires every capability, so flexibility is key.

- Maintaining the existing PSTN network, and use Next Generation Network (NGN) equipment to satisfy growing demands: legacy switches have many features and services.
- Operators may have to wait until new switches support all required features and services
- Out-of-region or in-region expansion of traditional services or new features

Diversity

Supporting businesses with critical operations, such as banking, requires strategies for predictable recovery, not only from regular network faults, but also from attacks on signaling networks. When planning to move to an SS7-over-IP network, the operator should consider equipment and connection diversity to assist in recovery.

The range of diversity will differ from customer to customer and it may include a multitude of factors:

- Entry diversity offers more than one cable entrance into a building
- Pair and cable diversity provides a local loop connection through multiple, nonadjacent pairs in more than one cable
- Path or route diversity provides end-to-end, physically or logically separate routes for a circuit
- Central office diversity provides local loops that terminate in more than one central office
- Site diversity provides alternative or backup locations

When to transition to an SS7-over-IP SIGTRAN network

Consider transitioning to an SS7-over-IP network if:

- Traffic-volume growth on the network is demanding additional capacity
- New networks are planned or IP services will be added to existing networks
- Traffic volume between signaling points is surpassing the bandwidth of 16-link linksets
- A data or voice-over-IP network is already present
- Signaling traffic is deployed over very high-latency or lossier networks, such as satellite links

If signaling messages are transported over a private intranet, security measures can be applied as deemed necessary by the network operator.

Oracle Communications Solutions

This chapter describes how Oracle products are a part of the SS7-over-IP solution - how the EAGLE functions as a gateway to internet networks; and describes the IAS, which provides several network management and performance tools including IP traffic monitoring through the IMF.

Overview

Oracle has set the standard for ultra-reliable, high-performance, scalable signaling in wireless and wireline networks around the world. Advanced solutions optimize network efficiency and save customer capital and operational costs. addresses network transition by providing the signaling bridge to seamlessly converge circuit and packet-switched technologies.

Operators can leverage existing TDM and ATM network resources as they transition at their own pace to new IP-based transport and services. Oracle's innovative switching solutions create cost-effective, fully scalable networks with built-in flexibility, making it quick and easy to roll out high-margin multimedia services to business and residential customers.

is the IP signaling leader and the first to recognize the value of IP Signaling by developing the TALI protocol (RFC 3094) in 1998. was first to market with an IP Signaling solution (IPLIMx application) in 2000, and has years of IP signaling deployment experience.

There are a variety of products available to implement a new IP network or upgrade an existing SS7 network.

EAGLE

The EAGLE is a robust SS7-over-IP solution that delivers centralized signaling routing and bridges legacy circuit-switched and packet networks. EAGLE provides seamless interworking between TDM resources such as Service Control Points and IP-enabled elements such as Media Gateway Controllers and next-generation databases. With its packet-based technology, the EAGLE can handle signaling requirements of the most complex networks, delivering dynamic bandwidth sharing to support increases in signaling traffic without adding new nodes. The same platform delivers full Signal Transfer Point (STP) capabilities and a complete portfolio of integrated applications.

Using the EAGLE to structure the network provides a predictable and reliable architecture with all required interfaces. It is easily scalable to cover huge core networks, with an independent control layer that allows expansion on different parts of the network independent of each other.

The EAGLE provides ease of database management for the SS7-over-IP architecture. Key benefits of using the SS7-over-IP solution include:

- **Decreased network congestion:** Oracle's packet-switched technology delivers dynamic bandwidth sharing to enable carriers to effectively expand their signaling network and reduce network bottlenecks. By replacing TDM links with an IP interface, service providers can significantly increase signaling capacity to Service Control Points.
- **Reduced transport costs:** Replacing long-haul, point-to-point SS7 links between network elements with IP connectivity can reduce recurring signaling transport costs by 40% to 70%.
- **More efficient networks:** Transitioning to SS7-over-IP signaling does not require expensive equipment replacement or costly software upgrades for existing end nodes. With Oracle solutions, carriers can streamline their networks while reducing administration, without service interruption during installation.
- **Migration to next-generation architecture:** The EAGLE can appear as an end office to the SS7 network by sharing its point code with the IP endpoints. This allows carriers to migrate to a packet-based architecture without adding a new point code or reconfiguring the network. Oracle's open, multi-protocol architecture (SS7, SCTP, M2PA, M3UA, and SUA) provides carriers the capability to grow and migrate their network with the independence to choose best-in-class products.

IPLIMx, IPGWx and IPSG applications

The EAGLE implements SIGTRAN with three applications:

- **IPLIMx**, which represents IPLIM for ANSI networks and IPLIMi for ITU-N and ITU-I networks
- **IPGWx**, which represents IPGWx for ANSI networks and IPGWi for ITU-N and ITU-I networks
- **IPSG**, which represents a unified application for both ANSI and ITU links on a single association

The IPLIMx application uses SCTP with M2PA protocols to support B-, C-, and D-links; but it can also be used for A-links to connect to SEPs on other vendor equipment that has M2PA SIGTRAN specifications implemented. IPLIMx is fully compliant with RFC 4165.

IPLIMx is installed on an E5-ENET, or E5-ENET-B card. Based on the card type, IPLIMx allows up to 16 links per E5-ENET or E5-ENET-B card, each with one SCTP association per link. IPLIMx can be implemented with just one card and expanded to 250 cards per system, as long as it does not exceed System TPS limitations (500k or 750k).

The IPGWx application uses SCTP with M3UA and SUA protocols to provide user part support such as SCCP and ISUP over A-links to IP-resident network elements such as Service Switching Points, Mobile Switching Centers, Service Control Points and Home Location Registers using SIGTRAN. Since IPGWx applications use M3UA/SUA to replace MTP3 functions, it cannot be used in mixed linksets of both M3UA/SUA and MTP3, as the application will not participate in any changeover/changeback procedure. IPGWx supports statically provisioned routing keys by selecting IP connections based on DPC/OPC/SI/CIC/SSN. The application also supports the End Office mode where the EAGLE shares its point codes with IP-remote applications. However, A-links for nodes requiring in-sequence delivery of messages should be configured on the IPLIMx application using M2PA; M3UA/SUA does not have sequence numbers to support lossless changeover/changeback procedures.

IPGWx is installed on an E5-ENET or E5-ENET-B card. IPGWx allows one link per card and up to 50 SCTP associations. The link terminates at a private adjacent point code. IPGWx is installed with just one card, and can be expanded to 250 cards per system, as long as it does not exceed System TPS limitations (500k or 750k).

The IPSG application uses SCTP with the M2PA protocol to support A-, B-, C-, D-links as previously mentioned for IPLIMx. It also uses SCTP with the M3UA protocol to support user part as IPGWx above. IPSG supports routing keys in the form of SS7 Routes referencing IPSG M3UA linksets, rather than as distinct 'routing key' managed elements or End Office capability as IPGWx does. IPSG is installed on an E5-ENET or E5-ENET-B card. IPSG can be implemented with just one card and expanded to 250 cards per system, as long as it does not exceed System TPS limitations (500k or 750k).

The IPSG feature provides conforming M3UA functionality that behaves more like other LIMs, providing the following benefits:

- The IPSG-application M3UA operational model equates Linkset (LS) and Application Server (AS). It equates a Signaling Link (SLK) with an AS-ASP (Routing Context + Association) instance. This allows each AS-ASP instance to be administered as a signaling link.
- A new signaling link type, IPSG-M3UA, can be assigned to linksets having up to 16 signaling links. This doubles the 8-link (and card) limitation of the current IPGWx linkset.
- Each IPSG card will host up to 128 signaling links.
- Each IPSG card will host up to 128 SCTP associations. A maximum of 16 IPSG-M3UA signaling links can be assigned to a single association.
- The adjacent point code (APC) of the IPSG-M3UA linkset is the point code assigned to the Application Server serviced by the linkset. The IPSG-M3UA linkset does not require a fake adjacent point code as the current IPGWx application does.
- Each IPSG-M3UA signaling link can have a single IP connection, unlike the current IPGWx signaling link which can have up to 50 IP connections.
- The state of the IPSG-M3UA signaling link will be based on the states of the assigned IP connection and AS-ASP instance. If the IP connection is unavailable for traffic, then the IPSG-M3UA signaling link will also be unavailable. If the AS-ASP instance is not available, then the IPSG-M3UA signaling link will also be unavailable.
- Multiple IPSG-M3UA signaling links (up to 16) can share one IP connection, as long as all of the IPSG-M3UA signaling links and corresponding IP connection are hosted by the same card. This enables multiple SS7 variant support across a single IP connection.

Integrated Application Solutions (IAS)

The IAS platform, integrated with EAGLE, provides tools to capture network traffic data and convert it into useful business intelligence for troubleshooting, managing traffic, roamers, services, and revenues. With its powerful and configurable filtering, IAS sorts through the data to create comprehensive dashboards and reports for all departments within the service-provider company. IAS includes a comprehensive array of performance- and revenue-management capabilities that provide reliable real-time or historical information based on network traffic.

The IAS is based on industry-standard network protocols, and provides one platform for all network technologies including **Voice over Internet Protocol (VoIP)** and IMS. It supports many different protocols including SS7, CLASS, SIGTRAN, IN, INAP, GSM, CDMA, CAMEL, WIN, MMS, SMPP, WAP, POP3, SMTP, FTP, and HTTP.

For more information on IAS, contact your Sales Representative.

Integrated Message Feeder (IMF)

The IMF is an integrated site collector that provides integrated data acquisition in conjunction with the EAGLE. IMF connects to the EAGLE via Ethernet and monitors signaling links on the EAGLE including LSL, ATM HSL, SE-HSL, M2PA and M3UA.

IMF allows remote access for administration and troubleshooting, and provides backup and upgrade capability, database management, and traffic management of captured signaling information.

IMF hardware supports NEBS 3 for central office environments. IMF provides a redundant LAN architecture for interface reliability and an N+1 server architecture in case of a single server failure within the managed subsystem.

For more information on IMF, contact your Oracle Sales Representative.

Transition Planning

The purpose of transitioning from an existing traditional SS7 network to an SS7-over-IP SIGTRAN network is to access valuable IP services at a reasonable cost and within the desired time frame, without losing any current functionality. While the transition can occur in phases and at the desired pace of the customer, the transition must be well planned to minimize impact on existing operations. This chapter provides guidelines on how to approach such a transition and points to the detailed information provided in this document.

Transition guidelines

The following steps should be followed in making the transition to a SS7-over-IP network.

1. [Resolve high-level network design](#)
2. [Collect network information](#)
3. [Analyze data](#)
4. [Prepare configurations](#)
5. [Implement and test](#)
6. [Analyze data](#)

Resolve high-level network design

Determine any issues by looking at the current network design compared to the new network architecture. Consider the protocols to be used, specific implementations, mated-pair redundancy and link engineering, unihoming versus multihoming, and IP redundancy.

General considerations about the overall network include the following topics:

- [Type of Network Change](#)
 - “Dedicated network versus converged IP network”
 - “Replacement versus expansion”
 - Diversity (see [Type of Network Change](#))
- [Security](#)

SIGTRAN protocols were designed to support specific paths between signaling points. The main protocols are M2PA and M3UA, each of which is built on top of the SCTP protocol. Read about the role of the protocols:

- [SCTP \(Stream Control Transmission Protocol\)](#)
- [“M2PA \(MTP2 User Peer-to-Peer Adaptation Layer\) protocol”](#)
- [M3UA \(MTP Level 3 User Adaptation Layer\) Protocol](#)
- [“SUA \(SCCP User Adaptation\) protocol”](#)

Be aware of Oracle-specific implementations or deviations and how they will impact your new network. Read about these implementations:

- [Protocol deviations](#)
 - [SCTP Timers](#)
 - [SCTP \(Stream Control Transmission Protocol\)](#)
 - [Multihoming](#)
 - [M3UA \(MTP Level 3 User Adaptation Layer\) Protocol](#)
- [Overview of products](#)
- [“Scalability”](#)
- [IPGW/M3UA deployment scenarios](#) and [IPSG Deployment Scenario](#)
- [“IPGWx congestion management options”](#)
- [“IPGWx mateset”](#)
- [“Signaling Link Selection \(SLS\) routing”](#)

Redundancy is achieved through linkset engineering, leveraging unihoming or multihoming, and IP network redundancy. Read about redundancy, links, linksets, and associations:

- [Redundancy and link engineering](#)
 - [“Unihoming versus multihoming”](#)
 - [“Mated Signal Transfer Point redundancy”](#)
 - [“IPGWx mateset”](#)
 - [“Signaling Link Selection \(SLS\) routing”](#)
- [Additional Deployment Scenarios](#)
- [“Scalability”](#)

Collect network information

Developing a physical and logical diagram of the network will help organize the information clearly. Detailed documentation should include:

- [Hardware data of the infrastructure's physical structure](#)
- [Software data including the existence and configuration of protocols used on the network](#)
- [Logical organization of the network](#)

- Name and address resolution methods
- The existence and configuration of services used
- Location of the network sites and the available bandwidth

The physical network diagram should present the following information about your existing network:

- Details of physical communication links, such as cable length, grade, and approximation of the physical paths of the wiring, analog, and ISDN lines
- Servers with name, IP address (if static), server role, and domain membership. A server can operate in many roles.
- Location of devices such as hubs, switches and routers that are on the network
- WAN communication links and the available bandwidth between sites (this could be an approximation or the actual measured capacity)

The logical network diagram should show the network architecture, including the following information:

- Domain architecture including the existing domain hierarchy, names, and addressing scheme.
- Server roles including primary and backup

IP addresses, subnet masks, default gateways and LAN parameters (e.g. Full/Half Duplex, 10/100 Speed, MAC Layer) will also be needed for implementation. Refer to *Database Administration - IP7 User's Guide* manual of the current EAGLE documentation for affected parameters and detailed information.

Before an association is established, the exact RTT is impossible to measure accurately because only the transmitter's SCTP will be able to measure the exact amount of elapsed time from each transmit until the acknowledgment. A good estimate can be gained using a number of ping requests at different times of the day or from a network analyzer. Remember, however, that ping uses ICMP echo packets that are often given a lower QoS in IP networks.

To gather the information required to determine configuration parameters of the M2PA and M3UA association(s) between an EAGLE node and each Signaling End Point (SEP), a spreadsheet per EAGLE node can be very helpful. Every node connected by a SIGTRAN link should appear as a row in the spreadsheet, with the headings listed in the table along the top row.

Table 4-1 M2PA and M3UA configuration parameter data

Heading Text	Explanation
Node Name	The unique network name for the node
Node ID	The unique network ID for the node
Site Name	The unique network name for the site in which the node resides
Node Type	STP, MSC, HLR, SMSC, IN, MSS, MGC, etc.
Connected SGW(s)	The EAGLE node connection to which this data refer

Table 4-1 (Cont.) M2PA and M3UA configuration parameter data

Heading Text	Explanation
Total # SGWs	Total number of STPs to which this node connects
SIGTRAN Protocol	M2PA, M3UA or SUA
RTT to STP	Measured or estimated RTT between the two nodes
Jitter %	The percentage variation in RTT
Dim %	The normal designed maximum utilization of a link (20%, 40%, etc.)
Avg. MSU Size	The expected average MSU size between this node and the EAGLE
% SCCP Class 1	The percentage of SCCP Class 1 traffic expected to be sent to this node
Peak MSU/s	The planned number of MSU/s expected to be sent to this node from all EAGLEs in worst-case conditions
Max Assoc	The maximum number of associations that this node supports to this EAGLE

See also:

- [Configure the IPGWx Application](#)
- [Configure the IPLIMx Application](#)
- [Configure the IPSPG Application](#)
- *Database Administration - IP7 User's Guide* of your current EAGLE documentation

Analyze data

Follow the guidelines in [Engineering Rules for Determining IP7 Application Throughput](#) (TR005007) to determine expected throughput from IPLIMx and IPGWx applications, and for details on other criteria to achieve these advertised capacities.

Additional information on card throughput (MSU/s) can be found in ["Achieving IPLIMx and IPGWx applications' Advertised Capacity"](#).

Oracle has guidelines for implementing SS7-over-IP, which can be found at:

- ["SIGTRAN engineering guidelines"](#)
- ["Calculate the number of cards required"](#)

To determine association configuration parameters, see:

- ["Define RTO parameter"](#)
- ["Configure Congestion Window Minimum \(CWMIN\) parameter"](#)

Prepare configurations

Once card and association throughput are determined, they can be compared to the traffic dimensioning required for signaling end points (from customers) to determine the number of linksets to use, number of cards in a linkset, and number of associations per card. Consider other factors such as limitations enforced by the connected node (e.g., limits to the number of supported associations).

Note: Combining IP links and low-speed links in same linkset will limit bandwidth availability and scalability. Creating dedicated linksets for IP links and low-speed links also can cause load sharing issues (load sharing across more than two linksets).

Implement and test

- ["Configuration"](#)
- ["Retransmission concept"](#)
- ["Define RTIMES association retransmits"](#)
- ["Define RTO parameter"](#)
- ["System verification"](#)
- ["Troubleshooting"](#)

Refine timers and parameters

[Refine Timers and Parameters](#)

Dimensioning

This chapter describes dimensioning issues and calculations required to maximize the efficiency of the new network, addressing scalability, redundancy schemes, throughput calculations for both normal and failover mode, LAN/WAN considerations, and retransmission concepts.

About bandwidth, throughput, transaction units, and TPS

Bandwidth is the maximum amount of data that can pass through a network at any given time; it is the Advertised Capacity of a card.

Throughput is the amount of data that is actually transmitted in that given time. Throughput reflects an end-to-end rate, which is affected by various conditions during the transmission. Throughput is always lower than bandwidth.

Transactions versus transaction units and TPS

In SS7 signaling, a **transaction** is typically defined as one MSU transmitted and one MSU received, and assumes a worst-case scenario of that many MSUs both transmitted and received simultaneously per second.

IP signaling capacity is not usually constrained by the IP network (**bandwidth**), but rather by the processing platform (CPU or memory). The cost of a given transaction varies based upon the feature set triggered by the transaction. Not all MSUs are the same, and not all configurations are the same. Rather than to continue to engineer product capacity for the worst case and thereby penalizing customers who are not using worst-case scenarios, Oracle is providing the **Transaction Unit (TU)** model to allow customers flexibility in how to use application or card capacity.

Under the TU model, a **transaction unit** indicates the relative cost of an IP signaling transaction; the **base transaction unit** is 1.0. Some transactions are more expensive than others in terms of IP signaling card capacity. A transaction that is less expensive than the base has a transaction unit less than 1.0, and a transaction that is more expensive is greater than 1.0. The total transaction units consumed by an MSU are the sum of the base transaction unit value and the additional transaction unit value. **Transaction Units per Second (TPS)** are then calculated with the total transaction unit value and the Advertised Card capacity.

For detailed information on how to calculate IP signaling TPS and the number of cards required to carry MSU traffic, see [How to calculate transaction units per second \(TPS\)](#) and [Calculate the Number of Cards Required](#).

Scalability

Scalability is the ability to increase total throughput under an increased load proportionally to added resources such as hardware or software. For example, to add traffic and to increase throughput in a current system, the operator can replace low-

speed links with IP-based links; IP-based links are much more efficient than standard TDM links. This change requires at least one card that runs the IPGWx, IPLIMx or IPSP application.

Link equivalency

Table 5-1 shows that a single IPLIMx application can take the place of 52 to 80 56K DS0 low-speed links; a single application (M3UA) can take the place of 12 to 80 56K DS0 low-speed links.

Table 5-1 EAGLE Link Equivalency for IPLIMx/IPGWx

ATM <-> Low speed link				M2PA <-> ATM <-> Low speed link				M3UA <-> ATM <-> Low speed link			
Avg. MSU size (MTP 2 + MTP 3)	Eagle ATM link Msu / Sec	56K links ATM equiv alent	64K links ATM equiv alent	Eagle M2P A Msu / Sec	ATM link equiv alent	56K links IP equiv alent	64K links IP equiv alent	Eagle M3U A Msu / Sec	ATM links Equi v-alent	56K links IP equiv alent	64K links IP equiv alent
20	2000	6	5	4000	2	12	10	4000	2	12	10
30	2000	9	8	4000	2	18	15	4000	2	18	15
40	1800	11	9	4000	3	23	20	4000	3	23	20
50	1800	13	12	4000	3	29	25	4000	3	29	25
60	1800	16	14	4000	3	35	30	4000	3	35	30
70	1800	18	16	4000	3	40	35	4000	3	40	35
80	1800	21	18	4000	3	46	40	4000	3	46	40
90	1200	16	14	4000	4	52	45	4000	4	52	45
100	1200	18	15	4000	4	58	50	4000	4	58	50
110	1200	19	17	4000	4	63	55	4000	4	63	55
120	1200	21	18	4000	4	69	60	4000	4	69	60
130	1200	23	20	4000	4	75	65	4000	4	75	65
140	900	18	16	4000	5	80	70	4000	5	80	70
150	900	20	17	4000	5	86	75	2800	4	60	53
160	900	21	18	4000	5	92	80	2800	4	64	56
170	900	22	20	4000	5	98	85	2800	4	68	60
180	900	24	21	4000	5	103	90	2800	4	72	63
190	720	20	18	4000	6	109	95	2800	4	76	67
200	720	21	18	4000	6	115	100	2800	4	80	70
210	720	22	19	4000	6	120	105	2800	4	84	74
220	720	23	20	4000	6	126	110	2800	4	88	77
230	720	24	21	4000	6	132	115	2800	4	92	81
240	600	21	18	4000	7	138	120	2800	5	96	84

Table 5-1 (Cont.) EAGLE Link Equivalency for IPLIMx/IPGWx

ATM <->Low speed link				M2PA<-> ATM <->Low speed link				M3UA<-> ATM <->Low speed link			
250	600	22	19	4000	7	143	125	2800	5	100	88
260	600	23	20	4000	7	149	130	2800	5	104	91
270	600	24	21	4000	7	155	135	2800	5	108	95

Table 5-2 EAGLE Link Equivalency for IPSG on E5-ENET

ATM <->Low speed link				M2PA<-> ATM <->Low speed link				M3UA<-> ATM <->Low speed link			
Avg. MSU size (MTP 2 + MTP 3)	Eagle ATM link Msu / Sec	56K links ATM equiv - alent	64K links ATM equiv - alent	Eagle M2P A Msu / Sec	ATM link Equi v- alent	56K links IP equiv - alent	64K links IP equiv - alent	Eagle M3U A Msu / Sec	ATM links Equi v- alent	56K links IP equiv - alent	64K links IP equiv - alent
20	2000	6	5	5000	3	15	13	5000	3	15	13
30	2000	9	8	5000	3	22	19	5000	3	22	19
40	1800	11	9	5000	3	29	25	5000	3	29	25
50	1800	13	12	5000	3	36	32	5000	3	36	32
60	1800	16	14	5000	3	43	38	5000	3	43	38
70	1800	18	16	5000	3	50	44	5000	3	50	44
80	1800	21	18	5000	3	58	50	5000	3	58	50
90	1200	16	14	5000	5	65	57	5000	5	65	57
100	1200	18	15	5000	5	72	63	5000	5	72	63
110	1200	19	17	5000	5	79	69	5000	5	79	69
120	1200	21	18	5000	5	86	75	5000	5	86	75
130	1200	23	20	5000	5	93	82	5000	5	93	82
140	900	18	16	5000	6	100	88	5000	6	100	88
150	900	20	17	5000	6	108	94	5000	6	108	94
160	900	21	18	5000	6	115	100	5000	6	115	100
170	900	22	20	5000	6	122	107	5000	6	122	107
180	900	24	21	5000	6	129	113	5000	6	129	113
190	720	20	18	5000	7	136	119	5000	7	136	119
200	720	21	18	5000	7	143	125	5000	7	143	125
210	720	22	19	5000	7	150	132	5000	7	150	132
220	720	23	20	5000	7	158	138	5000	7	158	138
230	720	24	21	5000	7	165	144	5000	7	165	144

Table 5-2 (Cont.) EAGLE Link Equivalency for IPSG on E5-ENET

ATM <-> Low speed link				M2PA <-> ATM <-> Low speed link				M3UA <-> ATM <-> Low speed link			
240	600	21	18	5000	9	172	150	5000	9	172	150
250	600	22	19	5000	9	179	157	5000	9	179	157
260	600	23	20	5000	9	186	163	5000	9	186	163
270	600	24	21	5000	9	193	169	5000	9	193	169

Table 5-3 EAGLE Link Equivalency for IPSG on E5-ENET-B (E5-ENET-B when IPSG High Throughput Feature OFF, E5-ENET)

ATM <-> Low speed link				M2PA <-> ATM <-> Low speed link				M3UA <-> ATM <-> Low speed link			
Avg. MSU size (MTP 2 + MTP 3)	Eagle ATM link Msu / Sec	56K links ATM equiv - alent	64K links ATM equiv - alent	Eagle M2P A Msu / Sec	ATM link Equi v- alent	56K links IP equiv - alent	64K links IP equiv - alent	Eagle M3U A Msu / Sec	ATM links Equi v- alent	56K links IP equiv - alent	64K links IP equiv - alent
20	2000	6	5	6500	3	19	16	6500	3	19	16
30	2000	9	8	6500	3	28	24	6500	3	28	24
40	1800	11	9	6500	4	37	33	6500	4	37	33
50	1800	13	12	6500	4	46	41	6500	4	46	41
60	1800	16	14	6500	4	56	49	6500	4	56	49
70	1800	18	16	6500	4	65	57	6500	4	65	57
80	1800	21	18	6500	4	74	65	6500	4	74	65
90	1200	16	14	6500	5	83	73	6500	5	83	73
100	1200	18	15	6500	5	92	81	6500	5	92	81
110	1200	19	17	6500	5	102	89	6500	5	102	89
120	1200	21	18	6500	5	112	97	6500	5	112	97
130	1200	23	20	6500	5	120	105	6500	5	120	105
140	900	18	16	6500	7	130	114	6500	7	130	114
150	900	20	17	6500	7	138	122	6500	7	138	122
160	900	21	18	6500	7	148	130	6500	7	148	130
170	900	22	20	6500	7	159	138	6500	7	159	139
180	900	24	21	6500	7	167	148	6500	7	167	148
190	720	20	18	6500	9	176	155	6500	9	176	155
200	720	21	18	6500	9	186	163	6500	9	186	163
210	720	22	19	6500	9	197	171	6500	9	197	171
220	720	23	20	6500	9	203	181	6500	9	203	181

Table 5-3 (Cont.) EAGLE Link Equivalency for IPSG on E5-ENET-B (E5-ENET-B when IPSG High Throughput Feature OFF, E5-ENET)

ATM <-> Low speed link				M2PA <-> ATM <-> Low speed link				M3UA <-> ATM <-> Low speed link			
230	720	24	21	6500	9	217	186	6500	9	217	186
240	600	21	18	6500	11	224	197	6500	11	224	197
250	600	22	19	6500	11	232	203	6500	11	232	203
260	600	23	20	6500	11	241	210	6500	11	241	210
270	600	24	21	6500	11	250	217	6500	11	250	217

Table 5-4 EAGLE Link Equivalency for IPSG on E5-ENET-B (E5-ENET-B IPSG High Throughput Feature ON)

ATM <->Low speed link				M2PA <-> ATM <-> Low speed link				M3UA <-> ATM <-> Low speed link			
Avg. MSU size (MTP 2 + MTP 3)	Eagle ATM link Msu / Sec	56K links ATM equiv - alent	64K links ATM equiv - alent	Eagle M2P A Msu / Sec	ATM link Equi v- alent	56K links IP equiv - alent	64K links IP equiv - alent	Eagle M3U A Msu / Sec	ATM links Equi v- alent	56K links IP equiv - alent	64K links IP equiv - alent
20	2000	6	5	9500	5	27	24	9048	4	25	22
30	2000	9	8	9500	5	41	36	9048	4	38	33
40	1800	11	9	9500	5	54	48	9048	4	50	44
50	1800	13	12	9500	5	68	59	9048	4	63	55
60	1800	16	14	9500	5	81	71	9048	4	76	66
70	1800	18	16	9500	5	95	83	9048	4	88	77
80	1800	21	18	9500	5	108	95	9048	4	101	88
90	1200	16	14	9500	8	122	107	9048	7	114	99
100	1200	18	15	9500	8	136	118	9048	7	126	110
110	1200	19	17	9500	8	148	132	9048	7	139	121
120	1200	21	18	9500	8	164	142	9048	7	151	132
130	1200	23	20	9387	8	176	153	8870	7	161	141
140	900	18	16	9277	11	190	167	8700	10	170	149
150	900	20	17	9170	11	202	179	8535	9	179	156
160	900	21	18	9065	11	216	190	8377	9	187	164
170	900	22	20	8962	11	232	202	8225	9	195	171
180	900	24	21	8862	11	244	216	8078	9	203	177
190	720	20	18	8764	13	257	226	7936	11	210	184
200	720	21	18	8668	13	271	238	7800	11	218	190

Table 5-4 (Cont.) EAGLE Link Equivalency for IPSG on E5-ENET-B (E5-ENET-B IPSG High Throughput Feature ON)

ATM <-> Low speed link				M2PA <-> ATM <-> Low speed link				M3UA <-> ATM <-> Low speed link			
210	720	22	19	8574	13	288	250	7668	11	225	196
220	720	23	20	8482	13	297	264	7540	10	231	202
230	720	24	21	8392	13	317	271	7416	10	238	208
240	600	21	18	8304	16	328	288	7296	12	244	214
250	600	22	19	8218	16	339	297	7180	12	250	219
260	600	23	20	8134	16	352	306	7068	12	256	224
270	600	24	21	8051	16	365	317	6960	12	262	229

Hardware and software requirements

For SS7-over-IP networks, Oracle Communications uses E5-ENET and E5-ENET-B cards to achieve IP connectivity, using the IPLIMx, IPGWx, and IPSG applications.

The **IPLIMx application** implements the M2PA protocol, which is used mainly for B-, C-, and D-links. Once either of the cards is loaded with the IPLIMx application, the card is referred to as the IPLIMx card.

The **IPGWx application** implements the M3UA and SUA protocols, which are used for A-links. Once either of the cards is loaded with the IPGWx application, the card is referred to as the IPGWx card.

The **IPSG application** implements the M2PA and M3UA protocols, which are used for A-links (IPSG-M3UA) and B-, C-, and D-links (IPSG-M2PA) signaling links. Once the card is loaded with the IPSG application, it is referred to as an IPSG card.

The number of MSU/s supported by each card is dependent on various factors including MSU size, percentage of MSUs triggering the SCCP Class 1 sequencing feature, and the Integrated Monitoring feature.

System capacity

Each of the IP7 applications may have a unique set of TPS ratings based on the card type used. System capacity for the EAGLE is assumed to include 160-byte average message size, including up to 150,000 Class-1 Sequenced SCCP TPS. Without the HIPR2 High Rate Mode feature, the system capacity is defined as 500,000 TPS; with this feature turned on, system capacity is defined as 750,000 TPS. While this limit is not enforced by the provisioning sub-system, the rated capacity of all IP7 applications running in an EAGLE must not exceed the available system capacity.

Note: Other features, such as Integrated Monitoring, will also require system capacity and must be considered when calculating the available system capacity.

The EAGLE is engineered to support a system total capacity as defined in this section where:

- Each E5-ENET or E5-ENET-B card running the IPLIMx or IPGWx application has a maximum capacity of 4000 TPS.
- Each E5-ENET card running the IPSPG application has a maximum capacity of 5000 TPS.
- Each E5-ENET-B card running the IPSPG application when the E5-ENET-B IPSPG High Throughput feature is OFF has a maximum capacity of 6500 TPS.
- Each E5-ENET-B card running the IPSPG application when the E5-ENET-B IPSPG High Throughput feature is ON has a maximum capacity of 9500 TPS.
- Each SLIC card running the IPSPG application when the IPSPG High Throughput feature is OFF has a maximum capacity of 10000 TPS.
- Each SLIC card running the IPSPG application when the IPSPG High Throughput feature is ON has a maximum capacity of 10000 TPS.

The system total depends on the system TPS. The total maximum allowed system TPS is 750,000 when the HIPR2 High Rate Mode feature is turned on and 500,000 TPS if the HIPR2 High Rate Mode feature is turned off.

When considering other factors or additional configurations that impact the IMT, contact your Sales Representative for more information.

Achieving IP Signaling Applications' Advertised Capacity

A goal of properly engineered networks is to eliminate congestion. Advertised Capacity refers to the maximum TPS that can be sustained without congestion. Several factors affect TPS calculations and must be considered when calculating the expected throughput for the IPLIMx, IPGWx and IPSPG applications.

The IPGWx application implements traffic flow control based upon the TPS value allocated to its signaling link, which is derived from the `iptps` parameter setting of its linkset. Presenting a load in excess of the signaling link TPS value will result in congestion.

Factors Affecting Advertised Capacity

The following factors affect the IP application's Advertised Capacity:

- Host card

Performance Characteristics of the host card can impact the capacity.

- CPU utilization

Various factors determine the processing resources required by IP applications to manage a given traffic load, and cause the processing of each MSU to be more expensive. For example, the EAGLE provides a feature that enables support of Class-1 Global Title traffic. When the feature is enabled and a triggering message is received by an IP signaling application, the application sends the MSU to an SCCP card for translation, and after translation, the MSU is sent back to the originating IP signaling card for post-translation routing. This extra IMT hop results in significant processing overhead in the receiving IP signaling card.

- Message buffers

The amount of memory allocated for traffic buffers determines the maximum traffic rate and average message size that can be sustained for a certain network configuration. The buffer size is configurable through associations. For example, within the constraints of memory on the card, each association can have from 8 kb up to 400 kb of send-and-receive buffer space for SCTP.

- Card communication interfaces

The capacity of the card's external interfaces can become a constraint for certain configurations. For example, the IMT interface capacity is affected by high-utilizing features, or the Ethernet interface configurable capacity is set to half-duplex (not 100Mb/sec full-duplex).

- E5-ENET-B IPSP High Throughput feature

Turning on the E5-ENET-B IPSP High Throughput feature impacts the baseline configuration for the E5-ENET-B IPSP card as shown in [Table 5-5](#)

Table 5-5 Baseline Configuration Changes for the E5-ENET-B IPSP High Throughput Feature

E5-ENET-B Card Baseline Configuration	E5-ENET-B when IPSP High Throughput Feature OFF, E5-ENET	E5-ENET-B IPSP High Throughput feature ON
Maximum TPS for the card	6500	9500
Average MSU size (bytes)	0-272	0-120
Max RTT (MS)	120	50
Max number of links/ associations	16	4
Protocol	M2PA and M3UA	M2PA

- Card de-rating

If the E5-ENET-B IPSP High Throughput feature is turned on, the traffic rate is greater than 6500 TPS, and the E5-ENET-B IPSP card exceeds the limits shown in [Table 5-5](#), then the card is de-rated according to the following calculations:

- SLK TU cost factor = $1 + (\text{RoundDown}(((\text{Number of links} - 1)/4) * 0.025))$
- MSU size TU cost factor for M2PA links = $1 + (\text{RoundUp}(((\text{Average MSU size} - 120)/10) * 0.012))$
- MSU size TU cost factor for M3UA links = $1 + (\text{RoundUp}(((\text{Average MSU size} - 120)/10) * 0.02))$
- Association RTT cost factor (if greater than 50) = $1 + (\text{RoundDown}((\text{Association RTT}/25) * 0.04))$
- Protocol TU cost factor for M3UA links = 1.05

Note: When calculating the values for the Average MSU SIF size >120, Number of Links >4, and Association RTT > 50, the values from the division in the formula are rounded to the quotient. In addition, the final values for the Transaction Unit Adjustment and Transaction Unit Cost values for Average MSU SIF size are rounded to the nearest 10 value if the delta is not a multiple of 10.

Given the derating factors, a derived SLK IP TPS for an MSU would be calculated as follows:

$$\begin{aligned} \text{Derived SLK IP TPS for an MSU} = & 1 \text{ TU (Actual SLK IP TPS)} + \\ & (\text{RoundDown}(((\text{Number of links} - 1)/4) * 0.025) \text{ (for number of links} > 4) + \\ & (\text{RoundUp}(((\text{Average MSU size} - 120)/10) * 0.012) \text{ (for M2PA) OR} \\ & + (\text{RoundUp}(((\text{Average MSU size} - 120)/10) * 0.02) \text{ (for M3UA)} \\ & + (\text{RoundDown}((\text{Association RTT}/25) * 0.04) \text{ (for RTT} > 50 \text{ ms)} + \\ & 0.05 \text{ (for M3UA)} \end{aligned}$$

For detailed descriptions of factors that affect advertised card capacity, see [Engineering Rules for Determining IP7 Application Throughput](#).

Base transaction unit

The base IP signaling transaction unit involves an MSU sent and an MSU received. If the E5-ENET-B, E5-ENET when IPSP High Throughput Feature is turned OFF, then each MSU has a **Service Information Field (SIF)** of less than or equal to 160 bytes. If the E5-ENET-B IPSP High Throughput feature is turned on, then each MSU has a SIF of less than or equal to 120 bytes.

The base Advertised Capacity of EAGLE IP signaling cards assumes an average transaction unit cost of 1.0, so a TPS rating of 2,000 = 2,000 **Transaction Units per Second (TPS)**, each having a cost of 1.0. If the average transaction cost increases above 1.0, then the Advertised Capacity (TPS rating) of the IP signaling card decreases proportionally.

[Table 5-6](#) shows the base Advertised Capacity for IPSP application on applicable cards.

Table 5-6 Base Advertised Capacity for IPSP Cards

Card	Base Advertised Capacity (TPS)
E5-ENET	5,000 for IPSP 4000 for IPGWx/IPLIMx
E5-ENET-B (E5-ENET-B when IPSP High Throughput Feature OFF, E5-ENET or SLIC)	6500 for IPSP 4000 for IPGWx/IPLIMx
E5-ENET-B (E5-ENET-B IPSP High Throughput ON)	9500 for IPSP 4000 for IPGWx/IPLIMx
SLIC	10000 for IPSP

Exceeding the Advertised Capacity may result in signaling congestion, and in combination with the E5IS Data Feed feature, may result in the application discarding E5IS Data Feed messages.

Base Transaction Unit Rules: IPLIMx, IPGWx, and IPST (E5-ENET-B when IPST High Throughput Feature OFF, E5-ENET)

The base transaction unit rules are applied to establish the base transaction unit costs:

1. Sufficient IP TPS is assigned to the linkset to which the IPGWx signaling link is assigned. (IPGWx only) or sufficient IP TPS (both Reserved and Max SLKPTS is assigned to each link of an IPST linkset).
2. The traffic is not monitored via the E5IS or Fast Copy features.
3. For IPGWx and IPLIMx, the percentage of received traffic that triggers the enabled EAGLE SCCP Class-1 Sequencing feature is less than or equal to 50%.
4. For IPST, none of the received traffic triggers the enabled Eagle SCCP Class-1 Sequencing feature.
5. The IP packet-loss rate is 25 per 100,000 or less.
6. The IP connection message buffer memory is of a sufficient size on the local SCTP association and peer network elements to sustain traffic for the network's RTT and worst-case packet loss.
7. The IP connection retransmission mode must be linear (RMODE=LIN) for SCTP associations.
8. The IP connection retransmit time-out is configured to a value that is appropriate for the expected network latency (RMIN for SCTP associations).
9. Number of open IP connections is less than or equal to 8 (IPGW links) or 16 (IPST links).
10. Number of active SLKs is less than or equal to half the maximum supported on the IPLIMx card (<=8 for E5-ENET or E5-ENET-B).
11. M2PA Timer T7 (Excess Delay in ACK) is configured to have a value appropriate for the expected network latency (IPLIMx and IPST M2PA links).
12. The IP connection minimum congestion window (CWMIN) is configured to an appropriate value to achieve the target IP TPS on the link.
13. The peer network element acknowledgment timer (SACK timer) is set to an appropriate value in correlation with the local IP connection RMIN and the expected network latency.

Base Transaction Unit Rules (E5-ENET-B IPST High Throughput ON)

In addition to the rules specified in [Base Transaction Unit Rules: IPLIMx, IPGWx, and IPST \(E5-ENET-B when IPST High Throughput Feature OFF, E5-ENET\)](#), the following base transaction rules apply to E5-ENET-B IPST cards when the E5-ENET-B IPST High Throughput feature is turned on:

1. Number of links provisioned is less than or equal to 4
2. The average MSU size per second carried by IPST links is less than or equal to 120 bytes.
3. The network round trip time (RTT) is less than or equal to 50 ms.

4. The traffic is carried by M2PA links.

For IPSP configuration exceeding these rules, additional TU adjustment costs as shown in [Table 5-11](#) are enforced for deriving TUs consumed by a signaling link (SLK). If the derived TU cost exceeds the configured SLKTPS/MAXSLKTPS on an IPSP SLK, it will result in congestion of the link and discard of the MSUs.

Base Transaction Unit Costs: IPLIMx, IPGWx

The base transaction unit cost is based on the configuration rules shown in [Base Transaction Unit Rules: IPLIMx, IPGWx, and IPSP \(E5-ENET-B when IPSP High Throughput Feature OFF, E5-ENET\)](#). Any additional configurations are applied to the adjusted transaction unit.

Table 5-7 Base Transaction Unit Cost Per MSU SIF Size

MSU SIF	M2PA	M3UA	SUA
0..140	1	1	1.33
141..272	1	1.4	2
273..544	2	2	N/A
545..816	3	3	N/A
817..1088	4	4	N/A
1089..1360	5	5	N/A
1361..1632	6	6	N/A
1633..1904	7	7	N/A
1905..2176	8	8	N/A
2177..2448	9	9	N/A
2449..2720	10	10	N/A
2721..2992	11	11	N/A
2993..3264	12	12	N/A
3265..3536	13	13	N/A
3537..3808	14	14	N/A
3809..4080	15	15	N/A
4081..4095	16	16	N/A

Base Transaction Unit Costs: IPSP

The base transaction unit cost for IPSP cards is based on the configuration rules shown in [Base Transaction Unit Rules: IPLIMx, IPGWx, and IPSP \(E5-ENET-B when IPSP High Throughput Feature OFF, E5-ENET\)](#) and [Base Transaction Unit Rules \(E5-ENET-B IPSP High Throughput ON\)](#). Any additional configurations are applied to the adjusted transaction unit.

Note: When calculating the values for the Average MSU SIF size >120, the values from the division in the formula are rounded to the quotient. In addition, the final values for the Transaction Unit Adjustment and Transaction Unit Cost values for Average MSU SIF size are rounded to the nearest 10 value if the delta is not a multiple of 10.

Table 5-8 Base Transaction Unit Cost Per MSU SIF Size for IPSP Cards

MSU SIF or UA Data Parm Size	E5-ENET IPSP Transaction Unit Cost	E5-ENET-B IPSP Transaction Unit Cost*	E5-ENET-B IPSP High Throughput Feature
0-160	1	1	OFF
161-272	1.15	1.15	OFF
0-120	1	1	ON
121-272	Defaults to the TU costs used for the E5-ENET-B card when the E5-ENET-B IPSP High Throughput feature is OFF.	M2PA: 1 + (RoundUp((Average MSU size - 120)/10)) * 0.012) M3UA: 1 + (RoundUp((Average MSU size - 120)/10)) * 0.02)	ON
273..544	2	2	N/A
545..816	3	3	N/A
817..1088	4	4	N/A
1089..1360	5	5	N/A
1361..1632	6	6	N/A
1633..1904	7	7	N/A
1905..2176	8	8	N/A
2177..2448	9	9	N/A
2449..2720	10	10	N/A
2721..2992	11	11	N/A
2993..3264	12	12	N/A
3265..3536	13	13	N/A
3537..3808	14	14	N/A
3809..4080	15	15	N/A
4081..4095	16	16	N/A

Note: *Values in the "E5-ENET-B IPSP Transaction Unit Cost" column apply to IPSP cards where type=enetb and the card is routing more than 6500 MSU/s. Other IPSP scenarios use the "E5-ENET IPSP Transaction Unit Cost" column values.

Adjusted transaction unit

The **adjusted transaction unit** is the value calculated and tested by Oracle that represents additional cost per base transaction unit when the configuration deviates from the base configuration.

Configuration scenarios and their TU values for IPGWx (M3UA), IPLIMx (M2PA) and IPSG (M3UA and M2PA) are shown in [Table 5-9](#), [Table 5-10](#), and [Table 5-11](#). For more information on calculating throughput based on transaction units, see [How to calculate transaction units per second \(TPS\)](#).

Note: When computing TU cost for configuration attributes such as size and number of connections/links on IPSG cards the TU used will be from [Table 5-10](#) or [Table 5-11](#), depending on whether an E5-ENET or E5-ENET-B card is used and the status of the E5-ENET-B IPSG High Throughput feature.

Table 5-9 Additional IPLIMx/IPGWx Transaction Units for Advanced Configurations

MSU SIF Size	Adapter	Monitored E5IS Data Feed	Number of Open Conns ¹	SLAN and/or SCCP Conversion	Base TU	TU Adjustment	Total TU	Max MSU/s 2000	Max MSU/s 4000
0..140	M3UA	Yes	<= 8	No	1.0	0.43	1.43	1400	2800
0..140	M3UA	Yes	<= 8	Yes	1.0	0.67	1.67	1200	2400
0..140	M3UA	Yes	> 8	No	1.0	0.82	1.82	1100	2200
0..140	M3UA	Yes	> 8	Yes	1.0	1.00	2.00	1000	2000
141..272	M3UA	Yes	<= 8	No	1.43	0.80	2.23	900	1800
141..272	M3UA	Yes	<= 8	Yes	1.43	1.24	2.67	750	1500
141..272	M3UA	Yes	> 8	No	1.43	1.65	3.08	650	1300
141..272	M3UA	Yes	> 8	Yes	1.43	1.91	3.34	600	1200
0..140	M2PA	Yes	<= half max per card	No	1.0	0	1.00	2000	4000
0..140	M2PA	Yes	<= half max per card	Yes	1.0	0.38	1.38	1450	2900
0..140	M2PA	Yes	> half max per card	No	1.0	0.11	1.11	1800	3600

Table 5-9 (Cont.) Additional IPLIMx/IPGWx Transaction Units for Advanced Configurations

MSU SIF Size	Adapter	Monitored E5IS Data Feed	Number of Open Conns ¹	SLAN and/or SCCP Conversion	Base TU	TU Adjustment	Total TU	Max MSU/s 2000	Max MSU/s 4000
0..140	M2PA	Yes	> half max per card	Yes	1.0	0.54	1.54	1300	2600
141..272	M2PA	Yes	<= half max per card	No	1.0	0.54	1.54	1300	2600
141..272	M2PA	Yes	<= half max per card	Yes	1.0	1.00	2.00	1000	2000
141..272	M2PA	Yes	> half max per card	No	1.0	0.67	1.67	1200	2400
141..272	M2PA	Yes	> half max per card	Yes	1.0	1.11	2.11	950	1900

¹ Open Connections and Active SLKs are not always synonymous, depending on the GPL. For IPLIM, one SLK equals one connection. For IPGW, one SLK can equal up to 50 connections. For IPSG, one connection equals at least one SLK.

Additional Transaction Units cost enforced by the IPSG application per Transaction for an E5-ENET-B card when the E5-ENET-B IPSG High Throughput feature is turned off, an E5-ENET card is shown in [Table 5-10](#).

Table 5-10 IPSG Additional Transaction Units for Advanced Configurations (E5-ENET-B when IPSG High Throughput Feature OFF, E5-ENET)

Configuration Attribute	Average MSU SIF Size	Transaction Unit Adjustment (per MSU with attribute)	Transaction Unit Cost (per MSU with attribute)
MSU Size	0..160	0	1.0
	161..272	0.15	1.15
More than 16 open IP connections on IPSG card	0..272	$0.135 * \text{INT}(\# \text{ of connections} / 16)$	$1 + (.135 * \text{INT}(\# \text{ of connections} / 16))$
MSU triggers enabled SCCP Class-1 Sequencing feature	0..272	0.2	1.2

Table 5-10 (Cont.) IPSP Additional Transaction Units for Advanced Configurations (E5-ENET-B when IPSP High Throughput Feature OFF, E5-ENET)

Configuration Attribute	Average MSU SIF Size	Transaction Unit Adjustment (per MSU with attribute)	Transaction Unit Cost (per MSU with attribute)
MSU triggers SLAN copy	0..272	$0.00143 * \text{MSU Size}$	$1 + (0.00143 * \text{MSU Size})$
MTP-routed SCCP Conversion feature enabled	0..272	$0.00143 * \text{MSU Size}$	$1 + (0.00143 * \text{MSU Size})$
MSU is copied by E5IS Data Feed	0..272	0.43	1.43
MSU is copied by Fast Copy	0..272	0	1.0

Additional Transaction Units cost enforced by IPSP application per Transaction when the E5-ENET-B IPSP configuration deviates from the configuration described in [Table 5-5](#) and the E5-ENET-B IPSP High Throughput feature is turned on are shown in [Table 5-11](#).

Note: When calculating the values for the Average MSU SIF size >120, Number of Links >4, and Association RTT > 50, the values from the division in the formula are rounded to the quotient. In addition, the final values for the Transaction Unit Adjustment and Transaction Unit Cost values for Average MSU SIF size are rounded to the nearest 10 value if the delta is not a multiple of 10.

Table 5-11 IPSP Additional Transaction Units for Advanced Configurations (E5-ENET-B IPSP High Throughput Feature ON)

Configuration Attribute	Attribute Value	Transaction Unit Adjustment (per MSU with Attribute)	Transaction Unit Cost (per MSU with Attribute)
Average MSU SIF size >120 bytes	121-272	M2PA: $(\text{RoundUp}((\text{Average MSU size} - 120)/10))) * 0.012$ M3UA: $(\text{RoundUp}((\text{Average MSU size} - 120)/10)) * 0.02$	M2PA: $1 + (\text{RoundUp}((\text{Average MSU size} - 120)/10))) * 0.012$ M3UA : $1 + (\text{RoundUp}((\text{Average MSU size} - 120)/10))) * 0.02$
Number of links > 4	5 - 32	$(\text{RoundDown}((\text{Number of links} - 1)/4))) * 0.025$	$1 + (\text{RoundDown}((\text{Number of links} - 1)/4))) * 0.025$
Association RTT > 50 ms	51 - 200 ms	$(\text{RoundDown}(\text{Association RTT} / 25)) * 0.04$	$1 + (\text{RoundDown}(\text{Association RTT} / 25)) * 0.04$
Protocol	M3UA	0.05	1.05

For an E5-ENET-B IPSP Capacity calculation with the E5-ENET-B IPSP High Throughput feature turned on, the total TU adjustments factors should be derived by adding TU factors for each of the following as applicable:

- Additional features such as SCCP Class-1 Sequencing, SLAN/IMF copy, SCCP conversion as shown in [Table 5-10](#)
- Large MSU as shown in [Table 5-8](#)
- Configuration above baseline as shown in [Table 5-11](#)

How to calculate transaction units per second (TPS)

TPS can be calculated for IPGW, IPLIM, and IPSP cards. If E5-ENET-B cards are used as IPSP cards, then the TPS is calculated depending on whether the E5-ENET-B IPSP High Throughput feature is ON or OFF.

- [Calculating TPS for IPGW and IPLIM Cards](#)
- [Calculating TPS for IPSP Cards: E5-ENET-B when IPSP High Throughput Feature OFF, E5-ENET](#)
- [Calculating TPS for IPSP Cards: E5-ENET-B IPSP High Throughput Feature ON](#)

Calculating TPS for IPGW and IPLIM Cards

Refer to [Table 5-12](#) to follow the process.

1. Determine which application will carry the traffic (IPGW_x, IPLIM_x).
2. Determine the adapter protocol type of the association(s) that will carry the traffic. For IPGW and IPLIM cards the adapter is always M3UA.
3. Determine how many distinct categories of traffic will be carried by the card. Characteristics that distinguish categories include:
 - Average SIF size
 - Whether or not the traffic is monitored (all rows have monitoring by E5IS)
 - How many connections per card will carry the traffic (2)
 - Whether Signal Transfer Point SLAN or SCCP Conversion is applied to the traffic (3)

Distinct traffic categories are identified by rows (**A**, **B**).

4. Select the TU value that applies to each distinct category of traffic (6)
5. If the total bi-directional MSU rate of each category ((A7), (B7)) is known in advance, then the:
 - Total TU rate for a category = MSU rate x TU value ((A7) x (A6))
 - Total TU rate to be carried by the card = Sum of all TU rates of the traffic categories ((A6) x (A7) + (B6) x (B7))

Then compare that value to the Base Card Capacity (7).

6. If the fraction of total traffic that applies to each category is known, then the maximum total MSU rate, that is, the actual Advertised Capacity, can be

determined by dividing the Base Advertised Capacity (7) by the total TU value of the traffic mix (6).

Table 5-12 Calculating TPS for IPGW and IPLIM Cards

	1 MSU SIF Size	2 # of Open Conns ¹	3 SLAN and/or SCCP Conver- -sion	4 Base TU	5 Adjust- ment	6 Total TU	7 Max MSU/s 2000	Max MSU/s 4000	Max MSU/s 5000 ²
A	0..140	<=8	No	1.0	0.43	1.43	1400	2800	3500
	0..140	<=8	Yes	1.0	0.67	1.67	1200	2400	3000
	0..140	>8	No	1.0	0.82	1.82	1100	2200	2750
	0..140	>8	Yes	1.0	1.00	2.00	1000	2000	2500
	141..27 2	<=8	No	1.43	0.80	2.23	900	1800	2250
B	141..27 2	<=8	Yes	1.43	1.24	2.67	750	1500	1875
	141..27 2	>8	No	1.43	1.65	3.08	650	1300	1620
	141..27 2	>8	Yes	1.43	1.91	3.34	600	1200	1500

¹ Open Connections and Active SLKs are not always synonymous, depending on the GPL. For IPLIM, one SLK equals one connection. For IPGW, one SLK can equal up to 50 connections. For IPSP, one connection equals at least one SLK.

² E5IS Data Feed refers to STC-style monitoring. Fast Copy does support Large MSUs and has a zero transaction unit cost.

Calculating TPS for IPSP Cards: E5-ENET-B when IPSP High Throughput Feature OFF, E5-ENET

Refer to [Table 5-13](#) to follow the process:

1. Determine whether an E5-ENET or E5-ENET-B card is used.
2. Determine the adapter protocol type of the association(s) that will carry the traffic .
3. Determine how many distinct categories of traffic will be carried by the card. Characteristics that distinguish categories include:
 - Average SIF size (1)
 - Whether or not traffic is monitored
 - How many connections per card will carry the traffic (2)
 - Whether Signal Transfer Point SLAN or SCCP Conversion applies to the traffic (4)
 - Whether the MSU is copied by E5IS Data Feed (5)

Distinct traffic categories are identified by rows (**A**, **B**)

4. Select the TU value that applies (7).
5. The maximum total MSU rate, (actual Advertised Capacity), can be determined by dividing the Max MSU/s for the card by the total TU (7).

Table 5-13 Calculating TPS for IPSP Cards: E5-ENET-B when IPSP High Throughput Feature OFF, E5-ENET

	1 MSU SIF Size	2 Numb er of links	3 Protoc ol	4 MSU Triggers SLAN or SCCP copy	5 MSU Copied by E5IS Data Feed	6 TU Adjust -ment Factor	7 Total TU	8 Max MSU/s 5000 (E5- ENET)	9 Max MSU/s 6500 (E5- ENET- B)
A	0.160	<=16	M2PA	No	No	0	1.0	5000	6500
	0.160	<=16	M3UA	No	No	0	1.0	5000	6500
	0.160	<=16	M2PA	Yes	No	0.0014 3 * MSU Size	1 + (0.00 143 * MSU Size)	-- (MSU size depend ent)	5687
	0.160	<=16	M3UA	Yes	No	0.0014 3 * MSU Size	1 + (0.00 143 * MSU Size)	-- (MSU size depend ent)	5687
	0.160	<=16	M2PA	No	Yes	0.43	1.43	3496	4545
	0.160	<=16	M3UA	No	Yes	0.43	1.43	3496	4545
	0.160	>16	M2PA	No	No	0.135	1.135	4405	5727
	0.160	>16	M3UA	No	No	0.135	1.135	4405	5727
B	161..27 2	<=16	M2PA	No	No	0.15	1.15	4348	5652
	161..27 2	<=16	M3UA	No	No	0.15	1.15	4348	5652
	161..27 2	<=16	M2PA	Yes	No	0.0014 3 * MSU Size	1 + (0.00 143 * MSU Size)	-- (MSU size depend ent)	5687
	161..27 2	<=16	M3UA	Yes	No	0.0014 3 * MSU Size	1 + (0.00 143 * MSU Size)	-- (MSU size depend ent)	5687
	161..27 2	<=16	M2PA	No	Yes	0.43	1.43	3496	4545

Table 5-13 (Cont.) Calculating TPS for IPSG Cards: E5-ENET-B when IPSG High Throughput Feature OFF, E5-ENET

1 MSU SIF Size	2 Number of links	3 Protocol	4 MSU Triggers SLAN or SCCP copy	5 MSU Copied by E5IS Data Feed	6 TU Adjust- ment Factor	7 Total TU	8 Max MSU/s 5000 (E5- ENET)	9 Max MSU/s 6500 (E5- ENET- B)
161..27 2	<=16	M3UA	No	Yes	0.43	1.43	3496	4545
161..27 2	>16	M2PA	No	No	0.15	1.15	4348	5652
161..27 2	>16	M3UA	No	No	0.15	1.15	4348	5652

Calculating TPS for IPSG Cards: E5-ENET-B IPSG High Throughput Feature ON

Refer to [Table 5-14](#) to follow the process for an IPSG card when the E5-ENET-B IPSG High Throughput feature is turned on.

1. Determine whether the card meets the standards shown in [Table 5-5](#). If the card does not meet the optimized configuration, determine whether the card is being de-rated.
2. Determine the adapter protocol type of the association(s) that will carry the traffic (4).
3. Select the TU value that applies (6).
4. The maximum total MSU rate, (actual Advertised Capacity), can be determined by dividing the Max MSU/s for the card by the total TU (6).

Table 5-14 Calculating TPS for E5-ENET-B IPSG Cards: E5-ENET-B IPSG High Throughput Feature ON

1 Avg MSU SIF size (excluding large MSUs)	2 Association Round Trip Time RTT (ms)	3 Number of Links	4 Protocol	5 TU Adjust- ment Factor	6 Total TU	8 Max MSU/s 5000 (E5- ENET)	7 Max MSU/s 9500(E5- ENET-B)
0..120	<=50	<=4	M2PA	0	1.0	5000	9500
0..120	<=50	<=4	M3UA	0.05	1.05	5000	9048
160	<=50	<=4	M2PA	0.048	1.048	5000	9065
1..120	70	<=4	M3UA	0.13	1.13	5000	8407
1..120	<=50	8	M2PA	0.025	1.025	5000	9268
150	90	16	M3UA	0.281	1.281	5000	7416

Calculation example

This example uses a IPLIM or IPGW card. Refer to [Table 5-12](#) to follow this calculation:

- The signaling link is being monitored by E5IS (Data Feed) (A3, B3).
- Fail traffic uses M3UA adapter (A2, B2).
- Eight IP connections are open and allowed (A4, B4).
- Eighty percent of traffic involves ISUP MSUs having a SIF size less than or equal to 140 bytes (80% of A8).
- Twenty percent of traffic involves SCCP-converted MSUs having a SIF size greater than 140 bytes and less than or equal to 272 bytes (20% of B8).

$$\begin{aligned}
 &(\text{Base Advertised Capacity}) = \\
 &((0.80 * (1.43)) + (0.20 * (2.67))) * (\text{Actual Advertised Capacity}) = \\
 &(1.14 + 0.53) * (\text{Actual Advertised Capacity}) = \\
 &1.67 * (\text{Actual Advertised Capacity}) \\
 &(\text{Actual Advertised Capacity}) = (\text{Base Advertised Capacity}) / (1.14 + 0.53) = 4000 / 1.67 = 2395
 \end{aligned}$$

Once the needed throughput is established, calculate the number of cards required to support this need (see [Calculate the Number of Cards Required](#)).

Rules for Integrated Datafeed using STC cards

"[Engineering Rules for Determining IP7 Application Throughput](#)" contains additional rules related to Integrated Datafeed (for IMF using STC cards).

Follow the guidelines and consult the tables in "[Engineering Rules for Determining IP7 Application Throughput](#)" for the following information:

- Effects of different Integrated Monitoring configurations
- **Association** buffer sizes
- Throughput per association
- Congestion Window Minimum size

Functionality of Configurable SCTP Buffer Sizes per Association

The amount of memory allocated for traffic buffers determines the maximum traffic rate and average message size that can be sustained for a specific network configuration. Memory is a constraint in achieving advertised capacity due to queuing, message storing and packet retention for retransmission over the Ethernet physical transport. As a general rule, the greater the Round Trip Time (RTT) for a packet, the greater the need for memory to store the unacknowledged packets being sent to the peer. Since each card has a finite amount of memory, the allocation is spread across all the links or connections on the card. This means that as a card's hosted-association(s) buffer sizes increase, the maximum number of associations that can be hosted by the card decrease.

The SCTP buffer size is configurable per association. Within the constraints of memory on the card, each association can have 8 kb to 400 kb of send-and-receive buffer space for SCTP.

Table 5-15 lists the maximum memory available for SCTP buffers on each card type.

Table 5-15 SCTP Buffer Space per Connection, Card and Application

Application	Card	Max # Conns	Default Conn Buffer	Max Conn Buffer	Max Total Buffer
IPLIMx	E5-ENET/ E5-ENET-B	16	200KB	400KB	3200KB
IPGWx	E5-ENET/ E5-ENET-B	50	16KB	400KB	3200KB
IPSG	E5-ENET/ E5-ENET-B	32	200KB	400KB	6400KB
IPSG	SLIC	128	200KB	400KB	6400KB

Note: No card or application combination supports the maximum number of connections with each connection having the maximum buffer size.

System Constraints Affecting Total IP Signaling Capacity

Previous sections focused on the Maximum and Advertised Capacity of particular applications on particular cards for various configurations. This section focuses on constraints involved in using multiple IP signaling cards and applications.

Table 5-16 IPLIMx and IPGWx Connectivity Data

Feature	IPLIM	IPGWx	Notes
Cards per system	250	250	Worst-case inter-shelf IMT utilization is a key factor. Total number IPLIMx cards cannot exceed 250.
Link connectivity type	Point to point (1 connection per link)	Point to multipoint	---
Link type replacement	Any	A	---
Typical application	Interconnect transfer point	Interconnect a front-end SS7 gateway to a back-end service element	---
Links per card	8/16	1/1	Worst-case inter-shelf IMT utilization is a key factor. Virtual signaling link. Terminates SS7 network (IPGWx)

Table 5-16 (Cont.) IPLIMx and IPGWx Connectivity Data

Feature	IPLIM	IPGWx	Notes
Links per link set	16	8	Assumes unmated configuration. Link set defines the scope of a mateset/SG. If mated, then only one link is allowed in the link set.
Supports combined link sets	Yes	No	---
IP connections per system	4000	4000	---
IP connections per card	8/16	50/50	SCTP associations
Routing keys per system	---	2,500	---
IP connections per routing key	---	16	---
Application Servers per system	---	250	---
Associations per Application Server	---	16	---
Ethernet interfaces per card	2	2	Uni-homed connection on either interface, multi-homed using both interfaces
EAGLE Hardware Redundancy Model	2N	2N	---
Capacity (TU)	2000/4000 MSU/s	2000/4000 MSU/s	
Failure mode (80%)	1600/3200 MSU/s	1600/3200 MSU/s	Capacity growth required at this point
Multi-homing support	Yes	Yes	---
Connection model	Peer to peer	Server	---
SS7 routing	Traditional least-cost based	Two-step traditional SS7 least-cost plus route keys	---
Supports lossless	Yes	No	IPGWx relies on SCTP changeover for sequencing
Supports network management	Yes	Yes	---

Table 5-16 (Cont.) IPLIMx and IPGWx Connectivity Data

Feature	IPLIM	IPGWx	Notes
Number of DTA Point Codes	1	1	Implies one IPGWx mateset if DTA PC route involves IPGWx link set
Number of internal point codes per network	1	1	Implies one IPGWx mateset per network domain for end-office mode of operation
IPTPS for System	---	Purchase quantity	Total pool of capacity distributed by user across IPGWx link sets
IPTPS per IPGWx link set	---	System IPTPS	---
IPTPS per IPGWx signaling link	---	Link set IPTPS	---
IMT Inter-Shelf Capacity, each bus, ring topology	1 GB/sec	1 GB/sec	Full-Duplex

Table 5-17 IPSPG Connectivity Data

Feature	M2PA	M3UA	Notes
Cards per system	250	250	Worst-case inter-shelf IMT utilization is a key factor. Total number of E5-ENET/ENET-B cards for IPLIMx cannot exceed 250. The number of IPSPG (including SLIC) cards that can be provisioned depends on various conditions, assuming each card is hosting links/linksets with max card capacity TPS values. See
Link connectivity type	Point to point (1 connection per link)	Point to multi-point	---
Link type replacement	Any	Any	---
Typical application	Interconnect transfer point	Interconnect a front-end SS7 gateway to a back-end service element	---

Table 5-17 (Cont.) IPSP Connectivity Data

Feature	M2PA	M3UA	Notes
Links per card	32	32	Worst-case inter-shelf IMT utilization is a key factor. Virtual signaling link. Terminates SS7 network (IPGWx)
Links per link set	16	16	Assumes unmated configuration. Link set defines the scope of a mateset/SG. If mated, then only one link is allowed in the link set.
Supports combined link sets	Yes	Yes	---
IP connections per system	4000	4000	---
IP connections per card	32	32	SCTP associations
Routing keys per system	---	---	---
IP connections per routing key	---	---	---
Application Servers per system	---	---	---
Associations per Application Server	---	---	---
Ethernet interfaces per card	2	2	Uni-homed connection on either interface, multi-homed using both interfaces
EAGLE Hardware Redundancy Model	2N	2N	---
Capacity (TU)	5000 MSU/s (E5-ENET card) 6500 MSU/s (E5-ENET-B when IPSP High Throughput Feature OFF, E5-ENET) 9500 MSU/s (E5-ENET-B card with E5-ENET-B IPSP High Throughput feature ON)	5000 MSU/s (E5-ENET card) 6500 MSU/s (E5-ENET-B when IPSP High Throughput Feature OFF, E5-ENET) 9045 MSU/s (E5-ENET-B card with E5-ENET-B IPSP High Throughput feature ON)	

Table 5-17 (Cont.) IPSPG Connectivity Data

Feature	M2PA	M3UA	Notes
Failure mode (80%)	4000 MSU/s (E5-ENET card) 5200 MSU/s (E5-ENET-B when IPSPG High Throughput Feature OFF) 7600 MSU/s (E5-ENET-B card with E5-ENET-B IPSPG High Throughput feature ON)	4000 MSU/s (E5-ENET card) 5200 MSU/s (E5-ENET-B when IPSPG High Throughput Feature OFF) 7236 MSU/s (E5-ENET-B card with E5-ENET-B IPSPG High Throughput feature ON)	Capacity growth required at this point
Multi-homing support	Yes	Yes	---
Connection model	Server	Server	---
SS7 routing	Peer to peer	Traditional least-cost based	---
Supports lossless	Yes	No	---
Supports network management	Yes	Yes	---
Number of DTA Point Codes	1	1	---
Number of internal point codes per network	1	1	---
IPTPS for System	---	---	Total pool of capacity distributed by user across IPSPG link sets
IPTPS OR M3UA link set	---	System IPTPS	---
IPTPS Signaling link	---	Link set IPTPS	---
IMT Inter-Shelf Capacity, each bus, ring topology	1 GB/sec	1 GB/sec	Full-Duplex
Maximum TPS per E5-ENET IPSPG linkset	80000	8000	M3UA or M2PA
Maximum TPS per E5-ENET-B IPSPG linkset with E5-ENET-B IPSPG High Throughput feature turned OFF	104000	104000	M3UA or M2PA

Table 5-17 (Cont.) IPSG Connectivity Data

Feature	M2PA	M3UA	Notes
Maximum TPS per E5-ENET-B IPSG linkset with E5-ENET-B IPSG High Throughput feature turned ON	152000	---	M2PA
Maximum TPS per SLIC IPSG linkset	160000	160000	M3UA or M2PA

Note: If an E5-ENET-B card is used and the E5-ENET-B IPSG High Throughput Capacity feature is turned ON, then the card must operate within the limits described in [Table 5-5](#) or the card will de-rate.

SIGTRAN Engineering Guidelines

This section provides general SIGTRAN engineering guidelines with examples of normal and failover scenarios and resulting MSU calculations. Some overall guidelines to keep in mind include:

- Perform SIGTRAN engineering like TDM links
- Utilize Transaction Unit (TU/MSU) mapping
- For an IPGWx, IPLIMx or IPSG card, the total capacity per card is considered as one erlang

Erlang is a statistical measure of the volume of telecommunications traffic. Traffic of one erlang refers to a single resource being in continuous use, or two channels being at 50% use, and so on.
- In a normal scenario, run the card at a maximum of 40% total capacity (0.4 erlang)
- In failover scenarios, the card runs at 80% of total capacity (0.8 erlang)

The IPx (IPGWx, IPLIMx, and IPSG) applications can be configured as either an IPLIMx or IPSG supporting M2PA B-, C-, and D-Links; or as an IPGWx or IPSG card supporting A- and E-Links (see the note in [M3UA \(MTP Level 3 User Adaptation Layer\) Protocol](#) for more information about A-links).

Every IP link should carry 0.4 erlang (or 40% TU) in normal operation. For an E5-ENET card with a maximum of 2,000 TU per card, 40% is 800 TU. This scenario is depicted in [Figure 5-1](#).

Figure 5-1 SIGTRAN: Every IP Link at 0.4 Erlang

Every IP link should be carrying 0.4 erlang (or 40% TU) in normal operation

If SSEDCCM card with maximum 2,000 TU per card, then 40% is 800 TU

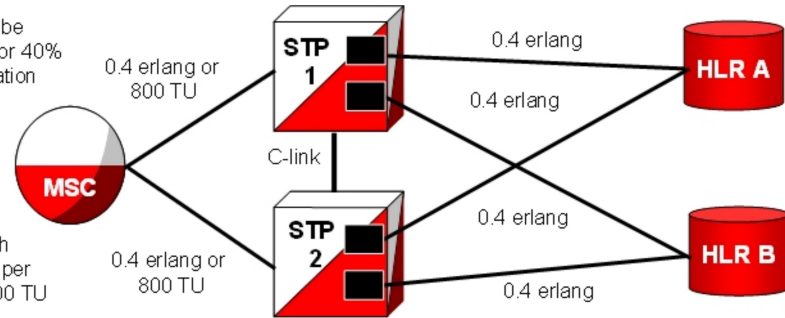

If the linkset to STP2 fails, another linkset to STP1 now carries 0.8 erlang. For an ECDM-A card with a maximum of 2,000 TU per card, 80% is 1,600 TU. This scenario is depicted in Figure 5-2.

Figure 5-2 SIGTRAN: Failover at 0.8 Erlang

If linkset to the STP 2 fails, other linkset to STP1 now carries .8 erlang

If SSEDCCM card with maximum 2,000 TU per card, then 80% is 1600 TU

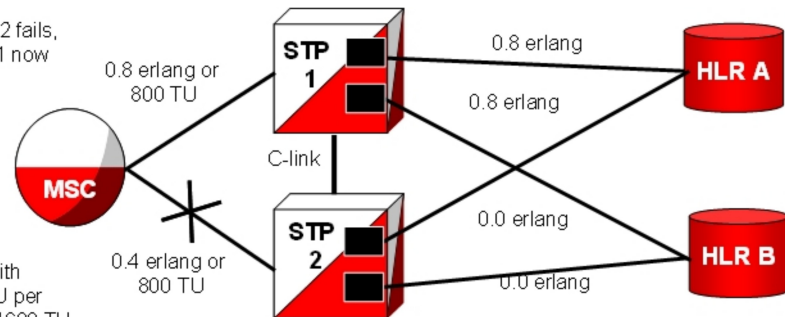

If the link is IPGWx M3UA with an EDCM-A, a 100-byte MSU, no IMF, and 4 or less connections at 0.4 erlang, each link carries 800 MSU/s (2000×0.4). This scenario is depicted in Figure 5-3.

Figure 5-3 SIGTRAN: Every Link at 0.4 Erlang and 800 MSU/s

If the link is M3UA with SSEDCCM, MSU=100 byte, No IMF, <= 4 connections, @ 0.4, each link is carrying $2000 \times 0.4 = 800$ MSU/s

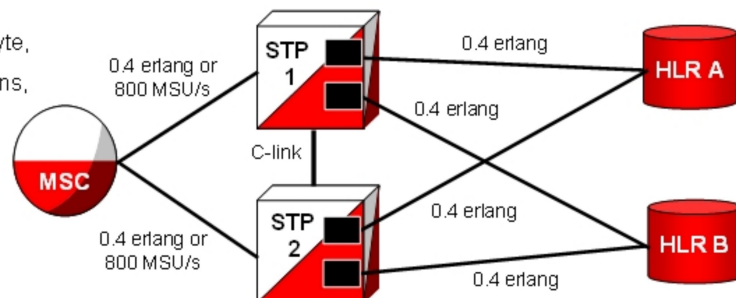

If the linkset to STP2 fails, another linkset to STP1 now carries 0.8 erlang. If the link is IPGWx M3UA with an E5-ENET, a 100-byte MSU, no IMF, and 4 or less connections at 0.8 erlang, each link carries 1600 MSU/s (2000×0.8). This scenario is depicted in Figure 5-4.

Figure 5-4 EAGLE: Failover at 0.8 Erlang and 1600 MSU/s

If linkset to the STP 2 fails, other linkset to STP 1 now carries 0.8 erlang

If the link is M3UA with SSEDCLM, MSU=100 byte, No IIVF, <= 4 connections, @ 0.8, each link is carrying 2000*0.8=1600 MSU/s

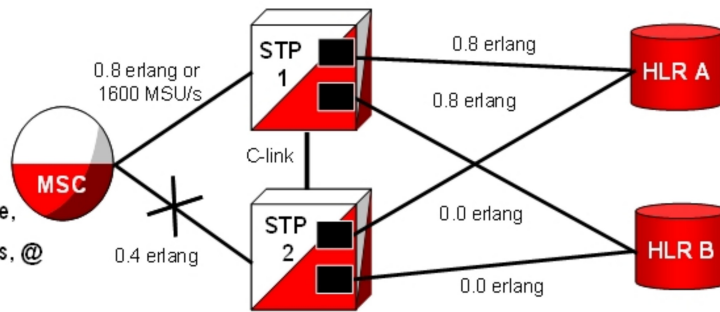

Calculate the Number of Cards Required

Below are examples of calculations to determine how many cards are needed. These are somewhat simplified; precise calculations require data about the specific network and the traffic running over it.

Example (without monitoring)

Assumptions:

- Mated pair of Signal Transfer Points
- Customer needs 10,000 MSU/s from Mobile Switching Center to Signal Transfer Point
- Average MSU size is 100 bytes/MSU over M3UA
- Less than 5 connections per IP E5-ENET card
- No monitoring is required

Calculation:

- During normal operation, each Signal Transfer Point should handle 5000 MSU/s.
- During failover operation, each Signal Transfer Point should handle 10,000 MSU/s.
- Each E5-ENET over M3UA with up to 4 connections and 100 byte/MSU without monitoring can support 2000 MSU/s.

So 2,000 MSU/s is 1 erlang

40% of 2,000 is 800 MSU/card

To support 5,000 MSU/sec @ 40% rate, 7 cards per Signal Transfer Point are required.

Example (with monitoring)

Assumptions:

- Mated pair of Signal Transfer Points
- Customer needs 10,000 MSU/s from Mobile Switching Center to Signal Transfer Point
- Average MSU size is 100 bytes/MSU over M3UA
- Less than 5 connections per IP E5-ENET card

- Monitoring is required

Calculation:

- During normal operation, each Signal Transfer Point should handle 5000 MSU/s
- During failover operation, each Signal Transfer Point should handle 10,000 MSU/s
- Each E5-ENET over M3UA with up to 4 connections and 100 byte/MSU with monitoring can support 1400 MSU/s

So, 1,400 MSU/s is 1 erlang

40% of 1,400= 560 MSU/card

To support 5,000 MSU/sec @ 40% rate, 9 cards per Signal Transfer Point are required.

IPLIMx linksets are permitted up to 16 links or, if one link per card, 16 cards. linksets are permitted up to 8 links; at one per card, 8 cards are allowed. An Application Server (i.e., in M3UA, a point code) is not permitted to span linkset boundaries, so the prescribed traffic rate would require a different architecture. For example, two Application Servers with different point codes could be used, one with 4 cards and one with 5 cards. A better solution, however, would be to segregate the traffic by type prior to reaching the SS7-over-IP cards, using smaller multiple servers and smaller linksets.

Guidelines for Maximum Provisionable IPSG Cards

The guidelines for maximum number of IPSG cards that can be provisioned depends on the following factors and is shown in [Table 5-18](#).

- IPSG card hardware type (E5-ENET, E5-ENET-B or SLIC)
- System TPS capacity
- Status of the E5-ENET-B IPSG High Throughput feature

Table 5-18 Guidelines for Maximum Provisionable IPSG Cards

HIPR2 High Rate Mode Feature	E5-ENET-B IPSG High Throughput Feature	E5-ENET IPSG	E5-ENET-B IPSG	SLIC
ON	ON	150	78	75
ON	OFF	150	115	75
OFF	ON	100	52	N/A
OFF	OFF	100	76	N/A

IPGWx Congestion Management Options

There are two options for congestion management: either discard new messages (which is how MTP3 congestion is handled) or fail a connection.

The IPGWx application is designed to match MTP3 congestion procedures. With this option, the connection congestion status is not shared, and altering routing strategy based on congestion events is stopped. Instead, new messages destined to the congested connection are discarded, a new measurement is pegged, and response-

method Transfer Controlled (TFC) messages are generated. This routing strategy only changes due to adapter state events.

A configurable timer (False Connection Congestion Timer) sets the maximum amount of time that a connection can remain congested before it is failed. This timer is similar to the MTP3 False Link Congestion timer (T31).

This Match MTP3 Congestion Procedures option has several advantages: it is simple to implement, prevents mis-sequencing during connection congestion, and notifies the originator of a discarded MSU due to the congestion. The primary disadvantage is that MSUs may be discarded that otherwise may have been transmitted (which is the same as for link congestion).

The configurable UA Parameter Set (UAPS) Timer 'False Connection Congestion Timer' allows the user to specify the maximum amount of time an association can remain congested before it is taken out of service. The default setting for the timer is 3,000 ms, the minimum is 0 ms, and the maximum setting (enforced by the IPGWx L2 software, not by the chg-uaps command) is 30,000 ms.

Redundancy and Link Engineering

A properly designed SS7 network always provides at least two physically separate ways to transmit user data. To provide the same level of redundancy using the IP-based solution, node and card redundancy can be used.

The EAGLE can be deployed with completely redundant IP network paths, each of which must be capable of sustaining the worst-case traffic load; or a redundancy model that relies on a mate Signal Transfer Point for IP path redundancy, although this option is less robust (and less expensive).

Unihoming versus Multihoming

EAGLE can be deployed with completely redundant IP network paths, each of which must be capable of sustaining the worst-case traffic load. Either of these two methods can be applied, depending on the application used:

- Unihomed links (for M2PA links)
- Multihomed links (for M2PA, M3UA and SUA links)

Unihoming

For unihoming, a set of IPLIMx or IPSPG cards, which are configured for worst-case traffic load, hosts one signaling link per linkset. Each signaling link is assigned to a unihomed SCTP association, where half of the associations are assigned to one independent IP network path, and the other half are assigned to another independent IP network path. Each network path must have dedicated bandwidth sufficient to sustain the worst-case traffic load.

Multihoming

For multihoming, a set of IPLIMx or IPSPG cards, which are configured for worst-case traffic load, is hosting one signaling link per linkset. Each signaling link is assigned to a multihomed SCTP association, which is mapped to an IP network having at least two completely redundant paths. Each network path must have dedicated bandwidth sufficient to sustain the worst-case traffic load.

Multihoming is very important for M3UA and SUA connections because it is the only means of lossless handover in the event of a path failure.

Multihoming provides network-level resilience for SCTP associations by providing information on alternate paths to a signaling end point for a single association.

SCTP multihoming supports only communication between two end points, of which one or both are assigned with multiple IP addresses on possibly multiple network interfaces. Each IPx card maintains a single static IP route table, utilized by both Ethernet interfaces or ports. By checking the destination address in this IP route table, the router determines the port from which the message is transmitted by the IPx card.

This means that it is not possible to have a route to a single destination from both ports of an IP card – it must be one port or the other. SCTP multihoming does not support communication ends that contain multiple end points (i.e., clustered end points) that can switch over to an alternate end point in case of failure of the original end point.

Figure 5-5 Unihoming versus multihoming

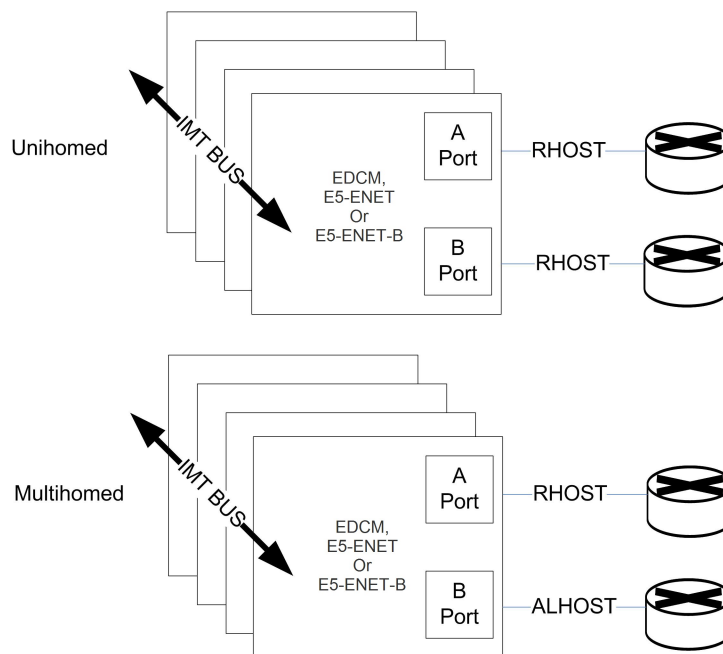

Multi-homing can be used for M2PA links if the M2PA linkset has only one link.

If the M2PA linkset has more than one link, then the value of the M2PA Timer T7 should be lower than $RMIN * RTIMES$ in order for the MTP3 level to trigger a Change Over procedure for MTP3 links.

Note: $RMIN * RTIMES$ is the minimum time required for an association to restart due to the RTIMES retransmission (via the primary and alternate path in round robin fashion) for an association without receiving any SACK. If the association is closed before the T7 expiration, then the buffer is cleared before the Change Over procedure is triggered by the MTP3 level.

Choosing a Redundancy Method for M2PA Links

Unihoming is simpler to configure but more expensive than multihoming, in terms of computational power and network bandwidth to handle worst-case failure.

Unihoming requires change-over procedures and rerouting if a network path is interrupted, whereas a multihomed SCTP association will simply switch to the alternate network path.

SCTP multihoming, in general, is less mature than MTP3 change-over procedures. In addition, the lack of ARHOST configurability in the EAGLE can result in asymmetrical traffic on a multihomed connection when both paths are available, which may be undesirable.

The EAGLE fully supports both options for M2PA, but Oracle recommends unihoming.

Mated Signal Transfer Point Redundancy

If a completely redundant IP network path is not available, then a redundancy model that relies on a mate Signal Transfer Point for IP path redundancy is supported by Oracle. This model is less robust but also less expensive.

Figure 5-6 Mated Signal Transfer Point Redundancy

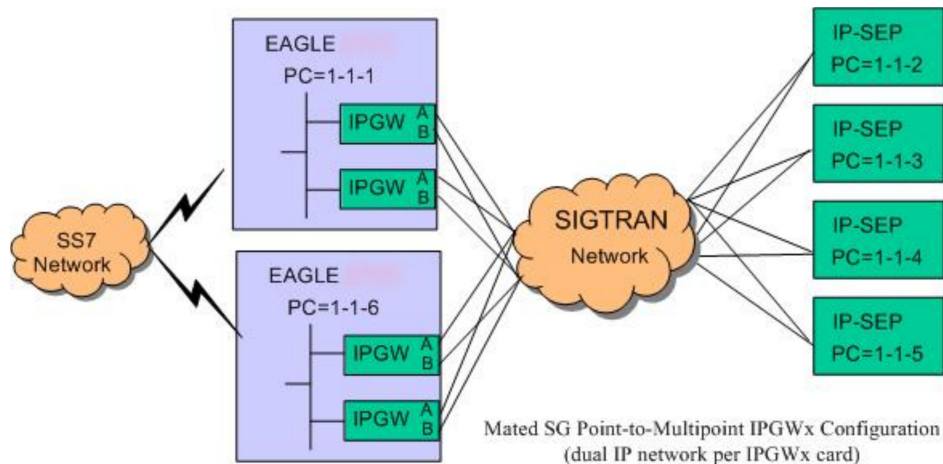

IPGWx mateset

An **IPGWx mateset** is an IPGWx card linkset configuration with a setting of mated, meaning two IPGWx or IPSG linksets are allowed in a mateset by using the `matelsn` linkset parameter. The limitation of this approach is that each linkset can have only one card. This configuration for IPGWx is supported to be backward compatible with previous EAGLE software versions.

IPGWx status sharing

Each IPGWx and IPSG card supports up to 50 IP connections, each of which can be available or unavailable for SS7 traffic. Expanding the number of cards in a mateset also means that the worst-case number of status messages to be communicated during run-time grows by the square of the number of cards. The exponential increase in status messages can have a significant impact on IMT bus utilization.

IP destination status

Proper implementation of SS7 network management on behalf of IP-based point codes requires that the cards comprising an IPGWx linkset have a common view of destination availability. Destination availability status is based upon the availability of IP connections assigned to various routing keys. Each card must know which other cards in the linkset have connections available for a given destination. When the total count of available connections for a destination changes from 0 to 1, then a **Transfer Allowed (TFA)** needs to be generated. When the total count changes from 1 to 0, then a **Transfer Prohibited (TFP)** needs to be generated.

SS7 network status

IPGW_x cards within a mateset must maintain a shared view of SS7 network status and inform IP Signaling Points of changes in this shared view. There are three kinds of SS7 network status:

- SS7 destination availability
- Route congestion status
- User part unavailability

Signaling Link Selection (SLS) Routing

A **Signaling Link Selection (SLS)** value is a 5- or 8-bit integer (ANSI) or 4-bit integer (ITU) that is used to identify the linkset and link to which a message is to be transported.

The SLS value is included in the SLS field, which is part of the MSU's MTP routing label. The SLS is used to evenly distribute traffic across routes and links, assuming that the SLS values are randomly distributed by the originating node.

The Oracle Communications SS7-over-IP solution follows standard SLS load sharing with IPLIM_x. With IPGW_x, SLS values are distributed over the associations in the Application Servers.

LAN/WAN Considerations

The operational characteristics of the LAN/WAN need to be quantified. General rules for the LAN/WAN environment devoted to SS7-over-IP traffic follow.

- Keep the number of nodes per LAN subnet as low as possible.

The number of nodes attached to a LAN segment is a major influence in overall LAN performance. As the number of nodes increases on a LAN segment, the performance will tend to decrease due to contention for the LAN resource. For optimal performance, this number should be kept as low as possible.

- Be aware of all the node and traffic types on the LAN.
- Dedicate sufficient bandwidth to your IP Signaling traffic.

From the SS7-over-IP perspective, there are two types of nodes: SS7-over-IP-related nodes (which are IP-equipped nodes involved in the overall signaling solution, such as the EAGLE, IP Service Control Points, Media Gateway Controllers and Media Gateways, and any management platforms doing work directly related to the SS7-over-IP solution) and non-SS7-over-IP nodes. Non-SS7-over-IP nodes are any other devices that could be on the LAN using LAN bandwidth, such as file servers or other hosts not directly involved in the signaling solution. If non-SS7-over-IP nodes are deployed on the same LAN as SS7-over-IP nodes, then the nodes share the LAN resources.

- Restrict, or severely limit, the number of non-SS7-over-IP nodes.

If non-SS7-over-IP nodes are on the network, their LAN throughput needs to be well understood, and the worst-case traffic from these sources needs to be considered. Normally it is easier to monitor (baseline) and predict network behavior when the nodes are similar. This is an important factor that will influence network performance.

- Plan for and allocate LAN capacity to handle worst-case scenarios.
Consider all traffic sources and compute worst-case numbers to estimate LAN throughput, including failure scenarios that may switch traffic from one LAN to another. The evaluation of throughput should always be based on the worst-case traffic for each device.
 - Monitor LAN performance and make adjustments as necessary.
Once the network is implemented, the LAN throughput and utilization should be monitored for a period of time sufficient to fully understand the traffic on that LAN. Measure the LAN utilization over time and ensure that it is always at an acceptable limit (≤ 35 percent of maximum LAN throughput).
 - Once the network is implemented, the RTT should be checked.
Confirm that the RTT is appropriate to achieve the maximum desired throughput, and that the RTT is acceptable from the viewpoint of the applications that are originating the traffic.
- IP network planning must be executed carefully to realize the benefits of SS7-over-IP deployments. Oracle can assist with characterizing your LAN/WAN QoS parameters and engineering an SS7-over-IP solution. Contact your Oracle Sales Representative for more information related to this Professional Service.

Retransmission Concept

The Oracle-recommended IP network environment for signaling traffic has:

- RTTs set according to traffic (see [Refine RTO Parameter](#))
- Minimal errors ($< 0.01\%$)
- Minimal jitter

A transport protocol provides transport reliability through two mechanisms:

1. Explicit Data Acknowledgements: the sending side retains transmitted data until the receiving side explicitly acknowledges its receipt
2. Retransmission Timer: the sending side maintains a timer, and if the timer expires prior to receiving an acknowledgement for the transmitted data, then the sender will “retransmit” the data to the receive end

Retransmissions and Destination Status

When transmitting data on a multihomed association, the initial transmission is made to the primary address on the primary path. If the initial transmission times out, then the first retransmission is made to an alternate destination in a round-robin, consecutive fashion. The SCTP layer will continue to send the initial transmission of new data arriving for transmission from upper layers on the primary path.

If a unihomed **SCTP endpoint** is not in contact after $RTIMES$ errors, the end point address is marked as unreachable. For multihomed associations, if an endpoint’s address is not in contact after $RTIMES/2$ errors, the address is marked as unreachable.

An error is a failure to Selectively Acknowledge (SACK) a transmitted packet or acknowledge a heartbeat within a Retransmission Time Out (RTO). Alternate paths exchange heartbeats as a means of confirming connectivity, and failure to

acknowledge heartbeats would cause an alternate destination to be marked as unreachable.

SCTP Timers

Oracle provides two retransmission modes: RFC and Linear. The SCTP retransmission control feature allows the tailoring of retransmissions to detect a network fault in a timely fashion through these configuration parameters:

- **RMODE:** Selects desired retransmission mode (RFC or LIN)
- **RTIMES:** Maximum number of retransmits attempted before the connection is declared lost (3 to 12); the default is 10
- **RTO:** Time to wait before the current retransmit attempt is declared a failure. This time is dynamic because it is a moving average of the network
- **RMAX:** Upper bound of calculated RTO (10 ms to 1,000 ms); the default is 800; Oracle suggests $3 * RMIN$
- **RMIN:** Lower bound of calculated RTO (10 ms to 1,000 ms). The default is 120; Oracle suggests the greater of $(1.2 * \text{average RTT})$ or $(10 \text{ ms} + \text{average RTT})$.
- **CWMIN:** Minimum Congestion Window Size (1,500 to 192K); the default is 3K

RFC Timer Setting

With an exponential timer setting, the RTO value is doubled for each retransmit attempt. When transmitting a packet, the RTO has to expire before attempting to retransmit. With the second attempt, the last RTO value is doubled ($RTO * 2$) before retransmitting; with the third attempt, the last RTO value is doubled again ($RTO * 4$); and so on. This method significantly increases the time to determine that a link is lost.

For example, if data is being transmitted for five retransmits, the time to determine a lost link is:

$$RTO.min * Path.Max.Retransmits \text{ (or } 1 + 2 + 4 + 8 + 16 + 32) = 63 \text{ sec}$$

Table 5-19 shows RFC timers and their RFC and Oracle-recommended default values.

Table 5-19 SCTP Configuration Data Descriptions for Oracle EAGLE

RFC Name	Description	RFC Recommended Default Value	Oracle Default Value	Oracle Configurable ?	Oracle Ranges
RTO.initial	Initial RTO Value	3 seconds	120 ms	Yes Assoc RMIN parameter	1-1000 ms
RTO.max	Upper limit of RTO	60 seconds	800 ms	Yes Assoc RMAX parameter	1-1000 ms

Table 5-19 (Cont.) SCTP Configuration Data Descriptions for Oracle EAGLE

RFC Name	Description	RFC Recommended Default Value	Oracle Default Value	Oracle Configurable ?	Oracle Ranges
RTO.min	Lower limit of RTO	1 second	120 ms	Yes Assoc RMIN parameter	1-1000 ms
Max.Init. Retransmits	Maximum Initial Retransmit Attempts	8 attempts	10 attempts	Yes Assoc RTIMES parameter. Not configurable independently of Assoc.max. retrans	1-12
Association.max. retrans	Maximum Association Data Retransmit Attempts	10 attempts	10 attempts	Yes Assoc RTIMES parameter	1-12 ms
Path.max. retrans	Maximum Data Retransmit attempts per Destination (used for multi-homing only)	5 attempts	5 attempts	Indirectly ½ of the assoc RTIMES parameter	1-6 ms
Acknowledgment timer	SACK Transmit	User Configurable not to exceed 500 ms	½ RTO or 200 ms, whichever is less	Indirectly RTO is bound by the assoc RMIN and RMAX parameters	5-200 ms
T3-rtx	Timer Data Retransmit	RTO (see RTO.initial for initial value)	RTO (see RTO.initial for initial value)	Yes RTO is bounded by the assoc RMIN and RMAX parameters	10-1000 ms

Table 5-19 (Cont.) SCTP Configuration Data Descriptions for Oracle EAGLE

RFC Name	Description	RFC Recommended Default Value	Oracle Default Value	Oracle Configurable ?	Oracle Ranges
T1-init	Timer Init retransmit timer	Initially 3 seconds RTO thereafter	Initially 1 second, RTO thereafter	No for initial value Indirectly thereafter via RMIN/RMAX bounding of RTO	10-1000 ms
HB.Interval	Heart Beat Interval	30 seconds	RTO+500 ms	Yes RTO + Assoc HBTIMER parameter	RTO+500 ms to RTO+10000 ms
Shutdown timer	Shutdown timer t2	RTO	RTO	Indirectly RTO is bound by the assoc RMIN and RMAX parameters	10-1000 ms
Cookie Timer	Cookie-t1 – Cookie Echo retransmit timer	Initially 3 seconds RTO thereafter	Initially 1 second RTO thereafter	No for initial value Indirectly thereafter via RMIN/RMAX bounding of RTO	10-1000 ms
Cookie life	Cookie Life	60 seconds	5 seconds	No	5 seconds

Note: SCTP Heart Beats (HBs) are sent after every HB interval on an idle path of the SCTP association. If more than one idle path exists, then HBs are sent alternately on each idle path, after each HB interval.

LIN Timer Setting

Oracle has implemented a more aggressive timer method called Linear (LIN), in which the RTO between attempts is constant. Oracle recommends this setting to detect a failure more quickly than the RFC method.

With the LIN timer setting, the time to declare the association down is at least

$RMIN * RTIMES$

For very high-throughput associations, `RTIMES` (and if possible, `RMIN`) should be lowered and `CWMIN` increased. `CWMIN` is the parameter that sets the minimum size of the congestion window, which determines the number of packets that can be sent without having received the corresponding ACK packets.

On the far end, the `LIN` mode can coexist with `RFC` mode, but in contrast to the Signaling Gateway, the far-end may experience congestion in the ASP-to-SGP direction because of network impairments.

Jitter Effects

Since the `RTO` is a moving average of network RTT samples, as the jitter range increases, bounding the lower limit of the `RTO` at or near the average will cause the amount of unnecessary retransmissions to increase, since for each transmission that takes longer than the current `RTO` to acknowledge a retransmission will occur, wasting bandwidth..

If the lower limit of the `RTO` is bounded to the upper end of the jitter range to minimize retransmits, then connection failure detection time is similarly increased.

So, minimizing jitter in the network translates into a small range for network RTT, and the `RTO` can be bounded to minimize retransmissions while being able to detect a loss of connection in a timely fashion.

Configure Congestion Window Minimum (CWMIN) Parameter

The `CWMIN` parameter is important in managing traffic flow and retransmissions under varying network conditions. Changing the congestion window by setting `CWMIN` to a higher value affects how long it takes to recover from the retransmit event. This limits how far the window gets closed in a retransmit-event condition. In the extreme case, one could set `CWMIN` to the configured buffer size, which allows the entire buffer bandwidth to be used. As a general rule, setting `CWMIN` to a value equal to half of the traffic rate in an RTT interval should allow adequate retransmit-recovery time while preventing excessive load to the peer.

$$\text{CWMIN} = (\text{Bytes/Sec} * \text{RTT}) / 2 \text{ bytes}$$

Note: Setting `CWMIN` to a value much higher than `MTU` will result in periodic intermediate node overloads. `CWMIN` can't be set less than 3K and should not exceed the remote peer reception window (Advertized Reception window). When possible `CWMIN` is normally set to ~64K or greater. The specific value chosen for the sender should take into account network latency, configuration, packet loss, capacity, and traffic characteristics. It is important that `RMIN` be set to a value greater than the expected average RTT to minimize false retransmissions. `CWMIN` could be set to a value between 10% and 20% of the remote peer Reception window.

Implementation

This chapter provides hardware information, high-level configuration steps for the IPLIMx, IPGWx, and IPSP applications, how to refine timers and parameters after the installation, and high-level system verification steps.

Hardware requirements

Some of the hardware requirements specific for a Oracle Communications SS7-over-IP network are described here. However, for a full list customized for your planned network, contact your Sales Representative.

EAGLE

An EAGLE fully configured for SS7-over-IP consists of at least one IPLIMx, IPGWx, or IPSP application. The applications can be installed on an E5-ENET, E5-ENET-B or SLIC card.

Two HIPR2 cards are required in shelves equipped with E5-ENET or E5-ENET-B cards. If HIPR2 cards are installed, all other shelves must be equipped with all HIPR2 cards in one shelf.

Table 6-1 shows the cards and their Advertised Capacity in TPS.

Table 6-1 EAGLE IP Signaling Maximum Capacities by Card and Application

EAGLE Card Name	IPLIMx Capacity	IPGWx Capacity	IPSP Capacity
E5-ENET	4,000	4,000	5,000
E5-ENET-B (E5-ENET-B when IPSP High Throughput Feature OFF, E5-ENET or SLIC)	4,000	4,000	6,500
E5-ENET-B (E5-ENET-B IPSP High Throughput feature ON)	4,000	4,000	9,500
SLIC (IPSP High Throughput feature OFF)	4,000	4,000	12,000

The capacities listed in this table are achieved when the traffic carried by the application involves no feature or network attribute that requires excessive CPU, memory, or transport capacity. Rates in excess of the values shown will result in signaling link or IP connection congestion.

Integrated Message Feeder (IMF)

When monitoring IPx links using **IMF**, Oracle requires that HIPR2 cards and at least one STC card are configured on the same shelf as the IPx cards. Only M2PA links that are RFC 4165 compliant can be monitored. A minimum of two STC cards are required per system to turn on the monitoring feature in the EAGLE.

The E5IS Data Feed or monitoring subsystem requires a significant amount of CPU and memory resources from the IPx cards when monitoring M2PA, M3UA and SUA links. When enabled, this capability causes the of the IPx applications to drop well below the maximum capacity of the platform. For a detailed analysis of IP7 throughput for provisioning purposes, refer to [Engineering Rules for Determining IP7 Application Throughput](#).

Installation of the SS7-over-IP system includes both hardware installation and software provisioning, and is detailed in the EAGLE customer documentation.

Converting Non-IPSG-M2PA Linksets to IPSG-M2PA Linksets

IPSG-M2PA signaling links can reside in a linkset with other non-IPGWx, non-IPSG-M2PA links. Having non-IPSG-M2PA links in a IPSG-M2PA linkset is supported to allow non-IPSG-M2PA linksets to be converted to IPSG-M2PA linksets, and should be a temporary condition. In the case of IPSG-M2PA linksets that contain other link types, the non-IPSG-M2PA links will not be subject to the configured SLKTPS. The `rept-stat-iptps` command will not report any link IP TPS data or raise link IP TPS alarms for the non-IPSG links that are not reporting IP TPS information.

To convert an existing non-IPSG-M2PA linkset to an IPSG-M2PA linkset, perform the following steps:

1. Existing linkset (LINKSETA) with IPGWAPC=NO and IPSG=NO (i.e. contains links of any type except IPGW or IPSG)
2. Enter `chg-ls:lsn=LINKSETA:ipsg=YES:slktps=XXXX`
3. Provision new IPSG cards and M2PA associations
4. Add new IPSG-M2PA links to linkset and remove non-IPSG-M2PA links from linkset, soaking modifications as required

To back out the above conversion:

1. Remove IPSG-M2PA links from linkset and add original non-IPSG-M2PA links to linkset.
2. Enter `chg-ls:lsn=LINKSETA:ipsg=NO`

Using the `chg-card` Command to Migrate IPLIM to IPSG

The `chg-card` command allows the IPLIM application running on E5-ENET or E5-ENET-B cards, to be migrated to IPSG, if the following requirements are met:

- The IPLIM application must be running on E5-ENET or E5-ENET-B cards.
- The hardware can be changed to IPSG running on E5-ENET or E5-ENET-B cards.
- The card must be manually inhibited prior to successful execution of the change command.

- All IP associations configured for the card must use adapter type M2PA.
- All links configured for the card must have an association configured.
- The migrated IPSP card TPS and system TPS must pass limit checks.
- The card must be manually allowed after successful execution.

Note: If changing the configuration from IPLIM to IPSP exceeds the Transactions per Second (TPS) limits of the card or system, then the command is rejected.

Converting IPGWx M3UA Application Servers to IPSP-M3UA Linksets

IPGWx links and IPSP-M3UA links cannot co-exist in the same linkset for the following reasons:

- IPGWx linksets require provisioning of Routing Keys and Application Server (AS) table entries in the EAGLE to communicate with M3UA ASs; IPSP-M3UA linksets require only SS7 routes, since the IPSP-M3UA linkset defines the scope of the AS
- The M3UA AS's point code is a non-adjacent route accessed by a provisioned EAGLE Routing Key for an IPGWx linkset; this point code is the adjacent point code of an IPSP-M3UA linkset. This results in significant differences in network management behavior between IPGWx and IPSP-M3UA
- IPSP implements IP TPS control with subtle differences from IPGWx that result in incompatibilities

IPGWx M3UA AS must have the following attributes to qualify for conversion to IPSP-M3UA linksets:

- The Routing Key(s) used by the M3UA AS must be DPC-only; or the use of DPC-only Routing Key(s) would not degrade current or planned capability
- The M3UA AS-Pending procedure using a non-zero value for T (recovery) must not be a critical function provided by the Signaling Gateway
- M3UA ASP Failure notifications must not be a critical function provided by the Signaling Gateway
- The number of IPGWx-M3UA Application Servers to be converted to IPSP-M3UA linksets must not result in the total EAGLE link or linkset limits being exceeded. A maximum of 2,000 links and 1,024 linksets are supported.
- IPGWx cards that will be redeployed as IPSP cards MUST be E5-ENET or E5-ENET-B cards.

The method by which a customer migrates from existing IPGWx M3UA deployments to IPSP-M3UA deployments will vary based primarily on the following:

- The number of Routing Keys and ASs provisioned on the IPGWx linkset being converted
- The IPGWx redundancy model used
- The connected AS's reliance on AS procedures

- The connected AS's maximum supported number of connections and attached Signaling Gateways

Examples of typical deployments and possible conversion strategies are listed below, but contact your Oracle Communications sales representative to assist in planning an actual conversion:

- [IPGWx to IPSP-M3UA Conversion Example 1](#)
- [IPGWx to IPSP-M3UA Conversion Example 2](#)
- [IPGWx to IPSP-M3UA Conversion Example 2A.](#)

The `chg-card` command allows the IPLIM application running on E5-ENET, E5-ENET-B, or SLIC cards to be migrated to the IPSP application, if the following requirements are met:

- The IPLIM application must be running on an E5-ENET, E5-ENET-B or SLIC card.
- The hardware can be changed to IPSP running on E5-ENET, E5-ENET-B cards or SLICs.
- The card must be manually inhibited prior to successful execution of the change command
- All IP associations configured for the card must use adapter type M2PA.
- All links configured for the card must have an association configured.
- The migrated IPSP card TPS and system TPS must pass limit checks.
- The card must be manually allowed after successful execution.

Note: If changing the configuration from IPLIM to IPSP exceeds the Transactions per Second (TPS) limits of the card or system, then the command is rejected.

If the `chg-card` command will not be used, then it is highly recommended that ProComm scripts or other automated EAGLE provisioning functionality be used to further mitigate risk.

IPGWx to IPSP-M3UA Conversion Example 1

[Figure 6-1](#) depicts one strategy to convert a simple IPGWx deployment to IPSP-M3UA.

Figure 6-1 IPGWx to IPSG-M3UA Conversion Strategy Example 1

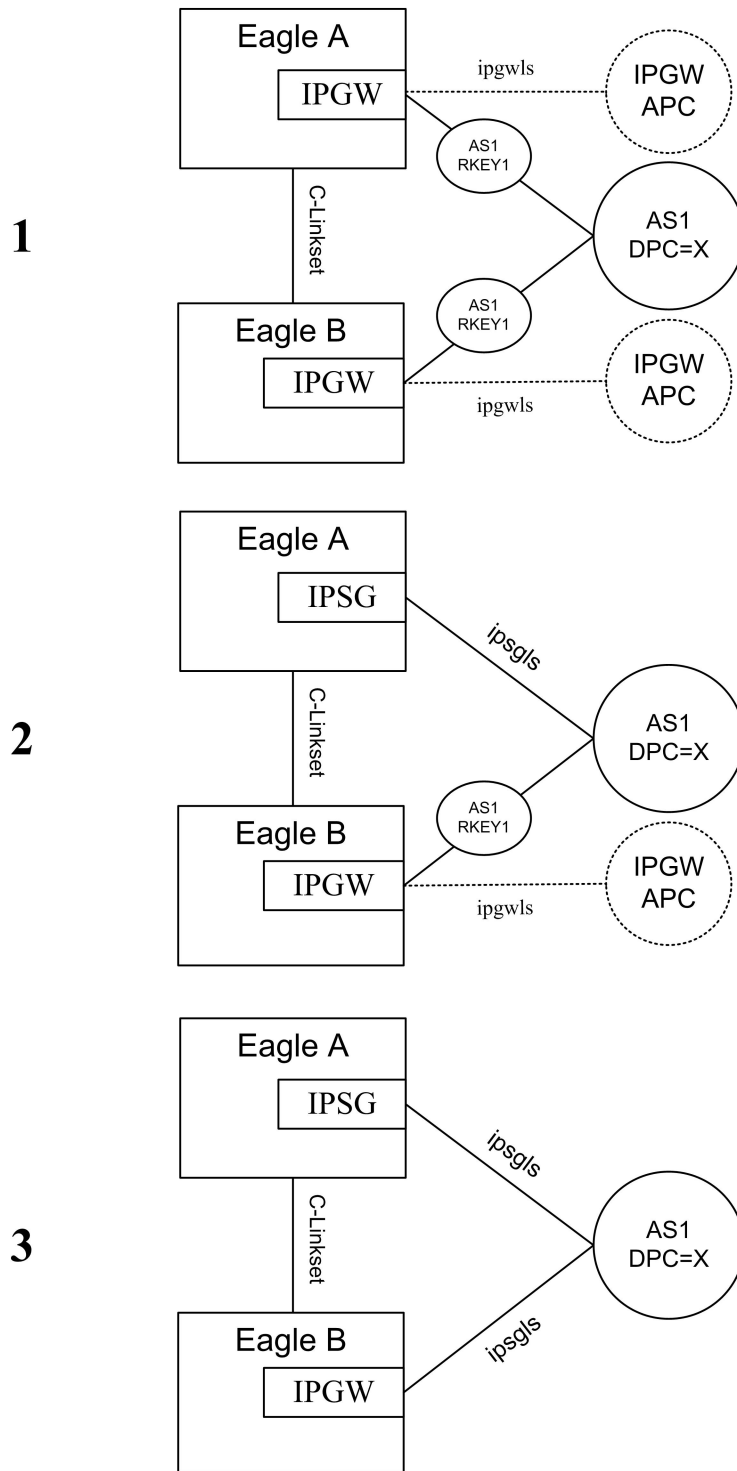

The IPGWx deployment shown in #1 of [Figure 6-1](#) has the following attributes:

- Each STP in the mated pair of STPs utilizes a single IPGWx card to provide connectivity to AS1
- Each IPGWx card hosts a single M3UA association referenced by AS1
- AS1 is referenced by a single DPC-only Routing Key with DPC=X in each STP

The configuration shown in #2 of [Figure 6-1](#) is a result of the following steps:

- The IPGWx signaling link in the top EAGLE is gracefully removed from service.
- The Routing Keys for AS1/DPC=X and AS1 are deleted from the EAGLE database.
- The M3UA association settings are recorded for use when the association is re-entered on the IPGS card.
- The M3UA association is deleted from the EAGLE database .
- The SS7 routes to DPC X and the IPGWx APC are deleted from the EAGLE database.
- The IPGWx Signaling Link and Linkset is deleted from the EAGLE database.
- The IP-CARD, IP-LNK, and IP-RTE settings for the IPGWx card are recorded. These settings are not preserved when the IPGWx card is deleted.
- The IPGWx card is deleted from the EAGLE database and entered as an IPGS card (assumes that there is an E5-ENET, E5-ENET-B or SLIC card in the slot).
- The IP-CARD, IP-LNK, and IP-RTE entries are updated in the EAGLE database for the new IPGS card with the setting recorded for the IPGWx card prior to its deletion.
- An M3UA association is entered into the EAGLE database and is updated with any non-default settings recorded for the IPGWx association prior to its deletion.
- A new IPGS-M3UA linkset with APC=X is provisioned in the EAGLE database with the appropriate SLKTPS.
- A single IPGS-M3UA SLK is added to the IPGS-M3UA linkset referencing the M3UA association that is hosted by the IPGS card.
- An SS7 route to DPC X over the IPGS-M3UA linkset is entered into the EAGLE database. The relative cost of this route is determined by the customer's requirements and approach to proving and soaking the IPGS-M3UA link. Initially, it may be desirable for the cost of the route over the IPGS-M3UA linkset to be higher than the cost of the route over the C-linkset; however, it should be noted that this approach will not prevent the AS from sending SS7 traffic over the IPGS-M3UA link once the IPGS-M3UA link becomes IS-NR.
- The IPGS-M3UA association is opened and SCTP connectivity is confirmed. The state of the IPGS-M3UA SLK should be OOS-MT-DISABLED. The state of the AS-ASP instance should be ASP-INACTIVE, assuming the ASP is not administratively blocked at the AS.
- The IPGS-M3UA SLK is activated; it's state should become IS-NR. The state of the AS-ASP instance should be ASP-ACTIVE, assuming the ASP is not administratively blocked at the AS.
- The cost of the SS7 route to DPC X in EAGLE A is adjusted as appropriate to allow/prevent EAGLE A from using the IPGS-M3UA linkset to deliver MSU traffic destined for DPC X.

The configuration shown in #3 of [Figure 6-1](#) is a result of utilizing the same steps used in EAGLE A to convert the IPGWx linkset in EAGLE B to IPGS-M3UA.

IPGWx to IPSG-M3UA Conversion Example 2

Figure 6-2 depicts one strategy to convert a more complex IPGWx deployment to IPSG-M3UA.

Figure 6-2 IPGWx to IPSG-M3UA Conversion Strategy Example 2

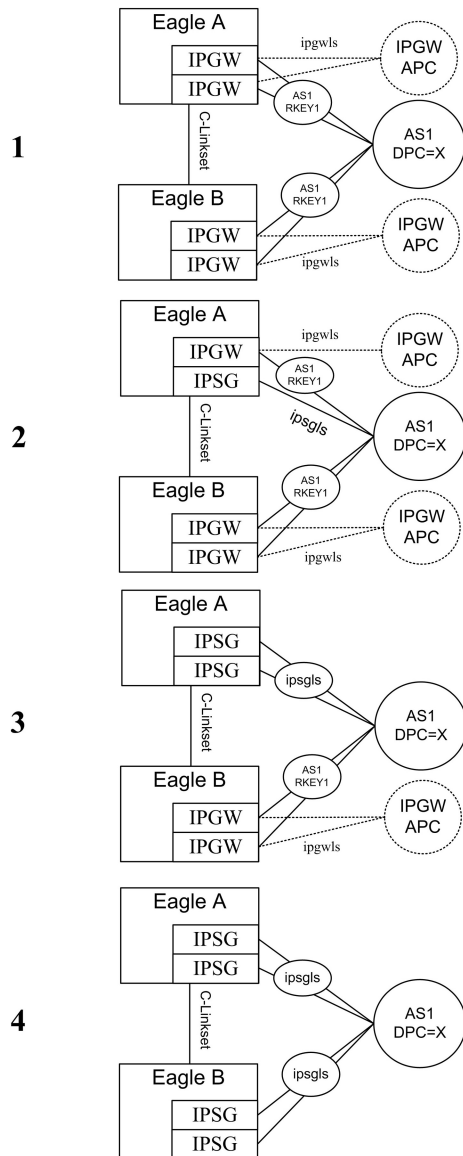

It should be noted that the IPGWx deployment shown in #1 of Figure 6-2 has the following attributes:

- Each STP in the mated pair of STPs utilizes two IPGWx cards to provide connectivity to AS1
- Each IPGWx card hosts a single M3UA association referenced by AS1
- AS1 is referenced by a single DPC-only Routing Key with DPC=X in each STP

The configuration shown in #2 of Figure 6-2 is a result of re-provisioning one of the IPGWx cards in EAGLE A to be a single-link IPSG-M3UA linkset with an APC of X, while leaving one of the original IPGWx links in place. From the M3UA AS's

perspective, provisioning the IPSP-M3UA link in EAGLE A while the remaining IPGWx links in EAGLE A and EAGLE B are still provisioned may be viewed as:

- Effectively connecting a third Signaling Gateway to the AS; this will be true if the AS relies on AS Notifications to operate correctly, since EAGLE treats AS1 over IPGWx linkset as a separate AS than AS1 over the IPSP-M3UA linkset.

OR

- No configuration change; this will be true if the AS does not rely on AS Notifications to operate correctly. In this case, AS notifications sent by EAGLE A are ignored by the AS and the IPSP-M3UA link is simply used as a path to the SS7 network if it is ACTIVE. The fact that the AS notifications sent by EAGLE A are not scoped across the IPGWx and the IPSP-M3UA linkset is not applicable. For ASs with this attribute, it may be desirable to disable AS notifications on the IPSP-M3UA linkset by setting the `asnotif` linkset parameter to NO.

Similar to the earlier example, the relative cost of the route to DPC X over the IPSP-M3UA linkset in #2 of [Figure 6-2](#) is dependent on the customer's cutover strategy. It is important to note here again that the AS may begin sending SS7 traffic over the IPSP-M3UA link once the ASP becomes ACTIVE and the IPSP-M3UA link becomes IS-NR regardless of the relative cost of this route in the EAGLE.

The configuration shown in #3 of [Figure 6-2](#) is a result of re-provisioning the remaining IPGWx card in EAGLE A to be an IPSP card hosting a single IPSP-M3UA link and adding the link to the existing IPSP-M3UA linkset connected to AS1. From the AS's perspective, this change may be viewed as 1) reducing the number of connected Signaling Gateways back to the original two OR 2) no change. In either case, once the second IPSP-M3UA link is brought into service in EAGLE A, conversion activities are complete for EAGLE A.

The configuration shown in #4 of [Figure 6-2](#) is a result of performing the same steps in EAGLE B as described for EAGLE A in steps #2 and #3.

IPGWx to IPSP-M3UA Conversion Example 2A

[Figure 6-3](#) depicts an alternative strategy to convert the IPGWx configuration from the one described in [IPGWx to IPSP-M3UA Conversion Example 2](#) to IPSP-M3UA.

Figure 6-3 IPGWx to IPSP-M3UA Conversion Strategy Example 2A

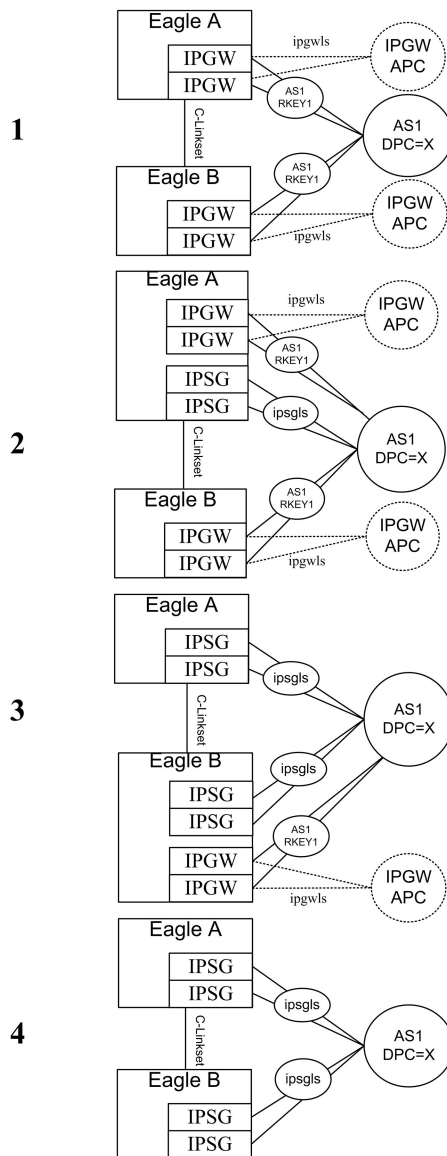

The strategy shown in Figure 6-3 can be used to minimize risk and increase the flexibility in switching traffic between the IPGWx and IPSP-M3UA links and is dependent on:

- The customer's willingness and ability to provision new E5-ENET, E5-ENET-B or SLIC cards and associated cabling and network connectivity for the IPSP links while leaving the existing IPGWx cards and associated cabling and network connectivity in place during the soak period
- The AS's ability to support the configuration shown in #2 and #3 of Figure 6-3. As described earlier, the IPSP-M3UA linksets may be viewed by the AS as additional Signaling Gateway instances or simply additional M3UA connections to the SS7 network.

In #2 and #3 of Figure 6-3, the SS7 route cost for the routes to DPC X over the IPGWx linkset, the IPSP-M3UA linkset, and the C-linkset provides maximum control over which path is used to deliver MSUs destined for DPC X to the M3UA AS. It should be noted that multiple-link IPGWx linksets were not designed to be in combined linksets

(i.e having SS7 routes to the connected ASs with equal cost to other SS7 routes in the same EAGLE) and so there exists the potential for the loadsharing across associations in a multiple link IPGWx linkset to be uneven when the IPGWx and IPSPG-M3UA route costs are the same, especially if one or more SLKs or connections is not IS-NR.

Configuration

This section describes the configuration sequence for the IPLIMx, IPGWx and IPSPG applications.

Note: As of Release 44.0, all Ethernet ports are OFF by default. The in-service port and associated light will be turned ON by running the relevant application. The light for the unused port will remain OFF.

Configure the IPSPG Application

This section provides a basic overview of the steps involved to provision the IPSPG application for M3UA. For detailed procedures, see *Database Administration - IP7 User's Guide* of your current EAGLE documentation suite.

1. Declare the E5-ENET, E5-ENET-B card or the **SLIC** application to be ipsg (ent-card).
2. Define the IP settings for the Ethernet port (chg-ip-lnk):
 - a. Declare what card and port you are defining with this command
 - b. Associate an IP address to that card and port
 - c. Set the Ethernet settings for the card and port
3. Associate an IP address to a host name that will be used in configuring the Association (ent-iphost).

This step sets up a static IP address Host Table, which associates Domain Names to IP addresses so that the computer can look up Domain Names and place the corresponding IP address in the packet header. The alternative is to use a DNS server.

4. Enter an Application Server Process and bind an SCTP association with it (ent-assoc).

This command configures the SCTP association in the Internet Protocol Application Socket (IPAPSOCK) table. This command permits the association to transport protocol data units and adaptive layer peer messages. Each association is connected to a process at the far end. The IPAPSOCK table is used to associate the Local Host/Local Port to a Remote Host/Remote Port.

5. Define the Site ID (chg-sid).
6. Enter adjacent point code (ent-dstn).

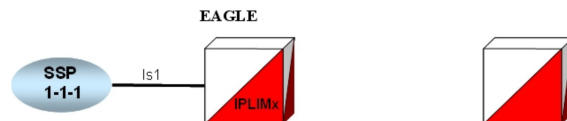

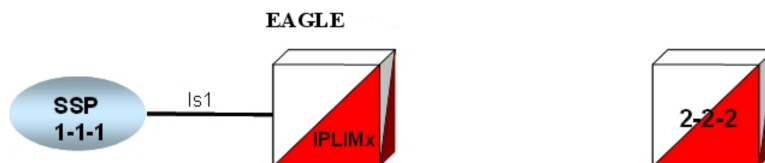

7. Define capacity and use alarm (ent-ls).

```
ent-ls:lsn=ls1201:apc=10-10-10:lst=a:adapter=m3ua:ipsg=yes:rcontext=1:slktps=100
```

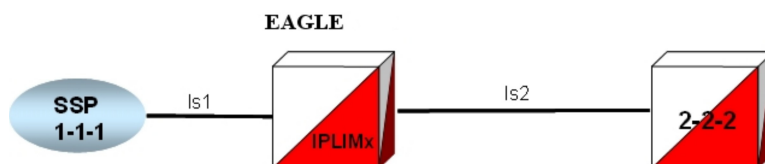

8. Tell the EAGLE that this is a SIGTRAN M3UA link (ent-slk).

9. Enter route (ent-rte).

SS7 Routing Table

DPC	lsn	rc
1-1-1	ls1	10
2-2-2	ls2	10

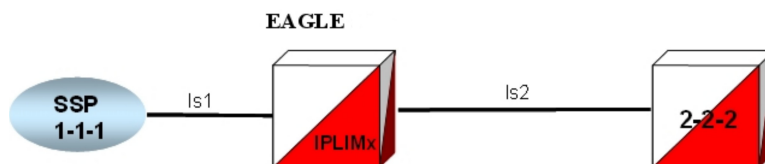

10. Allow and open the SCTP association (chg-assoc).

11. Activate signaling link (act-slk).

Configure the IPSP Application on the Same Card

The following series of commands may be used to provision an IPSP-M2PA link on the same card, assuming the card, IP addresses and hosts are already configured.

1. Enter an Application Server Process and bind an SCTP association with it (ent-assoc).
2. Enter adjacent point code (ent-dstn).
3. Define capacity and use alarm (ent-ls).
4. Tell the EAGLE that this is a SIGTRAN M2PA link (ent-slk).
5. Enter route (ent-rte).

SS7 Routing Table

DPC	Isn	rc
1-1-1	Is1	10
2-2-2	Is2	10

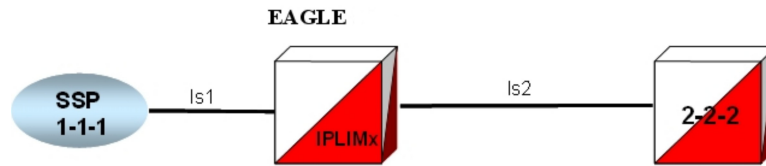

6. Allow and open the SCTP association (chg-*assoc*).
7. Activate signaling link (act-*slk*).

Configure the IPLIMx Application

This section provides a basic overview of the steps involved to provision the IPLIMx application for M2PA. For detailed procedures, see the *Database Administration Manual - IP7 Secure Gateway* of your current EAGLE documentation suite.

1. Declare the DCM to be iplim or iplimi (ent-*card*).

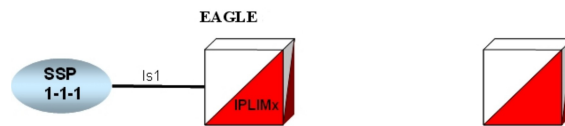

2. Enter adjacent point code (ent-*dstn*).

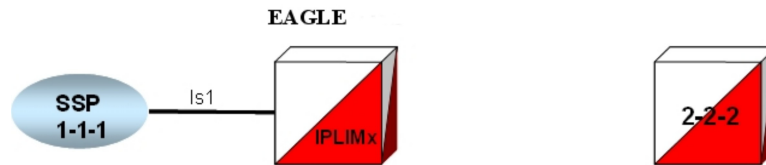

3. Define capacity and use alarm (ent-*ls*).

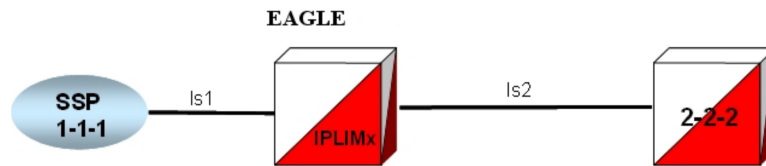

4. Tell the EAGLE that this is a SIGTRAN M2PA link (ent-*slk*).
5. Enter route (ent-*rte*).

SS7 Routing Table

DPC	Isn	rc
1-1-1	Is1	10
2-2-2	Is2	10

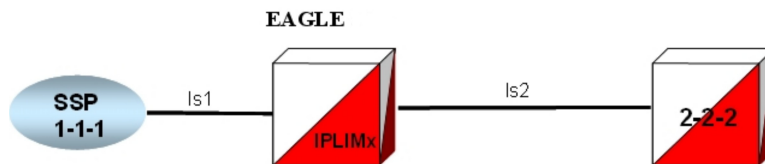

6. Define the IP settings for the Ethernet port (`chg-ip-lnk`):
 - a. Declare what card and port you are defining with this command
 - b. Associate an IP address to that card and port
 - c. Set the Ethernet settings for the card and port
7. Associate an IP address to a host name that will be used in configuring the Association (`ent-ip-host`).

This step sets up a static IP address Host Table, which associates Domain Names to IP addresses so that the computer can look up Domain Names and place the corresponding IP address in the packet header. The alternative is to use a DNS server.

8. Define the network devices that the DCM card will access, for example, DNS or router (`chg-ip-card`).
9. Define routes through routers other than the default router defined in the `ent-ip-rte` command (optional).

Limits:

- 64 routes per card
- 1,024 routes per EAGLE

10. Enter an **Application Server Process** and bind an SCTP association with it (`ent-assoc`).

This command configures the SCTP association in the Internet Protocol Application Socket (IPAPSOCK) table. This command permits the association to transport protocol data units and adaptive layer peer messages. Each association is connected to a process at the far end.

The IPAPSOCK table is used to associate the Local Host/Local Port to a Remote Host/Remote Port.

11. Allow card (`alw-card`).
12. Activate signaling link (`act-slk`).

Configure the IPGWx Application

This section provides a basic overview of the steps involved to provision the IPGWx application for M3UA. For detailed procedures, see *Database Administration - IP7 User's Guide* of your current EAGLE documentation suite.

1. Enable the feature with the part number and feature access key (FAK) (`enable-ctrl-feat`).

IPGWx IP TPS implies a true system limit. Each IPGWx linkset will have a configurable “linkset IP TPS,” and the total of all the provisioned linkset IP TPS values must be less than or equal to the IPGWx system IP TPS.

2. To help manage IPGWx system IP TPS, view the system-wide IP TPS usage (`rept-stat-iptps`).
3. Declare the E5-ENET or E5-ENET-B to be ipgwx (`ent-card`).

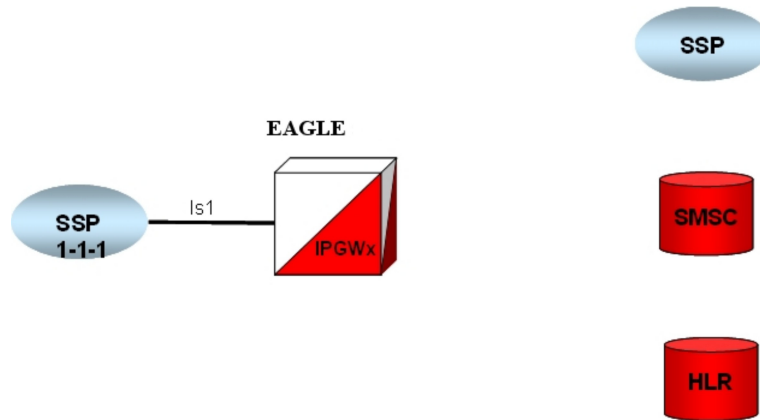

4. Enter the virtual point code (`ent-dstn`).

To create a virtual IPGWx SS7 link, first create an SS7 linkset and an Adjacent Point Code (APC).

The adjacent node functionality for an IPGWx linkset is performed by the IPGWx software to provide SS7-to-IP interworking. For this reason, IPGWx APCs are referred to as “adjacent” point codes. Syntaxes that are normally not allowed for point codes, such as 0-0-1, are allowed for virtual adjacent point codes to minimize depletion of point code space. In addition, beginning with EAGLE 34.0, private point codes can be utilized (and are recommended by Oracle Communications) for IPGWx APCs. Private point codes are used for internal routing within the EAGLE and are not known outside of the EAGLE. By making APCs private, it is possible to have a point code value indicated as private and still have the same point code value (as not private) available for network configuration.

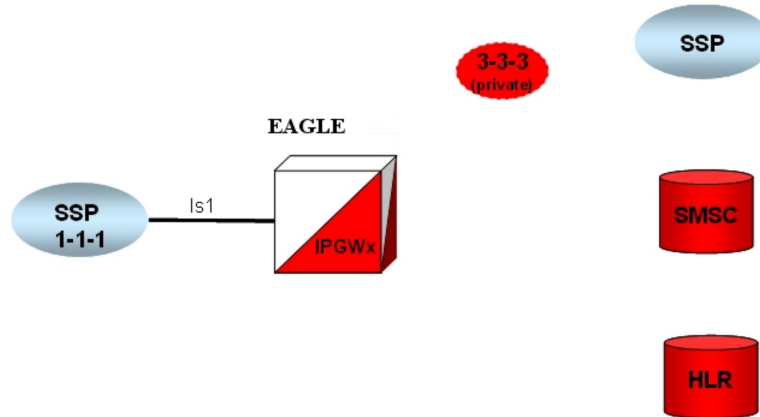

5. Define bandwidth and use alarm (`ent-ls`).

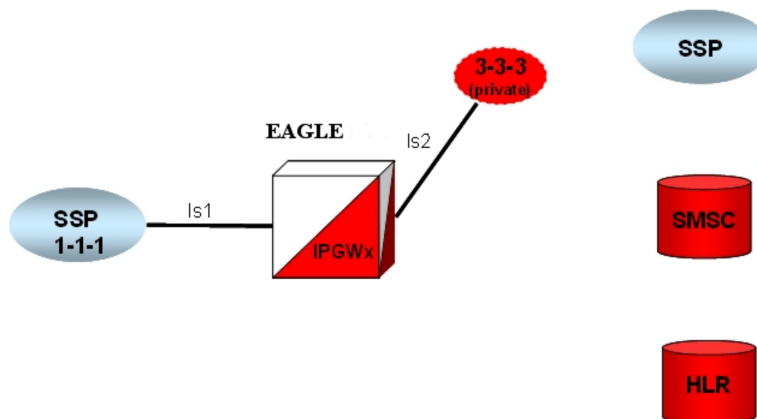

6. Tell the EAGLE that this is a SIGTRAN M3UA link (`ent-slk`).
7. Enter SEP point codes (`ent-dstn`).

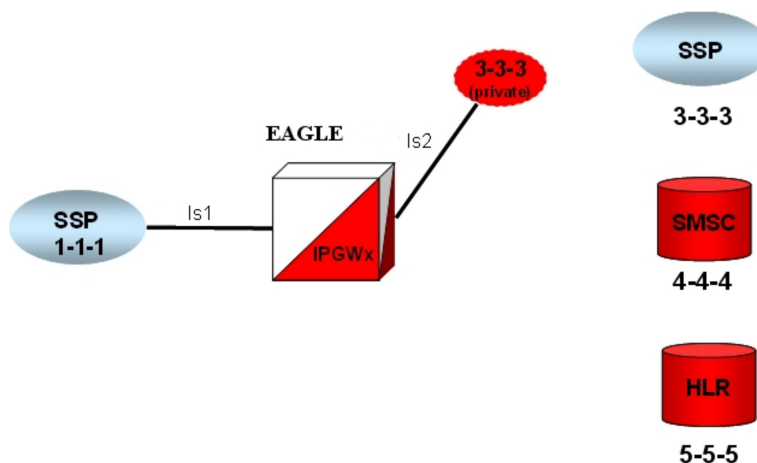

8. Enter route (`ent-rte`).

SS7 Routing Table		
DPC	lsn	rc
1-1-1	ls1	10
3-3-3p	ls2	10
3-3-3	ls2	10
4-4-4	ls2	10
5-5-5	ls2	10

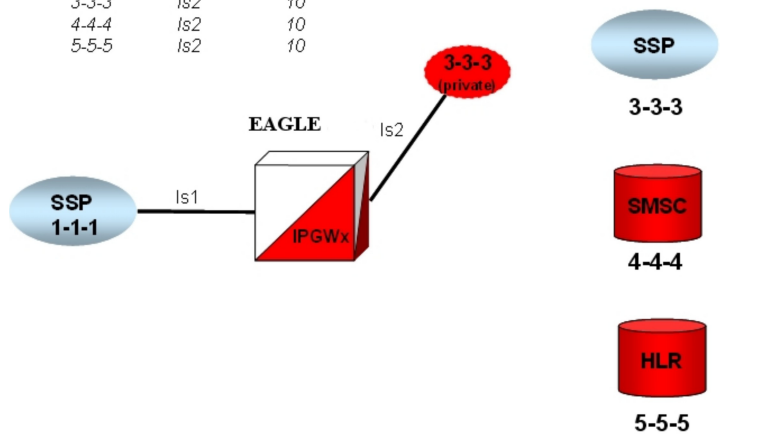

9. Define the IP settings for the Ethernet port (`chg-ip-lnk`).

10. Associate an IP address to a host name that will be used in configuring the association (`ent ip- host`).
11. Define the network devices that the DCM card will access (`chg-ip-card`).
12. Enter an Application Server Process and bind an SCTP association with it (`ent- assoc`).
13. Define the IP settings for the Ethernet port (`chg-ip-lnk`).

Enter an Application Server Process and bind an SCTP association with it (`ent- assoc`)

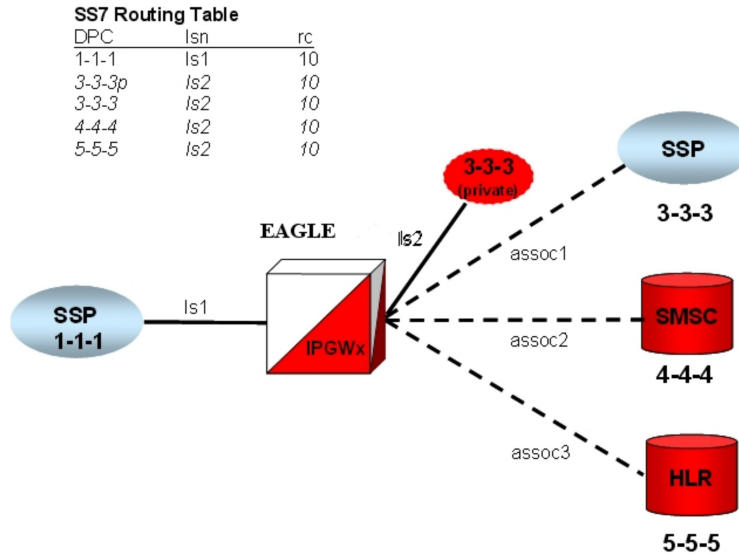

Multihomed end points are SCTP associations configured with both the LHOST and ALHOST parameters specified. In this case, the LHOST represents an IP address corresponding to one of the network interfaces (A or B) of the IP application card, while the ALHOST represents an IP address corresponding to the other network interface of the same IP application card.

This command includes the `rmin` and `rmax` parameters.

14. Enter an Application Server Process and bind an SCTP association with it (`ent- assoc`).
15. Associate a routing key to an association name (`ent-as`).

An Application Server is a logical entity serving a specific routing key or set of routing keys. The first `ent-as` command entered creates the Application Server, and subsequent `ent-as` commands add additional associations to the existing Application Server.

16. Set the network context for the message, either for the **Signaling Gateway process (SGP)** or application server process (`ent-na`).
17. Allow card (`alw-card`).
18. Activate signaling link (`act-slk`).

Refine Timers and Parameters

The performance of the SS7-over-IP may be improved by examining and setting timer values as described in the following sections.

- [Define RTIMES Association Retransmits](#)
- [Define RTO Parameter](#)
- [Measure Jitter](#)
- [Refine RTO Parameter.](#)

Define RTIMES Association Retransmits

Set the `RTIMES` parameter such that an association will be marked unavailable after a reasonable amount of time, based on the values of the `RMODE`, `RMIN` and `RMAX` parameters.

For M2PA, this should be just after M2PA T7 expires (default 1.2 sec).

For example, consider a unihomed M2PA link with `RMIN` set to 100 msec and `RMODE` is `LINEAR`:

Time to mark as failed = `RMIN * RTIMES` 1200 msec = 100 msec * 12

As long as `RTIMES` = 12, the association will fail at about the same time MTP3 starts changeover procedures (12 is the maximum for `RTIMES`).

In this case, decrease M2PA T7 slightly using the `chg-m2pa-tset` command to guarantee that it will expire before the association is taken down.

For M3UA connections, make this a reasonable amount of time for the network, remembering that multihomed associations could be taken down after only `RTIMES/2` retransmits.

Define RTO Parameter

Use the ping-result average RTT measurement for calculation of `RMIN`.

`RMIN` should be set to whichever is greater of $1.2 * (\text{Avg. RTT})$ or $(\text{Avg. RTT}) + 10 \text{ ms}$.

If errors are greater than 1 per 250,000, then investigate to determine if this can be improved in the network.

`RMAX` can be set to the worst recorded RTT and further tuned after the association has been established and `assocrtt` measured.

Define RTXTHR Parameter

`:rtxthr` –The retransmission threshold for the association. The `RTXTHR` parameter value indicates the number of packet re-transmissions that can occur on the association (per monitoring time period of 2 seconds). Alarm "IP Connection Excess Retransmits" (UAM 536) will be raised if the number of packets re-transmitted is greater than the configured `RTXTHR` parameter value, during 5 such consecutive monitoring periods. Once alarm is raised, it may require up to 12 consecutive monitoring periods with the number of re-transmissions < `RTXTHR` to clear the alarm.

The design allows the alarm to come on at low error rates, and not come for occasional errors.

The value of this parameter is 0 to 65,535. The value of this parameter is shown in the RTXTHR field of the `rtrv-assoc:aname=<association name>` output. The `rtxthr` parameter value can be changed if the open parameter value is either "yes" or "no". It is possible to configure the RTXTHR so that UAM 536 alarms if the error rate on association is above the recommended maximum packet loss of 0.025%. If the error rate is more than 0.025%, investigate to determine if this can be improved in the network.

Measure Jitter

Measure jitter using ping samples taken from the network. Ideally, a relatively small subset of the samples deviate from the overall Average RTT for the network. The SCTP RMIN parameter value should be adjusted during deployment such that RMIN is approximately equal to $1.2 * \text{Average RTT}$ time in the network. RTT in the network should not exceed 120 ms for E5-ENET or E5-ENET-B cards, or 50 ms for E5-ENET-B cards running the IPSP application when the E5-ENET-B IPSP High Throughput feature is turned on.

Refine RTO Parameter

After an association is established, the EAGLE `pass` command should be used to get the true RTT as experienced by the association.

1. Reset the counters: `pass:loc=XXXX:cmd="assocrtt -r <assoc name>".`
2. Wait a reasonable interval (preferably 24 hours) before collecting the measurements: `pass:loc=XXXX:cmd="assocrtt <assoc name>".`
3. Perform the `sctp -g peps` or `sctp -a assocname` command to determine if any retransmissions have occurred.
4. Use the values reported to further tune RMIN and RMAX. Use the Weighted Average RTT in this case for defining RMIN.

```
;
pass:loc=1105:cmd="assocrtt c7000"

Command Accepted - Processing

rlghncxa03w 00-01-27 08:10:00 EST EAGLE5 31.6.0
pass:loc=1105:cmd="assocrtt c7000"
Command entered at terminal #1

rlghncxa03w 00-01-27 08:10:00 EST EAGLE5 31.6.0
PASS: Command sent to card

rlghncxa03w 00-01-27 08:10:00 EST EAGLE5 31.6.0

ASSOCRTT: Association round trip time report (in milliseconds)

Retransmission Configuration
Retransmission Mode : LIN
Minimum RTO : 120
Maximum RTO : 800

Traffic Round-Trip Times
```

```

Minimum round-trip time : 5
Maximum round-trip time : 120
Weighted Average round-trip time : 10
Last recorded round-trip time : 10

Measured Congested Traffic Round-Trip Times

Minimum round-trip time : 0
Maximum round-trip time : 0
Weighted Average round-trip time : 0
Last recorded round-trip time : 0

rlghncxa03w 00-01-27 08:10:00 EST EAGLE5 31.6.0
ASSOCRTT command complete

```

System Verification

Once the EAGLE has been configured for SS7-over-IP, verify its correctness using the following section:

- [Verify Network Connectivity](#)
- [Verify IPLIMx configuration](#) or [Verify IPGWx configuration](#), as appropriate.

For details on the commands, see *Commands User's Guide*.

Verify Network Connectivity

1. Is the IPLIM/IPGWx card IS-NR (In-service Normal)?

```
rept-stat-card:mode=full:loc=<IP CARD location>
```

2. Is the Ethernet port up or down?

```
rept-stat-card:mode=full:loc=<IP CARD location>
```

3. Are there errors on the Ethernet Interfaces? Are there collisions? CRC errors? Alignment errors? Retransmits?

```
pass:loc=<IP card location>:cmd=netstat -d 0 <For Ethernet
Interface A>
```

```
pass:loc=<IP card location>:cmd=netstat -d 1 <For Ethernet
Interface B>
```

4. Are there checksum errors?

```
pass:loc=<IP card location>:cmd="netstat -p sctp
```

Change the SCTP checksum if there are errors, `rtrv-sg-opts` will show you what checksum is set at; this must match on both ends.

5. Is the far end reachable? Does ping or traceroute work? Is the RTT acceptable? Is there Packet loss?

```
pass:loc=<IP card location>:cmd=ping <far-end IP address>
```

```
pass:loc=<IP card location>:cmd="traceroute <far-end IP
Address>"
```

6. What is the delay or jitter of the network?

```
pass:loc=<IP card location>:cmd="assocrtt <association>"
```

7. What is the far end advertising?

```
pass:loc=<IP card location>:cmd="sctp -a association"
```

Verify IPLIMx configuration

1. Is there an IPLIMx application in the system?

```
rtrv-card
```

2. Is the IP-LNK table data filled properly? Duplex? 10 or 100 Mbps? Auto=no? IP address Correct? Subnet Mask Correct?
3. Is the IP-CARD table correct? Def router?
4. Is the IP-HOST table data filled? Local hosts specified? Remote hosts specified?
5. Are the Signaling Links built?

```
rtrv-card:loc=<IP Card location>
```

```
rtrv-slk:loc=<ip card location>:port=<SS7 port>
```

6. Is the IPLIMx linkset built?

```
pass:loc=<IP card location>:cmd="assocrtt <association>"
```

7. Is the adjacent point code built in the destination and route table?

```
rtrv-dstn:dpc=<far end point code>
```

```
rtrv-rte:dpc=<far end point code>
```

8. Are there associations using the IPLIMx application?

```
rtrv-assoc:display=all
```

9. What is the status of the associations?

```
rept-stat-assoc
```

10. What is the status of the linkset?

```
rept-stat-ls:lsn=<IPLIM linkset>
```

11. What is the status of the SLKs?

```
rept-stat-slk:loc=<ip card location>:port=<SS7 port>
```

12. What is the status of the adjacent point code?

```
rept-stat-rte:mode=full:dpc=<adjacent point code>
```

Verify IPGWx configuration

1. Is there an IPGWx application in the system?

```
rtrv-card
```

2. Is the IP-LNK table data filled properly? Duplex? 10 or 100 Mbps? Auto=no? IP address Correct? Subnet Mask Correct?
3. Is the IP-CARD table correct? Def router?
4. Is the IP-HOST table data filled? Local hosts specified? Remote hosts specified?
5. Are the signaling links built?

```
rtrv-card:loc=<IP Card location>
rtrv-slk:loc=<ip card location>:port=<SS7 port>
```

6. Is the IPGWx linkset built? Does it have sufficient TPS?

```
pass:loc=<IP card location>:cmd="assocrtt <association>"
```

7. Is the virtual adjacent point code built in the destination and route table?

```
rtrv-dstn:dpc=<virtual adjacent point code>
rtrv-rte:dpc=<virtual adjacent point code>
```

8. Are the far-end point codes built in the destination and route table?

```
rtrv-dstn:dpc=<far-end point code>
rtrv-rte:dpc=<far-end point code>
```

9. Are there associations using the IPGWx application?

```
rtrv-assoc:display=all
```

10. Is an Application Server using the associations?

```
rtrv-as
```

11. Is routing built in the APPL-RTKEY table for the far end nodes? SI of 0 is not necessary.

```
rtrv-appl-rtkey:display=all
```

12. What is the status of the associations?

```
rept-stat-assoc
```

13. What is the status of the Application Servers?

```
rept-stat-as
```

Note: Having associations from two different IPGWx linksets in the same Application Server is an unsupported configuration.

14. What is the status of the linkset?

```
rept-stat-ls:lsn=<IPLIM linkset>
```

15. What is the status of the adjacent point code?

```
rept-stat-rte:mode=full:dpc=<adjacent point code>
```

16. What is the status of the far-end point code?

rept-stat-rte:mode=full:dpc=<far-end point code>

Troubleshooting

This chapter offers troubleshooting procedures based on symptoms occurring in the network.

General troubleshooting

1. Work from the bottom of the protocol stack up: first, IP Network; then the SS7 link or connection; then traffic routing.
2. Review provisioning and verify configuration in this order:
 - Card
 - Signaling (SS7) link
 - Linkset
 - IP link or IP network
 - Association or Application Server (IPGWx only)
 - Traffic routing or SS7 route and route key (IPGWx only)

General troubleshooting tools include the following:

- `Ethereal` – PC-based network analyzer (sniffer) – www.ethereal.com/ / www.wireshark.com
- `netstat/sctp` pass commands to display TCP/IP or SCTP/IP network statistics
- `ualog/asplug/linkinfo` pass command to retrieve logs of events in stack and control messages transmitted or received
- `msucount` pass command to display traffic counts of MSUs that have been transmitted, received, rerouted, or discarded, and the discard reason

Verify UIMs and UAMs

1. If there are any **Unsolicited Information Messages (UIMs)** or **Unsolicited Alarm Messages (UAMs)** occurring related to the SIGTRAN configuration, refer to *Unsolicited Alarms and Information Messages Reference*.

Is the card configured correctly?

1. Card in system?

```
rtrv-card
```

`rept-stat-card`

- IP link configured correctly? (`rtrv-ip-lnk`; preferred settings are 100/full duplex on card AND switch - no AUTO configure)
- IP link configured correctly? (`rtrv-ip-lnk`; preferred settings are 100/full duplex on card AND switch - no AUTO configure)
- IP host table configured? (`rtrv-ip-host`; check for local and remote addresses)
- Signalling links (SLKs) and linksets configured correctly? (`rept-stat-slk/rept-stat-ls`)

2. IP link configured correctly?

`rtrv-ip-lnk`

Preferred settings are 100/full duplex on card AND switch - no AUTO configure

3. IP routing configured?

`rtrv-ip-rte`

`rtrv-ip-card`

4. IP host table configured?

`rtrv-ip-host`

Check for local and remote addresses.

5. Signalling links (SLKs) and linksets configured correctly?

`rept-stat-slk`

`rept-stat-ls`

Connection does not become established

1. Card up and stable?

`rept-stat-card`

2. Association status?

`rept-stat-assoc`

3. Network connectivity?

`netstat -I`

`rept-stat-card:mode=full`

4. Errors (collisions, etc.) on the network interface?

`netstat -d 0/1t`

5. Far end reachable?

`ping`

`tracert`

6. Near end and far end use same SCTP CRC?

```
netstat -p
sctp/rtrv-sg-opts
```

Connection bounces and is unstable

1. Transport stable?

```
netstat -i
netstat -d
```

2. RMIN set too low?

```
ping
assocrtt
rtrv-assoc
```

Rule of thumb is above 1.2 * average RTT

AS/PC in route key does not become available or ACTIVE (IPGWx only)

1. Connection in correct AS?

```
rtrv-as
```

2. Routing key provisioned for AS?

```
rtrv-appl-rtkey
```

3. Network appearance/**routing context** required and matched?

```
rtrv-appl-rtkey
ualog
```

4. AS/**ASP** activated at far end?

```
aslog
ualog
```

5. SS7 APC/SAPC and associated route exists in the same network (and group code) as the PC?

```
rtrv-rte
rtrv-ls
```

IP destination is not informed of SS7 destination status changes; network management is not working correctly (IPGWx only)

1. Route key is not provisioned for IPGWx linkset virtual APC, but SS7 route is?

```
rtrv-rte
rtrv-appl-rtkey/display==all
```

2. AS connections hosted by cards in different linksets/matesets; is the mateset equivalent to linkset?

```
rtrv-as  
rtrv-assoc  
rtrv-ls
```

Traffic not arriving at IP destination or traffic is lost

1. Route to destination's PC entered and available?
2. Traffic being received/discarded on IP card? IPGWx application has numerous discard reasons!

```
rept-stat-dstn  
  
msucount -l
```

Are connection(s) congesting?

1. Is SCTP buffering set correctly for network RTT?
2. Is IPTPS set correctly for IPGWx?
3. Is an interface set to half-duplex somewhere in the path to the far end, causing excessive retransmissions?

```
rtrv-assoc  
assocrtt,  
sctp
```

```
rept-stat-iptps  
rtrv-ls
```

```
rtrv-ip-lnk  
sctp
```

Traffic not load-balanced properly

1. Source traffic has uneven SLS distribution?
2. All cards in linkset or mateset do not host a connection to the IP Application Server(IPGWx only)?

```
rtrv-assoc  
rtrv-as
```

3. IPGWx cards in mateset with no established connections have signaling link deactivated to minimize 'double-hopping' (IPGWx only)?

```
rept-stat-card  
msucount -l
```

Link Level Events

1. IPLIM `pass` command

```
linkinfo -l
```

2. IPLIMx `linkinfo` has other interesting options?

```
-c
```

```
-m
```

3. IPGWx `pass` command

```
ualog
```

```
aslog
```

4. Both commands have event filtering (link events vs. traffic), so look at options

Association

1. IPLIM/ `pass` command

```
sctp -a
```

Additional Deployment Scenarios

This chapter provides various additional scenarios for deployment of SS7-over-IP using SIGTRAN.

IPSG Deployment Scenario

Figure A-1 Example Deployment of IPSG Application

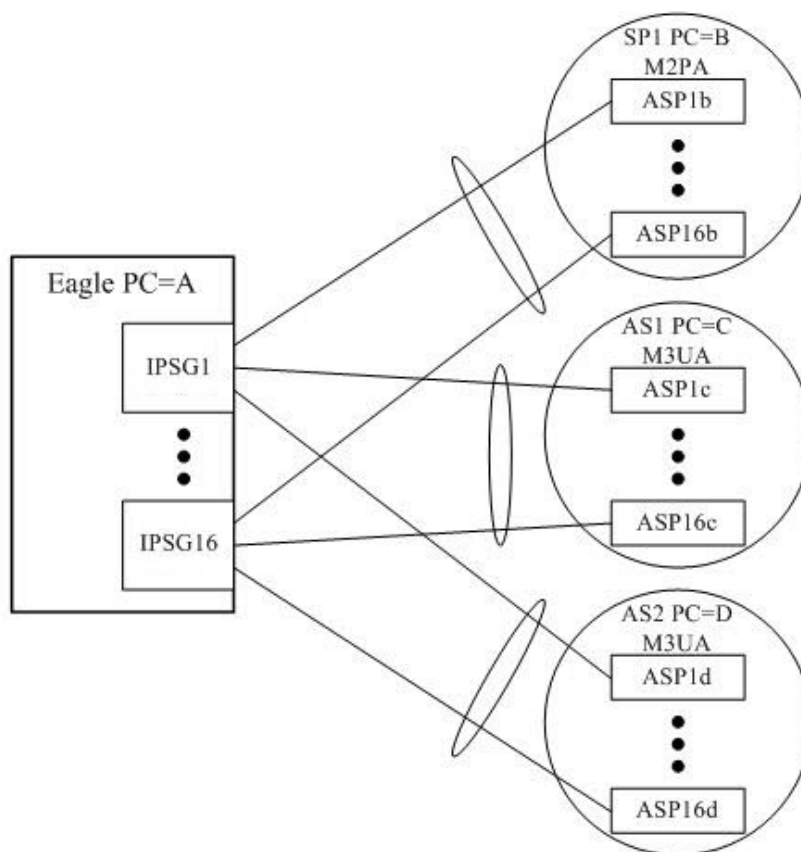

Note:

- Each IP-attached signaling point or application server is represented in EAGLE as a linkset (ovals).
 - Up to 16 IPSG links are supported per linkset (IPGWx only supports 8)
 - If an E5-ENET-B card is used as the IPSG card, and if the E5-ENET-B IPSG High Throughput feature is turned ON, then the card supports a maximum of 4 links before de-rating. See [Factors Affecting Advertised Capacity](#) for additional information.
 - Each connecting line represents a SS7 signaling link and an SCTP association.
 - Multiple linksets are supported.
 - Each linkset supports one SIGTRAN adapter type (M2PA or M3UA).
 - Point Codes 'B', 'C', and 'D' can involve any mixture of ANSI and ITU point codes. If different variants are in use, then Eagle must have a point code in each of the networks.
 - Multiple signaling links per card are supported.
-

The IPSG feature provides M3UA functionality that behaves more like other LIMs, providing the following benefits:

- The new IPSG application M3UA operational model equates Linkset (LS) and Application Server (AS). It equates Signaling Link (SLK) with an AS-ASP (Routing Context + Association) instance. This allows each AS-ASP instance to be administered as a signaling link.
- A new signaling link type, IPSG-M3UA, can be assigned to linksets having up to 16 signaling links. This is double the 8-link (and card) limitation of the current IPGWx linkset.
- Each IPSG card will host up to 128 signaling links.
- Each IPSG card will host up to 128 SCTP associations. A maximum of 16 IPSG-M3UA signaling links can be assigned to a single association.
- The adjacent point code (APC) of the IPSG-M3UA linkset is the point code assigned to the Application Server serviced by the linkset. The IPSG-M3UA linkset does not require a fake adjacent point code as the current IPGWx application does.
- Each IPSG-M3UA signaling link can have a single IP connection, unlike the current IPGWx signaling link which can have up to 50 IP connections.
- The state of the IPSG-M3UA signaling link will be based on the states of the assigned IP connection and AS-ASP instance. If the IP connection is unavailable for traffic, then the IPSG-M3UA signaling link will also be unavailable. If the AS-ASP instance is not available, then the IPSG-M3UA signaling link will also be unavailable. *

- Multiple IPSP-M3UA signaling links (up to 16) can share one IP connection, as long as all of the IPSP-M3UA signaling links and corresponding IP connection are hosted by the same card. This enables multiple SS7 variant support across a single IP connection.
- The IPSP-M3UA signaling links provide MTP3 routing only. The IPSP application does not implement secondary routing-key routing, so every attached AS must be uniquely identified in the network by a point code.

IPGW/M3UA deployment scenarios

Active/standby configurations

Figure A-2 IPGWx active/standby configuration

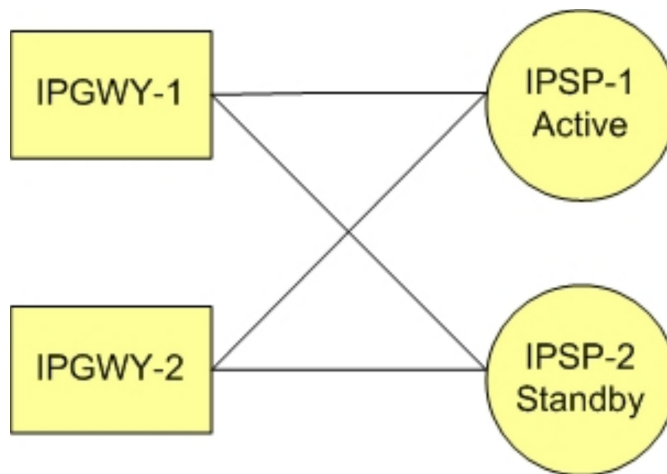

- Active/standby configurations should be implemented at the IP Signaling Points (IPSPs) rather than at the EAGLE.
- All DCMs assigned to an IPGWx mateset should host connections to nodes comprising an Application Server and should loadshare traffic in the absence of failures. Deployments of active/standby DCMs result in excessive IMT utilization in the absence of failures due to double-hopped outbound traffic.

Two-pair IPGWx

Figure A-3 Two-Pair IPGWx for maximum TPS

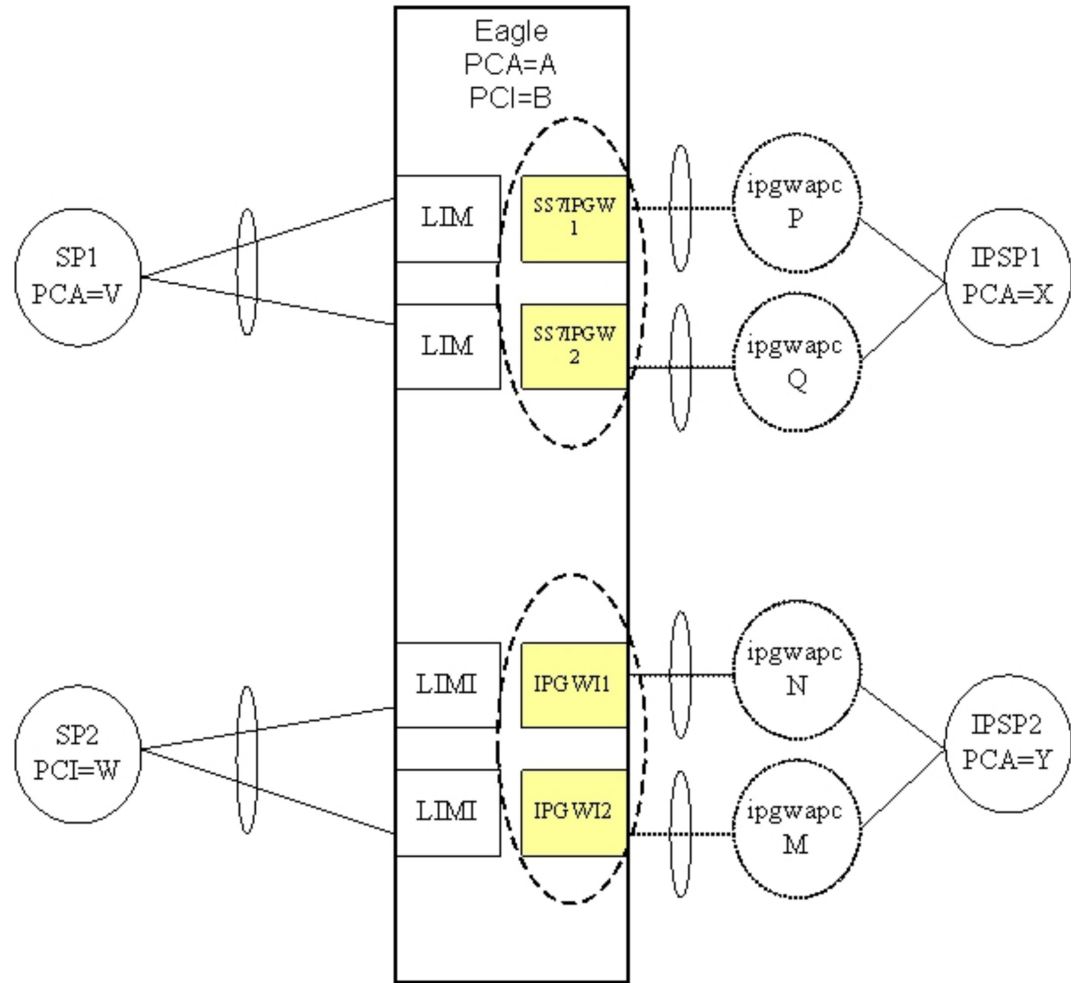

- Two IPGWx cards are deployed as a mateset. No more than two cards for each application are allowed.
- Each card has one signaling link, represented by a hatched line. Each IPGWx signaling link is alone in a linkset, represented by an ellipse.
- Each card has a fake adjacent signaling point represented by a hatched circle and having an IPGWx Adjacent Point Code. Each of the IPGWx linksets has an IPGWAPC.
- Two equal cost routes are provisioned for X, thereby combining the two SS7IPGW linksets. Two equal cost routes are provisioned for Y, thereby combining the two IPGWI linksets.
- Each card has one or more IP connections to the IPSP, represented by a solid line. Each IP connection has only an indirect relationship to a signaling link.
- If each card is rated at 2,000 TPS, then the maximum transaction rate to/from a point code is 2,000 TPS (1+1 redundancy), and the total system-wide TPS supported is 4,000 TPS.

- This feature will continue to allow the preceding deployment (two pairs, combined linksets) to be used, and will expand the number of deployment variations supported. It will do this by modifying the definition of a SS7IPGW or IPGWI mateset.

Four IPGWx pairs

Figure A-4 Four IPGWx pairs (two SS7IPW pairs and two IPGWI pairs)

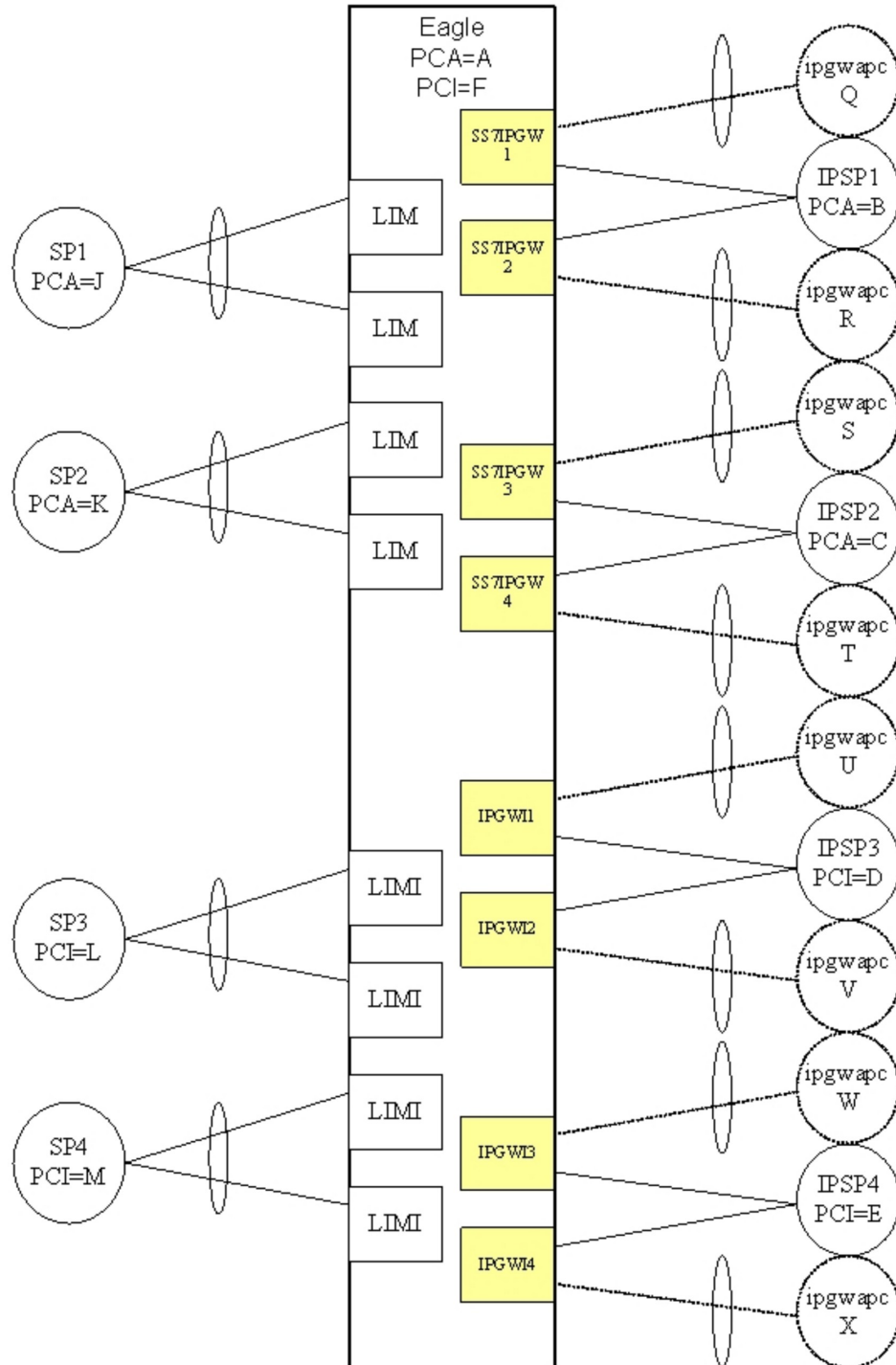

- There are four IPGWx matesets, each comprised of two linksets (a combined linkset).
- Each IPSP is only connected to cards within an IPGWx mateset. No IPSP (or Application Server) crosses IPGWx mateset boundaries.
- This deployment is 1+1 redundancy.
- Another supported variation of this deployment would involve different numbers pairs or linksets, and possibly one linkset per pair.

Eight IPGWx cards

Figure A-5 Eight IPGWx cards, two mates, three linksets

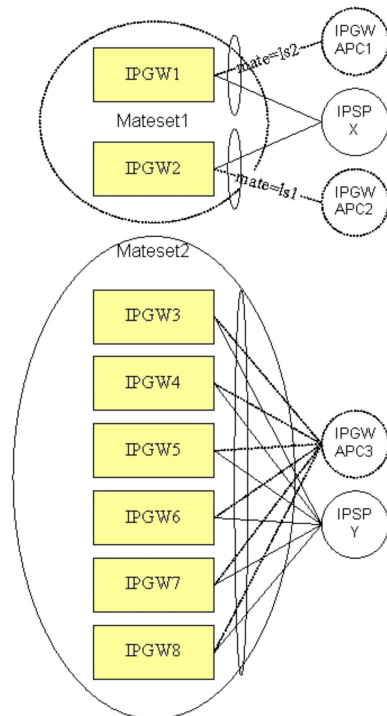

- Eight IPGWx cards are present, each having a single signaling link. IPGW1 and IPGW2 have their links assigned to distinct linksets. The remaining IPGWx cards have their links assigned to a common linkset.
- The route-set to PC X involves a combined linkset, i.e. two equal-cost routes.
- Connectivity to the IPSPs does not cross IPGWx mateset boundaries.
- More than two IPSPs can be supported in either IPGWx mateset. The actual limit is based on IP connections and routing keys.
- Other supported variations of this deployment involve different numbers of cards in the Mateset2 or different numbers of IPSPs.

Four IPGWx cards

Figure A-6 Four IPGWx cards, one linkset for end office

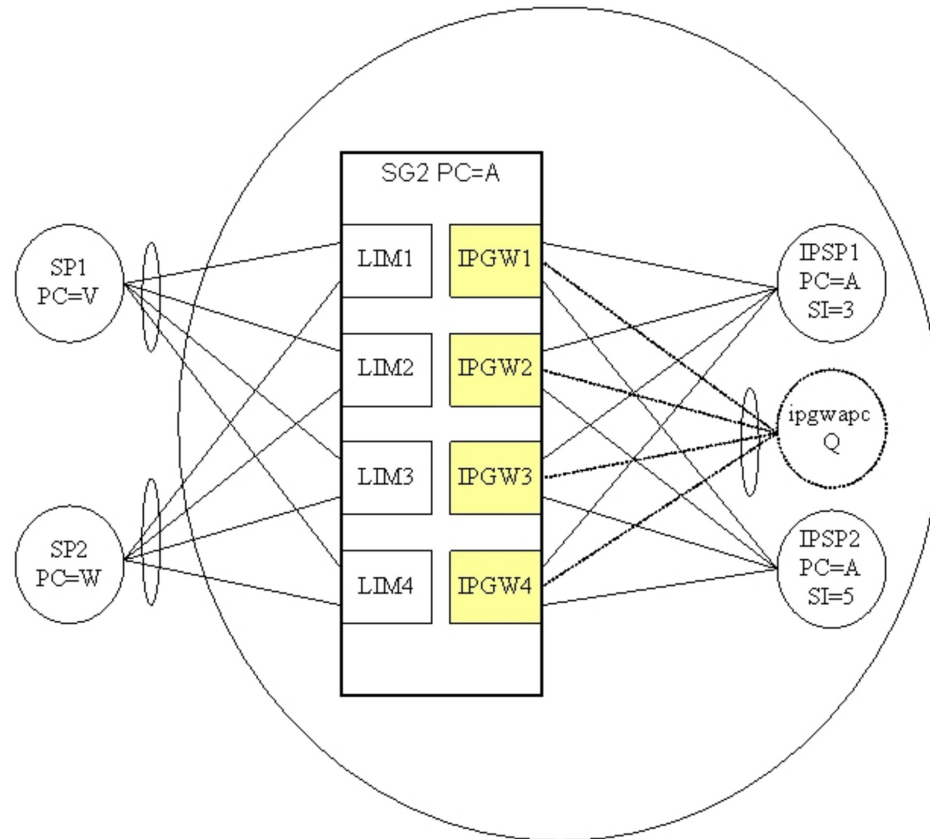

- Four IPGWx cards are present, each having a single signaling link. All of the IPGWx signaling links are assigned to a linkset having an IPGWAPC (virtual point code) of Q.
- Two IP-based signaling points or Application Servers are each connected to the full set of IPGWx cards and are distinguished by user part (SI).
- Because the IPGWx signaling links are part of a single linkset, each card cannot use TFP/TFA to divert traffic to other IPGWx cards.
- The EAGLE is operating in End Office Mode. This means that the IPSPs are IP-attached remote user-parts that share the true and secondary point codes of EAGLE (PC=A). In order to route from the inbound LIMs to the outbound IPGWx cards, an internal point code (IPC) is used.
- Because only one IPC is currently supported, only one IPGWx mateset is supported for End Office mode traffic. There can be other IPGWx matesets, but only one can serve End Office remote applications.
- Other supported variations of this deployment involve different numbers of cards in the mateset or different numbers of IPSPs.

Unsupported Scenarios

Figure A-7 shows that the route to IPGWx linksets 1 and 2 are combined. Combined linksets are not supported.

Figure A-7 Unsupported deployment scenario: combined linksets (1)

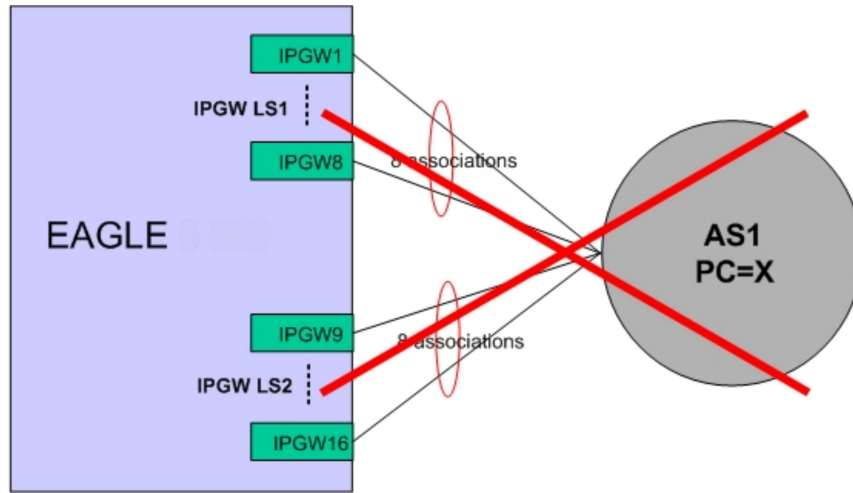

- EAGLE route to PC=X is a combined linkset for IPGW LS1 and IPGW LS2
- SLS determines which card in either IPGWLS1 or IPGWLS2 is chosen to send traffic to AS1
- Each card in each IPGWLS has 1 association to AS1

Figure A-8 shows that the route to IPGWx linksets 1 and 2 are combined for AS1; and linksets 2 and 3 are combined for AS2. Combined linksets are not supported.

Figure A-8 Unsupported deployment scenario: combined linksets (2)

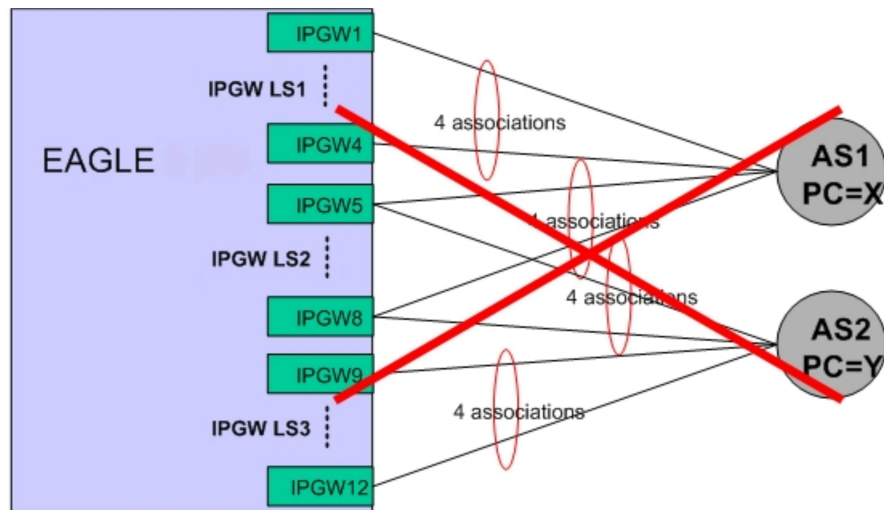

- EAGLE route to AS1 PC=X is combined linkset for IPGW LS1 and IPGW LS2
- EAGLE route to AS2 PC=Y is combined linkset for IPGW LS2 and IPGW LS3

References

This appendix lists Oracle-internal and external references used in this manual. Customers requiring access to Oracle-internal references should contact their Sales Representative to obtain equivalent information. This section also provides the location of customer documentation on the Oracle Customer Support site.

Oracle Communications Internal References

1. Sigtran Implementation, David Prince, April 2007
2. Oracle Engineering Rules for Determining IP7 Application Throughput, Oracle, TR005007
3. Engineering Rules for IP Networks for IP7 Application Deployment, Oracle, TR002826
4. TK149 V4.1 Student Guide.ppt
5. SCTP RFC 4960 Compliance Matrix, Oracle, CM005105
6. M2PA RFC 4165 Compliance Matrix, Oracle, CM005086
7. M3UA RFC 4666 Compliance Matrix, Oracle, CM005022
8. SUA RFC 3868 Compliance Matrix, Oracle, CM005002
9. Increase System-Wide IPGWx TPS, FD005446
10. SigTran_Training_24 October 06 for Customers.ppt, Oracle
11. TK149-SIGTRAN IPLIM and IPGW Provisioning Student Guide, Rev. 4.1, Oracle, 2007

External References

1. *Database Administration - IP7 User's Guide*, of your current EAGLE documentation. Instructions for locating these documents can be found in the [Locate Product Documentation on the Oracle Help Center Site](#) section.
2. *IETF RFCs* <http://tools.ietf.org/wg/sigtran/>
3. *Site Security Handbook, RFC 2196* <http://tools.ietf.org/html/rfc2196#section-1.5>
4. *BITS GUIDE TO BUSINESS-CRITICAL TELECOMMUNICATIONS SERVICES* <http://www.bitsinfo.org/downloads/Publications%20Page/bitstelecomguide.pdf>

5. *Quality of Service Technical White Paper* <http://www.microsoft.com/technet/prodtechnol/windows2000serv/plan/qosover2.mspx>

Index

A

additional transaction unit value, [5-1](#)
adjusted configuration scenarios, [5-13](#)
adjusted transaction unit, [5-11](#), [5-13](#)
advertised capacity, [5-7](#), [6-2](#)
Advertised Capacity, [5-1](#), [5-7](#), [5-9](#)
Advertised Card, [5-1](#)
Application Server, [2-3](#), [5-29](#), [7-4](#), [A-3](#)
Application Server Process, [2-6](#), [6-13](#)
AS, [7-3](#)
ASP, [5-38](#), [7-3](#)
association, [5-37](#), [7-2](#), [7-5](#)
Association, [5-20](#)
association throughput, [4-5](#)
associations, [4-5](#)
ATM, [2-4](#)
audience, [1-1](#)
average message size, [5-20](#)

B

bandwidth, [2-1](#), [2-9](#), [2-11](#), [3-1](#), [4-3](#), [4-5](#), [5-1](#), [5-31](#),
[5-33](#), [5-38](#)
base transaction unit, [5-1](#)
base transaction unit cost, [5-11](#)
base transaction unit rules, [5-10](#)

C

calculate the number of cards required, [5-28](#)
calculate transaction units per second, [5-16](#)
capacity, [2-11](#)
card communication interfaces, [5-8](#)
configurable capacity, [5-8](#)
configuration, [4-1](#), [4-3](#), [4-5](#), [5-7](#), [5-8](#), [5-11](#), [5-32](#), [5-35](#),
[5-38](#), [7-1](#), [A-3](#)
congestion, [5-7](#), [5-9](#)
congestion window, [5-38](#)
Congestion Window Minimum size, [5-20](#)
connectivity, [2-8](#), [3-2](#), [5-6](#), [5-35](#), [7-2](#), [A-6](#)
Converged IP Network, [2-10](#)

CPU utilization, [5-7](#)
CWMIN parameter, [5-38](#)

D

Data Feed, [5-20](#), [6-2](#)
Data Feed feature, [5-9](#)
destination availability, [5-32](#)
double-hopping, [7-4](#)

E

E5-ENET, [3-2](#), [5-6](#), [5-7](#)
End Office mode, [3-2](#)

F

False Connection Congestion Timer, [5-30](#)
flexibility, [2-9](#), [3-1](#)

G

Global Title Translations, [2-6](#)

H

heartbeat, [5-35](#)
HIPR2, [6-2](#)
Home Locator Register, [2-4](#)
Home Location Register (HLR), [2-9](#)
hop, [2-6](#)
host, [2-7](#), [2-8](#), [6-2](#)
host card, [5-7](#)

I

IAS, [3-3](#)
IETF, [2-2](#), [2-3](#)
IMF, [3-4](#)
IMT interface capacity, [5-8](#)
Internet Engineering Task Force (IETF), [2-1](#)
IP network planning, [5-34](#)

IP packet loss rate, [5-10](#)
IP Signaling Point (IPSP), [A-3](#)
IPGWx, [1-3](#), [3-2](#), [4-4](#), [5-2](#), [5-7](#), [5-10](#), [5-13](#), [5-29](#), [5-30](#),
[5-32](#), [6-14](#), [6-20](#), [7-1](#), [7-3-7-5](#), [A-3](#)
IPGWx application, [3-2](#), [5-6](#)
IPLIM, [7-5](#)
IPLIMx, [1-3](#), [2-6](#), [3-2](#), [4-4](#), [5-2](#), [5-10](#), [5-13](#), [5-29](#), [6-12](#),
[6-20](#)
IPLIMx application, [3-2](#), [5-6](#)
ISUP, [2-4](#), [2-5](#), [3-2](#), [5-20](#)

J

jitter, [2-10](#)

L

LAN, [1-3](#), [2-8](#), [3-4](#), [4-3](#), [5-33](#)
LAN utilization, [5-34](#)
latency, [2-11](#), [5-10](#)
link equivalency, [5-2](#)

M

M2PA, [2-4](#)
M3UA, [2-5](#), [3-2](#)
M3UA AS-Pending procedure, [6-3](#)
M3UA ASP Failure notifications, [6-3](#)
mateset, [7-4](#)
maximum traffic rate, [5-20](#)
Media Gateway, [5-33](#)
Media Gateway Controller, [5-33](#)
Media Gateway Controller (MGC), [2-6](#)
Media Gateway Controllers, [3-1](#)
memory, [5-20](#)
message buffers, [5-7](#)
Message Signaling Unit (MSU), [2-6](#)
Message Transfer Part (MTP), [2-4](#)
MGC, [2-6](#)
Mobile Switching Center (MSC), [2-6](#), [2-9](#)
MSU, [5-1](#), [5-6](#), [5-7](#), [5-9](#), [5-20](#), [5-26](#), [5-28](#), [5-33](#)
MTP2 User Peer-to-Peer Adaptation Layer (M2PA)
protocol; RFC 4165, [2-2](#)
MTP3 User Adaptation Layer (M3UA) protocol; RFC
4666, [2-2](#)
multihomed association, [5-34](#)
multihoming, [5-31](#)

N

network management, [2-1](#), [5-32](#)

P

packet, [2-2](#), [2-3](#), [2-6](#), [2-7](#), [2-9](#), [2-10](#), [3-1](#), [4-3](#), [5-20](#),
[5-35](#), [5-38](#)

performance- and revenue-management capabilities,
[3-3](#)
primary path, [5-34](#)
provisioning, [7-1](#)
Public Switched Telephone Network (PSTN), [2-2](#)

Q

QoS, [2-10](#), [4-3](#), [5-34](#)
Quality of Service (QoS), [2-8](#)

R

retransmission, [5-34](#), [5-38](#)
retransmission mode, [5-10](#)
RFC 4165, [6-2](#)
Round Trip Time (RTT), [2-10](#), [5-20](#)
routing context, [7-3](#)
routing key, [5-32](#), [6-16](#), [7-3](#), [A-6](#)
routing keys, [2-6](#)
RTIMES, [5-38](#)
RTO, [5-37](#)

S

scalability, [2-1](#), [4-5](#), [5-2](#)
scalable, [3-1](#)
SCCP Class 1 sequencing feature, [5-6](#)
SCCP User Adaptation Layer (SUA) protocol; RFC
3868, [2-2](#)
SCTP association, [3-2](#)
SCTP buffering, [7-4](#)
SCTP buffers, [5-21](#)
SCTP endpoint, [2-3](#), [5-34](#)
Service Control Point, [5-33](#)
Service Information Field (SIF), [5-9](#)
Service Switching Point, [1-3](#), [2-4](#), [3-2](#)
SGP, [5-38](#)
Short Message Service (SMS), [2-9](#)
Short Message Service Center (SMSC), [1-3](#), [2-9](#)
Signaling Control Point, [2-4](#)
Signaling End Point (SEP), [2-6](#)
signaling end point,, [2-5](#)
Signaling Gateway, [2-6](#)
Signaling Gateway (SG), [2-6](#)
Signaling Gateway Process, [6-16](#)
Signaling Information Field (SIF), [2-5](#)
Signaling Link Selection (SLS), [2-4](#)
Signaling Link Selection value, [5-33](#)
signaling transport protocols, [2-2](#)
SIGTRAN, [3-2](#)
SIGTRAN architecture, [2-2](#)
SLS, [7-4](#)
SS7-over-IP, [2-9](#), [2-11](#)
SS7-over-IP solution, [3-1](#)
SSEDCM, [5-7](#)

STC card, [6-2](#)
Stream Control Transmission Protocol (SCTP); RFC
4960, [2-2](#)
SUA, [2-5](#), [3-2](#)

T

TDM, [1-2](#), [2-4](#)
throughput, [2-9](#), [5-1](#), [5-13](#), [5-34](#)
total transaction unit value, [5-1](#)
TPS value, [5-7](#)
traffic flow control, [5-7](#)
transaction, [5-1](#)
transaction unit, [5-1](#)
Transaction Unit (TU) model, [5-1](#)
Transaction Units per Second (TPS), [5-1](#), [5-9](#)
Transfer Allowed (TFA), [5-32](#)
Transfer Controlled (TFC), [5-30](#)
Transfer Prohibited (TFP), [5-32](#)

transport address, [2-3](#)
TU values, [5-13](#)

U

unihoming, [5-31](#)
Unsolicited Alarm Message (UAM), [7-1](#)
Unsolicited Information Message (UIM), [7-1](#)

V

value-added services, [2-9](#)
Voice over Internet Protocol (VoIP), [3-4](#)
voice-over-IP, [2-11](#)

W

WAN, [1-3](#), [2-8](#), [4-3](#), [5-33](#)

