

EAGLE

Installation Guide

Release 46.6

Revision 1

March 2018

EAGLE Installation Guide, Release 46.6

Revision 1

Copyright © 1993, 2018, Oracle and/or its affiliates. All rights reserved.

This software and related documentation are provided under a license agreement containing restrictions on use and disclosure and are protected by intellectual property laws. Except as expressly permitted in your license agreement or allowed by law, you may not use, copy, reproduce, translate, broadcast, modify, license, transmit, distribute, exhibit, perform, publish, or display any part, in any form, or by any means. Reverse engineering, disassembly, or decompilation of this software, unless required by law for interoperability, is prohibited.

The information contained herein is subject to change without notice and is not warranted to be error-free. If you find any errors, please report them to us in writing.

If this is software or related documentation that is delivered to the U.S. Government or anyone licensing it on behalf of the U.S. Government, then the following notice is applicable:

U.S. GOVERNMENT END USERS: Oracle programs, including any operating system, integrated software, any programs installed on the hardware, and/or documentation, delivered to U.S. Government end users are "commercial computer software" pursuant to the applicable Federal Acquisition Regulation and agency-specific supplemental regulations. As such, use, duplication, disclosure, modification, and adaptation of the programs, including any operating system, integrated software, any programs installed on the hardware, and/or documentation, shall be subject to license terms and license restrictions applicable to the programs. No other rights are granted to the U.S. Government.

This software or hardware is developed for general use in a variety of information management applications. It is not developed or intended for use in any inherently dangerous applications, including applications that may create a risk of personal injury. If you use this software or hardware in dangerous applications, then you shall be responsible to take all appropriate fail-safe, backup, redundancy, and other measures to ensure its safe use. Oracle Corporation and its affiliates disclaim any liability for any damages caused by use of this software or hardware in dangerous applications.

Oracle and Java are registered trademarks of Oracle and/or its affiliates. Other names may be trademarks of their respective owners.

Intel and Intel Xeon are trademarks or registered trademarks of Intel Corporation. All SPARC trademarks are used under license and are trademarks or registered trademarks of SPARC International, Inc. AMD, Opteron, the AMD logo, and the AMD Opteron logo are trademarks or registered trademarks of Advanced Micro Devices. UNIX is a registered trademark of The Open Group.

This software or hardware and documentation may provide access to or information about content, products, and services from third parties. Oracle Corporation and its affiliates are not responsible for and expressly disclaim all warranties of any kind with respect to third-party content, products, and services unless otherwise set forth in an applicable agreement between you and Oracle. Oracle Corporation and its affiliates will not be responsible for any loss, costs, or damages incurred due to your access to or use of third-party content, products, or services, except as set forth in an applicable agreement between you and Oracle.

This documentation is in preproduction status and is intended for demonstration and preliminary use only. It may not be specific to the hardware on which you are using the software. Oracle Corporation and its affiliates are not responsible for and expressly disclaim all warranties of any kind with respect to this documentation and will not be responsible for any loss, costs, or damages incurred due to the use of this documentation.

The information contained in this document is for informational sharing purposes only and should be considered in your capacity as a customer advisory board member or pursuant to your beta trial agreement only. It is not a commitment to deliver any material, code, or functionality, and should not be relied upon in making purchasing decisions. The development, release, and timing of any features or functionality described in this document remains at the sole discretion of Oracle.

This document in any form, software or printed matter, contains proprietary information that is the exclusive property of Oracle. Your access to and use of this confidential material is subject to the terms and conditions of your Oracle Master Agreement, Oracle License and Services Agreement, Oracle PartnerNetwork Agreement, Oracle distribution agreement, or other license agreement which has been executed by you and Oracle and with which you agree to comply. This document and information contained herein may not be disclosed, copied, reproduced, or distributed to anyone outside Oracle without prior written consent of Oracle. This document is not part of your license agreement nor can it be incorporated into any contractual agreement with Oracle or its subsidiaries or affiliates.

Contents

1 Introduction

Overview	1-1
Scope and Audience	1-1
Documentation Admonishments	1-2
Manual Organization	1-2
My Oracle Support (MOS).....	1-3
Problem Report (PR)	1-3
Emergency Response.....	1-4
Related Publications	1-5
Customer Training	1-5
Locate Product Documentation on the Oracle Help Center Site	1-5
Regulatory Compliance and Certification	1-5
Environmental Requirements	1-7
Hardware Repair and Return.....	1-7
Repair and Return Shipping Instructions	1-8
Returning a Crate	1-10

2 Safety Information

General	2-1
Frames	2-1
Power.....	2-2
Electrostatic Discharge	2-4
Components.....	2-5

3 General Installation Information

Hardware Operational Testing	3-1
Components Overview	3-1
Card Installation and Replacement.....	3-3
Labeling	3-4
Cable Labeling	3-4
Fuse and Alarm Panel Labeling	3-6
EAGLE Post-Installation Inspection	3-7

4 Frames and Shelves

Unpacking.....	4-1
Floor Preparation.....	4-6
Recommended Tools.....	4-7
Raised Floor.....	4-8
Concrete Floor.....	4-15
Recommended Tools.....	4-15
Anchoring to Overhead Rack of Heavy Duty Frame.....	4-17
Removing Frame Panels.....	4-18
Installing Unit Separation Brackets.....	4-19
Rear Covers.....	4-20
Shelves.....	4-21
Labeling.....	4-23
End Aisle Labeling.....	4-23
Frame Labeling.....	4-28
Shelf Labeling.....	4-31

5 Fuses and Alarm Panel

Fuse and Alarm Panels.....	5-1
Fuses.....	5-1
Fuse and Alarm Panel (P/N 870-2804-01).....	5-2
Fuse and Alarm Panel (P/N 870-1606-xx/870-2320-xx).....	5-7
Provision Rules for FAP Fuse Locations.....	5-12
Installing Power Cables.....	5-13
Recommended Tools.....	5-14
Frame Ground and Logic Ground Cabling Procedures.....	5-16
Recommended Tools.....	5-16
Ground Frame.....	5-17
Connect Ground Cable to Control Frame.....	5-19
Logic Ground Connections to the System Ground Bar.....	5-21
Logic Ground Cables.....	5-25
Fuse Verification.....	5-27
Verification of Fuse Alarm Function.....	5-29
FAP Alarm System Test.....	5-30
Fuse Assignments.....	5-32
Fuse and Card Locations.....	5-33
Card Locations in Control and Extension Shelves.....	5-50

6 Assemblies

Intra-system Cable Installation.....	6-1
Install IMT Cables.....	6-2
Interface Cable Installation.....	6-5

LAN Ethernet Cable Installation for ACM.....	6-11
E5-ENET/E5-ENET-B and Fan Option, EDCM, E5-SM4G/E5-SM8G-B Cabling.....	6-15
User Upgrade Procedures.....	6-18
Upgrading to E5-MCPM-B Module (MCPM)	6-18
Measurement Collection and Polling Module (MCPM).....	6-24
Removing a Card in an Existing EAGLE System	6-30
Fan Assembly Installation and Cabling.....	6-31
Installing Fan Assembly 890-0001-04	6-32
Installing Fan Cables.....	6-41
Powering Up the Fan Assembly.....	6-42
Installing Fan Assembly 890-1038-01 or 890-1038-02.....	6-44
Installing Fan Cables.....	6-48
Powering Up the Fan Assembly.....	6-49
Testing the Fan Assembly.....	6-52
Master Timing	6-53
HS Master and Composite Clock Cables on Backplane P/N 850-0330-06/07	6-57
HS Master and Composite Clock Cables on Backplane P/N 850-0330-03/04	6-66
A Clock and B Clock Cable Replacement.....	6-75
Procedure — Replacing A Frame Clock Cables.....	6-77
Procedure — Replacing B Frame Clock Cables	6-81
Termination of Alarm, Clock Supply, and Terminal Cables	6-85
Alarm Cable Termination.....	6-86
Terminate Clock Supply Cables	6-87
Terminal Cables	6-87
Holdover Clock Installation	6-88
Output Panel Connections.....	6-89
Holdover Clock Switch Settings.....	6-91
Clock Input DIP Switch Settings	6-91
Output Panel Connections.....	6-93
Holdover Clock Alarm Connections	6-93
Replacing Holdover Clock Rear Cover	6-96
Install Holdover Clock Fuses.....	6-96
Ohms Converter International Market.....	6-97
Hardware Acceptance.....	6-101
-48VDC Power Source	6-103
Verify -48VDC	6-103

A LED Information

Introduction.....	A-1
CI, Clock Interface Card, Holdover Clock	A-1
E5-ATM-B Interface Module	A-2
E5-E1T1-B Interface Module	A-3
E5-ENET-B Interface Module.....	A-4

E5-MASP Card	A-5
E5-MCPM-B Module	A-6
E5-MDAL Card	A-8
E5-SM8G-B Module	A-9
HIPR2, High-Speed IMT Packet Router 2 Module	A-11
MIS, Maintenance Interface System, Holdover Clock.....	A-12
MCA, Matrix Controller Assembly Card, Holdover Clock.....	A-14
SLIC Module.....	A-15
ST3, Stratum-3 Clock Card, Holdover Clock.....	A-17
TOCA, Timing Output Composite Automatic, Holdover Clock.....	A-18

B Backplane Connectors

Control Shelf Connectors.....	B-1
Control Shelf Backplane 04	B-2
Control Shelf Backplane 06/07.....	B-2
Overview of the Control Shelf Backplane Connectors.....	B-3
Power Connectors	B-7
Alarm Connectors	B-11
System Clock Connectors.....	B-16
Shelf Clock Connectors (for Control Shelf Backplane -04 only)	B-18
BITS Clock Connectors	B-21
Serial Port Connectors	B-22
Interface Connectors	B-23
Interprocessor Message Transport Connectors.....	B-43
General Purpose Relay Connectors	B-44
General Purpose Serial Interface Connectors.....	B-46
Extension Shelf	B-47
Extension Shelf Backplane 04	B-48
Power Connectors	B-48
System Clock Connectors.....	B-49
Interface Connectors	B-52
Interprocessor Message Transport Connectors.....	B-60

C Cables and Adapters

Labeling Cables	C-1
Procedure - Cable Labeling	C-1
Cables and Adapters	C-3
Cable and Adapter Use.....	C-3
Alarm Cable (Holdover Clock)	C-6
Alarm NETRA Server Cable (P/N 830-0900-xx)	C-7
B-Clock Cable.....	C-8
BNC- to-BNC Cable Assembly (P/N 830-0624-xx)	C-9
BNC/Open End Cable.....	C-10

Breaker-to-Terminal Strip Power Cable	C-11
CD ROM Cable	C-12
Converter	C-12
Crossover (CAT-5) Cable	C-12
Crossover DCM Patch Panel Cable.....	C-13
DCM, 100-BASE TX Interface	C-15
Drive Power Cable	C-16
DS1 Cable.....	C-16
E1 Cable	C-17
E1 Patch Cable.....	C-18
E5-ATM Adapter	C-20
E5-ENET ADAPTER (DB26 Male-to-Dual RJ45)	C-20
E5-ENET ADAPTER (DB26 Male-to-DB26 Female).....	C-21
E5-ENET FAST COPY ADAPTER, LOWER.....	C-22
E5-ENET FAST COPY ADAPTER, UPPER	C-23
ENET Adapter 15-Pin to 26-Pin (P/N 830-0425-01)	C-25
External Alarm Cable (Custom).....	C-25
Fan Power and Alarm Cable.....	C-26
Fifty Position Hard Drive I/O Cable.....	C-27
Filter Rack Alarm Cable	C-27
Force Transition Card.....	C-28
Hazard Ground Cable.....	C-29
High Speed Master Timing Adapter	C-29
IMT Cable High Speed	C-30
Interface Cable	C-31
Local Maintenance Center Cable	C-32
Loop Back Cable Adapter	C-34
Master Clock Cable (BITS/High-speed).....	C-34
Master High Speed Clock Adapter.....	C-35
MMI Port Cable	C-35
Modem/Terminal Cable.....	C-37
Network Cable.....	C-38
Null Modem Cable.....	C-39
Null-Modem for Terminal Cable.....	C-39
Power Cable	C-40
Power Cable, -48V	C-42
RAID Power Cable	C-42
Remote Maintenance Center Cable.....	C-43
RJ45/RJ45 Cable (CAT-5) (Yellow).....	C-44
RJ45/RJ45 Cable (CAT-5) (Blue).....	C-45
RJ45-to-9 Pin Adapter	C-46
Row Alarm Cable	C-47
Router Power Cable	C-48

RS232	C-49
Serial I/O Transition Card	C-50
Serial Interface/Modem Adapter	C-52
Serial Interface, Terminal, and Printer Adapter	C-53
Shielded Straight Through Cable (CAT-5)	C-53
Straight-Through Patch-Panel Cable	C-54
Switch-to-Frame Ground Cable	C-55
Terminal/Converter Cable	C-55
Terminal/Printer Cable	C-56
Terminal/Server Serial Cable with Flow Control	C-57
Terminal/Server Serial Port Adapter, NTW	C-58
Terminal/Server Serial Port Adapter, MRV	C-59
Terminal/Server Serial Port Adapter, EAGLE/Cyclades	C-60
Tone and Announcement Server Alarm Cable	C-61

D Part Numbers

Overview	D-1
Cables, Adapters	D-2
Components	D-7
Frames, Backplanes, FAPs, and Fans	D-9
Labels	D-11
Miscellaneous Parts	D-12
Power Cords for Peripherals	D-14

List of Figures

1-1	European Directives CE Mark.....	1-6
1-2	Combined UL Mark for the United States and Canada.....	1-6
1-3	Hazardous Substances.....	1-6
2-1	Removing a Card.....	2-6
3-1	Removing an EAGLE card.....	3-4
3-2	Installer's Cable Running List Example.....	3-5
3-3	Control Frame Fuse Label.....	3-6
3-4	FAP, Fuse Label Kit (P/N 870-1915-02).....	3-7
4-1	Shipping Container for Heavy Duty Frame.....	4-1
4-2	Shipping Container for Heavy Duty Frame.....	4-2
4-3	Shipping, Detach Dolly Heavy Duty Frame.....	4-3
4-4	Heavy Duty Frame Dolly.....	4-4
4-5	Heavy Duty Frame with Dolly.....	4-5
4-6	Typical Frame Layout.....	4-7
4-7	Typical Floor Layout for Frames.....	4-7
4-8	Isolation Sheet/Template for Frame.....	4-8
4-9	Raised Floor Installation Elements.....	4-11
4-10	Raised Floor With Overhead Rack.....	4-12
4-11	Raised Floor Installation With Unistrut.....	4-13
4-12	Earthquake Bracing.....	4-14
4-13	Anchor Assembly.....	4-16
4-14	Anchor Installation of Heavy Duty Frame.....	4-17
4-15	Heavy Duty Frame Installation With Cable Rack.....	4-18
4-16	Heavy Duty Frame Panels.....	4-19
4-17	Unit Separation Bracket Installation.....	4-20
4-18	Rear Cover Installation.....	4-21
4-19	EAGLE Frame with Door Ground.....	4-22
4-20	EAGLE Frame with Shelves.....	4-23
4-21	Frame Lineup Identification Placard (P/N 658-0816-01).....	4-24
4-22	Frame Type and System/Shelf Equipment Label Sheets (P/N 658-1093-01).....	4-27
4-23	Heavy-Duty Frame Label Location.....	4-28
4-24	Frame and Shelf Label Locations.....	4-30
4-25	Frame Label Location - Detail.....	4-31
4-26	Shelf Label Location - Detail.....	4-33
5-1	Fuse (GMT Brand Shown).....	5-2
5-2	Fuse and Alarm Panel - Front View (P/N 870-2804-xx).....	5-3
5-3	Fuse and Alarm Panel Rear (P/N870-2804-01).....	5-4
5-4	Shorting Board Faceplate, Normal Mode.....	5-6
5-5	Shorting Board Faceplate, Maintenance Mode.....	5-6
5-6	Shorting Board Faceplate, Maintenance Mode.....	5-7
5-7	Shorting Board Faceplate, Normal Mode.....	5-7
5-8	Fuse and Alarm Panel (P/N 870-1606-xx/870-2320-xx) Front.....	5-8
5-9	Fuse and Alarm Panel (P/N 870-1606-xx/870-2320-xx) Rear.....	5-9
5-10	Jumper Board FAP.....	5-10
5-11	Jumper Connector - Maintenance Mode.....	5-10
5-12	Jumper Connector - Operational Mode.....	5-11
5-13	Jumper Connector - Operational Mode.....	5-12
5-14	Lug Installation.....	5-15
5-15	1U Fuse and Alarm Panel Rear (P/N 870-2804-01).....	5-15
5-16	3U Fuse and Alarm Panel Rear (P/N 870-2320-03).....	5-15
5-17	System Frame Grounding.....	5-18

5-18	System Logic Grounding.....	5-20
5-19	Clamp Reading on System Frame and Logic.....	5-21
5-20	System Logic Ground Bar and Cable.....	5-23
5-21	System Logic Grounding.....	5-24
5-22	1U Fuse and Alarm Panel Rear (P/N 870-2804-01).....	5-25
5-23	3U Fuse and Alarm Panel Rear (P/N 870-2320-03).....	5-25
5-24	Ground Bar and Logic Ground Installation.....	5-26
5-25	System Logic Ground Connection.....	5-27
5-26	Alarm Cable Arm.....	5-27
5-27	Fuse (GMT Brand Name).....	5-30
5-28	Control Frame FAP (P/N 870-0243-08 and P/N 870-1606-xx).....	5-32
5-29	Extension Frame FAP (P/N 870-0243-08 and P/N 870-1606-xx).....	5-33
5-30	Control Frame CF-00 Numbering Plan.....	5-51
5-31	Extension Frame EF-00 Numbering Plan.....	5-52
5-32	Extension Frame EF-01 Numbering Plan.....	5-53
5-33	Extension Frame EF-02 Numbering Plan.....	5-54
5-34	Extension Frame EF-03 Numbering Plan.....	5-55
5-35	Extension Frame EF-04 Numbering Plan.....	5-55
6-1	Interprocessor Message Transport Cables.....	6-2
6-2	Three-Frame Configuration.....	6-3
6-3	Six-Frame Configuration.....	6-4
6-4	Control Shelf Cabling.....	6-5
6-5	Interface Cable Cross-Connect Panel Connection.....	6-10
6-6	Adapter Slide Latch.....	6-14
6-7	LAN Ethernet Cable Installation.....	6-15
6-8	E5-ENET/E5-ENET-B Family Cabling, Enhanced Bulk Download.....	6-16
6-9	Interface Cable Routing, Control Shelf.....	6-17
6-10	Interface Cable Routing, Extension Shelf.....	6-18
6-11	Push Inject/Eject Clamps Outward.....	6-30
6-12	Push in Inject/Eject Clamps.....	6-31
6-13	System Air Baffle.....	6-33
6-14	Attach side fan bracket to front frame rail.....	6-34
6-15	Slide the side fan brackets flush with the Frame.....	6-35
6-16	Side bracket mounting positions on fan tray bracket.....	6-36
6-17	Insert fan tray bracket.....	6-37
6-18	Attaching the fan tray bracket to the side brackets - inside front.....	6-38
6-19	Fan Tray.....	6-38
6-20	Fan tray inserted into fan tray bracket in the frame- front view.....	6-39
6-21	Tighten rear fan tray screws.....	6-40
6-22	Tighten fan side bracket screws.....	6-41
6-23	Fan card with LEDs on front of fan assembly.....	6-43
6-24	System Air Baffle.....	6-45
6-25	Fan Assembly with Grill and Filter.....	6-46
6-26	Installing Fan Assembly.....	6-46
6-27	Fan Bracket Installation.....	6-47
6-28	Fan with Brackets and Screws.....	6-48
6-29	Front Card Suite with Fan Switch.....	6-50
6-30	Fan Assembly with Grill and Filter.....	6-52
6-31	Control Shelf (P/N 850-0330-06 or -07) BITS Connectors.....	6-59
6-32	Wire Coding of High-Speed Master and Composite Clock Cable (P/N 830-0873-xx or P/N 830-1189-xx)	6-62
6-33	Wire Coding of High-Speed Master and Composite Clock Cable (P/N 830-0873-xx or P/N 830-1189-xx)	6-65
6-34	Control Shelf (P/N 850-0330-03 or -04) BITS Connectors.....	6-69

6-35	Wire Coding of High-Speed Master and Composite Clock Cable (P/N 830-0873-xx or P/N 830-1189-xx)	6-70
6-36	High-Speed Master Timing Adapter Cable (P/N 830-0846-01)	6-72
6-37	Cable (P/N 830-0404-xx).....	6-76
6-38	Cable 830-0398-xx or 830-1150-xx.....	6-77
6-39	Backplane P/N 850-0330-06 or -07 Control Shelf.....	6-79
6-40	Backplane P/N 850-0356-04 Extension Shelf.....	6-80
6-41	Backplane P/N 850-0330-06 or -07 Control Shelf.....	6-83
6-42	Backplane P/N 850-0356-04 Extension Shelf.....	6-84
6-43	Holdover clock.....	6-89
6-44	TOLA Master Timing Leads.....	6-90
6-45	Holdover Clock Power Connector.....	6-91
6-46	Holdover Clock and Output Panel, Rear.....	6-92
6-47	Holdover Clock FAP Connections.....	6-92
6-48	Holdover Clock FAP Connections.....	6-92
6-49	CUST ALM 1 J35 and (not supported) CUST ALM 2 J66 Connectors on Control Shelf Backplane -06 or -07.....	6-94
6-50	Holdover Clock Alarm Connections.....	6-95
6-51	BITS Clock Source Connections.....	6-96
6-52	Miscellaneous Frame with 120 Ohm Converter.....	6-98
6-53	120 Ohms Converter and Shelf.....	6-99
6-54	120 Ohms Converter Rear.....	6-100
6-55	Converter Rear Detail.....	6-101
6-56	Test Points 1U FAP (P/N 870-2804-01).....	6-104
6-57	Test Points 3U FAP (P/N 870-2320-03).....	6-104
A-1	Holdover Clock CI Card LEDs.....	A-1
A-2	E5-ATM-B Interface Module.....	A-2
A-3	E5-E1T1-B Interface Module.....	A-3
A-4	E5-ENET-B Interface Module.....	A-4
A-5	E5-MASP Card.....	A-5
A-6	E5-MCPM-B Module.....	A-6
A-7	E5-MDAL Card.....	A-8
A-8	E5-SM8G-B Interface Module.....	A-9
A-9	HIPR2 LEDs.....	A-11
A-10	Holdover Clock MIS Card LEDs.....	A-12
A-11	Holdover Clock MCA Card LEDs.....	A-14
A-12	SLIC Module.....	A-16
B-1	Control Shelf Backplane 04.....	B-2
B-2	Control Shelf Backplane 06/07).....	B-3
B-3	Power Connector.....	B-7
B-4	Control/Extension FAP Rear View.....	B-8
B-5	Alarm Interface Connector.....	B-8
B-6	Shelf Power Connector.....	B-9
B-7	Rack Alarm Connector.....	B-10
B-8	Fan Power Connector.....	B-11
B-9	Local Maintenance Center Alarm Connector.....	B-12
B-10	Remote Maintenance Center Alarm Connector.....	B-12
B-11	Rack Alarm Connector.....	B-13
B-12	Row Alarm Connector.....	B-14
B-13	External Alarm Connector.....	B-15
B-14	OAP Alarm Connector.....	B-16
B-15	A Clock 0 Through A Clock 5 Connectors.....	B-17
B-16	B Clock 0 through B Clock 5 Connectors.....	B-17
B-17	Clock A In Connector on Backplane.....	B-18

B-18	Clock A Out Connector.....	B-19
B-19	Clock B In Connector on Backplane.....	B-20
B-20	Clock B Out Connector on Backplane.....	B-21
B-21	BITS Clock Connector.....	B-21
B-22	Serial Port Connector.....	B-22
B-23	Interface Connector.....	B-23
B-24	Control Shelf Backplane Pin-Outs, Top Connector.....	B-25
B-25	Control Shelf Backplane Pin-Outs, Bottom Connector.....	B-28
B-26	Maintenance Disk and Alarm Connector, Top.....	B-32
B-27	MDAL Backplane, Bottom.....	B-34
B-28	TDM, Top.....	B-36
B-29	TDM Backplane Pin-outs, Bottom.....	B-40
B-30	IMT Connector.....	B-44
B-31	General Purpose Relay Connector 01.....	B-44
B-32	General Purpose Relay Connector 02.....	B-45
B-33	General Purpose Serial Interface Connector 01, GPSI.....	B-46
B-34	Extension Shelf Backplane 04.....	B-48
B-35	Power Connector.....	B-49
B-36	Clock A In Extension Shelf Connector.....	B-49
B-37	Clock A Out Extension Shelf Connector.....	B-50
B-38	Clock B In Extension Shelf Connector.....	B-51
B-39	Clock B Out Extension Shelf Connector.....	B-52
B-40	Extension Shelf Interface Connector.....	B-52
B-41	Extension Shelf Backplane Pin-Outs, Top Connector.....	B-54
B-42	Extension Shelf Backplane Pin-Outs, Bottom Connector.....	B-57
B-43	IPMX Connector.....	B-61
C-1	Installer's Cable Running List Example.....	C-2
C-2	Holdover Clock Alarm Cable.....	C-6
C-3	Alarm NETRA Server Cable.....	C-7
C-4	Clock Cable.....	C-9
C-5	BNC to BCN Cable Assembly (P/N 830-0624-xx).....	C-10
C-6	BNC/Open End Cable.....	C-10
C-7	Power Cable to Breaker Strip.....	C-11
C-8	CD ROM Cable.....	C-12
C-9	Crossover CAT-5 Cable.....	C-13
C-10	Crossover DCM Patch Panel Cable.....	C-14
C-11	DCM, 100-BASE TX Interface.....	C-15
C-12	Drive Power Cable.....	C-16
C-13	DS1 Cable DS1 Cable.....	C-17
C-14	E 1 Cable.....	C-18
C-15	E1 Patch Cable.....	C-19
C-16	E5-ATM Adapter.....	C-20
C-17	DB26 Male to Dual RJ45 Adapter.....	C-21
C-18	DB26 Male-to-DB26 Female Adapter.....	C-22
C-19	E5-ENET FAST COPY ADAPTER, LOWER, P/N 830-1343-02	C-23
C-20	E5-ENET FAST COPY ADAPTER, UPPER, P/N 830-1343-01	C-24
C-21	ENET Adapter 15-Pin to 26-Pin (P/N 830-0425-01).....	C-25
C-22	External Alarm Cable (Custom).....	C-26
C-23	Fifty Position/Hard Drive I/O Cable.....	C-27
C-24	Filter Rack Alarm Cable.....	C-28
C-25	Force Transition Card.....	C-28
C-26	Hazard Ground Cable.....	C-29
C-27	High Speed Master Timing Adapter.....	C-29
C-28	IMT Cable.....	C-31

C-29	Interface Cable.....	C-32
C-30	Local Maintenance Center Cable.....	C-33
C-31	Loop Back Cable Adapter.....	C-34
C-32	Master Clock Cable (BITS/High-speed).....	C-34
C-33	Master High Speed Clock Adapter.....	C-35
C-34	Man-Machine Interface Port Cable.....	C-37
C-35	Modem/Terminal Cable.....	C-38
C-36	Network Cable.....	C-38
C-37	Null Modem Cable.....	C-39
C-38	Null-MODEM for Terminal.....	C-40
C-39	Power Cable.....	C-41
C-40	-48V Power Cable.....	C-42
C-41	RAID Power Cable.....	C-43
C-42	Remote Maintenance Center Cable.....	C-44
C-43	RJ45/RJ45 Cable (CAT-5).....	C-45
C-44	RJ45/RJ45 Cable (CAT-5).....	C-46
C-45	RJ 45 to 9 Pin Adapter.....	C-46
C-46	Row Alarm Cable.....	C-47
C-47	Router Power Cable.....	C-49
C-48	RS232.....	C-50
C-49	Serial I/O Transition Card.....	C-51
C-50	Serial Interface/Modem Adapter.....	C-52
C-51	Serial Interface, Adapter.....	C-53
C-52	Straight Through Cable (CAT-5).....	C-54
C-53	Straight Through Patch Panel Cable.....	C-54
C-54	Switch to Frame Ground Cable.....	C-55
C-55	Terminal/Printer Cable.....	C-56
C-56	Terminal Server Serial Cable with Flow Control (P/N 830-1201-xx).....	C-57
C-57	Terminal/Server Serial Port Adapter, NTW (P/N 830-0915-01).....	C-58
C-58	Terminal/Server Serial Port Adapter, MRV (P/N 830-0915-02).....	C-59
C-59	Terminal/Server Serial Port Adapter, EAGLE/Cyclades (P/N 830-0915-03).....	C-60
C-60	TAS Alarm Cable.....	C-61

List of Tables

1-1	Admonishments.....	1-2
1-2	Basic RMA Types.....	1-7
1-3	RMA Reasons for Return.....	1-8
2-1	Admonishments.....	2-1
3-1	EAGLE Components.....	3-1
4-1	Frame Type and Labels.....	4-24
4-2	Frame Labels and Part Numbers.....	4-28
4-3	Shelf Labels and Part Numbers.....	4-31
5-1	Fuse Color Codes of Alarm Flags.....	5-2
5-2	Fuse and Alarm Panel Front Items (P/N 870-2804-xx).....	5-3
5-3	Fuse State and LED condition (P/N 870-2804-01).....	5-4
5-4	Fuse and Alarm Panel Rear Items (P/N870-2804-01).....	5-4
5-5	Fuse and Alarm Panel Specifications (P/N 870-2804-01).....	5-5
5-6	Fuse and Alarm Panel Front Items.....	5-8
5-7	Fuse and Alarm Panel (P/N 870-1606-xx/870-2320-xx) Rear.....	5-9
5-8	Fuse and Alarm Panel (P/N 870-1606-xx/870-2320-xx) Specifications.....	5-9
5-9	Power Cable Conductor Sizes.....	5-13
5-10	Fuse Color Codes of Alarm Flags.....	5-28
5-11	Fuses and Card Locations.....	5-33
6-1	ACM Card and Backplane Interface.....	6-12
6-2	Feature Requirement Matrix.....	6-55
6-3	Holdover Clock Wire Colors and Connections.....	6-90
6-4	Discontinued Legacy Part Numbers.....	6-99
6-5	Telect® Replacement System for Cross-Connect Implementation.....	6-99
6-6	Physical Conditions.....	6-100
A-1	E5-SM8G Interface Module LEDs.....	A-9
A-2	MIS LEDs.....	A-12
A-3	MCA LEDs.....	A-15
A-4	SLIC Front Panel LEDs.....	A-16
A-5	ST3 LEDs.....	A-17
A-6	TOCA LEDs.....	A-18
B-1	Control Shelf Backplanes -04 and -06/07.....	B-3
B-2	Power Connector.....	B-7
B-3	Alarm Interface Connector.....	B-8
B-4	Shelf Power Connector.....	B-9
B-5	Rack Alarm Connector.....	B-10
B-6	Fan Power Connector.....	B-11
B-7	Local Maintenance Center Alarm Connector.....	B-12
B-8	Remote Maintenance Center Alarm Connector.....	B-12
B-9	Rack Alarm Connector.....	B-13
B-10	Row Alarm Connector.....	B-14
B-11	External Alarm Connector.....	B-15
B-12	OAP Alarm Connector.....	B-16
B-13	A Clock 0 Through A Clock 5 Connectors.....	B-17
B-14	B Clock 0 through B Clock 5 Connectors.....	B-18
B-15	Clock A In Connector on Control Shelf Backplane 04.....	B-18
B-16	Clock A Out Connector.....	B-19
B-17	Clock B In Connector on Control Shelf backplane 04.....	B-20
B-18	Clock B Out Connector on Control Shelf backplane 04.....	B-21
B-19	BITS Clock Connector.....	B-22
B-20	Serial Port Connector.....	B-22

B-21	Interface Connector Pins and Signal.....	B-23
B-22	Interface Connectors, Ports, and Card Slots.....	B-24
B-23	Control Shelf Backplane Pin-Outs, Top Connector.....	B-25
B-24	Control Shelf Backplane Pin-Outs, Bottom Connector.....	B-28
B-25	Backplane Pin-Out Symbols.....	B-31
B-26	MDAL Backplane, Top.....	B-32
B-27	MDAL Backplane, Bottom.....	B-34
B-28	TDM Backplane, Top.....	B-37
B-29	TDM Backplane Pin-outs, Bottom.....	B-40
B-30	IMT Connector Pins.....	B-44
B-31	General Purpose Relay Connector 01.....	B-45
B-32	General Purpose Relay Connector 02.....	B-45
B-33	General Purpose Serial Interface Connector 01, GPSI.....	B-46
B-34	Power Connector.....	B-49
B-35	Clock A In Extension Shelf Connector.....	B-50
B-36	Clock A Out Extension Shelf Connector.....	B-50
B-37	Clock B In Extension Shelf Connector.....	B-51
B-38	Clock B Out Extension Shelf Connector.....	B-52
B-39	Extension Shelf Interface Connector Pins and Signals.....	B-53
B-40	Connectors, Ports, and Card Slots.....	B-53
B-41	Extension Shelf Backplane Pin-Outs, Top Connector.....	B-54
B-42	Extension Shelf Backplane Pin-Outs, Bottom Connector.....	B-57
B-43	Extension Shelf Backplane Pin-Out Symbols.....	B-59
B-44	IPMX Connector.....	B-61
C-1	Cable/Adapter Use - New Installation.....	C-3
C-2	Alarm NETRA Server Cable (P/N 830-0900-xx).....	C-7
C-3	Clock Cable.....	C-8
C-4	BNC to BCN Cable Assembly (P/N 830-0624-xx).....	C-9
C-5	BNC/Open End Cable.....	C-10
C-6	Power Cable to Breaker Strip.....	C-11
C-7	Crossover CAT-5 Cable.....	C-12
C-8	Crossover DCM Patch Panel Cable.....	C-13
C-9	DS1 Cable.....	C-16
C-10	E1 Cable.....	C-17
C-11	E1 Patch Cable.....	C-18
C-12	External Alarm Cable (Custom).....	C-25
C-13	Filter Rack Alarm Cable.....	C-27
C-14	Hazard Ground Cable.....	C-29
C-15	Interface Cable High Speed.....	C-30
C-16	Interface Cable.....	C-31
C-17	Local Maintenance Center Cable.....	C-32
C-18	MMI Port Cable.....	C-35
C-19	Modem/Terminal Cable.....	C-37
C-20	Null-MODEM for Terminal.....	C-39
C-21	Power Cable.....	C-40
C-22	RAID Power Cable.....	C-42
C-23	Remote Maintenance Center Cable.....	C-43
C-24	RJ45/RJ45 Cable (CAT-5).....	C-44
C-25	RJ45/RJ45 Cable (CAT-5).....	C-45
C-26	Row Alarm Cable.....	C-47
C-27	Router Power Cable.....	C-48
C-28	RS232.....	C-49
C-29	Serial I/O Transition Card.....	C-50
C-30	Shielded Straight Through CAT-5 Cable.....	C-53

D-1	EAGLE Cables, Connectors, and Power Cords.....	D-2
D-2	EAGLE Components.....	D-7
D-3	EAGLE Frames, Backplanes, FAPs, and Fans.....	D-9
D-4	EAGLE Labels.....	D-11
D-5	EAGLE Miscellaneous Part Numbers.....	D-12
D-6	Power Cords for Peripherals.....	D-14

Introduction

This chapter contains information to help assemblers understand and use this document.

Note: These instructions are not intended to be followed in any particular sequence; select and use the instructions as needed for your assembly.

Overview

This guide provides installation information for new systems or components based on Oracle Communications **EAGLE** releases 45.0 and later. For installation information of previous releases, contact your sales representative.

NOT_SUPPORTED: Be sure to wear a wrist strap connected to the wrist strap grounding point of the **EAGLE** before performing any installation procedures on the **EAGLE**.

Scope and Audience

This manual is intended for qualified technical installation and test personnel that must have thorough knowledge of telecommunication installation specifications, procedures, and equipment standards.

Note: All personnel must be aware of and conform to the safety information provided in [Safety Information](#) and through out this document.

This manual does not cover testing or system software.





[Hardware Operational Testing](#) is designed to verify the functionality of the finalized construction of the hardware at the customer site. The demarcation line for the testing is, up to and including the patch panel, directly connected to the system. All installations are site specific, therefore a comprehensive site survey is necessary for all installations.

For hardware descriptions or basic site engineering information, refer to *Hardware Reference* included with your system documentation. For replacement procedures of existing hardware components, refer to *Maintenance Guide* included with your system documentation.

Documentation Admonishments

Admonishments are icons and text throughout this manual that alert the reader to assure personal safety, to minimize possible service interruptions, and to warn of the potential for equipment damage.

Table 1-1 Admonishments

Icon	Description
 DANGER	Danger: (This icon and text indicate the possibility of <i>personal injury</i> .)
 WARNING	Warning: (This icon and text indicate the possibility of <i>equipment damage</i> .)
 CAUTION	Caution: (This icon and text indicate the possibility of <i>service interruption</i> .)
 TOPPLE	Topple: (This icon and text indicate the possibility of <i>personal injury and equipment damage</i> .)

Manual Organization

This guide is organized into the following chapters:

- [Introduction](#) provides information about the manual, products, and installation support.
- [Safety Information](#) provides important safety information for installers. Know this information prior to attempting an installation.
- [General Installation Information](#) lists Signaling Products components that make up the systems, explains in general how to label cables, and how to install a module.
- [Frames and Shelves](#) describes the unpacking, floor preparation, installation, anchoring, and labeling of frames and shelves.
- [Fuses and Alarm Panel](#) describes fuse and alarm panels and circuit breaker installation and cabling for power and grounding. This chapter also provides information on fuse verification.
- [Assemblies](#) describes EAGLE assemblies, including cabling, clock, and termination information, fan assemblies, master timing, Ohm converter, and hardware acceptance information.
- [LED Information](#) provides Light Emitting Diode (LED) information.

- [Backplane Connectors](#) provides information on connectors.
- [Cables and Adapters](#) provides information on cables and adapters.
- [Part Numbers](#) provides part number information on orderable items.

My Oracle Support (MOS)

MOS (<https://support.oracle.com>) is your initial point of contact for all product support and training needs. A representative at Customer Access Support (CAS) can assist you with MOS registration.

Call the CAS main number at 1-800-223-1711 (toll-free in the US), or call the Oracle Support hotline for your local country from the list at <http://www.oracle.com/us/support/contact/index.html>. When calling, make the selections in the sequence shown below on the Support telephone menu:

1. Select 2 for New Service Request
2. Select 3 for Hardware, Networking and Solaris Operating System Support
3. Select one of the following options:
 - For Technical issues such as creating a new Service Request (SR), Select 1
 - For Non-technical issues such as registration or assistance with MOS, Select 2

You will be connected to a live agent who can assist you with MOS registration and opening a support ticket.

MOS is available 24 hours a day, 7 days a week, 365 days a year.

Problem Report (PR)

The assigned Technical Support engineer opens a problem report (**PR**) using problem criteria as defined in “TL-9000 Quality System Metrics (Book Two, Release 3.0)” and the following sections.

Critical

Critical problems severely affect service, capacity/traffic, billing, and maintenance capabilities and requires immediate corrective action, regardless of time of day or day of the week, as viewed by a customer upon discussion with the supplier. For example:

- A loss of service that is comparable to the total loss of effective functional capacity of an entire switching or transport system.
- A reduction in capacity or traffic handling capacity such that expected loads cannot be handled.
- Any loss of safety or emergency capability (for example, 911 calls).

Major

Major problems cause conditions that seriously affect system operations, maintenance, and administration, etc., and require immediate attention as viewed by the customer upon discussion with the supplier. The urgency is less than in a critical situations because of a lesser immediate or impending effect on system performance, customer, and the customer’s operation and review. For example:

- Reduction in any capacity/traffic measurement function

- Any loss of functional visibility and/or diagnostic capability
- Short outage equivalent to system or subsystem outages, with accumulated duration of greater than two minutes in any 24-hour period, or that continue to repeat during longer periods
- Repeated degradation of **DS1** or higher rate spans or connections
- Prevention of access for routine administrative activity
- Degradation of access for maintenance or recovery operations
- Degradation of the system's ability to provide any required critical or major trouble notification
- Any significant increase in product related customer trouble reports
- Billing error rates that exceed specifications
- Corruption of system or billing databases

Minor

Other problems that a customer does not view as critical or major are considered minor. Minor problems do not significantly impair the functioning of the system and do not significantly affect service to customers. These problems are tolerable during system use.

Engineering complaints are classified as minor unless otherwise negotiated between the customer and supplier.

Emergency Response

In the event of a critical service situation, emergency response is offered by the Customer Access Support (CAS) main number at 1-800-223-1711 (toll-free in the US), or by calling the Oracle Support hotline for your local country from the list at <http://www.oracle.com/us/support/contact/index.html>. The emergency response provides immediate coverage, automatic escalation, and other features to ensure that the critical situation is resolved as rapidly as possible.

A critical situation is defined as a problem with the installed equipment that severely affects service, traffic, or maintenance capabilities, and requires immediate corrective action. Critical situations affect service and/or system operation resulting in one or several of these situations:

- A total system failure that results in loss of all transaction processing capability
- Significant reduction in system capacity or traffic handling capability
- Loss of the system's ability to perform automatic system reconfiguration
- Inability to restart a processor or the system
- Corruption of system databases that requires service affecting corrective actions
- Loss of access for maintenance or recovery operations
- Loss of the system ability to provide any required critical or major trouble notification

Any other problem severely affecting service, capacity/traffic, billing, and maintenance capabilities may be defined as critical by prior discussion and agreement with Oracle.

Related Publications

For information about additional publications related to this document, refer to the Oracle Help Center site. See [Locate Product Documentation on the Oracle Help Center Site](#) for more information on related product publications.

Customer Training

Oracle University offers training for service providers and enterprises. Visit our web site to view, and register for, Oracle Communications training:

<http://education.oracle.com/communication>

To obtain contact phone numbers for countries or regions, visit the Oracle University Education web site:

www.oracle.com/education/contacts

Locate Product Documentation on the Oracle Help Center Site

Oracle Communications customer documentation is available on the web at the Oracle Help Center (OHC) site, <http://docs.oracle.com>. You do not have to register to access these documents. Viewing these files requires Adobe Acrobat Reader, which can be downloaded at <http://www.adobe.com>.

1. Access the Oracle Help Center site at <http://docs.oracle.com>.
2. Click `Industries`.
3. Under the Oracle Communications subheading, click the `Oracle Communications documentation` link.

The Communications Documentation page appears. Most products covered by these documentation sets will appear under the headings "Network Session Delivery and Control Infrastructure" or "Platforms."

4. Click on your Product and then the Release Number.

A list of the entire documentation set for the selected product and release appears.

5. To download a file to your location, right-click the `PDF` link, select `Save target as` (or similar command based on your browser), and save to a local folder.

Regulatory Compliance and Certification

Oracle Communications products are tested to meet the following regulatory standards:

- Network Equipment Building System (NEBS) level 3 as listed in Telcordia SR-3580.
- Applicable Telcordia Electromagnetic Compatibility and Electrical Safety requirements in GR-1089-CORE.

- Applicable Physical Protection requirements in GR-63-CORE.
- Relevant directives and harmonized standards in support of the products
Compliance European (CE) mark required in Europe. [Figure 1-1](#) shows the mark used to indicate this compliance.

Figure 1-1 European Directives CE Mark



- Relevant standards in ElectroMagnetic Compatibility (EMC) directive 2004/108/EC.
- Relevant standards in Safety directive 2006/95/EC, supported by Certified Body (CB) Test Certificates issued by the National Certification Body as tested to IEC 60950 with national differences for participating countries .
- Underwriters Laboratories (UL) listed under UL File E200146 for USA and c-UL for Canada. [Figure 1-2](#) shows the mark used to indicate this compliance.

Figure 1-2 Combined UL Mark for the United States and Canada



- Relevant standards in SJ/T 11363-2006 for limits of certain hazardous substances.

Figure 1-3 Hazardous Substances

部件名称 (Parts)	有毒有害物质或元素 (Hazardous Substance)					
	铅 (Pb)	汞 (Hg)	镉 (Cd)	六价铬 (Cr ⁶⁺)	多溴联苯 (PBB)	多溴二苯醚 (PBDE)
金属部件 (Metal Parts)	○	○	○	○	○	○
电路模块 (Circuit Modules)	×	○	○	○	○	○
电缆及电缆组件 (Cables & Cable Assemblies)	×	○	○	○	○	○
塑料和聚合物部件 (Plastic and Polymeric parts)	○	○	○	○	○	○

- : 表示该有毒有害物质在该部件所有均质材料中的含量均在SJ/Txxxx-xxxx标准规定的限量要求以下。
Indicates that the concentration of the hazardous substance in all homogeneous materials in the parts is below the relevant threshold of the SJ/T 11363-2006 standard.
- ×: 表示该有毒有害物质至少在该部件的某一均质材料中的含量超出SJ/Txxxx-xxxx标准规定的限量要求。
Indicates that the concentration of the hazardous substance of at least one of all homogeneous materials in the parts is above the relevant threshold of the SJ/T 11363-2006 standard.

Environmental Requirements

The environmental conditions for the system must be maintained to the following specifications.

Temperature Variation

Typical environmental conditions are temperature and humidity controlled. With loss of environmental control the equipment covered in this manual complies with these conditions:

- Operating: 5° C to 40° C (41° F to 104° F)
- Storage: -5° C to 50° C (23° F to 122° F)

Relative Humidity

- Operating: 5% to 85% non-condensing (maximum absolute humidity of 0.024 kg of water per kg of dry air)
- Short Term Operating: 5% to 90% non-condensing (maximum absolute humidity of 0.024 kg of water per kg of dry air)

Elevation

Operating: 60m below sea level at ambient temperature of 30° C to +4000m above sea level at ambient temperature of 40° C.

Building Requirements

The building requirements are standard telephony industry requirements for equipment installation.

The building must provide a clear, uncluttered route between the loading/receiving dock and the planned location. In order to move the equipment to the proper location, recommend hall clearance is at least 4.5 feet, (1.4 meters) wide by 8 feet, (2.4. meters) tall.

Four feet, (1.2 meter) side aisles should be used to allow maneuvering frames into place and provide ample work space around the equipment.

Hardware Repair and Return

Any system components being returned for repair or replacement must be processed through the Oracle Return Material Authorization (RMA) procedures. A hardware repair is defined as an item returned to Oracle due to a failure, with the returned item being repaired and returned to the customer. It is essential that serial numbers are recorded correctly. RMAs cannot be created without a valid serial number. All repair and quality information is tracked by serial number. [Table 1-2](#) lists the basic RMA types. [Table 1-3](#) lists the RMA return reasons.

Table 1-2 Basic RMA Types

Replacement Type	Description	Turnaround
Priority Advance Replacement	Customer requests the URGENT replacement of a damaged product	Same Day Shipment

Table 1-2 (Cont.) Basic RMA Types

Replacement Type	Description	Turnaround
Advance Replacement	Customer request the replacement of a damaged product	Shipment Within 3 Business Days
Repair / Return	Customer will return a damaged product for repair	Shipment Within 5 Days After Receipt
Expendable	A damaged part, such as a cable, is replaced, but the Customer does not return the damaged product	Depends on Urgency - Shipment Within 3 Business Days

Table 1-3 RMA Reasons for Return

Reason for Return	Description
Damaged by Environment	Product damaged by environmental phenomena such as water damage or earthquake.
Damaged in Shipment	Damaged between shipment from Oracle and receipt at the Customer's installation site.
DOA – Dead on Arrival	Product is not functional when it is first installed at the Customer's location.
Lab Return	Products returned from lab sites.
Product Capture	Defect to be captured by Quality or Engineering (not Product Recall).
Product Deficiency	Anything wrong with the part that doesn't fall into another category.
Product Recall	Products recalled by divisions for the repair of a defect or replacement of defective products.
Return – No Product Deficiency	Anything returned without the product being defective.

Repair and Return Shipping Instructions

All returned equipment, assemblies, or subassemblies must be shipped to the Oracle Repair and Return Facility specified by the [My Oracle Support \(MOS\)](#). The item being returned must be shipped in the original carton or in an equivalent container assuring proper static handling procedures and with the freight charges prepaid.

The assigned RMA number must be clearly printed on the "RMA#:" line of the shipping label on the outside of the shipping package. If the RMA number is not placed on the label, the return could be delayed.

Procedure - RMA

1. Obtain and confirm the following information before contacting the [My Oracle Support \(MOS\)](#):

- Your name:
- Company name:
- Call-back number:
- Email address:
- Which product you are calling about?
- Site location:
- CLEI number
- System serial number (NT, CE, LM, DS, etc.):
- Complete software release (e.g., 28.0.1-41.53.0):
- Upgrade forms
 - WI005153
 - WI005154
 - WI005218
 - WI005219
 - WI005220
- Oracle card type: (e.g., E5-APP-B, E5-ENET, etc.):
- Oracle card part number (870-####-##):
- Associated serial number (102#####):
- Reason for return or replacement (isolated from system):
- Full name of person the replacement card is being shipped to:
- Shipping address:

Note: If possible, include associated alarms (UAMs) and a copy of the associated output (capture file).

2. Contact the [My Oracle Support \(MOS\)](#) and request a Return of Material Authorization (RMA).
3. If the item is a like-for-like advance replacement, the [My Oracle Support \(MOS\)](#) arranges for shipment of the replacement item to the customer.
- a. Wait for the replacement component to arrive.
 - b. Package the defective component in the box of materials you received with your replacement. Use proper static handling procedures.
 - c. Label the outside and inside of the box with your RMA number clearly visible. Place the packing slip from the received replacements on the inside of your box.

- d. Ship the defective component to the return address listed on the packing slip.
4. If the item is a repair/return, the [My Oracle Support \(MOS\)](#) arranges for shipment of the replacement item to the customer.
 - a. Package the defective component in a suitable package for shipping. Use proper static handling procedures.
 - b. Label the outside and inside of the box with your RMA number clearly visible. Include a packing slip with all the information from [1](#) along with the RMA number.
 - c. Ship the defective component to the following address:

ORACLE
Attn: RMA Department
5200 Paramount Parkway
Morrisville, NC 27560
RMA#: <assigned by Oracle>
 - d. Wait for the repaired component to arrive.

Returning a Crate

Use the following procedure to return a shipping crate and dollies to Oracle.

1. Replace the retaining brace.
2. Replace the shipping container front panel using the bolts saved previously and arrange the return shipment by contacting:

Shipping Manager **ORACLE**

Attn: **RMA** Department

5200 Paramount Parkway

Morrisville, NC

27560RMA#: <assigned by Oracle>

3. After the frame is positioned and the dollies are removed from the frame, the dollies are returned to the same address as the shipping container listed above.

If the equipment is being immediately installed ship the dollies back to Oracle in the crate after use. After installing the equipment bolt the dollies securely in the crate and return to Oracle.

OR

If the equipment is not being immediately installed ship the dollies back to Oracle in the box supplied with the crate. After unpacking the equipment return the crate to Oracle and retain the box to return the dollies. After installing the equipment remove the dollies and return to Oracle in the supplied box.

Note:

It is the site supervisor's responsibility to assure the crate and dollies are returned to Oracle.

Safety Information

This chapter lists important safety information to protect personnel and equipment.

General

These icons and text throughout this manual are to alert the reader, to assure personnel safety, to minimize service interruptions, and to warn of potential equipment damage.

Table 2-1 Admonishments



TOPPLE/DANGER:

(This icon and text indicate the possibility of *personnel injury and equipment damage* .)



DANGER:

(This icon and text indicate the possibility of *personnel injury* .)



WARNING:

(This icon and text indicate the possibility of *equipment damage* .)



CAUTION:

(This icon and text indicate the possibility of *service interruptions* .)

warning: All personnel associated with the installation of these systems must adhere to all safety precautions and use required protection equipment to avoid the possibility of injury, equipment damage, service degradation, or service interruption.

warning: Some procedures may interrupt service. When possible, perform maintenance during low traffic and database provisioning periods, such as the maintenance window.

Frames

topple: Always read and understand instructions thoroughly and completely before working on, moving, raising or lowering the frame, any portion of the frame, attachments to the frame, or equipment.

topple: Never try to unpack any frame from the shipping container without at least two people to steady any movement of the frame and related components. At least two people are required to safely move and position a frame into place.

topple: Never pull out the shelf of a frame that is not anchored properly. Systems with sliding shelves must be securely anchored to the floor and to the overhead cable racks. Extending a shelf without correctly anchoring the frame can cause the frame to topple and endanger personnel and damage equipment.

topple: Frames are required to be attached to over-head ladder-racks before shelves are extended.

NOT_SUPPORTED: Moving an application server chassis requires two people. Each chassis weighs approximately 25 kg (55 lbs) and may cause injury or damage to internal components due to shock and vibration if not handled properly.

warning: Before drilling holes in any flooring, verify with facilities personnel that the area is free of gas or water pipes, ventilation plenum, and electrical wiring conduits.

warning: Finger-tighten nuts on threaded rods inside the frames above the raised floor before finger tightening the nuts below the raised floor.

Caution: Frame ground. *Do not* “double lug”: The practice of using one bolt through a lug and the ground bar, and through another lug on the other side of the ground bar, held in place by one nut.

A bolt through any nut must show at least two threads beyond the nut.

Power

NOT_SUPPORTED: Strictly observe all grounding requirements to reduce the risk of electric shock.

NOT_SUPPORTED: Do not use or place commercially AC-powered equipment within 7 ft. of -48V equipment. Close proximity can create a shock or current loop that is severely hazardous to personnel and equipment.

warning: The intra-building port(s) of the equipment or subassembly is suitable for connection to intra-building or unexposed wiring or cabling only. The intra-building port(s) of the equipment or subassembly **MUST NOT** be metallically connected to interfaces that connect to the Outside Plant (OSP) or its wiring. These interfaces are designed for use as intra-building interfaces only (Type 2 or Type 4 ports as described in GR-1089-CORE, Issue 4) and require isolation from the exposed OSP cabling. The addition of Primary Protectors is not sufficient protection in order to connect these interfaces metallically to OSP wiring.

warning: The power (-48 VDC) and return connections of Fuse and Alarm Panels (**FAP**) 870-0243-08 and 870-1606-xx are physically reversed at the input terminal.

warning: Before testing -48VDC power source:

- Ensure that no power is being provided to the system from the -48VDC power source, such as a power board
 - Ensure that no circuit cards are installed in the shelves
 - Remove all fuses from the fuse and alarm panels
 - Recheck wiring and connections for proper polarity
-
-

warning: Always install an isolator pad between the frame and ground. Oracle frames are shipped with isolator pads to completely isolate the frames from ground. If a non-Oracle frame is used, an isolator pad must be provided.

warning: Frames with **HCMIM** cards require 60A breakers, **ELAP** frames use 30A and 60A breakers, and **EPAP** frames use 30A breakers. Existing frames that are fused at 40A can be upgraded to support 60A with a **FAP** upgrade kit.

warning: Verify that all breakers for application servers are set to the OFF (O) position. An application server chassis is redundantly powered from both A and B -48VDC buses. Ensure that both the circuit breaker supplying A power to the chassis and the circuit breaker supplying B power to the chassis are turned OFF by measuring the voltage with a **VOM** on the cable that connects the chassis to its breakers. Both A and B power **LEDs** on the front panel of the chassis should be OFF.

Caution: Redundant systems allow service during normal maintenance. When repairs require a total power disconnect, both input supply sources must be disconnected. This causes service interruption and takes down the systems.

Caution: This equipment has a connection between the earthed conductor of the DC supply circuit and the earthing conductor.

Caution: The Branch Circuit Overcurrent Protection shall be rated at 48V minimum and 40A maximum.

Caution: Install equipment in restricted access areas in accordance with articles 110-16, 110-17, and 110-18 of the National Electric Code, ANSI/NFPA 70.

Caution: Incorporate a readily accessible approved disconnect device in the field wiring.

Caution: Connect to a reliably grounded SELV source that is reliably earthed and electrically isolated from the AC source.

Caution: Use only listed closed-loop connectors for connection to the power supply.

Electrostatic Discharge

NOT_SUPPORTED: Do not wear metal, chains, rings, watches, or jewelry or carry exposed metal, keys, or tools in pockets when working on system equipment or other related electrostatic-sensitive components.

NOT_SUPPORTED: Always wear a wrist strap or other electrostatic protection when handling printed circuit cards and other electrostatic-sensitive devices.

warning: Observe proper ESD procedures when handling the application server chassis. Always wear an ESD wrist strap connected to a grounded bench or frame.

warning: Use the antistatic wrist strap connected to the wrist strap grounding point on the frame when performing these procedures.

warning: Do not leave or allow unused metal objects, such as screws or washers, to remain anywhere within the equipment. Remove all unused material from the equipment.

warning: Do not allow any metal shavings to remain in the equipment area. Shavings may occur from over tightened screws or bolts. These small metal particles are hazardous to electronic equipment. Be careful not to over tighten screws or bolts.

warning: Do not use tie wraps on or above the top traverse arms on a frame. Always trim tie wrap flush and turn the trimmed tie wrap to the rear of the cable. Contact the Site Supervisor for site-specific customer information.

Components

warning: If components arrive in containers that might have been subjected to extreme temperatures or variations in humidity (such as air transport), allow 6 hours for the components to acclimatize to your site conditions before operating.

warning: Metal points on Printed Circuit Boards conducts -48VDC and can cause shorts, shocks, and damage if not handled properly.

Caution: New CPCI cards may have a small plastic cover over the screws or the alignment ejector pins. Remove and discard these plastic covers. If inserting the cards takes an excessive amount of force, check for obstructions. Forcing the card into a slot may damage the ejector handle or pin.

Caution: In EAGLE, make sure that the DCM card is inserted into the correct odd numbered slots. In IP⁷ Secure Gateway systems, there are no slot provisioning requirements. Cards may be provisioned in any slot where they physically fit except for the HMUX and MAS dedicated card slots.

Caution: After the frame has been shipped or moved, remove all cards prior to applying power. Carefully reset cards to avoid possible faulty connections.

To remove or install a card, use the module locking tabs at the top and bottom of the card faceplate. See to [Figure 2-1](#).

Figure 2-1 Removing a Card

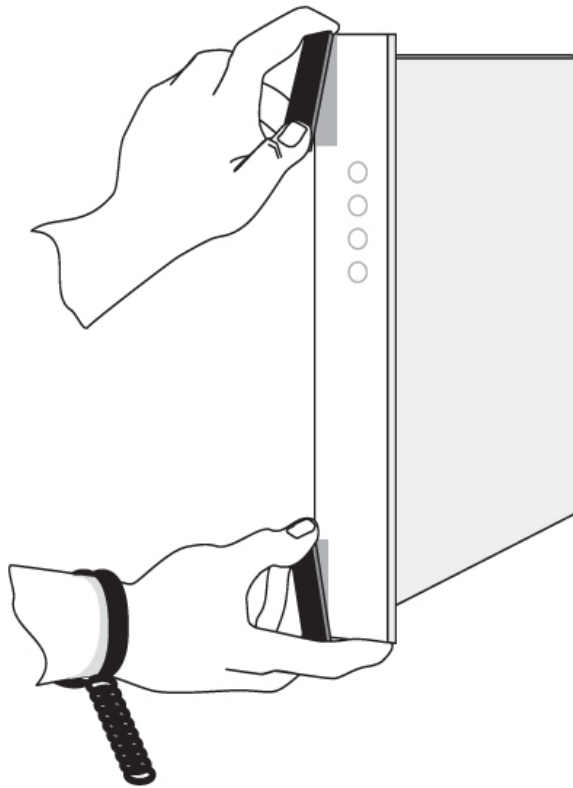

Caution: Do not impact the faceplate in order to mate the connectors. Any impact to the card's faceplate can damage the faceplate, the pins, or the connectors.

Caution: Be sure to install the fan assembly 890-0001-04 before installing the HCMIM card.

Caution: Before powering up the fans, ensure that the shelf directly above the fan does not contain any empty slots. Install an air management card in any empty slots to ensure proper air flow. These filler cards have no electrical connection to the system.

Caution: *Do not* form FAN POWER cables with LIM cables.

General Installation Information

Hardware Operational Testing

Hardware operational testing is designed to verify the functionality of the finalized construction of the hardware at the customer site. The demarcation line for the testing is up to and including the patch panel directly connected to the system. All cabling, alarm output, clock input, and other equipment is also verified operational per the *Hardware Operational Test Manual* provided with the test equipment..

NOT_SUPPORTED: If components arrive in containers that might have been subjected to extreme temperatures or variations in humidity (such as air transport), allow 6 hours for the components to acclimatize to your site conditions before operating.

Components Overview

The name, function, and part number(s) of the most current EAGLE components are listed in alphabetical order. For a detailed hardware description, refer to *Hardware Reference*. For more history and part numbers of these components, refer to [LED Information](#).

Table 3-1 EAGLE Components

Acronym	Name	Function
	Air Management Card	Filler card without electrical connections
CI	Clock Interface Card (Holdover Clock)	Input signal redundancy
DCMX	Expandable Database Communications Module	IP connectivity
DSM	Database Service Module	Large-capacity SCCP database

Table 3-1 (Cont.) EAGLE Components

Acronym	Name	Function
E5-APP-B	EAGLE Application B Card	General-purpose application server (AS) that offers high transaction rates with low latency
E5-E1T1	E5-E1/T1 Interface Module	Single slot card providing eight trunk terminations processing up to 32 signaling links of configurable channelized E1 or T1 connectivity
E5-ENET	E5-ENET Interface Module	one or more Ethernet interfaces
E5-SM4G	Database Service Module	SCCP Database
E5-SLAN	E5-ENET Interface Module	IP connectivity
E5-STC	E5-ENET Interface Module	IP connectivity
E5-TSM	Translation Service Module	GLS functionality
HIPR2	High-Speed IMT Packet Router 2 Module	Provides Interprocessor Message Transport (IMT) bus continuity for all cards connected to the IMT bus at a rate of 2.5 Gbps for large systems
LIM	Link Interface Module	Provides specific SS7 interfaces
MCA	Matrix Controller Automatic (Holdover Clock)	Controls output protection switch matrix
MIS	Maintenance Interface System Card (Holdover Clock)	Provides alarms output to system control shelf
MPS	Multi-purpose Server	Database/reload functionality to various applications

Table 3-1 (Cont.) EAGLE Components

Acronym	Name	Function
SLIC	Service and Link Interface Card	Single/multi-use card that runs multiple applications
TOCA	Timing Output Composite Automatic (Holdover Clock)	Clocks outputs (TO1 and TO2) for A and B through the system control shelf

Card Installation and Replacement

The frame arrives configured with the cards in place. After installing the frame in its final location, remove all cards prior to powering up the frame. Reinstall all cards in the control shelf, extension shelves, and other frames carefully to avoid possible faulty connections. When installing a card, be aware of possible electrostatic discharge or shorts.

warning: Always wear a wrist strap or other electrostatic protection when handling electronic cards or electrostatic sensitive devices.

Cam-out/lock-in levers on the front edge of the card assist in insertion and removal of the card. Grasp the card at the top and bottom, as shown in the figure below, and slide the card into the appropriate slot. Using the card slot guides in the shelf, slide the card into the shelf until the connectors on the card seat with the connectors on the backplane. Press both tabs in until they lock the card in place. To ensure proper seating, the levers must be held in the release position until the locking tabs can engage with the upper and lower flange on the shelf. Once the locking tabs on the levers engage the shelf plane, the tabs are pressed to the card faceplate, and must be flush with the faceplate when the card is completely seated.

Figure 3-1 Removing an EAGLE card

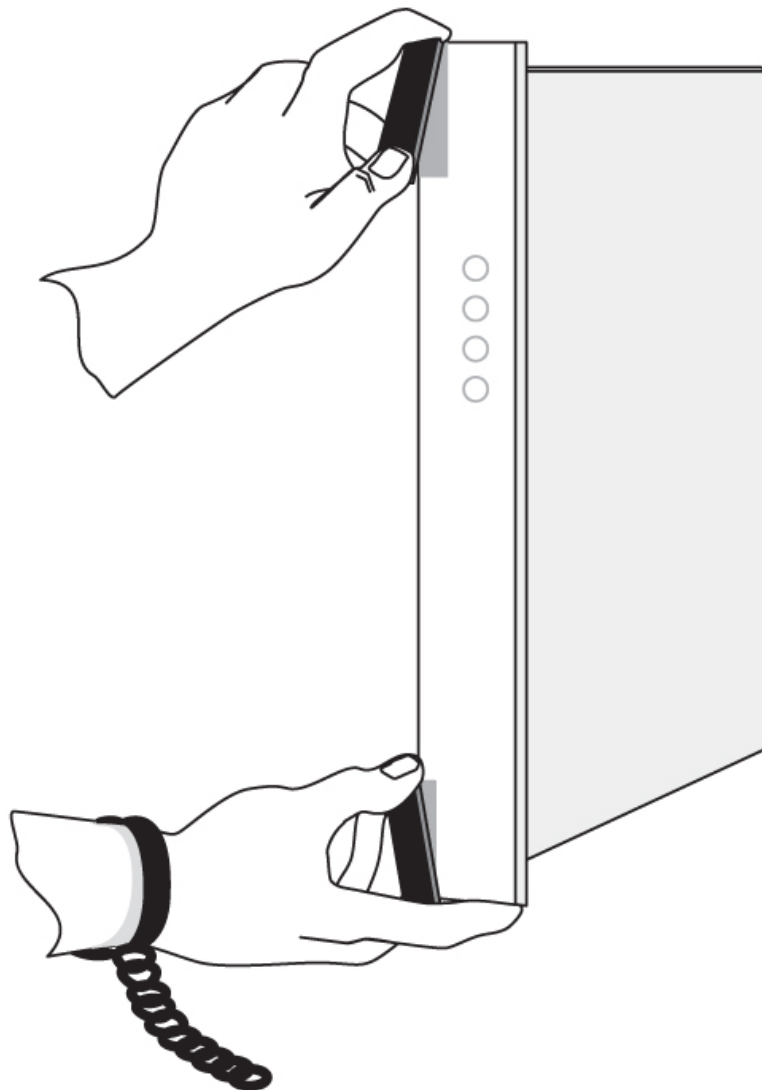

Part number, **LEDs**, text and bar code (**CLEI** and serial number) are located on the faceplate of each card. The cards in the frames are configured with specific functions and services.

Labeling

This section provides general labeling instructions for cables, frames, shelves, and fuse and alarm panels.

Cable Labeling

Before installing, use this procedure to label the cables to ensure connection to the proper ports and ease of future maintenance.

Tools

- Installer's Cable Running List
- All cables listed in Installer's Cable Running List

- Any non-Oracle cables
 - Cable labels (including blank labels for non-Oracle cables)
 - Fine point marker
1. Locate the Installer's Cable Running List in the *Equipment Specification* for the site.

Refer to for an example.

Figure 3-2 Installer's Cable Running List Example

ITEM	FEET	CA QTY or PART NO.	CABLE TYPE or PART NO.	CKT NO.	FROM	TO (FRAME)	TO (LOCATION)	LED DESIG.	TERM
8.0 LINK INTERCONNECTS, CONTROL FRAME [CF-00], EXTENSION SHELF [SH2]									
8.01	35	32 1	830-1149-02	1201A	CF-00 [105.09] SH2 J24	RR 106.03	PNL 1 JK 13	T,R(XMT) T1,R1(RCV)	
8.02	35	32 2	830-1149-02	1201B	CF-00 [105.09] SH2 J40	RR 106.03	PNL 1 JK 14	T,R(XMT) T1,R1(RCV)	

2. Locate the labels included with the cable shipment.
3. Take one cable and identify the cable's part number in the *Cable Type* column of the cable running list.
4. Match the cable with its corresponding pair of labels:
 - a. Go to the cable's *From* column of the cable running list.
 - b. Match the *From* column information to the *From* information on one label.
 - c. Match the *From* column information to the *To* information on the other label.

Note: The label for the connector end of these cables can be identified by the presence of a "J" number, for example: J32, that appears in the "From" area of the label.

Note: Make sure that all cables specific to an A or B side are clearly labeled as A cable and B cable.

5. Repeat 4 for each cable to ensure that all labels are present and that originations and destinations of all cables are clearly identified.
6. For cables that come from the factory with connectors already installed, apply the appropriate label onto each end of the cable approximately two inches from the connector.

Note: Ensure that the labels are positioned so they are still readable after the cables are installed.

7. For cables that need to be cut to the appropriate length: After the cable is cut to the appropriate length, affix labels with the item number approximately two inches from the end of the cable insulation.
8. For cables not ordered through Oracle, confirm source, part number, and origination/destination points before labeling them.

Note: All cables must be labeled “TO” and “FROM”

After you have labeled all cables, you are ready for cable installation.

Fuse and Alarm Panel Labeling

EAGLE frames arrive from the factory with labels in place. If a frame is assembled at a site, a labeling kit may be necessary.

Label Kit for FAP (P/N 870-2804-001)

A label Kit contains sheets of die-cut stick-on labels for the FAP:

- For FUSEBANK A
 - For FUSEBANK B
1. Peel the individual die-cut label that designates a specific frame from one of the three die-cut sheets of labels.
 2. The label designates either CONTROL FRAME or EF-00 through EF-04. The labels must be pressed onto the drip tray of the correct frame.
 3. Press the sticky side of the label into the silk screened area on the front of the drip tray located just below the Fuse and Alarm Panel for the specific frame.

Place the label marked FUSE BANK A on the left side of the drip tray faceplate. The label marked FUSE BANK B is placed on the right side of the drip tray faceplate.

Figure 3-3 Control Frame Fuse Label

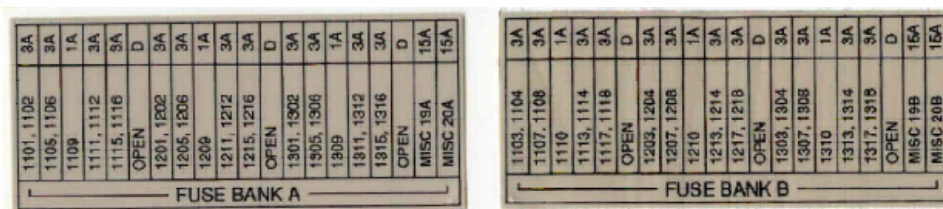

Label Kit for FAP (P/N 870-1606-xx/870-2320-xx)

Label Kit (P/N 870-1915-02) contains large sheets of die-cut stick-on labels for the appropriate frames. There are three large sheets of die-cut, stick-on labels:

- Sheet (P/N 658-0604-01) is for FUSEBANK A, CONTROLFRAME through EF-04
- Sheet (P/N 658-0604-02) is for FUSEBANK B, CONTROLFRAME through EF-04
- Sheet (P/N 658-0604-03) is for MISCFRAME

Also included in the Label Kit (P/N 870-1915-02) are smaller die-cut stick-on labels for different fuses relating to different amps and individual pieces of site-specific equipment; these are to be pressed into fuse **OPEN** spaces.

1. Peel the individual die-cut label that designates a specific frame from one of the three large die-cut sheets of labels.
2. Press the sticky side of the label into the silk screened area on the front of the faceplate of the Fuse and **Alarm** Panel (P/N 870-1606-xx) for the specific frame. (refer to [Figure 5-8](#)).

The left side of the faceplate is marked A and the right side of the faceplate is marked B.

3. The labels must be pressed into place on the front faceplate of the correct frame.

The left side of the faceplate is marked A and the right side of the faceplate is marked B.

Figure 3-4 FAP, Fuse Label Kit (P/N 870-1915-02)

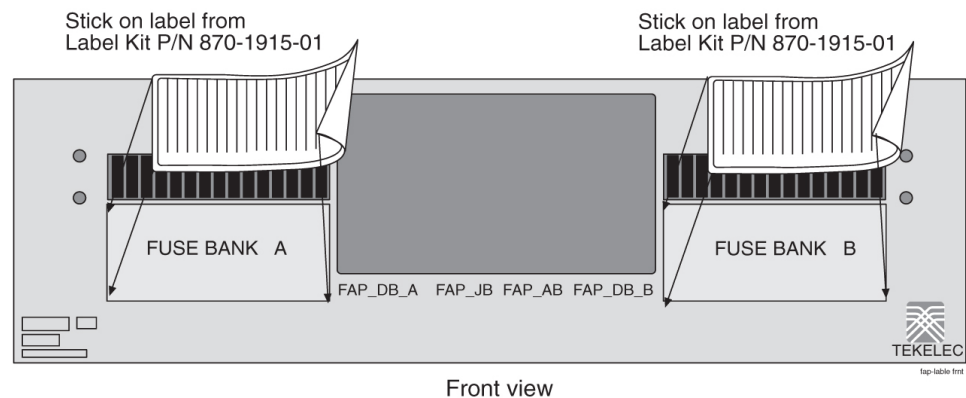

The label designates **CONTROLFRAME** or **EF-00** through **EF-04**.

There are also labels for the **MISCFRAME**.

EAGLE Post-Installation Inspection

This section describes a general EAGLE system inspection after installation.

Verify the following:

1. All items listed in the Equipment Specification have been installed.
2. Shipping container is properly packed with ramp and frame dollies shipped.
3. Cabling is neatly installed and the labels are correct and easily readable.
4. Power cabling does not run through a cable rack.
5. Power cabling is not be routed together with any other cables and has at least six inches of clearance.
6. Racks have protective paper between the rack and any cables that would otherwise touch the rack.

7. The main central office ground cable is correctly labeled and is marked “**TO** and “**FROM**” with the “Do Not Remove” tag installed on both ends of the cable at the central office grounding bar.
8. The –48VDC power feeds are correctly labeled at the central office power distribution panel.

There should be an A feed and a B feed for each breaker panel and **FAP**.
9. The –48VDC returns are correctly labeled.

Each frame has an A return and a B return for each breaker panel or **FAP**.
10. Frames are level.
11. Earthquake bracing, if any, is properly installed.
12. Adequate floor clearances have been maintained.
13. Rear panels are installed.
14. Cable connections are tight at the backplane connections.
15. Cable sheets are properly marked and located in door pocket.
16. All documentation has been received and is available.
17. Terminals and printers connected to the system are operational.
18. Data cartridges have been received and are properly stored.
19. Any attached modems are operational.
20. Any attached Media Access Units (**MAUs**) are operational with power indicator on.

Frames and Shelves

Unpacking

NOT_SUPPORTED: At least two people are required to safely move and position the frames. Read and understand this procedure completely before continuing.

1. Before opening any shipping container, inspect it for evidence of damage during shipment. Report any damage to the carrier for investigation and possible claims. Also report any damage to the Oracle site supervisor.
2. Check the packing slips against the equipment specification list for this installation site. Report any discrepancies to the [My Oracle Support \(MOS\)](#)
3. Use the 9/16 inch wrench to remove all of the bolts that hold the front to the shipping container. Do not discard the bolts. Remove the shipping container front panel. Place the bolts into the bag provided inside the shipping container. The shipping container will be returned before and separately from the dolly holding the frame in place. The dolly is used to move and position the frame. Save all bolts and hardware.

Figure 4-1 Shipping Container for Heavy Duty Frame

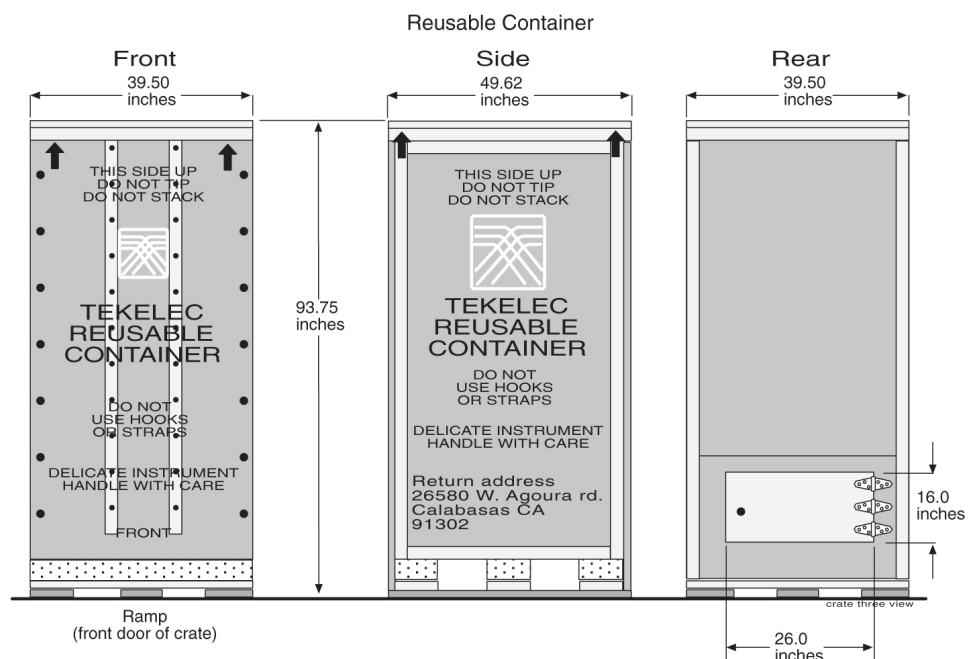

4. Use the front panel of the shipping container as a ramp to remove the frame from the shipping compartment. Place the ramp against the front of the container making sure the angle side is up and slants away from the frame in the container. Place the ramp against the front edge of the shipping container. Insert the U-bolts in the holes to secure the ramp support and container together.
5. Open the rear door of the shipping container

Figure 4-2 Shipping Container for Heavy Duty Frame

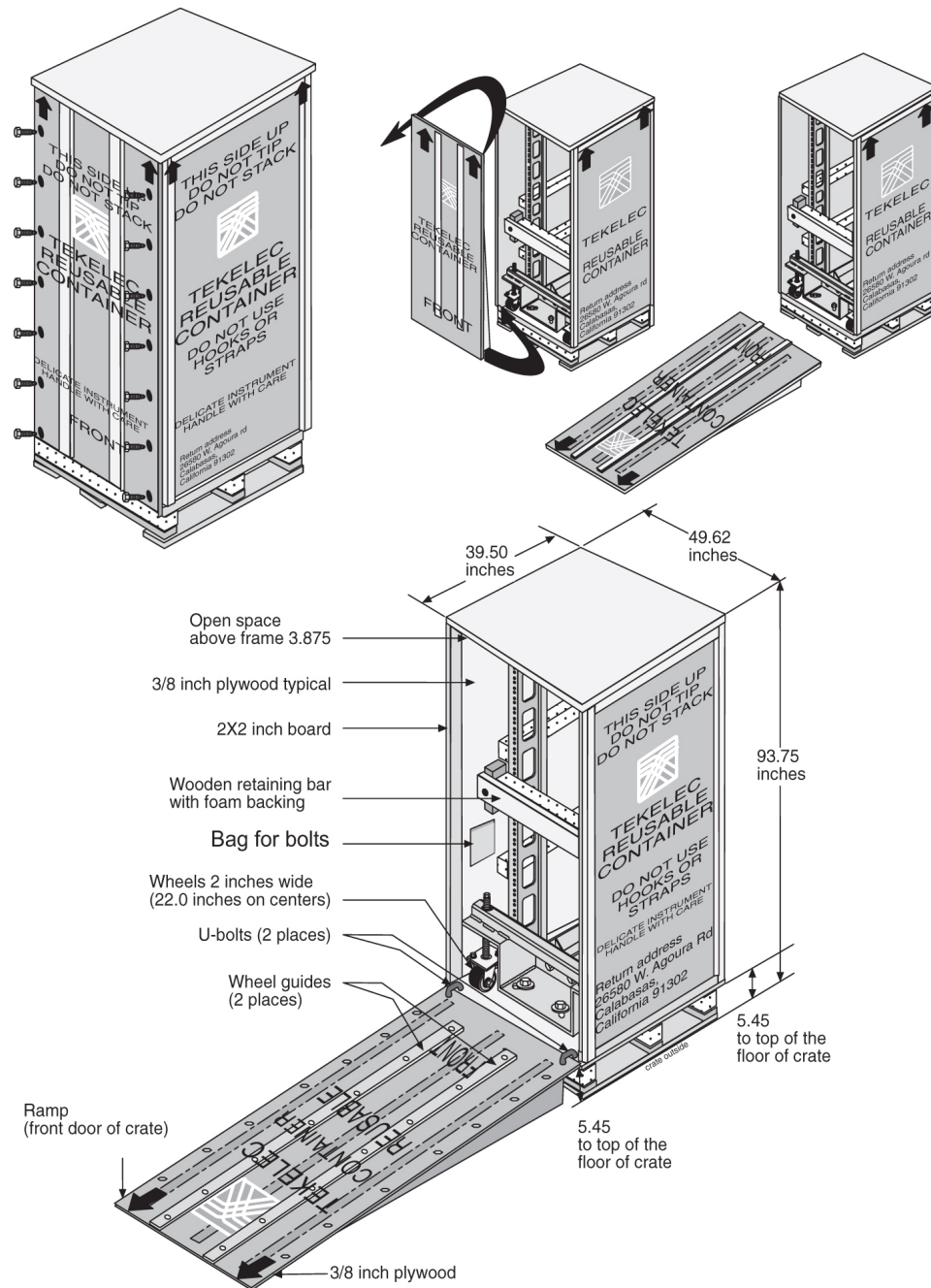

6. Use the 9/16 inch wrench to unbolt the wooden retaining bar across the front of the frame. Do not discard the retaining brace or the bolts. At this time Do not remove the bolts holding the dolly to the frame. Refer to [Figure 4-3](#).

7. At least two people are required any time a frame is moved. Use the 9/16 inch wrench to turn the threaded rod counter clockwise to lower the wheels of the dolly and to raise the frame and dolly enough to clear the front edge of the shipping container, approximately 1-1/2 inches. The threaded bolts must be turned at the same time by two people, one in the front and one in the rear to avoid making the frame tilt.
8. Only raise the frame high enough to clear the angle created by the front ramp. When the frame and dolly have been raised enough to clear the angle created by the front ramp, slowly and carefully roll the frame out of the shipping container.

Note: For clarity, the frame in the shipping container is shown without system hardware components.

Figure 4-3 Shipping, Detach Dolly Heavy Duty Frame

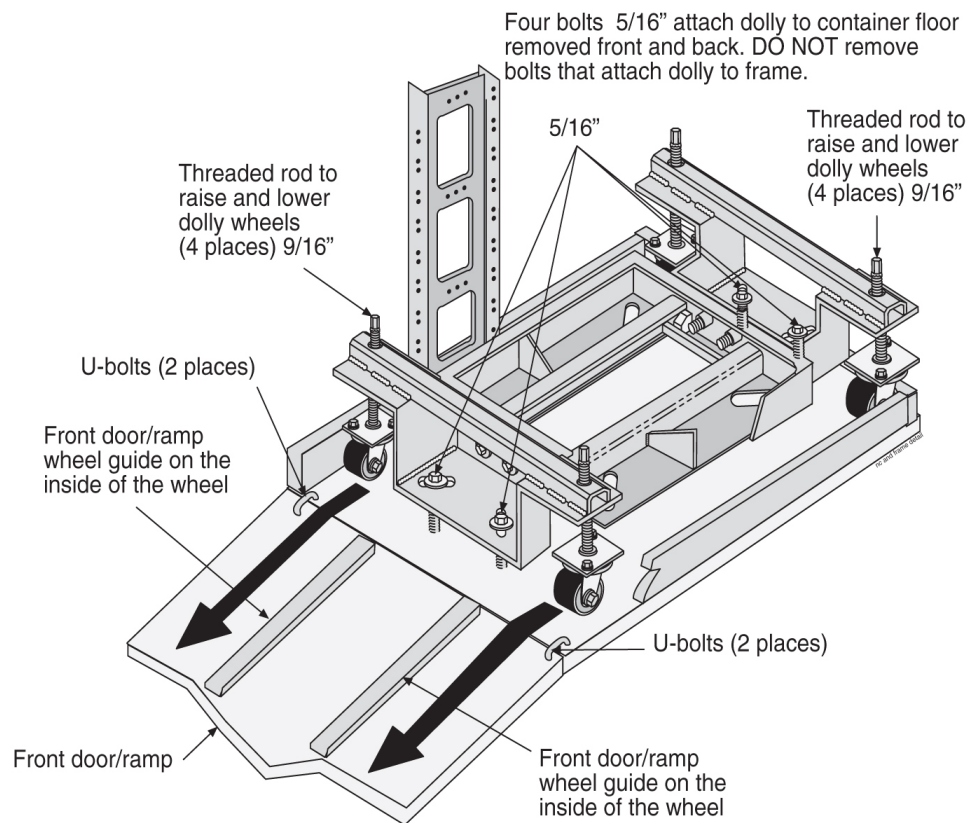

9. With a minimum of two people, carefully move the frame to the next location.
10. At the correct site location, turn the threaded rods counter clockwise to lower the frame by raising the wheels of the dolly. Again two technicians must turn the threaded rods at the same time avoid tilting. Refer to [Figure 4-4](#) for the location of the threaded rods attached to wheels.

Figure 4-4 Heavy Duty Frame Dolly

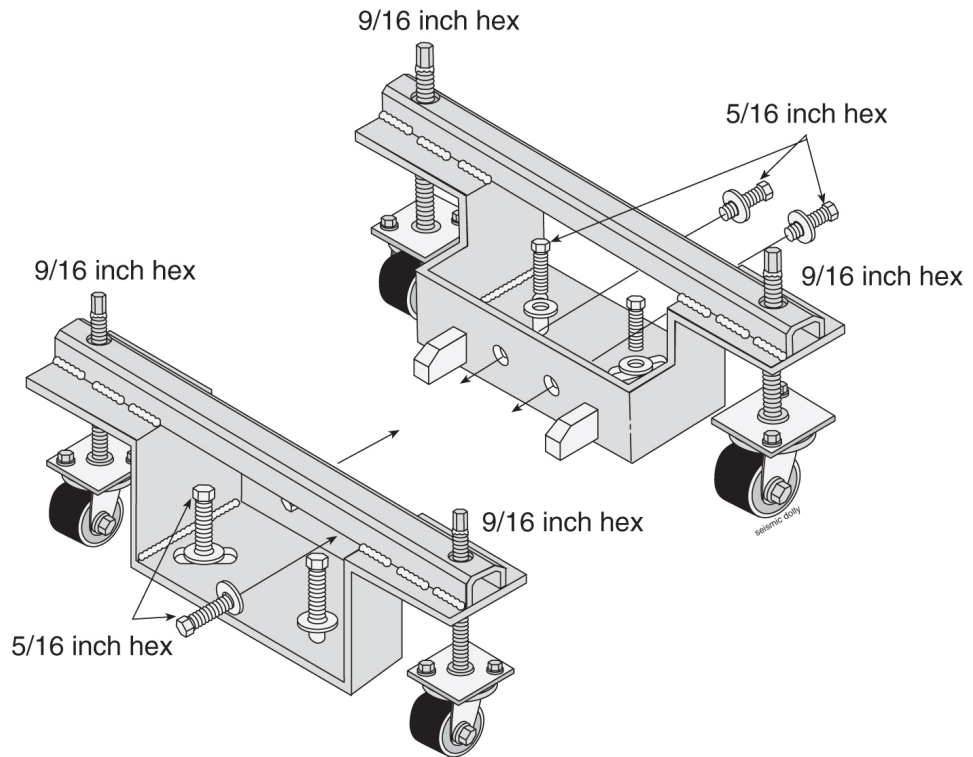

11. Remove the bolts, front and rear, that attach the dolly to the frame. Refer to [Figure 4-5](#).

Note: For clarity, the Frame is shown without system hardware components.

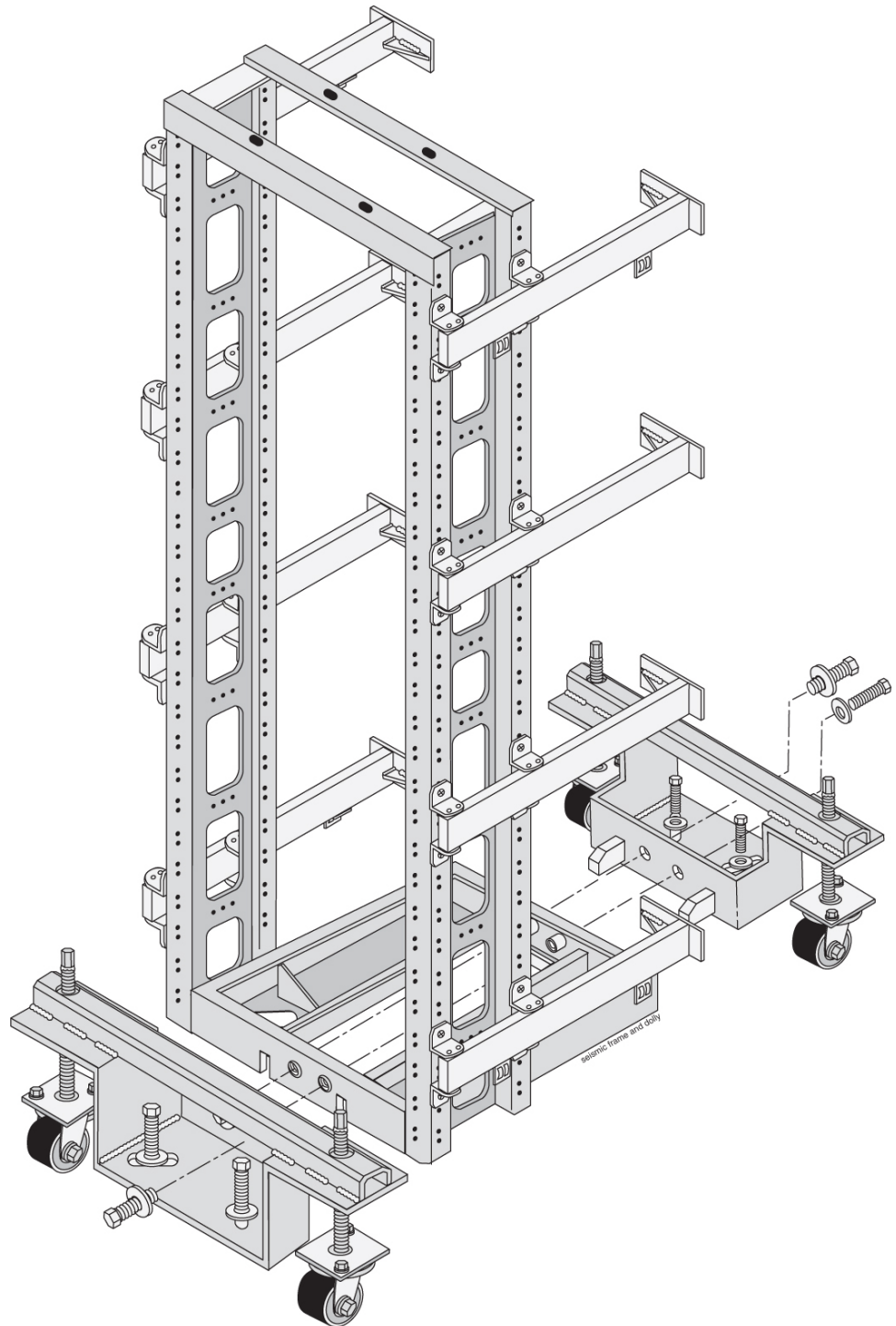
Figure 4-5 Heavy Duty Frame with Dolly

12. When the dollies are removed from the frame after the frame has been moved to a permanent location, the dollies are returned separately from the shipping container.
13. Inventory the shipment to make sure that all items listed on the pick list have been received in good condition. Report any discrepancies or damaged equipment to the [My Oracle Support \(MOS\)](#).

14. Do not allow the empty shipping containers to become a safety problem or a fire hazard. Contact the site supervisor for specific instructions. Dispose of leftover packaging materials according to local recycling procedures.

15. Follow this procedure when opening all similar shipping containers.

Use this procedure if the shipping container is to be returned to Oracle.

1. Replace the retaining brace and re-attach the ramp support to the front of the shipping container using the bolts saved previously.

If the shipping container has been returned already, ship both dollies to the same location listed in the next step.

2. After replacing the shipping container front panel arrange the return shipment by contacting:

Shipping Manager Oracle

Attn: **RMA** Department

5200 Paramount Parkway

Morrisville, NC 27560

RMA#: <assigned by Oracle>

Floor Preparation

This section describes how to lay out the floor plan for on-site flooring, and how to prepare a raised floor or a concrete floor for frame installation. For specific types of flooring refer to [Concrete Floor](#) or [Anchoring to Overhead Rack of Heavy Duty Frame](#).

General Floor Preparation

The floor layout for the frame is site specific. The most typical frame layout is constructed with Extension Frames to the right of the Control Frame when viewed from the front. The **OAP** Frame (if applicable) is typically on the left of the Control Frame. Miscellaneous Frames and other support or feature specific frames are lined up to the left of the Control Frame. Refer to the figure below.

Typically, the aisle space from the rear of the frame to the front of other frames or equipment is three feet. The end of the frame layout must be no less than 12 inches from other telco frames.

Note: The recommended minimum aisle spacing is 2-1/2 ft. (75 cm) front and rear.

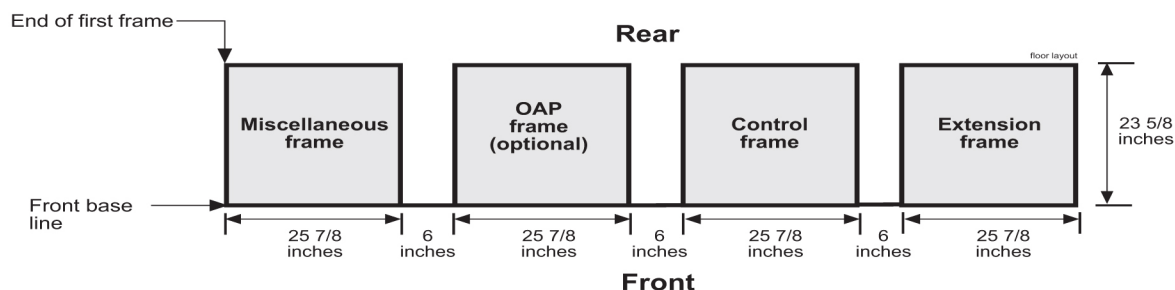
Figure 4-6 Typical Frame Layout

Recommended Tools

Oracle tools should be labeled "Property of ORACLE" with either a press-on Field Tool Identification label or Field Tool Identification wrap.

- Safety glasses
 - Chalk-line, with chalk
 - Fiberglass tape measure
 - Felt tip pen
 - Isolation sheet (template in mounting hardware kit) to mount one frame
1. Verify with a customer representative that the required area dimensions and equipment location corresponds to the marked floor plan.
 2. Use the floor plan provided with the engineering site file specifications to mark the front base line and the borders of the first frame with the chalk line (refer to [Figure 4-7](#)).

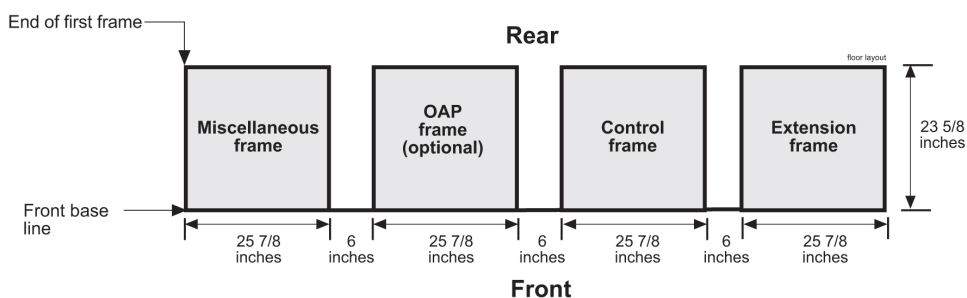
Figure 4-7 Typical Floor Layout for Frames

3. Align the frame isolation sheet/template (refer to [Figure 4-8](#)) along the chalk line to mark anchor location in the middle of each oval anchor slot and to mark the corners of the first frame.

Create another chalk line that allows 6 inches between each frame for correct spacing. Align the template again against the chalk line and continue the process of aligning, marking, and moving the template until the site specific number of frame spaces have been laid out on the floor.

4. Use the felt tip pen to mark the anchor location in the middle of each slot and corners for each successive frame.

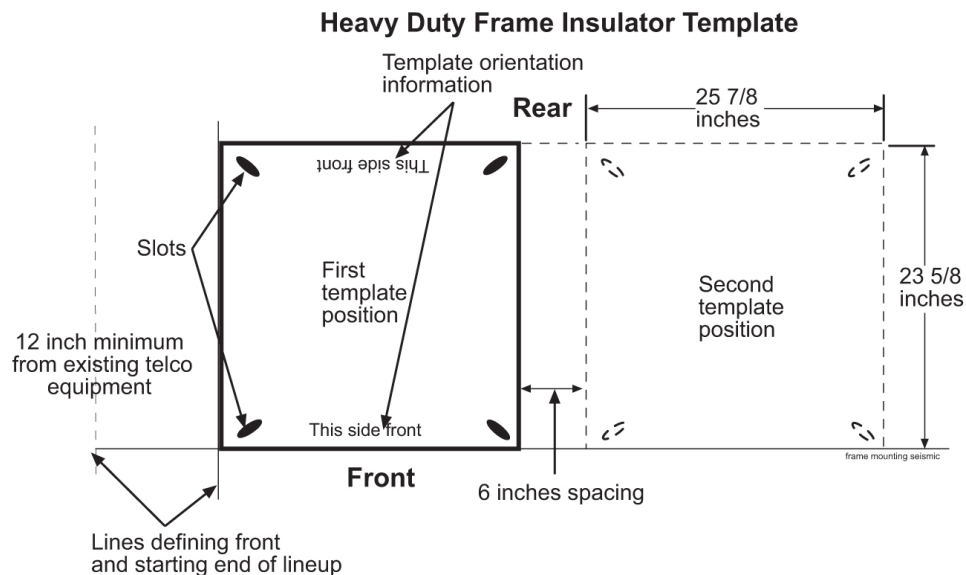
Figure 4-8 Isolation Sheet/Template for Frame

The next section describes how to prepare a raised floor for frame installation.

Raised Floor

This section describes how to prepare a raised floor for a heavy duty frame installation with anchors. Always get permission from facility personnel before drilling holes.

Recommended Tools

Oracle tools should be labeled "Property of **ORACLE**" with either a press-on Field Tool Identification label or Field Tool Identification wrap.

- Safety glasses
- Rotary impact drill
- 18 mm masonry drill-bit
- 1 inch drill-bit (hole saw)
- Extension cord
- Vacuum cleaner (an approved, industrial type, that prevents escaping dust particles that may contaminate electronic equipment)
- Masking tape
- Fiberglass tape measure
- Isolation sheet (in mounting hardware kit P/N 840-0092-01)
- Subfloor marking tool
- Ear protectors
- Felt tipped marking pen
- File

- Mounting hardware kit (furnished with each heavy duty frame)

The procedure for preparing raised flooring is **highly site specific**. For more information, refer to the site specific specification as per the Method Of Procedure (MOP) for the particular installation.

warning: Before drilling holes in any flooring, verify with facilities personnel that the area will support a loaded frame and is free of gas or water pipes, ventilation ducts, electrical wiring conduits, or any other items that may be damaged. If the hole is drilled at an angle the anchor and frame will not come together properly. After marking anchor locations, remove the tiles and take them to an approved location for drilling. *Do not* drill tiles in the equipment area.

1. On the raised floor mark the corners of the tiles so that the same tile will be returned to the same place when the job is complete.

Mark the spot to be drilled, and remove the tiles from the equipment area.

2. Drill a 1 inch (2.54 cm) diameter hole in the tiles corresponding to the marked anchor locations.

Use a vacuum cleaner to collect the shavings while drilling.

3. Use a file to remove any sharp edges or protrusions from metal parts if applicable and vacuum.
4. Return to the equipment area and replace the tiles, making sure the holes match, where the frames will be installed.
5. Insert the raised floor marking tool into the anchor holes, making sure that the tool is perpendicular with the hole.

If the hole is drilled at an angle the anchor and frame will not come together properly. With a hammer, tap the head of the star bit with enough force to mark the concrete floor. Repeat this step for each hole associated with all frames.

6. Remove the floor tiles for access to the concrete floor.
7. Drill an 18 mm diameter hole in the concrete floor to a depth of 3 inches (7.7 cm).

Use a vacuum cleaner to collect the dust while drilling any hole and clean out each hole after the drilling is complete.

Drill Cable Holes

Mark holes and remove tiles from the equipment area, using a carbide-toothed hole saw of the appropriate diameter. Drill any cable holes required in the raised floor tiles. Replace tiles in the original tiles location.

Heavy Duty Frame Anchoring

This section describes how to anchor a frame on a raised floor.

1. If necessary, remove the tiles and finish drilling the anchor holes in the concrete using an 18 mm diameter masonry bit.

2. Insert the anchor assembly, including the threaded rod, into the drilled holes in the concrete floor.
3. Install a flat washer and nut onto the anchor assembly, as shown in [Figure 4-9](#).
4. Lock the anchor assembly into the concrete by tightening the nut
5. If earthquake bracing is required, perform the procedure described in [Raised Floor Earthquake Bracing](#) before continuing.

Note: Earthquake bracing is required in earthquake zones 3 and 4 when installing a frame onto a raised floor with a spacing of 1.5 feet or more between the raised floor and the subfloor.

6. Install a nut onto the threaded rod.
The nut will need to be threaded approximately 2 inches below the top of the raised floor
7. Install the washers onto the threaded rod.
8. Adjust the nut until the washer and nuts are flush with the bottom of the floor tile.

Note: Do not over adjust as this may cause the tile or frame to tilt.

9. If removed, reinstall the floor tiles.
10. Install the isolation sheet.
11. Mount the frame onto the threaded rods.

Caution: Two people are needed to position the frame onto threaded rods.

12. Install hold down plates, washers, and nuts in the bottom of the frame.
13. Finger tighten the nuts on threaded rods located inside the frame above the raised floor.
14. Tighten the nuts below the raised floor.
15. Securely tighten the nuts inside the frame.
16. Replace tiles if necessary.

The following figure shows a heavy duty frame installed on a raised floor.

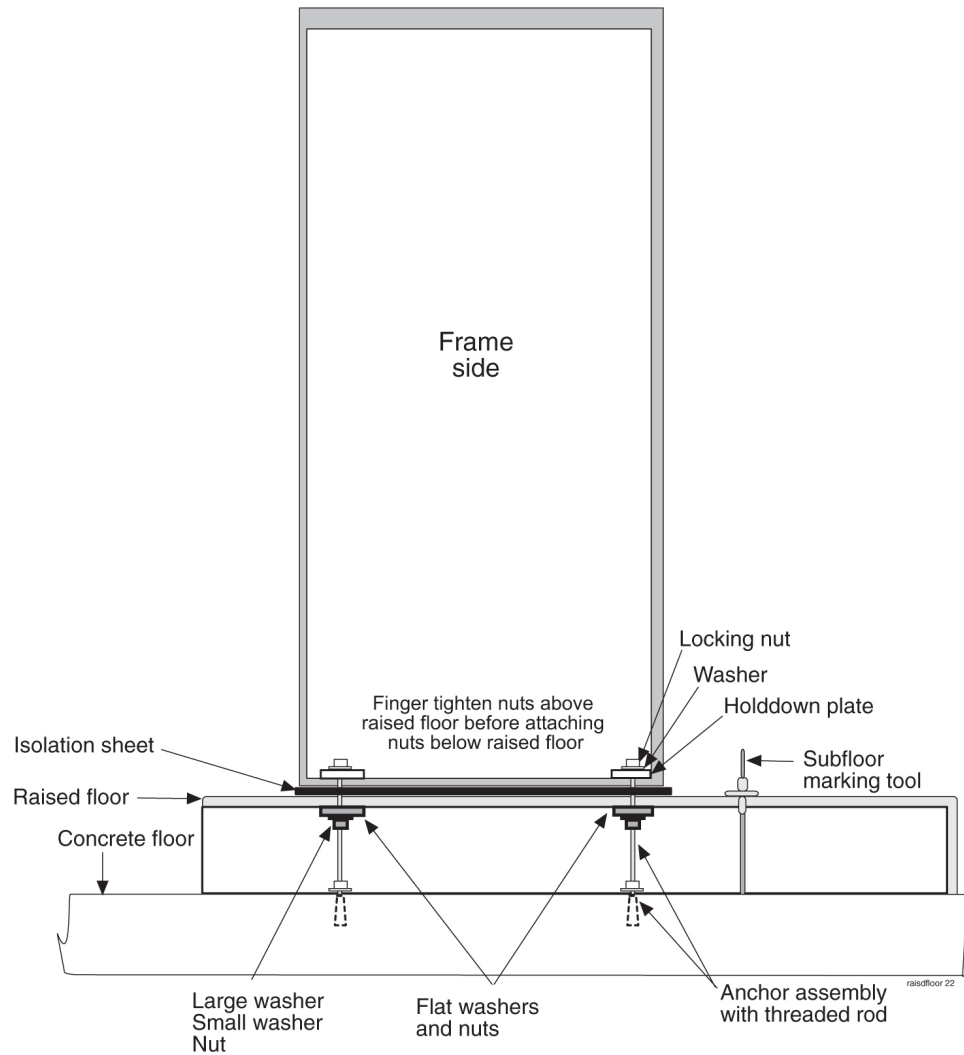
Figure 4-9 Raised Floor Installation Elements

warning: Finger tighten nuts on threaded rods inside the frames above the raised floor before tightening the nuts below the raised floor.

Refer to [Figure 4-10](#) when installing the heavy duty frame on a raised floor using overhead racks, flat washers, and nuts, Cable Rack Mounting Kit.

Figure 4-10 Raised Floor With Overhead Rack

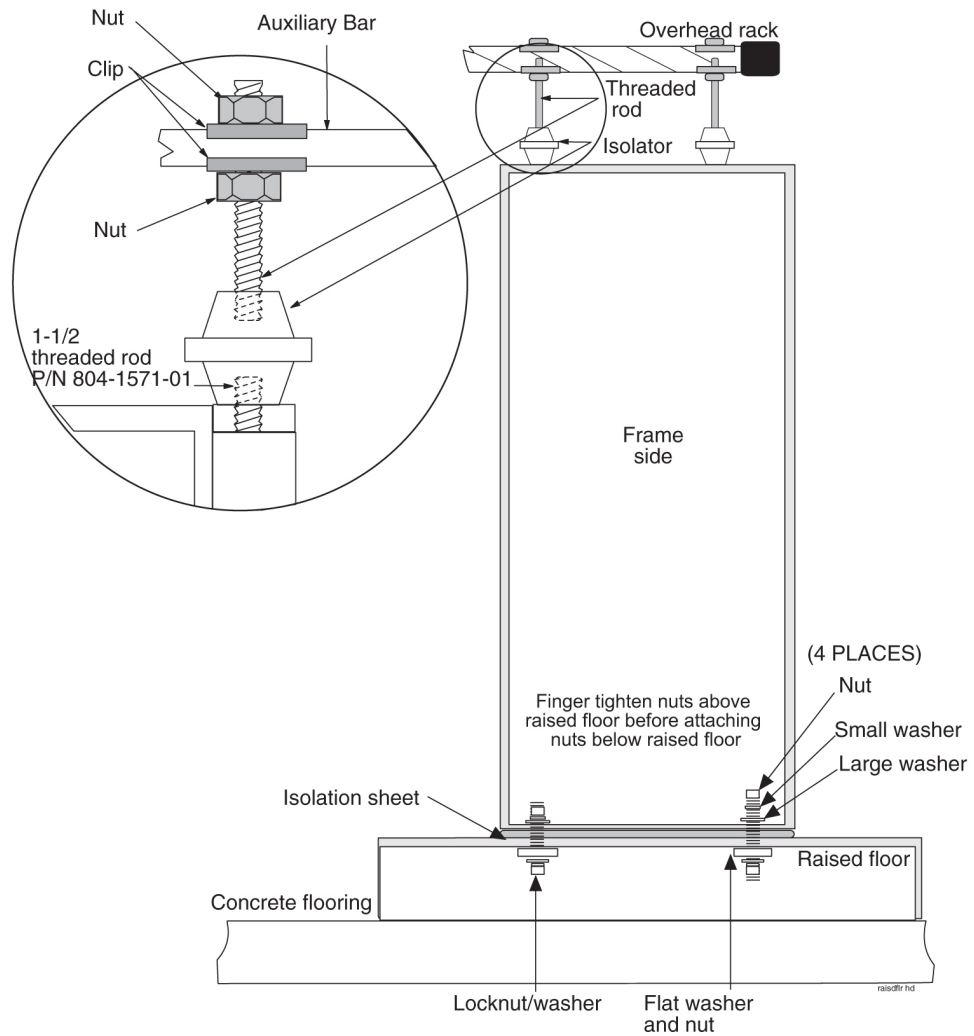

warning: Finger tighten nuts on threaded rods inside the frames above the raised floor before tightening the nuts below the raised floor.

Refer to [Figure 4-11](#) when installing the heavy duty frame on a raised floor using Unistruts and the Cable Rack Mounting Kit (P/N 804-0219-01).

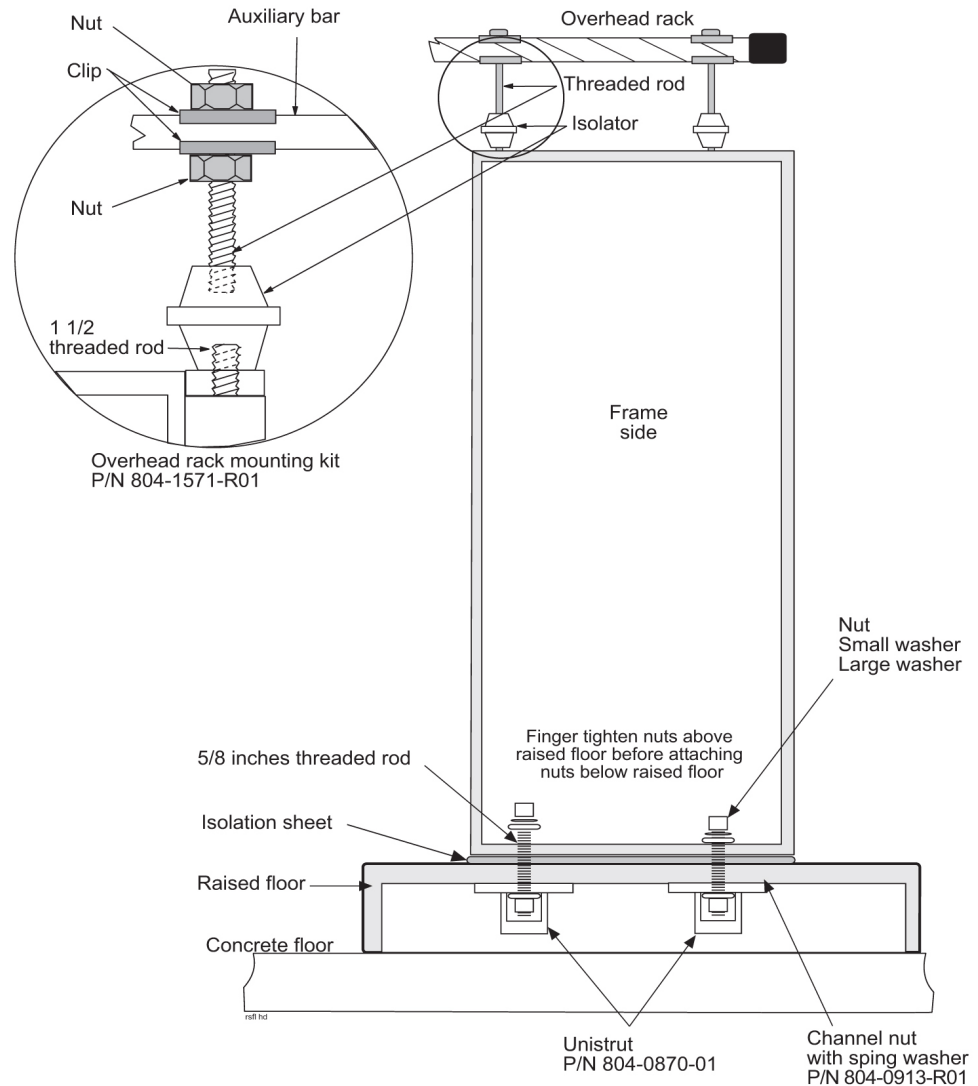
Figure 4-11 Raised Floor Installation With Unistrut

warning: Finger tighten nuts on threaded rods inside the frames above the raised floor before tightening the nuts below the raised floor.

Raised Floor Earthquake Bracing

This section describes how to install earthquake bracing to a raised floor installation. Bracing is required in earthquake zones 3 and 4 when installing a frame onto a raised floor with a spacing of 1.5 feet or more between the raised floor and the subfloor.

1. Assemble the Earthquake Brace by securing the 45 degree bar steel pieces to the flat 90 degree bar.

Use the Earthquake Brace Kit P/N 982-0065-R01.

Figure 4-12 Earthquake Bracing

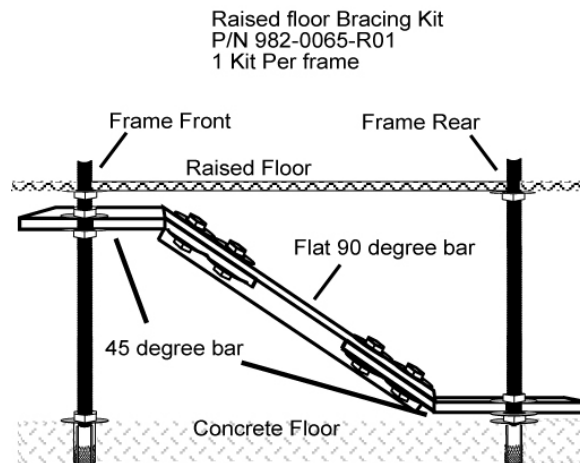

2. On the threaded rod located at the front of the frame:
 - a. Install a 5/8 nut onto the rod.
The nut will need to be threaded approximately 5 inches from the top of the raised floor .
 - b. Place a helical washer onto the rod.
 - c. Place a flat washer onto the rod.
3. On the threaded rod located at the back of the frame, place a Flat washer on the threaded rod so that the washer is sitting on the nut holding the anchor in place.
4. Place a flat washer on the back threaded rod.
5. Slide the Earthquake brace onto the threaded rod from the front threaded rod to the back threaded rod. Refer to the figure above.

Note: Do not over adjust as this may cause the tile or frame to tilt.

6. On the threaded rod located at the rear of the frame:
 - a. Place a flat washer onto the rod.
 - b. Place a helical washer onto the rod.
 - c. Install a 5/8 nut onto the rod and secure tightly, but do not overtighten.
7. On the threaded rod located at the front of the frame:
 - a. Place a flat washer onto the rod.
 - b. Place a helical washer onto the rod.
 - c. Install a 5/8 nut onto the rod.
8. Adjust the front rod nuts and washers so that the flat portion of the Earthquake bracing bar attached at the threaded rod is level.
9. Repeat all the above steps for all additional sets of front and back threaded rods.

10. Once all Earthquake Bracing is installed, continue with the installation of the frames to the raised floor.

Concrete Floor

This section describes how to prepare a concrete floor for heavy duty frame installation. Always get permission from facility personnel before drilling holes. Before drilling holes in any flooring, verify with facilities personnel that the area is free of gas or water pipes, ventilation ducts, electrical wiring conduits, or any other items that may be damaged.

Recommended Tools

Oracle tools should be labeled "Property of **ORACLE**" with either a press-on Field Tool Identification label or Field Tool Identification wrap.

- Safety glasses
- Rotary impact drill
- 18 mm masonry drill-bit
- Extension cord
- Vacuum cleaner (an approved, industrial type, that prevents escaping dust particles that may contaminate electronic equipment)
- Masking tape
- Fiberglass tape measure
- Isolation sheet (in mounting hardware kit)
- Ear protectors
- Felt tipped marking pen
- Mounting hardware kit (furnished with each heavy duty frame)

Caution: All personnel associated with the installation of this system must adhere to all safety precautions and use required protection equipment to avoid the possibility of injury to personnel, service degradation, and/or service interruption.

Caution: This is a redundant system to allow service during normal maintenance. When repairs require a total power disconnect, both input supply sources must be disconnected. Disconnection will cause service interruption and take down the any system.

warning: Before drilling holes in any flooring, verify with facilities personnel that the area is free of gas or water pipes, ventilation and electrical wiring conduits.

The personnel must have a thorough knowledge of telecommunication installation specifications and procedures. **If the holes are drilled at an angle the anchor and frame will not come together properly.**

1. Drill an 18 mm hole at the marked anchor location in the concrete floor to a depth of 3 inches (7.7 cm).

Use the vacuum cleaner to collect the dust while drilling holes. Clean out each hole after drilling is completed.

Note: If any obstruction is encountered while drilling the hole, fill the unusable hole with “pour stone” or an equivalent product. After allowing sufficient set time, drill the hole in another spot within the marked area.

2. Check the hole to make sure the fully assembled anchors can be set into the concrete three inches.

The metal sleeve shown in [Figure 4-13](#) must be below the floor.

Figure 4-13 Anchor Assembly

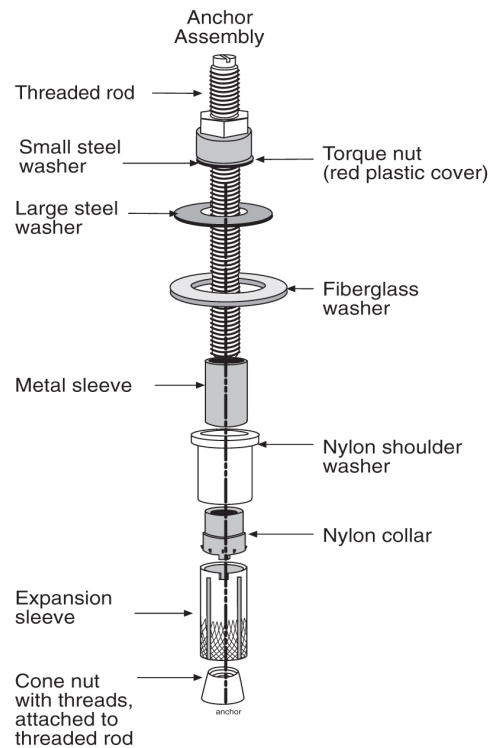

3. Install two square washers below the round fiberglass washer as shown in [Figure 4-13](#).
4. Install the anchor assemblies in the order shown in [Figure 4-13](#).

The large steel washer, nylon shoulder washer, and round fiberglass washer are found in the mounting hardware kit.

Note: When reassembling an anchor bolt assembly, lightly finger tighten only.

When reassembling an anchor stud assembly, the stud must be flush with the bottom of the cone nut and the torque nut must be near the top of the stud.

5. Insert each anchor into an anchor hole through the three square washers, frame base, and isolation sheet (refer to [Figure 4-14](#)).

Figure 4-14 Anchor Installation of Heavy Duty Frame

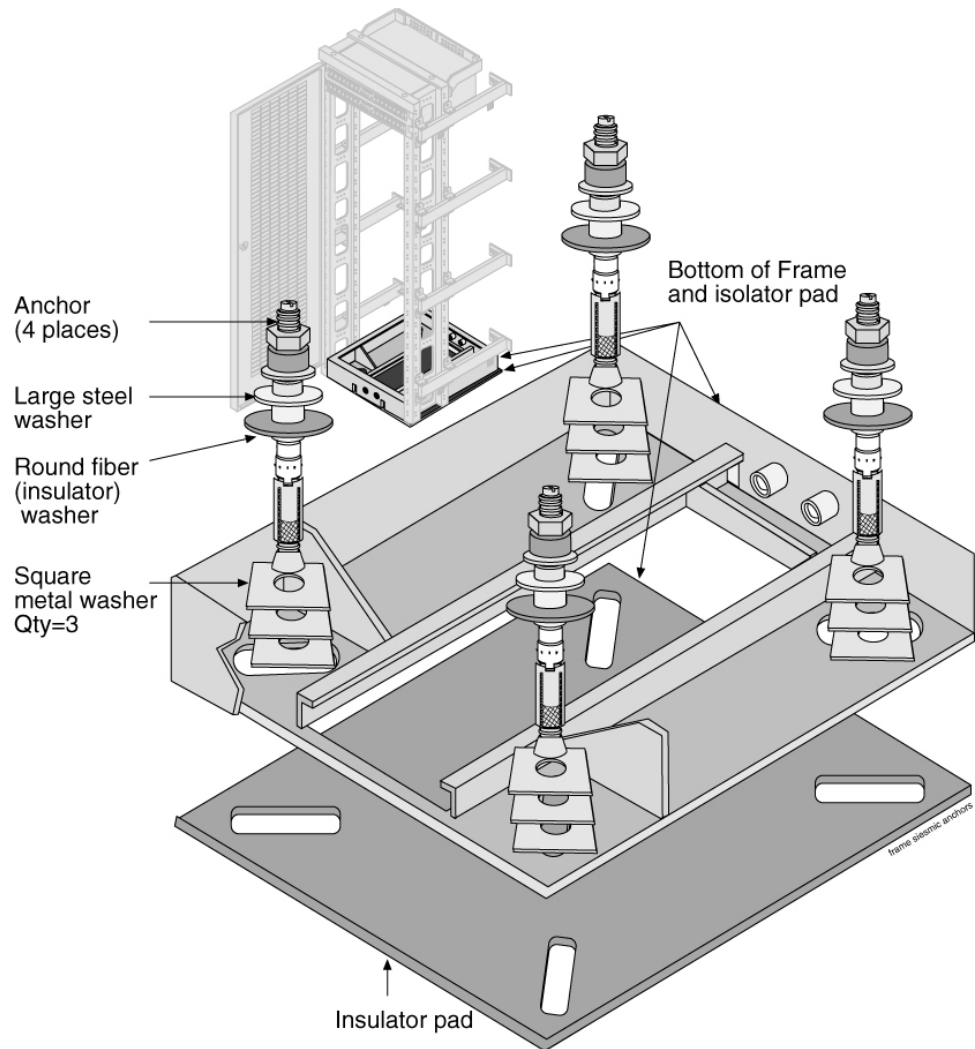

6. Tighten the torque nut on the anchor stud assembly with a box end wrench until the top of the nut breaks free.
7. Discard the hex nut or the broken-free portion of the torque nut.

Anchoring to Overhead Rack of Heavy Duty Frame

Frames with shelves that may be extended by pulling the shelf into the aisle must be attached to overhead ladder racks to prevent toppling.

1. Using the Cable Rack Mounting kit comprised of ladder hooks threaded rods and insulators, place the assembly directly above the frame for overhead support.
2. Secure the top of the frame to the overhead cable ladder rack using a threaded rod with hardware as shown in [Figure 4-15](#).

Figure 4-15 Heavy Duty Frame Installation With Cable Rack

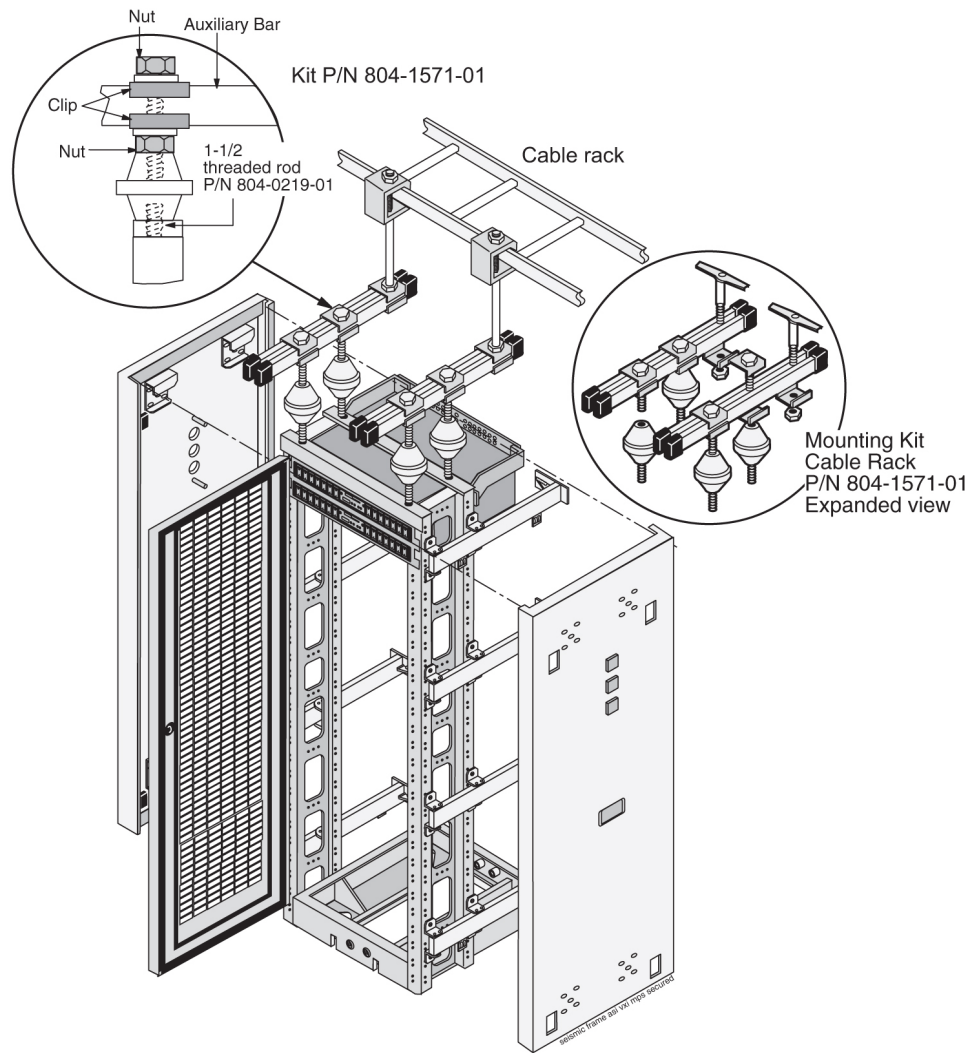

Removing Frame Panels

1. Pull down on the upper panel clips and pull the panel away from the frame.
2. Pull down on the lower panel clips and pull the panel away from the frame.
3. Grasp the handle in the middle panel and lift the panel off of the frame bracket shown in [Figure 4-16](#).

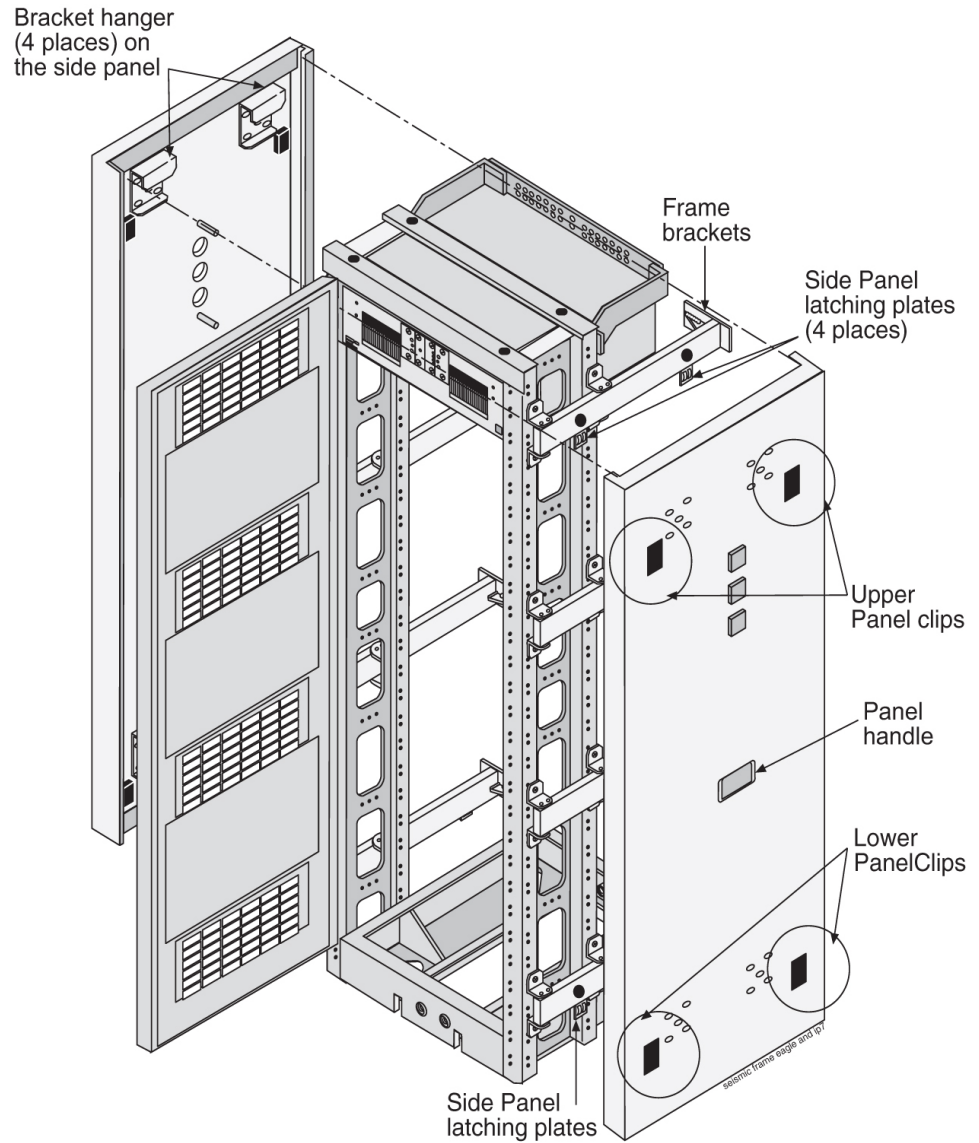
Figure 4-16 Heavy Duty Frame Panels

Installing Unit Separation Brackets

1. Use pre-existing holes in the frames.
2. Use 12 screws to attach three unit separation brackets with studs as shown in [Figure 4-17](#).

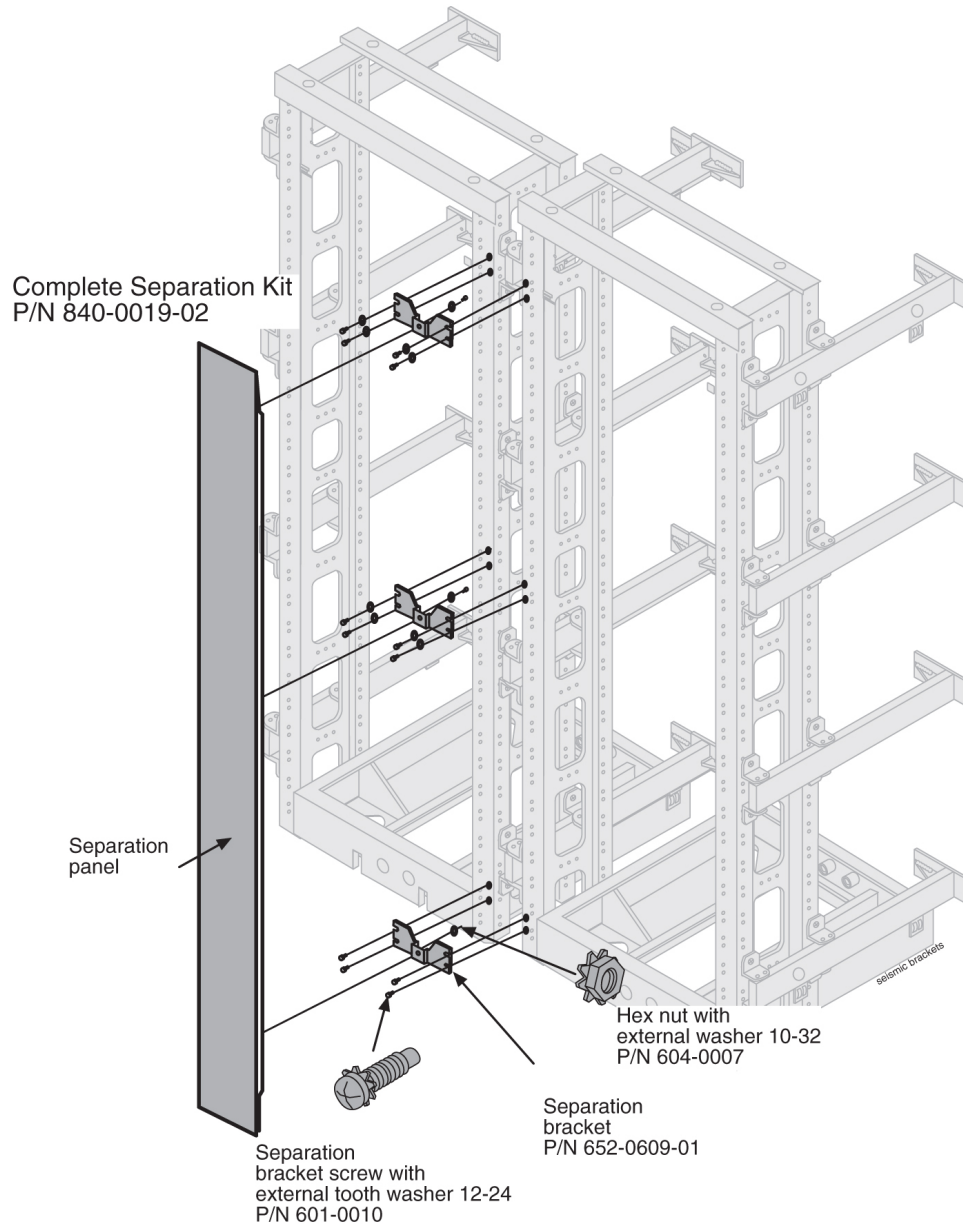
Figure 4-17 Unit Separation Bracket Installation

Rear Covers

Gray tinted plastic rear covers with round holes are provided, three per frame, to physically protect the system backplanes and cables, see [Figure 4-18](#).

1. Carefully peel off the protective wrapper from each cover.
2. With the round holes up, place the cover into the support groove.
3. Line up the rear cover holes with the holes in the frame support arm.
4. Secure rear cover in place with two screws.

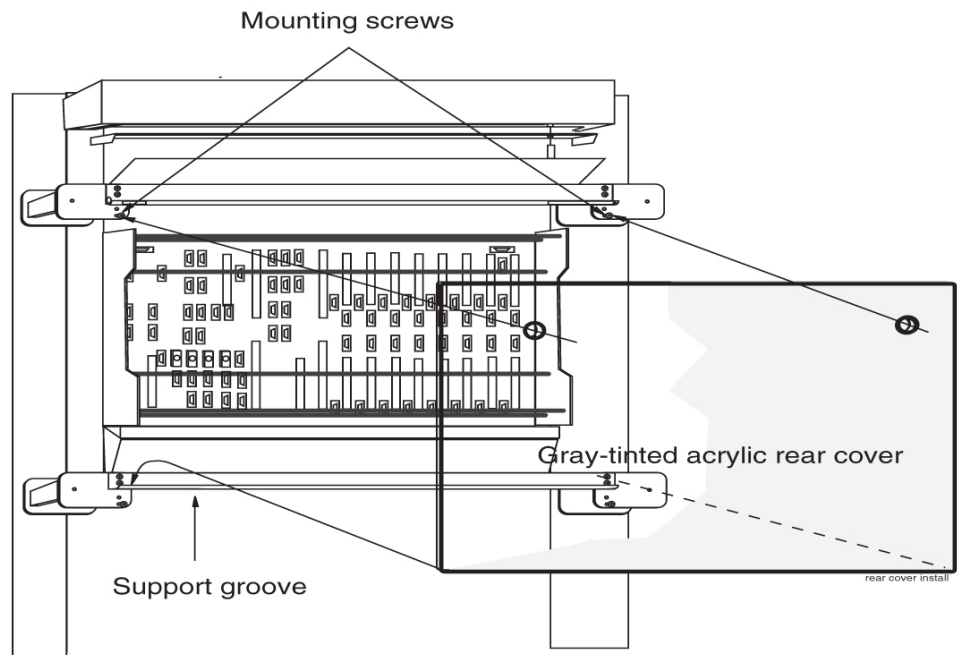
Figure 4-18 Rear Cover Installation

For more information on Frames and Shelves refer to the *Hardware Description Manual* included in your current documentation suite.

Shelves

[Figure 4-19](#) shows the frame door ground.

Figure 4-19 EAGLE Frame with Door Ground

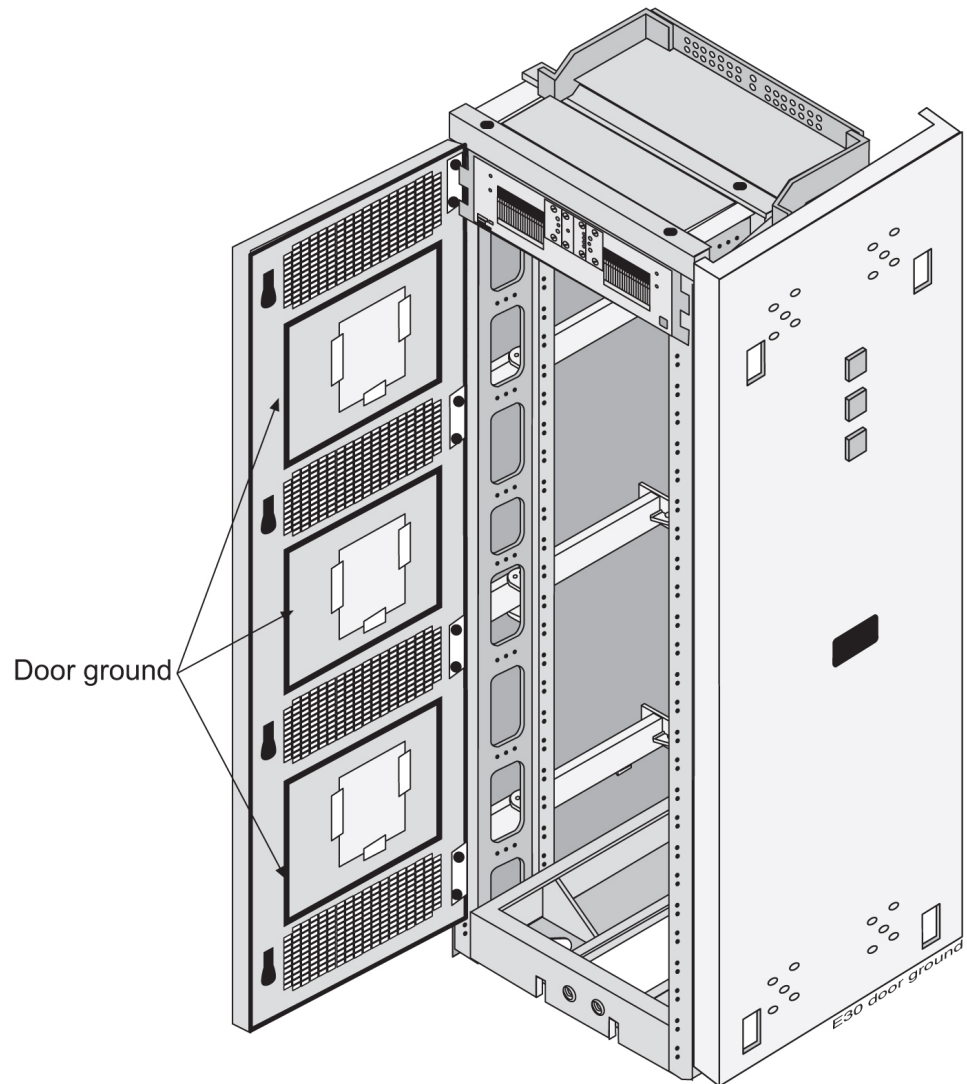
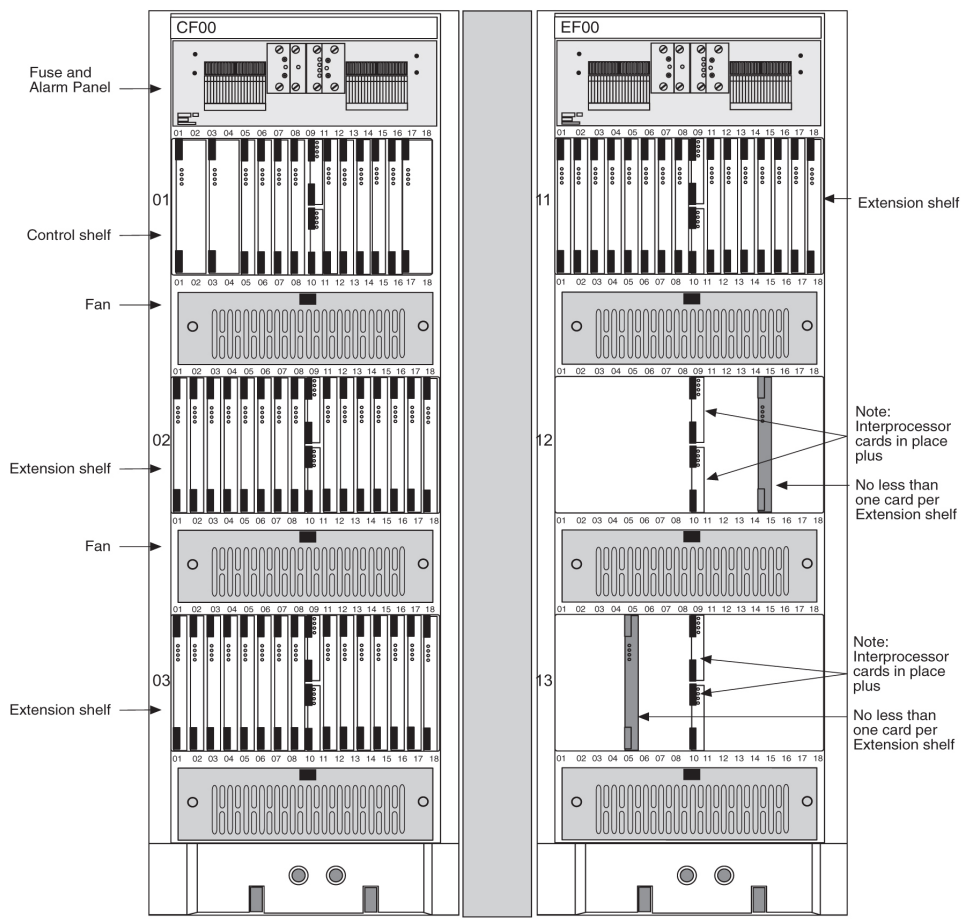

Figure 4-20 shows a frame with possible shelf population.

Figure 4-20 EAGLE Frame with Shelves



Labeling

End Aisle Labeling

This section details the application of the frame lineup end aisle labels. All of the frame lineups are labeled the same way on end panels.

The frame lineup identification placard (P/N 658-0816-01) is applied to the side panel of the end aisle frame. This placard, when populated, shows each frame type and shelf used in the lineup. Frame Type labels and System/Shelf Equipment labels from the equipment identification sheets (P/N 658-1093-01) are used to populate the placard.

The placard lists the frame lineup with the top line of the placard corresponding to the frame nearest the end aisle to which the placard is attached.

1. Locate the clear pocket containing all labels.

This pocket is located on the side panel that has the Alarm indicators. This should be the end aisle frame.

2. From the clear pocket, remove the frame lineup identification placard (P/N 658-0816-01).

Figure 4-21 Frame Lineup Identification Placard (P/N 658-0816-01)

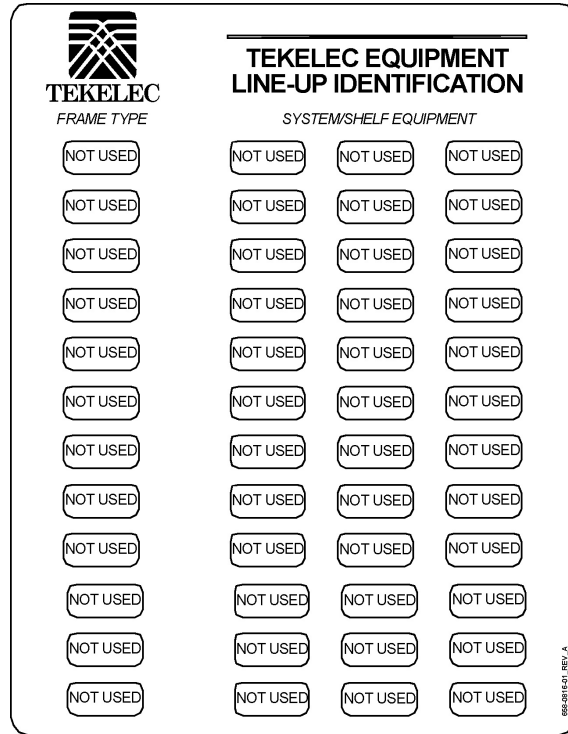

3. From the clear pocket, remove the equipment identification sheets (P/N 658-0816-01).
4. From the equipment identification sheets (P/N 658-1093-01), remove the appropriate Frame Type label and System/Shelf Equipment labels and place them on the frame lineup identification placard. See [Table 4-1](#).

Note: The top line of the placard corresponds to the frame nearest the end aisle to which the placard is attached.

Table 4-1 Frame Type and Labels

Application	Frame Type	System/Shelf Equipment	
EAGLE- Control FrameCF- 00 Single Control Shelf		11	
	EAGLE		
	CF-00		
EAGLE- Control Frame CF-00 Single Control Shelf + 1200 extension shelf		11	12

Table 4-1 (Cont.) Frame Type and Labels

Application	Frame Type	System/Shelf Equipment		
EAGLE- Control Frame CF-00 Single Control Shelf + 1200 and 1300 extension shelf		11	12	13
EAGLE- Extension Frame EF-00 with 2100 extension shelf		21		
EAGLE- Extension Frame EF-00 with 2100 and 2200 extension shelves	EAGLE EF-00	21	22	
EAGLE- Extension Frame EF-00 with 2100, 2200 and 2300 extension shelves		21	22	23
EAGLE- Extension Frame EF-01 with 3100 extension shelf		31		
EAGLE- Extension Frame EF-01 with 3100 and 3200 extension shelves	EAGLE EF-01	31	32	
EAGLE- Extension Frame EF-01 with 3100, 3200 and 3300 extension shelves		31	32	33
EAGLE- Extension Frame EF-02 with 4100 extension shelf	EAGLE EF-02	41		

Table 4-1 (Cont.) Frame Type and Labels

Application	Frame Type	System/Shelf Equipment		
EAGLE- Extension Frame EF-02 with 4100, and 4200 extension shelves		41	42	
EAGLE- Extension Frame EF-02 with 4100, 4200 and 4300 extension shelves		41	42	43
EAGLE- Extension Frame EF-03 with 5100 extension shelf		51		
EAGLE- Extension Frame EF-03 with 5100 and 5200 extension shelves	EAGLE EF-03	51	52	
EAGLE- Extension Frame EF-03 with 5100, 5200 and 5300 extension shelves		51	52	53
EAGLE- Extension Frame EF-04 with 6100 extension shelf	EAGLE EF-04	61		
Misc Frame	GPF-00			
MPS	GPF-00 thru GPF-05			MPS
LSMS	GPF-00 thru GPF-05			MPS
Sentinel	SPF-00 thru SPF-05			Sentinel
SCS	SCS-00 thru SCS-02			SCS
IMF	IMF-00 thru IMF-02			IMF

Table 4-1 (Cont.) Frame Type and Labels

Application	Frame Type	System/Shelf Equipment
PMF	PMF-00 thru PMF-01	PMF

Figure 4-22 Frame Type and System/Shelf Equipment Label Sheets (P/N 658-1093-01)

EAGLE STP CF-00	EAGLE 5 ISS CF-00	IP7 SG CF-00	IP7 EDGE CF-00	IP7 FE CF-00	MF-00	GPF-00	SPF-00
EAGLE STP EF-00	EAGLE 5 ISS EF-00	IP7 SG EF-00	IP7 EDGE EF-00	IP7 FE EF-00	MF-01	GPF-01	SPF-01
EAGLE STP EF-01	EAGLE 5 ISS EF-01	IP7 SG EF-01	IP7 EDGE EF-01	IP7 FE EF-01	MF-02	GPF-02	SPF-02
EAGLE STP EF-02	EAGLE 5 ISS EF-02	IP7 SG EF-02	IP7 EDGE EF-02	IP7 FE EF-02	PMF-00	GPF-03	SPF-03
EAGLE STP EF-03	EAGLE 5 ISS EF-03	IP7 SG EF-03	IP7 EDGE EF-03	IP7 FE EF-03	PMF-01	GPF-04	SPF-04
EAGLE STP EF-04	EAGLE 5 ISS EF-04	IP7 SG EF-04	IP7 EDGE EF-04	IP7 FE EF-04	PMF-02	GPF-05	SPF-05
EAGLE STP EF-05	EAGLE 5 ISS EF-05	IP7 SG EF-05	IP7 EDGE EF-05	IP7 FE EF-05			
IMF-00	IAS-00						
IMF-01	IAS-01						
IMF-02	IAS-02						
	IAS-03						
	OAPF						
	PDF						

FRAME TYPE LABELS

IMF	11	31	51	OAP
IAS	12	32	52	EOAP
MPS	21	41	61	MGTS
PMF	22	42	62	

SYSTEM/SHELF EQUIPMENT LABELS

- Place any unused labels back into the clear pocket.
- Place the populated frame lineup identification placard into the clear pocket such that the populated side of the placard is visible.

Frame Labeling

This section details the application of frame and shelf labels. Additional labels on the newer heavy duty frame shown in [Figure 4-23](#) come pre-installed.

Figure 4-23 Heavy-Duty Frame Label Location

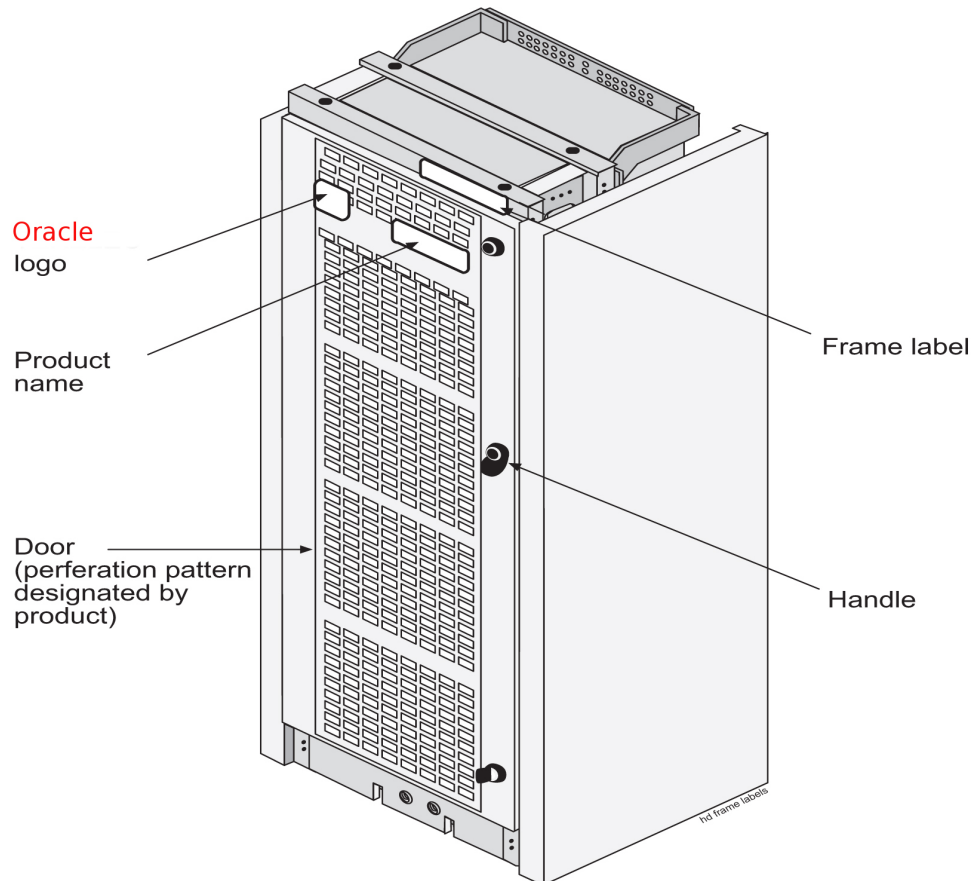

Note: The heavy-duty frame comes from manufacturing with the assembly information label in place.

All of the frames shown in [Table 4-2](#) are labeled the same way on end panels and separation panels, see [Figure 4-24](#) and [Figure 4-25](#).

Apply frame labels to the front of each frame as shown in [Figure 4-24](#).

Table 4-2 Frame Labels and Part Numbers

Frame	Label	Label Part Number
Control frame	CF-00	658-0486-01
Extension frame 00	EF-00	658-0486-02
Extension frame 01	EF-01	658-0486-03

Table 4-2 (Cont.) Frame Labels and Part Numbers

Frame	Label	Label Part Number
Extension frame 02	EF-02	658-0486-04
Extension frame 03	EF-03	658-0486-05
Extension frame 04	EF-04	658-0486-06
Miscellaneous frame 00	MF-00	658-0374-01
Miscellaneous frame 01	MF-01	658-0374-02
Heavy Duty Frame	GPF	658-0374-01

1. Remove the protective backing from the frame label.
2. Firmly press the label into place as shown in [Figure 4-24](#) and [Figure 4-25](#)..

Figure 4-24 Frame and Shelf Label Locations

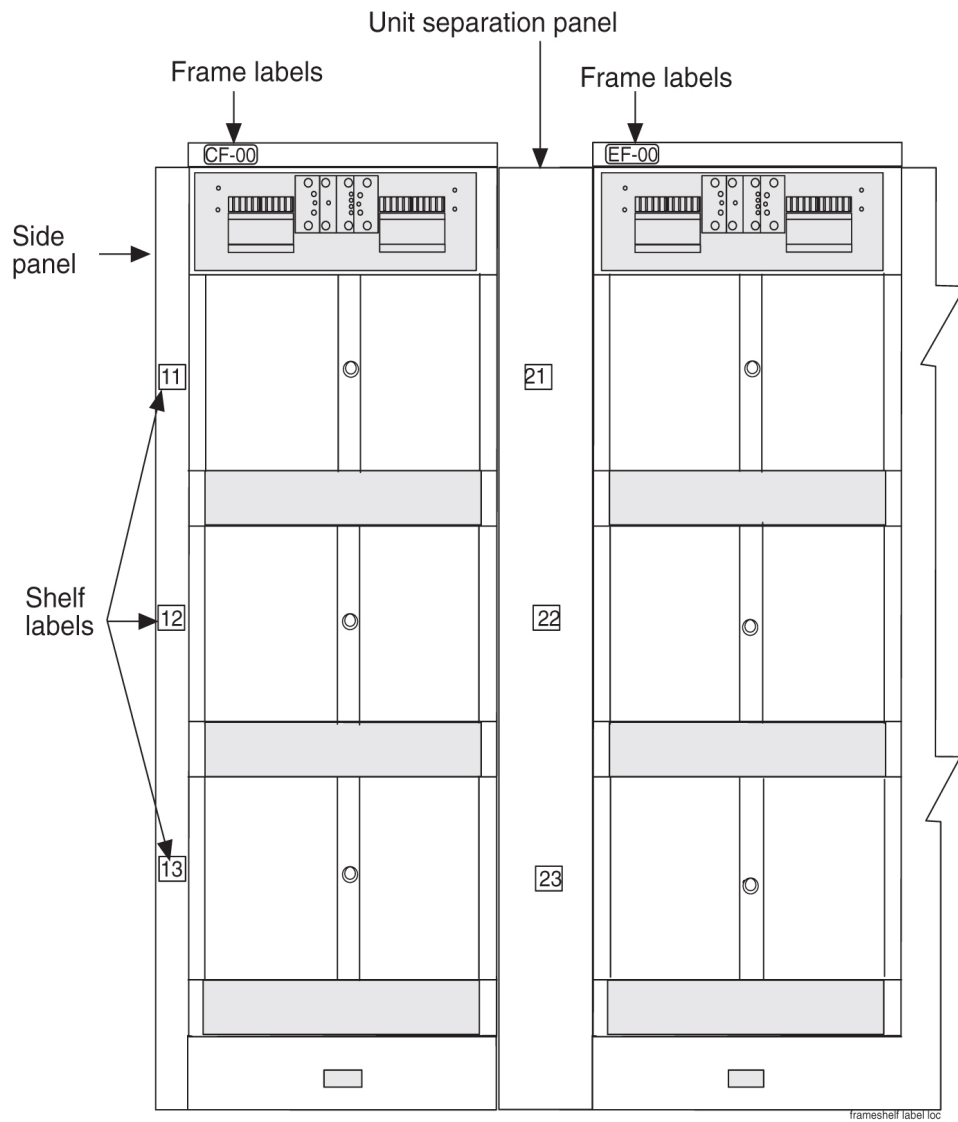
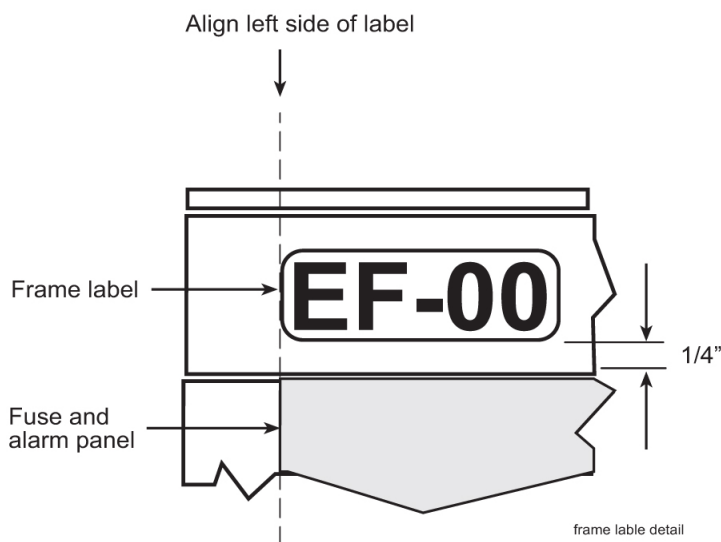

Figure 4-25 Frame Label Location - Detail

Shelf Labeling

Apply shelf labels to the frames of the system as shown in [Frame Labeling](#). Refer to [Figure 4-26](#) for exact placement. Refer to [Table 4-3](#) for the proper label for each shelf.

Note: The procedure for the placement of labels is the same on most of the frames. Typically, the system is pre-labeled.

Table 4-3 Shelf Labels and Part Numbers

Frame	Shelf	Label	Label Part Number
Control Frame CF-00 The Control Frame is always the FIRST frame	1	11= Frame 1 and Shelf 1	658-0490-01
	2	12= Frame 1 and Shelf 2	658-0490-02
	3	13= Frame 1 and Shelf 3	658-0490-03
Extension Frame EF-00 Extension Frame 00 is the first extension frame but the second frame in the line-up	1	21= Frame 2 and Shelf 1	658-0490-04
	2	22= Frame 2 and Shelf 2	658-0490-05
	3	23= Frame 2 and Shelf 3	658-0490-06
Extension Frame EF-01 Extension Frame 01 is the second extension frame but the third frame in the line-up	1	31= Frame 3 and Shelf 1	658-0490-07
	2	32= Frame 3 and Shelf 2	658-0490-08

Table 4-3 (Cont.) Shelf Labels and Part Numbers

Frame	Shelf	Label	Label Part Number
(numbering continues in additional frames)	3	33= Frame 3 and Shelf 3	658-0490-09
Extension Frame EF-02	1	41	658-0490-10
	2	42	658-0490-11
	3	43	658-0490-12
Extension Frame EF-03	1	51	658-0490-13
	2	52	658-0490-14
	3	53	658-0490-15
Extension Frame EF-04	1	61	658-0490-16
Heavy Duty Frame	As needed	As needed	658-0374-01

1. Remove the protective backing from the shelf label.
2. Firmly press the label into place as shown in [Frame Labeling](#) and [Figure 4-26](#).

Figure 4-26 Shelf Label Location - Detail

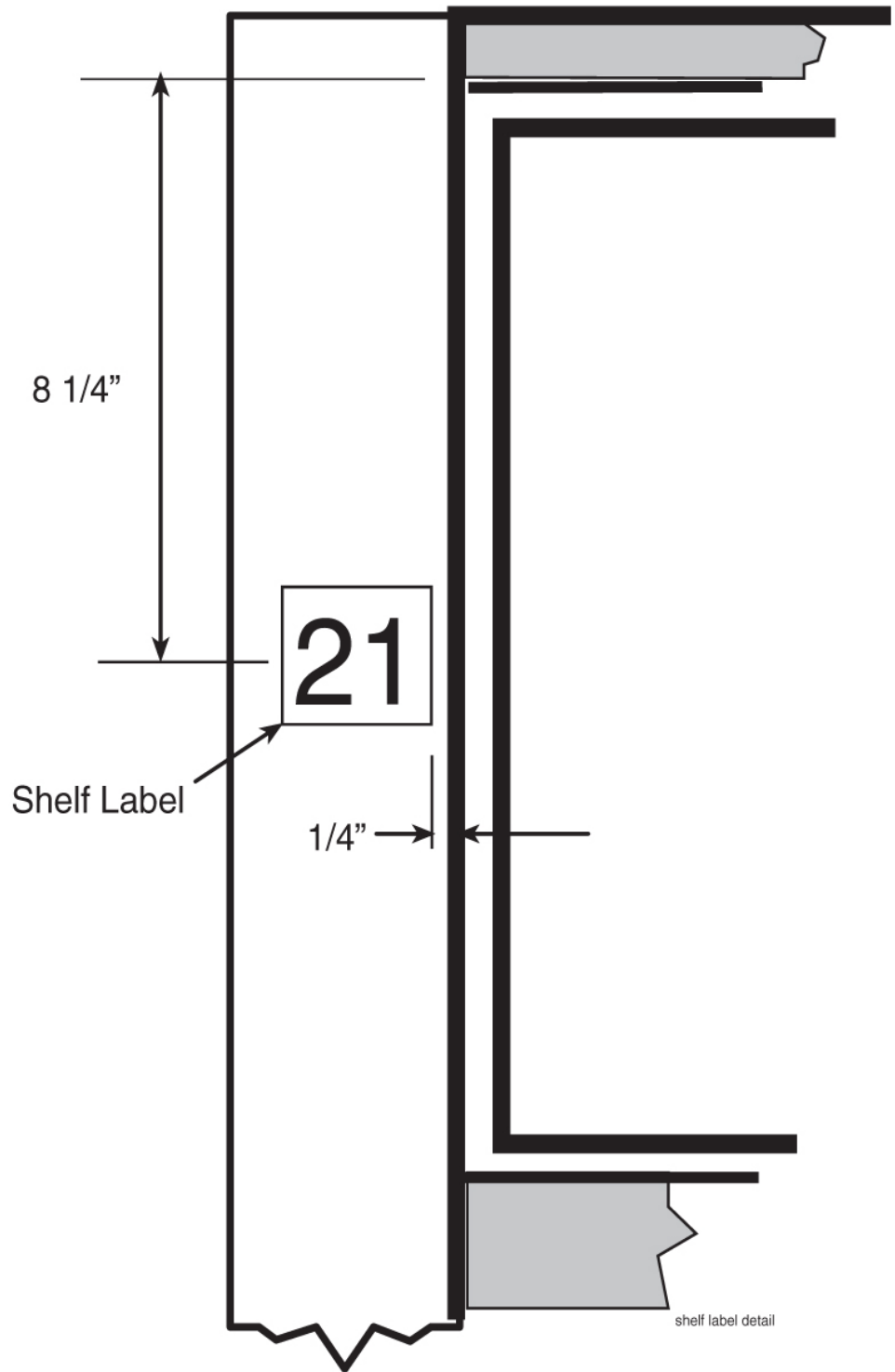

Fuses and Alarm Panel

Fuse and Alarm Panels

The Fuse and Alarm Panel (FAP) provides protected distribution of -48VDC power to the shelves in the frame. The site voltage input to each frame should be between -40VDC and -57.5VDC. Allowing for the full population of a frame and for the failure of one primary supply, new installations of Control and Extension frames require two 60A feeds. See the "Hardware Power Calculator Tool" section in *Hardware* for more information.

The FAP is installed at the top of the frame and uses two cables to bring A and B power to the frame. The FAP contains two separate circuits, A and B. Current flows from the input terminals to the fuse bus. Protection is provided by fuses placed in fuse holders on the front panel. When a fuse is installed in a fuse holder, the circuit is completed to the output connector.

warning: Existing frames that are fused at 40 amps may be upgraded to support 60 amps with a FAP upgrade kit. Frames that contain HC-MIMs must be upgraded to support 60 amps. Customers do not perform a FAP upgrade; these upgrades are performed by Oracle Communications personnel.

warning: The FAP P/N 870-1606-02 Revs A-B can be upgraded to FAP P/N 870-1606-02 Rev C with FAP upgrade kit P/N 840-0139-01. The FAP P/N 870-2320-01 Revs A-I can be upgraded to FAP P/N 870-2320-01 Rev J with FAP upgrade kit P/N 870-0139-02.

Caution: All personnel associated with the installation of this system must adhere to all safety precautions and protection equipment required to avoid the possibility of injury to personnel, service degradation, and/or service interruption.

Caution: This is a redundant system to allow service during normal maintenance. When repairs require a total power disconnect, both input supply sources must be disconnected. This will cause service interruption and take down the system.

Fuses

The fuse and alarm panel uses GMT-type fuses of different amperage ratings for individual circuit protection. If a frame circuit fuse is blown the alarm is indicated by

an LED on the front panel and a small colored flag on the fuse shows the fuse that has failed (refer to [Figure 5-1](#)). Refer to *Maintenance* for procedures on replacing fuses and the FAP assembly.

Caution: Always use a fuse of the same type and amperage rating when replacing a failed fuse.

Figure 5-1 Fuse (GMT Brand Shown)

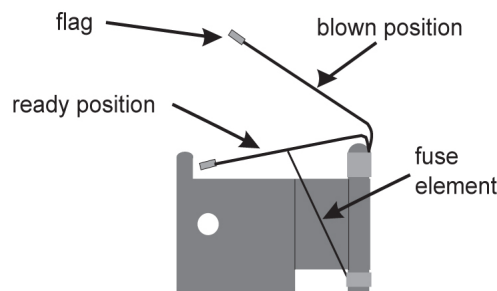

Table 5-1 Fuse Color Codes of Alarm Flags

Fuse Amp	Fuse Flag Color	Fuse Amp	Fuse Flag Color
0.18A	Orange-Red	2A	Orange
0.2A	Black-Red	2.5A	White-Orange
0.25A	Violet	3A	Blue
0.33A	Yellow-Green	3.5A	White-Blue
0.375A	White-Green	4A	White -Brown
0.5A	Red	5A	Green
0.65A	Black	7.5A	Black-White
0.75A	Brown	10A	Red-White
1A	Gray	12A	Yellow-Green
1.33A	White	15A	Red-Blue
1.5A	White-Yellow		

Fuse and Alarm Panel (P/N 870-2804-01)

The FAP (P/N 870-2804-01) is a low-profile (1U) unit that can be installed in the Control Frame (CF) and the Extension Frame (EF).

The Power Alarm LED indicates the input power state to the FAP. The LED is green when input power is applied to that bus of the FAP and is red when there is no input power to that bus of the FAP. An unlit Power Alarm LED indicates a failed LED or no input power to either bus of the FAP.

Alarm LEDs to indicate Critical, Major, and Minor alarms are located to the left of the diode board. The LEDs indicate alarms generated by the system that are applicable to that frame which the FAP is installed.

The FAP contains a Diode board and a Shorting board. These boards are located at the front center of the FAP. The FAP also contains two fuse blocks, one to the left (A-side) and one to the right (B-side) of diode and shorting boards, consisting of 20 fuse positions each. The Fuse Alarm LED indicates the failure of a fuse.

The diode board in the FAP contains power diodes and circuitry which allow one bus to pick up the entire load when there is a loss of input power on the other bus.

The Shorting board allows the removal of the diode board without taking down the system. This permits periodic maintenance of the diodes without having to power down or remove the unit from the shelf. For maintenance operation, the Shorting board has to be removed, flipped over, and reinstalled. In the bypass position, both A and B power is connected to the fuse blocks so the diode board can be safely removed. The Shorting board has an LED which is off when the board is in normal operational mode and is green when in the bypass mode of operation. With the Shorting board in the bypass mode, the OR'ing function is not available. Refer to *Maintenance* for additional information to place the FAP into Maintenance Mode of operation.

Figure 5-2 and Table 5-2 describes the front panel configuration of the fuse and alarm panel (P/N 870-2804-01).

Figure 5-2 Fuse and Alarm Panel - Front View (P/N 870-2804-xx)

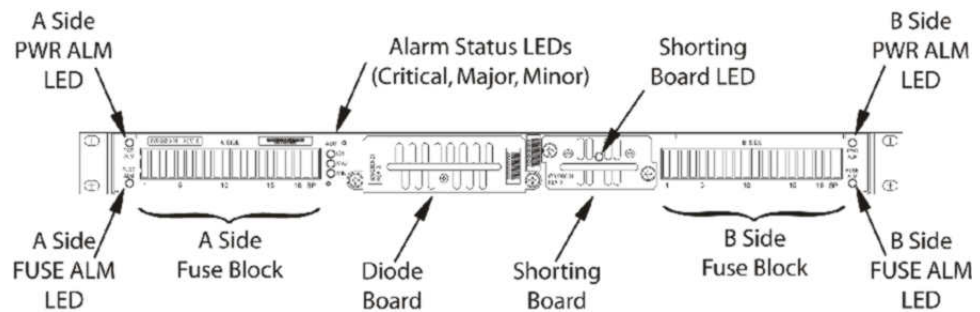

Table 5-2 Fuse and Alarm Panel Front Items (P/N 870-2804-xx)

Fuse Panel Item	Description
Fuse Positions	Two groups of 20 GMT fuses
Shorting Board LED	LED indicator for shorting board.
FuseAlarm	LED indicator for fuse fail alarm
PowerAlarm	LED indicator for input power
CriticalAlarm	LED indicator for critical alarm
MajorAlarm	LED indicator for major alarm
MinorAlarm	LED indicator for minor alarm

Table 5-3 presents possible alarm LED states and corresponding fuse conditions.

Table 5-3 Fuse State and LED condition (P/N 870-2804-01).

Fuse State A side	Fuse State B side	Fuse LEDs A side	Fuse LEDs B side
No fuses blown	No fuses blown	Green	Green
No fuses blown	At least 1 fuse blown	Green	Red
At least 1 fuse blown	No fuses blown	Red	Green
At least 1 fuse blown	At least 1 fuse blown	Red	Red
Shorting board enabled (in bypass mode), Shorting board LED is green.		Red	Red
Shorting board in normal operational mode, Shorting board LED is off. No fuses blown.		Green	Green

Figure 5-3 and Table 5-4 describes the rear panel configuration. Refer to *Installation* for cabling connection information.

Figure 5-3 Fuse and Alarm Panel Rear (P/N870-2804-01).

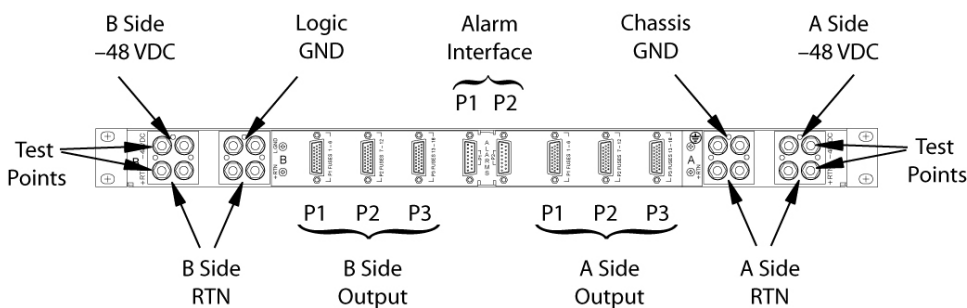

Table 5-4 Fuse and Alarm Panel Rear Items (P/N870-2804-01).

Fuse Panel Item	Description
Input Terminal Block A	Input and Return for power source A and FAP Chassis Ground
Input Terminal Block B	Input and Return for power source B and FAP Logic Ground
-48VDC Outputs A	26-pin "D" connectors for A-side outputs: <ul style="list-style-type: none"> • P1 - Fuses 1 through 6 • P2 - Fuses 7 through 12 • P3 - Fuses 13 through 18

Table 5-4 (Cont.) Fuse and Alarm Panel Rear Items (P/N870-2804-01).

Fuse Panel Item	Description
-48VDC Outputs B	26-pin "D" connectors for B-side outputs: <ul style="list-style-type: none"> • P1 - Fuses 1 through 6 • P2 - Fuses 7 through 12 • P3 - Fuses 13 through 18
Alarm Interface	15-pin "D" connectors: <ul style="list-style-type: none"> • P1 to the EAGLE • P2 to a power distribution breaker panel

Table 5-5 presents the power requirements and physical dimensions for the FAP.

Table 5-5 Fuse and Alarm Panel Specifications (P/N 870-2804-01).

	Dimensions
Height	1.75 inches (4.4 cm)
Width	21.5 inches (53.8 cm)
Depth	10 inches (25 cm)

Shorting Board

The Shorting board allows the removal of the diode board without taking down the system. This permits periodic maintenance of the diodes without having to power down or remove the unit from the shelf. The Shorting board has an LED which is off when the board is in normal operational mode and is green when in the bypass mode of operation. With the Shorting Board in the maintenance mode, the Diode Board can be removed for maintenance while still allowing the FAP to operate. No OR'ed power is available in this mode. After installing the Diode Board, the Shorting Board must be reset to normal mode.

Maintenance Mode

This section describes how to place the Shorting Board into maintenance (bypass) mode. Maintenance mode allows the removal of the Diode Board without taking down the system.

Procedure — Shorting Board Maintenance Mode

1. Check to verify the Shorting Board LED is not on, indicating the FAP is in normal mode.
2. Locate two screws securing the Shorting Board in its slot (see [Figure 5-4](#)). Note the orientation of the Shorting Board LED. Turn the screws at each corner of the board to the left until they disengage.

Figure 5-4 Shorting Board Faceplate, Normal Mode

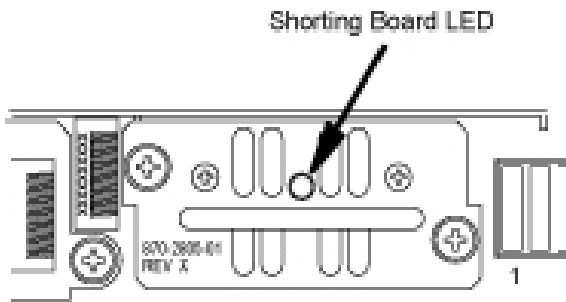

3. Pull the board straight out of the FAP until the board is clear of the frame.
4. Turn the Shorting Board over and reinsert the board into its slot. Note the orientation of the Shorting Board LED (see [Figure 5-5](#)).

Figure 5-5 Shorting Board Faceplate, Maintenance Mode

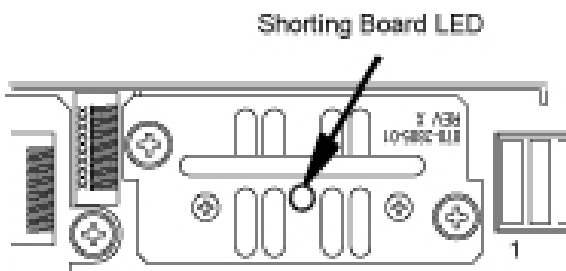

The Shorting Board LED turns green and the fuse alarm LEDs turn red.

5. Ensure the board is seated properly and tighten the two screws to secure the board.
6. The Shorting Board is now in the maintenance (bypass) mode of operation.

Normal Mode

Use this procedure to place the Shorting board into normal mode. This mode of operation allows one bus to pick up the entire load when there is a loss of input power on the other bus.

Procedure — Shorting Board Normal Mode

1. Check to verify the Shorting Board LED is green, indicating the FAP is in maintenance mode.
2. Locate two screws securing the Shorting Board in its slot. Note the orientation of the Shorting Board LED ([Figure 5-6](#)). Turn the screws at each corner of the board to the left until they disengage.

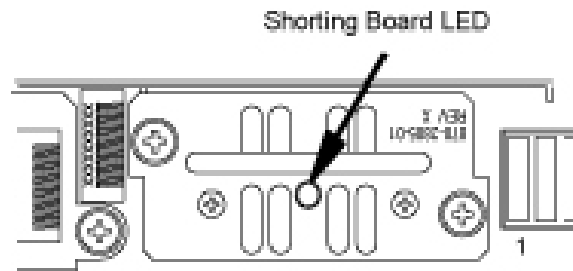
Figure 5-6 Shorting Board Faceplate, Maintenance Mode

3. Pull the board straight out of the FAP until the board is clear of the frame.
4. Turn the Shorting Board over and reinsert the board into its slot. Note the orientation of the Shorting Board LED (see [Figure 5-7](#)).

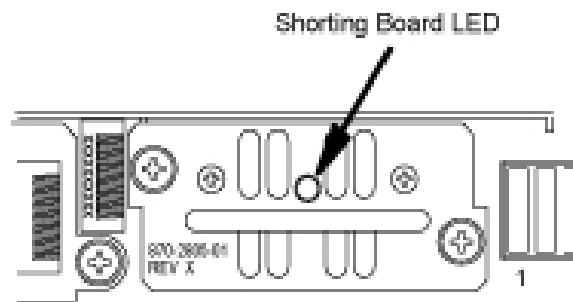
Figure 5-7 Shorting Board Faceplate, Normal Mode

Note: The Shorting Board LED is off and the fuse alarm LEDs turn green.

5. Ensure the board is seated properly and tighten the two screws to secure the board.
6. The Shorting Board is now in the normal mode of operation.

Fuse and Alarm Panel (P/N 870-1606-xx/870-2320-xx)

The FAP P/N 870-1606-xx can be installed in standard frames. The FAP P/N 870-2320-xx can be installed in heavy duty frames.

The FAP contains an alarm board, two diode boards, and a jumper board. These boards are located at the front center of the FAP. The fuse holders are to the left and right of these boards as shown in [Figure 5-8](#).

The alarm board contains a FUSELED to indicate a failed fuse (for either bus A or B) and LEDs to indicate Critical, Major, and Minor alarms generated by the system that are applicable to that frame which the FAP is installed.

There are two diode boards in the FAP, one for bus A and one for bus B. Each diode board contains power diodes and circuitry which allow one bus to pick up the entire load when there is a loss of input power on the other bus. An LED indicates the input power state to the FAP. The LED is green when input power is applied to that bus of the FAP and is red when there is no input power to that bus of the FAP.

The Maintenance (Jumper) board allows the removal of one or both diode boards without taking down the system. The Jumper board has two connectors and a connector plug. During normal operation, the connector plug is seated on the first

connector. For maintenance operation, the jumper board has to be removed and the connector plug moved to the second connector. In the maintenance position, the connector plug connects both A and B power feeds to the fuse panels so one or both diode boards can be safely removed. The OP/MAINTLED is green when the Jumper board is in normal operational mode and is red when in the maintenance mode of operation. Refer to *Maintenance*.

Figure 5-8 and Table 5-6 describes the front panel configuration of the fuse and alarm panel (P/N 870-1606-xx/870-2320-xx).

Figure 5-8 Fuse and Alarm Panel (P/N 870-1606-xx/870-2320-xx) Front

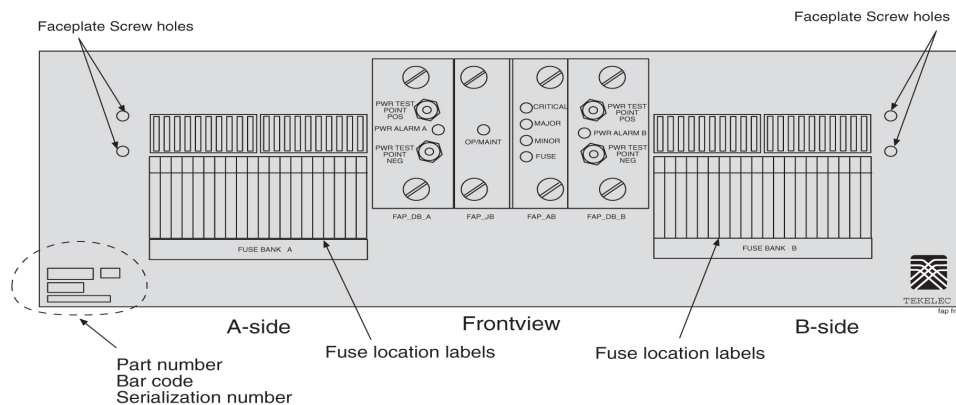

Table 5-6 Fuse and Alarm Panel Front Items

Fuse Panel Item	Description
Fuse Positions	Two groups of 20 GMT fuses
PWR ALARM	LED indicator for A or B diode board input power <ul style="list-style-type: none"> Green - input power applied Red - no input power to board
OP/MAINT	LED indicator for mode of operation <ul style="list-style-type: none"> Green - normal Red - maintenance
FUSE	LED indicator for fuse fail alarm <ul style="list-style-type: none"> Green - normal Red - blown fuse
CRITICAL	LED indicator for frame critical alarm
MAJOR	LED indicator for frame major alarm
MINOR	LED indicator for frame minor alarm

Figure 5-9 and Table 5-7 describes the rear panel configuration of fuse and alarm panel (P/N 870-1606-xx). Refer to *Installation* for cabling connection information.

Figure 5-9 Fuse and Alarm Panel (P/N 870-1606-xx/870-2320-xx) Rear

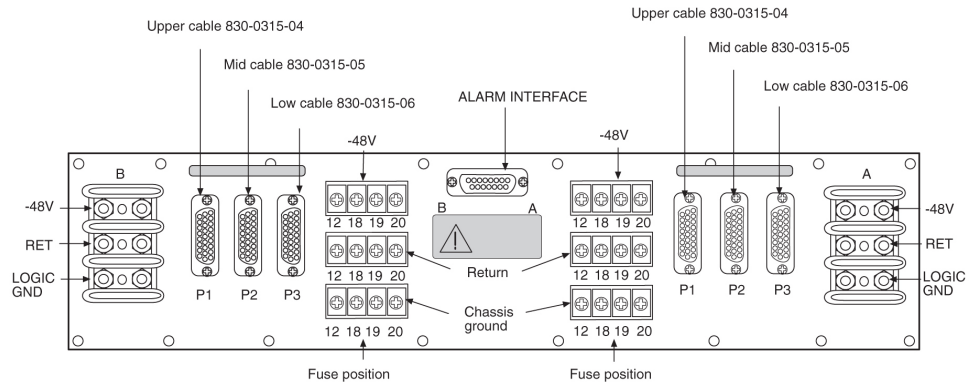

Table 5-7 Fuse and Alarm Panel (P/N 870-1606-xx/870-2320-xx) Rear

Fuse Panel Item	Description
Input Terminal Block A	Logic Ground, Return, and Input for power source A
Input Terminal Block B	Logic Ground, Return, and Input for power source B
Output Terminal Block A	-48VDC, Chassis Ground, and RTN for Fuse location 12, 18, 19, and 20 for side A. These are miscellaneous extra capacity fuses refer to Provision Rules for FAP Fuse Locations .
Output Terminal Block B	-48VDC, Chassis Ground, and RTN for Fuse location 12, 18, 19, and 20 for side B. These are miscellaneous extra capacity fuses refer to Provision Rules for FAP Fuse Locations
-48VDC, Chassis Ground, and RTN Outputs A	26-pin “D” connectors, P1, P2, and P3 for A-side outputs.
-48VDC, Chassis Ground, and RTN Outputs B	26-pin “D” connectors, P1, P2, and P3 for B-side outputs.

Table 5-8 Fuse and Alarm Panel (P/N 870-1606-xx/870-2320-xx) Specifications

	Dimensions
Height	3 inches (7.6 cm)
Width	17 inches (43.2 cm)
Depth	10.25 inches (26 cm)

Jumper Board

The Jumper board has two connectors and a connector plug. During normal operation, the connector plug is seated on the first connector. For maintenance operation, the jumper board has to be removed and the connector plug moved to the second connector. In the maintenance position, the connector plug connects both A and B power feeds to the fuse panels so one or both diode boards can be safely removed. The

OP/MAINT LED is green when the Jumper board is in normal operational mode and is red when in the maintenance mode of operation.

Maintenance Mode

Use this procedure to place the jumper board into maintenance mode. Maintenance mode allows the removal of one or both diode boards without taking down the system.

Procedure — Maintenance Mode

1. Locate the jumper board on the Fuse and Alarm Panel (FAP). See [Figure 5-10](#).

Figure 5-10 Jumper Board FAP

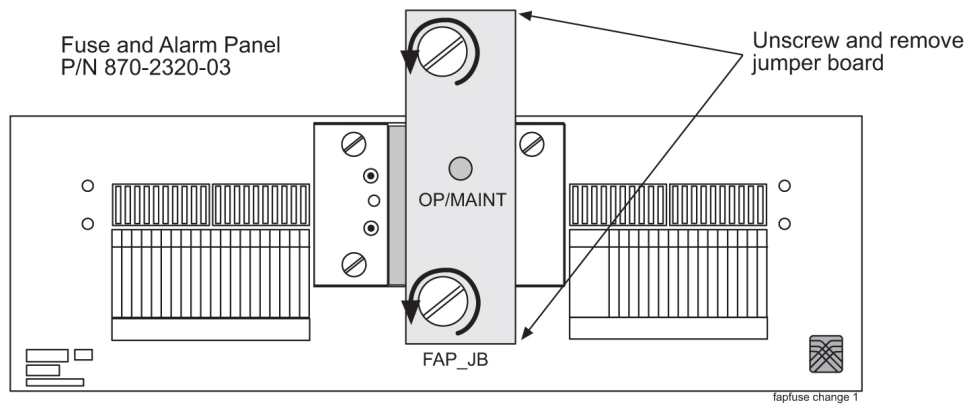

2. Remove the Jumper Board (FAP_JB) by turning the top and bottom screws to the left until they disengage.
3. Pull the board straight out of the FAP until the board is clear of the frame.
4. On the jumper circuit board, unclip the 12-pin connector jumper from P71 and re-attach it to P72. Insert it until the plastic retaining clips “snap”. See [Figure 5-11](#). Note that the jumper has a retaining strap so it will not get dropped or lost. This repositioning overrides the diodes, establishing a direct connection between the input and fuse panels.

Figure 5-11 Jumper Connector - Maintenance Mode.

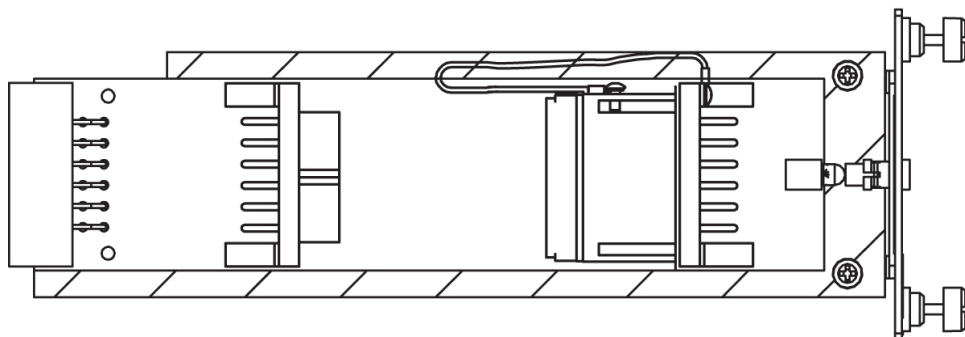

5. Slide the jumper board back into the FAP and verify both of the following alarms display:
 - the OP/MAINT LED lights red on the FAP
 - an EAGLE fuse alarm displays on the terminal

You may now remove either or both diode circuit boards without affecting **EAGLE** service.

Note: Using the jumper override negates the backpower protection usually provided by the diode board.

The jumper board maintenance mode procedure is completed.

Procedure — Operational Mode

1. Locate the jumper board on the Fuse and **Alarm** Panel (**FAP**).
2. Unscrew the two thumbscrews securing the **FAP** jumper board and remove the board.
3. On the jumper circuit board, unclip the 12-pin connector jumper from P72 and re-attach it to P71. Insert it until the plastic retaining clips “snap”. See [Figure 5-12](#). Note that the jumper has a retaining strap so it will not get dropped or lost. This repositioning establishes a connection between the diode boards with the input and fuse panels.

Figure 5-12 Jumper Connector - Operational Mode.

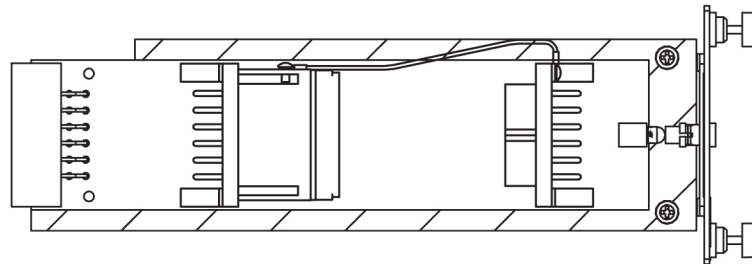

4. Slide the jumper board back into the **FAP**. Verify the **OP/MAINT LED** lights green. The fuse alarm **LED** returns to green.

The jumper board operational mode procedure is completed.

Operational Mode

Use this procedure to place the jumper board into operational mode. This mode of operation allows one bus to pick up the entire load when there is a loss of input power on the other bus.

Procedure — Operational Mode

1. Locate the jumper board on the Fuse and **Alarm** Panel (**FAP**).
2. Unscrew the two thumbscrews securing the **FAP** jumper board and remove the board.
3. On the jumper circuit board, unclip the 12-pin connector jumper from P72 and re-attach it to P71. Insert it until the plastic retaining clips “snap”. Note that the jumper has a retaining strap so it will not get dropped or lost. This repositioning establishes a connection between the diode boards with the input and fuse panels.

Figure 5-13 Jumper Connector - Operational Mode.

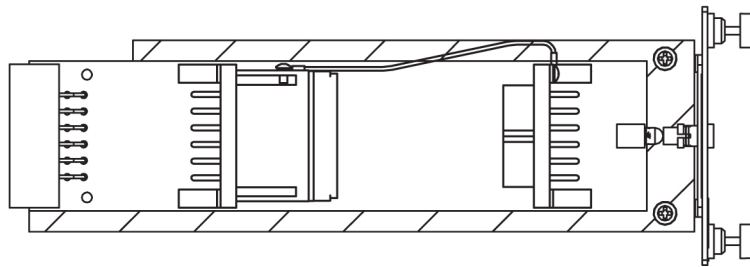

4. Slide the jumper board back into the **FAP**. Verify the **OP/MAINT LED** lights green. The fuse alarm **LED** returns to green.

The jumper board operational mode procedure is completed.

Provision Rules for FAP Fuse Locations

The following are provisioning rules for fuse placement apply to FAP P/N870-2804-xx:

- Maximum fuse size 3 amp.
- Fuse positions 19 and 20 not used.
- Power feed must originate from the same power source.
- Fuse and Alarm Panel Shorting board in bypass mode must be less than 40 amp per distributed output side.

These provisioning rules for fuse placement apply to **FAPs** P/N 870-1606-xx and P/N 870-2320-xx.

- Maximum fuse size 3 amp for Fuse one through Fuse 18 when P1, P2, or P3 are used for power output
- P2 cannot be used if the Terminal Strip (output) position 12 is used.
- P3 cannot be used if the Terminal Strip (output) position 18 is used.
- Fuse maximum of 15 amp for fuse positions 12, 18, 19, and 20, all other fuse positions are 3 amp.

Note: For fuse locations 12, 18, 19, and 20, the fuse maximum is 10 amp when adjacent locations are used.

- Power feed must originate from the same power source.
- Fuse and **Alarm** Panel, Jumper Board (P/N 870-1641-01) fuse size on boards 40 amp per side for P/N 870-1606-02 Rev A and B, and for P/N 870-2320-01 Rev A through I. Fuse size on boards 60 amp per side for P/N 870-1606-02 Rev C and 870-2320-01 Rev J.
- Fuse and **Alarm** Panel, Jumper board in maintenance mode must be less than 40 amp per distributed output side.

Installing Power Cables

Each frame is divided into A and B power buses. If loss of power on one of the buses occurs, the other bus must be able to supply current for the entire frame. Therefore, each bus requires wiring sized to match the **FAP** selection, with a maximum voltage drop of 0.5 volts. All frames containing **HCMIM** cards require 60A. The site voltage input to each frame should be between -40VDC and -57.5VDC. To meet this specification:

- Fuse and wire each bus to support 40A if you have a **FAP** 870-2320-03 Rev A through Rev I, 870-0243-08 Rev C, or 870-0243-09 Rev C.

Note: Existing frames that are fused at 40A can be upgraded to support 60A with a **FAP** upgrade kit. 60A are required for frames that contain **HC-MIMs**. Upgrades will be performed by Oracle personnel. Contact [My Oracle Support \(MOS\)](#) for more information.

- Fuse and wire each bus to support 60A if you have a **FAP** 870-2320-04 Rev J, or 870-2804-01 Rev A.
- For Input Power, RTN, and Logic GND use only the following for Fuse and Alarm Panel connectors:
 - **FAP** P/N 870-2804-001; Straight, two-hole lugs, 1/4-inch on 5/8-inch centers, long barrel with windows (504-0817-02)
 - All other **FAPs**; Straight, two-hole lugs, #10 hole on 5/8-inch centers, long barrel with windows (502-0085-R01)

All connections to the **FAP** are #6AWG (number 6 American Wire Gage). [Table 5-9](#) shows the list of required wiring sizes based on the length of the cable run. H-tap to the main feed where larger gauge wire is required for long cable runs.

Use H-taps at the fuse and alarm panel and power board to reduce the wire size to #6 AWG.

Note: Specific wire sizes may be determined by the site requirements.

Table 5-9 Power Cable Conductor Sizes

Breaker Size in Amperes	Cable Length	Conductor Size (AWG)
40A	up to 40 ft. (12.2 meters)	#6
	up to 70 ft. (21.3 meters)	#4
	up to 110 ft. (33.5 meters)	#2
	up to 170 ft. (51.8 meters)	1/0
	up to 200 ft. (61 meters)	2/0
	up to 220 ft. (67.1 meters)	4/0

Table 5-9 (Cont.) Power Cable Conductor Sizes

Breaker Size in Amperes	Cable Length	Conductor Size (AWG)
60A	up to 40 ft. (12.2 meters)	#2
	up to 70 ft. (21.3 meters)	1/0
	up to 110 ft. (33.5 meters)	2/0
	up to 170 ft. (51.8 meters)	4/0
	up to 200 ft. (61 meters)	350MCM
	up to 220 ft. (67.1 meters)	350MCM

Note: Where the cable leaves the cable rack, the cable must be protected with fiber paper throughout the system.

Recommended Tools

Oracle tools should be labeled “Property of **ORACLE**” with either a press-on Field Tool Identification label or Field Tool Identification wrap.

- Safety glasses
- Multimeter
- Lacing cord
- Cable cutters
- Cable stripper
- Crimping tool, embossing dies
- Socket wrench set with 1/4-inch or 3/8-inch drive or open end wrenches
- Heat-shrink gun (hot air blower)
- Torque wrench
- Fiber paper

Note: It is a requirement that when mating dissimilar metals non oxidizing grease is used between them as a corrosion inhibitor.

1. Apply the cable tags provided with the system to both ends of the supply and return cables.
2. Ensure that power is off at the central office power distribution board for the circuits being wired.

Use a multimeter.

3. Remove the clear plastic cover from the back of the fuse and alarm panel.
4. Run, form, and dress the cable from the power distribution board, over the cable racks, to the fuse and alarm panel.
5. Strip the cable ends, slide a one-inch length of clear heat-shrink tubing over and past the portion of stripped cable.
6. Apply non oxidizing grease to the stripped end of the cable, and install the lug.

The stripped cable must fill lug completely to the end of the barrel of the lug and be visible in the end window of the lug.

Figure 5-14 Lug Installation

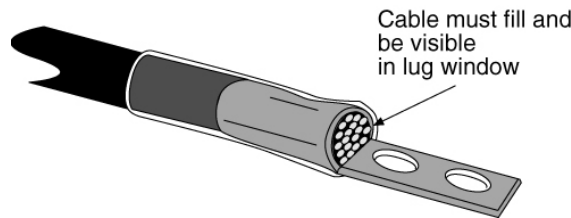

Note: Input Power and RTN use straight, two hole lugs, 1/4-inch hole on 5/8-inch centers, long barrel with window (P/N 804-0817-02).

7. Double crimp the lugs onto the cable end using the embossing crimper.
8. Slide the one-inch length of clear tubing over the crimped lug and heat-shrink the one-inch length of clear tubing.
9. Fasten the lugs of the cables to the respective A-side and B-side -48VDC and RTN points on the FAP. Refer to [Figure 5-15](#) and [Figure 5-16](#).

Figure 5-15 1U Fuse and Alarm Panel Rear (P/N 870-2804-01)

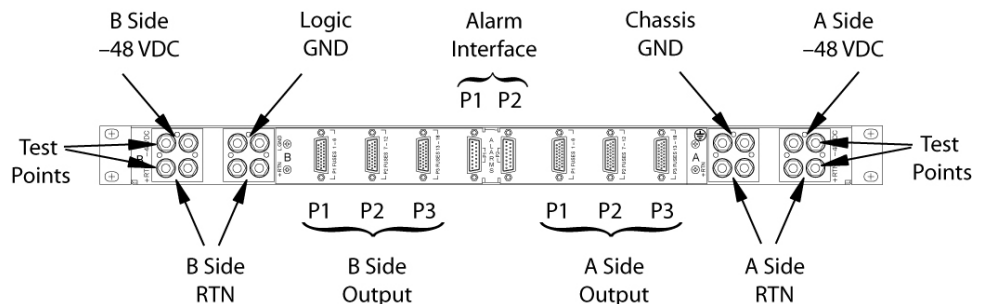
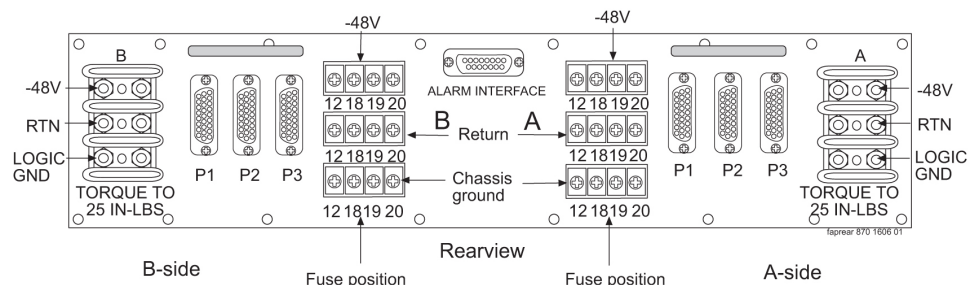

Figure 5-16 3U Fuse and Alarm Panel Rear (P/N 870-2320-03))



Tighten the lugs to:

- 1U FAP, torque to 50 inch-pounds
- 3U FAP, torque to 25 inch-pounds

10. Verify correct connection with a multimeter by running continuity check.

11. Replace the clear plastic cover on the back of the fuse and alarm panel.

12. Secure the power cables to the cable rack with lacing cord.

Note: Where the cable leaves the cable rack, the cable must be protected with fiber paper throughout the system.

Frame Ground and Logic Ground Cabling Procedures

This section covers these procedures:

- [Ground Frame](#)
- [Connect Ground Cable to Control Frame](#)
- [Logic Ground Connections to the System Ground Bar](#)
- [Logic Ground Cables](#)

Grounding Requirements

NOT_SUPPORTED: Strictly observe all grounding requirements to reduce the risk of electric shock.

The system operates as a digital isolated ground plane system in a central office environment and requires a single connection to the central office ground window. The system's ground cables must provide the sole grounding connection between the entire system and the central office grounding.

Recommended Tools

Oracle tools should be labeled "Property of **ORACLE**" with either a press-on Field Tool Identification label or Field Tool Identification wrap.

- Safety glasses
- Power knife
- Cable cutters
- Cable stripper
- Flush cutters
- Crimping tool with embossing dies (test before using)
- Socket wrench set, 1/4-inch or 3/8-inch drive or open-end wrenches
- Non oxidizing grease

Note: It is a requirement that when mating dissimilar metals non oxidizing grease is used between them as a corrosion inhibitor.

- Lacing cord and nylon cable ties
- Heat-shrink gun (hot air blower)
- Torque wrench
- Fiber paper

Ground Frame

1. Install the continuous ground conductor to the Ground Window. Run the conductor the length of the equipment lineup (see the figure below).

The separate #6 American Wire Gauge (**AWG**) cable ground that runs to each frame will allow removal of a frame from the lineup without interrupting the grounding of other frames in the lineup.

2. Install the branch ground conductor to the frame using screws and washers.

The continuous aisle ground conductor will be H-tapped to the branch (see the figure below). Torque screws to 45 inch-pounds.

Figure 5-17 System Frame Grounding

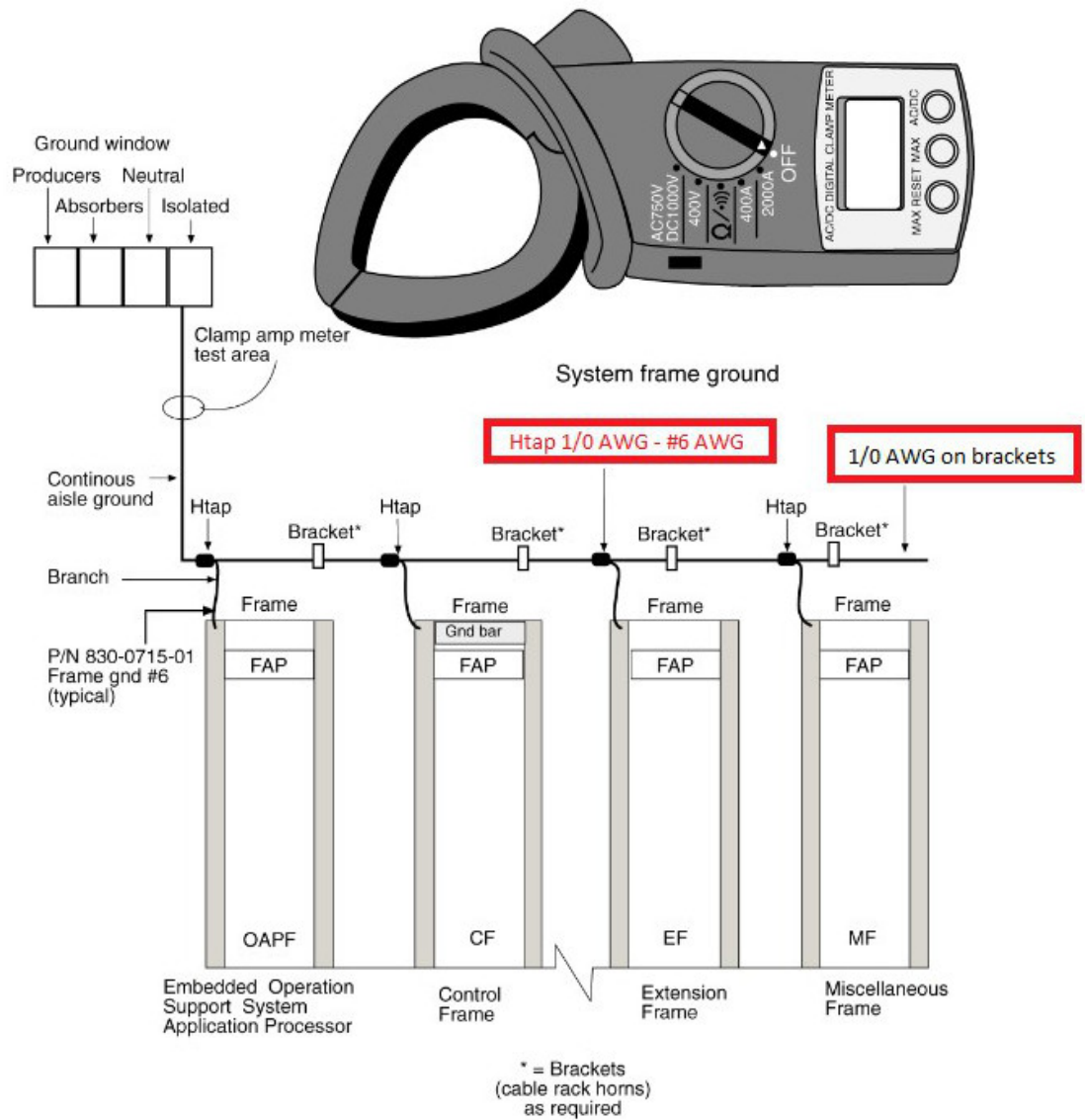

3. Secure the cable to the cable brackets with lacing cord.
4. Cables must be labeled, 145P tags should have "TO" and "FROM" location information.

Example: **FROM MGB** (Main Ground Bar), **TO** system ground bar Control Frame, **CF00**.
5. DO NOT "double lug": The practice of using one bolt through a lug and the ground bar, and through another lug on the other side of the ground bar, held in place by one nut.
6. A bolt through any nut must show at least two threads beyond the nut but no more than four threads should be showing.

Connect Ground Cable to Control Frame

Caution: This equipment has a connection between the earthed conductor of the DC supply circuit and the earthing conductor.

Note: It is a requirement that when mating dissimilar metals non oxidizing grease is used between them as a corrosion inhibitor.

1. Run the 1/0 ground cable from the central office Main Ground Bar (**MGB**) over the cable rack horns to the system Control Frame, **CF-00**.
2. At the control frame end of the cable:
 - a. Cut the 1/0 Green Ground Cable (P/N 690-0108-R07) to length and strip the end.
 - b. Slide the clear heat-shrink (P/N 804-0229-01) on the cut and stripped end of the cable.

Move the heat-shrink past the stripped portion of the cable to allow access to the uncovered wire.
 - c. Apply a thin coat of non oxidizing grease to the stripped end of the cable.
 - d. Slide the 1/0 pink lug (P/N 804-0977-R01) to the stripped cable.

Secure the lug to the cable by double crimping the barrel of the lug using a crimping tool with embossing dies. The stripped cable must fill lug completely to the end of the barrel of the lug and be visible in the end window of the lug.
 - e. Slide the heat-shrink down over the barrel of the lug and the cable.
 - f. Use a Heat-shrink gun (hot air blower) to shrink the clear heat-shrink to the barrel of the lug and cable.
3. Secure the cable to the cable rack horns with lacing cord.

Note: Tie-wraps are not allowed on the top frame horn or above. On the top horn/bracket and above use only lacing cord.

4. Apply a small amount of non oxidizing grease to the mounting holes on a copper system ground bar where the lug contacts the ground bar; on a tinned ground bar non oxidizing grease is not needed.
5. Install the ground cable lug using the 3/8-inch # 6 copper-plated hardware provided.

Use the attachment sequence shown in [Figure 5-18](#).

Figure 5-18 System Logic Grounding

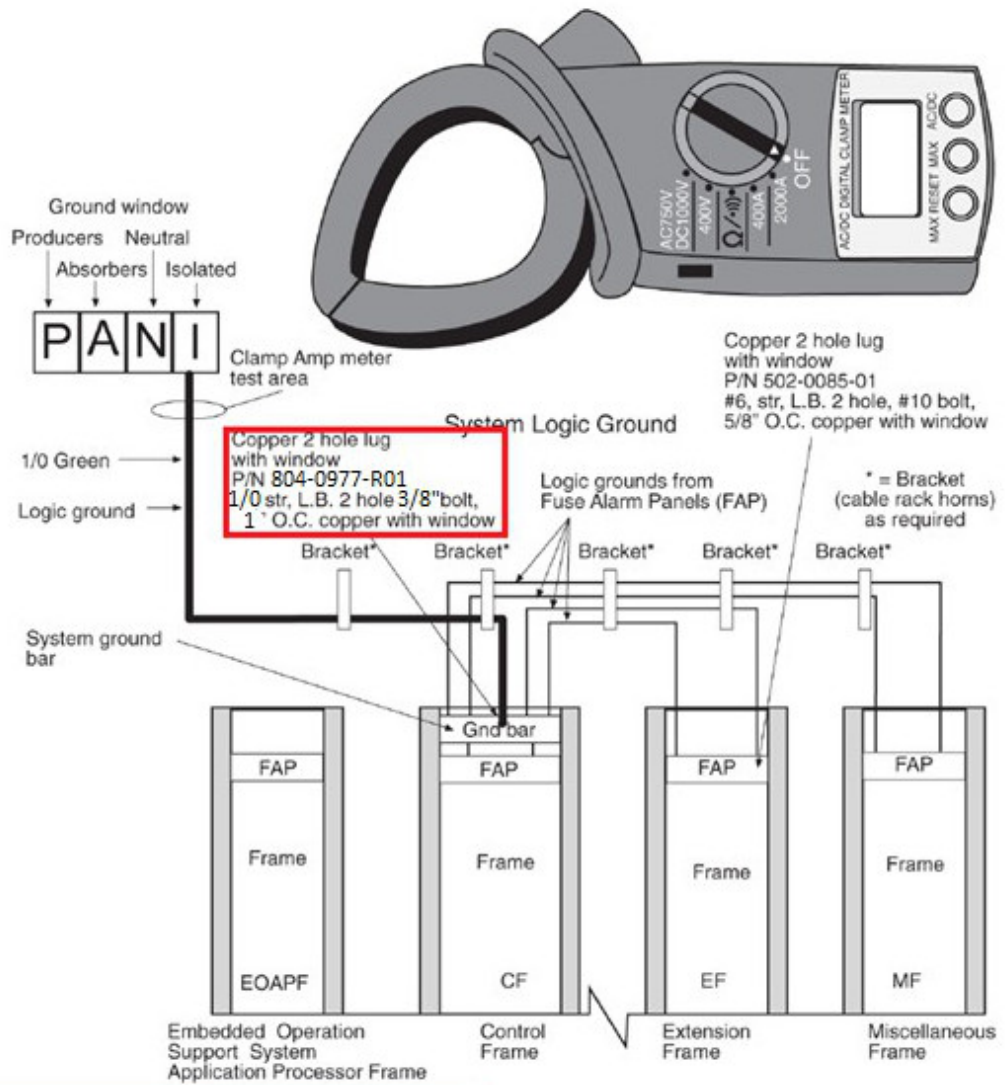

6. Tighten the bolts to 15.5 foot-pounds of torque.
7. Use the lacing cord to secure a "DONOTDISCONNECTLEAD" tag at each end of the cable, just beyond the lug.

Note: System Ground: 1/0 cable from the system ground bar to the "I" section of the ground window. If no ground window exists, the customer will designate the termination point.

Note: Frame Ground: A cable #6 AWG from a frame is H-tapped into 1/0 cable and also terminates on the "I" section of the ground window.

Note: The size of the cable is determined by the overall length of the cable run. Refer to the Site File Book.

Figure 5-19 Clamp Reading on System Frame and Logic

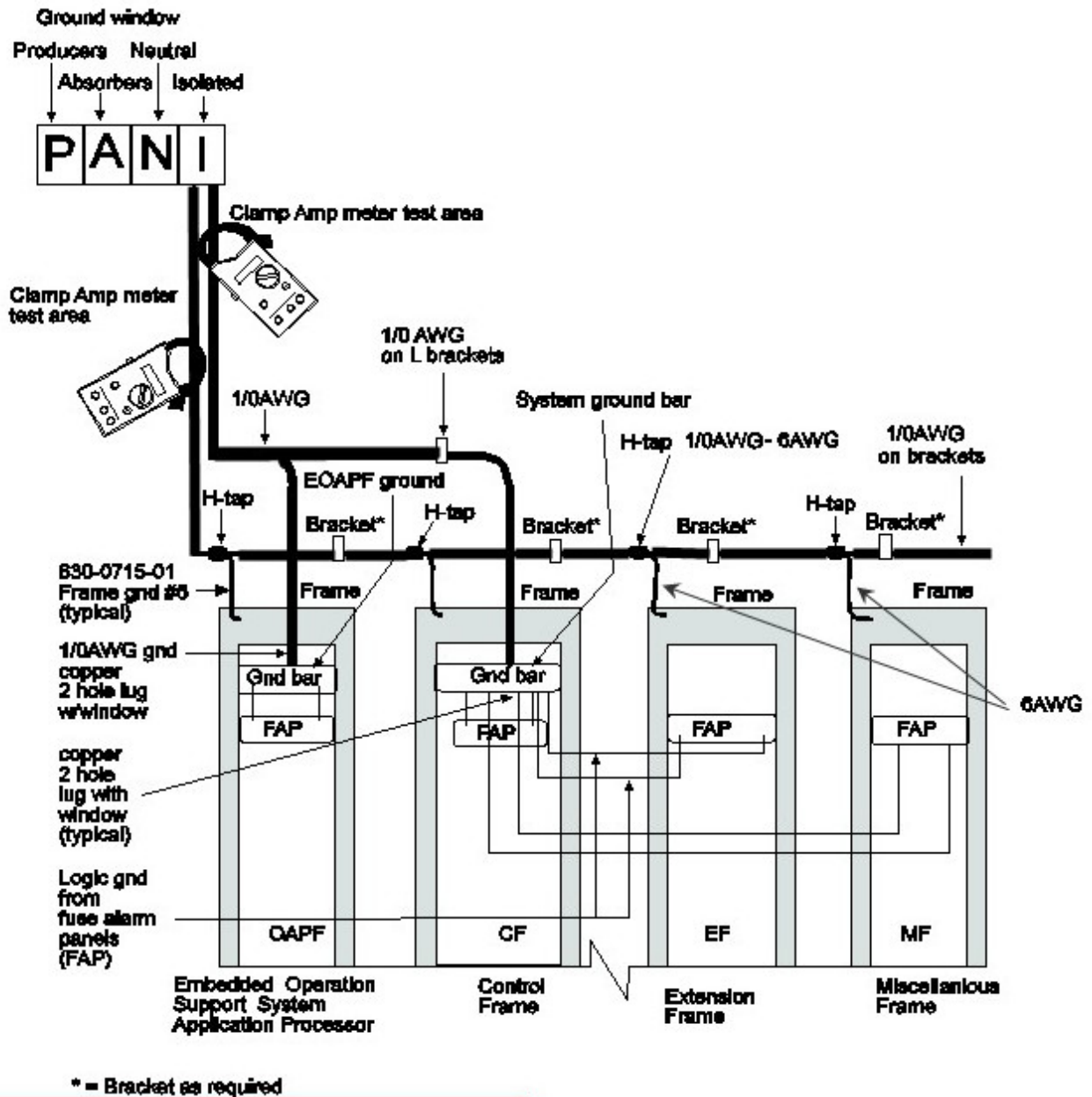

Logic Ground Connections to the System Ground Bar

Note: It is a requirement that when mating dissimilar metals non oxidizing grease is used between them as a corrosion inhibitor.

1. Place a clear heat-shrink on the cable.
2. Butt, strip the end of the cable, and apply a small amount of non oxidizing grease to the conductor.

The stripped cable must fill lug completely to the end of the barrel of the lug and be visible in the end window of the lug.

3. Crimp #6 American Wire Gauge (AWG) lug with window on the cable, using an embossing crimper.
4. Apply a small amount of non oxidizing grease to the mounting holes on a copper system ground bar, *Non oxidizing grease is not needed on a tin ground bar*, where the lug contacts the ground bar.
5. Crimp a #6 AWG lug with a window on the cable.

Use an embossing crimper. The stripped cable must fill lug completely to the end of the barrel of the lug and be visible in the end window of the lug.

warning: All logic ground connections *must* be made to the system ground bar.

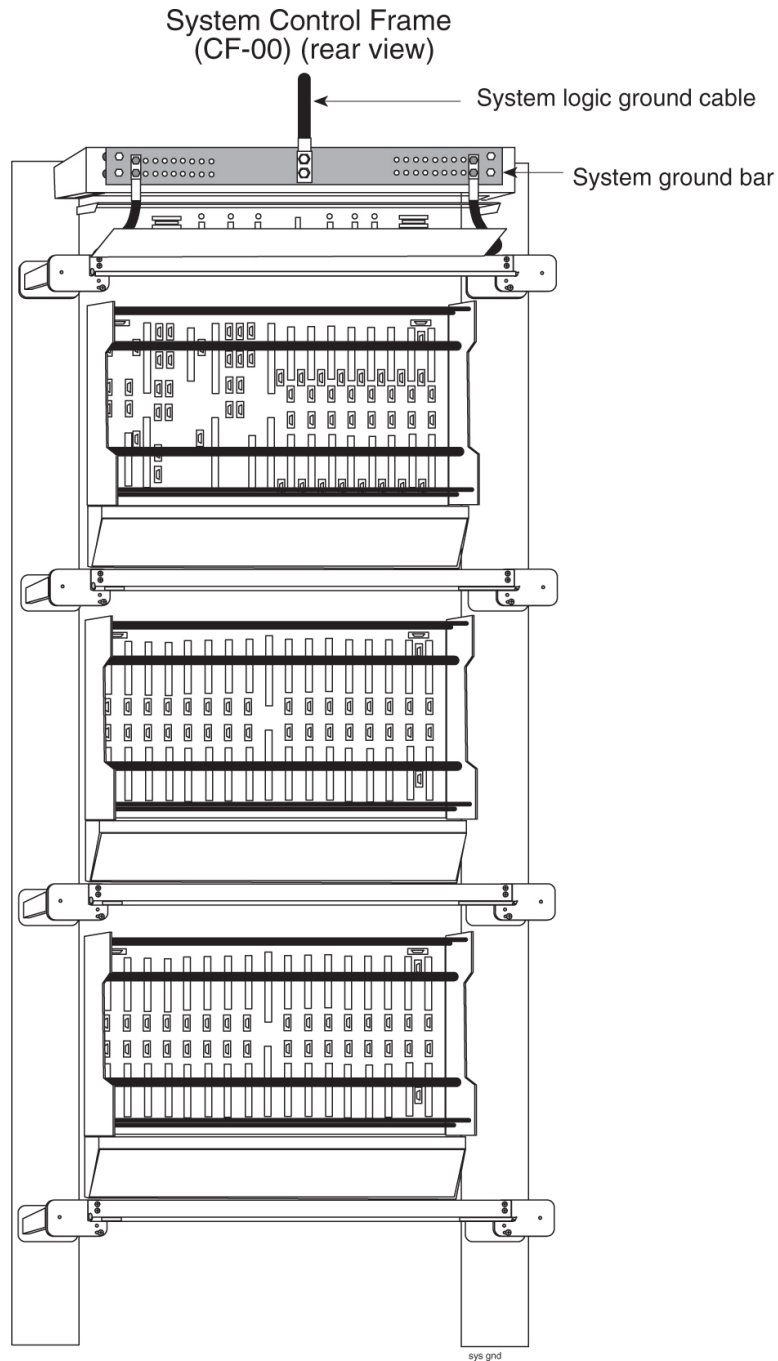
Figure 5-20 System Logic Ground Bar and Cable

Note: It may be necessary to drill the central office ground window bar to accept the 3/8-inch bolts on one-inch centers. Apply the 145P cable tags (see [Figure 5-24](#)) provided to both ends of the ground cable, including the “Do Not Disconnect”.

6. Install the logic ground cable lugs P/N 804-0817-R02 using the 1/4-inch 20 copper-plated hardware provided (refer to [Figure 5-20](#)).

Tighten the bolts to 68 inch-pounds.

Figure 5-21 System Logic Grounding

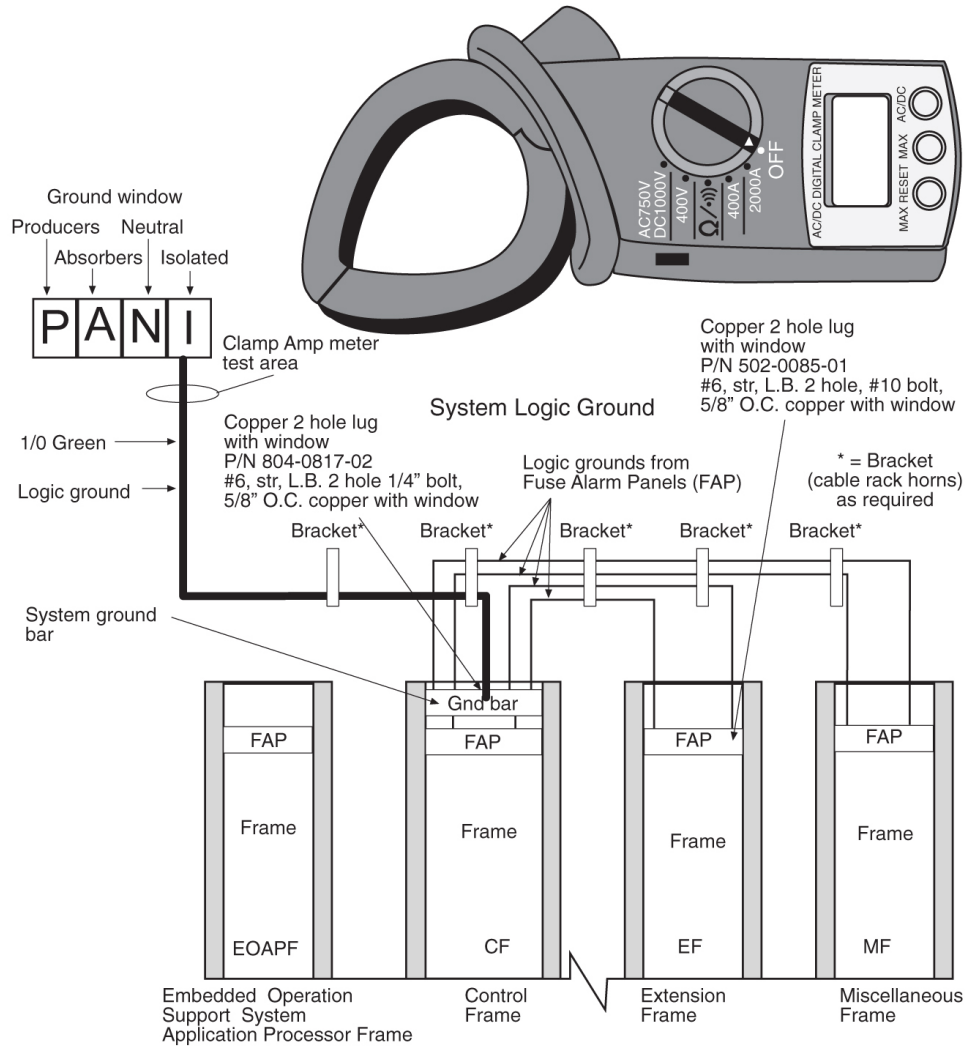

Note: The only ground cables that are terminated to the system ground bar are the logic grounds from the fuse and alarm panel.

Note: DONOT run Logic Ground or Power Cables on the cable horns in the top middle of a frame. The horn is for Row Alarm Cables only.

warning: All logic ground connections *must* be made to the system ground bar.

- Repeat 2, 3, and 4, on the fuse and alarm panel end.

Note: 1U FAP: On the frame, use straight, two hole lugs, 1/4-inch hole on 5/8-inch centers, long barrel with window (P/N 804-0817-02). The FAP Chassis GND and Logic GND use 90-degree, 2-hole lug, 1/4" hole on 5/8-inch centers, long barrel with window (P/N 502-0081-02).

Note: All other FAPs: #6-gauge lug (P/N 502-0085-R01) must be used on the fuse and alarm panel end of the cable.

8. Terminate the fuse and alarm panel end of the cable on the terminal strip at the position marked **LOGICGROUND**.

Figure 5-22 1U Fuse and Alarm Panel Rear (P/N 870-2804-01)

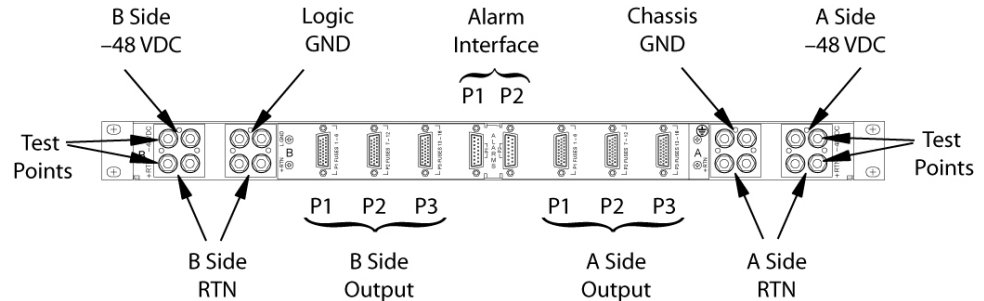
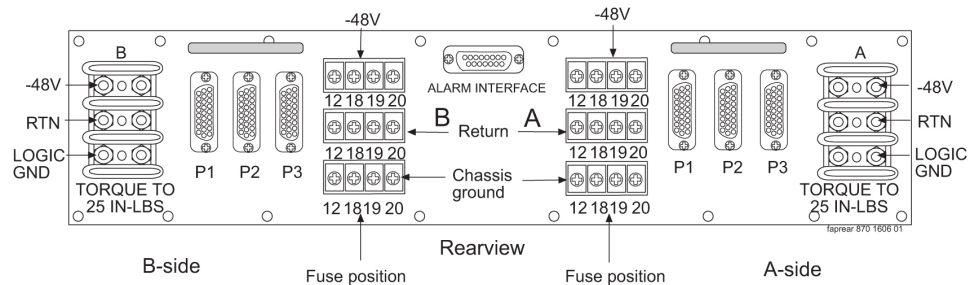

Figure 5-23 3U Fuse and Alarm Panel Rear (P/N 870-2320-03)



9. Tighten the nuts on the fuse and alarm panel.

Tighten the lugs to:

- 1U FAP, torque to 50 inch-pounds.
- 3U FAP, torque to 25 inch-pounds.

Logic Ground Cables

The logic ground cables are a part of the internal power distribution. They provide a ground connection between the backplane of each system shelf and the system ground bar in the Control Frame (CF). The logic ground is connected from each shelf to the fuse and alarm panel by the consolidated power cables, cable #6 AWG (P/N 690-0131-R01), terminal lug (P/N 804-0817-R02), and heat-shrink (P/N 804-0228-01).

Note: It is a requirement that when mating dissimilar metals non oxidizing grease is used between them as a corrosion inhibitor.

1. Run green cable, #6 AWG (P/N 690-0131-R01).
2. Butt, strip, and apply non oxidizing grease to conductor.

The stripped cable must fill lug completely to the end of the barrel of the lug and be visible in the end window of the lug.

3. Place clear heat-shrink on butted end of wire below stripped end.
4. Place lug onto the stripped end of the cable and crimp the lug using embossing dies.

The stripped cable must fill lug completely to the end of the barrel of the lug and be visible in the end window of the lug.

Note: Terminal lug (P/N 804-0817-R02) must have two holes and with a window. The stripped cable must fill lug completely to the end of the barrel of the lug and be visible in the end window of the lug.

- a. To install the cable on the system ground bar, wipe a small amount of non oxidizing grease at the mounting hole.

Attach the lug with the 1/4-inch #20 copper-plated hardware provided. Torque to 68 inch-pounds.

- b. Secure the cable to cable rack horn using lacing cord.
- c. Label each cable **TO** ____ and **FROM** ____ for later use.

Figure 5-24 Ground Bar and Logic Ground Installation

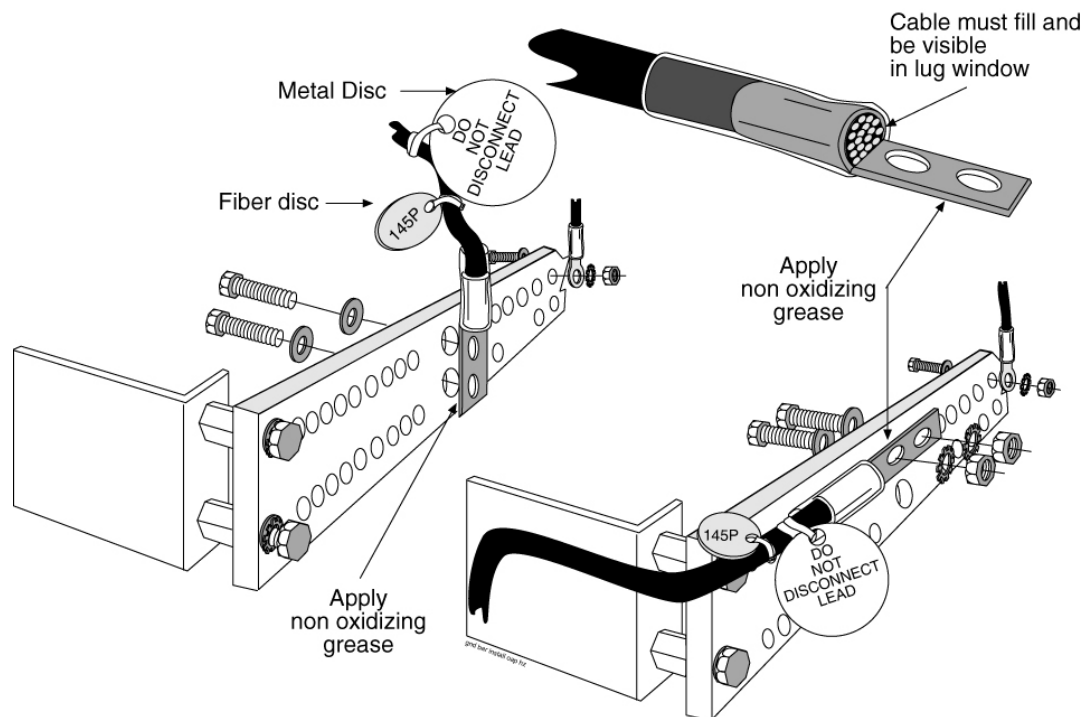

5. Cables must be labeled: 145P tags should have “TO” and “FROM” location information.

Example: **TO** system ground bar Control Frame, **CF00FROMMGB** (Main Ground Bar),.

6. **DONOT** “double lug”: The practice of using one bolt through a lug and the ground bar, and through another lug on the other side of the ground bar, held in place by one nut.

A bolt through any nut must show at least two threads beyond the nut but no more than four threads should be showing.

Figure 5-25 System Logic Ground Connection

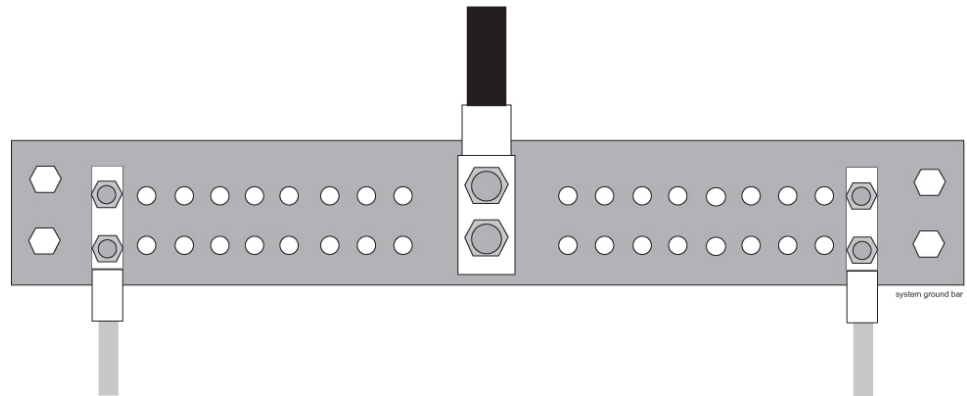
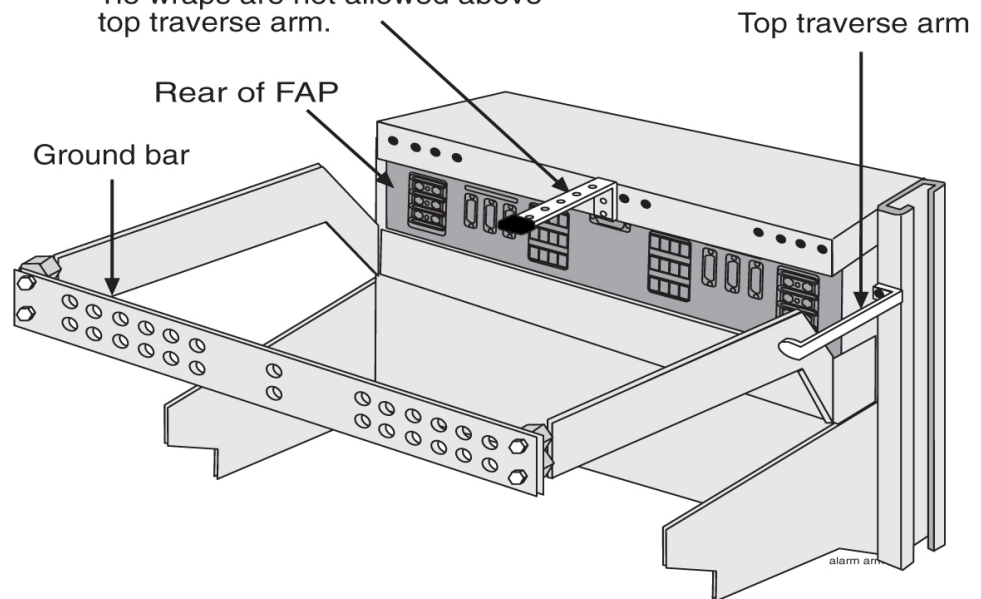

Figure 5-26 Alarm Cable Arm

Alarm cable arm or Alarm cable horn is for alarm and clock cable only. Cables must be laced in place. Tie wraps are not allowed above top traverse arm.



Note: The alarm cable arm is for alarm cable which maybe a clock cable.

Fuse Verification

For each fuse location, verify that individual fuse failures affect only the circuits assigned to the specific fuse location.

For those fuse locations that do not yet have circuit cards assigned, use fuses and circuit cards assigned to other locations for the test procedure and then remove them.

Verify each fuse using the following tools:

- The steps in this procedure to perform the verification.

warning: Use the antistatic wrist strap connected to the wrist strap grounding point on the frame when performing these procedures.

- [Fuse and Card Locations](#) to determine fuse and card locations.

Note: The card location numbers in the table indicate the shelf and the slot for that card. The left two digits indicate the shelf and the right two digits indicate the card slot in that shelf. For example, a location of 1215 indicates a card in shelf 12, slot 15.

- [Figure 5-2](#) and [Figure 5-8](#) to physically locate the fuse holders.
- [Fuse and Card Locations](#) to physically locate a card in a shelf.

Table 5-10 Fuse Color Codes of Alarm Flags

Fuse Amp	Fuse Flag Color	Fuse Amp	Fuse Flag Color
0.18A	Orange-Red	2A	Orange
0.2A	Black-Red	2.5A	White-Orange
0.25A	Violet	3A	Blue
0.33A	Yellow-Green	3.5A	White-Blue
0.375A	White-Green	4A	White -Brown
0.5A	Red	5A	Green
0.65A	Black	7.5A	Black-White
0.75A	Brown	10A	Red-White
1A	Gray	12A	Yellow-Green
1.33A	White	15A	Red-Blue
1.5A	White-Yellow		

Procedure - Verify Individual Fuse Positions

1. Ensure that all fuses have been removed.
2. Ensure that all circuit cards have been removed.
3. Confirm that the system is receiving power from the -48VDC power source.
(Ensure that voltage is present by checking it with a volt ohm meter.)
4. Install a fuse of the rating specified for that position.
5. Install circuit cards appropriate for the slots powered by that fuse.
6. Check that LEDs of the applicable cards are on.

Note: For each fuse position, perform Steps 7 through 16.

7. Pull the fuse for the A-side position.
8. Check that the Fuse Alarm LED for the A-side is red.
9. Check that the LEDs of the cards in the specified locations are illuminated after the removal of the fuse.
10. Replace the fuse for the A-side position.
11. Check that the Fuse Alarm LED for the A-side is green.
12. Check that the LEDs of the cards in the specified locations are illuminated.
13. Pull the fuse for the B-side position.
14. Check that the Fuse Alarm LED for the B-side is red.
15. Check that the LEDs of the cards in the specified locations are illuminated after the removal of the fuse.
16. Pull the fuse for the A-side position.
17. Check that the Fuse Alarm LED for the A-side is red.
18. Check that the LEDs of the cards in the specified locations are not illuminated after the removal of the fuse.
19. Replace the fuse for the A-side and B-side position.
20. Check that the Fuse Alarm LED for the A-side and B-side is green.
21. Check that the LEDs of the cards in the specified locations are illuminated after the replacing of the fuses.

This completes individual fuse position testing of the FAP. Return the frame to service.

Verification of Fuse Alarm Function

This procedure verifies that appropriate fuse alarms are generated by the system.

warning: Use the antistatic wrist strap connected to the wrist strap grounding point when performing these procedures.

1. Ensure that all fuses have been removed.
2. Use a multi-meter to ensure that each frame has -48VDC power, see [Figure 5-3](#) and [Figure 5-9](#).
3. Insert a blown fuse, see [Figure 5-2](#) and [Figure 5-8](#), into fuse bank A of the Fuse and Alarm Panel (FAP) on the control frame.

Fuse alarm and major alarm Light Emitting Diodes (LEDs) of that frame should light and an audible alarm should sound.

4. Remove the blown fuse.

The fuse alarm should immediately go out, the major alarm should go out after a few seconds, and the audible alarm should stop.

- Repeat 3 and 4 for fuse bank B of the control frame and for fuse banks A and B of each extension frame.

Figure 5-27 Fuse (GMT Brand Name)

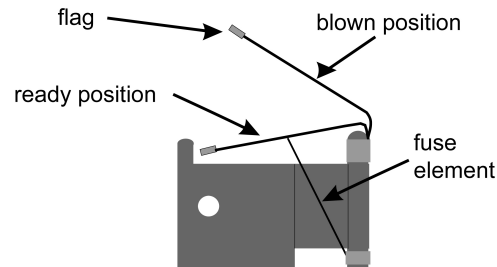

FAP Alarm System Test

The following procedure describes system wide fuse alarm testing of the FAP.

- Issue the command to login to the STP terminal 1.
- Enter the password.
- Press the F11 key for KSR mode. The following command response is displayed.

```
Command Accepted - Processing
```

```
tekelecstp 00-05-31 06:55:22 EST Rel XX.X.X-XX.X.X
LOGIN:UID=EAGLE
Command entered at terminal #1.
;
tekelecstp 00-05-31 06:55:23 EST Rel XX.X.X-XX.X.X
NOTICE: This is a private computer system.
Unauthorized access or use may lead to prosecution.
0 LOGIN failures since last successful LOGIN
Last successful LOGIN was on port 1 on 00-05-31 @ 06:46:46
```

- Issue the command to change the terminal security features to "ALL = YES" for terminal 2.

```
> chg-secu-trm:all=yes:trm=2
```

- The following command response is displayed.

```
Command Accepted - Processing
```

```
channel 00-05-31 06:10:28 EST Rel XX.X.X-XX.X.X
CHG-SECU-TRM:ALL=YES:TRM=2
Command entered at terminal #1.
;
channel 00-05-31 06:10:29 EST Rel XX.X.X-XX.X.X
CHG-SECU-TRM: MASP A - COMPLTD
```

- Issue the command to set the system monitoring feature for the terminal you are logged into.

```

> chg-trm:all=no:sys=yes:trm=1
Command Accepted - Processing

tekelecstp 12-12-23 08:52:15 EST Rel XX.X.X-XX.X.X
chg-trm:all=no:sys=no:trm=1
Command entered at terminal #1.
;
tekelecstp 12-12-23 08:52:16 EST Rel XX.X.X-XX.X.X
CHG-TRM: MASP A - COMPLTD

```

- Remove a fuse from the first position of A-side fuse bank on the FAP and insert a blown fuse in its place. This will be done on the A-side then the B-side of the FAP

The FUSE ALM LED for that side and the Major LED should illuminate RED after the blown fuse has been inserted indicating the presence of a blown fuse.

- The VT terminal of the STP should report the presence of a blown fuse.

```

Tekelecstp 00-05-31 11:18:42 EST Rel XX.X.X-XX.X.X
** 5050.0082 ** FUSE PANEL 11xx      Alarm in Fuse Panel

```

- Enter the command to display the system alarms.

```
> rept-stat-trbl
```

- The following command response is displayed.

Verify that the alarm condition appears in the rept-stat-trbl screen.

```

Command Accepted - Processing

tekelecstp 00-05-31 11:15:38 EST Rel XX.X.X-XX.X.X
rept-stat-trbl
Command entered at terminal #1.
;
tekelecstp 00-05-31 11:15:38 EST Rel XX.X.X-XX.X.X
Searching devices for alarms...
;
tekelecstp 00-05-31 11:15:38 EST Rel XX.X.X-XX.X.X
SEQN UAM AL DEVICE ELEMENT TROUBLE TEXT
5012.0048 * TERMINAL 2 Terminal failed
5014.0048 * TERMINAL 3 Terminal failed
5016.0048 * TERMINAL 4 Terminal failed
5042.0082 ** FUSE PANEL 11xx Alarm in Fuse Panel
5043.0308 *C SYSTEM Node isolated due to SLK
failures
Command Completed.

```

- Re-insert the good fuse and verify that the alarm clears. FAP light should return to its normal state GREEN.

```

tekelecstp 00-05-31 11:18:55 EST Rel XX.X.X-XX.X.X
5051.0083 FUSE PANEL 11xx Fuse Panel alarm has
cleared

```

- Repeat Steps 7 - 11 for FAP sides A and B for each fuse location.

This completes fuse alarm testing of the FAP. Return the frame to service.

Fuse Assignments

Refer to *Installation* “Fuse and Card Locations” section for information on the fuse assignments for the Control Frame, CF-00 and five Extension Frames, EF-00 through EF-04.

The power distribution for the control frame and the extension frame are shown in the following figures:

- Control frame, [Figure 5-28](#)
- Extension frame, [Figure 5-29](#)

Figure 5-28 Control Frame FAP (P/N 870-0243-08 and P/N 870-1606-xx)

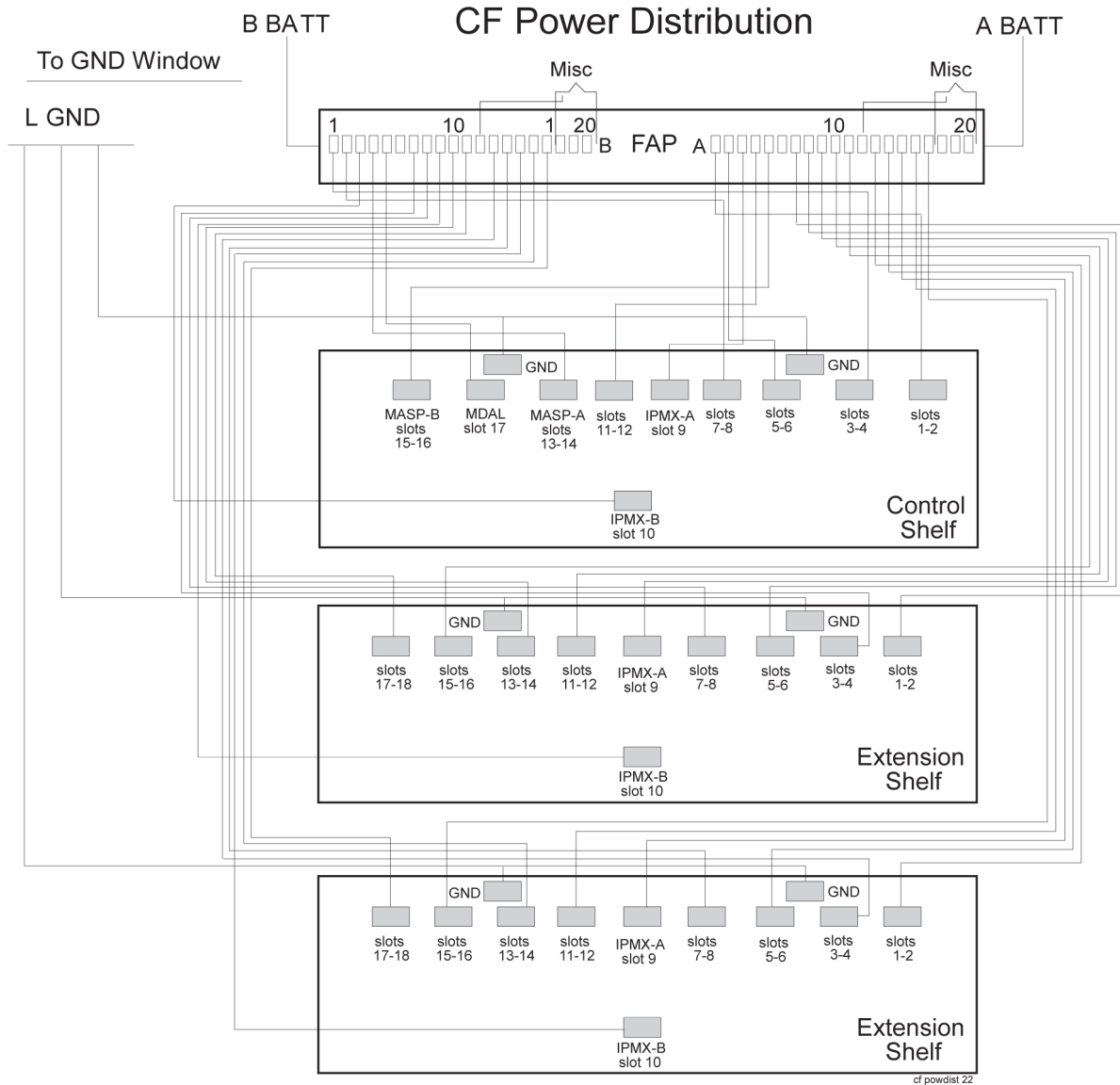
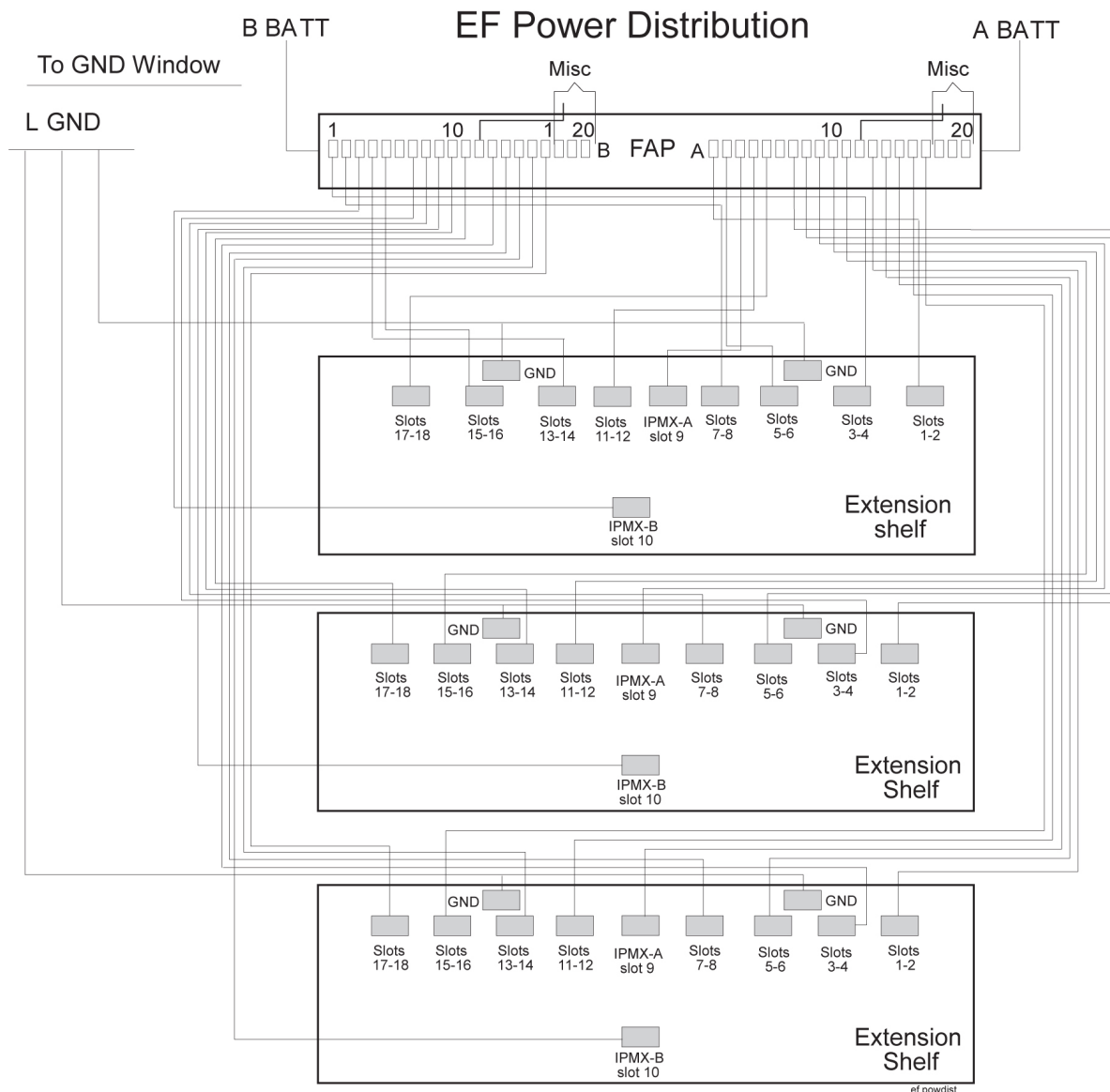

Figure 5-29 Extension Frame FAP (P/N 870-0243-08 and P/N 870-1606-xx)



Fuse and Card Locations

This section describes fuse assignments for the Control Frame (CF-00) and five Extension Frames (EF-00 through EF-04) are shown.

Table 5-11 Fuses and Card Locations

Fuse Location/ Capacity	Card Location/Type
Control Frame 00 (CF-00) Fuse and Alarm Panel side A (refer to Figure 5-30)	
Fuse 1A/ 3Amp	1101, 1102/LIMs, E/DCM*, or E5-E1T1

Table 5-11 (Cont.) Fuses and Card Locations

Fuse Location/ Capacity	Card Location/Type
Fuse 2A/ 3Amp	1105, 1106/ LIMs , E/ DCM* , or E1-T1
Fuse 3A/Amp	1109
Fuse 4A/ 3Amp	1111, 1112/ LIMs , E/ DCM* , or E1-T1
Fuse 5A/ 3Amp	1115, 1116/ MASP - B and MCAP
Fuse 6A/ dummy fuse	Designated for FAN 3 Amp
Fuse 7A/ 3Amp	1201, 1202/ LIMs , E/ DCM* , or E1-T1
Fuse 8A/ 3Amp	1205, 1206/ LIMs , E/ DCM* , or E1-T1
Fuse 9A/ 1Amp	1209
Fuse 10A/ 3Amp	1211, 1212/ LIMs , E/ DCM* , or E1-T1
Fuse 11A/ 3Amp	1215, 1216/ LIMs , E/ DCM* , or E1-T1
Fuse 12A/ dummy fuse	Designated for FAN 3 Amp
Fuse 13A/ 3Amp	1301, 1302/ LIMs , E/ DCM* , or E1-T1
Fuse 14A/ 3Amp	1305, 1306/ LIMs , E/ DCM* , or E1-T1
Fuse 15A/ 1Amp	1309
Fuse 16A/ 3Amp	1311, 1312/ LIMs , E/ DCM* , or E1-T1
Fuse 17A/ 3Amp	1315, 1316/ LIMs , E/ DCM* , or E1-T1
Fuse 18A/ dummy fuse	Designated for FAN 3 Amp
Fuse 19A/ dummy fuse	OPEN

Table 5-11 (Cont.) Fuses and Card Locations

Fuse Location/ Capacity	Card Location/Type
Fuse 20A/ dummy fuse	OPEN
Control Frame 00 (CF-00) Fuse and Alarm Panel side B (refer to Figure 5-30)	
Fuse 1B/ 3Amp	1103, 1104/ LIMs, E/DCM* , or E1-T1
Fuse 2B/ 3Amp	1107, 1108/ LIMs, E/DCM* , or E1-T1
Fuse 3B/ 1Amp	1110
Fuse 4B/ 3Amp	1113, 1114/ MASP - A, and MCAP
Fuse 5B/ 3Amp	1117, 1118/ HIPR/HIPR2
Fuse 6B/ dummy fuse	Designated for FAN 3 Amp
Fuse 7B/ 3Amp	1203, 1204/ LIM, E1-T1, DCM*
Fuse 8B/ 3Amp	1207, 1208/ LIM, E1-T1, DCM*
Fuse 9B/ 1Amp	1210
Fuse 10B/ 3Amp	1213, 1214/ LIMs, E/DCM* , or E1-T1
Fuse 11B/ 3Amp	1217, 1218/ LIMs, E/DCM* , or E1-T1
Fuse 12B/ dummy fuse	Designated for FAN 3 Amp
Fuse 13B/ 3Amp	1303, 1304/ LIMs, E/DCM* , or E1-T1
Fuse 14B/ 3Amp	1307, 1308/ LIMs, E/DCM* , or E1-T1
Fuse 15B/ 1Amp	1310

Table 5-11 (Cont.) Fuses and Card Locations

Fuse Location/ Capacity	Card Location/Type
Fuse 16B/ 3Amp	1313, 1314/ LIMs, E/DCM* , or E1-T1
Fuse 17B/ 3Amp	1317, 1318/ LIMs, E/DCM* , or E1-T1
Fuse 18B/ dummy fuse	Designated for FAN 3 Amp
Fuse 19B/ dummy fuse	OPEN
Fuse 20B/ dummy fuse	OPEN
Extension Frame 00 (EF-00) Fuse and Alarm Panel side A (refer to Figure 5-31)	
Fuse 1A/ 3Amp	2101, 2102/ LIMs, E/DCM* , or E1-T1
Fuse 2A/ 3Amp	2105, 2106/ LIMs, E/DCM* , or E1-T1
Fuse 3A/ 1Amp	2109
Fuse 4A/ 3Amp	2111, 2112/ LIMs, E/DCM* , or E1-T1
Fuse 5A/ 3Amp	2115, 2116/ LIMs, E/DCM* , or E1-T1
Fuse 6A/ dummy fuse	Designated for FAN 3 Amp
Fuse 7A/ 3Amp	2201, 2202/ LIMs, E/DCM* , or E1-T1
Fuse 8A/ 3Amp	2205, 2206/ LIMs, E/DCM* , or E1-T1
Fuse 9A/ 1Amp	2209
Fuse 10A/ 3Amp	2211, 2212/ LIMs, E/DCM* , or E1-T1
Fuse 11A/ 3Amp	2215, 2216/ LIMs, E/DCM* , or E1-T1

Table 5-11 (Cont.) Fuses and Card Locations

Fuse Location/ Capacity	Card Location/Type
Fuse 12A/ dummy fuse	Designated for FAN 3 Amp
Fuse 13A/ 3Amp	2301, 2302/LIMs, E/DCM*, or E1-T1
Fuse 14A/ 3Amp	2305, 2306/LIMs, E/DCM*, or E1-T1
Fuse 15A/ 1Amp	2309
Fuse 16A/ 3Amp	2311, 2312/LIMs, E/DCM*, or E1-T1
Fuse 17A/ 3Amp	2315, 2316/LIMs, E/DCM*, or E1-T1
Fuse 18A/ dummy fuse	Designated for FAN 3 Amp
Fuse 19A/ dummy fuse	OPEN
Fuse 20A/ dummy fuse	OPEN
Extension Frame 00 (EF-00) Fuse and Alarm Panel side B (refer to Figure 5-31)	
Fuse 1B/ 3Amp	2103, 2104/LIMs, E/DCM*, or E1-T1
Fuse 2B/ 3Amp	2107, 2108/LIMs, E/DCM*, or E1-T1
Fuse 3B/ 1Amp	2110
Fuse 4B/ 3Amp	2113, 2114/LIMs, E/DCM*, or E1-T1
Fuse 5B/ 3Amp	2117, 2118/LIMs, E/DCM*, or E1-T1
Fuse 6B/ dummy fuse	Designated for FAN 3 Amp
Fuse 7B/ 3Amp	2203, 2204/LIMs, E/DCM*, or E1-T1

Table 5-11 (Cont.) Fuses and Card Locations

Fuse Location/ Capacity	Card Location/Type
Fuse 8B/ 3Amp	2207, 2208/ LIMs , E/ DCM* , or E1-T1
Fuse 9B/ 1Amp	2210
Fuse 10B/ 3Amp	2213, 2214/ LIMs , E/ DCM* , or E1-T1
Fuse 11B/ 3Amp	2217, 2218/ LIMs , E/ DCM* , or E1-T1
Fuse 12B/ dummy fuse	Designated for FAN 3 Amp
Fuse 13B/ 3Amp	2303, 2304/ LIMs , E/ DCM* , or E1-T1
Fuse 14B/ 3Amp	2307, 2308/ LIMs , E/ DCM* , or E1-T1
Fuse 15B/ 1Amp	2310
Fuse 16B/ 3Amp	2313, 2314/ LIMs , E/ DCM* , or E1-T1
Fuse 17B/ 3Amp	2317, 2318/ LIMs , E/ DCM* , or E1-T1
Fuse 18B/ (dummy fuse)	Designated for FAN 3 Amp
Fuse 19B/ dummy fuse	OPEN
Fuse 20B/ dummy fuse	OPEN
Extension Frame 01 (EF-01) Fuse and Alarm Panel side A (refer to Figure 5-32)	
Fuse 1A/ 3Amp	3101, 3102/ LIMs , E/ DCM* , or E1-T1
Fuse 2A/ 3Amp	3105, 3106/ LIMs , E/ DCM* , or E1-T1
Fuse 3A/ 1Amp	3109

Table 5-11 (Cont.) Fuses and Card Locations

Fuse Location/ Capacity	Card Location/Type
Fuse 4A/ 3Amp	3111, 3112/ LIMs, E/DCM* , or E1-T1
Fuse 5A/ 3Amp	3115, 3116/ LIMs, E/DCM* , or E1-T1
Fuse 6A/ dummy fuse	Designated for FAN 3 Amp
Fuse 7A/ 3Amp	3201, 3202/ LIMs, E/DCM* , or E1-T1
Fuse 8A/ 3Amp	3205, 3206/ LIMs, E/DCM* , or E1-T1
Fuse 9A/ 1Amp	3209
Fuse 10A/ 3Amp	3211, 3212 / LIMs, E/DCM* , or E1-T1
Fuse 11A/ 3Amp	3215, 3216/ LIM, E1-T1, DCM* , or EDCM
Fuse 12A/ dummy fuse	Designated for FAN 3 Amp
Fuse 13A/ 3Amp	3301, 3302/ LIMs, E/DCM* , or E1-T1
Fuse 14A/ 3Amp	3305, 3306/ LIMs, E/DCM* , or E1-T1
Fuse 15A/ 1Amp	3309
Fuse 16A/ 3Amp	3311, 3312/ LIMs, E/DCM* , or E1-T1
Fuse 17A/ 3Amp	3315, 3316/ LIMs, E/DCM* , or E1-T1
Fuse 18A/ (dummy fuse)	Designated for FAN 3 Amp
Fuse 19A/ dummy fuse	OPEN
Fuse 20A/ dummy fuse	OPEN

Table 5-11 (Cont.) Fuses and Card Locations

Fuse Location/ Capacity	Card Location/Type
Extension Frame 01 (EF-01) Fuse and Alarm Panel side B (refer to Figure 5-32)	
Fuse 1B/ 3Amp	3103, 3104/LIMs, E/DCM*, or E1-T1
Fuse 2B/ 3Amp	3107, 3108/LIMs, E/DCM*, or E1-T1
Fuse 3B/ 1Amp	3110
Fuse 4B/ 3Amp	3113, 3114/LIMs, E/DCM*, or E1-T1
Fuse 5B/ 3Amp	3117, 3118/LIMs, E/DCM*, or E1-T1
Fuse 6B/ dummy fuse	Designated for FAN 3 Amp
Fuse 7B/ 3Amp	3203, 3204/LIMs, E/DCM*, or E1-T1
Fuse 8B/ 3Amp	3207, 3208/LIMs, E/DCM*, or E1-T1
Fuse 9B/ 1Amp	3210
Fuse 10B/ 3Amp	3213, 3214/LIMs, E/DCM*, or E1-T1
Fuse 11B/ 3Amp	3217, 3218/LIMs, E/DCM*, or E1-T1
Fuse 12B/ (dummy fuse)	Designated for FAN 3 Amp
Fuse 13B/ 3Amp	3303, 3304/LIMs, E/DCM*, or E1-T1
Fuse 14B/ 3Amp	3307, 3308/LIMs, E/DCM*, or E1-T1
Fuse 15B/ 1Amp	3310
Fuse 16B/ 3Amp	3313, 3314/LIMs, E/DCM*, or E1-T1
Fuse 17B/ 3Amp	3317, 3318/LIMs, E/DCM*, or E1-T1

Table 5-11 (Cont.) Fuses and Card Locations

Fuse Location/ Capacity	Card Location/Type
Fuse 18B/ dummy fuse	Designated for FAN 3 Amp
Fuse 19B/ dummy fuse	OPEN
Fuse 20B/ dummy fuse	OPEN
Extension Frame 02 (EF-02) Fuse and Alarm Panel side A (refer to Figure 5-33)	
Fuse 1A/ 3Amp	4101, 4102/LIMs, E/DCM*, or E1-T1
Fuse 2A/ 3Amp	4105, 4106/LIMs, E/DCM*, or E1-T1
Fuse 3A/ 1Amp	4109
Fuse 4A/ 3Amp	4111, 4112/LIMs, E/DCM*, or E1-T1
Fuse 5A/ 3Amp	4115, 4116/LIMs, E/DCM*, or E1-T1
Fuse 6A/ dummy fuse	Designated for FAN 3 Amp
Fuse 7A/ 3Amp	4201, 4202/LIMs, E/DCM*, or E1-T1
Fuse 8A/ 3Amp	4205, 4206/LIMs, E/DCM*, E5-E1T1, or E5-TSM
Fuse 9A/ 1Amp	4209
Fuse 10A/ 3Amp	4211, 4212/LIMs, E/DCM*, or E1-T1
Fuse 11A/ 3Amp	4215, 4216/LIMs, E/DCM*, or E1-T1
Fuse 12A/ dummy fuse	Designated for FAN 3 Amp
Fuse 13A/ 3Amp	4301, 4302/LIMs, E/DCM*, or E1-T1

Table 5-11 (Cont.) Fuses and Card Locations

Fuse Location/ Capacity	Card Location/Type
Fuse 14A/ 3Amp	4305, 4306/ LIMs , E/ DCM* , or E1-T1
Fuse 15A/ 1Amp	4309
Fuse 16A/ 3Amp	4311, 4312/ LIMs , E/ DCM* , or E1-T1
Fuse 17A/ 3Amp	4315, 4316/ LIMs , E/ DCM* , or E1-T1
Fuse 18A/ dummy fuse	Designated for FAN 3 Amp
Fuse 19A/ dummy fuse	OPEN
Fuse 20A/ dummy fuse	OPEN
Extension Frame 02 (EF-02) Fuse and Alarm Panel side B (refer to Figure 5-33)	
Fuse 1B/ 3Amp	4103, 4104/ LIMs , E/ DCM* , or E1-T1
Fuse 2B/ 3Amp	4107, 4108/ LIMs , E/ DCM* , or E1-T1
Fuse 3B/ 1Amp	4110
Fuse 4B/ 3Amp	4113, 4114/ LIMs , E/ DCM* , or E1-T1
Fuse 5B/ 3Amp	4117, 4118/ LIMs , E/ DCM* , or E1-T1
Fuse 6B/ (dummy fuse)	Designated for FAN 3 Amp
Fuse 7B/ 3Amp	4203, 4204/ LIMs , E/ DCM* , or E1-T1
Fuse 8B/ 3Amp	4207, 4208/ LIMs , E/ DCM* , or E1-T1
Fuse 9B/ 1Amp	4210

Table 5-11 (Cont.) Fuses and Card Locations

Fuse Location/ Capacity	Card Location/Type
Fuse 10B/ 3Amp	4213, 4214/ LIMs , E/ DCM* , or E1-T1
Fuse 11B/ 3Amp	4217, 4218/ LIMs , E/ DCM* , or E1-T1
Fuse 12B/ (dummy fuse)	Designated for FAN 3 Amp
Fuse 13B/ 3Amp	4303, 4304/ LIMs , E/ DCM* , or E1-T1
Fuse 14B/ 3Amp	4307, 4308/ LIMs , E/ DCM* , or E1-T1
Fuse 15B/ 1Amp	4310
Fuse 16B/ 3Amp	4313, 4314/ LIMs , E/ DCM* , or E1-T1
Fuse 17B/ 3Amp	4317, 4318/ LIMs , E/ DCM* , or E1-T1
Fuse 18B/ dummy fuse	Designated for FAN 3 Amp
Fuse 19B/ dummy fuse	OPEN
Fuse 20B/ dummy fuse	OPEN
Extension Frame 03 (EF-03) Fuse and Alarm Panel side A (refer to Figure 5-34)	
Fuse 1A/ 3Amp	5101, 5102/ LIMs , E/ DCM* , or E1-T1
Fuse 2A/ 3Amp	5105, 5106/ LIMs , E/ DCM* , or E1-T1
Fuse 3A/ 1Amp	5109
Fuse 4A/ 3Amp	5111, 5112/ LIMs , E/ DCM* , or E1-T1
Fuse 5A/ 3Amp	5115, 5116/ LIMs , E/ DCM* , or E1-T1

Table 5-11 (Cont.) Fuses and Card Locations

Fuse Location/ Capacity	Card Location/Type
Fuse 6A/ (dummy fuse)	Designated for FAN 3 Amp
Fuse 7A/ 3Amp	5201, 5202/ LIMs , E/ DCM* , or E1-T1
Fuse 8A/ 3Amp	5205, 5206/ LIMs , E/ DCM* , or E1-T1 ,
Fuse 9A/ 1Amp	5209
Fuse 10A/ 3Amp	5211, 5212/ LIMs , E/ DCM* , or E1-T1
Fuse 11A/ 3Amp	5215, 5216/ LIMs , E/ DCM* , or E1-T1
Fuse 12A/ (dummy fuse)	Designated for FAN 3 Amp
Fuse 13A/ 3Amp	5301, 5302/ LIMs , E/ DCM* , or E1-T1
Fuse 14A/ 3Amp	5305, 5306/ LIMs , E/ DCM* , or E1-T1
Fuse 15A/ 1Amp	5309
Fuse 16A/ 3Amp	5311, 5312/ LIMs , E/ DCM* , or E1-T1
Fuse 17A/ 3Amp	5315, 5316/ LIM , E1-T1 , DCM*
Fuse 18A/ (dummy fuse)	Designated for FAN 3 Amp
Fuse 19A/ dummy fuse	OPEN
Fuse 20A/ dummy fuse	OPEN
Extension Frame 03 (EF-03) Fuse and Alarm Panel side B (refer to Figure 5-34)	
Fuse 1B/ 3Amp	5103, 5104/ LIMs , E/ DCM* , or E1-T1

Table 5-11 (Cont.) Fuses and Card Locations

Fuse Location/ Capacity	Card Location/Type
Fuse 2B/ 3Amp	5107, 5108/ LIMs , E/ DCM* , E1-T1 , or TSM ,
Fuse 3B/ 1Amp	5110
Fuse 4B/ 3Amp	5113, 5114/ LIMs , E/ DCM* , or E1-T1
Fuse 5B/ 3Amp	5117, 5118/ LIMs , E/ DCM* , E5-E1T1 , or E5-TSM
Fuse 6B/ (dummy fuse)	Designated for FAN 3 Amp
Fuse 7B/ 3Amp	5203, 5204/ LIMs , E/ DCM* , or E1-T1
Fuse 8B/ 3Amp	5207, 5208/ LIMs , E/ DCM* , or E1-T1
Fuse 9B/ 1Amp	5210
Fuse 10B/ 3Amp	5213, 5214/ LIMs , E/ DCM* , or E1-T1
Fuse 11B/ 3Amp	5217, 5218/ LIMs , E/ DCM* , or E1-T1
Fuse 12B/ (dummy fuse)	Designated for FAN 3 Amp
Fuse 13B/ 3Amp	5303, 5304/ LIMs , E/ DCM* , or E1-T1
Fuse 14B/ 3Amp	5307, 5308/ LIMs , E/ DCM* , or E1-T1
Fuse 15B/ 1Amp	5310
Fuse 16B/ 3Amp	5313, 5314/ LIMs , E/ DCM* , or E1-T1
Fuse 17B/ 3Amp	5317, 5318/ LIMs , E/ DCM* , or E1-T1
Fuse 18B/ (dummy fuse)	Designated for FAN 3 Amp

Table 5-11 (Cont.) Fuses and Card Locations

Fuse Location/ Capacity	Card Location/Type
Fuse 19B/ dummy fuse	OPEN
Fuse 20B/ dummy fuse	OPEN
Extension Frame 04 (EF-04) Fuse and Alarm Panel side A (refer to Figure 5-35)	
Fuse 1A/ 3Amp	6101, 6102/ LIMs , E/ DCM* , or E1-T1
Fuse 2A/ 3Amp	6105, 6106/ LIMs , E/ DCM* , or E1-T1
Fuse 3A/ 1Amp	6109
Fuse 4A/ 3Amp	6111, 6112/ LIMs , E/ DCM* , or E1-T1
Fuse 5A/ 3Amp	6115, 6116/ LIMs , E/ DCM* , or E1-T1
Fuse 6A/ dummy fuse	
Fuse 7A/ dummy fuse	
Fuse 8A/ dummy fuse	
Fuse 9A/ dummy fuse	
Fuse 10A/ dummy fuse	
Fuse 11A/ dummy fuse	
Fuse 12A/ dummy fuse	
Fuse 13A/ dummy fuse	
Fuse 14A/ dummy fuse	

Table 5-11 (Cont.) Fuses and Card Locations

Fuse Location/ Capacity	Card Location/Type
Fuse 15A/ dummy fuse	
Fuse 16A/ dummy fuse	
Fuse 17A/ dummy fuse	
Fuse 18A/ dummy fuse	
Fuse 19A/ dummy fuse	
Fuse 20A/ dummy fuse	
Extension Frame 04 (EF-04) Fuse and Alarm Panel side B (refer to Figure 5-35)	
Fuse 1B/ 3Amp	6103, 6104/ LIMs , E/ DCM* , or E1-T1
Fuse 2B/ 3Amp	6107, 6108/ LIMs , E/ DCM* , or E1-T1
Fuse 3B/ 1Amp	6110
Fuse 4B/ 3Amp	6113, 6114/ LIMs , E/ DCM* , or E1-T1
Fuse 5B/ 3Amp	6117, 6118/ LIMs , E/ DCM* , or E1-T1
Fuse 6B/ dummy fuse	
Fuse 7B/ dummy fuse	
Fuse 8B/ dummy fuse	
Fuse 9B/ dummy fuse	
Fuse 10B/ dummy fuse	

Table 5-11 (Cont.) Fuses and Card Locations

Fuse Location/ Capacity	Card Location/Type
----------------------------	--------------------

Fuse 11B/ dummy fuse	
-------------------------	--

Fuse 12B/ dummy fuse	
-------------------------	--

Fuse 13B/ dummy fuse	
-------------------------	--

Fuse 14B/ dummy fuse	
-------------------------	--

Fuse 15B/ dummy fuse	
-------------------------	--

Fuse 16B/ dummy fuse	
-------------------------	--

Fuse 17B/ dummy fuse	
-------------------------	--

Fuse 18B/ dummy fuse	
-------------------------	--

Fuse 19B/ dummy fuse	
-------------------------	--

Fuse 20B/ dummy fuse	
-------------------------	--

Fuse 2A	
---------	--

Fuse 3A/ dummy fuse	
------------------------	--

Fuse 4A/ dummy fuse	
------------------------	--

Fuse 5A/ dummy fuse	
------------------------	--

Fuse 6A/ dummy fuse	
------------------------	--

Fuse 7A/ dummy fuse	
------------------------	--

Fuse 8A/ dummy fuse	
------------------------	--

Fuse 9A/ dummy fuse	
------------------------	--

Table 5-11 (Cont.) Fuses and Card Locations

Fuse Location/ Capacity	Card Location/Type
Fuse 10A/ dummy fuse	
Fuse 11A/ dummy fuse	
Fuse 12A/ dummy fuse	
Fuse 13A/ dummy fuse	
Fuse 14A/ dummy fuse	
Fuse 15A/ dummy fuse	
Fuse 16A/ dummy fuse	
Fuse 17A/ dummy fuse	
Fuse 18A/ dummy fuse	
Fuse 19A	(10 A) A power (FAP P/N 870-2320-03 for heavy duty frame)
Fuse 20A	(10 A) A power (FAP P/N 870-2320-03 for heavy duty frame)
Fuse 3B/ dummy fuse	
Fuse 4B/ dummy fuse	
Fuse 5B/ dummy fuse	
Fuse 6B/ dummy fuse	
Fuse 7B/ dummy fuse	
Fuse 8B/ dummy fuse	
Fuse 9B/ dummy fuse	

Table 5-11 (Cont.) Fuses and Card Locations

Fuse Location/ Capacity	Card Location/Type
Fuse 10B/ dummy fuse	
Fuse 11B/ dummy fuse	
Fuse 12B/ dummy fuse	
Fuse 13B/ dummy fuse	
Fuse 14B/ dummy fuse	
Fuse 15B/ dummy fuse	
Fuse 16B/ dummy fuse	
Fuse 17B/ dummy fuse	
Fuse 18B/ dummy fuse	
Fuse 19B	(10 A) B power (FAP P/N 870-2320-03)
Fuse 20B	(10 A) B power (FAP P/N 870-2320-03)

Card Locations in Control and Extension Shelves

Figure 5-30 through Figure 5-35 show the card locations in Control and Extension shelves.

Figure 5-30 shows the numbering of the shelves, with the shelf identification **DIP** switch settings and backplane wiring, and card locations on the Control Frame (CF) and Extension Frame (EF).

Figure 5-31 Extension Frame EF-00 Numbering Plan

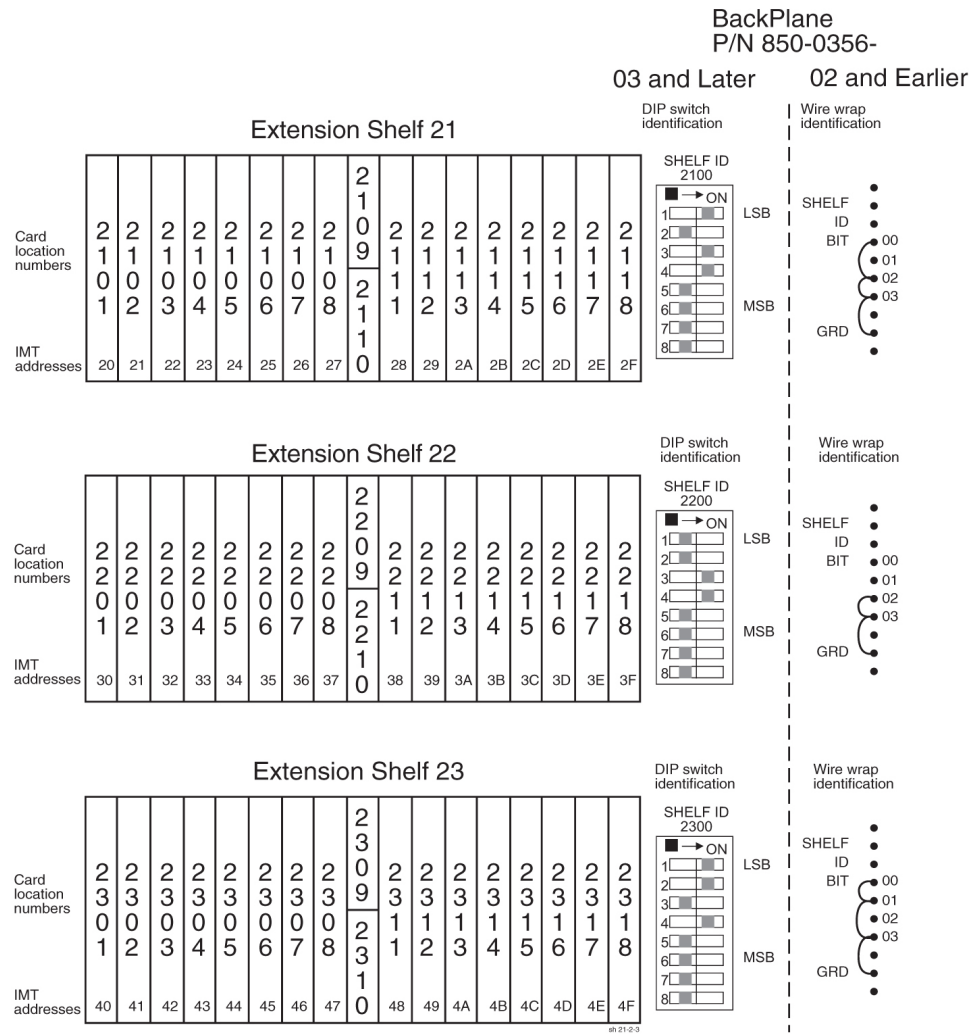

Figure 5-32 Extension Frame EF-01 Numbering Plan

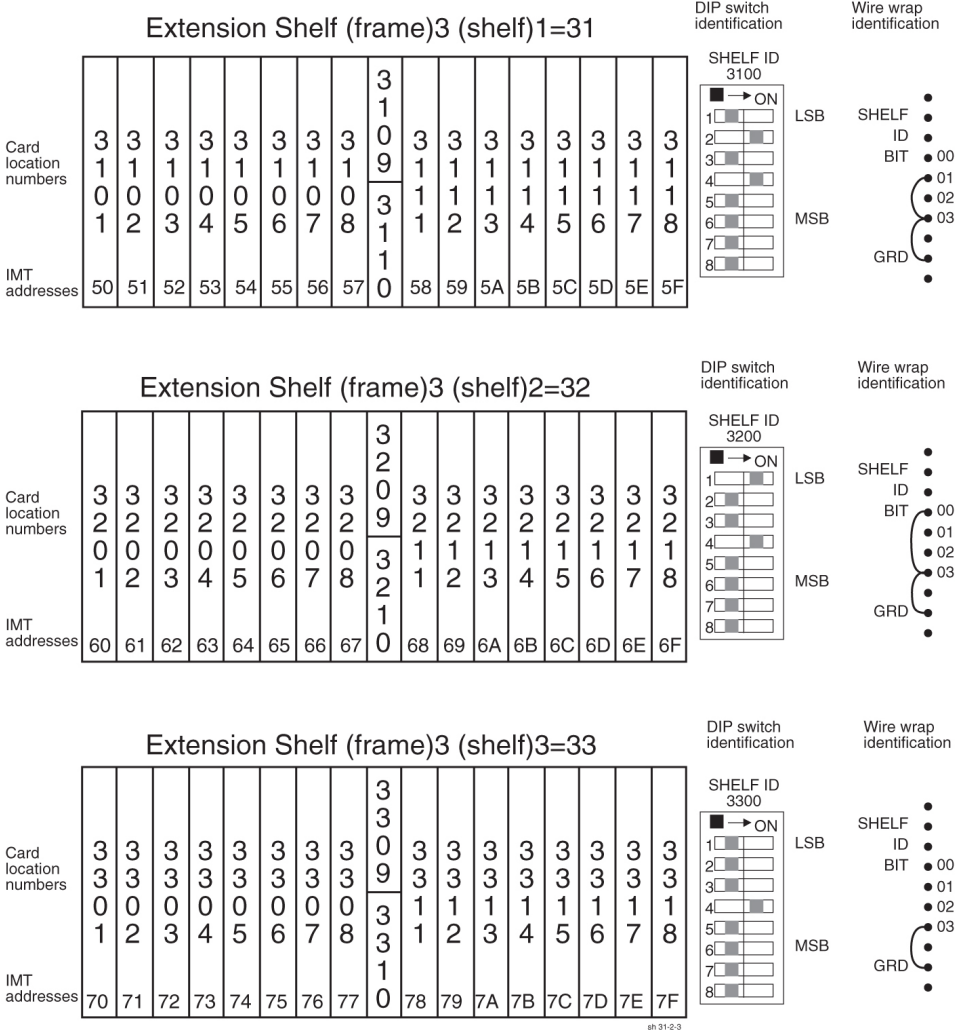

Figure 5-33 Extension Frame EF-02 Numbering Plan

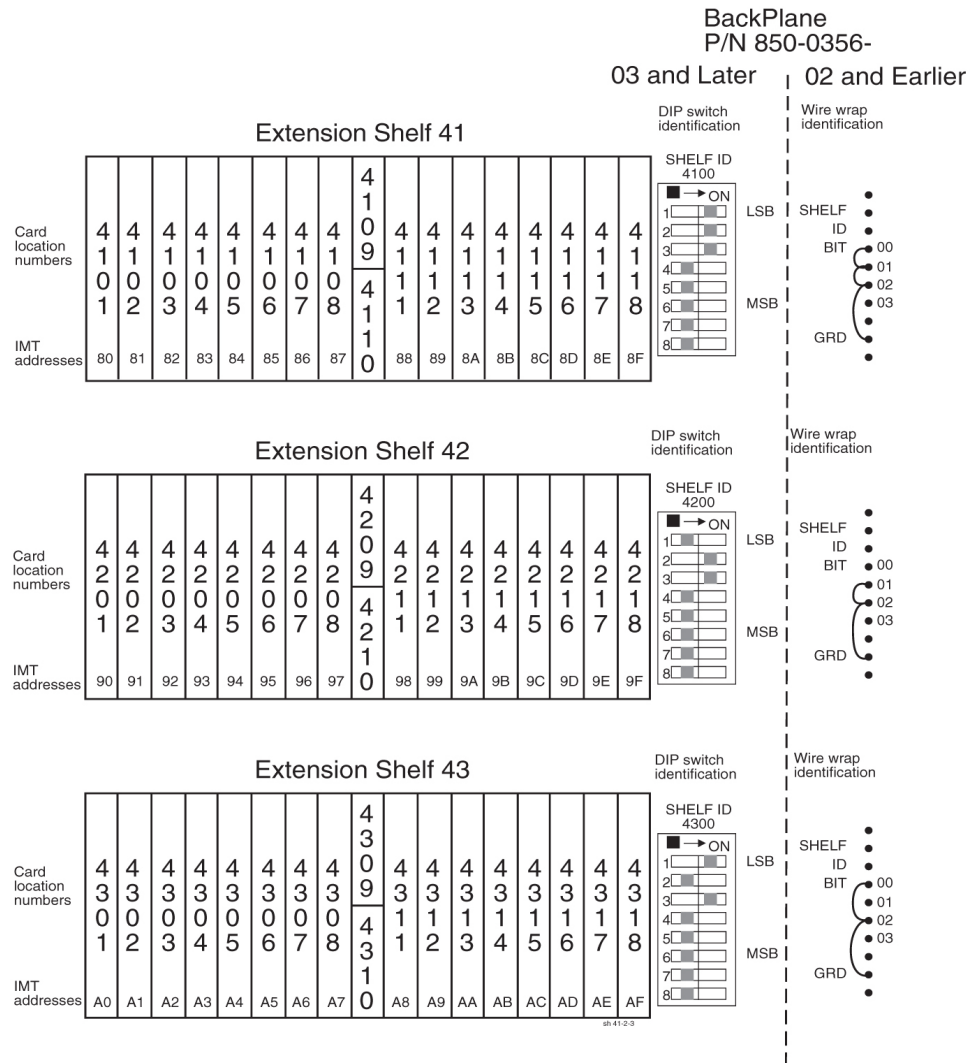

Figure 5-34 Extension Frame EF-03 Numbering Plan

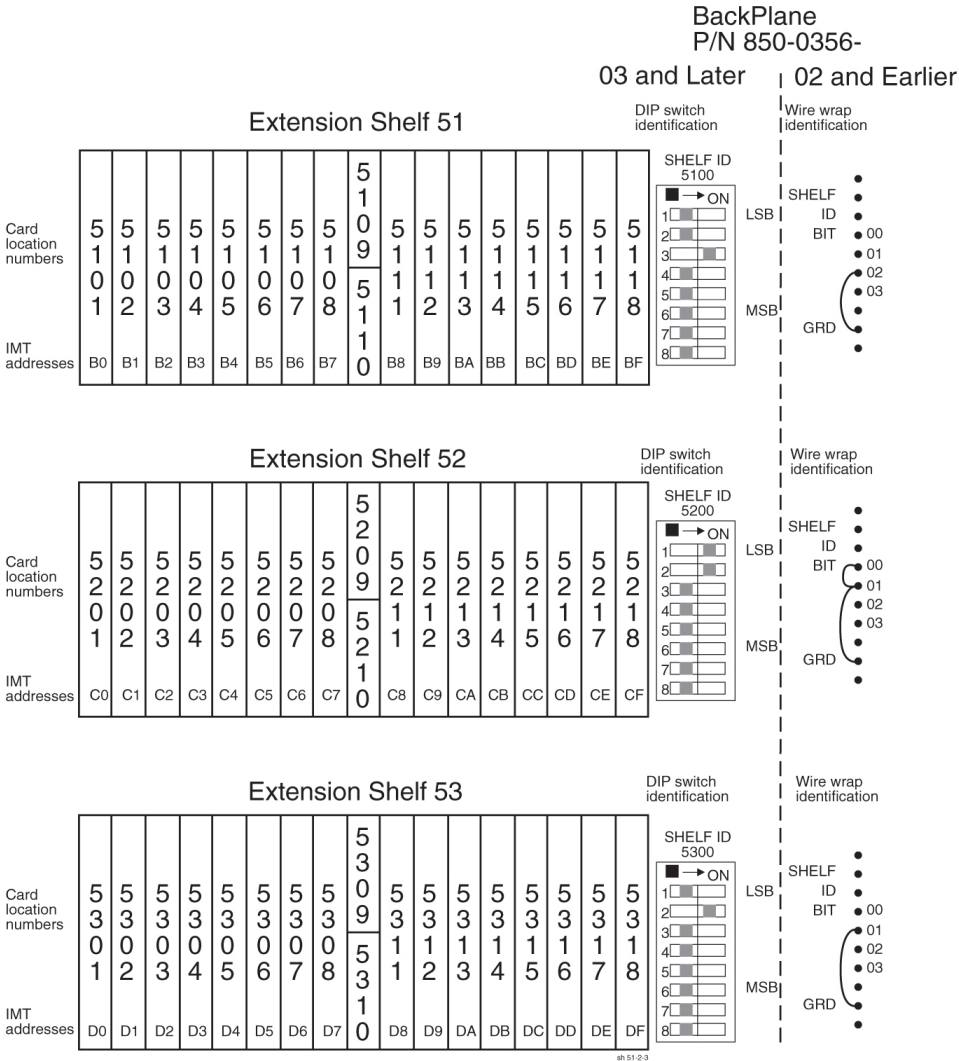
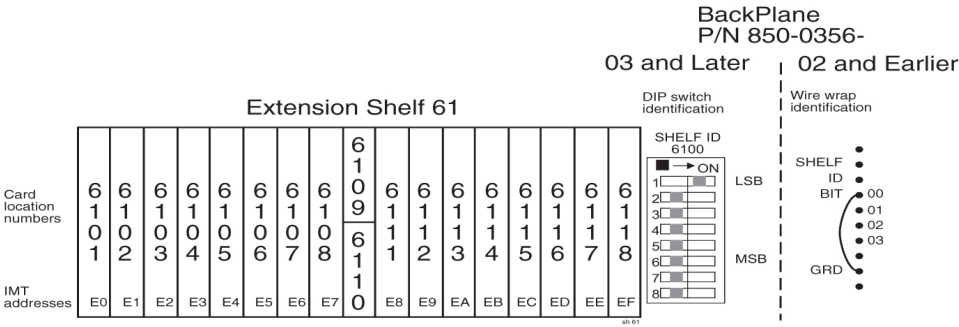

Figure 5-35 Extension Frame EF-04 Numbering Plan



Intra-system Cable Installation

This section covers the installation of cables that run within frames and between frames in a multiple frame installation. The cables covered in this section have been connected at one end in the factory and have connectors and are labeled at the other end for ease of installation. Consult the *Equipment Specification* for this installation and the label at the unconnected end of each cable to determine its connection point.

warning: The intra-building port(s) of the equipment or subassembly is suitable for connection to intra-building or unexposed wiring or cabling only. The intra-building port(s) of the equipment or subassembly **MUST NOT** be metalically connected to interfaces that connect to the Outside Plant (OSP) or its wiring. These interfaces are designed for use as intra-building interfaces only (Type 2 or Type 4 ports as described in GR-1089-CORE, Issue 4) and require isolation from the exposed OSP cabling. The addition of Primary Protectors is not sufficient protection in order to connect these interfaces metalically to OSP wiring.

The cables covered in this section are:

- Interprocessor Message Transport (IMT) cables
- Clock/**Alarm** cables
- Interface cables

For additional information concerning cables and cable replacement, see [Cables and Adapters](#).

Recommended Tools

Oracle tools should be labeled "Property of **ORACLE**" with either a press-on Field Tool Identification label or Field Tool Identification wrap.

- Safety glasses
- Tie-wrap tool
- Flush cutters
- Slotted screwdriver, 1/8-inch blade with 8-inch shank preferred
- Phillips screwdrivers #2 and #3
- Wrist strap

Install IMT Cables

The Interprocessor Message Transport (IMT) cables are specific lengths, based on their application. Termination information is furnished on the cable labels. Refer to [Cables and Adapters](#) and [Part Numbers](#)

NOT_SUPPORTED: Always wear a wrist strap or other electrostatic protection when handling printed circuit cards and other electrostatic-sensitive devices.

Procedure — Install IMT Cables

1. Route the cable and connect to the backplane connector specified on the cable label.
The IMT cables route down the left side of the frames, see [Figure 6-4](#).
2. For the IMT cables, tighten the barrel securely on each connector.

Figure 6-1 Interprocessor Message Transport Cables

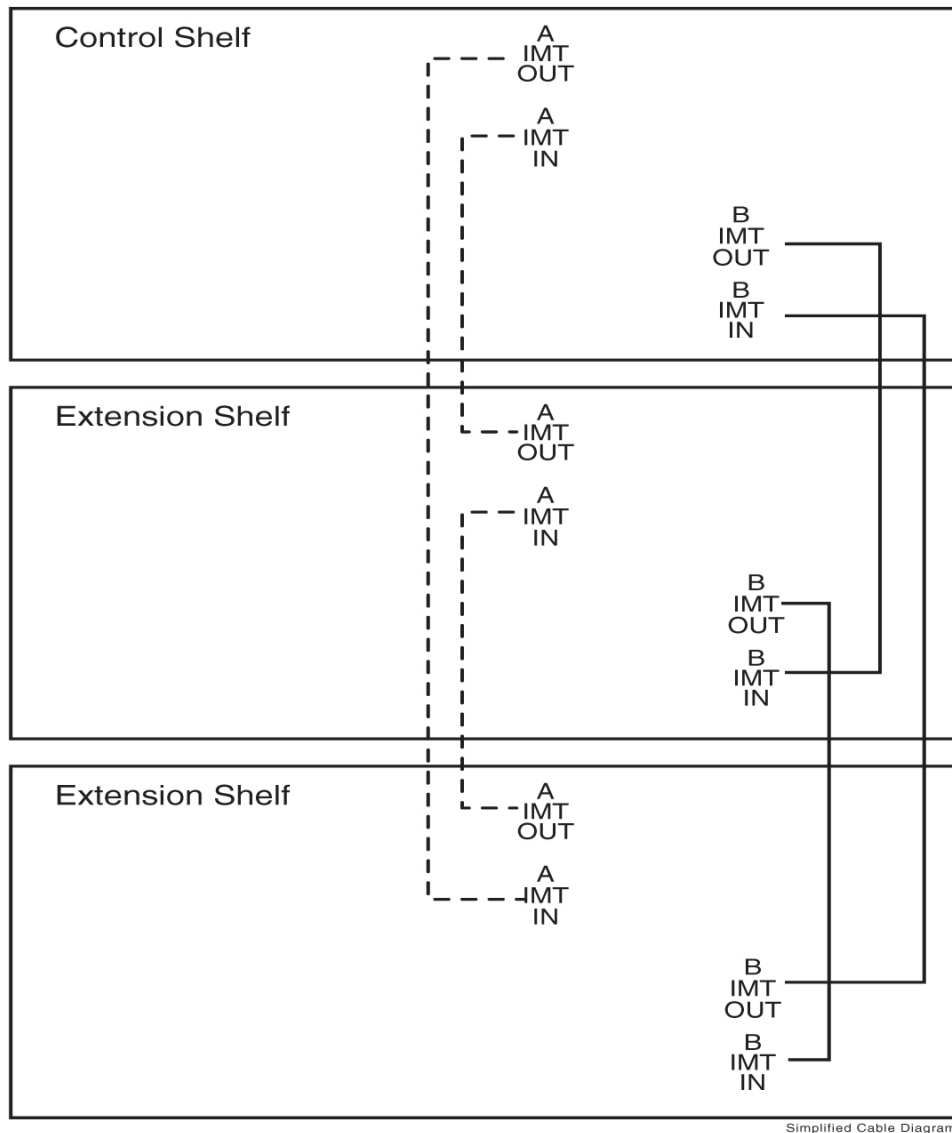

Simplified Cable Diagram

3. Dress each cable and secure with cable ties.

Ensure that each cable tie strap is cut flush with the cable tie head so that no sharp edges are exposed.

Figure 6-2 Three-Frame Configuration

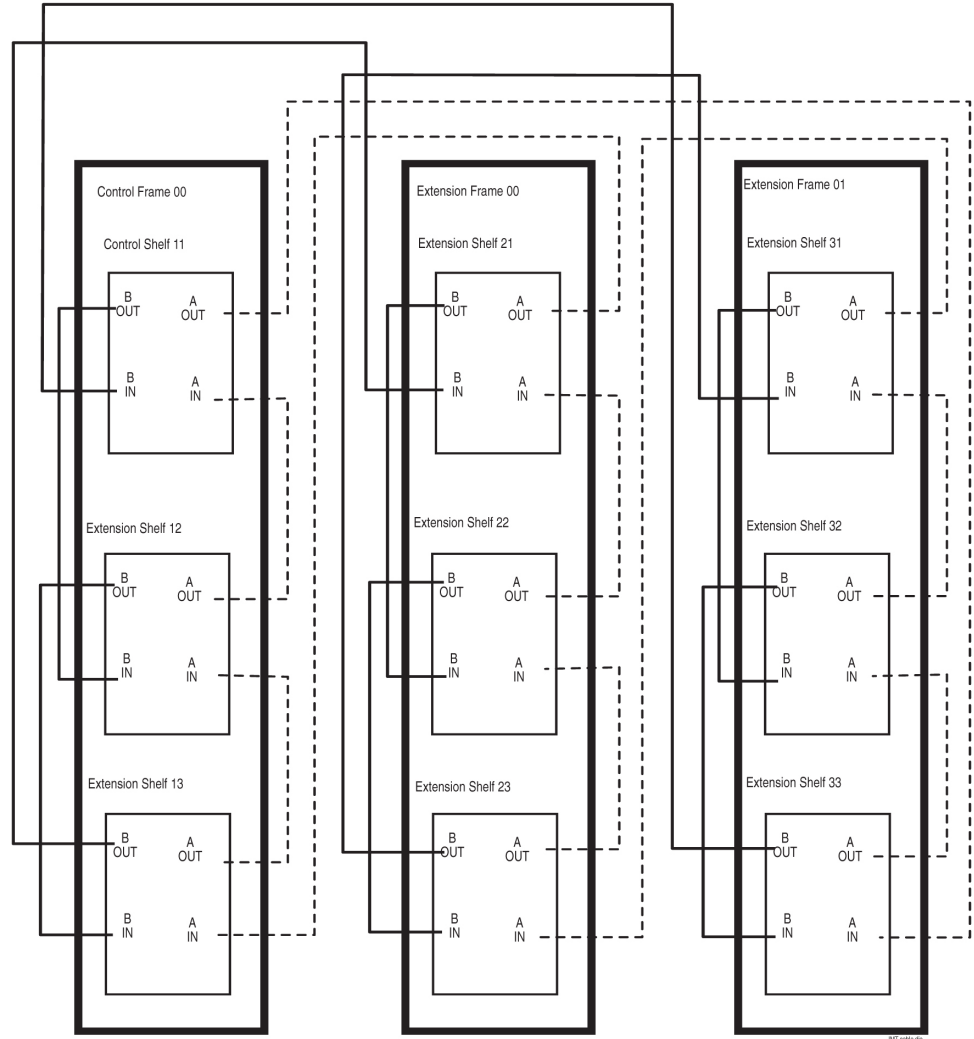

Note: This is not a cable routing diagram, this is a high-level diagram.

Figure 6-3 Six-Frame Configuration

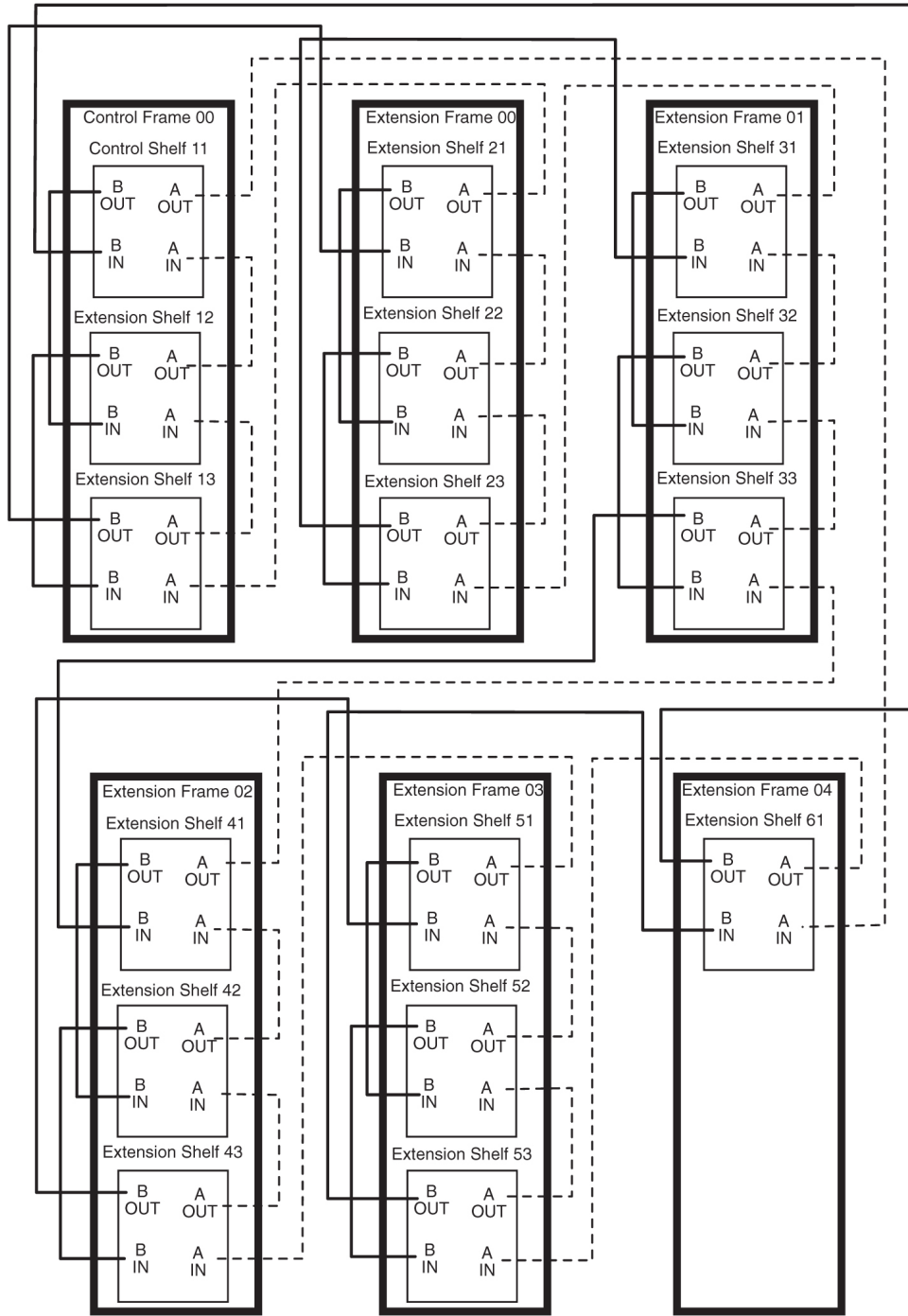

Note: This is not a cable routing diagram, this is a high-level diagram.

Rack Alarm and Row Alarm Cable Routing

The rack alarm cable leads from ports in the control backplane and connects up to six frames in the row. See [Figure 6-4](#) and [A Clock and B Clock Cable Replacement](#).

The row alarm cable leads from J34 on backplane 850-0330-06/07 or 7333412 on the control shelf backplane and terminates in the control frame end panel.

Note: The clocking and fan control signals used to support frame 6 and frame 7 are eliminated in the 850-0330-06 or -07 version and later of the **Control Shelf Backplane** because those frames are no longer supported in the **EAGLE STP** system.

Figure 6-4 Control Shelf Cabling

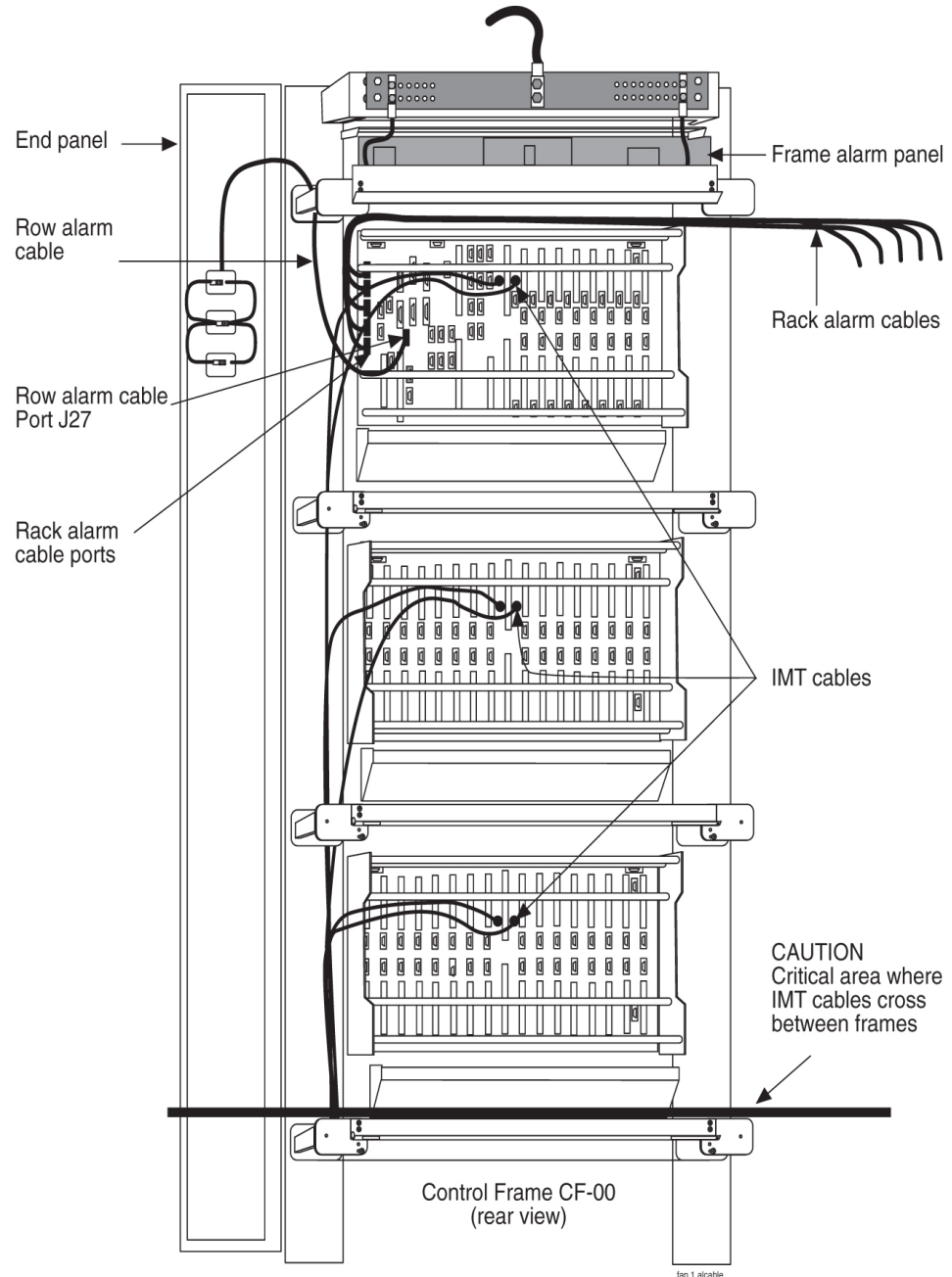

Interface Cable Installation

The procedure in this section is used to install the interface cables. The interface cables, one per signaling link, contain solid conductor twisted pairs for both directions of

transmission in a single shield. They have connectors at one end for connection to the system backplanes.

Note: Run **Link** Interface Module (**LIM**) cables on traverse arms, behind **IMT** and clock cables.

The ends without connectors are normally terminated on a **DSX** cross-connect panel with wire-wrap terminals.

1. Secure the connector to the designated receptacle on the **DSX** panel.
2. Plug the connector in and turn one of the connector screws to start the screw into the threaded hole.
3. Start the other screw into the other threaded hole.

With both screws started alternate tightening the screws until both screws are snug, finger tight. Complete tightening to **FIVE** inch-pounds only, **NO MORE** or the screws will twist off and the connection can be broken.

Note: Tightening must be done in an alternating pattern.

Termination information is furnished in the *Cable Running List* in the *Equipment Specification* for the site. See the [Interface Cable Installation Order](#) for a typical interface cable cross-connect panel connection.

Note: All cable ends must be labeled “**TO**” and “**FROM**” location information from Port to Backplane.

Interface Cable Installation Order

Interface cables should be installed in the following order.

Control Frame CF-00 Backplane

(P/N 850-0330-04/06/07) or 7333412

Control shelf 11

1101 A through 1108 A (P/N 850-0330-06 or -07 connectors J45 through J38)

1101 B through 1108 B (P/N 850-0330-06 or -07 connectors J59 through J52)

1111 A through 1112 A (P/N 850-0330-06 or -07 connectors J37 and J36)

1111 B through 1112 B (P/N 850-0330-06 or -07 connectors J51 and J50)

Extension shelf 12

1201 A through 1208 A (connectors J24 through J17)

1201 B through 1208 B (connectors J40 through J33)

1211 A through 1218 A (connectors J16 through J9)

1211 B through 1218 B (connectors J32 through J25)

Extension shelf 13 Backplane (P/N 850-0356-03)

1301 A through 1308 A (connectors J24 through J17)

1301 B through 1308 B (connectors J40 through J33)

1311 A through 1318 A (connectors J16 through J9)

1311 B through 1318 B (connectors J32 through J25)

Extension Frame EF-00

Extension shelf 21

2101 A through 2108 A (connectors J24 through J17)

2101 B through 2108 B (connectors J40 through J33)

2111 A through 2118 A (connectors J16 through J9)

2111 B through 2118 B (connectors J32 through J25)

Extension shelf 22

2201 A through 2208 A (connectors J24 through J17)

2201 B through 2208 B (connectors J40 through J33)

2211 A through 2218 A (connectors J16 through J9)

2211 B through 2218 B (connectors J32 through J25)

Extension shelf 23

2301 A through 2308 A (connectors J24 through J17)

2301 B through 2308 B (connectors J40 through J33)

2311 A through 2318 A (connectors J16 through J9)

2311 B through 2318 B (connectors J32 through J25)

Extension Frame EF-01

Extension shelf 31

3101 A through 3108 A (connectors J24 through J17)

3101 B through 3108 B (connectors J40 through J33)

3111 A through 3118 A (connectors J16 through J9)

3111 B through 3118 B (connectors J32 through J25)

Extension shelf 32

3201 A through 3208 A (connectors J24 through J17)

3201 B through 3208 B (connectors J40 through J33)

3211 A through 3218 A (connectors J16 through J9)

3211 B through 3218 B (connectors J32 through J25)

Extension shelf 33

3301 A through 3308 A (connectors J24 through J17)

3301 B through 3308 B (connectors J40 through J33)

3311 A through 3318 A (connectors J16 through J9)

3311 B through 3318 B (connectors J32 through J25)

Extension Frame EF-02

Extension shelf 41

4101 A through 4108 A (connectors J24 through J17)

4101 B through 4108 B (connectors J40 through J33)

4111 A through 4118 A (connectors J16 through J9)

4111 B through 4118 B (connectors J32 through J25)

Extension shelf 42

4201 A through 4208 A (connectors J24 through J17)

4201 B through 4208 B (connectors J40 through J33)

4211 A through 4218 A (connectors J16 through J9)

4211 B through 4218 B (connectors J32 through J25)

Extension shelf 43

4301 A through 4308 A (connectors J24 through J17)

4301 B through 4308 B (connectors J40 through J33)

4311 A through 4318 A (connectors J16 through J9)

4311 B through 4318 B (connectors J32 through J25)

Extension Frame EF-03

Extension shelf 51

5101 A through 5108 A (connectors J24 through J17)

5101 B through 5108 B (connectors J40 through J33)

5111 A through 5118 A (connectors J16 through J9)

5111 B through 5118 B (connectors J32 through J25)

Extension shelf 52

5201 A through 5208 A (connectors J24 through J17)

5201 B through 5208 B (connectors J40 through J33)

5211 A through 5218 A (connectors J16 through J9)

5211 B through 5218 B (connectors J32 through J25)

Extension shelf 53

5301 A through 5308 A (connectors J24 through J17)

5301 B through 5308 B (connectors J40 through J33)

5311 A through 5318 A (connectors J16 through J9)

5311 B through 5318 B (connectors J32 through J25)

Extension Frame EF-04

Extension shelf 61

6101 A through 6108 A (connectors J24 through J17)

6101 B through 6108 B (connectors J40 through J33)

6111 A through 6118 A (connectors J16 through J9)

6111 B through 6118 B (connectors J32 through J25)

Recommended Tools

Oracle tools should be labeled “Property of **ORACLE**” with either a press-on Field Tool Identification label or Field Tool Identification wrap.

- Safety glasses
- Tie-wrap tool
- Diagonal cutters
- Flush cutters
- Slotted screwdriver, 1/8-inch blade with 8-inch shank
- 3/8-inch shrink-wrap
- Heat-shrink gun (hot air blower)
- Torque screwdriver
- Wire-wrap gun
- 22-gauge wire-wrap bit
- 24-gauge wire-wrap bit

Interface Cable Installation

Examine the labels on the ends of the interface cables to determine the system backplane connection location “FROM” information on label and DSX cross-connect panel location “TO” information on label for each cable.

Run the cables on the cable rack to the cross-connect panel on the Miscellaneous Frame in groups of eight. There are four groups per extension shelf and groups per control shelf (a total of 20 per control shelf). The jack numbering on the cross-connect panel determines which side of the frame to run the cable. Viewing the frame from the rear, cables going to jacks #1 through #32 are run on the right side of the frame and cables #33 through #64 are run on the left side of the frame.

Procedure — Install Interface Cable

1. Secure connector to its respective receptacle on the backplanes. See [Interface Cable Installation](#).
2. Tie cables to the shelf cable tie bar at the rear of the shelf.
3. Pull slack from each cable towards the cross-connect panel.
4. Dress cable bundles neatly and tie to the cable tie bars at the side of the frame.
5. Lace the bundles to the cable rack.

Note: All cables must be laced onto the top traverse arms of each frame. Only lacing is used from the top traverse arms and above, on the frame and on the cable rack.

Note: Where the cable leaves the cable rack, the cable must be protected with fiber paper through out the system.

Procedure — Preparing Cables for Wire-Wrap

1. Remove the insulation from the cable where it is even with the bracket of the associated cross-connect panel as shown in [Figure 6-5](#).

Note: *Do not* remove the inner sheath.

2. Attach the label for the cross-connect end of the cable approximately two inches above the end of the insulation.
3. Apply a 1-1/2-inch length of 1/4-inch shrink-wrap tubing, taking care to center the tubing on the end of the cable insulation.

Use heat gun to shrink tubing.

Note: *Do not* overheat the cable.

4. Run the interface cable wires through the cross-connect panel cable tray.
5. Remove the cable sheathing directly below the cross-connect jack.
6. Cut the wires to length, strip and wire-wrap to the cross-connect panel.
7. Cut the cable tie strap flush with the cable tie head.

Figure 6-5 Interface Cable Cross-Connect Panel Connection

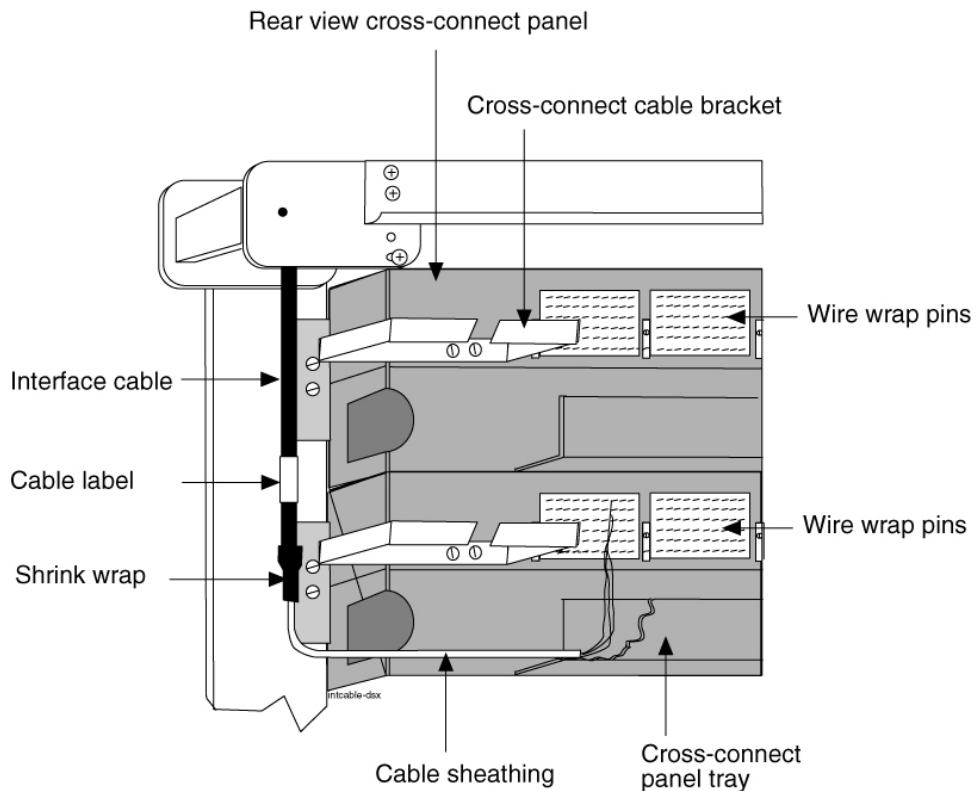

8. Label DSX panel

LAN Ethernet Cable Installation for ACM

This section contains the procedures for installing the **Local Area Network (LAN)** Ethernet cable, see [Figure 6-7](#) for the location of equipment. The LAN provides selected data to a remote host system through an Ethernet network. In the system, communications with the host is interfaced through an Application Communication Module (**ACM**). Communications with the **ACM** is accomplished through:

- The system backplane interface connector associated with that particular **ACM**
- A 15-pin to 26-pin adapter
- A single port Ethernet transceiver **Media Access Unit (MAU)**
- A 10BASE-2 Thin net coax connection or 10BASE-T twisted pair connection to the Ethernet network

Customer Supplied Ethernet Cable Requirements

If a customer chooses to supply their own Ethernet cables for EAGLE (customer-supplied cables are not subject to Oracle warranty), the following requirements must be met:

Customer-supplied Ethernet cables for EAGLE must be shielded, meet the industry standard, and avoid dissimilar metals at the RJ45 connector interface. The required standards include:

Metallization (30 or 50 μ in. Au over 50 μ in. Ni), at the connector interface. The wire required follows: Category 5E SFTP 26AWG 7/34 tinned copper 4 PR per IEC 11801, TIA/EIA 568B, EN 50173 with Overall shield, 26 AWG stranded T.C. drain wire, UL CMR, C(UL) CMR rating, or other agency listing.

Signaling Cables (for example, T1, ATM) are EAGLE proprietary and must be purchased from Oracle.

Recommended Tools

Oracle tools should be labeled "Property of **ORACLE**" with either a press-on Field Tool Identification label or Field Tool Identification wrap.

- Safety glasses
- Diagonal cutters
- Coax crimping tool
- Tie-wrap tool
- Flush cutters
- Slotted screwdriver with 1/8-inch blade with 8-inch shank
- Multimeter

LAN Ethernet Cable Installation

1. Run each 10BASE-2 Thin net coax cable or 10BASE-T twisted pair cable from the Ethernet network onto the cable rack.

2. Run each cable down the respective side of the system, outside the cable tie bars, and around the top or bottom edge of the terminating shelf.

Note: Use [Table 6-1](#) to locate the **ACM** backplane interface connector for each Ethernet connection.

The **ACM** location number in [Table 6-1](#) consists of the shelf (left two digits) and the slot (right two digits) that contain the **ACM**. For example, an **ACM** location of 1108 indicates slot 08 of the **Control Shelf** (shelf 11). For **ACMs** located in an **Extension Shelf**, replace “**XX**” in the **ACM** location number with the number for that shelf (12, 13, 21, 22, 23, 31, 32, or 33).

Table 6-1 ACM Card and Backplane Interface

Shelf	ACM Location	Backplane (P/N 850-0330-03/04/06) Connector
Control Shelf	1101	J45
	1102	J44
	1103	J43
	1104	J42
	1105	J41
	1106	J40
	1107	J39
	1108	J38
	1111	J37
	1112	J36
		Backplane (P/N 850-0356-03) Connector
Extension Shelves (XX is shelf location)	XX01	J24
	XX02	J23
	XX03	J22
	XX04	J21
	XX05	J20
	XX06	J19
	XX07	J18
	XX08	J17
	XX11	J16
	XX12	J15

Table 6-1 (Cont.) ACM Card and Backplane Interface

Shelf	ACM Location	Backplane (P/N 850-0330-03/04/06) Connector
	XX13	J14
	XX14	J13
	XX15	J12
	XX16	J11
	XX17	J10
	XX18	J9

3. Attach a **BNC** connector to the end of the 10BASE-2 coax cable.

If necessary, attach an **RJ45** type connector to the end of the 10BASE-T twisted pair cable.

4. Secure each cable, see [Figure 6-7](#) to its respective connector on the system backplane as follows:
 - a. Plug the 26-pin side of the adapter into the backplane interface connector.
 - b. Start one of the adapter connector screws, and then alternately tighten the two adapter screws.
 - c. Ensure the adapter slide latch is in the unlocked (up) position see to [Figure 6-6](#).
 - d. Plug the single port **MAU** into the adapter.
 - e. Move the adapter slide latch to the locked (down) position.
 - f. For the 10BASE-2 **MAU**, push the **BNC** connector on the coax cable onto the **MAU** and lock the connector in place by twisting the connector clockwise.

For a 10BASE-T **MAU**, push the **RJ45** connector into the **MAU** until it snaps into place.

Figure 6-6 Adapter Slide Latch

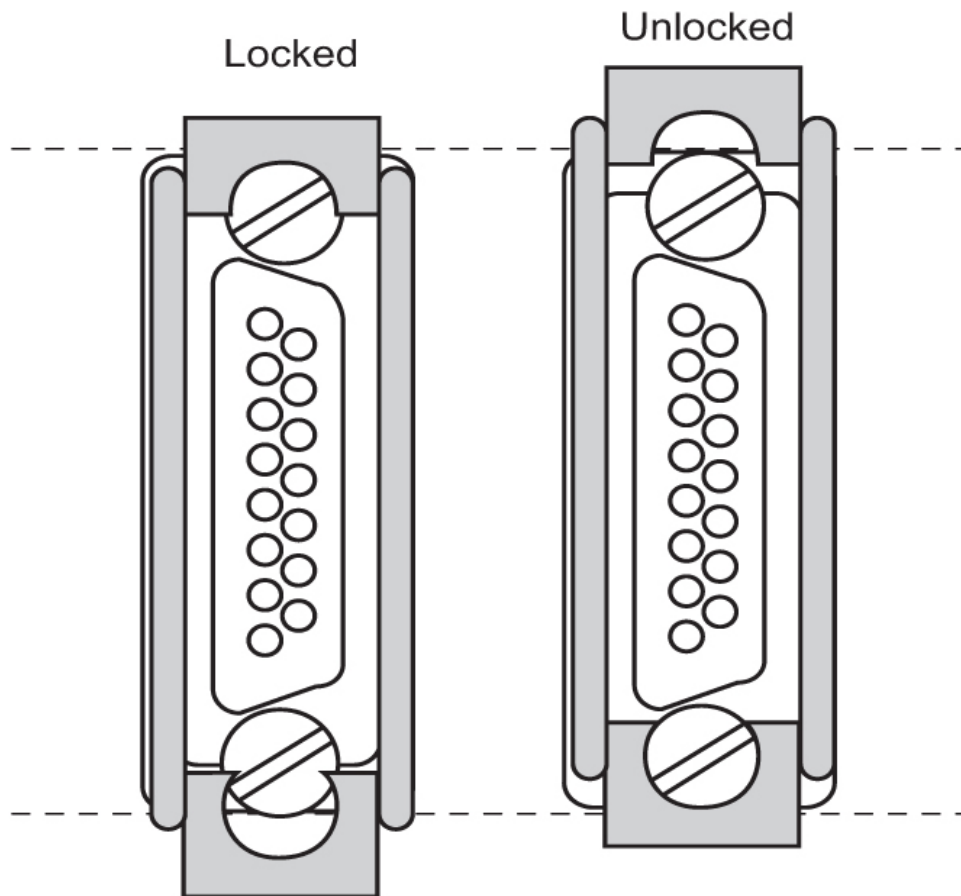

5. Tie-wrap each cable to the cable tie bar at the rear of the shelf and then to the cable tie bars at the side of the frame.
6. Pull the slack back toward the other end of the cables and lace to the cable rack.
7. Ensure that each tie-wrap strap is cut flush with the tie-wrap heads so that no sharp edges are exposed.

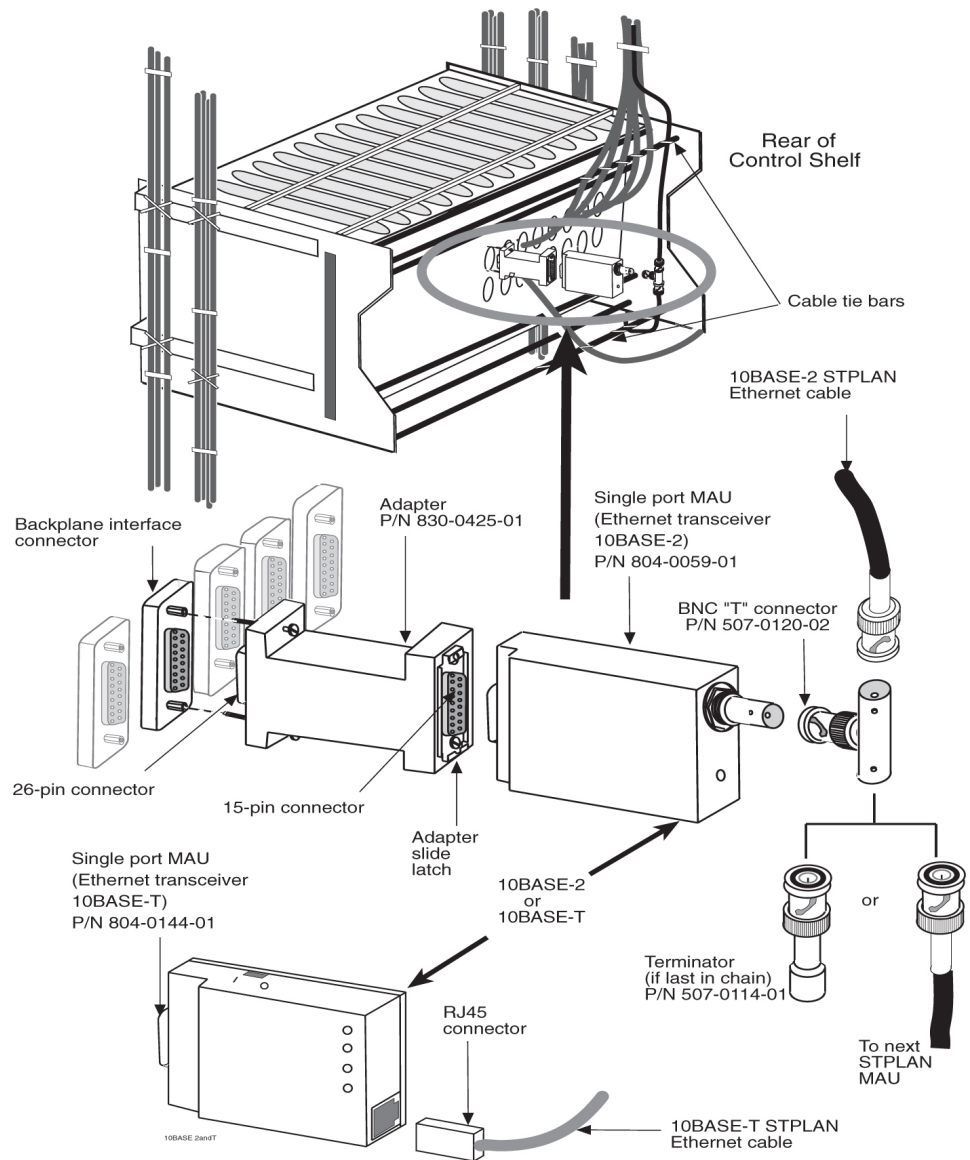
Figure 6-7 LAN Ethernet Cable Installation

E5-ENET/E5-ENET-B and Fan Option, EDCM, E5-SM4G/E5-SM8G-B Cabling

E5-ENET/E5-ENET-B and EDCM Modules

The following cabling procedures apply to E5-ENET/E5-ENET-B, EDCM and E5-SM4G/E5-SM8G-B cards in the latest EAGLE.

1. When the **Database Communications Module (E5-ENET/E5-ENET-B)** cards have been configured in the system, run the Ethernet cables straight through.
2. The Ethernet cables have a **DB26** connector on the system end, and a **RJ45** on the other end of the cable.

One cable is required for each E5-ENET/E5-ENET-B card.

3. On the system end (**DB26**), if the card is in slots 1,3,5, or 7, the cable is run down the right side of the frame (as seen from the back of the frame).

If **E5-ENET/E5-ENET-B** cards are in slots 11,13,15, or 17, the cables is run down the left side of the frame (as seen from the back of the frame).

4. Run the cable off the side of the cable rack on the correct side of the frame.

Route the cable down the traverse arms to the correct shelf location.

5. Route the cable around the top edge of the shelf and connect it to the A connector, of the odd numbered card slot where the **E5-ENET/E5-ENET-B** card is located, see [Figure 6-8](#).

Caution: Always trim tie-wrap flush and turn the trimmed tie-wrap to the rear of the cable bundle when facing the rear of the frame.

6. All cable ends must be labeled “**TO**” and “**FROM**” location information on both ends.

Figure 6-8 E5-ENET/E5-ENET-B Family Cabling, Enhanced Bulk Download

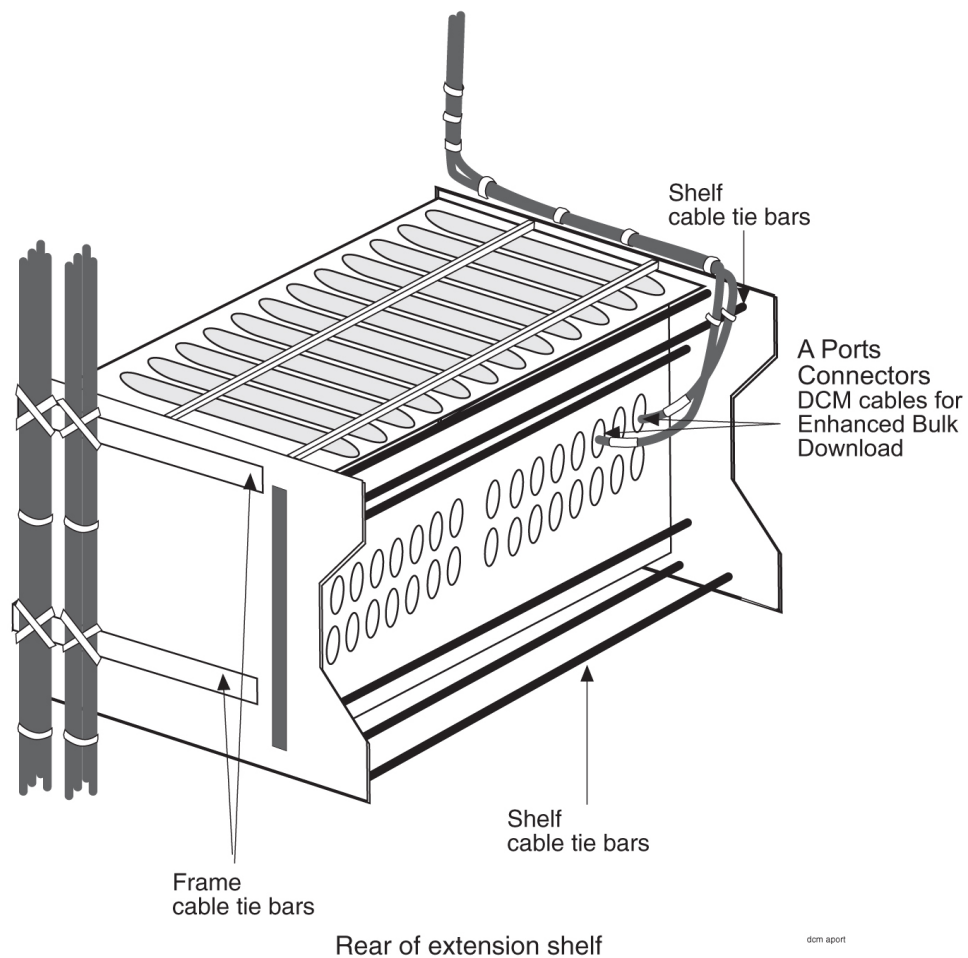
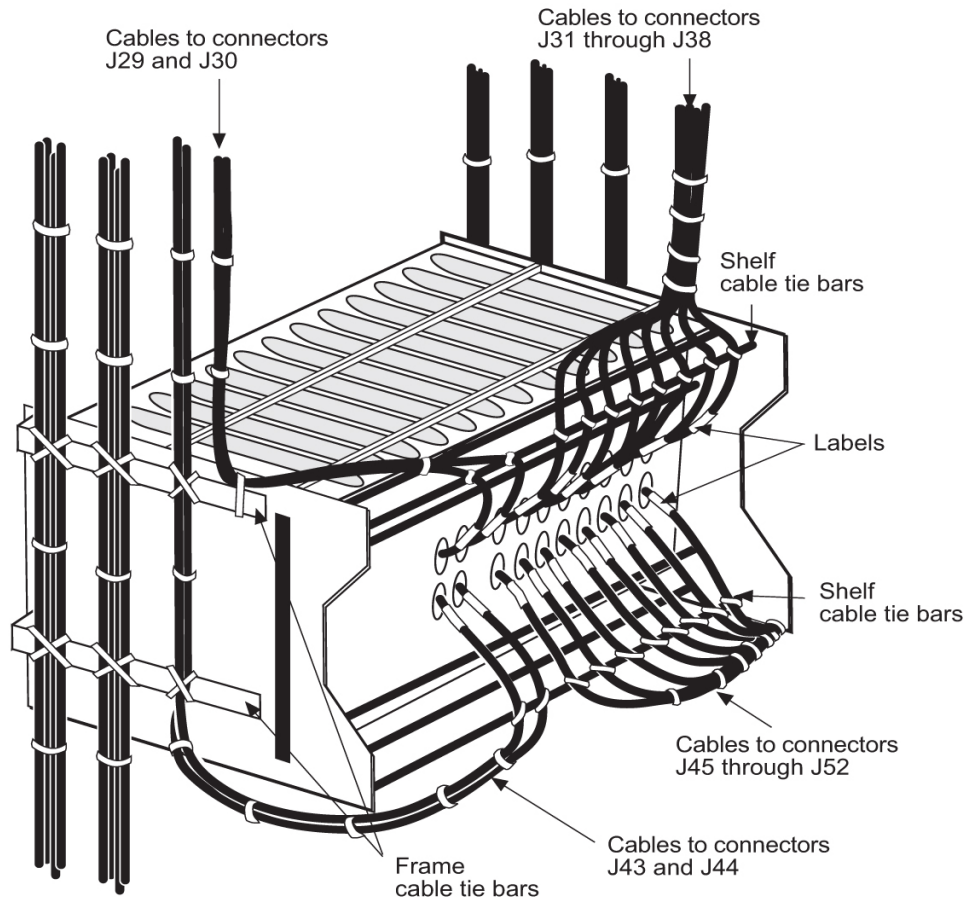

Figure 6-9 Interface Cable Routing, Control Shelf



Rear of Control Shelf

Backplane P/N 850-0330-03/04/06

intcables-cs21

Figure 6-10 Interface Cable Routing, Extension Shelf

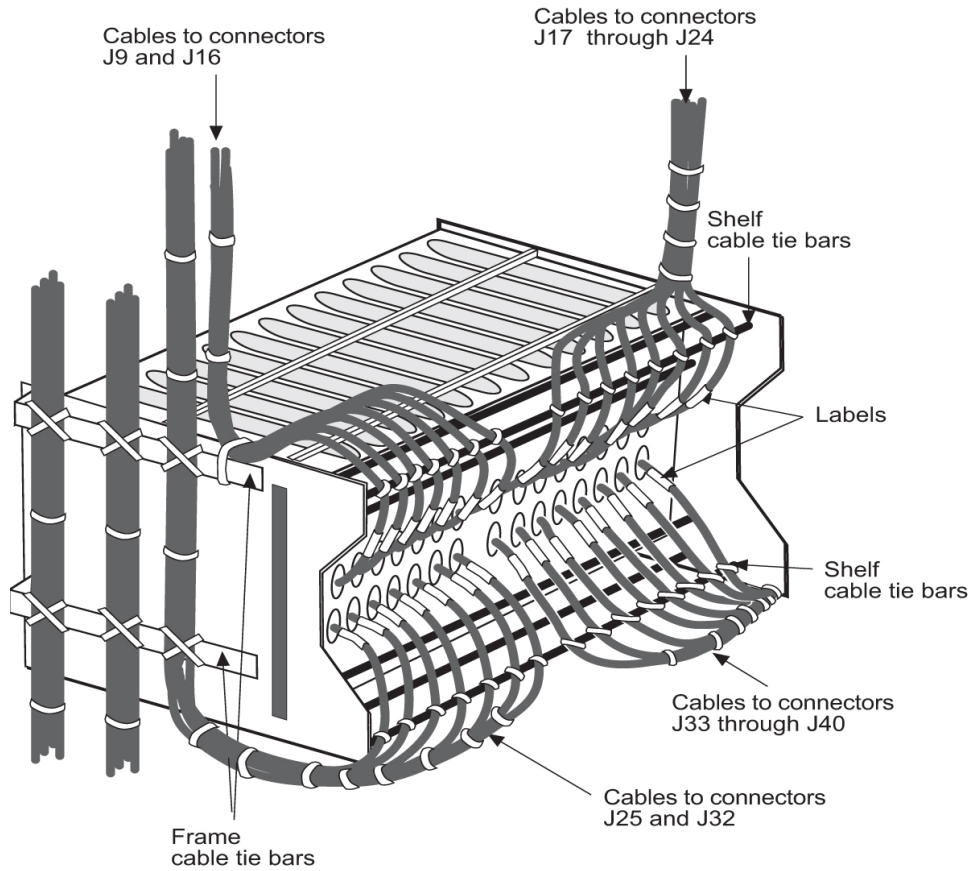

Rear of Extension Shelf
Backplane P/N 850-0356-XX

intcables-e121

User Upgrade Procedures

This section describes procedures for upgrading your **ASM** and **TDM** cards, and your **DSM** cards loaded with the **MCPM** application.

This section describes procedures that include:

- [Upgrading to E5-MCPM-B Module \(MCPM\)](#)
- [Measurement Collection and Polling Module \(MCPM\)](#)
- [Removing a Card in an Existing EAGLE System](#)

Note: **DSM** and **EDSM** cards loaded with the **MCPM** application and the **E5-MCPM-B** card will be referred to as “**MCPM** cards.”

Upgrading to E5-MCPM-B Module (MCPM)

This procedure upgrades **EDSM-2G** cards with **E5-MPCM-B** cards. The optimal time of day to run the procedure is between xx35 and xx58 where xx is any value between 01

and 23. The stated times provide the best opportunity for minimal interference with normal collection and reporting operations.

Note: Do not attempt this procedure during the first hour of the day (0000 to 0059).

Note: Throughout this document, the term MCPM refers to both the **E5-MCPM-B** (P/N 870-3089-xx) and the EDSM-2G loaded with the MCPM application (P/N 870-2372-03) cards unless specifically noted otherwise.

The Primary **MCPM** card performs all measurements collection and reporting functions and provides on-card **RAM** storage for collected data and scheduled reports. The Secondary MCPM provides a redundant backup for the Primary module, and assumes collection and reporting responsibilities on the loss of the Primary. **TCP/IP** connections are used to deliver measurement reports from the Primary MCPM card to the customer via an **FTP** client. The FTP configuration can be customized to support automatic transfer of scheduled reports from the client to the server.

1. Enter the following command to determine the status and number of the MCPM cards.

```
rept-stat-meas
```

The following is an example of the possible output.

```

MEAS SS                                PST   SST   AST
ALARM STATUS = ** 0516 MEAS degraded with card out of service
CARD   VERSION   TYPE   PST   SST   AST
1107   P 101-9-000  MCPM  IS-NR Active  -----
      IP Link A                IS-NR Active  Available
1109   101-9-000  MCPM  OOS-MT Fault  -----
      IP Link A                OOS-MT Fault  Unavailable
CARD 1107 ALARM STATUS = No Alarms
CARD 1109 ALARM STATUS = Card is isolated from the system
Command Completed.
;

```

2. Verify the location of the primary and secondary MCPM.

The primary is noted by the **P** beside the card location in the output of `rept-stat-meas`.

Note: The secondary MCPM should be upgraded before the primary MCPM.

3. Enter the following command to remove the secondary MCPM card from service.

- If there is more than one MCPM card in service, enter:

```
inh-card:loc=xxxx
```

- If there is only one MCPM card in service, enter:

```
inh-card:loc=xxx:force=yes
```

where `xxxx` is the secondary MCPM card location.

Do not use the `force` command unless this is the only MCPM card in service; MCPM collection and reporting service should be maintained at all times.

Note: Removing the last MCPM or only MCPM from service will cause loss of measurements data.

4. Remove the secondary MCPM card.

See [Removing a Card in an Existing EAGLE System](#) for removal procedures.

- a. Place the removed MCPM card into an ESD container.

Note: Do not put it into the spare card storage shelf.

- b. Place the new MCPM (E5-MCPM-B) card into its place.

- c. Be sure the revision numbers of the card is compatible with the EAGLE software release.

- If they are not, go to [5](#) to flash the card to the software release level of the EAGLE system.
- If your card is compatible with the EAGLE software release level, go to [7](#).
- If in doubt about the compatibility of your new hardware, call the [My Oracle Support \(MOS\)](#).

5. Enter the following command to flash the card:

```
init-flash:loc=xxxx:code=appr
```

where `xxxx` is the location of the card.

The following is sample output.

```
rlghncxa03w 01-03-02 13:05:05 EST Rel 44.0
FLASH Memory Downloading for card 1105 Started.
rlghncxa03w 01-03-02 13:05:05 EST Rel 44.0
BLMCAP Downloading for card 1105 Complete.
rlghncxa03w 01-03-02 13:05:05 EST Rel 44.0
Command Completed.
;
```

6. Enter the following command to activate the **FLASHGPL** on the card:

```
act-flash:loc=xxxx
```

where `xxxx` is the location of the card.

The following is sample output:

```
rlghncxa03w 04-02-04 13:05:05 EST EAGLE 44.0
FLASH Memory Activation for card 1105 Started.
;
rlghncxa03w 04-02-04 13:05:05 EST EAGLE 44.0
FLASH Memory Activation for card 1105 Completed.
;
rlghncxa03w 04-02-04 13:05:05 EST EAGLE 44.0
```

Command Completed.
;

7. Enter the following command to return the upgraded MCPM card into service.

```
alw-card:loc=xxxx
```

where *xxxx* is the MCPM card location.

- This causes the **MASP** to begin downloading tables to the new MCPM card.
- When the card has been successfully loaded there will be a response on the terminal that downloading is complete.
- This can take up to 10 minutes.

8. Enter the following command to verify the card is operational (**IS-NR**).

```
rept-stat-meas
```

- If the secondary MCPM card is operational, go to 9.
- If it is not, call the [My Oracle Support \(MOS\)](#).

9. If you want to upgrade a spare MCPM, go to 10.

Otherwise, got to 18.

10. Remove the spare MCPM card from the spare card storage shelf.

11. Place it into an **ESD** container.

12. Enter the following command to remove the previously upgraded secondary MCPM card from service.

- If there is more than one MCPM card in service, enter:

```
inh-card:loc=xxxx
```

- If there is only one MCPM card in service, enter:

```
inh-card:loc=xxx:force=yes
```

where *xxxx* is the secondary MCPM card location.

This card will become the spare.

Do not use the force command unless this is the only MCPM card in service; MCPM collection and reporting service should be maintained at all times.

Note: Removing the last MCPM or only MCPM from service will cause loss of measurements data.

13. Remove the MCPM card.

See [Removing a Card in an Existing EAGLE System](#) for removal procedures.

- a. Place the removed MCPM card into the spare card storage shelf.
- b. Place the new MCPM (E5-MCPM-B) card into its place.

- c. Be sure the revision numbers of the card is compatible with the EAGLE software release.
 - If they are not, go to [14](#) to flash the card to the software release level of the EAGLE system.
 - If your card is compatible with the EAGLE software release level, go to [16](#).
 - If in doubt about the compatibility of your new hardware, call the [My Oracle Support \(MOS\)](#).

14. Enter the following command to flash the card:

```
init-flash:loc=xxxx:code=appr
```

where xxxx is the location of the card.

The following is sample output.

```
rlghncxa03w 01-03-02 13:05:05 EST Rel 44.0
FLASH Memory Downloading for card 1105 Started.
rlghncxa03w 01-03-02 13:05:05 EST Rel 44.0
BLMCAP Downloading for card 1105 Complete.
rlghncxa03w 01-03-02 13:05:05 EST Rel 44.0
Command Completed.
;
```

15. Enter the following command to activate the FLASH GPL on the card:

```
act-flash:loc=xxxx
```

where xxxx is the location of the card.

The following is sample output:

```
rlghncxa03w 04-02-04 13:05:05 EST EAGLE 44.0
FLASH Memory Activation for card 1105 Started.
;
rlghncxa03w 04-02-04 13:05:05 EST EAGLE 44.0
FLASH Memory Activation for card 1105 Completed.
;
rlghncxa03w 04-02-04 13:05:05 EST EAGLE 44.0
Command Completed.
;
```

16. Enter the following command to return the upgraded MCPM card into service.

```
.alw-card:loc=xxxx
```

where xxxx is the MCPM card location.

- This causes the MASP to begin downloading tables to the new MCPM card.
- When the card has been successfully loaded (there will be a response on the terminal that downloading is complete).
- This can take up to 10 minutes.

17. Enter the following command to verify the card is operational (IS-NR).

```
rept-stat-meas
```

- If the secondary MCPM card is operational, go to [18](#).
- If it is not, call the [My Oracle Support \(MOS\)](#).

18. Enter the following command to remove the primary MCPM card from service.

- If there is more than one MCPM card in service, enter:

```
inh-card:loc=xxxx
```

- If there is only one MCPM card in service, enter:

```
inh-card:loc=xxx:force=yes
```

where xxxx is the primary MCPM card location.

Do not use the force command unless this is the only MCPM card in service; MCPM collection and reporting service should be maintained at all times.

Note: Removing the last MCPM or only MCPM from service will cause loss of measurements data.

19. Remove the MCPM card.

See [Removing a Card in an Existing EAGLE System](#) for removal procedures.

- Place the removed MCPM card into an ESD container.

Note: Do not put it into the spare card storage shelf.

- Place the new MCPM (E5-MCPM-B) card into its place.
- Be sure the revision numbers of the card is compatible with the EAGLE software release.
 - If they are not, go to [20](#) to flash the card to the software release level of the EAGLE system.
 - If your card is compatible with the EAGLE software release level, go to [22](#).
 - If in doubt about the compatibility of your new hardware, call the [My Oracle Support \(MOS\)](#).

20. Enter the following command to flash the card:

```
init-flash:loc=xxxx:code=appr
```

where xxxx is the location of the card.

The following is sample output.

```
rlghncxa03w 01-03-02 13:05:05 EST Rel 44.0
FLASH Memory Downloading for card 1105 Started.
rlghncxa03w 01-03-02 13:05:05 EST Rel 44.0
BLMCAP Downloading for card 1105 Complete.
rlghncxa03w 01-03-02 13:05:05 EST Rel 44.0
Command Completed.
;
```

21. Enter the following command to activate the FLASHGPL on the card:

```
act-flash:loc=xxxx
```

where xxxx is the location of the card.

The following is sample output:

```
rlghncxa03w 04-02-04 13:05:05 EST EAGLE 44.0
FLASH Memory Activation for card 1105 Started.
;
rlghncxa03w 04-02-04 13:05:05 EST EAGLE 44.0
FLASH Memory Activation for card 1105 Completed.
;
rlghncxa03w 04-02-04 13:05:05 EST EAGLE 44.0
Command Completed.
;
```

22. Enter the following command to return the upgraded MCPM card into service.

```
alw-card:loc=xxxx
```

where xxxx is the MCPM card location.

- This causes the MASP to begin downloading tables to the new MCPM card.
- When the card has been successfully loaded (there will be a response on the terminal that downloading is complete.
- This can take up to 10 minutes.

Note: Ensure that the primary FTP server points to the primary card.

23. Enter the following command on the primary card to return the card to the status recorded in 1 prior to the upgrade:

```
init-card:loc=xxxx
```

where xxxx is the location of the primary card.

24. Enter the following command to verify the card is operational (IS-NR).

```
rept-stat-meas
```

Measurement Collection and Polling Module (MCPM)

This procedure upgrades **DSM** cards loaded with the **MCPM** application (870-2371-03) to **EDSM** cards with 32 **MBFSRAM** and 2 **GBRAM** loaded with the **MCPM** application (870-2372-03).

Note: **DSM** and **EDSM** cards loaded with the **MCPM** application will be referred to as “**MCPM** cards.”

The Primary **MCPM** card performs all measurements collection and reporting functions and provides on-card **RAM** storage for collected data and scheduled reports. The Secondary **MCPM** provides a redundant backup for the Primary module, and assumes collection and reporting responsibilities on the loss of the Primary. **TCP/IP**

connections are used to deliver measurement reports from the Primary **MCPM** card to the customer via an **FTP** client. The **FTP** configuration can be customized to support automatic transfer of scheduled reports from the client to the server.

1. Enter the following command to determine the status and number of the **MCPM** cards.

```
rept-stat-meas
```

The following is an example of the possible output.

```

MEAS SS                                PST    SST    AST
                                OOS-MT Fault  -----
ALARM STATUS =                    ** 0516 MEAS degraded with card out of service
CARD      VERSION      TYPE    PST    SST    AST
1107     P 101-9-000   MCPM   IS-NR  Active  -----
IP Link A                                IS-NR  Active  Available
1109     101-9-000    MCPM   OOS-MT  Fault  -----
IP Link A                                OOS-MT  Fault  Unavailable
CARD 1107 ALARM STATUS = No Alarms
CARD 1109 ALARM STATUS = Card is isolated from the system
Command Completed.
;
```

2. Verify the location of the primary and secondary **MCPM**.

The primary is noted by the P beside the location in the output of `rept-stat-meas`. Upgrade the secondary **MCPM** first.

3. Enter the following command to remove the secondary **MCPM** card from service.

Do not use the force command unless this is the only **MCPM** card in service; **MCPM** collection and reporting service should be maintained at all times.

Note: Removing the last **MCPM** or only **MCPM** from service will cause loss of measurements data.

If there is more than one **MCPM** card in service, enter:

```
inh-card:loc=xxxx
```

where xxxx is the secondary **MCPM** card location.

If there is only one **MCPM** card in service, enter:

```
inh-card:loc=xxx:force=yes
```

where xxxx is the secondary **MCPM** card location.

4. Remove the **MCPM** card.

See [Removing a Card in an Existing EAGLE System](#) for removal procedures. Place the removed **MCPM** card into an **ESD** container; do not put it into the spare card storage shelf. Place the new **MCPM** (**EDSM**) card into its place. Be sure the revision numbers of the card is compatible with the **EAGLE** software release. If they are not, go to [5](#) to flash the card to the software release level of the **EAGLE** system. If your

card is compatible with the **EAGLE** software release level, go to **7** . If in doubt about the compatibility of your new hardware, call the [My Oracle Support \(MOS\)](#).

5. Enter the following command to flash the card:

```
init-flash:loc=xxxx:code=appr
```

Where **xxxx** is the location of the card.

The following is sample output.

```
rlghncxa03w 01-03-02 13:05:05 EST Rel 28.1.0
FLASH Memory Downloading for card 1105 Started.
rlghncxa03w 01-03-02 13:05:05 EST Rel 28.1.0
BPDCM Downloading for card 1105 Complete.
rlghncxa03w 01-03-02 13:05:05 EST Rel 28.1.0
Command Completed.
;
```

6. Enter the following command to activate the **FLASHGPL** on the card:

```
act-flash:loc=xxxx
```

Where **xxxx** is the location of the card.

The following is sample output:

```
rlghncxa03w 04-02-04 13:05:05 EST EAGLE 31.3.0
FLASH Memory Activation for card 1105 Started.
;
rlghncxa03w 04-02-04 13:05:05 EST EAGLE 31.3.0
FLASH Memory Activation for card 1105 Completed.
;
rlghncxa03w 04-02-04 13:05:05 EST EAGLE 31.3.0
Command Completed.
;
```

7. Enter the following command to return the upgraded **MCPM** card into service.

This causes the **MASP** to begin downloading tables to the new **MCPM** card.

```
alw-card:loc=xxxx
```

Where **xxxx** is the **MCPM** card location.

When the card has been successfully loaded (there will be a response on the terminal that downloading is complete).

This can take up to 10 minutes.

8. Enter the following command to verify the card is operational (**IS-NR**).

```
rept-stat-meas
```

If the secondary **MCPM** card is operational, go to **9** . If it is not, call the [My Oracle Support \(MOS\)](#).

9. If you want to upgrade a spare **MCPM**, go to **10** .

Otherwise, got to **16** .

10. Remove the spare **MCPM** card from the spare card storage shelf and place it into an **ESD** container.

Next, enter the following command to remove the previously upgraded secondary **MCPM** card from service. This card will become the spare. Do not use the force command unless this is the only **MCPM** card in service; **MCPM** collection and reporting service should be maintained at all times.

Note: Removing the last **MCPM** or only **MCPM** from service will cause loss of measurements data.

If there is more than one **MCPM** card in service, enter:

```
inh-card:loc=xxxx
```

where xxxx is the secondary **MCPM** card location.

If there is only one **MCPM** card in service, enter:

```
inh-card:loc=xxx:force=yes
```

where xxxx is the secondary **MCPM** card location.

11. Remove the **MCPM** card.

See [Removing a Card in an Existing EAGLE System](#) for removal procedures. Place the removed **MCPM** card into the spare card storage shelf. Place the new **MCPM** (**EDSM**) card into its place. Be sure the revision numbers of the card is compatible with the **EAGLE** software release. If they are not, go to **12** to flash the card to the software release level of the **EAGLE** system. If your card is compatible with the **EAGLE** software release level, go to **14**. If in doubt about the compatibility of your new hardware, call the [My Oracle Support \(MOS\)](#).

12. Enter the following command to flash the card:

```
init-flash:loc=xxxx:code=appr
```

Where xxxx is the location of the card.

The following is sample output.

```
rlghncxa03w 01-03-02 13:05:05 EST Rel 28.1.0
FLASH Memory Downloading for card 1105 Started.
rlghncxa03w 01-03-02 13:05:05 EST Rel 28.1.0
BPDCM Downloading for card 1105 Complete.
rlghncxa03w 01-03-02 13:05:05 EST Rel 28.1.0
Command Completed.
;
```

13. Enter the following command to activate the **FLASHGPL** on the card:

```
act-flash:loc=xxxx
```

Where xxxx is the location of the card.

The following is sample output:

```
rlghncxa03w 04-02-04 13:05:05 EST EAGLE 31.3.0
FLASH Memory Activation for card 1105 Started.
;
rlghncxa03w 04-02-04 13:05:05 EST EAGLE 31.3.0
FLASH Memory Activation for card 1105 Completed.
;
rlghncxa03w 04-02-04 13:05:05 EST EAGLE 31.3.0
Command Completed.
;
```

14. Enter the following command to return the upgraded **MCPM** card into service.

This causes the **MASP** to begin downloading tables to the new **MCPM** card

```
.alw-card:loc=xxxx
```

Where *xxxx* is the **MCPM** card location.

When the card has been successfully loaded (there will be a response on the terminal that downloading is complete). This can take up to 10 minutes.

15. Enter the following command to verify the card is operational (**IS-NR**).

```
rept-stat-meas
```

If the secondary **MCPM** card is operational, go to 16. If it is not, call the [My Oracle Support \(MOS\)](#).

16. Enter the following command to remove the primary **MCPM** card from service.

Do not use the force command unless this is the only **MCPM** card in service; **MCPM** collection and reporting service should be maintained at all times.

Note: Removing the last **MCPM** or only **MCPM** from service will cause loss of measurements data.

If there is more than one **MCPM** card in service, enter:

```
inh-card:loc=xxxx
```

where *xxxx* is the primary **MCPM** card location.

If there is only one **MCPM** card in service, enter:

```
inh-card:loc=xxx:force=yes
```

where *xxxx* is the primary **MCPM** card location.

17. Remove the **MCPM** card.

See [Removing a Card in an Existing EAGLE System](#) for removal procedures. Place the removed **MCPM** card into an **ESD** container; do not put it into the spare card storage shelf. Place the new **MCPM (EDSM)** card into its place. Be sure the revision numbers of the cards are compatible with the **EAGLE** software release. If they are not compatible, you should go to 18 to flash the card to the software release level of the **EAGLE** system. If your card is compatible with the **EAGLE** software release level, proceed to 20. If in doubt about the compatibility of your new hardware, call the [My Oracle Support \(MOS\)](#).

18. Enter the following command to flash the card:

```
init-flash:loc=xxxx:code=appr
```

Where `xxxx` is the location of the card.

The following is sample output.

```
rlghncxa03w 01-03-02 13:05:05 EST Rel 28.1.0
FLASH Memory Downloading for card 1105 Started.
rlghncxa03w 01-03-02 13:05:05 EST Rel 28.1.0
BPDCM Downloading for card 1105 Complete.
rlghncxa03w 01-03-02 13:05:05 EST Rel 28.1.0
Command Completed.
;
```

- 19.** Enter the following command to activate the **FLASHGPL** on the card:

```
act-flash:loc=xxxx
```

Where `xxxx` is the location of the card.

The following is sample output:

```
rlghncxa03w 04-02-04 13:05:05 EST EAGLE 31.3.0
FLASH Memory Activation for card 1105 Started.
;
rlghncxa03w 04-02-04 13:05:05 EST EAGLE 31.3.0
FLASH Memory Activation for card 1105 Completed.
;
rlghncxa03w 04-02-04 13:05:05 EST EAGLE 31.3.0
Command Completed.
;
```

- 20.** Enter the following command to return the upgraded **MCPM** card into service.

This causes the **MASP** to begin downloading tables to the new **MCPM** card.

```
alw-card:loc=xxxx
```

Where `xxxx` is the **MCPM** card location.

When the card has been successfully loaded (there will be a response on the terminal that downloading is complete). This can take up to 10 minutes.

Note: Ensure that the primary **FTP** server points to the primary card.

- 21.** Enter the following command on the primary card to return the card to the status recorded in **1** prior to the upgrade:

```
init-card:loc=xxxx
```

where `xxxx` is the location of the primary card.

- 22.** Enter the following command to verify the card is operational (**IS-NR**).

```
rept-stat-meas
```

Removing a Card in an Existing EAGLE System

Use this procedure anytime a card is removed from a previously operational **EAGLE** system for upgrade purposes. See *Maintenance Guide* for card replacement. Failure to use this procedure may result in equipment damage. Use the procedures at the beginning of this section before physically removing any cards.

NOT_SUPPORTED: Before performing any maintenance procedures on the **EAGLE**, make sure you wear a wrist strap connected to the wrist strap grounding point of the **EAGLE** System.

Before removing, reseating, or initializing a card, inhibit any **OAP** terminal ports that are in-service normal (**IS-NR**) to ensure the card loads properly. No database updates or single command line entries should be made while the card is loading.

NOT_SUPPORTED: This procedure may interrupt service. When possible, perform maintenance during low traffic and database provisioning periods, such as the maintenance window.

1. Locate the card to be removed.

Note: To ensure no loss of service, be sure to check that the green **LED** on the card is not lit when you remove the card.

2. Push the inject/eject clamps outward from the card's faceplate (top clamp in the "UP" position, bottom clamp in the "DOWN" position). Pull the levers away from the shelf until they are parallel to the floor.

Gently pull the card towards you until the card clears the shelf.

Figure 6-11 Push Inject/Eject Clamps Outward



3. Place the card you have removed in an electrostatic discharge (ESD) protective container, or place the card in the spare card storage shelf.
4. Be sure that the replacement card has the same part number and revision number as the card you have just removed (unless this is an upgrade).
5. Open the ejector levers on the replacement card.

Carefully align the card's edges with the top and bottom card guides. Then push the card along the length of the card guides until the rear connectors on the card engage the mating connectors on the target shelf backplane.

6. Press the front of the card's faceplate using constant pressure until you feel the card's progress cease.

NOT_SUPPORTED: Do not impact the faceplate in order to mate the connectors. Any impact to the card's faceplate can damage the faceplate, the pins, or the connectors.

7. Push in the top and bottom inject/eject clamps.

This locks the card in place and ensures a strong connection with the pins on the target shelf backplane.

Figure 6-12 Push in Inject/Eject Clamps

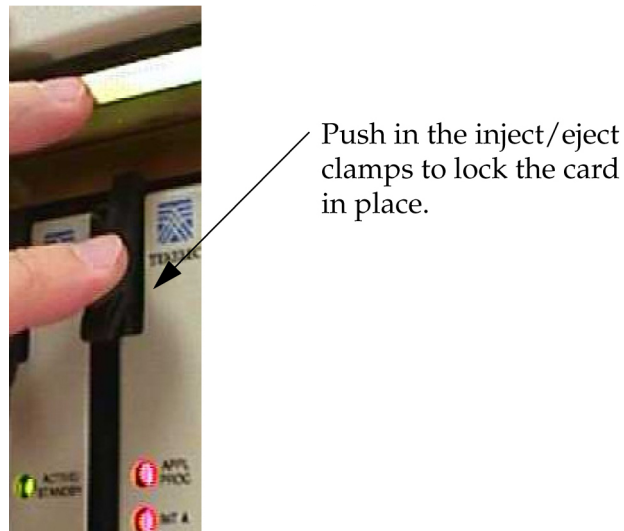

8. Verify that both IMT bus LEDs are green.
9. Record the activity in the site maintenance log.

Fan Assembly Installation and Cabling

warning: Do not carry exposed metal keys or tools in pockets or on belts when working on or around system equipment.

warning: *Do not* wear metal rings, watches, or jewelry on wrists or hands when working on system equipment or other related electrostatic sensitive components. Always wear a wrist strap or other electrostatic protection when handling printed circuit cards and other electrostatic sensitive devices.

Caution: Be sure to install the fan assembly 890-0001-04 before installing the **HCMIM** card.

This section shows how to install the optional Fan Assembly 890-0001-04 and Fan Assembly 890-1038-01/890-1038-02. All of these fan assemblies can be installed in the standard frame and the Heavy Duty Frame. Be sure to determine which type of frame you have before performing these procedures.

Installing Fan Assembly 890-0001-04

Note: Beginning with **EAGLE** software release 33.0, all systems with **HCMIM** cards must have the 890-0001-04 fan assembly installed.

Tools needed:

- #1 Flat screwdriver
- #2 Philips screwdriver (long)
- Fiber Paper (Approximately 2' x 3')
- 5/16" ratchet socket wrench
- Tie Wraps

Procedure — Install and Retrofitting Fans

1. Determine which shelves will have **HCMIM** modules installed and be aware of hardware that needs to be retained or installed in a specific way.
2. Place a piece of fiber paper on the top of the shelf below where the fan is to be installed to ensure that nothing will drop into equipment below the new fan.
3. Make sure to pull both dummy fuses from the appropriate fuse locations for the A and B fan power. Use the following guidelines to determine fuse locations:
 - The fuse card located on the Fuse and **Alarm** Panel is marked **FAN A** and **FAN B**. Fuse positions 6, 12, and 18 are the correct locations on the **FAP** faceplate.
 - Fuse position 6 is for the fan unit directly below the x100 shelf.
 - Fuse position 12 is for the fan directly below the x200 shelf.
 - Fuse position 18 is for the fan directly below the x300 shelf.
 - All fans are to be fused at 3As, with blue flags, per feed. Fill out the fuse card completely.
 - Ensure the **FAP** fuse location for the fan is properly labeled.

4. If you are installing the fan assembly into an existing frame, remove the four screws (two on each side) that attach the air baffle to the mounting brackets. Do not remove the screws holding the side brackets to the frame at this time. Support the baffle while you remove the screws.

Figure 6-13 System Air Baffle

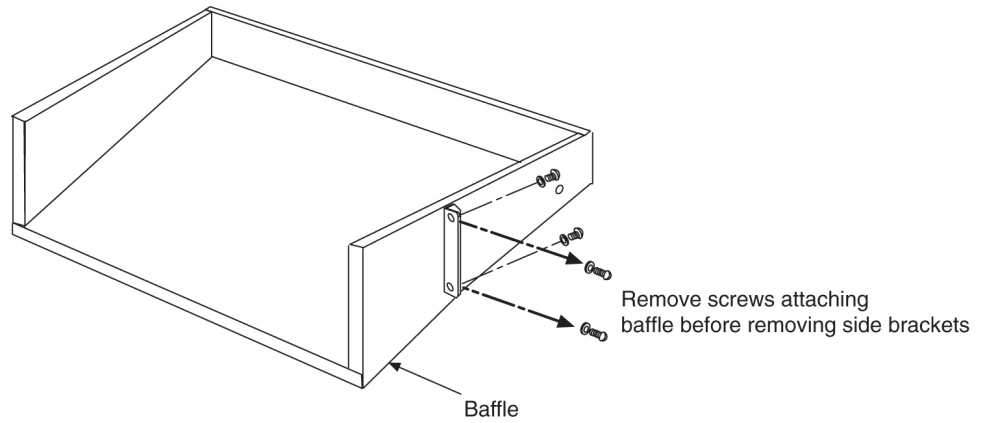

5. Remove the baffle through the front of the frame. Then, remove the two screws holding the left and right side baffle brackets to the frame and remove the brackets.
6. Install the new side brackets for the new fan tray into the frame. The side brackets are installed from the front of the frame just below the shelf containing that cards that require the fan. Use the 12-24-x1/2 screws provided to attach the brackets to the left and right front frame rails. The top screw hole is 5/16 inch below the shelf containing the cards. Be sure not to completely tighten the brackets at this time.

Figure 6-14 Attach side fan bracket to front frame rail



7. Slide the brackets in toward the center of the frame so the outside of the bracket is flush with the side of the frame as shown in [Figure 6-15](#).

Figure 6-15 Slide the side fan brackets flush with the Frame



8. Verify whether the frame type is a standard or heavy duty so that you can ensure the fan tray bracket will be mounted correctly. Use the following mounting positions:
 - Use the side holes on the fan tray bracket that are closest to the front of the frame if you are installing in a standard frame.
 - Use the holes closest to the rear of the frame if installing in a heavy duty frame.

Figure 6-16 Side bracket mounting positions on fan tray bracket.

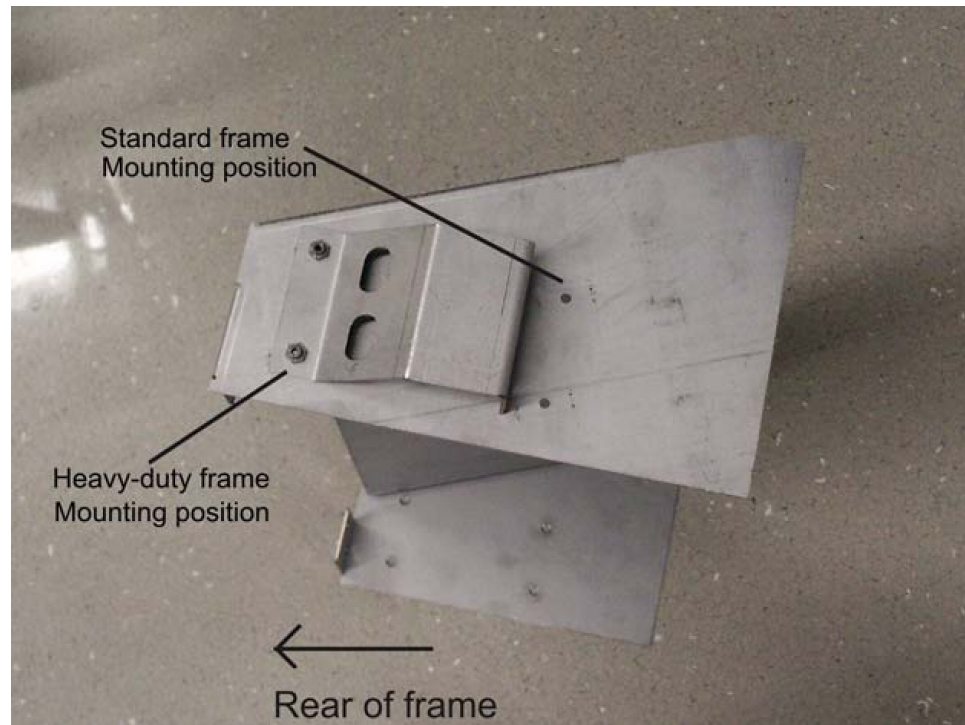

9. Insert the fan tray bracket (P/N 652-0012-01) into the space left by the baffle under the card shelf. The untightened side brackets will slide outward slightly to accommodate the fan tray bracket as it is inserted. They should remain flush against the fan tray bracket.

Figure 6-17 Insert fan tray bracket

Note: When inserting the fan tray bracket, be sure not to pinch cables between the bottom of the shelf and the fan tray bracket.

10. From inside the frame, screw the fan tray bracket to the side brackets with one hand while using the other hand to support the fan tray bracket. Use two 8-32 phillips screws for each side bracket. See [Figure 6-18](#).

Figure 6-18 Attaching the fan tray bracket to the side brackets - inside front



11. Remove the new fan tray from the container. The fan tray is shipped with the three fans already installed.

Figure 6-19 Fan Tray

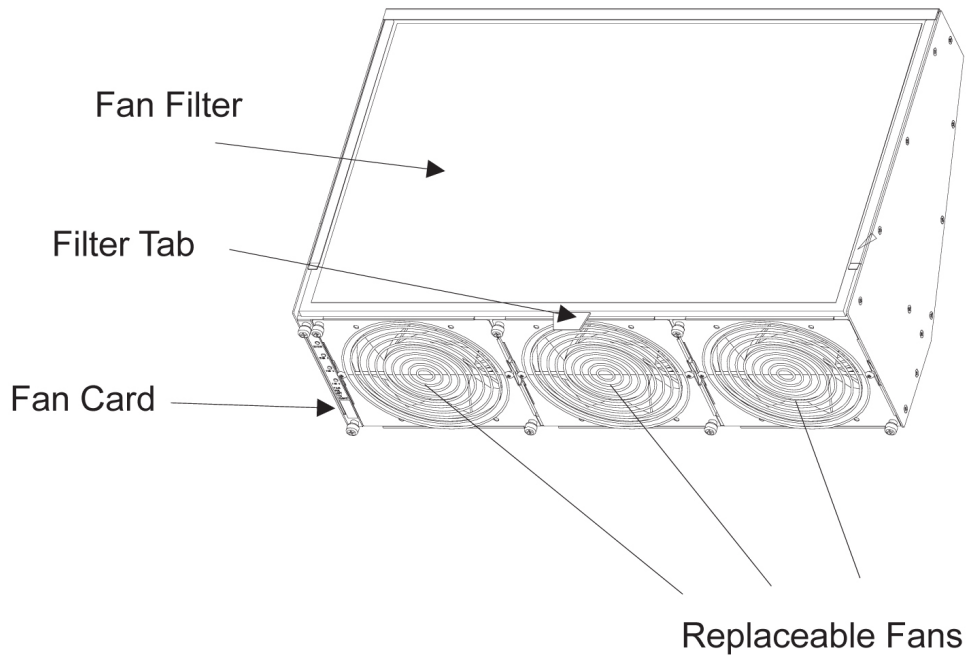

12. Insert the fan tray into the fan tray bracket. You might need to tilt the fan tray up as it is pushed in so that it is completely inserted into the bracket. After insertion, be sure the front of the fan tray is recessed in 1/2 inch with respect to the front frame rails.

Figure 6-20 Fan tray inserted into fan tray bracket in the frame- front view



13. When the fan tray is aligned and in place, attach the fan tray to the fan tray bracket by tightening the screws on the left and right sides of the rear of the fan tray bracket. There are two screws on each side. These screws must be tightened from the rear of the frame.

Figure 6-21 Tighten rear fan tray screws



14. At this time check and tighten all screws, including the screws holding the side brackets to the frame. The side bracket screws should be tightened fully from the rear of the frame. Use a long hex driver or flat head screw driver.

Figure 6-22 Tighten fan side bracket screws

15. Remove the piece of fiber paper on the top of the shelf below where the fan assembly was installed. This procedure is complete.

Caution: Before powering up the fans, ensure that the shelf directly above the fan does not contain any empty slots. Install an air management card in any empty slots to ensure proper air flow. These filler cards have no electrical connection to the system. See [Card Installation and Replacement](#) for general card installation guidelines.

Installing Fan Cables

On the control and extension shelf backplanes, the connectors are marked **A FAN POWER** and **B FAN POWER**.

- Control shelf:

On backplane (P/N 850-0330-06 or -07) the connectors are **A FAN POWER**, J-9 and **B FAN POWER**, J-8.

These connectors are located at the upper middle of the backplane on both the control shelf and the extension shelves.

- Extension shelf: The backplane connectors are A, J-3 and B J-2.

- For A fan power:

The fan cable 830-1157-01 is included with the fan assembly. Plug one end of the cable into J-9 on the backplane. **Route** the cable to the left of the frame, faced from the rear, and to the assembly, to the connection marked **FAN A POWER**.

- For B fan power:

Plug one end of the cable 830-1157-01 into J-8 on the backplane. **Route** the cable to the right of the frame, faced from the rear, and to the fan assembly, to the connection marked **FAN B POWER**. Form and dress the two cables together and check the security of all of the connections.

1. To cable the fan assembly, plug a cable onto the shelf on backplane **FAN A POWER**, and connector J9.

Tighten the screws on the connector.

2. When the cable is connected to the backplane route the cable to the top tie-down rod and secure the cable with a tie-wrap.
3. Route the cable to the right side of the frame.

Run the cable between the shelf and the traverse arms.

Caution: *Do not* form the cable with the **LIM** cables.

4. Secure the fan cables to the back side of the traverse arm using tie-wraps.
5. Plug the other end of the cable onto the fan unit connector marked **FAN A POWER**.

Tighten the screws on the connector.

6. The other fan cable (P/N 830-0690-01) plugs into the backplane connector J8.

Tighten the screws on the connector.

7. Route the cable out to the top tie down rod and secure it using a tie-wrap.

Run the cable down between the shelf and traverse arm.

Caution: *Do not* form **FAN POWER** cables with **LIM** cables.

8. Secure the cables to the back side of the traverse arms using tie-wraps.
9. Plug the other end of the cable onto the fan unit connector marked **FAN B POWER**.

Secure the connector.

Powering Up the Fan Assembly

All fans are fused at 3A (blue) per feed.

warning: Before powering up the fans, ensure that the shelf above the fan does not contain any empty slots. Install the air management card in any empty slots. See [Card Installation and Replacement](#) for general card installation guidelines.

Procedure — Power up Fan Assembly

1. After the fan is installed, the powering up process depends on the shelf location.
 - The fuse card located on the Fuse and **Alarm** Panel are marked **FAN A** and **FAN B**, fuse positions 6, 12, and 18 are marked correct locations on the **FAP** faceplate.
 - Fuse position 6 is for the fan unit directly below the x100 shelf.
 - Fuse position 12 is for the fan directly below the x200 shelf.
 - Fuse position 18 is for the fan directly below the x300 shelf.

- All fans are to be fused at 3As, with blue flags, per feed.
 - Fill out the fuse card completely.
 - Ensure the FAP fuse location for the fan is properly labeled.
2. Fifteen seconds after both the A side and B side power is connected to the fan assembly all of the **LEDs** on the fan controller card (located on the left side of the front of the fan assembly) are green.

Figure 6-23 Fan card with LEDs on front of fan assembly



3. When the fans are powered up and running, a test must be conducted to ensure proper service.

Go to the system terminal.

4. Check to see if the fan feature is activated. At the terminal, enter the command:

```
rtrv-feat
```

If the fan feature is off, go to 5. Otherwise, go to 6.

5. At the terminal, enter the command:

```
chg-feat : fan=on
```

Note: UAM 0080 will be raised for HC-MIM, E5-EPM-B or E5-SM8G-B if shelf FAN bit is OFF. These cards can be provisioned with `ent-cardcommand`. UAM 0080 will be cleared once shelf FAN bit is turned ON.

With this command the user will perform the tests beginning with 7.

6. At the terminal, enter the command:

```
rept-stat-trbl
```

Check to see that there are no fan errors. Specifically, check that there are no “#302 Cooling Fan Failure” errors. Next, perform the tests beginning with 6.

7. Fan Verification (perform 7 through 12 for each fan assembly).

Move to the rear of the frame and remove the A **POWER** cable from the **FAN** unit. Result: Fan 2 and Fan 3 **LEDs** will blink as the fans speed up to maximum speed. This may take up to 15 seconds. Once maximum speed has been reached Fan 2 and Fan 3 **LEDs** on the Fan Controller card will be solid green. Fan 1 **LED** should be red. The controller **LED** should be blinking green. Fan 1 should stop running and the **MINORLED** is lit.

8. At the system terminal enter the command:

```
rept-stat-trbl
```

This step is repeated for each fan. Test each fan to ensure that the alarm and the units are working correctly. Result: The terminal reports:

```
# 302 Cooling Fan Normal.
```

9. Replace the A **POWER** cable on the back of the **FAN** unit and secure the connector.

Result: All fans are running and the **MINORLED** is not lit.

```
Terminal reports alarm: # 303 Cooling Fan Normal
```

```
.
```

10. Remove the B **POWER** cable from the **FAN** unit.

Result: Fan 1 and Fan 2 **LEDs** will blink as the fans speed up to maximum speed. This may take up to 15 seconds. Once maximum speed has been reached Fan 1 and Fan 2 **LEDs** will be solid green. Fan 3 **LED** should be red. The fan controller **LED** should be blinking. Fan 3 should stop running and the **MINORLED** is lit.

11. At the system terminal enter the command:

```
rept-stat-trbl
```

Test each fan to ensure that the alarms and the unit is working correctly. Result: The terminal reports:

```
# 302 Cooling Fan Normal.
```

12. Replace the B **POWER** cable on the back of the **FAN** unit and secure the connector.

Result: The fans are running and the **MINORLED** is not lit. The terminal reports alarm:

```
# 303 Cooling Fan Normal.
```

13. Repeat 7 through 12 for each fan unit installed.

This procedure is complete.

Installing Fan Assembly 890-1038-01 or 890-1038-02

Tools needed:

- #1 Flat screwdriver

- #2 Philips screwdriver (long)
 - Fiber Paper (Approximately 2' x 3')
 - Tie Wraps
1. Determine where the fan assembly will be installed and be aware of hardware that needs to be retained or installed in a specific way, see [Figure 6-25](#).
 2. Place a piece of fiber paper on the top of the shelf below where the fan is to be installed, to ensure that nothing will drop into the area and equipment below.
 - a. The fan unit is secured with the same screws that are removed from the frame holding the baffle in place.
 - b. The brackets are installed from the rear of the frame using the screws provided with the brackets (standard frame).
 - c. When the brackets are attached, secure them to the frame using external tooth washers and four screws.
 3. Remove the four screws, two on each side, from the mounting brackets on the frame that hold the baffle in place, on both sides.

This will allow the removal of the baffle.

Figure 6-24 System Air Baffle

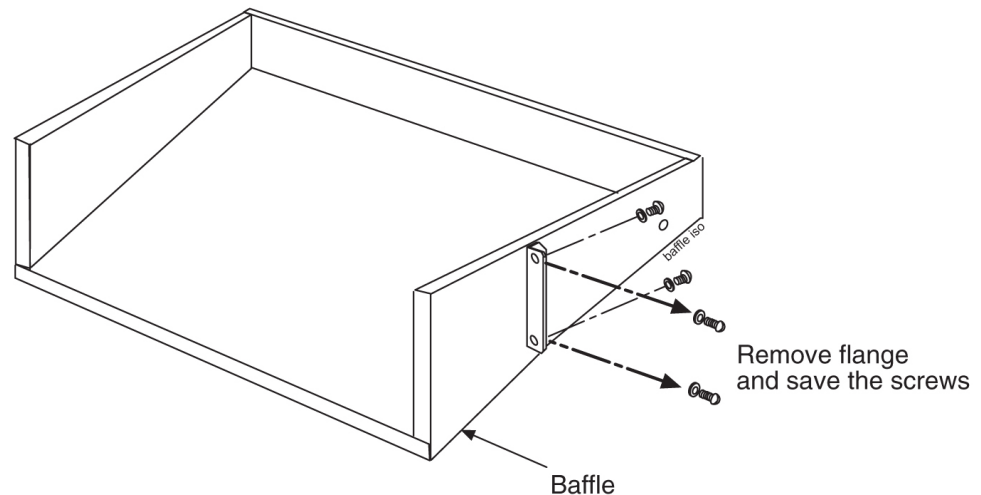

4. Place the screws in a safe place because they are used later in this procedure.
5. Remove the baffle through the front of the frame.
6. Remove the fan unit from the container and remove the grill and filter from the unit assembly.

The fan is shipped with the side flange not attached. Set the grill and filter in a safe location; it will be used later in this procedure.

Figure 6-25 Fan Assembly with Grill and Filter

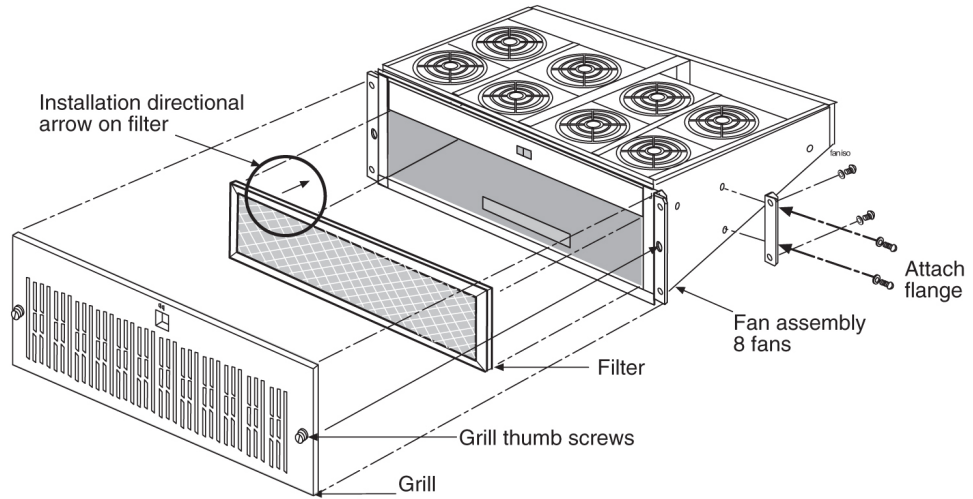

7. Install the fan unit in the space left by the baffle.

Figure 6-26 Installing Fan Assembly

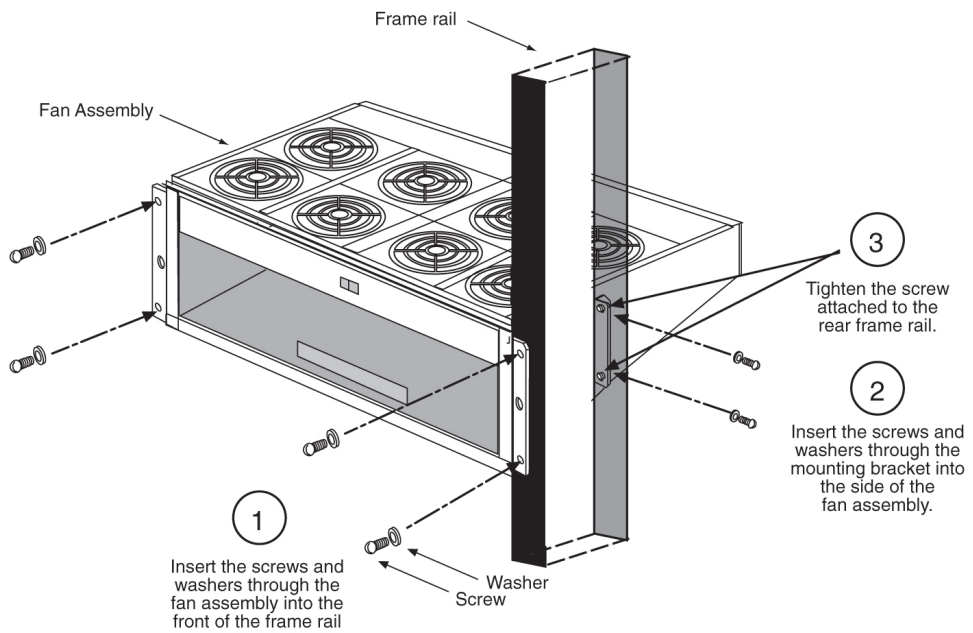
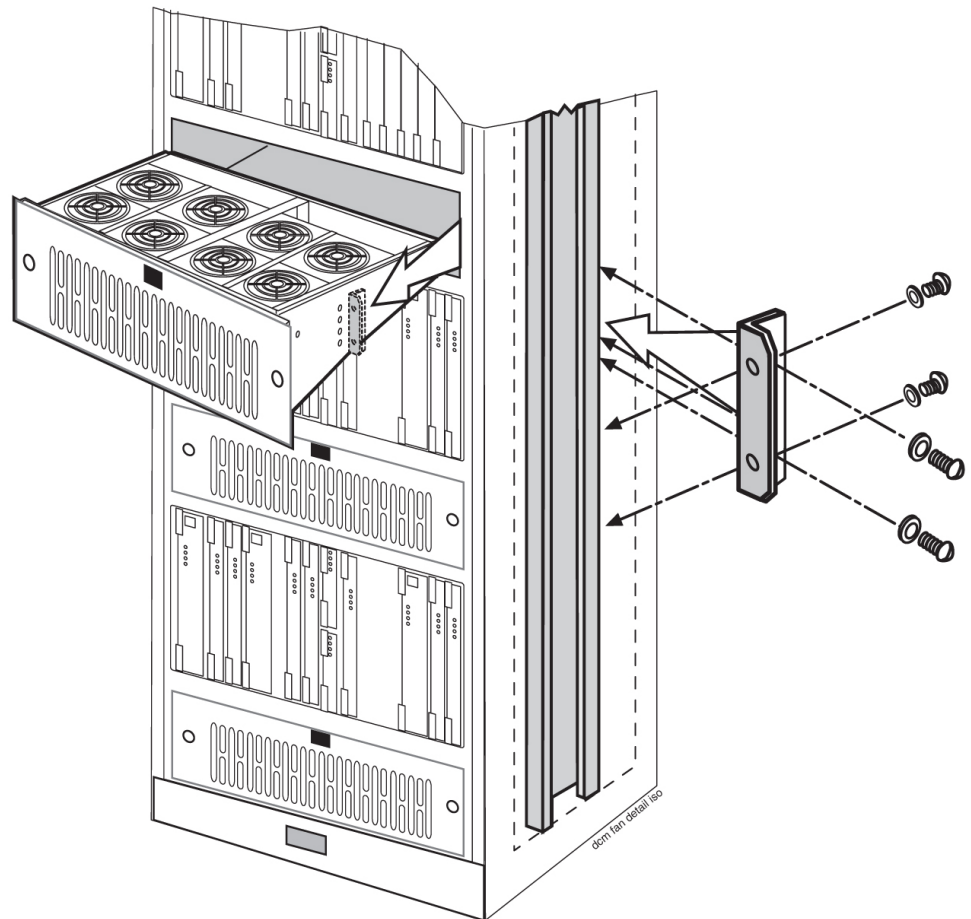

Figure 6-27 Fan Bracket Installation

8. Secure the fan unit with the same screws that were removed from the frame holding the baffle in place.

Do not tighten the screws at this time to allow for some minor adjustment. See [Figure 6-27](#).

Note: When mounting the fan unit, be sure not to pinch cables between the bottom of the shelf and the fan unit.

9. From the front of the frame, install the four screws and tighten.

At this time, check and tighten all screws

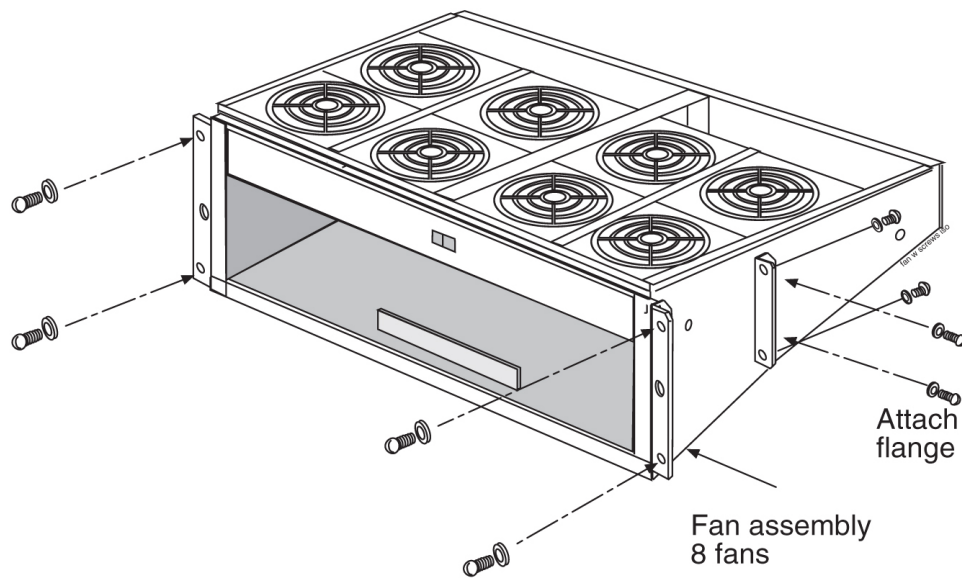
Figure 6-28 Fan with Brackets and Screws

10. Return to the back of the frame and tighten the screws in the mounting brackets into the side of the fan unit.
11. When the fan unit is aligned and in place, tighten the screws in the brackets on the sides of the frame.
12. Reinstall the fan filter.
The filter has an arrow stamped on the top edge to indicate the direction of the air flow. The arrow points **toward** the fans.
13. Install the fan grill, placing it back on the front of the unit and **FINGER TIGHTEN** the thumb screws on the front of the grill.
14. Remove the piece of fiber paper on the top of the shelf below where the fan is to be installed.

Installing Fan Cables

On the control and extension shelf backplanes, the connectors are marked **A FAN POWER** and **B FAN POWER**.

- Control shelf:
On backplane (P/N 850-0330-06 or -07) the connectors are **A FAN POWER**, J-9 and **B FAN POWER**, J-8.
These connectors are located at the upper middle of the backplane on both the control shelf and the extension shelves.
- Extension shelf: The backplane connectors are A, J-3 and B J-2.
- For A fan power:
The fan cable is included with the fan assembly. Plug one end of the cable into J-9 on the backplane. **Route** the cable to the left of the frame, faced from the rear, and to the assembly, to the connection marked **FAN A POWER**.

- For B fan power:

Plug one end of the cable into J-8 on the backplane. **Route** the cable to the right of the frame, faced from the rear, and to the fan assembly, to the connection marked **FAN B POWER**. Form and dress the two cables together and check the security of all of the connections.

1. To cable the fan assembly, plug a cable onto the shelf on backplane **FAN A POWER**, and connector J9.

Tighten the screws on the connector.

2. When the cable is connected to the backplane route the cable to the top tie-down rod and secure the cable with a tie-wrap.

3. Route the cable to the right side of the frame.

Run the cable between the shelf and the traverse arms.

Caution: *Do not* form the cable with the **LIM** cables.

4. Secure the fan cables to the back side of the traverse arm using tie-wraps.

5. Plug the other end of the cable onto the fan unit connector marked **FAN A POWER**.

Tighten the screws on the connector.

6. The other fan cable plugs into the backplane connector J8.

Tighten the screws on the connector.

7. Route the cable out to the top tie down rod and secure it using a tie-wrap.

Run the cable down between the shelf and traverse arm.

Caution: *Do not* form **FAN POWER** cables with **LIM** cables.

8. Secure the cables to the back side of the traverse arms using tie-wraps.

9. Plug the other end of the cable onto the fan unit connector marked **FAN B POWER**.

Secure the connector.

Powering Up the Fan Assembly

All fans are fused at 2A (orange) per feed.

1. After the fan assembly is installed, the powering up process depends on the shelf location.
 - a. The fuse card located on the Fuse and **Alarm** Panel are marked **FAN A** and **FAN B**, fuse positions 6, 12, and 18 are marked correct locations on the **FAP** faceplate.
 - b. Fuse position 6 is for the fan unit directly below the x100 shelf.
 - c. Fuse position 12 is for the fan directly below the x200 shelf.

- d. Fuse position 18 is for the fan directly below the x300 shelf.
 - e. All 890-1038-xx fans are to be fused at 2As, with orange flags, per feed.
 - f. Fill out the fuse card completely.
2. When the fan units are powered up, the switch in the middle front of the fan unit must be turned to the ON position.

Do not set the switch to the AUTO position.

Figure 6-29 Front Card Suite with Fan Switch

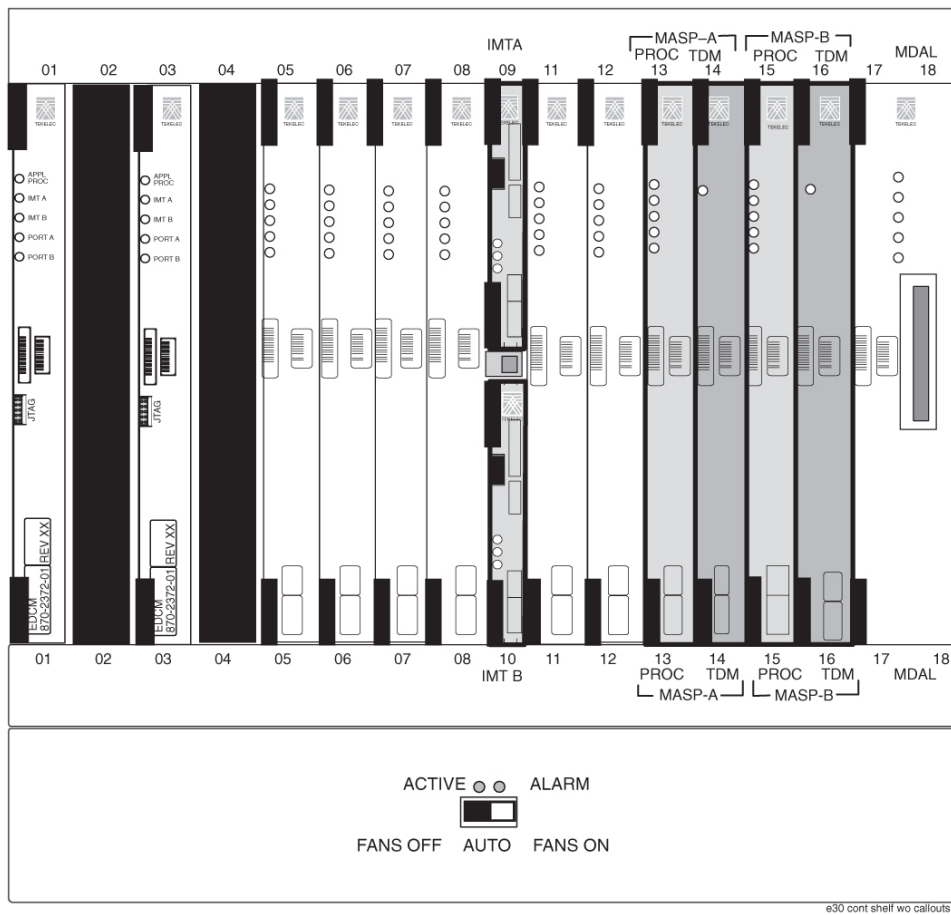

e30 cont shelf wo callouts

3. When the fans are powered up and running, a test must be conducted to ensure proper service.

Go to the system terminal.

4. At the terminal, enter the command:

```
chg-feat : fan=on
```

Note: UAM 0080 will be raised for HC-MIM, E5-EPM-B or E5-SM8G-B if shelf FAN bit is OFF. These cards can be provisioned with `ent-cardcommand`. UAM 0080 will be cleared once shelf FAN bit is turned ON.

With this input this command the user will perform the tests beginning with 6.

5. At the terminal, enter the command:

```
rept-stat-trbl
```

Check to see that there are no fan errors.

6. Fan Verification (perform 6 through 14 for each fan assembly).

On the front of the fan unit toggle the switch to the **OFF** position (switch to **FANSOFF**). Result: The fans stop running and the **MINORLED** is lit.

7. At the terminal, type:

```
rept-stat-trbl
```

Result: The terminal will show:

```
0055.0302 * SYSTEM    Cooling Fan Failure
```

MINORLED is lit.

8. Fan Verification: On the front of the fan unit, toggle the fan switch to the **ON** position (switch to **FANSON**).

Result: The fans are running and the **MINORLED** is not lit. Terminal reports alarm:

```
# 303 Cooling Fan Normal
```

.

Note: The normal setting for the fan unit is **ON**.

9. Move to the rear of the frame and remove the A **POWER** cable from the **FAN** unit.

Result: The fans stop running and the **MINORLED** is lit.

10. At the system terminal enter the command:

```
rept-stat-trbl
```

This step is repeated for each fan. Test each fan to ensure that the alarm and the units are working correctly. Result: The terminal reports:

```
# 302 Cooling Fan Normal
```

11. Replace the A **POWER** cable on the back of the **FAN** unit and secure the connector.

Result: The fans are running and the **MINORLED** is not lit.

```
Terminal reports alarm: # 303 Cooling Fan Normal
```

.

12. Remove the B **POWER** cable from the **FAN** unit.

Result: The B powered fans stop running and the **MINORLED** is lit.

13. At the system terminal enter the command:

```
rept-stat-trbl
```

Test each fan to ensure that the alarms and the unit is working correctly. Result: The terminal reports:

302 Cooling Fan Failure.

14. Replace the B POWER cable on the back of the FAN unit and secure the connector.

Result: The fans are running and the MINORLED is not lit. The terminal reports alarm:

303 Cooling fan Normal.

15. Repeat 6 through 14 for each fan unit installed.

Testing the Fan Assembly

1. Log in and verify the FAN feature is on using the `rtrv-feat` command.
2. If the FAN feature is off, turn it on using the `chg-feat : fan=on` command.
3. Remove the applicable fuses (one at a time) associated with each Fan (6A, 12A, 18A, 6B, 12B, and 18B).

Verify that with each fuse pulled, the corresponding fans loses power. IE: 6A= 1st half of the 1100 fan, 12A = 1st half of the 1200 fan, 18A = 1st half of the 1300, 6B=2nd half of the 1100 fan, 12B=2nd half of the 1200 fan, and 18B=2nd half of the 1300 fan.

4. Replace the fan grill by placing it back over the filter on the front of the assembly.

Hand-tighten the grill thumb screws.

Figure 6-30 Fan Assembly with Grill and Filter

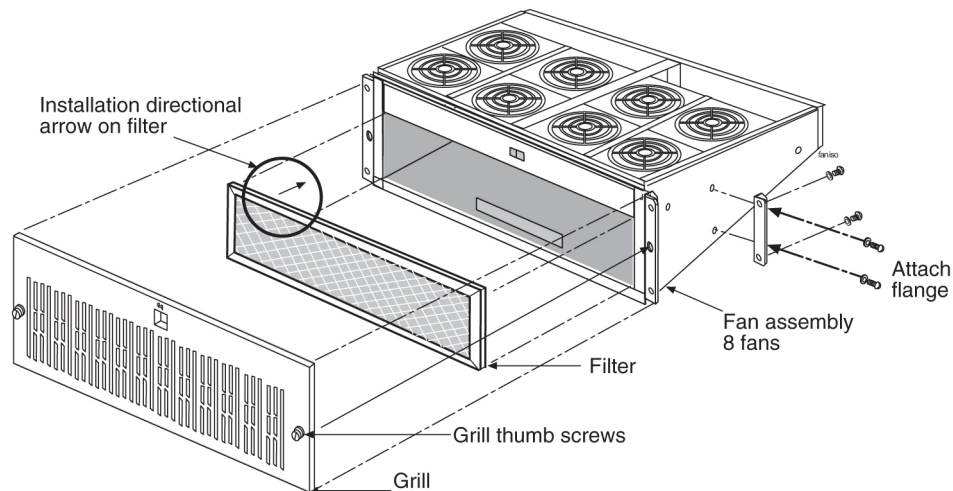

5. Turn off the 1100,1200 and 1300 shelf fans and verify the EAGLE and Fan unit displays the alarm.

For the EAGLE use the `rept-stat-trbl` command, and for the fan unit, verify the LED near the Fan switch is RED (10x03/x04 software must be installed).

Master Timing

The EAGLE connects to the customer provided Building Integrated Time System (BITS) clocks through the backplane of the control shelf. The BITS clock provides a primary and secondary set of two separate clock signals; a composite (64KHz) clock signal and a high speed (2.048Mhz or 1.544Mhz) clock signal.

The section provides information about the High-Speed Master Timing feature and instructions on how to implement the feature. Procedures include the replacement of the composite clock cables.

Note: This feature does not cover the replacement of the control shelf, the control shelf backplane, or an EAGLE software upgrade. For these items, contact [My Oracle Support \(MOS\)](#) for assistance.

Master Timing Overview

The High-Speed (HS) Master Timing feature offers a mode of operation that allows a high speed capable (**T1** or **E1** rate) Link Interface Module (**LIM-ATM**) or **E1/T1MIM** installed in an **EAGLE STP** to receive its transit timing reference directly from an external **HS** master clock source, instead of slaving to the timing information contained in the received data. The timing information is then encoded into the **T1** or **E1** transmitted data stream used to synchronize downstream equipment. The site clock sources (both **HS** and composite) are connected with an **RS422** compatible cable to the primary and secondary clock inputs of the **EAGLE STP**.

The high-speed master clock source provides the **EAGLE STP** with a second system clock input in addition to the original composite clock. Timing signals from both system clocks is distributed within the **EAGLE STP** to all **LIM** card slots.

The **HS** Master Timing feature is integrated into the EAGLE Control Card set.

Implementation of the **HS** Master Timing feature might require the correct Control Card set, the installation or presence of at least one **ATMLIM** card or **E1/T1MIM**, the replacement of both composite clock cables or adding new cables, and the provisioning of at least one **ATMLIM** card or **E1/T1MIM**. **ATMLIM** cards or **E1/T1MIM** that do not use the high-speed clock source and **LIM** cards that continue using the composite clock source do not require any changes to card provisioning.

OAP terminals must be inhibited before replacing the Control Card set for the **HS** Master Timing feature to ensure that no **OAP** updates are inadvertently sent to the database during the implementation.

The composite clock cables connect the site's composite (**BITS**) clocks with the **EAGLE STP** control shelf. Implementation of the **HS** Master Timing feature requires the replacement of both composite clock cables with two new **HS** master clock cables (**RS422** compatible) on control shelf backplane (P/N 850-0330-06 or -07 and later).

Only **ATMLIM** cards or **E1/T1MIM** can be configured or re-configured for the **HS** Master Timing feature. Once the baseline hardware requirements for the **HS** Master Timing feature have been met, see the [Master Timing Feature Requirement Matrix](#), install the cards.

Caution: These are redundant systems to allow service during normal maintenance. When repairs require a total power disconnect, both input supply sources must be disconnected. This will cause service interruption and takes down the systems.

- Install an **ATM** card, add the card to the system database, and enable it for the **HS** Master Timing feature (ent-slk:atmtsel=external); or
- Install an **E1/T1MIM**, add the card to the system database, and enable it for the **HS** Master Timing feature (ent-e1:e1tsel=external).

Reconfigure any existing **ATMLIM** card or **E1/T1MIM** to use the **HS** Master Timing feature. **LIM** cards that will continue using the composite clock will not require any changes to the card provisioning.

Note: The EAGLE terminal output screens refer to the composite clocks as Building Integrated Timing Source (**BITS**) clocks. In this document, references to **BITS** and composite clocks are interchangeable.

Master Timing Site Requirements

Implementation of the **HS** Master Timing feature requires the following software and hardware baselines:

- One of the following Control Card/Software Release sets:
 - E5-based Control Cards with Software Release 40.1 or later

Note: See "Hardware Baseline Table" in *Release Notes* for compatible card and control shelf and extension backplane part numbers.

- Control shelves with backplane (P/N 850-0330-03 or 04), if adapter cables P/N 830-1183-01 are installed with **HS** clock cables P/N 830-0873-xx or P/N 830-1189-xx.

Note: Replace the existing composite clock cables (P/N 830-0226-xx) with **RS422** compatible **HS** master and composite clock cables P/N 830-0873-xx or P/N 830-1189-xx. For control shelves with backplane (P/N 850-0330-06 or -07 or later), connect the cables to J48 and J49 (primary and secondary **BITS**) and connect the other ends to the site clock sources.

Note: For control shelves with backplane (P/N 850-0330-03 or 04), connect the adapter cables (P/N 830-1183-01) between connectors J57 and J56 (**ACLK3** and **ACLK4**) on the backplane and to the site **HS** clock source using **HS** clock cables. Leave the existing composite clock cables connected to J42 and J41 (Primary and Secondary **BITS**).

- Control shelves with backplane P/N 850-0330-06 or -07 or later using **HS** master and composite clock cables P/N 830-0873-xx or P/N 830-1189-xx.

Note: Replace the existing composite clock cables (P/N 830-0226-xx) with **RS422** compatible **HS** master and composite clock cables P/N 830-0873-xx or P/N 830-1189-xx. For control shelves with backplane (P/N 850-0330-06 or -07 or later), connect the cables to J48 and J49 (primary and secondary **BITS**) and connect the other ends to the site clock sources.

Note: Control shelf backplane (P/N 850-0330-05) cannot be used with the **HMUX** card required to implement the Large System feature.

- **ATMLIM** card(s) or **E1/T1MIM**(s)
- High-speed clock source (**T1** or **E1**)
 - T1 clock source (**RS422** compatible), 1.544 **MHz** ± 200 Hz square wave output.
 - **E1** clock source (**RS422** compatible), 2.048 **MHz** ± 103 Hz square wave output.
 - ITU G.703 Sec 5 UnFramed T1
 - T1-T1.101 /T1-T1.102 Framed T1
 - E1-G.703-sec. 9 Framed E1
 - E1-G.703-sec. 13 Unframed E1

Master Timing Feature Requirement Matrix

Use [Table 6-2](#) to identify the hardware or software that is required to prepare your **EAGLE STP** for the **HS** Master Timing feature. Perform the procedures in the order listed. Skip any procedure that does not apply.

Note: Perform the procedures mentioned in this document during a maintenance window.

Table 6-2 Feature Requirement Matrix

If you do not have...	do this...	using procedures...	Notes
Control shelf backplane P/N 850-0330-06 or -07 or later	Replace the backplane	Contact My Oracle Support (MOS) for assistance.	
	If you have a control shelf with backplane P/N 850-0330-03 /04, install adapter cable (P/N 830-1183-01) and HS clock cable (P/N 830-0873-xx)	See HS Master and Composite Clock Cables on Backplane P/N 850-0330-03/04 .	

Table 6-2 (Cont.) Feature Requirement Matrix

If you do not have...	do this...	using procedures...	Notes
HS master and composite clock cables (P/N 830-0873-xx) installed	Replace composite clock cables with HS master and composite clock cables and adapter cable if necessary	See HS Master and Composite Clock Cables on Backplane P/N 850-0330-06/07 or A Clock and B Clock Cable Replacement .	Replace one cable at a time.
In an EAGLE using legacy Control Cards: GPSM II cards (P/N 870-2360-01) TDM (P/N 870-0774-10 or later).	Replace MASP (TDM 10 or later as needed)	Contact My Oracle Support (MOS) for assistance replacing the MASP.	Always start with standby MASP
<hr/> <p>Note: Beginning with EAGLE Software Release 31.6 TDM cards must be P/N 870-0774-18 to support Global Timing Interface (TDM-GTI).</p> <hr/>			
In an EAGLE using E5-based Control Cards: E5-MASP cards	Replace legacy MASP (TDM 10 or later as needed)	Contact My Oracle Support (MOS) for assistance replacing the MASP.	Always start with standby MASP
E1/T1MIM installed	Install E1/T1	Refer to <i>Maintenance Guide</i> or <i>Database Administration - SS7 User's Guide</i> .	

Table 6-2 (Cont.) Feature Requirement Matrix

If you do not have...	do this...	using procedures...	Notes
E1/T1MIM configured	Configure E1/T1	Adding an SS7 Signaling Link or Provisioning the E1/T1 in the Database as described in <i>Database Administration - SS7 User's Guide</i> .	

Tools and Equipment

Have the following tools and equipment ready for the cable replacement:

- Two high speed master and composite clock cables (P/N 830-0873-xx)
- Two adapter cables (P/N 830-0846-01) if using control shelf backplane (P/N 850-0330-03/04) with HS cables (P/N 830-0873-xx).
- T1 or E1 LIM card(s)
- ESD safe slotted screw driver
- Cable ties

HS Master and Composite Clock Cables on Backplane P/N 850-0330-06/07

On systems with backplane (P/N 850-0330-06/07) the HS master and composite clock cable (P/N 830-0873-xx) is used to transmit the clock outputs from the customer HS master and composite clock sources to the EAGLE control shelf backplane, providing the EAGLE with a second synchronized system clock. The EAGLE connects to the site master clock through two DB 15 style connectors (J49 and J48) on the backplane of the control shelf for primary and secondary clock signals. The two connectors are labeled *Primary BITS* and *Secondary BITS*. Both primary and secondary clock signals are sent to each terminal disk module (TDM). The TDM cards select between the primary and secondary clock signals to provide A and B system clocks to the rest of the EAGLE.

This procedure replaces the existing composite clock cables (P/N 830-0226-xx) with RS422 compatible cables (P/N 830-0873-xx or P/N 830-1189-xx) connected to the customer HS and composite clock sources.

Caution: A system with DS0A links cannot run without a composite clock source. Take extreme caution when replacing the composite clock source cables. Remove one cable at a time and confirm between removals that the other composite clock source is active.

Caution: Perform this procedure during a maintenance window.

Caution: Prior to adding or replacing the high-speed master and composite clock cables, perform an EAGLE system health check.

Caution: HS clock alarms are only generated if an external BITS clock source is being used.

Caution: Always replace the IDLE clock cable first, whether it is the primary or secondary cable position. After the replacement of the first (IDLE) cable position, ensure the system reports the clock status properly with an ACTIVE and IDLE clock output. If the output reports the correct status the ACTIVE cable can be disconnected for replacement. Disconnecting the ACTIVE cable will transition the previously IDLE clock to the ACTIVE clock forcing the system to use the new clock cable that was installed.

Note: In this procedure, the high-speed clock status indicated in the output of the `rept-stat-clk` command reflects the presence of at least one ATM LIM card or E1/T1 MIM in the system. The status fields remain empty until the card is configured to use the high-speed clock.

Procedure — Replace or Add HS Master Timing Clock Cables with backplane (P/N 850-0330-06/07)

1. Before starting the cable replacement, physically locate the:
 - primary and secondary composite clock and high-speed clock connections at the backplane of the customer composite clock source (customer will provide positions).
 - existing composite clock cables (P/N 830-0226-xx) that are routed from the primary and secondary composite clock connections of the customer clock source to the *Primary BITS* and *Secondary BITS* clock connectors J49 and J48 on the control shelf. [Figure 6-31](#) shows the location of these connectors on the control shelf backplane.

Figure 6-31 Control Shelf (P/N 850-0330-06 or -07) BITS Connectors

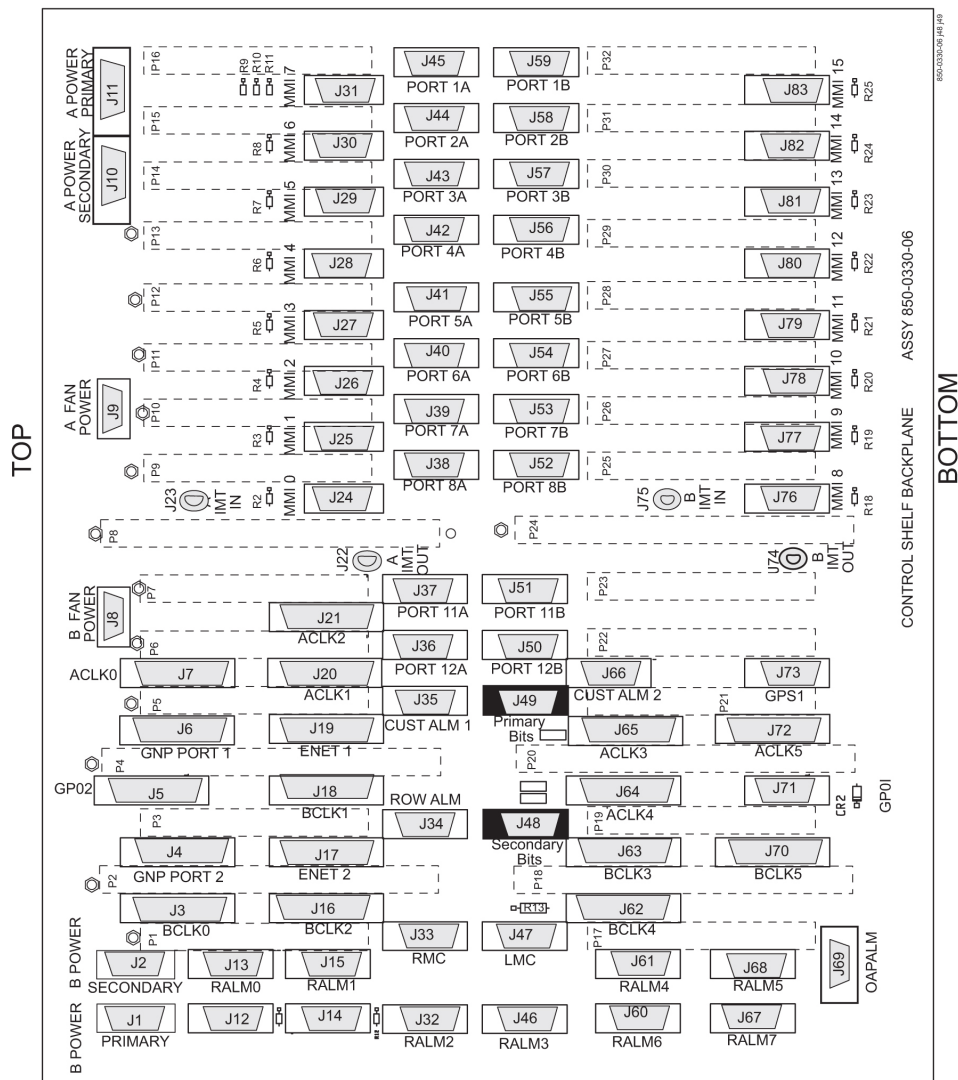

Warning: ⚡ Conducts -48VDC for the printed circuit board (HOT). Metal points on printed circuit boards conducts -48VDC and can cause shorts, shocks, and damage if not handled properly.

2. Obtain the two new primary and secondary high-speed master and composite clock cables (P/N 830-0873-xx or P/N 830-1189-xx). Cut out the cable ties along the route of the existing composite clock cables (P/N 830-0226-xx).
3. Route the new primary and secondary high-speed master and composite clock cables (P/N 830-0873-xx or P/N 830-1189-xx) to the frame using new cable ties.

Note: Route but do not connect the new cables to the back panel at this time to avoid any accidental pull on cable connectors that could disconnect them from the composite clock source. Always route clock cables on separate cable racks, if provided, for redundancy.

4. Prior to cable replacement, check your system for any troubles. At the EAGLE terminal, enter:

```
rept-stat-trbl
```

Record any troubles and ensure that no clock problems exist.

Note: If clock errors exist that cannot be resolved, contact the [My Oracle Support \(MOS\)](#) for assistance before starting the cable replacement.

5. Generate a clock status report to ensure that the current primary and secondary composite clock sources are running and determine which MASP is active or on standby; enter:

```
rept-stat-clk
```

The output displays the card status and the presence of the primary and secondary clocks, the number of cards that use clocks A and B, and the number of cards using bad clocks.

```
tekelecstp 00-12-10 11:35:15 EST Rel 26.0.0
CARD LOC = 1114 (Active )   CARD LOC = 1116 (Standby)
PRIMARY BITS      = Active  PRIMARY BITS      = Active
SECONDARY BITS    = Idle    SECONDARY BITS    = Idle

      PSTSSTAST
      SYSTEM CLOCKIS-NRActive-----
# Cards using CLK A = 11   # Cards with bad CLK A = 0
# Cards using CLK B = 3   # Cards with bad CLK B = 0
# Cards using CLK I = 0
      PSTSSTAST
Command Completed.
```

where:

- `CARD LOC` is the TDM card location and the status of the MASP .
- `PRIMARY BITS` is the status of the primary composite clock
 - `Idle` indicates that the present clock source is valid but not selected as active clock source
 - `Active` indicates that the present clock source is valid and selected as active clock source
 - `Fault` indicates that no clock source is present .
- `SECONDARY BITS` is the status of the secondary composite clock
 - `Idle` indicates that the present clock source is valid but not selected as active clock source
 - `Active` indicates that the present clock source is valid and selected as active clock source
 - `Fault` indicates that no clock source is present .
- `# Cards using CLK A, B, I` is the number of cards using clocks A, B, and I.
- `# Cards using CLK A, B` is the number of cards using clock A or clock B, when clock A or B is bad. NOTE: If any card indicates a bad clock, troubleshoot the card using the `rept-stat-trbl` command. Replace the card if necessary. If the bad clock error cannot be resolved, contact the [My Oracle Support \(MOS\)](#) for assistance before starting the cable replacement.

Note: There should be no cards using bad clocks. If any card indicates a bad clock, troubleshoot the card using the `rept-stat-trbl` command. Replace the card if necessary. If the bad clock error cannot be resolved, contact the [My Oracle Support \(MOS\)](#) for assistance before starting the cable replacement.

6. From the output in 5, determine the IDLE clock cable.

Caution: Always replace the IDLE clock cable first, whether it is the primary or secondary cable position. After the replacement of the first (IDLE) cable position, ensure the system reports the clock status properly with an ACTIVE and IDLE clock output. If the output reports the correct status the ACTIVE cable can be disconnected for replacement. Disconnecting the ACTIVE cable will transition the previously IDLE clock to the ACTIVE clock forcing the system to use the new clock cable that was installed.

7. Perform the following to prepare the open end of the new IDLE high-speed master and composite clock cable (P/N 830-0873-xx or P/N 830-1189-xx) for connection to the customer's high-speed and composite clock sources.
- Remove the outer insulation to expose the wires.
 - Cut back any unused wires as shown in [Figure 6-32](#).
 - Slide on a 1-1/2 inch length of shrink-wrap tubing.
 - Center the tubing on the end of the cable insulation before shrinking tubing with a heat gun.
 - Ensure that each tie-wrap strap is cut flush with the tie-wrap head so that no sharp edges are exposed.

Caution: A system with DS0A links cannot run without a composite clock source. Take extreme caution when replacing the composite clock source cables. Remove one cable at a time and confirm between removal that the other composite clock source is active.

8. Remove the IDLE clock cable on the control shelf by removing the IDLE composite clock connector of cable (P/N 830-0226-xx) from the appropriate connector (J48 or J49) on the control shelf backplane.

At the terminal, the EAGLE displays the following alarms:

```
tekelecstp 00-12-10 12:17:10 EST Rel 26.0.0
* 4306.0167 * CLOCK SYSTEM          1114-S clock failed
tekelecstp 00-12-10 12:17:10 EST Rel 25.0.0-26.0.0
** 4307.0169 ** CLOCK SYSTEM        1114-S, 1116-S clocks failed
tekelecstp 00-12-10 12:05:04 EST Rel 25.0.0-26.0.0
* 4276.0161 * CLOCK SYSTEM          1116-S clock failed
Legend: minor (*), major (**), critical (C*), and inhibited (I) alarms.
```

Caution: If Both PRIMARY BITS and SECONDARY BITS clocks show FAULT condition, reconnect the cable (P/N 830-0226-xx) to the appropriate connector (J48 or J49) and abort this procedure. Contact the [My Oracle Support \(MOS\)](#) for assistance.

9. At the output panel of the customer composite clock source, locate the end of the composite/BITS clock cable (P/N 830-0226-xx) that was disconnected in 8 and remove all wires.
10. Connect the new high-speed master clock and composite cable (P/N 830-0873-xx or P/N 830-1189-xx) to the site HS clock source.
 - a. Cut the wires to length and strip.
 - b. Wire-wrap to the appropriate IDLE (primary or secondary) clock connections on the customer clock source. Refer to the cable wire coding (P/N 830-0873-xx or P/N 830-1189-xx) shown in Figure 6-32 for connection information.
 - Connect the HS clock source to the orange and white/orange wires.
 - Connect the composite clock source to the blue and white/blue wires.

Figure 6-32 Wire Coding of High-Speed Master and Composite Clock Cable (P/N 830-0873-xx or P/N 830-1189-xx)

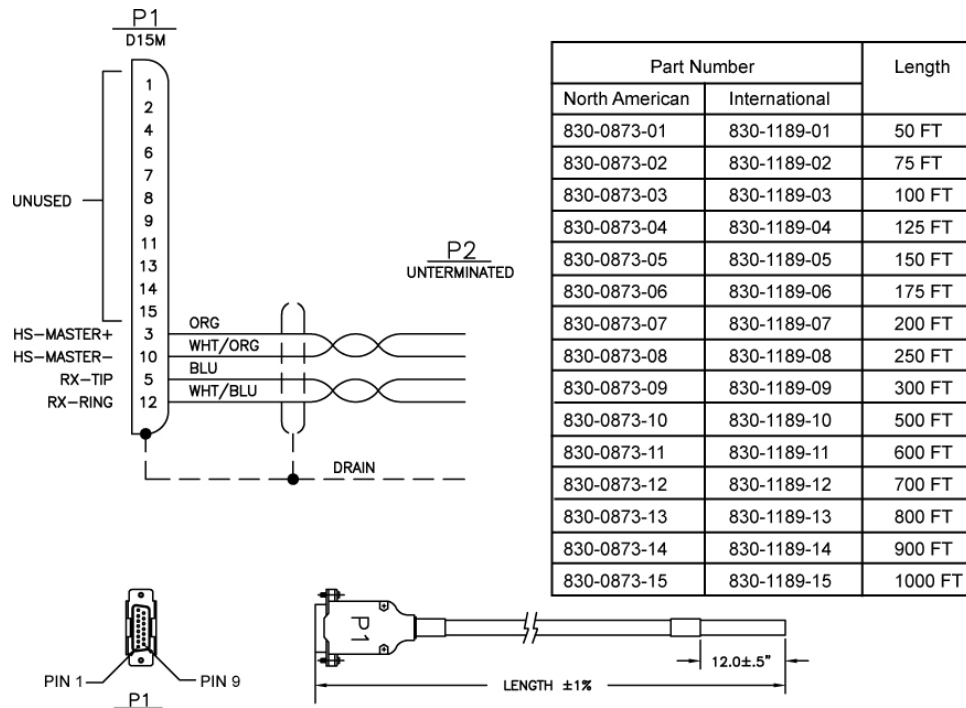

11. Connect P1 of the high-speed master and composite clock cable (P/N 830-0873-xx or P/N 830-1189-xx) connector end to the appropriate IDLE clock connector (J48 or J49). Tighten the connector with a slotted screw driver.

After the cable (P/N 830-0873-xx or P/N 830-1189-xx) wires are attached correctly to the site clock sources and connected to the control shelf (J48 or J49), the EAGLE terminal returns the message that alarms have been cleared:

```
tekelecstp 99-12-10 12:05:04 EST Rel 25.0.0-26.0.0
4277.0113    CLOCK SYSTEM          Clock alarm(s) cleared
```

12. At the EAGLE terminal, reenter the clock status command to ensure that both primary and secondary BITS clocks are available again, enter:

```
rept-stat-clk
```

The output indicates whether the BITS clocks are running.

```
tekelecstp 00-12-10 11:35:15 EST Rel 25.0.0-26.0.0
CARD LOC = 1114 (Active )  CARD LOC = 1116 (Standby)
PRIMARY BITS    = Active  PRIMARY BITS    = Active
SECONDARY BITS  = Idle    SECONDARY BITS  = Idle
```

```
      PSTSSTAST
      SYSTEM CLOCKIS-NRActive-----
# Cards using CLK A = 11  # Cards with bad CLK A = 0
# Cards using CLK B = 3   # Cards with bad CLK B = 0
# Cards using CLK I = 0
      PSTSSTAST
Command Completed.
```

Refer to [5](#) for output legend

Note: There should be no bad clocks present in the output of the rept-stat-clk command. If bad clocks are present, contact the [My Oracle Support \(MOS\)](#) for assistance.

13. Verify that you don't have any new alarms, refer to the recorded output obtained in [4](#). If you check the system for clock alarms, the output should show no clock errors; enter:

```
rept-stat-trbl
```

Note: There should be no clock error messages present in the output of the rept-stat-trbl command. If clock error messages are present, contact the [My Oracle Support \(MOS\)](#) for assistance.

14. Perform the following to prepare the open end of the second new high-speed master and composite clock cable, currently the ACTIVE, (P/N 830-0873-xx or P/N 830-1189-xx) for connection to the customer's high-speed and composite clock sources.
- Remove the outer insulation to expose the wires.
 - Cut back any unused wires as shown in [Figure 6-32](#).
 - Slide on a 1-1/2 inch length of shrink-wrap tubing.
 - Center the tubing on the end of the cable insulation before shrinking tubing with a heat gun.
 - Ensure that each tie-wrap strap is cut flush with the tie-wrap head so that no sharp edges are exposed.

Caution: A system with DS0A links cannot run without a composite clock source. Take extreme caution when replacing the composite clock source cables. Remove one cable at a time and confirm between removal that the other composite clock source is active.

15. Remove the ACTIVE clock cable on the control shelf by removing the ACTIVE composite clock connector of cable (P/N 830-0226-xx) from the appropriate connector (J48 or J49) on the control shelf backplane.

At the terminal, the EAGLE displays the following alarms:

```
tekelecstp 00-12-10 12:17:10 EST Rel 26.0.0
* 4306.0167 * CLOCK SYSTEM          1114-P clock failed
tekelecstp 00-12-10 12:17:10 EST Rel 25.0.0-26.0.0
** 4307.0169 ** CLOCK SYSTEM        1114-P, 1116-P clocks failed
tekelecstp 00-12-10 12:05:04 EST Rel 25.0.0-26.0.0
* 4276.0161 * CLOCK SYSTEM          1116-P clock failed
Legend: minor (*), major (**), critical (C*), and inhibited (I) alarms.
```

Caution: If Both PRIMARY BITS and SECONDARY BITS clocks show FAULT condition, reconnect the cable (P/N 830-0226-xx) to the appropriate connector (J48 or J49) and abort this procedure. Contact the [My Oracle Support \(MOS\)](#) for assistance.

16. If you check the system for clock alarms, the output will show clock errors; enter:

```
rept-stat-trbl
```

The output will show any minor (*), major (**), critical (C*), and inhibited (I) alarms. The following display shows possible error messages with their alarm indicators:

```
* 0014.0021 *   CARD 1116 OAM Clock A for card failed, Clock B normal
* 0014.0022 *   CARD 1116 OAM Clock B for card failed, Clock A normal
* 0014.0023 *   CARD 1116 OAM Clocks A and B for card failed
**0046.0023 *   CARD 1201 ATMANSI Clocks A and B for card failed
**4307.0164 ** CLOCK SYSTEM 1114-P, 1116-P clocks failed
Legend: minor (*), major (**), critical (C*), and inhibited (I) alarms.
```

17. At the output panel of the customer composite clock source, locate the end of the composite/BITS clock cable (P/N 830-0226-xx) that was disconnected in 15 and remove all wires.

18. Connect the new high-speed master clock and composite cable (P/N 830-0873-xx or P/N 830-1189-xx) to the site HS clock source.

- a. Cut the wires to length and strip.
- b. Wire-wrap to the appropriate IDLE (primary or secondary) clock connections on the customer clock source. Refer to the cable wire coding (P/N 830-0873-xx or P/N 830-1189-xx) shown in [Figure 6-32](#) for connection information.
 - Connect the HS clock source to the orange and white/orange wires.
 - Connect the composite clock source to the blue and white/blue wires.

Figure 6-33 Wire Coding of High-Speed Master and Composite Clock Cable (P/N 830-0873-xx or P/N 830-1189-xx)

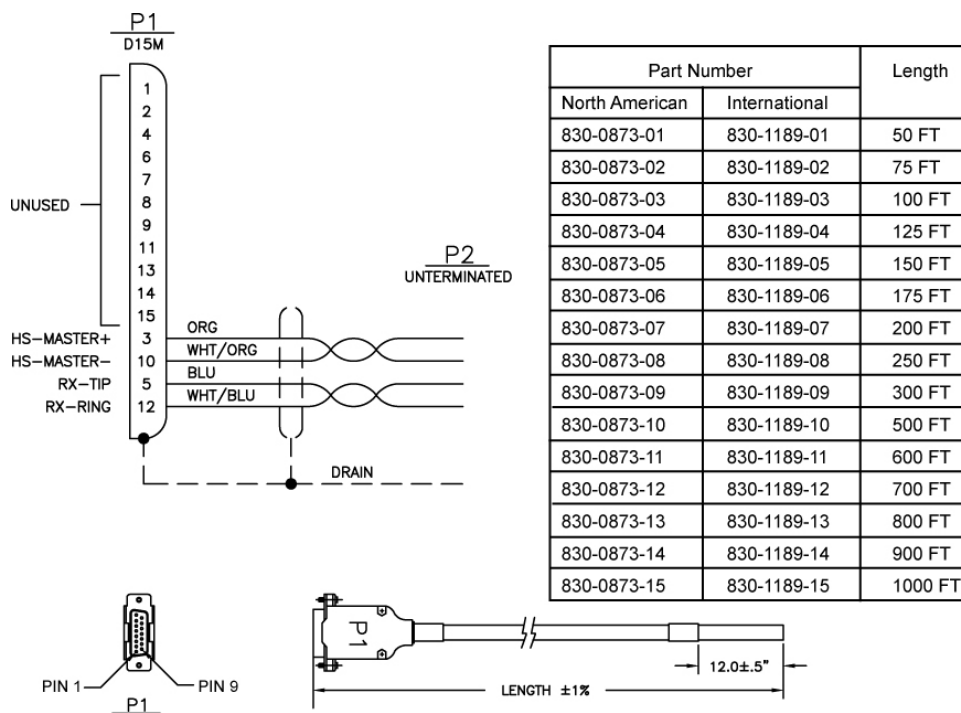

19. Connect P1 of the high-speed master and composite clock cable (P/N 830-0873-xx or P/N 830-1189-xx) connector end to the appropriate clock connector (J48 or J49). Tighten the connector with a slotted screw driver.

After the cable (P/N 830-0873-xx or P/N 830-1189-xx) wires are attached correctly to the site clock sources and connected to the control shelf (J48 or J49), the EAGLE terminal returns the message that alarms have been cleared:

```
tekelecstp 99-12-10 12:05:04 EST Rel 25.0.0-26.0.0
4277.0113    CLOCK SYSTEM          Clock alarm(s) cleared
```

20. At the EAGLE terminal, reenter the clock status command to ensure that both primary and secondary BITS clocks are available again, enter:

```
rept-stat-clk
```

The output indicates whether the BITS clocks are running.

```
tekelecstp 00-12-10 11:35:15 EST Rel 25.0.0-26.0.0
CARD LOC = 1114 (Active )  CARD LOC = 1116 (Standby)
PRIMARY BITS = Idle        PRIMARY BITS = Idle
SECONDARY BITS = Active    SECONDARY BITS = Active
```

```
PSTSSTAST
SYSTEM CLOCKIS-NRActive-----
# Cards using CLK A = 11    # Cards with bad CLK A = 0
# Cards using CLK B = 3    # Cards with bad CLK B = 0
# Cards using CLK I = 0
PSTSSTAST
Command Completed.
```

Refer to 5 for output legend

Note: There should be no bad clocks present in the output of the `rept-stat-clk` command. If bad clocks are present, contact the [My Oracle Support \(MOS\)](#) for assistance.

21. Verify that you don't have any new alarms, refer to the recorded output obtained in 4. If you check the system for clock alarms, the output should show no clock errors; enter:

```
rept-stat-trbl
```

Note: There should be no clock error messages present in the output of the `rept-stat-trbl` command. If clock error messages are present, contact the [My Oracle Support \(MOS\)](#) for assistance.

You have completed the cable replacement procedure for the high-speed master and composite clock cables on EAGLE systems with backplane (P/N 850-0330-06/07).

HS Master and Composite Clock Cables on Backplane P/N 850-0330-03/04

On systems with control shelf backplane (P/N 850-0330-03/04), the high-speed master clock cable (P/N 830-0873-xx or P/N 830-1189-xx) sends only high-speed clock signals to the EAGLE. The existing composite clock cables (P/N 830-0226-xx) continue to provide the low-speed clock connections to connectors J42 and J41 (Primary BITS and Secondary BITS) on the backplane. The HS cables (P/N 830-0873-xx or P/N 830-1189-xx) send the HS primary and secondary clock signals through adapter cables (P/N 830-0846-01) to connectors J57 and J56 on the backplane. The two connectors are labeled ACLK3 and ACLK4.

This procedure describes the steps required to install the HS clock cables on the EAGLE with control shelf backplane (P/N 850-0330-03/04) using adapter cable (P/N 830-0846-01).

Caution: A system with DS0A links cannot run without a composite clock source. This procedure requires removing and replacing the ACLK3 cables to frame 3 (shelves 4100, 4200, 4300) and frame 4, ACLK4 (shelves 5100, 5200, 5300). Take extreme caution when removing and replacing the ACLK cables. Remove one cable at a time and confirm before removal that the BCLK clock source is active to that frame.

Caution: Perform this procedure during a maintenance window.

Caution: Prior to adding or replacing the high-speed master and composite clock cables, perform an EAGLE system health check.

Caution: HS clock alarms are only generated for ATM LIM cards and E1/T1 MIM if the card is provisioned to use the HS clock.

Caution: Always replace the IDLE clock cable first, whether it's the primary or secondary cable position. After the replacement of the first (Idle) cable position, ensure the system reports the clock status properly with an active and idle clock output. If the output reports the correct status you are know able to replace the active cable which will force the system to use the new clock cable (idle) position and it will transition state to active.

Caution: Connectors ACLK3 and ACLK4 propagate system A clocks to frame 3 (shelves 4100, 4200, and 4300) and frame 4 (shelves 5100, 5200, 5300). System A clock signals to cards in these shelves will be lost during this procedure. If the EAGLE contains these shelves with cards installed the cards switch automatically to the system B clock sources when the A clock sources are removed.

Note: In this procedure, the high-speed clock status indicated in the output of the `rept-stat-clk` command reflects the presence of at least one ATM LIM card or E1/T1 MIM in the system. The status fields remain empty until the card is configured to use the high-speed clock.

Procedure — Replace or Add HS Master Timing Clock Cables with:backplane (P/N 850-0330-03/04)

1. Prior to cable replacement, check your system for any troubles. At the EAGLE terminal, enter:

```
rept-stat-trbl
```

Record any troubles and ensure that no clock problems exist.

Note: If clock errors exist that cannot be resolved, contact the [My Oracle Support \(MOS\)](#) for assistance before starting the cable replacement.

2. Generate a clock status report to ensure that the current primary and secondary composite clock sources are running and determine which MASP is active or on standby; enter:

```
rept-stat-clk
```

The output displays the card status and the presence of the primary and secondary clocks, the number of cards that use clocks A and B, and the number of cards using bad clocks.

```
tekelecstp 00-12-10 11:35:15 EST Rel 26.0.0
CARD LOC = 1114 (Active )   CARD LOC = 1116 (Standby)
PRIMARY BITS = Active     PRIMARY BITS = Active
SECONDARY BITS = Idle     SECONDARY BITS = Idle
```

```

PSTSSTAST
SYSTEM CLOCKIS-NRActive-----
# Cards using CLK A = 11   # Cards with bad CLK A = 0
# Cards using CLK B = 3   # Cards with bad CLK B = 0
# Cards using CLK I = 0
PSTSSTAST
Command Completed.
```

where:

- `CARD LOC` is the TDM card location and the status of the MASP.
- `PRIMARY BITS` is the status of the primary composite clock
 - `Idle` indicates that the present clock source is valid but not selected as active clock source
 - `Active` indicates that the present clock source is valid and selected as active clock source
 - `Fault` indicates that no clock source is present.
- `SECONDARY BITS` is the status of the secondary composite clock
 - `Idle` indicates that the present clock source is valid but not selected as active clock source
 - `Active` indicates that the present clock source is valid and selected as active clock source
 - `Fault` indicates that no clock source is present.
- `# Cards using CLK A, B, I` is the number of cards using clocks A, B, and I.
- `# Cards using CLK A, B` is the number of cards using clock A or clock B, when clock A or B is bad. NOTE: If any card indicates a bad clock, troubleshoot the card using the `rept-stat-trbl` command. Replace the card if necessary. If the bad clock error cannot be resolved, contact the [My Oracle Support \(MOS\)](#) for assistance before starting the cable replacement.

Note: There should be no cards using bad clocks. If any card indicates a bad clock, troubleshoot the card using the `rept-stat-trbl` command. Replace the card if necessary. If the bad clock error cannot be resolved, contact the [My Oracle Support \(MOS\)](#) for assistance before starting the cable replacement.

3. Before starting the cable replacement, physically locate the:

- two new HS clock cables (P/N 830-0873-xx) to be connected to the customers HS clock source.
- adapter cables (P/N (830-0846-01).
- the existing composite clock cables (P/N 830-0226-xx) connected to the primary and secondary BITS clock sources and connectors (J42 and J41) on the control shelf backplane.
- any existing ACLK cables connected to ACLK3 and ACLK4 (J57 and J56) on the control shelf backplane.

Note: Depending on the amount of extension shelves in the system the cables connecting ACLK3 and ACLK4 to extension frames may not be installed. If these cables are not installed the P2 (DB25) end of the adapter cables (P/N 830-0846-01) are not used. Secure the unused P2 end of the adapter cables with tie-wraps.

Note: Route but do not connect the new cables to the backpanel at this time to avoid any accidental pull on cable connectors that could disconnect them from the composite clock source. Always route clock cables on separate cable racks, if provided, for redundancy.

Ensure that each tie-wrap strap is cut flush with the tie-wrap head so that no sharp edges are exposed.

6. Prepare the open end of the new primary high-speed master and composite clock cable (P/N 830-0873-xx or P/N 830-1189-xx) for connection to the customer's primary clock and high-speed clock sources. Remove the outer insulation to expose the wires.
7. Slide on a 1-1/2 inch length of shrink-wrap tubing. Center the tubing on the end of the cable insulation before shrinking tubing with a heat gun.
8. Connect the open cable end wires to the site primary and secondary high-speed clock sources. Connect the primary and secondary HS master clock source cables (P/N 830-0873-xx or P/N 830-1189-xx) to the wires attached to connector P1, pins 10 and 3, on each cable.

Figure 6-354 shows the connector pin outs of the high-speed master clock cable adapter cable (P/N 830-0873-xx or P/N 830-1189-xx).

Figure 6-35 Wire Coding of High-Speed Master and Composite Clock Cable (P/N 830-0873-xx or P/N 830-1189-xx)

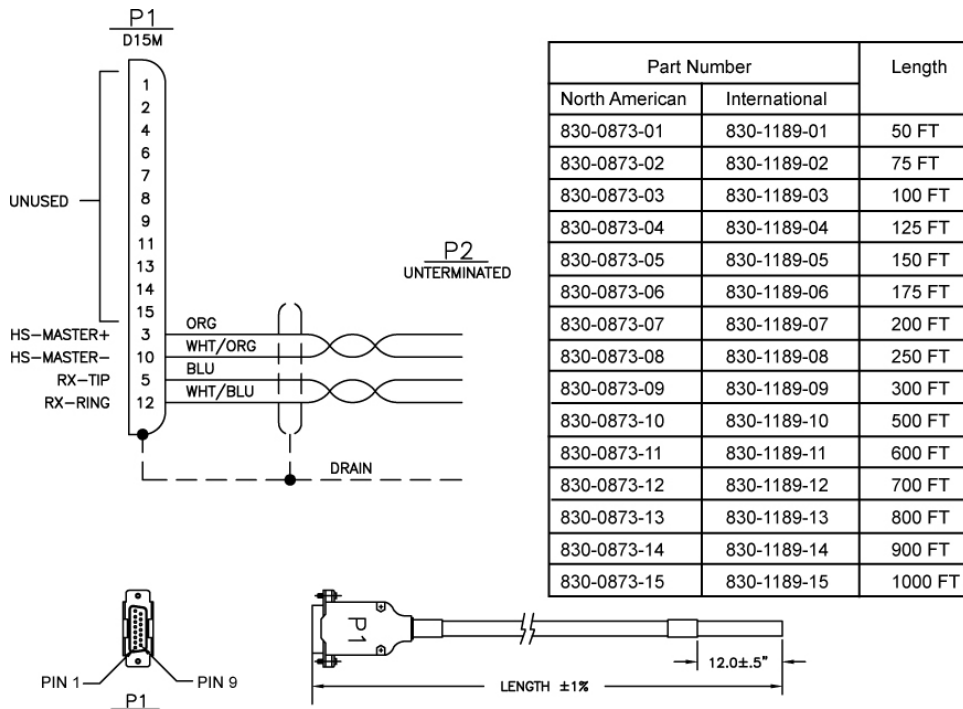

Caution: A system with DS0A links cannot run without a composite clock source. Take extreme caution when replacing the composite clock source cables. Remove one cable at a time and confirm between removal that the other composite clock source is active.

Note: If the ACLK3 or ACLK4 connectors did not have cables connected as indicated in 3 the P2 (DB 25) end of the adapter cable is not used. Using tie-wraps secure the P2 end of the cable.

9. Start adding the primary HS clock cable (P/N 830-0873-xx) and adapter cable (P/N 830-0846-01) on the control shelf by removing the cable end at ACLK3 connector J57.

At the terminal, the EAGLE displays alarms indicating loss of ACLK to cards on shelves 4100, 4200, and 4300 with BCLK normal.

10. Generate a clock status report to confirm that the secondary composite clock is now active. Enter the following command:

```
rept-stat-clk
```

The system returns output similar to the following:

```
tekelecstp 00-12-10 11:35:15 EST Rel 26.0.0
CARD LOC = 1114 (Active ) CARD LOC = 1116 (Standby )
PRIMARY BITS = Fault PRIMARY BITS = Fault
SECONDARY BITS = Active SECONDARY BITS = Active
PSTSSTAST
SYSTEM CLOCKIS-NRActive-----
# Cards using CLK A = 11 # Cards with bad CLK A = 0
# Cards using CLK B = 3 # Cards with bad CLK B = 0
# Cards using CLK I = 0
PSTSSTAST
Command Completed.
```

Refer to 2 for output legend.

Caution: If cards on shelves 4100, 4200, and 4300 indicate bad ACLK and BCLK reconnect the ACLK3 cable to connector J57 and abort this procedure. Contact the [My Oracle Support \(MOS\)](#) for assistance.

Note: In the following steps reference [Figure 6-36](#) for cabling connections.

11. Connect the adapter cable (P/N 830-0846-01) P1 (DB25) to ACLK3 connector J57 on the control shelf backplane. Tighten the connector with a slotted screw driver.

Figure 6-36 High-Speed Master Timing Adapter Cable (P/N 830-0846-01)

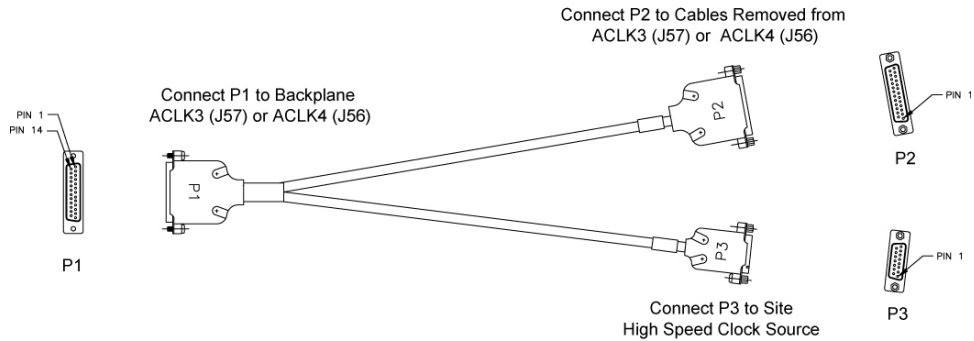
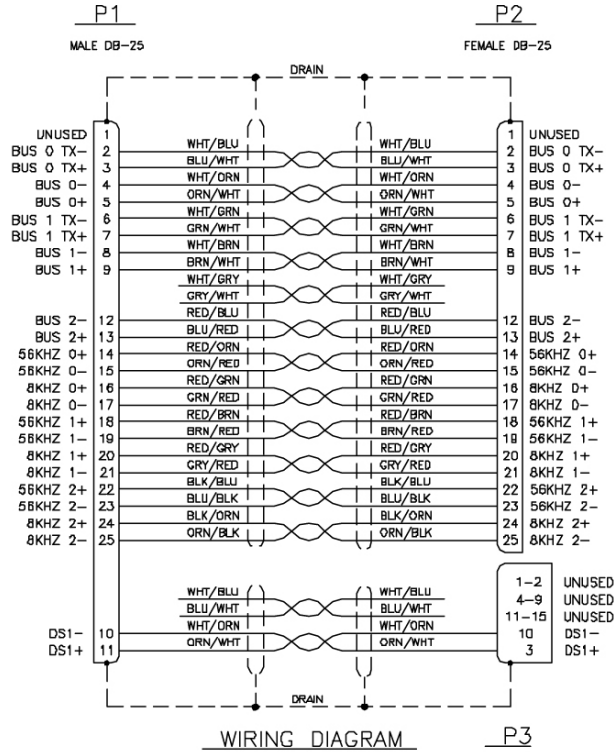

12. Connect the adapter cable (P/N 830-0846-01) P2 (DB25) to the end of the ACLK cable removed in Step \ Tighten the connector with a slotted screw driver.

This step reconnects the ACLK3 signals to shelves 4100, 4200, 4300.

At the terminal, the EAGLE displays messages indicating return of ACLK to cards on shelves 4100, 4200, and 4300 with BCLK normal.

13. Connect the primary HS master clock cable (P/N 830-0873-xx) connector end to adapter cable (P/N 830-0846-01) P3 (DB15). Tighten the connector with a slotted screw driver.

This step connects the customer primary HS clock source to the TDM card through the unused contacts of the ACLK3 connector J57.

After the wires are attached correctly, the EAGLE terminal returns the following message:

```
tekelecstp 00-12-10 12:05:04 EST Rel 26.0.0
4277.0113    CLOCK SYSTEM          Clock alarm(s) cleared
```

14. At the EAGLE terminal, reenter the clock status command to ensure that both primary and secondary BITS clocks are available again, enter:

```
rept-stat-clk
```

The output indicates whether the BITS clocks are running. In this example, the secondary BITS clock is still active and the primary BITS clock is running but in standby mode.

```
tekelecstp 00-12-10 11:35:15 EST Rel 25.0.0-26.0.0
CARD LOC = 1114 (Active ) CARD LOC = 1116 (Standby)
PRIMARY BITS = Idle PRIMARY BITS = Idle
SECONDARY BITS = Active SECONDARY BITS = Active
```

```
PSTSSTAST
SYSTEM CLOCKIS-NRActive-----
# Cards using CLK A = 11 # Cards with bad CLK A = 0
# Cards using CLK B = 3 # Cards with bad CLK B = 0
# Cards using CLK I = 0
PSTSSTAST
Command Completed.
```

Refer to 2 for output legend

Note: There should be no bad clocks present in the output of the rept-stat-clk command. If bad clocks are present, contact the [My Oracle Support \(MOS\)](#) for assistance.

15. Verify that you don't have any new alarms, refer to the recorded output obtained in 1. If you check the system for clock alarms, the output should show no clock errors; enter:

```
rept-stat-trbl
```

Note: There should be no clock error messages present in the output of the rept-stat-trbl command. If clock error messages are present, contact the [My Oracle Support \(MOS\)](#) for assistance.

16. To continue this procedure to add the secondary HS clock cables go to 13.

Caution: A system with DS0A links cannot run without a composite clock source. Take extreme caution when replacing the ACLK to extension shelf cables. Remove one cable at a time and confirm between removal that the other composite clock source on that shelf is active.

17. Start adding the secondary HS clock cable the cable (P/N 830-0873-xx) and adapter (P/N 830-0846-01) on the control shelf by removing the cable end at ACLK4 connector J56.

At the terminal, the EAGLE displays alarms indicating loss of ACLK to cards on shelves 5100, 5200, and 5300 and BCLK normal.

18. Generate a clock status report to confirm that cards on shelves 5100, 5200, and 5300 are using the BCLK. Enter the following command:

```
rept-stat-clk
```

The output indicates whether the BITS clock is running again. In this example, the primary BITS clock is active and the secondary BITS clock has failed.

```
tekelecstp 00-12-10 11:35:15 EST Rel 26.0.0
CARD LOC = 1114 (Active )CARD LOC = 1116 (Standby )
PRIMARY BITS      = Active  PRIMARY BITS      = Active
SECONDARY BITS    = Fault   SECONDARY BITS    = Fault
PSTSSTAST
SYSTEM CLOCKIS-NRActive-----
# Cards using CLK A = 11   # Cards with bad CLK A = 0
# Cards using CLK B = 3   # Cards with bad CLK B = 0
# Cards using CLK I = 0
PSTSSTAST
Command Completed.
```

Refer to Step 2 for output legend.

Caution: If cards on shelves 5100, 5200, and 5300 indicate bad ACLK and BCLK, reconnect the ACLK3 cable to connector J57 and abort this procedure. Contact the [My Oracle Support \(MOS\)](#) for assistance.

19. Connect the adapter cable (P/N 830-0846-01) P1 (DB25) to ACLK4 connector J56 on the control shelf backplane. Tighten connector with slotted screw driver.

Note: If the ACLK3 and ACLK4 connectors did not have cables connected as indicated in 3 the P2 (DB 25) end of the adapter cable is not used. Using tie-wraps secure the P2 end of the cable.

20. Connect the adapter cable (P/N 830-0846-01) P2 (DB25) to the end of the ACLK cable removed in 3. Tighten the connector with a slotted screw driver. This step reconnects the ACLK4 signals to shelves 5100, 5200, 5300.

At the terminal, the EAGLE displays messages indicating return of ACLK to cards on shelves 5100, 5200, and 5300 and BCLK normal.

21. Connect the secondary HS master clock cable (P/N 830-0873-xx) connector end to adapter cable (P/N 830-0846-01) P3 (DB15). Tighten the connector with a slotted screw driver.

This step connects the customer secondary HS clock source to the TDM card through the unused contacts of the ACLK4 connector J56.

After the cables are attached correctly, the EAGLE terminal returns the following message:

```
tekelecstp 00-12-10 12:05:04 EST Rel 26.0.0
4277.0113   CLOCK SYSTEM           Clock alarm(s) cleared
```

22. At the EAGLE terminal, reenter the clock status command to ensure that both primary and secondary BITS clocks are available again, enter:

```
rept-stat-clk
```

The output indicates whether the BITS clocks are running. In this example, the secondary BITS clock is still active and the primary BITS clock is running but in standby mode.

```

tekelecstp 00-12-10 11:35:15 EST Rel 26.0.0
CARD LOC = 1114 (Active )CARD LOC = 1116 (Standby )
PRIMARY BITS      = Active  PRIMARY BITS      = Active
SECONDARY BITS    = Fault   SECONDARY BITS    = Fault
PSTSSTAST
SYSTEM CLOCKIS-NRActive-----
# Cards using CLK A = 11   # Cards with bad CLK A = 0
# Cards using CLK B = 3   # Cards with bad CLK B = 0
# Cards using CLK I = 0
PSTSSTAST
Command Completed.

```

Refer to [2](#) for output legend.

Note: There should be no bad clocks present in the output of the `rept-stat-clk` command. If bad clocks are present, contact the [My Oracle Support \(MOS\)](#) for assistance.

23. Verify that you don't have any new alarms, refer to the recorded output obtained in [1](#). If you check the system for clock alarms, the output should show no clock errors; enter:

```
rept-stat-trbl
```

Note: There should be no clock error messages present in the output of the `rept-stat-trbl` command. If clock error messages are present, contact the [My Oracle Support \(MOS\)](#) for assistance.

You have completed the cable replacement procedure for the high-speed master clock cables on EAGLE systems with control shelf backplane (P/N 850-0330-03/04).

A Clock and B Clock Cable Replacement

Proper support for HMUX and alarm reporting require that all A and B clock cables be of P/N 830-0398-xx (domestic) or P/N 830-1150-xx (international). Clock cables of P/N 830-0404-xx must be replaced. The A and B clock cables typically are from the control shelf and those coming in from an extension shelf. These cables contain proper alarm alert capabilities and support HMUX. See [Figure 6-37](#) and [Figure 6-38](#).

This procedure can also be used for regular clock cable replacement.

Perform the replacement during a maintenance window and prior to fan assembly installation.

Figure 6-37 Cable (P/N 830-0404-xx)

Cable P/N 830-0404-xx will not support HMUX and must be replaced by Cable P/N 830-0398-xx for Eagle Release 30.0

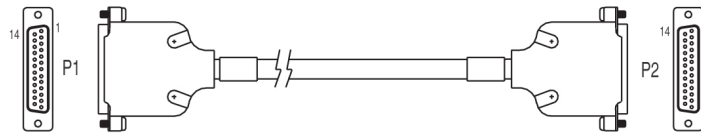

Cable P/N 830-0404-xx

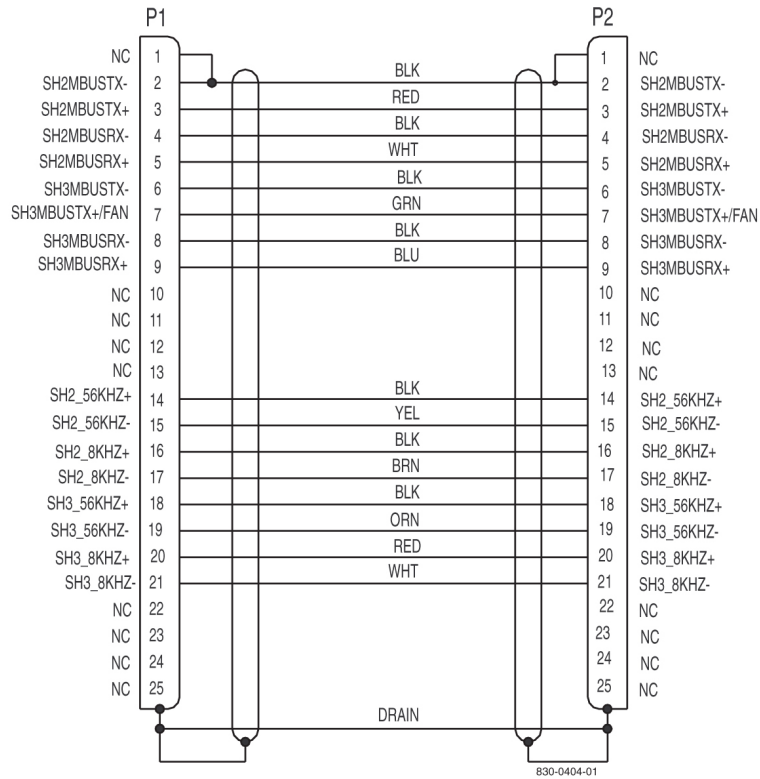
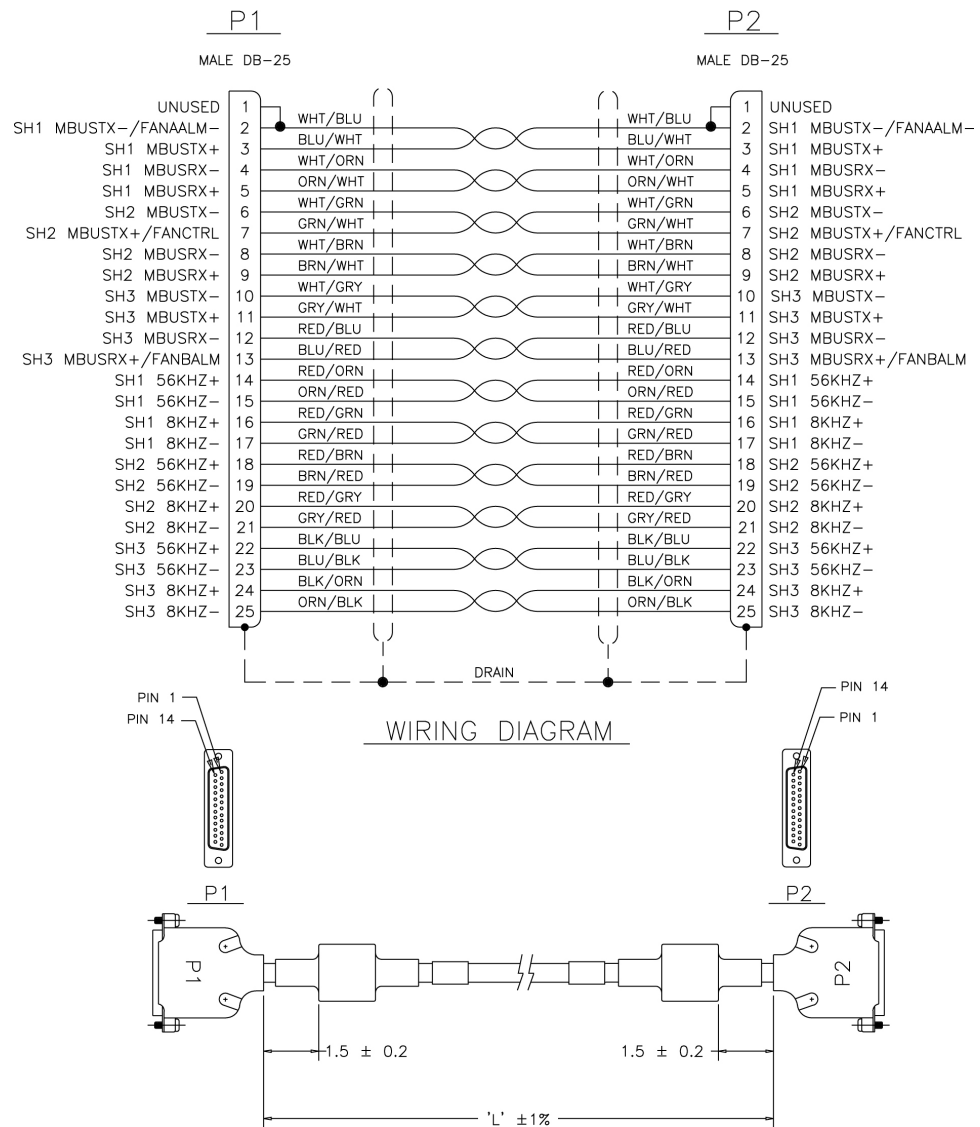

Figure 6-38 Cable 830-0398-xx or 830-1150-xx

Procedure — Replacing A Frame Clock Cables

This procedure explains the replacement of one A frame clock cable. The steps show the replacement of one frame clock cable and are repeated for every frame clock cable that is to be replaced.

1. Remove the plastic panels from the back of all shelves that require the frame clock cables be replaced.
2. Install Pin Protector Assembly on all shelves that require the frame clock cables be replaced.

The pin protectors are placed over the ID pins directly to the right and left of the A CLK IN cables connectors on each shelf. **Shelf ID** pins must be covered with pin protectors. If contact is made with the **ID** pins, the shelf may lose its identity.

3. Connect a laptop or access by way of a monitor, the EAGLE system and start a terminal emulator program such as ProComm.

4. Open a captured file by simultaneously pressing the **Alt** and **F1** keys

Name the file the last four digits of the [NT#]xyyz.CAP

Example: 2641E1T1_A.cap

5. Issue the command to report clock status.

```
rept-stat-clk
```

Response to the clock status command is displayed.

```
tekelecstp 03-02-10 05:34:03 HST Rel XX.x.x-XX.x.x
```

```
rept-stat-clk
```

```
Command entered at terminal #1.
```

```
;
```

```
tekelecstp 03-02-10 05:34:03 HST Rel XX.x.x-XX.x.x
CARD LOC= 1114 (Standby)    CARD LOC= 1116 (Active)
PRIMARY BITS      = Active  PRIMARY BITS      = Active
SECONDARY BITS    = Idle    SECONDARY BITS    = Idle
HS PRIMARY CLK    = Active  HS PRIMARY CLK    = Active
HS SECONDARY CLK  = Idle
```

```
HS SECONDARY CLK  = Idle
                PST          SST          AST
SYSTEM CLOCK      IS-NR      Active     -----
# Cards using CLK A = 7    # Cards with bad CLK A = 000
# Cards using CLK B = 0    # Cards with bad CLK B = 000
# Cards using CLK I = 0
Command Completed.

                PST          SST          AST
HS SYSTEM CLOCK   IS-NR      Active     -----
# Cards using HS CLK A = 1  # Cards with bad HS CLK A = 0
# Cards using HS CLK B = 0  # Cards with bad HS CLK B = 0
# Cards using HS CLK I = 0
```

```
Command Completed.
```

```
;
```

6. Verify that both **BITS** clocks are either in **IDLE** or **ACTIVE** state on both **ACTIVE** and **STANDBYMASP**

All underlined cards-with-bad-CLK values should equal zero.

7. For the A frame clock cable being replaced remove all tie wraps or lacing cord securing the cable in the frame.
8. Remove the A frame clock cable from the shelf's A **CLKOUT** connector.

Figure 6-39 Backplane P/N 850-0330-06 or -07 Control Shelf

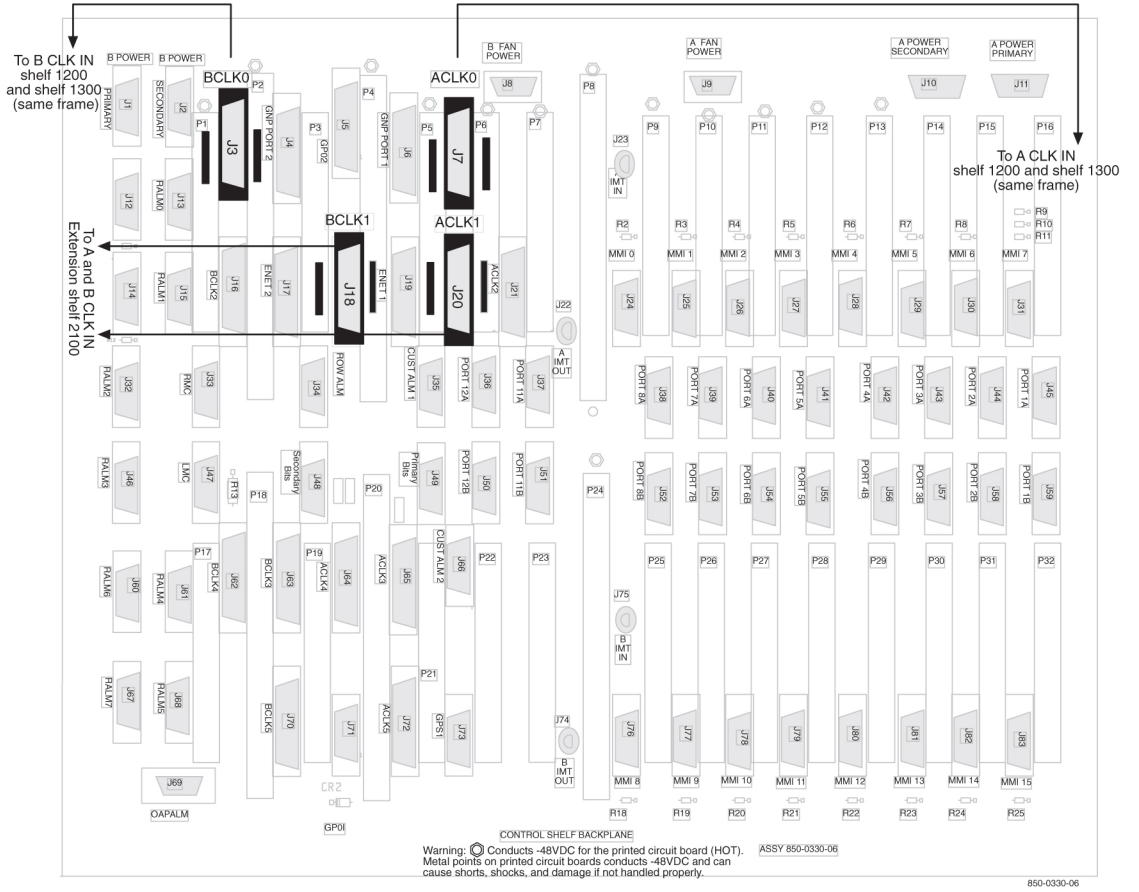
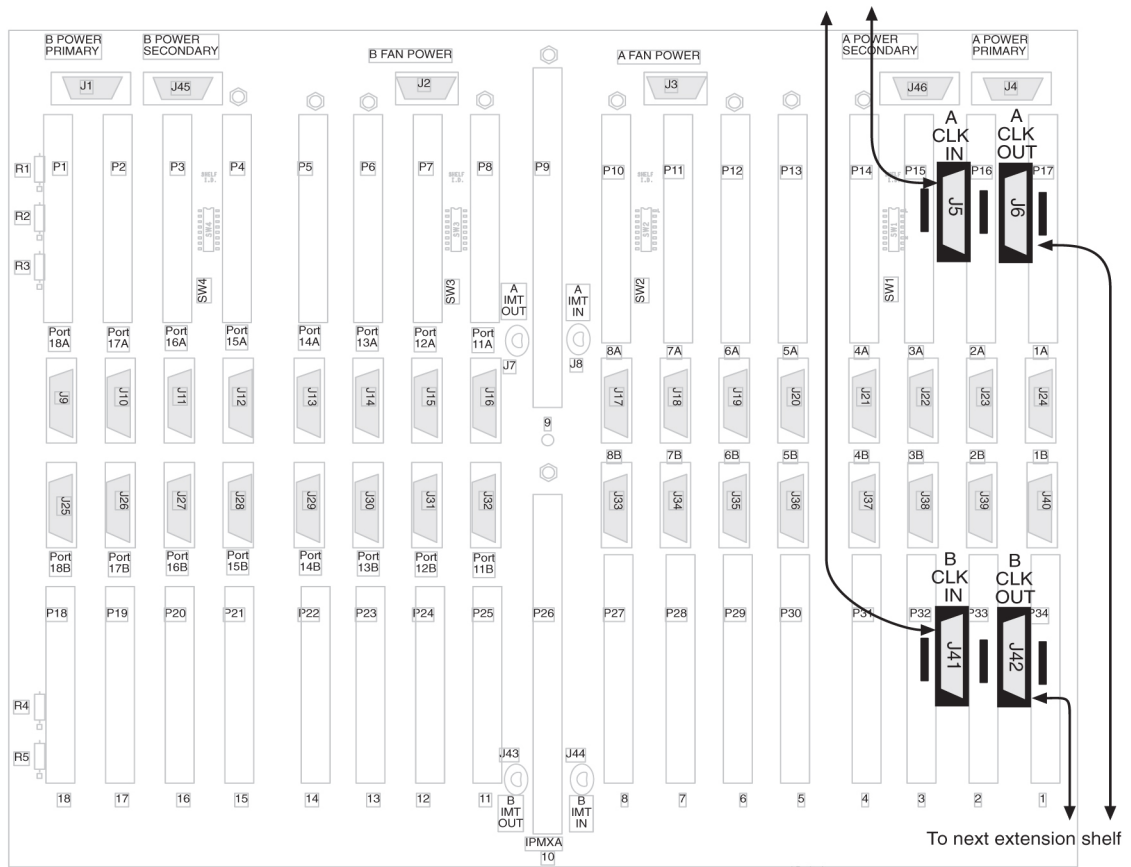

Figure 6-40 Backplane P/N 850-0356-04 Extension Shelf



Warning: Conducts -48VDC for the printed circuit board (HOT). Metal points on printed circuit boards conducts -48VDC and can cause shorts, shocks, and damage if not handled properly.

9. Remove the other end of the frame clock cable from the next shelf's A CLKIN connector.
10. Select the new frame clock cable (P/N 830-0398-xx or P/N 830-1150-xx) and connect it to the A CLKOUT connector, refer to 8
11. Route the clock cable in the frame following the routing directions in this manual.
12. Connect the other end of the new frame clock cable (P/N 830-0398-xx or P/N 830-1150-xx) from A CLKOUT, refer to 10, to the next shelf's A CLKIN connector.
13. Issue the command to report clock status.

```
rept-stat-clk
```

Response to the clock status command is displayed.

```
tekelecstp 03-02-10 05:34:03 HST Rel XX.x.x-XX.x.x
rept-stat-clk
Command entered at terminal #1.
```

```
;
tekelecstp 03-02-10 05:34:03 HST Rel XX.x.x-XX.x.x
CARD LOC= 1114 (Standby)    CARD LOC= 1116 (Active)
PRIMARY BITS      = Active  PRIMARY BITS      = Active
SECONDARY BITS   = Idle    SECONDARY BITS   = Idle
HS PRIMARY CLK   = Active  HS PRIMARY CLK   = Active
```

```
HS SECONDARY CLK = Idle
```

```

HS SECONDARY CLK = Idle
                PST           SST           AST
SYSTEM CLOCK    IS-NR        Active    -----
# Cards using CLK A = 7    # Cards with bad CLK A =
000
# Cards using CLK B = 0    # Cards with bad CLK B =
000
# Cards using CLK I = 0
Command Completed.

                PST           SST           AST
HS SYSTEM CLOCK IS-NR        Active    -----
# Cards using HS CLK A = 1    # Cards with bad HS CLK A = 0
# Cards using HS CLK B = 0    # Cards with bad HS CLK B = 0
# Cards using HS CLK I = 0
Command Completed.
;

```

14. Verify that both **BITS** clocks are either in **IDLE** or **ACTIVE** state on both **ACTIVE** and **STANDBYMASP**

All underlined cards-with-bad-CLK values should equal zero.

15. If any other A frame clock cables need to be replaced in the system repeat 5 through 14
16. After all the A frame clock cables in the system are replaced secure the cables with tie wraps or lacing cord according to specifications.
17. If any B frame clock cables need to be replaced move to the next Procedure **Replacing B Frame Clock Cables** in this document
18. If no other frame clock cables are to be replaced and if the pin protectors are needed remove the **ID** pin protectors.
19. If no other frame clock cables need replacing, return the plastic panels that were removed for this procedure to original locations. Put all plastic panels back in place.

Procedure — Replacing B Frame Clock Cables

This procedure explains the replacement of one B frame clock cable. The steps show the replacement of one frame clock cable and are repeated for every frame clock cable that is to be replaced.

1. Remove any plastic panels from the back of all shelves that require the frame clock cables replaced.
2. Install pin protectors on all shelves that require the frame clock cables to be replaced.

The pin protectors are placed over the **ID** pins directly to the right and left of the **B CLK IN** cables connectors on each shelf. **Shelf ID** pins must be covered with pin protectors. If contact is made with the **ID** pins, the shelf may lose its identity.

3. Connect a laptop or access by way of a monitor, the **EAGLE** system and start ProComm or a terminal emulator program.
4. Open a captured file by simultaneously pressing the **Alt** and **F1** keys.

Name the file the last four digits of the **[NT#]xyyz.CAP**

Example: 2641E1T1_A.cap

5. Issue the command to report clock status.

```
rept-stat-clk
```

Response to the clock status command is displayed.

```
tekelecstp 03-02-10 05:34:03 HST Rel XX.x.x-XX.x.x
rept-stat-clk
Command entered at terminal #1.
;
tekelecstp 03-02-10 05:34:03 HST Rel XX.x.x-XX.x.x
CARD LOC= 1114 (Standby)    CARD LOC= 1116 (Active)
PRIMARY BITS      = Active PRIMARY BITS      = Active
SECONDARY BITS    = Idle    SECONDARY BITS    = Idle
HS PRIMARY CLK    = Active HS PRIMARY CLK    = Active
HS SECONDARY CLK  = Idle
```

```

HS SECONDARY CLK  = Idle
                    PST          SST          AST
SYSTEM CLOCK      IS-NR          Active      -----
# Cards using CLK A = 7    # Cards with bad CLK A =
000
# Cards using CLK B = 0    # Cards with bad CLK B =
000
# Cards using CLK I = 0
Command Completed.

                    PST          SST          AST
HS SYSTEM CLOCK   IS-NR          Active      -----
# Cards using HS CLK A = 1  # Cards with bad HS CLK A = 0
# Cards using HS CLK B = 0  # Cards with bad HS CLK B = 0
# Cards using HS CLK I = 0
```

```
Command Completed.
```

```
;
```

6. Verify that both **BITS** clocks are either in **IDLE** or **ACTIVE** state on both **ACTIVE** and **STANDBYMASP**

All underlined cards-with-bad-**CLK** values should equal zero.

7. For the B frame clock cable being replaced remove all tie wraps or lacing cord securing the cable in the frame.

- Remove the B frame cable from the shelf's B CLKOUT connector.

Figure 6-41 Backplane P/N 850-0330-06 or -07 Control Shelf

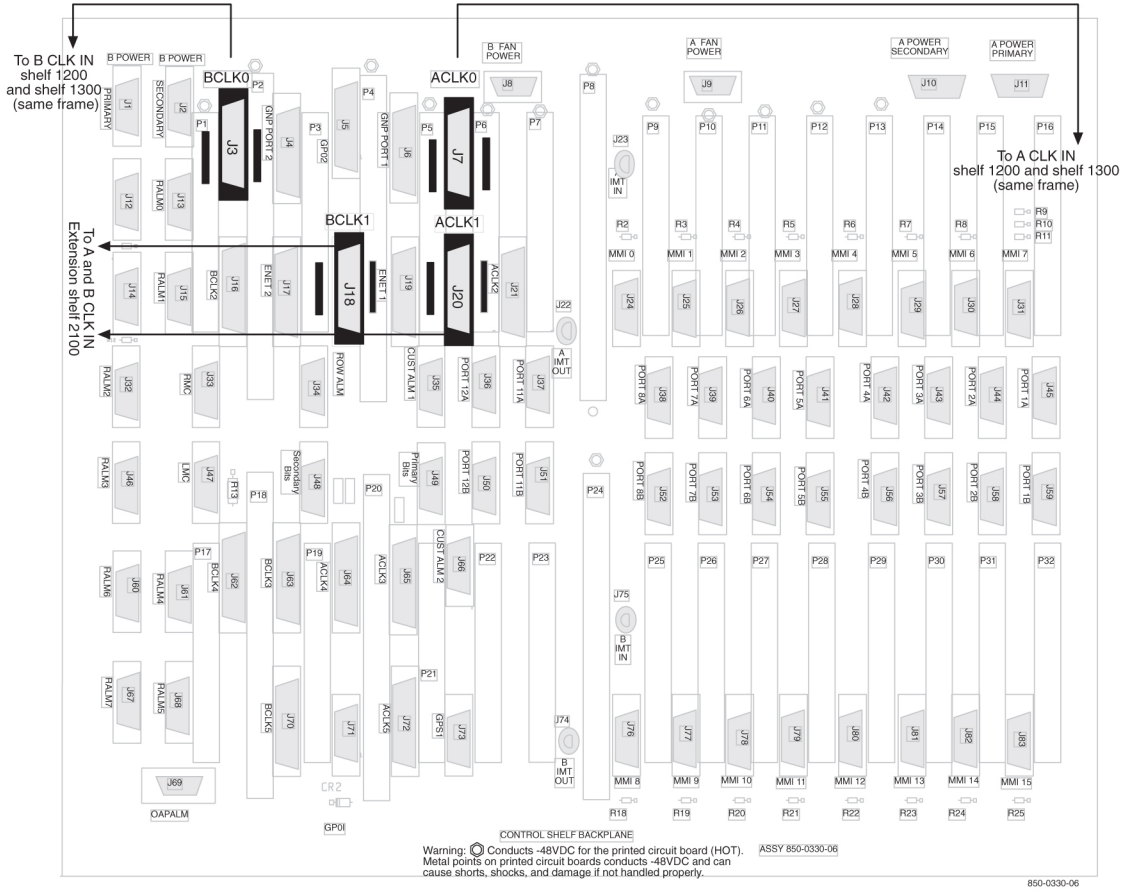
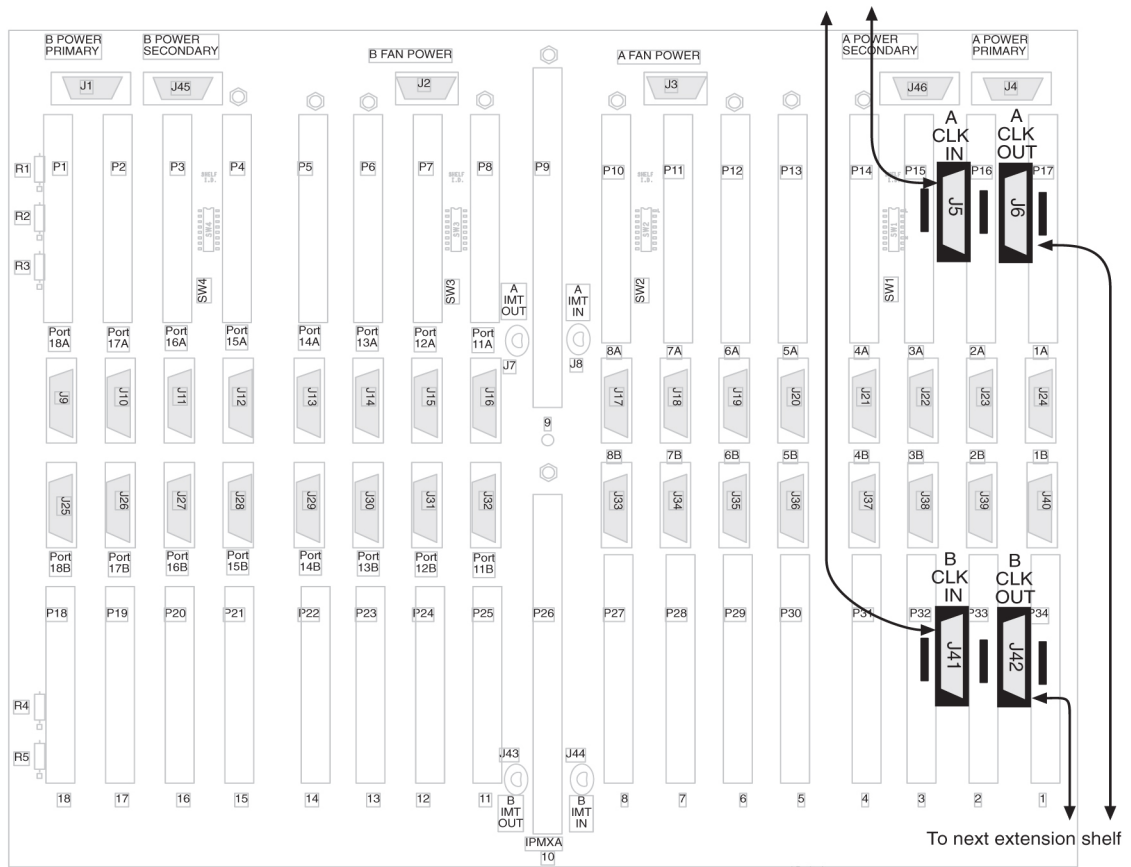

Figure 6-42 Backplane P/N 850-0356-04 Extension Shelf



Warning: Conducts -48VDC for the printed circuit board (HOT). Metal points on printed circuit boards conducts -48VDC and can cause shorts, shocks, and damage if not handled properly.

9. Remove the other end of the frame clock cable from the next shelf's **B CLKIN** connector.
10. Select a new frame clock cable and connect it to the **B CLKOUT** connector, refer to 8.
11. Route the clock cable in the frame following the routing directions in this manual.
12. Connect the other end of the new frame clock cable from **B CLKOUT**, refer to 10, to the next shelf's **B CLKIN** connector.
13. Issue the command to report clock status.

```
rept-stat-clk
```

Response to the clock status command is displayed.

```
tekelecstp 03-02-10 05:34:03 HST Rel XX.x.x-XX.x.x
rept-stat-clk
Command entered at terminal #1.
```

```
;
tekelecstp 03-02-10 05:34:03 HST Rel XX.x.x-XX.x.x
CARD LOC= 1114 (Standby)    CARD LOC= 1116 (Active)
PRIMARY BITS      = Active  PRIMARY BITS      = Active
SECONDARY BITS    = Idle    SECONDARY BITS    = Idle
HS PRIMARY CLK    = Active  HS PRIMARY CLK    = Active
```



```
HS SECONDARY CLK = Idle
```

```

HS SECONDARY CLK = Idle
                PST           SST           AST
SYSTEM CLOCK    IS-NR        Active    -----
# Cards using CLK A = 7    # Cards with bad CLK A =
000
# Cards using CLK B = 0    # Cards with bad CLK B =
000
# Cards using CLK I = 0
Command Completed.

                PST           SST           AST
HS SYSTEM CLOCK IS-NR        Active    -----
# Cards using HS CLK A = 1    # Cards with bad HS CLK A = 0
# Cards using HS CLK B = 0    # Cards with bad HS CLK B = 0
# Cards using HS CLK I = 0

Command Completed.
;

```

- 14.** Verify that both **BITS** clocks are either in **IDLE** or **ACTIVE** state on both **ACTIVE** and **STANDBYMASP**

All underlined cards-with-bad-CLK values should equal zero.

- 15.** If any other B frame clock cables need to be replaced in the system, repeat **5** through **14**.
- 16.** After all the B frame clock cables in the system are replaced, secure the cables with tie wraps or lacing cord according to specifications.
- 17.** If no other frame clock cables are to be replaced and if the pin protectors are needed, remove the **ID** pin protectors.
- 18.** If no other frame clock cables need replacing, return the plastic panels that were removed for these procedures to original locations. Put all plastic panels back in place.

Termination of Alarm, Clock Supply, and Terminal Cables

Termination information for the alarm, Building Integrated Timing System (**BITS**), and terminal cables is furnished in the "Cable Running List" in the *Equipment Specification* for the site.

All of the alarm and clock supply cables are shielded and contain wires with solid conductors. They are intended for wire-wrap terminations at the customer end. The terminal cables have connectors on both ends.

NOT_SUPPORTED: Always wear a wrist strap or other electrostatic protection when handling printed circuit cards and other electrostatic-sensitive devices.

Recommended Tools

Oracle tools should be labeled “Property of **ORACLE**” with either a press-on Field Tool Identification label or Field Tool Identification wrap.

- Safety glasses
- Tie-wrap tool
- Diagonal cutters
- Flush cutters
- Wire-wrap gun and bit
- Slotted screwdriver with 1/8-inch blade and 8-inch shank
- Stripper
- Heat gun

Alarm Cable Termination

The rack alarm cable for the control frame may be factory installed at both ends or the row alarm cable may come from the factory installed at the alarm end-panel only.

NOT_SUPPORTED: Always wear a wrist strap or other electrostatic protection when handling printed circuit cards and other electrostatic-sensitive devices.

warning: Always trim tie-wraps flush and turn the trimmed tie-wraps to the rear of the cable bundle, when facing the back of the frame.

The rack alarm cables lead from ports in the system control backplane and connect with other frames in the row.

The backplane alarm ports are:

- **FAP** (Frame and **A**larm Panel) in the control frame J13 on 850-0330-06 or -07
- **FAP** extension frame 00 J15 on P/N 850-0330-06 or -07
- **FAP** extension frame 01 J32 on P/N 850-0330-06 or -07
- **FAP** extension frame 02 J46 on P/N 850-0330-06 or -07
- **FAP** extension frame 03 J61 on P/N 850-0330-06 or -07
- **FAP** extension frame 04 J68 on P/N 850-0330-06 or -07
- End panel J34 on P/N 850-0330-06 or -07 (use cable row alarm cable 830-1145-01)
- J35 and J66 o 850-0330-06 or -07 to holdover clock
- J69 on 850-0330-06 or -07 to **OAPF**
- **LMC** J47 on 850-0330-06 or -07
- **RMC** J33 on 850-0330-06 or -07

From the rear of the frame these cables should be routed from the connector around the left side of the frame. **Route** the cables up the side of the frame to the **FAP** and secure the cables with lacing cord to the cross arms on the side of the frame. Across the top of the frame secure the cables to the cross arms above the **FAP** with lacing cord also.

Note: **Alarm** cables should not be formed with power cables and should have a lacing cord approximately every three inches. There should be no less than two lacing cord ties between frames.

Note: If the end panel does not mount on the control frame, the cable will route the same as alarm rack cables, from port J34 on backplane 850-0330-06 or -07 from the rear of the frame, up the left side of the frame, across the top of the **FAP**, and formed and dressed with the alarm rack cables to the end panel.

The following cables have connectors for termination on the control shelf. The cables listed below are cross-referenced for additional connector information:

- [Remote Maintenance Center Alarm Connector](#) and [Remote Maintenance Center Cable \(RMC\)](#)
- [Local Maintenance Center Alarm Connector](#) and [Local Maintenance Center Cable \(LMC\)](#)
- [Rack Alarm Connectors \(RALM0 - RALM5\)](#)
- [Row Alarm Connector](#) and [Row Alarm Cable \(ROW ALARM\)](#)
- [External Alarm Cable \(Custom\)](#) and [External Alarm Connector \(XALM\)](#)

Cables are supplied as follows:

- With the exception of the rack alarms and the row alarm, one of each type of alarm cable is supplied for each system.
- One rack alarm cable is supplied for each Control, Extension, or **OAP** Frame present in the system.
- One row alarm cable for each system equipped with an alarm end panel containing alarm indicator lamps.

Terminate Clock Supply Cables

The Building Integrated Timing System (**BITS**) clocks come directly from the central office **BITS** clock source or indirectly from an optional holdover clock installed in the system.

See [Holdover Clock Installation](#) for optional holdover clock installation information.

Refer to [BITS Clock Connectors](#) for cable connector information.

Terminal Cables

There are 16 I/O ports on the control shelf backplane that are used to support external printers, terminals, or modems.

Use terminal/printer cable 830-0535-xx or 830-1154-xx. Different combinations of adapters are possible, see [Table 6-3](#).

Refer to [Cables and Adapters](#) for detailed cable and adapter connector information.

1. See the “Cable Running List” in the *Equipment Specification* to determine how to connect the external cables.

All cable ends must be labeled with “TO” and “FROM” location information from Port to Backplane.

2. Place the cables on the cable rack.

Feed the cable ends (with connectors) down the side of the system, outside the cable tie bars, around the top or bottom edge of the control shelf and fan out to the connectors.

3. Secure each connector to the designated receptacle on the control shelf backplane.

Plug the connector in, start one of the connector screws, fully tighten the second screw, then fully tighten the first screw.

4. Tie-wrap each cable to the cable tie bar at the rear of the shelf.

5. Dress the cables neatly and tie-wrap to the cable tie bars at the side of the frame.

Pull the slack in the cable back toward the other end of the cables and lace to the cable rack.

6. Ensure that each tie-wrap strap is cut flush with the tie-wrap head so sharp edges are not exposed.

7. Attach any necessary adapter to the end of the cable, see [1](#) of this procedure; then attach cable or cable plus adapter to the device.

Connect terminal cable adapter 830-0535-xx or 830-1154-xx to modem adapter 830-0535-xx or 830-1153-04.

Holdover Clock Installation

The holdover clock option and its associated output panel are normally factory installed in a miscellaneous frame. Use the following procedures to complete the holdover clock installation.

Card Placement

The holdover clock cards must be installed in the positions illustrated in [Figure 6-43](#). Check that the proper cards are installed in the indicated locations.

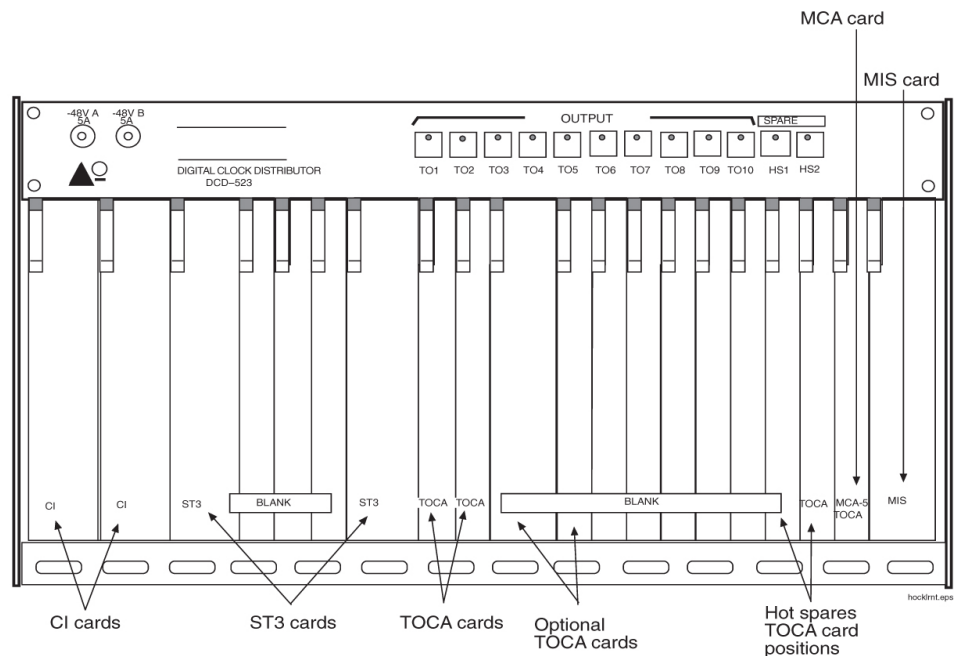
Figure 6-43 Holdover clock

Recommended Tools

Oracle tools should be labeled "Property of **ORACLE**" with either a press-on Field Tool Identification label or Field Tool Identification wrap.

- Safety glasses
- Wire-wrap tool and bit
- Diagonal cutters
- Flush cutters
- Slotted screwdriver with 1/8-inch blade and 8-inch shank, preferred.
- Phillips screwdrivers, #2 and #3
- 3/8-inch shrink-wrap
- Heat-shrink gun (hot air blower)

Output Panel Connections

The following output panel connections are factory installed and should be checked during installation.

TOCA Ribbon Cables

Timing Output Composite Clock Automatic (**TOCA**) ribbon cable; check to insure that the ribbon cables connecting the holdover clock with the output panel are connected as shown in [Figure 6-46](#). **OUT 1** on the holdover clock to J1 on the output panel and **OUT 2** on the holdover clock to J2 on the output panel

Note: These cables connect the clock outputs from the **TOCA** cards to the output panel.

TOLA Card

When Using a Timing Output Logic Clock Automatic (**TOLA**) card; only terminate the clock cable leads to the odd pin positions 1, 3, 5, 7, and 9. Set **DIP** switch settings to the **OFF** position. Once switches are set, seat the card.

Figure 6-44 TOLA Master Timing Leads

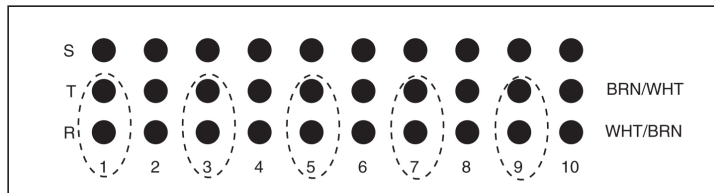

Note: Master Timing leads can only be terminated on the ODD ports on the Holdover Clock Interface Panel. Do not wire on the sleeve pin.

Output Panel Frame Ground

Check that the output panel frame ground cable is installed between **TB2** on the output panel and an output panel mounting screw, see [Figure 6-46](#).

Note: This cable (P/N 690-0009) consists of black #16 AWG and a terminal ring.

Power Connections

Check that the holdover clock power connections are installed according to [Table 6-3](#) for holdover clock and fuse and alarm panel connections.

See [Figure 6-45](#) and [Figure 6-46](#) for holdover clock connector locations.

See [Figure 6-47](#) and [Figure 6-48](#) for fuse and alarm panel connector locations.

Table 6-3 Holdover Clock Wire Colors and Connections

Holdover Clock Connector	Wire Color	FAP Connection
TB1 -48VDC	Red	B side -48VDC #1
TB1 RTN	Black	B side -48VDC return #1
TB2 -48VDC	Red	A side -48VDC #1
TB2 RTN	Black	A side -48VDC return #1
TB1 GND	White	A side Chassis GND
TB2 GND	White	B side Chassis GRD

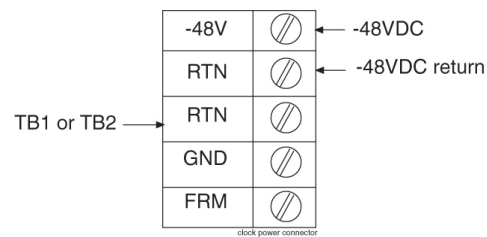
Figure 6-45 Holdover Clock Power Connector

Holdover Clock Switch Settings

Set the switches on the back of the holdover clock to the following positions, see [Clock Input DIP Switch Settings](#):

- **SHELF MODE (SW1) - ST3** (down)
- **POWER ALARM (SW2) - MAJ** (down)
- **HOLDOVER ALARM (SW3) - MAJ** (down)
- **REFA (SW4) - TERM** (down)
- **REFB (SW5) - TERM** (down)

Clock Input DIP Switch Settings

The Dual In-line Package (**DIP**) switch settings for the Clock Input are:

- Transmission 1.544 mb -**TI** (On)
- Composite Clock - **CC** (Off)
- Extended Superframe Format - **ESF** (On)
- Bipolar 8Bit Zero Substitution - **B8ZS** (On)

Figure 6-46 Holdover Clock and Output Panel, Rear

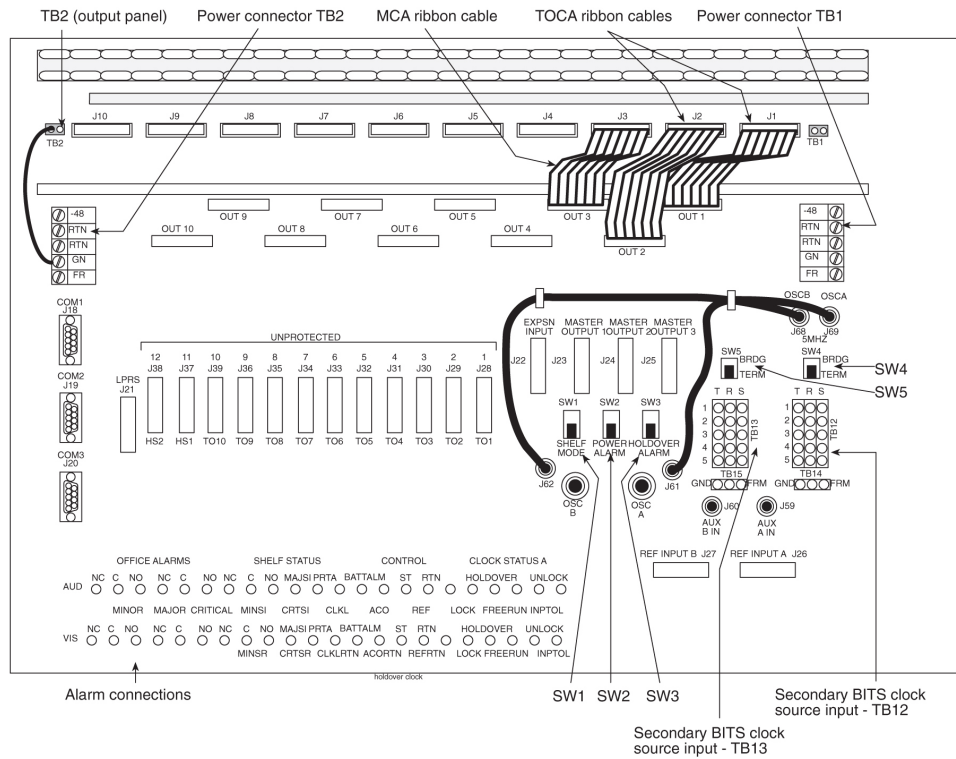

The Fuse and Alarm Panel connections for the Holdover Clock are shown in [Figure 6-47](#).

Figure 6-47 Holdover Clock FAP Connections

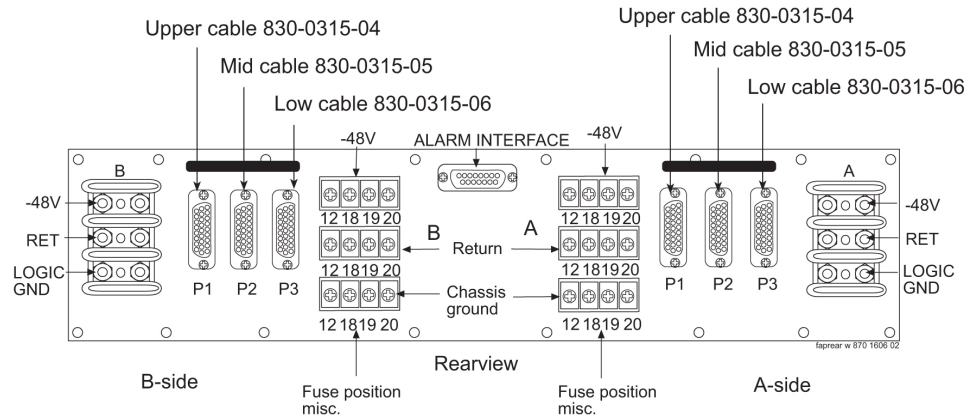
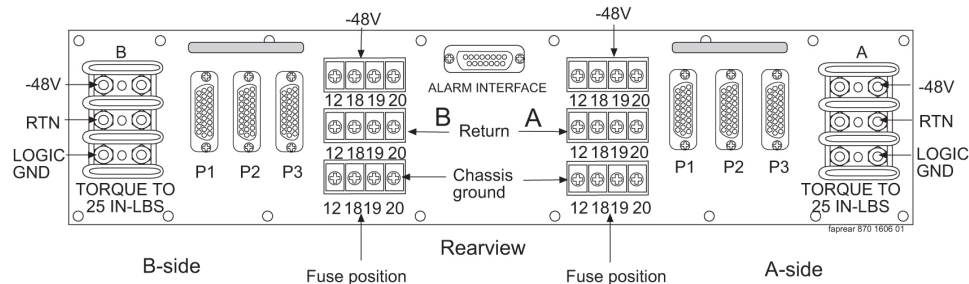

Figure 6-48 Holdover Clock FAP Connections



Output Panel Connections

The following output panel connections are made during installation.

Connections on the system backplane:

- First **Building Integrated Timing System (BITS)** clock cable to Primary **BITS** connector on J42, and connector J49 on backplane (P/N 850-0330-06 or -07), J49.
- Second **BITS** clock cable to the **SECONDARY BITS** connector J48 on backplane (P/N 850-0330-06 or -07).

Clock Output Connections

The **BITS** clock cables are used to transmit the clock outputs from the holdover clock output panel to the control shelf backplane.

Holdover Clock Alarm Connections

The installation connections are shown in the wiring layouts in [Figure 6-50](#) and [Figure 6-51](#).

A holdover clock alarm cable is used to send alarms from the holdover clock to the control shelf backplane.

1. Before using the following procedures, loosen the screws holding the clear plastic cover on the back of the holdover clock and remove the cover by lifting it off of the screws
2. Connect the **DB26** connector of the holdover clock alarm cable to the **EXTALM** connector and **CUSTALM 1** connector J35, J66 on backplane (P/N 850-0330-06 or -07) on the system control shelf backplane, see [Figure 6-49](#).

Secure connector screws.

3. **EXTALM** cable connects directly to the Holdover clock.

The external alarm cable is an optional cable that may go from the **EXTALM** to a terminal block see [Figure 6-50](#).

warning: Metal points on Printed Circuit Boards conducts -48VDC and can cause shorts, shocks, and damage if not handled properly.

Figure 6-49 CUST ALM 1 J35 and (not supported) CUST ALM 2 J66 Connectors on Control Shelf Backplane -06 or -07

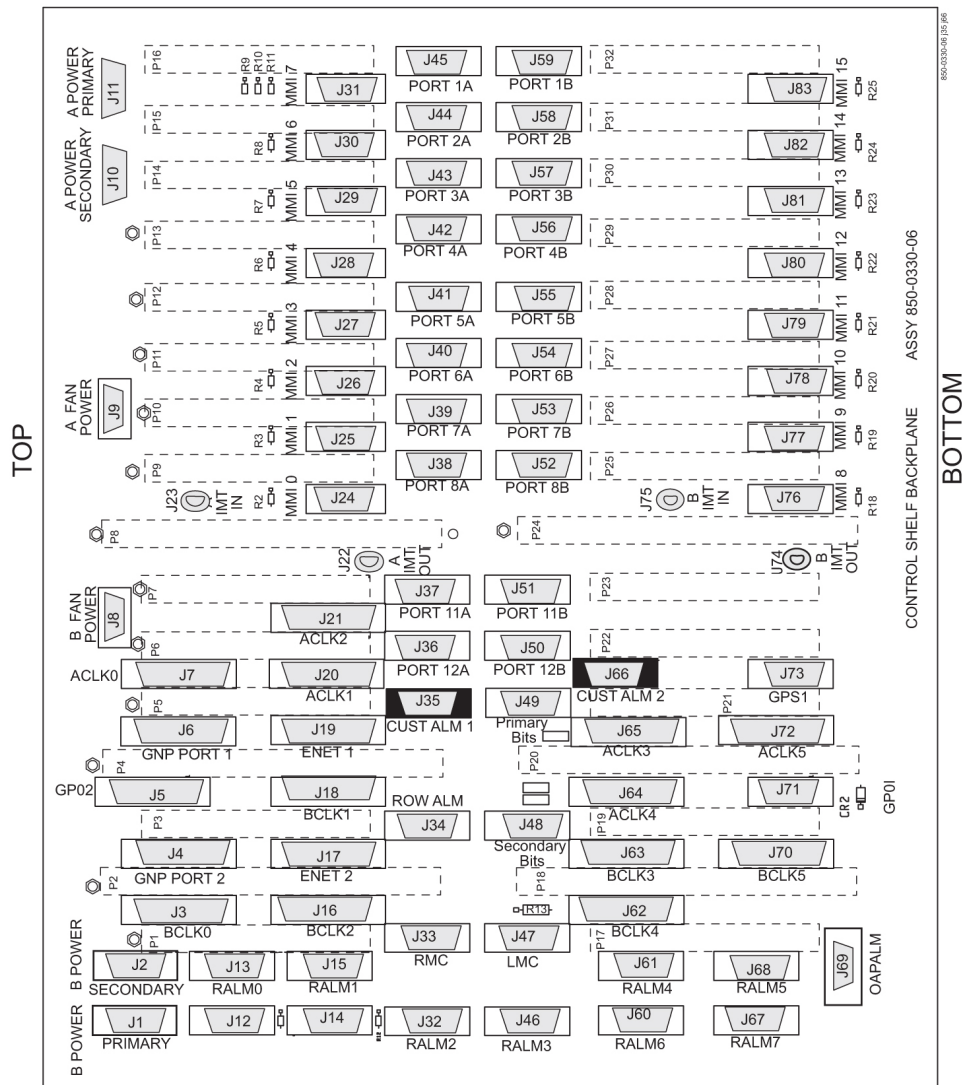

Warning: ⚡ Conducts -48VDC for the printed circuit board (HOT). Metal points on printed circuit boards conducts -48VDC and can cause shorts, shocks, and damage if not handled properly.

4. Route the cable up the left side of the control frame, viewed from the rear, over to the miscellaneous frame containing the holdover clock, and down the left side of the miscellaneous frame to the cable tie bar next to the alarm connections, see [Figure 6-46](#).
5. Tie-wrap the cable to the control shelf cable tie bar at the rear of the shelf.
6. Pull the slack out of the cable towards the holdover clock.
7. Dress the cable neatly and tie-wrap to the cable tie bars at the side of the frames.

Note: All cables must be laced (no tie-wraps) to the top traverse arms and above to the cable rack.

8. Prepare the cable for wire-wrapping by removing the outer insulation of the cable even with a point two inches from the left end of the lower holdover clock cable tie bar.
9. Apply a 1-1/2-inch length of shrink-wrap tubing.
Center the tubing on the end of the cable insulation before shrinking tubing with a heat gun.
10. Wire-wrap a 24-gauge jumper-wire between the minor and major common alarm connector pins as shown in Figure 6-50.
11. Cut the wires to length, strip, and wire-wrap to the holdover clock at the locations shown in Figure 6-50.

Figure 6-50 Holdover Clock Alarm Connections

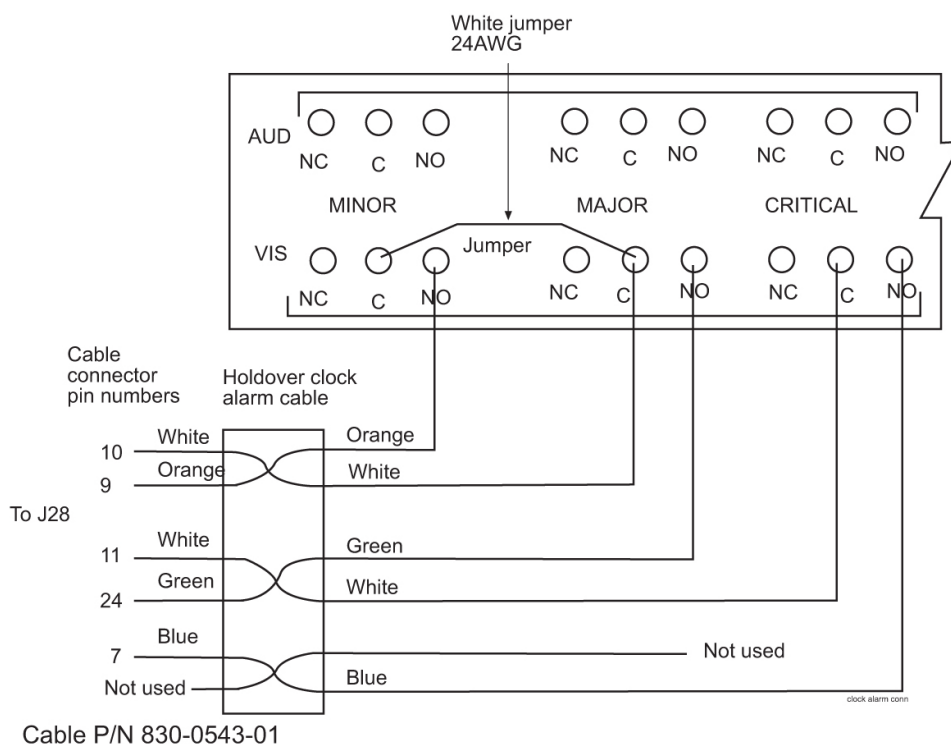

12. Tie-wrap the alarm cable to the lower holdover clock cable tie bar.
13. Ensure that each tie-wrap strap is cut flush with the tie-wrap head so that no sharp edges are exposed.

BITS Clock Source Cables

This cable connects the holdover clock to the central office **Building Integrated Timing System (BITS)** clock sources.

1. Connect the cables to the primary and secondary central office **BITS** clock sources.
2. Route the cables to the system's miscellaneous frame containing the holdover clock.
3. Route the cables down the right side (viewed from the rear) of the frame.

4. Pull the slack out of the cable towards the holdover clock.
5. Dress the cable neatly and tie-wrap to the cable tie bars at the side of the frame.

Note: All cables must be laced (no tie-wraps) onto the top traverse arm and above to the cable rack.

6. Remove the outer insulation of each cable even with the top of the output panel.
7. Apply a 1-1/2-inch length of shrink-wrap tubing.

Center the tubing on the end of the cable insulation before shrinking tubing with a heat gun.

8. Cut the wires to length, strip, and wire-wrap to the holdover clock at the locations, **TB12** and **TB13**, see [Figure 6-51](#).

See [Clock Input DIP Switch Settings](#) for locations of these connectors.

Figure 6-51 BITS Clock Source Connections

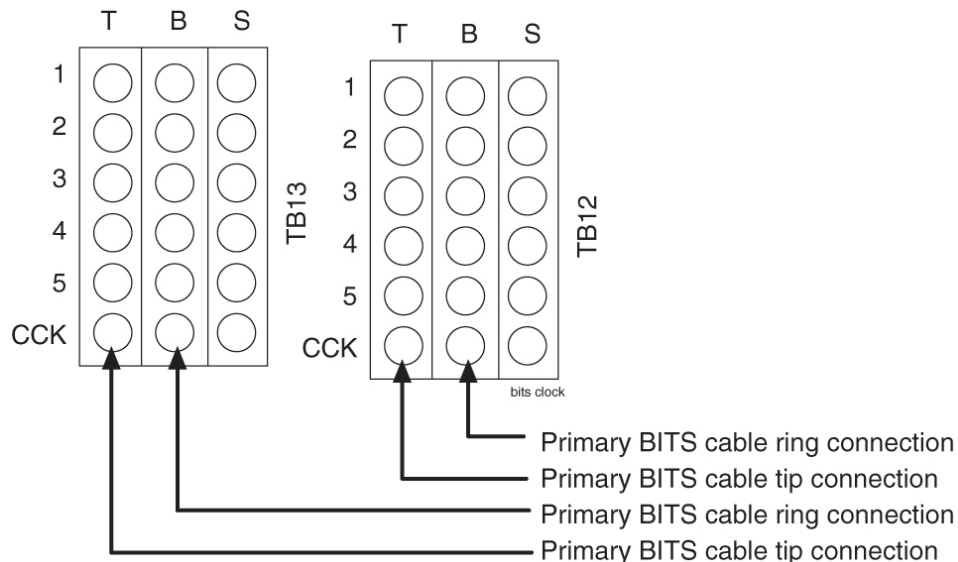

9. Ensure that each tie-wrap strap is cut flush with the tie-wrap head and turned to the rear of the cable so that no sharp edges are exposed.

Replacing Holdover Clock Rear Cover

When all connections are complete, slide the holdover clock rear cover back onto its mounting screws and then tighten the screws.

Install Holdover Clock Fuses

Install 7.5A (black and white flag) **GMT** fuses in positions A1 and B1 of the miscellaneous frame fuse and alarm panel that contains the holdover clock.

Ohms Converter International Market

The ohms converter is used mostly outside of North America. The converter Super Multiple-Interface Cross-Connect (SuperMIX) is a modular device for cross-connecting, patching, and monitoring these digital signal rates:

- E1 (2.048 Mb/s at 120 Ohms impedance)

The third party SuperMIX modules backplanes will be configured to accommodate a variety of input/output (I/O) termination connector types. Any combination or "mix" of backplanes in one chassis is acceptable. Refer to Telect® "SUPER MULTIPLE-INTERFACE CROSS-CONNECT (SUPERMIX) USER MANUAL" 110339 issue A Rev. 1

Note: This information is for 120 to 75 ohms only.

Figure 6-52 Miscellaneous Frame with 120 Ohm Converter

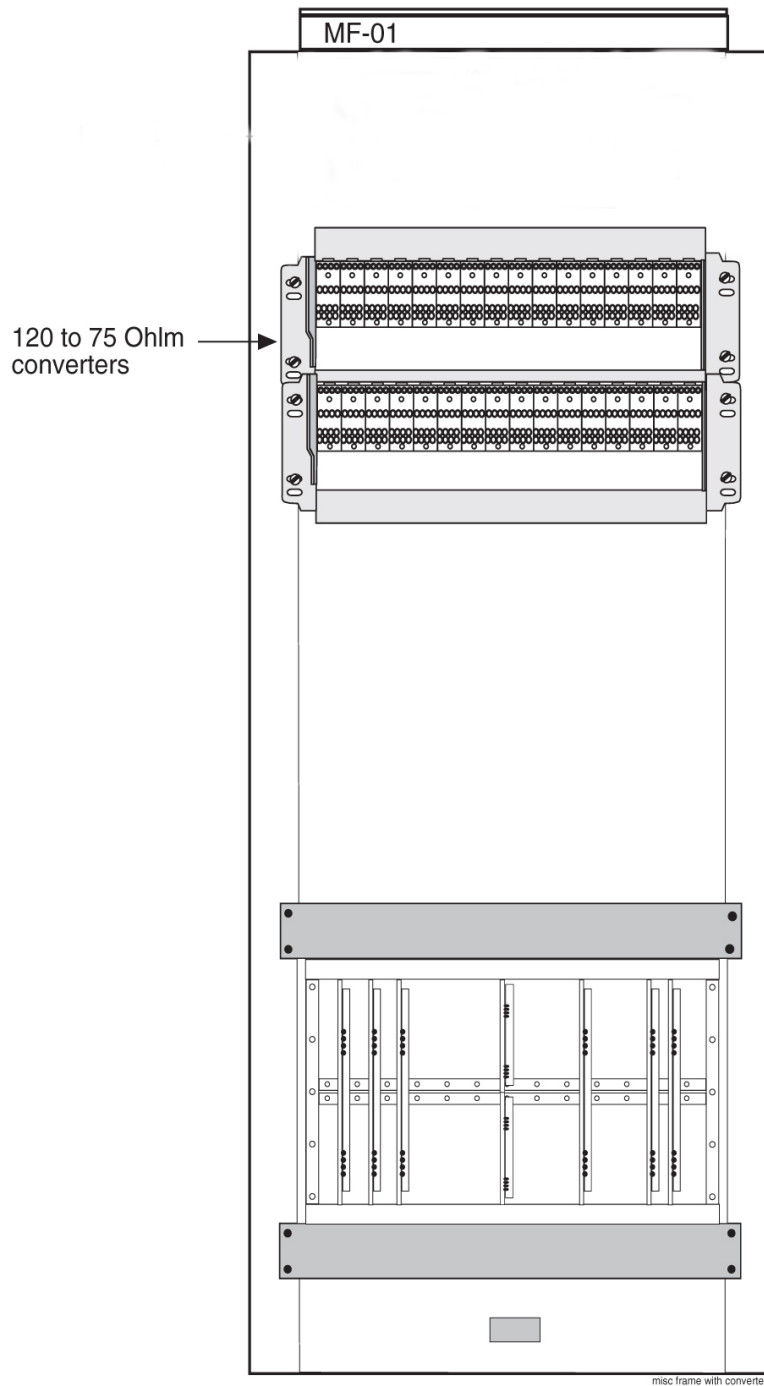

Note: Customers may purchase the miscellaneous frame from Oracle.

Table 6-4 Discontinued Legacy Part Numbers

Part Numbers	OEM part numbers	Description
804-0982-01 or 804-0982-R01	010-0000-2701	Chassis
804-0983-01 or 804-0983-R01	010-2704-1100	Wire-wrap
804-0984-01 or 804-0984-R01	010-2704-1200	Bayonet Connector (BNC)

Note: There is no compatibility between the discontinued Legacy hardware and the replacement hardware; for reference only. No longer available for new deployment.

Table 6-5 Telect® Replacement System for Cross-Connect Implementation

Manufacturer Part Number	Description	Description
DNX-2323	84-Term/21-Module, 23" x 5.25" Chassis	Chassis
DNX-9324	Wire-Wrap front to Wire-Wrap rear Module	Wire-wrap
DNX-9321	Wire-Wrap front to BNC rear	Bayonet Connector (BNC)

Note: Power distribution and replacement ohm converters are to be supplied by the customer.

Figure 6-53 120 Ohms Converter and Shelf

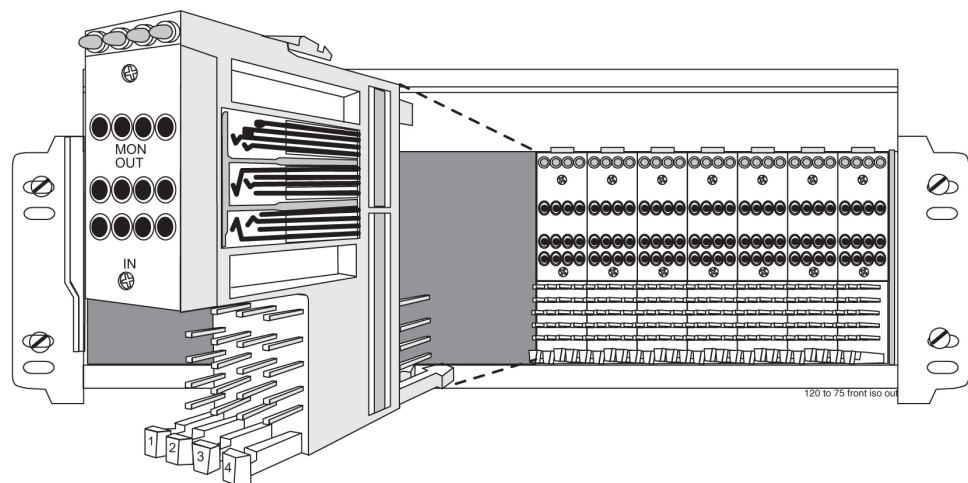
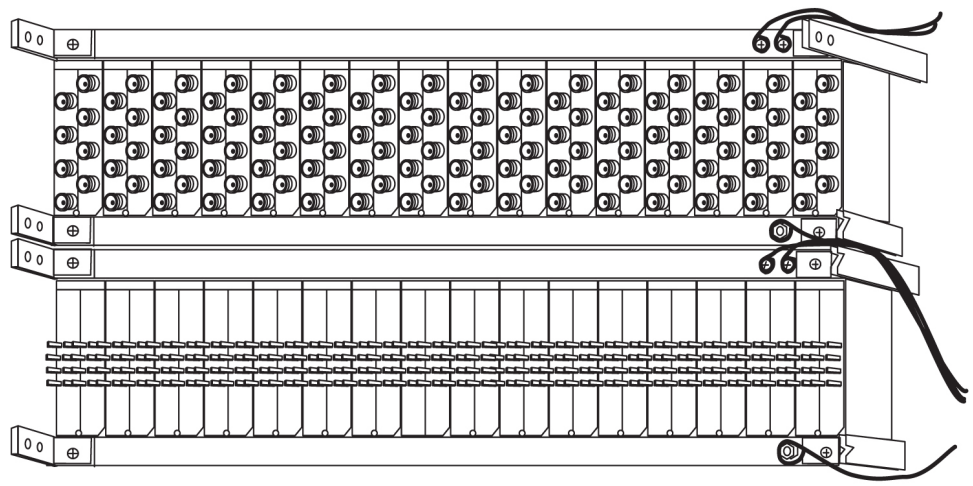

Table 6-6 Physical Conditions

Mechanical	
Insertion force	4.17lb (1.9kg) average
Withdrawal force	5.21lb (2.4kg) average
Life	Minimum 20,000 insertion/withdrawal cycles
Environmental	
Humidity	To 95% (operating and non-operating)
Moisture Resistance	Per MIL-STD-202F, Method 106E
Salt Spray	Per MIL-STD-202F, Method 101D
Temperature	-40 to 149°F (-40 to 65°C) operating -67 to 185°F (-55 to 85°C) non-operating
Thermal Shock	Per MIL-STD-202F, Method 107D

Figure 6-54 120 Ohms Converter Rear



Rear 120 ohms to 75 ohms converter

Figure 6-55 Converter Rear Detail

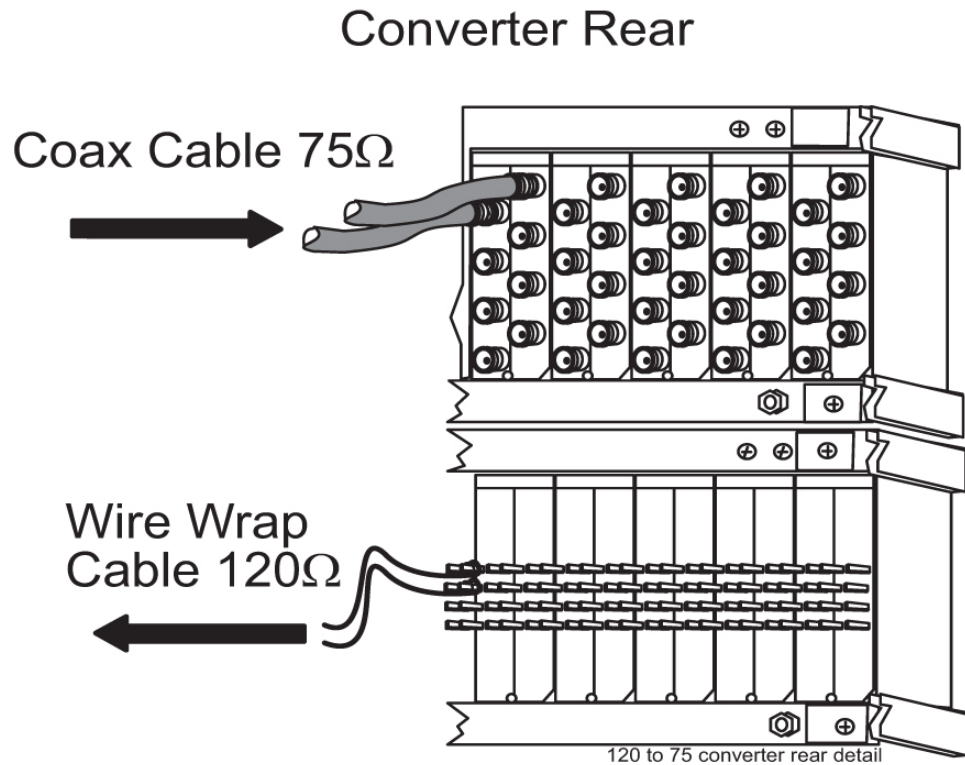

Hardware Acceptance

This section is intended for installation and test personnel. This section describes an inspection of the general system installation but does not attempt to cover testing of the system software.

NOT_SUPPORTED: No commercially AC powered equipment may be used or placed within 7 ft. of -48V equipment. This may create a shock or current loop that can be severely hazardous to personnel and equipment.

Hardware operational testing is designed to verify the functionality of the finalized construction of the hardware at the customer site. The demarcation line for the testing is up to and including the patch panel directly connected to the system. The ability to route traffic through this system is verified using a Message Generator Traffic Simulator (MGTS). All cabling, alarm output, clock input, and other Oracle equipment is also verified operational per the *Hardware Operational Test Manual* provided with the test equipment.

Caution: All personnel associated with the installation of this system must adhere to all safety precautions and use required protection equipment, to avoid the possibility of injury to personnel, service degradation, and/or service interruption.

Caution: This is a redundant system, to allow service during normal maintenance. When repairs require a total power disconnect, both input supply sources must be disconnected. This will cause service interruption and takes down the system.

The customer frame layout is site specific, however the most typical frame layout is constructed with Extension Frames to the right of the Control Frame when viewed from the front. The **OAP** Frame is normally on the left of the Control Frame. Other frames (Miscellaneous and other support or feature specific frames) are lined up to the left of the Control Frame. General Inspection.

Procedure — Perform General Installation Inspection

Verify the following:

1. All items listed in the Equipment Specification have been installed.
2. Cabling is neatly installed and the labels are correct and easily readable.
3. Power cabling does not run through a cable rack.
4. Power cabling is not routed together with any other cables and has at least six inches of clearance.
5. Racks have Nomex paper between the rack and any power cables that would otherwise touch the rack.
6. The main central office ground is correctly labeled and has the “Do Not Remove” tag installed on the central office grounding bar. No “double lugs” are allowed. Any bolt through a nut must show at least two threads beyond the nut but no more than four threads should be showing.
7. The –48VDC power feeds are correctly labeled at the central office power distribution panel. There should be an A feed and a B feed for each frame.
8. The –48VDC returns are correctly labeled. There should be an A return and a B return for each frame.
9. Frames are level.
10. Earthquake bracing, if any, is properly installed.
11. Adequate floor clearances have been maintained.
12. Rear panels are installed.
13. Cable connections are tight at the backplane connections.
14. Cable sheets are properly marked and located in door pocket.
15. All documentation has been received and is available.
16. Terminals and printers connected to the system are operational.
17. Data cartridges have been received and are properly stored.
18. Any attached modems are operational.
19. Any attached **MAUs** are operational with power indicator on.

20. Shipping container is properly packed with ramp and frame dollies prepared for shipment.
21. The area is clean and unused material has been properly disposed of.

-48VDC Power Source

This section verifies that the -48VDC Power Source has been labeled and connected correctly to the corresponding system frame's Fuse and **Alarm** Panels (**FAPs**). Your system may not include all of the frames described.

NOT_SUPPORTED: No commercially **AC** powered equipment may be used or placed within 7 ft. of -48V equipment. This may create a shock or current loop that can be severely hazardous to personnel and equipment.

warning: *Do not* carry exposed metal keys or tools in pockets or on belts when working on or around electronic equipment. *Do not* wear metal rings, watches, or jewelry on wrists or hands when working on any electronic equipment or other related electrostatic sensitive components. Always wear a wrist strap or other electrostatic protection when handling printed circuit cards and other electrostatic sensitive devices.

warning: Before beginning any of the following procedures, ensure that all breakers that provide power to the system are open.

warning: Before performing the following procedures do the following:

- Ensure that no power is being provided to the system from the -48VDC power source, such as a power board
 - Ensure that no circuit cards are installed in the shelves
 - Remove all fuses from the fuse and alarm panels
 - Recheck wiring and connections for proper polarity
-
-

Caution: All personnel associated with the installation of this system must adhere to all safety precautions and use required protection equipment, to avoid the possibility of injury to personnel, service degradation, and/or service interruption.

Caution: This is a redundant system, to allow service during normal maintenance. When repairs require a total power disconnect, both input supply sources must be disconnected. This will cause service interruption and takes down the system.

Verify -48VDC

The following procedure verifies -48VDC.

1. Turn on breaker, or insert fuse for control frame A side -48VDC power source.
2. Check for nominal -48VDC at the control frame fuse and alarm panel A side test point.

For test points used see [Figure 6-56](#) and [Figure 6-57](#).

Note: Input voltage range is -40 VDC to -57.5 VDC.

Figure 6-56 Test Points 1U FAP (P/N 870-2804-01)

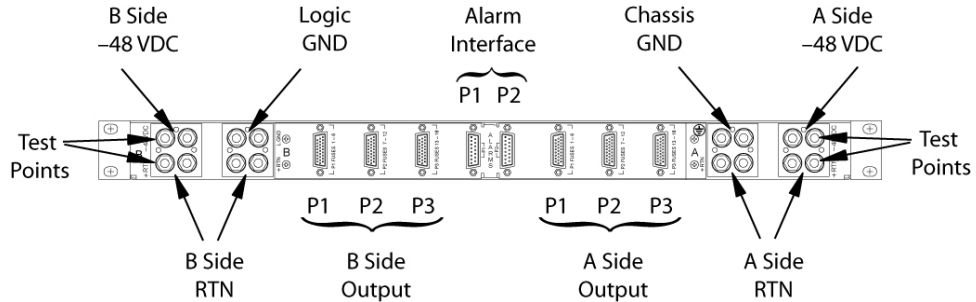
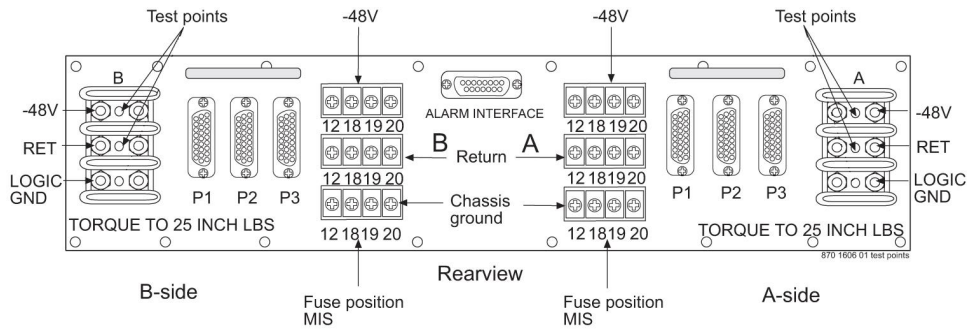

Figure 6-57 Test Points 3U FAP (P/N 870-2320-03)



3. Repeat 1 and 2 for the control frame B side -48VDC power source.
4. Repeat 1 and 2 for each -48VDC A side and B side power source for all extension and miscellaneous frames.

This completes the procedure.

LED Information

Introduction

This section shows the card face plates and describes the Light Emitting Diodes (LEDs) for each card. This section assists maintenance personnel in troubleshooting.

EAGLE frames are configured with modules (cards) that provide specific functions and services. LEDs together with part numbers, text and bar codes are located on the faceplates of the cards. The cards are listed in alphabetical order of the full card name. Each card is identified by its acronym first, then by the full name of the card.

CI, Clock Interface Card, Holdover Clock

Figure A-1 Holdover Clock CI Card LEDs

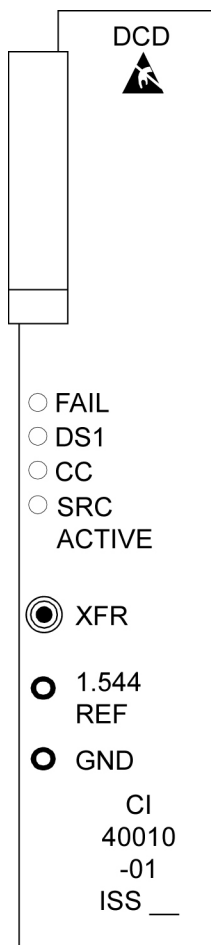

LEDs	Descriptions
FAIL	RED - this card or its input has failed. The card's output is disabled and a minor alarm is generated. BLANK - no card or input failure detected.
DS1	GREEN - DS1 source is present. BLANK - DS1 source is not present.
CC	GREEN - CC (composite clock) source is present. BLANK - CC source is not present.
SRC ACTIVE	GREEN - the card is on-line providing a DCD reference to ST3 and output cards. BLANK - card is in standby mode.

E5-ATM-B Interface Module

Figure A-2 E5-ATM-B Interface Module

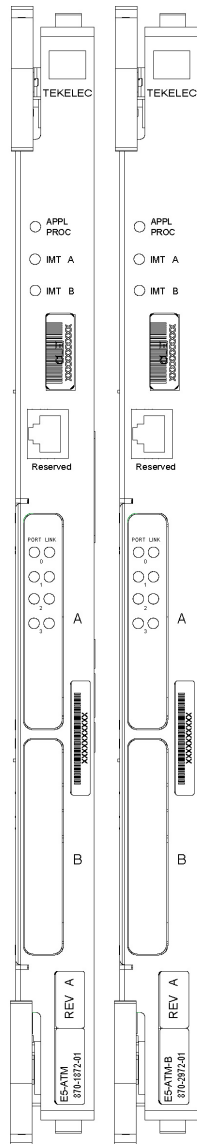

LED	Color	Description
APPL PROC	OFF	No power
	RED	Transitioning or Error
	AMBER	Not Active
	GREEN	Card is up and application is running
IMT (A/B)	RED	Card is not attached to IMT bus
	GREEN	Card is attached to IMT bus
PORT (0/1/2)	RED	Port not provisioned
	RED blinking	Loss of signal
	AMBER	Remote alarm condition or loss of cell delineation
	AMBER blinking	Loss of Frame Synchronization
	GREEN	E1/T1 framing is established
LINK (0/1/2)	RED	Signaling Link is not provisioned
	RED blinking	Signaling Link Out Of Service
	AMBER	Signaling Link is ready to start alignment
	AMBER blinking	Signaling Link alignment in progress
	GREEN blinking	Signaling Link alignment successful, awaiting far end INSV
	GREEN	Signaling Link is aligned
PORT (3)	OFF	Not used
LINK (3)	OFF	Not used

E5-E1T1-B Interface Module

Figure A-3 E5-E1T1-B Interface Module

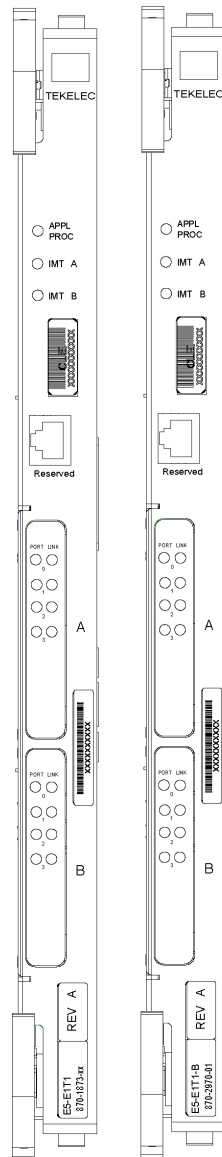

LED	Color	Description
APPL PROC	OFF	No power
	RED	Transitioning or Error
	AMBER	Not Active
	GREEN	Card is up and application is running
IMT (A/B)	RED	Card is not attached to IMT bus
	GREEN	Card is attached to IMT bus
PORT	RED	Port not provisioned
	RED blinking	Loss of signal and remaining errors
	AMBER	Remote alarm condition
	AMBER blinking	Loss of Frame Synchronization
	GREEN	No alarms, port has acquired timing and framing synchronization.
LINK (Aggregated Channel Status)	RED	No channels are provisioned
	RED blinking	All channels provisioned = OOS
	AMBER	Indicates port is the "reflected" port in Channel Bridging mode of operation. Applies only to "even" numbered ports.
	AMBER blinking	Any channel provisioned = OOS
	GREEN	All channels provisioned = IS-NR

E5-ENET-B Interface Module

Figure A-4 E5-ENET-B Interface Module

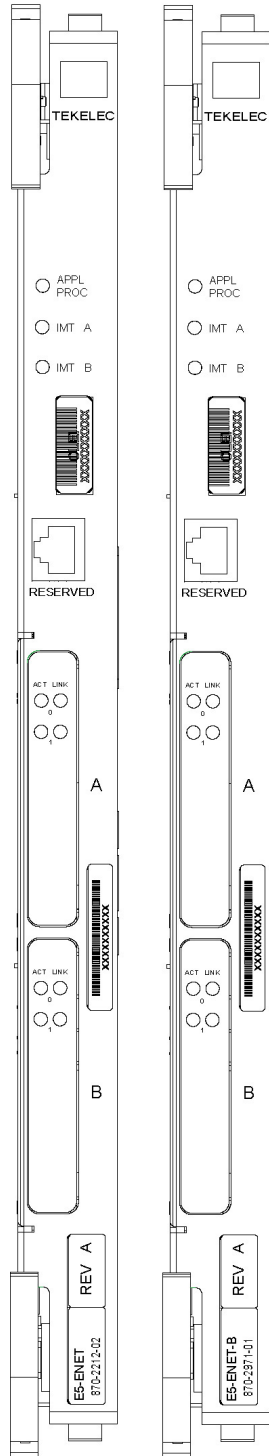

Front Faceplate LED Indicators

LED	Status	Description
APPL PROC	Off	No power
	Red	Card is booting
	Amber	Card is loading
	Green	Card is up and application is running
IMT A	Red	Not connected to bus
	Amber	Testing not complete
	Green	Active and connected to the bus
IMT B	Red	Not connected to bus
	Amber	Testing not complete
	Green	Active and connected to the bus

EROUTE/SLAN

LED	ACT	LINK
Red	Signaling links inactive, or 1 or more active links are out-of-service	N/A
Green	All active links are in-service	Ethernet signal detected
Off	Card nonfunctional	No Ethernet signal detected

ACT Status LED states for IPLIMx/IPSG

SLK States (Port A or Port B)	ACT Status LED
No links configured	Off
All provisioned links are OOS-MT-DSBLD	Red
Sync	Green

ACT Status LED states for IPGWx

IPGWx SLK PST	ACT Status LED	
	A0	B0
None configured (card must be inhibited)	Off	Off
OOS-MT-DSBLD	Red	Red
IS-NR or IS-ANR	Green	Green

Note: Must be used with the E5-MASP card.

Note: The E5-ENET-B is provisionable for multiple functions, but does not support multiple functions on a single card simultaneously.

E5-MASP Card

Figure A-5 E5-MASP Card

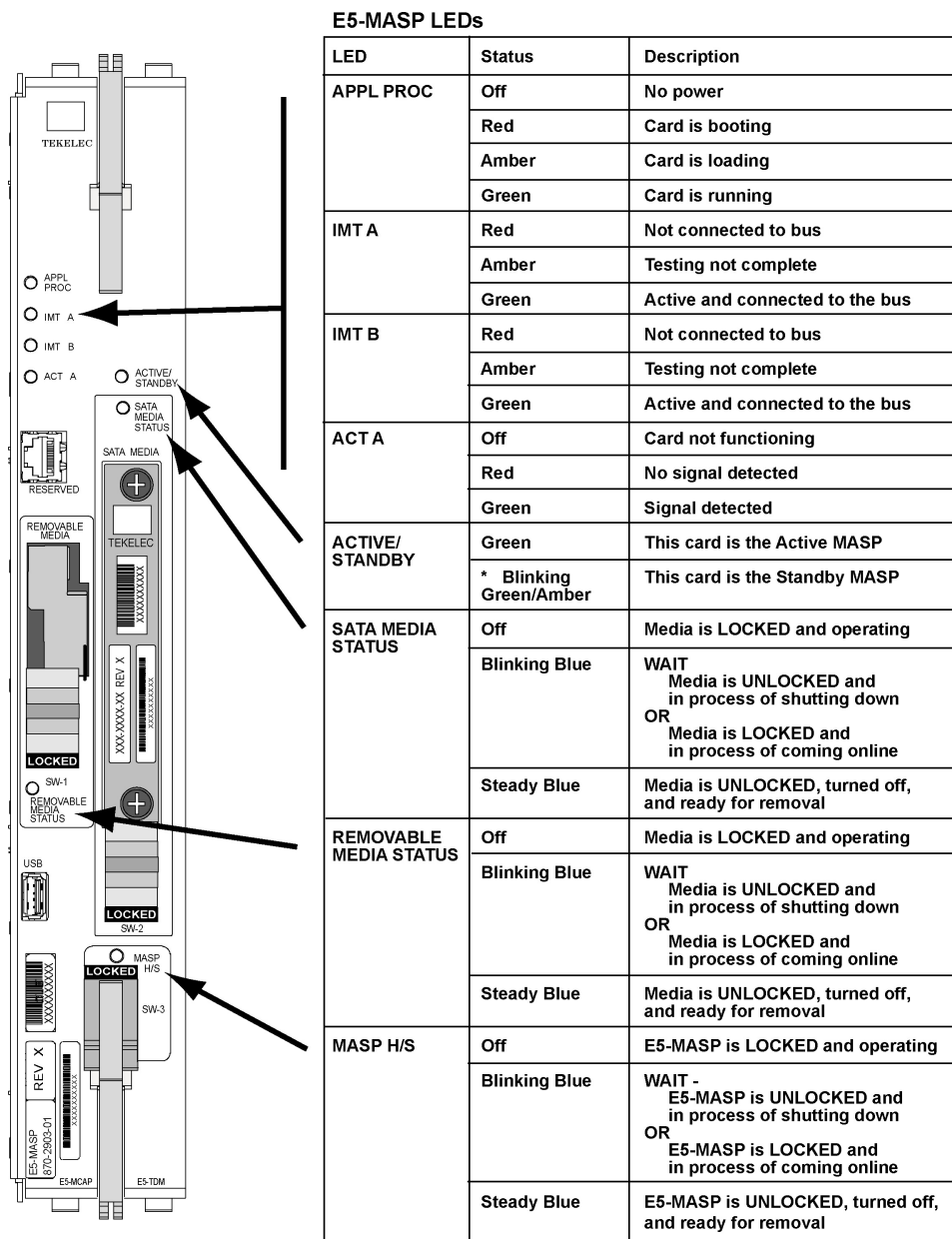

* The LED blinks Green/Amber at a rate of 3 Green to 1 Amber.

Note: Must be used with the E5-MASP card.

E5-MCPM-B Module

Figure A-6 E5-MCPM-B Module

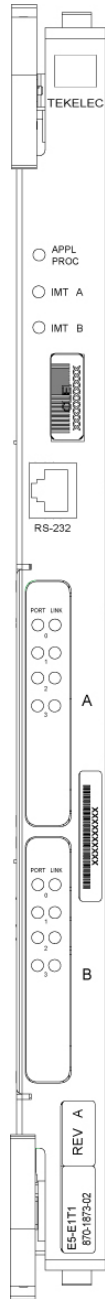

LED	Color	Description
APPL PROC	RED	Application processor is not running or is failing diagnostics.
	AMBER	Card is loading an application or is being polled (may be prevented from loading by maintenance out of service condition).
	GREEN	Card is running an application.
IMT	RED	Card is off IMT bus.
	AMBER	Card is on IMT bus, but testing is not complete.
	GREEN	Card is on IMT.
	BLANK	Communication processor is not operating.
PORT	RED	Port not provisioned.
	RED blinking	Loss of signal and remaining errors.
	AMBER	Remote alarm condition.
	AMBER blinking	Loss of Frame Synchronization.
	GREEN	No alarms, port has acquired timing and framing synchronization.
LINK	RED	No channels are provisioned.
	RED blinking	All channels provisioned = OOS.
	AMBER	Indicates port is the "reflected" port in Channel Bridging mode of operation. Applies only to "even" numbered ports
	AMBER blinking	Any channels provisioned = OOS.
	GREEN	All channels provisioned = ISNR.

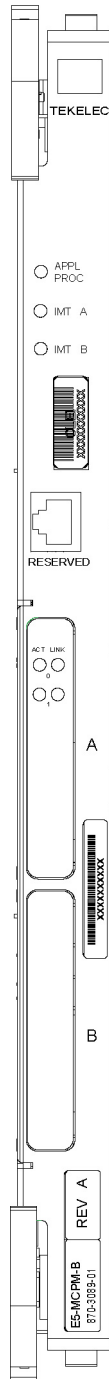

Front Faceplate LED Indicators

LED	Status	Description
APPL PROC	Off	No power
	Red	Card is booting
	Amber	Card is loading
	Green	Card is up and application is running
IMT A	Red	Not connected to bus
	Amber	Testing not complete
	Green	Active and connected to the bus
IMT B	Red	Not connected to bus
	Amber	Testing not complete
	Green	Active and connected to the bus
ACT	Red	Loss of signal
	Green	Signal active
LINK		NOT USED

E5-MDAL Card

Figure A-7 E5-MDAL Card

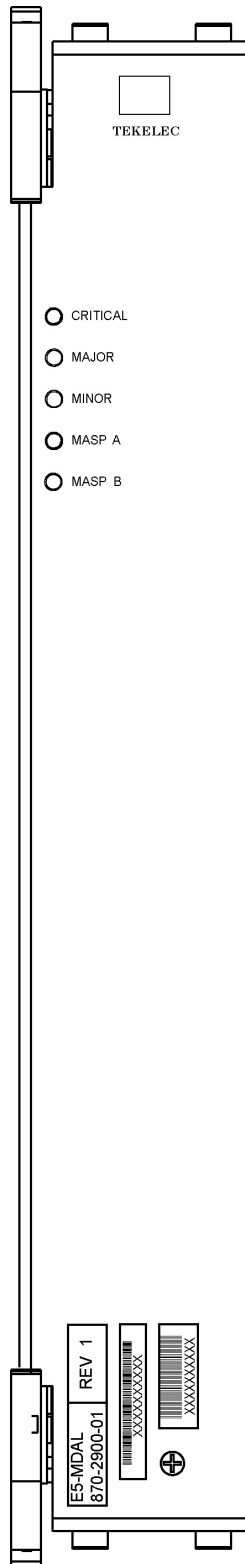

E5-MDAL LEDs

LED	Status	Description
CRITICAL	Red	A critical system alarm has been detected
	Green	No Alarm
MAJOR	Red	A major system alarm has been detected
	Green	No Alarm
MINOR	Amber	A minor system alarm has been detected
	Green	No Alarm
MASP A	Green	This is the master MASP
	Off	This is the standby MASP
MASP B	Green	This is the master MASP
	Off	This is the standby MASP

Note: Must be used with the E5-MASP card.

E5-SM8G-B Module

Figure A-8 E5-SM8G-B Interface Module

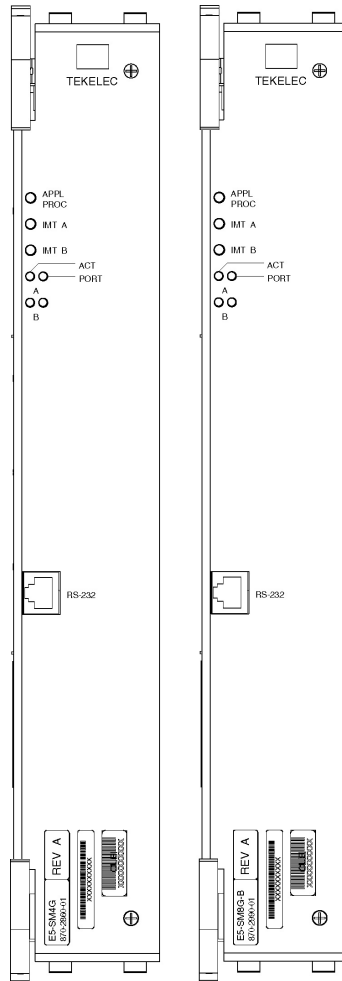

Front Faceplate LED Indicators

LED	Status	Description
APPL PROC	Off	No power
	Red	Card is booting
	Amber	Card is loading
	Green	Card is up and application is running
IMT A	Red	Not connected to bus
	Amber	Testing not complete
	Green	Active and connected to the bus
IMT B	Red	Not connected to bus
	Amber	Testing not complete
	Green	Active and connected to the bus
ACT	Off	Card non-functional
	Red	No signal detected
	Green	Signal detected
PORT	Off	Card non-functional
	Amber	Data link active operating at 1 Gbps
	Green	Data link active operating at 10/100 Mbps

Table A-1 E5-SM8G Interface Module LEDs

LED	Color	Descriptions
APPL PROC	Red	Application processor is not running or is failing diagnostics.
	Amber	Card is loading an application or is being polled (may be prevented from loading by maintenance-out-of-service condition)
	Green	Card is running an application.
IMT	Red	Card is off IMT bus
	Amber	Card is on IMT bus, but testing is not complete.
	Green	Card is on IMT bus

Table A-1 (Cont.) E5-SM8G Interface Module LEDs

LED	Color	Descriptions
	Blank	Communication processor is not operating.
ACT	Red	No signal detected
	Green	Signal detected
	Off	Card nonfunctional
PORT	Amber	Data link active operating at 1 Gbps
	Green	Data link active operating at 10/100 Mbps
	Off	Card non-functional

HIPR2, High-Speed IMT Packet Router 2 Module

Figure A-9 HIPR2 LEDs

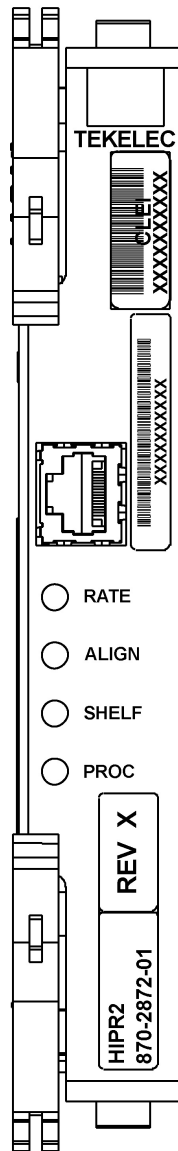

HIPR2 State	LED			
	RATE	ALIGN	SHELF	PROC
No power	Off	Off	Off	Off
Power on (cold start)	Off	Off	Off	RED
Reset (warm start)	Off	Off	AMBER	RED
Programming (cold start)	Off	Off	Off	AMBER
Programming (warm start)	Off	Off	AMBER	AMBER
Programming Complete	---	AMBER	AMBER	GREEN
Shelf Address Capture:				
Timer Started	---	AMBER	AMBER	GREEN
Successful	---	GREEN	AMBER	GREEN
Unsuccessful	---	RED	AMBER	GREEN
Code Running	---	GREEN	Note 2	GREEN
IMT is operational at:				
low-rate (1 Gbps)	GREEN			
high-rate (2.5 Gbps)	GREEN			
	Blinking			
IMT is rate negotiating or in proving period	AMBER			
IMT is not operational	RED			

Notes:

- ALIGN and SHELF LEDs are not accessible to software until the FPGA has been programmed. So for the same point in the HIPR bootstrap sequence, the state of these two LEDs can be different depending on whether a warm or cold start is in progress.
- State depends on the address received from OAM and written to Assigned Shelf Address Register and compared to the value previously read from the Assigned Shelf Address Register.
 - RED - Does Not Match
 - GREEN - Matches

MIS, Maintenance Interface System, Holdover Clock

Figure A-10 Holdover Clock MIS Card LEDs

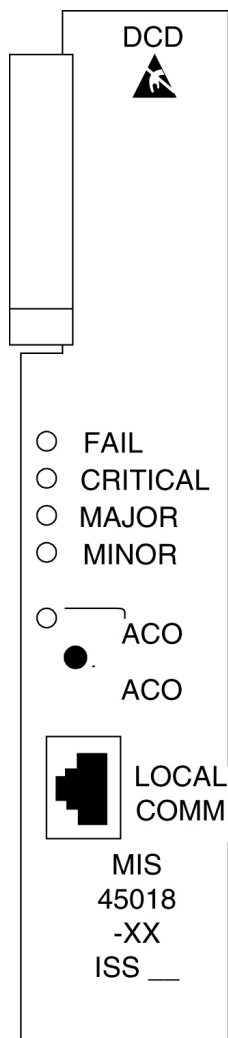

Table A-2 MIS LEDs

LEDs	Descriptions
FAIL	<p>RED – This card or its power supply has failed.</p> <p>BLANK – No card or power supply failure detected.</p>
CRITICAL	<p>RED – Holdover clock system has failed.</p> <p>BLANK – No holdover clock system failure detected.</p>
MAJOR	<p>RED – Holdover clock system or any holdover clock card has a major alarm.</p> <p>BLANK – No major alarm detected.</p>

Table A-2 (Cont.) MIS LEDs

LEDs	Descriptions
MINOR	YELLOW – Holdover clock system or any holdover clock card has a minor alarm. BLANK – No minor alarm detected.
ACO	GREEN – The ACO push button has been pressed to silence the alarm during an alarm state.

MCA, Matrix Controller Assembly Card, Holdover Clock

Figure A-11 Holdover Clock MCA Card LEDs

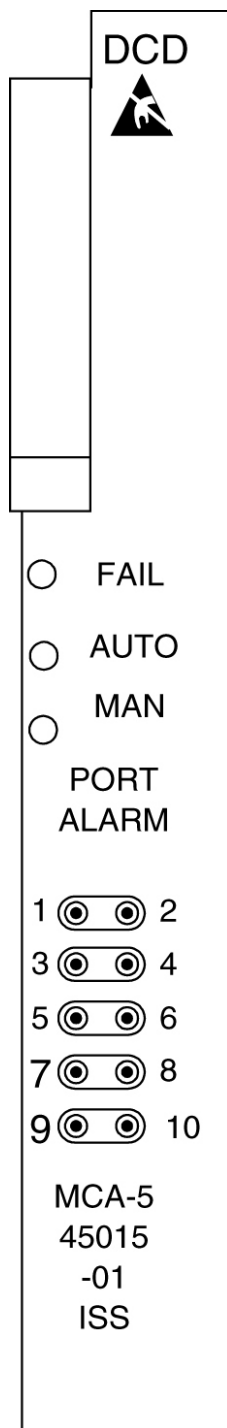

Table A-3 MCA LEDs

LEDs	Descriptions
FAIL	RED – This card has failed or there is a loss of all input references to this card. BLANK – No card or input reference failure detected.
AUTO	GREEN – Indicates output failure was protected automatically. BLANK – No failures detected.
MAN	GREEN – Indicates output failure was protected manually. BLANK – No failures detected.

SLIC Module

Alarms and LEDs

The SLIC has 21 LEDs visible on the faceplate. The LEDs are visible with the aid of a light pipe, which directs the light from the LED to the front panel.

Figure A-12 SLIC Module

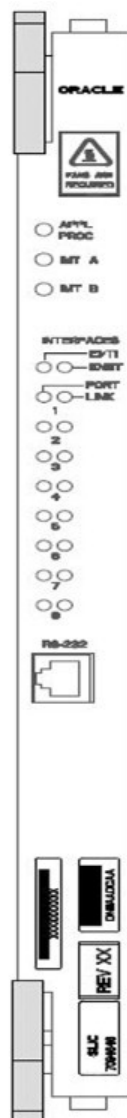

Table A-4 SLIC Front Panel LEDs

LED Name	Control	Colors	Definition
APPL	FPGA / Application Software	Off / Red / Green	Off - No power Red - Card is booting Green - Card is running Application

Table A-4 (Cont.) SLIC Front Panel LEDs

LED Name	Control	Colors	Definition
IMTA	LIIC FPGA / Communication Software	Red / Green	Red - Not connected to BUS Green - Active and Connected to Bus Amber - MUX card on the same shelf is seated and not inhibited; bus not available
IMTB	LIIC FPGA / Communication Software	Red / Green	Red - Not connected to BUS Green - Active and Connected to Bus Amber - MUX card on the same shelf is seated and not inhibited; bus not available
INTERFAC ES E1/T1	FPGA / Application Software	Green / Off	Green - Enabled Off - Disabled
INTERFAC ES ENET	FPGA / Application Software	Green / Off	Green - Enabled Off - Disabled
PORT1- PORT8	PHY / Application Software	Off / Red / Green	Off - Not configured Red - Cable removed and/or not synced Green - 10/100Mb link speed
LINK1- LINK8	FPGA / Application Software	Off / Red / Green	Off - No SLKS configured Red - All Configured SLKS OOS Green - All SLKS aligned

ST3, Stratum-3 Clock Card, Holdover Clock

Table A-5 ST3 LEDs

LEDs	Descriptions
FAIL	RED – This card has failed. BLANK – No card failure detected.
LOCK	RED – Input has failed. BLANK – No input failure detected.

Table A-5 (Cont.) ST3 LEDs

LEDs	Descriptions
REF A	<p>GREEN – Card is tracking the output of clock input card A.</p> <p>BLANK – Not tracking output of clock input card A.</p>
REF B	<p>GREEN – Card is tracking the output of clock input card B.</p> <p>BLANK – Not tracking output of clock input card B.</p>

Note:

If the **FAIL** and **LOCK LEDs** are both illuminated, the **ST3** is in holdover mode and the card has not failed. Holdover Clock **ST3 Card LEDs**

TOCA, Timing Output Composite Automatic, Holdover Clock

Table A-6 TOCA LEDs

LEDs	Descriptions
FAIL	<p>RED – This card has failed or there is a loss of all input references to this card.</p> <p>BLANK – No card or input reference failure detected.</p>
PORT ALM	<p>RED – One to five outputs have failed or have been externally shorted.</p> <p>BLANK – No output failures detected.</p>
ST	<p>GREEN – An active clock is supplying the input reference for this card.</p> <p>BLANK – No active clock detected.</p>
INPUT	<p>GREEN – Card is receiving a reference signal from one or more of the following: clock input A, clock input B, clock card A, clock card B.</p> <p>BLANK – Card is not receiving a reference signal from any of the above sources.</p>
500'	Not used
1000'	Not used

Backplane Connectors

Control Shelf Connectors

This section describes the Control shelf backplanes and their connectors. The control shelf backplane provides connectors for the system circuit cards. These connectors are four column High Density Interconnect (**HDI**) male headers with shrouds of varying pin quantities, depending on card position.

The control shelf backplane provides –48VDC power and ground to all card positions. The power is distributed into two parts, A and B. Power is brought to the shelf from the Fuse and **Alarm Panel (FAP)** using two cables. The connectors on the control shelf backplane are **DB-26** high density connectors. The power is distributed over two separate pins per power connection to handle the current load.

- Power connectors
 - Fuse and **Alarm Panel (FAP)** connectors
 - Fan Power connectors
- **Alarm** connectors
 - Remote Maintenance Center **Alarm** connector
 - Local Maintenance Center **Alarm** connector
 - Rack **Alarm** connectors
 - Row **Alarm** connector
 - External **Alarm** connector
 - **CUST Alarm 1** connector
 - **CUST Alarm 2** connector
 - **OAP Alarm** connector
- System clock connectors
- **Shelf** clock connectors (850-0330-04 only)
- **BITS** connectors
- Serial port connectors
- Interface connectors
- **IMT** connectors

- General purpose relay connectors
- General purpose serial interface connectors

Control Shelf Backplane 04

Figure B-1 Control Shelf Backplane 04

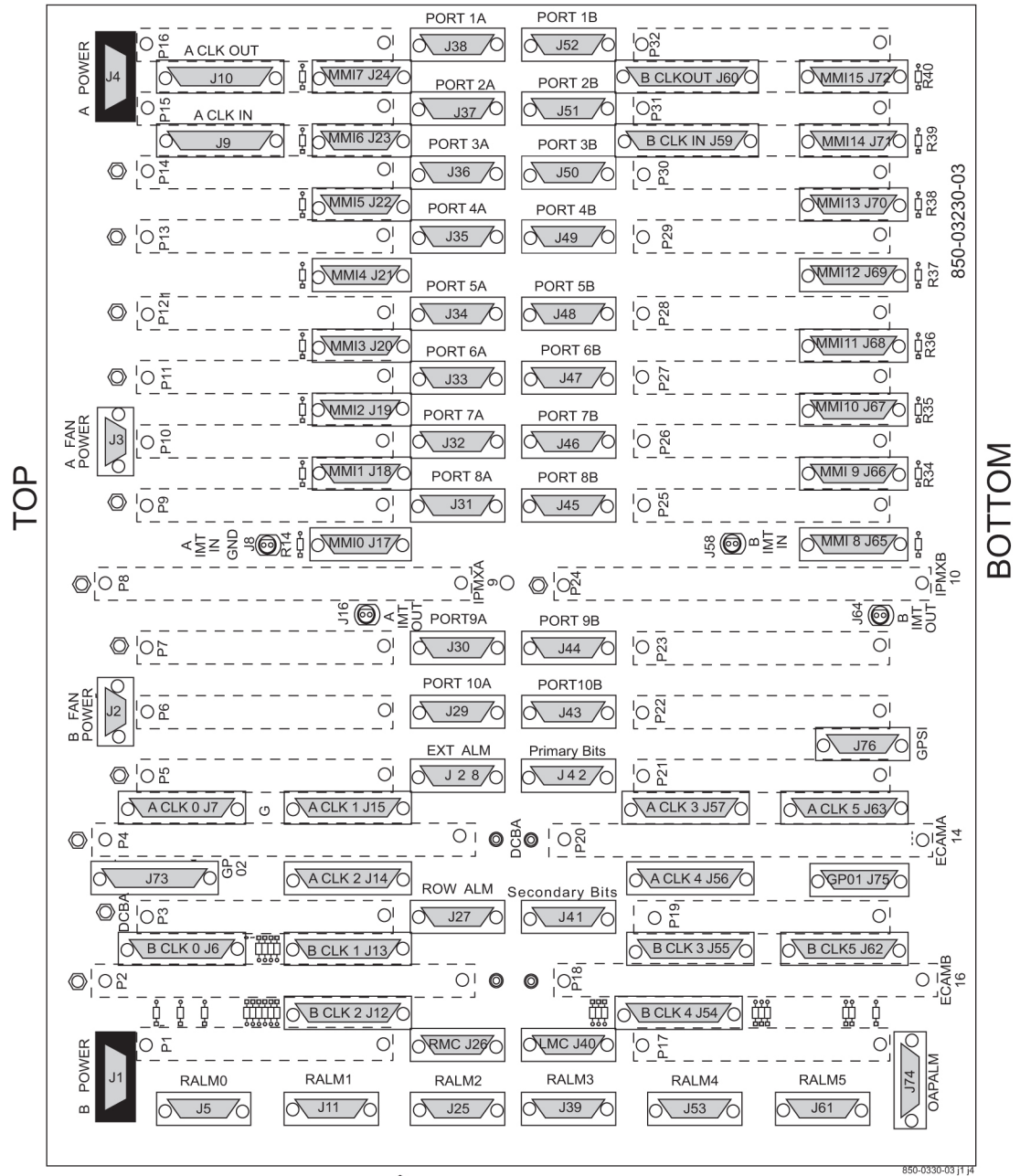

Control Shelf Backplane 06/07

The connectors on backplanes -06 and -07 are identical.

Figure B-2 Control Shelf Backplane 06/07

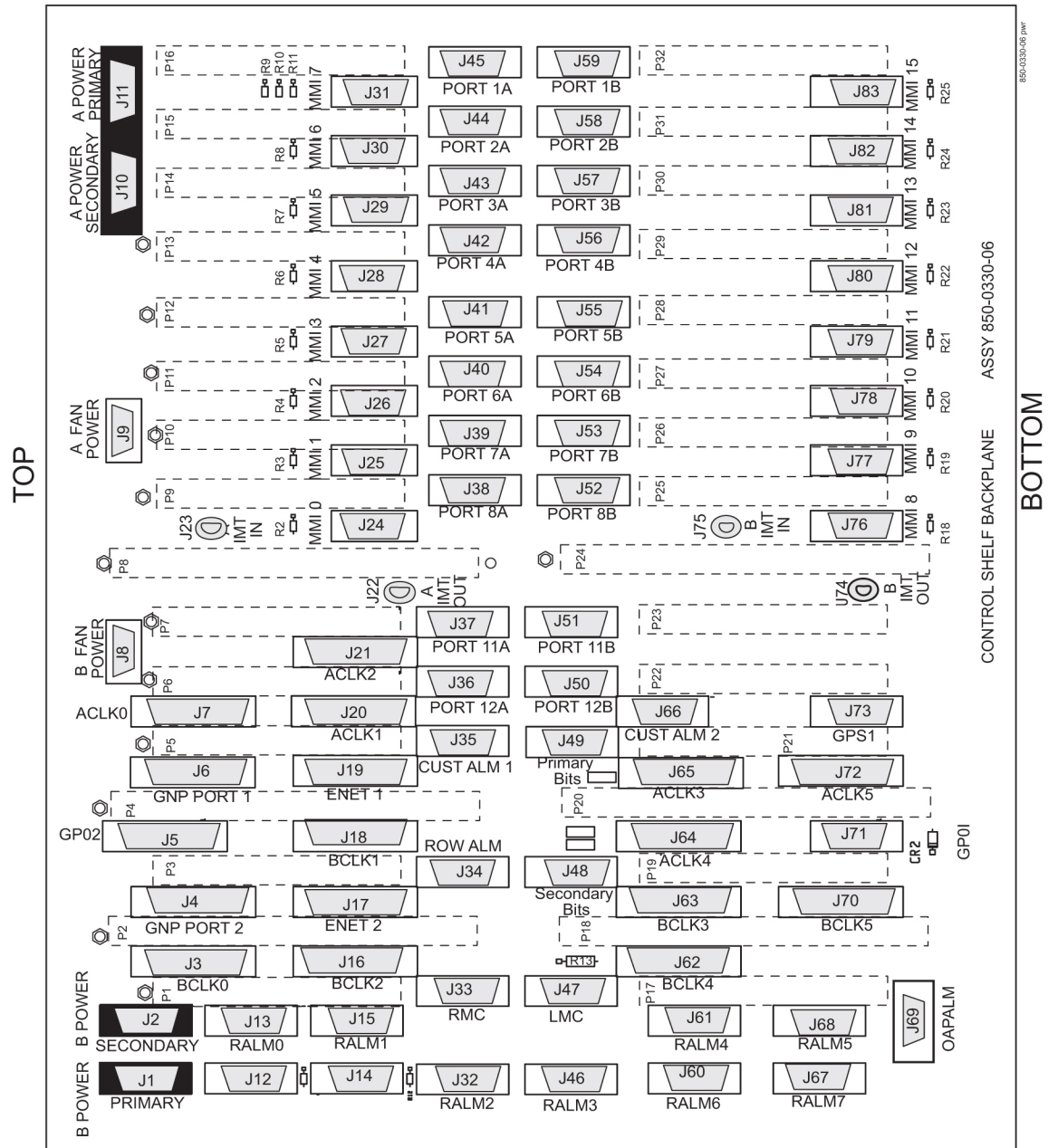

Warning: ⚡ Conducts -48VDC for the printed circuit board (HOT). Metal points on printed circuit boards conducts -48VDC and can cause shorts, shocks, and damage if not handled properly.

Overview of the Control Shelf Backplane Connectors

Table B-1 compares the connectors of Control Shelf backplane 04 with the connectors of Control Shelf backplane 06/07.

Table B-1 Control Shelf Backplanes -04 and -06/07

Control Shelf Backplane (P/N 850-0330-04)	Control Shelf Backplane (P/N 850-0330-06/07)
J-1 B POWER	J-1 B POWER PRIMARY

Table B-1 (Cont.) Control Shelf Backplanes -04 and -06/07

Control Shelf Backplane (P/N 850-0330-04)	Control Shelf Backplane (P/N 850-0330-06/07)
J-2 B FAN POWER	J-8 B FAN POWER
J-3 A FAN POWER	J-9 A FAN POWER
	J-10 A POWER SECONDARY
	J-2 B POWER SECONDARY
J-4 A POWER	J-11 A POWER PRIMARY
J-5 RALM0	J-13 RALM0
J-6 B CLK 0	J-3 B CLK 0
	J-4 B CLK 6
J-7 A CLK 0	J-7 A CLK 0
	J-6 A CLK 6
J-8 A IMT IN GND	J-23 A IMT IN
J-9 A CLK IN	N/A
J-10 A CLK OUT	J-14 CI
J-11 RALM 1	J-15 RALM 1
J-12 B CLK 2	J-16 B CLK 2
J-13 B CLK 1	J-18 B CLK 1
J-14 A CLK 2	J-21 A CLK 2
J-15 A CLK 1	J-20 A CLK 1
J-16 A IMT OUT	J-22 A IMT OUT
J-17 MMI 0	J-24 MMI 0
J-18 MMI 1	J-25 MMI 1
J-19 MMI 2	J-26 MMI 2
J-20 MMI 3	J-27 MMI 3
J-21 MMI 4	J-28 MMI 4
J-22 MMI 5	J-29 MMI 5
J-23 MMI 6	J-30 MMI 6
J-24 MMI 7	J-31 MMI 7
J-25 RALM2	J-32 RALM2
J-26 RMC	J-33 RMC

Table B-1 (Cont.) Control Shelf Backplanes -04 and -06/07

Control Shelf Backplane (P/N 850-0330-04)	Control Shelf Backplane (P/N 850-0330-06/07)
J-27 ROW ALM	J-34 ROW ALM
J-28 EXT ALARM	J-35 CUST ALM 1 J-66 CUST ALM 2
J-29 PORT 10A	J-36 PORT 10A
J-30 PORT 9A	J-37 PORT 9A
J-31 PORT 8A	J-38 PORT 8A
J-32 PORT 7A	J-39 PORT 7A
J-33 PORT 6A	J-40 PORT 6A
J-34 PORT 5A	J-41 PORT 5A
J-35 PORT 4A	J-42 PORT 4A
J-36 PORT 3A	J-43 PORT 3A
J-37 PORT 2A	J-44 PORT 2A
J-38 PORT 1A	J-45 PORT 1A
J-39 RALM 3	J-46 RALM 3
J-40 LMC	J-47 LMC
J-41 SECONDARY BITS	J-48 SECONDARY BITS
J-42 PRIMARY BITS	J-49 PRIMARY BITS
J-43 PORT 10B	J-50 PORT 10B
J-44 PORT 9B	J-51 PORT 9B
J-45 PORT 8B	J-52 PORT 8B
J-46 PORT 7B	J-53 PORT 7B
J-47 PORT 6B	J-54 PORT 6B
J-48 PORT 5B	J-55 PORT 5B
J-49 PORT 4B	J-56 PORT 4B
J-50 PORT 3B	J-57 PORT 3B
J-51 PORT 2B	J-58 PORT 2B
J-52 PORT 1B	J-59 PORT 1B
J-53 RALM4	J-61 RALM4 J-60 RALM 6

Table B-1 (Cont.) Control Shelf Backplanes -04 and -06/07

Control Shelf Backplane (P/N 850-0330-04)	Control Shelf Backplane (P/N 850-0330-06/07)
J-54 B CLK4	J-62 B CLK 4
J-55 B CLK 3	J-63 B CLK 3
J-56 A CLK 4	J-64 A CLK 4
J-57 A CLK 3	J-65 A CLK 3
J-58 B IMT IN	J-75 B IMT IN
J-59 B CLK IN	N/A
J-60 B CLK OUT	N/A
J-61 RALM5	J-68 RALM5
J-62 B CLK 5	J-70 B CLK 5 J-71 GP01
J-63 A CLK 5	J-72 A CLK 5
J-64 B IMT OUT	J-74 B IMT OUT
J-65 MMI 8	J-76 MMI 8
J-66 MMI 9	J-77 MMI 9
J-67 MMI 10	J-78 MMI 10
J-68 MMI 11	J-79 MMI 11
J-69 MMI 12	J-80 MMI 12
J-70 MMI 13	J-81 MMI 13
J-71 MMI 14	J-82 MMI 14
J-72 MMI 15	J-83 MMI 15
J-73 GP02	J-69 OAPALM
J-74 OAPALM	J-5 GP02
J-75 GP01	J-71 GP01
J-76 GPSI	J-73 GPS1
	J-67 RALM7
	J-17 ENET 2 MASP B
	J-19 ENET 1 MASP A

Power Connectors

The control shelf backplane provides –48VDC power and ground to all card positions. The power is distributed into two parts, A and B. Power is brought to the shelf from the Fuse and **Alarm Panel (FAP)** using two cables. The connectors on the control shelf backplane are **DB-26** high density connectors. The power is distributed over two separate pins per power connection to handle the current load.

J1, J4 on **Control Shelf** backplane 04 J1, J11 Primary and J2, J10 Secondary on **Control Shelf** backplane 06/07

Figure B-3 Power Connector

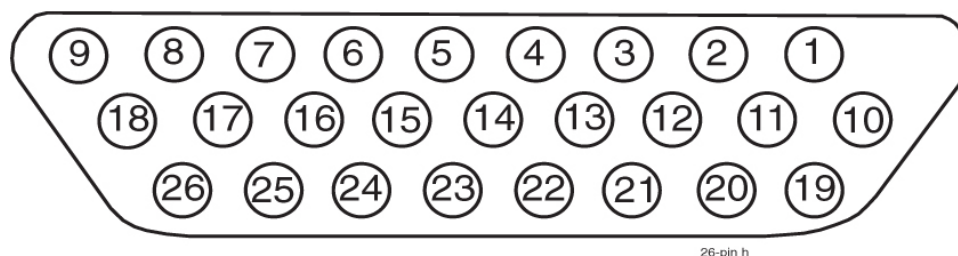

Table B-2 Power Connector

Pin	Signal	Pin	Signal
1	P5\$48VDC	14	LGND
2	P5\$48RTN	15	P3\$48RTN
3	P4\$48VDC	16	P3\$48VDC
4	P4\$48RTN	17	P2\$48RTN
5	LGND	18	P2\$48VDC
6	P3\$48RTN	19	P1\$48RTN
7	P3\$48VDC	20	P1\$48RTN
8	P2\$48RTN	21	P1\$48VDC
9	P2\$48VDC	22	P1\$48VDC
10	P5\$48VDC	23	PF\$48RTN
11	P5\$48RTN	24	PF\$48RTN
12	P4\$48VDC	25	PF\$48VDC
13	P4\$48RTN	26	PF\$48VDC

\$= A or B, A **POWER** (J4) or B **POWER** (J1)

Fuse and Alarm Panel 870-2320-01/03

The **FAP** provides protected distribution of power to the system. Protection is provided by fuses placed in fuse holders on the front panel. The **FAP** contains a fuse fail alarm circuit that operates when one or more fuses fail.

Figure B-4 Control/Extension FAP Rear View

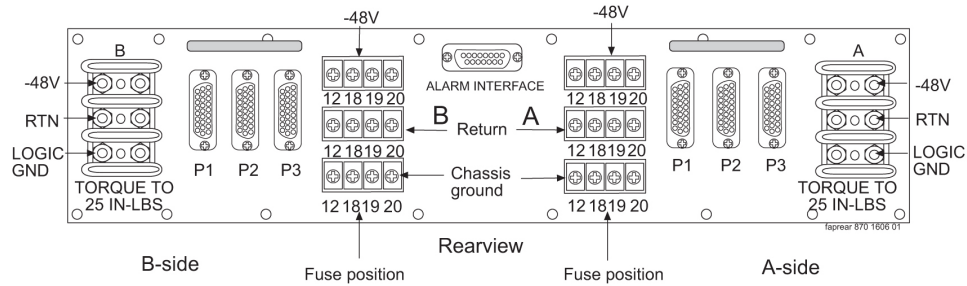

Figure B-5 Alarm Interface Connector

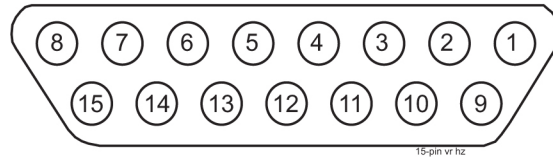
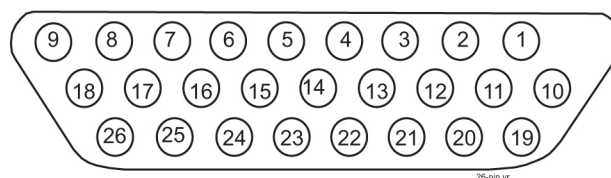

Table B-3 Alarm Interface Connector

Pin	Circuit Descriptions
1 / 2 / 3 / 4	
5	Critical Alarm
6 / 7	
8	Fuse Normally Closed
9	
10	Minor Alarm
11	Major Alarm
12	Common
13	
14	Test
15	Fuse Normally Open

Shelf Power

The Fuse and Alarm Panel powers up to three shelves in the frame through the **FAP** connectors P1, P2, and P3.

Figure B-6 Shelf Power Connector**Table B-4 Shelf Power Connector**

Connector	Fuse Position	Pin Numbers	Circuit Descriptions
P1 (to top shelf in frame)	1	3 and 12	+48VDC
		2 and 11	48VDC return
	2	1 and 10	+48VDC
		19 and 20	48VDC return
	3	21 and 22	+48VDC
		4 and 13	48VDC return
	4	23 and 24	+48VDC
		6 and 15	48VDC return
	5	9 and 18	+48VDC
		8 and 17	48VDC return
	6	7 and 16	+48VDC
		25 and 26	48VDC return
P2 (to middle shelf in frame)	7	3 and 12	+48VDC
		2 and 11	48VDC return
	8	1 and 10	+48VDC
		19 and 20	48VDC return
	9	21 and 22	+48VDC
		4 and 13	48VDC return
	10	23 and 24	+48VDC
		6 and 15	48VDC return
	11	9 and 18	+48VDC
		8 and 17	48VDC return
	12	7 and 16	+48VDC

Table B-4 (Cont.) Shelf Power Connector

Connector	Fuse Position	Pin Numbers	Circuit Descriptions
P3 (to bottom shelf in frame)	13	25 and 26	48VDC return
		3 and 12	+48VDC
	14	2 and 11	48VDC return
		1 and 10	+48VDC
	15	19 and 20	48VDC return
		21 and 22	+48VDC
	16	4 and 13	48VDC return
		23 and 24	+48VDC
	17	6 and 15	48VDC return
		9 and 18	+48VDC
18	8 and 17	48VDC return	
	7 and 16	+48VDC	
P1, P2, and P3		25 and 26	48VDC return
		5 and 14	logic ground

NOTES: A side and B side connectors, fuse positions, and pins are identical.
All return pins are common.

Rack Alarm (Alarm Interface)

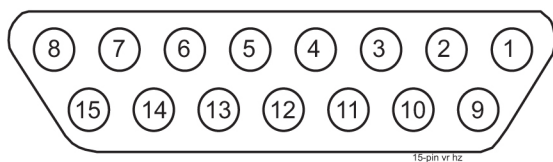
Figure B-7 Rack Alarm Connector**Table B-5 Rack Alarm Connector**

Pin	Circuit Descriptions
1 / 2 / 3 / 4	
5	Critical Alarm
6 / 7	
8	Fuse Normally Closed

Table B-5 (Cont.) Rack Alarm Connector

Pin	Circuit Descriptions
9	
10	Minor Alarm
11	Major Alarm
12	Common
13	
14	Test
15	Fuse Normally Open

Fan Power

J2, J3 on **Control Shelf** backplane 04 and J8, J9 on **Control Shelf** backplane 06/07

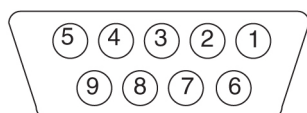
Figure B-8 Fan Power Connector**Table B-6 Fan Power Connector**

Pin	Signal	Pin	Signal
1	PF\$48RTN	6	FAN\$ALM-
2	PF\$48RTN	7	
3		8	CHASSIS GND
4	PF\$48VDC	9	FANCNTRL
5	PF\$48VDC		

\$= A or B, A fan power (J3) or B fan power (J2)

Alarm Connectors**Local Maintenance Center Alarm Connector**

Local Maintenance Center **Alarm** Connector connector provides the system's alarm condition indicators to the local maintenance center.

J40 on **Control Shelf** backplane 04 and J47 on **Control Shelf** backplane 06/07

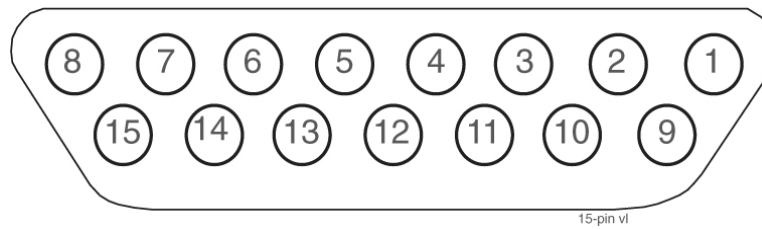
Figure B-9 Local Maintenance Center Alarm Connector**Table B-7 Local Maintenance Center Alarm Connector**

Pin	Signal
1, 3, 4, 5, 11, 12	Not used
2	LMCANC - Local Maintenance Center Audible Alarm , Normally Closed
6	LMCVMJNC - Local Maintenance Center Major Alarm , Normally Closed
7	LMCVMNNC - Local Maintenance Center Minor Alarm , Normally Closed
8	LMCVCRNC - Local Maintenance Center Critical Alarm , Normally Closed
9	LMCACOM - Local Maintenance Center Audible Alarm Common
10	LMCANO - Local Maintenance Center Audible alarm, normally Open
13	LMCVCOM - Local Maintenance Center Common
14	LMCVMJNO - Local Maintenance Center Major Alarm , Normally Open
15	LMCVMNNO - Local Maintenance Center Minor Alarm , Normally Open

Remote Maintenance Center Alarm Connector

The Remote Maintenance Center **Alarm** connector provides system alarm condition indicators to the remote maintenance center.

J26 on **Control Shelf** backplane 04 and J33 on **Control Shelf** backplane 06/07

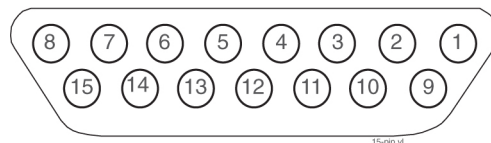
Figure B-10 Remote Maintenance Center Alarm Connector**Table B-8 Remote Maintenance Center Alarm Connector**

Pin	Signal
1, 3, 4, 5, 9, 11, 12	not used

Table B-8 (Cont.) Remote Maintenance Center Alarm Connector

Pin	Signal
2	RMCA NC - Remote Maintenance Center Audible Alarm , Normally Closed
6	RMCM JNC - Remote Maintenance Center Major Alarm , Normally Closed
7	RMCM NNC - Remote Maintenance Center Minor Alarm , Normally Closed
8	RMCC RNC - Remote Maintenance Center Critical Alarm , Normally Closed
10	RMCA NO - Remote Maintenance Center Audible Alarm , Normally Open
13	RMCC OM - Remote Maintenance Center Common
14	RMCM JNO - Remote Maintenance Center Major Alarm , Normally Open
15	RMCM NNO - Remote Maintenance Center Minor Alarm , Normally Open

Rack Alarm Connectors

The output of the Rack **Alarm** Connectors control the alarm condition indicators on each control or extension frame fuse and alarm panel.

J5, J11, J25, J39, J53, J61 on **Control Shelf** backplane 04 and J13, J15, J32, J46, J61, J68 on **Control Shelf** backplane 06/07

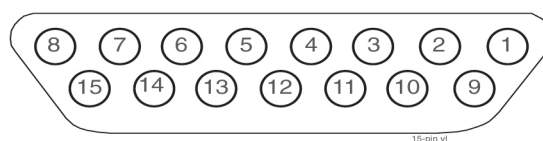
Figure B-11 Rack Alarm Connector**Table B-9 Rack Alarm Connector**

Pin	Signal
1, 2, 6, 7, 9, 13, 14	Not used
3	R\$ M NNC - Rack Alarm , Minor, Normally Closed
4	R\$ M JNC - Rack Alarm , Major, Normally Closed
5	R\$ C RNC - Rack Alarm , Critical, Normally Closed
8	R\$ F A+ - Rack Fuse Alarm (+)
10	R\$ M NNO - Rack Alarm , Minor, Normally Open

Table B-9 (Cont.) Rack Alarm Connector

Pin	Signal
11	R\$MJNO - Rack Alarm, Major, Normally Open
12	R\$COM - Rack Alarm, Common
15	R\$FA- - Rack Fuse Alarm (-)

\$= 0 through 5, RALM0 through RALM5 (J5, J11, J25, J39, J53, J61 respectively)

Row Alarm Connector

Row Alarm Connector controls the alarm condition indicators on an end panel at the end of a set of the frames.

J27 on Control Shelf backplane 04 and J34 on Control Shelf backplane 06/07

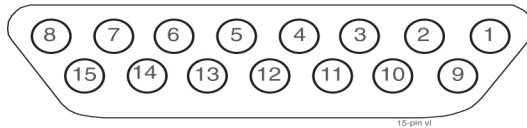
Figure B-12 Row Alarm Connector**Table B-10 Row Alarm Connector**

Pin	Signal
1, 2, 3, 6, 7, 8, 9, 13, 14, 15	Not used
4	-48VDC
5	RACRNC - Row Alarm, Critical, Normally Closed
10	RAMNNO - Row Alarm, Minor, Normally Open
11	RAMJNO - Row Alarm, Major, Normally Open
12	48VDC return

External Alarm Connector

External Alarm Connector is also used for alarm condition inputs from an optional holdover clock.

J28 on Control Shelf backplane 04 External Alarm J35 on Control Shelf backplane 06/07 CUST ALM 1 J66 on Control Shelf backplane 06/07 CUST ALM 2 (not supported by software)

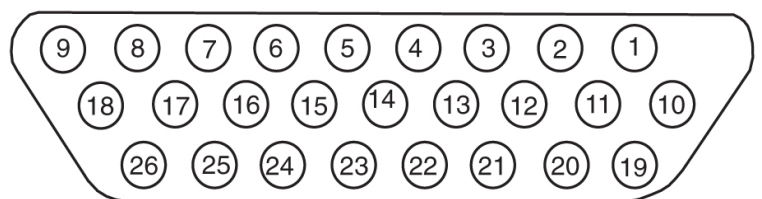
Figure B-13 External Alarm Connector**Table B-11 External Alarm Connector**

Pin	Signal	Description
2	CUFA13	Signals a customer defined trouble #13 to the system when connected to P5A48RTN (pin 10) or P4B48RTN (pin 11).
3	CUFA14	Signals a customer defined trouble #14 to the system when connected to P5A48RTN (pin 10) or P4B48RTN (pin 11).
4	CUFA3	Signals a customer defined critical alarm (trouble #3) to the system when connected to P5A48RTN (pin 10) or P4B48RTN (pin 11).
5	CUFA1	Reserved
6	CUFA9	Reserved
7	CUFA2	Signals a holdover clock critical alarm to the system when connected to P5A48RTN (pin 10) or P4B48RTN (pin 11).
8	CUFA4	Signals a customer defined critical alarm (trouble #4) to the system when connected to P5A48RTN (pin 10) or P4B48RTN (pin 11).
9	CUFA10	Signals a holdover clock minor alarm to the system when connected to P5A48RTN (pin 10) or P4B48RTN (pin 11).
10	P5A48RTN	Signal return path
11	P4B48RTN	Signal return path
19	CUFA8	Signals customer defined major alarm (trouble #8) to the system when connected to P5A48RTN (pin 10) or P4B48RTN (pin 11).
20	CUFA16	Signals a customer defined trouble #16 to the system when connected to P5A48RTN (pin 10) or P4B48RTN (pin 11).
21	CUFA7	Signals a customer defined major alarm (trouble #7) to the system when connected to P5A48RTN (pin 10) or P4B48RTN (pin 11).
22	CUFA15	Signals a customer defined trouble #15 to the system when connected to P5A48RTN (pin 10) or P4B48RTN (pin 11).
23	CUFA12	Signals a customer defined minor alarm (trouble #12) to the system when connected to P5A48RTN (pin 10) or P4B48RTN (pin 11).
24	CUFA6	Signals a holdover clock major alarm to the system when connected to P5A48RTN (pin 10) or P4B48RTN (pin 11).
25	CUFA5	Reserved

Table B-11 (Cont.) External Alarm Connector

Pin	Signal	Description
26	CUFA11	Signals a customer defined minor alarm (trouble #11) to the system when connected to P5A48RTN (pin 10) or P4B48RTN (pin 11).

OAP Alarm Connector

The **OAP** alarm connector controls the alarm condition indicators on an **OAP** frame.

J74 on **Control Shelf** backplane 04 and J69 on **Control Shelf** backplane 06/07

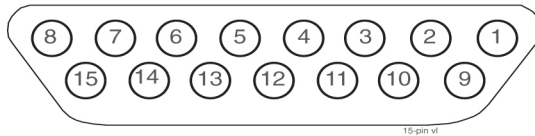
Figure B-14 OAP Alarm Connector**Table B-12 OAP Alarm Connector**

Pin	Signal
1, 2, 6, 7, 13, 14	Not used
3	OAPMNNC - OAP Alarm, Minor, Normally Closed
4	OAPMJNC - OAP Alarm, Major, Normally Closed
5	OAPCRNC - OAP Alarm, Critical, Normally Closed
8	OAPFA+ - OAP Fuse Alarm (+)*
9	OAPBNO - OAP Alarm, busy, Normally Open*
10	OAPMNNO - OAP Alarm, minor, normally Open
11	OAPMJNO - OAP Alarm, Major, Normally Open
12	OAPCOM - OAP Alarm, Common
15	OAPFA- - Row Fuse Alarm (-)*

* not currently supported

System Clock Connectors

The control shelf backplane provides system clock output to the rest of the system from the **TDMs**. Redundancy is accomplished by allowing **TDM A** and **TDM B** to distribute clocks independently of each other.

A Clock 0 through A Clock 5

J7, J14, J15, J56, J57, J63 on **Control Shelf** backplane 04 and J7, J21, J20, J64, J65, J72 on **Control Shelf** backplane 06/07

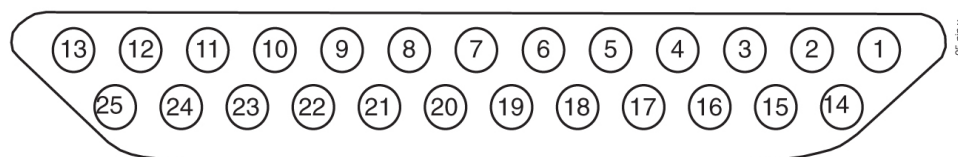
Figure B-15 A Clock 0 Through A Clock 5 Connectors**Table B-13 A Clock 0 Through A Clock 5 Connectors**

Connector	Pin	Signal	Pin	Signal	Pin	Signal	Pin	Signal
850-0330-04 J7 (CF00) (rack 0) 850-0330-06/ 07	1		8	MBUS1RX- _50	15	A56KHZ0- _50	22	A56KHZ2+_ 50
	2	MBUS0TX- _50	9	MBUS1RX +_50	16	A8KHZ0+_ 50	23	A56KHZ2- _50
	3	MBUS0TX +_50	10	MBUS2TX- _50	17	A8KHZ0- _50	24	A8KHZ2+_ 50
	4	MBUS0RX- _50	11	MBUS2TX +_50	18	A56KHZ1+_ 50	25	A8KHZ2- _50
	5	MBUS0RX +_50	12	MBUS2RX- _50	19	A56KHZ1- _50		
	6	MBUS1TX- _50	13	MBUS2RX +_50	20	A8KHZ1+_ 50		
	7	MBUS1TX +_50	14	A56KHZ0+_ 50	21	A8KHZ1- _50		
850-0330-06/ 07 J64, J65, J72	not currently supported							

B Clock 0 through B Clock 5

J6, J12, J13, J54, J55, J62 on **Control Shelf** backplane 04 and J3, J16, J18, J62, J63, J70 on **Control Shelf** backplane 06/07

Figure B-16 B Clock 0 through B Clock 5 Connectors

Table B-14 B Clock 0 through B Clock 5 Connectors

Connector	Pin	Signal	Pin	Signal	Pin	Signal	Pin	Signal
850-0330-03 J6 (CF00) (rack 0) 850-0330-06/ 07 J3	1	R0FAALM-	8		15	B56KHZ0- _50	22	B56KHZ2+_ 50
	2		9		16	B8KHZ0+_ 50	23	B56KHZ2- _50
	3		10		17	B8KHZ0- _50	24	B8KHZ2+_ 50
	4		11		18	B56KHZ1+_ 50	25	B8KHZ2- _50
	5		12		19	B56KHZ1- _50		
	6		13	R0FBALM-	20	B8KHZ1+_ 50		
	7	R0FANCTRL	14	B56KHZ0+_ 50	21	B8KHZ1- _50		
850-0330-06/ 07 J62, J63, J70	not currently supported							

Shelf Clock Connectors (for Control Shelf Backplane -04 only)

Connectors for both A and B clocks are provided using 25 pin D type connectors at J9, J10, J59, and J60 on **Control Shelf** backplane 04.

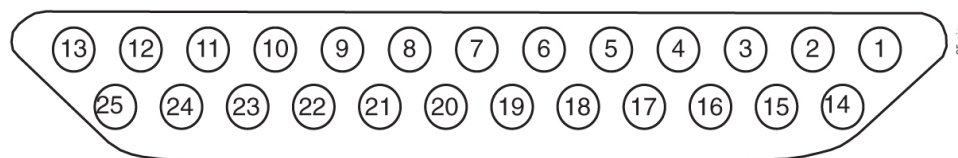
System clock connectors are used on **Control Shelf** backplane 06/07.

Clock A In Connector

J9 on backplane (P/N 850-0330-04).

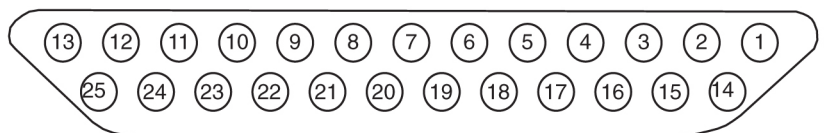
Figure B-17 Clock A In Connector on Backplane**Table B-15 Clock A In Connector on Control Shelf Backplane 04**

Pin	Signal	Pin	Signal
1		14	MA56KHZ+_50
2	MBUSSTX-_50	15	MA56KHZ-_50

Table B-15 (Cont.) Clock A In Connector on Control Shelf Backplane 04

Pin	Signal	Pin	Signal
3	MBUSSTX+_50	16	MA8KHZ+_50
4	MBUSSRX-_50	17	MA8KHZ-_50
5	MBUSSRX+_50	18	SH2A56KHZ+_50
6	SH2MBUSTX-_50	19	SH2A56KHZ-_50
7	SH2MBUSTX+_50	20	SH2A8KHZ+_50
8	SH2MBUSRX-_50	21	SH2A8KHZ-_50
9	SH2MBUSRX+_50	22	SH3A56KHZ+_50
10	SH3MBUSTX-_50	23	SH3A56KHZ-_50
11	SH3MBUSTX-_50	24	SH3A8KHZ+_50
12	SH3MBUSRX-_50	25	SH3A8KHZ-_50
13	SH3MBUSRX+_50		

Clock A Out Connector

J10 on Control Shelf backplane 04.

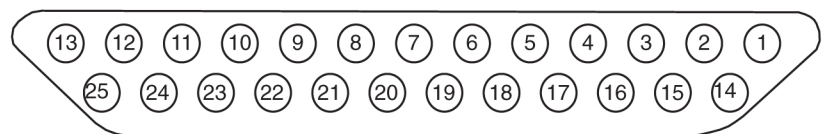
Figure B-18 Clock A Out Connector**Table B-16 Clock A Out Connector**

Pin	Signal	Pin	Signal
1		14	SH2A56KHZ+_50
2	SH2MBUSTX-_50	15	SH2A56KHZ-_50
3	SH2MBUSTX+_50	16	SH2A8KHZ+_50
4	SH2MBUSRX-_50	17	SH2A8KHZ-_50
5	SH2MBUSRX+_50	18	SH3A56KHZ+_50
6	SH3MBUSTX-_50	19	SH3A56KHZ-_50
7	SH3MBUSTX+_50	20	SH3A8KHZ+_50
8	SH3MBUSRX-_50	21	SH3A8KHZ-_50

Table B-16 (Cont.) Clock A Out Connector

Pin	Signal	Pin	Signal
9	SH3MBUSRX+_50	22	
10		23	
11		24	
12		25	
13			

Clock B In Connector

J59 on Control Shelf backplane 04

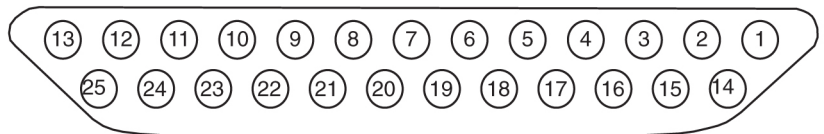
Figure B-19 Clock B In Connector on Backplane**Table B-17 Clock B In Connector on Control Shelf backplane 04**

Pin	Signal	Pin	Signal
1	FANAALM-	14	MB56KHZ+_50
2		15	MB56KHZ-_50
3		16	MB8KHZ+_50
4		17	MB8KHZ-_50
5		18	SH2B56KHZ+_50
6		19	SH2B56KHZ-_50
7	FANCNTRL	20	SH2B8KHZ+_50
8		21	SH2B8KHZ-_50
9		22	SH3B56KHZ+_50
10		23	SH3B56KHZ-_50
11		24	SH3B8KHZ+_50
12		25	SH3B8KHZ-_50
13	FANBALM-		

Clock B Out Connector

J60 on Control Shelf backplane 04.

Figure B-20 Clock B Out Connector on Backplane

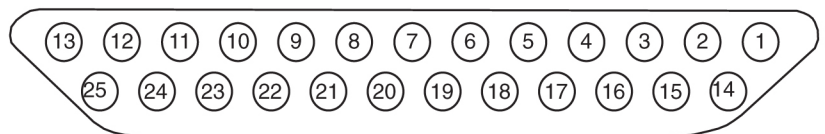

Table B-18 Clock B Out Connector on Control Shelf backplane 04

Pin	Signal	Pin	Signal
1	FANAALM-	14	SH2B56KHZ+_50
2		15	SH2B56KHZ-_50
3		16	SH2B8KHZ+_50
4		17	SH2B8KHZ-_50
5		18	SH3B56KHZ+_50
6		19	SH3B56KHZ-_50
7	FANCNTRL	20	SH3B8KHZ+_50
8		21	SH3B8KHZ-_50
9		22	
10		23	
11		24	
12		25	
13	FANBALM-		

BITS Clock Connectors

The system connects to the **Building Integrated Timing System (BITS)** clocks using two **DB-15** style connectors. The two clocks are labeled Primary and Secondary and are supplied from the central office clock. Both clocks go to both **TDMs**, where one is selected to provide the system clocks used to provide system timing.

J41, J42 on Control Shelf backplane 04 and J48, J49 on Control Shelf backplane 06/07

Figure B-21 BITS Clock Connector

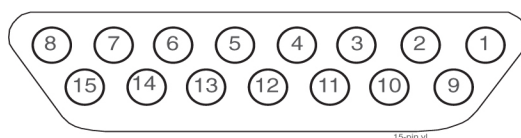

Table B-19 BITS Clock Connector

Pin	Signal	Pin	Signal
1		9	
2		10	
3		11	
4		12	\$BITSIN-_60
5	\$BITSIN+_60	13	
6		14	
7		15	
8			

\$= P for primary BITS clock (J42), S for secondary BITS clock (J41)

Serial Port Connectors

The control shelf backplane provides an interface for 16 separate serial port connections from the TDMs. These connections provide RS-232 interfaces for terminals, printers, and modems. The system is set up as **Data Terminal Equipment (DTE)**.

J17 - J24, J65 - J72 on **Control Shelf** backplane 04 and J24 - J31, J76 - J83 on **Control Shelf** backplane 06/07

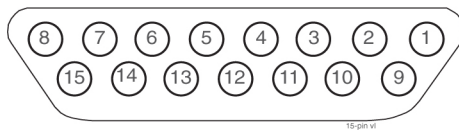
Figure B-22 Serial Port Connector**Table B-20 Serial Port Connector**

Pin	Signal	Pin	Signal
1		9	
2		10	
3	DCD\$	11	
4	RX\$	12	
5	TX\$	13	CTS\$
6	DTR\$	14	RTS\$
7	logic ground	15	

Table B-20 (Cont.) Serial Port Connector

Pin	Signal	Pin	Signal
8			
\$= 0 through 15, MMI0 through MMI15 respectively, J17 through J24 and J65 through J72 respectively			

Interface Connectors

For slots 1 through 8, 11, and 12 on the control shelf backplane, there are two associated **DB-26** interface connectors for each slot. These provide interfacing to the outside world in the form of Ethernet networks or **SS7** links networks.

J29 - J38, J43 - J52 on **Control Shelf** backplane 04 and J36 - J45, J50 - J59 on **Control Shelf** backplane 06/07

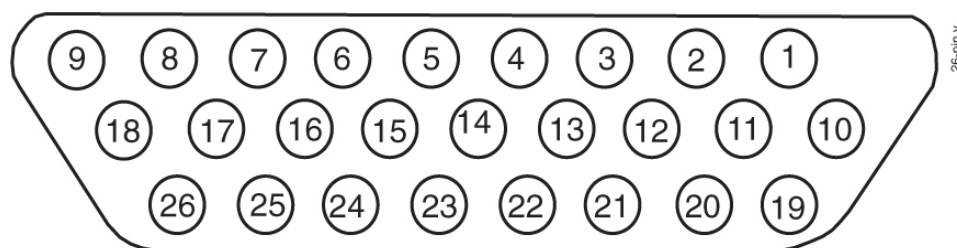
Figure B-23 Interface Connector**Table B-21 Interface Connector Pins and Signal**

DB-26 Pin	DS0A/OCU Signal	DB-26 Pin	DS0A/OCU Signal ATM
1		14	
2		15	
3		16	
4		17	
5		18	
6		19	
7		20	TX-RING
8		21	TX-TIP
9		22	RX-RING
10		23	RX-TIP
11		24	

Table B-21 (Cont.) Interface Connector Pins and Signal

DB-26 Pin	DS0A/OCU Signal	DB-26 Pin	DS0A/OCU Signal ATM
12		25	
13		26	

Table B-22 Interface Connectors, Ports, and Card Slots

Card slot	Port	Connector	Port	Connector
01	1A	J38	1B	J52
02	2A	J37	2B	J51
03	3A	J36	3B	J50
04	4A	J35	4B	J49
05	5A	J34	5B	J48
06	6A	J33	6B	J47
07	7A	J32	7B	J46
08	8A	J31	8B	J45
11	9A	J30	9B	J44
12	10A	J29	10B	J43

Control Shelf Modules

This section details the backplane circuit board connectors used for

- Link Interface Module (LIM)
- E5 Interface Modules
- E5-TSM Modules
- E5-SLAN Modules
- E5-STC Modules
- E5-IPSM Modules
- E5-MCPM-B Modules

Control Shelf Backplane top connectors are P6, P7, and P9 through P16; bottom connectors are P22, P23, and P25 through P32.

Control Shelf Backplane Pin-Outs, Top Connector

[Table B-23](#) lists pinouts for connectors P6, P7, and P9 through P16 on the control shelf.

Refer to [Table B-25](#) for signal symbol values (\$, #, &, @, and ^).

Figure B-24 Control Shelf Backplane Pin-Outs, Top Connector



Table B-23 Control Shelf Backplane Pin-Outs, Top Connector

Pi n	Signal	Pi n	Signal	Pi n	Signal	Pi n	Signal
A 01	LGND	B0 1	LGND	C 01	LGND	D 01	LGND
A 02	ASEROD-_50	B0 2	LGND	C 02	ASEROE-_50	D 02	LGND
A 03	ASEROD+_50	B0 3	LGND	C 03	ASEROE+_50	D 03	LGND
A 04	LGND	B0 4	ASELD-	C 04	LGND	D 04	ASELE-
A 05	ASERID-_50	B0 5	LGND	C 05	ASERIE-_50	D 05	LGND
A 06	ASERID+_50	B0 6	LGND	C 06	ASERIE+_50	D 06	LGND
A 07	LGND	B0 7	AIND-	C 07	LGND	D 07	AINE-
A 08	ASEROC-_50	B0 8	LGND	C 08	ASEROF-_50	D 08	LGND
A 09	ASEROC+_50	B0 9	LGND	C 09	ASEROF+_50	D 09	LGND
A 10	ABMUXIN-	B1 0	ASELC-	C 10	LGND	D 10	ASELF-
A 11	ASERIC-_50	B1 1	LGND	C 11	ASERIF-_50	D 11	LGND
A 12	ASERIC+_50	B1 2	LGND	C 12	ASERIF+_50	D 12	LGND
A 13	LGND	B1 3	AINC-	C 13	LGND	D 13	AINF-
A 14	ASEROB-_50	B1 4	LGND	C 14	ASEROG-_50	D 14	LGND

Table B-23 (Cont.) Control Shelf Backplane Pin-Outs, Top Connector

Pi n	Signal	Pi n	Signal	Pi n	Signal	Pi n	Signal
A 15	ASEROB+_50	B1 5	LGND	C 15	ASEROG+_50	D 15	LGND
A 16	LGND	B1 6	ASELB-	C 16	LGND	D 16	ASELG-
A 17	ASERIB-_50	B1 7	LGND	C 17	ASERIG-_50	D 17	LGND
A 18	ASERIB+_50	B1 8	LGND	C 18	ASERIG+_50	D 18	LGND
A 19	LGND	B1 9	AINB-	C 19	LGND	D 19	AING-
A 20		B2 0	LGND	C 20	ASEROH-_50	D 20	LGND
A 21		B2 1	LGND	C 21	ASEROH+_50	D 21	LGND
A 22	LGND	B2 2		C 22	LGND	D 22	ASELH-
A 23		B2 3	LGND	C 23	ASERIH-_50	D 23	LGND
A 24		B2 4	LGND	C 24	ASERIH+_50	D 24	LGND
A 25	LGND	B2 5		C 25	LGND	D 25	AINH-
A 26	ASEROA-_50	B2 6	LGND	C 26	ASEROI-_50	D 26	LGND
A 27	ASEROA+_50	B2 7	LGND	C 27	ASEROI+_50	D 27	LGND
A 28	LGND	B2 8	ASELA-	C 28	LGND	D 28	ASELI-
A 29	ASERIA-_50	B2 9	LGND	C 29	ASERII-_50	D 29	LGND
A 30	ASERIA+_50	B3 0	LGND	C 30	ASERII+_50	D 30	LGND
A 31	LGND	B3 1	AINA-	C 31	LGND	D 31	AINI-

Table B-23 (Cont.) Control Shelf Backplane Pin-Outs, Top Connector

Pin	Signal	Pin	Signal	Pin	Signal	Pin	Signal
A 32		B3 2	LGND	C 32	ASEROJ-_50	D 32	LGND
A 33		B3 3	LGND	C 33	ASEROJ+_50	D 33	LGND
A 34	LGND	B3 4		C 34	LGND	D 34	ASELJ-
A 35		B3 5	LGND	C 35	ASERIJ-_50	D 35	LGND
A 36		B3 6	LGND	C 36	ASERIJ+_50	D 36	LGND
A 37	LGND	B3 7		C 37	LGND	D 37	AINJ-
A 38		B3 8	LGND	C 38	ASEROK-_50	D 38	LGND
A 39		B3 9	LGND	C 39	ASEROK+_50	D 39	LGND
A 40	LGND	B4 0		C 40	LGND	D 40	ASELK-
A 41		B4 1	LGND	C 41	ASERIK-_50	D 41	LGND
A 42		B4 2	LGND	C 42	ASERIK+_50	D 42	LGND
A 43	LGND	B4 3		C 43	LGND	D 43	AINK-
A 44		B4 4	LGND	C 44	ASEROL-_50	D 44	LGND
A 45		B4 5	LGND	C 45	ASEROL+_50	D 45	LGND
A 46	LGND	B4 6		C 46	LGND	D 46	ASELL-
A 47		B4 7	LGND	C 47	ASERIL-_50	D 47	LGND
A 48		B4 8	LGND	C 48	ASERIL+_50	D 48	LGND

Table B-23 (Cont.) Control Shelf Backplane Pin-Outs, Top Connector

Pi n	Signal	Pi n	Signal	Pi n	Signal	Pi n	Signal
A 49	LGND	B4 9		C 49	LGND	D 49	AINL-
A 50	AIN-_78	B5 0	LGND	C 50	AIMTOUT-_78	D 50	LGND
A 51	AIMTIN+_78	B5 1	LGND	C 51	AIMTOUT+_78	D 51	LGND
A 52	LGND	B5 2	LGND	C 52	LGND	D 52	LGND
A 53		B5 3	MBUSSRX-_50	C 53	MBUSSRX+_50	D 53	
A 54		B5 4	MBUSSTX-_50	C 54	MBUSSTX+_50	D 54	LGND
A 55	CHASSIS GND	B5 5	CHASSIS GND	C 55	CHASSIS GND	D 55	CHASSIS GND

E2 P3A48RTN

Control Shelf Backplane Pin-Outs, Bottom Connector

Table B-24 Pinouts for DCM/DSM/LIM/MPL/TSM Control Shelf Backplane bottom connectors P22, P23, and P25 through P32

Figure B-25 Control Shelf Backplane Pin-Outs, Bottom Connector



Table B-24 Control Shelf Backplane Pin-Outs, Bottom Connector

Pi n	Signal	Pi n	Signal	Pi n	Signal	Pi n	Signal
A 01	LGND	B0 1	&-IF1_60	C 01	&-IF10_60	D 01	IN2-
A 02	&-IF3_60	B0 2	&-IF2_60	C 02	&-IF19_60	D 02	LGND
A 03	LGND	B0 3		C 03	&-IF20_60	D 03	LGND

Table B-24 (Cont.) Control Shelf Backplane Pin-Outs, Bottom Connector

Pin	Signal	Pin	Signal	Pin	Signal	Pin	Signal
A04	&-IF4_60	B04		C04	&-IF21_60	D04	LGND
A05	&-IF5_60	B05		C05	&-IF22_60	D05	LGND
A06	&-IF6_60	B06	&-IF24_60	C06	&-IF23_60	D06	LGND
A07	&-IF7_60	B07	&-IF26_60	C07		D07	@-IF25_60
A08	&-IF8_60	B08	&-IF9_60	C08	&-IF18_60	D08	LGND
A09	LGND	B09		C09		D09	LGND
A10		B10		C10	EBI_^XSP2	D10	EBI_^XSP3
A11	LGND	B11	LGND	C11	EBI_^XBE0-	D11	EBI_^XD00
A12	BSERO@-_50	B12	LGND	C12	EBI_^XBE1-	D12	EBI_^XD01
A13	BSERO@-_50	B13	LGND	C13	EBI_^XBE2-	D13	EBI_^XD02
A14	LGND	B14	LGND	C14	EBI_^XBE3-	D14	EBI_^XD03
A15		B15	LGND	C15	EBI_^XBS8-	D15	EBI_^XD04
A16		B16	LGND	C16	EBI_^XBS16-	D16	EBI_^XD05
A17	LGND	B17	LGND	C17	EBI_^ADS0-	D17	EBI_^XD06
A18	BSEL@-	B18		C18	EBI_^ADS1-	D18	EBI_^XD07
A19		B19		C19	EBI_^XW/R	D19	EBI_^XD08
A20	BMUXIN-	B20		C20	EBI_^XM/IO	D20	EBI_^XD09

Table B-24 (Cont.) Control Shelf Backplane Pin-Outs, Bottom Connector

Pi n	Signal	Pi n	Signal	Pi n	Signal	Pi n	Signal
A 21	LGND	B2 1	BIN@-	C 21	EBI_^XSP1	D 21	EBI_^XD10
A 22		B2 2	LGND	C 22	EBI_^XINTA-	D 22	EBI_^XD11
A 23		B2 3	LGND	C 23	EBI_^XRDY-	D 23	EBI_^XD12
A 24	LGND	B2 4	LGND	C 24	EBI_^XCAS0-	D 24	EBI_^XD13
A 25	BSERI@-_50	B2 5	LGND	C 25	EBI_^XCAS1-	D 25	EBI_^XD14
A 26	BSERI@+_50	B2 6	LGND	C 26	EBI_^XCAS2-	D 26	EBI_^XD15
A 27	LGND	B2 7	LGND	C 27		D 27	
A 28		B2 8		C 28		D 28	LGND
A 29	LGND	B2 9		C 29		D 29	
A 30		B3 0		C 30		D 30	LGND
A 31	LGND	B3 1		C 31	MB56KHZ+_50	D 31	
A 32		B3 2		C 32	MB56KHZ-_50	D 32	LGND
A 33	LGND	B3 3		C 33	MB8KHZ+_50	D 33	
A 34		B3 4		C 34	MB8KHZ-_50	D 34	LGND
A 35	CHASSIS GND	B3 5	CHASSIS GND	C 35	CHASSIS GND	D 35	CHASSIS GND

Control Shelf Backplane Pin-Out Symbols

Table B-25 lists the signal symbol values used in Table B-23 through Table B-43.

Table B-25 Backplane Pin-Out Symbols

Slot/Connector	Interface Port	Address	Signal Symbol Values				
			\$	#	&	@	^
1 top / P16	0A	0	1A	L	0A		0
1 bottom / P32	0B	0	1A		0B	A	0
2 top / P15	1A	1	1A	K	1A		0
2 bottom / P31	1B	1	1A		1B	B	0
3 top / P14	2A	2	1B	J	2A		2
3 bottom / P30	2B	2	1B		2B	C	2
4 top / P13	3A	3	1B	I	3A		2
4 bottom / P29	3B	3	1B		3B	D	2
5 top / P12	4A	4	2A	H	4A		4
5 bottom / P28	4B	4	2A		4B	E	4
6 top / P11	5A	5	2A	G	5A		4
6 bottom / P27	5B	5	2A		5B	F	4
7 top / P10	6A	6	2B	F	6A		6
7 bottom / P26	6B	6	2B		6B	G	6
8 top / P9	7A	7	2B	E	7A		6
8 bottom / P25	7B	7	2B		7B	H	6
11 top/P7	8A	8	4A	D	8A		8
11 bottom/P23	8B	8	4A		8B	I	8
12 top/P6	9A	9	4A	C	9A		8
12 bottom/P22	9B	9	4A		9B	J	8

Maintenance Disk and Alarm Connector

MDAL Pin-Outs, Top Connector

[Table B-26](#) lists pinouts for connectors P1 on the control shelf.

Figure B-26 Maintenance Disk and Alarm Connector, Top

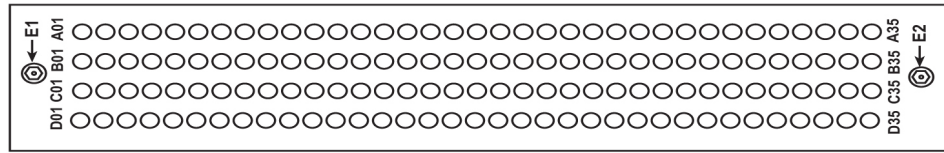

Table B-26 MDAL Backplane, Top

Pi n	Signal	Pi n	Signal	Pi n	Signal	Pi n	Signal
A 01	BALMEN0-	B0 1	BALMD0-	C 01		D 01	LGND
A 02	BALMEN1-	B0 2	BALMD1-	C 02	LGND	D 02	LGND
A 03	BALMEN2-	B0 3	BALMD2-	C 03	LGND	D 03	
A 04	BALMEN3-	B0 4	BALMD3-	C 04	LGND	D 04	
A 05	BALMEN4-	B0 5	BALMD4-	C 05		D 05	LGND
A 06	BALMCK-	B0 6	BALMD5-	C 06		D 06	
A 07	BALMD7-	B0 7	BALMD6-	C 07	R0CRNC	D 07	LGND
A 08	R0FANCTRL	B0 8	LGND	C 08	R0MJNC	D 08	R0COM
A 09	AALMEN0-	B0 9	AALMD0-	C 09	R0MNNC	D 09	R0MJNO
A 10	AALMEN1-	B1 0	AALMD1-	C 10	R0BNC	D 10	R0MNNO
A 11	AALMEN2-	B1 1	AALMD2-	C 11		D 11	R0BNO
A 12	AALMEN3-	B1 2	AALMD3-	C 12	LGND	D 12	LGND
A 13	AALMEN4-	B1 3	AALMD4-	C 13		D 13	LGND
A 14	AALMCK-	B1 4	AALMD5-	C 14	LGND	D 14	LGND
A 15	AALMD7-	B1 5	AALMD6-	C 15		D 15	LGND

Table B-26 (Cont.) MDAL Backplane, Top

Pi n	Signal	Pi n	Signal	Pi n	Signal	Pi n	Signal
A 16	CHASSIS GND	B1 6	CHASSIS GND	C 16	CHASSIS GND	D 16	CHASSIS GND
A 17		B1 7	LGND	C 17		D 17	
A 18	LGND	B1 8	LGND	C 18	LGND	D 18	
A 19	LGND	B1 9	LGND	C 19		D 19	
A 20	R0FBALM-	B2 0		C 20	R1FBALM-	D 20	
A 21	R0FAALM-	B2 1	LGND	C 21	R1FAALM-	D 21	
A 22	LGND	B2 2	R2FBALM-	C 22		D 22	
A 23	LGND	B2 3	R2FAALM-	C 23	R1CRNC	D 23	R1COM
A 24	LGND	B2 4		C 24	R1MJNC	D 24	R1MJNO
A 25	R1FANCTRL	B2 5	LGND	C 25	R1MNNC	D 25	R1MNNO
A 26	R2FANCTRL	B2 6	LGND	C 26	R1BNC	D 26	R1BNO
A 27	LGND	B2 7		C 27		D 27	
A 28	RACRNC	B2 8	RACOM	C 28	R2CRNC	D 28	R2COM
A 29	RAMJNC	B2 9	RAMJNO	C 29	R2MJNC	D 29	R2MJNO
A 30	RAMNNC	B3 0	RAMNNO	C 30	R2MNNC	D 30	R2MNNO
A 31	RABNC	B3 1	RABNO	C 31	R2BNC	D 31	R2BNO
A 32	RMCANC	B3 2		C 32		D 32	LGND

Table B-26 (Cont.) MDAL Backplane, Top

Pin	Signal	Pin	Signal	Pin	Signal	Pin	Signal
A 33	RMCBNC	B3 3		C 33	LGND	D 33	RMCANO
A 34	RMCMJNC	B3 4	RMCMNNC	C 34	RMCCOM	D 34	RMCBNO
A 35	RMCCRNC	B3 5		C 35	RMCMNNO	D 35	RMCMJNO
E2	LGND						

MDAL Pin-Outs, Bottom Connector

Table B-27 lists pinouts of the bottom connector P17 on the control shelf.

Figure B-27 MDAL Backplane, Bottom



Table B-27 MDAL Backplane, Bottom

Pin	Signal	Pin	Signal	Pin	Signal	Pin	Signal
A 01	LMCANO	B0 1		C 01	LMCACOM	D 01	LMCANC
A 02	LMCVMJNC	B0 2		C 02		D 02	LMCVCOM
A 03	LMCVCRNC	B0 3	LMCVMNNC	C 03	LMCVMJNO	D 03	LMCVMNNO
A 04	R3FANCTRL	B0 4		C 04	LGND	D 04	
A 05	R4FANCTRL	B0 5	R4FBALM-	C 05	R3CRNC	D 05	R3COM
A 06		B0 6	R4FAALM-	C 06	R3MJNC	D 06	R3MJNO
A 07	R3FBALM-	B0 7		C 07	R3MNNC	D 07	R3MNNO

Table B-27 (Cont.) MDAL Backplane, Bottom

Pi n	Signal	Pi n	Signal	Pi n	Signal	Pi n	Signal
A 08	R3FAALM-	B0 8		C 08	R3BNC	D 08	R3BNO
A 09	LGND	B0 9	LGND	C 09		D 09	LGND
A 10		B1 0		C 10	R4CRNC	D 10	R4COM
A 11	LGND	B1 1	LGND	C 11	R4MJNC	D 11	R4MJNO
A 12		B1 2		C 12	R4MNNC	D 12	R4MNNO
A 13	LGND	B1 3	LGND	C 13	R4CRNC	D 13	R4BNO
A 14		B1 4		C 14		D 14	
A 15	TPWR	B1 5	LGND	C 15		D 15	
A 16	AUDCTOFF-	B1 6		C 16	LGND	D 16	
A 17	ALMTRANS-	B1 7	LGND	C 17	R5FBALM-	D 17	
A 18	AMS/BMS-	B1 8	SDB0_100	C 18	R5FAALM-	D 18	
A 19	MASBSAN-	B1 9	SDB1_100	C 19		D 19	
A 20	MASASAN-	B2 0	SDB2_100	C 20		D 20	
A 21	LGND	B2 1	SDB3_100	C 21		D 21	LGND
A 22		B2 2	SDB4_100	C 22		D 22	
A 23		B2 3	SDB5_100	C 23		D 23	
A 24		B2 4	SDB6_100	C 24		D 24	

Table B-27 (Cont.) MDAL Backplane, Bottom

Pi n	Signal	Pi n	Signal	Pi n	Signal	Pi n	Signal
A 25		B2 5	SDB7-_100	C 25		D 25	
A 26		B2 6	SDBP-_100	C 26		D 26	
A 27		B2 7	SBSY-_100	C 27		D 27	
A 28		B2 8	SATN-_100	C 28	R5CRNC	D 28	R5COM
A 29		B2 9	SACK-_100	C 29	R5MJNC	D 29	R5MJNO
A 30	LGND	B3 0	SRST-_100	C 30	R5MNNC	D 30	R5MNNO
A 31	LGND	B3 1	SMSG-_100	C 31	R5CRNC	D 31	R5BNO
A 32	R5FANCTRL	B3 2	SSEL-_100	C 32		D 32	
A 33		B3 3	SI/O-_100	C 33		D 33	
A 34		B3 4	SC/D-_100	C 34		D 34	
A 35	LGND	B3 5	SREQ-_100	C 35		D 35	
E2	P5B48RTN						

Terminal Disk Module

Terminal Disk Module P2, P4, P18, P20

TDM Pin-Outs, Top Connectors

TDM, Top Connectors P2, P4

Figure B-28 TDM, Top

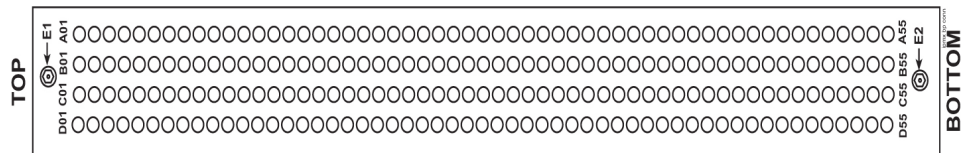

Table B-28 TDM Backplane, Top

Pi n	Signal	Pi n	Signal	Pi n	Signal	Pi n	Signal
A 01	LGND	B0 1	R0FA+	C 01	\$ALMEN0-	D 01	\$ALMD0-
A 02	LGND	B0 2	R0FA-	C 02	\$ALMEN1-	D 02	\$ALMD1-
A 03	CUFA1	B0 3		C 03	\$ALMEN2-	D 03	\$ALMD2-
A 04	CUFA2	B0 4	LGND	C 04	\$ALMEN3-	D 04	\$ALMD3-
A 05	MBUS2RX+_50	B0 5	LGND	C 05	\$ALMEN4-	D 05	\$ALMD4-
A 06	MBUS2RX-_50	B0 6	\$8KHZ2-_50	C 06	\$ALMCK-	D 06	\$ALMD5-
A 07	MBUS2TX+_50	B0 7	\$8KHZ2+_50	C 07	\$ALMD7-	D 07	\$ALMD6-
A 08	MBUS2TX-_50	B0 8	\$56KHZ2-_50	C 08	EBI_\$XA02	D 08	EBI_\$XA14
A 09	MBUS1RX+_50	B0 9	\$56KHZ2+_50	C 09	EBI_\$XA03	D 09	EBI_\$XA15
A 10	MBUS1RX-_50	B1 0	\$8KHZ1-_50	C 10	EBI_\$XA04	D 10	EBI_\$XA16
A 11	MBUS1TX+_50	B1 1	\$8KHZ1+_50	C 11	EBI_\$XA05	D 11	EBI_\$XA17
A 12	MBUS1TX-_50	B1 2	\$56KHZ1-_50	C 12	EBI_\$XA06	D 12	EBI_\$XA18
A 13	MBUS0RX+_50	B1 3	\$56KHZ1+_50	C 13	EBI_\$XA07	D 13	EBI_\$XA19
A 14	MBUS0RX-_50	B1 4	\$8KHZ0-_50	C 14	EBI_\$XA08	D 14	EBI_\$XA20
A 15	MBUS0TX+_50	B1 5	\$8KHZ0+_50	C 15	EBI_\$XA09	D 15	EBI_\$XA21
A 16	MBUS0TX-_50	B1 6	\$56KHZ0-_50	C 16	EBI_\$XA10	D 16	EBI_\$XA22
A 17		B1 7	\$56KHZ0+_50	C 17	CUFA13	D 17	EBI_\$XA23

Table B-28 (Cont.) TDM Backplane, Top

Pi n	Signal	Pi n	Signal	Pi n	Signal	Pi n	Signal
A 18	LGND	B1 8		C 18	CUFA14	D 18	EBI_\$XA24
A 19	CUFA3	B1 9	CUFA9	C 19	HST/GST	D 19	EBI_\$XA25
A 20	CUFA4	B2 0	CUFA10	C 20		D 20	EBI_\$XA26
A 21	LGND	B2 1	LGND	C 21	LGND	D 21	EBI_\$XA27
A 22	CUFA5	B2 2	CUFA11	C 22		D 22	MBUS8RX+_50
A 23	CUFA6	B2 3	CUFA12	C 23	LGND	D 23	\$8KHZ8-_50
A 24	LGND	B2 4	LGND	C 24	CUFA15	D 24	MBUS8RX-_50
A 25	CUFA7	B2 5	LGND	C 25	CUFA16	D 25	\$8KHZ8+_50
A 26	CUFA8	B2 6	LGND	C 26	MBUS8TX+_50	D 26	\$56KHZ8-_50
A 27	LGND	B2 7		C 27	MBUS8TX-_50	D 27	\$56KHZ8+_50
A 28	EBI_\$XSP5	B2 8	R1FA+	C 28	MBUS7RX+_50	D 28	\$8KHZ7-_50
A 29	EBI_\$XSP4	B2 9	R1FA-	C 29	MBUS7RX-_50	D 29	\$8KHZ7+_50
A 30	EBI_\$XA11	B3 0	EBI_\$XA12	C 30	MBUS7TX+_50	D 30	\$56KHZ7-_50
A 31	EBI_\$XA13	B3 1	EBI_\$BREQ-	C 31	MBUS7TX-_50	D 31	\$56KHZ7+_50
A 32	EBI_\$BG-	B3 2	EBI_\$XIRQ-	C 32	MBUS6RX+_50	D 32	\$8KHZ6-_50
A 33	EBI_\$HOSTSAN-	B3 3	EBI_\$GSTSAN-	C 33	MBUS6RX-_50	D 33	\$8KHZ6+_50
A 34	MBUS5RX+_50	B3 4	\$8KHZ5-_50	C 34	MBUS6TX+_50	D 34	\$56KHZ6-_50

Table B-28 (Cont.) TDM Backplane, Top

Pi n	Signal	Pi n	Signal	Pi n	Signal	Pi n	Signal
A 35	MBUS5RX-_50	B3 5	\$8KHZ5+_50	C 35	MBUS6TX-_50	D 35	\$56KHZ6+_50
A 36	MBUS5TX+_50	B3 6	\$56KHZ5-_50	C 36	RTS0	D 36	RTS4
A 37	MBUS5TX-_50	B3 7	\$56KHZ5+_50	C 37	CTS0	D 37	CTS4
A 38	MBUS4RX+_50	B3 8	\$8KHZ4-_50	C 38	TX0	D 38	TX4
A 39	MBUS4RX-_50	B3 9	\$8KHZ4+_50	C 39	RX0	D 39	RX4
A 40	MBUS4TX+_50	B4 0	\$56KHZ4-_50	C 40	DCD0	D 40	DCD4
A 41	MBUS4TX-_50	B4 1	\$56KHZ4+_50	C 41	RTS1	D 41	RTS5
A 42	MBUS3RX+_50	B4 2	\$8KHZ3-_50	C 42	CTS1	D 42	CTS5
A 43	MBUS3RX-_50	B4 3	\$8KHZ3+_50	C 43	TX1	D 43	TX5
A 44	MBUS3TX+_50	B4 4	\$56KHZ3-_50	C 44	RX1	D 44	RX5
A 45	MBUS3TX-_50	B4 5	\$56KHZ3+_50	C 45	DCD1	D 45	DCD5
A 46		B4 6		C 46	RTS2	D 46	RTS6
A 47		B4 7		C 47	CTS2	D 47	CTS6
A 48	LGND	B4 8	LGND	C 48	TX2	D 48	TX6
A 49		B4 9	LGND	C 49	RX2	D 49	RX6
A 50		B5 0		C 50	DCD2	D 50	DCD6
A 51	LGND	B5 1	LGND	C 51	RTS3	D 51	RTS7

Table B-28 (Cont.) TDM Backplane, Top

Pi n	Signal	Pi n	Signal	Pi n	Signal	Pi n	Signal
A 52		B5 2		C 52	CTS3	D 52	CTS7
A 53	RAFA+	B5 3		C 53	TX3	D 53	TX7
A 54	RAFA-	B5 4	R2FA+	C 54	RX3	D 54	RX7
A 55		B5 5	R2FA-	C 55	DCD3	D 55	DCD7
E1	P#\$48VDC	\$ = A or B, for TDM connectors P4 and P2 respectively # = 4 or 5, for TDM connectors P4 and P2 respectively					
E2	P#\$48RTN						

TDM Pin-Outs, Bottom Connector

TDM, Bottom Connectors P18, P20 Control Shelf Backplane

Figure B-29 TDM Backplane Pin-outs, Bottom



Table B-29 TDM Backplane Pin-outs, Bottom

Pi n	Signal	Pi n	Signal	Pi n	Signal	Pi n	Signal
A 01	CHASSIS GND	B0 1	CHASSIS GND	C 01	CHASSIS GND	D 01	CHASSIS GND
A 02		B0 2		C 02	LGND	D 02	
A 03	PBITSIN+_60	B0 3	LGND	C 03	SBITSIN+_60	D 03	LGND
A 04	PBITSIN-_60	B0 4		C 04	SBITSIN-_60	D 04	
A 05	LGND	B0 5	LGND	C 05		D 05	
A 06	LGND	B0 6		C 06		D 06	SPARE1

Table B-29 (Cont.) TDM Backplane Pin-outs, Bottom

Pin	Signal	Pin	Signal	Pin	Signal	Pin	Signal
A07		B07	LGND	C07	LGND	D07	R3FA+
A08		B08		C08		D08	R3FA-
A09		B09		C09		D09	R4FA+
A10	LGND	B10	LGND	C10	LGND	D10	R4FA-
A11	MBUS11RX+_50	B11	\$8KHZ11-_50	C11	MBUS14RX+_50	D11	
A12	MBUS11RX-_50	B12	\$8KHZ11+_50	C12	MBUS14RX-_50	D12	\$8KHZ14-_50
A13	MBUS11TX+_50	B13	\$56KHZ11-_50	C13	MBUS14TX+_50	D13	\$8KHZ14+_50
A14	MBUS11TX-_50	B14	\$56KHZ11+_50	C14	MBUS14TX-_50	D14	\$56KHZ14-_50
A15		B15		C15	MBUS13RX+_50	D15	\$56KHZ14+_50
A16	MBUS10RX+_50	B16	\$8KHZ10-_50	C16	MBUS13RX-_50	D16	\$8KHZ13-_50
A17	MBUS10RX-_50	B17	\$8KHZ10+_50	C17	MBUS13TX+_50	D17	\$8KHZ13+_50
A18	MBUS10TX+_50	B18	\$56KHZ10-_50	C18	MBUS13TX-_50	D18	\$56KHZ13-_50
A19	MBUS10TX-_50	B19	\$56KHZ10+_50	C19	MBUS12RX+_50	D19	\$56KHZ13+_50
A20	MBUS9RX+_50	B20	\$8KHZ9-_50	C20	MBUS12RX-_50	D20	\$8KHZ12-_50
A21	MBUS9RX-_50	B21	\$8KHZ9+_50	C21	MBUS12TX+_50	D21	\$8KHZ12+_50
A22	MBUS9TX+_50	B22	\$56KHZ9-_50	C22	MBUS12TX-_50	D22	\$56KHZ12-_50
A23	MBUS9TX-_50	B23	\$56KHZ9+_50	C23		D23	\$56KHZ12+_50

Table B-29 (Cont.) TDM Backplane Pin-outs, Bottom

Pi n	Signal	Pi n	Signal	Pi n	Signal	Pi n	Signal
A 24	EBI_\$XD00	B2 4	EBI_\$XBE0-	C 24	EBI_\$XSP2	D 24	EBI_\$XSP3
A 25	EBI_\$XD01	B2 5	EBI_\$XBE1-	C 25		D 25	LGND
A 26	EBI_\$XD02	B2 6	EBI_\$XBE2-	C 26		D 26	
A 27	EBI_\$XD03	B2 7	EBI_\$XBE3-	C 27	LGND	D 27	SPARE2
A 28	EBI_\$XD04	B2 8	EBI_\$XBS8-	C 28	LGND	D 28	TPWR
A 29	EBI_\$XD05	B2 9	EBI_\$XBS16-	C 29		D 29	AUDCTOFF-
A 30	EBI_\$XD06	B3 0	EBI_\$ADS0-	C 30		D 30	ALMTRANS-
A 31	EBI_\$XD07	B3 1	EBI_\$ADS1-	C 31	SDB0-_100	D 31	AMS/BMS
A 32	EBI_\$XD08	B3 2	EBI_\$XW/R	C 32	SDB1-_100	D 32	MASASAN-
A 33	EBI_\$XD09	B3 3	EBI_\$XM/IO	C 33	SDB2-_100	D 33	MASBSAN-
A 34	EBI_\$XD10	B3 4	EBI_\$XSP1	C 34	SDB3-_100	D 34	R5FA+
A 35	EBI_\$XD11	B3 5	EBI_\$XINTA-	C 35	LGND	D 35	R5FA-
A 36	EBI_\$XD12	B3 6	EBI_\$XRDY-	C 36	RTS8	D 36	RTS12
A 37	EBI_\$XD13	B3 7	EBI_\$XCAS0-	C 37	CTS8	D 37	CTS12
A 38	EBI_\$XD14	B3 8	EBI_\$XCAS1-	C 38	TX8	D 38	TX12
A 39	EBI_\$XD15	B3 9	EBI_\$XCAS2-	C 39	RX8	D 39	RX12
A 40	LGND	B4 0		C 40	DCD8	D 40	DCD12

Table B-29 (Cont.) TDM Backplane Pin-outs, Bottom

Pi n	Signal	Pi n	Signal	Pi n	Signal	Pi n	Signal
A 41		B4 1		C 41	RTS9	D 41	RTS13
A 42	LGND	B4 2	SDB4-_100	C 42	CTS9	D 42	CTS13
A 43		B4 3	SDB5-_100	C 43	TX9	D 43	TX13
A 44	LGND	B4 4	SDB6-_100	C 44	RX9	D 44	RX13
A 45	MBUS15RX +_50	B4 5	SDB7-_100	C 45	DCD9	D 45	DCD13
A 46	\$8KHZ15-_50	B4 6	SDBP-_100	C 46	RTS10	D 46	RTS14
A 47	MBUS15RX-_50	B4 7	SBSY-_100	C 47	CTS10	D 47	CTS14
A 48	\$8KHZ15+_50	B4 8	SATN-_100	C 48	TX10	D 48	TX14
A 49	MBUS15TX+_50	B4 9	SACK-_100	C 49	RX10	D 49	RX14
A 50	\$56KHZ15-_50	B5 0	SRST-_100	C 50	DCD10	D 50	DCD14
A 51	MBUS15TX-_50	B5 1	SMSG-_100	C 51	RTS11	D 51	RTS15
A 52	\$56KHZ15+_50	B5 2	SSEL-_100	C 52	CTS11	D 52	CTS15
A 53	+12VB	B5 3	SI/O-_100	C 53	TX11	D 53	TX15
A 54	SIG GND	B5 4	SC/D-_100	C 54	RX11	D 54	RX15
A 55	SIG GND	B5 5	SREQ-_100	C 55	DCD11	D 55	DCD15

Interprocessor Message Transport Connectors

Inter-processor Message Transport (IMT) connectors on the control shelf backplane provide connections between the system shelves as part of the two high speed IMT buses.

J8, J16, J58, J64 on **Control Shelf** backplane 04 and J23, J22, J75, J74 on **Control Shelf** backplane 06/07

Figure B-30 *IMT Connector*

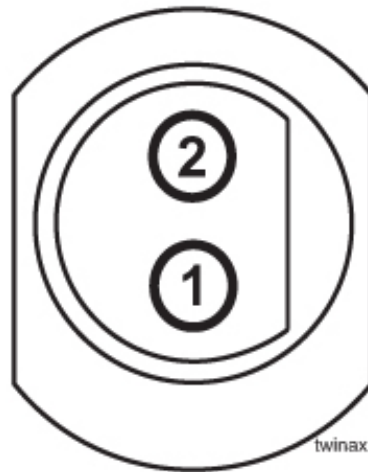

Table B-30 *IMT Connector Pins*

Connector	Pin	Signal
A IMT IN backplane (P/N 850-0330-04)(J8)	1	AIMTIN+_78
A IMT IN backplane (P/N 850-0330-06/07)(J23)	2	AIMTIN-_78
A IMT OUT backplane (P/N 850-0330-04)(J16)	1	AIMTOUT+_78
A IMT OUT backplane (P/N 850-0330-06/07)(J22)	2	AIMTOUT-_78
B IMT IN backplane (P/N 850-0330-04)(J58)	1	BIMTIN+_78
B IMT IN backplane (P/N 850-0330-06/07)(J75)	2	BIMTIN-_78
B IMT OUT backplane (P/N 850-0330-04)(J64)	1	BIMTOUT+_78
B IMT OUT backplane (P/N 850-0330-06/07)(J74)	2	BIMTOUT-_78

General Purpose Relay Connectors

General Purpose Relay connectors provide software controlled, general purpose outputs for the system. Currently, Generic Program (GP01) provides reset signals for any optional OAPs that may be present in the system.

GP01

J75 on **Control Shelf** backplane 04 and J71 on **Control Shelf** backplane 06/07

Figure B-31 *General Purpose Relay Connector 01*

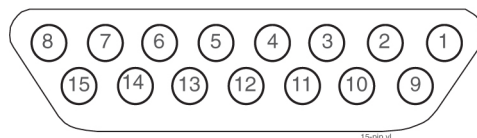
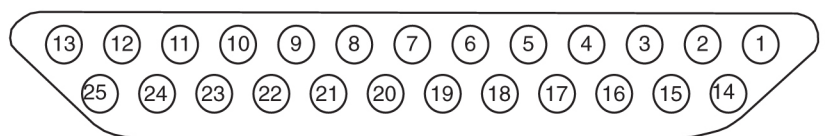

Table B-31 General Purpose Relay Connector 01

Pin	Signal
4, 8, 10, 15	not used
1	GPRNO0 - General Purpose Relay 0, Normally Open
2	GPRCOM0 - General Purpose Relay 0, Common
3	GPRNC0 - General Purpose Relay 0, Normally Closed
5	GPRNO1 - General Purpose Relay 1, Normally Open
6	GPRCOM1 - General Purpose Relay 1, Common
7	GPRNC1 - General Purpose Relay 1, Normally Closed
9	Logic ground
11	OAP1_RST+ - OAP 1 reset, +
12	OAP1_RST- - OAP 1 reset, -
13	OAP2_RST+ - OAP 2 reset, +
14	OAP2_RST- - OAP 2 reset, -

GP02

J73 on **Control Shelf** backplane 04 and J75 on **Control Shelf** backplane 06/07

Figure B-32 General Purpose Relay Connector 02**Table B-32 General Purpose Relay Connector 02**

Pin	Signal
1, 2, 13, 14, 18, 25	not used
3	GPRNC2 - General Purpose Relay 2, Normally Closed
4	GPRCOM2 - General Purpose Relay 2, Common
5	GPRNO2 - General Purpose Relay 2, Normally Open
6	GPRNC2 - General Purpose Relay 3, Normally Closed
7	GPRCOM2 - General Purpose Relay 3, Common
8	GPRNO2 - General Purpose Relay 3, Normally Open

Table B-32 (Cont.) General Purpose Relay Connector 02

Pin	Signal
9	GPRNC2 - General Purpose Relay 4, Normally Closed
10	GPRCOM2 - General Purpose Relay 4, Common
11	GPRNO2 - General Purpose Relay 4, Normally Open
12	Logic ground
15	GPRNC2 - General Purpose Relay 5, Normally Closed
16	GPRCOM2 - General Purpose Relay 5, Common
17	GPRNO2 - General Purpose Relay 5, Normally Open
19	GPRNC2 - General Purpose Relay 6, Normally Closed
20	GPRCOM2 - General Purpose Relay 6, Common
21	GPRNO2 - General Purpose Relay 6, Normally Open
22	GPRNC2 - General Purpose Relay 7, Normally Closed
23	GPRCOM2 - General Purpose Relay 7, Common
24	GPRNO2 - General Purpose Relay 7, Normally Open

General Purpose Serial Interface Connectors

The General Purpose Serial Interface connector provides a General Purpose Serial Interfaces (**GPSI**) for the system. The **GPSI** also provides communications between an optional holdover clock system and the rest of the system.

J76 on **Control Shelf** backplane 04 and J73 on **Control Shelf** backplane 06/07

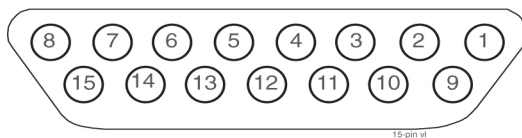
Figure B-33 General Purpose Serial Interface Connector 01, GPSI**Table B-33 General Purpose Serial Interface Connector 01, GPSI**

Pin	Signal
1, 2, 3, 8, 9, 10, 11, 12, 13, 14, 15	Not used
4	RX_HO - Holdover Clock Receive Data
5	TX_HO - Holdover Clock Transmit Data
6	DTR_HO - Holdover Clock Data Terminal Ready

Table B-33 (Cont.) General Purpose Serial Interface Connector 01, GPSI

Pin	Signal
7	Logic ground

Extension Shelf

The extension shelf backplane provides connectors for 18 circuit cards. These connectors are four column High Density Interconnect (**HDI**) male headers with shrouds of varying pin quantities depending on card position. The reverse or component side of the backplane contains **DB** style connectors for interfacing to the rest of the system.

- Power connectors
- System clock connectors
- Interface connectors
- **IMT** connectors

Extension Shelf Backplane 04

Figure B-34 Extension Shelf Backplane 04

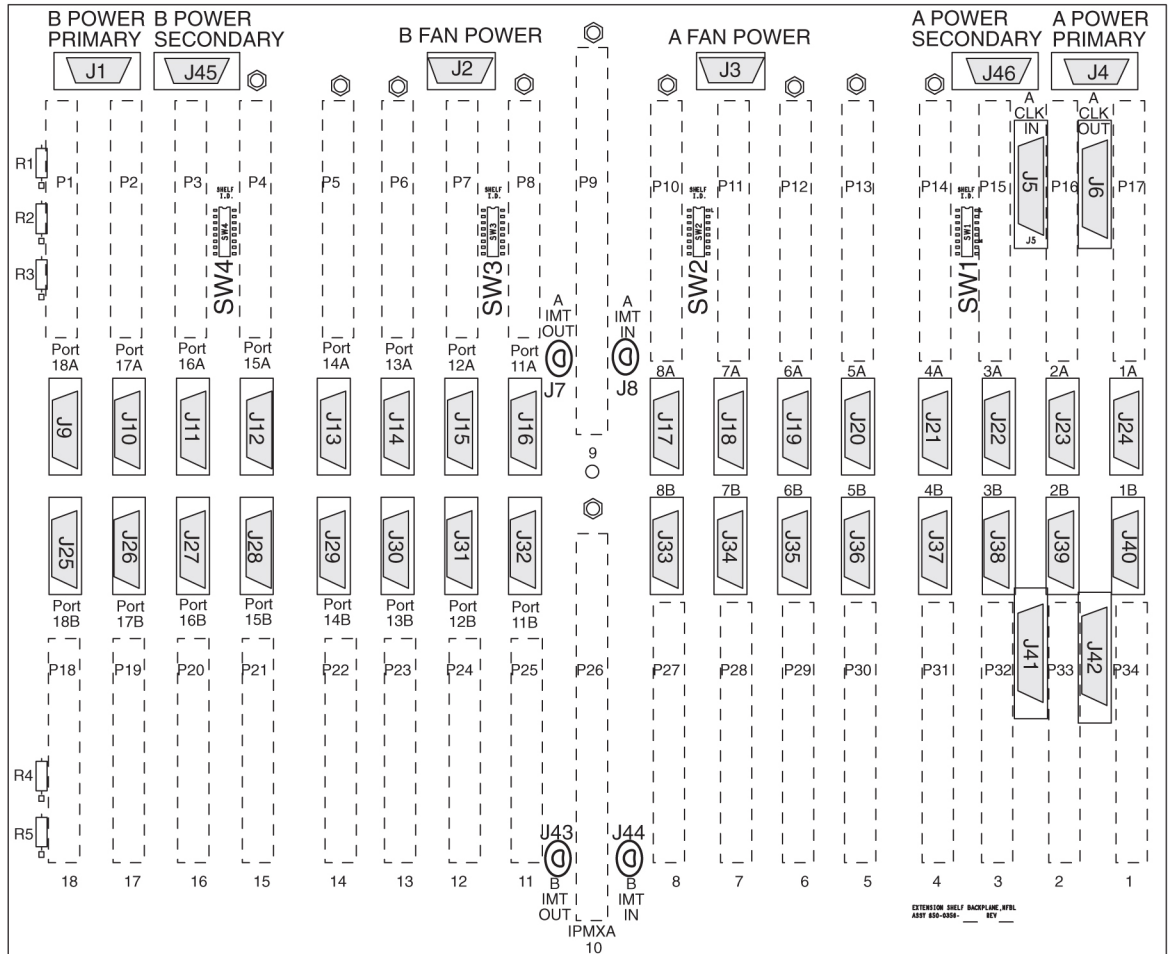

NOTE: Ⓞ Conducts -48VDC for the printed circuit board (HOT)

850-0356-04

Power Connectors

The extension shelf backplane provides -48VDC power and return to all card positions. The power is divided into parts A and B and brought to the shelf from the Fuse and Alarm Panel (FAP) using two cables. The power connectors on the extension shelf backplane are DB-26 high density connectors with two pins per power connection to handle the current load.

J1, J4 on **Extension Shelf** backplane 01

J1, J4, Primary and J45, J46 Secondary on **Extension Shelf** backplane 03

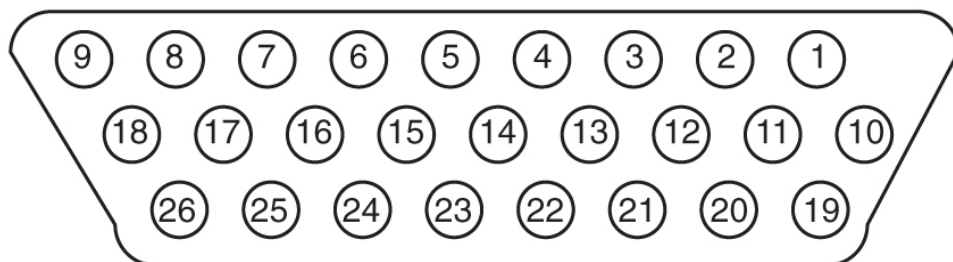
Figure B-35 Power Connector**Table B-34 Power Connector**

Pin	Signal	Pin	Signal
1	P5\$48VDC	14	LGND
2	P5\$48RTN	15	P3\$48RTN
3	P4\$48VDC	16	P3\$48VDC
4	P4\$48RTN	17	P2\$48RTN
5	LGND	18	P2\$48VDC
6	P3\$48RTN	19	P1\$48RTN
7	P3\$48VDC	20	P1\$48RTN
8	P2\$48RTN	21	P1\$48VDC
9	P2\$48VDC	22	P1\$48VDC
10	P5\$48VDC	23	PF\$48RTN
11	P5\$48RTN	24	PF\$48RTN
12	P4\$48VDC	25	PF\$48VDC
13	P4\$48RTN	26	PF\$48VDC

\$= A or B, A POWER (J4) or B POWER (J1)

System Clock Connectors

Each extension shelf receives and passes along Clock signals A (J5 and J6) and B (J41 and J42).

Clock A In Connector J5

Figure B-36 Clock A In Extension Shelf Connector

Table B-35 Clock A In Extension Shelf Connector

Pin	Signal	Pin	Signal
1		14	MA56KHZ+_50
2	MBUSSTX-_50	15	MA56KHZ-_50
3	MBUSSTX+_50	16	MA8KHZ+_50
4	MBUSSRX-_50	17	MA8KHZ-_50
5	MBUSSRX+_50	18	SH2A56KHZ+_50
6	SH2MBUSTX-_50	19	SH2A56KHZ-_50
7	SH2MBUSTX+_50	20	SH2A8KHZ+_50
8	SH2MBUSRX-_50	21	SH2A8KHZ-_50
9	SH2MBUSRX+_50	22	SH3A56KHZ+_50
10	SH3MBUSTX-_50	23	SH3A56KHZ-_50
11	SH3MBUSTX+_50	24	SH3A8KHZ+_50
12	SH3MBUSRX-_50	25	SH3A8KHZ-_50
13	SH3MBUSRX+_50		

Clock A Out Connector J6

Figure B-37 Clock A Out Extension Shelf Connector

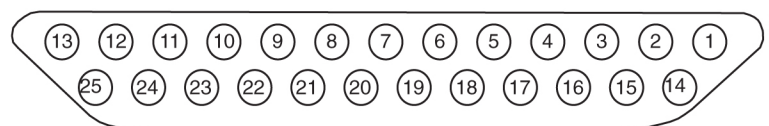
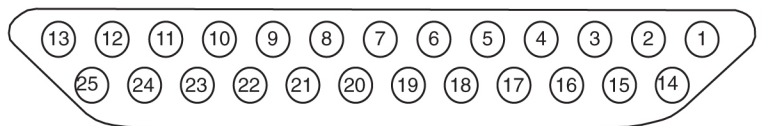

Table B-36 Clock A Out Extension Shelf Connector

Pin	Signal	Pin	Signal
1		14	SH2A56KHZ+_50
2	SH2MBUSTX-_50	15	SH2A56KHZ-_50
3	SH2MBUSTX+_50	16	SH2A8KHZ+_50
4	SH2MBUSRX-_50	17	SH2A8KHZ-_50
5	SH2MBUSRX+_50	18	SH3A56KHZ+_50
6	SH3MBUSTX-_50	19	SH3A56KHZ-_50
7	SH3MBUSTX+_50	20	SH3A8KHZ+_50

Table B-36 (Cont.) Clock A Out Extension Shelf Connector

Pin	Signal	Pin	Signal
8	SH3MBUSRX-_50	21	SH3A8KHZ-_50
9	SH3MBUSRX+_50	22	
10		23	
11		24	
12		25	
13			

Clock B In Extension Shelf Connector J41

Figure B-38 Clock B In Extension Shelf Connector

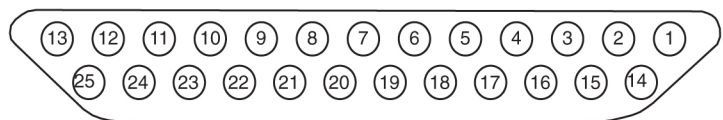

Table B-37 Clock B In Extension Shelf Connector

Pin Number	Signal	Pin Number	Signal
1	FANAALM-	14	MB56KHZ+_50
2		15	MB56KHZ-_50
3		16	MB8KHZ+_50
4		17	MB8KHZ-_50
5		18	SH2B56KHZ+_50
6		19	SH2B56KHZ-_50
7	FANCNTRL	20	SH2B8KHZ+_50
8		21	SH2B8KHZ-_50
9		22	SH3B56KHZ+_50
10		23	SH3B56KHZ-_50
11		24	SH3B8KHZ+_50
12		25	SH3B8KHZ-_50
13	FANBALM-		

Clock B Out Extension Shelf Connector J42

Figure B-39 Clock B Out Extension Shelf Connector

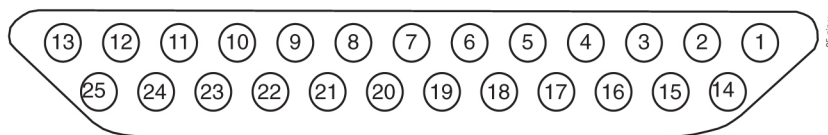

Table B-38 Clock B Out Extension Shelf Connector

Pin Number	Signal	Pin Number	Signal
1	FANAALM	14	SH2B56KHZ+_50
2		15	SH2B56KHZ-_50
3		16	SH2B8KHZ+_50
4		17	SH2B8KHZ-_50
5		18	SH3B56KHZ+_50
6		19	SH3B56KHZ-_50
7	FANCNTRL	20	SH3B8KHZ+_50
8		21	SH3B8KHZ-_50
9		22	
10		23	
11		24	
12		25	
13	FANBALM		

Interface Connectors

Behind each slot on the extension shelf backplane are two DB-26 connectors. These provide connection to the outside world in the form of TCP/IP networks or SS7 links networks. The interface connectors are designated as J9 through J40.

Extension Shelf Interface Connectors J9 through J40

Figure B-40 Extension Shelf Interface Connector

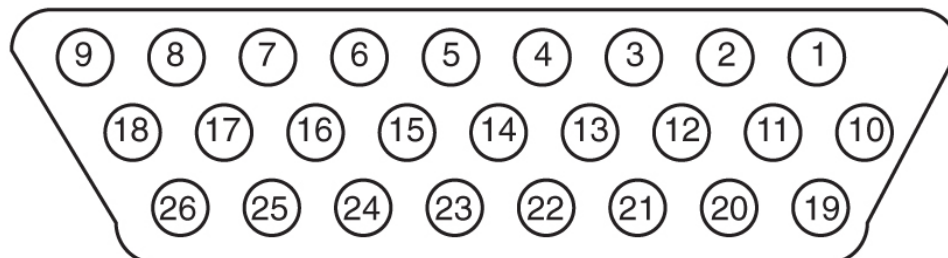

Table B-39 Extension Shelf Interface Connector Pins and Signals

Pin	DS0A/OCU Signal ATM	Pin	DS0A/OCU Signal ATM
1		14	
2		15	
3		16	
4		17	
5		18	
6		19	
7		20	TX-RING
8		21	TX-TIP
9		22	RX-RING
10		23	RX-TIP
11		24	
12		25	
13		26	

Table B-40 Connectors, Ports, and Card Slots

Card Slot	Port	Connector	Port	Connector
01	1A	J24	1B	J40
02	2A	J23	2B	J39
03	3A	J22	3B	J38
04	4A	J21	4B	J37
05	5A	J20	5B	J36
06	6A	J19	6B	J35
07	7A	J18	7B	J34
08	8A	J17	8B	J33
11	9A	J16	9B	J32
12	10A	J15	10B	J31
13	11A	J14	11B	J30

Table B-40 (Cont.) Connectors, Ports, and Card Slots

Card Slot	Port	Connector	Port	Connector
14	12A	J13	12B	J29
15	13A	J12	13B	J28
16	14A	J11	14B	J27
17	15A	J10	15B	J26
18	16A	J9	16B	J25

Extension Shelf Modules

This section details the **Extension Shelf** backplane circuit board pin-outs used for

- Link Interface Module (LIM)
- E5 Interface Modules
- E5-TSM Modules
- E5-SLAN Modules
- E5-STC Modules
- E5-MCPM-B Modules

Refer to [Table B-43](#) for signal symbol values (\$, #, &, @, and ^).

Extension Shelf Backplane Pin-Outs, Top Connector

[Table B-41](#) lists pinouts for **DCM/DSM/LIM/MPL/TSM Extension Shelf Backplane Top Connectors P1 through P8 and P10 through P17.**

Figure B-41 Extension Shelf Backplane Pin-Outs, Top Connector

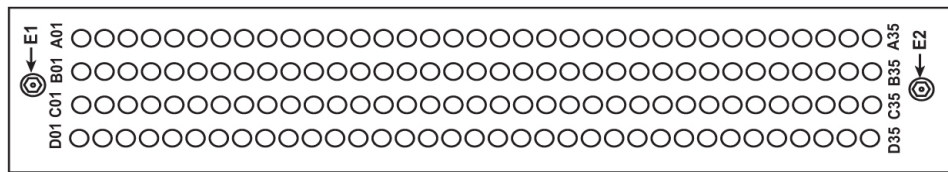

Table B-41 Extension Shelf Backplane Pin-Outs, Top Connector

Pi n	Signal	Pi n	Signal	Pi n	Signal	Pi n	Signal
A 01	LGND	B0 1	LGND	C 01	EBI_ ^XA02	D 01	EBI_ ^XA14
A 02	ASERO#-_50	B0 2	LGND	C 02	EBI_ ^XA03	D 02	EBI_ ^XA15
A 03	ASERO#+_50	B0 3	LGND	C 03	EBI_ ^XA04	D 03	EBI_ ^XA16

Table B-41 (Cont.) Extension Shelf Backplane Pin-Outs, Top Connector

Pin	Signal	Pin	Signal	Pin	Signal	Pin	Signal
A 04	LGND	B0 4	LGND	C 04	EBI_ ^XA05	D 04	EBI_ ^XA17
A 05		B0 5	LGND	C 05	EBI_ ^XA06	D 05	EBI_ ^XA18
A 06		B0 6	LGND	C 06	EBI_ ^XA07	D 06	EBI_ ^XA19
A 07	LGND	B0 7	LGND	C 07	EBI_ ^XA08	D 07	EBI_ ^XA20
A 08	ASEL#-	B0 8		C 08	EBI_ ^XA09	D 08	EBI_ ^XA21
A 09		B0 9		C 09	EBI_ ^XA10	D 09	EBI_ ^XA22
A 10	AMUXIN-	B1 0		C 10		D 10	EBI_ ^XA23
A 11	LGND	B1 1	AIN#-	C 11		D 11	EBI_ ^XA24
A 12		B1 2	LGND	C 12		D 12	EBI_ ^XA25
A 13		B1 3	LGND	C 13		D 13	EBI_ ^XA26
A 14	LGND	B1 4	LGND	C 14		D 14	EBI_ ^XA27
A 15	ASERI#-_50	B1 5	LGND	C 15		D 15	
A 16	ASERI#+_50	B1 6	LGND	C 16		D 16	
A 17	LGND	B1 7	LGND	C 17		D 17	
A 18		B1 8		C 18		D 18	
A 19	LGND	B1 9	MBUSSRX+_50	C 19	LGND*	D 19	
A 20		B2 0	MBUSSRX-_50	C 20		D 20	LGND

Table B-41 (Cont.) Extension Shelf Backplane Pin-Outs, Top Connector

Pi n	Signal	Pi n	Signal	Pi n	Signal	Pi n	Signal
A 21	LGND	B2 1	MBUSSTX+_50	C 21	MA56KHZ+_50	D 21	
A 22		B2 2	MBUSSTX-_50	C 22	MA56KHZ-_50	D 22	LGND
A 23	LGND	B2 3		C 23	MA8KHZ+_50	D 23	
A 24	&-IF1_60	B2 4		C 24	MA8KHZ-_50	D 24	LGND
A 25	LGND	B2 5		C 25	EBI_^XSP4	D 25	EBI_^XSP5
A 26	&-IF2_60	B2 6		C 26	EBI_^XA11	D 26	
A 27	LGND	B2 7		C 27	EBI_^XA12	D 27	
A 28	&-IF3_60	B2 8	&-IF10_60	C 28	EBI_^XA13	D 28	LGND
A 29	LGND	B2 9	&-IF19_60	C 29	EBI_^BREQ-	D 29	
A 30	&-IF4_60	B3 0	&-IF20_60	C 30	EBI_^BG-	D 30	LGND
A 31	&-IF5_60	B3 1	&-IF21_60	C 31	EBI_^XIRQ-	D 31	
A 32	&-IF6_60	B3 2	&-IF22_60	C 32	EBI_^HOSTSA N-	D 32	LGND
A 33	&-IF7_60	B3 3	&-IF23_60	C 33	EBI_^GSTSAN-	D 33	
A 34	&-IF8_60	B3 4	&-IF25_60	C 34	&-IF24_60	D 34	LGND
A 35	&-IF9_60	B3 5	&-IF18_60	C 35	&-IF26_60	D 35	

E2 LGND *Connection to logic ground for slots 2 (P16), 4 (P14), 6 (P12), 8 (P10) only.

Extension Shelf Backplane Pin-Outs, Bottom Connector

Table B-42 lists Pinouts for DCM/DSM/LIM/MPL/TSM Extension Shelf Backplane Bottom Connectors P18 through P25, and P27 through P34.

Figure B-42 Extension Shelf Backplane Pin-Outs, Bottom Connector



Table B-42 Extension Shelf Backplane Pin-Outs, Bottom Connector

Pi n	Signal	Pi n	Signal	Pi n	Signal	Pi n	Signal
A 01	LGND	B0 1	&-IF1_60	C 01	&-IF10_60	D 01	IN2-
A 02	&-IF3_60	B0 2	&-IF2_60	C 02	&-IF19_60	D 02	LGND
A 03	LGND	B0 3		C 03	&-IF20_60	D 03	LGND
A 04	&-IF4_60	B0 4		C 04	&-IF21_60	D 04	LGND
A 05	&-IF5_60	B0 5		C 05	&-IF22_60	D 05	LGND
A 06	&-IF6_60	B0 6	&-IF24_60	C 06	&-IF23_60	D 06	LGND
A 07	&-IF7_60	B0 7	&-IF26_60	C 07		D 07	@-IF25_60
A 08	&-IF8_60	B0 8	&-IF9_60	C 08	&-IF18_60	D 08	LGND
A 09	LGND	B0 9		C 09		D 09	LGND
A 10		B1 0		C 10	EBI_^XSP2	D 10	EBI_^XSP3
A 11	LGND	B1 1	LGND	C 11	EBI_^XBE0-	D 11	EBI_^XD00
A 12	BSERO@-_50	B1 2	LGND	C 12	EBI_^XBE1-	D 12	EBI_^XD01
A 13	BSERO@-_50	B1 3	LGND	C 13	EBI_^XBE2-	D 13	EBI_^XD02
A 14	LGND	B1 4	LGND	C 14	EBI_^XBE3-	D 14	EBI_^XD03

Table B-42 (Cont.) Extension Shelf Backplane Pin-Outs, Bottom Connector

Pi n	Signal	Pi n	Signal	Pi n	Signal	Pi n	Signal
A 15		B1 5	LGND	C 15	EBI_^XBS8-	D 15	EBI_^XD04
A 16		B1 6	LGND	C 16	EBI_^XBS16-	D 16	EBI_^XD05
A 17	LGND	B1 7	LGND	C 17	EBI_^ADS0-	D 17	EBI_^XD06
A 18	BSEL@-	B1 8		C 18	EBI_^ADS1-	D 18	EBI_^XD07
A 19		B1 9		C 19	EBI_^XW/R	D 19	EBI_^XD08
A 20	BMUXIN-	B2 0		C 20	EBI_^XM/IO	D 20	EBI_^XD09
A 21	LGND	B2 1	BIN@-	C 21	EBI_^XSP1	D 21	EBI_^XD10
A 22		B2 2	LGND	C 22	EBI_^XINTA-	D 22	EBI_^XD11
A 23		B2 3	LGND	C 23	EBI_^XRDY-	D 23	EBI_^XD12
A 24	LGND	B2 4	LGND	C 24	EBI_^XCAS0-	D 24	EBI_^XD13
A 25	BSERI@-_50	B2 5	LGND	C 25	EBI_^XCAS1-	D 25	EBI_^XD14
A 26	BSERI@+_50	B2 6	LGND	C 26	EBI_^XCAS2-	D 26	EBI_^XD15
A 27	LGND	B2 7	LGND	C 27		D 27	
A 28		B2 8		C 28		D 28	LGND
A 29	LGND	B2 9		C 29		D 29	
A 30		B3 0		C 30		D 30	LGND
A 31	LGND	B3 1		C 31	MB56KHZ+_50	D 31	

Table B-42 (Cont.) Extension Shelf Backplane Pin-Outs, Bottom Connector

Pin	Signal	Pin	Signal	Pin	Signal	Pin	Signal
A 32		B3 2		C 32	MB56KHZ-_50	D 32	LGND
A 33	LGND	B3 3		C 33	MB8KHZ+_50	D 33	
A 34		B3 4		C 34	MB8KHZ-_50	D 34	LGND
A 35	CHASSIS GND	B3 5	CHASSIS GND	C 35	CHASSIS GND	D 35	CHASSIS GND
E1	P\$48VDC						
E2	LGND						

Extension Shelf Backplane Pin-Out Symbols

Table B-43 lists the signal symbol values used in Table B-23 through Table B-43.

Table B-43 Extension Shelf Backplane Pin-Out Symbols

Slot/Connector	Interface	Address	Signal Symbol Values				
			\$	#	&	@	^
1 top / P17	0A	0	1A	P	0A		0
1 bottom / P34	0B	0	1A	P	0B	A	0
2 top / P16	1A	1	1A	O	1A		0
2 bottom / P33	1B	1	1A	O	1B	B	0
3 top / P15	2A	2	1B	N	2A		2
3 bottom / P32	2B	2	1B	N	2B	C	2
4 top / P14	3A	3	1B	M	3A		2
4 bottom / P31	3B	3	1B	M	3B	D	2
5 top / P13	4A	4	2A	L	4A		4
5 bottom / P30	4B	4	2A	L	4B	E	4
6 top / P12	5A	5	2A	K	5A		4
6 bottom / P29	5B	5	2A	K	5B	F	4
7 top / P11	6A	6	2B	J	6A		6

Table B-43 (Cont.) Extension Shelf Backplane Pin-Out Symbols

Slot/Connector	Interface	Addresses	Signal Symbol Values				
			\$	#	&	@	^
7 bottom / P28	6B	6	2B	J	6B	G	6
8 top / P10	7A	7	2B	I	7A		6
8 bottom / P27	7B	7	2B	I	7B	H	6
11 top / P8	8A	8	4A	H	8A		8
11 bottom / P25	8B	8	4A	H	8B	I	8
12 top / P7	9A	9	4A	G	9A		8
12 bottom / P24	9B	9	4A	G	9B	J	8
13 top / P6	10A	A	4B	F	10A		A
13 bottom / P23	10B	A	4B	F	10B	K	A
14 top / P5	11A	B	4B	E	11A		A
14 bottom / P22	11B	B	4B	E	11B	L	A
15 top / P4	12A	C	5A	D	12A		C
15 bottom / P21	12B	C	5A	D	12B	M	C
16 top / P3	13A	D	5A	C	13A		C
16 bottom / P20	13B	D	5A	C	13B	N	C
17 top / P2	14A	E	5B	B	14A		E
17 bottom / P19	14B	E	5B	B	14B	O	E
18 top / P1	15A	F	5B	A	15A		E
18 bottom / P18	15B	F	5B	A	15B	P	E

Interprocessor Message Transport Connectors

The extension shelf backplane provides connections for the two high speed Interprocessor Message Transport (IMT) buses. The connections use twin-axial type connectors at J7, J8, J43, and J44.

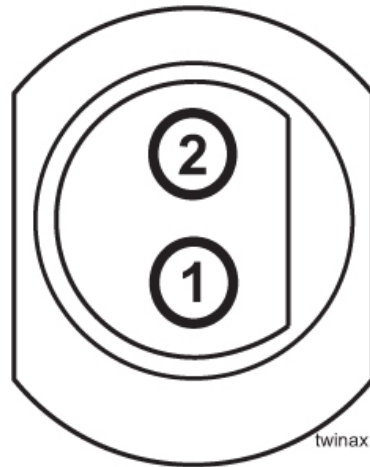
Figure B-43 IPMX Connector**Table B-44 IPMX Connector**

Connector	Pin	Signal
A IMT IN J8	1	AIMTIN+_78
	2	AIMTIN+_78
A IMT OUT J7	1	AIMTOUT+_78
	2	AIMTOUT+_78
B IMT IN J44	1	BIMTIN+_78
	2	BIMTIN+_78
B IMT OUT J43	1	BIMTOUT+_78
	2	BIMTOUT+_78

Cables and Adapters

Labeling Cables

This section provides general labeling instructions for cables.

Before installing any cable use this procedure to label the cables to ensure connection to the proper ports and ease of future maintenance.

warning: The intra-building port(s) of the equipment or subassembly is suitable for connection to intra-building or unexposed wiring or cabling only. The intra-building port(s) of the equipment or subassembly **MUST NOT** be metalically connected to interfaces that connect to the Outside Plant (OSP) or its wiring. These interfaces are designed for use as intra-building interfaces only (Type 2 or Type 4 ports as described in GR-1089-CORE, Issue 4) and require isolation from the exposed OSP cabling. The addition of Primary Protectors is not sufficient protection in order to connect these interfaces metalically to OSP wiring.

Recommended Tools

- Installer's Cable Running List
- All cables listed in Installer's Cable Running List
- Any non-Oracle cables
- Cable labels (including blank labels for non-Oracle cables)
- Fine point marker

Procedure - Cable Labeling

Perform this procedure to label cables.

1. Locate the Installer's Cable Running List in the *Equipment Specification* for the site.

Refer to [Figure C-1](#) for an example.

Figure C-1 Installer's Cable Running List Example

INSTALLER'S CABLE RUNNING LIST									
ITEM	FEET	CA QTY or PART NO.	CABLE TYPE or PART NO.	CKT NO.	FROM	TO (FRAME)	TO (LOCATION)	LED DESIG.	TERM
8.0 LINK INTERCONNECTS, CONTROL FRAME [CF-00], EXTENSION SHELF [SH2]									
8.01	35	32 1	830-1149-02	1201A	CF-00 [105.09] SH2 J24	RR 106.03	PNL 1 JK 13	T,R(XMT) T1,R1(RCV)	
8.02	35	32 2	830-1149-02	1201B	CF-00 [105.09] SH2 J40	RR 106.03	PNL 1 JK 14	T,R(XMT) T1,R1(RCV)	

2. Locate the labels included with the cable shipment.
3. Take one cable and identify the cable's part number in the *Cable Type* column of the cable running list.
4. Match the cable with its corresponding pair of labels:
 - a. Go to the cable's *From* column of the cable running list.
 - b. Match the *From* column information to the *From* information on one label.
 - c. Match the *From* column information to the *To* information on the other label.

Note: The label for the connector end of these cables can be identified by the presence of a "J" number, for example: J32, that appears in the "From" area of the label.

Note: Make sure that all cables specific to an A or B side are clearly labeled as A cable and B cable.

5. Repeat 4 for each cable to ensure that all labels are present and that originations and destinations of all cables are clearly identified.
6. For cables that come from the factory with connectors already installed, apply the appropriate label onto each end of the cable approximately two inches from the connector.

Note: Ensure that the labels are positioned so they are still readable after the cables are installed.

7. For cables that need to be cut to the appropriate length: After the cable is cut to the appropriate length, affix labels with the item number approximately two inches from the end of the cable insulation.
8. For cables not ordered through Oracle, confirm source, part number, and origination/destination points before labeling them.

Note: All cables must be labeled with "TO" and "FROM" destinations

After you have labeled all cables, you are ready for cable installation.

Cables and Adapters

Cables and adapters are listed in alphabetical order.

The words **NOT TERMINATED** or **UNTERMINATED** refers to the end of the cable that is not equipped with a connector in manufacturing and the wires must be cut, dressed, and connected at the site specific location.

Cable and Adapter Use

Table C-1 shows the cables and adapters used for E5-type cards in new installations in a vacant uncabled slot in a shelf.

Note: References to E5- type cards include E5-B type cards.

Note: Exceptions, additions, and clarifications to the following tables are by superscript numeric notation relating to the listed notes located at the end of this section. The notations are indicated as a numbered step reference (such as 1) which corresponds to the appropriate note which is shown at the end of this section. For example, a table cell with X^{1,2} would indicate that notes 1 and 2 are applicable to that component.

Table C-1 Cable/Adapter Use - New Installation

Card P/N	Application	Adapter	Qty	Cable	Qty
E5-E1T1-B 870-2970-xx	E1	No adapters required		830-1132-XX or non-ROHS 830-0011-XX ⁵	1
	T1	No adapters required		7112462 830-1197-XX or non-ROHS 830-0949-XX	2
E5-ENET-B 870-2971-xx	IPLIM	830-1102-XX	2	830-1174-XX or non-ROHS 870-0724-XX	2
	IPGW IPSG SLAN STC	OR 830-1103-XX	2	830-1204-XX or non-ROHS 830-0978-XX ²	2
	FAST COPY	830-1343-01 ³	1	830-1204-XX or non-ROHS 830-0978-XX	1

Table C-1 (Cont.) Cable/Adapter Use - New Installation

Card P/N	Application	Adapter	Qty	Cable	Qty
				830-1174-XX or non-ROHS 870-0724-XX	1
		AND 830-1343-02 ⁴	1	830-1204-XX or non-ROHS 830-0978-XX	1
				830-1174-XX or non-ROHS 870-0724-XX	1
		OR 830-1102-XX	2	830-1174-XX or non-ROHS 870-0724-XX	4
E5-SM8G-B 870-2990-01	SCCP (ExAP Interface)	830-1104-XX	2	830-1174-XX or non-ROHS 870-0724-XX	2
	GTT	No adapters required		No cables required	
E5-ENET-B 870-2971-xx	IPSM	OR 830-1103-XX	1	830-1204-XX or non-ROHS 830-0978-XX	1
E5-ATM-B 870-2972-01	ATM-T1	No adapters required		7112462 830-1197-XX or non-ROHS 830-0949-XX ⁵	1
	ATM-E1	No adapters required		830-1132-XX or non-ROHS 830-0011-XX ⁵	1
	ATM-T1	830-1342-05 OR 830-1342-06	1	7112462 830-1197-XX or non-ROHS 830-0949-XX ⁶	2
	ATM-E1	830-1342-05 OR 830-1342-06	1	830-1132-XX or non-ROHS 830-0011-XX ⁶	2

Table C-1 (Cont.) Cable/Adapter Use - New Installation

Card P/N	Application	Adapter	Qty	Cable	Qty
E5-MASP 7346924 870-2903-xx	OAM	830-1333-02	1		
E5-MCPM-B	MCP	830-1102-XX	1	830-1174-XX or non-ROHS 870-0724-XX	1
SLIC 7094646	ENUM DEIR SIP SCCP (ExAP Interface) STPLAN	830-1102-03	2	830-1174-XX CAT6A 830-1404-xx	2
	IPSG	830-1102-03	2	830-1174-XX CAT6A 830-1404-xx	4
	IPS MCP STC	830-1102-03	1	830-1174-XX	1
	GTT	No adapters required		No cables required	
SLIC 7094646	E1	No adapters required		830-1132-XX or non-ROHS 830-0011-XX ⁵	1
	T1	No adapters required		7112462 830-1197-XX or non-ROHS 830-0949-XX	2

Notes:

- All references to ROHS are ROHS compliant.
- If these older cables exist, they may be used in lieu of newer cables.
 - Non-ROHS 830-0788-XX/ROHS 830-1177-XX DB26 – RJ45 (Straight thru Shielded)
 - Non-ROHS 830-0789-XX/ROHS 830-1178-XX DB26 – RJ45 (Crossover Shielded)
- Backplane connector A (must be used with adapter 870-1343-02).

4. Backplane connector B (must be used with adapter 870-1343-01).
5. This configuration is used if both ATM links in one cable.
6. This configuration is used if the A and the B port to carry the ATM links over 2 cables.
7. LNP Node 384 Million or ELAP 8.0 .
8. Existing cables must be replaced with 830-1174-XX or non-ROHS 870-0724-XX.
9. ADD 830-1132-xx cable to drop the second physical port to the B port.
10. ADD 830-1184-xx or 830-1197-XX to drop the second physical port to the B port.

Alarm Cable (Holdover Clock)

Figure C-2 Holdover Clock Alarm Cable

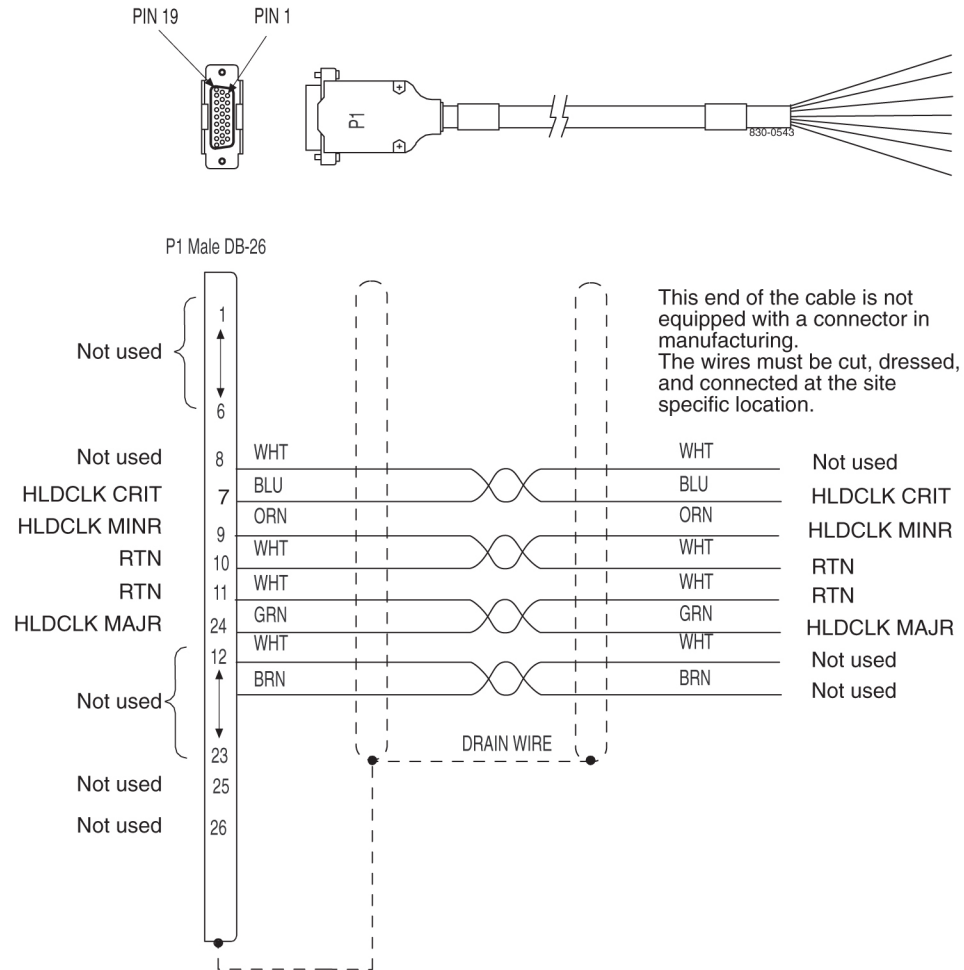

Alarm NETRA Server Cable (P/N 830-0900-xx)

Table C-2 Alarm NETRA Server Cable (P/N 830-0900-xx)

Part Number	Length
830-0900-01	50.0 FT
830-0900-02	75.0 FT
830-0900-03	100.0 FT
830-0900-04	125.0 FT
830-0900-05	150.0 FT
830-0900-06	175.0 FT
830-0900-07	200.0 FT

Figure C-3 Alarm NETRA Server Cable

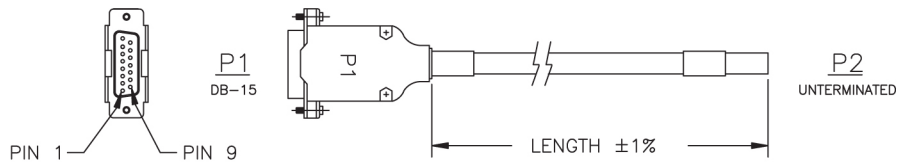

830-0900-XX

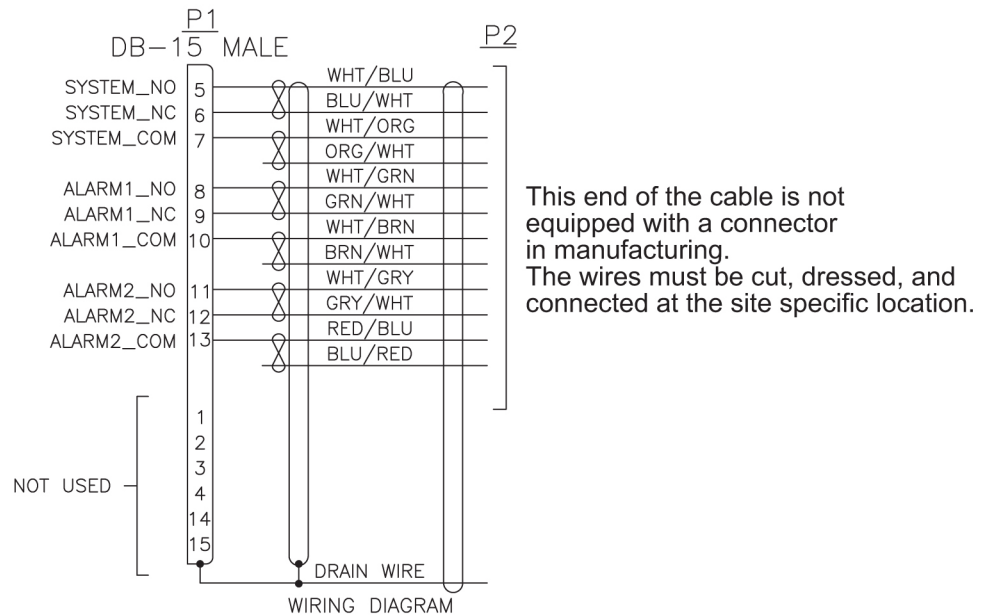

B-Clock Cable**Table C-3 Clock Cable**

Part Number		Length (inches)	Part Number		Length (inches)
North American	International		North American	International	
830-0398-01	830-1150-01	96	830-0398-12	--	164
830-0398-02	--	144	830-0398-13	830-1150-13	176
830-0398-03	--	192	830-0398-14	830-1150-14	208
830-0398-04	830-1150-04	240	830-0398-15	--	224
830-0398-05	--	288	830-0398-16	--	232
830-0398-06	830-1150-06	360	830-0398-17	830-1150-17	252
830-0398-07	--	18	830-0398-18	--	272
830-0398-08	--	48	830-0398-19	830-1150-19	284
830-0398-09	--	84	830-0398-20	830-1150-20	52
830-0398-10	830-1150-10	116	830-0398-21	830-1150-21	78
830-0398-11	830-1150-11	132			

Figure C-4 Clock Cable

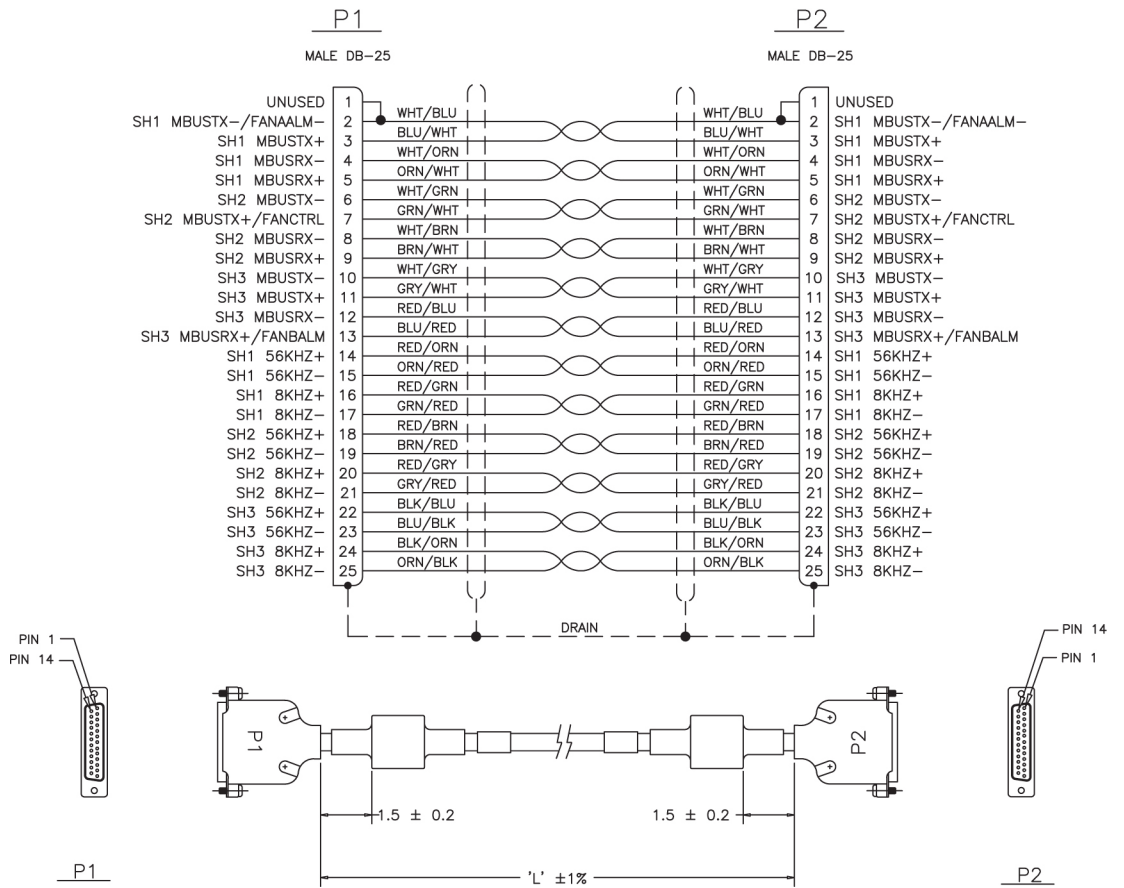

BNC- to-BNC Cable Assembly (P/N 830-0624-xx)

Table C-4 BNC to BCN Cable Assembly (P/N 830-0624-xx)

Part Number	Length (FT)
830-0624-01	15.0
830-0624-02	25.0
830-0624-03	50.0
830-0624-04	75.0
830-0624-05	100.0
830-0624-06	125.0
830-0624-07	150.0
830-0624-08	175.0
830-0624-09	200.0
830-0624-10	250.0
830-0624-11	300.0
830-0624-12	500.0

Table C-4 (Cont.) BNC to BCN Cable Assembly (P/N 830-0624-xx)

Part Number	Length (FT)
830-0624-13	1000.0

Figure C-5 BNC to BCN Cable Assembly (P/N 830-0624-xx)

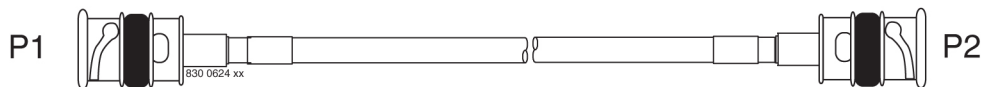

BNC/Open End Cable

Table C-5 BNC/Open End Cable

Part Number		Length	
North American	International	feet	meters
830-0625-01	830-1161-01	15	4.57
830-0625-02	830-1161-02	25	7.62
830-0625-03	830-1161-03	50	15.24
830-0625-04	830-1161-04	75	22.86
830-0625-05	830-1161-05	100	30.48
830-0625-06	830-1161-06	125	38.10
830-0625-07	830-1161-07	150	45.72
830-0625-08	830-1161-08	175	53.34
830-0625-09	830-1161-09	200	60.96
830-0625-10	830-1161-10	250	76.2
830-0625-11	830-1161-11	300	91.44
830-0625-12	830-1161-12	500	152.4
830-0625-13	830-1161-13	1000	304.8

Figure C-6 BNC/Open End Cable

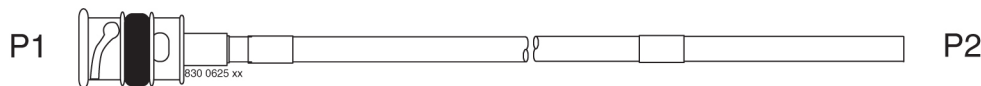

Breaker-to-Terminal Strip Power Cable

Table C-6 Power Cable to Breaker Strip

Part Number		Length		P1 Long Lead	P2 Long Lead	Label "A" usage	Label "B" usage
North American	Internationa l	Inches	Meters				
830-0866-01	830-1236-01	48.5	14.78	Black	Red	BP-1, POS 1B	TB1, POS 3 and 4
830-0866-02	830-1236-02	51.5	15.69	Black	Black	BP-2, POS 1B	TB2, POS 3 and 4
830-0866-03	830-1236-03	53.5	16.30	Black	Red	BP-1, POS 1A	TB3, POS 3 and 4
830-0866-04	830-1236-04	46.5	14.17	Black	Black	BP-2, POS 1B	TB4, POS 3 and 4
830-0866-05	---	86.0	26.21	Black	Red	BP-2, POS 3B	TB2, POS 3 and 4
830-0866-06	---	88.0	88.0	Black	Black	BP-1, POS 3A	TB3, POS 3 and 4

Figure C-7 Power Cable to Breaker Strip

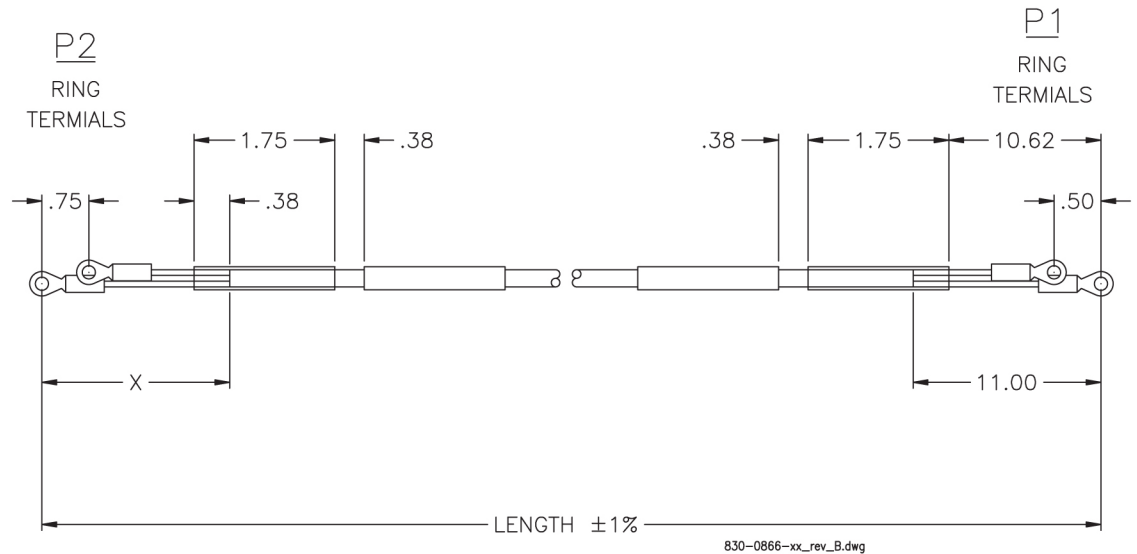

CD ROM Cable

Figure C-8 CD ROM Cable

PART NUMBER	LENGTH	
	INCHES	CENTIMETERS
830-0421-01	3.50	8.87
830-0421-02	2.50	6.33

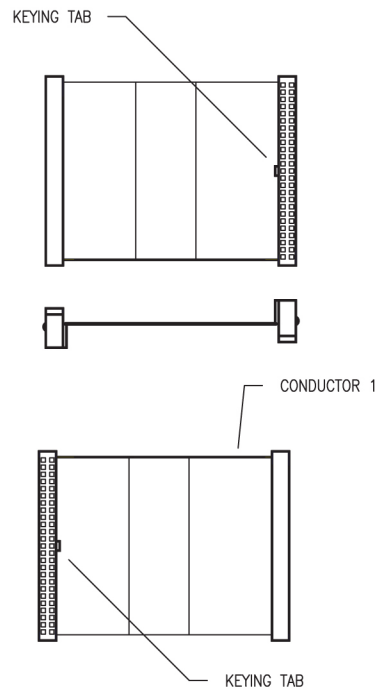

830-0421-XX

Converter

This straight through converter is a purchased part. There is no illustration or wiring diagram.

Crossover (CAT-5) Cable

Table C-7 Crossover CAT-5 Cable

Part Number		Length	
North American	International	meters	feet
830-0723-01	830-1173-01	0.30	1
830-0723-02	830-1173-02	0.90	3
830-0723-03	830-1173-03	1.37	4.5
830-0723-xx	830-1173-xx	available in many more lengths	

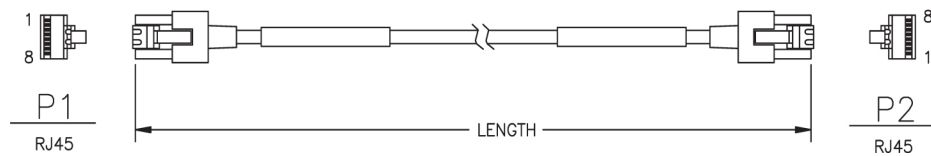
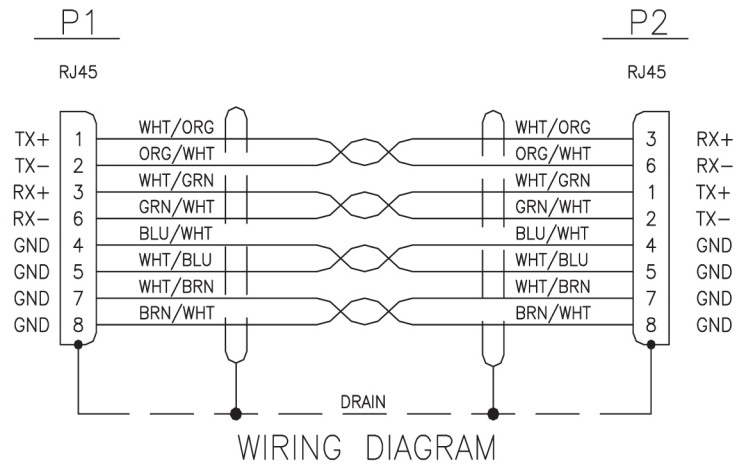
Figure C-9 Crossover CAT-5 Cable**Crossover DCM Patch Panel Cable****Table C-8 Crossover DCM Patch Panel Cable**

Part Number		Length	
North American	International	feet	meters
830-0789-01	830-1178-01	15	4.57
830-0789-02	830-1178-02	25	7.62
830-0789-03	830-1178-03	35	10.67
830-0789-04	830-1178-04	50	15.25
830-0789-05	830-1178-05	75	45.75
830-0789-06	830-1178-06	100	30.50
830-0789-07	830-1178-07	150	45.75
830-0789-08	830-1178-08	200	60.10
830-0789-09	830-1178-09	250	76.25
830-0789-10	830-1178-10	328	107.54

Figure C-10 Crossover DCM Patch Panel Cable

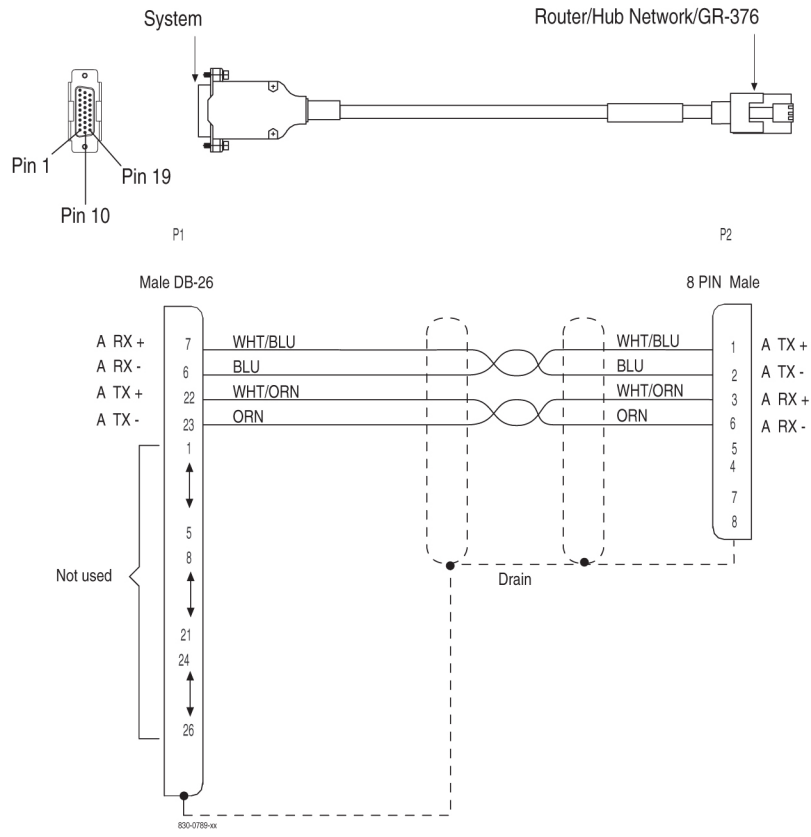

DCM, 100-BASE TX Interface

Figure C-11 DCM, 100-BASE TX Interface

DASH NUMBER	LENGTH	
	FEET	METERS
830-0711-01	15	4.57
830-0711-02	25	7.62
830-0711-03	35	10.66
830-0711-04	50	15.24
830-0711-05	75	22.86
830-0711-06	100	30.48
830-0711-07	150	45.72
830-0711-08	200	60.96
830-0711-09	250	76.2
830-0711-10	328	99.99

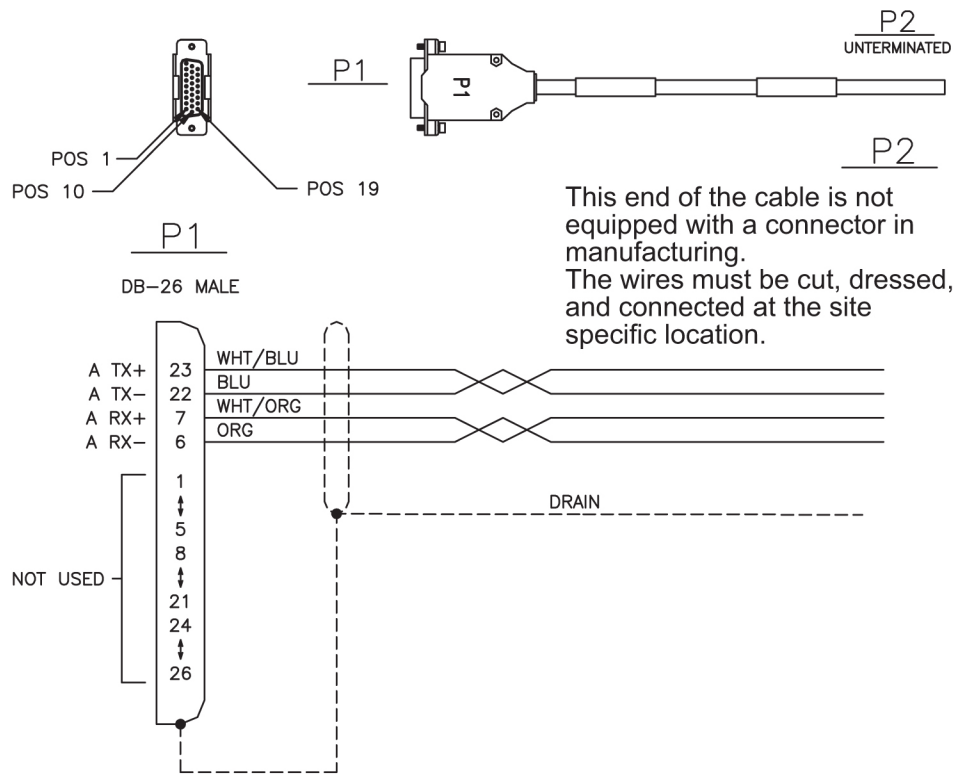

Drive Power Cable

Figure C-12 Drive Power Cable

PART NUMBERS	INCHES	CENTIMETERS
830-0224-01	4.50	11.41
830-0224-02	3.50	8.87

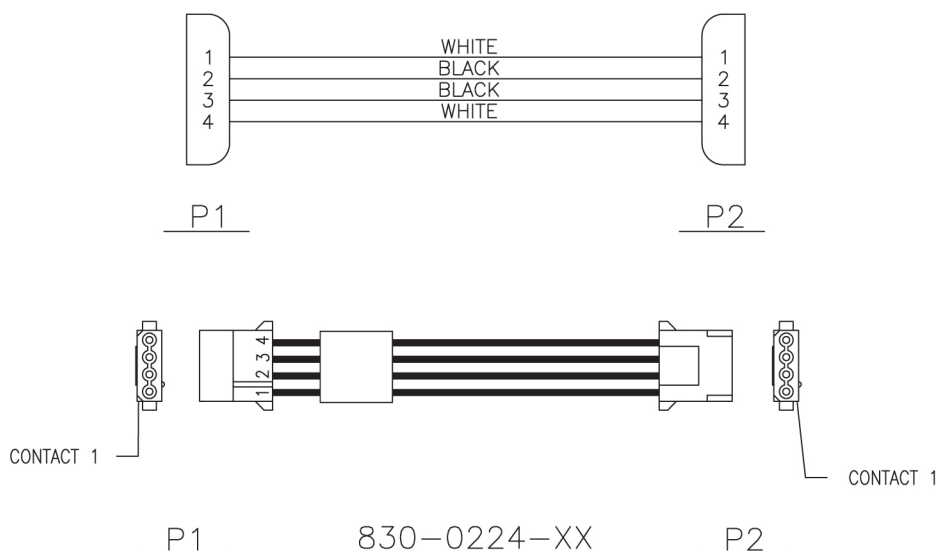

DS1 Cable

Table C-9 DS1 Cable

Part Number		Length	
North American	International	feet	meters
830-0849-01	830-1184-01	15	4.57
830-0849-02	830-1184-02	20	6.09
830-0849-03	830-1184-03	25	7.62
830-0849-04	830-1184-04	30	9.14
830-0849-05	830-1184-05	35	10.66
830-0849-06	830-1184-06	50	15.24
830-0849-07	830-1184-07	75	22.86
830-0849-08	830-1184-08	100	30.48
830-0849-09	830-1184-09	125	38.10
830-0849-10	830-1184-10	150	45.72

Table C-9 (Cont.) DS1 Cable

Part Number		Length	
North American	International	feet	meters
830-0849-11	830-1184-11	175	53.34
830-0849-12	830-1184-12	200	60.96
830-0849-13	830-1184-13	250	76.20
830-0849-14	830-1184-14	300	91.44
830-0849-15	830-1184-15	500	152.40
830-0849-16	830-1184-16	650	198.12

Figure C-13 DS1 Cable DS1 Cable

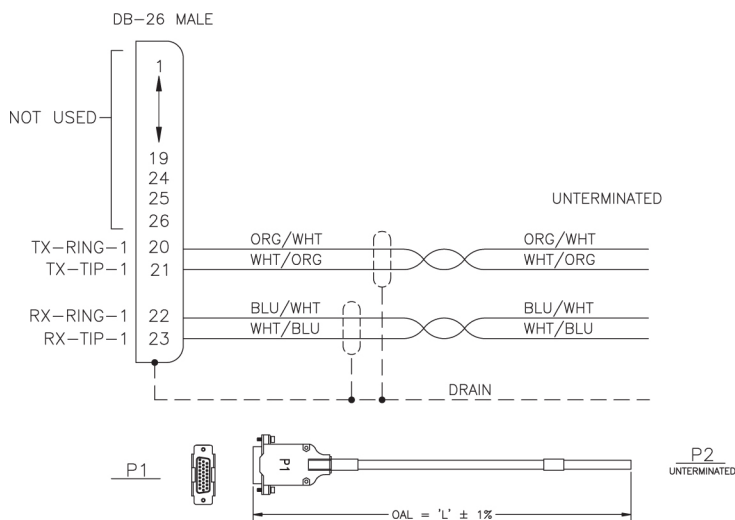

E1 Cable

Table C-10 E1 Cable

Part Number		Length		Part Number		Length	
North American	International	feet	meters	North American	International	feet	meters
830-0622-01	830-1233-01	15	4.57	830-0622-08	830-1233-08	175	53.34
830-0622-02	830-1233-02	25	7.62	830-0622-10	830-1233-09	200	60.96
830-0622-03	830-1233-03	50	15.24	830-0622-11	830-1233-10	250	76.20
830-0622-04	830-1233-04	75	22.86	830-0622-12	830-1233-11	300	91.44
830-0622-05	830-1233-05	100	30.48	830-0622-13	830-1233-12	500	152.40

Table C-10 (Cont.) E1 Cable

Part Number		Length		Part Number		Length	
North American	International	feet	meters	North American	International	feet	meters
830-0622-06	830-1233-06	125	38.10	830-0622-14	830-1233-13	1000	304.8
830-0622-07	830-1233-07	150	45.72	830-0622-15	830-1233-15	400	121.92

Figure C-14 E 1 Cable

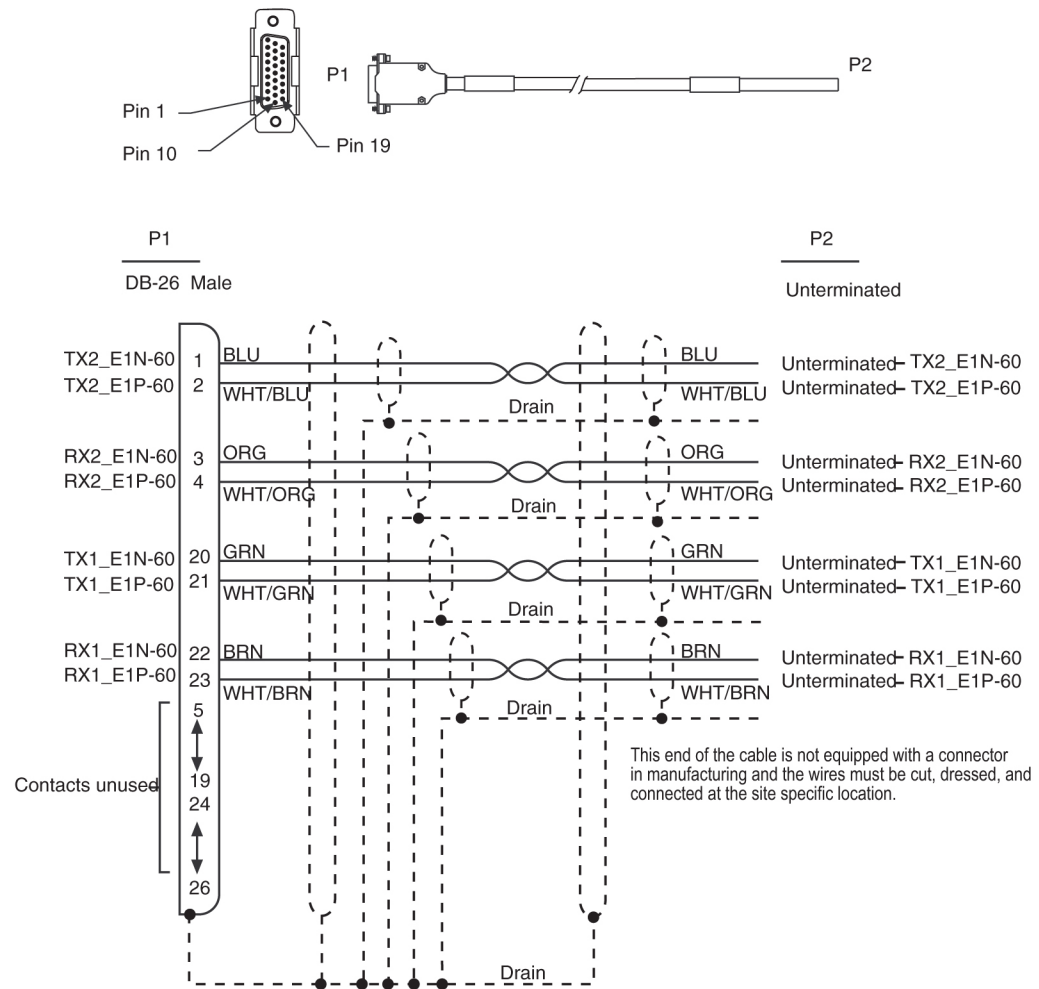

E1 Patch Cable

Table C-11 E1 Patch Cable

Part Number		Length	
North American	International	Inches	Centimeters
830-0605-01	--	12	30.48

Table C-11 (Cont.) E1 Patch Cable

Part Number		Length	
North American	International	Inches	Centimeters
830-0605-02	830-1116-02	15	38.1

Figure C-15 E1 Patch Cable

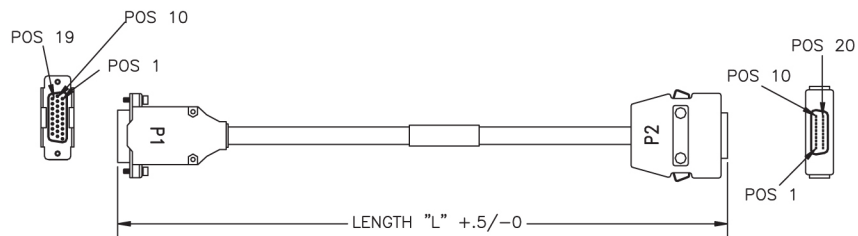
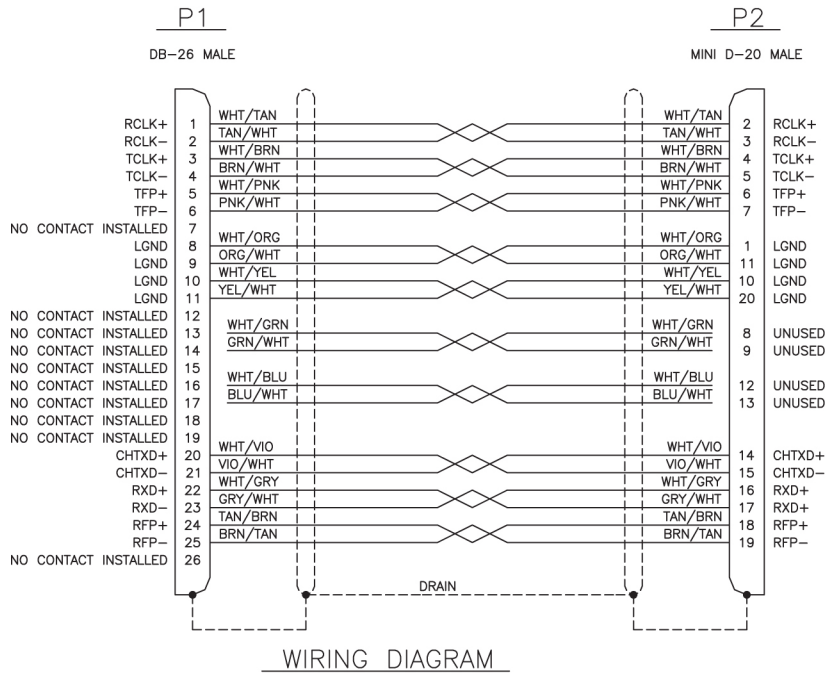

E5-ATM Adapter

Figure C-16 E5-ATM Adapter

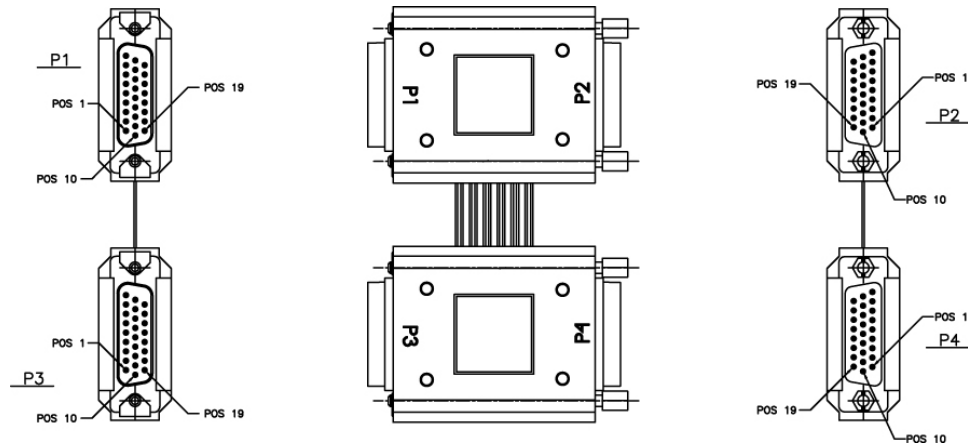

E5-ENET ADAPTER (DB26 Male-to-Dual RJ45)

The Ethernet cable pinouts differ between the **E5-ENET** card and the **DCM** or single-slot **EDCM** cards.

Adapter 830-1102-02 is required for installation of the **E5-ENET** when the **DCM** cable is replaced with a **CAT5** straight-through cable 830-0724-xx. The adapter is connected to the backplane and the **CAT5** straight-through cable cable is connected from the other side of the adapter to a switch, or a hub, or a patch panel (same place the **DCM** cable was terminated). If the card inserted into the slot does not match the backplane connector, the interface will not function.

Figure C-17 DB26 Male to Dual RJ45 Adapter

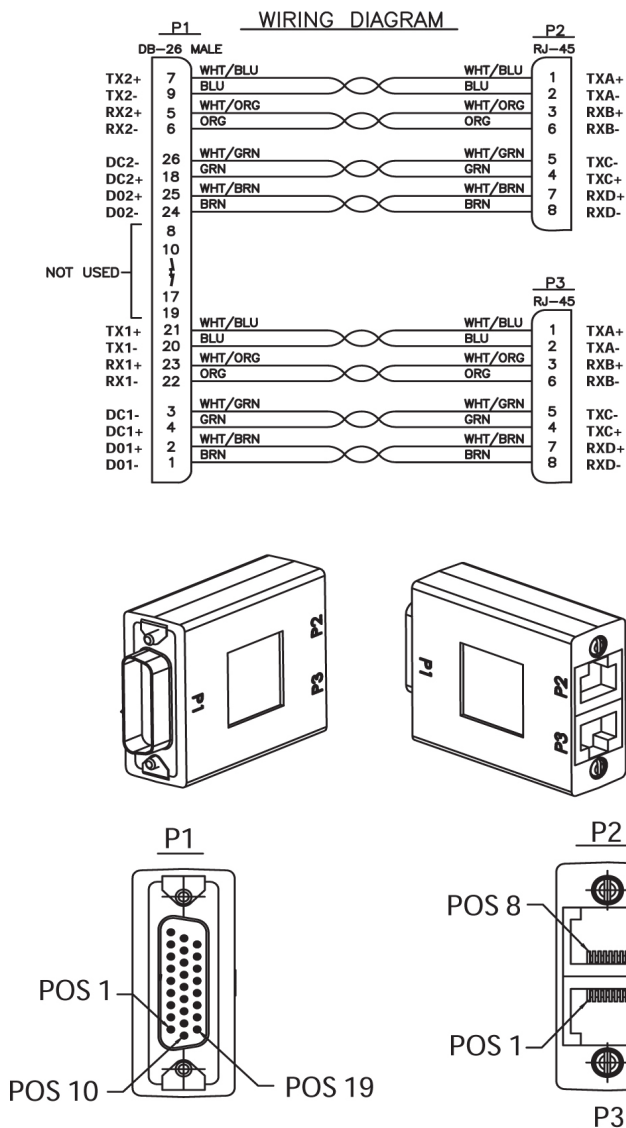

E5-ENET ADAPTER (DB26 Male-to-DB26 Female)

The Ethernet cable pinouts differ between the **E5-ENET** card and the **DCM** or single-slot **EDCM** cards.

Adapter 830-1103-02 is required for each **E5-ENET** interface used when using the existing **DCM** cable 830-0978-xx. The adapter is connected between the backplane connector and the existing **DCM** cable for the card.

Figure C-18 DB26 Male-to-DB26 Female Adapter

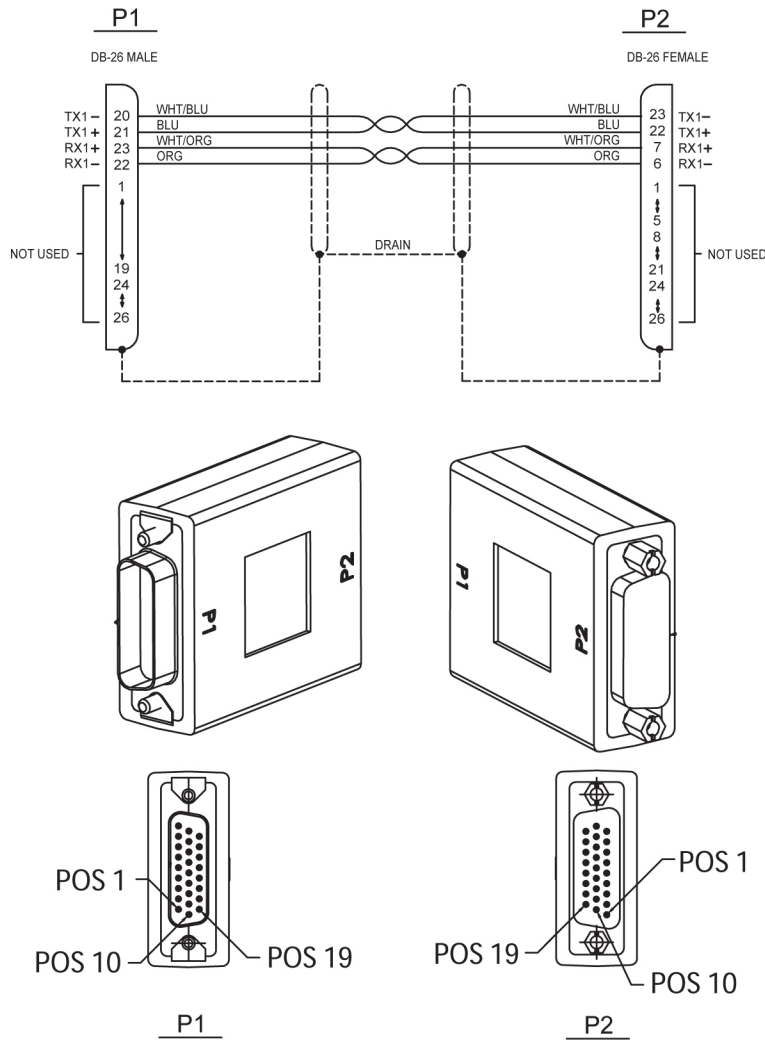

E5-ENET FAST COPY ADAPTER, LOWER

The Ethernet cable pinouts differ between the E5-ENET card and the DCM or single-slot EDCM cards.

Adapter P/N 830-1343-02 is required for each E5-ENET interface used when using the FAST COPY feature. The adapter is connected between the backplane connector and the existing DCM cable for the card.

Figure C-19 E5-ENET FAST COPY ADAPTER, LOWER, P/N 830-1343-02

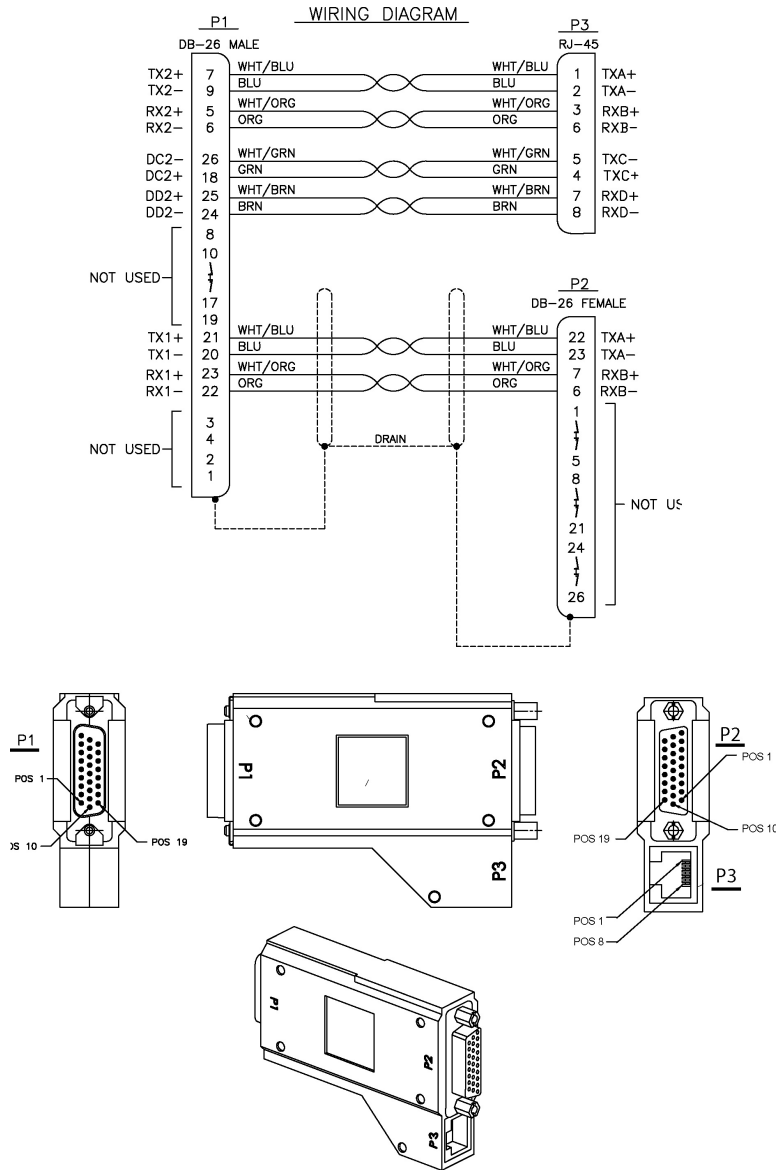

E5-ENET FAST COPY ADAPTER, UPPER

The Ethernet cable pinouts differ between the E5-ENET card and the DCM or single-slot EDCM cards.

Adapter P/N 830-1343-01 is required for each E5-ENET interface used when using the FAST COPY feature. The adapter is connected between the backplane connector and the existing DCM cable for the card.

Figure C-20 E5-ENET FAST COPY ADAPTER, UPPER, P/N 830-1343-01

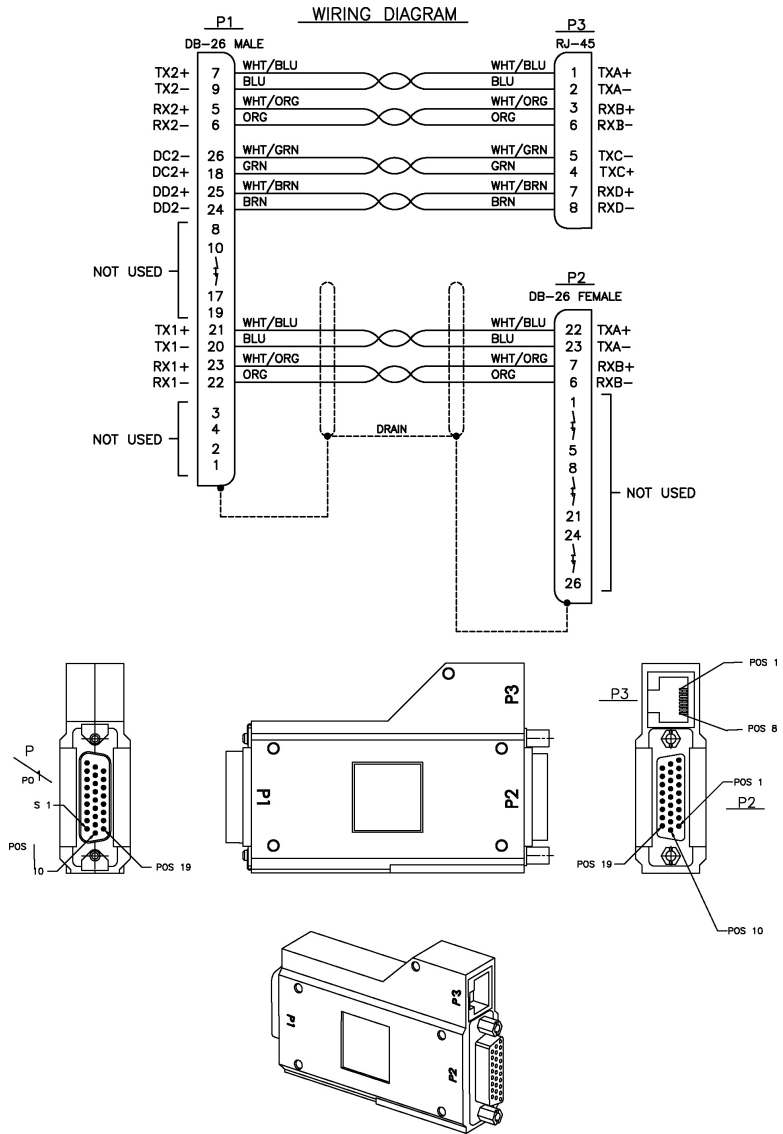

ENET Adapter 15-Pin to 26-Pin (P/N 830-0425-01)

Figure C-21 ENET Adapter 15-Pin to 26-Pin (P/N 830-0425-01)

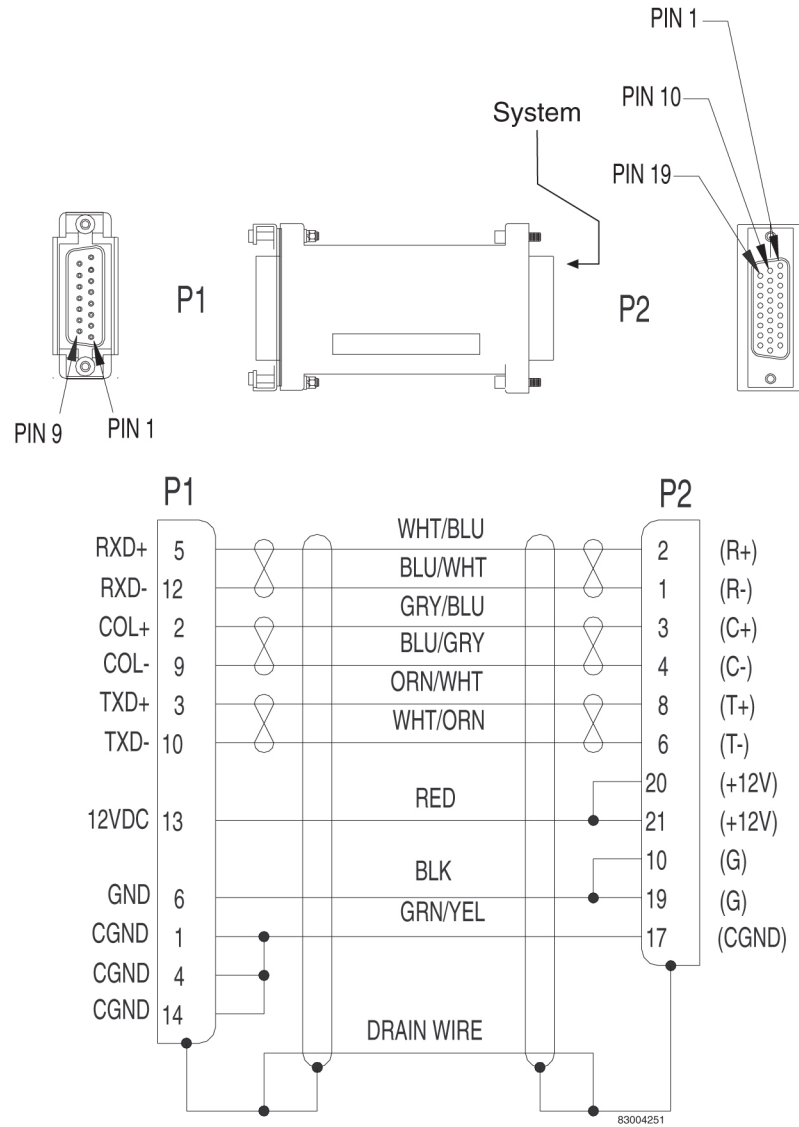

External Alarm Cable (Custom)

Table C-12 External Alarm Cable (Custom)

Part Number		Length	
North American	International	feet	meters
830-0435-01	830-1151-01	50	15.24
830-0435-02	830-1151-02	75	22.86
830-0435-03	830-1151-03	100	30.48

Table C-12 (Cont.) External Alarm Cable (Custom)

Part Number		Length	
North American	International	feet	meters
830-0435-04	830-1151-04	125	38.10
830-0435-05	830-1151-05	150	45.72
830-0435-06	830-1151-06	175	53.34
830-0435-07	830-1151-07	200	61.96
830-0435-08	830-1151-08	250	76.20
830-0435-09	830-1151-09	300	91.40
830-0435-10	830-1151-10	500	152.40
830-0435-11	830-1151-11	1000	304.80

Figure C-22 External Alarm Cable (Custom)

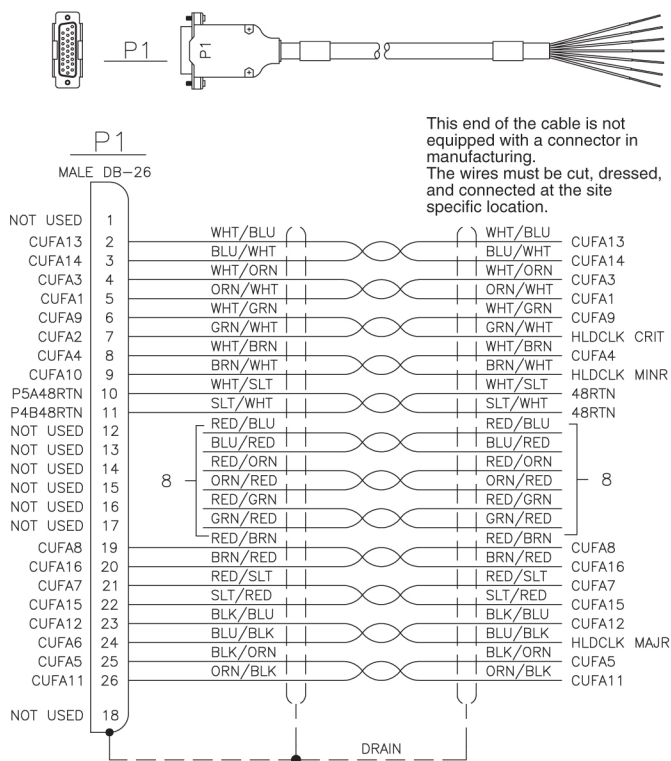

Fan Power and Alarm Cable

The fan power and alarm cable is part of the fan assembly.

For A fan power, plug one end of the cable into J-9 on backplane 850-0330-06. Route the cable to the left of the frame, faced from the rear, and to the assembly, to the connection marked **FAN A POWER**.

For B fan power, plug one end of the cable into J-8 on the backplane 850-0330-06. Route the cable to the left of the frame, faced from the rear, and to the fan assembly, to the connection marked **FAN B POWER**. Form and dress the two cables together and check the security of all of the connections.

Fifty Position Hard Drive I/O Cable

Figure C-23 Fifty Position/Hard Drive I/O Cable

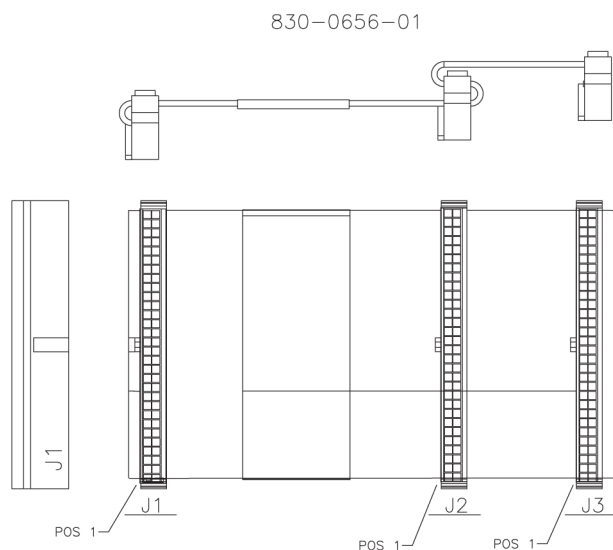

Filter Rack Alarm Cable

Table C-13 Filter Rack Alarm Cable

Part Number		Length	
North American	International	feet	meters
830-0638-01	830-1163-01	5.0	1.524
830-0638-02	830-1163-02	8.0	2.438
830-0638-03	830-1163-03	11.0	3.352
830-0638-04	830-1163-04	14.0	4.267
830-0638-05	830-1163-05	17.0	5.182
830-0638-06	830-1163-06	20.0	6.069
830-0638-07	830-1163-07	21.5	6.553
830-0638-08	830-1163-08	27.5	8.382

Figure C-24 Filter Rack Alarm Cable

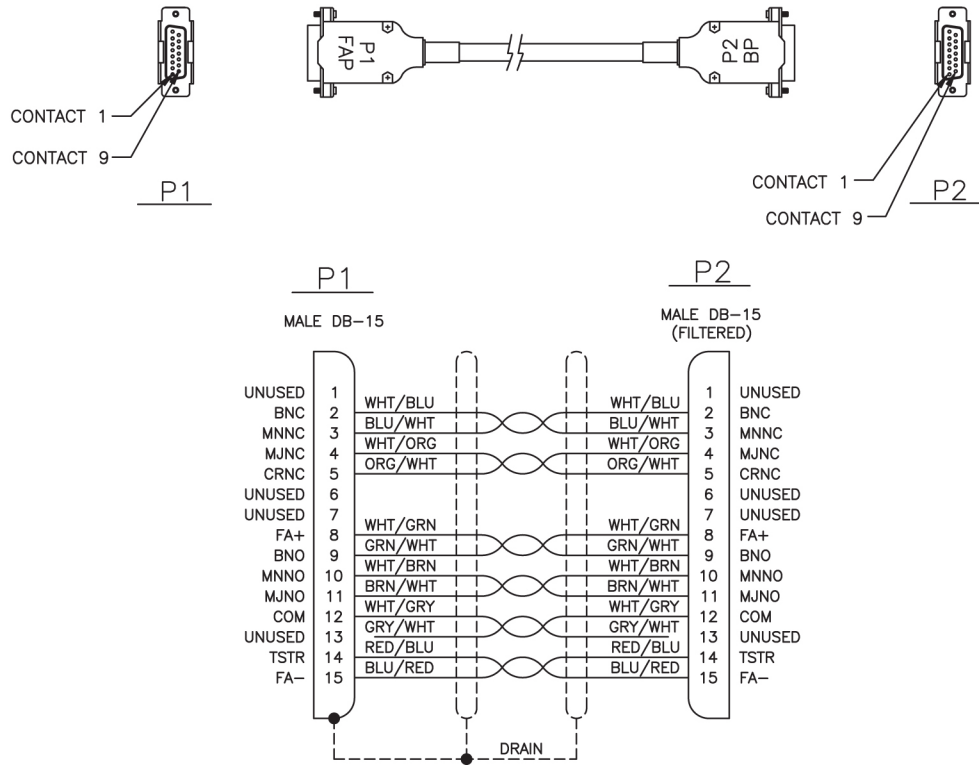

Force Transition Card

Figure C-25 Force Transition Card

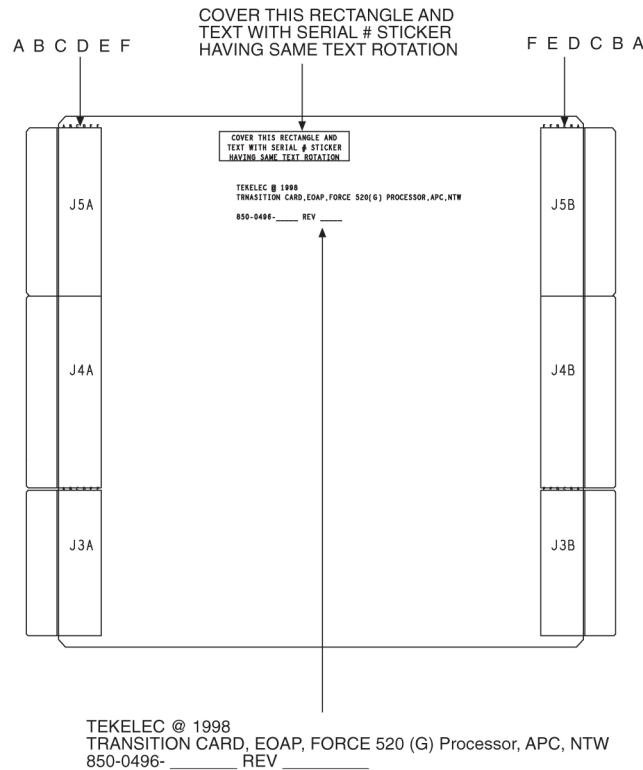

Hazard Ground Cable

Table C-14 Hazard Ground Cable

Part Number	Length		Part Number	Length	
	inches	centimeters		inches	centimeters
830-0257-01	15	38.1	830-0257-03	36	91.4
830-0257-02	24.75	62.9	830-0257-04	36	91.4

Figure C-26 Hazard Ground Cable

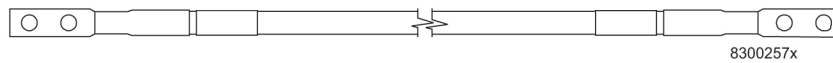

High Speed Master Timing Adapter

Figure C-27 High Speed Master Timing Adapter

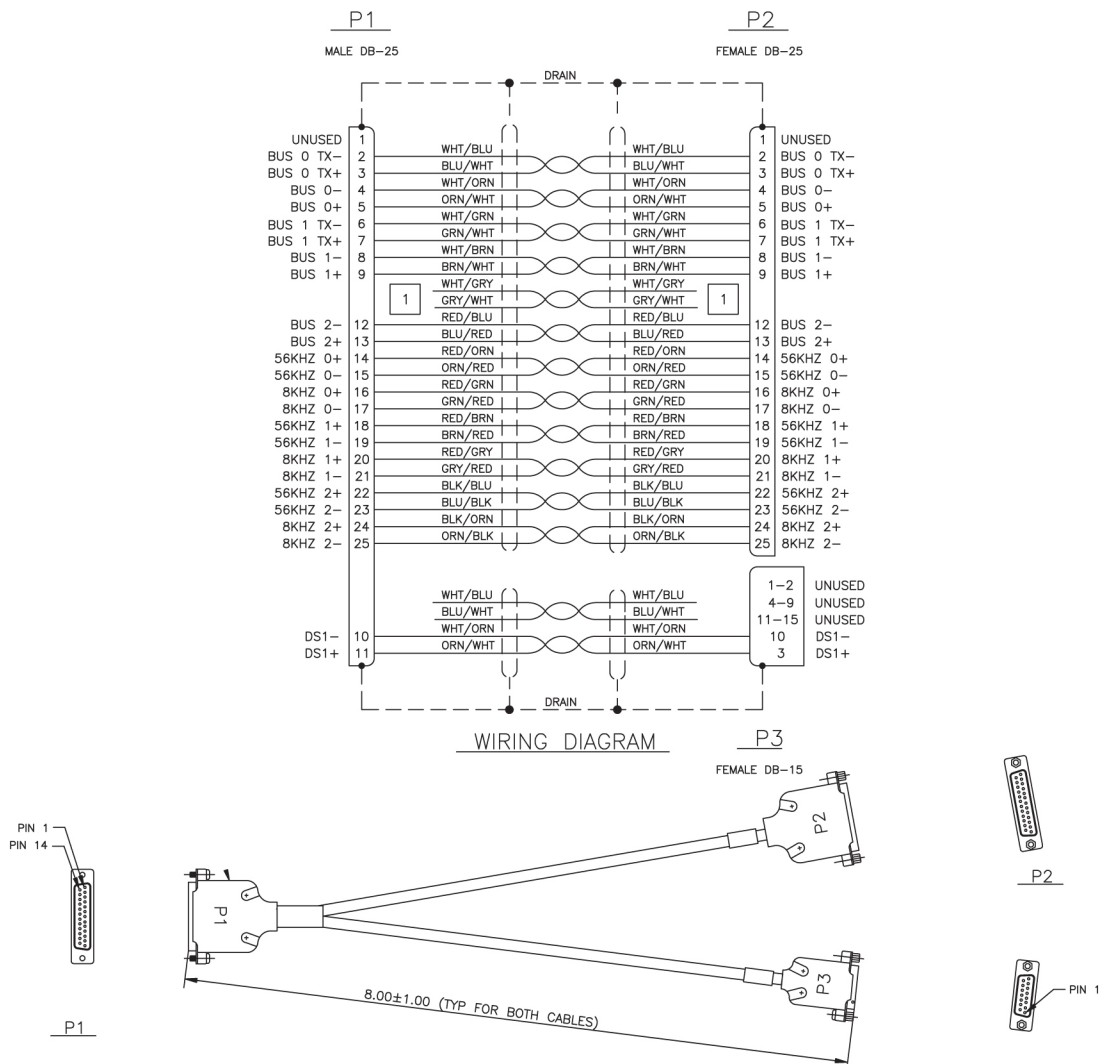

IMT Cable High Speed**Table C-15 Interface Cable High Speed**

Part Number	Length	
	feet	meters
830-1344-01	5.75	1.75
830-1344-02	7.67	2.34
830-1344-04	0.5	0.15
830-1344-05	14.0	4.27
830-1344-06	12.0	3.66
830-1344-07	13.0	3.96
830-1344-08	16.0	4.88
830-1344-09	19.0	5.79
830-1344-10	21.0	6.4
830-1344-11	23.0	7.01
830-1344-12	25.0	7.62
830-1344-15	11.0	3.35
830-1344-17	27.0	8.23

Figure C-28 *IMT Cable*

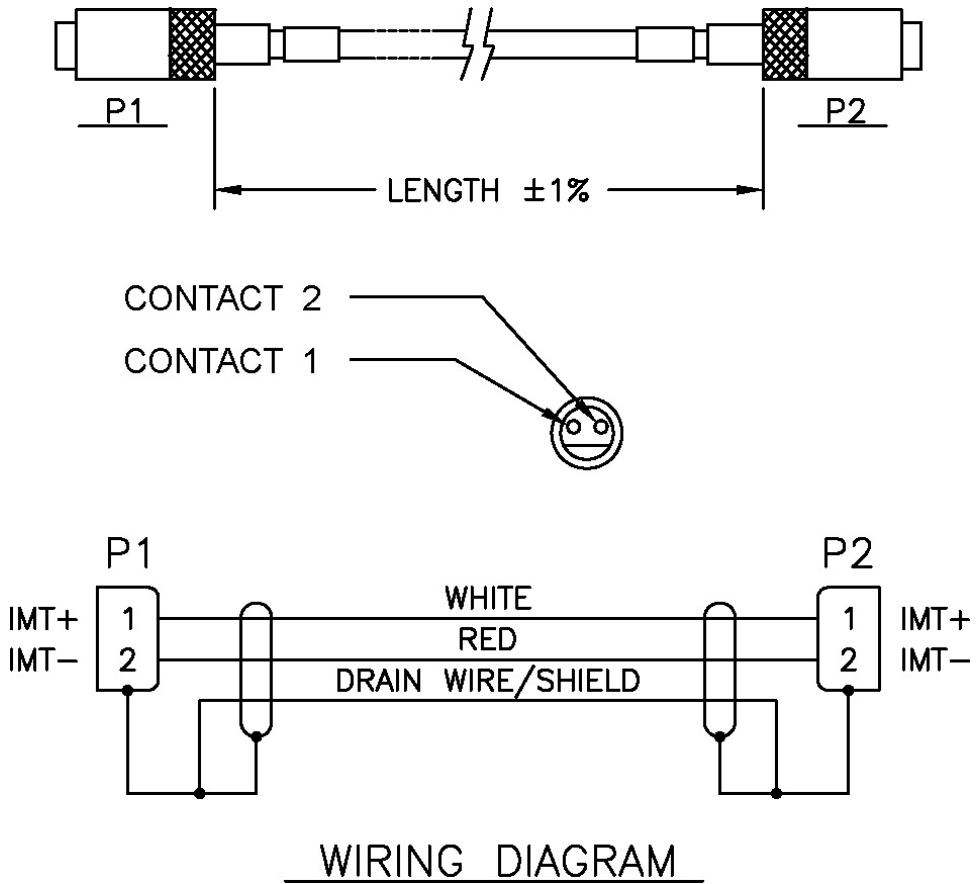

Interface Cable

Table C-16 *Interface Cable*

Part Number		Length	
North American	International	feet	meters
830-0366-01	830-1149-01	25	7.63
830-0366-02	830-1149-02	35	10.68
830-0366-03	830-1149-03	50	15.25
830-0366-04	830-1149-04	75	22.88
830-0366-05	830-1149-05	100	30.50
830-0366-06	830-1149-06	125	38.13
830-0366-07	830-1149-07	150	45.75
830-0366-08	830-1149-08	175	53.38
830-0366-09	830-1149-09	200	61.00

Table C-16 (Cont.) Interface Cable

Part Number		Length	
North American	International	feet	meters
830-0366-10	830-1149-10	250	76.25
830-0366-11	830-1149-11	300	91.50
830-0366-12	830-1149-12	500	152.50
830-0366-13	830-1149-13	1000	305.00
830-0366-14	830-1149-14	15	4.58
830-0366-15	830-1149-15	20	6.10
830-0366-16	830-1149-16	30	9.15

Figure C-29 Interface Cable

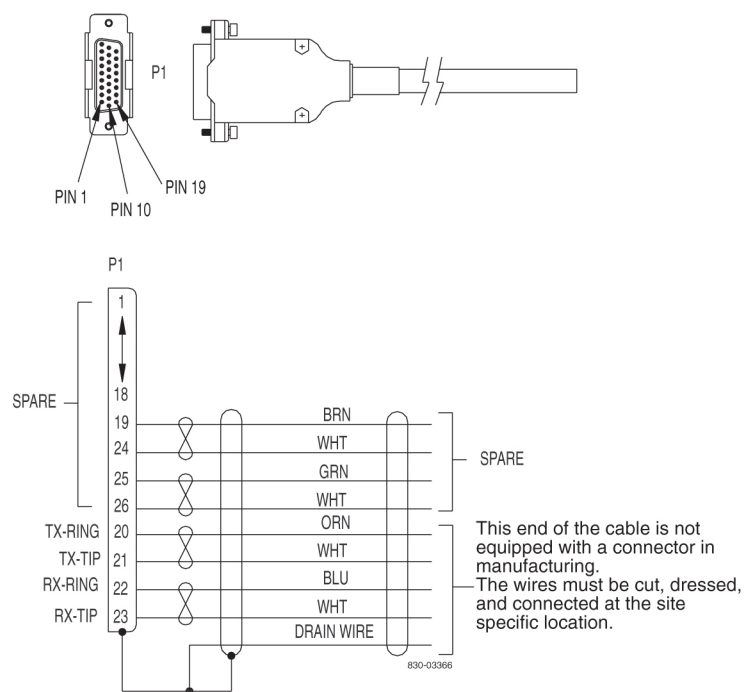

Local Maintenance Center Cable

Table C-17 Local Maintenance Center Cable

Part Number		Length	
North American	International	feet	meters
830-0231-01	830-1144-01	50	15.25
830-0231-02	830-1144-02	75	22.88

Table C-17 (Cont.) Local Maintenance Center Cable

Part Number		Length	
North American	International	feet	meters
830-0231-03	830-1144-03	100	30.50
830-0231-04	830-1144-04	125	38.13
830-0231-05	830-1144-05	150	45.75
830-0231-06	830-1144-06	175	53.38
830-0231-07	830-1144-07	200	61.00
830-0231-08	830-1144-08	250	76.25
830-0231-09	830-1144-09	300	91.50
830-0231-10	830-1144-10	500	152.50
830-0231-11	--	1000	305.00

Figure C-30 Local Maintenance Center Cable

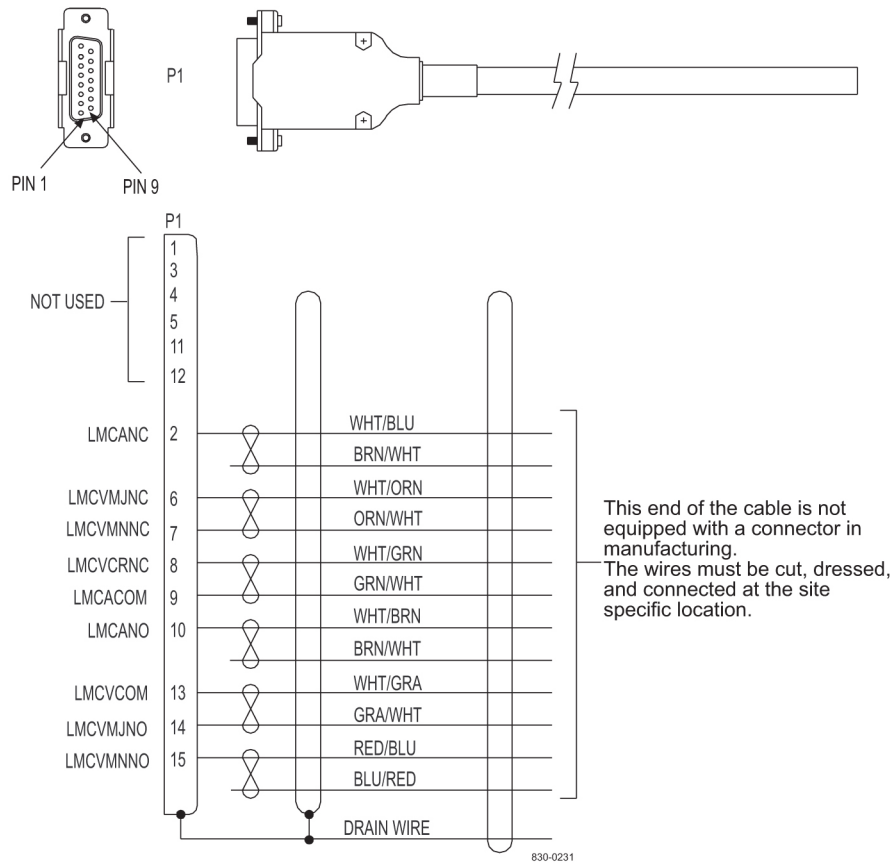

Loop Back Cable Adapter

Figure C-31 Loop Back Cable Adapter

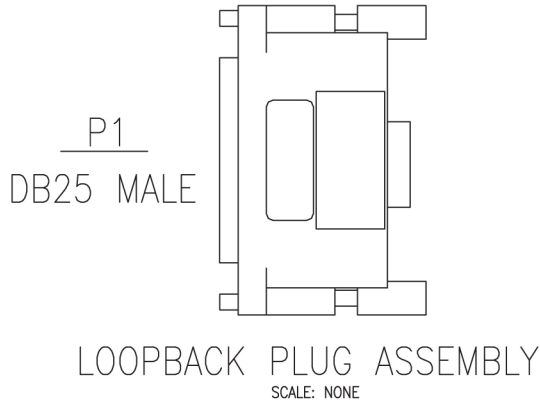

Master Clock Cable (BITS/High-speed)

Figure C-32 Master Clock Cable (BITS/High-speed)

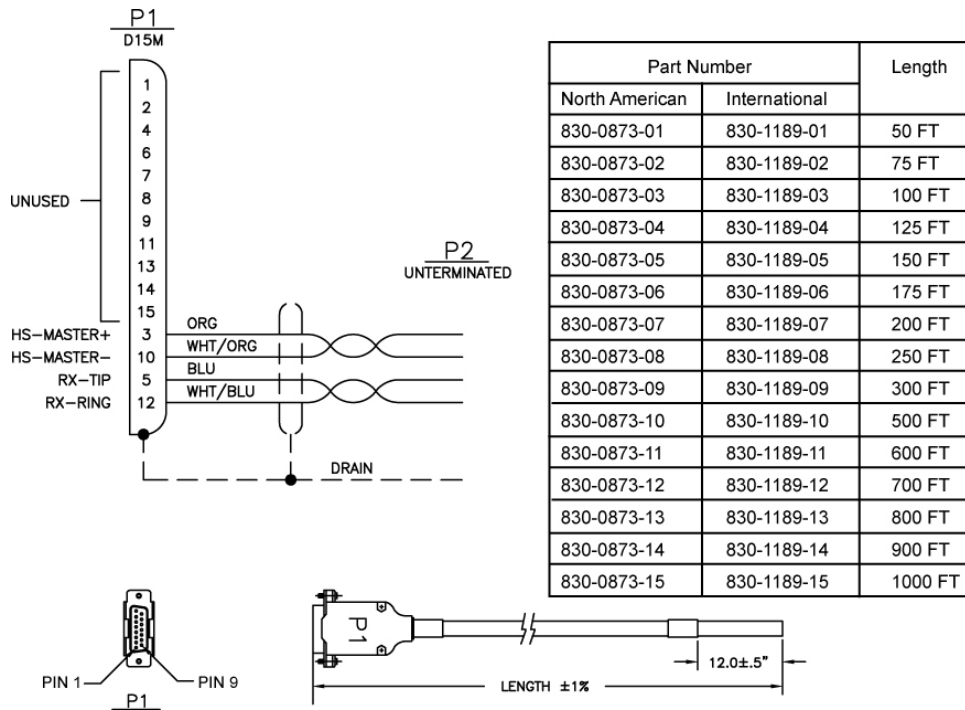

Master High Speed Clock Adapter

Figure C-33 Master High Speed Clock Adapter

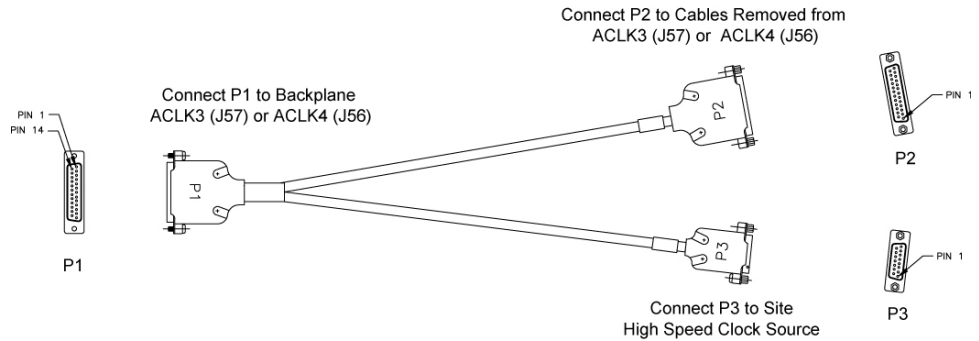
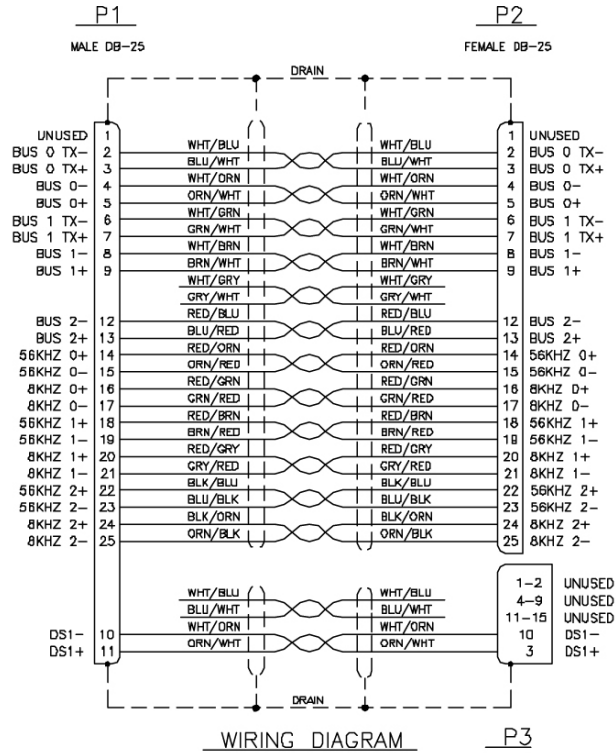

MMI Port Cable

Table C-18 MMI Port Cable

Part Number		Length		Part Number		Length	
North American	International	feet	meters	North American	International	feet	meters
830-0708-01	830-1169-01	25	7.62	830-0708-14	830-1169-01	35 0	106.68
830-0708-02	830-1169-01	15	4.57	830-0708-15	830-1169-01	40 0	121.92

Table C-18 (Cont.) MMI Port Cable

Part Number		Length		Part Number		Length	
North American	International	feet	meters	North American	International	feet	meters
830-0708-03	830-1169-01	50	15.24	830-0708-16	830-1169-01	45 0	137.16
830-0708-04	830-1169-01	75	22.86	830-0708-17	830-1169-01	55 0	167.64
830-0708-05	830-1169-01	10 0	30.48	830-0708-18	830-1169-01	60 0	182.88
830-0708-06	830-1169-01	12 5	38.10	830-0708-19	830-1169-01	65 0	198.12
830-0708-07	830-1169-01	15 0	45.72	830-0708-20	830-1169-01	70 0	213.36
830-0708-08	830-1169-01	17 5	53.34	830-0708-21	830-1169-01	75 0	228.60
830-0708-09	830-1169-01	20 0	60.96	830-0708-22	830-1169-01	80 0	243.84
830-0708-10	830-1169-01	25 0	76.20	830-0708-23	830-1169-01	85 0	259.08
830-0708-11	830-1169-01	30 0	91.40	830-0708-24	830-1169-01	90 0	274.32
830-0708-12	830-1169-01	50 0	152.40	830-0708-25	830-1169-01	95 0	289.56
830-0708-13	830-1169-01	10 00	304.80				

Figure C-34 Man-Machine Interface Port Cable

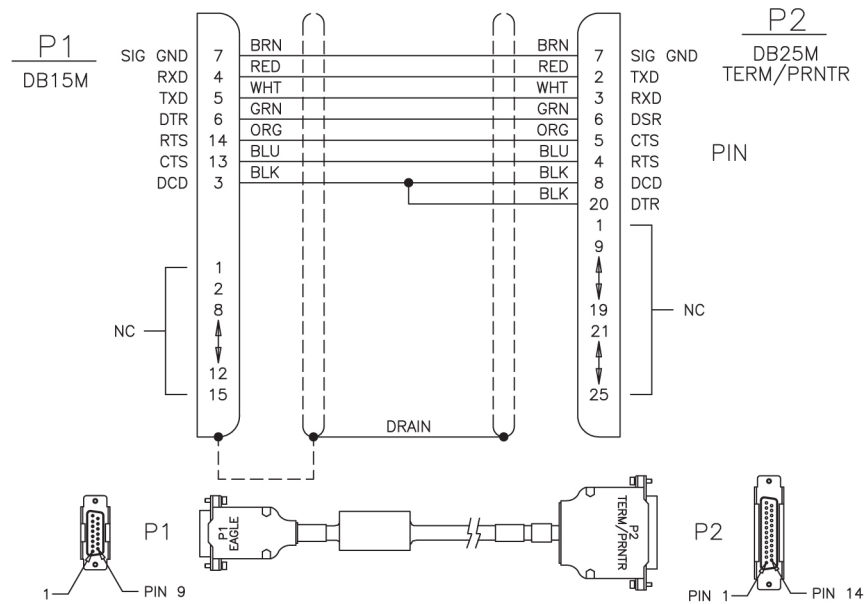

Modem/Terminal Cable

Table C-19 Modem/Terminal Cable

Part Number		Length	
North American	International	inches	centimeters
830-0709-01	830-1170-01	180.0 +/- 1.8	457.2
830-0709-02	830-1170-02	300.0 +/- 3.0	762.0
830-0709-03	830-1170-03	600.0 +/- 6.0	1524.0
830-0709-04	830-1170-04	900.0 +/- 9.0	2286.0
830-0709-05	830-1170-05	1200.0 +/- 12.0	3048.0
830-0709-06	830-1170-06	1500.0 +/- 15.0	3810.0
830-0709-07	830-1170-07	1800.0 +/- 18.0	4572.0

Figure C-35 Modem/Terminal Cable

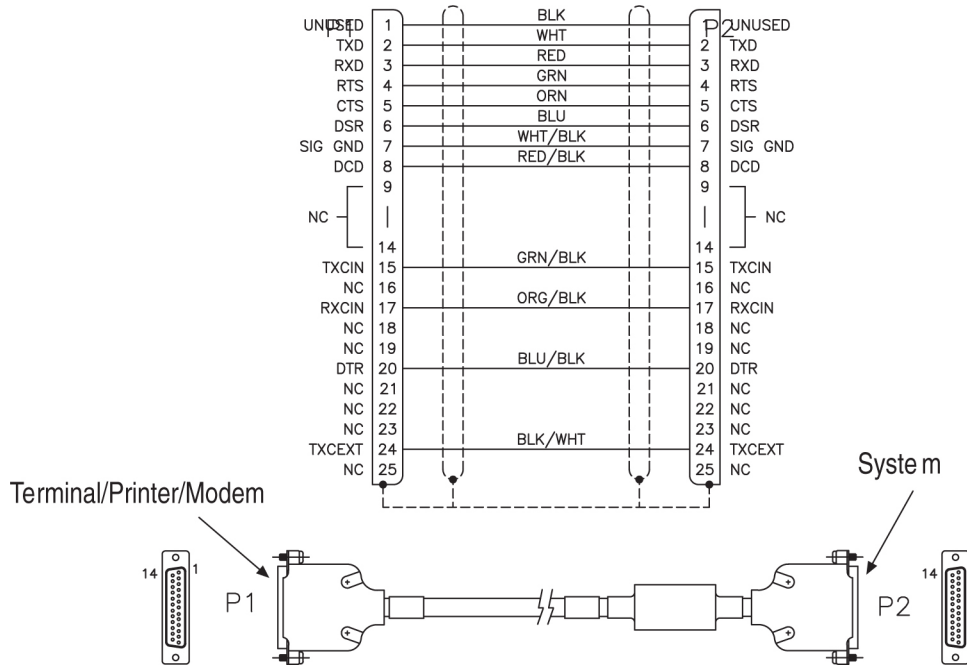

Network Cable

Figure C-36 Network Cable

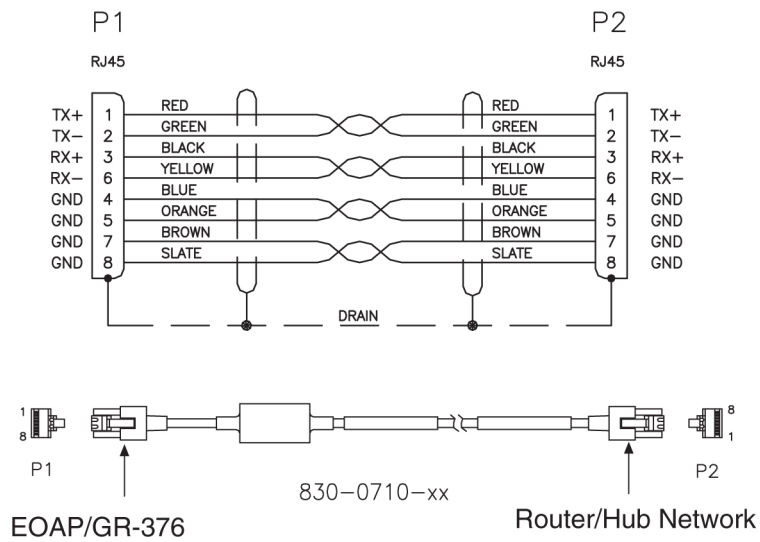

Null Modem Cable

Figure C-37 Null Modem Cable

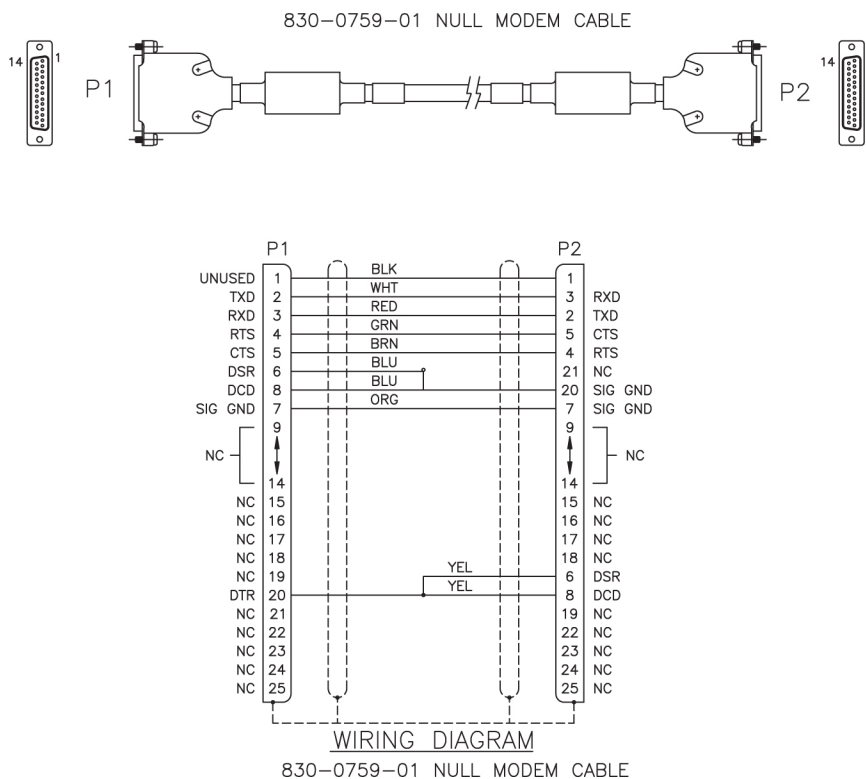

Null-Modem for Terminal Cable

Table C-20 Null-MODEM for Terminal

Part Number		Length			Rev Level
North American	International	feet	inches	meters	
830-0859-01	830-1186-01	.5	6	0.152	A
830-0859-02	830-1186-02	10	120	3.48	A
830-0859-03	830-1186-03	15	180	4.57	A
830-0859-04	830-1186-04	20	240	6.96	A
830-0859-05	830-1186-05	25	300	7.62	A
830-0859-06	830-1186-06	30	360	9.14	A
830-0859-07	830-1186-07	35	420	10.66	A
830-0859-08	830-1186-08	50	600	15.24	A
830-0859-09	830-1186-09	75	900	22.86	A

Table C-20 (Cont.) Null-MODEM for Terminal

Part Number		Length			Rev Level
North American	International	feet	inches	meters	
830-0859-10	830-1186-10	100	1200	30.48	A
830-0859-11	830-1186-11	125	1500	38.10	A
830-0859-12	830-1186-12	150	1800	45.72	A
830-0859-13	830-1186-13	200	2400	60.96	A
830-0859-14	830-1186-14	6.0	72	1.82	A
830-0859-15	830-1186-15	7.0	84	2.13	A

Figure C-38 Null-MODEM for Terminal

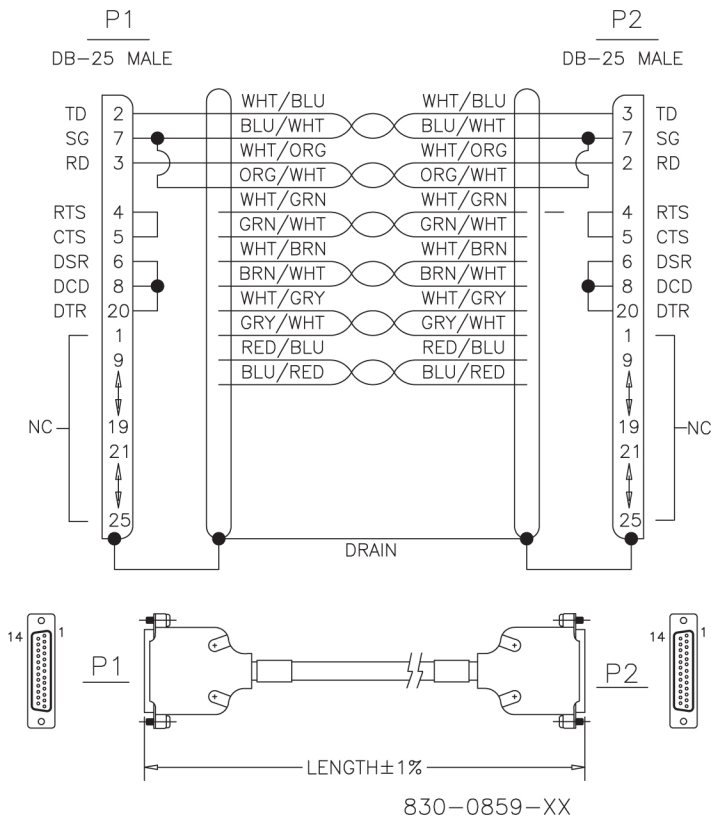

Power Cable

Table C-21 Power Cable

Part Number		Length	
North American	International	feet	meters
830-0315-01	--	4.0	1.07

Table C-21 (Cont.) Power Cable

Part Number		Length	
North American	International	feet	meters
830-0315-02	--	6.0	1.07
830-0315-03	--	8.0	2.29
830-0315-04	830-1147-04	4.5	1.22
830-0315-05	830-1147-05	6.5	1.98
830-0315-06	830-1147-06	8.5	2.58

Figure C-39 Power Cable

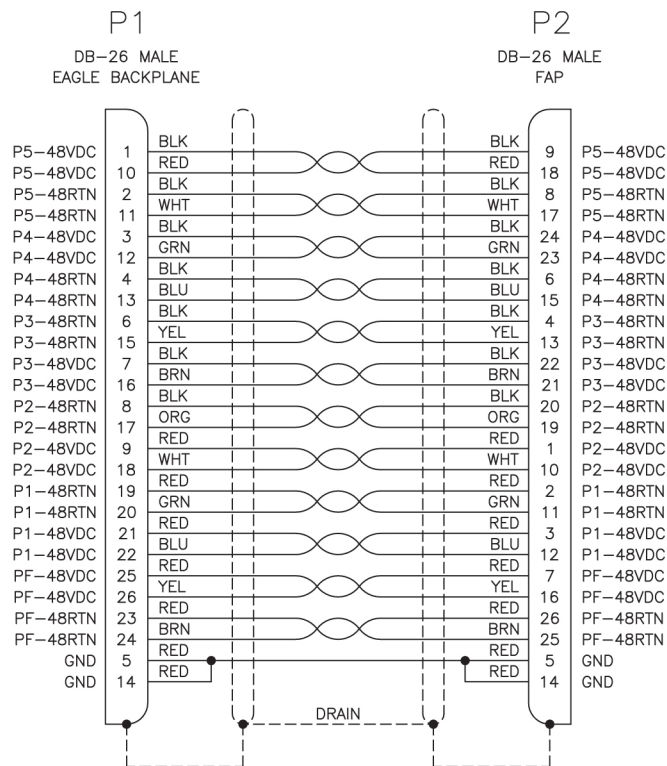
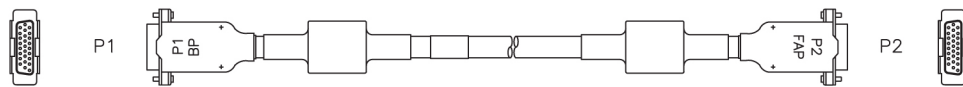

WIRING DIAGRAM

Power Cable, -48V

Figure C-40 -48V Power Cable

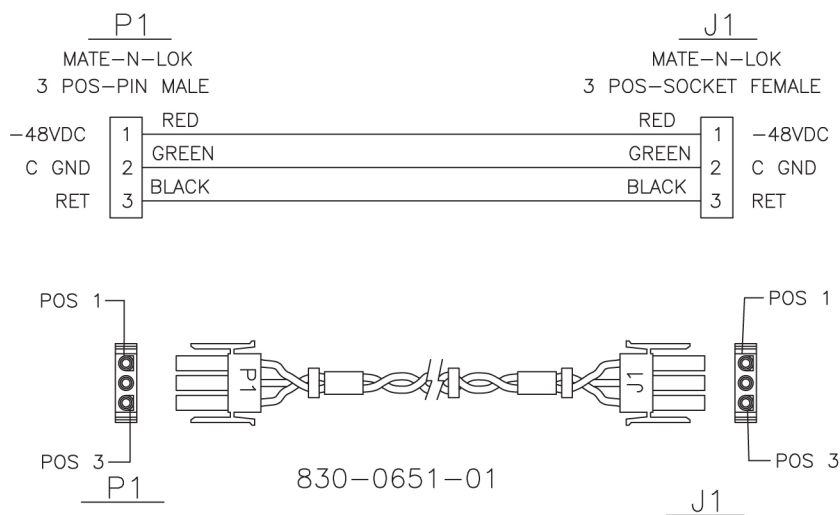

RAID Power Cable

Table C-22 RAID Power Cable

Part Number	Length		P1 Long Lead	P2 Long Lead	Label "A" usage	Label "B" usage
	inches	meters				
830-0872-01	91.0	27.73	Black	Red	BP-1, POS 3A	RAID A, PS A
830-0872-02	89.5	27.27	Black	Black	BP-2, POS 3B	RAID A, PS B
830-0872-03	95.0	28.95	Black	Red	BP-2, POS 3A	RAID B, PS A
830-0872-04	93.5	28.49	Black	Black	BP-1, POS 3B	RAID B, PS B
830-0872-05	95.0	28.95	Black	Red	Input Power	PS A
830-0872-06	93.5	28.49	Black	Black	Input Power	PS B
830-0872-07	49.0	14.93	Black	Red	BP-1, POS 5A	RAID A, PS A
830-0872-08	47.5	14.47	Black	Black	BP-2, POS 5B	RAID A, PS B
830-0872-09	79.5	24.23	Black	Red	BP-2, POS 5A	RAID B, PS A
830-0872-10	78.0	23.77	Black	Black	BP-1, POS 5B	RAID B, PS B

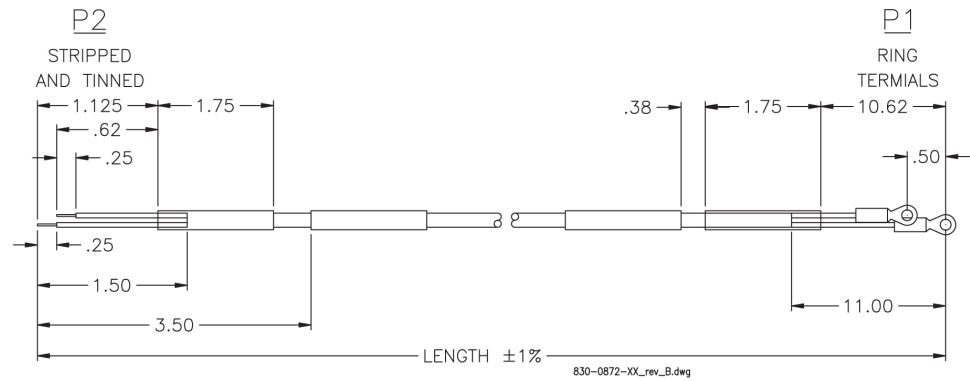
Figure C-41 RAID Power Cable

Remote Maintenance Center Cable

Table C-23 Remote Maintenance Center Cable

Part Number		Length	
North American	International	feet	meters
830-0233-01	830-1146-01	50	15.25
830-0233-02	830-1146-02	75	22.88
830-0233-03	830-1146-03	100	30.50
830-0233-04	830-1146-04	125	38.13
830-0233-05	830-1146-05	150	45.75
830-0233-06	830-1146-06	175	53.38
830-0233-07	830-1146-07	200	61.00
830-0233-08	830-1146-08	250	76.25
830-0233-09	830-1146-09	300	91.50
830-0233-10	830-1146-10	500	152.50
830-0233-11	830-1146-11	1000	305.00

Figure C-42 Remote Maintenance Center Cable

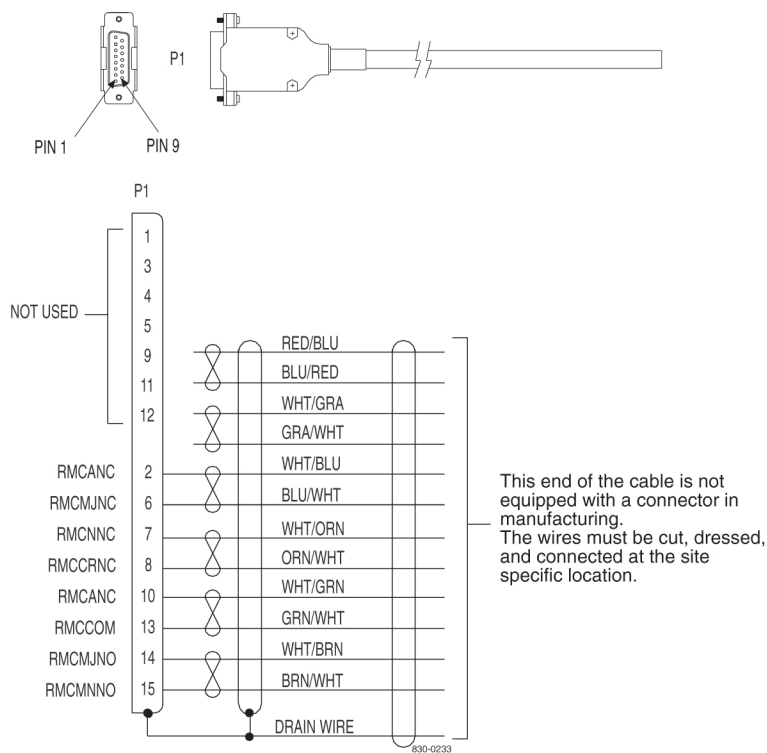

RJ45/RJ45 Cable (CAT-5) (Yellow)

Table C-24 RJ45/RJ45 Cable (CAT-5)

Part Number		Length	
North American	International	feet	meters
830-0888-01	--	1.0	.304
830-0888-02	--	5.5	1.67
830-0888-03	830-1191-03	6.0	1.82
830-0888-04	830-1191-04	6.5	1.98
830-0888-05	830-1191-05	7.0	2.13
830-0888-06	830-1191-06	8.0	2.43
830-0888-07	830-1191-07	10.0	3.04
830-0888-08	--	12.0	3.65
830-0888-09	--	15.0	4.57
830-0888-10	--	16.0	4.87
830-0888-11	830-1191-11	3.0	.91

Figure C-43 RJ45/RJ45 Cable (CAT-5)

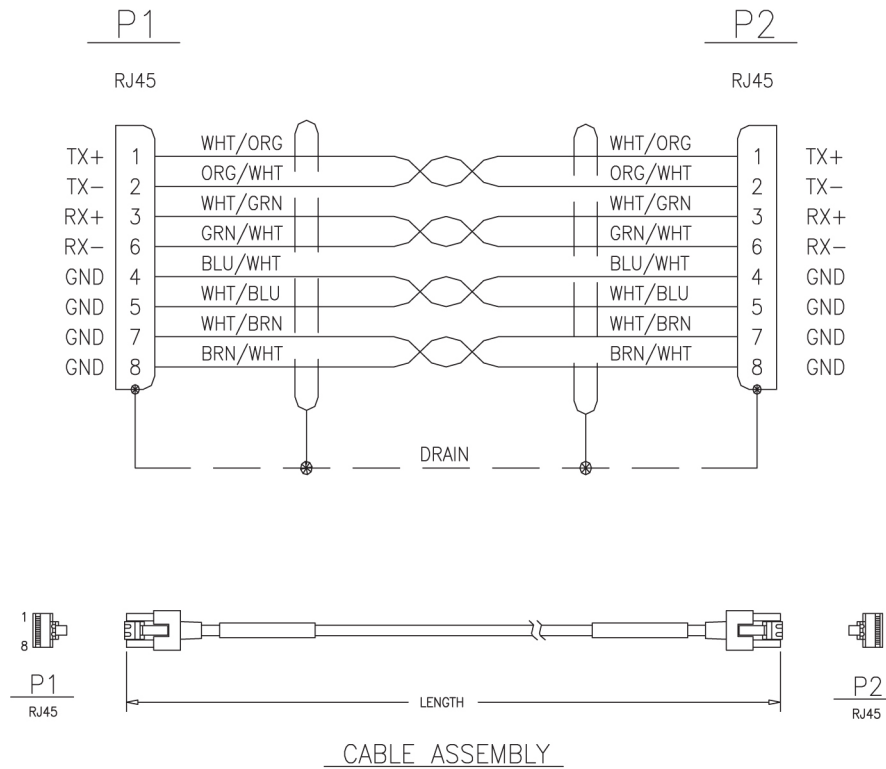

RJ45/RJ45 Cable (CAT-5) (Blue)

Table C-25 RJ45/RJ45 Cable (CAT-5)

Part Number		Length	
North American	International	feet	meters
830-0889-01	--	1.0	.304
830-0889-02	830-1192-02	5.5	1.67
830-0889-03	830-1192-03	6.0	1.82
830-0889-04	830-1192-04	6.5	1.98
830-0889-05	830-1192-05	7.0	2.13
830-0889-06	830-1192-06	8.0	2.43
830-0889-07	830-1192-07	10.0	3.04
830-0889-08	--	12.0	3.65
830-0889-09	--	15.0	4.57
830-0889-10	--	16.0	4.87

Figure C-44 RJ45/RJ45 Cable (CAT-5)

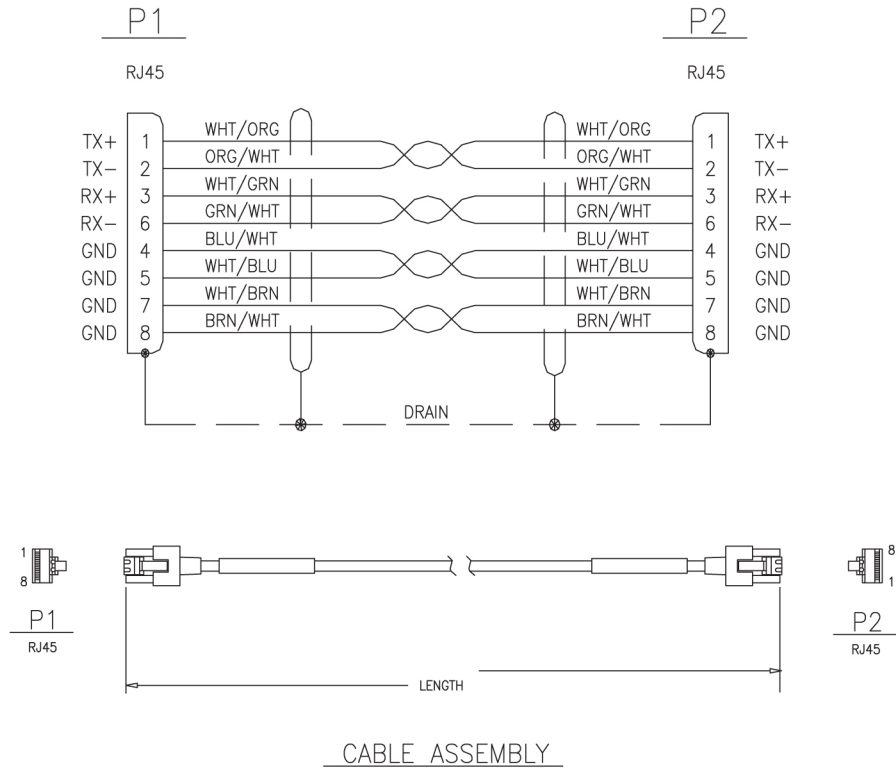

RJ45-to-9 Pin Adapter

Figure C-45 RJ 45 to 9 Pin Adapter

RJ-45 to DB9 ADAPTER
P/N 830-0917-01

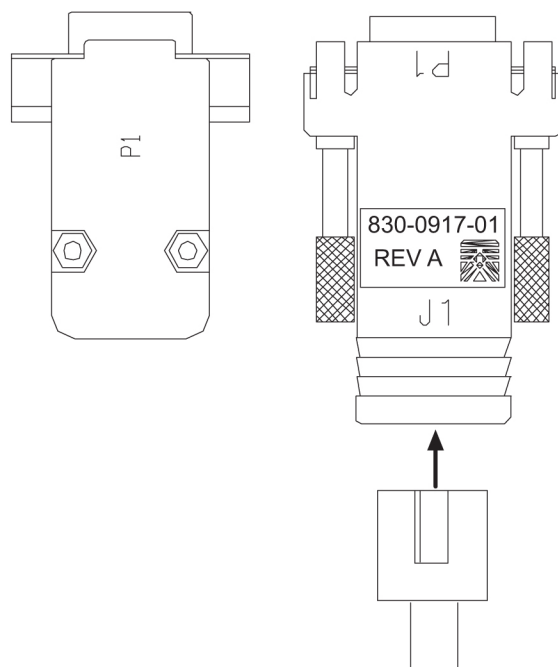

Row Alarm Cable

Table C-26 Row Alarm Cable

Part Number		Length	
North American	International	feet	meters
830-0232-01	830-1145-01	5	1.53
830-0232-02	830-1145-02	8	2.44
830-0232-03	830-1145-03	10	3.05
830-0232-04	830-1145-04	12	3.66
830-0232-05	830-1145-05	14	4.27
830-0232-06	830-1145-06	175	53.38
830-0232-12	830-1145-12	20	6.1
830-0232-13	830-1145-13	30	9.25
830-0232-14	830-1145-14	40	12.2
830-0232-15	830-1145-15	50	15.25

Figure C-46 Row Alarm Cable

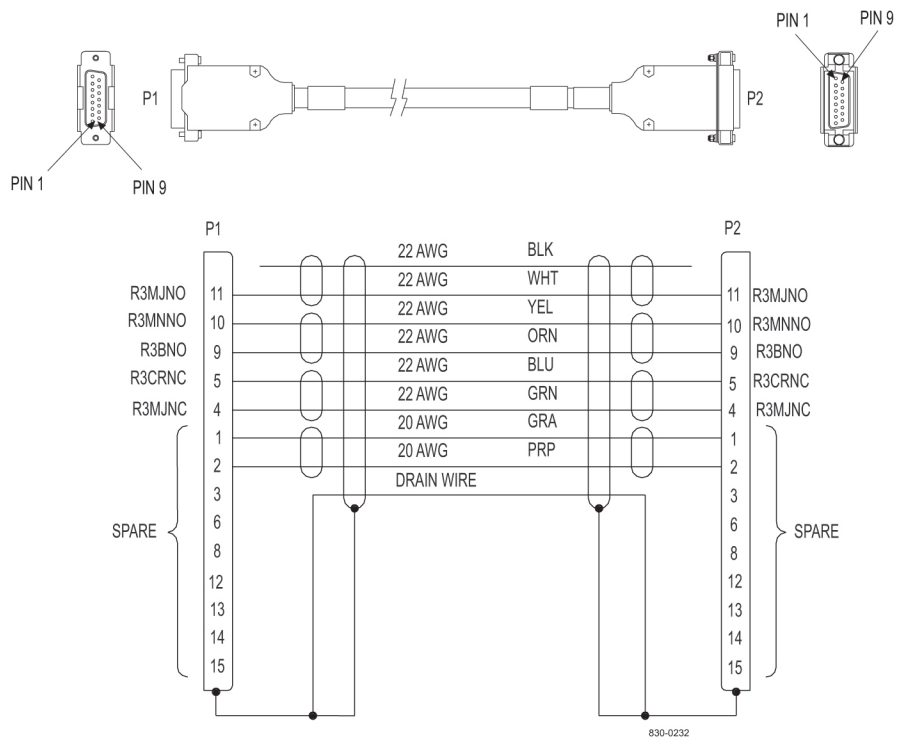

Router Power Cable

Table C-27 Router Power Cable

Part Number		Rev Level	Length (inches)	X (inches)	P1 Long Lead	P2 Long Lead	Label "A" usage	Label "B" usage
North American	International							
830-0869-01	--	C	72	11	Black	Red	BP-1, POS 3A	ISO Router A
830-0869-02	--	C	79	17	Black	Red	BP-1, POS 3B	Dial-in Router
830-0869-03	830-1188-03	C	78	17	Black	Red	BP-2, POS 3B	ISO Router B
830-0869-04	830-1188-04	C	78	17	Black	Red	BP-1, POS 6B	Dial-in Router
830-0869-05	--	C	72	11	Black	Red	BP-1, POS 5A	ISO Router A
830-0869-06	--	C	78	17	Black	Red	BP-1, POS 5B	ISO Router B
830-0869-07	830-1188-07	A	82	22	Black	Red	To BP-1, POS 6B from Router	To Router YEL from BP-1 POS 6A
830-0869-08	830-1188-08	A	74	14	Black	Red	To BP-1, POS 6B from Router	To Router BLU from BP-1 POS 6A
830-0869-09	--	A	38	11	Black	Red	BP-2, POS 4A	Dial-in Router

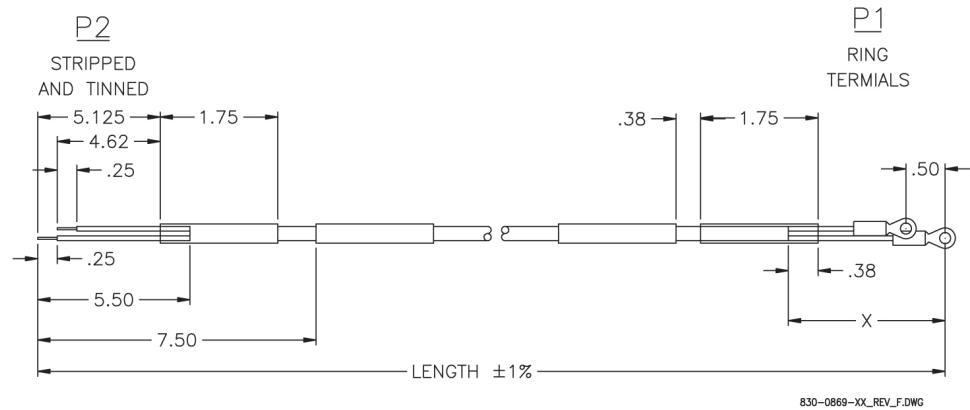
Figure C-47 Router Power Cable**RS232**

Standard Purchased part. Serial port connected to an optional second asynchronous maintenance modem and connections between the TTYA and a VT-520 terminal.

Table C-28 RS232

Part Number		Length	
North American	International	feet	meters
830-0527-01	830-1152-01	15	4.57
830-0527-02	830-1152-02	25	7.62
830-0527-03	830-1152-03	50	15.24
830-0527-04	830-1152-04	75	22.86
830-0527-05	830-1152-05	100	30.48
830-0527-06	830-1152-06	125	38.10
830-0527-07	830-1152-07	150	45.72

Figure C-48 RS232

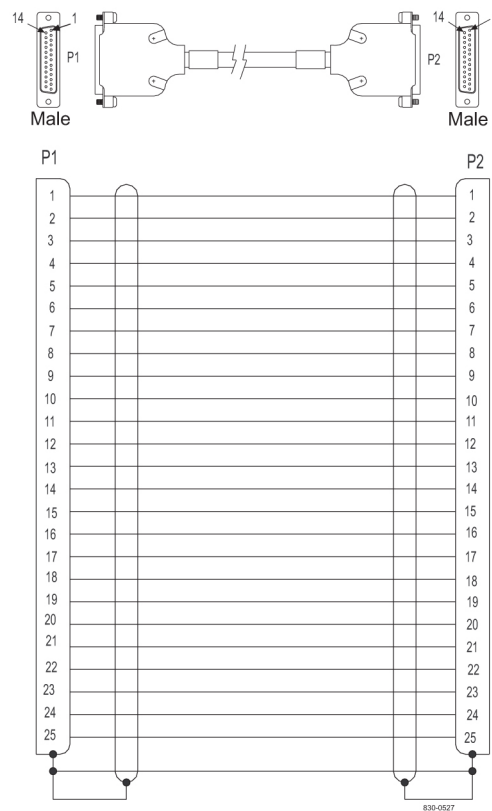

Serial I/O Transition Card

Table C-29 Serial I/O Transition Card

Part Number		Length	
North American	International	feet	meters
830-0514-01	---	5	1.53
830-0514-02	---	10	3.05
830-0514-03	---	15	4.57
830-0514-04	---	20	6.1
830-0514-05	---	25	7.62

Figure C-49 Serial I/O Transition Card

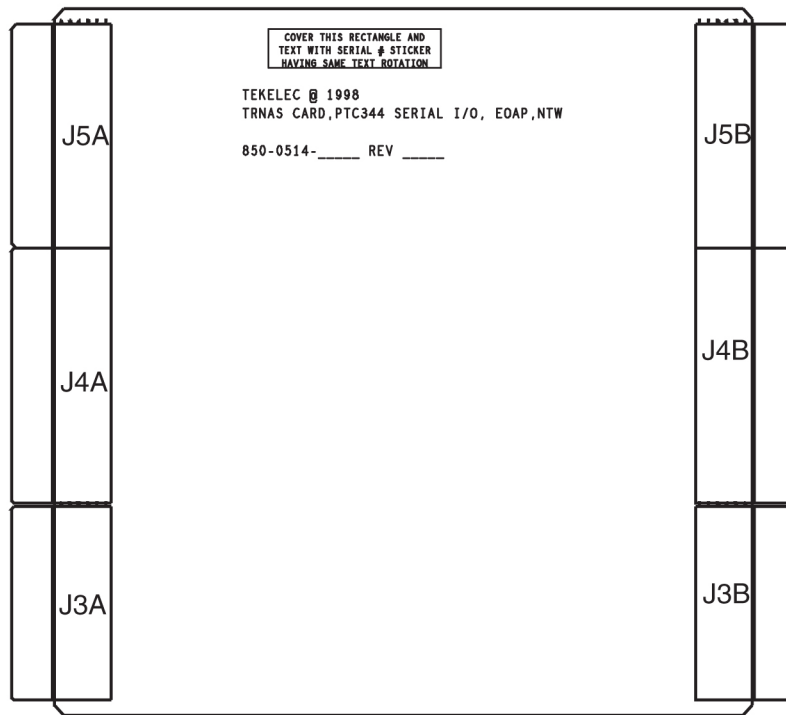

Serial Interface/Modem Adapter

Figure C-50 Serial Interface/Modem Adapter

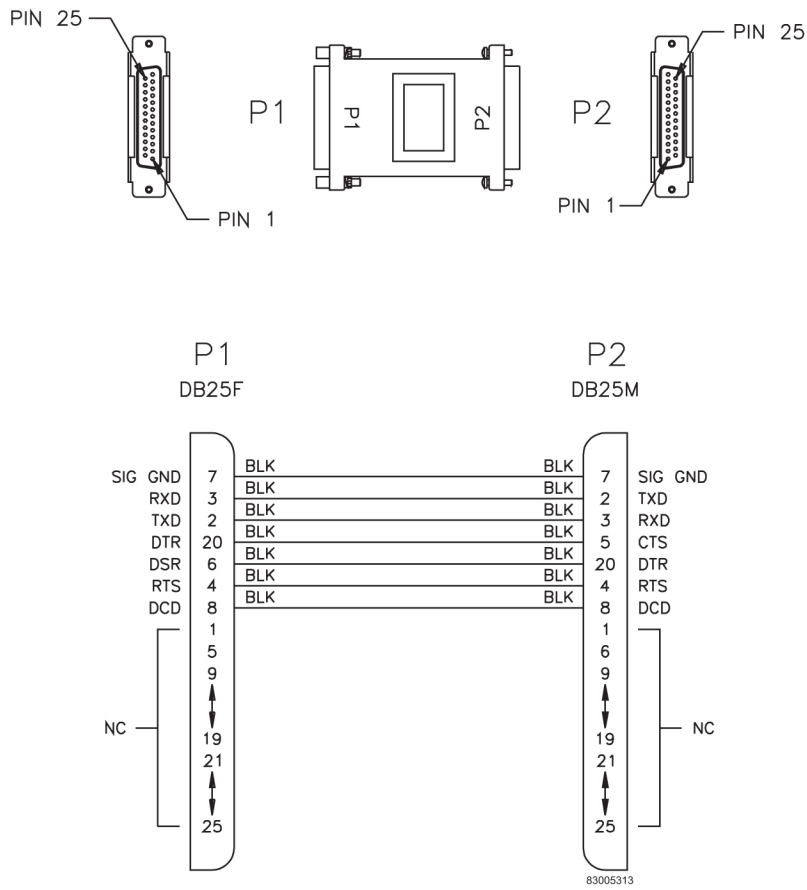

Serial Interface, Terminal, and Printer Adapter

Figure C-51 Serial Interface, Adapter

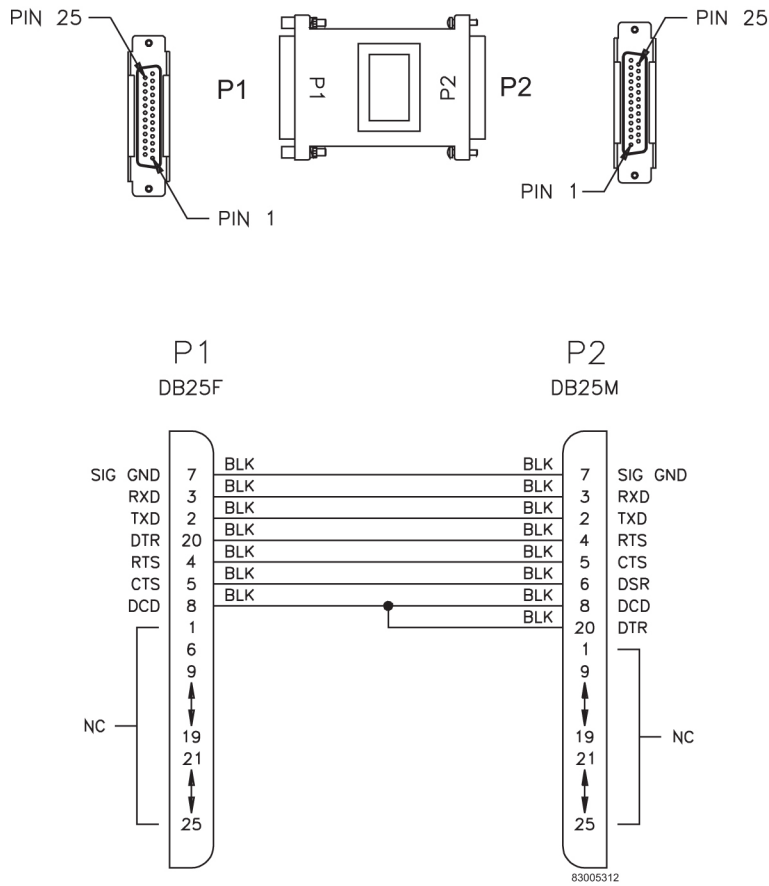

Shielded Straight Through Cable (CAT-5)

Table C-30 Shielded Straight Through CAT-5 Cable

Part Number		Length	
North American	International	meters	feet
830-0724-10	830-1174-10	30.48	100.0
830-0724-43	830-1174-43	60.96	200.0
830-0724-63	830-1174-63	91.44	300.0

Figure C-52 Straight Through Cable (CAT-5)

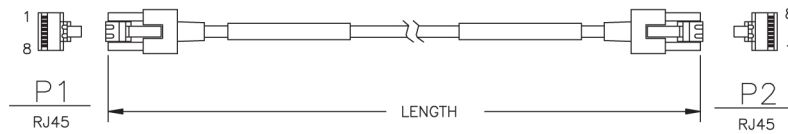
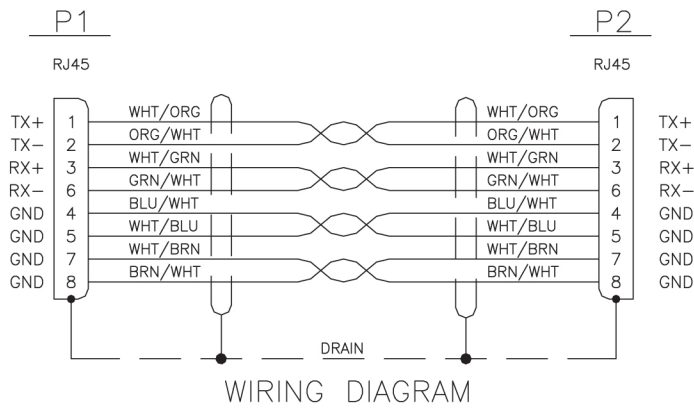

Straight-Through Patch-Panel Cable

DB26 to RJ-45

Figure C-53 Straight Through Patch Panel Cable

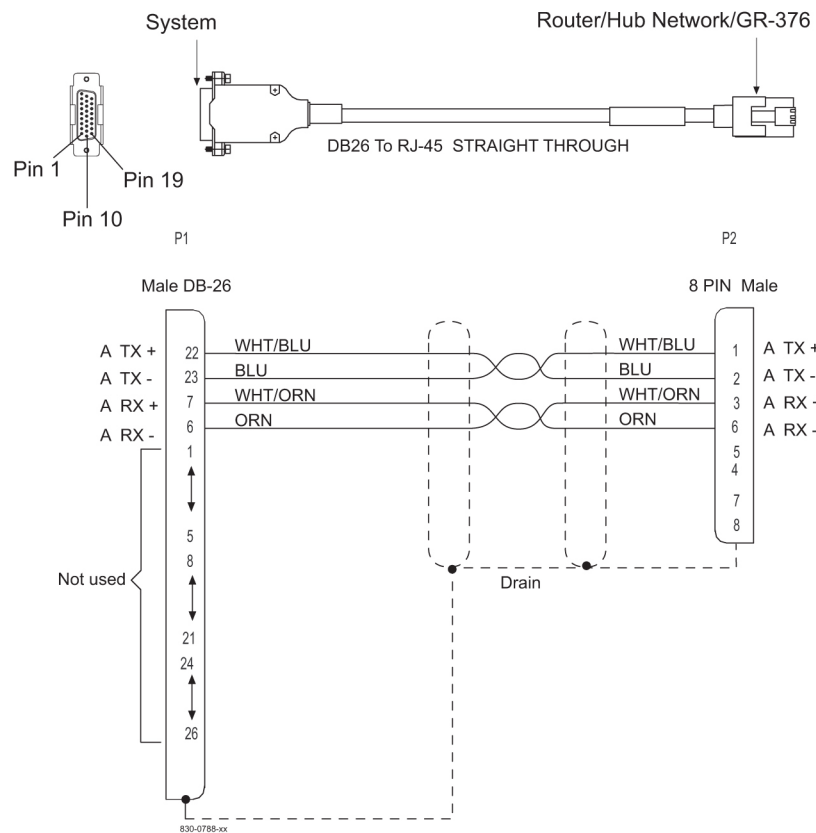

Switch-to-Frame Ground Cable

Figure C-54 Switch to Frame Ground Cable

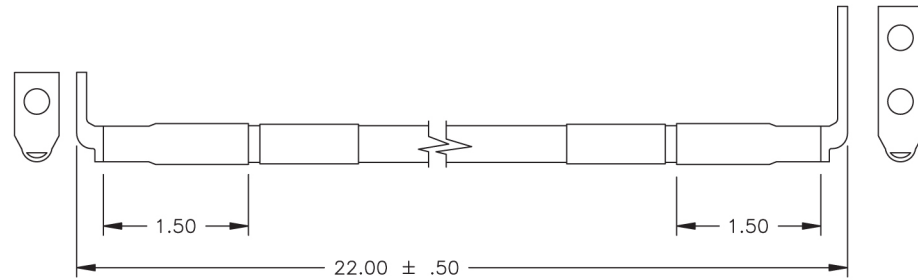

PART NUMBER	LENGTH (IN) ±.50	LABEL 'A' USAGE	LABEL 'B' USAGE	APPLICATION
830-0884-01	22.00	FRAME	SWITCH	CABLE GROUND, SWITCH TO FRAME, NTW

830-0884-01gnd

Terminal/Converter Cable

This converter is a purchased part and the pin-out is that of a straight through converter. The cable is 2 ft long. There is no illustration or wiring diagram.

Terminal/Printer Cable

Figure C-55 Terminal/Printer Cable

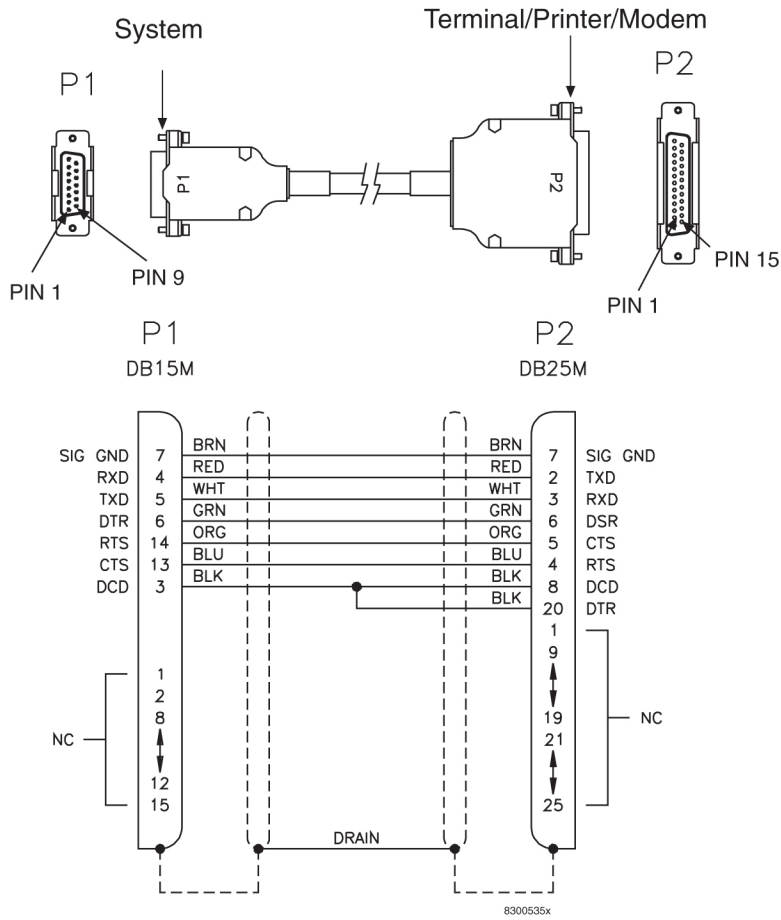

Terminal/Server Serial Cable with Flow Control

Figure C-56 Terminal Server Serial Cable with Flow Control (P/N 830-1201-xx)

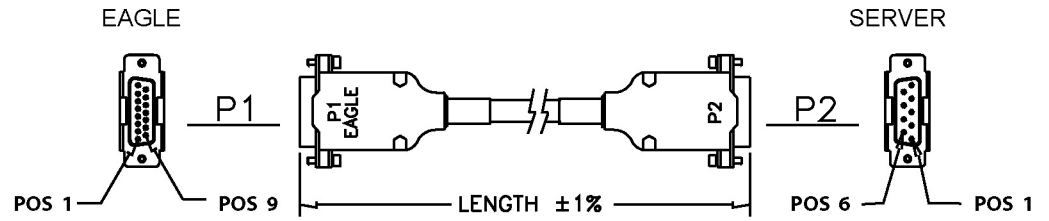

PART NUMBER	LENGTH (INCHES)
830-1201-01	60.0±1%
830-1201-02	120.0±1%
830-1201-03	180.0±1%
830-1201-04	240.0±1%
830-1201-05	300.0±1%
830-1201-06	600.0±1%
830-1201-07	900.0±1%
830-1201-08	1,200.0±1%

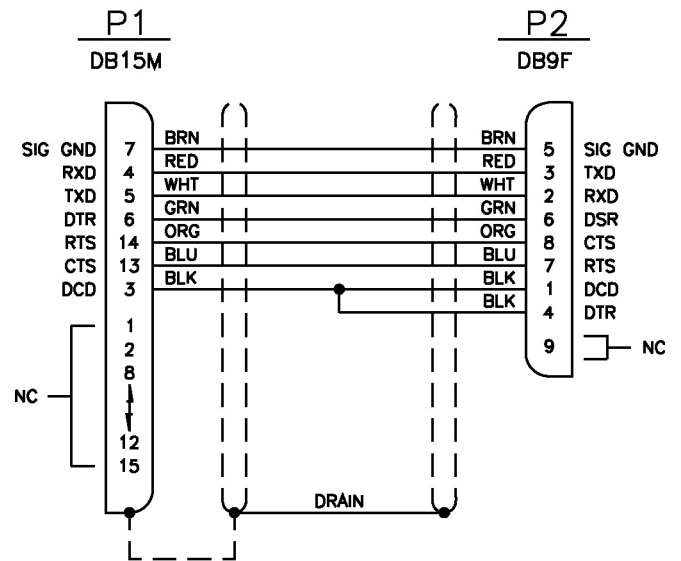

Terminal/Server Serial Port Adapter, NTW

Figure C-57 Terminal/Server Serial Port Adapter, NTW (P/N 830-0915-01)

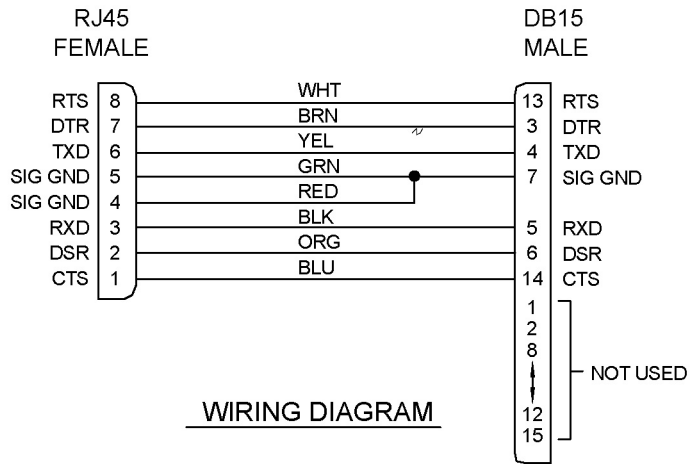
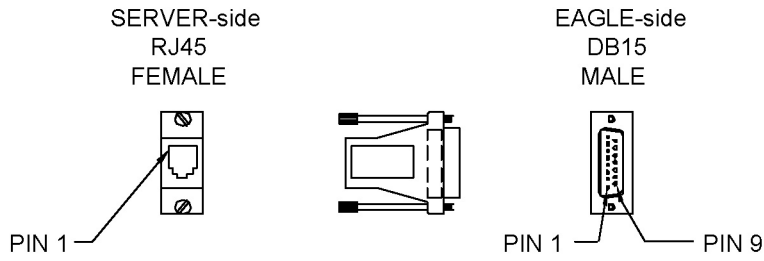

Terminal/Server Serial Port Adapter, MRV

Figure C-58 Terminal/Server Serial Port Adapter, MRV (P/N 830-0915-02)

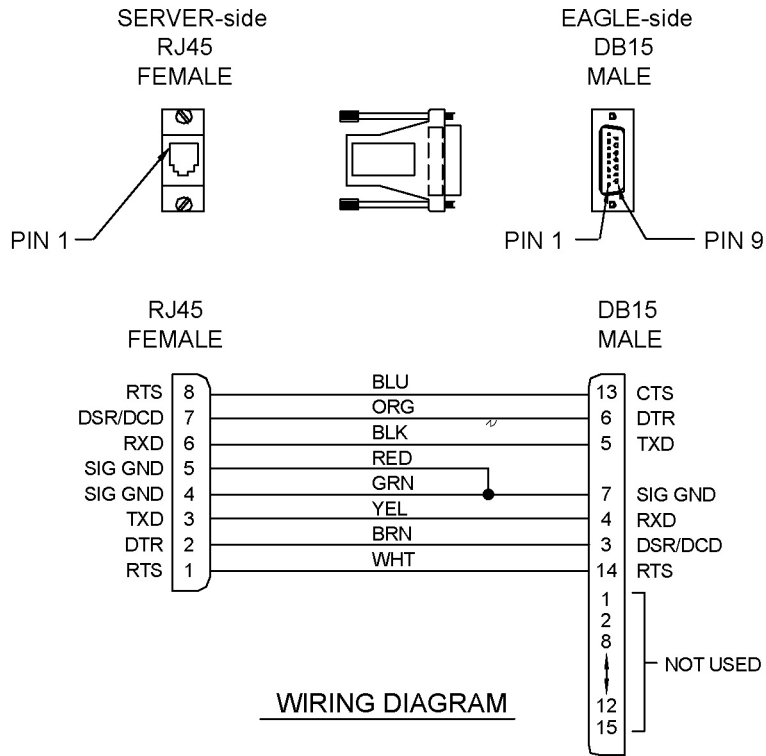

Terminal/Server Serial Port Adapter, EAGLE/Cyclades

Figure C-59 Terminal/Server Serial Port Adapter, EAGLE/Cyclades (P/N 830-0915-03)

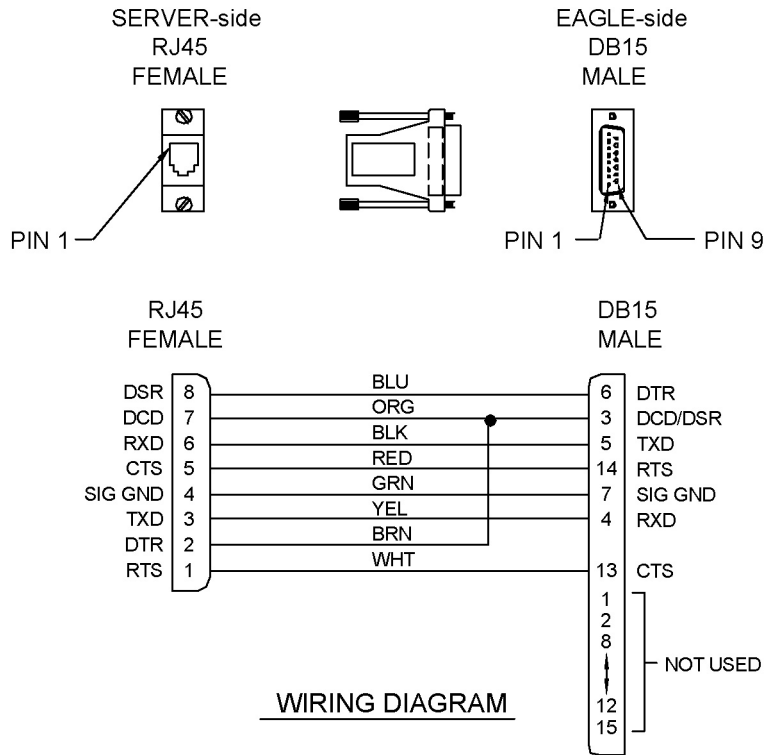

Tone and Announcement Server Alarm Cable

Figure C-60 TAS Alarm Cable

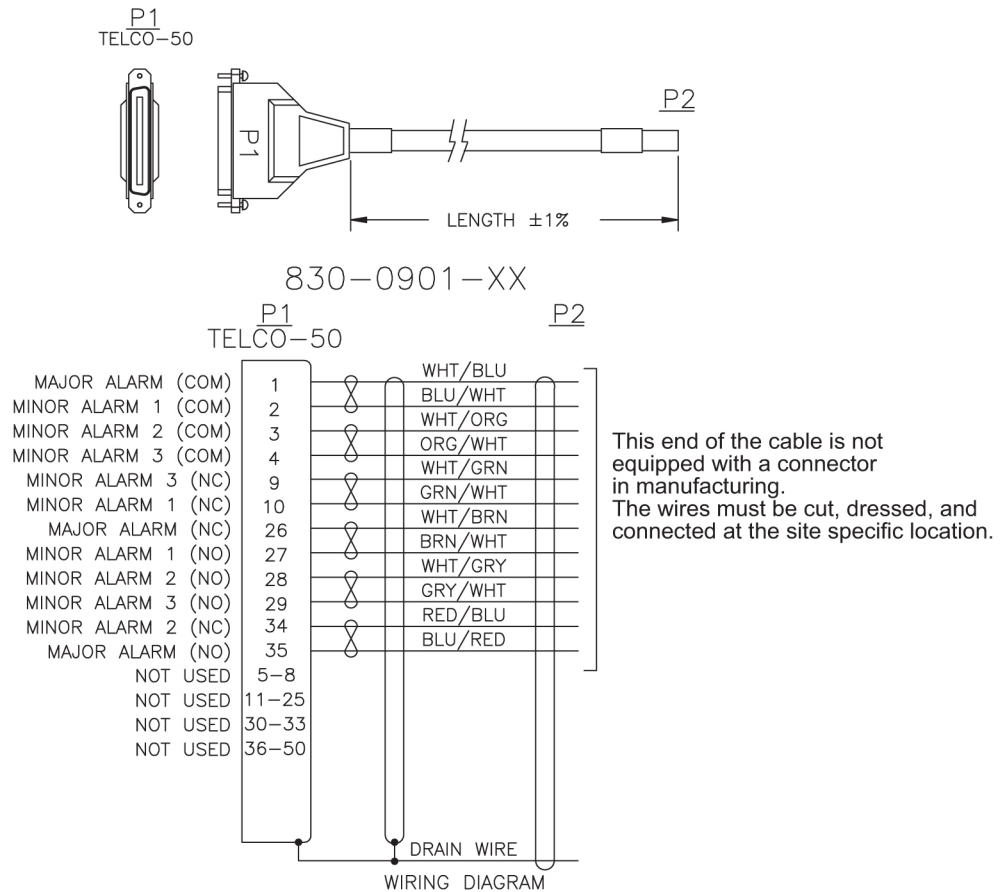

Part Numbers

Overview

This chapter lists the part numbers of Oracle equipment, components, cables, and miscellaneous parts described in this manual.

Each table provides the item name, part number, and related notes. Items are listed by their name (as described in this manual) in alphabetical order. Shaded part numbers indicate that the item is obsolete or no longer shipped. Unless the item is indicated as obsolete, the item is still supported in the field.

Note: Oracle reserves the right to ship compatible part numbers or revisions for new installations and replacements. Always check the latest Hardware Baseline for your release. The latest hardware baseline can be found in the Feature Notice of your release.

RoHS 5/6 - As of July 1, 2006, all products that comprise new installations shipped to European Union member countries will comply with the EU Directive 2002/95/EC "RoHS" (Restriction of Hazardous Substances). The exemption for lead-based solder described in the Annex will be exercised. RoHS 5/6 compliant components will have unique part numbers and are identified as the International part number in this manual.

Note: International part numbers will eventually replace North American part numbers to make all part numbers RoHS compliant. The items of either part number are of equivalent function or quality otherwise.



WEEE - All products shipped to European Union member countries comply with the EU Directive 2002/96/EC, Waste Electronic and Electrical Equipment. All components that are **WEEE** compliant will be appropriately marked. For more information regarding Oracle's **WEEE** program, contact your sales representative.

Cables, Adapters

Table D-1 EAGLE Cables, Connectors, and Power Cords

Name	Part Numbers		Note
	North America	International	
Adapter, 15-Pin to 26-Pin	830-0425-01	---	
Adapter cables	830-0846-01	830-1183-01	backplanes -03 and -04 for master timing and HS clock cable 830-0873-xx
Alarm cable	830-0543-01	---	Holdover Clock
Alarm cable	830-0638-xx	830-1163-xx	see Filtered Rack Alarm cable
Alarm NETRA Server Cable	830-0900-xx	---	
ATM Cable	830-0987-xx	---	SCSI/DB44
ATME1/T1 cable	830-0959-xx	---	EMS; DB-44 to RJ45 4 Port
B Clock Cable	830-0404-xx	---	replaced by 830-0398-xx (NA) or 830-1150-xx (I) both are for HMUX
B Clock Cable	830-0398-xx	830-1150-xx	
A and B Frame Clock cable	---	---	see B Clock Cable
BITS clock cable	830-0226-xx	830-1146-xx	Backplanes -03 and -04
BITS clock cable	830-0873-xx	---	Backplane -06
BNC pen end cable	830-0625-xx	830-1161-xx	
BNC to BNC cable assembly	830-0624-xx	830-1160-xx	
Breaker-to-Terminal Strip Power Cable	830-0866-xx	830-1236-xx	
CD-ROM Cable	830-0421-xx	---	
Frame Ground cable	830-0715-xx	830-1171-xx	ESP
Composite clock cable	---	---	See BITS clock cable

Table D-1 (Cont.) EAGLE Cables, Connectors, and Power Cords

Name	Part Numbers		Note
	North America	International	
Converter	804-0176-01	---	
Crossover (CAT-5) Cable	830-0723-xx	830-1173-xx	
Crossover Patch Panel Cable	830-0789-xx	830-1178-xx	DCM
DB-26 to RJ-45	830-1102-02	830-1102-02	for new installations, with shielded Cat 5E cable; E5-ENET
DB-26 to DB-26	830-1103-02	830-1103-02	for current installations that use DCM cable, 830-0978-xx. Does not support Gigabit Ethernet; E5-ENET
DCM, 100-BASET X Interface to unterminated -xx	830-0711-xx	---	
DCM_100 BASET X Interface_DB26 to Non-shielded RJ45	830-0978-xx	---	
DCM 100BASE TX Interface_DB26 to RJ45 Plus to Minus	830-0788-xx	830-1177-xx	
Drive Power Cable	830-0224-xx	---	
DS1 Cable	830-0849-xx	830-1184-xx	
E1 cable	830-0622-xx	830-1233-xx	
E1 patch cable	830-0605-02	830-1116-02	
E1-T1MIM 22 AWG	830-0932-01	830-1106-xx	
E1/T1MIMLIM Cable	830-0948-01	830-1197-xx	4 Port 24 AWG
E1/T1MIMLIM to MPL Adapter	830-0949-01	830-1197-01	
E5-ENET Fast Copy Adapter - Lower	830-1343-01		
E5-ENET Fast Copy Adapter - Upper	830-1343-02		

Table D-1 (Cont.) EAGLE Cables, Connectors, and Power Cords

Name	Part Numbers		Note
	North America	International	
E5-MASP Ethernet Adapter	830-1333-02	830-1333-02	Connects to J-17 and J19 on Ctrl shelf backplane 06/07 for E5-OAM Integrated Meas
Ethernet cable*	830-0788-xx	830-1177-xx	DCM, DSM and EDCM
External alarm cable	830-0435-xx	830-1151-xx	
Fan cable	830-0690-01	---	AC power
Fan power/alarm cable	830-0609-01	830-1157-01	incl. with fan assembly
Fifty Position Cable Hard Drive I/O	830-0656-01	---	
Filter Rack Alarm Cable	830-0638-xx	830-1163-xx	
Force Transition Card	850-0496-01	---	
Frame Ground cable	830-0715-xx	830-1171-xx	ESP
Ground Breaker Panel-to-Frame cable	830-0830-01	830-1181-01	ESP
Ground Hub-to-Frame cable	830-0822-xx	---	ESP
Hazard Ground Cable	830-0257-xx	---	
High Speed (BITS) Clock Cable	830-0873-xx	830-1189-xx	
High Speed Master Timing Adapter	830-0846-01	830-1183-01	
HMUX Adapter Cable	830-0857-01	830-1185-01	
1/0 Green Ground Cable	690-0108-07	690-0108-R07	
IMT Cable	830-1344-xx	830-1344-xx	
Interface Cable	830-0366-xx	830-1149-xx	
Local Maintenance Center Cable	830-0231-xx	830-1144-xx	
Loop Back Cable Adapter	830-0763-01	830-1176-xx	

Table D-1 (Cont.) EAGLE Cables, Connectors, and Power Cords

Name	Part Numbers		Note
	North America	International	
MMI Port Cable	830-0708-xx	830-1169-xx	
Modem/Terminal Cable	830-0709-xx	830-1170-xx	
Multi-port LIM Diagnostic Cable	803-0029-0	---	
Multi-port LIM DS0 cable	830-0772-xx	---	26 AWG, inactive
Multi-port LIM DS0 cable	830-0892-xx	830-1194-xx	24 AWG, inactive
Multi-Port Power Cable	830-0814-xx	830-1282-xx	
Network Cable	830-0710-xx	830-1257-xx	
Null Modem Cable	830-0759-xx	---	
Null-Modem for Terminal Cable	830-0859-xx	830-1186-xx	
Output panel frame ground cable	690-0009	---	
Pin Protector Assembly	830-0880-01	---	use with clock cable replacement (66 min for 6 shelves)
Power Cable	830-0315-xx	830-1147-xx	
Power Cable, -48V	830-0651-xx	---	
Power Cable, DC, BP to Hub	830-0868-xx	830-1235-xx	
Power Cable, DC, Netra 1400	830-0814-xx	830-1282-xx	
Power Cable, MPS	830-0965-xx		
Power Ring	830-0908-xx	---	AXi
Rack Alarm Cable	---	---	see Filtered Rack Alarm cable
RAID Power Cable	830-0872-xx	---	DC
Remote Maintenance Center Cable	830-0233-xx	830-1146-xx	
RJ45/RJ45 Cable (CAT-5) (Yellow)	830-0888-xx	---	

Table D-1 (Cont.) EAGLE Cables, Connectors, and Power Cords

Name	Part Numbers		Note
	North America	International	
RJ45/RJ45 Cable (CAT-5) (Blue)	830-0889-xx	830-1192-xx	
RJ45 to 9 Pin Adapter	830-0917-01	---	
Row Alarm Cable	830-0232-xx	830-1145-xx	
Router Power Cable	830-0869-xx	830-1188-xx	DC
RS232 Cable	830-0527-xx	830-1152-xx	
ATM Cable	830-0987-xx	---	SCSI/DB44
Serial I/O Transition Card	850-0514-01	---	
Serial Interface Converter Cable	830-0531-01	---	inactive
Serial Interface/Modem Adapter	830-0531-03	830-1153-03	use with 830-0394- xx
Serial Interface/Modem Adapter	830-0531-04	830-1153-04	use with 830-0535- xx
Serial DB44 to DB9 (X4) cable	830-0972-01	830-1231-01	36-inch T1x00 AS
Serial Interface, Terminal, Printer Adapter	830-0531-02	830-1153-02	use with 830-0394- xx
Straight Through Cable (CAT-5)	830-0724-xx	---	RJ-45 CAT-5E
Straight Through Cable (Patch Panel)	---	---	see DCM 100BASE TX Interface_DB26 to RJ45 Plus to Minus
Switch-to-Frame Ground Cable	830-0884-01	---	
Terminal/Converter Cable	830-0528-01	---	
Terminal/Printer Cable	830-0535-xx	830-1154-xx	
Terminal/Server Serial Cable	---	830-1201-xx	DB9F/DB15M Serial w/Flow Control
Terminal/Server Serial Port Adapter	830-0915-01	---	RJ45-DB15M Adapter_NTW

Table D-1 (Cont.) EAGLE Cables, Connectors, and Power Cords

Name	Part Numbers		Note
	North America	International	
Terminal/Server Serial Port Adapter	830-0915-02	---	RJ45-DB15M Adapter_MRV
Terminal/Server Serial Port Adapter	830-0915-03	---	RJ45-DB15M Adapter_EAGLE/Cyclades
Tone and Announcement Server Alarm Cable	830-0901-xx	---	
T1LIM-to-MPL Cable Adapter	830-0895-01	---	
T1MIM cable	830-0894-xx	---	
Terminal cable adapter	---	---	see Terminal/Printer cable

* See [Customer Supplied Ethernet Cable Requirements](#) for customer-supplied Ethernet cable requirements.

Components

Table D-2 EAGLE Components

Acronym	Name	Part Numbers		Note
		North America	International	
---	Air Management Card	870-1824-01	870-1824-02	single slot, needed for empty slots when using Fan Tray 890-0001-02
---	Breaker Panel Alarm Card	804-1489-01	804-1489-R01	
CI	Clock Interface Card (Holdover Clock)	804-0165-01	---	
DSM	Database Service Module	870-2371-08	870-2371-13	1GB

Table D-2 (Cont.) EAGLE Components

Acronym	Name	Part Numbers		Note
		North America	International	
E5-APP-B	EAGLE Application B Card	870-3096-XX		See <i>EAGLE Application B Card Hardware and Installation Guide</i>
E5-ATM-B	E5-ATM-B Interface Module	870-2972-01	870-2972-01	
E5-ENET-B	E5-ENET-B Interface Module	870-2971-01	870-2971-01	
E5-MASP	E5 Maintenance Administration Subsystem Processor Card	7346924 870-2903-01		
E5-MCPM-B	E5-MCPM-B Measurements Collection and Polling Module	870-3089-01	870-3089-01	
E5-MDAL	E5 Maintenance Disk and Alarm Card	7346923 870-2900-01		
E5-SM8G-B	E5-SM8G-B DSM Module	870-2990-01	870-2990-01	
EDCM	Enhanced Database Communications Module	870-2197-01	---	double-slot Pre-IP ⁷ SG 4.0
HIPR2	High-Speed IMT Packet Router 2 Module	7333484 870-2872-01	870-2872-01	Replaces IPMX, HMUX, HIPR
IPMX	Interprocessor Message Transport Power and Multiplexer	870-1171-01	---	replaced by HMUX
MCA	Matrix Controller Automatic (Holdover Clock)	000-0028-xx	---	
MCAP	Maintenance Administration Subsystem (MAS) Communications Applications Processor	870-1013-xx 870-1307-xx	---	Replaced by GPSM-II as of 30.0

Table D-2 (Cont.) EAGLE Components

Acronym	Name	Part Numbers		Note
		North America	International	
MIS	Maintenance Interface System Card (Holdover Clock)	804-0175-xx	---	
MPS	Multi-purpose Server	890-1287-xx 890-1374-xx	--- ---	OEM Open System
SLIC	Service and Link Interface Card	7094646		Runs multiple applications
TOCA	Timing Output Composite Automatic (Holdover Clock)	804-0166-xx	---	

Frames, Backplanes, FAPs, and Fans

Table D-3 EAGLE Frames, Backplanes, FAPs, and Fans

Acronym	Name	Part Numbers		Note
		North America	International	
BP	Breaker Panel	804-1423-01	804-1423-R01	
BP	Breaker Panel	870-1814-01	---	
	Control Shelf Backplane -02	850-0330-02	---	inactive
	Control Shelf Backplane -03	850-0330-03	---	inactive
	Control Shelf Backplane -04	850-0330-04	---	
	Control Shelf Backplane -05	850-0330-05	---	not active
	Control Shelf Backplane -06	850-0330-06	850-0330-07	shelves 6 and 7 no longer supported
	Control Shelf Backplane	7333412		ROHS number
	E1 Backplane	850-0459-01	850-0459-02	

Table D-3 (Cont.) EAGLE Frames, Backplanes, FAPs, and Fans

Acronym	Name	Part Numbers		Note
		North America	International	
	Extension Shelf Backplane	850-0356-01	---	inactive
	Extension Shelf Backplane	850-0356-02	---	inactive
	Extension Shelf Backplane	850-0356-03	---	inactive
	Extension Shelf Backplane	850-0356-04	850-0356-06	
	Extension Shelf Backplane	7333417		ROHS number
	Fan Assembly	7315823		ROHS number
	Fan Assembly	890-0001-02	890-0001-04	All systems with HCMIMs EAGLE 33.0
	Fan Assembly	890-1038-01	890-1038-03 890-1038-04	Standard frame Heavy Duty frame
	Filter, fan tray	551-0032-01	---	
	Fan filter	551-0022-01	---	
FAP	Fuse and Alarm Panel	860-0434-01	860-0434-03 860-0434-04	Heavy Duty Frame
FAP	Fuse and Alarm Panel	870-1606-02 Rev C	---	Standard Frame 60 Amp feeds
FAP	Fuse and Alarm Panel	870-1606-02 Rev B	---	Standard 40 Amp feeds
FAP	Fuse and Alarm Panel	870-2320-028 Rev J	870-2320-04	Heavy Duty Frame 60 Amp feeds
FAP	Fuse and Alarm Panel	870-2320-01 Rev A - I	870-2320-03	Heavy Duty Frame 40 Amp feeds
FAP	Fuse and Alarm Panel	870-0243-08 Rev C	---	Control/ Extension Frame

Table D-3 (Cont.) EAGLE Frames, Backplanes, FAPs, and Fans

Acronym	Name	Part Numbers		Note
		North America	International	
FAP	Fuse and Alarm Panel	870-0243-09 Rev C	---	Misc Frame
	FAP Jumper Board	870-1641-01	---	
	FAP Jumper Board	870-1641-02	---	
	Heavy Duty Frame	860-0434-01	---	
FAP	Fuse and Alarm Panel	870-2804-01	870-2804-01	Control/Extension Frame
	FAP Shorting Board	870-2805-01	870-2805-01	
	FAP Jumper Board	870-2806-01	870-2806-01	

Labels

Table D-4 EAGLE Labels

Name	Part Numbers
Label, Control frame	658-0486-01
Label, Extension frame 00	658-0486-02
Label, Extension frame 01	658-0486-03
Label, Extension frame 02	658-0486-04
Label, Extension frame 03	658-0486-05
Label, Extension frame 04	658-0486-06
Label, Miscellaneous frame 00	658-0374-01
Label, Miscellaneous frame 01	658-0374-02
Label, Heavy Duty Frame	658-0374-01
Label, CF-00, Shelf 1	658-0490-01
Label, CF-00, Shelf 2	658-0490-02
Label, CF-00, Shelf 3	658-0490-03

Table D-4 (Cont.) EAGLE Labels

Name	Part Numbers
Label, EF-00, Shelf 1	658-0490-04
Label, EF-00, Shelf 2	658-0490-05
Label, EF-00, Shelf 3	658-0490-06
Label, EF-01, Shelf 1	658-0490-07
Label, EF-01, Shelf 2	658-0490-08
Label, EF-01, Shelf 3	658-0490-09
Label, EF-02, Shelf 1	658-0490-10
Label, EF-02, Shelf 2	658-0490-11
Label, EF-02, Shelf 3	658-0490-12
Label, EF-03, Shelf 1	658-0490-13
Label, EF-03, Shelf 2	658-0490-14
Label, EF-03, Shelf 3	658-0490-15
Label, EF-04, Shelf 1	658-0490-16
Label, Field Tool Identification	658-0941-01
Label, Field Tool Identification wrap	658-0941-02

Miscellaneous Parts

Table D-5 EAGLE Miscellaneous Part Numbers

Name	Part Numbers		Note
	North America	International	
Drives			
Dual CD-RW\DVD-ROM	870-2746-01	870-2746-02	T1x00 AS
Disk Drive, 120GB	804-1804-01	804-1804-R01	ULTRAATA/ 100/133_7200RPM
Panels			
Alarm side panel	870-0259-02	---	
Alarm indicator lamps	525-0067-R01	---	

Table D-5 (Cont.) EAGLE Miscellaneous Part Numbers

Name	Part Numbers		Note
	North America	International	
Blank side panel	840-0017-02	---	
Gray tinted plastic rear covers	654-0075-01	654-0075-R01	
Brackets, unit separation	652-0609-01	652-0609-02	
Bracket	652-0954-01	652-0954-02	Fan
Kits			
Cable Rack Mounting Kit	804-1571-01	---	Heavy duty frame
Cable Rack Mounting Kit	804-0219-01	804-0219-R01	raised floor
	804-0219-02	804-0219-R02	
External tooth washers	606-0062-01	---	fan bracket
Diode Board A	870-1608-01	---	
Diode Board A	870-1608-03	---	
Diode Board B	870-1608-02	---	
Diode Board B	870-1608-04	---	
Diode Upgrade kit	840-0139-01	---	For 870-1606-02
Diode Upgrade kit	840-0139-02	---	For 870-2320-01
E1 Interface Kit	890-1037-01	890-1037-06	
Mounting hardware kit	840-0092-01	840-0092-03	For heavy duty frame. South America/India only
Brackets, Screws, and other small items			
Brackets, unit separation	652-0609-01	652-0609-02	
Bracket	652-0954-01	652-0954-02	Fan
Bracket, fan tray	652-0012-01	652-0012-02	Fan tray
Bracket, side, fan tray	652-0015-01	652-0015-02	Fan tray
Heat-shrink	804-0229-01	---	
Heat-shrink	804-0228-01	---	
Lugs, # 6 two-hole	502-0085-01	502-0085-R01	FAP connector
#6 AWG	690-0131-01	690-0131-R01	

Table D-5 (Cont.) EAGLE Miscellaneous Part Numbers

Name	Part Numbers		Note
	North America	International	
1/0 pink lug	804-0977-01	804-0977-R01	
Pin Protector Assembly	830-0880-01		
Screws (12)	601-0010-01	---	
Screws	600-0193-01	---	12x24 .500 cs zinc fan bracket
Terminal lug	804-0817-02	804-0817-R02	
Terminating resistor	104-0032-01	---	E1 backplane

Power Cords for Peripherals

Table D-6 Power Cords for Peripherals

Country	Part Number	Country	Part Number
USA	Cord provided	Latvia	804-1185-R01
Argentina	804-1185-R02	Liechtenstein	804-1185-R11
Australia	804-1185-R02	Lithuania	804-1185-R01
Austria	804-1185-R01	Luxembourg	804-1185-R01
Belgium	804-1185-R01	Malaysia	804-1185-R03
Brazil	804-1185-R01	Malta	804-1185-R03
Bulgaria	804-1185-R01	Mexico	Cord provided
Canada	Cord provided	Monaco	804-1185-R01
Chile	804-1185-R01	Netherlands	804-1185-R01
China	804-1185-R09	New Zealand	804-1185-R02
Columbia	Cord provided	Norway	804-1185-R01
Cyprus	804-1185-R03	Peru	804-1185-R01
Czech Republic	804-1185-R01	Philippines	Cord provided
Denmark	804-1185-R04	Poland	804-1185-R01
Egypt	804-1185-R01	Portugal	804-1185-R01
Estonia	804-1185-R01	Romania	804-1185-R01

Table D-6 (Cont.) Power Cords for Peripherals

Country	Part Number	Country	Part Number
Finland	804-1185-R01	Russia	804-1185-R01
France	804-1185-R07	Saudi Arabia	Cord provided
Germany	804-1185-R01	Singapore	804-1185-R03
Greece	804-1185-R01	Slovakia	804-1185-R01
Hong Kong	804-1185-R03	South Africa	804-1185-R06
Hungary	804-1185-R01	South Korea	804-1185-R01
Iceland	804-1185-R01	Spain	804-1185-R01
India	804-1185-R06	Sweden	804-1185-R01
Ireland	804-1185-R03	Switzerland	804-1185-R11
Israel	804-1185-R12	Taiwan	Cord provided
Italy	804-1185-R07	Turkey	804-1185-R01
Ivory Coast	804-1185-R01	United Kingdom	804-1185-R03
Japan	804-1185-R10	United Arab	804-1185-R03

Symbols

145P tag, [5-18](#)
830-0404-xx, [6-75](#)
830-0531-04, [6-88](#)
830-0535-xx, [6-88](#)
830-0609-01, [6-41](#)
830-1145-01, [6-86](#)
830-1153-01, [6-41](#)
850-0330-04, [6-6](#)
850-0330-06 or -07, [6-86](#)

A

ACM, [6-11](#)
air management card, [2-6](#), [6-41](#)
American Wire Gage, [5-13](#)
anchor and frame, [4-9](#)
anchor assembly, [4-10](#)
anchor bolt, [4-16](#)
Application Communication Module, [6-11](#)
ATM, [6-53](#)
ATM LIM, [6-53](#)
AWG, [5-13](#)

B

backpower protection, [5-11](#)
BITS, [6-85](#), [6-87](#), [6-95](#)
brace bolts, [4-2](#)
brackets, [6-45](#)
Building Integrated Timing System, [6-85](#), [6-87](#)
bus, [5-13](#)

C

cable ends, [5-15](#)
Cable Rack Mounting Kit, [4-11](#)
Cable Running List, [6-88](#)
cables
 labeling, [3-4](#), [C-1](#)
Cables, [5-26](#)
Capacity, [5-33](#)

card installation, [3-3](#)
card replacement, [3-3](#)
central office ground, [5-23](#)
CI, [3-1](#), [D-7](#)
clock, [6-85](#)
CLOCK, [6-91](#)
clock cables, [6-93](#)
Clock/Alarm, [6-1](#)
composite clock, [6-53](#)
Control frame, [4-28](#)
Control Frame, [5-50](#)
control shelf connectors, [B-1](#)
copper-plated hardware, [5-19](#)
crimp, [5-26](#)
crimp the lugs, [5-15](#)
Crimping tool, [5-16](#)

D

DCM, [3-1](#)
diode boards, removing, [5-11](#)
dollies, [4-5](#)
DSM, [3-1](#)
DSX, [6-6](#), [6-9](#)

E

E1/T1 MIM, [6-53](#)
E5-ATM-B, [D-8](#)
E5-ENET-B, [D-8](#)
E5-MASP, [D-8](#)
E5-MCPM-B, [D-8](#)
E5-MDAL, [D-8](#)
E5-SM8G-B, [D-8](#)
Ear protectors, [4-15](#)
EDCM, [D-8](#)
electric shock, [2-2](#), [5-16](#)
embossing dies, [5-19](#)
Extension frame, [4-28](#)
Extension Frame, [5-51](#)
Extension frame 01, [4-28](#)
Extension frame 02, [4-29](#)

Extension frame 03, [4-29](#)
Extension frame 04, [4-29](#)
external alarm cable installation, [6-87](#)
external tooth washer, [6-45](#)

F

FAP, [5-1](#), [5-7](#), [5-29](#)
FAP_JB (Jumper Board), [5-10](#)
floor plan, [4-7](#)
fuse, [5-27](#)
Fuse and Alarm Panel, [5-1](#), [5-7](#)
Fuse Location, [5-33](#)

G

GMT, [6-96](#)
green cable, [5-25](#)
ground bar, [5-18](#)
ground cable, [5-19](#)
Ground Cable, [5-19](#), [D-4](#)
ground plane, [5-16](#)
Ground Window, [5-17](#)

H

H-tapped, [5-17](#)
hardware testing, [3-1](#)
heat-shrink, [5-19](#)
Heat-shrink gun, [5-19](#)
Heat-shrink gun (hot air blower), [5-17](#)
Heavy Duty Frame, [4-29](#), [4-32](#)
High-Speed Master Timing, [6-53](#)
HMUX, [6-55](#)
holdover clock, [6-93](#)
holes are drilled, [4-16](#)
hot air blower, [5-19](#)
HS Master Timing, [6-54](#)
Htap, [5-13](#)

I

IMT Cables, [6-2](#)
Installer's Cable Running List, [3-5](#), [C-1](#)
Interdependencies, [6-55](#)
Interface cables, [6-1](#)
Interprocessor Message Transport, [6-2](#)
Interprocessor Message Transport (IMT), [6-1](#)
Isolation sheet, [4-15](#)

J

J-8, [6-41](#), [6-48](#)
J-9, [6-41](#), [6-48](#)
jumper board, [5-10](#), [5-11](#)

L

label
 cables, [3-4](#), [C-1](#)
Label each cable, [5-26](#)
Label Kit, [3-6](#)
LIM, [3-2](#)
Link Interface Module (LIM), [6-53](#)
local maintenance center cable installation, [6-87](#)
logic ground, [5-22](#), [5-24](#)
LOGIC GROUND, [5-25](#)
logic ground cable
 P/N 804-0817-02, [5-23](#)
logic grounds, [5-24](#)

M

Main Ground Bar, [5-18](#)
Masking tape, [4-15](#)
masonry drill-bit, [4-15](#)
MASP, [6-56](#)
Master Timing, [6-53](#)
MAU, [6-11](#), [6-13](#), [6-102](#)
MAU (Media Access Unit), [3-8](#)
Media Access Unit (MAU), [3-8](#)
Miscellaneous frame, [4-29](#)
modem, [6-88](#)

N

non oxidizing grease, [5-19](#), [5-22](#)

O

one-inch diameter hole, [4-9](#)

P

P/N 502-0085-01, [5-25](#)
P/N 658-0374-01 (Label - General Purpose Frame),
 [4-32](#)
P/N 690-0108-07, [5-19](#)
P/N 690-0131-01, [5-25](#)
P/N 804-0219-01, [4-12](#)
P/N 804-0228-01, [5-25](#)
P/N 804-0229-01 window clear heat shrink, [5-19](#)
P/N 804-0817-02, [5-25](#)
P/N 804-0977-01 long barrel lug, [5-19](#)
P/N 830-0543-01, [6-93](#)
P/N 830-0873-xx, [6-54](#)
P/N 870-2320-01, [5-13](#)
pink lug, [5-19](#), [D-14](#)
power cables, [5-16](#)
prepare a concrete floor, [4-15](#)

R

rack alarm cable installation, [6-87](#)
rack horns, [5-19](#)
ramp, [4-2](#)
rear covers, [4-20](#), [D-13](#)
Remote Maintenance Center, [6-87](#)
remote maintenance center cable installation, [6-87](#)
removing diode boards, [5-11](#)
Replace tiles, [4-9](#)
Requirements
 ATM or E1 LIM card(s), [6-55](#)
 backplane (P/N 850-0330-04), [6-54](#)
 backplane (P/N 850-0330-05), [6-54](#)
 T1 or E1 clock source (RS 422), [6-55](#)
reseat card, [3-3](#)
return cables, [5-14](#)
return shipment, [1-10](#), [4-6](#)
risk of electric shock, [2-2](#), [5-16](#)
RMC, [6-87](#)
Rotary impact drill, [4-15](#)

row alarm cable installation, [6-87](#)

S

Safety glasses, [4-15](#)
screws, [6-45](#)
shipping container, [4-1](#)
Shipping Manager, [4-6](#)
System Ground, [5-20](#)

T

Tie-wrap, [5-19](#)
tinned ground, [5-19](#)
TOCA, [3-3](#), [D-9](#)

V

Vacuum cleaner, [4-15](#)

