

# Oracle® Communications EAGLE Maintenance Guide



Release 46.8  
F11910 Revision 1  
June 2019

The Oracle logo, consisting of a solid red square with the word "ORACLE" in white, uppercase, sans-serif font centered within it.

ORACLE®

Oracle Communications EAGLE Maintenance Guide, Release 46.8

F11910 Revision 1

Copyright © 1993, 2019, Oracle and/or its affiliates. All rights reserved.

This software and related documentation are provided under a license agreement containing restrictions on use and disclosure and are protected by intellectual property laws. Except as expressly permitted in your license agreement or allowed by law, you may not use, copy, reproduce, translate, broadcast, modify, license, transmit, distribute, exhibit, perform, publish, or display any part, in any form, or by any means. Reverse engineering, disassembly, or decompilation of this software, unless required by law for interoperability, is prohibited.

The information contained herein is subject to change without notice and is not warranted to be error-free. If you find any errors, please report them to us in writing.

If this is software or related documentation that is delivered to the U.S. Government or anyone licensing it on behalf of the U.S. Government, then the following notice is applicable:

U.S. GOVERNMENT END USERS: Oracle programs, including any operating system, integrated software, any programs installed on the hardware, and/or documentation, delivered to U.S. Government end users are "commercial computer software" pursuant to the applicable Federal Acquisition Regulation and agency-specific supplemental regulations. As such, use, duplication, disclosure, modification, and adaptation of the programs, including any operating system, integrated software, any programs installed on the hardware, and/or documentation, shall be subject to license terms and license restrictions applicable to the programs. No other rights are granted to the U.S. Government.

This software or hardware is developed for general use in a variety of information management applications. It is not developed or intended for use in any inherently dangerous applications, including applications that may create a risk of personal injury. If you use this software or hardware in dangerous applications, then you shall be responsible to take all appropriate fail-safe, backup, redundancy, and other measures to ensure its safe use. Oracle Corporation and its affiliates disclaim any liability for any damages caused by use of this software or hardware in dangerous applications.

Oracle and Java are registered trademarks of Oracle and/or its affiliates. Other names may be trademarks of their respective owners.

Intel and Intel Xeon are trademarks or registered trademarks of Intel Corporation. All SPARC trademarks are used under license and are trademarks or registered trademarks of SPARC International, Inc. AMD, Opteron, the AMD logo, and the AMD Opteron logo are trademarks or registered trademarks of Advanced Micro Devices. UNIX is a registered trademark of The Open Group.

This software or hardware and documentation may provide access to or information about content, products, and services from third parties. Oracle Corporation and its affiliates are not responsible for and expressly disclaim all warranties of any kind with respect to third-party content, products, and services unless otherwise set forth in an applicable agreement between you and Oracle. Oracle Corporation and its affiliates will not be responsible for any loss, costs, or damages incurred due to your access to or use of third-party content, products, or services, except as set forth in an applicable agreement between you and Oracle.

This documentation is in preproduction status and is intended for demonstration and preliminary use only. It may not be specific to the hardware on which you are using the software. Oracle Corporation and its affiliates are not responsible for and expressly disclaim all warranties of any kind with respect to this documentation and will not be responsible for any loss, costs, or damages incurred due to the use of this documentation.

The information contained in this document is for informational sharing purposes only and should be considered in your capacity as a customer advisory board member or pursuant to your beta trial agreement only. It is not a commitment to deliver any material, code, or functionality, and should not be relied upon in making purchasing decisions. The development, release, and timing of any features or functionality described in this document remains at the sole discretion of Oracle.

This document in any form, software or printed matter, contains proprietary information that is the exclusive property of Oracle. Your access to and use of this confidential material is subject to the terms and conditions of your Oracle Master Agreement, Oracle License and Services Agreement, Oracle PartnerNetwork Agreement, Oracle distribution agreement, or other license agreement which has been executed by you and Oracle and with which you agree to comply. This document and information contained herein may not be disclosed, copied, reproduced, or distributed to anyone outside Oracle without prior written consent of Oracle. This document is not part of your license agreement nor can it be incorporated into any contractual agreement with Oracle or its subsidiaries or affiliates.

# Contents

## 1 About This User's Guide

---

Overview	1-1
Scope and Audience	1-1
Documentation Admonishments	1-2
Manual Organization	1-2
My Oracle Support (MOS)	1-3
Emergency Response	1-3
Related Publications	1-4
Customer Training	1-4
Locate Product Documentation on the Oracle Help Center Site	1-4
Hardware Repair and Return	1-4
Repair and Return Shipping Instructions	1-5
Maintenance Strategy	1-7
System Maintenance Log	1-8

## 2 Preventive Maintenance

---

Introduction	2-1
Maintaining the Fuse and Alarm Panel	2-1
1U FAP P/N 870-2804-01	2-2
FAP Components	2-2
Alarms	2-3
Diode Testing and the Shorting Board	2-4
3U FAP	2-7
FAP Components	2-7
Alarms	2-11
Diode Testing and the Diode Jumper	2-11
Removable Drives	2-15
Removable USB Drive	2-15
Fixed SATA Drive	2-18
Daily Procedures	2-37
Backing Up the Database Daily	2-37
System Reports Analysis	2-38

Reports Description	2-39
File Transfer for LNP and INP Measurements	2-39
Weekly Procedures	2-40
Database Archive (Weekly)	2-40
Printer Inspection	2-41
Remote Access Verification	2-42
Monthly Procedures	2-42
Database Archive (Monthly)	2-43
FAP Load Balance Verification (PN 870-0243-XX only)	2-44
Change the Fan Tray Filter	2-48
Changing the Air Supply Filter	2-48
Cleaning Printer	2-50
Fuse Spares Inventory	2-50
Wrist Strap Test	2-50
Quarterly Procedures	2-51
Database Archive (Quarterly)	2-51
Preventing Dust Buildups	2-52
Rectifier Voltage Inspection/Recording	2-52
Semi-Annual Procedures	2-53

### 3 Corrective Maintenance

---

Introduction	3-1
System Alarm Levels	3-2
Trouble Detection	3-2
Output Messages	3-9
Alarm Clearing Procedures	3-10
Retrieve Trouble Report	3-11
Hourly Status Message Reports	3-12
Maintenance System Event Logs	3-16
Obituaries	3-17
Terminal Not Responding	3-18
Printer Not Working	3-19
Modem Not Working	3-21
Link Maintenance	3-21
Link Maintenance Enhancements	3-27
Power Down of In-Service System	3-34
Power Up of the System	3-37

## A Card Removal/Replacement Procedures

---

Introduction	A-1
EAGLE Replacement Parts List	A-1
E5-MASP Card Replacement	A-1
E5-MDAL Card Replacement	A-12
HIPR2 Card Replacement	A-15
Determine Card Changeout Time	A-18
E5-ATM-B Card Replacement	A-19
SS7 and IP7 Card Replacement	A-22
E5-ENET-B Module	A-26
IP SIGTRAN on E5-ENET-B	A-28
STPLAN/EROUTE on E5-ENET-B	A-33
Database Services Module (DSM)	A-36
E5-SM8G-B Card Replacement	A-39
E5-ENET-B Card Replacement	A-42
Replacing Cards with SLIC Hardware	A-46
Database Communications Module (DCM)	A-46
Measurement Collection and Polling Module (E5-MCPM)	A-48
Replacing a Card in the EAGLE	A-49
Replacing Cards in the Holdover Clock	A-52
Non-Failed Clock Input (CI) Card Replacement	A-53
ST3 Card Replacement	A-54
MIS Card Replacement	A-55
TOCA Card Replacement	A-56
Fan Assembly P/N 890-0001-xx	A-59
Replace the Fan Unit	A-60
Replace Fan Controller Card	A-60
Replace Fan Assembly	A-61
Procedure - Power Down the Fan Assembly	A-61
Procedure - Remove Fan Cables and Fan Assembly	A-62
Procedure - Install the Fan Assembly	A-63
Procedure - Power Up the Fan Assembly	A-66

## B Holdover Clock Troubleshooting Procedures

---

Introduction	B-1
Interpreting System Alarms, Lamps And Trouble Isolation	B-1

## C Part Numbers

---

Overview	C-1
----------	-----

Cables, Adapters	C-2
Customer Supplied Ethernet Cable Requirements	C-5
Components	C-6
Frames, Backplanes, FAPs, and Fans	C-7
Labels	C-9
Miscellaneous Parts	C-9
Power Cords for Peripherals	C-11

## Index

---

## List of Figures

---

2-1	FAP High-Level Block Diagram	2-2
2-2	Shorting Board Faceplate, Normal Mode	2-4
2-3	Shorting Board Faceplate, Maintenance Mode	2-5
2-4	Diode Board Faceplate	2-5
2-5	Diode Board Edge Connector J1	2-6
2-6	Shorting Board Faceplate, Maintenance Mode	2-7
2-7	Shorting Board Faceplate, Normal Mode	2-7
2-8	Location of FAP Components	2-8
2-9	FAP Component Functions	2-9
2-10	Removable USB Drive LOCKED	2-16
2-11	Removable USB Drive UNLOCKED	2-17
2-12	SATA Drive Locked	2-22
2-13	SATA Drive UNLOCKED	2-23
2-14	Open Diode Example	2-46
2-15	Steady State Example	2-46
2-16	Fan Assembly	2-48
2-17	Fan Filter Replacement	2-49
3-1	MDAL Alarm LEDs	3-4
3-2	GMT Fuse	3-5
3-3	Fuse and Alarm Panel Front Layout (870-2804-01)	3-6
3-4	Fuse and Alarm Panel Front Layout (870-0243-xx)	3-6
3-5	Fuse and Alarm Panel Front Layout (870-1606-xx/870-2320-xx)	3-7
3-6	Output Message Format	3-9
3-7	Format of Hourly Status Message Output	3-13
3-8	Signaling Link Network Connections	3-28
A-1	E5-MASP Card Inject/Eject Hardware Switch, UNLOCKED	A-4
A-2	E5-MASP Card Inject/Eject Hardware Switch, LOCKED	A-5
A-3	E5-MASP LEDs	A-12
A-4	E5-MDAL LEDs	A-14
A-5	HIPR2 LEDs	A-18
A-6	E5-ATM-B LEDs	A-22
A-7	DS0A-LIM LEDs	A-26
A-8	E5-ENET-B LEDs	A-28
A-9	E5-SM8G-B LEDs	A-42
A-10	DCM LEDs	A-48

A-11	Push Inject/Eject Clamps Outward	A-50
A-12	Push in Inject/Eject Clamps	A-51
A-13	Holdover Clock CI Card LEDs	A-52
A-14	Holdover clock ST3 card LEDs	A-55
A-15	Holdover Clock MIS Card LEDs	A-56
A-16	Holdover Clock TOCA Card LEDs	A-58
A-17	Holdover Clock MCA Card LEDs	A-59
A-18	Fan Unit Mounting Screws	A-60
A-19	Fan card with LEDs on front of fan assembly unit	A-62
A-20	Fan Assembly Rear Bracket Screws.	A-63
A-21	Fan Assembly	A-63
A-22	Fan tray inserted into fan tray bracket in the frame - front view	A-64
A-23	Tighten rear fan tray screws	A-65
A-24	Tighten fan side bracket screws	A-66
A-25	Fan card with LEDs on front of fan assembly	A-67



## List of Tables

---

1-1	Admonishments	1-2
1-2	Basic RMA Types	1-5
1-3	RMA Reasons for Return	1-5
1-4	System Maintenance Log	1-8
2-1	FAP Component Replacement	2-2
2-2	FAP Alarm Conditions	2-3
2-3	Additional Alarm Indicators	2-4
2-4	Power Diode Test Points	2-6
2-5	FAP Component Replacement	2-9
2-6	FAP Alarm Conditions	2-11
2-7	Additional Alarm Indicators	2-11
2-8	FAP Part Numbers and Corresponding Procedures	2-12
2-9	Oracle Method of Procedure Test Record	2-47
3-1	Fuse and Alarm Panel Front Items (870-2804-01)	3-5
3-2	Fuse and Alarm Panel Front Items (870-0243-xx)	3-6
3-3	Fuse and Alarm Panel Front Items (870-1606-xx/870-2320-xx)	3-6
3-4	IMT Bus Alarm Levels	3-9
3-5	Remote Link Element types	3-22
3-6	Link Fault Sectionalization Test Types	3-22
3-7	Link Fault Sectionalization Test Patterns	3-23
3-8	Hardware/Card/APPL LFS Support	3-23
3-9	Link Fault Sectionalization Data Entry Parameters	3-25
3-10	Link Fault Sectionalization Test Parameters	3-26
3-11	Command Driven Loopback Support	3-27
3-12	tst-slk Support	3-28
3-13	tst-e1/tst-t1 Support	3-29
3-14	Loopback AST Field Display	3-34
A-1	Card Locations	A-2
A-2	DCM Card Locations	A-47
B-1	Input and ST3 Alarm Conditions	B-2
B-2	Input and ST3 Corrective Actions	B-3
B-3	Shelf and Output Alarm Conditions - Not Related to Input and ST Conditions	B-5
B-4	Shelf and Output Corrective Actions - Not Related to Input and ST Conditions	B-7
C-1	EAGLE Cables, Connectors, and Power Cords	C-2
C-2	EAGLE Components	C-6

C-3	EAGLE Frames, Backplanes, FAPs, and Fans	C-7
C-4	EAGLE Labels	C-9
C-5	EAGLE Miscellaneous Part Numbers	C-9
C-6	Power Cords for Peripherals	C-11

# 1

## About This User's Guide

This chapter describes the content and structure of the user's guide, indicates how to obtain help, details where to find related documentation, and provides other general information.

### Overview

*Maintenance Guide* provides preventive and corrective maintenance procedures used in maintaining the Oracle Communications EAGLE and the **Multi-Purpose Server (MPS)** systems.

#### **NOT\_SUPPORTED:**

Be sure to wear a wrist strap connected to the wrist strap grounding point of the **EAGLE** before performing any installation procedures on the EAGLE.

The manual is organized as follows:

- [About This User's Guide](#) provides general information about the organization of this manual, a description of the EAGLE maintenance strategy, and a list of acronyms and abbreviations.
- [Preventive Maintenance](#) provides recommended scheduled routines for the EAGLE.
- [Corrective Maintenance](#) provides procedures to use in response to all system alarms by the EAGLE.

In addition, these appendices of this manual provide useful reference material for maintenance, diagnostic, and troubleshooting activities.

- [Card Removal/Replacement Procedures](#)
- [Holdover Clock Troubleshooting Procedures](#)
- [Part Numbers](#)

### Scope and Audience

This manual is intended for maintenance personnel who must maintain the EAGLE. The technician should be familiar with **SS7** protocols. The manual provides preventive and corrective procedures that will aid maintenance personnel in maintaining the EAGLE.





Preventive maintenance procedures are routines to be carried out on a scheduled basis to help prevent system failures. These routines are industry-standard recommendations and may be adopted to fit any company maintenance plan.

The corrective maintenance procedures are those used in response to a system alarm or output message. These procedures are EAGLE-specific and aid in the detection, isolation, and repair of faults.

# Documentation Admonishments

Admonishments are icons and text throughout this manual that alert the reader to assure personal safety, to minimize possible service interruptions, and to warn of the potential for equipment damage.

**Table 1-1 Admonishments**

Icon	Description
 DANGER	Danger: (This icon and text indicate the possibility of <i>personal injury</i> .)
 WARNING	Warning: (This icon and text indicate the possibility of <i>equipment damage</i> .)
 CAUTION	Caution: (This icon and text indicate the possibility of <i>service interruption</i> .)
 TOPPLE	Topple: (This icon and text indicate the possibility of <i>personal injury and equipment damage</i> .)

## Manual Organization

*Maintenance Guide* is organized into the following chapters:

- [About This User's Guide](#) — Contains general information about manual organization, the scope of this manual, its targeted audience, brief explanations of the various systems, typical content of a Documentation Suite delivered with each system, how to handle hardware repairs and returns, and how to get technical assistance.
- [Preventive Maintenance](#) — Contains recommended routine maintenance procedures to be performed on a scheduled basis.
- [Corrective Maintenance](#) — Contains corrective maintenance and alarm clearing procedures used to correct issues.
- [Card Removal/Replacement Procedures](#) — Contains card removal and replacement procedures, including administrative commands required to take a card out of service and place it back into service.
- [Holdover Clock Troubleshooting Procedures](#) — Describes holdover clock alarm conditions and offers troubleshooting procedures.
- [Part Numbers](#) — Contains the part numbers of Oracle equipment, components, cables, and miscellaneous parts described in this guide.

## My Oracle Support (MOS)

MOS (<https://support.oracle.com>) is your initial point of contact for all product support and training needs. A representative at Customer Access Support (CAS) can assist you with MOS registration.

Call the CAS main number at 1-800-223-1711 (toll-free in the US), or call the Oracle Support hotline for your local country from the list at <http://www.oracle.com/us/support/contact/index.html>. When calling, make the selections in the sequence shown below on the Support telephone menu:

1. Select 2 for New Service Request
2. Select 3 for Hardware, Networking and Solaris Operating System Support
3. Select one of the following options:
  - For Technical issues such as creating a new Service Request (SR), Select 1
  - For Non-technical issues such as registration or assistance with MOS, Select 2

You will be connected to a live agent who can assist you with MOS registration and opening a support ticket.

MOS is available 24 hours a day, 7 days a week, 365 days a year.

## Emergency Response

In the event of a critical service situation, emergency response is offered by the Customer Access Support (CAS) main number at 1-800-223-1711 (toll-free in the US), or by calling the Oracle Support hotline for your local country from the list at <http://www.oracle.com/us/support/contact/index.html>. The emergency response provides immediate coverage, automatic escalation, and other features to ensure that the critical situation is resolved as rapidly as possible.

A critical situation is defined as a problem with the installed equipment that severely affects service, traffic, or maintenance capabilities, and requires immediate corrective action. Critical situations affect service and/or system operation resulting in one or several of these situations:

- A total system failure that results in loss of all transaction processing capability
- Significant reduction in system capacity or traffic handling capability
- Loss of the system's ability to perform automatic system reconfiguration
- Inability to restart a processor or the system
- Corruption of system databases that requires service affecting corrective actions
- Loss of access for maintenance or recovery operations
- Loss of the system ability to provide any required critical or major trouble notification

Any other problem severely affecting service, capacity/traffic, billing, and maintenance capabilities may be defined as critical by prior discussion and agreement with Oracle.

## Related Publications

For information about additional publications related to this document, refer to the Oracle Help Center site. See [Locate Product Documentation on the Oracle Help Center Site](#) for more information on related product publications.

## Customer Training

Oracle University offers training for service providers and enterprises. Visit our web site to view, and register for, Oracle Communications training:

<http://education.oracle.com/communication>

To obtain contact phone numbers for countries or regions, visit the Oracle University Education web site:

[www.oracle.com/education/contacts](http://www.oracle.com/education/contacts)

## Locate Product Documentation on the Oracle Help Center Site

Oracle Communications customer documentation is available on the web at the Oracle Help Center (OHC) site, <http://docs.oracle.com>. You do not have to register to access these documents. Viewing these files requires Adobe Acrobat Reader, which can be downloaded at <http://www.adobe.com>.

1. Access the Oracle Help Center site at <http://docs.oracle.com>.
2. Click `Industries`.
3. Under the Oracle Communications subheading, click the `Oracle Communications documentation` link.

The Communications Documentation page appears. Most products covered by these documentation sets will appear under the headings "Network Session Delivery and Control Infrastructure" or "Platforms."

4. Click on your Product and then the Release Number.  
A list of the entire documentation set for the selected product and release appears.
5. To download a file to your location, right-click the PDF link, select `Save target as` (or similar command based on your browser), and save to a local folder.

## Hardware Repair and Return

Any system components being returned for repair or replacement must be processed through the Oracle Return Material Authorization (RMA) procedures. A hardware repair is defined as an item returned to Oracle due to a failure, with the returned item being repaired and returned to the customer. It is essential that serial numbers are recorded correctly. RMAs cannot be created without a valid serial number. All repair and quality information is tracked by serial number. [Table 1-2](#) lists the basic RMA types. [Table 1-3](#) lists the RMA return reasons.

**Table 1-2 Basic RMA Types**

Replacement Type	Description	Turnaround
Priority Advance Replacement	Customer requests the URGENT replacement of a damaged product	Same Day Shipment
Advance Replacement	Customer request the replacement of a damaged product	Shipment Within 3 Business Days
Repair / Return	Customer will return a damaged product for repair	Shipment Within 5 Days After Receipt
Expendable	A damaged part, such as a cable, is replaced, but the Customer does not return the damaged product	Depends on Urgency - Shipment Within 3 Business Days

**Table 1-3 RMA Reasons for Return**

Reason for Return	Description
Damaged by Environment	Product damaged by environmental phenomena such as water damage or earthquake.
Damaged in Shipment	Damaged between shipment from Oracle and receipt at the Customer's installation site.
DOA – Dead on Arrival	Product is not functional when it is first installed at the Customer's location.
Lab Return	Products returned from lab sites.
Product Capture	Defect to be captured by Quality or Engineering (not Product Recall).
Product Deficiency	Anything wrong with the part that doesn't fall into another category.
Product Recall	Products recalled by divisions for the repair of a defect or replacement of defective products.
Return – No Product Deficiency	Anything returned without the product being defective.

## Repair and Return Shipping Instructions

All returned equipment, assemblies, or subassemblies must be shipped to the Oracle Repair and Return Facility specified by the [My Oracle Support \(MOS\)](#). The item being returned must be shipped in the original carton or in an equivalent container assuring proper static handling procedures and with the freight charges prepaid.

The assigned RMA number must be clearly printed on the "RMA#:" line of the shipping label on the outside of the shipping package. If the RMA number is not placed on the label, the return could be delayed.

### Procedure - RMA

- Obtain and confirm the following information before contacting the [My Oracle Support \(MOS\)](#):
  - Your name:

- Company name:
- Call-back number:
- Email address:
- Which product you are calling about?
- Site location:
- CLEI number
- System serial number (NT, CE, LM, DS, etc.):
- Complete software release (e.g., 28.0.1-41.53.0):
- Upgrade forms
  - WI005153
  - WI005154
  - WI005218
  - WI005219
  - WI005220
- Oracle card type: (e.g., E5-APP-B, E5-ENET, etc.):
- Oracle card part number (870-####-##):
- Associated serial number (102#####):
- Reason for return or replacement (isolated from system):
- Full name of person the replacement card is being shipped to:
- Shipping address:

 **Note:**

If possible, include associated alarms (UAMs) and a copy of the associated output (capture file).

2. Contact the [My Oracle Support \(MOS\)](#) and request a Return of Material Authorization (RMA).
3. If the item is a like-for-like advance replacement, the [My Oracle Support \(MOS\)](#) arranges for shipment of the replacement item to the customer.
  - a. Wait for the replacement component to arrive.
  - b. Package the defective component in the box of materials you received with your replacement. Use proper static handling procedures.
  - c. Label the outside and inside of the box with your RMA number clearly visible. Place the packing slip from the received replacements on the inside of your box.
  - d. Ship the defective component to the return address listed on the packing slip.
4. If the item is a repair/return, the [My Oracle Support \(MOS\)](#) arranges for shipment of the replacement item to the customer.
  - a. Package the defective component in a suitable package for shipping. Use proper static handling procedures.



- b. Label the outside and inside of the box with your RMA number clearly visible. Include a packing slip with all the information from 1 along with the RMA number.
- c. Ship the defective component to the following address:  
ORACLE  
Attn: RMA Department  
5200 Paramount Parkway  
Morrisville, NC 27560  
RMA#: <assigned by Oracle>
- d. Wait for the repaired component to arrive.

## Maintenance Strategy

The EAGLE is equipped with an automated surveillance system, which allows many failures to be detected and repaired autonomously. When trouble is detected, and its cause determined, the system software attempts to isolate the trouble and recover itself through reinitialization. Because of the use of distributed processing throughout the system, the reinitialization can be localized with little or no impact on the rest of the system or network.

If the system software is unable to correct the problem, an output message is generated and maintenance personnel are provided with equipment location, nature of the trouble, and alarm severity.

There are three levels of recovery in the EAGLE:

- Application self recovery
- System maintenance software intervention
- Maintenance personnel intervention.

### Application Self Recovery

This is the most desirable method of recovery, as it is nearly transparent to the network, and does not require any system resources. Examples of applications capable of self recovery:

- **Link** failure
- **Link** set failure
- **Route** failure
- Interprocessor message transport (IMT) bus failure.

Failure of a link relies on **SS7** maintenance to correct the trouble. This usually entails placing the link out of service (**OS**), re-aligning the link, then placing the link back in service.

**Route** failures also rely on **SS7** maintenance. Transfer restricted (**TFR**) and transfer prohibited (**TFP**) are commonly used to reroute messages around a node.

### System Maintenance Software Intervention

The system maintenance software operates at two levels, maintenance and administration subsystem (**MAS**) and application subsystem (**SS7**, **GLS**, **DTA**, and **STPLAN**). All troubles detected at the application level are reported to the maintenance and administration subsystem (**MAS**), which is responsible for generating system alarms and output messages.

### Maintenance Personnel Intervention

Maintenance personnel intervention is required when hardware fails, or when software is unable to recover. There are few occurrences of maintenance that would require maintenance personnel intervention. Examples include:

- Blown fuses
- Loss of power

 **Note:**

Maintenance personnel intervention is required to restore the power. Once power is restored, the EAGLE recovers automatically.

- **Card failure**

## System Maintenance Log

The purpose of the System Maintenance Log is to provide both maintenance personnel and [My Oracle Support \(MOS\)](#) with a complete trouble history for a specific site. This history aids in spotting trouble trends, which, if left unrecorded, would be impossible to detect. Record all maintenance regardless of nature.

On the following page is an example of a system maintenance log. Use this page to generate copies for your site. Oracle recommends this log be completed after every preventive and corrective maintenance procedure.

This is a troubleshooting aid, and should be filled out completely. Printouts or any other supportive material should be referenced whenever possible. [My Oracle Support \(MOS\)](#) may ask for some of this information at a later time, if a particular trend begins to develop.

The trouble code field in the log is for recording EAGLE trouble messages. All maintenance (regardless of nature) should be recorded on this log for reference when troubleshooting.

**Table 1-4 System Maintenance Log**

---

**System Maintenance Log**

---

# 2

## Preventive Maintenance

### Introduction

The procedures on the following pages are routine maintenance procedures to be performed on a scheduled basis. These procedures are recommendations that if followed will aid in maintaining system performance and data integrity.

These routines aid in detecting trouble trends and intermittent troubles. As with any maintenance activity, personnel should be encouraged to maintain a log of all routines performed. This aids the maintenance technician as well as [My Oracle Support \(MOS\)](#) in determining the source of system troubles and ways to prevent certain troubles from occurring again.

Instructions for performing required maintenance routines are provided. In the event another document may be required for a specific task, that document is referenced.

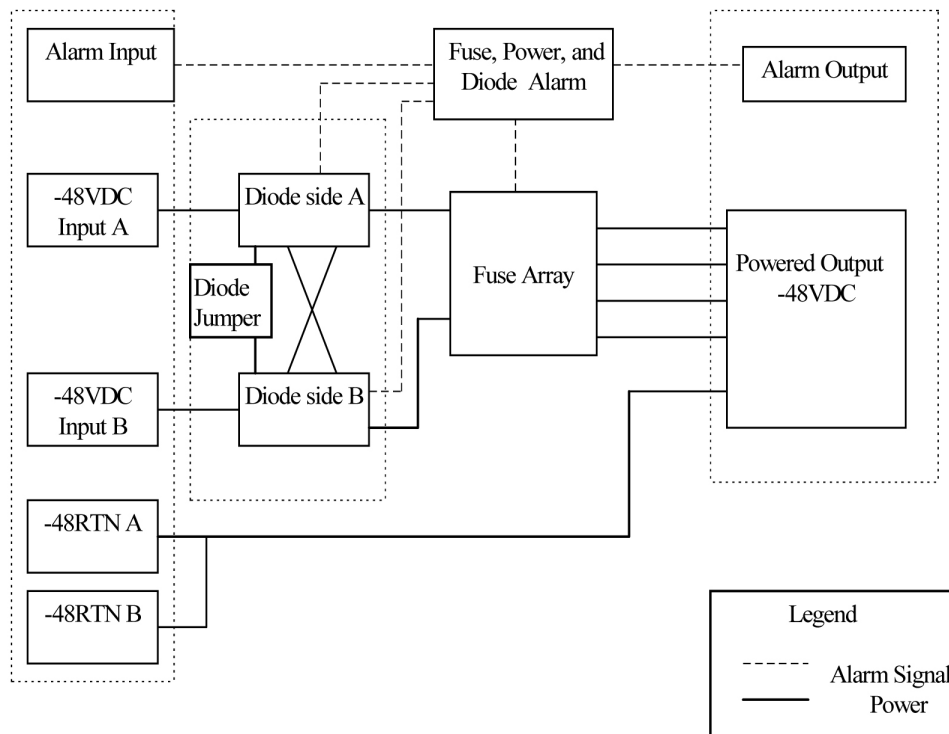
### Maintaining the Fuse and Alarm Panel

The Fuse and **Alarm Panel (FAP)** serves as a central location for identifying a variety of potential problem conditions. However, you may have to occasionally perform corrective maintenance on the **FAP**, itself.

The **FAP** consist of five major functions:

- Input connections
- Diodes
- Fuse Arrays
- **Alarm** circuitry
- Output connections

**Figure 2-1 FAP High-Level Block Diagram**



To assist your **FAP** maintenance efforts, this section provides information about the **FAP** unit:

- The **FAP** components
- **FAP** alarms
- Diode testing and the diode jumper

For more detailed information on the **FAP** and its components, refer to the *FAP Technical Reference (820-2888-01)*.

## 1U FAP P/N 870-2804-01

The 1U FAP (P/N 870-2804-01) is a low-profile unit that provides protected distribution of –48VDC power to the shelves in the frame. Allowing for the full population of a frame and for the failure of one primary supply, new installations of Control and Extension frames require two 60A feeds.

## FAP Components

The **FAP** is composed of three field replaceable units, of which two can be hot-swapped.

**Table 2-1 FAP Component Replacement**

Component	Replacement Requirements	Part Number
Diode Board	Field replaceable	870-2806-01
Shorting Board	Field replaceable	870-2805-01

**Table 2-1 (Cont.) FAP Component Replacement**

Component	Replacement Requirements	Part Number
1U FAP	Field replaceable (with service interruption)	870-2804-01 (includes Diode and Shorting Boards)

**Diode Board**

The diode board in the FAP contains power diodes and circuitry which allow one bus to pick up the entire load when there is a loss of input power on the other bus.

**Shorting Board**

The Shorting board allows the removal of the diode board without taking down the system. This permits periodic maintenance of the diodes without having to power down or remove the unit from the shelf. In the bypass position, both A and B power is connected to the fuse blocks so the diode board can be safely removed. The Shorting board has an LED which is off when the board is in normal operational mode and is green when in the bypass mode of operation.

## Alarms

The FAP provides visual alarms, by means of a lit LED, for a variety of status alarms.

**Table 2-2 FAP Alarm Conditions**

Alarm	Alarm Condition	Remote Indications
Critical LED	<ul style="list-style-type: none"> <li>EAGLE command through E5-TDM</li> <li>E5-MDAL not present and E5-MDAL_P jumper off</li> </ul>	Dependent on EAGLE software
Major LED	EAGLE command through E5-TDM	Dependent on EAGLE software
Minor LED	EAGLE command through E5-TDM	Dependent on EAGLE software
Fuse LED	<ul style="list-style-type: none"> <li>Distribution fuse blown</li> <li>Alarm circuit board removed (no LED indication)</li> <li>Jumper on the jumper circuit board is on</li> <li>Power feed failure</li> </ul>	Fuse alarm to EAGLE through E5-TDM
PWR A LED	Power feed A is off, but power is available to B.	Fuse alarm to EAGLE through E5-TDM
PWR B LED	Power feed B is off, but power is available to A.	Fuse alarm to EAGLE through E5-TDM
Shorting Board LED	Shorting board in maintenance mode.	Fuse alarm to EAGLE through E5-TDM

A fuse alarm identifies the following problems or conditions within the FAP:

- blown fuse(s)
- power loss for side A or B
- alarm card removed

- maintenance mode

Use the following indicators to determine the nature of the problem:

**Table 2-3 Additional Alarm Indicators**

Indicator	Alarm Condition
Fuse alarm and fuse flag down	Blown fuse
Fuse alarm and <b>PWR A LED</b>	Input power loss on A
Fuse alarm and <b>PWR B LED</b>	Input power loss on B
Fuse alarm red and Shorting Board LED is green	Shorting Board in maintenance mode (bypassing diodes)
Fuse alarm red and Shorting Board LED is off	Shorting Board in normal mode, blown fuse

## Diode Testing and the Shorting Board

The Diode Board must be tested periodically. To test the Diode Board without powering down the entire EAGLE, perform the following procedures.

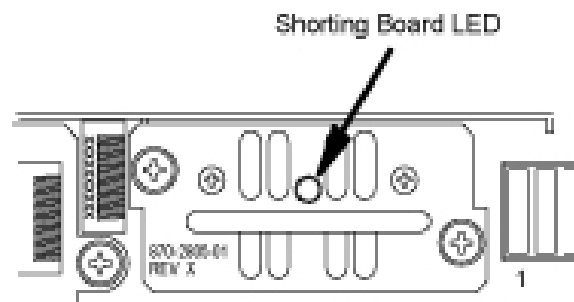
### Maintenance Mode

This section describes how to place the Shorting Board into maintenance (bypass) mode. Maintenance mode allows the removal of the Diode Board without taking down the system.

#### Procedure — Shorting Board Maintenance Mode

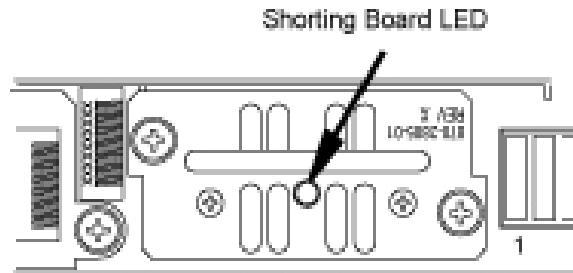
1. Check to verify the Shorting Board LED is not on, indicating the FAP is in normal mode.
2. Locate two screws securing the Shorting Board in its slot (see [Figure 2-2](#)). Note the orientation of the Shorting Board LED. Turn the screws at each corner of the board to the left until they disengage.

**Figure 2-2 Shorting Board Faceplate, Normal Mode**



3. Pull the board straight out of the FAP until the board is clear of the frame.
4. Turn the Shorting Board over and reinsert the board into its slot. Note the orientation of the Shorting Board LED (see [Figure 2-3](#)).

**Figure 2-3 Shorting Board Faceplate, Maintenance Mode**



The Shorting Board LED turns green and the fuse alarm LEDs turn red.

5. Ensure the board is seated properly and tighten the two screws to secure the board.
6. The Shorting Board is now in the maintenance (bypass) mode of operation.

## Diode Board

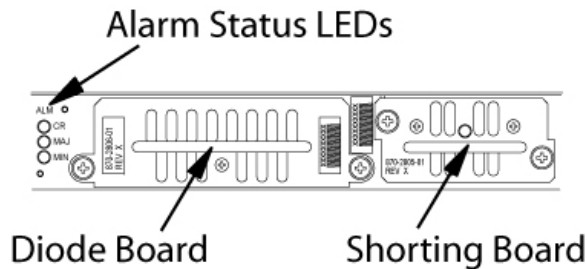
This section describes how to remove and test the Diode Board.

### Procedure — Remove the Diode Board

Use this procedure to remove the Diode Board for diode testing.

1. Check to verify the Shorting Board LED is on, indicating the FAP is in maintenance (bypass) mode.
2. Locate two screws securing the Diode Board in its slot. Turn the screws to the left until they disengage.

**Figure 2-4 Diode Board Faceplate**

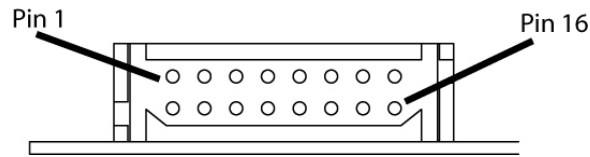


3. Pull the board straight out of the FAP until the board is clear of the frame.

### Procedure - Diode Testing

Use this procedure to test the power diodes on the Diode Board. A Digital Volt/Ohm Meter (DVM) with a Diode Setting is required. All testing is performed at the edge connector (J1) on the board.

**Figure 2-5 Diode Board Edge Connector J1**



1. Set the DVM to test diodes.
2. Connect the DVM positive (+) lead and negative (-) lead to the pins indicated for each power diode.

**Table 2-4 Power Diode Test Points**

Diode	J1 Pin Positive (+) Lead	J1 Pin Negative (-) Lead
CR1 #1	3	16
CR1 #2	6	16
CR2 #1	14	1
CR2 #2	11	1
CR3 #1	4	16
CR3 #2	5	16
CR4 #1	13	1
CR4 #2	12	1

The DVM should indicate a short circuit ( $>0.1V$ ,  $<0.2V$ ). Record the measurement.

3. Reverse the leads.  
The DVM should indicate an open circuit (OL). Record the measurement.
4. If any measurements are in error, the diode board must be replaced.
5. If the measurements are within acceptable parameters, reinstall the Diode Board.

## Normal Mode

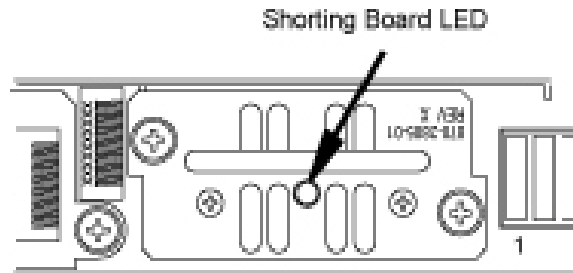
Use this procedure to place the Shorting board into normal mode. This mode of operation allows one bus to pick up the entire load when there is a loss of input power on the other bus.

### Procedure — Shorting Board Normal Mode

1. Check to verify the Shorting Board LED is green, indicating the FAP is in maintenance mode.
2. Locate two screws securing the Shorting Board in its slot. Note the orientation of the Shorting Board LED (Figure 2-6). Turn the screws at each corner of the board to the left until they disengage.

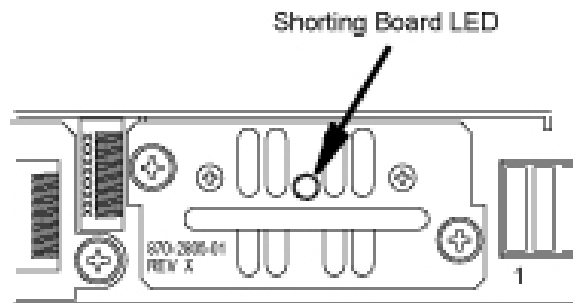


**Figure 2-6 Shorting Board Faceplate, Maintenance Mode**



3. Pull the board straight out of the FAP until the board is clear of the frame.
4. Turn the Shorting Board over and reinsert the board into its slot. Note the orientation of the Shorting Board LED (see [Figure 2-7](#)).

**Figure 2-7 Shorting Board Faceplate, Normal Mode**



**Note:**

The Shorting Board LED is off and the fuse alarm LEDs turn green.

5. Ensure the board is seated properly and tighten the two screws to secure the board.
6. The Shorting Board is now in the normal mode of operation.

## 3U FAP

The 3U FAP is a normal-profile unit that provides protected distribution of –48VDC power to the shelves in the frame. Allowing for the full population of a frame and for the failure of one primary supply, new installations of Control and Extension frames require two 60A feeds. The 3U FAP may be one of the following:

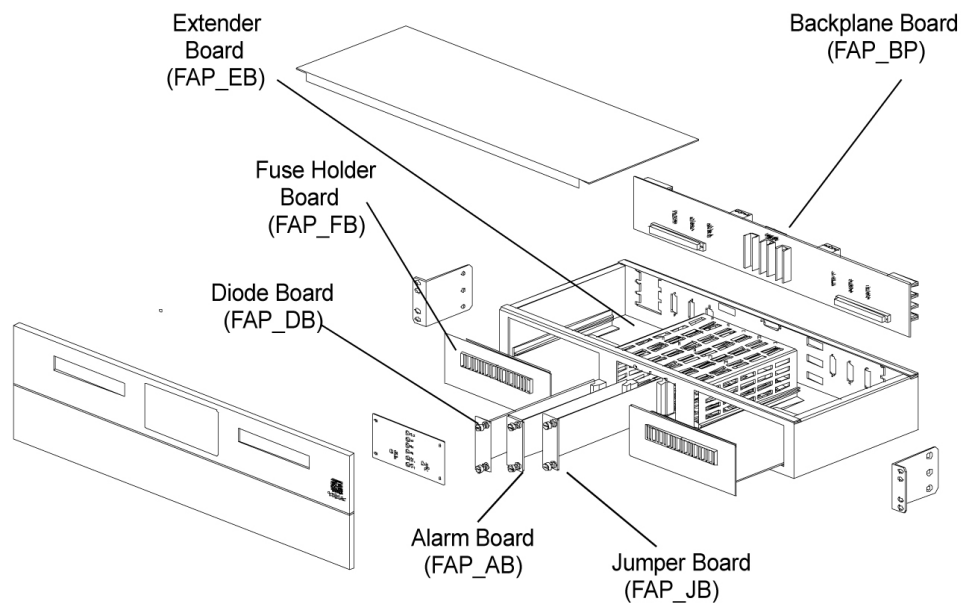
- 870-1606-01 (all revisions)
- 870-1616-02 with a revision G or lower
- 870-2320-01 with a revision B or lower

## FAP Components

The **FAP** consists of nine printed circuit boards, each identified by an acronym on its label (see [Figure 2-8](#)):

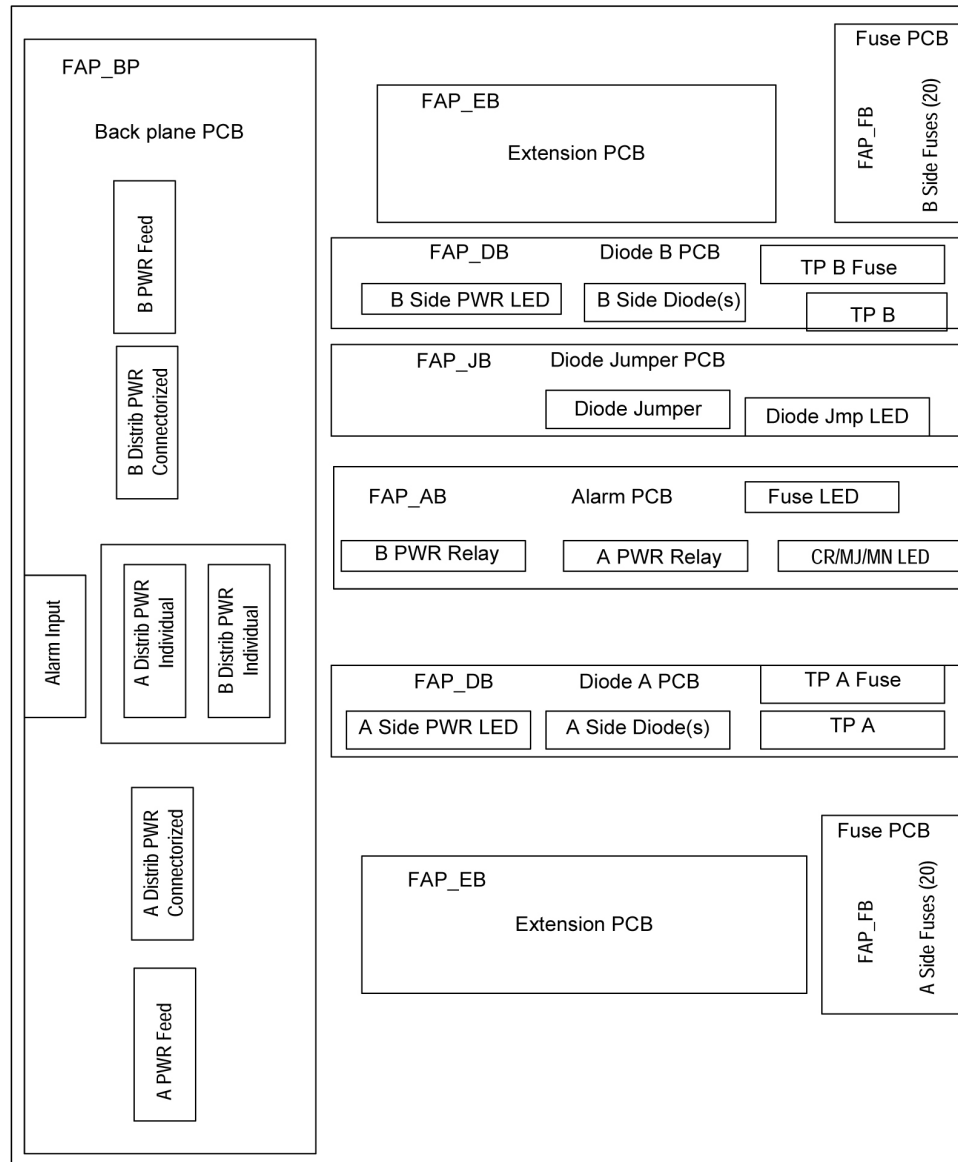
- Backplane (**FAP\_BP**): Located inside the **FAP** unit, parallel to the back side of the **FAP** box.
- **Alarm** board (**FAP\_AB**): Located on the center-right of the front panel, set vertically inside the **FAP** unit, perpendicular to the front panel.
- Diode boards (**FAP\_DB**): Two boards located on the front panel, flanking the **Alarm** and Jumper boards on the left and right, and perpendicular to the front panel. Set vertically inside the **FAP** unit.
- Extender boards (**FAB-EB**): Two boards located inside the **FAP** unit, parallel to the bottom of the **FAP** box, on the far right and left of the unit.
- Fuse holder boards (**FAP\_FB**): Two boards located inside and parallel to the front panel, on the far right and left of the **FAP** unit.
- Jumper board (**FAP\_JB**): Located on the center-left of the front panel, set vertically in the unit, perpendicular to the front panel.

**Figure 2-8 Location of FAP Components**



Each of the **FAP** components has associated functions.

**Figure 2-9 FAP Component Functions**



The **FAP** is composed of nine circuit boards. Eight of these circuit boards are field replaceable, and can be hot-swapped.

**Table 2-5 FAP Component Replacement**

Component	Replacement Requirements	Part Number
<b>FAP</b> Backplane ( <b>FAP_BP</b> )	Must be replaced through factory	850-0515-xx
<b>FAP</b> Alarm Board ( <b>FAP_AB</b> )	Field replaceable	850-0518-xx (card) 870-1609-xx (assembly)

**Table 2-5 (Cont.) FAP Component Replacement**

<b>Component</b>	<b>Replacement Requirements</b>	<b>Part Number</b>
<b>FAP Diode Boards</b> ( <b>FAP_DB_A</b> and <b>FAP_DB_B</b> )	Field replaceable (one at a time)	850-0517-xx (card) 870-1608-xx (assembly)
<b>FAP Extender Boards</b> ( <b>FAP_EB</b> )	Field replaceable (one at a time <b>with service interruption</b> )	850-0519-xx
<b>FAP Fuse Holder Boards</b> ( <b>FAP_FB</b> )	Field replaceable (one at a time <b>with service interruption</b> )	850-0516-xx
<b>FAP Jumper Board</b> ( <b>FAP_JB</b> )	Field replaceable	850-0523-xx (card) 870-1641-xx (assembly)

The following sections describe each type of circuit board:

#### **Backplane Board (FAP\_BP)**

The backplane circuit board provides all of the external connections for the **FAP**. It consists primarily of circuit routing and connectors, but also has one pull-down resistor, which provides a default alarm signal for the Fuse **Alarm** in the event the alarm board is removed from the **FAP**.

#### **Alarm Board (FAP\_AB)**

The alarm circuit board provides indicators and relays for the **EAGLE** status and fuse alarms. This board includes a jumper (**JMP50**) for future use. This jumper is installed for all existing configurations.

#### **Diode Boards (FAP\_DB)**

The diode circuit boards provide power diodes and power input test points. Four diode footprints are included: two for Assembly A and two for Assembly B. Only one of the four positions is intended to be populated; the second footprint is provided for future part rating changes or additional heat-dissipation capabilities.

#### **Extender Boards (FAP\_EB)**

The extender board provides connection between the backpanel board and the fuse holder boards.

#### **Fuse Holder Boards (FAP\_FB)**

The fuse holder boards provide 20 fuses with a common alarm.

#### **Jumper Board (FAP\_JB)**

The jumper board provides the capability to by-pass the diode boards with a fuse. Use this board only for maintenance operations.

## Alarms

The **FAP** provides visual alarms, by means of a lit **LED**, for a variety of status alarms (see [Table 2-6](#)).

**Table 2-6 FAP Alarm Conditions**

Alarm	Alarm Condition	Remote Indications
Critical <b>LED</b>	<ul style="list-style-type: none"> <li>EAGLE command through <b>E5-MCAP</b></li> <li><b>E5-MDAL</b> not present and <b>E5-MDAL_P</b> jumper off</li> </ul>	Dependent on EAGLE software
Major <b>LED</b>	EAGLE command through <b>E5-MCAP</b>	Dependent on EAGLE software
Minor <b>LED</b>	EAGLE command through <b>E5-MCAP</b>	Dependent on EAGLE software
Fuse <b>LED</b>	<ul style="list-style-type: none"> <li>Distribution fuse blown</li> <li><b>Alarm</b> circuit board removed (no <b>LED</b> indication)</li> <li>Jumper on the jumper circuit board is on</li> <li>Power feed failure</li> </ul>	Fuse alarm to EAGLE through <b>E5-MCAP</b>
<b>PWR A LED</b>	Power feed A is off, but power is available to B.	Fuse alarm to EAGLE through <b>E5-MCAP</b>
<b>PWR B LED</b>	Power feed B is off, but power is available to A.	Fuse alarm to EAGLE through <b>E5-MCAP</b>
<b>OP/MAINTLED</b>	Jumper on the jumper circuit board is on.	Fuse alarm to EAGLE through <b>E5-MCAP</b>

A fuse alarm identifies the following problems or conditions within the **FAP**:

- blown fuse(s)
- power loss for side A or B
- alarm card removed
- maintenance mode

Use the following indicators to determine the nature of the problem:

**Table 2-7 Additional Alarm Indicators**

Indicator	Alarm Condition
Fuse alarm and fuse flag down	Blown fuse
Fuse alarm and <b>PWR A LED</b>	Input power loss on A
Fuse alarm and <b>PWR B LED</b>	Input power loss on B
Fuse alarm and <b>OP/MAINT LED</b> is red	Diode jumper is installed (by-passing diodes)

## Diode Testing and the Diode Jumper

The diode board must be tested periodically. To test a diode circuit board without powering down the entire **EAGLE**, perform the procedure listed in [Table 2-8](#) for the corresponding **FAP** part number.

**Table 2-8 FAP Part Numbers and Corresponding Procedures**

Part Number	FAP Procedure
870-1606-01 (all revisions)	Procedure 1
870-1616-02 revision G or lower	Procedure 1
870-1606-02 revision H or higher	Procedure 2
870-2320-01 revision B or lower	Procedure 1
870-2320-01 revision C or higher (or 870-2320-03)	Procedure 2

**Procedure 1.**

This procedure to test a diode circuit board without powering down the entire **EAGLE** applies to the following **FAPs**:

- 870-1606-01 (all revisions)
  - 870-1616-02 with a revision G or lower
  - 870-2320-01 with a revision B or lower
1. Check to verify the **OP/MAINT LED** is green, indicating the **FAP** is not in maintenance mode.
  2. Unscrew the two thumbscrews securing the **FAP** jumper board and remove the board.
  3. On the jumper circuit board, move the jumper (the **DB-26** male connector) from P71 to P72. Tighten the thumbscrews connecting the jumper to its mate, to ensure a good connection. This repositioning overrides the diodes, establishing a direct connection between input and fuse panels.

 **warning:**

If fuses are blown, **DONOT** continue with this procedure. Instead, contact [My Oracle Support \(MOS\)](#) at the appropriate number.

4. Make sure the glass fuses are installed and verify they are “good” by using the multimeter to check for continuity across each of the glass fuses.
5. Verify that two glass fuses are behind the P72 connector. If these fuses are not present, install them before continuing.
6. Slide the jumper board back into the **FAP** and verify both of the following alarms display:
  - the **OP/MAINT LED** lights red on the **FAP**
  - an **EAGLE** fuse alarm displays on the terminal

You may now remove either or both diode circuit boards without affecting **EAGLE** service.



**Note:**

Using the jumper override negates the backpower protection usually provided by the diode board.

7. Locate diode board A and unscrew the two thumbscrews securing the board. Remove the board from the **FAP**.
8. Locate the diode to be tested. It has three pins and is attached to the large heat sink. The diode is labeled **CR43**.
9. Set your digital multimeter to measure resistance.
10. Measure the resistance between the center pin of the diode and either of the outside pins. Record this measurement.
11. Measure the resistance between these same pins again, but switch the multimeter leads, so the positive lead is now on the opposite pin. Record this measurement.
12. Compare the two measurements. If the diode is functioning properly, one reading should be less than 10K ohms and the other should be much greater.  
  
If both readings are above or below 10K ohms, the diode may have failed. Replace the failed board with a spare diode board.
13. Repeat steps 9 through 11, measuring the resistance between the *other* outside pin and the center pin.  
  
This completes the test for diode board A.
14. Repeat steps 6 through 12, using diode board B. This completes the test for diode board B.
15. Reinsert the two functional diode boards. Tighten the thumbscrews on each board to secure it to the **FAP**.
16. Unscrew the two thumbscrews securing the **FAP** jumper board and remove the board.
17. On the jumper circuit board, move the jumper (the **DB-26** male connector) back from P72 to its original position on P71. Tighten the thumbscrews connecting the jumper to its mate, to ensure a good connection. This repositioning returns the diodes to their original, non-maintenance position.
18. Slide the jumper board back into the **FAP**. Verify the **OP/MAINT LED** lights green. The fuse alarm **LED** returns to green.

The diode board testing procedure is completed.

**Procedure 2.**

This procedure to test a diode circuit board without powering down the entire **EAGLE** applies to the following **FAPs**:

- 870-1606-02 with revision H or higher
  - 870-2320-01 with revision C or higher (or 870-2320-03)
1. Check to verify the **OP/MAINTLED** is green, indicating the **FAP** is not in maintenance mode.
  2. Unscrew the two thumbscrews securing the **FAP** jumper board and remove the board.
  3. On the jumper circuit board, unclip the 12 pin connector jumper from P71 and re-attach it to P72.

Insert it until the plastic retaining clips "snap". Note that the jumper has a retaining strap so it won't get dropped or lost. This repositioning overrides the diodes, establishing a direct connection between input and fuse panels.

 **warning:**

If fuses are blown, **DONOT** continue with this procedure. Instead, contact [My Oracle Support \(MOS\)](#) at the appropriate number.

4. Slide the jumper board back into the **FAP** and verify both of the following alarms display:
  - the **OP/MAINTLED** lights red on the **FAP**
  - an EAGLE fuse alarm displays on the terminal  
You may now remove either or both diode circuit boards without affecting EAGLE service.
5. Locate diode board A and unscrew the two thumbscrews securing the board.  
Remove the board from the **FAP**.
6. Locate the diode to be tested.  
There are two power diodes, each with three pins. They are labeled **CR43** and **CR44** for diode board A.
7. Set your digital multimeter to diode check mode..
8. Measure the voltage drop between the center pin of the **CR43** diode and either of the outside pins with the ground probe on the center lead.  
Record this measurement.
9. Measure the voltage drop between these same pins again, but switch the multimeter leads, so the positive lead is now on the opposite pin.  
Record this measurement.
10. Compare the two measurements.  
If the diode is functioning properly, the first reading should be between 0.2 and 0.1 volts and the other should be read as an open circuit. Otherwise, replace<sup>2</sup> the failed board with a spare diode board.
11. Repeat 9 through 10, measuring the voltage between the *other* outside pin and the center pin of **CR43**.
12. Repeat 6 through 10, using diode board B.  
This completes the test for diode board B.
13. Reinsert the two functional diode boards.  
Tighten the thumbscrews on each board to secure it to the **FAP**.
14. Unscrew the two thumbscrews securing the **FAP** jumper board and remove the board.
15. On the jumper circuit board, unclip the 12 pin connector jumper back from P72 to its original position on P71.  
Insert it until the plastic retaining clips "snap." This repositioning returns the diodes to their original, non-maintenance position.
16. Slide the jumper board back into the **FAP**.



Verify the **OP/MAINTLED** lights green. The fuse alarm **LED** returns to green. The diode board testing procedure is completed.

## Removable Drives

This section provides information about the removable drives associated with the EAGLE Maintenance Administration Subsystem Processor (MASP).

A removable drive is used for two purposes:

- To hold an off-line, backup copy of the administered data and system **GPLs**
- To hold a copy of the measurement tables

To use a removable drive to hold the system data, it must be formatted for system data. To use a removable drive to hold measurements data, it must be formatted for measurements data. The EAGLE provides the user the ability to format a removable drive for either of these purposes. A removable drive can be formatted on the EAGLE by using the `format-disk` command. For more information on the `format-disk` command refer to *Commands User's Guide*.

Removable drives described in this section include:

- [Removable USB Drive](#)
- [Fixed SATA Drive](#)

## Removable USB Drive

### **Purpose:**

This section is referenced in this manual by many procedures requiring the use of the removable USB thumb disk in the E5-MASP card. The procedures found in this section are recommended procedures for handling the removable USB drive in the E5-MASP card.

### **Requirements:**

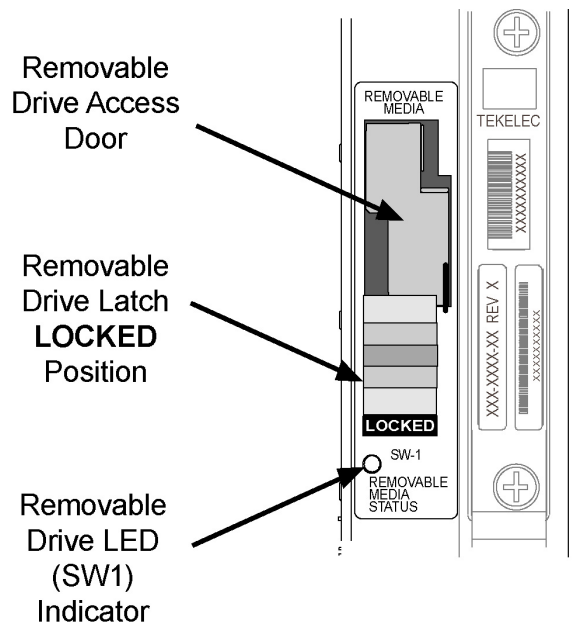
None

### **Procedure - Remove USB Drive**

1. Verify that the removable USB drive is locked in position and in use.

The removable drive latch (SW1) is in the **LOCKED** position and the Removable Media Status **LED** on the E5-MASP is Off. Refer to [Figure 2-10](#).

Figure 2-10 Removable USB Drive LOCKED



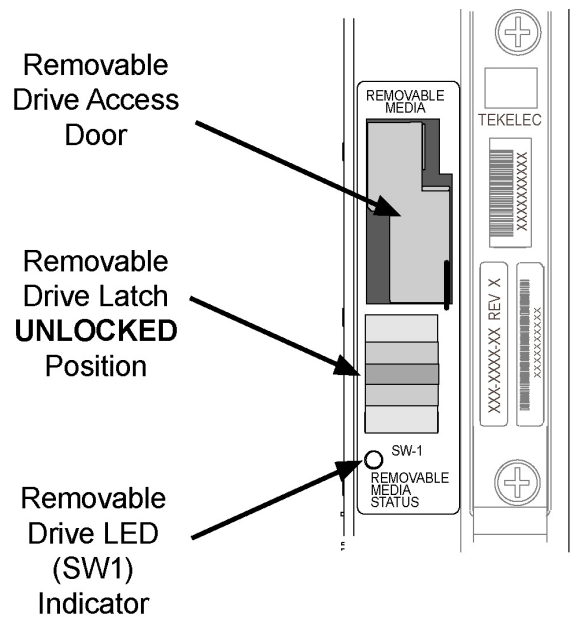
2. Move SW1 from the LOCKED to the unlocked position and wait for the LED to indicate a steady blue state. See [Figure 2-11](#).

When SW1 is transitioned from locked to unlocked, the LED will flash blue to indicate the drive is unlocked and in process of shutting down.

 **Caution:**

Removal of the drive prior to the LED indicating steady blue could result in drive corruption.

**Figure 2-11 Removable USB Drive UNLOCKED**



3. When the LED indicates a steady blue state, the removable USB drive can be safely removed. The **LED** is off when the USB drive is fully ejected from the drive media.  
The USB drive can now be removed from the drive media.
4. Lift the access door up, swing it past the detent position so that the door remains open on its own.
5. Grasp the pull tab of the slide and pull the slide out slowly until it stops (it travels about a half inch).

**Caution:**

The full travel of the slide is less than an inch, do not try to pull the assembly to expose the full length of the thumb drive as this is beyond the slide's designed travel.

6. The USB drive is disengaged and can be taken from the inject eject assembly.
7. Insert a USB drive into the inject-eject assembly.
8. Grasp the pull tab of the slide and push the slide in slowly until you feel the USB drive is seated in its slot (it travels about a half inch).
9. Close the access door.
10. Move SW1 from the unlocked to the LOCKED position.  
When SW1 is transitioned from unlocked to locked, the LED will flash blue to indicate the drive is locked and in process of coming online.
11. When the LED turns Off, the removable USB drive is ready for use.

## Fixed SATA Drive

### Purpose:

This section is referenced in this user's guide by many procedures requiring the use of the fixed SATA drive in the E5-MASP card. The procedures found in this section are recommended procedures for handling the fixed drive in the E5-MASP card.

### Requirements

- The new SATA Drives to be installed should be at the current system release.
- Before beginning this procedure, make sure there is a copy of the current release GPLs on a removable USB drive on-hand.
- System backups should be performed prior to the start of this procedure. Refer to [Daily Procedures](#).
- You must be logged in to the EAGLE prior to performing this procedure.

### Procedure - Remove Fixed SATA Drive

1. Enter the following command to verify that the Measurement feature bit is on.

```
rtrv-feat
```

The following is an example of a possible output. The **MEASPLAT** field shows whether the Measurement feature is on or off. In this example, Measurement feature is **ON**.

```
eagle3 02-01-05 00:51:32 EST EAGLE5 41.2.0-62.69.65
rtrv-feat
Command entered at terminal #7.
;

eagle3 02-01-05 00:51:32 EST EAGLE5 41.2.0-62.69.65
EAGLE FEATURE LIST

GTT      = on      GWS      = on      NRT      = off
X25G     = off     LAN      = on      CRMD     = off
SEAS     = off     LFS      = off     MTPRS    = off
FAN      = on      DSTN5000 = off     WNP      = off
CNCF     = off     TLNP     = off     SCCPCNV  = off
TCAPCNV  = off     IPISUP   = off     X252000  = off
PLNP     = off     NCR      = off     ITUMTPRS = on
SLSOCB   = off     EGTG     = on      VGTG     = on
MPC      = on      ITUDUPPC = on      MEASPLAT = on
TSCSYNC  = off     E5IS     = off
```

If feature bit is turned **OFF**, go to 5.

2. Enter the following command to retrieve the measurements setup.

```
rtrv-meas-sched
```

The following is an example of a possible output. The **COLLECT** field shows whether measurement collection is on or off. In this example, measurement collection is **ON**.

```
npeeagle4 02-02-04 21:13:49 EST EAGLE5 41.2.0-62.69.65
rtrv-meas-sched
Command entered at terminal #1.
;

npeeagle4 02-02-04 21:13:49 EST EAGLE5 41.2.0-62.69.65
```

```

COLLECT          = ON
GTWYLSFLTR      = (both)
-----
SYSTOT-STP      = (off)
SYSTOT-TT       = (off)
SYSTOT-STPLAN   = (off)
COMP-LNKSET     = (off)
COMP-LINK       = (off)
GTWY-STP        = (off)
GTWY-LNKSET     = (off)
MTCD-STP        = (on)
MTCD-LINK       = (on)
MTCD-STPLAN     = (on)
MTCD-LNKSET     = (on)

```

```
;
```

If measurement collection is **OFF**, go to 5.

- Issue the following command to turn **OFF** measurement collection.

```
chg-meas:collect=off
```

The following is an example of a possible output.

```

tekelecstp YY-MM-DD hh:mm:ss TTTT PPP  XX.x.x-YY.y.y
chg-meas:collect=off
Command entered at terminal #10.

```

```
;
```

```

tekelecstp YY-MM-DD hh:mm:ss TTTT PPP  XX.x.x-YY.y.y
CHG-MEAS: MASP A - COMPLTD

```

```
;
```

- Enter the following command to verify measurements collection is **OFF**.

```
rtrv-meas-sched
```

The following is an example of a possible output. The **COLLECT** field shows whether measurement collection is on or off. In this example, measurement collection is **OFF**.

```

npeeagle4 02-02-04 21:13:49 EST  EAGLE5 41.2.0-62.69.65
rtrv-meas-sched
Command entered at terminal #1.

```

```
;
```

```

npeeagle4 02-02-04 21:13:49 EST  EAGLE5 41.2.0-62.69.65
COLLECT          = OFF
GTWYLSFLTR      = (both)
-----
SYSTOT-STP      = (off)
SYSTOT-TT       = (off)
SYSTOT-STPLAN   = (off)
COMP-LNKSET     = (off)
COMP-LINK       = (off)
GTWY-STP        = (off)
GTWY-LNKSET     = (off)
MTCD-STP        = (on)
MTCD-LINK       = (on)
MTCD-STPLAN     = (on)
MTCD-LNKSET     = (on)

```

```
;
```

- Enter the following command to display the card status:

```
rept-stat-card:appl=oam
```

The following is an example of a possible output.

```
Command Accepted - Processing
```

```
tekelecstp YY-MM-DD hh:mm:ss TTTT PPP XX.x.x-YY.y.y
rept-stat-card:appl=oam
Command entered at terminal #14.
```

```
;
```

```
tekelecstp 10-04-19 16:47:51 EDT EAGLE5 41.1.0-62.64.1
CARD  VERSION      TYPE      GPL      PST      SST      AST
1113  132-064-000    E5MCAP    OAMHC    IS-NR    Standby  -----
1115  132-064-000    E5MCAP    OAMHC    IS-NR    Active   -----
```

```
Command Completed.
```

```
;
```

- Enter the following command to display the card status:

```
this rept-stat-card
```

The following is an example of a possible output.

```
e5oam 08-12-01 15:38:32 EST EAGLE 46.0.0
CARD  VERSION      TYPE      GPL      PST      SST      AST
1108  -----      MCPM      MCP      OOS-MT-DSBLD  Manual  -----
1109  030-009-000    HIPR2     HIPR2     IS-NR     Active  -----
1110  030-009-000    HIPR2     HIPR2     IS-NR     Active  -----
1111  030-010-000    IPSM      IPS       IS-NR     Active  -----
1113  030-010-008    E5MCAP    OAMHC     IS-NR     Standby  -----
1114  -----      E5TDM     E5TDM     IS-NR     Active  -----
1115  030-010-008    E5MCAP    OAMHC     IS-NR     Active  -----
1116  -----      E5TDM     E5TDM     IS-NR     Active  -----
1117  -----      E5MDAL     E5MDAL     OOS-MT     Isolated  -----
```

```
Command Completed.
```

In this sample output, 1113/1114 are standby and 1115/1116 are active.

Verify the E5-MASP card containing the fixed SATA drive to be replaced is in the **Standby** position before continuing.

- If it is **Standby**, go to [10](#).
  - If it is not **Standby**, go to [7](#).
- Enter the following command to force the **Active** E5-MASP card to become **Standby**

```
init-card:loc=xxxx
```

where *xxxx* is the card location (1113 or 1115).

#### Note:

User will need to login after executing this command.

- Enter the following command to re-login:
 

```
login:uid=eagle
```
- Enter the password to complete login:

```
Enter Password : xxxxxx
```

 **Note:**

This document does not provide the passwords required in the procedures. Passwords should be acquired from the customer.

The following is an example of a possible output.

```
Command Accepted - Processing
```

```
tekelecstp YY-MM-DD hh:mm:ss TTTT PPP XX.x.x-YY.y.y
Command entered at terminal #13.
;
tekelecstp YY-MM-DD hh:mm:ss TTTT PPP XX.x.x-YY.y.y
NOTICE: This is a private computer system.
Unauthorized access or use may lead to prosecution.
0 LOGIN failures since last successful LOGIN
Last successful LOGIN was on port 13 on 09-03-04 @ 14:18:21
;

```

10. Inhibit the **Standby** card location from service by entering the following command:

```
inh-card:loc=xxxx
```

wherexxx is the **Standby** card location.

The following is an example of a possible output.

```
Command Accepted - Processing
```

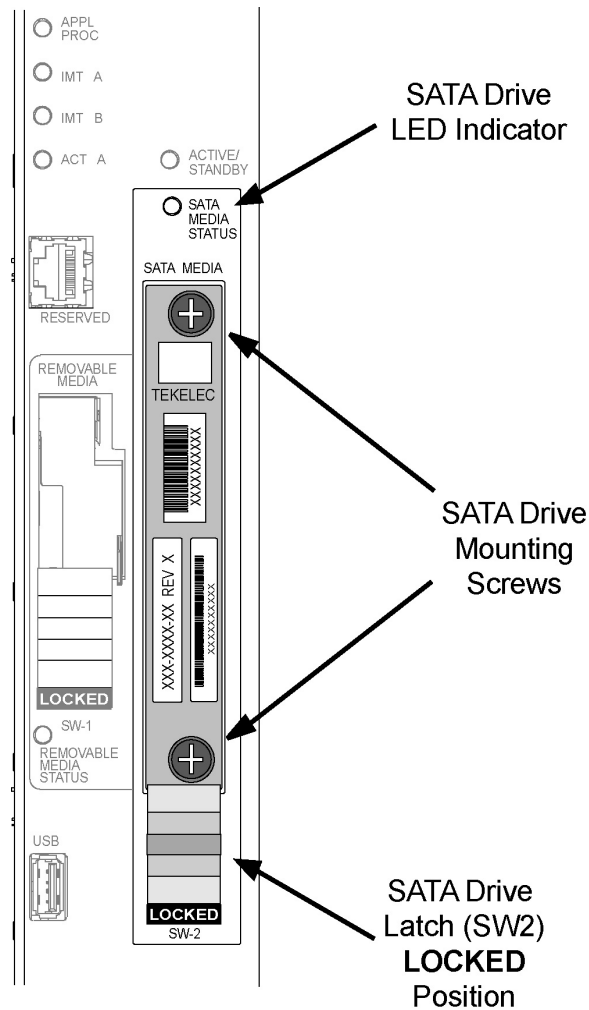
```
eagle3 02-01-18 18:00:06 EST EAGLE 41.2.0-62.69.65
inh-card:loc=1113
Command entered at terminal #1.
;
eagle3 02-01-18 18:00:06 EST EAGLE 41.2.0-62.69.65
Card has been inhibited.
;
eagle3 02-01-18 18:00:06 EST EAGLE 41.2.0-62.69.65
Command Completed.
;

```

11. Verify that the SATA drive is locked in position and in use. Refer to [Figure 2-12](#).

The SATA drive latch (SW2) is in the LOCKED position and the SATA Media Status LED on the E5-MASP is Off.

Figure 2-12 SATA Drive Locked



12. Move SW2 from the LOCKED to the unlocked position and wait for the LED to indicate a steady blue state. See [Figure 2-13](#).

When SW2 is transitioned from locked to unlocked, the LED will flash blue to indicate the drive is unlocked and in process of shutting down.

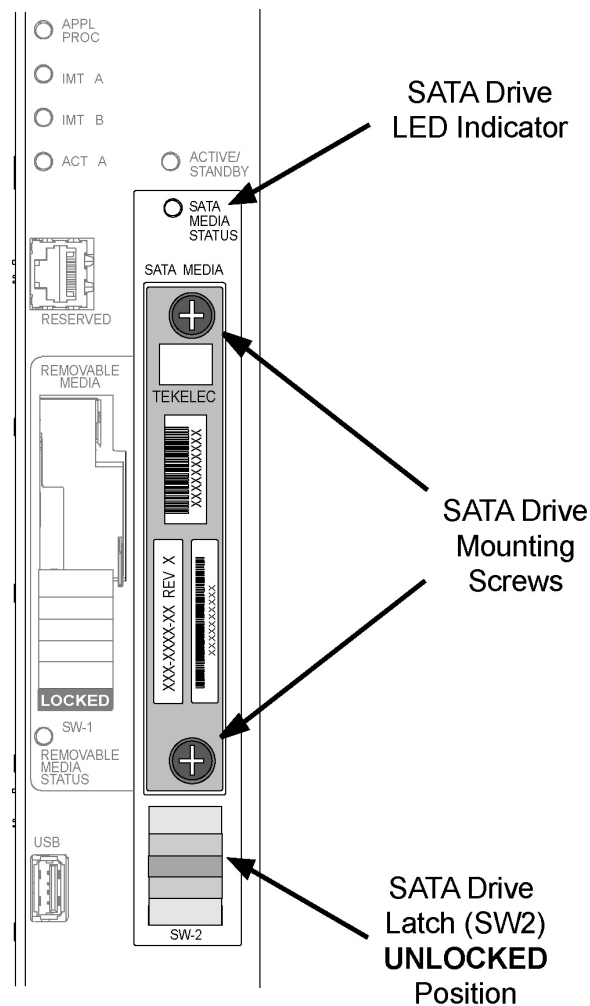
**Caution:**

Removal of the drive prior to the LED indicating steady red could result in drive corruption.

**Caution:**

If locking switch is transitioned from locked to unlocked and the E5-MASP is in service, removal of the drive module will result in a card obit. All drive LEDs will blink red.



**Figure 2-13** SATA Drive UNLOCKED

13. When the LED indicates a steady blue state, the SATA drive can be safely removed. The LED is off when the drive is fully ejected from the drive.

The drive can now be removed from the slot.

14. Loosen the SATA drive mounting screws.
15. Grasp the screws and pull the drive out slowly until it is free from the card.
16. Slide a SATA drive into the drive slot on the card.
17. Gently push the drive in slowly until it is properly seated.
18. Tighten the mounting screws.
19. Move SW2 from the unlocked to the LOCKED position.

When SW2 is transitioned from unlocked to locked, the LED will flash blue to indicate the drive is locked and in process of coming online.

20. When the LED turns Off, the SATA drive is ready for use.
21. Enter the following command to verify the card is in Standby and OOS-MT-DSBLD.

```
rept-stat-card:loc=xxxx:mode=full
where xxxx is the card location (1113 or 1115).
```

The following is an example of a possible output.

Command Accepted - Processing

```
eagle3 02-01-01 00:35:50 EST EAGLE5 41.2.0-62.69.65
rept-stat-card:loc=1115:mode=full
Command entered at terminal #1.
;

eagle3 02-01-01 00:35:50 EST EAGLE5 41.2.0-62.69.65
CARD   VERSION      TYPE      GPL       PST       SST       AST
1115   -----      E5MCAP   OAMHC    OOS-MT-DSBLD  Manual   -----
ALARM STATUS      = ** 0514 Standby MASP is inhibited
BLMCAP GPL version = 132-068-000
IMT BUS A         = -----
IMT BUS B         = -----
CLOCK A          = ----
CLOCK B          = ----
CLOCK I          = ----
MBD BIP STATUS   = Valid
MOTHER BOARD ID  = E5-MCAP
DBD STATUS       = Valid
DBD TYPE         = 1G ENET
DBD MEMORY SIZE  = 4096M
HW VERIFICATION CODE = ----
CURRENT TEMPERATURE = 29C ( 85F)
PEAK TEMPERATURE: = 29C ( 85F) [02-01-01 00:23]
TROUBLE TEXT VER. = ----

Command Completed.
;
```

22. Issue the command to retrieve GPL versions.

```
rept-stat-gpl:loc=<stby E5-MASP>
where <stby E5-MASP> is the card location (1113 or 1115).
```

The following is an example of a possible output.

Command Accepted - Processing

```
eagle3 02-01-01 00:36:25 EST EAGLE5 41.2.0-62.69.65
rept-stat-gpl:loc=1115
Command entered at terminal #1.
;

eagle3 02-01-01 00:36:25 EST EAGLE5 41.2.0-62.69.65
GPL Auditing ON

GPL      CARD      RUNNING      APPROVED      TRIAL
OAMHC    1115      -----      132-069-061  132-069-061  *
          BLMCAP    132-068-000  132-068-000  132-068-000

Command Completed.
;
```

Verify that the OAMHC and BLMCAP GPLs match on the Running, Approved and Trial columns.

 **Note:**

If GPL are in alarm contact [My Oracle Support \(MOS\)](#) and have system USB drives available for corrections

23. Enter the following command to put the card that was inhibited in back into service.

```
alw-card:loc=xxxx
```

where `xxxx` is the card location used in 6.

Following is an example of a possible output.

```
Command Accepted - Processing
```

```
eagle3 02-01-18 18:02:20 EST EAGLE5 41.2.0-62.69.65
alw-card:loc=1113
Command entered at terminal #1.
```

```
;
```

```
eagle3 02-01-18 18:02:20 EST EAGLE5 41.2.0-62.69.65
Card has been allowed.
```

```
;
```

```
eagle3 02-01-18 18:02:20 EST EAGLE5 41.2.0-62.69.65
Command Completed.
```

```
;
```

 **Note:**

Allow the card to run for 5 minutes before continuing.

24. Enter the following command to verify the database is not consistent (different level as the other cards in the system).

```
rept-stat-db:display=version
```

The following is an example of a possible output.

```
Command Accepted - Processing
```

```
eagle3 02-01-10 21:52:58 EST EAGLE5 41.2.0-62.69.65
rept-stat-db:display=version
Command entered at terminal #1.
```

```
;
```

```
eagle3 02-01-10 21:52:59 EST EAGLE5 41.2.0-62.69.65
DATABASE STATUS: >> OK <<
          E5TDM 1114 ( ACTV )                E5TDM 1116 ( STDBY)
          C  LEVEL    TIME LAST BACKUP      C  LEVEL    TIME LAST BACKUP
          - - - - -
-----
          FD BKUP Y      79 02-01-05 18:06:16 EST Y      1 02-01-05 00:06:16
EST
          FD CRNT Y      79                    Y      1
          MCAP 1113                    MCAP 1115
          - - - - -
          RD BKUP -      -                    -      -
          USB BKP -      -                    -      -
```

CARD/APPL	LOC	C	T	LEVEL	TIME LAST UPDATE	VERSION STATUS
OAMHC-RMV	1113	-	-	-	-	-
OAMHC-USB	1113	-	-	-	-	-
E5TDM-CRNT	1114	Y	N	79	02-01-04 23:46:18	132-013-000
NORMAL						
E5TDM-BKUP	1114	Y	-	79	02-01-04 23:46:18	132-013-000
NORMAL						
OAMHC-RMV	1115	-	-	-	-	-
E5TDM-CRNT	1116	Y	N	1	02-01-04 00:06:16	132-013-000
NORMAL						
E5TDM-BKUP	1116	Y	-	1	02-01-04 00:06:16	132-013-000
NORMAL						

EPAP A (NOACCS)

C	BIRTHDATE	LEVEL	EXCEPTION
PDB	-	-	-
RTDB	-	-	-
RTDB-EAGLE	-	-	-

EPAP B (NOACCS)

C	BIRTHDATE	LEVEL	EXCEPTION
PDB	-	-	-
RTDB	-	-	-
RTDB-EAGLE	-	-	-

;

Compare the VERSION STATUS of the E5-MASP cards. The DB Level in the new drive is expected to be different.

If the database VERSION on the new disk is not the same as the active disk, stop the procedure and contact [My Oracle Support \(MOS\)](#).

25. Enter the following command to show the version numbers of the GPLs stored on each fixed disk (E5-MASP).

```
rtrv-gpl
```

The following is an example of a possible output.

```
tekelecstp 18-01-18 21:23:11 EST EAGLE 46.5.1.5.0-73.10.0
rtrv-gpl
Command entered at terminal #18.
```

;

Command Accepted - Processing

```
tekelecstp 18-01-18 21:23:11 EST EAGLE 46.5.1.5.0-73.10.0
GPL Auditing ON
```

GPL	CARD	RELEASE	APPROVED	TRIAL	REMOVE TRIAL
OAMHC	1114	143-010-000	143-010-000	ALM	-----
OAMHC	1116	143-010-000	143-010-000	ALM	-----
OAMHC	1115	-----	-----	-----	-----
OAMHC69	1114	143-010-000	143-010-000	ALM	-----
OAMHC69	1116	143-010-000	143-010-000	ALM	-----
OAMHC69	1115	-----	-----	-----	-----
IPSG32	1114	143-010-000	143-010-000	143-010-000	-----
IPSG32	1116	143-010-000	143-010-000	143-010-000	-----
IPSG32	1115	-----	-----	-----	-----

BLMCAP	1114	143-010-000	143-010-000		143-010-000	-----
BLMCAP	1116	143-010-000	143-010-000		143-010-000	-----
BLMCAP	1115	-----	-----		-----	-----
HIPR2	1114	143-010-000	143-010-000		143-010-000	-----
HIPR2	1116	143-010-000	143-010-000		143-010-000	-----
HIPR2	1115	-----	-----		-----	-----
SFAPP	1114	143-010-000	143-010-000	ALM	143-010-000	-----
SFAPP	1116	143-010-000	143-010-000	ALM	143-010-000	-----
SFAPP	1115	-----	-----		-----	-----
SS7HC	1114	143-010-000	143-010-000		143-010-000	-----
SS7HC	1116	143-010-000	143-010-000		143-010-000	-----
SS7HC	1115	-----	-----		-----	-----
SCCPHC	1114	143-010-000	143-010-000		143-010-000	-----
SCCPHC	1116	143-010-000	143-010-000		143-010-000	-----
SCCPHC	1115	-----	-----		-----	-----
ERTHC	1114	143-010-000	143-010-000		143-010-000	-----
ERTHC	1116	143-010-000	143-010-000		143-010-000	-----
ERTHC	1115	-----	-----		-----	-----
IPSHC	1114	143-010-000	143-010-000		143-010-000	-----
IPSHC	1116	143-010-000	143-010-000		143-010-000	-----
IPSHC	1115	-----	-----		-----	-----
ATMHC	1114	143-010-000	143-010-000		143-010-000	-----
ATMHC	1116	143-010-000	143-010-000		143-010-000	-----
ATMHC	1115	-----	-----		-----	-----
IPSG	1114	143-010-000	143-010-000		143-010-000	-----
IPSG	1116	143-010-000	143-010-000		143-010-000	-----
IPSG	1115	-----	-----		-----	-----
PKTGHC	1114	143-010-000	143-010-000		-----	-----
PKTGHC	1116	143-010-000	143-010-000		-----	-----
PKTGHC	1115	-----	-----		-----	-----
BLIXP	1114	143-010-000	143-010-000		143-010-000	-----
BLIXP	1116	143-010-000	143-010-000		143-010-000	-----
BLIXP	1115	-----	-----		-----	-----
MCPHC	1114	143-010-000	143-010-000		143-010-000	-----
MCPHC	1116	143-010-000	143-010-000		143-010-000	-----
MCPHC	1115	-----	-----		-----	-----
SIPHC	1114	143-010-000	143-010-000		143-010-000	-----
SIPHC	1116	143-010-000	143-010-000		143-010-000	-----
SIPHC	1115	-----	-----		-----	-----
DEIRHC	1114	143-010-000	143-010-000		143-010-000	-----
DEIRHC	1116	143-010-000	143-010-000		143-010-000	-----
DEIRHC	1115	-----	-----		-----	-----
ENUMHC	1114	143-010-000	143-010-000		143-010-000	-----
ENUMHC	1116	143-010-000	143-010-000		143-010-000	-----
ENUMHC	1115	-----	-----		-----	-----
PKTG64	1114	143-010-000	143-010-000		-----	-----
PKTG64	1116	143-010-000	143-010-000		-----	-----
PKTG64	1115	-----	-----		-----	-----
BLDC64	1114	143-010-000	-----		143-010-000	-----
BLDC64	1116	143-010-000	000-000-000	ALM	143-010-000	-----
BLDC64	1115	-----	-----		-----	-----
SCCP64	1114	143-010-000	143-010-000		143-010-000	-----
SCCP64	1116	143-010-000	143-010-000		143-010-000	-----
SCCP64	1115	-----	-----		-----	-----
BLSLC32	1114	143-010-000	143-010-000		143-010-000	-----
BLSLC32	1116	143-010-000	143-010-000		143-010-000	-----
BLSLC32	1115	-----	-----		-----	-----
BLSLC64	1114	143-010-000	143-010-000		143-010-000	-----
BLSLC64	1116	143-010-000	143-010-000		143-010-000	-----
BLSLC64	1115	-----	-----		-----	-----
SIP64	1114	143-010-000	143-010-000		143-010-000	-----

```

SIP64      1116  143-010-000  143-010-000  143-010-000  -----
SIP64      1115  -----
DEIR64     1114  143-010-000  143-010-000  143-010-000  -----
DEIR64     1116  143-010-000  143-010-000  143-010-000  -----
DEIR64     1115  -----
ENUM64     1114  143-010-000  143-010-000  143-010-000  -----
ENUM64     1116  143-010-000  143-010-000  143-010-000  -----
ENUM64     1115  -----
BLDC32     1114  143-010-000  -----
BLDC32     1116  143-010-000  -----
BLDC32     1115  -----
MCPHC69    1114  143-010-000  143-010-000  143-010-000  -----
MCPHC69    1116  143-010-000  143-010-000  143-010-000  -----
MCPHC69    1115  -----
IPSHC69    1114  143-010-000  143-010-000  143-010-000  -----
IPSHC69    1116  143-010-000  143-010-000  143-010-000  -----
IPSHC69    1115  -----
BLSL932    1114  143-010-000  143-010-000  143-010-000  -----
BLSL932    1116  143-010-000  143-010-000  143-010-000  -----
BLSL932    1115  -----

```

```

;
Command Executed

```

If the new SATA drive shows alarmed GPLs, contact [My Oracle Support \(MOS\)](#).

26. Enter the following command to repair the standby's **E5-MASP** database:

```
chg-db:action=repair
```

The `action=repair` copies the current and backup databases from the active to the standby fixed disk.

The following is an example of a possible output.

```

RLGHNCXA03W 03-08-27 03:46:49 EST  EAGLE 34.0.0
chg-db:action=repair
Command entered at terminal #10.
;
RLGHNCXA03W 03-08-27 03:46:50 EST  EAGLE 34.0.0
REPAIR: MASP A - Repair starts on standby MASP.
;

```

 **Note:**

Observe that the command execution time may require approximately 20 to 45 minutes.

```

RLGHNCXA03W 03-08-27 04:15:22 EST  EAGLE 34.0.0
REPAIR: MASP A - Repair from fixed disk complete.
;

```

Wait for the 'repair complete' message to display and for the **E5-MASP** to return to in-service status.

27. Issue the report status command for the standby E5-MASP.

```
rept-stat-card:loc=xxxx:mode=full
```

Where `xxxx` is the STBY E5-MASP slot from 6.

The following is an example of a possible output.

```

tekelecstp YY-MM-DD hh:mm:ss TTTT PPP XX.x.x-YY.y.y
rept-stat-card:loc=xxxx
Command entered at terminal #10.
;
tekelecstp YY-MM-DD hh:mm:ss TTTT PPP XX.x.x-YY.y.y
CARD  VERSION  TYPE      GPL      PST      SST      AST
xxxx  XXX-XXX-XXX E5MCAP   OAMHC   IS-NR    Standby
-----
ALARM STATUS      = No Alarms.
BLMCAP  GPL version = XXX-XXX-XXX
IMT BUS A         = Conn
IMT BUS B         = Conn
CLOCK A          = Active
CLOCK B          = Idle
CLOCK I          = Idle
MBD BIP STATUS   = Valid
MOTHER BOARD ID  = E5-MCAP
DBD STATUS       = Valid
DBD TYPE         = 1G ENET
DBD MEMORY SIZE  = 4096M
HW VERIFICATION CODE = ----
CURRENT TEMPERATURE = 44C (112F)
PEAK TEMPERATURE:  = 46C (115F)      [09-03-31 08:18]
TROUBLE TEXT VER. = ----

Command Completed.
;

```

Verify that the standby goes to IS-NR.

28. Enter the following command to verify that the database counts of both MASPs.

```
rept-stat-db:display=all
```

The following is an example of the possible output for a good database.

```

eagle3 02-01-11 16:11:25 EST EAGLE5 41.2.0-62.69.65
rept-stat-db:display=version
Command entered at terminal #1.
;
eagle3 02-01-11 16:11:26 EST EAGLE5 41.2.0-62.69.65
DATABASE STATUS: >> OK <<
      E5TDM 1114 ( ACTV )                E5TDM 1116 ( STDBY)
      C  LEVEL  TIME LAST BACKUP      C  LEVEL  TIME LAST BACKUP
      - - - - -
-----
FD BKUP Y      79 02-01-05 18:06:16 EST Y 79 02-01-05 18:06:16 EST
FD CRNT Y      79
      MCAP 1113                          MCAP 1115
      - - - - -
RD BKUP Y      79 02-01-05 11:15:16 EST - - - - -
USB BKP -      - - - - -
      CARD/APPL  LOC  C  T  LEVEL      TIME LAST UPDATE  VERSION STATUS
      - - - - -
OAMHC-RMV      1113 - - - - -
OAMHC-USB      1113 - - - - -
E5TDM-CRNT     1114 Y  N   79      02-01-04 23:46:18 132-013-000 NORMAL
E5TDM-BKUP     1114 Y  -   79      02-01-04 23:46:18 132-013-000 NORMAL
OAMHC-RMV      1115 - - - - -

```

```
E5TDM-CRNT 1116 Y N 79 02-01-04 23:46:18 132-013-000 NORMAL
E5TDM-BKUP 1116 Y - 79 02-01-04 23:46:18 132-013-000 NORMAL
```

```
EPAP A (NOACCS)
C BIRTHDATE LEVEL EXCEPTION
- - - - -
PDB - - - -
RTDB - - - -
RTDB-EAGLE - - - -
```

```
EPAP B (NOACCS)
C BIRTHDATE LEVEL EXCEPTION
- - - - -
PDB - - - -
RTDB - - - -
RTDB-EAGLE - - - -
```

;

29. Repeat 5 - 28 on all remaining SATA Drives identified for replacement.
30. If 3 was executed, issue the command to turn the measurements collection on.

```
chg-meas:collect=on
```

Execute this command only if measurement feature bit is turned on from 1.

The following is an example of a possible output.

```
tekelecstp YY-MM-DD hh:mm:ss TTTT PPP XX.x.x-YY.y.y
chg-meas:collect=on
Command entered at terminal #10.
```

;

```
tekelecstp YY-MM-DD hh:mm:ss TTTT PPP XX.x.x-YY.y.y
CHG-MEAS: MASP A - COMPLTD
```

;

31. Enter command to copy measurements

```
copy-meas
```

To execute this command, measurement collection must be turned off. If measurement collection is on, enter the `chg-meas:collect=off` command to turn off measurement collection.

The removable drive:

- must be inserted
- must be initialized

The following is an example of a possible output.

```
eagle3 02-01-11 19:09:16 EST EAGLE5 41.2.0-62.69.65
copy-meas
Command entered at terminal #1.
```

;

```
COPY MEASUREMENTS: MASP A - COPY STARTS ON ACTIVE MASP
COPY MEASUREMENTS: MASP A - COPY TO REMOVABLE USB DRIVE COMPLETE
```

;

32. Issue the command to retrieve measurement setup.

```
rtrv-meas-sched
```



The following is an example of a possible output. The **COLLECT** field shows whether measurement collection is on or off.

```
npeeagle4 02-02-04 01:13:49 EST EAGLE5 41.2.0-62.69.65
rtrv-meas-sched
Command entered at terminal #1.
;

npeeagle4 02-02-04 01:13:49 EST EAGLE5 41.2.0-62.69.65
COLLECT          = on
GTWYLSFLTR      = (both)
-----
SYSTOT-STP      = (off)
SYSTOT-TT       = (off)
SYSTOT-STPLAN   = (off)
COMP-LNKSET     = (off)
COMP-LINK       = (off)
GTWY-STP        = (off)
GTWY-LNKSET     = (off)
MTCB-STP        = (on)
MTCB-LINK       = (on)
MTCB-STPLAN     = (on)
MTCB-LNKSET     = (on)
;

```

If COLLECT=ON, continue to next step, otherwise repeat 30.



#### Note:

If 30 is repeated and measurements do not turn on contact [My Oracle Support \(MOS\)](#).

#### 33. Issue the report card status command.

```
rept-stat-card:appl=oam
```

The following is an example of a possible output.

```
Command Accepted - Processing
```

```
eagle3 02-01-01 00:29:24 EST EAGLE5 41.2.0-62.69.65
rept-stat-card:appl=oam
Command entered at terminal #1.
;

eagle3 02-01-01 00:29:24 EST EAGLE5 41.2.0-62.69.65
CARD  VERSION      TYPE      GPL      PST      SST      AST
1113  132-069-061  E5MCAP  OAMHC    IS-NR    Active  -----
1115  132-069-061  E5MCAP  OAMHC    IS-NR    Standby -----

Command Completed.
;

```

#### 34. Issue the command to display database status.

```
rept-stat-db:display=all
```

The following is an example of a possible output.

```
eagle3 02-01-11 16:11:25 EST EAGLE5 41.2.0-62.69.65
rept-stat-db:display=version
```



```

eagle3 02-01-18 18:10:28 EST EAGLE5 41.2.0-62.69.65
CARD VERSION TYPE GPL PST SST AST
1113 132-069-061 E5MCAP OAMHC IS-NR Standby -----
ALARM STATUS = No Alarms.
BLMCAP GPL version = 132-068-000
IMT BUS A = Conn
IMT BUS B = Conn
CLOCK A = Active
CLOCK B = Idle
CLOCK I = Idle
MBD BIP STATUS = Valid
MOTHER BOARD ID = E5-MCAP
DBD STATUS = Valid
DBD TYPE = 1G ENET
DBD MEMORY SIZE = 4096M
HW VERIFICATION CODE = ----
CURRENT TEMPERATURE = 30C ( 86F)
PEAK TEMPERATURE: = 30C ( 86F) [02-01-18 17:58]
TROUBLE TEXT VER. = ----

```

Command Completed.

;

### 36. Issue the command to OAM database.

```
rept-stat-card:appl=oam
```

The following is an example of a possible output.

Command Accepted - Processing

```

tekelecstp YY-MM-DD hh:mm:ss TTTT PPP XX.x.x-YY.y.y
rept-stat-card:appl=oam
Command entered at terminal #14.

```

;

```

tekelecstp 10-04-19 16:47:51 EDT EAGLE5 41.1.0-62.64.1
CARD VERSION TYPE GPL PST SST AST
1113 132-064-000 E5MCAP OAMHC IS-NR Standby -----
1115 132-064-000 E5MCAP OAMHC IS-NR Active -----

```

Command Completed.

;

### 37. Issue the command to display Clock status.

```
rept-stat-clk
```

The following is an example of a possible output.

Command Accepted - Processing

```

tekelecstp YY-MM-DD hh:mm:ss TTTT PPP XX.x.x-YY.y.y
rept-stat-clk
Command entered at terminal #1.

```

;

```

tekelecstp YY-MM-DD hh:mm:ss TTTT PPP XX.x.x-YY.y.y
COMPOSITE PST SST AST
SYSTEM CLOCK IS-NR Idle -----
ALARM STATUS = No Alarms.
Primary Comp Clk 1114 (CLK A) IS-NR Active
Primary Comp Clk 1116 (CLK B) IS-NR Active
Secondary Comp Clk 1114 (CLK A) IS-NR Idle
Secondary Comp Clk 1116 (CLK B) IS-NR Idle

```

```

Clock      Using      Bad
CLK A      3              0
CLK B      0              0
CLK I      0              --

HIGH SPEED                                PST      SST      AST
SYSTEM CLOCK                              IS-NR    Idle    -----
ALARM STATUS = No Alarms.
Primary HS Clk 1114 (HS CLK A) OOS-MT    Fault
Primary HS Clk 1116 (HS CLK B) OOS-MT    Fault
Secondary HS Clk 1114(HS CLK A) OOS-MT    Fault
Secondary HS Clk 1116(HS CLK B) OOS-MT    Fault

HS CLK TYPE 1114      = RS422
HS CLK LINELEN 1114  = -----
HS CLK TYPE 1116      = RS422
HS CLK LINELEN 1116  = -----

Clock      Using      Bad
HS CLK A   0              0
HS CLK B   0              0
HS CLK I   0              --

```

Command Completed.

;

Verify that there are no Clock alarms.

- If there are no clock alarms then proceed to next step.
- If clock alarms are present note the alarms and contact [My Oracle Support \(MOS\)](#).

 **Note:**

E5-MASP may require card initialization if clock errors are being reported.

 **Note:**

Card initialization is not required if customer is not using CLOCK.

38. If required, prepare E5-MASP for Clock Acceptance

 **Note:**

Both E5-MASP must installed.

39. Issue the following command to check clock status.

```
rept-stat-clk
```

The following is an example of a possible output.

```

regnsk0613w 10-05-06 11:13:10 CST  EAGLE 41.1.2-62.69.1
rept-stat-clk
Command entered at terminal #21.

```

```

;
Command Accepted - Processing
regnsk0613w 10-05-06 11:13:10 CST EAGLE 41.1.2-62.69.1
COMPOSITE                                PST          SST          AST
      SYSTEM CLOCK                        IS-NR        Idle         -----
ALARM STATUS = No Alarms.
      Primary Comp Clk 1114 (CLK A) OOS-MT        Fault
      Primary Comp Clk 1116 (CLK B) OOS-MT        Fault
      Secondary Comp Clk 1114 (CLK A) OOS-MT        Fault
      Secondary Comp Clk 1116 (CLK B) OOS-MT        Fault

Clock      Using      Bad
CLK A      10         0
CLK B      3         0
CLK I      0         --

HIGH SPEED                                PST          SST          AST
      SYSTEM CLOCK                        IS-NR        Idle         -----
ALARM STATUS = No Alarms.
      Primary HS Clk 1114 (HS CLK A) IS-NR        Active
      Primary HS Clk 1116 (HS CLK B) IS-NR        Active
      Secondary HS Clk 1114(HS CLK A) OOS-MT        Fault
      Secondary HS Clk 1116(HS CLK B) IS-NR        Idle

HS CLK TYPE 1114      = T1 FRAMED
HS CLK LINELEN 1114  = LONGHAUL
HS CLK TYPE 1116      = T1 FRAMED
HS CLK LINELEN 1116  = LONGHAUL

Clock      Using      Bad
HS CLK A   0         0
HS CLK B   0         0
HS CLK I   0         --

Command Completed.
;

```

In this example, the secondary clock is in some condition other than Idle or Active.

#### 40. Issue the command to check clock options.

```
rtrv-clkopts
```

The following is an example of a possible output.

```

Command Accepted - Processing
regnsk0613w 10-05-06 11:13:19 CST EAGLE 41.1.2-62.69.1
CLK OPTIONS
-----

PRIMARY
-----
HSCLKSRC      tlframed
HSCLKLL       longhaul

SECONDARY
-----
HSCLKSRC      rs422
HSCLKLL       longhaul

```

```
;
Command Executed
```

41. Issue the command to change clock options for the secondary.

```
chg-clkopts:clock=secondary:hsclksrc=tlframed:force=yes
```

 **Note:**

Issue this command only if alarms were recorded in 37.

The following is an example of a possible output.

```
Command Accepted - Processing
regnsk0613w 10-05-06 11:14:14 CST EAGLE 41.1.2-62.69.1
CHG-CLKOPTS: MASP B - COMPLTD
;
```

42. Issue the command to change clock options primary.

```
chg-clkopts:clock=primary:hsclksrc=tlframed:force=yes
```

 **Note:**

Issue this command only if alarms were recorded in 37.

The following is an example of a possible output.

```
Command Accepted - Processing
regnsk0613w 10-05-06 11:14:14 CST EAGLE 41.1.2-62.69.1
CHG-CLKOPTS: MASP B - COMPLTD
;
```

43. Issue the following command to check clock status.

```
rept-stat-clk
```

The following is an example of a possible output.

```
Command Executed
> rept-stat-clk

regnsk0613w 10-05-06 11:14:27 CST EAGLE 41.1.2-62.69.1
rept-stat-clk
Command entered at terminal #21.
;
```

```
Command Accepted - Processing
regnsk0613w 10-05-06 11:14:28 CST EAGLE 41.1.2-62.69.1
COMPOSITE PST SST AST
SYSTEM CLOCK IS-NR Idle -----
ALARM STATUS = No Alarms.
Primary Comp Clk 1114 (CLK A) OOS-MT Fault
Primary Comp Clk 1116 (CLK B) OOS-MT Fault
Secondary Comp Clk 1114 (CLK A) OOS-MT Fault
Secondary Comp Clk 1116 (CLK B) OOS-MT Fault

Clock Using Bad
CLK A 10 0
```

```

CLK B      3      0
CLK I      0      --

HIGH SPEED                                PST      SST      AST
SYSTEM CLOCK                               IS-NR    Idle    -----
ALARM STATUS = No Alarms.
Primary HS Clk 1114 (HS CLK A) IS-NR      Active
Primary HS Clk 1116 (HS CLK B) IS-NR      Active
Secondary HS Clk 1114(HS CLK A) IS-NR      Idle
Secondary HS Clk 1116(HS CLK B) IS-NR      Idle

HS CLK TYPE 1114      = T1 FRAMED
HS CLK LINELEN 1114   = LONGHAUL
HS CLK TYPE 1116      = T1 FRAMED
HS CLK LINELEN 1116   = LONGHAUL

Clock      Using      Bad
HS CLK A   0          0
HS CLK B   0          0
HS CLK I   0          --

```

```

Command Completed.
;

```

44. Procedure complete.

## Daily Procedures

The procedures found in this section are recommended procedures for daily routine preventive maintenance. Some procedures may refer to other chapters within this document.

### Backing Up the Database Daily

#### Purpose:

This procedure is used to make a backup of the database on the fixed disk and provide a current copy of the system data to be stored on-site. This procedure can then be used in the event a fixed disk is damaged. This procedure should not be confused with the other database archival procedures. Should the backup removable USB drive created with this procedure become unreadable, the other procedures in this chapter will ensure that a good copy of the database is still available.

#### Requirements:

- The databases in the current partitions of both **MASPs (FDCRNT)** must be coherent.
- At least one removable USB drive formatted for system data is needed for this routine. Each removable USB drive should be labeled as “Daily Backup.” Each day, select the removable USB drive with this label and perform the backup procedure.

#### Interval:

Daily

#### Procedure - Backing Up the Database

1. Enter the following command to check the operational status of the database:

```
rept-stat-db
```

If necessary, refer to *Commands User's Guide* to interpret the output.

2. Enter the following command to create a backup of the database on the fixed disk:

```
chg-db:action=backup
```

This command should take no longer than 30 minutes to execute. It could take longer depending on other system activity that is in progress when this command is entered. During command execution, these messages appear (the active **MASP** is displayed first):

```
BACKUP (FIXED) : MASP A - Backup starts on active MASP.  
BACKUP (FIXED) : MASP A - Backup on active MASP to fixed disk complete.  
BACKUP (FIXED) : MASP B - Backup starts on standby MASP.  
BACKUP (FIXED) : MASP B - Backup on standby MASP to fixed disk complete.
```

3. Insert the removable USB drive labeled “Daily Backup” into the removable USB media slot.

Reference: [Removable Drives](#)

4. Enter the following command to create a backup of the database on the removable USB drive:

```
chg-db:action=backup:dest=remove
```

During command execution, these messages should appear.

```
BACKUP (REMOVABLE) : MASP A - Backup starts on active MASP.  
BACKUP (REMOVABLE) : MASP A - Backup to removable USB drive complete.
```

5. Verify that the databases on the removable USB drive (**RDBKUP**) and the current partition of the active **MASP (FDCRNT)** are coherent by entering the following command:  
`rept-stat-db`

If necessary, refer to *Commands User's Guide* to interpret the output.

6. Remove the removable USB drive from the removable USB media slot.

Reference: [Removable Drives](#)

7. Make an entry in the site maintenance log that a backup was performed.

Place the removable USB drive in a safe place, easily accessible in the event of a catastrophic failure.

## System Reports Analysis

### Purpose:

The purpose of this routine is to inspect the printer outputs for possible trouble messages and routinely check the status of the **STP** through traffic measurements. By inspecting printouts and measurements on a daily basis, system trends can be detected and resolved.

### Requirements:

Printer must be configured to receive traffic reports. Measurements collection must be activated before reports containing current data can be printed. Enter the following command to activate measurements collection, if necessary:  
`chg-meas:collect=on`

Refer to *Commands User's Guide* for more information. If measurements are already allowed, an error message indicates this.



## Reports Description

**Purpose:**

This includes a system terminal and printer output system related messages as well as network protocol messages. Any abnormal activity (this is network dependent) should be highlighted and saved for later retrieval. Refer to [Corrective Maintenance](#) for a description of system related messages and procedures for recovery.

**Requirements:**

None

**Interval:**

Daily

**Variables:**

hh = The end half-hour interval (0 - 2330) for requested interval

**Procedure - Print Report**

1. Enter the following command to print a measurements report for the **STP** entity  
`type:rept-meas:type=systot:enttype=stp`
2. Enter the following command to print a measurements report for the link entity type (this command requires either the loc and port parameters or the lsn parameter): `rept-meas:type=comp:enttype=link`
3. Review the **STP** report and compare with the link report.

If excessive errors exist on any one particular link, enter the following command to print a report for the time period the errors occurred:

```
rept-meas:enttype=link:period=specific:hh
```

Refer to *Commands User's Guide* for more information on using the `rept-meas` command.

4. From this report, determine what events may have occurred during the 30 minute measurements collection period.

## File Transfer for LNP and INP Measurements

**Purpose:**

The purpose of this procedure is to output **LNP/INP** measurements to the file transfer area (**FTA**) so the measurements can be collected.

**Requirements:**

A computer with a **VT320** or **KSR** connection to the EAGLE. A communication program that both emulates **VT** terminals and supports Kermit file transfer. Previous **LNP/INP** measurement files must have been successfully transferred and deleted (`dlr-fta`) before the start of this procedure. A spreadsheet program that can import Comma Separated Value (**CSV**) text files. A **PC** running ProComm© for Windows and Microsoft Excel© can also be used.

**Interval:**

Daily and/or weekly.

**Procedure - File Transfer**

1. From the **EAGLEVT320** or **KSR** terminal, enter the following command to display the contents of the **FTA:disp-fta-dir:loc=xxxx**  
  
Where *xxxx* = the active **E5-TDM** (1114 or 1116).
2. From the **EAGLEVT320** or **KSR** terminal, enter the following command to delete any existing files from the **FTA:dlt-fta:loc=xxxx:all=yes**  
  
Where *xxxx* = the active **E5-TDM** (1114 or 1116)
3. In this example, from the **EAGLEVT320** or **KSR** terminal, enter the following command to send **LNP** daily measurements to the **FTA:rept-meas:enttype=lnp:type=mtcd**
4. Enter the following command to acquire a list of the files transferred to the **FTA** in step 4:  
**disp-fta-dir:loc=xxxx**  
  
Where *xxxx* = the active **E5-TDM** (1114 or 1116).
5. Enter the following command to activate the file transfer:  
**act-file-trns:loc=xxxx**  
  
Where *xxxx* = the active **E5-TDM** (1114 or 1116).
6. Transfer the desired files (with .csv suffixes) to the **PC** by using the get command from within the communications program configured to run Kermit in **ASCII** mode.  
  
An example of the Kermit commands to extract the previous day's records are as follows:  
> get mon\_lnp.csv > get tues\_ssp.csv > get thu\_lrn.csv > get sat\_npa.csv > finish
7. Run a spreadsheet program and open each of the files collected to view the **LNP/INP** measurement data.
8. Once all the files are successfully transferred and confirmed, enter the following command to remove the files from the **FTA:dlt-fta:loc=xxxx:all=yes**  
  
Where *xxxx* = the active **E5-TDM** (1114 or 1116)

## Weekly Procedures

The procedures found in this section are recommended for weekly routine preventive maintenance. Some procedures may refer to other chapters within this document.

### Database Archive (Weekly)

**Purpose:**

The purpose of this procedure is to create a copy of the database on a weekly basis over a period of four weeks to be stored in an archive. The copies can then be used in the event a removable USB drive is damaged, and a new copy is required. This routine will generate four copies of the database, all taken at weekly intervals.

Each tape in this cycle should be designated as Week 1, Week 2, Week 3, or Week 4. When all four removable USB drives have been used, repeat the process starting with the Week 1 USB drive.

**Requirements:**

Four removable USB drives formatted for system data are required for this routine. The removable USB drive should be labeled "Week 1" through "Week 4." Once each week, select the removable USB drive with the appropriate label and perform the backup procedure. Each

week, select the removable USB drive with the next sequential number and perform this procedure.

**Interval:**  
Weekly

### Procedure - Archive Database (Weekly)

1. Enter the following command to check the operational status of the database:

```
rept-stat-db
```

If necessary, refer to *Commands User's Guide* to interpret the output.

2. Insert the removable USB drive labeled “Week x” into the removable USB drive media slot.

Reference: [Removable Drives](#).

3. Enter the following command to create a backup of the database on the removable USB drive:

```
chg-db:action=backup:dest=remove
```

During command execution, these messages should appear.

```
BACKUP (REMOVABLE) : MASP A - Backup starts on active MASP.  
BACKUP (REMOVABLE) : MASP A - Backup to removable USB drive complete.
```

4. Verify that the databases on the removable USB drive backup partition (**RD BKUP**) and the current partition of the active maintenance and administration subprocessor system (**MASP**) fixed disk current partition (**FD CRNT**) are coherent by entering the following command:

```
rept-stat-db
```

If necessary, refer to *Commands User's Guide* to interpret the output.

5. Remove the removable USB drive from the removable USB drive media slot.

Reference: [Removable Drives](#)

6. Make an entry in the site maintenance log that a backup was performed for the appropriate week (Week 1, Week 2, Week 3, or Week 4).

Place the removable USB drive in a safe place, easily accessible in the event of a catastrophic failure.

## Printer Inspection

### Purpose:

This procedure verifies the printer is operational and the ribbon does not need replacement. Should the printer cease operation, system reports and trouble reports would not be printed at the system printer. Use the following procedure to verify the operation of the printer.

### Requirements:

A printer connected through an **RS232** to a serial port on the EAGLE control shelf backplane. Refer to the printer user manual (provided by the printer manufacturer) for detailed specifics on maintaining the printer.

**Interval:**  
Weekly

**Variables:**

x = TDM serial port number (1-16)

**Procedure -Printer Inspection**

1. Verify the carriage assembly is free of any debris.  
Remove the top of the printer if necessary.
2. Check that the power indicator is illuminated (on).  
If not, verify the power cord is plugged in.
3. Check the online indicator.  
If off, press the select button. Verify the indicator is illuminated.
4. Verify the presence of on-line indicators using the printer *Users Manual*.
5. Enter the following command to send output to the printer: `act-echo:trm=x`.
6. Type the following command at a terminal to verify the printer is operating: `rept-stat-trm`  
  
If the printer does not print any messages, check the printer cable and verify it is connected to a system terminal. If not, reconnect the printer cable (refer to the *Installation Guide* for cable pinouts).
7. Look at the printout.  
  
If the ink is faded and difficult to read, replace the ribbon. Refer to the *Users Manual* provided by the manufacturer for ribbon replacement procedures.

## Remote Access Verification

**Purpose:**

The purpose of this routine is to verify proper operation of the modem used for remote access of the EAGLE system.

**Requirements:**

Remote terminal and modem.

**Interval**

Weekly

**Procedure - Remote Access Verification**

1. From a remote PC or terminal, dial the telephone number of the modem connected to the Eagle.
2. When connected, verify you are able to log in to the EAGLE system and enter commands.
3. Once you have verified the operation of the modem, logoff from the EAGLE and terminate your connection.

## Monthly Procedures

The procedures found in this section are recommended procedures for monthly routine preventive maintenance. Some procedures may refer to other chapters within this document.

## Database Archive (Monthly)

### Purpose:

The purpose of this procedure is to create a copy of the database on a monthly basis over a period of four months to be stored in an archive. The copies can then be used in the event a removable USB drive is damaged, and a new copy is required. This routine will generate four copies of the database, all taken at monthly intervals.

Each tape in this cycle should be designated as Month 1, Month 2, Month 3, or Month 4. When all four removable USB drives have been used, repeat the process starting with the Month 1 USB drive.

### Requirements:

Four removable USB drives formatted for system data are required for this routine. The removable USB drive should be labeled “Month 1” through “Month 4.” Once each month, select the removable USB drive with the appropriate label and perform the backup procedure. Each month, select the removable USB drive with the next sequential number and perform this procedure.

### Interval

Monthly

### Procedure - Database Archive (Monthly)

1. Enter the following command to check the operational status of the database:

```
rept-stat-db
```

If necessary, refer to *Commands User's Guide* to interpret the output.

2. Insert the removable USB drive labeled “Month x” into the removable USB drive media slot.

Reference: [Removable Drives](#)

3. Enter the following command to create a backup of the database on the removable USB drive:

```
chg-db:action=backup:dest=remove
```

```
BACKUP (REMOVABLE) : MASP A - Backup starts on active MASP.
```

```
BACKUP (REMOVABLE) : MASP A - Backup to removable USB drive complete.
```

4. Verify that the databases on the removable USB drive (**RDBKUP**) and the current partition of the active **MASP (FDCRNT)** are coherent by entering the following command:

```
rept-stat-db
```

If necessary, refer to *Commands User's Guide* to interpret the output.

5. Remove the removable USB drive from the removable USB drive media.

Reference: [Removable Drives](#)

6. Make an entry in the site maintenance log that a backup was performed for the appropriate month (Month 1, Month 2, Month 3, or Month 4).

Place the removable USB drive in a safe place, easily accessible in the event of a catastrophic failure.

## FAP Load Balance Verification (PN 870-0243-XX only)

### Purpose:

This procedure is used to verify the Load Balance Factor (**LBF**) for the A and B power supplied to each Fuse and **Alarm Panel (FAP)** in the EAGLE. This procedure applies **ONLY** to installed **FAPs** with P/N 870-0243-XX.

The **LBF** is an empirically derived number that provides an indication if a Oracle **STP** System Frame has an open power distribution diode. The difference in amperage between the “A” versus “B” battery leads should be within a “typical” range. Values outside of this range should be an indication of a potential problem and requires further investigation.

### Requirements:

Oracle recommends that the verification be performed using a Clamping Type Multimeter (Clamp Amp Meter). If the Clamp Meter has different settings or functions than the ones described in this procedure, consult the instruction manual for this meter and determine substitute settings or functions. Results of this verification should be recorded on the form provided with this procedure and filed with the **STP** System maintenance records.

### Caution:

This procedure must be performed with the utmost Caution. All safety precautions associated with in service equipment and power must be strictly followed. Any equipment that is below the shelf that is being worked on must be protected from falling tools or debris. All jewelry, rings, watches must be removed before this procedure is started. Read this procedure completely before proceeding.

### Interval:

Monthly

### Procedure - FAP Load Balance

1. Login to system via a dedicated terminal or connect a **PC** to an EAGLE terminal port.  
Open a capture log via ProComm Plus or other **PC** communications program.
2. Enter the following command to determine the status of all the cards in the system.  

```
rept-stat-card
```

If necessary, refer to *Commands User's Guide* to interpret the output. Save the results to compare with the outputs at the conclusion of this procedure.
3. Enter the following command to verify the status of the signaling links.  

```
rept-stat-slk
```

If necessary, refer to *Commands User's Guide* to interpret the output. Save the results to compare with the outputs at the conclusion of this procedure.
4. Enter the following command to get a report of all the device trouble notifications that are currently logged in the **OAMRAM** storage area.  

```
rept-stat-trbl
```

If necessary, refer to *Commands User's Guide* to interpret the output. Save the results to compare with the outputs at the conclusion of this procedure.
5. Enter the following command to check the status of the IMT.

```
rept-stat-imt
```

If necessary, refer to *Commands User's Guide* to interpret the output. Save the results to compare with the outputs at the conclusion of this procedure.

6. Enter the following command to check the status of the **SCCP** subsystem.

```
rept-stat-sccp
```

If necessary, refer to *Commands User's Guide* to interpret the output. Save the results to compare with the outputs at the conclusion of this procedure.

7. Enter the following command to check the operational status of the database.

```
rept-stat-db
```

If necessary, refer to *Commands User's Guide* to interpret the output. Save the results to compare with the outputs at the conclusion of this procedure. Verify that **FDCRNT** and **FDBKUP** for **E5-TDM 1114** and **E5-TDM 1116** match. If they do not match, perform [Daily Procedures](#) before continuing.

 **warning:**

Do not proceed to the next step if the backup fails.

8. Set the Clamp Amp Meter to measure **DC** amps.

Set the dial to the **DC 400A** setting and zero out/adjust the meter by turning the **0 ADJ** control. The meter must read 00.0.

 **Note:**

On the inside of the Clamp Amp Meter there should be an arrow. The arrow must always be pointing towards the frame when clamped around the cable. If the meter cannot be directly observed, the **DATAHOLD** function can be utilized, if the meter is so equipped, and the reading will hold. The jaws of the meter must be around the cable for the **DATAHOLD** function to operate. Values of less than 1.0 Amp on **BOTH** the “A” and “B” sides are not applicable. Ignore plus (+) or minus (-) in the meter reading.

9. Measure the current on the **A** side of the EAGLE Frame **FAP** selected for verification.

Clamp the meter around the **-48VDC A** battery cable on the **FAP**. Record the reading on the [Oracle](#).

10. Depress the **DATAHOLD** function again, if this option was utilized in 9 Verify the Clamp Amp Meter reading is 00.0.

The meter must read 00.0 before proceeding with 11.

11. Measure the current on the **B** side of the EAGLE Frame **FAP** selected in 9.

Clamp the meter around the **-48VDC B** battery cable on the **FAP**. Record the reading on the [Oracle](#).

12. Calculate the Load Balance Factor (**LBF**) and record on the [Oracle](#).

- a. Compute the difference between **A** and **B** sides (A-B) or (**B-A**).

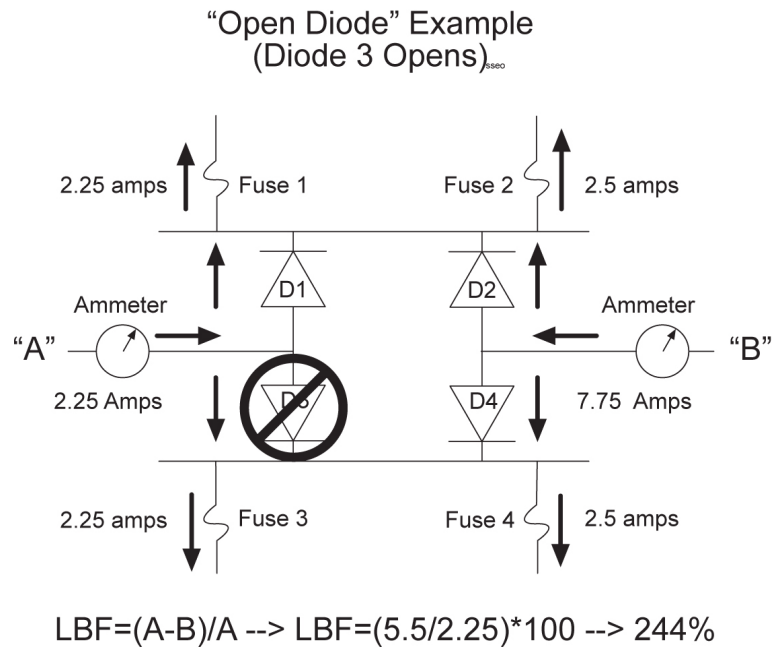
- b. The difference is divided by the lower of the two (2) measured values (**A** or **B**) and expressed as a percentage.

This percentage is the **LBF**.

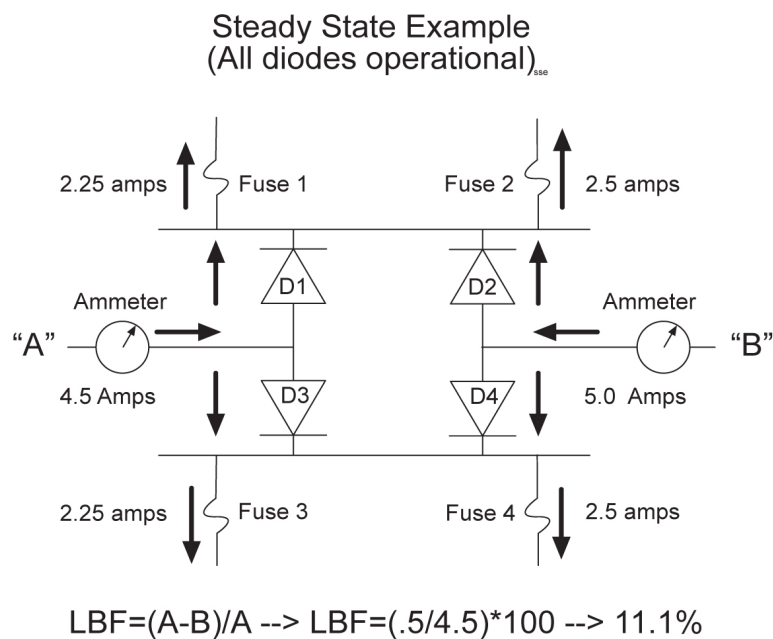
- c. Enter the **LBF** in the appropriate space on the Test Record form.

Refer to [Figure 2-14](#) and [Figure 2-15](#) for examples of this formula. Data indicates that the acceptable range can be between 0% and 125%. The 125% point is a **Flag** that indicates further investigation is warranted. It indicates the potential for at least one open diode.

**Figure 2-14 Open Diode Example**



**Figure 2-15 Steady State Example**





13. [My Oracle Support \(MOS\)](#), for values above the 125% threshold.
14. Depress the **DATAHOLD** function again, if this option was utilized in [9](#) .  
Verify the Clamp Amp Meter reading is 00.0. The meter must read 00.0 before proceeding with [15](#).
15. Repeat Steps [8](#) through [14](#) for all **EAGLEFAPs**.
16. Enter the following command to determine the status of all the cards in the system.  
`rept-stat-card`  
Compare the output with the results from [2](#). The outputs should be the same as initially recorded.
17. Enter the following command to verify the status of the signaling links.  
`rept-stat-slk`  
Compare the output with the results from [3](#). The outputs should be the same as initially recorded.
18. Enter the following command to get a report of all the device trouble notifications that are currently logged in the **OAMRAM** storage area.  
`rept-stat-trbl`  
Compare the output with the results from [4](#). The outputs should be the same as initially recorded.
19. Enter the following command to check the status of the IMT.  
`rept-stat-imt`  
Compare the output with the results from [5](#). The outputs should be the same as initially recorded.
20. Enter the following command to check the status of the **SCCP** subsystem:  
`rept-stat-sccp`  
Compare the output with the results from [6](#). The outputs should be the same as initially recorded.
21. Enter the following command to check the operational status of the database.  
`rept-stat-db`  
Compare the output with the results from [7](#). The outputs should be the same as initially recorded.

**Table 2-9 Oracle Method of Procedure Test Record**

ORACLE Method of Procedure Test Record					
Frame	A Battery	B Battery	A-B Delta (Amps)	Load Balance Factor (LBF)	Technician/Date
CF 00					
EF 00					
EF 01					
EF 02					
EF 03					
EF 04					
MISC					

 **Note:**

Complete this test record for all **FAP** tests. Retain this record in the Oracle EAGLE STP System maintenance files.

## Change the Fan Tray Filter

**Purpose:**

The purpose of this routine is to make sure a clean and adequate supply of air is available to cool the **HC MIM** cards.

**Requirements:**

A replacement fan tray filter.

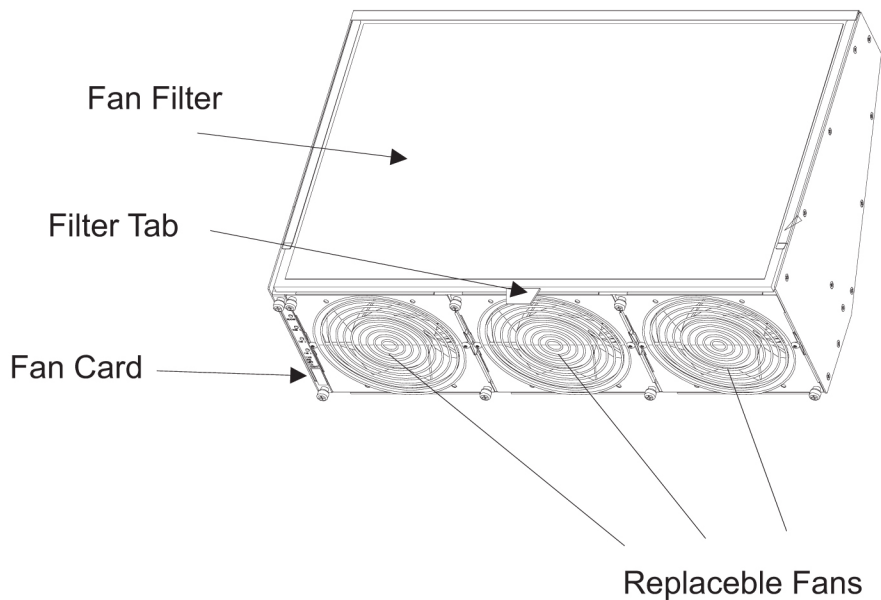
**Interval:**

Monthly

**Procedure - Change Fan Tray Filter**

1. Locate the filter tab on the fan assembly.

**Figure 2-16 Fan Assembly**



2. Pull the filter tab to remove the fan tray filter.
3. Insert the replacement filter into the fan filter slot.  
Align the filter over the replaceable fans.

## Changing the Air Supply Filter

**Purpose:**

The purpose of this routine is to prevent dirt and dust from building up around the fan units, hindering them from cooling the shelf effectively.

**Requirements:**

A replacement air filter (P/N 551-0011-01).

**Interval**

Every 45 days.

**Procedure - Change Air Supply Filter**

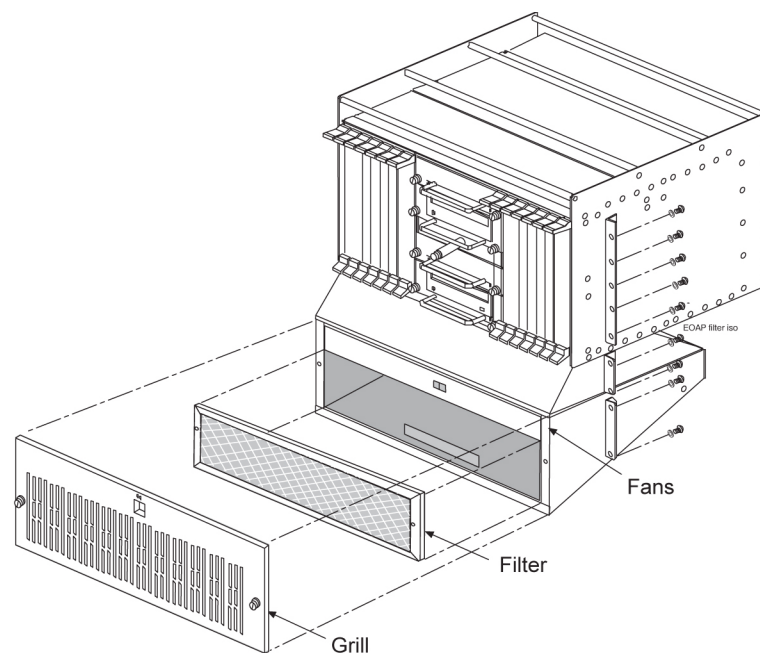
1. Turn the fan power switch to the **OFF** position.

The **ActiveLED** under the fans becomes unlit and the fan **Alarm LED** turns red. The EAGLE generates a **UAM** indicating a fan failure.

2. Unscrew the two thumbscrews securing the grill and remove it.

The air filter is now accessible.

**Figure 2-17 Fan Filter Replacement**



3. Remove and discard the old air filter.

4. Position the new air filter so that it covers the opening to the fan assembly.

Check the bottom edge of the filter to make sure the airflow indicator arrows are pointing away from you and towards the fan assembly.

5. To replace the grill, position it on the fan assembly and screw in the two thumbscrews to secure the grill in place.

6. Turn the fan power switch to the **ON** position.

The two **LEDs** for the fan assembly turn green and the EAGLE generates a **UIM** to indicate the fan alarm is cleared.

## Cleaning Printer

**Purpose:**

The purpose of this routine is to prevent the system printer from building up dirt and dust around the print heads and carriage assemblies, preventing it from operating.

**Requirements:**

Printer cleaning kit, or cleaning solvent. Cotton swabs and damp cloth.

**Interval**

Monthly

**Procedure - Clean Printer**

1. Follow the manufacturer's procedures for cleaning the print head and carriage assembly.

## Fuse Spares Inventory

**Purpose:**

This routine verifies ample spare fuses are available. Fuses are used in the fuse and alarm panel (**FAP**).

**Requirements**

None

**Interval**

Monthly

**Procedure - Fuse Inventory**

Two types of fuses are used in the EAGLE:

1. Industry standard **GMT** fuse 1 amp
2. Industry standard **GMT** fuse 3 amp

Spare fuses are stored in a fuse tray located on the side of each frame. Check that both types of **GMT** fuses are in this tray. Oracle recommends no fewer than five of each fuse type be readily accessible. If the EAGLE is not located at the end of a bay, check your facility's spare fuse storage. **GMT** fuses are industry standard fuses and are provided by Oracle during installation of the system. Additional inventory of these fuses should be purchased through Oracle.

## Wrist Strap Test

**Purpose:**

The purpose of this routine is to verify the integrity of the anti-static wrist strap and ground cord used when handling cards from the EAGLE.

**Requirements:**

Ohmmeter, wrist strap (equipped with the EAGLE).

**Interval:**

Monthly

**Procedure - Wrist Strap Test**

1. Detach the grounding cord from the wrist strap.

**NOT\_SUPPORTED:**

If the resistance measured is less than 800 Kohms, you may be electrocuted if the equipment short circuits while you are wearing the wrist strap. If the resistance measured is greater than 1200 Kohms, you may damage your equipment.

2. Using an ohmmeter, measure the resistance between the two ends of the ground cord.
3. If you measure a resistance between 800 Kohms and 1200 Kohms, the ground cord is safe to continue using.
4. If you measure a resistance that is not between 800 Kohms and 1200 Kohms, discard the ground cord and wrist strap.  
They are no longer safe to use.

## Quarterly Procedures

The procedures found in this section are recommended procedures for quarterly routine preventive maintenance. Some procedures may refer to other chapters within this document.

### Database Archive (Quarterly)

**Purpose:**

The purpose of this routine is to create an archive copy of the EAGLE database. This archive copy should be stored off-site and saved for emergency recovery when all other procedures have failed. This routine will reuse the same removable USB drive each quarter.

**Requirements**

This procedure requires a removable USB drive formatted for system data.

**Interval**

Quarterly

**Procedure \_Database Archive (Quarterly)**

1. Enter the following command to check the operational status of the database:

```
rept-stat-db
```

If necessary, refer to *Commands User's Guide* to interpret the output.

2. Insert the removable USB drive labeled "Archive" into the removable USB drive media slot.

Reference:[Removable Drives](#)

3. Enter the following command to create a backup of the database on the removable USB drive:

```
chg-db:action=backup:dest=remove
```

```
BACKUP (REMOVABLE) : MASP A - Backup starts on active MASP.
```

```
BACKUP (REMOVABLE) : MASP A - Backup to removable USB drive complete.
```

4. Verify that the databases on the removable USB drive (**RDBKUP**) and the current partition of the active **MASP (FDCRNT)** are coherent by entering the following command:

```
rept-stat-db
```

If necessary, refer to *Commands User's Guide* to interpret the output.

5. Remove the removable USB drive from the removable USB drive media slot.

Reference: [Removable Drives](#)

6. Make an entry in the site maintenance log that a backup was performed on the “Archive” removable USB drive.

Place the removable USB drive in a safe place off-premise. This copy is for emergency recovery in the event all other methods of database recovery failed.

## Preventing Dust Buildups

### Purpose:

The purpose of this routine is to prevent dust build-up in and around the cabinet. Collection of dust within the EAGLE can allow electrostatic charges to build around circuit cards, possibly damaging cards installed in the system.

### Requirements:

Damp cloth

### Interval:

Quarterly

### Procedure - Prevent Dust Buildup

1. Open the cabinet doors on the front of the cabinet(s).

 **Note:**

Do not use compressed air. Do not remove the plexiglass panels from the rear of the frame. This procedure is to be used for removing dust from the front of the system and from around the card cages only.

Using a damp cloth, wipe the dust from the doors and from the front of the card cages.

2. Using the same cloth, wipe the dust from the air intakes and around the exterior of the system frames.

## Rectifier Voltage Inspection/Recording

### Purpose:

The purpose of this routine is to verify that the rectifier is providing adequate voltages and has not become a marginal supply. By identifying power supply problems early, the possibility of failure can be circumvented.

### Requirements:

Volt meter capable of measuring **DC** voltages in the range of -20VDC to -60VDC.

**Interval**

Quarterly

**Procedure - Rectifier Voltage Inspection**

1. Locate the power source for the EAGLE.
2. Using a **VOM**, measure the -48VDC supply.
3. Verify voltages are between -46VDC and -52VDC.

(If voltages are higher or lower, refer to the manufacturers maintenance procedures for appropriate action).

## Semi-Annual Procedures

The procedure found in this section is recommended for semi-annual (every 6 months) routine preventive maintenance. Some procedures may refer to other chapters within this document.

**Spare Inventory Rotation**

**Purpose:**

The purpose of this routine is to verify the integrity of spare cards. By rotating spares on a regular basis, their operation can be verified before they are needed as replacements.

**Requirements**

None

**Interval**

Semi-annually (every 6 months)

**Procedure - Semi-annual Procedures**

1. Identify the spare cards in your inventory.



**warning:**

This procedure may interrupt service. Verify the type of card and service it provides, and only use this routine during the maintenance window.

2. Locate the card in service that matches the configuration of your spare card.
3. Verify the part numbers and revision numbers of the cards are compatible.
4. Refer to [Card Removal/Replacement Procedures](#) for the proper procedure for each card type.
5. Place the card from your spares inventory into the now empty slot.

Perform any administrative commands described in [Card Removal/Replacement Procedures](#).

6. Make an entry in the site maintenance log and place the card removed from the system into your spares inventory.

# 3

## Corrective Maintenance

### Introduction

The EAGLE trouble detection is distributed throughout the system. Each processor continually monitors its internal subsystems and certain external subsystems. Whenever a trouble condition changes state, the processor analyzes the change and stores the analysis for reporting to the active **E5-MASP**. The trouble detection software does not affect the service quality of the system.

Each **E5-MASP** is made up of two cards, the **E5-MCAP** card and the **E5-TDM** (terminal disk module).

The E5-MCAP card is equipped with 4 GB of physical application processor memory. The primary data interface to the E5-MCAP is RS-232 interfaces (i.e.: terminals) through the E5-TDM.

The E5-MCAP card contains one **latched USB port** for use with removable flash media (“thumb drive”), and one flush-mounted USB port for use with a plug-in flash drive. The removable media drive is used to install and back up customer data. The flush-mounted USB port is used for upgrade and could be used for disaster recovery. The removable flash media is used as a replacement for the legacy Magneto-Optic (MO) Drive. The E5-MCAP card is a replacement for the obsoleted legacy GPSM-II card used for the **MCAP** function.

 **Note:**

The E5-MCAP card can not be used for the other functions for which the GPSM-II class (e.g.: MCP, IPS, DCM) card is used.

The **E5-TDM** card contains four major subsystems: the Terminal Processor Subsystem, the System Clock/Control Subsystem, the SATA Subsystem, and a Power Subsystem. These subsystems provide the EAGLE with 16 user-accessible terminals, distributes Composite Clocks and High Speed Master clocks throughout the EAGLE, distributes Shelf ID to the EAGLE, and disk storage for an E5-MCAP card. The E5-TDM card provides an interface to the E5-MDAL card for system alarms.

The E5-TDM card contains one fixed solid-state SATA drive that is removable and used to store primary and backup system databases, measurements, and Generic Program Loads (GPLs).

To determine which **MASP** is active either enter the `rept-stat-db` command, or enter the `rept-stat-card` command, or examine the **LEDs** on both **E5-TDM** cards. If the **LED** on the **E5-TDM** card is green, the associated **E5-MASP** is active. (If the **LED** on the **E5-TDM** card toggles between green and amber, the associated **E5-MASP** is standby.)

The output of the `rept-stat-db` command shows which **E5-MASP** is active with the indicator (**ACTV**) following the **E5-TDM** card location. The indicator (**STDBY**) following the **E5-TDM** card location shows which **E5-MASP** is standby.



The output of the `rept-stat-card` command shows which **E5-MASP** is active with the entry **ACTIVE** in the **SST** field for the **E5-MCAP** card. The entry **STANDBY** in the **SST** field for the **E5-MCAP** card shows which **E5-MASP** is standby.

The database commands, such as `rept-stat-db`, refer to the **E5-TDM** because the **E5-TDM** contains the fixed disk drive and the removable USB media for the **E5-MASP**.

## System Alarm Levels

There are three levels of alarms in the EAGLE system. They are:

### Critical

A critical alarm is an indication of a severe service affecting problem that can be related to traffic, billing, and maintenance capabilities and requires immediate maintenance attention, regardless of time of day.

### Major

A major alarm is an indication of a problem that seriously affects system operation, maintenance and administration, etc. and requires immediate attention. The urgency is less than in critical situations because of a lesser immediate or impending effect on system performance, customers, and operating company operations and revenue.

### Minor

A minor alarm is an indication of a problem that does not have a serious impact on service, and does not require immediate maintenance attention.



### Note:

Some UAMs are considered informational if they satisfy the following conditions in the SNMP V2 traps generated by EAGLE E5OAM:

1. The Alarm Level is stated as "No alarm condition" in this user's guide.
2. The alarm is not intended to clear any higher severity UAM as per the corresponding UAM Balancing Matrix.

These UAMs are informational only and neither contribute to the total number of alarms in the system nor change the alarm state of the device on EAGLE.

## Trouble Detection

The first step in analyzing a system trouble is to know when a trouble exists. The EAGLE handles this task through:

- Audible alarms
- Visual alarms
- Event/error messages

### Audible Alarms

The EAGLE has three types of audible alarms: critical, major and minor. Audible alarms are generated by the E5-maintenance disk and alarm card (**E5-MDAL**), and can be heard through

the electronic sonalert device installed on the card. Each alarm has its own distinct cadence as described in the following:

- Critical - Two tones 0.5 seconds apart, separated by 1.5 seconds of silence.
- Major - Single tone, separated by 1.5 seconds of silence.
- Minor - Single tone of 5 seconds or continuous tone for power plant alarm.

### Visual Alarms

The EAGLE has several types of visual alarms. They are:

- **AlarmLEDs** on the Fuse and **Alarm Panel (FAP)**
- Alarms displayed on the system terminal
- **LEDs** on application cards
- End cabinet alarm indicators

Maintenance personnel usually see the alarm **LEDs** on the fuse and alarm panel (**FAP**) and the alarms displayed on the system terminal screen to alert them that a system problem exists. The **LEDs** on a card help maintenance personnel diagnose where a problem exists.

### MDAL LEDs

Following are the five alarm **LEDs** on the face of the obsoleted **MDAL** card. Although the card is obsolete, the functionality remains uniform. See [Figure 3-1](#):

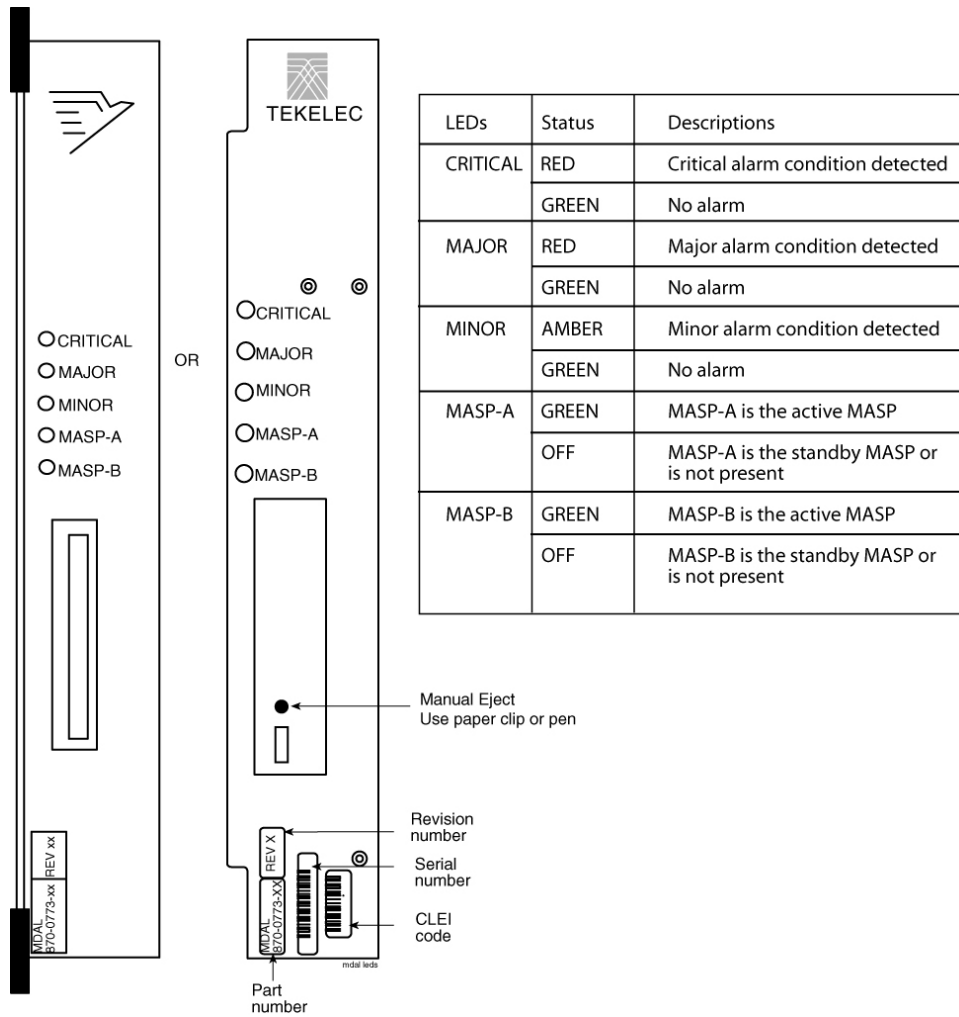
- Critical
- Major
- Minor
- **MASP-A**
- **MASP-B**

When the system detects an alarm, the appropriate alarm level and location (**MASP-A** or **MASP-B**) **LEDs** illuminate. See [Figure 3-1](#).

 **Note:**

Verify the state of the **MDAL** card by observing the **LEDs** on the face of the **MDAL** card. The fuse and alarm panel do not reflect any alarms caused by the **MDAL** card.

**Figure 3-1 MDAL Alarm LEDs**



**Alarm LEDs on the Fuse and Alarm Panel (FAP)**

There are six alarm LEDs on the FAP that indicate:

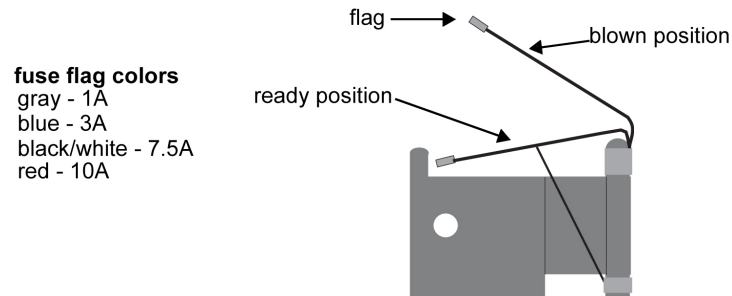
- Power alarm LEDs (A and B)
- A critical alarm
- A major alarm
- A minor alarm
- A fuse alarm

The FAP provides protected distribution of power to the system. Protection is provided by the fuses placed in the GMT fuse holders used in the panel. The FAP contains a fuse fail alarm circuit that operates when one or more of the panel’s fuses fail. An LED changes from green to red when a fuse has failed. The LED remains red until the fuse has been replaced.

The fuse and alarm panel uses GMT fuses for individual circuit protection (see Figure 3-2). The EAGLE uses 3A and 1A fuses, depending on the application. When a fuse fails due to an overload condition, a small colored flag on the fuse shows the position of the fuse that has

failed. The flag is gray on 1A fuses, blue on 3A fuses, black/white on 7.5A fuses, and red on 10A fuses.

**Figure 3-2 GMT Fuse**



The panel contains two separate circuits, A and B. Current flows from the input terminals to the fuse bus. When a fuse is installed in a fuse holder, the circuit is completed to the output connector. The Fuse Fail **Alarm LED** on the front panel indicates the condition of the panel. Green is indicated if power is applied to the panel and there are no failed fuses. The green **LED** changes to red when a fuse fails. An unlit **LED** indicates a failed **LED** or no power to the fuse and alarm panel.

The fuse and alarm panel is also equipped with frame alarm **LEDs** that display the critical, major, and minor alarms generated by the EAGLE system.

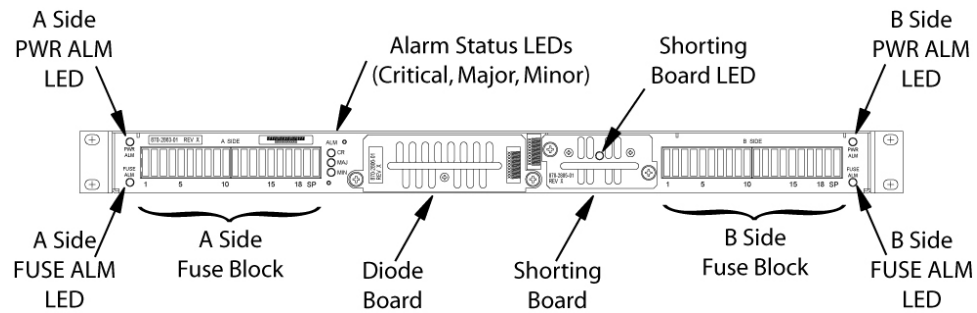
The fuse and alarm panels have the A and B buses connected through diodes to allow one bus to pick up the entire load when the other bus loses power.

[Table 3-1](#), [Table 3-2](#) and [Table 3-3](#) describe the front panel configuration of the fuse and alarm panels.

**Table 3-1 Fuse and Alarm Panel Front Items (870-2804-01)**

Fuse Panel Item	Description
Fuse Positions	2 groups of 20 GMT fuses
PWR ALM	LED indicator for A or B diode board input power <ul style="list-style-type: none"> <li>• Green - input power applied</li> <li>• Red - no input power to board</li> </ul>
FUSE ALM	LED indicator for fuse fail alarm <ul style="list-style-type: none"> <li>• Green - normal</li> <li>• Red - blown fuse</li> </ul>
CR	<b>LED</b> indicator for frame critical alarm
MAJ	<b>LED</b> indicator for frame major alarm
MIN	<b>LED</b> indicator for frame minor alarm
Shorting Board	LED indicator for mode of operation <ul style="list-style-type: none"> <li>• Off - normal</li> <li>• Green - maintenance</li> </ul>

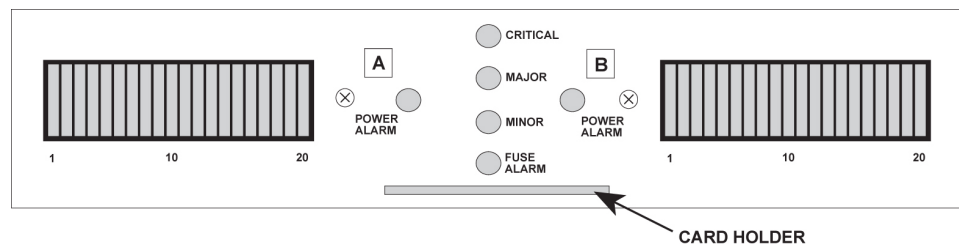
**Figure 3-3 Fuse and Alarm Panel Front Layout (870-2804-01)**



**Table 3-2 Fuse and Alarm Panel Front Items (870-0243-xx)**

Fuse Panel Item	Description
Fuse Positions	2 groups of 20 GMT fuses
Card Holder	slide-card holder with 2 designation cards for 20 fuse positions each
Fuse Alarm	LED indicator for fuse fail alarm
Critical Alarm	LED indicator for critical alarm
Major Alarm	LED indicator for major alarm
Minor Alarm	LED indicator for minor alarm
Power Alarm	LED indicator for loss of power on either A bus or B bus

**Figure 3-4 Fuse and Alarm Panel Front Layout (870-0243-xx)**



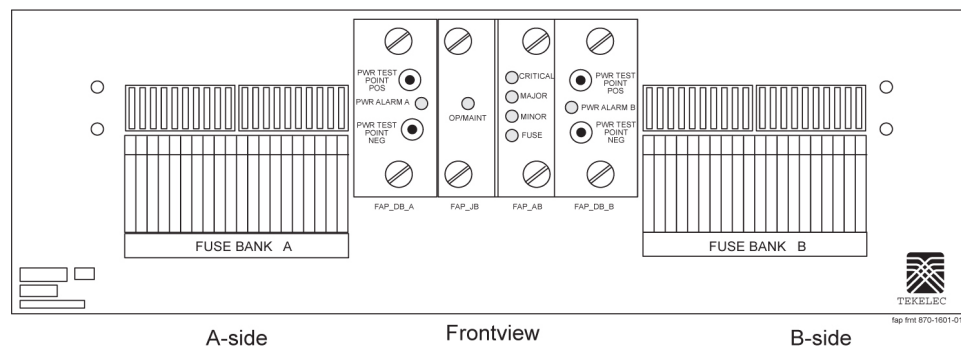
**Table 3-3 Fuse and Alarm Panel Front Items (870-1606-xx/870-2320-xx)**

Fuse Panel Item	Description
Fuse Positions	Two groups of 20 GMT fuses
PWR ALARM	LED indicator for A or B diode board input power Green - input power applied Red - no input power to board
OP/MAINT	LED indicator for mode of operation Green - normal Red - maintenance

**Table 3-3 (Cont.) Fuse and Alarm Panel Front Items (870-1606-xx/870-2320-xx)**

Fuse Panel Item	Description
<b>FUSE</b>	<b>LED</b> indicator for fuse fail alarm Green - normal Red - blown fuse
<b>CRITICAL</b>	<b>LED</b> indicator for frame critical alarm
<b>MAJOR</b>	<b>LED</b> indicator for frame major alarm
<b>MINOR</b>	<b>LED</b> indicator for frame minor alarm

**Figure 3-5 Fuse and Alarm Panel Front Layout (870-1606-xx/870-2320-xx)**



### Alarms appearing on a terminal screen

Three types of alarms may be displayed on a system terminal screen:

- **CRIT** - Indicates a critical alarm
- **MAJR** - Indicates a major alarm
- **MINR** - Indicates a minor alarm

These appear as three highlighted boxes in the top left corner of a terminal. If an alarm condition exists, it is displayed in one of the highlighted boxes. There is a fourth box next to the three alarm boxes that is not used. To obtain information about the alarm, use the `rept-stat-alm` command at the system terminal, followed by a carriage return.

This command provides all current alarm status. Refer to *Commands User's Guide* for more information about the `rept-stat-alm` command.

### Alarms on Application Cards

Each application card has **LEDs** that indicate the condition of the card. **Alarm** conditions appear on the card if the card has a fault. Refer to *Installation Guide* for the location and description of the card **LEDs**.

### End Cabinet Alarm Indicators

There are three alarm **LEDs** on the end cabinet:

- A critical alarm **LED**

- A major alarm **LED**
- A minor alarm **LED**

When an alarm condition is present, one or more of these **LEDs** illuminate in the signifying the overall system alarm level. Refer to *Installation Guide* for alarm indicators.

### Event/Error Messages

Unsolicited messages are used in the EAGLE for trouble notification and to communicate the status of the system to Operations Services (**OS**). The EAGLE outputs two types of unsolicited messages.

- Unsolicited **Alarm** Messages (**UAMs**) are used to denote a persistent problem with device or object that needs the attention of a craftsperson. Some examples are a link failure, a subsystem being out of service, or a card not receiving a system clock.
- Unsolicited Informational Messages (**UIMs**) are indications of transient events that have occurred. **UIM** examples include messages that an **MSU** contains invalid data or failed a gateway screening function.

The location of a card with a fault is displayed with the event/error message. The location is displayed as a card number. **Card** numbers are used to locate the card in the EAGLE system. Refer to *Installation Guide* for card locations.

Following is an example of an event/error message displaying the card location:

```
RLGHNCXA21W 00-02-07 12:01:43 EST EAGLE 35.0.0
** 0014.0008 ** CARD 1113 OAM Active MASP has become isolated
```

The card location always follows the word “**CARD**” in the message. In this example, the card number is **1113**.

### IMT Bus States

The states of the IMT bus are combined from the primary state (**PST**) and secondary state (**SST**) for each IMT bus. See *Commands User's Guide* for information about **PST** and **SST** states and definitions.

The `rept-stat-imt` command is used to report the status of the IMT bus. An example of the output follows:

```
RLGHNCXA03W 00-09-27 16:50:24 EST EAGLE 31.5.0
IMT PST SST AST
A IS-NR Active -----
ALARM STATUS = No alarms
IMT PST SST AST
B IS-ANR Fault -----
ALARM STATUS = ** 0108 Major IMT Failure Detected
Command Completed.
```

### IMT System Alarm Level Determination

The state of the IMT subsystem is determined from the state of each IMT bus. If both buses are **IS-NR** active, the IMT subsystem is **IS-NR** active. If only one IMT bus is manually disabled (**IS-ANR** manual), the IMT subsystem is **IS-ANR** manual. Otherwise, the IMT subsystem state is **IS-ANR** fault.

The alarm level of an IMT bus in the **IS-ANR** fault state is determined by how many bad card connections it has. The number of bad connections required for a major alarm or a minor alarm are as follows:

- 0 failures = no alarm
- 1-2 failures = minor alarm
- 3 or more = major alarm

The alarm levels on the individual buses combine to give the overall alarm level for the IMT subsystem. Table 3-4 shows the rules that are used to determine the overall alarm level of the system of IMT buses.

**Table 3-4 IMT Bus Alarm Levels**

Bus A Alarm Level	Bus B Alarm Level	Overall Alarm Level
Normal	Normal	Normal
Normal	Minor	Normal
Minor	Normal	Normal
Normal	Major	Minor
Major	Normal	Minor
Minor	Minor	Major
Minor	Major	Major
Major	Minor	Major
Major	Major	Critical

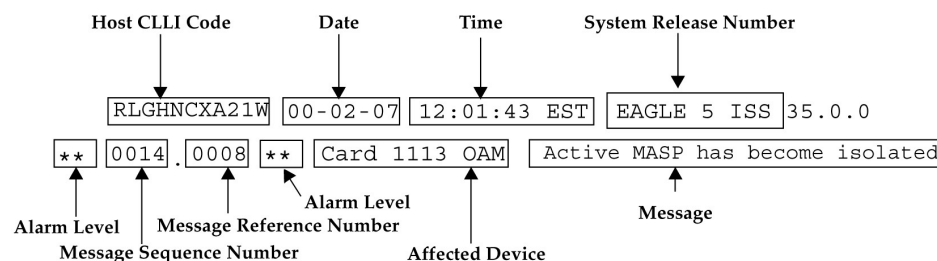
## Output Messages

The EAGLE generates output messages in response to command input or fault conditions in the EAGLE or in the network. The format for these messages is generally uniform. Some messages include additional data.

Network messages provide the text description of the event, and on the lines below the text line, any additional information.

The following example shows the general format of an output message.

**Figure 3-6 Output Message Format**



The fields in an output message (shown in the figure above) are described next:



- Host **CLLI** code - a maximum of one alpha character and ten alphanumeric characters. The **CLLI** code uniquely identifies the system in terms of its physical location. The **CLLI** code must be unique among all elements in the system.  
The **CLLI** code consists of the following:
  - City = 4 characters
  - State = 2 characters
  - Building = 2 characters
  - Equipment type = 3 characters
- **Date** - The date the message was generated, in the format *year-month-day*.
- **Time** - The time the message was generated with time zone, in the format *hour: minutes: second time zone*.
- **System Release Number** - contains a system identifier and the version ID number. The system identifier, can be **EAGLE** or **EAGLE5** depending on the product key enabled on the system. The version ID number has the software release specific GPL set that is expected to be installed on the system as approved loads. The format of the version ID number is in the form of **maj.min.maint**, defined as follows:
  - **maj** - the major release ID
  - **min** - the minor release ID
  - **maint** - the maintenance release ID
- **Alarm Level** - a one or two character indicator of the alarm level, defined as follows:
  - **\*C** = Critical Alarm
  - **\*\*** = Major Alarm
  - **\*** = Minor Alarm
  - *blank* = No Alarm
- **Message Sequence Number** - This number is an index for all output messages. The number increments sequentially for every message. The output messages originating from the card in location 1113 has a range from 0001 through 4999. The range for location 1115 is 5000 through 9999.
- **Message Reference Number** - Messages that are associated with a specific action are numbered for reference. These messages are defined in this chapter, along with a corrective action.
- **Affected Device** - The device that caused the message to be generated. This generally describes the card type.

Network messages with additional data display the additional lines below the text string and message reference number (**MRN**). See individual messages for examples of output.

All network messages are non-alarm and are used to notify the user of network events. There may or may not be a procedure associated with these messages.

## Alarm Clearing Procedures

After an audible has sounded, it can be silenced by entering the following command:

```
rls-alm:lvl=xxxx
```

where `xxxx` can be:

- `minr` - Silences a minor alarm
- `majr` - Silences a major alarm
- `crit` - Silences a critical alarm.

All alarm types can be silenced with the following command:

```
rls-alm
```

The `rls-alm` command does not clear visual alarms on the terminals or alarm indicators on the fuse and alarm panel (**FAP**) or frame panels.

Once an audible alarm is silenced, any new alarm conditions cause the alarm to sound again.

Silencing a specific alarm when a lower level alarm is also present results in the next highest audible alarm level being activated. For example, the system has both critical and major alarms present. When the critical alarm is silenced, the audible major alarm begins to sound.

## Retrieve Trouble Report

Application maintenance software is responsible for monitoring trouble on a card. There are three types of troubles or faults:

- Abnormal situation is being reported by software.
- An **SS7** message has a problem (an invalid **DPC**, for example)
- A hardware fault is being reported.

Trouble reports are used by [My Oracle Support \(MOS\)](#) to help analyze problems with the EAGLE system. To help [My Oracle Support \(MOS\)](#), retain any printouts of the trouble report. The output of the `rtrv-trbl` command should be reviewed with a member of [My Oracle Support \(MOS\)](#). To display the current trouble reports, enter the following command at the system terminal:

```
rtrv-trbl:loc=1115:num=1:mode=c
```

The `mode=c` parameter provides a continuous output of the trouble reports as they occur. The `loc=` parameter specifies the active **E5-MCAP**. The `num` parameter indicates how many trouble reports you want to display.

A typical trouble report looks similar to this:

```
tekelecstp 00-05-15 19:04:05 EST EAGLE 35.0.0
  Card 1115 Module tc_utl.c Line 1617 Class 1103 Severity 1
    00 02 f6 00 01 23 06 22 05 00
  Report Date 00-05-15 Time19:04:05
```

The trouble reports include:

- **Card** number
- Module name
- Line number
- Class
- Severity

## Hourly Status Message Reports

The system provides hourly reports that include a list of all alarms and any devices that are manually deactivated or inhibited. The report contains the alarms that exist at the time the report is generated. Any alarms that have occurred, and have been cleared in the last hour, are not reported. The hourly status message report is automatically generated at the beginning of each hour (08:00, 09:00, and so forth). The system sends the report to all system terminals that can receive unsolicited program update messages.

The information shown in the hourly status report can also be displayed by entering one or more of the following commands.



### Note:

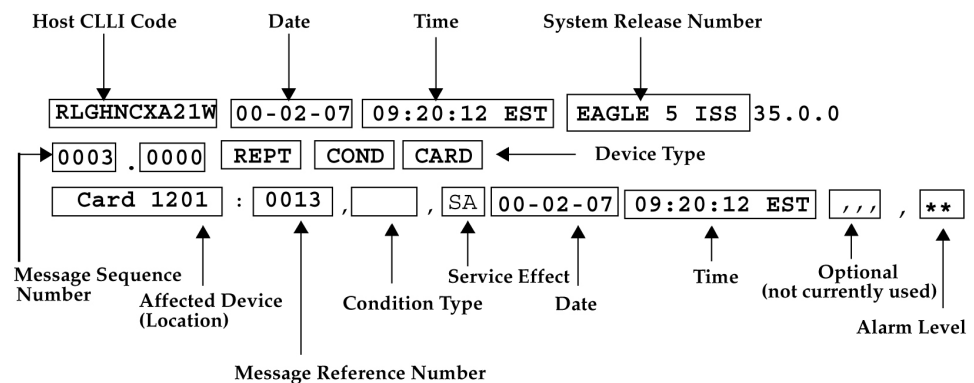
Systems supporting an ITU network are not configured with the **LNP** or **SEAS** features.

- `rept-stat-alm`: Displays the summary of all alarm counts.
- `rept-stat-card`: When used with the **stat** parameter, displays all cards with the state specified by the **stat** parameter. Refer to *Commands User's Guide* for additional information on the use of parameters with this command.
- `rept-stat-cdt`: Displays the customer defined troubles.
- `rept-stat-clk`: Displays the status of the clocks.
- `rept-stat-cluster`: Displays the summary status and statistical information for all configured cluster point codes.
- `rept-stat-db`: When used with the `display=except` parameter, displays the status of the system database by displaying the database level of the cards whose database level does not match the active fixed disk current partition. Refer to *Commands User's Guide* for additional information on the use of parameters with this command.
- `rept-stat-dlk`: When used with the **:stat** parameter, displays the status of the **TCP/IP** data links. Refer to *Commands User's Guide* for additional information on the use of parameters with this command.
- `rept-stat-dstn`: When used with the **stat** parameter, displays the destination point codes with the state specified by the **stat** parameter. Refer to *Commands User's Guide* for additional information on the use of parameters with this command.
- `rept-stat-dstn`: When used with the **mode=full** parameter, displays the subsystem status. Refer to *Commands User's Guide* for additional information on the use of parameters with this command.
- `rept-stat-mps`: Displays in a single report, the overall status of the **EPAP** (EAGLE Provisioning Application Processor) subsystem.
- `rept-stat-gpl`: Displays the version of the **GPL** currently being used by an application and which versions of the **GPL** are the trial and approved versions of that **GPL**.
- `rept-stat-imt`: Displays the primary, secondary, and associated maintenance states of the IMT buses.

- `rept-stat-lnp`: Displays the status and statistics related to **LNP**.
- `rept-stat-ls`: When used with the **stat** parameter, displays the linksets that have the state specified by the `stat` parameter. Refer to *Commands User's Guide* for additional information on the use of parameters with this command.
- `rept-stat-sccp`: Displays the status of the **TSMs** running the **SCCP** application.
- `rept-stat-seas`: Displays the status of the **SEAS** subsystem.
- `rept-stat-slan`: Displays the status of the cards that make up the **STPLAN** subsystem.
- `rept-stat-slk`: When used with the **stat** parameter, displays the signaling links that have the state specified by the `stat` parameter. Refer to *Commands User's Guide* for additional information on the use of parameters with this command.
- `rept-stat-sys`: Displays the status of these items: alarms, IMT buses, **SS7** signaling links, linksets, destination point codes (**DPCs**), the maintenance and administration subsystem (**MAS**), clocks, **TSMs** loaded with the **SCCP** or **GLS** application, security subsystem, and the **SEAS** subsystem.
- `rept-stat-trbl`: Displays a report of all the device trouble notifications that are currently logged in the **OAMRAM** storage area. The severity of each alarm is also identified in the report.
- `rept-stat-trm`: Displays the status of the terminal serial ports.
- `rept-stat-xlist`: Displays the statistics related to the storage of exception list (x-list) entries.

If the message reference number (**MRN**) field has a null value (no field entry), the device has been manually removed from service (through `inh-card`, `canc-slk`, and so forth). There is no alarm for the device and the condition type is **SCMMA** (state change due to manual action). The date and time in the report refer to the date and time of the alarm or when the device was removed from service. The format of the output is in [Figure 3-7](#).

**Figure 3-7 Format of Hourly Status Message Output**



The following is a list of the device types and subsystems (with the **ID** of the affected device or subsystem) that the hourly status message report displays reports for. For example, if the device type being reported on is **CARD**, then card locations are displayed. Only those device types and subsystems that have disabled devices or alarm conditions are displayed in the hourly status message report. If there is more than one device type or subsystem to display, they are displayed in the following order.

1. **CARD** - the card location
2. **IMT** - the IMT bus A or IMT bus B
3. **BITS** - the **BITS** clock
4. **TRM** - the terminal port
5. **SLK** - the linkset name and the signaling link code (**SLC**)
6. **DLK** - the data links
7. **LS** - the linkset name
8. **DPC** - the destination point code
9. **CDT** - the customer defined trouble number
10. **FUSEPNL** - the frame **ID** of the system
11. **SYSTEM** - system
12. **ALM** - alarms
13. **SYSCLK** - system clock
14. **SYSIMT** - system IMT
15. **SCCPSS** - **SCCP** subsystem
16. **GLSSS** - **GLS** subsystem
17. **GPL\_SS** - the name of the **GPL**
18. **SLANSS** - **STP/LAN** subsystem
19. **XLISTSS** - **XLIST** subsystem
20. **SEASSS** - **SEAS** subsystem
21. **SECULOG** - Security log
22. **LNPSS** - **LNP** subsystem
23. **LSMS Q.3 Association** - Local Services Management System **Association**
24. **LSMSSS** - Local Services Management System subsystem
25. **HS System CLK** - High-Speed system clock
26. **EMDC Links** - Element Measurement & Data Collection Application Links
27. **NDCSS** - Network Data Collection subsystem
28. **NDC Q.3 Association** - Network Data Collection Q.3 association
29. **GSMSS** - **GSM** subsystem
30. **MPS (ELAP/EPAP)** - **Multi-Purpose Server**
31. **DSM Links** - **Database Services Module**
32. **INPSS** - **INP** subsystem
33. **SECURITYSS** - Security subsystem

Within each device type or subsystem being reported, the subsets of the report are displayed in the following order.

1. Disabled Devices
2. Minor Alarms

3. Major Alarms
4. Critical Alarms

The *cond type* field supports five values for this release:

- **SCMMA**: The device has been disabled due to manual maintenance action. This condition applies regardless of a previous alarm state.
- **MTCEINT-0**: The reported device is off normal (**ANR**), but there is no alarm associated with this device. An alarmed condition for another device typically affects the state of this device. For example, out-of-service (**OOS**) links affect the condition of the linksets.
- **MAN**: The reported device is off-normal (**OOS-MT**), but there is no alarm associated with this device. The off-normal condition was caused by manual intervention (by entering the *ent-dstn* command, for example).
- **NULL**: No specific *cond type* is supported. There is sufficient information to ascertain the device condition from the report. You should use a *rept-stat* command for further information.
- **INAUDB**: The user has manually inhibited alarms for this device. The time when the device was inhibited is recorded and displayed during the hourly report.

Following is an example of the report:

```

RLGHNCXA21W 00-07-16 12:20:12 EDT EAGLE 35.0.0
1240.0000 REPT COND CARD
"CARD 1101:0013,,SA,00-07-16,10:03:29,,,,**"
"CARD 1107:,SCMMA,,00-07-16,10:03:29,,,,"
"CARD 1113:0143,,NSA,00-07-16,10:03:29,,,*"

RLGHNCXA21W 00-07-16 12:20:12 EDT EAGLE 35.0.0
1241.0000 REPT COND SLK
"SLK 1s1201-0,,NSA,00-07-16,10:03:29,,,*"
"SLK 1s1201-1,,NSA,00-07-16,10:03:30,,,*"
"SLK 1s1202-0,,NSA,00-07-16,10:03:31,,,*"
"SLK 1s1202-1,,NSA,00-07-16,10:03:32,,,*"

RLGHNCXA21W 00-07-16 12:20:12 EDT EAGLE 35.0.0
1242.0000 REPT COND LS
"LS 1s1201:,MTCEINT-0,,00-07-16,10:03:29,,,,"
"LS 1s1202:0318,,NSA,00-07-16,10:03:29,,,*"
"LS 1s1203:0318,,00-07-16,10:03:29,,,*"
"LS 1sx23 :0318,,NSA,00-07-16,10:03:33,,,*"

RLGHNCXA21W 00-07-16 12:20:12 EDT EAGLE 35.0.0
1243.0000 REPT COND DPC
"DPC 001-001-001:0313,,SA,00-07-16,10:03:29,,,,*C"
"DPC 002-002-002:0313,,SA,00-07-16,10:03:30,,,,*C"
"DPC 003-003-003:0313,,SA,00-07-16,10:03:31,,,,*C"
"DPC 001-005-* :0313,,SA,00-07-16,10:03:32,,,,*C"
"DPC 006-006-006:,MAN,,00-07-16,10:03:32,,,,"

RLGHNCXA21W 00-07-16 12:20:12 EDT EAGLE 35.0.0
1244.0000 REPT COND TRM
"TRM 2: .SCMMA,00-07-16,10:03:29,,,,"
"TRM 3:0048,,NSA,00-07-16,10:03:29,,,*"

```

## Maintenance System Event Logs

The `rtrv-log` command is used to retrieve records from the active or standby event logs generated by the maintenance system. This command selects these records based on a span of time or a specific log file index. There are numerous ways to sort and filter the output. Refer to *Commands User's Guide* for details on using the `rtrv-log` command. A sample output follows:

```
rtrv-log:sdate=030715:stime=220000:num=50:snum=106:enum=350
ncralstp00001 10-03-16 10:15:29 EST EAGLE 42.0.0
Card 1113; SYS REL= 31.3.0; STP CLLI= ncralstp00001; Timezone= EST

****03-07-16 00:23:55****
3161.0200 SLK 1103,B RCVRY-LKF: link available
****03-07-16 01:42:18****
3162.0155 * DLK 2117,A STPLAN Exceededn unavailable
****03-07-16 01:43:51****
3163.0317 LSET A123456789 RCVRY-LKSTO: linkset allowed
****03-07-16 03:00:23****
3165.0108 ** IMT BUS A Major IMT fault detected
****03-07-16 03:37:59****
3166.0292 *C GLS SYSTEM GLS is not available
****03-07-16 07:22:06****
3167.0313 *C DPC 021-005-000 DPC is prohibited
****03-07-16 09:33:17****
3168.0348 * SEAS SYSTEM SEAS is at minimum service
****03-07-16 09:34:01****
3169.0112 * IMT SYSTEM Major Failures detected on both
****03-07-16 09:35:07****
3170.0160 * CLOCK SYSTEM 1116-S clock failed
****03-07-16 09:36:34****
3171.0160 * CARD 1116 OAM 1116-S clock failed
****03-07-16 09:38:12****
3173.0308 *C SYSTEM Node isolated due to SLK failure
****03-07-16 09:39:56****
3174.0331 *C SCCP SYSTEM SCCP is not available
****03-07-16 09:41:34****
3176.0153 *C SLAN SYSTEM STPLAN not available
****03-07-16 09:45:29****
3180.0321 * XLIST X-LIST occupancy threshold Exceeded
****03-07-16 09:48:48****
3181.0175 * SECURITY 1114 LOGBUFROVL-SECULOG - upload required
;

UAM Report terminated - end of log reached.
END OF LOG REPORT.
;
```

The `rtrv-trbltx` command is used to retrieve alarm and **UIM** message information including **MRN** (message reference number), level (for Alarms), Output Group and text.

The default `rtrv-trbltx` report displays all Alarms (in numerical order), and then all **UIMs**. Using the optional parameters, the capability exists to display a range of Alarms or **UIMs**, search for Alarms, **UIMs** or both message types matching a specific Output Group or sort all entries by Output Group. Refer to *Commands User's Guide* for details on using the `rtrv-log` command. A sample output follows:

```

rtrv-trbltx:OUTGRP=all
ncralstp00001 03-07-16 10:15:29 EST Rel XX.X.X

Card 1113; SYS REL= XX.X.X; STP CLLI= ncralstp00001; Timezone= EST
Alarm Report
      MRN      LEVEL  OUTPUT GROUP      TEXT
-----
      Output Group - SYS
      0001  MAJR   SYS                Card has reset
      0002  MINR   SYS                Card is not running approved GPL
      :
      0912  NONE   SYS                Dynamic database is now consistent
      :
      Output Group - LINK
      0155  MINR   LINK               STPLAN connection unavailable
      0156  NONE   LINK               STPLAN connection available
      :
      0479  NONE   LINK               Link not Monitored
UIM Report
      MRN              OUTPUT GROUP      TEXT
-----
      Output Group - SYS
      1000              SYS                MTP rcvd UPU - user part is not
SCCP
      1001              SYS                MTP rcvd Transfer Controlled (TFC)
      :
      1499              SYS                Invalid MRN detected
      :
      Output Group - LINK
      13nn              LINK               Example text
END OF RTRV-TRBLTX REPORT.
;

```

## Obituaries

An obituary is a set of data that describes the status of the system just before a processor restarted due to a fault in hardware or software. The data includes a register and stack dump of the processor, card location, reporting module number, software code location, and class of the fault detected. In most situations, obituary reports are generated automatically when a card is reset. Obituary reports can also be retrieved manually using the `rtrv-obit` command. Refer to *Commands User's Guide* for information on using the `rtrv-obit` command. Obituaries should immediately be reported to the [My Oracle Support \(MOS\)](#).

To help [My Oracle Support \(MOS\)](#), retain any printouts of the obituary. [My Oracle Support \(MOS\)](#) can use the report to analyze the problem. A typical obituary looks like the following:

```

rtrv-obit:loc=1115:num=2

rlghncxa03w
13-04-19
12:09:15 EST EAGLE5 45.0.0-64.62.0
-----
STH: Received a BOOT APPL-Obituary reply for restart
      Card 1115  Module crc_mgr.c Line 482 Class 01d3
      Register Dump :
      EFL=00000246   CS =0008           EIP=0064d4d8   SS =0010

```



```

EAX=00000000    ECX=00000000    EDX=00c8fc70    EBX=0b86570c
ESP=030f5fa0    EBP=030f5fb0    ESI=0000000a    EDI=00000000
DS =0010        ES =0010        FS =0010        GS =0010

Stack Dump :
[SP+1E]=eeee    [SP+16]=0b80    [SP+0E]=0b86    [SP+06]=0000
[SP+1C]=eeee    [SP+14]=42ed    [SP+0C]=570c    [SP+04]=0246
[SP+1A]=0000    [SP+12]=030f    [SP+0A]=0000    [SP+02]=0000
[SP+18]=000a    [SP+10]=5fd0    [SP+08]=0000    [SP+00]=0008

User Data Dump :
07 ff 00 00 80 ca 11 04 00 00 03 00 00 00 00 00 .....
00 00 00 00 00 00 00 00 00 00 00 00 00 00 00 .....
00 00 00 80 ca 10 04 00 .....
Report Date:13-04-12 Time:09:16:30
-----
;
rlghncxa03w 13-04-19 12:09:16 EST EAGLE5 45.0.0-64.62.0
-----
STH: Received a BOOT APPL-Obituary reply for restart
Card 1213 Module radb_mgr.c Line 652 Class 01d7
Register Dump :
EFL=00000246    CS =0008        EIP=0061bea8    SS =0010
EAX=06c25c83    ECX=000005e8    EDX=00000000    EBX=06c25c38
ESP=0251fed0    EBP=0251fee0    ESI=0be2a582    EDI=00000200
DS =0010        ES =0010        FS =0010        GS =0010

Stack Dump :
[SP+1E]=0000    [SP+16]=0b97    [SP+0E]=06c2    [SP+06]=0b97
[SP+1C]=00d4    [SP+14]=a454    [SP+0C]=5c38    [SP+04]=c429
[SP+1A]=06c2    [SP+12]=0251    [SP+0A]=0250    [SP+02]=0251
[SP+18]=5c38    [SP+10]=ff10    [SP+08]=0f14    [SP+00]=fee0

User Data Dump :
8f 82 fb ed 01 01 5a 01 5a 0b 00 86 00 00 00 99 .....Z.Z.....
54 8c 1a 87 00 00 00 f0 54 8c 1a 77 00 08 00 00 T.....T..w....
00 00 00 00 00 00 00 00 .....
Report Date:13-04-12 Time:10:40:36
-----
;

```

## Terminal Not Responding

When a terminal is not responding, perform the following procedure:

1. Verify the terminal is connected to the **MMI** port on the back of the control shelf.
2. Verify the terminal is set up for 7-E-1.
3. From a working terminal, enter the following command to determine the port connected to the faulty terminal:

```
rtrv-trm
```

Note the port number. From the output message, verify the settings are correct. If no working terminal is available, contact the [My Oracle Support \(MOS\)](#).

4. Enter the following command to inhibit the terminal failing to respond:

```
inh-trm:trm=x
```

where *x* is the terminal that is not responding.

5. Enter the following command to re-activate the terminal failing to respond:

```
alw-trm:trm=x
```

where *x* is the terminal that is not responding. If the terminal fails to respond, go to 6.

6. Enter the following command to ensure that the other terminal devices are functioning:

```
rept-stat-trm
```

Following is an example of the output:

```
RLGHNCXA03W 00-02-07 09:50:17 EST EAGLE 35.0.0
TRM  PST          SST          AST
 1   IS-NR        Active        -----
 2   IS-NR        Active        -----
 3   IS-NR        Active        -----
 4   OOS-MT-DSBLD  MANUAL        -----
 5   IS-NR        Active        -----
 6   IS-NR        Active        -----
 7   IS-NR        Active        -----
 8   IS-NR        Active        -----
 9   IS-NR        Active        -----
10   IS-NR        Active        -----
11   IS-NR        Active        -----
12   IS-NR        Active        -----
13   OOS-MT-DSBLD  MANUAL        -----
14   OOS-MT-DSBLD  MANUAL        -----
15   OOS-MT-DSBLD  MANUAL        -----
16   OOS-MT-DSBLD  MANUAL        -----
Command Completed.
```

7. Verify the problem is not with the terminal by swapping terminals with a known good terminal.

Make sure the physical connections are firmly seated. If the terminal works, replace the original terminal.

8. If a single terminal is not functioning and you have verified that the terminal is good, the connections are good, and the settings are correct, then from another terminal inhibit the terminal port with the following command:

```
rmv-trm:trm=x
```

where *x* is the terminal port number (1 through 16).

9. Enable the terminal port with the following command:

```
rst-trm:trm=x
```

where *x* is the terminal port number (1 through 16). If this action corrects the problem, you are done with this procedure.

10. If the terminal still does not respond, contact the [My Oracle Support \(MOS\)](#).

## Printer Not Working

Perform the following procedure if the printer is not working.

1. Enter the following command to determine the port connected to the faulty printer:

```
rtrv-trm
```

Note the port number. From the output message, verify the settings are correct.

2. Verify the printer is connected, and the power is on.

Run a printer test to verify the printer is operational (refer to the printer manual for printer tests). If there is no problem with the printer, continue with 3. If there is a problem with the printer, go to 4.

3. Enter the following command to ensure that the other terminal devices are functioning on the **E5-TDM** in the active **E5-MASP**:

```
rept-stat-trm
```

Following is an example of the output:

```
RLGHNCXA03W 00-02-07 09:50:17 EST EAGLE 35.0.0
TRM  PST          SST          AST
 1   IS-NR        Active        -----
 2   IS-NR        Active        -----
 3   IS-NR        Active        -----
 4   OOS-MT-DSBLD  MANUAL       -----
 5   IS-NR        Active        -----
 6   IS-NR        Active        -----
 7   IS-NR        Active        -----
 8   IS-NR        Active        -----
 9   IS-NR        Active        -----
10   IS-NR        Active        -----
11   IS-NR        Active        -----
12   IS-NR        Active        -----
13   OOS-MT-DSBLD  MANUAL       -----
14   OOS-MT-DSBLD  MANUAL       -----
15   OOS-MT-DSBLD  MANUAL       -----
16   OOS-MT-DSBLD  MANUAL       -----
Command Completed.
```

4. Verify the problem is not with the printer by swapping printers with a known good printer.

Make sure the physical connections are firmly seated. If the printer works, replace the original.

5. If a single port is not functioning and it has been verified the printer is good, the connections are good, and the settings are correct, inhibit the printer port with the following command:

```
rmv-trm:trm=x
```

where *x* is the printer port number (1 through 16).

6. Enable the printer port with the following command:

```
rst-trm:trm=x
```

where *x* is the terminal port number (1 through 16). If this action corrects the problem, you are done with this procedure.

7. If none of the ports are active, trying resetting and then reseating the **E5-TDM** card.

8. If the problem persists, replace the **E5-TDM** card.

See [Card Removal/Replacement Procedures](#).

9. If the terminal still does not respond, contact the [My Oracle Support \(MOS\)](#).

10. If only the printer port is inactive, inhibit the printer with the following command:

```
rmv-trm:trm=x
```

where *x* is the printer number (1 through 16).

11. Enable the printer with the following command:

```
rst-trm:trm=x
```

If this action corrects the problem, you are done with this procedure. If the problem persists, reseal the **E5-TDM** card.

12. If reseating the **E5-TDM** card does not correct the problem, replace the **E5-TDM** card. See [Card Removal/Replacement Procedures](#).
13. If the printer still does not respond, contact the [My Oracle Support \(MOS\)](#).

## Modem Not Working

Using Procomm Plus and a modem connected to a serial port on the system, the system can be accessed remotely. If there are problems connecting to the modem, perform the following procedure:

1. Check the physical connection.

The connector to the modem should be an **RS-232** connection and firmly seated in both the serial port of the system and the modem.

2. Verify the flow control is set to **software**.
3. Start Procomm Plus and check the modem settings.

The following are possible modem settings for the recommended modem, the Motorola **UDS**. (Other types of modems may have different settings):

- **AT&F0** - Load factory profile and defaults
- **AT&C1** - Make **DCD** true
- **ATE0** - Disable command echo. If you use this command, you do not see the commands that you enter. Be careful to enter the commands correctly.
- **ATQ1** - Stop the results codes to the terminal
- **AT&W0** - Store profile in memory location 0
- **AT&Y** - Select stored profile 0 on power up

## Link Maintenance

**Link** maintenance covers the proper functionality of a signaling link, from an **EAGLE MTP** card to a remote **NE**.

### Link Fault Sectionalization

The link fault sectionalization (**LFS**) feature allows maintenance personnel to perform **DSOA** link fault sectionalization tests, a series of far end loopback tests, from the system and identify faulty segments of an **SS7** transmission path up to and including the remote network element.

The point on the signaling link at which each loopback test ends is the far end loopback point. A far end loopback point is achieved when the remote link element sends the received data back to the transmitter, allowing the transmitter to verify the received data. The remote link elements are shown in [Table 3-5](#).

**Table 3-5 Remote Link Element types**

Element	Description	Valid for the Latching Link Fault Sectionalization Test?	Valid for the Non-latching Link Fault Sectionalization Test?
<b>DSO</b>	<b>DSO</b> Dataport	yes	no
<b>OCU</b>	<b>OCU</b> Dataport	yes*	yes
<b>CSU</b>	<b>CSU</b> Dataport	yes*	yes
<b>DSU</b>	<b>DSU</b> Dataport	yes*	yes
<b>NEI</b>	<b>Network Element</b> Interface	yes	no

\* The **OCU**, **CSU** and **DSU** must be strapped or optioned to support latching link fault sectionalization loopback.

The loopback point is moved along the signaling link path until the point is in the far end network element. Therefore, each loopback point along the link requires the initiation of one link fault sectionalization test on the **SS7LIM**.

The link fault sectionalization test types for loopback tests are shown in [Table 3-6](#).

**Table 3-6 Link Fault Sectionalization Test Types**

Link Fault Sectionalization Test Types	Description
Latching link fault sectionalization test ( <b>LLT</b> -auto)	A loopback point is established using signaling commands and remains until it is removed by signaling commands.
Latching link fault sectionalization test ( <b>LLT</b> -man)	A loopback point is established by manual means and remains until it is removed by manual means.
Non-latching link fault sectionalization test ( <b>NLT</b> )	A loopback command is interleaved with the test data.

The **SS7LIM** must be powered up and in service with the signaling link deactivated (**OOS-MT-DSBLD**) before starting the link fault sectionalization tests. No signaling traffic is on the signaling link by the **SS7LIM** while the link is performing a link fault sectionalization test.

The system supports a maximum of 32 remote link elements for each **SS7** link.

The system allows a maximum of 1024 **SS7** simultaneous **LFS** tests.

### Hardware Configuration

The link fault sectionalization feature requires a **LIM** hardware configured as shown in [Table 3-8](#). The test data is guaranteed to be a continuous data stream, and the commands provide the ability to put any element in the link into latched loopback.

The test data is provided is shown in [Table 3-7](#). The data stream sent is verified against the data stream received and a bit error count is updated. If the bit error count is 255 or greater in one second period, the value of the bit error count remains at 255, does not overflow and the test is terminated.

**Table 3-7 Link Fault Sectionalization Test Patterns**

Test Pattern	Data	Description
B2047	N/A	2047-bit Bert pattern sent until it is terminated by software.
B2047 Non Latching	N/A	2047-bit Bert pattern sent interleaved with loopback command until it is terminated by software.
B511	N/A	511-bit Bert pattern sent until it is terminated by software.
B511 Non latching	N/A	511-bit Bert pattern sent interleaved with loopback command until it is terminated by software.
<b>OCTET</b>	default =h'32	A continuous series of the specified octet data is sent until it is terminated by software. (Latching only)
<b>ALTERNATE</b>	default = h'FF	A count of 100 octets of the specified data followed by 100 octets of 0 is sent alternating until it is terminated by software. (Latching only)

**LFS** tests initiated by the **EAGLE** are used to test the functionality of a signaling link (**SLK**) from an **EAGLEMTP** card through multiple channel banks to a remote **Network Element**. The number of simultaneous tests that can be run on a specific card are shown in parenthesis () in [Table 3-8](#). The maximum number of simultaneous tests for a card is determined by hardware type. [Table 3-8](#) shows the relationship between hardware type and **LFS** support. A key for the values follows:

- **NV** indicates **APPL** is not valid for the given hardware.
- **No** indicates **LFS** testing is not supported for this combination of hardware, provisioned type, and provisioned application.
- **Yes** indicates **LFS** testing is supported (max tests per card is shown in parenthesis)

**Table 3-8 Hardware/Card/APPL LFS Support**

		Provisioned Application	
<b>MPL</b>		Yes (1)	<b>NV</b>
<b>MPL-T</b>		Yes (8)	<b>NV</b>
<b>E1/T1MIM</b>	<b>LIMT1</b>	Yes (8)	Yes (8)
	<b>LIMCH*</b>	Yes (8)	Yes (8)
<b>HC MIM</b>	<b>LIMT1</b>	Yes (64)	Yes (64)

\*If associated parent card is **LIMT1**

### Test Indicators

Two indicators are used by the `rept-stat-slk` and `rept-stat-ls` commands to show whether the signaling link has a far end loopback condition and if a link fault sectionalization test is in progress.

When the signaling link is in a far end loopback condition:

- The primary state (**PST**) is **OOS-MT-DSBLD**.
- The secondary state (**SST**) is **LPBK**.
- The associate state (**AST**) is **FE**.

When a link fault sectionalization test is in progress:

- The primary state (**PST**) is **OOS-MT-DSBLD**.
- The secondary state (**SST**) is **LPBK**.
- The associate state (**AST**) is **LFS**.

When both the signaling link is in a far end loopback condition and a link fault sectionalization test is in progress:

- The primary state (**PST**) is **OOS-MT-DSBLD**.
- The secondary state (**SST**) is **LPBK**.
- The associate state (**AST**) is **FE-LFS**.

### Test Report

Test results are displayed to the terminal when the link fault sectionalization tests have completed. The following is an example of a link fault sectionalization test report.

```
RLGHNCXA03W 96-04-16 16:02:05 EST EAGLE 35.0.0
LOC = 1205 Port = B LSN = ----- Start time = 11:10:34
PATTERN = ALTERNATE DATA= FF MAXERR = 10 TIME = 00:02:00
TEST STATUS = ERROR, bit error exceeded threshold.
LBP CLLI          RLE REP LFST BIT_ERROR ERRORED_SEC DURATION
2  rlgncxa05w    DSO 0  LLT  0           0           00:02:00
3  ----- OCU 0  NLT  8           2           00:02:00
5  ----- NEI 0  LLT  15          1           00:01:20
```

### LFS Test Details

- *EAGLE Initiated LFS Loopback Test Details*  
**Loopback Test Type:** EAGLE initiated Level 1 **DS0LFS** test

**Link State:** Link is down.

**Equipment tested:** Level 1 element(s) in a signaling path.

**Purpose:** Test the error rates of a signaling path.

**Description:** Sends loopback code to establish loopback and then performs **BERT** test for a specified period of time.

**Typical use:** To validate signaling path has acceptable error rate.

**Testing Limits:** 1024 concurrent link tests per system.

- *Remote Initiated LFS Loopback Test Details*

**Loopback Test Type:** Remote Loopback **FAREND** initiated **DS0LFS** test.

**Link State:** Link can be up or down.

**Equipment tested:** Near end H/W up to level 2 (**LXVR**) and far end H/W level 1 interface.

**Purpose:** Auto-loopback a **BERT** test to the far end.

**Description:** When receiving a loopback code, deactivate the link and go into loopback.

**Typical use:** Used to remotely test the far end with standard **DS0BERT** tests.

**Testing Limits:** No limit on number of cards.

### Link Fault Test Commands

The link fault sectionalization feature uses the following commands:

- `ent-lbp` — add link fault sectionalization test data to the database.
- `chg-lbp` — change existing link fault sectionalization test data in the database.
- `dlt-lbp` — remove link fault sectionalization test data from the database.
- `rtrv-lbp` — display link fault sectionalization test data in the database.
- `act-lbp` — start a link fault sectionalization test.
- `dact-lbp` — stop a link fault sectionalization test.
- `rept-stat-lfs` — generates a report of all links that are under test.

The link fault sectionalization data is configured in the database using the parameters shown in [Table 3-9](#).

**Table 3-9 Link Fault Sectionalization Data Entry Parameters**

Link Fault Sectionalization Data Entry Parameters	Description
Card Location	<b>SS7LIM</b> card location
Port Number	Port a or b, and a1, a2, a3, b1, b2, b3 on the <b>MPL</b>
Loopback Point Number	Identifies the remote link element for setting the loopback point. Value is from 1 to 32.
<b>CLLI</b>	Description of the remote link element
<b>Remote Link Element Type</b>	The remote element type from <a href="#">Table 3-5</a> .
Repetition Count	A repetition of the same element type in the link path. This is needed for configuring the link element as a latched loopback point. The value is from 0 to 31.
<b>Link Fault Sectionalization Test Type</b>	<b>Link</b> fault sectionalization test type from <a href="#">Table 3-6</a> ( <b>LFS-man</b> not supported for the database)

Use the `act-lbp` command to start one or a sequence of link fault sectionalization tests. The data stream sent is verified against the data stream received and the bit error counts and block error counts are displayed when the test completes.



The link fault sectionalization test parameters are described in [Table 3-7](#). If either the remote link element type, repetition count, or link fault sectionalization test type are specified with the `act-lbp` command, they must all be specified and the loopback point number parameter is ignored. Otherwise the values for remote link element type, repetition count, or link fault sectionalization test type are read from the data entered with the `ent-lbp` command using the loopback point number parameter value. The test data parameter is only valid for test patterns **OCTET** and **ALTERNATE**.

If all **LBP**s are selected for the loopback point number parameter, a sequential test of the **LBP**s, as entered in the database with the `ent-lbp` command for that signaling link, is performed until the entire signaling link has been tested. When performing a test with all **LBP**s, the test is aborted with the first failed test.

The test is stopped either because the amount of time for the test has expired or if the bit error threshold has been exceeded. The time duration parameter specifies the maximum time duration for one link fault sectionalization loopback point test. The default value is one second (00:00:01) and the maximum value that can be entered is 24 hours (24:00:00). The bit error threshold parameter specifies the maximum number of bit errors allowed for one link fault sectionalization loopback point test. The default value is 56 errors and the maximum value that can be entered is 4,838,400 (24 hours x 56 errors per second).

**Table 3-10 Link Fault Sectionalization Test Parameters**

Parameters	Description
Card Location	SS7LIM card location
Port /Link Number	Signaling link id a to a63 and b to b63
Loopback Point Number	The remote link element for setting the loopback point. Value is from 1 to 32, or if this parameter is not specified, all <b>LBP</b> s are selected.
Remote Link Element Type	The remote element type from <a href="#">Table 3-5</a> .
Repetition Count	A repetition of the same element type in the link path. The value is from 0 to 31.
Link Fault Sectionalization Test Type	<b>Link</b> fault sectionalization test type from <a href="#">Table 3-6</a> .
Time duration	Time for one loopback point in hours, minutes, and seconds (hh:mm:ss). The value is from 00:00:01 to 24:00:00. The default value is 1 second (00:00:01).
Error threshold	Bit error threshold. The value is from 0 to 4838400. The default value is 56.
Test pattern	The test pattern from <a href="#">Table 3-7</a> . The default value is B2047.
Test data	The octet to be used for test pattern <b>OCTET</b> or <b>ALTERNATE</b> only.

 **Note:**

Links A32-A63 and B32-B63 are only applicable for SLIC cards running the IPSPG application.

The `dact-lbp` command stops the link fault sectionalization test in progress and cancels any pending link fault sectionalization tests for the **SS7** link. The pending tests are the next sequential **LBP**s for the **SS7** signaling link when an entire link test was initiated.

## Link Maintenance Enhancements

The **Link Maintenance Enhancements** feature covers the following areas:

- Allows the operator to force a card into loopback. Without this enhancement, a card will go in and out of loopback as determined by loopback codes sent by the far end.
- `tst-slk` enhancements for **ATM** customers. The loopback parameters for **ATM** cards in the `tst-slk` command act in a similar fashion as the `act-lbp` command for standard **DS0** loopbacks. Other `tst-slk` enhancements not specifically related to **ATM** are also provided.

### Command Driven Loopback

Command Driven Loopback (**CDL**) is the ability to locally drive a signaling link into a manual line loopback. The data received on the signaling link is echoed (transmitted) back. Commands are used to provide this capability on an individual signaling link basis. **CDL** allows loopback testing of a signaling link when either far-end initiated loopbacks are prevented or when a constant loopback state is desired. This command driven setting of loopback is similar in functionality to a remote initiated loopback. [Table 3-11](#) shows a breakdown of support for Command Driven Loopback based on the **MTP** card type. [Figure 3-8](#) shows a conceptual view of a signaling links network connections. Local transceiver (**LXVR**) is a `tst-slk` initiated test in which the line transmit is looped back to the line receive internal to the card. **CDL** is "**LXVR** in reverse", the line receive is looped back to the line transmit.

**Table 3-11 Command Driven Loopback Support**

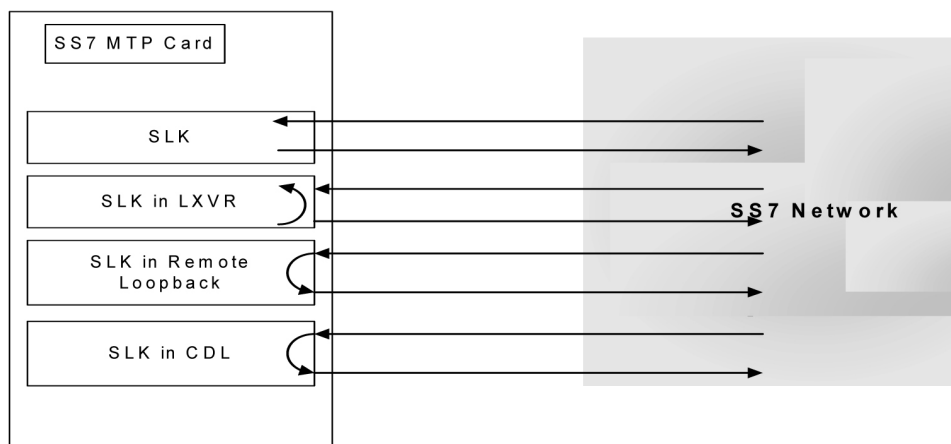
MTPCard Type	Supported	MTPCard Type	Supported
MPL (DSO)	Yes	T1-ATM	Yes
E1-ATM	Yes	T1MIM (Channel)	Yes
E1MIM (Channel)	Yes	IPLIM	No
		IPGTWY	No

### Test Indicators

If an **MTP** card boots, then all links on this card, by default, are not in **CDL**. A link in **CDL** is persistent across an **OAM switchover**. Signaling links must be inhibited (**OOS-MT-DSBLD**) to perform command driven loopback. Signaling links in **CDL** have the following conditions:

- The primary state (**PST**) is **OOS-MT-DSBLD**.
- The secondary state (**SST**) is **LPBK**.
- The associate state (**AST**) is **CDL**.

**Figure 3-8 Signaling Link Network Connections**



### Test Signaling Link

The *tst-slk* command is used to flush out intermittent link problems that are not captured with the one shot testing. The *tst-slk* command allows for duration tests up to 24 hours, stopping of an in-progress test, and forcing the execution of a test. The *tst-slk* command is grouped into two categories, message based tests and hardware-based tests.

The **SLTC** and **OAM** tests are message based. These tests involve sending a message to the far end and expecting an appropriate reply. The **LXVR**, **LINE**, and **PAYLOAD** tests are hardware-based. These tests involve setting hardware registers and after an appropriate duration resetting hardware registers. To prevent overloading of a signaling link, message based tests are delayed 1 to 10 seconds between receipt of an appropriate reply and sending of the next test message. [Table 3-12](#) shows a breakdown of support for each *tst-slk* test based on **MTP** card.

**Table 3-12 tst-slk Support**

MTP Card Type	tst-slk Test	tst-slk Test	tst-slk Test	tst-slk Test	tst-slk Test
	SLTC	LXVR	OAM	LINE	PAYLOAD
<b>OCU</b>	Yes	Yes	No	No	No
<b>MPL (DSO)</b>	Yes	Yes	No	No	No
<b>E1-ATM</b>	Yes	Yes	Yes	No	No
<b>T1-ATM</b>	Yes	Yes	Yes	Yes	Yes
<b>T1MIM (Channel)</b>	Yes	No	No	No	No
<b>E1MIM (Channel)</b>	Yes	No	No	No	No
<b>IPLIM</b>	Yes	No	No	No	No
<b>IPGTWY</b>	No	No	No	No	No
<b>E1 HC MIM</b>	Yes	No	No	No	No
<b>T1 HC MIM</b>	Yes	No	No	No	No
<b>T1 HC MIM</b>	Yes	No	No	No	No

### Test Signaling Links Test (tst-slk) Indicators

Signaling links performing `tst-slk` commands have a secondary state of **LPBK**, and an associated state corresponding to the type of loopback (**SLTC**, **OAM**, **LXVR**, **PAYLOAD**, **LINE**). The link must be **OOS-MT-DSBLD** for **LXVR**, **PAYLOAD**, and **LINE** tests.

If an **OAM switchover** occurs, while the `tst-slk` command is running, the test is aborted. If an **MTP** card with an active test boots then the test is aborted.

### Test E1 and T1 Ports

The `tst-e1` and `tst-t1` commands initiate loopback testing of the specified **E1** and **T1** ports on the **HC MIM** and **E5-E1T1** cards. There are 8 physical ports on the **HC MIM** or **E5-E1T1** card. This `tst-e1/t1` command is not used for any other **MTP** card type. [Table 3-13](#) shows a breakdown of support for each `tst-e1/t1` test based on **MTP** card.

**Table 3-13** `tst-e1/tst-t1` Support

MTPCard Type	tst-e1 Test	tst-t1 Test
<b>E1 HC MIM</b>	Yes	Yes
<b>T1 HC MIM</b>	Yes	Yes
<b>E5-E1T1</b>	Yes	Yes

### Test E1/T1 Port (tst-e1/t1) Indicators

Signaling links performing `tst-e1/t1` commands have a secondary state of **LPBK**, and an associated state corresponding to the type of loopback. For `tst-e1` the loopback types are: (**LXVR**, **LINE**, and **PAYLOAD**). For `tst-t1`, the loopback types are: (**LXVR**, **LINE**, **FELINE**, **PAYLOAD**, and **FEPAYLOAD**).

If an **OAM switchover** occurs, while the `tst-e1/t1` command is running, the test is aborted. If an **MTP** card with an active test boots then the test is aborted.

### tst-slk and tst-e1/t1 Loopback Test Details

- SLTC Loopback Test Details*

**Loopback Test Type:** **SLTC** (EAGLE initiated Level 3 **SS7SLT**).

**Link State:** **Link** is up.

**Equipment tested:** Near and far end up to Level 3.

**Purpose:** Test the entire path to the far end at Level 3.

**Description:** Valid only for `tst-slk` This will send an **SLTM** out and expects an **SLTA** back.

**Typical use:** To validate connectivity of a signaling path.

**Testing Limits:** 1024 concurrent link tests per system.
- OAM Loopback Test Details*

**Loopback Test Type:** **OAM** (EAGLE initiated Level 1 **ATM** test).

**Link State:** **Link** is down.

**Equipment tested:** Near and far end level 1 S/W and H/W including all hardware on the cards.

**Purpose:** Test the entire near and far end level 1 H/W by exchanging **ATM** cells.

**Description:** Valid only for `tst-slk` Sends **OAM** cells out to far end for 60 seconds if no errors, 2 minutes when errors are received.

**Typical use:** Verifies **ATM** cells can be exchanged between 2 signaling points.

**Testing Limits:** 1024 concurrent link tests per system.

- *LINE/FELINE*> *Loopback Test Details*

**Loopback Test Type:** **LINE/FELINE** (EAGLE initiated Level 1-2 **ATM** test)

**Link State:** **Link** is down.

**Equipment tested:** Near end H/W up to level 2 (**LXVR**) and far end H/W level 1 interface.

**Purpose:** H/W continuity check between near and far end.

**Description:** This detail sequence is valid for `tst-slk:loopback=line` and `tst-t1:loopback=feline`.

`tst-t1:loopback=line` installs the local line loopback (receive to transmit) similar to an `act-cdl:loopback=line`.

The following steps occur:

1. Device under test (**DUT**) sends **T1** bit oriented code (**BOC**) to remote device.
2. Remote device receives **BOC** and programs hardware.
3. **DUT** attempts level 2 alignment.
4. If link aligns (level 2), test passes, else test fails.
5. **DUT** sends **BOC** to remote device to remove loopback.
6. Remote device receives **BOC** and re-programs hardware.

 **Note:**

If the **DUT** boots in the middle of the sequence, the remote device needs to have the link activated/de-activated and it will return to the original programming.

**Typical use:** Used for a link in line timing to check continuity from the near end level 2 H/W to the level 1 interface at the far end.

**Testing Limits:** 1024 concurrent link tests per system.

- *PAYLOAD/FEPLAYLOAD* *Loopback Test Details*

**Loopback Test Type:** **PAYLOADFEPLAYLOAD** (EAGLE initiated Level 1-2 **ATM** test)

**Link State:** **Link** is down.

**Equipment tested:** Near end H/W up to level 2 (**LXVR**) and far end H/W level 1 interface.

**Purpose:** H/W continuity check between near and far end.

**Description:** This detail sequence is valid for `tst-slk:loopback=payload` and `tst-t1:loopback=fepayload`.

`tst-t1:loopback=payload` installs the local payload loopback (receive to transmit) similar to an `act-cdl:loopback=payload`.

The following steps occur:

1. Device under test (**DUT**) sends **T1** bit oriented code (**BOC**) to remote device.
2. Remote device receives **BOC** and programs hardware.
3. **DUT** attempts level 2 alignment.
4. If link aligns (level 2), test passes, else test fails.
5. **DUT** sends **BOC** to remote device to remove loopback.
6. remote device receives **BOC** and re-programs hardware.

 **Note:**

If the **DUT** boots in the middle of sequence, the remote device needs to have the link activated/de-activated and it will return to the original programming

**Typical use:** Used for a link in master timing to check continuity from the near end level 2 H/W to the level 1 interface at the far end.

**Testing Limits:** 1024 concurrent link tests per system.

- *LXVR Loopback Test Details*

**Loopback Test Type:** **LXVR** (EAGLE initiated Level 1 Internal card loopback)

**Link State:** Link is down.

**Equipment tested:** Local card.

**Purpose:** Test the near end card only.

**Description:** Valid for both `tst-slk` and `tst-t1`. This tests the near end card up through level 2.

**Typical use:** To validate the **Card** on the Eagle as good.

**Testing Limits:** 1024 concurrent link tests per system.

### Link Maintenance Enhancements Commands

The link maintenance enhancements feature utilizes the following commands:

- `act-cdl` — this command initiates a command driven loopback for testing a signaling link.
- `dact-cdl` — this command deactivates a previously initiated Command Driven Loopback if active. If not, it will attempt to clear both near-end and far-end latched loopback points.
- `rept-stat-cdl` — this command generates a report of the signaling links currently in command driven loopback (along with the amount of time the link has been in **CDL**). The following is an example of a possible output.

```
tekelecstp 96-04-16 16:02:05 EST EAGLE 35.0.05
SLK      CDL      CDL-TIME
1102,A1  LINE    00:04:01
1201,A   PAYLOAD 01:04:11
1203,A   LINE    00:22:21
1203,B   LINE    20:04:01
1208,A   LINE    01:05:22
1211,A   PAYLOAD 00:14:01
```

- `tst-slk` — this command provides several methods for testing **SLKs**.
- `rept-stat-tstslk` — this command generates a report of the status of the **MTP** signaling links currently under test. The report includes the type of test and the elapsed time for the test. The following is an example of a possible output.

```
tekelecstp 96-04-16 16:02:05 EST EAGLE 35.0.0
  SLK      LOOPBACK  MAX-TIME  TEST-TIME
  1102,A1  SLTC       01:00:00  00:04:01
  1201,A   OAM       02:00:00  01:04:11
  1203,A   LXVR     00:50:00  00:22:21
  1203,B   LXVR     24:00:00  20:04:01
  1208,A   PAYLOAD  01:10:00  01:05:22
  1211,A   LINE     21:30:00  00:14:01
;
```

- `tst-el` — this command initiates the testing of **E1** Ports. The loopback parameter on this command is used to select local transceiver (lxvr), line, and payload loopback tests. This command is rejected if a loopback test is not compatible with the port type. This command is only supported on **HCMIM** and **E5-E1T1** hardware. The following is an example of a possible output.

 **Note:**

Faults are not reported with this test. Refer to the `rept-stat-el` command and output for port status results.

```
> tst-el:elport=1:loc=1203:loopback=lxvr

  rlghncxa03w 05-01-07 16:19:08 EST EAGLE5 33.0.0
  Command Accepted: Test Port message is sent.
;
  rlghncxa03w 05-01-07 16:19:08 EST EAGLE5 33.0.0
  Command Completed.
;

> tst-el:elport=1:loc=1203:action=stop

  rlghncxa03w 05-01-07 16:19:08 EST EAGLE5 33.0.0
  Command Accepted: Stop Port test message is sent.
;
  rlghncxa03w 05-01-07 16:19:08 EST EAGLE5 33.0.0
  Command Completed.
;
```

- `tst-tl` — this command initiates the testing of **T1** Ports. The loopback parameter on this command is used to select local transceiver (lxvr), line, far end line (feline), payload, and fare end payload (fepayload) loopback tests. This command is rejected if a loopback test is not compatible with the port type. This command is only supported on **HCMIM** and **E5-E1T1** hardware.

The command for stopping the tests differ for feline and fepayload. In order to stop the loopback tests, for loopback=line, payload, and lxvr, the command syntax used is `tst-t1:loc=<card loc>;tlport=<tlport number>;action=stop`. For the feline and fepayload loopback types, the command syntax used is `tst-t1:loc=<card`

loc>:tlport=<tlport number>:action=stop:loopback=<feline or fepayload>. The following is an example of a possible output.

 **Note:**

Faults are not reported with this test. Refer to the `rept-stat-t1` command and output for port status results.

```
> tst-t1:loc=1101:tlport=2:action=start:loopback=payload

Command Accepted - Processing

e5oam 02-02-08 23:58:38 MST UNKNOWN ????.?-61.11.0
tst-t1:loc=1101:tlport=2:action=start:loopback=payload
Command entered at terminal #6.
;

e5oam 02-02-08 23:58:38 MST UNKNOWN ????.?-61.11.0
Command Accepted: Test Port message is sent.
;

e5oam 02-02-08 23:58:38 MST UNKNOWN ????.?-61.11.0
Command Completed.
;

> tst-t1:loc=1101:tlport=2:action=stop

Command Accepted - Processing

e5oam 02-02-08 23:59:01 MST UNKNOWN ????.?-61.11.0
tst-t1:loc=1101:tlport=2:action=stop
Command entered at terminal #6.
;

e5oam 02-02-08 23:59:01 MST UNKNOWN ????.?-61.11.0
Command Accepted: Stop Test Port message is sent.
;

e5oam 02-02-08 23:59:01 MST UNKNOWN ????.?-61.11.0
Command Completed.
;
```

- `rept-stat-e1`— this command generates a report of the status of the E1 port and signaling link for cards with provisioned E1 ports. The following is an example of a possible output.

```
rept-stat-e1:loc=1203:e1port=1
rlghncxa03w 05-01-04 07:01:08 EST EAGLE5 33.0.0
LOC   E1PORT  PST      SST      AST
1203  1         IS-NR    Avail    PARENT
ALARM STATUS      = No Alarms.
UNAVAIL REASON    = --
SLK   TS  PST      SST      AST
A     1  IS-NR    Avail    ---
A1    2  IS-NR    Avail    ---
Command Completed.
;
```



- `rept-stat-t1`— this command generates a report of the status of the T1 port and signaling link for cards with provisioned T1 ports. The following is an example of a possible output while `loopback=line` is in progress.

```
> rept-stat-t1:loc=1204:t1port=1

Command Accepted - Processing

tekelecstp 04-01-19 07:26:03 EST UNKNOWN ???.?-63.47.1
rept-stat-t1:loc=1204:t1port=1
Command entered at terminal #5.
;

tekelecstp 04-01-19 07:26:03 EST UNKNOWN ???.?-63.47.1
LOC  T1PORT  PST           SST           AST
1204  1       OOS-MT-DSBLD  LPBK          LINE
ALARM STATUS      = No Alarms.
UNAVAIL REASON    = No errors, allow device
SLK   TS   PST           SST           AST
A     1   OOS-MT-DSBLD  Manual        -----

Command Completed.
;
```

Table 3-14 lists how the AST field will display depending on the loopback type.

**Table 3-14 Loopback AST Field Display**

Loopback Type	AST Field Display
Local transceiver (lxvr)	LXVR
Line (line)	LINE
Far end line (feline)	FE LINE
Payload (payload)	PAYLOAD
Far end payload (fepayload)	FE PAYLD

## Power Down of In-Service System

### **warning:**

This procedure will isolate the system and put the network in a degraded mode. [My Oracle Support \(MOS\)](#) before any part of this procedure is performed.

### **Note:**

If the EAGLE loses power or both OAM cards are removed at the same time, then OAM may not retain the current date and time once the MASP cards are back in service. The user may need to manually update the system date and time using `set-date` & `set-time` commands.

To minimize the impact on the rest of the network during power up, proper network planning must be performed. This requires having the **MTP** Restart Feature configured on the system. This power down procedure does not require any special configuration on the system. This procedure should be performed in emergency situations or with prior planning assistance from [My Oracle Support \(MOS\)](#). Terminal access to the system is required to deactivate the links. If there is no terminal access to the system, proceed to [19](#).

1. If this is an emergency power down, proceed with [11](#) Otherwise continue with [2](#) .
2. Enter the following command to check the operational status of the database:

```
rept-stat-db
```

If necessary, refer to *Commands User's Guide* to interpret the output.

3. Enter the following command to backup the database on the fixed disk:

```
chg-db:action=backup:dest=fixed
```

This command takes a minimum of 2 minutes to execute. It may take longer depending on other system activity that is in progress when this command is entered.

4. Verify that the databases of both **MASPs** are coherent by entering the following command:

```
rept-stat-db
```

The following is an example of the output from a coherent database.

```
> rept-stat-db
Command Accepted - Processing
  oflnmoxallw 00-10-08 15:56:40 CDT EAGLE 35.0.0
  rept-stat-db
  Command entered at terminal #4.
;
  oflnmoxallw 00-10-08 15:56:40 CDT EAGLE 35.0.0
  DATABASE STATUS: >> OK <<
                TDM 1114 ( STDBY)                TDM 1116 ( ACTV )
                C  LEVEL    TIME LAST BACKUP    C  LEVEL    TIME LAST BACKUP
                - - - - -
-----
  FD BKUP  Y   342256 00-10-07 00:40:29 CDT  Y   342256 00-10-07 00:40:29
  CDT
  FD CRNT  N   342374
  E5-MDAL 1117
  -----
```

If necessary, refer to *Commands User's Guide* to interpret the output.

5. Insert a pre-formatted (for system data) removable USB drive into the removable USB drive media slot.

Refer to [Removable Drives](#). Continue with [6](#).

6. Enter the following command to create a backup of the database on the removable USB drive:

```
chg-db:action=backup:dest=remove
```

7. Verify that the databases on the removable USB drive (**RDBKUP**) and the current partition of the active **MASP** (**FDCRNT**) are coherent by entering the following command:

```
rept-stat-db
```

The following is an example of the output from a coherent database.

```

> rept-stat-db
Command Accepted - Processing
  oflnmoxallw 00-10-08 15:56:40 CDT EAGLE 35.0.0
  rept-stat-db
  Command entered at terminal #4.
;
  oflnmoxallw 00-10-08 15:56:40 CDT EAGLE 35.0.0
  DATABASE STATUS: >> OK <<
          TDM 1114 (STDBY)                TDM 1116 ( ACTV )
          C  LEVEL    TIME LAST BACKUP    C  LEVEL    TIME LAST BACKUP
  -----
  FD BKUP  Y  32256   00-10-07 00:40:29 CDT Y  32256   00-10-07 00:40:29
CDT
  FD CRNT  N  32374
          E5-MDAL 1117
          - - - - -

```

If necessary, refer to the *Commands User's Guide* to interpret the output.

8. Remove the removable USB drive from the removable USB drive media slot.

Refer to [Removable Drives](#).

9. Make an entry in the site maintenance log that a backup was performed.
10. Enter the following command to verify the status of the mate EAGLE:

```
rept-stat-trbl
```

If there is any trouble or abnormal condition, [My Oracle Support \(MOS\)](#).

11. Enter the following command to retrieve the linksets.

```
rtrv-ls
```

12. Enter the following command to retrieve the links.

```
rtrv-slk
```

13. Enter the following command to deactivate all E-links.

Use the outputs from [11](#) and [12](#).

```
dact-slk:loc=xxxx:port=y
```

where *xxxx* is the card location stenciled on the shelf of the system and *y* is the port number on the card specified in the *loc* parameter.

14. Enter the following command to deactivate all A-links.

Use the outputs from [11](#) and [12](#).

```
dact-slk:loc=xxxx:port=y
```

where *xxxx* is the card location stenciled on the shelf of the system and *y* is the port number on the card specified in the *loc* parameter.

15. Enter the following command to deactivate all B-links.

Use the outputs from [11](#) and [12](#).

```
dact-slk:loc=xxxx:port=y
```

where *xxxx* is the card location stenciled on the shelf of the system and *y* is the port number on the card specified in the *loc* parameter.

16. Enter the following command to deactivate all D-links.

Use the outputs from [11](#) and [12](#).

```
.dact-slk:loc=xxxx:port=y
```

where *xxxx* is the card location stenciled on the shelf of the system and *y* is the port number on the card specified in the *loc* parameter.

17. Enter the following command to deactivate all C-links.

Use the outputs from 11 and 12..

```
dact-slk:loc=xxxx:port=y
```

where *xxxx* is the card location stenciled on the shelf of the system and *y* is the port number on the card specified in the *loc* parameter.

18. Enter the following command to verify all links on the system are OOS-MT.

```
rept-stat-slk
```

Repeat 13 through 17 for any links not having the proper status.

19. Pull the fuses or open the breaker at the customer power distribution frame to turn off power to the system.

## Power Up of the System

### warning:

If the reason for the EAGLE Power Off is unknown or if damage to the EAGLE is suspected, do not perform this procedure. contact the [My Oracle Support \(MOS\)](#).

1. Verify that there is no USB drive in the **E5-MDAL** card.

If there is a USB drive in the **E5-MDAL**, replace the **E5-MDAL** card with a spare **E5-MDAL** card without a USB drive. If the spare **E5-MDAL** card has a USB drive installed, remove the **E5-MDAL** card. This power up will take place without a **E5-MDAL** card installed.

2. At the power distribution frame, insert fuses or close the breaker to restore power to the system.

All frames with the EAGLE shelves must be powered up. Links that were deactivated during the power down are automatically activated during the power up.

3. Enter the following commands to monitor the system during the power-up:

```
rept-stat-card
```

```
rept-stat-slk
```

```
rept-stat-trbl
```

Contact [My Oracle Support \(MOS\)](#) if there is any trouble or abnormal condition during system recovery.

4. Install **E5-MDAL** card and remove removable USB drive, if necessary.

# A

## Card Removal/Replacement Procedures

### Introduction

This appendix explains how to remove a card from the EAGLE. The procedures include the administrative commands required to take a card out of service and place it back into service.

In the event a numbered event message is encountered, refer to the appropriate procedure in *Unsolicited Alarm and Information Messages Reference*.

Additional information about each command can be found in *Commands User's Guide*.

#### **Caution:**

Always wear a wrist strap or other electrostatic protection when handling EAGLE cards.

#### **Caution:**

Always place removed cards into an electrostatic protection bag before sending to Oracle, or storing in inventory (unless the card is being stored in the optional spare card storage shelf).

### EAGLE Replacement Parts List

For a listing of field replaceable parts and cables used in the **EAGLE** and their part numbers, refer to the tables in [Part Numbers](#).

All parts must be replaced through the Return Material Authorization (**RMA**) process. Contact the [My Oracle Support \(MOS\)](#), before replacing any parts.

### E5-MASP Card Replacement

This procedure is to replace an **E5-MASP** card. Before the E5-MASP is replaced, it must be verified that it is the standby **MASP**.

The E5-MASP (made up of the E5-MCAP and E5-TDM cards) contains the removable USB drive, the fixed disk drive, the terminal processor for the 16 serial I/O ports, and an interface to the maintenance disk and alarm (**E5-MDAL**) card.

1. Before beginning this procedure, make sure there is a copy of the current release **GPLs** on a removable USB drive on-hand.
2. If the active E5-MASP card fails, the EAGLE automatically switches activity to the standby **MASP**.

- Enter the following command to display the card status:

```
rept-stat-card
```

The following is an example of a possible output.

```
e5oam 08-12-01 15:38:32 EST EAGLE 40.1.0
CARD  VERSION      TYPE      GPL      PST      SST      AST
1108  -----      MCPM      MCP      OOS-MT-DSBLD  Manual  -----
1109  030-009-000     HIPR2     HIPR2     IS-NR      Active  -----
1110  030-009-000     HIPR2     HIPR2     IS-NR      Active  -----
1111  030-010-000     IPSM      IPS       IS-NR      Active  -----
1113 030-010-008 E5MCAP OAMHC IS-NR Standby -----
1114  -----      E5TDM      IS-NR      Active  -----
1115  030-010-008     E5MCAP     OAMHC     IS-NR      Active  -----
1116  -----      E5TDM      IS-NR      Active  -----
1117  -----      E5MDAL      OOS-MT      Isolated  -----

Command Completed.
```

In this sample output, 1113/1114 are standby and 1115/1116 are active. Perform 5 only if the card to be replaced is not Standby.

- From the output of the `rept-stat-card` command, executed in 3, determine the **MASP** activity.

Record which E5-MCAP is Active and Standby. Record the card locations of both sets of E5-MCAPs and E5-TDMs.

**Table A-1 Card Locations**

Card	Location
Active E5MCAP	
Active E5TDM	
Standby E5MCAP	
Standby E5TDM	

- Verify the E5-MASP card to be replaced (failing or non-failing) is Standby before continuing.
  - If the E5-MASP card is failing it should already be Standby. Go to 7
  - If the card is not Standby and needs replacement, enter the following command to verify the database:

```
rept-stat-db:display=all
```

Verify all the cards in the system have the same database count. If the counts do not match, contact [My Oracle Support \(MOS\)](#).
  - Enter the following command to force the active E5-MASP card to become Standby:

```
init-card:loc=x
```

where *x* is the card location (1113 or 1115) from 3.
- If 5 was performed, execute the `rept-stat-card` command and verify if the card to be replaced is part of the Standby **MASP**.
- If a failing E5-TDM card is to be replaced, perform a database backup before replacing the failed card.

Insert the removable USB drive with the current release **GPLs** into the Active E5-MASP removable USB port. Using [Daily Procedures](#), create a backup of the database on the Active removable USB drive. Then go to [9](#).

 **warning:**

Do not proceed to [9](#) if the backup fails. Contact [My Oracle Support \(MOS\)](#).

8. If a non-failing E5-TDM card is to be replaced, insert the removable USB drive containing the copy of the current release GPLs into the Active E5-MASP.
9. Enter the following command to verify that the security log on the standby **MASP** contains no entries that must be copied to the **FTA** area of the fixed disk:

```
rept-stat-seculog
```

The following is an example of a possible output.

```
RLGHNCXA03W 96-10-04 15:59:06 EDT EAGLE 34.0.0
      -- SINCE LAST UPLOAD -- OLDEST  NEWEST  LAST
LOC  ROLE  ENTRIES %FULL OFLO FAIL  RECORD  RECORD  UPLOAD
1114 Active  8312   84   No   No   95-08-12 96-01-04 96-12-16
      11:23:56 15:59:06 14:02:22
1116 Standby 693    7   No   No   95-09-12 95-09-30 95-09-30
      11:24:12 14:00:06 14:02:13
```

- If the number shown in the **ENTRIES** field for the standby **MASP** (shown with the entry *Standby* in the **ROLE** field) is 0, go to [12](#).
- If the number shown in the **ENTRIES** field for the standby **MASP** is greater than 0, these entries must be copied to the **FTA** area of the fixed disk.

To copy these entries, go to the next step.

10. Copy the security log entries on the standby **MASP** to the **FTA** area on the fixed disk using the following command:

```
copy-seculog:slog=stb:dloc=act
```

The following is a possible output of the message that should appear (the `copy-seculog:slog=stb` command was used).

```
RLGHNCXA03W 96-10-04 15:59:06 EDT EAGLE 34.0.0
Security log on E5TDM 1116 copied to file 961004s.log on E5TDM 1114
```

11. Remove the card from service by entering the following command:

```
rmv-card:loc=xxxx
```

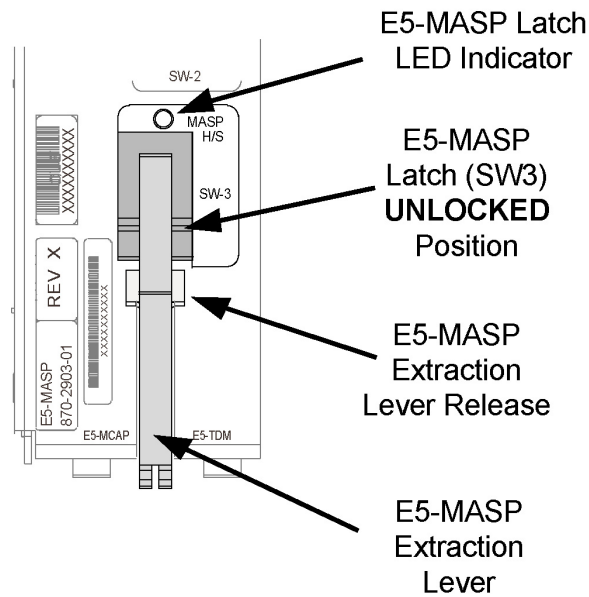
where `xxxx` is the card location.

12. Replace the Standby E5-MASP. Refer to [Figure A-3](#) for description of the E5-MASP LEDs.
  - a. On the standby E5-MASP card determined in [6](#), slide the MASP H/S switch (SW3) up to the UNLOCKED position (see [Figure A-1](#)).

 **Caution:**

When the Ejector switch goes from locked to unlocked and the E5-APP-B card is in service, the card will halt.

**Figure A-1 E5-MASP Card Inject/Eject Hardware Switch, UNLOCKED**



- b. WAIT for the MASP H/S LED to go from blinking blue to a steady blue.
- c. Grasp the upper and lower card Inject/Eject (I/E) lever release interlock, located just underneath the I/E lever, and press it to meet the I/E lever. This is the mechanical interlock for the card.
- d. While holding the I/E interlock and lever, pull the levers away from the shelf until they are parallel to the floor.
- e. Remove the standby E5-MASP card. Gently pull the card towards you until the card clears the shelf.

 **Note:**

UAMs are generated during this step. An audible alarm is generated.

- f. Place the card you have removed in an electrostatic discharge (ESD) protective container, or place the card in the spare card storage shelf.
- g. Be sure that the replacement card has the same Oracle part number and revision number as the card you have just removed.
- h. Open the ejector levers on the replacement card. Insert the spare E5-MASP card. Carefully align the card's edges with the top and bottom card guides. Then push the card along the length of the card guides until the rear connectors on the card engage the mating connectors on the target shelf backplane.



**Note:**

UAMs are generated during this step. An audible alarm is generated. Wait for the E5-MASP card to come up to standby mode.

- i. Push in the top and bottom inject/eject clamps.

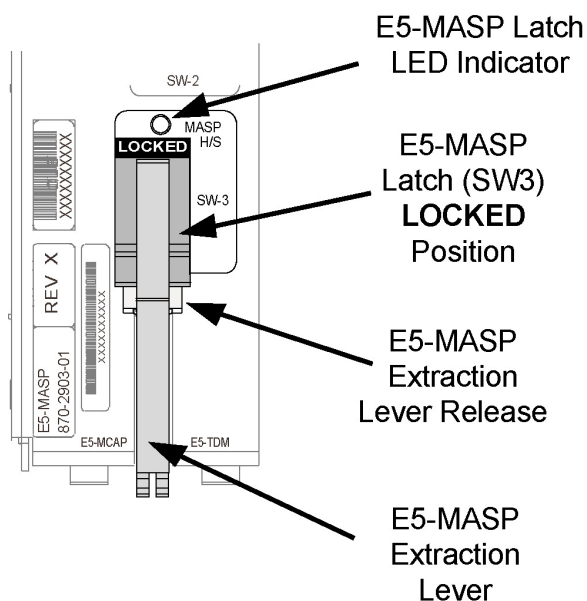
This locks the card in place and ensures a strong connection with the pins on the target shelf backplane.

- j. Slide the MASP H/S switch (SW3) down to the LOCKED position (see [Figure A-2](#)).

**Note:**

When the Ejector switch goes from UNLOCKED to LOCKED, the E5-APP-B Eject Status LED blinks red as the E5-MASP card goes online.

**Figure A-2 E5-MASP Card Inject/Eject Hardware Switch, LOCKED**



- k. WAIT for the MASP H/S LED to go from blinking blue to off.

13. Insert the removable USB drive containing the appropriate GPLs from 1 into the newly installed E5-MASP. (Refer to [Removable USB Drive](#).)

14. Enter the following command to change the state of the appropriate card to the out of service - maintenance disabled state:

```
inh-card:loc=xxxx:force=yes
```

where xxx is the card location stenciled on the shelf of the EAGLE. Following is an example of a possible output:

```
RLGHNCXA03W 00-06-05 11:11:28 EDT EAGLE 34.0.0  
Card has been inhibited.
```



- If they are identical, continue to the next step.
  - If they are not the same, go to [23](#)
19. Enter the following command to repair the standby's **E5-MASP** database:

```
chg-db:action=repair
```

 **Note:**

The system requires approximately two minutes after [16](#) to acquire duplex mode. As a result, the system will reject the `chg-db:action= repair` until duplex operation fully returns.

The following is an example of a possible output.

```
RLGHNCXA03W 03-08-27 03:46:49 EST EAGLE 34.0.0
chg-db:action=repair
Command entered at terminal #10.
;
RLGHNCXA03W 03-08-27 03:46:50 EST EAGLE 34.0.0
REPAIR: MASP A - Repair starts on standby MASP.
;
```

 **Note:**

Observe that the command execution time may require approximately 20 to 45 minutes.

```
RLGHNCXA03W 03-08-27 04:15:22 EST EAGLE 34.0.0
REPAIR: MASP A - Repair from fixed disk complete.
;
```

Wait for the 'repair complete' message to display and for the to **MASP** return to in-service status. When the 'repair complete' message has displayed, proceed to [20](#)

 **Note:**

Perform this step only if you are coming from [18](#).

20. Enter the following command to show the version numbers of the **GPLs** stored on each fixed disk (**E5-TDM**).

```
rtrv-gpl
```

The following is an example of a possible output.

```
tekelecstp 18-01-18 21:23:11 EST EAGLE 46.5.1.5.0-73.10.0
rtrv-gpl
Command entered at terminal #18.
;
```

```
Command Accepted - Processing
```

tekelecstp 18-01-18 21:23:11 EST EAGLE 46.5.1.5.0-73.10.0  
GPL Auditing ON

GPL	CARD	RELEASE	APPROVED	TRIAL	REMOVE TRIAL
OAMHC	1114	143-010-000	143-010-000	ALM	-----
OAMHC	1116	143-010-000	143-010-000	ALM	-----
OAMHC	1115	-----	-----	-----	-----
OAMHC69	1114	143-010-000	143-010-000	ALM	-----
OAMHC69	1116	143-010-000	143-010-000	ALM	-----
OAMHC69	1115	-----	-----	-----	-----
IPSG32	1114	143-010-000	143-010-000	143-010-000	-----
IPSG32	1116	143-010-000	143-010-000	143-010-000	-----
IPSG32	1115	-----	-----	-----	-----
BLMCAP	1114	143-010-000	143-010-000	143-010-000	-----
BLMCAP	1116	143-010-000	143-010-000	143-010-000	-----
BLMCAP	1115	-----	-----	-----	-----
HIPR2	1114	143-010-000	143-010-000	143-010-000	-----
HIPR2	1116	143-010-000	143-010-000	143-010-000	-----
HIPR2	1115	-----	-----	-----	-----
SFAPP	1114	143-010-000	143-010-000	ALM	143-010-000
SFAPP	1116	143-010-000	143-010-000	ALM	143-010-000
SFAPP	1115	-----	-----	-----	-----
SS7HC	1114	143-010-000	143-010-000	143-010-000	-----
SS7HC	1116	143-010-000	143-010-000	143-010-000	-----
SS7HC	1115	-----	-----	-----	-----
SCCPHC	1114	143-010-000	143-010-000	143-010-000	-----
SCCPHC	1116	143-010-000	143-010-000	143-010-000	-----
SCCPHC	1115	-----	-----	-----	-----
ERTHC	1114	143-010-000	143-010-000	143-010-000	-----
ERTHC	1116	143-010-000	143-010-000	143-010-000	-----
ERTHC	1115	-----	-----	-----	-----
IPSHC	1114	143-010-000	143-010-000	143-010-000	-----
IPSHC	1116	143-010-000	143-010-000	143-010-000	-----
IPSHC	1115	-----	-----	-----	-----
ATMHC	1114	143-010-000	143-010-000	143-010-000	-----
ATMHC	1116	143-010-000	143-010-000	143-010-000	-----
ATMHC	1115	-----	-----	-----	-----
IPSG	1114	143-010-000	143-010-000	143-010-000	-----
IPSG	1116	143-010-000	143-010-000	143-010-000	-----
IPSG	1115	-----	-----	-----	-----
PKTGHC	1114	143-010-000	143-010-000	-----	-----
PKTGHC	1116	143-010-000	143-010-000	-----	-----
PKTGHC	1115	-----	-----	-----	-----
BLIXP	1114	143-010-000	143-010-000	143-010-000	-----
BLIXP	1116	143-010-000	143-010-000	143-010-000	-----
BLIXP	1115	-----	-----	-----	-----
MCPHC	1114	143-010-000	143-010-000	143-010-000	-----
MCPHC	1116	143-010-000	143-010-000	143-010-000	-----
MCPHC	1115	-----	-----	-----	-----
SIPHC	1114	143-010-000	143-010-000	143-010-000	-----
SIPHC	1116	143-010-000	143-010-000	143-010-000	-----
SIPHC	1115	-----	-----	-----	-----
DEIRHC	1114	143-010-000	143-010-000	143-010-000	-----
DEIRHC	1116	143-010-000	143-010-000	143-010-000	-----
DEIRHC	1115	-----	-----	-----	-----
ENUMHC	1114	143-010-000	143-010-000	143-010-000	-----
ENUMHC	1116	143-010-000	143-010-000	143-010-000	-----
ENUMHC	1115	-----	-----	-----	-----
PKTG64	1114	143-010-000	143-010-000	-----	-----
PKTG64	1116	143-010-000	143-010-000	-----	-----
PKTG64	1115	-----	-----	-----	-----

```

BLDC64 1114 143-010-000 ----- 143-010-000 -----
BLDC64 1116 143-010-000 000-000-000 ALM 143-010-000 -----
BLDC64 1115 ----- -----
SCCP64 1114 143-010-000 143-010-000 143-010-000 -----
SCCP64 1116 143-010-000 143-010-000 143-010-000 -----
SCCP64 1115 ----- -----
BLSLC32 1114 143-010-000 143-010-000 143-010-000 -----
BLSLC32 1116 143-010-000 143-010-000 143-010-000 -----
BLSLC32 1115 ----- -----
BLSLC64 1114 143-010-000 143-010-000 143-010-000 -----
BLSLC64 1116 143-010-000 143-010-000 143-010-000 -----
BLSLC64 1115 ----- -----
SIP64 1114 143-010-000 143-010-000 143-010-000 -----
SIP64 1116 143-010-000 143-010-000 143-010-000 -----
SIP64 1115 ----- -----
DEIR64 1114 143-010-000 143-010-000 143-010-000 -----
DEIR64 1116 143-010-000 143-010-000 143-010-000 -----
DEIR64 1115 ----- -----
ENUM64 1114 143-010-000 143-010-000 143-010-000 -----
ENUM64 1116 143-010-000 143-010-000 143-010-000 -----
ENUM64 1115 ----- -----
BLDC32 1114 143-010-000 ----- 143-010-000 -----
BLDC32 1116 143-010-000 ----- 143-010-000 -----
BLDC32 1115 ----- -----
MCPHC69 1114 143-010-000 143-010-000 143-010-000 -----
MCPHC69 1116 143-010-000 143-010-000 143-010-000 -----
MCPHC69 1115 ----- -----
IPSHC69 1114 143-010-000 143-010-000 143-010-000 -----
IPSHC69 1116 143-010-000 143-010-000 143-010-000 -----
IPSHC69 1115 ----- -----
BLSL932 1114 143-010-000 143-010-000 143-010-000 -----
BLSL932 1116 143-010-000 143-010-000 143-010-000 -----
BLSL932 1115 ----- -----

```

```

;
Command Executed

```

21. Examine the output of the previous step.
  - a. If any version is different continue with 22.
  - b. If there are no differences, go to 27.
22. Enter the following command to load the GPLs from the removable USB drive inserted in 13:

```
copy-gpl:sloc=xxxx:dloc=yyyy
```

where xxxx is the card location used in 14 and yyyy is the mated E5-TDM location.

The following is an example of a possible output.

```

rlghncxa03w 09-01-07 00:57:31 EST EAGLE 40.1.0
COPY GPL: MASP B - COPY STARTS ON REMOVABLE DRIVE
;

```

```

rlghncxa03w 09-01-07 01:01:27 EST EAGLE 40.1.0
COPY GPL: MASP B - COPY TO STANDBY MASP COMPLETE

```

When the command has completed, go to 27

23. Enter the following command to verify whether measurement collection is on or off:

```
rtrv-meas-sched
```

The following is an example of a possible output. The **COLLECT** field shows whether measurement collection is on or off. In this example, measurement collection is on.

```
RLGHNCXA03W 95-04-03 12:22:55 EST EAGLE 34.0.0
COLLECT      = on
-----
SYSTOT-STP   = off
SYSTOT-TT    = off
SYSTOT-STPLAN = on
COMP-LNKSET  = off
COMP-LINK    = on
MTC-D-STP    = on
MTC-D-LINK   = on
MTC-D-STPLAN = on
```

- If measurement collection is on, continue with [24](#).
- If measurement collection is off, proceed to [25](#).

24. Enter the following command to inhibit all measurements:

```
chg-meas:collect=off
```

#### **Caution:**

Measurements must be inhibited or the `copy-disk` command cannot be executed. The `chg-meas:collect=on` command should not be executed while the `copy-disk` command is in progress. When measurements are inhibited, measurement collection is stopped. For the entire period of time when measurements are inhibited, those measurements will be lost. If possible do not inhibit measurements at midnight since doing so can result in the loss of measurements for an entire day.

The following is an example of a possible output of the message that should appear.

```
RLGHNCXA03W 94-02-07 16:12:50 EST EAGLE 34.0.0
CHG-MEAS: MASP A - COMPLTD
```

25. Enter the following `copy-disk` command along with the card location of the standby **E5-TDM** (shown by the indicator **STDBY** in the command output in [17](#)) that the data is being copied to.

```
copy-disk:dloc=xxxx:format=yes
```

Where `xxxx` is the card location of the standby **E5-TDM**.

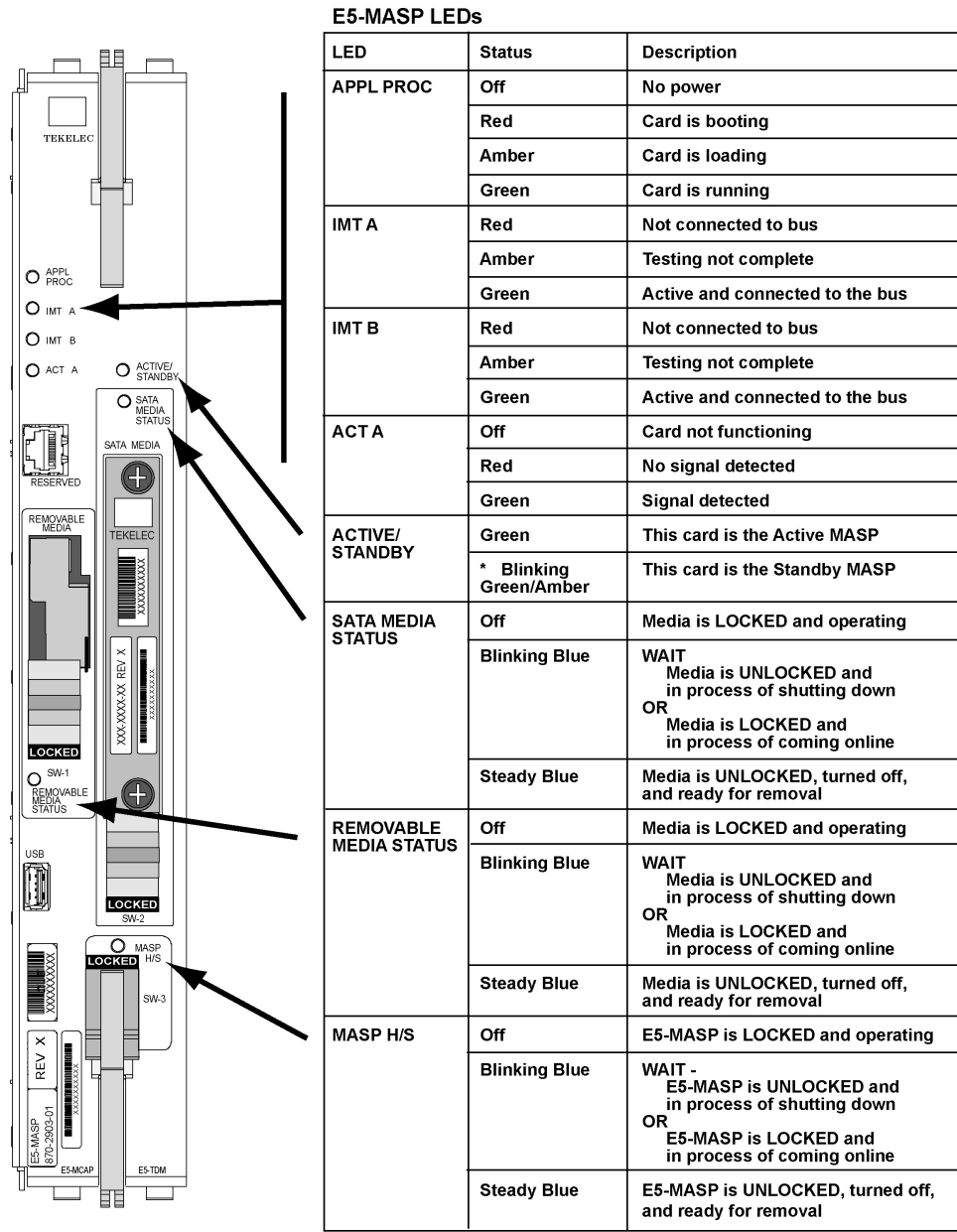
This command can take from 33 minutes to 1 hour 46 minutes to execute. It can take even longer depending on other system activity in progress when this command is entered.

The following is an example of a possible output of the message that should appear when the command has executed and completed. For this example, the `copy-disk:dloc=1116` command was entered.

```
Copy-disk (fixed): from active (1114) to standby (1116) started.
Extended processing required, please wait.
Copy-disk (fixed): from active (1114) to standby (1116) completed.
Measurements collection may be turned on now if desired.
```



Figure A-3 E5-MASP LEDs



\* The LED blinks Green/Amber at a rate of 3 Green to 1 Amber.

## E5-MDAL Card Replacement

### Description

The **E5-MDAL** (Figure A-4) provides for external alarm indicators, such as bells, horns and lamp indicators.

1. Remove the card from service as described in the section titled, [Replacing a Card in the EAGLE](#).

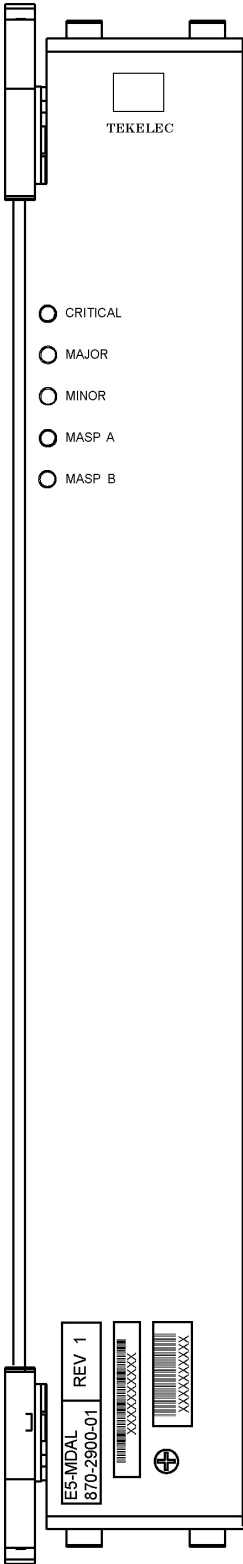




**Note:**

Removing the **E5-MDAL** creates a critical alarm at the Remote Maintenance Center (**RMC**) as well as the local office.

Figure A-4 E5-MDAL LEDs



E5-MDAL LEDs

LED	Status	Description
CRITICAL	Red	A critical system alarm has been detected
	Green	No Alarm
MAJOR	Red	A major system alarm has been detected
	Green	No Alarm
MINOR	Amber	A minor system alarm has been detected
	Green	No Alarm
MASP A	Green	This is the master MASP
	Off	This is the standby MASP
MASP B	Green	This is the master MASP
	Off	This is the standby MASP

# HIPR2 Card Replacement

Use this procedure to remove a High-Speed Inter-processor Message Transport Packet Router 2 (HIPR2) card.

Each shelf contains two **HIPR2** cards, one for each IMT bus, that provide continuity of the IMT bus signals even with failed or missing circuit modules. LEDs on the **HIPR2** (Figure A-5) indicate connectivity to the IMT

1. Enter the following command to verify the status of the IMT buses.

```
rept-stat-imt
```

### warning:

Be sure to inhibit the correct IMT bus. If you inhibit the wrong IMT bus and then remove the **HIPR2**, total nodal isolation will occur. Wait until the IMT has returned to **IS-NR** before replacing the other **HIPR2**.

The following is an example of the possible output.

```
RLGHNCXA03W 98-09-27 16:50:24 EST EAGLE 34.0.0
IMT  PST          SST          AST
A    IS-NR        Active     -----
ALARM STATUS      = No alarms
IMT  PST          SST          AST
B    IS-ANR       Fault      -----
ALARM STATUS      = ** 0108 Major IMT Failure Detected
Command Completed.
```

2. Enter the following command to inhibit the IMT bus associated with the HIPR2 being removed (top HIPR2 accesses bus A, bottom HIPR2 accesses bus B).

```
rmv-imt:bus=x
```

where *x* is the IMT bus to be inhibited.

3. Remove the HIPR2, per the card replacement procedure described in the section titled [Replacing a Card in the EAGLE](#).

Place the new HIPR2 into its place. Be sure the revision numbers are compatible (if in doubt, contact [My Oracle Support \(MOS\)](#)).

4. Enter the following command to restore the IMT bus.

```
alw-imt:bus=x
```

where *x* is the IMT bus inhibited.

### Note:

If **UAM 0002** is output, the newly installed HIPR2 card needs to be flashed.

5. Enter the following command to determine if the newly replaced card's memory needs to be flashed:

```
rept-stat-gpl:gpl=xxxxxx
```

where `xxxxxx` is `hipr2`.

Following is an example of a HIPR2 output:

```
tekelecstp 09-07-09 16:53:23 EST EAGLE5 41.1
Output:
  GPL      CARD      RUNNING      APPROVED      TRIAL
  HIPR2    1109      128-021-000  128-021-000  128-021-000
  HIPR2    1110      128-021-000  128-021-000  128-021-000

  Command Completed.
;
```

 **Note:**

Mismatched GPLs should occur only during upgrades or running a trial GPL.

6. Examine the output from 5.
  - If the **GPLs** match, continue with 15.
  - If there is a **GPL** mismatch, continue with 7.
7. Enter the following command to verify **GPL** Auditing is **ON**.

```
chg-gpl:audit=on
```

8. Enter the following command to load the **GPL** onto the HIPR2 card.

```
init-flash:code=appr:loc=xxxx
```

where `xxxx` is the card location newly replaced card.

Following is an example of a HIPR2 output using card location 1309:

```
RLGHNCXA03W 00-06-05 11:11:28 EDT EAGLE 34.0.0
FLASH Memory Downloading for card 1309 Started.
;
RLGHNCXA03W 00-06-05 11:11:28 EDT EAGLE 34.0.0
HIPR2 Downloading for card 1309 Complete.
;
RLGHNCXA03W 00-06-05 11:11:28 EDT EAGLE 34.0.0
Command Completed.
```

9. Enter either of the following commands to initialize the HIPR2.

 **Caution:**

These commands boot the HIPR2 processor and bring down the respective IMT bus temporarily (approximately 10 seconds) until the HIPR2 card comes back into service.

Enter either

```
init-mux:bus=[a/b]
```

or

```
init-mux:loc=xxxx
```

where *xxxx* is the card location used in 8.

 **Note:**

Allow the card to run for 5 minutes before continuing.

10. Enter the following command to activate the **GPL** loaded onto the HIPR2 card in 8:

```
act-flash:loc=xxxx
```

where *xxxx* is the card location used in 8.

Following is an example of the output using card location 1309:

```

RLGHNCXA03W 00-06-05 11:11:28 EDT EAGLE 34.0.0
FLASH Memory Activation for card 1309 Completed.
;
RLGHNCXA03W 00-06-05 11:11:28 EDT EAGLE 34.0.0
Command Completed.
```

11. Enter the following command to verify the approved **GPLs** match the running **GPLs**:

```
rept-stat-gpl:gpl=hipr2
```

12. If the **GPLs** match, continue with 15.

If the **GPLs** do not match, continue with 13.

13. Enter the following command determine which cards are in alarm condition (indicated by the acronym **ALM** in the `rept-stat-gpl` display):

```
rept-stat-gpl
```

14. Note which cards are in an alarm condition and, if in doubt, [My Oracle Support \(MOS\)](#).

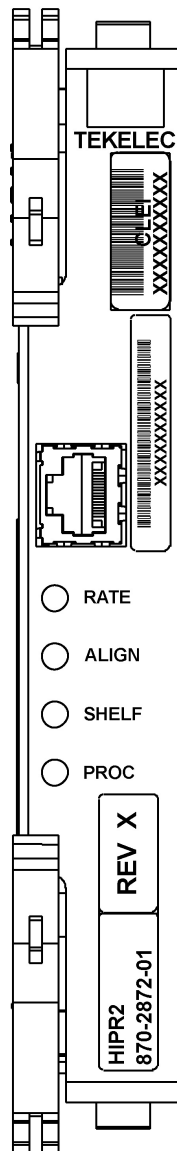
15. Enter the following command to verify that the HIPR2 card is in service and the IMT bus has been restored.

```
rept-stat-imt
```

```

RLGHNCXA03W 98-09-27 16:50:24 EST EAGLE 34.0.0
IMT  PST          SST          AST
 A   IS-NR        Active      -----
ALARM STATUS      = No alarms
IMT  PST          SST          AST
 B   IS-NR        Active      -----
ALARM STATUS      = No alarms
Command Completed.
```

Figure A-5 HIPR2 LEDs



HIPR2 State	LED			
	RATE	ALIGN	SHELF	PROC
No power	Off	Off	Off	Off
Power on (cold start)	Off	Off	Off	RED
Reset (warm start)	Off	Off	AMBER	RED
Programming (cold start)	Off	Off	Off	AMBER
Programming (warm start)	Off	Off	AMBER	AMBER
Programming Complete	---	AMBER	AMBER	GREEN
Shelf Address Capture:				
Timer Started	---	AMBER	AMBER	GREEN
Successful	---	GREEN	AMBER	GREEN
Unsuccessful	---	RED	AMBER	GREEN
Code Running	---	GREEN	Note 2	GREEN
IMT is operational at:				
low-rate (1 Gbps)	GREEN			
high-rate (2.5 Gbps)	GREEN			
	Blinking			
IMT is rate negotiating or in proving period	AMBER			
IMT is not operational	RED			

Notes:

- ALIGN and SHELF LEDs are not accessible to software until the FPGA has been programmed. So for the same point in the HIPR bootstrap sequence, the state of these two LEDs can be different depending on whether a warm or cold start is in progress.
- State depends on the address received from OAM and written to Assigned Shelf Address Register and compared to the value previously read from the Assigned Shelf Address Register.
  - RED - Does Not Match
  - GREEN - Matches

## Determine Card Changeout Time

### Description

This procedure assists the customer in deciding if the card should be changed immediately or during the Maintenance Window.

- Replace the card immediately if *any* of the following conditions exist:
  - If there is only one link on the card
  - If there is no other in-service link on this card
  - If there is no other in-service link on this card
  - If any destination is prohibited by the current failure.

2. Wait until the maintenance window to replace the card if *all* of the following conditions exist:
  - If the faulty link is not the only in-service link on the card
  - If deactivating the link will prohibit a destination
  - If no destination is prohibited by the current failure.

## E5-ATM-B Card Replacement

This E5-ATM-B Module provides access to remote SS7, IP and other network elements, such as a Signaling Control Point (SCP). This card is equipped with an industry-standard ATM, or DS0 interface.

1. Enter the following command to determine which links are serviced by this card:

```
rept-stat-card:loc=xxxx
```

Where *xxxx* is the card location. The following is an example of the possible output.

```
RLGHNCXA03W 98-09-27 16:43:42 EST EAGLE 34.0.0
CARD VERSION      TYPE      APPL      PST      SST      AST
1201 021-002-000 LIMDS0 CCS7ITU IS-NR      Active    -----
  ALARM STATUS      = * 0022 Clock B for card failed.
  IMT VERSION        = 021-001-000
  PROM VERSION       = 021-001-000
  IMT BUS A          = Conn
  IMT BUS B          = Fault
  SLK A PST          = IS-NR      LS=lsnssp2  CLLI=-----
  SLK B PST          = IS-NR      LS=lsnstpi  CLLI=-----
  SCCP SERVICE CARD = 1212
  SLAN SERVICE CARD = ----
Command Completed.
```

2. Refer to procedure to determine when to change the card.

### Note:

The `inh-slk` command will be rejected if inhibiting the link would cause a **DPC** to become unavailable.

3. Enter the following command to inhibit the links on both ports of this card (a and b).

```
inh-slk:loc=xxxx:port=y
```

Where *xxxx* location of the card from [1](#) and *y* is the port.

4. Enter the following command to change the status of the link to out of service - maintenance disabled (`oos-mt-dsbl`).

```
dact-slk:loc=xxxx:port=y
```

Where *xxxx* location used in [3](#) and *y* are the ports used in [3](#).

5. Enter the following command to ensure the signaling link status is `oos-mt-dsbl` (out of service - maintenance disabled).

```
rept-stat-slk
```

The following is an example of the possible output.

```

RLGHNCXA03W 98-09-27 17:00:36 EST EAGLE 34.0.0
rept-stat-slk
SLK   LSN           CLLI           PST           SST           AST
1201,A lsnsspn2   ----- OOS-MT-DSBLD Unava   ----
1201,B lsnstpi    ----- OOS-MT-DSBLD Unava   ----
1202,A lsnstpn    ----- IS-NR           Avail   ----
1202,B lsnstpi    ----- IS-NR           Avail   ----
1203,A lsnstpa    ----- IS-NR           Avail   ----
1203,B lsnscpa    ----- IS-NR           Avail   ----
1205,A lsnscpi    ----- IS-NR           Avail   ----
1205,B lsnsspi1   ----- IS-NR           Avail   ----
1207,A lsnstpa    ----- IS-NR           Avail   ----
1207,B lsnsspa1   ----- IS-NR           Avail   ----
1211,A lsnstpn    ----- IS-NR           Avail   ----
1211,B lsnsspn1   ----- IS-NR           Avail   ----
Command Completed.

```

6. Enter the following command to inhibit the card and disconnect it from the IMT bus.

```
rmv-card:loc=xxxx
```

Where *xxxx* location used in 3 and 4.

7. Remove the card, per the card replacement procedure described in the section titled [Replacing a Card in the EAGLE..](#)

Place the new card into its place. Be sure the revision numbers are compatible (if in doubt, contact the [My Oracle Support \(MOS\)](#)).

8. Enter the following command to download generic program loads and database information:

```
alw-card:loc=xxxx
```

Where *xxxx* location used in 6.

9. Enter the following command to determine which links are serviced by this card:

```
rept-stat-card:loc=xxxx
```

Where *xxxx* is the location of the replaced card.

### Note:

The signaling link alarms will be present until the links are restored in 11.

10. Examine the output from 9.

Refer to [Corrective Maintenance](#) to clear any **GPL** related alarms on the newly replaced card before continuing.

11. Enter the following command to return the links to service.

Make sure this is done on all links:

```
act-slk:loc=xxxx:port=y
```

Where *xxxx* location used in 3 and 4 and *y* are the ports used in 3 and 4.

12. Enter the following command to change the link status to **IS-NR**.

Make sure this is done on both ports, *a* and *b*.

```
unhb-slk:loc=xxxx:port=y
```

Where *xxxx* location used in 3 and 4 and *y* are the ports used in 3 and 4.



13. Enter the following command to verify the status of the card and its associated links:

```
rept-stat-card:loc=xxxx
```

Where xxxx is the card location. The following is an example of the possible output.

```
RLGHNCXA03W 98-09-27 16:43:42 EST EAGLE 34.0.0
CARD VERSION      TYPE      APPL      PST      SST      AST
1201 024-002-000 LIMDS0
SS7ANSI
  IS-NR           Active    -----
ALARM STATUS     = No Alarms.
IMT VERSION      = 024-001-000
PROM VERSION     = 024-001-000
IMT BUS A       = Conn
IMT BUS B       = Conn
SLK A PST       = IS-NR           LS=lsnssp2  CLLI=-----
SLK B PST       = IS-NR           LS=lsnstpi  CLLI=-----
SCCP SERVICE CARD = 1212
SLAN SERVICE CARD = ----
Command Completed.
```

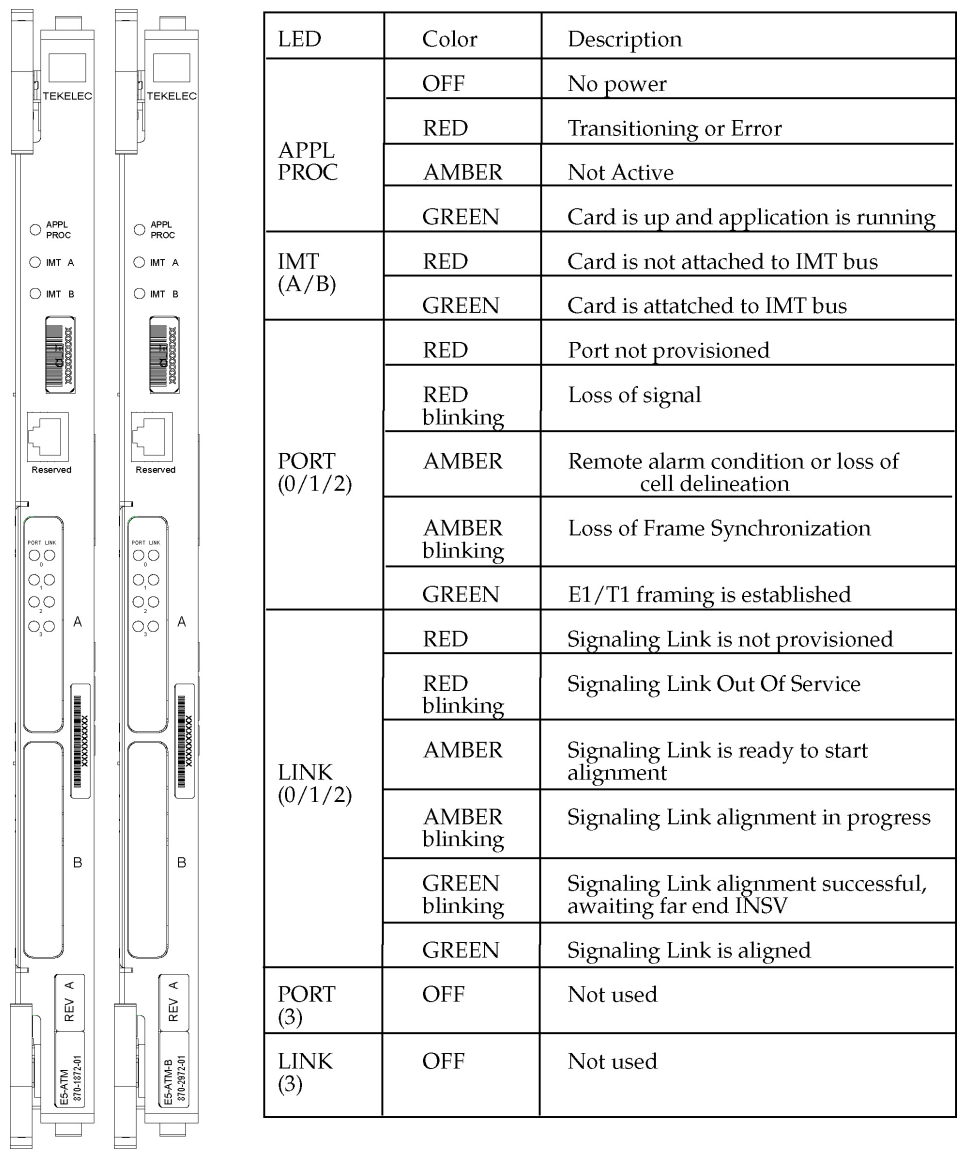
14. Enter the following command to verify the links are properly aligned and are returned to full service:

```
rept-stat-slk
```

The following is an example of the possible output.

```
RLGHNCXA03W 98-09-27 17:00:36 EST EAGLE 34.0.0
rept-stat-slk
SLK  LSN          CLLI          PST          SST          AST
1201,A lsnssp2    ----- IS-NR        Avail        ----
1201,B lsnstpi    ----- IS-NR        Avail        ----
1202,A lsnstpn    ----- IS-NR        Avail        ----
1202,B lsnstpi    ----- IS-NR        Avail        ----
1203,A lsnstpa    ----- IS-NR        Avail        ----
1203,B lsnscpa    ----- IS-NR        Avail        ----
1205,A lsnscpi    ----- IS-NR        Avail        ----
1205,B lsnsspil   ----- IS-NR        Avail        ----
1207,A lsnstpa    ----- IS-NR        Avail        ----
1207,B lsnssp1    ----- IS-NR        Avail        ----
1211,A lsnstpn    ----- IS-NR        Avail        ----
1211,B lsnssp1    ----- IS-NR        Avail        ----
Command Completed.
```

Figure A-6 E5-ATM-B LEDs



## SS7 and IP7 Card Replacement

This **Link Interface Module (LIM)** ([#GUID-8C99FC6C-BB31-4A24-88BB-986D927A4BF9/V946963](#)) provides access to remote **SS7**, **IP** and other network elements, such as a Signaling Control Point (**SCP**). This card is equipped with an industry-standard **ATM**, or **DS0** interface.

The types of Link Interface Modules (**LIM**)s currently available are:

- **LIM**
- The E5-E1/T1-B
- SLIC

1. Enter the following command to determine which links are serviced by this card:

```
rept-stat-card:loc=xxxx
```

Where *xxxx* is the card location. The following is an example of the possible output.

```

RLGHNCXA03W 98-09-27 16:43:42 EST EAGLE 34.0.0
CARD VERSION      TYPE      APPL      PST          SST          AST
1201 021-002-000 LIMDS0  CCS7ITU  IS-NR        Active       -----
  ALARM STATUS     = * 0022 Clock B for card failed.
  IMT VERSION      = 021-001-000
  PROM VERSION     = 021-001-000
  IMT BUS A        = Conn
  IMT BUS B        = Fault
  SLK A PST        = IS-NR          LS=lsnssp2  CLI=-----
  SLK B PST        = IS-NR          LS=lsnstpi  CLI=-----
  SCCP SERVICE CARD = 1212
  SLAN SERVICE CARD = ----
Command Completed.

```

2. Refer to [Determine Card Changeout Time](#) procedure to determine when to change the card.

 **Note:**

The `inh-slk` command will be rejected if inhibiting the link would cause a **DPC** to become unavailable.

3. Enter the following command to inhibit the links on both ports of this card (a and b).

```
inh-slk:loc=xxxx:port=y
```

Where *xxxx* location of the card from 1 and *y* is the port.

4. Enter the following command to change the status of the link to out of service - maintenance disabled (`oos-mt-dsbl`).

Enter the same location and ports from 3

```
dact-slk:loc=xxxx:port=y
```

Where *xxxx* location used in 3 and *y* are the ports used in 3 .

5. Enter the following command to ensure the signaling link status is `oos-mt-dsbl` (out of service - maintenance disabled).

```
rept-stat-slk
```

The following is an example of the possible output.

```

RLGHNCXA03W 98-09-27 17:00:36 EST EAGLE 34.0.0
rept-stat-slk
SLK  LSN          CLI          PST          SST          AST
1201,A lsnssp2    ----- IS-NR        Avail       ----
1201,B lsnstpi    ----- OOS-MT-DSBLD LPBK       ----
1202,A lsnstpn    ----- IS-NR        Avail       ----
1202,B lsnstpi    ----- IS-NR        Avail       ----
1203,A lsnstpa    ----- IS-NR        Avail       ----
1203,B lsnscpa    ----- IS-NR        Avail       ----
1205,A lsnscpi    ----- IS-NR        Avail       ----
1205,B lsnsspi1   ----- IS-NR        Avail       ----
1207,A lsnstpa    ----- IS-NR        Avail       ----
1207,B lsnsspa1   ----- IS-NR        Avail       ----
1211,A lsnstpn    ----- IS-NR        Avail       ----
1211,B lsnssp1    ----- IS-NR        Avail       ----
Command Completed.

```

6. Enter the following command to inhibit the card and disconnect it from the IMT bus.  

```
rmv-card:loc=xxxx
```

 Where *xxxx* location used in 3 and 4 .
7. Remove the **LIM/E5E1T1-B/SLIC**, per the card replacement procedure described in the section titled [Replacing a Card in the EAGLE](#)..  
 Place the new **SS7LIM** into its place. Be sure the revision numbers are compatible (if in doubt, contact the [My Oracle Support \(MOS\)](#)).
8. Enter the following command to download generic program loads and database information from the **E5-TDM** card to the new **LIM/E5E1T1-B/SLIC**:  

```
alw-card:loc=xxxx
```

 Where *xxxx* location used in 6 .
9. Enter the following command to determine which links are serviced by this card:  

```
rept-stat-card:loc=xxxx
```

 Where *xxxx* is the location of the replaced card.

 **Note:**

The signaling link alarms will be present until the links are restored in 11.

10. Examine the output from 9.  
 Refer to [Corrective Maintenance](#) to clear any **GPL** related alarms on the newly replaced card before continuing.
11. Enter the following command to return the links to service.  
 Make sure this is done on all links:  

```
act-slk:loc=xxxx:port=y
```

 Where *xxxx* location used in 3 and 4 and *y* are the ports used in 3 and 4.
12. Enter the following command to change the link status to **IS-NR**.  
 Make sure this is done on both ports, *a* and *b*.  

```
unhb-slk:loc=xxxx:port=y
```

 Where *xxxx* location used in 3 and 4 and *y* are the ports used in 3 and 4.
13. Enter the following command to verify the status of the card and its associated links:  

```
rept-stat-card:loc=xxxx
```

 Where *xxxx* is the card location. The following is an example of the possible output.

```

RLGHNCXA03W 98-09-27 16:43:42 EST EAGLE 34.0.0
CARD VERSION      TYPE  APPL  PST      SST      AST
1201 024-002-000 LIMDS0
SS7ANSI
  IS-NR           Active  -----
ALARM STATUS     = No Alarms.
IMT VERSION       = 024-001-000
PROM VERSION      = 024-001-000
IMT BUS A        = Conn
IMT BUS B        = Conn
SLK A PST        = IS-NR           LS=lsnssp2  CLLI=-----

```

```

SLK B PST          = IS-NR          LS=lsnstpi  CLLI=-----
SCCP SERVICE CARD = 1212
SLAN SERVICE CARD = ----
Command Completed.

```

14. Enter the following command to verify the links are properly aligned and are returned to full service:

```
rept-stat-slk
```

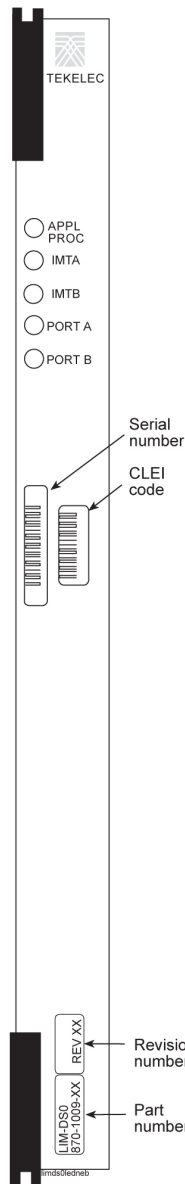
The following is an example of the possible output.

```

RLGHNCXA03W 98-09-27 17:00:36 EST  EAGLE 34.0.0
rept-stat-slk
SLK   LSN          CLLI          PST          SST          AST
1201,A lsnssp2    ----- IS-NR          Avail        ----
1201,B lsnstpi    ----- OOS-MT-DSBLD LPBK        ----
1202,A lsnstpn    ----- IS-NR          Avail        ----
1202,B lsnstpi    ----- IS-NR          Avail        ----
1203,A lsnstpa    ----- IS-NR          Avail        ----
1203,B lsnscpa    ----- IS-NR          Avail        ----
1205,A lsnscpi    ----- IS-NR          Avail        ----
1205,B lsnsspi1   ----- IS-NR          Avail        ----
1207,A lsnstpa    ----- IS-NR          Avail        ----
1207,B lsnsspa1   ----- IS-NR          Avail        ----
1211,A lsnstpn    ----- IS-NR          Avail        ----
1211,B lsnssp1    ----- IS-NR          Avail        ----
Command Completed.

```

Figure A-7 DS0A-LIM LEDs



LEDs	Descriptions
APPL PROC	RED – Application processor is not running or is failing diagnostics. AMBER – LIM-DS0A is loading an application or is being polled (may be prevented from loading by maintenance out of service condition). GREEN – LIM-DS0A is running an application.
IMTA	RED – LIM-DS0A is off IMT bus A. AMBER – LIM-DS0A is on IMT bus A, but testing is not complete. GREEN – LIM-DS0A is on IMT bus A. BLANK – Communication processor is not operating.
IMTB	RED – LIM-DS0A is off IMT bus B. AMBER – LIM-DS0A is on IMT bus B, but testing is not complete. GREEN – LIM-DS0A is on IMT bus B. BLANK – Communication processor is not operating.
PORT A	RED – Link is out of service. GREEN – Link is aligned and in service.
PORT B	RED – Link is out of service. GREEN – Link is aligned and in service.

## E5-ENET-B Module

The term E5-ENET refers to the E5-ENET-B (P/N 870-2971-xx).

The E5-ENET-b module (refer to [Figure A-8](#)) can run different applications. Removal and replacement procedures differ depending on the application.

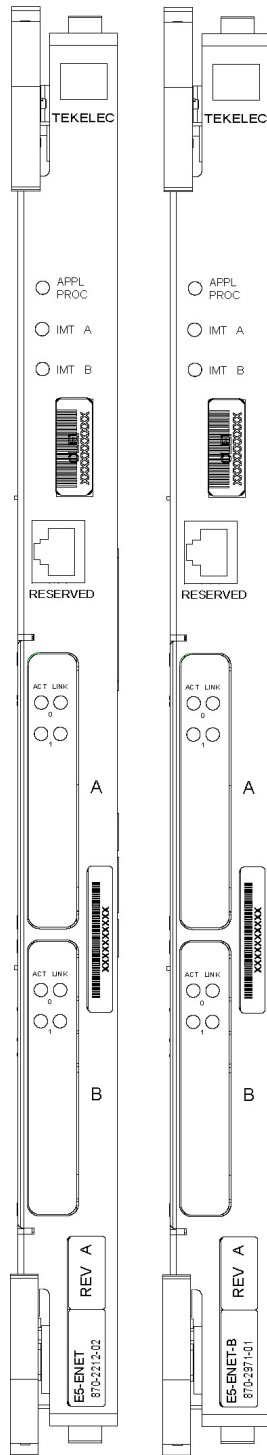
 **Note:**

If this card is removed, the link supported by this card becomes out of service.

For removal and replacement procedures for a like-for-like card:

- If the E5-ENET-B card is operating with signaling interfaces such as IPLIM, IPGW or IPSG, refer to [IP SIGTRAN on E5-ENET-B](#).
- If the E5-ENET-B card is operating with signaling interfaces such as SLAN or EROUTE, refer to [STPLAN/EROUTE on E5-ENET-B](#).

Figure A-8 E5-ENET-B LEDs



**Front Faceplate LED Indicators**

LED	Status	Description
APPL PROC	Off	No power
	Red	Card is booting
	Amber	Card is loading
	Green	Card is up and application is running
IMT A	Red	Not connected to bus
	Amber	Testing not complete
	Green	Active and connected to the bus
IMT B	Red	Not connected to bus
	Amber	Testing not complete
	Green	Active and connected to the bus

**EROUTE/SLAN**

LED	ACT	LINK
Red	Signaling links inactive, or 1 or more active links are out-of-service	N/A
Green	All active links are in-service	Ethernet signal detected
Off	Card nonfunctional	No Ethernet signal detected

**ACT Status LED states for IPLIMx/IPSG**

SLK States (Port A or Port B)	ACT Status LED
No links configured	Off
All provisioned links are OOS-MT-DSBLD	Red
Sync	Green

**ACT Status LED states for IPGWx**

IPGWx SLK PST	ACT Status LED	
	A0	B0
None configured (card must be inhibited)	Off	Off
OOS-MT-DSBLD	Red	Red
IS-NR or IS-ANR	Green	Green

**IP SIGTRAN on E5-ENET-B**

The term E5-ENET refers to the E5-ENET-B (P/N 870-2971-xx).



Use this procedure to remove and replace an E5-ENET-B card running an application such as IPLIM, IPLIMI, IPGWI, SS7IPGW, or IPSG, or SLIC running the IPSG application.

 **Note:**

See the "Conversion of SLIC Cards" section in *Database Administration - System Management* for 32-bit to 64-bit conversion and vice versa.

See the "EAGLE Card Applications and GPLs" table in *Database Administration - System Management* for details on the flash and application GPLs that are run/required based on different card configurations.

1. Enter the following command to determine which links are serviced by this card.

```
rept-stat-card:loc=xxxx
```

Where *xxxx* is the card location.

The following is an example of the possible output.

```
rlghncxa03w 06-06-01 16:43:42 EST EAGLE 46.6.0.0
CARD  VERSION      TYPE      GPL      PST      SST      AST
1301  082-000-039    E5-ENET    IPLHC    IS-NR    Active
```

-----

```
ALARM STATUS      = No Alarms.
BLMCAP GPL version = 126-002-000
IMT BUS A         = Conn
IMT BUS B         = Disc
```

SIGNALING LINK STATUS

SLK	PST	LS	CLLI	E5IS
A	IS-NR	ls1m2pa	-----	INACTIVE
B	OOS-MT	ls1m2pa	-----	INACTIVE
A1	OOS-MT	ls1m2pa	-----	INACTIVE
B1	OOS-MT	ls1m2pa	-----	INACTIVE
A2	OOS-MT	ls1m2pa	-----	INACTIVE
B2	OOS-MT	ls1m2pa	-----	INACTIVE
A3	OOS-MT	ls1m2pa	-----	INACTIVE
B3	OOS-MT	ls1m2pa	-----	INACTIVE

Command Completed.

;

2. Refer to [Determine Card Changeout Time](#) procedure to determine when to change the card.
3. Enter the following command to inhibit the links on both ports of this card (*a* and *b*):

```
inh-slk:loc=xxxx:port=y
```

 **Note:**

This step is not applicable for IPSG-M3UA and IPGW links.

Where *xxxx* is the location of the card and *y* is the port.

 **Note:**

The `inh-slk` command will be rejected if inhibiting the link would cause a **DPC** to become unavailable.

The following is an example of the possible output.

```
rlghncxa03w 05-01-07 11:11:28 EST EAGLE5 33.0.0
Inhibit Link message sent to card
;
```

4. Enter the following command to change the status of the link to out of service - maintenance disabled (`oos-mt-dsblld`).

```
dact-slk:loc=xxxx:port=y
```

Where `xxxx` is the card location and `y` is the port used.

The following is an example of the possible output.

```
rlghncxa03w 04-01-07 11:11:28 EST EAGLE5 33.0.0
Deactivate Link message sent to card
;
```

5. Enter the following command to ensure the signaling link status is `oos-mt-dsblld` (out of service - maintenance disabled).

```
rept-stat-slk
```

The following is an example of the possible output.

```
RLGHNCXA03W 98-09-27 17:00:36 EST EAGLE 34.0.0
rept-stat-slk
SLK   LSN           CLLI           PST           SST           AST
1201,A lsnssp2   ----- IS-NR           Avail         ----
1201,B lsnstpi   ----- OOS-MT-DSBLD LPBK         ----
1202,A lsnstpn   ----- IS-NR           Avail         ----
1202,B lsnstpi   ----- IS-NR           Avail         ----
1203,A lsnstpa   ----- IS-NR           Avail         ----
1203,B lsnscpa   ----- IS-NR           Avail         ----
1205,A lsnscpi   ----- IS-NR           Avail         ----
1205,B lsnsspil  ----- IS-NR           Avail         ----
1207,A lsnstpa   ----- IS-NR           Avail         ----
1207,B lsnspa1   ----- IS-NR           Avail         ----
1211,A lsnstpn   ----- IS-NR           Avail         ----
1211,B lsnssp1   ----- IS-NR           Avail         ----
Command Completed.
```

6. Enter the following command to inhibit the card and disconnect it from the IMT bus.

```
rmv-card:loc=xxxx
```

Where `xxxx` is the location.

The following is an example of the possible output.

```
rlghncxa03w 04-01-07 11:11:28 EST EAGLE 31.3.0
Card has been inhibited.
;
```

7. Remove the E5-ENET card per the card replacement procedure described in the section titled [Replacing a Card in the EAGLE](#).

Place the new E5-ENET card into its place. Be sure the revision numbers are compatible (if in doubt, contact [My Oracle Support \(MOS\)](#)).

8. Enter the following command to verify GPL versions:

```
rept-stat-gpl:loc=xxxx,
```

Where `xxxx` is the location of the replaced card.

The following is an example of the possible output:

```
eaglestp YY-MM-DD hh:mm:ss TTTT EAGLE XX.x.x-YY.yy.y
  GPL          CARD          RUNNING          APPROVED          TRIAL
  IPGS          XXXX          -----          XXX-XXX-XXX      XXX-XXX-XXX
                   ZZZZZZ          YYY-YYY-YYY          YYY-YYY-YYY      YYY-YYY-YYY
```

Command Completed.

Where `ZZZZZZ` is the Flash GPL name (BLMCAP, BLSLC32, for example). If the Flash GPL is not getting displayed, then wait for the card to be back on the IMT and run the command again.

9. If replacing an E5-ENETB card with a SLIC card, change the card type to SLIC using the `chg-card:type=slic:loc=xxxx` command,

Where `xxxx` is the location of the replaced card.

10. Examine the output from

Refer to [Corrective Maintenance](#) to clear any Flash GPL related alarms on the newly replaced card before continuing.

11. Enter the following command to put the card back into service:

```
alw-card:loc=xxxx
```

where `xxxx` is the card location used in [6](#)

The following is an example of a possible output:

```
Command Accepted - Processing
eagle3 02-01-18 18:02:20 EST EAGLE5 41.2.0-62.69.65
alw-card:loc=1112
Command entered at terminal #1.
;
eagle3 02-01-18 18:02:20 EST EAGLE5 41.2.0-62.69.65
Card has been allowed.
;
eagle3 02-01-18 18:02:20 EST EAGLE5 41.2.0-62.69.65
Command Completed.
;
```

12. Enter the following command to return the links to service.

```
act-slk:loc=xxxx:port=y
```

Where `xxxx` is the location and `y` are the ports used in [3](#) and [4](#).

Make sure this is done on all links.

The following is an example of the possible output.

```
tekelecstp 05-01-21 17:00:36 EST EAGLE5 33.0.0
Activate Link message sent to card
;
```

13. Enter the following command to change the link status to **IS-NR**:

```
unhb-slk:loc=xxxx:port=y
```

 **Note:**

This step is not applicable for IPSP-M3UA and IPGW links.

Make sure this is done on both ports, *a* and *b*.

Where *xxxx* is the location used in 3 and 4 and *y* are the ports used in the same steps, respectively.

The following is an example of the possible output.

```
rlghncxa03w 03-03-23 13:20:59 EST EAGLE 31.3.0
Allow Link message sent to card
;
```

- Enter the following command to verify the status of the card and its associated links.

```
rept-stat-card:loc=xxxx
```

Where *xxxx* is the card location.

The following is an example of the possible output.

```
rlghncxa03w 06-06-01 16:43:42 EST EAGLE 46.6.0.0
CARD   VERSION      TYPE      GPL      PST      SST      AST
1301   082-000-039    E5-ENET   IPLHC    IS-NR    Active
-----
ALARM STATUS           = No Alarms.
BLMCAP GPL version = 126-002-000
IMT BUS A              = Conn
IMT BUS B              = Disc
SIGNALING LINK STATUS
  SLK  PST          LS          CLLI          E5IS
  A    IS-NR       ls1m2pa     -----      INACTIVE
  B    OOS-MT     ls1m2pa     -----      INACTIVE
  A1   OOS-MT     ls1m2pa     -----      INACTIVE
  B1   OOS-MT     ls1m2pa     -----      INACTIVE
  A2   OOS-MT     ls1m2pa     -----      INACTIVE
  B2   OOS-MT     ls1m2pa     -----      INACTIVE
  A3   OOS-MT     ls1m2pa     -----      INACTIVE
  B3   OOS-MT     ls1m2pa     -----      INACTIVE

Command Completed.
;
```

- Enter the following command to verify the links are properly aligned and are returned to full service.

```
rept-stat-slk
```

The following is an example of the possible output.

```
RLGHNCXA03W 98-09-27 17:00:36 EST EAGLE 34.0.0
rept-stat-slk
SLK  LSN          CLLI          PST          SST          AST
1201,A lsnssp2  -----      IS-NR        Avail        ----
1201,B lsnstpi  -----      OOS-MT-DSBLD LPBK         ----
1202,A lsnstpn  -----      IS-NR        Avail        ----
1202,B lsnstpi  -----      IS-NR        Avail        ----
1203,A lsnstpa  -----      IS-NR        Avail        ----
```

```

1203,B lsnsdpa ----- IS-NR Avail ----
1205,A lsnsdpi ----- IS-NR Avail ----
1205,B lsnsdpi ----- IS-NR Avail ----
1207,A lsnstpa ----- IS-NR Avail ----
1207,B lsnsdpa ----- IS-NR Avail ----
1211,A lsnstpn ----- IS-NR Avail ----
1211,B lsnsdpn ----- IS-NR Avail ----
Command Completed.

```

Procedure complete.

## STPLAN/EROUTE on E5-ENET-B

The term E5-ENET refers to either the E5-ENET-B (P/N 870-2971-xx).

Use this procedure to remove and replace an E5-ENET-B card running an application such as STPLAN or EROUTE.

1. Enter the following command to determine what **TCP/IP** data links are configured.

```
rept-stat-card
```

The following is an example of a possible output.

```

rlghncxa03w 10-01-09 16:35:57 IST EAGLE 46.0.0

CARD   VERSION   TYPE      GPL      PST      SST      AST
1101   125-020-000 TSM       GLS      IS-NR    Active   -----
1102   128-002-000 LIMATM    ATMHC    IS-NR    Active   -----
1103   125-020-000 E5SM4G    SCCPHC   IS-NR    Active   -----
1105   125-020-000 E5SM4G    SCCPHC   IS-NR    Active   -----
1106   130-001-000 TSM       GLSHC    IS-NR    Active   -----
1107   125-020-000 STC       SLANHC   IS-NR    Active   -----
1109   125-020-000 HIPR2     HIPR2    IS-NR    Active   -----
1110   125-020-000 HIPR2     HIPR2    IS-NR    Active   -----
1111   125-020-000 IPSM      IPS       IS-NR    Active   -----
1112   125-020-000 EDSM      MCP       IS-NR    Active   -----
1113   070-019-002 E5MCAP    OAMHC    IS-NR    Standby  -----
1114   -----     E5TDM                    IS-NR    Active   -----
1115   070-019-002 E5MCAP    OAMHC    IS-NR    Active   -----
1116   -----     E5TDM                    IS-NR    Active   -----
1117   -----     E5MDAL                   IS-NR    Active   -----
1201   125-020-000 LIMDS0    SS7ANSI  IS-NR    Active   -----
1202   -----     LIMCH     SS7ANSI  OOS-MT-DSBLD Manual   -----
1203   125-020-000 LIMCH     SS7ANSI  IS-NR    Active   -----
1205   125-020-000 E5ENETB   SLANHC   IS-NR    Active   -----
1206   125-020-000 E5ENETB   SLANHC   IS-NR    Active   -----
1207   125-020-000 E5ENETB   SLANHC   IS-NR    Active   -----
1208   125-020-000 E5ENETB   SLANHC   IS-NR    Active   -----
1209   125-020-000 HIPR2     HIPR2    IS-NR    Active   -----
1210   125-020-000 HIPR2     HIPR2    IS-NR    Active   -----
1211   125-020-000 LIMATM    ATMANSI  IS-NR    Active   -----
1213   125-020-000 LIME1ATM ATMITU   IS-NR    Active   -----
1301   048-019-022 LIME1     SS7ANSI  IS-NR    Active   -----
1303   125-022-000 LIME1     SS7ANSI  IS-NR    Active   -----
1305   125-022-000 LIME1     CCS7ITU  IS-NR    Active   -----
1309   125-017-000 HIPR2     HIPR2    IS-NR    Active   -----
1310   125-017-000 HIPR2     HIPR2    IS-NR    Active   -----
1311   125-020-000 STC       SLANHC   IS-NR    Active   -----
1313   125-020-000 DCM       VXWSLAN  IS-NR    Active   -----
2101   104-002-000 LIMV35    CCS7ITU  IS-NR    Active   -----

```

```

2103 128-018-000 DCM      IPLHC      IS-NR      Active     -----
2107 104-001-000 LIMCH     CCS7ITU    IS-NR      Active     -----
2108 128-018-000 DCM      SLANHC     IS-NR      Active     -----
2109 128-022-000 HIPR2     HIPR2     IS-NR      Active     -----
2110 128-022-000 HIPR2     HIPR2     IS-NR      Active     -----
2111 128-018-000 STC      ERTHC     IS-NR      Active     -----
1213 053-000-058 E5ENET    IPSG      IS-NR      Active     -----
Command Completed.

```

```
;
```

- Enter the following command to determine the status of the **TCP/IP** data link assigned to the card to be replaced.

```
rept-stat-dlk
```

The following is an example of the possible output.

```

rlghncxa03w 10-01-27 17:00:36 EST  EAGLE 42.0.0
DLK          PST          SST          AST
1104         IS-NR        Active       ----
1206         IS-NR        Active       ALMINH
Command Completed.

```

```
;
```

- Note the status of the **TCP/IP** data link.
  - If the link is out of service - maintenance disabled (**OOS-MT-DSBLD**), go to 5.
  - If the link is not out of service, go to the next step.
- Enter the following command to change the status of the **TCP/IP** data link to **OOS-MT-DSBLD**.

```
canc-dlk:loc=xxxx
```

Where *xxxx* is the card location.

The following is an example of a possible output.

```

rlghncxa03w 04-01-27 17:00:36 EST  EAGLE 31.3.0
Deactivate Link message sent to card.
Command Completed.

```

```
;
```

- Enter the following command to inhibit the card and disconnect it from the IMT bus.

```
rmv-card:loc=xxxx
```

Where *xxxx* is the card location.

#### Note:

If this is the last type **ENET** card in the system, the `:force=yes` parameter must be used with this command.

The following is an example of a possible output.

```

rlghncxa03w 04-01-07 11:11:28 EST  EAGLE 31.3.0
Card has been inhibited.

```

```
;
```

- Remove the **E5-ENET**, per the card replacement procedure described in the section titled [Replacing a Card in the EAGLE](#).

Place the new **E5-ENET-B** into its place. Be sure the revision numbers are compatible (if in doubt, contact [My Oracle Support \(MOS\)](#)).

- Enter the following command to put the new **E5-ENET-B** card back into service and connect it to the IMT bus.

```
alw-card:loc=xxxx
where xxxx = card location.
```

The following is an example of a possible output.

```
rlghncxa03w 04-01-07 11:11:28 EST EAGLE 31.3.0
Card has been allowed.
;
```

- Enter the following command to return the **TCP/IP** data link to service.

```
act-dlk:loc=xxxx
where xxxx is the card location.
```

The following is an example of a possible output.

```
rlghncxa03w 04-01-17:00:36 EST EAGLE 31.3.0
Activate Link message sent to card.
Command Completed.
;
```

- Enter the following command to verify the status of the card and its associated **TCP/IP** data link.

```
rept-stat-card
```

The following is an example of a possible output.

```
rlghncxa03w 10-01-09 16:35:57 IST EAGLE 46.0.0
```

CARD	VERSION	TYPE	GPL	PST	SST	AST
1101	125-020-000	TSM	GLS	IS-NR	Active	-----
1102	128-002-000	LIMATM	ATMHC	IS-NR	Active	-----
1103	125-020-000	E5SM4G	SCCPHC	IS-NR	Active	-----
1105	125-020-000	E5SM4G	SCCPHC	IS-NR	Active	-----
1106	130-001-000	TSM	GLSHC	IS-NR	Active	-----
1107	125-020-000	STC	SLANHC	IS-NR	Active	-----
1109	125-020-000	HIPR2	HIPR2	IS-NR	Active	-----
1110	125-020-000	HIPR2	HIPR2	IS-NR	Active	-----
1111	125-020-000	IPSM	IPS	IS-NR	Active	-----
1112	125-020-000	EDSM	MCP	IS-NR	Active	-----
1113	070-019-002	E5MCAP	OAMHC	IS-NR	Standby	-----
1114	-----	E5TDM		IS-NR	Active	-----
1115	070-019-002	E5MCAP	OAMHC	IS-NR	Active	-----
1116	-----	E5TDM		IS-NR	Active	-----
1117	-----	E5MDAL		IS-NR	Active	-----
1201	125-020-000	LIMDS0	SS7ANSI	IS-NR	Active	-----
1202	-----	LIMCH	SS7ANSI	OOS-MT-DSBLD	Manual	-----
1203	125-020-000	LIMCH	SS7ANSI	IS-NR	Active	-----
1205	125-020-000	E5ENETB	SLANHC	IS-NR	Active	-----
1206	125-020-000	E5ENETB	SLANHC	IS-NR	Active	-----
1207	125-020-000	E5ENETB	SLANHC	IS-NR	Active	-----
1208	125-020-000	E5ENETB	SLANHC	IS-NR	Active	-----
1209	125-020-000	HIPR2	HIPR2	IS-NR	Active	-----
1210	125-020-000	HIPR2	HIPR2	IS-NR	Active	-----

```

1211 125-020-000 LIMATM  ATMANSI  IS-NR      Active  -----
1213 125-020-000 LIME1ATM ATMITU  IS-NR      Active  -----
1301 048-019-022 LIME1    SS7ANSI  IS-NR      Active  -----
1303 125-022-000 LIME1    SS7ANSI  IS-NR      Active  -----
1305 125-022-000 LIME1    CCS7ITU  IS-NR      Active  -----
1309 125-017-000 HIPR2    HIPR2    IS-NR      Active  -----
1310 125-017-000 HIPR2    HIPR2    IS-NR      Active  -----
1311 125-020-000 STC      SLANHC   IS-NR      Active  -----
1313 125-020-000 DCM      VXWSLAN  IS-NR      Active  -----
2101 104-002-000 LIMV35   CCS7ITU  IS-NR      Active  -----
2103 128-018-000 DCM      IPLHC    IS-NR      Active  -----
2107 104-001-000 LIMCH    CCS7ITU  IS-NR      Active  -----
2108 128-018-000 DCM      SLANHC   IS-NR      Active  -----
2109 128-022-000 HIPR2    HIPR2    IS-NR      Active  -----
2110 128-022-000 HIPR2    HIPR2    IS-NR      Active  -----
2111 128-018-000 STC      ERTHC    IS-NR      Active  -----
1213 053-000-058 E5ENET   IPSG     IS-NR      Active  -----
Command Completed.
;

```

- Enter the following command to verify that the **TCP/IP** data link has returned to full service.

```
rept-stat-dlk
```

The following is an example of the possible output.

```

rlghncxa03w 10-01-27 17:00:36 EST  EAGLE 42.0.0
DLK          PST          SST          AST
1104         IS-NR      Active       ----
1206         IS-NR      Active       ALMINH
Command Completed.
;

```

- Procedure is complete.

## Database Services Module (DSM)

### Description

**DSM** (Figure A-10) cards are related to the **TSM/DCM** family, but differ by having an **AMD K-6** processor and from 1 to 4 **GB** of memory on an applique board. The **DSM** card also differs from the **TSM** cards by having ethernet ports. The **DSMs** run a version of the **SCCP** application that has been ported to the VxWorks **OS**. To differentiate the **DSM-VxWorks-SCCP** from the **SCCP** that runs on the **TSM** cards, the **DSM** version has been named **VSCCP**. The extra memory is required to hold a copy of the **RTDB**. Ethernet ports are required to connect to the **EPAP** to download the **RTDB**. Multiple **DSMs** are used to provide a means of load balancing in high-traffic situations. Each **DSM** contains an identical database. Furthermore, the **DSM RTDBs** need to be identical to the one maintained by the **EPAPs**.

#### Note:

If there are provisioning scripts, such as LARG data, the DSM replacement activity should be coordinated with the DB/Admin operations to avoid extended provision otherwise RADB resets may occur.

- Enter the following command to determine which cards are in service.



```
rept-stat-card:loc=xxxx
Where xxxx is the DSM card location.
```

This will indicate which link interface modules (**LIMs**) will be affected by removal of the **DSM** card.

2. Enter the following command to determine the number of **DSM** cards in service providing **GTT**.

```
rept-stat-sccp
```

The following is an example of the possible output.

```
RLGHNCXA03W 98-02-04 15:10:19 EST EAGLE 34.0.0
SCCP SUBSYSTEM REPORT IS-NR      Active      -----
GSM  SUBSYSTEM REPORT IS-NR      Active      -----
INP  SUBSYSTEM REPORT IS-ANR     Restricted  -----
      ASSUMING MATE'S LOAD
      INPQS: SSN STATUS = Allowed   MATE SSN STATUS = Prohibited

SCCP Cards Configured= 4  Cards IS-NR= 2  Capacity Threshold = 100%
CARD  VERSION      PST          SST          AST          MSU USAGE  CPU USAGE
-----
-
1212  103-001-000  IS-NR      Active      ALMINH      45%        30%
1301 P 103-001-000  IS-NR      Active      -----      35%        40%
1305  -----      OOS-MT     Isolated   -----      0%         0%
2112  -----      OOS-MT-DSBLD Manual     -----      0%         0%
-----
-
SCCP Service Average MSU Capacity = 40%      Average CPU Capacity = 35%
AVERAGE CPU USAGE PER SERVICE:
  GTT  = 15%  GFLEX = 5%  GPORT = 10%
  INPMR = 2%  INPQS = 3%
TOTAL SERVICE STATISTICS:
SERVICE  SUCCESS  ERRORS  WARNINGS  FORWARD TO GTT  TOTAL
GTT:      1995    5       -          -              2000
GFLEX:    500    1       4          10             515
GPORT:    800    0       2          3              805
INPMR:    50     5       0          15             70
INPQS:    499    1       -          -              500
Command Completed.
```



**Caution:**

Inhibiting/removing all DSM cards at one time will cause an SCCP nodal outage.

3. Enter the following command to remove the **DSM** card from service.

 **Caution:**

Removing/inhibiting the last IS-NR DSM card will cause an SCCP outage on the affected node. Before removing the last IS-NR DSMP card from service, ensure the mated STP DSM cards are IS-NR and capable of supporting the rerouted SCCP traffic.

```
rmv-card:loc=xxxx
```

Where *xxxx* is the **DSM** card location.

If this is the last **DSM** card in service, the:**force=yes** parameter must be specified.

4. Remove the **DSM** card, per the card replacement procedure described in the section titled [Replacing a Card in the EAGLE](#).

Place the new **DSM** card into its place. Be sure the revision numbers are compatible (if in doubt, [My Oracle Support \(MOS\)](#)).

5. Enter the following command to return the **DSM** card into service.

```
alw-card:loc=xxxx
```

Where *xxxx* is the **DSM** card location.

This causes the **MASP** to begin downloading tables to the new **DSM** card. When the card has been successfully loaded (there will be a response on the terminal that downloading is complete). This can take up to 4 hours.

6. Enter the following command to verify the card is operational and providing **SCCP** services.

```
rept-stat-sccp
```

The following is an example of the possible output.

```
RLGHNCXA03W 98-02-04 15:10:19 EST EAGLE 34.0.0
SCCP SUBSYSTEM REPORT IS-NR      Active      -----
GSM  SUBSYSTEM REPORT IS-NR      Active      -----
INP  SUBSYSTEM REPORT IS-ANR     Restricted  -----
      ASSUMING MATE'S LOAD
      INPQS: SSN STATUS = Allowed   MATE SSN STATUS = Prohibited

SCCP Cards Configured= 4  Cards IS-NR= 2  Capacity Threshold = 100%
CARD  VERSION      PST      SST      AST      MSU USAGE  CPU USAGE
-----
-
1212  103-001-000  IS-NR      Active      ALMINH      45%      30%
1301 P 103-001-000  IS-NR      Active      -----      35%      40%
1305  -----      OOS-MT     Isolated   -----      0%      0%
2112  -----      OOS-MT-DSBLD Manual     -----      0%      0%
-----
-
SCCP Service Average MSU Capacity = 40%      Average CPU Capacity = 35%
AVERAGE CPU USAGE PER SERVICE:
  GTT  = 15%  GFLEX = 5%  GPORT = 10%
  INPMR = 2%  INPQS = 3%
TOTAL SERVICE STATISTICS:
SERVICE  SUCCESS  ERRORS  WARNINGS  FORWARD TO GTT  TOTAL
GTT:      1995      5      -      -      2000
```

```

GFLEX:      500      1      4      10      515
GPORT:      800      0      2      3      805
INPMR:       50      5      0      15      70
INPQS:      499      1      -      -      500
Command Completed.

```

## E5-SM8G-B Card Replacement

The term E5-SM4G refers to either the E5-SM8G-B (P/N 870-2990-01).

The E5-SM8G-B card is a database service module (DSM) designed to operate in the EAGLE shelf. The E5-SM8G-B is a replacement for the DSM card (P/N 870-1984-xx) and the E5-SM4G card. Ethernet ports connect to the EPAP to download the RTDB. Multiple cards are used to provide a means of load balancing in high-traffic situations. Each card contains an identical database. Furthermore, the E5-SM4G RTDBs need to be identical to the one maintained by the EPAPs.

### Note:

See the "Conversion of SM8G-B Cards" section in *Database Administration - System Management* for 32-bit to 64-bit conversion and vice versa.

### Note:

If there are provisioning scripts, such as LARG data, the E5-SM4G replacement activity should be coordinated with the DB/Admin operations to avoid extended provision otherwise RADB resets may occur.

1. Enter the following command to determine which cards are in service. This will indicate which link interface modules (LIMs) will be affected by removal of the E5-SM4G card.

```
rept-stat-card:loc=xxxx
```

Where xxxx is the E5-SM4G card location.

2. Enter the following command to determine the number of E5-SM4G cards in service providing GTT.

```
rept-stat-sccp
```

The following is an example of the possible output.

```

RLGHNCXA03W 98-02-04 15:10:19 EST EAGLE 34.0.0
SCCP SUBSYSTEM REPORT IS-NR      Active      -----
GSM  SUBSYSTEM REPORT IS-NR      Active      -----
INP  SUBSYSTEM REPORT IS-ANR     Restricted  -----
      ASSUMING MATE'S LOAD
      INPQS: SSN STATUS = Allowed   MATE SSN STATUS = Prohibited

SCCP Cards Configured= 4  Cards IS-NR= 2  Capacity Threshold = 100%
CARD  VERSION      PST      SST      AST      MSU USAGE  CPU USAGE
-----
-
1212  103-001-000  IS-NR      Active      ALMINH      45%      30%
1301 P 103-001-000  IS-NR      Active      -----      35%      40%

```

```
1305 ----- OOS-MT      Isolated    -----      0%      0%
2112 ----- OOS-MT-DSBLD Manual    -----      0%      0%
```

```
-----
-
SCCP Service Average MSU Capacity = 40%      Average CPU Capacity = 35%
```

```
AVERAGE CPU USAGE PER SERVICE:
GTT   = 15%  GFLEX = 5%  GPORT = 10%
INPMR = 2%  INPQS = 3%
```

```
TOTAL SERVICE STATISTICS:
SERVICE    SUCCESS    ERRORS    WARNINGS    FORWARD TO GTT    TOTAL
GTT:        1995        5         -           -                 2000
GFLEX:       500         1         4           10                515
GPORT:       800         0         2           3                 805
INPMR:       50          5         0           15                70
INPQS:       499         1         -           -                 500
```

Command Completed.

 **Caution:**

Inhibiting/removing all E5-SM4G cards at one time will cause an SCCP nodal outage.

3. Enter the following command to remove the E5-SM4G card from service. If this is the last E5-SM4G card in service, the `:force=yes` parameter must be specified.

 **Caution:**

Removing/inhibiting the last IS-NR E5-SM4G card will cause an SCCP outage on the affected node. Before removing the last IS-NR E5-SM4G card from service, ensure the mated STP E5-SM4G cards are IS-NR and capable of supporting the rerouted SCCP traffic.

```
rmv-card:loc=xxxx
```

Where `xxxx` is the E5-SM4G card location.

4. Remove the E5-SM4G card, per the card replacement procedure described in [Replacing a Card in the EAGLE](#). Place the new E5-SM8G-B card into its place. Be sure the revision numbers are compatible (if in doubt, contact the [My Oracle Support \(MOS\)](#)).
5. Enter the following command Use the `alw-card` command to return the E5-SM4G card into service. This causes the MASP to begin downloading tables to the new E5-SM8G-B card.

```
alw-card:loc=xxxx
```

Where `xxxx` is the E5-SM8G-B card location.

This causes the MASP to begin downloading tables to the new E5-SM8G-B card. When the card has been successfully loaded (there will be a response on the terminal that downloading is complete). This can take up to 4 hours.

6. Enter the following command to verify the card is operational and providing SCCP services.

```
rept-stat-sccp
```

The following is an example of the possible output.

```

RLGHNCXA03W 98-02-04 15:10:19 EST EAGLE 34.0.0
SCCP SUBSYSTEM REPORT IS-NR      Active      -----
GSM  SUBSYSTEM REPORT IS-NR      Active      -----
INP  SUBSYSTEM REPORT IS-ANR     Restricted  -----
      ASSUMING MATE'S LOAD
      INPQS: SSN STATUS = Allowed   MATE SSN STATUS = Prohibited

SCCP Cards Configured= 4  Cards IS-NR= 2  Capacity Threshold = 100%
CARD  VERSION      PST          SST          AST          MSU USAGE  CPU USAGE
-----
-
1212  103-001-000  IS-NR      Active      ALMINH      45%        30%
1301 P 103-001-000  IS-NR      Active      -----      35%        40%
1305  -----      OOS-MT     Isolated    -----      0%         0%
2112  -----      OOS-MT-DSBLD Manual    -----      0%         0%
-----
-
SCCP Service Average MSU Capacity = 40%      Average CPU Capacity = 35%

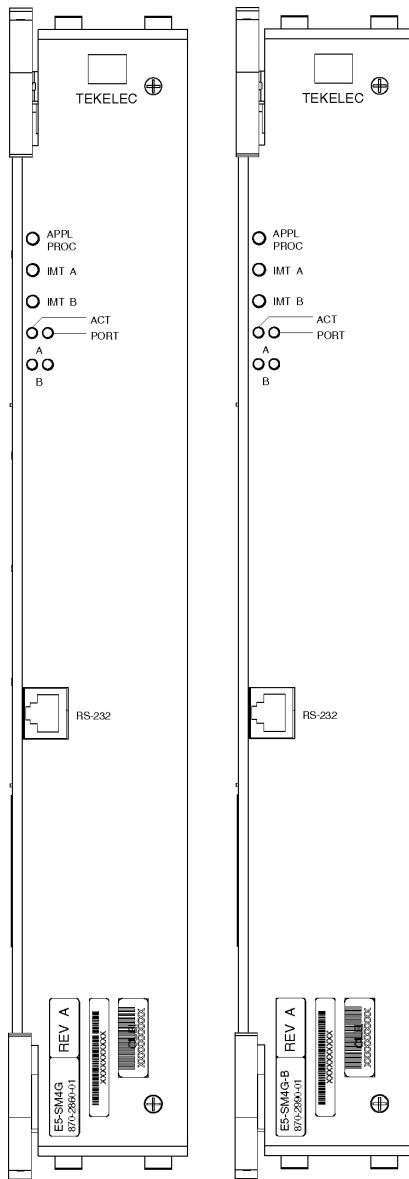
AVERAGE CPU USAGE PER SERVICE:
GTT   = 15%  GFLEX = 5%  GPORT = 10%
INPMR = 2%  INPQS = 3%

TOTAL SERVICE STATISTICS:
SERVICE  SUCCESS  ERRORS  WARNINGS  FORWARD TO GTT  TOTAL
GTT:      1995    5       -          -              2000
GFLEX:    500     1       4          10             515
GPORT:    800     0       2          3              805
INPMR:    50      5       0          15             70
INPQS:    499     1       -          -              500

Command Completed.

```

Figure A-9 E5-SM8G-B LEDs



Front Faceplate LED Indicators

LED	Status	Description
APPL PROC	Off	No power
	Red	Card is booting
	Amber	Card is loading
	Green	Card is up and application is running
IMT A	Red	Not connected to bus
	Amber	Testing not complete
	Green	Active and connected to the bus
IMT B	Red	Not connected to bus
	Amber	Testing not complete
	Green	Active and connected to the bus
ACT	Off	Card non-functional
	Red	No signal detected
	Green	Signal detected
PORT	Off	Card non-functional
	Amber	Data link active operating at 1 Gbps
	Green	Data link active operating at 10/100 Mbps

## E5-ENET-B Card Replacement

This procedure is for the replacement of E5-ENET-B (P/N 870-2971-xx) cards running IPS. The E5-ENET-B can be exchanged with IPSM cards running IPS, without any changes in provisioning information.

When command ENT-CARD is issued for IPSHC, the APPL parameter would be specified as IPS and TYPE would be specified as IPSM. The determination of actual **GPL** that needs to be loaded on the card is made by **OAM** based on the hardware board identification provided by the card itself.

1. Enter the following command to retrieve the terminal types and port numbers:

```
rtrv-trm
```

The following is an example of the possible display of the terminal settings with the IP User Interface feature enabled and three IPSM cards equipped.

```
rlghncxa03w 03-11-01 16:02:08 EST EAGLE 31.3.0
TRM  TYPE      COMM      FC      TMOUT  MXINV  DURAL
1    VT320     9600 -7-E-1 SW    0      5      00:01:00
2    VT320     9600 -7-E-1 SW    0      5      00:01:00
3    VT320     9600 -7-E-1 SW    0      5      00:01:00
4    KSR       9600 -7-E-1 SW    0      5      00:01:00
5    NONE      9600 -7-E-1 SW   30     5      00:01:00
6    NONE      9600 -7-E-1 SW   30     5      00:01:00
7    NONE      9600 -7-E-1 SW   30     5      00:01:00
8    NONE      9600 -7-E-1 SW   30     5      00:01:00
9    VT320     9600 -7-E-1 SW    0      5      00:01:00
10   VT320     9600 -7-E-1 SW    0      5      00:01:00
11   VT320     9600 -7-E-1 SW    0      5      00:01:00
12   KSR       9600 -7-E-1 SW    0      5      00:01:00
13   NONE      9600 -7-E-1 SW   30     5      00:01:00
14   NONE      9600 -7-E-1 SW   30     5      00:01:00
15   NONE      9600 -7-E-1 SW   30     5      00:01:00
16   NONE      9600 -7-E-1 SW   30     5      00:01:00
```

```
TRM  TYPE      LOC      TMOUT  MXINV  DURAL
17   TELNET    1201     60     5      00:30:00
18   TELNET    1201     60     5      00:30:00
19   TELNET    1201     60     5      00:30:00
20   TELNET    1201     60     5      00:30:00
21   TELNET    1201     60     5      00:30:00
22   TELNET    1201     60     5      00:30:00
23   TELNET    1201     60     5      00:30:00
24   TELNET    1201     60     5      00:30:00
25   TELNET    1203     60     5      00:30:00
26   TELNET    1203     60     5      00:30:00
27   TELNET    1203     60     5      00:30:00
28   TELNET    1203     60     5      00:30:00
29   TELNET    1203     60     5      00:30:00
30   TELNET    1203     60     5      00:30:00
31   TELNET    1203     60     5      00:30:00
32   TELNET    1203     60     5      00:30:00
33   TELNET    1208     60     5      00:30:00
34   TELNET    1208     60     5      00:30:00
35   TELNET    1208     60     5      00:30:00
36   TELNET    1208     60     5      00:30:00
37   TELNET    1208     60     5      00:30:00
38   TELNET    1208     60     5      00:30:00
39   TELNET    1208     60     5      00:30:00
40   TELNET    1208     60     5      00:30:00
```

;

```

                                LNP LNP
TRM  TRAF LINK SA  SYS PU  DB  DB  SUB  UIMRD
1    YES YES  YES YES YES YES YES YES YES
2    YES YES  YES YES YES YES YES YES YES
3    YES YES  YES YES YES YES YES YES YES
4    YES YES  YES YES NO  YES YES YES YES
5    YES YES  YES YES YES YES YES YES YES
6    NO  YES  YES YES YES YES YES YES YES
7    NO  YES  YES YES YES YES YES YES YES
8    YES YES  YES YES YES YES YES YES YES
9    YES YES  YES YES YES YES YES YES YES
10   NO  NO   NO  NO  NO  NO  NO  NO  NO
11   NO  NO   NO  NO  NO  NO  NO  NO  NO
```

12	NO	NO	NO	NO	NO	NO	NO	NO	NO
13	NO	NO	NO	NO	NO	NO	NO	NO	NO
14	NO	NO	NO	NO	NO	NO	NO	NO	NO
15	NO	NO	NO	NO	NO	NO	NO	NO	NO
16	NO	NO	NO	NO	NO	NO	NO	NO	NO
17	NO	NO	NO	NO	NO	NO	NO	NO	NO
18	NO	NO	NO	NO	NO	NO	NO	NO	NO
19	NO	NO	NO	NO	NO	NO	NO	NO	NO
20	NO	NO	NO	NO	NO	NO	NO	NO	NO
21	NO	NO	NO	NO	NO	NO	NO	NO	NO
22	NO	NO	NO	NO	NO	NO	NO	NO	NO
23	NO	NO	NO	NO	NO	NO	NO	NO	NO
24	NO	NO	NO	NO	NO	NO	NO	NO	NO
25	NO	NO	NO	NO	NO	NO	NO	NO	NO
26	NO	NO	NO	NO	NO	NO	NO	NO	NO
27	NO	NO	NO	NO	NO	NO	NO	NO	NO
28	NO	NO	NO	NO	NO	NO	NO	NO	NO
29	NO	NO	NO	NO	NO	NO	NO	NO	NO
30	NO	NO	NO	NO	NO	NO	NO	NO	NO
31	NO	NO	NO	NO	NO	NO	NO	NO	NO
32	NO	NO	NO	NO	NO	NO	NO	NO	NO
33	NO	NO	NO	NO	NO	NO	NO	NO	NO
34	NO	NO	NO	NO	NO	NO	NO	NO	NO
35	NO	NO	NO	NO	NO	NO	NO	NO	NO
36	NO	NO	NO	NO	NO	NO	NO	NO	NO
37	NO	NO	NO	NO	NO	NO	NO	NO	NO
38	NO	NO	NO	NO	NO	NO	NO	NO	NO
39	NO	NO	NO	NO	NO	NO	NO	NO	NO
40	NO	NO	NO	NO	NO	NO	NO	NO	NO

APP APP

TRM	SERV	SS	CARD	CLK	DBG	GTT	GWS	MEAS	MON	MPS	SEAS	SLAN
1	YES	YES	YES	YES	YES	YES	YES	YES	YES	YES	NO	NO
2	YES	YES	YES	YES	YES	YES	YES	YES	YES	YES	NO	NO
3	YES	YES	YES	YES	YES	YES	YES	YES	YES	YES	NO	NO
4	YES	YES	YES	YES	YES	NO	YES	YES	YES	YES	NO	NO
5	YES	YES	YES	YES	YES	YES	YES	YES	YES	YES	NO	NO
6	YES	YES	YES	YES	YES	YES	YES	YES	YES	YES	NO	NO
7	NO	YES	YES	YES	YES	YES	YES	YES	YES	YES	NO	NO
8	YES	YES	YES	YES	YES	YES	YES	YES	YES	YES	YES	YES
9	YES	YES	YES	YES	YES	YES	YES	YES	YES	YES	YES	YES
10	NO	NO	NO	NO	NO	NO	NO	NO	NO	NO	NO	NO
11	NO	NO	NO	NO	NO	NO	NO	NO	NO	NO	NO	NO
12	NO	NO	NO	NO	NO	NO	NO	NO	NO	NO	NO	NO
13	NO	NO	NO	NO	NO	NO	NO	NO	NO	NO	NO	NO
14	NO	NO	NO	NO	NO	NO	NO	NO	NO	NO	NO	NO
15	NO	NO	NO	NO	NO	NO	NO	NO	NO	NO	NO	NO
16	NO	NO	NO	NO	NO	NO	NO	NO	NO	NO	NO	NO
17	NO	NO	NO	NO	NO	NO	NO	NO	NO	NO	NO	NO
18	NO	NO	NO	NO	NO	NO	NO	NO	NO	NO	NO	NO
19	NO	NO	NO	NO	NO	NO	NO	NO	NO	NO	NO	NO
20	NO	NO	NO	NO	NO	NO	NO	NO	NO	NO	NO	NO
21	NO	NO	NO	NO	NO	NO	NO	NO	NO	NO	NO	NO
22	NO	NO	NO	NO	NO	NO	NO	NO	NO	NO	NO	NO
23	NO	NO	NO	NO	NO	NO	NO	NO	NO	NO	NO	NO
24	NO	NO	NO	NO	NO	NO	NO	NO	NO	NO	NO	NO
25	NO	NO	NO	NO	NO	NO	NO	NO	NO	NO	NO	NO
26	NO	NO	NO	NO	NO	NO	NO	NO	NO	NO	NO	NO
27	NO	NO	NO	NO	NO	NO	NO	NO	NO	NO	NO	NO
28	NO	NO	NO	NO	NO	NO	NO	NO	NO	NO	NO	NO
29	NO	NO	NO	NO	NO	NO	NO	NO	NO	NO	NO	NO



```

30 NO NO NO NO NO NO NO NO NO NO NO NO NO
31 NO NO NO NO NO NO NO NO NO NO NO NO NO
32 NO NO NO NO NO NO NO NO NO NO NO NO NO
33 NO NO NO NO NO NO NO NO NO NO NO NO NO
34 NO NO NO NO NO NO NO NO NO NO NO NO NO
35 NO NO NO NO NO NO NO NO NO NO NO NO NO
36 NO NO NO NO NO NO NO NO NO NO NO NO NO
37 NO NO NO NO NO NO NO NO NO NO NO NO NO
38 NO NO NO NO NO NO NO NO NO NO NO NO NO
39 NO NO NO NO NO NO NO NO NO NO NO NO NO
40 NO NO NO NO NO NO NO NO NO NO NO NO NO

```

;

2. Enter the following command to change the state of the appropriate card to the out of service - maintenance disabled state:

```
inh-card:loc=xxxx:force=yes
```

where *xxxx* is the card location stenciled on the shelf of the EAGLE. Following is an example of the output:

```

RLGHNCXA03W 00-06-05 11:11:28 EDT EAGLE 34.0.0
Card has been inhibited.

```

3. Remove and replace the card as described in the section titled, [Replacing a Card in the EAGLE](#).
4. Enter the following command to load and activate the approved **GPL** onto the inhibited card:

```
flash-card:code=appr:loc=xxxx:force=yes
```

where *xxxx* is the card location used in the previous step. The optional *force=yes* is used to force the command to work on an IS-NR card. Links provisioned on the card are inhibited during command execution. The card and inhibited links are restored to their previous state when the command is completed

Following is an example of the possible output using card location 1112:

```
Command Accepted - Processing
```

```

tekelecstp 18-01-18 16:06:22 MST EAGLE 46.5.1.5.0-73.3.0
flash-card:code=appr:force=yes:loc=1112
Command entered at terminal #1.

```

;

```

tekelecstp 18-01-18 16:06:55 MST EAGLE 46.5.1.5.0-73.3.0
Flash Card: FLASH GPL required to be downloaded on card 1112
BLMCAP      : Running version 143-001-000 Expected version 143-002-000

```

;

```

tekelecstp 18-01-18 16:07:14 MST EAGLE 46.5.1.5.0-73.3.0
Flash Card: Downloading BLMCAP on card 1112
Flash Card: Card(s) will reset after the flash GPL download.

```

;

```

tekelecstp 18-01-18 16:07:56 MST EAGLE 46.5.1.5.0-73.3.0
Flash Card: Activating BLMCAP on card 1112

```

;

```

tekelecstp 18-01-18 16:08:25 MST EAGLE 46.5.1.5.0-73.3.0
Flash Card: Card 1112 flash activation complete.

```

```

;
Flash Card: Activating links on card 1112.
;
tekelecstp 18-01-11 16:09:11 EST EAGLE5 39.0.0
Command Completed.
;

```

5. After the card has been reloaded (a message appears to confirm completion of the load), enter the following command to verify the database is consistent (same level as the other cards in the system).

```
rept-stat-card
```

The following is an example of the possible output.

```

tekelecstp 07-02-25 10:02:42 EST EAGLE 37.0.0
CARD  VERSION      TYPE      GPL      PST      SST      AST
1201  128-013-026  IPSM      IPS      IS-NR    Active   -----
ALARM STATUS      = No Alarms.
BPDCM GPL version = 128-013-012
IMT BUS A         = Conn
IMT BUS B         = Conn

Command Completed.

```

## Replacing Cards with SLIC Hardware

The SLIC card supports multiple applications. The `chg-card` command parameters differ depending on the hardware being replaced. See the "EAGLE Card Applications and GPLs" table in *Database Administration - System Management* for details on the flash and application GPLs that are run/required based on different card configurations.

1. Refer to specific card replacement procedures ("SS7 and IP7, HC-MIM Card Replacement," "E5-ENET-B Card Replacement," "E5-SM8G-B Card Replacement") to complete the replacement steps.
2. Enter the following command when the card replacement procedure states the old card is to be removed and the new card is to be inserted into the system (for the applications that support `type=slic`, as shown in the "EAGLE Card Applications and GPLs" table):

```
chg-card:type=slic:loc=xxxx
where xxxx is the card location.
```

## Database Communications Module (DCM)

The database communication module (**DCM**) (Figure A-10) provides access to a remote host for use by the **STP LAN** feature. The **DCM** consists of a 80486-based main assembly and an ethernet applique. Connection to a host is achieved through an ethernet **LAN** using the **TCP/IP** protocol.

If this card is removed, the **TCP/IP** data link supported by this card becomes out of service. Any data to be transmitted to the remote **TCP/IP** host connected by this **TCP/IP** data link is lost.

The **DCM** can only be inserted in the odd numbered card slots of the shelf. Slot 09 of each shelf contains the **IPMX** card; thus the **DCM** cannot be inserted in slot 09. The **DCM** can be inserted in the control shelf, but only in slots 01, 03, 05, 07, and 11. Slots 13, 15, and 17 refer to the extension shelf only. The **DCM** occupies two card slots, so the even numbered card slot adjacent to the odd numbered slot where the **DCM** has been inserted must be empty as shown

in [Table A-2](#). The **DCM** is connected to the network through the odd numbered card slot connector.

**Table A-2 DCM Card Locations**

Location of the DCM	Empty Card Location	Location of the DCM	Empty Card Location
Slot 01	Slot 02	Slot 11	Slot 12
Slot 03	Slot 04	Slot 13	Slot 14
Slot 05	Slot 06	Slot 15	Slot 16
Slot 07	Slot 08	Slot 17	Slot 18

The Double-Slot Enhanced **Database** Communications Module is a version of the **DCM** that includes more main memory and better processing performance. The double-slot **EDCM** can be placed in any slot odd or even that is provisioned. Physically the next higher slot can not be provisioned for a card because of the double-slot **EDCM** card width.

1. Enter the following command to determine what **TCP/IP** data links are configured:`rept-stat-card`
2. Enter the following command to determine the status of the **TCP/IP** data link assigned to the card to be replaced:`rept-stat-dlk`

The following is an example of the possible output.

```

RLGHNCXA03W 97-09-27 17:00:36 EST EAGLE 34.0.0
DLK    PST    SST    AST
1104   IS-NR  Avail  ----
1206   IS-NR  Avail  ALMINH
Command Completed.

```

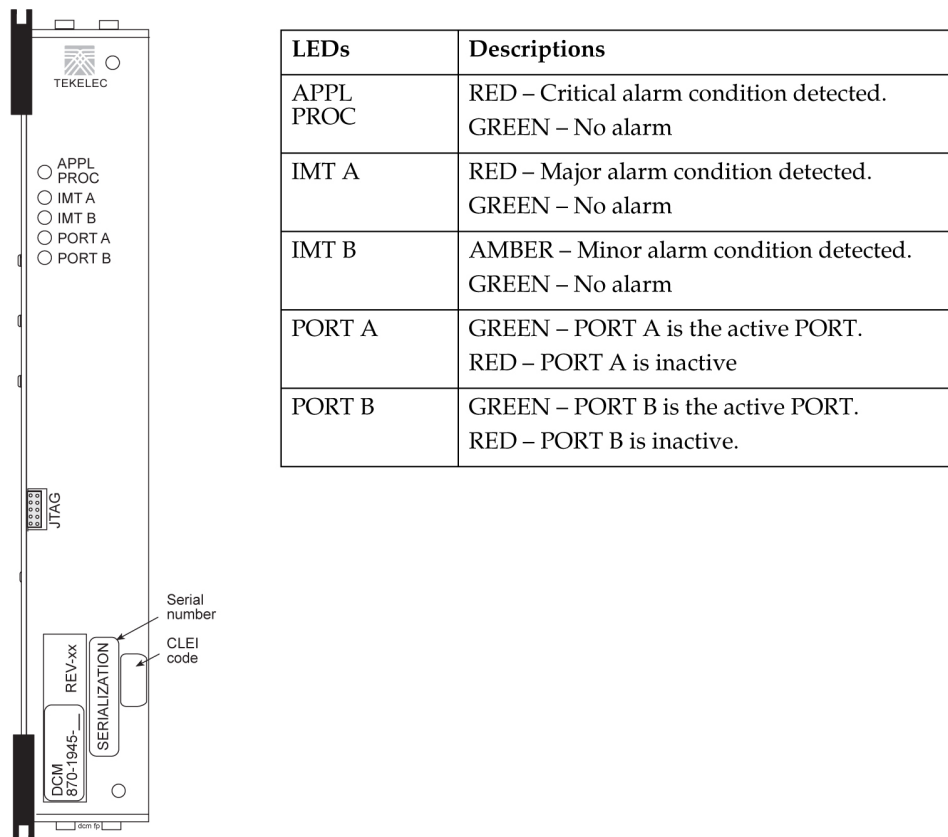
3. If the status of the **TCP/IP** data link is not out of service - maintenance disabled (**OOS-MT-DSBLD**), use the `canc-dlk` command to change the status of the **TCP/IP** data link to **OOS-MT-DSBLD**.`canc-dlk:loc=xxxx`  
Where `xxxx` is the card location.
4. Enter the following command to inhibit the card and disconnect it from the IMT bus.  
If this is the last **DCM** in the system, the `:force=yes` parameter must be used with this command.`rmv-card:loc=xxxx`Where `xxxx` is the card location.
5. Remove the **DCM**, per the card replacement procedure described in the section titled [Replacing a Card in the EAGLE](#).  
Place the new **DCM** into its place. Be sure the revision numbers are compatible (if in doubt, contact the [My Oracle Support \(MOS\)](#)).
6. Enter the following command to put the new **DCM** card back into service and connect it to the IMT bus:`alw-card:loc=xxxx`  
where `xxxx` = card location.
7. Enter the following command to return the **TCP/IP** data link to service:`act-dlk:loc=xxxx`  
where `xxxx` = card location.
8. Enter the following command to verify the status of the card and its associated **TCP/IP** data link:`rept-stat-card`

- Enter the following command to verify that the **TCP/IP** data link has returned to full service: `rept-stat-dlk`

The following is an example of the possible output.

```
RLGHNCXA03W 97-09-27 17:00:36 EST EAGLE 34.0.0
DLK   PST   SST   AST
1104  IS-NR Avail  ----
1206  IS-NR Avail  ALMINH
Command Completed.
```

**Figure A-10 DCM LEDs**



## Measurement Collection and Polling Module (E5-MCPM)

**Note:**

Throughout this document, the term MCPM refers to the **E5-MCPM-B** (P/N 870-3089-xx) card unless specifically noted otherwise.

The primary **MCPM** card performs all measurements collection and reporting functions and provides on-card **RAM** storage for collected data and scheduled reports. The Secondary

**MCPM** provides a redundant backup for the Primary card, and assumes collection and reporting responsibilities on the loss of the Primary. **TCP/IP** connections are used to deliver measurement reports from the Primary **MCPM** card to the customer via an **FTP** client. The **FTP** configuration can be customized to support automatic transfer of scheduled reports from the client to the server.

1. Enter the following command to determine the status of the **MCPM** cards.

```
rept-stat-meas
```

2. Enter the following command to remove the faulty **MCPM** card from service.

If this is the last **MCPM** card in service, the `:force=yes` parameter must be specified:

```
rmv-card:loc=xxxx
```

where `xxxx` is the **MCPM** card location.

3. Remove the **MCPM** card, per the card replacement procedure described in the section titled [Replacing a Card in the EAGLE](#).

Place the new **MCPM** card into its place. Be sure the revision numbers are compatible (if in doubt, [My Oracle Support \(MOS\)](#)).

4. Enter the following command to return the **MCPM** card into service.

```
alw-card:loc=xxxx
```

Where `xxxx` is the **MCPM** card location.

This causes the **MASP** to begin downloading tables to the new **MCPM** card. When the card has been successfully loaded (there will be a response on the terminal that downloading is complete). This can take up to 10 minutes.

 **Note:**

If the card has not loaded in 30 minutes, enter the `init-card` command to reboot the **MCPM** card.

5. Enter the following command to verify the card is operational:

```
rept-stat-meas
```

## Replacing a Card in the EAGLE

This procedure describes the physical removal and replacement of a card in the EAGLE system.

 **Note:**

Before removing or reseating a card, the card must be taken out of service.

Card replacement procedures in this section refer to this procedure. Locate and perform the appropriate replacement procedure for the card in order to properly take the card out of service.

 **warning:**

Failure to follow appropriate removal procedures may result in equipment damage.

 **warning:**

Before performing any maintenance procedures on the EAGLE, make sure you wear a wrist strap connected to the wrist strap grounding point of the EAGLE.

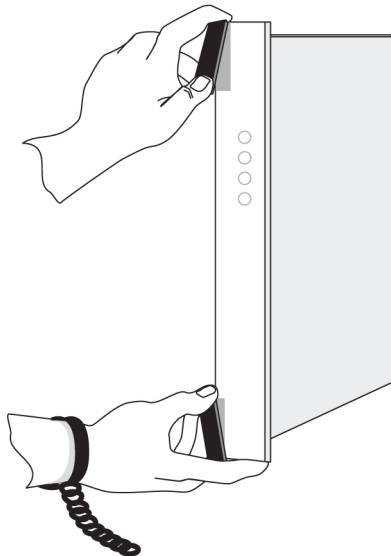
 **warning:**

This procedure may interrupt service. When possible, perform maintenance during low traffic and database provisioning periods, such as the maintenance window.

1. Locate the card to be removed.
2. Use both hands to open injector/ejector module locking tabs out from the faceplate of the card.

Push the inject/eject clamps outward from the card's faceplate (top clamp in the “**UP**” position, bottom clamp in the “**DOWN**” position). Pull the levers away from the shelf until they are parallel to the floor. Gently pull the card towards you until the card clears the shelf.

**Figure A-11 Push Inject/Eject Clamps Outward**



3. Place the card you have removed in an electrostatic discharge (ESD) protective container, or place the card in the spare card storage shelf.
4. Be sure that the replacement card has the same part number and revision number as the card you have just removed (unless this is an upgrade).

5. Open the ejector levers on the replacement card.

Carefully align the card's edges with the top and bottom card guides. Then push the card along the length of the card guides until the rear connectors on the card engage the mating connectors on the target shelf backplane.

6. Press the left edge of the card's faceplate using constant pressure until you feel the card's progress cease.

To ensure proper seating, the tabs must be held in the release position until the locking tabs can engage with the upper and lower flange on the shelf.

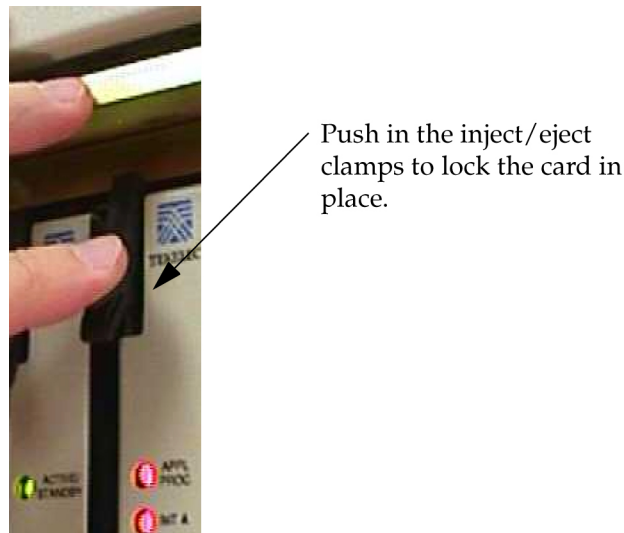
 **Warning:**

Do not impact the faceplate in order to mate the connectors. Any impact to the card's faceplate can damage the faceplate, the pins, or the connectors.

7. Push in the top and bottom inject/eject clamps.

This locks the card in place and ensures a strong connection with the pins on the target shelf backplane.

**Figure A-12 Push in Inject/Eject Clamps**



8. Verify that both IMT bus LEDs are green.
9. Record the activity in the site maintenance log.
10. Return to the appropriate card removal/replacement procedure to return the card to service (such as initializing, flashing, and allowing).

 **Note:**

If any UAMs are generated in the system after the card comes into service, refer to *Maintenance Guide* to find the recommended steps in diagnosing and clearing the UAM.

# Replacing Cards in the Holdover Clock

## Failed Clock Input (CI) Card Replacement

### Description

Use this procedure to replace a failed clock input (CI) card in shelves equipped with ST3 clock cards. The input card FAIL lamp should be lit.

1. If the shelf is equipped with ST3 cards and the input card FAIL lamp is not lit, check the status of the SRCACT/SRCACTIVE lamp.

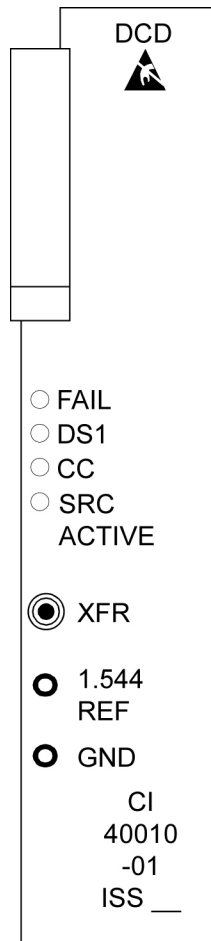
If lit, press the transfer (XFR) button on either input card. If the input card FAIL lamp is lit, go to 2. The SRCACT/SRCACTIVE lamp on the other input card lights and the lamp goes off.

2. Remove the failed card or the card to be removed from the shelf.
3. Set the option switches on the replacement card to the correct settings.

(See *Installation Guide*.) Wait for the input card to acquire the input reference signal (about 40 seconds). Then, press the XFR button to make the new input card active.

### CI, Clock Interface Card, Holdover Clock

Figure A-13 Holdover Clock CI Card LEDs



LEDs	Descriptions
FAIL	RED - this card or its input has failed. The card's output is disabled and a minor alarm is generated. BLANK - no card or input failure detected.
DS1	GREEN - DS1 source is present. BLANK - DS1 source is not present.
CC	GREEN - CC (composite clock) source is present. BLANK - CC source is not present.
SRC ACTIVE	GREEN - the card is on-line providing a DCD reference to ST3 and output cards. BLANK - card is in standby mode.



## Non-Failed Clock Input (CI) Card Replacement

### Description

Use this procedure to replace non-failed clock input (CI) cards which have valid input reference signals.

1. Remove the input reference signal to the shelf associated with the clock input card to be removed.

#### Caution:

Removing a non-failed clock input card with a valid input reference signal from a shelf equipped with **ST3** cards, causes the **DCD** system outputs to run and hit all the network elements timed from the **DCD** system. To properly remove a non-failed clock input card, the input reference must be removed first. This squelches the **CI** card output. This does not apply to failed input cards.

Perform one of the following:

- a. If the reference input has a miscellaneous **SYNC** jack at the **DSX-1**, insert an open plug or the end of a patch card in the **SYNC** jack to squelch the input reference signal. If the input reference has an external bridging repeater, insert an open plug or the end of a patch cord in the **OUT** jack at the bridging repeater to squelch the input reference signal.
- b. If the input reference signal is directly cabled from the source to the **DCD** shelf, either lift the leads of the **TB12** or **TB13** wire-wrap terminals on the backplane of the **DCD** shelf, or short the tip (T) and ring (R) together at **TB12** or **TB13** on the backplane.

#### Caution:

Use a clip cord that is no longer than two inches. A longer clip cord may not appear as a short to the **CI** card and the input reference may continue to drive it.

The **DS1** lamp should be off and the **FAIL** lamp lit on the **CI** card. If this is not true, do not proceed. This indicates the input reference has not been removed.

2. Remove the **CI** card.  
This has no effect on the outputs.
3. Set the option switches on the replacement card to the correct settings.  
(See *Installation Guide*.) The **DS1** lamp should be off and the **FAIL** lamp lit on the **CI** card.
4. Restore the input reference by removing the open plug, clip cord, or reconnecting the leads to **TB12** or **TB13** wire-wrap terminals on the **DCD** shelf backplane.
5. Wait for the input card to acquire the input reference signal (about 40 seconds).  
If you want the new **CI** card to be active, press the **XFR** button.

## ST3 Card Replacement

### Description

Use this procedure to replace **ST3** cards. The only time an **ST3** card should be replaced is if the **FAIL** lamp is lit, or if it is in the **ST A** slot and the **LOCK** or **LOCK** and **FAIL** lamps are not lit and the network elements receiving timing from the shelf are reporting slips. (However, the second condition is more likely a timing loop rather than a bad **ST3** card.)

#### Note:

The **ST3** card in slot B (**ST B**) in shelves equipped with **ST3** clock cards may be removed from the shelf without any negative effect to the output, regardless if the **ST3** has failed. If an **ST3** is installed and not failed in slot A (**ST A**), it is the preferred source for the output cards. If you remove the card from the shelf, it may cause a hit to the outputs.

1. Remove the **ST3** card from the shelf.

If it is in slot A and has not failed, the **ST B** clock card automatically become the preferred source for the outputs. The **TO** cards **ST** and **INPUT** lamps should remain green.

#### Note:

There may be a one-time phase hit to the outputs. If **ST A** has failed, the **ST B** clock card is already the preferred source for the outputs. If **ST B** is being replaced, it is in standby and may be removed without negative effect to the outputs.

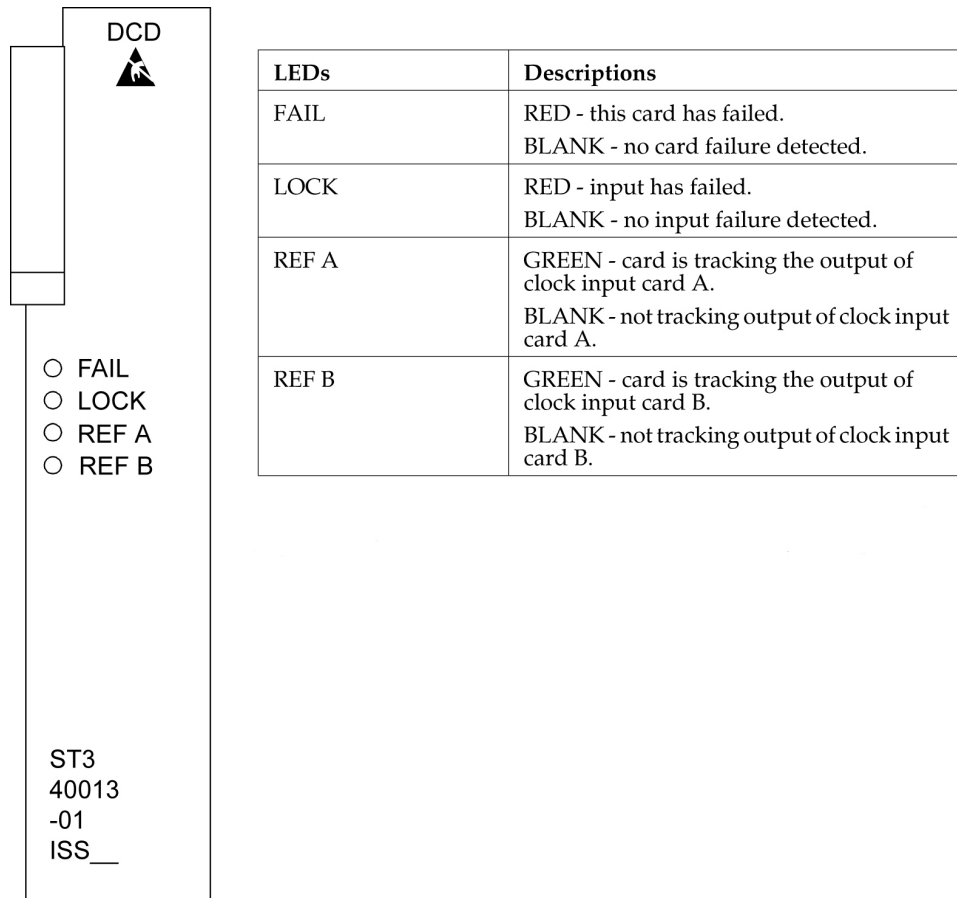
2. Insert the replacement card in the shelf.

Lock it into place by rotating the locking lever downward. The **FAIL** lamp should remain lit until it has acquired the frequency and phase of the input reference signal and then go off (about one minute). If **ST A** is being replaced, it automatically becomes the preferred source for the output when the **FAIL** and **LOCK** lamps go off. The **TO** cards **ST** and **INPUT** lamps should remain lit.

#### Note:

If you are replacing both **ST3** cards, allow five minutes for the first card to stabilize before replacing the other.

Figure A-14 Holdover clock ST3 card LEDs



**Note:**

If the **FAIL** and **LOCK** LEDs are both illuminated, the **ST3** is in holdover mode and the card has not failed.

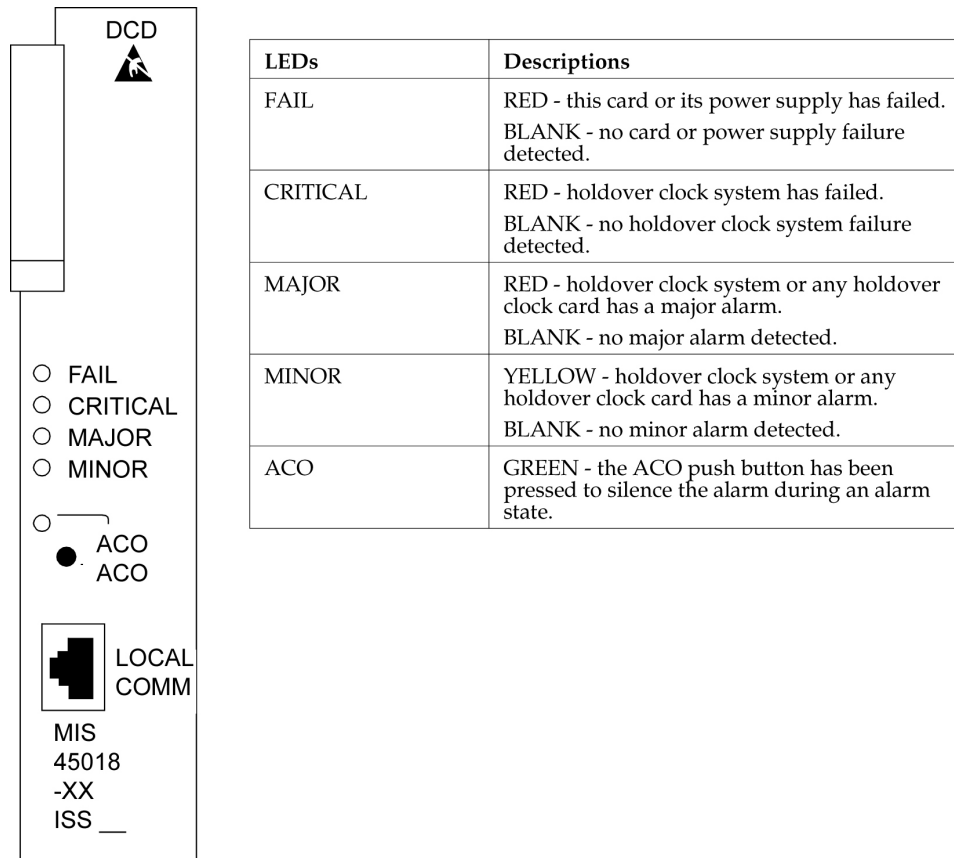
## MIS Card Replacement

### Description

The Maintenance Interface System (**MIS**) card may be removed or inserted into the shelf at any time without a negative effect to the operation of the shelf. The office alarms and shelf status (except for the battery alarm) do not function while the **MIS** card is removed from the shelf.

1. Remove the **MIS** card from the shelf.
2. Insert the replacement card.

Figure A-15 Holdover Clock MIS Card LEDs



## TOCA Card Replacement

When an **MCA-5** is installed in the **MCA** slot, an **HS** protection switch automatically activates when the **TOFAIL** or **PORTALM** lamp is lit. If the **TOPORTALM** lamp is lit, you must determine whether it is actually a card port failure, or a shorted or unterminated cable external to the shelf. If you determine that the **PORTALM** is actually a port failure on the card, replace the **TO** card.

1. Verify that an **HS** protection switch has been activated.  
If an automatic protection switch has been activated, the output protection button lamps are lit over the failed card and **HSTO** card. The **MCA-5 AUTO** lamp flashes for 6 seconds during the automatic protection switch activation, and then lights steadily.
2. If an **HS** protection is not activated, manually activate a switch by simultaneously pressing the output protection buttons over the **TO** card with **FAIL** or **PORTALM** lamp lit and a like **HSTO** card.

The output protection button lamps should light over the failed **TO** card and a like **HSTO** card, and the **MCA-5 MAN** lamp flashes until the switch is released.

 **Caution:**

The **TO** cards must not be removed without first activating an **HS** protection switch to minimize the loss of output signals. The possible output loss times are as follows:

- a. **TO** card removal: up to 6 seconds
- b. Port or card failure: up to 3 seconds
- c. Manual switch activation/deactivation: approximately one ms.

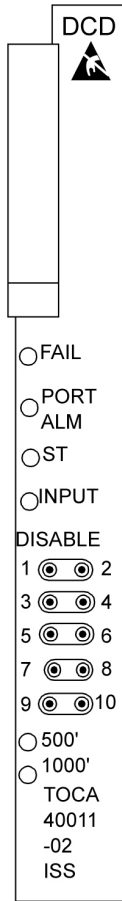
3. Remove the **TO** card from the shelf.

Set the option switches on the replacement card to the correct settings. Insert the replacement card. The **FAIL** lamp on the replacement card should remain off and the **INPUT** lamp should light. The **ST** lamp should also light if the system is equipped with clock cards.

4. Wait 10 seconds after all the lamps normalize to allow the card to warm-up and generate outputs.
5. Press the lit output protection button for the **HSTO** card slot until the lamp goes out.

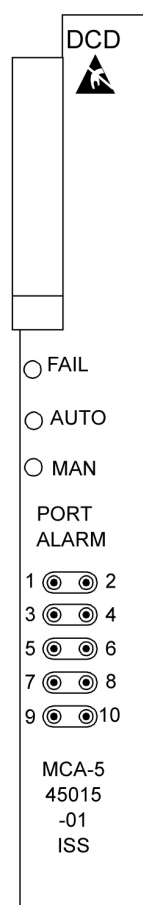
The lamp over the output protection button should go off. This releases the **HS** protection switch and puts the replacement card online.

**Figure A-16 Holdover Clock TOCA Card LEDs**



LEDs	Descriptions
FAIL	RED - this card has failed or there is a loss of all input references to this card. BLANK - no card or input reference failure detected.
PORT ALM	RED - if one to five outputs have failed or have been externally shorted. BLANK - no output failures detected.
ST	GREEN - an active clock is supplying the input reference for this card. BLANK - no active clock detected.
INPUT	GREEN - card is receiving a reference signal from one or more of the following: clock input A, clock input B, clock card A, clock card B. BLANK - card is not receiving a reference signal from any of the above sources.
500'	not used
1000'	not used

Figure A-17 Holdover Clock MCA Card LEDs



LEDs	Descriptions
FAIL	RED - this card has failed or there is a loss of all input references to this card. BLANK - no card or input reference failure detected.
AUTO	GREEN - indicates output failure was protected automatically. BLANK - no failures detected.
MAN	GREEN - indicates output failure was protected manually. BLANK - no failures detected.

## Fan Assembly P/N 890-0001-xx

The Fan Assembly P/N 890-0001-xx is used for cooling shelves in the **EAGLE** frame. The assembly includes 3 fan units and a controller card.

### Caution:

Do not perform procedures to [Replace Fan Assembly](#) if the Fan Assembly is used to cool shelves with **HCMIM** or **HIPR2** cards. contact the [My Oracle Support \(MOS\)](#).

Refer to the following procedures to:

- [Replace the Fan Unit](#)
- [Replace Fan Controller Card](#)
- [Replace Fan Assembly](#)

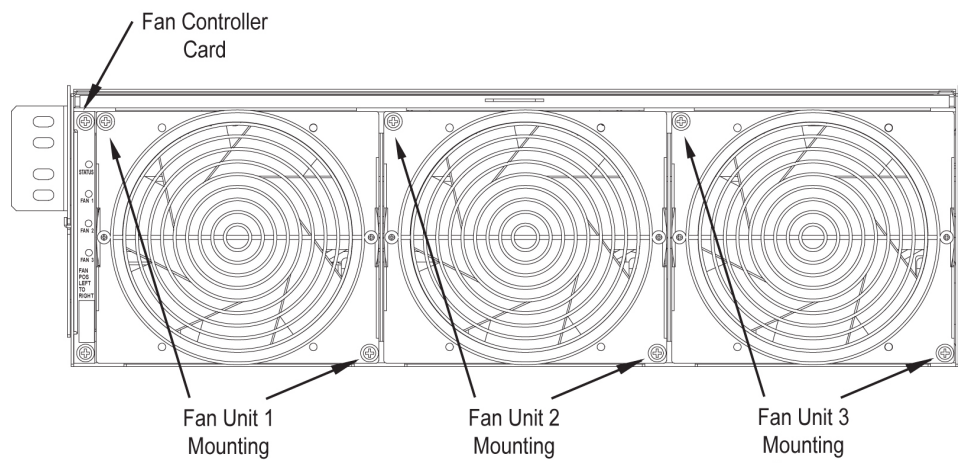
## Replace the Fan Unit

### **Caution:**

Be careful when removing fans. Fan blades are exposed along the sides and back of the units. The fan blade speeds of remaining fans will increase after any fan is removed.

1. Loosen the two captive screws used to secure the fan to be replaced.  
Fan 1 is located next to the Fan controlled card.

**Figure A-18 Fan Unit Mounting Screws**



2. Firmly grasp the fan and pull straight out.  
The corresponding **LED** on the fan controller card is now red.
3. Insert the replacement fan into the appropriate slot and secure the two captive screws.  
The replaced fan should immediately come up to speed and the speeds of other fans should return to normal. The corresponding **LED** on the fan controller card is now green.

## Replace Fan Controller Card

1. Remove Fan 1 by removing the two captive screws used to secure Fan 1 (Refer to [Replace Fan Assembly](#)).

### **Caution:**

Be careful when removing fans. Fan blades are exposed along the sides and back of the units. The fan blade speeds of Fan 2 and FAN 3 will increase after FAN 1 is removed.

Fan 1 is located next to the Fan card. Firmly grasp Fan 1 and pull straight out.



2. Remove the fan controller card by removing the two captive screws used to secure the fan controller card.

Remove Fan Controller **Card** by pulling straight out.

3. Insert the replacement fan controller card into the appropriate slot and secure the two captive screws.
4. Insert Fan 1 back into the space next to the fan controller card and secure (finger tighten) using the two captive screws.

Fan 1 should immediately come up to speed and the speeds of Fans 2 and 3 should return to normal.

## Replace Fan Assembly

### **Caution:**

Do not perform this procedures if the Fan Assembly is used to cool shelves with **HCMIM** or **HIPR2** cards. contact [My Oracle Support \(MOS\)](#).

The following procedures are used to replace Fan Assembly P/N 890-0001-xx when it is used to cool shelves not populated with **HCMIM** or **HIPR2** cards.

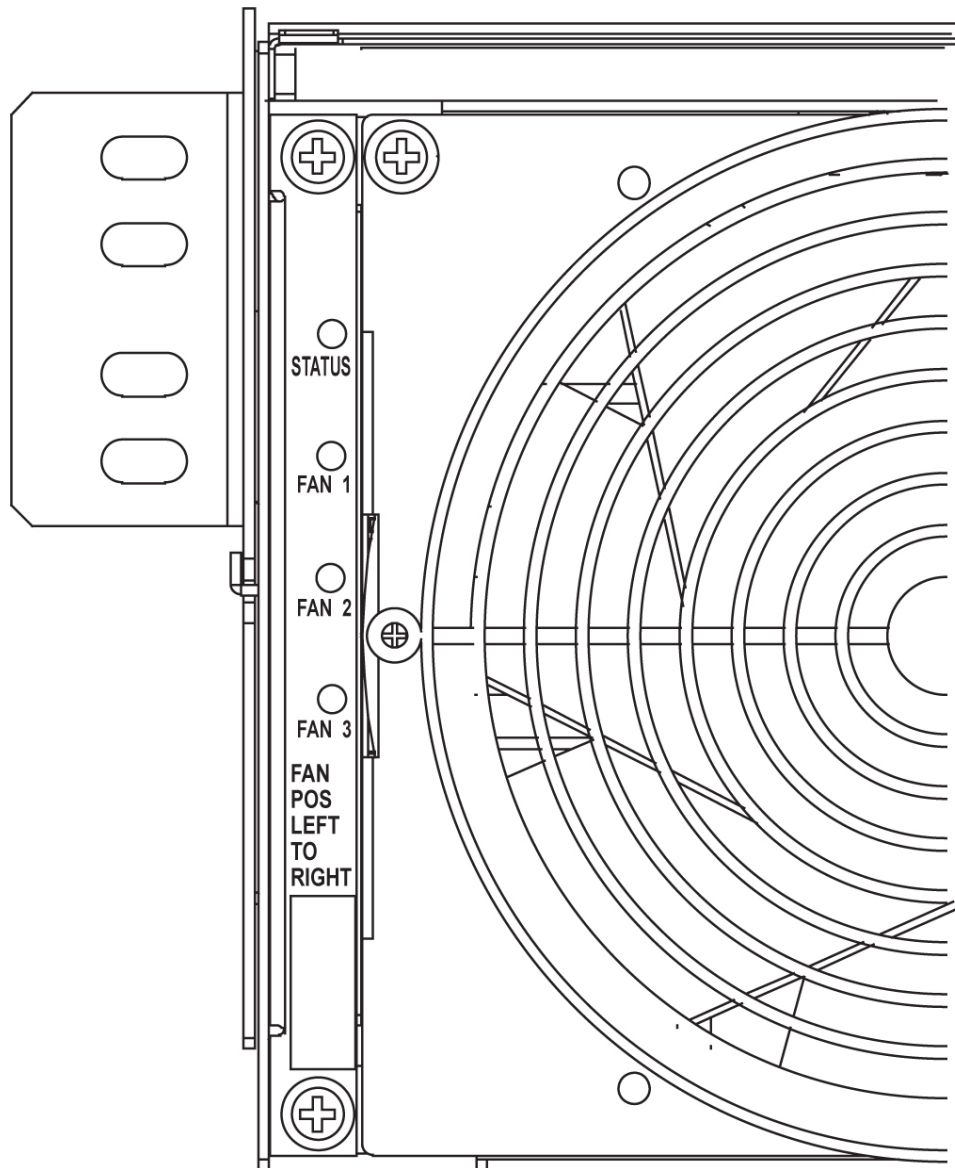
- [Procedure - Power Down the Fan Assembly](#)
- [Procedure - Remove Fan Cables and Fan Assembly](#)
- [Procedure - Install the Fan Assembly](#)
- [Procedure - Power Up the Fan Assembly](#)

## Procedure - Power Down the Fan Assembly

Use the following procedure to power down the fan assembly.

1. The fuse card located on the Fuse and **Alarm** Panel is marked **FAN A** and **FAN B**. Fuse positions 6, 12, and 18 are the correct locations on the **FAP** faceplate. The fans are fused at 3As, with blue flags per feed. Remove the appropriate fuse for the fan assembly being replaced according to the following:
  - Fuse position 6 is for the fan unit directly below the x100 shelf.
  - Fuse position 12 is for the fan directly below the x200 shelf.
  - Fuse position 18 is for the fan directly below the x300 shelf.
2. When both the A side and B side power is removed from the fan unit, all of the **LEDs** on the fan controller card (located on the left side of the front of the fan unit) are no longer illuminated and the all fan motors are off.

Figure A-19 Fan card with LEDs on front of fan assembly unit



## Procedure - Remove Fan Cables and Fan Assembly

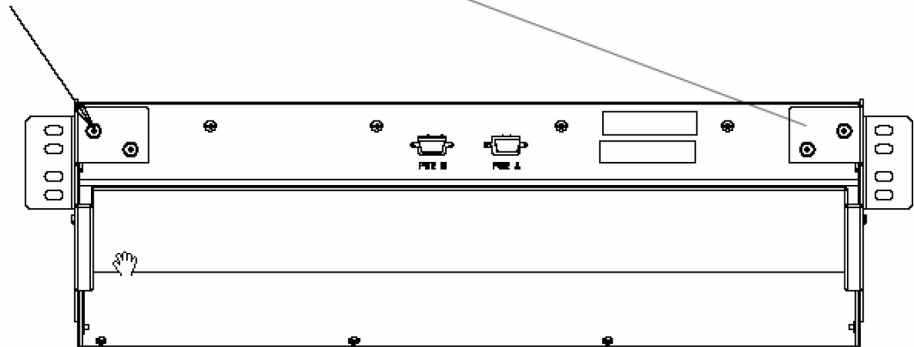
Use the following procedure to remove fan cables and fan assembly.

1. At the fan assembly, place fiber paper on the shelf below where the fan is to be replaced. This ensures that nothing drops into the area or equipment below.
2. From the front of the frame remove the fan filter from the fan assembly.
3. From the rear of the fan unit, loosen the screws on the fan unit connector marked **FAN A POWER**. Remove the connector from the fan unit.
4. From the rear of the fan unit, loosen the screws on the fan unit connector marked **FAN B POWER**. Remove the connector from the fan unit.

5. Remove the screws from the the left and right sides of the rear of the fan tray bracket. There are two screws on each side. These screws must be removed from the rear of the frame.

**Figure A-20 Fan Assembly Rear Bracket Screws.**

Screws to be removed. Note: total of 4, 2 on each side



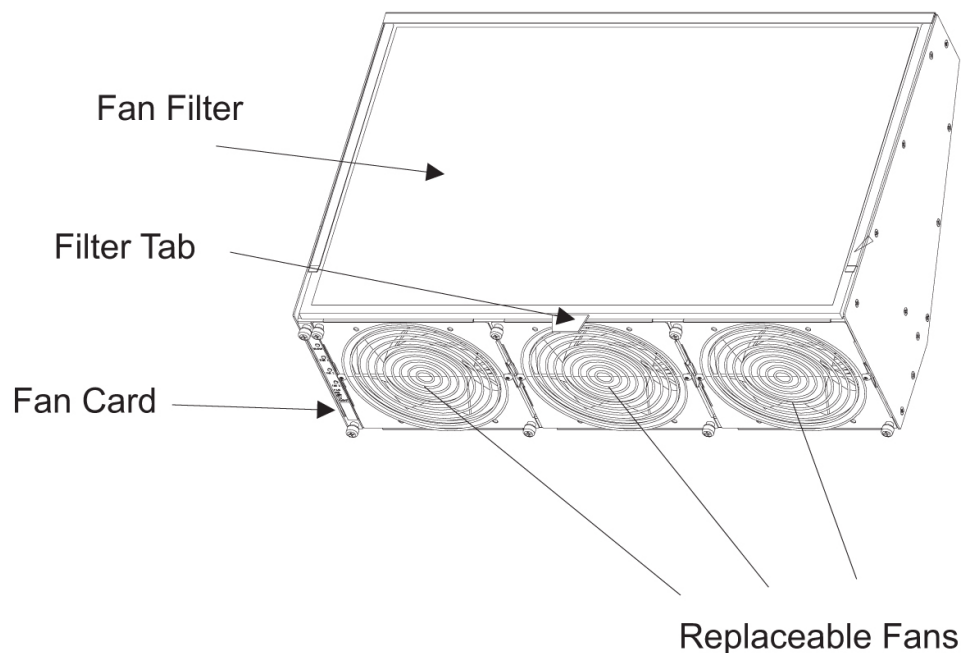
6. With the screws removed, carefully push on the rear of the unit until the fan assembly moves forward about an inch.
7. From the front of the frame remove the fan assembly from the the fan bracket. For easier removal, tilt the unit as it is removed.

## Procedure - Install the Fan Assembly

Use the following procedure to install the fan assembly.

1. Remove the new fan unit from the container. The fan unit is shipped with the three fans already installed.

**Figure A-21 Fan Assembly**



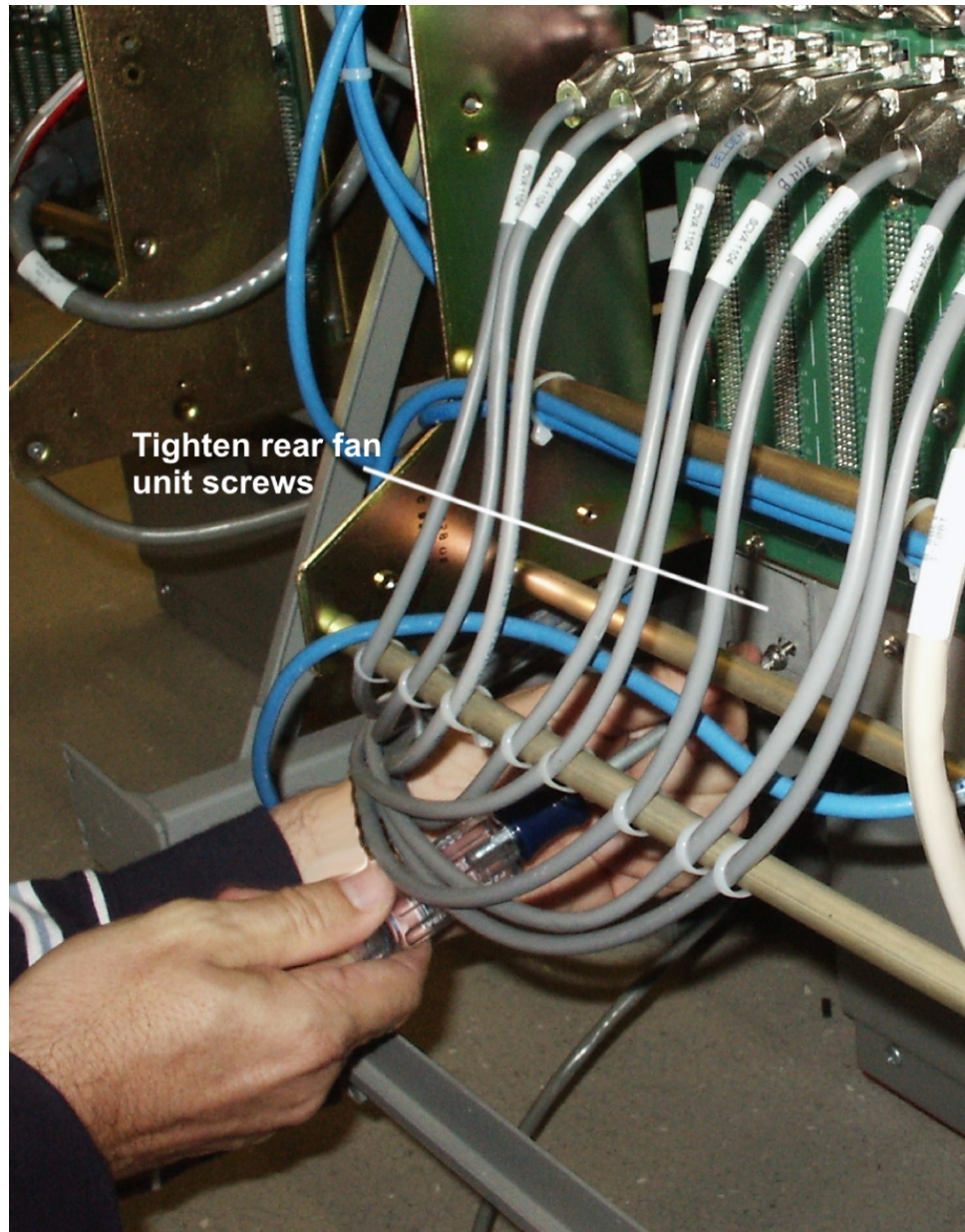
2. Insert the fan unit into the fan bracket. Tilt the unit up as it is pushed in and completely inserted into the bracket. After insertion, be sure the front of the fan unit is recessed about 1/2 inch from the front frame rails to allow the door to close.

**Figure A-22 Fan tray inserted into fan tray bracket in the frame - front view**



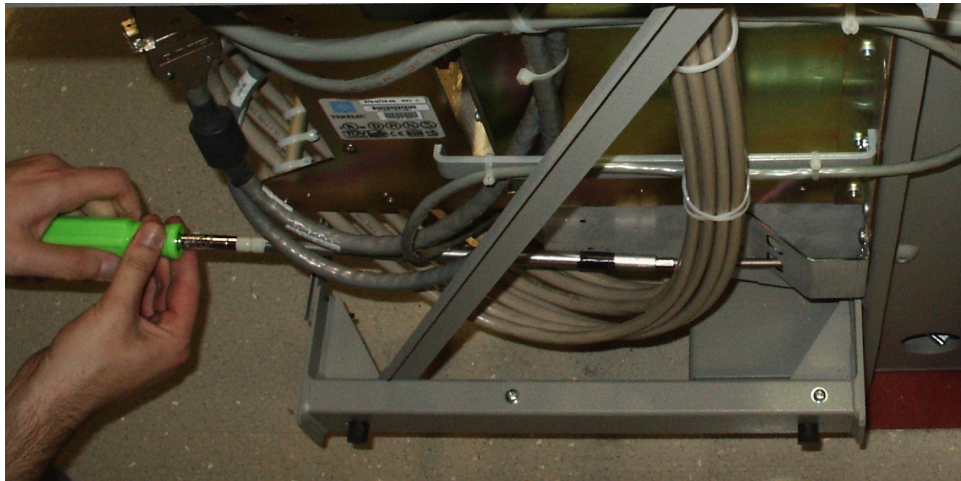
3. When the fan unit is aligned and in place, attach the fan unit to the fan tray bracket by tightening the screws on the left and right sides of the rear of the fan tray bracket. There are two screws on each side. These screws must be tightened from the rear of the frame.

Figure A-23 Tighten rear fan tray screws



4. From the front of the frame install the fan filter into the fan assembly.
5. At this time check and tighten all screws, including the screws holding the side brackets to the frame (if necessary). The side bracket screws should be tightened fully from the rear of the frame. Use a long hex driver or flat head screw driver.

Figure A-24 Tighten fan side bracket screws



6. Connect the fan cable at the rear of the fan assembly on the J9 connector to the **FAN A POWER**.
7. Connect the fan cable at the rear of the fan assembly on the J8 connector to the **FAN B POWER**.
8. Remove the piece of fiber paper on the top of the shelf below where the fan assembly was installed. This procedure is complete.

 **Caution:**

Before powering up the fans, ensure that the shelf directly above the fan does not contain any empty slots. Install an air management card in any empty slots to ensure proper air flow. These filler cards have no electrical connection to the system. See [Replacing a Card in the EAGLE](#) for general card installation guidelines.

## Procedure - Power Up the Fan Assembly

Use the following procedure to power up the fan assembly.

All fans are fused at 3A (blue) per feed.

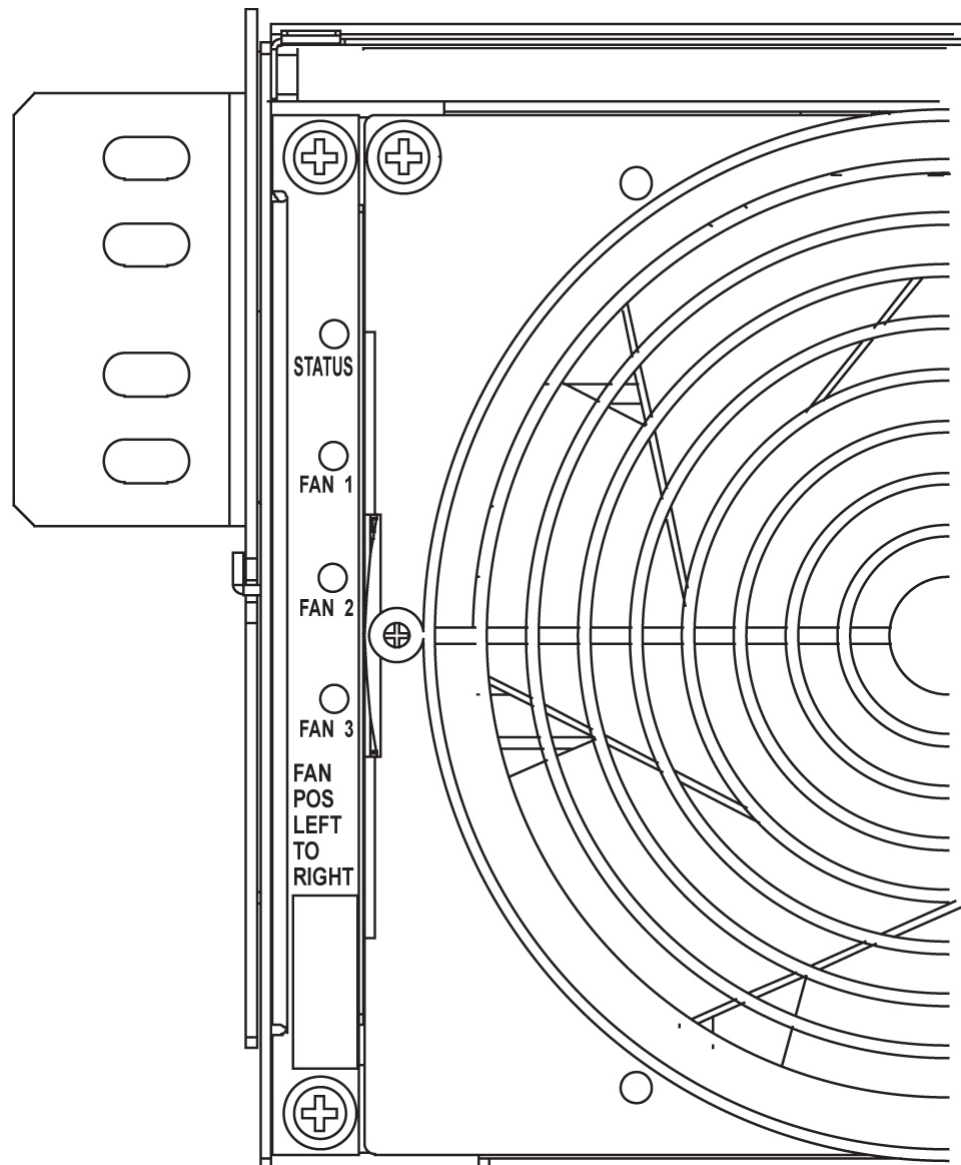
 **Caution:**

Before powering up the fans, ensure that the shelf directly above the fan does not contain any empty slots. Install an air management card in any empty slots to ensure proper air flow. These filler cards have no electrical connection to the system. See [Replacing a Card in the EAGLE](#) for general card installation guidelines.

1. After the fan is installed, the powering up process depends on the shelf location.
  - a. The fuse cards located on the Fuse and **Alarm** Panel are marked **FAN A** and **FAN B**, fuse positions 6, 12, and 18 are marked correct locations on the **FAP** faceplate.
  - b. Fuse position 6 is for the fan unit directly below the x100 shelf.

- c. Fuse position 12 is for the fan directly below the x200 shelf.
  - d. Fuse position 18 is for the fan directly below the x300 shelf.
  - e. All fans are to be fused at 3As, with blue flags, per feed.
  - f. Fill out the fuse card completely.
  - g. Ensure the FAP fuse location for the fan is properly labeled.
2. Fifteen seconds after both the A side and B side power is connected to the fan assembly all of the **LEDs** on the fan controller card (located on the left side of the front of the fan assembly) are green.

**Figure A-25 Fan card with LEDs on front of fan assembly**



3. When the fans are powered up and running, a test must be conducted to ensure proper service.  
Go to the system terminal.

4. Check to see if the fan feature is activated.

At the terminal, enter the command:

```
rtrv-feat
```

Example output:

```
rlghncxa03w 04-01-28 11:34:04 EST EAGLE 34.0.0.
EAGLE FEATURE LIST
GTT      = on      GWS      = off      NRT      = off
X25G     = off     LAN      = off     CRMD     = off
SEAS     = off     LFS      = off     MTPRS    = off
FAN      = off     DSTN5000 = off     WNP      = off
CNCF     = off     TLNP     = off     SCCPCNV  = off
TCAPCNV  = off     IPISUP   = off     DYNRTK   = off
X252000  = off     INP      = off     PLNP     = off
NCR      = off     ITUMTPRS = off     SLSOCB   = off
EGTT     = off     VGGT     = off     MGGT     = off
MPC      = off     ITUDUPPC = off     GFLEX    = off
GPORT    = off     MEASPLAT = off     TSCSYNC  = off
E5IS     = off
;
```

If the fan feature is off (illustrated in the example), go to 5. Otherwise, go to 6.

5. At the terminal, enter the command: `chg-feat : fan=on`

With this command the user will perform the tests beginning with 7.

6. At the terminal, enter the command: `rept-stat-trbl`

Check to see that there are no fan errors. Specifically, check that there are no “#302 Cooling Fan Failure” errors. Next, perform the tests beginning with 7.

7. Fan Verification (perform 7 through 12 for each fan assembly).

Move to the rear of the frame and remove the A **POWER** cable from the **FAN** unit. Result: Fan 2 and Fan 3 **LEDs** will blink as the fans speed up to maximum speed. This may take up to 15 seconds. Once maximum speed has been reached Fan 2 and Fan 3 **LEDs** on the Fan Controller card will be solid green. Fan 1 **LED** should be red. The controller **LED** should be blinking green. Fan 1 should stop running and the **MINORLED** should be lit.

8. At the system terminal enter the command: `rept-stat-trbl`

Test each fan to ensure that the alarm and the units are working correctly. The terminal reports:

```
# 302 Cooling Fan Failure
```

9. Replace the A **POWER** cable on the back of the **FAN** unit and secure the connector.

Result: All fans are running and the **MINORLED** is not lit. The terminal reports:

```
# 303 Cooling Fans Normal
```

10. Remove the B **POWER** cable from the **FAN** unit.

Result: Fan 1 and Fan 2 **LEDs** will blink as the fans speed up to maximum speed. This may take up to 15 seconds. Once maximum speed has been reached Fan 1 and Fan 2 **LEDs** will be solid green. Fan 3 **LEDs** should be red. The fan controller **LED** should be blinking. Fan 3 should stop running and the **MINORLED** should be lit.



11. At the system terminal enter the command: `rept-stat-trbl`

Test each fan to ensure that the alarm and the units are working correctly. The terminal reports:

```
# 302 Cooling Fan Failure
```

12. Replace the **B POWER** cable on the back of the **FAN** unit and secure the connector.

Result: The fans are running and the **MINORLED** is not lit. The terminal reports:

```
# 303 Cooling Fans Normal
```

13. Repeat 7 through 12 for each fan unit installed.

This procedure is complete.

# B

## Holdover Clock Troubleshooting Procedures

### Introduction

Most alarm conditions in the holdover clock are not out-of service or service-affecting conditions. The system is designed with redundant power, reference inputs, clock input cards, stratum clock cards and output card protection switching.

The only true out-of-service condition is when all power is lost to a shelf, or all reference inputs and both stratum clock cards fail. Before taking any action on the system, such as removing cards, first consider the following troubleshooting guidelines:

- Do not touch the shelf until you have analyzed the condition and know the possible result of any planned corrective actions.
- Do not touch the shelf until you have been properly grounded.
- Both major and minor alarms in the shelf require immediate attention. But, very few alarms in the holdover clock system are service affecting. Improper corrective actions could be service affecting.
- Do not remove an **ST3** clock card from the shelf, unless you are certain it is the cause of the condition. This is especially true if the **ST** clock card(s) is (are) in the holdover mode (the **HOLD OV/HOLDOVER** lamp is lit, or the **HOLD OV/HOLDOVER** and **INP TOL** lamps are lit). Removing both **ST** clock cards in this condition causes total loss of all outputs from the shelf and/or system.
- Write down any alarm and normal lamp conditions in the shelf. These will help you to determine where to look for the cause of the condition.

### Interpreting System Alarms, Lamps And Trouble Isolation

Alarms generated by the holdover clock are reported through the Eagle. All alarm conditions are defined in [Corrective Maintenance](#).

When troubleshooting, write down all abnormal and normal lamp conditions for the shelf with the alarm lamp lit on the **SAI** card. This will assist in analyzing and isolating the cause of the condition. Do not start removing or replacing cards to attempt to clear alarms, as it could lead to crashing EAGLE.

Tables to aid in troubleshooting are listed in the following sections. Once the basic trouble has been isolated and it has been determined that an individual card is defective, perform the appropriate card replacement procedure in [Card Removal/Replacement Procedures](#).

**Table B-1 Input and ST3 Alarm Conditions**

SAI/ MISLAMPS	ABNORMAL CARD LAMPS	ACTIVATED OFFICE ALARMS AND SHELF STATUS	ACTIVATED CLOCK STATUS A AND B	CONDITION TYPE # (NOTE)
<b>MAJOR and MINOR lit</b>	<b>ST3 A and B = FAIL, LOCK, and REF B lit</b>	Visual = <b>MAJOR</b> and <b>MINOR</b>  Shelf Status = <b>MAJSI</b> , <b>MINSI</b> , and <b>CLKL</b> . <b>(HOLDOVERALAR</b> <b>M</b> switch <b>SW3</b> on backplane is set to <b>MAJ</b> or <b>MIN</b> )	None	1
<b>MAJOR and MINOR lit</b>	Input cards A and B = <b>FAIL</b> lit, frequency/bit rate lamp off, <b>SRFL</b> lit ( <b>ACI</b> only) <b>ST3 A and B = FAIL, LOCK,</b> and <b>REF B</b> lit	Visual = <b>MAJOR</b> and <b>MINOR</b>  Shelf Status = <b>MAJSI</b> , <b>MINSI</b> , and <b>CLKL</b> . <b>(HOLDOVERALAR</b> <b>M</b> switch <b>SW3</b> on backplane is set to <b>MAJ</b> or <b>MIN</b> )	None	2
<b>MINOR lit</b>	Input card A or B = <b>FAIL</b> lit, frequency/bit rate lamp off or lit, <b>SRFL</b> lit ( <b>ACI</b> only) <b>ST3 A and B = REF (A or B)</b> lamp lit (associated with input card with <b>FAIL</b> lamp off)	Visual = <b>MINOR</b>  Shelf Status = <b>MINSI</b> , and <b>CLKL</b> <b>(HOLDOVERALAR</b> <b>M</b> switch <b>SW3</b> on backplane is set to <b>MAJ</b> or <b>MIN</b> )	None	3
<b>MINOR lit</b>	<b>ST3 A and B = LOCK</b> lit	Visual = <b>MINOR</b>  Shelf Status = <b>MINSI</b> <b>(HOLDOVERALAR</b> <b>M</b> switch <b>SW3</b> on backplane is set to <b>MAJ</b> or <b>MIN</b> )	None	4

**Table B-1 (Cont.) Input and ST3 Alarm Conditions**

SAI/ MISLAMPS	ABNORMAL CARD LAMPS	ACTIVATED OFFICE ALARMS AND SHELF STATUS	ACTIVATED CLOCK STATUS A AND B	CONDITION TYPE # (NOTE)
<b>MINOR</b> periodically lights, then goes off	Input card A and/or B = <b>FAIL</b> periodically goes on and off. First occurrence only the <b>SRACT/</b> <b>SRACTIVE</b> on <b>FAIL</b> card goes off and lights on the other card.	Visual = Periodic <b>MINOR</b> <b>Shelf Status = Periodic</b> <b>MINSI and CLKL</b> <b>( HOLDOVERALAR</b> <b>M switch SW3 on</b> <b>backplane set to MAJ</b> <b>or MIN)</b>	None	5
<b>MAJOR</b> lit	<b>ST3</b> A or B = <b>FAIL</b> lit	Visual = <b>MAJOR</b> <b>Shelf Status = MAJSI</b> <b>(HOLDOVERALAR</b> <b>M switch SW3 on</b> <b>backplane is set to</b> <b>MAJ or MIN)</b>	None	6

For the corrective action to take for each condition type, refer to [Table B-2](#).

**Table B-2 Input and ST3 Corrective Actions**

CONDITIONTYPE # (From <a href="#">Table B-1</a> )	CONDITION AND PROBABLE CAUSE	CORRECTIVE ACTION
1	No input cards installed. Outputs are as accurate as free-running clock cards. Timed network elements reporting high slip rate.	Install at least one input card.(See Appendix A).
2	Input references A and B have failed (frequency/bit rate lamp off) or have exceeded <b>BPV</b> , <b>OOF</b> , or excessive zeros parameters (frequency/bit rate lamp lit).  The input reference facility framing format rearranged from D4 to <b>ESF</b> , or vice versa, and the input card options were not changed to match it.  The input reference has been recently reassigned, and the signal amplitude is too high.  Both input cards have failed.	Check input reference connections at the shelf and source ends. Reconnect if required. Isolate and repair input reference facilities, if required.  Change the option switch settings to match the current framing format. See <i>Installation Guide</i> .  Wire a 100 ohm, 1/4 watt resistor across T and R input terminals on the shelf backplane.  Replace both input cards (See Appendix A).

**Table B-2 (Cont.) Input and ST3 Corrective Actions**

CONDITIONTYPE # (From Table B-1)	CONDITION AND PROBABLE CAUSE	CORRECTIVE ACTION
3	Input reference A or B has failed (frequency/bit rate lamp off) or has exceeded <b>BPV</b> , <b>OOF</b> , or excessive zeros parameters (frequency/bit rate lamp lit).	Check input reference connections at the shelf and source ends. Reconnect if required. Isolate and repair input reference A or B facility (if required).
	Input card A or B has failed.	Replace the input card with the <b>FAIL</b> lamp lit (See Appendix A).
	The input reference facility framing format rearranged from D4 to <b>ESF</b> , or vice versa, and the input card options were not changed to match it.	Change the option switch settings to match the current framing format.
	The input reference has been recently reassigned, and the signal amplitude is too high.	Wire a 100 ohm, 1/4 watt resistor across T and R input terminals on the shelf backplane.
4	Active input reference has exceeded pull-in range of <b>ST3</b> cards. Timed network elements reporting high slip rate.	Press transfer ( <b>XFR</b> ) pushbutton on either input card to switch <b>SRC</b> (source) <b>ACTIVE</b> lamp to the other input card. <b>ST3</b> A and <b>B LOCK</b> lamps go off in less than 40 seconds.  Isolate source of frequency offset on input reference facility and repair.
	5	Input reference facility (A and/or B) line coding rearranged from <b>AMI</b> to <b>B8ZS</b> and input card(s) option switches were not set to match the change. Input card <b>BPV</b> spec periodically exceeded.
6	<b>ST3</b> A or B card has failed and squelched its outputs. Outputs are receiving their reference from the <b>ST3</b> with its <b>FAIL</b> lamp off. Outputs are not affected.	Replace the <b>ST3</b> card (A or B) with the <b>FAIL</b> lamp lit (Appendix A).



**Note:**

For a description of each condition type, refer to [Table B-3](#).

**Table B-3 Shelf and Output Alarm Conditions - Not Related to Input and ST Conditions**

SAI/MISLAMPS	ABNORMAL SHELF AND CARD LAMPS	ACTIVATED OFFICE ALARMS AND SHELF STATUS	ACTIVATED CLOCK STATUS A AND B	CONDITION TYPE # (NOTE)
None lit	All lamps on all cards are off	Visual = <b>CRITICAL (MISONLY), MAJOR, and MINOR</b>  Shelf Status = <b>CRTSI (MIS only), MAJSI, MINSI, and BATTALM</b>	None	1
<b>MINOR</b> lit	<b>MCA-5 = All 10 PORTALM</b> lamps lit	Visual = <b>MINOR</b>  Shelf Status = <b>MINSI</b>	None	2
<b>MINOR</b> lit	Any <b>TO</b> card = <b>PORTALM</b> lit  Output protection pushbutton lamps = Lamp over <b>TO</b> card with <b>PORTALM</b> lit, and like <b>HSTO</b> card light for a short period of time (approx 3 seconds) then goes off  <b>MCA-5 = AUTO</b> lamp flashes for approx 6 seconds when <b>HS</b> protection switch is activated and released.	Visual = <b>MINOR</b>  Shelf Status = <b>MINSI</b> and <b>PRTA (SW1 positions 3 and 5 on MCA-5 set to MAJ or MIN)</b>	None	3
<b>MINOR</b> lit	<b>Shelf</b> fuse A or B = Lamp lit	Visual = <b>MINOR</b>  Shelf Status = <b>MINSI, and BATTALM.</b> <b>POWERALARM</b> switch <b>SW2</b> on backplane is set to <b>MIN</b> )	None	4
<b>MAJOR</b> lit	Any <b>TO, ST,</b> or <b>MCA-5 = FAIL</b> lit	Visual = <b>MAJOR</b>  Shelf Status = <b>MAJSI (MCA-5 SW1, positions 3 and 5 set to MAJ)</b>	Visual = <b>MAJOR</b>  Shelf Status = <b>MAJSI (MCA-5 SW1, positions 3 and 5 set to MAJ)</b>	5
<b>FAIL</b> and <b>MAJOR</b> lit ( <b>MIS</b> only)	<b>MIS = FAIL</b> lit	Visual = <b>MAJOR</b>  Shelf Status = <b>MAJSI</b>	None	5

**Table B-3 (Cont.) Shelf and Output Alarm Conditions - Not Related to Input and ST Conditions**

SAI/MISLAMP	ABNORMAL SHELF AND CARD LAMPS	ACTIVATED OFFICE ALARMS AND SHELF STATUS	ACTIVATED CLOCK STATUS A AND B	CONDITION TYPE # (NOTE)
<b>MAJOR</b> and <b>MINOR</b> lit	Shelf fuse A or B = Lamp lit	Visual = <b>MAJOR</b> <b>Shelf</b> Status = <b>MAJSI</b> , <b>MINSI</b> , and <b>BATTALM</b> . ( <b>POWERALARM</b> switch <b>SW2</b> on backplane is set to <b>MAJ</b> )	None	4
<b>MAJOR</b> and <b>MINOR</b> lit	Any <b>TO</b> card = <b>FAIL</b> lamp lit  Output protection pushbutton lamp = Lamps lit over <b>TO</b> with <b>FAIL</b> lamp lit and like <b>HSTO</b> card ( <b>HS</b> protection switch activated).	Visual = <b>MAJOR</b> and <b>MINOR</b>  <b>Shelf</b> Status = <b>MAJSI</b> and <b>MINSI</b> ( <b>MCA-5 SW1</b> , positions 3 and 5 set to <b>MIN</b> )	None	5
<b>MAJOR</b> and <b>MINOR</b> lit or <b>MINOR</b> lit or None lit ( <b>MAJOR</b> and <b>MINOR</b> lit if <b>MCA-5 SW1</b> , positions 3 and 5 set to <b>MAJ</b> ; if <b>SW1</b> set to <b>MIN</b> , then <b>MIN</b> lit; if set to <b>NOALARM</b> , then None lit)	Output protection pushbutton lamps = Lamps over <b>TO</b> cards and <b>HS</b> cards alternately light and then go off.	Visual = <b>MAJOR</b> and <b>MINOR</b> or <b>MINOR</b> or None <b>Shelf</b> Status = <b>MAJSI</b> and <b>MINSI</b> or <b>MINSI</b> or None ( <b>MAJOR</b> and <b>MINOR</b> if <b>MCA-5</b> card <b>SW1</b> set to <b>MAJ</b> ; <b>MINOR</b> if <b>SW1</b> set to <b>MIN</b> ; none if <b>SW1</b> set to <b>NOALARM</b> )	None	6
<b>MINOR</b> lit or <b>MAJOR</b> and <b>MINOR</b> lit ( <b>MINOR</b> if <b>MCA-5 SW1</b> , positions 3 and 5, are set to <b>MIN</b> or <b>NOALARM</b> ; <b>MAJOR</b> and <b>MINOR</b> lit if set to <b>MAJ</b> )	Any <b>TO</b> card = <b>PORTALM</b> lit  Output protection pushbutton lamps = Lamps lit over <b>TO</b> card with <b>PORTALM</b> lit, and like <b>HSTO</b> card.	Visual = <b>MINOR</b> or <b>MAJOR</b> and <b>MINOR</b> <b>Shelf</b> Status = <b>MINSI</b> and <b>PRTA</b> or <b>MAJSI</b> , <b>MINSI</b> , and <b>PRTA</b> ( <b>MINOR</b> if <b>SW1</b> positions 3 and 5 on <b>MCA-5</b> set to <b>MIN</b> or <b>NOALARM</b> ; <b>MAJOR</b> and <b>MINOR</b> if set to <b>MAJ</b> )	None	7

**Table B-3 (Cont.) Shelf and Output Alarm Conditions - Not Related to Input and ST Conditions**

SAI/MISLAMP	ABNORMAL SHELF AND CARD LAMPS	ACTIVATED OFFICE ALARMS AND SHELF STATUS	ACTIVATED CLOCK STATUS A AND B	CONDITION TYPE # (NOTE)
<p><b>MINOR</b> lit or <b>MAJOR</b> lit or None lit (<b>MINOR</b> lit if <b>MCA-5 SW1</b>, positions 3 and 5 set to <b>MIN</b>; if <b>SW1</b> set to <b>MAJ</b>, then <b>MAJOR</b> is lit; if set to <b>NOALARM</b>, then None lit)</p>	<p>Output protection pushbutton lamps = Lamps lit over a <b>TO</b> card and like <b>HSTO</b> cards <b>MCA-5 = MAN</b> lamp is flashing</p>	<p>Visual = <b>MINOR</b> or <b>MAJOR</b> or None <b>Shelf Status = MINSI</b> or <b>MAJSI</b> or None (<b>MINOR</b> lit if <b>MCA-5 SW1</b>, positions 3 and 5 set to <b>MIN</b>; if <b>SW1</b> set to <b>MAJ</b>, then <b>MAJOR</b> is lit; if set to <b>NOALARM</b>, then None lit)</p>	<p>None</p>	<p>8</p>

**Note:**  
For the corrective action to take for each condition type, refer to [Table B-4](#).

**Table B-4 Shelf and Output Corrective Actions - Not Related to Input and ST Conditions**

CONDITIONTYPE # (FROM <a href="#">Table B-3</a> )	CONDITION AND PROBABLE CAUSE	CORRECTIVE ACTIONS
1	<p>Loss of Battery A and B to shelf. All outputs are squelched. Causes could be from operating error, office battery source failure, blown fuses, or a component failure, e.g., isolation diode which shorts battery to battery return.</p>	<p>1. Determine cause of loss of battery and repair. 2. Restore office battery source. 3. Replace blown fuses in battery distribution bays, miscellaneous fuse bays, and panels, and/or on <b>DCD</b> shelf.</p>



**Table B-4 (Cont.) Shelf and Output Corrective Actions - Not Related to Input and ST Conditions**

CONDITIONTYPE # (FROM Table B-3)	CONDITION AND PROBABLE CAUSE	CORRECTIVE ACTIONS
2	<p>Communication between <b>MCA-5</b> and <b>TO</b> cards is not functioning.</p> <p>Microprocessor on the <b>MCA-5</b> is failed or garbled.</p> <p>Does not affect outputs.</p> <p>Automatic <b>TO</b> protection switching function disabled.</p> <p>Manual <b>TO</b> protection switching function is still operational.</p>	<ol style="list-style-type: none"> <li>1. No <b>TO</b> cards in shelf. Install at least one <b>TO</b> card.</li> <li>2. No input references or input cards, and no clock cards installed. Install at least one clock (<b>ST</b>) card (See Appendix A.)</li> <li>3. <b>MCA-5</b> communications bus or microprocessor garbled. Remove and reinsert the <b>MCA-5</b> card to clear bus and microprocessor.</li> <li>4. <b>MCA-5</b> microprocessor failed. Replace <b>MCA-5</b> card (Appendix A).</li> </ol>
3	<p><b>HS</b> protection switch activated, then released because of:</p> <ul style="list-style-type: none"> <li>• Unterminated cable on <b>TOTA</b> or <b>TOTL</b> output,</li> </ul> <p>or,</p> <ul style="list-style-type: none"> <li>• Shorted cable on <b>TO</b> output.</li> </ul> <p>When the condition occurred, an <b>HS</b> protection switch was activated, <b>PORTALM</b> on <b>TO</b> goes off, and lights on the <b>HSTO</b> card, output protection pushbutton lamps over the <b>TO</b> and <b>HS</b> light, <b>MCA-5 AUTO</b> lamp flashes, <b>HS</b> protection switch releases, <b>PORTALM</b> on <b>HSTO</b> goes off and lights on <b>TO</b>, output protection pushbutton lamps go off, and <b>MCA-5 AUTO</b> lamp stops flashing (duration = 3 to 6 seconds). Non-failed ports on <b>TO</b> with <b>PORTALM</b> lit lost output for one millisecond during <b>HS</b> protection switch activation and release. Failed <b>TO</b> port is out of service.</p>	<ol style="list-style-type: none"> <li>1. Press and hold the output protection pushbutton over the <b>TO</b> card with <b>PORTALM</b> lamp lit. <b>MCA-5</b> lights <b>PORTALM</b> lamp(s) of failed <b>TO</b> port. Release pushbutton.</li> <li>2. Isolate and repair cable or <b>NE</b> connected to that <b>TO</b> port.</li> <li>3. If port connection is new and not yet terminated at <b>NE</b>, then either insert disabling pin in that port's disabling jack on <b>TO</b> card faceplate, or remove cable from output wire-wrap panel, or place an appropriate resistor termination across tip (T) and ring (R) of cable at <b>NE</b> end, until ready to connect cable at <b>NE</b> end.</li> </ol>
4	<p>Loss of Battery A or B to shelf.</p> <p>Does not affect outputs. Causes could be from operating error, blown fuse, or a component failure, e.g., isolation diode which shorts battery to battery return.</p>	<ol style="list-style-type: none"> <li>1. Determine cause of loss of battery and repair.</li> <li>2. Replace blown fuses in battery distribution bays, miscellaneous fuse bays, and panels, and/or on <b>DCD</b> shelf.</li> </ol>

**Table B-4 (Cont.) Shelf and Output Corrective Actions - Not Related to Input and ST Conditions**

CONDITIONTYPE # (FROM Table B-3)	CONDITION AND PROBABLE CAUSE	CORRECTIVE ACTIONS
5	<p><b>Card</b> with <b>FAIL</b> lamp lit has failed, except for input card which causes a <b>MINOR</b> alarm when its <b>FAIL</b> lamp lights. Outputs are not affected if <b>MCA-5</b> and <b>HS</b> slots are equipped.</p>	<p>Replace the card with the <b>FAIL</b> lamp lit (Appendix A). Release <b>HS</b> protection switch, if activated, by pressing lit <b>HS</b> pushbutton until switch releases.</p>
6	<p>A <b>TO</b> card's microprocessor has lost its ability to process data. The <b>TO</b> cards are alternately being switched to <b>HS</b> protection and then released. One millisecond loss of outputs each time a <b>TO</b> is switched to or released from <b>HS</b> protection.</p>	<p>Manually switch each <b>TO</b> card to the <b>HS</b>, replace the <b>TO</b> card (Appendix A) and release the <b>HS</b> switch. Continue until the malfunctioning <b>TO</b> card is located and removed from the shelf.</p>
7	<p>Output port failed on <b>TO</b> card with <b>PORTALM</b> lamp lit. <b>HS</b> protection switch activated. Loss of output on failed port. Other output on same <b>TO</b> lost for one millisecond when <b>HS</b> protection switch activated.</p> <p>When condition occurred, an <b>HS</b> protection switch was activated, <b>PORTALM</b> lamp on <b>TO</b> card remained lit, output protection pushbutton lamps over <b>TO</b> and <b>HS</b> slots lit, and <b>MCA-5</b> card's <b>AUTO</b> lamp flashes for 6 seconds and then lights steady.</p>	<ol style="list-style-type: none"> <li>1. Press and hold the output protection pushbutton over the <b>TO</b> card with the <b>PORTALM</b> lamp lit. <b>MCA-5</b> lights <b>PORTALM</b> lamp(s) of failed <b>TO</b> port. Release pushbutton.</li> <li>2. Remove <b>TO</b> card with <b>PORTALM</b> lamp lit.</li> <li>3. Set option switch settings on the replacement <b>TO</b> card identical to settings on removed <b>TO</b> card.</li> <li>4. Insert replacement <b>TO</b> card in shelf slot and wait 10 seconds for <b>TO</b> to warm-up. Verify <b>ST</b>, <b>INPUT</b> and <b>OPTION</b> lamps are lit and <b>PORTALM</b> and/or <b>FAIL</b> lamps are not lit.</li> <li>5. Press output protection pushbutton over <b>HSTO</b> until pushbutton lamps go out (releases <b>HS</b> switch). <b>MCA-5</b> card's <b>AUTO</b> lamp flashes for 6 seconds and then lights steady.</li> </ol>
8	<p><b>TO</b> card manually switched to <b>HSTO</b> card</p>	<p>Release the manual <b>HS</b> switch by pressing the lit pushbutton over the <b>HSTO</b> card for 3 seconds.</p>

**Note:**

For a description of each condition type, refer to [Table B-3](#).

# C

## Part Numbers

### Overview

This chapter lists the part numbers of Oracle equipment, components, cables, and miscellaneous parts described in this manual.

Each table provides the item name, part number, and related notes. Items are listed by their name (as described in this manual) in alphabetical order. Shaded part numbers indicate that the item is obsolete or no longer shipped. Unless the item is indicated as obsolete, the item is still supported in the field.

#### Note:

Oracle reserves the right to ship compatible part numbers or revisions for new installations and replacements. Always check the latest Hardware Baseline for your release. The latest hardware baseline can be found in the Feature Notice of your release.

RoHS 5/6 - As of July 1, 2006, all products that comprise new installations shipped to European Union member countries will comply with the EU Directive 2002/95/EC "RoHS" (Restriction of Hazardous Substances). The exemption for lead-based solder described in the Annex will be exercised. RoHS 5/6 compliant components will have unique part numbers and are identified as the International part number in this manual.

#### Note:

International part numbers will eventually replace North American part numbers to make all part numbers RoHS compliant. The items of either part number are of equivalent function or quality otherwise.



**WEEE** - All products shipped to European Union member countries comply with the EU Directive 2002/96/EC, Waste Electronic and Electrical Equipment. All components that are **WEEE** compliant will be appropriately marked. For more information regarding Oracle's **WEEE** program, contact your sales representative.

# Cables, Adapters

**Table C-1 EAGLE Cables, Connectors, and Power Cords**

Name	Part Numbers		Note
	North America	International	
Adapter, 15-Pin to 26-Pin	830-0425-01	---	
Adapter cables	830-0846-01	830-1183-01	backplanes -03 and -04 for master timing and <b>HS</b> clock cable 830-0873-xx
<b>Alarm</b> cable	830-0543-01	---	Holdover Clock
<b>Alarm</b> cable	830-0638-xx	830-1163-xx	see Filtered Rack <b>Alarm</b> cable
<b>AlarmNETRA</b> Server Cable	830-0900-xx	---	
<b>ATM</b> Cable	830-0987-xx	---	<b>SCSI/DB44</b>
<b>ATME1/T1</b> cable	830-0959-xx	---	<b>EMS; DB-44 to RJ45</b> 4 Port
B Clock Cable	830-0404-xx	---	replaced by 830-0398-xx (NA) or 830-1150-xx (I) both are for <b>HMUX</b>
B Clock Cable	830-0398-xx	830-1150-xx	
A and B Frame Clock cable	---	---	see B Clock Cable
<b>BITS</b> clock cable	830-0226-xx	830-1146-xx	Backplanes -03 and -04
<b>BITS</b> clock cable	830-0873-xx	---	Backplane -06
<b>BNC</b> pen end cable	830-0625-xx	830-1161-xx	
<b>BNC</b> to <b>BNC</b> cable assembly	830-0624-xx	830-1160-xx	
Breaker-to-Terminal Strip Power Cable	830-0866-xx	830-1236-xx	
<b>CD-ROM</b> Cable	830-0421-xx	---	
Frame Ground cable	830-0715-xx	830-1171-xx	<b>ESP</b>
Composite clock cable	---	---	See <b>BITS</b> clock cable
Converter	804-0176-01	---	
Crossover ( <b>CAT-5</b> ) Cable	830-0723-xx	830-1173-xx	
Crossover Patch Panel Cable	830-0789-xx	830-1178-xx	<b>DCM</b>
<b>DB-26</b> to <b>RJ-45</b>	830-1102-02	830-1102-02	for new installations, with shielded Cat 5E cable; <b>E5-ENET</b>

**Table C-1 (Cont.) EAGLE Cables, Connectors, and Power Cords**

Name	Part Numbers		Note
	North America	International	
<b>DB-26 to DB-26</b>	830-1103-02	830-1103-02	for current installations that use <b>DCM</b> cable, 830-0978-xx. Does not support Gigabit Ethernet; <b>E5-ENET</b>
<b>DCM</b> , 100- <b>BASETX</b> Interface to unterminated -xx	830-0711-xx	---	
<b>DCM_100 BASETX</b> Interface_DB26 to Non-shielded <b>RJ45</b>	830-0978-xx	---	
<b>DCM 100BASE TX</b> Interface_DB26 to <b>RJ45</b> Plus to Minus	830-0788-xx	830-1177-xx	
Drive Power Cable	830-0224-xx	---	
<b>DS1</b> Cable	830-0849-xx	830-1184-xx	
<b>E1</b> cable	830-0622-xx	830-1233-xx	
<b>E1</b> patch cable	830-0605-02	830-1116-02	
<b>E1-T1MIM 22 AWG</b>	830-0932-01	830-1106-xx	
<b>E1/T1MIMLIM</b> Cable	830-0948-01	830-1197-xx	4 Port 24 <b>AWG</b>
<b>E1/T1MIMLIM</b> to <b>MPL</b> Adapter	830-0949-01	830-1197-01	
E5-ENET Fast Copy Adapter - Lower	830-1343-01		
E5-ENET Fast Copy Adapter - Upper	830-1343-02		
E5-MASP Ethernet Adapter	830-1333-02	830-1333-02	Connects to J-17 and J19 on Ctrl shelf backplane 06/07 for E5-OAM Integrated Meas
Ethernet cable*	830-0788-xx	830-1177-xx	<b>DCM</b> , <b>DSM</b> and <b>EDCM</b>
External alarm cable	830-0435-xx	830-1151-xx	
Fan cable	830-0690-01	---	<b>AC</b> power
Fan power/alarm cable	830-0609-01	830-1157-01	incl. with fan assembly
Fifty Position Cable Hard Drive I/O	830-0656-01	---	
Filter Rack <b>Alarm</b> Cable	830-0638-xx	830-1163-xx	
Force Transition <b>Card</b>	850-0496-01	---	
Frame Ground cable	830-0715-xx	830-1171-xx	<b>ESP</b>
Ground Breaker Panel-to-Frame cable	830-0830-01	830-1181-01	<b>ESP</b>

**Table C-1 (Cont.) EAGLE Cables, Connectors, and Power Cords**

Name	Part Numbers		Note
	North America	International	
Ground Hub-to-Frame cable	830-0822-xx	---	<b>ESP</b>
Hazard Ground Cable	830-0257-xx	---	
High Speed ( <b>BITS</b> ) Clock Cable	830-0873-xx	830-1189-xx	
High Speed Master Timing Adapter	830-0846-01	830-1183-01	
<b>HMUX</b> Adapter Cable	830-0857-01	830-1185-01	
1/0 Green Ground Cable	690-0108-07	690-0108-R07	
IMT Cable	830-1344-xx	830-1344-xx	
Interface Cable	830-0366-xx	830-1149-xx	
Local Maintenance Center Cable	830-0231-xx	830-1144-xx	
Loop Back Cable Adapter	830-0763-01	830-1176-xx	
<b>MMI</b> Port Cable	830-0708-xx	830-1169-xx	
Modem/Terminal Cable	830-0709-xx	830-1170-xx	
Multi-port <b>LIM</b> Diagnostic Cable	803-0029-0	---	
Multi-port <b>LIM DS0</b> cable	830-0772-xx	---	26 <b>AWG</b> , inactive
Multi-port <b>LIM DS0</b> cable	830-0892-xx	830-1194-xx	24 <b>AWG</b> , inactive
Multi-Port Power Cable	830-0814-xx	830-1282-xx	
Network Cable	830-0710-xx	830-1257-xx	
Null Modem Cable	830-0759-xx	---	
Null-Modem for Terminal Cable	830-0859-xx	830-1186-xx	
Output panel frame ground cable	690-0009	---	
Pin Protector Assembly	830-0880-01	---	use with clock cable replacement (66 min for 6 shelves)
Power Cable	830-0315-xx	830-1147-xx	
Power Cable, -48V	830-0651-xx	---	
Power Cable, <b>DC</b> , <b>BP</b> to Hub	830-0868-xx	830-1235-xx	
Power Cable, <b>DC</b> , Netra 1400	830-0814-xx	830-1282-xx	
Power Cable, <b>MPS</b>	830-0965-xx		
Power Ring	830-0908-xx	---	<b>AXi</b>
Rack <b>Alarm</b> Cable	---	---	see Filtered Rack <b>Alarm</b> cable
<b>RAID</b> Power Cable	830-0872-xx	---	<b>DC</b>
Remote Maintenance Center Cable	830-0233-xx	830-1146-xx	
<b>RJ45/RJ45</b> Cable ( <b>CAT-5</b> ) (Yellow)	830-0888-xx	---	
<b>RJ45/RJ45</b> Cable ( <b>CAT-5</b> ) (Blue)	830-0889-xx	830-1192-xx	
<b>RJ45</b> to 9 Pin Adapter	830-0917-01	---	

**Table C-1 (Cont.) EAGLE Cables, Connectors, and Power Cords**

Name	Part Numbers		Note
	North America	International	
Row <b>Alarm</b> Cable	830-0232-xx	830-1145-xx	
Router Power Cable	830-0869-xx	830-1188-xx	<b>DC</b>
<b>RS232</b> Cable	830-0527-xx	830-1152-xx	
<b>ATM</b> Cable	830-0987-xx	---	<b>SCSI/DB44</b>
Serial I/O Transition <b>Card</b>	850-0514-01	---	
Serial Interface Converter Cable	830-0531-01	---	inactive
Serial Interface/Modem Adapter	830-0531-03	830-1153-03	use with 830-0394-xx
Serial Interface/Modem Adapter	830-0531-04	830-1153-04	use with 830-0535-xx
Serial <b>DB44</b> to <b>DB9</b> (X4) cable	830-0972-01	830-1231-01	36-inch T1x00 <b>AS</b>
Serial Interface, Terminal, Printer Adapter	830-0531-02	830-1153-02	use with 830-0394-xx
Straight Through Cable ( <b>CAT-5</b> )	830-0724-xx	---	<b>RJ-45 CAT-5E</b>
Straight Through Cable (Patch Panel)	---	---	see <b>DCM 100BASE TX Interface_DB26 to RJ45 Plus to Minus</b>
Switch-to-Frame Ground Cable	830-0884-01	---	
Terminal/Converter Cable	830-0528-01	---	
Terminal/Printer Cable	830-0535-xx	830-1154-xx	
Terminal/Server Serial Cable	---	830-1201-xx	DB9F/DB15M Serial w/Flow Control
Terminal/Server Serial Port Adapter	830-0915-01	---	RJ45-DB15M Adapter_NTW
Terminal/Server Serial Port Adapter	830-0915-02	---	RJ45-DB15M Adapter_MRV
Terminal/Server Serial Port Adapter	830-0915-03	---	RJ45-DB15M Adapter_EAGLE/Cyclades
Tone and Announcement Server <b>Alarm</b> Cable	830-0901-xx	---	
<b>TILIM</b> -to- <b>MPL</b> Cable Adapter	830-0895-01	---	
<b>TIMIM</b> cable	830-0894-xx	---	
Terminal cable adapter	---	---	see Terminal/Printer cable

\* See [Customer Supplied Ethernet Cable Requirements](#) for customer-supplied Ethernet cable requirements.

## Customer Supplied Ethernet Cable Requirements

If a customer chooses to supply their own Ethernet cables for EAGLE (customer-supplied cables are not subject to Oracle warranty), the following requirements must be met:

Customer-supplied Ethernet cables for EAGLE must be shielded, meet the industry standard, and avoid dissimilar metals at the RJ45 connector interface. The required standards include:

Metallization (30 or 50 $\mu$  in. Au over 50 $\mu$  in. Ni), at the connector interface. The wire required follows: Category 5E SFTP 26AWG 7/34 tinned copper 4 PR per IEC 11801, TIA/EIA 568B, EN 50173 with Overall shield, 26 AWG stranded T.C. drain wire, UL CMR, C(UL) CMR rating, or other agency listing.

Signaling Cables (for example, T1, ATM) are EAGLE proprietary and must be purchased from Oracle.

## Components

**Table C-2 EAGLE Components**

Acronym	Name	Part Numbers		Note
		North America	International	
---	Air Management <b>Card</b>	870-1824-01	870-1824-02	single slot, needed for empty slots when using Fan Tray 890-0001-02
---	Breaker Panel <b>Alarm Card</b>	804-1489-01	804-1489-R01	
<b>CI</b>	Clock Interface <b>Card</b> (Holdover Clock)	804-0165-01	---	
<b>DSM</b>	<b>Database</b> Service Module	870-2371-08	870-2371-13	1GB
E5-APP-B	EAGLE Application B Card	870-3096-XX		See <i>EAGLE Application B Card Hardware and Installation Guide</i>
E5-ATM-B	E5-ATM-B Interface Module	870-2972-01	870-2972-01	
E5-E1T1-B	E5-E1T1-B Interface Module	870-2970-xx		
E5-ENET-B	E5-ENET-B Interface Module	870-2971-01	870-2971-01	
E5-MASP	E5 Maintenance Administration Subsystem Processor Card	7346924 870-2903-01		
E5-MCPM-B	E5-MCPM-B Measurements Collection and Polling Module	870-3089-01	870-3089-01	
E5-MDAL	E5 Maintenance Disk and Alarm Card	7346923 870-2900-01		
E5-SM8G-B	E5-SM8G-B DSM Module	870-2990-01	870-2990-01	
<b>EDCM</b>	Enhanced <b>Database</b> Communications Module	870-2197-01	---	double-slot Pre-IP <sup>7</sup> SG 4.0
HIPR2	High-Speed IMT Packet Router 2 Module	7333484 870-2872-01	870-2872-01	Replaces IPMX, HMUX, HIPR
<b>IPMX</b>	Interprocessor Message Transport Power and Multiplexer	870-1171-01	---	replaced by <b>HMUX</b>



**Table C-2 (Cont.) EAGLE Components**

Acronym	Name	Part Numbers		Note
		North America	International	
<b>MCA</b>	Matrix Controller Automatic (Holdover Clock)	000-0028-xx	---	
<b>MCAP</b>	Maintenance Administration Subsystem ( <b>MAS</b> ) Communications Applications Processor	870-1013-xx 870-1307-xx	---	Replaced by <b>GPSM-II</b> as of 30.0
<b>MIS</b>	Maintenance Interface System <b>Card</b> (Holdover Clock)	804-0175-xx	---	
<b>MPS</b>	Multi-purpose Server	890-1287-xx 890-1374-xx	---	<b>OEM</b> Open System
<b>SLIC</b>	Service and Link Interface Card	7094646		Runs multiple applications
<b>TOCA</b>	Timing Output Composite Automatic (Holdover Clock)	804-0166-xx	---	

## Frames, Backplanes, FAPs, and Fans

**Table C-3 EAGLE Frames, Backplanes, FAPs, and Fans**

Acronym	Name	Part Numbers		Note
		North America	International	
<b>BP</b>	Breaker Panel	804-1423-01	804-1423-R01	
<b>BP</b>	Breaker Panel	870-1814-01	---	
	<b>Control Shelf</b> Backplane -02	850-0330-02	---	inactive
	<b>Control Shelf</b> Backplane -03	850-0330-03	---	inactive
	<b>Control Shelf</b> Backplane -04	850-0330-04	---	
	<b>Control Shelf</b> Backplane -05	850-0330-05	---	not active
	<b>Control Shelf</b> Backplane -06	850-0330-06	850-0330-07	shelves 6 and 7 no longer supported
	<b>Control Shelf</b> Backplane	7333412		ROHS number
	<b>E1</b> Backplane	850-0459-01	850-0459-02	
	<b>Extension Shelf</b> Backplane	850-0356-01	---	inactive
	<b>Extension Shelf</b> Backplane	850-0356-02	---	inactive

**Table C-3 (Cont.) EAGLE Frames, Backplanes, FAPs, and Fans**

Acronym	Name	Part Numbers		Note
		North America	International	
	<b>Extension Shelf</b> Backplane	850-0356-03	---	inactive
	<b>Extension Shelf</b> Backplane	850-0356-04	850-0356-06	
	<b>Extension Shelf</b> Backplane	7333417		ROHS number
	Fan Assembly	7315823		ROHS number
	Fan Assembly	890-0001-02	890-0001-04	All systems with <b>HCMIMs</b> <b>EAGLE 33.0</b>
	Fan Assembly	890-1038-01	890-1038-03 890-1038-04	Standard frame Heavy Duty frame
	Filter, fan tray	551-0032-01	---	
	Fan filter	551-0022-01	---	
<b>FAP</b>	Fuse and <b>Alarm</b> Panel	860-0434-01	860-0434-03 860-0434-04	Heavy Duty Frame
<b>FAP</b>	Fuse and <b>Alarm</b> Panel	870-1606-02 Rev C	---	Standard Frame 60 Amp feeds
<b>FAP</b>	Fuse and <b>Alarm</b> Panel	870-1606-02 Rev B	---	Standard 40 Amp feeds
<b>FAP</b>	Fuse and <b>Alarm</b> Panel	870-2320-028 Rev J	870-2320-04	Heavy Duty Frame 60 Amp feeds
<b>FAP</b>	Fuse and <b>Alarm</b> Panel	870-2320-01 Rev A - I	870-2320-03	Heavy Duty Frame 40 Amp feeds
<b>FAP</b>	Fuse and <b>Alarm</b> Panel	870-0243-08 Rev C	---	Control/ Extension Frame
<b>FAP</b>	Fuse and <b>Alarm</b> Panel	870-0243-09 Rev C	---	Misc Frame
	<b>FAP Jumper Board</b>	870-1641-01	---	
	<b>FAP Jumper Board</b>	870-1641-02	---	
	Heavy Duty Frame	860-0434-01	---	
<b>FAP</b>	Fuse and <b>Alarm</b> Panel	870-2804-01	870-2804-01	Control/ Extension Frame
	<b>FAP Shorting</b> Board	870-2805-01	870-2805-01	
	<b>FAP Jumper Board</b>	870-2806-01	870-2806-01	

# Labels

**Table C-4 EAGLE Labels**

Name	Part Numbers
Label, Control frame	658-0486-01
Label, Extension frame 00	658-0486-02
Label, Extension frame 01	658-0486-03
Label, Extension frame 02	658-0486-04
Label, Extension frame 03	658-0486-05
Label, Extension frame 04	658-0486-06
Label, Miscellaneous frame 00	658-0374-01
Label, Miscellaneous frame 01	658-0374-02
Label, Heavy Duty Frame	658-0374-01
Label, CF-00, Shelf 1	658-0490-01
Label, CF-00, Shelf 2	658-0490-02
Label, CF-00, Shelf 3	658-0490-03
Label, EF-00, Shelf 1	658-0490-04
Label, EF-00, Shelf 2	658-0490-05
Label, EF-00, Shelf 3	658-0490-06
Label, EF-01, Shelf 1	658-0490-07
Label, EF-01, Shelf 2	658-0490-08
Label, EF-01, Shelf 3	658-0490-09
Label, EF-02, Shelf 1	658-0490-10
Label, EF-02, Shelf 2	658-0490-11
Label, EF-02, Shelf 3	658-0490-12
Label, EF-03, Shelf 1	658-0490-13
Label, EF-03, Shelf 2	658-0490-14
Label, EF-03, Shelf 3	658-0490-15
Label, EF-04, Shelf 1	658-0490-16
Label, Field Tool Identification	658-0941-01
Label, Field Tool Identification wrap	658-0941-02

# Miscellaneous Parts

**Table C-5 EAGLE Miscellaneous Part Numbers**

Name	Part Numbers		Note
	North America	International	
<b>Drives</b>			

**Table C-5 (Cont.) EAGLE Miscellaneous Part Numbers**

Name	Part Numbers		Note
	North America	International	
Dual <b>CD-RW/DVD-ROM</b>	870-2746-01	870-2746-02	T1x00 AS
Disk Drive, 120GB	804-1804-01	804-1804-R01	<b>ULTRAATA/</b> 100/133_7200RPM
<b>Panels</b>			
<b>Alarm</b> side panel	870-0259-02	---	
<b>Alarm</b> indicator lamps	525-0067-R01	---	
Blank side panel	840-0017-02	---	
Gray tinted plastic rear covers	654-0075-01	654-0075-R01	
Brackets, unit separation	652-0609-01	652-0609-02	
Bracket	652-0954-01	652-0954-02	Fan
<b>Kits</b>			
Cable Rack Mounting Kit	804-1571-01	---	Heavy duty frame
Cable Rack Mounting Kit	804-0219-01	804-0219-R01	raised floor
	804-0219-02	804-0219-R02	
External tooth washers	606-0062-01	---	fan bracket
Diode Board A	870-1608-01	---	
Diode Board A	870-1608-03	---	
Diode Board B	870-1608-02	---	
Diode Board B	870-1608-04	---	
Diode Upgrade kit	840-0139-01	---	For 870-1606-02
Diode Upgrade kit	840-0139-02	---	For 870-2320-01
<b>E1</b> Interface Kit	890-1037-01	890-1037-06	
Mounting hardware kit	840-0092-01	840-0092-03	For heavy duty frame. South America/India only
<b>Brackets, Screws, and other small items</b>			
Brackets, unit separation	652-0609-01	652-0609-02	
Bracket	652-0954-01	652-0954-02	Fan
Bracket, fan tray	652-0012-01	652-0012-02	Fan tray
Bracket, side, fan tray	652-0015-01	652-0015-02	Fan tray
Heat-shrink	804-0229-01	---	
Heat-shrink	804-0228-01	---	
Lugs, # 6 two-hole	502-0085-01	502-0085-R01	<b>FAP</b> connector
<b>#6 AWG</b>	690-0131-01	690-0131-R01	
1/0 pink lug	804-0977-01	804-0977-R01	
Pin Protector Assembly	830-0880-01		
Screws (12)	601-0010-01	---	
Screws	600-0193-01	---	12x24 .500 cs zinc fan bracket

**Table C-5 (Cont.) EAGLE Miscellaneous Part Numbers**

Name	Part Numbers		Note
	North America	International	
Terminal lug	804-0817-02	804-0817-R02	
Terminating resistor	104-0032-01	---	E1 backplane

## Power Cords for Peripherals

**Table C-6 Power Cords for Peripherals**

Country	Part Number	Country	Part Number
USA	Cord provided	Latvia	804-1185-R01
Argentina	804-1185-R02	Liechtenstein	804-1185-R11
Australia	804-1185-R02	Lithuania	804-1185-R01
Austria	804-1185-R01	Luxembourg	804-1185-R01
Belgium	804-1185-R01	Malaysia	804-1185-R03
Brazil	804-1185-R01	Malta	804-1185-R03
Bulgaria	804-1185-R01	Mexico	Cord provided
Canada	Cord provided	Monaco	804-1185-R01
Chile	804-1185-R01	Netherlands	804-1185-R01
China	804-1185-R09	New Zealand	804-1185-R02
Columbia	Cord provided	Norway	804-1185-R01
Cyprus	804-1185-R03	Peru	804-1185-R01
Czech Republic	804-1185-R01	Philippines	Cord provided
Denmark	804-1185-R04	Poland	804-1185-R01
Egypt	804-1185-R01	Portugal	804-1185-R01
Estonia	804-1185-R01	Romania	804-1185-R01
Finland	804-1185-R01	Russia	804-1185-R01
France	804-1185-R07	Saudi Arabia	Cord provided
Germany	804-1185-R01	Singapore	804-1185-R03
Greece	804-1185-R01	Slovakia	804-1185-R01
Hong Kong	804-1185-R03	South Africa	804-1185-R06
Hungary	804-1185-R01	South Korea	804-1185-R01
Iceland	804-1185-R01	Spain	804-1185-R01
India	804-1185-R06	Sweden	804-1185-R01
Ireland	804-1185-R03	Switzerland	804-1185-R11
Israel	804-1185-R12	Taiwan	Cord provided
Italy	804-1185-R07	Turkey	804-1185-R01
Ivory Coast	804-1185-R01	United Kingdom	804-1185-R03
Japan	804-1185-R10	United Arab	804-1185-R03

# Index

## A

---

action=backup\  
    dest=fixed, [3-35](#)  
air supply grille, removing, [2-49](#)  
airflow indicator arrows, [2-49](#)  
alarms, critical, [2-3](#), [2-11](#)  
alarms, fuse, [2-3](#), [2-11](#)  
alarms, major, [2-3](#), [2-11](#)  
alarms, minor, [2-3](#), [2-11](#)

## B

---

backpower protection, [2-13](#)  
blown fuse, [2-3](#), [2-11](#)

## C

---

chg-db, [3-35](#)  
CI, [C-6](#)  
Command Driven Loopback (CDL), [3-27](#)  
Corrective Maintenance, [1-1](#)  
critical alarms, [2-3](#), [2-11](#)

## D

---

diode boards, removing, [2-12](#), [2-14](#)

## E

---

E5-ATM-B, [C-6](#)  
E5-E1T1-B, [C-6](#)  
E5-ENET-B, [C-6](#)  
E5-MASP, [C-6](#)  
E5-MCPM-B, [C-6](#)  
E5-MDAL, [C-6](#)  
E5-SM8G-B, [C-6](#)  
EDCM, [C-6](#)  
End Cabinet Alarm Indicators, [3-7](#)

## F

---

fan door, replacing, [2-49](#)  
FAP functions, [2-1](#)

fuse alarm, [2-3](#), [2-11](#)  
fuse, blown, [2-3](#), [2-11](#)

## G

---

GMT fuse holders, [3-4](#)  
GMT fuses, [3-4](#)  
grille, removing, [2-49](#)  
Ground Cable, [C-4](#)

## J

---

jumper, P71, [2-12](#), [2-13](#)  
jumper, P72, [2-12](#), [2-13](#)

## L

---

LEDs, OP/MAINT, [2-11](#)  
LEDs, PWR A, [2-3](#), [2-11](#)  
LEDs, PWR B, [2-3](#), [2-11](#)  
link fault sectionalization test procedure, [3-25](#)  
link fault sectionalization test, commands, [3-25](#)  
link fault sectionalization test, configuring data, [3-25](#)  
link fault sectionalization test, hardware configuration, [3-22](#)  
link fault sectionalization test, indicators, [3-24](#)  
link fault sectionalization test, report, [3-24](#)  
link fault sectionalization test, restrictions, [3-22](#)  
link fault sectionalization test, starting, [3-25](#)  
link fault sectionalization test, stopping, [3-27](#)  
Link Maintenance Commands  
    act-cdl, [3-31](#)  
    act-lbp, [3-25](#)  
    chg-lbp, [3-25](#)  
    dact-cdl, [3-31](#)  
    dact-lbp, [3-25](#)  
    dlt-lbp, [3-25](#)  
    ent-lbp, [3-25](#)  
    rept-stat-cdl, [3-31](#)  
    rept-stat-lfs, [3-25](#)  
    rept-stat-tstslk, [3-32](#)  
    rtrv-lbp, [3-25](#)  
    tst-slk, [3-28](#), [3-32](#)

## M

---

major alarms, [2-3](#), [2-11](#)  
minor alarms, [2-3](#), [2-11](#)

## O

---

OP/MAINT LED, [2-11](#)

## P

---

pink lug, [C-10](#)  
Preventive Maintenance, [1-1](#)  
PWR A LED, [2-3](#), [2-11](#)  
PWR B LED, [2-3](#), [2-11](#)

## R

---

rear covers, [C-10](#)  
removing diode boards, [2-12](#), [2-14](#)  
rtrv-log command, [3-16](#)  
rtrv-trbltx command, [3-16](#)  
rtrv-trbltx report, [3-16](#)

## S

---

Shorting Board LED, [2-3](#)

## T

---

TOCA, [C-7](#)  
tst-slk command, [3-28](#)