

Oracle9i Application Server

Installation Guide

Release 2 (9.0.2) for Sun SPARC Solaris

April 2002

Part No. A90324-01

ORACLE®

Part No. A90324-01

Copyright © 2002 Oracle Corporation. All rights reserved.

Primary Author: Kurt Heiss

Contributors: Priya Darshane, Sanjay Singh, Francisco Abedrabbo, Biju Albert, Marilyn Hollinger, Pavana Jain, Beth Roeser.

The Programs (which include both the software and documentation) contain proprietary information of Oracle Corporation; they are provided under a license agreement containing restrictions on use and disclosure and are also protected by copyright, patent and other intellectual and industrial property laws. Reverse engineering, disassembly or decompilation of the Programs, except to the extent required to obtain interoperability with other independently created software or as specified by law, is prohibited.

The information contained in this document is subject to change without notice. If you find any problems in the documentation, please report them to us in writing. Oracle Corporation does not warrant that this document is error-free. Except as may be expressly permitted in your license agreement for these Programs, no part of these Programs may be reproduced or transmitted in any form or by any means, electronic or mechanical, for any purpose, without the express written permission of Oracle Corporation.

If the Programs are delivered to the U.S. Government or anyone licensing or using the programs on behalf of the U.S. Government, the following notice is applicable:

Restricted Rights Notice Programs delivered subject to the DOD FAR Supplement are "commercial computer software" and use, duplication, and disclosure of the Programs, including documentation, shall be subject to the licensing restrictions set forth in the applicable Oracle license agreement. Otherwise, Programs delivered subject to the Federal Acquisition Regulations are "restricted computer software" and use, duplication, and disclosure of the Programs shall be subject to the restrictions in FAR 52.227-19, Commercial Computer Software - Restricted Rights (June, 1987). Oracle Corporation, 500 Oracle Parkway, Redwood City, CA 94065.

The Programs are not intended for use in any nuclear, aviation, mass transit, medical, or other inherently dangerous applications. It shall be the licensee's responsibility to take all appropriate fail-safe, backup, redundancy, and other measures to ensure the safe use of such applications if the Programs are used for such purposes, and Oracle Corporation disclaims liability for any damages caused by such use of the Programs.

Oracle is a registered trademark, and Oracle*MetaLink*, Oracle Store, Oracle9i, Oracle9iAS Discoverer, SQL*Plus, and PL/SQL are trademarks or registered trademarks of Oracle Corporation. Other names may be trademarks of their respective owners.

Perspective for Java licensed from Three D Graphics, Inc. Copyright © 2000, 2002, Three D. Graphics, Inc.

Contents

Send Us Your Comments	ix
Preface.....	xi
1 Installation Concepts	
1.1 Oracle9iAS Install Overview	1-2
1.2 Oracle9iAS Installation	1-4
1.3 Oracle9iAS Infrastructure Installation	1-8
1.4 Oracle9iAS Developer Kits Installation.....	1-10
1.5 Deployment Topologies	1-10
1.5.1 J2EE and Web Cache Installation.....	1-11
1.5.2 J2EE and Web Cache with Oracle9iAS Infrastructure	1-12
1.5.3 Multiple Instances of Oracle9iAS with Oracle9iAS Infrastructure	1-13
1.5.4 Oracle9iAS and Customer Database Usage	1-14
1.5.5 Oracle9iAS using v.1.0.2.2 Origin Database.....	1-16
1.5.6 Other Topology Considerations.....	1-16
2 Getting Started	
2.1 Hardware Requirements	2-2
2.2 Operating System Requirements	2-4
2.3 Online Documentation Requirements.....	2-6
2.4 Certified Software	2-6
2.5 Preinstallation Tasks	2-7
2.5.1 Release Notes.....	2-7

2.5.2	Component Dependent Configuration	2-7
2.5.3	Setting Environment Variables.....	2-8
2.5.4	Hostnames File Configuration	2-13
2.5.5	Creating UNIX Accounts and Groups	2-14
2.5.6	Port Allocation	2-16
2.5.7	Configuring Kernel Parameters	2-19
2.6	Oracle Universal Installer	2-20
2.6.1	About Oracle Universal Installer	2-20
2.6.2	Oracle Universal Installer Prerequisite Checks.....	2-21
2.6.3	oraInventory Directory	2-22
2.6.4	Starting Oracle Universal Installer.....	2-23
2.7	Installation	2-25
2.7.1	Oracle9i Application Server Installation.....	2-25
2.7.2	Oracle9iAS Infrastructure Installation	2-28
2.7.3	Oracle9iAS Developer Kits Installation.....	2-30
2.8	Additional Oracle9iAS Product Installations	2-32
2.8.1	Oracle9iAS Supplemental Components.....	2-32

3 Oracle9i Application Server

3.1	Oracle9iAS Installation	3-2
3.2	Oracle9iAS Install Types.....	3-10
3.3	Oracle9iAS Postinstallation.....	3-36
3.3.1	Starting the Oracle Enterprise Manager Web Site	3-36
3.3.2	Installing the Oracle9i Application Server Patches	3-36
3.3.3	Component Dependent Configuration	3-37
3.3.4	Configuring Additional Components	3-37
3.3.5	Postinstallation Configuration Tasks	3-37
3.3.6	Starting and Stopping Components	3-38
3.3.7	Component Port Numbers.....	3-39
3.3.8	Changing the X Server Display	3-40
3.3.9	Oracle9iAS Demonstration Software.....	3-40
3.3.10	Additional Oracle9iAS Product Installations.....	3-40
3.3.11	Additional Documentation	3-40

4 Oracle9iAS Infrastructure

4.1	Oracle9iAS Infrastructure Installation	4-2
4.2	Oracle9iAS Infrastructure Postinstallation	4-27
4.2.1	Starting Oracle Enterprise Manager Web Site	4-27
4.2.2	Installing the Oracle9iAS Infrastructure Patches.....	4-27
4.2.3	Starting and Stopping Components	4-28
4.2.4	Component Port Numbers.....	4-28
4.2.5	Additional Oracle9iAS Product Installations.....	4-29
4.2.6	Additional Documentation.....	4-29

5 Oracle9iAS Developer Kits

5.1	Oracle9iAS Developer Kits Installation.....	5-2
5.2	Oracle9iAS Developer Kits Postinstallation	5-19
5.2.1	Starting Oracle Enterprise Manager Web site.....	5-19
5.2.2	Starting and Stopping Components	5-19
5.2.3	Component Port Numbers.....	5-20
5.2.4	Additional Oracle9iAS Product Installations.....	5-21
5.2.5	Additional Documentation.....	5-21

6 Silent and Non-Interactive Installation

6.1	Introduction.....	6-2
6.1.1	Silent Installation.....	6-2
6.1.2	Non-Interactive Installation.....	6-3
6.2	Requirements	6-3
6.3	Creating Files for Silent and Non-Interactive Installation	6-3
6.3.1	oraInst.loc file creation	6-4
6.3.2	emtab file creation.....	6-4
6.3.3	oratab file creation.....	6-4
6.4	Selecting a Response File.....	6-5
6.5	Editing the Response File	6-6
6.6	Specifying a Response File	6-7
6.7	Running the Root.sh Script	6-8
6.7.1	Root.sh and Silent Installation.....	6-8
6.7.2	Root.sh and Non-Interactive Installation.....	6-9

6.8	Error Handling.....	6-10
6.9	Deinstallation	6-10
7	Coexistence	
7.1	Migration	7-2
7.2	Oracle9iAS Installation Coexistence with other Oracle products	7-3
8	Deinstallation and Reinstallation	
8.1	Deinstallation	9-2
8.1.1	Deinstalling Using Oracle Universal Installer.....	9-3
8.2	Reinstallation.....	9-9
A	Java Access Bridge Installation	
A.1	Setting-Up the Java Access Bridge	A-2
A.2	Setup for JRE 1.3.1	A-3
A.3	Setup for JRE 1.1.8	A-3
A.3.1	Setup for Oracle Universal Installer	A-3
A.3.2	Setup for Oracle Installed Components	A-5
B	Oracle9iAS Client Installation	
B.1	Introduction.....	B-2
B.2	Oracle9i Options	B-2
B.3	Preinstallation Requirements.....	B-2
B.3.1	Single Oracle Home Components.....	B-3
B.3.2	Client Component System Requirements.....	B-4
B.3.3	Oracle9i Database Client Products for Installation	B-5
B.3.4	Mandatory Individual Component Requirements.....	B-7
B.3.5	Linking and Relinking Applications	B-8
B.3.6	Networking Protocol Vendor Requirements.....	B-9
B.4	Installation	B-10
B.4.1	Preinstallation Tasks	B-10
B.4.2	Installing Oracle Components.....	B-11
B.4.3	Reviewing the Installation Session Log	B-13
B.4.4	Deinstalling Oracle Components and Services.....	B-14

B.4.5	Removing Oracle Keys from the Registry on Windows 98	B-17
B.5	Postinstallation Configuration Tasks	B-19
B.5.1	About NTFS File System and Windows NT Registry Permissions	B-19
B.5.2	Individual Component Postinstallation Configuration Tasks	B-22
B.6	Individual Components Available for Installation	B-23
B.6.1	Oracle9i Database Client Components	B-23
B.7	Installing Oracle Components in Noninteractive Mode.....	B-25

C Oracle9iAS InterConnect Installation and Configuration

C.1	Oracle9iAS InterConnect Installation Overview	C-2
C.1.1	Oracle9iAS InterConnect Installation Types.....	C-2
C.1.2	Dependent Products and Topologies.....	C-3
C.1.3	Hardware Requirements.....	C-7
C.1.4	Software Requirements	C-8
C.1.5	Multiple Oracle9iAS InterConnect Components on One Machine	C-11
C.2	Starting the Oracle9iAS InterConnect Installation	C-12
C.3	Oracle9iAS InterConnect Hub Installation.....	C-14
C.3.1	Oracle9iAS InterConnect Hub Pre-Installation Steps.....	C-14
C.3.2	Oracle9iAS InterConnect Hub Installation Steps for Topologies 1 and 3.....	C-15
C.3.3	Oracle9iAS InterConnect Hub Installation Steps for Topology 2	C-16
C.3.4	Oracle9iAS InterConnect Hub Post-Installation Steps (required for Oracle Workflow users only).....	C-18
C.4	Oracle9iAS InterConnect Adapter Installation	C-34
C.5	Oracle9iAS InterConnect Development Kit Installation	C-36
C.5.1	Installing the Development Kit.....	C-36
C.5.2	Oracle9iAS InterConnect Development Kit Post-Installation Steps.....	C-37
C.6	Oracle9iAS InterConnect Management Infrastructure Installation.....	C-39
C.7	How to Start Oracle9iAS InterConnect	C-40
C.7.1	Topology 1 and 3.....	C-40
C.7.2	Topology 2.....	C-41
C.8	How to Change Passwords for the Oracle9iAS InterConnect and Oracle Workflow Schemas.....	C-42
C.8.1	Topology 1 and 3.....	C-42
C.8.2	Topology 2.....	C-43
C.9	How to Create Multiple Repository Schemas in the Same Database	C-44

D Information for Release 1 Users

D.1	Oracle9iAS Install Types.....	D-2
D.2	Oracle9iAS Install Architecture	D-3
D.3	Oracle9iAS Dependency on Customer Database.....	D-4
D.4	Oracle9iAS Space Requirements by Install Type.....	D-5
D.5	Oracle9iAS Memory Requirements	D-6
D.6	Migration	D-7

E Components

F Default Port Numbers and Port Ranges

F.1	Oracle9iAS Port Usage (Sorted by Component)	F-2
F.2	Oracle9iAS Port Usage (Sorted by Port Number).....	F-6

G Installing the Documentation Library

G.1	Documentation Library Titles.....	G-2
G.2	Installing the Documentation Library	G-6
G.2.1	File Copy Installation.....	G-6
G.2.2	Oracle Universal Installer Installation.....	G-6
G.3	Viewing the Documentation Library	G-7

Index

Send Us Your Comments

**Oracle9i Application Server Installation Guide, Release 2 (9.0.2) for Sun SPARC Solaris
Part No. A90324-01**

Oracle Corporation welcomes your comments and suggestions on the quality and usefulness of this document. Your input is an important part of the information used for revision.

- Did you find any errors?
- Is the information clearly presented?
- Do you need more information? If so, where?
- Are the examples correct? Do you need more examples?
- What features did you like most?

If you find any errors or have any other suggestions for improvement, please indicate the document title and part number, and the chapter, section, and page number (if available). You can send comments to us in the following ways:

- Electronic mail: iasdocs_us@oracle.com
- FAX: 650-506-7407 Attn: Oracle9i Application Server Documentation Manager
- Postal service:
Oracle Corporation
Oracle9i Application Server Documentation
500 Oracle Parkway, M/S 2op3
Redwood Shores, CA 94065
USA

If you would like a reply, please give your name, address, telephone number, and (optionally) electronic mail address.

If you have problems with the software, please contact your local Oracle Support Services.

Preface

This guide describes the installation process for Oracle9i Application Server (Oracle9iAS).

This preface contains these topics:

- [Audience](#)
- [Organization](#)
- [Related Documentation](#)
- [Conventions](#)
- [Documentation Accessibility](#)

Audience

This installation guide is intended for database administrators and others responsible for installing Oracle products. You should be familiar with client/server relationships and database concepts.

Organization

This document contains:

[Chapter 1, "Installation Concepts"](#)

This chapter provides installation and configuring concepts for Oracle9iAS and provides feature information about each type of Oracle9iAS installation.

[Chapter 2, "Getting Started"](#)

This chapter provides information about hardware and software requirements, online documentation requirements, and preinstallation tasks for installation of Oracle9iAS.

[Chapter 3, "Oracle9i Application Server"](#)

This chapter guides you through the installation and postinstallation steps for Oracle9iAS.

[Chapter 4, "Oracle9iAS Infrastructure"](#)

This chapter guides you through the installation and postinstallation steps for Oracle9iAS Infrastructure.

[Chapter 5, "Oracle9iAS Developer Kits"](#)

This chapter guides you through the installation and postinstallation steps for Oracle9iAS Developer Kits.

[Chapter 6, "Silent and Non-Interactive Installation"](#)

This chapter guides you through Silent and Non-interactive installation steps for Oracle9iAS.

[Chapter 7, "Coexistence"](#)

This chapter provides information about the extra steps needed to insure coexistence of Oracle9i products on one computer.

[Chapter 8, "Deinstallation and Reinstallation"](#)

This chapter guides you through the deinstallation and reinstallation steps for Oracle9iAS.

[Appendix A, "Java Access Bridge Installation"](#)

This appendix guides you through the Java Access Bridge installation for use with assistive technologies.

[Appendix B, "Oracle9iAS Client Installation"](#)

This appendix guides you through the Oracle9i Database Client on the Oracle9iAS Client CD installation.

[Appendix C, "Oracle9iAS InterConnect Installation and Configuration"](#)

This appendix guides you through the Oracle9iAS Applications InterConnect installation and configuration.

[Appendix D, "Information for Release 1 Users"](#)

This appendix shows the compares Oracle9iAS Release 1 Version 1.0.2.2 to Release 2 Version 9.0.2.

[Appendix E, "Components"](#)

This appendix provides brief descriptions of all of the components that are available with Oracle9iAS.

[Appendix F, "Default Port Numbers and Port Ranges"](#)

This appendix lists the port numbers used by Oracle9iAS components.

[Appendix G, "Installing the Documentation Library"](#)

This appendix contains the contents of the Oracle9iAS Documentation Library CD-ROM, and provides instructions for installing and viewing the documentation.

Related Documentation

For more information, see these Oracle resources:

- Oracle9iAS Documentation Library CD-ROM
- Oracle9iAS Platform Specific Documentation on Oracle9iAS Disk 1

In North America, printed documentation is available for sale in the Oracle Store at <http://oraclestore.oracle.com/>

Customers in Europe, the Middle East, and Africa (EMEA) can purchase documentation from

<http://www.oraclebookshop.com/>

Other customers can contact their Oracle representative to purchase printed documentation.

To download free release notes, installation documentation, white papers, or other collateral, please visit the Oracle Technology Network (OTN). You must register online before using OTN; registration is free and can be done at

<http://technet.oracle.com/membership/index.htm>

If you already have a username and password for OTN, then you can go directly to the documentation section of the OTN Web site at

<http://technet.oracle.com/docs/index.htm>

Conventions

This section describes the conventions used in the text and code examples of this documentation set. It describes:

- [Conventions in Text](#)
- [Conventions in Code Examples](#)

Conventions in Text

We use various conventions in text to help you more quickly identify special terms. The following table describes those conventions and provides examples of their use.

Convention	Meaning	Example
Bold	Bold typeface indicates terms that are defined in the text or terms that appear in a glossary, or both.	When you specify this clause, you create an index-organized table .
<i>Italics</i>	Italic typeface indicates book titles or emphasis.	<i>Oracle9i Concepts</i> Ensure that the recovery catalog and target database do <i>not</i> reside on the same disk.
UPPERCASE monospace (fixed-width font)	Uppercase monospace typeface indicates elements supplied by the system. Such elements include parameters, privileges, datatypes, RMAN keywords, SQL keywords, SQL*Plus or utility commands, packages and methods, as well as system-supplied column names, database objects and structures, usernames, and roles.	You can specify this clause only for a NUMBER column. You can back up the database by using the BACKUP command. Query the TABLE_NAME column in the USER_TABLES data dictionary view. Use the DBMS_STATS.GENERATE_STATS procedure.
lowercase monospace (fixed-width font)	Lowercase monospace typeface indicates executables, filenames, directory names, and sample user-supplied elements. Such elements include computer and database names, net service names, and connect identifiers, as well as user-supplied database objects and structures, column names, packages and classes, usernames and roles, program units, and parameter values. Note: Some programmatic elements use a mixture of UPPERCASE and lowercase. Enter these elements as shown.	Enter sqlplus to open SQL*Plus. The password is specified in the orapwd file. Back up the datafiles and control files in the /disk1/oracle/dbs directory. The department_id, department_name, and location_id columns are in the hr.departments table. Set the QUERY_REWRITE_ENABLED initialization parameter to true. Connect as oe user. The JRepUtil class implements these methods.
lowercase monospace (fixed-width font) <i>italic</i>	Lowercase monospace italic font represents placeholders or variables.	You can specify the <i>parallel_clause</i> . Run <i>Uold_release</i> .SQL where <i>old_release</i> refers to the release you installed prior to upgrading.

Conventions in Code Examples

Code examples illustrate SQL, PL/SQL, SQL*Plus, or other command-line statements. They are displayed in a monospace (fixed-width) font and separated from normal text as shown in this example:

```
SELECT username FROM dba_users WHERE username = 'MIGRATE';
```

The following table describes typographic conventions used in code examples and provides examples of their use.

Convention	Meaning	Example
[]	Brackets enclose one or more optional items. Do not enter the brackets.	DECIMAL (<i>digits</i> [, <i>precision</i>])
{ }	Braces enclose two or more items, one of which is required. Do not enter the braces.	{ENABLE DISABLE}
	A vertical bar represents a choice of two or more options within brackets or braces. Enter one of the options. Do not enter the vertical bar.	{ENABLE DISABLE} [COMPRESS NOCOMPRESS]
...	Horizontal ellipsis points indicate either: <ul style="list-style-type: none"> That we have omitted parts of the code that are not directly related to the example That you can repeat a portion of the code 	CREATE TABLE ... AS <i>subquery</i> ; SELECT <i>col1</i> , <i>col2</i> , ... , <i>coln</i> FROM employees;
.	Vertical ellipsis points indicate that we have omitted several lines of code not directly related to the example.	
Other notation	You must enter symbols other than brackets, braces, vertical bars, and ellipsis points as shown.	acctbal NUMBER(11,2); acct CONSTANT NUMBER(4) := 3;
<i>Italics</i>	Italicized text indicates placeholders or variables for which you must supply particular values.	CONNECT SYSTEM/ <i>system_password</i> DB_NAME = <i>database_name</i>
UPPERCASE	Uppercase typeface indicates elements supplied by the system. We show these terms in uppercase in order to distinguish them from terms you define. Unless terms appear in brackets, enter them in the order and with the spelling shown. However, because these terms are not case sensitive, you can enter them in lowercase.	SELECT last_name, employee_id FROM employees; SELECT * FROM USER_TABLES; DROP TABLE hr.employees;

Convention	Meaning	Example
lowercase	Lowercase typeface indicates programmatic elements that you supply. For example, lowercase indicates names of tables, columns, or files. Note: Some programmatic elements use a mixture of UPPERCASE and lowercase. Enter these elements as shown.	<pre>SELECT last_name, employee_id FROM employees; sqlplus hr/hr CREATE USER mjones IDENTIFIED BY ty3MU9;</pre>

Documentation Accessibility

Our goal is to make Oracle products, services, and supporting documentation accessible, with good usability, to the disabled community. To that end, our documentation includes features that make information available to users of assistive technology. This documentation is available in HTML format, and contains markup to facilitate access by the disabled community. Standards will continue to evolve over time, and Oracle Corporation is actively engaged with other market-leading technology vendors to address technical obstacles so that our documentation can be accessible to all of our customers. For additional information, visit the Oracle Accessibility Program Web site at:

<http://www.oracle.com/accessibility/>

Accessibility of Links to External Web Sites in Documentation

This documentation may contain links to Web sites of other companies or organizations that Oracle Corporation does not own or control. Oracle Corporation neither evaluates nor makes any representations regarding the accessibility of these Web sites.

Installation Concepts

This chapter discusses the installation and configuring concepts for Oracle9i Application Server (Oracle9iAS) and provides feature information about each Oracle9iAS installation. Oracle recommends reading this chapter before proceeding with your intended installation so that you will have a better understanding of the concepts and intent of each Oracle9iAS installation. The following topics are covered in this chapter:

- [Oracle9iAS Install Overview](#)
- [Oracle9iAS Installation](#)
- [Oracle9iAS Infrastructure Installation](#)
- [Oracle9iAS Developer Kits Installation](#)
- [Deployment Topologies](#)

See also: *Oracle9i Application Server Concepts Guide*

1.1 Oracle9iAS Install Overview

This section describes the three types of Oracle9iAS installation. The Oracle9iAS installation consists of:

- **Oracle9iAS Installation:** The Oracle9iAS installation creates a scalable, secure, and integrated middle-tier platform that enables you to deliver Web content, host Web applications, connect to back-office applications, and access your data on wireless devices. All Oracle9iAS applications run on the middle tier.
- **Oracle9iAS Infrastructure Installation:** The Oracle9iAS Infrastructure installation creates a combination of a metadata repository database, single sign-on server, Lightweight Directory Access Protocol (LDAP), version 3 (v3) directory server, and management server that supports Oracle9iAS deployment. The database contains a collection of schemas and metadata that enable Oracle9iAS components. Oracle9iAS Infrastructure is a prerequisite for many Oracle9iAS middle-tier components.

Note: Oracle9iAS Infrastructure must be installed and configured prior to most installations of Oracle9iAS. Oracle recommends installing Oracle9iAS Infrastructure on a separate computer for optimal performance.

- **Oracle9iAS Developer Kits Installation:** The Oracle9iAS Developer Kits installation enables you to create XML applications, develop portlets, enable wireless applications, integrate Web sites with wireless devices, and develop application provider Web services. The Oracle9iAS Developer Kits installation is not required, but is an option if you want to setup a test environment.

Note: You must use the same operating system account when adding additional Oracle9iAS installations on the same host.

Figure 1-1 shows an overview of the architecture of Oracle9iAS. Your architecture will depend on the type of Oracle9iAS installation you select.

Figure 1-1 Oracle9iAS Architecture

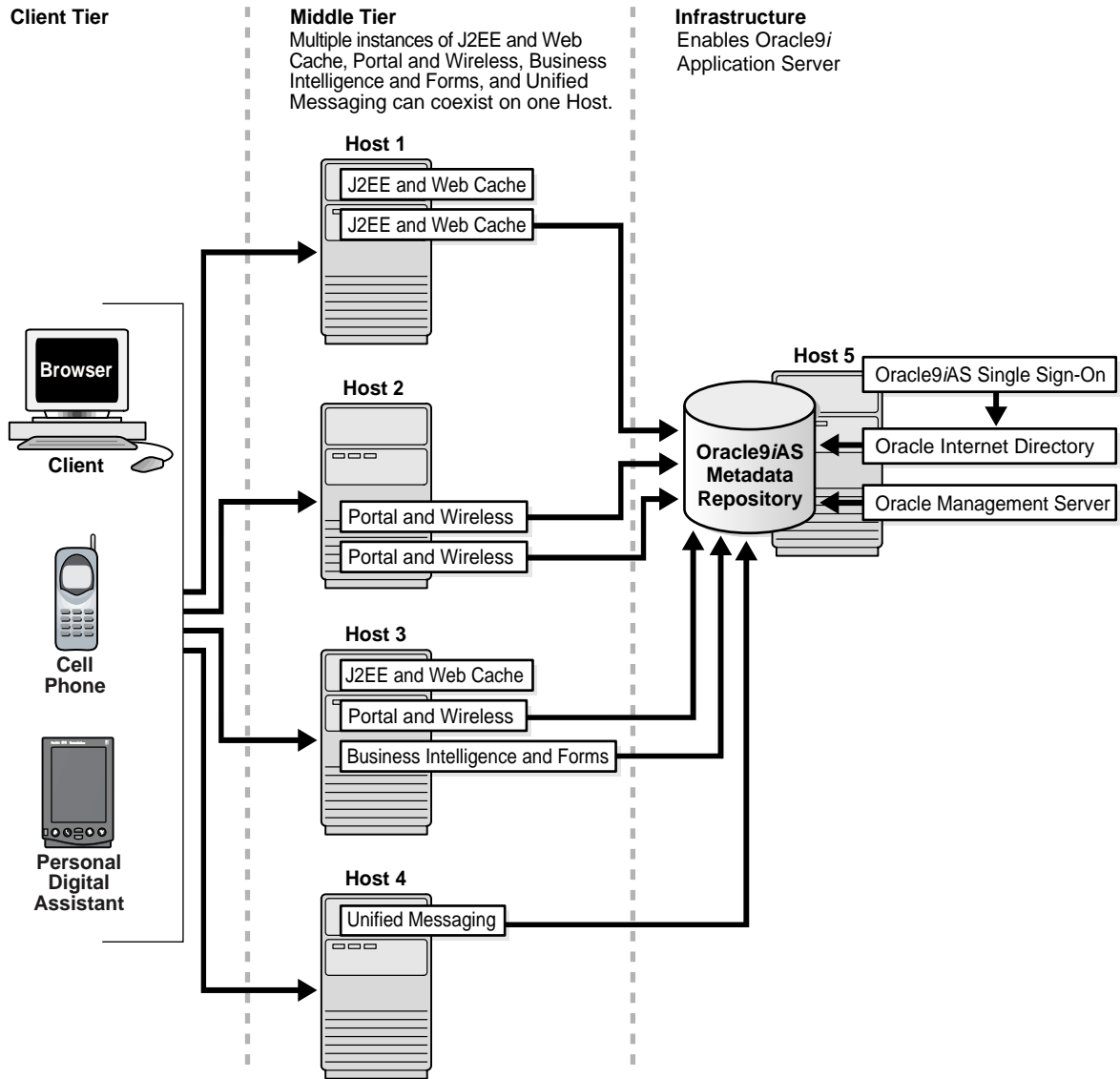

1.2 Oracle9iAS Installation

All Oracle9iAS applications run on the middle tier.

The Oracle9iAS installation offers the following install types:

- **J2EE and Web Cache:** Provides a Web server that enables you to develop and deploy Java 2 Enterprise Edition (J2EE) applications, use J2EE and Simple Object Access Protocol (SOAP) based Web services, and accelerates Web site performance with Oracle9iAS Web Cache.
- **Portal and Wireless:** Enables the deployment of enterprise portals and wireless applications. Includes all Oracle9iAS components available in the J2EE and Web Cache install type.
- **Business Intelligence and Forms:** Enables analysis of clickstream data, personalization of applications, use of forms-based applications, and deployment of Decision Support System and Web-based reports. Includes all Oracle9iAS components available in the Portal and Wireless install type.
- **Unified Messaging:** Enables the messaging capabilities of Oracle9iAS. Includes all of the Oracle9iAS components available in the Business Intelligence and Forms install type.

[Table 1-1](#) lists the four installation options for Oracle9iAS, and the Oracle9iAS components that are installed with each option.

Table 1–1 Oracle9iAS Components

Component	J2EE and Web Cache	Portal and Wireless	Business Intelligence and Forms	Unified Messaging
Oracle9iAS Web Cache	YES	YES	YES	YES
Oracle HTTP Server ¹	YES	YES	YES	YES
Oracle9iAS Container for J2EE	YES	YES	YES	YES
Oracle Enterprise Manager Web site	YES	YES	YES	YES
Oracle9iAS Portal ²	no	YES	YES	YES
Oracle9iAS Wireless	no	YES	YES	YES
Oracle9iAS Discoverer ³	no	no	YES	YES
Oracle9iAS Reports Services	no	no	YES	YES
Oracle9iAS Clickstream Intelligence	no	no	YES	YES
Oracle9iAS Forms Services	no	no	YES	YES
Oracle9iAS Personalization	no	no	YES	YES
Oracle9iAS Unified Messaging	no	no	no	YES

¹ Oracle HTTP Server installs the following Oracle mods: mod_oc4j, mod_jserv, mod_osso, mod_ossl, mod_plsql, mod_proxy, DMS, FastCGI, HiAv Infrastructure, Oracle9iAS Object Caching Services for Java, SOAP, DBI/DBD, Clickstream Collector Agent.

² Oracle9iAS Portal installs Oracle Ultra Search and Oracle9i Syndication Server.

³ Oracle9iAS Discoverer installs Discoverer Viewer and Discoverer Plus.

See Also:

- [Appendix E, "Components"](#)
- *Oracle9i Application Server Concepts Guide.*

Prior to installing an instance of the Portal and Wireless, Business Intelligence and Forms, or Unified Messaging install type, *you must* install and configure the Oracle9iAS Infrastructure somewhere in your network, optimally on a separate computer.

The J2EE and Web Cache install type does not require Oracle9iAS Infrastructure.

During the installation you will be asked if you want to use single sign-on or clustering functionality. An application server cluster is a collection of application server instances with identical configuration and application deployment. Clusters enforce homogeneity between member instances so that a cluster of application server instances can appear and function as a single instance. With appropriate front-end load balancing, any instance in an application server cluster can serve client requests. This simplifies configuration and deployment across multiple instances and enables fault tolerance among clustered instances.

Clustering enables you to expand your application server capabilities and single sign-on simplifies security over your network. If you want to use either of these features, then you need to install Oracle9iAS Infrastructure first. Information about the application server cluster is maintained in the Oracle9iAS Infrastructure Metadata Repository. If you are not sure, you can configure for clustering and single sign-on later.

See Also:

- *Oracle9i Application Server Administrator's Guide*
- *Oracle9iAS Single Sign-On Administrator's Guide*
- *Oracle9iAS Containers for J2EE User's Guide*

Figure 1–2 shows the decision process you need to consider before installing Oracle9iAS.

Figure 1–2 Oracle9iAS Decision Tree

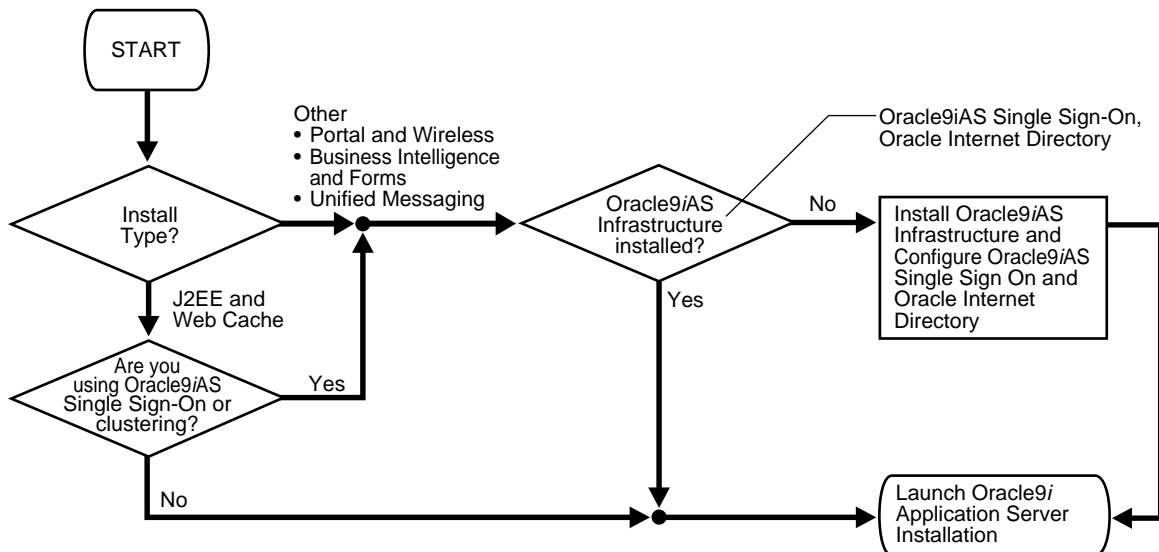

Based on your Oracle9iAS install type selection, all Oracle9iAS components for that install type are installed on your computer. However, you can selectively configure the Oracle9iAS components you wish to use. You can configure Oracle9iAS components during the install session, or you can use the Oracle Enterprise Manager Web site to complete the Oracle9iAS component configuration later.

[Chapter 2, "Getting Started"](#) lists the hardware and software requirements for installing Oracle9iAS.

[Chapter 3, "Oracle9i Application Server"](#) describes installing the four Oracle9iAS install types.

See Also: *Oracle9i Application Server Administrator's Guide*

1.3 Oracle9iAS Infrastructure Installation

The Oracle9iAS Infrastructure installation consists of:

- **Oracle9iAS Metadata Repository:** Pre-seeded database containing metadata needed to run Oracle9iAS instances.
- **Oracle Internet Directory:** Directory service that enables sharing information about dispersed users and network resources. Oracle Internet Directory implements the LDAP, v3.
- **Oracle9iAS Single Sign-On:** Creates an enterprise-wide user authentication to access multiple accounts and Oracle9iAS applications.
- **Oracle Management Server:** Processes system management tasks and administers the distribution of these tasks across the network using the Oracle Enterprise Manager Console. The Console and its three-tier architecture can be used with the Oracle Enterprise Manager Web site to manage not only Oracle9iAS, but your entire Oracle environment.
- **J2EE and Web Cache:** For internal use with Oracle9iAS Infrastructure. Not used for component application deployment.

Note: Oracle does not support the use of this copy of J2EE and Web Cache for customer application deployment. This installation of J2EE and Web Cache configures Oracle HTTP Server and Oracle9iAS Container for J2EE.

Oracle9iAS Infrastructure is required for all of the Oracle9iAS middle-tier applications except when installing the J2EE and Web Cache install type without single sign-on or clustering. Prior to installing an instance of either the Portal and Wireless, Business Intelligence and Forms, or Unified Messaging install types, *you must* install and configure the Oracle9iAS Infrastructure somewhere in your network. Oracle recommends installing Oracle9iAS Infrastructure on a separate computer.

Typical infrastructure configuration includes one Oracle9iAS Single Sign-On instance and one Oracle Internet Directory instance in a network, with one or more installations of Oracle Management Server.

Oracle recommends using the version of Oracle Internet Directory that ships with Oracle9iAS. However, if you have an existing version of Oracle Internet Directory that you want to use for your installation of Oracle9iAS, then refer to *Oracle9i Application Server: Migrating from Oracle9i Application Server 1.0.2.2* for further instructions on configuration and deployment. For more certification information about Oracle Internet Directory, go to:

<http://metalink.oracle.com>

Chapter 2, "Getting Started" lists the hardware and software requirements for installing Oracle9iAS.

Chapter 4, "Oracle9iAS Infrastructure" describes installing Oracle9iAS Infrastructure.

1.4 Oracle9iAS Developer Kits Installation

The Oracle9iAS Developer Kits installation enables the user to create XML applications, develop portlets, enable wireless applications, integrate Web sites with wireless devices, and develop application provider Web services.

Oracle9iAS Developer Kits installs:

- Oracle XML Developer's Kit
- Oracle9iAS Portal Developer's Kit
- Oracle9iAS Wireless Developer's Kit
- Oracle LDAP Developer's Kit.

Oracle9iAS Developer Kits components are also included with the Oracle9iAS installation.

1.5 Deployment Topologies

All of the Oracle9iAS middle-tier and Oracle9iAS Infrastructure components should share the same management and security infrastructure, and typically share the same metadata repository. However, it is possible to use more than one metadata repository.

The following sections show possible installations of Oracle9iAS:

- [J2EE and Web Cache Installation](#)
- [J2EE and Web Cache with Oracle9iAS Infrastructure](#)
- [Multiple Instances of Oracle9iAS with Oracle9iAS Infrastructure](#)
- [Oracle9iAS and Customer Database Usage](#)

Note: The Oracle9iAS installation can be installed as single or multiple instances on one or many hosts.

See Also: [Figure 1-1, "Oracle9iAS Architecture"](#)

1.5.1 J2EE and Web Cache Installation

[Figure 1–3](#) shows an installation of J2EE and Web Cache on a host. This topology supports a Web server that can support the deployment of J2EE-compliant applications and cache Web pages. This topology *does not* support single sign-on or application server clustering functionality. In order to use single sign-on or clustering functionality you must install Oracle9iAS Infrastructure.

Figure 1–3 J2EE and Web Cache Installation

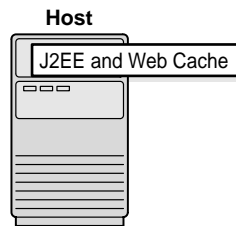

See Also: [Figure 1–4, "J2EE and Web Cache with Oracle9iAS Infrastructure"](#)

1.5.2 J2EE and Web Cache with Oracle9iAS Infrastructure

Figure 1-4 shows an installation of J2EE and Web Cache using Oracle9iAS Infrastructure. The installation of J2EE and Web Cache is on a different host from the Oracle9iAS Infrastructure installation. (Oracle recommends installing Oracle9iAS Infrastructure on a separate computer for optimal performance). The Oracle9iAS Infrastructure installation enables deployment of applications that use enterprise-wide single sign-on capabilities, as well as application server instance clustering.

The Portal and Wireless, Business Intelligence and Forms, or Unified Messaging install types feature the same installation architecture shown in Figure 1-4. Oracle9iAS Infrastructure must be installed and configured prior to installation.

Figure 1-4 J2EE and Web Cache with Oracle9iAS Infrastructure

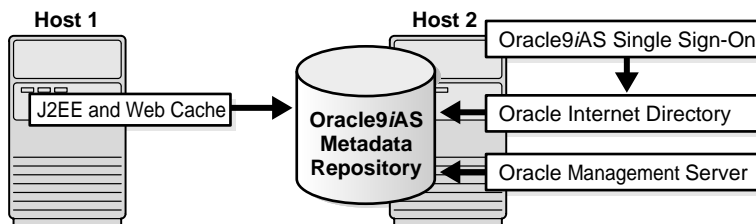

1.5.3 Multiple Instances of Oracle9iAS with Oracle9iAS Infrastructure

You can install single or multiple instances of Oracle9iAS install types, J2EE and Web Cache, Portal and Wireless, Business Intelligence and Forms, and Unified Messaging, on the same host.

Figure 1-5 shows instances of J2EE and Web Cache, and Portal and Wireless installed on Host 1, and Business Intelligence and Forms, and Unified Messaging installed on Host 2, using the installation of Oracle9iAS Infrastructure on Host 3. Multiple instances of different Oracle9iAS install types can use one instance of Oracle9iAS Infrastructure.

Figure 1-5 Multiple Instances of Oracle9iAS with Oracle9iAS Infrastructure

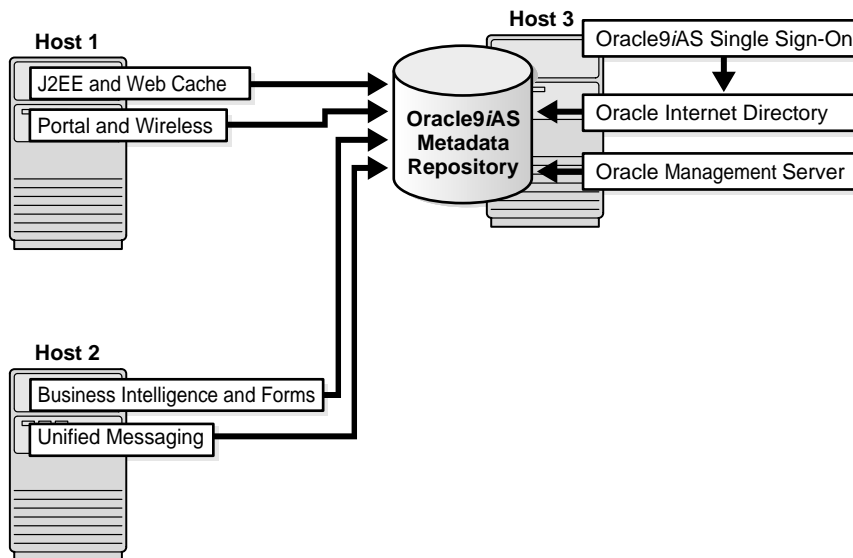

See Also: *Oracle9i Application Server Administrator's Guide*

1.5.4 Oracle9iAS and Customer Database Usage

Figure 1–6 is the same as Figure 1–5 except that the instance of Oracle9iAS Unified Messaging on Host 2 is also using an Oracle9i customer database on Host 4.

Oracle9iAS components that interact with customer data use the customer database for metadata schema storage. Multiple Oracle9iAS component installations of the same type can use the same, or different customer databases. A single database instance can hold metadata schemas and data for different types of Oracle9iAS components.

The following Oracle9iAS components must connect to a customer database:

- Oracle9iAS Unified Messaging
- Oracle9iAS Discoverer
- Oracle9iAS Personalization
- Oracle9iAS Portal (optional)
- Oracle9iAS Clickstream Intelligence (optional)

Oracle9iAS Portal and Oracle9iAS Clickstream Intelligence can connect to a customer database or use the Oracle9iAS Metadata Repository

After you configure the middle tier to use one of the above Oracle9iAS components, you must run the component configuration tool to place the required data into your database. Refer to component documentation for the following:

- Oracle9iAS Unified Messaging (*Oracle9iAS Unified Messaging Administrator's Guide*)
- Oracle9iAS Discoverer (*Oracle9iAS Discoverer Administrator's Guide*)
- Oracle9iAS Personalization (*Oracle9iAS Personalization Administrator's Guide*)
- Oracle9iAS Portal (*Oracle9iAS Portal User's and Administrator's Guide*)
- Oracle9iAS Clickstream Intelligence (*Oracle9iAS Clickstream Intelligence Release Notes* and *Oracle9iAS Clickstream Intelligence Administrator's Guide*)

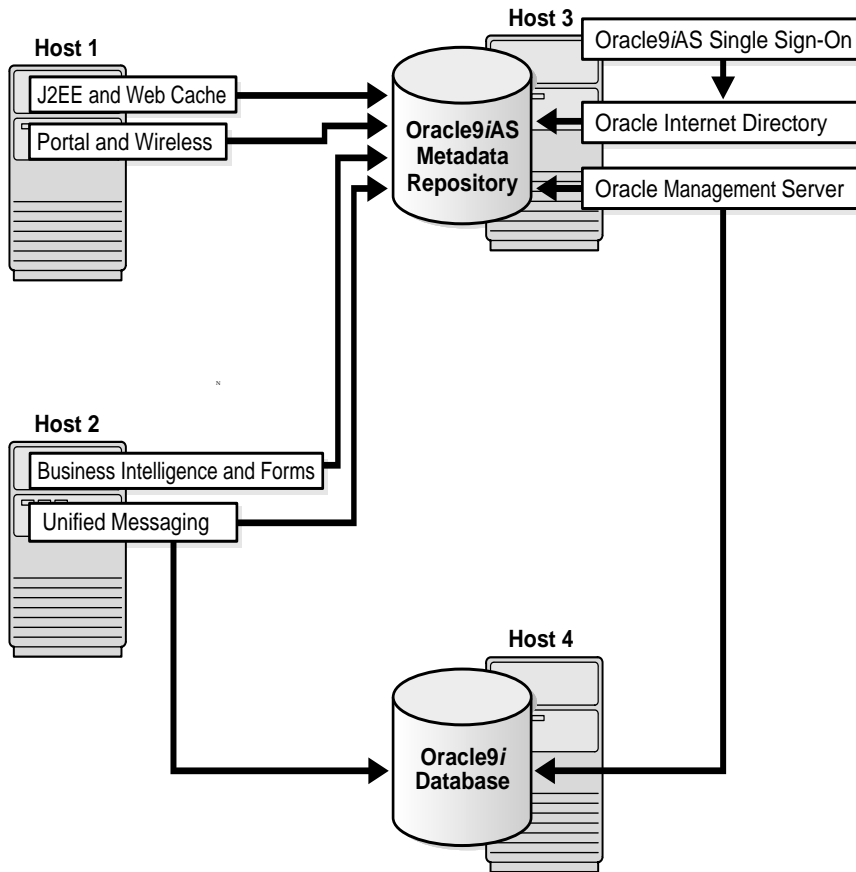
Figure 1-6 Oracle9iAS and Customer Database Usage

See Also: *Oracle9i Application Server Administrator's Guide*

1.5.5 Oracle9iAS using v.1.0.2.2 Origin Database

You can use an existing Oracle9iAS (v.1.0.2.2) database for specific Oracle9iAS components. Refer to *Oracle9i Application Server: Migrating from Oracle9i Application Server 1.0.2.2*.

1.5.6 Other Topology Considerations

You can achieve optimal performance for extensively used Oracle9iAS components by connecting to a metadata repository located on a separate host. This type of configuration is accomplished by installing Oracle9iAS Infrastructure on the separate host *without* installing Oracle9iAS Single Sign-On and Oracle Internet Directory. Connect the Oracle9iAS components to the new metadata repository by clicking on the **Use Infrastructure** link on the Oracle Enterprise Manager Web site.

See Also:

- [Section 3.3.1, "Starting the Oracle Enterprise Manager Web Site"](#)
- *Oracle9i Application Server Administrator's Guide*
- *Oracle9i Application Server: Migrating from Oracle9i Application Server 1.0.2.2*

Getting Started

This chapter provides information about how to start installing Oracle9i Application Server (Oracle9iAS). The topics include:

- [Hardware Requirements](#)
- [Operating System Requirements](#)
- [Online Documentation Requirements](#)
- [Certified Software](#)
- [Preinstallation Tasks](#)
- [Oracle Universal Installer](#)
- [Installation](#)
- [Additional Oracle9iAS Product Installations](#)

2.1 Hardware Requirements

Table 2-1, Table 2-2, Table 2-3, and Table 2-4 contain the minimum hardware requirements for Oracle9iAS.

Table 2-1 Oracle9iAS Hardware Requirements

Information	Example Values
CPU ¹	A SPARC Processor
Disk Space ²	Oracle9iAS <ul style="list-style-type: none"> ■ J2EE and Web Cache: 435MB ■ Portal and Wireless: 1.20 GB ■ Business Intelligence and Forms: 1.91 GB ■ Unified Messaging: 2.02 GB Oracle9iAS Infrastructure: 1.91 GB Oracle9iAS Developer Kits: 701 MB
TMP or Swap Space	1 GB
/var/tmp Space	Oracle9iAS <ul style="list-style-type: none"> ■ J2EE and Web Cache: 5 MB ■ Portal and Wireless: 12 MB ■ Business Intelligence and Forms: 95 MB ■ Unified Messaging: 95 MB Oracle9iAS Infrastructure: 7 MB Oracle9iAS Developer Kits: 5 MB
Monitor	256 color viewing capability

¹ Oracle recommends a multiple CPU computer.

² The disk space must be available on a single disk. Oracle9iAS does not support spanning the installation over multiple disks.

Table 2–2 Oracle9iAS Memory Requirements

Install Type	Component Configuration	Minimum Memory Requirements
J2EE and Web Cache	<ul style="list-style-type: none"> ■ Oracle HTTP Server ■ Oracle9iAS Containers for J2EE ■ Oracle9iAS Web Cache ¹ 	128 MB
All other Oracle9iAS install types	Configure up to three additional Oracle9iAS components	256 MB
All other Oracle9iAS install types	Configure four or more additional Oracle9iAS components	512 MB

¹ Memory for Oracle9iAS Web Cache should be based on the following formula: (average HTTP object size) * (maximum number of objects you want to cache). Thus, if you want to cache 1,000,000 objects and the average size of the objects is 3 KB, then set the maximum cache size to at least 3 GB.

Table 2–3 Oracle9iAS Infrastructure Memory Requirements

Install Type	Component Configuration	Minimum Memory Requirements
Oracle9iAS Infrastructure	<ul style="list-style-type: none"> ■ Oracle9iAS Metadata Repository ■ Oracle9iAS Single Sign-On ■ Oracle Internet Directory ■ Oracle Management Server ■ J2EE and Web Cache 	512 MB

Table 2–4 Oracle9iAS Developer Kits Memory Requirements

Install Type	Component Configuration	Minimum Memory Requirements
Oracle9iAS Developer Kits	<ul style="list-style-type: none"> ■ Oracle XML Developer Kit ■ Oracle9iAS Portal Developer's Kit ■ Oracle9iAS Wireless Developer's Kit ■ Oracle LDAP Developer's Kit ■ J2EE and Web Cache 	128 MB

2.2 Operating System Requirements

Oracle9iAS installs on the following Solaris Operating Environments:

- [Solaris 2.6](#)
- [Solaris 7](#)
- [Solaris 8](#)

Table 2–5 lists the Solaris Operating System patches you need to download and install before installing Oracle9iAS. You can download the patches from:

<http://sunsolve.sun.com>

Table 2–5 Solaris Operating System and Required Patches

Operating System	Version
Solaris 2.6	<ul style="list-style-type: none"> ■ Latest recommended patch cluster ■ Linker patch: 107733-09 or higher ■ /usr/lib/libthread.so.1 patch: 105568-23 or higher ■ libaio, libc, watchmalloc patch: 105210-38 or higher ■ X Input & Output Method patch: 106040-17 or higher ■ OpenWindows 3.6: Xsun patch: 105633-59 or higher¹ ■ Chinese TrueType fonts: 106409-01 or higher² ■ SunOS 5.6: ssJDK1.2.1_03 fails with fatal errors in ISO8859-01 Locales: 108091-03 or higher³ ■ CDE 1.2: libDtSvc patch (recommended): 105669-10 or higher ■ Motif 1.2.7: Runtime library patch: 105284-45 or higher ■ SunOS 5.6: Kernel update patch (required):105181-30 or higher ■ Patchadd and patchrm patch: 106125-11 or higher ■ /kernel/drv/mm patch: 106429-02 or higher ■ C++ shared library patch: 105591-12 or higher ■ Euro support patch: 106842-09 or higher and 106841-01 or higher

Table 2–5 Solaris Operating System and Required Patches(Cont.)

Operating System	Version
Solaris 7	<ul style="list-style-type: none"> ■ Latest recommended patch cluster ■ Libthread patch: 106980-17 or higher ■ Kernal update patch: 106541-17 or higher ■ /kernal/fs/sockfs patch: 109104-04 or higher ■ /usr/lib/fs/fsck patch: 107544-03 or higher ■ Motif Runtime library patch: 107081-37 or higher ■ X Input & Output Method patch: 107636-08 or higher ■ OpenWindows 3.6.1 Xsun patch: 108376-29 or higher¹ ■ CDE Windows manager patch: 107226-18 or higher ■ CDE 1.3 libDT Widget patch: 108374-05 or higher ■ Patch for replacing bad font in zh.GBK locale: 107153-01 or higher ■ Linker patch: 106950-16 or higher ■ Shared library for C++ patch: 106300-10 or higher, and 106327-11 or higher ■ Open Windows 3.6.1 libX+Patch: 107656-07 or higher ■ CDE 1.3: dtsession patch: 107702-09 or higher
Solaris 8	<ul style="list-style-type: none"> ■ Latest recommended patch cluster ■ Xsun patch: 108652-37 or higher ■ CDE dtwm patch: 108921-13 or higher ■ Motif 2.1 patch: 108940-37 or higher ■ Portal and Wireless patch: 112138-01 or higher

¹ This patch is only required for Asian locales.

² This patch is only required to display Traditional Chinese characters in Swing applications.

³ This patch is only required for any locale that uses the ISO8859-1 or ISO8859-15 character encoding.

2.3 Online Documentation Requirements

You can view Oracle9iAS documentation online using a Web browser or Portable Data Format (PDF) Viewer.

[Table 2-6](#) lists the documentation viewing tools for Oracle9iAS online documentation.

See Also: [Appendix G, "Installing the Documentation Library"](#)

Table 2-6 *Online Documentation Requirements*

Requirement	Items
Online Readers	Requires any one of the following: HTML <ul style="list-style-type: none"> ■ Netscape Navigator 4.7 or higher ■ Microsoft Internet Explorer 5.0 or higher PDF <ul style="list-style-type: none"> ■ Acrobat Reader 3.0 or higher ■ Acrobat Reader+Search 3.0 or higher ■ Acrobat Exchange 3.0 or higher ■ PDFViewer Web browser plug-in 1.0 or higher
Library-wide HTML search and navigation	Active Internet Connection
Disk Space	310 MB

2.4 Certified Software

Installing and operating Oracle9iAS requires a Web browser. Some of the Oracle9iAS installations require an Oracle database. A complete list of certified software, including databases and Web browsers, for Oracle9iAS is located at Oracle MetaLink:

<http://metalink.oracle.com>

2.5 Preinstallation Tasks

Review and complete the following preinstallation tasks before installing Oracle9iAS:

- [Release Notes](#)
- [Component Dependent Configuration](#)
- [Setting Environment Variables](#)
- [Hostnames File Configuration](#)
- [Creating UNIX Accounts and Groups](#)
- [Port Allocation](#)
- [Configuring Kernel Parameters](#)

2.5.1 Release Notes

Oracle recommends reading the *Oracle9i Application Server Release Notes* prior to installing Oracle9iAS. *Oracle9i Application Server Release Notes* are available with Oracle platform-specific documentation and are available at the OTN Web site at:

<http://technet.oracle.com/docs/index.htm>

2.5.2 Component Dependent Configuration

The following section describes dependent configuration requirements for Oracle9iAS Unified Messaging.

2.5.2.1 Oracle9iAS Unified Messaging

In order to store data on a customer database, the database must be configured before Oracle9iAS Unified Messaging installation. Information about Oracle9iAS Unified Messaging is available in the *Oracle9iAS Unified Messaging Administrator's Guide*.

2.5.3 Setting Environment Variables

The following environment variables must be verified before starting Oracle Universal Installer:

- [ORACLE_HOME](#)
- [DISPLAY](#)
- [TMP](#)
- [TNS_ADMIN](#)
- [UNIX Group Name for the Oracle Universal Installer Inventory](#)
- [UNIX Account to Own Oracle Software](#)
- [UNIX Group Names for Privileged Groups](#)

2.5.3.1 ORACLE_HOME

Oracle home is the root directory in which Oracle software is installed.

Oracle homes are identified by name. The Oracle home name identifies the program group associated with a specific Oracle home and the installed Oracle services associated with the home.

Multiple instances of Oracle9iAS install types (J2EE and Web Cache, Business Intelligence and Forms, Portal and Wireless, and Unified Messaging) must be installed in separate Oracle homes on the same computer. However, a previous Oracle9iAS instance can be extended to larger install type using Oracle Universal Installer. It is not possible to downgrade a larger install type to a smaller install type.

You must install Oracle9iAS Infrastructure in its own Oracle home directory, preferably on a separate host. The Oracle9iAS installation cannot exist in the same Oracle home as the Oracle9iAS Infrastructure installation.

Components from the Oracle9iAS Developer Kits installation are installed as part of the Oracle9iAS installation. Oracle9iAS Developer Kits can be installed on a separate host to set up a development environment.

Oracle9iAS installations require a unique instance name and administrative (ias_admin) password during initial installation on a host. Additional installations of Oracle9iAS on the host in the *same* Oracle home require the ias_admin password to continue with the installation. Installations in a *different* Oracle home require an instance name and the ias_admin password before continuing with the installation.

See Also:

- [Chapter 1, "Installation Concepts"](#)
- *Oracle9i Application Server Administrator's Guide*

2.5.3.1.1 Preventing Conflicts With Other Oracle Homes

To prevent a conflict between the software in an existing Oracle home and the Oracle9iAS installation, you must remove all references to the existing Oracle home in your environment. Follow these steps to remove these references.

1. Unset your existing Oracle home variable using the following command.

C shell	Bourne/Korn shell
prompt> unsetenv ORACLE_HOME	prompt> unset ORACLE_HOME

2. Edit your PATH, CLASSPATH, and LD_LIBRARY_PATH environment variables so they do not use the existing Oracle home value.

Note: Be sure to set your LD_LIBRARY_PATH environment variable to include `ORACLE_HOME/lib`.

Note: Be sure your PATH, LD_LIBRARY_PATH, and CLASSPATH environment variables do not exceed 1,024 characters. Longer variable names might generate errors such as "Word too long" during installation.

2.5.3.2 DISPLAY

Set the `DISPLAY` environment variable to refer to the X Server that will display the installer. The format of the `DISPLAY` environment variable is:

hostname:display_number.screen_number

Oracle9iAS requires a running X server to properly create graphics for the installer, Web applications, and management tools. The frame buffer X server installed with your operating system requires that you remain logged in and have the frame buffer running at all times. If you do not wish to do this, then you must use a virtual frame buffer, such as X Virtual Frame Buffer (XVFB) or Virtual Network Computing (VNC).

The installer configures this instance to use the same X server from the installation process for applications and management tools. This X server must either always be running or you must reconfigure Oracle9iAS to use another X server that is always running after the installation completes.

Note: Oracle Applications users must read article 181244.1 at:

<http://metalink.oracle.com>

This article contains applications-specific X server requirements and configuration information.

See Also:

- Your operating system documentation for more information on the `DISPLAY` environment variable.
- Oracle Technology Network (<http://otn.oracle.com>) for further information about obtaining and installing XVFB or other virtual frame buffer solutions. Search OTN for "frame buffer".

2.5.3.2.1 Installing From a Remote Machine

Setting the `DISPLAY` environment variable enables you to run the Oracle Universal Installer remotely from another workstation. On the system where you launch the Oracle Universal Installer, set `DISPLAY` to the system name or IP address of your local workstation.

Note: You can use a PC X emulator to run the install if it supports a PseudoColor color model or PseudoColor visual. Set the PC X emulator to use a PseudoColor visual, and then start the installer. Refer to the X emulator documentation for instructions on how to change the color model or visual settings.

If you get an Xlib error similar to "Failed to connect to server", "Connection refused by server," or "Can't open display" when starting the installer, then run the commands on your local workstations as listed in the table below.

Shell Types	On server where the installer is running	In session on your workstation
C shell	<code>prompt> setenv DISPLAY hostname:0.0</code>	<code>prompt> xhost +server_name</code>
Bourne or Korn shell	<code>prompt> DISPLAY=hostname:0.0;export DISPLAY</code>	<code>prompt> xhost +server_name</code>

2.5.3.3 TMP

During installation, Oracle Universal Installer uses a temporary directory for swap space. This directory must meet the requirements listed in [Section 2.1, "Hardware Requirements"](#) before installing Oracle9iAS. The installation may fail if you do not have sufficient space. The installer checks for the `TMP` environment variable to locate the temporary directory. If this environment variable does not exist, then the installer uses the `/tmp` directory. Set the `TMP` environment variable using the following command.

C shell	Bourne/Korn shell
<code>prompt> setenv TMP full_path</code>	<code>prompt> TMP=full_path; export TMP</code>

2.5.3.4 TNS_ADMIN

`TNS_ADMIN` points to the directory where Net configuration files are stored.

If `TNS_ADMIN` is set on your system, you will have conflicts between that directory and the directory where the Oracle9iAS Net configuration files are created. You will also have conflicts if the configuration files are in a common directory outside of the Oracle home for your other Oracle product. For example, your system may use `/var/opt/oracle/tnsnames.ora` for database aliases.

To prevent conflicts between the Net configuration files for different Oracle products, copy the configuration files from either `TNS_ADMIN` or the common directory to `ORACLE_HOME/network/admin` for the other products and unset `TNS_ADMIN` using the following command.

C shell	Bourne/Korn shell
<code>prompt> unsetenv TNS_ADMIN</code>	<code>prompt> unset TNS_ADMIN</code>

2.5.4 Hostnames File Configuration

Oracle Universal Installer requires that the fully qualified hostname information appear in the configuration files for your computer. A fully qualified hostname includes both the name of the system and its domain.

Verify that `/etc/hosts.*` has the following format:

```
IP_ADDRESS FULLY_QUALIFIED_HOSTNAME SHORT_HOSTNAME ALIASES
```

The following example shows a properly configured `/etc/hosts.*` file:

```
148.87.9.44 oasdocs.us.oracle.com oasdocs oracleinstall
```

In addition to `/etc/hosts`, ensure the following files use the fully qualified hostname:

- `/etc/nodename`
- `/etc/inet/hosts`
- `/etc/hostname.*`
- `/etc/net/ticlts/hosts`
- `/etc/net/ticots/hosts`
- `/etc/net/ticotsord/hosts`
- `/etc/inet/ipnodes`

Note: The hostname may appear in each of these files more than once. You must add the domain information to every occurrence of the hostname

Failure to properly configure the hostname information in the listed files may result in runtime errors during Oracle9iAS installation.

2.5.5 Creating UNIX Accounts and Groups

The following UNIX account and groups are required for the installation process:

- [UNIX Group Name for the Oracle Universal Installer Inventory](#)
- [UNIX Account to Own Oracle Software](#)
- [UNIX Group Names for Privileged Groups](#)

2.5.5.1 UNIX Group Name for the Oracle Universal Installer Inventory

Use the `admintool` or `groupadd` utility to create a group name. For example, `oinstall`. The `oinstall` group will own Oracle Universal Installer's `oraInventory` directory. The `oracle` user account that runs the installation must have the `oinstall` group as its primary group.

For more information on these utilities, refer to your operating system documentation.

2.5.5.2 UNIX Account to Own Oracle Software

The `oracle` account is the UNIX account that owns Oracle software for your system. You must run Oracle Universal Installer from this account.

Create an `oracle` account with the properties listed in [Table 2-7](#).

Table 2-7 Oracle Account Properties

Variable	Property
Login Name	Select any name to access the account. This document refers to the name as the <code>oracle</code> account.
Group Identifier	The <code>oinstall</code> group.
Home Directory	Select a home directory consistent with other user home directories.
Login Shell	The default shell can be either the C, Bourne, or Korn shell.

Note: Use the `oracle` account only for installing and maintaining Oracle software. Never use it for purposes unrelated to the Oracle Universal Installer. Do not use `root` as the `oracle` account.

2.5.5.3 UNIX Group Names for Privileged Groups

Two groups, the database operator group and the database administrator group, are required for Oracle9iAS Infrastructure installation. Oracle documentation refers to these groups as OSOPER and OSDBA, respectively. Databases use these groups for operating system authentication. This is necessary in situations where the database is shut down and database authentication is unavailable.

The privileges of these groups are given to either a single UNIX group or two corresponding UNIX groups. There are two ways to choose which groups get the privileges:

- If the `oracle` account is a member of the `dba` group before starting the installer, then `dba` is given the privileges of both OSOPER and OSDBA.
- If the `oracle` account is not a member of the `dba` group, then the installer will prompt you for the group names that get these privileges.

The following table lists the privileges for the OSOPER and OSDBA groups.

Group	Privileges
OSOPER	Permits the user to perform STARTUP, SHUTDOWN, ALTER DATABASE OPEN/MOUNT, ALTER DATABASE BACKUP, ARCHIVE LOG, and RECOVER, and includes the RESTRICTED SESSION privilege.
OSDBA	Contains all system privileges with ADMIN OPTION, and the OSOPER role; permits CREATE DATABASE and time-based recover.

2.5.6 Port Allocation

Following installation, Oracle Universal Installer creates a file showing the port assignments during installation of Oracle9iAS components. The installation process automatically detects any port conflicts and selects an alternate port in the range allocated for that component. [Appendix F, "Default Port Numbers and Port Ranges"](#) lists the default port ranges. The file titled `portlist.ini` is located at:

```
OracleHome/install/portlist.ini
```

This file lists component entries as "port name = port value". For example:

```
Oracle HTTP Server port = 7777
Oracle HTTP Server SSL port = 4443
Oracle HTTP Server listen port = 7778
Oracle HTTP Server SSL listen port = 4444
Oracle HTTP Server Jserv port = 8007
Enterprise Manager Servlet port = 1810
```

You can also view the port numbers by pointing your browser to the Oracle9iAS Welcome page and selecting the **Ports** tab

See Also:

- [Section 3.3.1, "Starting the Oracle Enterprise Manager Web Site"](#)
- *Oracle9i Application Server Administrator's Guide*

2.5.6.1 Oracle9iAS Infrastructure Port Usage

Installation of Oracle9iAS Infrastructure requires exclusive use of port 1521 on your computer. If one of your current system applications uses this port, then complete one of the following actions before installing Oracle9iAS Infrastructure:

- If you have an existing application using port 1521, then reconfigure the existing application to use another port.
- If you have an existing Oracle Net listener and an Oracle9i database, then proceed with the installation of Oracle9iAS Infrastructure. Your Oracle9iAS Infrastructure will use the existing Oracle Net listener.
- If you have an existing Net8 listener in use by an Oracle8i database, then you must upgrade to the Oracle9i Net listener version by installing Oracle9iAS Infrastructure. See [Section 2.5.6.1.1, "To upgrade your existing Net8 listener"](#).

2.5.6.1.1 To upgrade your existing Net8 listener

Note: Your Oracle8i database will be unavailable when performing the upgrade.

1. Stop the Net8 listener prior to installing Oracle9iAS Infrastructure.
2. Install Oracle9iAS Infrastructure.
3. Compare your Net8 listener configuration with your Oracle Net listener configuration.
 - a. If your Net8 listener and Oracle Net listener configurations consist only of the following two network addresses:
 - TCP/IP port 1521
 - IPC key EXTPROCThen no further network address modification is necessary.
 - b. If there are additional network addresses configured on your Net8 listener, then add these addresses to your Oracle Net listener configuration.
4. Your Net8 listener configuration may have SID_DESC entries for your Oracle8i database. Add these SID_DESC entries for your Oracle8i database to the SID_LIST of your Oracle Net listener configuration. If you do not have SID_DESC entries for you Oracle8i database, then no further modification is necessary.
5. Start the Oracle Net listener.

The Oracle Net listener supports the Oracle8i database as well as Oracle9iAS Infrastructure.

2.5.7 Configuring Kernel Parameters

The Oracle9iAS Metadata Repository and Oracle Internet Directory, installed as part of the Oracle9iAS Infrastructure installation, requires you to configure your system kernel parameters. Review your kernel parameter settings to ensure that they meet Oracle9iAS Metadata Repository and Oracle Internet Directory requirements. You may experience errors during installation or operational errors after installation if this is not completed.

Table 2–8 shows the kernels and their default setting.

Table 2–8 Kernel Parameter Settings

Kernel	Setting	Purpose
SEMMNI	100	Defines the maximum number of semaphore sets in the entire system.
SEMMNS	256	Defines the maximum semaphores on the system. This setting is a minimum recommended value, for initial installation only. The SEMMNS parameter should be set to the sum of the PROCESSES parameter for each Oracle database, adding the largest one twice, and then adding an additional 10 for each database.
SEMMSL	256	Defines the minimum recommended value, for initial installation only.
SHMMAX	4294967295	Defines the maximum allowable size of one shared memory segment. 4 GB = 4294967295
SHMMIN	1	Defines the minimum allowable size of a single shared memory segment.
SHMMNI	100	Defines the maximum number of shared memory segments in the entire system.
SHMSEG	10	Defines the maximum number of shared memory segments one process can attach.

2.6 Oracle Universal Installer

This section describes how Oracle9iAS uses Oracle Universal Installer for installation. It includes the following topics:

- [About Oracle Universal Installer](#)
- [Oracle Universal Installer Prerequisite Checks](#)
- [oraInventory Directory](#)
- [Starting Oracle Universal Installer](#)

2.6.1 About Oracle Universal Installer

Oracle9iAS uses Oracle Universal Installer to guide you through each step of the installation process.

The Oracle Universal Installer provides the following features:

- Describes installation options for Oracle9iAS
- Detects pre-set environment variables and configuration settings
- Sets environment variables and configuration during installation
- Offers configuration options for a customized installation of Oracle9iAS
- Deinstalls Oracle9iAS products

2.6.2 Oracle Universal Installer Prerequisite Checks

The Oracle Universal Installer automatically checks your computer prior to installation to verify that your system meets operational requirements. [Table 2–9](#) lists the prerequisite checks that are performed.

Table 2–9 Oracle Universal Installer Automatic Prerequisite Checks

Prerequisite Checks	See Also
Check for enough disk space for Oracle home installation	Table 2–1, "Oracle9iAS Hardware Requirements"
Check for TMP (<code>/var/tmp</code>) variable and sufficient swap space	Table 2–1, "Oracle9iAS Hardware Requirements"
Check that the install host has enough RAM	Table 2–2, "Oracle9iAS Memory Requirements"
Verify existence of one infrastructure per host installation (All Oracle9iAS instances on one host share the same infrastructure)	Chapter 1, "Installation Concepts"
Check the <code>/etc/hosts</code> file.	Section 2.5.4, "Hostnames File Configuration"
Prohibit installation of Oracle9iAS into an existing 8.0.x or 8.1.x Oracle home	NA
Prohibit installation of Oracle9iAS Infrastructure into an existing Oracle9iAS home	NA
Check for Solaris Operating Environment 32 version 2.6 or later	Section 2.2, "Operating System Requirements"
Ensure that the value of <code>ORACLE_HOME</code> does not contain spaces	Section 2.5.3.1, "ORACLE_HOME"
Verify the monitor has 256 color viewing capability	Section 2.1, "Hardware Requirements"
Verify installation of correct Solaris kernel patches	Table 2–5, "Solaris Operating System and Required Patches"
Verify operational requirements of the CPU	Table 2–1, "Oracle9iAS Hardware Requirements"
Verify paths of <code>LD_LIBRARY_PATH</code> , <code>PATH</code> , and <code>CLASSPATH</code>	Section 2.5.3.1.1, "Preventing Conflicts With Other Oracle Homes"

2.6.3 oraInventory Directory

The Oracle Universal Installer creates the `oraInventory` directory the first time it is run on a computer. The `oraInventory` directory keeps an inventory of products that the Oracle Universal Installer installs on your computer, as well as other installation information. If you have previously installed Oracle products, then you may already have an `oraInventory` directory.

When a UNIX group name is created and specified, it grants the specified group the permission to write to the `oraInventory` directory. If another group attempts to run the installer, then they must have permission to write to the `oraInventory` directory. If they do not have permission, then the installation will fail.

The location of `oraInventory` is defined in `/var/opt/oracle/oraInst.loc`.

The latest log file is:

```
/your_base_directory/oraInventory/logs/installActiontodays_date_time.log
```

The *your_base_directory* identifier is the location for your installation files and *todays_date_time* is the date and time of installation. Log file names of previous installation sessions take the form `installActionsdatetime.log`.

A complete listing of log files is included in the *Oracle9i Application Server Administrator's Guide*.

Do not delete or manually alter the `oraInventory` directory or its contents. Doing so can prevent the installer from locating products that you have installed on your system.

2.6.4 Starting Oracle Universal Installer

Follow these steps to launch Oracle Universal Installer and install Oracle9iAS:

1. Insert the CD labelled Disk 1 into the CD-ROM drive.
2. Mount the installation CD-ROM.

The Oracle Product Installation CD-ROM is in RockRidge format. If you are using the Solaris Volume Management software (installed by default with Solaris Operating Environment), then the CD-ROM is mounted automatically to `cdrom/9ias_902disk1` when you insert it in the disk drive.

If you are not using the Solaris Volume Management software, then you must mount the CD-ROM manually. To manually mount or unmount the CD-ROM, you must have root privileges. Be sure to unmount the CD-ROM before removing it from the drive.

Follow these steps to manually mount Disk 1 CD-ROM:

- a. Log in as the root user.
- b. Create the CD-ROM mount point directory:
- c. Mount the CD-ROM drive on the mount point directory and exit the root account:

```
prompt> mkdir mount_point
```

```
prompt> mount options device_name mount_point
prompt> exit
```

The following example mounts the CD-ROM manually on `/cdrom`, without using the Solaris Volume Management software. Execute the following commands as root user:

```
prompt> mkdir /cdrom
prompt> mount -r -F hsfs device_name /cdrom
```

- d. Log out as the root user.

3. Run Oracle Universal Installer from the CD-ROM.

Note: Be sure you are **not** logged in as the root user when you start the Oracle Universal Installer. If you are, then only the root user will have permissions to manage Oracle9iAS.

- a. Log in as the `oracle` user.
- b. Start the installer by entering:

```
prompt> mount_point/9ias_902disk1/runInstaller
```

Note: Do not use `mount_point` as your working directory when you start the installer. If you do, then you will not be able to eject Disk 1 during the installation process to insert Disk 2.

This launches Oracle Universal Installer, which installs Oracle9iAS.

2.7 Installation

The following sections provide the sequence and briefly describe the installation screens that you will encounter for the three types of Oracle9iAS installation. Oracle recommends reviewing the installation sequence for a better understanding of the Oracle9iAS installation process.

This section describes the installation sequence for the following Oracle9iAS installations:

- [Oracle9i Application Server Installation](#)
- [Oracle9iAS Infrastructure Installation](#)
- [Oracle9iAS Developer Kits Installation](#)

2.7.1 Oracle9i Application Server Installation

1. **Welcome screen:** Provides information about the Oracle Universal Installer.
2. **Inventory Location screen:** Verify the location of the base directory for installation files (First time installation).
3. **File Locations screen:** Verify the source path, destination name, and destination path for your Oracle9iAS installation.
4. **Available Products screen:** Select the Oracle9i Application Server installation.
5. **Installation Types screen:** Select one of the four Oracle9iAS install types listed--J2EE and Web Cache, Portal and Wireless, Business Intelligence and Forms, or Unified Messaging.
6. **Component Configuration and Startup screen:** Select the components to configure during the installation process.

7. One of the following screens appears based on the presence or absence of an instance of Oracle9iAS Single Sign-On on the install host:
 - **Oracle9iAS Infrastructure Use screen:** The Oracle9iAS Infrastructure [Use](#) screen appears for the installation of J2EE and Web Cache. The Oracle9iAS Infrastructure [Use](#) screen allows you to select whether you will use Oracle9iAS Single Sign-On or clustering (with Oracle9iAS Infrastructure) or not with installation of the J2EE and Web Cache install type.
 - **Existing Oracle9iAS Single Sign-On screen:** The Existing Oracle9iAS Single Sign-On screen appears for the Portal and Wireless, Business Intelligence and Forms, or Unified Messaging install types. Enter the Host Name and port number of your Oracle9iAS Single Sign-On instance.
8. **Oracle Internet Directory screen:** Enter the username and password for your registration of Oracle9iAS configuration information into Oracle Internet Directory. The username you enter must be a member of the IASAdmins group.

9. One of the following screens appears based on whether Oracle9iAS has been installed on your computer:
 - **Create Instance Name and ias_admin Password screen:** This screen appears if this is a first time installation of Oracle9iAS on this host. Enter the following instance information:
 - **Instance Name:** Identifies the installation instance of Oracle9iAS on this host.
 - **ias_admin Password:** The ias_admin users password used to administer any Oracle9iAS on this host. This password is required for installation of additional Oracle9iAS instances.
 - **Enter ias_admin Password screen:** This screen appears if the Oracle Universal Installer has detected a previous installation of Oracle9iAS in your Oracle home. Enter the ias_admin users password created from the previous installation.
 - **Create Instance Name screen:** This screen appears if the Oracle Universal Installer has detected a previous installation of Oracle9iAS on this host but in a different Oracle home. Enter an instance name to identify this instance of Oracle9iAS.
10. **Metadata Repository screen:** Select the Oracle9iAS Metadata Repository you would like to use for this Oracle9iAS installation. This screen appears if the Oracle Universal Installer detects multiple installations of Oracle9iAS Metadata Repository.
11. **Outgoing Mail Server screen:** Enter the outgoing mail server to use with Oracle9iAS Reports Services. This screen appears if you have selected Oracle9iAS Reports Services for installation.
12. **Installation Summary screen:** Review the summary of your Oracle9iAS installation and begin the installation process.
13. **Install screen:** Appears while the product is installing. The screen shows installation operations. No user interaction is required.
14. **Oracle9iAS Configuration Tools screen:** Review the status of Oracle9iAS configuration tools for components you have selected. No user interaction is required.
15. **End of Installation screen:** Appears at the end of the installation process. It notifies you whether the installation was successful or unsuccessful and provides information about accessing the Oracle9iAS instance.

2.7.2 Oracle9iAS Infrastructure Installation

1. **Welcome screen:** Provides information about the Oracle Universal Installer.
2. **Inventory Location screen:** Verify the location of the base directory for installation files (First time installation).
3. **File Locations screen:** Verify the source path, destination name, and destination path for your Oracle9iAS installation.
4. **Available Products screen:** Select the Oracle9iAS Infrastructure installation.
5. **Select Configuration Options screen:** Select to either accept installer recommendations for Oracle9iAS Infrastructure components, or specify existing instances of components.
6. One of the following two screens may appear based on your configuration choices on the [Select Configuration Options Screen](#)
 - **Existing Oracle9iAS Single Sign-On:** This screen appears if you have unchecked the configuration of Oracle9iAS Single Sign-On on the [Component Configuration and Startup screen](#).
 - **Existing Oracle Internet Directory:** This screen appears if you have unchecked the configuration of Oracle Internet Directory on the [Component Configuration and Startup screen](#).

The Oracle Universal Installer configures both Oracle Internet Directory and Oracle9iAS Single Sign-On whether they are deselected or not. This is completed to verify connectivity between Oracle Internet Directory and Oracle9iAS Single Sign-On.

7. One of the following screens appears based on whether Oracle9iAS has been installed on your computer:
 - **Create Instance Name and ias_admin Password screen:** This screen appears if this is a first time installation of Oracle9iAS on this host. Enter the following instance information:
 - **Instance Name:** Identifies the installation instance of Oracle9iAS on this host.
 - **ias_admin Password:** The ias_admin users password used to administer any Oracle9iAS on this host. This password is required for installation of additional Oracle9iAS instances.
 - **Create Instance Name screen:** This screen appears if the Oracle Universal Installer has detected a previous installation of Oracle9iAS on this host but in a different Oracle home. Enter an instance name to identify this instance of Oracle9iAS.
8. **Privileged Operating System Groups screen:** This screen appears only if the `oracle` account is not a member of the `dba` group. Enter the database administrator and operator group name.
9. **Database Character Set screen:** Select the Database Character Set from the list you would like to use.
10. **Installation Summary screen:** Review the summary of your Oracle9iAS installation and begin the installation process.
11. **Install screen:** Appears while the product is installing. The screen shows installation operations. No user interaction is required.
12. **Oracle9iAS Configuration Tools screen:** Review the status of Oracle9iAS configuration tools for components you have selected. No user interaction is required.
13. **End of Installation screen:** Appears at the end of the installation process. It notifies you whether the installation was successful or unsuccessful and provides information about accessing the Oracle9iAS instance.

2.7.3 Oracle9iAS Developer Kits Installation

1. **Welcome screen:** Provides information about the Oracle Universal Installer.
2. **Inventory Location screen:** Verify the location of the base directory for installation files (First time installation).
3. **File Location screen:** Verify the source path, destination name, and destination path for your Oracle9iAS installation.
4. **Available Products screen:** Select the Oracle9iAS Infrastructure installation.
5. One of the following screens appears based on whether Oracle9iAS has been installed on your computer:
 - **Create Instance Name and ias_admin Password screen:** This screen appears if this is a first time installation of Oracle9iAS on this host. Enter the following instance information:
 - **Instance Name:** Identifies the installation instance of Oracle9iAS on this host.
 - **ias_admin Password:** The ias_admin users password used to administer any Oracle9iAS on this host. This password is required for installation of additional Oracle9iAS instances.
 - **Enter ias_admin Password screen:** This screen appears if the Oracle Universal Installer has detected a previous installation of Oracle9iAS in your Oracle home. Enter the ias_admin users password created from the previous installation.
 - **Create Instance Name screen:** This screen appears if the Oracle Universal Installer has detected a previous installation of Oracle9iAS on this host but in a different Oracle home. Enter an instance name to identify this instance of Oracle9iAS.

6. **Installation Summary screen:** Review the summary of your Oracle9iAS installation and begin the installation process.
7. **Install screen:** Appears while the product is installing. The screen shows installation operations. No user interaction is required.
8. **Oracle9iAS Configuration Tools screen:** Review the status of Oracle9iAS configuration tools for components you have selected. No user interaction is required.
9. **End of Installation screen:** Appears at the end of the installation process. It notifies you whether the installation was successful or unsuccessful and provides information about accessing the Oracle9iAS instance.

2.8 Additional Oracle9iAS Product Installations

When you are planning a subsequent Oracle9iAS installation, Oracle recommends the following steps:

- Review the preinstallation tasks covered previously in this chapter.
- Do not delete or modify the `/var/opt/oracle` directory for subsequent Oracle9iAS installations.
- Make sure any previously installed Oracle9iAS instances are running when you initiate installation.
- Specify a different Oracle home than the first Oracle9iAS installation.
- Use the same oraInventory directory for subsequent Oracle9iAS installations.
- Review [Chapter 7, "Coexistence"](#) in this guide to ensure successful coexistence of Oracle products.

See Also:

- [Section 2.5.3.1, "ORACLE_HOME"](#)
- [Section 2.6.3, "oraInventory Directory"](#)

2.8.1 Oracle9iAS Supplemental Components

Refer to appendices or specific guides for the following supplemental components available with Oracle9iAS, version 9.0.2:

- Oracle9iAS Client ([Appendix B, "Oracle9iAS Client Installation"](#))
- Oracle9iAS InterConnect ([Appendix C, "Oracle9iAS InterConnect Installation and Configuration"](#))
- Oracle9iAS Migration Assistant (*Oracle9i Application Server: Migrating from Oracle9i Application Server 1.x*)
- Oracle Internet File System (*Oracle Internet File System Installation Guide*)
- Oracle9iAS Unified Messaging Telephony Services (*Oracle9iAS Unified Messaging Administrator's Guide* and *Oracle9iAS Unified Messaging Telephony User's Guide*)
- Oracle9i Application Server Documentation Library ([Appendix G, "Installing the Documentation Library"](#))

Oracle9*i* Application Server

This chapter guides you through the steps for the Oracle9*i* Application Server (Oracle9*i*AS) installation. The topics include:

- [Oracle9*i*AS Installation](#)
- [Oracle9*i*AS Install Types](#)
- [Oracle9*i*AS Postinstallation](#)

3.1 Oracle9iAS Installation

The following instructions guide you through the installation steps for the four install types for Oracle9iAS.

[Table 3–1](#) lists required information for Oracle9iAS installation. Enter your values for the listed information in the **Your Information** column before beginning.

Table 3–1 Installation Information

Information	Example Values	Your Information
Oracle base directory ¹ (Section 2.5.3.1, "ORACLE_HOME")	/private/oraInventory	
Oracle home location (Section 2.5.3.1, "ORACLE_HOME")	/private/ora9ias	
Instance Name (Section 2.5.3.1, "ORACLE_HOME")	instance1	
ias_admin Password (Section 2.5.3.1, "ORACLE_HOME")	oracle1	
Oracle9iAS Single Sign-On Server Host Name ² (Section 1.3, "Oracle9iAS Infrastructure Installation")	oasdocs.us.oracle.com	
Oracle9iAS Single Sign-On Port Number ² (Appendix F, "Default Port Numbers and Port Ranges")	7777	
Oracle Internet Directory Username ² (Step 4 on page 21)	orcladmin	
Oracle Internet Directory Password ² (Step 4 on page 3-21)	welcome1	

Table 3–1 Installation Information(Cont.)

Information	Example Values	Your Information
Oracle9iAS Metadata Repository (Section 1.3, "Oracle9iAS Infrastructure Installation") ³	oasdocs.us.oracle.com	
Oracle9iAS Reports Services Outgoing Mail Server Information (Step 7 on page 3-30)	oasdocs.us.oracle.com	

¹ Required for first time installation of Oracle9iAS.

² Required for Portal and Wireless, Business Intelligence and Forms, and Unified Messaging install types. Also required for application server clustering with J2EE and Web Cache install type. See the *Oracle9i Application Server Administrator's Guide* for more information about clustering.

³ Required for multiple metadata repository availability.

1. Review the Oracle Universal Installer Welcome screen and click **Next**.

The Welcome screen provides information about the Oracle Universal Installer. The following function buttons appear on the installation screens:

- **Deinstall Products:** Deinstall individual components or the entire product. This button appears only on the Welcome screen.
- **About Oracle Universal Installer:** View the version number of the installer in use.
- **Exit:** Quit the installation process and exit the installer.
- **Help:** Access detailed information about the functionality of each screen.
- **Installed Products:** View currently installed products or deinstall the entire product or components.
- **Previous:** Return to the previous screen.
- **Next:** Proceed to the next screen.

2. Verify the location of the base directory for installation files and click **OK**.

Figure 3–1 Inventory Location Screen

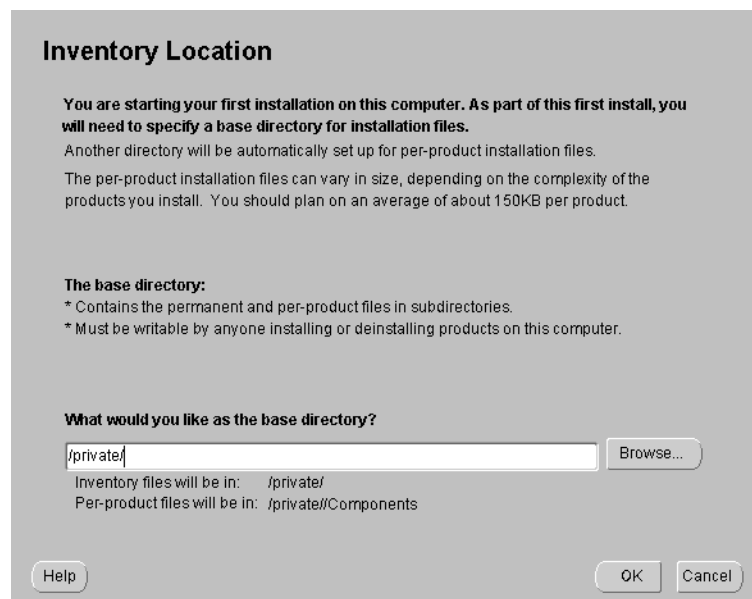

The Inventory Location screen appears during the *first installation* on a host to set a location for installation files. Product components use a different directory. The installation files can vary in size depending on the complexity of the product. For file storage considerations, assume a file size of 150 KB per product.

- **Browse:** Navigate through the available directory to select a location for the base directory for your installation.

The base directory has the following attributes:

- Contains the permanent and per-product component files in subdirectories
- Must be writable by anyone in the same user group installing or deinstalling products on the install computer

Input where you would like the base directory to be stored. For example:

```
/private
```

The storage location for product component files is the `Components` directory. For example:

```
/private/oraInventory/Components
```

- You need root privileges to execute certain actions before the installation can continue. You need to run a shell script with root privileges that is stored in the `oraInstRoot.sh` file. (You may need to execute the shell script by typing `./` before `oraInstRoot.sh`). The `Root.sh` installation screen shows the location of the `oraInstRoot.sh` file. The script creates pointers to the components as the installer installs them in the system, so that they can be identified later in the installation procedure. It produces the `/var/opt/oracle/oraInst.loc` file, which provides a pointer to the `oraInventory` directory.

After you execute the shell script, continue with the installation process.

3. Verify the source path, destination name, and destination path for your Oracle9iAS installation and click **Next**.

Figure 3–2 File Locations Screen

File Locations

Source...
Enter the full path of the file representing the product(s) you want to install:
Path:

Destination...
Enter or select an Oracle Home name and its full path:
Name:
Path:

ORACLE

The File Locations screen allows you to enter the full path for the source and destination locations for your installation.

- **Source:** This is the full path to the `products.jar` file from which the product will be installed. The installer detects and uses the default values of the `products.jar` file of the installation program. Do not change the path.
- **Name:** Enter an Oracle home name or select a name from the drop-down list. You may use the default Oracle home name of `ora9ias` provided or select your own name. If you do not have a home created on your computer, one is created for you during the installation.

Oracle homes are identified by name. The Oracle home name identifies the program group associated with a specific Oracle home and the installed Oracle services associated with the home.

The Oracle home name must consist of 1 to 16 characters long and can only include alphanumeric characters and underscores; spaces are not allowed.

- **Destination:** This is the full path to the Oracle home where the product will be installed. The installer defaults to the Oracle home set in the preinstallation chapter.

Note: The Oracle home path must be an absolute path. It cannot contain environment variables or spaces.

See Also: [Section 2.5.3.1, "ORACLE_HOME"](#)

- **Browse:** Navigate through the file system to find source and destination locations.

Do not install Oracle9iAS into any of the following directories:

- Oracle9iAS Infrastructure home directory
- Oracle9iAS home directory (unless it is for an install extension)
- Oracle9i Database home directory
- Oracle8i Database home directory

4. Select the Oracle9i Application Server installation and click **Next**.

Figure 3–3 Available Products Screen

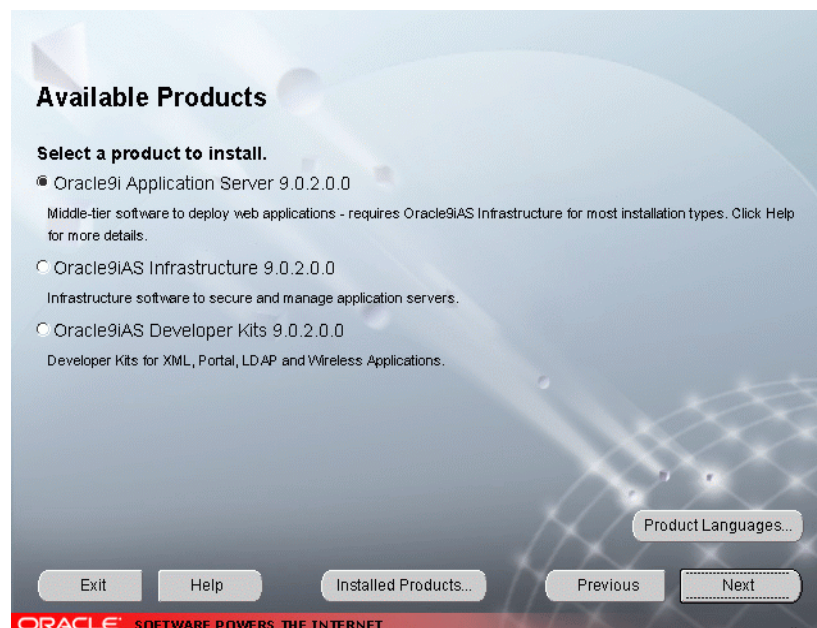

After choosing the Oracle9iAS install, select one of the four install types listed in [Section 3.2, "Oracle9iAS Install Types"](#).

- Product Languages:** Select product language for installation. The languages available for this product are Arabic, Bengali, Brazilian Portuguese, Bulgarian, Canadian French, Catalan, Croatian, Czech, Danish, Dutch, Egyptian, English, English (United Kingdom), Estonian, Finnish, French, German, Greek, Hebrew, Hungarian, Icelandic, Indonesian, Italian, Japanese, Korean, Latin American Spanish, Latvian, Lithuanian, Malay, Mexican Spanish, Norwegian, Polish, Portuguese, Romanian, Russian, Simplified Chinese, Slovak, Slovenian, Spanish, Swedish, Thai, Traditional Chinese, Turkish, Ukrainian, and Vietnamese. The default language is English.

3.2 Oracle9iAS Install Types

The Oracle9iAS installation offers the following install types:

- **J2EE and Web Cache:** Provides a Web server that enables you to develop and deploy Java and Enterprise Edition (J2EE) applications, use J2EE and Simple Object Access Protocol (SOAP) based Web services, and accelerates Web site performance with Oracle9iAS Web Cache.
- **Portal and Wireless:** Enables the deployment of enterprise portals and wireless applications. Includes all Oracle9iAS components available in the J2EE and Web Cache install type.
- **Business Intelligence and Forms:** Enables analysis of clickstream data, personalization of applications, use of forms-based applications, and deployment of Decision Support System and Web-based reports. Includes all Oracle9iAS components available in the Portal and Wireless install type.
- **Unified Messaging:** Enables the messaging capabilities of Oracle9iAS. Includes all of the Oracle9iAS components available in the Business Intelligence and Forms install type.

Table 3–2 lists the four installation options for Oracle9iAS and the Oracle9iAS components that are installed with each option.

See Also:

- [Appendix E, "Components"](#)
- *Oracle9i Application Server Concepts Guide*

Table 3–2 Oracle9iAS Components

Component	J2EE and Web Cache	Portal and Wireless	Business Intelligence and Forms	Unified Messaging
Oracle9iAS Web Cache	YES	YES	YES	YES
Oracle HTTP Server ¹	YES	YES	YES	YES
Oracle9iAS Container for J2EE	YES	YES	YES	YES
Oracle Enterprise Manager Web site	YES	YES	YES	YES
Oracle9iAS Portal ²	no	YES	YES	YES
Oracle9iAS Wireless	no	YES	YES	YES
Oracle9iAS Discoverer ³	no	no	YES	YES
Oracle9iAS Reports Services	no	no	YES	YES
Oracle9iAS Clickstream Intelligence	no	no	YES	YES
Oracle9iAS Forms Services	no	no	YES	YES
Oracle9iAS Personalization	no	no	YES	YES
Oracle9iAS Unified Messaging	no	no	no	YES

¹ Oracle HTTP Server installs the following mods: mod_oc4j, mod_jserv, mod_osso, mod_oss, mod_plsql, mod_proxy, DMS, FastCGI, HiAv Infrastructure, Oracle9iAS Object Caching Services for Java, SOAP, DBI/DBD, Clickstream Collector Agent.

² Oracle9iAS Portal installs Oracle Ultra Search and Oracle9i Syndication Server.

³ Oracle9iAS Discoverer installs Discoverer Viewer and Discoverer Plus.

1. Select the Oracle9iAS install type you would like to install and click **Next**.

Figure 3–4 *Installation Types Screen*



The J2EE and Web Cache install type does not require Oracle9iAS Infrastructure.

During the installation you will be asked if you would like to use the single sign-on or clustering functionality. An application server cluster is a collection of application server instances with identical configuration and application deployment. Clusters enforce homogeneity between member instances so that a cluster of application server instances can appear and function as a single instance. With appropriate front-end load balancing, any instance in an application server cluster can serve client requests. This simplifies configuration and deployment across multiple instances and enables fault tolerance among clustered instances.

Clustering enables you to expand your application server capabilities and single sign-on simplifies security over your network. If you want to use either of these features you need to install Oracle9iAS Infrastructure first. Information about the application server cluster is maintained in the Oracle9iAS Infrastructure Metadata Repository. If you are not sure, you can configure for application server clustering and single sign-on later.

Prior to installing the Portal and Wireless, Business Intelligence and Forms, and Unified Messaging install types, *you must* install and configure the Oracle9iAS Infrastructure somewhere in your network, optimally on a separate machine. The Oracle9iAS Infrastructure components, Oracle9iAS Single Sign-On, Oracle Internet Directory, and Oracle9iAS Metadata Repository must be running before proceeding with installation.

Note: The installation size shown in parentheses for the four Oracle9iAS install types may vary based on your system settings and file allocation during installation. Accurate install file size is available from the Summary screen in Step 8.

2. Select the Oracle9iAS components to configure during the installation process and click **Next**.

Figure 3–5 Component Configuration and Startup Screen

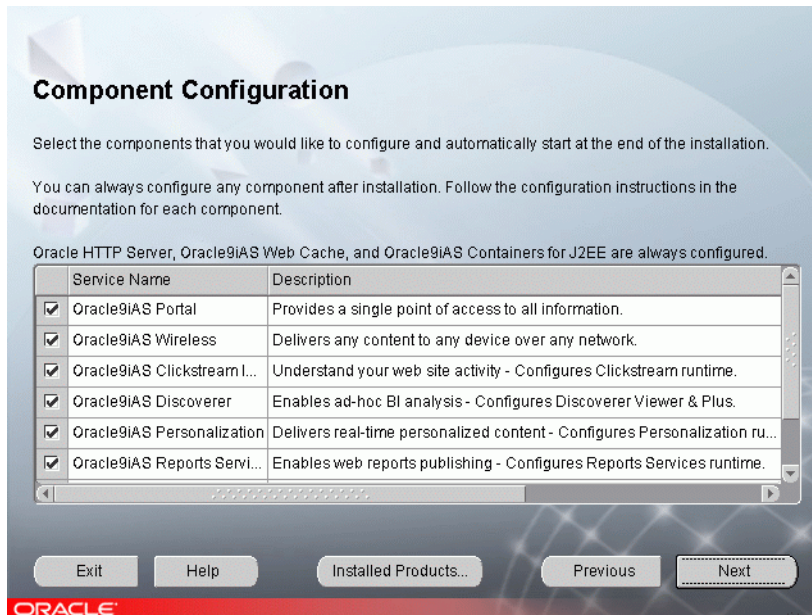

The Oracle9iAS components listed for configuration and startup will differ depending on the Oracle9iAS install type you choose.

If you de-select a component here, then the installer installs it, but does not configure or start it. After installation, the installer starts the selected Oracle9iAS component. If you decide to use the Oracle9iAS component at a later time, launch the Oracle Enterprise Manager Home Page for component configuration.

Oracle9iAS Portal and Oracle9iAS Clickstream Intelligence use the Oracle9iAS Metadata Repository for metadata. If you want to use existing database metadata, *do not* select to configure Oracle9iAS Portal and Oracle9iAS Clickstream Intelligence.

See Also:

- [Section 3.3.5.4, "Using a Customer Database"](#)
- *Oracle9iAS Portal User's Guide and Administrator's Guide*
- *Oracle9iAS Clickstream Intelligence Administrator's Guide*
- *Oracle9iAS Clickstream Intelligence Release Notes*

In order to use mod_OraDAV with your Oracle9iAS Metadata Repository you must select and configure Oracle9iAS Portal.

Oracle recommends selection and configuration of Oracle9iAS Portal for installations of Portal and Wireless, Business Intelligence and Forms, and Unified Messaging install types. Oracle9iAS Portal enables enhancement of features for Oracle9iAS Discoverer, Oracle9iAS Reports Services, and Oracle9iAS Clickstream Intelligence.

Oracle recommends selection and configuration of Oracle9iAS Discoverer for Oracle9iAS Clickstream Intelligence installation. Oracle9iAS Discoverer enables enhancement of many of Oracle9iAS Clickstream Intelligence features.

See Also:

- *Oracle9iAS Reports Services: Publishing Reports to the Web*
- *Oracle9iAS Clickstream Intelligence Release Notes*
- *Oracle9iAS Discoverer Plus User's Guide*

3. One of the following screens will appear based on the presence or absence of an instance of Oracle9iAS Single Sign-On on the install host:
 - **Infrastructure Summary:** The Infrastructure Summary screen appears if you have an installation of Oracle9iAS Infrastructure on the install host.
 - **Oracle9iAS Infrastructure Use:** The Oracle9iAS Infrastructure Use screen appears for the installation of J2EE and Web Cache.
 - **Existing Oracle9iAS Single Sign-On:** The Existing Oracle9iAS Single Sign-On screen appears for all other Oracle9iAS install types.

a. Infrastructure Summary

If you have installed Oracle9iAS Infrastructure on the install computer, the Infrastructure Summary screen appears. Review and note the information provided on the screen and click **Next**.

The Infrastructure Summary screen provides you with the domain and port numbers for the installations of Oracle9iAS Single Sign-On and Oracle Internet Directory on the install computer.

b. Oracle9iAS Infrastructure Use

Select whether to use Oracle9iAS Infrastructure and click **Next**.

Figure 3–6 Oracle9iAS Infrastructure Use Screen

Oracle9iAS Infrastructure Use

To use Clustering or Single Sign-On with J2EE Applications, you need an existing Oracle9iAS Infrastructure. If you do not specify an Infrastructure now, you may do so after installation. If you want to specify an Infrastructure now, you must identify the Infrastructure by specifying the Single Sign-On Host and Port. This is required even if you only intend to use Clustering.

Do you want to specify an Infrastructure at this time?

No

Yes

Single Sign-on Host Name:

Single Sign-on Port Number:

Exit Help Installed Products... Previous Next

ORACLE

The Oracle9iAS Infrastructure **Use** screen appears for:

- The first time installation of Oracle9iAS.
- Other Oracle9iAS instances on the installation host are not using single sign-on or clustering functionality.

The Oracle9iAS Infrastructure [Use](#) screen allows you to select whether or not you will use Oracle9iAS Single Sign-On or clustering (with Oracle9iAS Infrastructure) with this installation of J2EE and Web Cache. This screen offers two options:

- **Do not use Oracle9iAS Single Sign-On:** Install a Web server without Oracle9iAS Infrastructure functionality.
- **Use Oracle9iAS Single Sign-On:** Use an existing Oracle9iAS Single Sign-On with Oracle9iAS Infrastructure that enables an authenticated user to access multiple accounts and Oracle9iAS applications, and enable clustering.

In order to use Oracle9iAS Single Sign-On you must have the following information:

- **Host Name:** The name of the host where your instance of Oracle9iAS Single Sign-On and Oracle9iAS Infrastructure is located.
- **Port Number:** The port number of the host for your instance of Oracle9iAS Single Sign-On.

Oracle9iAS Single Sign-On is installed as part of the Oracle9iAS Infrastructure installation.

See Also:

- [Chapter 1, "Installation Concepts"](#)
- [Chapter 4, "Oracle9iAS Infrastructure"](#)

c. Existing Oracle9iAS Single Sign-On

Enter the Host Name and Port for your existing Oracle9iAS Single Sign-On instance and click **Next**.

Figure 3–7 Existing Oracle9iAS Single Sign-On Screen

Existing Oracle9iAS Single Sign-On

Provide the host name and port number for the existing instance of Oracle9iAS Single Sign-On that you wish to use with this installation of Oracle9iAS Infrastructure. If you do not have Oracle9iAS Single Sign-On installed, return to the Component Configuration step and select the default configuration option for Oracle9iAS Single Sign-On.

Host Name:

Port:

Exit Help Installed Products... Previous Next

ORACLE

This screen appears for you to enter information about an existing instance of Oracle9iAS Single Sign-On that you will be using for your installation of Oracle9iAS.

The [Existing Instance of Oracle9iAS Single Sign-On screen](#) enables you to enter the following:

- **Host Name:** The location (host) of your Oracle9iAS Single Sign-On instance.
- **Port:** The port number of your Oracle9iAS Single Sign-On instance.

4. Enter a username and password to logon to Oracle Internet Directory and click **Next**.

Figure 3–8 Oracle Internet Directory Screen

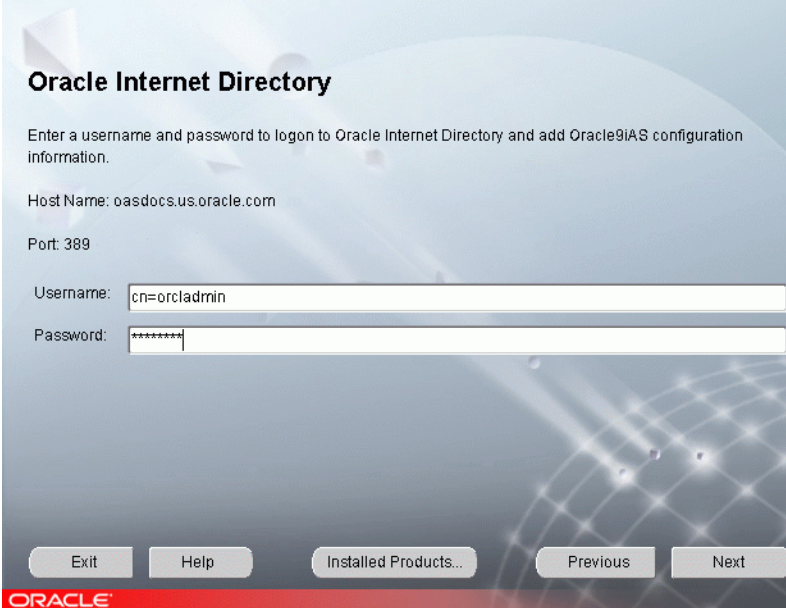

Oracle Internet Directory

Enter a username and password to logon to Oracle Internet Directory and add Oracle9iAS configuration information.

Host Name: oasdocs.us.oracle.com

Port: 389

Username:

Password:

Exit Help Installed Products... Previous Next

ORACLE

In order to configure an instance of Oracle9iAS (J2EE and Web Cache, Portal and Wireless, Business Intelligence and Forms, or Unified Messaging) to use Oracle9iAS Infrastructure, the instance must be registered in Oracle Internet Directory.

Oracle Internet Directory enables retrieval of shared information about dispersed users and network resources. Oracle Internet Directory implements the Lightweight Directory Access Protocol (LDAP), version 3.

You will need the following information to add information about an Oracle9iAS instance into Oracle Internet Directory:

- **Username:** The name used for connection to Oracle Internet Directory.
- **Password:** The password for user to access Oracle Internet Directory.

The username and password are defined in Oracle Internet Directory as either the:

- **orcladmin** (root user)
- a member of the IASAdmins group in Oracle Internet Directory

The username creates a user entity in Oracle Internet Directory. The user must be a member of the IASAdmins group. By default, orcladmin (the Oracle Internet Directory administrator) is also a member of the IASAdmins group. If the Oracle Internet Directory administrator does not wish to give out the orcladmin password, the administrator creates a username and password for a member of the IASAdmins group.

Enter the username and password for your registration of Oracle9iAS configuration information into Oracle Internet Directory. The username you enter must be a member of the IASAdmins group.

The default user is orcladmin. The default password for the orcladmin user is the same as the password for the ias_admin user on the host where Oracle Internet Directory is configured. The Oracle Internet Directory administrator may add other users and assign a different password for this group.

See Also:

- [Chapter 4, "Oracle9iAS Infrastructure"](#)
- *Oracle Internet Directory Administrator's Guide*

5. One of the following screens appears based on whether Oracle9iAS has been installed on this host:
 - **Create Instance Name and ias_admin Password:** This screen appears if this is a first time installation of Oracle9iAS on this host.
 - **Enter ias_admin Password:** This screen appears if the Oracle Universal Installer has detected a previous installation of Oracle9iAS in your Oracle home.
 - **Create Instance Name:** This screen appears if the Oracle Universal Installer has detected a previous installation of Oracle9iAS on this host but in a different Oracle home.

The following terms may be used on the following three screens:

Instance Name: Identifies the installation instance of Oracle9iAS on this host.

ias_admin Password: The ias_admin users password used to administer any Oracle9iAS this host. This password is required for installation of additional Oracle9iAS instances.

a. Create Instance Name and ias_admin Password

Enter a unique Oracle9iAS instance name and ias_admin password and click **Next**.

Figure 3–9 Create Instance Name and ias_admin Password Screen

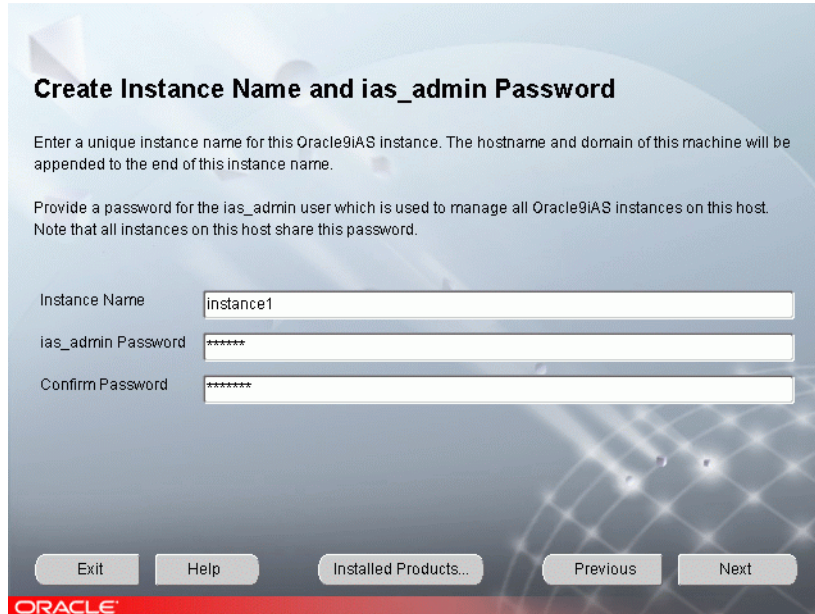

This screen appears if this is a first time installation of Oracle9iAS on this host.

Enter a unique name in the instance name field for this installation of Oracle9iAS. The instance name must contain alphanumeric and underscore characters only.

Select an ias_admin password for this instance of Oracle9iAS and then re-enter the password for confirmation. The ias_admin password must consist of at least five alphanumeric characters. Additionally, at least one of the characters must be a number.

The unique instance name will be used to identify this installation of Oracle9iAS on the install host.

The `ias_admin` password enables you to:

- Manage all instances of Oracle9iAS across the install host
- Run management tools
- Facilitate future installations
- Access the Oracle Enterprise Manager Home Page

Note: If you are configuring Oracle9iAS Portal as part of this installation, the `portal` and `portal_admin` user accounts in Oracle Internet Directory use the `ias_admin` password by default. Refer to the following URL for more Oracle9iAS Portal information:

<http://portalstudio.oracle.com>

b. Enter ias_admin Password

Enter your Oracle9iAS ias_admin password and click **Next**.

Figure 3–10 *Enter ias_admin Password Screen*



If the Oracle Universal Installer detects a previous installation of Oracle9iAS in your Oracle home, this screen appears. The existing Oracle9iAS instance name will be used for this installation. Enter your existing Oracle9iAS ias_admin password for this host to continue with the installation.

If you forget your ias_admin users password following installation, refer to the *Oracle9i Application Server Administrator's Guide* for the steps you can follow to reset the password.

c. Create Instance Name

Enter a unique Oracle9iAS instance name and the `ias_admin` password and click **Next**.

Figure 3–11 *Create Instance Name Screen*

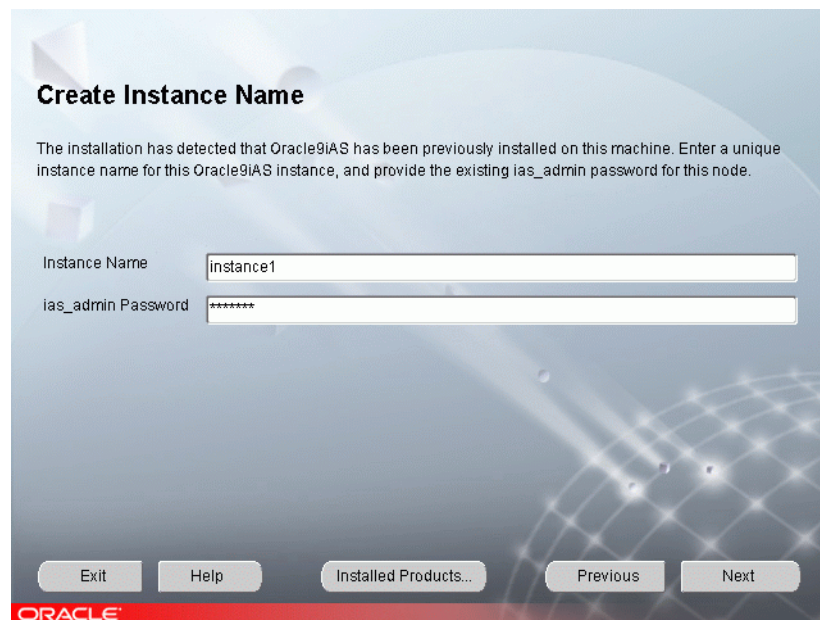

Create Instance Name

The installation has detected that Oracle9iAS has been previously installed on this machine. Enter a unique instance name for this Oracle9iAS instance, and provide the existing `ias_admin` password for this node.

Instance Name

ias_admin Password

Exit Help Installed Products... Previous Next

ORACLE

If the Oracle Universal Installer has detected a previous installation of Oracle9iAS on this host but in a different Oracle home, this screen appears. Enter a unique instance name and the existing `ias_admin` password for this host to continue with the installation. The instance name must contain alphanumeric and underscore characters only.

If you forget your `ias_admin` users password following installation, refer to the *Oracle9i Application Server Administrator's Guide* for the steps you can follow to reset the password.

- This screen appears if the Oracle Universal Installer detects multiple installations of Oracle9iAS Metadata Repository. Oracle9iAS Metadata Repository installs as part of the Oracle9iAS Infrastructure installation.
Select the Oracle9iAS Metadata Repository you would like to use for this Oracle9iAS installation and click **Next**.

Figure 3–12 Oracle9iAS Metadata Repository Screen

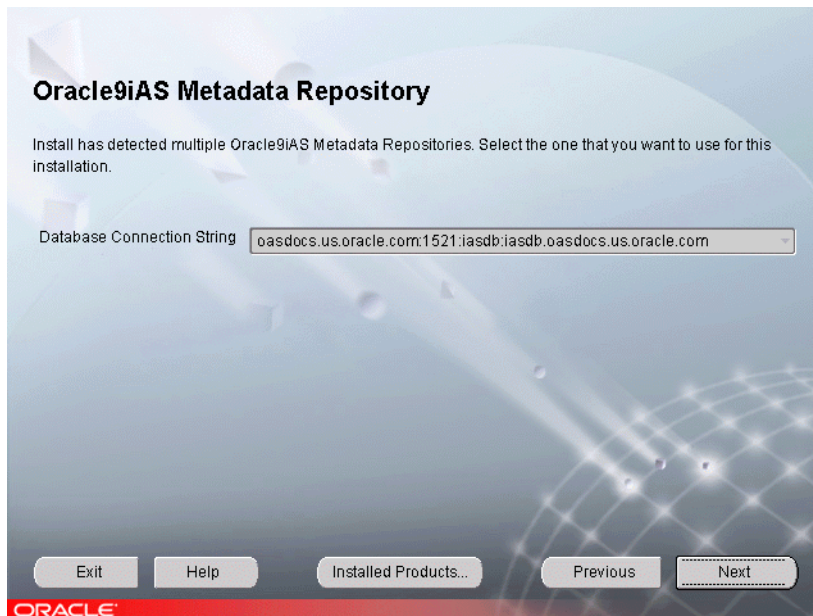

Oracle Universal Installer has detected multiple Oracle9iAS Metadata Repositories registered in your Oracle Internet Directory. Select the Oracle9iAS Metadata Repository you want to use with this installation of Oracle9iAS.

If you want to implement application server instance clustering, you must select the metadata repository used by other application server instances in your network.

If you do not want to use application server instance clustering, select any listed metadata repository. Your selection will be the default location for Oracle9iAS component metadata.

If you want an Oracle9iAS component within this Oracle9iAS installation to use a different database, use the Oracle Enterprise Manager Home Page following installation to change database connectivity.

See Also:

- [Chapter 1, "Installation Concepts"](#)
- [Chapter 4, "Oracle9iAS Infrastructure"](#)
- [Section 3.3.1, "Starting the Oracle Enterprise Manager Web Site"](#)

7. The Provide Outgoing Mail Server Information screen appears if you have selected Oracle9iAS Reports Services for installation.
Enter the outgoing mail server to use with Oracle9iAS Reports Services and click **Next**.

Figure 3–13 Provide Outgoing Mail Server Information Screen

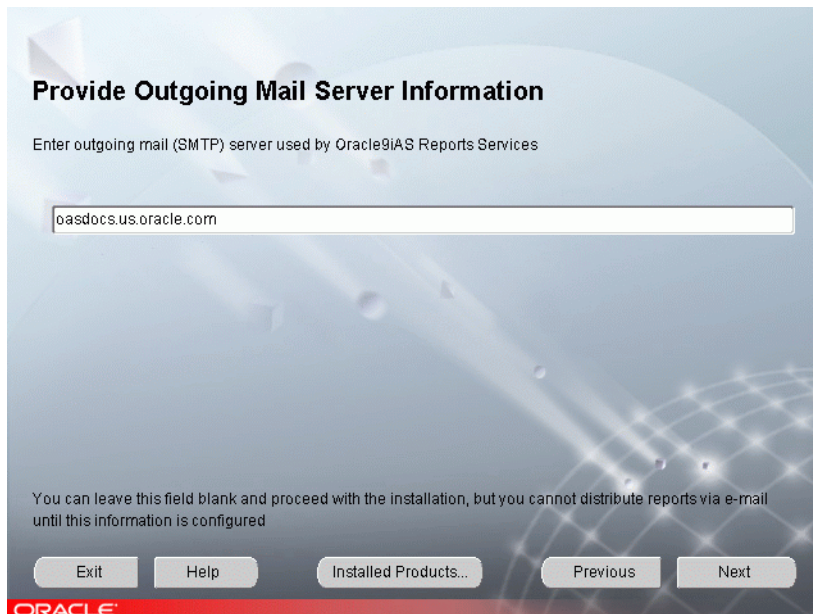

Oracle9iAS Reports Services supports distribution of reports via email. To use this feature, you must provide the name of the outgoing mail server. For example:

```
oasdocs.us.oracle.com
```

You can leave this field blank and proceed with the installation. At a later time you can make changes to the outgoing email server in the Oracle9iAS Reports Services configuration file at the following location:

```
ORACLE_HOME/reports/conf/reports_server_name.conf
```

8. Review the Summary screen and click **Install** to begin the installation process.

The Summary screen allows you to review all the settings before the installation begins. These settings include source, destination, installation type, product language, install file sizes, and a list of components.

- To make changes to any of these settings, click **Previous** to return to the respective screens.

Note: Insufficient disk space is indicated in red under **Space Requirements**.

When you click **Install**, the installation process begins.

9. Monitor the installation process and after the installer finishes, click **Next**.

The Install screen appears while the product is installing. The Install screen shows installation operations, including executing actions such as file copy and linking, and executing decision points and calculations. It displays the full path of the installation log.

- **Cancel:** Discontinues the installation process. You can then choose to stop the installation of an individual component or the entire product.

For more information about the installation log, refer to [Section 2.6.3, "oraInventory Directory"](#).

Running root.sh

During installation of Oracle9iAS, the installer prompts you to run the `root.sh` script.

Use the following steps to run the `root.sh` script.

- a. Log on as the root user.
- b. Run the `root.sh` script in the Oracle home directory.

```
prompt> ORACLE_HOME/root.sh
```

You may need to execute the shell script by typing `./` before `root.sh`.

- c. Exit root user.

Once you see "Finished running generic part of the root.sh script" and "Now product-specific root actions will be performed," exit root user and return to the Install screen.

The `root.sh` script detects:

- Settings of `ORACLE_OWNER`, `ORACLE_HOME` and `ORACLE_SID` environment variables.
- Full path of local `bin` directory. You can accept the default or change to a different local `bin` directory.

10. Review the status of Oracle9iAS configuration tools and click **Next.**

The Components Configuration and Startup screen appears for components to configure and start. The screen lists the configuration tools for all installed components.

Depending on the configurations selected you will see some component configuration screens, but no input is required.

Monitor the progress of each configuration tool by scrolling down the tools list to review the configuration status of each tool. The status changes as each component is configured.

The installer performs the following functions in this screen:

- Executes a configuration tool for each component selected previously in the Component Configuration and Startup screen.
- Allows you to view data for failed executions in the display window. You can either fix the error and click **Retry** to execute the configuration tool again, or ignore the error and click **Next** to proceed to the next screen.
- **Retry**: Re-executes the configuration script if the configuration of a component fails.
- **Stop**: Quits the configuration process.
- **Exit**: Quit the configuration tool and continue with the installation.

11. Review the End of Installation screen. Click **Exit** to quit the installer or click **Next Install** to install additional Oracle9iAS instances.

Figure 3–14 End of Installation Screen

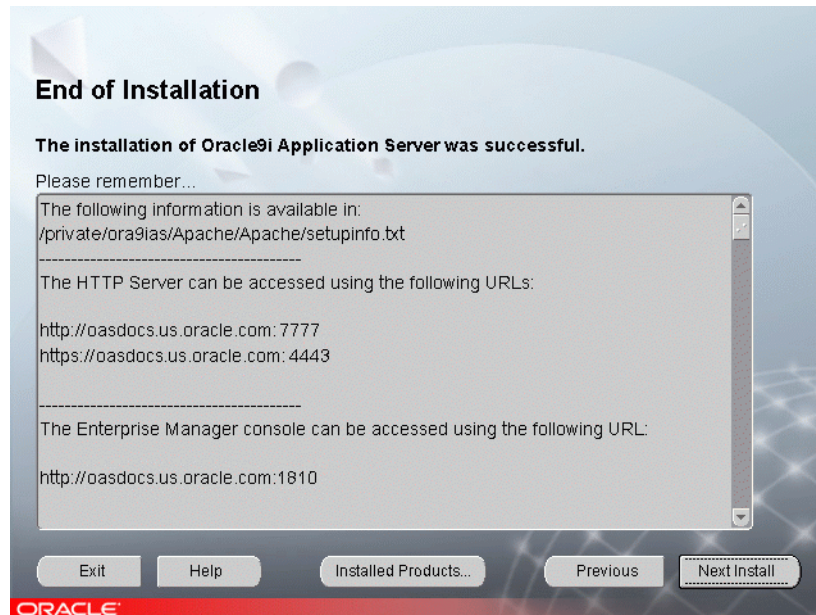

The End of Installation screen appears at the end of the installation process. It notifies you whether the installation was successful or unsuccessful and provides information about accessing the Oracle9iAS instance.

The End of Installation screen displays the URL and port number for accessing the Oracle HTTP Server page and the Oracle Enterprise Manager Web site. The default Oracle HTTP Server page is the Oracle9iAS Welcome page. The Oracle9iAS Welcome page provides links to demonstrations and information about new features.

See Also:

- [Section 3.3.1, "Starting the Oracle Enterprise Manager Web Site"](#)
- *Oracle9i Application Server Administrator's Guide*

You can view the Install Log for the completed installation at:

`/your_base_directory/oraInventory/logs/installActiontodays_date_time.log`

in which *your_base_directory* is the location for your installation files and *todays_date_time* is the date and time of installation.

A complete listing of log files is included in the *Oracle9i Application Server Administrator's Guide*.

You have successfully installed your selected Oracle9iAS install type. Proceed to [Section 3.3, "Oracle9iAS Postinstallation"](#) to complete the installation process.

3.3 Oracle9iAS Postinstallation

The following instructions guide you through the basic postinstallation tasks for Oracle9iAS.

The postinstallation section contains the following topics:

- [Starting the Oracle Enterprise Manager Web Site](#)
- [Component Dependent Configuration](#)
- [Configuring Additional Components](#)
- [Postinstallation Configuration Tasks](#)
- [Starting and Stopping Components](#)
- [Component Port Numbers](#)
- [Additional Oracle9iAS Product Installations](#)
- [Additional Documentation](#)

3.3.1 Starting the Oracle Enterprise Manager Web Site

The Oracle Enterprise Manager Web site is available after Oracle9iAS installation and component configuration. The Oracle Enterprise Manager Web site is comprised of Oracle Enterprise Manager Home Pages. Each Oracle Enterprise Manager Home Page is used to manage an installed Oracle9iAS component or instance.

Oracle strongly recommends that you use the Secure Socket Layer (SSL) protocol and HTTPS for all connections to the Oracle Enterprise Manager Web site. Refer to the *Oracle9i Application Server Administrator's Guide* for setup information.

3.3.2 Installing the Oracle9i Application Server Patches

Following successful installation and configuration of Oracle9i Application Server you must download and install the Oracle9i Application Server patches. You can download the patches from:

<http://metalink.oracle.com>

Select the **Patches** link. On the patch download form, select Oracle9i Application Server in the **Product Family** field and then submit the form.

3.3.3 Component Dependent Configuration

Interdependencies between Oracle9iAS components and what the configuration of the component is dependent upon can be found in the *Oracle9i Application Server Administrator's Guide*.

3.3.4 Configuring Additional Components

You can configure additional Oracle9iAS components following installation. Configuration of additional Oracle9iAS components is described in Chapter 9, "Reconfiguring the Application Server", in the *Oracle9i Application Server Administrator's Guide*.

3.3.5 Postinstallation Configuration Tasks

3.3.5.1 Java Authentication and Authorization Service

You must configure Java Authentication and Authorization Service (JAAS) components before using your JAAS-based applications. JAAS configuration tasks are described in the *Oracle9i Application Server Security Guide*.

3.3.5.2 Oracle9iAS Discoverer

In order for Discoverer Plus or Discoverer Viewer to query a database, you must set up a Discoverer End User Layer. Oracle9i Discoverer Administrator creates the End User Layer. Installation information is available in the *Oracle9i Discoverer Administrator's Guide* that is shipped with the Oracle9i Developer Suite, Release 2.

Additional product and component information can be found at the OTN Web site at:

<http://technet.oracle.com/docs/index.htm>

3.3.5.3 Using the Oracle9iAS Metadata Repository

For information on using Oracle9iAS Clickstream Intelligence with the Oracle9iAS Metadata Repository, refer to *Oracle9iAS Clickstream Intelligence Release Notes*.

3.3.5.4 Using a Customer Database

In order to use the following Oracle9iAS components you must use an existing customer database. Refer to component documentation for the following:

- Oracle9iAS Unified Messaging (*Oracle9iAS Unified Messaging Administrator's Guide*)
- Oracle9iAS Discoverer (*Oracle9iAS Discoverer Administrator's Guide*)
- Oracle9iAS Personalization (*Oracle9iAS Personalization Administrator's Guide*)
- Oracle9iAS Portal (optional) (*Oracle9iAS Portal User's and Administrator's Guide*)
- Oracle9iAS Clickstream Intelligence (optional) (*Oracle9iAS Clickstream Intelligence Release Notes* and *Oracle9iAS Clickstream Intelligence Administrator's Guide*)

Oracle9iAS Portal and Oracle9iAS Clickstream Intelligence can connect to a customer database or use the Oracle9iAS Metadata Repository.

By default Oracle Management Server configuration will use the Oracle9iAS Metadata Repository that is installed and configured in the same Oracle home. If you want to configure Oracle Management Server to use a different installation of Oracle9iAS Metadata Repository or Oracle9i Database Server, follow the steps detailed in *Oracle9i Application Server Administrator's Guide*.

3.3.5.5 Using mod_plsql

In order to use mod_plsql to deploy PL/SQL applications with an existing customer database, without using Oracle9iAS Portal, follow the instructions in the *Oracle9i Application Server mod_plsql User's Guide*.

3.3.6 Starting and Stopping Components

Oracle9iAS components can be started and stopped using the Oracle Enterprise Manager Home Page. For information on manual starting and stopping of Oracle9iAS components, refer to component specific documentation.

3.3.7 Component Port Numbers

Following installation, the Oracle Universal Installer creates a file showing the port assignments during installation of Oracle9iAS components. The installation process automatically detects any port conflicts and chooses an alternate port in the range allocated for that component. The file `portlist.ini` is located at:

```
OracleHome/install/portlist.ini
```

This file lists component entries as "port name = port value". For example:

```
Oracle HTTP Server port = 7777
Oracle HTTP Server SSL port = 4443
Oracle HTTP Server listen port = 7778
Oracle HTTP Server SSL listen port = 4444
Oracle HTTP Server Jserv port = 8007
Enterprise Manager Servlet port = 1810
```

You can also view the port numbers by pointing your browser to the Oracle9iAS Welcome page and selecting the **Ports** tab.

Note: The Oracle Universal Installer uses the port numbers for select components during installation of Oracle9iAS. If you are planning on adding additional Oracle9iAS instances, make sure the installed instances are running at the time of additional installation.

See Also:

- [Section 3.3.1, "Starting the Oracle Enterprise Manager Web Site"](#)
- [Appendix F, "Default Port Numbers and Port Ranges"](#)
- [Section 2.5, "Preinstallation Tasks"](#)
- *Oracle9i Application Server Administrator's Guide*

3.3.8 Changing the X Server Display

To change the X server display following installation you must edit the `opmn.xml` file installed on your computer.

The `opmn.xml` file is located at:

```
ORACLE_HOME/opmn/conf/opmn.xml
```

The format of the `opmn.xml` file is:

```
<prop name="DISPLAY" value="hostname:display_number.screen_number"/>
```

`hostname:display_number.screen_number` is the X server you want to use.

After you modify the `opmn.xml` file, restart all of your OC4J instances.

See Also: [Section 2.5.3.2, "DISPLAY"](#)

3.3.9 Oracle9iAS Demonstration Software

Oracle9iAS provides demonstration applications for many Oracle9iAS components.

In order to run a demonstration for a specific Oracle9iAS component, you must have an Oracle9iAS installation that contains the component, the component must be configured, and the required component instances must be running.

To obtain more information and run the demonstration software go to the Oracle Enterprise Manager Home Page and click **Demonstrations**.

See Also: *Oracle9i Application Server Administrator's Guide*

3.3.10 Additional Oracle9iAS Product Installations

For information on installing additional Oracle9iAS installations, refer to [Section 2.8, "Additional Oracle9iAS Product Installations"](#), and [Chapter 7, "Coexistence"](#).

3.3.11 Additional Documentation

For further information on postinstallation and configuration tasks, refer to the *Oracle9i Application Server Administrator's Guide* and component-specific documentation. For information on viewing and installing the documentation, refer to [Appendix G, "Installing the Documentation Library"](#).

Oracle9*i*AS Infrastructure

This chapter guides you through the steps for the Oracle9*i*AS Infrastructure installation. The topics include:

- [Oracle9*i*AS Infrastructure Installation](#)
- [Oracle9*i*AS Infrastructure Postinstallation](#)

4.1 Oracle9iAS Infrastructure Installation

The following instructions guide you through the Oracle9iAS Infrastructure installation of Oracle9i Application Server (Oracle9iAS).

Note: J2EE and Web Cache installs with Oracle9iAS Infrastructure, but is for internal use only. Oracle does not support the use of this copy of J2EE and Web Cache for customer application deployment. This installation of J2EE and Web Cache configures Oracle HTTP Server and Oracle9iAS Container for J2EE.

Table 4–1 lists required information for Oracle9iAS Infrastructure installation. Enter your values for the listed installation information in the **Your Information** column before beginning.

Table 4–1 Installation Information

Information	Example Values	Your Information
Oracle base directory ¹ (Section 2.5.3.1, "ORACLE_HOME")	/private/oraInventory	
Oracle home location (Section 2.5.3.1, "ORACLE_HOME")	/private/ora9ias	
OSDBA group ¹ (Section 2.5.5.3, "UNIX Group Names for Privileged Groups")	svrtech	
OSOPER group ¹ (Section 2.5.5.3, "UNIX Group Names for Privileged Groups")	svrtech	
Instance Name (Section 2.5.3.1, "ORACLE_HOME")	instance1	
ias_admin Password (Section 2.5.3.1, "ORACLE_HOME")	oracle1	

Table 4-1 Installation Information(Cont.)

Information	Example Values	Your Information
Oracle9iAS Single Sign-On Server Host Name ² (Section 1.3, "Oracle9iAS Infrastructure Installation")	oasdocs.us.oracle.com	
Oracle9iAS Single Sign-On Port Number ² (Appendix F, "Default Port Numbers and Port Ranges")	7777	
Oracle Internet Directory Host Name (Section 1.3, "Oracle9iAS Infrastructure Installation")	oasdocs.us.oracle.com	
Oracle Internet Directory Port Number (Appendix F, "Default Port Numbers and Port Ranges")	389	
Database Character Set (Step 9 on page 4-21)	default	

¹ Required for first time installation of Oracle9iAS.

² Required for Portal and Wireless, Business Intelligence and Forms, and Unified Messaging install types. Also required for application server clustering with J2EE and Web Cache install type. See the *Oracle9i Application Server Administrator's Guide* for more information about clustering.

1. Review the Oracle Universal Installer Welcome screen and click **Next**.

The Welcome screen provides information about the Oracle Universal Installer. The following function buttons appear on the installation screens:

- **Deinstall Products:** Deinstall individual components or the entire product. This button appears only on the Welcome screen.
- **About Oracle Universal Installer:** View the version number of the installer in use.
- **Exit:** Quit the installation process and exit the installer.
- **Help:** Access detailed information about the functionality of each screen.
- **Installed Products:** View currently installed products or deinstall the entire product or components.
- **Previous:** Return to the previous screen.
- **Next:** Proceed to the next screen.

2. Verify the location of the base directory for installation files and click **OK**.

Figure 4–1 Inventory Location Screen

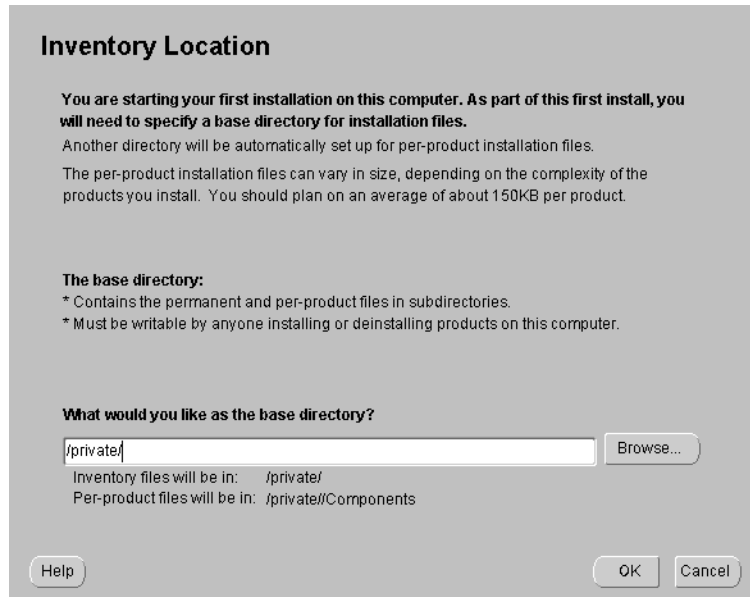

The Inventory Location screen appears during the *first installation* on a host to set a location for installation files. Product components use a different directory. The installation files can vary in size depending on the complexity of the product. For file storage considerations, assume a file size of 150 KB per product.

- **Browse:** Navigate through the available directory to select a location for the base directory for your installation.

The base directory has the following attributes:

- Contains the permanent and per-product component files in subdirectories
- Must be writable by anyone in the same user group installing or deinstalling products on the install computer

Input where you would like the base directory to be stored. For example:

```
/private
```

The storage location for product component files is the `Components` directory. For example:

```
/private/oraInventory/Components
```

- You need root privileges to execute certain actions before the installation can continue. You need to run a shell script with root privileges that is stored in the `oraInstRoot.sh` file. (You may need to execute the shell script by typing `./` before `oraInstRoot.sh`). The `Root.sh` installation screen shows the location of the `oraInstRoot.sh` file. The script creates pointers to the components as the installer installs them in the system, so that they can be identified later in the installation procedure. It produces the `/var/opt/oracle/oraInst.loc` file, which provides a pointer to the `oraInventory` directory.

After you execute the shell script, continue with the installation process.

3. Verify the source path, destination name, and destination path for your Oracle9iAS installation and click **Next**.

Figure 4–2 File Locations Screen

File Locations

Source...
Enter the full path of the file representing the product(s) you want to install:
Path:

Destination...
Enter or select an Oracle Home name and its full path:
Name:
Path:

ORACLE

The File Locations screen allows you to enter the full path for the source and destination locations for your installation.

- **Source:** This is the full path to the `products.jar` file from which the product will be installed. The installer detects and uses the default values of the `products.jar` file of the installation program. Do not change the path.
- **Name:** Enter an Oracle home name or select a name from the drop-down list. You may use the default Oracle home name of `ora9ias` provided or select your own name. If you do not have a home created on your computer, one is created for you during the installation.

Oracle homes are identified by name. The Oracle home name identifies the program group associated with a specific Oracle home and the installed Oracle services associated with the home.

The Oracle home name must consist of 1 to 16 characters long and can only include alphanumeric characters and underscores; spaces are not allowed.

- **Destination:** This is the full path to the Oracle home where the product will be installed. The installer defaults to the Oracle home set in the preinstallation chapter.

Note: The Oracle home path must be an absolute path. It cannot contain environment variables or spaces.

See Also: [Section 2.5.3.1, "ORACLE_HOME"](#)

- **Browse:** Navigate through the file system to find source and destination locations.

Oracle9iAS Infrastructure needs to be installed in a separate Oracle home, preferably on a separate host from any Oracle9iAS installations. Do not install Oracle9iAS Infrastructure into an existing:

- Oracle9i Database home directory
- Oracle8i Database home directory
- Another Oracle9iAS Infrastructure home directory unless it is for an upgrade
- Another Oracle9iAS instance home directory

4. Select the Oracle9iAS Infrastructure product type and click **Next**.

Figure 4–3 Available Products Screen

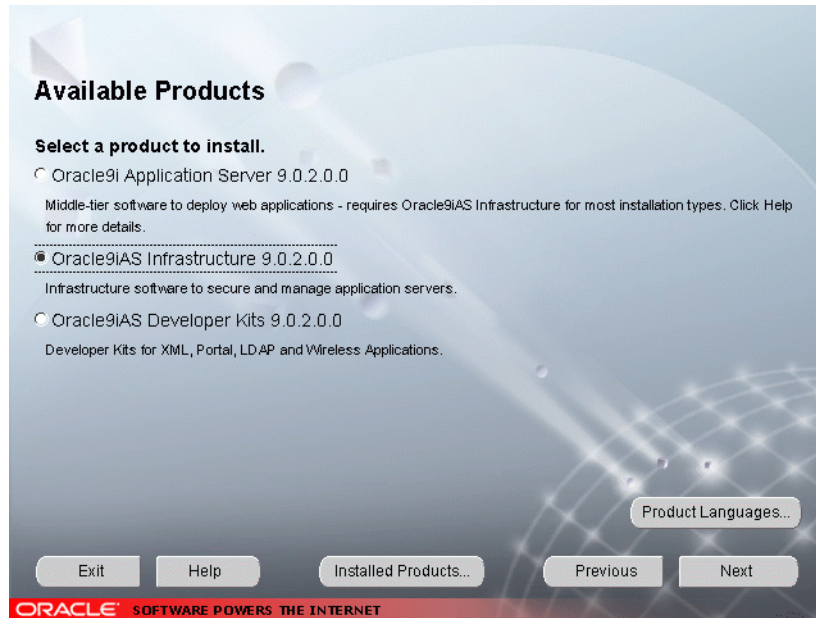

Oracle9iAS Infrastructure installs Oracle9iAS Metadata Repository, Oracle Internet Directory, Oracle9iAS Single Sign-On, and Oracle Management Server. Oracle9iAS Infrastructure is required for all of the Oracle9iAS middle-tier applications except when installing the J2EE and Web Cache install type without single sign-on or clustering. Prior to installing an instance of either Portal and Wireless, Business Intelligence and Forms, or Unified Messaging, you must install and configure the Oracle9iAS Infrastructure somewhere in your network.

See Also : *Oracle9i Application Server Concepts Guide*

- Choose to either accept installer recommendations for Oracle9iAS Infrastructure components, or specify existing instances of components and click **Next**.

Figure 4–4 Select Configuration Options Screen

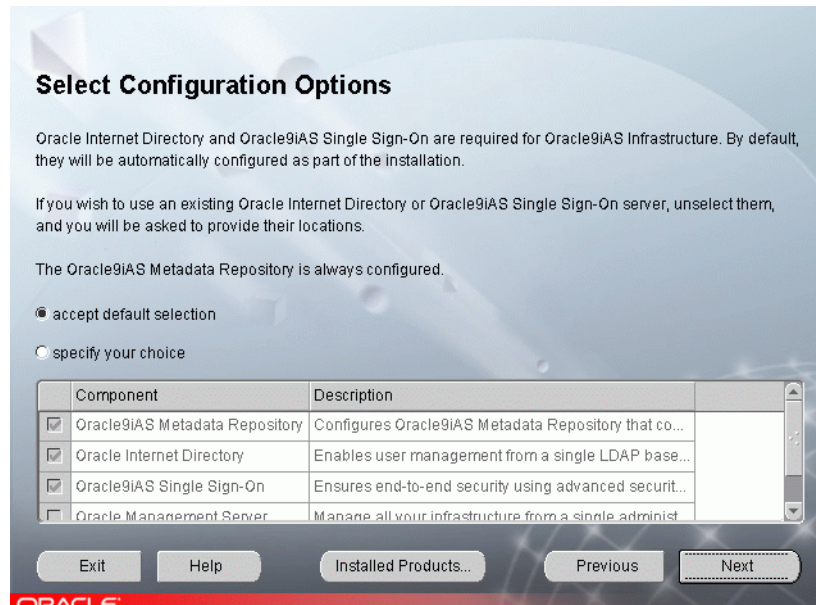

The Select Configuration Options screen offers two configuration options

- Accept default selection:** Installation and configuration of Oracle9iAS Metadata Repository, Oracle Internet Directory, and Oracle9iAS Single Sign-On is completed at the end of the installation process.
- Specify your choice:** Previous instances of Oracle Internet Directory and Oracle9iAS Single Sign-On are available for use. If you wish to use an existing Oracle Internet Directory or Oracle9iAS Single Sign-On server, deselect each component, and you will be asked to provide their locations. Choose this option if you also want to configure Oracle Management Server.

If you de-select a component here, the installer installs it, but does not configure or start it. After installation, the installer starts the selected Oracle9iAS component. If you decide to use that component at a later time, then launch the Oracle Enterprise Manager Home Page to configure that component.

If you would like to configure Oracle Internet Directory and Oracle9iAS Single Sign-On on separate hosts:

- a. Select configuration of Oracle Internet Directory and deselect configuration of Oracle9iAS Single Sign-On, on the first host, Host 1.
- b. Select configuration of Oracle9iAS Single Sign-On and deselect configuration of Oracle Internet Directory, on the second host, Host 2.
- c. Point the Oracle9iAS Single Sign-On configuration on Host 2 to the Oracle Internet Directory configuration on Host 1.

If you plan to install copies of Oracle Internet Directory on different hosts to form a directory replication network, configure Oracle9iAS Single Sign-On with only one of the Oracle Internet Directory copies. The remaining copies of Oracle Internet Directory must not associate with any Oracle9iAS Single Sign-On configuration. Refer to the *Oracle Internet Directory Administrator's Guide* for more information.

Oracle9iAS Metadata Repository is always configured and started during Oracle9iAS Infrastructure installation.

6. One of the following two screens may appear based on your configuration choices on the "Select Configuration Options Screen", (Figure 4-4)
 - **Existing Oracle9iAS Single Sign-On:** This screen appears if you have unchecked the configuration of Oracle9iAS Single Sign-On on the [Component Configuration and Startup screen](#).
 - **Existing Oracle Internet Directory:** This screen appears if you have unchecked the configuration of Oracle Internet Directory on the [Component Configuration and Startup screen](#).

a. Existing Oracle9iAS Single Sign-On

Enter the host name and port number for the existing instance of Oracle9iAS Single Sign-On that you wish to use with this installation of Oracle9iAS Infrastructure and click **Next**.

Figure 4–5 Existing Oracle9iAS Single Sign-On Screen

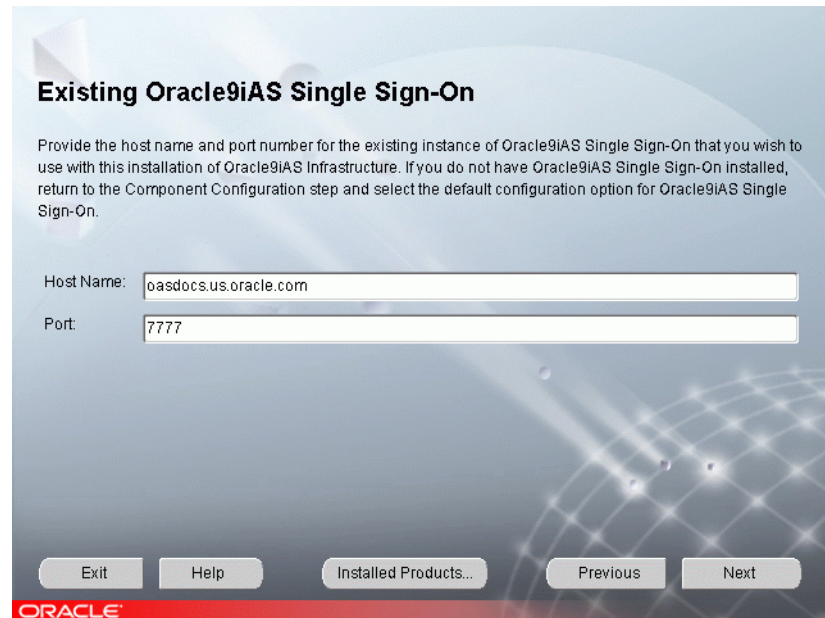

Existing Oracle9iAS Single Sign-On

Provide the host name and port number for the existing instance of Oracle9iAS Single Sign-On that you wish to use with this installation of Oracle9iAS Infrastructure. If you do not have Oracle9iAS Single Sign-On installed, return to the Component Configuration step and select the default configuration option for Oracle9iAS Single Sign-On.

Host Name:

Port:

Exit Help Installed Products... Previous Next

ORACLE

If you do not have Oracle9iAS Single Sign-On installed, return to the [Component Configuration and Startup screen](#) and select the default configuration option for Oracle9iAS Single Sign-On.

b. Existing Oracle Internet Directory

Enter the host name and port number for the existing instance of Oracle Internet Directory that you wish to use with this installation of Oracle9iAS Infrastructure and click **Next**.

Figure 4–6 Existing Oracle Internet Directory Screen

Existing Oracle Internet Directory

Provide the host name, port number, username and password for the existing instance of Oracle Internet Directory that you wish to use with this installation of Oracle9iAS Infrastructure. If you do not have Oracle Internet Directory installed, return to the Component Configuration step and select the default configuration option for Oracle Internet Directory.

Host Name:

Port:

Username:

Password:

Exit Help Installed Products... Previous Next

ORACLE

This screen appears if you have unchecked the configuration of Oracle Internet Directory on the Component Configuration and Startup screen.

If you do not have Oracle Internet Directory installed, you must install it through the Oracle9iAS Infrastructure installation before proceeding with this installation.

Oracle Internet Directory and Oracle9iAS Single Sign-On are required components for using Infrastructure.

–**Host Name:** The unique identity for each computer within a domain. Enter the host name where Oracle Internet Directory is located. For example, us.oracle.com domain.

–**Port:** The number used to route transmitted data to and from a particular program. Enter the port number where Oracle Internet Directory is located.

You will need the following to add information about the Oracle9iAS instance into Oracle Internet Directory:

–**Username:** The name used for connection to Oracle Internet Directory.

–**Password:** The password for users to access Oracle Internet Directory.

The username and password are defined in Oracle Internet Directory as either the:

–**orcladmin** (root user)

–a member of the IASAdmins group in Oracle Internet Directory

The username creates a user entity in Oracle Internet Directory. The user must be a member of the IASAdmins group. By default, orcladmin (the Oracle Internet Directory administrator) is also a member of the IASAdmins group. If the Oracle Internet Directory administrator does not wish to give out the orcladmin password, the administrator creates a username and password for a member of the IASAdmins group. Refer to the *Oracle Internet Directory Administrator's Guide* for more information.

7. One of the following screens will appear based on whether an Oracle9iAS installation exists on this host:
 - **Create Instance Name and ias_admin Password Screen:** This screen appears if this is a first time installation of Oracle9iAS on this host.
 - **Create Instance Name Screen:** This screen appears if the Oracle Universal Installer has detected a previous Oracle9iAS installation on this host but in a different Oracle home.

The following terms may be used on the following three screens:

Instance Name: Identifies the installation instance of Oracle9iAS Infrastructure on this host.

ias_admin password: The ias_admin users password used to administer any Oracle9iAS on this host. This password is required for installing additional Oracle9iAS instances. If you are configuring Oracle Internet Directory, the default administrative user, "orcladmin", will be assigned the same password as the ias_admin user by default. The orcladmin user is a superuser for Oracle Internet Directory.

a. Create Instance Name and ias_admin Password

Enter a unique instance name and ias_admin users password for this installation of Oracle9iAS Infrastructure and click **Next**.

Figure 4–7 Create Instance Name and ias_admin Password Screen

Create Instance Name and ias_admin Password

Enter a unique instance name for this Oracle9iAS instance. The hostname and domain of this machine will be appended to the end of this instance name.

Provide a password for the ias_admin user which is used to manage all Oracle9iAS instances on this host. Note that all instances on this host share this password.

Instance Name

ias_admin Password

Confirm Password

Exit Help Installed Products... Previous Next

ORACLE

This screen appears if this is a first time installation of Oracle9iAS on this host.

Enter a unique name in the instance name field for this installation of Oracle9iAS Infrastructure. The instance name must contain alphanumeric and underscore characters only.

Select an ias_admin password for this instance of Oracle9iAS Infrastructure and then re-enter the password for confirmation. The ias_admin password must consist of at least five alphanumeric characters. Additionally, at least one of the characters must be a number.

The unique instance name will be used to identify this installation of Oracle9iAS Infrastructure on the install host.

The `ias_admin` password allows you to:

- Manage all instances of Oracle9iAS across the install host
- Run management tools
- Facilitate future installations
- Access the Oracle Enterprise Manager Home Page

Note: If you are configuring Oracle Internet Directory as part of this installation, the default administrative user, "orcladmin", will be assigned the same password as the `ias_admin` user by default.

b. Create Instance Name

Enter a unique instance name and the `ias_admin` password for this installation of Oracle9iAS Infrastructure and click **Next**.

Figure 4–8 Create Instance Name Screen

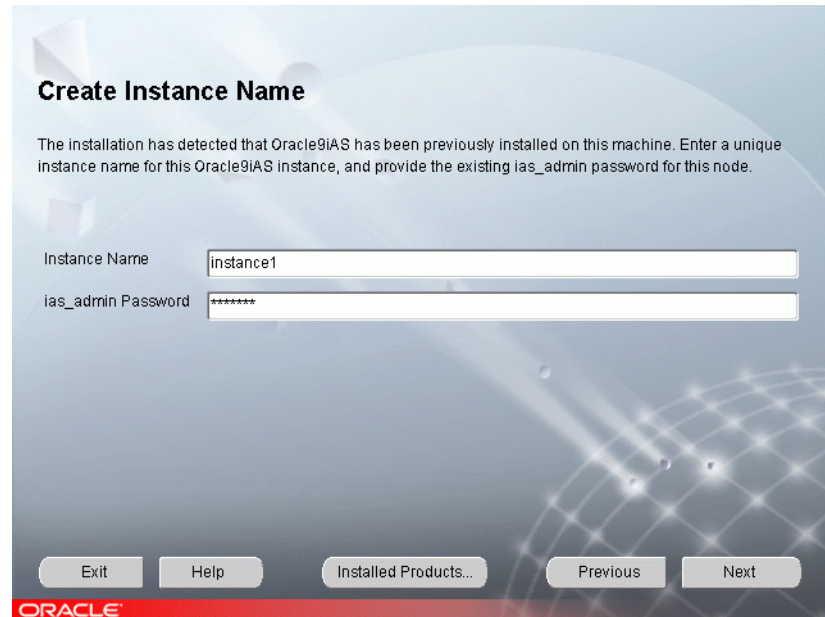

Create Instance Name

The installation has detected that Oracle9iAS has been previously installed on this machine. Enter a unique instance name for this Oracle9iAS instance, and provide the existing `ias_admin` password for this node.

Instance Name

`ias_admin` Password

Exit Help Installed Products... Previous Next

ORACLE

If the Oracle Universal Installer has detected a previous Oracle9iAS installation on this host but in a different Oracle home this screen appears. Enter a unique instance name and the existing `ias_admin` password for this host to continue with the installation. The instance name must contain alphanumeric and underscore characters only.

If you forget your `ias_admin` users password following installation, refer to the *Oracle9i Application Server Administrator's Guide* for the steps you can follow to reset the password.

- This screen appears only if the `oracle` account is not a member of the `dba` group. Enter the database administrator and operator group name and click **Next**.

Figure 4–9 Privileged Operating System Groups Screen

Privileged Operating System Groups

SYSDBA and SYSOPER privileges are required to create a database using operating system (OS) authentication. These are granted through membership in the UNIX groups OSDBA and OSOPER, respectively, and the `dba` group is usually used for this purpose. You are not a member of this group, so enter the names of the UNIX groups of which you are a member, to be used for OSDBA and OSOPER.

Database Administrator (OSDBA) Group

Database Operator (OSOPER) Group

Exit Help Installed Products... Previous **Next**

ORACLE

The Privileged Operating System Groups screen allows you to enter the database administrator and operator group name for installation of the Oracle9iAS Metadata Repository. For more information regarding privileged group names, refer to [Section 2.5.5.3, "UNIX Group Names for Privileged Groups"](#). The installer detects and defaults to the your OS group.

- **Database Administrator (OSDBA) Group:** The UNIX group that has database administrator privileges
- **Database Operator (OSOPER) Group:** The UNIX group that has database operator privileges

9. Select the Database Character Set you would like to use and click **Next**.

Figure 4–10 Database Character Set Screen

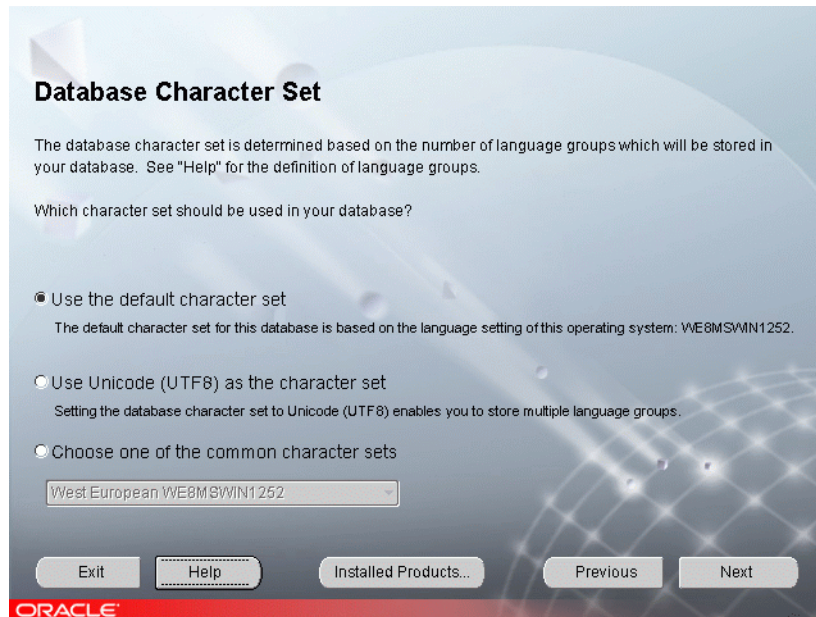

Choose from one of the three following character sets for your database:

- **Default character set:** Based on the language of the install operating system. If you intend to store data in one language, accept the default database character set
- **Unicode as the character set:** Enables you to store multiple language groups
- **Choose one of the common character sets:** Click **Help** to view the list of available common character sets

10. Review the Summary screen and click **Install** to begin the installation process.

The Summary screen allows you to review all the settings before the installation begins. These settings include source, destination, installation type, product language, install file sizes, and a list of Oracle9iAS components.

- To make changes to any of these settings, click **Previous** to return to the respective screens.

Note: Insufficient disk space is indicated in red under **Space Requirements**.

When you click **Install**, the installation process begins.

11. Monitor the installation process and after the installer finishes, click **Next**.

The Install screen appears while the product is installing. The Install screen shows installation operations, including executing actions such as file copy and linking, and executing decision points and calculations. It displays the full path of the installation log.

- **Cancel:** Discontinues the installation process. You can then choose to stop the installation of an individual component or the entire product.

See Also: [Section 2.6.3, "oraInventory Directory"](#)

Running root.sh

During installation of Oracle9iAS, the installer prompts you to run the `root.sh` script.

Use the following steps to run the `root.sh` script.

- a. Log on as the root user.
- b. Run the `root.sh` script in the Oracle home directory.

```
prompt> ORACLE_HOME/root.sh
```

- c. Exit root user.

Once you see "Finished running generic part of the root.sh script" and "Now product-specific root actions will be performed," exit root user and return to the Install screen.

The `root.sh` script detects:

- Settings of `ORACLE_OWNER`, `ORACLE_HOME` and `ORACLE_SID` environment variables.
- Full path of local `bin` directory. You can accept the default or change to a different local `bin` directory.

12. Review the status of Oracle9iAS configuration tools and click **Next.**

The Components Configuration and Startup screen appears for Oracle9iAS components to configure and start. The screen lists the configuration tools for all installed components.

Depending on the configurations selected you will see some component configuration screens, but no input is required.

Monitor the progress of each configuration tool by scrolling down the tools list to review the configuration status of each tool. The status changes as each component is configured.

The installer performs the following functions in this screen:

- Executes a configuration tool for each component selected previously in the Component Configuration and Startup screen.
- Allows you to view data for failed executions in the display window. You can either fix the error and click **Retry** to execute the configuration tool again, or ignore the error and click **Next** to proceed to the next screen.
- **Retry**: Re-executes the configuration script if the configuration of a component fails.
- **Stop**: Quits the configuration process.

13. Review the End of Installation screen. Click **Exit** to quit the installer or click **Next Install** to install additional Oracle9iAS instances.

Figure 4–11 End of Installation Screen

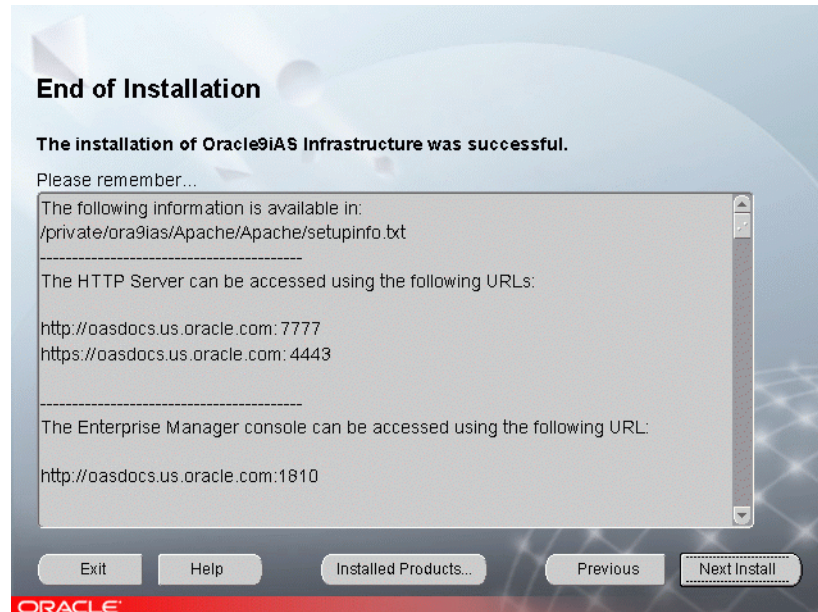

The End of Installation screen appears at the end of the installation process. It notifies you whether the installation was successful or unsuccessful and provides information about accessing the Oracle9iAS instance.

The End of Installation screen displays the URL and port number for accessing the Oracle HTTP Server page and the Oracle Enterprise Manager Web Site. The default Oracle HTTP Server page is the Oracle9iAS Welcome page. The Oracle9iAS Welcome page provides links to demonstrations and information about new features.

See Also:

- [Section 4.2.1, "Starting Oracle Enterprise Manager Web Site"](#)
- *Oracle9i Application Server Administrator's Guide*

You can view the Install Log for the completed installation at:

`/your_base_directory/oraInventory/logs/installActiontodays_date_time.log`

in which *your_base_directory* is the location for your installation files and *todays_date_time* is the date and time of installation.

A complete listing of log files is included in the *Oracle9i Application Server Administrator's Guide*.

You have successfully installed the Oracle9iAS Infrastructure installation of Oracle9iAS.

Proceed to [Section 4.2, "Oracle9iAS Infrastructure Postinstallation"](#) to complete the installation process.

4.2 Oracle9iAS Infrastructure Postinstallation

The following instructions guide you through the basic postinstallation tasks for Oracle9iAS Infrastructure.

The postinstallation contains the following sections:

- [Starting Oracle Enterprise Manager Web Site](#)
- [Installing the Oracle9iAS Infrastructure Patches](#)
- [Starting and Stopping Components](#)
- [Component Port Numbers](#)
- [Additional Oracle9iAS Product Installations](#)
- [Additional Documentation](#)

4.2.1 Starting Oracle Enterprise Manager Web Site

The Oracle Enterprise Manager Web Site is available after Oracle9iAS Infrastructure installation and component configuration. The Oracle Enterprise Manager Web Site is comprised of Oracle Enterprise Manager Home Pages. Each Oracle Enterprise Manager Home Page is used to manage an installed Oracle9iAS component or instance.

Oracle strongly recommends that you use the Secure Socket Layer (SSL) protocol and HTTPS for all connections to the Oracle Enterprise Manager Web Site. Refer to the *Oracle9i Application Server Administrator's Guide* for setup information.

4.2.2 Installing the Oracle9iAS Infrastructure Patches

Following successful installation and configuration of Oracle9iAS Infrastructure you must download and install the Oracle9iAS Infrastructure patches. You can download the patches from:

<http://metalink.oracle.com>

Select the **Patches** link. On the patch download form, select Oracle9i Application Server in the **Product Family** field and then submit the form.

4.2.3 Starting and Stopping Components

Oracle9iAS components can be started and stopped using the Oracle Enterprise Manager Home Page. For information on manual starting and stopping of Oracle9iAS components refer to the component specific documentation.

4.2.4 Component Port Numbers

Following installation, the Oracle Universal Installer creates a file showing the port assignments during installation of Oracle9iAS components. The installation process automatically detects any port conflicts and chooses an alternate port in the range allocated for that component. [Appendix F, "Default Port Numbers and Port Ranges"](#) lists the default port ranges. The file `portlist.ini` is located at:

```
OracleHome/install/portlist.ini
```

This file lists component entries as "port name = port value". For example:

```
Oracle HTTP Server port = 7777
Oracle HTTP Server SSL port = 4443
Oracle HTTP Server listen port = 7778
Oracle HTTP Server SSL listen port = 4444
Oracle HTTP Server Jserv port = 8007
Enterprise Manager Servlet port = 1810
```

You can also view the port numbers by pointing your browser to the Oracle9iAS Welcome page and selecting the **Ports** tab

Note: The Oracle Universal Installer uses the port numbers for select components during installation of Oracle9iAS. If you are planning on adding additional Oracle9iAS instances, make sure the installed instances are running at the time of additional installation.

See Also:

- [Section 4.2.1, "Starting Oracle Enterprise Manager Web Site"](#)
- [Appendix F, "Default Port Numbers and Port Ranges"](#)
- [Section 2.5, "Preinstallation Tasks"](#)
- *Oracle9i Application Server Administrator's Guide*

4.2.5 Additional Oracle9iAS Product Installations

For information regarding installation of additional Oracle9iAS installations, refer to [Section 2.8, "Additional Oracle9iAS Product Installations"](#), and [Chapter 7, "Coexistence"](#).

4.2.6 Additional Documentation

For further information on postinstallation and configuration tasks, refer to the *Oracle9i Application Server Administrator's Guide* and component-specific documentation. For information on viewing and installing the documentation, refer to [Appendix G, "Installing the Documentation Library"](#).

Oracle9iAS Developer Kits

This chapter guides you through the steps for the Oracle9iAS Developer Kits installation. The topics include:

- [Oracle9iAS Developer Kits Installation](#)
- [Oracle9iAS Developer Kits Postinstallation](#)

5.1 Oracle9iAS Developer Kits Installation

The following instructions guide you through the Oracle9iAS Developer Kits installation of Oracle9i Application Server (Oracle9iAS).

[Table 5–1](#) lists required information for Oracle9iAS Developer Kits installation. Enter your values for the listed information in the **Your Information** column before beginning.

Table 5–1 *Installation Information*

Information	Example Values	Your Information
Oracle base directory ¹ (Section 2.5.3.1, "ORACLE_HOME")	/private/oraInventory	
Oracle home location (Section 2.5.3.1, "ORACLE_HOME")	/private/ora9ias	
Instance Name (Section 2.5.3.1, "ORACLE_HOME")	instance1	
ias_admin Password (Section 2.5.3.1, "ORACLE_HOME")	oracle1	

¹ Required for first time installation of Oracle9iAS.

1. Review the Oracle Universal Installer Welcome screen and click **Next**.

The Welcome screen provides information about the Oracle Universal Installer. The following function buttons appear on the installation screens:

- **Deinstall Products:** Deinstall individual components or the entire product. This button appears only on the Welcome screen.
- **About Oracle Universal Installer:** View the version number of the installer in use.
- **Exit:** Quit the installation process and exit the installer.
- **Help:** Access detailed information about the functionality of each screen.
- **Installed Products:** View currently installed products or deinstall the entire product or components.
- **Previous:** Return to the previous screen.
- **Next:** Proceed to the next screen.

2. Verify the location of the base directory for installation files and click **OK**.

Figure 5–1 Inventory Location Screen

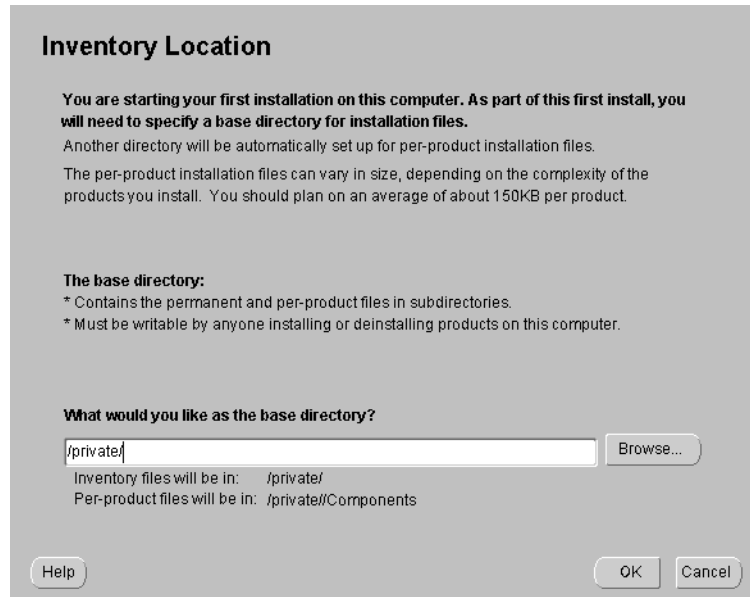

The Inventory Location screen appears during the *first installation* on a host to set a location for installation files. Product components use a different directory. The installation files can vary in size depending on the complexity of the product. For file storage considerations, assume a file size of 150 KB per product.

- **Browse:** Navigate through the available directory to select a location for the base directory for your installation.

The base directory has the following attributes:

- Contains the permanent and per-product component files in subdirectories
- Must be writable by anyone in the same user group installing or deinstalling products on the install computer

Input where you would like the base directory to be stored. For example:

```
/private
```

The storage location for product component files is the `Components` directory. For example:

```
/private/oraInventory/Components
```

- You need root privileges to execute certain actions before the installation can continue. You need to run a shell script with root privileges that is stored in the `oraInstRoot.sh` file. (You may need to execute the shell script by typing `./` before `oraInstRoot.sh`). The `Root.sh` installation screen shows the location of the `oraInstRoot.sh` file. The script creates pointers to the components as the installer installs them in the system, so that they can be identified later in the installation procedure. It produces the `/var/opt/oracle/oraInst.loc` file, which provides a pointer to the `oraInventory` directory.

After you execute the shell script, continue with the installation process.

3. Verify the source path, destination name, and destination path for your Oracle9iAS installation and click **Next**.

Figure 5–2 File Locations Screen

File Locations

Source...

Enter the full path of the file representing the product(s) you want to install:

Path:

Destination...

Enter or select an Oracle Home name and its full path:

Name:

Path:

ORACLE

The File Locations screen allows you to enter the full path for the source and destination locations for your installation.

- **Source:** This is the full path to the `products.jar` file from which the product will be installed. The installer detects and uses the default values of the `products.jar` file of the installation program. Do not change the path.
- **Name:** Enter an Oracle home name or select a name from the drop-down list. You may use the default Oracle home name of `ora9ias` provided or select your own name. If you do not have a home created on your computer, one is created for you during the installation.

Oracle homes are identified by name. The Oracle home name identifies the program group associated with a specific Oracle home and the installed Oracle services associated with the home.

The Oracle home name must consist of 1 to 16 characters long and can only include alphanumeric characters and underscores; spaces are not allowed.

- **Destination:** This is the full path to the Oracle home where the product will be installed. The installer defaults to the Oracle home set in the preinstallation chapter.

Note: The Oracle home path must be an absolute path. It cannot contain environment variables or spaces.

See Also: [Section 2.5.3.1, "ORACLE_HOME"](#)

- **Browse:** Navigate through the file system to find source and destination locations.

4. Select the Oracle9iAS Developer Kits install type and click **Next**.

Figure 5–3 Available Products Screen

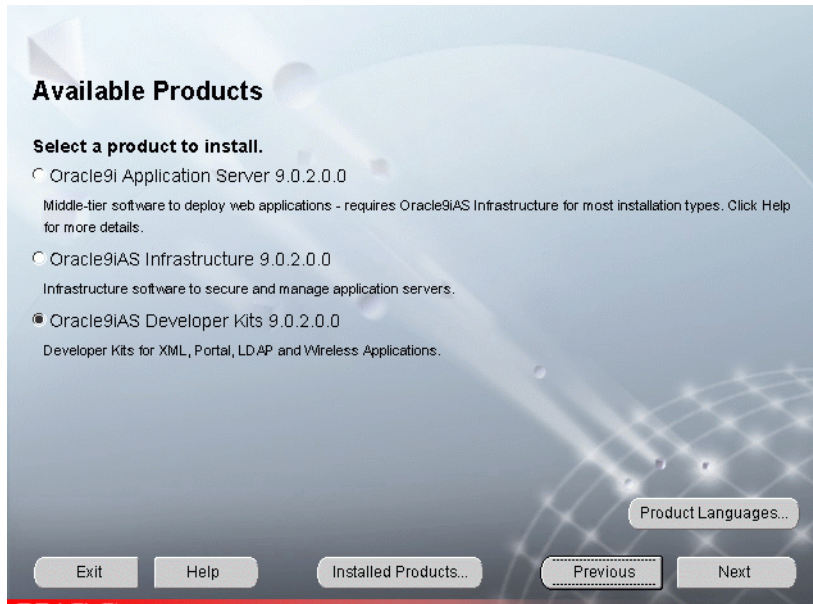

Oracle9iAS Developer Kits: Installs Oracle XML Developer's Kit, Oracle9iAS Portal Developer's Kit, Oracle9iAS Wireless Developer's Kit, Oracle LDAP Developer's Kit.

Oracle9iAS Developer Kits also installs a J2EE and Web Cache instance that can be used in a testing environment.

- **Product Languages:** Select product language for installation. The languages available for this product are Arabic, Bengali, Brazilian Portuguese, Bulgarian, Canadian French, Catalan, Croatian, Czech, Danish, Dutch, Egyptian, English, English (United Kingdom), Estonian, Finnish, French, German, Greek, Hebrew, Hungarian, Icelandic, Indonesian, Italian, Japanese, Korean, Latin American Spanish, Latvian, Lithuanian, Malay, Mexican Spanish, Norwegian, Polish, Portuguese, Romanian, Russian, Simplified Chinese, Slovak, Slovenian, Spanish, Swedish, Thai, Traditional Chinese, Turkish, Ukrainian, and Vietnamese. The default language is English.

See Also: [Appendix E, "Components"](#)

5. One of the following screens appears based on whether an Oracle9iAS installation has been installed on this host:
 - **Create Instance Name and ias_admin Password:** This screen appears if this is a first time installation of Oracle9iAS on this host.
 - **Enter ias_admin Password:** This screen appears if the Oracle Universal Installer has detected a previous installation of Oracle9iAS in your Oracle home.
 - **Create Instance Name:** This screen appears if the Oracle Universal Installer has detected a previous installation of Oracle9iAS on this host but in a different Oracle home.

The following terms may be used on the following three screens:

Instance Name: Identifies the installation instance of Oracle9iAS Developer Kits on this host.

ias_admin Password: The ias_admin users password used to administer any Oracle9iAS on this host. This password is required for installation of additional Oracle9iAS instances.

a. Create Instance Name and ias_admin Password

Enter a unique Oracle9iAS Developer Kits instance name and ias_admin password and click **Next**.

Figure 5–4 Create Instance Name and ias_admin Screen

Create Instance Name and ias_admin Password

Enter a unique instance name for this Oracle9iAS instance. The hostname and domain of this machine will be appended to the end of this instance name.

Provide a password for the ias_admin user which is used to manage all Oracle9iAS instances on this host. Note that all instances on this host share this password.

Instance Name

ias_admin Password

Confirm Password

Exit Help Installed Products... Previous Next

ORACLE

This screen appears if this is a first time installation of Oracle9iAS on this host.

Enter a unique name in the instance name field for this installation of Oracle9iAS Developer Kits. The instance name must contain alphanumeric and underscore characters only.

Select an ias_admin password for this instance of Oracle9iAS Developer Kits and then re-enter the password for confirmation. The ias_admin password must consist of at least five alphanumeric characters. Additionally, at least one of the characters must be a number.

The unique instance name will be used to identify this installation of Oracle9iAS Developer Kits on the install host.

The `ias_admin` password allows you to:

- Manage all instances of Oracle9iAS across the install host
- Run management tools
- Facilitate future installations
- Access the Oracle Enterprise Manager Home Page

b. Enter ias_admin Password

Enter your Oracle9iAS ias_admin password and click **Next**.

Figure 5–5 *Enter ias_admin Password Screen*



If the Oracle Universal Installer detects a previous installation of Oracle9iAS in your Oracle home, this screen appears. The existing Oracle9iAS instance name will be used for this installation. Enter your existing Oracle9iAS ias_admin password for this host to continue with the installation.

If you forget your ias_admin users password following installation, refer to the *Oracle9i Application Server Administrator's Guide* for the steps you can follow to reset the password.

c. Create Instance Name

Enter a unique Oracle9iAS instance name and the `ias_admin` password and click **Next**.

Figure 5–6 *Create Instance Name Screen*

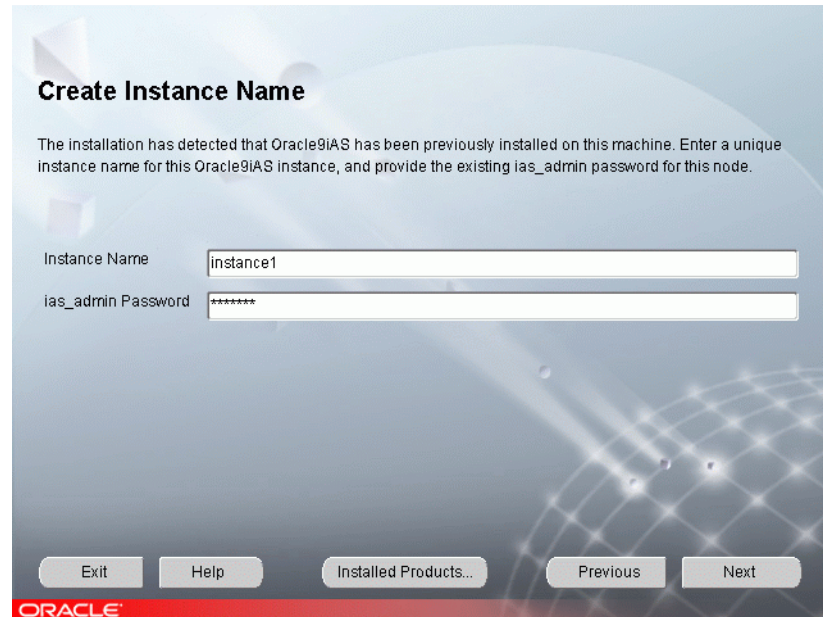

Create Instance Name

The installation has detected that Oracle9iAS has been previously installed on this machine. Enter a unique instance name for this Oracle9iAS instance, and provide the existing `ias_admin` password for this node.

Instance Name

ias_admin Password

Exit Help Installed Products... Previous Next

ORACLE

If the Oracle Universal Installer has detected a previous installation of Oracle9iAS on this host but in a different Oracle home, this screen appears. Enter a unique instance name and the existing `ias_admin` password for this host to continue with the installation. The instance name must contain alphanumeric and underscore characters only.

If you forget your `ias_admin` users password following installation, refer to the *Oracle9i Application Server Administrator's Guide* for the steps you can follow to reset the password.

6. Review the Summary screen and click **Install** to begin the installation process.

The Summary screen allows you to review all the settings before the installation begins. These settings include source, destination, installation type, product language, install file sizes, and a list of components.

- To make changes to any of these settings, click **Previous** to return to the respective screens.

Note: Insufficient disk space is indicated in red under **Space Requirements**.

When you click **Install**, the installation process begins.

7. Monitor the installation process and after the installer finishes, click **Next**.

The Install screen appears while the product is installing. The Install screen shows installation operations, including executing actions such as file copy and linking, and executing decision points and calculations. It displays the full path of the installation log.

- **Cancel:** Discontinues the installation process. You can then choose to stop the installation of an individual component or the entire product.

For more information about the installation log, refer to [Section 2.6.3, "oraInventory Directory"](#).

Running root.sh

During installation of Oracle9iAS, the installer prompts you to run the `root.sh` script.

Use the following steps to run the `root.sh` script.

- a. Log on as the root user.
- b. Run the `root.sh` script in the Oracle home directory.

```
prompt> ORACLE_HOME/root.sh
```

You may need to execute the shell script by typing `./` before `root.sh`.

- c. Exit root user.

Once you see "Finished running generic part of the root.sh script" and "Now product-specific root actions will be performed," exit root user and return to the Install screen.

The `root.sh` script detects:

- Settings of `ORACLE_OWNER`, `ORACLE_HOME` and `ORACLE_SID` environment variables.
- Full path of local `bin` directory. You can accept the default or change to a different local `bin` directory.

8. Review the status of Oracle9iAS configuration tools and click **Next**.

The Components Configuration and Startup screen appears for components to configure and start. The screen lists the configuration tools for all installed components.

Depending on the configurations selected you will see some component configuration screens, but no input is required.

Monitor the progress of each configuration tool by scrolling down the tools list to review the configuration status of each tool. The status changes as each component is configured.

The installer performs the following functions in this screen:

- Executes a configuration tool for each component selected previously in the Component Configuration and Startup screen.
- Allows you to view data for failed executions in the display window. You can either fix the error and click **Retry** to execute the configuration tool again, or ignore the error and click **Next** to proceed to the next screen.
- **Retry**: Re-executes the configuration script if the configuration of a component fails.
- **Stop**: Quits the configuration process.
- **Exit**: Quit the configuration tool and continue with the installation.

9. Review the End of Installation screen. Click **Exit** to quit the installer or click **Next Install** to install additional Oracle9iAS instances.

Figure 5–7 End of Installation Screen

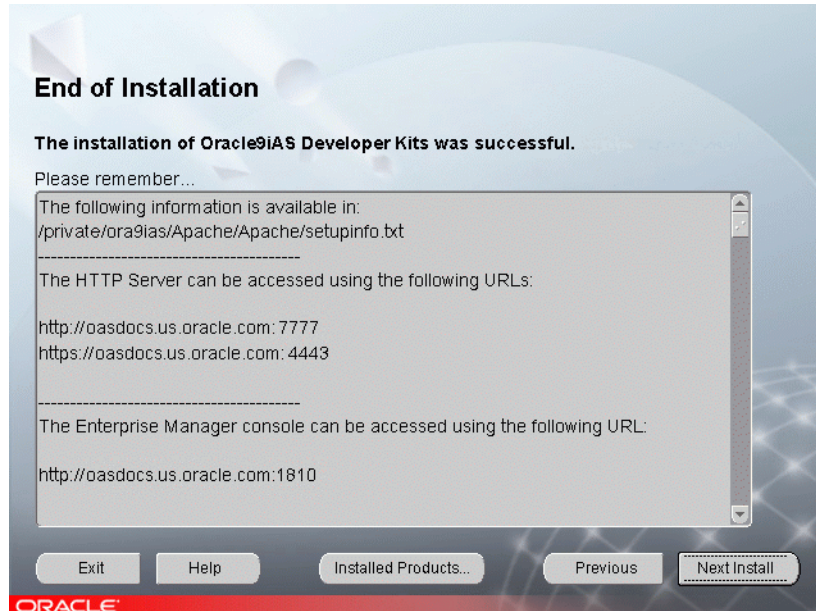

The End of Installation screen appears at the end of the installation process. It notifies you whether the installation was successful or unsuccessful and provides information about accessing the Oracle9iAS instance.

The End of Installation screen displays the URL and port number for accessing the Oracle HTTP Server page and the Oracle Enterprise Manager Web site. The default Oracle HTTP Server page is the Oracle9iAS Welcome page. The Oracle9iAS Welcome page provides links to demonstrations and information about new features.

See Also:

- [Section 5.2.1, "Starting Oracle Enterprise Manager Web site"](#)
- *Oracle9i Application Server Administrator's Guide*

You can view the Install Log for the completed installation at:

`/your_base_directory/oraInventory/logs/installActiontodays_date_time.log`

in which `your_base_directory` is the location for your installation files and `todays_date_time` is the date and time of installation.

A complete listing of log files is included in the *Oracle9i Application Server Administrator's Guide*.

You have successfully installed Oracle9iAS Developer Kits. Proceed to [Section 5.2, "Oracle9iAS Developer Kits Postinstallation"](#) to complete the installation process.

5.2 Oracle9iAS Developer Kits Postinstallation

The following instructions guide you through the basic postinstallation tasks for Oracle9iAS Developer Kits.

The postinstallation contains the following sections:

- [Starting Oracle Enterprise Manager Web site](#)
- [Starting and Stopping Components](#)
- [Component Port Numbers](#)
- [Additional Oracle9iAS Product Installations](#)
- [Additional Documentation](#)

5.2.1 Starting Oracle Enterprise Manager Web site

The Oracle Enterprise Manager Web site is available after Oracle9iAS Developer Kits installation and component configuration. The Oracle Enterprise Manager Web site is comprised of Oracle Enterprise Manager Home Pages. Each Oracle Enterprise Manager Home Page is used to manage an installed Oracle9iAS component or instance.

Oracle strongly recommends that you use the Secure Socket Layer (SSL) protocol and HTTPS for all connections to the Oracle Enterprise Manager Web site. Refer to the *Oracle9i Application Server Administrator's Guide* for setup information.

5.2.2 Starting and Stopping Components

Oracle9iAS components can be started and stopped using the Oracle Enterprise Manager Home Page. For information on manual starting and stopping of Oracle9iAS components refer to the component specific documentation.

5.2.3 Component Port Numbers

Following installation, the Oracle Universal Installer creates a file showing the port assignments during installation of Oracle9iAS components. The installation process automatically detects any port conflicts and chooses an alternate port in the range allocated for that component. [Appendix F, "Default Port Numbers and Port Ranges"](#) lists the default port ranges. The file `portlist.ini` is located at:

```
OracleHome/install/portlist.ini
```

This file lists component entries as "port name = port value". For example:

```
Oracle HTTP Server port = 7777
Oracle HTTP Server SSL port = 4443
Oracle HTTP Server listen port = 7778
Oracle HTTP Server SSL listen port = 4444
Oracle HTTP Server Jserv port = 8007
Enterprise Manager Servlet port = 1810
```

You can also view the port numbers by pointing your browser to the Oracle9iAS Welcome page and selecting the **Ports** tab

Note: The Oracle Universal Installer uses the port numbers for select components during installation of Oracle9iAS. If you are planning on adding additional Oracle9iAS instances, make sure the installed instances are running at the time of additional installation.

See Also:

- [Section 5.2.1, "Starting Oracle Enterprise Manager Web site"](#)
- [Appendix F, "Default Port Numbers and Port Ranges"](#)
- [Section 2.5, "Preinstallation Tasks"](#)
- *Oracle9i Application Server Administrator's Guide*

5.2.4 Additional Oracle9iAS Product Installations

For information regarding installation of additional Oracle9iAS installations, refer to [Section 2.8, "Additional Oracle9iAS Product Installations"](#), and [Chapter 7, "Coexistence"](#).

5.2.5 Additional Documentation

For further information on postinstallation and configuration tasks, refer to the *Oracle9i Application Server Administrator's Guide* and component-specific documentation. For information on viewing and installing the documentation, refer to [Appendix G, "Installing the Documentation Library"](#).

Silent and Non-Interactive Installation

This chapter guides you through the silent and non-interactive installation of Oracle9i Application Server (Oracle9iAS). The topics include:

- [Introduction](#)
- [Requirements](#)
- [Creating Files for Silent and Non-Interactive Installation](#)
- [Selecting a Response File](#)
- [Editing the Response File](#)
- [Specifying a Response File](#)
- [Running the Root.sh Script](#)
- [Error Handling](#)
- [Deinstallation](#)

6.1 Introduction

Oracle9iAS features two non-interacting methods of installation:

- [Silent Installation](#)
- [Non-Interactive Installation](#)

6.1.1 Silent Installation

Silent installation of Oracle9iAS is accomplished by supplying the Oracle Universal Installer with a response file and specifying the `-silent` flag. The installer uses the variables and values contained in this text file to provide answers to all of the installer user prompts. You include responses for all of the installer prompts in the response file. Silent installation displays *no graphical* output.

If this is a first time installation of Oracle9iAS, you will also need to manually create three files before starting. These files are used by Oracle Universal Installer during the installation. File creation is described in [Section 6.3, "Creating Files for Silent and Non-Interactive Installation"](#).

Following installation of Oracle9iAS, you will need to run the `root.sh` script. The `root.sh` script detects settings of environmental variables and allows you to enter the full path of the local bin directory.

Use silent installation of Oracle9iAS when there are similar installations on more than one computer. Additionally, use silent install when performing the Oracle9iAS installation from a remote location using the command line. Silent installation eliminates the need to monitor the Oracle9iAS installation because there is no graphical output and no input by the user.

See Also: [Section 2.5.3.2, "DISPLAY"](#) for more information about remote installation.

6.1.2 Non-Interactive Installation

Non-interactive installation of Oracle9iAS is also accomplished by supplying the Oracle Universal Installer with a response file but without specifying the `-silent` flag. The installer uses the variables and values contained in this text file to provide answers to some or all of the installer user prompts. There is graphical output and if you have not provided responses to all of the installer prompts, you may need to enter information during the installation.

You will need to run the `root.sh` script during the installation process. The `root.sh` script detects settings of environmental variables and allows you to enter the full path of the local bin directory.

6.2 Requirements

For a complete list of installation requirements, refer to [Chapter 2, "Getting Started"](#).

6.3 Creating Files for Silent and Non-Interactive Installation

If the `oraInst.loc`, `emtab`, and `oratab` files do not exist on your computer, you need to create them before starting the silent installation of Oracle9iAS. These three files are typically stored in the `/var/opt/oracle/` directory. They are used by the Oracle Universal Installer during the silent installation.

The following sections show you how to create the three files.

6.3.1 oraInst.loc file creation

As the root user, create the `oraInst.loc` file in the `/var/opt/oracle/` directory. Make sure the file has read and write permission for the `oracle` user group. The `oracle` user group is the group performing the installation. The `inventory_loc` is the location for inventory files. If `inventory_loc` is not located in your `ORACLE_HOME` ensure that the directory where it is located has read and write permission for the `oracle` user group.

The `oraInst.loc` file should have the text input as shown:

```
inst_group=<oracle_user_group>
inventory_loc=ORACLE_HOME
```

for example if your `ORACLE_HOME` is `/private2/oracle/ias`, the content of the file is:

```
inventory_loc=/private2/oracle/iasinst_group=oracle user group
```

6.3.2 emtab file creation

Create the `emtab` file in the `/var/opt/oracle/` directory. Make sure the file has read and write permission for the `oracle` user's group. The `emtab` file should have the text input as shown:

```
DEFAULT=$ORACLE_HOME
```

for example if your `ORACLE_HOME` is `/private2/oracle/ias`, the content of the file is:

```
DEFAULT=/private2/oracle/ias
```

6.3.3 oratab file creation

Create the `oratab` file in the `/var/opt/oracle/` directory. Make sure the file is empty and has read and write permission for the `oracle` user's group.

6.4 Selecting a Response File

There are multiple Oracle Universal Installer response files depending on your choice of Oracle9iAS installation. These files are included on the Oracle9iAS, Release 2 (9.0.2) CD-ROM. You must edit the response file to suit your installation, silent or non-interactive.

To use a response file, copy the response file from the Oracle9iAS CD-ROM to your system. For example:

```
prompt> cd mount_point/Disk1/stage/Response/  
prompt> cp oracle.iappserver.iapptop.j2ee.rsp private/ora9ias/Response/
```

The Oracle9iAS, Release 2 (9.0.2) CD-ROM contains the following response files:

- Oracle9iAS installation
 - J2EE and Web Cache (oracle.iappserver.iapptop.j2ee.rsp)
 - Portal and Wireless (oracle.iappserver.iapptop.Portals.rsp)
 - Business Intelligence and Forms
(oracle.iappserver.iapptop.Business.rsp)
 - Unified Messaging (oracle.iappserver.iapptop.UM.rsp)
- Oracle9iAS Infrastructure installation
(oracle.iappserver.infrastructure.Infrastructure.rsp)
- Oracle9iAS Developer Kits installation
(oracle.iappserver.devcorner.DevKit.rsp)

6.5 Editing the Response File

Using any text editor, edit the response file to include information specific for your system. The response file text identifies information that you must provide.

You must specify values for variables in your response file. Each variable listed in the response file is associated with a comment. The comment identifies the variable type. For example:

```
string = "Sample Value"  
Boolean = True or False  
Number = 1000  
StringList = {"StringValue 1", "String Value 2"}
```

The values that are given as <Value Required> must be specified for silent installation.

Remove the comment from the variable values in the response file you will use before starting the Oracle9iAS installation.

6.6 Specifying a Response File

To make the installer use the response file at install time, follow the same steps to launch the installer, but specify the location of the response file that you wish to use as a parameter when starting the installer:

```
prompt> ./runInstaller -responseFile absolute_path_and_filename
```

To perform a completely silent installation session, use the `-silent` parameter:

```
prompt> ./runInstaller -silent -responseFile absolute_path_and_filename
```

The success or failure of the non-interactive installation is logged in `installActions.log` and for silent installation in `silentInstall.log`. The log files are created in the `oraInventory` directory during installation.

See Also:

- [Section 2.6.3, "oraInventory Directory"](#)
- [Section 2.6.4, "Starting Oracle Universal Installer"](#)

Note: The installer will fail if you attempt a silent session without appropriately configuring a response file.

6.7 Running the Root.sh Script

During silent and non-interactive installation you must run the `root.sh` script either before or after installation of Oracle9iAS.

6.7.1 Root.sh and Silent Installation

During silent installation of Oracle9iAS, you will not be prompted to run the `root.sh` script. You must run the `root.sh` script after silent installation.

Use the following steps to run the `root.sh` script.

1. Log on as the root user.
2. Run the `root.sh` script in the Oracle home directory.

```
prompt> Oracle_Home/root.sh
```

3. Exit root user.

6.7.1.1 Oracle HTTP Server

During silent installation, Oracle Universal Installer will attempt to start Oracle HTTP Server. However, Oracle HTTP Server will not start until the `root.sh` script is run. Ignore any error messages generated due to the inability to start Oracle HTTP Server.

After running the `root.sh` script, re-start Oracle HTTP Server using the following commands:

```
ORACLE_HOME/opmn/bin opmnctl stopall  
ORACLE_HOME/opmn/bin opmnctl startall
```

6.7.1.2 Using Oracle HTTP Server On a Different Port

If you want to use Oracle HTTP Server on a port number that is less than 1024, you must complete the following steps:

1. Do not run the `root.sh` script.
2. Execute the following script as the root user:

```
ORACLE_HOME/Apache/Apache/bin/root_sh_append.sh
```

The `root_sh_append.sh` script sets the necessary permission for the Oracle HTTP Server to be run on a port less than 1024.

6.7.2 Root.sh and Non-Interactive Installation

During non-interactive installation of Oracle9iAS, the installer prompts you to run the `root.sh` script.

Use the following steps to run the `root.sh` script.

1. Log on as the root user.
2. Run the `root.sh` script in the Oracle home directory.

```
prompt> Oracle_Home/root.sh
```

3. Exit root user.

For non-interactive installation, once you see “Finished running generic part of the `root.sh` script” and “Now product-specific root actions will be performed,” exit root user and return to the Install screen.

The `root.sh` script detects:

- Settings of `ORACLE_OWNER`, `ORACLE_HOME`, and `ORACLE_SID` environment variables
- Full path of local `bin` directory. You can accept the default or change to a different local `bin` directory

6.8 Error Handling

Values for variables that are of the wrong context, format, or type are treated as if no value were specified. Variables that are outside any section are ignored.

If you attempt a silent or non-interactive installation with an incorrect or incomplete response file, or the installer encounters an error, such as insufficient disk space, the installation will fail.

If you attempt a non-interactive installation without specifying a response file, the installation will fail.

The results of either your silent or non-interactive installation are recorded in the installation session log file .

See Also: [Section 2.6.3, "oraInventory Directory"](#)

6.9 Deinstallation

If your silent or non-interactive installation fails, you must completely deinstall any files remaining from your Oracle9iAS installation attempt.

See Also: [Chapter 8, "Deinstallation and Reinstallation"](#)

Coexistence

This chapter describes the extra steps to enable coexistence of Oracle products on one computer. The topics include:

- [Migration](#)
- [Oracle9iAS Installation Coexistence with other Oracle products](#)

7.1 Migration

If you are migrating from a previous version of Oracle9i Application Server (Oracle9iAS), perform the tasks described in the *Oracle9i Application Server: Migrating from Oracle9i Application Server 1.x*.

The Oracle9iAS Migration Assistant enables you to migrate existing J2EE and Web Cache components from an Oracle9iAS Release 1, Version 1.0.2.2 installation to a Release 2, Version 9.0.2 installation. The Oracle9iAS Migration Assistant upgrades existing 1.0.2.2 versions of Oracle HTTP Server, Oracle9iAS Web Cache, and Oracle9iAS Containers for J2EE for compatibility with 9.0.2.

Instructions for using and installing the Oracle9iAS Migration Assistant are available in the *Oracle9i Application Server: Migrating from Oracle9i Application Server 1.x*.

7.2 Oracle9iAS Installation Coexistence with other Oracle products

Your Oracle9iAS, Oracle9iAS Infrastructure, or Oracle9iAS Developer Kits installation can coexist with previously installed Oracle products on your computer. Your installation can coexist with existing installations of:

- Oracle9i Database
- Oracle 8.1.7 Database
- Oracle9iAS Release 1 (1.0.2.2.x)

The following steps describe how to enable coexistence of your installation with other Oracle products:

1. Verify that you are a member of the administrative group for existing installations of Oracle9i Database, Oracle 8.1.7 Database, or Oracle9iAS Release 1 (1.0.2.2.x).
2. Ensure that the Oracle Home directory selected for your Oracle9iAS installation is different from the previously installed Oracle products Home.

Oracle9iAS Infrastructure must be installed in its own Oracle home directory, preferably on a separate host. The Oracle9iAS Infrastructure installation cannot exist in the same Oracle Home as the installed Oracle products.

3. Make sure that Oracle8i database is running during Oracle9iAS installation so that port conflicts can be resolved.

7.2.0.1 Oracle9iAS Infrastructure Port Usage

Installation of Oracle9iAS Infrastructure requires the use of port 1521 on your computer. If one of your current system applications uses this port, complete one of the following actions before installing Oracle9iAS Infrastructure:

- Reconfigure an existing application to use another port.
- If you have an existing Oracle Net listener and an Oracle9i database, proceed with the installation of Oracle9iAS Infrastructure. Your Oracle9iAS Infrastructure will use the existing Oracle Net listener.
- If you have an existing Oracle Net8 listener using an Oracle8i database, you must upgrade to the Oracle9i Net listener version by installing Oracle9iAS Infrastructure. Stop running the Oracle Net8 listener prior to installing Oracle9iAS Infrastructure. Migrate any Oracle Net8 listener configuration specific to your Oracle8i database into the configuration for the Oracle Net listener, and restart the Oracle Net listener. The Oracle Net listener supports the Oracle8i database as well as Oracle9iAS Infrastructure. Your Oracle8i database will be unavailable when performing the upgrade.

Deinstallation and Reinstallation

This chapter guides you through the deinstallation and reinstallation process for Oracle9i Application Server (Oracle9iAS). The topics include:

- [Deinstallation](#)
- [Reinstallation](#)

8.1 Deinstallation

The following steps guide you through the deinstallation process of Oracle9iAS.

In order to successfully deinstall Oracle9iAS from your host, Oracle recommends deinstalling all secondary (or subsequent) Oracle9iAS installations before you deinstall the primary (or first) installation.

Note: Stop all services and processes before starting the deinstallation process.

Note: Oracle Universal Installer does not permit custom deinstallation of select components or Oracle9iAS instances. Confirm deinstall objectives before launching deinstallation.

8.1.1 Deinstalling Using Oracle Universal Installer

1. Start the Oracle Universal Installer.

Once Oracle Universal Installer is launched, the Welcome screen appears. Click **Deinstall Products**.

The Welcome screen provides information about Oracle Universal Installer.

The installer provides you with two ways to deinstall products:

- **Deinstall Products:** Deinstalls the entire product.
- **Installed Products:** View currently installed products and deinstall the entire product.

See Also: [Section 2.6.4, "Starting Oracle Universal Installer"](#)

2. Review the installations and check the one you wish to deinstall. Click **Remove**.

Note: Oracle Universal Installer does not permit deinstallation of select components or Oracle9iAS instances. Confirm deinstall objectives before launching deinstallation.

Figure 8–1 Inventory Screen

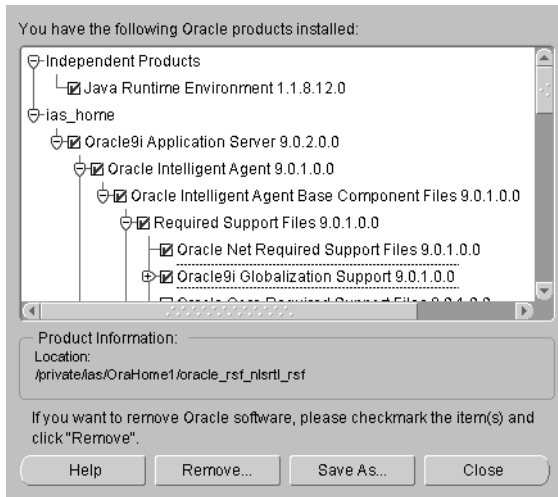

The Inventory screen appears when you click **Deinstall Products** on the Welcome screen, or **Installed Products** on any screen.

The Inventory screen displays all the components installed in Oracle home.

The following buttons and product information appear on the Inventory screen:

- **Help:** Access detailed information about the functionality of the Inventory screen.
- **Remove:** Deinstall all checked components from Oracle home.
- **Save As:** Save the inventory as text. A file browser dialog pops up when you click **Save As**. Accept a file name and the complete inventory list as displayed by the inventory screen will be logged into this file as text.
- **Close:** Quit the Inventory screen.
- **Location:** View the full location path of the selected component.

3. Verify the components selected for deinstallation, and click **Yes**.

Figure 8–2 Confirmation Screen

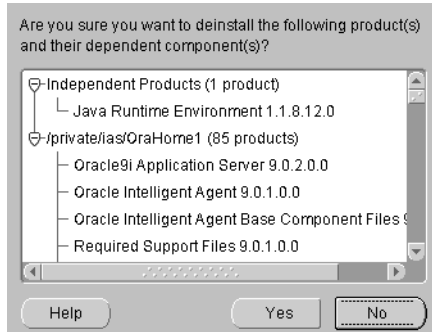

The Confirmation screen lists all the components selected for deinstallation in the previous step. Scroll down the screen to verify selected components.

Note: Oracle Universal Installer does not deinstall all the files and directories during deinstallation. Remaining files must be removed manually.

The following buttons appear on the Confirmation screen:

- **Help:** Access detailed information about the functionality of the Confirmation screen.
- **Yes:** Start deinstallation of listed components.
- **No:** Return to the Inventory screen. Listed components are not removed from Oracle home.

4. The following Oracle9iAS Administration Service screen appears prior to deinstallation. Click OK to continue.

Figure 8–3 Oracle9iAS Administration Service Screen

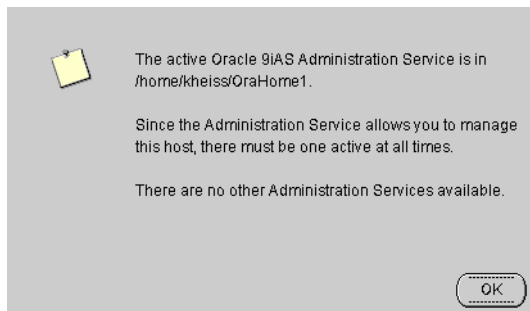

This screen presents one of the following messages:

- The active Oracle9iAS Administration Service is in `/private/OraHome1`. There are no other Administration Services available.

This message appears when there is only one Oracle9iAS installation on the host and you are about to deinstall it.

- The active Oracle9iAS Administration Service is in `/private/OraHome1`. You may select one of the Administration Services below to become the active one.

This message appears when there are multiple Oracle9iAS installations on the host and you are about to deinstall the primary installation. You must select one of the remaining Oracle9iAS installations which will then become the primary installation and the new location for the Oracle9iAS Administration Service.

5. Monitor the deinstallation process.

The Remove Progress Bar screen appears when you click **Remove**. The installer detects all components chosen for deinstallation from the Inventory screen and removes them from Oracle home.

- **Cancel:** To discontinue the deinstallation process.

Note: If you deinstall a product or component, then all of its dependent components and files will also be deinstalled.

You have successfully deinstalled Oracle9iAS.

8.2 Reinstallation

Oracle Universal Installer does not allow reinstallation of Oracle9iAS over an installed version. To reinstall Oracle9iAS over the same version, deinstall and then install the product.

See Also: [Section 8.1, "Deinstallation"](#)

Java Access Bridge Installation

This appendix describes the procedures required for installation of a Java Access Bridge. The topics include:

- [Setting-Up the Java Access Bridge](#)
- [Setup for JRE 1.3.1](#)
- [Setup for JRE 1.1.8](#)

A.1 Setting-Up the Java Access Bridge

This section contains setup information for enabling Oracle components to use a screen reader.

Java Access Bridge enables assistive technologies, such as the JAWS screen reader, to read Java applications running on the Windows platform. Assistive technologies can read Java-based interfaces, such as Oracle Universal Installer and Oracle Enterprise Manager.

Your Oracle9i Application Server (Oracle9iAS) installation CD-ROMs contain two different versions of the Java Runtime Environment (JRE) that is used by the Oracle Universal Installer during installation. The CD-ROMs contain JRE 1.31 and JRE 1.1.8. The JREs enable use of the Java Access Bridge during installation.

Complete the following procedures to install and configure the access bridge for each of the JREs.

This section contains the following topics:

- [Setup for JRE 1.3.1](#)
- [Setup for JRE 1.1.8](#)

A.2 Setup for JRE 1.3.1

To setup the access bridge with JRE 1.3.1, run the batch file on the first Oracle9iAS CD-ROM. The batch file is located at:

```
<Disk1>\install\win32\access_setup.bat
```

A.3 Setup for JRE 1.1.8

This section features the following topics regarding use of the access bridge with JRE 1.1.8:

- [Setup for Oracle Universal Installer](#)
- [Setup for Oracle Installed Components](#)

A.3.1 Setup for Oracle Universal Installer

Install and configure Java Access Bridge for Windows before installing Oracle components to enable assistive technologies to read Oracle Universal Installer windows.

Before you begin Java Access Bridge installation exit any assistive technology software that is running.

To install the Java Access Bridge:

1. From the first Oracle9iAS component CD-ROM, copy
 \AccessBridge\accessbridge1_0.zip to a location on your hard drive.
2. Extract the files onto your computer hard drive. For example:

```
c:\accessbridge
```

3. Add `access-bridge.jar` and `jaccess-1_1.jar` to the `CLASSPATH` user environment variable.

Open the Windows System Control Panel. For Windows NT or Windows 2000, choose **Start > Settings > Control Panel > System**.

On Windows NT, choose the Environment tab.

On Windows 2000, choose the Advance tab. Then, click the Environment Variables button.

4. Add the following to the `CLASSPATH` user environment variable:

```
c:\AccessBridge-1_0\installer\installerFiles\access-bridge.jar  
c:\AccessBridge\installer\installerFiles\jaccess-1_1.jar
```

where `c:\AccessBridge-1_0` is the full path of the Access Bridge location on your computer hard drive.

5. Copy `JavaAccessBridge.dll` and `WindowsAccessBridge.dll` from:

```
c:\AccessBridge-1_0\installer\installerFiles\  
  
to  
  
operating system\system32\.
```

Following successful installation, Java Access Bridge documentation is located at:

```
\AccessBridge-1_0\doc
```

A.3.2 Setup for Oracle Installed Components

Install and configure Java Access Bridge for Windows after installing Oracle components to enable assistive technologies to read Oracle component windows.

To install the Java Access Bridge:

1. From the first Oracle*9iAS* component CD-ROM, copy `\AccessBridge\accessbridge1_0.zip` to a location on your hard drive.
2. Extract the files onto your computer hard drive. For example:

```
c:\accessbridge
```

3. Install the Java Access Bridge into the right subdirectory used by Oracle components.

Java Access Bridge must be installed into the subdirectory of Java Runtime Environment (JRE) 1.1.8 used by Oracle components. By default, the JRE 1.1.8 used by Oracle is installed in:

```
c:\Program Files\Oracle\jre\1.1.8.
```

The following [Table A-1](#) list the files to copy from the Java Access Bridge location on your computer hard drive to the appropriate subdirectory of the JRE used by Oracle components.

Table A-1 Copy Files To Subdirectory

Copy...	To...
\AccessBridge-1_0\installer\installerFiles\ jaccess-1_1.jar	\lib\jaccess.jar (rename jaccess-1_1.jar to jaccess.jar)
\AccessBridge-1_0\access-bridge.jar	\lib\
\AccessBridge-1_0\JavaAccessBridge.dll	\bin\
\AccessBridge-1_0\WindowsAccessBridge.dll	\bin\

4. In the destination folder, rename `jaccess-1_1.jar` to `jaccess.jar`.
5. Use a text editor to modify `\lib\awt.properties` file that is located in the subdirectory of JRE 1.1.8 used by Oracle components.
6. Add the following lines to `awt.properties` file:

```
AWT.EventQueueClass=com.cun.java.accessibility.util.EventQueueMonitor
AWT.assistive_technologies=com.sun.java.accessibility.AccessBridge
```

Following successful installation, Java Access Bridge documentation is located at:

```
\AccessBridge-1_0\doc
```

To Configure Oracle Components to use the Java Access Bridge:

1. Set the system environment variable `ORACLE_OEM_CLASSPATH` to point to the installed Java Access Bridge files.

Open the Windows System Control Panel. For Windows NT or Windows 2000, choose **Start > Settings > Control Panel > System**.

Windows NT:

- a. Choose the Environment tab.
- b. Select a variable in the System Variables list.
- c. In the Variable field, enter `ORACLE_OEM_CLASSPATH`.
- d. In the Value field, enter the full path of `jaccess.jar` and `access-bridge.jar`. For example, if JRE 1.1.8 is installed in the default location, then the paths are:

```
c:\Program Files\Oracle\jre\1.1.8\lib\jaccess.jar;  
c:\Program Files\Oracle\jre\1.1.8\lib\ access-bridge.jar
```

- e. Select **Set**.
- f. Select **OK**.

Windows 2000:

- a. Choose the Advanced tab.
- b. Click the Environment Variables button.
The Environment Variables dialog appears.
- c. Click the New button under the System Variable list.
The New System Variable dialog appears.
- d. In the Variable Name field, enter the `ORACLE_OEM_CLASSPATH`.
- e. In the Variable Value field, enter the full path of `jaccess.jar` and `access-bridge.jar`. For example, if JRE 1.1.8 is installed in the default location, then the paths are:

```
c:\Program Files\Oracle\jre\1.1.8\lib\jaccess.jar;  
c:\Program Files\Oracle\jre\1.1.8\lib\ access-bridge.jar
```

- f. Select **OK**.

Oracle9iAS Client Installation

This appendix explains how to install the Oracle9i Database Client software from the Oracle9iAS Client CD-ROM.

This appendix contains the following topics:

- [Introduction](#)
- [Oracle9i Options](#)
- [Preinstallation Requirements](#)
- [Installation](#)
- [Postinstallation Configuration Tasks](#)
- [Individual Components Available for Installation](#)
- [Installing Oracle Components in Noninteractive Mode](#)

B.1 Introduction

This section provides information about Oracle Universal Installer, installation types, and concepts you should be aware of in planning an installation.

B.2 Oracle9i Options

The following products require a separate license:

- Oracle Advanced Security
- Oracle Diagnostics Pack
- Oracle Tuning Pack

See Also:

- *Global License Terms* for additional licensing information
- [Section B.6.1, "Oracle9i Database Client Components"](#)

B.3 Preinstallation Requirements

This section contains the following topics:

- [Single Oracle Home Components](#)
- [Client Component System Requirements](#)
- [Oracle9i Database Client Products for Installation](#)
- [Mandatory Individual Component Requirements](#)
- [Linking and Relinking Applications](#)
- [Networking Protocol Vendor Requirements](#)

B.3.1 Single Oracle Home Components

Most of the Oracle9i Database Client components can be installed multiple times on the same computer. However, the following components can only be installed once for each computer:

- Oracle Objects for OLE
- Oracle Provider for OLE DB

Oracle Universal Installer detects that these products are already installed in another Oracle home and automatically removes them from the installation process without prompting you. The following information is logged to the `installActions.log` file in the following locations:

```
c:\Program Files\Oracle\Inventory\logs directory.
```

```
# product_name is a single oracle home product. It is already installed in  
currently_installed_location.
```

If you are performing an installation and notice that one or more single Oracle home components are not available for installation during the current session, check to see if any of these components or any previous versions of these components are installed in another Oracle home. If you want to install these in the current Oracle home, deinstall the conflicting versions.

B.3.2 Client Component System Requirements

The following sections list the system requirements for the Oracle9i Database Client. The Oracle9i Database Client contains several individual components. Some components also have requirements that must be satisfied before installation.

Important: The hard disk requirements for client components includes 25 MB to install Java Runtime Environment (JRE) and Oracle Universal Installer on the installation partition. If sufficient space is not detected, the installation fails.

B.3.2.1 System Requirements for FAT and NTFS File Systems

This section lists system requirements for both the File Allocation Table (FAT) and Windows NT File System (NTFS) file systems. Because of the difference in space allocation on both file systems, hard disk requirements vary.

Oracle Corporation recommends installing NTFS for Windows NT, Windows 2000, Windows XP, and FAT32 for Windows 98.

See Also: [Section B.5.1, "About NTFS File System and Windows NT Registry Permissions"](#)

Important: Oracle Corporation recommends that you review the FAT and NTFS system requirements to determine if you have enough hard disk space for installation.

B.3.3 Oracle9i Database Client Products for Installation

The Oracle9i Application Server (Oracle9iAS) Database Client includes a set of products, services, and client-side utilities used to connect to a backend Oracle9i database.

- Oracle9i Database Client

Installs the Oracle Enterprise Manager Console, including enterprise management tools, networking services, utilities, and basic client software.

- Oracle9i SOAP Client

Installs the Oracle9i SOAP Client software.

See Also: [Section B.6, "Individual Components Available for Installation"](#) for a list of individual components installed with each installation type

Table B-1 shows the system requirements for Oracle9i Database Client.

Table B-1 Oracle9i Database Client System Requirements

Requirement	Database Client ¹ and SOAP Client
Operating System	Windows 98, Windows NT 4.0 ² , Windows 2000 ³ , Windows XP ⁴ , and Windows Terminal Server ⁵
Windows NT 4.0 Service Pack	Certified with Service Pack 5 or higher
Windows 2000 Service Pack	Not required; certified with Service Pack 1 or higher
Minimal Processor	Pentium 166
Recommended Processor	Pentium I 266
RAM	128 MB (minimal); 256 MB (recommended)
FAT file system:	
■ Oracle home disk space	1 GB
■ System disk space	51 MB
NTFS file system:	
■ Oracle home disk space	650 MB
■ System disk space	51 MB
Web browser (if using Oracle Enterprise Manager Web Site)	<ul style="list-style-type: none"> ■ Netscape Navigator 4.7 or higher ■ Microsoft Internet Explorer 5.0 or higher

¹ The processor and RAM requirements identified are applicable to an Enterprise Manager Client installation and to a thin Web-based Enterprise Manager Client.

² Windows NT includes: Windows NT Workstation 4.0, Windows NT Server 4.0, Windows NT Server Enterprise Edition 4.0, and Windows NT 4.0 Server Terminal Server Edition.

³ Windows 2000 includes: Windows 2000 Professional, Windows 2000 Server, Windows 2000 Advanced Server, and Windows 2000 Datacenter.

⁴ Windows XP Professional Edition.

⁵ Oracle supports Terminal Services on Windows 2000 Server, Windows 2000 Advanced Server, and Windows 2000 Datacenter. See "[Unsupported Components and Features on Windows Terminal Servers](#)" on page B-7 for additional information.

B.3.3.1 Unsupported Components and Features on Windows Terminal Servers

The following products are not supported on Windows Terminal Servers:

- Oracle Migration Workbench
- Oracle Services for Microsoft Transaction Server

See Also:

- The Microsoft Web site for more information on terminal servers:
<http://www.microsoft.com/>
- The Oracle *MetaLink* Web site for the latest Terminal Server certification information:
<http://metalink.oracle.com/>

B.3.4 Mandatory Individual Component Requirements

[Table B-2](#) describes mandatory individual component preinstallation requirements. Refer to [Section B.6, "Individual Components Available for Installation"](#) for a list of the individual components that can be installed. Appropriate documentation for preinstallation procedures is also identified.

Table B–2 Mandatory Individual Component Requirements

Component	Description	See Also...
Oracle Advanced Security	You must satisfy hardware and software requirements to use authentication support with Oracle components. In addition, using Oracle Advanced Security with Secure Socket Layer (SSL) and public key infrastructure (PKI) requires preinstallation of a Lightweight Directory Access Protocol (LDAP) directory such as Oracle Internet Directory (provided on the component CD-ROM).	<i>Oracle Advanced Security Administrator's Guide</i> This manual is not on the Oracle 9iAS Documentation CD-ROM. You can view it at: http://tahiti.oracle.com
Oracle9i integration with Active Directory	The user performing the Oracle9i installation must perform preinstallation requirements for integration to be successful.	"Using Oracle9i Directory Server Features with Active Directory" of <i>Oracle9i Network, Directory, and Security Guide for Windows</i> This manual is not on the Oracle 9iAS Documentation CD-ROM. You can view it at: http://tahiti.oracle.com

B.3.5 Linking and Relinking Applications

Oracle Corporation recommends that you upgrade your client software to match the current server software. If you upgrade your Oracle server to the current release, then Oracle Corporation recommends upgrading the client software to the same release. Keeping the server and client software current ensures application stability and provides enhanced functionality and performance enhancements.

B.3.6 Networking Protocol Vendor Requirements

Table B-3 lists the supported vendor for each networking protocol:

Table B-3 Supported Networking Protocol Vendors

Protocol Feature	Operating System	Supported Vendor
TCP/IP protocol	Windows NT and Windows 98	Microsoft TCP/IP
Named Pipes protocol	Windows NT and Windows 98	Microsoft NETBEUI
Host naming method	Windows NT	Microsoft TCP/IP
Windows native authentication method	Windows NT and Windows 98	Microsoft
Logical Unit Type 6.2 (LU6.2) protocol	Windows NT	LU6.2 protocol support is obsolete in this release.

Note: The VI protocol is not supported on Windows platforms.

B.4 Installation

This section includes the following topics:

- [Preinstallation Tasks](#)
- [Installing Oracle Components](#)
- [Reviewing the Installation Session Log](#)
- [Deinstalling Oracle Components and Services](#)

B.4.1 Preinstallation Tasks

Complete the following preinstallation tasks before installing the Oracle9i Database Client.

Note: The *ORACLE_HOME* environment variable is automatically set in the registry. Setting this variable is not necessary or recommended and prevents multiple Oracle home environments from functioning properly.

To perform preinstallation tasks:

1. Verify system and component requirements listed in [Section B.3, "Preinstallation Requirements"](#) before you begin installation.
2. Start your operating system.
3. Log on as a member of the Administrators group to the computer on which to install Oracle components.
4. If applicable, install and test your network hardware and software.
5. Stop all Oracle services (if any are running) for the Oracle home into which you want to install Oracle components:
 - a. On Windows NT, choose Start > Settings > Control Panel > Services. On Windows 2000, choose Start > Programs > Administrative Tools > Services.
 - b. If any Oracle services (their names begin with Oracle) exist and have the status *Started*, select the service and choose Stop on Windows NT, or choose Action > Stop on Windows 2000.
 - c. Choose Close to exit the Services window.
6. Continue to [Section B.4.2, "Installing Oracle Components"](#).

B.4.2 Installing Oracle Components

Complete the following steps to install Oracle components:

1. Ensure that you have followed all preinstallation steps described in [Section B.4.1, "Preinstallation Tasks"](#).
2. Insert the Oracle9iAS Client CD-ROM.

The Autorun window automatically appears. If the Autorun window does not appear:

- a. Select Start > Run.
- b. Enter the following:

```
DRIVE_LETTER:\autorun\autorun.exe
```

The Autorun window appears.

3. Select to install the Oracle9i Database Client from the CD-ROM.

4. Select **Next**.
5. The File Locations window appears.
6. Enter the Oracle home name and directory path in which to install Oracle components in the Destination fields.

The directory path must be a mapped drive. Do *not* change the directory path in the Source field. This is the location of installation files.

Attention:

- If you have an existing Oracle home created with a pre-9.0.x release, you *must* change the default installation location to a new Oracle home.
 - Universal Naming Convention names are not supported.
-
-

The Oracle home name can be up to 16 characters in length and must consist of alphanumeric characters and underscores. Spaces are not allowed. Do not use a number as the first character in the Name field. The default directory path is C:\oracle\ora9ias.

7. Click **Next**.
The Available Products window appears.
8. Select Oracle9i Database Client or Oracle9i SOAP Client and click **Next**.
9. If Oracle9i SOAP Client was selected, the SOAP Server Location window appears. Enter the address for the server. If Oracle9i Database Client was selected, go to step 10.
10. The Summary window appears. Click **Install**.

See Also: [Section B.4.3, "Reviewing the Installation Session Log"](#) for a summary of your installation session

B.4.3 Reviewing the Installation Session Log

The first time Oracle Universal Installer runs, it creates the *SYSTEM_DRIVE:\Program Files\Oracle\Inventory\logs* directory. An inventory of installed components and installation actions performed are kept in this directory.

Log file names of installation sessions are in this directory and take the form *installActionsdate_time.log*

for example:

```
installActions2001-07-14_09-00-56-am.log
```

You can also view a list of installed components by selecting Installed Products on any window of Oracle Universal Installer.

Note: Do not delete or manually alter the *Inventory* directory or its contents. Doing so can prevent Oracle Universal Installer from locating products that you have installed on your system.

B.4.4 Deinstalling Oracle Components and Services

This section describes how to deinstall Oracle components, utilities, and services.

Note: Silent deinstallations are not supported.

This section contains the following topics:

- [Stopping Oracle Services for Windows](#)
- [Removing Oracle Keys From the Registry on Windows NT, Windows 2000, and Windows XP](#)
- [Removing Oracle Keys from the Registry on Windows 98](#)

Note: Manual removal of components is permitted only if you exit Oracle Universal Installer during an installation. For example:

- Choosing Cancel
 - Turning off the computer
 - If the installation does not complete (that is, all required configuration tools do not run at the end of the installation process)
 - In these cases, Oracle Universal Installer does not register the installation in its inventory. However, files may have been copied to your Oracle home. Remove these files manually and restart the installation.
-
-

B.4.4.1 Stopping Oracle Services for Windows

You must first stop the Oracle for Windows NT services before deinstalling Oracle components or removing any registry entries.

To stop Windows NT services:

1. Choose Start > Settings > Control Panel > Services.
2. If any Oracle services (names begin with `Oracle` or `Ora`) exist and have the status *Started*, select the service, and choose Stop.
3. Choose Close to exit the Services window.
4. Exit the Control Panel.

B.4.4.2 Removing Oracle Keys From the Registry on Windows NT, Windows 2000, and Windows XP

You may want to correct serious system problems by completely removing Oracle components from the computer.

To remove the Oracle Net Service Registry Entry:

1. Log in as a member of the Administrators group.
2. Follow the instructions listed in [Section B.4.4.1, "Stopping Oracle Services for Windows"](#).
3. Start the registry at the command prompt:

```
C:\> regedt32
```

4. Go to `HKEY_LOCAL_MACHINE\SYSTEM\CurrentControlSet\Services` and delete the `OracleHOME_NAME\TNSListener` registry entry if you also have an Oracle9i database installed. Oracle Universal Installer automatically deletes all other Oracle Net Services.
5. Exit the registry.

To remove all Oracle components from a computer on Windows NT, Windows 2000, and Windows XP:

Caution: These instructions remove *all* Oracle components, services, and registry entries from your computer. In addition, any database files under `ORACLE_BASE\oradata\DB_NAME` are also removed. Exercise extreme care when removing registry entries. Removing incorrect entries can break your system.

1. Log in as a member of the Administrators group.
2. Follow the instructions listed in [Section B.4.4.1, "Stopping Oracle Services for Windows"](#).
3. Start the registry at the command prompt:

```
C:\> regedt32
```
4. Go to `HKEY_CLASSES_ROOT` and delete any key that starts with Oracle, ORA, or ORCL.
5. Go to `HKEY_LOCAL_MACHINE\SOFTWARE` and delete the ORACLE and Apache Group keys.

6. Go to `HKEY_LOCAL_MACHINE\SOFTWARE\ODBC\odbcinst.ini` and delete the Oracle in `HOME_NAME` key.
7. Go to `HKEY_LOCAL_MACHINE\SYSTEM\CurrentControlSet\Services` and delete all keys under here that begin with ORACLE.
8. Go to `HKEY_LOCAL_MACHINE\SYSTEM\CurrentControlSet\Services\Eventlog\Application` and delete all keys under here that begin with ORACLE.
9. Go to `HKEY_CURRENT_USER` and delete ORACLE.
10. Go to `HKEY_CURRENT_USER\SOFTWARE\ORACLE` and delete keys that start with Oracle or ORCL (if any exist).
11. Go to `HKEY_CURRENT_USER\SOFTWARE\ODBC\odbcinst.ini` and delete any Oracle keys (if any exist).
12. Close the registry and restart your computer.

B.4.4.3 Update the System Variable Path

1. Go to Start > Settings > Control Panel > System > Environment tab.
2. Select the system variable path and modify the Path variable.
3. Remove any Oracle entries from the path. For example, if JRE was installed by Oracle, remove the `%ORACLE_HOME%\BIN` path and the JRE path. The path should be:

```
C:\oracle\ora92\bin;G:\program files\oracle\jre\1.1.7\bin
```
4. Exit the Control Panel.

B.4.4.4 Remove Oracle from the Start Menu

1. Go to `SYSTEM_DRIVE:\winnt\profiles\all users\start menu\programs`. On Windows XP go to `SYSTEM_DRIVE:\documents and settings\all users\start menu\programs`.
2. Delete the following icons:
 - Oracle - `HOME_NAME`
 - Oracle Installation Productswhere `HOME_NAME` is the previous Oracle home name.
3. Delete `SYSTEM_DRIVE:\program files\oracle` through Windows Explorer.
4. Delete all `ORACLE_BASE` directories on your hard drive.
5. Restart your computer.

B.4.5 Removing Oracle Keys from the Registry on Windows 98

To remove all Oracle components from a computer on Windows 98:

1. Start the registry at the command prompt:

```
C:\> regedit
```
2. Go to `HKEY_CLASSES_ROOT` and delete any key that starts with Oracle or ORCL.
3. Go to `HKEY_LOCAL_MACHINE\SOFTWARE\ORACLE` and delete the ORACLE key.
4. Go to `HKEY_LOCAL_MACHINE\SOFTWARE\ODBC\odbcinst.ini` and delete the Oracle ODBC Driver key.
5. Go to `HKEY_CURRENT_USER\SOFTWARE\ORACLE` and delete keys that start with Oracle or ORCL (if any exist).
6. Go to `HKEY_CURRENT_USER\SOFTWARE\ODBC\odbcinst.ini` and delete any Oracle keys.
7. Close the registry and restart your computer.

B.4.5.1 Update the System Variable Path

Edit your `autoexec.bat` file and remove your `%ORACLE_HOME%\BIN` and `JRE` paths from the path setting.

B.4.5.2 Remove Oracle from the Start Menu

1. Delete *SYSTEM_DRIVE*:\Program Files\Oracle through Windows Explorer.
2. Delete icons from:
 - *SYSTEM_DRIVE*:\windows\start menu\programs\oracle - *HOME_NAME*
 - *SYSTEM_DRIVE*:\windows\start menu\programs\oracle installation productswhere *HOME_NAME* is the previous Oracle home name.
3. Delete all *ORACLE_BASE* directories on your hard drive.
4. Restart your computer.

B.5 Postinstallation Configuration Tasks

This section includes the following topics:

- [About NTFS File System and Windows NT Registry Permissions](#)
- [Individual Component Postinstallation Configuration Tasks](#)

B.5.1 About NTFS File System and Windows NT Registry Permissions

Oracle Corporation recommends that you configure Oracle9i database files, directories, and registry settings to allow only authorized database administrators (DBAs) to have full control. These topics describe how to perform these tasks:

- [Setting NTFS File System Security](#)
- [Setting Windows NT Registry Security](#)

See Also: Your Windows NT documentation for more information about modifying NTFS file system and Windows NT registry settings

B.5.1.1 Setting NTFS File System Security

The Oracle9i database uses files to store database data, backup data, log information, and other database information. The Oracle9i database process runs under a security account. The Windows NT LocalSystem account, called `SYSTEM`, enables the user to create and access these database files. The security account is assigned to the service that the Oracle9i database uses (in the Windows Control Panel). This account requires full file system permissions to create, read, write, delete, and execute files.

To ensure that only authorized users have full file system permissions:

1. Go into Windows NT Explorer.
2. Right-click Oracle9i database files (in the `ORACLE_BASE\oradata\DB_NAME` directory), executables and dynamic link libraries (in the `ORACLE_HOME\bin` directory), and directories.
3. Select Properties from the menu that appears.
4. Select file and directory permissions to ensure that:
 - Only the security account that the Oracle9i database is configured to use has full control permissions to these files
 - User accounts that must run Oracle applications (for example, SQL*Plus and Pro*C) have read privileges on their executables (for example, `sqlplus.exe` for SQL*Plus)

Note: The Oracle9i database uses the Windows NT LocalSystem built-in security account. Therefore, file permissions must be granted to the `SYSTEM` account of the local computer running the Oracle9i database.

B.5.1.2 Setting Windows NT Registry Security

Oracle Corporation recommends that you remove write permissions from users who are *not* Oracle9i DBAs or system administrators in HKEY_LOCAL_MACHINE\SOFTWARE\ORACLE of the Windows NT registry.

To remove write permissions:

1. Open the registry.
2. Go to HKEY_LOCAL_MACHINE\SOFTWARE\ORACLE and select Permissions from the Security main menu.

The Registry Key Permissions dialog box appears.

3. Remove write permissions from any users who are not Oracle9i DBAs or system administrators. The SYSTEM account must have Full Control, since this is the account with which the Oracle9i database runs.
4. Verify that user accounts that must run Oracle applications have read privileges.
5. Select OK and exit the registry.

B.5.2 Individual Component Postinstallation Configuration Tasks

Table B-4 lists configuration requirements for specific postinstallation configuration procedures. The manuals listed in the following table are not included on the 9iAS Documentation CD-ROM. You can view them at:

<http://tahiti.oracle.com>

Table B-4 Individual Component Postinstallation Configuration Tasks

Component	Description	See Also...
Oracle Advanced Security	Authentication, encryption, integrity support, and enterprise user security require configuration.	<i>Oracle Advanced Security Administrator's Guide</i>
Oracle Net Services network software	<p>Oracle Net Configuration Assistant is a tool that assists you in configuring your Oracle network.</p> <p>If you installed Oracle Net Services, Oracle Net Configuration Assistant automatically guided you through network configuration of client computers and Oracle9i database servers.</p> <p>You can also configure your Oracle network after installation with the Oracle Net Configuration Assistant and Oracle Net Manager tools.</p>	<i>Oracle9i Net Services Administrator's Guide</i>
Pro*COBOL	Pro*COBOL supports specific compilers.	<i>Pro*COBOL Precompiler Getting Started for Windows</i>
SQL*Plus help file	If you want to use online help with SQL*Plus, you must populate the SQL*Plus tables with help files.	<i>SQL*Plus Getting Started for Windows</i>

B.6 Individual Components Available for Installation

This section includes information on Oracle9i Database Client Components.

B.6.1 Oracle9i Database Client Components

Table B-5 alphabetically lists the components available.

Table B-5 Oracle9i Database Client Components

Component	Database Client	SOAP Client
Advanced Queueing API	Yes	No
Object Type Translator	Yes	No
Oracle Advanced Security	Yes	No
Oracle Call Interface	Yes	No
Oracle Dynamic Services Server	Yes	No
Oracle Enterprise JavaBeans and CORBA Tools	Yes	No
Oracle Enterprise Manager	Yes	No
Oracle <i>interMedia</i> Annotator	Yes	No
Oracle <i>interMedia</i> Client Option	Yes	No
Oracle Internet Directory Client	Yes	No
Oracle SOAP Client software	No	Yes
Oracle JDBC Drivers	Yes	No
Oracle Net Services	Yes	No
Oracle Objects for OLE	Yes	No
Oracle ODBC Driver	Yes	No
Oracle Provider for OLE DB	Yes	No
Oracle SQLJ	Yes	No
Oracle Syndication Server	Yes	No
Oracle Ultra Search Middle Tier	Yes	No
Oracle Universal Installer	Yes	No
Oracle Utilities	Yes	No
Oracle XML Developer's Kit	Yes	No

Table B-5 Oracle9i Database Client Components (Cont.)

Component	Database Client	SOAP Client
Oracle XML SQL Utility	Yes	No
PL/SQL	Yes	No
Pro*C/C++	Yes	No
Pro*COBOL 9.0.1	Yes	No
Pro*COBOL 1.8.76	Yes	No
Replication Management API	Yes	No
SQL*Plus	Yes	No

B.7 Installing Oracle Components in Noninteractive Mode

This section includes information on installing Oracle Components in the Noninteractive Mode.

Note: Noninteractive deinstallations are not supported.

Typically, Oracle Universal Installer runs in interactive mode, which means you are prompted to provide information in windows. However, experienced users can also run Oracle Universal Installer in noninteractive (also called silent) mode by using response files. These are text files containing variables and values used by Oracle Universal Installer during the installation process.

Silent installations are recommended in cases when no interaction with the user is intended or when a nongraphical terminal is used. The user needs to first edit a response file to specify the components to install. With Oracle Universal Installer release 1.7.x or earlier, the target installation system still requires login to a desktop system on Windows NT.

Using silent installation enables you to bypass the graphical user interface (GUI) of Oracle Universal Installer interactive mode. The response files, shown in [Table B-6](#), are available in the `\Response` directory on the component CD-ROM:

Table B-6 *Response Files*

Response File Name	This File Silently Runs ...
<code>oracle.iappserver.dbclient.client_administrator.rsp</code>	Oracle9i Database Client
<code>oracle.soap.client.Complete.rsp</code>	Oracle9i SOAP Client

Oracle9iAS InterConnect Installation and Configuration

This appendix guides you through the steps for the Oracle9iAS InterConnect installation. The topics include:

- [Oracle9iAS InterConnect Installation Overview](#)
- [Starting the Oracle9iAS InterConnect Installation](#)
- [Oracle9iAS InterConnect Hub Installation](#)
- [Oracle9iAS InterConnect Adapter Installation](#)
- [Oracle9iAS InterConnect Development Kit Installation](#)
- [Oracle9iAS InterConnect Management Infrastructure Installation](#)
- [How to Start Oracle9iAS InterConnect](#)
- [How to Change Passwords for the Oracle9iAS InterConnect and Oracle Workflow Schemas](#)
- [How to Create Multiple Repository Schemas in the Same Database](#)

C.1 Oracle9iAS InterConnect Installation Overview

Oracle9iAS InterConnect is a hub-and-spoke, end-to-end integration solution. This section describes the following topics:

- [Oracle9iAS InterConnect Installation Types](#)
- [Dependent Products and Topologies](#)
- [Hardware Requirements](#)
- [Software Requirements](#)
- [Multiple Oracle9iAS InterConnect Components on One Machine](#)

C.1.1 Oracle9iAS InterConnect Installation Types

Oracle9iAS InterConnect has different installation types, depending on what you are installing:

Table C-1 Oracle9iAS InterConnect Installation Types

Installation Type	Description
Hub	Installs the InterConnect repository and Oracle Workflow. This is typically installed on top of an Oracle9i Application Server (Oracle9iAS) middle tier and serves as the central node for the integrated environment.
Adapter	Installs Oracle9iAS InterConnect adapters. You get to select which adapter you want to install. The adapters are typically installed on spoke machines and serve as the interface from applications to the hub.
Development Kit	Installs JStudio (Windows NT/2000 only) and the InterConnect Development Kit. The development kit is typically installed on a separate machine from the hub and the adapters, and provides mechanisms to model and create new InterConnect integrations.
Oracle9iAS InterConnect Management Infrastructure	Installs the Enterprise Manager Java console along with the Oracle9iAS InterConnect console plug-in. This is typically installed on a separate machine from the hub and allows you to manage the Oracle9iAS InterConnect environment.

These installation types appear in the installer in the Install Types screen.

C.1.2 Dependent Products and Topologies

You can run Oracle9iAS InterConnect in three different topologies.

- In the recommended topology, you run Oracle9iAS InterConnect with Oracle9iAS. See [Section C.1.2.1, "Topology 1 \(with Oracle9iAS\)"](#).
- In the second topology, you run Oracle9iAS InterConnect with an Oracle database. See [Section C.1.2.2, "Topology 2 \(with Oracle database\)"](#).
- In the third topology, you run Oracle9iAS InterConnect with the Oracle9iAS Infrastructure database. See [Section C.1.2.3, "Topology 3 \(with Oracle9iAS Metadata Repository\)"](#).

C.1.2.1 Topology 1 (with Oracle9iAS)

Running Oracle9iAS InterConnect with Oracle9iAS is the recommended topology. In this topology, you need the following:

- Install Oracle9iAS Infrastructure and one of the Oracle9iAS installation types (J2EE and Web Cache, Portal and Wireless, Business Intelligence and Forms, or Unified Messaging).
- Install Oracle9iAS InterConnect hub (Oracle Workflow included) in the same Oracle home as your Oracle9iAS installation.

The following figure shows the recommended topology. Oracle9iAS InterConnect hub uses the Oracle9iAS Infrastructure database as the hub database.

Figure C-1 Recommended Topology with Oracle9iAS

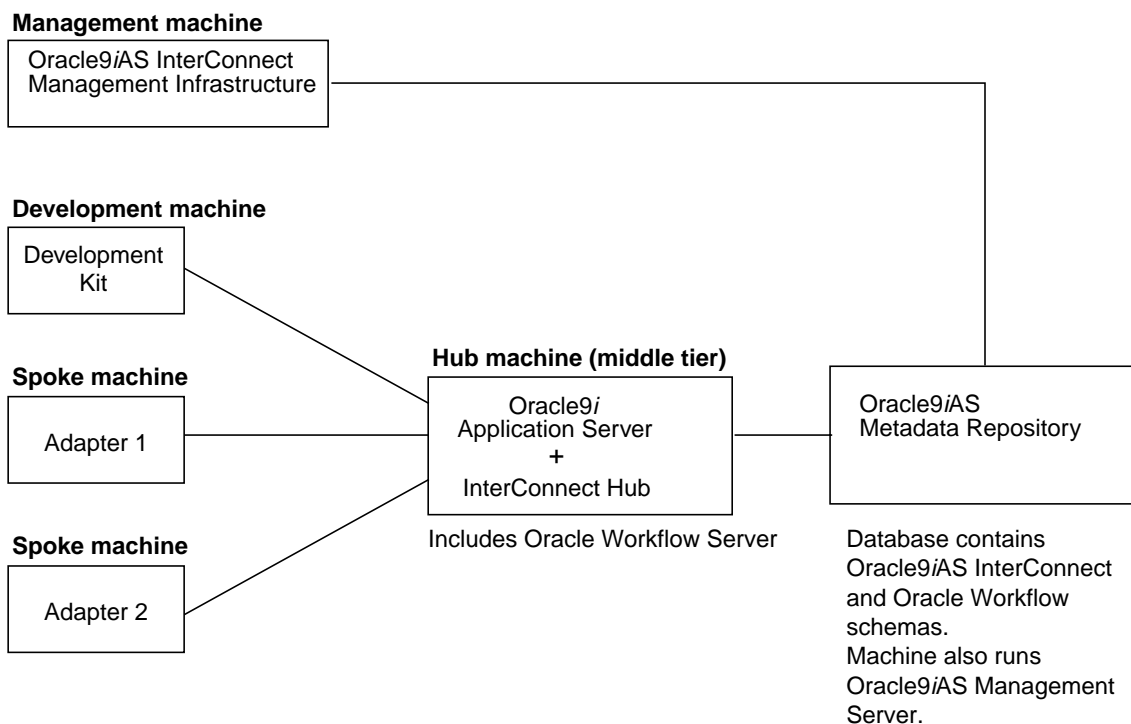

C.1.2.2 Topology 2 (with Oracle database)

In this topology, you need an Oracle8*i* or Oracle9*i* database. Oracle9*i*AS InterConnect uses the database as the hub database to store its schemas. In this topology, you need the following:

- Install Oracle9*i*AS InterConnect hub (Oracle Workflow included) on the same machine as the Oracle database or on a different machine. If you are installing Oracle9*i*AS InterConnect hub on the same machine as the database, you must install it in an Oracle home separate from the Oracle database.

The following figure shows such a topology.

Figure C–2 Topology with Oracle9i Database

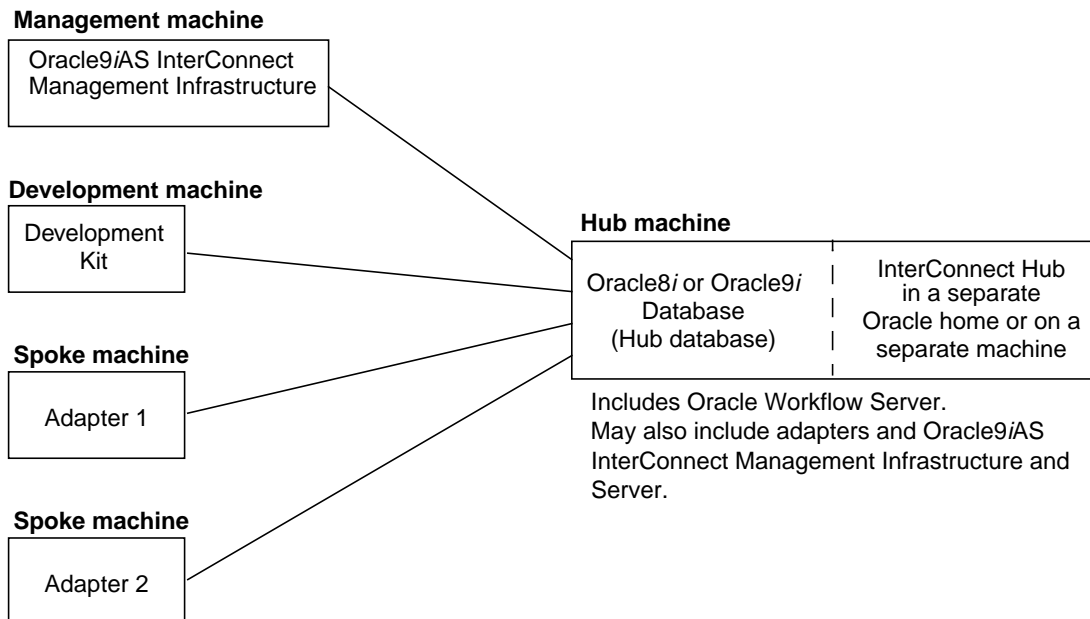

C.1.2.3 Topology 3 (with Oracle9iAS Metadata Repository)

This topology is similar to Topology 1 in that Oracle9iAS InterConnect uses the Oracle9iAS Infrastructure database as the hub database. The difference between the two topologies is that in Topology 3, you install only the Infrastructure from Oracle9iAS; you do not install Oracle9iAS installation types in the middle tier. You can use this topology if you do not wish to use Oracle9iAS.

The following figure shows such a topology.

Figure C-3 Topology with Oracle9iAS Metadata Repository

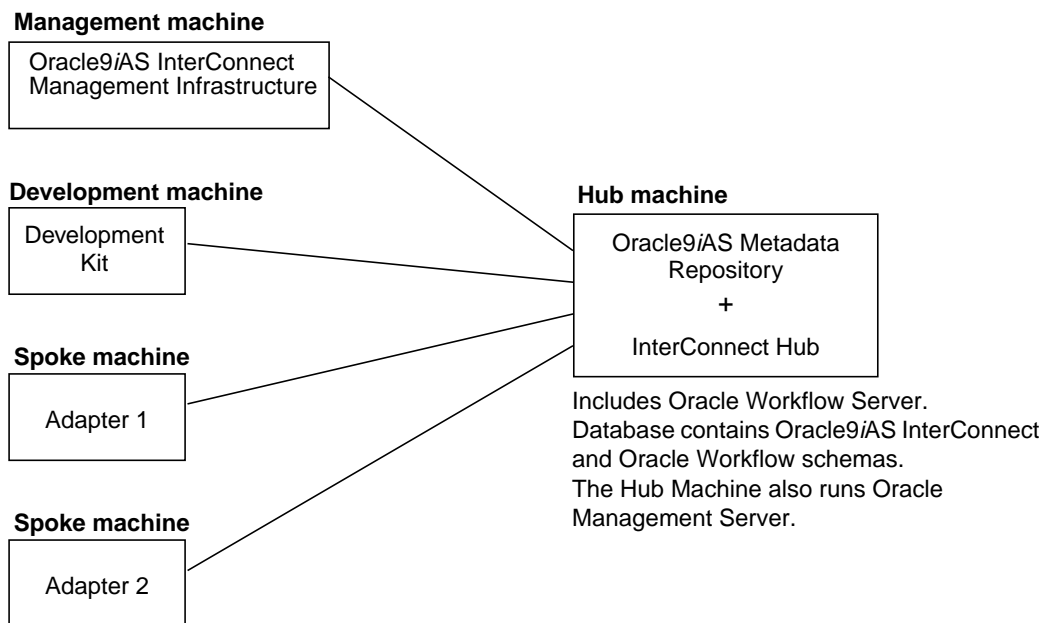

C.1.2.4 Setup Recommendations Common to All Topologies

For all topologies, you have to perform the following steps:

- Install the adapters:

Install the adapters on the same machines as the applications they connect to, provided they are hosted on a platform that supports Oracle9iAS InterConnect. These machines are known as Oracle9iAS InterConnect Spoke machines.

If the adapters are not on the same machines as the applications, assign one spoke machine per application. You can have one spoke machine for all applications if it meets your throughput needs.
- Assign one machine for the Development Kit installation or use the hub or one of the spoke machines.
- Assign one machine for Oracle9iAS InterConnect Management Infrastructure or use the hub or one of the spoke machines.

C.1.3 Hardware Requirements

Note: Do not run an install on a UNIX computer using Exceed on a remote machine. This can cause problems during install.

C.1.3.1 Hardware Requirements for the Hub Machine

If you are installing Oracle9iAS InterConnect hub on a machine that also contains Oracle9iAS, the machine should already meet the requirements listed in [Section 2.1, "Hardware Requirements"](#).

If you are installing Oracle9i_{AS} hub on a machine that does not have an Oracle9i_{AS} installation, the machine should meet the requirements listed in [Table C-2](#).

Table C-2 Hardware Requirements for the Hub Machine (non-Oracle9iAS)

Hardware	Windows NT/2000	UNIX
Memory	500 MB	500 MB
Service Pack	4.0 Service Pack 6 or later	n/a
Disk Space	10 GB	10 GB
CD-ROM Device	A CD-ROM drive to install, or the ability to access a CD-ROM device over the network	A CD-ROM drive to install, or the ability to access a CD-ROM device over the network

C.1.3.2 Hardware Requirements for the Spoke Machine

[Table C-3](#) lists the hardware requirements for the spoke machine (for adapters).

Table C-3 *Hardware Requirements for the Spoke Machine*

Hardware	Windows NT/2000	UNIX
Memory	256 MB	256 MB
Service Pack	4.0 Service Pack 6 or later	n/a
Disk Space	500 MB	500 MB

C.1.3.3 Hardware Requirements for Development Kit Machines

[Table C-4](#) lists the hardware requirements for Development Kit machines.

Table C-4 *Hardware Requirements for Development Kit Machines*

Hardware	Windows NT/2000	UNIX
Memory	128 MB	n/a
Service Pack	4.0 Service Pack 3 or later	n/a
Disk Space	500 MB	n/a

See Also: *Oracle Workflow Guide* for hardware requirements

C.1.4 Software Requirements

This section describes:

- [Operating System Requirements](#)
- [JRE Requirements](#)
- [Notification Mailer \(optional\)](#)

C.1.4.1 Operating System Requirements

The hub machine, the spoke machine, and iStudio run on the following operating systems:

- Sun SPARC Solaris 2.6, 2.7, 2.8 (32-bit)
- Windows NT 4.0, with Service Pack 6a or above
- Linux RedHat 7.1
- IBM AIX 4.3.3, 64-bit only
- Compaq Tru64 UNIX 5.0a, 5.1, 5.1a
- HP-UX 11.0, 11i (64-bit only)

C.1.4.2 JRE Requirements

Oracle9iAS InterConnect runs on JRE 1.3.1.

JRE is bundled with Oracle9iAS on Sun SPARC Solaris or Windows NT. When you install Oracle9iAS on these platforms, it installs JRE for you. If you are installing Oracle9iAS on other platforms, you have to download and install JRE prior to installing Oracle9iAS. See the platform-specific installation guide for details.

C.1.4.3 Solaris Patches

See [Section 2.2, "Operating System Requirements"](#) for a list of required patches.

C.1.4.4 Notification Mailer (optional)

The Notification Mailer is required only if you are using Oracle Workflow. If you are not using Oracle Workflow, you can skip this section.

The notification component of Oracle Workflow includes a program called the Notification Mailer. This program communicates notifications to users via e-mail and interprets responses. The Notification Mailer has implementations that can integrate directly with UNIX sendmail or MAPI-compliant mail applications.

- The UNIX sendmail implementation is installed automatically during the Oracle Workflow Server installation process. This implementation requires UNIX sendmail to be installed on the same server as Oracle Workflow.
- The MAPI-compliant implementation is installed on your Windows NT PC using the Oracle Universal Installer from the Oracle9iAS Client CD. This implementation requires a Windows NT MAPI-compliant mail application installed on the PC that is acting as your mail server.

The MAPI-compliant implementation is available with Oracle9iAS for Windows NT only. It is not available with Oracle9iAS for Solaris.

Note: The Microsoft Outlook E-mail Security Update that was released on June 7, 2000 desupports the MAPI Common Messaging Calls (CMC) interface used by the Oracle Workflow MAPI Mailer. (See: *OL2000: Developer Information About the Outlook E-mail Security Update*, <http://support.microsoft.com/support/kb/articles/Q262/7/01.ASP>.) As a result, the Oracle Workflow MAPI Mailer is not certified on any Microsoft Windows platforms where this Microsoft Outlook E-mail Security Update or above has been applied. The Oracle Workflow MAPI Mailer is not certified on Windows XP.

Oracle Workflow customers running on NT/2000 are certified to install the UNIX version of the Oracle Workflow Notification Mailer (on UNIX) and connect to a Oracle Workflow Server database running on NT/2000.

C.1.5 Multiple Oracle9iAS InterConnect Components on One Machine

The installer does not allow you to install more than one of the same Oracle9iAS InterConnect component per Oracle home. When you install the same component the second time, it deinstalls the first installation before doing the second installation. For example, you cannot install more than one database adapter in one Oracle home.

You have two options if you need to install more than one instance of the same component on the same machine:

- Define multiple Oracle homes on the machine and install the component in each Oracle home. When you install a component the second time, choose a different Oracle home than the one where you first installed it.
- Use the `copyAdapter` script located in `<ORACLE_HOME>/oai/9.0.2/bin/` to install multiple adapters of the same type in the same Oracle home.

Usage:

```
copyAdapter <app1> <app2>
```

The script creates an adapter `app2` that is of the same type as `app1`. If you want to service a different application with this adapter, you need to edit the application connectivity information in the `adapter.ini` file accordingly.

C.2 Starting the Oracle9iAS InterConnect Installation

You perform the following steps in the Oracle Universal Installer to display the Install Types screen, which enables you to select the install type you want. See [Section C.1.1, "Oracle9iAS InterConnect Installation Types"](#) for descriptions of the types.

1. Insert the CD-ROM in your CD-ROM drive.
2. Start the Oracle Universal Installer:
 - On Windows NT, double-click on `setup.exe`.
 - On UNIX, type `runInstaller`.

The Welcome screen displays.

3. Oracle Universal Installer Welcome Screen

The Welcome screen provides information about the Oracle Universal Installer.

- a. Review the Oracle Universal Installer Welcome screen. The following buttons appear on the screen:
 - **Deinstall Products:** Deinstall individual components or the entire product. This button appears only on the Welcome screen.
 - **About Oracle Universal Installer:** View the version number of the installer in use.
 - **Exit:** Quit the installation process and exit the installer.
 - **Help:** Access detailed information about the functionality of each screen.
 - **Installed Products:** View currently installed products or to deinstall the entire product or components.
 - **Previous:** Return to the previous screen.
 - **Next:** Proceed to the next screen.
- b. Click **Next**.

4. File Locations Screen

- a. Enter the following in the fields provided:

Field	Value
Source	The default value displays; do not change this value.
Destination	Enter or select an existing Oracle home name and directory path.

- b. Click **Next**.

5. Oracle9iAS InterConnect Install Types Screen

- a. Select the Oracle9iAS InterConnect type from the following:

- Oracle9iAS InterConnect Hub
- Oracle9iAS InterConnect Adapters
- Oracle9iAS InterConnect Development Kit
- Oracle9iAS InterConnect Management Infrastructure

See [Section C.1.1, "Oracle9iAS InterConnect Installation Types"](#) for information about these installation types.

- b. Click **Next**.

[Table C-5](#) directs you to the installation information for the components selected on this screen.

Table C-5 Component-Specific Installation Information

To install this component	See this section
Hub	Section C.3, "Oracle9iAS InterConnect Hub Installation"
Adapters	Section C.4, "Oracle9iAS InterConnect Adapter Installation"
Development Kit	Section C.5, "Oracle9iAS InterConnect Development Kit Installation"
Management Infrastructure	Section C.6, "Oracle9iAS InterConnect Management Infrastructure Installation"

C.3 Oracle9iAS InterConnect Hub Installation

The hub installation installs Oracle Workflow Server and the InterConnect repository. This section contains the following topics:

- [Oracle9iAS InterConnect Hub Pre-Installation Steps](#)
- [Oracle9iAS InterConnect Hub Installation Steps for Topologies 1 and 3](#)
- [Oracle9iAS InterConnect Hub Installation Steps for Topology 2](#)
- [Oracle9iAS InterConnect Hub Post-Installation Steps \(required for Oracle Workflow users only\)](#)

C.3.1 Oracle9iAS InterConnect Hub Pre-Installation Steps

These steps apply only to Topology 2.

1. Verify the values of the following parameters in the `init.ora` file for the metadata repository database:

- **AQ_TM_PROCESSES:** Oracle Workflow requires the time manager process in Oracle9i Advanced Queuing (AQ) to monitor delay events in queues, as in the case of the Oracle Workflow standard Wait activity. The minimum recommended number of time manager processes for Oracle Workflow is one. Verify that the `AQ_TM_PROCESSES` parameter is set in the `init.ora` file. For example:

```
AQ_TM_PROCESSES = 1
```

- **JOB_QUEUE_PROCESSES:** Oracle Workflow leverages Oracle9i Advanced Queuing, which requires job queue processes to handle message propagation. You must start at least one job queue process to enable message propagation. The minimum recommended number of processes for Oracle Workflow is two and may need to be increased to five or ten if not enough processes are available for propagation. Verify that the `JOB_QUEUE_PROCESSES` parameter is set in the `init.ora` file to specify the number of SNP job queue processes for your instance. For example:

```
JOB_QUEUE_PROCESSES = 10
```

You can either modify these parameters in the `init.ora` file and restart your database to make the changes effective, or you can use the `ALTER SYSTEM` statement to dynamically modify the parameter values for the duration of the instance. For more information, refer to *Oracle9i Reference* and *Oracle9i Application Developer's Guide - Advanced Queuing*.

2. (Oracle Workflow only) Ensure that there are no users accessing the Oracle Workflow server. Otherwise, locks in the database prohibit a successful upgrade.
3. (Oracle Workflow only) If you have an existing Oracle Workflow server, check that it is release 2.6.0 or higher. If you have an earlier version, you need to upgrade it to release 2.6 before you can upgrade to 2.6.2.

C.3.2 Oracle9iAS InterConnect Hub Installation Steps for Topologies 1 and 3

When you install the hub on a machine with Oracle9iAS, you see a dialog that enables you to reset the password for the `oaihub902` and `owf_mgr` schemas. This dialog displays after you select Oracle9iAS InterConnect Hub on the Oracle9iAS InterConnect Install Types screen.

1. Select **Oracle9iAS InterConnect Hub** from the Oracle9iAS InterConnect Install Types screen.

See [Section C.2, "Starting the Oracle9iAS InterConnect Installation"](#) for instructions on how to display the Install Types screen.

2. Oracle9iAS Metadata Repository: Enter Oracle Internet Directory Administrator Password Screen

In this screen, enter the password of the Oracle Internet Directory administrator (`cn=orcladmin`) so that the installer can retrieve configuration information.

- a. Enter or view information in the following fields:
 - **OiD Hostname:** This field is filled in for you and cannot be changed. It displays the machine running Oracle Internet Directory.
 - **OiD Port:** This field is filled in for you and cannot be changed. It displays the port number for Oracle Internet Directory.
 - **OiD DN:** This field is filled in for you and cannot be changed. It displays the distinguished name (DN) of the Oracle Internet Directory administrator (`cn=orcladmin`).
 - **OiD Password:** Enter the Oracle Internet Directory administrator's password in this field.

- b. Click **Next**.

3. Change Oracle9iAS InterConnect Schema Password Screen

To properly configure all pieces of the Oracle9iAS InterConnect installation, you must create a new password for the Oracle9iAS InterConnect schemas.

- a. Enter information in the following fields:
 - **Database:** This field is filled in for you. It points to the metadata repository database.
 - **Schema Names:** This field is also filled in for you. It specifies the schema names: `oaihub902` and `owf_mgr`.
 - **Password:** The new password for the schemas. You will need the new password to install other Oracle9iAS InterConnect components.
Note that the same password is used for both `oaihub902` and `owf_mgr` schemas.
 - **Confirm Password:** Reenter the new password.
- b. Click **Next**.

4. Summary Screen

This screen displays the selections made on previous screens. Review the selections and click **Install**.

When the installation is complete, the file `<ORACLE_HOME>/oai/9.0.2/hub/hub.ini` is empty. This is the correct result of the installation.

C.3.3 Oracle9iAS InterConnect Hub Installation Steps for Topology 2

When you install the hub on a machine that does not have Oracle9iAS, you see two dialogs: one dialog enables you to specify the database to use as the hub database, and the second dialog enables you to set the password for the Oracle9iAS InterConnect schema.

These dialogs display after you select Oracle9iAS InterConnect Hub on the Oracle9iAS InterConnect Install Types screen.

Note that the installer does not permit you to install Oracle9iAS InterConnect hub in the same Oracle home as the database. You have to select another Oracle home.

If you have an existing Workflow Server setup, you need to migrate it to Oracle9iAS Workflow Server after the hub install. The Oracle9iAS Workflow Server is installed as part of InterConnect Hub install. See the *Migrating from Oracle9iAS Release 1 (1.0.2.2.x) to Release 2 Guide* for more information on Workflow Migration.

1. Select **Oracle9iAS InterConnect Hub** from the Oracle9iAS InterConnect Install Types screen.

See [Section C.2, "Starting the Oracle9iAS InterConnect Installation"](#) for instructions on how to display the Install Types screen.

2. Oracle9iAS InterConnect Hub Database Screen - Specify database connection information
 - a. Enter database connection information in the following fields:
 - **Host Name:** The host name for the database. The default is localhost.
 - **Port Number:** The port number for the database. The default is 1521.
 - **Database SID:** The SID for the database. The default is iasdb.
 - b. Click **Next**.
3. Oracle9iAS InterConnect Metadata Repository - Set Schema Passwords
 - a. Enter information in the following fields:
 - **Database:** The database indicated on the previous screen. The value is entered as `host:port:sid`.
 - **Schema Names:** The schema name for the database: oaihub902.
 - **Password:** The new password for the schema.
 - **Confirm Password:** Reenter the new password.
 - b. Click **Next**.

The Summary screen displays.

4. Create the Oracle9iAS InterConnect schema in the hub database.

See `$ORACLE_HOME/oai/9.0.2/repository/post_installation.txt` for instructions on how to do this. You do not have to run this step in Topology 1 and 3 because the schema was created for you automatically.
5. (required for Oracle Workflow users only) Create the Oracle Workflow schema in the hub database using the Oracle Workflow Configuration Assistant. For details, see the *Oracle Workflow Guide*.

C.3.4 Oracle9iAS InterConnect Hub Post-Installation Steps (required for Oracle Workflow users only)

If you are using Oracle Workflow, you need to perform the steps in this section after installing Oracle9iAS InterConnect hub. The hub installation installs Oracle Workflow automatically; if you are not planning to use Oracle Workflow, you can skip this section.

Note: The workflow.log file produced during installation and configuration of Oracle Workflow may contain sensitive information. To protect this sensitive information, you can delete the file after the installation is complete or change the permissions for the file so that only authorized administrators can access it.

The post-installation steps are:

- Step 1: "Run Oracle Workflow Configuration Assistant"
- Step 2: "Create a database access descriptor (DAD) for Oracle Workflow"
- Step 3: "Verify Oracle Workflow virtual directory mappings"
- Step 4: "Set up Oracle Workflow HTML help"
- Step 5: "Set up a directory service for Oracle Workflow"
- Step 6: "Implement Oracle Internet Directory integration (optional)"
- Step 7: "Verify your base URL"
- Step 8: "Install additional languages (optional)"
- Step 9: "Configure Oracle Workflow with Oracle9iAS InterConnect"
- Step 10: "Perform generic configuration steps"

Step 1 Run Oracle Workflow Configuration Assistant

Note: This step is required for Topology 2 users only. If you are using Topologies 1 or 3, you can skip this step.

You need to run this step if you are upgrading Oracle Workflow, or if you need to reconfigure a new installation.

If you are installing Oracle Workflow for the first time, Oracle Universal Installer automatically loads Oracle Workflow into your database.

If you are upgrading an existing installation of Oracle Workflow, or if you need to reconfigure Oracle Workflow, you can run Oracle Workflow Configuration Assistant manually.

Before you run Oracle Workflow Configuration Assistant, you should close other applications you may have running, including Java applications, Oracle-based applications, and any other applications that consume large amounts of memory, hard disk space, or CPU time. However, you should not close any components of the Oracle9i database where you want to load Oracle Workflow.

When you run Oracle Workflow Configuration Assistant on Windows, several command windows open and close automatically. You should ignore these windows. You must not manually close any of these command windows, or you will interrupt the configuration process.

To configure Oracle Workflow:

Note: To upgrade to Release 2.6.2, your existing Oracle Workflow Server must be Release 2.6.0 or higher. If you have an earlier version, you must upgrade it to Release 2.6 before you can upgrade to Release 2.6.2.

1. Start the Oracle Workflow Configuration Assistant using the following commands:
 - On UNIX, run: `$ORACLE_HOME/wf/install/wfinstall.`
 - On Windows NT, run: `%ORACLE_HOME%\wf\install\wfinstall.bat.`
2. In the Oracle Workflow Configuration Assistant window, enter the following user information:
 - **Workflow Account:** The user name of your Oracle Workflow database account. The default account for a new installation is OWF_MGR.
 - **Workflow Password:** The password for your Oracle Workflow database account. This password must be the same as the password for the oaihub902 schema.

Note: If you are performing a new installation of Oracle Workflow, Oracle Workflow Configuration Assistant creates a new database account for Oracle Workflow with the user name and password you specify. This password must be the same as the password for the `oaihub902` schema. The default tablespace for this account is `USERS`, and the temporary tablespace is `TEMP`.

If you are upgrading an existing installation of Oracle Workflow, you should enter the user name and password for your existing Oracle Workflow database account.

- **SYS Password:** Your `SYS` password. See your Oracle DBA if you need more information.
 - **SYSTEM Password:** Your `SYSTEM` password. See your Oracle DBA if you need more information.
 - **Install Option:** Select **Upgrade** to upgrade an existing installation of Oracle Workflow.
 - **Language Selection:** Leave blank. This information is only required for the Add Language install option. See [Step 8: "Install additional languages \(optional\)"](#).
 - **Connect Method:** Select **Local** to connect to a local database using the Oracle SID, or select **Remote** to connect to a remote database through Oracle Net using `LOCAL` on Windows or `TWO_TASK` on UNIX.
 - **Connect String:** If you choose the Remote connect method, enter the connect string for the remote database.
3. Click **Submit** to begin the configuration. You can also click **Quit** to exit Oracle Workflow Configuration Assistant without performing the configuration.
 4. When the configuration is complete, a confirmation window appears. Click **OK**.
 5. You can check the status of the configuration by reviewing the `workflow.log` file in the `wf/install` subdirectory within your Oracle home.

Note: The workflow.log file produced during installation and configuration of Oracle Workflow may contain sensitive information. To protect this sensitive information, you can delete the file after the installation is complete or change the permissions for the file so that only authorized administrators can access it.

Step 2 Create a database access descriptor (DAD) for Oracle Workflow

Oracle Workflow requires Oracle HTTP Server as your Web server. The Web server must be able to access the Oracle Workflow Java area, the Oracle Workflow icon area, and the Oracle Workflow documentation area.

After installing Oracle HTTP Server and Oracle Workflow, you must create a database access descriptor (DAD) for Oracle Workflow in Oracle HTTP Server.

1. Using your web browser, navigate to the Oracle Enterprise Manager Web site.

`http://<host_name>:<port_number>/`

For example:

`http://test:1810/`

2. Log in using the Oracle9iAS administrator username and password.
The default username for the administrator is `ias_admin`. The default password was specified during the installation of Oracle9iAS.
3. In the Oracle9iAS Farm Home Page, select your application server instance.
4. In the Oracle9iAS Instance Home Page, select "HTTP Server" in the System Components section.
5. In the HTTP Server page, select "PL/SQL Properties" in the Administration section.
6. In the `mod_plsql` Services page, select the **Create** button in the DAD Status region to create a new DAD.
7. In the Create DAD: DAD Type page, select **General** and click **Next**.
8. In the Create DAD: Database Connection page, enter the following settings:
 - DAD Name: `pls/<your_workflow_DAD>`
 - Database Connection String: `<CONNECT_STRING>`
 - Default Page: `wfa_html.home`

- Authentication Mode: Basic

Click **Next**.

Note: Be sure you leave the Database Username and Database Password null to enable mod_plsql database authentication. You can also leave any remaining settings blank.

9. In the Create DAD: Document, Alias and Session page, select **Stateless-ResetPackageState** in the Session State Management field. Leave the remaining settings blank. Click **Next**.

10. In the Create DAD: Advanced page, leave all the settings blank and click **Finish**.

Oracle Enterprise Manager displays your new DAD in the DAD Status section of the mod_plsql Services page.

11. Restart Oracle HTTP Server.

For more information, see the *Oracle HTTP Server Administration Guide*.

12. To access Oracle Workflow's web services, navigate to the following URL:

http://<server_name>[:<portID>]/pls/<your_Workflow_DAD>/wfa_html.home

Note: The icons on the Oracle Workflow Web pages appear as broken images if the virtual directory mapping to the Oracle Workflow icon area has not been added. See [Step 3: "Verify Oracle Workflow virtual directory mappings"](#).

Step 3 Verify Oracle Workflow virtual directory mappings

Oracle Workflow requires the following virtual directory mappings:

Virtual directory	Physical directory	Description
/OA_JAVA/	<ORACLE_HOME>/jlib/	Points to the directory that contains Oracle Workflow JAR files
/OA_MEDIA/	<ORACLE_HOME>/wf/java/ oracle/apps/fnd/wf/ icons/	Points to Oracle Workflow icons and other graphics used by the Oracle Workflow Web interface

Virtual directory	Physical directory	Description
/OA_DOC/	<ORACLE_HOME>/wf/doc/	Points to the documentation

If you installed Oracle HTTP Server and Oracle Workflow in the same Oracle home, the virtual directory mappings are set by default. Verify these mappings and add them, if necessary.

To add the virtual directory mappings in Oracle HTTP Server:

1. Add aliases for the jlib directory and the Oracle Workflow icon and doc directories to the <ORACLE_HOME>/Apache/Apache/conf/httpd.conf or httpds.conf file.

The Alias directive has the following format:

```
Alias <fakename> <realname>
```

Examples (UNIX):

```
Alias /OA_JAVA/ "/oracle9ias/jlib/"
Alias /OA_MEDIA/ "/oracle9ias/wf/java/oracle/apps/fnd/wf/icons/"
Alias /OA_DOC/ "/oracle9ias/wf/doc/"
```

Examples (Windows NT):

```
Alias /OA_JAVA/ "C:\oracle9ias\jlib/"
Alias /OA_MEDIA/ "C:\oracle9ias\wf\java\oracle\apps\fnd\wf\icons/"
Alias /OA_DOC/ "C:\oracle9ias\wf\doc/"
```

Note: Be sure to add a trailing slash to each alias name and physical directory path.

2. Restart Oracle HTTP Server.

Step 4 Set up Oracle Workflow HTML help

Oracle Workflow provides access to HTML help from the Help button on each of its web pages. The HTML help that appears is context sensitive and provides links to the entire contents of the Oracle Workflow Guide.

To set up the HTML help, unzip the `<ORACLE_HOME>/wf/wfdoc262.zip` and verify that you have a virtual directory mapping called `/OA_DOC/` in your web listener that points to the documentation area on your file system.

If you installed Oracle HTTP Server in the same Oracle home as Oracle Workflow, the `/OA_DOC/` virtual directory mapping is set by default. Verify this mapping and add it, if necessary.

1. Use an unzip utility to extract the doc directory tree from the `<ORACLE_HOME>/wf/wfdoc262.zip` file.

You need at least 5 Mb of free disk space to extract the zip file.

Extract the files to `<ORACLE_HOME>/wf/`. You should get the following subdirectories:

Directory	Contents
<code><ORACLE_HOME>/wf/doc/<lang>/wf</code>	Oracle Workflow Guide
<code><ORACLE_HOME>/wf/doc/<lang>/wfcust</code>	Custom Help. You can add your own customized Workflow help in this directory.

Alternatively, you can install the doc directory tree on a PC file system. Create a directory for the HTML help on your PC. Then transfer the HTML help zip file to the new directory on your PC. Use an unzip utility to extract the doc directory tree from the zip file in that directory.

2. (optional) After extracting the doc directory tree, you can remove the zip file.
3. Verify that you have a virtual directory mapping called `/OA_DOC/` in your web listener. See [Step 3: "Verify Oracle Workflow virtual directory mappings"](#).
4. Try accessing the HTML help from the Help button on any Oracle Workflow Web page. You can also access any HTML help file directly by appending its virtual path to your web listener base URL.

The path for the contents page of the Oracle Workflow Guide is:

```
http://<server_name>[:<portID>]/OA_DOC/<lang>/wf/toc.htm
```

The path for the contents page of your Oracle Workflow Custom Help is:

`http://<server_name>[:<portID>]/OA_DOC/<lang>/wfcust/wfcust.htm`

5. (optional) If you want to add custom help, you can replace the placeholder file in the wfcust directory, wfcust.htm, with your own help material. The HTM file that is the main entry point for your custom help must be named wfcust.htm and must contain an anchor named contents. Your custom help will be accessible through the Custom Help link on the contents page of the *Oracle Workflow Guide*.

Step 5 Set up a directory service for Oracle Workflow

Note: See the section "Setting up an Oracle Workflow Directory Service" in Chapter 2 of the *Oracle Workflow Guide* for more details.

You must map Oracle Workflow directory service views to your organization's users and roles. The directory service views are WF_USERS, WF_ROLES, and WF_USER_ROLES.

Oracle Universal Installer automatically executes the `<ORACLE_HOME>/wf/sql/wfdirouv.sql` script to map the directory service views to your native Oracle database users and roles. This script bases the views on the tables DBA_USERS, WF_LOCAL_USERS, DBA_ROLES, and WF_LOCAL_ROLES.

To map Oracle Workflow directory service views, do **one** of the following:

- Create your own script or customize and rerun the `wfdirouv.sql` script to map the directory service views to the users and roles defined in your organization's directory repository.

The `wfdirouv.sql` script sets each native Oracle user's e-mail address to the user's respective username. As a minimal setup step, edit the script to either link your native Oracle users to an existing mail directory store through the WF_ROLES view definition, or, if the usernames and e-mail account names match, then simply add the domain for your organization, such as `@oracle.com`, to the usernames in the WF_USERS view definition. Typically, the columns that should change are EMAIL_ADDRESS in WF_USERS and EMAIL_ADDRESS in WF_ROLES.

OR

- Run the `<ORACLE_HOME>/wf/sql/wfdircsv.sql` script to map the directory service views only to the WF_LOCAL_USERS and WF_LOCAL_ROLES tables.

Note: If you want to implement Oracle Internet Directory integration, you must run the `wfdircsv.sql` script, because only the `WF_LOCAL_USERS` table is synchronized with Oracle Internet Directory.

After setting up your directory service, run the `wfdirchk.sql` script in SQL*Plus to verify the integrity of your directory service data model. The script is located on your Oracle Workflow server in the Oracle Workflow `admin/sql` subdirectory. See the "Workflow Administration Scripts" chapter of the *Oracle Workflow Guide* for more information.

Step 6 Implement Oracle Internet Directory integration (optional)

Note: See the section "Synchronizing Workflow Directory Services with Oracle Internet Directory" in Chapter 2 of the *Oracle Workflow Guide* for more details.

You can optionally implement LDAP integration and single signon for Oracle Workflow through Oracle Internet Directory and Oracle9iAS Single Sign-On Server.

To implement Oracle Internet Directory integration:

1. Ensure that Oracle Internet Directory, Oracle9iAS Single Sign-On Server, and Oracle Portal are installed.
2. Ensure that `mod_osso` is installed and configured with Oracle HTTP Server. For more information, see "Developing Applications for Mod_osso" in the *Oracle9iAS Single Sign-On Application Developer's Guide*.

You must protect the Database Access Descriptor you created by adding the following entry in your `mod_osso` configuration file (replace "your_Workflow_DAD" with the name of the DAD you created in [Step 2: "Create a database access descriptor \(DAD\) for Oracle Workflow"](#)):

```
<Location /pls/your_Workflow_DAD>
  require valid-user
  authType Basic
</Location>
```

3. Run the `<ORACLE_HOME>/wf/sql/wfdircsv.sql` script to map the directory service views only to the `WF_LOCAL_USERS` and `WF_LOCAL_ROLES` tables.

`WF_LOCAL_USERS` is the only table that is synchronized with Oracle Internet Directory. Only users are maintained through Oracle Internet Directory, not Oracle Workflow roles.

4. If you are upgrading a previous installation of Oracle Workflow, migrate existing Oracle Workflow user information to Oracle Internet Directory.

You must perform a one-time migration of existing Oracle Workflow user information to Oracle Internet Directory to enable single signon and single administration. Ensure that you migrate all the necessary data from `WF_LOCAL_USERS` as well as any other user tables in which you previously stored user information. After performing the migration, you should maintain your user information only through Oracle Internet Directory.

Oracle Internet Directory provides a migration tool called `ldifMigrator`. To use this tool:

- a. Extract your user information from the database into an intermediate LDAP Data Interchange Format (LDIF) file, with substitution variables wherever necessary.

The `ldifMigrator` tool converts the intermediate entries in the file to actual LDIF entries by replacing the variables based on arguments provided at runtime or information retrieved from the LDAP directory.

- b. Upload the LDIF file produced by `ldifMigrator` into Oracle Internet Directory using Oracle Internet Directory bulk tools.

For more information about the `ldifMigrator`, the format required for the intermediate LDIF file, and Oracle Internet Directory bulk upload tools, see Appendix A, "Syntax for LDIF and Command-Line Tools" in the *Oracle Internet Directory Administrator's Guide*.

5. Load the following PL/SQL packages required for LDAP synchronization:
 - `DBMS_LDAP`: This package contains the functions and procedures that can be used to access data from LDAP servers. If this package is not already installed, you must load it manually. To check whether the package is installed, connect to SQL*Plus and use the following command:

```
desc DBMS_LDAP
```

If the package does not exist, load it manually by running the `<ORACLE_HOME>/rdbms/admin/catldap.sql` script. Run this script as the SYS user. For example, use the following command:

```
sqlplus "SYS/<SYS password> as sysdba" @$ORACLE_HOME/rdbms/admin/
catldap.sql
```

- **WFA_SEC:** This package contains Oracle Workflow security functions and procedures. To load this package, run the `<ORACLE_HOME>/wf/sql/wfsecwsb.sql` script. Run this script as the Oracle Workflow user. For example, use the following command:

```
sqlplus owf_mgr/<passwd> @$ORACLE_HOME/wf/sql/wfsecwsb.sql
```

6. Use the WF_LDAP APIs to synchronize your Oracle Workflow directory service with Oracle Internet Directory.

For details, see “Synchronizing Oracle Workflow Directory Services with Oracle Internet Directory” and “Setting Up Oracle Workflow” in the *Oracle Workflow Guide*.

Step 7 Verify your base URL

To invoke Oracle Workflow Web services, you simply append the appropriate procedure and arguments to your base URL. Once you define your Web security and Web users, you can verify your base URL by connecting to the Oracle Workflow home page as a valid user:

```
http://<server_name>[:<portID>]/pls/<your Workflow DAD>/wfa_html.home
```

When using Oracle HTTP Server, you can authenticate yourself with a database username and password. When you install Oracle Workflow and its demonstration workflow processes, you also install a demonstration data model that seeds a set of demonstration users in the directory service and creates these same users as database accounts. The users are: sysadmin, wfadmin, blewis, cdouglas, kwalker, and spierson. To set passwords for these accounts, connect to the SYSTEM database account using SQL*Plus and specify a password for each account using the ALTER USER command. For more information, see: ALTER USER, *Oracle9i SQL Reference*.

With Oracle HTTP Server, you can authenticate your connection to an Oracle Workflow Web page with any of these database usernames and passwords. Public grants and synonyms were created so that these database accounts have full access to the Oracle Workflow Web-based user interface.

Note: For security reasons, the installation process locks these user accounts after creating them. Before you can use the accounts, you must unlock them using the script `<ORACLE_HOME>/wf/demo/wfdemoul.sql`. Connect to the SYSTEM database account using SQL*Plus and run the script using the following command:

```
sqlplus SYSTEM/<SYSTEM pwd> @wfdemoul
```

See your Oracle DBA if you need more information about the SYSTEM account and password.

Step 8 Install additional languages (optional)

The Oracle Workflow server installation and upgrade are available only in English. To support access to Oracle Workflow in another language, you must load that language after the installation and configuration steps using Oracle Workflow Configuration Assistant.

Note: Before you run Oracle Workflow Configuration Assistant, you should close other applications you may have running, including Java applications, Oracle-based applications, and any other applications that consume large amounts of memory, hard disk space, or CPU time. However, you should not close any components of the Oracle9i database where you want to load Oracle Workflow.

When you run the Oracle Workflow Configuration Assistant on Windows, several command windows open and close automatically. You should ignore these windows. You must not manually close any of these command windows, or you will interrupt the configuration process.

To load additional languages:

1. Start Oracle Workflow Configuration Assistant:
 - On UNIX, run: `$ORACLE_HOME/wf/install/wfinstall.`
 - On Windows NT, run: `%ORACLE_HOME%\wf\install\wfinstall.bat.`

2. In the Oracle Workflow Configuration Assistant window, enter the following user information:
 - **Workflow Account:** The user name of your Oracle Workflow database account. The default Oracle Workflow account for a fresh installation is OWF_MGR.
 - **Workflow Password:** The password for your Oracle Workflow database account.
 - **SYS Password:** Your SYS password. See your Oracle DBA if you need more information.
 - **SYSTEM Password:** Your SYSTEM password. See your Oracle DBA if you need more information.
 - **Install Option:** Select **Add Language**.
 - **Language Selection:** Select the language abbreviation for the language you want to add. For a list of standard language abbreviations in Oracle9i, see "Locale Data" in the *Oracle9i National Language Support Guide*.
 - **Connect Method:** Select **Local** to connect to a local database using the Oracle SID, or select **Remote** to connect to a remote database through Oracle Net using LOCAL on Windows or TWO_TASK on UNIX.
 - **Connect String:** If you choose the Remote connect method, enter the connect string for the remote database.
3. Click **Submit** to begin the configuration. You can also click **Quit** to exit the Oracle Workflow Configuration Assistant without performing the configuration.
4. When the configuration is complete, a confirmation window appears. Click **OK**.
5. You can check the status of the configuration by reviewing the `workflow.log` file located in the `wf/install` subdirectory within your Oracle home.

Note: The `workflow.log` file produced during installation and configuration of Oracle Workflow may contain sensitive information. To protect this sensitive information, you can delete the file after the installation is complete or change the permissions for the file so that only authorized administrators can access it.

Step 9 Configure Oracle Workflow with Oracle9iAS InterConnect

The steps in this section are specific to configuring Oracle Workflow to run with Oracle9iAS InterConnect.

1. Navigate to your Oracle Workflow home page. Under **Global Workflow Preferences**, check that the System Status is set to Enabled.
2. Under **Check Setup**, Listeners for local inbound agents, schedule listeners for Agents WF_IN and WF_ERROR. Setting the listener to run every 10 seconds is recommended. If you would like faster response times, schedule additional listeners rather than lowering the interval between runs. See "Scheduling Listeners for Local Inbound Agents" in the *Oracle Workflow Guide* for details.
3. Under Event Subscriptions, add three new subscriptions for the following events:
 - oracle.apps.wf.event.agent.create
 - oracle.apps.wf.event.event.create
 - oracle.apps.wf.event.subscription.create

For each subscription, specify these values:

Field	Value
System	<i><your_workflow_system></i>
Source Type	External
Event Filter	<i>the event you are creating the subscription for (one of the three listed above)</i>
Status	Enabled
Rule Data	Key
Rule Function	wf_event_functions_pkg.receive
Description	Oracle9iAS InterConnect Subscription

See Also: "To Define an Event Subscription" in Oracle Workflow documentation

Step 10 Perform generic configuration steps

The configuration steps in this section are generic to Oracle Workflow (that is, these steps are not specific to using Oracle Workflow with Oracle9iAS InterConnect).

1. Configure the default global user preferences for your enterprise.

See the section "Step 2: Setting Global User Preferences" in Chapter 2 of the *Oracle Workflow Guide* for details.

2. Create a view called WF_LANGUAGES that identifies the languages defined in your Oracle9i installation.

The `wfdirouv.sql` script run by the Oracle Universal Installer automatically creates a sample WF_LANGUAGES view. If you want to use this view, you should verify it first by connecting to SQL*Plus using your Oracle Workflow database account and querying the view for all languages defined in your Oracle9i installation.

See the section "Step 5: Creating the WF_LANGUAGES View" in Chapter 2 of the *Oracle Workflow Guide* for details.

3. If your Oracle Workflow Server is installed on a UNIX platform, define an environment variable called WF_RESOURCES.

See the section "Step 7: Setting the WF_RESOURCES Environment Variable" in Chapter 2 of the *Oracle Workflow Guide* for details.

4. Initiate background Oracle Workflow engines to process deferred work and timed out activities.

See the section "Step 9: Setting up Background Workflow Engines" in Chapter 2 of the *Oracle Workflow Guide* for details.

5. (optional) Customize Oracle Workflow.

You may need to perform these customizations, depending on the feature that you want to implement. The following table lists the steps, along with a pointer to the section in the *Oracle Workflow Guide* where you can find instructions on how to perform the step.

Table C-6 *Optional steps for customizing Oracle Workflow*

Step	See this section in the <i>Oracle Workflow Guide</i>:
Configure and run the Notification Mailer program to allow users to receive e-mail notifications or e-mail notification summaries.	Section "Step 10: Implementing the Notification Mailer" in Chapter 2
Customize e-mail notification templates.	Section "Step 11: Modifying Your Message Templates" in Chapter 2
Customize the logo displayed on Oracle Workflow Web pages.	Section "Step 12: Customizing the Logo on Oracle Workflow's Web Pages" in Chapter 2
Add custom icons to Oracle Workflow.	Section "Step 13: Adding Custom Icons" in Chapter 2
Start the Java Function Activity Agent to run external Java functions.	Section "Step 14: Setting up the Java Function Activity Agent" in Chapter 2
Set up database links and queues for the Business Event System to communicate events between systems.	Section "Step 15: Setting up the Business Event System" in Chapter 2
Schedule Business Event System listeners and propagations to receive and send event messages.	Chapter 13, "Managing Business Events"
Set up event subscriptions to synchronize Business Event System data on different systems.	Chapter 13, "Managing Business Events"

C.4 Oracle9iAS InterConnect Adapter Installation

To install any number of the Oracle9iAS InterConnect adapters, start the Oracle Universal Installer and complete the following steps.

1. Installation Types Screen
 - a. Select **Oracle9iAS InterConnect Adapters**.
 - b. Click **Next**.
2. Available Product Components Screen
 - a. Select the adapter you want to install. The following components are available:
 - Oracle9iAS InterConnect AQ Adapter
 - Oracle9iAS InterConnect Database Adapter
 - Oracle9iAS InterConnect FTP Adapter
 - Oracle9iAS InterConnect HTTP Adapter
 - Oracle9iAS InterConnect MQ Series Adapter
 - Oracle9iAS InterConnect SMTP Adapter
 - Oracle9iAS InterConnect PeopleSoft 7.5x Adapter
 - Oracle9iAS InterConnect SAP R/3 Adapter
 - Oracle9iAS InterConnect CICS Adapter
 - Oracle9iAS InterConnect Siebel 2000 Adapter
 - Oracle9iAS InterConnect JDEdwards Adapter

See [Table C-7](#) for component-specific installation steps.

Table C-7 Component-Specific Installation Information

Adapter	Installation Instructions
AQ	<i>Oracle9iAS InterConnect Adapter for AQ Installation and User's Guide</i>
Database	<i>Oracle9iAS InterConnect Adapter for DB Installation and User's Guide</i>
FTP	<i>Oracle9iAS InterConnect Adapter for FTP Installation and User's Guide</i>
HTTP	<i>Oracle9iAS InterConnect Adapter for HTTP Installation and User's Guide</i>
MQ Series	<i>Oracle9iAS InterConnect Adapter for MQ Series Installation and User's Guide</i>
SMTP	<i>Oracle9iAS InterConnect Adapter for SMTP Installation and User's Guide</i>
PeopleSoft 7.5x	<i>Oracle9iAS InterConnect Adapter for PeopleSoft 7.5x Installation and User's Guide</i>
SAP R/3	<i>Oracle9iAS InterConnect Adapter for SAP R/3 Installation and User's Guide</i>
CICS	<i>Oracle9iAS InterConnect Adapter for CICS Installation and User's Guide</i>
Siebel 2000	<i>Oracle9iAS InterConnect Adapter for Siebel 2000 Installation and User's Guide</i>
JDEdwards	<i>Oracle9iAS InterConnect Adapter for JDEdwards Installation and User's Guide</i>

b. Click Next.

C.5 Oracle9iAS InterConnect Development Kit Installation

This section describes how to install the Oracle9iAS InterConnect development kit.

In Oracle9iAS for Solaris, the Oracle Workflow Client includes Oracle Workflow Builder.

In Oracle9iAS for Windows NT, the Oracle Workflow Client includes Oracle Workflow Builder and the MAPI-compliant Notification Mailer.

C.5.1 Installing the Development Kit

If you want to write your own custom Oracle9iAS InterConnect Adapter, you must install the Development Kit in a new Oracle home. This installs all dependencies. If you have not installed the Oracle9iAS InterConnect hub, you need to do so before proceeding with this installation.

Perform the following steps to install the Development Kit:

1. Available Product Components Screen
 - a. Select **Oracle9iAS InterConnect Development Kit**.
 - b. Click **Next**.
2. Oracle9iAS InterConnect Hub Database Screen - Specify database connection information

Note that this screen appears only when ALL of the following conditions are met:

- You are installing the Development Kit on the Solaris platform.
- The Oracle home in which you are installing the Development Kit does not have any Oracle9iAS InterConnect components.
- You are installing the Development Kit on a machine that is not a middle-tier machine for Oracle9iAS.

Enter the following information about the Oracle9iAS InterConnect hub (usually an Oracle9iAS Metadata Repository) to use.

- **Host Name:** The host name of the Oracle9iAS InterConnect hub. The default is the current host.
- **Port Number:** The port number of the Oracle9iAS InterConnect hub. The default is 1521.
- **Database SID:** The database SID. The default is `iasdb1`.

- **Password:** The password for the Oracle9iAS InterConnect hub. The default is blank.

3. Summary Screen

Review the selections made on previous screens and click **Install**.

The Development Kit is installed on your machine in the following directory:

Platform	Directory
Windows NT	%ORACLE_HOME%\oai\9.0.2\sdk
UNIX	\$ORACLE_HOME/oai/9.0.2/sdk

4. Configure Oracle Net using the Oracle Net Configuration Assistant. Follow the directions in the configuration assistant to complete the configuration.

C.5.2 Oracle9iAS InterConnect Development Kit Post-Installation Steps

Perform these steps after installing Oracle Workflow Client only if you are using Oracle Workflow.

Step 1 Set up the Oracle Workflow HTML help

When you install Oracle Workflow Builder, the Oracle Universal Installer copies a zip file containing the HTML help to the Workflow directory in your Oracle home. The zip file is <ORACLE_HOME>\wf\wfdoc262.zip. To view the HTML help, extract the doc directory tree from the zip file to your file system:

1. Use an unzip utility to extract the doc directory tree from the zip file within the Workflow directory.

You need at least 5 Mb of free disk space to extract the zip file.

Extract the files to <ORACLE_HOME> /wf /. You should get the following subdirectories:

Directory	Contents
<ORACLE_HOME>\wf\doc\<lang>\wf	Oracle Workflow Guide
<ORACLE_HOME>\wf\doc\<lang>\wfcust	Custom Help. You can add your own customized Workflow help in this directory.

2. (optional) After extracting the doc directory tree, you can remove the zip file.

3. You can now view the HTML help using a Web browser.

The path for the contents page of the Oracle Workflow Guide is:

```
<ORACLE_HOME>\wf\doc\<lang>\wf\toc.htm
```

The path for the contents page of your Oracle Workflow Custom Help is:

```
<ORACLE_HOME>\wf\doc\<lang>\wfcust\wfcust.htm
```

4. (optional) To add custom help, replace the placeholder file in the `wfcust` directory, `wfcust.htm`, with your own help material. The HTML file that is the main entry point for your custom help must be named `wfcust.htm` and must contain an anchor named `contents`. Your custom help will be accessible through the Custom Help link on the contents page of the *Oracle Workflow Guide*.

Step 2 Modify fonts in Oracle Workflow Builder (optional)

If you are installing Oracle Workflow Builder in another language, such as Japanese, you can modify the font used by the windows in Oracle Workflow Builder to a font that is appropriate for your language. Any change you make applies to all windows within the program.

1. Choose **Font** from the View menu in Oracle Workflow Builder to display the Fonts properties page.
2. Select the font you want to use in the labels for your icons and in the navigator tree. The Sample region shows the appearance of the font you select. For example, when using Oracle Workflow Builder in Japanese, you might choose the font MS PGothic.
3. Select the font style: Regular, Bold, Italic, or Bold Italic. Some fonts have a limited selection of font styles.
4. Select the font size. Some fonts have a limited selection of font sizes.
5. Select the Underline or Strikeout check boxes to apply those effects.
6. Click **OK** when you are finished.
7. Close and restart Oracle Workflow Builder. The new font settings should then take effect.

Step 3 Review documentation for custom adapters (optional)

If you need to create custom adapters and browsers, see the documentation in

```
<ORACLE_HOME>/oai/9.0.2/sdk/cookbook.zip.
```

C.6 Oracle9iAS InterConnect Management Infrastructure Installation

Oracle9iAS InterConnect Management Infrastructure is required for managing InterConnect components.

In Topology 1 and 3, Oracle Management Server was installed as part of the Oracle9iAS Infrastructure installation. The remaining step is to install the Oracle9iAS InterConnect Management Infrastructure; see instructions below.

In Topology 2, you need to install both Oracle9iAS InterConnect Management Infrastructure and Oracle Management Server:

- Install Oracle Management Server in the hub database's Oracle home. If you already have an existing Oracle Management Server, you can upgrade it. See the *Oracle9i Application Server: Migrating from Oracle9i Application Server 1.x*.
- Install Oracle9iAS InterConnect Management Infrastructure; see instructions below.

To install Oracle9iAS InterConnect Management Infrastructure:

1. Available Product Components Screen
 - a. Select **Oracle9iAS InterConnect Management Infrastructure**.
 - b. Click **Next**.
2. Summary Screen

Review the selections made on previous screens and click **Install**.
3. Configure Oracle Net using the Oracle Net Configuration Assistant. Follow the directions in the configuration assistant to complete the configuration.
4. See the file `<ORACLE_HOME>/oai/9.0.2/console/post_installation.txt` for post-installation steps.

C.7 How to Start Oracle9iAS InterConnect

The following sections describe how to start Oracle9iAS InterConnect.

C.7.1 Topology 1 and 3

1. Start the hub database. This is also the Oracle9iAS Infrastructure database.
2. Start the hub database listener.
3. Start Oracle Internet Directory.

See the *Oracle Internet Directory Administrator's Guide* for details.

4. Start Oracle Management Server.
5. Start InterConnect Repository.

Note: On both Windows NT and UNIX, you must run the `start` command from the `repository` directory, as indicated below.

On UNIX, you use the `start` command.

```
cd $ORACLE_HOME/oai/9.0.2/repository
./start
```

On Windows NT, you can use the `start.bat` command or you can use the NT service for the repository:

```
cd %ORACLE_HOME%\oai\9.0.2\repository
.\start.bat
```

6. Use iStudio to design integration metadata.

To start iStudio, use the following shortcut from the Start menu:

Start > Programs > Oracle - `ORACLE_HOME_NAME` > Application Development

7. Start adapter(s).

See the corresponding adapter documentation.

8. Start Oracle Enterprise Manager (installed as a part of Management Infrastructure).

C.7.2 Topology 2

1. Start the hub database. This is the Oracle8i or Oracle9i database.
2. Start the hub database listener.
3. Start Oracle Management Server.
4. Start InterConnect Repository.

Note: On both Windows NT and UNIX, you must run the `start` command from the `repository` directory, as indicated below.

On UNIX, you use the `start` command.

```
cd $ORACLE_HOME/oai/9.0.2/repository
./start
```

On Windows NT, you can use the `start.bat` command or you can use the NT service for the repository:

```
cd %ORACLE_HOME%\oai\9.0.2\repository
.\start.bat
```

5. Use iStudio to design integration metadata.

To start iStudio, use the following shortcut from the Start menu:

Start > Programs > Oracle - `ORACLE_HOME_NAME` > Application Development

6. Start adapter(s).
See the corresponding adapter documentation.
7. Start Oracle Enterprise Manager (installed as a part of Management Infrastructure).

C.8 How to Change Passwords for the Oracle9iAS InterConnect and Oracle Workflow Schemas

You might need to change the passwords of the `oaihub902` and `owf_mgr` schemas on a regular basis, depending on your company's security policy. How you change the passwords depends on the topology of your setup.

`oaihub902` is the schema for Oracle9iAS InterConnect, and `owf_mgr` is the schema for Oracle Workflow.

C.8.1 Topology 1 and 3

To change passwords of the `oaihub902` and `owf_mgr` schemas in the Infrastructure database:

1. Obtain the necessary system privileges to change schema passwords in the Infrastructure database.
See the *Oracle9iAS Administration Guide* for details on changing schema passwords in the Infrastructure database.
2. Encrypt the new password using the `encrypt` utility in the `$ORACLE_HOME/oai/9.0.2/bin` directory.
Run `encrypt`. The command prompts you to enter the password to encrypt.
3. Update the appropriate parameter in the `.ini` files with the encrypted password:

Table C-8 Update files with encrypted password

Enter the encrypted password for this schema	In this parameter	In this file	On these machines
<code>oaihub902</code>	<code>encrypted_hub_password</code>	<code>\$ORACLE_HOME/oai/9.0.2/hub/hub.ini</code>	Non-middle tier or Infrastructure machines
<code>owf_mgr</code>	<code>encrypted_aq_bridge_password</code>	<code>\$ORACLE_HOME/oai/9.0.2/workflow/adapter.ini</code>	Middle tier or Infrastructure machine

C.8.2 Topology 2

To change passwords of the `oaihub902` and `owf_mgr` schemas in the Oracle database:

1. Obtain the necessary system privileges to change schema passwords in the database.

See the Oracle database documentation for details on changing schema passwords.

2. Encrypt the new password using the `encrypt` utility in the `$ORACLE_HOME/oai/9.0.2/bin` directory. This is the InterConnect Oracle home (as opposed to the database Oracle home).

Run `encrypt`. The command prompts you to enter the password to encrypt.

3. Update the appropriate parameter in the `.ini` files with the encrypted password: This is the InterConnect Oracle home (as opposed to the database Oracle home).

Table C-9 Update files with encrypted password

Enter the encrypted password for this schema	In this parameter	In this file	On these machines
<code>oaihub902</code>	<code>encrypted_hub_password</code>	<code>\$ORACLE_HOME/hub/hub.ini</code>	All machines
<code>owf_mgr</code>	<code>encrypted_aq_bridge_password</code>	<code>\$ORACLE_HOME/workflow/adaptor.ini</code>	Hub machine

C.9 How to Create Multiple Repository Schemas in the Same Database

You created the first schema in the repository database when you ran the hub installation for any of the three topologies. If you need a second schema in the repository database, you can create it by following this procedure:

1. Run the installation procedure for topology 2, which is described in [Section C.3.3, "Oracle9iAS InterConnect Hub Installation Steps for Topology 2"](#).

When the installer prompts you for database information, you enter hub information (database host, port, and SID) that is identical to the hub information in the first install.

2. Make a copy of the following files so that you have a copy of the original. You will be making changes to these files:

- `ORACLE_HOME/oai/9.0.2/repository/hubschema`
- `ORACLE_HOME/oai/9.0.2/repository/oaiexport`
- `ORACLE_HOME/oai/9.0.2/repository/oaiimport`
- `ORACLE_HOME/oai/9.0.2/repository/sql/hub1.sql`
- `ORACLE_HOME/oai/9.0.2/repository/sql/deinstall_schema.sql`
- `ORACLE_HOME/oai/9.0.2/hub/hub.ini`

3. Replace all occurrences of "oaihub902" with the name of the new schema in the original files.

For example, if you want the new schema to be called "oaihub", you would replace "oaihub902" with "oaihub".

4. Execute the modified **hubschema** script to create the new hub user ("oaihub" in this example) in the hub database.
5. Run post-installation steps as described in [Section C.3.4, "Oracle9iAS InterConnect Hub Post-Installation Steps \(required for Oracle Workflow users only\)"](#).

Information for Release 1 Users

This appendix compares Oracle9i Application Server (Oracle9iAS) Release 1, Version 1.0.2.2.x, and Release 2, Version 9.0.2. The topics include:

- [Oracle9iAS Install Types](#)
- [Oracle9iAS Install Architecture](#)
- [Oracle9iAS Dependency on Customer Database](#)
- [Oracle9iAS Space Requirements by Install Type](#)
- [Oracle9iAS Memory Requirements](#)
- [Migration](#)

D.1 Oracle9iAS Install Types

Table D-1 compares install types for Oracle9iAS Release 1, Version 1.0.2.2.x, and Release 2, Version 9.0.2.

Table D-1 Oracle9iAS Install Types

Oracle9iAS Version 1.0.2.2.x	Oracle9iAS Version 9.0.2
<ul style="list-style-type: none"> ■ Core Edition (HTTP Server, Oracle9iAS Containers for J2EE (OC4J), Web Cache, Oracle9i Business Components for Java (BC4J)) ■ Minimal Edition (HTTP Server, Portal, Wireless, BC4J, Oracle Database Client Developer Kit, Oracle LDAP Client Kit, Oracle XML Developer's Kit) ■ Standard Edition (HTTP Server, Portal, Wireless, Enterprise Java Engine, BC4J, Oracle Database Client Developer Kit, Oracle LDAP Client Kit, Oracle XML Developer's Kit) ■ Enterprise Edition (EE) (HTTP Server, Portal, Wireless, Enterprise Java Engine, Database Cache, Forms, Reports, Discoverer, Internet File System, BC4J, Oracle Management Server, Oracle Database Client Developer Kit, Oracle LDAP Client Kit, Oracle XML Developer's Kit) 	<ul style="list-style-type: none"> ■ J2EE and Web Cache (HTTP Server, Web Cache, Oracle9iAS Containers for J2EE (OC4J), Oracle Enterprise Manager Web site) ■ Portal and Wireless (HTTP Server, Web Cache, OC4J, Portal, Wireless, Oracle Enterprise Manager Web site) ■ Business Intelligence and Forms (HTTP Server, Web Cache, OC4J, Portal, Wireless, Forms, Reports, Discoverer, Clickstream Intelligence, Personalization, Oracle Enterprise Manager Web site) ■ Unified Messaging (HTTP Server, Web Cache, OC4J, Portal, Wireless, Forms, Reports, Discoverer, Clickstream Intelligence, Personalization, Unified Messaging, Oracle Enterprise Manager Web site) ■ Oracle9iAS Infrastructure (Oracle9iAS Metadata Repository, Oracle Internet Directory, Oracle9iAS Single Sign-On, Oracle Management Server, Oracle Enterprise Manager Web site)

D.2 Oracle9iAS Install Architecture

Table D-2 compares the install architecture for Oracle9iAS Release 1, Version 1.0.2.2.x, and Release 2, Version 9.0.2.

Table D-2 Oracle9iAS Install Architecture

Oracle9iAS Version 1.0.2.2.x	Oracle9iAS Version 9.0.2
<ul style="list-style-type: none"> ▪ Client Tier Install (Database Client, Wireless Client, SOAP Client, Enterprise Manager Client) ▪ Middle Tier Install (Minimal Edition, Standard Edition, Enterprise Edition) ▪ Database Tier Install (Oracle9iAS components overlaid on top of existing databases only. This is completed as part of the install process) 	<ul style="list-style-type: none"> ▪ Client Tier Install (Database Client, SOAP Client) ▪ Middle Tier Install (J2EE and Web Cache, Portal and Wireless, Business Intelligence and Forms, Unified Messaging, Oracle9iAS Infrastructure) ▪ Database Tier Install (Specialized Case: Customer would load the metadata into an existing customer database only for some components as part of a postinstallation step)

D.3 Oracle9iAS Dependency on Customer Database

[Table D-3](#) compares the dependency on a customer database for Oracle9iAS Release 1, Version 1.0.2.2.x, and Release 2, Version 9.0.2.

Table D-3 Oracle9iAS Dependency on a Customer Database

Oracle9iAS Version 1.0.2.2.x	Oracle9iAS Version 9.0.2
Enterprise Java Engine, Database Cache, Database Client, Portal, Wireless, OID/Login Server, Discoverer, Reports, Forms, Personalization, Email Server, Unified Messaging, Oracle Application InterConnect(OAI), Workflow	Personalization, Unified Messaging, Discoverer

D.4 Oracle9iAS Space Requirements by Install Type

Table D-4 compares space requirements by install type for Oracle9iAS Release 1, Version 1.0.2.2.x, and Release 2, Version 9.0.2.

Table D-4 Oracle9iAS Space Requirement by Install Type

Version 1.0.2.2.x Installation	Disk Space	Version 9.0.2 Installation	Disk Space
Core Edition	450 MB	J2EE and Web Cache	435MB
<ul style="list-style-type: none"> ■ Oracle HTTP Server ■ Oracle9iAS Containers for J2EE (OC4J) ■ Oracle9iAS Web Cache ■ Oracle9i Business Components for Java (BC4J) 		<ul style="list-style-type: none"> ■ Oracle HTTP Server ■ Oracle9iAS Web Cache ■ OC4J ■ Oracle Enterprise Manager Web site 	
Minimal Edition (includes Core Components)	725 MB	Portal and Wireless (includes J2EE and Web Cache Components)	1.20 GB
<ul style="list-style-type: none"> ■ Oracle9iAS Portal ■ Oracle9iAS Wireless ■ Oracle Database Client Developer Kit ■ Oracle LDAP Client Kit ■ Oracle9iAS XML Developer's Kit 		<ul style="list-style-type: none"> ■ Oracle9iAS Portal ■ Oracle9iAS Wireless ■ Oracle Enterprise Manager Web site 	
Standard Edition (includes Minimal Edition Components)	2.25 GB	Business Intelligence and Forms (includes Portal and Wireless components)	1.91 GB
<ul style="list-style-type: none"> ■ Enterprise Java Engine 		<ul style="list-style-type: none"> ■ Oracle9iAS Forms Services ■ Oracle9iAS Reports Services ■ Oracle9iAS Discoverer ■ Oracle9iAS Clickstream Intelligence ■ Oracle9iAS Personalization 	
Enterprise Edition (includes Standard Edition Components)	4.50 GB	Unified Messaging (includes Business Intelligence and Forms)	2.02 GB
<ul style="list-style-type: none"> ■ Oracle9iAS Database Cache ■ Oracle9iAS Forms Services ■ Oracle9iAS Reports Services ■ Oracle9iAS Discoverer ■ Oracle Internet File System ■ Oracle Management Server 		<ul style="list-style-type: none"> ■ Oracle9iAS Unified Messaging 	

D.5 Oracle9iAS Memory Requirements

[Table D-5](#) compares memory requirements for Oracle9iAS Release 1, Version 1.0.2.2.x, and Release 2, Version 9.0.2.

Table D-5 Oracle9iAS Memory Requirements

Oracle9iAS Version 1.0.2.2.x	Oracle9iAS Version 9.0.2
<ul style="list-style-type: none">■ Core Edition: 128 MB■ Minimal Edition: 128 MB■ Standard Edition: 128 MB■ Enterprise Edition: 128 MB	<ul style="list-style-type: none">■ J2EE and Web Cache: 128 MB■ Oracle9iAS Infrastructure: 512 MB■ Portal and Wireless: 256 MB■ Business Intelligence and Forms: 512 MB■ Unified Messaging: 512 MB■ Oracle9iAS Developer Kits: 128 MB

D.6 Migration

If you are migrating from a previous version of Oracle9iAS, perform the tasks described in the *Oracle9i Application Server: Migrating from Oracle9i Application Server 1.x*.

The Oracle9iAS Migration Assistant allows you to migrate existing J2EE and Web Cache components from an Oracle9iAS Release 1, Version 1.0.2.2 installation to a Release 2, Version 9.0.2 installation. The Oracle9iAS Migration Assistant upgrades existing 1.0.2.2 versions of Oracle HTTP Server, Oracle9iAS Web Cache, and Oracle9iAS Containers for J2EE for compatibility with 9.0.2.

Instructions for using and installing the Oracle9iAS Migration Assistant are available in the *Oracle9i Application Server: Migrating from Oracle9i Application Server 1.x*.

Components

This appendix briefly describes the components available through the Oracle9i Application Server (Oracle9iAS), Oracle9iAS Infrastructure, and Oracle9iAS Developer Kits installations.

See Also: *Oracle9i Application Server Overview Guide* in the Oracle9i Application Server Documentation Library for detailed information about each component.

Oracle9iAS Web Cache

Oracle9iAS Web Cache is a server accelerator caching service that improves the performance, scalability, and availability of frequently used e-business Web sites that run on Oracle9iAS and Oracle database. By storing frequently accessed URLs in virtual memory, Oracle9iAS Web Cache eliminates the need to repeatedly process requests for those URLs on the Web server, and it caches both static and dynamically-generated HTTP content from one or more Web applications.

Oracle HTTP Server

Oracle9iAS uses the Oracle HTTP Server, which is built on Apache Web server technology. Oracle HTTP Server offers scalability, stability, speed, and extensibility. It also supports Java Servlets, JavaServer Pages, Perl, PL/SQL, and CGI applications.

Oracle9iAS Containers for J2EE

Oracle9iAS provides a complete set of Java 2 Enterprise Edition (J2EE) containers written entirely in Java that execute on the Java Virtual Machine (JVM) of the standard Java Development Kit (JDK). You can run Oracle9iAS Containers for J2EE (OC4J) on the standard JDK that exists on your operating system.

Oracle Enterprise Manager Web Site

The Oracle Enterprise Manager Web site provides Web-based management tools designed specifically for Oracle9iAS. Using this Web site and its Oracle9iAS Home Pages, you can monitor and configure the components of Oracle9iAS installations. You can deploy applications, manage security, and create and manage Oracle9iAS clusters. The Oracle Enterprise Manager Web is installed on every Oracle9iAS host as part of the Oracle9iAS installation option.

Oracle Enterprise Manager Console

The Oracle Enterprise Manager Console and its three-tier architecture provide a wider view of your Oracle environment, beyond Oracle9iAS. Use the Console to automatically discover and manage Oracle databases, application servers, and Oracle applications across your entire network. The Console and its related tools are installed as part of the Oracle9iAS Infrastructure installation option.

Oracle9iAS Portal

Oracle9iAS Portal is a complete solution for building, deploying, and monitoring Web database applications and content-driven Web sites. Oracle9iAS Portal enables you to create and view database objects through an easy-to-use, HTML-based interface, and provides tools for creating HTML-based interfaces. It also allows you to resolve performance problems using performance tracking facilities, and enables you to manage database security through its interface.

Oracle9iAS Wireless

Oracle9iAS Wireless is a portal service for delivering information and applications to mobile devices. Using Oracle9iAS Wireless, you can create custom portal sites that use different kinds of content, including Web pages, custom Java applications, and XML-based applications. Oracle9iAS Wireless sites make this diverse information accessible to mobile devices without you having to rewrite the content for each target device platform.

Oracle9iAS Discoverer

Oracle9iAS Discoverer is a business intelligence tool for analyzing data. With the Discoverer user interface, users can access and analyze database data. There are two Oracle9iAS Discoverer components:

- Oracle9iAS Discoverer Plus is the Internet version of the award-winning Windows version of Discoverer. With Discoverer Plus, business professionals can get and analyze data in a company's database without having to understand complex database concepts. Using Wizard dialogs and menus, Discoverer Plus guides users through the steps to get and analyze data to support their business decisions.
- Oracle9iAS Discoverer Viewer is a tool for viewing workbooks created by Discoverer Plus users. Discoverer Viewer can also be used to integrate database output into a Web site and portal. In addition, it is easy to customize Discoverer Viewer to conform to a particular Web site look-and-feel, and to build custom Discoverer applications for the Web. Discoverer Viewer is optimized for performance and designed to minimize network traffic.

Oracle9iAS Reports Services

Oracle9iAS Reports Services provides an easy-to-use, scalable, and manageable solution for high-quality database publishing and reporting by creating dynamic reports for the Web and across the enterprise. It enables you to implement a multi-tiered architecture for running your reports.

Oracle9iAS Clickstream Intelligence

Oracle9iAS Clickstream Intelligence collects data from Web site activities and presents it in reports. You can use Oracle9iAS Clickstream Intelligence to:

- Read Web server logs, parsing cookies and query string data to identify many Web site activities
- Transform Web server log data into business information, such as number of hits and time spent on a page by an user
- Integrate Web traffic data with business transaction data from CRM and ERP applications
- Condense enormous volumes of data into meaningful reports

Oracle9iAS Forms Services

Oracle9iAS Forms Services deploys Forms applications with database access to Java clients in a Web environment. Oracle9iAS Forms Services automatically optimizes class downloads, network traffic, and interactions with Oracle databases. Applications are automatically load-balanced across multiple servers and, therefore, can easily scale to service any number of requests.

Oracle9iAS Personalization

Oracle9iAS Personalization provides real-time analysis and recommendations for e-business sales channels, such as Web stores, application hosting environments, and business call centers. Oracle9iAS Personalization provides an integrated real-time recommendation engine that is deployed via Oracle9iAS.

Oracle9iAS Unified Messaging

Oracle9iAS Unified Messaging provides access to all message types using any access method. Voice mail, e-mail, fax, and any other mail type are available to users through their choice of access channel and device. A single message store is used for voice mail, e-mail, and fax messages that provides storage, management, and access to all types of information. The message store provides delivery, telephone processing, wireless notification, browser-based clients (both Web and wireless), and administration utilities.

Oracle9iAS Metadata Repository

Oracle9iAS Metadata Repository is a pre-seeded database containing metadata needed to run Oracle9iAS instances.

Oracle Internet Directory

Oracle Internet Directory enables sharing information about dispersed users and network resources. Oracle Internet Directory implements the Lightweight Directory Access Protocol (LDAP), version 3.

Oracle9iAS Single Sign-On

Oracle9iAS Single Sign-On creates an enterprise-wide user authentication to access multiple accounts and Oracle9iAS applications.

Oracle Management Server

Processes system management tasks and administers the distribution of these tasks across the network using the Oracle Enterprise Manager Console. The Console and its three-tier architecture can be used with the Oracle Enterprise Manager Web site to manage not only Oracle9iAS, but your entire Oracle environment.

Oracle XML Developer Kit

The Oracle XML Developer Kit (XDK) contains the necessary XML component libraries and utilities to give developers the ability to easily XML-enable applications and Web sites. Oracle XDK supports development in Java, C, C++, and PL/SQL with a collection of libraries, command-line utilities, and tools.

Oracle9iAS Portal Developer's Kit

The Oracle9iAS Portal Developer's Kit (PDK) is the framework for seamless integration into Oracle9iAS Portal. Oracle9iAS PDK supports development of portlets and services on platforms using Oracle9iAS Portal.

Oracle9iAS Wireless Software Developer Kit

Oracle9iAS Wireless Software Developer Kit (SDK) is a light development version of Oracle9iAS Wireless. It is an off-line environment that enables developers to create and test Mobile XML applications. With Oracle9iAS Wireless SDK, application developers can test and simulate applications without needing to support a complete Oracle9iAS Wireless installation.

Oracle LDAP Developer's Kit

Oracle LDAP Developer's Kit supports client interaction with any LDAP-compliant directory server, for example, Oracle Internet Directory. The toolkit provides tools and development libraries to support client calls to directory services, encrypted connections, and enables you to manage your directory data.

Default Port Numbers and Port Ranges

Oracle9i Application Server (Oracle9iAS) automatically assigns port numbers to a component when the component is configured. It chooses the port number from a pre-allocated set of default port numbers and port ranges.

Oracle9iAS uses the following method to assign port numbers:

1. Determine if the default port number is already in use by an Oracle9iAS or non-Oracle9iAS process.
2. If the default port number is not in use, assign it to the component.
3. If the default port number is already in use, attempt to assign a number from the port range, starting with the lowest number, until a free port number is found. This appendix contains the following tables:
 - [Oracle9iAS Port Usage \(Sorted by Component\)](#)
 - [Oracle9iAS Port Usage \(Sorted by Port Number\)](#)

F.1 Oracle9iAS Port Usage (Sorted by Component)

Table F-1 lists Oracle9iAS ports by components names.

Table F-1 Oracle9iAS Port Usage (Sorted by Component)

Component	Default Port Number	Port Number Range
Oracle9iAS Clickstream Intelligence		
Oracle9iAS Clickstream Collector Server	6675	Fixed
Oracle9iAS Clickstream Execution Engine	6676	Fixed
Oracle9iAS Clickstream Intelligence Viewer	Same as Oracle HTTP Server	Same as Oracle HTTP Server
Oracle9iAS Clickstream Runtime Administrator	Same as Oracle HTTP Server	Same as Oracle HTTP Server
Oracle9iAS Containers for J2EE (OC4J)		
OC4J AJP	3001	3001-3100
OC4J RMI	3101	3101-3200
OC4J JMS	3201	3201-3300
OC4J HTTP Listener	3301	3301-3400
Oracle9iAS Discoverer		
Oracle9iAS Discoverer	Same as Oracle HTTP Server	Same as Oracle HTTP Server
IIOF	16001	16001-16020
Oracle9iAS Forms Services		
Oracle9iAS Forms Services	Same as Oracle HTTP Server	Same as Oracle HTTP Server
Oracle HTTP Server		
Oracle HTTP Server- non-SSL	7777	7777-7877
Oracle HTTP Server- SSL	4443	4443-4543
Oracle HTTP Server Listen- non-SSL	7777	7777-7877
Oracle HTTP Server- non-SSL- Oracle9iAS Web Cache is installed and configured	7778	7777-7877

Table F-1 Oracle9iAS Port Usage (Sorted by Component) (Cont.)

Component	Default Port Number	Port Number Range
Oracle HTTP Server- SSL	4443	4443-4543
Oracle HTTP Server- SSL- Oracle9iAS Web Cache is installed and configured	4444	4443-4543
Oracle HTTP Server JServ Servlet Engine	8007	8007-8107
Oracle HTTP Server- Oracle Notification Service Requested Port	6003	6003-6099
Oracle HTTP Server- Oracle Notification Service Local Port	6100	6100-6199
Oracle HTTP Server- Oracle Notification Service Remote Port	6200	6200-6299
Oracle HTTP Server- Java Object Cache	7000	7000-7010
Oracle9iAS Clickstream Intelligence Collector Agent	6666	6666-6674
Oracle9iAS Portal		
Oracle9iAS Portal	Same as Oracle HTTP Server	Same as Oracle HTTP Server
Oracle9iAS Single Sign-On	5000-5099	5000-5099
Oracle9iAS Reports Services		
Oracle9iAS Reports Services	3000	3000-3010
SQL*Net- For 6i Backward Compatibility Only	1950	1950-1960
Visigenics CORBA- Reports 9i	14000	14000-14010
Oracle9iAS Unified Messaging		
Oracle9iAS Unified Messaging	5100-5200	5100-5200
IMAP4	143	Fixed
IMAP4- SSL	993	Fixed
POP3	110	Fixed
POP3- SSL	995	Fixed
SMTP	25	Fixed

Table F-1 Oracle9iAS Port Usage (Sorted by Component) (Cont.)

Component	Default Port Number	Port Number Range
NNTP	119	Fixed
NNTP- SSL	563	Fixed
Oracle9iAS Web Cache		
Oracle9iAS Web Cache HTTP Listen- non-SSL	7777	7777-7877
Oracle9iAS Web Cache HTTP Listen- SSL	4443	4443-4543
Oracle9iAS Web Cache Administration	4000	4000-4030
Oracle9iAS Wireless		
Oracle9iAS Wireless	Same as Oracle HTTP Server	Same as Oracle HTTP Server
Oracle9iAS Wireless Integration Server	5555	9000-9100
Oracle Enterprise Manager		
Oracle Enterprise Manager Application Server Administration Service	1810, 1811	1812-1820
Oracle Enterprise Manager Intelligent Agent	1748, 1754, 1808, 1809	Fixed
Oracle Management Server	7771, 7772, 7773	7771-7773
Oracle Internet Directory		
Oracle Internet Directory	4031-4040	4031-4040
Oracle Internet Directory- non-SSL	389	Fixed
Oracle Internet Directory- SSL	636	Fixed
Oracle Internet File System		
Oracle Internet File System Domain Controller and Nodes	53140	Fixed
Oracle Internet File System Domain Controller	53140	Fixed
Main Oracle Internet File System Node	53141, 53142	53141-53142
Oracle Internet File System HTTP Node	53143, 53144	53143-53144

Table F-1 Oracle9iAS Port Usage (Sorted by Component) (Cont.)

Component	Default Port Number	Port Number Range
LDAP- non-SSL	Same as Oracle Internet Directory	Same as Oracle Internet Directory
LDAP- SSL	Same as Oracle Internet Directory	Same as Oracle Internet Directory
AFP	548	Fixed
FTP	21	2100-2100
NFS	2049	4048-4049 for Mount Server
IMAP	Same as Oracle Internet Directory	Same as Oracle Internet Directory
IMAP4- SSL	Same as Oracle Internet Directory	Same as Oracle Internet Directory
Servlet	13138	13138-13140
SMTP	Same as Oracle Internet Directory	Same as Oracle Internet Directory
SMB	139	Fixed
CUP	4180	4180-4200
WCP	Same as Oracle Internet Directory	Same as Oracle Internet Directory
Oracle Workflow		
TNS	1521	Fixed

F.2 Oracle9iAS Port Usage (Sorted by Port Number)

Table F-2 lists Oracle9iAS ports in ascending order.

Table F-2 Oracle9iAS Port Usage (Sorted By Port Number)

Port Number	Component
21	Oracle Internet File System - FTP
110	Oracle9iAS Unified Messaging - POP
119	Oracle9iAS Unified Messaging - NNTP
139	Oracle Internet File System - SMB
389	Oracle Internet Directory- non-SSL
548	Oracle Internet File System - AFP
563	Oracle9iAS Unified Messaging NNTP- SSL
636	Oracle Internet Directory- SSL
995	Oracle9iAS Unified Messaging POP- SSL
1521	Oracle Workflow - TNS
1748	Oracle Enterprise Manager Intelligent Agent
1754	Oracle Enterprise Manager Intelligent Agent
1808	Oracle Enterprise Manager Intelligent Agent
1809	Oracle Enterprise Manager Intelligent Agent
1810	Oracle Enterprise Manager Application Server Service
1811	Oracle Enterprise Manager Application Server Service
1950	Oracle9iAS Reports Services SQL Net
2049	Oracle Internet File System - NFS
2070	Oracle9iAS Syndication Server; To access OSS
3001	Oracle9iAS Containers for J2EE - AJP
3101	Oracle9iAS Containers for J2EE - RMI
3201	Oracle9iAS Containers for J2EE - JMS
3301	Oracle9iAS Containers for J2EE HTTP Listener
4000	Oracle9iAS Web Cache Administration Port

Table F-2 Oracle9iAS Port Usage (Sorted By Port Number) (Cont.)

Port Number	Component
4001	Oracle9iAS Web Cache Invalidation Port
4002	Oracle9iAS Web Cache Statistics
4031	Oracle Internet Directory
4180	Oracle Internet File System - CUP
4443	Oracle HTTP Server- SSL, Oracle HTTP Server Listen- SSL, Oracle9iAS Web Cache Listen- SSL
4444	Oracle HTTP Server Listen- SSL if Oracle9iAS Web Cache is installed and configured
5000	Oracle9iAS Single Sign-On
5100	Oracle9iAS Unified Messaging
5555	Oracle9iAS Wireless Web Integration Server
6003	Oracle HTTP Server- Oracle Notification Service Request Port
6100	Oracle HTTP Server- Oracle Notification Service Local Port
6200	Oracle HTTP Server- Oracle Notification Service Remote Port
6666	Oracle9iAS Clickstream Collector Agent
6675	Oracle9iAS Clickstream Collector Server
6676	Oracle9iAS Clickstream Execution Engine
7000	Oracle HTTP Server Java Object Cache
7771	Oracle Management Server
7772	Oracle Management Server
7773	Oracle Management Server
7777	Oracle HTTP Server- non-SSL, Oracle HTTP Server Listen- non-SSL, Oracle9iAS Web Cache Listen- non-SSL
7778	Oracle HTTP Server Listen- non-SSL if Oracle9iAS Web Cache is installed and configured
8007	Oracle HTTP Server JServ Servlet Engine
13138	Oracle Internet File System Servlet
14000	Oracle9iAS Reports Services Visigenics - CORBA
16001	IIOP

Table F-2 Oracle9iAS Port Usage (Sorted By Port Number) (Cont.)

Port Number	Component
53140	Oracle Internet File System Domain Controller and Nodes
53141	Oracle Internet File System Main Node
53142	Oracle Internet File System Main Node
53143	Oracle Internet File System HTTP Node
53144	Oracle Internet File System HTTP Node

Installing the Documentation Library

The Oracle9i Application Server (Oracle9iAS) Documentation Library CD-ROM contains the documentation set for this product. The documentation on the CD-ROM is available in both HTML and PDF formats. The following topics describe the contents of the CD-ROM and provide instructions for installing and viewing the documentation:

- [Documentation Library Titles](#)
- [Installing the Documentation Library](#)
- [Viewing the Documentation Library](#)

G.1 Documentation Library Titles

The Documentation Library CD-ROM contains the documentation listed in the tables on the following pages. Titles that have a part number are available as printed and bound manuals from the Oracle Store at:

<http://store.oracle.com>

Table G–1 Core Documentation

Part Number	Title
NA	<i>Oracle9i Application Server Quick Tour</i>
A95926-01	<i>Oracle9i Application Server Concepts Guide</i>
A92171-01	<i>Oracle9i Application Server Administrator's Guide</i>
A90146-01	<i>Oracle9i Application Server Security Guide</i>
A95101-01	<i>Oracle9i Application Server Application Developer's Guide</i>
A92110-01	<i>Oracle9i Application Server Globalization Support Guide</i>
NA	<i>Oracle9i Application Server List of All Books</i>
NA	<i>Oracle9i Application Server Master Index</i>
NA	<i>Oracle9i Application Server Master Glossary</i>

Table G–2 J2EE & Internet Applications

Part Number	Title
A92173-01	<i>Oracle HTTP Server Administration Guide</i>
A90855-01	<i>Oracle9i Application Server mod_plsql User's Guide</i>
A90856-01	<i>Oracle9i Application Server PL/SQL Web Toolkit Reference</i>
NA	<i>Oracle9iAS Containers for J2EE Quick Reference Card</i>
A95880-01	<i>Oracle9iAS Containers for J2EE User's Guide</i>
A95879-01	<i>Oracle9iAS Containers for J2EE Services Guide</i>
A95882-01	<i>Oracle9iAS Containers for J2EE Support for JavaServer Pages Reference</i>
A95883-01	<i>Oracle9iAS Containers for J2EE JSP Tag Libraries and Utilities Reference</i>
A95878-01	<i>Oracle9iAS Containers for J2EE Servlet Developer's Guide</i>
A95881-01	<i>Oracle9iAS Containers for J2EE Enterprise JavaBeans Developer's Guide and Reference</i>
NA	<i>JAAS Provider API Reference (Javadoc)</i>

Table G–2 J2EE & Internet Applications (Cont.)

Part Number	Title
A90211-01	<i>Oracle9i JDBC Developer's Guide and Reference</i>
A90212-01	<i>Oracle9i SQLJ Developer's Guide and Reference</i>
NA	<i>Oracle9i SQLJ API Reference (Javadoc)</i>
A90214-01	<i>Oracle9i JPublisher User's Guide</i>
NA	<i>Oracle9i Business Components for Java Developing Business Components</i>
NA	<i>Oracle9i Business Components for Java API Reference (Javadoc)</i>
A95453-01	<i>Oracle9iAS Web Services Developer's Guide</i>
NA	<i>Oracle9iAS Web Services Proxy API Reference (Javadoc)</i>
NA	<i>Oracle9iAS Web Services UDDI Client API Reference (Javadoc)</i>
NA	<i>Oracle9iAS Web Services Oracle9iAS SOAP API Reference (Javadoc)</i>
A92175-01	<i>Oracle9iAS Forms Services Deployment Guide</i>
A88894-01	<i>Oracle9i Application Developer's Guide - XML</i>
A88895-01	<i>Oracle9i Case Studies - XML Applications</i>
A88899-01	<i>Oracle9i XML Reference</i>

Table G–3 Portals

Part Number	Title
A90852-01	<i>Oracle9iAS Portal Configuration Guide</i>
A95917-01	<i>Oracle Syndication Server User's and Administrator's Guide</i>
NA	<i>Oracle9i Syndication Server API Reference (Javadoc)</i>

Table G–4 Wireless

Part Number	Title
A90486-01	<i>Oracle9iAS Wireless Getting Started and System Guide</i>
A90485-01	<i>Oracle9iAS Wireless Developer's Guide</i>
NA	<i>Oracle9iAS Wireless API Reference (Javadoc)</i>

Table G-5 Caching

Part Number	Title
A95404-01	<i>Oracle9iAS Web Cache Administration and Deployment Guide</i>
NA	<i>Oracle9iAS Web Cache Invalidation API Reference (Javadoc)</i>

Table G-6 Business Intelligence

Part Number	Title
A92102-01	<i>Oracle9iAS Reports Services Publishing Reports to the Web</i>
A95458-01	<i>Oracle9iAS Discoverer Configuration Guide</i>
A90879-02	<i>Oracle9iAS Discoverer Plus User's Guide</i>
A90880-01	<i>Oracle9iAS Discoverer Plus Tutorial</i>
A90888-01	<i>Oracle9iAS Clickstream Intelligence User's Guide</i>
A90500-01	<i>Oracle9iAS Clickstream Intelligence Administrator's Guide</i>
A95243-02	<i>Oracle9iAS Personalization Administrator's Guide</i>
A95245-01	<i>Oracle9iAS Personalization Programmer's Guide</i>
A95244-01	<i>Oracle9iAS Personalization User's Guide</i>
NA	<i>Oracle9iAS Personalization API Reference (Javadoc)</i>

Table G-7 E-Business Integration

Part Number	Title
A95265-02	<i>Oracle Workflow Guide</i>
A92174-01	<i>Oracle9iAS InterConnect User's Guide</i>
A95454-01	<i>Oracle9iAS Unified Messaging Administrator's Guide</i>
A95456-01	<i>Oracle9iAS Unified Messaging User's Guide</i>
A95455-01	<i>Oracle9iAS Unified Messaging Application Developer's Guide</i>
NA	<i>Oracle9iAS Unified Messaging API Reference (Javadoc)</i>

Table G-8 Management and Security

Part Number	Title
A95411-01	<i>Oracle Enterprise Manager Concepts Guide</i>
A95410-01	<i>Oracle Enterprise Manager Configuration Guide</i>

Table G–8 Management and Security (Cont.)

Part Number	Title
A95407-01	<i>Oracle Enterprise Manager Administrator's Guide</i>
A89872-01	<i>Oracle Enterprise Manager Event Test Reference Manual</i>
A95406-01	<i>Oracle Enterprise Manager Addendum to Event Test Reference Manual</i>
A88758-01	<i>Oracle Enterprise Manager Messages Manual</i>
A95412-01	<i>Oracle Intelligent Agent User's Guide</i>
A88768-01	<i>Oracle SNMP Support Reference Guide</i>
A96115-01	<i>Oracle9iAS Single Sign-On Administrator's Guide</i>
A96114-01	<i>Oracle9iAS Single Sign-On Application Developer's Guide</i>
NA	<i>Oracle9iAS Single Sign-On API Reference (Javadoc)</i>
A95192-01	<i>Oracle Internet Directory Administrator's Guide</i>
A95193-01	<i>Oracle Internet Directory Application Developer's Guide</i>

G.2 Installing the Documentation Library

You can install the documentation from the CD-ROM in either of two ways:

- Copying the files from the CD-ROM to your local system
- Using the Oracle Universal Installer included with Oracle9iAS

G.2.1 File Copy Installation

The simplest installation method is to copy the files directly from the CD-ROM to your computer. Use your operating system's commands to copy the contents of the `doc` directory on the CD-ROM to the appropriate installation directory on your system. For consistency with installations that the Oracle Universal Installer performs, Oracle recommends that you name the directory `doc`.

The following commands copy the documentation from the CD-ROM to your Oracle home directory.

For UNIX, enter the following command:

```
prompt> cp -r mount_point/doc ORACLE_HOME
```

For Windows, enter the following command at the command prompt:

```
prompt> xcopy /s cdrom_drive\doc ORACLE_HOME
```

Note: This method may overwrite files if the destination directory already exists.

G.2.2 Oracle Universal Installer Installation

You can also use the Oracle Universal Installer to install documentation onto your computer from the CD-ROM. To use this method you must have an instance of Oracle9iAS installed. If you do not have an instance installed, you must use the [File Copy Installation](#) method.

Note: You can only install the documentation library using Oracle Universal Installer on Windows and Solaris operating systems. For all other operating systems, use the installation instructions in [Section G.2.1, "File Copy Installation"](#).

The following instructions describe how to install the documentation using the Oracle Universal Installer.

1. Launch the Oracle Universal Installer from Oracle9iAS Disc 1 (the CD you used to install the product).

See Also: [Section 2.6.4, "Starting Oracle Universal Installer"](#)

2. At the Welcome screen, click **Next**.
3. At the File Locations screen do the following:
 - a. Eject the Oracle9iAS CD-ROM and replace it with the Documentation Library CD-ROM.
 - b. In the **Path:** field in the Source section:
For UNIX, enter `mount_point/stage/products.jar`.
For Windows, enter `cdrom-drive\stage\products.jar`.
This directs the installer to the installation file for the documentation library.
 - c. In the **Name:** field in the Destination section, enter an Oracle home name or select one from the list. The Oracle home name must be one to sixteen characters long, and can only include alphanumeric characters and underscores. It cannot include spaces.
 - d. In the **Path:** field in the Destination section, enter the path to the Oracle home you are installing the documentation to. The documentation will be installed in the `doc` directory under Oracle home.
 - e. Click **Next** to continue.
4. At the Summary screen, review the summary and click **Install** to begin the installation process.
5. After installation, the End of Installation screen will appear. Click **Exit** to quit the installer.

G.3 Viewing the Documentation Library

You can view the Oracle9iAS documentation library directly from the CD-ROM or from the directory where you installed it. For information about the tools necessary to view the documentation, refer to ["Online Documentation Requirements"](#) on page 2-6.

To view the HTML and PDF documentation from a local installation or from the CD-ROM, follow these steps:

1. Use your browser to open the top-level `index.htm` file from the `doc` directory on either the CD-ROM or the Oracle home directory.
2. Click on a solution area tab to see the documentation relating to a particular component.

Index

A

- Active Directory support
 - preinstallation requirements for integration with Oracle, B-8
- adapter
 - Oracle9iAS InterConnect, C-2
- adapter installation
 - Oracle9iAS InterConnect, C-34
- additional languages
 - Oracle Workflow, C-29
- Administrator installation type
 - definition, B-5
 - system requirements for, B-6
- Administrators group
 - requirements for Oracle installations, B-11
- Advanced Queueing
 - installation types available with, B-23
- AJP
 - port numbers, F-2
- alias, C-23
- Application Server, 3-1
 - installation, 3-1
 - postinstallation
 - component port number, 3-39
 - environment scripts, 3-38
- application server cluster, 1-6
- architecture
 - Oracle9i Application Server, 1-2
- authentication support
 - preinstallation requirements, B-8

B

- base directory, 3-6, 4-6, 5-5
- base URL, C-28
- Bourne shell
 - DISPLAY, 2-11
 - ORACLE_HOME, 2-9, 2-12
- Business Intelligence and Forms, 1-4, 3-10
- buttons
 - about Oracle Universal Installer, 3-4, 4-4, 5-3
 - browse, 3-8, 4-8, 5-7
 - cancel, 9-8
 - close, 9-5
 - deinstall products, 3-4, 4-4, 5-3, 9-3
 - exit, 3-4, 4-4, 5-3
 - help, 3-4, 4-4, 5-3, 9-5, 9-6
 - installed products, 3-4, 4-4, 5-3, 9-3
 - location, 9-5
 - next, 3-4, 4-4, 5-3
 - no, 9-6
 - previous, 3-4, 4-4, 5-3
 - remove, 9-5
 - retry, 3-33, 4-24, 5-16
 - save as, 9-5
 - stop, 3-33, 4-24, 5-16
 - yes, 9-6

C

- C shell
 - DISPLAY, 2-11
 - ORACLE_HOME, 2-9, 2-12
- certified software requirements, 2-5
- change passwords

- Oracle Workflow schemas, C-42
- Oracle9iAS InterConnect, C-42
- client components
 - system requirements, B-4
- client installations
 - instructions, B-11
- common character set, 4-21
- Component, 3-39
- component configuration and startup screen, 3-14
- component port number, 3-39, 4-28, 4-29, 5-20, 5-21
- components
 - installation of single Oracle home components, B-3
 - installing, B-11
 - installing single Oracle home components a second time, B-3
 - mandatory preinstallation requirements, B-7
 - Oracle9i Application Server, 1-5
 - Oracle9iAS, 1-4
 - postinstallation configuration guidelines, B-22
 - removing manually on Windows 98, B-17
 - removing manually on Windows NT, B-15
- components directory, 3-6, 4-6, 5-5
- configuration tools, A-1, E-1
- confirmation screen, 9-6
- CPU, 2-2
- create instance name and ias_admin password screen, 3-24
- creating
 - UNIX group name, 2-15

D

- database access descriptor, C-21
- database administrator group, 4-20
- database operator group, 4-20
- default character set, 4-21
- deinstallation, 9-1, 9-2
 - confirmation screen, 9-6
 - of Oracle components, B-15, B-17
 - Oracle9i Application Server, 9-2
 - using Oracle Universal Installer, 9-3
- destination
 - file locations screen, G-7
- Developer Kits, 5-1

- installation, 5-1, 5-2
- development kit
 - Oracle9iAS InterConnect, C-2, C-36
- directories
 - cdrom/9ias__disk1, 2-23
 - doc, G-6
 - /tmp, 2-12
- directory service
 - Oracle Workflow, C-25
- disk space, 2-2
 - online documentation, 2-6
- DISPLAY, 2-10
- documentation library
 - installation, G-1
 - file copy installation, G-6
 - Oracle Universal Installer, G-6
 - installation options, G-6
 - titles, G-2
 - viewing, G-7

E

- emtab file creation, 6-4
- end of installation screen, 3-34, 4-25, 5-17
- end user layer, 3-37
- Error, 6-10

F

- FAT
 - system requirements, B-4
- file copy installation, G-6
- file locations screen, 3-7, 4-7, 5-6
 - destination, 3-8, 4-8, 5-7, G-7
 - source, 3-7, 4-7, 5-6, G-7
- file systems
 - system requirements, B-4
- files
 - installation logs, 6-7
 - Oracle Universal Installer log files, B-13
 - silentInstall.log, 6-7

G

generic configuration
Oracle Workflow, C-32

H

hardware requirements, 2-2
CPU, 2-2
disk space, 2-2
for the hub machine, C-7
Oracle9iAS InterConnect, C-7
help
Oracle Workflow, C-24
host name, 3-19
host naming adapter
supported vendors, B-9
hub
Oracle9iAS InterConnect, C-2

I

ias_admin Password, 3-2, 4-2
ias_admin password, 3-23, 5-2
IASAdmins group, 3-22
IIOP
port numbers, F-2
Infrastructure, 4-1
installation, 4-1
postinstallation
component port number, 4-28, 4-29, 5-20,
5-21
component-specific tasks, 4-28, 5-19
installactions.log file, B-3
installation, 4-1
Developer Kits, 5-1
documentation library, G-1
in noninteractive mode, B-25
Infrastructure, 4-1
non-interactive
log files, 6-7
of single Oracle home components, B-3
Oracle9iAS InterConnect, C-12
preinstallation, B-10
requirements, B-4
reviewing a log of an installation session, B-13

steps, B-11
installation concepts, 1-1
installation information
Oracle9i Application Server, 3-2
Oracle9iAS Developer Kits, 5-2
Oracle9iAS Infrastructure, 4-2
installation log files, 2-22
installation options
documentation library, G-6
installation types
with Oracle9i Client, B-5, B-23
installation types screen, 3-12
instance name, 3-2, 3-23, 4-2, 5-2
Inventory directory, B-13
inventory screen, 9-4

J

J2EE and Web Cache, 1-4, 1-8, 3-10
Java Authentication and Authorization
Service, 3-37
java object cache
port numbers, F-3
Java Runtime Environment
requirements, B-4
JMS
port numbers, F-2
JRE
Oracle9iAS InterConnect, C-9
JRE requirements, C-9

K

Korn shell
DISPLAY, 2-11
ORACLE_HOME, 2-9, 2-12

L

listener
stopping before installation, B-11
log files
reviewing an installation session, B-13
LU6.2 protocol support
desupported vendors, B-9

M

management infrastructure
 Oracle9iAS InterConnect, C-2
mandatory individual component
 requirements, B-7
migration, 2-16
mod_plsql, 3-38

N

Named Pipes protocol support
 supported vendors, B-9
non-interactive installation, 6-1, 6-3
 error handling, 6-10
 introduction, 6-2
 requirements, 6-3
noninteractive installation
 overview, B-25
notification mailer, C-10
NTFS
 file system permission setting, B-19
 system requirements, B-4

O

Object Type Translator
 installation types available with, B-23
OC4J
 port numbers, F-2
OCI
 installation types available with, B-23
oinstall group
 UNIX group name, 2-14
online documentation
 disk space, 2-6
 online format, 2-6
 HTML, 2-6
 PDF, 2-6
 requirements, 2-6
operating system requirements, C-9
optional steps
 Oracle Workflow, C-33
oracle account
 UNIX account, 2-14
Oracle Advanced Security

 postinstallation configuration tasks, B-22
 preinstallation requirements, B-8
Oracle Call Interface
 installation types available with, B-23
Oracle Dynamic Services Server
 installation types available with, B-23
Oracle Enterprise JavaBeans and CORBA Tools
 installation types available with, B-23
Oracle Enterprise Manager
 port numbers, F-4
Oracle Enterprise Manager Client
 Web-enabled system requirements, B-6
Oracle Enterprise Manager Home Pages, 3-36,
 4-27, 5-19
Oracle Enterprise Manager Web Site
 supported Web browsers, B-6
Oracle Enterprise Manager Web site, 3-36, 4-27,
 5-19
Oracle home
 installing single homes components a second
 time, B-3
 single Oracle home components, B-3
Oracle home location, 3-2, 4-2, 5-2
Oracle HTTP Server, E-1
 port numbers, F-2, F-3
Oracle *interMedia* Annotator
 installation types available with, B-23
Oracle *interMedia* Client Option
 installation types available with, B-23
Oracle Internet Directory, 1-8
 password, 3-2, 3-22
 port numbers, F-4
 username, 3-2, 3-22
Oracle Internet Directory Client
 installation types available with, B-23
Oracle inventory
 log files, B-13
Oracle inventory directory, 3-2, 4-2, 5-2
Oracle Management Server, 1-8
 port numbers, F-4
Oracle Net Services
 postinstallation configuration tasks, B-22
Oracle Objects for OLE
 installation types available with, B-23
 single Oracle home component, B-3

- Oracle ODBC Driver
 - installation types available with, B-23
- Oracle Provider for OLE DB
 - installation types available with, B-23
 - single Oracle home component, B-3
- Oracle services
 - stopping, B-11, B-14
- Oracle Store, xiv
- Oracle Syndication Server
 - installation types available with, B-23
- Oracle Technology Network, xiv
- Oracle Ultra Search Middle Tier
 - installation types available with, B-23
- Oracle Universal Installer, 2-22, 2-23
 - inventory, B-13
 - log files, B-13
 - mounting
 - CD-ROM, 2-23
 - running in noninteractive mode, B-25
 - running silently, B-25
 - starting, 2-23
 - UNIX group name, 2-14
- Oracle Windows NT services
 - stopping, B-11, B-14
- Oracle Workflow
 - additional languages, C-29
 - directory service, C-25
 - generic configuration, C-32
 - help, C-24
 - optional steps, C-33
 - port numbers, F-5
- Oracle Workflow Configuration Assistant, C-18, C-29
- Oracle Workflow schemas
 - change passwords, C-42
- Oracle XML Developer Kit, E-5
- Oracle XML Developer's Kit
 - installation types available with, B-23
- Oracle XML SQL Utility
 - installation types available with, B-24
- ORACLE_HOME
 - Bourne shell, 2-9, 2-12
 - C shell, 2-9, 2-12
 - Korn shell, 2-9, 2-12
- Oracle9i Advanced Queuing, C-14
- Oracle9i Application Server, 1-2
 - deinstallation, 9-2
 - installation, installation
 - Oracle9i Application Server, 3-2
- Oracle9i Application Server
 - components
 - Oracle HTTP Server, E-1
 - Oracle XML Developer Kit, E-5
 - Oracle9iAS Discoverer, E-3
 - Oracle9iAS Forms Services, E-4
 - Oracle9iAS Reports Services, E-3
 - Oracle9iAS Web Cache, E-1
 - Oracle9iAS Wireless, E-3
 - deinstallation, 9-1
 - reinstallation, 9-1, 9-9
- Oracle9i Client
 - defined, B-5
 - installation types available with, B-5, B-23
- Oracle9iAS
 - components, 1-4
- Oracle9iAS Clickstream Collector Server
 - port numbers, F-2
- Oracle9iAS Clickstream Execution Engine
 - port numbers, F-2
- Oracle9iAS Clickstream Intelligence
 - port numbers, F-2
- Oracle9iAS Clickstream Intelligence Viewer
 - port numbers, F-2
- Oracle9iAS Clickstream Runtime Administrator
 - port numbers, F-2
- Oracle9iAS Developer Kits, 1-2
- Oracle9iAS Discoverer, E-3
 - port numbers, F-2
- Oracle9iAS Discoverer Plus, E-3
- Oracle9iAS Discoverer Viewer, E-3
- Oracle9iAS Forms Services, E-4
 - port numbers, F-2
- Oracle9iAS Infrastructure, 1-2
 - installation, 4-2
 - postinstallation, 4-27
- Oracle9iAS InterConnect
 - adapter installation, C-34
 - change passwords, C-42
 - development kit, C-36
 - hardware requirements, C-7

- installation, C-12
- installation types, C-2
- JRE, C-9
- multiple components, C-11
- operating system requirements, C-9
- postinstallation, C-18
- preinstallation, C-14
- software requirements, C-8
- topology, C-3
- Oracle9iAS InterConnect Management
 - Infrastructure, C-39
- Oracle9iAS Metadata Repository, 1-8, 3-3, 3-28
- Oracle9iAS Migration Assistant, 7-2
- Oracle9iAS Portal
 - port numbers, F-3
- Oracle9iAS Reports Services, 3-30
- Oracle9iAS Reports Services, E-3
 - port numbers, F-3
- Oracle9iAS Single Sign-On, 1-8
- Oracle9iAS Single Sign-On
 - port numbers, F-3
- Oracle9iAS Single Sign-On Port Number, 3-2, 4-3
- Oracle9iAS Single Sign-On Server Host Name, 3-2, 4-3
- Oracle9iAS Unified Messaging
 - port numbers, F-3
 - IMAP4, F-3
 - IMAP4-SSL, F-3
 - NNTP, F-4
 - NNTP-SSL, F-4
 - POP3, F-3
 - POP3-SSL, F-3
 - SMTP, F-3
- Oracle9iAS Web Cache, E-1
 - memory requirement, 2-2
 - port numbers, F-4
- Oracle9iAS Wireless, E-3
 - port numbers, F-4
- oraInst.loc file creation, 6-4
- oraInstRoot.sh, 3-6, 4-6, 5-5
- oraInventory directory, 2-22
 - location, 2-22
 - UNIX group name, 2-14
- oratab file creation, 6-4
- orcladmin, 3-22

- OSDBA, 2-15
- OSOPER, 2-15
- OTT
 - installation types available with, B-23
- outgoing mail server information screen, 3-30

P

- password
 - ias_admin, 3-23
 - Oracle Internet Directory, 3-22
- patches
 - Solaris, C-9
 - Solaris Operating System, 2-4
- PL/SQL
 - installation types available with, B-24
- port changes, 2-16
- port number, 3-19
- port numbers, F-1
 - IIOP, F-2
 - OC4J, F-2
 - AJP, F-2
 - HTTP listener, F-2
 - JMS, F-2
 - RMI, F-2
- Oracle Enterprise Manager, F-4
 - administration, F-4
 - Intelligent Agent, F-4
- Oracle HTTP Server, 4-29, 5-21, F-2
 - non-SSL, F-2
 - SSL, F-2, F-3
- Oracle Internet Directory, F-4
 - non-SSL, F-4
 - SSL, F-4
- Oracle Internet File System, F-4
 - AFP, F-5
 - CUP, F-5
 - domain controller, F-4
 - domain controller and nodes, F-4
 - FTP, F-5
 - HTTP node, F-4
 - IMAP, F-5
 - IMAP4-SSL, F-5
 - LDAP-non-SSL, F-5
 - LDAP-SSL, F-5

- main node, F-4
- NFS, F-5
- servlet, F-5
- SMB, F-5
- SMTP, F-5
- WCP, F-5
- Oracle Management Server, F-4
- Oracle Workflow, F-5
 - TNS, F-5
- Oracle9iAS Clickstream Collector Server, F-2
- Oracle9iAS Clickstream Execution Engine, F-2
- Oracle9iAS Clickstream Intelligence, F-2
- Oracle9iAS Clickstream Intelligence Viewer, F-2
- Oracle9iAS Clickstream Runtime
 - Administrator, F-2
- Oracle9iAS Discoverer, F-2
- Oracle9iAS Forms Services, F-2
- Oracle9iAS Portal, F-3
- Oracle9iAS Reports Services, F-3
 - Visigenics CORBA, F-3
- Oracle9iAS Single Sign-On, F-3
- Oracle9iAS Unified Messaging, F-3
 - IMAP4, F-3
 - IMAP4-SSL, F-3
 - NNTP, F-4
 - NNTP-SSL, F-4
 - POP3, F-3
 - POP3-SSL, F-3
 - SMTP, F-3
- Oracle9iAS Web Cache, F-4
 - administration, F-4
 - HTTP Listen non-SSL, F-4
 - HTTP Listen SSL, F-4
- Oracle9iAS Wireless, F-4
 - integration server, F-4
- OracleHTTP Server
 - java object cache, F-3
 - JServ servlet, F-3
 - Oracle Notification Service local port, F-3
 - Oracle Notification Service remote port, F-3
 - Oracle Notification Service report port, F-3
 - Oracle Notification Service requested port, F-3
- sorted by component, F-2
- sorted by port numbers, F-6
- SQL*Net, F-3
- port ranges, F-1
- Portal and Wireless, 1-4, 3-10
- portlist.ini, 3-39
- postinstallation
 - additional documentation, 4-29, 5-21
 - configuration requirements for individual components, B-22
 - Oracle9i Application Server, 3-36
 - Oracle9iAS Infrastructure, 4-27
 - Oracle9iAS InterConnect, C-18
 - setting NTFS file system permissions, B-19
 - setting Windows NT registry security, B-21
- preinstallation
 - creating
 - UNIX account, 2-14
 - UNIX group name, 2-14
 - environment variables, 2-8
 - DISPLAY, 2-10
 - TMP, 2-12
 - migration, 2-16
 - Oracle9iAS InterConnect, C-14
 - port changes, 2-16
 - requirements for individual components, B-7
 - requirements for Oracle Advanced Security, B-8
 - requirements for Oracle9i integration with Active Directory, B-8
 - stop services, B-11
 - tasks, B-10
- privileged groups, 2-15
- Pro*C/C++
 - installation types available with, B-24
- Pro*COBOL
 - installation types available with, B-24
 - postinstallation configuration tasks, B-22
- protocol stack vendors
 - requirements, B-9
- protocol support
 - supported vendors, B-9

R

- registry
 - exercise care when using, B-15
 - setting security, B-21

- reinstallation, 9-1
 - Oracle9i Application Server, 9-9
- removing
 - Oracle components manually on Windows 98, B-17
 - Oracle components manually on Windows NT, B-15
- Replication Management API
 - installation types available with, B-24
- requirements
 - certified software, 2-5
 - for Administrator installation type, B-6
 - for client components, B-4
 - for individual components, B-7
 - for Java Runtime Environment, B-4
 - hardware, 2-2
 - online documentation, 2-6
 - postinstallation for Oracle components, B-22
 - preinstallation, B-10
 - preinstallation requirements for individual components, B-7
- response file, 6-2, 6-5
 - specifying, 6-7
- response files
 - on CD-ROM, B-25
 - using, B-25
- RMI
 - port numbers, F-2
- root.sh, 3-6, 3-32, 4-6, 5-5, 5-15
- root.sh script, 4-23

S

- screens
 - available products, 3-9, 4-9, 5-8
 - component configuration and startup, 3-14
 - components configuration and startup, 3-33, 5-16
 - confirmation, 9-6
 - create instance Name, 4-19
 - create instance name, 3-27, 5-13
 - create instance name and ias_admin, 5-10
 - create instance name and ias_admin password, 3-24, 4-17
 - database character set, 4-21
 - end of installation, 3-34, 4-25, 5-17, G-7
 - enter ias_admin password, 5-12
 - existing Oracle Internet Directory, 4-14
 - existing Oracle9iAS Single Sign-On, 3-20, 4-13
 - file locations, 3-7, 4-7, 5-6, G-7
 - install, 3-32, 4-23, 5-15
 - installation types, 3-12
 - inventory, 9-4
 - inventory location, 3-5, 4-5, 5-4
 - Oracle Internet Directory, 3-21
 - Oracle Universal Installer Welcome, 3-4, 4-4, 5-3
 - Oracle9iAS Infrastructure use, 3-18
 - Oracle9iAS Metadata Repository, 3-28
 - outgoing mail server information, 3-30
 - privileged operating system groups, 4-20
 - select configuration options, 4-10
 - summary, 3-31, 4-22, 5-14, G-7
 - the components configuration and startup, 4-24
 - welcome, G-7
- SecurID Authentication Adapter
 - supported vendors, B-9
- services
 - stopping, B-11, B-14
- setting
 - DISPLAY, 2-10
 - TMP, 2-12
- Silent, 6-1
- silent installation, 6-2
 - overview, B-25
- silentInstall.log, 6-7
- single Oracle home
 - components, B-3
 - installing single home components a second time, B-3
- single sign-on, 1-6
- software requirements
 - operating system
 - Solaris 2.6, 2-4
 - Solaris 2.7, 2-5
 - Solaris 2.8, 2-5
 - Oracle9iAS InterConnect, C-8
- Solaris Operating System
 - patches, 2-4
- Solaris patches, C-9
- source

- file locations screen, G-7
- specifying
 - response file, 6-7
- SQL*Net
 - port numbers, F-3
- SQL*Plus
 - installation types available with, B-24
 - installing online help of, B-22
- starting, 2-23
 - Oracle Universal Installer, 2-23
- Starting and Stopping Components, 4-28, 5-19
- system requirements
 - for Administrator installation type, B-6
 - for client components, B-4
 - for FAT and NTFS file systems, B-4
 - operating system, C-9

T

- TCP/IP protocol support
 - supported vendors, B-9
- TMP, 2-12
- TNS_ADMIN, 2-10, 2-12
- topology
 - Oracle9iAS InterConnect, C-3
- troubleshooting
 - Inventory log files, B-13

U

- unicode character set, 4-21
- Unified Messaging, 1-4, 3-10
- UNIX account, 2-14
 - oracle account, 2-14
- UNIX group name, 2-14
 - admintool utility, 2-14
 - creating, 2-15
 - groupadd utility, 2-14
 - oinstall group, 2-14
 - oraInventory directory, 2-14
 - privileged groups, 2-15
- username
 - Oracle Internet Directory, 3-22

V

- VI protocol
 - support, B-9
- viewing
 - documentation library, G-7
- Visigenics CORBA
 - port numbers, F-3

W

- Web browser
 - supported browsers for running Oracle Enterprise Manager Web Site, B-6
- Windows native authentication
 - supported vendors, B-9
- workflow account, C-19
- workflow password, C-19
- workflow.log file, C-18

X

- XML
 - Oracle XML Developer's Kit, B-23
 - Oracle XML SQL utility, B-24

