

Oracle9i Application Server

Installation Guide

Release 2 (9.0.3) for Solaris Operating System (SPARC)

September 2002

Part No. B10014-01

Oracle9i Application Server Installation Guide, Release 2 (9.0.3) for Solaris Operating System (SPARC)

Part No. B10014-01

Copyright © 2002 Oracle Corporation. All rights reserved.

Primary Author: Kurt Heiss

Contributors: Priya Darshane, Sanjay Singh, Francisco Abedrabbo, Santosh Poonen, Marilyn Hollinger, Pavana Jain, Beth Roeser, Larry Aydlett, Tony Quan, Valarie Moore

The Programs (which include both the software and documentation) contain proprietary information of Oracle Corporation; they are provided under a license agreement containing restrictions on use and disclosure and are also protected by copyright, patent and other intellectual and industrial property laws. Reverse engineering, disassembly or decompilation of the Programs, except to the extent required to obtain interoperability with other independently created software or as specified by law, is prohibited.

The information contained in this document is subject to change without notice. If you find any problems in the documentation, please report them to us in writing. Oracle Corporation does not warrant that this document is error-free. Except as may be expressly permitted in your license agreement for these Programs, no part of these Programs may be reproduced or transmitted in any form or by any means, electronic or mechanical, for any purpose, without the express written permission of Oracle Corporation.

If the Programs are delivered to the U.S. Government or anyone licensing or using the programs on behalf of the U.S. Government, the following notice is applicable:

Restricted Rights Notice Programs delivered subject to the DOD FAR Supplement are "commercial computer software" and use, duplication, and disclosure of the Programs, including documentation, shall be subject to the licensing restrictions set forth in the applicable Oracle license agreement. Otherwise, Programs delivered subject to the Federal Acquisition Regulations are "restricted computer software" and use, duplication, and disclosure of the Programs shall be subject to the restrictions in FAR 52.227-19, Commercial Computer Software - Restricted Rights (June, 1987). Oracle Corporation, 500 Oracle Parkway, Redwood City, CA 94065.

The Programs are not intended for use in any nuclear, aviation, mass transit, medical, or other inherently dangerous applications. It shall be the licensee's responsibility to take all appropriate fail-safe, backup, redundancy, and other measures to ensure the safe use of such applications if the Programs are used for such purposes, and Oracle Corporation disclaims liability for any damages caused by such use of the Programs.

Oracle is a registered trademark, and Oracle*MetaLink*, Oracle Store, Oracle9i, Oracle9iAS Discoverer, SQL*Plus, and PL/SQL are trademarks or registered trademarks of Oracle Corporation. Other names may be trademarks of their respective owners.

Perspective for Java licensed from Three D Graphics, Inc. Copyright © 2000, 2002, Three D. Graphics, Inc.

Contents

Send Us Your Comments	vii
Preface.....	ix
Audience	x
Organization.....	x
Related Documentation	xi
Conventions.....	xi
Documentation Accessibility	xiv
1 Installation Concepts	
1.1 Oracle9iAS 9.0.3 Installation Overview	1-2
1.2 Using an Oracle9iAS Infrastructure 9.0.2.....	1-4
1.2.1 Oracle9iAS Infrastructure 9.0.2	1-4
1.2.2 Farm	1-6
1.2.3 Clustering	1-7
1.3 Deployment Topologies	1-10
1.3.1 Oracle9iAS 9.0.3 Installation.....	1-10
1.3.2 Oracle9iAS 9.0.3 with Oracle9iAS Infrastructure 9.0.2	1-11
1.3.3 Multiple Instances of Oracle9iAS 9.0.3 with Oracle9iAS Infrastructure 9.0.2.....	1-12
1.4 Additional Products.....	1-14
1.4.1 Oracle9iAS TopLink.....	1-14
1.4.2 Oracle9iAS Portal Developer Kit for J2EE and Web Services.....	1-14

2 Getting Started

2.1	Preinstallation Summary	2-2
2.2	Hardware Requirements	2-3
2.2.1	Network Requirements	2-4
2.3	Operating System Requirements.....	2-5
2.3.1	Font Package for Java Requirement.....	2-6
2.4	Certified Software.....	2-6
2.5	Preinstallation Tasks	2-6
2.5.1	Release Notes	2-6
2.5.2	Creating UNIX Accounts and Groups	2-7
2.5.3	Setting Environment Variables.....	2-8
2.5.4	Host Name File Configuration	2-14
2.5.5	Port Allocation	2-16
2.6	Oracle Universal Installer	2-17
2.6.1	About Oracle Universal Installer	2-17
2.6.2	Oracle Universal Installer Prerequisite Checks.....	2-18
2.6.3	Oracle Universal Installer oraInventory Directory.....	2-19
2.6.4	Starting Oracle Universal Installer.....	2-19
2.7	Installation	2-22
2.7.1	Installation Sequence	2-22
2.7.2	Installation Considerations	2-25
2.7.3	Additional Oracle ⁹ⁱ AS 9.0.3 Installations	2-26

3 Installation

3.1	Installation	3-2
3.2	Postinstallation.....	3-28
3.2.1	Installing the Oracle ⁹ⁱ Application Server 9.0.2.1 Patch.....	3-28
3.2.2	About the Oracle Enterprise Manager Web Site.....	3-29
3.2.3	Associating an Instance with an Infrastructure (Joining a Farm)	3-29
3.2.4	Component Dependent Configuration	3-29
3.2.5	Configuring Additional Components	3-29
3.2.6	Multi-User Installations.....	3-30
3.2.7	Postinstallation Configuration Tasks	3-31

3.2.8	Starting and Stopping Components	3-31
3.2.9	Component Port Numbers.....	3-32
3.2.10	Changing the X Server Display	3-33
3.2.11	Oracle9iAS 9.0.3 Demonstration Software	3-33
3.2.12	Oracle9iAS TopLink.....	3-33
3.2.13	Oracle9iAS Portal Developer Kit for J2EE and Web Services.....	3-34
3.2.14	Additional Oracle9iAS 9.0.3 Installations.....	3-34
3.2.15	Additional Documentation.....	3-34

4 Silent and Non-Interactive Installation

4.1	Introduction.....	4-2
4.1.1	Silent Installation.....	4-2
4.1.2	Non-Interactive Installation.....	4-3
4.2	Requirements	4-3
4.3	Preinstallation	4-4
4.4	Create the Response File.....	4-5
4.4.1	Oracle9iAS 9.0.3 Without Oracle9iAS Single Sign-On.....	4-6
4.4.2	Oracle9iAS 9.0.3 With Oracle9iAS Single Sign-On.....	4-7
4.5	Start the Installation	4-8
4.6	Postinstallation.....	4-9
4.6.1	Oracle9iAS 9.0.3 without Oracle9iAS Single Sign-On	4-10
4.6.2	Oracle9iAS 9.0.3 with Oracle9iAS Single Sign-On	4-11
4.7	Response File Parameter Definitions.....	4-12

5 Deinstallation and Reinstallation

5.1	Deinstallation	5-2
5.1.1	Deinstalling an Oracle9iAS 9.0.3 Instance	5-3
5.1.2	Deinstalling by Manually Removing All Oracle Products.....	5-7
5.2	Reinstallation.....	5-8

A Default Port Numbers and Port Ranges

A.1	Oracle9iAS 9.0.3 Port Usage (Sorted by Component)	A-2
A.2	Oracle9iAS 9.0.3 Port Usage (Sorted by Port Number)	A-4

B Troubleshooting

B.1	Troubleshooting the Installation	B-2
B.1.1	Verify Hardware and Preinstallation Requirements	B-2
B.1.2	What to Do If An Installation Error Occurs.....	B-4
B.2	Troubleshooting Oracle9iAS Configuration Assistants.....	B-5
B.2.1	Configuration Assistant Failure	B-5
B.2.2	Failure During Component Configuration and Startup.....	B-5
B.2.3	Fatal Errors	B-6
B.3	Descriptions of Oracle9iAS Configuration Assistants	B-7
B.3.1	BC4J Configuration Assistant	B-8
B.3.2	Clickstream Collector Agent Configuration Assistant	B-9
B.3.3	DCM Repository Backup Assistant	B-10
B.3.4	Enterprise Manager Web site Configuration Assistant	B-11
B.3.5	HTTP Server Configuration Assistant.....	B-12
B.3.6	Infrastructure Use Configuration Assistant	B-13
B.3.7	Java Security Configuration Assistant	B-14
B.3.8	OC4J Configuration Assistant	B-15
B.3.9	OC4J Instance Configuration Assistant.....	B-16
B.3.10	OPMN Configuration Assistant.....	B-18
B.3.11	Oracle9iAS Instance Configuration Assistant.....	B-19
B.3.12	Oracle9iAS Web Cache Configuration Assistant.....	B-20

Index

Send Us Your Comments

Oracle9i Application Server Installation Guide, Release 2 (9.0.3) for Solaris Operating System (SPARC)

Part No. B10014-01

Oracle Corporation welcomes your comments and suggestions on the quality and usefulness of this document. Your input is an important part of the information used for revision.

- Did you find any errors?
- Is the information clearly presented?
- Do you need more information? If so, where?
- Are the examples correct? Do you need more examples?
- What features did you like most?

If you find any errors or have any other suggestions for improvement, please indicate the document title and part number, and the chapter, section, and page number (if available). You can send comments to us in the following ways:

- Electronic mail: iasdocs_us@oracle.com
- FAX: 650-506-7407 Attn: Oracle9i Application Server Documentation Manager
- Postal service:
Oracle Corporation
Oracle9i Application Server Documentation
500 Oracle Parkway, M/S 2op3
Redwood Shores, CA 94065
USA

If you would like a reply, please give your name, address, telephone number, and (optionally) electronic mail address.

If you have problems with the software, please contact your local Oracle Support Services.

Preface

This guide describes the installation process for Oracle*9i* Application Server Release 2 (9.0.3) (Oracle*9iAS* 9.0.3).

This preface contains these topics:

- [Audience](#)
- [Organization](#)
- [Related Documentation](#)
- [Conventions](#)
- [Documentation Accessibility](#)

Audience

This installation guide is intended for database administrators and others responsible for installing Oracle products. You should be familiar with client/server relationships and database concepts.

Organization

This document contains:

Chapter 1, "Installation Concepts"

This chapter provides installation and configuring concepts for Oracle9iAS 9.0.3.

Chapter 2, "Getting Started"

This chapter provides information about hardware and software requirements, online documentation requirements, and preinstallation tasks for installation of Oracle9iAS 9.0.3.

Chapter 3, "Installation"

This chapter guides you through the installation and postinstallation steps for Oracle9iAS 9.0.3.

Chapter 4, "Silent and Non-Interactive Installation"

This chapter guides you through Silent and Non-Interactive installation steps for Oracle9iAS 9.0.3.

Chapter 5, "Deinstallation and Reinstallation"

This chapter guides you through the deinstallation and reinstallation steps for Oracle9iAS 9.0.3.

Appendix A, "Default Port Numbers and Port Ranges"

This appendix lists the port numbers used by Oracle9iAS 9.0.3 components.

Appendix B, "Troubleshooting"

This appendix lists some methods for troubleshooting your Oracle9i Application Server Release 2 (9.0.3) (Oracle9iAS 9.0.3) installation.

Related Documentation

For more information, see these Oracle resources:

- Oracle9iAS Platform Specific Documentation on Oracle9iAS Disk 1
- Oracle9iAS Installation Frequently Asked Questions at:
<http://otn.oracle.com/products/ias/1>

Printed documentation is available for sale in the Oracle Store at

<http://oraclestore.oracle.com>

To download free release notes, installation documentation, white papers, or other collateral, please visit the Oracle Technology Network (OTN). You must register online before using OTN; registration is free and can be done at

<http://otn.oracle.com/membership>

If you already have a username and password for OTN, then you can go directly to the documentation section of the OTN Web site at

<http://otn.oracle.com/docs>

Conventions

This section describes the conventions used in the text and code examples of this documentation set. It describes:

- [Conventions in Text](#)
- [Conventions in Code Examples](#)

Conventions in Text

We use various conventions in text to help you more quickly identify special terms. The following table describes those conventions and provides examples of their use.

Convention	Meaning	Example
Bold	Bold typeface indicates terms that are defined in the text or terms that appear in a glossary, or both.	When you specify this clause, you create an index-organized table .

Convention	Meaning	Example
<i>Italics</i>	Italic typeface indicates book titles or emphasis.	<i>Oracle9i Concepts</i> Ensure that the recovery catalog and target database do <i>not</i> reside on the same disk.
UPPERCASE monospace (fixed-width font)	Uppercase monospace typeface indicates elements supplied by the system. Such elements include parameters, privileges, datatypes, RMAN keywords, SQL keywords, SQL*Plus or utility commands, packages and methods, as well as system-supplied column names, database objects and structures, usernames, and roles.	You can specify this clause only for a NUMBER column. You can back up the database by using the BACKUP command. Query the TABLE_NAME column in the USER_TABLES data dictionary view. Use the DBMS_STATS.GENERATE_STATS procedure.
lowercase monospace (fixed-width font)	Lowercase monospace typeface indicates executables, filenames, directory names, and sample user-supplied elements. Such elements include computer and database names, net service names, and connect identifiers, as well as user-supplied database objects and structures, column names, packages and classes, usernames and roles, program units, and parameter values. Note: Some programmatic elements use a mixture of UPPERCASE and lowercase. Enter these elements as shown.	Enter sqlplus to open SQL*Plus. The password is specified in the orapwd file. Back up the datafiles and control files in the /disk1/oracle/dbs directory. The department_id, department_name, and location_id columns are in the hr.departments table. Set the QUERY_REWRITE_ENABLED initialization parameter to true. Connect as oe user. The JRepUtil class implements these methods.
<i>lowercase monospace (fixed-width font) italic</i>	Lowercase monospace italic font represents placeholders or variables.	You can specify the <i>parallel_clause</i> . Run <i>Uold_release</i> .SQL where <i>old_release</i> refers to the release you installed prior to upgrading.

Conventions in Code Examples

Code examples illustrate SQL, PL/SQL, SQL*Plus, or other command-line statements. They are displayed in a monospace (fixed-width) font and separated from normal text as shown in this example:

```
SELECT username FROM dba_users WHERE username = 'MIGRATE';
```

The following table describes typographic conventions used in code examples and provides examples of their use.

Convention	Meaning	Example
[]	Brackets enclose one or more optional items. Do not enter the brackets.	DECIMAL (<i>digits</i> [, <i>precision</i>])
{ }	Braces enclose two or more items, one of which is required. Do not enter the braces.	{ENABLE DISABLE}
	A vertical bar represents a choice of two or more options within brackets or braces. Enter one of the options. Do not enter the vertical bar.	{ENABLE DISABLE} [COMPRESS NOCOMPRESS]
...	Horizontal ellipsis points indicate either: <ul style="list-style-type: none"> ■ That we have omitted parts of the code that are not directly related to the example ■ That you can repeat a portion of the code 	CREATE TABLE ... AS <i>subquery</i> ; SELECT <i>col1</i> , <i>col2</i> , ... , <i>coln</i> FROM employees;
.	Vertical ellipsis points indicate that we have omitted several lines of code not directly related to the example.	
Other notation	You must enter symbols other than brackets, braces, vertical bars, and ellipsis points as shown.	acctbal NUMBER(11,2); acct CONSTANT NUMBER(4) := 3;
<i>Italics</i>	Italicized text indicates placeholders or variables for which you must supply particular values.	CONNECT SYSTEM/ <i>system_password</i> DB_NAME = <i>database_name</i>
UPPERCASE	Uppercase typeface indicates elements supplied by the system. We show these terms in uppercase in order to distinguish them from terms you define. Unless terms appear in brackets, enter them in the order and with the spelling shown. However, because these terms are not case sensitive, you can enter them in lowercase.	SELECT last_name, employee_id FROM employees; SELECT * FROM USER_TABLES; DROP TABLE hr.employees;

Convention	Meaning	Example
lowercase	<p>Lowercase typeface indicates programmatic elements that you supply. For example, lowercase indicates names of tables, columns, or files.</p> <p>Note: Some programmatic elements use a mixture of UPPERCASE and lowercase. Enter these elements as shown.</p>	<pre>SELECT last_name, employee_id FROM employees; sqlplus hr/hr CREATE USER mjones IDENTIFIED BY ty3MU9;</pre>

Documentation Accessibility

Our goal is to make Oracle products, services, and supporting documentation accessible, with good usability, to the disabled community. To that end, our documentation includes features that make information available to users of assistive technology. This documentation is available in HTML format, and contains markup to facilitate access by the disabled community. Standards will continue to evolve over time, and Oracle Corporation is actively engaged with other market-leading technology vendors to address technical obstacles so that our documentation can be accessible to all of our customers. For additional information, visit the Oracle Accessibility Program Web site at:

<http://www.oracle.com/accessibility/>

Accessibility of Links to External Web Sites in Documentation

This documentation may contain links to Web sites of other companies or organizations that Oracle Corporation does not own or control. Oracle Corporation neither evaluates nor makes any representations regarding the accessibility of these Web sites.

Installation Concepts

This chapter discusses the installation concepts for Oracle*9i* Application Server Release 2 (9.0.3) (Oracle*9iAS* 9.0.3). Oracle recommends reading this chapter before proceeding with your installation to gain a better understanding of the concepts and intent of the installation. This chapter covers the following topics:

- [Oracle*9iAS* 9.0.3 Installation Overview](#)
- [Using an Oracle*9iAS* Infrastructure 9.0.2](#)
- [Deployment Topologies](#)
- [Additional Products](#)

See also: *Oracle*9i* Application Server Concepts Guide*

Note: Oracle*9iAS* 9.0.3 contains only the J2EE and Web Cache install type of Oracle*9iAS* Release 2

1.1 Oracle9iAS 9.0.3 Installation Overview

The Oracle9iAS 9.0.3 installation creates a scalable, secure, and integrated middle-tier platform that enables you to deliver Web content, host Web applications, and connect to back-office applications. Oracle9iAS 9.0.3 provides a container that enables you to develop and deploy Java2 Enterprise Edition (J2EE) 1.3 compatible applications, develop and deploy Web services, and accelerate Web site performance with Oracle9iAS Web Cache.

Oracle9iAS 9.0.3 is the first J2EE 1.3 compatible release of Oracle9iAS. You can use this release to build and deploy applications that take advantage of the latest J2EE 1.3 features.

Oracle9iAS 9.0.3 includes the following Oracle9iAS components:

- **Oracle9iAS Web Cache:** Oracle9iAS Web Cache is a server accelerator caching service that improves the performance, scalability, and availability of frequently used e-business Web sites that run on either Oracle9iAS or other application servers. By storing frequently accessed pages in virtual memory, Oracle9iAS Web Cache eliminates the need to repeatedly process requests for those pages on the Web server, and it caches both static and dynamically-generated HTTP content from one or more Web applications.
- **Oracle HTTP Server:** Oracle HTTP Server (OHS), which is built on Apache Web server technology, offers scalability, stability, speed, and extensibility to your Web applications. Oracle HTTP Server supports Java Servlets, JavaServer Pages (JSPs), Perl, PL/SQL, and CGI applications.
- **Oracle9iAS Containers for J2EE:** Oracle9iAS Containers for J2EE (OC4J) provides a complete set of J2EE containers written entirely in Java that execute on the Java Virtual Machine (JVM) of the standard Java Development Kit (JDK). OC4J provides a complete J2EE environment that includes a JSP translator and runtime, a servlet engine, an Enterprise JavaBeans (EJB) container, and the rest of the J2EE services such as Java Database Connectivity (JDBC).
- **Oracle Enterprise Manager Web site:** The Oracle Enterprise Manager Web site provides Web-based management tools. Using this Web site and its Oracle9iAS Home Pages, you can monitor and configure the components of your Oracle9iAS installations. You can deploy applications, manage security, and create and manage application server clusters.

Oracle9iAS 9.0.3 is compatible with Oracle9iAS Infrastructure 9.0.2 for clustering, management, and security. It can also coexist with Oracle9iAS 9.0.2 middle-tiers installed on the same or a different machine.

Note: Oracle9iAS 9.0.3 cannot be used to run any of the Oracle9iAS 9.0.2 mid-tier install types. For example, you cannot run Oracle9iAS Portal, Oracle9iAS Forms Services, or Oracle9iAS Discoverer on top of Oracle9iAS 9.0.3.

See Also: [Section 1.4.2, "Oracle9iAS Portal Developer Kit for J2EE and Web Services"](#) for information about building J2EE portlets with your installation of Oracle9iAS 9.0.3.

During Oracle9iAS 9.0.3 installation, all components delivered in the J2EE and Web Cache install type are installed on your computer. However, you can selectively enable the Oracle9iAS 9.0.3 components you wish to use. You can configure Oracle9iAS 9.0.3 components during the install session, or you can use the Oracle Enterprise Manager Web site to complete the Oracle9iAS 9.0.3 component configuration later, after the initial install.

See Also:

- [Chapter 2, "Getting Started"](#)
- [Chapter 3, "Installation"](#)

1.2 Using an Oracle9iAS Infrastructure 9.0.2

During the Oracle9iAS 9.0.3 installation, you will be asked if you want to use single sign-on or clustering. If you want to use either single sign-on or cluster management, then you must use Oracle9iAS Infrastructure 9.0.2. Oracle9iAS 9.0.3 is compatible with Oracle9iAS Infrastructure 9.0.2. This section features the following topics:

- [Oracle9iAS Infrastructure 9.0.2](#)
- [Farm](#)
- [Clustering](#)

1.2.1 Oracle9iAS Infrastructure 9.0.2

The Oracle9iAS Infrastructure 9.0.2 is a type of application server installation that provides centralized security, management services, and data repositories for middle-tier application server installations. Typically, there is one infrastructure in an application server enterprise, and all middle-tier application servers are configured to use it.

An infrastructure is custom-tuned and configured to support middle-tier application server installations. Many of the services provided by an infrastructure are configured automatically during installation and used programmatically by middle-tier application servers.

Oracle9iAS Infrastructure 9.0.2 includes software for the following:

- Management, security, and directory services
- Metadata repository to store product metadata

You can install Oracle9iAS 9.0.3 on the same or a different host from Oracle9iAS Infrastructure 9.0.2:

- If you are installing Oracle9iAS 9.0.3 on the same or a different host as Oracle9iAS Infrastructure 9.0.2, then you can associate Oracle9iAS 9.0.3 with the infrastructure during, or after the Oracle9iAS 9.0.3 installation.
- If you are installing Oracle9iAS 9.0.3 on a host that has an Oracle9iAS 9.0.3 or Oracle9iAS 9.0.2 instance that is associated with an Oracle9iAS Infrastructure 9.0.2, then the new Oracle9iAS 9.0.3 install associates with the same infrastructure.

Note: Oracle recommends installing Oracle9iAS Infrastructure 9.0.2 on a separate computer for optimal performance.

See Also:

- *Oracle9i Application Server 9.0.2 Installation Guide*
- *Oracle9i Application Server Administrator's Guide*
- *Oracle9iAS Single Sign-On Administrator's Guide*
- *Oracle9i Application Server Security Guide*

1.2.2 Farm

A farm is a set of application server instances associated with the same infrastructure. The application server instances that belong to a farm can be installed anywhere on the network. A farm can consist of a heterogeneous collection of Oracle9iAS 9.0.3 and Oracle9iAS 9.0.2 instances or clusters. It is only within the constraint of a farm that you can create a cluster. All application server instances in a cluster must be either Oracle9iAS 9.0.3 or Oracle9iAS 9.0.2. You cannot create a cluster that consists of J2EE and Web Cache 9.0.3 instances with J2EE and Web Cache 9.0.2 instances.

See Also: *Oracle9i Application Server Administrator's Guide*

1.2.3 Clustering

A cluster is a set of application server instances configured to act in concert to deliver greater scalability and availability than a single instance can provide. While a single application server instance can only leverage the operating resources of a single host, a cluster can span multiple hosts, distributing application execution over a greater number of CPUs. While a single application server instance is vulnerable to the failure of its host and operating system, a cluster continues to function despite the loss of an operating system or host, hiding any such failure from clients.

Clusters leverage the combined power and reliability of multiple application server instances while maintaining the simplicity of a single application server instance. For example, browser clients of applications running in a cluster interact with the application as if it were running on a single server. The client has no knowledge of whether the application is running on a single application server or in an application server cluster. From the management perspective, an application server administrator can perform operations on a cluster as if the administrator was interacting with a single server. An administrator can deploy an application to an individual server; the application is propagated automatically to all application server instances in the cluster.

All Oracle9iAS 9.0.3 components in a managed cluster share the same infrastructure management, security, and directory service as well as the same metadata repository to store product metadata.

You can also create non-managed application server clusters by not associating the cluster with an infrastructure. A non-managed application server cluster does not require a metadata repository and therefore has no database dependency. Non-managed clusters provide scalability and availability, but *not* manageability. In a non-managed cluster, it is the administrator's responsibility to synchronize the configuration of the application server instances.

See Also: *Oracle9i Application Server Administrator's Guide*

All application server instances in a single cluster must be homogeneous: the instances must be from either Oracle9iAS 9.0.3 or Oracle9iAS 9.0.2. You cannot create a cluster that consists of J2EE and Web Cache 9.0.3 instances with J2EE and Web Cache 9.0.2 instances. The J2EE and Web Cache instances in an application server cluster can be on different hosts, however, all J2EE and Web Cache instances in a single cluster must reside on hosts that use the same operating system type (for example, Linux). This is because the configuration information that is shared between instances in a cluster contains operating system-specific information, such as file path names.

Figure 1–1 shows an overview of the architecture of Oracle9iAS 9.0.3 and Oracle9iAS Infrastructure 9.0.2. The figure shows a stand-alone instance of J2EE and Web Cache on Host 1 and the two instances of a J2EE and Web Cache cluster on Host 2 using an Oracle9iAS Infrastructure 9.0.2. The J2EE and Web Cache instances on Host 1 and Host 2 can be either Oracle9iAS 9.0.3 or Oracle9iAS 9.0.2. If you are creating a cluster, then the two instances of J2EE and Web Cache on Host 2 must both be of the same version: either Oracle9iAS 9.0.3 or Oracle9iAS 9.0.2.

Clustering, using Oracle9iAS 9.0.3 and Oracle9iAS 9.0.2 instances, has the following properties:

- A cluster can contain only J2EE and Web Cache instances.
- A cluster manages only OHS and OC4J within a J2EE and Web Cache instance.
- All members of a cluster must be part of the same farm and share the same infrastructure.
- All application server instances in a cluster must be either Oracle9iAS 9.0.3 or Oracle9iAS 9.0.2. You cannot create a cluster that consists of J2EE and Web Cache 9.0.3 instances with J2EE and Web Cache 9.0.2 instances.
- Application server instances in a single cluster must reside on hosts that use the same operating system type (for example, Linux).

Figure 1–1 Oracle9iAS 9.0.3 and Oracle9iAS Infrastructure 9.0.2 Architecture

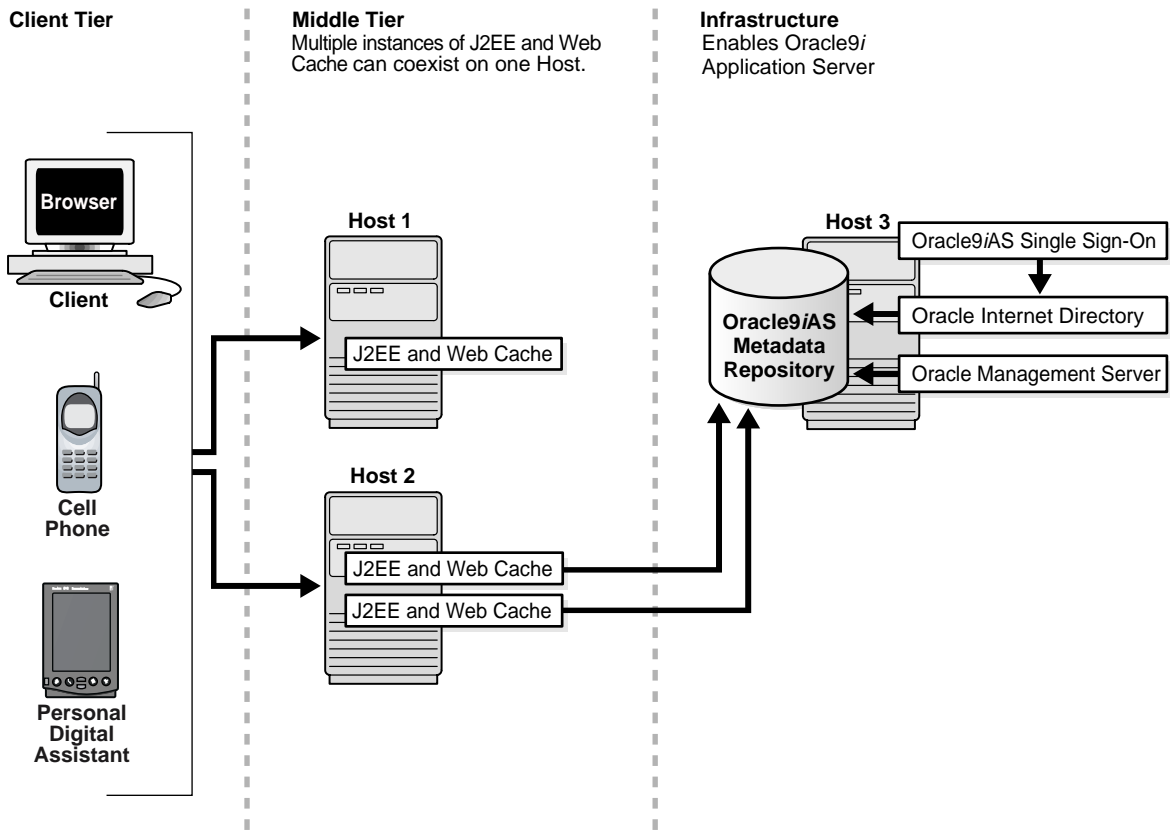

See Also:

- *Oracle9i Application Server 9.0.2 Installation Guide*
- *Oracle9i Application Server Administrator's Guide*
- *Oracle9iAS Single Sign-On Administrator's Guide*
- *Oracle9iAS Containers for J2EE User's Guide*

1.3 Deployment Topologies

The following sections describe possible installations of Oracle9iAS 9.0.3:

- [Oracle9iAS 9.0.3 Installation](#)
- [Oracle9iAS 9.0.3 with Oracle9iAS Infrastructure 9.0.2](#)
- [Multiple Instances of Oracle9iAS 9.0.3 with Oracle9iAS Infrastructure 9.0.2](#)

1.3.1 Oracle9iAS 9.0.3 Installation

[Figure 1–2](#) shows an installation of Oracle9iAS 9.0.3 J2EE and Web Cache on a host. This topology supports a Web server that supports the deployment of J2EE 1.3 compliant applications and cache Web pages. It also supports single server management. The topology shown *does not* support centralized management, single sign-on, or application server clustering functionality. In order to use single sign-on or managed cluster functionality you must install an Oracle9iAS Infrastructure 9.0.2.

Figure 1–2 Oracle9iAS 9.0.3 Installation

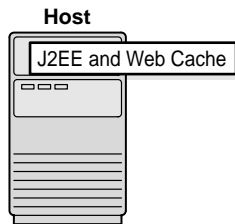

See Also: [Figure 1–3, "Oracle9iAS 9.0.3 with Oracle9iAS Infrastructure 9.0.2"](#)

1.3.2 Oracle9iAS 9.0.3 with Oracle9iAS Infrastructure 9.0.2

You can install Oracle9iAS 9.0.3 on the same or a different host from Oracle9iAS Infrastructure 9.0.2. Oracle recommends installing Oracle9iAS Infrastructure 9.0.2 on a separate computer for optimal performance.

- If you are installing Oracle9iAS 9.0.3 on the same or a different host as Oracle9iAS Infrastructure 9.0.2, then you can associate Oracle9iAS 9.0.3 with the infrastructure during, or after the Oracle9iAS 9.0.3 installation.
- If you are installing Oracle9iAS 9.0.3 on a host that has an Oracle9iAS 9.0.3 or Oracle9iAS 9.0.2 instance that is associated with an Oracle9iAS Infrastructure 9.0.2, then the new Oracle9iAS 9.0.3 install associates with the same infrastructure.

Figure 1–3 shows an installation of Oracle9iAS 9.0.3 using Oracle9iAS Infrastructure 9.0.2. The installation of Oracle9iAS 9.0.3 is on a different host from the Oracle9iAS Infrastructure 9.0.2 installation. The Oracle9iAS Infrastructure 9.0.2 installation enables deployment of applications that use enterprise-wide single sign-on capabilities, as well as management of application server instance clusters.

See Also: *Oracle9i Application Server 9.0.2 Installation Guide*

Figure 1–3 Oracle9iAS 9.0.3 with Oracle9iAS Infrastructure 9.0.2

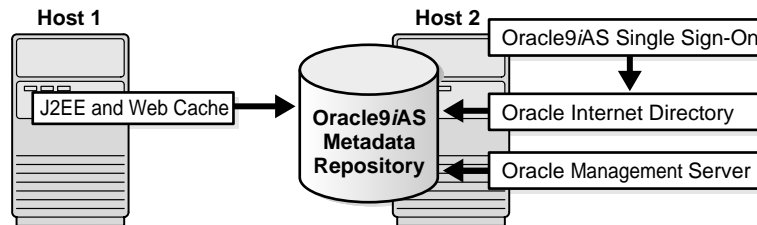

1.3.3 Multiple Instances of Oracle9iAS 9.0.3 with Oracle9iAS Infrastructure 9.0.2

You can install single or multiple instances of Oracle9iAS 9.0.3 on the same host.

Figure 1–4 shows instances of J2EE and Web Cache installed on Host 1 and Host 2, using the installation of Oracle9iAS Infrastructure 9.0.2 on Host 3.

Figure 1–4 Multiple Instances of Oracle9iAS 9.0.3 with Oracle9iAS Infrastructure 9.0.2

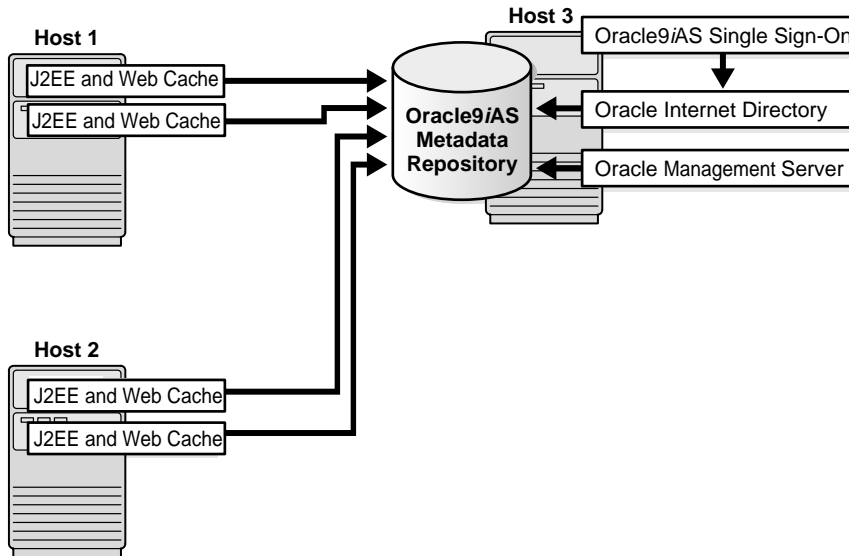

The two instances of J2EE and Web Cache on Host 1 and Host 2 can be either Oracle9iAS 9.0.3 or Oracle9iAS 9.0.2.

If you want to create an application server cluster, then the two instances of J2EE and Web Cache on Host 1 and Host 2 must all be the same version; either Oracle9iAS 9.0.3 or Oracle9iAS 9.0.2. You cannot create a cluster that consists of J2EE and Web Cache 9.0.3 instances and J2EE and Web Cache 9.0.2 instances. The J2EE and Web Cache instances in an application server cluster can be on different hosts, however, all J2EE and Web Cache instances in a single cluster must reside on hosts that use the same operating system type (for example, Linux).

You can create a farm using application server instances. A farm is a group of multiple application server instances that associate with the same metadata repository. The farm can consist of a collection of Oracle9iAS 9.0.3 or Oracle9iAS 9.0.2 instances.

See Also: *Oracle9i Application Server Administrator's Guide*

1.4 Additional Products

The following sections describe additional Oracle9iAS products that can be used with your installation of Oracle9iAS 9.0.3:

- [Oracle9iAS TopLink](#)
- [Oracle9iAS Portal Developer Kit for J2EE and Web Services](#)

1.4.1 Oracle9iAS TopLink

Oracle9iAS TopLink enables you to map a Java object model to a relational database and non-relational data sources. This bridges the gap between objects and the relations that exist among them and relational databases. Objects are a very flexible way of storing data and relationships between data, so representing objects in a relational database can be complicated. Oracle9iAS TopLink is supported by Oracle9iAS 9.0.3 and Oracle9iAS 9.0.2. Oracle9iAS TopLink is available in the Oracle9iAS CD pack. Refer to the Oracle9iAS TopLink CD for more information.

1.4.2 Oracle9iAS Portal Developer Kit for J2EE and Web Services

The Oracle9iAS Portal Developer Kit for J2EE and Web Services (9.0.2.0.2) can be used to develop portlets based upon J2EE 1.3 applications running in Oracle9iAS 9.0.3. You can also develop portlets from available Web Services. These portlets can be registered with an Oracle9iAS Portal 9.0.2 environment. The Oracle9iAS Portal Developer Kit for J2EE and Web Services is available for download from

<http://portalstudio.oracle.com>.

Getting Started

This chapter provides information about how to start installing Oracle9i Application Server Release 2 (9.0.3) (Oracle9iAS 9.0.3). The topics include:

- [Preinstallation Summary](#)
- [Hardware Requirements](#)
- [Operating System Requirements](#)
- [Certified Software](#)
- [Preinstallation Tasks](#)
- [Oracle Universal Installer](#)
- [Installation](#)

2.1 Preinstallation Summary

Review and verify that you have completed the items listed on the following preinstallation summary before you begin your installation of Oracle9iAS 9.0.3.

Table 2–1 Oracle9iAS 9.0.3 Preinstallation Summary

Preinstallation Task	Details
Hardware Requirements	<ul style="list-style-type: none">■ Table 2–2, "Oracle9iAS 9.0.3 Hardware Requirements"■ Table 2–3, "Oracle9iAS 9.0.3 Requirements and Recommendation"
Operating System Requirements	<ul style="list-style-type: none">■ Section 2.3, "Operating System Requirements"■ Table 2–4, "Solaris Operating System and Required Patches"■ Section 2.3.1, "Font Package for Java Requirement"
Certified Software	<ul style="list-style-type: none">■ http://metalink.oracle.com
Preinstallation Tasks	<ul style="list-style-type: none">■ Section 2.5.1, "Release Notes"■ Section 2.5.2, "Creating UNIX Accounts and Groups"■ Section 2.5.3, "Setting Environment Variables"■ Section 2.5.4, "Host Name File Configuration"■ Section 2.5.5, "Port Allocation"

2.2 Hardware Requirements

Table 2–2 shows the hardware requirements for installing Oracle9iAS 9.0.3.

Table 2–3 shows the minimal installation requirements and recommendations for production environments. While considering hardware configurations, note that optimal sizing for an Oracle9iAS 9.0.3 installation depends on:

- the profile of your Oracle9iAS 9.0.3 installation (which Oracle9iAS 9.0.3 components are configured and used)
- the size of your applications
- the nature of your applications (largely transactional in nature or primarily read-only)
- user load (number of concurrent users)
- pattern of usage (peak usage or low usage)
- throughput and response time goals

Increasing the amount of hardware resources can improve the performance of your Oracle9iAS 9.0.3 installation and the number of supported concurrent users.

See Also: *Oracle9i Application Server Performance Guide*

Table 2–2 Oracle9iAS 9.0.3 Hardware Requirements

Information	Requirements
CPU ¹	A SPARC Processor
Disk Space	457MB
TMP or Swap Space	256 MB
/var/tmp Space	200 MB
Monitor	256 color display ²

¹ Oracle recommends a multiple CPU computer.

² Oracle Universal Installer fails to appear if the display is set to 16 colors. Oracle Universal Installer uses Java Runtime Environment (JRE) 1.3.1 which supports display drivers with 256 colors or more.

Table 2–3 Oracle9iAS 9.0.3 Requirements and Recommendation

Information	Minimum Installation Requirement	Production Environment Recommendations
Memory	256 MB ¹	512 MB or greater
TMP or Swap Space	256 MB	1 GB or greater

¹ Memory for Oracle9iAS Web Cache should be based on the following formula: (average HTTP object size) * (maximum number of objects you want to cache). Thus, if you want to cache 1,000,000 objects and the average size of the objects is 2 KB, then set the maximum cache size to at least 2 GB.

2.2.1 Network Requirements

Oracle9iAS 9.0.3 does not support the following network configurations and scenarios:

- Changing the domain after installation.
- Using Network File System (NFS) to access and share files.

2.3 Operating System Requirements

Oracle certifies Oracle*9iAS* 9.0.3 to install and run on the following operating systems:

- [Solaris 2.6](#)
- [Solaris 7](#)
- [Solaris 8](#)

[Table 2–4](#) lists the Solaris Operating System patches you need to download and install before installing Oracle*9iAS* 9.0.3. You can download the patches from:

<http://sunsolve.sun.com>

Table 2–4 Solaris Operating System and Required Patches

Operating System	Version
Solaris 2.6	<ul style="list-style-type: none"> ■ The latest Solaris 2.6 recommended patch cluster ■ 106409-01 or higher¹: Chinese TrueType fonts ■ 108091-03 or higher²: SunOS 5.6: ssJDK1.2.1_03 fails with fatal errors in ISO8859-01 Locales ■ 106842-09 or higher: Euro support patch ■ 106841-01 or higher: Euro support patch
Solaris 7	<ul style="list-style-type: none"> ■ The latest Solaris 2.7 recommended patch cluster ■ 107226-18 or higher: CDE Windows manager patch ■ 107153-01 or higher: patch for replacing bad font in zh.GBK locale
Solaris 8	<ul style="list-style-type: none"> ■ The latest Solaris 2.8 recommended patch cluster ■ 108921-14 or higher: CDE dtwm patch ■ 108940-41 or higher: Motif 2.1 patch

¹ This patch is only required to display Traditional Chinese characters in Swing applications.

² This patch is only required for any locale that uses the ISO8859-1 or ISO8859-15 character encoding.

2.3.1 Font Package for Java Requirement

You may need different character settings for different locales. For Solaris Font Packages for Java, you always need both SUNWilof and SUNWxwfont packages for all locales. You may need additional font packages depending on your locale. For detailed list of Solaris Font Packages, refer to:

<http://java.sun.com/j2se/1.3/font-requirements.html>

2.4 Certified Software

Installing and operating Oracle9iAS 9.0.3 requires a Web browser. A complete list of certified software for Oracle9iAS 9.0.3 is located at the Oracle*MetaLink* site:

<http://metalink.oracle.com>

2.5 Preinstallation Tasks

Review and complete the following preinstallation tasks before installing Oracle9iAS 9.0.3:

- [Release Notes](#)
- [Creating UNIX Accounts and Groups](#)
- [Setting Environment Variables](#)
- [Host Name File Configuration](#)
- [Port Allocation](#)

2.5.1 Release Notes

Oracle recommends reading the *Oracle9i Application Server 9.0.3 Release Notes* prior to installing Oracle9iAS 9.0.3. *Oracle9i Application Server 9.0.3 Release Notes* are available with Oracle platform-specific documentation and are available at the OTN Web site at:

<http://otn.oracle.com/products/ias/content.html>

2.5.2 Creating UNIX Accounts and Groups

The following UNIX account and groups are required for the installation process:

- [UNIX Group Name for the Oracle Universal Installer Inventory](#)
- [UNIX Account to Own Oracle Software](#)

2.5.2.1 UNIX Group Name for the Oracle Universal Installer Inventory

Use the `admintool` or `groupadd` utility to create a group name. For example, `oinstall`. The `oinstall` group will own Oracle Universal Installer's `oraInventory` directory. The `oracle` user account that runs the installation must have the `oinstall` group as its primary group.

For more information on these utilities, refer to your operating system documentation.

2.5.2.2 UNIX Account to Own Oracle Software

The `oracle` account is the UNIX account that owns Oracle software for your system. You must run Oracle Universal Installer from this account.

Create an `oracle` account with the properties listed in [Table 2-5](#).

Table 2-5 Oracle Account Properties

Variable	Property
Login Name	Select any name to access the account. This document refers to the name as the <code>oracle</code> account.
Group Identifier	The <code>oinstall</code> group.
Home Directory	Select a home directory consistent with other user home directories.
Login Shell	The default shell can be either the C, Bourne, or Korn shell.

Note: Use the `oracle` account only for installing and maintaining Oracle software. Never use it for purposes unrelated to the Oracle Universal Installer. Do not use `root` as the `oracle` account.

2.5.3 Setting Environment Variables

Verify the requirements for the following environment variables before starting Oracle Universal Installer:

- [ORACLE_HOME](#)
- [DISPLAY](#)
- [TMP](#)
- [TNS_ADMIN](#)

Note: Make sure you have write access to the `/tmp`, `TEMP`, and `/var/tmp` directories on your system before you start the installation of Oracle9iAS 9.0.3.

2.5.3.1 ORACLE_HOME

Oracle home is the directory in which Oracle software is installed.

Oracle homes are identified by name. The Oracle home name identifies the program group associated with a specific Oracle home and the installed Oracle services associated with the home.

Your Oracle home name must not contain spaces and can not be longer than 127 characters.

Note: The Oracle9iAS 9.0.3 instance must be installed in its own Oracle home. For example, you cannot install Oracle9iAS 9.0.3 into an Oracle9iAS 9.0.2 Oracle home. The Oracle9iAS 9.0.3 instance can be installed on the same or a different host from Oracle9iAS Infrastructure 9.0.2.

Do not install Oracle9iAS 9.0.3 into any existing Oracle home directories. For example:

- Oracle9iAS 9.0.2 home directory
- Oracle9iAS Infrastructure 9.0.2 home directory
- Oracle9iAS Developer Kits 9.0.2 home directory
- Oracle9i Database home directory
- Oracle8i Database home directory
- Oracle9i Developer Suite directory

Note: Oracle9iAS 9.0.3 cannot be used to run any of the Oracle9iAS 9.0.2 mid-tier install types. For example, you cannot run Oracle9iAS Portal, Oracle9iAS Forms Services, or Oracle9iAS Discoverer on top of Oracle9iAS 9.0.3.

The Oracle9iAS 9.0.3 installation requires an instance name and an administrative password (for the `ias_admin` user) during initial installation on a host. The `ias_admin` user's password enables Oracle9iAS 9.0.3 instance management through the Oracle Enterprise Manager. If Oracle9iAS 9.0.3 or another Oracle9iAS product has already been installed on the host, then a unique instance name and the existing `ias_admin` user's password must be provided before continuing with the installation. An Oracle9iAS 9.0.3 installation in a *different* Oracle home on the same host requires a unique instance name and the existing `ias_admin` user's password before continuing with the installation.

See Also:

- [Section 2.2, "Hardware Requirements"](#)
- [Chapter 1, "Installation Concepts"](#)
- *Oracle9i Application Server Administrator's Guide*

2.5.3.2 DISPLAY

Set the `DISPLAY` environment variable to refer to the X Server that will display the installer. The format of the `DISPLAY` environment variable is:

```
hostname:display_number.screen_number
```

For example:

```
hostname:0.0
```

Oracle9iAS 9.0.3 requires a running X server to properly create graphics for the installer, Web applications, and management tools. The frame buffer X server installed with your operating system requires that you remain logged in and have the frame buffer running at all times. If you do not wish to do this, then you must use a virtual frame buffer, such as X Virtual Frame Buffer (XVFB) or Virtual Network Computing (VNC).

The installer configures this instance to use the same X server from the installation process for applications and management tools. This X server must either always be running or you must reconfigure Oracle9iAS 9.0.3 to use another X server that is always running after the installation completes.

Note: Oracle Applications users must read article 181244.1 at:

<http://metalink.oracle.com>

This article contains applications-specific X server requirements and configuration information.

See Also:

- Your operating system documentation for more information on the `DISPLAY` environment variable.
- Oracle Technology Network (<http://otn.oracle.com>) for further information about obtaining and installing XVFB or other virtual frame buffer solutions. Search OTN for "frame buffer".

2.5.3.2.1 Installing From a Remote Workstation

Setting the `DISPLAY` environment variable enables you to run the Oracle Universal Installer remotely from another workstation. On the system where you launch the Oracle Universal Installer, set `DISPLAY` to the system name or IP address of your local workstation.

Note: You can use a PC X emulator to run the install if it supports a PseudoColor color model or PseudoColor visual. Set the PC X emulator to use a PseudoColor visual, and then start the installer. Refer to the X emulator documentation for instructions on how to change the color model or visual settings.

If you get an Xlib error similar to "Failed to connect to server," "Connection refused by server," or "Can't open display" when starting the installer, then run the commands on your local workstations as listed in the table below.

Shell Types	On server where the installer is running	In session on your workstation
C shell	<code>prompt> setenv DISPLAY host:0.0¹</code>	<code>prompt> xhost +host</code>
Bourne or Korn shell	<code>prompt> DISPLAY=host:0.0;export DISPLAY</code>	<code>prompt> xhost +host</code>

¹ Host is the hostname or IP address of the workstation on which you want to display the installer.

2.5.3.3 TMP

During installation, Oracle Universal Installer uses a temporary directory for swap space. This directory must meet the requirements listed in [Section 2.2, "Hardware Requirements"](#) before installing Oracle9iAS 9.0.3. The installation may fail if you do not have sufficient space. The installer checks for the `TMP` environment variable to locate the temporary directory. If this environment variable does not exist, then the installer uses the `/tmp` directory. Set the `TMP` environment variable using the following command.

C shell	Bourne/Korn shell
<code>prompt> setenv TMP full_path</code>	<code>prompt> TMP=full_path; export TMP</code>

2.5.3.4 TNS_ADMIN

TNS_ADMIN points to the directory where Net configuration files are stored.

If TNS_ADMIN is set on your system, you will have conflicts between that directory and the directory where the Oracle9iAS 9.0.3 Net configuration files are created. You will also have conflicts if the configuration files are in a common directory outside of the Oracle home for any other installed Oracle products. For example, your system may use `/var/opt/oracle/tnsnames.ora` for database aliases.

To prevent conflicts between the Net configuration files for different Oracle products, copy the configuration files from either TNS_ADMIN or the common directory to `ORACLE_HOME/network/admin` for the other products and unset TNS_ADMIN using the following command.

C shell	Bourne/Korn shell
<code>prompt> unsetenv TNS_ADMIN</code>	<code>prompt> unset TNS_ADMIN</code>

2.5.4 Host Name File Configuration

Oracle Universal Installer requires that the fully qualified host name information appear in the configuration files for your computer. A fully qualified host name includes both the name of the system and its domain.

Verify that `/etc/hosts.*` has the following format:

```
IP_ADDRESS FULLY_QUALIFIED_HOSTNAME SHORT_HOSTNAME ALIASES
```

The following example shows a properly configured `/etc/hosts.*` file:

```
148.87.9.44 oasdocs.us.oracle.com oasdocs oracleinstall
```

In addition to `/etc/hosts`, ensure the following files use the fully qualified hostname:

- `/etc/nodename`
- `/etc/inet/hosts`
- `/etc/hostname.*`
- `/etc/net/ticlts/hosts`
- `/etc/net/ticots/hosts`
- `/etc/net/ticotsord/hosts`
- `/etc/inet/ipnodes`

Note: The host name may appear in each of these files more than once. You must add the domain information to every occurrence of the hostname.

Failure to properly configure the hostname information in the listed files may result in runtime errors during Oracle9iAS 9.0.3 installation.

After you have properly configured the hostname information, reboot your computer before starting Oracle9iAS 9.0.3 installation.

2.5.4.1 Host Domain Name

Oracle Universal Installer requires specific conventions for the host domain name. If the host domain name does not conform to the following requirements, the Oracle9iAS 9.0.3 installation will fail:

- No blank spaces or underscores are permitted as part of the domain name.
- Domain names can be upper or lower case.
- The first character of the host domain name must be a letter of the alphabet.
- The last character of the host domain name must not be a minus sign or period.
- A host which serves as an Internet gateway should have "GATEWAY" or "GW" as part of the domain name.

2.5.5 Port Allocation

Following installation, Oracle Universal Installer creates a file showing the port numbers assigned during installation of Oracle9iAS 9.0.3 components. The installation process automatically detects any port conflicts and selects an alternative port in the range allocated for that component. [Appendix A, "Default Port Numbers and Port Ranges"](#) lists the default port ranges. The `portlist.ini` file is located at:

```
ORACLE_HOME/install/portlist.ini
```

This file lists component entries as "`port_name = port_value`". For example:

```
Oracle HTTP Server port = 7777
Oracle HTTP Server SSL port = 4443
Oracle HTTP Server listen port = 7778
Oracle HTTP Server SSL listen port = 4444
Oracle HTTP Server Jserv port = 8007
Enterprise Manager Servlet port = 1810
```

You can also view the port numbers by pointing your browser to the Oracle9iAS Welcome page and selecting the **Ports** tab.

See Also:

- [Section 3.2.2, "About the Oracle Enterprise Manager Web Site"](#)
- *Oracle9i Application Server Administrator's Guide.*

2.6 Oracle Universal Installer

This section describes how Oracle9iAS 9.0.3 uses Oracle Universal Installer for installation. It includes the following topics:

- [About Oracle Universal Installer](#)
- [Oracle Universal Installer Prerequisite Checks](#)
- [Oracle Universal Installer oraInventory Directory](#)
- [Starting Oracle Universal Installer](#)

2.6.1 About Oracle Universal Installer

Oracle9iAS 9.0.3 uses Oracle Universal Installer to guide you through each step of the installation process.

The Oracle Universal Installer provides the following features:

- Describes installation options for Oracle9iAS 9.0.3
- Detects pre-set environment variables and configuration settings
- Sets environment variables and configuration during installation
- Offers configuration options for a customized installation of Oracle9iAS 9.0.3
- Deinstalls Oracle9iAS 9.0.3

Note: Oracle Universal Installer fails to appear if the display uses less than 256 colors. Oracle Universal Installer uses JRE 1.3.1, which supports display drivers with 256 colors or more.

2.6.2 Oracle Universal Installer Prerequisite Checks

The Oracle Universal Installer automatically checks your computer prior to installation to verify that your system meets operational requirements. [Table 2–6](#) lists the prerequisite checks that are performed.

Table 2–6 Oracle Universal Installer Automatic Prerequisite Checks

Prerequisite Checks	See Also
Check for enough disk space for Oracle home installation	Table 2.2, "Hardware Requirements"
Check for TMP variable and sufficient swap space	Table 2.2, "Hardware Requirements"
Check that the install host has enough RAM	Table 2–3, "Oracle9iAS 9.0.3 Requirements and Recommendation"
Check the <code>/etc/hosts</code> file.	Section 2.5.4, "Host Name File Configuration"
Prohibit installation of Oracle9iAS 9.0.3 into an existing Oracle home	Section 2.5.3.1, "ORACLE_HOME"
Check for Solaris Operating Environment version 2.6 or later	Section 2.3, "Operating System Requirements"
Ensure that the value of <code>ORACLE_HOME</code> does not contain spaces or is longer than 127 characters	Section 2.5.3.1, "ORACLE_HOME"
Verify the monitor has 256 color viewing capability	Section 2.2, "Hardware Requirements"
Verify operational requirements of the CPU	Table 2.2, "Hardware Requirements"
Port detection and resolution	Section 2.5.5, "Port Allocation"

2.6.3 Oracle Universal Installer oraInventory Directory

The Oracle Universal Installer creates the `oraInventory` directory the first time it is run on a computer. The `oraInventory` directory keeps an inventory of products that the Oracle Universal Installer installs on your computer, as well as other installation information. If you have previously installed Oracle products, then you may already have an `oraInventory` directory.

When a UNIX group name is created and specified, it grants the specified group the permission to write to the `oraInventory` directory. If another group attempts to run the installer, then they must have permission to write to the `oraInventory` directory. If they do not have permission, then the installation will fail.

The location of `oraInventory` is defined in `/var/opt/oracle/oraInst.loc`.

The latest log file is:

```
/your_base_directory/oraInventory/logs/installActiontoday's_date_time.log
```

The `your_base_directory` identifier is the location for your installation files and `today's_date_time` is the date and time of installation. Log file names of previous installation sessions take the form `installActionsdate_time.log`.

A complete listing of log files is included in the *Oracle9i Application Server Administrator's Guide*

Do not delete or manually alter the `oraInventory` directory or its contents. Doing so can prevent the installer from locating products that you have installed on your system.

2.6.4 Starting Oracle Universal Installer

Follow these steps to start Oracle Universal Installer and install Oracle9iAS 9.0.3:

1. Insert the CD labelled Disk 1 into the CD-ROM drive.
2. Mount the installation CD-ROM.

The Oracle Product Installation CD-ROM is in RockRidge format. If you are using the Solaris Volume Management software (installed by default with Solaris Operating Environment), then the CD-ROM is mounted automatically to `/cdrom/9ias_903disk1` when you insert it in the disk drive.

If you are not using the Solaris Volume Management software, then you must mount the CD-ROM manually. To manually mount or unmount the CD-ROM, you must have root privileges. Be sure to unmount the CD-ROM before removing it from the drive.

Follow these steps to manually mount Disk 1 CD-ROM:

a. Log in as the root user.

b. Create the CD-ROM mount point directory:

```
prompt> mkdir mount_point
```

c. Mount the CD-ROM drive on the mount point directory and exit the root account:

```
prompt> mount options device_name mount_point  
prompt> exit
```

The following example mounts the CD-ROM manually on `/cdrom`, without using the Solaris Volume Management software. Execute the following commands as root user:

```
prompt> mkdir /cdrom  
prompt> mount -r -F hsfs device_name /cdrom
```

d. Log out as the root user.

3. Run Oracle Universal Installer from the CD-ROM.

Note: Be sure you are **not** logged in as the root user when you start the Oracle Universal Installer. If you are, then only the root user will have permissions to manage Oracle9iAS 9.0.3.

- a. Log in as the `oracle` user.
- b. Start the installer by entering:

```
prompt> mount_point/9ias_903disk1/runInstaller
```

This launches Oracle Universal Installer through which you can install Oracle9iAS 9.0.3.

Note: Do not start the installation inside the `mount_point` directory. If you do, then you may not be able to eject the installation disk.

2.7 Installation

The following sections provide the sequence of the installation screens that you will encounter during the installation process, installation considerations, and additional installation information for Oracle9iAS 9.0.3. This section contains the following topics:

- [Installation Sequence](#)
- [Installation Considerations](#)
- [Additional Oracle9iAS 9.0.3 Installations](#)

2.7.1 Installation Sequence

Oracle recommends reviewing the installation sequence for a better understanding of the Oracle9iAS 9.0.3 installation process.

Note: Before installation on a host that already has an Oracle9iAS instance, you must stop the Oracle Enterprise Manager Web site. Your primary Oracle9iAS installation contains the active Oracle Enterprise Manager Web site. Run the following command in your primary installation *ORACLE_HOME*:

```
prompt> ORACLE_HOME/bin/emctl stop
```

Following Oracle9iAS 9.0.3 installation, restart the Oracle Enterprise Manager Web site using the following command:

```
prompt> ORACLE_HOME/bin/emctl start
```

The following screens appear during installation of Oracle9iAS 9.0.3:

1. **Welcome screen:** Review information about the Oracle Universal Installer.
2. **Inventory Location screen:** Verify the location of the base directory for installation files (first time installation).
3. **File Locations screen:** Verify the source path, destination name, and destination path for your Oracle9iAS 9.0.3 installation.
4. **Component Configuration and Startup screen:** Select the components to configure during the installation process.
5. **Oracle9iAS Infrastructure Use screen:** Allows you to select whether or not you will use Oracle9iAS Single Sign-On or cluster management (with Oracle9iAS Infrastructure 9.0.2) with your installation of Oracle9iAS 9.0.3 (Oracle9iAS Single Sign-On installs with Oracle9iAS Infrastructure 9.0.2).
6. **Oracle Internet Directory screen (optional):** Enter the username and password for your registration of Oracle9iAS 9.0.3 configuration information into Oracle Internet Directory. (Oracle Internet Directory installs with Oracle9iAS Infrastructure 9.0.2.) The username you enter must be a member of the IASAdmins group (for example, `orcladmin`).

If you are associating Oracle9iAS 9.0.3 with an Infrastructure, you must provide the username and password for the Oracle Internet Directory associated with that Infrastructure.

7. One of the following screens appears based on whether Oracle9iAS 9.0.3 has been installed on your computer:
 - **Create Instance Name and ias_admin Password screen:** This screen appears if this is a first time installation of Oracle9iAS 9.0.3 on this host. Enter the following instance information:
 - **Instance Name:** Identifies the installation instance of Oracle9iAS 9.0.3 on this host.
 - **ias_admin Password:** The `ias_admin` user's password used to administer any Oracle9iAS 9.0.3 instance on this host. This password is required for installation of additional Oracle9iAS 9.0.3 instances or other Oracle9i Application Server products.
 - **Create Instance Name screen:** This screen appears if the Oracle Universal Installer has detected a previous installation of Oracle9iAS 9.0.3 or other Oracle9i Application Server products on this host but in a different Oracle

home. Enter an instance name to identify this instance of Oracle9iAS 9.0.3.
Enter the `ias_admin` user's password created from the previous installation.

8. **Metadata Repository screen** (optional): Select the Oracle9iAS Metadata Repository you would like to use for this Oracle9iAS 9.0.3 installation. This screen appears if the Oracle Universal Installer detects multiple installations of Oracle9iAS Metadata Repository 9.0.2 (Oracle9iAS Metadata Repository installs with Oracle9iAS Infrastructure 9.0.2).
9. **Installation Summary screen**: Review the summary of your Oracle9iAS 9.0.3 installation and begin the installation process.
10. **Install screen**: Appears while the product is installing. The screen shows installation operations. No user interaction is required.
11. **Oracle9iAS Configuration Tools screen**: Review the status of Oracle9iAS configuration tools for components you have selected. No user interaction is required.
12. **End of Installation screen**: Appears at the end of the installation process. It notifies you whether the installation was successful or unsuccessful and provides information about accessing the Oracle9iAS 9.0.3 instance from a Web browser.

Note: After the installer finishes, you must perform the tasks in [Section 3.2, "Postinstallation"](#) to complete your Oracle9iAS 9.0.3 installation.

2.7.2 Installation Considerations

Please review the following installation considerations for Oracle9iAS 9.0.3:

- Oracle9iAS 9.0.3 cannot be used to run any of the Oracle9iAS 9.0.2 mid-tier install types. For example, you cannot run Oracle9iAS Portal, Oracle9iAS Forms Services, or Oracle9iAS Discoverer on top of Oracle9iAS 9.0.3.
- Oracle9iAS 9.0.3 cannot be installed in an existing Oracle home. For example, you cannot install Oracle9iAS 9.0.3 into an Oracle9iAS 9.0.2 Oracle home.
- You cannot create a cluster that consists of J2EE and Web Cache 9.0.3 instances and J2EE and Web Cache 9.0.2 instances.
- The J2EE and Web Cache instances in an application server cluster can be on different hosts, however, all J2EE and Web Cache instances in a single cluster must reside on hosts that use the same operating system type (for example, Linux). This is because the configuration information that is shared between instances in a cluster contains operating system-specific information, such as file path names.
- If you are installing Oracle9iAS Infrastructure 9.0.2 on the same host as Oracle9iAS 9.0.3, then you must install the Oracle9iAS Infrastructure 9.0.2 first. You can associate Oracle9iAS 9.0.3 with the Oracle9iAS Infrastructure 9.0.2 during, or after the Oracle9iAS 9.0.3 installation.
- If you are installing Oracle9iAS Infrastructure 9.0.2 on a different host from Oracle9iAS 9.0.3, then you can install the infrastructure before, or after the Oracle9iAS 9.0.3 installation. You can associate Oracle9iAS 9.0.3 with the infrastructure during, or after the Oracle9iAS 9.0.3 installation.
- If you associate your Oracle9iAS 9.0.3 instance with an Oracle9iAS Infrastructure 9.0.2, you can not remove and reassociate the Oracle9iAS 9.0.3 instance with the infrastructure.

See Also: *Oracle9i Application Server Administrator's Guide* for more information on clustering and associating an instance with an infrastructure.

2.7.2.1 Installing the Oracle9i Application Server 9.0.2.1 patch

If you will be using Oracle9iAS 9.0.3 on the same host or farm as Oracle9iAS 9.0.2, then you must install the Oracle9i Application Server 9.0.2.1 patch. You must apply the 9.0.2.1 patch to all Oracle9iAS 9.0.2 instances, either before or after your installation of Oracle9iAS 9.0.3.

You can download the patch from:

<http://metalink.oracle.com>

Select the Patches link. On the patch download form, select Oracle9i Application Server in the Product Family field and then submit the form.

2.7.3 Additional Oracle9iAS 9.0.3 Installations

Oracle recommends reviewing the following before performing additional Oracle9iAS 9.0.3 installations on the same host:

- Review the preinstallation tasks covered previously in this chapter.
- Ensure all installation users are members of the same operating system group.
- Do not delete or modify the `/var/opt/oracle` directory.
- Specify a different Oracle home than the first Oracle9iAS 9.0.3 installation.
- Use the same oraInventory directory for all Oracle9iAS 9.0.3 installations.
- Stop Oracle Enterprise Manager Web site before subsequent Oracle9iAS 9.0.3 installations. For more information refer to the *Oracle9i Application Server Administrator's Guide*.
- If you install more than one instance of Oracle9iAS 9.0.3, and each instance does not use Oracle9iAS Single Sign-On, then each instance name must be unique.
- If an Oracle9iAS 9.0.3 installation is associated with an Oracle9iAS Infrastructure 9.0.2, then all subsequent Oracle9iAS 9.0.3 installations on the same host are automatically associated with the same infrastructure.
- If you perform multiple Oracle9iAS 9.0.3 installations, on different hosts, using the same Oracle9iAS Infrastructure 9.0.2, Oracle recommends performing only one installation at a time. Simultaneous Oracle9iAS 9.0.3 installations and configurations pointing to a common Oracle9iAS Infrastructure 9.0.2 can result in a failure during OC4J deployment with some resource dead lock errors.
- After completion of your Oracle9iAS 9.0.3 installation, exit Oracle Universal Installer before installing another instance of Oracle9iAS 9.0.3. If the same

installation session is used to install another instance of Oracle9iAS 9.0.3, then applications may fail in the second instance with "URL not found" errors.

- You can perform multiple Oracle9iAS 9.0.3 installs on the same host as different users. For more information refer to [Section 3.2.6, "Multi-User Installations"](#).

See Also:

- [Section 2.5.3.1, "ORACLE_HOME"](#)
- [Section 2.6.3, "Oracle Universal Installer oraInventory Directory"](#)

3

Installation

This chapter guides you through the steps for the Oracle9i Application Server Release 2 (9.0.3) (Oracle9iAS 9.0.3) installation. The topics include:

- [Installation](#)
- [Postinstallation](#)

3.1 Installation

The following instructions guide you through the installation steps for Oracle*9i*AS 9.0.3.

During the Oracle*9i*AS 9.0.3 installation, you will be asked if you want to use single sign-on or clustering. If you want to use either single sign-on or enable cluster management, then you need to install Oracle*9i*AS Infrastructure 9.0.2. Oracle*9i*AS 9.0.3 is compatible with Oracle*9i*AS Infrastructure 9.0.2.

When you are installing Oracle*9i*AS 9.0.3 and will be using an existing Oracle*9i*AS Infrastructure 9.0.2, ensure that the following components are running on the infrastructure host:

- Oracle*9i*AS Metadata Repository
- Oracle Internet Directory
- Oracle*9i*AS Single Sign-On
- Oracle HTTP Server
- The OC4J_DAS instance of Oracle*9i*AS Containers for J2EE

Note: You must have write access to the `/tmp`, `$TEMP`, and `/var/tmp` directories on your system before you start the installation of Oracle*9i*AS 9.0.3.

Note: If you will be using Oracle*9i*AS 9.0.3 on the same host or farm as Oracle*9i*AS 9.0.2, then you must install the Oracle*9i* Application Server 9.0.2.1 patch. See [Section 2.7.2.1, "Installing the Oracle*9i* Application Server 9.0.2.1 patch"](#) for more information.

See Also:

- [Chapter 1, "Installation Concepts"](#)
- *Oracle*9i* Application Server 9.0.2 Installation Guide*
- *Oracle*9i* Application Server Administrator's Guide*

Table 3–1 lists required information for Oracle9iAS 9.0.3 installation. Enter your values for the listed information in the **Your Information** column before beginning.

Table 3–1 Installation Information

Information	Example Values	Your Information
Oracle base directory ¹ (Section 2.6.3, "Oracle Universal Installer oraInventory Directory")	/private/oraInventory	
Oracle home location (Section 2.5.3.1, "ORACLE_HOME")	/private/ora9ias	
Instance Name (Section 2.5.3.1, "ORACLE_HOME")	instance1	
ias_admin Password (Section 2.5.3.1, "ORACLE_HOME")	welcome1	
Oracle9iAS Single Sign-On Server Host Name ² (Oracle9i Application Server 9.0.2 Installation Guide)	iasdocs.us.oracle.com	
Oracle9iAS Single Sign-On Port Number ² (Oracle9i Application Server 9.0.2 Installation Guide)	7777	
Oracle Internet Directory Username ² (Oracle9i Application Server 9.0.2 Installation Guide)	orcladmin	
Oracle Internet Directory Password ² (Oracle9i Application Server 9.0.2 Installation Guide)	welcome1 ³	
Oracle9iAS Metadata Repository ⁴ (Oracle9i Application Server 9.0.2 Installation Guide)	iasdocs.us.oracle.com	

¹ Required for first time installation of Oracle9iAS 9.0.3.

² Required for using single sign-on functionality or enabling application server cluster management. See the *Oracle9i Application Server Administrator's Guide* for more information about clustering.

³ The default password for orcladmin user is the same as the password for the ias_admin user.

⁴ Required for multiple metadata repository availability.

Note: Before installation on a host that already has an Oracle9iAS instance, you must stop the Oracle Enterprise Manager Web site. Your primary Oracle9iAS installation contains the active Oracle Enterprise Manager Web site. Run the following command in your primary installation *ORACLE_HOME*:

```
prompt> ORACLE_HOME/bin/emctl stop
```

Following Oracle9iAS 9.0.3 installation, restart the Oracle Enterprise Manager Web site using the following command:

```
prompt> ORACLE_HOME/bin/emctl start
```

1. Review the Oracle Universal Installer Welcome screen and click **Next**.

The Welcome screen provides information about the Oracle Universal Installer. The following function buttons appear on the installation screens:

- **Deinstall Products:** Deinstall individual components or the entire product. This button appears only on the Welcome screen.
- **About Oracle Universal Installer:** View the version number of the installer in use.
- **Exit:** Quit the installation process and exit the installer.
- **Help:** Access detailed information about the functionality of each screen.
- **Installed Products:** View currently installed products or deinstall the entire product or components.
- **Previous:** Return to the previous screen.
- **Next:** Proceed to the next screen.

2. Verify the location of the base directory for installation files and click **OK**.

Figure 3–1 Inventory Location Screen

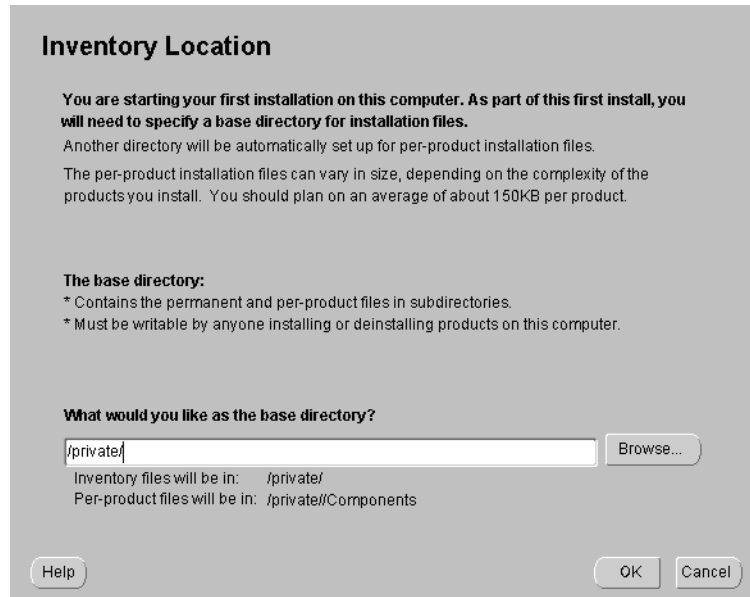

The Inventory Location screen appears during the *first installation* on a host to set a location for installation files. Product components use a different directory. The installation files can vary in size depending on the complexity of the product. For file storage considerations, assume a file size of 150 KB per product.

- **Browse:** Navigate through the available directory to select a location for the base directory for your installation.

The base directory has the following attributes:

- Contains the permanent and per-product component files in subdirectories
- Must be writable by anyone in the same user group installing or deinstalling products on the install computer

Input where you would like the base directory to be stored. For example:

/private

The storage location for product component files is the `Components` directory. For example:

```
/private/oraInventory/Components
```

- You need root privileges to execute certain actions before the installation can continue. You need to run a shell script with root privileges that is stored in the `oraInstRoot.sh` file. (You may need to execute the shell script by typing `./` before `oraInstRoot.sh`.) The `Root.sh` installation screen shows the location of the `oraInstRoot.sh` file. The script creates pointers to the components as the installer installs them in the system, so that they can be identified later in the installation procedure. It produces the `/var/opt/oracle/oraInst.loc` file, which provides a pointer to the `oraInventory` directory.

After you execute the shell script, continue with the installation process.

3. Verify the source path, destination name, and destination path for your Oracle9iAS 9.0.3 installation and click **Next**.

Figure 3–2 File Locations Screen

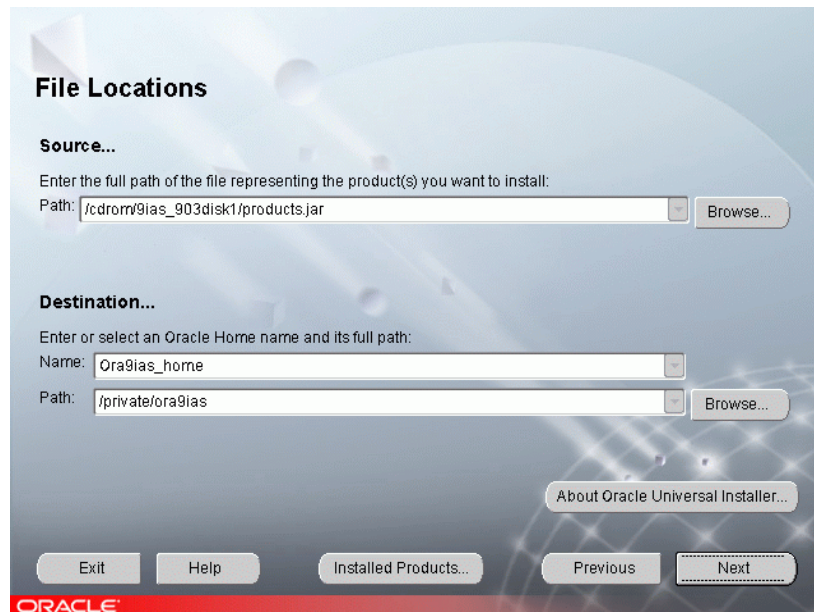

The File Locations screen allows you to enter the full path for the source and destination locations for your installation.

- **Source:** This is the full path to the `products.jar` file from which the product will be installed. The installer detects and uses the default values of the `products.jar` file of the installation program. Do not change the path.
- **Name:** Enter an Oracle home name or select a name from the drop-down list. You may use the default Oracle home name of **Ora9ias_home** and path name **ora9ias** provided or select your own name and path. If you do not have a home created on your computer, one is created for you during the installation.

Oracle homes are identified by name. The Oracle home name identifies the program group associated with a specific Oracle home and the installed Oracle services associated with the home.

The Oracle home name must consist of 1 to 16 characters and can only include alphanumeric characters and underscores; spaces are not allowed.

- **Destination:** This is the full path to the Oracle home where the product will be installed. The installer defaults to the Oracle home set in the preinstallation chapter.

Note: The Oracle9iAS 9.0.3 instance must be installed in its own Oracle home. For example, you cannot install Oracle9iAS 9.0.3 into any Oracle9iAS 9.0.2 Oracle home. The Oracle9iAS 9.0.3 instance can be installed on the same or a different host from Oracle9iAS Infrastructure 9.0.2.

See Also: [Section 2.5.3.1, "ORACLE_HOME"](#)

- **Browse:** Navigate through the file system to find source and destination locations.

Do not install Oracle9iAS 9.0.3 into any existing Oracle directories. For example:

- Oracle9i Application Server 9.0.2 home directory
- Oracle9iAS Infrastructure 9.0.2 home directory
- Oracle9iAS Developer Kits 9.0.2 home directory
- Oracle9i Database home directory
- Oracle8i Database home directory
- Oracle9i Developer Suite directory

4. Select the Oracle9iAS 9.0.3 components to configure during the installation process and click **Next**.

Figure 3–3 Component Configuration and Startup Screen

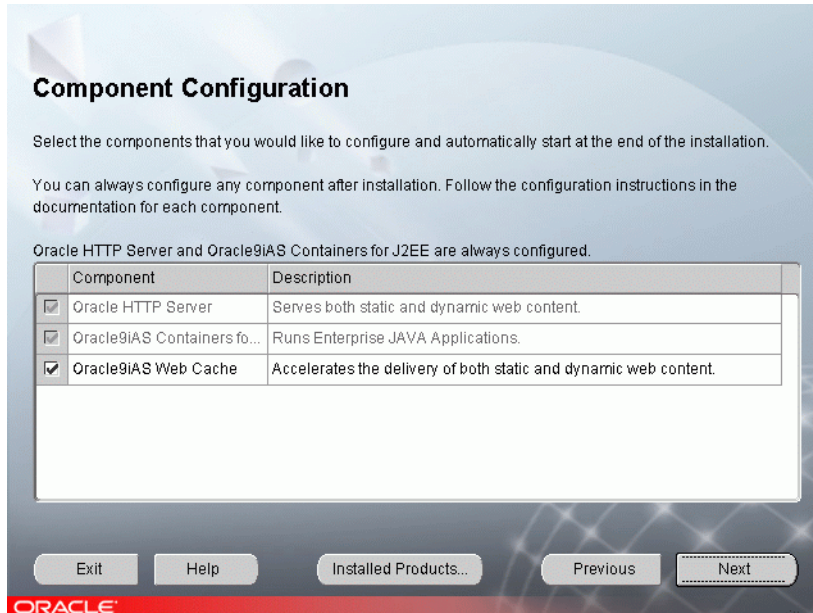

If you de-select a component here, then the installer installs it, but does not configure or start it. After installation, the installer starts the selected Oracle9iAS 9.0.3 components. If you decide to use the Oracle9iAS 9.0.3 component at a later time, launch the Oracle Enterprise Manager Web site and click **Configure Component** on the Instance Home Page.

See Also: [Section 1.1, "Oracle9iAS 9.0.3 Installation Overview"](#)

-
5. One of the following screens will appear based on whether you will use Oracle9iAS Infrastructure 9.0.2, or if an Oracle9iAS Infrastructure 9.0.2 is on the install host:
- **Oracle9iAS Infrastructure Use:** The Oracle9iAS Infrastructure Use screen appears to allow you to associate with an existing installation of Oracle9iAS Infrastructure 9.0.2.
 - **Infrastructure Summary:** The Infrastructure Summary screen appears if you have an installation of Oracle9iAS 9.0.3 that is already associated with an Oracle9iAS Infrastructure 9.0.2.

Note: To associate an instance of Oracle9iAS 9.0.3 with an Infrastructure, make sure the required Infrastructure components are running. See [Section 3.1, "Installation"](#) for details.

a. Oracle9iAS Infrastructure Use

The Oracle9iAS Infrastructure Use screen appears to enable single sign-on or clustering functionality on the Oracle9iAS 9.0.3 installation host. Oracle9iAS Infrastructure 9.0.2 enables management of the application server cluster. Select whether to use an existing Oracle9iAS Infrastructure 9.0.2 and click **Next**.

Figure 3–4 Oracle9iAS Infrastructure Use Screen

Oracle9iAS Infrastructure Use

To use Clustering or Single Sign-On with J2EE Applications, you need an existing Oracle9iAS Infrastructure. If you do not specify an Infrastructure now, you may do so after installation. If you want to specify an Infrastructure now, you must identify the Infrastructure by specifying the Single Sign-On Host and Port. This is required even if you only intend to use Clustering.

Do you want to specify an Infrastructure at this time?

No

Yes

Single Sign-on Host Name:

Single Sign-on Port Number:

Exit Help Installed Products... Previous Next

ORACLE

Oracle9iAS Single Sign-On is installed as part of the Oracle9iAS Infrastructure 9.0.2 installation. The single sign-on host name refers to the existing Oracle9iAS Infrastructure 9.0.2.

The Oracle9iAS Infrastructure Use screen allows you to select whether or not you will use Oracle9iAS Infrastructure 9.0.2 with this installation of Oracle9iAS 9.0.3. This screen offers two options:

- **No:** Install Oracle9iAS 9.0.3 without Oracle9iAS Infrastructure 9.0.2 functionality.
- **Yes:** Use an existing Oracle9iAS Single Sign-On with Oracle9iAS Infrastructure 9.0.2 that enables an authenticated user to access multiple

accounts and Oracle*9i*AS 9.0.3 applications, and enable cluster management.

In order to use Oracle*9i*AS Single Sign-On you must have the following information:

- **Host Name:** The name of the host where your instance of Oracle*9i*AS Single Sign-On and Oracle*9i*AS Infrastructure 9.0.2 is located.
- **Port Number:** The port number of the host for your instance of Oracle*9i*AS Single Sign-On.

Oracle*9i*AS Single Sign-On is installed as part of the Oracle*9i*AS Infrastructure 9.0.2 installation.

See Also:

- [Chapter 1, "Installation Concepts"](#)
- *Oracle9i Application Server 9.0.2 Installation Guide*

Note:

- You cannot create a cluster that consists of J2EE and Web Cache 9.0.3 instances and J2EE and Web Cache 9.0.2 instances.
 - The J2EE and Web Cache instances in an application server cluster can be on different hosts, however, all J2EE and Web Cache instances in a single cluster must reside on hosts that use the same operating system type (for example, Linux). This is because the configuration information that is shared between instances in a cluster contains operating system-specific information, such as file path names.
-
-

b. Infrastructure Summary

Review the Infrastructure Summary screen and click **Next**.

Figure 3–5 Infrastructure Summary Screen

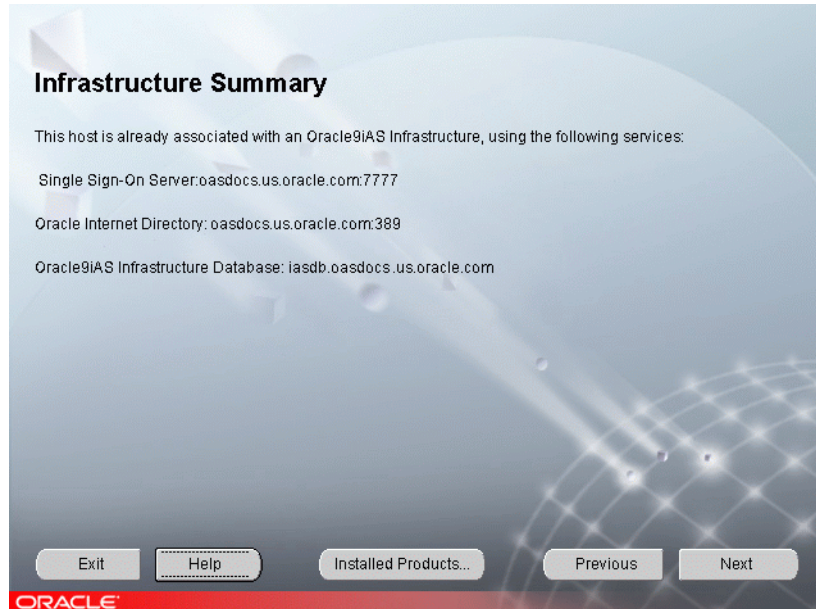

If you have an installation of Oracle9iAS 9.0.3 on the install host that is already associated with an Oracle9iAS Infrastructure 9.0.2, the Infrastructure Summary screen appears. Review and note the information provided on the screen.

The Infrastructure Summary screen provides you with the following information about the associated Oracle9iAS Infrastructure 9.0.2:

- The Oracle9iAS Single Sign-On domain and port number
- The Oracle Internet Directory domain and port number
- The Oracle9iAS Infrastructure 9.0.2 Database (Metadata Repository) name

6. Enter a username and password to log onto Oracle Internet Directory and click **Next**.

Figure 3–6 Oracle Internet Directory Screen

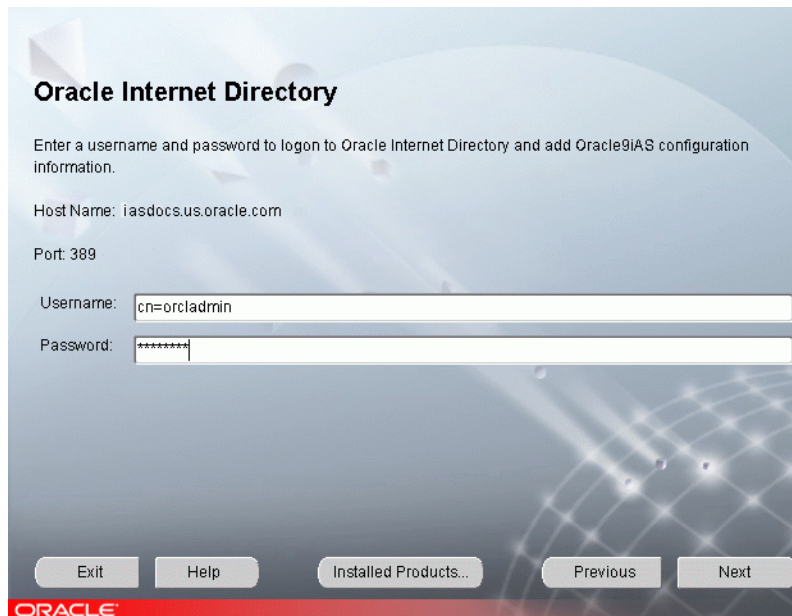

Oracle Internet Directory

Enter a username and password to logon to Oracle Internet Directory and add Oracle9iAS configuration information.

Host Name: iasdocs.us.oracle.com

Port: 389

Username:

Password:

Exit Help Installed Products... Previous Next

ORACLE

In order to associate an instance of Oracle9iAS 9.0.3 with an Infrastructure, the instance must be registered in the Oracle Internet Directory associated with the Infrastructure.

Oracle Internet Directory enables retrieval of shared information about users and network resources. Oracle Internet Directory implements the Lightweight Directory Access Protocol (LDAP), version 3.

You will need the following information to add information about an Oracle9iAS 9.0.3 instance into Oracle Internet Directory:

- **Username:** The name used to log into Oracle Internet Directory.
- **Password:** The password for the user.

The username and password are defined in Oracle Internet Directory as one of the following:

- **orcladmin** (root user)
- a user who is member of the IASAdmins group in Oracle Internet Directory

For additional Oracle9iAS 9.0.3 installations using Oracle Internet Directory, you must use a username that is a member of the IASAdmins group. By default, orcladmin (the Oracle Internet Directory administrator) is also a member of the IASAdmins group. If the Oracle Internet Directory administrator does not wish to give out the orcladmin password, the administrator creates a user and password. The administrator then adds this user to the IASAdmins group.

You are prompted to enter username and password during subsequent Oracle9iAS 9.0.3 installs that use Oracle Internet Directory. The username and password you enter enables the registration of Oracle9iAS 9.0.3 configuration information into Oracle Internet Directory.

The default user is orcladmin. The default password for the orcladmin user is the same as the password for the ias_admin user on the host where Oracle Internet Directory is configured. The Oracle Internet Directory administrator may add other users and assign a different password for this group.

See Also:

- *Oracle9i Application Server Administrator's Guide*
- *Oracle9i Application Server 9.0.2 Installation Guide*

7. One of the following screens appears based on whether an instance of Oracle*9i*AS 9.0.3 or Oracle*9i*AS 9.0.2 has been installed on this host:
 - **Create Instance Name and ias_admin Password:** This screen appears if this is a first time installation of Oracle*9i*AS 9.0.3 on this host.
 - **Create Instance Name:** This screen appears if the Oracle Universal Installer has detected a previous installation of Oracle*9i*AS 9.0.3 or Oracle*9i*AS 9.0.2 on this host but in a different Oracle home.

a. **Create Instance Name and ias_admin Password**

Enter a unique Oracle9iAS 9.0.3 instance name and ias_admin password and click **Next**.

Figure 3–7 Create Instance Name and ias_admin Password Screen

Create Instance Name and ias_admin Password

Enter a unique instance name for this Oracle9iAS instance. The hostname and domain of this machine will be appended to the end of this instance name.

Provide a password for the ias_admin user which is used to manage all Oracle9iAS instances on this host. Note that all instances on this host share this password.

Instance Name

ias_admin Password

Confirm Password

Exit Help Installed Products... Previous Next

ORACLE

This screen appears if this is a first time installation of Oracle9iAS 9.0.3 on this host.

Instance Name: Enter an instance name for this installation of Oracle9iAS 9.0.3. The instance name must contain alphanumeric and underscore characters only.

The instance name identifies this instance of Oracle9iAS 9.0.3 on this host. Instance names are unique for each host.

ias_admin Password: Enter a password for the ias_admin user for this instance of Oracle9iAS 9.0.3, and then re-enter the password for confirmation. The ias_admin user's password must consist of at least five alphanumeric characters. Additionally, at least one of the characters must be a number.

The `ias_admin` user's password enables you to:

- Manage all instances of Oracle9iAS 9.0.3 across the install host
- Run management tools
- Facilitate future installations
- Access the Oracle Enterprise Manager Home Page

If you forget your `ias_admin` user's password following installation, refer to the *Oracle9i Application Server Administrator's Guide* for the steps you can follow to reset the password.

b. Create Instance Name

Enter a unique Oracle9iAS 9.0.3 instance name and the `ias_admin` password and click **Next**.

Figure 3–8 Create Instance Name Screen

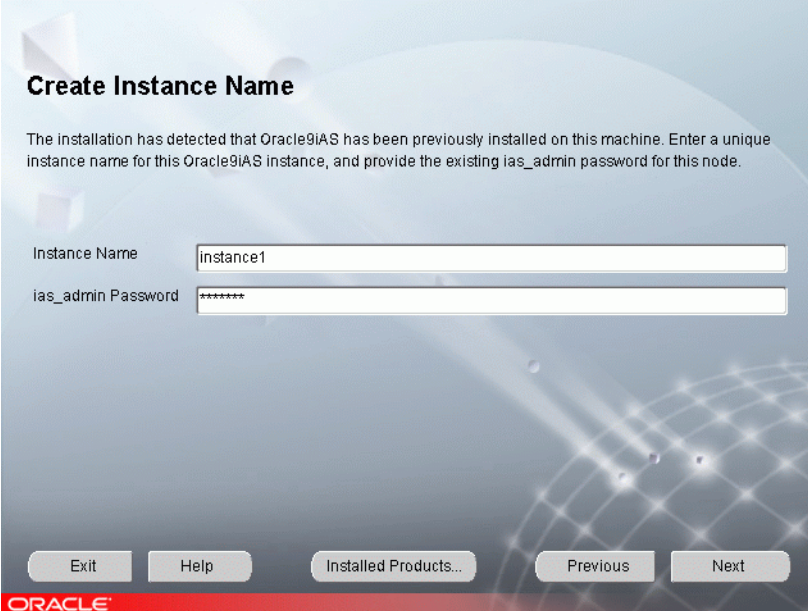

Create Instance Name

The installation has detected that Oracle9iAS has been previously installed on this machine. Enter a unique instance name for this Oracle9iAS instance, and provide the existing `ias_admin` password for this node.

Instance Name

ias_admin Password

Exit Help Installed Products... Previous Next

ORACLE

If the Oracle Universal Installer has detected a previous installation of Oracle9iAS 9.0.3 or another Oracle9i Application Server product on this host but in a different Oracle home, this screen appears.

Instance Name: Enter the instance name for this installation of Oracle9iAS 9.0.3. Because instance names identify instances of Oracle9iAS on a host, the instance name must be unique on each host.

Instance names can only contain alphanumeric and underscore characters.

ias_admin Password: Enter the existing password for the `ias_admin` user for this host.

If you forget your `ias_admin` user's password following installation, refer to the *Oracle9i Application Server Administrator's Guide* for the steps you can follow to reset the password.

8. This screen appears if the Oracle Universal Installer detects the availability of multiple installations of Oracle*9iAS* Metadata Repository with which you can associate your Oracle*9iAS* 9.0.3 installation. Oracle*9iAS* Metadata Repository installs as part of the Oracle*9iAS* Infrastructure 9.0.2 installation.

Select the Oracle*9iAS* Metadata Repository you would like to use for this Oracle*9iAS* 9.0.3 installation and click **Next**.

Figure 3–9 Oracle*9iAS* Metadata Repository Screen

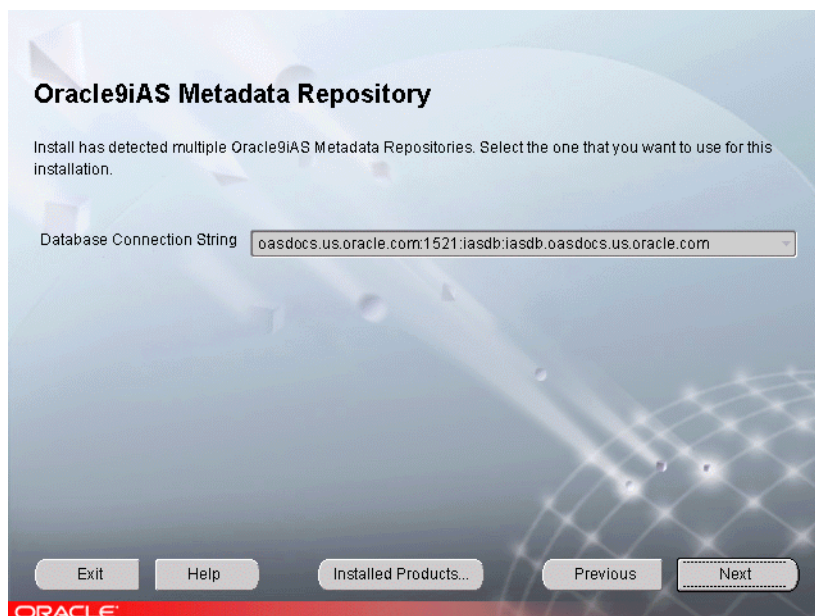

Oracle Universal Installer has detected multiple Oracle*9iAS* Metadata Repositories registered in your Oracle Internet Directory. Select the Oracle*9iAS* Metadata Repository that you want to use with this installation of Oracle*9iAS* 9.0.3.

If you want to implement application server instance clustering, you must select the metadata repository used by other Oracle9iAS 9.0.3 instances in your network.

If you do not want to use Oracle9iAS 9.0.3 instance clustering, select any listed metadata repository. Your selection will be the default location for Oracle9iAS 9.0.3 component metadata.

If you want an Oracle9iAS 9.0.3 component within this installation to use a different database, use the Oracle Enterprise Manager Home Page following installation to change database connectivity.

See Also:

- [Chapter 1, "Installation Concepts"](#)
- [Section 3.2.2, "About the Oracle Enterprise Manager Web Site"](#)
- *Oracle9i Application Server 9.0.2 Installation Guide*

9. Review the Summary screen and click **Install** to begin the installation process.

The Summary screen allows you to review all the settings before the installation begins. These settings include source, destination, installation type, product language, install file sizes, and a list of components.

- To make changes to any of these settings, click **Previous** to return to the respective screens.

Note: Insufficient disk space is indicated in red under **Space Requirements**.

When you click **Install**, the installation process begins.

10. Monitor the installation process.

The Install screen appears while the product is installing. The Install screen shows installation operations, including executing actions such as file copy and linking, and executing decision points and calculations. It displays the full path of the installation log.

- **Cancel:** Discontinues the installation process. You can then choose to stop the installation of an individual component or the entire product.

For more information about the installation log, refer to [Section 2.6.3, "Oracle Universal Installer oraInventory Directory"](#).

Running root.sh

During installation of Oracle9iAS 9.0.3, the installer prompts you to run the `root.sh` script.

Use the following steps to run the `root.sh` script.

- a. Log on as the root user.
- b. Run the `root.sh` script in the Oracle home directory.

```
prompt> ORACLE_HOME/root.sh
```

You may need to execute the shell script by typing `./` before `root.sh`.

- c. Exit root user.

Once you see "Finished running generic part of the root.sh script" and "Now product-specific root actions will be performed," exit root user and return to the Install screen.

The `root.sh` script detects:

- Settings of `ORACLE_OWNER`, `ORACLE_HOME`, and `ORACLE_SID` environment variables.
- Full path of local `bin` directory. You can accept the default or change to a different local `bin` directory.

11. Review the status of Oracle9iAS 9.0.3 configuration tools.

The Components Configuration and Startup screen appears and displays Oracle9iAS 9.0.3 components that will be configured and started. The screen lists the configuration tools for all installed components.

Depending on the configurations selected you will see some component configuration screens, but no input is required.

Monitor the progress of each configuration tool by scrolling down the tools list to review the configuration status of each tool. The status changes as each component is configured.

The installer performs the following functions in this screen:

- Executes a configuration tool for each component selected previously in the Component Configuration and Startup screen.
- Allows you to view data for failed executions in the display window. You can either fix the error and click **Retry** to execute the configuration tool again, or ignore the error and click **Next** to proceed to the next screen.
- The installer automatically creates log files to show the status of Oracle9iAS Configuration Tools. You can determine why a specific Oracle9iAS Configuration Tool failed by reviewing these files. Refer to [Appendix B, "Troubleshooting"](#) for a list of configuration tool log files.
- **Retry**: Re-executes the configuration script if the configuration of a component fails.
- **Stop**: Quits the configuration of a selected component.
- **Exit**: Quit the configuration tool and continue with the installation.

- Review the End of Installation screen. Click **Exit** to quit the installer or click **Next Install** to install additional Oracle9iAS 9.0.3 instances.

Figure 3–10 End of Installation Screen

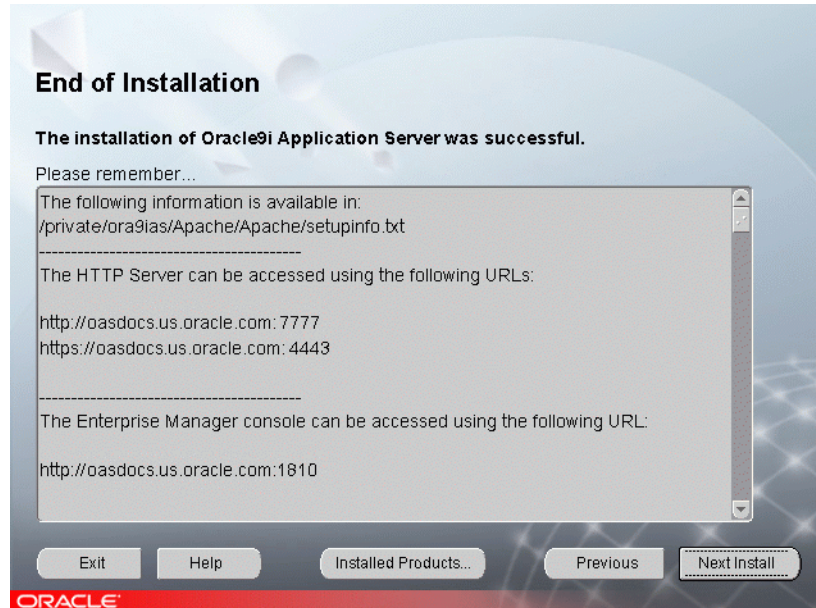

The End of Installation screen appears at the end of the installation process. It notifies you whether the installation was successful or unsuccessful and provides information about accessing the Oracle9iAS 9.0.3 instance.

The End of Installation screen displays the URL and port number for accessing the Oracle HTTP Server page and the Oracle Enterprise Manager Web site. The default Oracle HTTP Server page is the Oracle9iAS Welcome page. The Oracle9iAS Welcome page provides links to demonstrations and information about new features.

See Also:

- [Section 3.2.2, "About the Oracle Enterprise Manager Web Site"](#)
- *Oracle9i Application Server Administrator's Guide*

You can view the Install Log for the completed installation at:

`/your_base_directory/oraInventory/logs/installActiondate_time.log`

`your_base_directory` is the location for your installation files.

`date_time` is the date and time of installation.

A complete listing of log files is included in the *Oracle9i Application Server Administrator's Guide*.

You have successfully installed Oracle9iAS 9.0.3. Proceed to [Section 3.2, "Postinstallation"](#) to complete the installation process.

3.2 Postinstallation

The following instructions guide you through the postinstallation tasks for Oracle9iAS 9.0.3.

The postinstallation section contains the following topics:

- [Installing the Oracle9i Application Server 9.0.2.1 Patch](#)
- [About the Oracle Enterprise Manager Web Site](#)
- [Associating an Instance with an Infrastructure \(Joining a Farm\)](#)
- [Component Dependent Configuration](#)
- [Configuring Additional Components](#)
- [Multi-User Installations](#)
- [Postinstallation Configuration Tasks](#)
- [Starting and Stopping Components](#)
- [Component Port Numbers](#)
- [Changing the X Server Display](#)
- [Oracle9iAS 9.0.3 Demonstration Software](#)
- [Oracle9iAS TopLink](#)
- [Oracle9iAS Portal Developer Kit for J2EE and Web Services](#)
- [Additional Oracle9iAS 9.0.3 Installations](#)
- [Additional Documentation](#)

3.2.1 Installing the Oracle9i Application Server 9.0.2.1 Patch

If you will be using Oracle9iAS 9.0.3 on the same host or farm as Oracle9iAS 9.0.2, then you must install the Oracle9i Application Server 9.0.2.1 patch. You must apply the 9.0.2.1 patch to all Oracle9iAS 9.0.2 instances, either before or after your installation of Oracle9iAS 9.0.3. You can download the patch from:

<http://metalink.oracle.com>

Select the Patches link. On the patch download form, select Oracle9i Application Server in the Product Family field and then submit the form.

3.2.2 About the Oracle Enterprise Manager Web Site

The Oracle Enterprise Manager Web site is available after Oracle9iAS 9.0.3 installation and component configuration. The Oracle Enterprise Manager Web site is comprised of Oracle Enterprise Manager Home Pages. Each Oracle Enterprise Manager Home Page is used to manage an installed Oracle9iAS 9.0.3 component or instance.

Oracle strongly recommends that you use the Secure Socket Layer (SSL) protocol and HTTPS for all connections to the Oracle Enterprise Manager Web site. Refer to the *Oracle9i Application Server Administrator's Guide* for setup information.

3.2.3 Associating an Instance with an Infrastructure (Joining a Farm)

If you have an Oracle9iAS 9.0.3 instance that is not associated with an infrastructure and you would like to use Oracle9iAS Single Sign-On or clustering, you can associate the instance with an existing infrastructure using the Oracle Enterprise Manager Web site. Refer to the *Oracle9i Application Server Administrator's Guide* for more information.

3.2.4 Component Dependent Configuration

Interdependencies between Oracle9iAS 9.0.3 components and component configuration dependencies can be found in the *Oracle9i Application Server Administrator's Guide*.

3.2.5 Configuring Additional Components

You can configure additional Oracle9iAS 9.0.3 components following installation. Configuration of additional Oracle9iAS 9.0.3 components is described in the *Oracle9i Application Server Administrator's Guide*.

3.2.6 Multi-User Installations

You can perform multiple Oracle9iAS 9.0.3 installs on the same host but as different users. However, the users must be members of the same group. If you have installed one or more installations of Oracle9iAS 9.0.3, you must complete the following steps before enabling multi-user installations.

Note: There is a limitation to having different users install Oracle9iAS 9.0.3 on the same host: if you have multiple instances of Oracle9iAS 9.0.3 on the same host and they were installed by different users, you can use Oracle Enterprise Manager to manage only the instance that was installed by the first user. You cannot use Oracle Enterprise Manager to manage instances installed by other users.

1. Determine the location of the active Enterprise Manager. Check the `ACTIVE_EMD_HOME` entry in `/var/opt/oracle/emtab`.

2. Stop the Oracle Enterprise Manager Web site using the following command:

```
prompt> ORACLE_HOME/bin/emctl stop
```

`ORACLE_HOME` is the Oracle home for the active Enterprise Manager, as determined in the previous step.

3. Give additional user(s) "write" privileges to the `lockdir` directory located in `ORACLE_HOME/install/`.
4. Start the Oracle9iAS 9.0.3 installation(s).
5. After successful additional user(s) installations, restart the Oracle Enterprise Manager Web site using the following command:

```
prompt> ORACLE_HOME/bin/emctl start
```

Note: Oracle Enterprise Manager manages the Oracle9i Application Server instances installed under the same operating system user identification as the active Enterprise Manager. The active Enterprise Manager home is listed in the `/var/opt/oracle/emtab` file.

3.2.7 Postinstallation Configuration Tasks

This section includes postinstallation configuration tasks for the following:

- [Oracle9iAS Java Authentication and Authorization Service](#)
- [Enabling Oracle9iAS Web Cache and mod_osso](#)

3.2.7.1 Oracle9iAS Java Authentication and Authorization Service

You must configure Oracle9iAS Java Authentication and Authorization Service (JAAS) components before using applications that use JAAS. JAAS configuration tasks are described in the *Oracle9i Application Server Security Guide*.

3.2.7.2 Enabling Oracle9iAS Web Cache and mod_osso

This section applies only if your Oracle9iAS 9.0.3 instance is associated with an Infrastructure.

When the Oracle Universal Installer initially registers mod_osso with Oracle9iAS Single Sign-On, it passes the registration URLs containing the port number of Oracle HTTP Server, instead of the port number of Oracle9iAS Web Cache. Because Oracle Universal Installer passes the incorrect port number, it bypasses Oracle9iAS Web Cache.

In order for mod_osso to work correctly, you must manually re-register mod_osso using URLs that have the Oracle9iAS Web Cache port.

For more information refer to the *Oracle9i Application Server Administrator's Guide*.

3.2.8 Starting and Stopping Components

Oracle9iAS 9.0.3 components can be started and stopped using the Oracle Enterprise Manager Web site. For information on manually starting and stopping of Oracle9iAS 9.0.3 components, refer to *Oracle9i Application Server Administrator's Guide*.

3.2.9 Component Port Numbers

Following installation, the Oracle Universal Installer creates a file showing the port assignments during installation of Oracle*9iAS* 9.0.3 components. The installation process automatically detects any port conflicts and chooses an alternative port in the range allocated for that component. The `portlist.ini` file is located at:

```
ORACLE_HOME/install/portlist.ini
```

This file lists component entries as "port name = port value". For example:

```
Oracle HTTP Server port = 7777
Oracle HTTP Server SSL port = 4443
Oracle HTTP Server listen port = 7778
Oracle HTTP Server SSL listen port = 4444
Oracle HTTP Server Jserv port = 8007
Enterprise Manager Servlet port = 1810
```

You can also view the port numbers by pointing your browser to the Oracle*9iAS* Welcome page and selecting the **Ports** tab.

Note: The Oracle Universal Installer uses the port numbers for select components during installation of Oracle*9iAS* 9.0.3. If you are planning on adding additional Oracle*9iAS* 9.0.3 instances, make sure the installed instances (with the exception of Enterprise Manager) are running at the time of additional installation.

See Also:

- [Section 3.2.2, "About the Oracle Enterprise Manager Web Site"](#)
- [Appendix A, "Default Port Numbers and Port Ranges"](#)
- [Section 2.5, "Preinstallation Tasks"](#)
- *Oracle*9i* Application Server Administrator's Guide.*

3.2.10 Changing the X Server Display

To change the X server display following installation you must edit the `opmn.xml` file installed on your computer.

The `opmn.xml` file is located at:

```
ORACLE_HOME/opmn/conf/opmn.xml
```

The format of the `opmn.xml` file is:

```
<prop name="DISPLAY" value="hostname:display_number.screen_number"/>
```

`hostname:display_number.screen_number` is the X server you want to use.

After you modify the `opmn.xml` file, restart all of your OC4J instances.

See Also: [Section 2.5.3.2, "DISPLAY"](#)

3.2.11 Oracle9iAS 9.0.3 Demonstration Software

Oracle9iAS 9.0.3 provides demonstration applications for Oracle9iAS 9.0.3 components.

In order to run a demonstration for an Oracle9iAS 9.0.3 component, you must have an Oracle9iAS 9.0.3 installation that contains the component, the component must be configured, and the required component instances must be running.

For more information and to run the demonstration software, go to the Welcome Page and click **Demonstrations**.

See Also: *Oracle9i Application Server Administrator's Guide*

3.2.12 Oracle9iAS TopLink

Oracle9iAS TopLink enables you to map a Java object model to a relational database and non-relational data sources. This bridges the gap between objects and the relations that exist among them and relational databases. Objects are a very flexible way of storing data and relationships between data, so representing objects in a relational database can be complicated. Oracle9iAS TopLink is supported by Oracle9iAS 9.0.3 and Oracle9iAS 9.0.2. Oracle9iAS TopLink is available in the Oracle9iAS CD pack. Refer to the Oracle9iAS TopLink CD for more information.

3.2.13 Oracle9iAS Portal Developer Kit for J2EE and Web Services

The Oracle9iAS Portal Developer Kit for J2EE and Web Services (9.0.2.0.2) can be used to develop portlets based upon J2EE 1.3 applications running in Oracle9iAS 9.0.3. You can also develop portlets from available Web Services. These portlets can be registered with an Oracle9iAS Portal 9.0.2 environment. The Oracle9iAS Portal Developer Kit for J2EE and Web Services is available for download from

<http://portalstudio.oracle.com>.

3.2.14 Additional Oracle9iAS 9.0.3 Installations

For information on installing additional Oracle9iAS 9.0.3 installations, refer to [Section 2.7.3, "Additional Oracle9iAS 9.0.3 Installations"](#).

3.2.15 Additional Documentation

For further information on postinstallation and configuration tasks, refer to the *Oracle9i Application Server Administrator's Guide* and component-specific documentation.

Silent and Non-Interactive Installation

This chapter guides you through the silent and non-interactive installation of Oracle9i Application Server Release 2 (9.0.3) (Oracle9iAS 9.0.3). The topics include:

- [Introduction](#)
- [Requirements](#)
- [Preinstallation](#)
- [Create the Response File](#)
- [Start the Installation](#)
- [Postinstallation](#)
- [Response File Parameter Definitions](#)

4.1 Introduction

Oracle9iAS 9.0.3 features two methods of non-interactive installation:

- [Silent Installation](#)
- [Non-Interactive Installation](#)

4.1.1 Silent Installation

Silent installation of Oracle9iAS 9.0.3 is accomplished by supplying the Oracle Universal Installer with a response file and specifying the `-silent` flag on the command line. The response file is a text file.

The installer uses the variables and parameter values contained in the response file to provide answers to all of the installer prompts. You include responses for all of the installer prompts in the response file. Silent installation displays *no graphical* output.

If this is the first silent installation of Oracle9iAS 9.0.3, you must create a response file before starting. File creation is described in [Section 4.3, "Preinstallation"](#). File parameters are described in [Section 4.7, "Response File Parameter Definitions"](#).

Following installation of Oracle9iAS 9.0.3, you need to run the `root.sh` script. The `root.sh` script detects settings of environmental variables and allows you to enter the full path of the local bin directory.

Use silent installation of Oracle9iAS 9.0.3 when there are similar installations on more than one computer. Additionally, use silent install when performing the Oracle9iAS 9.0.3 installation from a remote location using the command line. Silent installation eliminates the need to monitor the Oracle9iAS 9.0.3 installation because there is no graphical output and no input by the user.

Note: The installer will fail if you attempt a silent session without appropriately configuring a response file.

4.1.2 Non-Interactive Installation

Non-interactive installation of Oracle*9iAS* 9.0.3 is also accomplished by supplying the Oracle Universal Installer with a response file but without specifying the `-silent` flag on the command line. The response file is a text file. The installer uses the variables and parameter values contained in the response file to provide answers to some or all of the installer user prompts. There is graphical output and if you have not provided responses to all of the installer prompts, you may need to enter information during the installation.

If this is a first non-interactive installation of Oracle*9iAS* 9.0.3, you must create a response file before starting. File creation is described in [Section 4.3, "Preinstallation"](#). File parameters are described in [Section 4.7, "Response File Parameter Definitions"](#).

Following installation of Oracle*9iAS* 9.0.3, you need to run the `root.sh` script. The `root.sh` script detects settings of environmental variables and allows you to enter the full path of the local bin directory.

Use non-interactive installation of Oracle*9iAS* 9.0.3 when there are specific screens you want to observe during installation. Additionally, you can use non-interactive installation when performing the Oracle*9iAS* 9.0.3 installation from a remote location using the command line.

See Also: [Section 2.5.3.2, "DISPLAY"](#) for more information about remote installation.

4.2 Requirements

For a complete list of Oracle*9iAS* 9.0.3 installation requirements, refer to [Chapter 2, "Getting Started"](#).

4.3 Preinstallation

If the `oraInst.loc` file does not exist on your computer, you must create the file before starting the silent and non-interactive installation of Oracle9iAS 9.0.3.

The `oraInst.loc` file is typically stored in the `/var/opt/oracle/` directory. The file is used by the Oracle Universal Installer during installation.

As the root user, create the `oraInst.loc` file in the `/var/opt/oracle/` directory. The `oracle` group is the group performing the installation.

Enter the following line of text in the `oraInst.loc` file:

```
inventory_loc=/full_path/oui_inventory
```

The `oraInst.loc` file specifies `inventory_loc` location for inventory files. If the `oraInst.loc` file is not located in your Oracle home, make sure the file has read and write permission for the `oracle` group.

See Also: [Chapter 2, "Getting Started"](#)

4.4 Create the Response File

Before silent or non-interactive installation you must provide information specific to your installation.

You must create a response file using any text editor or use the templates available in the `stage/Response` directory on Disk1 of your Oracle9iAS 9.0.3 product CD-ROM. The response file you use must match the examples shown. Each type of Oracle9iAS 9.0.3 installation uses the response parameters listed below:

```
[SESSION]
UNIX_GROUP_NAME="your_unix_group_name"
FROM_LOCATION="/mount_point/stage/products.jar"
FROM_LOCATION_CD_LABEL="Oracle9i Application Server 9.0.3.0.0"
ORACLE_HOME="ORACLE_HOME"
ORACLE_HOME_NAME="ORACLE_HOME_NAME"
SHOW_SPLASH_SCREEN=true
SHOW_WELCOME_PAGE=false
SHOW_COMPONENT_LOCATIONS_PAGE=false
SHOW_CUSTOM_TREE_PAGE=false
SHOW_SUMMARY_PAGE=false
SHOW_INSTALL_PROGRESS_PAGE=true
SHOW_REQUIRED_CONFIG_TOOL_PAGE=false
SHOW_OPTIONAL_CONFIG_TOOL_PAGE=false
SHOW_RELEASE_NOTES=false
SHOW_ROOTSH_CONFIRMATION=false
SHOW_END_SESSION_PAGE=false
SHOW_EXIT_CONFIRMATION=false
NEXT_SESSION=false
NEXT_SESSION_ON_FAIL=false
SHOW_DEINSTALL_CONFIRMATION=false
SHOW_DEINSTALL_PROGRESS=true
```

Note: Oracle recommends specifying either "true" or "false" for Boolean parameters.

See Also: [Section 4.7, "Response File Parameter Definitions"](#)

4.4.1 Oracle9iAS 9.0.3 Without Oracle9iAS Single Sign-On

The following text shows the parameter definitions for installation of Oracle9iAS 9.0.3 without Oracle9iAS Single Sign-On:

```
[oracle.iappserver.iapptop_9.0.3.0.0]
  szl_InstanceInformation={"iASInstanceName", "iASInstancePassword",
  "iASInstancePassword"}
  b_configureCalypso=true
  SSOselectStatus="N"
  SSOport="sso_port"
  SSOhost="sso_hostname.domain"
  SHOW_IAS_COMPONENT_CONFIG_PAGE=false
  nValidationOID=0
  nValidationInstanceInfo=0
  nValidationCoreSSO=0
```

See Also: [Section 4.7, "Response File Parameter Definitions"](#)

4.4.2 Oracle9iAS 9.0.3 With Oracle9iAS Single Sign-On

The following text shows the parameter definitions for installation of Oracle9iAS 9.0.3 with Oracle9iAS Single Sign-On:

```
[oracle.iappserver.iapptop_9.0.3.0.0]
OIDport="oid_port"
OIDhost="oid_hostname.domain"
szl_OIDUserOutput={"cn=orcladmin", "oid_password"}
szl_InstanceInformation={"iASInstanceName",
"iASInfrastructureInstancePassword", "iASInfrastructureInstancePassword"}
b_configureCalypso=true
SSOselectStatus="Y"
SSOport="sso_port"
SSOhost="sso_hostname.domain"
SHOW_IAS_COMPONENT_CONFIG_PAGE=false
nValidationOID=0
nValidationInstanceInfo=0
nValidationCoreSSO=0
```

See Also: [Section 4.7, "Response File Parameter Definitions"](#)

Note: The Oracle9iAS Infrastructure 9.0.2 *ORACLE_*
HOME/install/portlist.ini and *ORACLE_*
HOME/config/ias.properties files show port assignments.

4.5 Start the Installation

To make the installer use the response file at install time, open a command prompt window and specify the location of the response file that you wish to use as a parameter when starting the installer.

To perform a non-interactive installation session:

```
prompt> setenv DISPLAY ias_hostname:0.0
prompt> ./runInstaller -responseFile path/responsefile
```

To perform a completely silent installation session, use the `-silent` parameter:

```
prompt> setenv DISPLAY ias_hostname:0.0
prompt> ./runInstaller -silent -responseFile path/responsefile
```

See Also: [Chapter 2.6.4, "Starting Oracle Universal Installer"](#)

4.6 Postinstallation

The success or failure of the non-interactive and silent installations is logged in the `installActions.log` file. Additionally, the silent installation creates the `silentInstall.log` file. The log files are created in the `oraInventory` directory during installation.

The `silentInstall.log` file contains the following line if your installation was successful:

```
The installation of Oracle9iAS Installation_Type was successful.
```

The `installActions.log` file contains specific information for each Oracle9iAS 9.0.3 installation. The following sections show information specific to each type of Oracle9iAS 9.0.3 installation:

- [Oracle9iAS 9.0.3 without Oracle9iAS Single Sign-On](#)
- [Oracle9iAS 9.0.3 with Oracle9iAS Single Sign-On](#)

See Also: [Section 2.6.3, "Oracle Universal Installer oraInventory Directory"](#)

4.6.1 Oracle9iAS 9.0.3 without Oracle9iAS Single Sign-On

The `installActions.log` file contains the following information for successful Oracle9iAS 9.0.3 without Oracle9iAS Single Sign-On installation:

```
Configuration tool Java Security Configuration Assistant succeeded
Configuration tool HTTP Server Configuration Assistant succeeded
Configuration tool OC4J Configuration Assistant succeeded
Configuration tool BC4J Configuration Assistant succeeded
Configuration tool Clickstream Collector Agent Configuration Assistant succeeded
Configuration tool Oracle9iAS Web Cache Configuration Assistant succeeded
Configuration tool Oracle9iAS Instance Configuration Assistant succeeded
Configuration tool OC4J Instance Configuration Assistant succeeded
Configuration tool OPMN Configuration Assistant succeeded
Configuration tool Enterprise Manager Web Site Configuration Assistant succeeded
Configuration tool DCM Repository Backup Assistant succeeded
```

Note: Enterprise Manager Web Site Configuration Assistant and Distributed Configuration Management (DCM) Repository Backup Assistant success messages appear during installation of Oracle9iAS 9.0.3.

4.6.2 Oracle9iAS 9.0.3 with Oracle9iAS Single Sign-On

The `installActions.log` file contains the following information for successful Oracle9iAS 9.0.3 with Oracle9iAS Single Sign-On installation:

```
Configuration tool Infrastructure Use Configuration Assistant succeeded
Configuration tool Java Security Configuration Assistant succeeded
Configuration tool HTTP Server Configuration Assistant succeeded
Configuration tool OC4J Configuration Assistant succeeded
Configuration tool BC4J Configuration Assistant succeeded
Configuration tool Clickstream Collector Agent Configuration Assistant succeeded
Configuration tool Oracle9iAS Web Cache Configuration Assistant succeeded
Configuration tool Oracle9iAS Instance Configuration Assistant succeeded
Configuration tool OC4J Instance Configuration Assistant succeeded
Configuration tool OPMN Configuration Assistant succeeded
Configuration tool Enterprise Manager Web Site Configuration Assistant succeeded
Configuration tool DCM Repository Backup Assistant succeeded
```

Note: Enterprise Manager Web Site Configuration Assistant and DCM Repository Backup Assistant success messages appear during installation of Oracle9iAS 9.0.3.

4.7 Response File Parameter Definitions

The section describes the parameters used for silent and non-interactive installation.

UNIX_GROUP_NAME: The name of the UNIX group performing the installation.

FROM_LOCATION: The location of the Oracle9iAS 9.0.3 installation CD-ROM.

FROM_LOCATION_CD_LABEL: The label of the Oracle9iAS 9.0.3 installation CD-ROM.

ORACLE_HOME: The installation location of your Oracle home.

ORACLE_HOME_NAME: The name of your Oracle home for your Oracle9iAS 9.0.3 installation. The ORACLE_HOME_NAME must be unique for each Oracle9iAS 9.0.3 installation.

See Also: [Section 2.5.3.1, "ORACLE_HOME"](#)

SHOW Screens: For a silent installation leave these parameters at <Value Unspecified>. For a non-interactive installation, choose which screens will be seen (true) and not seen (false).

szl_OIDUserOutput: Set this parameter if you are pointing your Oracle9iAS 9.0.3 installation to an existing Oracle Internet Directory 9.0.2.

Add the following values for Oracle9iAS 9.0.3 installation:

- **cn=orcladmin:** Assumes orcladmin is the Oracle Internet Directory 9.0.2 user, in your existing Oracle Internet Directory 9.0.2 instance.
- **oid_password:** The password for the orcladmin, in the Oracle Internet Directory 9.0.2 instance.

OIDport: The port used by your existing Oracle Internet Directory 9.0.2 instance. Refer to the `ORACLE_HOME/install/portlist.ini` file in the Oracle9iAS Infrastructure 9.0.2 Oracle home to find the actual port number. This value must match the value specified in the `oid_port` in `szl_OIDUserOutput` parameter.

OIDhost: The host name and domain for your existing Oracle Internet Directory 9.0.2 instance. This value must match the value specified in the `oid_hostname.domain` in `szl_OIDUserOutput` parameter.

Ssoport: The port used by your existing Oracle9iAS Single Sign-On instance. Refer to the `install/portlist.ini` file in the Oracle9iAS Infrastructure 9.0.2 Oracle home to find the actual port number. This value must match the value specified for `sso_port` in the `szl_SsoUserOutput` parameter.

SSOhost: The host name and domain of your existing Oracle*9i*AS Single Sign-On instance. This value must match the value specified for `sso_hostname.domain` in the `szl_SSOUserOutput` parameter.

szl_InstanceInformation: Specify the following values:

- Instance Name for this Oracle*9i*AS 9.0.3 installation instance.
- Instance Password for this Oracle*9i*AS 9.0.3 installation instance.
 - If this is the first Oracle*9i*AS 9.0.3 on your computer you must specify a password.
 - If you are installing Oracle*9i*AS 9.0.3, and an existing Oracle*9i*AS 9.0.3 or Oracle*9i*AS 9.0.2 installation is on your computer, then you must use the same password created for the previous installation.

See Also:

- [Section 2.5.3.1, "ORACLE_HOME"](#)
- *Oracle9i Application Server 9.0.2 Installation Guide*

szl_RepositoryUserInput: Set this parameter if you have more than one Oracle*9i*AS Infrastructure 9.0.2 database registered in Oracle Internet Directory 9.0.2. In that case, specify the following values:

- **inf_hostname:** The host name of your Oracle*9i*AS Infrastructure 9.0.2 Installation.
- **inf_dbport:** The port of your Oracle*9i*AS Infrastructure 9.0.2 Database.
- **inf_SID:** The SID of your Oracle*9i*AS Infrastructure 9.0.2 Database.
- **inf_GlobalDBName:** The Global Database Name of your Oracle*9i*AS Infrastructure 9.0.2 Database.

SSOselectStatus: Set this parameter for Oracle*9i*AS 9.0.3 installation. Specify one of the following values:

- "Y": if you are configuring the installation with Oracle*9i*AS Single Sign-On
- "N": if you are not configuring with Oracle*9i*AS Single Sign-On

b_configureCalypso: Use this boolean parameter to specify whether (true, by default) or not (false) you want to launch the Oracle*9i*AS Web Cache Configuration Assistant at the end of the installation.

Mandatory Settings: The following parameter values, where required, must be specified exactly as shown:

```
SHOW_IAS_COMPONENT_CONFIG_PAGE=false  
nValidationInstanceInfo=0  
nValidationOID=0  
nValidationCoreSSO=0
```

Deinstallation and Reinstallation

This chapter guides you through the deinstallation and reinstallation process for Oracle9i Application Server Release 2 (9.0.3) (Oracle9iAS 9.0.3). The topics include:

- [Deinstallation](#)
- [Reinstallation](#)

5.1 Deinstallation

This section guides you through the deinstallation process of Oracle9iAS 9.0.3. This section includes the following topics:

- [Deinstalling an Oracle9iAS 9.0.3 Instance](#)
- [Deinstalling by Manually Removing All Oracle Products](#)

In order to successfully deinstall Oracle9iAS 9.0.3 from your host, Oracle recommends deinstalling all secondary (or subsequent) Oracle9iAS 9.0.3 installations before you deinstall the primary (or first) installation.

Your primary installation contains the active Oracle Enterprise Manager Web site (Oracle9iAS Administration Service). If you deinstall the primary installation and there are other installations of Oracle9iAS 9.0.3 on your host, the Oracle Universal Installer requests that you designate one of the remaining Oracle9iAS 9.0.3 installations to be the primary installation. The new primary installation will maintain the configuration information for the remaining Oracle9iAS 9.0.3 installations on the host.

You must stop all Oracle services and applications before starting the deinstallation process. Refer to the *Oracle9i Application Server Administrator's Guide* for instructions on starting and stopping the Oracle Enterprise Manager Web site.

Note: Oracle Universal Installer does not permit custom deinstallation of select components of Oracle9iAS 9.0.3 instances. Confirm deinstall objectives before launching deinstallation.

Note: Use the version of Oracle Universal Installer that comes with this release to deinstall any Oracle products installed on your system.

5.1.1 Deinstalling an Oracle9iAS 9.0.3 Instance

1. Start the Oracle Universal Installer. Once Oracle Universal Installer is launched, the Welcome screen appears.

Click **Deinstall Products**.

See Also: [Section 2.6.4, "Starting Oracle Universal Installer"](#)

2. Review the installations on the Inventory screen and check the one you wish to deinstall. Click **Remove**.

Note: The "+" sign before a product name indicates that there are more components and files installed within that particular product. Click on it to view dependent components. If you choose to remove a product or component, then all of its dependent components are also deinstalled. Confirm deinstall objectives before launching deinstallation.

Figure 5–1 Inventory Screen

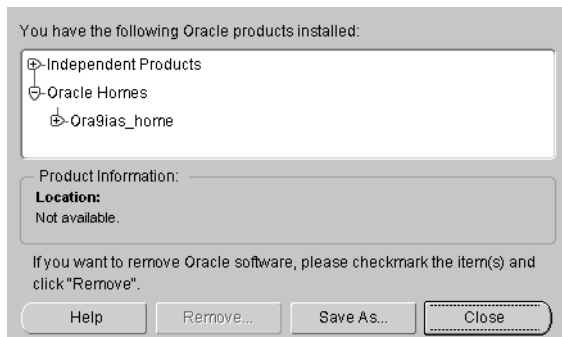

The Inventory screen appears when you click **Deinstall Products** on the Welcome screen, or **Installed Products** on any screen.

The Inventory screen displays installed components installed in an Oracle home.

The Inventory screen contains the following:

- **Product Information:** View the full location path of the selected component.
 - **Help:** Access detailed information about the functionality of the Inventory screen.
 - **Remove:** Deinstall all checked components from Oracle home.
 - **Save As:** Save the inventory to a text file. A file browser dialog pops up when you click **Save As**. Enter a file name to save the complete inventory list.
 - **Close:** Quit the Inventory screen and return to Oracle Universal Installer.
3. Verify the components selected for deinstallation, and click **Yes**.

Figure 5–2 Confirmation Screen

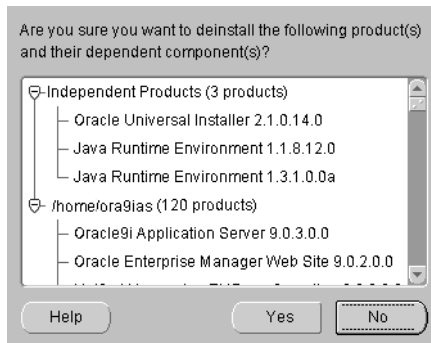

The Confirmation screen lists all the components selected for deinstallation in the Inventory screen. Scroll down the screen to verify selected components.

The following buttons appear on the Confirmation screen:

- **Help:** Access detailed information about the functionality of the Confirmation screen.
- **Yes:** Start deinstallation of listed components.
- **No:** Return to the Inventory screen. Listed components are not removed.

4. The following Oracle9iAS Administration Service screen appears if you are deinstalling the primary Oracle9iAS installation on the host. Confirm deinstallation objectives and click OK to continue.

Figure 5–3 Oracle9iAS Administration Service Screen

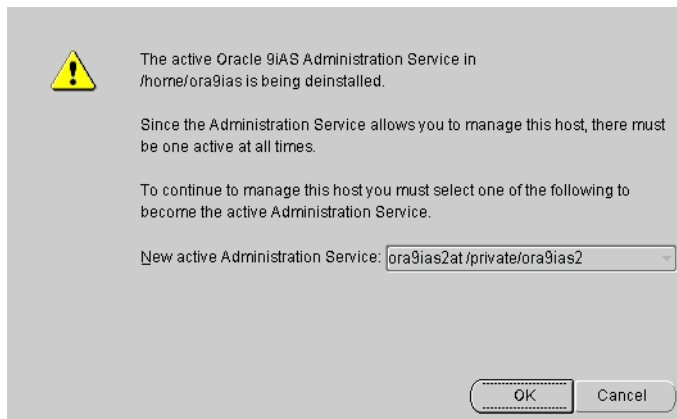

This screen presents one of the following messages:

- "The active Oracle9iAS Administration Service in your Oracle home is being deinstalled. There are no other Administration Services available."

This message appears when there is only one Oracle9iAS installation on the host and you are about to deinstall it.

- "The active Oracle9iAS Administration Service in your Oracle home is being deinstalled. Since the Administration Service allows you to manage this host, there must be one active at all times. To continue to manage this host you must select one of the following to become the active Administration Service."

A drop down list allows you to choose a new active Administration Service.

This message appears when there are multiple Oracle9iAS installations on the host and you are about to deinstall the primary installation. You can select one of the remaining Oracle9iAS installations which will then become the primary installation and the new location for the Oracle9iAS Administration Service.

5. Monitor the deinstallation process.

The Remove Progress Bar screen appears when you click **Remove**. The installer detects all components chosen for deinstallation from the Inventory screen and removes them from Oracle home.

- **Cancel:** To discontinue the deinstallation process.

Note: If you deinstall a product or component, then all of its dependent components will also be deinstalled.

6. Following deinstallation of Oracle9iAS 9.0.3 using Oracle Universal Installer, restart your computer to stop any remaining processes associated with the deinstallation.
7. Perform the following manual tasks to remove all remaining references to the instance from your computer:
 - a. Back up any files you want to save from the Oracle home directory for this instance.
 - b. Delete the Oracle home directory for this instance.
 - c. As the root user, open `/var/opt/oracle/oratab` in a text editor. Remove all lines that include the Oracle home directory.
8. If your Oracle9iAS 9.0.3 was associated with an Oracle9iAS Infrastructure on another host, then you must manually remove entries from the Oracle Internet Directory. Refer to the *Oracle9i Application Server Administrator's Guide* for further instructions.

5.1.2 Deinstalling by Manually Removing All Oracle Products

The following steps remove all Oracle products from your computer.

Caution: These instructions remove all Oracle components, services, and registry entries from your computer. Exercise extreme care when removing registry entries. Removing incorrect entries can cause a system failure. Oracle recommends following these steps after trying all other options.

1. If your Oracle9iAS 9.0.3 installation is associated with an Oracle9iAS Infrastructure that is on another host, then remove it from the DCM repository by running the following command:

```
prompt> ORACLE_HOME/dcm/bin/dcmctl destroyInstance -i myInstance
```

2. Stop all Oracle9iAS 9.0.3 processes.
3. Log in as the root user.
4. Delete the `oracle` directory located under `/var/opt` directory.
5. Delete the `oraInventory` directory.
6. Delete all directories and files located in your `ORACLE_HOME` directory.
7. Delete any Oracle files located in the `/tmp` and `/var/tmp` directories.
8. Reboot the system.
9. If your Oracle9iAS 9.0.3 was associated with an Oracle9iAS Infrastructure on another host, then you must manually remove entries from the Oracle Internet Directory. Refer to the *Oracle9i Application Server Administrator's Guide* for further instructions.

5.2 Reinstallation

Oracle Universal Installer does not allow reinstallation of Oracle*9iAS* 9.0.3 over an installed version. To reinstall Oracle*9iAS* 9.0.3 over the same version, deinstall and then install the product.

If you deinstall an Oracle*9iAS* 9.0.3 instance that uses an Oracle*9iAS* Infrastructure 9.0.2, you cannot reuse the same Oracle*9iAS* 9.0.3 instance name of that deinstalled instance when installing subsequent Oracle*9iAS* 9.0.3 instances. In order to reuse the Oracle*9iAS* 9.0.3 instance name, you must manually delete the entry for the deinstalled Oracle*9iAS* 9.0.3 instance in Oracle Internet Directory.

See Also:

- [Section 5.1, "Deinstallation"](#)
- *Oracle9i Application Server Administrator's Guide*

Default Port Numbers and Port Ranges

Oracle9i Application Server Release 2 (9.0.3) (Oracle9iAS 9.0.3) automatically assigns port numbers to a component when the component is configured. It chooses the port number from a pre-allocated set of default port numbers and port ranges.

Oracle9iAS 9.0.3 uses the following method to assign port numbers:

1. Determine if the default port number is already in use by
 - any Oracle product.
 - any running product.
2. If the default port number is not in use, assign it to the component.
3. If the default port number is already in use, attempt to assign a number from the port range, starting with the lowest number, until a free port number is found.

This appendix contains the following tables:

- [Oracle9iAS 9.0.3 Port Usage \(Sorted by Component\)](#)
- [Oracle9iAS 9.0.3 Port Usage \(Sorted by Port Number\)](#)

A.1 Oracle9iAS 9.0.3 Port Usage (Sorted by Component)

Table A-1 lists Oracle9iAS 9.0.3 ports by component names.

Table A-1 Oracle9iAS 9.0.3 Port Usage (Sorted by Component)

Component	Default Port Number	Port Number Range
OPMN		
Oracle Notification Service Requested Port	6003	6003-6099
Oracle Notification Service Local Port	6100	6100-6199
Oracle Notification Service Remote Port	6200	6200-6299
Oracle9iAS Containers for J2EE (OC4J)		
OC4J AJP	3001	3001-3100
OC4J RMI	3101	3101-3200
OC4J JMS	3201	3201-3300
OC4J HTTP Listener	3301	3301-3400
Oracle HTTP Server		
Oracle HTTP Server- non-SSL	7777	7777-7877
Oracle HTTP Server- SSL	4443	4443-4543
Oracle HTTP Server Listen- non-SSL	7777	7777-7877
Oracle HTTP Server- non-SSL- Oracle9iAS Web Cache is installed and configured	7778	7777-7877
Oracle HTTP Server- SSL	4443	4443-4543
Oracle HTTP Server- SSL- Oracle9iAS Web Cache is installed and configured	4444	4443-4543
Oracle HTTP Server JServ Servlet Engine	8007	8007-8107
Oracle HTTP Server- Java Object Cache	7000	7000-7010

Table A–1 Oracle9iAS 9.0.3 Port Usage (Sorted by Component) (Cont.)

Component	Default Port Number	Port Number Range
Oracle9iAS Web Cache		
Oracle9iAS Web Cache HTTP Listen-non-SSL	7777	7777-7877
Oracle9iAS Web Cache HTTP Listen-SSL	4443	4443-4543
Oracle9iAS Web Cache Administration	4000	4000-4030
Oracle9iAS Web Cache Invalidation	4001	4000-4030
Oracle9iAS Web Cache Statistics	4002	4000-4030
Oracle Enterprise Manager		
Oracle Enterprise Manager Application Server Administration Service	1810, 1811	1812-1820
Oracle Enterprise Manager Intelligent Agent	1748, 1754, 1808, 1809	Fixed

A.2 Oracle9iAS 9.0.3 Port Usage (Sorted by Port Number)

Table A-2 lists Oracle9iAS 9.0.3 ports in ascending order.

Table A-2 Oracle9iAS 9.0.3 Port Usage (Sorted By Port Number)

Port Number	Component
1748	Oracle Enterprise Manager Intelligent Agent
1754	Oracle Enterprise Manager Intelligent Agent
1808	Oracle Enterprise Manager Intelligent Agent
1809	Oracle Enterprise Manager Intelligent Agent
1810 - 1820	Oracle Enterprise Manager Application Server Service
3001 - 3100	Oracle9iAS Containers for J2EE - AJP
3101 - 3200	Oracle9iAS Containers for J2EE - RMI
3201 - 3300	Oracle9iAS Containers for J2EE - JMS
3301 - 3400	Oracle9iAS Containers for J2EE HTTP Listener
4000 - 4030	Oracle9iAS Web Cache Administration Port
4001	Oracle9iAS Web Cache Invalidation Port
4002	Oracle9iAS Web Cache Statistics
4443 - 4543	Oracle HTTP Server- SSL, Oracle HTTP Server Listen- SSL, Oracle9iAS Web Cache Listen- SSL
6003	OPMN- Oracle Notification Service Request Port
6100	OPMN- Oracle Notification Service Local Port
6200	OPMN- Oracle Notification Service Remote Port
7000 - 7010	Oracle HTTP Server Java Object Cache
7777 - 7877	Oracle HTTP Server- non-SSL, Oracle HTTP Server Listen- non-SSL, Oracle9iAS Web Cache Listen- non-SSL
8007 - 8107	Oracle HTTP Server JServ Servlet Engine

B

Troubleshooting

This appendix lists some methods for troubleshooting your Oracle9i Application Server Release 2 (9.0.3) (Oracle9iAS 9.0.3) installation. It includes the following topics:

- [Troubleshooting the Installation](#)
- [Troubleshooting Oracle9iAS Configuration Assistants](#)
- [Descriptions of Oracle9iAS Configuration Assistants](#)

B.1 Troubleshooting the Installation

Oracle recommends reviewing the following for troubleshooting your Oracle9iAS 9.0.3 installation:

- [Verify Hardware and Preinstallation Requirements](#)
- [What to Do If An Installation Error Occurs](#)

B.1.1 Verify Hardware and Preinstallation Requirements

Note the following information before performing any of the troubleshooting steps in this appendix:

- Do the host specifications meet the requirements specified in [Chapter 2, "Getting Started"](#)?

Review the following sections, which specifically describe requirements and preinstallation tasks:

- [Section 2.1, "Preinstallation Summary"](#)
 - [Section 2.2, "Hardware Requirements"](#)
 - [Section 2.3, "Operating System Requirements"](#)
 - [Section 2.5, "Preinstallation Tasks"](#)
 - [Section 2.6.2, "Oracle Universal Installer Prerequisite Checks"](#)
- If your installation is using an Oracle9iAS Infrastructure, then was the infrastructure running during this installation?

B.1.1.1 Release Notes

Oracle recommends reading the *Oracle9i Application Server 9.0.3 Release Notes* prior to installing Oracle9iAS 9.0.3. *Oracle9i Application Server 9.0.3 Release Notes* are available with the platform-specific documentation. The latest version of the Release Notes are available on OTN at

<http://otn.oracle.com/products/ias/content.html>

B.1.1.2 Verify TMP or Swap Space

Use the following command to display free swap space:

```
prompt> swap -s
```

Your host must meet the minimum swap space requirement described in [Section 2.2, "Hardware Requirements"](#). If you do not have enough swap space, then perform the following tasks:

1. Login as the system root user.
2. Create an empty swap file using the following command:

```
prompt> mkfile sizeM swap_file_name
```

The minimum size of this file must be greater than the difference between the currently available swap space and required swap space. For example, if you have 100 MB of free swap space and the installation requires 256 MB, then this swap file must be at least 156 MB.

3. Add the file to the swap space using the following command:

```
prompt> swap -a swap_file_name
```

4. Verify that the new swap space meets the requirements by running the following command:

```
prompt> swap -s
```

B.1.2 What to Do If An Installation Error Occurs

If you encounter an error during installation of Oracle9iAS 9.0.3:

- When an error occurs, do not exit Oracle Universal Installer. This makes it easier to find the log files.
- If you entered incorrect information on one of the install screens during the interview phase, then you can return to previous installation screens by clicking **Previous** until you reach the screen you would like to edit.
- If you encounter an error while the installer is copying or linking files, then you must perform the following tasks:
 1. Note the error and review the installation logs at for causes:
 - * `oraInventory_location/logs/installActionstimestamp.log`
 - * `oraInventory_location/logs/oraInstalltimestamp.err`
 - * `oraInventory_location/logs/oraInstalltimestamp.out`
 2. Remove the failed installation by following the steps in [Chapter 5, "Deinstallation and Reinstallation"](#).
 3. Correct the issue that caused the error.
 4. Start the Oracle9iAS 9.0.3 installation again.

B.2 Troubleshooting Oracle9iAS Configuration Assistants

To troubleshoot an installation error that occurs when the Oracle9iAS Configuration Assistants are running:

- Review the log files listed in [Section B.1.2, "What to Do If An Installation Error Occurs"](#) and the component log files in [Section B.3, "Descriptions of Oracle9iAS Configuration Assistants"](#). Try to fix the issue that caused the error.
- If you see a 'Fatal Error. Reinstall' message, then try to find the cause of the problem by analyzing the log files. Refer to [Section B.2.3, "Fatal Errors"](#) for further instructions.

B.2.1 Configuration Assistant Failure

Oracle9iAS Configuration Assistant failures are noted at the bottom of the Installation Screen. The Oracle9iAS Configuration Assistant interface, if applicable, displays additional information. The Oracle9iAS Configuration Assistant execution status will be identified by the result code called <exit-code>.The result codes are:

Status	Result Code
Configuration Assistant Succeeded	0
Configuration Assistant Failed	1
Configuration Assistant Cancelled	-1

This result code is written to the following log file:

oraInventory/logs/installActionstimestamp.log

B.2.2 Failure During Component Configuration and Startup

During installation, configuration assistants launch when the Configuration Tools screen appears. If a configuration assistant fails at this point, then try the following procedure to correct the problem.

1. Review the installation log files for this instance.
2. Review the log files for the configuration assistant.
3. Correct the problem that caused the failure.

4. Refer to the section describing the configuration assistant in [Section B.3, "Descriptions of Oracle9iAS Configuration Assistants"](#).
 - a. If the failing configuration assistant has any dependencies, then run the dependencies again. You must do this, even if the dependency completed successfully.
 - b. Run the failing configuration assistant again. If you are using the installer, then select the configuration assistant and click the **Retry** button. If you are running the configuration assistant from a command prompt, then run it using the command in the "Command Line" section of the description.

Note: If a configuration assistant has an "Initial Tasks" section, then you must perform these tasks before running the assistant.

B.2.3 Fatal Errors

Some configuration assistant failures are "fatal errors." You will not be able to recover from a fatal error by correcting the problem and continuing. You must remove the current installation and then restart the process of installing Oracle9iAS 9.0.3. The following tasks describe the recovery procedure:

1. Deinstall the failed installation using the procedure in [Section 5.1.1, "Deinstalling an Oracle9iAS 9.0.3 Instance"](#).
2. Correct the issue that caused the fatal error.
3. Reinstall Oracle9iAS.
4. If the fatal error reoccurs, then you must remove all Oracle installations from your host using the procedure in [Section 5.1.2, "Deinstalling by Manually Removing All Oracle Products"](#).

B.3 Descriptions of Oracle9iAS Configuration Assistants

This section lists the Oracle9iAS Configuration Assistants in alphabetical order. Different installations will use different configuration assistants depending on configuration options. Refer to the

This section describes the following assistants:

- [BC4J Configuration Assistant](#)
- [Clickstream Collector Agent Configuration Assistant](#)
- [DCM Repository Backup Assistant](#)
- [Enterprise Manager Web site Configuration Assistant](#)
- [HTTP Server Configuration Assistant](#)
- [Infrastructure Use Configuration Assistant](#)
- [Java Security Configuration Assistant](#)
- [OC4J Configuration Assistant](#)
- [OC4J Instance Configuration Assistant](#)
- [OPMN Configuration Assistant](#)
- [Oracle9iAS Instance Configuration Assistant](#)
- [Oracle9iAS Web Cache Configuration Assistant](#)

B.3.1 BC4J Configuration Assistant

The BC4J Configuration Assistant integrates BC4J with the Oracle Enterprise Manager Web site.

Modifies the Following Configuration Files

ORACLE_HOME/sysman/emd/targets.xml

Writes to the Following Log Files

None.

Initial Tasks

Remove all BC4J entries from the configuration files above, if they exist.

Command Line

```
ORACLE_HOME/jdk/bin/java -classpath ORACLE_HOME/jlib/emConfigInstall.jar:\  
ORACLE_HOME/jlib/repository.jar:\  
ORACLE_HOME/sysman/webapps/emd/WEB-INF/lib/bc4joem.jar \  
oracle.jbo.server.emd.ConfigOEM ORACLE_HOME instance_name.hostname.domain
```

Dependencies

None.

B.3.2 Clickstream Collector Agent Configuration Assistant

The Clickstream Collector Agent Configuration Assistant integrates the Oracle9iAS Clickstream Collector Agent with the Oracle Enterprise Manager Web site.

Modifies the Following Configuration Files

ORACLE_HOME/sysman/emd/targets.xml

ORACLE_HOME/sysman/webapps/emd/WEB-INF/config/consoleConfig.xml

ORACLE_HOME/dcm/config/sysmgmtProperties.xml

Writes to the Following Log Files

None.

Initial Tasks

Remove all Oracle9iAS Clickstream Collector Agent entries in the configuration files above.

Command Line

```
ORACLE_HOME/jdk/bin/java -classpath ORACLE_HOME/click/lib/click.jar:\
ORACLE_HOME/sysman/jlib/emConfigInstall.jar:\
ORACLE_HOME/jlib/emConfigInstall.jar:ORACLE_HOME/jlib/repository.jar \
oracle.click.common.OEMIntegrate ORACLE_HOME
```

Dependencies

[Infrastructure Use Configuration Assistant](#)

B.3.3 DCM Repository Backup Assistant

The DCM Repository Backup Assistant enables you to back up your DCM repository.

Modifies the Following Configuration Files

None.

Writes to the Following Log Files

ORACLE_HOME/dcm/logs/dcmctl_logs/log.xml

ORACLE_HOME/dcm/logs/emd_logs/log.xml

Initial Tasks

None.

Command Line

```
ORACLE_HOME/dcm/bin/dcmctl saveInstance -dir backup_directory
```

Note: If *backup_directory* does not exist, then this configuration assistant will create it. If *backup_directory* exists, then it must be empty. If it is not empty then the assistant will fail.

Dependencies

None.

B.3.4 Enterprise Manager Web site Configuration Assistant

The Enterprise Manager Web site Configuration Assistant configures Oracle9iAS components to deploy applications through the Oracle Enterprise Manager Web site.

Modifies the Following Configuration Files

None.

Writes to the Following Log Files

ORACLE_HOME/sysman/log/em-servlet.log

ORACLE_HOME/sysman/log/emd.log

ORACLE_HOME/sysman/log/em.log

ORACLE_HOME/sysman/log/server.log

ORACLE_HOME/sysman/log/em-application.log

ORACLE_HOME/sysman/log/em-web-access.log

ORACLE_HOME/sysman/log/rmi.log

ORACLE_HOME/dcm/logs/dcmctl_logs/log.xml

ORACLE_HOME/dcm/logs/emd_logs/log.xml

Initial Tasks

None.

Command Line

ORACLE_HOME/bin/emctl start -silent

Dependencies

None.

B.3.5 HTTP Server Configuration Assistant

The HTTP Server Configuration Assistant adds the Oracle HTTP Server target to the *ORACLE_HOME/sysman/emd/targets.xml* file.

Modifies the Following Configuration Files

ORACLE_HOME/sysman/emd/targets.xml

Writes to the Following Log Files

None.

Initial Tasks

Remove the Oracle HTTP Server target from *targets.xml*.

Command Line

```
ORACLE_HOME/jdk/bin/java -jar ORACLE_HOME/jlib/emConfigInstall.jar \  
targets ORACLE_HOME/Apache/Apache/conf/ohstarget.xml
```

Dependencies

None.

B.3.6 Infrastructure Use Configuration Assistant

The Infrastructure Use Configuration Assistant enables Oracle9iAS 9.0.3 usage with Oracle9iAS Infrastructure 9.0.2.

Modifies the Following Configuration Files

ORACLE_HOME/Apache/Apache/conf/httpd.conf
ORACLE_HOME/dcm/config/dcm.conf
ORACLE_HOME/dcm/repository/*
ORACLE_HOME/j2ee/home/config/jazn.xml

Writes to the Following Log Files

ORACLE_HOME/config/useinfratool.log
ORACLE_HOME/dcm/logs/dcmctl_logs/log.xml
ORACLE_HOME/dcm/logs/emd_logs/log.xml

Initial Tasks

1. Open *ORACLE_HOME*/config/infratool.properties in a text editor.
2. Change the flag at the end of each line from \$0 to \$-1.

Command Line

```
ORACLE_HOME/jdk/bin/java -classpath .:ORACLE_HOME/sso/lib/ossoreg.jar:\
ORACLE_HOME/jlib/ojmisc.jar:ORACLE_HOME/jlib/repository.jar:\
ORACLE_HOME/j2ee/home/jazn.jar:ORACLE_HOME/j2ee/home/jaas.jar:\
ORACLE_HOME/jdk/lib/dt.jar:ORACLE_HOME/jdk/lib/tools.jar:\
ORACLE_HOME/jlib/infratool.jar \
oracle.ias.configtool.UseInfrastructure \
-f ORACLE_HOME/config/infratool.properties \
-h hostname.domain -p OID_port -u cn=orcladmin -w oidadmin_password \
-s infrastructure_hostname.domain -r midtier_OHS_port \
-o ORACLE_HOME -m instance_name.hostname.domain \
-infra infrastructureDB_service_name
```

Dependencies

None.

B.3.7 Java Security Configuration Assistant

The Java Security Configuration Assistant sets and reassigns new passwords for JAAS security.

Modifies the Following Configuration Files

ORACLE_HOME/j2ee/home/config/jazn_data.xml

Writes to the Following Log Files

None.

Initial Tasks

Set the *LD_LIBRARY_PATH* environment variable to *ORACLE_HOME/lib*.

Command Line

```
ORACLE_HOME/jdk/bin/java \  
-classpath ORACLE_HOME/dcm/lib/dcm.jar:ORACLE_HOME/j2ee/home/jazn.jar:\  
ORACLE_HOME/j2ee/home/jaas.jar:ORACLE_HOME/j2ee/home/oc4j.jar:\  
ORACLE_HOME/jlib/ojmisc.jar \  
-Doracle.security.jazn.config=ORACLE_HOME/j2ee/home/jazn/install/jazn.xml \  
oracle.security.jazn.util.JAZNInstallHelper -realm jazn.com \  
-user admin -oldpwd welcome -newpwd new_password
```

Note: "welcome" is the default password when this assistant fails. If it completes successfully, then the assistant will store a more secure password in *jazn_data.xml*.

Dependencies

None.

B.3.8 OC4J Configuration Assistant

The OC4J Configuration Assistant integrates OC4J with the Oracle Enterprise Manager Web site.

Modifies the Following Configuration Files

ORACLE_HOME/sysman/emd/targets.xml

Writes to the Following Log Files

None.

Initial Tasks

None.

Command Line

```
ORACLE_HOME/jdk/bin/java -classpath \  
ORACLE_HOME/install/lib/oc4jcfg.jar:ORACLE_HOME/jlib/emConfigInstall.jar:\   
ORACLE_HOME/jlib/repository.jar:ORACLE_HOME/lib/xmlparserv2.jar:\   
ORACLE_HOME/jdbc/lib/classes12.zip:ORACLE_HOME/jdbc/lib/nls_charset12.jar:\   
ORACLE_HOME/jlib/jndi.jar:ORACLE_HOME/jlib/rt.jar:ORACLE_HOME/jdk/lib/i18n.jar:\   
ORACLE_HOME/jlib/ldapjclnt9.jar:ORACLE_HOME/jlib/ojmisc.jar:\   
ORACLE_HOME/j2ee/home/jazn.jar:ORACLE_HOME/j2ee/home/jaas.jar \  
oc4jConfig -oh ORACLE_HOME
```

Dependencies

None.

B.3.9 OC4J Instance Configuration Assistant

The OC4J Instance Configuration Assistant configures OC4J instances for deployed Oracle9iAS applications.

Modifies the Following Configuration Files

ORACLE_HOME/Apache/Apache/conf/mod_oc4j.conf
ORACLE_HOME/j2ee/OC4J_Demos/*
ORACLE_HOME/j2ee/home/application-deployments/*
ORACLE_HOME/j2ee/home/applications/*
ORACLE_HOME/j2ee/home/connectors/*
ORACLE_HOME/j2ee/home/config/*
ORACLE_HOME/j2ee/home/persistence/*
ORACLE_HOME/dcm/config/dcm.conf
ORACLE_HOME/dcm/repository/*
ORACLE_HOME/opmn/conf/opmn.xml
ORACLE_HOME/opmn/conf/ons.conf

Writes to the Following Log Files

ORACLE_HOME/j2ee/OC4J_Demos/application-deployments*/OC4J_Demos_default_island_1/application.log
ORACLE_HOME/j2ee/OC4J_Demos/log/OC4J_Demos_default_island_1/server.log
ORACLE_HOME/j2ee/OC4J_Demos/log/OC4J_Demos_default_island_1/global-application.log
ORACLE_HOME/j2ee/OC4J_Demos/log/OC4J_Demos_default_island_1/default-web-access.log
ORACLE_HOME/j2ee/OC4J_Demos/log/OC4J_Demos_default_island_1/jms.log
ORACLE_HOME/j2ee/OC4J_Demos/log/OC4J_Demos_default_island_1/rmi.log
ORACLE_HOME/opmn/logs/OC4J_Demos*
ORACLE_HOME/j2ee/home/log/home_default_island_1/server.log
ORACLE_HOME/j2ee/home/log/home_default_island_1/global-application.log
ORACLE_HOME/j2ee/home/log/home_default_island_1/default-web-access.log
ORACLE_HOME/j2ee/home/log/home_default_island_1/jms.log
ORACLE_HOME/j2ee/home/log/home_default_island_1/rmi.log
ORACLE_HOME/j2ee/home/application-deployments*/home_default_island_1/application.log
ORACLE_HOME/opmn/logs/home*
ORACLE_HOME/dcm/logs/dcmctl_logs/log.xml
ORACLE_HOME/dcm/logs/emd_logs/log.xml
ORACLE_HOME/j2ee/home/log/log.xml

Initial Tasks

1. If your installation uses Oracle9iAS Infrastructure and the OC4J Instance Configuration Assistant fails, then there is a fatal error and you cannot recover without reinstalling.

See Also: [Section B.2.3, "Fatal Errors"](#) on page B-6

2. Shutdown opmn and all managed processes with the following command:

```
prompt> ORACLE_HOME/opmn/bin/opmnctl stopall
```

3. Remove files from the failed deployment with the following command:

```
prompt> rm -rf ORACLE_HOME/dcm/repository/*
prompt> rm -rf ORACLE_HOME/dcm/config/dcm.conf
prompt> rm -rf ORACLE_HOME/opmn/conf/ons.conf
prompt> rm -rf ORACLE_HOME/j2ee/OC4J_*
prompt> rm -rf ORACLE_HOME/j2ee/home/log/log.xml
```

4. If `deploy.ini` does not exist in the `ORACLE_HOME/j2ee` directory, then rename `deploy.ini.number.bak` to `deploy.ini`.
5. In `ORACLE_HOME/opmn/conf/opmn.xml` remove sections related to all OC4J instances except for the `home` instance. For example, the section for the OC4J.Demos instance looks like the following:

```
<oc4j instanceName="OC4J_Demos" gid="OC4J_Demos">
    ....
</oc4j>
```

Command Line

```
ORACLE_HOME/jdk/bin/java -mx512M \
-classpath ORACLE_HOME/j2ee/home/jaznplugin.jar:ORACLE_HOME/j2ee/home/jazn.jar:\
ORACLE_HOME/jlib/emConfigInstall.jar:ORACLE_HOME/lib/xmlparserv2.jar:\
ORACLE_HOME/lib/xschem.jar:ORACLE_HOME/dcm/lib/dcm.jar:\
ORACLE_HOME/jdbc/lib/classes12.jar:ORACLE_HOME/lib/dms.jar:\
ORACLE_HOME/j2ee/home/oc4j.jar:ORACLE_HOME/opmn/lib/ons.jar:\
ORACLE_HOME/dcm/lib/oc4j_deploy_tools.jar \
-Doracle.ias.sysmgmt.logging.logdir=ORACLE_HOME/j2ee/home/log \
oracle.j2ee.tools.deploy.Oc4jDeploy \
-oraclehome ORACLE_HOME -verbose -infile ORACLE_HOME/j2ee/deploy.ini
```

Dependencies

None.

B.3.10 OPMN Configuration Assistant

The OPMN Configuration Assistant enables the monitoring of Oracle9iAS processes in the `ORACLE_HOME/opmn/conf/opmn.xml` file.

Modifies the Following Configuration Files

None.

Writes to the Following Log Files

```
ORACLE_HOME/Apache/Apache/logs/error_log
ORACLE_HOME/Apache/Apache/logs/ssl_engine_log
ORACLE_HOME/Apache/Apache/logs/access_log
ORACLE_HOME/Apache/Apache/logs/ssl_request_log
ORACLE_HOME/opmn/logs/HTTP_Server.log
ORACLE_HOME/j2ee/home/log/home_default_island_1/server.log
ORACLE_HOME/j2ee/home/log/home_default_island_1/global-application.log
ORACLE_HOME/j2ee/home/log/home_default_island_1/default-web-access.log
ORACLE_HOME/j2ee/home/log/home_default_island_1/jms.log
ORACLE_HOME/j2ee/home/log/home_default_island_1/rmi.log
ORACLE_HOME/j2ee/home/application-deployments/*/home_default_island_1/application.log
ORACLE_HOME/opmn/logs/home.default_island.1
ORACLE_HOME/j2ee/OC4J_Demos/application-deployments/*/OC4J_Demos_default_island_1/application.log
ORACLE_HOME/j2ee/OC4J_Demos/log/OC4J_Demos_default_island_1/server.log
ORACLE_HOME/j2ee/OC4J_Demos/log/OC4J_Demos_default_island_1/global-application.log
ORACLE_HOME/j2ee/OC4J_Demos/log/OC4J_Demos_default_island_1/default-web-access.log
ORACLE_HOME/j2ee/OC4J_Demos/log/OC4J_Demos_default_island_1/jms.log
ORACLE_HOME/j2ee/OC4J_Demos/log/OC4J_Demos_default_island_1/rmi.log
ORACLE_HOME/opmn/logs/OC4J_Demos.default_island.1
ORACLE_HOME/opmn/logs/ons.log
ORACLE_HOME/opmn/logs/ipm.log
```

Initial Tasks

If there are any `opmn.exe` processes running in the current `ORACLE_HOME`, then stop them by running the following command:

```
prompt> ORACLE_HOME/opmn/bin/opmnctl stopall
```

Command Line

```
ORACLE_HOME/opmn/bin/opmnctl startall
```

Dependencies

[OC4J Instance Configuration Assistant](#)

B.3.11 Oracle9iAS Instance Configuration Assistant

The Oracle9iAS Instance Configuration Assistant adds Oracle9iAS instance name into the `targets.xml` file.

Modifies the Following Configuration Files

`ORACLE_HOME/sysman/emd/targets.xml`

Writes to the Following Log Files

None.

Initial Tasks

Remove the following entry from `targets.xml`:

```
<Target TYPE="oracle_ias" NAME="instance_name" VERSION="1.0">
  <Property NAME="OracleHome" VALUE="ORACLE_HOME" />
  <Property NAME="host" VALUE="hostname" />
</Target>
```

Command Line

```
ORACLE_HOME/jdk/bin/java -jar ORACLE_HOME/jlib/emConfigInstall.jar \  
targets ORACLE_HOME/config/targets2add.xml
```

Dependencies

None.

B.3.12 Oracle9iAS Web Cache Configuration Assistant

The Oracle9iAS Web Cache Configuration Assistant establishes caching rules, listening ports, and security passwords.

Modifies the Following Configuration Files

ORACLE_HOME/config/ias.properties

Writes to the Following Log Files

ORACLE_HOME/webcache/logs/event_log

ORACLE_HOME/webcache/logs/access_log

Initial Tasks

None.

Command Line

```
ORACLE_HOME/jdk/bin/java -classpath \  
ORACLE_HOME/sysman/webapps/emd/WEB-INF/lib/webcachecfg.jar:\  
ORACLE_HOME/sysman/webapps/emd/WEB-INF/lib/emd.jar:\  
ORACLE_HOME/jlib/emConfigInstall.jar:ORACLE_HOME/jlib/repository.jar:\  
ORACLE_HOME/lib/xmlparserv2.jar:ORACLE_HOME/jdbc/lib/classes12.zip:\  
ORACLE_HOME/jdbc/lib/nls_charset12.jar:ORACLE_HOME/jlib/jndi.jar:\  
ORACLE_HOME/jlib/rt.jar:ORACLE_HOME/jdk/lib/i18n.jar:\  
ORACLE_HOME/jlib/ldapjclnt9.jar:ORACLE_HOME/jlib/ojmisc.jar:\  
ORACLE_HOME/j2ee/home/jazn.jar:ORACLE_HOME/j2ee/home/jaas.jar \  
oracle.ias.webcache.config.WebcacheConfig -oh ORACLE_HOME
```

Dependencies

None.

Index

A

additional Oracle9iAS 9.0.3 installations, 2-26

AJP

port numbers, A-2

Application Server, 3-1

installation, 3-1

postinstallation

component port number, 3-32

environment scripts, 3-31

architecture

Oracle9i Application Server, 1-5, 1-8, 1-9

B

base directory, 3-6

BC4J Configuration Assistant, B-8

Bourne shell

DISPLAY, 2-12

ORACLE_HOME, 2-12, 2-13

buttons

about Oracle Universal Installer, 3-5

browse, 3-9

cancel, 5-6

close, 5-4

deinstall products, 3-5

exit, 3-5

help, 3-5, 5-4

installed products, 3-5

next, 3-5

no, 5-4

previous, 3-5

remove, 5-4

retry, 3-25

save as, 5-4

stop, 3-25

yes, 5-4

C

C shell

DISPLAY, 2-12

ORACLE_HOME, 2-12, 2-13

changing

the X server display, 3-33

Clickstream Collector Agent Configuration

Assistant, B-9

cluster, 1-7

clustering, 1-4, 3-2

Component, 3-32

component configuration and startup screen, 3-10

troubleshooting, B-5

component port number, 3-32

components directory, 3-7

configuration assistants, B-5

BC4J Configuration Assistant, B-8

Clickstream Collector Agent Configuration

Assistant, B-9

DCM Repository Backup Assistant, B-10

dependencies, B-6

descriptions, B-7

Enterprise Manager Web site Configuration

Assistant, B-11

HTTP Server Configuration Assistant, B-12

Infrastructure Use Configuration

Assistant, B-13

Java Security Configuration Assistant, B-14

OC4J Configuration Assistant, B-15

- OC4J Instance Configuration Assistant, B-16
- OPMN Configuration Assistant, B-18
- Oracle9iAS Infrastructure Use Configuration Assistant, B-9
- Oracle9iAS Instance Configuration Assistant, B-19
- Oracle9iAS Web Cache Configuration Assistant, B-20
 - troubleshooting, B-5
- confirmation screen, 5-4
- correcting, B-1
- CPU, 2-3
- create instance name and ias_admin password screen, 3-18

D

- DCM Repository Backup Assistant, B-10
- deinstallation, 5-1, 5-2
 - confirmation screen, 5-4
 - Oracle9i Application Server, 5-2
 - using Oracle Universal Installer, 5-3
- demonstration applications, 3-33
- directories
 - cdrom/9ias_disk1, 2-19
 - /tmp, 2-12
- disk space, 2-3
- DISPLAY, 2-11
- DISPLAY environment variable, 2-11

E

- end of installation screen, 3-26
- Enterprise Manager Web site Configuration Assistant, B-11
- environment variable
 - DISPLAY, 2-11
 - TMP, 2-12
 - TNS_ADMIN, 2-13
- environment variable, Oracle home, 2-9
- error codes
 - configuration assistants, B-5
- errors, B-1

F

- farm, 1-6
- fatal error, B-6
- file locations screen, 3-8
 - destination, 3-9
 - source, 3-8
- files
 - installation logs, 4-9
 - silentInstall.log, 4-9

G

- group identifier, 2-7

H

- hardware requirements, 2-3
 - CPU, 2-3
 - disk space, 2-3
- host domain name, 2-15
- host name, 2-14, 3-13
- HTTP Server Configuration Assistant, B-12

I

- ias_admin Password, 3-3
- ias_admin password, 3-18, 3-20
- IASAdmins group, 3-16
- infrastructure, 1-4
- Infrastructure Use Configuration Assistant, B-13
- installActions.log, 4-9
- installation
 - non-interactive
 - log files, 4-9
 - installation concepts, 1-1
 - installation information
 - Oracle9i Application Server, 3-3
 - installation log files, 2-19, B-4
 - instance name, 3-3, 3-18, 3-20
 - inventory screen, 5-3

J

Java 2 Enterprise Edition, 1-2
Java Authentication and Authorization Service, 3-31
java object cache
 port numbers, A-2
Java Security Configuration Assistant, B-14
JMS
 port numbers, A-2

K

Korn shell
 DISPLAY, 2-12
 ORACLE_HOME, 2-12, 2-13

L

log file, 2-19, B-4
login name, 2-7
login shell, 2-7

M

migration, 2-16
multi-user installation, 2-27, 3-30

N

non-interactive installation, 4-1, 4-3
 introduction, 4-2
 requirements, 4-3

O

OC4J, 1-2
 port numbers, A-2
OC4J Configuration Assistant, B-15
OC4J Instance Configuration Assistant, B-16
oinstall group, 2-7
 UNIX group name, 2-7
OPMN
 port numbers, A-2
OPMN Configuration Assistant, B-18
Oracle, 2-9

oracle account
 UNIX account, 2-7
Oracle Enterprise Manager
 port numbers, A-3
Oracle Enterprise Manager Home Pages, 3-29
Oracle Enterprise Manager Web site, 1-2, 3-29
Oracle home, 2-9
Oracle home destination, 3-9
Oracle home environment variable, 2-9
Oracle home location, 3-3
Oracle home name, 3-8
Oracle HTTP Server, 1-2
 port numbers, A-2
Oracle Internet Directory
 password, 3-3, 3-16
 username, 3-3, 3-16
Oracle inventory directory, 3-3
Oracle Universal Installer, 2-17, 2-19
 mounting
 CD-ROM, 2-19
 starting, 2-19
 UNIX group name, 2-7
ORACLE_HOME
 Bourne shell, 2-12, 2-13
 C shell, 2-12, 2-13
 Korn shell, 2-12, 2-13
Oracle9i Application Server
 deinstallation, 5-2
 installation, installation
 Oracle9i Application Server, 3-2
Oracle9i Application Server
 deinstallation, 5-1
 reinstallation, 5-1, 5-8
Oracle9iAS Administration Service, 5-5
Oracle9iAS Containers for J2EE, 1-2
Oracle9iAS Infrastructure Use Configuration Assistant, B-9
Oracle9iAS Instance Configuration Assistant, B-19
Oracle9iAS Metadata Repository, 3-3, 3-21
Oracle9iAS Single Sign-On Port Number, 3-3
Oracle9iAS Single Sign-On Server Host Name, 3-3
Oracle9iAS Web Cache, 1-2
Oracle9iAS Web Cache
 port numbers, A-3

- Oracle9iAS Web Cache Configuration
 - Assistant, B-20
- oraInst.loc file creation, 4-4
- oraInstRoot.sh, 3-7
- oraInventory directory, 2-19, B-4
 - location, 2-19
 - UNIX group name, 2-7
- orcladmin, 3-16

P

- password
 - ias_admin, 3-18, 3-20
 - Oracle Internet Directory, 3-16
- patches
 - Solaris Operating System, 2-5
- port changes, 2-16
- port number, 3-13
- port numbers, A-1
 - OC4J, A-2
 - AJP, A-2
 - HTTP listener, A-2
 - JMS, A-2
 - RMI, A-2
 - OPMN, A-2
 - Oracle Notification Service local port, A-2
 - Oracle Notification Service remote port, A-2
 - Oracle Notification Service requested port, A-2
 - Oracle Enterprise Manager, A-3
 - administration, A-3
 - Intelligent Agent, A-3
 - Oracle HTTP Server, A-2
 - java object cache, A-2
 - JServ servlet, A-2
 - non-SSL, A-2
 - Oracle Notification Service remote port, A-2
 - SSL, A-2
 - Oracle9iAS Web Cache, A-3
 - administration, A-3
 - HTTP Listen non-SSL, A-3
 - HTTP Listen SSL, A-3
 - sorted by component, A-2
 - sorted by port numbers, A-4
- port ranges, A-1

- portlist.ini, 2-16, 3-32
- postinstallation
 - Oracle9i Application Server, 3-28
- preinstallation
 - creating
 - UNIX account, 2-7
 - UNIX group name, 2-7
 - environment variables, 2-8
 - DISPLAY, 2-11
 - TMP, 2-12
 - migration, 2-16
 - port changes, 2-16
- prerequisite checks, 2-18
- product information, 5-4

R

- reinstallation, 5-1, 5-8
 - Oracle9i Application Server, 5-8
- remote workstation installation, 2-12
- requirements
 - hardware, 2-3
- response file, 4-2
 - specifying, 4-8
- RMI
 - port numbers, A-2
- root.sh, 3-7, 3-24

S

- screens
 - component configuration and startup, 3-10
 - components configuration and startup, 3-25
 - confirmation, 5-4
 - create instance name, 3-20
 - create instance name and ias_admin password, 3-18
 - end of installation, 3-26
 - file locations, 3-8
 - infrastructure summary, 3-14
 - install, 3-24
 - inventory, 5-3
 - inventory location, 3-6
 - Oracle Internet Directory, 3-15
 - Oracle Universal Installer Welcome, 3-5

- Oracle9iAS Infrastructure use, 3-12
- Oracle9iAS Metadata Repository, 3-21
- summary, 3-23
- setting
 - DISPLAY, 2-11
 - TMP, 2-12
- Silent, 4-1
- silent installation, 4-2
- silentInstall.log, 4-9
- single sign-on, 1-4, 3-2
- software requirements
 - operating system
 - Solaris 2.6, 2-5
 - Solaris 2.7, 2-5
 - Solaris 2.8, 2-5
- Solaris Operating System
 - patches, 2-5
- specifying
 - response file, 4-8
- starting, 2-19
 - Oracle Universal Installer, 2-19
- swap space, 2-12

T

- the X server display, 3-33
- TMP, 2-12
- TMP environment variable, 2-12
- TNS_ADMIN, 2-13
 - environment variable, 2-13
- TNS_ADMIN environment variable, 2-13
- today's_date_time, 2-19
- troubleshooting, B-1
 - configuration assistants, B-5
 - fatal error, B-6

U

- UNIX account, 2-7
 - oracle account, 2-7
- UNIX account and groups, 2-7
- UNIX group name, 2-7
 - admintool utility, 2-7
 - groupadd utility, 2-7
 - oinstall group, 2-7

- oraInventory directory, 2-7
- username
 - Oracle Internet Directory, 3-16

W

- Web, 1-2

X

- X server, 2-11

Y

- your_base_directory, 2-19

