

**Oracle® Application Server Containers for J2EE**

Enterprise JavaBeans Developer's Guide

10g Release 2 (10.1.2)

**Part No. B15505-01**

November 2004

Oracle Application Server Containers for J2EE Enterprise JavaBeans Developer's Guide 10g Release 2 (10.1.2)

Part No. B15505-01

Copyright © 2002, 2004 Oracle. All rights reserved.

Primary Author: Sheryl Maring

Contributing Author: Kevin Hwang

The Programs (which include both the software and documentation) contain proprietary information; they are provided under a license agreement containing restrictions on use and disclosure and are also protected by copyright, patent, and other intellectual and industrial property laws. Reverse engineering, disassembly, or decompilation of the Programs, except to the extent required to obtain interoperability with other independently created software or as specified by law, is prohibited.

The information contained in this document is subject to change without notice. If you find any problems in the documentation, please report them to us in writing. This document is not warranted to be error-free. Except as may be expressly permitted in your license agreement for these Programs, no part of these Programs may be reproduced or transmitted in any form or by any means, electronic or mechanical, for any purpose.

If the Programs are delivered to the United States Government or anyone licensing or using the Programs on behalf of the United States Government, the following notice is applicable:

U.S. GOVERNMENT RIGHTS Programs, software, databases, and related documentation and technical data delivered to U.S. Government customers are "commercial computer software" or "commercial technical data" pursuant to the applicable Federal Acquisition Regulation and agency-specific supplemental regulations. As such, use, duplication, disclosure, modification, and adaptation of the Programs, including documentation and technical data, shall be subject to the licensing restrictions set forth in the applicable Oracle license agreement, and, to the extent applicable, the additional rights set forth in FAR 52.227-19, Commercial Computer Software--Restricted Rights (June 1987). Oracle Corporation, 500 Oracle Parkway, Redwood City, CA 94065

The Programs are not intended for use in any nuclear, aviation, mass transit, medical, or other inherently dangerous applications. It shall be the licensee's responsibility to take all appropriate fail-safe, backup, redundancy and other measures to ensure the safe use of such applications if the Programs are used for such purposes, and we disclaim liability for any damages caused by such use of the Programs.

Oracle is a registered trademark of Oracle Corporation and/or its affiliates. Other names may be trademarks of their respective owners.

The Programs may provide links to Web sites and access to content, products, and services from third parties. Oracle is not responsible for the availability of, or any content provided on, third-party Web sites. You bear all risks associated with the use of such content. If you choose to purchase any products or services from a third party, the relationship is directly between you and the third party. Oracle is not responsible for: (a) the quality of third-party products or services; or (b) fulfilling any of the terms of the agreement with the third party, including delivery of products or services and warranty obligations related to purchased products or services. Oracle is not responsible for any loss or damage of any sort that you may incur from dealing with any third party.

---

---

# Contents

<b>Send Us Your Comments</b> .....	xi
<b>Preface</b> .....	xiii
Who Should Read This Guide? .....	xiii
Documentation Accessibility .....	xiii
Prerequisite Reading .....	xiii
Suggested Reading .....	xiv
How This Guide Is Organized .....	xiv
Conventions .....	xv
<b>1 How Do Applications Use EJBs?</b>	
<b>New Features of EJB 2.0</b> .....	1-1
Local Interface Support .....	1-1
Remote Access .....	1-2
Local Access .....	1-2
Local Interfaces and Container-Managed Relationships .....	1-2
Local Compared to Remote Access .....	1-2
Home Interface Business Methods .....	1-2
Message-Driven Beans .....	1-3
Enterprise JavaBeans Query Language (EJB QL) .....	1-3
CMP Relationships .....	1-3
Oracle Application Server Object-Relational Mapping .....	1-4
Third Party O-R Mappings - TopLink Integration .....	1-4
CORBA Support - RMI-over-IIOP .....	1-5
<b>Changes in Defaults for Oracle Application Server</b> .....	1-6
<b>Which Type of EJB Should You Use in Your Application?</b> .....	1-6
What is a Session Bean? .....	1-6
Retrieving the Context Using <code>getSessionContext</code> .....	1-7
What is a Stateless Session Bean? .....	1-8
What is a Stateful Session Bean? .....	1-9
What is an Entity Bean? .....	1-10
Entity Beans are Uniquely Identified by a Primary Key .....	1-10
Managing the Persistent Data Within the Entity Bean .....	1-11
Manage Your Persistent Data With Container-Managed Persistence .....	1-13
What is the Difference Between Session and Entity Beans? .....	1-14

When Do You Use a Message-Driven Bean? .....	1-15
<b>What Makes Up An EJB?</b> .....	1-16
Interfaces for Bean Implementation is Based on Bean Type.....	1-18
Parameter Passing Conventions for Your EJBs.....	1-18
How to Handle Returned Parameter Objects .....	1-19
<b>What Container Services Can You Use for EJBs?</b> .....	1-19

## 2 How to Access EJBs

<b>Steps for Accessing Any EJB</b> .....	2-1
Client Installation of OC4J.JAR.....	2-2
Setting JNDI Properties.....	2-2
No JNDI Properties.....	2-2
JNDI Properties File.....	2-2
JNDI Properties Within The Implementation.....	2-3
JNDI Properties for OC4J Standalone .....	2-4
When Do You Use the Different Initial Context Factory Classes? .....	2-4
An Initial Context Factory Specific to DNS Load Balancing .....	2-5
How to Lookup the EJB Reference .....	2-5
Configuring the EJB Reference Information .....	2-6
<b>Example of How a Client Invokes an EJB</b> .....	2-6
<b>Accessing an EJB in a Remote Server</b> .....	2-10
<b>Accessing an EJB in Another Application</b> .....	2-11
<b>JAAS Support for EJBs</b> .....	2-12
<b>Using the RIMInitialContextFactory Object</b> .....	2-12
<b>Recovering From Deadlock Conditions</b> .....	2-12
<b>Recovering From a NamingException While Accessing a Remote EJB</b> .....	2-12
<b>Recovering From NullPointerException While Accessing a Remote EJB</b> .....	2-12

## 3 Implementing Session Beans

<b>Developing Session Beans</b> .....	3-2
Implement the Session Bean.....	3-2
Creating the Home Interfaces .....	3-2
Creating the Component Interfaces .....	3-3
Implementing the Bean.....	3-4
Create the Deployment Descriptor.....	3-6
Archive the EJB Application.....	3-7
<b>Prepare the EJB Application for Assembly</b> .....	3-7
Modify the Application.XML File.....	3-8
Create the EAR File.....	3-9
<b>Deploy the Enterprise Application to OC4J</b> .....	3-9
<b>When Does Stateful Session Bean Passivation Occur?</b> .....	3-9
Object Types Enabled for Passivation.....	3-11
Storage of Passivated EJBs.....	3-11
<b>Using Timers With Your Stateless Session Bean</b> .....	3-11

## 4 Entity Beans

<b>Entity Bean Overview</b> .....	4-1
<b>Creating Entity Beans</b> .....	4-2
Implement the Entity Bean Home Interface.....	4-3
Implement the Entity Bean Component Interfaces.....	4-4
Implement the Entity Bean Class.....	4-4
<b>How to Define and Use Primary Keys for Your Entity Bean</b> .....	4-6
Defining the Entity Bean Primary Key in a Class.....	4-8
Defining an Auto-Generated Primary Key for Your Entity Bean.....	4-9
<b>Create Data Consistency in Your Entity Bean by Using Persistence</b> .....	4-10
<b>Tie Entity Beans Together Through Container-Managed Relationships</b> .....	4-10
<b>Managing the Entity Bean Lifecycle</b> .....	4-11
Configuring Pool Sizes For Entity Beans .....	4-11
<b>How to Avoid Database Resource Contention</b> .....	4-12
Using Database Isolation Modes to Protect Against Resource Contention.....	4-12
Configuring Entity Bean Concurrency Modes For Handling Resource Contention .....	4-13
Specifying Exclusive Write Access to the Database.....	4-14
Effects of the Combination of the Database Isolation and Bean Concurrency Modes .....	4-14
Differences Between Pessimistic and Optimistic/Serializable.....	4-15
Affects of Concurrency Modes on Clustering.....	4-15
<b>Using Transactions With Entity Beans</b> .....	4-15
<b>Providing Security for Your Entity Beans</b> .....	4-15
<b>Using Timers With Your Entity Bean</b> .....	4-15

## 5 CMP Entity Beans

<b>Persistence Fields</b> .....	5-1
Default Mapping of Persistent Fields to the Database .....	5-2
Explicit Mapping of Persistent Fields to the Database .....	5-3
<b>Configuring Lazy Loading on CMP Entity Bean Finder Methods</b> .....	5-5
<b>Conversion of CMP Types to Database Types</b> .....	5-6
Simple Data Types .....	5-6
Serializable Classes .....	5-7
Other Entity Beans or Collections.....	5-7

## 6 Entity Relationship Mapping

<b>Transaction Requirements</b> .....	6-1
<b>Defining Entity-To-Entity Relationships</b> .....	6-2
Choosing Cardinality and Direction .....	6-2
One-To-One Relationship Overview .....	6-2
One-To-Many or Many-To-One Relationship Overview .....	6-2
Many-To-Many Relationship Overview.....	6-3
Requirements in Defining Relationships.....	6-3
Define the Get/Set Methods for Each Relationship Field.....	6-4
Set the Relationships in the Bean Implementation .....	6-4
Declare the Relationships in the Deployment Descriptor.....	6-5
Decide Whether to Use the Cascade Delete Option.....	6-8

<b>Mapping Object Relationship Fields to the Database</b> .....	6-9
Default Mapping of Relationship Fields to the Database .....	6-9
Example of a Default Mapping of the One-To-One Relationship .....	6-11
Example of a Default Mapping of One-To-Many and Many-To-Many Relationships..	6-11
Explicit Mapping of Relationship Fields to the Database .....	6-12
Quick Cookbook for Matching an Existing Database to the Bean Mappings.....	6-13
Steps for Modifying CMR Mapping Elements .....	6-13
Hand-Editing the orion-ejb-jar.xml File to Map Bean Relationships to Database Tables .....	6-14
One-To-One Relationship Explicit Mapping .....	6-16
Table Mapping For Primary Keys That Use AutoId.....	6-21
Using a Foreign Key with the One-To-Many Relationship .....	6-21
Association Table Explicit Mapping for Relationships Overview.....	6-27
XML Structure for One-to-Many Relationship Mapping.....	6-31
Using an Association Table with a One-to-Many Bidirectional Relationship .....	6-33
Using an Association Table in a One-to-Many Unidirectional Relationship .....	6-35
Using an Association Table in Many-to-Many Relationships .....	6-40
<b>Using a Foreign Key in a Composite Primary Key</b> .....	6-44
<b>How to Override a Foreign Key Database Constraint</b> .....	6-50
<b>Performing Inner or Outer Joins on One-to-One Relationships</b> .....	6-50
<b>Batching SQL statements in your entity beans</b> .....	6-50
<b>How to map a CMP field and a CMR field to the same row in the database</b> .....	6-51
<b>Synchronizing Data during Bean Creation</b> .....	6-51

## 7 EJB Query Language

<b>EJB QL Overview</b> .....	7-2
<b>Query Methods Overview</b> .....	7-2
Finder Methods .....	7-2
Select Methods.....	7-3
Return Objects .....	7-3
<b>Deployment Descriptor Semantics</b> .....	7-4
<b>Finder Method Example</b> .....	7-5
Specifying Finder Methods With EJB QL Syntax.....	7-5
Define the Finder Method in the Home Interface .....	7-5
Define the Finder Method Definition in the Deployment Descriptor.....	7-6
Relationship Finder Example.....	7-6
Specifying Finder Methods With OC4J-Specific Syntax.....	7-7
Add the Finder Method to Home Interface .....	7-7
Add the Query to the OC4J-Specific Deployment Descriptor.....	7-7
<b>Select Method Example</b> .....	7-9
Define the Select Method in the Bean Class .....	7-10
Define the Select Method Definition in the Deployment Descriptor .....	7-10
<b>Oracle EJB QL Type Extensions: Date, Time, Timestamp, and SQRT</b> .....	7-11

## 8 BMP Entity Beans

<b>Creating BMP Entity Beans</b> .....	8-2
<b>Component and Home Interfaces</b> .....	8-2

<b>BMP Entity Bean Implementation</b> .....	8-3
The ejbCreate Implementation .....	8-3
The ejbFindByPrimaryKey Implementation .....	8-6
Other Finder Methods .....	8-6
The ejbStore Implementation .....	8-7
The ejbLoad Implementation .....	8-7
The ejbPassivate Implementation .....	8-8
The ejbActivate Implementation.....	8-8
The ejbRemove Implementation .....	8-9
<b>Modify XML Deployment Descriptors</b> .....	8-9
<b>Create Database Table and Columns for Entity Data</b> .....	8-10

## 9 Message-Driven Beans

<b>MDB Overview</b> .....	9-2
<b>MDB Example</b> .....	9-3
MDB Implementation Example .....	9-3
EJB Deployment Descriptor (ejb-jar.xml) for the MDB .....	9-7
<b>MDB Using OracleAS JMS</b> .....	9-9
Configure OracleAS JMS in the XML files .....	9-10
JMS Destination Object Configuration .....	9-10
Create the OC4J-Specific Deployment Descriptor to Use OracleAS JMS .....	9-10
OracleAS JMS .....	9-11
Specify the Destination and Connection Factory .....	9-11
Map Any Resource References to JNDI Names .....	9-12
Deploying the MDB .....	9-12
<b>MDB Using Oracle JMS</b> .....	9-13
Install and Configure the JMS Provider.....	9-14
Create User and Assign Privileges .....	9-14
Create JMS Destination Objects .....	9-14
Configure the OC4J XML Files for the JMS Provider .....	9-16
Configure the DataSource.....	9-16
Identify the JNDI Name of the Oracle JMS Data Source.....	9-16
Create the OC4J-Specific Deployment Descriptor to Use Oracle JMS.....	9-17
OracleAS JMS .....	9-17
Specify the Destination and Connection Factory .....	9-17
Map Any Resource References to JNDI Names .....	9-19
Deploy the MDB.....	9-20
<b>Client Access of MDB</b> .....	9-20
Using an Explicit Name for the JNDI Lookup .....	9-21
Accessing OracleAS JMS Destination with Explicit JNDI Names .....	9-21
Accessing Oracle JMS Destination with Explicit JNDI Names .....	9-22
Steps for Sending a Message to an MDB .....	9-22
Using a Logical Name When Client Accesses the MDB.....	9-25
JNDI Naming for OracleAS JMS .....	9-26
JNDI Naming for Oracle JMS.....	9-27
Client Sends JMS Message Using Logical Names.....	9-27
<b>Windows Considerations When Using MDBs</b> .....	9-28

Failover Scenarios When Using a RAC Database .....	9-28
Using Timers With Your MDB .....	9-29

## 10 Understanding Environment, Deployment, and Packaging

Directory Structure Recommendations for EJB Development .....	10-1
Create the Deployment Descriptor .....	10-2
Archive the EJB Application .....	10-3
Prepare the EJB Application for Assembly .....	10-4
Modify the Application.XML File.....	10-4
Create the EAR File.....	10-5
Deploy the Enterprise Application to OC4J.....	10-5
Out Of Memory Error During Deployment.....	10-5
Sharing Classes .....	10-6
Out of Memory During Execution.....	10-7
ClassCastException.....	10-7
Static Block in an EJB .....	10-7
OC4J Instances Terminating Due To ping Timeout.....	10-7
Configuring Environment References .....	10-8
Environment Variables.....	10-9
Environment References To Other Enterprise JavaBeans .....	10-10
Examples of References to a Local Interface .....	10-10
Accessing EJBs Using Environment References.....	10-12
Examples of References to a Remote Interface .....	10-13
Environment References To Resource Manager Connection Factory References .....	10-14
JDBC DataSource .....	10-14
Mail Session .....	10-15
URL .....	10-17

## 11 Using Timers

How to Create Timers .....	11-1
Configuring Regularly Scheduled Timers (Cron Timers).....	11-2
How to Retrieve Information About the Timer.....	11-4
How to Retrieve a Persisted Timer.....	11-4
Executing the Timer Within the Scope of a Transaction .....	11-4
What Does a NoSuchObjectLocalException Mean with Timers?.....	11-4

## 12 Configuring EJB Application Security

Granting Permissions in Browser .....	12-1
Authenticating and Authorizing EJB Applications.....	12-1
Specifying Users and Groups.....	12-2
Specifying Logical Roles in the EJB Deployment Descriptor .....	12-3
Specifying Unchecked Security for EJB Methods.....	12-5
Specifying the runAs Security Identity.....	12-5
Mapping Logical Roles to Users and Groups .....	12-6
Specifying a Default Role Mapping for Undefined Methods.....	12-7
Specifying Users and Groups by the Client .....	12-8



<b>Specifying Credentials in EJB Clients</b> .....	12-8
Credentials in JNDI Properties.....	12-8
Credentials in the InitialContext.....	12-9
<b>13 EJB Clustering</b>	
<b>EJB Clustering Overview</b> .....	13-1
Stateless Session Clustering.....	13-2
Stateful Session Bean Clustering.....	13-2
Combination of HTTP and EJB Clustering.....	13-3
<b>Enabling Clustering For EJBs</b> .....	13-3
Configure the Multicast Address for EJB Clustering.....	13-3
Configure EJB Replication for Stateful Session Beans .....	13-4
VM Termination Replication.....	13-4
End of Call Replication .....	13-4
<b>EJB Clustering Includes JNDI Namespace Replication</b> .....	13-4
<b>Load Balancing Options</b> .....	13-5
Load Balancing Using Static Retrieval .....	13-5
DNS Load Balancing.....	13-5
<b>A XML Reference for ORION-EJB-JAR.XML</b>	
<b>OC4J-Specific Deployment Descriptor for EJBs</b> .....	A-2
Enterprise Beans Section .....	A-3
Session Bean Section.....	A-3
Entity Bean Section .....	A-6
Message Driven Bean Section .....	A-11
AC4J Active EJB Section.....	A-13
EJB 1.1 CMP Field Mapping Section .....	A-14
Method Definition.....	A-15
Assembly Descriptor Section.....	A-15
<b>Element Description</b> .....	A-16
<b>B Third Party Licenses</b>	
Apache HTTP Server .....	B-1
<b>Index</b>	



---

---

# Send Us Your Comments

## **Oracle Application Server Containers for J2EE Enterprise JavaBeans Developer's Guide, 10g Release 2 (10.1.2)**

**Part No. B15505-01**

Oracle welcomes your comments and suggestions on the quality and usefulness of this publication. Your input is an important part of the information used for revision.

- Did you find any errors?
- Is the information clearly presented?
- Do you need more information? If so, where?
- Are the examples correct? Do you need more examples?
- What features did you like most about this manual?

If you find any errors or have any other suggestions for improvement, please indicate the title and part number of the documentation and the chapter, section, and page number (if available). You can send comments to us in the following ways:

- Electronic mail: [appserverdocs\\_us@oracle.com](mailto:appserverdocs_us@oracle.com)
- FAX: 650-506-7225 Attn: Oracle Java Platform Group, Information Development Manager
- Postal service:

Oracle Corporation  
Information Development Manager  
500 Oracle Parkway, Mailstop 4op978  
Redwood Shores, CA 94065  
USA

If you would like a reply, please give your name, address, telephone number, and electronic mail address (optional).

If you have problems with the software, please contact your local Oracle Support Services.



---

---

# Preface

This guide gets you started building Enterprise JavaBeans for Oracle Application Server Containers for J2EE (OC4J). It includes code examples to help you develop your application.

## Who Should Read This Guide?

Anyone developing Enterprise JavaBeans for OC4J will benefit from reading this guide. Written especially for programmers, it will also be of value to architects, systems analysts, project managers, and others interested in EJB applications. To use this guide effectively, you must have a working knowledge of J2EE.

## Documentation Accessibility

Our goal is to make Oracle products, services, and supporting documentation accessible, with good usability, to the disabled community. To that end, our documentation includes features that make information available to users of assistive technology. This documentation is available in HTML format, and contains markup to facilitate access by the disabled community. Standards will continue to evolve over time, and Oracle is actively engaged with other market-leading technology vendors to address technical obstacles so that our documentation can be accessible to all of our customers. For additional information, visit the Oracle Accessibility Program Web site at

<http://www.oracle.com/accessibility/>

**Accessibility of Code Examples in Documentation** JAWS, a Windows screen reader, may not always correctly read the code examples in this document. The conventions for writing code require that closing braces should appear on an otherwise empty line; however, JAWS may not always read a line of text that consists solely of a bracket or brace.

**Accessibility of Links to External Web Sites in Documentation** This documentation may contain links to Web sites of other companies or organizations that Oracle does not own or control. Oracle neither evaluates nor makes any representations regarding the accessibility of these Web sites.

## Prerequisite Reading

Before consulting this Guide, you should read the following:

- Any J2EE book that enables you to understand the basics of J2EE programming.

- The Oracle Application Server Containers for J2EE User's Guide. This guide helps you to understand the minimum requirements for a J2EE application in the OC4J environment.
- The Sun Microsystems EJB 2.0 specification as a supplement to this guide. This guide assumes that you already have a base understanding of the EJB 2.0 specification details.

## Suggested Reading

### Books

- *Professional Java Server Programming, J2EE Edition*, Wrox Press Ltd, 2000.
- *Mastering Enterprise JavaBeans and the Java2 Platform Enterprise Edition*, by Ed Roman. Wiley Computer Publishing, 1999.
- *Designing Enterprise Applications with the Java2 Platform, Enterprise Edition*, Addison-Wesley, 2000.
- *Core Java* by Cornell & Horstmann, second edition, Volume II (Prentice-Hall, 1997) demonstrates several Java concepts relevant to EJBs.
- *The Developer's Guide to Understanding Enterprise JavaBeans*, an overview of EJBs, is available at <http://www.Nova-Labs.com>.

### Online Sources

There are many useful online sources of information about Java. For example, you can view or download guides and tutorials from the Sun Microsystems home page on the Web:

<http://www.sun.com>

The current 2.0 EJB specification is available at:

<http://java.sun.com/products/ejb/docs.html>

Another popular Java Web site is:

<http://www.gamelan.com>

For Java API documentation, see:

<http://www.javasoft.com>

## How This Guide Is Organized

This guide consists of the following:

- [Chapter 1, "How Do Applications Use EJBs?"](#), presents a brief overview of EJBs.
- [Chapter 2, "How to Access EJBs"](#), discusses how to access an EJB from a servlet within the application server or from outside the application server—either from an EJB within another application server or from a local client. .
- [Chapter 3, "Implementing Session Beans"](#), discusses how to begin developing J2EE applications.
- [Chapter 4, "Entity Beans"](#), discusses entity beans.
- [Chapter 5, "CMP Entity Beans"](#), discusses a CMP entity bean and advanced issues connected with CMP entity beans.

- [Chapter 6, "Entity Relationship Mapping"](#), discusses container-managed relationships (CMR) within the entity bean for OC4J.
- [Chapter 7, "EJB Query Language"](#), provides an overview and examples of setting up query methods that use EJB QL.
- [Chapter 8, "BMP Entity Beans"](#), discusses a BMP entity bean.
- [Chapter 9, "Message-Driven Beans"](#), discusses an MDB entity bean.
- [Chapter 10, "Understanding Environment, Deployment, and Packaging"](#), discusses how to set up your development environment, as well as packaging and deploying your applications.
- [Chapter 12, "Configuring EJB Application Security"](#), discusses EJB application security.
- [Chapter 11, "Using Timers"](#), discusses the use of timers within different EJB types.
- [Chapter 13, "EJB Clustering"](#), discusses how to cluster EJBs across OC4J nodes.
- [Appendix A, "XML Reference for ORION-EJB-JAR.XML"](#) describes the OC4J-specific deployment descriptor.
- [Appendix B, "Third Party Licenses"](#), contains the third party software licenses for this product.

## Conventions

The following conventions are used in this manual:

Convention	Meaning
. . .	Vertical ellipsis points in an example mean that information not directly related to the example has been omitted.
...	Horizontal ellipsis points in statements or commands mean that parts of the statement or command not directly related to the example have been omitted
<b>boldface text</b>	Boldface type in text indicates a term defined in the text, the glossary, or in both locations.
<>	Angle brackets enclose user-supplied names.
[ ]	Brackets enclose optional clauses from which you can choose one or none.





---

---

# How Do Applications Use EJBs?

This chapter discusses EJB concepts that are specified fully in the J2EE specification. The remainder of the chapters in this book show only the tasks necessary to develop your EJBs.

For more details and examples of the concepts presented in this chapter, refer to books written by Sun Microsystems that discuss EJBs and J2EE Blueprint Architecture recommendations.

This chapter includes the following topics:

- [New Features of EJB 2.0](#)
- [Changes in Defaults for Oracle Application Server](#)
- [Which Type of EJB Should You Use in Your Application?](#)
- [What Makes Up An EJB?](#)
- [What Container Services Can You Use for EJBs?](#)

## New Features of EJB 2.0

The following sections describe the new features to EJB 2.0:

- [Local Interface Support](#)
- [Home Interface Business Methods](#)
- [Message-Driven Beans](#)
- [Enterprise JavaBeans Query Language \(EJB QL\)](#)
- [CMP Relationships](#)
- [CORBA Support - RMI-over-IIOP](#)

## Local Interface Support

Oracle Application Server provides complete support for local interfaces.

A client may access a session or an entity bean only through the methods defined in the bean's interfaces which define the client's view of a bean. All other aspects of the bean - method implementations, deployment descriptor settings, abstract schemas, database access calls - are hidden from the client providing modularity and encapsulation. Well designed interfaces simplify the development and maintenance of J2EE applications by shielding clients from any complexities in the business logic and also allowing the EJBs to change internally without affecting the clients. EJBs support two types of client access - remote or local.

### **Remote Access**

A remote client of an enterprise bean has the following traits:

1. It may run on a different machine and a different Java Virtual Machine (JVM) than the enterprise bean it accesses.
2. It can be a Web component, a J2EE application client, or another enterprise bean.
3. To a remote client, the location of the enterprise bean is transparent. To create an enterprise bean with remote access, you must code a remote interface and a home interface. The remote interface defines the business methods that are specific to the bean.

### **Local Access**

A local client has these characteristics:

1. It must run in the same JVM as the enterprise bean it accesses.
2. It may be a web component or another enterprise bean.
3. To the local client, the location of the enterprise bean it accesses is not transparent.
4. It is often an entity bean that has a container-managed relationship with another entity bean. To build an enterprise bean that allows local access, you must code a local interface and a local home interface. The local interface defines the bean's business methods and the local home interface defines its life-cycle and finder methods.

### **Local Interfaces and Container-Managed Relationships**

If an entity bean is the target of a container-managed relationship, then it must have local interfaces. Further, if the relationship between the EJBs is bidirectional, both beans must have local interfaces. Moreover, since they require local access, entity beans that participate in a container-managed relationship must reside in the same EJB container. The primary benefit of this locality is increased performance - local calls are usually faster than remote calls.

### **Local Compared to Remote Access**

The decision on whether to allow local or remote access depends on the following factors:

1. Container-Managed Relationships - If an entity bean is the target of a container-managed relationship, it must use local access.
2. Tight or Loose Coupling of Related Beans - tightly coupled beans depend on one another. For example, a completed sales order must have one or more line items, which cannot exist without the order to which they belong. The `OrderEJB` and `LineItemEJB` beans that model this relationship are tightly coupled. Tightly coupled beans are good candidates for local access. Since they fit together as a logical unit, they probably call each other often and would benefit from the increased performance that is possible with local access.

## **Home Interface Business Methods**

Home interface business methods are used for public usage of methods that do not use entity bean persistent data. If you want to supply methods that perform duties for you that are not associated with any specific bean, a home interface business method allows you to publicize this method.

## Message-Driven Beans

You can implement EJB 2.0 message-driven beans with Oracle JMS. A full example is provided in [Chapter 9, "Message-Driven Beans"](#).

## Enterprise JavaBeans Query Language (EJB QL)

EJB QL defines the queries for the finder and select methods of an entity bean with container-managed persistence. A subset of SQL92, EJB QL has extensions that allow navigation over the relationships defined in an entity bean's abstract schema. The abstract schema is part of an entity bean's deployment descriptor and defines the bean's persistent fields and relationships. The term "abstract" distinguishes this schema from the physical schema of the underlying datastore. The abstract schema name is referenced by EJB QL queries since the scope of an EJB QL query spans the abstract schemas of related entity beans that are packaged in the same EJB JAR file. For an entity bean with container-managed persistence, an EJB QL query must be defined for every finder method (except `findByPrimaryKey`). The EJB QL query determines the query that is executed by the EJB container when the finder method is invoked.

Oracle Application Server provides complete support for EJB QL with the following important features:

- **Automatic Code Generation:** EJB QL queries are defined in the deployment descriptor of the entity bean. When the EJBs are deployed to Oracle Application Server, the container automatically translates the queries into the SQL dialect of the target data store. Because of this translation, entity beans with container-managed persistence are portable -- their code is not tied to a specific type of data store.
- **Optimized SQL Code Generation:** Further, in generating the SQL code, Oracle Application Server makes several optimizations such as the use of bulk SQL, batched statement dispatch, and so on to make database access efficient.
- **Support for Oracle and Non-Oracle Databases:** Further, Oracle Application Server provides the ability to execute EJB QL against any database - Oracle, MS SQL-Server, IBM DB/2, Informix, and Sybase.
- **CMP with Relationships:** Oracle Application Server supports EJB QL for both single entity beans and also with entity beans that have relationships, with support for any type of multiplicity and directionality.

See [Chapter 7, "EJB Query Language"](#) for more information and examples.

## CMP Relationships

The EJB 2.0 specification enables the specification of relationships between entity beans. An entity bean can be defined so as to have a relationship with other entity beans. For example, in a project management application the `ProjectEJB` and `TaskEJB` beans would be related because a project is made up of a set of tasks. You implement relationships differently for entity beans with bean-managed-persistence than those entity beans that utilize container-managed-persistence. With bean-managed persistence, the code that you write implements the relationships. With container-managed persistence, the EJB container takes care of the relationships for you. For this reason, relationships in entity beans with container-managed persistence are often referred to as container-managed relationships.

- **Relationship Fields -** A relationship field in an EJB identifies a related bean. A relationship field is virtual and is defined in the enterprise bean class with access

methods. Unlike a persistent field, a relationship field does not represent the bean's state.

- **Multiplicity in Container-Managed Relationships** - There are four types of multiplicities all of which are supported by Oracle Application Server:
  - **One-to-One** - Each entity bean instance is related to a single instance of another entity bean.
  - **One-to-Many** - An entity bean instance is related to multiple instances of the other entity bean.
  - **Many-to-One** - Multiple instances of an entity bean may be related to a single instance of the other entity bean. This multiplicity is the opposite of one-to-many.
  - **Many-to-Many** - The entity bean instances may be related to multiple instances of each other.
- **Direction in Container-Managed Relationships** - The direction of a relationship may be either bi-directional or unidirectional. In a bi-directional relationship, each entity bean has a relationship field that refers to the other bean. Through the relationship field, an entity bean's code can access its related object. If an entity bean has a relative field, then we often say that it "knows" about its related object. For example, if an `ProjectEJB` bean knows what `TaskEJB` beans it has and if each `TaskEJB` bean knows what `ProjectEJB` bean it belongs to, then they have a bi-directional relationship. In a unidirectional relationship, only one entity bean has a relationship field that refers to the other. Oracle Application Server supports both unidirectional and bi-directional relationships between EJBs.
- **EJBQL and CMP With Relationships** - EJB QL queries often navigate across relationships. The direction of a relationship determines whether a query can navigate from one bean to another. With Oracle Application Server, EJBQL queries can traverse CMP Relationships with any type of multiplicity and with both unidirectional and bi-directional relationships.

For more information, see [Chapter 5, "CMP Entity Beans"](#), [Chapter 6, "Entity Relationship Mapping"](#), and [Chapter 7, "EJB Query Language"](#).

### **Oracle Application Server Object-Relational Mapping**

Oracle Application Server furnishes, out of the box, its own persistence manager for entity beans, which supplies both simple (1:1) mapping and complex relationship (1:n, m:n) mapping. Oracle Application Server provides complete support for the EJB 2.0 O-R mapping specification.

For more information, see [Chapter 6, "Entity Relationship Mapping"](#).

### **Third Party O-R Mappings - TopLink Integration**

Oracle Application Server integrates leading third party O-R mapping solutions including TopLink for Java, with the EJB container. TopLink provides developers with the flexibility to map objects and Enterprise Java Beans to a relational database schema with minimal impact. TopLink for Java provides advanced mapping capabilities such as bean/object identity mapping, type and value transformation, relationship mapping (1:1, 1:n and m:n), object caching and locking, batch writing, and advanced and dynamic query capabilities. TopLink offers a GUI mapping tool - the TopLink Mapping Workbench - which simplifies the process of mapping J2EE components to database objects. TopLink provides EJB 2.0 support, automatic or developer-configured bi-directional relationship maintenance, automatic or developer-configured cache synchronization session management via XML, and

optimistic read locking. Oracle Application Server is also integrated with other leading O-R mapping solutions in the market.

For more information on TopLink, see the *Oracle Application Server TopLink Getting Started Guide*.

## CORBA Support - RMI-over-IIOP

RMI over IIOP is part of the J2EE 1.3 Specification and provides two important benefits:

- RMI over IIOP provides the ability to write CORBA applications for the Java platform without learning CORBA Interface Definition Language (IDL).
- IIOP eases legacy application and platform integration by allowing applications written in C++, Smalltalk, and other CORBA supported languages to communicate with J2EE components.

Oracle Application Server supports RMI-over-IIOP providing the following important facilities:

- Automatic IDL Stub and Helper Class Generation - To work with CORBA applications in other languages, IDL, CORBA stubs and skeletons can be generated:
  1. Automatically by Oracle Application Server when the J2EE Application is deployed to it.
  2. IDL can also be generated from J2EE interfaces using the `rmic` compiler with the `-idl` option. Further, developers can use the `rmic` compiler with the `-iiop` option to generate IIOP stub and tie classes, rather than Java Remote Messaging Protocol (JRMP) stub and skeleton classes.
- Objects-By-Value - The Oracle Application Server RMI-IIOP implementation provides flexibility by allowing developers to pass any serializable Java object (Objects By Value) between application components.
- POA Support - The Portable Object Adapter (POA) is designed to provide an object adapter that can be used with multiple ORB implementations with a minimum of rewriting needed to deal with different vendors' implementations. The POA is also intended to allow persistent objects -- at least, from the client's perspective. That is, as far as the client is concerned, these objects are always alive, and maintain data values stored in them, even though physically, the server may have been restarted many times, or the implementation may be provided by many different object implementations. Oracle Application Server provides complete POA support.
- Interoperating with Other ORBs - The Oracle Application Server RMI-IIOP implementation will interoperate with other ORBs that support the CORBA 2.3 specification. It will not interoperate with older ORBs, because these are unable to handle the IIOP encodings for Objects By Value. This support is needed to send RMI value classes (including strings) over IIOP. Oracle Application Server also provides complete support for the Interoperable Naming, Security, and Transactions elements in the J2EE 1.3 specification allowing developers to build J2EE applications and interoperate them with J2EE applications on other Application Servers and with legacy systems through CORBA.

See the RMI/Interoperability chapter in the *Oracle Application Server Containers for J2EE Services Guide* for more information.

## Changes in Defaults for Oracle Application Server

Default values in version 9.0.3 have been modified as follows:

- Lazy loading for CMP finder methods is now turned off as the default.
- For relationship mapping for a one-to-many relationship, the default scenario used an association table. Now, the default is to use a foreign key. You can restore the previous behavior to use an association table by default by starting OC4J with the `-DassociateUsingThirdTable=true` system property.
- The default value for the `trans-attribute` for CMP 2.0 entity beans is changed to `Required`. For more information, see the JTA chapter in the *Oracle Application Server Containers for J2EE Services Guide*.
- The JTA two-phase commit (2pc) function does not work with Oracle Database version 9.2. Instead, use Oracle Database version 9.2.0.4 or higher to enable the 2pc functionality.
- The `max-tx-retries` default value is zero. See the EJB section in the *Oracle Application Server Performance Guide* for more information.
- The `max-instances` default value is set to zero for all EJBs.

## Which Type of EJB Should You Use in Your Application?

Enterprise JavaBeans (EJBs) can be one of three types: session beans, entity beans, or message-driven beans.

- Session beans can be stateful or stateless and are used for business logic functionality.
  - Stateless session beans are used for business services. They do not retain client state across calls.
  - Stateful session beans do maintain state across client calls. Thus, these beans manage business functions for a specific client for the life of that client.
- Entity beans are normally used for managing persistent data.
- Message-driven beans are used for receiving messages from a JMS queue or topic.

Each EJB type is described in the sections below:

- [What is a Session Bean?](#)
- [What is an Entity Bean?](#)
- [When Do You Use a Message-Driven Bean?](#)

### What is a Session Bean?

A session bean implements one or more business tasks. A session bean might contain methods that query and update data in a relational table. Session beans are often used to implement services. For example, an application developer might implement one or several session beans that retrieve and update inventory data in a database.

Session beans are transient because they do not survive a server crash or a network failure. If, after a crash, you instantiate a bean that had previously existed, the state of the previous instance is not restored. State can be restored only to entity beans.

A session bean implements the `javax.ejb.SessionBean` interface, which has the following definition:

```
public interface javax.ejb.SessionBean extends javax.ejb.EnterpriseBean {
    public abstract void ejbActivate();
    public abstract void ejbPassivate();
    public abstract void ejbRemove();
    public abstract void setSessionContext(SessionContext ctx);
}
```

At a minimum, the session bean must implement the following methods, as specified in the `javax.ejb.SessionBean` interface:

EJB Method	Description
<code>ejbCreate()</code>	The container invokes this method right before it creates the bean. Stateless session beans must do nothing in this method. Stateful session beans can initiate state in this method.
<code>ejbActivate()</code>	The container invokes this method right after it reactivates the bean.
<code>ejbPassivate()</code>	The container invokes this method right before it passivates the bean. You can turn off passivation for stateful session beans.
<code>ejbRemove()</code>	A container invokes this method before it ends the life of the session object. This method performs any required clean-up—for example, closing external resources such as file handles.
<code>setSessionContext (SessionContext ctx)</code>	This method associates a bean instance with its context information. The container calls this method after the bean creation. The enterprise bean can store the reference to the context object in an instance variable, for use in transaction management. Beans that manage their own transactions can use the session context to get the transaction context.

For more information on how to develop session beans, see [Chapter 3, "Implementing Session Beans"](#).

### Retrieving the Context Using `setSessionContext`

You use this method to obtain a reference to the context of the bean. Session beans have session contexts that the container maintains and makes available to the beans. The bean may use the methods in the session context to make callback requests to the container.

The container invokes `setSessionContext` method, after it first instantiates the bean, to enable the bean to retrieve the session context. The container will never call this method from within a transaction context. If the bean does not save the session context at this point, the bean will never gain access to the session context.

When the container calls this method, it passes the reference of the `SessionContext` object to the bean. The bean can then store the reference for later use. The following example shows the bean saving the session context in the `sessctx` variable.

```
import javax.ejb.*;
import oracle.oas.ejb.*;

public class myBean implements SessionBean {
    SessionContext sessctx;

    void setSessionContext(SessionContext ctx) {
        sessctx = ctx;    // session context is stored in
                        // instance variable
    }
    // other methods in the bean
}
```

```
}

```

The `javax.ejb.SessionContext` interface has the following definition:

```
public interface SessionContext extends javax.ejb.EJBContext {
    public abstract EJBObject getEJBObject();
}
```

And the `javax.ejb.EJBContext` interface has the following definition:

```
public interface EJBContext {
    public EJBHome      getEJBHome();
    public Properties   getEnvironment();
    public Principal    getCallerPrincipal();
    public boolean      isCallerInRole(String roleName);
    public UserTransaction getUserTransaction();
    public boolean      getRollbackOnly();
    public void         setRollbackOnly();
}
```

A bean needs the session context when it wants to perform the operations listed in [Table 1-1](#).

**Table 1-1** *SessionContext Operations*

Method	Description
<code>getEnvironment()</code>	Get the values of properties for the bean.
<code>getUserTransaction()</code>	Get a transaction context, which allows you to demarcate transactions programmatically. This is valid only for beans that have been designated transactional.
<code>setRollbackOnly()</code>	Set the current transaction so that it cannot be committed.
<code>getRollbackOnly()</code>	Check whether the current transaction has been marked for rollback only.
<code>getEJBHome()</code>	Retrieve the object reference to the corresponding <code>EJBHome</code> (home interface) of the bean.

There are two types of session beans:

- **What is a Stateless Session Bean?**—Stateless session beans do not share state or identity between method invocations. They are useful mainly in middle-tier application servers that provide a pool of beans to process frequent and brief requests.
- **What is a Stateful Session Bean?**—Stateful session beans are useful for conversational sessions, in which it is necessary to maintain state, such as instance variable values or transactional state, between method invocations. These session beans are mapped to a single client for the life of that client.

For more information on how to develop session beans, see [Chapter 3, "Implementing Session Beans"](#).

### What is a Stateless Session Bean?

A stateless session bean does not maintain any state for the client. It is strictly a single invocation bean. It is employed for reusable business services that are not connected to any specific client, such as generic currency calculations, mortgage rate calculations, and so on. Stateless session beans may contain client-independent, read-only state



across a call. Subsequent calls are handled by other stateless session beans in the pool. The information is used only for the single invocation.

The EJB container maintains a pool of these stateless beans to service multiple clients. An instance is taken out of the pool when a client sends a request. There is no need to initialize the bean with any information. There is implemented only a single `create/ejbCreate` with no parameters—containing no initialization for the bean within these methods. There is no need to implement any actions within the `remove/ejbRemove`, `ejbPassivate`, `ejbActivate`, and `setSessionContext` methods. In addition, there is no need for the intended use for these methods in a stateless session bean. Instead, these methods are used mostly for EJBs with state—for stateful session beans and entity beans. Thus, these methods should be empty or extremely simple.

Implementation	Methods
Home Interface	Extends <code>javax.ejb.EJBHome</code> and requires a single <code>create()</code> factory method, with no arguments, and a single <code>remove()</code> method.
Component Interface (remote or local)	Extends <code>javax.ejb.EJBObject</code> for the remote interface and <code>javax.ejb.EJBLocalObject</code> for the local interface. It defines the business logic methods, which are implemented in the bean implementation.
Bean implementation	Implements <code>SessionBean</code> . This class must be declared as <code>public</code> , contain a <code>public</code> , empty, default constructor, no <code>finalize()</code> method, and implements the methods defined in the component interface. Must contain a single <code>ejbCreate</code> method, with no arguments, to match the <code>create()</code> method in the home interface. Contains empty implementations for the container service methods, such as <code>ejbRemove</code> , and so on.

For more information on how to develop session beans, see [Chapter 3, "Implementing Session Beans"](#).

### What is a Stateful Session Bean?

A stateful session bean maintains its state between method calls. Thus, there is one instance of a stateful session bean created for each client. Each stateful session bean contains an identity and a one-to-one mapping with an individual client. The state of this type of bean is maintained across several calls through serialization of its state, called passivation. This is why the state that you passivate must be serializable. However, this information does not survive system crashes.

To maintain state for several stateful beans in a pool, it serializes the conversational state of the least recently used stateful bean to a secondary storage. When the bean instance is requested again by its client, the state is activated to a bean within the pool. Thus, all resources are used performantly, and the state is not lost.

The type of state that is saved does not include resources. The container invokes the `ejbPassivate` method within the bean to provide the bean with a chance to clean up its resources, such as sockets held, database connections, and hash tables with static information. All these resources can be reallocated and recreated during the `ejbActivate` method.

---

**Note:** You can turn off passivation for stateful session beans.

---

If the bean instance fails, the state can be lost—unless you take action within your bean to continually save state. However, if you must make sure that state is persistently saved in the case of failovers, you may want to use an entity bean for your implementation. Alternatively, you could also use the `SessionSynchronization` interface to persist the state transactionally.

For example, a stateful session bean could implement the server side of a shopping cart on-line application, which would have methods to return a list of objects that are available for purchase, put items in the customer's cart, place an order, change a customer's profile, and so on.

Implementation	Methods
Home Interface	Extends <code>javax.ejb.EJBHome</code> and requires one or more <code>create()</code> factory methods, and a single <code>remove()</code> method.
Component Interface (remote or local)	Extends <code>javax.ejb.EJBObject</code> for the remote interface and <code>javax.ejb.EJBLocalObject</code> for the local interface. It defines the business logic methods, which are implemented in the bean implementation.
Bean implementation	Implements <code>SessionBean</code> . This class must be declared as <code>public</code> , contain a <code>public</code> , empty, default constructor, no <code>finalize()</code> method, and implement the methods defined in the remote interface. Must contain <code>ejbCreate</code> methods equivalent to the <code>create()</code> methods defined in the home interface. That is, each <code>ejbCreate</code> method is matched—by its parameter signature—to a <code>create</code> method defined in the home interface. Implements the container service methods, such as <code>ejbRemove</code> , and so on. Also, implements the <code>SessionSynchronization</code> interface for Container-Managed Transactions, which includes <code>afterBegin</code> , <code>beforeCompletion</code> , and <code>afterCompletion</code> .

For more information on how to develop session beans, see [Chapter 3, "Implementing Session Beans"](#).

## What is an Entity Bean?

An entity bean is a complex business entity. An entity bean models a business entity or models multiple actions within a business process. Entity beans are often used to facilitate business services that involve data and computations on that data. For example, an application developer might implement an entity bean to retrieve and perform computation on items within a purchase order. Your entity bean can manage multiple, dependent, persistent objects in performing its necessary tasks.

An entity bean is a remote object that manages persistent data, performs complex business logic, potentially uses several dependent Java objects, and can be uniquely identified by a primary key. Entity beans are normally coarse-grained persistent objects, because they utilize persistent data stored within several fine-grained persistent Java objects.

Entity beans are persistent because they do survive a server crash or a network failure. When an entity bean is re-instantiated, the state of previous instances is automatically restored.

For detailed information on how to create entity beans, see [Chapter 4, "Entity Beans"](#).

### Entity Beans are Uniquely Identified by a Primary Key

Each entity bean has a persistent identity associated with it. That is, the entity bean contains a unique identity that can be retrieved if you have the primary key—given

the primary key, a client can retrieve the entity bean. If the bean is not available, the container instantiates the bean and repopulates the persistent data for you.

The type for the unique key is defined by the bean provider.

---

**Note:** For more information on primary keys, see ["How to Define and Use Primary Keys for Your Entity Bean"](#) on page 4-6.

---

### Managing the Persistent Data Within the Entity Bean

The persistence for entity bean data is provided both for saving state when the bean is passivated and for recovering the state when a failover has occurred. Entity beans are able to survive because the data is stored persistently by the container in some form of data storage system, such as a database. Entity beans persist business data using one of the two following methods:

- Automatically by the container using a container-managed persistent (CMP) entity bean.
- Programmatically through methods implemented in a bean-managed persistent (BMP) entity bean. These methods use JDBC or SQLJ to manage persistence.

An entity bean manages its data persistence through callback methods, which are defined in the `javax.ejb.EntityBean` interface. When you implement the `EntityBean` interface in your bean class, you develop each of the callback functions as designated by the type of persistence that you choose: bean-managed persistence or container-managed persistence. The container invokes the callback functions at designated times.

The `javax.ejb.EntityBean` interface has the following definition:

```
public interface javax.ejb.EntityBean extends javax.ejb.EnterpriseBean {
    public abstract void ejbActivate();
    public abstract void ejbLoad();
    public abstract void ejbPassivate();
    public abstract void ejbRemove();
    public abstract void ejbStore();
    public abstract void setEntityContext(EntityContext ctx);
    public abstract void unsetEntityContext();
}
```

The container expects these methods to have the following functionality:

**Table 1–2 A Description of the EJB Bean Implementation Methods**

EJB Method	Description
<code>ejbCreate</code>	<p>You must implement an <code>ejbCreate</code> method corresponding to each <code>create</code> method declared in the home interface. When the client invokes the <code>create</code> method, the container first invokes the constructor to instantiate the object, then it invokes the corresponding <code>ejbCreate</code> method. The <code>ejbCreate</code> method performs the following:</p> <ul style="list-style-type: none"> <li>■ creates any persistent storage for its data, such as database rows</li> <li>■ initializes a unique primary key and returns it</li> </ul>
<code>ejbPostCreate</code>	<p>The container invokes this method after the environment is set. For each <code>ejbCreate</code> method, an <code>ejbPostCreate</code> method must exist with the same arguments. This method can be used to initialize parameters within or from the entity context.</p>

**Table 1–2 (Cont.) A Description of the EJB Bean Implementation Methods**

<b>EJB Method</b>	<b>Description</b>
<code>ejbRemove</code>	The container invokes this method before it ends the life of the session object. This method can perform any required clean-up, for example closing external resources such as file handles.
<code>ejbStore</code>	The container invokes this method right before a transaction commits. It saves the persistent data to an outside resource, such as a database.
<code>ejbLoad</code>	The container invokes this method when the data should be reinitialized from the database. This normally occurs after activation of an entity bean.
<code>setEntityContext</code>	<p>Associates the bean instance with context information. The container calls this method after the bean creation. The enterprise bean can store the reference to the context object in an instance variable, for use in transaction management. Beans that manage their own transactions can use the session context to get the transaction context.</p> <p>You can also allocate any resources that will exist for the lifetime of the bean within this method. You should release these resources in <code>unsetEntityContext</code>.</p>
<code>unsetEntityContext</code>	Unset the associated entity context and release any resources allocated in <code>setEntityContext</code> .
<code>ejbActivate</code>	The container calls this method directly before it activates an object that was previously passivated. Perform any necessary requisition of resources in this method.
<code>ejbPassivate</code>	The container calls this method before it passivates the object. Release any resources that can be easily re-created in <code>ejbActivate</code> , and save storage space. Normally, you want to free resources that cannot be passivated, such as sockets or database connections. Retrieve these resources in the <code>ejbActivate</code> method.

**Create the Entity Bean Using `ejbCreate` and `ejbPostCreate`** An entity bean is similar to a session bean because certain callback methods, such as `ejbCreate`, are invoked at specified times. Entity beans use callback functions for managing its persistent data, primary key, and context information. The following diagram shows what methods are called when an entity bean is created.

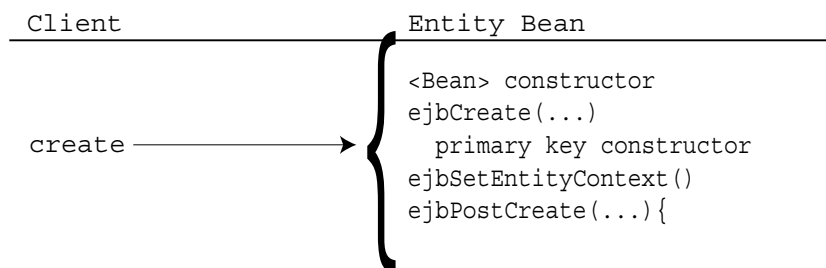
**Figure 1–1 Creating the Entity Bean**

**Retrieve the Entity Bean Context With `setEntityContext`** An entity bean instance uses this method to retain a reference to its context. Entity beans have contexts that the container maintains and makes available to the beans. The bean may use the methods in the entity context to retrieve information about the bean, such as security, and transactional role. Refer to the Enterprise JavaBeans specification from Sun

Microsystems for the full range of information that you can retrieve about the bean from the context.

The container invokes the `setEntityContext` method, after it first instantiates the bean, to enable the bean to retrieve the context. The container will never call this method from within a transaction context. If the bean does not save the context at this point, the bean will never gain access to the context.

---

**Note:** You can also use the `setEntityContext` and `unsetEntityContext` methods to allocate and destroy any resources that will exist for the lifetime of the instance.

---

When the container calls this method, it passes the reference of the `EntityContext` object to the bean. The bean can then store the reference for later use. The following example shows the bean saving the context in the `this.ctx` variable.

```
public void setEntityContext(EntityContext ctx) { this.ctx = ctx; }
```

**Remove the Entity Bean With `ejbRemove`** When the client invokes the `remove` method, the container invokes the methods shown in [Figure 1-2](#).

**Figure 1-2 Removing the Entity Bean**

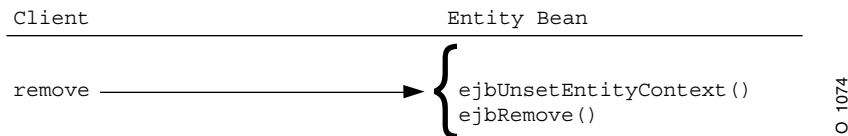

**Manage the Persistent Data With `ejbStore` and `ejbLoad`** In addition, the `ejbStore` and `ejbLoad` methods are called for managing your persistent data. These are the most important callback methods—for bean-managed persistent beans. Container-managed persistent beans can leave these methods empty, because the persistence is managed by the container.

- The `ejbStore` method is called by the container before the object is passivated or whenever a transaction is about to end. Its purpose is to save the persistent data to an outside resource, such as a database.
- The `ejbLoad` method is called by the container before the object is activated or whenever a transaction has begun, or when an entity bean is instantiated. Its purpose is to restore any persistent data that exists for this particular bean instance.

### Manage Your Persistent Data With Container-Managed Persistence

You can choose to have the container manage your persistent data for the bean. You do not have to implement some of the callback methods to manage persistence for your bean's data, because the container stores and reloads your persistent data to and from the database. When you use container-managed persistence, the container invokes a persistence manager class that provides the persistence management business logic. In addition, you do not have to provide management for the primary key: the container provides this key for the bean.

- **Callback methods**—The container still invokes the callback methods, so you can add logic for other purposes. At the least, you must provide an empty implementation for all callback methods.

- **Primary key**—The primary key fields in a CMP bean must be declared as container-managed persistent fields in the deployment descriptor. All fields within the primary key are restricted to be either primitive, serializable, and types that can be mapped to SQL types.

---

**Note:** For more information on primary keys, see ["How to Define and Use Primary Keys for Your Entity Bean"](#) on page 4-6.

---

The following table details the implementation requirements for the callback functions of the bean class:

Callback Method	Functionality Required
<code>ejbCreate</code>	You must initialize all container-managed persistent fields, including the primary key.
<code>ejbPostCreate</code>	You have the option to provide any additional initialization, which can involve the entity context.
<code>ejbRemove</code>	No functionality for removing the persistent data from the outside resource is required. You must at least provide an empty implementation for the callback, which means that you can add logic for performing any cleanup functionality you require.
<code>ejbFindByPrimaryKey</code>	No functionality is required for returning the primary key to the container. The container manages the primary key—after it is initialized by the <code>ejbCreate</code> method. You still must provide an empty implementation for this method.
<code>ejbStore</code>	No functionality is required for saving persistent data within this method. The persistent manager saves all persistent data to the database for you. However, you must provide at least an empty implementation.
<code>ejbLoad</code>	No functionality is required for restoring persistent data within this method. The persistence manager restores all persistent data for you. However, you must provide at least an empty implementation.
<code>setEntityContext</code>	Associates the bean instance with context information. The container calls this method after the bean creation. The enterprise bean can store the reference to the context object in an instance variable, for use in transaction management. Beans that manage their own transactions can use the session context to get the transaction context.  You can also allocate any resources that will exist for the lifetime of the bean within this method. You should release these resources in <code>unsetEntityContext</code> .
<code>unsetEntityContext</code>	Unset the associated entity context and release any resources allocated in <code>setEntityContext</code> .

---

**Note:** For more information on container-managed persistence, see [Chapter 5, "CMP Entity Beans"](#).

---

## What is the Difference Between Session and Entity Beans?

The major differences between session and entity beans are that entity beans involve a framework for persistent data management, a persistent identity, and complex

business logic. The following table illustrates the different interfaces for session and entity beans. Notice that the difference between the two types of EJBs exists within the bean class and the primary key. All of the persistent data management is done within the bean class methods.

J2EE Subject	Entity Bean	Session Bean
Local interface	Extends <code>javax.ejb.EJBLocalObject</code>	Extends <code>javax.ejb.EJBLocalObject</code>
Remote interface	Extends <code>javax.ejb.EJBObject</code>	Extends <code>javax.ejb.EJBObject</code>
Local Home interface	Extends <code>javax.ejb.EJBLocalHome</code>	Extends <code>javax.ejb.EJBLocalHome</code>
Remote Home interface	Extends <code>javax.ejb.EJBHome</code>	Extends <code>javax.ejb.EJBHome</code>
Bean class	Extends <code>javax.ejb.EntityBean</code>	Extends <code>javax.ejb.SessionBean</code>
Primary key	Used to identify and retrieve specific bean instances	Not used for session beans. Stateful session beans do have an identity, but it is not externalized.

## When Do You Use a Message-Driven Bean?

Message-Driven Beans (MDB) provide an easier method to implement asynchronous communication than using straight JMS. MDBs were created to receive asynchronous JMS messages. The container handles much of the setup required for JMS queues and topics. It sends all messages to the interested MDB.

Previously, EJBs could not send or receive JMS messages. It took creating MDBs for an EJB-type object to receive JMS messages. This provides all of the asynchronous and publish/subscribe abilities to an enterprise object that is able to be synchronous with other Java objects.

The purpose of an MDB is to exist within a pool and to receive and process incoming messages from a JMS queue. The container invokes a bean from the queue to handle each incoming message from the queue. No object invokes an MDB directly: all invocation for an MDB comes from the container. After the container invokes the MDB, it can invoke other EJBs or Java objects to continue the request.

A MDB is similar to a stateless session bean because it does not save conversational state and is used for handling multiple incoming requests. Instead of handling direct requests from a client, MDBs handle requests placed on a queue. [Figure 1-3](#) demonstrates this by showing how clients place requests on a queue. The container takes the requests off of the queue and gives the request to an MDB in its pool.

**Figure 1-3 Message Driven Beans**

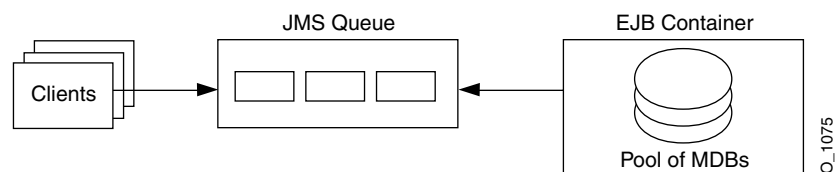

MDBs implement the `javax.ejb.MessageDrivenBean` interface, which also inherits the `javax.jms.MessageListener` methods. Within these interfaces, the following methods must be implemented:

Method	Description
<code>onMessage (msg)</code>	The container dequeues a message from the JMS queue associated with this MDB and gives it to this instance by invoking this method. This method must have an implementation for handling the message appropriately.
<code>setMessageDrivenContext (ctx)</code>	After the bean is created, the <code>setMessageDrivenContext</code> method is invoked. This method is similar to the EJB <code>setSessionContext</code> and <code>setEntityContext</code> methods.
<code>ejbCreate ()</code>	This method is used just like the stateless session bean <code>ejbCreate</code> method. No initialization should be done in this method. However, any resources that you allocate within this method will exist for this object.
<code>ejbRemove()</code>	Delete any resources allocated within the <code>ejbCreate</code> method.

The container handles JMS message retrieval and acknowledgment. Your MDB does not have to worry about JMS specifics. The MDB is associated with an existing JMS queue. Once associated, the container handles dequeuing messages and sending acknowledgments. The container communicates the JMS message through the `onMessage` method.

---

**Note:** For more information on MDBs and how to implement them, see [Chapter 9, "Message-Driven Beans"](#).

---

## What Makes Up An EJB?

An EJB has two client interfaces that a client uses to create and use an EJB:

- Component interface (remote or local)—The component interface specifies the business methods that the clients of the object can invoke.
- Home interface—The home interface defines EJB life cycle methods, such as a method to create and retrieve a reference to the bean object.

The client uses both of these interfaces when invoking a method on a bean.



Figure 1-4 Events in a Stateless Session Bean

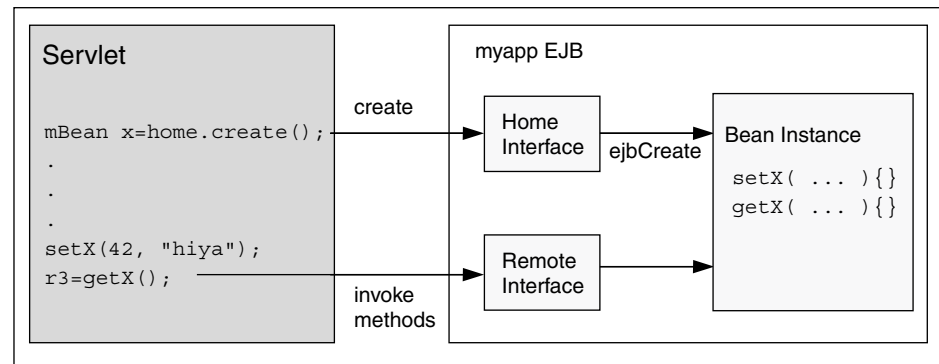

\*\*\*\*\*

Figure 1-4 demonstrates a stateless session bean and corresponds to the following steps:

1. The client, which can be a standalone Java client, servlet, JSP, or an applet, retrieves the home interface of the bean—normally through JNDI.
2. The client invokes the `create` method on the home interface reference (home object). This creates the bean instance and returns a reference to the component interface (remote or local interface) of the bean.
3. The client invokes a method defined in the component interface (remote or local interface), which delegates the method call to the corresponding method in the bean instance (through a stub).
4. The client can destroy the bean instance by invoking the `remove` method that is defined in the component interface (remote or local interface). Some beans, such as stateless session beans, cannot call the `remove` method. In this case, the container removes the bean.

For an example of a stateless session bean implementation, see "[Developing Session Beans](#)" on page 3-2.

When developing an EJB, you create the following four major components:

- the *home interface*
- the *component interface (remote or local interface)*
- the *implementation* of the bean
- a *deployment descriptor* for each EJB

Component	Description
The home interface	Specifies the interface to an object that the container itself implements: the <i>home object</i> . The home interface contains the life cycle methods, such as the <code>create()</code> methods that specify how a bean is created.
The component interface (remote or local)	Specifies the business methods that you implement in the bean. The bean must also implement additional container service methods. The EJB container invokes these methods at different times in the life cycle of a bean.

Component	Description
The bean implementation	Contains the Java code that implements the methods defined in the home interface (life cycle methods), component interface (business methods), and the required container methods (container callback functions).
The deployment descriptor	Specifies attributes of the bean for deployment. These designate configuration specifics, such as environment, interface names, transactional support, type of EJB, and persistence information.

Development issues for your EJBs are discussed in the following sections:

- [Interfaces for Bean Implementation is Based on Bean Type](#)
- [Parameter Passing Conventions for Your EJBs](#)
- [How to Handle Returned Parameter Objects](#)

## Interfaces for Bean Implementation is Based on Bean Type

Your bean implements the methods within either the `SessionBean`, `EntityBean`, or `MessageDrivenBean` interface. The implementation contains logic for lifecycle methods defined in the home interface, business methods defined in the component interface (remote or local), and container callback functions defined in the `SessionBean`, `EntityBean`, or `MessageDrivenBean` interface.

See the following chapters for details on each bean type:

- [Chapter 3, "Implementing Session Beans"](#)
- [Chapter 4, "Entity Beans"](#)
- [Chapter 9, "Message-Driven Beans"](#)

## Parameter Passing Conventions for Your EJBs

When you implement an EJB or write the client code that calls EJB methods, you must be aware of the parameter-passing conventions used with EJBs.

A parameter that you pass to a bean method—or a return value from a bean method—can be any Java type that is serializable. Java primitive types, such as `int`, `double`, are serializable. Any non-remote object that implements the `java.io.Serializable` interface can be passed. A non-remote object that is passed as a parameter to a bean or returned from a bean is passed by *value*, not by reference. So, for example, if you call a bean method as follows:

```
public class theNumber {
    int x;
}
...
bean.method1(theNumber);
```

then `method1()` in the bean receives a copy of `theNumber`. If the bean changes the value of `theNumber` object on the server, this change is not reflected back to the client, because of pass-by-value semantics.

If the non-remote object is complex—such as a class containing several fields—only the non-static and non-transient fields are copied.

When passing a remote object as a parameter, the stub for the remote object is passed. A remote object passed as a parameter must extend remote interfaces.

The next section demonstrates parameter passing to a bean, and remote objects as return values.

## How to Handle Returned Parameter Objects

The `EmployeeBean` `getEmployee` method returns an `EmpRecord` object, so this object must be defined somewhere in the application. In this example, an `EmpRecord` class is included in the same package as the EJB interfaces.

The class is declared as `public` and must implement the `java.io.Serializable` interface so that it can be passed back to the client by value, as a serialized remote object. The declaration is as follows:

```
package employee;

public class EmpRecord implements java.io.Serializable {
    public String ename;
    public int empno;
    public double sal;
}
```

---

**Note:** The `java.io.Serializable` interface specifies no methods; it just indicates that the class is serializable. Therefore, there is no need to implement extra methods in the `EmpRecord` class.

---

## What Container Services Can You Use for EJBs?

One of the advantages of using EJBs is that the EJB container provides security and transaction services for you. These services, as well as RMI/IIOP, JNDI, Data Source, and JMS, are documented in the following books:

**Table 1–3** Location of Information for J2EE Subjects

J2EE Subject	The Subject is Documented in this OC4J Documentation Book
JTA	<i>Oracle Application Server Containers for J2EE Services Guide</i>
Data Source	<i>Oracle Application Server Containers for J2EE Services Guide</i>
JNDI	<i>Oracle Application Server Containers for J2EE Services Guide</i>
JMS	<i>Oracle Application Server Containers for J2EE Services Guide</i>
RMI and RMI/IIOP	<i>Oracle Application Server Containers for J2EE Services Guide</i>
Security	<i>Oracle Application Server Containers for J2EE Security Guide</i>
CSIv2	<i>Oracle Application Server Containers for J2EE Security Guide</i>
JCA	<i>Oracle Application Server Containers for J2EE Services Guide</i>
Java Object Cache	<i>Oracle Application Server Containers for J2EE Services Guide</i>
Web Services	<i>Oracle Application Server Web Services Developer's Guide</i>
HTTPS	<i>Oracle Application Server Containers for J2EE Services Guide</i>



---

---

## How to Access EJBs

This chapter demonstrates how to access an EJB from a servlet within the application server or from outside the application server—either from an EJB within another application server or from a local client.

- [Steps for Accessing Any EJB](#)
- [Example of How a Client Invokes an EJB](#)
- [Accessing an EJB in a Remote Server](#)
- [Accessing an EJB in Another Application](#)
- [Recovering From Deadlock Conditions](#)
- [Recovering From a NamingException While Accessing a Remote EJB](#)
- [Recovering From NullPointerException While Accessing a Remote EJB](#)

You can download examples from the OC4J sample code page at <http://www.oracle.com/technology/tech/java/oc4j/demos> on the OTN Web site.

### Steps for Accessing Any EJB

To access an EJB from a client, you must do the following:

1. If you are remote, download the `oc4j.jar` file.
2. Set up JNDI properties for the connection, if necessary.
3. Determine which `InitialContextFactory` you will use for the connection.
4. Retrieve an EJB using either the JNDI name or an EJB reference, which is configured in the deployment descriptor.

These subjects are discussed in the following sections:

- [Client Installation of OC4J.JAR](#)
- [Setting JNDI Properties](#)
- [When Do You Use the Different Initial Context Factory Classes?](#)
- [How to Lookup the EJB Reference](#)
- [Configuring the EJB Reference Information](#)
- [Example of How a Client Invokes an EJB](#)

## Client Installation of OC4J.JAR

In order to access EJBs, the client-side must download `oc4j_client.zip` file from <http://www.oracle.com/technology/software/products/ias/devuse.htm>. Unzip the JAR into a directory that is in your CLASSPATH. This JAR contains the classes necessary for client interaction. If you download this JAR into a browser, you must grant certain permissions. See "[Granting Permissions in Browser](#)" on page 12-1 for a list of these permissions.

## Setting JNDI Properties

If the client is collocated with the target, the client exists within the same application as the target, or the target exists within its parent, then you do not need a JNDI properties file. Else, you must initialize your JNDI properties either within a `jndi.properties` file, in the system properties, or within your implementation, before the JNDI call. The following sections discuss these three options:

- [No JNDI Properties](#)
- [JNDI Properties File](#)
- [JNDI Properties Within The Implementation](#)
- [JNDI Properties for OC4J Standalone](#)

To specify credentials within the JNDI properties, see "[Specifying Credentials in EJB Clients](#)" on page 12-8.

---

---

**Note:** A full description of how to use JNDI, see the JNDI chapter in the *Oracle Application Server Containers for J2EE Services Guide*.

---

---

### No JNDI Properties

A servlet that is collocated with the target bean automatically accesses the JNDI properties for the node. Thus, accessing the EJB is simple: no JNDI properties are required.

```
//Get the Initial Context for the JNDI lookup for a local EJB
InitialContext ic = new InitialContext();
//Retrieve the Home interface using JNDI lookup
Object helloObject = ic.lookup("java:comp/env/ejb/HelloBean");
```

This is also true if the target bean is in the same application or an application that has been deployed as this application's parent. See the *Oracle Application Server Containers for J2EE User's Guide* for more information on how to set the parent of the application.

### JNDI Properties File

If setting the JNDI properties within the `jndi.properties` file, set the properties as follows. Make sure that this file is accessible from the CLASSPATH.

#### Factory

See "[When Do You Use the Different Initial Context Factory Classes?](#)" on page 2-4 for discussion on the initial context factory to use.

```
java.naming.factory.initial=
    com.evermind.server.ApplicationClientInitialContextFactory
```

## Location

All ports, including the RMI port, are dynamically set by OPMN when each OC4J instance starts. When you specify the following URL in the client JNDI properties, the client-side OC4J retrieves the dynamic ports for the instance, and chooses one from the list for communication.

```
java.naming.provider.url=
  opmn:ormi://<opmn_host>:<opmn_port>:<oc4j_instance>/<application-name>
```

The OPMN host name and port number is retrieved from the `opmn.xml` file. In most cases, OPMN is located on the same machine as the OC4J instance. However, you must specify the host name in case it is located on another machine. The OPMN port number is optional; if excluded, the default is port 6003. The OPMN port is specified in `opmn.xml`.

The OC4J instance name is defined in the Enterprise Manager.

## Security

When you access EJBs in a *remote* container, you must pass valid credentials to this container. Stand-alone clients define their credentials in the `jndi.properties` file deployed with the client's code.

```
java.naming.security.principal=<username>
java.naming.security.credentials=<password>
```

## JNDI Properties Within The Implementation

Set the properties with the same values, only with a different syntax. For example, JavaBeans running within the container pass their credentials within the `InitialContext`, which is created to look up the remote EJBs.

- In the `java.naming.provider.url`, the "opmn:ormi" location string is provided. Both OPMN and OC4J are located on the same host. The OPMN default port is used, so the port number is not specified.
- In the `java.naming.factory.initial`, the `ApplicationClientInitialContextFactory` object is used.

To pass JNDI properties within the `Hashtable` environment, set these as shown below:

```
Hashtable env = new Hashtable();
env.put("java.naming.provider.url",
       "opmn:ormi://opmnhost:oc4j_inst1/ejbsamples");
env.put("java.naming.factory.initial",
       "com.evermind.server.ApplicationClientInitialContextFactory");
env.put(Context.SECURITY_PRINCIPAL, "guest");
env.put(Context.SECURITY_CREDENTIALS, "welcome");
Context ic = new InitialContext (env);
Object homeObject = ic.lookup("java:comp/env/ejb/HelloBean");

// Narrow the reference to a HelloHome.
HelloHome empHome =
  (HelloHome) PortableRemoteObject.narrow(homeObject,
                                         HelloHome.class);
```

## JNDI Properties for OC4J Standalone

The rules for which initial context factory are the same for OC4J standalone applications. However, since OC4J standalone does not use OPMN, the location URL cannot use the `opmn:ormi://` prefix. Instead, the `ormi://` prefix is used.

The ORMI default port number is 23791, which can be modified in `config/rmi.xml`. Thus, set the URL in the `jndi.properties`, in one of the two ways:

```
java.naming.provider.url=ormi://<hostname>/<application-name>
or
java.naming.provider.url=ormi://<hostname>:23791/<application-name>
```

When you access EJBs in a remote container, you must pass valid credentials to this container. Stand-alone clients define their credentials in the `jndi.properties` file deployed with the client's code.

```
java.naming.security.principal=<username>
java.naming.security.credentials=<password>
```

If you set the properties within the bean implementation, then set them with the same values, just with different syntax. For example, JavaBeans running within the container pass their credentials within the `InitialContext`, which is created to look up the remote EJBs.

To pass JNDI properties within the `Hashtable` environment, set these as shown below:

```
Hashtable env = new Hashtable();
env.put("java.naming.provider.url", "ormi://myhost/ejbsamples");
env.put("java.naming.factory.initial",
        "com.evermind.server.ApplicationClientInitialContextFactory");
env.put(Context.SECURITY_PRINCIPAL, "guest");
env.put(Context.SECURITY_CREDENTIALS, "welcome");
Context ic = new InitialContext (env);
Object homeObject = ic.lookup("java:comp/env/ejb/HelloBean");

// Narrow the reference to a HelloHome.
HelloHome helloHome =
    (HelloHome) PortableRemoteObject.narrow(homeObject,
                                           HelloHome.class);
```

## When Do You Use the Different Initial Context Factory Classes?

The type of initial context factory that you use depends on who the client is. The initial context factory creates the initial context class for the client.

- If the client is a pure Java client outside of the OC4J container, use the `ApplicationClientInitialContextFactory` class.
- If the client is an EJB or servlet client within the OC4J container, use the `ApplicationInitialContextFactory` class. The `ApplicationInitialContextFactory` class is the default class; thus, each time you create a new `InitialContext` without specifying any initial context factory class, your client uses the `ApplicationInitialContextFactory` class.
- If the client is an administrative class that is going to manipulate or traverse the JNDI tree, use the `com.evermind.server.RMIInitialContextFactory` class.
- If the client is going to use DNS load balancing, use the `RMIInitialContextFactory` class.



For example, if you have a pure Java client, then you set the initial context factory class ("java.naming.factory.initial") to `ApplicationClientInitialContextFactory`. The following example sets the initial context factory in the environment, but you could also put this in the JNDI properties file.

```
env.put("java.naming.factory.initial",
        "com.evermind.server.ApplicationClientInitialContextFactory");
```

If the client is an EJB or a servlet calling an EJB in the same application, you can use the default by not setting the JNDI properties with an initial context factory and uses the `ApplicationInitialContextFactory` object by executing the following:

```
InitialContext ic = new InitialContext();
```

If you decide to use the `RMIInitialContextFactory` class, you must use the JNDI name in the lookup and not a logical name defined in the `<ejb-ref>` in your XML configuration file.

### An Initial Context Factory Specific to DNS Load Balancing

To use DNS for load balancing, you must do the following:

1. Within DNS, map a single host name to several IP addresses. Each of the port numbers must be the same for each IP address. Set up the DNS server to return the addresses either in a round-robin or random fashion.
2. Turn off DNS caching on the client. For UNIX machines, you must turn off DNS caching as follows:
  - a. Kill the NSCD daemon process on the client.
  - b. Start the OC4J client with the `-Dsun.net.inetaddr.ttl=0` option.
3. Within each client, use any initial context factory to create an initial context. You can use either the `opmn:orimi://` or the `orimi://` prefix in the provider URL. Use `opmn:orimi://` syntax for Oracle9iAS applications and the `orimi://` for standalone OC4J applications.
4. Set the `dedicated.rmicontext` property to true.

Each time the lookup occurs on the DNS server, the DNS server hands back a one of the many IP addresses that are mapped to it.

#### Example 2-1 RMIInitialContextFactory Example

```
java.naming.factory.initial=
    com.evermind.server.rmi.RMIInitialContextFactory
java.naming.provider.url=opmn:orimi://myserver:oc4j_inst/applname
java.naming.security.principal=admin
java.naming.security.credentials=welcome
dedicated.rmicontext=true
```

## How to Lookup the EJB Reference

Before you start implementing your call to the EJB in your client, you should consider the following for the JNDI retrieval of the EJB reference of the bean:

- Within your client code, you retrieve an EJB reference to the target bean in order to execute methods on that bean. Do you want to set up a logical name for the target bean or use the JNDI name?

- Use the logical name: Modify the client XML configuration file to set up the `<ejb-ref>` element with the target bean information. The logical name specified in the `<ejb-ref-name>` element is used in the JNDI lookup. See "[Configuring the EJB Reference Information](#)" on page 2-6 for more information on the `<ejb-ref>` and `<ejb-ref-name>` elements.
- Use the actual name: The actual name of the bean is used in the JNDI lookup. This name has been specified in the target bean's `ejb-jar.xml` XML deployment descriptors in the `<ejb-name>` element.
- The method for accessing EJBs depends on where your client is located relative to the bean it wants to invoke.
  - Is the client is collocated with the target bean? Deployed in the same application? Or is the target bean part of an application that is this client's parent? You do not need to set up any JNDI properties.
  - Otherwise, you must set up JNDI properties. There are two methods for setting up JNDI properties. See "[Setting JNDI Properties](#)" on page 2-2 for more information

## Configuring the EJB Reference Information

Specify the EJB reference information for the remote EJB in the `<ejb-ref>` or `<ejb-local-ref>` elements in the client's XML file:

- `application-client.xml`: The client is a pure-Java client, invoking the bean outside of the container.
- `ejb-jar.xml`: The client is another EJB.
- `web.xml`: The client is a servlet or JSP.

For example, if a client wants to access the remote interface of the `Hello` example, then the client's XML would define the following:

```
<ejb-ref>
  <ejb-ref-name>ejb/HelloBean</ejb-ref-name>
  <ejb-ref-type>Session</ejb-ref-type>
  <home>hello.HelloHome</home>
  <remote>hello.Hello</remote>
</ejb-ref>
```

If the client wants to access the local interface of the `Hello` example, then the client's XML would define the following:

```
<ejb-ref>
  <ejb-ref-name>ejb/HelloBean</ejb-ref-name>
  <ejb-ref-type>Session</ejb-ref-type>
  <local-home>hello.HelloLocalHome</local-home>
  <local>hello.HelloLocal</local>
</ejb-ref>
```

OC4J maps the logical name to the actual JNDI name on the client-side. The server-side receives the JNDI name and resolves it within its JNDI tree.

## Example of How a Client Invokes an EJB

All EJB clients implement the following steps to instantiate a bean, invoke its methods, and destroy the bean:

1. Look up the home interface through a JNDI lookup. Follow JNDI and the EJB specification conventions for retrieving the bean reference, including setting up JNDI properties if the bean is remote to the client. See "[How to Lookup the EJB Reference](#)" on page 2-5.
2. Narrow the returned object from the JNDI lookup to the home interface, as follows:
  - a. When accessing the remote interface, use the `PortableRemoteObject.narrow` method to narrow the returned object.
  - b. When accessing the local interface, cast the returned object with the local home interface type.
3. Create instances of the bean in the server through the returned object. Invoking the `create` method on the home interface causes a new bean to be instantiated and returns a bean reference.

---

**Note:** For entity beans that are already instantiated, you can retrieve the bean reference through one of its finder methods.

---

4. Invoke business methods, which are defined in the component (remote or local) interface.
5. After you are finished, invoke the `remove` method. This will either remove the bean instance or return it to a pool. The container controls how to act on the `remove` method.

These steps are demonstrated in [Example 2-2](#).

#### **Example 2-2 A Servlet Acting as a Local Client**

The following example is executed from a servlet that is collocated with the Hello bean. Thus, the session bean uses the local interface, and the JNDI lookup does not require JNDI properties.

---

**Note:** The JNDI name is specified in the `<ejb-local-ref>` element in this session bean EJB deployment descriptor as follows:

```
<ejb-local-ref>
  <ejb-ref-name>ejb/HelloBean</ejb-ref-name>
  <ejb-ref-type>Session</ejb-ref-type>
  <local-home>hello.HelloLocalHome</local-home>
  <local>hello.HelloLocal</local>
</ejb-local-ref>
```

---

```
package hello;

import javax.servlet.http.*;
import javax.servlet.*;
import javax.ejb.*;
import javax.naming.*;
import java.io.IOException;

public class HelloServlet extends HttpServlet
{
    HelloLocalHome helloHome;
    HelloLocal hello;
```

```
public void init() throws ServletException
{
    try {
        // 1. Retrieve the Home Interface using a JNDI Lookup
        // Retrieve the initial context for JNDI.
        // No properties needed when local
        Context context = new InitialContext();

        // Retrieve the home interface using a JNDI lookup using
        // the java:comp/env bean environment variable
        // specified in web.xml
        helloHome = (HelloLocalHome)
            context.lookup("java:comp/env/ejb/HelloBean");

        //2. Narrow the returned object to be an HelloHome object.
        // Since the client is local, cast it to the correct object type.
        //3. Create the local Hello bean instance, return the reference
        hello = (HelloLocal)helloHome.create();

    } catch(NamingException e) {
        throw new ServletException("Error looking up home", e);
    } catch(CreateException e) {
        throw new ServletException("Error creating local hello bean", e);
    }
}

public void doGet(HttpServletRequest request,
                  HttpServletResponse response)
    throws ServletException, IOException
{
    response.setContentType("text/html");
    ServletOutputStream out = response.getOutputStream();
    try
    {
        out.println("<html>");
        out.println("<body>");
        //4. Invoke a business method on the local interface reference.
        out.println(hello.sayHello("James Earl"));
        out.println("</body>");
        out.println("</html>");
    } catch(EJBException e) {
        out.println("EJBException error: " + e.getMessage());
    } catch(IOException e) {
        out.println("IOException error: " + e.getMessage());
    } finally {
        out.close();
    }
}
}
```

---

**Note:** You can download this example on OTN from the OC4J sample code page at <http://www.oracle.com/technology/tech/java/oc4j/demos/> on the OTN Web site.

---

**Example 2-3 A Java Client as a Remote Client**

The following example is executed from a pure Java client that is a remote client. Any remote client must set up JNDI properties before retrieving the object, using a JNDI lookup.

---

**Note:** The JNDI name is specified in the `<ejb-ref>` element in the this client's `application-client.xml` file—as follows:

```
<ejb-ref>
  <ejb-ref-name>ejb/HelloBean</ejb-ref-name>
  <ejb-ref-type>Session</ejb-ref-type>
  <home>hello.HelloHome</home>
  <remote>hello.Hello</remote>
</ejb-ref>
```

---

The `jndi.properties` file for this client is as follows:

```
java.naming.factory.initial=
    com.evermind.server.ApplicationClientInitialContextFactory
java.naming.provider.url=opmn:ormi://opmnhost:oc4j_inst1/helloworld
java.naming.security.principal=admin
java.naming.security.credentials=welcome
```

The pure Java client that invokes Hello remotely is as follows:

```
package hello;

import javax.ejb.*;
import javax.naming.*;
import javax.rmi.PortableRemoteObject;
import java.io.*;
import java.util.*;
import java.rmi.RemoteException;

/*
 * A simple client for accessing an EJB.
 */

public class HelloClient
{
    public static void main(String[] args)
    {
        System.out.println("client started...");
        try {
            // Initial context properties are set in the jndi.properties file
            //1. Retrieve remote interface using a JNDI lookup*
            Context context = new InitialContext();

            // Lookup the HelloHome object. The reference is retrieved from the
            // application-local context (java:comp/env). The variable is
            // specified in the application-client.xml.
            Object homeObject = context.lookup("java:comp/env/Helloworld");

            //2. Narrow the reference to HelloHome. Since this is a remote
            // object, use the PortableRemoteObject.narrow method.
            HelloHome home = (HelloHome) PortableRemoteObject.narrow
                (homeObject, HelloHome.class);

            //3. Create the remote object and narrow the reference to Hello.
```

```

Hello remote =
    (Hello) PortableRemoteObject.narrow(home.create(), Hello.class);

//4. Invoke a business method on the remote interface reference.
System.out.println(remote.sayHello("James Earl"));

} catch(NamingException e) {
    System.err.println("NamingException: " + e.getMessage());
} catch(RemoteException e) {
    System.err.println("RemoteException: " + e.getMessage());
} catch(CreateException e) {
    System.err.println("FinderException: " + e.getMessage());
}
}
}

```

---

**Note:** You can download this example on OTN from the OC4J sample code page at <http://www.oracle.com/technology/tech/java/oc4j/demos/> on the OTN Web site.

---

## Accessing an EJB in a Remote Server

A multi-tier situation exists when you have the servlets executing in one server which are to connect and communicate with EJBs in another server. Both the servlets and EJBs are contained in the same application. When you deploy the application to two different servers, the servlets normally look for the local EJB first.

In [Figure 2-1](#), the `HelloBean` application is deployed to both server 1 and 2. In order to ensure that the servlets only call out from server 1 to the EJBs in server 2, you must set the `remote` attribute appropriately in the application before deploying on both servers.

**Figure 2-1 Multi-Tier Example**

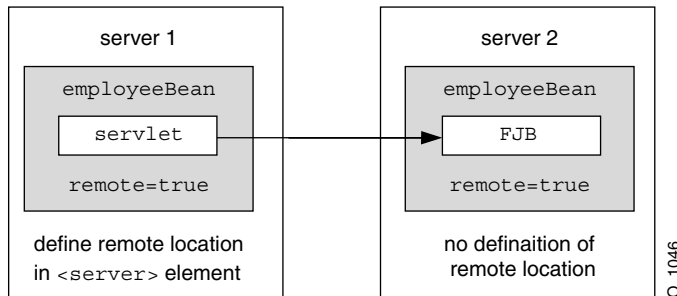

The `remote` attribute in the `<ejb-module>` element in `orion-application.xml` for the EJB module denotes whether the EJBs for this application are deployed or not.

1. In server 1, you must set `remote=true` in the `<ejb-module>` element of the `orion-application.xml` file and then deploy the application. The EJB module within the application will not be deployed. Thus, the servlets will not look for the EJBs locally, but will go out to the remote server for the EJB requests.
2. In server 2, you must set `remote=false` in the `<ejb-module>` element of the `orion-application.xml` file and then deploy the application. The application, including the EJB module, is deployed as normal. The default for the `remote`

attribute is false; thus, simply ensure that the `remote` attribute is not true and redeploy the application.

3. In the `<server>` element of the `rmi.xml` file of server 1, configure the location of server 2, which is the remote server. Provide the hostname, port number, username, and password of the remote server, as follows:

```
<server host=<remote_host> port=<remote_port> username=<username>
password=<password> />
```

If multiple remote servers are configured, the OC4J container searches all remote servers for the intended EJB application.

#### **Example 2-4 Servlet Accessing EJB in Remote OC4J Instance**

The following servlet uses the JNDI name for the target bean: `HelloBean`. This servlet provides the JNDI properties in an `RMIInitialContext` object. The environment is initialized as follows:

- The `INITIAL_CONTEXT_FACTORY` is initialized to a `RMIInitialContextFactory`.
- Instead of creating a new `InitialContext`, it is retrieved.
- The actual JNDI name is used in the lookup.
- The remote location URL is `opmn:ormi://host:oc4j_inst/application`. The OPMN port number uses the default and is omitted.

```
Hashtable env = new Hashtable();
env.put(Context.PROVIDER_URL, "opmn:ormi://theirhost:oc4j_inst/myapp");
env.put(Context.SECURITY_PRINCIPAL, "admin");
env.put(Context.SECURITY_CREDENTIALS, "welcome");
env.put(Context.INITIAL_CONTEXT_FACTORY,
"com.evermind.server.rmi.RMIInitialContextFactory");

Context ic =
new com.evermind.server.rmi.RMIInitialContextFactory().
getInitialContext(env);

Object homeObject = ic.lookup("ejb/HelloBean");

// Narrow the reference to a HelloHome.
HelloHome helloHome =
(HelloHome) PortableRemoteObject.narrow(homeObject,
HelloHome.class);
```

## Accessing an EJB in Another Application

Normally, you cannot have EJBs communicating across EAR files, that is, across applications that are deployed in separate EAR files. The only way for an EJB to access an EJB that was deployed in a separate EAR file is to declare it to be the parent of the client. Only children can invoke methods in a parent.

For example, there are two EJBs, each deployed within their EAR file, called `sales` and `inventory`, where the `sales` EJB needs to invoke the `inventory` EJB to check to see if enough widgets are available. Unless the `sales` EJB defines the `inventory` EJB to be its parent, the `sales` EJB cannot invoke any methods in the `inventory` EJB, because they are both deployed in separate EAR files. So, define the `inventory` EJB

to be the parent of the `sales` EJB and the `sales` EJB can now invoke any method in its parent.

You can only define the parent during deployment with the deployment wizard. See the "Deploying Applications" section in the "Configuration and Deployment" chapter in *Oracle Application Server Containers for J2EE User's Guide* on how to define the parent application of a bean. For broader issues on how to package your classes for method invocation, see "[Directory Structure Recommendations for EJB Development](#)" on page 10-1.

## JAAS Support for EJBs

If you invoke any EJB from an application client outside the EJB container, then Java Authentication and Authorization Service (JAAS) is not supported for the EJB. However, if you call the EJB from a servlet within the OC4J instance, then JAAS is supported.

## Using the `RMIInitialContextFactory` Object

If you access an EJB in an application from an EJB in a different application, then you cannot use the `RMIInitialContextFactory` object. In this scenario, you must use a parent-child relationship between these applications, and you must use the default initial context factory object.

## Recovering From Deadlock Conditions

If the call sequence of several beans cause a deadlock scenario, the OC4J container notices the deadlock condition and throws a `Remote` exception that details the deadlock condition in one of the offending beans.

## Recovering From a `NamingException` While Accessing a Remote EJB

If you are trying to remotely access an EJB and you receive an `javax.naming.NamingException` error, your JNDI properties are probably not initialized properly.

## Recovering From `NullPointerException` While Accessing a Remote EJB

When accessing a remote EJB from a Web application, you receive the following error: `"java.lang.NullPointerException: domain was null"`. In this case, you must set an environment property in your client while accessing the EJB set `dedicated.rmicontext` to `true`.

The following demonstrates how to use this additional environment property:

```
Hashtable env = new Hashtable( );
env.put (Context.INITIAL_CONTEXT_FACTORY,
        "com.evermind.server.rmi.RMIInitialContextFactory");
env.put (Context.SECURITY_PRINCIPAL, "admin");
env.put (Context.SECURITY_CREDENTIALS, "admin");
env.put (Context.PROVIDER_URL, "ormi://myhost-us/ejbsamples");
env.put ("dedicated.rmicontext", "true"); // for 9.0.2.1 and above
Context context = new InitialContext (env);
```

See "[Load Balancing Options](#)" on page 13-5 for more information on `dedicated.rmicontext`.



---

---

## Implementing Session Beans

After you have installed Oracle Application Server Containers for J2EE (OC4J) and configured the base server and default Web site, you can start developing J2EE applications. This chapter assumes that you have a working familiarity with simple J2EE concepts and a basic understanding for EJB development.

The following subjects describe how to develop and deploy EJB applications with OC4J:

- [Developing Session Beans](#)—Developing and testing an EJB module within the standard J2EE specification.
- [Prepare the EJB Application for Assembly](#)—Before deploying, you must modify an XML file that acts as a manifest file for the enterprise application.
- [Deploy the Enterprise Application to OC4J](#)—Archive the enterprise Java application into an Enterprise ARchive (EAR) file and deploy it to OC4J.
- [When Does Stateful Session Bean Passivation Occur?](#)
- [Using Timers With Your Stateless Session Bean](#)

This chapter demonstrates how to develop a stateless session bean. You can download the stateless session bean example from the OC4J sample code page at <http://www.oracle.com/technology/tech/java/oc4j/demos/> on the OTN Web site.

## Developing Session Beans

You develop EJB components for the OC4J environment in the same way as in any other standard J2EE environment. Here are the steps to develop EJBs:

1. **Implement the Session Bean**—Develop your EJB with its home interfaces, component interfaces, and bean implementation
2. **Create the Deployment Descriptor**—Create the standard J2EE EJB deployment descriptor for all beans in your EJB application.
3. **Archive the EJB Application**—Archive your EJB files into a JAR file.

### Implement the Session Bean

When you implement a session bean, create the following:

1. The home interfaces for the bean. The home interface defines the `create` method for your bean.
  - a. The remote home interface extends `javax.ejb.EJBHome`.
  - b. The local home interface extends `javax.ejb.EJBLocalHome`.
2. The component interfaces for the bean.
  - a. The remote interface declares the methods that a client can invoke remotely. It extends `javax.ejb.EJBObject`.
  - b. The local interface declares the methods that a collocated bean can invoke locally. It extends `javax.ejb.EJBLocalObject`.
3. The bean implementation includes the following:
  - a. The implementation of the business methods that are declared in the component interfaces.
  - b. The container callback methods that are inherited from the `javax.ejb.SessionBean`
  - c. The `ejb*` methods that match the home interface `create` methods:
    - \* For stateless session beans, provide an `ejbCreate` method with no parameters.
    - \* For stateful session beans, provide an `ejbCreate` method with parameters matching those of the `create` method as defined in the home interfaces.

### Creating the Home Interfaces

The home interfaces (remote and local) are used to create the bean instance; thus, they define the `create` method for your bean. The session bean can define the `create` method in the following ways:

EJB Type	Create Parameters
Stateless Session Bean	Can have only a single <code>create</code> method, with no parameters.
Stateful Session Bean	Can have one or more <code>create</code> methods, each with its own defined parameters.

For each `create` method, a corresponding `ejbCreate` method is defined in the bean implementation.

**Remote Invocation** Any remote client invokes the EJB through its remote interface. The client invokes the `create` method that is declared within the remote home interface. The container passes the client call to the `ejbCreate` method—with the appropriate parameter signature—within the bean implementation. You can use the parameter arguments to initialize the state of the new EJB object.

1. The remote home interface must extend the `javax.ejb.EJBHome` interface.
2. All `create` methods may throw the following exceptions:
  - `javax.ejb.CreateException`
  - `javax.ejb.EJBException` or another `RuntimeException`

### **Example 3-1 Remote Home Interface for Session Bean**

The following code sample illustrates a remote home interface for a stateless session bean called `HelloHome`.

```
package hello;

import javax.ejb.*;
import java.rmi.*;

public interface HelloHome extends EJBHome
{
    public Hello create() throws CreateException, RemoteException;
}
```

**Local Invocation** An EJB can be called locally from a client that exists in the same container. Thus, a collocated bean, JSP, or servlet invokes the `create` method that is declared within the local home interface. The container passes the client call to the `ejbCreate` method—with the appropriate parameter signature—within the bean implementation. You can use the parameter arguments to initialize the state of the new EJB object.

1. The local home interface must extend the `javax.ejb.EJBLocalHome` interface.
2. All `create` methods may throw the following exceptions:
  - `javax.ejb.CreateException`
  - `javax.ejb.EJBException` or another `RuntimeException`

### **Example 3-2 Local Home Interface for Session Bean**

The following code sample shows a local home interface for a stateless session bean called `HelloLocalHome`.

```
package hello;

import javax.ejb.*;

public interface HelloLocalHome extends EJBLocalHome
{
    public HelloLocal create() throws CreateException, EJBException;
}
```

## **Creating the Component Interfaces**

The component interfaces define the business methods of the bean that a client can invoke.

**Creating the Remote Interface** The remote interface defines the business methods that a remote client can invoke. Here are the requirements for developing the remote interface:

1. The remote interface of the bean must extend the `javax.ejb.EJBObject` interface, and its methods must throw the `java.rmi.RemoteException` exception.
2. You must declare the remote interface and its methods as `public` for remote clients.
3. The remote interface, all its method parameters, and return types must be serializable. In general, any object that is passed between the client and the EJB must be serializable, because RMI marshals and unmarshals the object on both ends.
4. Any exception can be thrown to the client, as long as it is serializable. Runtime exceptions, including `EJBException` and `RemoteException`, are transferred back to the client as remote runtime exceptions.

### ***Example 3–3 Remote Interface Example for Hello Session Bean***

The following code sample shows a remote interface called `Hello` with its defined methods, each of which will be implemented in the stateless session bean.

```
package hello;

import javax.ejb.*;
import java.rmi.*;

public interface Hello extends EJBObject
{
    public String sayHello(String myName) throws RemoteException;
}
```

**Creating the Local Interface** The local interface defines the business methods of the bean that a local (collocated) client can invoke.

1. The local interface of the bean must extend the `javax.ejb.EJBLocalObject` interface.
2. You declare the local interface and its methods as `public`.

### ***Example 3–4 Local Interface for Hello Session Bean***

The following code sample contains a local interface called `HelloLocal` with its defined methods, each of which will be implemented in the stateless session bean.

```
package hello;

import javax.ejb.*;

public interface HelloLocal extends EJBLocalObject
{
    public String sayHello(String myName) throws EJBException;
}
```

## **Implementing the Bean**

The bean contains the business logic for your application. It implements the following methods:

1. The signature for each of these methods must match the signature in the remote or local interface, except that the bean does not throw the `RemoteException`. Since both the local and the remote interfaces use the bean implementation, the bean implementation cannot throw the `RemoteException`.
2. The lifecycle methods are inherited from the `SessionBean` interface. These include the `ejb<Action>` methods, such as `ejbActivate`, `ejbPassivate`, and so on.
3. The `ejbCreate` methods that correspond to the `create` method(s) that are declared in the home interfaces. The container invokes the appropriate `ejbCreate` method when the client invokes the corresponding `create` method.
4. Any methods that are private to the bean or package used for facilitating the business logic. This includes private methods that your public methods use for completing the tasks requested of them.

### **Example 3-5 Hello Stateless Session Bean Implementation**

The following code shows the bean implementation for the Hello example.

---



---

**Note:** You can download the stateless session bean example from the OC4J sample code page at <http://www.oracle.com/technology/tech/java/oc4j/demos/> on the OTN Web site.

---



---

```
package hello;

import javax.ejb.*;

public class HelloBean implements SessionBean
{
    public SessionContext ctx;

    public HelloBean()
    {    // constructor
    }

    public void ejbCreate() throws CreateException
    {    // when bean is created
    }

    public void ejbActivate()
    {    // when bean is activated
    }

    public void ejbPassivate()
    {    // when bean is deactivated
    }

    public void ejbRemove()
    {    // when bean is removed
    }

    public void setSessionContext(SessionContext ctx)
    {    this.ctx = ctx;
    }

    public void unsetSessionContext()
```

```
{    this.ctx = null;
}

public String sayHello(String myName) throws EJBException
{
    return ("Hello " + myName);
}
}
```

---

**Note:** You can download this example on OTN from the OC4J sample code page at <http://www.oracle.com/technology/tech/java/oc4j/demos/> on the OTN Web site.

---

## Create the Deployment Descriptor

After implementing and compiling your classes, you must create the standard J2EE EJB deployment descriptor for all beans in the module. The XML deployment descriptor (defined in the `ejb-jar.xml` file) describes the EJB module of the application. It describes the types of beans, their names, and attributes. The structure for this file is mandated in the DTD file, which is provided at "[http://java.sun.com/dtd/ejb-jar\\_2\\_0.dtd](http://java.sun.com/dtd/ejb-jar_2_0.dtd)".

Any EJB container services that you want to configure is also designated in the deployment descriptor. For information about data sources and JTA, see the *Oracle Application Server Containers for J2EE Services Guide*. For information about security, see the *Oracle Application Server Containers for J2EE Security Guide*.

After creation, place the deployment descriptors for the EJB application in the `META-INF` directory that is located in the same directory as the EJB classes. See [Figure 3-1](#) for more information.

The following example shows the sections that are necessary for the `Hello` example, which implements both a remote and a local interface.

### **Example 3-6 XML Deployment Descriptor for Hello Bean**

The following is the deployment descriptor for a version of the `Hello` example that uses a stateless session bean. This example defines both the local and remote interfaces. You do not have to define both interface types; you may define only one of them.

```
<?xml version="1.0"?>
<!DOCTYPE ejb-jar PUBLIC "-//Sun Microsystems, Inc.//DTD Enterprise JavaBeans
1.1//EN" "http://java.sun.com/j2ee/dtds/ejb-jar_1_1.dtd">

<ejb-jar>
  <display-name>hello</display-name>
  <description>
    An EJB app containing only one Stateless Session Bean
  </description>
  <enterprise-beans>
    <session>
      <description>no description</description>
      <display-name>HelloBean</display-name>
      <ejb-name>HelloBean</ejb-name>
      <home>hello.HelloHome</home>
      <remote>hello.Hello</remote>
      <local-home>hello.HelloLocalHome</local-home>
```

```

        <local>hello.HelloLocal</local>
        <ejb-class>hello.HelloBean</ejb-class>
        <session-type>Stateless</session-type>
        <transaction-type>Container</transaction-type>
    </session>
</enterprise-beans>

<assembly-descriptor>
    <container-transaction>
        <method>
            <ejb-name>HelloBean</ejb-name>
            <method-name>*</method-name>
        </method>
        <trans-attribute>Supports</trans-attribute>
    </container-transaction>
    <security-role>
        <role-name>users</role-name>
    </security-role>
</assembly-descriptor>
</ejb-jar>

```

---

**Note:** You can download this example on OTN from the OC4J sample code page at <http://www.oracle.com/technology/tech/java/oc4j/demos/> on the OTN Web site.

---

## Archive the EJB Application

After you have finalized your implementation and created the deployment descriptors, archive your EJB application into a JAR file. The JAR file should include all EJB application files and the deployment descriptor.

---

**Note:** If you have included a Web application as part of this enterprise Java application, follow the instructions for building the Web application in the *Oracle Application Server Containers for J2EE User's Guide*.

---

For example, to archive your compiled EJB class files and XML files for the Hello example into a JAR file, perform the following in the `../hello/ejb_module` directory:

```
% jar cvf helloworld-ejb.jar .
```

This archives all files contained within the `ejb_module` subdirectory within the JAR file.

## Prepare the EJB Application for Assembly

To prepare the application for deployment, you do the following:

1. Modify the `application.xml` file with the modules of the enterprise Java application.
2. Archive all elements of the application into an EAR file.

These steps are described in the following sections:

- [Modify the Application.XML File](#)
- [Create the EAR File](#)

## Modify the Application.XML File

The `application.xml` file acts as the manifest file for the application and contains a list of the modules that are included within your enterprise application. You use each `<module>` element defined in the `application.xml` file to designate what comprises your enterprise application. Each module describes one of three things: EJB JAR, Web WAR, or any client files. Respectively, designate the `<ejb>`, `<web>`, and `<java>` elements in separate `<module>` elements.

- The `<ejb>` element specifies the EJB JAR filename.
- The `<web>` element specifies the Web WAR filename in the `<web-uri>` element, and its context in the `<context>` element.
- The `<java>` element specifies the client JAR filename, if any.

As [Figure 3-1](#) shows, the `application.xml` file is located under a `META-INF` directory under the parent directory for the application. The JAR, WAR, and client JAR files should be contained within this directory. Because of this proximity, the `application.xml` file refers to the JAR and WAR files only by name and relative path—not by full directory path. If these files were located in subdirectories under the parent directory, then these subdirectories must be specified in addition to the filename.

**Figure 3-1 Archive Directory Format**

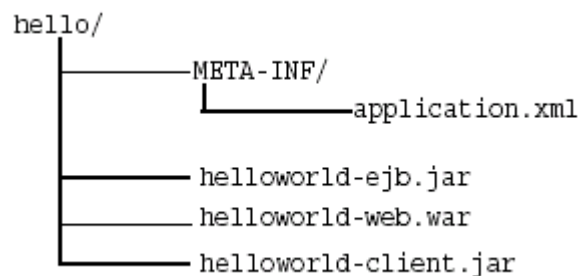

For example, the following example modifies the `<ejb>`, `<web>`, and `<java>` module elements within `application.xml` for the Hello EJB application that also contains a servlet that interacts with the EJB.

```

<?xml version="1.0"?>
<!DOCTYPE application PUBLIC "-//Sun Microsystems, Inc.//DTD J2EE Application
1.2//EN" "http://java.sun.com/j2ee/dtds/application_1_2.dtd">
<application>
  <display-name>helloworld j2ee application</display-name>
  <description>
    A sample J2EE application that uses a Helloworld Session Bean
    on the server and calls from java/servlet/JSP clients.
  </description>
  <module>
    <ejb>helloworld-ejb.jar</ejb>
  </module>
  <module>
    <web>
      <web-uri>helloworld-web.war</web-uri>
    </web>
  </module>
</application>
  
```



```

        <context-root>/helloworld</context-root>
    </web>
</module>
<module>
    <java>helloworld-client.jar</java>
</module>
</application>

```

## Create the EAR File

Create the EAR file that contains the JAR, WAR, and XML files for the application. Note that the `application.xml` file serves as the EAR manifest file.

To create the `helloworld.ear` file, execute the following in the `hello` directory contained in [Figure 3-1](#):

```
% jar cvf helloworld.ear .
```

This step archives the `application.xml`, the `helloworld-ejb.jar`, the `helloworld-web.war`, and the `helloworld-client.jar` files into the `helloworld.ear` file.

## Deploy the Enterprise Application to OC4J

After archiving your application into an EAR file, deploy the application to OC4J. See the *Oracle Application Server Containers for J2EE User's Guide* for information on how to deploy your application.

## When Does Stateful Session Bean Passivation Occur?

Passivation enables the container to preserve the conversational state of an inactive idle bean instance by serializing the bean and its state into a secondary storage and removing it from memory. Before passivation, the container invokes the `ejbPassivate()` method enabling the bean developer to clean up held resources, such as database connections, TCP/IP sockets, or any resources that cannot be transparently passivated using object serialization. The object types that can be serialized and passivated are listed at the end of this section.

---

**Note:** OC4J passivates only stateful session beans. Stateless session beans have no state to passivate and entity beans should have their state saved within the database.

---

When a client invokes one of the methods of the passivated bean instance, the preserved conversational state data is activated, by de-serializing the bean from secondary storage and brought back into memory. Before activation, the container invokes the `ejbActivate()` method so that the bean developer can restore the resources released during `ejbPassivate()`. For more information on passivation, see the EJB specification.

Passivation is enabled by default. You can turn off passivation for stateful session beans by setting the `<sfsb-config>` element in the `server.xml` file to `false`. A stateful session bean can passivate only certain object types, as designated in "[Object Types Enabled for Passivation](#)" on page 3-11. If you do not prepare your stateful session beans for passivation by releasing all resources and only allowing state to exist within the allowed object types, then passivation will fail everytime. If you do not want to change your object types and do not mind not passivating the object, you can

disable passivation. In another case, you may want to disable passivation for performance reasons: passivation carries an overhead with it, and if you desire speed and are not really worried about resources, then you can turn passivation off.

An example of how to turn off passivation is as follows:

```
<sfsb-config enable-passivation="false"/>
```

---

---

**Note:** See the `<sfsb-config>` element defined in the `server.xml` section of the *Oracle Application Server Containers for J2EE User's Guide* appendix for more information.

---

---

Passivation is invoked based on any combination of the following criteria:

- **idle timeout expires**

You can set an idle timeout in seconds for each bean. When this timeout expires, passivation occurs. Set the `idletime` attribute in `<session-deployment>` to the appropriate number of seconds. Default: 300 seconds. (5 minutes). To disable, specify "never."
- **out of resources**

Each of the following attributes in `<session-deployment>` define resource thresholds, when to check for those thresholds, and number of beans to passivate when the threshold is met.

  - `memory-threshold` - This attribute defines a threshold for how much used JVM memory is allowed before passivation should occur. Specify an integer that is translated as a percentage. When reached, beans are passivated, even if their idle timeout has not expired. Default: 80%. To disable, specify "never."
  - `max-instances-threshold` - This attribute defines a threshold for how many active beans exist in relation to the `max-instances` attribute definition. Specify an integer that is translated as a percentage. For example, if you define that the `max-instances` is 100 and the `max-instances-threshold` is 90%, then when the active bean instances reaches past 90, passivation of beans occurs. Default: 90%. To disable, specify "never."
  - `resource-check-interval` - The container checks all resources at this time interval. At this time, if any of the thresholds have been reached, passivation occurs. Default: 180 seconds (3 minutes). To disable, specify "never."
  - `passivate-count` - This attribute is an integer that defines the number of beans to be passivated if any of the resource thresholds have been reached. Passivation of beans is performed using the least recently used algorithm. Default: one-third of the `max-instances` attribute. You can disable this attribute by setting the count to zero or a negative number.
- **The number of bean instances allowed is reached**

This number is set within the `<session-deployment>` `max-instances` attribute. The `max-instances` attribute controls the number of bean instances allowed in memory. When this value is reached, the container attempts to passivate the oldest bean instance from memory. If unsuccessful, the container waits the number of milliseconds set in the `call-timeout` attribute to see if a bean instance is removed from memory, either thru another passivation, calling the `bean remove()` method, or bean expiration, before a `TimeoutExpiredException` is thrown back to the client. Leave the

`max-instances` value at zero to allow an infinite number of bean instances. Default is 0, which is infinite.

- OC4J instance termination

All bean instances in the container's memory that are not passivated are serialized to the secondary storage. Upon OC4J start-up, these passivated beans are restored back to memory.

If the passivation serialization fails, then the container attempts to recover the bean back to memory as if nothing happened. No future passivation attempts will occur for any beans that fail passivation. Also, if activation fails, the bean and its references are completely removed from the container.

If new bean data is propagated to a passivated bean in a cluster, then the bean instance data is overwritten by the propagated data.

## Object Types Enabled for Passivation

For serialization (during passivation) to the secondary storage to be successful, the conversational state of a bean must consist of only primitive values and the following special types:

- serializable objects
- null
- a reference to a component interface (`EJBObject` or `EJBLocalObject`)
- a reference to a home interface (`EJBHome` or `EJBLocalHome`)
- a reference to the `SessionContext` object
- a reference to the environment naming context
- a reference to the `UserTransaction` interface
- a reference to a resource manager connection factory

The bean developer is responsible for ensuring that all fields are of these types within the `ejbPassivate()` method. Any transient or non-serializable field should be set to null in this method.

## Storage of Passivated EJBs

When OC4J passivates the stateful session bean, it is placed in the directory and filename designated by the `persistence-filename` attribute of the `<session-deployment>` element in the OC4J deployment descriptor. Passivation uses space within this directory to store the passivated beans. The default is the `application-deployments/persistence` directory. If passivation allocates large amounts of disk space, you may need to change the directory to a place on your system where you have the space available or turn off passivation.

## Using Timers With Your Stateless Session Bean

Your stateless session bean can set up a timer where OC4J calls the bean at a specified time, after a specified elapsed time, or at specified intervals. These timers are for use in modeling of application-level processes, not for real-time events. For more information on how to set up timers, see [Chapter 11, "Using Timers"](#).

At this time, your stateful session beans cannot use timers.



---

## Entity Beans

This chapter demonstrates Entity Bean development with a basic configuration and deployment. Download the entity bean example from the OC4J sample code page at <http://www.oracle.com/technology/tech/java/oc4j/demos/> on the OTN Web site.

This chapter demonstrates the following:

- [Entity Bean Overview](#)
- [Creating Entity Beans](#)
- [How to Define and Use Primary Keys for Your Entity Bean](#)
- [Create Data Consistency in Your Entity Bean by Using Persistence](#)
- [Tie Entity Beans Together Through Container-Managed Relationships](#)
- [Managing the Entity Bean Lifecycle](#)
- [How to Avoid Database Resource Contention](#)
- [Using Transactions With Entity Beans](#)
- [Providing Security for Your Entity Beans](#)
- [Using Timers With Your Entity Bean](#)

See [Chapter 8, "BMP Entity Beans"](#), for an example of how to create a simple bean-managed persistent entity bean. For a description of persisting object relationships between EJBs, see [Chapter 6, "Entity Relationship Mapping"](#).

### Entity Bean Overview

With EJB 2.0 and the local interface support, most developers agree that entity beans should be paired with a session bean, servlet, or JSP that acts as the client interface. The entity bean is a coarse-grain bean that encapsulates functionality and represents data and dependent objects. Thus, you decouple the client from the data so that if the data changes, the client is not affected. For efficiency, the session bean, servlet, or JSP can be collocated with entity beans and can coordinate between multiple entity beans through their local interfaces. This is known as a session facade design. See the <http://java.sun.com/> Web site for more information on session facade design.

An entity bean can aggregate objects together and effectively persist data and related objects under the umbrella of transactional, security, and concurrency support through the container. This and the following chapters focus on how to use the persistence functionality of the entity bean.

An entity bean manages persistent data in one of two ways: container-managed persistence (CMP) and bean-managed persistence (BMP). The primary difference between the two is as follows:

- Container-managed persistence—The EJB container manages data by saving it to a designated resource, which is normally a database. For this to occur, you must define the data that the container is to manage within the deployment descriptors. The container manages the data by saving it to the database. For details on container-managed persistence and how to use it in your entity bean, see [Chapter 5, "CMP Entity Beans"](#).
- Bean-managed persistence—The bean implementation manages the data within callback methods. All the logic for storing data to your persistent storage must be included in the `ejbStore` method and reloaded from your storage in the `ejbLoad` method. The container invokes these methods when necessary. For details on bean-managed persistence and how to implement it within your entity bean, see [Chapter 8, "BMP Entity Beans"](#).

## Creating Entity Beans

The following steps are an overview of what you must do in creating an entity bean, which are similar to the steps for the session bean, described in [Chapter 3, "Implementing Session Beans"](#).

1. Create the home interfaces for the bean. The home interface defines the `create` and finder methods, including `findByPrimaryKey`, for your bean. See ["Implement the Entity Bean Home Interface"](#) page 3.
2. Create the component interfaces for the bean. The component interfaces declare the methods that a client can invoke. See ["Implement the Entity Bean Component Interfaces"](#) page 4.
3. Define the primary key for the bean. The primary key identifies each entity bean instance and is a serializable class. You can use a simple data type class, such as `java.lang.String`, or define a complex class, such as one with two or more objects as components of the primary key. See ["How to Define and Use Primary Keys for Your Entity Bean"](#) page 6.
4. Implement the bean. See ["Implement the Entity Bean Class"](#) page 4.
5. Create the bean deployment descriptor. The deployment descriptor specifies properties for the bean through XML elements. This step is where you identify the data within the bean that is to be managed by the container. See ["Persistence Fields"](#) page 1 for more information on persistence fields. If these fields describe relationships to other objects, see [Chapter 6, "Entity Relationship Mapping"](#).

Any EJB Container services that you want to configure is also designated in the deployment descriptor. For information about data sources and JTA, see the *Oracle Application Server Containers for J2EE Services Guide*. For information about security, see the *Oracle Application Server Containers for J2EE Security Guide*.

If the persistent data is saved to or restored from a database and you are not using the defaults provided by the container, then you must ensure that the correct tables exist for the bean. In the default scenario, the container creates the table and columns for your data based on deployment descriptor and datasource information.

6. Create an EJB JAR file containing the bean, component interface, home interface, and the deployment descriptors. Once created, configure the `application.xml` file, create an EAR file, and deploy the EJB to OC4J.

The following sections demonstrate a simple CMP entity bean. This example continues the use of the employee example, as in other chapters—without adding complexity.

- [Implement the Entity Bean Home Interface](#)
- [Implement the Entity Bean Component Interfaces](#)
- [Implement the Entity Bean Class](#)

## Implement the Entity Bean Home Interface

The home interface is primarily used for retrieving the bean reference, on which the client can request business methods.

- The local home interface extends `javax.ejb.EJBLocalHome`.
- The remote home interface extends `javax.ejb.EJBHome`.

The home interface must contain a `create` method, which the client invokes to create the bean instance. The entity bean can have zero or more `create` methods, each with its own defined parameters. All entity beans must define one or more finder methods, where at least one is a `findByPrimaryKey` method. Optionally, you can develop other finder methods, which are named `find<name>`, for the bean.

In addition to creation and retrieval methods, you can provide home interface business methods within the home interface. The functionality within these methods cannot access data of a particular entity object. Instead, the purpose of these methods is to provide a way to retrieve information that is not related to a single entity bean instance. When the client invokes any home interface business method, an entity bean is removed from the pool to service the request. Thus, this method can be used to perform operations on general information related to the bean.

Our employee example provides the local home interface with a `create`, `findByPrimaryKey`, `findAll`, and `calcSalary` methods. The `calcSalary` method is a home interface business method that calculates the sum of all employee salaries. It does not access the information of a particular employee, but performs a SQL inquiry against the database for all employees.

### **Example 4-1** Entity Bean Employee Home Interface

The employee home interface provides a method to create the component interface. It also provides two finder methods: one to find a specific employee by an employee number and one that finds all employees. Last, it supplies a home interface business method, `calcSalary`, to calculate how much all employees cost the business.

The home interface is required to extend `javax.ejb.EJBHome` and define the `create` and `findByPrimaryKey` methods.

```
package employee;

import javax.ejb.*;
import java.rmi.*;

public interface EmployeeLocalHome extends EJBLocalHome
{

    public EmployeeLocal create(Integer empNo) throws CreateException;

    // Find an existing employee
    public EmployeeLocal findByPrimaryKey (Integer empNo) throws FinderException;

    //Find all employees
```

```
public Collection findAll() throws FinderException;

//Calculate the Salaries of all employees
public float calcSalary() throws Exception;
}
```

## Implement the Entity Bean Component Interfaces

The entity bean component interfaces are the interfaces that the customer sees and invokes methods upon. The component interface defines the business logic methods for the entity bean instance.

- The local component interface extends `javax.ejb.EJBLocalObject`.
- The remote component interface extends `javax.ejb.EJBObject`.

The employee entity bean example exposes the local component interface, which contains methods for retrieving and updating employee information.

```
package employee;

import javax.ejb.*;

public interface EmployeeLocal extends EJBLocalObject
{
    public Integer getEmpNo();
    public void setEmpNo(Integer empNo);

    public String getEmpName();
    public void setEmpName(String empName);

    public Float getSalary();
    public void setSalary(Float salary);
}
```

## Implement the Entity Bean Class

The entity bean class implements the following methods:

- The target methods for the methods that are declared in the home interface, which include the following:
  - The `ejbCreate` and `ejbPostCreate` methods with parameters matching the associated `create` method defined in the home interface.
  - Finder methods, other than `ejbFindByPrimaryKey` and `ejbFindAll`, that are defined in the home interface. The container generates the `ejbFindByPrimaryKey` and `ejbFindAll` method implementations—although you must still provide an empty method for each of these.
  - any home interface business methods, which are prepended with `ejbHome` in the bean implementation. For example, the `calcSalary` method is implemented in the `ejbHomeCalcSalary` method.
- The business logic methods that are declared in the component interfaces.
- The methods that are inherited from the `javax.ejb.EntityBean` interface.

However, with container-managed persistence, the container manages most of the target methods and the data objects, thereby leaving little for you to implement.

```
package employee;
```



```
import javax.ejb.*;
import java.rmi.*;

public abstract class EmployeeBean implements EntityBean
{
    private EntityContext ctx;

    // Each CMP field has a get and set method as accessors
    public abstract Integer getEmpNo();
    public abstract void setEmpNo(Integer empNo);

    public abstract String getEmpName();
    public abstract void setEmpName(String empName);

    public abstract Float getSalary();
    public abstract void setSalary(Float salary);

    public void EmployeeBean()
    {
        // Constructor. Do not initialize anything in this method.
        // All initialization should be performed in the ejbCreate method.
        // The passivate() method may destroy these attributes when pooling
    }

    public float ejbHomeCalcSalary() throws Exception
    {
        Collection c = null;
        try {
            c = ((EmployeeLocalHome)this.ctx.getEJBLocalHome()).findAll();

            Iterator i = c.iterator();
            float totalSalary = 0;
            while (i.hasNext())
            {
                EmployeeLocal e = (EmployeeLocal)i.next();
                totalSalary = totalSalary + e.getSalary().floatValue();
            }
            return totalSalary;
        }
        catch (FinderException e) {
            System.out.println("Got finder Exception "+e.getMessage());
            throw new Exception(e.getMessage());
        }
    }

    public EmployeePK ejbCreate(Integer empNo, String empName, Float salary)
        throws CreateException
    {
        setEmpNo(empNo);
        setEmpName(empName);
        setSalary(salary);
        return new EmployeePK(empNo);
    }

    public void ejbPostCreate(Integer empNo, String empName, Float salary)
        throws CreateException
    {
        // Called just after bean created; container takes care of implementation
    }
}
```

```
public void ejbStore()
{
    // Called when bean persisted; container takes care of implementation
}

public void ejbLoad()
{
    // Called when bean loaded; container takes care of implementation
}

public void ejbRemove() throws RemoveException
{
    // Called when bean removed; container takes care of implementation
}

public void ejbActivate()
{
    // Called when bean activated; container takes care of implementation.
    // If you need resources, retrieve them here.
}

public void ejbPassivate()
{
    // Called when bean deactivated; container takes care of implementation.
    // if you set resources in ejbActivate, remove them here.
}

public void setEntityContext(EntityContext ctx)
{
    this.ctx = ctx;
}

public void unsetEntityContext()
{
    this.ctx = null;
}
}
```

---

---

**Note:** The entire CMP entity bean example (`cmpapp.jar`) is available on OTN from the OC4J sample code page at <http://www.oracle.com/technology/tech/java/oc4j/demos/> on the OTN Web site.

---

---

## How to Define and Use Primary Keys for Your Entity Bean

Each entity bean instance has a primary key that uniquely identifies it from other instances. You must declare the primary key (or the fields contained within a complex primary key) as a container-managed persistent field in the deployment descriptor. All fields within the primary key are restricted to either primitive, serializable, or types that can be mapped to SQL types. You can define your primary key in one of two ways:

- Define the type of the primary key to be a well-known type. The type is defined in the `<prim-key-class>` in the deployment descriptor. The data field that is identified as the persistent primary key is identified in the `<primkey-field>` element in the deployment descriptor. The primary key variable that is declared within the bean class must be declared as `public`.

- Define the type of the primary key as a serializable object within a `<name>PK` class that is serializable. This class is declared in the `<prim-key-class>` element in the deployment descriptor. This is an advanced method for defining a primary key and is discussed in "Defining the Entity Bean Primary Key in a Class" page 8.
- Specify an auto-generated primary key: If you specify a `java.lang.Object` as the primary key class type in `<prim-key-class>`, but do not specify the primary key name in `<primkey-field>`, then the primary key is auto-generated by the container. See [Defining an Auto-Generated Primary Key for Your Entity Bean](#) page 9 for more information.

For a simple CMP, you can define your primary key to be a well-known type by defining the data type of the primary key within the deployment descriptor.

The employee example defines its primary key as a `java.lang.Integer` and uses the employee number (`empNo`) as its primary key.

```
<enterprise-beans>
  <entity>
    <display-name>Employee</display-name>
    <ejb-name>EmployeeBean</ejb-name>
    <local-home>employee.EmployeeLocalHome</local-home>
    <local>employee.EmployeeLocal</local>
    <ejb-class>employee.EmployeeBean</ejb-class>
    <persistence-type>Container</persistence-type>
    <prim-key-class>java.lang.Integer</prim-key-class>
    <reentrant>False</reentrant>
    <cmp-version>2.x</cmp-version>
    <abstract-schema-name>Employee</abstract-schema-name>
    <cmp-field><field-name>empNo</field-name></cmp-field>
    <cmp-field><field-name>empName</field-name></cmp-field>
    <cmp-field><field-name>salary</field-name></cmp-field>
    <primkey-field>empNo</primkey-field>
  </entity>
  ...
</enterprise-beans>
```

Once defined, the container creates a column in the entity bean table for the primary key and maps the primary key defined in the deployment descriptor to this column.

---

**Note:** The entire CMP entity bean example (`cmpapp.jar`) is available on OTN from the OC4J sample code page at <http://www.oracle.com/technology/tech/java/oc4j/demos/> on the OTN Web site.

---

Within the `orion-ejb-jar.xml` file, the primary key is mapped to the underlying database persistence storage by mapping the CMP field or primary key field defined in the `ejb-jar.xml` file to the database column name. In the following `orion-ejb-jar.xml` fragment, the `EmpBean` persistence storage is defined as the `EMP` table in the database that is defined in the `jdbc/OracleDS` data source. Following the `<entity-deployment>` element definition, the primary key, `empNo`, is mapped to the `EMPNO` column in the `Emp` table, and the `empName` and `salary` CMP fields are mapped to `EMPNAME` and `SALARY` columns respectively in the `EMP` table.

```
<entity-deployment name="EmpBean" ...table="EMP"
  data-source="jdbc/OracleDS"... >
  <primkey-mapping>
    <cmp-field-mapping name="empNo" persistence-name="EMPNO" />
  </primkey-mapping>
```

```
<cmp-field-mapping name="empName" persistence-name="EMPNAME" />
<cmp-field-mapping name="salary" persistence-name="SALARY" />
```

## Defining the Entity Bean Primary Key in a Class

If your primary key is more complex than a simple data type, your primary key must be a class that is serializable of the name `<name>PK`. You define the primary key class within the `<prim-key-class>` element in the deployment descriptor.

The primary key variables must adhere to the following:

- Be defined within a `<cmp-field><field-name>` element in the deployment descriptor. This enables the container to manage the primary key fields.
- Be declared within the bean class as `public` and restricted to be either primitive, serializable, or types that can be mapped to SQL types.
- The names of the variables that make up the primary key must be the same in both the `<cmp-field><field-name>` elements and in the primary key class.

Within the primary key class, you implement a constructor for creating a primary key instance. Once the primary key class is defined in this manner, the container manages the class.

The following example places the employee number within a primary key class.

```
package employee;

public class EmployeePK implements java.io.Serializable
{
    public Integer empNo;

    public EmployeePK()
    {
        this.empNo = null;
    }

    public EmployeePK(Integer empNo)
    {
        this.empNo = empNo;
    }
}
```

The primary key class is declared within the `<prim-key-class>` element, and each of its variables are declared within a `<cmp-field><field-name>` element in the XML deployment descriptor, as follows:

```
<enterprise-beans>
  <entity>
    <description>no description</description>
    <display-name>EmployeeBean</display-name>
    <ejb-name>EmployeeBean</ejb-name>
    <local-home>employee.LocalEmployeeHome</home>
    <local>employee.LocalEmployee</remote>
    <ejb-class>employee.EmployeeBean</ejb-class>
    <persistence-type>Container</persistence-type>
    <prim-key-class>employee.EmployeePK</prim-key-class>
    <reentrant>False</reentrant>
    <cmp-version>2.x</cmp-version>
    <abstract-schema-name>Employee</abstract-schema-name>
    <cmp-field><field-name>empNo</field-name></cmp-field>
    <cmp-field><field-name>empName</field-name></cmp-field>
```

```

        <cmp-field><field-name>salary</field-name></cmp-field>
    </entity>
</enterprise-beans>

```

Once defined, the container creates a column in the entity bean table for the primary key and maps the primary key class defined in the deployment descriptor to this column.

The CMP fields are mapped in the `orion-ejb-jar.xml` in the same manner as described in ["How to Define and Use Primary Keys for Your Entity Bean"](#) page 6. With a complex primary key, the mapping contains more than a single field; thus, the `<cmp-field-mapping>` element of the `<primkey-mapping>` element contains another subelement: the `<fields>` element. All of the fields of a primary key are each defined in a separate `<cmp-field-mapping>` element within the `<fields>` element, as shown below.

```

<primkey-mapping>
  <cmp-field-mapping>
    <fields>
      <cmp-field-mapping name="empNo" persistence-name="EMPNO" />
    </fields>
  </cmp-field-mapping>
</primkey-mapping>

```

Special mapping needs to happen if you have a complex primary key that contains a foreign key. See ["Using a Foreign Key in a Composite Primary Key"](#) page 44 for directions.

## Defining an Auto-Generated Primary Key for Your Entity Bean

If you specify a `java.lang.Object` as the primary key class type in `<prim-key-class>`, but do not specify the primary key name in `<primkey-field>`, then the primary key is auto-generated by the container.

The employee example defines its primary key as a `java.lang.Object`. Thus, the container auto-generates the primary key.

```

<enterprise-beans>
  <entity>
    <display-name>Employee</display-name>
    <ejb-name>EmployeeBean</ejb-name>
    <local-home>employee.EmployeeLocalHome</local-home>
    <local>employee.EmployeeLocal</local>
    <ejb-class>employee.EmployeeBean</ejb-class>
    <persistence-type>Container</persistence-type>
    <prim-key-class>java.lang.Object</prim-key-class>
    <reentrant>False</reentrant>
    <cmp-version>2.x</cmp-version>
    <abstract-schema-name>Employee</abstract-schema-name>
    <cmp-field><field-name>empNo</field-name></cmp-field>
    <cmp-field><field-name>empName</field-name></cmp-field>
    <cmp-field><field-name>salary</field-name></cmp-field>
  </entity>
  ...
</enterprise-beans>

```

Once defined, the container creates a column called `autoId` in the entity bean table for the primary key of type `LONG`. The container uses random numbers for the primary key values. This is generated in the `orion-ejb-jar.xml` for the bean, as follows:

```
<primkey-mapping>
  <cmp-field-mapping name="auto_id"
    persistence-name="autoid"/>
</primkey-mapping>
```

## Create Data Consistency in Your Entity Bean by Using Persistence

There are two methods for managing the persistent data within an entity bean: bean-managed (BMP) and container-managed persistence (CMP). The main difference between BMP and CMP beans is defined by who manages the persistence of the entity bean's data. With CMP beans, the container manages the persistence—the bean deployment descriptor specifies how to map the data and where the data is stored. With BMP beans, the logic for saving the data and where it is saved is programmed within designated methods. These methods are invoked by the container at the appropriate moments.

In practical terms, the following table provides a definition for both types, and a summary of the programmatic and declarative differences between them:

Management Issues	Bean-Managed Persistence	Container-Managed Persistence
Persistence management	You are required to implement the persistence management within the <code>ejbStore</code> , <code>ejbLoad</code> , <code>ejbCreate</code> , and <code>ejbRemove</code> <code>EntityBean</code> methods. These methods must contain logic for saving and restoring the persistent data.  For example, the <code>ejbStore</code> method must have logic in it to store the entity bean's data to the appropriate database. If it does not, the data can be lost.	The management of the persistent data is done for you. That is, the container invokes a persistence manager on behalf of your bean.  You use <code>ejbStore</code> and <code>ejbLoad</code> for preparing the data before the commit or for manipulating the data after it is refreshed from the database. The container always invokes the <code>ejbStore</code> method right before the commit. In addition, it always invokes the <code>ejbLoad</code> method right after reinstating CMP data from the database.
Finder methods allowed	The <code>findByPrimaryKey</code> method and other finder methods are allowed.	The <code>findByPrimaryKey</code> method and other finder methods clause are allowed.
Defining CMP fields	N/A	Required within the EJB deployment descriptor. The primary key must also be declared as a CMP field.
Mapping CMP fields to resource destination	N/A	Required. Dependent on persistence manager.
Definition of persistence manager	N/A	Required within the Oracle-specific deployment descriptor. See the next section for a description of a persistence manager.

For more information on container-managed persistence, see [Chapter 5, "CMP Entity Beans"](#); for information on bean-managed persistence, see [Chapter 8, "BMP Entity Beans"](#).

## Tie Entity Beans Together Through Container-Managed Relationships

The EJB 2.0 specification enables the specification of relationships between entity beans. An entity bean can be defined so as to have a relationship with other entity beans. You implement relationships differently for entity beans with bean-managed-persistence than those entity beans that utilize container-managed-persistence. With bean-managed persistence, the code that you write implements the relationships. With container-managed persistence, the EJB container takes care of the relationships for

you. For this reason, relationships in entity beans with container-managed persistence are often referred to as container-managed relationships.

- **Relationship Fields** - A relationship field in an EJB identifies a related bean. A relationship field is virtual and is defined in the enterprise bean class with access methods. Unlike a persistent field, a relationship field does not represent the bean's state.
- **Multiplicity in Container-Managed Relationships** - There are four types of multiplicities all of which are supported by Oracle Application Server:
  - **One-to-One** - Each entity bean instance is related to a single instance of another entity bean.
  - **One-to-Many** - An entity bean instance is related to multiple instances of the other entity bean.
  - **Many-to-One** - Multiple instances of an entity bean may be related to a single instance of the other entity bean. This multiplicity is the opposite of one-to-many.
  - **Many-to-Many** - The entity bean instances may be related to multiple instances of each other.
- **Direction in Container-Managed Relationships** - The direction of a relationship may be either bi-directional or unidirectional. In a unidirectional relationship, only one entity bean has a relationship field that refers to the other. In a bi-directional relationship, each entity bean has a relationship field that refers to the other bean. Through the relationship field, an entity bean's code can access its related object. If an entity bean has a relative field, then we often say that it "knows" about its related object. Oracle Application Server supports both unidirectional and bi-directional relationships between EJBs.
- **EJBQL and CMP With Relationships** - EJB QL queries often navigate across relationships. The direction of a relationship determines whether a query can navigate from one bean to another. With Oracle Application Server, EJBQL queries can traverse CMP Relationships with any type of multiplicity and with both unidirectional and bi-directional relationships.

For more information, see [Chapter 5, "CMP Entity Beans"](#) for container-managed persistence, [Chapter 6, "Entity Relationship Mapping"](#) for CMR relationships, and [Chapter 7, "EJB Query Language"](#) for EJB QL.

## Managing the Entity Bean Lifecycle

You can manage the entity bean lifecycle through configuring pool sizes for your entity beans. This subject is covered in the following section:

- [Configuring Pool Sizes For Entity Beans](#)

### Configuring Pool Sizes For Entity Beans

You can set the minimum and maximum number of the bean instance pool, which contains EJB implementation instances that currently do not have assigned state. While the bean instance is in pool state, it is generic and can be assigned to a wrapper instance.

You can set the pool number with the following attributes of the `<entity-deployment>` element.

- The `max-instances` attribute sets the maximum entity bean instances to be allowed in the pool. An entity bean is set to a pooled state if not associated with a wrapper instance. Thus, it is generic.

The default is 0, which means infinite. If you wanted to set the maximum bean implementation instances to 20, you would do as follows:

```
<entity-deployment ... max-instances="20"
...
</entity-deployment>
```

- The `min-instances` attribute sets the minimum number allowed in the pool as follows:

```
<entity-deployment ... min-instances="2"
...
</entity-deployment>
```

## How to Avoid Database Resource Contention

In order to avoid resource contention and overwriting each others changes to database tables while allowing concurrent execution, entity bean concurrency and database isolation modes are provided.

- [Using Database Isolation Modes to Protect Against Resource Contention](#)
- [Configuring Entity Bean Concurrency Modes For Handling Resource Contention](#)
- [Specifying Exclusive Write Access to the Database](#)
- [Effects of the Combination of the Database Isolation and Bean Concurrency Modes](#)
- [Affects of Concurrency Modes on Clustering](#)

## Using Database Isolation Modes to Protect Against Resource Contention

The `java.sql.Connection` object represents a connection to a specific database. Database isolation modes are provided to define protection against resource contention. When two or more users try to update the same resource, a lost update can occur. That is, one user can overwrite the other user's data without realizing it. The `java.sql.Connection` standard provides four isolation modes, of which Oracle only supports two of these modes. These are as follows:

- `TRANSACTION_READ_COMMITTED`: Dirty reads are prevented; non-repeatable reads and phantom reads can occur. This level only prohibits a transaction from reading a row with uncommitted changes in it.
- `TRANSACTION_SERIALIZABLE`: Dirty reads, non-repeatable reads and phantom reads are prevented. This level includes the prohibitions in `TRANSACTION_REPEATABLE_READ` and further prohibits the situation where one transaction reads all rows that satisfy a `WHERE` condition, a second transaction inserts a row that satisfies that `WHERE` condition, and the first transaction rereads for the same condition, retrieving the additional "phantom" row in the second read.

---

---

**Note:** You cannot set the isolation level to serializable if you are using a non-emulated data source. If you do, the non-emulated data source will not work.

---

---



You can configure one of these database isolation modes for a specific bean. That is, you can specify that when the bean starts a transaction, the database isolation mode for this bean be what is specified in the OC4J-specific deployment descriptor. Specify the isolation mode on what is important for the bean: parallel execution or data consistency. The isolation mode for this bean is set for the entire transaction.

The isolation mode can be set for each entity bean in the `isolation` attribute of the `<entity-deployment>` element. The values can be `committed` or `serializable`. The default is `committed`. To change it to `serializable`, configure the following in the `orion-ejb-jar.xml` for the intended bean:

```
<entity-deployment ... isolation="serializable"
...
</entity-deployment>
```

There is always a trade-off between performance and data consistency. The `serializable` isolation mode provides data consistency; the `committed` isolation mode provides for parallel execution.

---

**Note:** There is a danger of lost updates with the `serializable` mode if the `max-tx-retries` element in the OC4J-specific deployment descriptor is greater than zero. The default for this value is zero. If this element is set to greater than zero, then the container retries the update if a second blocked client receives a `ORA-8177` exception. The retry would find the row unlocked and the update would occur. Thus, the second client's update succeeds and overwrites the first client's update. If you use `serializable`, you should consider leaving the `max-tx-retries` element as zero for data consistency.

---

If you do not set an isolation mode, you receive the mode that is configured in the database. Setting the isolation mode within the OC4J-specific deployment descriptor temporarily overrides the database configured isolation mode for the life of the global transaction for this bean. That is, if you define the bean to use the `serializable` mode, then the OC4J container will force the database to be `serializable` for this bean only until the end of the transaction.

You can specify both entity bean concurrency modes and database isolation modes, where the combination effects the outcome of your resource contention. See ["Effects of the Combination of the Database Isolation and Bean Concurrency Modes"](#) page 14 for more information.

## Configuring Entity Bean Concurrency Modes For Handling Resource Contention

OC4J also provides concurrency modes for handling resource contention and parallel execution within container-managed persistence (CMP) entity beans. Bean-managed persistence entity beans manage the resource locking within the bean implementation themselves. The concurrency modes configure when to block to manage resource contention or when to execute in parallel.

The concurrency modes are as follows:

- **PESSIMISTIC:** This manages resource contention and does not allow parallel execution. Only one user at a time is allowed to execute the entity bean at a single time.

- **OPTIMISTIC:** Multiple users can execute the entity bean in parallel. It does not monitor resource contention; thus, the burden of the data consistency is placed on the database isolation modes.
- **READ-ONLY:** Multiple users can execute the entity bean in parallel. The container does not allow any updates to the bean's state.

To enable the CMP entity bean concurrency mode, add the appropriate concurrency value of "pessimistic", "optimistic", or "read-only" to the `locking-mode` attribute of the `<entity-deployment>` element in the OC4J-specific deployment descriptor (`orion-ejb-jar.xml`). The default is "optimistic". To modify the concurrency mode to `pessimistic`, do the following:

```
<entity-deployment ... locking-mode="pessimistic"
...
</entity-deployment>
```

These concurrency modes are defined per bean and the effects of locking apply on the transaction boundaries.

Parallel execution requires that the pool size for wrapper and bean instances are set correctly. For more information on how to configure the pool sizes, see "[Configuring Environment References](#)" page 8.

You can specify both entity bean concurrency modes and database isolation modes, where the combination effects the outcome of your resource contention. See "[Effects of the Combination of the Database Isolation and Bean Concurrency Modes](#)" page 14 for more information.

## Specifying Exclusive Write Access to the Database

The `exclusive-write-access` attribute of the `<entity-deployment>` element states that this is the only bean that accesses its table in the database and that no external methods are used to update the resource. It informs the OC4J instance that any cache maintained for this bean will only be dirtied by this bean. Essentially, if you set this attribute to true, you are assuring the container that this is the only bean that will update the tables used within this bean. Thus, any cache maintained for the bean does not need to constantly update from the back-end database.

This flag does not prevent you from updating the table; that is, it does not actually lock the table. However, if you update the table from another bean or manually, the results are not automatically updated within this bean.

The default for this attribute is false. Because of the effects of the entity bean concurrency modes, this element is only allowed to be set to true for a `read-only` entity bean. OC4J will always reset this attribute to false for `pessimistic` and `optimistic` concurrency modes.

```
<entity-deployment ... exclusive-write-access="true"
...
</entity-deployment>
```

## Effects of the Combination of the Database Isolation and Bean Concurrency Modes

For the `pessimistic` and `read-only` concurrency modes, the setting of the database isolation mode does not matter. These isolation modes only matter if an external source is modifying the database.

If you choose `optimistic` with `committed`, you have the potential to lose an update. If you choose `optimistic` with `serializable`, you will never lose an

update. Thus, your data will always be consistent. However, you can receive an `ORA-8177` exception as a resource contention error.

### Differences Between Pessimistic and Optimistic/Serializable

An entity bean with the `pessimistic` concurrency mode does not allow multiple clients to execute a bean (either on the same or on different instances of the same primary key). Only one client is allowed to execute the instance at any one moment.

An entity bean with the `optimistic` concurrency mode allows multiple instances of the bean implementation to execute in parallel. However, it could result in potential lost updates (and conflicts), because two different transactions may update the same row simultaneously.

Setting the transaction isolation mode to `serializable` allows the detection of conflicts when they occur. At that moment, the update from one of the transactions raises a `SQLException` and that transaction is rolled back.

Optionally, you may set the `tx-retries` attribute of the `<entity-deployment>` element to a value more than one, so that the transaction is retried.

## Affects of Concurrency Modes on Clustering

All concurrency modes behave in a similar manner whether they are used within a standalone or a clustered environment. This is because the concurrency modes are locked at the database level. Thus, even if a pessimistic bean instance is clustered across nodes, the moment one instance tries to execute, the database locks out all other instances.

## Using Transactions With Entity Beans

All entity beans with CMP and CMR relationships must be involved in a transaction. As such, you cannot define any entity bean with a transaction attribute of `NEVER`, `SUPPORTS`, or `NOT_REQUIRED` as this would put the entity outside of a transaction.

For more information on how to use, configure, and manage transactions for entity beans, see the JTA chapter in the *Oracle Application Server Containers for J2EE Services Guide*.

## Providing Security for Your Entity Beans

OC4J provides security for your entity beans—whether you are interested in Java2 security or OracleAS JAAS Provider. However, you still have to configure the type of security that you desire. For more information, see the *Oracle Application Server Containers for J2EE Security Guide*.

## Using Timers With Your Entity Bean

Your entity bean can set up a timer where OC4J calls the bean at a specified time, after a specified elapsed time, or at specified intervals. These timers are for use in modeling of application-level processes, not for real-time events. For more information on how to set up timers, see [Chapter 11, "Using Timers"](#).



---

---

## CMP Entity Beans

This chapter demonstrates simple Container Managed Persistence (CMP) EJB development with a basic configuration and deployment. Download the CMP entity bean example (`cmpapp.jar`) from the OC4J sample code page at <http://www.oracle.com/technology/tech/java/oc4j/demos/> on the OTN Web site.

This chapter demonstrates the following:

- [Persistence Fields](#)
- [Configuring Lazy Loading on CMP Entity Bean Finder Methods](#)
- [Conversion of CMP Types to Database Types](#)

See [Chapter 8, "BMP Entity Beans"](#), for an example of how to create a simple bean-managed persistent entity bean. For a description of persisting object relationships between EJBs, see [Chapter 6, "Entity Relationship Mapping"](#).

### Persistence Fields

The persistent data in your CMP bean can be one of the following:

- Persistence field—Simple data type that is persisted to a database table. This field is a direct attribute of the bean.
- Relationship field—Relationship to another bean.

Each type results in its own complex rules of how to configure. This section discusses persistence fields. For information on relationship fields, see [Chapter 6, "Entity Relationship Mapping"](#).

In CMP entity beans, you define the persistent data both in the bean instance and in the deployment descriptor.

- Get/Set methods in the bean instance: For each persistence and relationship field, both a get and a set method is created. For persistence fields, the data type of the parameter returned from the get method and passed into the set method defines the simple data type of the field. The name of the field is designated by the name of the get and set methods.

The following XML shows the get and set methods for the employee name persistence field. A `String` is passed back from the get method and into the set method. Thus, the `String` is the simple data type of the field. If you remove the "get" and "set" from the method names and then lower the case of the first letter, you have the persistence field name. In this case, `empName` is the persistence field name.

```
public abstract String getEmpName() throws RemoteException;
public abstract void setEmpName(String empName) throws RemoteException;
```

- The deployment descriptor defines these fields as persistent. Each field name must be defined in a `<cmp-field><field-name>` element in the EJB deployment descriptor. In the employee example, three persistence data fields are defined in the data accessor methods: `empNo`, `empName`, and `salary`.

These fields are defined as persistent fields in the `ejb-jar.xml` deployment descriptor within the `<cmp-field><field-name>` element, as follows:

```
<enterprise-beans>
  <entity>
    <display-name>Employee</display-name>
    <ejb-name>EmployeeBean</ejb-name>
    <local-home>employee.EmployeeLocalHome</local-home>
    <local>employee.EmployeeLocal</local>
    <ejb-class>employee.EmployeeBean</ejb-class>
    <persistence-type>Container</persistence-type>
    <prim-key-class>java.lang.Integer</prim-key-class>
    <reentrant>False</reentrant>
    <cmp-version>2.x</cmp-version>
    <abstract-schema-name>Employee</abstract-schema-name>
    <cmp-field><field-name>empNo</field-name></cmp-field>
    <cmp-field><field-name>empName</field-name></cmp-field>
    <cmp-field><field-name>salary</field-name></cmp-field>
    <primkey-field>empNo</primkey-field>
  </entity>
  ...
</enterprise-beans>
```

For these fields to be mapped to a database, you can do one of the following:

- Accept the defaults for these fields and avoid more deployment descriptor configuration. See "[Default Mapping of Persistent Fields to the Database](#)" on page 5-2 on how the default mapping occurs.
- Map the persistent data fields to columns in a table that exists in a designated database. The persistent data mapping is configured within the `orion-ejb-jar.xml` file. See "[Explicit Mapping of Persistent Fields to the Database](#)" on page 5-3 for more information.

---

**Note:** The entire CMP entity bean example (`cmpapp.jar`) is available on OTN from the OC4J sample code page at <http://www.oracle.com/technology/tech/java/oc4j/demos/> on the OTN Web site.

---

## Default Mapping of Persistent Fields to the Database

If you simply define the persistent fields in the `ejb-jar.xml` file, then OC4J provides the following mappings of these fields to the database:

- Database—The default database as set up in your OC4J instance configuration. For the JNDI name, use the `<location>` element for emulated data sources and `<ejb-location>` element for non-emulated data sources.

Upon installation, the default database is a locally installed Oracle database that must be listening on port 1521 with a SID of `ORCL`. To customize the default database, change the first configured database to point to your database.

---



---

**Note:** See the Data Source chapter in the *Oracle Application Server Containers for J2EE Services Guide* for more information on configuring Data Source objects.

---



---

- **Table**—The container automatically creates a default table where the name of the table is guaranteed to be unique. For all future redeployments, copy the generated `orion-ejb-jar.xml` file with this table name into the same directory as your `ejb-jar.xml` file. Thus, all future redeployments have the same table names as first generated. If you do not copy this file over, different table names may be generated.

The table name is constructed with the following names, where each is separated by an underscore (\_):

- EJB name defined in `<ejb-name>` in the deployment descriptor.
- JAR file name, including the `.jar` extension. However, all dashes (-) and periods (.) are converted to underscores (\_) to follow SQL conventions. For example, if the name of your JAR file is `employee.jar`, then `employee_jar` is appended to the name.
- Application name: This is the name of the application name, which you define during deployment.

If the constructed name is greater than thirty characters, the name is truncated at twenty-four characters. Then six characters made up of an alphanumeric hash code is appended to the name.

For example, if the EJB name is `EmpBean`, the JAR file is `empl.jar`, and the application name is `employee`, then the default table name is `EmpBean_empl_jar_employee`.

- **Column names**—The columns in the entity bean table each have the same name as the `<cmp-field>` elements in the designated database. The data types for the database, translating Java data types to database data types, are defined in the specific database XML file, such as `oracle.xml`.

---



---

**Note:** Auto-creation of tables in third-party databases may fail for certain data types unless the persistent-type mapping for VARCHAR is defined in the `orion-ejb-jar.xml` as follows:

```
<cmp-field-mapping name="../"
                    persistence-name="..."
                    persistence-type="varchar(10)" />
```

---



---

## Explicit Mapping of Persistent Fields to the Database

As "[Default Mapping of Persistent Fields to the Database](#)" on page 5-2 discusses, your persistent data can be automatically mapped to a database table by the container. However, if the data represented by your bean is more complex or you do not want to accept the defaults that OC4J provides for you, then you can map the persistent data to an existing database table and its columns within the `orion-ejb-jar.xml` file. Once the fields are mapped, the container provides the persistence storage of the persistent data to the indicated table and rows.

For explicit mapping, Oracle recommends that you do the following:

1. Deploy your application with only the `ejb-jar.xml` elements configured.

OC4J creates an `orion-ejb-jar.xml` file for you with the default mappings in them. It is easier to modify these fields than to create them from scratch. This provides you a method for choosing all or part of the modifications that are discussed in this section.

2. Modify the `<entity-deployment>` element in the `orion-ejb-jar.xml` file to use the database table and columns you specify.

Once you define persistent fields, each within its own `<cmp-field>` element, you can map each to a specific database table and column. Thus, you can map CMP fields to existing database tables. The mapping occurs with the OC4J-specific deployment descriptor: `orion-ejb-jar.xml`.

The explicit mapping of CMP fields is completed within an `<entity-deployment>` element. This element contains all mapping for an entity bean. However, the attributes and elements that are specific to CMP field mapping is as follows:

```
<entity-deployment name="..." location="..."
  table="..." data-source="...">
  <primkey-mapping>
    <cmp-field-mapping name="..." persistence-name="..." />
  </primkey-mapping>
  <cmp-field-mapping name="..." persistence-name="..." />
  ...
</entity-deployment>
```

Element or Attribute Name	Description
<code>name</code>	Bean name, which is defined in the <code>ejb-jar.xml</code> file in the <code>&lt;ejb-name&gt;</code> element.
<code>location</code>	JNDI location
<code>table</code>	Database table name
<code>data-source</code>	Data source for the database where the table resides
<code>primkey-mapping</code>	Definition of how the primary key is mapped to the table.
<code>cmp-field-mapping</code>	The name attribute specifies the <code>&lt;cmp-field&gt;</code> in the deployment descriptor, which is mapped to a table column in the <code>persistence-name</code> attribute.

You can configure the following within the `orion-ejb-jar.xml` file:

1. Configure the `<entity-deployment>` element for every entity bean that contains CMP fields that will be mapped within it.
2. Configure a `<cmp-field-mapping>` element for every field within the bean that is mapped. Each `<cmp-field-mapping>` element must contain the name of the field to be persisted.
  - a. Configure the primary key in the `<primkey-mapping>` element contained within its own `<cmp-field-mapping>` element.
  - b. Configure simple data types (such as a primitive, simple object, or serializable object) that are mapped to a single field within a single `<cmp-field-mapping>` element. The name and database field are fully defined within the element attributes.



**Example 5-1 Mapping Persistent Fields to a Specific Database Table**

The following example demonstrates how to map persistent data fields in your bean instance to database tables and columns by mapping the employee persistence data fields to the Oracle database table EMP.

- The bean is identified in the `<entity-deployment>` name attribute. The JNDI name for this bean is defined in the `location` attribute.
- The database table name is defined in the `table` attribute. And the database is specified in the `data-source` attribute, which should be identical to the `<ejb-location>` name of a `DataSource` defined in the `data-sources.xml` file.
- The bean primary key, `empNo`, is mapped to the database table column, `EMPNO`, within the `<primkey-mapping>` element.
- The bean persistent data fields, `empName` and `salary`, are mapped to the database table columns `ENAME` and `SAL` within the `<cmp-field-mapping>` element.

```
<entity-deployment name="EmpBean" location="emp/EmpBean"
  wrapper="EmpHome_EntityHomeWrapper2" max-tx-retries="3"
  table="emp" data-source="jdbc/OracleDS">
  <primkey-mapping>
    <cmp-field-mapping name="empNo" persistence-name="empno" />
  </primkey-mapping>
  <cmp-field-mapping name="empName" persistence-name="ename" />
  <cmp-field-mapping name="salary" persistence-name="sal" />
  ...
</entity-deployment>
```

After deployment, OC4J maps the element values to the following:

Bean	Database
emp/EmpBean	EMP table, located at jdbc/OracleDS in the data-sources.xml file
empNo	EMPNO column as primary key
empName	ENAME column
salary	SAL column

## Configuring Lazy Loading on CMP Entity Bean Finder Methods

Each finder method retrieves one or more objects. In the default scenario (which is set to NO lazy loading), the finder method causes a single SQL select statement to be executed against the database. For a CMP bean, one or more objects are retrieved with all of their CMP fields. So, for example, with the `findAllEmployees` method, this finder retrieves all employee objects with all of the CMP fields in each employee object.

If you turn on lazy loading, then only the primary keys of the objects retrieved within the finder are returned. Then, only when you access the object within your implementation, the OC4J container uploads the actual object based on the primary key. With the `findAllEmployees` finder method example, all of the employee primary keys are returned in a `Collection`. The first time you access one of the employees in the `Collection`, OC4J uses the primary key to retrieve the single employee object from the database. You may want to turn on the lazy loading feature if the number of objects that you are retrieving is so large that loading them all into your local cache would be a performance degradation.

You have a performance consideration with lazy loading. If you retrieve multiple objects, but you only use a few of them, then you should turn on lazy loading. In addition, if you only use objects through the `getPrimaryKey` method, then you should also turn on lazy loading.

To turn on lazy loading in the `findByPrimaryKey` method, set the `findByPrimaryKey-lazy-loading` attribute to `true`, as follows:

```
<entity-deployment ... findByPrimaryKey-lazy-loading="true" ... >
```

To turn on lazy loading in any custom finder method, set the `lazy-loading` attribute to `true` in the `<finder-method>` element for that custom finder, as follows:

```
<finder-method ... lazy-loading="true" ...>
  ...
</finder-method>
```

## Conversion of CMP Types to Database Types

In defining the container-managed persistent fields in the `<cmp-field>` and the primary key types, you can define simple data types and Java user classes that are serializable.

- [Simple Data Types](#)
- [Serializable Classes](#)
- [Other Entity Beans or Collections](#)

### Simple Data Types

The following table provides a list of the supported simple data types, which you can provide in the `persistence-type` attribute, with the mapping of these types to SQL types and to Oracle database types. None of these mappings are guaranteed to work on non-Oracle databases.

**Table 5-1 Simple Data Types**

Known Type (native)	SQL type	Oracle type
<code>java.lang.String</code>	VARCHAR(255)	VARCHAR2(255)
<code>java.lang.Integer[]</code>	INTEGER	NUMBER(20,0)
<code>java.lang.Long[]</code>	INTEGER	NUMBER(20,0)
<code>java.lang.Short[]</code>	INTEGER	NUMBER(10,0)
<code>java.lang.Double[]</code>	DOUBLE PRECISION	NUMBER(30,0)
<code>java.lang.Float[]</code>	FLOAT	NUMBER(20,5)
<code>java.lang.Byte[]</code>	SMALLINT	NUMBER(10,0)
<code>java.lang.Character[]</code>	CHAR	CHAR(1)
<code>java.lang.Boolean[]</code>	BIT	NUMBER(1,0)
<code>java.util.Date</code>	DATETIME	DATE
<code>java.sql.Date</code>	DATE	DATE
<code>java.util.Time</code>	DATE	DATE
<code>java.sql.Timestamp</code>	TIMESTAMP	TIMESTAMP
<code>java.lang.String</code>	CLOB	CLOB

**Table 5–1 (Cont.) Simple Data Types**

Known Type (native)	SQL type	Oracle type
char[ ]	CLOB	CLOB
byte[ ]	BLOB	BLOB
java.io.Serializable (4KB limit)	LONGVARBINARY	BLOB

---

**Note:** You can modify the mapping of these data types in the `config/database-schema/<db>.xml` XML configuration files.

---

The `Date` and `Time` map to `DATE` in the database, because the `DATE` contains the time. The `Timestamp`, however, maps to `TIMESTAMP` in the database, which gives the time in nanoseconds.

Mapping `java.sql.CLOB` and `java.sql.BLOB` directly is not currently supported because these objects are not serializable. However you can map a `String` or `char[ ]` and `byte[ ]` to database column type `CLOB` and `BLOB` respectively. Mapping a `char[ ]` to a `CLOB` or a `byte[ ]` to a `BLOB` can only be done with an Oracle database. The Oracle JDBC API was modified to handle this operation.

There is a 4 KB limit when mapping a serialized object to a `BLOB` type over the JDBC Thin driver.

When `String` and `char[ ]` variables map to a `VARCHAR2` in the database, it can only hold up to 2K. However, you can map `String` object or `char[ ]` larger than 2K to a `CLOB` by doing the following:

1. The bean implementation uses the `String` or `char[ ]` objects.
2. The `persistence-type` attribute of the `<cmp-field-mapping>` element defines the object as a `CLOB`, as follows:

```
<cmp-field-mapping name="stringdata" persistence-name="stringdata"
  persistence-type="CLOB" />
```

In the same manner, you can map a `byte[ ]` in the bean implementation to a `BLOB`, as follows:

```
<cmp-field-mapping name="bytedata" persistence-name="bytedata"
  persistence-type="BLOB" />
```

## Serializable Classes

In addition to simple data types, you can define user classes that implement `Serializable`. These classes are stored in a `BLOB` in the database.

## Other Entity Beans or Collections

You should not define other entity beans or `Collections` as a CMP type. Instead, these are relationships and should be defined within a `CMR` field.

- A relationship to another entity bean is always defined in a `<cmr-field>` relationship.
- `Collections` promote a "many" relationship and should be configured within a `<cmr-field>` relationship. Other types, such as `Lists`, are sub-interfaces of `Collections`. Oracle recommends that you use `Collections`.



---

---

## Entity Relationship Mapping

This chapter discusses how to develop entity-to-entity relationships. As a developer, you can approach entity relationships from either of the following viewpoint:

- EJB development—You can use UML diagrams to design the entity beans, and the cardinality and direction of the relationship between each bean, from the perspective of the EJB objects.
- Database development—You can use ERD diagrams to design the database tables, complete with the cardinality and direction designated by primary and foreign keys, that support the entity beans. The focus is on how the database maps each entity bean and the relationships between them.

This chapter starts by discussing entity relationships from the EJB development viewpoint. Next, it demonstrates how the deployment descriptor maps to database tables. If you want to design with the database development viewpoint, skip to "[Mapping Object Relationship Fields to the Database](#)" on page 6-9.

---

---

**Note:** An object-relationship entity bean example (`ormapdemo.jar`) is available on OTN from the OC4J sample code page at <http://www.oracle.com/technology/tech/java/oc4j/demos/> on the OTN Web site.

---

---

This chapter covers the following topics:

- [Transaction Requirements](#)
- [Defining Entity-To-Entity Relationships](#)
- [Mapping Object Relationship Fields to the Database](#)
- [Using a Foreign Key in a Composite Primary Key](#)
- [How to Override a Foreign Key Database Constraint](#)

### Transaction Requirements

All entity beans with CMP and CMR relationships must be involved in a transaction. As such, you cannot define any entity bean with a transaction attribute of NEVER, SUPPORTS, or NOT\_REQUIRED as this would put the entity outside of a transaction.

## Defining Entity-To-Entity Relationships

The following sections describe what an entity bean relationship can be and how to define them.

- [Choosing Cardinality and Direction](#)
- [Requirements in Defining Relationships](#)

### Choosing Cardinality and Direction

Cardinality refers to the number of entity objects on each side of the relationship. Thus, you can define the following types of relationship between EJBs:

- one-to-one
- one-to-many or many-to-one (dependent on the direction)
- many-to-many

In addition, each relationship can be unidirectional or bidirectional. For example, a unidirectional relationship can be from an employee to an address. With the employee information, you can retrieve an address. However, with an address, you cannot retrieve the employee. An example of a bidirectional relationship is with an employee/projects example. Given a project number, you can retrieve the employees working on the project. Given an employee number, you can retrieve all projects that the employee is working on. Thus, the relationship is valid in both directions.

You can use a unidirectional relationship when you want to reuse the target from multiple entities. For example, both a husband and a wife may work for the same company. Both of their employee records could point to the same home phone number in a unidirectional relationship. You could not have this situation in a bidirectional relationship.

You define the cardinality and direction of the relationship between two beans in the deployment descriptor.

#### One-To-One Relationship Overview

A one-to-one relationship is the simplest relationship between two beans. One entity bean relates only to one other entity bean. If our company office contains only cubicles, and only a single employee can sit in each cubicle, then you have a one-to-one relationship: one employee in one designated cubicle. You define a unidirectional definition for this relationship as follows:

employee → cubicle

However, if you have a cubicle number and want to determine who is assigned to it, you can assign a bidirectional relationship. This would enable you to retrieve the employee and find what cubicle he/she sits in. In addition, you could retrieve the cubicle number and determine who sits there. You define this bidirectional one-to-one relationship as follows:

employee ↔ cubicle

#### One-To-Many or Many-To-One Relationship Overview

In a one-to-many relationship, one object can reference several instances of another. A many-to-one relationship is when many objects reference a single object. For example, an employee can have multiple addresses: a home address and an office address. If you define these relationships as unidirectional from the perspective of the employee, then you can look up the employee and see all of his/her addresses, but you cannot

look up an address to see who lives there. However, if you define this relationship as bidirectional, then you can look up any address and see who lives there.

### Many-To-Many Relationship Overview

A many-to-many relationship is complex. For example, each employee can be working on several projects. And each projects has multiple employees working on it. Thus, you have a many-to-many cardinality. The direction does not matter in this instance. You have the following cardinality:

employees <—> projects

In a many-to-many relationship, many objects can reference many objects. This cardinality is the most difficult to manage.

## Requirements in Defining Relationships

Here are the restrictions imposed on defining your relationships:

- You can define relationships only between CMP 2.0 entity beans.
- You must declare both EJBs in the relationship within the same deployment descriptor.
- Each relationship can use only the local interface of the target EJB.

The following are the requirements to define each cardinality type and its direction:

1. Define the abstract accessor methods (*get/set* methods) for each relationship field. The naming follows the same rules as for the persistence field abstract accessor methods. For example, *getAddress* and *setAddress* methods are abstract accessor methods for retrieving and setting an address.
2. Set the relationships in the bean implementation. The primary key must always be set in the *ejbCreate* method; the foreign key can be set anytime after the *ejbCreate* method, but not within it.
3. Define each relationship—its cardinality and direction—in the deployment descriptor. The relationship field name is defined in the `<cmr-field-name>` element. This name must be the same as the abstract accessor methods, without the *get/set* and the first letter in lower case. For example, the `<cmr-field-name>` would be `address` to compliment the *getAddress/setAddress* abstract accessor methods.
4. If you want cascade delete, then declare the cascade delete option for the one-to-one, one-to-many, and many-to-one relationships. The cascade delete is always specified on the slave side of the relationship, so that when the master entity is deleted, all of the slave entities related to it are subsequently deleted. For example, when an employee has multiple phone numbers, the cascade delete is defined on the phone numbers side. Then, when the employee is deleted, all of the related phone numbers are also deleted.

The following sections provides an example of how to implement each of these requirements:

- [Define the Get/Set Methods for Each Relationship Field](#)
- [Set the Relationships in the Bean Implementation](#)
- [Declare the Relationships in the Deployment Descriptor](#)
- [Decide Whether to Use the Cascade Delete Option](#)

### Define the Get/Set Methods for Each Relationship Field

Each relationship field must have the abstract accessor methods defined for it. In a relationship that sets or retrieves only a single entity, the object type passed back and forth must be the local interface of the target entity bean. In a relationship that sets or retrieves multiple objects, the object type passed back and forth is a `Set` or `Collection` containing local interface objects.

#### **Example 6-1** Definition of Abstract Accessor Methods for the Employee Example

In this example, the employee has an employee number and a single address. You can retrieve the employee number and address only through the employee. This defines one-to-one relationships that is unidirectional from the perspective of the employee. Then the abstract accessor methods for the employee bean are as follows:

```
public Integer getEmpNo();
public void setEmpNo(Integer empNo);
public AddressLocal getAddress();
public void setAddress(AddressLocal address);
```

Because the cardinality is one-to-one, the local interface of the address entity bean is the object type that is passed back and forth in the abstract accessor methods.

The cardinality and direction of the relationship are defined in the deployment descriptor.

#### **Example 6-2** Definition of One-To-Many Abstract Accessor Methods

If the employee example included a one-to-many relationship, the abstract accessor methods would pass back and forth a `Set` or `Collection` of objects, each of which contains target bean local interface objects. When you have a "many" relationship, multiple records are being passed back and forth.

A department contains many employees. In this one-to-many example, the abstract accessor methods for the department retrieves multiple employees. Thus, the abstract accessor methods pass a `Collection` or a `Set` of employees, as follows:

```
public Collection getDeptEmployees();
public void setDeptEmployees(Collection deptEmpl);
```

### Set the Relationships in the Bean Implementation

Once you have defined the get/set relationship methods, use them in the bean implementation to set up the relationships. All primary key relationships must be set within the `ejbCreate` method, as shown in ["Implement the Entity Bean Class"](#) on page 4-4. If you use a foreign key, as described in ["Using a Foreign Key in a Composite Primary Key"](#) on page 6-44, you can set the foreign key as early as the `ejbPostCreate` method.

When you set the primary key in the `ejbCreate`, the set methods populate the CMP fields that you define in the deployment descriptor. At the end of the `ejbCreate` method, these fields are written out to the appropriate database row.

The employee has a primary key of the employee number. The following sets the primary key for the department:

```
public Integer ejbCreate(Integer empNo) throws CreateException
{
    setEmpNo(empNo);
    return empNo;
}
```



## Declare the Relationships in the Deployment Descriptor

You define the relationships between entity beans in the same deployment descriptor the entity beans are declared. All entity-to-entity relationships are defined within the `<relationships>` element and you can define multiple relationships within this element. Each specific entity-to-entity relationship is defined within an `<ejb-relation>` element. The following XML demonstrates two entity-to-entity relationships defined within an application:

```
<relationships>
  <ejb-relation>
    ...
  </ejb-relation>
  <ejb-relation>
    ...
  </ejb-relation>
</relationships>
```

The following XML shows the full element structure for relationships:

```
<relationships>
  <ejb-relation>
    <ejb-relation-name> </ejb-relation-name>
    <ejb-relationship-role>
      <ejb-relationship-role-name> </ejb-relationship-role-name>
      <multiplicity> </multiplicity>
      <relationship-role-source>
        <ejb-name> </ejb-name>
      </relationship-role-source>
      <cmr-field>
        <cmr-field-name> </cmr-field-name>
        <cmr-field-type> </cmr-field-type>
      </cmr-field>
    </ejb-relationship-role>
  </ejb-relation>
</relationships>
```

---

**Note:** An object-relationship entity bean example is available on OTN from the OC4J sample code page at <http://www.oracle.com/technology/tech/java/oc4j/demos/> on the OTN Web site.

---

Table 6–1 describes the usage for each of these elements.

**Table 6–1 Description of Relationship Elements of the Deployment Descriptor**

Deployment Descriptor Element	Description
<code>&lt;ejb-relation&gt;</code>	Each entity-to-entity relationship is described in a single <code>&lt;ejb-relation&gt;</code> element.
<code>&lt;ejb-relation-name&gt;</code>	A user-defined name for the entity-to-entity relationship.
<code>&lt;ejb-relationship-role&gt;</code>	Each entity within the relationship is described within its own <code>&lt;ejb-relationship-role&gt;</code> . Thus, there are always two <code>&lt;ejb-relationship-role&gt;</code> entities within the <code>&lt;ejb-relation&gt;</code> .
<code>&lt;ejb-relationship-role-name&gt;</code>	A user-defined name to describe the role or involvement of the entity bean in the relationship.

**Table 6–1 (Cont.) Description of Relationship Elements of the Deployment Descriptor**

Deployment Descriptor Element	Description
<code>&lt;multiplicity&gt;</code>	The declaration of the cardinality for this entity. The value is "one" or "many."
<code>&lt;relationship-role-source&gt;&lt;ejb-name&gt;</code>	The name of the entity bean. This must equal an EJB name defined in an <code>&lt;entity&gt;&lt;ejb-name&gt;</code> element in the <code>ejb-jar.xml</code> file.
<code>&lt;cmr-field&gt;&lt;cmr-field-name&gt;</code>	A user-defined name to represent the target bean reference. This name must match the abstract accessor methods. For example, if the abstract accessor fields are <code>getAddress()</code> and <code>setAddress()</code> , the CMR field must be <code>address</code> .
<code>&lt;cmr-field&gt;&lt;cmr-field-type&gt;</code>	Optional. If "many", this type should be a <code>Collection</code> or <code>Set</code> . This is only specified for the "many" side to inform if a <code>Collection</code> or a <code>Set</code> is returned.

These relationships can be one-to-one, one-to-many, or many-to-many. The cardinality is defined within the `<multiplicity>` element. Each bean defines its cardinality within its own relationship. For example,

- One-to-one: For one employee to have a relationship with one address, the employee bean is declared with a `<multiplicity>` of one, and the address bean is declared with a `<multiplicity>` of one.
- One-to-many, many-to-one: For one department to have a relationship with multiple employees, the department bean is declared with a `<multiplicity>` of one, and the employee bean is declared with a `<multiplicity>` of many. For many employees to belong to a department, you define the same `<multiplicity>`.
- Many-to-many: For each employee to have a relationship with multiple projects and each project to have multiple employees working on it, the employee bean is declared with a `<multiplicity>` of many, and the project is declared with a `<multiplicity>` of many.

The direction of the relationship is defined by the presence of the `<cmr-field>` element. The reference to the target entity is defined within the `<cmr-field>` element. If the relationship is unidirectional, then only one entity within the relationship contains a reference to a target. In this case, the `<cmr-field>` element is declared in the source entity and contains the target bean reference. If the relationship is bidirectional, both entities should declare a reference to each other's bean within a `<cmr-field>` element.

The following demonstrates how to declare direction in the one-to-one employee and address example:

- Unidirectional: Define the `<cmr-field>` element within the employee bean section that references the address bean. Do not define a `<cmr-field>` element in the address bean section of the relationship.
- Bidirectional: Define a `<cmr-field>` element in the employee bean section that references the address bean. In addition, define a `<cmr-field>` element in the address bean section that references the employee bean.

Once you understand how to declare the cardinality and direction of the entity relationships, configuring the EJB deployment descriptor for each relationship is simple.

**Example 6-3 One-To-One Relationship Example**

The employee example defines a one-to-one unidirectional relationship in which each employee has only one address. This relationship is unidirectional because you can retrieve the address from the employee, but you cannot retrieve the employee from the address. Thus, the employee object has a relationship to the address object.

The `ejb-jar.xml` file is configured for this example, as follows:

```
<enterprise-beans>
  <entity>
    ...
    <ejb-name>EmpBean</ejb-name>
    <local-home>employee.EmpHome</local-home>
    <local>employee.Emp</local>
    <ejb-class>employee.EmpBean</ejb-class>
    ...
  </entity>
  <entity>
    ...
    <ejb-name>AddressBean</ejb-name>
    <local-home>employee.AddressHome</local-home>
    <local>employee.Address</local>
    <ejb-class>employee.AddressBean</ejb-class>
    ...
  </entity>
</enterprise-beans>
...
<relationships>
  <ejb-relation>
    <ejb-relation-name>Emp-Address</ejb-relation-name>
    <ejb-relationship-role>
      <ejb-relationship-role-name>Emp-has-Address
      </ejb-relationship-role-name>
      <multiplicity>One</multiplicity>
      <relationship-role-source><ejb-name>EmpBean</ejb-name>
      </relationship-role-source>
      <cmr-field>
        <cmr-field-name>address</cmr-field-name>
      </cmr-field>
    </ejb-relationship-role>
    <ejb-relationship-role>
      <ejb-relationship-role-name>Address-has-Emp
      </ejb-relationship-role-name>
      <multiplicity>One</multiplicity>
      <relationship-role-source><ejb-name>AddressBean</ejb-name>
      </relationship-role-source>
    </ejb-relationship-role>
  </ejb-relation>
</relationships>
```

The `ejb-jar.xml` file has defined the following:

- Configure each `<entity>` element within the `<enterprise-beans>` section for each of the entity beans involved in the relationship. For this example, these include an `<entity>` element for the employee with an `<ejb-name>` of `EmpBean` and an `<entity>` element for the address with an `<ejb-name>` of `AddressBean`.
- Configure the `<ejb-relationship>` element within the `<relationships>` section for the one-to-one relationship. For this example, it defines the following:

- An `<ejb-relationship-role>` element for the employee bean that defines its cardinality as "one" in its `<multiplicity>` element. The `<relationship-role-source>` element defines the `<ejb-name>` as `EmpBean`, which is the same name in the `<entity>` element.
- An `<ejb-relationship-role>` element for the address bean that defines its cardinality as "one" in its `<multiplicity>` element. The `<relationship-role-source>` element defines the `<ejb-name>` as `AddressBean`, which is the same name in the `<entity>` element.
- Configure a `<cmr-field>` element in the `EmpBean` relationship that points to the `AddressBean`. The `<cmr-field>` element defines `address` as the `AddressBean` reference. This element name matches the get and set method names, which are named `getAddress` and `setAddress`. These methods identify the local interface of the address entity bean as the data type that is returned from the get method and passed in on the set method.

---

**Note:** An object-relationship entity bean example is available on OTN from the OC4J sample code page at <http://www.oracle.com/technology/tech/java/oc4j/demos/> on the OTN Web site.

---

### Decide Whether to Use the Cascade Delete Option

When you have relationships between entity beans and the master entity bean is deleted, what happens to the slave beans? If you specify cascade delete, the deletion of a master entity bean automatically deletes all of its slave relationship entity beans. You specify the cascade delete option in the slave relationship definition, which is the object that is deleted automatically.

For example, an employee has a relationship with an address object. The address object specifies cascade delete. When the employee, as master in this relationship, is deleted, the address, the slave, is also deleted.

In some instances, you do not want a cascade delete to occur. If you have a department that has a relationship with multiple employees within the department, you do not want all employees to be deleted when you delete the department.

You can only specify a cascade delete on a relationship if the master entity bean has a `<multiplicity>` of one. Thus, in a one-to-one, the master is obviously a "one". You can specify a cascade delete in a one-to-many relationship, but not in a many-to-one or many-to-many relationship.

#### **Example 6-4 Cascade Delete Requested in the Employee Example**

The following deployment descriptor shows the definition of a one-to-one relationship with the employee and his/her address. When the employee is deleted, the slave entity bean—the address—is automatically deleted. You ensure the deletion by specifying the `<cascade-delete/>` element in the slave entity bean of the relationship. In this case, specify the `<cascade-delete/>` element in the `AddressBean` definition.

```
<relationships>
  <ejb-relation>
    <ejb-relation-name>Emp-Address</ejb-relation-name>
    <ejb-relationship-role>
      <ejb-relationship-role-name>Emp-has-Address
      </ejb-relationship-role-name>
      <multiplicity>One</multiplicity>
```

```

    <relationship-role-source><ejb-name>EmpBean</ejb-name>
  </relationship-role-source>
  <cmr-field>
    <cmr-field-name>address</cmr-field-name>
  </cmr-field>
</ejb-relationship-role>
<ejb-relationship-role>
  <ejb-relationship-role-name>Address-has-Emp
</ejb-relationship-role-name>
  <multiplicity>One</multiplicity>
  <cascade-delete/>
  <relationship-role-source><ejb-name>AddressBean</ejb-name>
</relationship-role-source>
</ejb-relationship-role>
</ejb-relation>
</relationships>

```

## Mapping Object Relationship Fields to the Database

Each entity bean maps to a table in the database. Each of its persistent and relationship fields are saved within a database table in columns. For these fields to be mapped to a database, do one of the following:

- Accept the defaults for these fields and avoid more deployment descriptor configuration. See ["Default Mapping of Relationship Fields to the Database"](#) on page 6-9 to learn how the default mapping occurs. The tables are automatically created for the bean based on the information in the `ejb-jar.xml` file.
- Map the fields to columns in a table that already exists in a designated database. The persistent data mapping is configured within the `orion-ejb-jar.xml` file. See ["Explicit Mapping of Relationship Fields to the Database"](#) on page 6-12 for more information.

## Default Mapping of Relationship Fields to the Database

---



---

**Note:** This section discusses how OC4J maps relationship fields to the database. [Chapter 5, "CMP Entity Beans"](#) discusses persistent field mapping.

---



---

When you declare relationship fields in the `ejb-jar.xml` file, OC4J provides default mappings of these fields to the database when it auto-generates the `orion-ejb-jar.xml` file. The default mapping for relationships is the same as for the persistent fields, as described in ["Default Mapping of Persistent Fields to the Database"](#) on page 5-2.

---



---

**Note:** For all future redeployments, copy the auto-generated `orion-ejb-jar.xml` file with this table name into the same directory as your `ejb-jar.xml` file from the `J2EE_HOME/application-deployments` directory. Thus, all future redeployments have the same table names as first generated. If you do not copy this file over, different table names may be generated.

---



---

In summary, these defaults include:

- Database—The default database as set up in your OC4J instance configuration.
- Default table—Each entity bean in the relationship represents data in its own database table. The name of the entity bean table makes an effort to be unique, and so it is constructed with the following names, where each is separated by an underscore (\_):
  - EJB name defined in `<ejb-name>` in the deployment descriptor.
  - JAR file name, including the `.jar` extension. However, all dashes (-) and periods (.) are converted to underscores (\_) to follow SQL conventions. For example, if the name of your JAR file is `employee.jar`, then `employee.jar` is appended to the name.
  - Application name: You define the application name during deployment.

If the constructed name is greater than thirty characters, the name is truncated at twenty-four characters. An underscore and then five characters made up of an alphanumeric hash code is appended to the name for uniqueness.

For example, if the EJB name is `EmpBean`, the JAR file is `empl.jar`, and the application name is `employee`, then the default table name is `EmpBean_empl.jar_employee`.

- Column names in each table—The container generates columns in each table based on the `<cmp-field>` and `<cmr-field>` elements defined in the deployment descriptor. A column is created for each `<cmp-field>` element that relates to the entity bean data. In addition, a column is created for each `<cmr-field>` element that represents a relationship. In a unidirectional relationship, only a single entity in the relationship defines a `<cmr-field>` in the deployment descriptor. In a bidirectional relationship, both entities in the relationship define a `<cmr-field>`.

For each `<cmr-field>` element, the container creates a foreign key that points to the primary key of the relevant object, as follows:

- In the default one-to-one relationship, the foreign key is created in the database table for the source EJB and is directed to the primary key of the target database table. For example, if one employee has one address, then the foreign key is created within the employee table that points to the primary key of the address table. For more information, see ["Example of a Default Mapping of the One-To-One Relationship"](#) on page 6-11.
- The default for one-to-many relationships uses a foreign key as described in ["Using a Foreign Key with the One-To-Many Relationship"](#) on page 6-21.
- The default for many-to-many relationships creates an association table (a third table). The association table contains two foreign keys, where each points to the primary key of one of the entity tables. For more information, see ["Example of a Default Mapping of One-To-Many and Many-To-Many Relationships"](#) on page 6-11.

Since the `<cmp-field>` and `<cmr-field>` elements represent Java data types, they may not convert to database types in the manner you believe that they should. See ["Conversion of CMP Types to Database Types"](#) on page 5-6 for a table of how the conversion occurs. However, you can modify the translation rules for converting Java data types to database data types in the specific database XML files, which are located in `j2ee/home/config/database-schemas`. This directory includes all database files. The Oracle database conversion file is named `oracle.xml`.

- Primary key generation—Both entity tables contain a primary key. The primary key can be defined or auto-generated. See ["How to Define and Use Primary Keys for Your Entity Bean"](#) on page 4-6 for a full description.
  - Defined primary key: The primary key is generated as designated in the `<primkey-field>` element as a simple data type or a class. Thus, the column name is the same as the name in the `<primkey-field>` element.
  - Composite primary key: The primary key is defined within a class, and is made up of several fields. Each field within the composite primary key is represented by a column in the database table, where each is considered part of the primary key in the table.
  - Auto-generated primary key: If you specify a `java.lang.Object` as the primary key class type in `<prim-key-class>`, but do not specify the primary key name in `<primkey-field>`, then the primary key is auto-generated by the container. The column is named AUTOID.

### Example of a Default Mapping of the One-To-One Relationship

The one-to-one entity relationship is managed between the entity tables with a foreign key. [Figure 6-1](#) demonstrates the default table mapping of a one-to-one unidirectional relationship between the employee and address bean.

**Figure 6-1 One-To-One Employee Relationship Example**

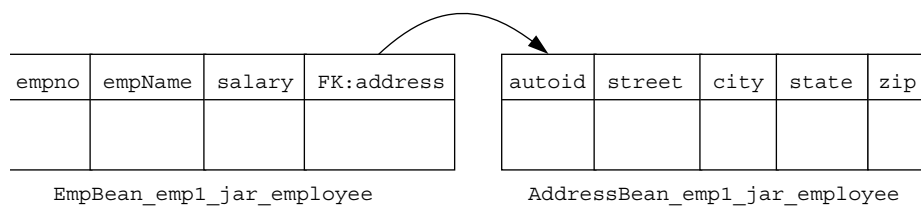

- The container generates the table names based on the entity bean names, the JAR file the beans are archived in, and the application name that they are deployed under. If the JAR filename is `emp1.jar` and the application name is `employee`, then the table names are `EmpBean_emp1_jar_employee` and `AddressBean_emp1_jar_employee`.
- The container generates columns in each table based on the `<cmp-field>` and `<cmr-field>` elements declared in the deployment descriptor.
  - The columns for the `EmpBean` table are `empno`, `empname`, and `salary`. A foreign key is created called `address`, from the `<cmr-field>` declaration, that points to the primary key column of the `AddrBean` table.
  - The columns for the `AddressBean` table are an auto-generated long primary key and columns for `street`, `city`, `state`, and `zip`.
- The primary key for the employee table is designated in the deployment descriptor as `empno`. The `AddressBean` is configured for an auto-generated primary key by specifying only `<primkey-class>` of `java.lang.Object`.

### Example of a Default Mapping of One-To-Many and Many-To-Many Relationships

As described in ["One-To-Many or Many-To-One Relationship Overview"](#) on page 6-2, one bean, such as a department, can have a relationship to multiple instances of another bean, such as employees. There are several employees in each department. Since this is a bidirectional relationship, you can look up the department from the

employee. The relationships between the DeptBean and EmpBean is represented by CMR fields, employees and dept, as shown in Figure 6-2.

**Figure 6-2 One-to-Many Bean Relationship**



How this relationship is mapped to database tables depends on your choices. The default method adds a foreign key to the table that defines the "many" side of the relationship—in this case, the table that represents the EmpBean. The foreign key points back to the department to which each employee belongs.

Figure 6-3 shows the department<—>employee example, where each employee belongs to only one department and each department can contain multiple employees. The department table has a primary key. The employee table has a primary key to identify each employee and a foreign key to point back to the employee's department. If you want to find the department for a single employee, a simple SQL statement retrieves the department information from the foreign key. To find all employees in a department, the container performs a JOIN statement on both the department and employee tables and retrieves all employees with the designated department number.

**Figure 6-3 Default Mapping for One-To-Many Bean Relationship Example**

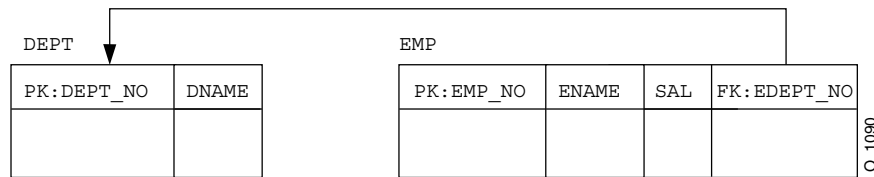

"Using a Foreign Key with the One-To-Many Relationship" on page 6-21 details how the deployment descriptors are configured for this behavior to occur. To keep the same defaults for all future redeployments, copy the auto-generated orion-ejb-jar.xml file with the default table name into the same directory as your ejb-jar.xml file from the J2EE\_HOME/application-deployments directory. Thus, all future redeployments have the same table names as first generated. If you do not copy this file over, different table names may be generated. To modify the defaults, copy the file over and follow the directions in "Using a Foreign Key with the One-To-Many Relationship" on page 6-21.

## Explicit Mapping of Relationship Fields to the Database

As "Default Mapping of Relationship Fields to the Database" on page 6-9 discusses, your relationship fields can be automatically mapped to the database tables by the container. However, if you do not want to accept the defaults that OC4J provides for you or if you need to map the fields to an existing database table, then you can map the relationships between entity beans to an existing database table and its columns in the orion-ejb-jar.xml file.

"Explicit Mapping of Persistent Fields to the Database" on page 5-3 discusses how to explicitly map CMP fields. This section is about mapping CMR fields and so builds on that information to show how the relationship mapping occurs.



---

---

**Important:** You modify elements and attributes of the `<entity-deployment>` element in the `orion-ejb-jar.xml` file to explicitly map relationship fields. JDeveloper was created to manage the complex mapping between the entity beans and the database tables. Thus, JDeveloper validates the deployment descriptors and prevents inconsistencies. You are allowed to modify the `orion-ejb-jar.xml` file on your own; however, we suggest that you use JDeveloper for modifying container-managed relationships. CMR configuration is complex and can be difficult to understand. You can download JDeveloper at the following site: <http://www.oracle.com/technology/software/products/jdev/index.html>

---

---

This chapter provides two levels of information about the `orion-ejb-jar.xml` elements:

- A quick, direct guide for identifying the fields in which you would modify if you mapped to an existing database. See "[Quick Cookbook for Matching an Existing Database to the Bean Mappings](#)" on page 6-13.
- An education on all elements used in the CMR mapping and directions on modifying them. See "[Steps for Modifying CMR Mapping Elements](#)" on page 6-13.

### Quick Cookbook for Matching an Existing Database to the Bean Mappings

If you want to know how to modify the `orion-ejb-jar.xml` file without understanding what each of the elements are for in this XML file and you do not want to use JDeveloper, then do the following:

1. Deploy your bean with the `autocreate-tables` element set to `false` in the `orion-application.xml` file.
2. Copy the `orion-ejb-jar.xml` file from the `application-deployments/` directory to your development directory.
3. Modify the `data-source` element to be the correct data source. Note that all beans that are associated with each other must use the same data source.
4. Modify the `table` attribute to be the correct table. Make sure that it is the correct table for the bean that is defined in the `<entity-deployments>` element.
5. Modify the `persistence-name` attributes to the correct column for each bean persistence type, whether a CMP or CMR field.
6. Set the `autocreate-tables` element in `orion-application.xml` file to `true`.
7. Rearchive your application and redeploy.

---

---

**Note:** An object-relationship entity bean example is available on OTN from the OC4J sample code page at <http://www.oracle.com/technology/tech/java/oc4j/demos/> on the OTN Web site.

---

---

### Steps for Modifying CMR Mapping Elements

If JDeveloper does not provide the mapping that you need or if you wish to manage the XML on your own, then you should perform the following steps:

1. Deploy your bean with the `autocreate-tables` element set to `false` in the `orion-application.xml` file and the `ejb-jar.xml` elements configured. OC4J creates an `orion-ejb-jar.xml` file for you, with the default mappings in it. It is easier to modify these fields than to create them from scratch.
2. Copy the container-created `orion-ejb-jar.xml` file from the `$J2EE_HOME/application-deployments` directory to your development environment.
3. Modify the `<entity-deployment>` element in the `orion-ejb-jar.xml` file to use the database table and columns you specify, based on the relationship type. See ["Hand-Editing the orion-ejb-jar.xml File to Map Bean Relationships to Database Tables"](#) on page 6-14 for an overview.

Each of the following sections describes how the CMR mapping occurs for each relationship type:

- [One-To-One Relationship Explicit Mapping](#)
  - [Table Mapping For Primary Keys That Use AutoId](#)
  - [Using a Foreign Key with the One-To-Many Relationship](#)
  - [Association Table Explicit Mapping for Relationships Overview](#)
  - [Using an Association Table with a One-to-Many Bidirectional Relationship](#)
  - [Using an Association Table in a One-to-Many Unidirectional Relationship](#)
  - [Using an Association Table in Many-to-Many Relationships](#)
4. Set the `autocreate-tables` element in `orion-application.xml` file to `true`.
  5. Rearchive your application and redeploy.

---

---

**Note:** If you deployed without setting `autocreate-tables` to `false`, then OC4J automatically created the default tables. You must drop all of these tables before redeploying the application. If you use an association table, this must be dropped also.

---

---

## Hand-Editing the orion-ejb-jar.xml File to Map Bean Relationships to Database Tables

The relationship between the beans is defined in the `<relationships>` element in the `ejb-jar.xml` file; the mapping between the bean and the database table and columns is specified in the `<entity-deployment>` element in the `orion-ejb-jar.xml` file.

The `orion-ejb-jar.xml` file maps the bean entity relationships to database table and columns within a `<cmp-field-mapping>` element. The following is the XML structure of the `<entity-deployment>` and `<cmp-field-mapping>` elements for a simple one-to-one relationship:

```
<entity-deployment name="SourceBeanName" location="JNDILocation"
table="TableName" data-source="DataSourceJNDIName">
...
<cmp-field-mapping name="CMRfield_name">
  <entity-ref home="targetBeanName">
    <cmp-field-mapping name="CMRfield_name"
persistence-name="targetBean_PKcolumn" />
  </entity-ref>
</cmp-field-mapping>
```

Within this element, you can define the bean name (the source of the relationship that indicates the direction), the JNDI location, the database table to which the information is persisted, and map each of the CMP and CMR fields defined in the `ejb-jar.xml` file to the underlying persistence storage—the database.

---

**Note:** This document refers to beans as the source or target of a relationship. If an employee owns many phones in a unidirectional relationship, then the employee is the source bean and it points to the phones, which are the target.

---

The attributes of the `<entity-deployment>` element define the following for the bean:

- The `name` attribute identifies the EJB name of the bean, which was defined in the `<ejb-name>` element in the `ejb-jar.xml` file. This name attribute connects the `ejb-jar.xml` file definition for the bean to its mapping to the database.
- The `location` attribute identifies the JNDI name of the bean.
- The `table` attribute identifies the database table to which this entity bean is mapped.
- The `data-source` attribute identifies the database in which the table resides. The data source must be the same for all beans that interact with each other or are associated with each other. This includes beans that are in the same application, part of the same transaction, or beans that are in a parent-child relationship.

The `<cmp-field-mapping>` element in the `orion-ejb-jar.xml` file maps the following fields to database columns.

- The `<cmp-field>` element in the `ejb-jar.xml` file defines a CMP field.
- The `<cmr-field>` element in the `ejb-jar.xml` file defines a CMR field.

Figure 6-4 displays how the `<cmr-field>` element in the `ejb-jar.xml` file maps to the `<cmp-field-mapping>` element in the `orion-ejb-jar.xml` file. The `name` attribute in the `<cmp-field-mapping>` provides the link between the two XML files. You must not modify any name attributes.

**Figure 6-4 Demonstration of Mapping for a One-To-One Relationship**

```

EJB-JAR.XML
<relationship-role-source>
  <ejb-name>EmpBean</ejb-name>
</relationship-role-source>
<cmr-field>
  <cmr-field-name>address</cmr-field-name>
</cmr-field>

ORION-EJB-JAR.XML
<cmp-field-mapping name="address">
  <entity-ref home="AddressBean">
    <cmp-field-mapping name="address"
      persistence-name="addressPK" />
  </entity-ref>
</cmp-field-mapping>

```

To fully identify and map CMR fields, nested `<cmp-field-mapping>` elements are used. The format of the nesting depends on the type of relationship. The database

column that is the primary key of the target bean is defined in the persistence-name attribute of the internal `<cmp-field-mapping>` element. If you have an existing database, you would be modifying the persistence-name attributes for each `<cmp-field-mapping>` element to match your column names.

The following sections talk about each relationship type and how the mapping occurs:

- [One-To-One Relationship Explicit Mapping](#)
- [Table Mapping For Primary Keys That Use AutoId](#)
- [Using a Foreign Key with the One-To-Many Relationship](#)
- [Association Table Explicit Mapping for Relationships Overview](#)
- [Using an Association Table with a One-to-Many Bidirectional Relationship](#)
- [Using an Association Table in a One-to-Many Unidirectional Relationship](#)
- [Using an Association Table in Many-to-Many Relationships](#)

### One-To-One Relationship Explicit Mapping

Figure 6–5 demonstrates a one-to-one unidirectional relationship between a single employee and his/her address. The `EmpBean` points to the `AddressBean` that is the employee's address using the CMR field, `address`.

**Figure 6–5 One-To-One Bean Relationship**

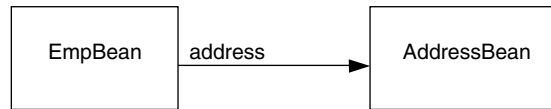
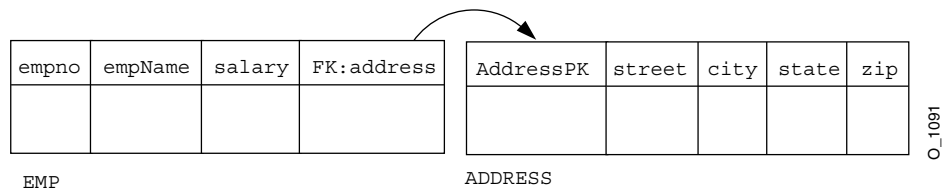

Figure 6–6 shows the database tables, `EMP` and `ADDRESS`, to which these beans will map. The `EMP` table has a foreign key, named `address`, which points to the primary key of the `ADDRESS` table, `AddressPK`.

**Figure 6–6 One-To-One Bean Relationship**



The beans and their relationships are specified in both of the deployment descriptors. As Figure 6–7 shows, in the `ejb-jar.xml` file, the one-to-one relationship between the `EmpBean` and `AddressBean` is defined within a `<relationships>` element. The direction is designated by one or two `<cmr-field>` elements.

The mapping of the beans to their database persistent storage is defined in the `orion-ejb-jar.xml` file. The one-to-one relationship—whether bidirectional or unidirectional—is mapped on both sides with an `<entity-ref>` element inside a `<cmp-field-mapping>` element. The `<entity-ref>` describes the target entity bean of the relationship.

Figure 6-7 Demonstration of Mapping for a One-To-One Relationship

```

EJB-JAR.XML
<relationships>
...
<ejb-relation>
...
<multiplicity> One</multiplicity>
<relationship-role-source>
  <ejb-name> EmpBean </ejb-name>
</relationship-role-source>
<cmr-field>
  <cmr-field-name> address </cmr-field-name>
</cmr-field>
...
</ejb-relation>
<ejb-relation>
...
  <relationship-role-source>
    <ejb-name> AddressBean </ejb-name>
  </relationship-role-source>^
...
</ejb-relation>

ORION-EJB-JAR.XML
<entity-deployment name="EmpBean"...
  <cmp-field-mapping name=" address " >
    <entity-ref home=" AddressBean " >
      <cmp-field-mapping name=" address "
        persistence-name=" addressPK " />
    </entity-ref>
  </cmp-field-mapping>
  ...
</entity-deployment>
<entity-deployment name="AddressBean" ...
  ...
  <cmp-field-mapping name="empNo">
    <entity-ref home="EmpBean">
      <cmp-field-mapping name="empNo"
        persistence-name="empno"/>
    </entity-ref>
  </cmp-field-mapping>
  ...
</entity-deployment>

```

Name of database column for foreign key

To map your bean fields to an existing database, you need to understand the fields within the `<cmp-field-mapping>` element in the `orion-ejb-jar.xml` file. This element has the following structure:

```

<cmp-field-mapping name="CMRfield_name">
  <entity-ref home="targetBeanName">
    <cmp-field-mapping name="CMRfield_name"
      persistence-name="targetBean_PKcolumn" />
  </entity-ref>
</cmp-field-mapping>

```

- The name attribute of the `<cmp-field-mapping>` element is the same as the `<cmp-field>` element in the `ejb-jar.xml` file. Do not modify the name attribute in the `<cmp-field-mapping>` element.
- The target bean name is specified in the `home` attribute of the `<entity-ref>` element.
- The database column that is the primary key of the target bean is defined in the `persistence-name` attribute of the internal `<cmp-field-mapping>` element.

If you have an existing database, modify the persistence-name attributes for each <cmp-field-mapping> element to match your column names.

**Example 6-5 The XML Configuration for One-to-One Unidirectional**

The ejb-jar.xml file configuration defines a one-to-one unidirectional relationship between the EmpBean and AddressBean.

```
<enterprise-beans>
  <entity>
    ...
    <ejb-name>EmpBean</ejb-name>
    <local-home>employee.EmpHome</local-home>
    <local>employee.Emp</local>
    <ejb-class>employee.EmpBean</ejb-class>
    ...
    <cmp-field><field-name>empNo</field-name></cmp-field>
    <cmp-field><field-name>empName</field-name></cmp-field>
    <cmp-field><field-name>salary</field-name></cmp-field>
    <primkey-field>empNo</primkey-field>
    <prim-key-class>java.lang.Integer</prim-key-class>
    ...
  </entity>
  <entity>
    ...
    <ejb-name>AddressBean</ejb-name>
    <local-home>employee.AddressHome</local-home>
    <local>employee.Address</local>
    <ejb-class>employee.AddressBean</ejb-class>
    ...
    <cmp-field><field-name>addressPK</field-name></cmp-field>
    <cmp-field><field-name>addressDescription</field-name></cmp-field>
    <primkey-field>addressPK</primkey-field>
    <prim-key-class>java.lang.Integer</prim-key-class>
    ...
  </entity>
</enterprise-beans>
<relationships>
  <ejb-relation>
    <ejb-relation-name>Emp-Address</ejb-relation-name>
    <ejb-relationship-role>
      <ejb-relationship-role-name>Emp-has-Address
      </ejb-relationship-role-name>
      <multiplicity>One</multiplicity>
      <relationship-role-source><ejb-name>EmpBean</ejb-name>
      </relationship-role-source>
      <cmr-field>
        <cmr-field-name>address</cmr-field-name>
      </cmr-field>
    </ejb-relationship-role>
    <ejb-relationship-role>
      <ejb-relationship-role-name>Address-has-Emp
      </ejb-relationship-role-name>
      <multiplicity>One</multiplicity>
      <relationship-role-source><ejb-name>AddressBean</ejb-name>
      </relationship-role-source>
    </ejb-relationship-role>
  </ejb-relation>
</relationships>
```

The `EmpBean` defines a `<cmr-field>` for the direction of the relationship showing that each employee has one address. The `EMP` table that supports `EmpBean` requires a foreign key to point to the table that supports the `AddressBean`.

The foreign key from the `EMP` table to the `ADDRESS` table is identified as `address` within the `<cmr-field-name>` element, which is required on the `name` attribute of the `<cmp-field-mapping>` element in the `orion-ejb-jar.xml` file. Thus, `address` is the identifier that links the relationship defined in the `ejb-jar.xml` file to the persistence storage mapping specified in the `orion-ejb-jar.xml` file.

The following is the `orion-ejb-jar.xml` file with the elements modified to map to the existing database tables:

```
<entity-deployment name="EmpBean" location="emp/EmpBean" ...
table="EMP" data-source="jdbc/OracleDS" ...>
  <primkey-mapping>
    <cmp-field-mapping name="empNo" persistence-name="EMPNO" />
  </primkey-mapping>
  <cmp-field-mapping name="empName" persistence-name="ENAME" />
  <cmp-field-mapping name="salary" persistence-name="SAL" />
  <cmp-field-mapping name="address">
    <entity-ref home="AddressBean">
      <cmp-field-mapping name="address"
        persistence-name="addressPK" />
    </entity-ref>
  </cmp-field-mapping>
  ...
</entity-deployment>
<entity-deployment name="AddressBean" location="emp/AddressBean" ...
table="ADDRESS" data-source="jdbc/OracleDS"... >
  <primkey-mapping>
    <cmp-field-mapping name="addressPK"
      persistence-name="addressPK" />
  </primkey-mapping>
  <cmp-field-mapping name="street" persistence-name="street" />
  <cmp-field-mapping name="city" persistence-name="city" />
  <cmp-field-mapping name="state" persistence-name="state" />
  <cmp-field-mapping name="zip" persistence-name="zip" />
  <cmp-field-mapping name="EmpBean_address">
    <entity-ref home="EmpBean">
      <cmp-field-mapping name="EmpBean_address"
        persistence-name="EMPNO" />
    </entity-ref>
  </cmp-field-mapping>
  ...
</entity-deployment>
```

---

---

**Note:** This section describes in detail how logical names defined in the `ejb-jar.xml` file relate to those in the `orion-ejb-jar.xml` file. And it describes how the logical variables defined in the `orion-ejb-jar.xml` file relate to the database table and column names. This chapter specifically chooses different names for closely aligned elements in the `ejb-jar.xml` and `orion-ejb-jar.xml` files in order that you can understand which names where the mappings occur. However, for efficiency and ease, you can make all related names the same. For example, instead of identifying `address` and `addressPK` for identifying the CMR field name and database column name, you could use one name, `address`, for all of them. **Your configuration is easier if all these names are the same.**

---

---

The `<entity-deployment>` mapping for the `EmpBean` specifies:

- The `<entity-deployment>` attributes define the following:
  - `name` attribute: The name of the source bean is `EmpBean`.
  - `location` attribute: The JNDI location is `emp/EmpBean`.
  - `table` attribute: The database table in which the persistent data for this entity bean is stored is `emp`.
  - `data-source` attribute: The database in which this table resides is defined by the data source `jdbc/OracleDS`.
- The `<cmp-field-mapping>` elements identify the table columns and the persistent data to be stored in each: The columns in this table are `empno`, `ename`, `sal`, and `address`.
  - The `empno` column contains the primary key, as defined in the `EmpBean` as `empNo`.
  - The `empName` and `salary` CMP data are saved in the `ename` and `sal` columns.
  - The `address` column is a foreign key in the `EmpBean` table, `EMP`, that points to the primary key of the `AddressBean` table.
- The `<cmp-field-mapping>` element for the foreign key defines the following:
  - Both of the name attributes identify the `<cmr-field>` that was defined in the `ejb-jar.xml` file. This name is `address`.
  - The `<entity-ref>` `home` attribute identifies the `<ejb-name>` of the target bean. The target in this example is the `AddressBean`.
  - The `persistency-name` attribute identifies the primary key column name of the target bean. In this example, the primary key of the `AddressBean` table, `ADDRESS`, is the `addressPK` column.

Figure 6–8 displays the relationship mapping of the `EmpBean` `address` foreign key to the `AddressBean` `addressPK` primary key.



**Figure 6–8 Demonstration of Explicit Mapping for a One-To-One Relationship**

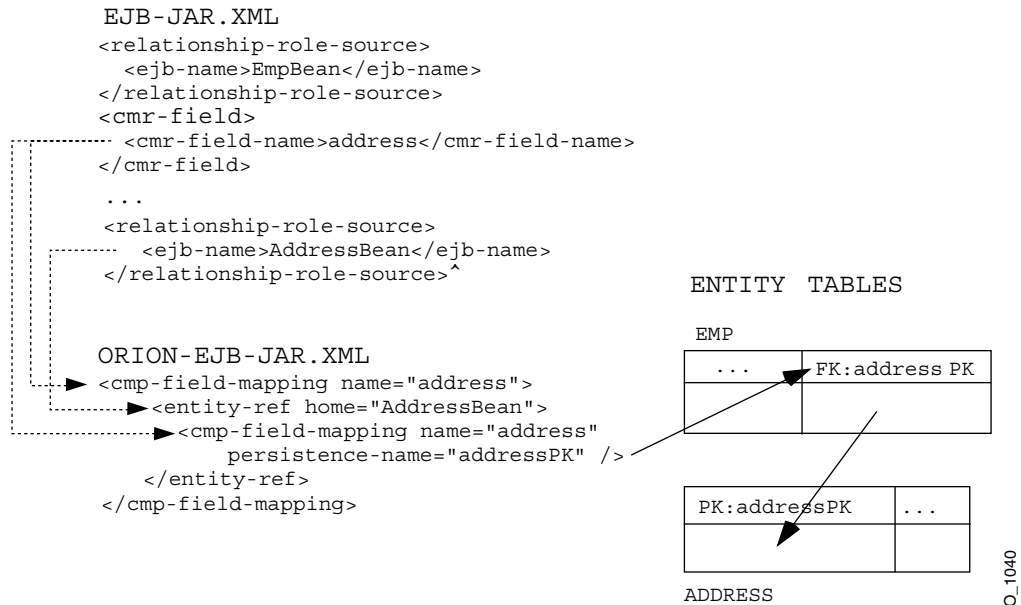

In summary, an address column in the EMP table is a foreign key that points to the primary key, addressPK, in the ADDRESS table. For the example in which the AddressBean has an auto-generated primary key, an address column in the EMP table is a foreign key that points to the primary key, autoId, in the ADDRESS table.

**Table Mapping For Primary Keys That Use Autoid**

As described in "Defining an Auto-Generated Primary Key for Your Entity Bean" on page 4-9, you can define that a table use an automatic identifier as the primary key. This results in the following XML configuration in the orion-ejb-jar.xml file for the bean:

```

<primkey-mapping>
  <cmp-field-mapping name="auto_id"
    persistence-name="autoid"/>
</primkey-mapping>
  
```

In our employee/address example, if the AddressBean had a primary key undefined, so that it defaulted to an autoId, then the table mapping would be as follows:

**Figure 6–9 One-To-One Employee Relationship Example with Auto-ID**

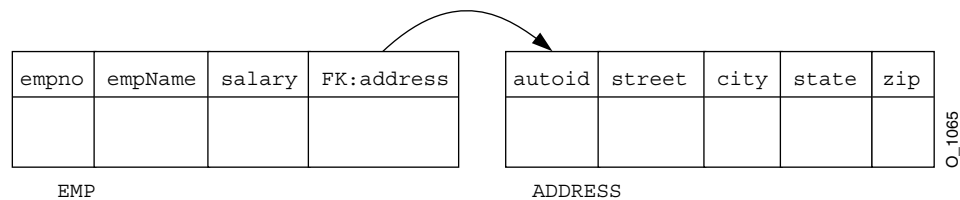

**Using a Foreign Key with the One-To-Many Relationship**

As described in "One-To-Many or Many-To-One Relationship Overview" on page 6-2, one bean, such as a department, can have a relationship to multiple instances of

another bean, such as employees. There are several employees in each department. Since this is a bidirectional relationship, you can look up the department from the employee. The relationships between the DeptBean and EmpBean is represented by CMR fields, employees and deptno, as shown in Figure 6–10.

**Figure 6–10 One-To-Many Bean Relationship**



How this relationship is mapped to database tables depends on your choices. The default method is add a foreign key to the table that defines the "many" side of the relationship—in this case, the table that represents the EmpBean. The foreign key points back to the department to which each employee belongs.

Figure 6–11 shows the department<—>employee example, where each employee belongs to only one department and each department can contain multiple employees. The department table has a primary key. The employee table has a primary key to identify each employee and a foreign key to point back to the employee's department. If you want to find the department for a single employee, a simple SQL statement retrieves the department information from the foreign key. To find all employees in a department, the container performs a JOIN statement on both the department and employee tables and retrieves all employees with the designated department number.

**Figure 6–11 Explicit Mapping for One-To-Many Bidirectional Relationship Example**

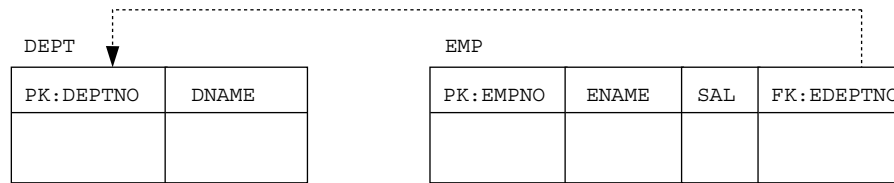

This is the default behavior. If you need to change the mappings to other database tables, then you use either JDeveloper or hand-edit the orion-ejb-jar.xml file to manipulate the <collection-mapping> or <set-mapping> element.

---

**Important:** You modify elements and attributes of the <entity-deployment> element in the orion-ejb-jar.xml file to explicitly map relationship fields. JDeveloper was created to manage the complex mapping between the entity beans and the database tables. Thus, JDeveloper validates the deployment descriptors and prevents inconsistencies. You are allowed to modify the orion-ejb-jar.xml file on your own; however, we suggest that you use JDeveloper for modifying container-managed relationships. CMR configuration is complex and can be difficult to understand. You can download JDeveloper at the following site: <http://www.oracle.com/technology/software/products/jdev/index.html>

---

Example 6–6 shows the table mapping for the bidirectional relationship of one department with many employees. The "one" side of the relationship is the department; the "many" side of the relationship is the employee. Figure 6–11 shows the table design. This demonstrates how to hand-edit the `orion-ejb-jar.xml` file for this relationship to use a foreign key.

#### Example 6–6 One-To-Many Relationship Using a Foreign Key

The `ejb-jar.xml` `<relationships>` section defines the department-employee bidirectional example, as follows:

```
<relationships>
  <ejb-relation>
    <ejb-relation-name>Dept-Emps</ejb-relation-name>
    <ejb-relationship-role>
      <ejb-relationship-role-name>Dept-has-Emps
      </ejb-relationship-role-name>
      <multiplicity>One</multiplicity>
      <relationship-role-source>
        <ejb-name>DeptBean</ejb-name>
      </relationship-role-source>
      <cmr-field>
        <cmr-field-name>employees</cmr-field-name>
        <cmr-field-type>java.util.Set</cmr-field-type>
      </cmr-field>
    </ejb-relationship-role>
    <ejb-relationship-role>
      <ejb-relationship-role-name>Emps-have-Dept
      </ejb-relationship-role-name>
      <multiplicity>Many</multiplicity>
      <cascade-delete/>
      <relationship-role-source>
        <ejb-name>EmpBean</ejb-name>
      </relationship-role-source>
      <cmr-field><cmr-field-name>dept</cmr-field-name></cmr-field>
    </ejb-relationship-role>
  </ejb-relation>
</relationships>
```

The `orion-ejb-jar.xml` file maps this definition in the following XML. If the table identified in the `<collection-mapping>` or `<set-mapping>` element of the "one" relationship (the department) is the name of the target bean's table (the employee bean table), then the one-to-many relationship is defined with a foreign key. For example, the table attribute in the department definition is `EMP`.

```
<?xml version = '1.0' encoding = 'windows-1252'?>
<!DOCTYPE orion-ejb-jar PUBLIC "-//Evermind//DTD Enterprise JavaBeans 2.0
runtime//EN" "
http://xmlns.oracle.com/ias/dtds/orion-ejb-jar.dtd">
<orion-ejb-jar>
  <enterprise-beans>
    <entity-deployment name="DeptBean" data-source="jdbc/scottDS" table="DEPT">
      <primkey-mapping>
        <cmp-field-mapping name="deptno" persistence-name="DEPTNO" /> /*PK*/
      </primkey-mapping>
      <cmp-field-mapping name="dname" persistence-name="DNAME" />
      <cmp-field-mapping name="employees">
        /*points from DEPTNO column in EMP to DEPTNO in DEPT*/
1. <collection-mapping table="EMP"> /*table where FK lives*/
      <primkey-mapping>
```

```

    <cmp-field-mapping name="DeptBean_deptno"> /*CMR field name*/
      <entity-ref home="DeptBean"> /*points to DeptBean*/
        <cmp-field-mapping name="DeptBean_deptno"
          persistence-name="EDEPTNO"/>
        </entity-ref>
      </cmp-field-mapping>
    </primkey-mapping>
    <value-mapping type="mypackage1.EmpLocal">
      <cmp-field-mapping name="EmpBean_empno">
        <entity-ref home="EmpBean">
          <cmp-field-mapping name="EmpBean_empno"
            persistence-name="EMPNO"/>
          </entity-ref>
        </cmp-field-mapping>
      </value-mapping>
    </collection-mapping>
  </cmp-field-mapping>
</entity-deployment>
<entity-deployment name="EmpBean" data-source="jdbc/scottDS" table="EMP">
  <primkey-mapping>
    <cmp-field-mapping name="empNo" persistence-name="EMPNO"/>
  </primkey-mapping>
  <cmp-field-mapping name="empName" persistence-name="ENAME" />
  <cmp-field-mapping name="salary" persistence-name="SAL" />
  <cmp-field-mapping name="dept"> /*foreign key*/
    <entity-ref home="DeptBean">
2. <cmp-field-mapping name="dept" persistence-name="EDEPTNO" />
    </entity-ref>
  </cmp-field-mapping>
</entity-deployment>
</enterprise-beans>
<assembly-descriptor>
  <default-method-access>
    <security-role-mapping impliesAll="true"
      name="&lt;default-ejb-caller-role>"/>
  </default-method-access>
</assembly-descriptor>
</orion-ejb-jar>

```

The foreign key is defined in the database table of the "many" relationship. In our example, the EDEPTNO foreign key column exists in the EMP database table. This is defined in a persistence-name attribute of the <cmp-field-mapping> element in the EmpBean configuration.

Thus, to manipulate the <collection-mapping> or <set-mapping> element in the orion-ejb-jar.xml file, modify the <entity-deployment> element for the "one" entity bean, which contains the Collection, as follows:

1. Modify the table in the <collection-mapping> or <set-mapping> table attribute in the "one" relationship to be the database table of the "many" relationship. In this example, you would modify this attribute to be the EMP table.
2. Modify the foreign key that points to the "one" relationship within the "many" relationship configuration. In this example, modify the <cmp-field-mapping> element to specify the EDEPTNO foreign key in the persistence-name attribute.

These steps are delineated in the code example in [Example 6-6](#).

**Unidirectional One-to-Many Relationship Using a Foreign Key** An example of a unidirectional one-to-many relationship is the employee/phones example. An employee can own

one or more phone numbers; however, you cannot look up an employee given a phone number. Figure 6-12 demonstrates the bean relationship.

**Figure 6-12 One-To-Many Bean Relationship**



Figure 6-13 shows the employee—>phone numbers example, where each employee can have multiple phone numbers. The employee table has a primary key. The phone numbers table has a auto-id for the primary key, the phone number, and a foreign key to point back to the employee. If you want to find all phone numbers for a single employee, the container performs a JOIN statement on both the employee and phone number tables and retrieves all phone numbers with the designated employee number.

**Figure 6-13 Explicit Mapping for One-to-Many Bean Relationship Example**

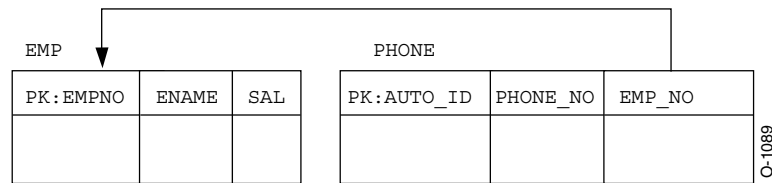

**Example 6-7 One-to-Many Unidirectional Example With Foreign Key**

The `ejb-jar.xml` `<relationships>` section defines the employee-phone numbers unidirectional example, as follows:

```

<entity>
  <ejb-name>EmpBean</ejb-name>
  ...
  <cmp-field><field-name>empNo</field-name></cmp-field>
  <cmp-field><field-name>empName</field-name></cmp-field>
  <cmp-field><field-name>salary</field-name></cmp-field>
  <primkey-field>empNo</primkey-field>
  <prim-key-class>java.lang.Integer</prim-key-class>
</entity>
<entity>
  <ejb-name>PhoneBean</ejb-name>
  ...
  <cmp-field><field-name>phoneNo</field-name></cmp-field>
  <prim-key-class>java.lang.Object</prim-key-class>
</entity>

<relationships>
  <ejb-relation>
    <ejb-relation-name>Emp-Phone</ejb-relation-name>
    <ejb-relationship-role>
      <ejb-relationship-role-name>Emp-has-Phones
    </ejb-relationship-role-name>
    <multiplicity>One</multiplicity>
    <relationship-role-source>
      <ejb-name>EmpBean</ejb-name>
    </relationship-role-source>
  </ejb-relation>
</relationships>
  
```

```

    <cmr-field>
      <cmr-field-name>phones</cmr-field-name>
    </cmr-field>
  </ejb-relationship-role>
</ejb-relationship-role>
  <ejb-relationship-role-name>Phones-have-Emp
</ejb-relationship-role-name>
  <multiplicity>Many</multiplicity>
  <cascade-delete/>
  <relationship-role-source>
    <ejb-name>PhoneBean</ejb-name>
  </relationship-role-source>
</ejb-relationship-role>
</ejb-relation>
</relationships>

```

The `orion-ejb-jar.xml` file maps this definition in the following XML. If the table identified in the `<collection-mapping>` or `<set-mapping>` element of the "one" relationship (the employee) is the name of the target bean's table (the phone bean table), then the container defines the one-to-many relationship with a foreign key. In this example, the target bean's table is the `PHONE` database table.

```

<entity-deployment name="EmpBean" table="EMP">
  <primkey-mapping>
    <cmp-field-mapping name="empNo" persistence-name="EMPNO" />
  </primkey-mapping>
  <cmp-field-mapping name="empName" persistence-name="ENAME" />
  <cmp-field-mapping name="salary" persistence-name="SAL" />
  <cmp-field-mapping name="phones">
    1.<collection-mapping table="PHONE">
      <primkey-mapping>
        <cmp-field-mapping name="EmpBean_empno">
          <entity-ref home="EmpBean">
            2.<cmp-field-mapping name="EmpBean_empNo"
              persistence-name="EMPNO"/>
          </entity-ref>
        </cmp-field-mapping>
      </primkey-mapping>
      <value-mapping type="hr.PhoneLocal">
        <cmp-field-mapping name="autoid">
          <entity-ref home="PhoneBean">
            <cmp-field-mapping name="autoid"
              persistence-name="AUTOID"/>
          </entity-ref>
        </cmp-field-mapping>
      </value-mapping>
    </collection-mapping>
  </cmp-field-mapping>
</entity-deployment>
<entity-deployment name="PhoneBean" table="PHONE">
  <primkey-mapping>
    <cmp-field-mapping name="autoid" persistence-name="AUTOID"/>
  </primkey-mapping>
  <cmp-field-mapping name="phoneNo" persistence-name="PHONE_NO" />
  <cmp-field-mapping name="EmpBean_phones">
    <entity-ref home="EmpBean">
      2.<cmp-field-mapping name="EmpBean_phones" persistence-name="EMPNO" />
    </entity-ref>
  </cmp-field-mapping>
</entity-deployment>

```

The foreign key is defined in the database table of the "many" relationship. In our example, the EMPNO foreign key column exists in the PHONE database table. This is defined in a `persistence-name` attribute of the `<cmp-field-mapping>` element in the `PhoneBean` configuration.

Thus, to manipulate the `<collection-mapping>` or `<set-mapping>` element in the `orion-ejb-jar.xml` file, modify the `<entity-deployment>` element for the "one" entity bean, which contains the `Collection`, as follows:

1. Modify the table in the `<collection-mapping>` or `<set-mapping>` table attribute in the "one" relationship to be the database table for the "many" relationship. In this example, you would modify this attribute to be the `PHONE` table.
2. Modify the foreign key that points to the "one" relationship within the "many" relationship configuration. In this example, modify the `<cmp-field-mapping>` element to specify the `EMPNO` foreign key in the `persistence-name` attribute.

These steps are delineated in the code example in [Example 6-7](#).

### Association Table Explicit Mapping for Relationships Overview

As described in ["One-To-Many or Many-To-One Relationship Overview"](#) on page 6-2, one bean, such as a department, can have a relationship to multiple instances of another bean, such as employees. There are several employees in each department. Since this is a bidirectional relationship, you can look up the department from the employee. The relationships between the `DeptBean` and `EmpBean` is represented by CMR fields, `employees` and `deptno`, as shown in [Figure 6-14](#).

**Figure 6-14** *One-To-Many Bidirectional Bean Relationship*



How this relationship is mapped to database tables depends on your choices. You could choose to use a separate table, known as an association table, which maps the two tables together appropriately with two foreign keys, where each foreign key points to each of the entity tables in the relationship.

---

**Note:** If you have a composite primary key in either or both tables, the foreign key will be a composite foreign key; thus, the association table will have the appropriate number of columns for each part of the composite foreign key.

---

This is not the default behavior. To have this type of relationship, do one or both of the following:

- Specify `-DassociateUsingThirdTable=true` on the OC4J startup options before deployment. Restart the OC4J instance. This generates the association table for all applications deployed after the restart.
- You can modify the mappings either through JDeveloper or by hand-editing the `orion-ejb-jar.xml` file.

**Important:** You modify elements and attributes of the `<entity-deployment>` element in the `orion-ejb-jar.xml` file to explicitly map relationship fields. JDeveloper was created to manage the complex mapping between the entity beans and the database tables. Thus, JDeveloper validates the deployment descriptors and prevents inconsistencies. You are allowed to modify the `orion-ejb-jar.xml` file on your own; however, we suggest that you use JDeveloper for modifying container-managed relationships. CMR configuration is complex and can be difficult to understand. You can download JDeveloper at the following site: <http://www.oracle.com/technology/software/products/jdev/index.html>

Figure 6–15 shows the tables that are created for the employee/project relationship.

**Figure 6–15 Many-to-Many Employee Bean Relationship Example**

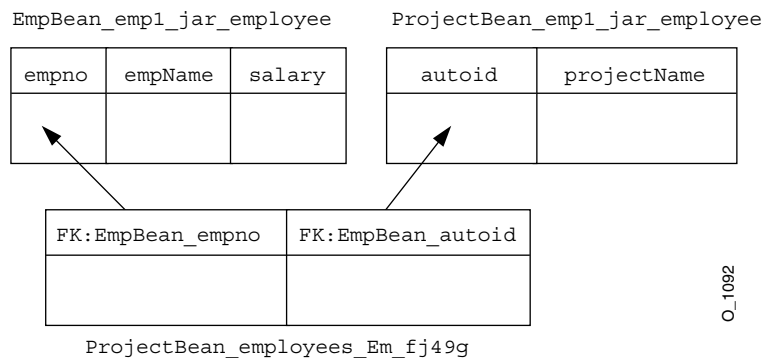

Each project can have multiple employees, and each employee can belong to several projects. Thus, the employee and project relationship is a many-to-many relationship. The container creates three tables to manage this relationship: the employee table, the project table, and the association table for both of these tables.

The association table for this example contains two foreign key columns: one that points to the employee table and one that points to the project table. The column names of the association table are a concatenation of the entity bean name in `<ejb-name>` element of the `ejb-jar.xml` file and its primary key name. If the primary key for the bean is auto-generated, then "autoid" is appended as the primary key name. For example, the following are the names for the foreign keys of our employee/project example:

- The foreign key that points to the employee table is the bean name of `EmpBean`, followed by the primary key name of `empno`, which results in the column name `EmpBean_empno`.
- The foreign key that points to the address table is the bean name of `ProjectBean` concatenated with `autoid`, because the primary key is auto-generated, which results in the column name `ProjectBean_autoid`.

The following is a demonstration of the association table for the employee/projects relationship. Employee 1 is assigned to projects a, b, and c. Project a involves employees 1, 2, and 3. The association table contains the following:



EmpBean_empno	ProjectBean_autoid
1	a
1	b
1	c
2	a
3	a

The association table details all relationships between the two entity beans.

#### **Example 6-8 Deployment Descriptor for a Many-To-Many Relationship**

The deployment descriptors for the employee/project many-to-many relationship contains an `<ejb-relation>` element in which each bean defines its `<multiplicity>` as many and defines a `<cmr-field>` to the other bean of type Collection or Set.

```

<enterprise-beans>
  <entity>
    ...
    <ejb-name>EmpBean</ejb-name>
    <local-home>employee.EmpHome</local-home>
    <local>employee.Emp</local>
    ...
    <cmp-field><field-name>empNo</field-name></cmp-field>
    <cmp-field><field-name>empName</field-name></cmp-field>
    <cmp-field><field-name>salary</field-name></cmp-field>
    <primkey-field>empNo</primkey-field>
    <prim-key-class>java.lang.Integer</prim-key-class>
    ...
  </entity>
  <entity>
    ...
    <ejb-name>ProjectBean</ejb-name>
    <local-home>employee.ProjectHome</local-home>
    <local>employee.Project</local>
    ...
    <cmp-field><field-name>projectName</field-name></cmp-field>
    <prim-key-class>java.lang.Object</prim-key-class>
    ...
  </entity>
</enterprise-beans>
<relationships>
  <ejb-relation>
    <ejb-relation-name>Emps-Projects</ejb-relation-name>
    <ejb-relationship-role>
      <ejb-relationship-role-name>Project-has-Emps</ejb-relationship-role-name>
      <multiplicity>Many</multiplicity>
      <relationship-role-source>
        <ejb-name>ProjectBean</ejb-name>
      </relationship-role-source>
      <cmr-field>
        <cmr-field-name>employees</cmr-field-name>
        <cmr-field-type>java.util.Collection</cmr-field-type>
      </cmr-field>
    </ejb-relationship-role>
    <ejb-relationship-role>

```

```

    <ejb-relationship-role-name>Emp-has-Projects</ejb-relationship-role-name>
    <multiplicity>Many</multiplicity>
    <relationship-role-source>
      <ejb-name>EmpBean</ejb-name>
    </relationship-role-source>
    <cmr-field>
      <cmr-field-name>projects</cmr-field-name>
      <cmr-field-type>java.util.Collection</cmr-field-type>
    </cmr-field>
  </ejb-relationship-role>
</ejb-relation>
</relationships>

```

The container maps this definition to the following:

- The container generates the entity tables based on the entity bean names, the JAR file that the beans are archived in, and the application name that they are deployed under. If the JAR filename is `empl.jar` and the application name is `employee`, then the table names are `EmpBean_empl_jar_employee` and `ProjectBean_empl_jar_employee`.
- The container generates columns in each entity table based on the `<cmr-field>` elements declared in the deployment descriptor.
  - The columns for the `EmpBean` table are `empno`, `empname`, and `salary`. The primary key is designated as the `empno` field.
  - The columns for the `ProjectBean` table are `autoid` for an auto-generated primary key and a `projectName` column. The primary key is auto-generated because the `<prim-key-class>` is defined as `java.lang.Object`, and no `<primkey-field>` element is defined.
- The container generates an association table in the same manner as the entity table.
  - The association table name is created to include the two `<cmr-field>` element definitions for each of the entity beans in the relationship. The format for the association table name consists of the following, separated by underscores: first bean name, its `<cmr-field>` to the second bean, second bean name, its `<cmr-field>` to the first bean, JAR file name, and application name. The rule of thirty characters also applies to this table name, as to the entity tables. Thus, the association table name for the `employee/projects` relationship is `ProjectBean_employees_EmpBean_projects_empl_jar_employee`. Because this name is over thirty characters, it is truncated to twenty-four characters, and then an underscore plus five characters of a hash code are added. Thus, the official association table would be something like `ProjectBean_employees_Em_fj49g`
  - Two foreign keys in the association table are created. In this example, each foreign key is defined in a column, where the name is a concatenation of the bean name and the primary key (or `autoid` if auto-generated). In our example, the column names would be `EmpBean_empno` and `ProjectBean_autoid`. These columns are foreign keys to the entity tables that are involved in the relationship. The `EmpBean_empno` foreign key points to the `employee` table; the `ProjectBean_autoid` foreign key points to the `projects` table.

**Example 6–9 Deployment Descriptor for One-To-Many Unidirectional Relationship**

Figure 6–16 shows the default database tables for the `employee/phone numbers` example.

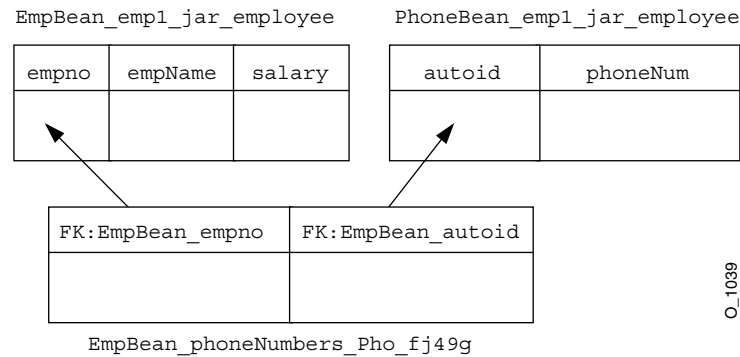
**Figure 6–16 One-To-Many Employee Bean Relationship Example**

O\_1039

Each employee can have multiple phone numbers. The employee entity bean, `EmpBean`, defines a `<cmr-field>` element designating a `Collection` of `phoneNumbers` within the `PhoneBean`. The deployment descriptors for this example are as follows:

```
<relationships>
  <ejb-relation>
    <ejb-relation-name>Emp-Phone</ejb-relation-name>
    <ejb-relationship-role>
      <ejb-relationship-role-name>Emp-PhoneNumbers</ejb-relationship-role-name>
      <multiplicity>One</multiplicity>
      <relationship-role-source>
        <ejb-name>EmpBean</ejb-name>
      </relationship-role-source>
      <cmr-field>
        <cmr-field-name>phoneNumbers</cmr-field-name>
        <cmr-field-type>java.util.Collection</cmr-field-type>
      </cmr-field>
    </ejb-relationship-role>
    <ejb-relationship-role>
      <ejb-relationship-role-name>Phone-has-Emp</ejb-relationship-role-name>
      <multiplicity>Many</multiplicity>
      <relationship-role-source>
        <ejb-name>PhoneBean</ejb-name>
      </relationship-role-source>
    </ejb-relationship-role>
  </ejb-relation>
</relationships>
```

---

**Note:** An object-relationship entity bean example is available on OTN from the OC4J sample code page at <http://www.oracle.com/technology/tech/java/oc4j/demos/> on the OTN Web site.

---

### XML Structure for One-to-Many Relationship Mapping

The relationship that is defined in the `ejb-jar.xml` file is mapped in the `orion-ejb-jar.xml` file within a `<cmp-field-mapping>` element. The `<cmp-field-mapping>` element contains either a `<collection-mapping>` or `<set-mapping>` element. Our example contains a department has many employees. The department describes its "many" relationship to employees with a `<collection-mapping>` element.

---

**Note:** The "many" side of the relationship is defined by the `<collection-mapping>` or `<set-mapping>` element. The "one" side of the relationship is defined by the `<entity-ref>` element. Thus, for a one-to-many relationship, a single `<collection-mapping>` element is used to describe the "many" side.

---

The XML structure for defining a one-to-many relationship includes the following:

```
<cmp-field-mapping name="CMRfield">
  <collection-mapping table="association_table">
    <primkey-mapping>
      <cmp-field-mapping name="CMRfield"
persistence-name="first_column_name_assoc_table" />
    </primkey-mapping>
    <value-mapping type="target_bean_local_home_interface">
      <cmp-field-mapping>
        <entity-ref home="target_bean_EJBname">
          <cmp-field-mapping name="CMRfield"
persistence-name="second_column_name_assoc_table"/>
        </entity-ref>
      </cmp-field-mapping>
    </value-mapping>
  </collection-mapping>
</cmp-field-mapping>
```

Element or Attribute	Description
<code>&lt;cmp-field-mapping&gt;</code>	<p>This element maps a persistent field or a relationship field. For relationship fields, it will contain either an <code>&lt;entity-ref&gt;</code> for a one-to-one mapping or a <code>&lt;collection-mapping&gt;</code> for a one-to-many, many-to-one, or many-to-many relationship.</p> <ul style="list-style-type: none"> <li>The <code>name</code> attribute identifies the <code>&lt;cmp-field&gt;</code> or <code>&lt;cmr-field&gt;</code> that is to be mapped. Do not change this name.</li> <li>The <code>persistence-name</code> attribute identifies the database column. <b>You can modify this name to match your database column name.</b></li> </ul>
<code>&lt;entity-ref&gt;</code>	<p>This element identifies the target bean and its primary key to which the foreign key points.</p> <ul style="list-style-type: none"> <li>The <code>home</code> attribute is not the home interface, but identifies the EJB name of the target bean. This is the logical name of the bean defined in <code>&lt;ejb-name&gt;</code> in the <code>ejb-jar.xml</code> file.</li> <li>The <code>&lt;cmp-field-mapping&gt;</code> within this element identifies the foreign key column name.</li> </ul>
<code>&lt;collection-mapping&gt;</code>	<p>This element explicitly maps the "many" side of a relationship.</p> <ul style="list-style-type: none"> <li>The <code>table</code> attribute identifies the association table. <b>You can modify this name to match your own association table name.</b></li> </ul> <p>This element defines two elements, one for each column in the association table:</p> <ul style="list-style-type: none"> <li><code>&lt;primkey-mapping&gt;</code> identifies the first foreign key in the association table.</li> <li><code>&lt;value-mapping&gt;</code> identifies the second foreign key in the association table.</li> </ul>

Element or Attribute	Description
<primkey-mapping>	Within the <collection-mapping>, use this element to identify the first foreign key. <b>You can modify the persistence-name attribute in this element to match the column name in your own association table.</b>
<value-mapping>	Use this element to specify the second foreign key. The type attribute identifies the local interface for the target bean. <b>You can modify the persistence-name attribute in this element to match the column name in your own association table.</b>

### Using an Association Table with a One-to-Many Bidirectional Relationship

The following example shows how a one-to-many bidirectional relationship is configured to use an association table. In the `ejb-jar.xml` file, the department defines itself as the "one" side of the relationship and shows that it expects to receive back "many" employees through the definition of a `Collection` in the `<cmr-field>` element. The employee defines itself as the "many" side of the relationship.

```
<relationships>
<ejb-relation>
<ejb-relation-name>Dept-Emps</ejb-relation-name>
<ejb-relationship-role>
<ejb-relationship-role-name>Dept-has-Emps
</ejb-relationship-role-name>
<multiplicity>One</multiplicity>
<relationship-role-source>
<ejb-name>DeptBean</ejb-name>
</relationship-role-source>
<cmr-field>
<cmr-field-name>employees</cmr-field-name>
<cmr-field-type>java.util.Collection</cmr-field-type>
</cmr-field>
</ejb-relationship-role>
<ejb-relationship-role>
<ejb-relationship-role-name>Emp-has-Dept
</ejb-relationship-role-name>
<multiplicity>Many</multiplicity>
<relationship-role-source>
<ejb-name>EmpBean</ejb-name>
</relationship-role-source>
<cmr-field>
<cmr-field-name>dept</cmr-field-name>
</cmr-field>
</ejb-relationship-role>
</ejb-relation>
</relationships>
```

In the `orion-ejb-jar.xml` file, the mapping of this relationship to an association table is described in a `<collection-mapping>` element. Since this is a one-to-many relationship, the "one" entity bean, the department, has the `<collection-mapping>` element as it receives back a `Collection` or `Set` of the target, the employees.

In the `orion-ejb-jar.xml` file, the `DeptBean` `<entity-deployment>` element defines the `<collection-mapping>` element to designate a `Collection` of employees. The `<collection-mapping>` element defines the association table.

```
<entity-deployment name="DeptBean" location="DeptBean"
table="DEPT" data-source="jdbc/OracleDS" ... >
<primkey-mapping>
```

```

<cmp-field-mapping name="deptNo" persistence-name="deptNo" />
</primkey-mapping>
<cmp-field-mapping name="deptName" persistence-name="deptName" />
<cmp-field-mapping name="employees">
<collection-mapping table="DEPT_EMP">
<primkey-mapping>
<cmp-field-mapping name="DeptBean_deptno">
<entity-ref home="DeptBean">
<cmp-field-mapping name="DeptBean_deptno"
persistence-name="DEPARTMENT" />
</entity-ref>
</cmp-field-mapping>
</primkey-mapping>
<value-mapping type="hr.EmpLocal">
<cmp-field-mapping name="EmpBean_empNo">
<entity-ref home="EmpBean">
<cmp-field-mapping name="EmpBean_empNo"
persistence-name="EMPLOYEE" />
</entity-ref>
</cmp-field-mapping>
</value-mapping>
</collection-mapping>
</cmp-field-mapping>
...
</entity-deployment>
<entity-deployment name="EmpBean" location="EmpBean"
table="EMP" data-source="jdbc/OracleDS" ... >
<primkey-mapping>
<cmp-field-mapping name="empNo" persistence-name="EMPNO" />
</primkey-mapping>
<cmp-field-mapping name="empName" persistence-name="ENAME" />
<cmp-field-mapping name="salary" persistence-name="SAL" />
<cmp-field-mapping name="dept">
<entity-ref home="DeptBean">
<cmp-field-mapping name="dept" persistence-name="DEPARTMENT" />
</entity-ref>
</cmp-field-mapping>
...
</entity-deployment>

```

The following describes how the DeptBean is configured in the orion-ejb-jar.xml file:

- The relationship from the department to the employee bean is defined in the employees field, which is mapped in the <collection-mapping> element.
- The association table name is specified in the table attribute, which currently defines the association table name as DEPT\_EMP.
- The foreign keys of the association table are defined as follows:
  - The <primkey-mapping> element defines the column name for the foreign key of the current entity bean in the persistence-name attribute, which is DEPARTMENT.
  - The <value-mapping> element defines the column name for the foreign key of the target bean in the persistence-name attribute, which is EMPLOYEE.
- The <value-mapping> element specifies the target entity bean.
  - The type attribute of the <value-mapping> element defines the local interface of the target bean that is returned to the source entity bean.

- The `<ejb-name>` of the target entity bean is defined in the `<entity-ref>` home attribute.

The following describes how the `EmpBean` is configured in the `orion-ejb-jar.xml` file:

- The relationship from the employee to the department bean is defined in the `dept` field, which is mapped in the `<cmp-field-mapping><entity-ref>` element. The `persistence-name` attribute contains the foreign key in the association table that points to the department bean.

### Using an Association Table in a One-to-Many Unidirectional Relationship

As described in ["One-To-Many or Many-To-One Relationship Overview"](#) on page 6-2, one bean, such as an employee, can have a relationship to multiple instances of another bean, such as phone numbers. For each employee, you can have one or more phone numbers. However, this is a unidirectional relationship. You cannot look up an employee given a phone number.

The relationships between the `EmpBean` and `PhoneBean` is represented by a CMR field, `phones`, as shown in [Figure 6-17](#).

**Figure 6-17** *One-To-Many Unidirectional Bean Relationship*



The relationship is mapped to database tables using an association table, which maps the two tables together appropriately. The association table consists of two foreign keys.

---

**Note:** If you have a composite primary key in either or both tables, the foreign key will be a composite foreign key; thus, the association table will have the appropriate number of columns for each part of the composite foreign key.

---

For a full description of how an association table works, see ["Example of a Default Mapping of One-To-Many and Many-To-Many Relationships"](#) on page 6-11. This section shows how to change the XML configuration for this mapping.

---

**Note:** If you do not want to use an association table, see ["Using a Foreign Key with the One-To-Many Relationship"](#) on page 6-21 for directions on how to use a foreign key in the "one" side of the relationship.

---

[Figure 6-18](#) shows the employee—>phone numbers example, where each employee can have multiple phone numbers. Both the employee and phone tables have a primary key. A separate table, the association table, contains two foreign keys. One foreign key points to the employee; the other foreign key points to the phone number. Every relationship has its own row denoting the relationship. Thus, for every phone number, a row is created where the first foreign key points to the employee to which the phone number belongs and the second foreign key points to the phone number

record. Figure 6-18 shows an association table, EMP\_PHONE, where the foreign keys are named EMPLOYEE and PHONEBEAN\_AUTOID.

**Figure 6-18 Explicit Mapping for One-to-Many Unidirectional Bean Relationship**

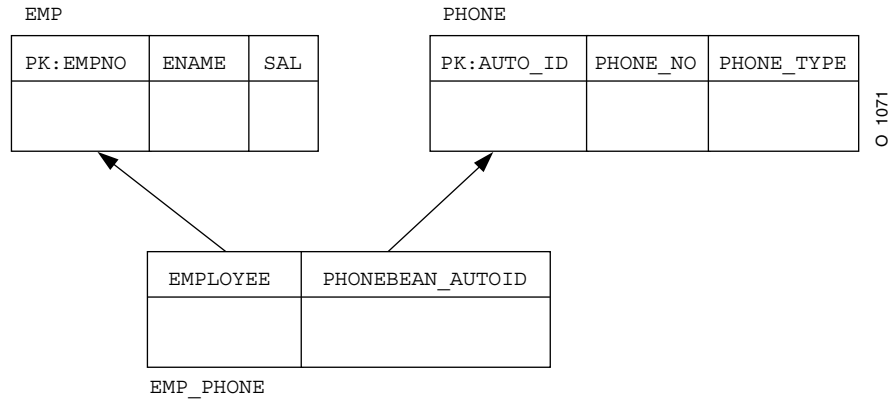

To change the mappings to other database tables, then you use either JDeveloper or hand-edit the `orion-ejb-jar.xml` file to manipulate the `<collection-mapping>` or `<set-mapping>` element.

---

**Important:** You modify elements and attributes of the `<entity-deployment>` element in the `orion-ejb-jar.xml` file to explicitly map relationship fields. JDeveloper was created to manage the complex mapping between the entity beans and the database tables. Thus, JDeveloper validates the deployment descriptors and prevents inconsistencies. You are allowed to modify the `orion-ejb-jar.xml` file on your own; however, we suggest that you use JDeveloper for modifying container-managed relationships. CMR configuration is complex and can be difficult to understand. You can download JDeveloper at the following site: <http://www.oracle.com/technology/software/products/jdev/index.html>.

---

**Specifying the One-to-Many Unidirectional Relationship in the XML Deployment Descriptors** In the `ejb-jar.xml` file, the cardinality is defined in the `<relationships>` element. The following is the `ejb-jar.xml` file configuration of the one-to-many unidirectional example of the employee and his/her phone numbers.

- The primary key field of the `EmpBean` is `empNo`, as defined in the `<primkey-field>` element.
- The primary key of the `PhoneBean` is not defined, as defined by the absence of the `<primkey-field>` element and the existence of the `<prim-key-class>` element. Thus, the primary key is auto-generated and represented by `AUTOID`. For more information on auto-generated primary keys, see "Defining an Auto-Generated Primary Key for Your Entity Bean" on page 4-9.
- The CMR field (`<cmr-field>` element) defining the "many" side of the relationship is a `Collection` that is identified as `phones`.

```
<entity>
<ejb-name>EmpBean</ejb-name>
...
```



```

<cmp-field><field-name>empNo</field-name></cmp-field>
<cmp-field><field-name>empName</field-name></cmp-field>
<cmp-field><field-name>salary</field-name></cmp-field>
...
<primkey-field>empNo</primkey-field>
<prim-key-class>java.lang.Integer</prim-key-class>
...
</entity>
<entity>
...
<ejb-name>PhoneBean</ejb-name>
...
<cmp-field><field-name>phoneNo</field-name></cmp-field>
<cmp-field><field-name>phoneType</field-name></cmp-field>
<prim-key-class>java.lang.Object</prim-key-class>
...
</entity>
<relationships>
  <ejb-relation>
    <ejb-relation-name>Emp-Phone</ejb-relation-name>
    <ejb-relationship-role>
      <ejb-relationship-role-name>Emp-PhoneNumbers</ejb-relationship-role-name>
      <multiplicity>One</multiplicity>
      <relationship-role-source>
        <ejb-name>EmpBean</ejb-name>
      </relationship-role-source>
      <cmr-field>
        <cmr-field-name>phones</cmr-field-name>
        <cmr-field-type>java.util.Collection</cmr-field-type>
      </cmr-field>
    </ejb-relationship-role>
    <ejb-relationship-role>
      <ejb-relationship-role-name>Phone-has-Emp</ejb-relationship-role-name>
      <multiplicity>Many</multiplicity>
      <relationship-role-source>
        <ejb-name>PhoneBean</ejb-name>
      </relationship-role-source>
    </ejb-relationship-role>
  </ejb-relation>
</relationships>

```

In the `orion-ejb-jar.xml` file, the mapping of this relationship to an association table is described in a `<collection-mapping>` element. The "one" side of the relationship, the employee, owns the "many" entities, the phone numbers; thus, the employee defines the `<collection-mapping>` element that describes the relationship with the phone numbers. In all one-to-many relationships, the entity bean that represents the "one" side of the relationship defines the `<collection-mapping>` element as it receives back a `Collection` or `Set` of the target entity bean. The entity bean on the "many" side of the relationship defines a `<cmp-field-mapping>` `<entity-ref>` element that shows the relationship back to the entity bean that is the "one" side of the relationship. So, the employee defines the `<collection-mapping>` element to define its relationship with the phone numbers: the phone numbers uses an `<entity-ref>` element to define its relationship with the employee.

In the `orion-ejb-jar.xml` file for the employee/phone numbers example, the `EmpBean` `<entity-deployment>` element defines the `<collection-mapping>` element to designate a `Collection` of phone numbers. The `<collection-mapping>` element specifies the association table.

```

<entity-deployment name="EmpBean" table="EMP">
<primkey-mapping>
<cmp-field-mapping name="empNo" persistence-name="EMPLOYEEENO" />
</primkey-mapping>
<cmp-field-mapping name="empName" persistence-name="EMPLOYEEENAME" />
<cmp-field-mapping name="salary" persistence-name="SAL" />
<cmp-field-mapping name="phones">
<collection-mapping table="EMP_PHONE">
<primkey-mapping>
<cmp-field-mapping name="EmpBean_empNo">
<entity-ref home="EmpBean">
<cmp-field-mapping name="EmpBean_empNo"
persistence-name="EMPLOYEEENO" />
</entity-ref>
</cmp-field-mapping>
</primkey-mapping>
<value-mapping type="hr.PhoneLocal">
<cmp-field-mapping name="PhoneBean_autoid">
<entity-ref home="PhoneBean">
<cmp-field-mapping name="PhoneBean_autoid"
persistence-name="AUTOID" />
</entity-ref>
</cmp-field-mapping>
</value-mapping>
</collection-mapping>
...
</entity-deployment>
<entity-deployment name="PhoneBean" table="PHONE">
<primkey-mapping>
<cmp-field-mapping name="autoid" persistence-name="AUTOID" />
</primkey-mapping>
<cmp-field-mapping name="phoneNo" persistence-name="PHONE_NO" />
<cmp-field-mapping name="phoneType" persistence-name="PHONE_TYPE" />
<cmp-field-mapping name="EmpBean_phones">
<entity-ref home="EmpBean">
<cmp-field-mapping name="EmpBean_phones"
persistence-name="EMPLOYEEENO" />
</entity-ref>
</cmp-field-mapping>
</entity-deployment>

```

The following describes how the `EmpBean` is defined in the `ejb-jar.xml` and `orion-ejb-jar.xml` files. See [Figure 6–18](#) for a graphic of this mapping.

- The `<cmr-field>` element in the `ejb-jar.xml` file defines a name for the relationship with the phone numbers as `phones`.
- The `phones <cmr-field>` element maps to the association table in the `orion-ejb-jar.xml` file. In the `orion-ejb-jar.xml` file, the `<cmp-field-mapping>` for `phones` contains a `<collection-mapping>` element. This `<collection-mapping>` element defines the association table name in the `table` attribute as `EMP_PHONE`.
- The association table has two foreign keys. In this example, the foreign keys are simple. However, if the primary keys are composite, then these foreign keys would be composite as well.

Both foreign keys for the association table are defined as follows:

- The `persistence-name` attribute in the `<primkey-mapping>` element defines the association table foreign key column name of the current entity bean, which is `EMPLOYEEENO`.
- The `persistence-name` attribute in the `<value-mapping>` element defines the association table foreign key column name of the target bean, which is `PhoneBean_AUTOID`.
- The `<value-mapping>` element specifies the target entity bean.
  - The `type` attribute of the `<value-mapping>` element defines the local interface of the target bean that is returned to the source entity bean. This example defines the local home interface of the phone bean as `hr.PhoneLocal`.
  - The `<ejb-name>` of the target entity bean is defined in the `<entity-ref>` `home` attribute, which in this example is `PhoneBean`.

The phone bean configuration in the `orion-ejb-jar.xml` file defines an `<entity-ref>` for a relationship to the employee bean.

- The `<ejb-name>` of the target entity bean is defined in the `<entity-ref>` `home` attribute, which in this example is `EmpBean`.
- The `persistence-name` attribute in the `<cmp-field-mapping>` element defines the association table foreign key of the current entity bean, which is `EMPLOYEEENO`.

Figure 6-19 shows the following:

- How the CMR field name maps to the `<cmp-field-mapping>` elements in the `orion-ejb-jar.xml` file.
- How the association table is defined by the `<collection-mapping>` element in the employee bean definition.

**Figure 6–19 Explicit Mapping for a One-to-Many Relationship**

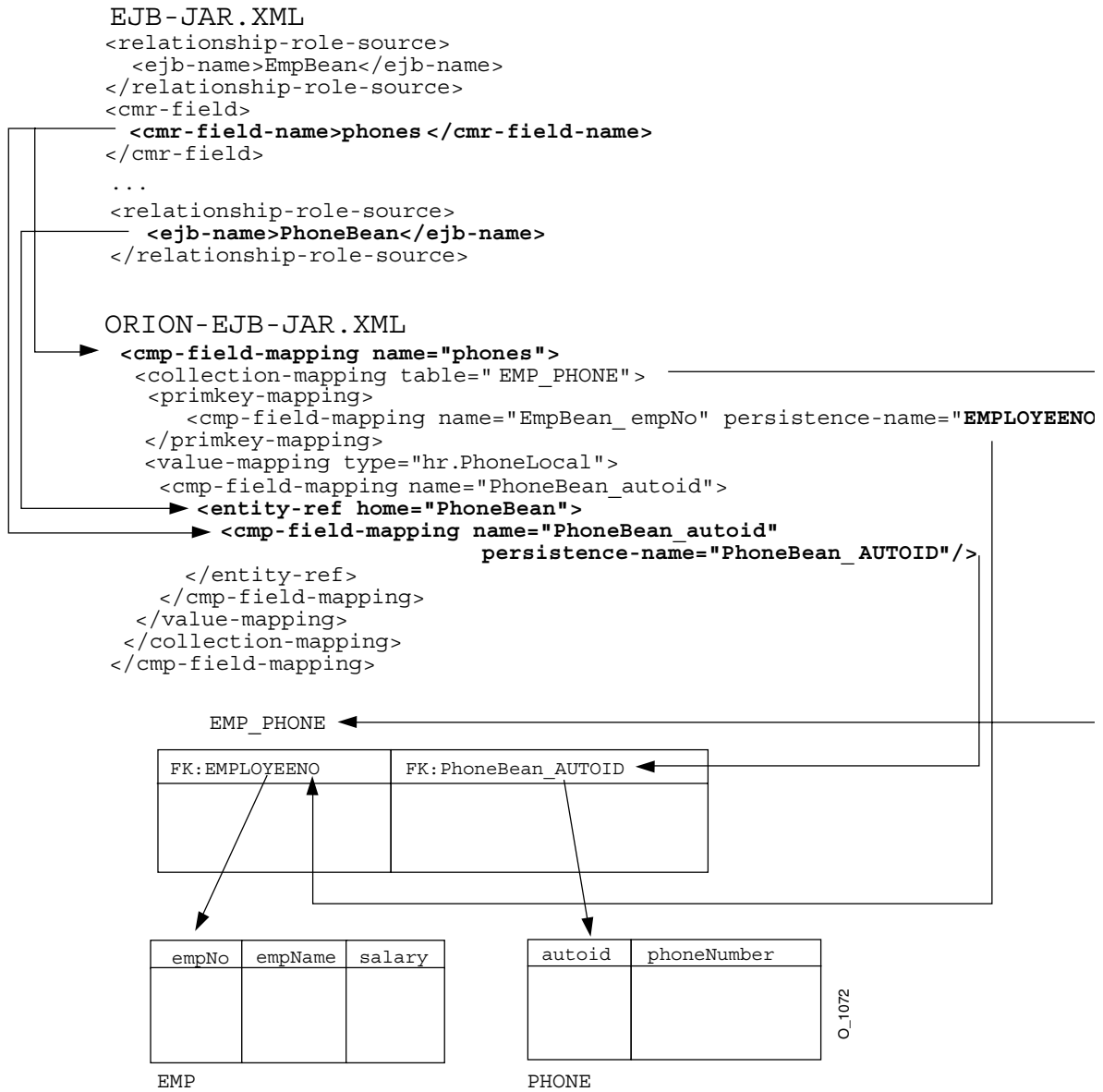

### Using an Association Table in Many-to-Many Relationships

As described in ["Many-To-Many Relationship Overview"](#) on page 6-3, many beans, such as employees, can have a relationship to multiple instances of another bean, such as projects. There are several employees in each project; each employee can be assigned to multiple projects. Since this is a bidirectional relationship, you can look up the project from the employee. The relationships between the ProjectBean and EmpBean is represented by CMR fields, employees and projects, as shown in [Figure 6–20](#).

**Figure 6-20 Many-to-Many Bidirectional Bean Relationship**

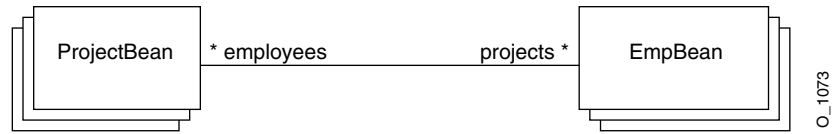

This relationship is mapped to database tables using an association table. The association table consists of two foreign keys.

---

**Note:** If you have a composite primary key in either or both tables, the foreign key will be a composite foreign key; thus, the association table will have the appropriate number of columns for each part of the composite foreign key.

---

For a full description of how an association table works, see ["Example of a Default Mapping of One-To-Many and Many-To-Many Relationships"](#) on page 6-11. This section shows how to change the XML configuration for this mapping.

Figure 6-21 shows the projects<—>employee example, where each employee belongs to one or more projects and each project can contain multiple employees. Both the project and employee tables have a primary key. A separate table, the association table, contains two foreign keys. One foreign key points to the project; the other foreign key points to the employee. Every relationship has its own row denoting the relationship. Thus, for every employee, a row is created where the first foreign key points to the project the employee belongs to and the second foreign key points to the employee record. The association table in Figure 6-21 shows an association table, PROJECT\_EMP, where the foreign keys are named PROJECT\_NO and EMPLOYEE\_NO.

**Figure 6-21 Explicit Mapping for One-to-Many Bidirectional Relationship Example**

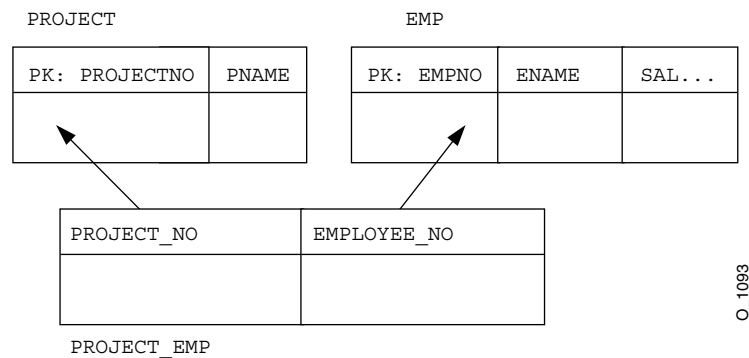

If you need to change the mappings to other database tables, then you use either JDeveloper or hand-edit the orion-ejb-jar.xml file to manipulate the <collection-mapping> or <set-mapping> element.

---

**Important:** You modify elements and attributes of the `<entity-deployment>` element in the `orion-ejb-jar.xml` file to explicitly map relationship fields. JDeveloper was created to manage the complex mapping between the entity beans and the database tables. Thus, JDeveloper validates the deployment descriptors and prevents inconsistencies. You are allowed to modify the `orion-ejb-jar.xml` file on your own; however, we suggest that you use JDeveloper for modifying container-managed relationships. CMR configuration is complex and can be difficult to understand. You can download JDeveloper at the following site: <http://www.oracle.com/technology/software/products/jdev/index.html>.

---

### **Example 6–10 XML Structure for Many-to-Many Relationship Mapping**

The relationship that is defined in the `ejb-jar.xml` file is mapped in the `orion-ejb-jar.xml` file within a `<cmp-field-mapping>` element. The `<cmp-field-mapping>` element contains either a `<collection-mapping>` or `<set-mapping>` element. The project/employee example describes both sides of the "many" relationship with a `<collection-mapping>` element; thus, both sides use a `<collection-mapping>` to describe their side of the relationship, even though the information is the same on both sides.

In the `ejb-jar.xml` file, both sides are define a "many" relationship to each other; thus, both sides declare the `<multiplicity>` element as `Many` and define a relationship to each other in a CMR field. The project bean defines the CMR field as `employees`; the employee bean defines the CMR field as `projects`. These CMR fields are used in the `orion-ejb-jar.xml` file to map these relationships in the database tables.

```
<entity>
...
<relationships>
<ejb-relation>
<ejb-relation-name>Emps-Projects</ejb-relation-name>
<ejb-relationship-role>
<ejb-relationship-role-name>Projects-have-Emps
</ejb-relationship-role-name>
<multiplicity>Many</multiplicity>
<relationship-role-source>
<ejb-name>ProjectBean</ejb-name>
</relationship-role-source>
<cmr-field>
<cmr-field-name>employees</cmr-field-name>
<cmr-field-type>java.util.Collection</cmr-field-type>
</cmr-field>
</ejb-relationship-role>
<ejb-relationship-role>
<ejb-relationship-role-name>Emps-have-Projects
</ejb-relationship-role-name>
<multiplicity>Many</multiplicity>
<relationship-role-source>
<ejb-name>EmpBean</ejb-name>
</relationship-role-source>
<cmr-field>
<cmr-field-name>projects</cmr-field-name>
<cmr-field-type>java.util.Collection</cmr-field-type>
</cmr-field>
```

```

</ejb-relationship-role>
</ejb-relation>
</relationships>
...
</entity>

```

Then in the `orion-ejb-jar.xml` file, both sides define the relationship with each other in a `<collection-mapping>` element. This element defines the association table. An association table is created that contains two foreign keys, where each foreign key points to the primary key of the source and target tables. Thus, explicit mapping of this relationship requires modifying the association table name and its foreign key names. You must modify both `<collection-mapping>` elements with the same information, because both `<collection-mapping>` elements contain the same information about the association table. The only difference is that the information is switched in the `<primary-key>` and `<value-mapping>` elements in each bean definition. What is defined in the `<primary-key>` element in the project bean definition will be defined in the `<value-mapping>` element in the employee bean definition.

```

<entity-deployment name="EmpBean" location="EmpBean"
table="EmpBean_ormap_ormap_ejb" data-source="jdbc/OracleDS" >
...
<entity-deployment name="EmpBean" table="EMP">
<primkey-mapping>
<cmp-field-mapping name="empNo" persistence-name="EMPNO" />
</primkey-mapping>
<cmp-field-mapping name="empName" persistence-name="ENAME" />
<cmp-field-mapping name="salary" persistence-name="SAL" />
<cmp-field-mapping name="projects">
<collection-mapping table="PROJECT_EMP">
<primkey-mapping>
<cmp-field-mapping name="EmpBean_empNo">
<entity-ref home="EmpBean">
<cmp-field-mapping name="EmpBean_empNo"
persistence-name="EMPLOYEE_NO" />
</entity-ref>
</cmp-field-mapping>
</primkey-mapping>
<value-mapping type="hr.ProjectLocal">
<cmp-field-mapping name="ProjectBean_projectNo">
<entity-ref home="ProjectBean">
<cmp-field-mapping name="ProjectBean_projectNo"
persistence-name="PROJECT_NO" />
</entity-ref>
</cmp-field-mapping>
</value-mapping>
</collection-mapping>
</cmp-field-mapping>
...
</entity-deployment>
...
<entity-deployment name="ProjectBean" location="ProjectBean"
table="ProjectBean_ormap_ormap_ejb" data-source="jdbc/OracleDS" >
<primkey-mapping>
<cmp-field-mapping name="projectNo" persistence-name="PROJECTNO" />
</primkey-mapping>
<cmp-field-mapping name="projectName" persistence-name="PNAME" />
<cmp-field-mapping name="employees">
<collection-mapping table="PROJECT_EMP">
<primkey-mapping>

```

```

<cmp-field-mapping name="ProjectBean_projectNo">
<entity-ref home="ProjectBean">
<cmp-field-mapping name="ProjectBean_projectNo"
persistence-name="PROJECT_NO" />
</entity-ref>
</cmp-field-mapping>
</primkey-mapping>
<value-mapping type="hr.EmpLocal">
<cmp-field-mapping name="EmpBean_empNo">
<entity-ref home="EmpBean">
<cmp-field-mapping name="EmpBean_empNo"
persistence-name="EMPLOYEE_NO" />
</entity-ref>
</cmp-field-mapping>
</value-mapping>
</collection-mapping>
</cmp-field-mapping>

```

The following describes the fields in the `orion-ejb-jar.xml` file:

- The project bean defines a `<cmr-field>` element in the `ejb-jar.xml` file defines a name for the relationship with employees as `employees`; the employees `<cmr-field>` element defines a name for the relationship with projects as `projects`.
- Both of the `projects` and `employees` `<cmr-field>` elements map to the association table in the `orion-ejb-jar.xml` file. In this file, each of the `<cmp-field-mapping>` elements for `projects` and `employees` contain a `<collection-mapping>` element. This `<collection-mapping>` element defines the association table name in the `table` attribute as `PROJECT_EMP`.
- The association has two foreign keys. In this example, the foreign keys are simple. However, if the primary keys are composite, then these foreign keys would be composite as well.

Both foreign keys in the `EmpBean` for the association table are defined as follows:

- The `persistence-name` attribute in the `<primkey-mapping>` element defines the association table foreign key of the current entity bean, which is `EMPLOYEE_NO`.
- The `persistence-name` attribute in the `<value-mapping>` element defines the association table foreign key of the target bean, which is `PROJECT_NO`.
- The `<value-mapping>` element in `EmpBean` specifies the target entity bean.
  - The `type` attribute of the `<value-mapping>` element defines the local interface of the target bean that is returned to the source entity bean. This example defines the local home interface of the phone bean as `hr.ProjectLocal`.
  - The `<ejb-name>` of the target entity bean is defined in the `<entity-ref>` `home` attribute, which in this example is `ProjectBean`.

## Using a Foreign Key in a Composite Primary Key

In the EJB specification, the primary key for an entity bean must be initialized within the `ejbCreate` method; any relationship that this bean has to another bean cannot be set in the `ejbCreate` method. The earliest that this relationship can be set in a foreign key is in the `ejbPostCreate` method.



However, if you have a foreign key within a composite primary key, you have the following problem:

- You must set all fields within the composite primary key in the `ejbCreate` method.
- You cannot set the foreign key in the `ejbCreate` method.

This section uses the following example to describe the way around this problem:

An order for a company can contain one or more items. The order bean has many items in it. Each item belongs to an order. The primary key for the item is a composite primary key consisting of the item identifier and the order identifier. The order identifier is a foreign key that points to the order.

You will have to modify the deployment descriptors and bean implementation to add a placeholder CMP field that mimics the actual foreign key field. This field is set during the `ejbCreate` method. However, both the placeholder CMP field and the foreign key point to the same database column. The actual foreign key is updated during the `ejbPostCreate` method.

The following example demonstrates how to modify both deployment descriptors and the bean implementation.

---

**Note:** You modify the `ejb-jar.xml` file with the placeholder CMP field and the foreign key. We recommend that you deploy the application with `autocreate-tables` element in the `orion-application.xml` file set to `false` to auto-generate the `orion-ejb-jar.xml` file, without creating any tables. Then modify the `orion-ejb-jar.xml` file to point to the correct database columns, set `autocreate-tables` element to `true`, and redeploy.

---

#### **Example 6-11 A Foreign Key That Exists in a Primary Key**

Each order contains one or more items. Thus, two beans are created, where the `OrderBean` represents the order and the `OrderItemBean` represents the items in the order. Each item has a primary key that consists of the item number and the order number to which it belongs. Thus, the primary key for the item contains a foreign key that points to an order bean.

To adjust for a composite primary key, do the following in the `ejb-jar.xml` file:

1. Define a CMP field in the primary key as a placeholder for the foreign key. This placeholder should be used in the composite primary key class definition.

In this example, an `orderId` CMP field is defined in a `<cmp-field>` element. The `orderId` and `itemId` CMP fields are used to identify the composite primary key in the `OrderItemPK.java`.

2. Define the foreign key outside of the primary key definition in its own `<cmr-field>` element in the `<relationships>` section.

In this example, the `belongToOrder` foreign key is defined in a `<cmr-field>` element for the `OrderItemBean`, defining the relationship from the item to the order.

```
<entity>
<ejb-name>OrderItemBean</ejb-name>
<local-home>OrderItemLocalHome</local-home>
<local>OrderItemLocal</local>
```

```

<ejb-class>OrderItemBean</ejb-class>
...
<cmp-field><field-name>itemId</field-name></cmp-field>
<cmp-field><field-name>orderId</field-name></cmp-field>
<cmp-field><field-name>price</field-name></cmp-field>
<prim-key-class>OrderItemPK</prim-key-class>
...
</entity>
<relationships>
<ejb-relation>
<ejb-relation-name>Order-OrderItem</ejb-relation-name>
<ejb-relationship-role>
<ejb-relationship-role-name>Order-Has-OrderItems
</ejb-relationship-role-name>
<multiplicity>One</multiplicity>
<relationship-role-source>
<ejb-name>OrderBean</ejb-name>
</relationship-role-source>
<cmr-field>
<cmr-field-name>items</cmr-field-name>
<cmr-field-type>java.util.Collection</cmr-field-type>
</cmr-field>
</ejb-relationship-role>
<ejb-relationship-role>
<ejb-relationship-role-name>OrderItems-form-Order
</ejb-relationship-role-name>
<multiplicity>Many</multiplicity>
<cascade-delete/>
<relationship-role-source>
<ejb-name>OrderItemBean</ejb-name>
</relationship-role-source>
<cmr-field>
<cmr-field-name>belongToOrder</cmr-field-name>
</cmr-field>
</ejb-relationship-role>
</ejb-relation>
</relationships>

```

The `OrderItemPK.java` class defines what is in the complex primary key, as follows:

```

public class OrderItemPK implements java.io.Serializable
{
    public Integer itemId;
    public Integer orderId;

    public OrderItemPK()
    {
        this.itemId = null;
        this.orderId = null;
    }

    public OrderItemPK(Integer itemId, Integer orderId)
    {
        this.itemId = itemId;
        this.orderId = orderId;
    }
}

public boolean equals(Object o)
{
    if (o instanceof OrderItemPK) {

```

```

        OrderItemPK pk = (OrderItemPK) o;
        if (pk.itemId.intValue() == itemId.intValue() &&
            pk.orderId.intValue() == orderId.intValue())
            return true;
    }
    return false;
}

public int hashCode()
{
    return itemId.hashCode() * orderId.hashCode();
}
}

```

If the auto-created database tables are sufficient for you, you do not need to modify the `orion-ejb-jar.xml` file. However, if you need to map to existing database tables, then you modify the `orion-ejb-jar.xml` file to point to these tables.

After you allow the `orion-ejb-jar.xml` file to auto-generate, copy it into your development directory. The database column names are defined in the `persistence-name` attributes in each of the CMP and CMR field name mappings. Ensure that the `persistence-name` attributes for both the placeholder CMP field and foreign key are the same.

The following is the `orion-ejb-jar.xml` file for the `order/order item` example. In the `<entity-deployment>` section for the `OrderItemBean`,

- The table is defined in the `table` attribute, which is `ORDER_ITEM` in this example.
- The column name for the `itemId` is defined in the `persistence-name` attribute as `Item_ID`.
- The column name for the placeholder CMP field, `orderId`, is defined in the `persistence-name` attribute as `Order_ID`.
- The foreign key, `belongsToOrder`, is mapped to the database column, `Order_ID`, which is the same column as the placeholder CMP field, `orderId`.

Both the foreign key, `belongsToOrder`, and the placeholder CMP field, `orderId`, must point to the same database column.

```

<entity-deployment name="OrderItemBean" table="ORDER_ITEM">
<primkey-mapping>
<cmp-field-mapping name="itemId" persistence-name="Item_ID" />
<cmp-field-mapping name="orderId" persistence-name="Order_ID" />
</primkey-mapping>
<cmp-field-mapping name="price" persistence-name="Price" />
<cmp-field-mapping name="belongsToOrder">
<entity-ref home="OrderBean">
<cmp-field-mapping name="belongsToOrder"
persistence-name="Order_ID" />
</entity-ref>
</cmp-field-mapping>
</entity-deployment>

<entity-deployment name="OrderBean" table="ORDER">
<primkey-mapping>
<cmp-field-mapping name="orderId" persistence-name="Order_ID" />
</primkey-mapping>
<cmp-field-mapping name="orderDesc"
persistence-name="Order_Description" />
<cmp-field-mapping name="items">

```

```
<collection-mapping table="ORDER_ITEM">
<primkey-mapping>
<cmp-field-mapping name="OrderBean_orderId">
<entity-ref home="OrderBean">
<cmp-field-mapping name="OrderBean_orderId"
persistence-name="Order_ID"/>
</entity-ref>
</cmp-field-mapping>
</primkey-mapping>
<value-mapping type="OrderItemLocal">
<cmp-field-mapping name="OrderItemBean_itemId">
<entity-ref home="OrderItemBean">
<cmp-field-mapping name="OrderItemBean_itemId">
<fields>
<cmp-field-mapping name="OrderItemBean_itemId"
persistence-name="Item_ID"/>
<cmp-field-mapping name="OrderItemBean_orderId"
persistence-name="Order_ID"/>
</fields>
</cmp-field-mapping>
</entity-ref>
</cmp-field-mapping>
</value-mapping>
</collection-mapping>
</cmp-field-mapping>
</entity-deployment>
```

Finally, you must update the bean implementation to work with both the placeholder CMP field and the foreign key.

1. In the `ejbCreate` method, do the following:
  - a. Create the placeholder CMP field that takes the place of the foreign key field.
  - b. Set a value in the placeholder CMP field in the `ejbCreate` method. This value is written out to the foreign key field in the database table.
2. In the `ejbPostCreate` method, set the foreign key to the value in the duplicate CMP field.

---

---

**Note:** Since the foreign key is part of a primary key, it can only be set once.

---

---

In our example, the CMP field, `orderId`, is set in the `ejbCreate` method and the relationship field, `belongsToOrder`, is set in the `ejbPostCreate` method.

```
public OrderItemPK ejbCreate(OrderItem orderItem) throws CreateException
{
    setItemId(orderItem.getItemId());
    setOrderId(orderItem.getOrderId());
    setPrice(orderItem.getPrice());
    return new OrderItemPK(orderItem.getItemId(), orderItem.getOrderId());
}

public void ejbPostCreate(OrderItem orderItem) throws CreateException
{
    // when just after bean created
    try {
        Context ctx = new InitialContext();
        OrderLocalHome orderHome =
```

```

(OrderLocalHome) ctx.lookup("java:comp/env/OrderBean");
OrderLocal order = orderHome.findByPrimaryKey(orderItem.getOrderId());

setBelongToOrder (order) ;
}
catch(Exception e) {
e.printStackTrace();
throw new EJBException(e);
}
}
}

```

The OrderItem object that is passed into the ejbCreate and ejbPostCreate methods is as follows:

```

public class OrderItem implements java.io.Serializable
{

    private Integer itemId;
    private Integer orderId;
    private Double price;

    public OrderItem(Integer itemId, Integer orderId, Double price)
    {
        this.itemId = itemId;
        this.orderId = orderId;
        this.price = price;
    }

    public Integer getItemId() {
        return itemId;
    }

    public void setItemId(Integer itemId) {
        this.itemId = itemId;
    }

    public Integer getOrderId() {
        return orderId;
    }

    public void setOrderId(Integer orderId) {
        this.orderId = orderId;
    }

    public Double getPrice() {
        return price;
    }

    public void setPrice(Double price) {
        this.price = price;
    }

    public boolean equals(Object other)
    {
        {
            if(other instanceof OrderItem) {
                OrderItem orderItem = (OrderItem)other;
                if (itemId.equals(orderItem.getItemId()) &&
                    orderId.equals(orderItem.getOrderId()) &&
                    price.equals(orderItem.getPrice()) ) {
                    return true;
                }
            }
        }
    }
}

```

```

        return false;
    }
}

```

## How to Override a Foreign Key Database Constraint

If you have defined your database columns with a constraint, such as NOT NULL, you may encounter an error after the `ejbCreate` method. An INSERT is performed after the `ejbCreate` method; thus, if any field in the database row was left null, the constraint raises a database table constraint violation. This occurs mostly with foreign keys as they cannot be assigned until the `ejbPostCreate` method. In order to avoid this problem, you must relax the constraint on the field in question.

You can relax the database constraints by redefining the offending column to DEFERRABLE. If you relax the constraint, you will have time to set the database field before the transaction commits and avoid the database constraint violation.

The following shows how to create a deferrable constraint for the TEST table:

```
create table test (test varchar2(10) not null INITIALLY DEFERRED DEFERRABLE )
```

## Performing Inner or Outer Joins on One-to-One Relationships

The Oracle database allows you to perform SQL using an inner or outer join. Using a join is more efficient. These are described in the database manuals. However, the definitions from these manuals are as follows:

- Inner join: An inner join (sometimes called a "simple join") is a join of two or more tables that returns only those rows that satisfy the join condition.
- An outer join extends the result of a simple join. An outer join returns all rows that satisfy the join condition and also returns some or all of those rows from one table for which no rows from the other satisfy the join condition.

For more information on inner and outer joins, see the Oracle database manuals.

Inside OC4J, if you have specified a one-to-one relationship between two entity beans, you automatically receive an outer join when retrieving data involving this relationship. Previously, OC4J would issue two SQL queries for each side of the relationship. Using the join improves performance by only issuing a single query.

You can change to using an inner join by modifying the one-to-one-join attribute on the relationship field to inner, as follows:

```
<cmr-field-mapping name="inventory" one-to-one-join="inner">
```

When the one-to-one mapping is unidirectional, place the one-to-one-join attribute on the origination of the relationship. When the relationship is bi-directional, specify the one-to-one-join attribute on both sides of the relationship.

## Batching SQL statements in your entity beans

To speed up the performance of your entity bean, you can configure two options for batching SQL statements, as follows:

- Batch SELECT statements: If you have more than one SELECT statement to execute, you can specify the number of rows to retrieve at a time with the prefetch-size attribute in the <finder-method> element. This attribute is documented fully in the 9.0.4. EJB documentation.

- Batch UPDATE statements: If you have several updates in a row (in `executeUpdate`), you can configure how many of these to batch together to go out to the database in one round trip in the `batch-size` attribute of the entity-deployment element. The default is no batching (size is 1).
- To learn more about batching update statements, see the JDBC documentation for the Oracle 10g database.

There is one exception to the batching size. If the code executes a SELECT statement within several UPDATE statements, the updates will be executed against the database before executing the select. This is done so that all updates are performed before you retrieve any data. If you know that it does not matter for this select to be performed, then you can stop the automatic flushing by specifying `delay-updates-until-commit` for the bean.

## How to map a CMP field and a CMR field to the same row in the database

When you define a relationship between beans, you define a CMP field and then you map a relationship to the bean. Both the CMP field and the relationship eventually map to the same row in the database. For instance, in the employee bean, a department ID is specified as a CMP field. When you define the CMR relationship between the employee and the department bean, the employee/department relationship is mapped through a CMR defined variable (`dept`) that is mapped to the employee bean's department ID. Since both fields map to the same row in the database, you must specify that one of these fields cannot be changed through the shared attribute. The shared attribute makes the particular CMP or CMR field read-only. Thus, to define that the CMP field, `deptID`, cannot be modified, do the following:

```
<cmp-field-mapping name="deptID" shared=true" persistence-name="deptID" />
```

---

**Note:** You cannot mark a Container-Managed Persistence (CMP) entity bean as read-only if it has a Container-Managed Relationships (CMR) relationship to another entity bean that is not read-only.

---

Defining the above in the employee entity bean states that the `deptID` field is "shared" and that you cannot modify the `deptID` to be another value through the `setDeptID` method. Instead, if you needed to modify the relationship, you would have to modify the relationship through the CMR relationship variable, `dept`, with the `setDept` method, pointing the employee entity bean to another bean (and thus, another row in the database).

In the case of complex primary keys, if you have a CMR field as part of the relationship, you can define it as shared, and then it takes on the same attribute as a primary key in that no one can modify it after it is initially set.

## Synchronizing Data during Bean Creation

In 9.0.4.1, data is now automatically synchronized after the `ejbPostCreate` method. Previously, data was synchronized with an INSERT after the `ejbCreate` method. Then, if you added a CMR relationship in the `ejbPostCreate` method, an UPDATE was performed after the `ejbPostCreate` method. This resulted in two SQL statements. For performance reasons, the default is now to have a single SQL INSERT statement after the `ejbPostCreate`. If, however, you wish to have the old way of data synchronization, you can set the `data-synchronization-option` attribute, as follows:

`data-synchronization-option="ejbCreate"`

The default setting is as follows:

`data-synchronization-option="ejbPostCreate"`

If you have a foreign key as part of your primary key, you must set the `data-synchronization-option` to "ejbPostCreate" (or accept the default setting), as the foreign key has a non-null constraint. Since the primary key is set in the `ejbCreate` method and the foreign keys are initialized in the `ejbPostCreate`, all aspects of the primary key, including the foreign key, are initialized at the same time after the `ejbPostCreate`.



---

---

## EJB Query Language

In EJB 2.0, you can specify query methods using the standardized query language, EJB Query Language (EJB QL).

Chapter 11 of the EJB 2.0 specification and various off-the-shelf books document EJB QL extensively. This chapter briefly overviews the development rules for these methods, but does not describe the EJB QL syntax in detail.

Refer to the EJB 2.0 specification and the following books for detailed syntax:

- *Enterprise JavaBeans, 3rd Edition* by Richard Monson-Haefel, O'Reilly Publishers
- *Special Edition Using Enterprise JavaBeans 2.0* by Chuck Cavaness and Brian Keeton, Que Publishers

This chapter covers the following subjects:

- [EJB QL Overview](#)
- [Query Methods Overview](#)
- [Deployment Descriptor Semantics](#)
- [Finder Method Example](#)
- [Select Method Example](#)
- [Oracle EJB QL Type Extensions: Date, Time, Timestamp, and SQRT](#)

## EJB QL Overview

EJB QL is a query language that is similar to SQL. In fact, your knowledge of SQL is beneficial in using EJB QL. SQL applies queries against tables, using column names. EJB QL applies queries against entity beans, using the abstract schema name and the CMP and CMR fields of the bean within the query. The EJB QL statement retains the object terminology.

The container translates the EJB QL statement to the appropriate database SQL statement when the application is deployed. Thus, the container is responsible for converting the entity bean name, CMP field names, and CMR field names to the appropriate database tables and column names. EJB QL is portable to all databases supported by your container.

## Query Methods Overview

Query methods can be finder or select methods:

- **Finder Methods:** Use finder methods to retrieve entity bean references.
- **Select Methods:** Select methods are for internal use for the entity bean only. Use them to retrieve either entity bean references or CMP values.

Both query method types must throw the `FinderException`.

## Finder Methods

Finder methods are used to retrieve entity bean references. The `findByPrimaryKey` finder method is always defined in both home interfaces (local and remote) to retrieve the entity reference for this bean using a primary key. You can define other finder methods in either or both the home interfaces to retrieve one or several entity bean references.

Do the following to define finder methods:

1. Define the `find<name>` method in the desired home interface. You can specify different finder methods in the remote or the local home interface. If you define the same finder method in both home interfaces, it maps to the same bean class definition. The container returns the appropriate home interface type.
2. Define the full query or just the conditional statement (the `WHERE` clause) for the finder method in the deployment descriptor.

You can define the query using either EJB QL syntax or OC4J-specific syntax. You can specify either a full query or only the conditional part of the query (the `WHERE` clause).

- EJB QL syntax is defined within the `ejb-jar.xml` file. The syntax is defined by Sun Microsystems in Chapter 11 of the EJB 2.0 specification. An EJB QL statement is created for each finder method in its own `<query>` element. The container uses this statement to translate the condition on how to retrieve the entity bean references into the relevant SQL statements.

Currently, EJB QL has limited support for `GROUP BY` and `ORDER BY` functions, such as `AVERAGE` and `SUM`.

See "[Specifying Finder Methods With EJB QL Syntax](#)" on page 7-5 for more information.

- OC4J-specific syntax is defined within the `orion-ejb-jar.xml` file. When you deploy your application, OC4J translates the EJB QL syntax into the

OC4J-specific syntax, which is specified in the `query` attribute of the `<finder-method>` element. You can modify the statement in the `query` attribute for a more complex query using the OC4J syntax. The OC4J-specific query statement in the `orion-ejb-jar.xml` file takes precedence over its EJB QL statement in the `ejb-jar.xml` file.

See ["Specifying Finder Methods With OC4J-Specific Syntax"](#) on page 7-7 for more information.

If you retrieve only a single entity bean reference, the container returns the same type as returned in the `find<name>` method. If you request multiple entity bean references, you must define the return type of the `find<name>` method to return a `Collection`. If you want to ensure that no duplicates are returned, specify the `DISTINCT` keyword in the EJB QL statement. An empty `Collection` is returned if no matches are found.

See the ["Finder Method Example"](#) on page 7-5 for more information on both types of finder methods.

## Select Methods

Select methods are used primarily to return values for CMP or CMR fields. All values are returned in their own object type; any primitive types are wrapped in objects that have similar functions (for example, a primitive `int` type is wrapped in an `Integer` object). See section 10.5.7 of the EJB 2.0 specification for more information on select methods.

These methods are for internal use within the bean. These methods cannot be called from a client. Thus, you do not define them in the home interfaces. Select methods are used to retrieve entity bean references or the value of a CMP field.

Do the following to define select methods:

1. Define an `ejbSelect<name>` method in the bean class for each select method. Each method is defined as `public abstract`. The SQL that is necessary for this method is not included in the implementation.
2. Define the full query or just the conditional statement (the `WHERE` clause) for the select method in the deployment descriptor. An EJB QL statement is created for each select method in its own `<query>` element. The container uses this statement to translate the condition into the relevant SQL statements.

See the ["Select Method Example"](#) on page 7-9 for more information on both types of finder methods.

## Return Objects

Here are the rules for defining return types for the select method:

- No objects: If no objects are found, a `FinderException` is raised.
- Single object: If you retrieve only a single item, the container returns the same type as returned in the `ejbSelect<name>` method. If multiple objects are returned, a `FinderException` is raised.
- Multiple objects: If you request multiple items, you must define the return type of the `ejbSelect<name>` method as either a `Set` or `Collection`. A `Set` eliminates duplicates. A `Collection` may include duplicates. For example, if you want to retrieve all zip codes of all customers, use a `Set` to eliminate duplicates. To retrieve all customer names, use a `Collection` to retrieve the full list. An empty `Collection` or `Set` is returned if no matches are found.

- Bean interface: If you return the bean interface, the default interface type returned within the `Set` or `Collection` is the local bean interface. You can change this to the remote bean interface in the `<result-type-mapping>` element, as follows:  

```
<result-type-mapping>Remote</result-type-mapping>
```
- CMP values: If you return a `Set` or `Collection` of CMP values, the container determines the object type from the EJB QL select statement.

## Deployment Descriptor Semantics

The structure required for defining both types of query methods is the same in the deployment descriptor.

1. You must define the `<abstract-schema-name>` element in the `<entity>` element for each entity bean referred to in the EJB QL statement. This element defines the name that identifies the entity bean in the EJB QL statement. Thus, if you define your `<abstract-schema-name>` as `Employee`, then the EJB QL uses `Employee` in its EJB QL to refer to the `EmpBean` entity bean.
2. Define the `<query>` element for each query method (finder and select), except for the `findByPrimaryKey` finder method.

---

**Note:** If you want to use the OC4J-specific syntax, you still start with configuring the EJB QL `<query>` element. Then, after deployment, you modify the query in the `orion-ejb-jar.xml` file to be the statement that you want.

---

The `<query>` element has two main elements:

- The `<method-name>` element identifies the finder or select method. The finder method is the same name as defined in the component home interfaces. The select method is the same name as defined in the bean class.
- The `<ejb-ql>` element contains the EJB QL statement for this method.

### **Example 7-1 Employee FindAll Deployment Descriptor Definition**

The following example shows the `EmpBean` entity bean definition.

- The `<entity>` element defines its `<abstract-schema-name>` as `Employee`.
- Two `<query>` elements define finder methods, `findAll` and `findByEmpNo`, in which the EJB QL statement refers to the `Employee` name.

```
<entity>
  <display-name>EmpBean</display-name>
  <ejb-name>EmpBean</ejb-name>
  ...
  <abstract-schema-name>Employee</abstract-schema-name>
  <cmp-field><field-name>empNo</field-name></cmp-field>
  <cmp-field><field-name>empName</field-name></cmp-field>
  <cmp-field><field-name>salary</field-name></cmp-field>
  <primkey-field>empNo</primkey-field>
  <prim-key-class>java.lang.Integer</prim-key-class>
  ...
  <query>
    <description></description>
```

```

        <query-method>
          <method-name>findAll</method-name>
          <method-params />
        </query-method>
        <ejb-ql>Select OBJECT(e) From Employee e</ejb-ql>
      </query>
    <query>
      <description></description>
      <query-method>
        <method-name>findByEmpNo</method-name>
        <method-params>
          <method-param>java.lang.Integer</method-param>
        </method-params>
      </query-method>
      <ejb-ql>SELECT OBJECT(e) FROM Employee e WHERE e.empNo = ?1
    </ejb-ql>
  </query>
  ...
</entity>

```

The EJB QL statement for the `findAll` method is simple. It selects objects, identified by the variable `e`, from the `Employee` entity beans. Thus, it selects all `Employee` entity bean objects. The EJB QL statement for the `findByEmpNo` method selects all objects where the employee name is equal to the first input parameter to the method. After deployment, OC4J translates the EJB QL statements into `<finder-method>` elements in the `orion-ejb-jar.xml` file, as follows:

```

<finder-method query=""> /*the empty where clause finds all employees*/
<finder-method query="$empname = $1"> /*this finds all records where
    employee is equal to the first input parameter.*/

```

See ["Finder Method Example"](#) on page 7-5 for more information and examples.

## Finder Method Example

To define finder methods in a CMP entity bean, do the following:

1. Define the finder method in one or both of the home interfaces.
2. Define the finder method definition in the deployment descriptor.

The following sections demonstrate how to create finder methods using either the EJB QL syntax or the OC4J-specific syntax:

- [Specifying Finder Methods With EJB QL Syntax](#)
- [Specifying Finder Methods With OC4J-Specific Syntax](#)

### Specifying Finder Methods With EJB QL Syntax

There are two steps for creating a finder method:

1. [Define the Finder Method in the Home Interface](#)
2. [Define the Finder Method Definition in the Deployment Descriptor](#)

#### Define the Finder Method in the Home Interface

You must add the finder method to the home interface. For example, if you want to retrieve all employees, define the `findAll` method in the home interface (local home interface for this example), as follows:

```
public Collection findAll() throws FinderException;
```

To retrieve data for a single employee, define the `findByEmpNo` in the home interface, as follows:

```
public EmployeeLocal findByEmpNo(Integer empNo) throws FinderException;
```

The returned bean interface is the local interface, `EmployeeLocal`. The input parameter is an employee number, `empNo`, which is substituted in the EJB QL `?1` parameter.

### Define the Finder Method Definition in the Deployment Descriptor

Each finder method is defined in the deployment descriptor in a `<query>` element. [Example 7-1](#) contains the EJB QL statement for the `findAll` method. The following example shows the deployment descriptor for the `findByEmpNo` method:

```
<query>
  <description></description>
  <query-method>
    <method-name>findByEmpNo</method-name>
    <method-params>
      <method-param>java.lang.Integer</method-param>
    </method-params>
  </query-method>
  <ejb-ql>SELECT OBJECT(e) FROM Employee e WHERE e.empNo = ?1
</ejb-ql>
</query>
```

The EJB QL statement for the `findByEmpName` method selects the `Employee` object where the employee number is substituted in the EJB QL `?1` parameter. The `?` symbol denotes a place holder for the method parameters. Thus, the `findByEmpNo` is required to supply at least one parameter. The `empNo` passed in on the `findByEmpNo` method is substituted in the `?1` position here. The variable, `e`, identifies the `Employee` object in the `WHERE` condition.

### Relationship Finder Example

For the EJB QL statement that involves a relationship between entity beans, both entity beans are referenced within the EJB QL statement. The following example shows the `findByDeptNo` method. This finder method is defined within the employee bean, which references the department entity bean. This method retrieves all employees that belong to a department.

```
<query>
  <description></description>
  <query-method>
    <method-name>findByDeptNo</method-name>
    <method-params>
      <method-param>java.lang.Integer</method-param>
    </method-params>
  </query-method>
  <ejb-ql>SELECT OBJECT(e) From Employee e, IN (e.dept)
        AS d WHERE d.deptNo = ?1
</ejb-ql>
</query>
```

The `<abstract-schema-name>` element for the employee bean is `Employee`. The employee bean defines a relationship with the department bean through a CMR field, called `dept`. Thus, the department bean is referenced in the EJB QL through the `dept`

CMR field. The department primary key is deptNo. The department number that the query is executed with is given in the input parameter and substituted in ?1.

## Specifying Finder Methods With OC4J-Specific Syntax

There are two steps for creating a finder method:

1. [Add the Finder Method to Home Interface](#)
2. [Add the Query to the OC4J-Specific Deployment Descriptor](#)

### Add the Finder Method to Home Interface

You must first add the finder method to the home interface. For example, with the employee entity bean, if we wanted to retrieve all employees, the `findAll` method would be defined within the home interface, as follows:

```
public Collection findAll() throws FinderException, RemoteException;
```

### Add the Query to the OC4J-Specific Deployment Descriptor

After specifying the finder method in the home interface, modify the `orion-ejb-jar.xml` file with the finder method query.

The `<finder-method>` element defines all finder methods—excluding the `findByPrimaryKey` method. The simplest finder method to define is the `findAll` method. The `query` attribute in the `<finder-method>` element can specify a full query or just the `WHERE` clause for the query. If you want all rows retrieved, then an empty query (`query=""`) returns all records.

OC4J-specific finder methods are configured in the `orion-ejb-jar.xml` file in a `<finder-method>` element. Each `<finder-method>` element specifies a partial or full SQL statement in its `query` attribute, as follows:

```
<finder-method query=""> /*the empty where clause finds all */
OR
<finder-method query="$empname = $1"> /*this finds all records where
    employee is equal to the first input parameter.*/
```

If you have a `<finder-method>` with a `query` attribute, it takes precedence over any EJB QL modifications to the same method in the `ejb-jar.xml` file.

To define a complex finder method, do the following:

1. Define a simple query that is similar using EJB QL in the `ejb-jar.xml` file.
2. Deploy the application. When you deploy, OC4J translates the EJB QL statement to the OC4J-specific equivalent. The full SQL statement that will be executed is displayed in a comment.
3. Modify the `query` attribute of the `<finder-method>` in the `orion-ejb-jar.xml` file to have the exact complexity you desire. When you redeploy, OC4J translates the new query and will write out a new comment with the exact SQL statement that will be executed. Check the comment to verify that you have the right syntax.

If you want to use the EJB QL syntax and you have an existing definition in `orion-ejb-jar.xml` file, then do the following:

1. Erase the `query` attribute of the `<finder-method>` in the `orion-ejb-jar.xml` file.

2. Redeploy the application. OC4J notes that the `query` attribute is not present and uses the EJB QL methodology from the `ejb-jar.xml` file instead.

### **Example 7-2 OC4J-Specific Finder Syntax**

The following example retrieves all records from the `EmployeeBean`. The method name is `findAll`, and it requires no parameters because it returns a `Collection` of all employees.

```
<finder-method query="">
<!-- Generated SQL: "select EmployeeBean.empNo, EmployeeBean.empName,
EmployeeBean.salary from EmployeeBean" -->
  <method>
    <ejb-name>EmployeeBean</ejb-name>
    <method-name>findAll</method-name>
    <method-params></method-params>
  </method>
</finder-method>
```

After deployment, OC4J will add the commented line of what query will be. Use the comment to verify that it is the type of query that you expect.

To be more specific, modify the `query` attribute with the appropriate `WHERE` clause. This clause refers to passed in parameters using the '\$' symbol: the first parameter is denoted by \$1, the second by \$2. All `<cmp-field>` elements that are used within the `WHERE` clause are denoted by `$(cmp-field) name`.

The following example specifies a `findByName` method (which should be defined in the home interface) where the name of the employee is given as in the method parameter, which is substituted for the \$1. It is matched to the CMP name, "empName". Thus, our `query` attribute is modified to contain the following for the `WHERE` clause: "\$empname=\$1".

```
<finder-method query="$empname = $1">
  <method>
    <ejb-name>EmployeeBean</ejb-name>
    <method-name>findByName</method-name>
    <method-params>
      <method-param>java.lang.String</method-param>
    </method-params>
  </method>
</finder-method>
```

If you have more than one method parameter, each parameter type is defined in successive `<method-param>` elements and referred to in the query statement by successive `$n`, where `n` represents the number.

---

**Note:** You can also specify a SQL JOIN in the `query` attribute.

---

If you wanted to specify a full query and not just the section after the `WHERE` clause, specify the `partial` attribute to `FALSE` and then define the full query in the `query` attribute. The default value for `partial` is `true`, which is why it is not specified on the previous finder-method example.

```
<finder-method partial="false"
  query="select * from EMP where $empName = $1">
  <!-- Generated SQL: "select * from EMP where EMP.ENAME = ?" -->
  <method>
    <ejb-name>EmployeeBean</ejb-name>
```



```

        <method-name>findByName</method-name>
        <method-params>
            <method-param>java.lang.String</method-param>
        </method-params>
    </method>
</finder-method>

```

Specifying the full SQL query is useful for complex SQL statements.

For entity bean finder methods, lazy loading can cause the select method to be invoked more than once. By default, lazy loading is turned off. If you are retrieving large numbers of objects, and you are accessing only a few of them, you should turn on lazy loading.

To turn on lazy loading, set the `lazy-loading` property to true.

```

<finder-method partial="false"
    query="select * from EMP where $empName = $1"
    lazy-loading=true>
<!-- Generated SQL: "select * from EMP where EMP.ENAME = ?" -->
<method>
    <ejb-name>EmployeeBean</ejb-name>
    <method-name>findByName</method-name>
    <method-params>
        <method-param>java.lang.String</method-param>
    </method-params>
</method>
</finder-method>

```

Additionally, you can state how many rows the JDBC driver fetches at a time by setting the `prefetch-size` attribute, as follows:

```

<finder-method partial="false"
    query="select * from EMP where $empName = $1"
    prefetch-size="15" >
<!-- Generated SQL: "select * from EMP where EMP.ENAME = ?" -->
<method>
    <ejb-name>EmployeeBean</ejb-name>
    <method-name>findByName</method-name>
    <method-params>
        <method-param>java.lang.String</method-param>
    </method-params>
</method>
</finder-method>

```

Oracle JDBC drivers include extensions that allow you to set the number of rows to prefetch into the client while a result set is being populated during a query. This reduces round trips to the database by fetching multiple rows of data each time data is fetched—the extra data is stored in client-side buffers for later access by the client. The number of rows to prefetch can be set as desired. The default number of rows to prefetch to the client is 10. The number set here is passed along to the JDBC driver. See the *Oracle9i JDBC Developer's Guide and Reference* for more information on using prefetch with a JDBC driver.

## Select Method Example

To define select methods in a CMP entity bean, do the following:

1. Define the select method in the bean class as `ejbSelect<name>`.
2. Define the select method definition in the deployment descriptor.

---

---

**Note:** You cannot modify the query statement for an `ejbSelect` method in the `orion-ejb-jar.xml` file, as you can for finder methods.

---

---

## Define the Select Method in the Bean Class

Add the select method in the bean class as an abstract method. For example, if you want to retrieve all employees whose salary falls within a range, define the `ejbSelectBySalaryRange` method, as follows:

```
public abstract Collection ejbSelectBySalaryRange(Float s1, Float s2)
    throws FinderException;
```

Because the select method retrieves multiple employees, a `Collection` is returned. The low and high end of the salary range are input parameters, which are substituted in the EJB QL `?1` and `?2` parameters. The first input parameter is returned in `?1`; the second input parameter is returned in `?2`. The order of the all declared method parameters is the same as the order of the `?1, ?2, ... ?n` EJB QL parameters.

## Define the Select Method Definition in the Deployment Descriptor

Each select method is defined in the deployment descriptor in a `<query>` element. The following example shows the deployment descriptor for both the `ejbSelectBySalaryRange` and `ejbSelectNameBySalaryRange` methods:

```
<query>
  <description></description>
  <query-method>
    <method-name>ejbSelectBySalaryRange</method-name>
    <method-params>
      <method-param>java.lang.Float</method-param>
      <method-param>java.lang.Float</method-param>
    </method-params>
  </query-method>
  <ejb-ql>SELECT DISTINCT OBJECT(e) From Employee e
    WHERE e.salary BETWEEN ?1 AND ?2
  </ejb-ql>
</query>
<query>
  <description></description>
  <query-method>
    <method-name>ejbSelectNameBySalaryRange</method-name>
    <method-params>
      <method-param>java.lang.Float</method-param>
      <method-param>java.lang.Float</method-param>
    </method-params>
  </query-method>
  <ejb-ql>SELECT e.empName From Employee e
    WHERE e.salary BETWEEN ?1 AND ?2
  </ejb-ql>
</query>
```

Both of these methods provide two input parameters of type float. The types of these expected input parameters are defined in the `<method-param>` elements.

The EJB QL is defined in the `<ejb-ql>` element. Both methods evaluate the CMP field of salary within the EJB QL statement by the `e.salary`. The `e` represents the

Employee objects; the salary represents the CMP field within that object. Separating it with a period shows the relationship between the entity bean and its CMP field.

The two input parameters designate the low and high salary ranges and are substituted in the ?1 and ?2 positions respectively.

The `ejbSelectBySalaryRange` method returns objects, where the `DISTINCT` keyword ensures that no duplicate records are returned. The `ejbSelectNameBySalaryRange` returns only the names of the employees, which is a `String`. This demonstrates one of the advantages of using select statements, in that you can return only the values of CMP fields within your objects.

## Oracle EJB QL Type Extensions: Date, Time, Timestamp, and SQRT

Even though the current version of the EJB specification does not support `Date`, `Time`, `Timestamp`, and `SQRT`, we have added support for these types, as follows:

- `SQRT(v)` : Both the double primitive type and the `java.lang.Double` types are supported for arguments.
- `java.util.Date`, `java.sql.Date`, `java.sql.Time`, and `java.sql.Timestamp` are allowed in an EJB QL binary expression, such as equality expressions.

The following show examples of how to use these EJB QL type extensions:

### Example 7-3 Using SQRT

```
<query>
  <query-method>
    <method-name>ejbSelectDoubleTypeSqrt</method-name>
    <method-params>
      <method-param>double</method-param>
    </method-params>
  </query-method>
  <result-type-mapping>Remote</result-type-mapping>
  <ejb-ql>
    SELECT OBJECT(a) FROM Dept a WHERE a.deptDoubleType = SQRT(?1)
  </ejb-ql>
</query>
```

### Example 7-4 Date Example

```
<query>
  <query-method>
    <method-name>ejbSelectDate</method-name>
    <method-params>
      <method-param>java.util.Date</method-param>
    </method-params>
  </query-method>
  <result-type-mapping>Remote</result-type-mapping>
  <ejb-ql>
    SELECT OBJECT(a) FROM Dept a WHERE a.deptDate = ?1
  </ejb-ql>
</query>
```

### Example 7-5 Another Date Example

```
<query>
  <query-method>
    <method-name>ejbSelectSqlDate</method-name>
```

```
<method-params>
  <method-param>java.sql.Date</method-param>
</method-params>
</query-method>
<result-type-mapping>Remote</result-type-mapping>
<ejb-ql>
  SELECT OBJECT(a) FROM Dept a WHERE a.deptSqlDate = ?1
</ejb-ql>
</query>
```

**Example 7-6 Timestamp Example**

```
<query>
  <query-method>
    <method-name>findByTimestamp</method-name>
    <method-params>
      <method-param>java.sql.Timestamp</method-param>
    </method-params>
  </query-method>
  <result-type-mapping>Remote</result-type-mapping>
  <ejb-ql>
    SELECT OBJECT(a) FROM Dept a WHERE a.deptTimestamp = ?1
  </ejb-ql>
</query>
```

**Example 7-7 Time Example**

```
<query>
  <query-method>
    <method-name>findByTimestamp</method-name>
    <method-params>
      <method-param>java.sql.Time</method-param>
    </method-params>
  </query-method>
  <result-type-mapping>Remote</result-type-mapping>
  <ejb-ql>
    SELECT OBJECT(a) FROM Dept a WHERE a.deptTime = ?1
  </ejb-ql>
</query>
```

---

## BMP Entity Beans

If you want to implement the manual storing and reloading of data, then use a bean-managed persistent (BMP) bean. The container manages the data within callback methods, which you must implement. All the logic for storing data to your persistent storage is included in the `ejbStore` method, and reloaded from your storage in the `ejbLoad` method. The container invokes these methods when necessary.

This chapter demonstrates simple BMP EJB development with a basic configuration and deployment. Download the BMP entity bean example from the OC4J sample code page at <http://www.oracle.com/technology/tech/java/oc4j/demos/> on the OTN Web site.

The following sections discuss how to implement data persistence:

- [Creating BMP Entity Beans](#)
- [Component and Home Interfaces](#)
- [BMP Entity Bean Implementation](#)
- [Create Database Table and Columns for Entity Data](#)

## Creating BMP Entity Beans

[Chapter 3, "Implementing Session Beans"](#) shows how to develop a stateless session bean. [Chapter 5, "CMP Entity Beans"](#) describes the extra steps necessary for implementing a CMP entity bean. In a CMP bean, the primary key and all functions for persistence are performed by the container; in a BMP bean, you must implement the primary key and all functions to save the persistence of your bean. The primary key is managed in the `ejbCreate` method. The persistence is managed within the following functions:

- Persistent saving of the data within the `ejbStore` method.
- Restoring the persistent data to the bean within your implementation of the `ejbLoad` method.
- Passivation of the bean instance within the `ejbPassivate` method.
- Activation of the passivated bean instance within the `ejbActivate` method.

The following is a summary of the steps mentioned in [Chapter 5, "CMP Entity Beans"](#) that you must do when creating your bean. See [Chapter 3, "Implementing Session Beans"](#) and [Chapter 5, "CMP Entity Beans"](#) for further details. The rest of this chapter covers how you implement the primary key and the persistence functions.

1. Create the component interfaces for the bean. The component interfaces declare the methods that a client can invoke.
2. Create the home interfaces for the bean. The home interface defines the `create` and finder methods, including `findByPrimaryKey`, for your bean.
3. Define the primary key for the bean. The primary key identifies each entity bean instance and is a serializable class. You can use a simple data type class, such as `java.lang.String`, or define a complex class, such as one with two or more objects as components of the primary key.
4. Implement the bean.
5. If the persistent data is saved to or restored from a database, you must ensure that the correct tables exist for the bean.
6. Create the bean deployment descriptor. The deployment descriptor specifies properties for the bean through XML elements.
7. Create an EJB JAR file containing the bean, component interface, home interface, and the deployment descriptors. Once created, configure the `application.xml` file, create an EAR file, and deploy the EJB to OC4J.

---

---

**Note:** This book does not cover EJB container services. See the JTA, Data Source, and JNDI chapters in the *Oracle Application Server Containers for J2EE Services Guide* for more information. Since transactions are not covered in this chapter, the example BMP bean uses container-managed transactions.

For security, see the Oracle Application Server Containers for J2EE Security Guide.

---

---

## Component and Home Interfaces

The BMP entity bean definition of the component and home interfaces is identical to the CMP entity bean. For examples of how the component and home interfaces are implemented, see ["Creating Entity Beans"](#) on page 4-2.

## BMP Entity Bean Implementation

Because the container is not managing the primary key or the saving of the persistent data, the bean callback functions must include the implementation logic for these functions. The container invokes the `ejbCreate`, `ejbFindByPrimaryKey`, other finder methods, `ejbStore`, and `ejbLoad` methods when appropriate.

The following sections talk about how you add the implementation for managing your BMP bean:

- [The `ejbCreate` Implementation](#)
- [The `ejbFindByPrimaryKey` Implementation](#)
- [Other Finder Methods](#)
- [The `ejbStore` Implementation](#)
- [The `ejbLoad` Implementation](#)
- [The `ejbPassivate` Implementation](#)
- [The `ejbActivate` Implementation](#)
- [The `ejbRemove` Implementation](#)

### The `ejbCreate` Implementation

The `ejbCreate` method is responsible primarily for the creation of the primary key. This includes the following:

1. Creating the primary key.
2. Creating the persistent data representation for the key.
3. Initializing the key to a unique value and ensuring no duplication.
4. Returning this key to the container.

The container maps the key to the entity bean reference.

The following example shows the `ejbCreate` method for the employee example, which initializes the primary key, `empNo`. It should automatically generate a primary key that is the next available number in the employee number sequence. However, for this example to be simple, the `ejbCreate` method requires that the user provide the unique employee number.

---



---

**Note:** All Try blocks within the samples have been removed in this discussion. However, the entire BMP entity bean example, including the Try blocks, is available on OTN from the OC4J sample code page at <http://www.oracle.com/technology/tech/java/oc4j/demos/> on the OTN Web site.

---



---

In addition, because the full data for the employee is provided within this method, the data is saved within the context variables of this instance. After initialization, it returns this key to the container.

```
// The create methods takes care of generating a new empNo and returns
// its primary key to the container
public Integer ejbCreate (Integer empNo, String empName, Float salary)
    throws CreateException
{
```

```

/* in this implementation, the client gives the employee number, so
   only need to assign it, not create it. */
this.empNo = empNo;
this.empName = empName;
this.salary = salary;

/* insert employee into database */
conn = getConnection(dsName);
ps = conn.prepareStatement("INSERT INTO EMPLOYEEBEAN (EmpNo, EmpName, SAL)
    VALUES ( "+this.empNo.intValue()+", "+this.empName+", "
        +this.salary.floatValue()+")");
ps.executeUpdate();
ps.close();

/* return the new primary key.*/
return (empNo);
}

```

The deployment descriptor defines only the primary key class in the `<prim-key-class>` element. Because the bean is saving the data, there is no definition of persistence data in the deployment descriptor. Note that the deployment descriptor does define the database the bean uses in the `<resource-ref>` element. For more information on database configuration, see ["Modify XML Deployment Descriptors"](#) on page 8-9.

```

<enterprise-beans>
  <entity>
    <display-name>EmployeeBean</display-name>
    <ejb-name>EmployeeBean</ejb-name>
    <local-home>employee.EmployeeHome</local-home>
    <local>employee.Employee</local>
    <ejb-class>employee.EmployeeBean</ejb-class>
    <persistence-type>Bean</persistence-type>
    <prim-key-class>java.lang.Integer</prim-key-class>
    <reentrant>False</reentrant>
    <resource-ref>
      <res-ref-name>jdbc/OracleDS</res-ref-name>
      <res-type>javax.sql.DataSource</res-type>
      <res-auth>Application</res-auth>
    </resource-ref>
  </entity>
</enterprise-beans>

```

Alternatively, you can create a complex primary key based on several data types. You define a complex primary key within its own class, as follows:

```

package employee;

public class EmployeePK implements java.io.Serializable
{
    public Integer empNo;
    public String empName;
    public Float salary;

    public EmployeePK(Integer empNo)
    {
        this.empNo = empNo;
        this.empName = null;
        this.salary = null;
    }
}

```



```

public EmployeePK(Integer empNo, String empName, Float salary)
{
    this.empNo = empNo;
    this.empName = empName;
    this.salary = salary;
}
}

```

For a primary key class, you define the class in the `<prim-key-class>` element, which is the same for the simple primary key definition.

```

<enterprise-beans>
  <entity>
    <display-name>EmployeeBean</display-name>
    <ejb-name>EmployeeBean</ejb-name>
    <local-home>employee.EmployeeHome</local-home>
    <local>employee.Employee</local>
    <ejb-class>employee.EmployeeBean</ejb-class>
    <persistence-type>Bean</persistence-type>
    <prim-key-class>employee.EmployeePK</prim-key-class>
    <reentrant>False</reentrant>
    <resource-ref>
      <res-ref-name>jdbc/OracleDS</res-ref-name>
      <res-type>javax.sql.DataSource</res-type>
      <res-auth>Application</res-auth>
    </resource-ref>
  </entity>
</enterprise-beans>

```

The employee example requires that the employee number is given to the bean by the user. Another method would be to generate the employee number by computing the next available employee number, and use this in combination with the employee's name and office location.

After defining the complex primary key class, you would create your primary key within the `ejbCreate` method, as follows:

```

public EmployeePK ejbCreate(Integer empNo, String empName, Float salary)
    throws CreateException
{
    pk = new EmployeePK(empNo, empName, salary);
    ...
}

```

The other task that the `ejbCreate` (or `ejbPostCreate`) should handle is allocating any resources necessary for the life of the bean. For this example, because we already have the information for the employee, the `ejbCreate` performs the following:

1. Retrieves a connection to the database. This connection remains open for the life of the bean. It is used to update employee information within the database. It should be released in `ejbPassivate` and `ejbRemove`, and reallocated in `ejbActivate`.
2. Updates the database with the employee information.

This is executed, as follows:

```

public EmployeePK ejbCreate(Integer empNo, String empName, Float salary)
    throws CreateException
{
    pk = new EmployeePK(empNo, empName, salary);
}

```

```
conn = getConnection(dsName);
ps = conn.prepareStatement("INSERT INTO EMPLOYEEBEAN (EmpNo, EmpName, SAL)
VALUES ( "+this.empNo.intValue()+", "+this.empName+", "
+this.salary.floatValue()+")");
ps.executeUpdate();
ps.close();
return pk;
}
```

## The ejbFindByPrimaryKey Implementation

The `ejbFindByPrimaryKey` implementation is a requirement for all BMP entity beans. Its primary responsibility is to ensure that the primary key corresponds to a valid bean. Once it is validated, it returns the primary key to the container, which uses the key to return the bean reference to the user.

This sample verifies that the employee number is valid and returns the primary key, which is the employee number, to the container. A more complex verification would be necessary if the primary key was a class.

```
public Integer ejbFindByPrimaryKey(Integer empNoPK)
    throws FinderException
{
    if (empNoPK == null) {
        throw new FinderException("Primary key cannot be null");
    }

    ps = conn.prepareStatement("SELECT EMPNO FROM EMPLOYEEBEAN
WHERE EMPNO = ?");
    ps.setInt(1, empNoPK.intValue());
    ps.executeQuery();
    ResultSet rs = ps.getResultSet();
    if (rs.next()) {
        /*PK is validated because it exists already*/
    } else {
        throw new FinderException("Failed to select this PK");
    }

    ps.close();

    return empNoPK;
}
```

## Other Finder Methods

You can create other finder methods in addition to the single `ejbFindByPrimaryKey`.

To create other finder methods, do the following:

1. Add the finder method to the home interface.
2. Implement the finder method in the BMP bean implementation.

Finders can retrieve one or more beans according to the `WHERE` clause. If more than a single bean is returned, then a `Collection` of primary keys must be returned by the BMP finder method. These finder methods need only to gather the primary keys for all of the entity beans that should be returned to the user. The container maps the primary keys to references to each entity bean within either a `Collection` (if multiple references are returned) or to the single class type.

The following example shows the implementation of a finder method that returns all employee records.

```
public Collection ejbFindAll() throws FinderException
{
    Vector recs = new Vector();

    ps = conn.prepareStatement("SELECT EMPNO FROM EMPLOYEEBEAN");
    ps.executeQuery();
    ResultSet rs = ps.getResultSet();

    int i = 0;

    while (rs.next())
    {
        retEmpNo = new Integer(rs.getInt(1));
        recs.add(retEmpNo);
    }

    ps.close();
    return recs;
}
```

## The ejbStore Implementation

The container invokes the `ejbStore` method when the persistent data should be saved to the database. This synchronizes the state of the instance to the entity in the underlying database. For example, the container invokes before the container passivates the bean instance or removes the instance. The BMP bean is responsible for ensuring that all data is stored to some resource, such as a database, within this method.

```
public void ejbStore()
{
    //Container invokes this method to instruct the instance to
    //synchronize its state by storing it to the underlying database
    ps = conn.prepareStatement("UPDATE EMPLOYEEBEAN SET EMPNAME=?,
        SALARY=? WHERE EMPNO=?");
    ps.setString(1, this.empName);
    ps.setFloat(2, this.salary.floatValue());
    ps.setInt(3, this.empNo.intValue());
    if (ps.executeUpdate() != 1) {
        throw new EJBException("Failed to update record");
    }
    ps.close();
}
```

## The ejbLoad Implementation

The container invokes the `ejbLoad` method whenever it needs to synchronize the state of the bean with what exists in the database. This method is invoked after activating the bean instance to refresh it with the state that is in the database. The purpose of this method is to repopulate the persistent data with the saved state. For most `ejbLoad` methods, this implies reading the data from a database into the instance data variables.

```
public void ejbLoad()
{
    //Container invokes this method to instruct the instance to
    //synchronize its state by loading it from the underlying database
```

```
    this.empNo = ctx.getPrimaryKey();
    ps = conn.prepareStatement("SELECT EMP_NO, EMP_NAME, SALARY WHERE EMPNAME=?");
    ps.setInt(1, this.empNo.intValue());
    ps.executeQuery();
    ResultSet rs = ps.getResultSet();
    if (rs.next()) {
        this.empNo = new Integer(rs.getInt(1));
        this.empName = new String(rs.getString(2));
        this.salary = new Float(rs.getFloat(3));
    } else {
        throw new FinderException("Failed to select this PK");
    }
    ps.close();
}
```

## The `ejbPassivate` Implementation

The `ejbPassivate` method is invoked directly before the bean instance is serialized for future use. It will be re-activated, through the `ejbActivate` method, the next time the user invokes a method on this instance.

Before the bean is passivated, you should release all resources and release any static information that would be too large to be serialized. Any large, static information that can be easily regenerated within the `ejbActivate` method should be released in this method.

In our example, the only resource that cannot be serialized is the open database connection. It is closed in this method and reopened in the `ejbActivate` method.

```
public void ejbPassivate()
{
    // Container invokes this method on an instance before the instance
    // becomes disassociated with a specific EJB object
    conn.close();
}
```

## The `ejbActivate` Implementation

The container invokes this method when the bean instance is reactivated. That is, the user has asked to invoke a method on this instance. This method is used to open resources and rebuild static information that was released in the `ejbPassivate` method.

---

---

**Note:** The container may call the `ejbActivate()` method multiple times when the bean is associated with several wrappers.

---

---

In addition, the container invokes this method after the start of any transaction.

Our employee example opens the database connection where the employee information is stored.

```
public void ejbActivate()
{
    // Container invokes this method when the instance is taken out
    // of the pool of available instances to become associated with
    // a specific EJB object
    conn = getConnection(dsName);
}
```

## The `ejbRemove` Implementation

The container invokes the `ejbRemove` method before removing the bean instance itself or by placing the instance back into the bean pool. This means that the information that was represented by this entity bean should be removed from within persistent storage. The employee example removes the employee and all associated information from the database before the instance is destroyed. Close the database connection.

```
public void ejbRemove() throws RemoveException
{
    //Container invokes this method befor it removes the EJB object
    //that is currently associated with the instance
    ps = conn.prepareStatement("DELETE FROM EMPLOYEEBEAN WHERE EMPNO=?");
    ps.setInt(1, this.empNo.intValue());
    if (ps.executeUpdate() != 1) {
        throw new RemoveException("Failed to delete record");
    }
    ps.close();
    conn.close();
}
```

## Modify XML Deployment Descriptors

In addition to the configuration described in ["Creating Entity Beans"](#) on page 4-2, you must modify and add the following to your `ejb-jar.xml` deployment descriptor:

1. Configure the persistence type to be "Bean" in the `<persistence-type>` element.
2. Configure a resource reference for the database persistence storage in the `<resource-ref>` element.

The employee example used the database environment element of "jdbc/OracleDS". This is configured in the `<resource-ref>` element as follows:

```
<resource-ref>
  <res-ref-name>jdbc/OracleDS</res-ref-name>
  <res-type>javax.sql.DataSource</res-type>
  <res-auth>Application</res-auth>
</resource-ref>
```

The database specified in the `<res-ref-name>` element maps to a `<ejb-location>` element in the `data-sources.xml` file. Our "jdbc/OracleDS" database is configured in the `data-sources.xml` file, as shown below:

```
<data-source
  class="com.evermind.sql.DriverManagerDataSource"
  name="Oracle"
  location="jdbc/OracleCoreDS"
  pooled-location="jdbc/pool/OraclePoolDS"
  ejb-location="jdbc/OracleDS"
  xa-location="jdbc/xa/OracleXADS"
  connection-driver="oracle.jdbc.driver.OracleDriver"
  url="jdbc:oracle:thin:@myhost:1521:orcl"
  username="scott"
  password="tiger"
  max-connections="300"
  min-connections="5"
  max-connect-attempts="10"
```

```
connection-retry-interval="1"  
inactivity-timeout="30"  
wait-timeout="30"  
</>
```

---

---

**Note:** The entire BMP entity bean example is available on OTN from the OC4J sample code page at <http://www.oracle.com/technology/tech/java/oc4j/demos/> on the OTN Web site.

---

---

## Create Database Table and Columns for Entity Data

If your entity bean stores its persistent data within a database, you need to create the appropriate table with the proper columns for the entity bean. This table must be created before the bean is loaded into the database. The container will not create this table for BMP beans, but it will create it automatically for CMP beans.

In our employee example, you must create the following table in the database defined in the `data-sources.xml` file:

Table	Columns
EMPLOYEEBEAN	<ul style="list-style-type: none"><li>employee number (EMPNO)</li><li>employee name (EMPNAME)</li><li>salary (SALARY)</li></ul>

The following shows the SQL commands that create these fields.

```
CREATE TABLE EMPLOYEEBEAN (  
  EMPNO NUMBER NOT NULL,  
  EMPNAME VARCHAR2(255) NOT NULL,  
  SALARY FLOAT NOT NULL,  
  CONSTRAINT EMPNO PRIMARY KEY  
)
```

---

---

**Note:** This book does not cover EJB container services. See the Data Source chapter in the *Oracle Application Server Containers for J2EE Services Guide* for information on how to configure your Data Source object.

---

---

---

---

## Message-Driven Beans

The following sections discuss the tasks in creating an MDB in Oracle Application Server Containers for J2EE (OC4J) and demonstrate MDB development with a basic configuration to use either Oracle Application Server JMS (OracleAS JMS) or Oracle JMS as the JMS provider.

- [MDB Overview](#)
- [MDB Example](#)
- [MDB Using OracleAS JMS](#)
- [MDB Using Oracle JMS](#)
- [Client Access of MDB](#)
- [Windows Considerations When Using MDBs](#)
- [Failover Scenarios When Using a RAC Database](#)
- [Using Timers With Your MDB](#)

Download the MDB example used in this chapter from the OC4J sample code page at <http://www.oracle.com/technology/tech/java/oc4j/demos/> on the OTN Web site.

## MDB Overview

A Message-Driven Bean (MDB) is a Java Message Service (JMS) message listener that can reliably consume messages from a queue or a topic. An MDB uses the asynchronous nature of a JMS listener with the benefit of the EJB container, which does the following:

- The EJB container creates a consumer of type `QueueReceiver` or `TopicSubscriber` for the listener.
- At deployment time, the EJB container registers the MDB with the consumer, which is either a `QueueReceiver` or `TopicSubscriber`, and its factory.
- The EJB container specifies the message acknowledgment mode.

Within normal JMS objects, a JMS message listener exists and must explicitly specify the consumer and its factory within its code. When you use MDBs, the container specifies the consumer and its factory for you; thus, an MDB is an easy method for creating a JMS message listener. You still have to retrieve the objects and create them given the interface, but the container does most of the work for you.

The OC4J MDB interacts with a JMS provider. This chapter highlights two JMS providers, OracleAS JMS and Oracle JMS, each of which must be installed and configured appropriately.

- OracleAS JMS is installed internally within the OC4J code base.
- Oracle JMS (Advanced Queuing) is installed and configured within an Oracle database. Before using Oracle JMS, you must create the appropriate queue or table in the database.

---

---

**Note:** A full description of how to use each JMS provider is discussed in the JMS chapter in the *Oracle Application Server Containers for J2EE Services Guide*. In addition, for information on security, see the *Oracle Application Server Containers for J2EE Security Guide*.

---

---

The following are generic steps to create and enable an MDB with a JMS provider:

1. Install the JMS provider.
2. Configure the JMS provider, the `Destination` objects for the MDB, and connection details for the MDB where the provider is installed.
3. Configure OC4J with the JMS provider details in the OC4J XML files.
4. Implement the MDB and map the JMS `Destination` objects used in its deployment descriptors.

This chapter describes how to implement each of these steps with both the OracleAS JMS and Oracle JMS providers. Each section uses an MDB example that is available for download from the OC4J sample code page at <http://www.oracle.com/technology/tech/java/oc4j/demos/> on the OTN Web site.

The main MDB implementation and the EJB deployment descriptor can be the same for both JMS types and is shown in the "MDB Example" on page 9-3. The OC4J-specific deployment descriptor for this MDB and the JMS configuration is different for each JMS type, so these are described specifically in each of the provider sections.

- [MDB Using OracleAS JMS](#)



- [MDB Using Oracle JMS](#)

## MDB Example

The MDB can process incoming asynchronous requests. Any message for the MDB is routed to the `onMessage` method of the MDB from the queue or topic. Other clients may have access to the same queue or topic to send messages for the MDB. Most MDBs receive messages from a queue or a topic, then invoke an entity bean to process the request contained within the message.

The steps to create an MDB, which are shown in the following sections, are as follows:

1. Implement the bean, as shown in "[MDB Example](#)" on page 9-3.
2. Create the MDB deployment descriptors.
  - a. Define the JMS connection factory and `Destination` used in the EJB deployment descriptor (`ejb-jar.xml`). Define if any durable subscriptions or message selectors are used. See "[EJB Deployment Descriptor \(ejb-jar.xml\) for the MDB](#)" on page 9-7 for details.
  - b. If using resource references, define these in the `ejb-jar.xml` file and map them to their actual JNDI names in the OC4J-specific deployment descriptor (`orion-ejb-jar.xml`).
  - c. If the MDB uses container-managed transaction demarcation, specify the `onMessage` method in the `<container-transaction>` element in the `ejb-jar.xml` file. All of the steps for an MDB should be in the `onMessage` method. Since the MDB is stateless, the `onMessage` method should perform all duties. Do not create the JMS connection and session in the `ejbCreate` method. However, if you are using OracleAS JMS, then you can optimize your MDB by creating the JMS connection and session in the `ejbCreate` method and destroying them in the `ejbRemove` method.
3. Create an EJB JAR file containing the bean and the deployment descriptors. Configure the application-specific `application.xml` file, create an EAR file, and install the EJB in OC4J.

The MDB implementation and the `ejb-jar.xml` deployment descriptor can be exactly the same for the OracleAS JMS or Oracle JMS providers—if you use resource references for the JNDI lookup of the connection factory and the `Destination` object. The `orion-ejb-jar.xml` deployment descriptor contains provider-specific configuration, including the mapping of the resource references. See "[MDB Using OracleAS JMS](#)" on page 9-9 and "[MDB Using Oracle JMS](#)" on page 9-13 for the specific configuration in the `orion-ejb-jar.xml` deployment descriptor.

---

---

**Note:** The example used for the MDB example uses resource references, so that the MDB is generic. If you want to see how to explicitly define a JNDI string for each JMS provider, see "[Client Access of MDB](#)" on page 9-20, as the client uses both explicit JNDI strings as well as resource references.

---

---

## MDB Implementation Example

The major points to do when you implement an MDB are as follows:

---



---

**Note:** See the EJB specification for the full details on all aspects of implementing a MDB.

---



---

1. The bean class must be defined as `public` (not `final` or `abstract`).
2. The bean class must implement the `javax.ejb.MessageDrivenBean` and `javax.jms.MessageListener` interfaces, which include the following:
  - the `onMessage` method in the `MessageListener` interface
  - the `setMessageDrivenContext` method in the `MessageDrivenBean` interface
3. The bean class must implement the container callback methods that normally match methods in the EJB home interface. Remote, local, and home interfaces are not implemented with an MDB. However, some of the callback methods required for these interfaces are implemented in the bean implementation. These methods include the following:
  - an `ejbCreate` method
  - an `ejbRemove` method

#### **Example 9-1** *MDB Implementation*

The following MDB example—`rpTestMdb` MDB—prints out a message sent to it through a queue and responds. The queue is identified in the deployment descriptors and the JMS configuration. In the `onMessage` method, the MDB creates a new message to be sent to the client. It sets the message selector property `RECIPIENT` to be for the `CLIENT`. Then, it sets the reply destination and sends the new message to the JMS client.

This example shows how to receive a message from a queue and send out a response. You can receive a message in several ways. This example uses the methods of the `Message` object to retrieve all attributes of the message.

To send out a response to a queue, you must first set up a sender, which requires the following:

1. Retrieve the `QueueConnectionFactory` object. This example uses a resource reference of `"jms/myQueueConnectionFactory,"` which is defined in the `ejb-jar.xml` file and mapped to the actual JNDI name in the `orion-ejb-jar.xml` file.
2. Create the JMS queue connection using the `createQueueConnection` method of the `QueueConnectionFactory` object.
3. Create a JMS session over the connection using the `createQueueSession` method of the `QueueConnection` object.
4. Once the session is set up, then create a sender that uses the session through the `createSender` method of the `QueueSession` object.

These steps are implemented as follows:

```
private QueueConnection      m_qc      = null;
private QueueSession        m_qs      = null;
private QueueSender         m_snd     = null;
QueueConnectionFactory qcf = (QueueConnectionFactory)
    ctx.lookup("java:comp/env/jms/myQueueConnectionFactory");
m_qc = qcf.createQueueConnection();
m_qs = m_qc.createQueueSession(false, Session.AUTO_ACKNOWLEDGE);
```

```
m_snd = m_qs.createSender(null);
```

Once the sender is created, you can send any message using the `send` method of the `QueueSender` object. This example puts together a response from the received message and then use the sender to send out that response.

5. Create a message using the `createMessage` method of the `Message` object.
6. Set properties of the message using methods of the `Message` object, such as `setStringProperty` and `setIntProperty`.
7. This example retrieves the destination for its response through the `getJMSReplyTo` method of the `Message` object. The destination was initialized in the message by the sender.
8. Send out the response using the sender through the `send` method of the `QueueSender` object. Provide the destination and the response message.

```
Message rmsg = m_qs.createMessage();
rmsg.setStringProperty("RECIPIENT", "CLIENT");
rmsg.setIntProperty("count",
    msg.getIntProperty("JMSXDeliveryCount"));
rmsg.setJMSCorrelationID(msg.getJMSMessageID());
Destination d = msg.getJMSReplyTo();
m_snd.send((Queue) d, rmsg);
```

### **Example 9–2 MDB Implementation**

The following is the complete example of the MDB that receives a message and sends back a response.

```
import java.util.*;
import javax.ejb.*;
import javax.jms.*;
import javax.naming.*;

public class rpTestMdb implements MessageDrivenBean, MessageListener
{
    private QueueConnection    m_qc    = null;
    private QueueSession      m_qs    = null;
    private QueueSender        m_snd   = null;
    private MessageDrivenContext m_ctx  = null;

    /* Constructor, which is public and takes no arguments.*/
    public rpTestMdb()
    {
    }

    /* setMessageDrivenContext method */
    public void setMessageDrivenContext(MessageDrivenContext ctx)
    {
        /* As with all EJBs, you must set the context in order to be
           able to use it at another time within the MDB methods. */
        m_ctx = ctx;
    }

    /* ejbCreate method, declared as public (but not final or
       * static), with a return type of void, and with no arguments.
       */
    public void ejbCreate()
    {
    }

    /* ejbRemove method */
```

```

public void ejbRemove()
{
}

/**
 * onMessage method
 * Receives the incoming Message and displays the text.
 */
public void onMessage(Message msg)
{
    /* An MDB does not carry state for an individual client. */
    try
    {
        Context ctx = new InitialContext();
        // 1. Retrieve the QueueConnectionFactory using a
        // resource reference defined in the ejb-jar.xml file.
        QueueConnectionFactory qcf = (QueueConnectionFactory)
            ctx.lookup("java:comp/env/jms/myQueueConnectionFactory");
        ctx.close();

        /*You create the queue connection first, then a session
        over the connection. Once the session is set up, then
        you create a sender */
        // 2. Create the queue connection
        m_qc = qcf.createQueueConnection();
        // 3. Create the session over the queue connection.
        m_qs = m_qc.createQueueSession(false, Session.AUTO_ACKNOWLEDGE);
        // 4. Create the sender to send messages over the session.
        m_snd = m_qs.createSender(null);

        /* When the onMessage method is called, a message has
        been sent. You can retrieve attributes of the message using the
        Message object. */
        String txt = ("mdb rcv: " + msg.getJMSMessageID());
        System.out.println(txt + " redel="
            + msg.getJMSRedelivered() + " cnt="
            + msg.getIntProperty("JMSXDeliveryCount"));

        /* Create a new message using the createMessage
        method. To send it back to the originator of the other message,
        set the String property of "RECIPIENT" to "CLIENT."
        The client only looks for messages with string property CLIENT.
        Copy the original message ID into new msg's Correlation ID for
        tracking purposes using the setJMSCorrelationID method. Finally,
        set the destination for the message using the getJMSReplyTo method
        on the previously received message. Send the message using the
        send method on the queue sender.
        */
        // 5. Create a message using the createMessage method
        Message rmsg = m_qs.createMessage();
        // 6. Set properties of the message.
        rmsg.setStringProperty("RECIPIENT", "CLIENT");
        rmsg.setIntProperty("count",
            msg.getIntProperty("JMSXDeliveryCount"));
        rmsg.setJMSCorrelationID(msg.getJMSMessageID());
        // 7. Retrieve the reply destination.
        Destination d = msg.getJMSReplyTo();
        // 8. Send the message using the send method of the sender.
        m_snd.send((Queue) d, rmsg);

        System.out.println(txt + " snd: " + rmsg.getJMSMessageID());
    }
}

```

```

        /* close the connection*/
        m_gc.close();
    }
    catch (Throwable ex)
    {
        ex.printStackTrace();
    }
}
}

```

---

**Note:** The entire MDB example is available on OTN from the OC4J sample code page at <http://www.oracle.com/technology/tech/java/oc4j/demos/> on the OTN Web site.

---

## EJB Deployment Descriptor (ejb-jar.xml) for the MDB

Within the EJB deployment descriptor (`ejb-jar.xml`), define the MDB name, class, JNDI reference, and JMS Destination type (queue or topic) in the `<message-driven>` element. If a topic is specified, you define whether it is durable. If you have used resource references, define the resource reference for both the connection factory and the Destination object.

The following example demonstrates the deployment information for the `rpTestMdb` MDB in the `<message-driven>` element, as follows:

- MDB name specified in the `<ejb-name>` element.
- MDB class defined in the `<ejb-class>` element, which ties the `<message-driven>` element to the specific MDB implementation.
- JMS Destination type is a Queue that is specified in the `<message-driven-destination><destination-type>` element.
- Message selector specifies that this MDB only receives messages where the RECIPIENT is MDB.

---

**Note:** You could also specify a topic in this type definition. If you did specify a Topic in the type, then you could also define the durability of the topic, which is specified in the `<message-driven-destination><subscription-durability>` element as "Durable" or "nonDurable."

---

- The type of transaction to use is defined in the `<transaction-type>` element. The value can be Container or Bean. If Container is specified, define the `onMessage` method within the `<container-transaction>` element with the type of CMT support.
- The resource reference for the connection factory is defined in the `<resource-ref>` element; the resource reference for the Destination object is defined in the `<resource-env-ref>` element. See ["Using a Logical Name When Client Accesses the MDB"](#) on page 9-25 for a full discussion on resource references for JMS object types.

```

<?xml version="1.0" encoding="UTF-8"?>
<!DOCTYPE ejb-jar PUBLIC "-//Sun Microsystems, Inc.//DTD Enterprise JavaBeans

```

```

2.0//EN' 'http://java.sun.com/dtd/ejb-jar_2_0.dtd'>

<ejb-jar>
  <display-name>Mdb Test</display-name>
  <enterprise-beans>
    <message-driven>
      <display-name>testMdb</display-name>
      <ejb-name>testMdb</ejb-name>
      <ejb-class>rpTestMdb</ejb-class>
      <transaction-type>Container</transaction-type>
      <message-selector>RECIPIENT='MDB'</message-selector>
      <message-driven-destination>
        <destination-type>javax.jms.Queue</destination-type>
      </message-driven-destination>
      <resource-ref>
        <description>description</description>
        <res-ref-name>jms/myQueueConnectionFactory</res-ref-name>
        <res-type>javax.jms.QueueConnectionFactory</res-type>
        <res-auth>Application</res-auth>
        <res-sharing-scope>Shareable</res-sharing-scope>
      </resource-ref>
      <resource-env-ref>
        <resource-env-ref-name>jms/persistentQueue
        </resource-env-ref-name>
        <resource-env-ref-type>javax.jms.Queue</resource-env-ref-type>
      </resource-env-ref>
    </message-driven>
  </enterprise-beans>

  <assembly-descriptor>
    <container-transaction>
      <method>
        <ejb-name>testMdb</ejb-name>
        <method-name>onMessage</method-name>
        <method-params>
          <method-param>javax.jms.Message</method-param>
        </method-params>
      </method>
      <trans-attribute>Required</trans-attribute>
    </container-transaction>
  </assembly-descriptor>
</ejb-jar>

```

If you were going to configure a durable Topic instead, then the <message-driven-destination> element would be configured as follows:

```

<message-driven-destination>
  <destination-type>javax.jms.Topic</destination-type>
  <subscription-durability>Durable</subscription-durability>
</message-driven-destination>

```

---

**Note:** The entire MDB example is available on OTN from the OC4J sample code page at <http://www.oracle.com/technology/tech/java/oc4j/demos/> on the OTN Web site.

---

The OC4J-specific deployment descriptor (orion-ejb-jar.xml) for this MDB and the JMS provider configuration necessary is shown in the following sections:

- [MDB Using OracleAS JMS](#)
- [MDB Using Oracle JMS](#)

Instructions on how a client sends a JMS message to the MDB is discussed in "[Client Access of MDB](#)" on page 9-20.

## MDB Using OracleAS JMS

The MDB can process incoming asynchronous requests using OracleAS JMS. When you use OracleAS JMS, this JMS provider is already available since it is bundled with OC4J. And all configuration for the JMS provider occurs within the OC4J XML files; thus, only steps three and four (as listed in "[MDB Overview](#)" on page 9-2) are necessary.

---

**Note:** The entire MDB example is available on OTN from the OC4J sample code page at <http://www.oracle.com/technology/tech/java/oc4j/demos/> on the OTN Web site.

---

[Figure 9-1](#) shows how a client sends an asynchronous request directly to the OracleAS JMS queue or topic that is located internally within OC4J. The MDB receives the message directly from OracleAS JMS.

**Figure 9-1** *Demonstration of an MDB Interacting with an OracleAS JMS Destination*

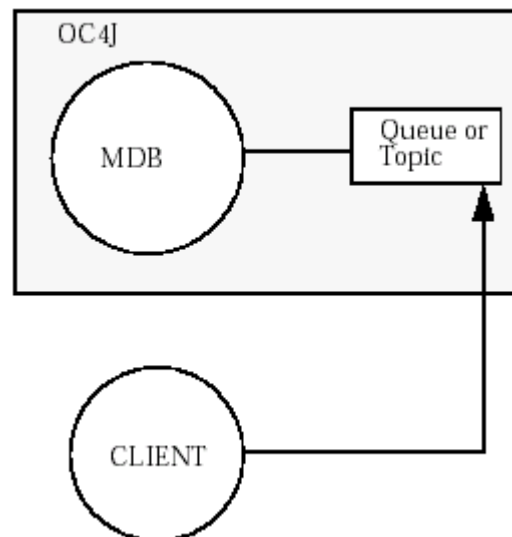

The following sections demonstrate an MDB that uses OracleAS JMS as the JMS provider.

- [Configure OracleAS JMS in the XML files](#)
- [Create the OC4J-Specific Deployment Descriptor to Use OracleAS JMS](#)
- [Deploying the MDB](#)

---

---

**Note:** A full description of how to use each JMS provider is available in the JMS chapter in the *Oracle Application Server Containers for J2EE Services Guide*.

---

---

## Configure OracleAS JMS in the XML files

OracleAS JMS is automatically enabled. You only configure the JMS `Destination` objects used by the MDB. If your MDB accesses a database for inquiries and so on, then you can configure the `DataSource` used. See "[JMS Destination Object Configuration](#)" on page 9-10 for the JMS configuration. For information on data source configuration, see the Data Source chapter in the *Oracle Application Server Containers for J2EE Services Guide*.

### JMS Destination Object Configuration

Configure the topic or queue in the `jms.xml` file to which the client sends all messages that are destined for the MDB. The name, location, and connection factory for either `Destination` type must be specified.

The following `jms.xml` file configuration specifies a queue—named `jms/Queue/rpTestQueue`—that is used by the `rpTestMdb` example. The queue connection factory is defined as `jms/Queue/myQCF`. In addition, a topic is defined named `jms/Topic/rpTestTopic`, with a connection factory of `jms/Topic/myTCF`.

```
<?xml version="1.0" ?>
<!DOCTYPE jms-server PUBLIC "OracleAS JMS server"
"http://xmlns.oracle.com/ias/dtds/jms-server.dtd">

<jms-server port="9128">
  <queue location="jms/Queue/rpTestQueue"> </queue>
  <queue-connection-factory location="jms/Queue/myQCF">
    </queue-connection-factory>

  <topic location="jms/Topic/rpTestTopic"> </topic>
  <topic-connection-factory location="jms/Topic/myTCF">
    </topic-connection-factory>

  <!-- path to the log-file where JMS-events/errors are stored -->
  <log>
    <file path="../log/jms.log" />
  </log>
</jms-server>
```

## Create the OC4J-Specific Deployment Descriptor to Use OracleAS JMS

The OC4J-specific deployment descriptor configures the following:

- Specify the `Destination` and connection factory JNDI locations to the MDB through the `<message-driven-deployment>` element in the `orion-ejb-jar.xml` file. See "[Specify the Destination and Connection Factory](#)" on page 9-17 for full details.
- Associate any logical names defined as resource references in the `ejb-jar.xml` file to the correct queue or topic, which, for OracleAS JMS, is defined in the `jms.xml` file. You could have several topics and queues defined in the `jms.xml` file. See "[Map Any Resource References to JNDI Names](#)" on page 9-19 for full details on mapping the resource references in the `orion-ejb-jar.xml` file.



## OracleAS JMS

Since this example uses resource references in the `ejb-jar.xml` file, the `orion-ejb-jar.xml` file maps these logical names to the actual JNDI names of the connection factory and the JMS Destination object, which are defined in the `jms.xml` file. In this example, the MDB uses a queue that is defined in the `jms.xml` file as `jms/Queue/rpTestQueue`. The queue connection factory is defined in the `jms.xml` file as `jms/Queue/myQCF`.

### Specify the Destination and Connection Factory

Map the Destination and connection factory JNDI locations to the MDB through the `<message-driven-deployment>` element in the `orion-ejb-jar.xml` file. The following is the `orion-ejb-jar.xml` deployment descriptor for the `rpTestMdb` example. It maps a JMS Queue to the `rpTestMdb` MDB, providing the following:

- MDB name, as defined in the `<ejb-name>` in the EJB deployment descriptor, is specified in the `name` attribute.
- JMS Destination, as defined in the `jms.xml` file, is specified in the `destination-location` attribute.
- JMS Destination Connection Factory, as defined in the `jms.xml` file, is specified in the `connection-factory-location` attribute.
- If this was a topic, then a durable topic name, which is user-defined, is specified in the `subscription-name` attribute.
- Listener threads, as defined in the `listener-threads` attribute, is an optional parameter. The listener threads are spawned off when MDBs are deployed and are used to listen for incoming JMS messages on the topic or queue. These threads concurrently consume JMS messages. The default is one thread. Topics always have only one thread.

Once all of these are specified in the `<message-driven-deployment>` element, the container knows how to map the MDB to the correct JMS Destination.

```
<enterprise-beans>
...
<message-driven-deployment name="rpTestMdb"
  connection-factory-location="jms/Queue/myQCF"
  destination-location="jms/Queue/rpTestQueue" >
</message-driven-deployment>
...
</enterprise-beans>
```

If you wanted to specify a topic, you must also include the subscription name, as follows:

```
<enterprise-beans>
<message-driven-deployment name="rpTestMdb"
  connection-factory-location="jms/Queue/myQCF"
  destination-location="jms/Queue/rpTestQueue"
  subscription-name="MDBSUB" >
...
</enterprise-beans>
```

---

---

**Note:** You cannot use logical names in these fields. You must specify the full JNDI syntax for both the connection factory and the Destination object.

---

---

### Map Any Resource References to JNDI Names

When you define logical names as resource references for your connection factory and Destination object, you have to map these to the actual JNDI names.

- Map the resource reference for the queue connection factory in the `<resource-ref-mapping>` element. In the `rpTestMdb` example, the logical name for the connection factory is `jms/myQueueConnectionFactory`. This must be mapped to the JNDI string of `jms/Queue/myQCF`, which is defined in the `jms.xml` file.
- Map the resource reference for the Destination object in the `<resource-env-ref-mapping>` element. In the `rpTestMdb` example, the logical name for the queue is `jms/persistentQueue`. This is mapped to the JNDI string of `jms/Queue/rpTestQueue`, which is defined in the `jms.xml` file.

```
<resource-ref-mapping name="jms/myQueueConnectionFactory"
    location="jms/Queue/myQCF"/>
<resource-env-ref-mapping name="jms/persistentQueue"
    location="jms/Queue/rpTestQueue" />
```

#### **Example 9-3** *The orion-ejb-jar.xml file for the rpTestMdb Example*

The following lists the complete `orion-ejb-jar.xml` file for the `rpTestMdb` example. It includes both the definition of the OracleAS JMS objects and the resource reference mappings.

```
<enterprise-beans>
  <message-driven-deployment name="testMdb"
    connection-factory-location="jms/Queue/myQCF"
    destination-location="jms/Queue/rpTestQueue" listener-threads="1">

    <resource-ref-mapping name="jms/myQueueConnectionFactory"
      location="jms/Queue/myQCF"/>
    <resource-env-ref-mapping name="jms/persistentQueue"
      location="jms/Queue/rpTestQueue" />
  </message-driven-deployment>
</enterprise-beans>
<assembly-descriptor>
  <default-method-access>
    <security-role-mapping name="&lt;default-ejb-caller-role&gt;"
      impliesAll="true" />
  </default-method-access>
</assembly-descriptor>
```

## Deploying the MDB

Archive your EJB into a JAR file. You deploy the MDB the same way as the session bean, which is detailed in [Prepare the EJB Application for Assembly](#) on page 3-7 and [Deploy the Enterprise Application to OC4J](#) on page 3-9.

---

---

**Note:** Instructions on how a client sends a JMS message to the MDB is discussed in ["Client Access of MDB"](#) on page 9-20.

---

---

## MDB Using Oracle JMS

The MDB processes incoming asynchronous requests using Oracle JMS (Advanced Queuing), as follows:

---



---

**Caution:** MDBs only work with certain versions of the Oracle database. See the certification matrix in the JMS chapter of the *Oracle Application Server Containers for J2EE Services Guide* for more information.

---



---

1. The MDB opens a JMS connection to the database using a data source with a username and password. The data source represents the Oracle JMS provider and uses a JDBC driver to facilitate the JMS connection.
2. The MDB opens a JMS session over the JMS connection.
3. Any message for the MDB is routed to the `onMessage` method of the MDB.

At any time, the client can send a message to the Oracle JMS topic or queue on which MDBs are listening. The Oracle JMS topic or queue is located in the database.

---



---

**Note:** The entire MDB example is available on OTN from the OC4J sample code page at <http://www.oracle.com/technology/tech/java/oc4j/demos/> on the OTN Web site.

---



---

**Figure 9–2 Demonstration of an MDB Interacting with an Oracle JMS Destination**

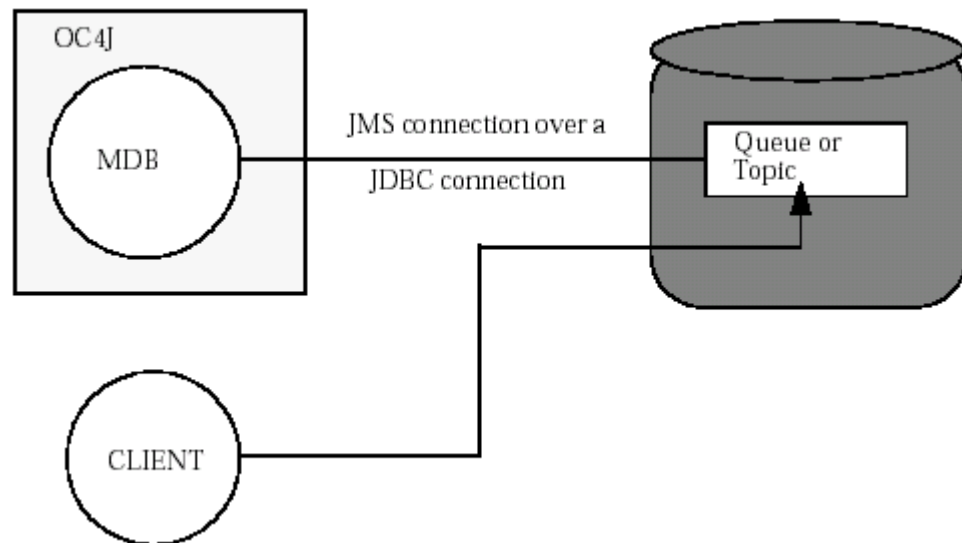

The following sections demonstrate an MDB that uses Oracle JMS as the JMS provider.

- [Install and Configure the JMS Provider](#)
- [Configure the OC4J XML Files for the JMS Provider](#)
- [Create the OC4J-Specific Deployment Descriptor to Use Oracle JMS](#)
- [Deploy the MDB](#)

---

---

**Note:** A full description of how to use Oracle JMS provider is discussed in the JMS chapter in the *Oracle Application Server Containers for J2EE Services Guide*. Also, see the *Oracle9i Application Developer's Guide - Advanced Queuing*.

---

---

## Install and Configure the JMS Provider

You or your DBA must install Oracle JMS according to the *Oracle9i Application Developer's Guide—Advanced Queuing for Release 2 (9.2)* and generic database manuals. Once you have installed and configured this JMS provider, you must apply additional configuration for each MDB. This includes the following:

1. You or your DBA should create an RDBMS user through which the MDB connects to the database. Grant this user appropriate access privileges to perform Oracle JMS operations. See "[Create User and Assign Privileges](#)" on page 9-14.
2. You or your DBA should create the tables and queues to support the JMS Destination objects. See "[Create JMS Destination Objects](#)" on page 9-14.

---

---

**Note:** The following sections use SQL for creating queues, topics, their tables, and assigning privileges that is provided within the MDB demo on OTN from the OC4J sample code page at <http://www.oracle.com/technology/tech/java/oc4j/demos/> on the OTN Web site.

---

---

### Create User and Assign Privileges

Create an RDBMS user through which the MDB connects to the database. Grant access privileges to this user to perform Oracle JMS operations. The privileges that you need depend on what functionality you are requesting. Refer to the *Oracle9i Application Developer's Guide—Advanced Queuing for Release 2 (9.2)* for more information on privileges necessary for each type of function.

The following example creates `jmsuser`, which must be created within its own schema, with privileges required for Oracle JMS operations. You must be a SYS DBA to execute these statements.

```
DROP USER jmsuser CASCADE ;

GRANT connect, resource,AQ_ADMINISTRATOR_ROLE TO jmsuser IDENTIFIED BY jmsuser ;
GRANT execute ON sys.dbms_aqadm TO jmsuser;
GRANT execute ON sys.dbms_aq TO jmsuser;
GRANT execute ON sys.dbms_aqin TO jmsuser;
GRANT execute ON sys.dbms_aqjms TO jmsuser;

connect jmsuser/jmsuser;
```

You may need to grant other privileges, such as two-phase commit or system administration privileges, based on what the user needs. See the JTA chapter in the *Oracle Application Server Containers for J2EE Services Guide* for the two-phase commit privileges.

### Create JMS Destination Objects

Each JMS provider requires its own method for creating the JMS Destination object. Refer to the *Oracle9i Application Developer's Guide—Advanced Queuing for Release 2 (9.2)*

for more information on the DBMS\_AQADM packages and Oracle JMS messages types. For our example, Oracle JMS requires the following methods:

---



---

**Note:** The SQL for creating the tables for the Oracle JMS example is included in the MDB example available on OTN from the OC4J sample code page at <http://www.oracle.com/technology/tech/java/oc4j/demos/> on the OTN Web site.

---



---

1. Create the tables that handle the JMS Destination (queue or topic).

In Oracle JMS, both topics and queues use a queue table. The rpTestMdb JMS example creates a single table: rpTestQTab for a queue.

To create the queue table, execute the following SQL:

```
DBMS_AQADM.CREATE_QUEUE_TABLE(
    Queue_table      => 'rpTestQTab',
    Queue_payload_type => 'SYS.AQ$_JMS_MESSAGE',
    sort_list => 'PRIORITY,ENQ_TIME',
    multiple_consumers => false,
    compatible      => '8.1.5');
```

The multiple\_consumers parameter denotes whether there are multiple consumers or not; thus, is always false for a queue and true for a topic.

2. Create the JMS Destination. If you are creating a topic, you must add each subscriber for the topic. The rpTestMdb JMS example requires a single queue—rpTestQueue.

The following creates a queue called rpTestQueue within the queue table rpTestQTab. After creation, the queue is started.

```
DBMS_AQADM.CREATE_QUEUE(
    Queue_name      => 'rpTestQueue',
    Queue_table     => 'rpTestQTab');

DBMS_AQADM.START_QUEUE(
    queue_name     => 'rpTestQueue');
```

If you wanted to add a topic, then the following example shows how you can create a topic called rpTestTopic within the topic table rpTestTTab. After creation, two durable subscribers are added to the topic. Finally, the topic is started and a user is granted a privilege to it.

---



---

**Note:** Oracle AQ uses the DBMS\_AQADM.CREATE\_QUEUE method to create both queues and topics.

---



---

```
DBMS_AQADM.CREATE_QUEUE_TABLE(
    Queue_table      => 'rpTestTTab',
    Queue_payload_type => 'SYS.AQ$_JMS_MESSAGE',
    multiple_consumers => true,
    compatible      => '8.1.5');
DBMS_AQADM.CREATE_QUEUE('rpTestTopic', 'rpTestTTab');
DBMS_AQADM.ADD_SUBSCRIBER('rpTestTopic',
    sys.aq$_agent('MDSUB', null, null));
DBMS_AQADM.ADD_SUBSCRIBER('rpTestTopic',
    sys.aq$_agent('MDSUB2', null, null));
```

```
DBMS_AQADM.START_QUEUE('rpTestTopic');
```

---

---

**Note:** The names defined here must be the same names used to define the queue or topic in the `orion-ejb-jar.xml` file.

---

---

## Configure the OC4J XML Files for the JMS Provider

To use the Oracle JMS provider, you must configure the following in the OC4J XML files:

- [Configure the DataSource](#)
- [Identify the JNDI Name of the Oracle JMS Data Source](#)

### Configure the DataSource

Configure a data source for the database where the Oracle JMS provider is installed. The JMS topics and queues use database tables and queues to facilitate messaging. The type of data source you use depends on the functionality you want.

**Transactional Functionality** For no transactions or single-phase transactions, you can use either an emulated or non-emulated data sources. For two-phase commit transaction support, you can use only a non-emulated data source.

#### *Example 9–4 Emulated DataSource With Thin JDBC Driver*

The following example contains an emulated data source that uses the thin JDBC driver. To support a two-phase commit transaction, use a non-emulated data source. For differences between emulated and non-emulated data sources, see the Data Source chapter in the *Oracle Application Server Containers for J2EE Services Guide*.

The example is displayed in the format of an XML definition; see the *Oracle Application Server Containers for J2EE User's Guide* for directions on adding a new data source to the configuration through the EM tool.

```
<data-source
  class="com.evermind.sql.DriverManagerDataSource"
  name="OracleDS"
  location="jdbc/emulatedOracleCoreDS"
  xa-location="jdbc/xa/emulatedOracleXADS"
  ejb-location="jdbc/emulatedDS"
  connection-driver="oracle.jdbc.driver.OracleDriver"
  username="jmsuser"
  password="jmsuser"
  url="jdbc:oracle:thin:@myhost.foo.com:1521:mydb"
/>
```

Customize this data source to match your environment. For example, substitute the host name, port, and SID of your database for `mysun:1521:orcl`.

---

---

**Note:** Instead of providing the password in the clear, you can use password indirection. For details, see the *Oracle Application Server Containers for J2EE Services Guide*.

---

---

### Identify the JNDI Name of the Oracle JMS Data Source

Identify the JNDI name of the data source that is to be used as the Oracle JMS provider within the `<resource-provider>` element.

- If this is to be the JMS provider for all applications (global), configure the `global-application.xml` file.
- If this is to be the JMS provider for a single application (local), configure the `orion-application.xml` file of the application.

The following code sample shows how to configure the JMS provider using XML syntax for Oracle JMS.

- `class` attribute—The Oracle JMS provider is implemented by the `oracle.jms.OjmsContext` class, which is configured in the `class` attribute.
- `property` attribute—Identify the data source that is to be used as this JMS provider in the `property` element. The topic or queue connects to this data source to access the tables and queues that facilitate the messaging.

The following example demonstrates that the data source identified by "jdbc/emulatedDS" is to be used as the Oracle JMS provider. This JNDI name is identified in the `ejb-location` element in [Example 9-4](#). If this example used a non-emulated data source, then the name would be the same as in the `location` element.

```
<resource-provider class="oracle.jms.OjmsContext" name="myProvider">
  <description> OJMS/AQ </description>
  <property name="datasource" value="jdbc/emulatedDS"></property>
</resource-provider>
```

## Create the OC4J-Specific Deployment Descriptor to Use Oracle JMS

The OC4J-specific deployment descriptor configures the following:

- Specify the `Destination` and connection factory JNDI locations to the MDB through the `<message-driven-deployment>` element in the `orion-ejb-jar.xml` file. See ["Specify the Destination and Connection Factory"](#) on page 9-17 for full details.
- Associate any logical names defined as resource references in the `ejb-jar.xml` file to the correct queue or topic, which, for Oracle JMS, was defined in the database through SQL. You could have several topics and queues defined in database. See ["Map Any Resource References to JNDI Names"](#) on page 9-19 for full details on mapping the resource references in the `orion-ejb-jar.xml` file.

### OracleAS JMS

Since this example uses resource references in the `ejb-jar.xml` file, the `orion-ejb-jar.xml` file maps these logical names to the actual JNDI names of the connection factory and the JMS `Destination` object, which are defined in the database. In this example, the MDB uses a queue that is defined in the database as `rpTestQueue`. The queue connection factory is not defined in the database, so any name can be used. For consistency, the queue connection factory name is `myQCF`.

### Specify the Destination and Connection Factory

Map the `Destination` and connection factory JNDI locations to the MDB through the `<message-driven-deployment>` element in the `orion-ejb-jar.xml` file. The following is the `orion-ejb-jar.xml` deployment descriptor for the `rpTestMdb` example. It maps a JMS `Queue` to the `rpTestMdb` MDB, providing the following:

- MDB name, as defined in the `<message-driven><ejb-name>` in the EJB deployment descriptor, is specified in the `name` attribute.
- JMS Destination Connection Factory, as specified by the user, is specified in the `connection-factory-location` attribute. The Oracle JMS syntax for the connection factory is `"java:comp/resource" + JMS provider name + "TopicConnectionFactory"` or `"QueueConnectionFactory"` + a user defined name. The user-defined name can be anything and does not match any other configuration. The `xxxConnectionFactory` details what type of factory is being defined. For this example, the JMS provider name is defined in the `<resource-provider>` element in the `application.xml` file as `myProvider`.
  - For a queue connection factory: Since the JMS provider name is `myProvider` and you decide to use a name of `myQCF`, the connection factory name is `"java:comp/resource/myProvider/QueueConnectionFactory/myQCF"`.
  - For a topic connection factory: Since the JMS provider name is `myProvider` and you decide to use a name of `myTCF`, the connection factory name is `"java:comp/resource/myProvider/TopicConnectionFactory/myTCF"`.

The user defined names, as shown above by `myQCF` and `myTCF`, are not used for anything else in your logic. So, any name can be chosen.

- JMS Destination, as defined in the database, is specified in the `destination-location` element. The Oracle JMS syntax for the Destination is `"java:comp/resource" + JMS provider name + "Topics" or "Queues" + Destination name`. The `Topic` or `Queue` details what type of Destination is being defined. The `Destination` name is the actual queue or topic name defined in the database.

For this example, the JMS provider name is defined in the `<resource-provider>` element in the `application.xml` file as `myProvider`. In the database, the topic name is `rpTestQueue`.

- For a queue: If the JMS provider name is `myProvider` and the queue name is `rpTestQueue`, then the JNDI name for the queue as `"java:comp/resource/myProvider/Queues/rpTestQueue."`
- For a topic: If the JMS provider name is `myProvider` and the topic name is `rpTestTopic`, then the JNDI name for the topic as `"java:comp/resource/myProvider/Topics/rpTestTopic."`
- If this was a topic, then a durable topic name, which is user-defined, is specified in the `subscription-name` attribute.
- Listener threads are an optional parameter and defined in the `listener-threads` attribute. The listener threads are spawned off when MDBs are deployed and are used to listen for incoming JMS messages on the topic or queue. These threads concurrently consume JMS messages. The default is one thread. Topics always use only one thread; queues can use more than one.
- Transaction timeout, as defined in the `transaction-timeout` attribute, is an optional parameter. This attribute controls the transaction timeout interval (in seconds) for any container-managed transactional MDB. The default is one day or 86,400 seconds. If the transaction has not completed in this time frame, the transaction is rolled back and the message is redelivered back to the Destination object.



The MDB `transaction-timeout` attribute applies only to CMT MDBs that use Oracle JMS as the JMS provider. This attribute setting has no effect on BMT MDBs or any MDBs that use OC4J JMS:

- JMS behavior with Oracle Application Server—JMS attempts to redeliver the message (defaults to five attempts and is set on the `DBMS_AQADM.CREATE_QUEUE` method when creating the queue in the database), after which the message is moved to the exception queue. You can browse messages in the exception queue using SQL\*Plus. For more information on setting redelivery attempts and browsing the exception queue, refer to the *Oracle9i Application Developer's Guide—Advanced Queuing for Release 2 (9.2)*.
- JMS behavior with OC4J—The `transaction-timeout` setting does not work for CMT MDBs that use OC4J JMS. The timeout is always one day and cannot be modified. When the timeout occurs, OC4J JMS redelivers the message indefinitely, until the delivery is successful. You cannot set a retry limit.

In addition, the global `transaction-timeout` attribute defined in the `server.xml` file does not have any effect on MDBs.

Once all of these are specified in the `<message-driven-deployment>` element, the container knows how to map the MDB to the correct JMS Destination.

```
<message-driven-deployment name="testMdb"
  connection-factory-location=
    "java:comp/resource/myProvider/QueueConnectionFactories/myQCF"
  destination-location="java:comp/resource/myProvider/Queues/rpTestQueue"
  listener-threads="5">
```

If you wanted to specify a topic, you must also include the subscription name, as follows:

```
<enterprise-beans>
  <message-driven-deployment
    name="rpTestMdb"
    connection-factory-location=
      "java:comp/resource/myProvider/TopicConnectionFactories/myTCF"
    destination-location="java:comp/resource/cartojms1/Topics/rpTestTopic"
    subscription-name="MDBSUB"
    listener-threads=1 >
    ...
</enterprise-beans>
```

---

**Note:** You cannot use logical names in these fields. You must specify the full JNDI syntax for both the connection factory and the Destination object.

---

### Map Any Resource References to JNDI Names

When you define logical names as resource references for your connection factory and Destination object, you have to map these to the actual JNDI names.

- Map the resource reference for the queue connection factory in the `<resource-ref-mapping>` element. In the `rpTestMdb` example, the logical name for the connection factory is `jms/myQueueConnectionFactory`. This must be mapped to the JNDI string of `java:comp/resource/myProvider/QueueConnectionFactories/myQCF`.

- Map the resource reference for the `Destination` object in the `<resource-env-ref-mapping>` element. In the `rpTestMdb` example, the logical name for the queue is `jms/persistentQueue`. This is mapped to the JNDI string of `java:comp/resource/myProvider/Queues/rpTestQueue`.

See ["Specify the Destination and Connection Factory"](#) on page 9-17 for how the Oracle JMS JNDI syntax was derived.

```
<resource-ref-mapping name="jms/myQueueConnectionFactory"
    location="java:comp/resource/myProvider/QueueConnectionFactories/myQCF" />
<resource-env-ref-mapping name="jms/persistentQueue"
    location="java:comp/resource/myProvider/Queues/rpTestQueue" />
```

#### **Example 9-5 The orion-ejb-jar.xml file for the rpTestMdb Example**

The following lists the complete `orion-ejb-jar.xml` file for the `rpTestMdb` example. It includes both the definition of the Oracle JMS objects and the resource reference mappings.

```
<enterprise-beans>
  <message-driven-deployment name="testMdb"
    connection-factory-location=
      "java:comp/resource/myProvider/QueueConnectionFactories/myQCF"
    destination-location="java:comp/resource/myProvider/Queues/rpTestQueue"
    listener-threads="5">

    <resource-ref-mapping name="jms/myQueueConnectionFactory"
      location="java:comp/resource/myProvider/QueueConnectionFactories/myQCF" />
    <resource-env-ref-mapping name="jms/persistentQueue"
      location="java:comp/resource/myProvider/Queues/rpTestQueue" />
  </message-driven-deployment>
</enterprise-beans>
<assembly-descriptor>
  <default-method-access>
    <security-role-mapping name="&lt;default-ejb-caller-role&gt;"
      impliesAll="true" />
  </default-method-access>
</assembly-descriptor>
```

## Deploy the MDB

Archive your MDB into a JAR file. You deploy the MDB in the same way as the session bean, which [Prepare the EJB Application for Assembly](#) on page 3-7 and ["Deploy the Enterprise Application to OC4J"](#) on page 3-9 describe.

---

**Note:** Instructions on how a client sends a JMS message to the MDB is discussed in ["Client Access of MDB"](#) on page 9-20.

---

## Client Access of MDB

The client sends a message to the MDB through a `JMS Destination`. The client can retrieve the `JMS Destination` and connection factory either through using its explicit name or by a logical name. The following sections describe both methods for retrieving the JNDI name.

- [Using an Explicit Name for the JNDI Lookup](#)
- [Using a Logical Name When Client Accesses the MDB](#)

---



---

**Note:** You may have to add the JNDI properties if the client is not co-located with the MDB. The examples provided in the following sections do not include setting the JNDI properties. See ["Setting JNDI Properties"](#) on page 2-2 for instructions on setting these properties.

---



---

## Using an Explicit Name for the JNDI Lookup

Within your client, you can use the actual JNDI name to retrieve the JMS `Destination` objects. Both OracleAS JMS and Oracle JMS have their own naming methodology, as explained in the following sections:

- [Accessing OracleAS JMS Destination with Explicit JNDI Names](#)
- [Accessing Oracle JMS Destination with Explicit JNDI Names](#)

---



---

**Note:** Alternatively, you can specify all of the JNDI names for the `Destination` and JMS provider objects as resource references in your `orion-ejb-jar.xml` file. See ["Using a Logical Name When Client Accesses the MDB"](#) on page 9-25 for more information.

---



---

### Accessing OracleAS JMS Destination with Explicit JNDI Names

The JNDI lookup for OracleAS JMS requires the OracleAS JMS `Destination` and connection factory as defined by you within the `jms.xml` file, prepended with `"java:comp/env/."` See ["JMS Destination Object Configuration"](#) on page 9-10 to see how the queue and topic for OracleAS JMS is configured.

---



---

**Note:** If you decide to use logical names instead, you would use the same JNDI syntax. Logical names are recommended, because they are portable. See ["Using a Logical Name When Client Accesses the MDB"](#) on page 9-25 for more information.

---



---

To lookup a queue in the JNDI lookup for the `testResourceProvider` example using OracleAS JMS are as follows:

```
//Lookup the Queue
queue = (Queue)jndiContext.lookup("java:comp/env/jms/Queue/rpTestQueue");

//Lookup the Queue Connection factory
queueConnectionFactory = (QueueConnectionFactory)
    jndiContext.lookup("java:comp/env/jms/Queue/myQCF");
```

To lookup a topic, you would have slightly different strings, designating a topic rather than a queue, as follows:

```
//Lookup the Topic
topic = (Topic)jndiContext.lookup("java:comp/env/jms/Topic/rpTestTopic");

//Lookup the Connection factory
topicConnectionFactory = (TopicConnectionFactory)
    jndiContext.lookup("java:comp/env/jms/Topic/myTCF");
```

Note that the same names for the topic and the connection factory are used in the client's configuration, the `jms.xml`, and the MDB deployment descriptors.

## Accessing Oracle JMS Destination with Explicit JNDI Names

The JNDI lookup—when using Oracle JMS—requires the Oracle JMS Destination and connection factory syntax, which is the same naming convention as described for the `connection-factory-location` and `destination-location` attributes in ["Specify the Destination and Connection Factory"](#) on page 9-17.

---



---

**Note:** If you decide to use logical names instead, you would use the same JNDI syntax. See ["Using a Logical Name When Client Accesses the MDB"](#) on page 9-25 for more information.

---



---

In your JNDI lookup, the implementation would be as follows for both a queue and a topic (See [Example 9-6](#) for the full example):

```
/* Retrieve an Oracle JMS Queue through JNDI */
queue = (Queue) ic.lookup("java:comp/resource/myProvider/Queues/rpTestQueue");
/*Retrieve the Oracle JMS Queue connection factory */
queueConnectionFactory = (QueueConnectionFactory) ic.lookup
    ("java:comp/resource/myProvider/QueueConnectionFactories/myQCF");

/* Retrieve an Oracle JMS Topic through JNDI */
topic = (Topic) ic.lookup("java:comp/resource/myProvider/Topics/rpTestTopic");
/*Retrieve the Oracle JMS Topic connection factory */
topicConnectionFactory = (TopicConnectionFactory) ic.lookup
    ("java:comp/resource/myProvider/TopicConnectionFactories/myTCF");
```

## Steps for Sending a Message to an MDB

Whether or not the implementation uses logical names or the actual JNDI names, the client sends a JMS message to the MDB by doing the following:

1. Retrieve both the configured JMS Destination and its connection factory using a JNDI lookup.
2. Create a connection from the connection factory. If you are receiving messages for a queue, then start the connection.
3. Create a session over the connection.
4. Providing the retrieved JMS Destination, create a sender for a queue, or a publisher for a topic.
5. Create the message.
6. Send out the message using either the queue sender or the topic publisher.
7. Close the queue session. Close the connection for either JMS Destination types.

### Example 9-6 Servlet Client Sends Message to Queue

```
public final class testResourceProvider extends HttpServlet
{
    private String resProvider = "myResProvider";
    private HashMap msgMap = new HashMap();
    Context ctx = new InitialContext();

    public void doGet(HttpServletRequest req, HttpServletResponse res)
        throws ServletException, IOException
    {
        doPost(req, res);
    }
}
```

```

public void doPost(HttpServletRequest req, HttpServletResponse res)
    throws ServletException, IOException
{
    //Retrieve the name of the JMS provider from the request, which is
    // to be used in creating the JNDI string for retrieval
    String rp = req.getParameter ("provider");
    if (rp != null)
        resProvider = rp;

    try
    {
        // 1a. Look up the Queue Connection Factory
        QueueConnectionFactory qcf = (QueueConnectionFactory)
            ctx.lookup ("java:comp/resource/" + resProvider +
                "/QueueConnectionFactories/myQCF");
        // 1b. Lookup the Queue
        Queue queue = (Queue) ctx.lookup ("java:comp/resource/" + resProvider +
            "/Queues/rpTestQueue");

        // 2 & 3. Retrieve a connection and a session on top of the connection
        // 2a. Create queue connection using the connection factory.
        QueueConnection qconn = qcf.createQueueConnection();
        // 2a. We're receiving msgs, so start the connection.
        qconn.start();

        // 3. create a session over the queue connection.
        QueueSession qsess = qconn.createQueueSession(false,
            Session.AUTO_ACKNOWLEDGE);

        // 4. Since this is for a queue, create a sender on top of the session.
        //This is used to send out the message over the queue.
        QueueSender snd = qsess.createSender (q);

        drainQueue (sess, q);
        TextMessage msg = null;

        /* Send msgs to queue. */
        for (int i = 0; i < 3; i++)
        {
            // 5. Create message
            msg = sess.createTextMessage();
            msg.setText ("TestMessage:" + i);

            // set property of the recipient to be the MDB
            //and set the reply destination.
            msg.setStringProperty ("RECIPIENT", "MDB");
            msg.setJMSReplyTo(q);

            //6. send the message using the sender.
            snd.send (msg);

            // You can store the messages IDs and sent-time in a map (msgMap),
            // so that when messages are received, you can verify if you
            // *only* received those messages that you were
            // expecting. See receiveFromMDB() method where msgMap gets used.
            msgMap.put (msg.getJMSMessageID(), new Long (msg.getJMSTimestamp()));
        }

        // receive a reply from the MDB.
    }
}

```

```

receiveFromMDB (sess, q);

    //7. Close sender, session, and connection for queue
    snd.close();
    sess.close();
    qconn.close();
}
catch (Exception e)
{
    System.err.println ("** TEST FAILED **" + e.toString());
    e.printStackTrace();
}
finally
{
}
}

/*
 * Receive any msgs sent to us via the MDB
 */
private void receiveFromMDB (QueueSession sess, Queue q)
    throws Exception
{
    //The MDB sends out a message (as a reply) to this client. The MDB sets
    // the recipient as CLIENT. Thus, we will only receive msgs that have
    // RECIPIENT set to 'CLIENT'
    QueueReceiver rcv = sess.createReceiver (q, "RECIPIENT = 'CLIENT'");

    int nrcvd = 0;
    long trtimes = 0L;
    long tctimes = 0L;
    // First msg needs to come from MDB. May take a little while
    //Receiving Messages
    for (Message msg = rcv.receive (30000); msg != null;
        msg = rcv.receive (30000))
    {
        nrcvd++;

        String rcp = msg.getStringProperty ("RECIPIENT");
        // Verify if msg in message Map
        // We check the msgMap to see if this is the message that we are
        // expecting.
        String corrid = msg.getJMSCorrelationID();
        if (msgMap.containsKey(corrid))
        {
            msgMap.remove(corrid);
        }
        else
        {
            System.err.println ("** received unexpected message
                [" + corrid + "] **");
        }
    }
    rcv.close();
}

/*
 * Drain messages from queue
 */
private int drainQueue (QueueSession sess,

```

```

                                Queue q)
throws Exception
{
    QueueReceiver rcv = sess.createReceiver (q);
    int nrcvd = 0;

    /*
     * First drain any old msgs from queue
     */
    for (Message msg = rcv.receive(1000);
         msg != null;
         msg = rcv.receive(1000))
        nrcvd++;
    rcv.close();

    return nrcvd;
}
}

```

## Using a Logical Name When Client Accesses the MDB

If you want to use a logical name in your client application code, then define the logical name in one of the following XML files:

- A standalone Java client—in the `application-client.xml` file
- An EJB that acts as a client—the `ejb-jar.xml` file
- For JSPs and servlets that act as clients—the `web.xml` file

Map the logical name to the actual name of the topic or queue name in the OC4J deployment descriptors.

You can create logical names for the connection factory and `Destination` objects, as follows:

- The connection factory is identified in the client's XML deployment descriptor file within a `<resource-ref>` element.
  - The logical name that you want the connection factory to be identified as is defined in the `<res-ref-name>` element.
  - The connection factory class type is defined in the `<res-type>` element as either `javax.jms.QueueConnectionFactory` or `javax.jms.TopicConnectionFactory`.
  - The authentication responsibility (`Container` or `Bean`) is defined in the `<res-auth>` element.
  - The sharing scope (`Shareable` or `Unshareable`) is defined in the `<res-sharing-scope>` element.
- The JMS `Destination`—the topic or queue—is identified in a `<resource-env-ref>` element.
  - The logical name that you want the topic or queue to be identified as is defined in the `<resource-env-ref-name>` element.
  - The `Destination` class type is defined in the `<resource-env-ref-type>` element as either `javax.jms.Queue` or `javax.jms.Topic`.

The following shows an example of how to specify logical names for a topic.

```

<resource-ref>
  <res-ref-name>myTCF</res-ref-name>
  <res-type>javax.jms.TopicConnectionFactory</res-type>
  <res-auth>Container</res-auth>
  <res-sharing-scope>Shareable</res-sharing-scope>
</resource-ref>
<resource-env-ref>
  <resource-env-ref-name>rpTestTopic</resource-env-ref-name>
  <resource-env-ref-type>javax.jms.Topic</resource-env-ref-type>
</resource-env-ref>

```

Then, you map the logical names to actual names in the OC4J deployment descriptors. The actual names, or JNDI names, are different in OracleAS JMS than in Oracle JMS. However, the mapping is defined in one of the following files:

- For a standalone Java client—the `orion-application-client.xml`
- For an EJB acting as a client—the `orion-ejb-jar.xml`
- For JSPs and servlets acting as a client—the `orion-web.xml` file.

The logical names in the client's deployment descriptor are mapped as follows:

- The logical name for the connection factory defined in the `<resource-ref>` element is mapped to its JNDI name in the `<resource-ref-mapping>` element.
- The logical name for the JMS Destination defined in the `<resource-env-ref>` element is mapped to its JNDI name in the `<resource-env-ref-mapping>` element.

See the following sections for how the mapping occurs for both OracleAS JMS and Oracle JMS:

- [JNDI Naming for OracleAS JMS](#)
- [JNDI Naming for Oracle JMS](#)

### JNDI Naming for OracleAS JMS

The JNDI name for the OracleAS JMS Destination and connection factory is defined by you within the `jms.xml` file. As shown in "[JMS Destination Object Configuration](#)" on page 9-10, the JNDI names for the topic and the topic connection factory are as follows:

- The JNDI name for the topic is `"jms/Topic/rpTestTopic."`
- The JNDI name for the topic connection factory is `"jms/Topic/myTCF."`

Prepend both of these names with `"java:comp/env/"` and you have the mapping in the `orion-ejb-jar.xml` file as follows:

```

<resource-ref-mapping
  name="myTCF"
  location="java:comp/env/jms/Topic/myTCF">
</resource-ref-mapping>

<resource-env-ref-mapping
  name="rpTestTopic"
  location="java:comp/env/jms/Topic/rpTestTopic">
</resource-env-ref-mapping>

```



## JNDI Naming for Oracle JMS

The JNDI naming for Oracle JMS `Destination` and connection factory objects is the same name that was specified in the `orion-ejb-jar.xml` file for the MDB as described in "Specify the Destination and Connection Factory" on page 9-17.

The following example maps the logical names for the connection factory and topic to their actual JNDI names. Specifically, the topic defined logically as "rpTestTopic" in the `ejb-jar.xml` file is mapped to its JNDI name of

"java:comp/resource/cartojms1/Topics/rpTestTopic."

```
<resource-ref-mapping
    name="myTCF"
    location="java:comp/resource/myProvider/TopicConnectionFactories/myTCF">
</resource-ref-mapping>
```

```
<resource-env-ref-mapping
    name="rpTestTopic"
    location="java:comp/resource/myProvider/Topics/rpTestTopic">
</resource-env-ref-mapping>
```

## Client Sends JMS Message Using Logical Names

Once the resources have been defined, the client sends a JMS message to the MDB by doing the following:

1. Retrieve both the configured JMS `Destination` and its connection factory using a JNDI lookup.
2. Create a connection from the connection factory. If you are receiving messages for a queue, start the connection.
3. Create a session over the connection.
4. Providing the retrieved JMS `Destination`, create a sender for a queue, or a publisher for a topic.
5. Create the message.
6. Send out the message using either the queue sender or the topic publisher.
7. Close the queue session. Close the connection for either JMS `Destination` types.

### Example 9-7 JSP Client Sends Message to a Topic

The method of sending a message over a topic is almost the same. Instead of creating a queue, you create a topic. Instead of creating a sender, you create subscribers.

The following JSP client code sends a message over a topic to the `MessageBean` MDB. The code uses logical names, which should be mapped in the OC4J deployment descriptor.

```
<%@ page import="javax.jms.*, javax.naming.*, java.util.*" %>
<%
```

```
//1a. Lookup the MessageBean topic
jndiContext = new InitialContext();
topic = (Topic)jndiContext.lookup("rpTestTopic");
```

```
//1b. Lookup the MessageBean Connection factory
topicConnectionFactory = (TopicConnectionFactory)
    jndiContext.lookup("myTCF");
```

```
//2 & 3. Retrieve a connection and a session on top of the connection
```

```
topicConnection = topicConnectionFactory.createTopicConnection();
topicSession = topicConnection.createTopicSession(true,
    Session.AUTO_ACKNOWLEDGE);

//5. Create the publisher for any messages destined for the topic
topicPublisher = topicSession.createPublisher(topic);

//6. Send out the message
for (int ii = 0; ii < numMsgs; ii++)
{
    message = topicSession.createBytesMessage();
    String sndstr = "1::This is message " + (ii + 1) + " " + item;
    byte[] msgdata = sndstr.getBytes();
    message.writeBytes(msgdata);

    topicPublisher.publish(message);
    System.out.println("--->Sent message: " + sndstr);
}

//7. Close publisher, session, and connection for topic
topicPublisher.close();
topicSession.close();
topicConnection.close();

%>
Message sent!
```

## Windows Considerations When Using MDBs

The `oracle.mdb.fastUndeploy` system property enables you to shutdown OC4J cleanly when you are running MDBs in a Windows environment or when the backend database is running on a Windows environment. Normally, when you use an MDB, it is blocked in a receive state waiting for incoming messages. However, if you shutdown OC4J while the MDB is in a wait state in a Windows environment, then the OC4J instance cannot be stopped and the applications are not undeployed since the MDB is blocked. However, you can modify the behavior of the MDB in this environment by setting the `oracle.mdb.fastUndeploy` system property. If you set this property to an integer, then when the MDB is not processing incoming messages and in a wait state, the OC4J container goes out to the database (requiring a database round-trip) and polls to see if the session is shut down. The integer denotes the number of seconds the system waits to poll the database. This can be expensive for performance. If you set this property to 60 (seconds), then every 60 seconds, OC4J is checking the database. If you do not set this property and you try to shutdown OC4J using CTRL-C, the OC4J process will hang for at least 2.5 hours.

## Failover Scenarios When Using a RAC Database

An application that uses an RAC database must handle database failover scenarios. The MDB run time does not fail over to the newly available database. To enable failover, the deployment descriptors `dequeue-retry-count` and `dequeue-retry-interval` must be specified in `orion-ejb-jar.xml` file. The first parameter, `dequeue-retry-count`, tells the container how many times to retry the database connection in case a failure happens; the default is 0. The second parameter, `dequeue-retry-interval`, tells the container how long to wait between attempts (to accommodate for the time it takes for database failover); the default value is 60 (seconds).

---

**Note:** The RAC-enabled attribute of a data source is discussed in Data Sources chapter in the Oracle Application Server Containers for J2EE Services Guide.

(RAC is real application clusters. For more information on using this flag with an infrastructure database, see *The Oracle9iAS High Availability Guide*.)

---

These parameters are attributes of the `<message-driven-deployment>` element, as shown in the following example:

```
<message-driven-deployment name="MessageBeanTpc"
  connection-factory-location=
    "java:comp/resource/cartojms1/TopicConnectionFactory/aqTcf"
  destination-location=
    "java:comp/resource/cartojms1/Topics/topic1"
  subscription-name="MDBSUB"
  dequeue-retry-count=3
  dequeue-retry-interval=90/>
```

A standalone OJMS client running against an RAC database must write similar code to obtain the connection again, by invoking the API `DbUtil.oracleFatalError()`, to determine if the connection object is invalid. It must then reestablish the database connection if necessary. The following example outlines the logic:

```
getMessage(QueueSession session)
{
    try
    {
        QueueReceiver rcvr;
        Message msgRec = null;
        QueueReceiver rcvr = session.createReceiver(rcvrQueue);
        msgRec = rcvr.receive();
    }
    catch(Exception e )
    {
        if (exc instanceof JMSEException)
        {
            JMSEException jmsexc = (JMSEException) exc;
            sql_ex = (SQLException)(jmsexc.getLinkedException());

            db_conn =
                (oracle.jms.AQjmsSession)session.getDBConnection();

            if ((DbUtil.oracleFatalError(sql_ex, db_conn))
                {
                    // failover logic
                }
            }
        }
    }
}
```

## Using Timers With Your MDB

Your MDB can set up a timer where OC4J calls the bean at a specified time, after a specified elapsed time, or at specified intervals. These timers are for use in modeling of application-level processes, not for real-time events. For more information on how to set up timers, see [Chapter 11, "Using Timers"](#).



---

# Understanding Environment, Deployment, and Packaging

Part of development includes setting up the environment, as well as packaging and deploying your applications.

- [Directory Structure Recommendations for EJB Development](#)
- [Create the Deployment Descriptor](#)
- [Archive the EJB Application](#)
- [Prepare the EJB Application for Assembly](#)
- [Deploy the Enterprise Application to OC4J](#)
- [Sharing Classes](#)
- [Configuring Environment References](#)

## Directory Structure Recommendations for EJB Development

Although you can develop your application in any manner, we encourage you to use consistent naming for locating your application easily. One method would be to implement your enterprise Java application under a single parent directory structure, separating each module of the application into its own subdirectory.

The hello example was developed using the directory structure mentioned in the *Oracle Application Server Containers for J2EE User's Guide*. Notice in [Figure 10-1](#) that the EJB and Web modules exist under the `hello` application parent directory and are developed separately in their own directory.

**Figure 10–1 Hello Directory Structure**

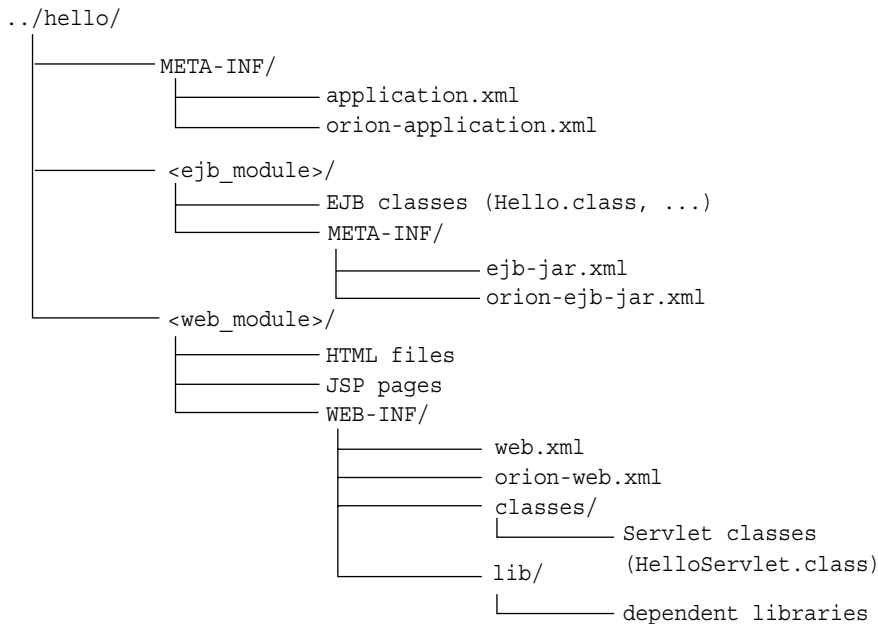

---

**Note:** For EJB modules, the top of the module (`ejb_module`) represents the start of a search path for classes. As a result, classes belonging to packages are expected to be located in a nested directory structure beneath this point. For example, a reference to a package class `'myapp.Hello.class'` is expected to be located in `"../hello/ejb_module/myapp/Hello.class"`.

---

## Create the Deployment Descriptor

After implementing and compiling your classes, you must create the standard J2EE EJB deployment descriptor for all beans in the module. The XML deployment descriptor (defined in the `ejb-jar.xml` file) describes the EJB module of the application. It describes the types of beans, their names, and attributes. The structure for this file is mandated in the DTD file, which is provided at "[http://java.sun.com/dtd/ejb-jar\\_2\\_0.dtd](http://java.sun.com/dtd/ejb-jar_2_0.dtd)".

Any EJB container services that you want to configure is also designated in the deployment descriptor. For information about data sources and JTA, see the *Oracle Application Server Containers for J2EE Services Guide*. For information about security, see the *Oracle Application Server Containers for J2EE Security Guide*.

After creation, place the deployment descriptors for the EJB application in the `META-INF` directory that is located in the same directory as the EJB classes. See [Figure 10–2](#) for more information.

The following example shows the sections that are necessary for the `Hello` example, which implements both a remote and a local interface.

### **Example 10–1 XML Deployment Descriptor for Hello Bean**

The following is the deployment descriptor for a version of the `Hello` example that uses a stateless session bean. This example defines both the local and remote

interfaces. You do not have to define both interface types; you may define only one of them.

```
<?xml version="1.0"?>
<!DOCTYPE ejb-jar PUBLIC "-//Sun Microsystems, Inc.//DTD Enterprise JavaBeans
1.1//EN" "http://java.sun.com/j2ee/dtds/ejb-jar_1_1.dtd">

<ejb-jar>
  <display-name>hello</display-name>
  <description>
    An EJB app containing only one Stateless Session Bean
  </description>
  <enterprise-beans>
    <session>
      <description>no description</description>
      <display-name>HelloBean</display-name>
      <ejb-name>HelloBean</ejb-name>
      <home>hello.HelloHome</home>
      <remote>hello.Hello</remote>
      <local-home>hello.HelloLocalHome</local-home>
      <local>hello.HelloLocal</local>
      <ejb-class>hello.HelloBean</ejb-class>
      <session-type>Stateless</session-type>
      <transaction-type>Container</transaction-type>
    </session>
  </enterprise-beans>

  <assembly-descriptor>
    <container-transaction>
      <method>
        <ejb-name>HelloBean</ejb-name>
        <method-name>*</method-name>
      </method>
      <trans-attribute>Supports</trans-attribute>
    </container-transaction>
    <security-role>
      <role-name>users</role-name>
    </security-role>
  </assembly-descriptor>
</ejb-jar>
```

---

**Note:** You can download this example on OTN from the OC4J sample code page at <http://www.oracle.com/technology/tech/java/oc4j/demos/> on the OTN Web site.

---

## Archive the EJB Application

After you have finalized your implementation and created the deployment descriptors, archive your EJB application into a JAR file. The JAR file should include all EJB application files and the deployment descriptor.

---

**Note:** If you have included a Web application as part of this enterprise Java application, follow the instructions for building the Web application in the *Oracle Application Server Containers for J2EE User's Guide*.

---

For example, to archive your compiled EJB class files and XML files for the `Hello` example into a JAR file, perform the following in the `../hello/ejb_module` directory:

```
% jar cvf helloworld-ejb.jar .
```

This archives all files contained within the `ejb_module` subdirectory within the JAR file.

## Prepare the EJB Application for Assembly

To prepare the application for deployment, you do the following:

1. Modify the `application.xml` file with the modules of the enterprise Java application.
2. Archive all elements of the application into an EAR file.

These steps are described in the following sections:

- [Modify the Application.XML File](#)
- [Create the EAR File](#)

## Modify the Application.XML File

The `application.xml` file acts as the manifest file for the application and contains a list of the modules that are included within your enterprise application. You use each `<module>` element defined in the `application.xml` file to designate what comprises your enterprise application. Each module describes one of three things: EJB JAR, Web WAR, or any client files. Respectively, designate the `<ejb>`, `<web>`, and `<java>` elements in separate `<module>` elements.

- The `<ejb>` element specifies the EJB JAR filename.
- The `<web>` element specifies the Web WAR filename in the `<web-uri>` element, and its context in the `<context>` element.
- The `<java>` element specifies the client JAR filename, if any.

As [Figure 10-2](#) shows, the `application.xml` file is located under a `META-INF` directory under the parent directory for the application. The JAR, WAR, and client JAR files should be contained within this directory. Because of this proximity, the `application.xml` file refers to the JAR and WAR files only by name and relative path—not by full directory path. If these files were located in subdirectories under the parent directory, then these subdirectories must be specified in addition to the filename.

**Figure 10-2** Archive Directory Format

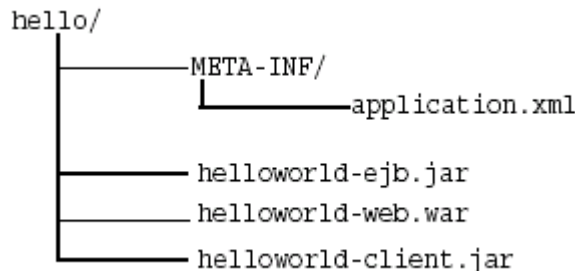



For example, the following example modifies the `<ejb>`, `<web>`, and `<java>` module elements within `application.xml` for the Hello EJB application that also contains a servlet that interacts with the EJB.

```
<?xml version="1.0"?>
<!DOCTYPE application PUBLIC "-//Sun Microsystems, Inc.//DTD J2EE Application
1.2//EN" "http://java.sun.com/j2ee/dtds/application_1_2.dtd">
<application>
  <display-name>helloworld j2ee application</display-name>
  <description>
    A sample J2EE application that uses a Helloworld Session Bean
    on the server and calls from java/servlet/JSP clients.
  </description>
  <module>
    <ejb>helloworld-ejb.jar</ejb>
  </module>
  <module>
    <web>
      <web-uri>helloworld-web.war</web-uri>
      <context-root>/helloworld</context-root>
    </web>
  </module>
  <module>
    <java>helloworld-client.jar</java>
  </module>
</application>
```

## Create the EAR File

Create the EAR file that contains the JAR, WAR, and XML files for the application. Note that the `application.xml` file serves as the EAR manifest file.

To create the `helloworld.ear` file, execute the following in the `hello` directory contained in [Figure 10-2](#):

```
% jar cvf helloworld.ear .
```

This step archives the `application.xml`, the `helloworld-ejb.jar`, the `helloworld-web.war`, and the `helloworld-client.jar` files into the `helloworld.ear` file.

## Deploy the Enterprise Application to OC4J

After archiving your application into an EAR file, deploy the application to OC4J. See the *Oracle Application Server Containers for J2EE User's Guide* for information on how to deploy your application.

## Out Of Memory Error During Deployment

If the deployment process is interrupted for any reason, you may need to clean up the temp directory, which by default is `/var/tmp`, on your system. The deployment wizard uses 20 MB in swap space of the temp directory for storing information during the deployment process. At completion, the deployment wizard cleans up the temp directory of its additional files. However, if the wizard is interrupted, it may not have the time or opportunity to clean up the temp directory. Thus, you must clean up any additional deployment files from this directory yourself. If you do not, this directory may fill up, which will disable any further deployment. If you receive an Out of Memory error, check for space available in the temp directory.

To change the temp directory, set the command-line option for the OC4J process to `java.io.tmpdir=<new_tmp_dir>`. You can set this command-line option in the Server Properties page. Drill down to the OC4J Home Page. Scroll down to the Administration Section. Select Server Properties. On this page, Scroll down to the Command Line Options section and add the `java.io.tmpdir` variable definition to the OC4J Options line. All new OC4J processes will start with this property.

## Sharing Classes

If you want to share classes between EJBs, you can do one of the following:

- If two EJBs use the same classes, include all classes and the EJBs in the same JAR file. After deployment, both EJBs can use the common classes.
- Place the shared classes in its own JAR file in the application. Reference the shared JAR file in the `class-path` of the EJB JAR `manifest.mf` file, as follows:

```
class-path:shared_classes.jar
```

The location of the `shared_classes.jar` is relative to where the JAR that references is located in the EAR file. In this example, the `shared_classes.jar` file is at the same level as the EJB JAR.

- If *all* applications reference these classes, archive the shared classes in a JAR file and place this JAR file in the shared library directory of the default application. The `home/lib` is a default shared library. However, you can set shared library directories using Enterprise Manager in the General Properties page of the "default" application.
- If you want only certain applications to reference these classes, archive the shared classes in its own application, deploy the EAR for the application, and have the applications that reference the shared classes declare the shared classes application as its parent. The default parent in Oracle9iAS is the "default" application.

The children see the namespace of its parent application. This is used in order to share services such as EJBs among multiple applications. See the *Oracle Application Server Containers for J2EE User's Guide* for directions on how to specify a parent application.

If you want to share classes between EJB and Web applications, you should place the referenced classes in a shared JAR.

If you receive a `ClassCastException`, then you probably have the following situation:

- You copied EJB interfaces into the WAR where the servlet resides for ease in development and forgot to delete them before creating the WAR file **AND**
- You turned on the `search_local_classes_first` attribute of the `<web-app-class-loader>` element in the `orion-web.xml` file.

To solve this problem, either eliminate the copied classes out of the WAR file or turn off the `search_local_classes_first` attribute. This attribute tells the class loader to load in the classes in the WAR file before loading in any other classes, including the classes within the EJB JAR file. For more information on this attribute, see the "Loading WAR File Classes Before System Classes in OC4J" section in the "Servlet Development" chapter of the *Oracle Application Server Containers for J2EE Servlet Developer's Guide*.

## Out of Memory During Execution

If you see that the OC4J memory is growing consistently while executing, then you may have invalid symbolic links in your `application.xml` file. OC4J loads all resources using the links in the `application.xml` file. If these links are invalid, then the C heap continues to grow causing OC4J to run out of memory. Ensure that all symbolic links are valid and restart OC4J.

In addition, keep the number of JAR files to a minimum in the in the directories where the symbolic links point. Eliminate all unused JARs from these directories. OC4J searches all JARs for classes and resources; thus, taking time and memory consumption by the file cache, as well as being mapped into the address space.

## ClassCastException

When you have an EJB or Web application that references other shared EJB classes, you should place the referenced classes in a shared JAR. In certain situations, if you copy the shared EJB classes into WAR file or another application that references them, you may receive a `ClassCastException` because of a class loader issue. To be completely safe, never copy referenced EJB classes into the WAR file of its application or into another application.

## Static Block in an EJB

During EJB deployment in OC4J, you load the bean class to find out its methods so that you can generate EJB wrappers. Because the code in the static block is executed as the class is being loaded, the JNDI environment context is not yet set up. Even during runtime, the bean is in the "does not exist" stage. In this stage of the life cycle, the JNDI environment context is undefined, and the bean provider cannot rely on it to be available.

To work around this problem, set up and cache the context during the construction of the bean, in the `ejbCreate()` method, or in the `setSessionContext()` method.

## OC4J Instances Terminating Due To ping Timeout

Under some conditions, the OPMN process monitoring software in Oracle Application Server may lose contact with an OC4J process. This can occur because of unexpected delays in the heartbeat protocol used by OPMN and OC4J to verify the proper functioning of the OC4J instance.

If this problem occurs sporadically, you can try increasing the ping timeout parameters as described in the following instructions.

However, if this occurs regularly, due to a consistent resource shortage, then you must increase the available hardware resources to solve the problem.

The following conditions can cause this problem:

- An overloaded host processor
- One or more computation-intensive applications running in the OC4J instance.
- Deployment of applications with large numbers (hundreds) of EJBs. Full garbage collections of large heaps can cause the OC4J process to become less responsive during the garbage collection phase. Although this should not occur during normal usage, deployment of large applications with many EJBs in a memory-constrained environment can trigger this behavior.

You can configure the behavior of the "ping protocol" between OPMN and OC4J in the `opmn.xml` configuration file.

When OC4J exceeds the timeout intervals specified for the ping protocol, the process monitoring software decides that the OC4J process has stopped responding and, therefore, terminates the OC4J process.

If you suspect this behavior in an Oracle Application Server installation, then use the following steps to troubleshoot and work around:

1. When OC4J instances are "mysteriously" terminating, first increase diagnostic logging to determine if ping failures are triggering the termination:
  - a. Increase the OPMN logging level to 5 so that you can see the pings.  
In the `opmn/conf/opmn.xml` file, edit the following line:  
`log-file path="$ORACLE_HOME/opmn/logs/ipm.log" level="5" ...`
  - b. Reload the daemon.  

```
opmn/bin/opmnctl reload
```
2. Look in `opmn/logs/ipm.log` for the following line :  
Process Ping Failed: OC4J~<instance name>~default\_island~1 (opmnid)
3. The line above indicates that the memory and CPU resources of the current host are probably not sufficient to perform the operation within the currently specified ping timeout interval (used by OPMN to determine OC4J "responsiveness").  
Change the settings as follows:
  - a. Increase the timeout and interval. For example:  

```
<ping timeout="60" interval="60"/>  
<data id="reverseping-failed-ping-limit" value="5" />
```
  - b. Reload the daemon.  

```
opmn/bin/opmnctl reload
```
  - c. Restart the appropriate OC4J instance.
4. Repeat the top-level operation that caused the timeout failure.

## Configuring Environment References

You can create three types of environment elements that are accessible to your bean during runtime: environment variables, EJB references, and resource managers. These environment elements are static and can not be changed by the bean.

ISVs typically develop EJBs that are independent from the EJB container. In order to distance the bean implementation from the container specifics, you can create environment elements that map to one of the following: defined variables, entity beans, or resource managers. This indirection enables the bean developer to refer to existing variables, EJBs, and a JDBC `DataSource` without specifying the actual name. These names are defined in the deployment descriptor and are linked to the actual names within the OC4J-specific deployment descriptor.

## Environment Variables

You can create environment variables that your bean accesses through a lookup on the `InitialContext`. These variables are defined within an `<env-entry>` element and can be of the following types: `String`, `Integer`, `Boolean`, `Double`, `Byte`, `Short`, `Long`, and `Float`. The name of the environment variable is defined within `<env-entry-name>`, the type is defined in `<env-entry-type>`, and its initialized value is defined in `<env-entry-value>`. The `<env-entry-name>` is relative to the `"java:comp/env"` context.

For example, the following two environment variables are declared within the XML deployment descriptor for `java:comp/env/minBalance` and `java:comp/env/maxCreditBalance`.

```
<env-entry>
  <env-entry-name>minBalance</env-entry-name>
  <env-entry-type>java.lang.Integer</env-entry-type>
  <env-entry-value>500</env-entry-value>
</env-entry>
<env-entry>
  <env-entry-name>maxCreditBalance</env-entry-name>
  <env-entry-type>java.lang.Integer</env-entry-type>
  <env-entry-value>10000</env-entry-value>
</env-entry>
```

Within the bean's code, you would access these environment variables through the `InitialContext`, as follows:

```
InitialContext ic = new InitialContext();
Integer min = (Integer) ic.lookup("java:comp/env/minBalance");
Integer max = (Integer) ic.lookup("java:comp/env/maxCreditBalance");
```

Notice that to retrieve the values of the environment variables, you prefix each environment element with `"java:comp/env/"`, which is the location that the container stored the environment variable.

If you wanted the value of the environment variable to be defined in the OC4J-specific deployment descriptor, you can map the `<env-entry-name>` to the `<env-entry-mapping>` element in the OC4J-specific deployment descriptor. This means that the value specified in the `orion-ejb-jar.xml` file overrides any value that may be specified in the `ejb-jar.xml` file. The type specified in the EJB deployment descriptor stays the same.

Figure 10-3 shows how the `minBalance` environment variable is defined as 500 within the OC4J-specific deployment descriptor.

**Figure 10-3 Environment Variable Mapping**

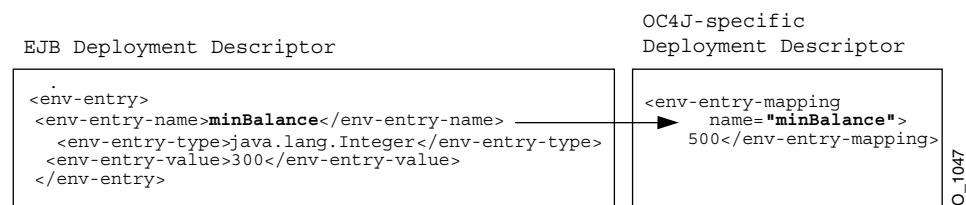

## Environment References To Other Enterprise JavaBeans

You can define an environment reference to an EJB through either its local or remote interface within the deployment descriptor. If your bean calls out to another bean, you can enable your bean to invoke the second bean using a reference defined within the deployment descriptors. You create a logical name within the EJB deployment descriptor, which is mapped to the concrete name of the bean within the OC4J-specific deployment descriptor.

Declaring the target bean as an environment reference provides a level of indirection: the originating bean can refer to the target bean with a logical name.

A reference to the local interface of a bean is defined in an `<ejb-local-ref>` element; a reference to the remote interface of a bean is defined in an `<ejb-ref>` element.

To define a reference to another EJB within the JAR or in a bean declared as a parent, you provide the following:

1. **Name**—provide a name for the target bean. This name is what the bean uses within the JNDI location for accessing the target bean. The name should begin with "ejb/", such as "ejb/myEmployee", and will be available within the "java:comp/env/ejb" context.
  - This name can be the actual name of the bean; that is, the name defined within the `<ejb-name>` element in the `<session>` or `<entity>` elements.
  - This name can be a logical name that you want to use in your implementation. But it is not the actual name of the bean. If you use a logical name, the actual name must either be specified in the `<ejb-link>` element or `<ejb-ref-mapping>` element in the OC4J-specific deployment descriptor.
2. **Type**—define whether the bean is a session or an entity bean. Value should be either "Session" or "Entity".
3. **Home**—provide the fully qualified home interface name.
4. **Remote**—provide the fully qualified remote interface name.
5. **Link**—provide the EJB name of the target bean. This is optional and only used if you used a logical name in the name attribute.

### Examples of References to a Local Interface

If you have two beans in the JAR: BeanA and BeanB. If BeanB creates a reference to the local interface of BeanA, you can define this reference in one of three methods:

- Provide the actual name of the bean. BeanB would define the following `<ejb-local-ref>` within its definition:

```
<ejb-local-ref>
  <ejb-ref-name>myBeans/BeanA</ejb-ref-name>
  <ejb-ref-type>Session</ejb-ref-type>
  <local-home>myBeans.BeanALocalHome</local-home>
  <local>myBeans.BeanALocal</local>
</ejb-local-ref>
```

Since the EJB name of the target is specified in the `<ejb-ref-name>` element, no `<ejb-link>` is necessary for this method. However, the BeanB implementation must refer to BeanA in the JNDI retrieval, which would use `java:comp/env/myBeans/BeanA` for retrieval within an EJB or Java client and use "myBeans/BeanA" within a servlet.

---



---

**Note:** Servlets do not require the prefix of "java:comp/env" in the JNDI lookup. Thus, they will always either reference just the actual JNDI name or the logical name of the EJB.

---



---

- Provide the EJB name of the bean in the `<ejb-link>` element. You can use any logical name in your bean implementation for the JNDI retrieval by defining a logical name in the `<ejb-ref-name>` element and then map it to the target bean by specifying the target EJB name in the `<ejb-link>` element. The following defines a logical name of `ejb/nextVal` that this bean can use in its code in the JNDI retrieval. The container maps it to the target bean, `myBeans/BeanA`, which is specified in the `<ejb-link>` element.

```
<ejb-local-ref>
  <ejb-ref-name>ejb/nextVal</ejb-ref-name>
  <ejb-ref-type>Session</ejb-ref-type>
  <local-home>myBeans.BeanALocalHome</local-home>
  <local>myBeans.BeanALocal</local>
  <ejb-link>myBeans/BeanA</ejb-link>
</ejb-local-ref>
```

BeanB would use `java:comp/env/ejb/nextVal` in the JNDI retrieval of BeanA.

- Provide the logical name of the bean in the `<ejb-ref-name>` and the actual name of the bean in the `<ejb-ref-mapping>` element in the OC4J-specific deployment descriptor.

The reference in the EJB deployment descriptor would be as follows:

```
<ejb-local-ref>
  <ejb-ref-name>ejb/nextVal</ejb-ref-name>
  <ejb-ref-type>Session</ejb-ref-type>
  <local-home>myBeans.BeanALocalHome</local-home>
  <local>myBeans.BeanALocal</local>
</ejb-local-ref>
```

The "ejb/nextVal" logical name is mapped to an actual name in the OC4J-deployment descriptor as follows:

```
<ejb-ref-mapping name="ejb/nextVal" location="myBeans/BeanA"/>
```

BeanB would use `java:comp/env/ejb/nextVal` in the JNDI retrieval of BeanA.

As shown in [Figure 10-4](#), the logical name for the bean is mapped to the JNDI name by providing the same name, "ejb/nextVal", in both the `<ejb-ref-name>` in the EJB deployment descriptor and the name attribute within the `<ejb-ref-mapping>` element in the OC4J-specific deployment descriptor.

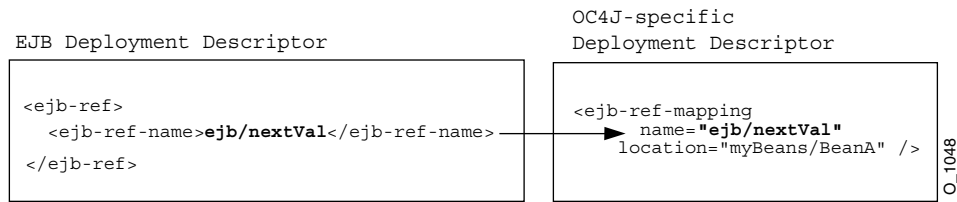
**Figure 10–4 EJB Reference Mapping**

## Accessing EJBs Using Environment References

To access a bean from within your implementation using a reference, use the `<ejb-ref-name>` defined in the EJB deployment descriptor in the JNDI lookup.

If you are using the default context when you retrieve the `InitialContext`, then you can do one of the following:

- Prefix the logical name defined within the `<ejb-ref-name>` element with `"java:comp/env/ejb/"`, which is where the container places the EJB references defined in the deployment descriptor.
- Do not prefix the logical name with any string and supply only the logical name defined in the `<ejb-ref-name>`.

The following is a lookup from an EJB client, using the `java:comp/env` prefix, assuming that the logical name is `ejb/HelloWorld`.

```
InitialContext ic = new InitialContext();
HelloHome hh = (HelloHome)ic.lookup("java:comp/env/ejb/HelloWorld");
```

The following is a lookup using only the logical name of `ejb/HelloWorld`.

```
InitialContext ic = new InitialContext();
HelloHome hh = (HelloHome)ic.lookup("ejb/HelloWorld");
```

However, if you are not using the default context, but are specifically using another context, such as the `RMIInitialContext` object, you can only use the logical name, as follows:

```
InitialContext ic = new InitialContext();
HelloHome hh = (HelloHome)ic.lookup("ejb/HelloWorld");
```

### Example 10–2 Defining a Local EJB Reference Within the Environment

The following example defines a reference to the local interface of the `Hello` bean, as follows:

1. The logical name used for the target bean within the originating bean is `"java:comp/env/ejb/HelloWorld"`.
2. The target bean is a session bean.
3. Its local home interface is `hello.HelloLocalHome`; its local interface is `hello.HelloLocal`.
4. The `<ejb-ref-name>` attribute is the logical name used within the originating bean. This is optional. In this example, this bean is defined in the EJB deployment descriptor under the `"ejb/HelloWorld"` name.

```
<ejb-local-ref>
  <description>Hello World Bean</description>
```



```

    <ejb-ref-name>ejb/HelloWorld</description>
    <ejb-ref-type>Session</ejb-ref-type>
    <local-home>hello.HelloLocalHome</local-home>
    <local>hello.Hello.Local</local>
  </ejb-local-ref>

```

The `<ejb-ref-name>` element in the EJB deployment descriptor is mapped to the name attribute within the `<ejb-ref-mapping>` element in the OC4J-specific deployment descriptor by providing the same logical name in both elements. The Oracle-specific deployment descriptor would have the following definition to map the logical bean name of "java:comp/env/ejb/HelloWorld" to the JNDI location "/test/myHello":

```

  <ejb-ref-mapping
    name="ejb/HelloWorld"
    location="/test/myHello"/>

```

To invoke this bean from within your implementation, you use the `<ejb-ref-name>` defined in the EJB deployment descriptor. In EJB or pure Java clients, you prefix this name with "java:comp/env/ejb/", which is where the container places the EJB references defined in the deployment descriptor. Servlets only require the logical name defined in the `<ejb-ref-name>`.

The following is a lookup from an EJB, acting as a client:

```

InitialContext ic = new InitialContext();
HelloHome hh = (HelloHome)ic.lookup("java:comp/env/ejb/HelloWorld");

```

Alternatively, you could lookup the name, as follows:

```

InitialContext ic = new InitialContext();
HelloHome hh = (HelloHome)ic.lookup("ejb/HelloWorld");

```

### Examples of References to a Remote Interface

Defining a reference to a remote interface uses exactly the same rules as the local interface, as described in ["Examples of References to a Local Interface"](#) on page 10-10. The only difference is as follows:

- Use the `<ejb-ref>` instead of the `<ejb-local-ref>` element.
- Use the `<home>` and `<remote>` elements instead of the `<local-home>` and `<local>` elements.

Everything else is the same.

The following uses an example with two beans in the JAR: BeanA and BeanB. If BeanB creates a reference to BeanA, you can define this reference in one of three methods:

- Provide the actual name of the bean.

```

  <ejb-ref>
    <ejb-ref-name>myBeans/BeanA</ejb-ref-name>
    <ejb-ref-type>Session</ejb-ref-type>
    <home>myBeans.BeanAHome</home>
    <remote>myBeans.BeanA</remote>
  </ejb-ref>

```

- Provide the EJB name of the bean in the `<ejb-link>` element.

```

  <ejb-ref>
    <ejb-ref-name>ejb/nextVal</ejb-ref-name>

```

```

    <ejb-ref-type>Session</ejb-ref-type>
    <home>myBeans.BeanAHome</home>
    <remote>myBeans.BeanA</remote>
    <ejb-link>myBeans/BeanA</ejb-link>
  </ejb-ref>

```

- Provide the logical name of the bean in the `<ejb-ref-name>` and the actual name of the bean in the `<ejb-ref-mapping>` element in the OC4J-specific deployment descriptor.

```

<ejb-ref>
  <ejb-ref-name>ejb/nextVal</ejb-ref-name>
  <ejb-ref-type>Session</ejb-ref-type>
  <home>myBeans.BeanAHome</home>
  <remote>myBeans.BeanA</remote>
</ejb-ref>

```

The "ejb/nextVal" logical name is mapped to an actual name in the OC4J-deployment descriptor as follows:

```
<ejb-ref-mapping name="ejb/nextVal" location="myBeans/BeanA"/>
```

Refer to ["Examples of References to a Local Interface"](#) on page 10-10 for more description and a code example.

## Environment References To Resource Manager Connection Factory References

The resource manager connection factory references can include resource managers such as JMS, Java mail, URL, and JDBC `DataSource` objects. Similar to the EJB references, you can access these objects from JNDI by creating an environment element for each object reference. However, these references can only be used for retrieving the object within the bean that defines these references. Each is fully described in the following sections:

- [JDBC DataSource](#)
- [Mail Session](#)
- [URL](#)

### JDBC DataSource

You can access a database through JDBC either using the traditional method or by creating an environment element for a JDBC `DataSource`. In order to create an environment element for your JDBC `DataSource`, you must do the following:

1. Define the `DataSource` in the `data-sources.xml` file.
2. Create a logical name within the `<res-ref-name>` element in the EJB deployment descriptor. This name should always start with "jdbc". In the bean code, the lookup of this reference is always prefaced by "java:comp/env/jdbc".
3. Map the logical name within the EJB deployment descriptor to the JNDI name, created in step 1, within the OC4J-specific deployment descriptor.
4. Lookup the object reference within the bean with the "java:comp/env/jdbc" preface and the logical name defined in the EJB deployment descriptor.

As shown in [Figure 10-5](#), the JDBC `DataSource` uses the JNDI name "test/OrderDataSource". The logical name that the bean knows this resource as is "jdbc/OrderDB". These names are mapped together within the OC4J-specific deployment descriptor. Thus, within the bean's implementation, the bean can retrieve

the connection to `OrderDataSource` by using the `"java:comp/env/jdbc/OrderDB"` environment element.

**Figure 10–5 JDBC Resource Manager Mapping**

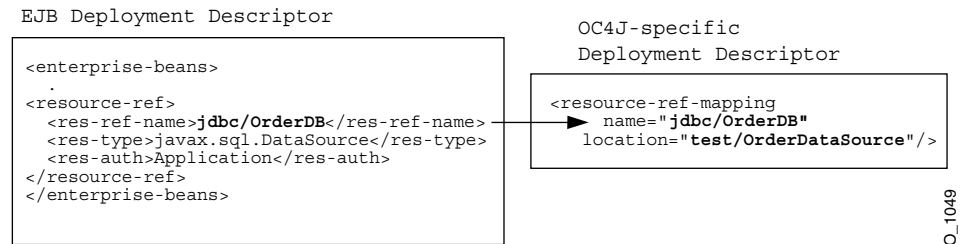

**Example 10–3 Defining an environment element for JDBC Connection**

The environment element is defined within the EJB deployment descriptor by providing the logical name, `"jdbc/OrderDB"`, its type of `javax.sql.DataSource`, and the authenticator of `"Application"`:

```
<resource-ref>
  <res-ref-name>jdbc/OrderDB</res-ref-name>
  <res-type>javax.sql.DataSource</res-type>
  <res-auth>Application</res-auth>
</resource-ref>
```

The environment element of `"jdbc/OrderDB"` is mapped to the JNDI bound name for the connection, `"test/OrderDataSource"` within the Oracle-specific deployment descriptor.

```
resource-ref-mapping
  name="jdbc/OrderDB"
  location="test/OrderDataSource"/>
```

Once deployed, the bean can retrieve the JDBC `DataSource` as follows:

```
javax.sql.DataSource db;
java.sql.Connection conn;
.
.
.
db = (javax.sql.DataSource) initCtx.lookup("java:comp/env/jdbc/OrderDB");
conn = db.getConnection();
```

---

**Note:** This example assumes that a `DataSource` is specified in the `data-sources.xml` file with the JNDI name of `"/test/OrderDataSource"`.

---

## Mail Session

You can create an environment element for a Java mail `Session` object through the following:

1. Bind the `javax.mail.Session` reference within the JNDI name space in the `application.xml` file using the `<mail-session>` element, as follows:

```
<mail-session location="mail/MailSession"
  smtp-host="mysmtp.oraclecorp.com">
  <property name="mail.transport.protocol" value="smtp"/>
```

```
<property name="mail.smtp.from" value="emailaddress@oracle.com"/>
</mail-session>
```

The location attribute contains the JNDI name specified in the location attribute of the <resource-ref-mapping> element in the OC4J-specific deployment descriptor.

2. Create a logical name within the <res-ref-name> element in the EJB deployment descriptor. This name should always start with "mail". In the bean code, the lookup of this reference is always prefaced by "java:comp/env/mail".
3. Map the logical name within the EJB deployment descriptor to the JNDI name, created in step 1, within the OC4J-specific deployment descriptor.
4. Lookup the object reference within the bean with the "java:comp/env/mail" preface and the logical name defined in the EJB deployment descriptor.

As shown in Figure 10-6, the Session object was bound to the JNDI name "/test/myMailSession". The logical name that the bean knows this resource as is "mail/testMailSession". These names are mapped together within the OC4J-specific deployment descriptor. Thus, within the bean's implementation, the bean can retrieve the connection to the bound Session object by using the "java:comp/env/mail/testMailSession" environment element.

**Figure 10-6 Session Resource Manager Mapping**

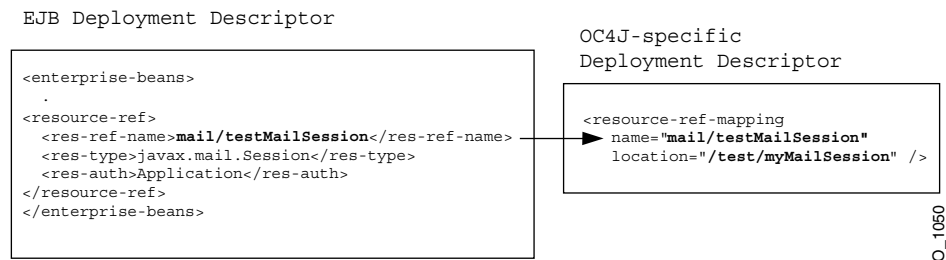

This environment element is defined with the following information:

Element	Description
<res-ref-name>	The logical name of the Session object to be used within the originating bean. The name should be prefixed with "mail/". In our example, the logical name for our mail session is "mail/testMailSession".
<res-type>	The Java type of the resource. For the Java mail Session object, this is javax.mail.Session.
<res-auth>	Define who is responsible for signing on to the database. The value can be "Application" or "Container" based on who provides the authentication information.

**Example 10-4 Defining an environment element for Java mail Session**

The environment element is defined within the EJB deployment descriptor by providing the logical name, "mail/testMailSession", its type of javax.mail.Session, and the authenticator of "Application":

```
<resource-ref>
  <res-ref-name>mail/TestMailSession</res-ref-name>
  <res-type>javax.mail.Session</res-type>
```

```
<res-auth>Application</res-auth>
</resource-ref>
```

The environment element of "mail/testMailSession" is mapped to the JNDI bound name for the connection, "test/myMailSession" within the OC4J-specific deployment descriptor:

```
<resource-ref-mapping
  name="mail/TestMailSession"
  location="/test/myMailSession"/>
```

Once deployed, the bean can retrieve the Session object reference as follows:

```
InitialContext ic = new InitialContext();
Session session = (Session) ic.lookup("java:comp/env/mail/testMailSession");

//The following uses the mail session object
//Create a message object
MimeMessage msg = new MimeMessage(session);

//Construct an address array
String mailTo = "whosit@oracle.com";
InternetAddress addr = new InternetAddress(mailto);
InternetAddress addrs[] = new InternetAddress[1];
addrs[0] = addr;

//set the message parameters
msg.setRecipients(Message.RecipientType.TO, addrs);
msg.setSubject("testSend()" + new Date());
msg.setContent(msgText, "text/plain");

//send the mail message
Transport.send(msg);
```

## URL

You can create an environment element for a Java URL object through the following:

1. Create a logical name within the `<res-ref-name>` element in the EJB deployment descriptor. This name should always start with "url". In the bean code, the lookup of this reference is always prefaced by "java:comp/env/url".
2. Map the logical name within the EJB deployment descriptor to the URL within the OC4J-specific deployment descriptor.
3. Lookup the object reference within the bean with the "java:comp/env/url" preface and the logical name defined in the EJB deployment descriptor.

As shown in [Figure 10-7](#), the URL object was bound to the URL "http://www.myURL.com". The logical name that the bean knows this resource as is "url/testURL". These names are mapped together within the OC4J-specific deployment descriptor. Thus, within the bean's implementation, the bean can retrieve a reference to the URL object by using the "java:comp/env/url/testURL" environment element.

**Figure 10-7 URL Resource Manager Mapping**

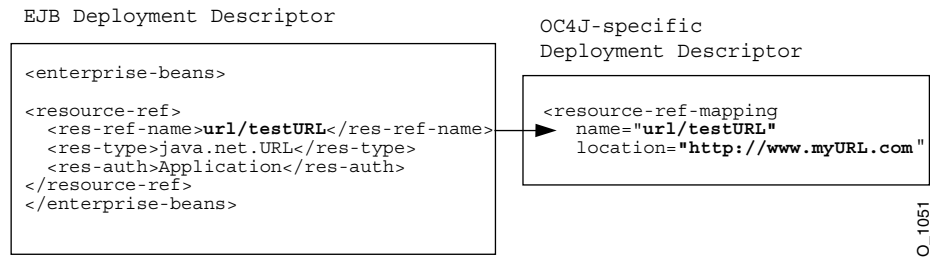

This environment element is defined with the following information:

Element	Description
<res-ref-name>	The logical name of the URL object to be used within the originating bean. The name should be prefixed with "url/". In our example, the logical name for our URL is "url/testURL".
<res-type>	The Java type of the resource. For the Java URL object, this is java.net.URL.
<res-auth>	Define who is responsible for signing on to the database. At this time, the only value supported is "Application". The application provides the authentication information.

**Example 10-5 Defining an Environment Element for a URL**

The environment element is defined within the EJB deployment descriptor by providing the logical name, "url/testURL", its type of java.net.URL, and the authenticator of "Application":

```

<resource-ref>
  <res-ref-name>url/testURL</res-ref-name>
  <res-type>java.net.URL</res-type>
  <res-auth>Application</res-auth>
</resource-ref>
    
```

The environment element of "url/testURL" is mapped to the URL "http://www.myURL.com" within the OC4J-specific deployment descriptor:

```

<resource-ref-mapping
  name="url/testURL"
  location="http://www.myURL.com"/>
    
```

Once deployed, the bean can retrieve the URL object reference as follows:

```

InitialContext ic = new InitialContext();
URL url = (URL) ic.lookup("java:comp/env/url/testURL");

//The following uses the URL object
URLConnection conn = url.openConnection();
    
```

---

## Using Timers

You can use timers within all types of EJBs—except stateful session beans. The EJB can set up a timer where OC4J calls the bean either at a specified time, after a specified elapsed time, or at specified intervals. These timers are for use in modeling of application-level processes, not for real-time events.

The following sections describe how to use timers:

- [How to Create Timers](#)
- [Configuring Regularly Scheduled Timers \(Cron Timers\)](#)
- [How to Retrieve Information About the Timer](#)
- [Executing the Timer Within the Scope of a Transaction](#)
- [What Does a `NoSuchObjectLocalException` Mean with Timers?](#)

### How to Create Timers

The EJB that creates the timer first retrieves the timer service—`TimerService` interface—through the `getTimerService` method of the `EJBContext` interface. From the `TimerService` interface, you can create a timer using one of the four provided `createTimer` methods that allow you to specify the timer as a single-event timer or as an interval timer. The timers are defined in milliseconds, even though most events are for much longer time periods. The expiration of the timer can be defined as a duration or in absolute time. In addition, the bean can pass some information to identify the timer, which must be serializable.

```
TimerService ts = ctx.getTimerService();
Timer myTimer = ts.createTimer(timeout, "EmpDurationTimer");
```

The timer is created by a bean to designate when a callback method is invoked. The business logic that is to be executed when the timer expires is implemented in a callback method—`ejbTimeout`—within the application bean class. The bean class that uses the timer service must implement the `javax.ejb.TimerObject` interface, which contains the `ejbTimeout` method.

The created timer is associated with the identity of the bean. For entity beans, the `ejbTimeout` is invoked on the bean instance that created the bean; for stateless session beans and MDBs, the `ejbTimeout` method is invoked on any bean instance in the pool.

```
public abstract class EmployeeBean implements EntityBean, TimerObject
...
    public void ejbTimeout(Timer timer)
    {
```

```
System.out.println("ejbTimeout() called at: " + new
    Date(System.currentTimeMillis()) + " with info: " + timer.getInfo());
return;
}
```

---

---

**Note:** There is no guarantee that the timers are executed in any order; therefore, your implementation within the `ejbTimeout` callback must be able to handle the callbacks in any sequence.

---

---

The `TimerService` provides the following methods for creating the different types of timers:

```
public interface javax.ejb.TimerService {
    /* After a specified duration*/
    public Timer createTimer(long duration, java.io.Serializable info);
    /* At a specified interval */
    public Timer createTimer(long initialDuration, long intervalDuration,
        java.io.Serializable info);
    /* At a certain time */
    public Timer createTimer(java.util.Date expiration, java.io.Serializable info);
    /* A certain duration after a specified date and time */
    public Timer createTimer(java.util.Date initialExpiration,
        long intervalDuration, java.io.Serializable info);
    public Collection getTimers();
}
```

The `getTimers` method retrieves all active timers associated with the bean.

---

---

**Note:** Timers and their handles are local objects; therefore, they should not be passed through the bean remote interface.

---

---

## Configuring Regularly Scheduled Timers (Cron Timers)

You can schedule a timer to execute regularly at specified intervals. In the UNIX world, these are known as cron timers.

The following are examples of the different methods you can use in scheduling a cron timer. Where there is an asterisk, all values are valid.

### **Example 11–1** How to Configure Different Timers

```
20 * * * * --> 20 minutes after every hour, such as 00:20, 01:20, and so on
5 22 * * * --> Every day at 10:05 P.M.
0 8 1 * * --> First day of every month at 8:00 A.M.
0 8 4 7 * --> The fourth of July at 8:00 A.M.
15 12 * * 5 --> Every Friday at 12:15 P.M.
```

The format of a cron time variable includes five time fields:

- Minute: 0-59
- Hour: 0-23
- Day of the Month: 1-31
- Month: 1-12 or specify with the following strings: Jan, Feb, Mar, Apr, May, Jun, Jul, Aug, Sep, Oct, Nov, Dec



- Day of the Week: 0-7 or with the following strings: Sun, Mon, Tue, Wed, Thu, Fri, Sat. Both 0 and 7 signify Sunday.

You can define complex timers by specifying multiple values in a field, separated by commas or a dash.

### Example 11–2 Complex Timers

```
0 8 * * 1,3,5 --> Every Monday, Wednesday, and Friday at 8:00 A.M.
0 8 1,15 * * --> The first and 15th of every month at 8:00 A.M.
0 8-17 * * 1-5 --> Every hour from 8 A.M. through 5 P.M., Monday through Friday
```

You can create cron timers either through the `createTimer` method that takes a `String` with the previous five fields in it—separated by spaces—or with the `createTimer` method that has variables for each field. To create the cron timers, use the following Oracle-specific `createTimer` APIs:

```
EJBTimer createTimer(String cronline, Serializable info) throws
IllegalArgumentException, IllegalStateException;
```

```
EJBTimer createTimer(int minute, int hour, int dayOfMonth, int month, int
dayOfWeek, int year, Serializable info) throws IllegalArgumentException,
IllegalStateException;
```

Create the cron timers in the same manner as other timers by retrieving the extended Oracle-specific timer service, and schedule a cron timer using the `createTimer` method. However, since cron timers are Oracle-specific, you cast the returned object as an `EJBTimerService` object. The following example provides a `String` with the five variables separated by spaces. The timer is scheduled to execute every minute.

```
import oracle.ias.container.timer.EJBTimer;
import oracle.ias.container.timer.EJBTimerService;
...
String cron = "1 * * * *";
EJBTimerService ets = (EJBTimerService) ctx.getTimerService();
EJBTimer et = ets.createTimer(cron, info);
```

You can also provide a class that is to be invoked within the `createTimer` method, as follows:

```
EJBTimer createTimer(String cronline, String className, Serializable info) throws
IllegalArgumentException, IllegalStateException;
```

```
EJBTimer createTimer(int minute, int hour, int dayOfMonth, int month, int
dayOfWeek, String className, Serializable info) throws IllegalArgumentException,
IllegalStateException;
```

For arbitrary Java classes, the `info` variable can be either `null` or be a `String []` of parameters to pass to the main method of the class.

For example, you can have the `mypackage.MyClass` invoked when the `et` timer fires:

```
EJBTimerService ets = (EJBTimerService) ctx.getTimerService();
EJBTimer et = ets.createTimer(cron,"mypackage.MyClass", info);
```

You must provide a main method within the `mypackage.MyClass`, which is used as the entry point, as follows:

```
public static void main( String args[] )
```

## How to Retrieve Information About the Timer

You can retrieve information and cancel the timer through the `Timer` object. The methods available are `cancel()`, `getTimeRemaining()`, `getNextTimeout()`, `getHandle()`, and `getInfo()`. To compare for object equality, use the `Timer.equals(Object obj)` method.

For a full example, see the timer example on the OC4J sample code page at <http://www.oracle.com/technology/tech/java/oc4j/demos/> on the OTN Web site.

## How to Retrieve a Persisted Timer

Timers must be able to be persisted so that they can survive the life cycle of the bean (`ejbLoad`, `ejbStore`, and so on). You can retrieve a persisted `Timer` object through its handle. Retrieve the `TimerHandle` through the `Timer.getHandle()` method. Then, you can retrieve the persisted `Timer` object through the `TimerHandle.getTimer()` method.

## Executing the Timer Within the Scope of a Transaction

The timer is normally created or cancelled within the scope of a transaction. Thus, the bean normally is configured as being within a transaction. Typically this is configured with `RequiresNew`. If the transaction is rolled back, then the container retries the timeout.

For more information on transactions, see the Oracle Application Server Containers for J2EE Services Guide.

## What Does a `NoSuchObjectLocalException` Mean with Timers?

When you try to invoke a method on a timer object that has been either successfully invoked or cancelled, you will receive a `NoSuchObjectLocalException`.

---

---

## Configuring EJB Application Security

EJB application security involves two realms: granting permissions if you download into a browser and configuring your application for authentication and authorization. This chapter talks about setting up users, roles, and groups for EJBs. However, for basic OC4J security configuration information, including CSiV2, see the Oracle Application Server Containers for J2EE Security Guide.

This chapter covers the following subjects:

- [Granting Permissions in Browser](#)
- [Authenticating and Authorizing EJB Applications](#)
- [Specifying Credentials in EJB Clients](#)

### Granting Permissions in Browser

If you download the EJB application as a client where the security manager is active, you must grant the following permissions before you can execute:

```
permission java.net.SocketPermission "*:*", "connect,resolve";
permission java.lang.RuntimePermission "createClassLoader";
permission java.lang.RuntimePermission "getClassLoader";
permission java.util.PropertyPermission ":", "read";
permission java.util.PropertyPermission "LoadBalanceOnLookup", "read,write";
```

### Authenticating and Authorizing EJB Applications

For EJB authentication and authorization, you define the principals under which each method executes by configuring of the EJB deployment descriptor. The container enforces that the user who is trying to execute the method is the same as defined within the deployment descriptor.

The EJB deployment descriptor enables you to define security roles under which each method is allowed to execute. These methods are mapped to users or groups in the OC4J-specific deployment descriptor. The users and groups are defined within your designated security user managers, which uses either the Oracle Application Server Java Authentication and Authorization Service (JAAS) Provider (OracleAS JAAS Provider) or XML user manager. For a full description of security user managers, see the *Oracle Application Server Containers for J2EE User's Guide* and *Oracle Application Server Containers for J2EE Services Guide*.

For authentication and authorization, this section focuses on XML configuration within the EJB deployment descriptors. EJB authorization is specified within the EJB and OC4J-specific deployment descriptors. You can manage the authorization piece of your security within the deployment descriptors, as follows:

- The EJB deployment descriptor describes access rules using logical roles.
- The OC4J-specific deployment descriptor maps the logical roles to concrete users and groups, which are defined either the OracleAS JAAS Provider or XML user managers.

Users and groups are identities known by the container. Roles are the *logical* identities each application uses to indicate access rights to its different objects. The username/passwords can be digital certificates and, in the case of SSL, private key pairs.

Thus, the definition and mapping of roles is demonstrated in [Figure 12–1](#).

**Figure 12–1 Role Mapping**

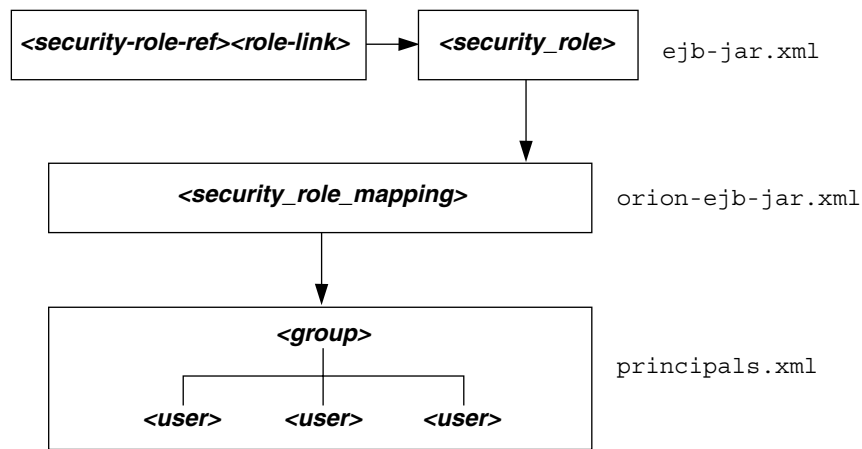

Defining users, groups, and roles are discussed in the following sections:

- [Specifying Users and Groups](#)
- [Specifying Logical Roles in the EJB Deployment Descriptor](#)
- [Specifying Unchecked Security for EJB Methods](#)
- [Specifying the runAs Security Identity](#)
- [Mapping Logical Roles to Users and Groups](#)
- [Specifying a Default Role Mapping for Undefined Methods](#)
- [Specifying Users and Groups by the Client](#)

---

**Note:** For basic OC4J security configuration information, including CSIv2, see the Oracle Application Server Containers for J2EE Security Guide.

---

## Specifying Users and Groups

OC4J supports the definition of users and groups—either shared by all deployed applications or specific to given applications. You define shared or application-specific users and groups within either the OracleAS JAAS Provider or XML user managers. See the *Oracle Application Server Containers for J2EE User's Guide* and *Oracle Application Server Containers for J2EE Services Guide* for directions.

## Specifying Logical Roles in the EJB Deployment Descriptor

As shown in [Figure 12-2](#), you can use a logical name for a role within your bean implementation, and map this logical name to the correct database role or user. The mapping of the logical name to a database role is specified in the OC4J-specific deployment descriptor. See ["Mapping Logical Roles to Users and Groups"](#) on page 12-6 for more information.

**Figure 12-2 Security Mapping**

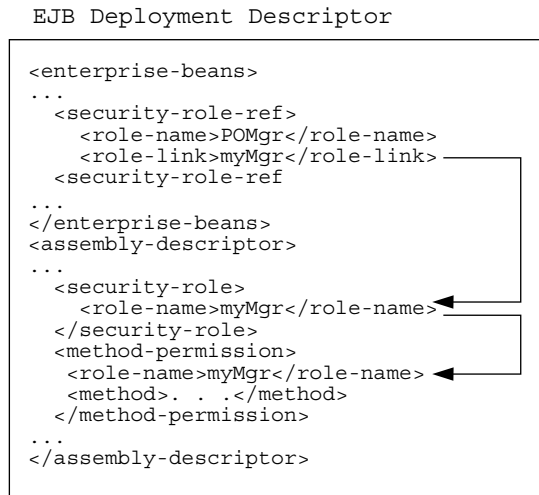

If you use a logical name for a database role within your bean implementation for methods such as `isCallerInRole`, you can map the logical name to an actual database role by doing the following:

1. Declare the logical name within the `<enterprise-beans>` section `<security-role-ref>` element. For example, to define a role used within the purchase order example, you may have checked, within the bean's implementation, to see if the caller had authorization to sign a purchase order. Thus, the caller would have to be signed in under a correct role. In order for the bean to not need to be aware of database roles, you can check `isCallerInRole` on a logical name, such as `POMgr`, since only purchase order managers can sign off on the order. Thus, you would define the logical security role, `POMgr` within the `<security-role-ref><role-name>` element within the `<enterprise-beans>` section, as follows:

```

<enterprise-beans>
...
  <security-role-ref>
    <role-name>POMgr</role-name>
    <role-link>myMgr</role-link>
  </security-role-ref>
</enterprise-beans>

```

The `<role-link>` element within the `<security-role-ref>` element can be the actual database role, which is defined further within the `<assembly-descriptor>` section. Alternatively, it can be another logical name, which is still defined more in the `<assembly-descriptor>` section and is mapped to an actual database role within the Oracle-specific deployment descriptor.

---

---

**Note:** The `<security-role-ref>` element is not required. You only specify it when using security context methods within your bean.

---

---

2. Define the role and the methods that it applies to. In the purchase order example, any method executed within the `PurchaseOrder` bean must have authorized itself as `myMgr`. Note that `PurchaseOrder` is the name declared in the `<entity | session><ejb-name>` element.

Thus, the following defines the role as `myMgr`, the EJB as `PurchaseOrder`, and all methods by denoting the `'*'` symbol.

---

---

**Note:** The `myMgr` role in the `<security-role>` element is the same as the `<role-link>` element within the `<enterprise-beans>` section. This ties the logical name of `POMgr` to the `myMgr` definition.

---

---

```
<assembly-descriptor>
  <security-role>
    <description>Role needed purchase order authorization</description>
    <role-name>myMgr</role-name>
  </security-role>
  <method-permission>
    <role-name>myMgr</role-name>
    <method>
      <ejb-name>PurchaseOrder</ejb-name>
      <method-name>*</method-name>
    </method>
  </method-permission>
  ...
</assembly-descriptor>
```

After performing both steps, you can refer to `POMgr` within the bean's implementation and the container translates `POMgr` to `myMgr`.

---

---

**Note:** If you define different roles within the `<method-permission>` element for methods in the same EJB, the resulting permission is a union of all the method permissions defined for the methods of this bean.

---

---

The `<method-permission><method>` element is used to specify the security role for one or more methods within an interface or implementation. According to the EJB specification, this definition can be of one of the following forms:

1. Defining all methods within a bean by specifying the bean name and using the `'*'` character to denote all methods within the bean, as follows:

```
<method-permission>
  <role-name>myMgr</role-name>
  <method>
    <ejb-name>EJBNAME</ejb-name>
    <method-name>*</method-name>
  </method>
</method-permission>
```

2. Defining a specific method that is uniquely identified within the bean. Use the appropriate interface name and method name, as follows:

```
<method-permission>
  <role-name>myMgr</role-name>
  <method>
<ejb-name>myBean</ejb-name>
<method-name>myMethodInMyBean</method-name>
  </method>
</method-permission>
```

---

**Note:** If there are multiple methods with the same overloaded name, the element of this style refers to all the methods with the overloaded name.

---

3. Defining a method with a specific signature among many overloaded versions, as follows:

```
<method-permission>
  <role-name>myMgr</role-name>
  <method>
<ejb-name>myBean</ejb-name>
<method-name>myMethod</method-name>
<method-params>
<method-param>javax.lang.String</method-param>
<method-param>javax.lang.String</method-param>
  </method-params>
  </method>
</method-permission>
```

The parameters are the fully-qualified Java types of the method's input parameters. If the method has no input arguments, the `<method-params>` element contains no elements. Arrays are specified by the array element's type, followed by one or more pair of square brackets, such as `int[ ][ ]`.

## Specifying Unchecked Security for EJB Methods

If you want certain methods to not be checked for security roles, you define these methods as unchecked, as follows:

```
<method-permission>
  <unchecked/>
  <method>
    <ejb-name>EJBNAME</ejb-name>
    <method-name>*</method-name>
  </method>
</method-permission>
```

Instead of a `<role-name>` element defined, you define an `<unchecked/>` element. When executing any methods in the EJBNAME bean, the container does not check for security. Unchecked methods always override any other role definitions.

## Specifying the runAs Security Identity

You can specify that all methods of an EJB execute under a specific identity. That is, the container does not check different roles for permission to run specific methods; instead, the container executes all of the EJB methods under the specified security identity. You can specify a particular role or the caller's identity as the security identity.

Specify the runAs security identity in the <security-identity> element, which is contained in the <enterprise-beans> section. The following XML demonstrates that the POMgr is the role under which all the entity bean methods execute.

```
<enterprise-beans>
  <entity>
    ...
    <security-identity>
      <run-as>
        <role-name>POMgr</role-name>
      </run-as>
    </security-identity>
    ...
  </entity>
</enterprise-beans>
```

Alternatively, the following XML example demonstrates how to specify that all methods of the bean execute under the identity of the caller:

```
<enterprise-beans>
  <entity>
    ...
    <security-identity>
      <use-caller-identity/>
    </security-identity>
    ...
  </entity>
</enterprise-beans>
```

## Mapping Logical Roles to Users and Groups

You can use logical roles or actual users and groups in the EJB deployment descriptor. However, if you use logical roles, you must map them to the actual users and groups defined either in the OracleAS JAAS Provider or XML User Managers.

Map the logical roles defined in the application deployment descriptors to OracleAS JAAS Provider or XML User Manager users or groups through the <security-role-mapping> element in the OC4J-specific deployment descriptor.

- The name attribute of this element defines the logical role that is to be mapped.
- The group or user element maps the logical role to a group or user name. This group or user must be defined in the OracleAS JAAS Provider or XML User Manager configuration. See *Oracle Application Server Containers for J2EE User's Guide* and *Oracle Application Server Containers for J2EE Services Guide* for a description of the OracleAS JAAS Provider and XML User Managers.

### **Example 12-1 Mapping Logical Role to Actual Role**

This example maps the logical role POMGR to the managers group in the orion-ejb-jar.xml file. Any user that can log in as part of this group is considered to have the POMGR role; thus, it can execute the methods of PurchaseOrderBean.

```
<security-role-mapping name="POMGR">
  <group name="managers" />
</security-role-mapping>
```

---

---

**Note:** You can map a logical role to a single group or to several groups.

---

---



To map this role to a specific user, do the following:

```
<security-role-mapping name="POMGR">
  <user name="guest" />
</security-role-mapping>
```

Lastly, you can map a role to a specific user within a specific group, as follows:

```
<security-role-mapping name="POMGR">
  <group name="managers" />
  <user name="guest" />
</security-role-mapping>
```

As shown in [Figure 12-3](#), the logical role name for POMGR defined in the EJB deployment descriptor is mapped to `managers` within the OC4J-specific deployment descriptor in the `<security-role-mapping>` element.

**Figure 12-3 Security Mapping**

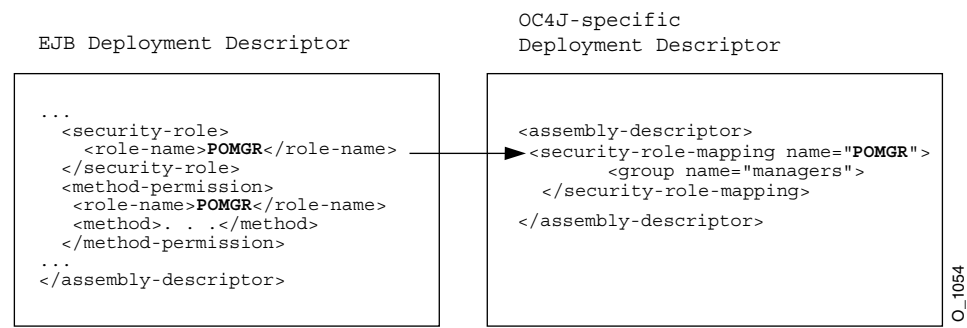

Notice that the `<role-name>` in the EJB deployment descriptor is the same as the name attribute in the `<security-role-mapping>` element in the OC4J-specific deployment descriptor. This is what identifies the mapping.

## Specifying a Default Role Mapping for Undefined Methods

If any methods have not been associated with a role mapping, they are mapped to the default security role through the `<default-method-access>` element in the `orion-ejb-jar.xml` file. The following is the automatic mapping for any insecure methods:

```
<default-method-access>
  <security-role-mapping name="&lt;default-ejb-caller-role&gt;"
    impliesAll="true" >
  </security-role-mapping>
</default-method-access>
```

The default role is `<default-ejb-caller-role>` and is defined in the name attribute. You can replace this string with any name for the default role. The `impliesAll` attribute indicates whether any security role checking occurs for these methods. This attribute defaults to true, which states that no security role checking occurs for these methods. If you set this attribute to false, the container will check for this default role on these methods.

If the `impliesAll` attribute is false, you must map the default role defined in the name attribute to a OracleAS JAAS Provider or XML user or group through the `<user>` and `<group>` elements. The following example shows how all methods not associated with a method permission are mapped to the "others" group.

```
<default-method-access>
  <security-role-mapping name="default-role" impliesAll="false" >
    <group name="others" />
  </security-role-mapping>
</default-method-access>
```

## Specifying Users and Groups by the Client

In order for the client to access methods that are protected by users and groups, the client must provide the correct user or group name with a password that the OracleAS JAAS Provider or XML User Manager recognizes. And the user or group must be the same one as designated in the security role for the intended method. See ["Specifying Credentials in EJB Clients"](#) on page 12-8 for more information.

---

---

**Note:** For basic OC4J security configuration information, including CSIv2, see the Oracle Application Server Containers for J2EE Security Guide.

---

---

## Specifying Credentials in EJB Clients

When you access EJBs in a *remote* container, you must pass valid credentials to this container. See ["Setting JNDI Properties"](#) on page 2-2 for more information.

- Pure Java clients define their credentials in the `jndi.properties` file deployed with the EAR file.
- Servlets or JavaBeans running within the container pass their credentials within the `InitialContext`, which is created to look up the remote EJBs.

---

---

**Note:** For basic OC4J security configuration information, including CSIv2, see the Oracle Application Server Containers for J2EE Security Guide.

---

---

## Credentials in JNDI Properties

Indicate the username (principal) and password (credentials) to use when looking up remote EJBs in the `jndi.properties` file.

For example, if you want to access remote EJBs as `POMGR/welcome`, define the following properties. The `factory.initial` property indicates that you will use the Oracle JNDI implementation:

```
java.naming.security.principal=POMGR
java.naming.security.credentials=welcome
java.naming.factory.initial=
com.evermind.server.ApplicationClientInitialContextFactory
java.naming.provider.url=opmn:ormi://opmnhost:oc4j_inst1/ejbsamples
```

In your application program, authenticate and access the remote EJBs, as shown below:

```
InitialContext ic = new InitialContext();
CustomerHome = (CustomerHome)ic.lookup("java:comp/env/purchaseOrderBean");
```

## Credentials in the InitialContext

To access remote EJBs from a servlet or JavaBean, pass the credentials in the `InitialContext` object, as follows:

```
Hashtable env = new Hashtable();
env.put("java.naming.provider.url",
"opmn:ormi://opmnhost:oc4j_inst1/ejbsamples");
env.put("java.naming.factory.initial",
"com.evermind.server.ApplicationClientInitialContextFactory");
env.put(Context.SECURITY_PRINCIPAL, "POMGR");
env.put(Context.SECURITY_CREDENTIALS, "welcome");
Context ic = new InitialContext (env);
CustomerHome =
(CustomerHome) ic.lookup ("java:comp/env/purchaseOrderBean");
```



---

---

## EJB Clustering

The methods for providing clustering—including load balancing and failover—are different for HTTP requests than for EJB communications because Web components use different protocols than EJB components. This chapter specifically discusses EJB clustering. For a complete overview of Oracle Application Server clustering—including the instructions for setting up the HTTP failover and load balancing environment—see the clustering chapter in the *Oracle Application Server Containers for J2EE User's Guide*.

The following is discussed in this chapter:

- [EJB Clustering Overview](#)
- [Enabling Clustering For EJBs](#)
- [EJB Clustering Includes JNDI Namespace Replication](#)
- [Load Balancing Options](#)

### EJB Clustering Overview

Clustered EJBs behave in their own manner. However, only stateful session beans are clustered. To create an EJB cluster, you specify nodes that are to be involved in the cluster, configure each OC4J instance within the node with the same multicast address, username, and password, and deploy the EJB to one of these nodes.

---

---

**Caution:** EJB clustering only works over the ORMI protocol, not over the RMI/IIOP protocol.

---

---

The following characteristics apply to EJB clustering:

- Unlike HTTP clustering, EJBs involved in a cluster cannot be sub-grouped in an island. Instead, all EJBs within the cluster are in one group.
- Transactions cannot failover. There is no reinstating an interrupted transaction in another bean. Instead, the transaction rolls back and must start over.
- Load balancing occurs in a random fashion throughout all OC4J processes in the cluster for EJBs.
- The performance for clustering stateful session beans is dependent on the type of replication and load balancing options you choose.

Clustering for each of the session bean types are discussed in the following sections:

- [Stateless Session Clustering](#)

- [Stateful Session Bean Clustering](#)
- [Combination of HTTP and EJB Clustering](#)

---

---

**Note:** For an overview of how clustering works, see the clustering chapter of the *Oracle Application Server Containers for J2EE User's Guide*.

---

---

## Stateless Session Clustering

Stateless session beans do not have any state to be replicated among hosts in a cluster. Thus, no failover option is necessary. Load balancing is provided automatically with OPMN, which uses a random algorithm. Stateless session beans are not clustered; the load balancing happens in any environment where the OPMN components know about each other. You can configure the frequency of the load balancing from the client using the options described in "[Load Balancing Options](#)" on page 13-5.

## Stateful Session Bean Clustering

Load balancing is provided automatically with OPMN, which uses a random algorithm. Failover requires that the state of the bean is replicated, so that when the original bean terminates unexpectedly, the request can be forwarded to another OC4J process. You can configure the frequency of the load balancing from the client using the options described in "[Load Balancing Options](#)" on page 13-5.

For failover, stateful session beans must replicate state among hosts. There are three options for stateful session bean replication, where each option defines the interval when the bean state is sent. All of the state is sent out to all other OC4J processes in the cluster, so it can have an impact on your performance. The fewer times the state is sent out, the better your performance. However, there is a trade-off between performance and the confidence that the bean state is replicated to cover for all areas of the bean instance failing. Thus, choose one of the following replication modes:

- JVM termination replication—The state of the stateful session bean is replicated to only one other host in the cluster (with the same multicast address, port) when the JVM is terminating. Since this uses JDK 1.3 shutdown hooks, you must use JVM version 1.3 or later. This is the most performant option, because the state is replicated only once. However, it is not very reliable for the following reasons:
  - Your state is not replicated if the host is terminated unexpectedly.
  - The state of the bean exists only on a single host at any time; you carry a higher risk that the state does not replicate and is lost.
- End of call replication—The state of the stateful session bean is replicated to all hosts in the cluster (with the same multicast address, port) at the end of each EJB method call. If the node loses power, then the state has already been replicated. This method is less performant than the JVM termination replication mode, because the state is sent out more often. However, the guarantee for reliance is higher.

See "[Configure EJB Replication for Stateful Session Beans](#)" on page 13-4 for configuration and implementation details for each of these stateful session bean clustering options.

## Combination of HTTP and EJB Clustering

If you have a servlet that invokes an EJB, you must configure both HTTP and EJB clustering. For HTTP clustering options, see the Clustering chapter of the *Oracle Application Server Containers for J2EE User's Guide*.

## Enabling Clustering For EJBs

For a full description of how to set up an OC4J cluster, see the *Oracle Application Server Containers for J2EE User's Guide*. This section describes how to only configure for EJB state replication within the cluster.

To enable the OC4J nodes for EJB clustering, you must perform the following tasks:

1. Configure each host in the cluster with an identical multicast address (host and port number), including a username and password.
2. If you have stateful session beans, choose state replication type.
3. Deploy the EJB to be clustered.

## Configure the Multicast Address for EJB Clustering

Within the OC4J Instance page in the Enterprise Manager, do the following:

1. Select the Administration page.
2. Select Replication Properties in the Instance Properties column.
3. Scroll down to the EJB Applications section. [Figure 13–1](#) shows this section.
4. Select the Replicate State checkbox.
5. Optionally, you can provide the multicast host IP address and port number. If you do not provide the host and port for the multicast address, it defaults to host IP address 230.230.0.1 and port number 9127. The host IP address must be between 224.0.0.2 through 239.255.255.255. Do not use the same multicast address for both HTTP and EJB multicast addresses.

You can test a network for multicast ability by pinging the following hosts:

- To ping all multicast hosts, execute: `ping 224.0.0.1`.
  - To ping all multicast routers, execute: `ping 224.0.0.2`.
6. Provide the username and password, which is used to authenticate itself to other hosts in the cluster over the multicast address. The username and password must be consistent in the multicast address to be in the same cluster.

**Figure 13-1 EJB State Replication Configuration**

## EJB Applications

✓ **TIP** EJB applications replicate state between all OC4J processes in the OC4J instance.

Replicate State

Multicast Host (IP)	<input type="text"/>
Multicast Port	<input type="text"/>
Username	<input type="text"/>
Password	<input type="text"/>
RMI Server Host	<input type="text" value="[ALL]"/>

This is usually the name of the machine where the OC4J instance is running.

7. Provide the host name where the OC4J Instance resides in the RMI Server Host field.

Configure the type of stateful session bean replication within the `orion-ejb-jar.xml` file within the JAR file. See "[Configure EJB Replication for Stateful Session Beans](#)" on page 13-4 for full details. You can configure these within the `orion-ejb-jar.xml` file before deployment or add this through the Enterprise Manager screens after deployment. If you add this after deployment, drill down to the JAR file from the application page.

## Configure EJB Replication for Stateful Session Beans

Modify the `orion-ejb-jar.xml` file to add the state replication configuration for stateful session beans. Since you configure the replication type for the stateful session bean within the bean deployment descriptor, each bean can use a different type of replication.

### VM Termination Replication

Set the `replication` attribute of the `<session-deployment>` tag in the `orion-ejb-jar.xml` file to "VMTermination". This is shown below:

```
<session-deployment replication="VMTermination" .../>
```

### End of Call Replication

Set the `replication` attribute of the `<session-deployment>` tag in the `orion-ejb-jar.xml` file to "EndOfCall". This is shown below:

```
<session-deployment replication="EndOfCall" .../>
```

## EJB Clustering Includes JNDI Namespace Replication

When EJB clustering is enabled, JNDI namespace replication is also enabled between the OC4J instances in a cluster. New bindings to the JNDI namespace in one OC4J instance are propagated to other OC4J instances in the cluster. Re-bindings and unbindings are not replicated. The replication is completed outside the scope of OC4J islands. In other words, multiple islands in an OC4J instance have visibility into the same replicated JNDI namespace. For more information see the *Oracle Application Server Containers for J2EE Services Guide*.



## Load Balancing Options

Load balancing for EJBs occurs across all OC4J processes included in the cluster.

The client retrieves a random OC4J process when the first lookup is executed. The selection of which OC4J process that services the client is always randomly chosen from among the pooled OC4J processes in the cluster. However, you can choose to have the client do the following:

- If you do not set any options, then the client interacts with the OC4J process that was initially chosen at the first lookup for the entire conversation.
- If you do set one of two options, then the client chooses another OC4J process with which to interact at specific points in the client's implementation. Each time a client requests another OC4J process, this process is also chosen randomly from the OC4J processes involved in the cluster.

These options are as follows:

- `LoadBalanceOnLookup` property: If this property is set to true, then the client randomly picks another OC4J process from the pooled processes in the cluster each time a lookup is executed. You should only use `RMIInitialContextFactory` object with this option.

The following configures the `LoadBalanceOnLookup` property on the client to true in the JNDI properties before retrieving the `InitialContext`:

```
env.put("LoadBalanceOnLookup", "true");
```

- `dedicated.rmicontext` property: If this property is set to true, then each time the client retrieves a new `InitialContext`, the client also retrieves a new OC4J process. If you want to use multiple OC4J processes within your client, this option is more performant and less burdensome on the application server than the `LoadBalanceOnLookup` property.

If you are not interested in EJB state replication, but want to load balance your request among OC4J processes, the following sections describe your options:

- [Load Balancing Using Static Retrieval](#)
- [DNS Load Balancing](#)

### Load Balancing Using Static Retrieval

If you decide to not use EJB replication, but you want to load balance the request across several OC4J processes, you can use static retrieval by providing the URLs for all of these processes in the JNDI URL property.

The JNDI addresses of all OC4J nodes that should be contacted for load balancing and failover are supplied in the lookup URL, and each address is separated by a comma. For example, the following URL definition provides the client container with three OC4J nodes to use for load balancing and failover.

```
java.naming.provider.url=ormi://s1:23791/ejbsamples,  
ormi://s2:23793/ejbsamples, ormi://s3:23791/ejbsamples;
```

### DNS Load Balancing

Alternatively, if you do not want to use EJB replications, but you want to load balance the request using DNS for load balancing, you can do the following:

1. Within DNS, map a single host name to several IP addresses. Each of the port numbers must be the same for each IP address. Set up the DNS server to return the addresses either in a round-robin or random fashion.

The IP address identifies the OC4J running; the port number is an RMI port number.

2. Turn off DNS caching on the client. For UNIX machines, you must turn off DNS caching as follows:
  - a. Kill the NSCD daemon process on the client.
  - b. Start the OC4J client with the `-Dsun.net.inetaddr.ttl=0` option.
3. Within each client, use ANY initial context factory to create an initial context. Use the `ormi://` prefix in the provider URL. Use the single host name in the DNS server to which the OC4J IP addresses are mapped and the common RMI port in the provider URL for the client.
4. Set the `dedicated.rmicontext` property to true.

Each time the lookup occurs on the DNS server, the DNS server hands back one of the many IP addresses that are mapped to it.

#### **Example 13–1 RMIInitialContextFactory Example**

This example uses an `RMIInitialContextFactory` object; however, you can use any initial context factory for DNS load balancing. In this example, `myserver` is the host name set up in the DNS server for the list of servers, and the RMI port is defaulting to the default port.

```
java.naming.factory.initial=
    com.evermind.server.rmi.RMIInitialContextFactory
java.naming.provider.url=ormi://myserver/applname
java.naming.security.principal=admin
java.naming.security.credentials=welcome
dedicated.rmicontext=true
```

---

## XML Reference for ORION-EJB-JAR.XML

This appendix describes the elements contained within the OC4J-specific EJB deployment descriptor: `orion-ejb-jar.dtd`. This appendix covers the structure and briefly describes the elements in this DTD; however, most of these elements are fully described in other sections of this book.

The DTD is located at

`http://xmlns.oracle.com/ias/dtds/orion-ejb-jar.dtd`.

The description of this deployment descriptor has been divided into the following sections:

- Overall description of each element section—Each section of elements of this XML file is described in "[OC4J-Specific Deployment Descriptor for EJBs](#)" on page A-2.
- Element description—An alphabetical listing and description for each element is discussed in "[Element Description](#)" on page A-16.

Whenever you deploy an application, OC4J automatically generates the OC4J-specific XML file with the default elements. If you want to change these defaults, you must copy the `orion-ejb-jar.xml` file to where your original `ejb-jar.xml` file is located and change it in this location. If you change the XML file within the deployed location, OC4J simply overwrites these changes when the application is deployed again. The changes only stay constant when changed in the development directories.

Oracle recommends that you add your OC4J-specific XML files within the recommended development structure as shown in [Figure A-1](#).

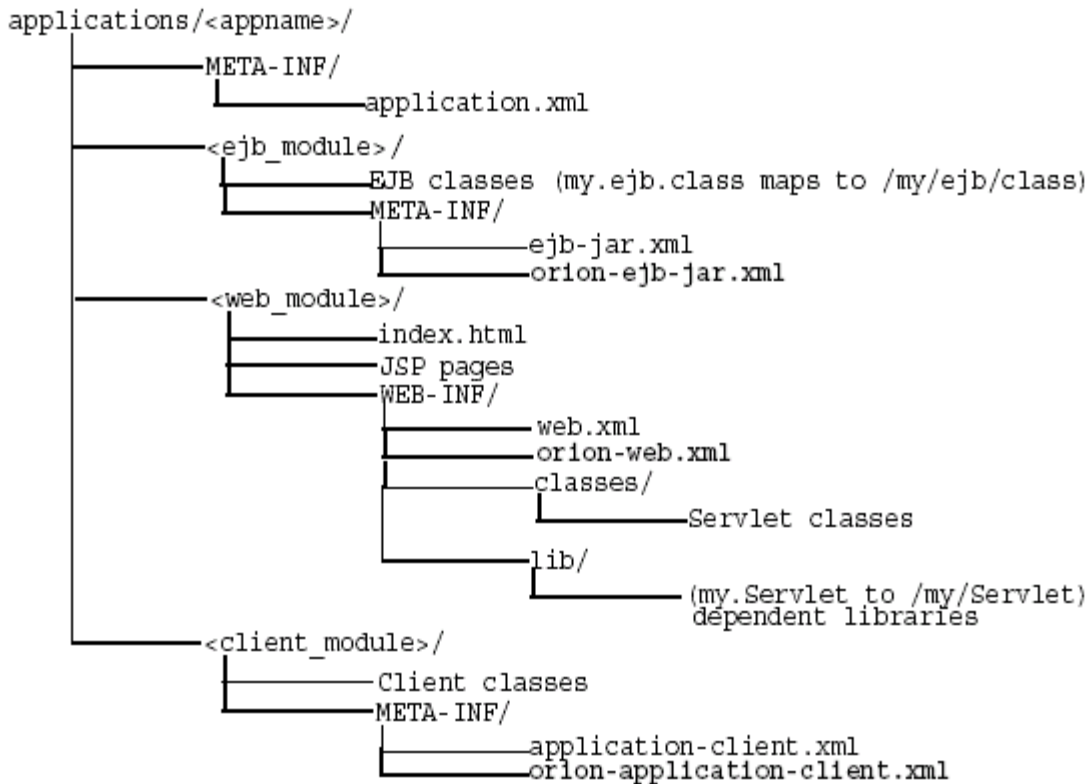
**Figure A-1 Development Application Directory Structure**

## OC4J-Specific Deployment Descriptor for EJBs

The OC4J-specific deployment descriptor contains extended deployment information for session beans, entity beans, message driven beans, and security for these EJBs. The major element structure within this deployment descriptor has the following structure:

```

<orion-ejb-jar deployment-time=... deployment-version=...>
  <enterprise-beans>
    <session-deployment ...></session-deployment>
    <entity-deployment ...></entity-deployment>
    <message-driven-deployment ...></message-driven-deployment>
    <jem-deployment ...></jem-deployment>
    <jem-server-extension ...></jem-server-extension>
  </enterprise-beans>
  <assembly-descriptor>
    <security-role-mapping ...></security-role-mapping>
    <default-method-access></default-method-access>
  </assembly-descriptor>
</orion-ejb-jar>

```

Each section under the `<orion-ejb-jar>` main tag has its own purpose. These are described in the sections below:

- [Enterprise Beans Section](#)
- [Assembly Descriptor Section](#)

## Enterprise Beans Section

The `<enterprise-beans>` section defines additional deployment information for all EJBs: session beans, entity beans, and message driven beans. There is a section for each type of EJB.

The following sections describe the elements within `<enterprise-beans>` element;

- [Session Bean Section](#)
- [Entity Bean Section](#)
- [Message Driven Bean Section](#)
- [EJB 1.1 CMP Field Mapping Section](#)
- [Method Definition](#)

### Session Bean Section

The `<session-deployment>` section provides additional deployment information for a session bean deployed within this JAR file. The `<session-deployment>` section contains the following structure:

```
<session-deployment pool-cache-timeout=... call-timeout=... copy-by-value=...
    location=... max-instances=... min-instances=... max-tx-retries=...
    tx-retry-wait=... name=... persistence-filename=... replication=...
    timeout=... idletime=... memory-threshold=... max-instances-threshold=...
    resource-check-interval=... passivate-count=... wrapper=...
    local-wrapper=...
<ior-security-config>
  <transport-config>
    <integrity></integrity>
    <confidentiality></confidentiality>
    <establish-trust-in-target></establish-trust-in-target>
    <establish-trust-in-client></establish-trust-in-client>
  </transport-config>
  <as-context>
    <auth-method></auth-method>
    <realm></realm>
    <required></required>
  </as-context>
  <sas-context>
    <caller-propagation></caller-propagation>
  </sas-context>
</ior-security-config>
<env-entry-mapping name=...> </env-entry-mapping>
<ejb-ref-mapping location=... name=... />
<resource-ref-mapping location=... name=... >
  <lookup-context location=...>
    <context-attribute name=... value=... />
  </lookup-context>
</resource-ref-mapping>
<resource-env-ref-mapping location=... name=... />
</session-deployment>
```

Each of the element groups are discussed in the following sections of the OC4J documentation set:

- A session bean example, which includes the `<session-deployment>` element, is described in ["Create the Deployment Descriptor"](#) on page 3-6 in [Chapter 3, "Implementing Session Beans"](#).

- The `<ior-security-config>` element is an interoperability element, which is discussed fully in the Interoperability chapter in the *Oracle Application Server Containers for J2EE Services Guide*.
- The `<env-entry-mapping>` element maps environment variables to JNDI names and is discussed in "Environment Variables" on page 10-9.
- The `<ejb-ref-mapping>` element maps any EJB references to JNDI names and is discussed in "Environment References To Other Enterprise JavaBeans" on page 10-10.
- The `<resource-ref-mapping>` element maps any EJB references to JNDI names and is discussed in "Environment References To Resource Manager Connection Factory References" on page 10-14.
- The `<resource-env-ref-mapping>` element is used to map an administered object for a resource. For example, to use JMS, the bean must obtain both a JMS factory object and a destination object. These objects are retrieved at the same time from JNDI. The `<resource-ref>` element declares the JMS factory and the `<resource-env-ref>` element is used to declare the destination. Thus, the `<resource-env-ref-mapping>` element maps the destination object. See "Using a Logical Name When Client Accesses the MDB" on page 9-25 for more information.

The attributes for the `<session-deployment>` element are as follows:

**Table A-1 Attributes for `<session-deployment>` Element**

Attribute	Description
<code>pool-cache-timeout</code>	<p>The <code>pool-cache-timeout</code> applies for stateless session EJBs. This parameter specifies how long to keep stateless sessions cached in the pool.</p> <p>For stateless session beans, if you specify a <code>pool-cache-timeout</code>, then at every <code>pool-cache-timeout</code> interval, all beans in the pool, of the corresponding bean type, are removed. If the value specified is zero or negative, then the <code>pool-cache-timeout</code> is disabled and beans are not removed from the pool.</p> <p>Default Value: 60 (seconds)</p>
<code>call-timeout</code>	<p>This parameter specifies the maximum time to wait for any resource to make a business/life-cycle method invocation. This is not a timeout for how long a business method invocation can take.</p> <p>If the timeout is reached, a <code>TimedOutException</code> is thrown. This excludes database connections.</p> <p>Default Values: 90000 milliseconds. Set to 0 if you want the timeout to be forever. See the EJB section in the <i>Oracle Application Server Performance Guide</i> for more information.</p>
<code>copy-by-value</code>	<p>Whether or not to copy (clone) all the incoming and outgoing parameters in EJB calls. Set to 'false' if you are certain that your application does not assume copy-by-value semantics for a speed-up. The default is 'true'.</p>
<code>location</code>	<p>The JNDI-name to which this bean will be bound.</p>

**Table A-1 (Cont.) Attributes for <session-deployment> Element**

Attribute	Description
max-instances	<p>The number of bean instances allowed in memory—either instantiated or pooled. When this value is reached, the container attempts to passivate the oldest bean instance from memory. If unsuccessful, the container waits the number of milliseconds set in the</p> <p>call-timeout attribute to see if a bean instance is removed from memory, either through passivation, its</p> <p>remove() method, or bean expiration, before a TimeoutExpiredException is thrown back to the client. To allow an infinite number of bean instances, the</p> <p>max-instances attribute can be set to zero. Default is 0, which means infinite. This applies to both stateless and stateful session beans</p> <p>.</p>
min-instances	<p>The number of minimum bean implementation instances to be kept instantiated or pooled. The default is 0. This setting is valid for stateless session beans only.</p>
max-tx-retries	<p>This parameter specifies the number of times to retry a transaction that was rolled back due to system-level failures. The default is 0.</p> <p>Generally, we recommend that you add retries only where errors are seen that could be resolved through retries. For example, if you are using serializable isolation and you want to retry the transaction automatically if there is a conflict, you might want to use retries. However, if the bean wants to be notified when there is a conflict, then in this case, you should leave max-tx-retries=0.</p> <p>Default Value: 0. See the EJB section in the <i>Oracle Application Server Performance Guide</i> for more information.</p>
tx-retry-wait	<p>This parameter specifies the time to wait in seconds between retrying the transaction. The default is 60 seconds.</p>
name	<p>The name of the bean, which matches the name of a bean in the assembly section of the EJB deployment descriptor (ejb-jar.xml).</p>
persistence-filename	<p>Path to the file where sessions are stored across restarts.</p>
replication	<p>Configuration of the state replication for stateful session beans. Values can be VMTermination, EndOfCall, or None. None is the default. See "<a href="#">Configure EJB Replication for Stateful Session Beans</a>" on page 13-4 for more information.</p>

**Table A-1 (Cont.) Attributes for <session-deployment> Element**

Attribute	Description
timeout	<p>The timeout in seconds applies for stateful session EJBs. If the value is zero or negative, then all timeouts are disabled.</p> <p>The timeout parameter is an inactivity timeout for stateful session beans. Every 30 seconds the pool clean up logic is invoked. Within the pool clean up logic, only the sessions that timed out, by passing the timeout value, are deleted.</p> <p>Adjust the timeout based on your applications use of stateful session beans. For example, if stateful session beans are not removed explicitly by your application, and the application creates many stateful session beans, then you may want to lower the timeout value.</p> <p>If your application requires that a stateful session bean be available for longer than 1800 seconds (equal to 30 minutes), then adjust the timeout value accordingly.</p> <p>Default Value: 1800 seconds (which equals 30 minutes)</p>
idletime	<p>You can set an idle timeout for each bean. When this timeout expires, passivation occurs. Set this attribute to the appropriate number of seconds. Default: 300 seconds. (5 min.). To disable, specify "never."</p>
memory-threshold	<p>This attribute defines a threshold for how much used JVM memory is allowed before passivation should occur.</p> <p>Specify an integer that is translated as a percentage.</p> <p>When reached, beans are passivated, even if their idle timeout has not expired. Default: 80%. To disable, specify "never."</p>
max-instances-threshold	<p>This attribute defines a threshold for how many actives beans exist in relation to the max-instances attribute definition. Specify an integer that is translated as a percentage. If you define that the max-instances is 100 and the max-instances-threshold is 90%, then when the active bean instances reaches past 90, passivation of beans occurs. Default: 90%. To disable, specify "never."</p>
resource-check-interval	<p>The container checks all resources at this time interval. At this time, if any of the thresholds have been reached, passivation occurs. Default: 180 sec. (3 min.). To disable, specify "never."</p>
passivate-count	<p>This attribute is an integer that defines the number of beans to be passivated if any of the resource thresholds have been reached. Passivation of beans is performed using the least recently used algorithm. Default: one-third of the max-instances attribute. You can disable this attribute by setting the count to zero or a negative number.</p>
wrapper	<p>Name of the OC4J wrapper class for this bean. This is an internal server value and should not be edited.</p>
local-wrapper	<p>Name of the OC4J local home wrapper class for this bean. This is an internal server value and should not be edited.</p>

### Entity Bean Section

The <entity-deployment> section provides additional deployment information for an entity bean deployed within this JAR file. The <entity-deployment> section contains the following structure:

```
<entity-deployment call-timeout=... clustering-schema=...
  copy-by-value=... data-source=... exclusive-write-access=...
  do-select-before-insert=... instance-cache-timeout=... isolation=...
  location=... locking-mode=... max-instances=... min-instances=...
```



```

        max-tx-retries=... tx-retry-wait=... update-changed-fields-only=...
        name=... pool-cache-timeout=...
        table=... validity-timeout=... force-update=...
        wrapper=... local-wrapper=... delay-updates-until-commit=...
        findByPrimaryKey-lazy-loading=... >
<ior-security-config>
  <transport-config>
    <integrity></integrity>
    <confidentiality></confidentiality>
    <establish-trust-in-target></establish-trust-in-target>
    <establish-trust-in-client></establish-trust-in-client>
  </transport-config>
  <as-context>
    <auth-method></auth-method>
    <realm></realm>
    <required></required>
  </as-context>
  <sas-context>
    <caller-propagation></caller-propagation>
  </sas-context>
</ior-security-config>
<primkey-mapping>
  <cmp-field-mapping ejb-reference-home=... name=... persistence-name=...
    persistence-type=...></cmp-field-mapping>
</primkey-mapping>
<cmp-field-mapping ejb-reference-home=... name=... persistence-name=...
  persistence-type=...> </cmp-field-mapping>
<finder-method partial=... query=... lazy-loading=... prefetch-size=... >
  <method></method>
</finder-method>
<env-entry-mapping name=...></env-entry-mapping>
<ejb-ref-mapping location=... name=... />
<resource-ref-mapping location=... name=... >
  <lookup-context location=...>
    <context-attribute name=... value=... />
  </lookup-context>
</resource-ref-mapping>
<resource-env-ref-mapping location=... name=... />
</entity-deployment>

```

Each of the element groups are discussed in the following sections of the OC4J documentation set:

- Entity bean examples, which includes the <entity-deployment> element, are described in [Chapter 5, "CMP Entity Beans"](#), [Chapter 6, "Entity Relationship Mapping"](#), [Chapter 7, "EJB Query Language"](#), and [Chapter 8, "BMP Entity Beans"](#).
- The <ior-security-config> element configures CSIv2 security policies for interoperability, which is discussed fully in the Interoperability chapter in the *Oracle Application Server Containers for J2EE Services Guide*.
- The <primkey-mapping> element maps the primary key to the CMP field it represents. See ["Explicit Mapping of Persistent Fields to the Database"](#) on page 5-3 for more information.
- The <cmp-field-mapping> element maps each <cmp-field> element to its database row. See ["Explicit Mapping of Persistent Fields to the Database"](#) on page 5-3 for more information.
- The <finder-method> element is used to create finder methods for EJB 1.1 entity beans. To create EJB 2.0 finder methods, see ["EJB Query Language"](#).

- The `<env-entry-mapping>` element maps environment variables to JNDI names and is discussed in "Environment Variables" on page 10-9.
- The `<ejb-ref-mapping>` element maps any EJB references to JNDI names and is discussed in "Environment References To Other Enterprise JavaBeans" on page 10-10.
- The `<resource-ref-mapping>` element maps any EJB references to JNDI names and is discussed in "Environment References To Resource Manager Connection Factory References" on page 10-14.
- The `<resource-env-ref-mapping>` element is used to map an administered object for a resource. For example, to use JMS, the bean must obtain both a JMS factory object and a destination object. These objects are retrieved at the same time from JNDI. The `<resource-ref>` element declares the JMS factory and the `<resource-env-ref>` element is used to declare the destination. Thus, the `<resource-env-ref-mapping>` element maps the destination object. See "Using a Logical Name When Client Accesses the MDB" on page 9-25 for more information.

The attributes for the `<entity-deployment>` element are as follows:

**Table A-2 Attributes for `<entity-deployment>` Element**

Attribute	Description
<code>call-timeout</code>	<p>This parameter specifies the maximum time to wait for any resource to make a business/life-cycle method invocation. This is not a timeout for how long a business method invocation can take.</p> <p>If the timeout is reached, a <code>TimedOutException</code> is thrown. This excludes database connections.</p> <p>Default Values: 90000 milliseconds. Set to 0 if you want the timeout to be forever. See the EJB section in the <i>Oracle Application Server Performance Guide</i> for more information.</p>
<code>clustering-schema</code>	Do not use. Not needed in this release.
<code>copy-by-value</code>	Whether or not to copy (clone) all the incoming and outgoing parameters in EJB calls. Set to 'false' if you are certain that your application does not assume copy-by-value semantics for a speed-up. The default is 'true'.
<code>data-source</code>	The name of the data source used if using container-managed persistence.

**Table A-2 (Cont.) Attributes for <entity-deployment> Element**

Attribute	Description
<code>exclusive-write-access</code>	<p>Whether or not the EJB-server has exclusive write (update) access to the database backend. This can be used only for entity beans that use a "read_only" locking mode. In this case, it increases the performance for common bean operations and enables better caching.</p> <p>This parameter corresponds to which commit option is used (A, B or C, as defined in the EJB specification). When <code>exclusive-write-access = true</code>, this is commit option A.</p> <p>Default is false for beans with <code>locking-mode=optimistic</code> or <code>pessimistic</code> and true for <code>locking-mode=read-only</code>.</p> <p>The <code>exclusive-write-access</code> is forced to false if locking is pessimistic or optimistic, and is not used with EJB clustering. The <code>exclusive-write-access</code> can be false with read-only locking, but read-only won't have any performance impact if <code>exclusive-write-access=false</code>, since <code>ejbStores</code> are already skipped when no fields have been changed. To see a performance advantage and avoid doing <code>ejbLoads</code> for read-only beans, you must also set <code>exclusive-write-access=true</code>.</p> <p>See <a href="#">"Specifying Exclusive Write Access to the Database"</a> on page 4-14 for more information.</p>
<code>do-select-before-insert</code>	<p>If false, you avoid executing a select before an insert. The extra select normally checks to see if the entity already exists before doing the insert to avoid duplicates.</p> <p>If a unique key constraint is defined for the entity, then we recommend setting this to false. If there is no unique key constraint, setting this to false leads to not detecting a duplicate insert. To prevent duplicate inserts in this case, leave it set to true.</p> <p>For performance, Oracle recommends setting this to false to avoid the extra select before insert. Default Value: true</p>
<code>instance-cache-timeout</code>	<p>The amount of time in seconds that entity wrapper instances are assigned to an identity. If you specify 'never', you retain the wrapper instances until they are garbage collected. The default is 60 seconds.</p>
<code>location</code>	<p>The JNDI-name to which this bean will be bound.</p>
<code>isolation</code>	<p>Specifies the isolation-level for database actions. The valid values for Oracle databases are 'serializable' and 'committed'. The default is 'committed'. Non-Oracle databases can be the following: 'none', 'committed', 'serializable', 'uncommitted', and 'repeatable_read'.</p> <p>For more information, see <a href="#">"Using Database Isolation Modes to Protect Against Resource Contention"</a> and <a href="#">"Configuring Entity Bean Concurrency Modes For Handling Resource Contention"</a> on page 4-12 and <i>Oracle Application Server Performance Guide</i>.</p>

**Table A-2 (Cont.) Attributes for <entity-deployment> Element**

Attribute	Description
locking-mode	<p>The concurrency modes configure when to block to manage resource contention or when to execute in parallel. For more information, see <a href="#">"Using Database Isolation Modes to Protect Against Resource Contention"</a> and <a href="#">"Configuring Entity Bean Concurrency Modes For Handling Resource Contention"</a> on page 4-12 and <i>Oracle Application Server Performance Guide</i>. The concurrency modes are as follows:</p> <ul style="list-style-type: none"> <li>■ <b>PESSIMISTIC:</b> This manages resource contention and does not allow parallel execution. Only one user at a time is allowed to execute the entity bean at a single time.</li> <li>■ <b>OPTIMISTIC:</b> Multiple users can execute the entity bean in parallel. It does not monitor resource contention; thus, the burden of the data consistency is placed on the database isolation modes. This is the default.</li> <li>■ <b>READ-ONLY:</b> Multiple users can execute the entity bean in parallel. The container does not allow any updates to the bean's state.</li> </ul>
max-instances	<p>The number of maximum bean implementation instances to be kept instantiated or pooled. The default is 0, which means infinite. See <a href="#">"Configuring Pool Sizes For Entity Beans"</a> on page 4-11 for more information.</p>
min-instances	<p>The number of minimum bean implementation instances to be kept instantiated or pooled. The default is 0. See <a href="#">"Configuring Pool Sizes For Entity Beans"</a> on page 4-11 for more information.</p>
max-tx-retries	<p>This parameter specifies the number of times to retry a transaction that was rolled back due to system-level failures. The default is 0.</p> <p>Generally, we recommend that you add retries only where errors are seen that could be resolved through retries. For example, if you are using serializable isolation and you want to retry the transaction automatically if there is a conflict, you might want to use retries. However, if the bean wants to be notified when there is a conflict, then in this case, you should leave max-tx-retries=0.</p> <p>Default Value: 0. See the EJB section in the <i>Oracle Application Server Performance Guide</i> for more information.</p>
tx-retry-wait	<p>This parameter specifies the time to wait in seconds between retrying the transaction. The default is 60 seconds.</p>
update-changed-fields-only	<p>Specifies whether the container updates only modified fields or all fields to persistence storage for CMP entity beans when <code>ejbStore</code> is invoked. The default is true, which specifies to only update modified fields. See <a href="#">"Create Data Consistency in Your Entity Bean by Using Persistence"</a> on page 4-10 for more information.</p>
name	<p>The name of the bean, which matches the name of a bean in the assembly section of the EJB deployment descriptor (<code>ejb-jar.xml</code>).</p>

**Table A-2 (Cont.) Attributes for <entity-deployment> Element**

Attribute	Description
pool-cache-timeout	The amount of time in seconds that the bean implementation instances are to be kept in the "pooled" (unassigned) state, specifying 'never' retains the instances until they are garbage collected. The default is 60.
table	The name of the table in the database if using container-managed persistence.
validity-timeout	<p>The maximum amount of time (in milliseconds) that an entity is valid in the cache (before being reloaded). Useful for loosely coupled environments where rare updates from legacy systems occur. This attribute is only valid for entity beans with locking mode of <code>read_only</code> and when <code>exclusive-write-access="true"</code> (the default).</p> <p>We recommend that if the data is never being modified externally (and therefore you've set <code>exclusive-write-access=true</code>), that you can set this to 0 or -1, to disable this option, since the data in the cache will always be valid for read-only EJBs that are never modified externally.</p> <p>If the EJB is generally not modified externally, so you're using <code>exclusive-write-access=true</code>, yet occasionally the table is updated so you need to update the cache occasionally, then set this to a value corresponding to the interval you think the data may be changing externally.</p>
force-update	If OC4J does not believe that any of the persistence data has changed, the <code>force-update</code> attribute set to <code>true</code> means that OC4J will still execute the EJB lifecycle by invoking the <code>ejbStore</code> method. This manages data in transient fields and sets appropriate persistent fields during the <code>ejbStore</code> method. For example, an image might be kept in one format in memory, but stored in a different format in the database. The default is <code>false</code> .
wrapper	Name of the OC4J remote home wrapper class for this bean. This is an internal server value and should not be edited.
local-wrapper	Name of the OC4J local home wrapper class for this bean. This is an internal server value and should not be edited.
delay-updates-until-commit	This attribute is valid only for CMP entity beans. Defers the flushing of transactional data until commit time or not. The default is <code>true</code> . Set this value to <code>false</code> to update persistence data after completion of every EJB method invocation - except <code>ejbRemove()</code> and the finder methods.

### Message Driven Bean Section

The <message-driven-deployment> section provides additional deployment information for a message driven bean deployed within this JAR file. The <message-driven-deployment> section contains the following structure:

```
<message-driven-deployment cache-timeout=... connection-factory-location=...
  destination-location=... name=... subscription-name=...
  listener-threads=... transaction-timeout=...
  dequeue-retry-count=... dequeue-retry-interval=... >
<env-entry-mapping name=...></env-entry-mapping>
<ejb-ref-mapping location=... name=... />
<resource-ref-mapping location=... name=... >
  <lookup-context location=...>
```

```

        <context-attribute name=... value=... />
    </lookup-context>
</resource-ref-mapping>
<resource-env-ref-mapping location=... name=... />
</message-driven-deployment>

```

Each of the element groups are discussed in the following sections of the OC4J documentation set:

- A message-driven bean example, which includes the `<message-driven-deployment>` element, is described in [Chapter 9, "Message-Driven Beans"](#).
- The `<env-entry-mapping>` element maps environment variables to JNDI names and is discussed in ["Environment Variables"](#) on page 10-9.
- The `<ejb-ref-mapping>` element maps any EJB references to JNDI names and is discussed in ["Environment References To Other Enterprise JavaBeans"](#) on page 10-10.
- The `<resource-ref-mapping>` element maps any EJB references to JNDI names and is discussed in ["Environment References To Resource Manager Connection Factory References"](#) on page 10-14.
- The `<resource-env-ref-mapping>` element is used to map an administered object for a resource. For example, to use JMS, the bean must obtain both a JMS factory object and a destination object. These objects are retrieved at the same time from JNDI. The `<resource-ref>` element declares the JMS factory and the `<resource-env-ref>` element is used to declare the destination. Thus, the `<resource-env-ref-mapping>` element maps the destination object. See ["Using a Logical Name When Client Accesses the MDB"](#) on page 9-25 for more information.

The attributes for the `<message-driven-deployment>` element are as follows:

**Table A-3 Attributes for `<message-driven-deployment>` Element**

Attribute	Description
cache-timeout	Do not use this element.
connection-factory-location	The JNDI location of the connection factory to use. The JMS Destination Connection Factory is specified in the <code>connection-factory-location</code> attribute. The syntax is "java:comp/resource" + resource provider name + "TopicConnectionFactory" or "QueueConnectionFactory" + user defined name. The xxxConnectionFactory details what type of factory is being defined. For more information, see <a href="#">"Create the OC4J-Specific Deployment Descriptor to Use Oracle JMS"</a> on page 9-17.
destination-location	The JNDI location of the destination (queue/topic) to use. The JMS Destination is specified in the <code>destination-location</code> attribute. The syntax is "java:comp/resource" + resource provider name + "Topics" or "Queues" + Destination name. The Topic or Queue details what type of Destination is being defined. The Destination name is the actual queue or topic name defined in the database. For more information, see <a href="#">"Create the OC4J-Specific Deployment Descriptor to Use Oracle JMS"</a> on page 9-17.
max-instances	Do not use this element. Use <code>listener-threads</code> instead

**Table A-3 (Cont.) Attributes for <message-driven-deployment> Element**

Attribute	Description
min-instances	Do not use this element.
name	The name of the bean, which matches the name of a bean in the assembly section of the EJB deployment descriptor (ejb-jar.xml).
subscription-name	If this is a topic, the subscription name is defined in the subscription-name attribute. For more information, see <a href="#">"Create the OC4J-Specific Deployment Descriptor to Use Oracle JMS"</a> on page 9-17.
listener-threads	The listener threads are used to concurrently consume JMS messages. The default is one thread. Topics can only have one thread. Queues can have more than one. For more information, see <a href="#">"Create the OC4J-Specific Deployment Descriptor to Use OracleAS JMS"</a> on page 9-10.
transaction-timeout	This attribute controls the transaction timeout interval (in seconds) for any container-managed transactional MDB. The default is one day or 86,400 seconds. If the transaction has not completed in this timeframe, the transaction is rolled back. For more information, see <a href="#">"Create the OC4J-Specific Deployment Descriptor to Use Oracle JMS"</a> on page 9-17.
dequeue-retry-count	Specifies how often the listener thread tries to re-acquire the JMS session once database failover has incurred. The default is "0." This value is only for CMT transactions in an MDB. See <a href="#">"Failover Scenarios When Using a RAC Database"</a> on page 9-28 for more information.
dequeue-retry-interval	Specifies the interval between retries. The default is 60 seconds.

### AC4J Active EJB Section

The <jem-server-extension> section defines the JNDI name of the database where the AC4J Databus is installed. The <jem-server-extension> contains the following structure:

```
<jem-server-extension data-source-location=... scheduling-threads=...>
  <description></description>
  <data-bus data-bus-name=... url=.../>
</jem-server-extension>
```

For more information on this element, see the *Oracle Application Server Containers for J2EE Services Guide*.

The <jem-deployment> section provides additional deployment information for an active EJB deployed within this JAR file. The <jem-deployment> section contains the following structure:

```
<jem-deployment jem-name=... ejb-name=...>
  <description></description>
  <data-bus data-bus-name=... url=.../>
  <called-by>
    <caller caller-identity=.../>
  </called-by>
  <security-identity>
    <description></description>
    <use-caller-identity></use-caller-identity>
  </security-identity>
</jem-deployment>
```

The `called-by` element lets the application deployer to control or restrict the usage of the asynchronous methods defined on the AC4J bean. In the following example "CLIUSER", "SVRUSER" and "XTRAUSER" can invoke all methods defined on AC4JBeanA, which corresponds to the EJB with name="ABean". If "USER1" or "USER2" invoke this AC4JBeanA, then the container throws `SecurityException`.

```
<jem-deployment jem-name="AC4JBeanA" ejb-name="ABean">
  <called-by>
    <caller caller-identity="CLIUSER"/>
    <caller caller-identity="SVRUSER"/>
    <caller caller-identity="XTRAUSER"/>
  </called-by>
</jem-deployment>
```

If the application deployer defines a security-role for the ABean EJB with role="USER1", then "USER1" can invoke all the methods on the ABean EJB synchronously. However, "USER1" can not invoke the same asynchronous methods in AC4JBeanA unless the `called-by` element is defined for "USER1".

For more information on this element, see the *Oracle Application Server Containers for J2EE Services Guide*.

### EJB 1.1 CMP Field Mapping Section

If you still use EJB 1.1 CMP entity beans, you use the following elements to map the CMP fields to the database.

The following are the XML elements used for CMP persistent data field mapping within the `orion-ejb-jar.xml` file:

```
<cmp-field-mapping ejb-reference-home=... name=... persistence-name=...
  persistence-type=...>
  <fields>
    <cmp-field-mapping ejb-reference-home=... name=... persistence-name=...
      persistence-type=...></cmp-field-mapping>
  </fields>
  <properties>
    <cmp-field-mapping ejb-reference-home=... name=... persistence-name=...
      persistence-type=...></cmp-field-mapping>
  </properties>
  <entity-ref home=...>
    <cmp-field-mapping ejb-reference-home=... name=... persistence-name=...
      persistence-type=...></cmp-field-mapping>
  </entity-ref>
  <collection-mapping table=...>
    <primkey-mapping>
      <cmp-field-mapping ejb-reference-home=... name=... persistence-name=...
        persistence-type=...></cmp-field-mapping>
    </primkey-mapping>
    <value-mapping immutable="true|false" type=...>
      <cmp-field-mapping ejb-reference-home=... name=... persistence-name=...
        persistence-type=...></cmp-field-mapping>
    </value-mapping>
  </collection-mapping>
  <set-mapping table=...>
    <primkey-mapping>
      <cmp-field-mapping ejb-reference-home=... name=... persistence-name=...
        persistence-type=...></cmp-field-mapping>
    </primkey-mapping>
    <value-mapping immutable="true|false" type=...>
      <cmp-field-mapping ejb-reference-home=... name=... persistence-name=...
```



```

        persistence-type=...>/cmp-field-mapping>
    </value-mapping>
</set-mapping>
</cmp-field-mapping>

```

### Method Definition

The following structure is used to specify the methods (and possibly parameters of that method) of the bean.

```

<method>
  <description></description>
  <ejb-name></ejb-name>
  <method-intf></method-intf>
  <method-name></method-name>
  <method-params>
    <method-param></method-param>
  </method-params>
</method>

```

The style used can be one of the following:

1. When referring to all the methods of the specified enterprise bean's home and remote interfaces, specify the methods as follows:

```

  <method>
  <ejb-name>EJBNAME</ejb-name>
  <method-name>*</method-name>
</method>

```

2. When referring to multiple methods with the same overloaded name, specify the methods as follows:

```

  <method>
  <ejb-name>EJBNAME</ejb-name>
  <method-name>METHOD</method-name>
</method>>

```

3. When referring to a single method within a set of methods with an overloaded name, you can specify each parameter within the method as follows:

```

  <method>
  <ejb-name>EJBNAME</ejb-name>
  <method-name>METHOD</method-name>
  <method-params>
    <method-param>PARAM-1</method-param>
    <method-param>PARAM-2</method-param>
    ...
    <method-param>PARAM-n</method-param>
  </method-params>
</method>

```

The `<method>` element is used within the security and MDB sections. See ["Specifying Logical Roles in the EJB Deployment Descriptor"](#) on page 12-3 for more information.

## Assembly Descriptor Section

In addition to specifying deployment information for individual beans, you can also specify addition deployment mapping information for security in the

<assembly-descriptor> section. The <assembly-descriptor> section contains the following structure:

```
<assembly-descriptor>
  <security-role-mapping impliesAll=... name=...>
    <group name=... />
    <user name=... />
  </security-role-mapping>
  <default-method-access>
    <security-role-mapping impliesAll=... name=...>
      <group name=... />
      <user name=... />
    </security-role-mapping>
  </default-method-access>
</assembly-descriptor>
```

Each of the element groups are discussed in the following sections of the OC4J documentation set:

- The <security-role-mapping> element is described in ["Mapping Logical Roles to Users and Groups"](#) on page 12-6.
- The <default-method-access> element is described in ["Specifying a Default Role Mapping for Undefined Methods"](#) on page 12-7.

## Element Description

### <assembly-descriptor>

The mapping of the assembly descriptor elements.

### <called-by>

Enables the application deployer to control or restrict the usage of the asynchronous methods defined on the AC4J bean. You specify the user identity that is allowed to execute all methods of the bean in this element. The identities that can be execute the AC4J beans are identified in one or more <caller> elements.

### <caller>

Each caller identity allowed to execute methods on the AC4J bean are defined in a single <caller> element.

Attributes:

- caller-identity - The security role that is allowed to execute the AC4J bean methods.

### <cmp-field-mapping>

Deployment information for a container-managed persistence field. If no subtags are used to define different behavior, the field is persisted through serialization or native handling of "recognized" primitive types.

Attributes:

- ejb-reference-home - The JNDI-location of the fields remote EJB-home if the field is an entity EJBObject or an EJBHome.
- name - The name of the field.
- persistence-name - The name of the field in the database table.
- persistence-type - The database type (valid values varies from database to database) of the field.

**<collection-mapping>**

Specifies a relational mapping of a Collection type. A Collection consists of n unordered items (order isn't specified and not relevant). The field containing the mapping must be of type `java.util.Collection`.

Attributes:

- `table` - The name of the table in the database.

**<context-attribute>**

An attribute sent to the context. The only mandatory attribute in JNDI is the `'java.naming.factory.initial'` which is the classname of the context factory implementation.

Attributes:

- `name` - The name of the attribute.
- `value` - The value of the attribute.

**<data-bus>**

The name and url of a specific Databus for an AC4J object.

Attributes:

- `data-bus-name` - The user-defined name of the Databus.
- `url` - The URL of the Databus, which is similar to a JDBC URL.

**<default-method-access>**

The default method access policy for methods not tied to a method-permission.

**<description>**

A short description.

**<ejb-name>**

The `ejb-name` element specifies an enterprise bean's name. This name is assigned by the `ejb-jar` file producer to name the enterprise bean in the `ejb-jar` file's deployment descriptor. The name must be unique among the names of the enterprise beans in the same `ejb-jar` file. The enterprise bean code does not depend on the name; therefore the name can be changed during the application-assembly process without breaking the enterprise bean's function. There is no architected relationship between the `ejb-name` in the deployment descriptor and the JNDI name that the Deployer will assign to the enterprise bean's home. The name must conform to the lexical rules for an NMTOKEN.

**<ejb-ref-mapping>**

The `ejb-ref` element that is used for the declaration of a reference to another enterprise bean's home. The `ejb-ref-mapping` element ties this to a JNDI-location when deploying.

Attributes:

- `location` - The JNDI location to look up the EJB home from.
- `name` - The `ejb-ref`'s name. Matches the name of an `ejb-ref` in `ejb-jar.xml`.

**<enterprise-beans>**

The beans contained in this EJB JAR file.

**<entity-deployment>**

Deployment information for an entity bean.

## Attributes:

- `call-timeout` - The time (long milliseconds in decimal) to wait for any resource that the EJB uses, except database connections, if it is busy (before throwing a `RemoteException`, treating it as a deadlock). This is also used as a SQL query timeout. If the timeout occurs before the SQL query finishes, a SQL exception is thrown. If zero, the timeout is disabled. The default is 90 seconds.
- `clustering-schema` - Not recommended to use.
- `copy-by-value` - Whether or not to copy all the incoming/outgoing parameters for all incoming and outgoing EJB calls. Set to 'false' if your application does not assume copy-by-value semantics for these parameters. The default is 'true'.
- `data-source` - The name of the data source used if using container-managed persistence.
- `delay-updates-until-commit` - Defers the flushing of transactional data until commit time or not. The default is true. If you want each change to be updated in the database, set this element to false.
- `do-select-before insert` - If false, you avoid executing a select before an insert. The extra select normally checks to see if the entity already exists before doing the insert to avoid duplicates.

If a unique key constraint is defined for the entity, then we recommend setting this to false. If there is no unique key constraint, setting this to false leads to not detecting a duplicate insert. To prevent duplicate inserts in this case, leave it set to true.

For performance, Oracle recommends setting this to false to avoid the extra select before insert. Default Value: true

- `exclusive-write-access` - Whether or not the EJB-server has exclusive write (update) access to the database backend. This can be used only for entity beans that use a "read\_only" locking mode. In this case, it increases the performance for common bean operations and enables better caching. The default is false. See ["Specifying Exclusive Write Access to the Database"](#) on page 4-14 for more information.
- `findByPrimaryKey-lazy-loading="true | false"` - For entity bean finder methods, lazy loading can cause the select method to be invoked more than once. To turn on lazy loading and enforce only a single execution of this finder method, set this property to true. The default is false. See ["Configuring Lazy Loading on CMP Entity Bean Finder Methods"](#) on page 5-6 for more information.
- `instance-cache-timeout` - The amount of time in seconds that entity wrapper instances are assigned to an identity. If you specify 'never', you retain the wrapper instances until they are garbage collected. The default is 60 seconds.
- `isolation` - Specifies the isolation-level for database actions. The valid values for Oracle databases are 'serializable' and 'committed'. The default is 'committed'. Non-Oracle databases can be the following: 'none', 'committed', 'serializable', 'uncommitted', and 'repeatable\_read'. For more information, see ["Using Database Isolation Modes to Protect Against Resource Contention"](#) and ["Configuring Entity Bean Concurrency Modes For Handling Resource Contention"](#) on page 4-12 and *Oracle Application Server Performance Guide*.
- `local-wrapper` - Name of the OC4J local home wrapper class for this bean. This is an internal server value and should not be edited.
- `location` - The JNDI-name this bean will be bound to.

- locking-mode - The concurrency modes configure when to block to manage resource contention or when to execute in parallel. For more information, see ["Using Database Isolation Modes to Protect Against Resource Contention"](#) and ["Configuring Entity Bean Concurrency Modes For Handling Resource Contention"](#) on page 4-12 and *Oracle Application Server Performance Guide*. The concurrency modes are as follows:
  - PESSIMISTIC: This manages resource contention and does not allow parallel execution. Only one user at a time is allowed to execute the entity bean at a single time.
  - OPTIMISTIC: Multiple users can execute the entity bean in parallel. It does not monitor resource contention; thus, the burden of the data consistency is placed on the database isolation modes. This is the default.
  - READ-ONLY: Multiple users can execute the entity bean in parallel. The container does not allow any updates to the bean's state.
- max-instances - The number of maximum bean implementation instances to be kept instantiated or pooled. The default is 0, which means infinite. See ["Configuring Pool Sizes For Entity Beans"](#) on page 4-11 for more information.
- min-instances - The number of minimum bean implementation instances to be kept instantiated or pooled. The default is 0. See ["Configuring Pool Sizes For Entity Beans"](#) on page 4-11 for more information.
- max-tx-retries—The number of times to retry a transaction that was rolled back due to system-level failures. The default is 0. Leave the setting to zero if using the serializable isolation level. Within a transaction, the container uses the max-tx-retries value of the first invoked bean within the transaction. The performance guide recommends that you leave this value at 0 and add retries only where errors are seen that could be resolved through a retry.
- tx-retry-wait—This parameter specifies the time to wait in seconds between retrying the transaction. The default is 60 seconds.
- name - The name of the bean, this matches the name of a bean in the assembly descriptor (`ejb-jar.xml`).
- pool-cache-timeout - The amount of time in seconds that the bean implementation instances are to be kept in the "pooled" (unassigned) state, specifying 'never' retains the instances until they are garbage collected. The default is 60.
- table - The name of the table in the database if using container-managed persistence.
- validity-timeout - The maximum amount of time (in milliseconds) that an entity is valid in the cache (before being reloaded). Useful for loosely coupled environments where rare updates from legacy systems occur. This attribute is only valid for entity beans with locking mode of `read_only` and when `exclusive-write-access="true"` (the default).

We recommend that if the data is never being modified externally (and therefore you've set `exclusive-write-access=true`), that you can set this to 0 or -1, to disable this option, since the data in the cache will always be valid for read-only EJBs that are never modified externally.

If the EJB is generally not modified externally, so you're using `exclusive-write-access=true`, yet occasionally the table is updated so you need to update the cache occasionally, then set this to a value corresponding to the interval you think the data may be changing externally.

- `update-changed-fields-only` - Specifies whether the container updates only modified fields or all fields to persistence storage for CMP entity beans when `ejbStore` is invoked. The default is `true`, which specifies to only update modified fields. See ["Create Data Consistency in Your Entity Bean by Using Persistence"](#) on page 4-10 for more information.
- `wrapper` - Name of the OC4J remote home wrapper class for this bean. (internal server attribute, do not edit)

**<entity-ref>**

Specifies the configuration for persisting an entity reference via its primary key. The child-tag of this tag is the specification of how to persist the primary key.

Attributes:

- `home` - JNDI location of the EJBHome to get lookup the beans at.

**<env-entry-mapping>**

Overrides the value of an `env-entry` in the assembly descriptor. It is used to keep the EAR clean from deployment-specific values. The body is the value.

Attribute:

- `name` - The name of the context parameter.

**<fields>**

Specifies the configuration of a field-based (java class field) mapping persistence for this field. The fields that are to be persisted have to be public, non-static, non-final and the type of the containing object has to have an empty constructor.

**<finder-method>**

The definition of a container-managed finder method. This defines the selection criteria in a `findByXXX()` method in the bean's home.

Attributes:

- `partial` - Whether or not the specified query is a partial one. A partial query is the 'where' clause or the 'order' (if it starts with `order`) clause of the SQL query. Queries are partial by default. If `partial="false"` is specified then the full query is to be entered as value for the query attribute and you need to make sure that the query produces a result-set containing all of the CMP fields. This is useful when doing advanced queries involving table joins and similar.
- `query` - The query part of an SQL statement. This is the section following the `WHERE` keyword in the statement. Special tokens are `$number` which denotes a method argument number and `$name` which denotes a `cmp-field` name. For instance the query for `"findByAge(int age)"` would be (assuming the `cmp-field` is named 'age'): `"$1 = $age"`.
- `lazy-loading` - For entity bean finder methods, lazy loading can cause the select method to be invoked more than once. To turn on lazy loading and enforce only a single execution of this finder method, set this property to `true`. The default is `false`. See ["Configuring Lazy Loading on CMP Entity Bean Finder Methods"](#) on page 5-5 for more information.
- `prefetch-size` - Oracle JDBC drivers include extensions that allow you to set the number of rows to prefetch into the client while a result set is being populated during a query. This reduces round trips to the database by fetching multiple rows of data each time data is fetched—the extra data is stored in client-side buffers for later access by the client. The number of rows to prefetch can be set as desired. The default number of rows to prefetch to the client is 10. The number set here is

passed along to the JDBC driver. See the *Oracle 9i JDBC Developer's Guide and Reference* for more information on using prefetch with a JDBC driver.

#### **<group>**

A group that this `<security-role-mapping>` implies. That is, all members of the specified group are included in this role.

Attributes:

- name - The name of the group.

#### **<ior-security-config>**

The `<ior-security-config>` element configures CSIv2 security policies for interoperability, which is discussed fully in the Interoperability chapter in the *Oracle Application Server Containers for J2EE Services Guide*.

#### **<jem-deployment>**

Specifies an active EJB for deployment into the AC4J container.

Attributes:

- jem-name - An AC4J name that is used to identify the bean within the AC4J calls
- ejb-name - Identifies the EJB defined in the `ejb-jar.xml` file as an active EJB.

#### **<jem-server-extension>**

Describes the database server where the Databus is installed

Attributes:

- data-source-location - Provides the JNDI data source definition of the database where the Databus exists. The data source is configured in the `data-sources.xml` file.
- scheduling-threads - If greater than 1, then multiple OC4J threads can act in parallel. Default is 1.

#### **<lookup-context>**

The specification of an optional `javax.naming.Context` implementation used for retrieving the resource. This is useful when using third party modules, such as a third party JMS server. Either use the context implementation supplied by the resource vendor or, if none exists, write an implementation that negotiates with the vendor software.

Attribute:

- location - The name looked for in the foreign context when retrieving the resource.

#### **<map-key-mapping>**

Specifies a mapping of the map key. Map keys are always immutable.

Attributes:

- type - The fully qualified class name of the type of the value. Examples are `com.acme.Product`, `java.lang.String` etc.

#### **<message-driven-deployment>**

Deployment information for a MDB.

Attributes:

- connection-factory-location: The JNDI location of the connection factory to use. The `JMS Destination Connection Factory` is specified in the

connection-factory-location attribute. The syntax is "java:comp/resource" + resource provider name + "TopicConnectionFactory" or "QueueConnectionFactory" + user defined name. The xxxConnectionFactory details what type of factory is being defined.

- destination-location: The JNDI location of the destination (queue/topic) to use. The JMS Destination is specified in the destination-location attribute. The syntax is "java:comp/resource" + resource provider name + "Topics" or "Queues" + Destination name. The Topic or Queue details what type of Destination is being defined. The Destination name is the actual queue or topic name defined in the database.
- name - The name of the bean, this matches the name of a bean in the assembly descriptor (ejb-jar.xml).
- subscription-name: If this is a topic, the subscription name is defined in the subscription-name attribute.
- listener-threads: The listener threads are used to concurrently consume JMS messages. The default is one thread. Topics can only have one thread; queues can have more than one thread.
- transaction-timeout: This attribute controls the transaction timeout interval (in seconds) for any container-managed transactional MDB. The default is one day or 86,400 seconds. If the transaction has not completed in this timeframe, the transaction is rolled back.
- dequeue-retry-count—Specifies how often the listener thread tries to re-acquire the JMS session once database failover has incurred. This value is only for CMT transactions in an MDB. The default is "0." See ["Failover Scenarios When Using a RAC Database"](#) on page 9-28 for more information.
- dequeue-retry-interval—Specifies the interval between retries. The default is 60 seconds.

**<method>**

Specify the methods (and possibly parameters of that method) of the bean.

**<method-intf>**

The method-intf element allows a method element to differentiate between the methods with the same name and signature that are defined in both the remote and home interfaces. The method-intf element must be one of the following: Home or Remote.

**<method-name>**

The method-name element contains a name of an enterprise bean method, or the asterisk (\*) character. The asterisk is used when the element denotes all the methods of an enterprise bean's remote and home interfaces.

**<method-param>**

The method-param element contains the fully-qualified Java type name of a method parameter.

**<method-params>**

The method-params element contains a list of the fully-qualified Java type names of the method parameters.



**<orion-ejb-jar>**

An `orion-ejb-jar.xml` file contains the OC4J-specific deployment information for an EJB. It is used to specify initial deployment properties. After each deployment the deployment file is reformatted and altered by the server for additional information.

Attributes:

- `deployment-time` - The time (long milliseconds in decimal) of the last deployment, if not matching the last editing date the jar will be redeployed. (internal server value, do not edit)
- `deployment-version` - The version of OC4J this jar was deployed with, if it's not matching the current version then it will be redeployed. (internal server value, do not edit)

**<primkey-mapping>**

Designates how the primary key is mapped.

**<properties>**

Specifies the configuration of a property-based (bean properties) mapping persistence for this field. The properties have to adhere to the usual JavaBeans specification and the type of the containing object has to have an empty constructor. This is also designated within the EJB specification.

**<resource-ref-mapping>**

The `resource-ref` element is used for the declaration of a reference to an external resource such as a data source, JMS queue, or mail session. The `resource-ref-mapping` ties this to a JNDI-location when deploying.

Attributes:

- `location` - The JNDI location to look up the resource factory from.
- `name` - The `resource-ref` name. Matches the name of an `resource-ref` in `ejb-jar.xml`.

**<resource-env-ref-mapping>**

The `resource-env-ref-mapping` element is used to map an administered object for a resource. For example, to use JMS, the bean must obtain both a JMS factory object and a destination object. These objects are retrieved at the same time from JNDI. The `<resource-ref>` element declares the JMS factory and the `<resource-env-ref>` element is used to declare the destination. Thus, the `<resource-env-ref-mapping>` element maps the destination object. See ["Using a Logical Name When Client Accesses the MDB"](#) on page 9-25 for more information.

Attributes:

- `location` - The JNDI location from which to look up the administered resource.
- `name` - The `resource-env-ref` name in `ejb-jar.xml`.

**<role-name>**

The security role that the AC4J EJB methods are run under when using the `<run-as-specified-identity>` element.

**<run-as-specified-identity>**

You can specify that all methods of an AC4J EJB execute under a specific identity. That is, the container does not check different roles for permission to run specific methods; instead, the container executes all of the AC4J EJB methods under the specified security identity.

**<security-identity>**

Describes if the AC4J Databus should use the caller or run-as identity for the AC4J bean security.

**<security-role-mapping>**

The runtime mapping (to groups and users) of a role. Maps to a security-role of the same name in the assembly descriptor.

Attributes:

- `impliesAll` - Whether or not this mapping implies all users. The default is false.
- `name` - The name of the role

**<session-deployment>**

Deployment information for a session bean.

Attributes:

- `pool-cache-timeout`—How long to keep stateless sessions cached in the pool. Only applies to stateless session beans. Legal values are positive integer values or 'never'. For stateless session beans, if you specify a `pool-cache-timeout`, then at every `pool-cache-timeout` interval, all beans in the pool, of the corresponding bean type, are removed. If the value specified is zero or negative, then the `pool-cache-timeout` is disabled and beans are not removed from the pool.

Default Value: 60 (seconds)

- `call-timeout`—The time (long milliseconds in decimal) to wait for any resource that the EJB uses, excluding database connections, if it is busy. After this times out, a `RemoteException` is thrown and the EJB is treated as involved in a deadlock. If value is set to 0, OC4J waits for the EJB "forever". This is the default.
- `copy-by-value`—Whether or not to copy (clone) all the incoming and outgoing parameters in EJB calls. Set to 'false' if you are certain that your application does not assume copy-by-value semantics for a speed-up. The default is 'true'.
- `local-wrapper`—Name of the OC4J wrapper class for this bean. This is an internal server value and should not be edited.
- `location`—The JNDI-name that this bean will be bound to.

`max-instances` - This attribute controls the number of bean instances allowed in memory—either instantiated or pooled. When this value is reached, the container attempts to passivate the oldest bean instance from memory. If unsuccessful, the container waits the number of milliseconds set in the `call-timeout` attribute to see if a bean instance is removed from memory, either through passivation, its `remove()` method, or bean expiration, before a `TimeoutExpiredException` is thrown back to the client. To allow an infinite number of bean instances, the `max-instances` attribute can be set to zero. Default is 0, which is infinite. This applies to both stateless and stateful session beans.

- `max-instances-threshold` - This attribute defines a threshold for how many active beans exist in relation to the `max-instances` attribute definition. Specify an integer that is translated as a percentage. If you define that the `max-instances` is 100 and the `max-instances-threshold` is 90%, then when the active bean instances reaches past 90, passivation of beans occurs. Default: 90%. To disable, specify "never".
- `max-tx-retries`—The number of times to retry a transaction that was rolled back due to system-level failures. The default is 0. Within a transaction, the container uses the `max-tx-retries` value of the first invoked bean within the transaction. The

performance guide recommends that you leave this value to 0 and add retries only where errors are seen that could be resolved through a retry.

- `tx-retry-wait`—This parameter specifies the time to wait in seconds between retrying the transaction. The default is 60 seconds.
- `memory-threshold` - This attribute defines a threshold for how much used JVM memory is allowed before passivation should occur. Specify an integer that is translated as a percentage. When reached, beans are passivated, even if their idle timeout has not expired. Default: 80%. To disable, specify "never."
- `min-instances` - The number of minimum bean implementation instances to be kept instantiated or pooled. The default is zero. This applies only to stateless session beans.
- `name`—The name of the bean, which matches the name of a bean in the assembly section of the EJB deployment descriptor (`ejb-jar.xml`).
- `resource-check-interval` - The container checks all resources at this time interval. At this time, if any of the thresholds have been reached, passivation occurs. Default: 180 sec. (3 min.). To disable, specify "never."
- `passivate-count` - This attribute is an integer that defines the number of beans to be passivated if any of the resource thresholds have been reached. Passivation of beans is performed using the least recently used algorithm. Default: one-third of the `max-instances` attribute. You can disable this attribute by setting the count to zero or a negative number.
- `persistence-filename`—Path to the file where sessions are stored across restarts.
- `timeout`—Inactivity timeout in seconds. If the value is zero or negative, then all timeouts are disabled. The default is 30 minutes. Every 30 seconds, the pool clean up logic is invoked. Within the pool clean up logic, only the sessions that timed out, by passing the timeout value, are deleted.  
  
Adjust the timeout based on your applications use of stateful session beans. For example, if stateful session beans are not removed explicitly by your application, and the application creates many stateful session beans, then you may want to lower the timeout value.  
  
If your application requires that a stateful session bean be available for longer than 30 minutes, then adjust the timeout value accordingly.
- `wrapper`—Name of the OC4J wrapper class for this bean. This is an internal server value and should not be edited.

#### **<set-mapping>**

Specifies a relational mapping of a Set type. A Set consists of n unique unordered items (order is not specified and not relevant). The field containing the mapping must be of type `java.util.Set`.

Attributes:

- `table` - The name of the table in the database.

#### **<use-caller-identity>**

You can specify that all methods of an AC4J EJB execute under the caller's identity.

#### **<user>**

A user that this security-role-mapping implies.

Attributes:

- name - The name of the user.

**<value-mapping>**

Specified a mapping of the primary key part of a set of fields.

Attributes:

- immutable - Whether or not the value can be trusted to be immutable once added to the `Collection`. Setting this to true will optimize database operations extensively. The default value is "true" for set-mapping and "false" for collection-mapping.
- type - The fully qualified class name of the type of the value. Examples are `com.acme.OrderEntry`, `java.lang.String`, and so on.

---

---

## Third Party Licenses

This appendix includes the Third Party License for all the third party products included with Oracle Application Server.

### Apache HTTP Server

Under the terms of the Apache license, Oracle is required to provide the following notices. However, the Oracle program license that accompanied this product determines your right to use the Oracle program, including the Apache software, and the terms contained in the following notices do not change those rights. Notwithstanding anything to the contrary in the Oracle program license, the Apache software is provided by Oracle "AS IS" and without warranty or support of any kind from Oracle or Apache.

Below is the Apache software license:

```
/* =====
 * The Apache Software License, Version 1.1
 *
 * Copyright (c) 2000 The Apache Software Foundation. All rights
 * reserved.
 *
 * Redistribution and use in source and binary forms, with or without
 * modification, are permitted provided that the following conditions
 * are met:
 *
 * 1. Redistributions of source code must retain the above copyright
 * notice, this list of conditions and the following disclaimer.
 *
 * 2. Redistributions in binary form must reproduce the above copyright
 * notice, this list of conditions and the following disclaimer in
 * the documentation and/or other materials provided with the
 * distribution.
 *
 * 3. The end-user documentation included with the redistribution,
 * if any, must include the following acknowledgment:
 * "This product includes software developed by the
 * Apache Software Foundation (http://www.apache.org/)."
 * Alternately, this acknowledgment may appear in the software itself,
 * if and wherever such third-party acknowledgments normally appear.
 *
 * 4. The names "Apache" and "Apache Software Foundation" must
 * not be used to endorse or promote products derived from this
 * software without prior written permission. For written
 * permission, please contact apache@apache.org.
 *
```

```
* 5. Products derived from this software may not be called "Apache",
*   nor may "Apache" appear in their name, without prior written
*   permission of the Apache Software Foundation.
*
* THIS SOFTWARE IS PROVIDED "'AS IS' AND ANY EXPRESSED OR IMPLIED
* WARRANTIES, INCLUDING, BUT NOT LIMITED TO, THE IMPLIED WARRANTIES
* OF MERCHANTABILITY AND FITNESS FOR A PARTICULAR PURPOSE ARE
* DISCLAIMED. IN NO EVENT SHALL THE APACHE SOFTWARE FOUNDATION OR
* ITS CONTRIBUTORS BE LIABLE FOR ANY DIRECT, INDIRECT, INCIDENTAL,
* SPECIAL, EXEMPLARY, OR CONSEQUENTIAL DAMAGES (INCLUDING, BUT NOT
* LIMITED TO, PROCUREMENT OF SUBSTITUTE GOODS OR SERVICES; LOSS OF
* USE, DATA, OR PROFITS; OR BUSINESS INTERRUPTION) HOWEVER CAUSED AND
* ON ANY THEORY OF LIABILITY, WHETHER IN CONTRACT, STRICT LIABILITY,
* OR TORT (INCLUDING NEGLIGENCE OR OTHERWISE) ARISING IN ANY WAY OUT
* OF THE USE OF THIS SOFTWARE, EVEN IF ADVISED OF THE POSSIBILITY OF
* SUCH DAMAGE.
* =====
*
* This software consists of voluntary contributions made by many
* individuals on behalf of the Apache Software Foundation. For more
* information on the Apache Software Foundation, please see
* <http://www.apache.org/>.
*
* Portions of this software are based upon public domain software
* originally written at the National Center for Supercomputing Applications,
* University of Illinois, Urbana-Champaign.
*/
```

## Symbols

---

- <abstract-schema-name> element, 7-4, 7-6
- <assembly-descriptor> element, A-16
- <caller> element, A-16
- <cascade-delete> element, 6-8
- <cmp-field-mapping> element, 5-7, 6-20, 6-38, 6-44, A-7, A-16
- <cmr-field> element, 5-7, 6-6, 6-10, 6-33
- <cmr-field-name> element, 6-3, 6-6
- <cmr-field-type> element, 6-6
- <collection-mapping> element, 6-22, 6-33, 6-34, 6-36, 6-37, 6-38, 6-41, 6-44, A-17
- <container-transaction> element, 9-3, 9-7
- <context-attribute> element, A-17
- <default-method-access> element, 12-7, A-16, A-17
- <delay-updates-until-commit> attribute, A-18
- <description> element, A-17
- <destination-type> element, 9-7
- <ejb> element, 3-8, 10-4
- <ejb-link> element, 10-11, 10-12
- <ejb-location> element, 8-9
- <ejb-mapping> element, 10-12
- <ejb-module> element, 2-10
- <ejb-name> element, 10-12, A-17
- <ejb-ql>, 7-4
- <ejb-ql> element, 7-10
- <ejb-ref> element, 2-5, 10-12
- <ejb-ref-mapping> element, 10-11, 10-13, A-4, A-8, A-12, A-17
- <ejb-ref-name> element, 2-6, 10-12, 10-13
- <ejb-ref-type> element, 10-12
- <ejb-relation> element, 6-5
- <ejb-relation-name> element, 6-5
- <ejb-relationship-role> element, 6-5
- <ejb-relationship-role-name> element, 6-5
- <enterprise-beans> element, A-3, A-17
- <entity-deployment> element, 4-13, 4-14, 6-13, 6-14, 6-20, 6-22, 6-28, 6-36, 6-42, A-6, A-7, A-17
- <entity-ref> element, A-20
- <env-entry> element, 10-9
- <env-entry-mapping> element, A-4, A-8, A-12, A-20
- <env-entry-name> element, 10-9
- <env-entry-type> element, 10-9
- <env-entry-value> element, 10-9
- <fields> element, A-20
- <finder-method> element, 7-7, A-7, A-20
- <group> element, A-21
- <home> element, 10-12
- <ior-security-config> element, A-4, A-7, A-21
- <java> element, 3-8, 10-4
- <jem-deployment> element, A-13, A-21
- <jem-server-extension> element, A-13, A-21
- <jndi-name> element, 10-12, 10-16, 10-18
- <lookup-context> element, A-21
- <map-key-mapping> element, A-21
- <mapping> element, 10-12, 10-16, 10-18
- <max-tx-retries> element, 1-6, 4-13
- <message-driven> element, 9-7
- <message-driven-deployment> element, 9-10, 9-11, 9-17, 9-19, A-11, A-12, A-21
- <message-driven-destination> element, 9-7
- <method> element, A-15, A-22
  - defined, 12-4
- <method-intf> element, A-22
- <method-name> element, 7-4, A-22
- <method-param> element, 7-10, A-22
- <method-params> element, A-22
- <method-permission> element, 12-2, 12-3, 12-4
- <module> element, 3-8, 10-4
- <multiplicity> element, 6-6
- <orion-ejb-jar> element, A-2, A-23
- <persistence-type> element, 8-9
- <prim-key-class> element, 4-6, 8-4
- <primkey-mapping> element, 6-34, 6-39, 6-44, A-7, A-23
- <properties> element, A-23
- <query> element, 7-2, 7-3, 7-4, 7-10
- <query> element., 7-6
- <relationship-role-source> element, 6-6
- <relationships> element, 6-5, 6-14, 6-36
- <remote> element, 10-12
- <res-auth> element, 10-16, 10-18
- <resource-env-ref> element, 9-25
- <resource-env-ref-mapping> element, A-4, A-8, A-12, A-23
- <resource-provider> element, 9-16
- <resource-ref> element, 8-9, 9-25
- <resource-ref-mapping> element, 10-16, 10-18, A-4, A-8, A-12, A-23
- <res-ref-name> element, 10-16, 10-18
- <res-type> element, 10-16, 10-18

- <result-type-mapping> element, 7-4
- <role-link> element, 12-2, 12-3
- <role-name> element, 12-2, 12-3
- <run-as> element, 12-6
- <security-identity> element, 12-6
- <security-role> element, 12-2, 12-3
- <security-role-mapping> element, 12-6, 12-7, A-16, A-24
- <security-role-ref> element, 12-2, 12-3
- <server> element, 2-11
- <session-deployment> element, 13-4, A-3, A-24
- <set-mapping> element, 6-22, 6-36, 6-41, A-25
- <sfsb-config> element, 3-9
- <subscription-durability> element, 9-7
- <transaction-type> element, 9-7
- <unchecked/> element, 12-5
- <use-caller-identity/> element, 12-6
- <user> element, A-25
- <value-mapping> element, A-26
- <value-mapping> element, 6-34, 6-39, 6-44
- <web> element, 3-8, 10-4

## A

---

- accessing EJBs, 2-1
- application.xml file, 3-7, 9-3, 10-4
  - example, 3-8, 10-5
  - overview, 3-8, 10-4
- archiving
  - directions, 3-7, 10-4
  - EAR file, 3-9, 10-5
  - EJBs, 3-7, 10-3
- association table, 6-27, 6-35, 6-40
- autocreate-tables element, 6-13, 6-14, 6-45

## B

---

- bean
  - accessing remotely, 1-16
  - activation, 1-7
  - creating, 3-2, 4-2
  - environment, 1-8
  - implementation, 3-4
  - interface, 1-6
  - overview, 1-1
  - passivation, 1-7
  - removal, 2-7
  - steps for invocation, 1-17
- bean-managed persistent, see BMP
- BLOB, 5-7
- BMP
  - create database tables, 8-10
  - creation process, 8-2
  - defined, 8-1
  - deployment descriptor, 8-9
  - ejbCreate implementation, 8-3
  - home and remote interfaces, 8-2
  - implementation details, 8-3
  - persistence, 1-13

## C

---

- cache-timeout attribute, A-12
- called-by attribute, A-16
- caller-identity attribute, A-16
- call-timeout attribute, A-4, A-8, A-18, A-24
- ClassCastException, 10-6, 10-7
- CLOB, 5-7
- clustering, 13-1 to 13-5
  - concurrency mode effect, 4-15
- clustering-schema attribute, A-18
- CMP
  - data types, 5-6
  - overview, 1-13
- CMR
  - association table, 6-27, 6-35, 6-40
  - cardinality, 6-6
  - cascade delete option, 6-8
  - default mapping, 6-9
  - define get/set methods, 6-4
  - deployment descriptor, 6-5
  - direction, 6-6
  - explicit relationship mapping, 6-12
  - many-to-many, 6-3, 6-6, 6-40
  - many-to-one, 6-2, 6-6
  - mapping relationships, 6-9
  - one-to-many, 6-2, 6-6, 6-11, 6-21, 6-27, 6-33, 6-35
  - one-to-one, 6-2, 6-6, 6-11
  - relationship definition, 6-3
  - types of relationships, 6-2
- CMT
  - retry JMS message, A-13, A-22
- Collections, 5-7
- command-line options, 10-6
- component interface
  - overview, 1-17
- concurrency modes, 4-12
  - clustering, 4-15
- connection-factory-location attribute, 9-11, 9-18, A-21
- context
  - session, 1-8
  - transaction, 1-8
- copy-by-value attribute, A-4, A-8, A-18, A-24
- create method, 2-7, 4-3, 4-4
  - EJBHome interface, 1-17, 3-2
- CreateException, 3-3

## D

---

- data types, 5-6
  - mapping, 5-6
- database constraints
  - foreign key, 6-50
- data-bus attribute, A-17
- data-source attribute, A-8, A-18
- DataSource object, 10-15
- data-source-location attribute, A-21
- data-sources.xml file, 8-9, 8-10
- Date, 7-11
- DBMS\_AQADM package, 9-15



- deadlock
  - recovery, 2-12
- dedicated.rmicontext property, 2-12, 13-5
- delay-updates-until-commit attribute, A-11
- deployment
  - error recovery, 10-5
- deployment descriptor, 1-17, 3-6, 4-2, 8-2, 10-2
  - BMP, 8-9
  - EJB QL, 7-4
  - EJB reference, 10-10
  - entity bean, A-6
  - environment variables, 10-8
  - JDBC DataSource, 10-14
  - MDB, 9-3
  - message-driven bean, A-11
  - security, 12-2, 12-3, 12-7
  - session bean, A-4
- dequeue-retry-count attribute, A-13, A-22
- dequeue-retry-interval attribute, A-13, A-22
- destination-location attribute, 9-11, 9-18, A-22
- DNS round-robin, 2-5, 13-5
- do-select-before-insert attribute, A-9, A-18
- DTD file, 3-6, 10-2

## E

---

- EAR file, 3-1
  - creation, 3-9, 10-5
- EJB
  - archive, 3-7, 10-3
  - clustering, 13-1 to 13-5
  - creating, 3-2, 3-4, 4-2
  - deployment descriptor, 3-6, 10-2
  - development suggestions, 10-1
  - difference between session and entity, 1-14
  - home interface, 3-2
  - JAAS support, 2-12
  - JAR file, 4-2, 8-2, 9-3
  - local interface, 3-4
  - overview, 1-1
  - parameter passing, 1-18
  - passivation, 3-9
  - referencing other EJBs, 10-6, 10-7
  - remote interface, 3-3
  - replication, 13-4
  - security, 12-1
  - setting pool size, 4-11
- EJB QL
  - ?1, 7-11
  - deployment descriptor, 7-4
  - DISTINCT keyword, 7-11
  - documentation, 7-1
  - finder method
    - example, 7-5
    - overview, 7-2
  - input parameter syntax, 7-11
  - overview, 7-2
  - query methods, 7-2
  - select method
    - example, 7-9

- overview, 7-3
- statement example, 7-5, 7-6
- EJB Query Language, see EJB QL
- ejbActivate method, 1-7, 1-12, 8-2, 8-8
- EJBContext interface, 1-8
- ejbCreate method, 1-11, 1-12, 1-14, 3-2, 4-4, 8-3
  - initializing primary key, 8-3
  - MDB, 9-4
  - SessionBean interface, 1-7
- EJBException, 3-3, 3-4
- ejbFindByPrimaryKey method, 1-14, 8-3, 8-6
- EJBHome interface, 3-2, 3-3, 4-3
  - create method, 4-3, 4-4
  - findByPrimaryKey method, 4-2, 4-3, 8-2
- ejb-jar.xml file, 3-6, 8-9, 10-2
- ejbLoad method, 1-12, 1-13, 1-14, 8-2, 8-7
- EJBLocalHome interface, 3-2, 3-3, 4-3
- EJBLocalObject interface, 3-2, 3-4, 4-4
- ejb-name attribute, A-21
- EJBObject interface, 3-2, 3-4, 4-4
- ejbPassivate method, 1-7, 1-12, 8-2, 8-8
- ejbPostCreate method, 1-11, 1-14, 4-4
- ejb-reference-home attribute, A-16
- ejbRemove method, 1-7, 1-12, 1-13, 1-14, 8-9
  - MDB, 9-4
- EJBs
  - accessing, 2-1
- ejbStore method, 1-12, 1-13, 1-14, 8-2, 8-7
- enable-passivation attribute, 3-10
- Enterprise Archive file, see EAR file
- Enterprise Java Beans, see EJB
- entity bean
  - class implementation, 4-4
  - context information, 1-12
  - creating, 1-12, 4-2, 4-3
  - deployment descriptor, A-6
  - finder methods, 4-3, 8-3
  - home interface, 4-3
  - overview, 1-6, 1-10
  - persistent data, 1-11, 1-13
  - primary key, 1-10
  - relationships, see CMR
  - remote interface, 4-4
  - removing, 1-13
- EntityBean interface, 1-11, 1-14, 1-18, 4-4
  - ejbActivate method, 1-12, 8-2
  - ejbCreate method, 1-11, 1-12, 1-14
  - ejbFindByPrimaryKey method, 1-14
  - ejbLoad method, 1-12, 1-13, 1-14, 8-2
  - ejbPassivate method, 1-12, 8-2
  - ejbPostCreate method, 1-11
  - ejbRemove method, 1-12, 1-13, 1-14
  - ejbStore method, 1-12, 1-13, 1-14, 8-2
  - setEntityContext method, 1-12, 1-14
  - unsetEntityContext method, 1-12
- environment references
  - URL, 10-17
- environment, retrieval, 1-8
- error recovery, 10-5, 10-7
  - ClassCastException, 10-7

- deadlock, 2-12
- NamingException thrown, 2-12
- NullPointerException thrown, 2-12
  - out of memory, 10-5
- exclusive-write-access attribute, 4-14, A-9, A-18

## F

---

- findByPrimaryKey method, 4-2, 8-2
- findByPrimaryKey-lazy-loading attribute, 5-6, A-18
- finder
  - lazy loading, 5-5
- finder method
  - backwards compatibility, 7-7
  - EJB QL example, 7-5
  - overview, 7-2
- finder methods, 8-3
  - BMP, 8-6
  - entity bean, 4-3
  - findByPrimaryKey method, 4-3
- force-update attribute, A-11
- foreign key
  - database constraints, 6-50
  - deferrable, 6-50

## G

---

- getEJBHome method, 1-8
- getEnvironment method, 1-8
- getRollbackOnly method, 1-8
- getUserTransaction method, 1-8

## H

---

- home interface
  - creating, 3-2, 4-2, 8-2
  - lookup, 2-7
  - overview, 1-16, 1-17

## I

---

- idletime attribute, 3-10, A-6
- immutable attribute, A-26
- impliesAll attribute, 12-7, A-24
- instance-cache-timeout attribute, A-9, A-18
- invoking EJBs, 2-1
- isCallerInRole method, 12-3
- isolation attribute, 4-13, A-9, A-18
- isolation modes, 4-12

## J

---

- JAAS support for EJBs, 2-12
- JAR
  - archiving command, 3-7, 10-4
- jar command, 3-7, 10-4
- JAR file, 4-2, 8-2, 9-3
  - EJB, 3-7, 10-3
- Java mail
  - Session object, 10-15
- jem-name attribute, A-21

## JMS

- Destination, 9-15
- durable subscriptions, 9-3
- handled by MDB, 1-15
- Oracle JMS, 9-13 to ??
- OracleAS JMS, 9-9 to 9-12
- queue, 9-11
- retry message, A-22
- Topic, 9-17

## JNDI

- clustering, 13-4
- lookup, 2-7
- namespace replication, 13-4

## L

---

- lazy loading, 1-6, 5-5
- lazy-loading attribute, 5-6, 7-9, A-20
- listener-threads attribute, 9-11, 9-18, A-13, A-22
- Lists, 5-7
- load balancing, 13-5
- LoadBalanceOnLookup property, 13-5
- local home interface
  - example, 3-3
- local interface
  - creating, 3-4
  - example, 3-4
  - overview, 1-17
- local-wrapper attribute, A-6, A-11, A-18, A-24
- location attribute, A-4, A-9, A-18, A-21, A-23, A-24
- locking-mode attribute, 4-14, A-10, A-19

## M

---

- mail
  - Session object, 10-15
- mapping
  - relationships, 6-12
- max-instances
  - default value, 1-6
- max-instances attribute, 4-12, A-5, A-10, A-12, A-19, A-24
- max-instances-threshold attribute, 3-10, A-6, A-24
- max-tx-retries attribute, A-5, A-10, A-19, A-24
- MDB
  - configuration, 9-11, 9-17, 9-19
  - creation, 9-3
  - deployment descriptor, 9-3
  - dequeue-retry-count attribute, A-22
  - dequeue-retry-intervale attribute, A-22
  - example, 9-3
  - onMessage method, 9-13
  - overview, 1-6, 1-15, 9-2
  - performance, 9-11, 9-18, A-22
  - transaction timeout, 9-18, A-22
- memory-threshold attribute, 3-10, A-6, A-25
- message-driven bean
  - deployment descriptor, A-11
- Message-Driven Beans, see MDB
- MessageDrivenBean interface, 1-16, 9-4

- setMessageDrivenContext method, 9-4
- MessageListener interface, 1-16, 9-4
  - onMessage method, 9-4
- min-instances attribute, 4-12, A-5, A-10, A-13, A-19, A-25
- multi-tier environment, 2-10

## N

---

- name attribute, A-5, A-10, A-13, A-19, A-22, A-24, A-25
- narrowing, 2-7
- NoSuchObjectLocalException, 11-4
- NullPointerException, 2-12

## O

---

- OC4J
  - command-line options, 10-6
  - Windows shutdown, 9-28
- OC4J instances terminating due to ping timeout, 10-7
- onMessage method, 1-16, 9-4, 9-13
- optimistic concurrency mode, 4-14
- optimistic concurrency mode, A-10, A-19
- ORA-8177 exception, 4-15
- Oracle JMS, 9-13 to 9-20, ?? to 9-20
  - create resource provider, 9-16
- OracleAS JMS, 9-9 to 9-12
- oracle.mdb.fastUndeploy property, 9-28
- orion-ejb-jar.xml file, 9-3
- out of memory, 10-7
- Out of Memory error, 10-5

## P

---

- packaging
  - referenced EJB classes, 10-6, 10-7
- parameters
  - object types, 1-19
  - passing conventions, 1-18
- parent application, 10-6
- partial attribute, A-20
- pass by reference, 1-18
- pass by value, 1-18
- passivate-count attribute, 3-10, A-6, A-25
- passivation criteria, 3-9 to 3-11
- performance setting
  - DNS load balancing option, 2-5, 13-5
- permissions, 12-1
- persistence
  - bean-managed, 1-13
  - container-managed, 1-13
  - container-managed vs. bean-managed, 4-10
  - create database tables, 8-10
  - data management, 1-12
  - managing, 4-2
  - managing in BMP, 8-2
  - overview, 1-11
- persistence-filename attribute, 3-11, A-5, A-25
- persistence-name attribute, A-16

- persistence-type attribute, 5-6, 5-7, A-16
  - mappings, 5-6
- pessimistic concurrency mode, A-10, A-19
- pessimistic concurrency mode, 4-13
- pool
  - setting size, 4-11
- pool-cache-timeout attribute, A-4, A-11, A-19, A-24
- PortableRemoteObject
  - narrow method, 2-7
- prefetch-size attribute, 7-9, A-20
- primary key, 4-2, 8-2
  - autoid
    - mapping to table, 6-21
  - complex class, 8-5
  - complex definition, 8-4
  - creating, 8-3
  - entity bean, 1-14, 4-6
  - management, 1-12
  - overview, 1-10, 4-6
  - simple definition, 8-4
- PropertyPermission, 12-1

## Q

---

- query attribute, A-20

## R

---

- read-only concurrency mode, 4-14, A-10, A-19
- remote
  - accessing, 2-10
- remote attribute, 2-10
- remote home interface
  - example, 3-3
- remote interface
  - business methods, 2-7
  - creating, 3-2, 3-3, 4-2, 8-2
  - example, 3-4
  - overview, 1-16, 1-17
- RemoteException, 3-4
- remove method, 2-7
  - EJBHome interface, 1-17
- replication attribute, A-5
- resource-check-interval attribute, 3-10, A-6, A-25
- runAs security identity, 12-5
- RuntimePermission, 12-1

## S

---

- scheduling-threads attribute, A-21
- security, 12-1
  - permissions, 12-1
- SecurityException, A-14
- security-identity element, A-24
- select method
  - EJB QL example, 7-9
  - overview, 7-3
- Serializable interface, 1-19
- session bean
  - class implementation, 1-18
  - context, 1-7

- deployment descriptor, A-3, A-4
- local home interface, 3-3
- methods, 1-7
- overview, 1-6
- remote home interface, 3-3
- removing, 1-7
- stateful, 1-6, 1-9
- stateless, 1-6, 1-8
- Session object, 10-15
- SessionBean interface, 1-18
  - EJB, 1-6, 3-2
  - ejbActivate method, 1-7
  - ejbCreate method, 1-7
  - ejbPassivate method, 1-7
  - ejbRemove method, 1-7
  - setSessionContext method, 1-7
- SessionContext
  - interface, 1-8
- setEntityContext method, 1-12, 1-14
- setMessageDrivenContext method, 1-16, 9-4
- setRollbackOnly method, 1-8
- setSessionContext method, 1-7, 1-13
- SocketPermission, 12-1
- SQRT, 7-11
- stateful session bean
  - clustering, 13-2
  - overview, 1-9
- stateless session bean
  - clustering, 13-2
  - overview, 1-8
- static block in an EJB, 10-7
- subscription-name attribute, A-13, A-22

## T

---

- table attribute, A-11, A-19
- Time, 7-11
- TimeoutException, A-4, A-8
- timeout attribute, A-6, A-25
- TimeoutExpiredException, A-5, A-24
- timers, 11-1
  - callback method implementation, 11-1
  - cancel, 11-4
  - creating, 11-1
  - ejbTimeout method, 11-1
  - executing within a transaction, 11-4
  - NoSuchObjectLocalException, 11-4
  - persistence, 11-4
  - retrieving information, 11-4
  - retrieving timer service, 11-1
- TimerService object, 11-1, 11-2
- Timestamp, 7-11
- transaction
  - commit, 1-8
  - context propagation, 1-8
  - retrieve status, 1-8
  - rollback, 1-8
- TRANSACTION\_READ\_COMMITTED, 4-12
- TRANSACTION\_SERIALIZABLE, 4-12
- transaction-timeout attribute, 9-18, A-13, A-22

- trans-attribute
  - default value, 1-6
- troubleshooting, 10-5, 10-7
  - OC4J instances terminating due to ping timeout, 10-7
  - static block in an EJB, 10-7
- tx-retry-wait attribute, A-5, A-10, A-19, A-25
- type attribute, A-21, A-26

## U

---

- unsetEntityContext method, 1-12, 1-14
- update-changed-fields-only attribute, A-10, A-20

## V

---

- validity-timeout attribute, A-11, A-19

## W

---

- Windows
  - shutdown, 9-28
- wrapper attribute, A-6, A-11, A-20, A-25

## X

---

- XML
  - BMP, 8-9
  - deployment descriptor, 4-2, 8-2