

PeopleSoft®

Enterprise PeopleTools 8.45 PeopleBook: PeopleSoft Cube Manager

June 2004

Enterprise PeopleTools 8.45 PeopleBook: PeopleSoft Cube Manager
SKU PT845CBM-B 0604
Copyright © 1988-2004 PeopleSoft, Inc. All rights reserved.

All material contained in this documentation is proprietary and confidential to PeopleSoft, Inc. ("PeopleSoft"), protected by copyright laws and subject to the nondisclosure provisions of the applicable PeopleSoft agreement. No part of this documentation may be reproduced, stored in a retrieval system, or transmitted in any form or by any means, including, but not limited to, electronic, graphic, mechanical, photocopying, recording, or otherwise without the prior written permission of PeopleSoft.

This documentation is subject to change without notice, and PeopleSoft does not warrant that the material contained in this documentation is free of errors. Any errors found in this document should be reported to PeopleSoft in writing.

The copyrighted software that accompanies this document is licensed for use only in strict accordance with the applicable license agreement which should be read carefully as it governs the terms of use of the software and this document, including the disclosure thereof.

PeopleSoft, PeopleTools, PS/nVision, PeopleCode, PeopleBooks, PeopleTalk, and Vantive are registered trademarks, and Pure Internet Architecture, Intelligent Context Manager, and The Real-Time Enterprise are trademarks of PeopleSoft, Inc. All other company and product names may be trademarks of their respective owners. The information contained herein is subject to change without notice.

Open Source Disclosure

PeopleSoft takes no responsibility for its use or distribution of any open source or shareware software or documentation and disclaims any and all liability or damages resulting from use of said software or documentation. The following open source software may be used in PeopleSoft products and the following disclaimers are provided.

Apache Software Foundation

This product includes software developed by the Apache Software Foundation (<http://www.apache.org/>). Copyright (c) 1999-2000 The Apache Software Foundation. All rights reserved.

THIS SOFTWARE IS PROVIDED "AS IS" AND ANY EXPRESSED OR IMPLIED WARRANTIES, INCLUDING, BUT NOT LIMITED TO, THE IMPLIED WARRANTIES OF MERCHANTABILITY AND FITNESS FOR A PARTICULAR PURPOSE ARE DISCLAIMED. IN NO EVENT SHALL THE APACHE SOFTWARE FOUNDATION OR ITS CONTRIBUTORS BE LIABLE FOR ANY DIRECT, INDIRECT, INCIDENTAL, SPECIAL, EXEMPLARY, OR CONSEQUENTIAL DAMAGES (INCLUDING, BUT NOT LIMITED TO, PROCUREMENT OF SUBSTITUTE GOODS OR SERVICES; LOSS OF USE, DATA, OR PROFITS; OR BUSINESS INTERRUPTION) HOWEVER CAUSED AND ON ANY THEORY OF LIABILITY, WHETHER IN CONTRACT, STRICT LIABILITY, OR TORT (INCLUDING NEGLIGENCE OR OTHERWISE) ARISING IN ANY WAY OUT OF THE USE OF THIS SOFTWARE, EVEN IF ADVISED OF THE POSSIBILITY OF SUCH DAMAGE.

OpenSSL

Copyright (c) 1998-2003 The OpenSSL Project. All rights reserved.

THIS SOFTWARE IS PROVIDED BY THE OpenSSL PROJECT "AS IS" AND ANY EXPRESSED OR IMPLIED WARRANTIES, INCLUDING, BUT NOT LIMITED TO, THE IMPLIED WARRANTIES OF MERCHANTABILITY AND FITNESS FOR A PARTICULAR PURPOSE ARE DISCLAIMED. IN NO EVENT SHALL THE OpenSSL PROJECT OR ITS CONTRIBUTORS BE LIABLE FOR ANY DIRECT, INDIRECT, INCIDENTAL, SPECIAL, EXEMPLARY, OR CONSEQUENTIAL DAMAGES (INCLUDING, BUT NOT LIMITED TO, PROCUREMENT OF SUBSTITUTE GOODS OR SERVICES; LOSS OF USE, DATA, OR PROFITS; OR BUSINESS INTERRUPTION) HOWEVER CAUSED AND ON ANY THEORY OF LIABILITY, WHETHER IN CONTRACT, STRICT LIABILITY, OR TORT (INCLUDING NEGLIGENCE OR OTHERWISE) ARISING IN ANY WAY OUT OF THE USE OF THIS SOFTWARE, EVEN IF ADVISED OF THE POSSIBILITY OF SUCH DAMAGE.

SSLey

Copyright (c) 1995-1998 Eric Young. All rights reserved.

THIS SOFTWARE IS PROVIDED BY ERIC YOUNG "AS IS" AND ANY EXPRESS OR IMPLIED WARRANTIES, INCLUDING, BUT NOT LIMITED TO, THE IMPLIED WARRANTIES OF MERCHANTABILITY AND FITNESS FOR A PARTICULAR PURPOSE ARE DISCLAIMED. IN NO EVENT SHALL THE AUTHOR OR CONTRIBUTORS BE LIABLE FOR ANY DIRECT, INDIRECT, INCIDENTAL, SPECIAL, EXEMPLARY, OR CONSEQUENTIAL DAMAGES (INCLUDING, BUT NOT LIMITED TO, PROCUREMENT OF SUBSTITUTE GOODS OR SERVICES; LOSS OF USE, DATA, OR PROFITS; OR BUSINESS INTERRUPTION) HOWEVER CAUSED AND ON ANY THEORY OF LIABILITY, WHETHER IN CONTRACT, STRICT LIABILITY, OR TORT (INCLUDING NEGLIGENCE OR OTHERWISE) ARISING IN ANY WAY OUT OF THE USE OF THIS SOFTWARE, EVEN IF ADVISED OF THE POSSIBILITY OF SUCH DAMAGE.

Loki Library

Copyright (c) 2001 by Andrei Alexandrescu. This code accompanies the book:

Alexandrescu, Andrei. "Modern C++ Design: Generic Programming and Design Patterns Applied". Copyright (c) 2001. Addison-Wesley. Permission to use, copy, modify, distribute and sell this software for any purpose is hereby granted without fee, provided that the above copyright notice appear in all copies and that both that copyright notice and this permission notice appear in supporting documentation.

Contents

General Preface

About This PeopleBookvii

PeopleSoft Application Prerequisites.....vii

PeopleSoft Application Fundamentals.....vii

Related Documentation.....viii

 Obtaining Documentation Updates.....viii

 Ordering Printed Documentation.....viii

Typographical Conventions and Visual Cues.....ix

 Typographical Conventions.....ix

 Visual Cues.....x

 Country, Region, and Industry Identifiers.....x

 Currency Codes.....xi

Comments and Suggestions.....xi

Common Elements in These PeopleBooksxi

Preface

PeopleSoft Cube Manager Preface.....xiii

PeopleSoft Cube Manager.....xiii

Chapter 1

Getting Started with PeopleSoft Cube Manager.....1

PeopleSoft Cube Manager Overview.....1

PeopleSoft Cube Manager Integrations.....1

PeopleSoft Cube Manager Implementation.....1

 Designing Cube Metadata.....1

 Designing Cubes.....2

 Building Cubes.....2

Other Sources of Information.....3

Chapter 2

Introducing PeopleSoft Cube Manager.....5

Understanding OLAP.....5

Understanding Cubes.....6
 Rollups.....8
 Working with PeopleSoft Cube Manager.....10
 Understanding Cube Manager.....10
 Cube Manager Architecture.....11
 PeopleSoft Metadata.....11
 PeopleSoft Process Scheduler Integration.....12
 Designing and Building OLAP Cubes.....12
 Using Supported OLAP Tools.....12
 PowerPlay.....13
 Essbase.....15

Chapter 3

Designing Cube Metadata.....17
 Using Trees.....17
 Creating Queries.....18
 Understanding Query Types.....18
 Dimension Queries.....19
 Attribute Queries.....24
 Data Source Queries.....26

Chapter 4

Designing Cubes.....29
 Understanding Cube Design and Components.....29
 Designing a Cube.....30
 Pages Used to Design a Cube.....31
 Defining the Dimensional Structures of the Cube31
 Defining Dimension Options36
 Defining Rollup Options.....37
 Specifying the Source of the Metadata for Each Rollup.....37
 Mapping Fields to a Role in the Rollup.....40
 Designing Cube Definitions.....42
 Pages Used to Design Cube Definitions.....42
 Mapping Data Sources to Dimensions and Selecting Dimensions for the Cube.....42
 Adding Cube Inputs to a Cube Definition.....44
 Mapping Source Query Fields to Cube Components.....45
 Designing Attribute Names.....46
 Page Used to Design Attribute Names.....47

Specifying User-Defined Attributes.....47

Chapter 5

Building Cubes.....49
 Understanding Cube Instance Definitions.....49
 Building Cube Instances.....49
 Pages Used to Build Cube Instances.....50
 Defining Cube Settings and Selecting Dimensions, Measures, and Attributes.....50
 Creating the Cube Filter.....52
 Defining Cube Settings for Essbase.....54
 Defining Cube Settings for Cognos PowerPlay.....57
 Adding a Prefix to Field and Record Objects.....60
 Defining Cube Aggregates.....60
 Building Cubes.....61
 Understanding Cube Creation.....61
 Pages Used to Build Cubes.....61
 Defining the Cube Build Specifications and Bind Variables.....62
 Defining Bind Variables.....64
 Defining a Cube Build Process Using Process Scheduler Manager.....67
 Running the Process to Build the Cube.....68

Chapter 6

Securing Cubes.....71
 Securing PeopleSoft Cube Manager Cubes.....71
 Pages Used to Secure PeopleSoft Cube Manager Cubes.....71
 Controlling User Operations.....71
 Setting User Actions.....72
 View Content References.....73

Appendix A

Installing PowerPlay.....75

Appendix B

ISO Country and Currency Codes.....77
 ISO Country Codes.....77
 ISO Currency Codes.....86

Glossary of PeopleSoft Terms.....97

Index113

About This PeopleBook

PeopleBooks provide you with the information that you need to implement and use PeopleSoft applications.

This preface discusses:

- PeopleSoft application prerequisites.
- PeopleSoft application fundamentals.
- Related documentation.
- Typographical conventions and visual cues.
- Comments and suggestions.
- Common elements in PeopleBooks.

Note. PeopleBooks document only page elements that require additional explanation. If a page element is not documented with the process or task in which it is used, then either it requires no additional explanation or it is documented with common elements for the section, chapter, PeopleBook, or product line. Elements that are common to all PeopleSoft applications are defined in this preface.

PeopleSoft Application Prerequisites

To benefit fully from the information that is covered in these books, you should have a basic understanding of how to use PeopleSoft applications.

See *Enterprise PeopleTools 8.45 PeopleBook: Using PeopleSoft Applications*.

You might also want to complete at least one PeopleSoft introductory training course.

You should be familiar with navigating the system and adding, updating, and deleting information by using PeopleSoft windows, menus, and pages. You should also be comfortable using the World Wide Web and the Microsoft Windows or Windows NT graphical user interface.

These books do not review navigation and other basics. They present the information that you need to use the system and implement your PeopleSoft applications most effectively.

PeopleSoft Application Fundamentals

Each application PeopleBook provides implementation and processing information for your PeopleSoft database. However, additional, essential information describing the setup and design of your system appears in a companion volume of documentation called the application fundamentals PeopleBook. Each PeopleSoft product line has its own version of this documentation.

The application fundamentals PeopleBook consists of important topics that apply to many or all PeopleSoft applications across a product line. Whether you are implementing a single application, some combination of applications within the product line, or the entire product line, you should be familiar with the contents of this central PeopleBook. It is the starting point for fundamentals, such as setting up control tables and administering security.

Related Documentation

This section discusses how to:

- Obtain documentation updates.
- Order printed documentation.

Obtaining Documentation Updates

You can find updates and additional documentation for this release, as well as previous releases, on the PeopleSoft Customer Connection website. Through the Documentation section of PeopleSoft Customer Connection, you can download files to add to your PeopleBook Library. You'll find a variety of useful and timely materials, including updates to the full PeopleSoft documentation that is delivered on your PeopleBooks CD-ROM.

Important! Before you upgrade, you must check PeopleSoft Customer Connection for updates to the upgrade instructions. PeopleSoft continually posts updates as the upgrade process is refined.

See Also

PeopleSoft Customer Connection, <https://www.peoplesoft.com/corp/en/login.jsp>

Ordering Printed Documentation

You can order printed, bound volumes of the complete PeopleSoft documentation that is delivered on your PeopleBooks CD-ROM. PeopleSoft makes printed documentation available for each major release shortly after the software is shipped. Customers and partners can order printed PeopleSoft documentation by using any of these methods:

- Web
- Telephone
- Email

Web

From the Documentation section of the PeopleSoft Customer Connection website, access the PeopleBooks Press website under the Ordering PeopleBooks topic. The PeopleBooks Press website is a joint venture between PeopleSoft and MMA Partners, the book print vendor. Use a credit card, money order, cashier's check, or purchase order to place your order.

Telephone

Contact MMA Partners at 877 588 2525.

Email

Send email to MMA Partners at peoplesoftpress@mmapartner.com.

See Also

PeopleSoft Customer Connection, <https://www.peoplesoft.com/corp/en/login.jsp>

Typographical Conventions and Visual Cues

This section discusses:

- Typographical conventions.
- Visual cues.
- Country, region, and industry identifiers.
- Currency codes.

Typographical Conventions

This table contains the typographical conventions that are used in PeopleBooks:

Typographical Convention or Visual Cue	Description
Bold	Indicates PeopleCode function names, method names, language constructs, and PeopleCode reserved words that must be included literally in the function call.
<i>Italics</i>	Indicates field values, emphasis, and PeopleSoft or other book-length publication titles. In PeopleCode syntax, italic items are placeholders for arguments that your program must supply. We also use italics when we refer to words as words or letters as letters, as in the following: Enter the letter <i>O</i> .
KEY+KEY	Indicates a key combination action. For example, a plus sign (+) between keys means that you must hold down the first key while you press the second key. For ALT+W, hold down the ALT key while you press the W key.
Monospace font	Indicates a PeopleCode program or other code example.
“ ” (quotation marks)	Indicate chapter titles in cross-references and words that are used differently from their intended meanings.
. . . (ellipses)	Indicate that the preceding item or series can be repeated any number of times in PeopleCode syntax.
{ } (curly braces)	Indicate a choice between two options in PeopleCode syntax. Options are separated by a pipe ().

Typographical Convention or Visual Cue	Description
[] (square brackets)	Indicate optional items in PeopleCode syntax.
& (ampersand)	<p>When placed before a parameter in PeopleCode syntax, an ampersand indicates that the parameter is an already instantiated object.</p> <p>Ampersands also precede all PeopleCode variables.</p>

Visual Cues

PeopleBooks contain the following visual cues.

Notes

Notes indicate information that you should pay particular attention to as you work with the PeopleSoft system.

Note. Example of a note.

If the note is preceded by *Important!*, the note is crucial and includes information that concerns what you must do for the system to function properly.

Important! Example of an important note.

Warnings

Warnings indicate crucial configuration considerations. Pay close attention to warning messages.

Warning! Example of a warning.

Cross-References

PeopleBooks provide cross-references either under the heading “See Also” or on a separate line preceded by the word *See*. Cross-references lead to other documentation that is pertinent to the immediately preceding documentation.

Country, Region, and Industry Identifiers

Information that applies only to a specific country, region, or industry is preceded by a standard identifier in parentheses. This identifier typically appears at the beginning of a section heading, but it may also appear at the beginning of a note or other text.

Example of a country-specific heading: “(FRA) Hiring an Employee”

Example of a region-specific heading: “(Latin America) Setting Up Depreciation”

Country Identifiers

Countries are identified with the International Organization for Standardization (ISO) country code.

See *About These PeopleBooks*, “ISO Country and Currency Codes,” ISO Country Codes.

Region Identifiers

Regions are identified by the region name. The following region identifiers may appear in PeopleBooks:

- Asia Pacific
- Europe
- Latin America
- North America

Industry Identifiers

Industries are identified by the industry name or by an abbreviation for that industry. The following industry identifiers may appear in PeopleBooks:

- USF (U.S. Federal)
- E&G (Education and Government)

Currency Codes

Monetary amounts are identified by the ISO currency code.

Appendix B, "ISO Country and Currency Codes" ISO Currency Codes.

Comments and Suggestions

Your comments are important to us. We encourage you to tell us what you like, or what you would like to see changed about PeopleBooks and other PeopleSoft reference and training materials. Please send your suggestions to:

PeopleSoft Product Documentation Manager PeopleSoft, Inc. 4460 Hacienda Drive Pleasanton, CA 94588

Or send email comments to doc@peoplesoft.com.

While we cannot guarantee to answer every email message, we will pay careful attention to your comments and suggestions.

Common Elements in These PeopleBooks

As of Date	The last date for which a report or process includes data.
Business Unit	An ID that represents a high-level organization of business information. You can use a business unit to define regional or departmental units within a larger organization.
Description	Enter up to 30 characters of text.
Effective Date	The date on which a table row becomes effective; the date that an action begins. For example, to close out a ledger on June 30, the effective date for the ledger closing would be July 1. This date also determines when

you can view and change the information. Pages or panels and batch processes that use the information use the current row.

Once, Always, and Don't Run

Select Once to run the request the next time the batch process runs. After the batch process runs, the process frequency is automatically set to Don't Run.

Select Always to run the request every time the batch process runs.

Select Don't Run to ignore the request when the batch process runs.

Report Manager

Click to access the Report List page, where you can view report content, check the status of a report, and see content detail messages (which show you a description of the report and the distribution list).

Process Monitor

Click to access the Process List page, where you can view the status of submitted process requests.

Run

Click to access the Process Scheduler request page, where you can specify the location where a process or job runs and the process output format.

Request ID

An ID that represents a set of selection criteria for a report or process.

User ID

An ID that represents the person who generates a transaction.

SetID

An ID that represents a set of control table information, or TableSets. TableSets enable you to share control table information and processing options among business units. The goal is to minimize redundant data and system maintenance tasks. When you assign a setID to a record group in a business unit, you indicate that all of the tables in the record group are shared between that business unit and any other business unit that also assigns that setID to that record group. For example, you can define a group of common job codes that are shared between several business units. Each business unit that shares the job codes is assigned the same setID for that record group.

Short Description

Enter up to 15 characters of text.

See Also

Enterprise PeopleTools 8.45 PeopleBook: PeopleSoft Process Scheduler

Enterprise PeopleTools 8.45 PeopleBook: Using PeopleSoft Applications

PeopleSoft Cube Manager Preface

This book discusses Cube Manager, a set of PeopleTools pages and processes that you use to create and maintain analytic data stores, also called OLAP (Online Analytical Processing) cubes.

PeopleSoft Cube Manager

This book explains the basic concepts of OLAP and the tools that are supported, as well as how to use PeopleTools to design analytic components, and build and troubleshoot cubes.

CHAPTER 1

Getting Started with PeopleSoft Cube Manager

This chapter provides an overview of PeopleSoft Cube Manager and discusses:

- PeopleSoft Cube Manager integrations.
- PeopleSoft Cube Manager implementations.

PeopleSoft Cube Manager Overview

PeopleSoft Cube Manager enables you to build Online Analytical Processing (OLAP) databases, or cubes, which are specifically designed for data analysis. OLAP cubes are a collections of related data—like a database with multiple dimensions. These dimensions, like database fields, are criteria that let you identify your data. An example dimension might be Time or Product. Dimensions in turn are subdivided into categories, called cube members. For instance, in the Time dimension, one member might be the year 2000.

Note. Cubes are not limited to three dimensions. They can consist of three, four, or more dimensions.

PeopleSoft Cube Manager Integrations

You can use PeopleSoft Cube Manager in tandem with the third-party OLAP platforms Cognos PowerPlay and Hyperion Essbase. In addition, you can use PeopleSoft Tree Manager and PeopleSoft Query to describe metadata to PeopleSoft Cube Manager.

Note. You do not need PowerPlay or Essbase installed to design cubes and dimensions with Cube Manager. However, you do need to install one of them before you can build cubes. Basically, you use Cube Manager to design platform-independent metadata that you can then use to build cubes on any of the supported platforms.

PeopleSoft Cube Manager Implementation

PeopleSoft Cube Manager implementation can be divided into the following phases:

- Design cube metadata.
- Design cubes.
- Build cubes.

Designing Cube Metadata

The initial piece of the process when creating cubes is to define their metadata—data that describes the cube's structure. You can do this with either PeopleSoft trees or queries.

Step	Attribute
Create new trees or use existing trees.	See Chapter 3, “Designing Cube Metadata,” Using Trees, page 17.
Create new queries or use existing trees.	See Chapter 3, “Designing Cube Metadata,” Creating Queries, page 18.

Designing Cubes

Once you have established the cube metadata, you can design the cube itself.

Step	Reference
1. Define the high-level dimensional structures of the cube.	See Chapter 4, “Designing Cubes,” Defining the Dimensional Structures of the Cube , page 31.
2. Define dimension options by naming blank members in your hierarchy to view in your cube.	See Chapter 4, “Designing Cubes,” Defining Dimension Options , page 36.
3. Define rollup options by identifying prefix and suffix options.	See Chapter 4, “Designing Cubes,” Defining Rollup Options, page 37.
4. Specify the source of the metadata for each rollup.	See Chapter 4, “Designing Cubes,” Specifying the Source of the Metadata for Each Rollup, page 37.
5. Map fields to a role in the rollup.	See Chapter 4, “Designing Cubes,” Mapping Fields to a Role in the Rollup, page 40.

In addition, you need to design cube definitions.

Step	Reference
1. Map data source to dimensions and select dimensions for the cube.	See Chapter 4, “Designing Cubes,” Mapping Data Sources to Dimensions and Selecting Dimensions for the Cube, page 42.
2. Add cube inputs to a cube definition.	See Chapter 4, “Designing Cubes,” Adding Cube Inputs to a Cube Definition, page 44.
3. Map source query fields to cube components.	See Chapter 4, “Designing Cubes,” Mapping Source Query Fields to Cube Components, page 45.

Finally, you need to choose cube attribute names.

Step	Reference
1. Specify user-defined attributes.	See Chapter 4, “Designing Cubes,” Specifying User-Defined Attributes, page 47.

Building Cubes

After you have designed the cube, you are ready to build it.

Step	Reference
1. Build the cube instance.	See Chapter 5, “Building Cubes,” Building Cube Instances, page 49.
2. Build the cube itself.	See Chapter 5, “Building Cubes,” Building Cubes, page 61.

Other Sources of Information

This section provides information to consider before you begin to use PeopleSoft Cube Manager.

Take advantage of all PeopleSoft sources of information, including the installation guides, release notes, PeopleBooks, red papers, the Updates + Fixes area of Customer Connection, and PeopleSoft’s curriculum courses.

See Also

[“PeopleSoft Cube Manager Preface,” page xiii](#)

Enterprise PeopleTools 8.45 PeopleBook: Getting Started with Enterprise PeopleTools

CHAPTER 2

Introducing PeopleSoft Cube Manager

This chapter provides an overview of online processing and cubes, and discusses how to:

- Work with PeopleSoft Cube Manager.
- Use supported OLAP tools.

Note. The information presented here is not a substitute for your PowerPlay, Essbase, or other third-party technology documentation, but should help you integrate your PeopleSoft data with one or more of these tools.

See Also

[Chapter 2, “Introducing PeopleSoft Cube Manager,” Using Supported OLAP Tools, page 12](#)

Understanding OLAP

Most business software users are familiar with Online Transaction Processing (OLTP) applications, which are for creating and maintaining information about business operations. The transactions stored by these applications are the heart of any business software. At the database level, OLTP applications are designed to allow speedy creation of data and to reduce redundant information. However, data structures of this design are not well suited to analysis.

The nature of OLTP databases poses a problem: how to analyze data in a database that is not designed for analysis. One solution is to use a product such as PS/nVision. Such products perform analysis on selected characteristics of the database. However, using a powerful tool, such as PS/nVision, on top of an OLTP database, takes time.

In contrast, Online Analytical Processing (OLAP) applications are designed specifically for data analysis. The source of information for analysis is an OLTP database. To make the OLTP data available to analytical applications, data is extracted and transformed into a format that is easier to analyze. You can store the resulting OLAP database in several different formats, depending on the tools that you used to access the data.

MOLAP

Multidimensional OLAP (MOLAP) is a format that stores all of the data hierarchically. This type of database is mainly for small-to-medium data marts. MOLAP databases like PowerPlay and Essbase are very fast at summarizing and navigating data. The only drawback of MOLAP systems is that as dimensional information, sizes, or numbers increase, the storage mechanism becomes less efficient.

ROLAP

Relational OLAP (ROLAP) is a format that stores the analytical data in relational tables. The main benefit of the ROLAP format is its ability to store vast amounts of data. But ROLAP data storage is not as efficient in accessing aggregate information at higher levels of the hierarchy.

The structures of the data schema can be one of two types: snowflake or star schema. Snowflake schemas are designed to keep very little redundant data, whereas star schemas encourage duplicate data. This release of PeopleSoft Cube Manager supports only the star schema, so we will focus our discussion on this format.

In a star schema, each dimension is represented in a single table. The *fact data*, data that is to be analyzed, is stored in a separate table. The fact table contains one column to represent each of the dimensions from which the data was created. The following diagram illustrates a typical star schema:

See [Chapter 2, “Introducing PeopleSoft Cube Manager,” Understanding Cubes, page 6](#).

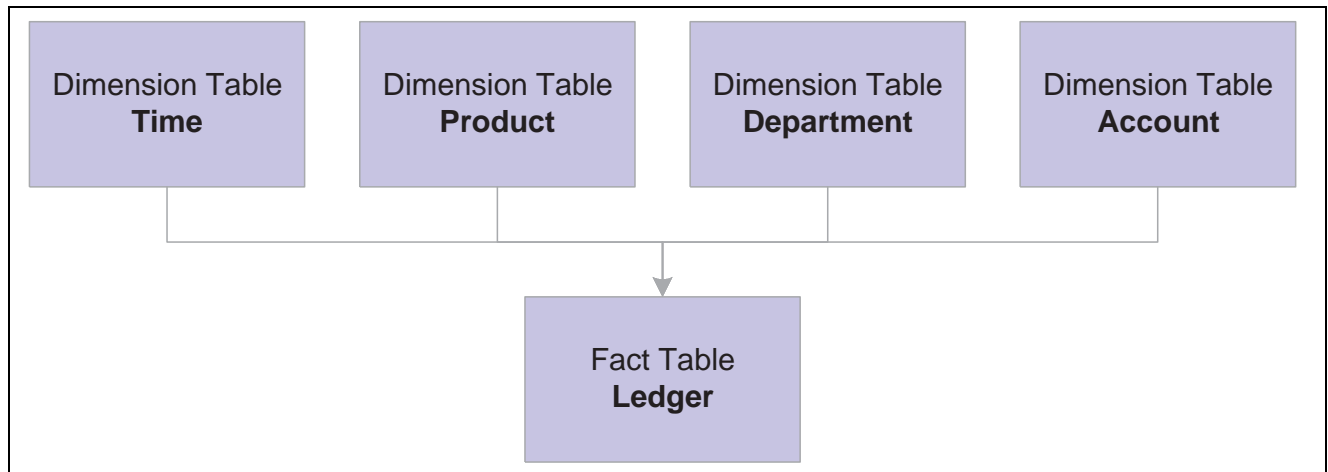

Star schema structure

HOLAP

Hybrid OLAP (HOLAP) is the latest type of analytical structure. As the name implies, the data is stored in a hybrid format. The base fact data is stored in a set of relational tables, while the summary data is stored in a multidimensional format. This strategy is powerful, but can pose problems when you are combining data from the relational tables with the multidimensional summary data.

Generally speaking, multidimensional analysis is not a technology. Rather, it is a type of analysis that enables you to easily view data from many perspectives. These tools allow users to explore, interact with, and "slice and dice" complex data, guiding them to the multidimensional information they can't easily discover with conventional reporting tools.

Understanding Cubes

The key concept of OLAP is that of a cube. This document uses the term *cube* when referring to any analytic data store, whether it is a MOLAP cube or a ROLAP star schema. An OLAP cube is a collection of related data—a database, really—having multiple dimensions. *Cube dimensions* are the rough equivalent of fields in a relational database. In terms of data analysis, dimensions can be thought of as criteria—such as time, account, and salesperson—that can pinpoint a particular piece of data. These pieces of data are usually transactions from an OLTP system.

Although they are called cubes, OLAP databases can have more than three dimensions. In fact, most cubes have anywhere from three to eight dimensions. To understand the concept of OLAP cubes, it is best to start with a simple data analysis model and then expand it.

Suppose you want to analyze your company's sales (in units). You could examine the total units sold in a particular year, but that would not help you understand much about your business. Instead, you might want to see unit sales broken down by time and by products. The matrix that you use to analyze this data might look something like the following table, which illustrates a cube with two dimensions:

Product	2001	2002	2003
Widgets	3000	<i>6500</i>	8200
Gadgets	1200	1450	3000
Doohickeys	2500	3400	2000
Whatzits	500	670	1300

Dimensions and Members

In OLAP terminology, the preceding matrix is an OLAP cube that represents Units Sold dimensioned by Time and Product. Time and Product are the dimensions of the cube, and Units Sold is the fact data.

In the example, each dimension is subdivided into categories, called *cube members*, which represent individual years and products. In the Time dimension, the members are 2001, 2002, and 2003. In the Product dimension, the members are widgets, gadgets, doohickeys, and whatzits.

Measures and Cells

In the preceding matrix, what values are we most interested in? Not years or products. The purpose of the matrix is to find the number of units sold. Units sold comprise the data element being evaluated or measured. In OLAP terminology, the number of units sold is called the *measure*, or *fact*, of this cube. The areas of the matrix where members intersect with other members represent individual measure/fact values. These intersections are called *cells*. The italicized cell in the preceding table represents the number of widgets sold in 2002: 6500 units.

Multiple Dimensions

The two-dimensional cube in the preceding illustration is basic, for reporting purposes. For example, it provides no idea about where any of the units were sold. We can provide this information by adding another dimension, *location*, to the model:

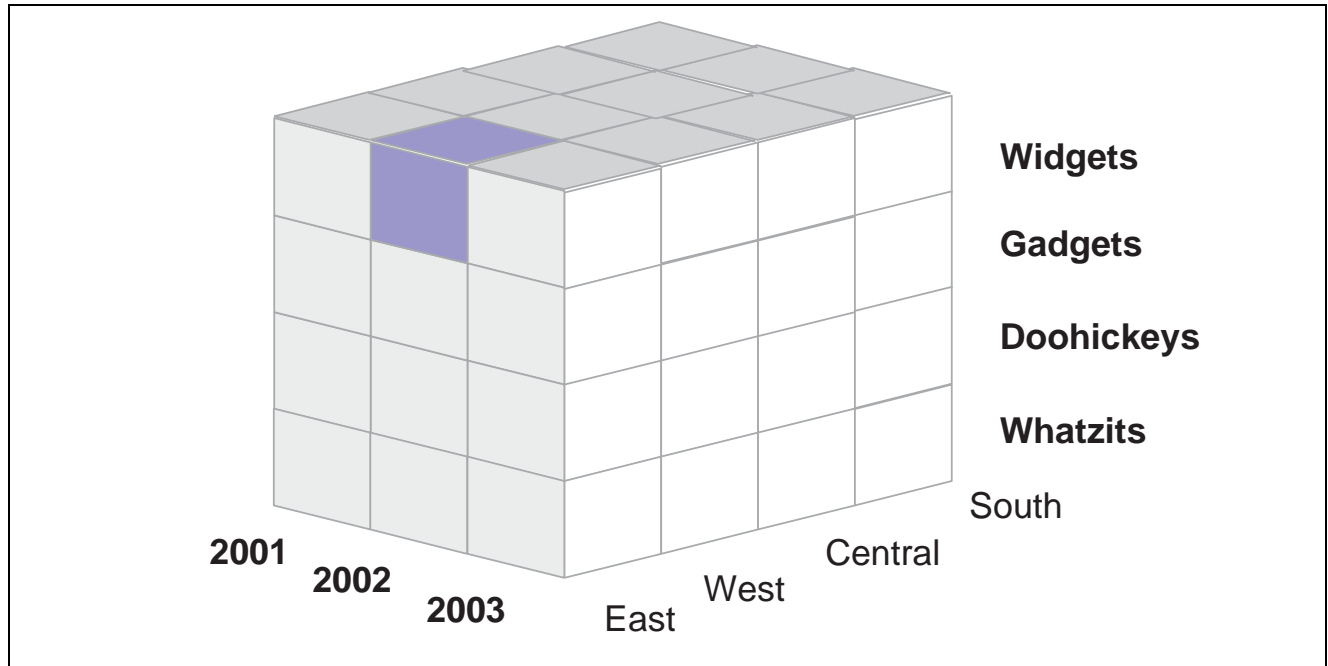

Illustration of a cube with three dimensions

The preceding three-dimensional OLAP cube represents units sold dimensioned by time, product, and location. (The location members are East, West, Central, and South.) The shaded cell represents the number of widgets sold in the East region in 2002. You could find the number of units sold for any other product in any other region at any other time by finding the cell at the intersection point of three members, one from each dimension.

Suppose you also want to factor customer accounts into the analysis. Although it is a challenge to depict four dimensions graphically, the result of this added dimension is clear. In this case, each cell of the OLAP cube represents the intersection of an account, a year, a region, and a product.

Rollups

A *rollup* is the organization of cube data elements with their reporting structures. It represents both the hierarchy and the method of consolidation in a dimension level.

Hierarchy

The example cube has only one level in each dimension. The Time dimension consists of one level containing three members (years); the Location dimension consists of one level containing four members (regions). However, the data used to build such OLAP cubes probably supports more than just one level in each dimension.

For example, when a company records a sale, that sale occurs in a particular month, which occurs in a particular quarter, in a particular year. So you can examine the time dimension at three levels: month, quarter, or year. Likewise, you could record that each sale occurs in a particular office, in a particular city, in a particular region. So the location dimension might also have three levels: office, city, and region.

As mentioned, the categories found at each level of a dimension are called members. You can envision multilevel dimensions as tree diagrams, the members of which relate to each other in various parent/child relationships. Some members are parents of other members, some are children, and some are both. For example, the follow diagram represents a portion of a typical time dimension, with its various levels and members:

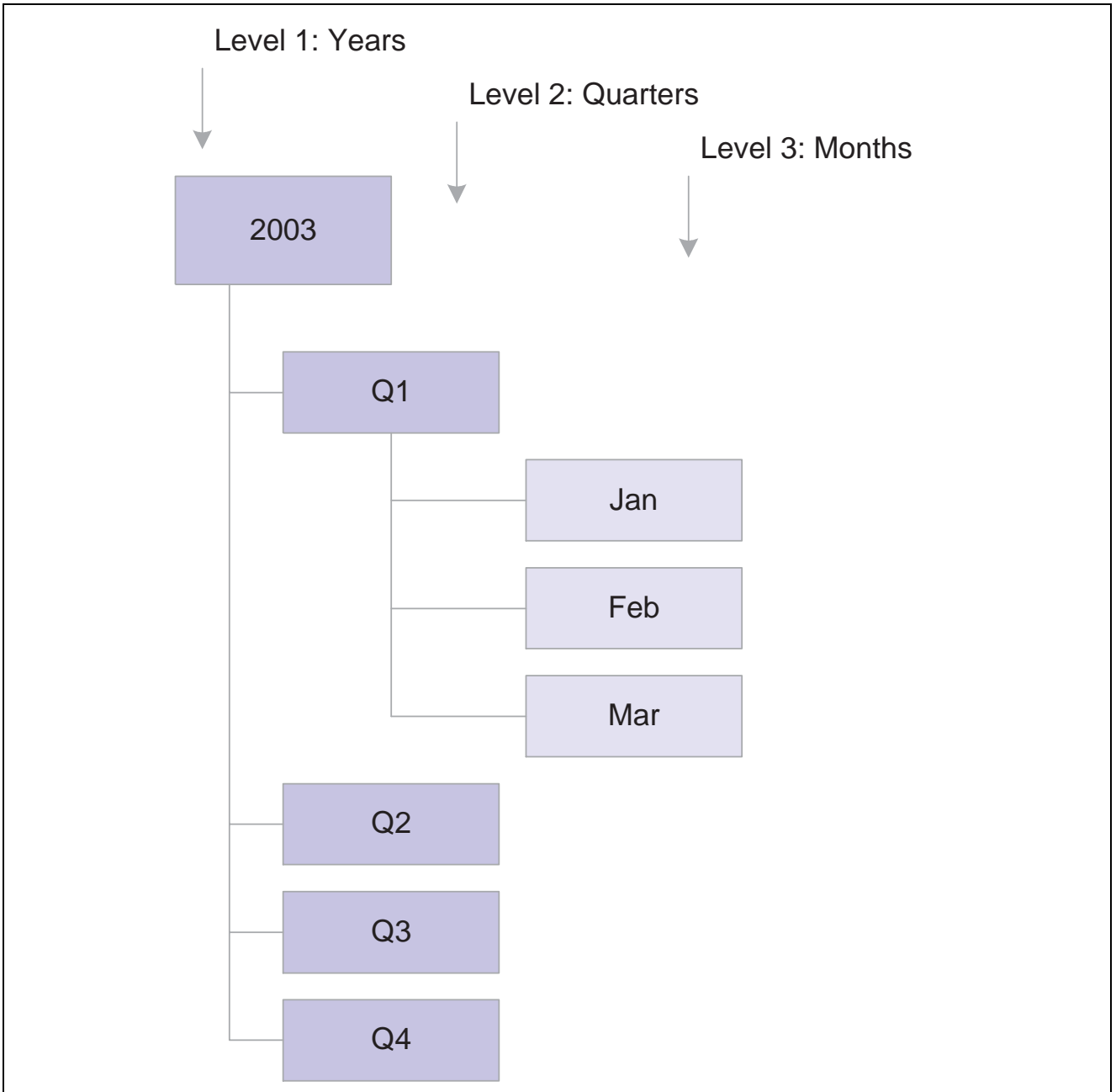

Illustration of a time hierarchy

Each box in the diagram represents a unique member. If you have used the PeopleSoft Tree Manager before, this diagram should look familiar. In fact, PeopleSoft trees can play an important role in defining the hierarchy of an OLAP cube.

See *Enterprise PeopleTools 8.45 PeopleBook: PeopleSoft Tree Manager*.

Consolidation

Viewing a dimension’s hierarchy tells you about the organization of its members, but there is another facet of the dimension to consider. You need to know how to consolidate into the value of their parent members the values found under child members. For example, are the children added together to equal the parent? This is certainly the case in a Time dimension, in which the value for each member is added to its siblings to equal the value of its parent. (Three months can be consolidated into their parent quarter, four quarters can be consolidated into their parent year, and so on.)

The following table illustrates the cube example adding a second level, quarters, to the time dimension of the original example.

Product	2001 Q1	2001 Q2	2001 Q3	2001 Q4	2002 Q1	2002 Q2	2002 Q3	2002 Q4	2003 Q1	2003 Q2	2003 Q3	2003 Q4
Widgets	400	700	950	400	1200	980	995	975	2200	990	750	500
Gadgets	300	300	300	300	300	300	400	450	600	650	850	900
Doohickeys	600	600	700	600	750	850	950	850	750	400	300	550
Whatzis	125	125	125	125	125	200	225	120	170	230	400	500

Consolidation example

How does the data represented at the quarterly level consolidate into the yearly level? It is simply added together. So the 2001 rollup is Q1/01 + Q2/01 + Q3/01 + Q4/01.

However, you might also find dimensions in which certain members are to be subtracted from their siblings, such as in a profit dimension. In such a dimension, suppose there are two members at the first level, *margin* and *total expenses*, both of which are reported as positive values. To find the total profits, you would not add margin and total expenses, but would instead subtract total expenses from margin.

Working with PeopleSoft Cube Manager

This section provides an overview of PeopleSoft Cube Manager, and discusses:

- Cube Manager architecture.
- PeopleSoft metadata.
- PeopleSoft Process Scheduler integration.

Understanding Cube Manager

It is possible to build an OLAP database out of PeopleSoft data without using PeopleSoft Cube Manager. In fact, customers have implemented custom OLAP solutions with previous PeopleSoft releases. However, PeopleSoft Cube Manager provides several important benefits when linking between your PeopleSoft application data and your OLAP platform.

PeopleSoft Cube Manager is a PeopleTool used to build Online Analytical Processing (OLAP) databases or cubes. It provides a framework for modeling your OLAP cubes through its design tools. This framework supports the definition of all dimensions, attributes, measures, and cubes that you might want to build from PeopleSoft sources. You can share all of these definitions across cubes to ensure that OLAP results are consistent across your enterprise.

You can also use components designed in PeopleSoft Cube Manager across all target OLAP platforms supported by PeopleSoft. PeopleSoft Cube Manager provides all these benefits while achieving a nearly platform-independent solution. You can apply the majority of a cube's design attributes to Hyperion Essbase, Cognos PowerPlay, or Generic Star Schema. PeopleSoft Cube Manager also lets you leverage your existing PeopleSoft metadata to define the cube structure.

Cube Manager Architecture

The following diagram illustrates the cube building process:

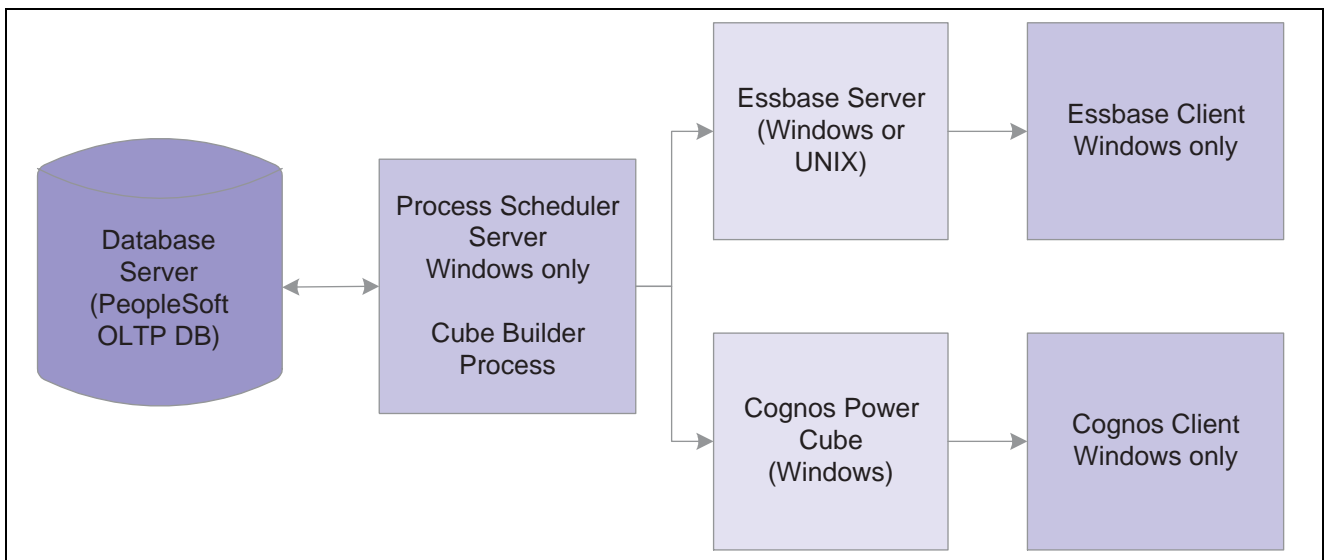

PeopleSoft Cube Manager: The big picture

The cube building process includes the following steps:

1. PeopleSoft Cube Manager extracts data from the PeopleSoft application (OLTP) database.
2. PeopleSoft Cube Manager writes to the OLAP data store.
3. A third-party reporting tool directly analyzes the OLAP data store.

PeopleSoft Metadata

Metadata is data that defines data. It conveys information about how data is formatted, structured, and stored. In an OLAP cube, metadata defines the cube's dimensions, levels, members, member attributes, and their interrelationships. PeopleSoft Cube Manager uses two types of PeopleSoft structures—trees and queries—to help define cubes.

PeopleSoft Trees

A PeopleSoft tree defines the summarization rules for a database field. It specifies, for purposes of reporting or security access, how the field values are grouped in the system.

For example, the values of the DEPTID field might identify individual departments in your organization. You could build a tree for the DEPTID field that defines the organizational hierarchy that specifies how each department relates to the others—that departments 10700 and 10800 report to the same manager, department 20200 is part of a different division, and so on.

It is easy to see how you can use PeopleSoft trees to define a cube structure. Like cube dimensions, trees consist of levels and members. (In PeopleSoft Tree Manager, members are called *nodes* and *leaves*.)

See *Enterprise PeopleTools 8.45 PeopleBook: PeopleSoft Tree Manager*.

PeopleSoft Queries

PeopleSoft queries are SQL statements created by PeopleSoft Query. You can use these SELECT statements to return field values based on certain criteria. The standard PeopleSoft security mechanism can secure the data returned by PeopleSoft Query. Also, PeopleSoft Query can return data in any of the database-supported globalized formats.

You can use queries in a number of ways to define an OLAP cube. Use them to define the rollup structure, although this process is not as straightforward as using a tree. You can also use queries to specify member attributes. For example, you can set an attribute that automatically flips the sign of member values (this approach is sometimes necessary for accounting purposes). Finally, you can use queries to populate OLAP cubes with data; the query results are the rows of data that fill the cube's cells..

See *Enterprise PeopleTools 8.45 PeopleBook: PeopleSoft Query*.

PeopleSoft Process Scheduler Integration

PeopleSoft Process Scheduler includes a process type definition specifically for use with PeopleSoft Cube Manager. This is the Cube Builder process type, and you invoke it whenever you launch the process to create a cube from the standard run control page. During this process, depending on the OLAP tool that you specify, the data and metadata are translated into a format understood by Essbase, PowerPlay, or another ROLAP tool that can read a star schema.

See Also

[Chapter 5, "Building Cubes," Defining a Cube Build Process Using Process Scheduler Manager, page 67](#)

Designing and Building OLAP Cubes

Identifying your requirements is the most important part of any analytical application. An analytical application always produces results, regardless of whether those results are meaningful. Identifying your requirements is essential to generating meaningful results.

You have to decide what aspects or processes of your business you want to capture. Some examples could be sales activity, claims processing, or marketing return on investment. You might want to analyze several unrelated aspects of your business. Do not try to make one cube for all of the aspects. Instead, treat each set of related information as a single cube.

Next, you must identify the measures that you use to quantify those results, such as sales amounts in dollars or units. This information is almost always numeric. Then, identify the criteria with which you want to view the data and the granularity of the data. These criteria form the dimensions. The most common dimensions are time, accounts, geography, products, and department.

See your Essbase, PowerPlay, or other third-party technology documentation.

Using Supported OLAP Tools

Each PeopleSoft customer has unique reporting and analysis needs. To address these needs, PeopleSoft provides support for various OLAP databases and tools such as Cognos PowerPlay and Hyperion Essbase.

If you have not chosen an OLAP platform, the following descriptions should help you decide which platform best suits your needs. This section discusses:

- PowerPlay.
- Essbase.

PowerPlay

PowerPlay includes a product called Transformer, which builds the portable data cube. This cube is easy to attach as a file to email.

PowerPlay includes two components: a database engine component (the PowerCube) and an end user component. This front-end component can be used not only for PowerPlay databases, but also for other OLAP databases, including Essbase.

There are several new components in PowerPlay 7.0 (Enterprise Server version) that work together to give you more functionality and to make PowerPlay cubes available to remote users. Only the pieces that PeopleSoft Cube Manager uses are described in this section. PeopleSoft Cube Manager has been modified to work with these new pieces.

This section discusses:

- Enterprise Server.
- PP Enterprise Server Administrator.
- PPAdmtool.
- PPAplications.
- How PeopleSoft Cube Manager uses the EP Server.

Enterprise Server

Enterprise Server (EP Server) is a Windows service that maintains cubes at a given location. Users from remote locations connect to this service and open the cubes in their choice of PowerPlay for Windows, PowerPlay for Excel, or PowerPlay for Web.

You can configure PeopleSoft Cube Manager to automatically register cubes with the EP Server. The EP Server needs a port number, server/machine name, user name, and password for registering a cube. However, PeopleSoft Cube Manager can only add cubes to the EP Server running locally, and only to the admin account. This means that users are required to only specify the port number and password for the admin account.

See *PowerPlay Enterprise Server documentation*.

Note. PeopleSoft Cube Manager and the EP Server must run on the same machine. When updating a cube, you should make sure that it is not being accessed by anyone prior to running PeopleSoft Cube Manager.

PP Enterprise Server Administrator

PP Enterprise Server Administrator is a Windows application that can talk to the EP Server, either locally or remotely, and can display the cubes that the EP Server is maintaining. Depending on the security privileges, you can add or remove cubes from the EP Server using this application. You can also change passwords from this application.

PPAdmtool

PPAdmtool is a command-line program that can talk to the EP Server. You can add or remove cubes from the EP Server using this program. To execute any commands using this program, you must specify the server/machine name, port number, and password.

The difference between the PP Enterprise Server Administrator and PPAdmtool is that PPAdmtool runs at the command prompt. The PP Enterprise Server Administrator is a Windows application that you must start before viewing or manipulating the cubes. You can use PPAdmtool from the prompt to connect to, view, add, or remove cubes, without performing the extra step of starting a program.

PPApplications

PPApplications are the actual Windows applications (PowerPlay for Windows, PowerPlay for Excel, or PowerPlay for Web) that can open the cube .mdc files. These applications need either direct access to the .mdc file (locally or on network) or access to the EP Server that is maintaining a particular cube.

How PeopleSoft Cube Manager Uses the EP Server

This example shows how PeopleSoft Cube Manager uses the new functionality of PowerPlay 6.6 to manage a cube that exists on the EP Server.

Step 1:

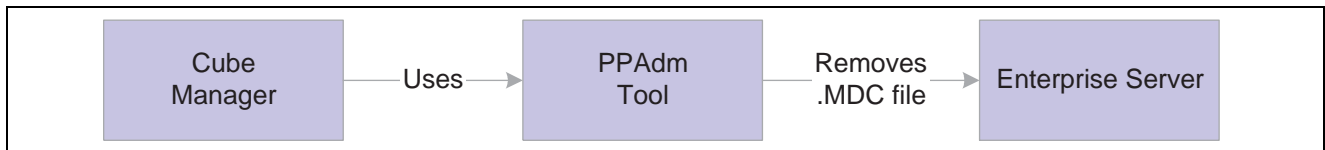

PPAdmtool removes the .mdc file from the EP server

Step 2:



PeopleSoft Cube Manager uses the transformer to create the .mdc file

Step 3:

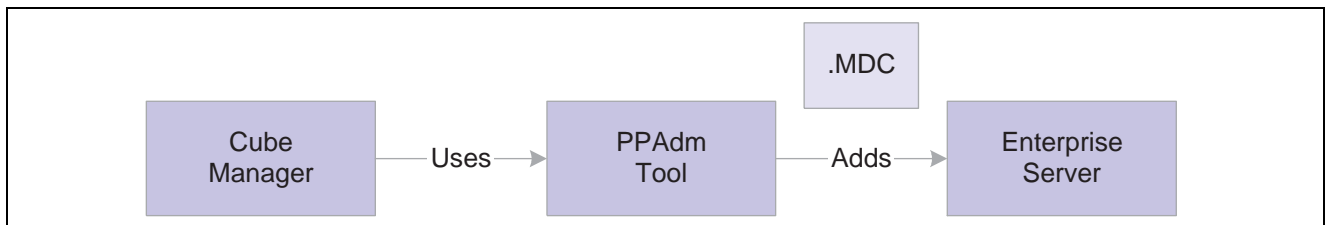

PeopleSoft Cube Manager uses PPAdmtool to add the .mdc file to the EP server

PeopleSoft Cube Manager’s Platform Options page for PowerPlay has been modified to take the extra information needed to talk to the EP Server.

See Also

[Chapter 5, “Building Cubes,” Defining Cube Settings for Cognos PowerPlay, page 57](#)

Essbase

Essbase is a robust, client/server-based product the scope of which goes well beyond individual users to the level of a data mart. While it has many powerful features, including its own scripting language, it might be somewhat more difficult to implement than PowerPlay. However, because it supports metadata updates, Essbase enables you to keep a persistent data store, whereas you must recreate PowerCubes whenever any metadata changes.

Essbase includes an add-in that lets you view OLAP cubes using Microsoft Excel—much like PS/nVision. Access Essbase cubes using PowerPlay as a front end. Essbase is shipped separately from PeopleTools (there are two licensing components for the integration and the end-user product).

CHAPTER 3

Designing Cube Metadata

There are several kinds of metadata that define an online analytical processing (OLAP) cube: dimensional metadata (hierarchy and members), member attribute metadata (consolidation method, sign flip, and label), and cube metadata (dimensions and measures). You use PeopleSoft Tree Manager and PeopleSoft Query to describe all of this metadata to PeopleSoft Cube Manager.

This chapter discusses how to:

- Use trees.
- Create queries.

See Also

Enterprise PeopleTools 8.45 PeopleBook: PeopleSoft Tree Manager, “Using PeopleSoft Tree Manager”

Enterprise PeopleTools 8.45 PeopleBook: PeopleSoft Query, “Creating and Running Simple Queries”

Using Trees

Metadata that exists in PeopleSoft trees can be particularly useful when designing cube dimensions. The main reason to use an existing tree is to leverage the rules associated with the outline that the tree represents. Because trees are used to validate information that is stored in the Online Transaction Processing (OLTP) database, all of that tree information is already related to the transactional data. Using effective-dated trees in a cube definition generates the automatic evolution of your data used for data analysis.

PeopleSoft Cube Manager leverages the information already stored in your PeopleSoft trees as outlines upon which to build each dimension. Using PeopleSoft Cube Manager’s Dimensions - Rollup Inputs Page, you map a tree to a dimension so that the rollup of the resulting cube dimension is the same as that of the specified tree.

By default, data is summarized exactly as the tree is defined. Each node and detail value becomes a member of the cube hierarchy for that dimension. The descriptions of the nodes and details become the labels, or aliases, of the members.

Note. What PeopleSoft call *levels* are called *generations* in Essbase.

You might want to use existing trees for your dimensions, or you might need to create new trees. If you have an existing tree that is close to, but not exactly what you want the dimension to look like, make a copy of the tree and modify the copy.

If the hierarchy that you want to use is a subset of an existing tree, you do not have to create a whole new tree. PeopleSoft Cube Manager enables you to use a subset of an existing tree by specifying a starting node (Top Node on the Dimensions - Rollup Inputs Page) and the number of levels below the top node of the tree to include in the hierarchy. You can use more than one tree belonging to the same business unit to define a single hierarchy.

In addition, if a tree does not provide the structure that you need for a dimension, you can add members, attributes, and levels by using one or more queries to provide the additional metadata.

Because you cannot have duplicate member names in a dimension, unless those members are shared, you cannot duplicate tree node names in your tree metadata. PeopleSoft Cube Manager treats uppercase and lowercase characters as distinct, so the names *ABC*, *Abc*, and *abc* are all considered unique member names. However, Essbase offers an option to change all member names to uppercase. If you enable this option, you create problems in PeopleSoft Cube Manager with members that are identical except for their letter casing.

Note. PeopleSoft Cube Manager permits duplicate node names, if you cannot avoid the duplication.

Cognos does not allow duplicate values at any level within the same hierarchy. Cognos wants the member values to be unique in the same hierarchy. Because of this, it drops duplicate values in the same hierarchy while generating the .mdl file is generated. Alternate hierarchies can have detail values (leaves) that appear in the other hierarchies. However, the non-detail values (non-leaf or node) cannot be the same as in any other hierarchy. Duplicate non-detail values cause Cognos to return an error when it is creating the cube.

In Essbase, a dimension could have multiple rollups. The resulting total for the first rollup is calculated differently than the resulting totals for those rollups calculated after the first rollup. For example, there is a dimension with two rollups. Two different trees are used for these two rollups. The first tree is set up as A-> B-> C, while the second tree is A-> D-> C.

Assume that A, B, C, D have the fact data values: 2, 5, 10, 20 (respectively). The total for the first rollup A, B, C is 17 because the total = 2 + 5 + 10. The total for the second rollup A, D, C is 10 because each parent gets its total from its children. Because C has the fact value 10, the total for C is 10. Because D is the parent of C, D gets its total from its children. Therefore, D gets 10 from C. A gets its total from its children, which is D. Therefore, A has the total value of 10.

See Also

[Chapter 4, “Designing Cubes,” Designing a Cube, page 30](#)

Creating Queries

This section provides an overview of query types and discusses:

- Dimension queries.
- Attribute queries.
- Data source queries.

Understanding Query Types

You can create several kinds of queries to use with PeopleSoft Cube Manager, all of which you must define as *user (ad hoc)* queries, as opposed to *role* queries, or *database agent* queries:

See [Chapter 3, “Designing Cube Metadata,” Dimension Queries, page 19](#).

See [Chapter 3, “Designing Cube Metadata,” Attribute Queries, page 24](#).

See [Chapter 3, “Designing Cube Metadata,” Data Source Queries, page 26](#).

Because you cannot have duplicate member names in a dimension, unless those members are shared (Essbase is the only platform that handles shared members), you cannot have duplicate query column names in your query metadata. PeopleSoft Cube Manager treats uppercase and lowercase characters as distinct, so the names *ABC*, *Abc*, and *abc* are all considered unique member names. However, Essbase offers an option to change all member names to uppercase. If you enable this option, you create problems with members that are identical except for their letter casing.

Note. PeopleSoft Cube Manager permits duplicate node names, if you cannot avoid the duplication.

Dimension Queries

Dimension queries enable you to define the dimension structure using query results instead of, or in addition to, a tree. However, keep in mind that you are using queries to create a tree-like structure. For narrow query definitions, each dimension query maps child members at a particular level to parent members at the next higher level. For wide query definitions, you only need one query to build the dimension. Optionally, these queries might contain extra members or level attributes, as well as the relationship information.

You can convey hierarchical information in one of two ways: by parent/child relationship (a narrow query) or by level specification (a wide query). This section discusses:

- Narrow query definition.
- Wide query definition.

Narrow Query Definition

When you use multiple queries to define dimensional structure, the first query you specify defines the first two levels of the dimension. To add lower levels, you must write one additional query for each additional level.

Suppose that you want to build a department dimension that contains the following departments within an organization:

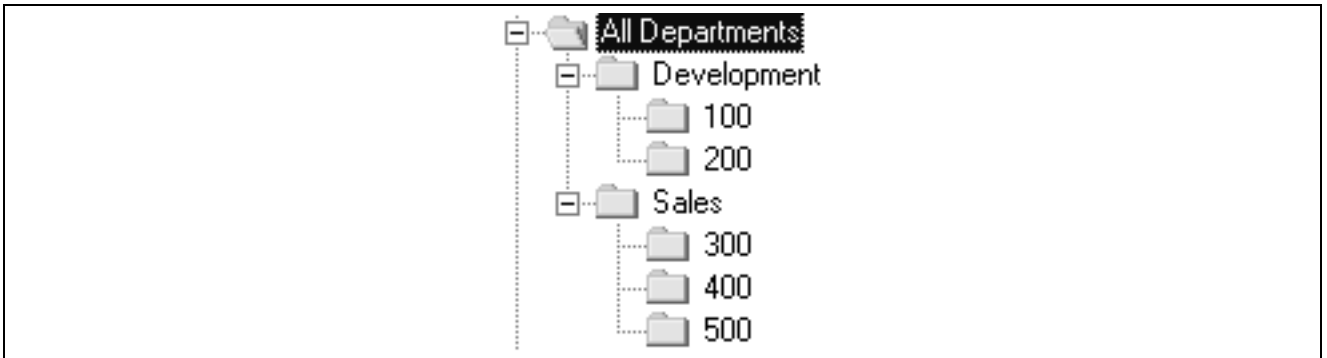

Example of departments within an organization

The levels of the organization might be described as follows:

Level 1 (top of dimension)	Level 2	Level 3
ALL DEPARTMENTS	DEVELOPMENT	100
		200

Level 1 (top of dimension)	Level 2	Level 3
	SALES	300
		400
		500

To create the dimension, you must write two queries to provide the preceding information: one to define the child members at level 2 and one to define the child members at level 3.

Query 1:

Parent	Member (Child)
ALL DEPARTMENTS	DEVELOPMENT
ALL DEPARTMENTS	SALES

Note. During the build, PeopleSoft Cube Manager knows that child members with an unspecified parent become level 2 members, directly under the top of the dimension. You can create an empty column in a query by adding a blank ("") expression. Be sure to enter some meaningful text for the Heading Text and Unique Field Name (such as "Top of Dimension") so that you can easily identify the blank column when mapping query columns to dimension levels.

Query 2:

Query 2 must return one column for the second-level members (DEVELOPMENT and SALES) and one column for the third-level members (100, 200, 300, 400, and 500). The query results look like this:

Parent	Member (Child)
DEVELOPMENT	100
DEVELOPMENT	200
SALES	300
SALES	400
SALES	500

To add additional levels, write one query for each additional level. Building on the previous example, assume that you want to create an employee dimension in addition to a department dimension. In this case, include a fourth level showing the employees in each department:

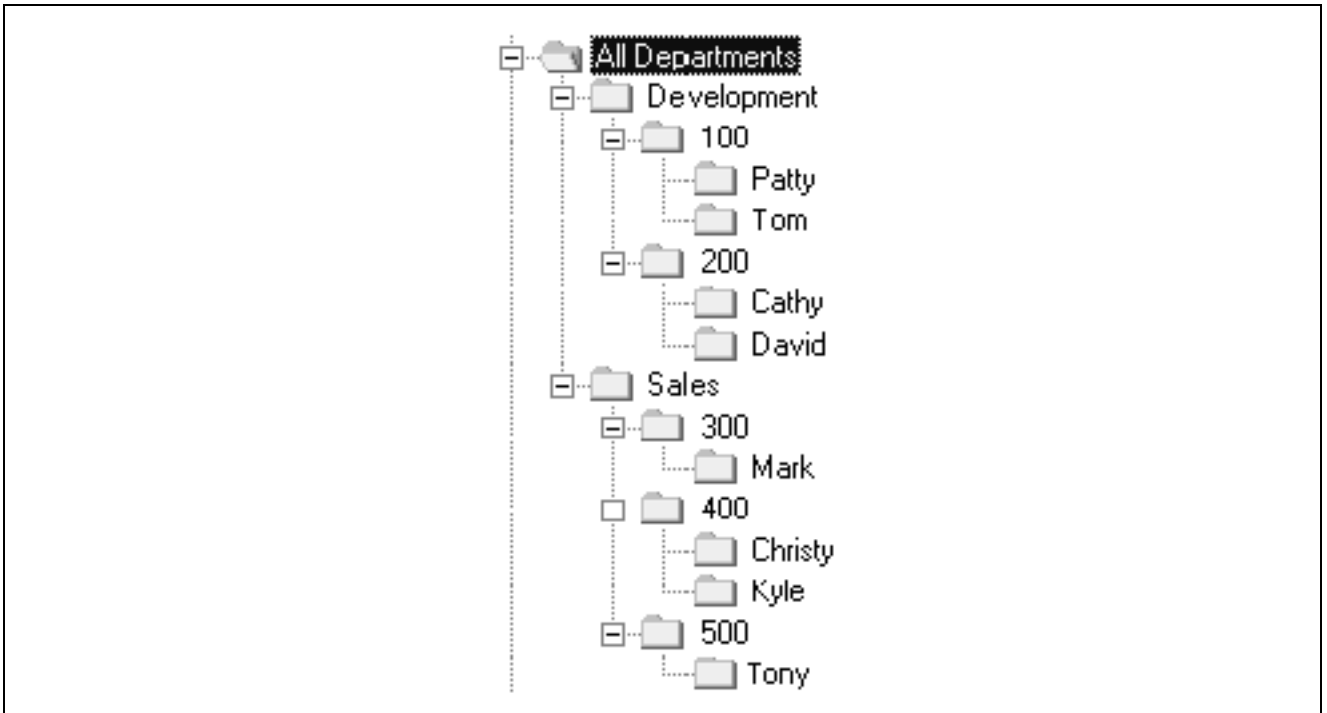

Example of employees within an organization

Now you might describe the levels of the organization as follows:

Level 1	Level 2	Level 3	Level 4
ALL DEPARTMENTS	DEVELOPMENT	100	Patty
			Tom
		200	Cathy
			David
	SALES	300	Mark
		400	Christy
			Kyle
		500	Tony

In addition to the two queries you create, you must create a third query with the following results in order to add the fourth level to the dimension:

Parent	Child
100	Patty
100	Tom
200	Cathy
200	David
300	Mark
400	Christy
400	Kyle
500	Tony

The following diagram illustrates how you supply three queries to create a dimension with four levels:

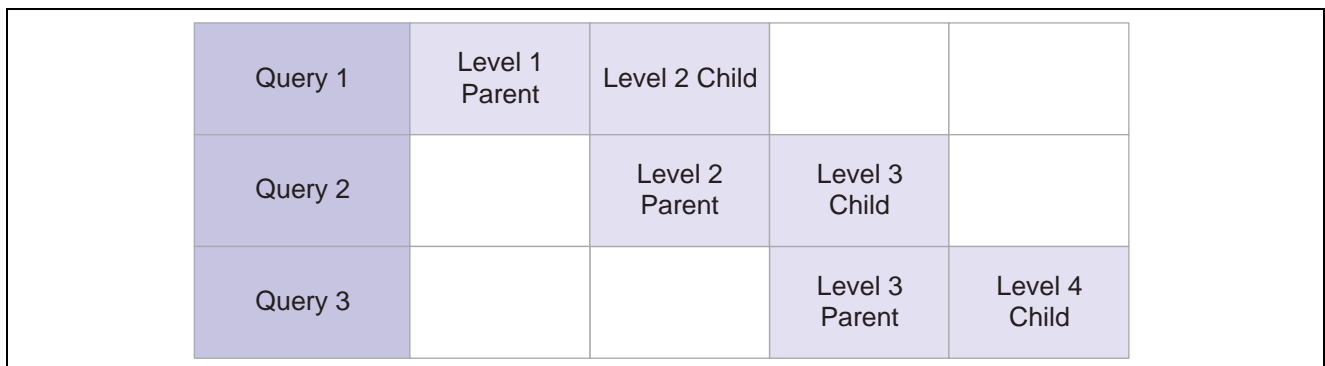

Four level dimension created using three queries

Your dimension queries should always produce at least two columns in the result set: one for the parent and one for the child (or member). Except for the top-level query, a parent column for a given level must always correspond to the child column of the previous level.

Optionally, you can include attributes in the query. All attributes that you specify in a narrow query are associated with the field specified as the member. You must add attributes for the topmost member using an attribute query.

Wide Query Definition

When defining your dimension with a wide query, follow the same logic used with narrow queries.

Using the previous example for narrow queries, the following table illustrates the dimension you want to build with a wide query:

Level 1	Level 2	Level 3	Level 4
ALL DEPARTMENTS	DEVELOPMENT	100	Patty
			Tom
		200	Cathy
			David
	SALES	300	Mark
		400	Christy
			Kyle
		500	Tony

Instead of writing multiple queries to build this dimension, write one that contains only this information. The query result set might look like the following:

Level 1	Level 2	Level 3	Level 4
ALL DEPARTMENTS	DEVELOPMENT	100	Patty
ALL DEPARTMENTS	DEVELOPMENT	100	Tom
ALL DEPARTMENTS	DEVELOPMENT	200	Cathy
ALL DEPARTMENTS	DEVELOPMENT	200	David
ALL DEPARTMENTS	SALES	300	Mark
ALL DEPARTMENTS	SALES	400	Christy
ALL DEPARTMENTS	SALES	400	Kyle
ALL DEPARTMENTS	SALES	500	Tony

As with narrow queries, the query can return attributes that you can associate with members. However, in the case of wide queries, you can assign the attributes to any member.

Attribute Queries

You can use attribute queries to set optional attributes on the members within a dimension. Set attributes on either node members or detail members of a dimension.

An attribute query should return at least two result columns: one that identifies the members whose attributes you want to define and one for each type of attribute to be set.

Member	Attribute 1	Attribute 2 (Optional)	Attribute 3 (Optional)
1000	XXX	XXX	
1100	XXX	XXX	XXX
1200	XXX		XXX
1300	XXX	XXX	

Most attribute types are platform-specific: they are used by one of the target platforms, but not all. Each attribute type uses its own set of conditions to determine whether to apply the attribute. In some cases, for the attribute to be applied, the attribute column must contain a specific value. In other cases, the attribute column must simply not be blank. An attribute query can return a subset of the members, in which case the specified attributes are set only on those members returned.

If an attribute query is on a table that uses a setID, you must select only the setID in which you're interested. The reasoning: There is only one member ID field to tie the query results to the dimension.

Note. In the preceding example, one query sets three attributes. If you prefer, you could create three separate queries in which you return the member and one attribute.

General Attributes

You can define numerous types of attributes using queries and PeopleSoft Cube Manager. We discuss the following valid attribute types:

- Flip sign.
Refers to the reversal of + and – signs for the member, which is sometimes necessary for accounting purposes. Valid values are blank (do not flip the sign) or nonblank (flip the sign). In a star schema, an attribute column is populated with a value of – 1 when a member has a sign to flip. In PowerPlay and Essbase, the data that is populated in a flip-signed cell has the opposite sign of the source query.
- Label.
Provides a description for a member. In an Essbase database, this equates to the default alias. In a PowerPlay PowerCube, it equates to the label. For star schemas, the label is a description of the member.
- User-defined.

Applies to Essbase only. Essbase enables you to specify user-defined attributes for members. You can then use calculation (calc) scripts to search for and manipulate members that have particular user-defined attribute values.

PeopleSoft Cube Manager supports user-defined attributes. To design your own user-defined attributes, select PeopleTools, Cube Manager, Attribute Definitions.

See [Chapter 4, “Designing Cubes,” Designing Attribute Names, page 46.](#)

Essbase Attributes

Essbase has the following valid attribute types:

- Currency category.

Applies to account-type dimensions. This attribute specifies a member that requires currency conversion to a specific category type. In the attribute query field, supply the type of conversion required (a value, normally in dollars).

- Currency conversion type.

Applies to account dimensions. This attribute equates to the Currency Conversion buttons on the Account tab of the Attributes dialog box for an account dimension in the Essbase Application Manager.

If the Currency Category attribute is set to a nonblank value on a member, that nonblank value is automatically applied to the Currency Conversion Type attribute. If the Currency Category attribute is set to blank, the Currency Conversion Type attribute is automatically set to inherit-use ancestor. If the Currency Category attribute is not applied at all, the Currency Conversion Type attribute is automatically applied with a value of no conversion ("").

If you set this attribute manually, valid values are blank (no conversion) or nonblank. If the query returns a nonblank value, that value is used as the Currency Category.

- Currency name.

Applies to country dimensions. The value of this attribute defines what type of currency the country or market region uses. This value identifies the type of currency in a currency cube.

- Data storage.

Tells Essbase what type of storage to allocate for the member. Valid values are 0/blank (store data), 1 (never share), 2 (label only), 3 (shared member), 4 (dynamic calculation and store), and 5 (dynamic calculation, no store). PeopleSoft Cube Manager sets the default value as store data for all members in the first rollup and the non-detail nodes of all other rollups. Detail nodes in secondary rollups are set to shared members.

- Expense item.

Expense item applies to account dimensions only. Essbase has certain built-in formulas that can take advantage of the knowledge that an item is an expense. To pass this knowledge on to Essbase, you should use this attribute. Valid values are *Blank* (set) and *non-Blank* (do not set).

- Time balance.

Affects how the parent time value is calculated. Valid values are 0, 1, 2, and 3, which correspond to none, first, last, and average, respectively.

- Unary operator.

Referred to as the consolidation attribute, this attribute enables you to define the mathematical operator used for rolling up members. Most often, you expect that data is added (using the + operator) when rolled up. However, you might occasionally need to specify other operators.

Valid Value	Action
+ (plus sign)	Add (default)
- (minus sign)	Subtract
* (asterisk)	Multiply
/ (forward slash)	Divide
Blank	Do not consolidate.
~ (tilde)	Do not consolidate.
% (percent sign)	Divide the total of previous member calculations by this member and multiply by 100.

PowerPlay Attributes

PowerPlay has the following valid attribute types:

- Long description.
Equates to any valid description in PowerPlay, meaning that it can contain unlimited text.
- Short label.
Equates to the short name. Valid values are any valid PowerPlay short name.

See Also

Essbase and PowerPlay Services documentation

Chapter 4, “Designing Cubes,” Defining Dimension Options , page 36

Data Source Queries

Data source queries define the data that you bring into the cube. Writing a data source query is straightforward: The query must return one column for each dimension and one column for each measure. Assume that you want to build a data source query for a cube containing amounts dimensioned by account, department, and period. The output of your query has four columns:

Account (Dimension)	Dept (Dimension)	Period (Dimension)	Amount (Measure)
XXX	XXX	XXX	XXX
XXX	XXX	XXX	XXX

You can use several queries as the data source for a single cube, thus defining multiple measures. Every data source query used must include an output column for every dimension used and for at least one measure. However, you are not required to provide an output column for every measure in every data source query.

The following example shows how you can use two separate queries as a data source for a cube. Note that both queries return columns for every dimension, as required, and that they differ only in which measure they include.

Results of Query 1:

Account (Dimension)	Dept (Dimension)	Period (Dimension)	Budget Amount (Measure 1)
1000	DEV	Q4 2003	4000
1100	SALES	Q4 2003	6000

Results of Query 2:

Account (Dimension)	Dept (Dimension)	Period (Dimension)	Actual Amount (Measure 2)
1000	DEV	Q4 2003	3000
1100	SALES	Q4 2003	5000

Resulting cube using Query 1 and Query 2 as data sources:

Account (Dimension)	Dept (Dimension)	Period (Dimension)	Budget Amount	Actualize Amount
1000	DEV	Q4 2003	4000	3000
1100	SALES	Q4 2003	6000	5000

CHAPTER 4

Designing Cubes

This chapter provides an overview of cube design and components and discusses how to:

- Design a cube.
- Design cube definitions.
- Design attribute names.

Understanding Cube Design and Components

Remember, before using PeopleSoft Cube Manager it is a good idea to define the specific goals and results that you expect from online data analysis. After defining your goals, you should design the PeopleSoft trees and queries that are appropriate for creating both the structure and the data of the cube that you plan to build. These trees and queries feed data from your PeopleSoft application to any cubes you create. After you establish your goals and create the necessary trees and queries upon which the resulting cube will be built, use PeopleSoft Cube Manager to begin designing a cube.

See [Chapter 3, “Designing Cube Metadata,” page 17](#).

Many different kinds of components make up the cubes you build with PeopleSoft Cube Manager.

Dimensions

The most basic component of a cube is a dimension. When you create a dimension, you specify the PeopleSoft metadata to be used to create the dimension’s rollup structure. PeopleSoft Cube Manager dimensions are platform-independent; you can reuse them again and again to build different cubes.

See [Chapter 2, “Introducing PeopleSoft Cube Manager,” Understanding Cubes, page 6](#).

Attributes

Dimension members may have various attributes associated with them. For example, if you have a product dimension, you might want to add color as an attribute of the actual product.

Level Attributes

Not Used.

Cube Definitions

A cube definition defines the basic structure of a cube. You select the dimensions and measures that make up the cube and the data source queries that populate the members and cube cells with data. Like dimensions, cube definitions are platform-independent and reusable.

Cube Instance Definitions

Cube instance definitions are platform-specific. In a cube instance definition, you specify the platform for which the cube will be built and

choose the cube definition on which the cube will be based. You then set various other options specific to the chosen platform.

Filters

You use filters on the cube instance definition to limit the contents of the cube being built. This lets you use a single cube definition when building different data marts. For example, you might define the rules for building a generic profitability cube, but give each region in your company a cube with its own information. Filters provide you with a mechanism for specifying the subset of the possible cube data to be contained in a specific cube.

Platform Options

Each of the online analytical processing (OLAP) target databases has an associated set of options with which PeopleSoft Cube Manager controls how the cube is built. These options can provide PeopleSoft Cube Manager with any required security information or how to allocate database space for dimensions in the cube.

Bookmarks

Bookmarks identify a set of facts in the cube. You use them to determine whether facts are being loaded for the first time or reloaded. PeopleSoft Cube Manager uses bookmarks to ensure that facts are not counted twice when they are reloaded into a cube.

Run Control IDs

When you have defined your dimensions, cube definition, and cube instance definition, you are ready to start the build process. PeopleSoft Process Scheduler runs this process and—as with all PeopleSoft Process Scheduler processes—you create a run control ID that defines the specifics of the process:

- Specify which cube instance definition you want to use to build the cube.
- Choose whether the build process is to create a new cube or update an existing one.
- Specify a post-build script to run on the cube.
- Define any query bind variables that you want to use to limit the data source queries during the build.

Cube Instance

A cube instance is the output of the PeopleSoft Cube Manager. It is a physical cube that is built by the Cube Builder process in PowerPlay or Essbase.

Designing a Cube

This section discusses how to:

- Define the dimensional structures of the cube.
- Define dimension options.
- Define rollup options.
- Specify the source of the metadata for each rollup.
- Map fields to a role in the rollup.

Pages Used to Design a Cube

Page Name	Object Name	Navigation	Usage
Dimension	DIMENSION	PeopleTools, Cube Manager, Dimensions, Dimension	Define the structure of each dimension. Define the PowerPlay time dimension.
Dimension Options	DIM_OPTIONS	Click the Dimension Options button on the Dimensions - Dimension Page. Click the Dimension Options button in the Dimensions - Rollup Inputs Page.	Name blank members of a hierarchy so that you can see them in your cube.
Rollup Options	DIM_ROLLUP_OPTIONS	Click the Rollup Options button on the Dimensions - Dimension Page. Click the Rollup Options button on the Dimensions - Rollup Inputs Page.	Name blank members of a hierarchy so that you can see them in your cube.
Dimensions - Rollup Inputs	DIM_ROLLUP_INPUTS	Dimensions, Dimension, Rollup Inputs	Define the source of the metadata for each rollup.
Dim Input Field	DIM_INPUT_FLD	Click the Field Map button on the Dimensions - Rollup Inputs Page.	Map the fields to a role in the rollup.

Defining the Dimensional Structures of the Cube

Access the Dimensions - Dimension page.

The screenshot shows the 'Rollup Inputs' configuration page for a dimension. At the top, there are two tabs: 'Dimension' and 'Rollup Inputs'. The 'Rollup Inputs' tab is active. Below the tabs, there are several fields and controls:

- Dimension ID:** DEPARTMENT
- Description:** DEPARTMENT
- *Dim Type:** Standard (dropdown menu)
- Dimension Options...** (link)
- Rollup Name:** DEPARTMENT 1
- Rollup Options...** (link) with '+' and '-' buttons.
- Rollup Levels:** A table with three levels:

*Level Name		
1	Division	+ -
2	Group	+ -
3	Department	+ -

At the bottom of the page, there are buttons for 'Save', 'Return to Search', 'Add', and 'Update/Display'. The breadcrumb 'Dimension | Rollup Inputs' is also visible.

Dimensions - Dimension page

Dimension ID

Identifies the dimension of the target OLAP database.

Note. You cannot rename or delete a dimension ID once you have saved it.

Description

Defaults to the dimension, but you can provide another description. This is used as the description of the dimension in the resulting cube.

Dimension Options

See [Chapter 4, “Designing Cubes,” Defining Dimension Options , page 36.](#)

Dim Type (dimension type)

Choose one of the following dimension types:

Standard: Select for every kind of dimension that does not contain account, time, currency, or country data. You can have many standard dimensions in each cube.

Account: Select if the dimension is based on account information. You can have only one account dimension for each cube.

Time: Select if the dimension is time-based. You can have only one time dimension for each cube.

Currency Partition: Valid only for Essbase. Select if the dimension is based on currency. You can have only one currency dimension for each cube.

Country: Valid only for Essbase. Select if the dimension is based on countries. You can have only one country dimension in each cube.

See your Essbase documentation.

Rollup Name

The default rollup name is based on the Dimension ID. You can change the rollup name, but the name cannot be identical to the Dimension ID.

The Rollup Name becomes the top node of the dimension if you specify more than one rollup in the dimension. If you have multiple rollups, rolling up to a single top node, this name is used only for the alternate rollups. A node is created for each rollup as a child of the dimension's top node.

Rollup Options

See [Chapter 4, “Designing Cubes,” Defining Rollup Options, page 37.](#)

Level Name

(Required) If you want to explicitly define level names in the rollup, specify them in the Rollup Levels group box. Level names defined in this manner override the level names that might be returned from the tree or any names that PeopleSoft Cube Manager creates as defaults. You are required to specify levels to be used in mapping wide queries or for defining aggregates.

When you enter multiple level names, Cube Manager assigns a level number to the declared level name in the order in which the level name is entered. This number also populates the Dim Input Field page.



Click the Add button to add a row for an additional level name.



Click the Remove button to remove a row, deleting that level name.

Designing a Dimension

The structure of a dimension is based on a PeopleSoft tree that you build, but dimensions can also be based on queries. You must create one dimension definition for each dimension of your cube.

Because dimensions are independent of cubes, you can use them in any number of cube definitions. Where possible (such as in star schemas), PeopleSoft Cube Manager creates dimensions that can be shared across conforming dimensions (unless the underlying data relies on different business units). This method ensures consistent results across different data marts.

To design a dimension:

1. Select PeopleTools, Cube Manager, Dimensions.
2. Click the Add a New Value tab.
3. Enter a value for Dimension/Measure/Attribute and click the Add button.

You must provide a unique name for each dimension that you define. The dimension ID uniquely identifies the dimension of the target OLAP database. After you enter a dimension ID, the Dimension page appears.

Warning! Once you create and save a dimension ID, you cannot rename or delete it. You can change the description, but you cannot remove the ID from the system.

4. Enter a Description and specify the Dim Type (dimension type).
5. Set additional parameters for the dimension by clicking the Dimension Options button.
The Dimension Options page appears.
6. Enter the desired dimension options and click OK.
7. Define the rollups for the dimension.

8. Define the level name or names.
9. Define additional rollup parameters by clicking the Rollup Options button.
The Rollup Options page appears.
10. Define the sources of the rollup structure and attributes by clicking the Rollup Inputs tab.
The Rollup Inputs page appears. The Rollups scroll area on the Dimension page determines which rollup appears on the Rollup Inputs page.

Defining PowerPlay Time Dimensions

For a PowerPlay time dimension, you do not need to set a tree or query as an input source. Instead, you must do the following:

- Identify the dimension as time.
- Define the levels.
- Set the corresponding date formats and date functions on the Dimension Page.
- Select the earliest date and latest date for the time dimension using the Cognos PowerPlay Options.

See [Chapter 5, “Building Cubes,” Defining Cube Settings for Cognos PowerPlay, page 57](#).

See your Cognos PowerPlay Transformer documentation.

If you are creating a time dimension specifically for another platform, you should build the dimension as you would any other dimension, ignoring the Date Function and Format columns on the Dimension Page. If you create a dimension that has both input source and the PowerPlay options, you can use it on any platform. PeopleSoft Cube Manager ignores the unnecessary information for the specific platform and uses only what is required on that platform.

To define a PowerPlay time dimension:

1. On the Dimension Page, specify *Time* as the Dim Type (dimension type).

This also sets the DimType in the .mdl file to *Date* when the cube is finally built, allowing the cube to use the PowerPlay date wizard.

Note. When building PowerPlay time dimensions, you are not required to complete the fields in the Dimensions - Rollup Inputs page or the Rollup Options page (Prefix/Suffix information for node and details). However, if you want to build a time definition for a platform-independent cube, you will still want to specify them. PeopleSoft Cube Manager ignores the input source while building a PowerPlay cube, even if you specify the source.

2. Identify each level name with a date function.

When you create a PowerPlay cube, the levels in the hierarchy must be identified by one of the following date functions. The cube build process ignores this information if the cube is intended for another platform.

Date Functions
None
Year

Date Functions
LunarYear
Quarter
LunarQuarter
Month
LunarMonth
LunarMonth445
LunarMonth454
LunarMonth544
Week
Day

Note. Do not mix lunar calendar and standard calendar in the Date Function column when setting levels. If you want to use both calendars, create two different time dimensions—one for the lunar calendar and one for the standard calendar.

- Identify each level name with a date format.

Specify the format in which you want to see a year, quarter, month, and so on. Select from the following available formats:

Format	Description	Comments
YY	two-digit year	01
YYYY	four-digit year	2001
Q	one-digit quarter indicator	1
MM	two-digit month	01
MMM	Abbreviated month name	Jan

Format	Description	Comments
MMMM	Full name of month	January
DD	two-digit day	01
DDDD	Day of week	Sunday
/, -, or space character	Separator characters	01/01/2001, 01-01-2001
Any quoted string	The quoted string	AD displays the abbreviation AD

4. Select the Earliest and Latest date options on the Cognos PowerPlay Options page.

These settings are optional. The default values are *1901-01-01* for the *Earliest Date* and *2100-12-31* for the *Latest Date*. The *Current Date* option is controlled by settings in Cognos. *As of Date* instructs the system to use the As of Date specified on the run control page.

5. Set up a fact query to return the lowest level of detail.

Defining Dimension Options

Access the Dimension Options page.

Not all data in the cube is associated with every dimension. For example, some data might be related to an account, but not to a product. In that case, the product dimension has blank members for that data. This means that there is an additional implied valid value of the product dimension that might not be on the product tree—blank (or No Product). You must provide a name to this blank member and make sure that it is on your dimension hierarchy because every valid member of a dimension must have a unique, nonblank name..

You can either add the unique, nonblank name to your tree or query and then specify it in the Dimension Options page, or just enter a name and let the Cube Builder add it to your dimension for you. Then, when the PeopleSoft Cube Manager is building the cube, it creates a new node directly off the top node of the dimension with the Blank Member name you specify. All blank members are grouped under this node name for this dimension. However, the blank member’s name does not accumulate cube data into a single-dimension member.

Blank Member

The default name is based on the dimension name. Enter a name for each dimension that might have data that is not already associated with a named hierarchy.

The default value is a name based on the dimension name you create. Change it if necessary. However, keep in mind that different dimensions within in a single cube must have unique names for blank members. Thus, if a cube has a Department dimension and a Product dimension, and both of these dimensions have blank members, the blank member names must be different, as in [No DEPARTMENT] and [No PRODUCT].

Of course, some dimensions, such as the Time dimension, may not have blank members. If you’re sure that a dimension falls into this category, you can delete the default Blank Member value and leave the field blank. If you do this and a blank member is found in the dimension, it is excluded from the dimension.

Note. Your blank member name can match a node/detail value elsewhere in the cube structure. This enables you to insert blank members at a level other than directly below the current dimension.

Label Prefix/Suffix

(Required) The default value is *None*.

Both Essbase and PowerPlay require unique member names and labels. You can apply a unique prefix or suffix to each member label to fulfill this requirement. To do so, select either *Prefix* or *Suffix* from the Label Prefix/Suffix drop-down list. To bypass this option, select *None*.

Defining Rollup Options

Access the Rollup Options page.

Type

In the Node Prefix/Suffix group box, set prefix/suffix preferences at the node level. You can choose between *Prefix*, *Suffix*, or *None*. The prefix or suffix you specify is applied to all members in the rollup, except the lowest level members, providing a convenient mechanism for ensuring that all node members have unique names between rollups.

In the Detail Prefix/Suffix group box, set prefix/suffix preferences at the detail level. As with nodes, choose *Prefix*, *Suffix*, or *None*. This value is valid only in the first rollup of the dimension.

Style

Choose to give your prefix or suffix no style, a custom style, or a dimension or level name. If you choose *Dimension* or *Level*, the text is either the name of the dimension in the Description field on the Dimension page, or the Level Name that you specified in the Rollup Levels section on the Dimension page.

Text

Enter the text to be used for the prefix or suffix, if applicable. This field is only editable if you have given your prefix or suffix a custom style.

Specifying the Source of the Metadata for Each Rollup

Access the Dimensions - Rollup Inputs page.

Dimension
Rollup Inputs

Dimension ID: DEPARTMENT

Description: DEPARTMENT

Dim Type: Standard

[Dimension Options...](#)

Rollup
View All
First
1 of 1
Last

Rollup Name: DEPARTMENT 1

[Rollup Options...](#)
+
-

Inputs
View All
First
1 of 1
Last

#	Src Type	Input Name	Top Node	Levels From Top	Field Map	Mapped		
1	Query	OLAP_DEPT_DIM_QRY <input type="text" value=""/>			Field Map	<input checked="" type="checkbox"/>	+	-

Save
 Return to Search
 Add
 Update/Display

[Dimension](#) | [Rollup Inputs](#)

Dimensions - Rollup Inputs page

Src Type (source type)

(Required) Select from one of the following options:

Calendar: This option is not yet implemented, but will enable you to use PeopleSoft Calendar.

Level Attr (level attribute): Not used.

Query: Specify how the hierarchical relationships, as well as member attributes, are defined.

Security: Not used.

Tree: Specify how the hierarchical relationships, as well as member attributes, are defined.

Note. PeopleSoft Cube Manager currently supports only trees keyed by setID or no additional key. For example, PeopleSoft Cube Manager does not support Business Unit (BU) or User Defined Node Key (UKV) trees.

Input Name

Enter the name of the tree or query to be used to define the dimension



Click the Lookup Input Name button to search for existing input names.

Top Node

Prepopulated with the top node from the tree based on the input name selected.



Click the Lookup Top Node button to search for the existing top node.

Levels From Top

Specify the level number from the Top Node (including the top node) to the *stop level* that corresponds to the lowest level of the tree to be included in the rollup. See the example in this section.



Click the Lookup Levels From Top button to search for existing levels from the top node.

Field Map

Available only when the source type is a query.

See [Chapter 4, “Designing Cubes,” Mapping Fields to a Role in the Rollup, page 40.](#)

Mapped

This check box is selected when the input name is mapped; if the field is not mapped, the box is clear. Map the field using the Field Map link.



Click the Add button to add a row to input an additional input name.



Click the Remove button to remove a row, deleting the input name.

Defining “Levels From Top” Example:

Use the following example for calculating the number of Levels from Top:

Definition	Description
Source Input:	QE_PERS_DATA tree
Top Node:	10100 Office of President
Top Node Level:	Company
Stop Level:	Department

10100 - Office of the President Level:COMPANY

Top Node Level

The Stop Level is *Department*, so the Levels From Top value is calculated by counting the number of levels from Company (1) to Department. Using the following list of levels, the Levels From Top value equals three.

Level Name	All Values	Description
CORPORATE	<input checked="" type="checkbox"/>	CORPORATE
COMPANY	<input type="checkbox"/>	COMPANY
DIVISION	<input type="checkbox"/>	DIVISION
DEPARTMENT	<input type="checkbox"/>	DEPARTMENT
BRANCH	<input type="checkbox"/>	BRANCH

Example of organization levels for calculating Levels from Top

Adding Rollup Inputs

Once you have defined the high-level dimensional metadata (identifying the dimension name, defining the number of different rollups, defining prefix and suffix options, and so on), the next step is to define the source of each rollup's metadata.

If there are multiple rollups for an Essbase dimension, only the total from the first rollup for the dimension is aggregated to the dimension total.

Note. Rollup-level names that you enter on the Rollup Inputs page appear in an Essbase cube only if the cube contains a dimension with a multiple rollup. Rollup-level names are always used in PowerPlay.

To add rollup inputs:

1. Click the Rollup Inputs page, or select PeopleTools, Cube Manager, Dimensions, Rollup Inputs.
The Dimension - Rollup Inputs page appears. On this page, define cube inputs, such as queries or trees, and their associated field mappings.
2. In the Src Type field, select the source input.
3. In the Input Name field, click the Lookup button to display and choose from the valid values.
4. If you selected *Tree* as the source type, specify a value for Top Node by clicking the Lookup button and specifying a valid value.
5. If you selected *Tree* as the source type, select a value for Levels from Top by clicking the Lookup button and selecting from the list.
6. If the source type is query, define how each field in the result set is used in the rollup.

Mapping Fields to a Role in the Rollup

Access the Dim Input Field page.

Dim Input Field

Dimension ID: DEPARTMENT

Descr: DEPARTMENT 1

Input Name: OLAP_DEPT_DIM_QRY

Input Field Map View All First 1-3 of 3 Last

#	*Query Fld Name	*	*Role	Level Name	Seq	Attribute
1	Company	Q	Parent			+ -
2	Department ID	Q	Member			+ -
3	Department ID	Q	Attribute			Flip Sign + -

Dim Input Field page

Query Fld Name (query field name)

Value is based on the query's column names.

Role

Choose from the following options:

Attribute: If you select *Attribute*, you must also select the Attribute Name.

Class ID: Not implemented.

Member: If all sources are members, select the level name.

Parent: If a parent exists, no level names or numbers can be selected. The parent is the top of the dimension, and the member is the child of the parent.

Level Name

Click in the field to display a list of valid level names, and select one of the names specified on the Dimension Page. This field is available only if all roles are set to *Member*.

Seq

Automatically assigned to the level name when the level name is declared on the Dimension Page.

Attribute Name

This field is available only if the Role field is set to *Attribute*.

Add to or change the values available in the drop-down list box on the Attribute Names - Attribute Name page.

Mapping Fields to a Role

Now that you have created the high-level rollup information, you must map each of the fields in the query-based rollup inputs to a role.

To add Dim Input Field (dimension input field) maps:

1. Click the Field Map button on the Dimension - Rollup Inputs page to define the fields you want to map from the input to the cube.
The Dim Input Field page appears with the source query fields already completed.
2. In the Input Field Map group box, specify the fields, roles, levels, and attributes of the cube dimension.

Note. Use unique attribute names when configuring a dimension with multiple attributes. If you duplicate a name, PeopleSoft Cube Manager only populates the first instance.

3. Click the OK button to save your changes, or the Cancel button to exit the page without saving changes.

Designing Cube Definitions

This section discusses how to:

- Map data sources to dimensions and select dimensions for the cube.
- Add cube inputs to a cube definition.
- Map source query fields to cube components.

Pages Used to Design Cube Definitions

Page Name	Object Name	Navigation	Usage
Cube Definitions - Cube Definition	CUBE_DEF	PeopleTools, Cube Manager, Cube Definitions, Cube Definition	Map data sources to any dimension you have defined using the Dimension page, and select which dimensions are used in the cube.
Cube Definitions - Cube Inputs	CUBE_DEF_INPUTS	Cube Manager, Cube Definitions, Cube Definition, Cube Inputs	Add cube inputs to your cube definition.
Cube Input Field	CUBE_INPUT_FLD	Click the Field Map button on the Cube Definitions - Cube Inputs page.	Map the fields of the source query to the appropriate cube components in order to associate the data from the source query to a dimension. The cube inputs are the source values for the facts to be created in the OLAP database.

Mapping Data Sources to Dimensions and Selecting Dimensions for the Cube

Access the Cube Definitions - Cube Definition page.

Cube Definition
Cube Inputs

Cube Def ID: EMPLOYMENT

Description:

Long Description:

Components View All First 1-4 of 4 Last

*Role	*Dimension/Measure/Attribute	Dim Type	Status
1 Dimension	DEPARTMENT	Standard	Mapped
2 Dimension	EMPL_STATUS	Standard	Mapped
3 Measure	HEADCOUNT		Mapped
4 Dimension	JOBCODE	Standard	Mapped

Save
Return to Search
Add
Update/Display

Cube Definition | [Cube Inputs](#)

Cube Definitions - Cube Definition page

Description

Enter the description that you want to associate with the cube. The description is not transferred to the resulting cube definition; it is used for prompting within PeopleSoft Cube Manager only.

Long Description

Enter the long description you want to associate with the cube. This description is not transferred to the resulting cube definition; it is used for prompting within PeopleSoft Cube Manager only.

Role

(Required) Select from the following options:

Cube Attribute: Select this option if the component is an attribute. A cube attribute is a field that can be included in the fact table for external processing. The Bookmark field on the fact table is an example of a cube attribute. You cannot use this bookmark in analysis, but PeopleSoft Cube Manager uses it to manage facts.

Dimension: Select this option if the component is a dimension.

Measure: Select this option if the component is a measure or fact.

Dimension/Measure/Attribute Specify the dimension, measure, or attribute that you want to associate with the cube.



Click the Open button to display the Cube Input Field page. This button is available only if you selected *Dimension* in the Dimension/Measure/Attribute field.

Dim Type (dimension type) This field is read-only. If you selected Dimension in the Dimension/Measure/Attribute field, Cube Manager displays the value you entered for Dim Type on the Dimension page.

Status This field is read-only. The value Cube Manager displays is based on the information you entered on the Dim Input Field page.



Click the Add button to add an additional component.



Click the Remove button to remove a row, deleting the component.

Designing a Cube Definition

After creating data source queries and defining the dimensions, you must define a cube definition by mapping fields from the data source queries to the dimensions you have defined. For each dimension, you must specify which field in the data source query is the source field for the dimension. You must define the dimensions, measures, and attributes that PeopleSoft Cube Manager uses to pull data into the cube you are defining. Once you define a component, its dimension and rollup types appear, as well as the mapped status.

To design a cube definition:

1. Select PeopleTools, Cube Manager, Cube Definitions.
2. Click the Add a New Value tab.
3. Enter a cube definition ID, and click the Add button.
Provide a unique name for each cube definition that you define. After you enter a cube definition ID, the Cube Definition page appears.
4. Enter a description and a long description for the cube definition.
5. Under Components, define the Role of the cube definition—whether Cube Attribute, Dimension, or Measure.
6. Specify a dimension, measure, or attribute to be used in the cube.

Because you can reuse the same dimension for various cubes, you have the opportunity to rename dimensions for use with this particular cube definition. By default, the label you enter here corresponds to the name of the dimension you have specified and is used as the dimension's alias/label in the resulting cube. You might want to put the word *ALL* in front of the dimension name—*ALL PRODUCTS*, *ALL REGIONS*, and so on.

The number to the left of the Role column determines the order in which the dimensions and measures appear to the user in the OLAP tool. When you add dimensions and measures, this number increments automatically.

7. Click the Add button to add additional dimensions/measures.
For each additional dimension or measure, repeat the previous two steps.
8. Click the Save button to save your cube definition and all of the components you have added.

It is important to save your new cube definition at this stage so that you can effectively add cube inputs.

Adding Cube Inputs to a Cube Definition

Access the Cube Definitions - Cube Inputs page.

Cube Definition
Cube Inputs

Cube Def ID: EMPLOYMENT

Description: Headcount of each department.

Long Description:

Inputs View All First ◀ 1 of 1 ▶ Last

*Input Name	Field Map	Mapped
1 <input style="border: 1px solid gray;" type="text" value="OLAP_EMP_DATA_QRY"/>	<input type="button" value="Field Map"/>	<input checked="" type="checkbox"/> <input type="button" value="+"/> <input type="button" value="-"/>

Cube Definition
Cube Inputs

Cube Definition - Cube Inputs page

Input Name Add the name of inputs by selecting from the list of valid values. Click the Add button to insert new rows for additional input names.

Specify as many input sources as you like; however, you must completely map all of them in order to save the cube definition.

Field Map Click to view how each field in the fact source data is mapped to a dimension.

Mapping Source Query Fields to Cube Components

Access the Cube Input Field page.

Cube Input Field



Cube Def ID: EMPLOYMENT

Description: Headcount of each department.

Input Name: OLAP_EMP_DATA_QRY

Input Field Map		View All	First ◀	1-4 of 4	▶ Last
	*Query Fld Name	Dimension/Measure/Attribute	Role		
1	Department ID <input type="text"/>	DEPARTMENT <input type="text"/>	Dimension	<input type="button" value="+"/>	<input type="button" value="-"/>
2	HeadCount <input type="text"/>	HEADCOUNT <input type="text"/>	Measure	<input type="button" value="+"/>	<input type="button" value="-"/>
3	Job Code <input type="text"/>	JOBCODE <input type="text"/>	Dimension	<input type="button" value="+"/>	<input type="button" value="-"/>
4	Status <input type="text"/>	EMPL_STATUS <input type="text"/>	Dimension	<input type="button" value="+"/>	<input type="button" value="-"/>

Cube Input Field page

- Query Fld Name** This field is populated from the Cube Definitions - Cube Inputs page.
- Dimension /Measure /Attribute** Specify the dimension, measure, or attribute to which you want to map the corresponding source field.
- Role** Indicates whether a field has been mapped to a dimension, measure, or attribute.
-  Click the Add button to add rows.
-  Click the Remove button to remove a row.
- OK** Click to save your changes. The system automatically selects the Mapped check box on the Cube Inputs page. This enables you to come back in the future and easily see whether fields have been mapped for this cube input.
- Cancel** Click to cancel the page without saving your changes.

Designing Attribute Names

You can specify member attributes yourself by using the Attribute Name page. This feature enables you to specify user-defined attributes for members. Users can also set these attributes in Essbase and Star Schema platforms. You can then use calculation scripts to search for and manipulate members with particular user-defined attribute values. PeopleSoft Workbenches uses calculation scripts extensively.

See Also

Chapter 3, “Designing Cube Metadata,” Attribute Queries, page 24

Page Used to Design Attribute Names

Page Name	Object Name	Navigation	Usage
Attribute Definitions - Attribute Name	OLAP_ATTRIB_NAM	PeopleTools, Cube Manager, Attribute Definitions, Attribute Names	Specify user-defined attributes for members.

Specifying User-Defined Attributes

Access the Attribute Definitions - Attribute Name page.

Attribute Name

View All First 1-9 of 18 Last

Attribute Number	Attribute Name	Created By	
10	Label	System	+ -
11	Short Label	System	+ -
12	Alias	System	+ -
13	Long Description	System	+ -
14	Flip Sign	System	+ -
15	Unary	System	+ -
16	Time Balance	System	+ -
17	Expense Item	System	+ -
18	Shared	System	+ -

Save

Attribute Definitions - Attribute Name page

Attribute Number

If you are dealing with large numbers of attributes, this field helps you group the attributes into more manageable categories. For example, you might want to list human resource attributes in the 100-300 range, and finance attributes in the 400-600 range. The attribute number is not used anywhere else in the system.

Attribute Name

Enter a descriptive name for the attribute.



Click the Add button to add an additional attribute name.



Click the Remove button to remove a row, deleting the attribute.

CHAPTER 5

Building Cubes

This chapter provides an overview of cube instance definitions and discusses how to:

- Build cube instances.
- Build cubes.

Understanding Cube Instance Definitions

PeopleSoft Cube Manager provides a powerful template feature that lets you set up cube instance definitions for use and reuse when building and updating cubes. Having a cube instance definition simplifies your work in managing updates to the cube structure, loading and reloading data, and setting platform-specific options when you create the cube. Without the benefit of PeopleSoft Cube Manager—and the Cube Instance Definition feature in particular—building or updating a cube would require tedious and error-prone steps.

Each cube instance definition is associated with a single physical cube. You typically have one cube instance definition for each cube. At times you might find it useful to have more than one. For example, you might have one cube instance definition for PowerPlay and one for Essbase.

Up to this point, everything that you have done in creating a cube is more or less generic, and does not require you to specify the platform (PowerPlay, Essbase, or Star Schema) that you will ultimately use. Thus, if you decide to switch platforms, the majority of your cube design remains unchanged. When building the cube instance definition, however, you must designate the specific platform for which you are creating the cube.

Building Cube Instances

This section discusses how to:

- Define cube settings and select dimensions, measures, and attributes.
- Create the cube filter.
- Define cube settings for Essbase.
- Define cube settings for Cognos PowerPlay.
- Identify field and record objects.

Note. The definition of a cube instance creates the link between the platform-independent definition of the cube and the actual physical storage mechanism of the cube. In essence, you tell PeopleSoft Cube Manager where to create the cube that you have defined.

Pages Used to Build Cube Instances

Page Name	Object Name	Navigation	Usage
Cube Instances - Cube Inst Def (Cube Instance Definition)	ANALYSIS_DB	PeopleTools, Cube Manager, Cube Instances, Cube Inst Def	Define cube settings (such as platform), and select dimensions, measures, and attributes to be included as cube instance definition components.
Cube Filter Criteria	CUBE_FILTER	Click the Updt Filter (update filter) button on the Cube Inst Def page: Filter tab.	Create the cube filter for use on the Filters tab in Cube Instances - Cube Inst Def page : Filter tab.
Essbase Advanced Options	ANALYSIS_DB_ESS	With Hyperion Essbase as the selected platform, click the Platform Options button on the Cube Inst Def page.	Define cube settings specifically for Essbase.
PowerPlay Options	ANALYSIS_DB_PPL	With Cognos PowerPlay as the selected platform, click the Platform Options button on the Cube Inst Def page.	Define cube settings specifically for PowerPlay.
Star Schema Options	ANALYSIS_DB_SS	With Generic Star Schema as the selected platform, click the Platform Options button on the Cube Inst Def page.	Identify the field and record objects generated by PeopleSoft Cube Manager.
Cube Instances - Aggregates	CUBE_AGGREGATE	Cube Manager, Cube Instances, Cube Inst Def, Aggregates	Page has not been implemented.

Defining Cube Settings and Selecting Dimensions, Measures, and Attributes

Access the Cube Instances - Cube Inst Def page.

Cube Inst Def
Aggregates

Cube Instance ID: HEADCOUNT

Description:

Long Description:

Platform

*Platform: ▼

Platform Options

Based On

Cube Definition Cube Instance

🔍 📄

Included Components
First ◀ 1-4 of 4 ▶ Last

Dimension
Filter

	*Dimension ID	Role	Dim Type	Status	*Sparsity		
4	<input type="text" value="HEAD COUNT"/> 🔍	Measure		Mapped	Default	+	-
1	<input type="text" value="DEPTTREE"/> 🔍	Dimension	Standard	Mapped	Dense	+	-
2	<input type="text" value="JOB CODE"/> 🔍	Dimension	Standard	Mapped	Dense	+	-
3	<input type="text" value="EMPL_STATUS"/> 🔍	Dimension	Standard	Mapped	Sparse	+	-

📄 Save
🔍 Return to Search
➕ Add
🔄 Update/Display

Cube Inst Def | [Aggregates](#)

Cube Instances - Cube Inst Def page: Dimension tab

Common Page Information

Cube Instance ID	Generic name to identify the cube instance.
Description	Used for prompting within PeopleSoft Cube Manager only. This description is not passed along to the resulting cube.
Long Description	Used for prompting within PeopleSoft Cube Manager only. This description is not passed along to the resulting cube.
Platform	Select one of the following: Hyperion Essbase, Cognos PowerPlay, or Generic Star Schema.
Platform Options	See Chapter 5, “Building Cubes,” Defining Cube Settings for Essbase, page 54. See Chapter 5, “Building Cubes,” Defining Cube Settings for Cognos PowerPlay, page 57.
Based On	<p><i>Cube Definition:</i> Refers to the cube definition ID you specified when designing your cube definition.</p> <p><i>Cube Instance:</i> Refers to a physical star schema that was created based on a particular cube definition. Once again, the value is the cube definition ID</p>

used to create the actual star schema. You can use this schema to create smaller data marts based on a previously created star schema.





Click the Open button to open the selected Cube Definition.

Dimension Tab

See the previous exhibit for a view of this tab.

Dimension ID	Name of the dimension or measure to include in the cube.
Role	Defines the role of the dimension, measure, or attribute.
Dim Type (dimension type)	The dimension type is specified on the Dimensions - Dimension page. See Chapter 4, “Designing Cubes,” Defining the Dimensional Structures of the Cube , page 31.
Status	Lets you check that your dimension has been mapped. If not, you must map it before you can use the dimension in a cube.
Sparsity	Specific to Essbase and refers to the Essbase option page. See Chapter 5, “Building Cubes,” Defining Cube Settings for Essbase, page 54.

Filter Tab

Updt Filter (update filter)	Click to create the cube filter criteria.
Filter	Indicates whether a filter has been created for this dimension.
Label	How the dimensions label appears in the results.
	Click the Add button to add an additional level name.
	Click the Remove button to remove a row, deleting the level name.

Creating the Cube Filter

Access the Cube Filter Criteria page.

Cube Filter Criteria

Cube Inst ID: EMPLOYMENT
Description: Department Headcount
Dimension ID: DEPARTMENT

Member List		View All	First	1 of 1	Last
	*Member Value				
1	<input type="text"/>			<input type="button" value="+"/>	<input type="button" value="-"/>

Cube Filter Criteria page

Member Value

Enter the value for the criteria. If your source dimension has more information than you want to report, you can create a filter to eliminate selected information. For example, if you have data from the U.S., U.K., and Japan, but want to view only the Japan data, create a Japan filter to eliminate the U.S. and U.K. data from the cube dimension.

To build a cube instance definition:

1. Design your cube definition.
2. Select PeopleTools, Cube Manager, Cube Instances, Cube Inst Def.
3. Click the Add a New Value tab.
4. Enter a Cube Instance ID and click the Add button to define the cube platform and included components.

You must provide a unique name for each cube instance definition you define. After you enter a cube instance ID, the Cube Inst Def page appears.

5. Enter a Description and Long Description.
6. Specify the platform.
7. Specify the criteria for this cube instance definition: either a cube definition or an existing star-schema-based cube instance.
8. Remove any dimensions or measures that you do not want created in this cube instance.

By default, PeopleSoft Cube Manager adds all of the dimensions and measures to the cube instance definition. However, if you do not need them all, you can remove any unwanted dimensions or measures by clicking the Remove (-) button to the right of the dimension name.

9. Click the Platform Options button to display platform-specific options based on which platform you selected from the drop-down list.

What page you see depends on which platform you chose. Platform options are as follows:

- Cognos PowerPlay.

See [Chapter 5, “Building Cubes,” Defining Cube Settings for Cognos PowerPlay, page 57.](#)

- Generic Star Schema.

See [Chapter 5, “Building Cubes,” Adding a Prefix to Field and Record Objects, page 60.](#)

- Hyperion Essbase.

See [Chapter 5, “Building Cubes,” Defining Cube Settings for Essbase, page 54.](#)

Defining Cube Settings for Essbase

Access the Essbase Advanced Options page.

Essbase Advanced Options page

- Server** Enter your server name.
- Application** (Required) Enter the application name. In Essbase, an application is a group of one or more databases.
- Database** (Required) Enter the database name. In Essbase, a database is, essentially, an online analytical process (OLAP) cube.
- User Access** (Required) Set the access to *Calculate*, *Design*, *Read-Only*, *Read-Write*, or *None*. This setting sets the default user security on the resulting cube, if

explicit security has not been granted in Essbase. It applies to everyone but the system administrator (to whom the User Name and Password options apply). You will typically set at least *Read-Only* access.

User Name

Enter your user name.

Password

Enter your password. Note that it should be same as the password that you use to set up Essbase server.

Meta-Data Update Action

(Required) Enables you to specify the update action that should occur in Essbase when a cube structure has been redesigned in PeopleSoft Cube Manager. Options are as follows:

Replace All: Refreshes the cube's structure. Any members defined in PeopleSoft that don't exist in the cube are added to the cube. Any members in the cube that are no longer defined in PeopleSoft are deleted from the cube, and any associated data is lost. Members moved in PeopleSoft—from one node to another, for example—are moved in the cube with any associated data preserved.

Incremental Update: Merges the metadata defined in your cube definition with the existing metadata of the cube. No members are deleted.

Data Update Action

(Required) Enables you to specify the update action that should occur in Essbase when a cube's data has been changed within a PeopleSoft application. You have three choices:

Delete Upper Level Data: Deletes all aggregate data.

Delete Non-Input Data: Deletes any data that has not been loaded into a cube by the build process—for example, data that you have entered manually in Essbase or data that results from a calculation in Essbase.

Incremental Update: Preserves existing data and enables you to add new data to the existing data for both multiple hierarchy and single hierarchy dimensions.

Note. Both the Meta-Data Update Action and Data Update Action fields refer to the metadata and data action options on the Build Cube page and apply only to updating existing cubes.

Rate Cube Action

If the cube definition contains the appropriate dimensions (account, time, and country), you can create a rate cube. This setting enables you to specify the following rate cube creation options:

Create All: Regenerates the currency cube definition from the cube defined in PeopleSoft Cube Manager. Then it populates the resulting currency rate cube with the data defined in the Rate Cube Mapping group box, if any mapping exists.

Rate Update Only: Replaces the existing data in the currency rate cube without regenerating the outline.

No Action: Does not perform any action on the currency rate cube.

Run Default Calc (run default calculation)

If you select this option, the default calculation script in Essbase is run when the cube is created. This means that Essbase aggregates the tree in the given rollups, but does not do anything else. You may instead decide to create a custom calculation script, in which case you might want to turn off this option.

**Auto Config Sparsity
(automatically configure
sparsity)**

If you clear this check box, you can manually set the sparsity levels on the Cube Instance Definition page. Otherwise, Essbase automatically sets sparsity levels. After you have cleared this check box, you can set the sparsity of each dimension in the template to either *Sparse* or *Dense*.

Note. Dimensions marked as *Sparse* might take up significantly more space in the resulting cube than those marked as *Dense*. If you mark every dimension as sparse, you could end up with an enormous cube that is not practical or even possible to store on even the most powerful servers. That's why the Time and Account dimensions default to *Dense*. It's possible to change these settings in Essbase after you create your cube. Whether you change the sparsity settings from PeopleSoft Cube Manager or from Essbase, take care when adjusting, and make sure to refer to the Essbase documentation.

Language Code

Choose to build an Essbase cube in multiple languages. When the cube is then viewed in Essbase, it does not appear in the user's preferred language. If the cube is not available in the user's language, the default language (developer's language) is used.

To add one additional language, select a language from the drop-down list.

Note. You do not have to select your own language. The cube is automatically built in your own language.

Rate Cube Name

Enables you to supply a rate cube mapping. PeopleSoft Cube Manager generates the actual currency rate cube by default.

Specify the Cube Name that you want PeopleSoft Cube Manager to create and map to the defined cube.

Query Name

Select the query that has your currency rate definition.

Time

Select the field name for time from the time dimension.

Account

Select the field name for currency category from the account dimension.

Country

Select the field name for currency name from the country dimension.

Type

Select the field name for currency type.

Rate

Select the field name for currency rate multiplier.

Default Currency Name

Enter the default currency name. If you do not specify a currency name for a member in your country dimension, the default currency name applies to the member.

Default Currency Category

Enter the default currency category. If you do not specify a currency category for a member in your account dimension, the default currency category applies to the member.

Multi-Currency Rate Cubes

Essbase supports multi-currency cubes. An Essbase multi-currency cube contains two databases: the regular main database and the currency rate database. The currency rate database is created out of the main database. Before you can generate the currency rate database from the main database, the main database *must* have the appropriate dimensions:

- Accounts dimension contains items that you want to measure, such as profit and inventory, and makes Essbase built-in accounting functionality available.
- Time dimension defines the time period for which you report and update data.
- Country dimension contains data about where business activities take place.

You can also specify the currency partition dimension (PeopleSoft Cube Manager also calls this *Currency Dimension*) in the main regular database for Essbase multi-currency cube. The currency partition dimension is for separating local currency members from a base currency defined in the application. If the base currency for analysis is U.S. dollars, the local currency members contain values that are based on the currency type of the region. The currency partition dimension is used only in the main regular database for currency conversion using Essbase script or other tools.

The following steps outline the things you specify for the *Accounts Dimension* and the *Country Dimension* specifically for Essbase multi-currency cubes. You need to create attribute queries for the Account and Country dimensions, and specify the queries as an input source in the Dimensions - Rollup Inputs page.

To create a multi-currency cube in Essbase:

1. Select PeopleTools, Cube Manager, Dimensions, Rollup Inputs.
2. Click the Field Map link for the appropriate Input Name.
3. Specify the Currency Category in your Accounts Dimension, for example P&L (for profit and loss).
4. Specify Currency Name in your Country Dimension, for example US\$.

Defining Cube Settings for Cognos PowerPlay

Access the PowerPlay Options page.

PowerPlay Options

Cube Instance ID: HEADCOUNT

PowerCube Path/File (.MDC):

Model Path/File (.MDL):

Data Working Directory:

Language Override: **Always Include**

Earliest Date	Latest Date	Enterprise Server Options
Use As Of Date <input type="radio"/> Use Current Date <input type="radio"/> Use Specific Date <input type="radio"/> <input type="text"/>	Use As Of Date <input type="radio"/> Use Current Date <input type="radio"/> Use Specific Date <input type="radio"/> <input type="text"/>	Enterprise Server <input type="checkbox"/> Service Port: <input type="text"/> Logon Password: <input type="text" value="*****"/>

PowerPlay Options page

PowerCube Path/File (.MDC)

PowerPlay requires both a PowerCube file and a model file. The PowerCube file has an .mdc extension and equates to a cube. Specify the path and file name.

Note. PowerPlay refers to a multidimensional database as a PowerCube, so we use this term in place of *cube* when referring specifically to the resulting cube in PowerPlay.

Model Path/File (.MDL)	Specify the path and file name. The model file has an .mdl filename extension and represents the cube structure.
Data Working Directory	Specify where the .dat file is written.
Language Override	If you are implementing the PowerCube in a non-English language, select a language.
Always Include	Select this check box to retain the category in the model and include it in cubes, even if it, or any of its descendants, fails to appear in the data source. The category is also included if any of its descendants are included and if the category has not been excluded, summarized, or cloaked in a dimension view. If necessary, the transformer includes ancestors of the category, regardless of their inclusion settings.
	<hr/> <p>Note. Always Include is selected when you create a time dimension. If you exclude categories, special categories that use relative time concepts (such as Last Month) do not work properly.</p> <hr/>
Earliest Date	The fields in this group box are optional and are used when designing and creating time dimensions for PowerPlay. If not specified, these default to the specific time of <i>1901-01-01</i> .
Use As of Date	Select to use the As of Date provided on the run control page.
Use Current Date	Select to use the current system date as controlled by settings in Cognos.
Use Specific Date	Select to set a specific date. If not specified, the default is <i>1901-01-01</i> .
Latest Date	The fields in this group box are optional; you use them when designing and creating time dimensions for PowerPlay. If not specified, these default to the specific time of <i>2100-12-31</i> .
Use As of Date	Select to use the As of Date provided on the run control page.
Use Current Date	Select to use the current system date as controlled by settings in Cognos.
Use Specific Date	Select to set a specific date. If not specified, the default is <i>2100-12-31</i> .
Enterprise Server	Select if you want PeopleSoft Cube Manager to automatically register your resulting cube on the PowerPlay Enterprise Server. If you do not select the Enterprise Server option, PeopleSoft Cube Manager creates the cube using the transformer, just as it would if you were using PowerPlay version 5.2.

Defining PowerPlay Cube Instance Definition Options

The following steps show both the optional and required options that enable PeopleSoft Cube Manager to build a Cognos PowerPlay cube.

Note. PeopleSoft Cube Manager and the Enterprise Server must be set up to run on the same machine.

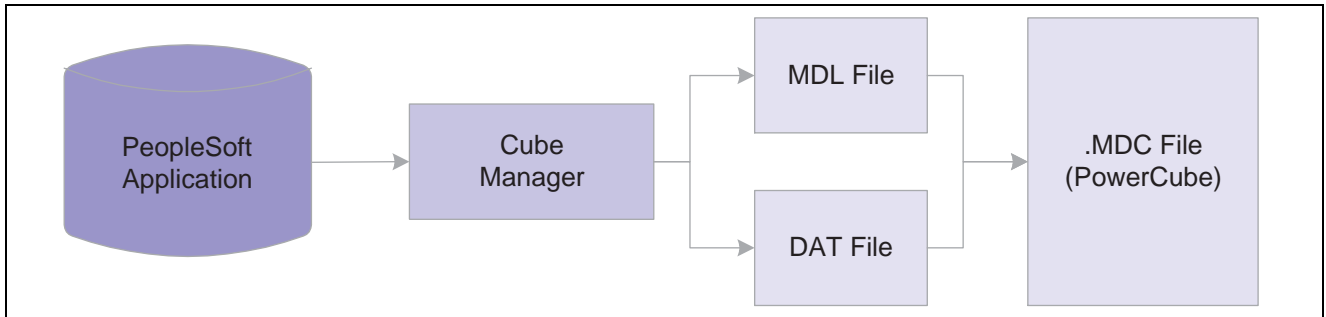

The .MDL file and .DAT files merge to create the PowerCube (.MDC file)

To define PowerPlay cube instance definition options:

1. On the PowerPlay Options page, specify the file names to be created when the cube is built.
2. Enter the data working directory.

When building a PowerCube, PeopleSoft Cube Manager sends output from each query used in the PowerCube to a flat data file before sending this data on to the PowerCube (.mdc) file. This data file has a .dat extension, and is written to the data working directory you specify.

Note. The data file created in the data working directory is not automatically deleted or overwritten when PeopleSoft Cube Manager builds a PowerCube. You must manually delete such files.

3. If necessary, select a Language Override.
4. Click the OK button if you are not using the Enterprise Server; otherwise, continue to the next step.
5. Select Enterprise Server check box if you want to use the Enterprise Server functionality.

The Cube Instance Definitions page appears.

The Service Port field defaults to *8010*. This should be the correct port for most machines. PowerPlay Enterprise Server is set to communicate on port number 8010 for both Windows and web connections.

Note. PeopleSoft Cube Manager assumes that the Enterprise Server is running locally. PeopleSoft Cube Manager retrieves the local machine name from the system to connect to the Enterprise Server.

PeopleSoft Cube Manager uses Ppadmtool.exe to talk to the locally running Enterprise Server to add or remove cubes. PeopleSoft Cube Manager first tries to remove the cube from the Enterprise Server. If the cube already exists, it removes the cube from the Enterprise Server. This prevents other users from trying to access the cube through the Enterprise Server while PeopleSoft Cube Manager is actually creating it. After removing the cube from the Enterprise Server, PeopleSoft Cube Manager uses the Transformer to generate the .mdc file.

If the cube is not listed in Enterprise Server at the moment, PeopleSoft Cube Manager uses the transformer to generate the .mdc file.

After creating the .mdc file, PeopleSoft Cube Manager uses the Ppadmtool.exe to add the .mdc file to the Enterprise Server. Once the cube has been added to the Enterprise Server, any user connected to it from a local or remote machine can view the newly added cube.

If you do not select the Enterprise Server option on the PowerPlay Options page, PeopleSoft Cube Manager creates the cube using the transformer, just as it would if you were using PowerPlay version 5.2.

Note. PowerPlay does not allow duplicate details in the same hierarchy, but it does allow duplicate details across hierarchies for the same dimension.

See Also

[Chapter 2, “Introducing PeopleSoft Cube Manager,” PowerPlay, page 13](#)

Adding a Prefix to Field and Record Objects

Access the Star Schema Options page.

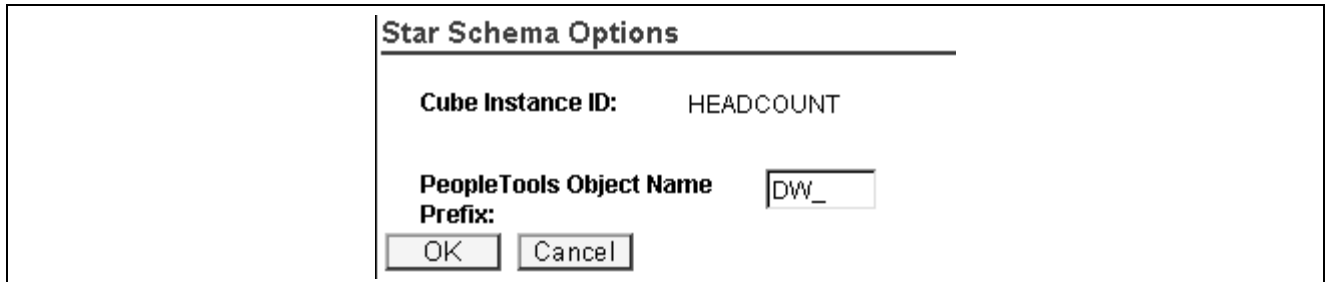

The image shows a dialog box titled "Star Schema Options". It contains the following fields and controls:

- Cube Instance ID:** HEADCOUNT
- PeopleTools Object Name Prefix:** DW_ (text input field)
- Buttons:** OK and Cancel

Star Schema Options page

Name Prefix

The prefix is applied to each record and field definition created by PeopleSoft Cube Manager. (The prefix provides some control over the record and field names.) The default is *DW_*.

Defining Cube Aggregates

Access the Cube Instances - Aggregates page.

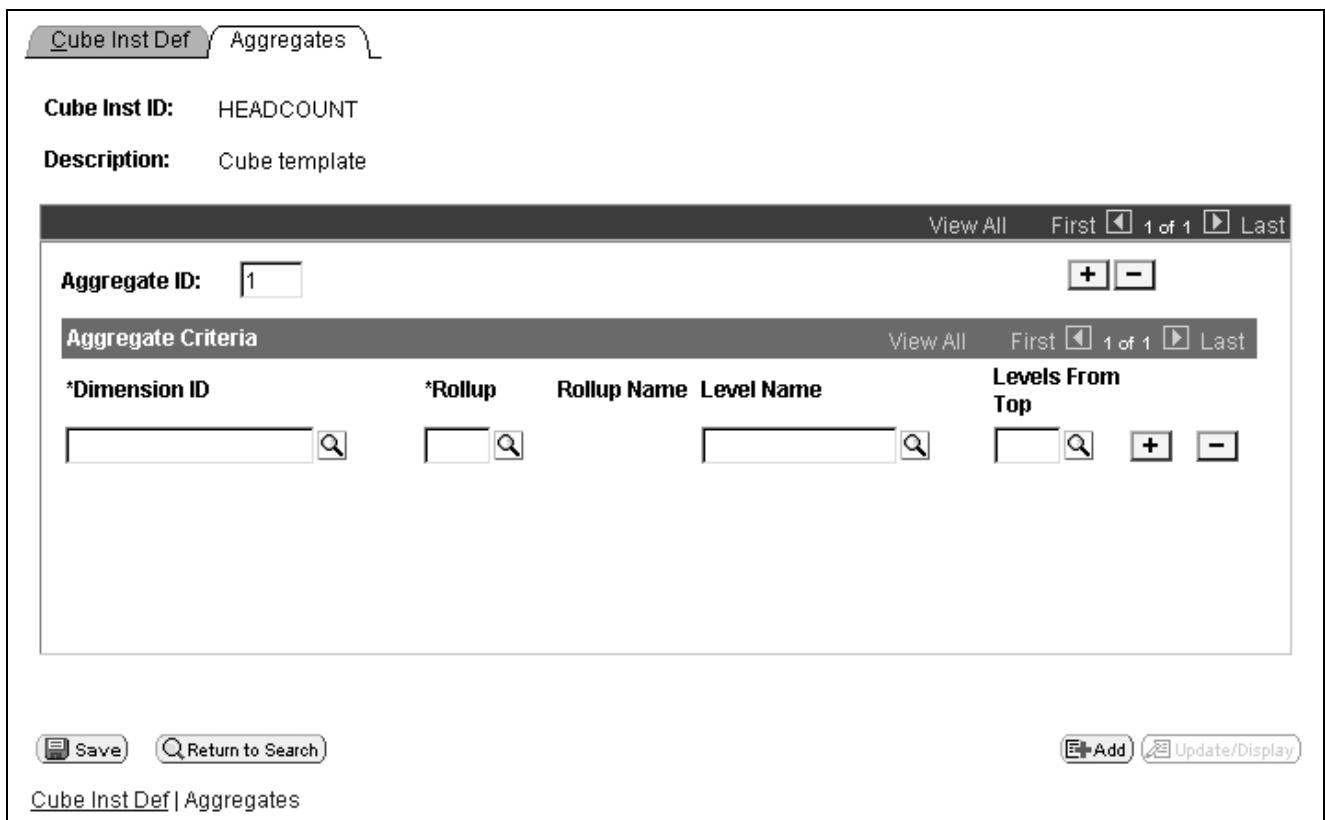

The image shows the "Cube Instances - Aggregates" page. It features a breadcrumb trail "Cube Inst Def > Aggregates".

Metadata fields:

- Cube Inst ID:** HEADCOUNT
- Description:** Cube template

Aggregate Definition:

- Aggregate ID:** 1 (text input field)
- Aggregate Criteria Table:**

*Dimension ID	*Rollup	Rollup Name	Level Name	Levels From Top
<input type="text"/>	<input type="text"/>		<input type="text"/>	<input type="text"/>

Navigation and Action Buttons:

- View All, First, 1 of 1, Last (for Aggregate ID)
- View All, First, 1 of 1, Last (for Aggregate Criteria)
- Save, Return to Search, Add, Update/Display

Page Footer: Cube Inst Def | Aggregates

Cube Instances - Aggregates page

Aggregates Page

This page has not been implemented.

Building Cubes

This section provides an overview of building cubes and discusses how to:

- Define the cube build specifications and bind variables.
- Define bind variables.
- Define cube build process using Process Scheduler Manager.
- Run the process to build the cube.

Understanding Cube Creation

When you are ready to build a cube, you need a place to specify the runtime parameters to be passed during the creation or update of the data cube using PeopleSoft Process Scheduler. The Build Cube page in PeopleSoft Cube Manager provides an example of how to pass this information from a PeopleSoft page to the resulting cube using a PeopleSoft Process Scheduler run control. But most likely, you are building cubes using pages that were either supplied with your PeopleSoft applications or pages that you have built yourself.

You can customize the way in which a cube is built by creating your own run control pages and process definitions using the Cube Builder process type. Certain PeopleSoft applications deliver their own pages for building cubes that leverage product-specific metadata.

Note. If you are building a Hyperion Essbase cube and it contains time, account, and country dimension types, PeopleSoft Cube Manager automatically builds a currency cube, if one is defined. The calculation for the currency cube always defaults to *Division*.

Pages Used to Build Cubes

Page Name	Object Name	Navigation	Usage
Build Cubes	RUN_MAKE_ANL_DB	PeopleTools, Cube Manager, Build Cubes, Build Cube	Define the cube build specifications and bind variables.
Build Cubes - Bind Variables	CUBE_BUILD_BIND	Cube Manager, Build Cubes, Build Cube, Bind Variables	Define bind variables that limit the data that is used to build a cube by prompting users for information when they start the build process.
Build Ledger Cubes	GL_OLAP_LED_REQ	Financial Application, Build Ledger Cubes	Run the background process that creates ledger cubes.
Process Definition	PRCSDEFN	PeopleTools, Process Scheduler, Processes	Define a cube build process request to run on the system.
Process Scheduler Request	PRCSRQSTDLG	Cube Manager, Build Cubes, Build Cube Click the Run button.	Run the process that builds the cube.

Defining the Cube Build Specifications and Bind Variables

Access the Build Cubes - Build Cube page.

The screenshot shows the 'Build Cubes - Build Cube page' with the 'Bind Variables' tab selected. At the top, there are tabs for 'Build Cube' and 'Bind Variables'. Below the tabs, the 'Run Control ID' is set to 'EMPLOYMENT'. To the right, there are buttons for 'Report Manager', 'Process Monitor', and 'Run'. The main content area is divided into three sections: 'Cube Specification', 'Actions', and 'Run Time Parameters'.
 - **Cube Specification:** Contains a text field for '*Cube Instance ID' with the value 'EMPLOYMENT', a search icon, and a folder icon. Below it are 'Description: Department Headcount' and 'Platform: Cognos PowerPlay'.
 - **Actions:** Contains three rows of radio buttons. 'Meta-Data' has 'Create' selected, 'Update', and 'None'. 'Data' has 'Create' selected, 'Update', and 'None'. 'Aggregation' has 'Create' and 'None' (selected) options.
 - **Run Time Parameters:** Contains a 'Business Unit' field, 'As of Date' set to '07/21/1997' with a calendar icon, 'Book Mark' set to 'INITIAL', and a 'Script' text area.
 At the bottom, there are buttons for 'Save', 'Return to Search', 'Add', and 'Update/Display'. A breadcrumb trail at the very bottom reads 'Build Cube | Bind Variables'.

Build Cubes - Build Cube page



To view the cube instance definition, click the Open Cube Instance Definition button. The Cube Instances - Cube Inst Def page appears with the instance definition you specify.

See [Chapter 5, “Building Cubes,” Defining Cube Settings and Selecting Dimensions, Measures, and Attributes, page 50.](#)

Meta-Data

Options are as follows:

Create: Create the cube. If the cube already exists, PeopleSoft Cube Manager re-creates it, overwriting any existing dimensions and data.

Update: This option in Generic Star updates the metadata. In Essbase, this option updates the structure of the cube according to the setting for the Meta-Data Update Action on the Essbase Cube Instance Definition page. For PowerPlay, this has the same effect as *Create*.

None: Do not make any changes to the structure of the cube or its individual dimensions (you may want to update the data only).

Data

Define the data action to take place when updating the cube:

Create: Reload the data, overwriting any existing data.

Update: Update the existing data in the cube. For Essbase, this option is linked to the Data Update Action selected on the Essbase Cube Instance Definition page.

None: Do not make any changes to the data in the cube. (You may want to update the structure only.)

Aggregation

Select from the following options:

Create: Reload the aggregates, overwriting any existing data.

None: Do not make any changes to the aggregates in the cube. (You may want to update the structure only.)

Business Unit

Enables you to get the appropriate set IDs for tree metadata. Leave this field blank if your trees do not use set IDs.

As of Date

Enables you to get the appropriate effective dates for tree metadata.

Bookmark

BookMarks identify a set of facts in the Generic Star Schema cube. These facts are used to determine whether facts are loaded for the first time or reloaded. The first time you create a build cube definition, the bookmark is set to *Initial*. You can also add a build script.

Script

Refers to platform-specific, post-build scripts, such as the .mdl file for PowerPlay or any command line for Windows. This feature enables you to extend the capabilities of PeopleSoft Cube Manager. For example, you can specify an Esscmd script that sets up security. Then, rather than having to configure security manually every time you build a cube, you can write a script once and specify it in the Script field to execute it for each build.

Report Manager

Shows you the report list in Report Manager.

See *Enterprise PeopleTools 8.45 PeopleBook: Using PeopleSoft Applications*, “Working With Processes and Reports”.

Process Monitor

Shows you the Process list in Process Monitor.

See *Enterprise PeopleTools 8.45 PeopleBook: PeopleSoft Process Scheduler*, “Using Process Monitor”.

Run

When you click this button, the Process Scheduler Request page appears.

To build a cube:

1. Build the cube instance definition.

See [Chapter 5, “Building Cubes,” Building Cube Instances, page 49](#).

2. Select Build Cubes, Build Cube.

Choose whether to add a new cube definition or to update/display an existing one.

3. Enter a *Run Control ID*, and click the OK button.

After you enter a run control ID, the Build Cube page appears.

4. In the Cube Specification group box, select a *Cube Instance ID*.

5. Define the run control information in the Run Time Parameters group box.

Note. If the default calculation script is defined to run in the Essbase Cube Instance Definition, the default calculation script runs first. Then the command line is invoked to run a subsequent script.

6. Define the metadata action that should occur during the build.
7. Define the data action that you want to occur during the build.
8. Define the aggregate action that you want to occur during the build.
9. Set your Process Scheduler parameters and save the page.

See *Enterprise PeopleTools 8.45 PeopleBook: PeopleSoft Process Scheduler*.

Note. When working in a three-tier environment, you *must* build your cubes on a Windows Process Scheduler server, not on the client.

Defining Bind Variables

Access the Build Cubes - Bind Variables page.

The screenshot shows the 'Build Cubes - Bind Variables' page. At the top, there are tabs for 'Build Cube' and 'Bind Variables'. Below the tabs, the 'Run Control ID' is set to 'EMPLOYMENT'. There are links for 'Report Manager' and 'Process Monitor', and a 'Run' button. A summary box contains the following information:

- Cube Instance ID:** EMPLOYMENT
- Platform:** PowerPlay
- Description:** Department Headcount

Below this is a table titled 'Bind Variables' with a header row containing 'Description' and 'Bind Value'. The table has one row with the value '1' in the 'Description' column. To the right of the table are 'View All', 'First', '1 of 1', and 'Last' buttons. At the bottom of the page, there are 'Save', 'Return to Search', 'Add', and 'Update/Display' buttons. The breadcrumb 'Build Cube | Bind Variables' is visible at the bottom left.

Build Cubes - Bind Variables page

If you want to use dynamic queries, you must create a query that joins the run control with the desired record and joins the operator ID and the run control ID.

You can make any PeopleSoft Cube Manager query (dimension query, data source query, or attribute query) dynamic by joining in runtime parameters. The parameter value must be stored in the database on a Cube Builder run control record or on a record that the run control record can join to. Then, in PeopleSoft Query, join the run control record and set prompts for the operator ID and the run control ID. These prompts are completed at runtime with the operator ID and run control ID of the run control used to launch the Cube Builder process. The Description and Bind Value fields on the sample Build Cube run control page provide one way to do this.

Adding Bind Variables

To add bind variables to a run control page:

1. Identify the run control record used to launch the Cube Builder process.
In the case of the sample Build Cube page delivered in the PTDMO database, this is MAKE_ANL_DB_REQ.
2. Identify the fields you want to use for parameters for runtime queries.
For example, values From and To for time periods.
3. Ensure that the fields identified in step 2 are available on the run control record, or that they are on a record that can be joined with the run control record.
See Enterprise PeopleTools 8.45 PeopleBook: PeopleSoft Application Designer, “Planning Records, Control Tables, and TableSets,” Record Definition Planning.
4. Ensure that these same fields are available on a page so that users can enter values for them.
If these fields exist on the run control record, they most likely also exist on the run control page.
See Enterprise PeopleTools 8.45 PeopleBook: PeopleSoft Application Designer, “Creating Field Definitions”.
5. In PeopleSoft Query, join the records that contain the fields mentioned above to the query that you want to make dynamic.
For example, assume that you want to bind in values for the From and To periods and that these fields exist on the run control record. In the data source query, join the From and To periods on the run control record to the From and To fields in the main data record (the primary record in the query that contains the data that you want to return).
See Enterprise PeopleTools 8.45 PeopleBook: PeopleSoft Query, “Working with Advanced Query Options,” Joining Records.
6. In PeopleSoft Query, set up prompts for the operator ID (first) and the run control ID (second).
Instead of prompting for these values at runtime, PeopleSoft Cube Manager automatically supplies the bind values that the user entered on the run control page.
7. Open the Bind Variables page by selecting the Bind Variables page in the Build Cubes component, or select Build Cubes, Build Cube, and enter a Cube Instance ID.
8. Click the Bind Variables tab.
The Bind Variables page appears.
9. Add variables and save your changes.
Enter a short text description and give the variable’s value.

Example of Bind Variables Used in PeopleSoft General Ledger

PeopleSoft General Ledger is just one of the PeopleSoft applications that provide a custom run control page. If you need to create a custom run control page, you might find it useful to follow the example that was delivered with this application.

The run control page in PeopleSoft General Ledger is the Build Ledger Cubes page. It provides a way for users to enter bind values for the Ledger, Currency Code, From Year, To Year, From Period, and To Period.

Note. Other than the bind variables mentioned above, the Build Ledger Cubes page is essentially the same as the sample Build Cube page delivered in the PeopleTools Demo database (PTDMO).

Build Ledger Cubes page

- Cube Instance ID** Enter the name of the cube template or select it from the menu.
- Open Cube Instance Definition** Click this link to change any settings on the Cube Instances - Cube Inst Def page.
- Business Unit** Select the setID for the tree you are using.
- As of Date** Select the effective date.
- Post-Build Script** This could be an Essbase, PowerPlay, or PS/ROLAP script that runs on the cube after the system builds and populates it.
- Ledger** Select the ledger that you want to use when populating the cube.
- Currency Code** Select the appropriate code, according to the currency type.
- From Year** Enter the starting time range for the ledger data that you want to appear in the cube.
- To Year** Enter the ending time range for the ledger data that you want to appear in the cube.
- From Period** Enter the starting period range for the ledger data that you want to appear in the cube.
- To Period** Enter the ending period range for the ledger data that you want to appear in the cube.
- Meta-Data Action** Select from the following choices:
 - Create:* If the cube already exists, the Cube Manager re-creates it, overwriting any existing dimensions and data.
 - Update:* In Essbase, this option updates the structure of the cube according to settings for Meta-Data Update Action on the Essbase Cube Instance Definition page. For PowerPlay, this option has the same effect as *Create*.

None: Do not make any changes to the structure of the cube or its individual dimensions. (You may want to update the data only.)

Data Action

Select from the following options:

Create: Reload the data, overwriting any existing data.

Update: Update the existing data in the cube. For Essbase, this option is linked to the Data Load Action on the Essbase Cube Instance Definition page. This option does not apply to PowerPlay.

None: Not applicable in PeopleSoft General Ledger.

Note. The General Ledger run control page makes it easy for a user to enter bind values by limiting the choices available. The user knows exactly the fields for which he or she is supplying values, because those controls are supplied on the page: Ledger, Currency Code, From Year, To Year, From Period, and To Period. This approach, while beneficial for the user, requires more time and care on the part of the designer.

Keep in mind that it is possible to create a run control page that is essentially identical to the sample Build Cube page—where the field for which the user supplies the bind values is determined at runtime by the user. In the Description text box, the user enters the name of the field that requires a bind value, and then enters that value in the Bind Value text box. Additional descriptions and bind values can be inserted as required.

See Also

PeopleSoft 8.8 PeopleBook: General Ledger

Defining a Cube Build Process Using Process Scheduler Manager

Access the Process Definition page

The screenshot shows the 'Process Definition' page with the following details:

- Process Type:** Cube Builder
- Name:** PSBLDHC
- *Description:** Build Cube
- Long Description:** (Empty text area)
- *Priority:** Medium
- *Process Category:** Default
- API Aware**
- Restart Enabled?**
- Retry Count:** 0

Process Definition page

Priority

Defines the relative priority used by the Process Scheduler Server Agent to determine which process to initiate first, if multiple processes are queued to run on a given server.

API Aware

Select this option if this process is application programming interface (API) aware. If this option is selected for any process that is not API-aware, Process

Scheduler includes it in the concurrent task count. This can result in improper server load balancing. Selecting this option does not mean that your process becomes API-aware. You must still add API code to your process.

Running the Process to Build the Cube

Access the Process Scheduler Request page by running the process to build a cube.

Process Scheduler Request

User ID: PTDMO **Run Control ID:** EMPLOYMENT

Server Name: **Run Date:** 

Recurrence: **Run Time:**

Time Zone:

Process List

Select	Description	Process Name	Process Type	*Type	*Format	
<input checked="" type="checkbox"/>	Build Cube	PSBLDHC	Cube Builder	(None)	NONE	

Process Scheduler Request page

Process Scheduler Request page

Server Name

The name of the server on which you want the process to run:

PSNT: a Microsoft Windows server. (PeopleSoft Cube Manager runs on only Windows.)

Recurrence

The recurring time intervals for a process request to run. Select either *Daily Purge* or *M-F at 5pm*.

See *Enterprise PeopleTools 8.45 PeopleBook: PeopleSoft Process Scheduler*.

Time Zone

Select the time zone in which your process runs. For example, you could be in Eastern Standard Time (EST) and schedule a process to run in Pacific Standard Time (PST).

Run Date

Select the date on which your process runs.

Run Time

Select the time when your process runs.

Reset to Current Date/Time

Sets the Run Date and Run Time to the present date and time.

Select

Specify the cube to be built. If you select this check box, the process is included in the build process.

Description

Uniquely identifies the process.

Process Name

The name of the process as it appears in the definition.

Type

The type of output. Enter *None*.

Format

The format of the output. Enter *None*.



Click the Distribution button to view a list of people who have the correct security to receive the output of this process.

OK

Click this button to run the process.

CHAPTER 6

Securing Cubes

This chapter describes how to secure PeopleSoft Cube Manager cubes.

Securing PeopleSoft Cube Manager Cubes

This section gives an overview of how to use the centralized Security feature in PeopleTools to set permissions for securing PeopleSoft Cube Manager cubes, and discusses how to:

- Control user operations
- Set user actions
- View content references

Pages Used to Secure PeopleSoft Cube Manager Cubes

Page Name	Object Name	Navigation	Usage
Component Permissions	ACL_COMPONENT2	PeopleTools, Security, Permissions & Roles, Permission Lists Click the Pages tab, then click Edit Components.	Control the operations a user is allowed to perform within PeopleSoft Cube Manager.
Page Permissions	ACL_PAGES2	PeopleTools, Security, Permissions & Roles, Permission Lists Click the Pages tab, click the Edit Components link, then click the Edit Pages link.	Set the actions a user can complete on a page.
Content References	PLIST_CREF	PeopleTools, Security, Permissions & Roles, Permission Lists Click the Pages tab, click the Edit Components link, then click the View link.	Shows all the content references in the database that point to the component.

Controlling User Operations

Access the Component Permissions page.

Component Permissions
Cube Manager

Components				
Authorized?	Component Name	Item Label	Edit Pages	View Content References for this Component
<input checked="" type="checkbox"/>	DIMENSION	Dimensions	Edit Pages	View
<input checked="" type="checkbox"/>	ANALYSIS_MODEL	Cube Definitions	Edit Pages	View
<input checked="" type="checkbox"/>	ATTRIBUTE_NAME	Attribute Names	Edit Pages	View
<input checked="" type="checkbox"/>	ANALYSIS_DB	Cube Instances	Edit Pages	View
<input checked="" type="checkbox"/>	BUILD_ANALYSIS_DB	Build Cubes	Edit Pages	View

Buttons: [Select All](#), [Deselect All](#)

Component Permissions page



- Authorized?** Shows which components the current permission list has access to.
- Component Name** The name of each component beneath the authorized menu.
- Item Label** The menu item label that you click to access a component.
- Edit Pages** This link appears for every component listed under the current menu.
- View Content References for this Component** The View link appears for every component listed under the current menu.
- Select All** Click this button if you want to grant access to (select, or highlight) all items. If you want to grant access to *most* menu items, click Select All, and then deselect the items you do not want selected.
- Deselect All** Clears the items that you previously selected.

Setting User Actions

Access the Page Permissions page.

Page Permissions

CUBE_MANAGER / Design / Dimensions

Pages			Actions	
Customize Find  First  1-2 of 2  Last				
Panel Item Name	Authorized?	Display Only		
Dimension	<input checked="" type="checkbox"/>	<input type="checkbox"/>	<input checked="" type="checkbox"/> Add	
Rollup Inputs	<input checked="" type="checkbox"/>	<input type="checkbox"/>	<input checked="" type="checkbox"/> Update/Display	
			<input type="checkbox"/> Update/Display All	
			<input type="checkbox"/> Correction	

Page Permissions page

Authorized?

Select this option to enable a user to access the page. After doing so, you must decide the degree to which a user is authorized on a page by selecting the Display Only check box or one or more of the available options in the Actions group box.

Display Only

Select this option to enable the user to view the information provided by the page, but not to alter any of the data. To enable write access to a page, you must clear this check box.

Actions

If you want the user to be able to alter the data presented by the page, select from the options that appear in the Actions group box, such as Add, Update/Display, and Correction. What options are available depends upon the options selected when the page was initially developed in PeopleSoft Application Designer.

Select All

Select this button to grant access to all pages and all the actions for each page.

Deselect All

Select this button to clear all previously selected items.

View Content References

Access the Content References page:

Content References

Component: Dimensions

The grid below shows all the content references in this database that point to this component.
 If the "Accessible" column is checked, this Permission List includes access to all parent folders of the content reference.

Portal Name	Name	Label	Accessible	Path
CUSTOMER	PT_DIMENSION_GBL	Dimensions	<input type="checkbox"/>	Root{PORTAL_ROOT_OBJECT}.PeopleTools{PT_CUBE_MANAGER}
EMPLOYEE	PT_DIMENSION_GBL	Dimensions	<input type="checkbox"/>	Root{PORTAL_ROOT_OBJECT}.PeopleTools{PT_CUBE_MANAGER}
PORTAL	DIMENSION1	Dimensions	<input checked="" type="checkbox"/>	Root{PORTAL_ROOT_OBJECT}.PeopleTools{CUBE_MANAGER}.Design{DESIGN}
PS_SITETEMPLATE	PT_DIMENSION_GBL	Dimensions	<input type="checkbox"/>	Root{PORTAL_ROOT_OBJECT}.PeopleTools{PT_CUBE_MANAGER}
SUPPLIER	PT_DIMENSION_GBL	Dimensions	<input type="checkbox"/>	Root{PORTAL_ROOT_OBJECT}.PeopleTools{PT_CUBE_MANAGER}

Content References page

The Content References page shows all the content references in the database that point to the selected component. If the Accessible check box is selected, the associated Permission List includes access to all parent folders of the content reference.

See Also

Enterprise PeopleTools 8.45 PeopleBook: Security Administration, "Setting Up Permission Lists"

APPENDIX A

Installing PowerPlay

If you have licensed Cognos Enterprise, see the third-party documentation provided on the PowerPlay CDs for the complete details on installing PowerPlay. To read the installation instructions, run the setup.exe on the CD and then select the option to read the installation instructions from the Setup menu.

This appendix provides a brief overview of the necessary configuration information to use PowerPlay with PeopleSoft Cube Manager. If you are using PowerPlay as a target for PeopleSoft Cube Manager, please note these install configuration items.

To make Author Mode available in the PowerPlay User Edition, you must select a custom install and then change the default setting to bring in this feature.

For the Enterprise Server Install, you must install the Enterprise Server on the same machine as PeopleSoft Cube Manager, which currently supports only the Windows platform. The Enterprise Server basically serves as a holding tank for PowerPlay cubes.

You must install the PowerPlay Transformation Windows Server CD on the same machine as the Enterprise Server. This allows PeopleSoft Cube Manager to automatically register the PowerPlay cubes it builds to the PowerPlay Server.

Note. If you choose not to install the PowerPlay Transformation Windows Server CD on the same machine as the Enterprise Server, you can still build PowerPlay cubes using PeopleSoft Cube Manager and the Transformer, which can be installed from the User subdirectory on the Enterprise Server CD. However, you must manually register/move the cubes to the Enterprise Server.

APPENDIX B

ISO Country and Currency Codes

PeopleBooks use International Organization for Standardization (ISO) country and currency codes to identify country-specific information and monetary amounts.

This appendix discusses:

- ISO country codes.
- ISO currency codes.

See Also

"About This PeopleBook." Typographical Conventions and Visual Cues

ISO Country Codes

This table lists the ISO country codes that may appear as country identifiers in PeopleBooks:

ISO Country Code	Country Name
ABW	Aruba
AFG	Afghanistan
AGO	Angola
AIA	Anguilla
ALB	Albania
AND	Andorra
ANT	Netherlands Antilles
ARE	United Arab Emirates
ARG	Argentina
ARM	Armenia
ASM	American Samoa
ATA	Antarctica

ISO Country Code	Country Name
ATF	French Southern Territories
ATG	Antigua and Barbuda
AUS	Australia
AUT	Austria
AZE	Azerbaijan
BDI	Burundi
BEL	Belgium
BEN	Benin
BFA	Burkina Faso
BGD	Bangladesh
BGR	Bulgaria
BHR	Bahrain
BHS	Bahamas
BIH	Bosnia and Herzegovina
BLR	Belarus
BLZ	Belize
BMU	Bermuda
BOL	Bolivia
BRA	Brazil
BRB	Barbados
BRN	Brunei Darussalam
BTN	Bhutan
BVT	Bouvet Island
BWA	Botswana
CAF	Central African Republic
CAN	Canada
CCK	Cocos (Keeling) Islands

ISO Country Code	Country Name
CHE	Switzerland
CHL	Chile
CHN	China
CIV	Cote D'Ivoire
CMR	Cameroon
COD	Congo, The Democratic Republic
COG	Congo
COK	Cook Islands
COL	Colombia
COM	Comoros
CPV	Cape Verde
CRI	Costa Rica
CUB	Cuba
CXR	Christmas Island
CYM	Cayman Islands
CYP	Cyprus
CZE	Czech Republic
DEU	Germany
DJI	Djibouti
DMA	Dominica
DNK	Denmark
DOM	Dominican Republic
DZA	Algeria
ECU	Ecuador
EGY	Egypt
ERI	Eritrea
ESH	Western Sahara

ISO Country Code	Country Name
ESP	Spain
EST	Estonia
ETH	Ethiopia
FIN	Finland
FJI	Fiji
FLK	Falkland Islands (Malvinas)
FRA	France
FRO	Faroe Islands
FSM	Micronesia, Federated States
GAB	Gabon
GBR	United Kingdom
GEO	Georgia
GHA	Ghana
GIB	Gibraltar
GIN	Guinea
GLP	Guadeloupe
GMB	Gambia
GNB	Guinea-Bissau
GNQ	Equatorial Guinea
GRC	Greece
GRD	Grenada
GRL	Greenland
GTM	Guatemala
GUF	French Guiana
GUM	Guam
GUY	Guyana
GXA	GXA - GP Core Country

ISO Country Code	Country Name
GXB	GXB - GP Core Country
GXC	GXC - GP Core Country
GXD	GXD - GP Core Country
HKG	Hong Kong
HMD	Heard and McDonald Islands
HND	Honduras
HRV	Croatia
HTI	Haiti
HUN	Hungary
IDN	Indonesia
IND	India
IOT	British Indian Ocean Territory
IRL	Ireland
IRN	Iran (Islamic Republic Of)
IRQ	Iraq
ISL	Iceland
ISR	Israel
ITA	Italy
JAM	Jamaica
JOR	Jordan
JPN	Japan
KAZ	Kazakstan
KEN	Kenya
KGZ	Kyrgyzstan
KHM	Cambodia
KIR	Kiribati
KNA	Saint Kitts and Nevis

ISO Country Code	Country Name
KOR	Korea, Republic of
KWT	Kuwait
LAO	Lao People's Democratic Rep
LBN	Lebanon
LBR	Liberia
LBY	Libyan Arab Jamahiriya
LCA	Saint Lucia
LIE	Liechtenstein
LKA	Sri Lanka
LSO	Lesotho
LTU	Lithuania
LUX	Luxembourg
LVA	Latvia
MAC	Macao
MAR	Morocco
MCO	Monaco
MDA	Moldova, Republic of
MDG	Madagascar
MDV	Maldives
MEX	Mexico
MHL	Marshall Islands
MKD	Fmr Yugoslav Rep of Macedonia
MLI	Mali
MLT	Malta
MMR	Myanmar
MNG	Mongolia
MNP	Northern Mariana Islands

ISO Country Code	Country Name
MOZ	Mozambique
MRT	Mauritania
MSR	Montserrat
MTQ	Martinique
MUS	Mauritius
MWI	Malawi
MYS	Malaysia
MYT	Mayotte
NAM	Namibia
NCL	New Caledonia
NER	Niger
NFK	Norfolk Island
NGA	Nigeria
NIC	Nicaragua
NIU	Niue
NLD	Netherlands
NOR	Norway
NPL	Nepal
NRU	Nauru
NZL	New Zealand
OMN	Oman
PAK	Pakistan
PAN	Panama
PCN	Pitcairn
PER	Peru
PHL	Philippines
PLW	Palau

ISO Country Code	Country Name
PNG	Papua New Guinea
POL	Poland
PRI	Puerto Rico
PRK	Korea, Democratic People's Rep
PRT	Portugal
PRY	Paraguay
PSE	Palestinian Territory, Occupie
PYF	French Polynesia
QAT	Qatar
REU	Reunion
ROU	Romania
RUS	Russian Federation
RWA	Rwanda
SAU	Saudi Arabia
SDN	Sudan
SEN	Senegal
SGP	Singapore
SGS	Sth Georgia & Sth Sandwich Is
SHN	Saint Helena
SJM	Svalbard and Jan Mayen
SLB	Solomon Islands
SLE	Sierra Leone
SLV	El Salvador
SMR	San Marino
SOM	Somalia
SPM	Saint Pierre and Miquelon
STP	Sao Tome and Principe

ISO Country Code	Country Name
SUR	Suriname
SVK	Slovakia
SVN	Slovenia
SWE	Sweden
SWZ	Swaziland
SYC	Seychelles
SYR	Syrian Arab Republic
TCA	Turks and Caicos Islands
TCD	Chad
TGO	Togo
THA	Thailand
TJK	Tajikistan
TKL	Tokelau
TKM	Turkmenistan
TLS	East Timor
TON	Tonga
TTO	Trinidad and Tobago
TUN	Tunisia
TUR	Turkey
TUV	Tuvalu
TWN	Taiwan, Province of China
TZA	Tanzania, United Republic of
UGA	Uganda
UKR	Ukraine
UMI	US Minor Outlying Islands
URY	Uruguay
USA	United States

ISO Country Code	Country Name
UZB	Uzbekistan
VAT	Holy See (Vatican City State)
VCT	St Vincent and the Grenadines
VEN	Venezuela
VGB	Virgin Islands (British)
VIR	Virgin Islands (U.S.)
VNM	Viet Nam
VUT	Vanuatu
WLF	Wallis and Futuna Islands
WSM	Samoa
YEM	Yemen
YUG	Yugoslavia
ZAF	South Africa
ZMB	Zambia
ZWE	Zimbabwe

ISO Currency Codes

This table lists the ISO country codes that may appear as currency identifiers in PeopleBooks:

ISO Currency Code	Description
ADP	Andorran Peseta
AED	United Arab Emirates Dirham
AFA	Afghani
AFN	Afghani
ALK	Old Lek
ALL	Lek
AMD	Armenian Dram

ISO Currency Code	Description
ANG	Netherlands Antilles Guilder
AOA	Kwanza
AOK	Kwanza
AON	New Kwanza
AOR	Kwanza Reajustado
ARA	Austral
ARP	Peso Argentino
ARS	Argentine Peso
ARY	Peso
ATS	Schilling
AUD	Australian Dollar
AWG	Aruban Guilder
AZM	Azerbaijani Manat
BAD	Dinar
BAM	Convertible Marks
BBD	Barbados Dollar
BDT	Taka
BEC	Convertible Franc
BEF	Belgian Franc
BEL	Financial Belgian Franc
BGJ	Lev A/52
BGK	Lev A/62
BGL	Lev
BGN	Bulgarian LEV
BHD	Bahraini Dinar
BIF	Burundi Franc
BMD	Bermudian Dollar

ISO Currency Code	Description
BND	Brunei Dollar
BOB	Boliviano
BOP	Peso
BOV	Mvdol
BRB	Cruzeiro
BRC	Cruzado
BRE	Cruzeiro
BRL	Brazilian Real
BRN	New Cruzado
BRR	Brazilian Real Dollar
BSD	Bahamian Dollar
BTN	Ngultrum
BUK	N/A
BWP	Pula
BYB	Belarussian Ruble
BYR	Belarussian Ruble
BZD	Belize Dollar
CAD	Canadian Dollar
CDF	Franc Congolais
CHF	Swiss Franc
CLF	Unidades de fomento
CLP	Chilean Peso
CNX	Peoples Bank Dollar
CNY	Yuan Renminbi
COP	Colombian Peso
CRC	Costa Rican Colon
CSD	Serbia Dinar

ISO Currency Code	Description
CSJ	Krona A/53
CSK	Koruna
CUP	Cuban Peso
CVE	Cape Verde Escudo
CYP	Cyprus Pound
CZK	Czech Koruna
DEM	Deutsche Mark
DJF	Djibouti Franc
DKK	Danish Krone
DOP	Dominican Peso
DZD	Algerian Dinar
ECS	Sucre
ECV	Unidad de Valor
EEK	Kroon
EGP	Egyptian Pound
EQE	Ekwele
ERN	Nakfa
ESA	Spanish Peseta
ESB	Convertible Peseta
ESP	Spanish Peseta
ETB	Ethiopian Birr
EUR	euro
FIM	Markka
FJD	Fiji Dollar
FKP	Falklands Isl. Pound
FRF	French Franc
GBP	Pound Sterling

ISO Currency Code	Description
GEK	Georgian Coupon
GEL	Lari
GHC	Cedi
GIP	Gibraltar Pound
GMD	Dalasi
GNE	Syli
GNF	Guinea Franc
GNS	Syli
GQE	Ekwele
GRD	Drachma
GTQ	Quetzal
GWE	Guinea Escudo
GWP	Guinea-Bissau Peso
GYD	Guyana Dollar
HKD	Hong Kong Dollar
HNL	Lempira
HRD	Dinar
HRK	Kuna
HTG	Gourde
HUF	Forint
IDR	Rupiah
IEP	Irish Pound
ILP	Pound
ILR	Old Shekel
ILS	New Israeli Sheqel
INR	Indian Rupee
IQD	Iraqi Dinar

ISO Currency Code	Description
IRR	Iranian Rial
ISJ	Old Krona
ISK	Iceland Krona
ITL	Italian Lira
JMD	Jamaican Dollar
JOD	Jordanian Dinar
JPY	Yen
KES	Kenyan Shilling
KGS	Som
KHR	Riel
KMF	Comoro Franc
KPW	North Korean Won
KRW	Won
KWD	Kuwaiti Dinar
KYD	Cayman Islands dollar
KZT	Tenge
LAJ	Kip Pot Pol
LAK	Kip
LBP	Lebanese Pound
LKR	Sri Lanka Rupee
LRD	Liberian Dollar
LSL	Loti
LSM	Maloti
LTL	Lithuanian Litas
LTT	Talonas
LUC	Convertib Franc
LUF	Luxembourg Franc

ISO Currency Code	Description
LUL	Financial Franc
LVL	Latvian Lats
LVR	Latvian Ruble
LYD	Libyan Dinar
MAD	Moroccan Dirham
MAF	Mali Franc
MDL	Moldovan Leu
MGF	Malagasy Franc
MKD	Denar
MLF	Mali Franc
MMK	Kyat
MNT	Tugrik
MOP	Pataca
MRO	Ouguiya
MTL	Maltese Lira
MTP	Maltese Pound
MUR	Mauritius Rupee
MVQ	Maldive Rupee
MVR	Rufiyaa
MWK	Malawian Kwacha
MXN	Mexican Peso
MXP	Mexican Peso
MXV	Mexican UDI
MYR	Malaysian Ringgit
MZE	Mozambique Escudo
MZM	Metical
NAD	Namibia Dollar

ISO Currency Code	Description
NGN	Naira
NIC	Cordoba
NIO	Cordoba Oro
NLG	Netherlands Guilder
NOK	Norwegian Krone
NPR	Nepalese Rupee
NZD	New Zealand Dollar
OMR	Rial Omani
PAB	Balboa
PEI	Inti
PEN	Nuevo Sol
PES	Sol
PGK	Kina
PHP	Philippine Peso
PKR	Pakistan Rupee
PLN	Zloty
PLZ	Zloty
PTE	Portuguese Escudo
PYG	Guarani
QAR	Qatari Rial
ROK	Leu A/52
ROL	Leu
RUB	Russian Ruble
RUR	Russian Federation Rouble
RWF	Rwanda Franc
SAR	Saudi Riyal
SBD	Solomon Islands

ISO Currency Code	Description
SCR	Seychelles Rupee
SDD	Sudanese Dinar
SDP	Sudanese Pound
SEK	Swedish Krona
SGD	Singapore Dollar
SHP	St Helena Pound
SIT	Tolar
SKK	Slovak Koruna
SLL	Leone
SOS	Somali Shilling
SRG	Surinam Guilder
STD	Dobra
SUR	Rouble
SVC	El Salvador Colon
SYP	Syrian Pound
SZL	Lilangeni
THB	Baht
TJR	Tajik Ruble
TJS	Somoni
TMM	Manat
TND	Tunisian Dinar
TOP	Pa'anga
TPE	Timor Escudo
TRL	Turkish Lira
TTD	Trinidad Dollar
TWD	New Taiwan Dollar
TZS	Tanzanian Shilling

ISO Currency Code	Description
UAH	Hryvnia
UAK	Karbovanet
UGS	Uganda Shilling
UGW	Old Shilling
UGX	Uganda Shilling
USD	US Dollar
USN	US Dollar (Next day)
USS	US Dollar (Same day)
UYN	Old Uruguay Peso
UYP	Uruguayan Peso
UYU	Peso Uruguayo
UZS	Uzbekistan Sum
VEB	Bolivar
VNC	Old Dong
VND	Dong
VUV	Vatu
WST	Tala
XAF	CFA Franc BEAC
XAG	Silver
XAU	GOLD
XBA	European Composite Unit
XBB	European Monetary Unit
XBC	European Unit of Account 9
XBD	European Unit of Account 17
XCD	East Caribbean Dollar
XDR	SDR
XEU	EU Currency (E.C.U)

ISO Currency Code	Description
XFO	Gold-Franc
XFU	UIC-Franc
XOF	CFA Franc BCEAO
XPD	Palladium
XPF	CFP Franc
XPT	Platinum
XTS	For Testing Purposes
XXX	Non Currency Transaction
YDD	Yemeni Din
YER	Yemeni Rial
YUD	New Yugoslavian Dinar
YUM	New Dinar
YUN	Yugoslavian Dinar
ZAL	Financial Rand
ZAR	Rand
ZMK	Zambian Kwacha
ZRN	New Zaire
ZRZ	Zaire
ZWC	Rhodesian Dollar
ZWD	Zimbabwe Dollar

Glossary of PeopleSoft Terms

absence entitlement	This element defines rules for granting paid time off for valid absences, such as sick time, vacation, and maternity leave. An absence entitlement element defines the entitlement amount, frequency, and entitlement period.
absence take	This element defines the conditions that must be met before a payee is entitled to take paid time off.
accounting class	In PeopleSoft Enterprise Performance Management, the accounting class defines how a resource is treated for generally accepted accounting practices. The Inventory class indicates whether a resource becomes part of a balance sheet account, such as inventory or fixed assets, while the Non-inventory class indicates that the resource is treated as an expense of the period during which it occurs.
accounting date	The accounting date indicates when a transaction is recognized, as opposed to the date the transaction actually occurred. The accounting date and transaction date can be the same. The accounting date determines the period in the general ledger to which the transaction is to be posted. You can only select an accounting date that falls within an open period in the ledger to which you are posting. The accounting date for an item is normally the invoice date.
accounting split	The accounting split method indicates how expenses are allocated or divided among one or more sets of accounting ChartFields.
accumulator	You use an accumulator to store cumulative values of defined items as they are processed. You can accumulate a single value over time or multiple values over time. For example, an accumulator could consist of all voluntary deductions, or all company deductions, enabling you to accumulate amounts. It allows total flexibility for time periods and values accumulated.
action reason	The reason an employee's job or employment information is updated. The action reason is entered in two parts: a personnel action, such as a promotion, termination, or change from one pay group to another—and a reason for that action. Action reasons are used by PeopleSoft Human Resources, PeopleSoft Benefits Administration, PeopleSoft Stock Administration, and the COBRA Administration feature of the Base Benefits business process.
action template	In PeopleSoft Receivables, outlines a set of escalating actions that the system or user performs based on the period of time that a customer or item has been in an action plan for a specific condition.
activity	<p>In PeopleSoft Enterprise Learning Management, an instance of a catalog item (sometimes called a class) that is available for enrollment. The activity defines such things as the costs that are associated with the offering, enrollment limits and deadlines, and waitlisting capacities.</p> <p>In PeopleSoft Enterprise Performance Management, the work of an organization and the aggregation of actions that are used for activity-based costing.</p> <p>In PeopleSoft Project Costing, the unit of work that provides a further breakdown of projects—usually into specific tasks.</p> <p>In PeopleSoft Workflow, a specific transaction that you might need to perform in a business process. Because it consists of the steps that are used to perform a transaction, it is also known as a step map.</p>

agreement	In PeopleSoft eSettlements, provides a way to group and specify processing options, such as payment terms, pay from a bank, and notifications by a buyer and supplier location combination.
allocation rule	In PeopleSoft Enterprise Incentive Management, an expression within compensation plans that enables the system to assign transactions to nodes and participants. During transaction allocation, the allocation engine traverses the compensation structure from the current node to the root node, checking each node for plans that contain allocation rules.
alternate account	A feature in PeopleSoft General Ledger that enables you to create a statutory chart of accounts and enter statutory account transactions at the detail transaction level, as required for recording and reporting by some national governments.
AR specialist	Abbreviation for <i>receivables specialist</i> . In PeopleSoft Receivables, an individual in who tracks and resolves deductions and disputed items.
arbitration plan	In PeopleSoft Enterprise Pricer, defines how price rules are to be applied to the base price when the transaction is priced.
assessment rule	In PeopleSoft Receivables, a user-defined rule that the system uses to evaluate the condition of a customer's account or of individual items to determine whether to generate a follow-up action.
asset class	An asset group used for reporting purposes. It can be used in conjunction with the asset category to refine asset classification.
attribute/value pair	In PeopleSoft Directory Interface, relates the data that makes up an entry in the directory information tree.
authentication server	A server that is set up to verify users of the system.
base time period	In PeopleSoft Business Planning, the lowest level time period in a calendar.
benchmark job	In PeopleSoft Workforce Analytics, a benchmark job is a job code for which there is corresponding salary survey data from published, third-party sources.
book	In PeopleSoft Asset Management, used for storing financial and tax information, such as costs, depreciation attributes, and retirement information on assets.
branch	A tree node that rolls up to nodes above it in the hierarchy, as defined in PeopleSoft Tree Manager.
budgetary account only	An account used by the system only and not by users; this type of account does not accept transactions. You can only budget with this account. Formerly called "system-maintained account."
budget check	In commitment control, the processing of source transactions against control budget ledgers, to see if they pass, fail, or pass with a warning.
budget control	In commitment control, budget control ensures that commitments and expenditures don't exceed budgets. It enables you to track transactions against corresponding budgets and terminate a document's cycle if the defined budget conditions are not met. For example, you can prevent a purchase order from being dispatched to a vendor if there are insufficient funds in the related budget to support it.
budget period	The interval of time (such as 12 months or 4 quarters) into which a period is divided for budgetary and reporting purposes. The ChartField allows maximum flexibility to define operational accounting time periods without restriction to only one calendar.
business event	In PeopleSoft Receivables, defines the processing characteristics for the Receivable Update process for a draft activity.

	In PeopleSoft Sales Incentive Management, an original business transaction or activity that may justify the creation of a PeopleSoft Enterprise Incentive Management event (a sale, for example).
business unit	A corporation or a subset of a corporation that is independent with regard to one or more operational or accounting functions.
buyer	In PeopleSoft eSettlements, an organization (or business unit, as opposed to an individual) that transacts with suppliers (vendors) within the system. A buyer creates payments for purchases that are made in the system.
catalog item	In PeopleSoft Enterprise Learning Management, a specific topic that a learner can study and have tracked. For example, "Introduction to Microsoft Word." A catalog item contains general information about the topic and includes a course code, description, categorization, keywords, and delivery methods. A catalog item can have one or more learning activities.
catalog map	In PeopleSoft Catalog Management, translates values from the catalog source data to the format of the company's catalog.
catalog partner	In PeopleSoft Catalog Management, shares responsibility with the enterprise catalog manager for maintaining catalog content.
categorization	Associates partner offerings with catalog offerings and groups them into enterprise catalog categories.
channel	In PeopleSoft MultiChannel Framework, email, chat, voice (computer telephone integration [CTI]), or a generic event.
ChartField	A field that stores a chart of accounts, resources, and so on, depending on the PeopleSoft application. ChartField values represent individual account numbers, department codes, and so forth.
ChartField balancing	You can require specific ChartFields to match up (balance) on the debit and the credit side of a transaction.
ChartField combination edit	The process of editing journal lines for valid ChartField combinations based on user-defined rules.
ChartKey	One or more fields that uniquely identify each row in a table. Some tables contain only one field as the key, while others require a combination.
checkbook	In PeopleSoft Promotions Management, enables you to view financial data (such as planned, incurred, and actual amounts) that is related to funds and trade promotions.
Class ChartField	A ChartField value that identifies a unique appropriation budget key when you combine it with a fund, department ID, and program code, as well as a budget period. Formerly called <i>sub-classification</i> .
clone	In PeopleCode, to make a unique copy. In contrast, to <i>copy</i> may mean making a new reference to an object, so if the underlying object is changed, both the copy and the original change.
collection	To make a set of documents available for searching in Verity, you must first create at least one collection. A collection is set of directories and files that allow search application users to use the Verity search engine to quickly find and display source documents that match search criteria. A collection is a set of statistics and pointers to the source documents, stored in a proprietary format on a file server. Because a collection can only store information for a single location, PeopleSoft maintains a set of collections (one per language code) for each search index object.

collection rule	In PeopleSoft Receivables, a user-defined rule that defines actions to take for a customer based on both the amount and the number of days past due for outstanding balances.
compensation object	In PeopleSoft Enterprise Incentive Management, a node within a compensation structure. Compensation objects are the building blocks that make up a compensation structure's hierarchical representation.
compensation structure	In PeopleSoft Enterprise Incentive Management, a hierarchical relationship of compensation objects that represents the compensation-related relationship between the objects.
condition	In PeopleSoft Receivables, occurs when there is a change of status for a customer's account, such as reaching a credit limit or exceeding a user-defined balance due.
configuration parameter catalog	Used to configure an external system with PeopleSoft. For example, a configuration parameter catalog might set up configuration and communication parameters for an external server.
configuration plan	In PeopleSoft Enterprise Incentive Management, configuration plans hold allocation information for common variables (not incentive rules) and are attached to a node without a participant. Configuration plans are not processed by transactions.
content reference	Content references are pointers to content registered in the portal registry. These are typically either URLs or iScripts. Content references fall into three categories: target content, templates, and template pagelets.
context	In PeopleCode, determines which buffer fields can be contextually referenced and which is the current row of data on each scroll level when a PeopleCode program is running. In PeopleSoft Enterprise Incentive Management, a mechanism that is used to determine the scope of a processing run. PeopleSoft Enterprise Incentive Management uses three types of context: plan, period, and run-level.
control table	Stores information that controls the processing of an application. This type of processing might be consistent throughout an organization, or it might be used only by portions of the organization for more limited sharing of data.
cost profile	A combination of a receipt cost method, a cost flow, and a deplete cost method. A profile is associated with a cost book and determines how items in that book are valued, as well as how the material movement of the item is valued for the book.
cost row	A cost transaction and amount for a set of ChartFields.
current learning	In PeopleSoft Enterprise Learning Management, a self-service repository for all of a learner's in-progress learning activities and programs.
data acquisition	In PeopleSoft Enterprise Incentive Management, the process during which raw business transactions are acquired from external source systems and fed into the operational data store (ODS).
data elements	Data elements, at their simplest level, define a subset of data and the rules by which to group them. For Workforce Analytics, data elements are rules that tell the system what measures to retrieve about your workforce groups.
dataset	A data grouping that enables role-based filtering and distribution of data. You can limit the range and quantity of data that is displayed for a user by associating dataset rules with user roles. The result of dataset rules is a set of data that is appropriate for the user's roles.

delivery method	<p>In PeopleSoft Enterprise Learning Management, identifies the primary type of delivery method in which a particular learning activity is offered. Also provides default values for the learning activity, such as cost and language. This is primarily used to help learners search the catalog for the type of delivery from which they learn best. Because PeopleSoft Enterprise Learning Management is a blended learning system, it does not enforce the delivery method.</p> <p>In PeopleSoft Supply Chain Management, identifies the method by which goods are shipped to their destinations (such as truck, air, rail, and so on). The delivery method is specified when creating shipment schedules.</p>
delivery method type	In PeopleSoft Enterprise Learning Management, identifies how learning activities can be delivered—for example, through online learning, classroom instruction, seminars, books, and so forth—in an organization. The type determines whether the delivery method includes scheduled components.
directory information tree	In PeopleSoft Directory Interface, the representation of a directory's hierarchical structure.
document sequencing	A flexible method that sequentially numbers the financial transactions (for example, bills, purchase orders, invoices, and payments) in the system for statutory reporting and for tracking commercial transaction activity.
dynamic detail tree	A tree that takes its detail values—dynamic details—directly from a table in the database, rather than from a range of values that are entered by the user.
edit table	A table in the database that has its own record definition, such as the Department table. As fields are entered into a PeopleSoft application, they can be validated against an edit table to ensure data integrity throughout the system.
effective date	A method of dating information in PeopleSoft applications. You can predate information to add historical data to your system, or postdate information in order to enter it before it actually goes into effect. By using effective dates, you don't delete values; you enter a new value with a current effective date.
EIM ledger	Abbreviation for <i>Enterprise Incentive Management ledger</i> . In PeopleSoft Enterprise Incentive Management, an object to handle incremental result gathering within the scope of a participant. The ledger captures a result set with all of the appropriate traces to the data origin and to the processing steps of which it is a result.
elimination set	In PeopleSoft General Ledger, a related group of intercompany accounts that is processed during consolidations.
entry event	In PeopleSoft General Ledger, Receivables, Payables, Purchasing, and Billing, a business process that generates multiple debits and credits resulting from single transactions to produce standard, supplemental accounting entries.
equitization	In PeopleSoft General Ledger, a business process that enables parent companies to calculate the net income of subsidiaries on a monthly basis and adjust that amount to increase the investment amount and equity income amount before performing consolidations.
event	<p>A predefined point either in the Component Processor flow or in the program flow. As each point is encountered, the event activates each component, triggering any PeopleCode program that is associated with that component and that event. Examples of events are FieldChange, SavePreChange, and RowDelete.</p> <p>In PeopleSoft Human Resources, also refers to an incident that affects benefits eligibility.</p>
event propagation process	In PeopleSoft Sales Incentive Management, a process that determines, through logic, the propagation of an original PeopleSoft Enterprise Incentive Management event and creates a derivative (duplicate) of the original event to be processed by other objects.

	Sales Incentive Management uses this mechanism to implement splits, roll-ups, and so on. Event propagation determines who receives the credit.
exception	In PeopleSoft Receivables, an item that either is a deduction or is in dispute.
exclusive pricing	In PeopleSoft Order Management, a type of arbitration plan that is associated with a price rule. Exclusive pricing is used to price sales order transactions.
fact	In PeopleSoft applications, facts are numeric data values from fields from a source database as well as an analytic application. A fact can be anything you want to measure your business by, for example, revenue, actual, budget data, or sales numbers. A fact is stored on a fact table.
forecast item	A logical entity with a unique set of descriptive demand and forecast data that is used as the basis to forecast demand. You create forecast items for a wide range of uses, but they ultimately represent things that you buy, sell, or use in your organization and for which you require a predictable usage.
fund	In PeopleSoft Promotions Management, a budget that can be used to fund promotional activity. There are four funding methods: top down, fixed accrual, rolling accrual, and zero-based accrual.
generic process type	In PeopleSoft Process Scheduler, process types are identified by a generic process type. For example, the generic process type SQR includes all SQR process types, such as SQR process and SQR report.
group	In PeopleSoft Billing and Receivables, a posting entity that comprises one or more transactions (items, deposits, payments, transfers, matches, or write-offs). In PeopleSoft Human Resources Management and Supply Chain Management, any set of records that are associated under a single name or variable to run calculations in PeopleSoft business processes. In PeopleSoft Time and Labor, for example, employees are placed in groups for time reporting purposes.
incentive object	In PeopleSoft Enterprise Incentive Management, the incentive-related objects that define and support the PeopleSoft Enterprise Incentive Management calculation process and results, such as plan templates, plans, results data, user interaction objects, and so on.
incentive rule	In PeopleSoft Sales Incentive Management, the commands that act on transactions and turn them into compensation. A rule is one part in the process of turning a transaction into compensation.
incur	In PeopleSoft Promotions Management, to become liable for a promotional payment. In other words, you owe that amount to a customer for promotional activities.
item	In PeopleSoft Inventory, a tangible commodity that is stored in a business unit (shipped from a warehouse). In PeopleSoft Demand Planning, Inventory Policy Planning, and Supply Planning, a noninventory item that is designated as being used for planning purposes only. It can represent a family or group of inventory items. It can have a planning bill of material (BOM) or planning routing, and it can exist as a component on a planning BOM. A planning item cannot be specified on a production or engineering BOM or routing, and it cannot be used as a component in a production. The quantity on hand will never be maintained.
	In PeopleSoft Receivables, an individual receivable. An item can be an invoice, a credit memo, a debit memo, a write-off, or an adjustment.
KPI	An abbreviation for <i>key performance indicator</i> . A high-level measurement of how well an organization is doing in achieving critical success factors. This defines the data value or calculation upon which an assessment is determined.

LDIF file	Abbreviation for <i>Lightweight Directory Access Protocol (LDAP) Data Interchange Format file</i> . Contains discrepancies between PeopleSoft data and directory data.
learner group	In PeopleSoft Enterprise Learning Management, a group of learners who are linked to the same learning environment. Members of the learner group can share the same attributes, such as the same department or job code. Learner groups are used to control access to and enrollment in learning activities and programs. They are also used to perform group enrollments and mass enrollments in the back office.
learning components	In PeopleSoft Enterprise Learning Management, the foundational building blocks of learning activities. PeopleSoft Enterprise Learning Management supports six basic types of learning components: web-based, session, webcast, test, survey, and assignment. One or more of these learning component types compose a single learning activity.
learning environment	In PeopleSoft Enterprise Learning Management, identifies a set of categories and catalog items that can be made available to learner groups. Also defines the default values that are assigned to the learning activities and programs that are created within a particular learning environment. Learning environments provide a way to partition the catalog so that learners see only those items that are relevant to them.
learning history	In PeopleSoft Enterprise Learning Management, a self-service repository for all of a learner's completed learning activities and programs.
ledger mapping	You use ledger mapping to relate expense data from general ledger accounts to resource objects. Multiple ledger line items can be mapped to one or more resource IDs. You can also use ledger mapping to map dollar amounts (referred to as <i>rates</i>) to business units. You can map the amounts in two different ways: an actual amount that represents actual costs of the accounting period, or a budgeted amount that can be used to calculate the capacity rates as well as budgeted model results. In PeopleSoft Enterprise Warehouse, you can map general ledger accounts to the EW Ledger table.
library section	In PeopleSoft Enterprise Incentive Management, a section that is defined in a plan (or template) and that is available for other plans to share. Changes to a library section are reflected in all plans that use it.
linked section	In PeopleSoft Enterprise Incentive Management, a section that is defined in a plan template but appears in a plan. Changes to linked sections propagate to plans using that section.
linked variable	In PeopleSoft Enterprise Incentive Management, a variable that is defined and maintained in a plan template and that also appears in a plan. Changes to linked variables propagate to plans using that variable.
load	In PeopleSoft Inventory, identifies a group of goods that are shipped together. Load management is a feature of PeopleSoft Inventory that is used to track the weight, the volume, and the destination of a shipment.
local functionality	In PeopleSoft HRMS, the set of information that is available for a specific country. You can access this information when you click the appropriate country flag in the global window, or when you access it by a local country menu.
location	Locations enable you to indicate the different types of addresses—for a company, for example, one address to receive bills, another for shipping, a third for postal deliveries, and a separate street address. Each address has a different location number. The primary location—indicated by a <i>1</i> —is the address you use most often and may be different from the main address.
logistical task	In PeopleSoft Services Procurement, an administrative task that is related to hiring a service provider. Logistical tasks are linked to the service type on the work order so that different types of services can have different logistical tasks. Logistical tasks include both preapproval tasks (such as assigning a new badge or ordering a new

laptop) and postapproval tasks (such as scheduling orientation or setting up the service provider email). The logistical tasks can be mandatory or optional. Mandatory preapproval tasks must be completed before the work order is approved. Mandatory postapproval tasks, on the other hand, must be completed before a work order is released to a service provider.

market template	In PeopleSoft Enterprise Incentive Management, additional functionality that is specific to a given market or industry and is built on top of a product category.
match group	In PeopleSoft Receivables, a group of receivables items and matching offset items. The system creates match groups by using user-defined matching criteria for selected field values.
MCF server	Abbreviation for <i>PeopleSoft MultiChannel Framework server</i> . Comprises the universal queue server and the MCF log server. Both processes are started when <i>MCF Servers</i> is selected in an application server domain configuration.
merchandising activity	In PeopleSoft Promotions Management, a specific discount type that is associated with a trade promotion (such as off-invoice, billback or rebate, or lump-sum payment) that defines the performance that is required to receive the discount. In the industry, you may know this as an offer, a discount, a merchandising event, an event, or a tactic.
meta-SQL	Meta-SQL constructs expand into platform-specific Structured Query Language (SQL) substrings. They are used in functions that pass SQL strings, such as in SQL objects, the SQLExec function, and PeopleSoft Application Engine programs.
metastring	Metastings are special expressions included in SQL string literals. The metastings, prefixed with a percent (%) symbol, are included directly in the string literals. They expand at run time into an appropriate substring for the current database platform.
multibook	In PeopleSoft General Ledger, multiple ledgers having multiple-base currencies that are defined for a business unit, with the option to post a single transaction to all base currencies (all ledgers) or to only one of those base currencies (ledgers).
multicurrency	The ability to process transactions in a currency other than the business unit's base currency.
national allowance	In PeopleSoft Promotions Management, a promotion at the corporate level that is funded by nondiscretionary dollars. In the industry, you may know this as a national promotion, a corporate promotion, or a corporate discount.
node-oriented tree	A tree that is based on a detail structure, but the detail values are not used.
pagelet	Each block of content on the home page is called a pagelet. These pagelets display summary information within a small rectangular area on the page. The pagelet provide users with a snapshot of their most relevant PeopleSoft and non-PeopleSoft content.
participant	In PeopleSoft Enterprise Incentive Management, participants are recipients of the incentive compensation calculation process.
participant object	Each participant object may be related to one or more compensation objects. See also <i>compensation object</i> .
partner	A company that supplies products or services that are resold or purchased by the enterprise.
pay cycle	In PeopleSoft Payables, a set of rules that define the criteria by which it should select scheduled payments for payment creation.
pending item	In PeopleSoft Receivables, an individual receivable (such as an invoice, a credit memo, or a write-off) that has been entered in or created by the system, but hasn't been posted.

PeopleCode	PeopleCode is a proprietary language, executed by the PeopleSoft application processor. PeopleCode generates results based upon existing data or user actions. By using business interlink objects, external services are available to all PeopleSoft applications wherever PeopleCode can be executed.
PeopleCode event	An action that a user takes upon an object, usually a record field, that is referenced within a PeopleSoft page.
PeopleSoft Internet Architecture	The fundamental architecture on which PeopleSoft 8 applications are constructed, consisting of a relational database management system (RDBMS), an application server, a web server, and a browser.
performance measurement	In PeopleSoft Enterprise Incentive Management, a variable used to store data (similar to an aggregator, but without a predefined formula) within the scope of an incentive plan. Performance measures are associated with a plan calendar, territory, and participant. Performance measurements are used for quota calculation and reporting.
period context	In PeopleSoft Enterprise Incentive Management, because a participant typically uses the same compensation plan for multiple periods, the period context associates a plan context with a specific calendar period and fiscal year. The period context references the associated plan context, thus forming a chain. Each plan context has a corresponding set of period contexts.
plan	In PeopleSoft Sales Incentive Management, a collection of allocation rules, variables, steps, sections, and incentive rules that instruct the PeopleSoft Enterprise Incentive Management engine in how to process transactions.
plan context	In PeopleSoft Enterprise Incentive Management, correlates a participant with the compensation plan and node to which the participant is assigned, enabling the PeopleSoft Enterprise Incentive Management system to find anything that is associated with the node and that is required to perform compensation processing. Each participant, node, and plan combination represents a unique plan context—if three participants are on a compensation structure, each has a different plan context. Configuration plans are identified by plan contexts and are associated with the participants that refer to them.
plan template	In PeopleSoft Enterprise Incentive Management, the base from which a plan is created. A plan template contains common sections and variables that are inherited by all plans that are created from the template. A template may contain steps and sections that are not visible in the plan definition.
planned learning	In PeopleSoft Enterprise Learning Management, a self-service repository for all of a learner's planned learning activities and programs.
planning instance	In PeopleSoft Supply Planning, a set of data (business units, items, supplies, and demands) constituting the inputs and outputs of a supply plan.
portal registry	In PeopleSoft applications, the portal registry is a tree-like structure in which content references are organized, classified, and registered. It is a central repository that defines both the structure and content of a portal through a hierarchical, tree-like structure of folders useful for organizing and securing content references.
price list	In PeopleSoft Enterprise Pricer, enables you to select products and conditions for which the price list applies to a transaction. During a transaction, the system either determines the product price based on the predefined search hierarchy for the transaction or uses the product's lowest price on any associated, active price lists. This price is used as the basis for any further discounts and surcharges.
price rule	In PeopleSoft Enterprise Pricer, defines the conditions that must be met for adjustments to be applied to the base price. Multiple rules can apply when conditions of each rule are met.

price rule condition	In PeopleSoft Enterprise Pricer, selects the price-by fields, the values for the price-by fields, and the operator that determines how the price-by fields are related to the transaction.
price rule key	In PeopleSoft Enterprise Pricer, defines the fields that are available to define price rule conditions (which are used to match a transaction) on the price rule.
process category	In PeopleSoft Process Scheduler, processes that are grouped for server load balancing and prioritization.
process group	In PeopleSoft Financials, a group of application processes (performed in a defined order) that users can initiate in real time, directly from a transaction entry page.
process definition	Process definitions define each run request.
process instance	A unique number that identifies each process request. This value is automatically incremented and assigned to each requested process when the process is submitted to run.
process job	You can link process definitions into a job request and process each request serially or in parallel. You can also initiate subsequent processes based on the return code from each prior request.
process request	A single run request, such as a Structured Query Report (SQR), a COBOL or Application Engine program, or a Crystal report that you run through PeopleSoft Process Scheduler.
process run control	A PeopleTools variable used to retain PeopleSoft Process Scheduler values needed at runtime for all requests that reference a run control ID. Do not confuse these with application run controls, which may be defined with the same run control ID, but only contain information specific to a given application process request.
product category	In PeopleSoft Enterprise Incentive Management, indicates an application in the Enterprise Incentive Management suite of products. Each transaction in the PeopleSoft Enterprise Incentive Management system is associated with a product category.
programs	In PeopleSoft Enterprise Learning Management, a high-level grouping that guides the learner along a specific learning path through sections of catalog items. PeopleSoft Enterprise Learning Systems provides two types of programs—curricula and certifications.
progress log	In PeopleSoft Services Procurement, tracks deliverable-based projects. This is similar to the time sheet in function and process. The service provider contact uses the progress log to record and submit progress on deliverables. The progress can be logged by the activity that is performed, by the percentage of work that is completed, or by the completion of milestone activities that are defined for the project.
project transaction	In PeopleSoft Project Costing, an individual transaction line that represents a cost, time, budget, or other transaction row.
promotion	In PeopleSoft Promotions Management, a trade promotion, which is typically funded from trade dollars and used by consumer products manufacturers to increase sales volume.
publishing	In PeopleSoft Enterprise Incentive Management, a stage in processing that makes incentive-related results available to participants.
record group	A set of logically and functionally related control tables and views. Record groups help enable TableSet sharing, which eliminates redundant data entry. Record groups ensure that TableSet sharing is applied consistently across all related tables and views.
record input VAT flag	Abbreviation for <i>record input value-added tax flag</i> . Within PeopleSoft Purchasing, Payables, and General Ledger, this flag indicates that you are recording input VAT

on the transaction. This flag, in conjunction with the record output VAT flag, is used to determine the accounting entries created for a transaction and to determine how a transaction is reported on the VAT return. For all cases within Purchasing and Payables where VAT information is tracked on a transaction, this flag is set to Yes. This flag is not used in PeopleSoft Order Management, Billing, or Receivables, where it is assumed that you are always recording only output VAT, or in PeopleSoft Expenses, where it is assumed that you are always recording only input VAT.

record output VAT flag	Abbreviation for <i>record output value-added tax flag</i> . See <i>record input VAT flag</i> .
reference data	In PeopleSoft Sales Incentive Management, system objects that represent the sales organization, such as territories, participants, products, customers, channels, and so on.
reference object	In PeopleSoft Enterprise Incentive Management, this dimension-type object further defines the business. Reference objects can have their own hierarchy (for example, product tree, customer tree, industry tree, and geography tree).
reference transaction	In commitment control, a reference transaction is a source transaction that is referenced by a higher-level (and usually later) source transaction, in order to automatically reverse all or part of the referenced transaction's budget-checked amount. This avoids duplicate postings during the sequential entry of the transaction at different commitment levels. For example, the amount of an encumbrance transaction (such as a purchase order) will, when checked and recorded against a budget, cause the system to concurrently reference and relieve all or part of the amount of a corresponding pre-encumbrance transaction, such as a purchase requisition.
regional sourcing	In PeopleSoft Purchasing, provides the infrastructure to maintain, display, and select an appropriate vendor and vendor pricing structure that is based on a regional sourcing model where the multiple ship to locations are grouped. Sourcing may occur at a level higher than the ship to location.
relationship object	In PeopleSoft Enterprise Incentive Management, these objects further define a compensation structure to resolve transactions by establishing associations between compensation objects and business objects.
remote data source data	Data that is extracted from a separate database and migrated into the local database.
REN server	Abbreviation for <i>real-time event notification server</i> in PeopleSoft MultiChannel Framework.
requester	In PeopleSoft eSettlements, an individual who requests goods or services and whose ID appears on the various procurement pages that reference purchase orders.
role	Describes how people fit into PeopleSoft Workflow. A role is a class of users who perform the same type of work, such as clerks or managers. Your business rules typically specify what user role needs to do an activity.
role user	A PeopleSoft Workflow user. A person's role user ID serves much the same purpose as a user ID does in other parts of the system. PeopleSoft Workflow uses role user IDs to determine how to route worklist items to users (through an email address, for example) and to track the roles that users play in the workflow. Role users do not need PeopleSoft user IDs.
roll up	In a tree, to roll up is to total sums based on the information hierarchy.
run control	A run control is a type of online page that is used to begin a process, such as the batch processing of a payroll run. Run control pages generally start a program that manipulates data.
run control ID	A unique ID to associate each user with his or her own run control table entries.

run-level context	In PeopleSoft Enterprise Incentive Management, associates a particular run (and batch ID) with a period context and plan context. Every plan context that participates in a run has a separate run-level context. Because a run cannot span periods, only one run-level context is associated with each plan context.
search query	You use this set of objects to pass a query string and operators to the search engine. The search index returns a set of matching results with keys to the source documents.
section	In PeopleSoft Enterprise Incentive Management, a collection of incentive rules that operate on transactions of a specific type. Sections enable plans to be segmented to process logical events in different sections.
security event	In commitment control, security events trigger security authorization checking, such as budget entries, transfers, and adjustments; exception overrides and notifications; and inquiries.
serial genealogy	In PeopleSoft Manufacturing, the ability to track the composition of a specific, serial-controlled item.
serial in production	In PeopleSoft Manufacturing, enables the tracing of serial information for manufactured items. This is maintained in the Item Master record.
session	In PeopleSoft Enterprise Learning Management, a single meeting day of an activity (that is, the period of time between start and finish times within a day). The session stores the specific date, location, meeting time, and instructor. Sessions are used for scheduled training.
session template	In PeopleSoft Enterprise Learning Management, enables you to set up common activity characteristics that may be reused while scheduling a PeopleSoft Enterprise Learning Management activity—characteristics such as days of the week, start and end times, facility and room assignments, instructors, and equipment. A session pattern template can be attached to an activity that is being scheduled. Attaching a template to an activity causes all of the default template information to populate the activity session pattern.
setup relationship	In PeopleSoft Enterprise Incentive Management, a relationship object type that associates a configuration plan with any structure node.
share driver expression	In PeopleSoft Business Planning, a named planning method similar to a driver expression, but which you can set up globally for shared use within a single planning application or to be shared between multiple planning applications through PeopleSoft Enterprise Warehouse.
single signon	With single signon, users can, after being authenticated by a PeopleSoft application server, access a second PeopleSoft application server without entering a user ID or password.
source transaction	In commitment control, any transaction generated in a PeopleSoft or third-party application that is integrated with commitment control and which can be checked against commitment control budgets. For example, a pre-encumbrance, encumbrance, expenditure, recognized revenue, or collected revenue transaction.
SpeedChart	A user-defined shorthand key that designates several ChartKeys to be used for voucher entry. Percentages can optionally be related to each ChartKey in a SpeedChart definition.
SpeedType	A code representing a combination of ChartField values. SpeedTypes simplify the entry of ChartFields commonly used together.
staging	A method of consolidating selected partner offerings with the offerings from the enterprise's other partners.

statutory account	Account required by a regulatory authority for recording and reporting financial results. In PeopleSoft, this is equivalent to the Alternate Account (ALTACCT) ChartField.
step	In PeopleSoft Sales Incentive Management, a collection of sections in a plan. Each step corresponds to a step in the job run.
storage level	In PeopleSoft Inventory, identifies the level of a material storage location. Material storage locations are made up of a business unit, a storage area, and a storage level. You can set up to four storage levels.
subcustomer qualifier	A value that groups customers into a division for which you can generate detailed history, aging, events, and profiles.
Summary ChartField	You use summary ChartFields to create summary ledgers that roll up detail amounts based on specific detail values or on selected tree nodes. When detail values are summarized using tree nodes, summary ChartFields must be used in the summary ledger data record to accommodate the maximum length of a node name (20 characters).
summary ledger	An accounting feature used primarily in allocations, inquiries, and PS/nVision reporting to store combined account balances from detail ledgers. Summary ledgers increase speed and efficiency of reporting by eliminating the need to summarize detail ledger balances each time a report is requested. Instead, detail balances are summarized in a background process according to user-specified criteria and stored on summary ledgers. The summary ledgers are then accessed directly for reporting.
summary time period	In PeopleSoft Business Planning, any time period (other than a base time period) that is an aggregate of other time periods, including other summary time periods and base time periods, such as quarter and year total.
summary tree	A tree used to roll up accounts for each type of report in summary ledgers. Summary trees enable you to define trees on trees. In a summary tree, the detail values are really nodes on a detail tree or another summary tree (known as the <i>basis</i> tree). A summary tree structure specifies the details on which the summary trees are to be built.
syndicate	To distribute a production version of the enterprise catalog to partners.
system function	In PeopleSoft Receivables, an activity that defines how the system generates accounting entries for the general ledger.
TableSet	A means of sharing similar sets of values in control tables, where the actual data values are different but the structure of the tables is the same.
TableSet sharing	Shared data that is stored in many tables that are based on the same TableSets. Tables that use TableSet sharing contain the SETID field as an additional key or unique identifier.
target currency	The value of the entry currency or currencies converted to a single currency for budget viewing and inquiry purposes.
template	A template is HTML code associated with a web page. It defines the layout of the page and also where to get HTML for each part of the page. In PeopleSoft, you use templates to build a page by combining HTML from a number of sources. For a PeopleSoft portal, all templates must be registered in the portal registry, and each content reference must be assigned a template.
territory	In PeopleSoft Sales Incentive Management, hierarchical relationships of business objects, including regions, products, customers, industries, and participants.
TimeSpan	A relative period, such as year-to-date or current period, that can be used in various PeopleSoft General Ledger functions and reports when a rolling time frame, rather

	than a specific date, is required. TimeSpans can also be used with flexible formulas in PeopleSoft Projects.
trace usage	In PeopleSoft Manufacturing, enables the control of which components will be traced during the manufacturing process. Serial- and lot-controlled components can be traced. This is maintained in the Item Master record.
transaction allocation	In PeopleSoft Enterprise Incentive Management, the process of identifying the owner of a transaction. When a raw transaction from a batch is allocated to a plan context, the transaction is duplicated in the PeopleSoft Enterprise Incentive Management transaction tables.
transaction state	In PeopleSoft Enterprise Incentive Management, a value assigned by an incentive rule to a transaction. Transaction states enable sections to process only transactions that are at a specific stage in system processing. After being successfully processed, transactions may be promoted to the next transaction state and “picked up” by a different section for further processing.
Translate table	A system edit table that stores codes and translate values for the miscellaneous fields in the database that do not warrant individual edit tables of their own.
tree	The graphical hierarchy in PeopleSoft systems that displays the relationship between all accounting units (for example, corporate divisions, projects, reporting groups, account numbers) and determines roll-up hierarchies.
unclaimed transaction	In PeopleSoft Enterprise Incentive Management, a transaction that is not claimed by a node or participant after the allocation process has completed, usually due to missing or incomplete data. Unclaimed transactions may be manually assigned to the appropriate node or participant by a compensation administrator.
universal navigation header	Every PeopleSoft portal includes the universal navigation header, intended to appear at the top of every page as long as the user is signed on to the portal. In addition to providing access to the standard navigation buttons (like Home, Favorites, and signoff) the universal navigation header can also display a welcome message for each user.
user interaction object	In PeopleSoft Sales Incentive Management, used to define the reporting components and reports that a participant can access in his or her context. All Sales Incentive Management user interface objects and reports are registered as user interaction objects. User interaction objects can be linked to a compensation structure node through a compensation relationship object (individually or as groups).
variable	In PeopleSoft Sales Incentive Management, the intermediate results of calculations. Variables hold the calculation results and are then inputs to other calculations. Variables can be plan variables that persist beyond the run of an engine or local variables that exist only during the processing of a section.
VAT exception	Abbreviation for <i>value-added tax exception</i> . A temporary or permanent exemption from paying VAT that is granted to an organization. This terms refers to both VAT exoneration and VAT suspension.
VAT exempt	Abbreviation for <i>value-added tax exempt</i> . Describes goods and services that are not subject to VAT. Organizations that supply exempt goods or services are unable to recover the related input VAT. This is also referred to as exempt without recovery.
VAT exoneration	Abbreviation for <i>value-added tax exoneration</i> . An organization that has been granted a permanent exemption from paying VAT due to the nature of that organization.
VAT suspension	Abbreviation for <i>value-added tax suspension</i> . An organization that has been granted a temporary exemption from paying VAT.
warehouse	A PeopleSoft data warehouse that consists of predefined ETL maps, data warehouse tools, and DataMart definitions.

work order	In PeopleSoft Services Procurement, enables an enterprise to create resource-based and deliverable-based transactions that specify the basic terms and conditions for hiring a specific service provider. When a service provider is hired, the service provider logs time or progress against the work order.
worksheet	A way of presenting data through a PeopleSoft Business Analysis Modeler interface that enables users to do in-depth analysis using pivoting tables, charts, notes, and history information.
worklist	The automated to-do list that PeopleSoft Workflow creates. From the worklist, you can directly access the pages you need to perform the next action, and then return to the worklist for another item.
XML schema	An XML definition that standardizes the representation of application messages, component interfaces, or business interlinks.
yield by operation	In PeopleSoft Manufacturing, the ability to plan the loss of a manufactured item on an operation-by-operation basis.
zero-rated VAT	Abbreviation for <i>zero-rated value-added tax</i> . A VAT transaction with a VAT code that has a tax percent of zero. Used to track taxable VAT activity where no actual VAT amount is charged. Organizations that supply zero-rated goods and services can still recover the related input VAT. This is also referred to as exempt with recovery.

Index

A

- account dimensions 32
- ad hoc queries 18
- additional documentation viii
- API aware 67
- application fundamentals vii
- As Of Date field 58
- Attribute Definitions - Attribute Name page 47
- attribute queries 24
 - Essbase attributes 25
 - general attributes 24
 - PowerPlay attributes 26
 - setting on detail members 24
 - setting on node members 24
- attributes 29
 - designing names 46
 - naming 41
 - selecting 50
 - specifying user defined 25, 47

B

- base currency 57
- bind variables
 - adding 65
 - defining 62, 64
- blank members 36
- bookmarks 30, 63
- Build Cubes - Bind Variables page 61, 64
- Build Cubes - Build Cube page 61, 62
- Build Ledger Cubes page 61
- Build Ledger Cubes run control pages 65

C

- calendars
 - lunar 35
 - standard 35
- cells 7
- Cognos PowerPlay 1, 13
 - applying cube design attributes to 11
 - attributes 26
 - date functions 34
 - defining cube instance definition
 - options 58
 - defining cube settings for 57

- defining time dimensions for 34
- duplicate values 18
- installing 1, 75
- PowerCube 13
- Transformer 13
- unique members 18
- comments, submitting xi
- common elements xi
- Component Permissions page 71
- consolidation 10
- contact information xi
- Content References page 71, 73
- content references, viewing 73
- country dimensions 32
- cross-references x
- cube attributes, choosing names 2
- Cube Builder process 30
- Cube Builder process type 12, 61
- cube components
 - mapping source query fields to 45
 - understanding 29
- cube definitions 29
 - adding cube inputs to 44
 - designing 2
- Cube Definitions - Cube Definition page 42
- Cube Definitions - Cube Inputs page 42, 44
- cube design 29
- cube dimensions
 - designing using tree metadata 17
 - understanding 6
- Cube Filter Criteria page 50, 52
- Cube Input Field page 42, 45
- cube inputs, adding to cube definitions 44
- cube instance definitions 29, 49
 - filters for 30
 - naming 53
 - platform specific 49
 - specifying 30
- cube instances
 - building 49
 - understanding definitions 49
- Cube Instances - Aggregates page 50, 60
- Cube Instances - Cube Inst Def page 50

Cube Manager, *See* PeopleSoft Cube Manager

cube members 7

cubes 6

adding inputs to definitions 44

building 2, 11, 12, 61, 63

choosing attribute names 2

consolidating 10

creating 61

creating filters for 52

creating instance definitions 53

creating new 30

defining aggregates for 60

defining build process in Process

Scheduler Manager 67

defining build specifications for 62

defining settings for 50

definitions 29

designing 2, 12

designing definitions 42, 44

filters 52

hierarchies 8

instance definitions 29, 49

instances 30

mapping source query fields to

components of 45

multi-currency rate 56

naming instance definitions 53

rollups 8

running post-build script 30

running the build process for 68

securing 71

selecting dimensions for 42

updating existing 30

currency category (Essbase attribute) 25

currency conversion type (Essbase attribute) 25

currency cubes, Hyperion Essbase 61

currency members, local 57

currency name (Essbase attribute) 25

currency partition dimensions 32, 57

currency rate database 56

currency, base 57

Current Date field 58

Customer Connection website viii

mapping to dimensions 42

using multiple queries as 27

data storage (Essbase attribute) 25

data store, persistent 15

data update action 55

data, updating 55

database agent queries 18

dates

Cognos PowerPlay functions 34

formats 35

default calculations 55

Dim Input Field page 31, 40

dimension members 7

Dimension Options page 31, 36

dimension queries 19

narrow 19

using level specification 19

using parent/child relationship 19

wide 22

dimensions 6, 7, 29

account type 32

attributes of members 29

children within 10

country type 32

currency partition 32, 57

defining options for 36

defining structures of 31

designing 33

IDs 32, 33

mapping data sources to 42

multiple 7

naming 33

parents within 10

selecting 50

selecting for cubes 42

sharing 33

standard type 32

time type 32

types 32

Dimensions - Dimension page 31

Dimensions - Rollup Inputs page 31, 37, 40

documentation

printed viii

related viii

updates viii

dynamic queries 64

E

Earliest Date field 58

D

dat file 58

data source queries 26

data sources

- effective-dated trees 17
- Enterprise Server 13
 - and PeopleSoft Cube Manager 14, 58
 - installing 75
 - running locally 59
- Enterprise Server field 58
- EP Server, *See* Enterprise Server
- Essbase, *See* Hyperion Essbase
- Essbase Advanced Options page 50, 54
- expense item (Essbase attribute) 25

F

- fact 7
- fact data 6, 7
- field objects
 - identifying 60
- fields
 - mapping 39
 - mapping source query fields to cube components 45
 - mapping to roles 40, 41
- filters 52
 - creating 52
 - understanding 30
- flip sign (general attribute) 24

G

- general attributes 24
- General Ledger, *See* PeopleSoft General Ledger
- generations 17
- globalized formats 12
- glossary 97

H

- hierarchies 8
- HOLAP 6
- hybrid OLAP, *See* HOLAP
- Hyperion Essbase 1, 15
 - applying cube design attributes to 11
 - attributes 25
 - consolidation attribute 25
 - currency cubes 61
 - defining cube settings for 54
 - generations 17
 - installing 1
 - metadata updates 15
 - multi-currency rate cubes 56, 57
 - rollups in 18

- scripting language 15

L

- label (general attribute) 24
- label prefixes 37
 - setting preferences 37
 - setting styles 37
- label suffixes 37
 - setting preferences 37
 - setting styles 37
- Language Override field 58
- languages
 - adding 56
 - default 56
 - multiple 56
 - preferred 56
- Latest Date field 58
- levels 17
 - names 33, 41
 - numbers 33
- levels from top
 - calculating 39
 - nodes 39
- local currency members 57
- long description (PowerPlay attribute) 26
- lunar calendars 35

M

- mapping
 - data sources to dimensions 42
 - fields 39
 - fields to roles 40, 41
 - source query fields to cube components 45
- mdc files 57
- mdl files 58
- measures
 - selecting 50
 - understanding 7
- members 7
 - blank 36
 - case sensitivity and names 18
 - label prefixes 37
 - label suffixes 37
 - naming 36
 - uniqueness and names in PowerPlay 18
- metadata 11
 - cube 17
 - defining source for rollups 37

- designing 1, 17
- dimensional 17
- member attribute 17
- updating 55
- metadata update action 55
- MMA Partners viii
- model file 58
- MOLAP 5
- multi-currency rate cubes
 - creating 57
 - understanding 56
- multidimensional analysis 6
- multidimensional OLAP, *See* MOLAP
- multilevel dimensions 8
- multiple dimensions 7

N

- narrow queries 19
- nodes
 - calculating levels from top 39
 - stop level 39
 - top 39
- notes x

O

- OLAP 5
 - cubes 1
 - data store 11
 - platform options for target databases 30
 - supported tools 12
- OLTP
 - extracting data 11
 - understanding 5
- Online Analytical Processing, *See* OLAP
- Online Transaction Processing, *See* OLTP

P

- Page Permissions page 71, 72
- PeopleBooks
 - ordering viii
- PeopleCode, typographical
 - conventions ix
- Peoplesoft Application Designer, available
 - actions 73
- PeopleSoft application fundamentals vii
- PeopleSoft Cube Manager 1, 10
 - and Enterprise Server 14
 - and PowerPlay Enterprise Server 13
 - architecture 11

- bookmarks 30
- implementing 1
- output 30
- PeopleSoft General Ledger, using bind
 - variables in 65
- PeopleSoft Process Scheduler
 - defining build process in Process
 - Scheduler Manager 67
 - integrating with 12
 - Process Monitor 63
 - Report Manager 63
 - run control IDs 30
 - run control pages 61
 - Server Agent 67
- PeopleSoft queries 12, 19, 24, 26
 - See Also* attribute queries; data source
 - queries; dimension queries
 - ad hoc 18
 - creating 18
 - database agent 18
 - defining cubes with 12
 - defining rollup structure with 12
 - dynamic 64
 - populating OLAP cubes with data
 - using 12
 - role 18
 - specifying member attributes with 12
 - understanding types of 18
 - user 18
- PeopleSoft Query 1, 12
 - bind variables and 64
- PeopleSoft Tree Manager 1, 9, 11
- PeopleSoft trees 11
 - copying 17
 - effective-dated 17
 - leaves 11
 - modifying 17
 - nodes 11
 - subsets of 17
 - using 17
- persistent data store 15
- platform options, for OLAP target
 - databases 30
- post-build scripts 30
- PowerCubes 58
 - defining 13
 - files 57
 - recreating when metadata changes 15
- PowerPlay, *See* Cognos PowerPlay
- PowerPlay Options page 50, 57

PowerPlay Transformation Windows Server
 CD 75

PP Enterprise Server Administrator
 understanding 13
 versus PPAdmtool 14

PPAdmtool
 understanding 14
 versus PP Enterprise Server
 Administrator 14

Ppadmtool.exe 59

PPApplications 14

prefixes 37
 adding to fields and record objects 60
 setting preferences 37
 setting styles 37

prerequisites vii

printed documentation viii

Process Definition page 61, 67

Process Monitor 63

Process Scheduler, *See* PeopleSoft Process
 Scheduler

Process Scheduler Manager, defining a
 cube build process using 67

Process Scheduler Request page 61, 68

PS/nVision 5

Q

queries, *See* PeopleSoft queries

Query, *See* PeopleSoft Query

query bind variables 30

R

rate cubes 55

record objects, identifying 60

related documentation viii

relational OLAP, *See* ROLAP

Report Manager 63

ROLAP 5

role queries 18

roles
 choosing 41, 43
 mapping to fields 40, 41

Rollup Options page 31, 37

rollup-level names
 in Essbase 40
 in PowerPlay 40

rollups 8
 adding inputs for 40
 defining metadata source for 37

defining options for 37

in Essbase 18

mapping fields to roles in 40

names 33

run control IDs 30

run control pages 61
 adding bind variables to 65

Build Ledger Cubes 65

custom 65

S

scripts 63

security 71
 setting user actions 72
 setting user options 71

SELECT statements 12

short label (PowerPlay attribute) 26

signs, changing the value of 24

source query fields, mapping to cube
 components 45

source type, choosing for metadata 38

sparsity levels 56

Specific Date field 58

SQL statements 12

standard calendars 35

standard dimensions 32

Star Schema Options page 50, 60

star schema, understanding 6

stop level 39

suffixes 37
 setting preferences 37
 setting styles 37

suggestions, submitting xi

T

terms 97

time balance (Essbase attribute) 25

time dimensions 32, 34

top node 39

Transformer 13, 59

Tree Manager, *See* PeopleSoft Tree
 Manager

trees, *See* PeopleSoft trees

typographical conventions ix

U

unary operator (Essbase attribute) 25

update
 data 55

Index

metadata 55
user queries 18
user-defined (general attribute) 24

V

visual cues x

W

warnings x
wide queries 22