

PeopleSoft®

---

EnterpriseOne  
Fixed Assets 8.9  
PeopleBook

---

**September 2003**



EnterpriseOne  
Fixed Assets 8.9 PeopleBook  
SKU REL9EFA0309

Copyright© 2003 PeopleSoft, Inc. All rights reserved.

All material contained in this documentation is proprietary and confidential to PeopleSoft, Inc. ("PeopleSoft"), protected by copyright laws and subject to the nondisclosure provisions of the applicable PeopleSoft agreement. No part of this documentation may be reproduced, stored in a retrieval system, or transmitted in any form or by any means, including, but not limited to, electronic, graphic, mechanical, photocopying, recording, or otherwise without the prior written permission of PeopleSoft.

This documentation is subject to change without notice, and PeopleSoft does not warrant that the material contained in this documentation is free of errors. Any errors found in this document should be reported to PeopleSoft in writing.

The copyrighted software that accompanies this document is licensed for use only in strict accordance with the applicable license agreement which should be read carefully as it governs the terms of use of the software and this document, including the disclosure thereof.

PeopleSoft, PeopleTools, PS/nVision, PeopleCode, PeopleBooks, PeopleTalk, and Vantive are registered trademarks, and Pure Internet Architecture, Intelligent Context Manager, and The Real-Time Enterprise are trademarks of PeopleSoft, Inc. All other company and product names may be trademarks of their respective owners. The information contained herein is subject to change without notice.

#### *Open Source Disclosure*

This product includes software developed by the Apache Software Foundation (<http://www.apache.org/>). Copyright (c) 1999-2000 The Apache Software Foundation. All rights reserved. THIS SOFTWARE IS PROVIDED "AS IS" AND ANY EXPRESSED OR IMPLIED WARRANTIES, INCLUDING, BUT NOT LIMITED TO, THE IMPLIED WARRANTIES OF MERCHANTABILITY AND FITNESS FOR A PARTICULAR PURPOSE ARE DISCLAIMED. IN NO EVENT SHALL THE APACHE SOFTWARE FOUNDATION OR ITS CONTRIBUTORS BE LIABLE FOR ANY DIRECT, INDIRECT, INCIDENTAL, SPECIAL, EXEMPLARY, OR CONSEQUENTIAL DAMAGES (INCLUDING, BUT NOT LIMITED TO, PROCUREMENT OF SUBSTITUTE GOODS OR SERVICES; LOSS OF USE, DATA, OR PROFITS; OR BUSINESS INTERRUPTION) HOWEVER CAUSED AND ON ANY THEORY OF LIABILITY, WHETHER IN CONTRACT, STRICT LIABILITY, OR TORT (INCLUDING NEGLIGENCE OR OTHERWISE) ARISING IN ANY WAY OUT OF THE USE OF THIS SOFTWARE, EVEN IF ADVISED OF THE POSSIBILITY OF SUCH DAMAGE.

PeopleSoft takes no responsibility for its use or distribution of any open source or shareware software or documentation and disclaims any and all liability or damages resulting from use of said software or documentation.



# Table of Contents

---

<b>Overviews for the Fixed Assets System</b>	<b>1</b>
Industry Overview for Fixed Assets .....	1
Industry Environment and Concepts for Fixed Assets .....	1
The Competitive Advantage for Fixed Assets .....	1
Fixed Assets Overview .....	3
Fixed Assets System Integration .....	3
Fixed Assets Process .....	6
Fixed Assets Primary Tables .....	8
Fixed Assets Secondary Tables .....	9
<b>Asset Identification Information</b>	<b>10</b>
Asset Master Record .....	10
Category Codes .....	11
Identification Numbers .....	11
Parent and Component Relationships .....	12
Creating an Asset Master Record .....	13
Entering Basic Asset Information .....	14
Deleting Asset Master Records .....	17
Locating Information .....	21
Processing Options for Asset Search (P1204) .....	23
Verifying Depreciation Information .....	30
Entering Additional Asset Information .....	33
Entering Insurance Information .....	33
Entering Financing Information .....	35
Entering Permit and License Information .....	36
Working with Message Logs .....	37
Adding an Attachment .....	39
Accessing Equipment Information .....	40
Entering Supplemental Information for Fixed Assets .....	40
Working with Parent and Component Information .....	42
Reviewing Parent and Component Information .....	42
Revising Parent and Component Information .....	43
Tracking the Location of an Asset .....	45
Transferring the Location of an Asset .....	47
Printing Location Information .....	48
<b>Processing G/L to Fixed Assets</b>	<b>49</b>
Working with G/L Journal Entries .....	50
Revising Unposted Journal Entries .....	50
Splitting Unposted Journal Entries .....	53
Printing the Unposted Fixed Asset Transactions Report .....	57
Posting G/L Journal Entries to Fixed Assets .....	59

Posting Transactions .....	59
Posting Journal Entries to Fixed Assets .....	60
Verifying the Post Process .....	63
Correcting Fixed Asset Balances .....	65
Correcting General Ledger Balances .....	66
Correcting Fixed Asset Balances .....	66
Correcting Depreciation Entries .....	67
Reviewing Asset and Maintenance Costs .....	67
Processing Options for Cost Summary (P122101) .....	70
<b>Asset Depreciation .....</b>	<b>74</b>
Understanding Asset Depreciation Methods .....	74
Elements of Asset Depreciation .....	74
Depreciation Concepts .....	77
Depreciation Rule Components .....	79
Depreciation Calculation - Process Flow .....	80
Entering Units of Production .....	80
Calculating Asset Depreciation .....	83
Running the Compute Depreciation Program .....	83
Generating the Depreciation Journal Report .....	84
Reviewing and Approving the Depreciation Journal .....	95
Reviewing the Depreciation Journal .....	95
Approving Batches of Journal Entries for Posting .....	97
Posting Depreciation to the General Ledger .....	99
Posting a Journal Entry Manually .....	99
Posting Multiple Batches of Journal Entries .....	99
Verifying the Post .....	100
Reviewing Depreciation Information Online .....	101
<b>Fixed Asset Journal Entries .....</b>	<b>103</b>
Splitting Fixed Assets .....	103
Entering Asset Split Information .....	105
Posting Journal Entries for Asset Splits .....	107
Transferring Fixed Assets .....	108
Asset Transfers .....	109
Processing Options for Asset Transfer (R12108) .....	110
Disposing of Fixed Assets .....	130
Fixed Asset Disposals .....	130
Performing Single Asset Disposals .....	134
Performing Mass Asset Disposals .....	137
<b>Asset Revaluation .....</b>	<b>146</b>
Understanding Asset Revaluation .....	146
Revaluation Indexes .....	147
Revaluation Calculation Methods .....	147
Revaluation by Index or Factor .....	148
Calculating Revaluation .....	149

Processing Options for Asset Revaluation Journal (R12845) .....	151
Working with Revaluation Journal Entries .....	158
Reviewing a List of Revaluation Batches .....	158
Revising the Revaluation Journal Entry Detail .....	159
Approving a Batch for Posting .....	160
Revising a Batch for Posting .....	160
Posting Revaluation to the General Ledger .....	161
Posting a Batch Journal Entry Manually .....	161
Posting Multiple Batches of Journal Entries .....	162
Verifying the Post of Journal Entries .....	163
<b>Year-End Processes</b> .....	<b>165</b>
Closing Annual Account Balances .....	165
Processing Options for Asset Account Balance Close (R12825).....	167
Closing Units of Production .....	169
Working with Depreciation Projections .....	170
Running the Depreciation Projections Program .....	170
Purging Depreciation Projections .....	178
<b>Fixed Asset Reports</b> .....	<b>180</b>
Printing Asset Information Reports.....	180
Printing the Asset Master Schedule Report .....	180
Printing the Assets by Finance Method Report .....	180
Printing the F/A Transaction Ledger Report.....	181
Printing the Cost Analysis Report.....	182
Printing Fixed Asset Supplemental Information .....	187
Printing Depreciation Reports .....	188
Printing the Depreciation Schedule .....	188
Printing the Depreciation Defaults Report .....	192
Printing the Depreciation Rules Report .....	193
Printing Depreciation Spread Patterns .....	193
Running Integrity Reports.....	194
Printing the Fixed Assets to G/L Integrity Report .....	194
Printing the Unposted Fixed Asset Transactions Report.....	196
Printing the Fixed Asset Transaction Integrity Report.....	197
Printing the G/L to Fixed Assets Integrity Report .....	199
Printing Quarterly and Year-to-Date Reports .....	202
Printing the Fixed Asset Reconciliation Report .....	202
Printing the Account Reconciliation Report .....	205
Printing the Fixed Asset Retirement Report .....	208
Printing the Depreciation Expense Report .....	213
Printing the Depreciation and Amortization Report .....	216
Printing the Sale of Business Property Report .....	217
Printing the Property Tax Worksheet.....	221
<b>Fixed Assets System Setup</b> .....	<b>224</b>
Setup Features.....	224
Setting Up Fixed Asset Constants.....	225
Setting Up User Defined Codes for Fixed Assets .....	227

Setting Up User Defined Depreciation .....	229
Defining the Requirements for Depreciation .....	229
Setting Up Depreciation Rules .....	232
Compute Direction .....	236
Disposal Year Rules .....	238
Working With Depreciation Formulas .....	246
Setting Up Depreciation Spread Patterns .....	250
Setting Up Date Pattern Override .....	251
Setting Up Short Years in Fixed Assets .....	252
Setting Up Automatic Accounting Instructions for Fixed Assets .....	255
AAIs for User Defined Depreciation .....	259
AAIs for Revaluation .....	260
Setting Up Next Numbers for Fixed Assets .....	261
Setting Up Asset Acquisition Years .....	263
Setting Up Depreciation Default Values .....	264
Copying Depreciation Default Values .....	266
Mapping Category Codes .....	267
Setting Up Ledger Type Rules for Fixed Assets .....	268
Setting Up Disposal Account Rules .....	270
Setting Up Beginning Balances .....	272
Setting Up Revaluation Indexes .....	275
Working with Units of Production Schedules .....	276
Setting Up a Units of Production Schedule .....	276
Printing the Units of Production Report .....	278
Setting Up Supplemental Data .....	278
<b>Fixed Asset Global Updates</b> .....	<b>280</b>
Updating Asset Information .....	280
Updating Depreciation Values .....	280
Updating the Location Code of an Asset .....	283
Updating the Balance Character Code .....	284
Updating the Message Log .....	285
Updating Global Depreciation Rules .....	285
Updating Accounts and Ledgers .....	289
Identifying New Entries .....	289
Adding New Ledgers to Assets .....	291
Updating Company Numbers and Accounts .....	293
Running the Repost Ledger Program .....	295
Updating the Asset Number in the Account Ledger .....	298
Purging Assets and Asset Information .....	299
Processing Options for Asset Master and Balances Purge (R12912) .....	300
<b>Predefined Depreciation Methods</b> .....	<b>309</b>
Method 00 - No Depreciation Method Used .....	310
Method 01 - Straight Line Depreciation .....	311

Method 02 - Sum of the Year's Digits.....	311
Methods 03, 04, and 05 - Declining Balance with Cross-Over.....	312
Method 06 - Fixed % on Declining Balance .....	313
Method 07 - ACRS Standard Depreciation .....	313
Personal Property.....	314
Real Property.....	314
Method 08 - ACRS Optional Depreciation.....	315
Method 09 - Units of Production Method.....	316
Method 11 - Fixed % Luxury Cars.....	316
Method 12 - MACRS Standard Depreciation .....	316
MACRS First Year Bonus Rule for HR 3090.....	317
Method 13 - MACRS Alternative Depreciation .....	318
Method 14 - ACRS Alternate Real Property.....	319
Method 15 - Fixed % on Cost.....	319
Method 16 - Fixed % on Declining Balance with Cross-Over.....	319
<b>International Depreciation Methods</b>	<b>321</b>
French Straight Line (Method 19).....	321
French Declining Balance (Method 20).....	322
French Derogatory (Method 21).....	323
German Building (Method 22) .....	326
German Declining Balance (Method 23) .....	328
German Compound (Method 24) .....	330
German Investment Tax Credit (Method 25).....	332
German Replacement Cost (Method 26) .....	334
Italy Straight Line (Method 27) .....	335
Italy Anticipated (Method 28).....	336
Italy Complete (Method 29).....	337
Spain Declining Balance (Method 30).....	338
Czechoslovakia % Rate (Method 31).....	339
Japan Fixed Installment (Method 32).....	340
Japan Declining Balance (Method 33) .....	342
Japan Beginning Special (Method 34) .....	343
Japan Accelerated (Method 35).....	344
Japan Increased (Method 36) .....	346
Japan Excess (Method 37).....	348
Japan Salvage (Method 38) .....	350

Japan Reserve Reduction (Method 39).....	351
Japan Composite (Method 40).....	353
Korea Straight Line (Method 41).....	355
Korea Revaluation SL (Method 42).....	357
Korea Capital Expenditure SL (Method 43).....	358
Korea Special Rate SL (Method 44).....	359
Korea Declining Balance (Method 45).....	361
Korea Revaluation Declining (Method 46).....	362
Korea Capital Expenditure DB (Method 47).....	363
Korea Special Rate SL (Method 48).....	364
Primary Secondary Tertiary (Method 49).....	365
<b>Formula Elements</b>	<b>368</b>
<b>Initial Term Apportionment Codes</b>	<b>381</b>

---

## Overviews for the Fixed Assets System

Financials are the backbone of corporations, and play an integral role in all levels and aspects of business. Many businesses require an efficient method of managing their assets. The J.D. Edwards Fixed Assets system provides an effective way to track assets for financial and reporting needs.

This section provides overview information about the financials industry, as well as overview information about how the Fixed Assets system operates.

---

## Industry Overview for Fixed Assets

To understand the critical role that fixed assets play in financials, you should understand the ways in which assets affect businesses, and how businesses can more efficiently track and manage their fixed assets through an enterprise-wide reporting system.

This chapter introduces the industry concepts associated with fixed assets. In addition, it outlines several problems that are inherent in a fixed asset environment, as well as J.D. Edwards solutions.

## Industry Environment and Concepts for Fixed Assets

Fixed assets are assets owned by a business enterprise that are permanent or have a long life, and that are used in the business. A fixed asset can be a tangible item, such as a computer, a vehicle, heavy equipment, leasehold improvements, or a building. A fixed asset can also be an intangible item, such as a patent or copyright, which often incurs research and development costs.

Over time, most fixed assets lose their ability to provide useful services. Therefore, companies often assign a useful life to an asset, depending on how long they estimate that the asset will help generate revenue. Companies then record over a specified period of time, or over the life of the asset, the depletion of each asset's usefulness. An asset's loss of usefulness is known as depreciation. The asset's estimated life determines the costs allocated as depreciation, which is recorded as an expense.

In some cases, government regulations determine the life of an asset and how companies capitalize the asset. Companies might also need to use specific depreciation methods to accommodate government regulations that control various tax benefits and liabilities.

The J.D. Edwards Fixed Assets system enables you to:

- Produce fixed asset reports.
- Maintain purchase requests for assets.
- Reconcile assets.
- Maintain tax information for reports to keep track of tax liabilities and benefits.

## The Competitive Advantage for Fixed Assets

The following table presents examples of typical problems with tracking fixed assets, the business activator that can resolve each problem, and the return on investment:

**Depreciation is not being calculated correctly because the methods that are attached to the asset are not correct.**

You can run a global update program to use the corrected defaults and to update the assets that have incorrect methods attached to them. After the assets are updated correctly, recalculate depreciation to correct the amounts that have been calculated incorrectly. If the assets are not set up correctly, the system might over- or understate the net book value of the assets or calculate taxes incorrectly. Global updates allow for quick change and prevent the need for hard coding or custom update programs.

**Changes have been made in your company that affected its chart of accounts, but the changes were not properly recorded. This situation resulted in numerous errors in the accounts.**

When a change in the account structure is made, you can run global updates to update the account number, business unit, or company to the fixed assets tables so that the integrity of the systems is retained. Global update programs ensure system and data integrity, and accommodate your need to make changes across your accounting structure rapidly and without the need for hard coding or custom programming.

**Your company has many of the same type of assets, but it does not have the resources to add the new assets manually.**

Through Fixed Assets automatic accounting instructions, you can set up accounts for which the system automatically creates asset master records for appropriate transactions. After you review the entries that are posted to the account for accuracy, you can run the Post G/L Entries to Fixed Assets report. The system creates asset master records automatically when you run this report.

**Your company has assets that require methods of computation that are not met by the 18 standard depreciation methods.**

For assets for which standard depreciation methods do not apply, you can use User Defined Depreciation (UDD) to create customized depreciation methods.

**For reporting purposes, your company requires its work-in-progress assets to be held along with the completed assets.**

You can add a category code to work-in-progress assets to distinguish these assets for reporting purposes or to exclude them from the depreciation process. These assets will still be recorded in the Fixed Assets system with all other live assets. Category codes can prevent errors that result from depreciation being calculated prematurely or from the inability to distinguish them from live assets. Use the category code to select and exclude data when computing depreciation. When the work-in-progress for the asset is complete, remove the category code from the asset so that it can be included in depreciation.

**For budgeting purposes, your company prefers to run depreciation projections month-by-month rather than yearly. Your company also wants additional details regarding the cost of specific assets.**

Set up an alternate ledger to track depreciation for the future. You can run the depreciation in final mode over the alternate ledger to generate the numbers that are needed for future periods. The detail of each asset will also be recorded on the alternate ledger to track future depreciation amounts back to the individual assets.

**Your company has grown through acquisitions or has had a change in the fiscal date pattern, resulting in a short tax year for fixed assets.**

To help you prevent errors in depreciation calculation that are a result of short tax years, J.D. Edwards recommends learning what changes need to be made to the Fixed Assets system to properly report depreciation during short years. To learn in advance what changes need to be made, you can use the Customer Support line or the self-service Knowledge Garden page for customers.

**Errors in recording entries and amounts resulted in assets that are attached to the wrong items, giving the assets an overstated net book value.**

You can use processing options to disallow entries to the Fixed Assets system that do not include an item number. This action helps to prevent any future errors. You do not need to make the processing option changes each time when a new entry is entered. Instead, you can add a menu option to call a specific version of the program that is used to create journal entries, vouchers, or receipts to a Fixed Assets account number.

## **Fixed Assets Overview**

---

The J.D. Edwards Fixed Assets system is a flexible system that can assist you in managing information and costs that are related to your fixed assets. Many companies delay processing fixed asset information until they are ready to compute period depreciation. You can use Fixed Assets system integration and features-- such as automated asset setup-- to update asset information on a daily, monthly, quarterly, or annual basis, depending on the needs of your organization.

### **Fixed Assets System Integration**

The J.D. Edwards Fixed Assets system links to many of the other J.D. Edwards systems that your company uses. System integration helps ensure that asset information and account transactions are consistent. You need to enter fixed asset and account information only once throughout your company. This one-time action saves considerable time and money, especially when you need to record numerous and complex business transactions daily, and update or revise asset information, such as depreciation rates and account numbers.

The Fixed Assets system is integrated with the following J.D. Edwards systems:

<b>Address Book</b>	Fixed Assets accesses the Address Book system to retrieve up-to-date name and address information for: <ul style="list-style-type: none"><li>• Tax authorities</li><li>• Lessors, financiers, and insurers</li><li>• Employees who are responsible for the asset</li></ul>
<b>General Accounting</b>	The Fixed Assets and General Accounting systems access and store detailed transaction information in the Account Ledger (F0911) table. To maintain integrity between the two systems, process all transactions through both the general ledger (G/L) and fixed assets.
<b>Procurement</b>	The Fixed Assets and Procurement systems access and store information in both the Account Ledger table (F0911) and the Asset Master File table (F1201) to keep company purchases and asset records concurrent and up-to-date. When you purchase assets, you must create asset master records in the Asset Master File table to identify the new assets in your system. The system creates the necessary general ledger accounts in the Account Ledger.
<b>Accounts Payable</b>	The Fixed Assets and Accounts Payable systems are integrated through the Account Ledger table (F0911). You can enter charges that are associated with fixed assets through Accounts Payable. The system automatically enters the asset number from the purchase order to the accounts payable voucher and updates table F0911.

## **Service Management**

In Service Management, an installed base record can be created to track products that you have sold or leased to customers. When these records are created, they are stored in the Asset Master File table (F1201). Before the records are created, the accounts that are used to track this information must be set up within the FX range of AAIs for the Fixed Assets system. These accounts must also have the default coding set up as regular cost accounts in the Fixed Assets system. Typically, installed base records are not depreciated; therefore, depreciation methods do not need to be created for these accounts.

Asset Master records for Service Management can be segregated from the regular Asset Master File records (F1201) by using the warranty date field. Service Management fills in the warranty date field as installed base records are created. Regular fixed asset master records do not use this field.

## **Equipment Plant Maintenance**

The Equipment Plant Maintenance system shares information from many tables in the Fixed Assets system, including:

- Asset Master table (F1201). This table stores the equipment master and fixed asset master information.
- Asset Account Balances File table (F1202). This table stores the equipment account balance and asset account balance information.
- Location Tracking Table (F1204). This table stores the current, historical, and planned location information for fixed assets and equipment.

The Equipment Plant Maintenance system also shares Fixed Assets Constants and automatic accounting instructions (AAIs). All accounts that are part of the Equipment/Plant Maintenance system must be set up in the FX range of AAIs. Other AAIs are used in the Equipment system to track additional cost and statistical information that is not normally used on regular fixed assets.

Fixed assets items and equipment items share the same category codes. If you use the Equipment Plant Maintenance system, you might want to reserve some of the category codes for equipment. For example, you could set aside the first ten category codes to use with equipment.

In addition to sharing tables and setup information, the Equipment Plant Maintenance and Fixed Assets systems have other similar features. For example, when entering, inquiring, and running reports for equipment and fixed asset master items, you use many of the same programs, such as Cost Summary, Supplemental Data, Location Search and Transfer, Asset Master Revisions, and so on.

Equipment items are similar to fixed asset items; however, the Equipment Plant Maintenance system allows you to add and track maintenance issues through work orders and maintenance schedules. The Equipment Plant Maintenance system tracks statistical information such as meter readings and other equipment-related detail.

## **Interoperability**

To fulfill the information requirements of an enterprise, companies sometimes use products from different software and hardware providers. Interoperability among products is key to successfully implementing an enterprise solution. Full interoperability among different systems results in a flow of data among the different products that is seamless to the user.

You can access Interoperability programs from the Asset Interoperability menu (G1233).

For Fixed Assets interoperability transactions, enter JDEFA in the Transaction field and F1201Z1 in the File Name field.

## Multiple Depreciation Books and Methods

You can maintain multiple sets of depreciation books for an asset. You can depreciate assets in different ways for different purposes. For example, you might set up the books for an asset to reflect a three-year life for taxation purposes and a five-year life for financial statement purposes. Or you might have a set of depreciation books for different currencies.

For each set of books that you maintain for an asset, you can assign either a user defined depreciation method or one of the provided predefined depreciation methods, in addition to null depreciation.

You can calculate depreciation daily, weekly, monthly, quarterly, or annually. You can also base your depreciation calculations on a 4-4-5 fiscal pattern or a 13-period pattern.

### User Defined Depreciation

Although the J.D. Edwards Fixed Assets system provides a wide range of depreciation rules, you might need a specific depreciation combination other than those provided with the standard depreciation rules. With user defined depreciation, you can substitute various depreciation conventions, formulas, and spread patterns to define depreciation methods that are specific to your company without using custom programming. For example, you can copy an existing rule and modify it to create a depreciation method for your specific needs.

You can set up user defined depreciation methods to establish the following:

- User-specific depreciation formulas without custom program modifications
- User-specific depreciation rules and conventions
- Depreciation methods for specific categories of assets
- Specific depreciation methods for assets placed in service during certain periods
- Specific depreciation methods for certain years

### Automated Asset Setup

You can use default rules to define default depreciation instructions for individual asset cost accounts by company. When you add newly acquired assets to the Fixed Assets system, the information that you establish in default rules is included automatically in the new asset records. You can override the defaults for special cases. Using default rules saves time, especially if you frequently add assets to the system. You can define default values for:

- Accounting class
- Equipment class
- Depreciation accounts
- Revenue accounts
- Depreciation information

### Asset Location

You can locate assets based on any of the following information:

- Company

- Equipment status
- Description
- Responsible business unit
- Current location
- Category codes

You can also track the history of an asset's movement from location to location.

## Insurance and Financing Information

You can record and access the insurance information for an asset, such as insurance company, policy number, premium cost, value, and replacement cost. You can also account for leased and mortgaged assets; and track monthly payments, purchase options, and contract information.

## Asset Transfers, Splits, and Disposals

You can use the Fixed Assets system to record asset transfers, splits, and disposals in your accounting ledgers.

**Asset transfers** You can transfer assets from one account to another, or from one business unit and account to another. You can transfer assets individually or in groups. You can also use the transfer program to change asset information globally without actually transferring assets.

**Asset splits** You can split an asset into one or more new assets. The system prorates the asset's cost and accumulated depreciation to the new assets, and creates the appropriate journal entries. Use asset splits when you want to dispose of or transfer part of an asset.

**Asset disposals** You can dispose of assets individually or in groups. The system automatically creates the journal entries for each asset disposal, based on your specifications.

## Fixed Assets Process

The process follows an asset from its purchase to its disposal and includes the yearly close. Use this example as a guideline only. Specific steps and procedures vary from company to company.

**Master and depreciation information** Enter the master information for the newly acquired asset and verify the default depreciation information.

**Voucher entry** Enter an accounts payable voucher for the asset.

<b>Post vouchers to the G/L and fixed assets</b>	Post the batch that contains the voucher for the asset.
<b>Compute depreciation</b>	Compute depreciation in preliminary mode to review journal entries that will be posted to fixed assets and the G/L when you compute depreciation in final mode.
<b>Transfer assets</b>	Transfer assets in preliminary mode to review journal entries that will be posted to fixed assets and the G/L when you transfer assets in final mode.
<b>Asset split</b>	The split program automatically creates and posts journal entries to the G/L and then to fixed assets.
<b>Asset disposal</b>	Dispose of assets in preliminary mode to review journal entries that will be posted to G/L and fixed assets when you dispose of assets in final mode.
<b>Annual asset balance close</b>	Close asset balances on a yearly basis after you run the final depreciation. The close program creates the balance records for the next year with cumulative and net balance forward amounts. The close program also carries forward depreciation information.

The following illustration provides a graphic representation of the process:

## Fixed Assets Process

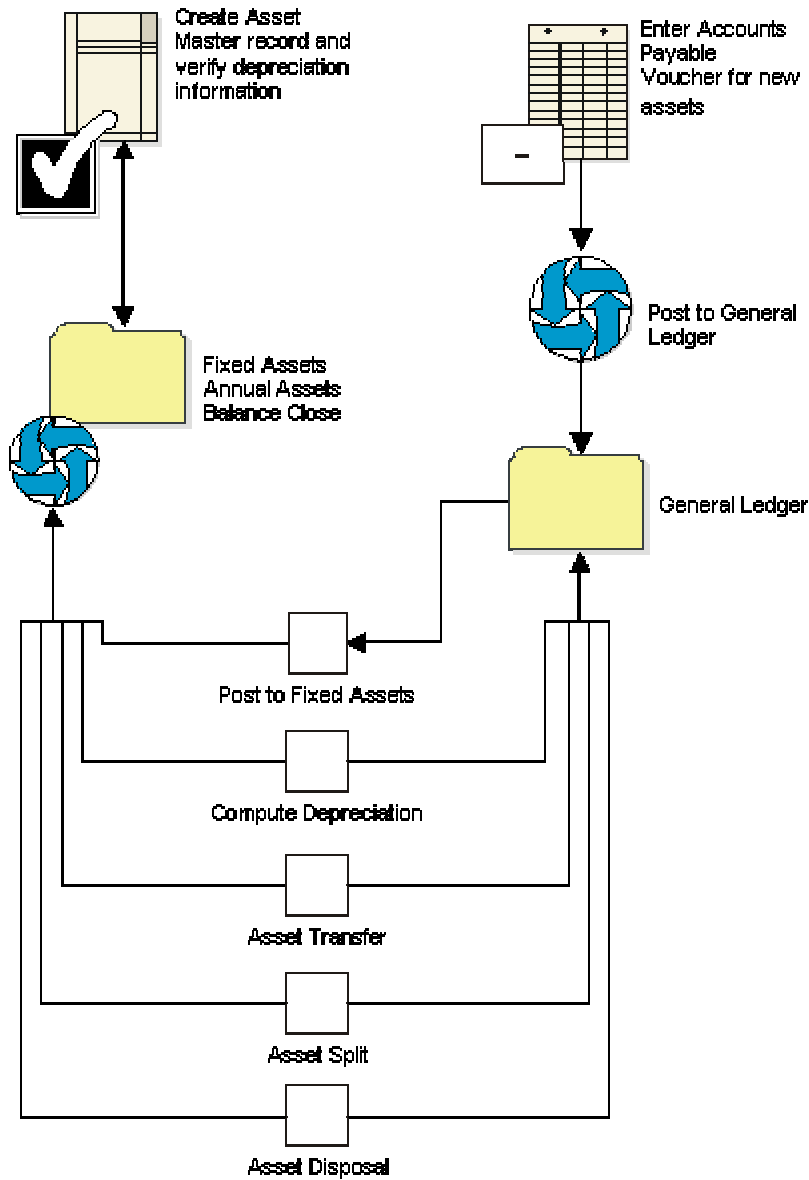

## Fixed Assets Primary Tables

The J.D. Edwards Fixed Assets system stores asset and transaction information in three primary tables:

<b>Asset Master File (F1201)</b>	Stores basic information about each asset, such as: <ul style="list-style-type: none"> <li>• Asset number</li> <li>• Asset description</li> <li>• Account coding</li> <li>• Category codes</li> </ul>
<b>Asset Account Balances File (F1202)</b>	Stores the balance amount for each asset account by ledger type for each year. This table also stores the depreciation information for each asset.
<b>Account Ledger (F0911)</b>	Stores audit trails of general ledger journal entries for both the Asset Account Balances File table (F1202) and the Account Balances table (F0902).

## Fixed Assets Secondary Tables

The Fixed Assets system also accesses the following secondary tables:

- Location Tracking Table (F1204)
- Equipment Messages (F1205)
- Units of Production Schedule Master File (F1208)
- Location History Text (F1210)
- Parent History (F1212)
- Default Accounting Constants (F12002)
- Default Depreciation Constants (F12003)
- Depreciation Rules (F12851)
- Annual Depreciation Rules (F12852)
- Depreciation Formulas (F12853)
- Depreciation Period Spread Rules (F12854)
- User Defined Codes (F0005)
- Ledger Type Master File (F0025)
- Address Book Master (F0101)
- Account Master (F0901)
- Automatic Accounting Instructions Master (F0012)
- Business Unit Master (F0006)
- Supplemental Data (F12090, F12092)
- Specification Data (F1216)
- Specification Cross Reference (F1215)
- Status History File (F1307)

---

## Asset Identification Information

You must identify every asset in the system before you can use the Fixed Assets system.

You must create an asset master record to identify each of your company's assets. You can also include supplemental information to further define the assets in the system.

---

## Asset Master Record

The asset master record includes the basic information that identifies an asset. You must create asset master records so that you can do the following:

- Manage asset depreciation.
- Track asset costs.
- Record asset splits, transfers, and disposals.

### Supplemental Information

You might need to store information about an asset or equipment that is not included in the standard master tables. J.D. Edwards refers to this additional information as supplemental data. You can use supplemental data to further define the assets in your system. After you set up supplemental data, you can use it to report and track details that are important to your company but are not included on the master record. You can define as many types of supplemental data as you need.

You define and maintain supplemental data by asset or equipment class. For example, you might set up supplemental data for an asset class that includes motor graders. The data might include fuel capacities, horsepower, oil readings, and so on.

### Message Logs

Use message logs to record and track short informational messages about assets or equipment that the master record and supplemental data forms cannot accommodate. For example, you can use message logs to:

- Indicate the status and condition of an asset.
- Record details about asset transfers or disposals.
- Log problems or complaints about a specific asset.
- Note special procedures for scheduled or preventive maintenance tasks.
- Report on actual maintenance.
- Log problems or complaints about a specific piece of equipment.

You can associate message logs with equipment to record operator notes or maintenance problems. You can also attach tickler dates to maintenance-due messages so that they appear on specified dates or intervals based on units such as miles or hours.

You can use paragraph, outline, or any other format that you choose to enter information in message logs.

## Category Codes

---

You can define up to 33 category codes to meet your organization's information needs. Use these category codes in the master record to further describe assets and equipment and to group similar types of equipment for ease of tracking, reporting, and data selection throughout the system.

J.D. Edwards recommends setting up the first category code to group assets into accounting classes. In this case, the first category code is typically referred to as the Major Accounting Class. You can set up this category code with a one-to-one relationship with asset cost accounts in the general ledger. You might also select another category code to identify assets by the depreciation methods for translation that you assign each one.

If you use Equipment/Plant Maintenance, Equipment Billing, or Service Management with the Fixed Assets system, the four systems access the same category code tables. Equipment/Plant Maintenance and Equipment Billing users frequently use the first ten category codes as selection criteria for several tasks, such as selecting equipment for updating meter readings, updating PM schedules, and so on. You should reserve as many of the first ten category codes in the equipment master as you need for equipment maintenance purposes.

### See Also

- ❑ *User Defined Codes* in the *Foundation Guide* for more information about reserving the first ten category codes for equipment and plant management

See the following topics in the *Fixed Assets Guide*:

- ❑ *Setting Up User Defined Codes for Fixed Assets* for more information about how user defined codes are used to organize asset information
- ❑ *Setting Up Depreciation Default Values* for more information about inserting default information into the asset master record

## Identification Numbers

---

You can use one of the following three numbers as the primary number to identify assets throughout your system:

- Asset number (8 characters)
- Unit number (12 characters)
- Serial number (25 characters)

Different branches of your company might refer to assets in different ways. For example, accounting personnel might identify equipment by asset number, and maintenance personnel might refer to equipment by unit number or the manufacturer's serial number.

Every asset master record in your system must include an asset number. You can enter unit and serial numbers if you need to do so. You must define which of these numbers is used as the primary number for identifying assets on the Fixed Assets Constants form. Any identification number that you assign to an asset on the asset master record must be unique throughout your entire system.

### See Also

- ❑ *Setting Up Fixed Asset Constants* in the *Fixed Assets Guide* for information about using asset identification numbers

## Parent and Component Relationships

---

You can set up parent and component relationships to group individual assets or pieces of equipment. For example, when you create master records, you can identify a computer as a parent item. You can identify the monitor, keyboard, and mouse as components of the computer. Those components, in turn, might be the parents of still other components, and so on.

Parent assets can be physical assets or pseudo assets. You can set up pseudo assets to group assets under a parent that does not directly incur costs or generate revenue. For example, you might set up departments as parent pseudo assets. Each department might have a certain number of cubicles as component assets. Each cubical might be the pseudo parent of real assets, such as computers, telephones, and so on.

You can establish up to 25 hierarchical levels of a parent item. The system assigns a number to each component according to its level in the hierarchy, which is particularly useful for tracking complex assets.

The following graphic illustrates a typical relationship between parent and component equipment:

### Relationship Between Parent Component Equipment

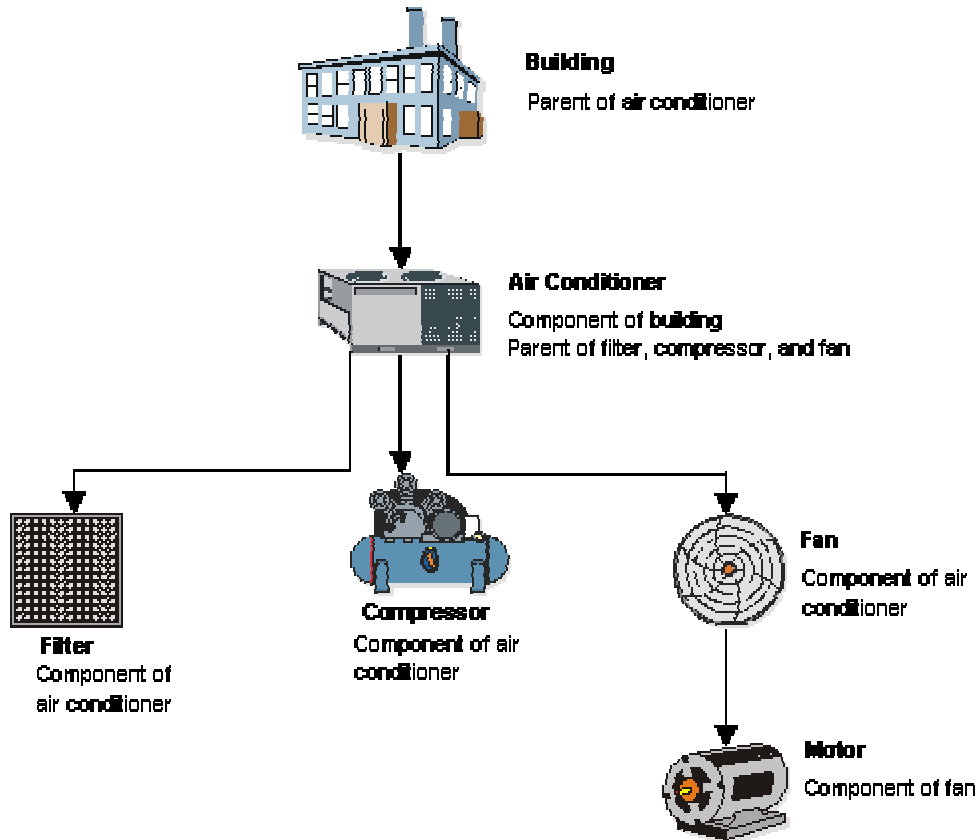

## Creating an Asset Master Record

---

You must create an asset master for every asset that you want to manage throughout the Fixed Assets system. When you create master records, you establish basic information about each asset, such as:

- Asset numbers to uniquely identify the asset
- The department that is responsible for the asset
- The cost account for the asset
- The date when you acquired the asset
- User-defined category code descriptions of asset status, class, and so on
- Textual descriptions or remarks to help you locate the asset

When you create master records for an asset, the system automatically creates:

- Ledgers in the Asset Account Balances File table (F1202)
- Depreciation information, based on depreciation rules that you define during system setup, including the depreciation start date (the asset's acquisition date)
- General ledger account information, based on depreciation account rules that you define during system setup

The system stores asset master records in the Asset Master File table (F1201). When you request specific asset transactions, the system accesses or updates the information in this table.

### Before You Begin

- Verify that all system setup activities are complete. See *Setting Up Fixed Asset Constants* in the *Fixed Asset Guide* for more information about setting up the Fixed Assets system.

## Entering Basic Asset Information

You use the Asset Master Revisions form to create an asset record. You use the Asset Master Revisions form to change the asset master information.

---

### Note

If you set up the Fixed Assets range for cost accounts in the Automatic Accounting Instructions (AAls), the system can automatically create asset master records. The system creates the records based on the default information that you specify when you set up the Fixed Assets system.

---

## Assigning Category Codes to Assets

After you enter basic asset information, you can assign values to any of the category code fields. Use category codes to further identify, track, and report on an asset. In addition, you can further identify assets by specifying financing and tax information. You can use the Category Code Mapping program to automatically assign category code values to assets based on the cost code values for the business units that are assigned to those assets. If a category code has been mapped, it does not allow manual changes on the category code form.

The Accounting Class and Equipment Class category codes can be derived from the Default Depreciation Coding values.

Use the Depreciation Category Code to divide assets into depreciation classes. The depreciation information is defined in Default Depreciation Values.

### See Also

The following topics in the *Fixed Assets Guide* provide more information about setting up depreciation category codes:

- [Setting Up Fixed Asset Constants](#)
- [Setting Up Depreciation Default Values](#)

► **To enter basic asset information**

---

*From the Fixed Asset Master Information menu (G1211), choose Master Information.*

1. On Work With Assets, click Add.
2. On Asset Master Revisions, complete the following fields on the Asset Information tab:

- Asset Number
- Description
- Company
- Responsible BU
- Account Number
- Date Acquired

3. Complete the following optional fields:

- Unit Number
- Serial Number
- Parent Number

If you change a parent number, you must specify the date that the parent number changed for the asset. You might change parent numbers to update or establish parent and component relationships.

- Status
- Subledger Inact.
- Employee

If you use the Equipment Plant Management system with the Fixed Assets system, you can change the status of an asset on the Asset Master Revisions form. If you change the status of an asset, you must indicate the date and time when the status of the asset changed, and whether you want the system to update all of the children of the asset to the same status. This field is shared between the Fixed Assets system and the Equipment Plant Management system.

4. Complete the following optional maintenance field:

- Inventory Number

5. To allow the asset to be entered in a work order, turn on the following option:

- Allow WO

6. To enter location information, click the Location tab and complete the following fields:

PeopleSoft®

Select Workspace: Active Foundation

Active Foundation Personalize Change Role Sign Out

Asset Master Revisions

Asset Number 1001 Last Asset Number Entered

Asset Information Location Category Codes Additional Info

**Identification**

Asset Number 1001  
 Unit Number AAB  
 Serial Number 96U4825  
 Parent Number 1001

**Description**

AA9 Motor Grader  
 Ripper, Power Assist, Push  
 Block, Scarifier, Encl Cab

**Accounting Information**

Company Number 00050 Project Management Company  
 Responsible BU YARD Yard  
 Account Number 50.2030 Heavy Equipment  
 Date Acquired 01/01/03 Date Disposed AFE

Status AV Available - On Job Site Date Time 00:00:00  
 Subledger Inact. Active Subledger  
 Employee 200 Manufacturing/Distribution Com  Allow WO  
 Inventory Number

- Location
  - Start Date
  - Current Item Qty
  - Original Item Qty
  - Equipment Status
  - Column
  - Row
7. To enter category code information, click the Category Codes tab and complete the category code fields that you want to use.
  8. To enter extended category code or tax information, click the Additional Info tab and complete the following fields:
    - Category Code 21
    - Category Code 22
    - Category Code 23
    - New or Used
    - Financing Method

- State/Province
  - Tax Entity
  - Investment Tax Credit
9. Click OK.

## Deleting Asset Master Records

You can delete asset master records only under the following circumstances:

- Transactions have not been posted to the fixed assets Asset Account Balances File table (F1202). After transactions have been posted to fixed assets, you cannot delete an asset even if the balance amounts are zero.
- The asset does not have associated amounts in Beginning Balance Setup. You must delete any asset amounts in Beginning Balance Setup before you can delete the asset master record.
- Any transactions that have not been posted to the Account Balances table (F0902) are deleted.
- Any transactions that have been posted to the Account Balances table (F0902) are voided. You cannot delete transactions that are posted to Account Balances.

### ► To delete an asset master record

---

*From the Fixed Asset Master Information menu (G1211), choose Master Information.*

1. On Work With Assets, click Find to view all assets.  
To restrict the assets that appear, click the tabs in the header area of the Work With Assets form, complete the appropriate information, and then click Find.
2. Choose the asset that you want to delete.
3. Click Delete.
4. Click OK.
5. On Work With Assets, click Find.  
The asset that you deleted should not appear.

## Processing Options for Asset Master Information (P1201)

### Edits Tab

---

Require Unit Number

Blank = Do not require unit number.

1 = Require unit number when doing 'add'

Use this processing option specify whether the system requires a unit number when adding an asset. Valid values are:

Blank

Do not require a unit number.

1

Require a unit number.

1. Location Default

Blank = No location

1 = Default location from responsible business unit

### Defaults Tab

Use this processing option to specify whether the location of an asset is derived from the responsible business unit. Valid values are:

Blank

Do not use the location from the responsible business unit.

1

Use the location from the responsible business unit as the default.

---

---

## 2. Location Start Effective Date

Blank = Default to the system date

1 = Default to the date acquired

Use this processing option to specify the effective start date for the location of an asset. Valid values are:

Blank

Use the system date as the effective start date.

1

Use the acquired date as the effective start date. You can use the acquired date as the effective start date only if the system date in the asset master record is blank.

## 3. Child Asset Cost Account Information Default

Blank = Do not default to parent asset

1 = Default to parent asset when adding children assets

Use this processing option to specify whether cost account information is derived from the parent asset. Valid values are:

Blank

Do not use the parent asset as the source for default cost account information.

1

Use the parent asset as the source for default cost account information.

## 4. Create Asset Account Balances (F1202)

---

---

Blank = Not create asset account balances

1 = Create asset account balances

Use this processing option to specify whether the system creates ledgers in the Asset Account Balances File table (F1202). Valid values are:

Blank

Do not create ledgers in the F1202.

1

Create ledgers in the F1202.

### **Exports Tab**

#### **1. Transaction Type**

Use this processing option to specify the transaction type for the export transaction.

Note: If you leave this processing option blank, the system does not perform interoperability processing.

#### **2. Version**

Use this processing option to specify the outbound processor version that the system uses when it runs interoperability processing. If you leave this processing option blank, the system uses version XJDE0002.

---

### **What You Should Know About Processing Options**

When the date acquired is after than the system date, the system date will be used for the location start effective date. The location start effective date cannot be later than the system date.

The system uses the values specified in the processing options as the default for Location Start Effective Date and Location Default.

## Locating Information

---

Use the Work With Assets form to locate asset information. For example, if you need to transfer a piece of equipment, but you do not know its identification number, you can locate the equipment by entering the description of the equipment on Equipment Search. You can also use other equipment information that you know, such as equipment status or location, to search for all of the pieces of equipment which share the same characteristics.

The Work With Assets form has tabs that you can use limit your search. When you click a tab, filtering fields appear. The information that you enter in these fields narrows the asset search. You can sequence the detail asset information by either asset number or asset description.

The following list details the criteria by which you can search for equipment:

- Company
- Equipment status
- Description
- Responsible business unit
- Location
- Category codes

After you locate equipment, you can access the following features and forms directly from Equipment Search:

- Equipment Master
- Location Transfer
- Parent History Inquiry
- Search Like Equipment
- Message Log
- Cost Summary
- Location History
- License Tracking
- Work Order Backlog
- Equipment Backlog
- Supplemental Data
- PM Schedule
- Completed PM

When you search for equipment, you can locate multiple pieces of similar equipment or individual pieces of equipment. The more fields that you complete on the search forms, the more you narrow your search.

For example, if you need to see a list of all of your company's backhoes, you can enter as much information as you know about the backhoes. The system searches the equipment information databases and displays all of the equipment that meets the criteria which you enter in the fields.

► **To locate information**

---

*From the Fixed Asset Master Information menu (G1211), choose Asset Search and Location.*

1. On Work With Assets, complete the following fields on the Display tab:
  - Skip To Description
  - Resp. Business Unit
  - Location
2. Click the Additional Selections tab.
3. Complete the following optional fields:
  - Equipment Status
  - Company
  - Inventory Number
4. Click the following optional options:
  - Display Children
  - Display Disposed
5. Click each of the Category Code tabs, and complete the appropriate category code fields.
6. Click Find.

Asset information appears in the detail area.

---

**Note**

When you search for an asset on the Work With Assets form, the Skip To Description field in the header area and the query-by-example fields in the detail area do not display data if asset descriptions have been translated. However, the Description - Compressed field displays data if the descriptions have been translated; you can conduct your search through this field.

---

7. Choose the asset that you want to review and click Select to access the complete master information.

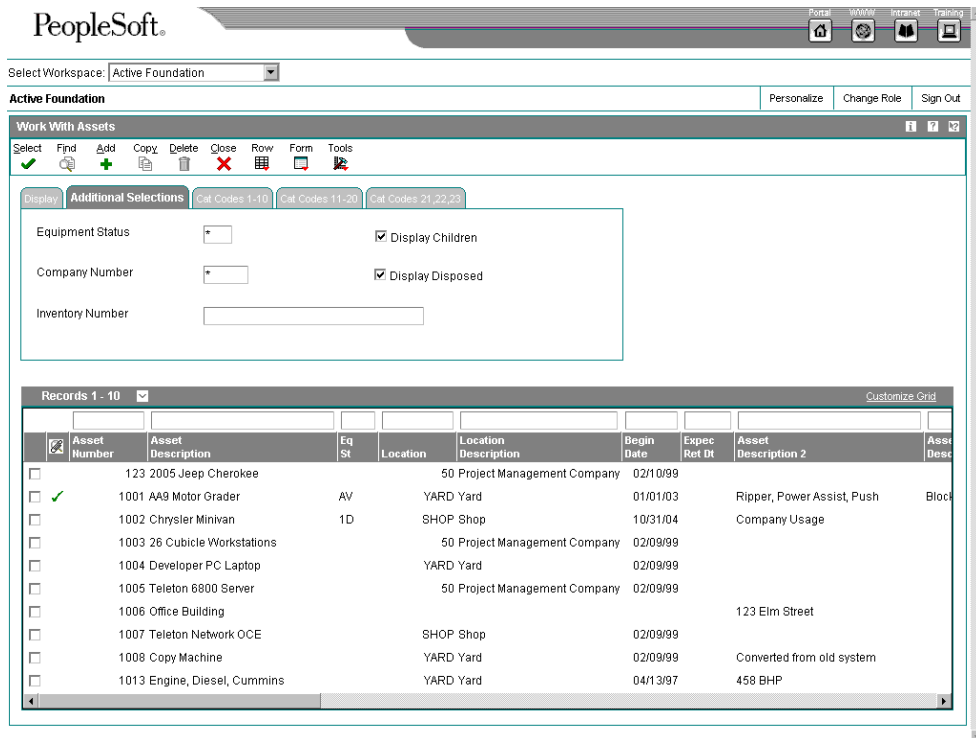

## Processing Options for Asset Search (P1204)

### Categories Tab

For information about a processing option, right-click the processing option field and choose What's This from the menu. Or, click the processing option field and press F1.

Use these processing options to define the defaults that are applied when you inquire on asset records.

#### 1. Category Code 1 (Accounting Class)

Use this processing option to enter the default for the Asset Master Category Code 1. A blank value will select all.

---

2. Category Code 2 (Equipment Class)

Use this processing option to enter the default for the Asset Master Category Code 2. A blank value will select all.

---

---

3. Category Code 3

Use this processing option to enter the default for the Asset Master Category Code 3. A blank value will select all.

---

---

4. Category Code 4

Use this processing option to enter the default for the Asset Master Category Code 4. A blank value will select all.

---

---

5. Category Code 5

Use this processing option to enter the default for the Asset Master Category Code 5. A blank value will select all.

---

---

6. Category Code 6

Use this processing option to enter the default for the Asset Master Category Code 6. A blank value will select all.

---

---

7. Category Code 7

Use this processing option to enter the default for the Asset Master Category Code 7. A blank value will select all.

---

---

8. Category Code 8

Use this processing option to enter the default for the Asset Master Category Code 8. A blank value will select all.

---

---

9. Category Code 9

Use this processing option to enter the default for the Asset Master Category Code 9. A blank value will select all.

---

---

## 10. Category Code 10

Use this processing option to enter the default for the Asset Master Category Code 10. A blank value will select all.

---

### **Defaults Tab**

For information about a processing option, right-click the processing option field and choose What's This from the menu. Or, click the processing option field and press F1.

---

#### Company

Use this processing option to specify a default company code.

---

---

#### Equipment Status

Use this processing option to specify a default equipment status.

---

---

#### Inventory Item Number

Use this processing option to specify a default inventory item number.

---

### **Versions Tab**

For information about a processing option, right-click the processing option field and choose What's This from the menu. Or, click the processing option field and press F1.

Use these processing options to define the application versions to execute.

---

1. Scheduling Workbench Version (P48201)

Blank = ZJDE0001

Use this processing option to enter the version of Scheduling Workbench (P48201) to be used. If left blank, ZJDE0001 will be used.

---

---

## 2. Select Button Exit

1 = Asset Master

2 = Financing Information

3 = Insurance Information

4 = Beginning Balance Setup

5 = Asset Split

6 = Depreciation Information

7 = Single Asset Disposal

Use this processing option to assign a specific application to the Select button. You can choose a row and click the Select button, or double-click the row to quickly exit to the application you specify. Valid values are:

1 Exit to the Asset Master. This is the default value.

2 Exit to Financing Information.

3 Exit to Insurance Information.

4 Exit to Beginning Balance Setup.

5 Exit to Asset Split.

6 Exit to Depreciation Information.

7 Exit to Single Asset Disposal.

---

---

3. Asset Master Version (P1201)

Blank = ZJDE0001

Use this processing option to enter the version of the Asset Master (P1201) to be used. If left blank, ZJDE0001 will be used.

---

---

4. Single Asset Disposal Version (P12105)

Blank = ZJDE0001

Use this processing option to enter the version of the Single Asset Disposal program (P12105) to be used. If you leave this processing option blank, the system uses the default version, ZJDE0001.

---

---

## 5. Beginning Balance (P12130)

Blank = ZJDE0001

Use this processing option to enter the version of the Beginning Balance Adjustments program (P12130) to be used. If you leave this processing option blank, the system uses the default version, ZJDE0001.

---

## **Verifying Depreciation Information**

---

When you create asset master records, the system automatically assigns depreciation information to each asset. You define the default values that the system assigns to new assets when you set up the constants and depreciation default coding for your system.

Every asset that you set up in the system has one master record. In addition, the asset can have several different ledgers. Each ledger is represented by a separate balance record in the Asset Account Balances File table (F1202). You can assign a different depreciation method to each ledger.

If you use subledgers, you must specify the same subledger for both the cost account and the accumulated depreciation account. If you specify a subledger on the depreciation account but do not specify a subledger for the cost account, the system does not recognize the accumulated depreciation when you run the depreciation program. When you use a subledger on the cost account, a separate accumulated depreciation account is created for each cost account that has a subledger.

The following illustration shows how Asset Master information flows through Depreciation Default Coding and is assigned to multiple ledgers in the Asset Account Balances table:

### Asset Master Information Flow

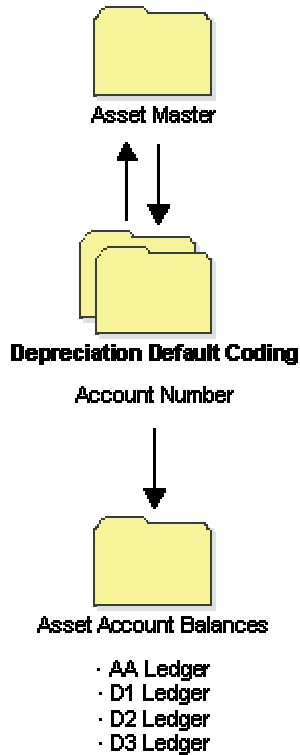

After you set up asset master records, you can review both master information and balance information on the Depreciation Information form. You might want to review Depreciation Information to verify that the depreciation rules that you have set up for the system are correct for individual assets. For example, you might want to verify the following information:

- Master record information, such as the business unit, object, and subsidiary accounts that the system uses to create journal entries
- All the ledgers assigned to the asset, such as budget and depreciation ledgers
- Depreciation methods for the asset

You can revise general ledger information only if you have not posted transactions to the accounts. If you want to revise cost account or accumulated depreciation account information after posting to the accounts, you can use the asset transfer programs.

When you enter master records for individual assets, you can review the default depreciation information that the system automatically completed based on the information that you set up for depreciation default coding. Use the Depreciation Information form when you want to:

- View depreciation information for an asset for any fiscal year.
- Override an asset's default depreciation information for current or future fiscal years.
- Add new ledger types and depreciation methods to individual assets.

► **To verify depreciation information**

On the Fixed Asset Master Information menu (G1211), choose Depreciation Information.

1. On Work With Assets, click Find to view all assets.

To narrow your search, click the tabs in the header area of the Work With Assets form, complete the appropriate information, and click Find.

When you are searching for an asset on the Work With Assets form, the Skip To Description field in the header area and the query-by-example fields in the detail area do not display data if asset descriptions have been translated. However, the Description - Compressed field displays data if the descriptions have been translated; you can conduct your search through this field.

2. Choose the asset.
3. From the Row menu, choose Asset Master Info, and then Depr Information.

PeopleSoft

Select Workspace: Active Foundation

Active Foundation Personalize Change Role Sign Out

Depreciation Information

OK Find Delete Cancel Form Row Tools

Asset Number: 1004 Company: 00050  
 Developer PC Laptop Fiscal Year: 2008

Asset Cost Account: 50.2070 Computer  
 Accum Depr Account: 50.2170 Accum Depr-Computer  
 Depr Exp Account: YARD.8336 Depreciation - Computer Equip  
 Revenue Account: YARD.8421 Revenue

LT	Ledger Type Description	Depr Meth	Depr Method Description	Life Mos	Depr Info	Meth Comp	Start Depr	Meth %	Meth 9 Sch No	Salvage Value
AA	General Ledger	01	Straight Line Depreciation	36		I	06/30/04			
<input type="checkbox"/>	D1	Federal Tax-Book1 04	150% Declining Bal wCr	60 Y		I	06/30/04			
<input type="checkbox"/>	D3	Earn. & Profit-MACRS 12	MACRS Standard Deprec	60 Y		C	06/30/04			
<input type="checkbox"/>	D4	Alter. Minimum-200% 05	200% Declining Bal wCr	60 Y		I	06/30/04			
<input type="checkbox"/>	D5	MACRS Alternative 13	MACRS Alternative Depre	60 Y		R	06/30/04			

4. On Depreciation Information, complete the following field and click Find to indicate the year for which you want to verify depreciation information:

- Fiscal Year

5. Verify the following account information fields:

- Asset Cost Account
- Accum Depr Account
- Depr Exp Account

- Revenue Account

If you use subledgers, the Asset Cost Account and Accumulated Depreciation Account must share the same subledger for depreciation to work correctly.

6. Verify the following depreciation information fields:

- LT
- Ledger Type Description
- Depr Meth
- Depr Method Description
- Life Mos
- Meth Comp
- Start Depr
- Meth %
- Meth 9 Sch No
- Salvage Value

## Entering Additional Asset Information

---

Additional asset information is detailed information about an asset that is included in the asset master record. This additional information further defines the assets in your system. Use this additional information to report and track information that is important to your company. For instance, you can add information about insurance coverage or financing for your assets.

### See Also

- *Locating Information* in the *Fixed Assets Guide* for information about completing the tab information that is necessary to locate specific assets

## Entering Insurance Information

You can record insurance information for an asset. The Fixed Assets system does not require insurance information, but this information can be helpful if you want to track the insurance company, policy number, renewal month, and so on, for an asset. The data that you enter on the Insurance Information form is informational only.

### ► To enter insurance information

---

*From the Fixed Asset Master Information menu (G1211), choose Insurance Information.*

1. On Work With Assets, click Find to view all assets.

To narrow your search, click the tabs in the header area of the Work With Assets form, complete the appropriate information, and click Find.

When you are searching for an asset on the Work With Assets form, the Skip To Description field in the header area and the query-by-example fields in the detail area do not display data if asset descriptions have been translated. However, the Description - Compressed field display data if the descriptions have been translated; you can conduct your search through this field.

2. Choose the asset.
3. From the Row menu, choose Asset Master Info, and then Insurance.

The screenshot shows the PeopleSoft interface for the 'Insurance Information' form. The form is titled 'Insurance Information' and is part of the 'Active Foundation' workspace. The form contains several input fields for recording insurance details:

Asset Number	1001
AA9 Motor Grader	
Insurance Company	Hartford
Insurance Policy Number	A7-44612
Renewal Month	
Insurance Premium	412.12
Insurance Value	25,000.00
Replacement Cost	29,000.00
Last Years Replacement Cost	28,000.00

4. On Insurance Information, complete any of the following fields to record insurance information, and click OK:
  - Insurance Company
  - Policy Number
  - Renewal Month
  - Insurance Premium
  - Insurance Value
  - Replacement Cost
  - Last Years Replacement Cost

## Entering Financing Information

You can record financing information for an asset. The Fixed Assets system does not require finance information, but this information can be helpful if you want to track the financier, type of financing, monthly payments, purchase options, and so on for an asset. You can also track contract and expiration dates. The data that you enter on the Financing Information form is informational only.

### ► To enter financing information

*From the Fixed Asset Master Information menu (G1211), choose Financing Information.*

1. On Work With Assets, click Find to view all assets.

To narrow your search, click the tabs in the header area of the Work With Assets form, complete the appropriate information, and click Find.

When you are searching for an asset on the Work With Assets form, the Skip To Description field in the header area and the query-by-example fields in the detail area do not display data if asset descriptions have been translated. However, the Description - Compressed field display data if the descriptions have been translated; you can conduct your search through this field.

2. Choose the asset.
3. From the Row menu, choose Asset Master Info, then Finance.

The screenshot shows the PeopleSoft interface for entering financing information. The browser window title is "PeopleSoft". The top navigation bar includes "Portal", "WWW", "Intranet", and "Training". The "Select Workspace" dropdown is set to "Active Foundation". The "Active Foundation" header includes "Personalize", "Change Role", and "Sign Out" options. The main form is titled "Financing Information" and contains the following fields:

Asset Number	1001
	AA9 Motor Grader
Financing Method	Capitalized Lease
Lessor, Rentor or Mortgagor Address	1001 J.D. Edwards & Company
Purchase Option	<input checked="" type="checkbox"/> Yes there is a purchase option
Purchase Option Price	
Purchase Option Maximum Credit	
Purchase Option Credit Percentage	
Contract Date	01/01/03
Date Expired	10/15/12
Monthly Payment	995.00
Explanation	
Explanation - Remark	

4. On Financing Information, complete any of the fields to record financing information, and click OK:
  - Financing Method
  - Lessor, Rentor or Mortgagor Address
  - Purchase Option
  - Purchase Option Price
  - Purchase Option Maximum Credit
  - Purchase Option Credit Percentage
  - Contract Date
  - Date Expired
  - Monthly Payment
  - Explanation
  - Explanation - Remark

## Entering Permit and License Information

Enter permit and license information to record permits, licenses, and certificates for equipment. You can also track renewal dates and multiple state licenses. For example, you can track certification information for equipment, such as bridge cranes, and license renewal information for equipment that you transport to areas under different licensing authorities.

### ► To enter permit and license information

---

*From the Fixed Asset Master Information menu (G1211), choose Master Information.*

1. On Work With Assets, click Find to view all assets.

To narrow your search, click the tabs in the header area of the Work With Assets form, complete the appropriate information, and click Find.

When you are searching for an asset on the Work With Assets form, the Skip To Description field in the header area and the query-by-example fields in the detail area do not display data if asset descriptions have been translated. However, the Description - Compressed field displays data if the descriptions have been translated; you can conduct your search through this field.

2. Choose the asset.
3. From the Row menu, choose Asset Master Info, and then Licenses.

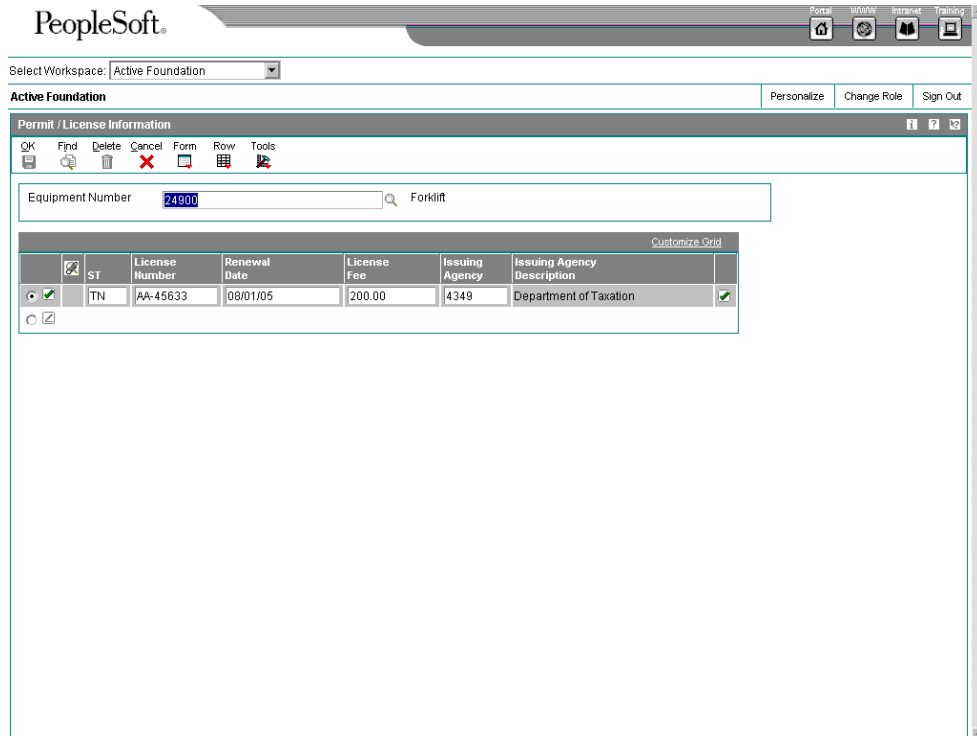

4. On Permit / License Information, review the existing permit and license information.
5. To enter new permit or license information, complete the following fields and click OK:
  - ST
  - License Number
  - Renewal Date
  - License Fee
  - Issuing Agency
6. To return to Work With Assets, click Cancel.

## Working with Message Logs

You can use the message log to enter short text messages that pertain to an asset, such as the notification of a particular problem with the asset. You can also set up tickler dates or units on which you want to receive a reminder message for the asset.

For example, you can indicate a unit meter reading on a specific date when you want to remember to make an appointment for the scheduled maintenance of an asset.

The system stores tickler dates and units in the account that you define for the AT00 automatic accounting instruction.

## ► To enter an asset message

---

*From the Fixed Asset Master Information menu (G1211), choose Master Information.*

1. On Work With Assets, click Find to view all assets.

To narrow your search, click the tabs in the header area of the Work With Assets form, complete the appropriate information, and click Find.

When you are searching for an asset on the Work With Assets form, the Skip To Description field in the header area and the query-by-example fields in the detail area do not display data if asset descriptions have been translated. However, the Description - Compressed field displays data if the descriptions have been translated; you can conduct your search through this field.

2. Choose the asset.
3. From the Row menu, choose Asset Master Info, and then Message Log.

The Work With Message Log form shows a summarized view of all messages for a particular piece of equipment. You can click Add to enter a new message, or you can enter an asset number to display messages and choose a message to review in detail.

4. On Work With Message Log, click Add.
5. On Message Log, complete the following fields:
  - Message From
  - Message Type
  - Tickler M/H
  - Tickler Date

If you do not enter a value for Tickler Miles/Hours, the system enters the current date in the Tickler Date field. Any value that you enter in the Tickler Date field overrides the date that is assigned by the system.

6. In the Message area, enter a message.

The Message Type field might already contain a default value.
7. To save your entries, click OK.
8. To return to Work With Assets, click Close.

## ► To review asset messages

---

*From the Fixed Asset Master Information menu (G1211), choose Master Information.*

1. On Work With Assets, click Find to view all assets.

To narrow your search, click the tabs in the header area of the Work With Assets form, complete the appropriate information, and click Find.

When you are searching for an asset on the Work With Assets form, the Skip To Description field in the header area and the query-by-example fields in the detail area do not display data if asset descriptions have been translated. However, the Description - Compressed field displays data if the descriptions have been translated; you can conduct your search through this field.

2. Choose the asset.
3. From the Row menu, choose Asset Master Info, and then Message Log.
4. On Work With Message Log, to review a specific message, choose the message and click Select.
5. On Message Log, to attach the message to another piece of equipment, complete the following field and click OK:
  - Send To AssetYou can change other information about the message before you attach it to another piece of equipment.
6. On Work With Message Log, to return to Work With Assets, click Close.

## Adding an Attachment

After you create a master record for an asset, you can add one or more of the following attachments:

- Text
- Image
- OLE
- Shortcut

These attachments are for internal reference only.

### ► To add an attachment

---

*From the Fixed Asset Master Information menu (G1211), choose Master Information.*

1. On Work With Assets, click Find to view all assets.

To narrow your search, click the tabs in the header area of the Work With Assets form, complete the appropriate information, and click Find.

When you are searching for an asset on the Work With Assets form, the Skip To Description field in the header area and the query-by-example fields in the detail area do not display data if asset descriptions have been translated. However, the Description - Compressed field displays data if the descriptions have been translated; you can conduct your search through this field.
2. Choose the asset.
3. From the Row menu, choose Attachments.
4. On Media Objects, from the File menu, choose New and then one of the following options:
  - Text
  - Image
  - OLE
5. Attach the text or object.
6. From the File menu, choose Save & Exit to return to the Work With Assets form.

On the Work With Assets form, an icon appears next to the asset for which you created an attachment.

## Accessing Equipment Information

If your asset is equipment, you can access equipment information that is managed by the Plant & Equipment Management system. On the Work With Assets form, choose an asset, and then perform one of the following actions from the Row menu:

- To populate the Work With Assets form with category codes 1-10 for a specific asset and to find other assets that have the same values, choose the asset, then choose Equipment Info, and then choose Like Equipment.
- To review work order information for an asset, choose the asset, then choose Equipment Info, and then choose WO Backlog.
- To review equipment backlog information for an asset, choose the asset, then choose Equipment Info, and then choose Equipment Backlog.
- To review preventive maintenance schedules for an asset, choose the asset, then choose Equipment Info, and then choose PM Schedule.
- To review preventive maintenance history for an asset, choose the asset, then choose Equipment Info, and then choose PM Backlog.

### See Also

See the following topics in the *Enterprise Asset Management Guide*:

- ❑ *Reviewing Work Order Costs from Equipment Backlog*
- ❑ *Locating Work Orders Using Equipment Backlog*
- ❑ *Working with PM Schedules*
- ❑ *Changing the Status of PMs to Complete*

## Entering Supplemental Information for Fixed Assets

*From the Fixed Asset Master Information menu (G1211), choose Data Entry.*

Supplemental information is information about an asset that is not included in the standard master tables. Enter supplemental information to track, review, and report on additional information that is not contained in the asset master record. You can define and maintain any type of supplemental data that you need by asset class. For example, you might set up supplemental data for motor graders. The data might include vibration readings, oil readings, condition reports, and so on.

### See Also

- ❑ *Working with Supplemental Data* in the *Address Book Guide*

### Before You Begin

- ❑ Set up supplemental databases and supplemental data types. See *Working with Supplemental Data* in the *Address Book Guide*.

## Reviewing Fixed Assets Supplemental Information

When you need to review supplemental information for an asset, you can quickly determine whether a particular supplemental data type contains information. On Work With Supplemental Data, a check mark appears in the leftmost field (unlabeled) next to rows for which supplemental data in code format has been entered. In addition, regardless of the data format, if narrative data exists for a supplemental data type, a paper clip icon appears when you place the computer pointer in the field.

You can review a list of additional asset information based on a particular supplemental data type. For example, assume that you have set up a supplemental data type for capacity. You can review a list of all assets for which you have assigned the supplemental data type for capacity. You can use data selections to limit the amount of information displayed by the system. You can also review a list of the additional information by supplemental data type that you assigned to individual assets. For example, you can review information for all supplemental data types that you assigned to a particular motor grader. You can use data selections to limit the amount of information that the system displays.

### ► To review supplemental information by data type

---

*From the Fixed Asset Master Information menu (G1211), choose Supplemental Data Inquiry by Data Type.*

1. On Supplemental Inquiry by Data Type, complete the following field:
  - Type Data
2. To limit the information displayed by the system, complete the following optional fields, and click Find:
  - Effective Date
  - Ending Effective Date
  - Skip to UDC

### ► To review supplemental information by asset

---

*From the Fixed Asset Master Information menu (G1211), choose Supplemental Data Inquiry by Asset.*

1. On Supplemental Inquiry by Asset, complete the following field:
  - Equipment Number
2. To limit the information displayed by the system, complete the following optional fields, and click Find:
  - Beginning Date
  - Ending Date

## Working with Parent and Component Information

---

After you establish parent and component relationships in the asset master, you can review all the components for a specific asset. You can track up to 25 levels of component relationships for a parent asset. Review parent and component information so that you can:

- Report on asset costs at the parent or component level.
- Track all of the components that have been assigned to a parent or the parents to which a specific component has been assigned.

After you review an asset's parent and component information, you can revise the parent information for individual components and change the sequence of the components.

### Reviewing Parent and Component Information

If you entered parent and component relationship information about an asset when you created the asset master record, you can use the Work With Parent History form to find an asset, and review parent and component relationships. If the asset is a parent, you can review all of the components related to that parent. If the asset is a component, you can review the parent for the component, as well as the other components that are associated with the parent.

You can also display all current or previous parents for a component, or all current or previous components for a parent. Use date fields to limit your search to selected dates, or leave the date fields blank to review the history of a component or parent.

From the Work With Parent History form, you can also:

- Review parent or component cost information.
- Review parent or component meter readings.
- Enter parent or component supplemental information.

#### See Also

- ❑ *Working With Meter Readings* in the *Equipment Plant Management Guide* for information about using the Meter Readings form
- ❑ *Entering Supplemental Information* in the *Fixed Assets Guide*

#### ► To review parent and component information

---

*Use one of the following navigations:*

*From the Fixed Asset Master Information menu (G1211), choose Parent History Inquiry.*

*From the Equipment Information menu (G1311), choose Parent History Inquiry.*

1. On Work With Parent History, complete the following field:
  - Asset Number
2. Complete the following optional fields:
  - Date From

- Date Thru

Alternatively, to view parent or component formats, choose Component Format or Parent Format from the View menu.

3. Click Find.
4. Review the parent and component relationship information.
5. After you locate and choose a parent or component detail, perform one of the following actions:
  - To review parent or component cost information, choose Cost Summary from the Row menu.  
The Work with Cost Summary form appears.
  - To review parent or component meter readings, choose Meter Reading Inq. from the Row menu.  
Review the meter information for the asset on the Meter Reading Inquiry form. To work with meter information, choose Meter Readings from the Form menu. The Meter Readings form appears.
  - To enter parent or component supplemental information, choose Supplemental Data from the Row menu.  
The Work With Supplemental Data form appears.
6. Perform one of the following actions to access other fixed assets information from the Work With Parent History form:
  - To find an asset, choose Asset Search from the Form menu.  
The Work With Assets form appears.
  - To see the parent information for the previous asset, choose Previous Asset from the Form menu.  
The Work With Parent History form re-appears with the information about the previous asset that you reviewed.

## Revising Parent and Component Information

After you review an asset's parent and component information, you can revise the parent information for individual components and change the sequence of the components.

### ► To revise parent information for a component

---

*From the Fixed Asset Master Information menu (G1211), choose Parent History Inquiry.*

1. On Work With Parent History, complete the following field and click Find:
  - Asset Number
2. Choose the asset for which you want to revise the parent number, and then click Select.
3. On Asset Master Revisions, complete the following fields and click OK:
  - Parent Number

- Date Acquired

► **To change the sequence of components**

*From the Fixed Asset Master Information menu (G1211), choose Parent History Inquiry.*

1. On Work With Parent History, complete the following field and click Find:
  - Asset Number
2. Choose the asset for which you want to revise the parent number, and then click Select.
3. On Asset Master Revisions, choose Equipment Info from the Form menu, and then Components and NBV.
4. On Work With Equipment Components, choose Change Sequence from the Form menu.

The screenshot shows the PeopleSoft interface for the 'Change Sequence' dialog. At the top, there is a 'Select Workspace' dropdown set to 'Active Foundation'. Below that, the 'Change Sequence' dialog box is open, featuring an 'Asset Number' input field containing '123'. Underneath the input field is a table with the following data:

Records 1 - 1					
	Display Seq	Level	Asset Number	Description	
<input checked="" type="checkbox"/>	<input checked="" type="checkbox"/>	1	123	2005 Jeep Cherokee	<input checked="" type="checkbox"/>

5. On Change Sequence, complete the following field for each component that you want to change, and click OK:
  - Display Seq

## **Tracking the Location of an Asset**

---

You can track physical asset movements and perform asset relocations. You also can review planned, current, and historical asset locations.

For example, if you want to know where an asset is scheduled to be on a certain date, you can review all the location information for the asset. You can also make any necessary changes to an asset location record or enter new location records. Finally, you can enter details about any of your revisions by entering location-tracking text for the location information.

You enter equipment location information into the system so you can track equipment locations as you physically transfer equipment from one job site or business unit to another. If you have multiple quantities of an equipment item, such as scaffolding, you can also do the following:

- Relocate quantities of the same equipment item to more than one current location.
- Relocate quantities of the same equipment item to a single location from more than one current location.

When you update the location information for an asset, the system automatically updates the following fields in the Asset Master File table (F1201):

- Equipment Status
- Location and Start Date (if the current transfer beginning date is greater than the existing location start date and you have only one current location)

You can assign beginning location and start dates to assets only when you create master records or relocate the asset.

When you relocate an asset, consider the following system features:

<b>Location dates</b>	<p>When you specify the dates for location information, note the following guidelines:</p> <ul style="list-style-type: none"> <li>• The system prevents you from entering location information if the relocation date is after the asset disposal date.</li> <li>• Any location information that you enter with a date after the system date must have a location code of Planned (P).</li> </ul>
<b>Multiple current locations</b>	<p>When the asset has multiple current locations, the Location and Start Date fields in the master record are blank. The system displays the message Multiple Current Locations in the location description line.</p>
<b>Consolidating assets in one location</b>	<p>The system automatically consolidates location records when you enter location information for multiple assets with identical billing information. For example, if you enter location information with identical relocation dates, times, and billing information for assets that are currently in multiple locations, the system creates one location record for all of the assets.</p>
<b>Relocating partial quantities</b>	<p>When you relocate partial quantities of an asset, the system modifies the original location record to a history record for the full quantity. The system also creates a new current record to show the quantity that remains at the original location and a new current record for the quantity that you relocated.</p>
<b>Entering location information out of sequence</b>	<p>You enter location information out-of-sequence when you record the relocation of an asset from a location where it does not currently reside. The system issues a warning message. If you do not change the From Location field, the system sorts out the location records by date, and determines whether to create a new location tracking line or to update an existing location record.</p> <p>For example, you might need to create location records out-of-sequence if the paperwork for the asset relocation is delayed. In this case, the paperwork might be entered after the asset is actually moved to the most current location.</p> <p>If you enter the new location information for the truck indicating the relocation from job site B to job site C, the system creates a history location for job site B and a current location for job site C. The history location for job site B indicates a duration of zero because you have not indicated when the truck was relocated from the yard to job site B.</p> <p>When you enter the relocation information regarding the transfer from the yard to job site B, the system revises the location dates for yard and job site B. The system also updates the duration that the equipment was actually at job site B.</p>
<b>Parent and component relationships</b>	<p>When you enter location information for an asset that is the parent of components, the system automatically relocates all of the components that are at the same location as the parent to the new location.</p>

## Transferring the Location of an Asset

You enter location information for an asset when you set up the asset master record. You can change the master record location information by using the Location Transfer program.

### Before You Begin

- Verify that location information for an asset is available. See *Entering Basic Asset Information* in the *Fixed Asset Guide*.

### ► To transfer the location of an asset

---

*From the Transfers, Splits & Disposals menu (G1222), choose Location Transfer.*

1. On Work With Locations, complete the following field, and click Find:
  - Asset Number
2. Select the asset that you want to transfer, and choose Location Transfer from the Row menu.
3. On Location Transfer, choose the asset you want to transfer, and complete the following fields:
  - To Location
  - Effective Date
  - Beginning Time
  - Transfer Number
  - From Location

PeopleSoft®

Select Workspace: Active Foundation

Active Foundation Personalize Change Role Sign Out

Location Transfer

OK Cancel Form Row Tools

To Location: 50 Transfer Number: 1

Effective Date: 06/30/05

Beginning Time: From Location: 70

Records 1 - 1

Equipment Number	Equipment Description	Location	Location Description	L	C	Begin Date	Begin Time	Ending Date

4. Click OK. To review location revision information for an asset, choose an asset and then choose Revisions from the Row menu.
5. On Location Revisions, review the location revision information for the asset.
6. To return to Location Transfer, click Cancel.
7. From the Location Transfer form, you can perform other tasks from the Form menu:
  - To review the billing rates for the asset, choose Billing Rates.
  - To locate and transfer another asset, choose Location Inquiry.
  - To review rental rules for an asset, choose Rental Rules.
  - To review meter readings for an asset, choose Meter Readings.
  - To update a meter reading for an asset, choose Update Meter.

## Printing Location Information

*From the Transfers, Splits, & Disposals menu (G1222), choose Print Location Information.*

You can print the location information to review current, historical, and planned locations for selected assets. This report prints information from the Location Tracking Table (F1204).

The report information is the same information that you can review on the Work With Locations form.

---

## Processing G/L to Fixed Assets

You can generate fixed asset journal entries through any J.D. Edwards system that creates entries in the G/L transaction table, the Account Ledger (F0911). Systems that frequently generate journal entries that affect the Fixed Assets system are listed below:

- Accounts Payable
- General Accounting
- Inventory Management
- Procurement
- Equipment Plant Management

The system identifies fixed asset journal entries based on the fixed asset range of accounts that you set up in the automatic accounting instructions (AAIs). Accounts that fall within the fixed asset (FX) range of the AAIs include the following:

- Asset cost accounts
- Accumulated depreciation accounts
- Operating expense accounts
- Asset disposal accounts

In addition to determining which accounts fall into the fixed asset range, you can use subledger functions to reflect another dimension of your costs. For example, you can use subledgers to show original cost; additions; and, if necessary, restatement or revaluation cost. These functions are useful when these components have different depreciation schedules.

After the system creates journal entries for the asset transactions that you enter, possibly including subledger information, you must post the entries first to the general ledger and then to fixed assets. When you post to the general ledger, the system updates the Account Balances table (F0902). When you post to fixed assets, the system updates the Asset Account Balances File table (F1202).

Before posting journal entries to fixed assets, the system verifies that each entry includes:

- A general ledger post code of P, which means that the journal entry has been posted to table F0902, except when posting ledgers with a transaction creation code of 2
- An account that falls within the fixed asset range of accounts set up in AAIs
- A fixed asset post code of blank to indicate that the system has not yet posted the journal entry to table F1202
- A valid asset number
- A hold code of blank

When you post journal entries to fixed assets, the system updates table F1202 and marks each transaction as posted.

The following graphic shows the type of journal entries that affect fixed assets and how the system assigns entries to the Fixed Assets system:

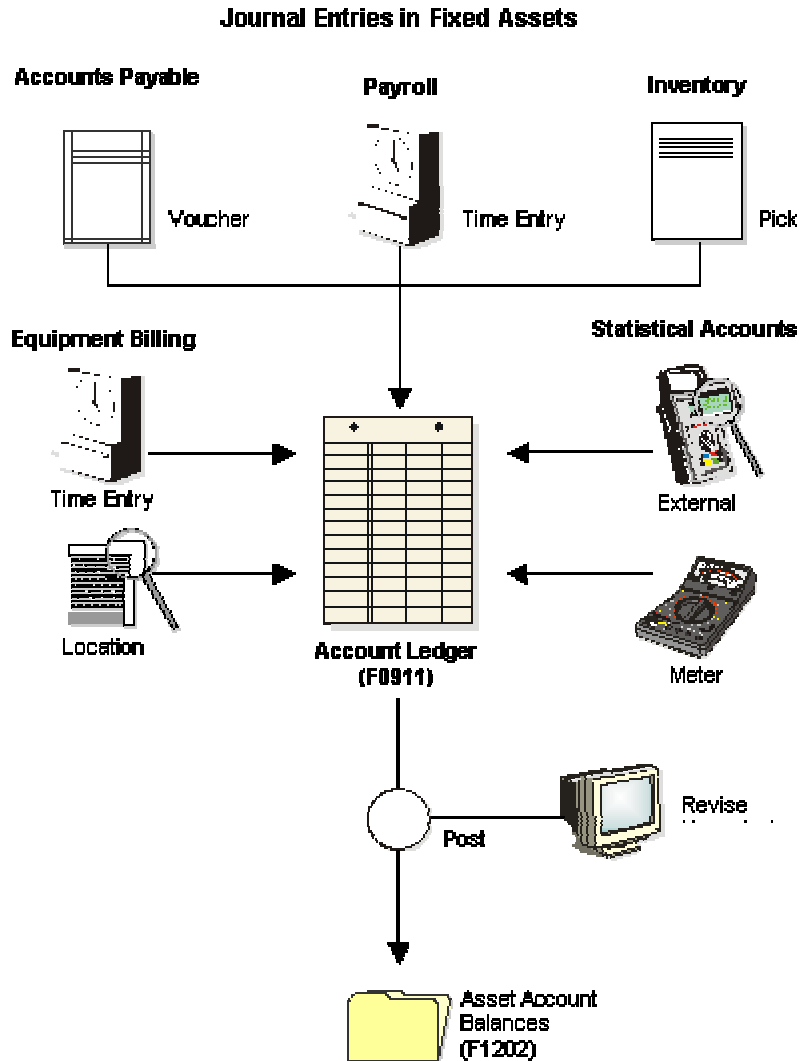

## Working with G/L Journal Entries

You can revise fixed asset journal entries that are posted to the general ledger before they are posted to fixed assets. For example, you might want to review journal entries to ensure that all of the fixed asset information, such as asset numbers, is included. You also work with G/L journal entries if you want to keep any transactions that fall within the fixed asset (FX) range of AAIs from posting to fixed assets. An example of this type of journal entry is for transactions that you record to make corrections to the general ledger.

### Revising Unposted Journal Entries

Use Revise Unposted Entries to make specific changes to journal entries before they are posted to fixed assets or equipment. The following list provides examples of changes you can make:

- Revise or add an asset or equipment number to a journal entry.
- Revise or add a description to further explain a journal entry.
- Create a master record for journal entries that include an asset cost account for an asset or a piece of equipment that is new to the system.
- Revise the hold or pass code on a journal entry to temporarily or permanently prevent it from posting to fixed assets or equipment.
- Post individual journal entries interactively to final assets rather than in a batch job.

---

**Note**

To ensure the integrity of your transaction records and audit trails, the system prevents changes to account information that has already been posted to the general ledger, such as:

- G/L account number
  - Amount
  - G/L date
- 

**See Also**

- ❑ *Creating an Equipment Master* in the *Equipment Billing Guide*
- ❑ *Working with Basic Journal Entries* in the *General Accounting Guide* for information about revising unposted journal entries

See the following topics in the *Fixed Assets Guide*:

- ❑ *Creating an Asset Master Record*
- ❑ *Adding an Attachment* for more information about working with media objects
- ❑ *Splitting Unposted Journal Entries* for more information about splitting a journal entry

**Before You Begin**

- ❑ Run the Identify New Entries program (R12803) to identify non-fixed asset transactions so that they will not be processed in the Fixed Assets system. When non-fixed assets are identified, the Revise Unposted Entries program (P12102) can quickly locate fixed asset journal entries without having to search through all general ledger transactions. See *Identifying New Entries* in the *Fixed Assets Guide*.

---

**► To revise unposted journal entries**

---

*From the Posting G/L to Fixed Assets menu (G1212), choose Revise Unposted Entries.*

1. On Work With Unposted Entries, complete any of the following fields to locate a transaction:
  - Account Number
  - BU and/or Object

- Batch Number/Type
  - Document No/Ty/Co
  - Asset Number
  - Company
  - Hold Code
  - Ledger Type
2. To limit the display of entries, click one of the following in the Fixed Assets Post/Passed Code field:
    - Unposted
    - Passed
    - All Entries
  3. Click Find.

PeopleSoft

Select Workspace: Active Foundation

Active Foundation Personalize Change Role Sign Out

Work With Unposted Entries

Select Find Close Row Form Tools

Account Number 50.2030 Company Number

BU and/or Object Hold Code

Batch Number/Type Ledger Type AA

Document No/Ty/Co

Asset Number

Fixed Asset Post/Passed Code  Unposted  Passed  All Entries

Asset Number	Explanation	Amount	Doc Ty	Doc Number	GL Date	H C	P C	Line Number	Ex
<input type="checkbox"/>	Replacement Blades	16,000.00	JE	3315	04/30/05			1.0	S
<input type="checkbox"/>	New Backhoe	5,800.00	JE	3316	05/15/05			1.0	F
<input type="checkbox"/>	Core Drilling Bit	8,500.00	OV	4176	06/30/05			1.0	D
<input type="checkbox"/>	Hydraulic Press	5,000.00	OV	4177	06/30/05			1.0	D
<input type="checkbox"/>	Heavy Equipment	169,683.52	PV	3104	04/30/05			1.0	D
<input type="checkbox"/>	<b>Total</b>	<b>204,983.52</b>							

4. To review or change a journal entry description, choose a journal entry, and then choose Revise Entries from the Row menu.  
Alternatively, click Select.
5. On Revise Unposted Entries, complete the following fields, and click OK:

- Asset Number
  - Batch Number/Type
  - Post/Passed Code
  - F/A Hold Code
  - Bill Code
  - DOI
6. To return to Work With Unposted Entries, click Cancel.
  7. On Work With Unposted Entries, click Find to see the journal entry change.
  8. To review additional journal entry information, you can perform the following actions:
    - To review or add an attachment for a journal entry, choose a journal entry, and then choose Attachments from the Row menu.
    - When you attach generic text to a journal entry, the attachment persists through the posting process. You can see the note through the Account Ledger Inquiry form after posting.
    - To review an existing asset master record or create a new asset master record, choose a journal entry, and then choose Asset Master from the Row menu.
    - To review the originating document, choose a journal entry, and then choose Original Source from the Row menu.
    - To post a single journal entry or multiple selected entries, choose a journal entry, and then choose Post from the Row menu.

For a transaction to be posted, it must contain a fixed asset Post/Passed Code value of blank, a G/L post code value of P (except when you are posting ledgers with a transaction creation code of 2), and a hold code value of blank.

When you post journal entries interactively, the system does not automatically generate the Journal Entries report. You can run the F/A Transaction Ledger report to review the results of your interactive post, or you can review the results online using the Work with Cost Summary form.

- To split a journal entry, choose a journal entry, and then choose Split from the Row menu.
- To review an asset's balance portfolio, choose a journal entry, and then choose Cost Summary from the Form menu.
- To review order information for an asset, choose Order Details from the Form menu. If a purchase order is attached to the journal entry, it is displayed in the Purchase Order fields on the Work With Unposted Entries and Revise Unposted Entries forms.

## Splitting Unposted Journal Entries

You can use the Revise Unposted Entries program (P12102) to split a journal entry into two or more entries before you post to fixed assets or equipment. For example, you might split unposted journal entries when an accounts payable invoice for multiple assets is distributed to one account; but you would need to capitalize each asset separately.

For example, an invoice for computers can be distributed in the full amount to the G/L asset account for computers. However, you might want to capitalize each computer separately in fixed assets. You can split the original journal entry for computers into several assets, such as central processing unit, printer, monitor, and keyboard.

You cannot split a portion of a journal entry. When you split a G/L journal entry into two or more entries, the new totals must add up to the total amount of the original journal entry.

After you split a journal entry, you can review the transactions on Revise Unposted Entries.

► **To split unposted journal entries**

---

*From the Posting G/L to Fixed Assets menu (G1212), choose Revise Unposted Entries.*

1. On Work With Unposted Entries, complete any of the following fields to locate a journal entry:
  - Account Number
  - BU and/or Object
  - Batch Number/Type
  - Document No/Ty/Co
  - Asset Number
  - Company
  - Hold Code
  - Ledger Type
2. To limit the display of entries, click one of the following in the Fixed Assets Post/Passed Code field:
  - Unposted
  - Passed
  - All Entries
3. Click Find.
4. Choose the journal entry that you want to split.
5. From the Row menu, choose Split.
6. On Split Journal Entry, complete the following fields, and click OK to split the journal entry:
  - Asset Number
  - Amount
  - Units
  - Explanation
  - H D

Select Workspace: Active Foundation

Active Foundation

Personalize Change Role Sign Out

Split Journal Entry

OK Cancel Tools

Document No/Ty/Co 3034 JE 00001

GL Date 06/30/05 Explanation Replacement Part

Account Number 50.2030 Ledger Type AA

Remaining Amount 3,711.61 Remaining Qty

Records 1 - 2 Customize Grid

	Asset Number	Amount	Units	Explanation -Remark-	H	D
<input type="checkbox"/>	1001	3,711.61		Adjustment to asset cost		
<input checked="" type="checkbox"/>						<input checked="" type="checkbox"/>

## Processing Options for Revise Unposted Entries (P12102)

### Process Tab

---

#### 1. Allow Different Cost

Blank = Prevent posting of cost to a different account in the account Master

1 = Allow posting of cost to a different account

Use this processing option to specify whether costs can be posted to a different account than the account specified in the asset master. Valid values are:

Blank

Do not allow costs to be posted to a different account.

1

Allow costs to be posted to a different account.

---

---

## 2. Create or Post to Units Ledger

Blank = Allow creation of and posting to Units Ledger in F1202

1 = Prevent creation of and posting to Units Ledger in F1202

Use this processing option to specify whether the system creates records in the Asset Account Balances File table (F1202) for the units ledger when the posted journal entry contains units. Valid values are:

Blank

Create F1202 records for the units ledger.

1

Do not create F1202 records for the units ledger. This value also prevents posting to existing units ledgers in the F1202.

## Versions Tab

### Version of Order Inquiry Details

**Use this processing option to specify the version that the system uses when you access the Purchase Orders program (P4310) from the form menu. If you leave this processing option blank, the system uses version ZJDE0006.**

---

## Printing the Unposted Fixed Asset Transactions Report

*From the Posting G/L to Fixed Assets menu (G1212), choose Unposted Fixed Asset Transactions.*

You can print a journal entries report to review a list of all the transactions that have been posted to the general ledger and are eligible to post to fixed assets, but have not yet been posted to fixed assets. The FX range of AAls identifies the beginning and ending range of asset accounts that can be posted to fixed assets.

The information in the report is the same information that you view on the Work with Unposted Entries form by choosing the Unposted option in the Fixed Asset Post/Passed Code field.

## Caution

If you post a journal entry through the batch post process that does not include an asset number, the message *No Item Master Record* appears on the report. You should create a master record for the asset and attach the new asset number to the journal entry. If you attempt to interactively post a journal entry without an asset number, you receive an error message.

Unposted Fixed Asset Transactions									
J.D. Edwards & Company									
Doc	Document	G/L	Account Number	LT	Amount	Units	Asset Number	Description	Page - JE Line Number
JE	Number	Date							H D
	R12301				20,000.00				90
	3284	2/29/2004	2002030	AA					
JE	3284	2/29/2004	Furniture & Office Equipment	AA	3,400.00			February Activity	10.0
JE	3284	2/29/2004	2002120	AA				February Activity	11.0
JE	3284	2/29/2004	Accum Depr-Buildings	AA	290.00			February Activity	12.0
JE	3284	2/29/2004	2002130	AA				February Activity	13.0
JE	3284	2/29/2004	Accum Depr-Heavy Equipment	AA	2,795.00			February Activity	33.0
JE	3284	2/29/2004	2002140	AA				February Activity	34.0
JE	3284	2/29/2004	Accum Depr-Vehicles	AA	2,498.00			February Activity	35.0
JE	3284	2/29/2004	2002170	AA				February Activity	
JE	3284	2/29/2004	Accum Depr-Computer	AA	4,000.00			February Activity	
JE	3284	2/29/2004	D30-8315	AA				February Activity	
JE	3284	2/29/2004	Depr Building & Improvement	AA	2,795.00			February Activity	
JE	3284	2/29/2004	D30-8320	AA				February Activity	
JE	3284	2/29/2004	Depr-Office Fumt/Equipment	AA	2,641.00			February Activity	
JE	3284	2/29/2004	D30-8330	AA				February Activity	
JE	3284	2/29/2004	Insurance-General Liability	AA				February Activity	
					20,483.00				
Manufacturing/Distribution Co.									

## Processing Options for Unposted Fixed Assets Transactions (R12301)

### Display Tab

---

Display Asset Number

1 = Asset Number

2 = Unit Number

3 = Serial Number

Use this processing option to specify which number the system prints to identify the asset.  
Valid values are:

- 1 Print the asset number.
  - 2 Print the unit number.
  - 3 Print the serial number.
- 

## Posting G/L Journal Entries to Fixed Assets

---

After you verify the information in the unposted fixed asset journal entries, you must post the entries to the Asset Account Balances File table (F1202). All journal entries that are within the fixed asset (FX) range of AAls must be posted to table F1202 to update the Fixed Assets system with current transaction records and to maintain the integrity of the Fixed Assets system.

## Posting Transactions

---

After you enter, review, and approve transactions, post them to the general ledger. All transactions such as journal entries, invoices, and vouchers must be posted to the Account Balances table (F0902) and the Asset Account Balances table (F1202) for fixed assets to update their respective systems with current transaction records and maintain the integrity of the systems.

---

**Note**

All journal entries that are within the FX range of accounts in the AAls must be posted to table F1202 to update the Equipment/Plant Management system with current transaction records.

---

The post program:

- Selects unposted transactions and validates each transaction
- Creates automatic offsets to the A/P and A/R trade and tax accounts
- Posts accepted transactions to the Account Balances table (F0902; F1202 for fixed assets)
- Marks the transactions as posted in the respective systems ledger tables, such as the Customer Ledger (F03B11), the Account Ledger (F0911), and the Accounts Payable Ledger (F0411)
- Sends workflow messages to the Employee Work Center for transactions in error
- Prints a general ledger report, a post detail report, or both

The Post program performs a number of complex tasks. J.D. Edwards strongly recommends that you do not customize the programming for it.

## Posting Journal Entries to Fixed Assets

*From the Posting G/L to Fixed Assets menu (G1212), choose Post G/L Entries to Fixed Assets.*

After you verify the information in the unposted fixed asset journal entries, you must post the entries to the Asset Account Balances table (F1202). All journal entries that fall within the fixed asset (FX) range of AAls must be posted to the Item Balances table to update the Fixed Assets system with current transaction records.

Before posting G/L journal entries to fixed assets, the system verifies that each entry includes the following:

- A G/L post code of P, which means that the records are posted to the Account Balances table (F0902) (except when posting ledgers with a transaction creation code of 2)
- An account within the FX range that you set up in the AAls
- A fixed asset post code of blank
- A valid asset number
- A hold code of blank

When you run the Post G/L Entries to Assets program, the system posts all fixed asset journal entries to the Asset Account Balances table. The post program updates the Asset Account Balances table and marks each transaction as posted.

You can set the processing options in the Post G/L Entries to Fixed Assets (R12800) or Revise Unposted Entries (P12102) programs to prevent the creation of records in the F1202 if there are unit ledgers in the journal entry you want to post.

## Processing Options for Post G/L Entries to Assets (R12800)

### Print Tab

For information about a processing option, right-click the processing option field and choose What's This from the menu. Or, click the processing option field and press F1.

Use these processing options to determine certain output aspects of the Post G/L Entries to Assets report.

---

#### 1. Asset Number Format

1 = Asset number

2 = Unit number

3 = Serial number

Use this processing option to specify how you want the asset number to print on the report. Valid values are:

1 Asset Number. This is the default.

2 Unit Number

3 Serial Number

---

---

## 2. Print Exception Report

Blank = Do not print the exception report

1 = Print the exception report

Use this processing option to identify whether you would like to print the Exception Report (R12800E). Valid values are:

Blank Do not print the Exception Report. This is the default.

1 Print the Exception Report.

---

### Process Tab

For information about a processing option, right-click the processing option field and choose What's This from the menu. Or, click the processing option field and press F1.

Use these processing options to determine the process control options when running the Post G/L Entries to Assets report.

---

### 1. Equipment Subledger

**Blank = Use the G/L asset number**

**1 = Use the asset number from the subledger type E**

**Use this processing option to determine how to update the journal entry's asset number. If the asset number is blank and an equipment subledger (subledger type E) exists, you can use that subledger number as the journal entry's asset number. Otherwise, you can use the G/L asset number when posting to Fixed Assets. Valid values are:**

**Blank Use the G/L asset number.**

**1 Use the asset number from the subledger type E.**

---

## 2. Asset Master Cost Account

**Blank = Prevent posting to a different cost account**

**1 = Allow posting of cost to a different account**

Use this processing option to allow the posting of cost to a different account defined in the Asset Master. Valid values are:

**Blank Prevent posting of cost to a different account defined in the Asset Master. This is the default.**

**1 Allow posting of cost to a different account defined in the Asset Master.**

---

---

## 3. Create or Post to Units Ledgers

**Blank = Allow creation of and posting to Units Ledger in F1202**

**1=Prevent creation of and posting to Units Ledger in F1202**

Use this processing option to specify whether the system creates records in the Asset Account Balances table (F1202) for the units ledger when the posted journal entry contains units. Valid Values are:

**Blank**

**Create a units ledger in the F1202.**

**1**

**Do not create a units ledger in the F1202. This value also prevents posting to existing units ledgers in the F1202.**

---

## Verifying the Post Process

After the post process is complete, the system generates two reports:

- Post G/L Entries to Fixed Assets report (R12800)
- Fixed Assets Detail Error report (R12800E) (if specified in the processing options)

You can review these reports to verify the results of the post.

You can also verify the results of the post to fixed assets online. To review posted fixed asset transactions and the effects of the post on other account information, access the following forms:

<b>Asset Search and Location</b>	Review new assets and corresponding master records that are generated by the post. This information is particularly useful if you split a general ledger transaction before running Post G/L Entries to Assets.
<b>Cost Summary</b>	Review how the new transactions affect cost accounts and balances.
<b>Assembly Components and NBV</b>	Review how parent or component relationships are affected by the post. You can also see any changes to the net book value of an asset.

## Post G/L Entries to Fixed Assets Report (R12800)

This report indicates whether journal entries were successfully posted and identifies any automatic processes that occurred during the post.

Two informational messages can appear in the Message Area column on this report:

**Asset Number Assigned** If you did not assign an asset number to an unposted journal entry, this message indicates that the system has automatically assigned an asset number that is based on the FA (Fixed Assets) range in the AAls. This step can be done only in the batch post process.

**Asset Master Record Created** This message indicates that the system created an asset master record and its corresponding balance record for a posted transaction. If you do not create these records for an asset before running the post program, the system automatically creates them under the following circumstances:

- The asset number is blank in the Account Ledger table (F0911).
- The cost object account falls within the FA range of AAls.
- The Post G/L Entries to Assets program runs the post.

The system creates asset masters and balance records that are based on the values, which you enter in Depreciation Account Rules and Ledger Depreciation Rules.

## Fixed Assets Detail Error Report (R12800E)

The Fixed Assets Detail Error report (R12800E) identifies all of the journal entries that were not posted and provides an explanation. The Fixed Assets Detail Error report also identifies any automatic processes that might have occurred during the post.

Several error messages can appear in the Message Area column on this report:

<b>Unable to Post - Depreciation Defaults Missing</b>	This message indicates that the Depreciation Defaults have not been set up for this ledger type.
<b>Ledger Type Invalid</b>	This message indicates that the ledger type does not exist in the Ledger Type Master File table (F0025).
<b>Unable to Post - Record is not in the Item Master Table</b>	This message indicates that you did not assign an asset number to an unposted journal entry and the system was unable to assign a number automatically.
<b>Unable to Post - Default Co or Accounts Invalid</b>	This message indicates that the company for the asset, cost account, or accumulated depreciation account does not match or that the account for the record is not valid.
<b>Unable to Post - Currency Codes are Different</b>	This message indicates that the currency code for the company does not match the currency code for the asset.
<b>Unable to Post - Cost Account Differs from that of Asset</b>	This message indicates that the cost account for the record to be posted differs from the cost account assigned to this asset in the Asset Master File table (F1201). You can use a processing option to allow posting of the cost to an account that is different from the account, which is designated in the Asset Master.
<b>Unable to Post - Asset is Disposed</b>	This message indicates that the date for disposal of the asset has passed, and you can no longer post to it.

## **Correcting Fixed Asset Balances**

---

If the balance in the Asset Account Balances File table (F1202) is correct, but the balance in the general ledger is incorrect, you must update the general ledger. If the balance in the general ledger is correct, but the balance in table F1202 is incorrect, you must update table F1202. For example, suppose that you transfer an asset's cost account to another cost account. After posting the information, you realize it should have stayed in the original account. To correct this error, you must create the appropriate adjusting journal entries, post them to the general ledger, and then post them to table F1202 in the Fixed Assets system.

### **See Also**

- ❑ *Running Integrity Reports* in the *Fixed Assets Guide* for more information about out-of-balance records in the general ledger or fixed assets

## Correcting General Ledger Balances

If the balance in the Asset Account Balances File table (F1202) for fixed assets is correct, but the balance in the general ledger is incorrect, you must create a journal entry to update the general ledger.

### ► To correct general ledger balances

---

*From the Journal Entry, Reports, & Inquiries menu (G0911), choose Journal Entry.*

1. To correct the balance in the general ledger, enter the adjusting journal entry.
2. From the Posting G/L to Fixed Assets menu (G1212), choose Revise Unposted Entries.
3. On Work With Unposted Entries, click Find to view unposted journal entries.
4. Click the adjusting journal entry, and choose Revise Entries from the Row menu.
5. On Revise Unposted Entries, complete the following field to keep the transaction from posting to Fixed Assets, and click OK:
  - Post/Passed Code

## Correcting Fixed Asset Balances

If the balance in the general ledger is correct, but the balance in the Asset Account Balances File table (F1202) is not, you must post an adjusting journal entry to the general ledger and table F1202 in the Fixed Assets system. Then you must void the entry in the general ledger.

Alternatively, you can post an adjusting journal entry to the general ledger that debits and credits the same account without affecting the balance. Then, on Revise Unposted Entries, you can choose the Passed option in the Post/Passed Code field for one of the transactions, and post the remaining debit or credit to table F1202.

### ► To correct fixed asset balances

---

*From the Journal Entry, Reports, & Inquiries menu (G0911), choose Journal Entry.*

1. On Work With Journal Entries, enter the adjusting journal entry to correct the balance in the general ledger.
2. Post the adjusting journal entry to the general ledger.
3. Post the adjusting journal entry to the Fixed Assets system.
4. To return the general ledger to the correct balance, void the general ledger entry.
5. From the Posting G/L to Fixed Assets menu (G1212), choose Revise Unposted Entries.
6. On Work With Unposted Entries, click Find to view unposted journal entries.
7. Click the adjusting journal entry, and choose Revise Entries from the Row menu.
8. On Revise Unposted Entries, complete the following field to pass the transaction to keep the adjusting journal entry from posting to Fixed Assets again, and click OK:
  - Post/Passed Code

## Correcting Depreciation Entries

If you enter an adjusting journal entry to correct a depreciation error, the journal entry might correct the depreciation in the current period, but the error recurs when you run the programs to calculate depreciation in the next period.

You can use journal entries to correct depreciation errors only when the Method of Computation is P or C. If you use Method of Computation P, the system calculates depreciation only for the current period. If you use Method of Computation C, the system allows journal entry corrections at the end of the fiscal year, after depreciation has been calculated. Before making a correction for Method P, depreciation must be calculated and posted in the period when the correction is made.

---

### Note

If depreciation is calculated after a correction is made within the same period, the correction is reversed out.

---

To correct depreciation errors that have been posted to the general ledger, you must void and post the voided entry to the general ledger; and then post the voided entry to the Fixed Assets system, or make a correcting entry.

To correct depreciation errors that have not been posted to the general ledger, you must post the final depreciation to the general ledger, which might result in posting to an invalid account that needs to be re-opened so that posting can occur. Void the general ledger entry, and then post the voided entry back to the Fixed Assets system. Alternatively, make an adjusting entry and post it back to Fixed Assets. Ensure that errors in the Fixed Assets system are corrected so that they do not recur.

If a depreciation entry is voided and corrections are made in the Fixed Assets system, then depreciation will need to be recalculated.

---

### Note

Do not void summarized journal entries. If you need to make corrections to summarized journal entries, you must enter a detailed journal entry and post the entry to the general ledger and the Fixed Assets system.

---

## Reviewing Asset and Maintenance Costs

---

Review asset and maintenance-related costs when you want to see inception-to-date, year-to-date, and period-to-date account balances for individual assets. You can also do the following:

- Review one subledger or all subledgers for a specific piece of equipment.
- Review detailed or summarized account balance information.

- Display equipment account balances in currency amounts or in units and per unit costs.
- Review maintenance costs by shop or job.

When you review costs by cost accounts, you get a financial perspective of business costs. View costs by cost account when you want to access:

- All account balances relating to a specific asset
- Asset acquisition costs, depreciation amounts, revenue, maintenance expenses, operating expenses, and so on, for a specific period
- Abbreviated income statement and balance sheet information for an asset

Detailed transactions (F0911 records) appear only under the following circumstances:

- Account balances were not updated directly by a conversion program, which did not create detailed transactions to support the balances.
- Transactions were not summarized by the G/L Summarization program.

You can review maintenance costs either by cost account or repair code. When you review by cost account, the system displays all accounts in object account order. When you review by repair code, the system displays accounts in subsidiary account order, beginning with the account that you indicate.

**Cost account**

An object account that represents a type of cost. Examples of cost accounts include:

- Labor
- Parts
- Materials

Review maintenance costs by cost account when you need an abbreviated income statement and balance sheet for a specific piece of equipment or for a shop.

**Repair code**

A subsidiary account that represents a subdivision of a cost account. You can use repair codes to keep detailed records of the accounting activity for a particular cost account. Examples of repair codes include:

- Preventive maintenance
- Emergency repairs
- Electrical repairs
- Mechanical repairs

Review maintenance costs by repair code when you need a managerial perspective of costs that are related to a specific type of repair.

**► To review asset and maintenance costs**

---

*From the Cost Information & Reports menu (G1213), choose Cost Summary.*

1. On Work with Cost Summary, complete the following required field on the Display tab to locate a specific asset:
  - Asset Number
2. To specify the costs that you want to review, complete the following optional fields:
  - Skip to Account or Code

- From Date/Period
- Thru Date/Period
- Ledger Type

Set a processing option to specify the ledger type default.

3. To further specify the costs that you want to review, click the Additional Selections tab.
4. Complete the following optional fields:
  - Units/Unit Cost  
Set a processing option to display amounts or statistical units.
  - Detail/Summary
  - Subledger
  - Sub Type

The screenshot shows the PeopleSoft 'Work with Cost Summary' window. The 'Additional Selections' tab is selected. The 'Units/Unit Cost' field is set to 'N', 'Detail/Summary' is set to 'D', and 'Subledger' is empty. The 'Totals' section has 'Total by Account (Object)' selected. The table below shows the following data:

Account	Code	Account Description	Inception To Date	Year To Date	Period To Date	Business Unit	Subledger	Sub Type
2040		Vehicles	32,000.00	32,000.00				
2140		Accum Depr-Vehicles	5,333.33	5,333.33	888.89		50	
		<b>Net Book Value</b>	<b>26,666.67</b>	<b>26,666.67</b>	<b>888.89</b>			
8330		Depreciation - Vehicles	5,333.33	5,333.33	888.89		YARD	
		<b>Revenue Earned</b>	<b>5,333.33</b>	<b>5,333.33</b>	<b>888.89</b>			
		<b>Total</b>	<b>32,000.00</b>	<b>32,000.00</b>				

5. Click one of the following options:
  - Total by Code (Subsidiary)
  - Total by Account (Object)
6. To review the posted transactions for an individual account balance, choose an account, and then choose Asset Ledger from the Row menu.

7. On Work with Asset Ledger Inquiry, to see transaction details, choose Account Ledger from the Row menu.
8. On Work With Account Ledger, choose Details from the Row menu.
9. To return to Work with Cost Summary:
  - On Account Ledger Detail, click Cancel.
  - On Work With Account Ledger, click Close.
  - On Work with Asset Ledger Inquiry, click Close.
10. To review or add an attachment for a transaction, choose Attachments from the Row menu.
11. To review open purchase orders, choose Open Orders from the Form menu on Work with Cost Summary.
12. To review asset revaluation information, choose Asset Revaluation from the Form menu on Work with Cost Summary.

## **Processing Options for Cost Summary (P122101)**

### **Defaults Tab**

Use these processing options to define the defaults that are applied when you inquire on asset balance records.

---

#### 1. Ledger Type

Blank = AA

Use this processing option to enter the ledger type to default to. Leave blank to default to the AA ledger. This is the default value. For a list of valid values, click the visual assist button next to this field.

---

---

## 2. Detail or Summary

D = No summarization

O = Summarize by object

R = Summarize by subsidiary

S = Summarize by AT AAI object

Use this processing option to specify how to summarize asset balances. Leave blank to default to D (No Summarization). Valid values are:

D No Summarization. This is the default.

O Summarize by Object. Valid when sequencing by object.

R Summarize by subsidiary. Valid when sequencing by subsidiary.

S Summarize by AT AAI Object.

Note: Do not drill down into Asset Ledger Inquiry unless D (No Summarization) is chosen.

---

---

### 3. Display Amounts or Statistical Units

N = Amounts

A = Statistical units - FMA AAI

B = Statistical units - FMB AAI

Y = Statistical units - AT00 AAI

Use this processing option to display amounts or statistical units. Leave blank to default to N (Amounts). Valid values are:

N Amounts. This is the default.

A Statistical Units - FMA AAI.

B Statistical Units - FMB AAI.

Y Statistical Units - AT00 AAI.

---

#### **Process Tab**

Use these processing options to specify what type of information will be processed when calculating asset balance records.

---

1. Object or Subsidiary Totals

Blank = By account code (object)

1 = By repair code (subsidiary)

Use this processing option to display the asset totals by account code (object) or repair code (subsidiary). Valid values are:

Blank Display by Account Code (Object).

1 Display by Repair Code (Subsidiary).

---

**Versions Tab**

Use this processing option to define the application version to execute.

---

1. Open Order Inquiry Version (P4310)

Blank = ZJDE0006

Use this processing option to enter the Open Order Inquiry (P4310) version for the related exit. If left blank, ZJDE0006 will be used.

---

---

## Asset Depreciation

The Fixed Assets system provides flexibility for defining depreciation methods. You have the option of creating a new user defined depreciation method, using a predefined method, or modifying a predefined method to create a new user defined method.

After you set up depreciation rules and establish master information, depreciation information, and account balances for the assets in your system, you can calculate asset depreciation.

### See Also

See the following topics in the *Fixed Assets Guide*:

- ❑ [Predefined Depreciation Methods](#)
- ❑ [Formula Elements](#) for information on the formulas for predefined depreciation methods

---

## Understanding Asset Depreciation Methods

When you create a master record, the system automatically assigns the depreciation method based on the depreciation default value that you set up. The system performs depreciation calculations based on the established depreciation rules for each depreciation method.

Although the J.D. Edwards Fixed Assets system provides a wide range of standard depreciation methods, you might need a specific depreciation algorithm. You can modify a standard depreciation method, or you can create your own depreciation method.

An organization that operates in a multisite, multinational, or multicurrency environment is likely to require a broad sample of the variations of the elements of depreciation. With asset depreciation, you can access all the elements of the depreciation equation. You can use these elements to define depreciation methods to meet your unique depreciation needs.

### Elements of Asset Depreciation

The following graphic shows the elements of asset depreciation:

### Elements of Asset Depreciation

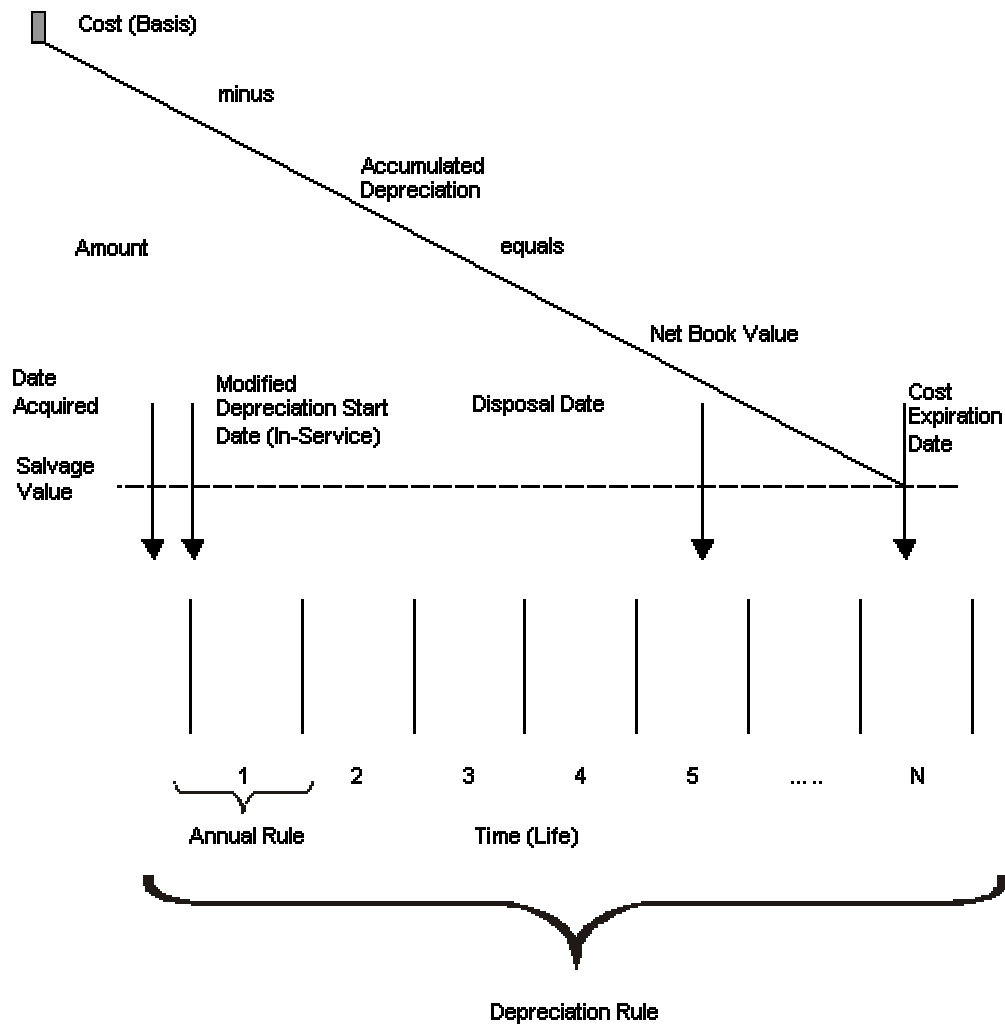

The following elements used with depreciation rules control how the system calculates depreciation:

**Cost** Costs can be divided in different ways for different assets according to the nature of the assets, such as buildings, equipment, vehicles, and so on. Cost also occurs for a single asset in multiple books or ledgers for such purposes as financial accounting, consolidated reporting, management and cost accounting, and regulatory purposes.

Cost can affect depreciation in many different ways. For example:

- Several elements of asset cost might exist in a single book or ledger.
- Several elements of cost might exist at one specific time or spread out over time.
- Cost might exist concurrently in multiple currencies.

**Time (life years)** The life of an asset is represented in the depreciation process as a subdivision of time. Different depreciation methods might use different subdivisions of time. For example, the subdivision of time might be:

- The same as the fiscal year of your organization
- Related to the date when the cost for the asset is incurred
- Related to the year of a political or regulatory entity

**Accumulated depreciation** At any time during the life of an asset, the total of all depreciation taken.

**Net book value** At any time during the life of an asset, the current or net book value is equal to the cost minus the accumulated depreciation.

For example, at the beginning of an asset's life, when no depreciation has been taken, the net book value is equal to the original cost. At the end of the asset's life, when all possible depreciation has been taken, the net book value is equal to the salvage value of the asset, if any.

**Salvage value and depreciable basis** At the end of the life of an asset, when it is no longer suitable for use within your organization, residual value might exist. This value, whether it is realized from the market or from scrapping and salvaging, is referred to as the salvage value. Depreciation stops at the salvage value. For example, if the cost of an asset was 1000 USD and the salvage value is 25 USD, accumulated depreciation never goes beyond 975 USD so that there is a residual value of 25 USD. Typically, the amount that is amortized over the life of an asset excludes the salvage value amount.

The salvage value is used in the depreciation process to arrive at the depreciable basis of that asset, or the cost less the salvage value.

**Remaining basis** Remaining basis is the amount to which an asset depreciates in the final year of the asset's life. It is defined as cost minus accumulated depreciation minus salvage value.

**Dates** Depreciation takes place over time. Consequently, many instances occur in the depreciation process in which different dimensions of time (dates) are important. Dates that might especially affect the depreciation process include:

- Asset acquisition dates
- Depreciation start dates
- Asset disposal dates
- Cost expiration date

Frequently, depreciation conventions require a modification of one or more of these dates.

**Annual rules** Each year of an asset's life can be subject to different allowances or requirements. For example, the first and last years of an asset's life can be subject to different regulatory requirements.

## Depreciation Concepts

The Fixed Assets system uses account rules and depreciation rules. Account rules define the association between cost accounts and the related accumulated depreciation and depreciation expense accounts. Depreciation rules define the algorithm that the system applies to the cost of an asset over the course of the asset's life every time that you compute depreciation.

Depreciation rules are the key to asset depreciation. To understand depreciation rules, you need to understand the following concepts:

**Cost** The cost for an asset is the focal point of the depreciation equation. The system uniquely identifies each cost for an asset.

**Dates** Depreciation rules are date-sensitive. When you set up depreciation rules, you must specify the dates when the rule is effective.

**Limits and bases** The amount that you depreciate an asset can be subject to limits and bases. The limits and bases might be sensitive to particular dates. For example, the entire depreciation formula might be appropriate to a specific period of time or to a specific portion of the life of the asset.

**Formulas** The depreciation formula might be as simple as a single percentage of the cost that applies to each year throughout the life of the asset. Or the formula might relate to the utilization of the asset. The potential for formula variations is virtually infinite. For example:

- Salvage value can be a factor in the depreciation formula.
- The formula might provide occasions when the depreciation stops and then resumes.
- Multiple depreciation formulas can relate to the same cost, possibly in different years or in different ledgers.

**Apportionment - periodic and cumulative** The system stores the cost apportionments in the Asset Account Balances File table (F1202). The apportionment of the cost over time is stored as a cumulative balance in the accumulated depreciation records. The periodic apportionment of the cost is stored in the depreciation expense records. Each depreciable cost has at least one cumulative record and one periodic record for each year of the life of an asset.

<b>Reporting years</b>	The reference points in time can be a variable in the depreciation process. For example, a single legal entity might be required to determine and report depreciation according to different patterns of dates. Also, the fiscal years of entities might change.
<b>General ledger accounts</b>	Each asset balance record is associated with an asset master record. The nature of an account refers to the type of cost. Asset costs are typically classified into categories, such as real property, machinery, equipment, and so on. The balance sheet business unit includes the cost and accumulated depreciation for the asset. For depreciation expense, the business unit might be an operating department, a project, or a location.
<b>Depreciation accounts</b>	<p>Two accounts are especially important in the depreciation process:</p> <ul style="list-style-type: none"> <li>• Depreciation Expense - As you compute depreciation for the basis of an asset, the system records the result as an expense of each of the years benefited by the cost.</li> <li>• Accumulated Depreciation - You need to know the original cost of an asset. The system records the expiration of the cost in an account that can be considered a part of the cost account. This contra account is called the Accumulated Depreciation account.</li> </ul> <p>In some cases, the depreciation mechanism might require multiple accumulated depreciation and depreciation expense accounts.</p>
<b>Asset account type</b>	<p>The system uses a character code to uniquely identify each asset balance record that is related to depreciation. The character code indicates whether a record is a cost, accumulated depreciation, or depreciation expense. Other accounts that are not related to the depreciation process, but are important to the depreciation equation, such as disposal accounts, are also identified by the system with an asset account type. Asset account type codes enable the system to identify and access specific records easily. Valid values are:</p> <ul style="list-style-type: none"> <li>• 1 Cost</li> <li>• 2 Accumulated Depreciation</li> <li>• 3 Secondary Accumulated Depreciation</li> <li>• 4 Depreciation Expense</li> <li>• 5 Depreciation Expense - Secondary</li> <li>• 6 Depreciation Expense - Tertiary</li> <li>• 7 Net Book Value - Disposal</li> <li>• 8 Disposal Clearing</li> <li>• 9 Disposal Proceeds</li> </ul>
<b>Asset</b>	The system associates cost with an asset. You use category codes to classify assets within an accounting category and a depreciation category.
<b>Annual depreciation amount</b>	The system accesses various depreciation rules for an asset by codes in table F1202. The codes identify depreciation method, computation direction, and so on, for each depreciation rule that you use. Based on the specific depreciation rule, the system calculates depreciation on an annual basis. The system stores the annual depreciation amount for an asset in the associated Asset Balance Accumulated Depreciation record. After the system calculates the annual depreciation amount, it then deals with the initial term apportionment. Any special conventions are applied, based on the options that you define for the specific rule.

**Periodic depreciation journal entries**

The annual depreciation amount is subject to spread patterns of percentages that determine how the annual depreciation is to be apportioned to periods within a year. The system applies any conventions that relate to special apportionment during the first, last, and disposal years. The system creates general ledger journal entries based on the rules that are established for each ledger. Based on the account rules, the system updates the Asset Account Balance records for the depreciation expense and accumulated depreciation expense.

## **Depreciation Rule Components**

The depreciation rules are defined in three components. Within these components, you use the elements of depreciation. The depreciation rule components are:

- Header
- Rule conventions
- Annual rules

### **Header**

Key to identifying the depreciation rule, the header information includes information such as:

- Depreciation method
- Initial term apportionment
- Compute direction (also called the method of computation)
- Life (periods)
- Relevant dates
- Rule description
- Date pattern reference

### **Rule Conventions**

The rule conventions define certain parameters within which the rules operate, such as:

- Depreciation expense business unit
- First year spread
- Last year spread
- Disposal year
- Secondary account percentage
- Life year reference
- Allow over depreciation
- Allow negative depreciation

### **Annual Rules**

The annual rules define the specifics of how the depreciation is actually calculated. For a given depreciation rule, one or more annual rules might exist. For a given year, primary and secondary rules might exist. Annual rule specifics include:

- Beginning and ending years for each annual rule
- Place in service months
- Annual multipliers
- Spread patterns
- Formula codes for depreciation, basis, lower limit, upper limit, and salvage value

## Depreciation Calculation - Process Flow

The system calculates depreciation for an asset cost based on the depreciation rules that you define. The rules relate to the category of the asset cost. The system determines which depreciation rule to use. The system associates accounting and depreciation categories in the asset master record and the cost account in the cost item balance record with the corresponding information in the depreciation rule.

The following graphic illustrates the depreciation calculation process:

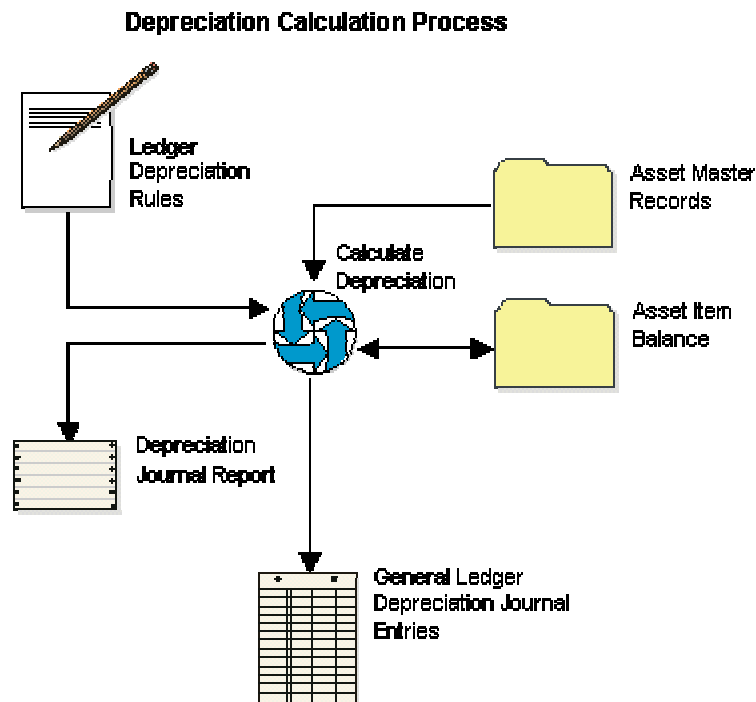

## Entering Units of Production

---

You enter units of production to provide the system with current production information to compute depreciation based on the units of production method (Standard Depreciation Method 09). Enter units of production only if your company uses units of production to compute depreciation. If you do not use units of production to compute depreciation, you do not need to enter units of production.

You can use the Units of Production Schedule form to track your original estimate of the total number of units in the reserve base, the total of your prior year revisions to the original estimate, and current year revisions to the original estimate. You can change these amounts as your estimates for production change throughout the year. When you run the annual close, the system automatically rolls the totals to prepare for the new year of estimates and revisions.

You must enter units of production before you run the Compute Depreciation program. The system calculates the units of production depreciation for a period only if you update the year-to-date production amount for the period.

### **Before You Begin**

- Set up the units of production schedule. See *Working with Units of Production Schedules* in the *Fixed Assets Guide*.

### **► To enter units of production**

---

*From the Advanced Operations menu (G1231), choose Units of Production Schedule.*

1. On Work with Units of Production Schedules, click Add to add a unit of production schedule.
2. On Production Schedule Revisions, complete the following fields:
  - Schedule Number
  - Ledger Type
  - Unit of Measure
  - Units - Original
  - Units - Prior Year Revisions
  - Units - Current Year Revisions
  - Prior Years Production

PeopleSoft®

Select Workspace: Active Foundation

Active Foundation Personalize Change Role Sign Out

Production Schedule Revisions

OK Cancel Tools

Schedule Number GRADER

Ledger Type AA

Description Motor Grader Hours

Unit of Measure HR Hour

Units - Original 10,000.00

Units - Prior Year Revisions

Units - Current Year Revisions

Prior Years Production 4,500.00

Depreciable Unit Base 5,500.00

Y-T-D Production 5,500.00

Current Unit of Production Factor 1.00000000

3. Click OK.
4. To return to Work with Units of Production Schedules, click Cancel.
5. On Work with Units of Production Schedules, complete the following fields, and click Find to locate a unit of production schedule:
  - Schedule No/Method 9
  - Ledger Type
6. Choose a schedule.
7. From the Row menu, choose Prod Schedule.
8. On Production Schedule Revisions, review or change the following fields:
  - Schedule Number
  - Ledger Type
  - Unit of Measure
  - Units - Original
  - Units - Prior Year Revisions
  - Units - Current Year Revisions

- Prior Years Production
  - Y-T-D Production
9. Click OK.
  10. To return to Work with Units of Production Schedules, click Cancel.

## Calculating Asset Depreciation

---

Run the Compute Depreciation program to calculate depreciation for your assets. The Compute Depreciation program calculates asset depreciation year-to-date, through the "as of" date that you specify. You can compute depreciation for each period, quarter, or year.

You can run the Compute Depreciation program in preliminary or final mode. J.D. Edwards strongly recommends that you run a preliminary depreciation for proofing purposes before you run the actual or final depreciation.

### See Also

See the following topics in the *Fixed Assets Guide* for more information about depreciation:

- ❑ *Verifying Depreciation Information*
- ❑ *Understanding Asset Depreciation Methods*
- ❑ *Setting Up User Defined Depreciation*

### Before You Begin

- ❑ You must run the annual close for the previous year account balances before the system can generate depreciation journal entries for a new fiscal year. See *Closing Annual Account Balances* in the *Fixed Asset Guide*.

## Running the Compute Depreciation Program

*Choose one of the following navigations:*

*From the Depreciation menu (G1221), choose Compute Depreciation.*

*From the Year End Processes menu (G1225), choose Compute Depreciation by Period.*

Run the Compute Depreciation program in preliminary mode so that you can check for errors and make any necessary corrections.

When you run Compute Depreciation in final mode, the system creates fixed asset and general ledger journal entries. The system automatically posts the fixed asset journal entries and then submits the general ledger journal entries for posting.

You can approve and post the general ledger journal entries, or you can set up your system to automatically post the entries when you run the depreciation program. For the system to automatically post depreciation journal entries to the general ledger, you must:

- Set Management Approval of Input to No (N) in General Accounting Constants
- Indicate a post version in the processing options for the Compute Depreciation program

The Compute Depreciation program calculates and stores the annual depreciation amount for each asset in the Asset Account Balances File table (F1202). The program refers to the Spread Pattern table that relates to the depreciation rule and applies the Year-to-Date Percentage to the annual depreciation amount. The resulting calculation is the depreciation amount for the current period.

## Generating the Depreciation Journal Report

The system generates a Depreciation Journal report for each preliminary and final depreciation computation that you run. To control the amount of detail information that prints on the report, use processing options and data selection. Use the report as an auditing tool to determine whether user defined rules and formulas reflect accurate asset depreciation information.

Each depreciation method prints on a separate page and includes the following three types of information:

**Asset numbers and journal entry amounts**

Lists each asset that you assigned to the account class and the depreciation for the period which is calculated by the specific depreciation method.

Depending on the processing options and data selections that you choose, you can review the specific depreciation formulas and element values that the depreciation calculation program used to arrive at the final depreciation amount for an individual asset.

**Company totals**

Prints the total amounts for accumulated depreciation and depreciation expense accounts by ledger and company. This section of the report also lists account numbers and subledger information.

R12855	J.D. Edwards & Company	4/3/2003	10:21:12
Preliminary Company:	User Defined Depreciation	Page -	1
		Ac'd	7/31/2005
Account Category:	00050 Project Management Company	Ledger Type:	AA General Ledger
Cost Account:	70 Computer Equipment	Major Equipment	
Accum Depr Acct:	602070	Subledger Type:	
Depr Method:	602170	Description:	Straight Line
Compute Divisor:	01 Straight Line Depreciation	Initial Term:	Month
		In Service:	1/1/1900
		Modified Dates:	Life
Asset Number	1006	Start	1/1/2005
		Disposal	12/31/2007
		End	1
		Year	1
		Cost	92,000.00
		Inception to Date	17,898.85
		Year to Date	17,898.85
		Accumulated Depreciation	16,333.33
		Current Balance	2,565.56
		Adjustments	
		Balance	

## Processing Options for User Defined Depreciation (R12855)

### Process Tab

These processing options enable you to:

- Specify the depreciation period or date through which depreciation will be calculated.
- Print assets based on current period adjustments.

- Summarize accumulated depreciation and depreciation expense account information.
- Prevent the system from creating actual amount transaction records.
- Indicate whether you want to use flex accounting.

These processing options also enable you to specify whether you want to run this program in preliminary or final mode.

When you run this program in preliminary mode, the system:

- Validates the information that you enter in the processing options
- Validates the accounts to which the system will post the depreciation journal entries
- Prints a report that shows the amounts that will post to each depreciation account when you run the final depreciation. This report also shows calculated results including costs, accumulated depreciation, and year-to-date depreciation for the assets that you specify.

When you run this program in final mode, the system:

- Validates the information that you enter in the processing options.
- Validates the accounts to which the system will post the depreciation journal entries.
- Prints a report that shows the amounts posted to the depreciation accounts for each asset number. If an error exists, the depreciation process does not create journal entries for that particular asset and you see an error message on the report.
- Updates the Asset Account Balances table (F1202).
- Creates fixed asset journal entries for the accumulated depreciation and depreciation expense accounts that are affected by the depreciation. These journal entries have a document type of DP (depreciation) and a batch type of X.
- Creates journal entries that are based on the value in the Transaction Creation field on the Fixed Asset Ledger Type Rules form. The system creates unposted journal entries if the Transaction Creation field contains a value of 2. The system creates posted journal entries if the Transaction Creation field contains a value of 1 or 3 for audit trail purposes.
- Allows you to submit depreciation journal entries for batch processing to post to the journal entries to General Accounting using the Versions processing option on the Versions tab.

---

## 1. Process Mode

Blank = Preliminary mode

1 = Final mode

Use this processing option to specify the mode in which you want to run this program. Valid values are:

Blank Run the program in preliminary mode. You should run the program in preliminary mode before running it in final mode. If the system finds errors, you will see an error message on the preliminary report. You should correct errors that appear on the report and rerun the program in preliminary mode.

Running this program in preliminary mode does not create journal entries or update any tables. You can run this program in preliminary mode as many times as required.

1 Run the program in final mode. When you run this program in final mode, the system posts accumulated depreciation and depreciation expense journal entries to the Asset Balances table (F1202) and create journal entries in the Account Ledger table (F0911). The system also submits the depreciation journal entries to the general ledger post program based on a version for the general ledger post.

Note: This processing option retains the value previously specified. For example, if you ran this program in final mode the last time you used it, the program will run in final mode again unless you change the value of this processing option.

---

---

## 2. Depreciation Period or Through Date

---

---

3. Select Assets to Print

Blank = Print all assets

1 = Print assets with balance adjustments for the current period or date

Use this processing option to print all of the assets in your current selection or limit assets based on balance adjustments. Valid values are:

Blank Print all assets.

1 Print only assets with balance adjustments for the current period or date.

---

---

#### 4. Summarize Transactions

Blank = Do not summarize account information

1 = Summarize account information

Use this processing option to specify whether you want the system to summarize accumulated depreciation and depreciation expense account information. Valid values are:

Blank Do not summarize account information.

1 Summarize account information.

Note: If you summarize your accumulated depreciation and depreciation expense account information, the system will not record transaction detail by Asset Number. This transaction detail information (F0911 transactions) supports the information in the Asset Balances table (F1202). Consequently, you will not be able to use the Fixed Asset Repost program (R12910).

---

---

## 5. Create Transaction Records

Blank = Create transaction records for the AA ledger

1 = Do not create transaction records for the AA ledger

Use this processing option to specify whether you want the system to create transaction records (F0911 records) for the AA ledger. Valid values are:

Blank Create transaction records for the AA ledger.

1 Do not create transaction records for the AA ledger.

Note: If you do not create transaction records for the AA ledger, you will have no information to support the information in the Asset Balances table (F1202). Consequently, you will not be able to use the Fixed Asset Repost program (R12910).

---

---

## 6. Flex Accounting

Blank = Do not use flex accounting

1 = Use flex accounting

Use this processing option to indicate whether you want to use flex accounting. Valid values are:

Blank Do not use flex accounting.

1 Use flex accounting.

---

---

## 7. Page Break Suppress

Blank = Allow page breaks and show header information.

1 = Eliminate page breaks and header detail information

Use this processing option to specify whether the system allows the User Defined Depreciation report (R12855) to set page breaks. If you do not allow page breaks, the system processes the report more efficiently and uses less paper to print. However, if you do not allow page breaks, the header does not appear. Additionally, the system limits the account information that appears to ledger type, depreciation expense account, and accumulated depreciation account. Valid values are:

Blank

Allow page breaks.

1

Do not allow page breaks.

---

---

## 8. Inception to Date Correction Processing

Blank = Spread adjustments over current year.

1 = Apply total adjustment to current period

Use this processing option to specify how adjustments will be made if you use the Inception to Date Compute Direction of I. Valid values are:

Blank

Spread adjustments over the current year. Any adjustments to depreciation will be spread over the remaining months of the fiscal year.

1

Apply total adjustments to the current period. The total adjustment will be made in the current period and the remaining months will be calculated using the updated amounts.

---

### **Print Tab**

These processing options determine how the asset number appears on the report, and whether depreciation expense details, calculated amount details, formula calculations and expressions, and summarized subledger totals appear on the report.

---

### 1. Asset Number Format

1 = Asset Number

2 = Unit Number

3 = Serial Number

Use this processing option to specify how you want the asset number printed on the report. Valid values are:

1. Asset Number

2. Unit Number

3. Serial Number

---

---

### 2. Depreciation Expense Details

Blank = Do not print depreciation expense details

1 = Print depreciation expense details

Use this processing option to specify whether you want depreciation expense details printed on the report. Valid values are:

Blank Do not print depreciation expense details on the report.

1 Print depreciation expense details on the report.

---

---

### 3. Calculated Amount Details

Blank = Do not print calculated amount details

1 = Print calculated amount details

Use this processing option to specify whether you want calculated depreciation amount, basis amount, lower limit, upper limit, salvage value, and apportionment percent details printed on the report. Valid values are:

Blank Do not print calculated amount details on the report.

1 Print calculated amount details on the report.

---

---

#### 4. Formula Calculations and Expressions

**Blank = Do not print calculations and expressions**

**1 = Print calculations and expressions**

Use this processing option to specify whether you want calculations and expressions for the depreciation, basis, lower limit, upper limit, and salvage value formulas printed on the report. Valid values are:

**Blank Do not print calculations and expressions on the report.**

**1 Print calculations and expressions on the report.**

---

#### 5. Summarize Subledger Totals

**Blank = Print totals for every subledger**

**1 = Print summarized subledger totals**

Use this processing option to specify whether you want to summarize subledger totals on the report. Valid values are:

**Blank Print totals for every subledger on the report.**

**1 Print summarized subledger totals on the report.**

---

#### Versions Tab

This processing option enables you to specify the Post General Journal version that you want the system to run automatically.

---

##### 1. General Ledger Post Version (R09801)

If you are running this program in final mode, use this processing option to specify the General Ledger Post (R09801) version you want the system to run automatically. For example, you can run ZJDE0016. This processing option works only under the following conditions:

- o You have set Management Approval to No (N) on System Constants.
-

- 
- o You enter a version that has already been added.
- 

## **Reviewing and Approving the Depreciation Journal**

---

After you enter journal entries, you can verify their accuracy before posting them to the Account Balances table (F0902).

### **Reviewing the Depreciation Journal**

You can review information at different levels before posting depreciation journal entries.

When you review journal entries for posting, you can display a list of batches that are based on the batch type, number, date, status, or your user ID. For example, you might want to review all of the batches with a posting status of pending.

If the batch review security feature is activated, the system might not list all of the batches that have been entered. Instead, the system lists only the batches that you are authorized to review and approve.

After you review a list of batches, you can access transaction detail within a specific batch of journal entries. For example, you can review the number of journal entries within a batch. You can also select a specific journal entry for review.

If you use batch control, the system shows the differences between what you expected to enter and what you actually entered. These differences are shown for both the input total and the number of documents. If you do not use batch control, the system subtracts your actual entries from zero, resulting in negative amounts in the fields that display the differences.

You can change the associated explanations and the G/L distributions of an unposted journal entry. You cannot change the following key fields:

- Document Type
- Document Number
- Document Company
- G/L Date
- Currency Code
- Ledger Type

The review program displays and updates information in the following tables:

- Batch Control Records (F0011)
- Account Ledger (F0911)

Consider the following features when you review journal entry information:

<b>Blank amounts</b>	The Amount field appears blank on General Journal Review if the journal entries are in balance.
<b>Revising a posted batch</b>	If you add, change, or void a transaction within a batch that has been posted, the system changes the batch status from posted to the default entry status (pending or approved). You must post the batch again. The system posts only the changed transactions.
<b>Adding journal entries to a batch</b>	To add a journal entry to a batch, choose a journal entry in that batch on General Journal Review, and click Add.

► **To review a list of depreciation batches**

---

*From the Depreciation menu (G1221), choose Depreciation Journal Review.*

1. On Work With Batches, display all of the batches for all users, or complete the following fields to limit your search:
  - Batch Number
  - Batch Type
2. Click one of the following options:
  - Unposted Batches
  - Posted Batches
  - All Batches
3. Click Find.
4. In the detail area of the form, review the list of batches.

► **To review and revise depreciation journal entry detail**

---

*From the Depreciation menu (G1221), choose Depreciation Journal Review.*

1. On Work With Batches, display all of the batches for all users, or complete one or more of the following fields to limit your search:
  - Batch Number
  - Batch Type
2. Choose one of the following options:
  - Unposted Batches
  - Posted Batches
  - All Batches
3. Click Find.

4. Choose a batch, and click Select to access the appropriate batch review form.
5. On the review form, choose an individual document to review, and click Select.
6. On the detail form, enter any necessary changes, and click OK.
7. To return to Work With Batches, click Cancel, and then click Close.

#### See Also

- ❑ *Approving Batches of Journal Entries for Posting* in the *Fixed Assets Guide* for more information about batch approval

See the following topics in the *General Accounting Guide* for more information about revising journal entries:

- ❑ *Revising an Unposted Journal Entry*
- ❑ *Revising a Posted Journal Entry*

## Approving Batches of Journal Entries for Posting

After you enter and review a batch of journal entries, you might need to approve it before posting can occur. This action depends on whether your company requires management approval before posting a batch. You can revise the batch job before you post it. Based on your company requirements, as defined in the general accounting constants, the system assigns either a pending or an approved status to the batch.

You can approve an out-of-balance batch job. You also can prevent an approved batch from posting.

### ► To approve a batch for posting

---

*From the Depreciation menu (G1221), choose Depreciation Journal Review.*

1. On Work With Batches, display all of the batches for all users, or complete one or more of the following fields to limit your search:
  - Batch Number
  - Batch Type
2. Choose one of the following options:
  - Posted Batches
  - Unposted Batches
  - All Batches
3. Click Find.
4. Choose the appropriate batch.
5. From the Row menu, choose Batch Approval.
6. On Batch Approval, click the Approved option.
7. Click OK.

8. On Work With Batches, click Find and verify that the following field has been updated to A:
  - Batch Status

► **To revise a batch job for posting**

---

*From the Depreciation menu (G1221), choose Depreciation Journal Review.*

1. On Work With Batches, complete one or more of the following fields:
  - Batch Number
  - Batch Type
2. Choose one of the following options:
  - Posted Batches
  - Unposted Batches
  - All Batches
3. Click Find.
4. Choose the appropriate batch.
5. From the Row menu, choose Revise.
6. On Create/Revise Batch Header, click the box for the following option to approve an out-of-balance batch job for posting:
  - Batch Is Approved
7. To prevent an approved batch job from posting, remove the information in the following field:
  - Batch StatusAn empty Batch Status field identifies the batch job as pending.
8. Click OK.

### **Processing Options for Batch Type (P0011)**

---

Batch Type  
Enter the Batch Type to be displayed.

Batch Type

---

## Posting Depreciation to the General Ledger

---

If you have depreciation batches that did not post during the depreciation process, you must manually post the depreciation journal entries to the general ledger. If you have many depreciation entries that did not post and you have corrected them, you can use the General Ledger Post Report to automatically post all the journal entries that have a status of Approved.

### Before You Begin

- ❑ Verify that the batch has an approved status. See *Approving Batches of Journal Entries for Posting* in the *Fixed Asset Guide*.
- ❑ Ensure that the job queue allows only one job to process at a time.

### Posting a Journal Entry Manually

You must manually post any depreciation journal entries to the general ledger that you approve on Depreciation Journal Review (from menu G1221).

#### ► To post a journal entry manually

---

*From the Depreciation menu (G1221), choose Depreciation Journal Review.*

1. On Work With Batches, display all batches for all users, or complete one or more of the following fields to limit your search:
  - Batch Number
  - Batch Type
2. Click one of the following options:
  - Unposted Batches
  - Posted Batches
  - All Batches
3. Click Find.
4. Choose the appropriate batch.
5. From the Row menu, choose Post by Batch.

### Posting Multiple Batches of Journal Entries

*From the Depreciation menu (G1221), choose General Ledger Post Report.*

The General Ledger Post Report program is a global post for all depreciation batches that have a status of Approved. Set a processing option for the Compute Depreciation program to automatically submit a general ledger post for depreciation journal entries. Usually the batch will post with no user intervention required. The only time that you need to use the General Ledger Post Report program is when the batch does not post.

---

**Caution**

You should not enter a batch number, user ID, or batch date on the processing option when you run the General Ledger Post Report to post a batch of journal entries. If you leave these fields blank, all batches post. If you enter one of these fields and then do not clear it after you have posted a batch, the next batch does not automatically post unless the batch data matches the information in the Batch Number, User ID, and Batch Date fields.

---

Run only one post program at a time.

Consider the following features when you post a batch of journal entries:

<b>Posting an alternate currency ledger</b>	If you use the alternate currency ledger (XA), set the appropriate processing option to update the ledger and produce a separate posting journal.
<b>Making changes during the posting process</b>	While the post is running, do not change accounts, AAls for the General Accounting system, intercompany settlements in the general accounting constants, or processing options for the post program.
<b>Specifying batches to be posted</b>	Choose a blank line for your data selection entry. Do not delete or type over the existing specifications for the posting status (A) and the batch type (G).
<b>Customizing the post program</b>	This program performs a number of complex tasks. J.D. Edwards strongly recommends that you do not customize the programming for it.

## Verifying the Post

After posting your transactions, verify that your batches posted successfully. If any of the batches did not post, you must correct all of the errors and set the batch to approved status before the program will post the batch. The system creates a variety of messages and reports to help you verify the posting information.

## Reviewing the General Ledger Post Report

To verify the transactions that were posted to the Account Balances and the Account Ledger tables, review the General Ledger Post Report (R09801).

The General Ledger Post Report lists batches that posted successfully. At the end of the report, if one or more batches contained errors, the report also includes a text box to alert you that the program found errors. You should review your workflow messages in the Employee Work Center for messages that provide more detail. From that point, you can access the Work With Batches and Journal Entry forms, where you can correct errors.

A General Ledger Post Report that contains only heading information indicates that the Post program could not post any batches and has sent messages to your electronic mail.

If you use Fixed Assets, the program produces a separate General Ledger Post Report.

## Reviewing the Post Detail Error Report

When you set up ledgers, you specify whether a ledger is required to balance. If the post program finds an out-of-balance condition in a ledger type that is required to balance, the program generates a report. If you determine that an out-of-balance journal entry is in error, correct the error and post the batch again.

In some cases, you might need to post an out-of-balance journal entry. For example:

- A power failure occurred during entry or posting.
- A valid, one-sided journal entry was entered to correct a conversion error that was made during setup.

## Reviewing Depreciation Information Online

---

Use the Online Depreciation Schedule program to review a list of assets and their corresponding depreciation expense and net book value amounts for each ledger.

You can also use this program as a tool to review your entries and help you reconcile differences between the Asset Account Balances table (F1202) and the Account Balances table (F0902).

### ► To review depreciation information online

---

*From the Cost Information & Reports menu (G1213), choose On-Line Depreciation Schedule.*

1. On On-line Depreciation Schedule, complete one of the following fields:
  - Asset Cost Account
  - Responsible Bus. Unit
  - Location
  - Accounting/Equip Class
  - Asset Number
2. To further define your search, click the Company/Dates tab and complete any of the following fields:
  - Company
  - Thru Date/Period
  - Ledger Type
  - Subledger/Type

- Asset Number
3. To narrow your search to disposed or non-disposed assets, click one of the following options:
- Disposed
  - Non-disposed

PeopleSoft

Select Workspace: Active Foundation

Active Foundation Personalize Change Role Sign Out

On-line Depreciation Schedule

Find Close Tools

Asset Cost Company/Date

Asset Cost Account

Responsible Bus. Unit

Location

Accounting/Equip Class

Asset Number 1002 Chrysler Minivan

Asset Number	Asset Description	Cost	Accumulated Depreciation	Net Book Value	YTD Depreciation	C/De
<input type="checkbox"/> 1002	Chrysler Minivan				6,778.23	
	<b>Total</b>				<b>6,778.23</b>	

4. Click Find.

---

## Fixed Asset Journal Entries

You can use the Fixed Assets system to record asset splits, transfers, and disposals in your accounting ledgers. When you indicate which assets you want to be affected by a split or transfer, the system automatically creates the necessary journal entries.

When you run the Compute Depreciation and the Asset Transfer programs in final mode, the system automatically posts transactions to the Asset Account Balances File table (F1202). You can review and, if necessary, make changes to the journal entries and then post them to the Account Balances table (F0902). When you run the Disposal program, the system creates transactions that you must approve before posting to table F0902 and then to table F1202. When you run the asset split program, the system automatically posts transactions to table F0902; then you must post to table F1202.

---

## Splitting Fixed Assets

You can split an existing asset into one or more new assets. The asset does not have to have a quantity greater than one. You can split assets by units, monetary value, or percentage. Percentages calculated for the asset split are based on the cost account as of the date of the split.

Use the Asset Split program to perform the following tasks:

- Split an asset entered as a bulk quantity into smaller lots or units. You do not have to have an asset quantity greater than one to split the asset.
- Remove a portion of an asset to create two independent assets.
- Split a component (part) of an asset to dispose of it.
- Split a component (part) of an asset to transfer it.
- Correct an asset that was entered as one item but should have been entered as multiple assets.
- Split an asset retroactively, which occurs as of a specified date.
- Split a secondary accumulated depreciation account.

When you complete the asset split process, the system automatically updates and creates the necessary asset records and accounts, as follows:

1. Creates asset master records for the new assets that were generated during the split, based on the original asset master record
2. Updates the Current Item Quantity field on the original asset master record
3. Creates location tracking records for the new assets, based on the original asset master record
4. Updates the Quantity field on the original asset's location tracking record
5. Creates F1202 records for the depreciation methods and ledger types for the new assets, based on the original asset record
6. Creates journal entries for both the original asset and the new assets, based on the original asset's costs and accumulated depreciation account numbers. The system creates these posted entries to the Account Balances table (F0902) for each ledger type.

7. Creates a subledger account for the new assets, based on the subledger for the original asset.
8. Submits the journal entries for posting to table F0902 for document type Asset Split (AS).

The following graphic illustrates how the Asset Split program works:

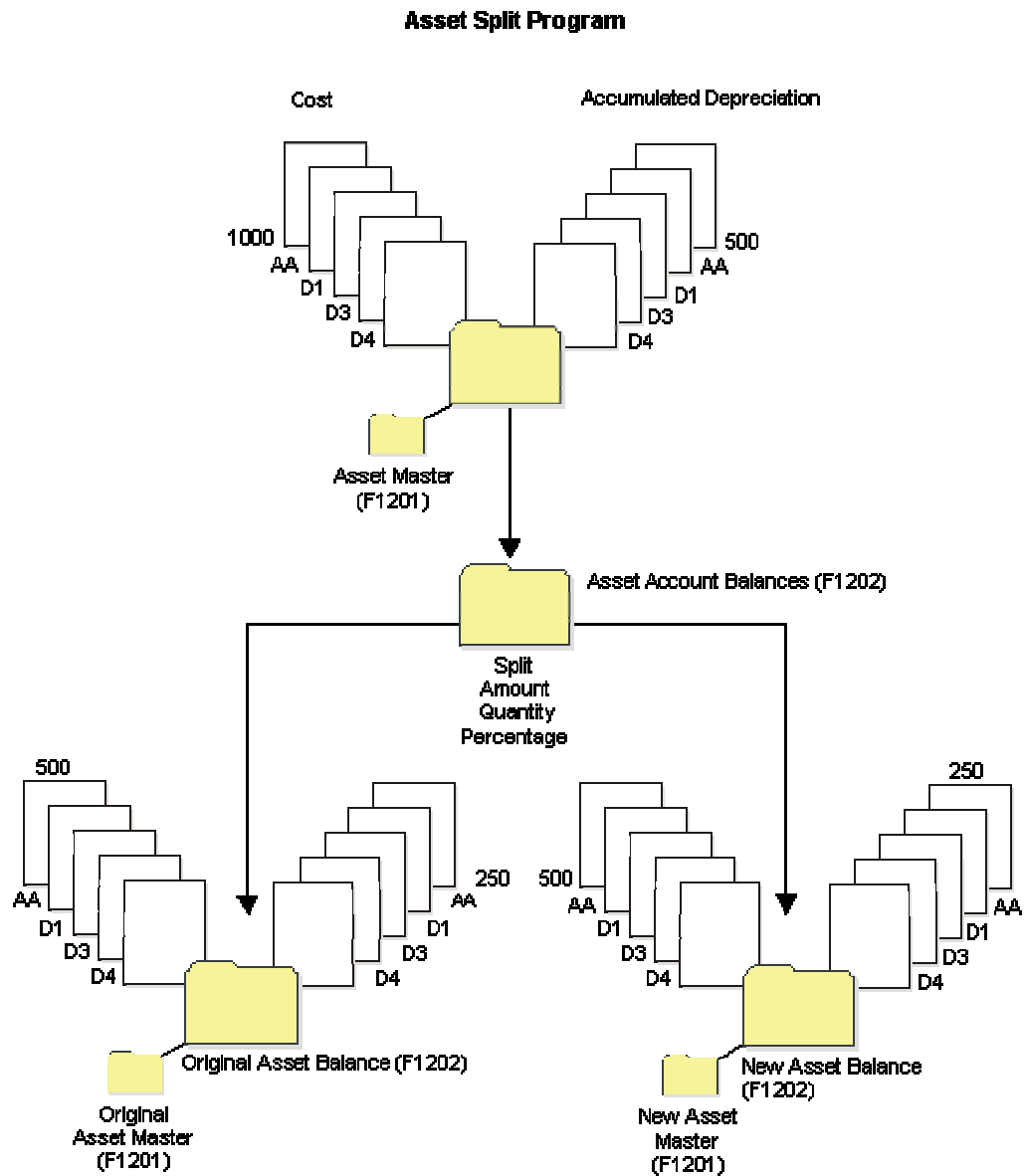

## Entering Asset Split Information

You must enter asset split information to indicate which assets you want to divide. You do not have to have an asset quantity greater than one to split the asset. When you split an asset, the journal entries for the split post to the same cost and accumulated depreciation account as the original asset. After you accept an asset split transaction, you cannot delete the split.

You can perform an asset split only if the asset has a single current location.

The system uses a percentage to calculate cost and accumulated depreciation for the split information that you enter on Asset Split. The system calculates this percentage, regardless of the method of split that you specify. When you exit the program, the system updates asset records, based on the percentage. If you review the asset split journal entries that the system creates, you might notice a rounding difference between the amounts that you entered and the amounts that post to cost and accumulated depreciation.

To maintain the integrity of your fixed asset records, the system prevents asset splits after the date that you dispose of the asset. You can split an asset only before its disposal date.

For retroactive splits, the amount that is defined as available for the split will equal the amount as of the specified G/L date. With retroactive splits, both the displayed amount and the amount in the journal entry will be equal as of the specified G/L date.

If you set up an alternative date pattern, the Asset Split program (P12106) uses the date pattern that you specify.

### See Also

- ❑ *Setting Up Date Pattern Override* in the *Fixed Assets Guide* for more information about setting up an alternative date pattern

### ► To enter asset split information

---

*From the Transfers, Splits & Disposals menu (G1222), choose Asset Split.*

1. On Work With Assets, click Find to view all assets.

To limit your search, click the tabs in the header area of the Work With Assets form and complete the appropriate information.

When you are searching for an asset on the Work With Assets form, the Skip To Description and Skip To Asset fields in the header area and the query-by-example fields in the detail area do not show data if asset descriptions have been translated or if the language preference is activated. However, the Description - Compressed field shows data if the descriptions have been translated; you can conduct your search through this field.

2. Choose the asset that you want to split.
3. From the Row menu, choose Asset Split.
4. On Asset Split, complete the following fields, and click OK to create a batch for the split journal entries:
  - Explanation
  - G/L Date
  - Method (A / U / %)

The system assigns a batch number that remains the same until you leave the Asset Split program. You can include journal entries that are related to multiple asset splits in a single batch.

The current information for the asset appears.

5. To establish information for the new asset, complete one of the following fields:

If the method is either A or blank:

- Asset Cost

If the method is U:

- Asset Quantity

If the method is %:

- Percent

Use the percentage method to fully deplete an original asset cost and split it into one or more new assets. When you deplete the original asset 100 percent, you prevent it from having any remaining balance amounts due to rounding.

6. Complete the following field:

- New Asset Description

7. Complete the following optional fields:

- Asset Number
- Unit Number
- Serial Number

To maintain the integrity of your fixed asset records, the system prevents an asset from being split into an existing asset number. When you split an asset, the system assigns the new asset a number from Next Numbers, or you can assign an asset number to the new asset.

PeopleSoft

Select Workspace: Active Foundation

Active Foundation

Personalize Change Role Sign Out

Asset Split

OK Cancel Form Tools

Batch Number: [ ] Explanation: Split Jeep

G/L Date: [ ]

Method (A/U/%) : U

Asset Number: 123 2005 Jeep Cherokee

Beginning: Cost: [ ] Quantity: [ ]

Remaining: Cost: [ ] Quantity: [ ]

Records 1 - 1

Asset Cost	Asset Quantity	Percent	New Asset Description	Asset Number	Unit Number	Se Nu
<input checked="" type="checkbox"/>						

8. Click OK.

The system updates the Remaining Cost and Quantity fields, based on the asset cost and quantity amounts that you enter. A verification message appears on Asset Split.

9. To accept the transaction, click Yes.

After you accept an asset split transaction, you cannot delete the split.

The program edits the information and clears the form. The system creates posted journal entries for the split to the Account Balances table (F0902). When you click Cancel, the system submits the batch for posting to fixed assets with the document type AS (Asset Split).

10. To view the transactions, choose Split Inquiry from the Form menu on Asset Split.
11. View the transactions on Work With Journal Entries.
12. To return to Work With Assets, click Close.
13. On Asset Split, click Cancel.

## Posting Journal Entries for Asset Splits

When you accept the asset split transaction, the system creates posted asset split journal entries to the Account Balances table (F0902).

When you click Cancel, the system submits the batch for posting to the Asset Account Balances File table (F1202). When you split an asset, the journal entries for the split post to the same cost and accumulated depreciation accounts as the original asset. The system calls

a separate version of the Post program that posts journal entries with the document type AS (Asset Split).

When you split an asset that existed in a prior year, the system creates journal entries on the last day of the prior year with a document type AS. For example, assume your company's calendar fiscal date pattern runs from 01/01/00 through 12/31/00. When you split an asset in fiscal year 2001 that existed in the prior year, the journal entries created use 12/31/00 as the G/L date, regardless of the period in the fiscal year 2001 when the asset was split. The journal entries are marked as posted in the Account Ledger (F0911) since they are from the same account, and do not affect the balance of that account. Therefore, journal entries created from an asset split do not affect balance sheets or income statements that might have already been issued for the prior year.

The system uses the prior year G/L date of 12/31/00 so that beginning balances are updated correctly. Beginning balances are used by the Compute Depreciation program (R12855) to accurately calculate depreciation for the asset split as well as the original asset. The Work with Asset Ledger Inquiry (W12211A) form also uses the beginning balance fields to accurately reflect the Inception-to-Date and Year-To-Date balances.

For assets that are added and then split in the current year, the G/L date for period that the split takes place is used.

#### **See Also**

- *Posting Journal Entries* in the *General Accounting Guide* for more information about the posting process

## **Transferring Fixed Assets**

---

*From the Transfers, Splits and Disposals menu (G1222), choose one of the following asset transfer programs:*

- Single Asset Transfer
- Mass Transfer

Use the transfer procedure to record assets that are transferred from one business unit or account to another. You can transfer assets based on the entire account structure (business unit, object, and subsidiary) or a portion of the account structure. For example, if you move a computer from one department to another department in your company, you use the transfer program to create the journal entries that reflect the move.

When information for a large block of assets changes, you can also use the transfer program to make global changes to the information with or without transferring the assets. When you make global changes to asset information using the Asset Transfer program, you enter new values only in the fields for the values that you want to change. Any fields that you leave blank are not affected by a change. If you want to change the value for a subsidiary or subledger to blank, you must enter \*blank in the field. For example, you can change the responsible business unit for a fleet of trucks without actually moving them. You can use the transfer program to change the following asset information:

- Responsible business unit
- Work center
- Property tax entity
- Property tax state

- Tax rate/area
- Location (if the asset has only one current location)
- Start date
- Category codes

You can use the transfer program to change a specific category code value for all of the assets within a company or asset class without having to change each master record individually, or you can change all the category codes in the Asset Master File table (F1201).

If you set up an alternative date pattern, the transfer program uses the date pattern that you specify.

### See Also

- *Setting Up Date Pattern Override* in the *Fixed Assets Guide* for more information about setting up an alternative date pattern

## Asset Transfers

When you complete the asset transfer process, the program automatically creates the appropriate journal entries with a document type of Asset Transfer (AT). The Asset Transfer program posts the journal entries for asset transfers to the Asset Account Balances File table (F1202) before posting to the Account Balances table (F0902).

---

### Note

When transferring fixed assets, do not use a posting edit code of S on accounts that will be posted to Fixed Assets. If you use a posting edit code of S, you will not be able to post detail information to tables F0902 and F1202 in a summarized format. When you run a fixed asset transfer, the resulting journal entries are prohibited from posting to table F0902 because the detail is missing subledgers. If you use a posting edit code S, you must include subledger information in table F0902.

---

When a transfer occurs in the same month in which a depreciation expense balance exists, the depreciation expense is apportioned to the new account, based on the transfer date.

## Asset Transfer and Depreciation Balance

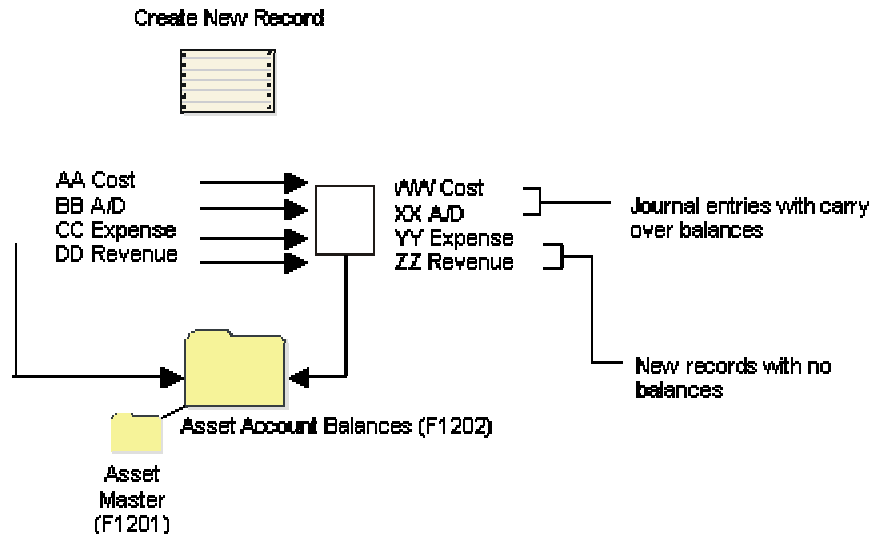

You can use the transfer program to change depreciation expense and revenue information in the asset master. The program can update this information, but it does not move the balances or create journal entries unless you transfer during the middle of the month. To transfer depreciation expense and revenue amounts at the end of the period, you must use journal entries.

You can use the transfer program to transfer secondary and tertiary accumulated depreciation accounts.

You can transfer assets individually or in mass quantities. The transfer program is the same for both single and mass transfers. You use data selection to indicate which asset or assets you are transferring.

---

### Note

To maintain the integrity of your fixed asset records, the system prevents asset transfers after the date that you dispose of the asset. You can transfer an asset only before its disposal date.

Do not use the Mass Transfer or Single Asset Transfer programs to enter asset location information for billing purposes. Use only the Location Transfer program to transfer assets with associated billing information.

---

## Processing Options for Asset Transfer (R12108)

### Process Tab

These processing options enable you to:

- Specify the date when you want to transfer the asset.

- Specify the accounts to which you are transferring the asset.
- Indicate whether you want to use flex accounting.
- Change asset master information and asset master category code information.

These processing options also enable you to specify whether you want to run this program in preliminary or final mode.

A preliminary asset account transfer performs the following tasks:

- Edits the transfer to information that you enter in the appropriate processing options
- Prints a report that shows the journal entries that the system creates when you run the final transfer

A preliminary asset information change performs the following tasks:

- Edits the new item master information that you enter in the processing options
- Prints a report that shows the original item master information and the new information that the system creates when you run the final transfer

A final asset account transfer performs the following tasks:

- Edits the transfer to information that you enter in the appropriate processing options
- Creates journal entries for the asset accounts that are affected by the asset transfer
- Prints a report showing the journal entries
- Updates the item master information in the Asset Master File table (F1201)
- Posts the journal entries to the Asset Account Balances File table (F1202), depending on the type of transfer

A final asset information change performs the following tasks:

- Edits the new asset information that you enter in the appropriate processing options
- Prints a report that shows the original asset master information and the new asset information that the system creates
- Updates the asset master information records in the Asset Master File table (F1201)

---

## 1. Process Mode

Blank = Preliminary mode

1 = Final mode

Use this processing option to specify the mode in which you want to run this program.  
Valid values are:

Blank Run the program in preliminary mode. You should run the program in preliminary mode before running it in final mode. The program will produce a report, which will help you ensure that the transfer journal entries created for a preliminary asset account transfer and asset information changes are correct. Running the program in preliminary mode does not update accounts.

1 Run the program in final mode. When you transfer an asset in final mode, this program automatically updates the records in the Item Balances table (F1202). You must then post the transfer journal entries to the general ledger. If the transfer journal entries are incorrect, you must correct the errors through the general ledger.

---

---

## 2. Transfer Date

Use this processing option to specify the date in which you want to transfer this asset.  
Final depreciation must be posted through this date.

---

---

## 3. Asset Cost Account

---

---

a. Asset Cost Business Unit

Use this processing option to specify the Asset Cost Business Unit to which you are transferring the asset. You must enter a valid value in this field in order for a transfer to occur. Leave this field blank if the Asset Cost Business Unit will remain the same.

---

---

b. Asset Cost Object

Use this processing option to specify the Asset Cost Object to which you are transferring the asset. You must enter a valid value in this field in order for a transfer to occur. Leave this field blank if the Asset Cost Object will remain the same.

---

---

c. Asset Cost Subsidiary

Use this processing option to specify the Asset Cost Subsidiary to which you are transferring the asset. You must enter a valid value in this field in order for a transfer to occur. Leave this field blank if the Asset Cost Subsidiary will remain the same. Type \*BLANK in this field to change the subsidiary to blank.

---

---

**4. Accumulated Depreciation Account**

---

---

a. Accum Depr Business Unit

Use this processing option to specify the Accumulated Depreciation Business Unit to which you are transferring the asset. You must enter a valid value in this field in order for a transfer to occur. Leave this field blank if the Accumulated Depreciation Business Unit will remain the same.

---

---

b. Accum Depr Object

Use this processing option to specify the Accumulated Depreciation Object to which you are transferring the asset. You must enter a valid value in this field in order for a transfer to occur. Leave this field blank if the Accumulated Depreciation Object will remain the same.

---

---

c. Accum Depr Subsidiary

Use this processing option to specify the Accumulated Depreciation Subsidiary to which you are transferring the asset. You must enter a valid value in this field in order for a transfer to occur. Leave this field blank if the Accumulated Depreciation Subsidiary will remain the same. Type \*BLANK in this field to change the subsidiary to blank.

---

---

**5. Cost and Accumulated Depreciation Account**

---

---

a. Cost and Accum Depr Subledger

Use this processing option to specify the Cost and Accumulated Depreciation Subledger to which you are transferring the asset. You must enter a valid value in this field in order for a transfer to occur. Leave this field blank if the Cost and Accumulated Depreciation Subledger will remain the same. Type \*BLANK in this field to change the subledger to blank.

---

---

b. Cost and Accum Depr Subledger Type

Use this processing option to specify the Cost and Accumulated Depreciation Subledger Type to which you are transferring the asset. You must enter a valid value in this field in order for a transfer to occur. Leave this field blank if the Cost and Accumulated Depreciation Subledger Type will remain the same.

---

---

**6. Depreciation Expense Account**

---

---

a. Depr Expense Business Unit

Use this processing option to specify the Depreciation Expense Business Unit to which you are transferring the asset. You must enter a valid value in this field in order for a transfer to occur. Leave this field blank if the Depreciation Expense Business Unit will remain the same.

---

---

b. Depr Expense Object

Use this processing option to specify the Depreciation Expense Object to which you are transferring the asset. You must enter a valid value in this field in order for a transfer to occur. Leave this field blank if the Depreciation Expense Object will remain the same.

---

---

c. Depr Expense Subsidiary

Use this processing option to specify the Depreciation Expense Subsidiary to which you are transferring the asset. You must enter a valid value in this field in order for a transfer to occur. Leave this field blank if the Depreciation Expense Subsidiary will remain the same. Type \*BLANK in this field to change the subsidiary to blank.

---

---

d. Depr Expense Subledger

Use this processing option to specify the Depreciation Expense Subledger to which you are transferring the asset. You must enter a valid value in this field in order for a transfer to occur. Leave this field blank if the Depreciation Expense Subledger will remain the same. Type \*BLANK in this field to change the subledger to blank.

---

---

e. Depr Exp Subledger Type

Use this processing option to specify the Depreciation Expense Subledger Type to which you are transferring the asset. You must enter a valid value in this field in order for a transfer to occur. Leave this field blank if the Depreciation Expense Subledger Type will remain the same.

---

---

**7. Asset Revenue Account**

---

---

a. Asset Revenue Business Unit

Use this processing option to specify the Asset Revenue Business Unit to which you are transferring the asset. You must enter a valid value in this field in order for a transfer to occur. Leave this field blank if the Asset Revenue Business Unit will remain the same.

---

---

b. Asset Revenue Object

Use this processing option to specify the Asset Revenue Object to which you are transferring the asset. You must enter a valid value in this field in order for a transfer to occur. Leave this field blank if the Asset Revenue Object will remain the same.

---

---

c. Asset Revenue Subsidiary

Use this processing option to specify the Asset Revenue Subsidiary to which you are transferring the asset. You must enter a valid value in this field in order for a transfer to occur. Leave this field blank if the Asset Revenue Subsidiary will remain the same. Type \*BLANK in this field to change the subsidiary to blank.

---

---

8. Explanation

When you transfer an asset in final mode, this program creates journal entries for the asset accounts that are affected by the asset transfer. Use this processing option to enter the explanation for these journal entries.

---

---

**9. Asset Master Changes**

---

---

a. Responsible Business Unit

Use this processing option to change Responsible Business Unit information.

You must enter a valid value in this field in order for the information to change. Leave this field blank if the Responsible Business Unit will remain the same.

---

---

b. Property Tax Entity

Use this processing option to change Property Tax Entity information. You must enter a valid value in this field in order for the information to change.

Leave this field blank if the Property Tax Entity will remain the same.

---

---

c. Property Tax State

Use this processing option to change Property Tax State information. You must enter a valid value in this field in order for the information to change.

Leave this field blank if the Property Tax State will remain the same.

---

---

d. Location

Use this processing option to change location information. You must enter a valid value in this field in order for the information to be changed. Leave this field blank if you do not want the information to change.

If you perform a location transfer using the Asset Transfer program, the transfer date must be less than or equal to today's date. Planned location transfers must be done through the Location Transfer program.

---

---

**10. Asset Master Category Code Changes**

**An "\*" asterisk in the Category Codes changes codes to blank.**

---

---

a. Category Code 01

Use this processing option to change Category Code 01 information. You must enter a valid value in this field in order for the information to change.

Leave this field blank if Category Code 01 information will remain the same.

---

---

b. Category Code 02

Use this processing option to change Category Code 02 information. You must enter a valid value in this field in order for the information to change.

Leave this field blank if Category Code 02 information will remain the same.

---

---

c. Category Code 03

Use this processing option to change Category Code 03 information. You must enter a valid value in this field in order for the information to change.

Leave this field blank if Category Code 03 information will remain the same.

---

---

d. Category Code 04

Use this processing option to change Category Code 04 information. You must enter a valid value in this field in order for the information to change.

Leave this field blank if Category Code 04 information will remain the same.

---

---

e. Category Code 05

Use this processing option to change Category Code 05 information. You must enter a valid value in this field in order for the information to change.

Leave this field blank if Category Code 05 information will remain the same.

---

---

f. Category Code 06

Use this processing option to change Category Code 06 information. You must enter a valid value in this field in order for the information to change.

Leave this field blank if Category Code 06 information will remain the same.

---

---

g. Category Code 07

Use this processing option to change Category Code 07 information. You must enter a valid value in this field in order for the information to change.

Leave this field blank if Category Code 07 information will remain the same.

---

---

h. Category Code 08

Use this processing option to change Category Code 08 information. You must enter a valid value in this field in order for the information to change.

Leave this field blank if Category Code 08 information will remain the same.

---

---

i. Category Code 09

Use this processing option to change Category Code 09 information. You must enter a valid value in this field in order for the information to change.

Leave this field blank if Category Code 09 information will remain the same.

---

---

j. Category Code 10

Use this processing option to change Category Code 10 information. You must enter a valid value in this field in order for the information to change.

Leave this field blank if Category Code 10 information will remain the same.

---

---

k. Category Code 11

Use this processing option to change Category Code 11 information. You must enter a valid value in this field in order for the information to change.

Leave this field blank if Category Code 11 information will remain the same.

---

---

l. Category Code 12

Use this processing option to change Category Code 12 information. You must enter a valid value in this field in order for the information to change.

Leave this field blank if Category Code 12 information will remain the same.

---

---

m. Category Code 13

Use this processing option to change Category Code 13 information. You must enter a valid value in this field in order for the information to change.

Leave this field blank if Category Code 13 information will remain the same.

---

---

n. Category Code 14

Use this processing option to change Category Code 14 information. You must enter a valid value in this field in order for the information to change.

Leave this field blank if Category Code 14 information will remain the same.

---

---

o. Category Code 15

Use this processing option to change Category Code 15 information. You must enter a valid value in this field in order for the information to change.

Leave this field blank if Category Code 15 information will remain the same.

---

---

p. Category Code 16

Use this processing option to change Category Code 16 information. You must enter a valid value in this field in order for the information to change.

Leave this field blank if Category Code 16 information will remain the same.

---

---

q. Category Code 17

Use this processing option to change Category Code 17 information. You must enter a valid value in this field in order for the information to change.

Leave this field blank if Category Code 17 information will remain the same.

---

---

r. Category Code 18

Use this processing option to change Category Code 18 information. You must enter a valid value in this field in order for the information to change.

Leave this field blank if Category Code 18 information will remain the same.

---

---

s. Category Code 19

Use this processing option to change Category Code 19 information. You must enter a valid value in this field in order for the information to change.

Leave this field blank if Category Code 19 information will remain the same.

---

---

t. Category Code 20

Use this processing option to change Category Code 20 information. You must enter a valid value in this field in order for the information to change.

Leave this field blank if Category Code 20 information will remain the same.

---

---

u. Category Code 21

Use this processing option to change Category Code 21 information. You must enter a valid value in this field in order for the information to change.

Leave this field blank if Category Code 21 information will remain the same.

---

---

v. Category Code 22

Use this processing option to change Category Code 22 information. You must enter a valid value in this field in order for the information to change.

Leave this field blank if Category Code 22 information will remain the same.

---

---

w. Category Code 23

Use this processing option to change Category Code 23 information. You must enter a valid value in this field in order for the information to change.

Leave this field blank if Category Code 23 information will remain the same.

---

---

#### 11. Flex Accounting

Blank = Do not use flex accounting

1 = Use flex accounting

Use this processing option to indicate whether to use flex accounting. Valid values are:

Blank Do not use flex accounting.

1 Use flex accounting.

---

#### **Versions Tab**

This processing option enables you to specify the General Ledger Post Report version that you want the system to run automatically.

---

1. General Ledger Post Version (R09801)

If you are running this program in final mode, use this processing option to specify the Post General Journal (R09801) version you want the system to run automatically. This processing option works only under the following conditions:

- o Final depreciation must be posted through the date specified in the Transfer Date processing option on the Process tab.

- o You have set Management Approval to No (N) on System Constants.

- o You enter a version that has already been added.

---

**Print Tab**

These processing options determine how the asset number appears on reports and where page breaks occur.

---

## 1. Asset Number Format

1 = Asset Number

2 = Unit Number

3 = Serial Number

Use this processing option to specify how you want the asset number printed on the report. Valid values are:

1. Asset Number.

2. Unit Number.

3. Serial Number.

---

---

## 2. Page Breaks

Blank = Skip to a new page when the asset number changes

1 = Do not skip to a new page when the asset number changes

Use this processing option to indicate whether you want the report to skip to a new page when the asset number changes. Valid values are:

Blank Skip to a new page when the asset number changes.

1 Do not skip to a new page when the asset number changes.

---

## Disposing of Fixed Assets

---

You can use the disposal programs in the Fixed Assets system to record asset disposals. You can also record new asset costs in the event of a trade-in.

When you dispose of an asset, you can indicate a specific method of disposal, such as scrapped, theft, or charity. The system updates the asset master record with the disposal date (unless you enter a date in the asset master record) and indicates the method of disposal in the Equipment Status field. The system also creates the journal entries for the disposal.

The system creates disposal journal entries only for the Actual Amounts (AA) ledger unless you specify additional ledgers in the processing options. You must post the disposal journal entries to the general ledger and fixed assets.

When you dispose of an asset, the system must access the following accounts to create the appropriate journal entries:

- Accumulated Depreciation and Cost. You set up these accounts when you create the asset master record.
- Net Book Value, Cash Clearing, Cash Proceeds. You set up these accounts when you set up the Disposal Account Rule Table.

If you define a secondary accumulated depreciation account (from the SDA AAI) for an asset, the disposal program handles the balance for that account.

The disposal programs create journal entries for accounts, based on the depreciation account rules that you set up. These rules can be very simple or complex, based on your company's needs. These rules replace information that was originally contained in the FDS series of automatic accounting instructions (AAIs).

You can use the disposal programs for secondary accumulated depreciation accounts.

If you set up an alternative date pattern, the disposal program uses the date pattern that you specify.

### See Also

- *Setting Up Date Pattern Override* in the *Fixed Assets Guide* for more information about setting up an alternative date pattern

## Fixed Asset Disposals

If you must dispose of more than one ledger-- a second currency ledger, for instance-- you can indicate which ledgers to include. In addition, different account information can be specified to preserve the cost and accumulated depreciation accounts, and to use a reserve account in their place. Different account information can also be used to comply with charitable deduction reporting requirements in some countries. If necessary, you can dispose of a single subledger for one or more assets.

Tax ledgers are not disposed but are carried to the end of the current year. When you do a final close, tax ledgers do not create balance forward records for the following year.

You do not have to remove the disposal date from the asset master record before you run disposal. You can leave the disposal date blank for the disposal program, and the system uses the date from the asset master. If both the asset master record and the disposal

program have blank dates, the system uses the G/L date. If you do use the disposal date in the disposal program and a date exists in the asset master record, you get a message that the date exists in the asset master. The date in the asset master record is not overwritten. The disposal date and equipment status is updated only if you are disposing of records in the AA ledger.

You can void disposal entries. Use the Single Asset Disposal program to void disposal journal entries that the system creates in the Mass Disposals program. When you void disposal journal entries, the system automatically updates the Disposal Date and Equipment Status in the Asset Master File table (F1201).

**Simple Disposal**

Item number 27830 has the following current account information:

60,000 Asset Cost  
 - 45,000 Accumulated Depreciation  
 -----  
 15,000 Net Book Value

Disposal entries are created as follows:

Account number	Account Description	Debit	Credit
50.2030	Cost		60,000
50.2130	Accumulated Depreciation	45,000	
Yard.9112	Net Book Value	15,000	

**Disposal with Cash Proceeds**

Item number 27828 has the following current account information:

50,000 Asset Cost  
 -25,000 Accumulated Depreciation  
 -----  
 25,000 Net Book Value

This asset is being sold for 10,000.

The following entries need to be created:

- 9. Record and post the cash to G/L and Fixed Assets (Cash Receipt Journal Entry).

Account number	Account Description	Debit	Credit
50.1110. BEAR	Cash	10,000	
YARD.9113	Cash/Clearing Account		10,000 (Item number 27828)

- 10. Disposal entries are created as follows:

Account number	Account Description	Debit	Credit
50.2030	Cost		50,000
50.2130	Accumulated Depreciation	25,000	
YARD.9112	Net Book Value	25,000	
YARD.9111	Proceeds from sale of assets		10,000
YARD.9113	Cash/Clearing Account	10,000	

An entry to the Gain/Loss account 9110 is not made. However, when you run financial transactions, the balances on accounts 9112, 9111, and 9113 are rolled into account 9110 per the level of detail rollup.

For example, the following table illustrates the results of using the Accounts by Business Units program to inquire on the YARD business unit:

Account	Subsidiary Description	LOD
9110	Gain on sale of assets	5
9111	Proceeds from asset disposal	6
9112	Net book value of assets disposed	6
9113	Cash proceeds clearing account	6

In this example, the following exists (<10,000> original entry + 10,000 entry made during disposal):

25,000	YARD 9112
<10,000>	YARD.9111
0	YARD.9113
<hr/>	
15,000	LOSS

### Trade-In

Item number 27830 has the following current account information:

60,000	Asset Cost
- 45,000	Accumulated Depreciation
<hr/>	
15,000	Net Book Value

The following entries need to be created:

- A new Asset Master Record, number 27836.
- Disposal entries are created as follows:

Account number	Account Description	Debit	Credit
50.2030	Cost		60,000 (Item number 27830)
50.2130	Accumulated Depreciation	45,000 (Item number 27830)	
50.2030	Cost	15,000 (Item number 27836)	

### Note

The debit amount to the Cost Account of the new asset is the NBV (Net Book Value) of the Original Asset.

### Disposal with Trade-In and Cash Proceeds

Item number 27828 has the following current account information:

50,000	Asset Cost
-25,000	Accumulated Depreciation
25,000	Net Book Value

This asset is being sold for 10,000.

The following tasks need to be completed:

- Record and post the cash to G/L and Fixed Assets (Cash Receipt Journal Entry):

#### Account number Account Description Debit Credit

50.1110.BEAR	Cash	10,000	
YARD.9113	Cash/Clearing account		10,000 (Item number 27828)

- A new Asset Master Record, Item number 27836.

- Disposal entries are created as follows:

Account number	Account Description	Debit	Credit
50.2030	Cost		50,000 (Item number 27828)
50.2130	Accumulated Depreciation	25,000 (Item number 27828)	
50.2030	Net Book Value	25,000 (Item number 27836)	
YARD.9111	Proceeds from sale of assets		10,000 (Item number 27828)
YARD.9113	Cash/Clearing Account	10,000 (Item number 27828)	

### Before You Begin

- Verify that the following tasks are complete:

- Disposal account rules are set up.
- Depreciation is recorded through the disposal date of the asset.
- Cash receipts from disposal proceeds are posted to fixed assets.
- Accounts payable vouchers for trade-ins are posted to fixed assets.

## **Performing Single Asset Disposals**

You can use Single Asset Disposal to dispose of assets individually. Dispose of assets individually to record the gains and losses that result from a disposal, and to record the new asset cost if a trade-in occurs. You can also use Single Asset Disposal to void or delete a disposal entry for a particular asset whether it was disposed of by the Mass Disposals or Single Asset Disposal procedures.

The system creates disposal journal entries, based on the disposal type that you specify when you enter disposal information. You can use Single Asset Disposal to perform four types of disposals:

**Simple disposal (with no proceeds)** Use simple disposal when the disposal does not involve proceeds. For example, use this disposal type if you dispose of an asset and do not receive cash for the asset because it was destroyed, given to charity, or so on.

The system uses the business unit in the Net Book Value account that you set up in the Disposal Account Rules Table (F12141). If the business unit in that account rule is blank, the system uses the responsible business unit from the asset's master record.

**Disposal with cash proceeds** Use a disposal with cash proceeds when you receive cash for an asset. When you specify this disposal type, the system debits the Cash/Clearing account and credits the Proceeds from Sale account. If you use this disposal type, you must attach the asset item number to the cash receipt entry for the Cash/Clearing Account and post this entry to Fixed Assets before disposing of the asset.

The system uses the business unit from the respective disposal account rules for Net Book Value, Cash/Clearing, or Proceeds from Sale accounts. If the business unit in any of these rules is blank, the system uses the responsible business unit from the asset's master record.

**Disposal with trade-in** Use a disposal with trade-in when you trade an asset in for another asset and no cash proceeds exist. When you use this type of disposal, you must enter the new asset's master information before you run the Single Asset Disposal program to dispose of the asset that you trade in.

**Disposal with cash proceeds and trade-in** Use a disposal with cash proceeds and trade-in when a disposal involves a combination of both cash and trade-in on an asset. Before you run the Single Asset Disposal program to dispose of the asset that you traded in, do the following:

- Enter the master record information for the new asset.
- Post the accounts payable entry to the general ledger and fixed assets if you paid additional cash for the new asset.

When you receive cash for an asset, you debit the cash account and credit the Cash/Clearing account. Then, when you dispose of the asset using the Single Asset Disposal program, the system debits the Cash/Clearing account and credits the Proceeds from Sale account.

## ► To enter disposal information

---

*From the Transfers, Splits & Disposals menu (G1222), choose Single Asset Disposal.*

1. On Work With Assets, click Find to view all assets.

To limit your search, click the tabs in the header area of the Work With Assets form and complete the appropriate information.

When you are searching for an asset on the Work With Assets form, the Skip To Description and Skip To Asset fields in the header area and the query-by-example fields in the detail area do not show data if asset descriptions have been translated or if the language preference is activated. However, the Description - Compressed field shows data if the descriptions have been translated; you can conduct your search through this field.

2. Choose the asset that you want to dispose.
3. From the Row menu, choose Asset Disposal.

4. On Single Asset Disposal, complete the following required field to add a new batch for the disposal journal entries:
    - Date Disposed or Retired
  5. Complete the following required fields:
    - G/L Date
    - Disposal Method
    - Type of Disposal
  6. Complete the following optional fields:
    - Subledger
    - Sub Type
- If you specify a subledger and subledger type in the disposal information, the asset disposal updates only the specified subledger. You can choose whether to update the disposal date or leave it blank.
7. Click OK.

---

**Note**

The batch number that is assigned by the system remains the same until you leave the asset disposal program. You can include journal entries that relate to multiple asset disposals in a single batch.

---

8. To accept the transactions, complete the following field:
    - Is this Information Correct? (Y/N)
  9. If you are disposing of a single subledger, complete the following field:
    - Should the Date Disposed be Updated? (Y/N)
- The system creates the disposal journal entries.

---

**► To review and revise disposal entries**

---

*From the Transfers, Splits & Disposals menu (G1222), choose Single Asset Disposal.*

1. On Work With Assets, click Find to view all assets.

To limit your search, click the tabs in the header area of the Work With Assets form and complete the appropriate information.

When you are searching for an asset on the Work With Assets form, the Skip To Description and Skip To Asset fields in the header area and the query-by-example fields in the detail area do not show display data if asset descriptions have been translated or if the language preference is activated. However, the Description - Compressed field shows data if the descriptions have been translated; you can conduct your search through this field.
2. Choose the asset that you want to dispose.
3. From the Row menu, choose Asset Disposal.

4. On Single Asset Disposal, choose Review Entries from the Form menu to review the journal entries for the assets.
5. On Single Asset Disposal, choose Void Entry from the Form menu to void a journal entry.
6. On Void/Delete Disposal Entries, choose the journal entry that you want to void.
7. From the Row menu, choose Void/Reverse JE.
8. On Void Journal Entry, change the following field, if needed:
  - G/L Date
9. Click OK.
10. On Asset Master Update, complete the following fields.
  - New Equipment Status
  - Effective Date
11. To save your entries, click OK.
12. To return to Work With Assets, click Close, then Cancel, and then Close.

## Posting the Disposal Entries

You must manually post single disposal journal entries to the general ledger and fixed assets. To perform this task, run the following posts:

- Disposal Post to G/L
- Post G/L Entries to Assets

---

### Note

The default version of the Post G/L Entries to Assets program posts all unposted fixed asset entries. To post only disposal entries, you must create your own version of the post program and attach it to the menu option.

---

### See Also

- *Posting Journal Entries in the General Accounting Guide*

See the following topics in the *Fixed Assets Guide*:

- *Setting Up Disposal Account Rules*
- *Posting Journal Entries to Fixed Assets*

## Performing Mass Asset Disposals

Use Mass Asset Disposals to accomplish the following:

- Dispose of multiple assets instead of a single asset.
- Use data selections to indicate the assets that you want to dispose of.

- Post the disposal entries to the general ledger automatically. The Mass Asset Disposals program performs this post automatically unless you specify Batch Approval in your system's setup.

The system creates disposal journal entries that are based on the disposal type that you specify when you enter disposal information. Set the processing options to specify which of the following types of disposals you want the Mass Asset Disposals to perform:

**Simple disposal (with no proceeds)** Use simple disposal when the disposals do not involve proceeds. For example, use this disposal type if you want to dispose of assets and do not receive cash for them because they were destroyed, given to charity, or so on.

The system uses the business unit in the Net Book Value account that you set up in the Disposal Account Rule Table (F12141). If the business unit in that account is blank, the system uses the responsible business unit from the asset master records.

**Disposal with cash proceeds** Use a disposal with cash proceeds when you receive cash for disposed assets. When you specify this disposal type, the system debits the Cash/Clearing account and credits the Proceeds from Sale account. If you use this disposal type, you must attach asset numbers to the cash receipt entries for the Cash/Clearing account and post this entry to Fixed Assets before disposing of the asset.

The system uses the business unit from the disposal account rule for Net Book Value, Clearing, or Proceeds from Sale accounts. If the business unit in any of these rules is blank, the system uses the responsible business unit from the asset master records.

**Disposal with and without cash proceeds** Use a disposal with and without cash proceeds to dispose of all of the assets that are specified in the data selection.  
If the business unit is blank, the system uses the responsible business unit from the asset master records.

You can use processing options to run a preliminary or final mass disposal. The preliminary disposal does not create disposal journal entries. Run a preliminary disposal for proofing purposes before you run the final disposal.

**Preliminary disposal**

The preliminary disposal performs the following tasks:

- Edits the disposal information that you selected
- Prints a report that shows the journal entries which the system creates when you run a final disposal

**Final disposal**

The final disposal performs the following tasks:

- Edits the disposal information that you selected
- Creates journal entries for the accounts that are affected by the disposals
- Prints a report that shows the journal entries
- Updates the Date Disposed and Equipment Status fields in master records for the disposed assets if you are disposing of records in the AA ledger
- Shows a zero cost basis for the disposed assets
- Submits the journal entries for posting to the general ledger if the processing options are used

**Note**

If the system finds any errors during the final disposal process, it does not create journal entries for the assets in error. Instead, the system prints an error message on the final report. Correct these errors and rerun the final disposal.

**► To enter mass disposal information**

---

*From the Transfers, Splits, & Disposals menu (G1222), choose Mass Asset Disposal.*

1. On Work With Batch Versions, choose the batch version.
2. From the Row menu, choose each of the following options and complete the appropriate information:
  - Processing Options
  - Data Selection
  - Data Sequencing
  - Version Detail
3. Use Data Selection to indicate the assets that you want to affect by the disposal. Company and item number are required data sequence items for the mass disposal procedure.

**Posting Journal Entries for Mass Disposals**

*From the Transfers, Splits, & Disposals menu (G1222), choose Post G/L Entries to Fixed Asset.*

If your system requires batch approval, you must post the disposal journal entries manually to the general ledger before you run Post G/L Entries to Assets.

If your system does not require batch approval, it automatically performs the post to the general ledger. You must run only the Post G/L Entries to Assets to post journal entries for mass disposals to fixed assets.

---

**Note**

The processing option for the G/L post submittal works only under the following conditions:

- You run the depreciation program in final mode.
  - You have Management Approval set to No (N) on System Constants.
- 

**See Also**

- *Posting G/L Journal Entries to Fixed Assets* in the *Fixed Assets Guide*
- *Posting Journal Entries* in the *General Accounting Guide*

**Processing Options for Mass Asset Disposals (R12104)****Process Tab**

---

## 1. Preliminary or Final Processing

Blank = Preliminary Mode.

1 = Final Mode

Use this processing option to specify whether to run the program in preliminary or final mode. Valid values are:

Blank

Preliminary mode

1

Final mode

---

---

## 2. Ledger Type

Use this processing option to specify the ledger types to be disposed. If you leave this processing option left blank, the system created entries only for the AA ledger.

---

---

## 12. Subledger - G/L

Blank = Dispose all Subledgers

\*BLANK = Dispose only blank Subledger.

Use this processing option to specify the subledger and subledger type to be disposed.  
Valid values are:

Blank

All subledgers and subledger types will be disposed.

\*BLANK

Only the blank subledger and blank subledger types will be disposed.

---

---

### 13. Subledger Type

Blank = Dispose all Subledger Types

\*BLANK = Dispose only blank Subledger Type

Use this processing option to specify the subledger and subledger type to be disposed.  
Valid values are:

Blank

All subledgers and subledger types will be disposed.

\*BLANK

Only the blank subledger and blank subledger types will be disposed.

---

---

### 14. Date - Disposed or Retired

Use this processing option to specify the disposal date.

---

---

### 15. G/L Date

Use this processing option to specify the G/L date for the journal entry if it differs from the disposal date.

---

---

## 16. Equipment Status

Use this processing option to specify the status of an asset (for example, whether the asset is available, down, or disposed). Valid values are maintained in UDC 12/ES.

---

---

## 17. Flex Accounting

Blank = Do not use flex accounting

1 = Use flex accounting

Use the processing option to specify whether the system uses flexible accounting. Valid values are:

Blank

Do not use flexible accounting.

1

Use flexible accounting.

---

---

## 18. Asset Disposal Type

Blank = Dispose all assets, with and without proceeds.

1 = Dispose only assets with proceeds.

2 = Dispose only assets without proceeds.

Use this processing option to specify the how the system handles the disposition of assets with and without proceeds. Valid values are:

Blank

Dispose all assets with and without proceeds.

1

Dispose only assets with proceeds.

2

Dispose only assets without proceeds.

## Asset Number Format

1 = Asset Number

2 = Unit Number

3 = Serial Number

## Print Tab

Use this processing option to specify which number the system prints to identify the asset. Valid values are:

1 Print the asset number.

---

2 Print the unit number.

3 Print the serial number.

**Versions Tab**

Version

Use this processing option to specify which version of the General Ledger Post Report program (R09801) the system runs when you process in final mode.

---

---

## Asset Revaluation

After you set up revaluation codes and revaluation indexes, you can calculate asset revaluation.

---

## Understanding Asset Revaluation

Revaluation is the process by which the costs of assets are restated in terms of current worth. The basic concept behind revaluation is that of comparability. The question is whether, over time, you can make a meaningful comparison between financial statements when such factors as the rate of inflation and the current cost of assets are considered.

A number of theories of revaluation exist. Two of the more prominent theories are:

- Constant currency accounting
- Current cost accounting

### Constant Currency Accounting

Under constant currency accounting, the effect of inflation is the major factor taken into consideration for asset revaluation. Inflation trends move upward, though it can vary widely from country to country: from virtually insignificant, single-digit rises to three- and even four-digit rates. Comparing costs from one year to the next in a hyperinflationary economy is meaningless unless the currency fluctuation is factored in. In some countries, you are required to adjust costs as the value of the currency changes. Even without a government mandate, you might want to revalue assets for reporting purposes.

### Current Cost Accounting

The current cost accounting model relies primarily on the assumption that, apart from any currency changes, the price of assets can change significantly, compared to the general price level. Within this model, the cost of replacing assets is of particular concern. One of the questions that this method brings up is whether a company has sufficient insurance coverage to replace a given asset with one that is comparable.

For example, a manufacturing facility purchased several years ago for 1,000,000 USD could most likely not be replaced for that same 1,000,000 USD today if it burned down. While inflation might account for some of the difference, the current cost of building supplies and labor might have risen beyond the rate of inflation. Conversely, if a personal computer, originally purchased three years ago for 4,000 USD is stolen, a comparable replacement can be found for less than that original cost because the cost of computer-related equipment has been decreasing. If a company revalues its assets for insurance purposes, it can ensure adequate coverage when such dramatic losses occur.

J.D. Edwards has chosen to create a highly flexible approach to revaluation. The revaluation of large numbers of assets is most often accomplished through the use of indexes. These indexes are obtained from sources that are external to the company, whether from governments or other organizations. They can be expressions of change over periods as short as a single day or as long as several years. The indexes can be applied to only current year balances or to prior year balances. The application of these indexes to the proper selection of assets to revalue through a method of calculation can yield significant results, whether your aim is to revalue for insurance purposes, to meet government reporting requirements, or to report to management for future planning.

## Revaluation Indexes

A revaluation index is a value that has been determined by an agency outside your company, governmental or private, that reflects a change in cost that can be applied to your assets. The change might relate to currency fluctuations or the price of certain kinds of assets in the marketplace, or some combination of factors. Depending on your approach to revaluation or government regulations concerning revaluation, you might need only a single index; or you might need several tables of indexes. These indexes are entered into the system manually and then applied to your assets in the method that you select.

## Revaluation Calculation Methods

The two revaluation calculation methods that you can choose when you run your revaluation are:

- Revaluation Year Balances
- Inception-to-Date

While both methods revalue both your cost and your accumulated depreciation amounts, the way that the posted balances are handled differentiates them.

### Revaluation Year Balances

When you select Revaluation Year Balances, the system revalues the current year-to-date balance separately and then revalues the beginning balance. Unless you specify otherwise, the system updates the cost, primary accumulated depreciation, and secondary accumulated depreciation accounts. The following is an example of the revaluation process for year balances:

1. The current year-to-date amounts for both primary and secondary accumulated depreciation are revalued, and the adjustment amount is calculated.
2. The beginning balances in both the depreciation accounts are revalued and their adjustment amounts are calculated.
3. The adjustments for both the year-to-date and the beginning balances are added together, and one journal entry is created for the ledger that you have specified in the processing options.
4. Offsetting journal entries are also created for posting to the current year offset account (to offset the year-to-date balance adjustment) and prior year offset account (to offset the beginning balance adjustment) that you set up in the FR AAls.

Revaluation for the asset cost is treated similarly, except that only a single offset exists.

### Inception-to-Date

When you select the Inception-to-Date calculation method, account balances for every year are revalued. For example, year-to-date activity in the asset cost account is revalued for each year; and the adjustment amount is calculated for each year. The adjustment amounts are then summed and a journal entry is created for that amount to post to the ledger that is specified in the processing options. The offsetting entry is created for posting to the cost offset account that you set up in the FR AAls. Both primary and secondary accumulated depreciation are treated similarly, except for the offsets.

If you need to track both current adjustments and prior year adjustments, you must set up offset accounts for both the FR2 (current year accumulated depreciation) and FR3 (prior year accumulated depreciation) AAIs. Offsetting journal entries are created automatically for these two offset accounts.

## Revaluation by Index or Factor

For either of the revaluation methods, you can specify whether to use the values entered in your index tables as true indexes or as factors. The two approaches yield different results, and the values in your index tables would probably be different, depending on the approach that is taken or mandated. For example, assume that an asset purchased in June 1999 at a cost of 25,000 USD must be revalued in June of 2000. Use the following index table:

<b>June 1999</b>	137.251
<b>July 1999</b>	140.049
<b>August 1999</b>	142.370
<b>September 1999</b>	145.317
<b>October 1999</b>	145.307
<b>November 1999</b>	151.964
<b>December 1999</b>	156.915
<b>January 2000</b>	162.556
<b>February 2000</b>	166.350
<b>March 2000</b>	170.012
<b>April 2000</b>	174.012
<b>May 2000</b>	178.032
<b>June 2000</b>	180.931

## Index Revaluation

In index revaluation, the values for June 1999 and June 2000 are combined into a fraction, using June 1999 as the denominator. This fraction is then multiplied by the original cost of the asset. The equation would look like:

$$\text{Cost} * (\text{June 2000 value} / \text{June 1999 value}) = \text{Revalued cost}$$

or

$$25,000 * (180.931 / 137.251) = 32,956.23$$

## Factor Revaluation

In factor revaluation, the values in the index table become simple multipliers. The values in the table would be considered valid as of June 2000, and the revaluation factor is then derived from the acquisition date. This number is then multiplied by the original cost. The following is an example equation:

$$\text{Cost} * \text{June 2000 value} = \text{Revalued cost}$$

or

$$25,000 * 180,931 = 4,523,275.00 * 100\% = 45,232.75$$

## Calculating Revaluation

---

*From the Asset Revaluation menu (G1234), choose Revaluation Journal.*

Use the Asset Revaluation Journal program to revalue your assets. The program can be run in preliminary mode to view the projected revaluation amounts or in final mode to update the Asset Master File (F1201), Asset Account Balances File (F1202), and Account Ledger (F0911) tables with these amounts. Unless you specify otherwise, the system updates the cost, primary accumulated depreciation, and secondary accumulated depreciation accounts. You determine which assets or asset groups to revalue through data selection. Set processing options to specify the from and to ledger types, subledgers, and subledger types.

To create an unrecognized gain or loss, you can designate a subledger to post the revaluation adjustment. With this method, you can preserve your historical cost while continuing to revalue your assets.

To calculate an inception to date revaluation, table F1202 records must exist for every year of the life of every asset that is included in the revaluation.

To revalue assets by set amounts or allocations, you must either manually create journal entries or use a report writer to create them.

The Revaluation Journal is printed asset by asset under each company. If you revalue large numbers of assets, the report can be long. You can maintain the report as a spool file unless you are required to print a report.

Use processing options to limit the effect of revaluation to updating either or both the Last Year Cost and the Replacement Cost fields in table F1201.

J.D. Edwards & Company  
Asset Revaluation Journal

R12845 Preliminary  
009 Reevaluation  
Asset Number 31053 Building - Paris Headquarters

As Of 6/30/2005  
From LT AA To LT DT

JE Date 6/30/2005  
Index Factor 15244902

Description	Account	Subledger Type	Date	Index Value	Base Amount	Reval Amount
Buildings	702020		6/30/2005	15244902	890,000.00	135,679.63
ASSET COST	702120		6/30/2005	15244902	18,541.67	2,826.66
Accum Dep-Buildings						
PRIMARY ACCUM DEPR						
Item Master Replacement Cost						
Old			Current Year			
New			135,679.63			
			135,679.63			

## Processing Options for Asset Revaluation Journal (R12845)

### Process Tab

---

#### 1. Mode

Blank = Preliminary Mode

1 = Final Mode

Use this processing option to specify whether to run the program in preliminary or final mode. Valid values are:

Blank

Preliminary mode

1

Final mode

---

---

#### 2. Journal Entry Date

Use this processing option to specify the journal entry date.

---

---

#### 3. 'From' Ledger Type

Use this processing option to specify the 'From' ledger type. If you leave this processing option blank, the system uses the default ledger type, AA.

---

---

#### 4. 'From' Subledger

Use this processing option to specify the "From" subledger. Leave this processing option blank to specify all subledgers.

---

---

#### 5. 'From' Subledger Type

Use this processing option to specify the "From" subledger. Leave this processing option blank to specify all subledgers.

---

---

#### 6. 'To' Ledger Type

Use this processing option to specify the "To" ledger type. Leave this processing option blank to specify the ledger type from the revaluation source.

---

---

#### 7. 'To' Subledger

Use this processing option to specify the 'To' subledger. If you leave this processing option blank, the system uses the subledger specified in the Revaluation Source field.

---

---

## 8. 'To' Subledger Type

Use this processing option to specify the 'To' subledger type. If you leave this processing blank, the system uses the subledger type specified in the Revaluation Source field.

---

---

## 9. Method of Calculation

1 = Balances of Revaluation Year (Default)

2 = Inception-to-Date

Use this processing option to enter the method of calculation. Valid values are:

1

Balances of Revaluation Year. This is the default.

2

Inception-to-Date. Inception-to-date is calculated as: period amounts from all selected years applied to Index/Factor in effect at End of Each year, summed to derive current year.

---

---

## 10. Revaluation Code

Use this processing option to specify the revaluation code from UDC 12/RI.

---

---

## 11. Revaluation As of Date

Use this processing option to specify the Revaluation As Of Date. If you leave this processing option blank, the system uses the G/L date.

---

---

## 12. Effective Date

1 = Date Acquired (Default)

2 = Depreciation Start Date

3 = Revaluation Date

Use this processing option to specify the Effective Date to use. Valid values are:

1

Date Acquired. This is the default.

2

Depreciation Start Date.

3

Revaluation Date.

---

---

### 13. Multiplier

1 = Index Formula

2 = Factor

Use this processing option to determine the multiplier used in calculation of revaluation.  
Valid values are:

1

Index formula. This is calculated as follows: (index as of revaluation date / index as of effective date). This is the default.

2

Factor.

---

---

14. Item Master Last Year Cost

Blank = Do not replace last year cost

1 = Replace last year cost

Use this processing option to specify whether the system replaces the last year cost from the asset master. Valid values are:

Blank

Do not replace the last year cost.

1

Replace the last year cost with the current year replacement cost.

---

---

15. Item Master current year replacement cost

Blank = Do not replace current year replacement cost

1 = Replace current year replacement cost

Use this processing option to specify whether the system replaces the current year replacement cost from the asset master. Valid values are:

Blank

Do not replace the current year replacement cost

1

Replace the current year replacement cost with the revaluation amount.

---

---

## 16. Flex Accounting

Blank = Do not use Flex Accounting

1 = Use Flex Accounting

Use this processing option to indicate whether you want to use flex accounting. Valid values are:

Blank Do not use flex accounting.

1 Use flex accounting.

### **Print Tab**

1. Suppress Audit Info

Blank = Print file changes and calculations

1 = Print only file changes

Use this processing option to specify whether to suppress printing of audit information. Valid values are:

Blank

Print file changes and calculations.

1

Print only file changes.

2. Suppress Page Break

---

Blank = Do not suppress page break.

1 = Suppress page break on each Asset Number

Use this processing option to specify whether the system inserts a page break at each asset number. Valid values are:

Blank

Insert a page break.

1

Do not insert a page break.

### **Versions Tab**

G/L Post Version

Use this processing option to specify the G/L Post version (R09801) to be executed automatically. This option is valid only if you are processing in final mode.

---

### **What You Should Know About Processing Options**

**Source and destination selections** If no source or destination selections are used, the asset is adjusted to the same ledger type, subledger, and subledger type.

**Using the To Subledger** If you use the To Subledger, you must also use the To Subledger Type.

---

## **Working with Revaluation Journal Entries**

When you run the Asset Revaluation Journal program in final mode, the system automatically posts journal entries to the general ledger. If a journal entry did not post, you can review and revise the journal entry, review and revise the batch information, and approve the batch of journal entries for posting to the general ledger.

### **Reviewing a List of Revaluation Batches**

Use the Asset Revaluation Journal program to review a list of revaluation batches that did not automatically post to the general ledger. You can display a list of batches based on the batch type, number, date, or status, or your user ID. If the batch review security feature is activated, the system might not list all of the batches that have been entered. Instead, the system lists only the batches that you are authorized to review and approve.

► **To review a list of revaluation batches**

---

*From the Asset Revaluation menu (G1234), choose Revaluation Journal Review.*

1. On Work With Batches, display all of the batches for all users or complete the following fields to limit your search:
  - Batch Number
  - Batch Type
2. Click one of the following options:
  - Unposted Batches
  - Posted Batches
  - All Batches
3. Click Find.
4. In the detail area of the form, review the list of batches.

## **Revising the Revaluation Journal Entry Detail**

After you review a list of batches, you can access transaction detail within a specific batch of journal entries. For example, you can review the number of journal entries within a batch. You can also select a specific journal entry to revise.

► **To revise revaluation journal entry detail**

---

*From the Asset Revaluation menu (G1234), choose Revaluation Journal Review.*

1. On Work With Batches, display all of the batches for all users, or complete one or more of the following fields to limit your search:
  - Batch Number
  - Batch Type
2. Click one of the following options:
  - Unposted Batches
  - Posted Batches
  - All Batches
3. Click Find.
4. Choose a batch and click Select to access the appropriate batch review form.

5. On the review form, choose an individual document to review, and click Select.
6. On the detail form, enter any necessary changes, and click OK.
7. To return to Work With Batches, click Close.

## Approving a Batch for Posting

After you enter and review a batch of journal entries, you might need to approve it before posting can occur. This action depends on whether your company requires management approval before posting a batch. Based on your company's requirements, as defined in the general accounting constants, the system assigns either a pending or an approved status to the batch.

### ► To approve a batch for posting

---

*From the Asset Revaluation menu (G1234), choose Revaluation Journal Review.*

1. On Work With Batches, display all batches for all users, or complete one or more of the following fields to limit your search:
  - Batch Number
  - Batch Type
2. Choose one of the following options:
  - Unposted Batches
  - Posted Batches
  - All Batches
3. Click Find.
4. Choose the appropriate batch.
5. From the Row menu, choose Batch Approval.
6. On Batch Approval, click the Approved option.
7. Click OK.
8. On Work With Batches, click Find and verify that the following field has been updated to A:
  - Batch Status

## Revising a Batch for Posting

Use the Asset Revaluation Journal program to approve an out-of-balance batch job and to prevent an approved batch from posting.

### ► To revise a batch for posting

---

*From the Asset Revaluation menu (G1234), choose Revaluation Journal Review.*

1. On Work With Batches, complete one or more of the following fields:
  - Batch Number
  - Batch Type
2. Choose one of the following options:
  - Unposted Batches
  - Posted Batches
  - All Batches
3. Click Find.
4. Choose the batch.
5. From the Row menu, choose Revise.
6. On Create/Revise Batch Header, click the following option to approve an out-of-balance batch job for posting:
  - Batch Is Approved
7. To prevent an approved batch job from posting, remove the information in the following field:
  - Batch StatusAn empty Batch Status field identifies the batch job as pending.
8. Click OK.

## **Posting Revaluation to the General Ledger**

---

If you have revaluation batches that did not post during the revaluation process, you must manually post the revaluation journal entries to the general ledger. If you have many revaluation entries that did not post, and you have corrected them, you can use the General Ledger Post Report to automatically post all the journal entries that have a status of Approved.

### **Before You Begin**

- Verify that the batch has an approved status.
- Ensure that the job queue allows only one job to process at a time.

### **Posting a Batch Journal Entry Manually**

You must manually post any revaluation journal entries to the general ledger that you approve on Asset Revaluation Journal.

#### **► To post a batch journal entry manually**

---

*From the Asset Revaluation menu (G1234), choose Revaluation Journal Review.*

1. On Work With Batches, display all batches for all users, or complete one or more of the following fields to limit your search:
  - Batch Number
  - Batch Type
2. Click one of the following options:
  - Unposted Batches
  - Posted Batches
  - All Batches
3. Click Find.
4. Choose the appropriate batch.
5. From the Row menu, choose Post by Batch.

## Posting Multiple Batches of Journal Entries

*From the Asset Revaluation menu (G1234), choose Revaluation Post to G/L.*

The General Ledger Post Report program is a blanket post for all revaluation batches that have a status of Approved. The Revaluation Journal program automatically submits a general ledger post for revaluation journal entries if it is run in final mode. Usually the batch posts with no user intervention required. The only time that you need to use the General Ledger Post Report program is when the batch does not post.

---

### Caution

You should not enter a batch number, user ID, or batch date on the processing option when you run the General Ledger Post Report to post a batch of journal entries. If you leave these fields blank, all of the batches post. If you complete one of these fields and then do not clear it after you have posted a batch, the next batch does not automatically post unless the batch data matches the information in the Batch Number, User ID, and Batch Date fields.

---

Consider the following features when you post a batch of journal entries:

<b>Posting an alternate currency ledger</b>	If you use the alternate currency ledger (XA), set the appropriate processing option to update the ledger and produce a separate posting journal.
<b>Making changes during the posting process</b>	While the post is running, do not change accounts, AAls for the General Accounting system, intercompany settlements in the general accounting constants, or processing options for the post program.
<b>Specifying batches to be posted</b>	Choose a blank line for your data selection entry. Do not delete or type over the existing specifications for the posting status (A) and the batch type (G).
<b>Customizing the post program</b>	This program performs a number of complex tasks. J.D. Edwards strongly recommends that you do not customize the programming for it.

## Verifying the Post of Journal Entries

After posting your journal entries, verify that your batches of journal entries posted successfully. If any batches did not post, you must correct all errors and set the batch to approved status before the system will post the batch. The system creates a variety of reports to help you verify the posting information.

### See Also

- *Revising Batches to Post Out-of-Balance* in the *General Accounting Guide* for information about how to post an out-of-balance batch

## Reviewing Your Electronic Mail for Error Messages

After you run the post program, review your electronic mail in Address Book for error messages (sometimes called action messages). You can access General Accounting forms from these error messages, which allows you to locate problems and make changes interactively.

## Reviewing the General Ledger Post Report

To verify the transactions that were posted to the Account Balances (F0902) and the Account Ledger (F0911) tables, review the General Ledger Post Report. It lists only those batches that posted successfully.

A General Ledger Post Report that contains only heading information indicates that the Post program could not post any batches and has sent messages to your electronic mail.

If you enter journal entries with multiple currencies, the General Ledger Post Report lists both the CA ledger and converted AA amounts for foreign currency transactions. Additionally, it lists the currency code of the CA ledger amount and the domestic currency of the company for the AA ledger amount.

If you use detailed currency restatement, the system produces separate reports for the XA, YA, and ZA ledgers.

On the reports generated for batches with multiple currencies, the CA amounts represent the foreign side of the entry. The AA amounts represent the domestic side of the entry. Both the CA and the AA ledgers must be in balance.

## Reviewing the Post FA Detail Error Report

If a balancing error exists, the system generates a report. If you are using multiple currencies, the report lists AA and CA ledger information. If an out-of-balance journal entry is in error, correct the error and post the batch again.

In some cases, you might need to post an out-of-balance journal entry. For example:

- A power failure occurred during entry or posting.
- A valid, one-sided journal entry was entered to correct a conversion error that was made during setup.

---

## Year-End Processes

The Fixed Assets system includes annual processing programs that you can run at the end of the fiscal year. Use these programs to create new records for a new fiscal year.

If your company uses depreciation method 09 to depreciate assets by units of production, you must run the Units of Production Close after you close your annual account balances. Do not run this close program unless you use method 09 to calculate depreciation.

Run year-end processing programs after you run your final depreciation for the year. You must run the annual close for current year account balances before you can run depreciation calculations for the next fiscal year.

---

## Closing Annual Account Balances

*From the Year End Processes menu (G1225), choose Asset Account Balance Close.*

Run Asset Account Balance Close to create the next year's balance records with cumulative and net balance forward amounts. The Asset Account Balance Close program also carries forward depreciation information to the next fiscal year. You must run Asset Account Balance Close for the current year before the system can generate depreciation journal entries for the next fiscal year.

When you run the close, new balance records are created in the Asset Account Balances File table (F1202) for each of the following:

- Asset
- Fiscal year
- Ledger type
- Subledger
- Account (business unit/object/subsidiary)

If you have assets with accounts in several companies, include all appropriate accounts and companies when you make your selections. If you close only some accounts for the asset, or if you do not close all of an asset's companies, the close information might be inaccurate.

To include a range of companies in your annual close, ensure that the companies share the same fiscal year pattern.

You can track cost and unit information for disposed assets by setting a processing option to specify the ledgers to which you want to carry balances forward.

You can use Asset Account Balance Close to:

- Close fixed assets** You can run the annual close program to close fixed assets any time before or after you close the general ledger.
- Rerun the annual close** You can run the Asset Account Balance Close as many times as needed. The first time that you run the annual close, the program creates Asset Account Balances records for the next year. If you rerun the close, the program creates records only if they do not already exist in the system. If the records do exist, the program updates balance information to reflect any new information. Rerunning the close does not update depreciation information.
- For example, after you close fixed assets, you might find that you have more transactions to enter. You can enter those transactions and run the close again. The system processes only those transactions that you entered since the previous close.
- Close more than one company at a time** You can close a specific company, range of companies, or all of the companies during the same annual close. You can also close a specific ledger or any other data selection field that is in the Asset Account Balances File table (F1202).

The asset account balance close is separate from the general ledger annual close. When you run Asset Account Balance Close, the program:

- Carries forward fixed asset beginning balance records for the next year by updating the amounts in the following Asset Account Balance fields:
  - Prior Year Net Postings
  - Prior Year End Balance
- Creates depreciation information records for the next year. You cannot run depreciation for the next fiscal year until you run the annual close.

The following graphic shows how the program creates depreciation information records for the next year:

### Creating Depreciation Information for Next Year

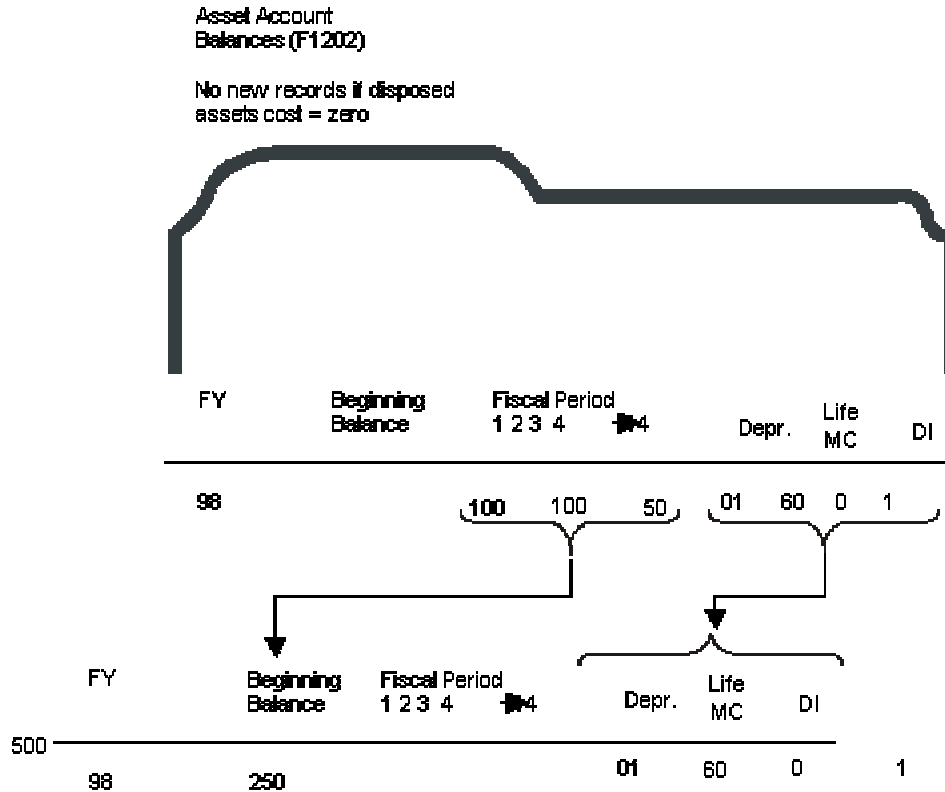

#### Before You Begin

- ❑ Verify that all transactions have been posted for the fiscal year that you plan to close.
- ❑ Verify that no one accesses the fixed asset tables while you run the Asset Account Balance Close. The program is unable to close records that are locked by other system applications. Records that a user accesses elsewhere in the system are not affected by the close.

### Processing Options for Asset Account Balance Close (R12825)

#### Process Tab

Use these processing options to define the fiscal year, costs, and accumulated depreciation for the AA and AU ledgers.

---

1. Fiscal Year you are closing (4 digits)

Use this processing option to specify the fiscal year in which the asset account balances should be closed and rolled forward to the next year. Enter a four-digit fiscal year in this field. If you leave this field blank, the system will use the date pattern established for the default company 00000.

---

---

2. Non Cost and Accumulated Depreciation (Disposed Asset)

- 1 = Carry balances forward for AA ledger only
- 2 = Carry balances forward for AA and AU ledgers
- 3 = Carry balances forward for all ledgers
- 4 = Do not carry balances forward for disposed assets

Use this processing option to specify how various balances should be carried forward for disposed assets with non-cost and accumulated depreciation accounts that continue to carry beginning balances (i.e. expense and revenue accounts).

- 1 Carry balances forward for AA ledger only.
  - 2 Carry balances forward for AA and AU ledgers.
  - 3 Carry balances forward for all ledgers.
  - 4 Do not carry balances forward for disposed assets.
-

---

### 3. Cost and Accumulated Depreciation

- 1 = Carry balances forward for AA ledger only
- 2 = Carry balances forward for AA and AU ledgers
- 3 = Carry balances forward for all ledgers
- 4 = Do not carry balances forward for disposed assets

Use this processing option to specify how to carry various balances forward for disposed assets with cost and accumulated depreciation accounts that continue to carry beginning balances.

- 1 Carry balances forward for AA ledger only.
- 2 Carry balances forward for AA and AU ledgers.
- 3 Carry balances forward for all ledgers.
- 4 Do not carry balances forward for disposed assets.

---

## **Closing Units of Production**

---

*From the Year End Processes menu (G1225), choose Units of Production Close.*

Use the Units of Production Close program to update the schedules that you have set up for the units of production method of depreciation (method 09). When you run the units of production close, the system makes the following adjustments:

- Rolls the year-to-date production amount into the Prior Year's Production field
- Clears the year-to-date production amount
- Rolls the current year revisions amount into the Prior Year's Revisions field
- Clears the current year's revisions amount

When you select Units of Production Close, the system submits the job to batch.

---

## Note

Run the Units of Production Close program only if your organization uses units of production to compute depreciation.

---

## Before You Begin

- ❑ Verify that your current year revisions and year-to-date production amounts are accurate.
- ❑ Run the final depreciation for the year. See *Calculating Asset Depreciation* in the *Fixed Assets Guide*.
- ❑ Run the Asset Account Balance Close program for fixed assets. See *Closing Annual Account Balances* in the *Fixed Assets Guide*.

---

## Working with Depreciation Projections

---

Companies must be able to forecast expenses and revenues, including depreciation expenses, for future years to use the results as budgets. Forecasting is used in the same way as projections.

## Running the Depreciation Projections Program

*Use one of the following navigations:*

*From the Year End Processes menu (G1225), choose Depreciation Projections.*

*From the Depreciation menu (G1221), choose Depreciation by Periods to run depreciation by period.*

You can run the Depreciation Projections program for the following purposes:

- To calculate projected depreciation balances for future years
- To calculate final depreciation for the current year

This batch program automates the processes of calculating depreciation and updating balances from a starting period through a specified period, for as many years into the future as you have date patterns set up.

Date patterns must be set up into future years when you project depreciation. You can set up as many future years as you need. Asset balances must exist in the start year.

If final depreciation balances exist (where the Depreciation Projection Calculation Field, DPCF, is blank and the Asset Account Balances File table (F1202) has balances exist), then projections will not override them. You should purge the depreciation projections before running final depreciation.

The Depreciation Projections program (R12865) runs the Asset Account Balance Close program (R12825) automatically to refresh balances in the From Year field. The Depreciation Projections program then runs the Compute Depreciation by Period report (R12855) and the Asset Account Balance Close report for the specified fiscal date range for each period in the range of dates. The system updates table F1202 for projections and differentiates it from final depreciation by placing a 1 in the Depreciation Projection Calculation Field (DPCF). Final

depreciation, splits, transfers, disposals, and beginning balances are not calculated for projection balances for records when DPCF=1 in table F1202.

---

### **Caution**

Only projection balances can be purged and rerun, not final depreciation. J.D. Edwards strongly recommends that you run this program in preliminary mode first to identify and correct any errors before running it in final mode.

---

### **See Also**

- *Fixed Assets Templates* in the *Manage Financial Statements and Reports Guide* for more information about using smart fields in the application report writer to identify projection balances

### **Technical Considerations**

Projection balances do not replace final depreciation balances and do not create audit trail records. One-half Final Depreciation Balances and one-half Projection Balances per year are not allowed by the system.

Fixed Asset applications display all of the asset balances from the Asset Account Balances File table (F1202), so you need to know which balances are projections and which are final depreciation balances. After projections are calculated, you can use reports that are provided by the system or the Fixed Assets Report Writer to produce reports over the depreciation projections and final depreciation. You can use a smart field in the application report writer to identify projection balances.

## **Processing Options for Depreciation Projections (R12865)**

### **Process Tab**

Use these processing options to specify how you want the system to process depreciation projections. You can specify the following:

- Whether to run in preliminary or final mode
- Whether to update the Asset Account Balances File table (F1202) in future fiscal years or with final depreciation values
- Whether to allow period or year-end processing
- Which periods and fiscal years to process
- The number of normal periods per year

---

## 1. Process Mode

Blank = Preliminary mode

1 = Final mode

Use this processing option to specify the mode in which you want to run this program.  
Valid values are:

Blank Preliminary mode. Run the program in preliminary mode before running it in final mode. You can run this program in preliminary mode as many times as required. Updated balances are required to calculate depreciation projections in future fiscal years.

1 Final mode. Run this program in final mode with depreciation projection updates. The system updates projection balances for accumulated depreciation and depreciation expense accounts in the Asset Balances table (F1202). When you run this program in final mode with final depreciation updates, the system posts accumulated depreciation and depreciation expense journal entries to the Asset Balances table and creates journal entries in the Account Ledger table (F0911).

Preliminary mode calculates values for only one fiscal year.

Final depreciation balances can't be calculated in future fiscal years.

---

---

## 2. Update Projection Balances

Blank = Projections

1 = Final depreciation

Use this processing option to specify how the system updates the Asset Balances table (F1202) in final process mode.

Valid values are:

Blank

Calculate depreciation values and update the Asset Account Balances File table in future fiscal years for budgeting. Depreciation projections can't be calculated with current year-to-date final depreciation balances.

1

Calculate depreciation values and update the Asset Account Balances File table with final depreciation balances. Final depreciation balances can't be calculated with projection balances. You must run the Depreciation Projections Purge program (R12859) to remove projection balances before calculating final depreciation. Final depreciation can be run only for one fiscal year. It is intended to be used with the depreciation by period processing option to allow posting by period.

---

---

### 3. Period or End of Year Processing

Blank = Period processing

1 = End of year processing

Use this processing option to specify processing by period adjustments or year-end adjustments.

Valid values are:

Blank

Calculate depreciation values and update the Asset Account Balances File table (F1202) by period adjustments. Use this value with depreciation methods that calculate by periods or when period adjustments are needed.

1

Calculate depreciation projection balances in the last period of the fiscal year. Only the From Fiscal Year and Through Fiscal Year processing options are used. (The From Period and Through Period processing options are not needed.) When you calculate depreciation projections in future fiscal years, period adjustments are not always needed. Year-end adjustments update the Asset Account Balances File table in the last period and roll the balances forward to continue calculating depreciation projections. This process is much faster than period adjustments because depreciation projections are calculated only once per future fiscal year.

---

---

### 4. Enter the range of dates to process

---

---

#### From Period Number

Use this option only when processing by period adjustments. Period adjustments start with the From Period or period 1 by default and continue to the Through Period and fiscal year. The From Period and From Fiscal Year must always be less than or equal to the Through Period and Through Fiscal Year.

---

---

#### From Fiscal Year (4 Digits)

Use this processing option to specify the fiscal year to begin calculating depreciation. This works with the From Period when processing by period adjustments. Enter a four-digit fiscal year in this field. If you leave this field blank, the system will use the date pattern established for the default company 00000.

---

---

#### Thru Period Number

Use this option only when processing depreciation by period adjustments. Period adjustments start with the From Period or period 1 by default and continue to the Through Period and Through Fiscal Year. When this option is left blank, the system uses the Normal Number of Periods processing option. The Through Period and Through Fiscal Year must always be greater than or equal to the From Period or period 1.

---

---

#### Thru Fiscal Year (4 Digits)

Use this processing option to specify the fiscal year to finish calculating depreciation. This works with the Through Period when processing by period adjustments. Enter a four-digit fiscal year in this field. If you leave this field blank, the Through Fiscal Year is set to the From Fiscal Year. The Through Fiscal Year must always be greater than or equal to the From Fiscal Year.

---

---

## 5. Number of normal periods per year

Use this processing option to specify the normal number of periods per year. This should match your company's normal number of periods. J.D. Edwards recommends that the data selection in versions should match that of companies with the same normal number of periods. The default normal number of periods is 12.

Note: The Asset Account Balance Close program (R12825) will automatically run when the normal number of periods has been reached when processing depreciation projections by periods in final mode.

---

### **Versions Tab**

Use these processing options to specify which version of the Calculate Depreciation and Asset Balance Close programs that you want the system to run. You can run these versions without projections to verify data selection.

---

#### 1. Calculate Depreciation Version (R12855)

Use this processing option to specify which version of the Calculate Depreciation program (R12855) you want the system to run. The data selection in the Calculate Depreciation version must match the data selection in the Asset Account Balance Close (R12825) version that is specified in the processing options. The default version is XJDE0003. The process mode and date information are passed into the Calculate Depreciation batch application.

---

---

## 2. Asset Balance Close Version (R12825)

Use this processing option to specify which version of the Asset Balance Close program (R12825) you want the system to run. The data selection in the Asset Account Balance Close version must match the data selection in the Calculate Depreciation (R12855) version that is specified in the processing options. The default version is XJDE0002. The date information is passed into the Asset Account Balance Close batch application when the system processes projection balances in final mode.

---

### What You Should Know About Processing Options

<b>Process Mode</b>	Preliminary mode calculates values for only one fiscal year, regardless of whether processing option 2 (Update Projection Balances) is set to Projections or Final Depreciation. Balance forwards are required for future fiscal years, and preliminary mode does not update balances.
<b>Update Projection Balances</b>	Projected depreciation results are recorded with a 1 in the Depreciation Projection Calculation Field (DPCF) in the Asset Account Balances File table (F1202), whereas final depreciation results are recorded with a blank. Final depreciation verifies that the current balances are not projection balances. If projection balances exist and final depreciation is needed, you must run the Purge Depreciation Projections (R12859) and Asset Account Balance Close (R12825) programs to create the most current balances.
<b>Period or Year-End Processing</b>	Any compute direction is allowed, but compute direction P should be run only by period.
<b>Number of Normal Periods Per Year</b>	If you enter two different companies in data selection that have two different, normal number of periods, then the annual close runs incorrectly for one of them. Correct this situation by purging the projections and rerunning the close correctly. If you enter the wrong number of periods, such as four periods when the company has 12, then the annual close runs after only four periods and start the next year incorrectly. Correct this situation by purging the projections and rerunning the close correctly.
<b>Versions</b>	Specific versions for the Compute Depreciation and Asset Account Balance Close are needed for flexibility and control of automated processing.

#### Data Selection

You cannot use data selection in Depreciation Projections because it calls the UDD version. Instead, use data selection in the User Defined Depreciation report (R12855) and the Asset Account Balance Close program (R12825).

Data selection must be the same for the Asset Account Balance Close and UDD Versions.

The range of dates that are specified in the processing options and data selection in versions is directly related to performance.

---

**Note**

You need to use data selection only over companies, business unit assets, and so on, and not over periods or years. Depreciation Projections asks for periods and years, as well as for preliminary or final mode, so neither the UDD nor Asset Account Balance Close versions that are run need to have processing options set for the correct years, or for preliminary or final mode.

---

## Purging Depreciation Projections

*From the Year End Processes menu (G1225), choose Purge Depreciation Projections.*

If projection balances exist when final depreciation is calculated, an error message notifies the user to purge projection balances before calculating final depreciation.

## Processing Options for Purge Depreciation Projections (R12859)

### Process Tab

Use these processing options to specify the range of fiscal years for which depreciation needs to be removed.

---

#### 1. From Fiscal Year (4 Digits)

Use this processing option to specify the beginning fiscal year from which depreciation projections need to be removed. Enter a four-digit fiscal year.

If you leave this field blank, all projection balances are removed through the date specified in the Through Fiscal Year field. The From Fiscal Year cannot be greater than the Through Fiscal Year.

---

---

2. Through Fiscal Year (4 Digits)

Use this processing option to specify the ending fiscal year through which depreciation projections need to be removed. Enter a four-digit fiscal year.

If you leave this field blank, all projection balances are removed starting with the date specified in the From Fiscal Year field. The Through fiscal year cannot be less than the From fiscal year.

---

---

## Fixed Asset Reports

Print and review fixed asset reports to access necessary information to manage your company's fixed assets.

---

### Printing Asset Information Reports

You can print asset information reports at any time with the report versions that are included in the Fixed Assets system. Use asset information reports to verify the fixed asset information that the system stores in the Asset Master File table (F1201).

### Printing the Asset Master Schedule Report

*From the Cost Information & Reports menu (G1213), choose Asset Master Schedule.*

You can print the Asset Master Schedule report to review the information that you enter on the Asset Master Revisions form when you create asset master records. For each asset that you specify, the report lists the following information:

- First three category codes
- Parent
- Asset, unit, and serial numbers
- Responsible business unit
- Date acquired
- Property tax information

The following abbreviated column headings appear on the Asset Master Schedule Report:

Abbreviated Column Heading	Description
Acc Cls	Accounting Class
Eqm Cls	Equipment Class
Mfg	Manufacturer
Mdl Yr	Model Year
Use M/H	Usage Miles or Hours
ST	State

### Printing the Assets by Finance Method Report

*From the Cost Information & Reports menu (G1213), choose Assets by Finance Method.*

To review the information that you entered for assets on the Financing Information form, print the Assets by Finance Method report. The Assets by Finance Method report includes the following information:

- Asset and parent number

- Description
- Lessor, renter, or mortgager
- Monthly amount owed

The following abbreviated column heading appears in the Assets by Finance Method Report:

Abbreviated Column Heading	Description
PO	Purchase Order

## Processing Options for Assets by Finance Method (R12421)

---

Print

Asset Number Format

- 1 = Asset Number (Default)
  - 2 = Unit Number
  - 3 = Serial Number
- 

Asset Number Format

- 1 = Asset Number (Default)
- 2 = Unit Number
- 3 = Serial Number

Use this processing option to specify which number the system prints to identify the asset.  
Valid values are:

- 1 Print the asset number.
  - 2 Print the unit number.
  - 3 Print the serial number.
- 

## Printing the F/A Transaction Ledger Report

*From the Posting G/L to Fixed Assets menu (G1212), choose F/A Transaction Ledger.*

You can print the F/A Transaction Ledger report to review all of the the transactions for an asset. The report prints the transactions by company in the order that they occurred. You can view the asset number, the affected account, a brief explanation, the G/L date, a currency and unit amount, and so on for each transaction. The report shows currency and unit totals for each company.

The transactions that print on the F/A Transaction Ledger report come from the Account Ledger table (F0911), which stores journal entry audit trails. Unless you specify otherwise, the report includes all asset transactions that have accumulated in the account ledger since the ledger was last summarized.

You can run two versions of this report:

**Posted** Prints asset transactions that are posted to fixed assets and the general ledger.

**Unposted** Prints asset transactions that are not posted to fixed assets. The transactions are not necessarily posted to the general ledger.

The following abbreviated column headings appear in the F/A Transaction Ledger report:

<b>Abbreviated Column Heading</b>	<b>Description</b>
<b>Do Ty</b>	Document Type
<b>LT</b>	Ledger Type
<b>HD</b>	Hold Code
<b>PC</b>	Posted Code

## **Printing the Cost Analysis Report**

*From the Cost Information & Reports menu (G1213), choose Cost Analysis.*

You can print the Cost Analysis report to review the various costs that are associated with an asset. Use the Cost Analysis report to measure the operating efficiency and effectiveness of assets, such as equipment. You can analyze these amounts in month-to-date, year-to-date, or inception-to-date increments. The Cost Analysis report includes user defined totals such as:

- Net book value
- Revenue earned
- Ownership costs
- Operating costs

Two columns on the report require further explanation:

**Period-to-Date** The amount, in currency or units, charged to the asset in the period that you designate in the Through Date/Period for the report.

**Period Unit Cost** The amount charged to the asset in the period that you designate in the Through Date/Period for the report, divided by a unit (for example, hours) that you designate in the processing options.

J.D. Edwards recommends you use data selection on cost center, object account, and subsidiary when running the Cost Analysis report. This data selection helps the system find records faster.

The following abbreviated column heading appears in the Cost Analysis Report:

Abbreviated Column Heading	Description
ST	Subledger Type

## Processing Options for Cost Analysis (R12424)

---

### Defaults

1. Period/Date

2. Fiscal Year

3. Ledger Type  
Process

1. Detail or Summary (Future)

D = Detailed Report, (Default)  
O = Summarization by Object  
R = Summarization by Subsidiary  
S = Summarization by AT AAI.

2. Unit Cost Suppression

Blank = Print Unit Cost  
1 = Suppress the Unit Cost columns

3. Unit Cost AAI's

Y = AT00  
A = FMA  
B = FMB

### Print

1. Zero Cost Print

2. Asset Number Print

1 = Asset Number  
2 = Unit Number  
3 = Serial Number

---

## 1. Period/Date

Use this processing option to specify the fiscal year for the period or date that is defined in the Period/Date field. Enter a four-digit fiscal year in this processing option. If you leave this processing option blank, the system uses the date pattern that is established for default company 00000.

---

---

## 2. Fiscal Year

Use this processing option to specify the fiscal year for the period or date that is defined in the Period/Date field. Enter a four-digit fiscal year in this processing option. If you leave this processing option blank, the system uses the date pattern that is established for default company 00000.

---

---

### 3. Ledger Type

Use this processing option to specify the ledger type for cost summary. If you leave this field blank, the system uses the AA ledger.

#### 1. Detail or Summary (Future)

**D = Detailed Report, (Default)**

**O = Summarization by Object**

**R = Summarization by Subsidiary**

**S = Summarization by AT AAI.**

#### Process Tab

Use this processing option to specify how the system summarizes information on the report. Valid values are:

**D**

**Detailed report**

**O**

**Summarization by object**

**R**

**Summarization by subsidiary**

**S**

**Summarization by AT AAI**

#### 2. Unit Cost Suppression

**Blank = Print Unit Cost**

**1 = Suppress the Unit Cost columns**

#### Print Tab

Use this processing option to specify whether the system prints the Unit Cost columns. Valid values are:

**Blank**

---

---

**Print the Unit Cost columns.**

**1**

**Do not print the Unit Cost columns.**

**3. Unit Cost AAI's**

**Y = AT00**

**A = FMA**

**B = FMB**

**Use this processing option to identify the automatic accounting instructions that the system uses for units in the Unit Cost columns when it prints unit cost. Valid values are:**

**Y**

**Use the AT00 AAI.**

**A**

**Use the FMA AAI.**

**B**

**Use the FMB AAI.**

1. Zero Cost Print

Use this processing option to specify which assets the system prints. Valid values are:

Blank

Do not print assets with zero cost.

1

Print all assets.

2. Asset Number Print

1 = Asset Number

---

---

2 = Unit Number

3 = Serial Number

Use this processing option to specify which number the system prints to identify the asset.  
Valid values are:

1 Print the asset number.

2 Print the unit number.

3 Print the serial number.

---

## Printing Fixed Asset Supplemental Information

*From the Batch and Interactive Version menu (GH0983), choose Batch Versions.*

You can print supplemental information for the Fixed Assets system by asset or data type.

### **Supplemental Data Report by Asset (R12400)**

This report includes the following information:

- Asset number
- Parent Company
- Location
- Type of data
- Quantity
- Date information

### **Supplemental Data Report by Data Type (R12440)**

This report lists the following information:

- Data type information
- Asset number
- Date information

---

#### **Note**

These reports are hard-coded for supplemental database code AM.

---

## Printing Depreciation Reports

---

The Fixed Assets system includes depreciation reports that you can use to review selected depreciation information.

### Printing the Depreciation Schedule

*From the Cost Information & Reports menu (G1213), choose Depreciation Schedule.*

You can print the Depreciation Schedule report to review a list of assets and their corresponding depreciation expense and net book value amounts for each ledger. You can specify the sequence of this report by depreciation expense account or by accumulated depreciation account as of any date.

The Depreciation Schedule report shows the balances in the Asset Account Balances File table (F1202) without computing depreciation.

You can also use the Depreciation Schedule report after you enter the beginning balances for assets during the conversion process to the Fixed Assets system. You can use this report as a tool to review your entries and help you reconcile differences between table F1202 and the Account Balances table (F0902).

The Depreciation Schedule report includes the following information:

<b>Cost</b>	The original acquisition cost of the asset.
<b>Accumulated depreciation</b>	The accumulated depreciation amount of the asset. This amount is a cumulative amount that is calculated according to the depreciation method that you specify for the asset.
<b>Depreciation expense year to date</b>	The amount of depreciation that is charged to the asset thus far this year.
<b>Depreciation expense current</b>	The amount of depreciation that is charged to the asset since the last final depreciation. This amount is based on the date that you specify for the report.
<b>Net book value (NBV)</b>	The difference between the asset cost and its accumulated depreciation.
<b>Remaining (REM) life</b>	The periods remaining until the asset is fully depreciated. If the disposal date of the asset is prior to the date when the asset will be fully depreciated, the system uses the month and year to determine the remaining periods that print on the report.

The following abbreviated column headings appear in the Depreciation Schedule Report:

LT  
DM  
DI  
MC

Ledger Type  
Depreciation Method  
Depreciation Information  
Method of Computation

R12411		J.D. Edwards & Company Depreciation Schedule by Depreciation Expense										4/3/2003 10/29/21					
Project Management Company		YARD 8538										Page- 1					
Asset Number	Description	Start Date	L	D	M	Life	T	M	C	Mths	Cost	Accumulated Depreciation	Year To Date	Depreciation Expense - Current	Net Book Value	Subledger	Item Lib
1004	Developer PC Laptop	6/1/2004	AA	01	1	36					5,525.00	1,450.24	1,450.24	243.20	4,065.76		00023
1005	50,2170 Teltektr 6800 Server	1/1/2005	AA	01	1	36					92,000.00	15,333.33	15,333.33	2,555.55	76,666.67		00050
1005	50,2170 Teltektr Network OCE	1/1/2005	AA	01	1	36					30,650.00	5,108.33	5,108.33	851.39	25,541.67		00050
50,2170 Depreciation Expense Total.....		AA									128,175.00	21,900.00	21,900.00	3,650.14	106,274.10		
Company Total.....		AA									128,175.00	21,900.00	21,900.00	3,650.14	106,274.10		
Grand Total.....		AA									128,175.00	21,900.00	21,900.00	3,650.14	106,274.10		

## Processing Options for Depreciation Schedule (R12411)

### Defaults Tab

---

#### 1. Period

Use this processing option to specify the as of period. Leave this processing option blank to use each company's current fiscal period.

---

---

#### 2. Fiscal Year (4 digits)

Use this processing option to specify the as of fiscal year. Leave this processing option blank to use each company's current fiscal year.

---

---

### 3. Ledger Type

Use this processing option to specify a single ledger type for the depreciation schedule. Leave this processing option blank to include all ledger types.

#### 1. Identify how to print Asset Number

**1 = Asset Number (Default)**

**2 = Unit Number**

**3 = Serial Number**

#### Print Tab

Use this processing option to specify which number the system prints to identify the asset. Valid values are:

**1 Print the asset number.**

**2 Print the unit number.**

**3 Print the serial number.**

#### 2. Print Assets

**Blank = Omit printing assets with zero cost. (Default)**

**1 = Print all assets.**

Use this processing option to specify which assets the system prints. Valid values are:

**Blank**

**Do not print assets with zero cost.**

**1**

**Print all assets.**

#### 3. Remaining periods or End Date

---

---

**0 = Print Remaining Periods.**

**1 = Print Month and Year asset will be fully depreciated.**

**Use this processing option to specify whether the system prints remaining periods or the end date. Valid values are:**

**0**

**Print remaining periods.**

**1**

**Print the month and year in which the asset will be fully depreciated.**

### **Process Tab**

Sequence

1 = Sequence by Accumulated Depreciation Account

2 = Sequence by Depreciation Expense Account.

Use this processing option to specify how the system sequences the Depreciation Schedule report (R12411). Valid values are:

1

Sequence the report by accumulated depreciation account.

2

Sequence the report by depreciation expense account.

---

## **Printing the Depreciation Defaults Report**

*From the Cost Information & Reports menu (G1213), choose Depreciation Defaults Report.*

After you set up your depreciation default information, you can generate the Depreciation Default report to review the depreciation values by company, object, and subsidiary.

The following abbreviated column headings appear in the Depreciation Defaults Report:

<b>Abbreviated Column Heading</b>	<b>Description</b>
<b>LT</b>	Ledger Type
<b>DM</b>	Depreciation Method
<b>DI</b>	Depreciation Information
<b>MC</b>	Method of Computation

## Printing the Depreciation Rules Report

*From the Cost Information & Reports menu (G1213), choose Depreciation Rules Report.*

You can print each depreciation rule that you have defined for the Fixed Assets system. The Depreciation Rules Report shows the following information:

- Depreciation method
- Computation method
- Depreciation information
- Life months
- Date from
- Effective beginning date

The following abbreviated column headings appear in the Depreciation Rules Report:

<b>Abbreviated Column Heading</b>	<b>Description</b>
<b>De Me</b>	Depreciation Method
<b>FP</b>	Fiscal Date Pattern
<b>Dsp Con</b>	Disposal Convention
<b>SA</b>	Secondary Account
<b>LY</b>	Life Year
<b>OU</b>	Over/Under allowed
<b>NA</b>	Negative allowed
<b>ED</b>	Edit disable

## Printing Depreciation Spread Patterns

*From the Cost Information & Reports menu (G1213), choose Depreciation Spread Pattern Print.*

You can print all codes in the spread pattern file with the associated period spread percentages.

## Running Integrity Reports

---

Run integrity test programs to supplement your internal balancing procedures by locating potential balancing problems and data inconsistencies. Integrity test programs generate reports to help ensure that your J.D. Edwards systems remain in balance. For example, the Asset Account Balances File table (F1202) might be out-of-balance with the general ledger under the following circumstances:

- Journal entries are posted to the general ledger but not to fixed assets, or vice versa.
- You made changes to the fixed asset (FX) range of accounts in the automatic accounting instructions (AAIs) and did not include an account that might have been previously included in the FX range, or vice versa.
- You made changes to the general ledger account numbers and have not run the Update Company Number, Business Unit/Object/Subsidiary program (R12802).
- Asset account records have been purged from the Account Balances table (F0902), but not from table F1202.

You can use integrity reports to identify and correct balance errors immediately. J.D. Edwards recommends that you run integrity reports at least once a week during the conversion process at new installation sites or during a learning period for new users. All other users should run integrity reports on a monthly basis, at a minimum.

### Before You Begin

- Post all fixed asset transaction batches. The system performs integrity tests only on posted records.

### Printing the Fixed Assets to G/L Integrity Report

*From the Fixed Asset Integrity Reports menu (G1224), choose Fixed Assets to G/L Integrity.*

Use the Fixed Assets to G/L Integrity report to compare account records in the Asset Account Balances File table (F1202) to the records in the Account Balances table (F0902). The system prints any records that are not in balance on the report.

## Processing Options for F/A to G/L Integrity (R127011)

### Process Tab

---

#### 1. As of Date

Use this processing option to enter the as of date. Leave this processing option blank to use each company's current period.

Note: The fiscal year specified in the processing options must match the fiscal year that you specify in data selection.

---

---

## 2. Ledger Type

Use this processing option to specify the ledger type for cost summary. If you leave this field blank, the system uses the AA ledger.

### Print Accounts

Blank = All accounts.

1 = Accounts where the Item Balance (F1202) net postings do not equal the Account Balance (F0902) net postings.

### Print Tab

Use this processing option to specify which accounts the system prints. Valid values are:

Blank

Print all accounts.

1

Print only those accounts in which the net postings from the Asset Account Balances table (F1202) do not equal the net postings from the Account Balance table (F0902).

---

## Printing the Unposted Fixed Asset Transactions Report

*From the Fixed Asset Integrity Reports menu (G1224), choose Unposted Fixed Asset Transactions.*

Print the Unposted Fixed Asset Transactions report to review the transaction ledger table. Any fixed asset transactions that are within the FX range in the AAls and are posted to the general ledger, but not to fixed assets, appear on this integrity report.

## Processing Options for Unposted Fixed Asset Transactions (R12301)

---

Display

Display Asset Number

- 1 = Asset Number
  - 2 = Unit Number
  - 3 = Serial Number
- 
- 

Display Asset Number

- 1 = Asset Number
- 2 = Unit Number
- 3 = Serial Number

Use this processing option to specify which number the system prints to identify the asset.  
Valid values are:

- 1 Print the asset number.
  - 2 Print the unit number.
  - 3 Print the serial number.
- 

### Printing the Fixed Asset Transaction Integrity Report

*From the Fixed Asset Integrity Reports menu (G1224), choose Fixed Asset Transaction Integrity.*

Print the Fixed Asset Transaction Integrity report to review all of the transactions in the Account Ledger table (F0911) for a specific account during the current fiscal year. The current fiscal year is based on the company that is associated with a particular account. Use

this transaction report to identify problems and discrepancies between the Asset Account Balances File table (F1202) and the Account Balances table (F0902).

The Fixed Asset Transaction Integrity report includes only those transactions that you have posted to the general ledger or fixed assets. The report does not include fixed asset balances that you entered through the Beginning Balances Setup program if you did not specify supporting transactions, nor does it include summarized depreciation transactions. You can specify summarized transactions when you run the final depreciation for your assets.

The report lists the following totals for each account:

- Total of all transactions
- Total of all transactions posted to the general ledger and posted to fixed assets
- Total of all transactions posted to the general ledger and unable to post to fixed assets
- Total of all transactions posted to the general ledger and not yet posted to fixed assets
- Total of all transactions not posted to the general ledger but posted to fixed assets
- Total of all transactions not posted to the general ledger and unable to post to fixed assets

---

#### Note

The Fixed Asset Transaction Integrity report prints one line per account ledger record. Use data selections to print only the transactions that you need to review for specific accounts and to keep the size of the report manageable.

---

#### Abbreviated Column Headings

**General ledger posted code (G/L P C)** A code that indicates whether a transaction has been posted to the general ledger.

**Fixed asset pass code (F/A P C)** A code that indicates whether a transaction has been posted to fixed assets. The system does not post transactions with an F/A pass code of P to fixed assets. A transaction can have an F/A pass code of P for the following reasons:

- The transaction has an account number that is not included in the FX range of AAls. The Identify New Entries program assigns P only to transactions that do not fall within the FX range of the AAls.
- You manually changed the pass code to P on Revise Unposted Entries so that the transaction would not post to the Asset Account Balances File table (F1202).

#### Before You Begin

- Post any transactions to the general ledger that have not yet been posted.
- Post any transactions to fixed assets that have not yet been posted.

## Printing the G/L to Fixed Assets Integrity Report

*From the Fixed Asset Integrity Reports menu (G1224), choose G/L to Fixed Assets Integrity.*

You can use the G/L to Fixed Assets Integrity report to compare account records in the general ledger balance table to the records in the fixed assets balance table. You use this report to find transactions that have been posted to the general ledger but have not been posted to the Fixed Assets system. If you are in a multicurrency environment, you can run this report over ledgers that reflect alternate currencies.

This report is the most powerful of the integrity reports. It uses the range of accounts that are defined in the FX AAIs to compare the Account Balances table (F0902) to the Asset Account Balances File table (F1202).

Through processing options, you can choose the following:

- Display transaction detail for exception transactions only
- Display year-to-date or inception-to-date balances with transaction detail

The system also reconciles any out-of-balance accounts on a transaction-by-transaction basis. When the system locates an out-of-balance account, it determines the difference between the balances and then processes each general ledger detail transaction as if it had been posted to fixed assets. A new difference is calculated for each detail transaction, attempting to reduce the difference to zero. The posting codes for each line also print and allow you to determine exactly which transactions are causing the problem.

To identify the exception transactions, the system compares the G/L Post Code with the Passed Code for each detail transaction from the Account Ledger table (F0911). The following table shows the comparison and result:

<b>G/L Post Code</b>	<b>Passed Code</b>	<b>Exception Identification</b>
----------------------	--------------------	---------------------------------

P	*	OK
P	P	Exception
P	H	Exception
P	Blank	Exception
Blank	*	Exception
Blank	P	Exception**
Blank	H	Exception**
Blank	Blank	Exception**

\*\* These do not cause an imbalance between the Account Balances (F0902) and the Asset Account Balances File (F1202) tables. However, the month-end balances might not be accurate without these postings.

## Processing Options for G/L to F/A Integrity (R127013)

---

### Process

1. As of Date
2. Ledger Type
3. Account Balances

Blank = Compare inception to date account balances.  
1 = Compare year to date account balances.

### Print

1. Print Accounts
2. Print Format

Blank = Print balance information only.  
1 = Print transaction detail.

---

---

### Print Tab

1. As of Date

Use this processing option to specify the as of date. Leave this processing option blank to use each company's current fiscal year and period.

---

---

2. Ledger Type

Use this processing option to specify the ledger type for cost summary. If you leave this field blank, the system uses the AA ledger.

---

---

### 3. Account Balances

Blank = Compare inception to date account balances.

1 = Compare year to date account balances.

Use this processing option to specify whether the system compares account balances.  
Valid values are:

Blank

Compare inception-to-date account balances.

1

Compare year-to-date account balances.

#### 1. Print Accounts

Use this processing option to specify which accounts the system prints. Valid values are:

Blank

Print all accounts.

1

Print only those accounts in which the net postings from the Asset Account Balances table (F1202) do not equal the net postings from the Account Balance table (F0902).

#### 2. Print Format

Blank = Print balance information only.

1 = Print transaction detail.

---

Use this processing option to specify the information that the system prints. Valid values are:

Blank

Print balance information only.

1

Print transaction detail.

---

## **Printing Quarterly and Year-to-Date Reports**

---

The Fixed Assets system includes quarterly and year-to-date reports that you can print to review selected fixed asset information.

### **Printing the Fixed Asset Reconciliation Report**

*From the Quarterly & YTD Fixed Asset Reports menu (G1223), choose Fixed Asset Reconciliation.*

You can run the Fixed Asset Item Reconciliation Report to help you reconcile a specific asset or all assets for a company. Run this report by asset to review the account activity for an asset's cost and accumulated depreciation. You can use the report to reconcile activity for a particular quarter or the entire fiscal year.

This report will not show all of the details for all types of asset transfers. If values such as Company or Business Unit have been transferred, run the Accounts Reconciliation report (R12435) or the Asset Report Writer (R1200001) to display more detailed transfer information.

The Fixed Asset Reconciliation Report includes the following information:

**Beginning balance** The beginning balance for the asset cost, accumulated depreciation, and net book value of an asset. The beginning balance for the asset cost and accumulated depreciation amounts are as of the end of the period prior to the quarter or the year that you request for the report. The beginning balance for the net book value equals the asset cost beginning balance less the accumulated depreciation beginning balance.

**Ending balance** The ending balance for the asset cost, accumulated depreciation, and net book value of an asset. The ending balance for the asset cost and accumulated depreciation amounts equals the beginning balances plus any additions and transfers in, less any transfers out and disposals. The ending balance for the net book value is the difference between the ending balances for the asset cost and accumulated depreciation.

## Processing Options for Fixed Asset Reconciliation Report (R12431)

---

### Process

1. Fiscal Year

2. Quarter

Blank = Year to Date.

1 = First Quarter

2 = Second Quarter

3 = Third Quarter

4 = Fourth Quarter

3. Ledger Type

Print

Asset Number Format

1 = Asset Number

2 = Unit Number

3 = Serial Number

---

---

### Print Tab

1. Fiscal Year

Use this processing option to specify the fiscal year for which the system reports activity. If you leave this processing option blank, the system uses the current fiscal year. Enter a four-digit value (for example, 2006).

---

---

## 2. Quarter

Blank = Year to Date.

1 = First Quarter

2 = Second Quarter

3 = Third Quarter

4 = Fourth Quarter

Use this processing option to specify the quarter for which the system reports activity. If you specify any value other than Blank (year-to-date), you must specify ledger type AA in the Ledger Type processing option. Valid values are:

Blank

Year-to-date

1

First quarter

2

Second quarter

3

Third quarter

4

Fourth quarter

---

---

### 3. Ledger Type

Use this processing option to specify the ledger type for the reconciliation report. If you leave this processing option blank, the system uses the AA ledger.

Note: If you specify a ledger type other than AA, leave the Quarter processing option blank to report year-to-date activity.

#### **Asset Number Format**

**1 = Asset Number**

**2 = Unit Numbe**

**3 = Serial Number**

Use this processing option to specify which number the system prints to identify the asset. Valid values are:

**1 Print the asset number.**

**2 Print the unit number.**

**3 Print the serial number.**

---

## **Printing the Account Reconciliation Report**

*From the Quarterly & YTD Fixed Asset Reports menu (G1223), choose F/A Account Reconciliation Report.*

You can print the Account Reconciliation report to help you reconcile the activity of a specific account or all of the accounts for a company. Run this report by account to review each item number within an account. You can use this report to reconcile the account's activity for a particular period, quarter, or fiscal year.

### **Processing Options for Account Reconciliation (R12435)**

---

Process

1. Fiscal Year

2. Quarter

---

---

Blank = Year to Date.

- 1 = First Quarter
- 2 = Second Quarter
- 3 = Third Quarter
- 4 = Fourth Quarter

### 3. Ledger Type

Print

Asset Number Format

- 1 = Asset Number
  - 2 = Unit Number
  - 3 = Serial Number
- 
- 

### **Print Tab**

#### 1. Fiscal Year

Use this processing option to specify the fiscal year for which the system reports activity. If you leave this processing option blank, the system uses the current fiscal year. Enter a four-digit value (for example, 2006).

---

---

## 2. Quarter

Blank = Year to Date.

1 = First Quarter

2 = Second Quarter

3 = Third Quarter

4 = Fourth Quarter

Use this processing option to specify the quarter for which the system reports activity. If you specify any value other than Blank (year-to-date), you must specify ledger type AA in the Ledger Type processing option. Valid values are:

Blank

Year-to-date

1

First quarter

2

Second quarter

3

Third quarter

4

Fourth quarter

---

---

### 3. Ledger Type

Use this processing option to specify the ledger type for cost summary. If you leave this field blank, the system uses the AA ledger.

#### **Asset Number Format**

**1 = Asset Number**

**2 = Unit Number**

**3 = Serial Number**

**Use this processing option to specify which number the system prints to identify the asset. Valid values are:**

**1 Print the asset number.**

**2 Print the unit number.**

**3 Print the serial number.**

---

## **Printing the Fixed Asset Retirement Report**

*From the Quarterly & YTD Fixed Asset Reports menu (G1223), choose F/A Retirements.*

You can print the Fixed Asset Retirement Report to review the gain or loss on the disposal of an asset for any ledger. You can print asset disposal information for actual amounts for a particular quarter or the entire year. You can also print and compare asset disposal information for two ledger types for an entire year, or any time after depreciation is fully calculated for non-AA ledger types.

The Fixed Asset Retirement Report includes the following information:

**Cost** The original asset cost plus any additional costs for the asset through the "as of" date that you specify for the report.

**First ledger less second ledger** The difference between the gain/loss amount of two ledgers, if you are comparing two ledgers on this report. For example, you can compare your book and federal tax gains and losses.

---

**Note**

You can print a Fixed Asset Retirement quarterly report for ledger type AA. You cannot print a quarterly report for non-AA ledger types unless the ledger type's depreciation is fully calculated for the year.

---

R12432		J.D. Edwards & Company Fixed Asset Retirement Report				4/3/2003 10:33:24		
		Disposal Proceeds		Asset Cost	Accumulated Depreciation	Net Book Value	Disposal Gain/Loss	Book/Tax Difference
Asset Number	Description	LT	Start Depre Date	Disposed Date				
1002	Chrysler Minivan	AA	10/31/2004	6/30/2006		32,500.00	6,778.23	25,721.77
		AA				32,500.00	6,778.23	25,721.77
40	Vehicles	AA				32,500.00	6,778.23	25,721.77
SHOP	Shop	AA				32,500.00	6,778.23	25,721.77
0050	Project Management Company	AA				32,500.00	6,778.23	25,721.77
	Grand Total	AA				32,500.00	6,778.23	25,721.77

## Processing Options for Fixed Asset Retirements (R12432)

Process

1. Fiscal Year

2. Quarter

Blank = Year to Date.

- 
- 1 = First Quarter
  - 2 = Second Quarter
  - 3 = Third Quarter
  - 4 = Fourth Quarter

3. Ledger Type

4. Second Comparison Ledger Type  
Print

Asset Number Format

- 1 = Asset Number
  - 2 = Unit Number
  - 3 = Serial Number
- 
- 

### **Print Tab**

1. Fiscal Year

Use this processing option to specify the fiscal year for which the system reports activity. If you leave this processing option blank, the system uses the current fiscal year. Enter a four-digit value (for example, 2006).

---

---

## 2. Quarter

Blank = Year to Date.

1 = First Quarter

2 = Second Quarter

3 = Third Quarter

4 = Fourth Quarter

Use this processing option to specify the quarter for which the system reports activity. If you specify any value other than Blank (year-to-date), you must specify ledger type AA in the Ledger Type processing option. Valid values are:

Blank

Year-to-date

1

First quarter

2

Second quarter

3

Third quarter

4

Fourth quarter

---

---

### 3. Ledger Type

Use this processing option to specify the ledger type for the reconciliation report. If you leave this processing option blank, the system uses the AA ledger.

Note: If you specify a ledger type other than AA, leave the Quarter processing option blank to report year-to-date activity.

---

---

### 4. Second Comparison Ledger Type

Use this processing option to specify a second ledger type to be used for comparison reporting. If you leave this processing option blank, the system does not perform comparison reporting.

#### **Asset Number Format**

- 1 = Asset Number**
- 2 = Unit Number**
- 3 = Serial Number**

Use this processing option to specify which number the system prints to identify the asset. Valid values are:

- 1 Print the asset number.**
  - 2 Print the unit number.**
  - 3 Print the serial number.**
- 

## **Printing the Depreciation Expense Report**

*From the Quarterly & YTD Fixed Asset Reports menu (G1223), choose Depreciation Expense Report.*

Print the Depreciation Expense Report to review an asset's current cost, depreciation expense, and net book value for a specific fiscal period, quarter, or year. The report also includes the status and depreciation information for each asset. You can use processing options to specify the ledger types, fiscal years, and fiscal periods that print on the report.

## **Processing Options for Depreciation Expense Report (R12430)**

### **Date Tab**

---

#### 1. Period Number

Use this processing option to specify the as of period. Leave this processing option blank to use each company's current fiscal period.

---

---

### Ledger Type Tab

#### 2. Fiscal Year (4 digits)

Use this processing option to specify the as of fiscal year. Leave this processing option blank to use each company's current fiscal year.

### Ledger Type

**Use this processing option to specify the ledger type for cost summary. If you leave this field blank, the system uses the AA ledger.**

#### 1. Asset Number Print

1 = Asset Number

2 = Unit Number

3 = Serial Number

### Print Tab

Use this processing option to specify which number the system prints to identify the asset. Valid values are:

1 Print the asset number.

2 Print the unit number.

3 Print the serial number.

2. Print All Assets

Blank = Omit printing assets with zero cost

1 = Print all assets

---

Use this processing option to specify which assets the system prints. Valid values are:

Blank

Do not print assets with zero cost.

1

Print all assets.

---

## Printing the Depreciation and Amortization Report

*From the Quarterly & YYD Fixed Asset Reports menu (G1223), choose Depreciation & Amortization Report.*

You can print the Depreciation and Amortization report to review asset cost and year-to-date depreciation as of the fiscal year that you specify for the report. You might use this report when preparing your taxes. The information in the Depreciation and Amortization report can be especially helpful if you need to prepare an IRS Form 4562.

Print the Depreciation and Amortization report for each ledger type that you use. The fiscal year that you choose should be the year for which you want to report depreciation taken. For example, if you are preparing your tax report for 2001, you would choose fiscal year 01.

If you transfer an asset to another company during the year, the entire depreciation expense amount for the year is reflected on the new company.

The Depreciation and Amortization report includes the following information:

**Depreciation information (DI)** A code that you use to specify additional depreciation information. The system uses this code for Investment Tax Credit (ITC) and averaging conventions, such as mid-month (M), mid-quarter (Q), and mid-year (Y).

**Cost** The original cost plus any additional costs for the asset through the "as of" date that you specify for the report.

## Processing Options for Depreciation and Amortization (R12433)

---

Print

1. Identify how to print asset number.

1 = Item Number (Default)

2 = Unit Number

3 = Serial Number

2. Fiscal Year

---

---

---

## Printing the Sale of Business Property Report

*From the Quarterly & YTD Fixed Asset Reports menu (G1223), choose Sale of Business Property.*

You can print the Sale of Business Property report to review information about disposed assets. You can print the Sale of Business Property report for personal property or real property. You might want to use these reports when you prepare your taxes. The information in the Sale of Business Property report can be especially helpful if you need to prepare an IRS Form 4797.

The personal property version of the report includes the following information:

<b>Disposal proceeds</b>	The amount received on the sale of the asset. The system determines this amount by the account that you set up in the Disposal Account Rules.
<b>Cost</b>	The original cost plus any additional costs for the asset through the fiscal year-end date that you specify for the report.
<b>Section 1245 recapture amount</b>	The accumulated depreciation or disposal gain amount, whichever is less (but not less than zero).
<b>Section 291</b>	This field does not apply to personal property.
<b>Section 1231 gain/loss</b>	The disposal gain or loss less the recapture amount for assets disposed of after the first year.
<b>Ordinary gain/loss</b>	The disposal gain or loss, less the recapture amount for assets disposed of in the first year.

If you choose to report on personal property, the system calculates the last four amount fields as follows:

- Recapture amount is accumulated depreciation or disposal gain or loss, whichever is less, but not less than zero.
- Nothing prints in the Section 291 column.
- Section 1231 gain/loss is disposal gain or loss, minus the recapture amount for assets not disposed of in the first year.
- Ordinary gain/loss is disposal gain or loss, minus the recapture amount for assets disposed of in the first year.

If you choose to report on real property, the system calculates the last four amount fields as follows:

- Recapture amount is accumulated depreciation less what accumulated depreciation would have been if using straight-line, inception-to-date method, or disposal gain or loss, whichever is less, but not less than zero.
- Section 291 is the amount that would go into the recapture amount if personal property, less what went into recapture amount for real property, is multiplied by 20%.

- Section 1231 gain/loss is disposal gain or loss, minus the recapture amount, and minus Section 291 for the asset that is not disposed of in the first year.
- Ordinary gain/loss is disposal gain or loss, minus the recapture amount, and minus Section 291 for assets that are disposed of in the first year.

The real property version of the report includes the following information:

<b>Disposal proceeds</b>	The amount earned on the sale of the asset. The system determines this amount by the account that you set up in the Disposal Account Rules.
<b>Cost</b>	The original cost plus any additional costs for the asset through the fiscal year-end date that you specify for the report.
<b>Accumulated depreciation</b>	The amount depreciated for the asset through the fiscal year-end date on the report.
<b>Disposal gain/loss</b>	The difference between the asset's disposal proceeds and its net book value.
<b>Section 1250 recapture amount</b>	The lesser of the following: <ul style="list-style-type: none"> <li>• Accumulated depreciation less the depreciation that would have been available under the straight-line method</li> <li>• Gain</li> </ul>
<b>Section 291</b>	Twenty percent of the excess of: <ul style="list-style-type: none"> <li>• The amount that would be recaptured as ordinary income if such property is under Section 1245</li> <li>• The amount recaptured under Section 1250</li> </ul>
<b>Section 1231 gain/loss</b>	The disposal gain or loss, less the recapture amount and less Section 291 for assets not disposed of in the first year.
<b>Ordinary gain/loss</b>	The disposal gain or loss, less the recapture amount for assets disposed of in the first year.

## Processing Options for Sale of Business Property (R12434)

### Process Tab

---

#### 1. Fiscal Year (4 digits)

Use this processing option to specify the as of fiscal year. Leave this processing option blank to use each company's current fiscal year.

---

---

## 2. Ledger Type

Use this processing option to specify the ledger type for cost summary. If you leave this field blank, the system uses the AA ledger.

---

---

### 3. Type of Property

1 = Personal Property

2 = Real property (Default)

Use this processing option to specify the type of property to which the report applies. Valid values are:

1

Personal property

2

Real propertyy

### **Asset Number Format**

**1 = Asset Number**

**2 = Unit Number**

**3 = Serial Number**

### **Print Tab**

**Use this processing option to specify which number the system prints to identify the asset. Valid values are:**

**1 Print the asset number.**

**2 Print the unit number.**

**3 Print the serial number.**

---

## Printing the Property Tax Worksheet

*From the Year End Processes menu (G1225), choose Property Tax Worksheet.*

You can print the Property Tax Worksheet to review summarized totals for assets by tax entity and year acquired. You can use the Property Tax Worksheet to prepare your property taxes for local governing authorities. The worksheet includes a work area for the tax preparer's notes.

The Property Tax Worksheet displays the following asset information:

- Company number and name
- Tax entity address book number and mailing information
- Accounting and equipment classes
- Asset number
- Description
- Date acquired
- Cost

## Processing Options for Property Tax Worksheet (R12422)

### Display Tab

This processing option enables you to specify the acquisition cutoff date. All assets acquired after this date are not shown on the report.

---

#### 1. Acquisition Cutoff Date

Use this processing option to specify the acquisition cutoff date. All assets acquired after this date will not be displayed on the report. If this date is left blank, the acquisition cutoff date will be based on the current period ending date for the asset's company.

---

### Process Tab

These processing options enable you to specify the date through which the report should be based, and whether you want an additional ledger type for cost reflected on your report.

---

#### 1. As Of Date

**Use this processing option to specify the date through which the report should be based upon. If this date is left blank, cost will be based on the current period ending date for the asset's company.**

---

---

## 2. Additional Ledger Type

**Use this processing option to specify an additional ledger type for cost. If an additional ledger type is specified, the report will reflect the cost of this ledger plus the cost of the AA ledger. If this option is left blank, only the AA ledger will be used to determine the cost.**

---

### Print Tab

These processing options enable you to specify whether you want the assets with zero cost printed on the report and how you want the asset number printed on the report.

---

#### 1. Omit Assets with Zero Cost

Blank = Print all assets

1 = Do not print assets with zero cost

Use this processing option to specify whether or not you want the assets with zero cost printed on the report. Valid values are:

Blank Print all assets on the report.

1 Do not print assets with zero cost on the report.

---

---

#### 2. Asset Number Format

1 = Asset Number

2 = Unit Number

3 = Serial Number

Use this processing option to specify how you want the asset number printed on the report. Valid values are:

---

---

1 Asset Number.

2 Unit Number.

3 Serial Number.

---

---

# Fixed Assets System Setup

Before you use the Fixed Assets system, you must define fixed asset information that you want the system to use during processing procedures. Set up this information to customize the Fixed Assets system for your specific business needs.

## See Also

- *Updating Company Numbers and Accounts in the Fixed Assets Guide*

---

## Setup Features

<b>Fixed Assets constants</b>	Establish system basics, such as: <ul style="list-style-type: none"><li>• Default business units for asset cost, accumulated depreciation, depreciation expense, and revenue accounts for an asset</li><li>• The category code number that you use to define the depreciation category for use in the depreciation rules</li><li>• Symbols that identify the three types of asset identification numbers, including your company's primary number</li><li>• The category code number that you use to define the asset class for use in the supplemental database</li></ul>
<b>User defined codes</b>	Define customized codes, such as: <ul style="list-style-type: none"><li>• Asset category codes, including major accounting class and major asset class</li><li>• Finance methods</li><li>• Asset status codes</li><li>• Asset message types</li></ul>
<b>User defined depreciation</b>	Set up user defined depreciation methods when you need specific depreciation algorithms other than the standard depreciation rules that are included in the Fixed Assets system.
<b>Automatic accounting instructions</b>	Define accounting information and general ledger relationships when the Fixed Assets system interacts with the General Accounting system.
<b>Next numbers</b>	Enable the system to automatically assign numbers to various items in the system that require unique numbers.
<b>Asset acquisition years</b>	Define date patterns in the system for every fiscal year in which assets are acquired and each year thereafter for any asset that you want to depreciate.

<b>Depreciation default values</b>	Simplify the creation of new asset master records by establishing default values for the Master Information form, such as: <ul style="list-style-type: none"> <li>• Major accounting class</li> <li>• Major equipment class</li> <li>• Depreciation accounts</li> <li>• Revenue account</li> <li>• Depreciation information</li> </ul>
<b>Category code mapping</b>	Map specific business unit category codes to specific asset category codes.
<b>Ledger type rules</b>	Control processing for specific ledger types. Specify any necessary ledger dependencies and associated transaction creation. Further define: <ul style="list-style-type: none"> <li>• Currency codes</li> <li>• Date pattern overrides</li> <li>• Period number overrides</li> <li>• Rounding rules</li> </ul>
<b>Disposal account rules</b>	Specify the accounts used for asset disposal.
<b>Beginning balances</b>	Simplify the initial conversion to the Fixed Assets system by recording beginning balances for assets in the Asset Account Balances table (F1202).
<b>Supplemental data</b>	Further define the assets in your system by setting up supplemental data type categories. After you establish these supplemental data types, you can track information about an asset that is important to your company but is not included in the asset master record.
<b>Revaluation indexes</b>	Automate revaluation so that you can easily keep pace with inflation or market fluctuations.
<b>Units of production schedules</b>	Establish units of production schedules so that the system can calculate depreciation by the measurements of production that you track and record in the system for your company.

## **Setting Up Fixed Asset Constants**

---

Fixed asset constants control how your business environment uses the features in the Fixed Assets system. For example, when you define a default business unit for depreciation expense in Fixed Asset Constants, the system automatically supplies the value to Depreciation Information whenever you add a new asset to the system. You can also specify the business unit that appears as a default value for the various asset accounts when you create a master record for a new asset.

Set up fixed asset constants only one time for the entire Fixed Assets system. You set up constant values for company 00000 so that all of the companies in your organization that access the Fixed Assets system use the same constant values.

---

**Caution**

J.D. Edwards recommends that you do not change your fixed asset constants. However, some situations might occur in which you might need to change a fixed asset constant, and you must understand the consequences.

- For example, if you change the default business unit for asset accounts, the change affects only the assets that you add to the system after the change.

If you must change a fixed asset constant and that change needs to be updated for previous assets, you must perform an additional process to update the system with your latest change.

- For example, if you change the symbol for your primary asset number in Fixed Asset Constants, you must run the Global Update program.

---

**Note**

The values that you set up for the Fixed Assets system in Fixed Asset Constants also affect the Equipment/Plant Management system.

---

---

**► To set up equipment and fixed asset constants**

---

*Use one of the following navigations:*

*For Fixed Assets, choose Fixed Asset Constants from the Fixed Asset System Setup menu (G1241).*

*For Enterprise Asset Management, choose Equipment Constants from the Plant & Equipment Management Setup menu (G1341).*

1. On Fixed Asset Constants, click the option for each of the following fields to establish where the business units for each fixed asset account come from when you add a new asset:
  - Accumulated Depreciation
  - Depreciation Expense
  - Revenue
2. To specify how the system identifies asset numbers, complete the following fields:
  - Symbol to Identify Asset Number
  - Symbol to Identify Unit Number
  - Symbol to Identify Serial Number
3. To specify which category code the system uses to group assets by depreciation types, complete the following field:
  - Depreciation Category Code
4. To specify which category code the system uses to assign supplemental data types, complete the following field:
  - Supplemental Category Code

5. If you use Equipment/Plant Maintenance to maintain your equipment, complete the following optional fields:
  - Inclusion Version
  - Maintenance Loop
6. Click OK.

## **Setting Up User Defined Codes for Fixed Assets**

---

Many fields throughout the Fixed Assets system accept only user defined codes. You can customize the Fixed Assets system by setting up user defined codes to meet the needs of your business environment.

User defined codes are stored in tables that are related to a specific system and code type. For example, 12/FM represents system 12 (Fixed Assets) and user defined code type FM (Finance Method). User defined code tables determine what codes are valid for the individual fields in your system. If you enter a code that is not valid for a field, the system displays an error message. For example, you can only enter codes in the Major Accounting Class Code field on the Work with Assets form that exist in the user defined code table for system 12 and code type C1.

You can access all user defined code tables through a single user defined code form. After you select a user defined code form from a menu, change the System Code field and the User Defined Codes field to access another user defined code table.

---

### **Note**

User defined code table 12/LT (Fixed Assets Ledger Type for Depr. J.E.s) has been replaced by the Ledger Type Master File table (F0025). You can access fixed asset ledger types that were formerly defined in this user defined code table through Ledger Type Master Setup from the Fixed Asset System Setup menu (G1241).

---

Equipment Plant Management uses the category codes from the Fixed Assets system (12). Many forms throughout Equipment Plant Management show the first 10 of 23 category codes. J.D. Edwards recommends that you assign specific equipment needs to as many of the first ten category codes as you need. This process helps you to perform online searches for equipment. You can then use the remaining codes for fixed asset reporting needs.

---

### **Caution**

User defined codes are central to J.D. Edwards systems. You must be thoroughly familiar with user defined codes before you change them. The effort that you put into designing the user defined codes which your company uses can greatly affect your overall satisfaction with the system.

---

The following user defined codes are the primary codes for the Fixed Assets system:

<b>Major Accounting Class (12/C1)</b>	<p>Use to group assets into categories, such as office equipment, furniture, heavy equipment, plant equipment, and so on.</p> <p>J.D. Edwards recommends that you set up a one-to-one relationship between major accounting class and the asset cost account to assist in running user defined depreciation.</p>
<b>Major Equipment Class (12/C2)</b>	<p>Use to further divide assets into subclasses. For example, set up codes to divide office equipment into groups, such as copiers, computers, printers, and so on.</p>
<b>Additional classification codes (12/C3 - C0 and F1 - F0, 21 - 23)</b>	<p>Use the following classification codes for any additional business requirements that you might have:</p> <ul style="list-style-type: none"> <li>• Manufacturer (Class Code 3)</li> <li>• Model Year (Class Code 4)</li> <li>• Usage Miles or Hours (Class Code 5)</li> <li>• Equipment Code (Class Code 6)</li> <li>• Category Code 7</li> <li>• Division (Class Code 8)</li> <li>• Category Code 9</li> <li>• Rate Group (Class Code 10)</li> <li>• Class Code 11-23</li> </ul> <p>If you use Equipment Billing, you must use category code 10 to define billing rate groups.</p>
<b>Finance Method (12/FM)</b>	<p>Use to specify how an asset was acquired, such as leased or purchased outright. Finance method information is stored in the Asset Master File table (F1201).</p>
<b>Revaluation Code (12/RI)</b>	<p>Use to identify revaluation index tables. For example, set up codes to identify revaluation tables for separate countries.</p>
<b>Depreciation Method (12/DM)</b>	<p>Use to define depreciation methods. In addition to the standard depreciation methods 00 - 18, you can define your own depreciation methods with user defined depreciation. Standard depreciation methods use numeric code identifiers. You must use alphabetic code identifiers for any user defined depreciation methods that you set up.</p> <p>Both standard and user defined depreciation methods are stored in UDC table 12/DM. When you run depreciation computation programs, the system distinguishes user defined depreciation methods from standard methods by a 1 in the Special Handling Code field.</p>
<b>Status or Disposal Code (12/ES)</b>	<p>Use to specify types of disposals, such as sold, scrapped, or charity. Status and disposal information is stored in the Asset Master File table (F1201).</p> <p>You can also use this category code to specify the operational status of equipment status, such as available, working, down, or disposed.</p>
<b>Equipment Message Type Code (12/EM)</b>	<p>Use to define and group different types of messages, such as planned maintenance, problem reporting, lease terms, and so on.</p>

The Fixed Assets system includes two classification codes that are hard coded, and cannot be changed or deleted:

- DP (Type of Disposal)
- DM (Depreciation Method)

#### **See Also**

- ❑ *User Defined Codes* in the *Foundation Guide* for overview information about user defined codes
- ❑ *Setting Up Ledger Type Rules for Fixed Assets* in the *Fixed Assets Guide*

## **Setting Up User Defined Depreciation**

---

The system uses depreciation rules to calculate depreciation. When you set up user defined depreciation methods, you must define the depreciation rules, formulas, and date spreads that you want the system to use to calculate depreciation for your fixed assets.

You can define as many specific depreciation methods as your company needs without custom programming. Set up user defined depreciation methods when you need specific depreciation algorithms other than the standard depreciation rules that are included in the Fixed Assets system. For example, you can copy an existing straight-line rule and insert the appropriate life period information to create a depreciation method for your specific needs.

The system stores both standard and user defined depreciation methods in UDC table 12/DM. When you run the program to calculate depreciation, the system distinguishes user defined methods from standard methods by a special handling code of 1. In addition, the predefined depreciation methods have a two-character numeric code. Predefined depreciation methods that you change or new depreciation methods that you create must have a two-character alpha code.

After you create a user defined depreciation method, you must set up depreciation default values to include the new depreciation method. When you create new asset master records, the system automatically assigns a depreciation method based on the asset cost account. After you create the asset master record, you should verify the depreciation method.

The User Defined Depreciation program uses processing similar to the Job Status Inquiry program (P512000) through the use of elements within an expression formula. The spread patterns are similar to those in the Global Pattern Code Update program (P1441). User Defined Depreciation can help eliminate localization for calculating depreciation.

### **Defining the Requirements for Depreciation**

Consider the following requirements when you calculate depreciation.

#### **Asset Life**

The following functions determine the length of an asset's life:

<b>Life Periods (ADLM)</b>	<p>Asset Life Days = (Life Periods / Normal Number of Period) * 365.25.</p> <p>Use the over/under convention to stop depreciating at the end of the asset's life.</p>
<b>Continue Depreciation Beyond the Asset's Life (OUDC)</b>	<p>Use the over/under convention to continue depreciation.</p> <p>Set up the Thru Life Year to 998 (Methods 06, 09, 15, 17, 18).</p>
<b>Life Year Reference (LYRC)</b>	<p>The default is determined by the Fiscal Year.</p> <p>The asset life year is determined by the modified start date and is calculated by period.</p>

### Balance Adjustments

The following values for the Compute Direction field (DIR1) determine how balance adjustments, or depreciation journal entries are made. Adjustments can be daily, monthly, or annual.

<b>Calculate by Period Adjustments (DIR1= P)</b>	<p>Depreciation is calculated by period with no catch up.</p> <p>The depreciation amount is apportioned each period (100%).</p>
<b>Calculate Annual Amount and Apportion by Period (DIR1 = C, R)</b>	<p>Depreciation is calculated by the annual amount.</p> <p>Depreciation is apportioned by period. For example, 12 periods = 8.3333%.</p>
<b>Calculate Amount from the start of an assets life (DIR1 = I)</b>	<p>Use inception-to-date for the first time to catch up, and then change the compute direction.</p> <p>If Compute Direction = I, then depreciation:</p> <ul style="list-style-type: none"> <li>• Starts at the modified start date.</li> <li>• Is calculated by the annual amount.</li> <li>• Is adjusted for inception-to-date through the current year.</li> <li>• Is apportioned by period. For example, 12 Periods = 8.3333%.</li> </ul>

### Modified Start Date

The modified start date is determined by the Initial Term Apportionment field (ITAC). The modified start date determines the end date of an asset. You can set the modified start date as:

- Start/Middle/End of the Month/Period
- Start/Middle/End of the Year
- Actual Date, Quarter Date, and so on

Most depreciation formulas require an Initial Year (or Period) Apportionment percent. When using a formula that requires this, you should use Element 50 to apply to the first year's percent and for period calculations.

## Calculations

You can use one of several methods to calculate depreciation, including:

<b>Demonstration data</b>	Use existing demonstration (predefined) data that has existing depreciation rules.
<b>Copy an existing depreciation rule</b>	If you copy an existing rule, you need to change the following fields: <ul style="list-style-type: none"><li>• Life Periods</li><li>• Initial Term Apportionment</li><li>• Any other appropriate fields to meet your business needs</li></ul>
<b>Define the exact calculation formula</b>	You can use: <ul style="list-style-type: none"><li>• Formula Multiplier or Annual Rule Multiplier</li><li>• Other elements listed in the formula definition</li></ul>
<b>Calculated formulas</b>	Calculation is completed in the following order: <ul style="list-style-type: none"><li>• Salvage Value</li><li>• Upper Limit</li><li>• Lower Limit</li><li>• Basis</li><li>• Depreciation Formula</li><li>• Default Value</li></ul>

## Disposals

Depreciation must be run before you dispose of cost. The disposal date creates the following processing order:

- 999 Life Year Rule calculated
- Specific Life Year Rule calculated (SPCN)
- Default back to Current Life Year Rule

Most tax ledgers keep cost through year-end. Do not dispose of these ledgers.

Use Life Year Rule 999 only for the disposal year of an asset.

## See Also

See the following topics in the *Fixed Assets Guide*

- To set up life year rules*
- To specify conventions for the rule*

## Technical Considerations

User Defined Depreciation is a powerful and flexible feature that allows you to define how the system computes depreciation. The program provides numeric depreciation rules as models that you can copy and modify to meet your business needs. Then, when depreciation

amounts are not being calculated correctly, you can resolve the problem by adjusting the depreciation rule.

When you set up user defined depreciation rules, you define depreciation methods, compute direction, conventions, life year rules, requirements, and formulas.

J.D. Edwards recommends that you observe the following guidelines when using User Defined Depreciation:

- Keep track of requirements such as the asset's life, the compute direction to use, the life years of the asset, any modified start date requirements, and the conventions to use for the assets.
- When creating a new formula, try to find a similar existing formula that you can copy.
- Know what you want your result to be before setting up a formula.
- Understand which element in the depreciation equation that you will need to use in your formula.
- Using the elements, create your formula and keep track of it (for example, write it down on a separate piece of paper) to help you follow it through and understand the results.
- Choose the processing options to print the formulas and the elements.
- Always run depreciation in proof mode when working with live data.
- Test your depreciation rule through the entire life of the asset, based on various fiscal date patterns.
- Use projections to automate the process.

#### **See Also**

- ❑ *Working with Budget Patterns* in the *General Accounting Guide* for information about budget spreads

See the following topics in the *Fixed Asset Guide* for more information about depreciation:

- ❑ *Setting Up Depreciation Rules*
- ❑ *Setting Up Depreciation Default Values*
- ❑ *Working with Depreciation Formulas*
- ❑ *Compute Direction*
- ❑ *Verifying Depreciation Information*
- ❑ *Updating Global Depreciation Rules*
- ❑ *Setting Up Depreciation Spread Patterns*

## **Setting Up Depreciation Rules**

---

Depreciation rules control how the system calculates depreciation for an asset. You must specify the rules that you want the system to follow when making calculations for user defined depreciation methods. When you set up rules for a depreciation method, you define a hierarchy of conventions that you want the system to apply to the cost of an asset.

The Fixed Assets system includes the base rules for computing standard depreciation methods. You cannot change the standard rules that are included in the Fixed Assets

system, but you can copy and modify these rules to define depreciation methods that are specific to your company. For example, if you want to set up a depreciation rule for straight-line depreciation with a life period combination that is not included in the Fixed Assets system, you can use Depreciation Rule Revisions to copy an existing straight-line rule and change the life periods.

User defined depreciation rules must have alpha identifiers to distinguish them from J.D. Edwards base depreciation rules. When you set up depreciation rules, the system stores the information in the Depreciation Rules (F12851), Annual Depreciation Rules (F12852), and Depreciation Formulas (F12853) tables.

---

**Note**

Numeric methods 00-18 are provided in the system. J.D. Edwards has created additional numeric methods beyond method 18 for country-specific reporting needs. Do not create additional numeric methods for 19 and above, or you risk the system overlaying its method 19 with your newly created method 19. You can add as many combinations to 00-18 as you need, and those will not be overlaid. No edit option exists to prohibit overlaying in the event you do not want a demonstration data refresh.

---

At the highest level, you can set up depreciation rules to apply to the entire period of time over which you want the cost of an asset to be apportioned. Or you can define rules for the period in which the asset is in service.

A depreciation rule consists of three parts:

<b>Rule header information</b>	<p>Rule header information references the depreciation method in which the rule is used, such as:</p> <ul style="list-style-type: none"><li>• The code that identifies the method</li><li>• The special characteristics of the rule</li><li>• The period over which the asset cost is to be apportioned</li><li>• The placed-in-service date for the asset</li><li>• The date through which the method is effective</li></ul> <p>You use the information in the header to tie a specific depreciation rule to an asset.</p>
<b>Rule conventions</b>	<p>Rule conventions dictate how the system calculates depreciation, based on the life year rules and formulas that you specify for the rule. These conventions apply to the entire apportionment period that is referenced by the rule. You can set up rule conventions to:</p> <ul style="list-style-type: none"><li>• Override the business unit destination of the depreciation expense.</li><li>• Spread the first and last year of cost apportionment. For example, you can designate a rule to spread depreciation throughout the year or spread the depreciation proportionately, beginning with the depreciation start or end date.</li><li>• Allow the use of a second annual rule.</li><li>• Use the asset's life periods or the fiscal year as the beginning reference point in determining the current life year of an asset.</li><li>• Depreciate more cost than exists for an asset.</li><li>• Allow negative depreciation amounts to be computed in the formula during the life of an asset.</li></ul>

**Life year rules** The basic equation for computing depreciation for a life year consists of a multiplier that is applied to a cost or basis. The resulting amount is subject to a minimum (base) and a maximum (limit). The basis amount that is multiplied might be subject to an overall floor or salvage value. The same rule might apply to multiple life years, or it might apply to a single life year of a cost.

You can define a rule for any asset life year. You can also define a separate rule for the disposal year of an asset.

The formulas that are used by the life year rules can be applied to any element in the depreciation equation, such as:

- Multiplier
- Depreciable basis
- Upper Limit
- Lower Limit
- Salvage value

Asset life years must be contiguous. For example, if the value in the Life Year Thru field for a given Life Year Rule is 1, then the Life Year From value in the subsequent Life Year Rule should be either 1 or 2, depending on whether the Secondary Account Percentage is being used or if In Service Months are specified.

If a depreciation rule uses In Service Months, the same In Service Month should be used consistently for all life years in the depreciation rule. For example, if In Service Months 1 and 2 are used for the first life year of a depreciation rule, then they should also be set up for every year of the depreciation rule. The Life Year From and Life Year Thru values must be the same for a life year that has an In Service Month specified.

When you set up user defined depreciation rules, you must address each part of the rule.

You can generate a report to review your depreciation rules.

### See Also

See the following topics in the *Fixed Asset Guide*:

- ❑ *Printing the Depreciation Rules Report*
- ❑ [Updating Global Depreciation Rules](#) for information about updating depreciation tables

### ► To add a depreciation method

---

*From the Set Up User Defined Depreciation menu (G1232), choose Depreciation Rule Revisions.*

1. On Work with Depreciation Rules, click the search button for the following field:
  - Depreciation Method
2. On Select User Define Code, choose Revisions from the Form menu.
3. On Work With User Defined Codes, click Add.
4. On User Defined Codes, complete the following fields in the first empty row:
  - Codes

- Description 1
- Description 2

New depreciation methods must be identified with a 2-character alpha code.

5. To identify the depreciation method as a user defined method, enter 1 in the following field:
  - Special Handling
6. Click OK.
7. To return to Work with Depreciation Rules:
  - On Work With User Defined Codes, click Close.
  - On Select User Define Codes, click Close.

► **To add a rule**

*From the Set Up User Defined Depreciation menu (G1232), choose Depreciation Rule Revisions.*

1. On Work with Depreciation Rules, click Add.

The screenshot shows the 'Add Depreciation Rules' dialog box in the PeopleSoft system. The dialog is titled 'Add Depreciation Rules' and is part of the 'Active Foundation' workspace. It features a search bar for 'Depreciation Method' with a magnifying glass icon. Below the search bar are several input fields and checkboxes: 'Initial Term Apportionment' (checkbox), 'Compute Direction' (checkbox), 'Life (Periods)' (checkbox), 'Date Pattern Reference' (checkbox), 'In Service From Date' (date picker), 'In Service Thru Date' (date picker), 'Effective From Date' (date picker), and 'Effective Thru Date' (date picker). At the bottom, there is a 'Rule Description' text area. The dialog has a standard toolbar with 'OK', 'Cancel', 'Form', and 'Tools' buttons.

2. On Add Depreciation Rules, complete the following fields:
  - Depreciation Method
  - Initial Term Apportionment

- Compute Direction
  - Life (Periods)
  - Date Pattern Reference
  - In Service From Date
  - In Service Thru Date
  - Effective From Date
  - Effective Thru Date
  - Rule Description
3. Click OK.
  4. To return to Work with Depreciation Rules, click Cancel.

## Compute Direction

Typically, when you convert to J.D. Edwards ERP software, you can choose which compute direction to use. If you are comfortable with how depreciation was computed in your old system, you can convert by using a compute direction of R (Remaining Life). This direction takes the remaining net book value and amortizes it over the remaining life periods of the asset. The system uses the Beginning Balance Forward field from the Asset Account Balances File table (F1202) during the computation of depreciation. This field determines the depreciable amount for the current year.

You might determine that you need to adjust the depreciation. For example, you might need to adjust the depreciation if your old system was not correct or a change in methods occurred. If you need to adjust depreciation, use a compute direction of I (Inception-to-Date). This compute direction causes the system to calculate depreciation for each previous year of the asset's life to determine the current depreciation amount. Inception-to-Date can result in a catch-up amount that is amortized over the first year that the asset is in the J.D. Edwards Fixed Assets system. A compute direction of I should be used only for the first year of the asset's life. After the first year, the compute direction should be changed to C (Current Year Depreciation). Due to the numerous years of formulas through which the system must compute, older assets require longer processing time. Therefore, using a compute direction of C improves processing.

### ► To specify conventions for the rule

---

*From the Set Up User Defined Depreciation menu (G1232), choose Depreciation Rule Revisions.*

1. On Work with Depreciation Rules, complete the following fields, and click Find:
  - Depreciation Method
  - In Service Date
  - Effective Date
2. Choose a rule.

- From the Row menu, choose Rule Conventions.

PeopleSoft

Select Workspace: Active Foundation

Active Foundation Personalize Change Role Sign Out

Rule Conventions

OK Cancel Form Tools

Depreciation Method	<input type="text" value="01"/>	Straight Line Depreciation	<input checked="" type="checkbox"/> Edit Disable
Initial Term Apportionment	<input type="checkbox"/>	First Day of First Month	
Compute Direction	<input type="text" value="C"/>	Current Year To Date	
Life (Periods)	<input type="text" value="36"/>		
Depreciation Expense Business Unit	<input type="checkbox"/>	No Override	
First Year Spread	<input type="checkbox"/>	Modified Depreciation Start	
Last Year Spread	<input type="checkbox"/>	Modified depreciation end date	
Disposal Year	<input type="checkbox"/>	To End of Disposal Period	
Secondary Acct/%	<input type="checkbox"/>	No Secondary Percentage	
Life Year Reference	<input type="checkbox"/>	1st day depreciation start	
Allow Over Depreciation	<input type="checkbox"/>	Over depreciation NOT allowed	
Allow Negative Depreciation	<input type="checkbox"/>	No	

- On Rule Conventions, complete any of the following optional fields to define the conventions of the depreciation rule:
  - Depreciation Expense Business Unit
  - First Year Spread
  - Last Year Spread
  - Disposal Year
  - Secondary Acct/%
  - Life Year Reference
  - Allow Over Depreciation
  - Allow Negative Depreciation
- To prevent changes to the rule, click the following field:
  - Edit Disable

You can use a processing option to disable this option for additional security.
- Click OK.

## Disposal Year Rules

Use disposal year rules to calculate depreciation on an asset to meet the requirements of a disposal year convention in the year that the asset was disposed. This type of disposal occurs during the life of the asset and not in the year that the asset is placed in service, nor in the final year that an asset becomes fully depreciated. In the first and final years in the life of an asset, the First Year Spread and Last Year Spread values override the disposal rules.

Disposal year rules only apply to a Compute Direction of I or C. If you are using a Compute Direction of R or P, disposal year processing is already set up; you do not have to create disposal year rules.

You can use two methods to set up a disposal year rule:

- Set up different disposal year rules by the life year in which that the asset is disposed. You must create life year rules that have a value of 9 in the Secondary % Continuation field on the Display Tab on the Life Year Rules form.
- Set up a disposal year with a depreciation calculation that covers all life years. You must create a 999 life year rule.

Adding disposal year rules to an existing depreciation rule does not affect other assets that are using the depreciation rule and have not yet been disposed. The User Defined Depreciation program (R12855) only calls the disposal year rules for assets that have a value in the Effective From field, which allows all other assets to continue to depreciate as normal. You must manually enter the date disposed field. Therefore, you do not need to create new depreciation rules; you can change the existing rules to meet your disposal year depreciation calculation needs.

For example, an asset that has a disposed-of date of April 30<sup>th</sup> and uses a depreciation rule set up for a mid-year disposal continues to depreciate through the middle of the year per the convention. If the asset has a disposed-of date in October and uses the mid-year disposal convention, then depreciation starts at the mid-year point when you compute depreciation.

After depreciation has been calculated, you can use one of the Asset Disposal programs (R12104, P12105) to dispose of the asset. You do not have to remove the date disposed that you manually entered prior to disposal.

### ► To set up life year rules

---

*From the Set Up User Defined Depreciation menu (G1232), choose Depreciation Rule Revisions.*

1. On Work with Depreciation Rules, complete the following fields, and click Find:
  - Depreciation Method
  - In Service Date
  - Effective Date
2. Choose a rule.
3. Choose Life Year Rules from the Row menu.

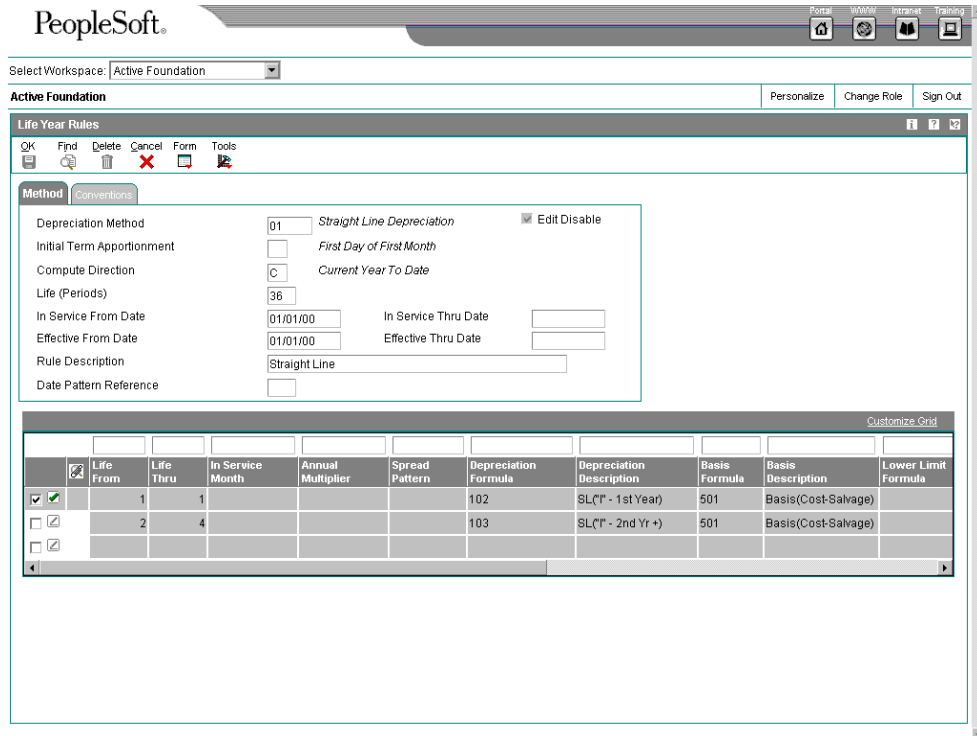

4. On Life Year Rules, complete the following fields in the detail area:

- Life From
- Life Thru
- In Service Month
- Annual Multiplier
- Spread Pattern
- Depreciation Formula
- Basis Formula
- Lower Limit Formula
- Upper Limit Formula
- Salvage Formula
- Secondary % Continuation

If you are setting up a life year rule for disposal year calculations, enter 9 in this field.

5. Click the Method tab and complete the following fields:
  - In Service Thru Date
  - Effective Thru Date
6. Click the Conventions tab and complete the following optional fields:
  - Depreciation Expense Business Unit
  - First Year Spread
  - Last Year Spread
  - Disposal Year
  - Secondary Acct/%
  - Life Year Reference
  - Allow Negative Depreciation
  - Allow Over Depreciation
7. Click OK.
8. To prevent changes to the rule, click the Method tab, and then click the following option:
  - Edit Disable

You can use a processing option to disable this option for additional security.

## Examples

The following examples use the 999 life year rules that you might need to set up for depreciation rules 1, 3, 4, 5, and 12. Because the setup for both of the ways to address disposal year calculations are nearly the same, the example will focus on the 999 setup.

### Declining Balance Methods

For depreciation rules 3, 4, and 5 (Declining Balance Methods) that have a Method of Computation of I or C, you might need to create a 999 life year rule to allow for depreciation calculations during the disposal year. Consider the following example when creating a 999 life year rule for your depreciation rule:

Set up two new depreciation formulas as follows. (The second formula is optional and only needs to be set up if you are requiring a Lower Limit.)

- Add a new depreciation formula by copying Formula 006 (provided in the demonstration data).
- Enter the following in the Formula field:
  - $((((10-51) / 03) * 49) * 11) * 56$

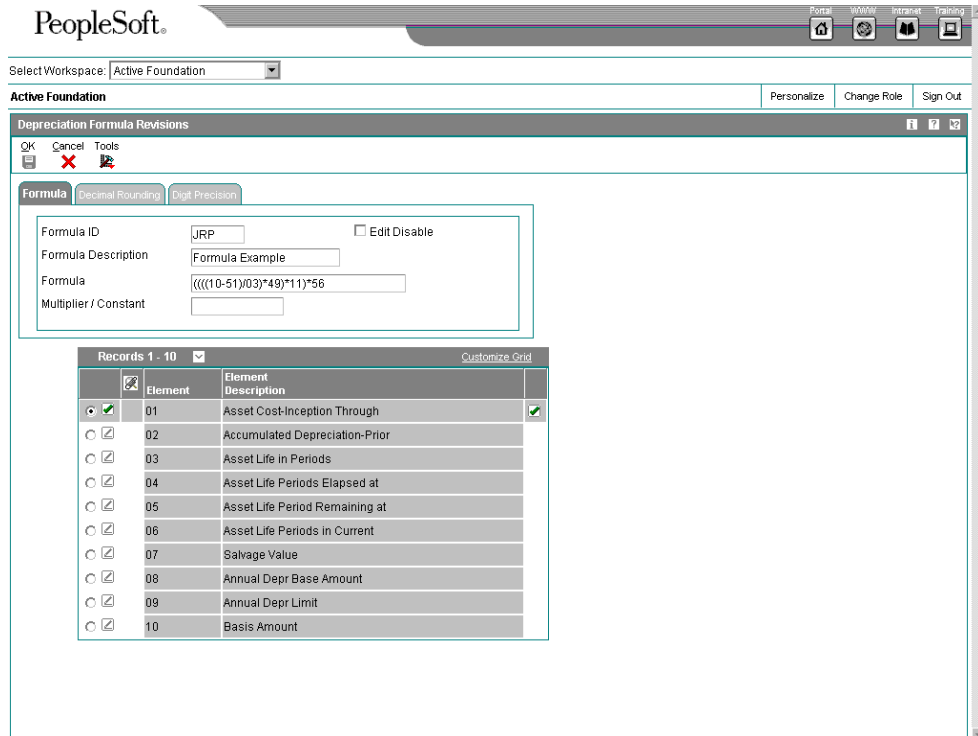

- If a Lower Limit is required for the disposal year depreciation calculation, create an additional formula by copying Formula 701 provided in the demonstration data.
- Enter the following in the Formula field:
  - $( (01-51) / (03 - (07) + 49 + (12-50) * 49) * 49) * 56$

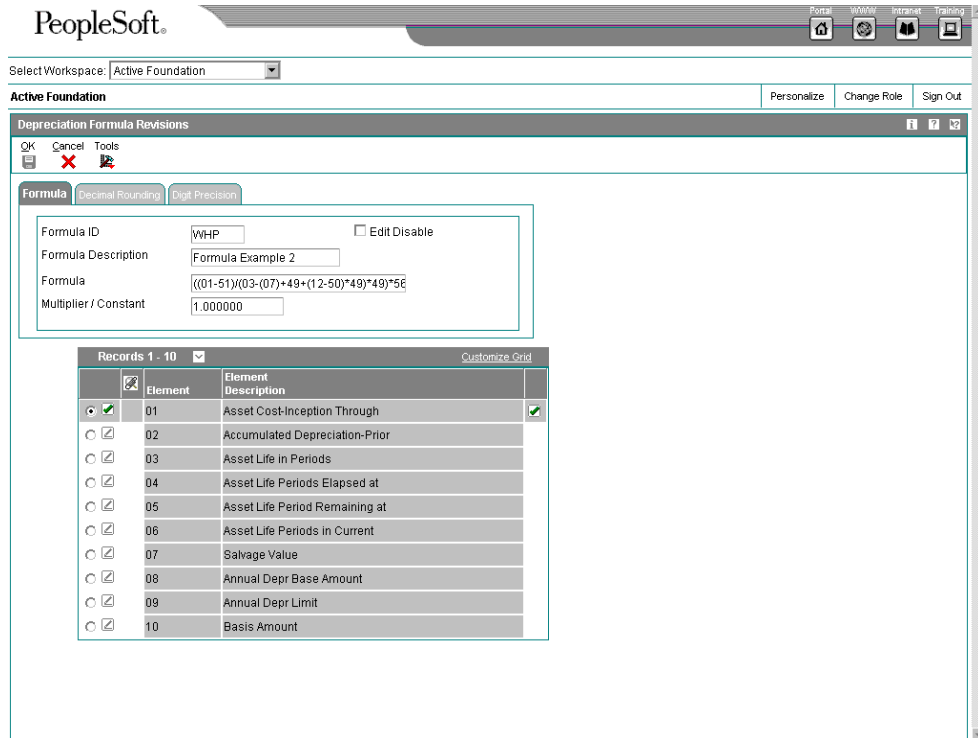

- Create an additional formula for salvage value formula and enter the following in the Formula field:
  - $(53 * 49)$

**Note**

This salvage value formula should be used only with a 999 disposal rule that uses the lower limit.

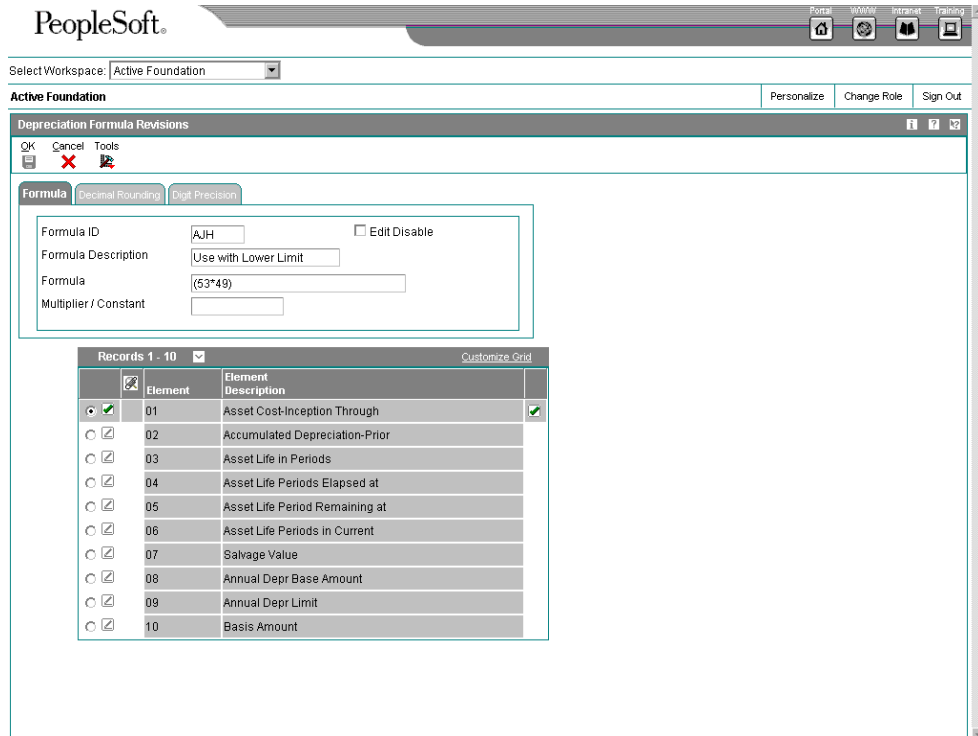

- Enter the following values in the Depreciation Formula field as separate line items:
  - The new depreciation formula
  - The new lower limit formula (if Lower Limit is required)
  - The new salvage formula (if you use the Lower Limit)
- Use the same value in the Basis Formula field for all of the depreciation formulas.

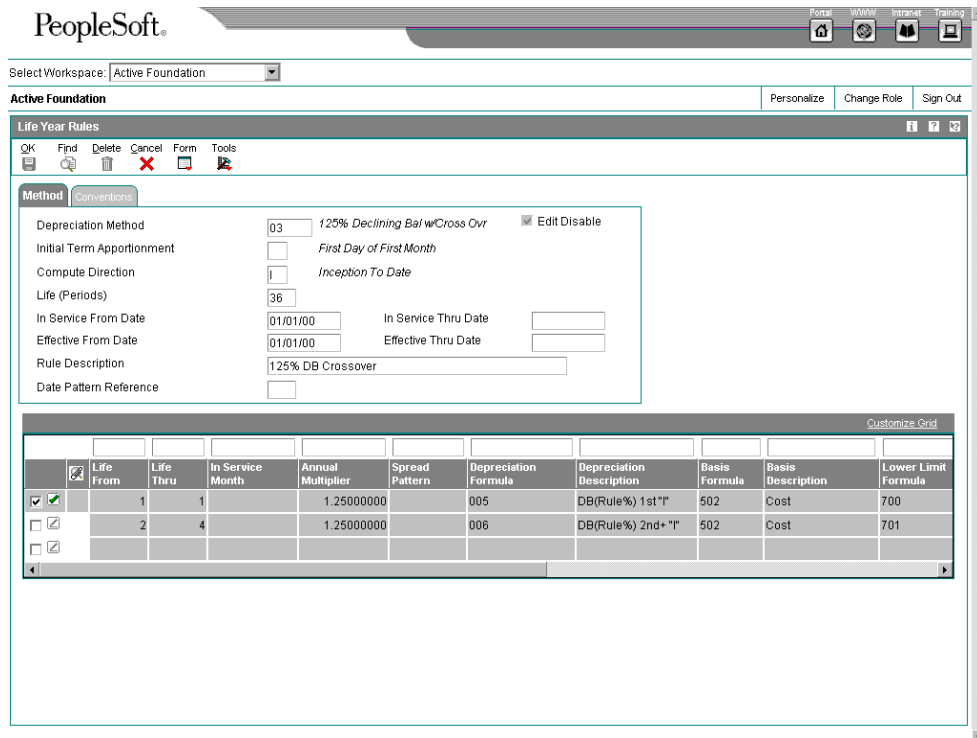

### Depreciation Rule 12 – MACRS Depreciation

If you use depreciation rule 12, you will need to change the 999 rule that is currently set up so that it includes the new depreciation formula that you set up above.

### Depreciation Rule 01 – Straight Line Depreciation

If you use Depreciation Rule 01, you might need to create a 999 rule to accurately calculate depreciation in the disposal year. Add a new depreciation formula and enter the following formula in the Formula field.

$$((10/03) * 49) * 56$$

You will not need to create a lower limit or salvage value when using Depreciation Rule 01.

### See Also

See the following topics in the *Fixed Asset Guide*:

- ❑ *Working With Depreciation Formulas* for information about setting up a depreciation formula
- ❑ *To set up life year rules* for more information about setting up a 999 life year rule

## Processing Options for Depreciation Rule Revisions (P12851)

### Edits Tab

---

#### 1. Edit Disable Protection

Blank = Do not protect

1 = Protect The Edit Disable Control

Use this processing option to specify whether to protect the edit disable control. Valid values are:

Blank

Do not protect the edit disable control.

1

Protect the edit disable control.

---

---

## 2. Edit Numeric Rules

Blank = Do not change Depreciation Rules

1 = Copy or change Depreciation Rules

Use this processing option to specify whether to edit numeric rules. Valid values are:

Blank

Do not change existing Demo Depreciation Rules.

1

Copy or change existing Demo Depreciation Rules (00 - 99).

### Defaults Tab

#### 1. Skip To In Service Date

**Use this processing option to specify a default value for the Skip To In Service Date field. If you leave this processing option blank, the system uses the current date.**

#### 2. Skip To Effective Date

**Use this processing option to specify a default value for the Skip To Effective Date field. If you leave this processing option blank, the system uses the current date.**

---

## Working With Depreciation Formulas

You can define or revise depreciation formulas. You can then attach the formulas to the elements of the depreciation equation in a life year rule. Use the four basic mathematical functions (+ - \* /) and parentheses for nesting amounts or quantities to construct depreciation formulas in algebraic format.

The Fixed Assets system includes codes that you can use to represent the elements that the system uses to retrieve the related amounts or quantities from the Asset Account Balances

File table (F1202), Asset Master File table (F1201), Date Fiscal Patterns table (F0008), and so on. For example, you can define a depreciation method that is based on a formula that you create to subtract salvage value from cost.

You can access the Depreciation Formula Revisions form (W12853H) directly from the Set Up User Defined Depreciation menu (G1232), or you can access the form from the Depreciation Rule Revisions program (P12851). For example, if you are revising depreciation rules and you want to update a formula that is associated with the rule, you can access the Depreciation Formula Revisions form to review and revise formulas that you have previously defined without exiting the Depreciation Rule Revisions program.

---

**Note**

User defined depreciation formulas must have alpha identifiers to distinguish them from J.D. Edwards base depreciation formulas. You can modify only the alpha formulas, but you can use the numeric formulas as a starting point to create your own formulas with alpha identifiers.

---

## Digit Precision

The Digit Precision option divides the current number by the scale range chosen. Scale ranges are determined by the ratio of the size of the number to digit precision. For example:

- <0 to 1
- >1 to 10
- >10 to 100
- >100 to 1000

To calculate digit precision, start at the left-most number and determine how precise you want the number to be. Typically, you need to use 9-digit precision.

The following form shows the digit precision options:

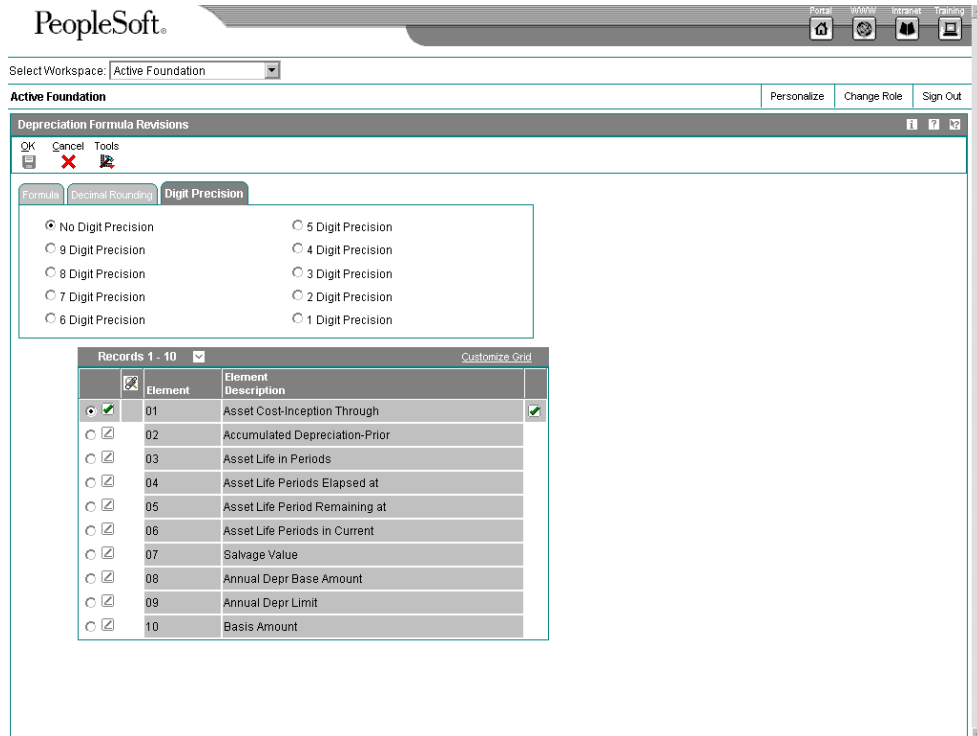

The following chart demonstrates how digit precision is calculated:

**Without 1-Digit Precision    With 1-Digit Precision**

100.50	100.00
858,585.8585	900,000.00
1.00	1.00

**Decimal Rounding**

You can adjust the formula results to the next decimal or whole number, depending on the size of the number. For example:

- A decimal value of 5 = 0.00001
- A decimal value of 4 = 0.0001
- A decimal value of 3 = 0.001
- A decimal value of 2 = 0.01
- A decimal value of 1 = 0.1
- A decimal value of 6 = 1
- A decimal value of 7 = 10

- A decimal value of 8 = 100
- A decimal value of 9 = 1000

The following form shows the decimal rounding options:

PeopleSoft

Select Workspace: Active Foundation

Active Foundation Personalize Change Role Sign Out

Depreciation Formula Revisions

OK Cancel Tools

Formula Decimal Rounding Digit Precision

No Decimal Rounding
  Round to 0.1  
 Round to 1000
  Round to 0.01  
 Round to 100
  Round to 0.001  
 Round to 10
  Round to 0.0001  
 Round to 1
  Round to 0.00001

Records 1 - 10 Customize Grid

Element	Element Description
<input checked="" type="checkbox"/> 01	Asset Cost-Inception Through
<input type="checkbox"/> 02	Accumulated Depreciation-Prior
<input type="checkbox"/> 03	Asset Life In Periods
<input type="checkbox"/> 04	Asset Life Periods Elapsed at
<input type="checkbox"/> 05	Asset Life Period Remaining at
<input type="checkbox"/> 06	Asset Life Periods In Current
<input type="checkbox"/> 07	Salvage Value
<input type="checkbox"/> 08	Annual Depr Base Amount
<input type="checkbox"/> 09	Annual Depr Limit
<input type="checkbox"/> 10	Basis Amount

### ► To set up depreciation formulas

From the Set Up User Defined Depreciation menu (G1232), choose Depreciation Formula Revisions.

1. On Work With Depreciation Formulas, click Add to set up a formula.
2. On Depreciation Formula Revisions, click the Formula tab and complete the following fields to revise or define the formula:
  - Formula ID
  - Formula Description
  - Formula
  - Multiplier / Constant

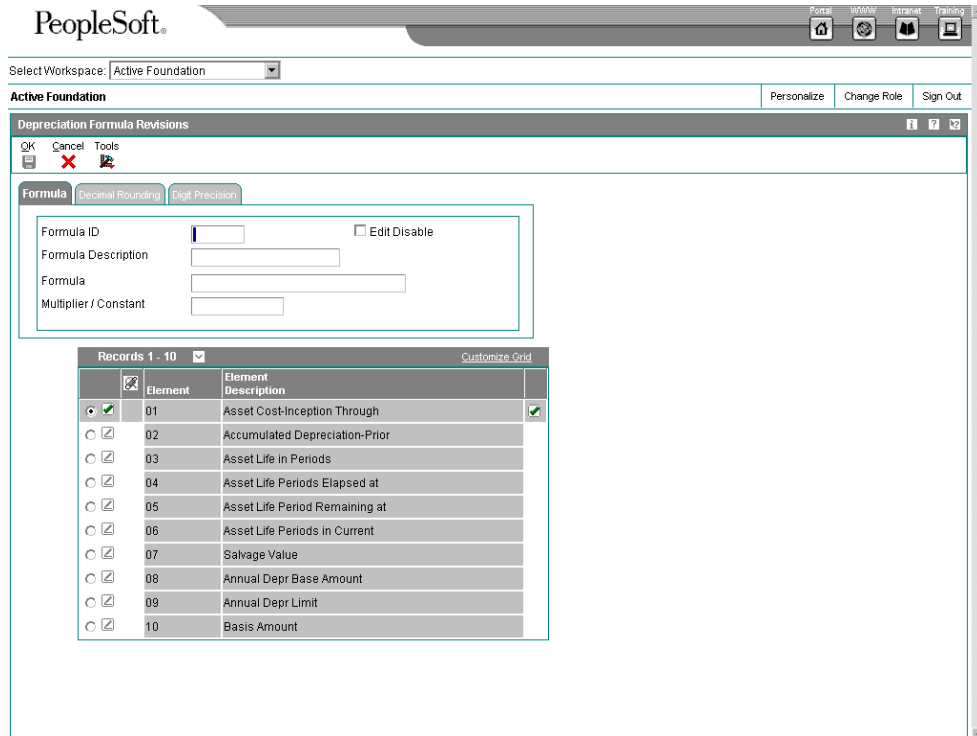

3. On the Decimal Rounding tab, choose a rounding option.
4. On the Digit Precision tab, choose a precision option.
5. To prevent changes to the formula, on the Formula tab, click the following field:
  - Edit Disable
 You can use a processing option to disable this option for additional security.
6. Click OK.

## Processing Options for Depreciation Formulas (R12853)

### Edits

1. Enter a '1' to protect the Edit Disable control.

### Edit Disable Protection

2. Enter a '1' to add, copy or change existing JDEdwards Demo Depreciation Formulas (000 - 999).

### Edit Numeric Formulas

## Setting Up Depreciation Spread Patterns

When you run depreciation, the system calculates an annual depreciation amount. Then the system calculates depreciation for a particular period, based on a percentage. You set up period pattern spread rules to specify how you want to recognize the annual depreciation amount within a year. If you do not set up a spread pattern for your depreciation rule, the

system spreads the annual depreciation amount equally among the normal number of periods that you set up for your organization.

You can enter spread amounts for periods 01 through 14. The total of the spread percentages that you enter must sum to 100 before the system allows the pattern to be added or an existing pattern changed. You can print the spread patterns.

The system stores depreciation spread patterns in the Depreciation Period Spread Rules table (F12854).

### See Also

- ❑ *Printing Depreciation Spread Patterns* in the *Fixed Assets Guide*

### ► To set up depreciation spread patterns

---

*From the Set Up User Defined Depreciation menu (G1232), choose Depreciation Spread Pattern.*

1. On Work with Depreciation Spread Patterns, click Add.
2. On Depreciation Spread Pattern Revisions, complete the following fields:
  - Spread Pattern Code
  - Spread Pattern Description
  - Period 01
3. Complete periods 02-14 as necessary.  
The total for periods 01-14 must equal 100.
4. To save your entries, click OK.
5. To return to Work with Depreciation Spread Patterns, click Cancel.

## Setting Up Date Pattern Override

The Fixed Assets system can track depreciation with a different date pattern or number of periods from what the company is set up with through the Ledger Type Master Setup program. You can use date pattern override if your company has a fiscal date pattern with an irregular number of periods, such as 13, and you need to report depreciation on a calendar date pattern for government requirements.

You cannot use date pattern override on ledger types AA, CA, and AZ.

### Posting to the Ledger

The ledger that you specify in data pattern overrides can derive cost from the AA ledger so that the system posts cost in the same manner as other ledger types.

You can also post cost from the ledger type that is specified in date pattern override. You can post the journal entry directly to the Fixed Assets system. To post the journal entry, use the Post G/L Entries to Assets program (R12800), and use version ZJDE0004. The G/L Post code does not need to be P (Posted) to post the amount to the Fixed Assets balances.

## Depreciation

User defined depreciation calculates and posts depreciation to the date pattern that is specified in the Ledger Type Master. The following programs and features work with date pattern override:

- Beginning Balances
- Asset Split
- Asset Transfer
- Asset Disposal
- Balance inquiries (including reports)

### Before You Begin

- Ensure that you use a valid ledger type set up in UDC 09/LT.

### ► To set up date pattern override

---

*From the Fixed Asset System Setup menu (G1241), choose Ledger Type Master Setup.*

1. On Work with Ledger Types, choose a ledger type, and then choose Fixed Asset Rules from the Row menu.
2. Enter 2 in the following field:
  - Transaction Creation
3. Perform one of the following actions, and click OK:  
To override the current date pattern, complete the following field:
  - Override Date Pattern  
To override the current number of periods, complete the following field:
  - Override Number of Periods

## Setting Up Short Years in Fixed Assets

When changing the fiscal year or setting up a new company within the fiscal year, you need to address setup issues for the short year minus the normal number of operating periods. For example, you must change the fiscal date pattern to reflect the short year and the new fiscal year format for subsequent years. Changing the date pattern might be a result of:

- A change in the company's policy to end the fiscal year at a different time
- A company merger or acquisition

You can also set up a short year for an existing company.

Date patterns are associated with a date pattern code that you set up on the Work with Companies form.

You can set up fiscal date patterns for the current fiscal year, the preceding fiscal year, and the next fiscal year.

## Depreciation Issues

Short-year issues create a short-tax-year issue that involves depreciation beginning in the first year under the new date pattern. Based on guidelines established by the tax code, you must change the assets with a remaining net book value (NBV) or the assets that exist in a short or prior year to a method of computation R. This change begins in the first year of the new date pattern following the short year and subsequent years. In addition, you cannot use depreciation methods that are based on the tax tables (for example, ACRS or MACRS depreciation methods 12 and 13) because the date pattern change prevents the system from tracking by using the tax tables. The system cannot align columns and rows for tax table values. Method of computation R cannot be used with all tax table methods. Therefore, you must change to methods 03, 04, or 05 for personal property as appropriate, or 01 for real property.

To change the method of computation, you can change Item Setup Default Coding and then run the Update of Depreciation Values program, which uses the defaults for the first full fiscal year under the new date pattern. After updating the necessary assets, change the default coding back to the desired value for new assets that are being added to the system in the first year of the new date patterns and into future years.

## Repost Option

If you choose to repost the General Ledger because of the change in fiscal years, you should run the repost in the Fixed Assets system to update the Asset Account Balances File table (F1202). A short year will not actually exist because you are updating the system's records to appear as though the system has always been on the new date pattern.

However, the Repost option does not work if depreciation entries have been summarized because the Account Ledger table (F0911) detail does not exist. To post back to Fixed Assets, the detail in the Account Ledger must exist.

If you cannot use the Repost option because of summarized depreciation, you can set up a parallel environment to run the Fixed Assets system. This action enables you to copy the fixed asset records from the production environment as though you are doing a Fixed Asset conversion. You can also use this method if you have a new date pattern that is in the same fiscal year as the old date pattern. If this scenario exists, you might want a J.D. Edwards consultant to help you with the process.

If you can repost, some depreciation consequences might occur. You might need to adjust your depreciation methods for assets using mid-year, mid-quarter, or mid-month conventions because assets can be misstated as a result of the repost change. In addition, you have to manipulate the depreciation setup to correctly reflect the depreciation balances and to change to a method of computation R.

---

## Caution

After this adjustment has been completed, depreciation should be run in preliminary mode, and the values should be checked for the first period of the new year. J.D. Edwards does not provide tax-consulting advice. A tax advisor should confirm all depreciation setup issues.

---

The short-year process described in this section is merely a guideline to help you achieve the desired results and is not meant to represent U.S. Tax Code Regulations.

## See Also

- *Setting Up Fiscal Date Patterns* in the *General Accounting Guide*

## Technical Considerations for New Date Patterns

- 4/4/5 Accounting** Set up the correct number of periods, usually 13, on the Company Names and Numbers/Asset Acquisition Years programs.
- You must also set up one year into the future.
- Reconciliation periods** Set up the reconciliation period as a separate period when in the fiscal date patterns. The 13th or 14th period is usually the reconciliation period, depending on whether you have regular periods or 4/4/5, respectively. The reconciliation period is not used for computing depreciation on an asset because it is usually a 1-day or 2-day period that is used for reconciliation adjustments only. When using a 4/4/5 date pattern, the system computes 13 periods of depreciation. The life months on the asset must be changed.
- For example, a 5-year (60-month) asset is now a 5-year (65-life-month) asset. To globally change your assets and their life months, change the item default coding; then run Update of Depreciation Values.
- Annual Close program (R098201)** After the date pattern is set up, verify that all postings have been completed for year end. Then change the date pattern code to the new date pattern code and run the Asset Account Balance Close program for the short year. This process moves balances forward.
- After you change to a new date pattern code, run the Annual Close, which populates the Balance Forward field in the new table F1202 with balances. The Asset Account Balance Close program recognizes that period 1 of the new year is now associated with the new date pattern and not with the old pattern. Therefore, by performing this process, you ensure that the system uses the new and correct period.

### ► To set up a short year in Fixed Assets

---

*From the Organization & Account Setup menu (G09411), choose Company Names & Numbers.*

1. On Work With Companies, choose the company for which you want to set up a short year, and then choose Date Pattern from the Form menu.
2. On Work With Fiscal Date Patterns, click Add.
3. On Set Up Fiscal Date Pattern, complete the following fields:
  - Fiscal Date Pattern
  - Date Fiscal Year Begins
4. Complete the following field for each period in the pattern:
  - End Date

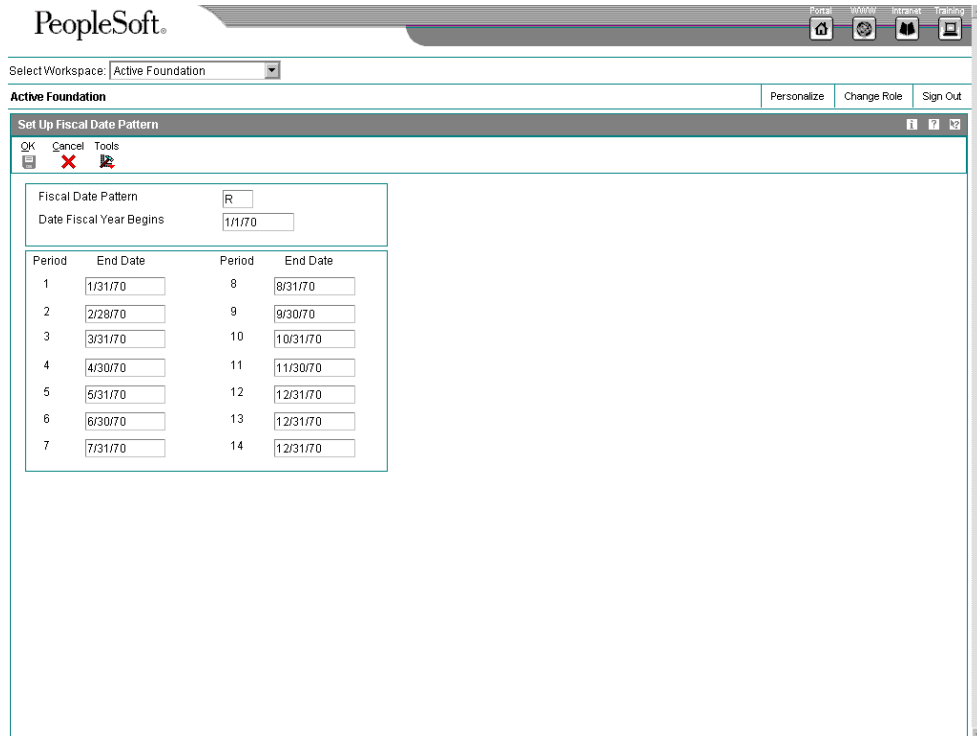

5. Set up the short year for the current date pattern, and click OK.  
For example, if the short year has only 9 periods, the last period of the short year repeats itself through period 14. The change is to move from a fiscal-year date pattern to a calendar-year date pattern.
6. Set up a new date pattern. This pattern must be set up from the year of the oldest asset in the system. It parallels the fiscal year coverage of the old date pattern. Therefore, if an asset dates back to 1970, you need to set up the new date pattern as of 1970.
7. Set up the new date pattern through the current year.
8. Click OK.

## **Setting Up Automatic Accounting Instructions for Fixed Assets**

Many J.D. Edwards programs need information about your account structure and specific account values to process business transactions properly. You define your account structure and specific account values using automatic accounting instructions (AAIs). The system stores the AAI values that you define for your company in the Automatic Accounting Instructions Master table (F0012). Whenever a program performs an accounting function, it accesses this table.

Some of the fixed assets AAIs can be set up as specific to your company, based on ranges of account numbers. The system includes predefined ranges. You must specify the business unit, object, and subsidiary accounts for the ranges as necessary.

The system uses single AAI values to find individual accounts and AAI ranges to find account ranges. When you set up AAI ranges, note the following:

- You can set up a maximum of 49 account ranges for a single company.
- The maximum number of account ranges that you can set up for all of your companies combined is 200.
- Do not skip AAI ranges. For example, do not set up FX range 01-02 and FX range 05-06, and leave FX range 03-04 blank for later use. If the system searches the AAIs for an account and finds a gap in a range, it stops searching.
- You must set up your AAI ranges consecutively, but you are not required to set up your object accounts in numerical order.

You must set up the following AAI ranges for the Fixed Assets system:

<b>FX</b>	Identifies accounts that post to fixed assets and equipment
<b>FA</b>	Identifies accounts for which the system can automatically create any necessary asset master records when you run a post to fixed assets
<b>FC</b>	Identifies asset cost accounts
<b>FD</b>	Identifies accumulated depreciation accounts
<b>AT</b>	Identifies accounts and descriptive text that define totals for summary reporting
<b>SDA</b>	Identifies the secondary accumulated depreciation account
<b>SDE1</b>	Identifies the secondary depreciation expense account
<b>SDE2</b>	Identifies the tertiary depreciation expense account
<b>DS1 - DS4</b>	Identifies depreciation statistics accounts
<b>DSA</b>	Identifies the asset balance for the specified ledger type
<b>FR1 - FR3</b>	Identifies revaluation offset accounts

---

**Caution**

Many programs in the Fixed Assets system use specific AAIs and AAI ranges. You should be thoroughly familiar with the use of an AAI or AAI range before you make any changes to the AAI values.

---

## FX Range

The system uses the FX range of accounts to determine which journal entries in the general ledger can be posted to fixed assets. You must specify all fixed asset accounts within the FX range of accounts. For example:

**FX01 - FX02** Beginning and ending range for asset cost accounts

**FX03 - FX04** Beginning and ending range for accumulated depreciation accounts

**FX05 - FX06** Beginning and ending range for depreciation expense accounts

When you set up the FX range of AAls, you must use the following guidelines:

- Define up to 49 FX ranges per company, starting with FX01-FX02 and ending with FX97-FX98 for each company.
- Use even numbers for ending ranges, such as FX02 and FX98.
- Set up company-specific FX ranges, or use the default company 00000 to set up the FX range for all of your companies at one time. If you set up a company-specific FX range for one company, you must set up the FX ranges (starting with FX01-FX02) for all companies.
- Specify an object account for each FX range.
- Include subsidiary accounts as needed. Subsidiary accounts are optional. If you want to include all subsidiaries in the FX range, include .99999999 in the ending range. For example, if you use subsidiary accounts, you might have a range of accounts that includes accounts 3000-4000.99999999. Then, if you add other subsidiaries to your chart of accounts at a later time, you do not have to change your AAls.

## FA Range

The system uses the FA range to identify which asset cost accounts allow the system to create necessary asset master records when you run a post to fixed assets. If you post a transaction with a cost account in the FA range for an asset, and you do not identify an asset with the transaction, the fixed asset post program automatically creates a master record for the unidentified asset.

The system creates master records by using the default information that is specified for accounts and depreciation. The description of the asset is derived from the following sources:

- Line 1 - Explanation 1 from the Account Ledger table (F0911)
- Line 2 - Explanation 2 from the Account Ledger table (F0911)
- Line 3 - Account Description from the Account Master table (F0901)

---

### Caution

If you set up the FA range and you enter a general ledger transaction without a value in the Asset Number field, the system automatically creates a new master record. If you have two transactions that are related to the same asset, the system creates two new assets.

---

When you set up the FA range of AAls, you must use the following guidelines:

- Define up to 49 FA ranges, starting with FA01-FA02 and ending with FA97-FA98 for each company.

- Define only asset cost accounts for this AAI range.
- Set up Depreciation Rules for the asset cost account. The system uses the default values on the Depreciation Information form to create asset master records.
- Set up company-specific FA ranges, or use the default company 00000 to set up the FA range for all of your companies at one time. If you set up a company-specific FA range for one company, you must set up the FA ranges (starting with FA01-FA02) for all companies.

---

**Caution**

J.D. Edwards recommends that you do not set up the FA ranges until you have finished converting to the Fixed Assets system.

---

**FC Range**

The system uses the FC range in the AAI to determine which account ranges are reserved for asset cost accounts.

When you set up the FC range of AAIs, you must use the following guidelines:

- Define up to 49 FC ranges.
  - Define account ranges for all asset cost accounts.
  - Set up FC account ranges for company 00000 only.
- The FC range is not company specific.

**FD Range**

The system uses the FD range in the AAI to determine which account ranges are reserved for accumulated depreciation accounts.

When you set up the FD range of AAIs, you must apply the following rules:

- Define up to 49 FD ranges.
  - Define account ranges for all accumulated depreciation accounts.
  - Set up FD account ranges for company 00000 only.
- The FD range is not company specific.

**AT AAIs**

The system uses the AT AAIs to determine which general ledger accounts are included in the summary lines on the Work with Cost Summary form. Use AT01-AT99 to specify these interim total accounts and wording that the system displays for each total on the Work with Cost Summary form. Use AT00 to define the account in which to store statistical information for hours. The AT range of AAIs is optional.

For example, you might specify that your balance sheet accounts are in account range 1000-3999, and your income and expense accounts are in account range 4000-8999. You could set up your AT AAIs as follows:

**AT01** Object account 4000. This interim total sums all object accounts below 4000, or accounts 0-3999. The system does not include object account 4000.

**AT02** Object account 9000. This interim total sums all object accounts between 4000-8999. The system does not include object account 9000.

The system automatically creates a grand total on the Work with Cost Summary form. You do not need to specify an interim total for the Cost Summary grand total.

Using the AT AAls is optional. If you set up the AT AAls, you must apply the following rules:

- Define interim totals between AT01-AT99.
- Use AT00 to define the account number that stores statistical information, such as hours or miles.

## **AAIs for User Defined Depreciation**

If you set up user defined depreciation for your assets, you must set up the following AAls:

### **SDA AAI**

The system uses the SDA AAI to determine which account to use as the secondary accumulated depreciation account.

### **SDE AAls**

The system uses the SDE AAls to determine which accounts to use as the secondary and tertiary depreciation expense accounts. J.D. Edwards recommends that you set up the SDE AAls as follows:

**SDE1** Use for the secondary depreciation expense account.

**SDE2** Use for the tertiary depreciation expense account.

### **DSxxx AAls**

The system uses the DSxxx AAls (where xxx is the depreciation category code that you specify on Fixed Asset Constants) to determine which accounts to use for depreciation statistical amounts. You must specify accounts for the following DSxxx AAls:

**DS1xxx** Use for year-to-date depreciation statistic.

**DS2xxx** Use for original-value depreciation statistic.

**DS3xxx** Use for base-value depreciation statistic.

**DS4xxx** Use for general-ledger depreciation statistic.

## DSA AAls

The system uses the DSA AAls to distinguish the Inception to Date asset balance for the ledger type that is specified in the AAl from either the Asset Account Balances File table (F1202) or the Account Balances table (F0902).

**DSA1** Use for Formula Element 57 for the AA ledger from table F1202.

**DSA2** Use for Formula Element 58 for the current ledger from table F1202.

**DSA3** Use for Formula Element 59 for the ledger specified in Description Line 4 from table F1202.

**DSA4** Use for Formula Element 60 for the AA ledger from table F0902.

**DSA5** Use for Formula Element 61 for the current ledger from table F0902.

**DSA6** Use for Formula Element 62 for the ledger specified in Description Line 4 from table F0902.

### See Also

- [Formula Elements](#) (specifically, elements 25–32 and 57–62) in the *Fixed Assets Guide* for more information about elements that are used in DSxxx and DSA AAls

## AAIs for Revaluation

If you compute revaluation for your assets, you must set up the FRxxx AAls.

### FRxxx AAls

The system uses the FRxxx AAls (where xxx is the revaluation code that you specify on Revaluation Index) to determine which accounts to use for revaluation offset amounts. You must specify accounts for the following FRxxx AAls:

**FR1xxx** Use for the cost revaluation offset account. This AAI is mandatory if you compute revaluation.

**FR2xxx** Use for the offset account for the current year portion of accumulated depreciation revaluation. This AAI is mandatory if you compute revaluation.

**FR3xxx** Use for the offset account of the prior year portion of accumulated depreciation revaluation. This AAI is optional if you compute revaluation.

The revaluation program calculates revaluation amount and adjustment on an account-by-account basis, based on the nature of the account. The revaluation program calculates the adjustment for all of the cost accounts, accounts that have a balance character code of 1, and adds the adjustment amount for the cost accounts. Create the entry to adjust the cost account with the offsetting entry to go to the account that is specified in the AAI for item FR1xxx. Accumulated depreciation accounts, accounts that have a balance character code of 2 and 3, are handled in a similar manner with the current year adjustment calculated separately from the beginning balance adjustment. Accumulated depreciation accounts are offset to two separate accounts as specified by the AAIs for FR2xxx; the current year portion; and for FR3xxx, the prior year portion.

If you direct the revaluation program to use the inception-to-date method, the adjustment for each AAI is calculated by year. Within each year, the adjustment is calculated for the year-to-date activity for the following three account types:

- Cost
- Accumulated depreciation
- Secondary accumulated depreciation

Amounts for prior year accumulated depreciation are added together to update AAI FR3xxx, the prior year account. The current year portion updates AAI FR2xxx, the current year offset account.

The secondary accumulated depreciation account uses the same business unit and object accounts as AAIs FR2xxx and FR3xxx, along with the SDA AAI subsidiary value.

AAIs FR1xxx and FR2xxx are required. If FR3xxx is not set up, the system uses FR2xxx. The xxx corresponds to the Revaluation Code user defined code (12/RI) values. A different set of offset accounts can be defined for each index. You can set up FR1, FR2, and FR3 as defaults. For AAIs FR1, FR2, and FR3, the Object field is a required field. If the Business Unit field is empty, the offset uses the Responsible Business Unit from the Asset Master table (F1201). The offset accounts are updated with Balance Character Codes of A, B, and C.

#### **See Also**

See the following topics in the *General Accounting Guide*:

- ❑ [Understanding AAIs for General Accounting](#) for conceptual information about automatic accounting instructions
- ❑ [Working with AAIs](#) for information about specific AAI tasks

## **Setting Up Next Numbers for Fixed Assets**

---

The Next Number program controls the automatic numbering in many J.D. Edwards systems. When you set up equipment next numbers, you enable the system to automatically assign

unique numbers for certain items. For example, when you create an equipment master for a new piece of equipment, the system assigns a unique equipment number to the equipment. The Fixed Assets system automatically assigns numbers to the following items:

<b>Asset number</b>	Use to identify the assets in your system by a number. The system generates an equipment (asset) number to uniquely identify each piece of equipment. Depending on how you set up equipment constants, you can use the equipment number as the primary number by which equipment is identified on forms and reports throughout Equipment Plant Management.
<b>Fixed asset documents</b>	Use to identify documents that the system creates when you run various Fixed Assets programs, including: <ul style="list-style-type: none"><li>• Compute Depreciation</li><li>• Single/Mass Asset Transfer</li><li>• Single/Mass Asset Disposal</li><li>• Enter Beginning Balances</li><li>• Asset Splits</li></ul>
<b>Location information and associated text</b>	Use to identify individual lines of location information and the associated text. The system assigns a text number to every location tracking record, whether you enter text for the record or not. Various programs in the system use the text key number internally.
<b>Location tracking information</b>	Use to group location tracking records. The transfer number can include multiple location information lines for multiple pieces of equipment. For example, when you enter location tracking information for several pieces of equipment on one form, the system generates a transfer number to group lines of information together as one transfer order.
<b>Equipment number</b>	The system generates an equipment (asset) number to uniquely identify each piece of equipment. Depending on how you set up equipment constants, you can use the equipment number as the primary number by which equipment is identified on forms and reports throughout Equipment/Plant Management.

---

**Caution**

You must specify the first next number for the Asset ID Number. The number must have a value of 1 or greater.

---

If you convert to the Fixed Assets system, you must specify an Asset ID Number that is greater than your highest asset identification number. Other next number specifications are optional.

J.D. Edwards recommends that you assign next numbers for the Fixed Assets system by company or by company and fiscal year for selected original documents.

The system stores these next numbers in the Fixed Assets system (system 12). The system generates next numbers from the Next Numbers - Automatic table (F0002).

---

**Caution**

J.D. Edwards strongly recommends that you do not use blank as a next number value. In addition, to ensure data integrity and prevent the system from assigning duplicate next numbers, you must never change a next number to a lesser value.

---

**See Also**

- ❑ *Setting Up System Next Numbers* in the *General Accounting Guide* for more information about specific tasks for Next Numbers

---

## Setting Up Asset Acquisition Years

---

The system uses date patterns and asset acquisition years to compute depreciation. Date patterns define the beginning date and all period-ending dates for a designated fiscal year. When you run the depreciation program, the system generates depreciation journal entries only for assets that have a date pattern that is set up for their year of acquisition and every year thereafter.

You must define asset acquisition years for every company. You must also define the date patterns for every asset acquisition year and each year thereafter for any asset that you are still depreciating. For example, if you have assets in the system that you acquired in 1945, you must set up 01/01/45 as an asset acquisition year and the date patterns for all the years from 1945 throughout the current fiscal year that is defined in the system.

If you use 4-4-5 or daily accounting to compute depreciation, you must define date patterns at least one year into the future for the expected life of your longest-lived asset.

**See Also**

- ❑ *Setting Up Fiscal Date Patterns* in the *General Accounting Guide* for more information about date patterns

---

**► To set up asset acquisition years**

---

*From the Fixed Assets System Setup menu (G1241), choose Asset Acquisition Years.*

1. On Work With Companies, choose Date Pattern from the Form menu.
2. On Work With Fiscal Date Patterns, click Add to access Set Up Fiscal Date Pattern.
3. On Set Up Fiscal Date Pattern, complete the following fields:
  - Fiscal Date Pattern
  - Date Fiscal Year Begins
4. Complete the End Date field for each period in the pattern, and click OK.

## Setting Up Depreciation Default Values

---

You can control the accounts and depreciation values that the system inserts into asset master and balance records when you add a new asset to the system. You simplify the entry process of new asset master records when you set up the following default values:

- Accounting class
- Equipment class
- Depreciation accounts
- Revenue accounts
- Depreciation information

---

### Caution

You must set up depreciation default values for every asset cost account in every company. Ensure that you set up depreciation default values for any new cost accounts or companies that you add to your system at a later time. If you make any changes to depreciation default values, you should verify that the defaults are correct before you enter new asset master records.

---

Any modifications that you make to the depreciation default values for an asset cost account or company affect only the new assets that you add to the system after making the changes. The modifications do not affect existing assets.

The company number that you associate with the asset cost and accumulated depreciation accounts must be the same as the company number that you assign to the asset.

J.D. Edwards recommends that you establish a one-to-one relationship between the asset cost account and the Major Accounting Code. If you establish this one-to-one relationship, you do not need to override the default values when you set up equipment masters.

---

### ► To set up depreciation default values

---

*From the Fixed Asset System Setup menu (G1241), choose Depreciation Default Coding.*

1. On Work With Depreciation Defaults, click Add.
2. On Depreciation Default Coding, complete the following fields:
  - Company
  - Asset Cost Obj/Subsidiary
  - Accumulated Depreciation
  - Depreciation Expense
3. Complete the following fields in the detail area:
  - LT

- Depr Meth
- Life Mos
- Depr Info
- Meth Comp

PeopleSoft

Select Workspace: Active Foundation

Active Foundation Personalize Change Role Sign Out

Depreciation Default Coding

OK Delete Cancel Row Form Tools

Company Number 00001 Financia/Distribution Company

Asset Cost Obj/Subsidiary 2060 Furniture & Office Equipment

Defaults To

Major Accounting Class 00 Furniture & Office Equipment

Major Equipment Class

Accumulated Depreciation 1,2160 Accum Depr-Furn. & Equip.

Depreciation Expense 9,8320 Depr-Office Furn/Equipment

Revenue Credit

LT	Ledger Type Description	Depr Meth	Depreciation Method Description	Life Mos	Depr Info	Meth Comp	Meth %	Meth 9 Sch No
<input checked="" type="checkbox"/>	AA General Ledger	01	Straight Line Depreciation	84		I		
<input type="checkbox"/>	D2 State - 150% Decline Bal	04	150% Declining Bal w/Cross Ovr	84		I		
<input type="checkbox"/>	D3 Earn. & Profit-MACRS	12	MACRS Standard Depreciation	120 Y		C		
<input type="checkbox"/>	D4 Alter. Minimum-200%	05	200% Declining Bal w/Cross Ovr	120 Y		I		
<input type="checkbox"/>	D5 MACRS Alternative	13	MACRS Alternative Depreciation	120 Y		R		

You must set up the AA ledger type as a minimum for all your assets. Use depreciation method 00 with the AA ledger for nondepreciating equipment. If you use depreciation method 00, you are not required to define a depreciation default value for the accumulated depreciation and depreciation expense accounts.

4. Complete the following optional fields:

- Major Accounting Class
- Major Equipment Class
- Revenue Credit

J.D. Edwards recommends that you establish a one-to-one relationship between the asset cost account and the Major Accounting Code (C1).

5. For fixed % depreciation methods, complete the following field:

- Meth %

6. Complete the following field only if the depreciation method is Units of Production (method 09):

- Meth 9 Sch No
7. Click OK.
  8. To create a report that shows the default values, choose Default List from the Report menu on Work With Depreciation Defaults.  
Alternatively, you can choose Depreciation Defaults Report from the Cost Information & Reports menu (G1213).

## Copying Depreciation Default Values

You can copy a set of depreciation default values from one existing company and asset cost account to another. This action can save substantial time by preventing the data entry of multiple companies and asset cost accounts that have similar depreciation default values.

When you copy depreciation default values, all of the information in the Default Depreciation Constants table (F12003) of the original company are copied into the new company.

### See Also

- *Setting Up Depreciation Default Values in the Fixed Assets Guide*

### ► To copy depreciation default values

---

*From the Fixed Asset System Setup menu (G1241), choose Depreciation Default Coding.*

1. On Work With Depreciation Defaults, locate and choose the record of the company and cost account that you need to copy, and click Copy.
2. On Depreciation Default Coding, complete the following fields:
  - Company
  - Asset Cost Obj/Subsidiary
  - Accumulated Depreciation
  - Depreciation Expense
  - Revenue Credit
3. Modify the following fields, if necessary, in the header area of the form:
  - Major Accounting Class
  - Major Equipment Class
4. Modify the following fields, if necessary, in the detail area of the form; and then click OK:
  - LT
  - Depr Meth
  - Life Mos

- Depr Info
- Meth Comp
- Meth %
- Meth 9 Sch No

## Mapping Category Codes

---

When you set up the responsible business units that you want to use throughout your system, you assign category codes to each unit. You can set up category codes for your business units that would also be helpful for tracking and reporting on assets. You can also map specific equipment category codes to specific work order category codes.

---

### Note

To use business unit category codes for tracking and reporting on assets, you can assign category code default values. You assign category code default values by associating, or mapping, the category codes that you set up for individual business units to the category codes that you use for fixed assets. The system uses the default category code values when you create master records for new assets.

---

The default values that you set up on Category Code Mapping appear on the Work with Assets and Work with Equipment Master forms only if the values are valid for the business unit and the asset. For example, if you assign the default value for category code 05 from the Revise Business Units form to category code 08 on the Work with Assets form, the values in both category code tables must match.

The system truncates any category codes that you assign from a business unit category code that is longer than three characters into a three-character category code field on the Work with Assets and Work with Equipment Master forms.

The system uses the responsible business unit that you enter on the Asset Master record to determine from which business unit to assign default category codes. If you change the responsible business unit for an asset, the system uses the default category codes that are based on the new business unit.

### ► To map category codes

---

*Use one of the following navigations:*

*From the Fixed Asset System Setup menu (G1241), choose Category Code Mapping.*

*From the Plant & Equipment Management Setup menu (G1341), choose Category Code Mapping.*

1. On Category Code Mapping, complete the following field to indicate how you want to map the category codes:
  - Mapping Type

2. Complete the following fields, and click OK:

- Map to Category Code
- Map from Category Code

Several category codes throughout the system exceed three characters in length. For codes that you map onto the equipment master or work order master, the system truncates any codes longer than three characters into a 3-character category code field.

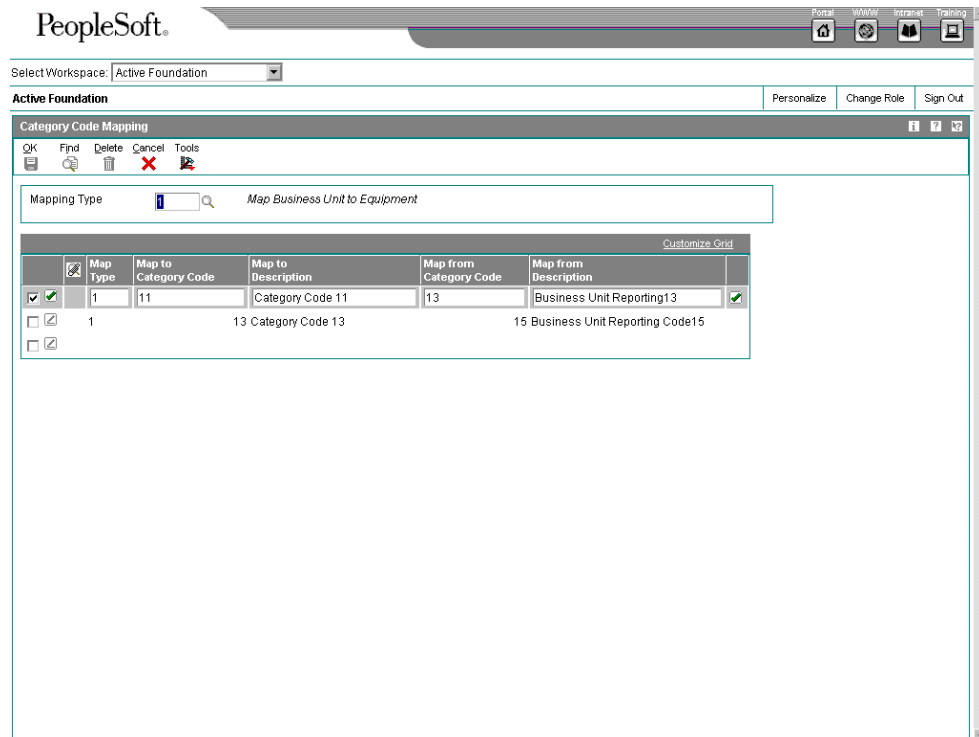

## Setting Up Ledger Type Rules for Fixed Assets

You use ledger type rules to control processing for a specific ledger type. You can simplify processing at the ledger level by specifying ledger dependencies and transaction creation parameters. For example, you can specify an alternate currency ledger and the tax ledgers that are associated with it.

You can also revise rules to comply with regulatory requirements. For example, some countries require that costs be rounded or truncated to one decimal place. You can specify that the ledger for that currency be rounded or truncated as necessary.

By revising ledger type rules, you override the normal default values. For example, you might have a default date pattern that you use for depreciation calculations for your company; but you might have to override this pattern for one tax ledger because of regulatory requirements.

You can control several aspects of processing for a ledger type, including:

- Relationships to other ledgers
- Currency of the ledger
- Override date and period patterns
- Transaction processing

You can specify that the cost from a ledger should be derived from another ledger type. If you specify that the cost in one ledger (for example, D1) should be derived from another ledger (for example, AA), then you must post cost to the other ledger, AA, first. The ledger type from which you derive the cost must be less than the ledger type to which you post the cost. For example, ledger type AA is alphanumerically less than ledger type D1. Therefore, costs in D1 could be derived from AA. Costs for the AA ledger cannot be derived from another ledger.

---

**Note**

Fixed asset ledger types that were formerly set up through user defined code table 12/LT are set up by using the Fixed Asset Ledger Type Rules form. Fixed Asset ledger types are stored in the Ledger Type Master File table (F0025).

Transaction creation, formerly controlled by special handling codes in the user defined code table 12/LT, is controlled by the Transaction Creation field on the Fixed Asset Ledger Type Rules form.

---

---

**► To set up ledger type rules for Fixed Assets**

---

*From the Fixed Asset System Setup menu (G1241), choose Ledger Type Master Setup.*

1. On Work with Ledger Types, choose the ledger, and then choose Fixed Asset Rules from the Row menu.
2. On Fixed Asset Ledger Type Rules, review the following fields and make any necessary changes:
  - Post Cost from this Ledger
  - Transaction Creation

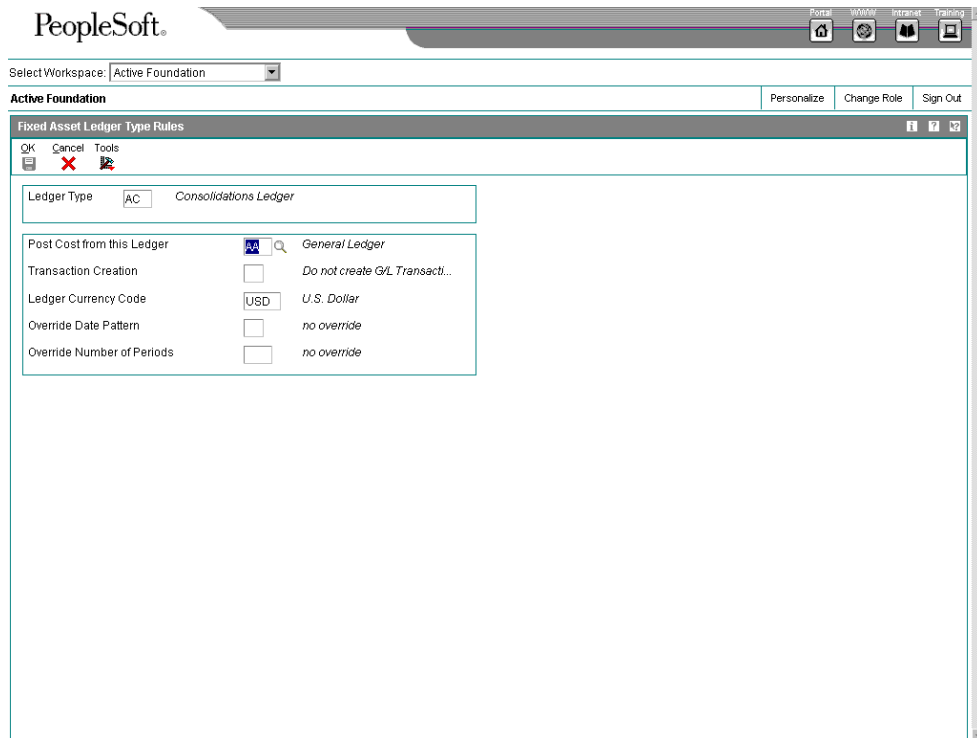

Note the following restrictions:

- For the Post Cost from this Ledger field, only the same ledger or the AA ledger is currently valid. If the Post Cost from this Ledger field is blank, the ledger type AA is used.
- For the Transaction Creation field, the value 3 is reserved for future use.
- The Ledger Currency Code field is for display only. Changes must be made by choosing Revise Ledger Type from the Row menu on Fixed Asset Ledger Type Rules.

## Setting Up Disposal Account Rules

Disposal account rules specify the accounts that the disposal program uses for disposal journal entries. You set up the disposal account rules to direct the disposal journal entries to the appropriate offsetting account.

The disposal account rules use the balance character code to determine the nature of the journal entry. You can create separate rules for net book value disposal accounts, disposal cash clearing accounts, and disposal proceeds accounts. In addition, you can specify override accounts for the cost and accumulated depreciation accounts. This action allows you to retain the amounts in the Asset Account Balances File table (F1202) and place these amounts in a reserve account.

If you specify account overrides for cost, the accounts must be within the FCXX AAI range. If you specify account overrides for primary accumulated depreciation or secondary accumulated depreciation, the accounts must be within the FDXX AAI range.

You can set up company-specific rules or use the default company 00000 to set up the rules for all companies at one time. You can also specify different accounts by disposal method and ledger type.

If you do not specify a business unit as part of the account number, the system retrieves the responsible business unit for the asset from the Asset Master File table (F1201).

---

**Caution**

You must set up at least a set of rules for company 00000 and ledger type AA. J.D. Edwards also recommends that you set up separate accounts for net book value, cash clearing, and proceeds.

---

---

**► To set up disposal account rules**

---

*From the Fixed Assets System Setup menu (G1241), choose Disposal Account Rules.*

1. On Disposal Account Rules, complete the following fields, and click Find:

- Skip to Company
- Disposal Method
- Ledger Type

If you want to dispose of ledgers other than the AA ledger, you must set up rules for those ledgers. Unless you set up these rules, the system disposes of only the AA ledger.

2. To set up more specific rules, complete the following fields:

- LT
- Balance Character
- Object

3. Complete the following optional fields, and click OK:

- Company
- Disposal Method
- Business Unit
- Subsidiary

PeopleSoft®

Select Workspace: Active Foundation

Active Foundation Personalize Change Role Sign Out

Disposal Account Rules

OK Find Delete Cancel Tools

Skip to Company

Disposal Method

Ledger Type

Records 1 - 10 Customize Grid

<input type="checkbox"/>	<input checked="" type="checkbox"/>	Company	Disposal Method	LT	Balance Character	Balance Character Description	Business Unit	Object	Subsidiary
<input checked="" type="checkbox"/>	<input checked="" type="checkbox"/>	00000		AA	7	Net Book Value - Disposal	YARD	9112	
<input type="checkbox"/>	<input checked="" type="checkbox"/>	00000		AA	8	Disposal - Clearing	YARD	9113	
<input type="checkbox"/>	<input checked="" type="checkbox"/>	00000		AA	9	Disposal - Proceeds	YARD	9111	
<input type="checkbox"/>	<input checked="" type="checkbox"/>	00000		D1	7	Net Book Value - Disposal	YARD	9112	
<input type="checkbox"/>	<input checked="" type="checkbox"/>	00000		D1	8	Disposal - Clearing	YARD	9113	
<input type="checkbox"/>	<input checked="" type="checkbox"/>	00000		D1	9	Disposal - Proceeds	YARD	9111	
<input type="checkbox"/>	<input checked="" type="checkbox"/>	00000		D3	7	Net Book Value - Disposal	YARD	9112	
<input type="checkbox"/>	<input checked="" type="checkbox"/>	00000		D3	8	Disposal - Clearing	YARD	9113	
<input type="checkbox"/>	<input checked="" type="checkbox"/>	00000		D3	9	Disposal - Proceeds	YARD	9111	
<input type="checkbox"/>	<input checked="" type="checkbox"/>	00000		D4	7	Net Book Value - Disposal	YARD	9112	

## Setting Up Beginning Balances

Use the Beginning Balance Adjustments program (P12130) to set up beginning balances for individual assets, groups of assets that share the same cost, accumulated depreciation, or secondary accumulated depreciation accounts. You can use Beginning Balance Adjustments whether you are starting out with the J.D. Edwards Fixed Assets system or converting to it. Beginning balances for your assets are stored in the Asset Account Balances File table (F1202).

The following illustration shows the relationship of the amounts that you enter through beginning balances with amounts in the general ledger:

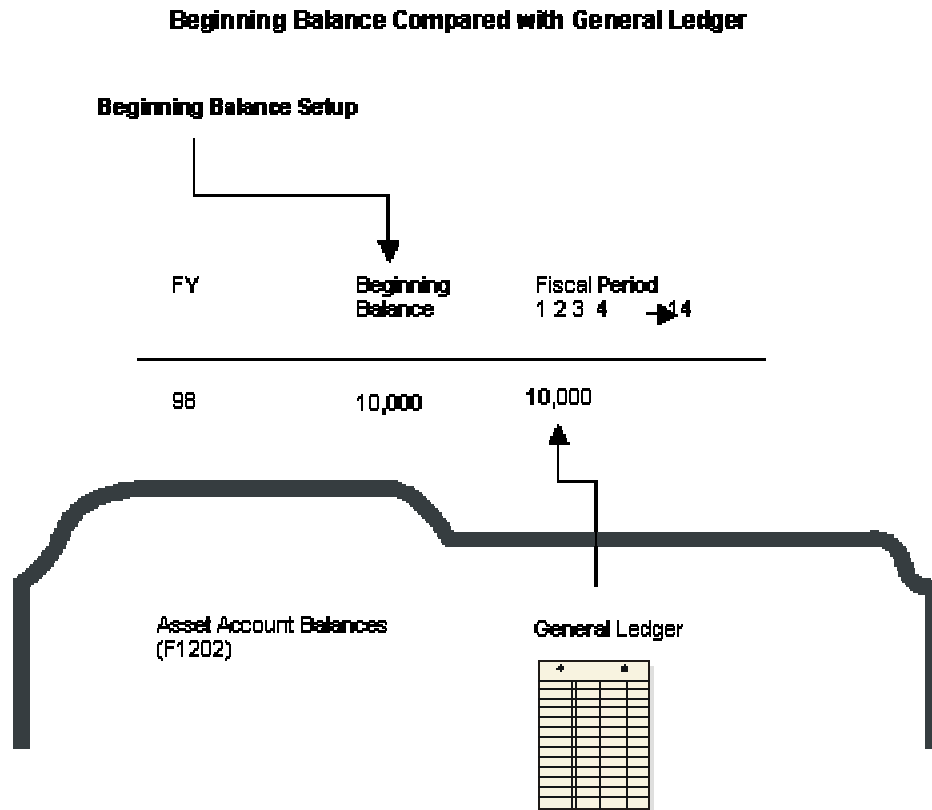

Use Beginning Balance Adjustments to complete the following tasks:

- Enter beginning balances at system setup or during a conversion after general ledger balances have already been converted.
- Change the cost basis of a ledger, other than the Actual Amounts (AA) ledger.

When you create beginning balances, you must first enter the master information for each asset in the system. Next, you must enter the cost, accumulated depreciation, and secondary accumulated depreciation balances for each asset, as of the last day of the previous fiscal year, into Beginning Balances. When you enter these amounts, the Beginning Balance Adjustments program automatically posts the entries to fixed assets. Finally, run the depreciation program to calculate depreciation for each month to update asset depreciation amounts to the current date.

If you set up an alternative date pattern, the Beginning Balance Adjustments program uses the date pattern that you specify.

After you finish setting up beginning balances, you can run the Fixed Assets to G/L Integrity test to verify that the cost, accumulated depreciation, or secondary accumulated depreciation amounts in the Asset Account Balances File table match the amounts in the Account Balances table (F0902).

You can set up beginning balances for an asset with multiple subledgers. To do so, you must enter a unique subledger in the Subledger/Type field when you first locate the asset. Enter

the beginning balances for that subledger, and then repeat the process for any remaining subledgers.

To copy cost, accumulated depreciation, and secondary accumulated depreciation amounts from the AA ledger type to all other ledgers that are associated with the asset for the accounts which are listed in the header, click Copy AA amounts to all ledger types.

When you want to change amounts for the cost accumulated depreciation, or secondary accumulated depreciation accounts, the following rules apply:

- If you entered balances using the Beginning Balance Adjustments program, the system displays the beginning balance amount for an asset when you locate the asset on the Beginning Balance Adjustments program. You can change the cost, accumulated depreciation, or secondary accumulated depreciation amounts by entering the full new amount.
- If you entered the beginning balances as journal entries and then posted the entries to fixed assets, the system does not display the beginning balance amount on the Beginning Balance Adjustments program. You must enter the change in the amounts (the difference), instead of entering the new amount.

The amounts that you enter on the Beginning Balance Adjustments program are updated in the Balance Forward field of the Asset Account Balances File table (F1202) for each asset.

You must enter the accumulated depreciation and secondary accumulated depreciation amounts for the asset as of the end of the prior fiscal year. The Compute Depreciation program calculates depreciation for each month as of the beginning of the fiscal year. For example, you might plan to use the Fixed Assets system in July.

You affect only the balances in table F1202 when you use the Beginning Balance Adjustments program. The program does not affect the balance in the general ledger unless you choose to create Account Ledger table (F0911) records in the processing option. The account ledger records created debit and credit the same account for cost, accumulated depreciation, and secondary accumulated depreciation; and are automatically posted.

Enter positive amounts to cost for debit entries, and to accumulated depreciation and secondary accumulated depreciation for credit entries. Inquire on the fiscal year for which of these entries is the balance forward.

#### **See Also**

- *Setting Up Date Pattern Override* in the *Fixed Assets Guide* for more information about alternative date patterns

#### **Before You Begin**

- Create master records for each asset in the system. See *Creating an Asset Master Record* in the *Fixed Asset Guide*.
- Verify that the amounts which you want to enter on the Beginning Balance Setup form are already posted to the general ledger.

#### **► To set up beginning balances**

---

*From the Fixed Asset System Setup menu (G1241), choose Beginning Balance Setup.*

1. On Work With Assets, click Find to view all assets.

To restrict the assets that appear, click the tabs in the header area of the Work With Assets form and complete the appropriate information.

2. Choose an asset.
3. From the Row menu, choose Asset Balance Info, and then Beginning Balance.
4. On Beginning Balance Adjustments, complete the following field to specify a fiscal year:
  - Fiscal Year

PeopleSoft

Select Workspace: Active Foundation

Active Foundation Personalize Change Role Sign Out

Beginning Balance Adjustments

OK Find Cancel Tools

Asset Number: 123 Fiscal Year: 2005

OR Cost Account: 50.2040 Batch Number:

and A/D Account: 50.2140 Explanation: Beginning Balance Adjustments

SubledgerType: Skip To Asset:

Copy AA amounts to all ledger types  Do not copy AA amounts

Asset Number	Asset Description	Cost Amount	A/D Amount	Secondary A/D Amount	LT
<input type="checkbox"/>	123	2005 Jeep Cherokee			AA
<input checked="" type="checkbox"/>	123	2005 Jeep Cherokee			D1
<input type="checkbox"/>	123	2005 Jeep Cherokee			D2
<input type="checkbox"/>	123	2005 Jeep Cherokee			D3
<input type="checkbox"/>	123	2005 Jeep Cherokee			D4
<input type="checkbox"/>	123	2005 Jeep Cherokee			D5

5. To specify a subledger, complete the following field:
  - Subledger/Type
6. To set up or revise beginning balance information, complete the following fields, and click OK:
  - Cost Amount
  - A/D Amount
  - Secondary A/D Amount

## Setting Up Revaluation Indexes

A revaluation index is a numerical value that you use to recalculate or restate the costs of your assets, most often in economies affected by hyperinflation or in situations where wide fluctuations in supply and demand for the assets occur. You can set up revaluation indexes to

restate cost in terms of either constant currency accounting or current cost. Typically, index values are obtained from either governments or outside agencies.

You can set up revaluation indexes to conform to whatever periodic recalculation is necessary. In truly hyperinflationary economies, some as high as triple digits, this process might be a daily procedure. The setup also accommodates weekly, monthly, quarterly, annual, or other periodic intervals as needed. You create tables of indexes, each identified by a revaluation code. You can create as many revaluation codes as you need in UDC 12/RI.

### ► **To set up revaluation indexes**

---

*From the Asset Revaluation menu (G1234), choose Revaluation Index.*

1. On Work With Revaluation Index, click Add.
2. On Revaluation Index, complete the following fields:
  - Revaluation Code
  - Effective Date
  - Rate FactorThe rate factor must have an effective date on or before the acquisition date.
3. Complete the following optional field, and click OK:
  - Skip to Date

## **Working with Units of Production Schedules**

---

Set up units of production schedules only if you use the Units of Production method of depreciation (Method 09). You can set up schedules by ledger for as many different units of measure as your company uses, such as tons or miles.

When you are ready to close your year, ensure that you run the Units of Production Close program (R12824). The Units of Production Close program rolls the current information into prior year fields and clears the current year fields for next year's revisions and current production amounts.

### **Setting Up a Units of Production Schedule**

The system performs two calculations based on the schedule information that you enter:

<b>Depreciable Unit Base</b>	$\text{Original Units} + \text{Prior Year Revisions} + \text{Current Year Revisions} - \text{Units Produced in the Prior Year} = \text{Depreciable Unit Base}$
<b>Current Units of Production</b>	$\text{Units Produced Year-to-Date} / \text{Depreciable Unit Base} = \text{Current Units of Production}$

For assets that use the Units of Production depreciation method (Method 09), you must set up units of production schedules before you create master records.

► **To set up a unit of production schedule**

From the Advanced Operations menu (G1231), choose Units of Production Schedule.

1. On Work with Units of Production Schedule, click Add.
2. On Production Schedule Revisions, complete the following fields, and click OK:
  - Schedule Number
  - Ledger Type
  - Description
  - Unit of Measure
  - Units - Original
  - Units - Prior Year Revisions
  - Units - Current Year Revisions
  - Prior Years Production
  - Y-T-D Production

The screenshot shows the PeopleSoft interface for the 'Production Schedule Revisions' form. The form is titled 'Production Schedule Revisions' and is located within the 'Active Foundation' workspace. The form contains several input fields for defining a production schedule unit. The fields are organized into three main sections:

Schedule Number	GRADER
Ledger Type	AA
Description	Motor Grader Hours

Unit of Measure	HR Hour
Units - Original	10,000.00
Units - Prior Year Revisions	
Units - Current Year Revisions	
Prior Years Production	4,500.00

Depreciable Unit Base	5,500.00
Y-T-D Production	5,500.00
Current Unit of Production Factor	1.00000000

The form also includes a header with 'PeopleSoft' logo, a 'Select Workspace' dropdown set to 'Active Foundation', and navigation buttons for 'Personalize', 'Change Role', and 'Sign Out'. The form title bar includes 'OK', 'Cancel', and 'Tools' buttons.

## Printing the Units of Production Report

*From the Advanced Operations menu (G1231), choose Units of Production.*

You can print the Units of Production Report to view all of the schedules that you have set up for the Units of Production depreciation method. You can use this report at the job site as a worksheet. For example, you can complete the production and revised unit reserves for your assets and then return the information to the main office.

You can run the Units of Production Report by one of the following:

- Schedule number
- Ledger type
- Unit of measure

Run the Units of Production Report to review the following information:

<b>Original units</b>	The original estimate of the total number of units in the reserve base.
<b>Prior year revisions</b>	The cumulative prior-year adjustments to the original estimated units.
<b>Current year revisions</b>	The current year adjustments to the original units.
<b>Units of production prior year</b>	The number of units that were produced in all prior years.
<b>Depreciable units</b>	An amount that is used to calculate the Current Unit of Production Factor. The system calculates this number by using the following formula:  $\text{Original Units} + \text{Prior Year Revisions} + \text{Current Year Revisions} - \text{Units of Production Prior Year} = \text{Depreciable Units}$
<b>Units of production year-to-date</b>	The number of units that were produced year-to-date is used to calculate the Current Unit of Production Factor.

## Setting Up Supplemental Data

---

You might need to store information about an asset that is not included in the standard master tables. J.D. Edwards refers to this additional information as supplemental data. You can use supplemental data to further define the assets in your system. After you set up supplemental data, you can use it to report and track asset details that are important to your company, but are not included on the asset master record. You can define as many types of supplemental data as you need.

You define and maintain supplemental data by asset class. For example, you might set up supplemental data for an asset class that includes motor graders. The data might include fuel capacities, horsepower, oil readings, and so on. The system stores the supplemental data types that you set up in the Asset Mgmt Supplemental Database Types table (F12090).

You can use that information to set up supplemental data for the Fixed Assets system, but choose Supplemental Data Setup from the Fixed Asset System Setup menu (G1241) instead of choosing Supplemental Data Setup from the CIF Supplemental Data menu.

**See Also**

- *Address Book Supplemental Data* in the *Address Book Guide* for detailed information about address book supplemental data

---

## Fixed Asset Global Updates

You can make system-wide changes to fixed assets by using global update processes.

---

### Updating Asset Information

You can update certain asset information globally to reduce the amount of processing time that is needed to maintain current information in the Fixed Assets system and throughout your organization.

### Updating Depreciation Values

*From the Advanced Operations menu (G1231), choose Update of Depreciation Values.*

If you change depreciation values for a cost account, the system automatically updates all depreciation records in the Asset Account Balances File table (F1202) for the asset, ledger type, and current fiscal year. If you want to update the depreciation records for prior fiscal years, you must run the Update of Depreciation Values program. The program updates every selected item that uses the asset cost account with the new depreciation information.

You should run Update of Depreciation Values (R12822) only under the following circumstances:

- You change the depreciation values for a specific asset cost account or group of assets in the depreciation rules.
- Asset Account Balances records for an asset, ledger type, and fiscal year are not the same.
- Depreciation amounts in the system are corrupted.

---

#### Caution

Ensure that your data selections specify only the depreciation records that you want to update.

---

Use the Depreciation Information Update Method processing options to control which depreciation information the program updates.

#### Before You Begin

- Back up the Asset Account Balances File table (F1202).
- Verify that no one accesses the fixed assets files while you run the update.

### Processing Options for Update of Depreciation Values (R12822)

---

Default

1. Ledger Type

2. Fiscal Year (4 digits)

Update

---

---

1. Depreciation Values Update Method

Blank = Current fiscal year's cost account depreciation values.  
1 = Default values.

2. Depreciation Start Date Update Method

Blank = Start date will not be updated.  
1 = Update Depreciation Start Date to the date acquired.  
2 = Update the start date to the date entered in option 3.

3. Depreciation Start Date

---

---

1. Ledger Type

Use this processing option to specify the ledger type you want to update. Leave this field blank to update all ledgers.

---

---

## 2. Fiscal Year (4 digits)

Use this processing option to specify the fiscal year that you want to update. Leave this field blank to update all fiscal years.

### Update Tab

#### 1. Depreciation Values Update Method

**Blank = Current fiscal year's cost account depreciation values.**

**1 = Default values.**

Use this processing option to specify the method of update for depreciation information values. Valid values are:

**Blank**

Update the current fiscal year's cost account depreciation values.

**1**

Update the default values.

#### 2. Depreciation Start Date Update Method

**Blank = Start date will not be updated.**

**1 = Update Depreciation Start Date to the date acquired.**

**2 = Update the start date to the date entered in option 3.**

Use this processing option to specify the method of update for the depreciation start date. This processing option is only applicable if processing option 1 is set to 1. Valid values are:

**Blank**

Do not update the start date.

**1**

Update the depreciation start date to the date acquired.

**2**

---

---

**Update the start date to the date entered in processing option 3.**

### **3. Depreciation Start Date**

**Use this processing option to enter the date with which to globally update the depreciation start date in all selected records. This processing option is only applicable if processing option 2 is set to 2. If you leave this processing option blank, and processing option 2 is set to 2, no change or update to the start date will occur.**

---

## **Updating the Location Code of an Asset**

*From the Advanced Operations menu (G1231), choose Update Location Code.*

You can update the location of an asset from a planned location to a current location. Run Update Location Code to change planned asset locations to current locations when the system reaches the "as of" date that you specify in the processing options.

For example, if you plan to distribute an asset to a different plant as of a certain date and you enter the information into the system as a planned location, you can run this program to automatically change the location information from a planned location status to a current location status. The system updates all planned locations that match the selection criteria that you specify.

When you run Update Location Code, the system updates the following tables:

- Location Tracking Table (F1204)
- Asset Master File (F1201)

---

### **Caution**

Ensure that the data selections which you make specify only the assets for which you want to update location information.

---

## **Processing Options for Update Location Code (R12810)**

---

Process

1. As Of Date

Blank = System Date

---

---

## 1. As Of Date

Blank = System Date

Use this processing option to specify the "as of" date that the system uses when updating planned locations in the Location Tracking Table (F1204). If you leave this processing option blank, the system uses the system date.

---

## Updating the Balance Character Code

*From the Set Up User Defined Depreciation menu (G1232), choose Asset Account Type Update.*

Run the Balance Character Code Update program to identify Asset Account Balances File table (F1202) records that are key to the user defined depreciation process among the other records that might exist for an asset, such as maintenance and other expense accounts. The system uses a balance character code to identify the asset balance records for the following accounts:

- Cost
- Accumulated depreciation
- Secondary accumulated depreciation
- Depreciation expense
- Depreciation expense - Secondary
- Depreciation expense - Tertiary
- Net book value
- Disposal clearing
- Disposal proceeds

The Balance Character Code Update program (R12920) identifies these records in table F1202 with a code. When you run Compute Depreciation, the program uses the balance character code to recognize records in table F1202 as belonging to cost, accumulated depreciation, and so on.

Run Balance Character Code Update when you:

- Set up your Fixed Assets system with user defined depreciation methods for the first time.
- Make a change in the AAIs that affects the cost and accumulated depreciation ranges (FC and FD).

---

**Note**

You do not need to run Balance Character Code Update for asset balances records that are created internally. The system automatically updates the Balance Character Code field when you create asset balance records through programs such as Beginning Balance Adjustments, Post G/L Entries to Fixed Assets, and Asset Split.

---

When you choose Balance Character Code Update, the system submits the job directly to batch.

## Updating the Message Log

*Use one of the following navigations:*

*From the Advanced Operations menu (G1231), choose Update Message Log.*

*From the Advanced Operations menu (G1331), choose Update Message Log.*

Run the Update Message Log program to keep tickler dates and units current in the message log. For example, if you set up a reminder message to appear at 3,000 miles for a piece of equipment, you use this update to ensure that the message does appear when the equipment reaches the 3,000-mile mark.

The Update Message Log program compares tickler dates that have the system date and tickler units (for example, miles or hours) to the current unit reading that you record for the corresponding piece of equipment. The program updates all of the units that have reached or exceeded the tickler amounts that you post in the AT00 automatic accounting instruction (AAI). When the update is complete, the corresponding equipment number on Equipment Search is highlighted to indicate that that message exists for the equipment.

---

**Note**

You should run this program only if you use the Tickler Miles/Hours field in the message log.

---

When you select Update Message Log, the system submits the job directly to batch. You should update the message log frequently to keep message tickler units current. J.D. Edwards recommends running Update Message Log as part of your unattended operations.

---

## Updating Global Depreciation Rules

---

*From the Setup User Defined Depreciation menu (G1232), choose Global Depreciation Rules Update.*

You can use the Global Depreciation Rules Update program to restore original demonstration data without deleting any combinations that you might have added, as well as add demonstration data for new numeric methods that J.D. Edwards creates over time.

The demonstration data tables for User Defined Depreciation are:

- Demo Depreciation Rules (F12851D)
- Demo Annual Depreciation Rules (F12852D)
- Demo Depreciation Formulas (F12853D)

J.D. Edwards Customer Support can update the demonstration data tables with data from your system's depreciation tables if demonstration data has been changed and needs to be restored. The standard user defined depreciation tables that are included with the system are:

- Depreciation Rules (F12851)
- Annual Depreciation Rules (F12852)
- Depreciation Formulas (F12853)

Over time, J.D. Edwards might add demonstration data to tables F12851D, F12852D, and F12853D. Numeric methods will always be used for J.D. Edwards demonstration data. You can use a processing option to specify whether to copy the new demonstration data from tables F12851D, F12852D, and F12853D to your system's tables F12851, F12852, and F12853.

### **WorldSoftware Conversion to User Defined Depreciation**

The Global Depreciation Rules Update program can facilitate the transition from the Compute Depreciation program (P12850) in WorldSoftware to the User Defined Depreciation program (R12855) in J.D. Edwards ERP software. The Global Depreciation Rules Update program searches the existing Asset Account Balances File table (F1202) and automatically creates the user defined depreciation tables (F12851, F12852, and F12853) when possible.

---

#### **Note**

UDD rules are created if no demonstration data rules exists that match the methods on your assets.

---

This program also automates user defined depreciation setup of existing assets that do not match the current user defined depreciation demonstration data. Prior to this program, companies had to set up a new user defined depreciation method, including life year rules, for every asset balance in which the depreciation information (F1202) did not match a user defined depreciation demonstration data rule (F12851).

### **Technical Considerations**

**Table updates** The Default Accounting Constants table (F12002) and the Default Depreciation Constants table (F12003) are not created when you run this global update.

## **Processing Options for Global Depreciation Rules Update (R12858)**

### **Process Tab**

Use processing options to specify whether to run this program in preliminary or final mode, restore data, and convert data from WorldSoftware to OneWorld.

---

## 1. Process Mode

Blank = Preliminary mode

1 = Final mode

Use this processing option to specify the mode in which you want to run this program.  
Valid values are:

Blank Preliminary mode. You should run the program in preliminary mode before running it in final mode to select the records to restore.

Running this program in preliminary mode does not update any tables. You can run this program in preliminary mode as many times as required. This is the default.

1 Final mode. When you run this program in final mode, the system updates the depreciation rules setup information printed on the report.

Note: This processing option retains the value previously specified. If this program was run in final mode the last time it was used, it will run in final mode again unless you specify otherwise.

---

---

## 2. Restore Demo Depreciation Data

Blank = Restore Data

1 = Restore Data with Edit Disable Checked

2 = Delete all and Restore Data

Use this processing option to specify the mode to restore J.D. Edwards Demo Depreciation. Valid values are:

Blank Restore data. Only matching numeric methods are updated from J.D. Edwards Demo Depreciation Data. A matching numeric method consists of Depreciation Method, Life Periods, Initial Term Apportionment, Compute Direction, In Service Start Date, and Effective Start Date. This does not include customer additions to numeric methods. This is the default.

1 Restore data with Edit Disable checked. The Edit Disable must be checked in the Depreciation Rule Revisions (P12851) to restore numeric methods. A matching numeric method consists of Depreciation Method, Life Periods, Initial Term Apportionment, Compute Direction, In Service Start Date, and Effective Start Date. This does not include customer additions to numeric methods.

2 Delete all and restore data. All numeric methods are deleted, including customer additions, and Depreciation Data is restored from J.D. Edwards Demo Depreciation Data. Only methods that are included in data selection will be restored.

J.D. Edwards reserves the use of numeric methods. Numeric methods include (00 - 99). Customer user defined methods are not used in this restoration process.

Customer additions are defined as J.D. Edwards numeric methods that have been copied and depreciation information has been modified.

The tables to restore from J.D. Edwards Demo Depreciation Data are:

- o F12851D to F12851

---

o F12852D to F12852

o F12853D to F12853

---

---

### 3. Create Demo Depreciation Rules

Blank = Create no Depreciation Rules

1 = Create Depreciation Rules

This processing option is used to create depreciation rules used by the WorldSoftware Compute Depreciation Program (P12850). This option is used to convert data to User Defined Depreciation. If you are only running OneWorld User Defined Depreciation (R12855) or already using the WorldSoftware User Defined Depreciation (P12855), this processing option is not necessary. Valid values are:

Blank Do not create Depreciation Rules. This is the default.

1 Create Depreciation Rules. The existing Asset Balances (F1202) are validated against current depreciation information. If depreciation information does not exist in the User Defined Depreciation rules setup, the existing rules are validated against the demonstration data tables. If a match exists, a new user defined depreciation rule is created. A matching numeric method consists of a Depreciation Method, Initial Term Apportionment, Compute Direction, In Service Start Date, and Effective Start Date. Life Periods are not included in this method.

---

## Updating Accounts and Ledgers

---

You need to update the accounts and ledgers in your system if you change your chart of accounts, frequently add new asset master records, add new ledgers or depreciation books for your assets, and so on, for your organization.

### Identifying New Entries

*From the Posting G/L to Fixed Assets menu (G1212), choose Identify New Entries.*

Run Identify New Entries (R12893) before you use the Revise Unposted Entries program (P12102) or post new general ledger transactions to the Asset Account Balances File table

(F1202). Run this program frequently to reduce the time that the system takes to post journal entries to the general ledger or fixed assets.

J.D. Edwards Fixed Assets and General Accounting systems share the same transaction table, the Account Ledger (F0911). Table F0911 contains many journal entries that do not affect fixed asset accounting. When you run the Identify New Entries program, the system identifies all non-fixed asset transactions. Flagged transactions are not processed in the Fixed Assets system. The Revise Unposted Entries program can process journal entries much faster because it does not have to search through all general ledger transactions to locate fixed asset journal entries.

The following graphic illustrates how the Identify New Entries program sorts and marks transactions in the system:

### Sorting and Marking New Entries

The system sorts transactions in the general ledger (F0911) . . .

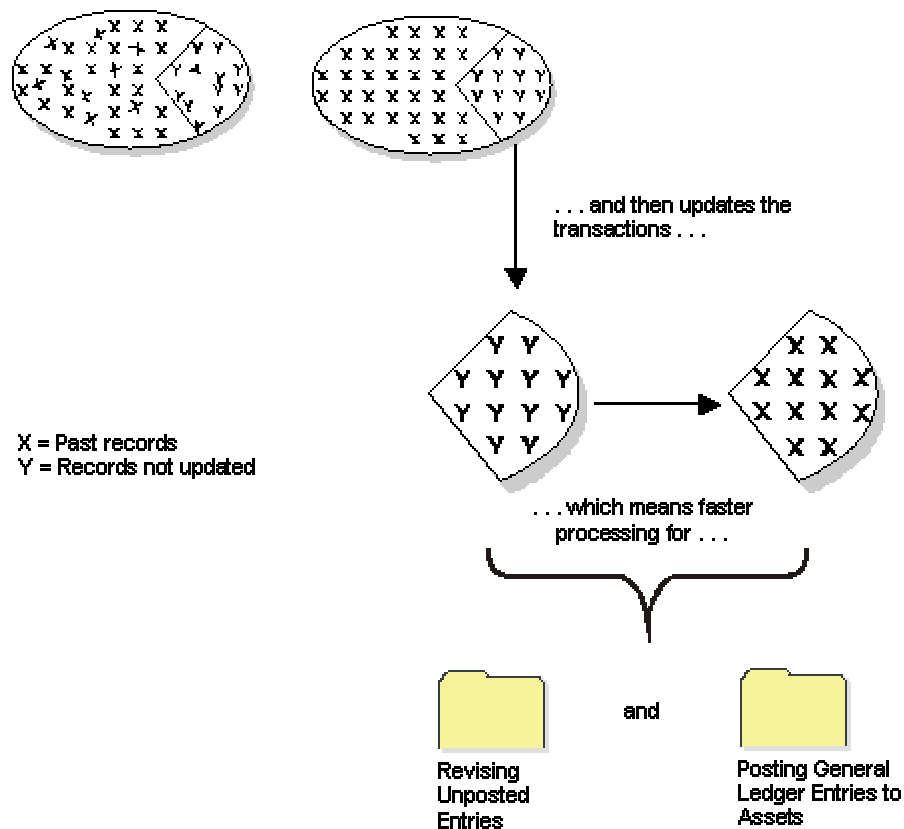

You should run this update whenever you add transactions to your system. This program does not create a report.

J.D. Edwards recommends running this program as part of your unattended operations.

---

**Caution**

Failure to run this program frequently and on a regular basis can have a significant impact on your ability to use the Revise Unposted Entries (P12102) and the Post G/L Entries to Assets (R12800) programs.

---

If you use both J.D. Edwards General Accounting and the Fixed Assets systems, the processing time increases for the Identify New Entries program. If you start the job and find that it is taking longer than expected, you can stop the program and start it again later. The program continues processing entries from where it left off.

---

**Note**

J.D. Edwards strongly recommends that you do not change the data selection for this program.

---

## Adding New Ledgers to Assets

*From the Advanced Operations menu (G1231), choose Add New Ledger to Assets.*

You can add new ledgers to the Asset Account Balances File table (F1202). Run the Add New Ledgers to Assets program (R12823) to add an additional ledger or tax book to all fixed assets.

After you define the new ledger type and add it to Depreciation Default Coding, you must select the fiscal year that you want to update with the new ledger. The system does the following:

- Creates beginning balance and period postings for asset cost accounts, based on the cost derivation ledger if the ledger is coded to duplicate cost.
- Performs an edit to ensure that the new ledger is valid in the Default Depreciation Constants table (F12003). If it is not, the system does not add the ledger.
- If the new ledger is coded not to duplicate cost, the ledger is added with a blank subledger and no balance amounts.

After you run the Add New Ledger to Assets program, you can use the Depreciation Information form to verify the results of the update. Locate an asset that uses one of the account numbers with the new ledger type. You should see the newly added ledger type for the year in which you added the ledger.

---

**Caution**

Ensure that you make data selections to specify only the records that you want to update with the new ledger.

---

## Processing Options for Add New Ledger to Assets (R12823)

### Process Tab

These processing options enable you to specify the mode in which you want to run this program, the type of ledger that you want to add or update, the fiscal year for the ledger that you want to add or update, and whether you want to update the depreciation information from the Default Depreciation Constants table (F12003).

---

#### 1. Process Mode

Blank = Do not update. Print report only

1 = Update and print report

Use this processing option to specify whether the processing mode is preliminary or final. Preliminary mode will print a report of affected assets with their depreciation information, but will not update the Asset Account Balances file (F1202). Final mode will update the affected assets' balances and depreciation information (F1202) and will print a report of the updated assets with their depreciation information.

Blank Processing is preliminary. Print the report of affected assets only. Do not update the Asset Account Balances file (F1202).

1 Processing is final. Update the Asset Account Balances file (F1202) and print a report of the updated assets with their depreciation information.

---

---

#### 2. Ledger Type (Required)

Use this processing option to specify the ledger you want to add or update in the Asset Account Balances file (F1202). The ledger type and its corresponding depreciation values (depreciation method, life months, etc.) must be previously set up for each affected asset cost account in the Depreciation Default Constants file (F12003) for associated balances and depreciation information to be added or updated.

You must specify a ledger type that has been previously set up in the General Accounting user defined code table for ledger types (UDC 09/LT) and in the Ledger Type Master file (F0025).

---

---

### 3. Fiscal Year (4 digits)

Blank = Asset's current fiscal year

Use this processing option to specify the fiscal year for the ledger you are adding to the Asset Account Balances table (F1202).

You must specify a four-digit fiscal year (i.e. 1999). If you leave this processing option blank, the ledger will be created for the Asset Account Balances table (F1202) in the asset company's current fiscal year.

---

---

### 4. Update Existing Ledger Depr Values

Blank = Do not update

1 = Update

Use this processing option to update the depreciation information values from the Depreciation Default Constants table (F12003) when the ledger already exists in the Asset Account Balances table (F1202).

Blank Do not update depreciation values when the ledger already exists in the Asset Account Balances table (F1202).

1 Update depreciation values when the ledger already exists in the Asset Account Balances table (F1202).

---

## Updating Company Numbers and Accounts

*From the Advanced Operations menu (G1231), choose Updt Co#, BU/Obj/Sub - F1202.*

You must update company numbers and accounts in the Asset Account Balances File table (F1202) to correct any situations in which the company numbers and account numbers (business unit/object/subsidiary) in the table F1202 do not match those in the Account Master table (F0901). Company and account numbers in the Asset Master File table (F1201) might not match those in table F0901 if you change existing account numbers or companies for accounts that are within the fixed asset (FX) range.

Run the Update CO#, BU/Obj/Sub - F1202 program any time that you change an existing account in your chart of accounts. For example, run this program when you:

- Change the object or subsidiary of an existing account.
- Assign existing accounts to a different business unit.
- Assign an existing business unit to a different company.

---

**Note**

You must run this program when you make changes to existing account numbers. You do not need to run this program when you add an account number.

---

The Update CO#, BU/Obj/Sub - F1202 program updates information from table F0901, based on the system-assigned, short account ID number. The program updates accounts in the table F1202 when it detects a change to a cost, accumulated depreciation, expense, or revenue account.

The following graphic illustrates how the Update Company Number, Business Unit/Object/Subsidiary program works:

**The Updating Company Number, Business Unit/Object/Subsidiary Program**

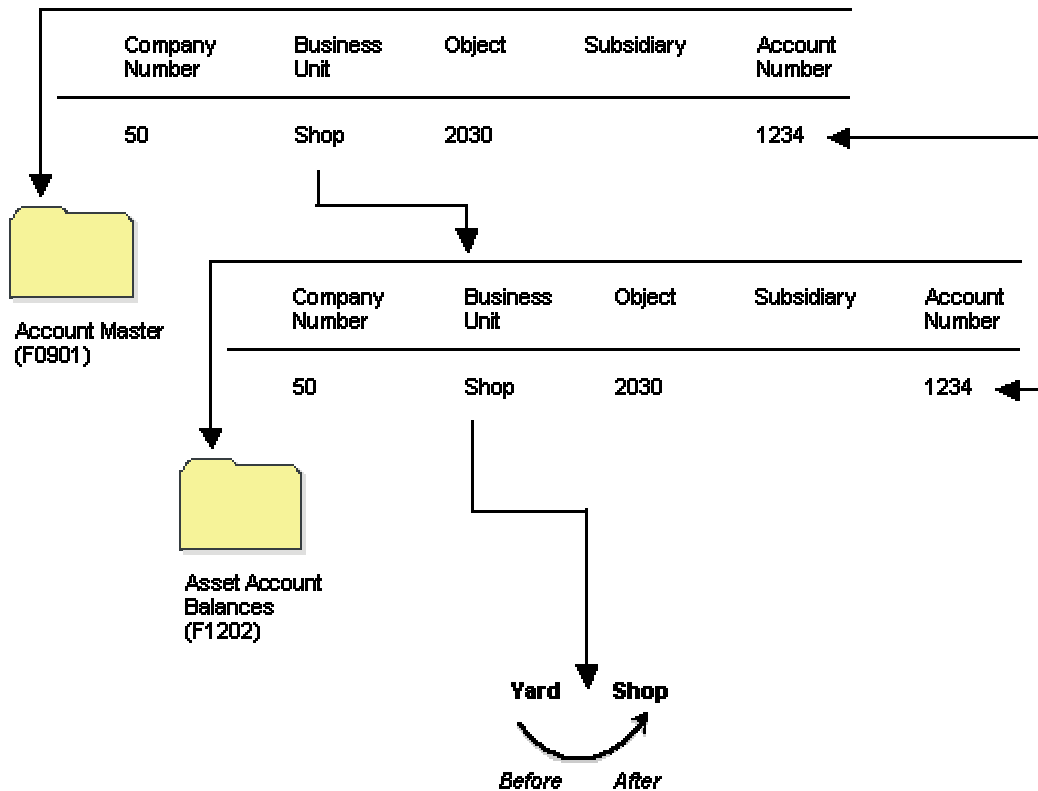

When you update company numbers and business unit/object/subsidiary, the job is submitted directly to batch.

---

**Caution**

The Repost Ledger program clears all summarized account balances to zero. Do not use this program if your system includes asset account balance records without general ledger transactions, as in the case of summarized depreciation computations or beginning balances that are created without an audit trail.

---

**Before You Begin**

- ❑ Verify that no one accesses the general accounting or fixed asset tables. The program is unable to update accounts that are locked by other system applications. Any account that a user accesses elsewhere in the system is not updated.

**Running the Repost Ledger Program**

*From the Advanced Operations menu (G1231), choose Fixed Asset Repost.*

You can repost damaged account balances in the Asset Account Balances File table (F1202) to restore system integrity. You should run the repost only if you have no other means of restoring account information. Run the repost, for example, if account balance information is damaged as a result of hardware failure.

This program reposts only the transactions that include all of the following:

- A valid period number.
- A code that indicates a post to both the general ledger and fixed assets.
- A valid asset number that exists in the Asset Master File table (F1201).
- A transaction ledger type set up in Depreciation Default Coding, if one does not already exist in table F1202.
- A transaction account number in the Account Master table (F0901). The account number must fall within the Item FX range of accounts in the AAls.
- Period postings for individual assets. The transaction must not be a balance forward record, and cannot be summarized by period and account.

---

**Caution**

The Repost Ledger program clears all of the summarized account balances to zero. Do not use this program if your system includes item balance records without general ledger transactions, as in the case of summarized depreciation computations or beginning balances that are created without an audit trail.

---

The following graphic illustrates how the Repost Ledger program searches the Account Ledger table (F0911) to create new asset balances in table F1202:

### Creating New Asset Balances

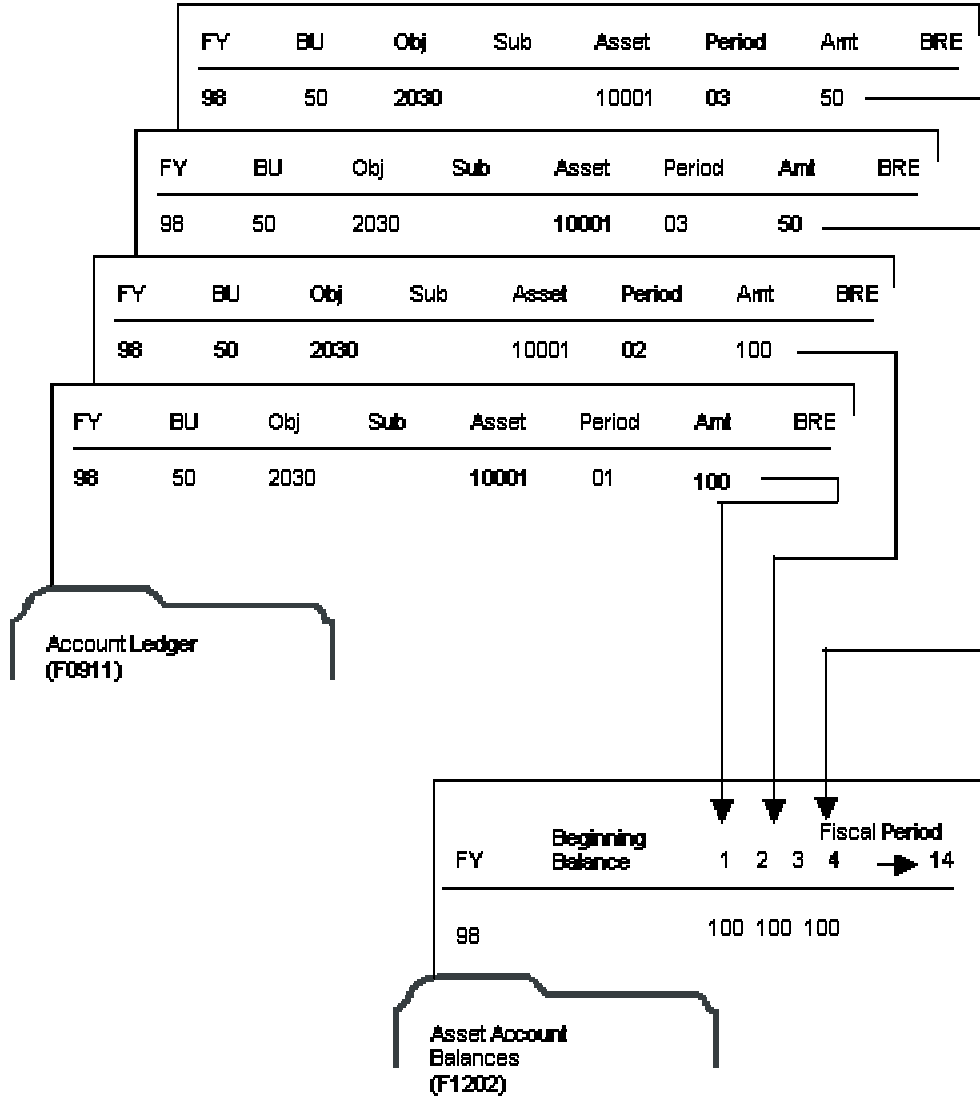

- FY = Fiscal Year
- BU = Business Unit
- Obj. = Object Account number
- Su = Subsidiary Account number
- Amt = Amount
- BRE = Fixed Asset Pass Code (Batch Rear End Code)

---

**Caution**

When you run Fixed Asset Repost, ensure that you make data selections that specify only the records for which you want to run the repost.

---

**Before You Begin**

- ❑ Verify that the following procedures are complete:
  - All transactions are posted first to the account ledger and then to fixed assets.
  - All depreciation and transfer transactions are posted first to fixed assets and then to the general ledger.
- ❑ Verify that no one accesses the general accounting or fixed asset tables. The program is unable to update accounts that are locked by other system applications. Any account that a user accesses elsewhere in the system is not updated.

**Processing Options for Fixed Asset Repost (R12910)****Print Tab**

---

## 1. Preliminary or Final Processing

Blank = Preliminary

1 = Final

Use this processing option to specify preliminary or final processing. Valid values are:

Blank

Print only the differences between the Account Ledger table (F0911) and the Asset Account Balances File table (F1202). This is the default.

1

Print differences and update the Asset Account Balances File table (F1202).

---

---

## 2. Asset Number Format

1 = Item Number (Default)

2 = Unit Number

3 = Serial Number

Use this processing option to specify which number the system prints to identify the asset.  
Valid values are:

1 Print the asset number.

2 Print the unit number.

3 Print the serial number.

---

## Updating the Asset Number in the Account Ledger

*From the Advanced Operations menu (G1231), choose Refresh Asset Number in F0911.*

Normally, the symbol that you use to identify the asset number in your system does not change. If you change this symbol, you need to update the asset number in the Account Ledger table (F0911). Run this program to ensure that all of the account ledger transactions that are posted contain the current format for the primary asset number.

The asset number and the symbol that is used to identify the asset number are stored in table F0911.

When you select Refresh Asset Number in F0911, the system submits the job directly to batch.

### Before You Begin

- Verify that no one accesses the general accounting or fixed asset tables. The program is unable to update accounts that are locked by other system applications. Any account that a user accesses elsewhere in the system will not be updated.

## Purging Assets and Asset Information

---

*From the Advanced Operations menu (G1231), choose Asset Master and Balances Purge.*

If you are only purging specific records, make data selections to specify the records that you want to purge.

Use the Asset Master and Balances Purge program (R12912) to purge old fixed assets records from your system. You can purge:

- A selected asset that you disposed of in a prior year
- Data tables for a prior year

Every record that the system purges during this procedure is transferred to a separate purge table. The purge table name is the same as the original table name with a P at the end. For example, the purge table for F1201 is F1201P.

This purge procedure automatically creates the appropriate purge tables when the purge program is run for the first time. These purge tables are stored in the same library where the corresponding tables are stored.

J.D. Edwards strongly recommends that you back up any of the following tables that you plan to purge:

- Asset Master File table (F1201)
- Asset Account Balances File table (F1202)
- Location Tracking Table (F1204)
- Equipment Messages table (F1205)
- Equipment License Master table (F1206)
- Maintenance Schedule File table (F1207)
- Parent History table (F1212)
- Equipment Rates table (F1301)
- Status History File table (F1307)

---

### Caution

Ensure that no one accesses the general accounting or fixed assets tables while you run this procedure. The program is unable to purge records that are locked by other system applications. Any records that a user accesses elsewhere in the system are not purged.

---

After the purge is complete, the program prints a report that includes the asset number, description, responsible business unit, and disposal date (if applicable) of the purged assets. The report also shows which tables had records that were purged and a summary showing how many records were purged from each table.

## Processing Options for Asset Master and Balances Purge (R12912)

### Process Tab

These processing options enable you to specify the mode in which you want to run the Asset Master and Balances Purge program and which tables you want to purge.

---

#### 1. Process Mode

Blank = Do not purge. Print report only

1 = Purge and print report

Use this processing option to specify the mode in which you want to run this program.  
Valid values are:

Blank Run the program in preliminary mode. You should run the program in preliminary mode before running it in final mode. The program will produce a report, which will help you ensure that the correct assets and tables are being purged. Running the program in preliminary mode will not purge rows from any of the tables. When you run this program in preliminary mode, the program will print a report that shows how many rows will be purged from each table for each asset.

1 Run the program in final mode. When you run the program in final mode, the program will produce a report that shows how many rows were purged from every table for each asset. Running the program in final mode will purge rows from the tables you have selected. When you run this program in final mode, the program will print a report showing how many rows were purged from each table for each asset and purge the tables that you have selected.

---

---

## 2. Purge All Tables

Blank = No

1 = Yes

Use this processing option to specify whether the Asset Master table (F1201) and all related tables are to be purged or just the tables you select in the Specify Tables processing option located on this tab. The rows that are purged will be deleted from the original tables and placed into their corresponding purge tables. For example, records purged from the F1201 table will be placed in the F1201P table. Valid values are:

Blank Rows will be purged from only the tables you specify in the Specify Tables processing option located on this tab.

1 Rows in the Asset Master table (F1201) will be purged along with rows in all related tables that contain the purged asset. Rows will only be purge for an asset that has a disposal date that is in a prior year and does not have any children attached to it.

---

## 3. Specify Tables

**Blank = Do not purge table**

**1 = Purge table**

---

---

F1202 - Asset Account Balances

Use this processing option to specify which tables you want to purge. This processing option only applies if the Purge All Tables processing option on this tab contains a value of Blank. Valid values are:

Blank Do not purge the Asset Account Balances table (F1202).

1 Purge the Asset Account Balances table (F1202).

---

---

F1301 - Equipment Rates

Use this processing option to specify which tables you want to purge. This processing option only applies if the Purge All Tables processing option on this tab contains a value of Blank. Valid values are:

Blank Do not purge the Equipment Rates table (F1301).

1 Purge the Equipment Rates table (F1301).

---

---

### F1204 - Location Tracking

Use this processing option to specify which tables you want to purge. This processing option only applies if the Purge All Tables processing option on this tab contains a value of Blank. Valid values are:

Blank Do not purge the Location Tracking table (F1204).

1 Purge the Location Tracking table (F1204).

---

---

### F1205 - Equipment Message

Use this processing option to specify which tables you want to purge. This processing option only applies if the Purge All Tables processing option on this tab contains a value of Blank. Valid values are:

Blank Do not purge the Equipment Message table (F1205).

1 Purge the Equipment Message table (F1205).

---

---

F1206 - Equipment License Master

Use this processing option to specify which tables you want to purge. This processing option only applies if the Purge All Tables processing option on this tab contains a value of Blank. Valid values are:

Blank Do not purge the Equipment License Master table (F1206).

1 Purge the Equipment License Master table (F1206).

---

---

F1207 - Maintenance Schedule

Use this processing option to specify which tables you want to purge. This processing option only applies if the Purge All Tables processing option on this tab contains a value of Blank. Valid values are:

Blank Do not purge the Maintenance Schedule table (F1207).

1 Purge the Maintenance Schedule table (F1207).

---

---

### F1212 - Parent History

Use this processing option to specify which tables you want to purge. This processing option only applies if the Purge All Tables processing option on this tab contains a value of Blank. Valid values are:

Blank Do not purge the Parent History table (F1212).

1 Purge the Parent History table (F1212).

---

---

### F1306 - Meter Reading Estimates

Use this processing option to specify which tables you want to purge. This processing option only applies if the Purge All Tables processing option on this tab contains a value of Blank. Valid values are:

Blank Do not purge the Meter Reading Estimates table (F1306).

1 Purge the Meter Reading Estimates table (F1306).

---

---

### F1307 - Status History

Use this processing option to specify which tables you want to purge. This processing option only applies if the Purge All Tables processing option on this tab contains a value of Blank. Valid values are:

Blank Do not purge the Status History table (F1307).

1 Purge the Status History table (F1307).

---

---

### F1308 - Equipment Routes

Use this processing option to specify which tables you want to purge. This processing option only applies if the Purge All Tables processing option on this tab contains a value of Blank. Valid values are:

Blank Do not purge the Equipment Routes table (F1308).

1 Purge the Equipment Routes table (F1308).

---

---

## F13907 - Associated Service Types

Use this processing option to specify which tables you want to purge. This processing option only applies if the Purge All Tables processing option on this tab contains a value of Blank. Valid values are:

Blank Do not purge the Associated Service Types table (F13907).

1 Purge the Associated Service Types table (F13907).

---

---

## 4. Start Year (4 Digits)

Use this processing option to specify the first year that Asset Account Balances table (F1202) rows are to be purged. All years prior to the year entered, including the year entered, will be purged. This processing option only applies if the Specify Tables processing option located on this tab contains a value of 1 for the Asset Account Balances table. If this option is left blank, only the current fiscal year's records will be retained, as all prior years' records will be purged.

---

## **Print Tab**

This processing option enables you to specify how you want the asset number printed on the report.

---

1. Asset Number Format

1 = Asset Number

2 = Unit Number

3 = Serial Number

Use this processing option to specify how you want the asset number printed on the report. Valid values are:

1 Asset Number.

2 Unit Number.

3 Serial Number.

---

---

## Predefined Depreciation Methods

The Fixed Assets system includes predefined, standard depreciation methods.

Depreciation methods 10 (MACRS Luxury Cars), 17 (AMT Luxury Cars), and 18 (ACE Luxury Cars) are user defined depreciation methods.

The following rules apply to the predefined depreciation methods that are included in the Fixed Assets system:

- The system does not allow accumulated depreciation to exceed the depreciable basis. The depreciable basis for an asset is the asset's original cost minus its salvage value. When the total of an asset's current depreciation and accumulated depreciation is greater than the depreciable basis, the system calculates current depreciation by subtracting the accumulated depreciation from the depreciable basis.
- The system calculates a full period's depreciation for the initial period that you acquire an asset. If you do not calculate depreciation for the month that you dispose of an asset, you should run the disposal before you run the depreciation. Exceptions to this rule are the mid-month, mid-quarter, and mid-year conventions.

The examples used throughout this section are based on the following information, unless otherwise noted:

<b>Cost</b>	100,000.00 USD
<b>Salvage value</b>	0.00
<b>Life months</b>	60
<b>Acquisition date</b>	08/01/96

### Technical Considerations

**Life months** Life months are not required for predefined depreciation methods 06, 09, 11, and 15. Entering life months for any of these methods is informational only. The system depreciates assets until the cost is fully depreciated or you dispose of the item.

Life months are required for all user-defined depreciation methods.

**Depreciating an asset after disposal** When you dispose of an asset, the disposal program zeros out the cost and accumulated depreciation amounts in the ledgers that are specified in the Disposal Account Rules program (P12141). When the specified ledger uses a mid-year convention for the asset's depreciation and the asset is not fully depreciated at the time of disposal, the depreciation program cannot calculate the final depreciation amount because cost and accumulated depreciation amounts are both zero as a result of the disposal program.

**Short years** You can set up short years for the Fixed Assets system.

**Depreciation methods that use the mid-year convention (Y)** The system begins depreciation calculations for all of the methods that use the mid-year convention at the mid-point of a regular tax year. Examples include:

- If an asset is placed in service during the first half of a calendar year (for example, in April, or period 4) and assigned MACRS depreciation with the mid-year convention, the system calculates depreciation only for one-half of a year, beginning in July.
- If an asset is placed in service during the second half of a calendar year (for example, in September, or period 9) and assigned MACRS depreciation with the mid-year convention, the system calculates depreciation only for the remaining periods.

### See Also

See the following topics in the *Fixed Assets Guide*:

- ❑ [Setting Up User Defined Depreciation](#) for information about adding a new method
- ❑ [Setting Up Short Years in Fixed Assets](#)

## Method 00 - No Depreciation Method Used

---

No depreciation is calculated.

## Method 01 - Straight Line Depreciation

---

The system depreciates the asset's cost (less salvage value) in equal amounts or daily (days in period/365.25) over the estimated useful life (life periods) of the asset, depending on the compute direction.

When you use the straight-line depreciation method, you can designate a mid-month, mid-quarter, or mid-year averaging convention. If you do not designate a convention, the system depreciates the full month for the period that you place the asset in service.

When you use straight-line depreciation, you must indicate one of the following computation methods:

**Inception-to-date (I) (daily depreciation)**

$$(((\text{Cost} - \text{Salvage Value}) / \text{life months}) * \text{elapsed months}) - \text{accumulated depreciation} = \text{period depreciation}$$

For example, depreciation for January 1997 is calculated as follows:

$$(((100,000.00 - 0) / 60) * 6) - 8,333.00 = 1,667.00$$

**Remaining life (R) (daily depreciation)**

$$(((\text{Net book value} - \text{salvage}) / \text{Remaining life periods}) * \text{months elapsed year-to-date}) - \text{year-to-date depreciation} = \text{period depreciation}$$

For example, depreciation for January 1997 is calculated as follows:

$$(((91,667.00 - 0) / 55) * 1) - 0 = 1,667.00$$

The following rules apply to this calculation:

- The cost less accumulated depreciation for prior years equals the net book value (NBV).
- If the NBV less salvage value is greater than zero, it is divided by the remaining life months as of the beginning of the current fiscal year.

**Current period (P) (equal amounts depreciation)**

$$\text{Adjusted cost} / \text{life months} = \text{period depreciation}$$

For example, depreciation for January 1997 is calculated as follows:

$$(100,000.00 - 0) / 60 = 1,667.00$$

## Method 02 - Sum of the Year's Digits

---

The system applies changing fractions each year to the adjusted cost of the asset. When you use this depreciation method, you must indicate the current year-to-date (C) computation method, as follows:

**Current  
year-to-  
date (C)**

(Cost - salvage value) \* remaining useful life / sum of the years = year's depreciation. Year's depreciation / number of normal periods in the year = period depreciation.

The following rules apply to this depreciation calculation:

- The system converts life periods into years: for example, 36 life months / 12 months = 3 years.
- The denominator is the sum-of-the-years digits (SYD), calculated as follows:
  - $SYD = n * ((n + 1) / 2)$  where n = useful life in years  
For example, if life months equals 36 (3 years), the SYD is 6:
    - $3 * ((3 + 1) / 2) = 6$
- The numerator is the remaining useful life at the beginning of the year.
- The system makes allocations throughout the useful life of the asset. For example, if you purchase an asset during the eighth month of the year, 5/12 of the first full year's depreciation is deductible in that year. In the second year, 7/12 of the first full year's depreciation, and 5/12 of the second year's depreciation are allowed. These allocations are followed for the entire life of the asset.
- To accommodate the mid-year convention for an asset, you must change the depreciation start date to the midpoint of the year.

## **Methods 03, 04, and 05 - Declining Balance with Cross-Over**

---

The declining balance to cross-over methods use the following percentages:

**Method 03** 125%

**Method 04** 150%

**Method 05** 200%

Although the system does not consider the salvage value of an asset during the depreciation calculation, it does not depreciate an asset below its salvage value.

When you use a declining balance to cross-over method to depreciate an asset, you must indicate one of the following methods of computation:

**Inception-to-date (I)**  $((NBV * \text{percentage}) / \text{life periods} * \text{elapsed periods}) - \text{Accumulated Depreciation} = \text{period depreciation}$

For example, using method 05, yearly depreciation is calculated as follows:

1997:  $((100,000.00 * 200\%) / 60) * 17 - 16,667.00 = 40,000.00$

1998:  $((100,000.00 - 16,667.00) * 200\% / 60) * 12 = 33,333.00$

The following rules apply to this depreciation calculation:

- The cost less accumulated depreciation for prior years equals the net book value (NBV).
- Calculate NBV at the beginning of the year.
- When the NBV divided by remaining life months is greater than the depreciation for the period, you have reached cross-over for the asset. At this point, the depreciation for the period equals the NBV divided by the remaining life months.

**Remaining life (R)**  $\text{NBV (if greater than zero)} * \text{percentage} / \text{remaining life periods} = \text{period depreciation}$

For example, yearly depreciation would be calculated as follows:

1996:  $100,000.00 * 200\% / 60 * 5 = 16,667.00$

1997:  $83,333.00 * 200\% / 60 * 12 = 33,333.00$

The following rules apply to this depreciation calculation:

- When NBV divided by the remaining periods is greater than the period depreciation, you have reached cross-over for the asset.
- The cost is reduced by the accumulated depreciation to calculate NBV at the end of each fiscal year.

**Alternative minimum tax (AMT)** You can use Method 04 (150% Declining Balance to Cross-over) for alternative minimum tax purposes.

## **Method 06 - Fixed % on Declining Balance**

---

When you use the fixed percent on declining balance depreciation method, you must indicate one of the following methods of computation:

**Current year-to-date (C)**  $((\text{Cost} - \text{accumulated depreciation}) * \text{fixed percent}) / \text{number of normal periods} = \text{period depreciation}$

**Current period (P)** The current period method of computation is the same as current year-to-date, except that it does not "catch up" depreciation amounts within the year. If you run your first depreciation in March, the system calculates depreciation for March only. The system does not calculate depreciation for January and February.

## **Method 07 - ACRS Standard Depreciation**

---

You can use the Accelerated Cost Recovery System (ACRS) method to compute the tax depreciation deduction for most tangible depreciable property that you place in service after

1980 but before 1987. Cost recovery methods and period are the same for both new and used property. The system does not use the asset's salvage value to compute ACRS allowances.

ACRS standard depreciation uses only one method of computation:

**Current year-to-date (C)**       $((\text{Cost} - \text{accumulated depreciation}) * \text{fixed percent based on ACRS IRS table}) / \text{number of normal periods} = \text{period depreciation}$

## Personal Property

The ACRS statutory recovery percentage for personal property that is placed in service after 1980 and before 1987 is determined by an IRS-prescribed table. The table takes into account the type of property (3-year, 5-year, 10-year, or 15-year) and the year that you placed the property in service.

## Real Property

Generally, the adjusted basis of real property is recovered over a period of 19 years for real property that is placed in service after May 8, 1985, but before 1987. For real property that is placed in service after March 15, 1984, but before May 9, 1985, the unadjusted basis is recovered over a period of 18 years. A 15-year recovery period applies to real property that is placed in service after 1980 but before March 16, 1984, and to low-income housing.

The recovery percentages for such property other than low-income housing is similar to the use of the 175% declining balance method with a later-year switch to the straight line method.

You can use the following conventions with the ACRS depreciation method:

- Full-month** Can be used for real property that you place in service before March 16, 1984, and for low-income housing. With the full-month convention, the system handles real property that you place in service at any time during a particular month as being placed in service on the first day of that month. This method allows a full month's cost recovery for the month that you placed the property in service. If you dispose of the property anytime during a particular month, but before the end of a recovery period, you are not allowed cost recovery for the month that you disposed of the property.
- Mid-month** Can be used for real property that you place in service after March 15, 1984. With the mid-month convention, the system handles real property that you place in service anytime during a particular month as being placed in service at the middle of that month. This method allows a one-half month's cost recovery for the month that you placed the property in service. If you dispose of the property during a month but before the end of a recovery period, you are allowed cost recovery for one-half of the month that you disposed of the property.
- Mid-year** With the regular method of ACRS standard depreciation, the mid-year convention is mandatory and built into the applicable tables. You are not allowed any deduction for the year that you dispose of an asset.

## **Method 08 - ACRS Optional Depreciation**

---

If you prefer a slower recovery on the cost of ACRS property than the percentages provided, you might elect to use a straight-line recovery method. This method provides a longer recovery period.

The ACRS optional depreciation method uses one of two methods of computation:

**Inception-to-date (I)** 
$$(((\text{Cost} - \text{Salvage Value}) / \text{life months}) * \text{elapsed months}) - \text{accumulated depreciation} = \text{period depreciation}$$

For example, depreciation for January 1997 is calculated as follows:

$$((( 100,000.00 - 0) / 60) * 6) - 8,333.00 = 1,667.00$$

**Remaining life (R)** 
$$(((\text{Net book value} - \text{salvage}) / \text{Remaining life periods}) * \text{months elapsed year-to-date}) - \text{year-to-date depreciation} = \text{period depreciation}$$

For example, depreciation for January 1997 is calculated as follows:

$$((( 91,667.00 - 0) / 55) * 1) - 0 = 1,667.00$$

The following rules apply to this calculation:

- The cost less prior years' accumulated depreciation equals the net book value (NBV).
- If the NBV less salvage value is greater than zero, it is divided by the remaining life months as of the beginning of the current fiscal year.

The calculation for ACRS Optional is the same as Straight Line, except for the following:

- The system bases the depreciation calculation on the cost, rather than the adjusted cost (cost less salvage value).

- The system uses the mid-year convention for personal property.
- The system calculates a full month of depreciation in the month that you acquire the property and no depreciation in the month that you dispose of it for 15-year real property.
- The system calculates one-half month of depreciation in the months that you acquire and dispose of 18- and 19-year real property.
- If depreciation information is 04 (ACRS method with Basis Reduction), the system reduces the cost by one-half of the Income Tax Credit (ITC) amount that is assigned on Master Information.

## **Method 09 - Units of Production Method**

---

When you use the units of production depreciation method, you must indicate the current year-to-date method of computation, as follows:

**Current year-to-date (C)** (Year-to-date production / depreciable unit base \* (asset cost - accumulated depreciation))

The system calculates the depreciable unit base as follows:

Original units revisions to estimate - prior year's production = depreciable unit base

You must run the Units of Production Close procedure to roll current year information forward into the following year.

## **Method 11 - Fixed % Luxury Cars**

---

Calculation:  $NBV * \text{fixed percent} = \text{year's depreciation}$ .  $\text{Year's depreciation} / \text{number of normal periods} = \text{period depreciation}$ .

The following rules apply to this method of depreciation:

- You must use the current year-to-date (C) method of computation.
- The depreciation amount for a year is limited to 2,000.00.

## **Method 12 - MACRS Standard Depreciation**

---

You must depreciate most tangible property that you place in service after 1986 using the Modified Accelerated Cost Recovery System (MACRS), for tax purposes. Depending on the type of property, you recover the cost over a 3-, 5-, 7-, 10-, 15-, 20-, 27 1/2-, 31 1/2-, or 39-year period. You recover the cost by using the applicable depreciation method, the applicable recovery period, and the applicable convention.

MACRS calculations use the following statutory recovery methods and conventions:

**3-, 5-, 7-, 10-, 15-, and 20-year period calculations** The system calculates depreciation using the 200% declining balance method, and the mid-year or mid-quarter convention with a switch to the straight-line method in later years.

**27 1/2-, 31 1/2-, and 39-year period calculations** The system calculates depreciation by using the straight line method and the mid-month convention.

To compute depreciation, the system uses MACRS depreciation tables, which contain the annual percentage depreciation rates to be applied to the adjusted basis of property in each tax year. The tables include the appropriate convention and a switch from the declining balance method to the straight-line method in the appropriate year.

Use one of the following conventions with this depreciation method:

**Mid-month** You can apply this convention to residential and nonresidential real property. Based on this convention, the system calculates one-half month's depreciation for the month that you acquired or disposed of the property.

**Half-year** Apply this convention to property other than residential and nonresidential property. Based on this convention, the system calculates one-half year's depreciation for the year that you acquire or dispose of the property.

**Mid-quarter** You can apply this convention to all property other than nonresidential real property and residential rental property if more than 40% of the total basis of such property is placed in service during the last three months of the tax year. Based on this convention, the system calculates depreciation at the midpoint of the quarter that you acquire or dispose of the property. The system computes the MACRS deduction for the first year by determining the depreciation for the full tax year and then multiplying it by one of the following percentages, depending on the quarter that you placed the property in service:

- First quarter 87 1/2%
- Second quarter 62 1/2%
- Third quarter 37 1/2%
- Fourth quarter 2 1/2%

## MACRS First Year Bonus Rule for HR 3090

This rule applies only to assets with a 20-year or less life span. [reference to the 30% 1<sup>st</sup> year bonus related to HR 3090 for assets placed in service between 9/11/01 and 9/10/04 here.]

Mid-month information does not apply to this rule.

### ► To add a MACRS 1<sup>st</sup> year bonus rule for HR 3090

1. Set up three new formulas, using the Depreciation Formula Revisions program (P12853D). Set up the formulas according to the following example:

Formula ID	Formula Description	Formula	Multiplier/Constant
541	First Year Bonus 30%	$((10-(10*12))*11)+(10*12)$	.300000
542	Basis*Multiplier	$10*11$	

543	70% of Cost	01*12	.700000
-----	-------------	-------	---------

- Run the Global Depreciation Rules Update program (R12858) to update these new formulas to the Depreciation Formulas table (F12853).
- Add the following value to user defined code table 12/DM:

Codes	Description 01
50	MACRS First Year Bonus

- Add the following values to the new formulas:

Depreciation Formula for year 1	541
Basis Formula for year 1	502
Depreciation Formula for years 2-11	542
Basis Formula for years 2-11	543

You should not change the 999 life year rule.

### Example

The following table is an example of a 10-year rule using the MACRS First Year Bonus Rule for HR 3090:

Depreciation Method	50
Initial Term Apportionment	Y
Compute Direction	C
Life	120
In Service From Date	09/11/01
Effective From Date	09/11/01
Rule Description	MACRS 1 <sup>st</sup> Year Bonus – 10 Year
In Service Through Date	09/10/04

### See Also

See the following topics in the *Fixed Assets Guide*:

- ❑ *Working With Depreciation Formulas* for information about how to set up formulas
- ❑ *Updating Global Depreciation Rules* for more information about the Depreciation Formulas table (F12853)

## Method 13 - MACRS Alternative Depreciation

---

You can use the MACRS alternative depreciation method for the following categories of property:

- Tangible property used outside the U.S.
- Property that is tax exempt
- Property that is tax exempt and bond financed
- Property that is imported from a foreign country for which an executive order is in effect because the country maintains trade restrictions or engages in other discriminatory acts
- Property for which you have made an alternative MACRS election

If you use the MACRS Alternative depreciation method, you must indicate the inception-to-date (I), current period (P), or remaining life (R) method of computation. You must also indicate a mid-month, half-year, or mid-quarter convention.

## **Method 14 - ACRS Alternate Real Property**

---

You can use this depreciation method to recover costs by using a straight-line method over the regular recovery period or a longer recovery period. You must make this election on your tax return for the year that you placed the property in service. The ACRS straight-line depreciation tables contain the annual percentage depreciation rates. The rates are applied to the unadjusted basis of property in each tax year.

You must indicate the current year-to-date method of computation with the ACRS Alternate Real Property depreciation method.

## **Method 15 - Fixed % on Cost**

---

The system calculates the fixed percent of cost depreciation method as follows:

$\text{Cost} * \text{fixed percent} = \text{year's depreciation}$ .  $\text{Year's depreciation} / \text{number of normal periods} = \text{period depreciation}$ .

You must indicate the current year-to-date (C) or current period (P) method of computation with this depreciation method. The current period method is the same as the current year-to-date with the exception that it does not "catch up" depreciation amounts within the year. If you run your first depreciation in March, the system calculates depreciation for the month of March only. The system does not calculate depreciation for January and February.

## **Method 16 - Fixed % on Declining Balance with Cross-Over**

---

You must indicate one of the following methods of computation with the fixed percent on declining balance to cross-over depreciation method:

**Remaining  
life (R)**

$\text{NBV (if greater than zero)} * \text{fixed percent} / \text{life months} = \text{period depreciation}$

You must apply the following rules to this calculation:

- You have reached cross-over when the NBV divided by the remaining period is greater than the period depreciation. At this point, the period depreciation equals the NBV divided by the remaining periods.
- The cost is reduced by accumulated depreciation for purposes of calculating NBV at the end of each fiscal year.

**Inception-to-  
date (I)**

$\text{NBV} * \text{fixed percent} / \text{number of life months} = \text{period depreciation}$

You must apply the following rules to this calculation:

- After each full year that an asset is in service, the cost is reduced by the accumulated depreciation to determine the NBV.
- You have reached cross-over when the NBV divided by remaining life months is greater than the period depreciation. At this point, the depreciation for the period equals the NBV divided by the remaining life months.

---

## International Depreciation Methods

The demonstration data that is included in J.D. Edwards software includes several depreciation methods that are designed to meet international requirements. This appendix provides an overview of these methods so that you can determine which of them meets your requirements.

---

### French Straight Line (Method 19)

---

For the example that follows, the following assumptions apply:

- Actual Start Date: 15/06/1997
- Modified Start Date: 15/06/1997
- Cost: 100.000 FRF (without tax)
- Asset Life: 5 years (60 life periods)

The table below shows the depreciation of an asset when using depreciation method 19:

Year	End of Year Date	Accumulated Depreciation	Depreciation Expense	Calculation
1997	31/12/1997	-10904.11	10904.11	$100.000 / 60 * 12 * 199 / 365$
1998	31/12/1998	-20000.00	2000.00	$100.000 / 60 * 12$
1999	31/12/1999	-20000.00	2000.00	$100.000 / 60 * 12$
2000	31/12/2000	-20000.00	2000.00	$100.000 / 60 * 12$
2001	31/12/2001	-20000.00	2000.00	$100.000 / 60 * 12$
2002	31/12/2002	-9095.89	9095.89	$100.000 / 60 * 12 * 166 / 365$

---

#### Note

Although the asset life is five years, the asset takes six fiscal years to depreciate. The first and last years are split, depending on the actual start date. The number of days in the first year is 200 because it includes the start and end dates. The French straight line method requires 199 days, so one day is subtracted in the formula to calculate the correct apportionment percent for the first year. By default, the last year takes the remaining basis and includes salvage value.

---

The following table explains the requirements for method 19:

<b>Asset life</b>	The demonstration data includes versions of method 19 for an asset life of 48 life periods and 60 life periods.
<b>Balance adjustments</b>	<ul style="list-style-type: none"> <li>• Year-end with annual depreciation</li> <li>• Apportioned by period in the year, based on percent</li> </ul>
<b>Modified start date</b>	The modified start date is the actual start date. This method calculates the initial year percent by the number of days in the first year.
	<p><b>Note</b></p> <p>Typically, the number of days in a year includes the start day and end day. However, the French straight-line method uses one fewer day. The French requirement is calculated by subtracting one day from the current number of days in the year.</p>
<b>Conventions</b>	The disposal year is the actual disposal date.
<b>Life year rules</b>	<ul style="list-style-type: none"> <li>• Life year 1 to 1 contains the formula that calculates the initial year apportionment.</li> <li>• Life years 2 to 4 contain the standard, straight line formula for an annual amount.</li> </ul>
<b>Calculations</b>	Formulas calculate a year of straight-line depreciation. The basis includes salvage value.
<b>Disposals</b>	Method 19 has no disposal rules.

## **French Declining Balance (Method 20)**

---

For the example that follows, the following assumptions apply:

- Actual Start Date: 15/06/1997
- Modified Start Date: 01/06/1997
- Cost: 100.000 FRF (without tax)
- Asset Life: 5 years (60 life periods)

The table below shows the depreciation of an asset when using depreciation method 20:

<b>Year</b>	<b>End of Year Date</b>	<b>Accumulated Depreciation</b>	<b>Depreciation Expense</b>	<b>Calculation</b>
1997	31/12/1997	-23.333,33	23.333,33	$100.000 * 40\% / 12 * 7$
1998	31/12/1998	-30.666,66	30.666,66	$(100.000 - 23.333,33) * 40\%$
1999	31/12/1999	-18.400,00	18.400,00	$(76.666,67 - 30.666,66) * 40\%$
2000	31/12/2000	-13.800,00	13.800,00	$(46.000,01 - 18.400,00) / 2$
2001	31/12/2001	-13.800,00	13.800,00	13.800,00

---

## Note

Even though the asset life is complete on 31/05/02, the system calculates depreciation for five complete periods in the fiscal year (31/12/01). The calculations for the initial year are based on periods, rather than on days.

---

The following table explains the requirements for method 19:

<b>Asset life</b>	The demonstration data includes versions of method 20 for an asset life of 36, 48, 60, 72, and 84 life periods.
<b>Balance adjustments</b>	<ul style="list-style-type: none"><li>• End of the year with annual depreciation</li><li>• Apportioned by period in the year, based on percent</li></ul>
<b>Modified start date</b>	The modified start date is the start of the period. This method calculates the initial year percent by periods in the first year.
<b>Conventions</b>	No conventions are needed.
<b>Life year rules</b>	<ul style="list-style-type: none"><li>• The first life year is from year 1 to 2 years less than the total number of years.</li><li>• The second life year is for 1 year less than the total number of years.</li><li>• The third life year is for the last year in the asset's life.</li></ul> <p>For example, if the asset has a life of five years, the first life year corresponds to years 1 through 3, the second life year corresponds to year 4, and the third life year corresponds to year 5.</p>
<b>Disposals</b>	Method 20 has no disposal rules.

## Calculations

The declining balance is based on a declining coefficient, as illustrated in the following table:

Declining Coefficient	Probable Asset Life	Declining Rate
1.5	3 and 4 years	50 and 37.5%
2	5 and 6 years	40 and 33.33%
2.5	More than 6 years	2.5*life%

- Subtract half of the basis in the year before the total number of years.
- Use the remaining basis for calculations.

---

## French Derogatory (Method 21)

---

Use the French Derogatory method to calculate the difference between the French Declining Balance method (Method 20) and the French Straight Line method (Method 19). The French Derogatory method requires you to set up the following AAls for depreciation to calculate correctly:

- DSA1 – Use this AAI to retrieve the amount from the AA ledger inception-to date balance from the Asset Account Balances File table (F1202) for the account that is identified on this AAI.
- DSA3 – Use this AAI to retrieve the amount from the D1 ledger inception-to-date balance from table F1202 for the account that is identified on this AAI.

The account that is used for both of the AAIs should be the Accumulated Depreciation account from the Depreciation Default Coding. Your AAIs should appear as follows for DSA1 and DSA3:

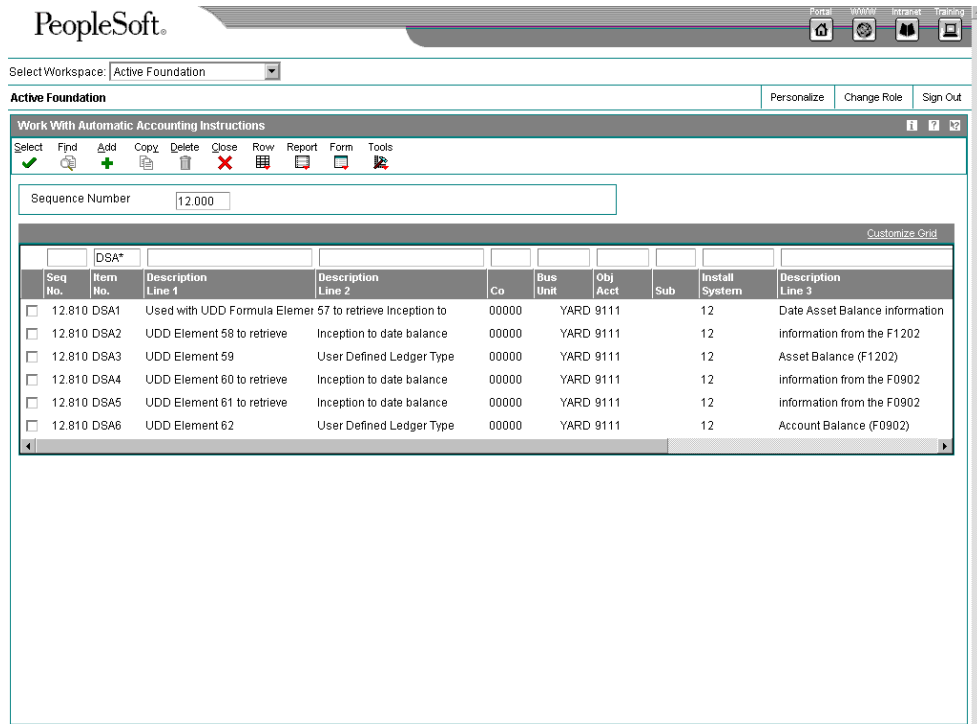

The French Derogatory method also requires you to set up the following depreciation default coding information:

Ledger Type	Depreciation Method
AA	French Straight Line (Method 19)
D1	French Declining Balance (Method 20)
D3	French Derogatory (Method 21)

The following illustration shows how depreciation default coding should be set up for a cost account that is used for 48 life-month French fixed assets:

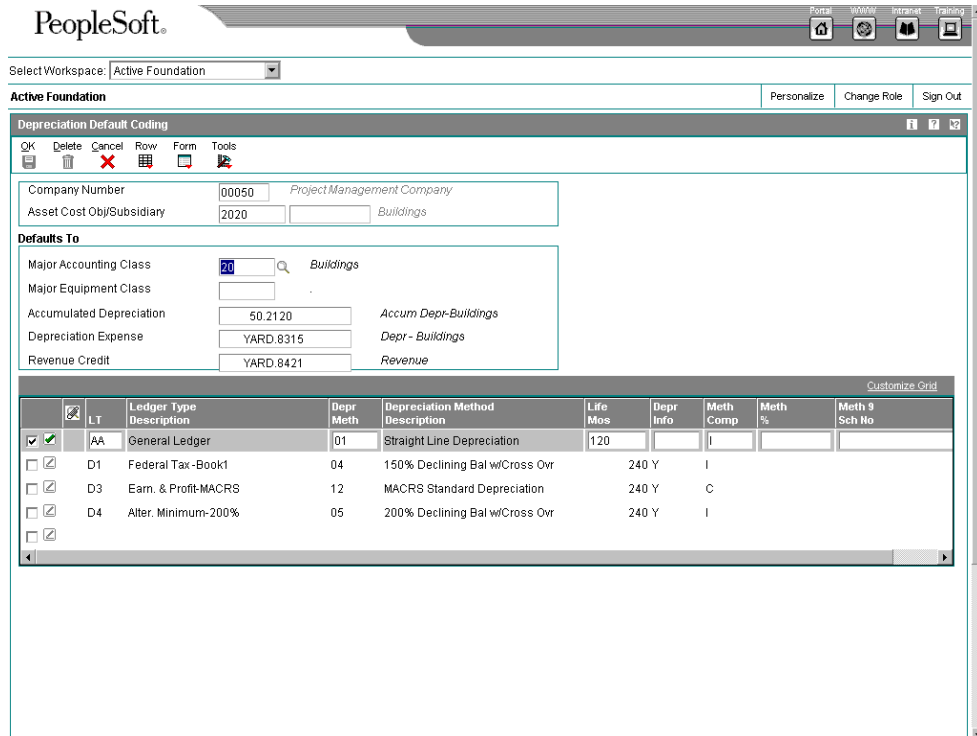

When you add assets to this account, the depreciation default information automatically defaults with these depreciation methods. Ensure that cost amounts are copied from the AA ledger to the D1 and D3 ledgers.

After setup is complete and assets are entered in the system, Method 21 computes the difference between the D1 ledger and the AA ledger. The results of 21 are stored in the D3 ledger.

### Note

To compute the depreciation for method 21, you must compute depreciation in final mode for the French Straight Line method and the French Declining Balance. You can compute depreciation for all three ledgers concurrently in final mode.

For the example that follows, these assumptions apply:

- Actual start date: 06/15/1997
- Modified start date: 01/06/1997
- Cost: 100.000 FRF (without tax)
- Asset life: 4 years (48 life periods)

The example below shows the depreciation of an asset when using depreciation method 21:

Year	End of Year Date	Declining Balance	Straight Line	Derogatory Depreciation
1997	31/12/1997	28.125	17.809	10.316

1998	31/12/1998	26.953	25.000	1.953
1999	31/12/1999	22.461	25.000	-2.539
2000	31/12/2000	22.461	25.000	-2.539
2001	31/12/2001	0	7.191	-7.191

---

### Note

This example uses the straight-line method in the AA ledger type and the declining balance method in a separate ledger type. The formula uses the calculated final balances to produce the balance adjustments for derogatory depreciation.

---

Alternatively, you can calculate derogatory depreciation is to use Enterprise Report Writer in one of the following ways:

- From the amounts that are computed on the D3 ledger, create a journal entry to the AA ledger for the appropriate offset accounts. Use one account for negative amounts, and the other account for positive amounts. The government can provide your company with the necessary statutory account numbers.
- Calculate the difference between the two ledger types, and create journal entries for posting.

The following table explains the requirements for method 21:

<b>Asset life</b>	The demonstration data includes versions of method 21 for an asset life of 48 life periods and 60 life periods.
<b>Balance adjustments</b>	<ul style="list-style-type: none"> <li>• Year-end with annual depreciation</li> <li>• Apportioned by period in the year, based on percent</li> </ul> <p>Straight-line and declining balance methods must be updated before derogatory depreciation can be calculated.</p>
<b>Modified start date</b>	The modified start date is the start of the period.
<b>Conventions</b>	<ul style="list-style-type: none"> <li>• Allow Over Depreciation is set to option 3 (accumulated depreciation might exceed adjusted basis and continue beyond the asset's life).</li> <li>• Negative depreciation is allowed.</li> </ul>
<b>Life year rules</b>	The life year from 1 to 998.
<b>Calculations</b>	Calculate the difference between declining balance and straight-line balance.
<b>Disposals</b>	Method 21 has no disposal rules.

---

## German Building (Method 22)

For the example that follows, the following assumptions apply:

- Actual Start Date: 15/03/1997
- Modified Start Date: 01/03/1997
- Cost: 3.600.000,00 DEM (without tax)
- Asset Life: 5 years (60 life periods)

The table below shows the depreciation of an asset when using depreciation method 22:

Year	End of Year Date	Accumulated Depreciation	Depreciation Expense	Calculation
1997	31/12/1997	-210.000	210.000	3.600.000 * 7% for 10 periods
1998	31/12/1998	-252.000	252.000	3.600.000 * 7% for 12 periods
1999	31/12/1999	-252.000	252.000	3.600.000 * 7% for 12 periods
2000	31/12/2000	-252.000	252.000	3.600.000 * 7% for 12 periods
2001	31/12/2001	-252.000	252.000	3.600.000 * 7% for 12 periods
2002	31/12/2002	-132.000	132.000	3.600.000 * 7% for 2 periods  3.600.000 * 5% for 10 periods
2003	31/12/2003	-108.000	108.000	3.600.000 * 5% for 12 periods
2004	31/12/2004	-108.000	108.000	3.600.000 * 5% for 12 periods
2005	31/12/2005	-108.000	108.000	3.600.000 * 5% for 12 periods
2006	31/12/2006	-108.000	108.000	3.600.000 * 5% for 12 periods
2007	31/12/2007	-132.000	132.000	3.600.000 * 5% for 2 periods  3.600.000 * 2.5% for 10 periods
2008	31/12/2008	-90.000	90.000	3.600.000 * 2.5% for 12 periods
2009-2025	31/12/20xx	-90.000	90.000	3.600.000 * 2.5% for 12 periods

2026	31/12/2026	-90.000	90.000	3.600.000 * 2.5% for 12 periods
2027	31/12/2027	-7.500	7.500	3.600.000 * 2.5% for 2 periods

---

**Note**

Use the life year reference to force depreciation to be calculated every period.

---

The following table explains the requirements for method 22:

<b>Asset life</b>	The demonstration data includes versions of method 22 for an asset life of 360 life periods.
<b>Balance adjustments</b>	<ul style="list-style-type: none"> <li>The depreciation percent changes, based on the asset life year.</li> <li>Use the asset life year reference to force period adjustments.</li> </ul>
<b>Modified start date</b>	The modified start date is the start of the period.
<b>Conventions</b>	The life year reference should come from the modified start date.
<b>Life year rules</b>	<p>Asset life years are used, instead of fiscal life years.</p> <ul style="list-style-type: none"> <li>Life year 1 to 5 takes 7%.</li> <li>Life year 6 to 10 takes 3%.</li> <li>Life year 11 to 20 takes 2.5%.</li> </ul>
<b>Calculations</b>	<ul style="list-style-type: none"> <li>Formulas must use the multiplier times the annual percent.</li> <li>The basis is cost.</li> </ul>
<b>Disposals</b>	Method 22 has no disposal rules.

## German Declining Balance (Method 23)

---

For the example that follows, the following assumptions apply:

- Actual Start Date: 15/03/1997
- Modified Start Date: 01/03/1997
- Cost: 100.000,00 DEM (without tax)
- Asset Life: 10 years (120 life periods)

The table below shows the depreciation of an asset when using depreciation method 23:

Year	End of Year Date	Accumulated Depreciation	Depreciation Expense	Calculation
1997	31/12/1997	-25.000	25.000	100.000*30% * (10/12) periods

1998	31/12/1998	-22.500	22.500	$(100.000-25.000) * 30\% * (12/12)$ periods
1999	31/12/1999	-15.750	15.750	$(100.000-47.500) * 30\% * (12/12)$ periods
2000	31/12/2000	-11.025	11.025	$(100.000-63.250) * 30\% * (12/12)$ periods
2001	31/12/2001	-7.717,5	7.717,5	$(100.000-74.275) * 30\% * (12/12)$ periods
2002	31/12/2002	-5.402,25	5.402,25	$(100.000-89.992,5) * 30\% * (12/12)$ periods
2003	31/12/2003	-3.781,58	3.781,58	$(100.000-87.394,75) * 30\% * (12/12)$ periods
2004	31/12/2004	-2.786,42	2.786,42	$(100.000-91.176,33) / (38*12)$ periods
2005	31/12/2005	-2.786,42	2.786,42	$(100.000-93.962,75) / (26*12)$ periods
2006	31/12/2006	-2.786,43	2.786,43	$(100.000-96.749,17) / (14*12)$ periods
2007	31/12/2007	-464,40	464,40	100.000-99.353,60 for last 2 periods

---

**Note**

The straight line lower limit replaces the declining balance calculation in the eighth year of the asset's life.

---

The following table explains the requirements for method 23:

<b>Asset life</b>	The demonstration data includes versions of method 23 for an asset life of 120 life periods.
<b>Balance adjustments</b>	<ul style="list-style-type: none"> <li>• Year-end with annual depreciation</li> <li>• Apportioned by period in the year, based on percent</li> </ul>
<b>Modified start date</b>	The modified start date is the start of the period.
<b>Conventions</b>	No conventions are needed.
<b>Life year rules</b>	Life year 1 to 10 takes 30% declining balance.

- Calculations**
- Use 30% as a multiplier for the declining balance.
  - The upper limit is three times straight line.
  - The lower limit is straight line.

**Disposals** Method 23 has no disposal rules.

## German Compound (Method 24)

---

For the example that follows, the following assumptions apply:

- Actual Start Date: 12/06/1997
- Modified Start Date: 01/06/1997
- Cost: 100.000,00 DEM (without tax)
- Asset Life: 12 years (144 life periods)

The tables below show the depreciation of an asset when using depreciation method 24:

Year	End of Year Date	Accumulated Depreciation	Depreciation Expense
1997	31/12/1997	-4.882,50	4.882,50
1998	31/12/1998	-8.327,63	8.327,63
1999	31/12/1999	-8.327,63	8.327,63
2000	31/12/2000	-8.350,44	8.350,44
2001	31/12/2001	-8.327,63	8.327,63
2002	31/12/2002	-8.327,63	8.327,63
2003	31/12/2003	-8.327,63	8.327,63
2004	31/12/2004	-8.350,44	8.350,44
2005	31/12/2005	-8.327,63	8.327,63
2006	31/12/2006	-8.327,63	8.327,63
2007	31/12/2007	-8.327,62	8.327,62
2008	31/12/2008	-8.350,44	8.350,44
2009	31/12/2009	-3.445,13	3.445,13

Year	2nd Accumulated Depreciation	2nd Depreciation Expense	Rule 1 Calculation	Rule 2 Calculation
------	------------------------------	--------------------------	--------------------	--------------------

1997	-7.328,77	7.328,77	100.000 / 4383 * 214 days	100.00 * 12.5% * 58.630,13 Initial Year %
1998	-12.500,00	12.500,00	(100.000 - 4.882,5) / 4169 * 365 days	100.000 * 12.5%
1999	-12.500,00	12.500,00	(100.000-13.215,13 / 3804 * 365 days	100.00 * 12.5%
2000	-12.500,00	12.500,00	(100.000 - 21.537,76) / 3439 * 366 days	100.00 * 12.5%
2001	-5.171,23	5.171,23	(100.000 - 29.888,20) / 3073 * 365 days	100.00 * 12.5% * 41.369,87 Last Year %
2002			(100.000 - 38.215,83) / 2708 * 365 days	
2003			(100.000 - 46.543,46) / 2343 * 365 days	
2004			(100.000 - 54.871,09) / 1978 * 366 days	
2005			(100.000 - 63.221,54) / 1612 * 365 days	
2006			(100.000 - 71.549,17) / 1247 * 365 days	
2007			(100.000 - 79.876,80) / 882 * 365 days	
2008			(100.000 - 88.204,43) / 517 * 366 days	
2009			(100.000 - 96.554,87) / 151 * 151 days	

---

**Note**

The compound 50% is apportioned over five fiscal years. The first and last year have an apportionment percent combined of 100% to allow four years of 12.5% compound depreciation. Continuing depreciation beyond the asset's life is needed, so remaining basis is not taken in the last year of the asset's life, which reverses the compound depreciation. AAls (SDA and SDE1) for secondary accounts were set up.

---

The following table explains the requirements for method 24:

<b>Asset life</b>	The demonstration data includes a version of method 24 for an asset life of 144 life periods.
<b>Balance adjustments</b>	<ul style="list-style-type: none"> <li>• Year-end with annual depreciation</li> <li>• Apportioned by period in the year, based on percent</li> </ul>
<b>Modified start date</b>	The modified start date is the start of the period.
<b>Conventions</b>	<ul style="list-style-type: none"> <li>• Secondary Accounts are set to two accumulated depreciation accounts and two depreciation expense accounts.</li> <li>• Allow Over Depreciation is set to exceed adjusted basis and to continue beyond the asset's life.</li> </ul>
<b>Life year rules</b>	<ul style="list-style-type: none"> <li>• Life years 1 to 998 take straight line for rule 1.</li> <li>• The demonstration data includes examples for 50% over the first four years and for 50% in the first year. Different rules for the first, middle, and last years control the life year percent that matches the fiscal year.</li> </ul>
<b>Calculations</b>	<ul style="list-style-type: none"> <li>• Remaining number of days are used for straight line.</li> <li>• An annual rule multiplier is used for the secondary 50%.</li> </ul>
<b>Disposals</b>	Method 24 has no disposal rules.

## **German Investment Tax Credit (Method 25)**

---

For the example that follows, the following assumptions apply:

- Actual Start Date: 15/06/1997
- Modified Start Date: 15/06/1997
- Cost: 100.000,00 DEM (without tax)
- Asset Life: 10 years (120 life periods)

The tables below show the depreciation of an asset when using depreciation method 25:

<b>Year</b>	<b>End of Year Date</b>	<b>Accumulated Depreciation</b>	<b>Depreciation Expense</b>
1997	31/12/1997	-5.476,45	5.476,45
1998	31/12/1998	-9.994,52	9.994,52
1999	31/12/1999	-9.994,52	9.994,52
2000	31/12/2000	-10.021,91	10.021,91
2001	31/12/2001	-9.994,52	9.994,52
2002	31/12/2002	-9.994,52	9.994,52
2003	31/12/2003	-9.994,53	9.994,53

2004	31/12/2004	-10.021,91	10.021,91
2005	31/12/2005	-4.507,12	4.507,12
2006	31/12/2006		
2007	31/12/2007		

Year	2nd Accumulated Depreciation	2nd Depreciation Expense	Rule 1 Calculation	Rule 2 Calculation
1997			$100.000 / 3652 * 200 \text{ days}$	
1998			$(100.000 - 5.476,45) / 3452 * 365 \text{ days}$	
1999			$(100.00 - 15.470,97) / 3087 * 365 \text{ days}$	
2000			$(100.000 - 25.465,49) / 2722 * 366 \text{ days}$	
2001			$(100.000 - 35.487,40) / 2356 * 365 \text{ days}$	
2002			$(100.000 - 45.481,92) / 1991 * 365 \text{ days}$	
2003			$(100.000 - 55.476,44) / 1626 * 365 \text{ days}$	
2004			$(100.000 - 65.470,97) / 1261 * 365 \text{ days}$	
2005	-8.156,42	8.156,42	$100.000 - 20.000 - 75.492,88$	$20.000 / 895 * 365 \text{ days}$
2006	-8.156,43	8.156,43	$(100.000 - 35.487,40) / 2356 * 365 \text{ days}$	$(20.000 - 8.156,42) / 530 * 365 \text{ days}$
2007	-3.687,15	3.687,15		$(20.000 - 16.312,85) / 165 * 165 \text{ days}$

---

**Note**

Remaining basis uses the investment tax credit as a salvage value to stop depreciating. AAls (SDA and SDE1) for secondary accounts were set up.

---

The following table explains the requirements for method 25:

<b>Asset life</b>	The demonstration data includes a version of method 25 for an asset life of 120 life periods.
<b>Balance adjustments</b>	<ul style="list-style-type: none"> <li>• Year-end with annual depreciation</li> <li>• Apportioned by period in the year, based on percent</li> </ul>
<b>Modified start date</b>	The modified start date is the actual start date.
<b>Conventions</b>	<ul style="list-style-type: none"> <li>• Secondary Accounts are set to two accumulated depreciation accounts and to two depreciation expense accounts.</li> <li>• Allow Over Depreciation is set to not exceed adjusted basis and continue beyond the asset's life.</li> <li>• Disposal Conventions is set to the actual disposal date.</li> </ul>
<b>Life year rules</b>	<ul style="list-style-type: none"> <li>• Life years 1 to 998 take straight line for rule 1 with Investment Tax Credit as part of salvage.</li> <li>• Start depreciating the Investment Tax Credit in a separate account in the eighth year.</li> </ul>
<b>Calculations</b>	<ul style="list-style-type: none"> <li>• Remaining number of days are used for straight line.</li> <li>• Remaining number of days are used for straight line of the Investment Tax Credit, which is used as basis.</li> </ul>
<b>Disposals</b>	Method 25 has no disposal rules.

## German Replacement Cost (Method 26)

---

For the example that follows, the following assumptions apply:

- Actual Start Date: 15/06/1997
- Modified Start Date: 01/06/1997
- Cost: 100.000,00 DEM (without tax)
- Asset Life: 5 years (60 life periods)

The table below shows the depreciation of an asset when using depreciation method 26:

Year	End of Year Date	GL Statistic	Accumulated Depreciation	Depreciation Expense	Rule 1 Calculation
1997	31/12/1997	95.000	-10.000	10.000	100.00 / 95.000 * 95.000
1998	31/21/1998	90.000	-9.473,68	9.473,68	100.00 / 95.000 * 90.000
1999	31/12/1999	85.000	-8.947,37	8.947,37	100.00 / 95.000 * 85.000
2000	31/12/2000	80.000	-8.421,05	8.421,05	100.00 / 95.000 * 80.000
2001	31/12/2001	75.000	-7.894,74	7.894,74	100.00 / 95.000 * 75.000
2002	31/12/2002	70.000	-7.368,42	7.368,42	100.00 / 95.000 * 70.000

---

**Note**

The AAI (DS4) must be set up for the GL Statistic. The GL Statistic must come from the AU ledger type. Other ledger types can be retrieved with elements from both Asset Account Balances File table (F1202) and the Account Balances table (F0902) balances. The calculation can continue beyond the asset's life.

---

The following table explains the requirements for method 26:

<b>Asset life</b>	The demonstration data includes a version of method 26 for an asset life of 60 life periods.
<b>Balance adjustments</b>	<ul style="list-style-type: none"><li>• Year-end with annual depreciation</li><li>• Apportioned by period in the year, based on percent</li></ul>
<b>Modified start date</b>	The modified start date is the start of the period.
<b>Conventions</b>	Allow Over Depreciation is set to not exceed adjusted basis and continue beyond the asset's life.
<b>Life year rules</b>	Life years 1 to 998 use the formula calculation.
<b>Calculations</b>	Use the cost divided by the insurance value and multiplied by the G/L Actual Unit Statistic.
<b>Disposals</b>	Method 26 has no disposal rules.

---

**Italy Straight Line (Method 27)**

---

For the example that follows, the following assumptions apply:

- Actual Start Date: 15/04/1997
- Modified Start Date: 01/01/1997
- Cost: 10.000.000 ITL (without tax)
- Asset Life: 5 years (60 life periods)

The table below shows the depreciation of an asset when using depreciation method 27:

<b>Year</b>	<b>End of Year Date</b>	<b>Accumulated Depreciation</b>	<b>Depreciation Expense</b>	<b>Calculation</b>
1997	31/12/1997		2.000.000	10.000.000 / 60 / 12
1998	31/12/1998	-2.000.000	2.000.000	10.000.000 / 60 / 12
1999	31/12/1999	-2.000.000	2.000.000	10.000.000 / 60 / 12
2000	31/12/2000	-2.000.000	2.000.000	10.000.000 / 60 / 12
2001	31/12/2001	-2.000.000	2.000.000	10.000.000 / 60 / 12

---

**Note**

Because the asset's life starts at the beginning of the fiscal year, the asset is fully depreciated in five complete years.

---

The following table explains the requirements for method 27:

<b>Asset life</b>	The demonstration data includes a version of method 27 for an asset life of 36, 60, and 120 life periods.
<b>Balance adjustments</b>	<ul style="list-style-type: none"><li>• Year-end with annual depreciation</li><li>• Apportioned by period in the year, based on percent</li></ul>
<b>Modified start date</b>	The modified start date is the whole year.
<b>Conventions</b>	No conventions are needed.
<b>Life year rules</b>	Life year 1 to the year-end of the asset
<b>Calculations</b>	<ul style="list-style-type: none"><li>• Formulas calculate a year of straight line depreciation for the whole year.</li><li>• Basis includes the salvage value.</li></ul>
<b>Disposals</b>	Method 27 has no disposal rules.

---

**Italy Anticipated (Method 28)**

---

For the example that follows, the following assumptions apply:

- Actual Start Date: 15/04/1997
- Modified Start Date: 01/01/1997
- Cost: 10.000.000 ITL (without tax)
- Asset Life: 4 years (48 life periods)

The tables below show the depreciation of an asset when using depreciation method 28:

<b>Year</b>	<b>End of Year Date</b>	<b>Accumulated Depreciation</b>	<b>Depreciation Expense</b>
1997	31/12/1997	-1.500.000	1.500.000
1998	31/12/1998	-1.500.000	1.500.000
1999	31/12/1999	-1.500.000	1.500.000
2000	31/12/2000	-1.000.000	1.000.000

<b>Year</b>	<b>2nd Accumulated Depreciation</b>	<b>2nd Depreciation Expense</b>	<b>Rule 1 Calculation</b>	<b>Rule 2 Calculation</b>
-------------	-------------------------------------	---------------------------------	---------------------------	---------------------------

1997	-1.500.000	1.500.000	10.000.000 * 15%	10.000.000 * 15%
1998	-1.500.000	1.500.000	10.000.000 * 15%	10.000.000 * 15%
1999	-1.500.000	1.500.000	10.000.000 * 15%	10.000.000 * 15%
2000			10.000.000 -30.000.00	-30.000.00

---

### Note

The AAls (SDA and SDE1) need to be set up for the secondary accounts. Other variations of the anticipated life-year percent are set up with method 28.

---

The following table explains the requirements for method 28:

<b>Asset life</b>	The demonstration data includes a version of method 28 for an asset life of 48 life periods at 15%, 48 life periods at 20%, 60 life periods at 30%, and 84 life periods at 10%.
<b>Balance adjustments</b>	<ul style="list-style-type: none"> <li>• Year-end with annual depreciation</li> <li>• Apportioned by period in the year, based on percent</li> </ul>
<b>Modified start date</b>	The modified start date is the whole year.
<b>Conventions</b>	<ul style="list-style-type: none"> <li>• Secondary Accounts are set to two accumulated depreciation accounts and to two depreciation expense accounts.</li> <li>• Allow Over Depreciation is set to not exceed adjusted basis and continue beyond the asset's life.</li> </ul>
<b>Life year rules</b>	<ul style="list-style-type: none"> <li>• Life year 1 to 3 times 15%.</li> <li>• Life year 4 takes the remaining basis in the primary rule (through year 998).</li> </ul>
<b>Calculations</b>	<ul style="list-style-type: none"> <li>• Multiply cost by 15%.</li> <li>• Basis includes the salvage value.</li> </ul>
<b>Disposals</b>	Method 28 has no disposal rules.

## Italy Complete (Method 29)

---

For the example that follows, the following assumptions apply:

- Actual Start Date: 15/04/1997
- Modified Start Date: 01/01/1997
- Cost: 10.000.000 ITL (without tax)
- Asset Life: 1 year (12 life periods)

The table below shows the depreciation of an asset when using depreciation method 29:

Year	End of Year Date	Accumulated Depreciation	Depreciation Expense	Calculation
1997	31/12/1997	-10.000.000	10.000.000	10.000.000

---

#### Note

The requirement to depreciate only assets with a cost under 1.000.000 lira can be done with data selection that is less than the amount in the Asset Account Balance File table (F1202) for Year to Date Amount (FLAPYN) or the Balance Forward (FLAPYC).

---

The following table explains the requirements for method 29:

<b>Asset life</b>	The demonstration data includes a version of method 29 for an asset life of 12 life periods.
<b>Balance adjustments</b>	<ul style="list-style-type: none"> <li>• Year-end with annual depreciation</li> <li>• Apportioned by period in the year, based on percent</li> </ul>
<b>Modified start date</b>	The modified start date is the whole year.
<b>Conventions</b>	No conventions are needed.
<b>Life Year Rules</b>	Life year 1 to 1
<b>Calculations</b>	<ul style="list-style-type: none"> <li>• Fully depreciate cost.</li> <li>• Basis includes the salvage value.</li> </ul>
<b>Disposals</b>	Method 29 has no disposal rules.

## Spain Declining Balance (Method 30)

---

For the example that follows, the following assumptions apply:

- Actual Start Date: 11/07/1997
- Modified Start Date: 11/07/1997
- Cost: 10.000.000 ESP (without tax)
- Asset Life: 6.66 years (72 life periods)

The table below shows the depreciation of an asset when using depreciation method 30:

Year	End of Year Date	Accumulated Depreciation	Depreciation Expense	Calculation
1997	31/12/1997	-1.430.137	1.430.137	$10.000.000 * 30\% * (174 / 365)$ Days
1998	31/12/1998	-2.570.959	2.570.959	$(10.000.000 - 1.430.137 * 30\%$
1999	31/12/1999	-1.799.671	1.799.671	$(10.000.000 - 4.001.096) * 30\%$

2000	31/12/2000	-1.259.770	1.259.770	(10.000.000 - 5.800.7670 * 30%
2001	31/12/2001	-881.839	881.839	(10.000.000 - 7.060.537) * 30%
2002	31/12/2002	-617.287	617.287	(10.000.000 - 7.942.376 * 30%
2003	31/12/2003	-1.440.337	1.440.337	10.000.000 - 8.559.663

---

**Note**

Life year 7 automatically depreciates to remaining basis.

---

The following table explains the requirements for method 30:

<b>Asset life</b>	The demonstration data includes a version of method 30 for an asset life of 72 life periods.
<b>Balance adjustments</b>	<ul style="list-style-type: none"> <li>• Year-end with annual depreciation</li> <li>• Apportioned by period in the year, based on percent</li> </ul>
<b>Modified start date</b>	The modified start date is the actual start date, next period date, or start of period.
<b>Conventions</b>	Disposal convention is the actual disposal date with the actual start date.
<b>Life year rules</b>	<ul style="list-style-type: none"> <li>• Life year 1 to 1 declining balance with initial year apportionment.</li> <li>• Life year 2 to 6 declining balance.</li> <li>• Life year 7 is remaining basis.</li> </ul>
<b>Calculations</b>	<ul style="list-style-type: none"> <li>• Declining balance of 30%.</li> <li>• Basis includes the salvage value.</li> </ul>
<b>Disposals</b>	Method 30 has no disposal rules.

## Czechoslovakia % Rate (Method 31)

---

For the example that follows, the following assumptions apply:

- Actual Start Date: 15/05/1997
- Modified Start Date: 01/01/1997
- Cost: 90.000 CSK (without tax)
- Asset Life: 4 years (48 life periods)

The table below shows the depreciation of an asset when using depreciation method 31:

Year	End of Year Date	Accumulated Depreciation	Depreciation Expense	Calculation
1997	31/12/1997	-12.780	12.780	90.000 * 14.2% * (12 / 12) Periods in Year

1998	31/12/1998	-25.740	25.740	90.000 * 28.6% * (12 / 12) Periods in Year
1999	31/12/1999	-25.740	25.740	90.000 * 28.6% * (12 / 12) Periods in Year
2000	31/12/2000	-25.740	25.740	90.000 * 28.6% * (12 / 12) Periods in Year
2001	31/12/2001			90.000 - 90.000

---

### Note

The compute direction by period uses the life year reference to calculate the percent rate based on the asset's life and not a fiscal year. The compute direction for current year calculates the percent rate based on a fiscal year and apportions the first year differently, depending on the start date of the asset. The five-year methods apply a different percent rate in later years.

---

The following table explains the requirements for method 31:

<b>Asset life</b>	The demonstration data includes a version of method 31 for an asset life of 48 and 60 life periods.
<b>Balance adjustments</b>	<ul style="list-style-type: none"> <li>• Year-end with annual depreciation</li> <li>• Apportioned by period in the year, based on percent</li> <li>• Period with life year reference</li> </ul>
<b>Modified start date</b>	The modified start date is the whole year, midyear, or start of period.
<b>Conventions</b>	<ul style="list-style-type: none"> <li>• No conventions are needed for current year compute direction.</li> <li>• Disposal convention is set for the midyear modified start date.</li> <li>• Life year reference is needed for compute direction by period.</li> </ul>
<b>Life year rules</b>	<ul style="list-style-type: none"> <li>• Life year 1 to 1, including initial year apportionment.</li> <li>• Life year 2 to 4 percent rate.</li> <li>• Life year 5 is remaining basis.</li> </ul>
<b>Calculations</b>	<ul style="list-style-type: none"> <li>• Basis times the percent rate of 14.2 for the 1st year and 28.6 for every year thereafter.</li> <li>• Basis includes the salvage value.</li> </ul>
<b>Disposals</b>	Method 31 has no disposal rules.

## Japan Fixed Installment (Method 32)

---

For the example that follows, the following assumptions apply:

- Actual Start Date: 15/05/1997

- Modified Start Date: 2/7/1997
- Cost: 10.000 JPY (without tax)
- Salvage: 10% of cost
- Asset Life: 5 years (60 life periods)

The table below shows the depreciation of an asset when using depreciation method 32:

Year	End of Year Date	Accumulated Depreciation	Depreciation Expense	Calculation
1997	31/12/1997	-900	900	$9.000 * 20\% * (6 / 12)$ Periods in Year
1998	31/12/1998	-1.800	1.800	$9.000 * 20\% * (12 / 12)$ Periods in Year
1999	31/12/1999	-1.800	1.800	$9.000 * 20\% * (12 / 12)$ Periods in Year
2000	31/12/2000	-1.800	1.800	$9.000 * 20\% * (12 / 12)$ Periods in Year
2001	31/12/2001	-1.800	1.800	$9.000 * 20\% * (12 / 12)$ Periods in Year
2002	31/12/2002	-900	900	$10.000 - 8.100 + 1.000$

---

**Note**

The years for a five-year asset overlap into a sixth fiscal year due to the initial term of apportionment.

---

The following table explains the requirements for method 32:

<b>Asset life</b>	The demonstration data includes versions of method 32 for an asset life of 60 life periods.
<b>Balance adjustments</b>	<ul style="list-style-type: none"> <li>• Year-end with annual depreciation</li> <li>• Apportioned by period in the year, based on percent</li> </ul>
<b>Modified start date</b>	The modified start date is the midyear, start of period, or half-year.
<b>Conventions</b>	Disposal conventions are set for modified start dates of midyear and half-year.
<b>Life year rules</b>	<ul style="list-style-type: none"> <li>• Life year 1 to 5 at a fixed rate percent.</li> <li>• Life year 6 is remaining basis.</li> </ul>
<b>Calculations</b>	<ul style="list-style-type: none"> <li>• Basis times the percent rate of 20%.</li> <li>• Basis includes the salvage value.</li> </ul>
<b>Disposals</b>	Method 32 has no disposal rules.

## Japan Declining Balance (Method 33)

---

For the example that follows, the following assumptions apply:

- Actual Start Date: 15/05/1997
- Modified Start Date: 2/7/1997
- Cost: 10.000 JPY (without tax)
- Salvage: 10% of cost
- Asset Life: 5 years (60 life periods)

The table below shows the depreciation of an asset when using depreciation method 33:

Year	End of Year Date	Accumulated Depreciation	Depreciation Expense	Calculation
1997	31/12/1997	-1.845	1.845	$10.000 * 36.9\% * (6 / 12)$ Periods in Year
1998	31/12/1998	-3.009	3.009	$(10.000 - 1.845) * 36.9\% * (12 / 12)$ Periods in Year
1999	31/12/1999	-1.899	1.899	$(10.000 - 4.854) * 36.9\% * (12 / 12)$ Periods in Year
2000	31/12/2000	-1.198	1.198	$(10.000 - 6.753) * 36.9\% * (12 / 12)$ Periods in Year
2001	31/12/2001	-756	756	$(10.000 - 7.951) * 36.9\% * (12 / 12)$ Periods in Year
2002	31/12/2002	-293	293	$10.000 - 8.707 + 1.000$

---

### Note

The years for a five-year asset overlap into a sixth fiscal year due to the initial term of apportionment.

---

The following table explains the requirements for method 33:

<b>Asset life</b>	The demonstration data includes versions of method 33 for an asset life of 60 life periods.
<b>Balance adjustments</b>	<ul style="list-style-type: none"> <li>• Year-end with annual depreciation</li> <li>• Apportioned by period in the year, based on percent</li> </ul>
<b>Modified start date</b>	The modified start date is the midyear, start of period, or half-year.
<b>Conventions</b>	Disposal conventions are set for modified start dates of midyear and half year.
<b>Life year rules</b>	<ul style="list-style-type: none"> <li>• Life year 1 to 5 at a fixed rate percent.</li> <li>• Life year 6 is remaining basis, including salvage.</li> </ul>
<b>Calculations</b>	<ul style="list-style-type: none"> <li>• Basis times the percent rate of 36.9%, including accumulated depreciation.</li> <li>• Basis includes the salvage value.</li> </ul>
<b>Disposals</b>	Method 33 has no disposal rules.

## Japan Beginning Special (Method 34)

---

For the example that follows, the following assumptions apply:

- Actual Start Date: 15/05/1997
- Modified Start Date: 2/7/1997
- Cost: 10.000 JPY (without tax)
- Salvage: 10% of cost
- Asset Life: 5 years (60 life periods)

The tables below show the depreciation of an asset when using depreciation method 34:

Year	End of Year Date	Accumulated Depreciation	Depreciation Expense
------	------------------	--------------------------	----------------------

1997	31/12/1997	-1.845	1.845
1998	31/12/1998	-2.456	2.456
1999	31/12/1999	-1.549	1.549
2000	31/12/2000	-978	978
2001	31/12/2001	-617	617
2002	31/12/2002	-55	55

Year	2nd Accumulated Depreciation	2nd Depreciation Expense	Rule 1 Calculation	Rule 2 Calculation
1997	-1.500	1.500	10.000 * 36.9% (6 / 12) Periods	10.000*15%

1998	$10.000 * 36.9\% * (12 / 12)$ Periods
1999	$(10.000 - 5.801) * 36.9\% * (12 / 12)$ Periods
2000	$(10.000 - 7.350) * 36.9\% * (12 / 1)$ Periods
2001	$(10.000 - 8.328) * 36.9\% * (12 / 12)$ Periods
2002	$(10.000 - 8.945) - 1.000$

This example uses primary and secondary rules. The demonstration data also includes a version using primary rules only. The primary and secondary rules use current year to date. The primary rules use only remaining compute direction.

---

### Note

The SDA and SDE1 AAls need to be set up for the secondary accounts. The AAls can be set up with the same account as the primary accounts. These calculations can be done using only primary rules by including the secondary calculations within the primary rule formulas.

---

The following table explains the requirements for method 34:

<b>Asset life</b>	The demonstration data includes versions of method 34 for an asset life of 60 life periods.
<b>Balance adjustments</b>	<ul style="list-style-type: none"> <li>• Year-end with annual depreciation</li> <li>• Apportioned by period in the year, based on percent</li> </ul>
<b>Modified start date</b>	The modified start date is the midyear, start of period, or half-year.
<b>Conventions</b>	<ul style="list-style-type: none"> <li>• The secondary account percent is set to allow two accumulated depreciation accounts and two depreciation expense accounts.</li> <li>• The disposal convention matches the midyear and half-year initial term apportionment.</li> </ul>
<b>Life year rules</b>	<ul style="list-style-type: none"> <li>• Life year 1 to 5 at a fixed rate percent.</li> <li>• Secondary rule 1 to 1 takes an extra 15% the first year.</li> <li>• Life year 6 is remaining basis (primary and secondary accounts), including salvage.</li> </ul>
<b>Calculations</b>	<ul style="list-style-type: none"> <li>• Basis times the percent rate of 36.9%, including accumulated depreciation.</li> <li>• Basis includes the salvage value.</li> </ul>
<b>Disposals</b>	Method 34 has no disposal rules.

## Japan Accelerated (Method 35)

---

For the example that follows, the following assumptions apply:

- Actual Start Date: 15/05/1997

- Modified Start Date: 2/7/1997
- Cost: 10.000 JPY (without tax)
- Salvage: 10% of cost
- Asset Life: 7 years (84 life periods)

The tables below show the depreciation of an asset when using depreciation method 35:

Year	End of Year Date	Accumulated Depreciation	Depreciation Expense
1997	31/12/1997	-1.400	1.400
1998	31/12/1998	-2.337	2.337
1999	31/12/1999	-1.572	1.572
2000	31/12/2000	-1.057	1.057
2001	31/12/2001	-714	714
2002	31/12/2002	-484	484
2003	31/12/2003	-244	244

Year	2nd Accumulated Depreciation	2nd Depreciation Expense	Rule 1 Calculation	Rule 2 Calculation
1997	-252	252	$10.000 * 28\% * (6 / 12) \text{ Periods}$	$10.000 * 28\% * (6 / 12) \text{ Periods} * 18\%$
1998	-397	397	$(10.000 - 1.400 - 252) * 28\% * (12 / 12) \text{ Periods} * 17\%$	$(10.000 - 1.400 - 252) * 28\% * (12 / 12) \text{ Periods} * 17\%$
1999	-267	267	$(10.000 - 3.737 - 649) * 28\% * (12 / 12) \text{ Periods}$	$(10.000 - 3.737 - 649) * 28\% * (12 / 12) \text{ Periods} * 17\%$
2000	-169	169	$(10.000 - 5.309 - 916) * 28\% * (12 / 12) \text{ Periods}$	$(10.000 - 5.309 - 916) * 28\% * (12 / 12) \text{ Periods} * 16\%$
2001	-107	107	$(10.000 - 6.366 - 1.085) * 28\% * (12 / 12) \text{ Periods}$	$(10.000 - 6.366 - 1.085) * 28\% * (12 / 12) \text{ Periods} * 15\%$
2002			$(10.000 - 7.080 - 1.192) * 28\% * (12 / 12) \text{ Periods}$	
2003			$10.000 - 7.564 - 1.192 - 1000$	

This example uses primary and secondary rules. The demonstration data also includes a version using primary rules only. The primary and secondary rules use current year to date. The primary rules use only remaining compute direction.

---

**Note**

The SDA and SDE1 AAls need to be set up for the secondary accounts. The AAls can be set up with the same account as the primary accounts. These calculations can be done using only primary rules by including the secondary calculations within the primary rule formulas.

---

The following table explains the requirements for method 35:

<b>Asset life</b>	The demonstration data includes versions of method 35 for an asset life of 84 life periods.
<b>Balance adjustments</b>	<ul style="list-style-type: none"><li>• Year-end with annual depreciation</li><li>• Apportioned by period in the year, based on percent</li></ul>
<b>Modified start date</b>	The modified start date is the midyear, start of period, or half-year.
<b>Conventions</b>	<ul style="list-style-type: none"><li>• The secondary account percent is set to allow two accumulated depreciation accounts and two depreciation expense accounts.</li><li>• The disposal convention matches the midyear and half-year initial term apportionment.</li></ul>
<b>Life year rules</b>	<ul style="list-style-type: none"><li>• Primary rule life year 1 to 6 at a declining rate of 28%.</li><li>• Primary rule life year 7 is remaining basis (primary and secondary accounts), including salvage.</li><li>• Secondary rule life year 1 takes 18% of the declining balance.</li><li>• Secondary rule life years 2 to 3 take 17% of the declining balance.</li><li>• Secondary rule life year 4 takes 16% of the declining balance.</li><li>• Secondary rule life year 5 takes 15% of the declining balance.</li></ul>
<b>Calculations</b>	<ul style="list-style-type: none"><li>• Basis times the percent rate of 28%, including accumulated depreciation.</li><li>• Basis includes the salvage value.</li></ul>
<b>Disposals</b>	Method 35 has no disposal rules.

---

## Japan Increased (Method 36)

---

For the example that follows, the following assumptions apply:

- Actual Start Date: 15/05/1997
- Modified Start Date: 2/7/1997
- Cost: 10.000 JPY (without tax)
- Salvage: 10% of cost
- Asset Life: 7 years (84 life periods)

The tables below show the depreciation of an asset when using depreciation method 36:

<b>Year</b>	<b>End of Year Date</b>	<b>Accumulated Depreciation</b>	<b>Depreciation Expense</b>
-------------	-------------------------	---------------------------------	-----------------------------

1997	31/12/1997	-1.400	1.400
1998	31/12/1998	-2.353	2.353
1999	31/12/1999	-1.579	1.579
2000	31/12/2000	-1.137	1.137
2001	31/12/2001	-785	785
2002	31/12/2002	-529	529
2003	31/12/2003	-261	261

Year	2nd Accumulated Depreciation	2nd Depreciation Expense	Rule 1 Calculation	Rule 2 Calculation
1997	-196	196	$10.000 * 28\% * (6 / 12) \text{ Periods}$	$10.000 * 28\% * (6 / 12) \text{ Periods} * 14\%$
1998	-412	412	$(10.000 - 1.400 - 196) * 28\% * (12 / 12) \text{ Periods}$	$(10.000 - 1.400 - 196) * 28\% * (12 / 12) \text{ Periods} * 17.5\%$
1999			$(10.000 - 3.737 - 649) * 28\% * (12 / 12) \text{ Periods}$	< 10%
2000	-119	119	$(10.000 - 5.332 - 608) * 28\% * (12 / 12) \text{ Periods}$	$(10.000 - 5.332 - 608) * 28\% * (12 / 12) \text{ Periods} * 10.5\%$
2001	-130	130	$(10.000 - 6.469 - 727) * 28\% * (12 / 12) \text{ Periods}$	$(10.000 - 6.469 - 727) * 28\% * (12 / 12) \text{ Periods} * 16.62\%$
2002	-99	99	$(10.000 - 7.254 - 857) * 28\% * (12 / 12) \text{ Periods}$	$(10.000 - 7.254 - 857) * 28\% * (12 / 12) \text{ Periods} * 18.72\%$
2003			$10.000 - 7.783 - 956 - 1000$	

This example uses primary and secondary rules. The demonstration data also includes a version using primary rules only. The primary and secondary rules use current year-to-date. The primary uses only remaining compute direction.

---

**Note**

The SDA and SDE1 AAls need to be set up for the secondary accounts. The AAls can be set up with the same account as the primary accounts. These calculations can be done using only primary rules by including the secondary calculations within the primary rule formulas.

---

The following table explains the requirements for method 36:

<b>Asset life</b>	The demonstration data includes versions of method 36 for an asset life of 84 life periods.
<b>Balance adjustments</b>	<ul style="list-style-type: none"> <li>• Year-end with annual depreciation</li> <li>• Apportioned by period in the year based on percent</li> </ul>
<b>Modified start date</b>	The modified start date is the midyear, start of period, or half-year.
<b>Conventions</b>	<ul style="list-style-type: none"> <li>• The secondary account percent is set to allow two accumulated depreciation accounts and two depreciation expense accounts.</li> <li>• The disposal convention matches the midyear and half-year initial term apportionment.</li> </ul>
<b>Life year rules</b>	<ul style="list-style-type: none"> <li>• Primary rule life years 1 to 6 at a declining rate of 28%.</li> <li>• Primary rule life year 7 is remaining basis (primary and secondary accounts), including salvage.</li> <li>• Secondary rule life year 1 takes 14% of the declining balance.</li> <li>• Secondary rule life year 2 takes 17.5% of the declining balance.</li> <li>• Secondary rule life year 3 takes 7%; but since it is less than 10%, no balances are adjusted.</li> <li>• Secondary rule life year 4 takes 10.5% of the declining balance.</li> <li>• Secondary rule life year 5 takes 16.2% of the declining balance.</li> <li>• Secondary rule life year 6 takes 18.72% of the declining balance.</li> </ul>
<b>Calculations</b>	<ul style="list-style-type: none"> <li>• Basis times the percent rate of 28% including accumulated depreciation.</li> <li>• Basis includes the salvage value.</li> </ul>
<b>Disposals</b>	Method 36 has no disposal rules.

## Japan Excess (Method 37)

---

For the example that follows, the following assumptions apply:

- Actual Start Date: 15/05/1997
- Modified Start Date: 2/7/1997
- Cost: 10.000 JPY (without tax)
- Salvage: 10% of cost
- Asset Life: 5 years (60 life periods)

The tables below show the depreciation of an asset when using depreciation method 37:

Year	End of Year Date	Accumulated Depreciation	Depreciation Expense
1997	31/12/1997	-900	900
1998	31/12/1998	-1.800	1.800
1999	31/12/1999	-1.800	1.800

2000	31/12/2000	-1.800	1.800	
2001	31/12/2001	-1.800	1.800	
2002	31/12/2002	-900	900	
<b>Year</b>	<b>2nd Accumulated Depreciation</b>	<b>2nd Depreciation Expense</b>	<b>Rule 1 Calculation</b>	<b>Rule 2 Calculation</b>
1997	-540	540	$10.000 - 1.000 * 20\% * (6 / 12)$ Periods * 60%	$10.000 - 1.000 * 20\% * (6 / 12)$ Periods * 60%
1998	-1.080	1.080	$10.000 - 1.000 * 20\% * (12 / 12)$ Periods	$10.000 - 1.000 * 20\% * (12 / 12)$ Periods * 60%
1999	-1.080	1.080	$10.000 - 1.000 * 20\% * (12 / 12)$ Periods	$10.000 - 1.000 * 20\% * (12 / 12)$ Periods * 60%
2000	-1.080	1.080	$10.000 - 1.000 * 20\% * (12 / 12)$ Periods	$10.000 - 1.000 * 20\% * (12 / 12)$ Periods * 60%
2001	-1.080	1.080	$10.000 - 1.000 - * 20\% * (12 / 12)$ Periods	$10.000 - 1.000 * 20\% * (12 / 12)$ Periods * 60%
2002	-540	540	$10.000 - 1.000 * 20\% * (6 / 12)$ Periods	$10.000 - 1.000 * 20\% * (6 / 12)$ Periods * 60%

This example uses primary and secondary rules. The demonstration data also includes a version using primary rules only. The primary and secondary rules use current year-to-date. The primary rules use only remaining compute direction.

---

#### Note

The SDA and SDE1 AAls need to be set up for the secondary accounts. The AAls can be set up with the same account as the primary accounts. These calculations can be done using only primary rules by including the secondary calculations within the primary rule formulas.

---

The following table explains the requirements for method 37:

<b>Asset life</b>	The demonstration data includes versions of method 37 for an asset life of 60 life periods.
<b>Balance adjustments</b>	<ul style="list-style-type: none"> <li>Year-end with annual depreciation</li> <li>Apportioned by period in the year, based on percent</li> </ul>
<b>Modified start date</b>	The modified start date is the midyear, start of period, or half-year.
<b>Conventions</b>	<ul style="list-style-type: none"> <li>The secondary account percent is set to allow two accumulated depreciation accounts and two depreciation expense accounts.</li> <li>The disposal convention matches the midyear and half-year initial term apportionment.</li> </ul>

- Life year rules**
- Primary rule life years 1 to 5 at a declining rate of 20%.
  - Primary rule life year 6 is remaining basis of the primary accounts, including salvage.
  - Secondary rule life year 1 to 5 take 60% at a declining rate of 20%.
  - Secondary rule life year 6 takes 60% of the remaining basis of the primary account, including salvage.
- Calculations**
- Basis times the percent rate of 20% including accumulated depreciation.
  - Basis includes the salvage value.
- Disposals**            Method 37 has no disposal rules.

## Japan Salvage (Method 38)

---

For the example that follows, the following assumptions apply:

- Actual Start Date: 15/05/1997
- Modified Start Date: 2/7/1997
- Cost: 10.000 JPY (without tax)
- Salvage: 5% of cost
- Asset Life: 5 years (60 life periods)

The table below shows the depreciation of an asset when using depreciation method 38:

Year	End of Year Date	Accumulated Depreciation	Depreciation Expense	Calculation
1997	31/12/1997	-1.845	1.845	$10.000 * 36.9\% * (6 / 12)$ Periods
1998	31/12/1998	-3.009	3.009	$(10.000 - 1.845) * 36.9\%$
1999	31/12/1999	-1.899	1.899	$(10.000 - 4.854) * 36.9\%$
2000	31/12/2000	-1.198	1.198	$(10.000 - 6.753) * 36.9\%$
2001	31/12/2001	-756	756	$(10.000 - 7.951) * 36.9\%$
2002	31/12/2002	-477	477	$(10.000 - 8.707) * 36.9\%$
2003	31/12/2003	-301	301	$(10.000 - 9.184) * 36.9\%$
2004	31/12/2004	-15	15	$(10.000 - 9.485) - 500$

This example stops at 5% of cost with the current year compute direction. The demonstration data also includes a depreciation version to 1 yen past the 5% salvage value, using the remaining compute direction.

---

**Note**

Depreciation to 1 yen can be accomplished by using remaining compute direction. The asset's life is 5 years, but depreciation of salvage continues beyond the asset's life.

---

The following table explains the requirements for method 38:

<b>Asset life</b>	The demonstration data includes versions of method 38 for an asset life of 60 life periods.
<b>Balance adjustments</b>	<ul style="list-style-type: none"><li>• Year-end with annual depreciation</li><li>• Apportioned by period in the year, based on percent</li></ul>
<b>Modified start date</b>	The modified start date is the midyear, start of period, or half-year.
<b>Conventions</b>	<ul style="list-style-type: none"><li>• Disposal conventions are set for the modified start dates of midyear and half-year.</li><li>• Set the convention to allow depreciation beyond the asset life but not to exceed remaining basis.</li></ul>
<b>Life year rules</b>	<ul style="list-style-type: none"><li>• Life year 1 to 1 uses a fixed rate percent of 36.9% with the initial periods apportionment.</li><li>• Life years 2 to 8 uses fixed rate percent of 36.9.</li><li>• Life years 9 to 10 uses formulas to depreciate the 5% of salvage for three years (DIR1 = Remaining).</li><li>• Life years 11 and onward depreciate to remaining basis of 1 year (DIR1 = Remaining).</li></ul>
<b>Calculations</b>	<ul style="list-style-type: none"><li>• Basis times the percent rate of 36.9%.</li><li>• Basis includes the salvage value.</li></ul>
<b>Disposals</b>	Method 38 has no disposal rules.

---

**Japan Reserve Reduction (Method 39)**

---

For the example that follows, the following assumptions apply:

- Actual Start Date: 15/05/1997
- Modified Start Date: 2/7/1997
- Cost: 20,000,000 JPY (without tax)
- Salvage: 10% of cost
- Investment Tax Credit: 10,000,000 JPY (government-subsidized amount for tax depreciation)
- Asset Life: 20 years (240 life periods)

The tables below show the depreciation of an asset when using depreciation method 39:

**Year End of Year Date    Accumulated Depreciation  
   Depreciation Expense**

1997 31/12/1997	-1.090.000	1.090.000
1998 31/12/1998	-2.061.190	2.061.190
1999 31/12/1999	-1.836.520	1.836.520
2000 31/12/2000	-1.636.340	1.636.340
2001 31/12/2001	-1.457.979	1.457.979
...		
2016 31/12/2016	-258.176	258.176
2017 31/12/2017	-110.415	110.415

Year	2nd Accumulated Depreciation	2nd Depreciation Expense	Rule 1 Calculation	Rule 2 Calculation
1997	-545	545	20.000.000 * 10.9% * (6 / 12) Periods	20.000.000 - 10.000.000 * 10.9% * (6 / 12) Periods
1998	-1.030.595	1.030.595	(20.000.000 - 1.090.000) * 10.9%	(20.000.000 - 10.000.000 - 545.000) * 10.9%
1999	-918.260	918.260	(20.000.000 - 3.151.190) * 10.9%	(20.000.000 - 10.000.000 - 1.575.595) * 10.9%
2000	-818.170	818.170	(20.000.000 - 4.987.710) * 10.9%	20.000.000 - 10.000.000 - 2.493.855) * 10.9%
2001	-728.989	728.989	(20.000.000 - 6.624.050) * 10.9%	(20.000.000 - 10.000.000 - 3.312.025) * 10.9%
...				
2016	-129.088	129.088	(20.000.000 - 17.631.409) * 10.9%	(20.000.000 - 10.000.000 - 8.815.703) * 10.9%
2017	-55.209	55.209	20.000.000 - 2.000.000 - 17.889.585	20.000.000 - 10.000.000 - 1.000.000 - 8.944.791

---

**Note**

The SDA and SDE1 AAls need to be set up for the secondary accounts. The secondary rules could be set up as primary rules so that only the subsidized tax amount is depreciated.

---

The following table explains the requirements for method 39:

<b>Asset life</b>	The demonstration data includes versions of method 39 for an asset life of 240 life periods.
<b>Balance adjustments</b>	<ul style="list-style-type: none"> <li>• Year-end with annual depreciation</li> <li>• Apportioned by period in the year, based on percent</li> </ul>
<b>Modified start date</b>	The modified start date is the midyear, start of period, or half year.
<b>Conventions</b>	<ul style="list-style-type: none"> <li>• Disposal conventions are set for the modified start dates of midyear and half-year.</li> <li>• Set the convention to allow depreciation beyond the asset life and to exceed remaining basis.</li> </ul>
<b>Life year rules</b>	<ul style="list-style-type: none"> <li>• Primary life years 1 to 998 use a fixed rate percent of 10.9%, including accumulated depreciation.</li> <li>• Secondary life years 1 to 998 use a fixed rate percent of 10.9%, including accumulated depreciation and tax credit.</li> </ul>
<b>Calculations</b>	<ul style="list-style-type: none"> <li>• Basis times the percent rate of 10.9%.</li> <li>• Basis includes the salvage value.</li> <li>• Secondary formulas include the investment tax credit for the subsidized government amount.</li> </ul>
<b>Disposals</b>	Method 39 has no disposal rules.

## Japan Composite (Method 40)

---

The tables below show the depreciation of an asset when using depreciation method 40.

Use a parent asset to group the assets as a composite. The cost accounts need to be the same for each parent composite group. No other assets should be booked to the composite cost account, except for assets within the composite. The general ledger cost balance is used in the depreciation calculation.

<b>Parent Composite</b>	<b>Cost</b>	<b>Salvage</b>
Asset 1	10.000	
Asset 2	12.000	
Asset 3	8.000	
Asset 4	15.000	
Asset 5	20.000	
Asset 6	25.000	
1997 Total	90.000	9.000
Asset 7	8.000	

Asset 8                    5.000

1998 Total                103.000 10.300

- Salvage: 10% of cost
- Asset life: 10 years (120 life periods)

Year	End of Year Date	Accumulated Depreciation	Depreciation Expense	Calculation
1997	31/12/1997	-9.270	9.270	90.000 * 20.6% * (6 / 12) Periods
1998	31/12/1998	-19.308	19.308	(103.000 - 9.270) * 20.6%
1999	31/12/1999	-15.331	15.331	(103.000 - 28.578) * 20.6%
2000	31/12/2000	-12.173	12.173	(103.000 - 43.909) * 20.6%
2001	31/12/2001	-9.665	9.665	(103.000 - 56.082) * 20.6%
2002	31/12/2002	-7.674	7.674	(103.000 - 65.747) * 20.6%
2003	31/12/2003	-6.903	6.903	(103.000 - 73.421) * 20.6%
2004	31/12/2004	-4.838	4.838	(103.000 - 79.514) * 20.6%
2005	31/12/2005	-3.841	3.841	(103.000 - 84.352) * 20.6%
2006	31/12/2006	-3.050	3.050	(103.000 - 88.193) * 20.6%
2007	31/12/2007	-1.457	1.457	103.000 - 91.243 - 10.300

---

**Note**

This rule uses a parent asset to depreciate a composite total. The asset must be booked into the same cost account to use the balance in the depreciation calculation. The DSA5 AAI must be set up for using element 61 to retrieve the general ledger balance.

---

You can set up the composite depreciation amount with the application report writer to combine totals and create journal entries for the desired calculation.

The following table explains the requirements for method 40:

<b>Asset life</b>	The demonstration data includes versions of method 40 for an asset life of 240 life periods.
<b>Balance adjustments</b>	<ul style="list-style-type: none"> <li>• Year-end with annual depreciation</li> <li>• Apportioned by period in the year, based on percent</li> </ul>
<b>Modified start date</b>	The modified start date is the midyear, start of period, or half-year.
<b>Conventions</b>	<ul style="list-style-type: none"> <li>• Disposal conventions are set for the modified start dates of midyear and half-year.</li> <li>• Set the convention to allow depreciation beyond the asset life and to exceed remaining basis.</li> </ul>
<b>Life year rules</b>	<ul style="list-style-type: none"> <li>• Primary life years 1 to 1 use a fixed rate percent of 20.6%, including initial year apportionment.</li> <li>• Primary life years 2 to 998 use a fixed rate percent of 20.6%, including accumulated depreciation.</li> </ul>
<b>Calculations</b>	<ul style="list-style-type: none"> <li>• Basis times the percent rate of 20.6%.</li> <li>• Basis (the cost from the general ledger balance) includes the salvage value.</li> </ul>
<b>Disposals</b>	Method 40 has no disposal rules.

## **Korea Straight Line (Method 41)**

---

For the example that follows, the following assumptions apply:

- Actual Start Date: 15/07/1997
- Modified Start Date: 1/1/1997
- Cost: 500.000 WON (without tax)
- Salvage: 1 WON
- Asset Life: 4 years (48 life periods)

The table below shows the depreciation of an asset when using depreciation method 41:

<b>Year</b>	<b>End of Year Date</b>	<b>Accumulated Depreciation</b>	<b>Depreciation Expense</b>	<b>Calculation</b>
1997	31/12/1997	-125.000	125.000	500.000 * 48 / 12
1998	31/12/1998	-125.000	125.000	500.000 * 48 / 12
1999	31/12/1999	-125.000	125.000	500.000 * 48 / 12
2000	31/12/2000	-124.00	124.000	500.000 - 375.000 - 1
2001	31/12/2001			

Example prior to 1/1/1995:

- Actual Start Date: 15/07/1994

- Modified Start Date: 1/1/1994
- Cost: 500.000 WON (without tax)
- Salvage: 10% cost for 48 periods, 8%, 6%, 4%, 2% of cost and 1000
- Asset Life: 4 years (48 life periods)

Year	End of Year Date	Accumulated Depreciation	Depreciation Expense	Calculation
1994	31/12/1994	-112.500	112.500	$(500.000 - 50.000) * 48 / 12$
1995	31/12/1995	-112.500	112.500	$(500.000 - 50.000) * 48 / 12$
1996	31/12/1996	-112.500	112.500	$(500.000 - 50.000) * 48 / 12$
1997	31/12/1997	-112.500	112.500	$(500.000 - 50.000) * 48 / 12$
1998	31/12/1998	-10.000	-10.000	$(500.000 - 450.000 - 40.000)$
1999	31/12/1999	-10.000	-10.000	$(500.000 - 460.000 - 30.000)$
2000	31/12/2000	-10.000	-10.000	$(500.000 - 470.000 - 20.000)$
2001	31/12/2001	-10.000	-10.000	$(500.000 - 480.000 - 10.000)$
2002	31/12/2002	-9.00	-9.000	$(500.000 - 490.000 - 1.000)$
2003	31/12/2003			

---

#### Note

The asset was revalued in the 4th year of the asset's life. The revaluation amount includes the remaining calculations to finish depreciation.

---

The following table explains the requirements for method 41:

<b>Asset life</b>	The demonstration data includes versions of method 41 for asset lives of 48 and 60 life periods.
<b>Balance adjustments</b>	<ul style="list-style-type: none"> <li>• Year-end with annual depreciation</li> <li>• Apportioned by period in the year, based on percent</li> </ul>
<b>Modified start date</b>	The modified start date is the whole year, first half/second half, or midyear.
<b>Conventions</b>	Disposal conventions are set for first half/second half.

- Life year rules**
- Life years 1 to 1 straight line with initial year apportionment.
  - Life years 2 to 4 straight line.
  - Life year 5 depreciates to 8% salvage.
  - Life year 6 depreciates to 6% salvage.
  - Life year 7 depreciates to 4% salvage.
  - Life year 8 depreciates to 2% salvage.
  - Life year 9 depreciates to 1.000.
- Calculations**
- Straight line is the asset life divided by normal number of periods.
  - Basis includes salvage value for the remaining compute direction.
- Disposals**                      Method 41 has no disposal rules.

## **Korea Revaluation SL (Method 42)**

---

For the example that follows, the following assumptions apply:

- Actual Start Date: 15/07/1997
- Modified Start Date: 1/1/1997
- Cost: 500.000 WON (without tax); additional revaluation 300.000 in 2000
- Salvage: 1,000 WON
- Asset Life: 4 years (48 life periods)

The table below shows the depreciation of an asset when using depreciation method 42:

<b>Year</b>	<b>End of Year Date</b>	<b>Accumulated Depreciation</b>	<b>Depreciation Expense</b>	<b>Calculation</b>
1997	31/12/1997	-125.000	125.000	500.000 * 25%
1998	31/12/1998	-125.000	125.000	500.000 * 25%
1999	31/12/1999	-125.000	125.000	500.000 * 25%
2000	31/12/2000	-212.500	212.500	(800.000 - 375.000) * 25%
2001	31/12/2001	-211.500	211.500	(800.000 - 587.500 - 1000

---

### **Note**

The asset was revalued in the 4th year of the asset's life. The revaluation amount is included in the remaining calculations to finish depreciation.

---

The following table explains the requirements for method 42:

<b>Asset life</b>	The demonstration data includes versions of method 42 for asset lives of 48 life periods.
<b>Balance adjustments</b>	<ul style="list-style-type: none"> <li>• Year-end with annual depreciation</li> <li>• Apportioned by period in the year, based on percent</li> </ul>
<b>Modified start date</b>	The modified start date is the whole year.
<b>Conventions</b>	Allow depreciation beyond the asset's life, but do not exceed remaining basis.
<b>Life year rules</b>	<ul style="list-style-type: none"> <li>• Life years 1 to 3 take 25%.</li> <li>• Life years 4 to 4 take 50% remaining basis, not including salvage.</li> <li>• Life year 5 depreciates remaining basis, including salvage.</li> </ul>
<b>Calculations</b>	<ul style="list-style-type: none"> <li>• Cost at the rate of 25%.</li> <li>• Half of remaining basis, not including salvage.</li> <li>• Basis includes salvage value.</li> </ul>
<b>Disposals</b>	Method 42 has no disposal rules.

## **Korea Capital Expenditure SL (Method 43)**

---

For the example that follows, the following assumptions apply:

- Actual Start Date: 15/07/1997
- Modified Start Date: 1/1/1997
- Cost: 500.000 WON (without tax); additional revaluation 300.000 in 2000
- Salvage: 1,000 WON
- Asset Life: 4 years (48 life periods)

The table below shows the depreciation of an asset when using depreciation method 43:

<b>Year</b>	<b>End of Year Date</b>	<b>Accumulated Depreciation</b>	<b>Depreciation Expense</b>	<b>Calculation</b>
1997	31/12/1997	-125.000	125.000	500.000 * 25%
1998	31/12/1998	-125.000	125.000	500.000 * 25%
1999	31/12/1999	-125.000	125.000	500.000 * 25%
2000	31/12/2000	-200.000	200.000	800.000 * 25%
2001	31/12/2001	-200.000	200.000	800.000 * 25%
2002	31/12/2002	-24.000	24.000	800.000 - 775.000 - 1.000

---

**Note**

The asset was revalued in the 4th year of the asset's life. The revaluation amount is included in the remaining calculations to finish depreciation.

---

The following table explains the requirements for method 43:

<b>Asset life</b>	The demonstration data includes versions of method 43 for asset lives of 48 life periods.
<b>Balance adjustments</b>	<ul style="list-style-type: none"><li>• Year-end with annual depreciation</li><li>• Apportioned by period in the year, based on percent</li></ul>
<b>Modified start date</b>	The modified start date is the whole year.
<b>Conventions</b>	Allow depreciation beyond the asset's life, but do not exceed remaining basis.
<b>Life year rules</b>	<ul style="list-style-type: none"><li>• Life years 1 to 3 take 25%.</li><li>• Life years 4 to 4 take 50% remaining basis, not including salvage.</li><li>• Life year 5 depreciates remaining basis, including salvage.</li></ul>
<b>Calculations</b>	<ul style="list-style-type: none"><li>• Cost at the rate of 25%.</li><li>• Half of remaining basis, not including salvage.</li><li>• Basis includes salvage value.</li></ul>
<b>Disposals</b>	Method 43 has no disposal rules.

---

**Korea Special Rate SL (Method 44)**

---

For the example that follows, the following assumptions apply:

- Actual Start Date: 15/07/1997
- Modified Start Date: 1/1/1997
- Cost: 500.000 WON (without tax)
- Salvage: 1,000 WON
- Asset Life: 4 years (48 life periods)

The tables below show the depreciation of an asset when using depreciation method 44:

<b>Year</b>	<b>End of Year Date</b>	<b>Accumulated Depreciation</b>	<b>Depreciation Expense</b>
1997	31/12/1997	-125.000	125.000
1998	31/12/1998	-125.000	125.000
1999	31/12/1999	-124.000	124.000

2000 31/12/2000

2001 31/12/2001

Year	2nd Accumulated Depreciation	2nd Depreciation Expense	Rule 1 Calculation	Rule 2 Calculation
1997	-62.500	62.500	$500.000 * 25\%$	$(500.000 * 25\%) * 50\%$
1998	-62.500	62.500	$500.000 * 25\%$	$(500.000 * 25\%) * 50\%$
1999			$500.000 - 250.000 - 125.000 - 1.000$	
2000				
2001				

---

#### Note

The SDA and SDE1 AAls need to be set up for the secondary accounts. The AAls can be set up with the same account as the primary accounts. These calculations can be done by using only primary rules, including the secondary calculations within the primary rule formulas.

---

The following table explains the requirements for method 44:

<b>Asset life</b>	The demonstration data includes versions of method 44 for asset lives of 48 life periods.
<b>Balance adjustments</b>	<ul style="list-style-type: none"><li>• Year-end with annual depreciation</li><li>• Apportioned by period in the year, based on percent</li></ul>
<b>Modified start date</b>	The modified start date is the whole year.
<b>Conventions</b>	<ul style="list-style-type: none"><li>• Allow depreciation beyond the asset's life, but do not exceed remaining basis.</li><li>• Set the convention to allow two accumulated depreciation accounts and two depreciation expense accounts.</li></ul>
<b>Life year rules</b>	<ul style="list-style-type: none"><li>• Primary life years 1 to 2 take 25% of cost.</li><li>• Secondary life years 1 to 2 take 25% of cost at the rate of 50%.</li><li>• Primary life year 3 and onward depreciate remaining basis, including salvage.</li></ul>
<b>Calculations</b>	<ul style="list-style-type: none"><li>• Primary 25%.</li><li>• Secondary 25% of cost at the rate of 50%.</li><li>• Basis includes salvage value.</li></ul>
<b>Disposals</b>	Method 44 has no disposal rules.

## Korea Declining Balance (Method 45)

---

For the example that follows, the following assumptions apply:

- Actual Start Date: 15/07/1997
- Modified Start Date: 1/1/1997
- Cost: 500.000 WON (without tax)
- Salvage: 1,000 WON
- Asset Life: 4 years (48 life periods)

The table below shows the depreciation of an asset when using depreciation method 45:

Year	End of Year Date	Accumulated Depreciation	Depreciation Expense	Calculation
1997	31/12/1997	-264.000	264.000	$500.000 * 52.8\%$
1998	31/12/1998	-124.608	124.608	$(500.000 - 264.000) * 52.8\%$
1999	31/12/1999	-58.815	58.815	$(500.000 - 388.608) * 52.8\%$
2000	31/12/2000	-51.577	51.577	$(500.000 - 447.423) - 1.000$
2001	31/12/2001			

---

### Note

Another rule is also set up for assets in service prior to January 1, 1995.

---

The following table explains the requirements for method 45:

<b>Asset life</b>	The demonstration data includes versions of method 45 for asset lives of 48 life periods.
<b>Balance adjustments</b>	<ul style="list-style-type: none"> <li>• Year-end with annual depreciation</li> <li>• Apportioned by period in the year, based on percent</li> </ul>
<b>Modified start date</b>	The modified start date is the whole year.
<b>Conventions</b>	No conventions are needed.
<b>Life year rules</b>	<ul style="list-style-type: none"> <li>• Life years 1 to 3 at a fixed rate of 52.8%, including accumulated depreciation.</li> <li>• Life year 4 is remaining basis, including salvage.</li> </ul>
<b>Calculations</b>	<ul style="list-style-type: none"> <li>• Basis times the percent rate of 52.8%, including accumulated depreciation .</li> <li>• Basis includes salvage value.</li> </ul>
<b>Disposals</b>	Method 45 has no disposal rules.

## Korea Revaluation Declining (Method 46)

---

For the example that follows, the following assumptions apply:

- Actual Start Date: 15/05/1997
- Modified Start Date: 1/1/1997
- Cost: 500.000 WON (without tax); 300.000 was added in 2000
- Salvage: 1,000
- Asset Life: 4 years (48 life periods)

The table below shows the depreciation of an asset when using depreciation method 46:

Year	End of Year Date	Accumulated Depreciation	Depreciation Expense	Calculation
1997	31/12/1997	-264.000	264.000	500.000 * 52.8%
1998	31/12/1998	-124.608	124.608	(500.000 - 264.000) * 52.8%
1999	31/12/1999	-58.815	58.815	(500.000 - 388.608) * 52.8%
2000	31/12/2000	-317.319	317.319	(800.000 - 447.423) * 90%
2001	31/12/2001	-34.258	34.258	800.000 - 764.742 - 1.000

---

### Note

The asset was revalued with an additional 300.000 in the third year of the life.

---

The following table explains the requirements for method 46:

<b>Asset life</b>	The demonstration data includes versions of method 46 for asset lives of 48 life periods.
<b>Balance adjustments</b>	<ul style="list-style-type: none"> <li>• Year-end with annual depreciation</li> <li>• Apportioned by period in the year, based on percent</li> </ul>
<b>Modified start date</b>	The modified start date is the whole year.
<b>Conventions</b>	Set the convention to continue depreciation beyond the asset's life, but not to exceed remaining basis.
<b>Life year rules</b>	<ul style="list-style-type: none"> <li>• Life years 1 to 3 at a fixed rate of 52.8%, including accumulated depreciation.</li> <li>• Life year 4 takes 90%, including accumulated depreciation.</li> <li>• Life years 5 to 998 take remaining basis, including salvage.</li> </ul>
<b>Calculations</b>	<ul style="list-style-type: none"> <li>• Basis times the percent rate of 52.8%, including accumulated depreciation.</li> <li>• Remaining basis includes salvage value.</li> </ul>
<b>Disposals</b>	Method 46 has no disposal rules.

## Korea Capital Expenditure DB (Method 47)

---

For the example that follows, the following assumptions apply:

- Actual Start Date: 15/05/1997
- Modified Start Date: 1/1/1997
- Cost: 500.000 WON (without tax); 300.000 was added in 2000
- Salvage: 1,000
- Asset Life: 4 years (48 life periods)

The table below shows the depreciation of an asset when using depreciation method 47:

Year	End of Year Date	Accumulated Depreciation	Depreciation Expense	Calculation
1997	31/12/1997	-264.000	264.000	500.000 * 52.8%
1998	31/12/1998	-124.608	124.608	(500.000 - 264.000) * 52.8%
1999	31/12/1999	-58.815	58.815	(500.000 - 388.608) * 52.8%
2000	31/12/2000	-186.161	186.161	(800.000 - 447.423) * 52.8%
2001	31/12/2001	-87.868	87.868	(800.000 - 633.584) * 52.8%
2002	31/12/2002	-77.549	77.549	800.000 - 721.451 - 1.000

---

### Note

The asset was revalued with an additional 300.000 in the third year of the life.

---

The following table explains the requirements for method 47:

<b>Asset life</b>	The demonstration data includes versions of method 47 for asset lives of 48 life periods.
<b>Balance adjustments</b>	<ul style="list-style-type: none"> <li>• Year-end with annual depreciation</li> <li>• Apportioned by period in the year, based on percent</li> </ul>
<b>Modified start date</b>	The modified start date is the whole year.
<b>Conventions</b>	Set the convention to continue depreciation beyond the asset's life, but not to exceed remaining basis.
<b>Life year rules</b>	<ul style="list-style-type: none"> <li>• Life years 1 to 5 at a fixed rate of 52.8%, including accumulated depreciation.</li> <li>• Life years 6 to 998 take remaining basis, including salvage.</li> </ul>
<b>Calculations</b>	<ul style="list-style-type: none"> <li>• Basis times the percent rate of 52.8%, including accumulated depreciation.</li> <li>• Remaining basis includes salvage value.</li> </ul>
<b>Disposals</b>	Method 47 has no disposal rules.

## Korea Special Rate SL (Method 48)

---

For the example that follows, the following assumptions apply:

- Actual Start Date: 15/07/1997
- Modified Start Date: 1/1/1997
- Cost: 500.000 WON (without tax)
- Salvage: 1,000 WON
- Asset Life: 4 years (48 life periods)

The tables below show the depreciation of an asset when using depreciation method 48:

Year	End of Year Date	Accumulated Depreciation	Depreciation Expense
1997	31/12/1997	-264.000	264.000
1998	31/12/1998	-54.912	54.912
1999	31/12/1999	-11.422	11.422
2000	31/12/2000	-3.499	3.499
2001	31/12/2001		

Year	2nd Accumulated Depreciation	2nd Depreciation Expense	Rule 1 Calculation	Rule 2 Calculation
1997	-132.000	132.000	$500.000 * 52.8\%$	$(500.000 * 52.8\%) * 50\%$
1998	-27.546	27.546	$(500.000 - 396.000) * 52.8\%$	$(500.000 - 396.000) * 52.8\% * 50\%$
1999	-5.711	5.711	$(500.000 - 478.368) * 52.8\%$	$(500.000 - 478.368) * 52.8\% * 50\%$
2000			$500.000 - 495.501 - 1.000$	
2001				

---

### Note

The SDA and SDE1 AAls need to be set up for the secondary accounts. The AAls can be set up with the same account as the primary accounts. These calculations can be done by using only primary rules, including the secondary calculations within the primary rule formulas.

---

The following table explains the requirements for method 48:

<b>Asset life</b>	The demonstration data includes versions of method 48 for asset lives of 48 life periods.
<b>Balance adjustments</b>	<ul style="list-style-type: none"> <li>• Year-end with annual depreciation</li> <li>• Apportioned by period in the year, based on percent</li> </ul>
<b>Modified start date</b>	The modified start date is the whole year.
<b>Conventions</b>	<ul style="list-style-type: none"> <li>• Allow depreciation beyond the asset's life, but do not exceed remaining basis.</li> <li>• Set the convention to allow two accumulated depreciation accounts and two depreciation expense accounts.</li> </ul>
<b>Life year rules</b>	<ul style="list-style-type: none"> <li>• Primary life years 1 to 3 take 52.8% of cost.</li> <li>• Secondary life years 1 to 3 take 52.8% of cost at the rate of 50%.</li> <li>• Primary life year 4 and onward depreciate remaining basis, including salvage.</li> </ul>
<b>Calculations</b>	<ul style="list-style-type: none"> <li>• Primary 52.8%.</li> <li>• Secondary 52.8% of cost at the rate of 50%.</li> <li>• Remaining basis includes salvage value.</li> </ul>
<b>Disposals</b>	Method 48 has no disposal rules.

## **Primary Secondary Tertiary (Method 49)**

---

For the example that follows, the following assumptions apply:

- Actual Start Date: 17/05/1997
- Modified Start Date: 17/05/1997
- Cost: 500.000
- Salvage: 10% at the end of the asset's life
- Asset Life: 6 years (72 life periods)

The table below shows the depreciation of an asset when using depreciation method 49:

<b>Year</b>	<b>End of Year Date</b>	<b>Accumulated Depreciation</b>	<b>Depreciation Expense</b>
1997	31/12/1997	-156.849	156.849
1998	31/12/1998	-250.000	250.000
1999	31/12/1999	-93.151	93.151
2000	31/12/2000		
2001	31/12/2001		
2002	31/12/2002		

2003 31/12/2003

Year	2nd Accumulated Depreciation	2nd Depreciation Expense	3rd Depreciation Expense	Rule 1 Calculation	Rule 2 Calculation
1997				500.000 * .5 * .62739726 (First %)	
1998				500.000 * .5	
1999	-156.849	156.849		500.000 * .5 * .37260284 (First %)	500.000 * .5 * .62739726 (First %)
2000	-250.000	250.000			500.000 * .5
2001	-93.151	93.151			500.000 * .5 * .37260284 (First %)
2002	345.068		-345.068		(500.000 - 500.000 - 500.000 - 50.000) * .62739726 (First %)
2003	204.932		-204.932		(500.000 - 500.000 154.932 + 50.000)

---

**Note**

The SDA, SDE1, and SDE2 AAIs need to be set up for the secondary accounts. The AAIs can be set up with the same account as the primary accounts.

---

The following table explains the requirements for method 49:

<b>Asset life</b>	The demonstration data includes versions of method 4 for asset lives of 72 life periods.
<b>Balance adjustments</b>	<ul style="list-style-type: none"> <li>• Year-end with annual depreciation.</li> <li>• Apportioned by period in the year, based on percent.</li> </ul>
<b>Modified start date</b>	The modified start date is the actual start date.
<b>Conventions</b>	<ul style="list-style-type: none"> <li>• Set the secondary accounts to allow two accumulated depreciation and three depreciation expense accounts.</li> <li>• Set the allow-over depreciation to exceed adjusted basis, but take remaining basis at the end of the life.</li> <li>• Set the allow negative depreciation.</li> </ul>
<b>Life year rules</b>	<ul style="list-style-type: none"> <li>• Primary rules: depreciate 100% of the cost in the first two years of the asset's life.</li> <li>• Secondary rules: after the primary has depreciated the cost, depreciate 100% of cost.</li> <li>• Secondary rules: recover the over-depreciated amount in the last two years to 10% of cost.</li> </ul>

**Calculations**

- Multiplier with apportionments for start, middle, and end years.
- Basis (primary and secondary depreciation) includes salvage value.

**Disposals**

Method 49 has no disposal rules.

---

## Formula Elements

The Fixed Assets system includes the following elements that you can include in your depreciation formulas:

- 01 Inception to Date Cost
- 02 Accumulated Depreciation Balance Forward Primary
- 03 Asset Life Periods
- 04 Asset Life Periods Elapsed at Beginning of Current Year
- 05 Asset Life Periods Remaining at Beginning of Current Year
- 06 Asset Life Periods Current Year
- 07 Salvage Value
- 08 Annual Depreciation Base Amount
- 09 Annual Depreciation Limit
- 10 Basis
- 11 Annual Rule Multiplier
- 12 Multiplier/Constant
- 13 Asset Life in Days
- 14 Asset Life in Days Expired at Beginning of Current Year
- 15 Asset Life in Days Remaining at Beginning of Current Year
- 16 Asset Life in Days to Depreciate Current Year
- 17 Asset Life Days Percent Expired at Beginning of Current Year
- 18 Asset Life Days Percent in Current Year
- 19 Asset Life Days Percent Remaining at Beginning of Current Year
- 20 Asset Life Days Percent Inception Through End of Current Year
- 21 Asset Life Days Percent in First Year
- 22 Year-to-Date Accumulated Depreciation Primary
- 23 Accumulated Depreciation Balance Forward Secondary
- 24 Year-to-Date Accumulated Depreciation Secondary
- 25 Statistic Percent Inception to Date Through Current Year
- 26 Statistic Percent Current Period
- 27 Statistic Unit Current Period DS1xxx
- 28 Statistic Year to Date DS1xxx
- 29 Statistic Unit Inception to Date Original DS2xxx
- 30 Statistic Unit Inception to Date Base DS3xxx
- 31 Statistic General Ledger Unit Inception to Date DS4xxx
- 32 Statistic General Ledger Percent

- 33 Units of Production Current Year Percent
- 34 Units of Production Current Year
- 35 Units of Production Prior Year
- 36 Units of Production Total
- 37 Sum of the Years Digits Denominator
- 38 Sum of the Years Digits Numerator
- 39 Sum of the Years Digits Inverse of Years Digit
- 40 Sum of the Years Digits First Year Percent
- 41 Sum of the Years Digits Last Year Percent
- 42 Asset Master Investment Tax Credit Amount
- 43 Replacement Cost
- 44 Replacement Cost Last Year
- 45 Insurance Value
- 46 Salvage Value From Asset Balances
- 47 Asset Method Percent
- 48 Company/LT Method Percent
- 49 Normal Number of Periods
- 50 Initial Year Apportionment Percent
- 51 Intermediate Accumulated Depreciation - Primary Rule
- 52 Intermediate Accumulated Depreciation - Secondary Rule
- 53 Life Year in Process
- 54 Intermediate Accumulated Depreciation - Best Rule
- 55 Asset Life Periods Current Year (Rounded to Half Periods)
- 56 Disposal Year Apportionment Percentage
- 57 Amount One (Asset Balances) DSA1 AAI
- 58 Amount Two (Asset Balances) DSA2 AAI
- 59 Amount Three (Asset Balances) DSA3 AAI
- 60 Amount One (General Ledger) DSA4 AAI
- 61 Amount Two (General Ledger) DSA5 AAI
- 62 Amount Three (General Ledger) DSA6 AAI
- 63 Initial Period Apportionment Percent

01

Source: F1202 (FLAPYC + period buckets)

**Asset Cost – Inception to  
Date Through Current  
Year**

Element 01 adds the beginning balance field with all of the current year posting amounts for Fixed Assets cost accounts. A cost record in the Fixed Assets Balances table (F1202) has a balance character code (FLCHCD) of 1.

<b>02</b>	Source: F1202 (FLAPYC)
<b>Accumulated Depreciation - Balance Forward (Primary)</b>	Element 02 uses the beginning balance field for the accumulated depreciation expense accounts to calculate the prior year ending balance amounts. A primary accumulated depreciation expense account in the Fixed Assets Balances table (F1202) has a balance character code (FLCHCD) of 2.
<b>03</b>	Source: F1202 (FLADLM)
<b>Asset Life in Periods</b>	Application: Depreciation Information (P1202) Element 03 uses the number of life months as it is stored in table F1202 for an asset.
<b>04</b>	Calculated: Element 3 (Asset Life in Periods) – Element 05 (Asset Life Periods Remaining at Beginning of Current Year)
<b>Asset Life in Periods Elapsed at Beginning of Current Year</b>	Use this element to determine the number of periods that have already elapsed for an asset.  For example, the asset life in periods is 60 months. The remaining periods at the beginning of the year is 36 months. 60 months – 36 months = 24 periods that have elapsed at the beginning of the year.
<b>05</b>	Calculated: Element 15. (Asset Life Days Remaining at Beginning of Current Year) / 365.25 * Element 49 (Normal Number of Periods)
<b>Asset Life Periods Remaining at Beginning of Current Year</b>	Use this element to determine the number of periods remaining for an asset at the beginning of the year.  For example, a 5-year asset has 1,096 days remaining at the beginning of the current fiscal year. This element calculates the number of days remaining at the beginning of the year / 365.25 * the normal number of periods. (1096/365.25) * 12 = 36 months
<b>06</b>	Calculated: Element 18 * Element 03 (Asset Life Days Percent in Current Year * Asset Life Periods)
<b>Asset Life Periods Current Year</b>	Use this element to determine an asset's life in periods for the current year.  For example, a 5-year asset has a life of 1826.25 days, or 365.25 days * 5 years. If the asset is in year 2 of its life, then the number of days that the asset is depreciable is 365.25 for the entire second year. The number of periods is calculated as (365.25/1826.25) * 60 = 12 periods.

07

Source: F12852 (LVFORS)

**Salvage Value**

Application: Depreciation Rule Revisions (P12851)

Calculated: Element 03 - Element 05. (Asset Life Periods - Assets Life Periods Remaining at Beginning of Current Year)

Calculate results from the formula that is associated with the Salvage Value formula defined in the current life year rule. Use this element in any formula for Upper/Lower Limits, Basis, or depreciation formulas. The default value is zero.

**Note**

Element 07 has precedence if both Element 07 and Element 46 are defined.

08

Source: F12852 (LVFORL)

**Annual Depreciation Base Amount**

Application: Depreciation Rule Revisions (P12851)

Calculate results from the formula that is associated with the Lower Limit formula defined in the current life year rule. Use the Lower Limit value (Element 08) in any formula for Basis, or Depreciation formulas. The default value is zero.

Runtime Processing after Depreciation Formula calculation:

Example 1:

Annual Depreciation = 800

Lower Limit = 1000

Adjust Annual Depreciation = 1000

Example 2:

Annual Depreciation = 1000

Lower Limit = 800

No Adjustment

09

Source: F12852 (LVFORU)

**Annual Depreciation Limit**

Application: Depreciation Rule Revisions (P12851)

Calculate results from the formula that is associated with the Upper Limit formula defined in the current life year rule. Use the Upper Limit value (Element 09) in any formula for Basis, or Depreciation formulas. The default value is zero.

Runtime Processing after Depreciation Formula calculation:

Example 1:

Annual Depreciation = 1000

Upper Limit = 800

Adjust Annual Depreciation = 800

Example 2:

Annual Depreciation = 800

Upper Limit = 1000

No Adjustment

<b>10</b>	Source: F12852 (LVFORB)
<b>Basis</b>	<p>Application: Depreciation Rule Revisions (P12851)</p> <p>Calculate results from the formula that is associated with the Basis formula defined in the current life year rule. Use the Basis value (Element 10) in Depreciation formulas. Default Value is Element 01 (Inception to Date Cost).</p>
<b>11</b>	Source: F12852 (LVANMP)
<b>Annual Rule Multiplier</b>	<p>Application: Depreciation Rule Revisions (P12851) Annual Rule Formula. Use this element as a constant multiplier for a life year rule.</p> <p>Calculated: Element 10, * Element 11. (Basis * Annual Rule Multiplier). For example, MACRS methods 12 and 13.</p> <p>This element is derived from the percent amount that you specify in the Annual Multiplier field on the Life Year Rules form (W12851E). Use this element to establish a fixed percentage that can be used in a formula for a specific period of time in an asset's life. If a depreciation formula is not defined, the system defaults to depreciation formula 95.</p>
<b>12</b>	Source: F12853 (LWDFAM)
<b>Multiplier/Constant</b>	<p>Application: Depreciation Formulas (P12853)</p> <p>This element is derived from the value that is specified in the Multiplier/Constant field in the depreciation formula. To define a constant for Upper/Lower limits, the formula is defined as 12 with the appropriate constant value in the Multiplier/Constant field.</p>
<b>13</b>	Calculated: Element 03 / Element 49. (Asset Life Periods / Normal Number of Periods * 365.25)
<b>Asset Life in Days</b>	<p>For example, if a 5-year asset's life is 60 periods and 12 periods are in a year, then <math>(60/12) * 365.25 = 1826</math>. This element does not use rounding or zero decimals.</p>
<b>14</b>	Calculated: Element 13 - Element 15. (Asset Life in Days - Asset Life in Days Remaining at Beginning of Current Year)
<b>Asset Life in Days Expired at Beginning of Current Year</b>	
<b>15</b>	Calculated: If (Modified Start Date Fiscal Year < F0008 Start PO Through Date Fiscal Year) Element 13 - F0008 Start PO Through Date - Modified Start Date else Element 13
<b>Asset Life in Days Remaining at Beginning of Current Year</b>	
<b>16</b>	Calculated: If (Modified Start Date Fiscal Year = F0008 Start PO Through Date Fiscal Year) F0008 Last Period - Modified Start Date else if (Fully Depreciated Date Fiscal Year = F0008 Start PO Through Date Fiscal Year) Fully Depreciated Date - F0008 Start PO Through Date else if (Disposal Date Fiscal Year = F0008 Start PO Through Date Fiscal Year) Disposal Date - F0008 Start PO Through Date else F0008 Last Period - F0008 Start PO Through Date
<b>Asset Life in Days to Depreciate Current Year</b>	

17	Calculated: Element 14 / Element 13. (Asset Life Days Expired at Beginning of Current Year / Asset Life in Days)
<b>Asset Life Days Percent Expired at Beginning of Current Year</b>	
18	Calculated: Element 16 / Element 13. (Asset Life in Days to Depreciate Current Year / Asset Life in Days)
<b>Asset Life Days Percent in Current Year</b>	For example, if a 5-year asset is in year 2 of its life, then the number of days that the asset is depreciable is 365.25. The percentage is calculated as $365.25/1826.25 = 20\%$ .
19	Calculated: Element 15 / Element 13. (Asset Life Days Remaining at Beginning of Current Year / Asset Life in Days)
<b>Asset Life Days Percent Remaining at Beginning of Current Year</b>	For example, if an asset had 1096 days remaining at the beginning of the year and its life was 1826 days, then the calculation is $1096/1826 = 60\%$ .
20	Calculated: (Element 14 + Element 16) / Element 13. ((Asset Life Days Expired at Beginning of Current Year + Asset Life in Days to Depreciate Current Year) / Asset Life in Days)
<b>Asset Life Days Percent Inception Through End of Current Year</b>	
21	Calculated: If ((Disposal Date <input type="checkbox"/> Blank) and (Disposal Date Fiscal Year < Modified Depreciation Start Date Fiscal Year)) (Disposal Date - Modified Depreciation Start Date + 1) / Element 13  Else (End of Fiscal Year Date for the modified start fiscal year - Modified Depreciation Start Date + 1) / Element 13
<b>Asset Life Days Percent in First Year</b>	
22	Source: F1202 (sum of period buckets)
<b>Year-to-Date Accumulated Depreciation Primary</b>	This element uses the sum of all the prior current period posting fields from the Asset Account Balances File table (F1202) for an asset, ledger type, subledger, or subledger type. The account type of 2 should be used for retrieval. (CHCD = 2 in F1202)
23	Source: F1202 (FLAPYC)
<b>Accumulated Depreciation Balance Forward Secondary</b>	The prior year balance from the Asset Account Balances File table (F1202) for an asset, ledger type, subledger, or subledger type that is related to secondary depreciation accounts. The SDA AAI identifies the secondary accumulated depreciation accounts. The account type of 3 should be used to retrieve the secondary depreciation. (CHCD = 3 in F1202)
24	Source: F1202 (sum of period buckets)
<b>Year-To-Date Accumulated Depreciation Secondary</b>	This element uses the sum of all of the prior current period posting fields from the Asset Accounts Balances File table (F1202) for an asset, ledger type, subledger, or subledger type. The account type of 3 should be used for retrieval. (CHCD = 3 in F1202)

25	<p>Calculated: Element 28 / Element 30. (Statistic Year to Date DS1xxx / Statistic Unit Inception To Date Base DS3xxx).</p> <p><b>Statistic Percent Inception to Date Through Current Year</b></p> <p>Ledger Type: AU from F1202</p>
26	<p>Calculated: Element 27 / Element 30. (Statistic Unit Current Period DS1xxx/ Statistic Unit Inception To Date Base DS3xxx)</p> <p><b>Statistic Percent Current Period</b></p> <p>Ledger Type: AU from F1202</p>
27	<p>Source: Concatenate the category number that is defined from Fixed Asset Constants (F1200.LNDPCC) with DS1, and validate the DS1xxx AAI with company 00000.</p> <p><b>Statistic Unit Current Period DS1xxx</b></p> <p>Ledger Type: AU from F1202</p> <p>If the DS1xxx AAI fails, validate the DS1 with company 00000.</p> <p>If the AAI is successful, use the F1202 Key:  FLNUMB = F1201.FANUMB (Asset Number)  FLCTRY = F1202.FLCTRY (Century)  FLFY = F1202.FLFY (Fiscal Year)  FLLT = AU (Actual Units) from F1202  FLMCU = F1201.FAMCU or F0012.KGMCU (Business Unit)  FLOBJ = F0012.KGOBJ (Object Account)  FLSUB = F0012.KGSUB (Subsidiary)</p> <p>The DS1 AAI is used with DS1xxx (category code) or DS1, company = 00000, MCU is optional, OBJ is required, and SUB is optional.</p> <p>If the table F1202 fetch is successful, use the Current Period for the Result (Period) else default value is zero.</p>
28	<p>Source: Concatenate the category number that is defined from Fixed Asset Constants (F1200.LNDPCC) with DS1, and validate the DS1xxx AAI with company 00000.</p> <p><b>Statistic Year to Date DS1xxx</b></p> <p>Ledger Type: AU from F1202</p> <p>If the DS1xxx AAI fails, validate the DSI with company 00000.</p> <p>If the AAI is successful, use the F1202 Key:  FLNUMB = F1201.FANUMB (Asset Number)  FLCTRY = F1202.FLCTRY (Century)  FLFY = F1202.FLFY (Fiscal Year)  FLLT = AU (Actual Units) from F1202  FLMCU = F1201.FAMCU or F0012.KGMCU (Business Unit)  FLOBJ = F0012.KGOBJ (Object Account)  FLSUB = F0012.KGSUB (Subsidiary)</p> <p>The DS1 AAI is used with DS1xxx (category code) or DS1, company = 00000, MCU is optional, OBJ is required, and SUB is optional. If the table F1202 fetch is successful, use Balance Forward with Balance Up to Current Period (FLAPYC + sum of period buckets) else default value is zero.</p>

29

**Statistic Unit Inception to  
Date Original DS2xxx**

Source: Concatenate the category number that is defined from Fixed Asset Constants (F1200.LNDPCC) with DS2, and validate the DS2xxx AAI with company 00000.

Ledger Type: AU from F1202

If the DS2xxx AAI fails, validate the DS2 with company 00000.

If the AAI is successful, use the F1202 Key:

FLNUMB = F1201.FANUMB (Asset Number)

FLCTRY = F1202.FLCTRY (Century)

FLFY = F1202.FLFY (Fiscal Year)

FLLT = AU (Actual Units) from F1202

FLMCU = F1201.FAMCU or F0012.KGMCU (Business Unit)

FLOBJ = F0012.KGOBJ (Object Account)

FLSUB = F0012.KGSUB (Subsidiary)

The DS2 AAI is used with DS2xxx (category code) or DS2, company = 00000, MCU is optional, OBJ is required, and SUB is optional. If the F1202 fetch is successful, use Balance Forward with Balance Up to Current Period (FLAPYC + sum of period buckets) else default value is zero.

30

**Statistic Unit Inception to  
Date Base DS3xxx**

Source: Concatenate the category number that is defined from Fixed Asset Constants (F1200.LNDPCC) with DS3, and validate the DS3xxx AAI with company 00000.

Ledger Type: AU from F1202

If the DS3xxx AAI fails, validate the DS3 with company 00000.

If the AAI is successful, use the F1202 Key:

FLNUMB = F1201.FANUMB (Asset Number)

FLCTRY = F1202.FLCTRY (Century)

FLFY = F1202.FLFY (Fiscal Year)

FLLT = AU (Actual Units) from F1202

FLMCU = F1201.FAMCU or F0012.KGMCU (Business Unit)

FLOBJ = F0012.KGOBJ (Object Account)

FLSUB = F0012.KGSUB (Subsidiary)

The DS3 AAI is used with DS3xxx (category code) or DS3, company = 00000, MCU is optional, OBJ is required, and SUB is optional. If the F1202 fetch is successful, use Balance Forward with Balance Up to Current Period (FLAPYC + sum of period buckets) else default value is zero.

<p><b>31</b></p> <p><b>Statistic General Ledger Unit Inception to Date DS4xxx</b></p>	<p>Source: Concatenate the category number defined from Fixed Asset Constants (F1200.LNDPCC) with DS4, and validate the DS4xxx AAI with company 00000.</p> <p>Ledger Type: AU from F0902</p> <p>If the DS4xxx AAI fails, validate the DS4 with Company 00000.</p> <p>If the AAI is successful, use the F1202 Key:  GBCTRY = F1202.FLCTRY (Century)  GBFY = F1202.FLFY (Fiscal Year)  GBLT = AU (Actual Units) from F0902  GBMCU = F1201.FAMCU or F0012.KGMCU (Business Unit)  GBOBJ = F0012.KGOBJ (Object Account)  GBSUB = F0012.KGSUB (Subsidiary)</p> <p>The DS4 AAI is used with DS4xxx (category code) or DS4, company = 00000, MCU is optional, OBJ is required, and SUB is optional. If the F0902 fetch is successful, use Balance Forward with Balance Up to Current Period (FLAPYC + sum of period buckets) else default value is zero.</p>
<p><b>32</b></p> <p><b>Statistic General Ledger Percent</b></p>	<p>Calculated: Element 31 / 100. (Statistic General Ledger Unit Inception to Date DS4xxx / 100)</p>
<p><b>33</b></p> <p><b>Units of Production Current Year Percent</b></p>	<p>Calculated: Element 34 / Element 36 - Element 35. (Units of Production Current Year / Units of Production Total - Units of Production Prior Year)</p>
<p><b>34</b></p> <p><b>Units of Production Current Year</b></p>	<p>Source: Retrieve Units of Production Current Year based on Schedule Number and Ledger Type. Fetch F1208 where F1208.FPADSN = F1202.FLADSN and F1208.FLLT = F1202.FLLT Units of Production Current Year (F1208.FPUPY)</p> <p>Application: Units of Production Schedule (P1208)</p>
<p><b>35</b></p> <p><b>Units of Production Prior Year</b></p>	<p>Source: Retrieve Units of Production Prior Year based on Schedule Number and Ledger Type.</p> <p>Fetch F1208 where F1208.FPADSN = F1202.FLADSN and F1208.FLLT = F1202.FLLT Units of Production Prior Year (F1208.FPUPP).</p> <p>Application: Units of Production Schedule (P1208)</p>
<p><b>36</b></p> <p><b>Units of Production Total</b></p>	<p>Source: Retrieve Units of Production Total based on Original units + Prior Year Revisions + Current Year Revisions.</p> <p>Fetch F1208 where F1208.FPADSN = F1202.FLADSN and F1208.FLLT = F1202.FLLT Units of Production Total Revisions = Original + Prior Year Revisions + Current Year Revisions (F1208.FPTOU + F1208.FPPRV + F1208.FPCRIV).</p> <p>Application: Units of Production Schedule (P1208)</p>

<b>37</b>	Calculated: Sum of the Asset's Life Years
<b>Sum of the Years Digits Denominator</b>	<p>Example 1: 4 yr. = 4+3+2+1=10</p> <p>Example 2: 5 yr. = 5+4+3+2+1=15</p>
<b>38</b>	Calculated: (Element 03 / Element 49) - Current Life Year +1. ((Asset Life Periods / Normal Number of Periods) - Current Life Year + 1)
<b>Sum of the Years Digits Numerator</b>	
<b>39</b>	Calculated: Element 38 + 1. (Sum of Years Digits Numerator + 1).
<b>Sum of the Years Digits Inverse of Years Digit</b>	
<b>40</b>	Calculated: Element 50. (Initial Year Apportionment Percent)
<b>Sum of the Years Digits First Year Percent</b>	<p><b>Note</b> Elements 40 and 50 are the same answer.</p>
<b>41</b>	Calculated: 1 - Element 50. (Initial Year Apportionment Percent)
<b>Sum of the Years Digits Last Year Percent</b>	
<b>42</b>	Source: F1201 (FAAITY)
<b>Asset Master Investment Tax Credit Amount</b>	<p>Application: Asset Master Information (P1201)</p> <p>Use the Asset Master Investment Tax Credit Amount.</p>
<b>43</b>	Source: F1201 (FAARPC)
<b>Replacement Cost</b>	<p>Application: Insurance Information (P12012)</p> <p>Use the replacement cost from the Asset Master, which is generally updated through Asset Revaluations.</p>
<b>44</b>	Source: F1201 (FAALRC)
<b>Replacement Cost Last Year</b>	<p>Application: Insurance Information (P12012)</p> <p>Use the replacement cost from last year in the Asset Master, which is generally updated through Asset Revaluations.</p>
<b>45</b>	Source: F1201 (FAAIV)
<b>Insurance Value</b>	<p>Application: Insurance Information (P12012)</p> <p>Use the Insurance value stored in the Asset Master.</p>

46	Source: F1202 (FLTKER)
<b>Salvage Value From Asset Balances</b>	Application: Depreciation Information (P1202) Use the salvage value that is stored in the Asset Balances.
	<b>Note</b> Element 07 has precedence if both Element 07 and Element 46 are defined.
47	Source: F1202 (FLADMP)
<b>Asset Method Percent</b>	Application: Depreciation Information (P1202) Use the asset method percent from the Asset Balances.
48	Source: F12003 (FFADMP) Fetch F12003 based on Key: FFCO = F1201.FACO (Company) FFDAOB = F1201.FAAOBJ (Object Account) FFDASB = F1201.FAASUB (Subsidiary) FFLT = F1202.FLLT (Ledger Type)
<b>Company/LT Method Percent</b>	Application: Depreciation Default Coding (P12002) Use the Asset Method Percent from the Depreciation Defaults.
49	Source: F0010 (CCCALD)
<b>Normal Number of Periods</b>	Application: Companies (P0010) This element uses the Normal Number of Periods value from the Company Master.
50	Calculated: The number of life days in the initial year calculated as a percentage of all the days in that year. This element must be included in the first year calculation because it adjusts the calculation for the modified start date in regards to the fiscal date pattern.
<b>Initial Year Apportionment Percent</b>	<b>Note</b> Most rules require a Year 1 through Year 1 rule that multiplies the rule * this element with I, C and R compute directions that are annual.
51	Calculated: Inception to date computation methods I or F only. The sum of yearly accumulated depreciation amounts calculated from inception through the Element 53 (Life Year in Process) for a primary life year rule.
<b>Intermediate Accumulated Depreciation - Primary Rule</b>	
52	Calculated: Inception to date computation methods I or F only. The sum of yearly accumulated depreciation amounts calculated from inception through the Element 53 (Life Year in Process) for a secondary life year rule.
<b>Intermediate Accumulated Depreciation - Secondary Rule</b>	

53	Calculated: The current Life Year in Process is calculated from the modified start date to the current through date. It counts the life year in the depreciation calculation process. Used only with computation methods I (depreciation calculated from inception through each life year in process) or F (inception to date for the primary rule). These computation methods calculate every life year to catch up any lost depreciation.
<b>Life Year In Process</b>	
54	Calculated: The best result of accumulated depreciation from Element 51 (Intermediate Accumulated Depreciation - Primary Rule) and Element 52 (Intermediate Accumulated Depreciation - Secondary Rule).
<b>Intermediate Accumulated Depreciation - Best Rule</b>	
55	Calculated: Element 06 (Asset Life Periods Current Year) rounded to the nearest half period.
<b>Asset Life Periods Current Year (Rounded to Half Periods)</b>	
56	Calculated: The number of life days in the disposal year as a percentage of all the days in that year.
<b>Disposal Year Apportionment Percentage</b>	<p>This calculation is based on one of the following:</p> <ul style="list-style-type: none"> <li>• (Disposal Date – Start of Through Date Fiscal Year) / Number of days in Current Fiscal Year</li> <li>• Disposal Year Apportionment = 1.0 – Element 50 (Apportionment % - Initial Year)</li> </ul> <p><b>Note</b></p> <p>This element is recommended on 999 rules, final year From and Through rules, and secondary % continuation of 9 as the rule * this element.</p>
57	Source: F1202 (FLAPYC + Period Buckets)
<b>Amount One (Asset Balances)</b>	Retrieve from DSA1 AAI. Default company is used (company 00000). Fetch the AA ledger type only. If Business Unit is left blank in AAI, use Responsible Business Unit from F1201 of the asset.
58	Source: F1202 (FLAPYC + Period Buckets)
<b>Amount Two (Asset Balances)</b>	Retrieve from DSA2 AAI. Default company is used (company 00000). Fetch the current ledger type only. If Business Unit is left blank in the AAI, use Responsible Business Unit from F1201 of the asset.
59	Source: F1202 (FLAPYC + Period Buckets)
<b>Amount Three (Asset Balances)</b>	Retrieve from DSA3 AAI. Fetch the ledger type definition line 4 of the AAI description. If Business Unit is left blank in the AAI, use Responsible Business Unit from F1201 of the asset.
60	Source: F0902 (FLAPYC + Period Buckets)
<b>Amount One (General Ledger)</b>	<p>Retrieve from DSA4 AAI. Default company is used (company 00000). Fetch the AA ledger type only. If Business Unit is left blank in the AAI, use Responsible Business Unit from F1201 of the asset.</p> <p>AAI Line 5 = LT</p>

<b>61</b>	Source: F0902 (FLAPYC + Period Buckets)
<b>Amount Two (General Ledger)</b>	Retrieve from DSA5 AAI. Default company is used (company 00000). Fetch the current ledger type only. If Business Unit is left blank in the AAI, use Responsible Business Unit from F1201 of the asset.
<b>62</b>	Source: F0902 (FLAPYC + Period Buckets)
<b>Amount Three (General Ledger)</b>	Retrieve from DSA6 AAI. Fetch the ledger type from AAI description line 4. If Business Unit is left blank in the AAI, use Responsible Business Unit from F1201 of the asset.  AAI Line 5 = LT
<b>63</b>	Calculated: Number of days elapsed / the number of actual days in a period
<b>Initial Period Apportionment Percent</b>	If the modified start date is not the start of or end of the period, this element calculates the apportionment percentage to us. Mid-Month or Actual Start Dates are examples of number of days that do not match full period results.
	<b>Note</b> For ITAC = P (Middle of Period) processing only. Recommend for use in Year 1 of assets that start during a period and use period depreciation.

## Initial Term Apportionment Codes

The following table contains all valid values for Initial Term Apportionment Codes. In addition, the right-hand column provides information about how each code is used.

<p><b>Blank</b></p> <p><b>First Day of the Month</b></p>	<p>If you leave the Initial Term Apportionment Code field blank, the system uses the default of the first day of the period that the asset is placed in service as the modified start date</p>
<p><b>A</b></p> <p><b>Actual Depreciation Start Date</b></p>	<p>The system uses the actual start date as the modified start date. The actual start date is retrieved from the FLDS field in the Asset Account Balances File table (F1202).</p>
<p><b>F</b></p> <p><b>First Half/Second Half Convention</b></p>	<p>To determine the modified start date, consider the following:</p> <ul style="list-style-type: none"> <li>• If the asset was placed in service in the first half of the year, then the modified start date is the first day of the year.</li> <li>• If the asset was placed in service in the second half of the year, then the modified start date is the first day of the succeeding year.</li> </ul>
<p><b>G</b></p> <p><b>German First/Second Half of Year</b></p>	<p>This code is designed for German depreciation requirements, but can also be used to meet the requirements of other countries. To determine the modified start date, consider the following:</p> <ul style="list-style-type: none"> <li>• If the asset is placed in service in the first half of the year, then the modified start date is the first day of the year.</li> <li>• If the asset was placed in service in the second half of the year, then the modified start date is the first day of the second half of the year.</li> </ul>
<p><b>H</b></p> <p><b>Half-Year (3/4 or 1/4)</b></p>	<p>The system determines the modified start date as indicated in the following examples.</p> <p><b>Note</b></p> <p>In the examples that follow, a regular calendar date pattern is used.</p> <ul style="list-style-type: none"> <li>• If the asset is placed in service in the first half of the year (between 01/01/XX and 06/30/XX), then the modified start date is 04/01/XX.</li> <li>• If the asset is placed in service in the second half of the year (between 07/01/XX and 12/31/XX), then the modified start date is 10/01/XX.</li> </ul>

<p><b>M</b></p> <p><b>Mid-Month Convention</b></p>	<p>The system assigns the 16<sup>th</sup> day of the month in which the asset is placed in service as the modified start date.</p> <p><b>Note</b></p> <p>If the asset is placed in service in February, then the system assigns February 15<sup>th</sup> as the modified start date.</p>
<p><b>N</b></p> <p><b>1<sup>st</sup> Day of Next Period</b></p>	<p>The system uses the first day of the next period in which the asset is placed in service as the modified start date.</p>
<p><b>P</b></p> <p><b>Middle of Period</b></p>	<p>The system determines the number of days between the end of the current period in which the asset is placed in service and the end of the prior period. It then divides that number by two and adds the result to the prior period end date to calculate the modified start date. Use this code for a more accurate mid-month calculation when you use 4-4-5 or similar accounting date patterns.</p>
<p><b>Q</b></p> <p><b>Mid-Quarter Convention</b></p>	<p>The system uses the midpoint of the quarter in which the asset was placed in service as the modified start date. For example, assuming a regular calendar date pattern, the system would calculate the modified start date as follows:</p> <ul style="list-style-type: none"> <li>• For assets placed in service between January 1<sup>st</sup> and March 31<sup>st</sup>, the system assigns February 15<sup>th</sup> as the modified start date.</li> <li>• For assets placed in service between April 1<sup>st</sup> and June 30<sup>th</sup>, the system assigns May 17<sup>th</sup> as the modified start date.</li> <li>• For assets placed in service between July 1<sup>st</sup> and September 29<sup>th</sup>, the system assigns August 17<sup>th</sup> as the modified start date.</li> <li>• For assets placed in service between September 30<sup>th</sup> and December 31<sup>st</sup>, the system assigns November 16<sup>th</sup> as the modified start date.</li> </ul>
<p><b>R</b></p> <p><b>First Day of Next Year</b></p>	<p>The system uses the first day of the year following the year in which the asset was placed in service as the modified start date</p>

<p><b>S</b></p> <p><b>1<sup>st</sup> Actual/2<sup>nd</sup> Period Start</b></p>	<p>Use this code when you have a primary life year rule and a secondary life year rule attached to your depreciation rule. The primary rule uses the asset's actual start date as the modified start date and the secondary rule uses the first day of the period in which the asset is placed in service as the modified start date.</p>
<p><b>W</b></p> <p><b>Whole Year Convention</b></p>	<p>The system uses the first day of the year in which the asset is placed in service as the modified start date.</p>
<p><b>Y</b></p> <p><b>Mid-Year Convention</b></p>	<p>The system uses the date at the midpoint of the year in which the asset is placed in service as the modified start date.</p>