

PeopleSoft®

---

EnterpriseOne  
Enterprise Report Writing 8.9  
PeopleBook

---

1 of 2

**September 2003**



EnterpriseOne  
Enterprise Report Writing 8.9 PeopleBook  
SKU REL9EOR0309V1

Copyright 2003 PeopleSoft, Inc. All rights reserved.

All material contained in this documentation is proprietary and confidential to PeopleSoft, Inc. ("PeopleSoft"), protected by copyright laws and subject to the nondisclosure provisions of the applicable PeopleSoft agreement. No part of this documentation may be reproduced, stored in a retrieval system, or transmitted in any form or by any means, including, but not limited to, electronic, graphic, mechanical, photocopying, recording, or otherwise without the prior written permission of PeopleSoft.

This documentation is subject to change without notice, and PeopleSoft does not warrant that the material contained in this documentation is free of errors. Any errors found in this document should be reported to PeopleSoft in writing.

The copyrighted software that accompanies this document is licensed for use only in strict accordance with the applicable license agreement which should be read carefully as it governs the terms of use of the software and this document, including the disclosure thereof.

PeopleSoft, PeopleTools, PS/nVision, PeopleCode, PeopleBooks, PeopleTalk, and Vantive are registered trademarks, and Pure Internet Architecture, Intelligent Context Manager, and The Real-Time Enterprise are trademarks of PeopleSoft, Inc. All other company and product names may be trademarks of their respective owners. The information contained herein is subject to change without notice.

#### *Open Source Disclosure*

This product includes software developed by the Apache Software Foundation (<http://www.apache.org/>). Copyright (c) 1999-2000 The Apache Software Foundation. All rights reserved. THIS SOFTWARE IS PROVIDED "AS IS" AND ANY EXPRESSED OR IMPLIED WARRANTIES, INCLUDING, BUT NOT LIMITED TO, THE IMPLIED WARRANTIES OF MERCHANTABILITY AND FITNESS FOR A PARTICULAR PURPOSE ARE DISCLAIMED. IN NO EVENT SHALL THE APACHE SOFTWARE FOUNDATION OR ITS CONTRIBUTORS BE LIABLE FOR ANY DIRECT, INDIRECT, INCIDENTAL, SPECIAL, EXEMPLARY, OR CONSEQUENTIAL DAMAGES (INCLUDING, BUT NOT LIMITED TO, PROCUREMENT OF SUBSTITUTE GOODS OR SERVICES; LOSS OF USE, DATA, OR PROFITS; OR BUSINESS INTERRUPTION) HOWEVER CAUSED AND ON ANY THEORY OF LIABILITY, WHETHER IN CONTRACT, STRICT LIABILITY, OR TORT (INCLUDING NEGLIGENCE OR OTHERWISE) ARISING IN ANY WAY OUT OF THE USE OF THIS SOFTWARE, EVEN IF ADVISED OF THE POSSIBILITY OF SUCH DAMAGE.

PeopleSoft takes no responsibility for its use or distribution of any open source or shareware software or documentation and disclaims any and all liability or damages resulting from use of said software or documentation.



---

# Table of Contents

<b>Enterprise Report Writing Overview</b>	<b>1</b>
The Report Design Tool .....	1
Reports Guide.....	2
Report Processing.....	2
Output Management.....	2
Report Components .....	2
Report Object.....	3
Report Template .....	3
Batch Versions.....	3
Report Sections .....	3
<b>Report Design</b>	<b>11</b>
J.D. Edwards Naming Conventions.....	14
Understanding J.D. Edwards Naming Conventions .....	14
Object Naming Conventions for Batch Applications.....	18
Section Names .....	18
Purge Table Program .....	19
Event Rule Variables.....	21
Report Objects .....	22
Default Settings for Reports .....	22
Creating a Report Object.....	22
Deleting a Report Object .....	26
Opening an Existing Report.....	26
Creating Detail Sections .....	27
Adding a Detail Section .....	27
Selecting a Business View .....	28
Adding Business View Columns to a Detail Section .....	29
Defining Section Data Sequencing.....	31
Defining Sort Properties .....	33
Defining Section Data Selection .....	34
<b>Report Design Director</b>	<b>37</b>
Creating a Columnar Report .....	37
Reviewing the Results of the Director .....	48
Example: Creating a Columnar Report with the Director .....	49
Creating a Group Report.....	51
Reviewing the Results of the Director .....	63
Example: Creating a Group Report with the Director.....	64
Creating a Tabular Report.....	66
Reviewing the Results of the Director .....	77
Example: Creating a Tabular Report with the Director.....	78
Creating an Application Report with the Director .....	81

Reviewing the Results of the Director .....	101
<b>Basic Report Enhancements</b>	<b>102</b>
Previewing a Report from Report Design.....	102
Adding Attachments or Comments.....	103
Viewing Properties for Report Sections, Fields, Columns, and Rows.....	105
Configuring Your Design Workspace .....	109
Adding Smart Fields .....	112
Creating Header and Footer Sections.....	113
Working with Level-Break Header and Footer Sections.....	117
Example: Adding Level Breaks to a Detail Section .....	124
Joining Subsections .....	126
Working with Objects in Report Sections .....	130
Working with Business View Columns .....	130
Understanding Data Fields .....	130
Changing Decimal Scaling .....	136
Working with Tabular Sections.....	137
Modifying the Appearance of Report Objects.....	152
Changing Detail Section Descriptions .....	152
Hiding Report Sections.....	152
Aligning Fields or Columns within or across Report Sections.....	154
Changing Field Length and Column Width.....	155
Changing Column or Row Spacing .....	157
Changing Font Properties.....	159
Changing Text Justification .....	168
Changing Numerical Formatting.....	169
Associating Lines and Boxes.....	170
Inserting Page Breaks .....	170
<b>Advanced Report Enhancements</b>	<b>173</b>
Working with Event Rules .....	174
Adding and Attaching Text Variables .....	180
Attaching a System Function to an Event .....	183
Creating an Event Rule Variable .....	186
Column Inclusion Versus Do Section Event Rules.....	188
Creating Custom Sections.....	189
Working with the Date Title for Financial Reports .....	192
Adding a Date Title to a Financial Report.....	192
Customizing the Date Title .....	196
Assigning Your Accounting Periods to the Column Headings .....	198
Working with the Drill Down Feature .....	199
Activating the Drill Down Feature .....	199
Reviewing an Audit Trail.....	202
Purging Drill Down Work Files.....	203
Setting Up Business Views as Favorites.....	204

Creating a Favorites Folder or Subfolder .....	204
Adding Business Views to a Favorites Folder or Subfolder .....	206
Using Notes with a Favorite, a Folder, or a Subfolder.....	206
Translating Descriptions of Favorites .....	208
Working with Processing Options Templates .....	209
Designing Processing Options Templates .....	210
Attaching a Processing Options Template to a Report .....	214
Working with Director Templates .....	215
Working with Smart Field Templates.....	215
Adding or Modifying Director Templates .....	218
Adding Text Attachments to a Report .....	220
Working with Report Properties.....	225
Using Dynamic Positioning.....	227
Activating Dynamic Positioning for a Server or Client.....	228
Defining Font Substitutions.....	228
Turning On or Off Font Substitutions for a Report.....	229
Applying Font Substitutions to a Report Template .....	230
Using Business View V8300005 in Financial Row Reports .....	230



---

## Enterprise Report Writing Overview

J.D. Edwards provides fully integrated applications for managing information throughout your enterprise. This information can include employee data, accounts receivable and payable, your company's financial data, or product information. J.D. Edwards software allows you to view and evaluate this information to make critical decisions about improving your business' operation and profitability. You can also distribute this data to others with whom you do business, such as shareholders, fellow employees, and business consultants.

Reports allow you to view data in an organized and useful format online or as printed material. J.D. Edwards software provides report templates that are suitable for general use. However, some of your reporting needs are truly specific to your business. To meet these needs, you must be able to design a report to extract and present the information that is vital to your company. You can use the Report Design tool to customize report templates or design your own reports.

The Enterprise Reporting solution includes a report design tool to create reports and batch processes, a batch engine for processing, and an output management system to output information.

---

## The Report Design Tool

You can use Report Design to create a variety of simple and complex reports. Report Design's interface is simple enough to use without programming expertise, yet powerful enough to create the most complex reports. You can use Report Design to create batch applications and create reports.

Report Design uses the Report Design Director to guide you through the report creation process. You can create different types of reports, including reports for specific uses such as financial reporting. In addition, you can configure the Director to help users create various reports that your company needs.

After using the Director to create your initial report, you can enhance your report by:

- Adding report sections or date fields
- Formatting
- Positioning
- Business logic processing
- Performing data field calculations and comparisons

Report Design also lets you set your preferences for the workspace on the Report Design form. You can configure your design workspace by changing user options, selecting toolbars, and moving docked windows.

You can use Report Design on terminal servers. However, as in a client/server environment, when you check out a report template on a terminal server, other terminal server users cannot access that template.

## Reports Guide

J.D. Edwards provides more than 300 commonly used reports across the Financials, Human Resources, Distribution and Logistics, and Manufacturing systems. You can easily generate and view these application reports online and in Adobe Acrobat. You can also export these reports for display and manipulation in software programs, such as a spreadsheet program. You can copy and customize any of the J.D. Edwards reports to meet your specific needs instead of creating a completely new report.

### See Also

- *Report Examples* in the *Enterprise Report Writing Guide* for a list of the specific application reports provided by J.D. Edwards

## Report Processing

---

Report processes are a type of batch process. A report becomes a batch process after it is designed and submitted for processing. Once submitted, a batch runs without user interaction. When you submit a report, you do not interact with it again until the report is completed.

After you start a batch process, you have no control over the flow of the logic within the batch process. If you need to change the flow of the logic within the process or report, you make those changes by using Report Design and then resubmitting the report.

## Output Management

---

Typically, after a report has been created, you want to see the output. You can send reports to different file types, printers, forms, and paper sizes. J.D. Edwards software accommodates simple output processes, such as printing a report online or directly to a printer, and more complex output processes, such as using a batch process to print three different versions of the same report to three different printers.

## Report Components

---

A report exists as a set of metadata that allows J.D. Edwards software to identify and process it. You can create variations of a report that are based on a single report template. The first step in creating a report is to create a report object within J.D. Edwards software. The report that you then create becomes a template from which additional versions can be created.

Furthermore, each report itself is comprised of one or more sections. These sections are the building blocks of all reports. Withing the template, you can add, remove, and rearrange report sections as needed.

## Report Object

J.D. Edwards software is object-based; therefore, each report is an object in the Object Management Workbench with a type of UBE (Universal Batch Engine). When you add a report object, you create a header record that contains information about the report, such as its name and description. The header record is stored in the Object Librarian Master table (F9860).

## Report Template

Report templates hold the master metadata, which you add through Report Design. These metadata describe the report to J.D. Edwards software and specify how the data is selected, sorted, displayed, and formatted. When fully designed, the template becomes the basis for all versions of the report.

## Batch Versions

Many of a template's properties can be overwritten at the version level, including data selection, data sequencing, event rules, and layout. Batch versions enable you to preserve template integrity. Instead of creating a template for each variation of a report that you might need, you can create different batch versions of a single template. For example, you might design a monthly variance report that contains totals for the entire company. However, if you need to run a quarterly variance report that includes only data for the Western region, you can create a batch version of the monthly variance report.

Each batch version is based on a specific report template. Typically, batch versions vary slightly from the report template upon which they are based in the data that they display or in their processing options. A batch version processes the metadata that is specified in the template and any changes that are overwritten in the version. You can create additional batch versions by copying an existing batch version.

## Report Sections

Report sections are the basic components of a report. Most reports have more than one section. You can reference one section in another section; or use sections for special purposes, such as performing calculations and totaling. Report sections include:

- Header section
- Footer section

Header and footer sections appear at the top and bottom of pages or reports. They commonly use constants and variables data fields.

- Detail section

Detail sections contain the information that the report was designed to convey. The three types of detail sections are:

- Columnar
- Group
- Tabular

The data that appears in detail sections is based on business views. A business view is used to access data from database tables. The business view selects specific columns from one or more tables, for which you have defined a relationship. Choosing columns from the business view provides a link between the data in your database and the report that you are creating.

In addition to selecting business view columns to build the report sections, you can define and add data fields, such as constants and variables.

In a report, a set of records that all have the same value for one of the fields is said to be in the same level. For example, in a report that is sequenced by telephone numbers, all of the records having the same area code are in the same level. When the value in that field changes, a level break occurs. Level breaks are useful because you can add processing when they occur. Two special report section types make adding processing to level breaks easy:

- Level-break header section
- Level-break footer section

## Characteristics of a Columnar Section

A columnar section consists of several column headings with associated column values listed under the headings. Each data field is a column, and each record is a row. The column heading is linked to its column data, and the two cannot be disconnected in the report. If one is deleted, the other is also deleted. Because you cannot change the column format, the columnar section is the least flexible detail section.

The following illustration is a columnar section:

### Columnar Section

Address Number	Alpha Name	Region Code	Search Type
1001	ABC Office Suppliers	DEN	C
1556	XYZ Manufacturing	NYC	C
1785	Abbot, Dominique	TOR	E
3452	Paper Suppliers, Inc.	CHI	V

Within a columnar section, you can:

- Attach any business view.
- Sequence data and designate level breaks, based on the data fields in the business view.
- Select data that is based on designated criteria.
- Total columns by using level-break sections.
- Attach event rules (logic statements that you create and attach to report objects).
- Call business functions (related groups of logic statements), such as period activity and journal entry.
- Call system functions. (logic that performs operations on ERP objects), such as a workflow.
- Use subsection joins.
- Make the section conditional (that is, it processes directly called from event rules).

You can include multiple columnar sections in a report.

To print level-break headers and totals on a columnar report, level-break header and footer sections are required. When the level break occurs, the level-break header prints above the column headings.

### **See Also**

See the following topics in the *Enterprise Report Writing Guide*:

- ❑ *Working with Event Rules* for information on event rules
- ❑ *Attaching a System Function to an Event* for information on system functions
- ❑ *Joining Subsections* for information on subsection joins

### **When to Use a Columnar Section**

The following criteria can help you decide when to use a columnar section in your report:

- The column layout is appropriate.
- The totaling levels in the report are mostly static; therefore, they are not subject to change at run time.
- The section needs to be joined to other sections.
- The section needs to be conditional.

### **Characteristics of a Group Section**

Group sections have a free-form layout; they are not restricted to standard column and row layout. The group section type is the most flexible because you can place data fields anywhere in the group section. Data fields within group sections are called database groups. Database groups are composed of constants and variables. Initially, the constant and variable of the database group are linked; however, you can disconnect the constant and variable to meet your reporting needs. Because of the free-form layout, group sections are almost always used for level-break header and footer sections.

The following illustration is a group section:

### Group Section

1001	ABC Office Suppliers DEN
1556	XYZ Manufacturing NYC
1785	Abbot, Dominique TOR
3452	Paper Suppliers, Inc. CHI

Within a group section, you can:

- Attach any business view.
- Sequence data and designate level breaks, based on the data fields in the business view.
- Select data that is based on designated criteria.
- Total data by using level-break sections.
- Attach event rules (logic statements that you create and attach to report objects).
- Call business functions (related groups of logic statements), such as period activity and journal entry.
- Call system functions (perform operations on ERP objects), such as workflow.
- Add subsection joins.
- Make the section conditional (that is, it processes only if directly called from event rules).

You can use multiple group sections for each report. Any description or heading in a group section prints for each row that is processed.

To print level-break headers and totals on a group report, level-break header and footer sections are required.

## See Also

See the following topics in the *Enterprise Report Writing Guide*:

- *Working with Event Rules* for information on event rules
- *Attaching a System Function to an Event* for information on system functions
- *Joining Subsections* for information on subsection joins

## When to Use a Group Section

The following criteria can help you decide when to use a group section in your report:

- Free-form layout is appropriate.
- The totaling levels in the report are mostly static; therefore, they are not subject to change at run time.
- The section needs to be joined to other sections.
- The section needs to be conditional.

## Characteristics of a Tabular Section

Although a tabular section appears in the same column-and-row format as a columnar section, it has built-in spreadsheet functions. Thus, the tabular section is suitable for presenting numerical data that has to be summarized with subtotals and grand totals.

The following illustration is a tabular section:

### Tabular Section

Account Description	Net June Posting
_____	_____
Revenue	376,697
Cost of Good	272,091
Gross Profit	104,606
General Expenses	63,911
Net Income	168,517

Within a tabular section, you can:

- Attach any business view.
- Sequence data and designate level breaks, based on the data fields in the business view.
- Select data that is based on designated criteria.
- Calculate grand totals.
- Attach event rules (logic statements that you create and attach to report objects).
- Call business functions (related groups of logic statements), such as period activity and journal entry.
- Call system functions (performs operations on ERP objects), such as workflow.
- Select data at the column level.
- Use drill-down functions (to research values in the report by creating a link between your report output file and the associated J.D. Edwards software application).

You can include multiple tabular sections in a report. The section processes when a level-break field changes.

Tabular sections automatically include the Description column. This column displays descriptions for rows, based on data sequencing and level-break fields.

Totaling is dynamic in a tabular section. If a column does not require totaling, you can turn the totaling function off. Because the totaling logic is built into a tabular section, you do not have to use level-break footer sections for totals, so you can change the totaling without redesigning the report.

### **See Also**

See the following topics in the *Enterprise Report Writing Guide*:

- *Working with Event Rules*
- *Attaching a System Function to an Event*
- *Joining Subsections*
- *Working with the Drill-Down Feature*

### **Advantages of Using Tabular Sections**

The advantages of using tabular reports are:

- Totaling is automatic.
- An audit trail can be created with the drill-down feature.
- Totaling levels can be changed easily by designating level breaks.
- Multiple descriptions can be displayed in the Description column.

### **When to Use a Tabular Section**

The following criteria can help you decide when to use a tabular section in your report:

- You need to do row level processing, such as calculations.
- You need to work with individual cell properties.
- The report requires totaling.
- The totaling level changes frequently.
- Data selection is required at the column, row, or cell level.
- You need to calculate grand totals.
- Drill-down functionality is required.

### **Characteristics of a Report Header Section**

A report can contain only one report header, which prints once at the beginning of the report. The report header can include the report title, the date when the report was processed, and a list of the names of the people who receive the report. Typically, report headers include data fields, such as constant and run-time fields; and alpha, numeric, and date variables.

The following illustration is a report header as it might appear on a report:

#### **Report Header**

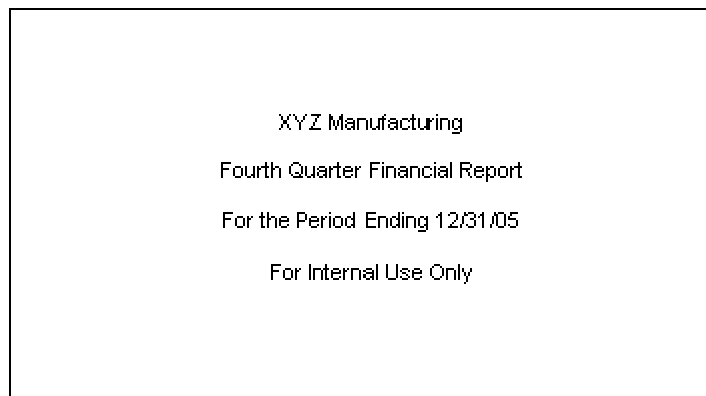

## Characteristics of a Page Footer Section

A report can contain only one page footer, which prints once at the end of each report page. A page footer might have an explanation about the contents of the report. Typically, page footers include data fields, such as constant and run-time fields; and alpha, numeric, and date variables.

The following illustration is a page footer as it might appear on a report:

### Page Footer



This page reflects revenue earnings for a single region or branch/plant

---

# Report Design

Before you can create a report, you must design it so that it is functional, useful, and complete. Report design entails determining user needs by asking questions of the stakeholders, creating a model of the report, and determining which sections to include on the report.

## Surveying Stakeholders

To determine user needs, you must answer the following questions:

- What is the purpose of the report?
- Who will use the report?
- What do the users want to see in the report?
- What information in the report will come directly from the database and what information needs to be calculated?
- What are the best business views to use?
- What data fields and records should be included in the report?
- In what order should the data be presented?
- What is the most useful format in which to present the information?
- What reports are used to produce this information now?
- Does a report already exist that could be copied or modified?
- Will a new version of an existing report meet the users' needs?
- How frequently will the report be run?
- Does the report output need to be exported to another software package by using output stream access (OSA) or comma separated values (CSV)?

## Creating a Report Model

Once you have determined user needs, you should create a report model, which helps you determine how you want to format the data and what section types best meet the users' requirements.

For example, suppose that you are creating a report that will be used for invoicing or ordering. A sample of a report model is shown below:

## Report Component

R09450	34 Quarterly Revenues	12/31/98 09:15:54 Page: 1		Page Header Section	
ABC Office Supplies-1244				Level-Break Header (Group Section)	
<u>Doc Type</u>	<u>Doc Number</u>	<u>Due Date</u>	<u>Amount</u>	Columnar Section	
PV	101	07/31/96	100.00		
PV	102	07/31/96	150.00		
			Total Revenue	250.00	Level-Break Footer (Group Section)
XYZ Manufacturing-8856					
<u>Doc Type</u>	<u>Doc Number</u>	<u>Due Date</u>	<u>Amount</u>		
PV	505	07/31/96	225.00		
PV	506	08/15/97	225.00		
			Total Revenue	450.00	
			Grand Total	700.00	Grand Total (Group Section)

### Determining the Report Sections

After the user and you agree on the model, you need to determine the sections of the report. For the previous example, you determined that the report should include a page header section to provide general information, level-break headers and footers (group sections) that display account information and subtotals, a columnar section that presents data in a columnar format, and a group section that displays totals

To determine what sections belong in a report, consider the following questions:

- Is a report header required at the beginning of the report for clear and meaningful presentation of the information?
- Is a report footer required at the end of the report to highlight an important function of or fact about the report?
- Is a page header required to present information on each page of the report?
- Is a page footer required to give the reader vital information on each page of the report?

- Does a business view already exist that contains the data fields on which you want to report?
- Do you need to create a subsection join?
- What is the best format to present the information?
  - Do you want the free-form format of the group section?
  - Do you want the columnar format of a columnar or tabular section?
  - Do you need the flexibility of a tabular section to create rows in your report?
- If you use a group or columnar section, do you need to add level-break headers or footers for totaling purposes?
- Would the automatic totaling features of a tabular section make it the best choice for your report?
- Does a director template exist to help you create a specific application report?
- Do you need to modify a director template or create a new one?
- How can you sequence the data fields and records from the business view?
- How can you sort the rows from your business view?
- What enhancements need to be made to report objects to make the report more useful? For example, do you want to emphasize the information in one column by changing the column spacing? Do you want to change the font size of the column's contents to call attention to the information?
- Are event rules required to define conditional, mathematical, or other logic for the report?
- Is an audit trail required?

After you have finished designing your report, you are ready to create it using the Report Design Director.

### **See Also**

See the following topics in the *Enterprise Report Writing Guide*:

- ❑ *Report Sections* for information on the characteristics of each section type and criteria for using a specific section
- ❑ *Report Design Director* for more information on creating a report by using this tool
- ❑ *Basic Report Enhancements* for information on modifying how your report looks and functions
- ❑ *Advanced Report Enhancements* for advanced information on modifying how your report looks and functions
- ❑ *Batch Versions for Reports* for information about creating and modifying batch versions
- ❑ *Submitting a Report* for information on how to select data and processing options, and how to view and print your report

## **J.D. Edwards Naming Conventions**

---

To provide consistency for developers and users, all J.D. Edwards objects follow standard naming conventions. The naming conventions require that each object, such as a table, report, interactive application, or menu, has a unique name. The naming conventions help you identify types of objects and prevent users from creating objects with duplicate names.

### **Understanding J.D. Edwards Naming Conventions**

A J.D. Edwards application is composed of multiple objects. You may further define the characteristics within an object. For example, when you create a table, you may designate a key that consists of more than one field within that table. When you create the index of the table, you should follow the standard for naming that index.

When you create a new object, you must name the object and provide a description. Naming conventions provide a standard for each object type that you can create

### **Naming Conventions for Objects**

Use the following chart as your guide when you name objects:

## Naming Conventions for Objects

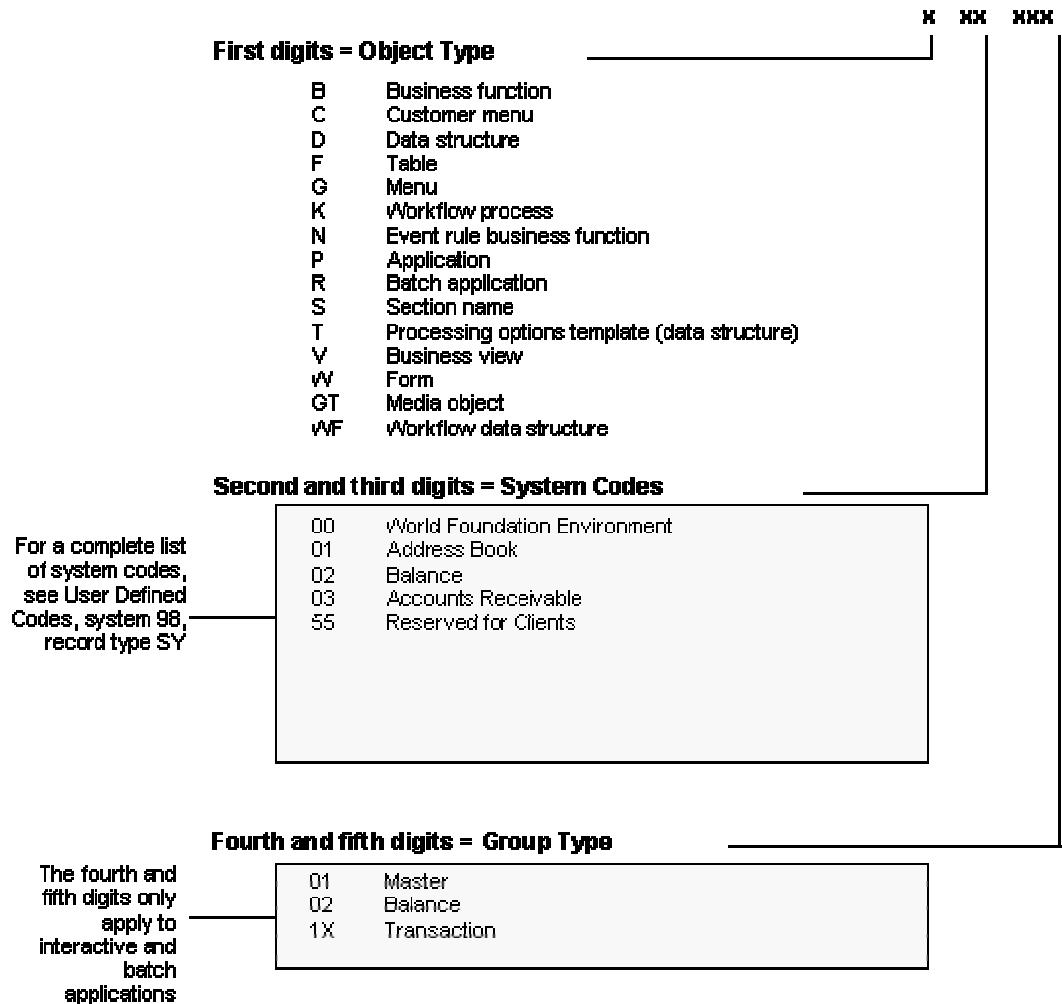

B and N represent business function names. These functions use a next number

D represents a data structure, which is used with business functions. Use the same naming convention for data structure that was used for business functions. Ensure that you use R69\* for table conversions.

### System Codes

The system code is included in an object name. For a complete list of J.D. Edwards system codes, see UDC table 98/SY.

If you are performing J.D. Edwards custom work, use system codes 60-69.

## Characteristics of a Report Footer Section

A report can contain only one report footer, which prints once at the end of the report. The report footer can contain a reminder that the contents of this report are for internal use only. Typically, report footers include data fields, such as constant fields; and alpha, numeric, and date variables.

The following illustration is a report footer as it might appear on a report:

### Report Footer

All information contained in this report is the legal and exclusive property of this company.
---

## Characteristics of a Page Header Section

A report can contain only one page header, which prints once at the beginning of each report page. A page header can have a company name, page number, and date. Page headers are usually generated by the system. However, you can manually create your own page header and include data fields, such as constant and run-time fields; and text, numeric, and date variables.

The following illustration is a page header as it might appear on a report:

### Page Header

R09450	XYZ Manufacturing	12/31/98 09:15:54
	Quarterly Revenues	Page: 1

### Example: Program and File Names

The following chart shows examples of the naming conventions for tables, forms, and applications:

#### Example: Program and File Names

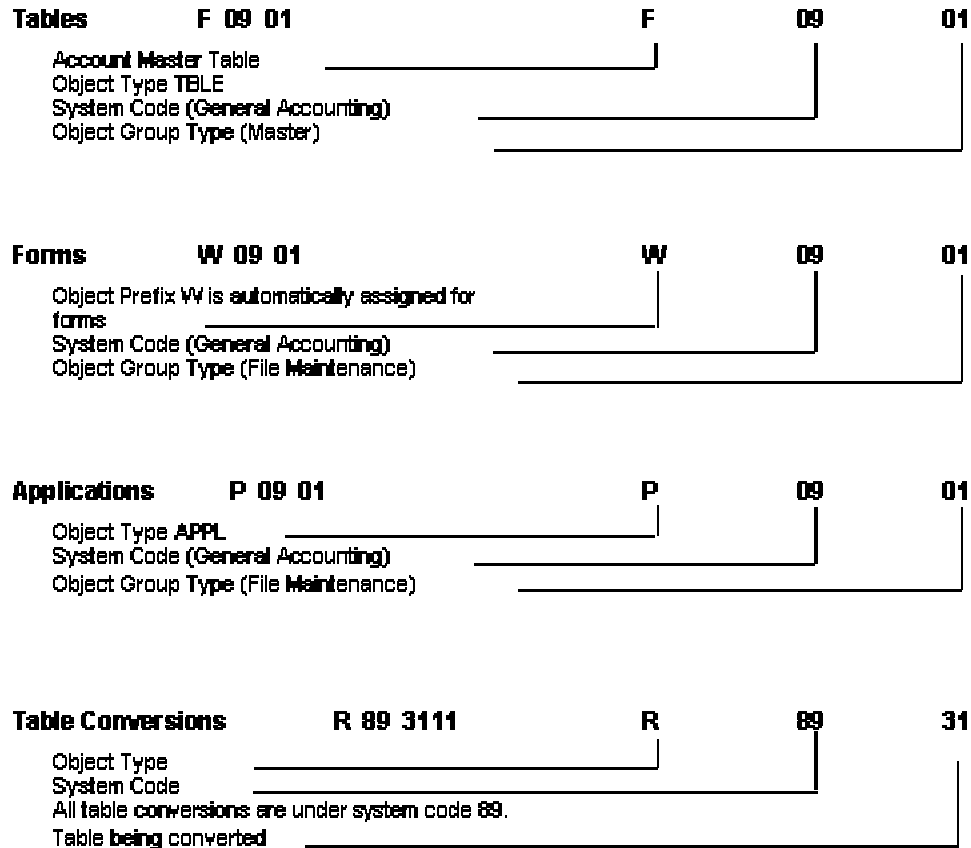

### Text Overrides and Jargon

J.D. Edwards software provides several options for overriding text in forms and reports to allow for different terms and languages. However, you should be aware of the following restrictions when you decide how to override text and use jargon:

- You can use jargon in the data dictionary to override text for the entire system, but if the text is overridden again in Form Design Aid or Report Design Aid, then jargon terms do not appear.
- You can use text variables to present different text strings under different conditions; but in such cases, it is difficult to determine whether you have allowed enough space on the form or report for translation.

## Object Naming Conventions for Batch Applications

Object naming conventions ensure consistency and make batch applications easier to identify and locate.

### Batch Applications

Object naming conventions ensure consistency and make batch applications easier to identify and locate. For batch applications, the name can be a maximum of eight characters and should be formatted as *Rxyyyyyy*, such as R09800, R30440, and so on, where:

*R* = Batch (report) application

*xx* = System code

*yyyyy* = For these digits, follow the same naming convention as you use on the AS/400.

The Function Use field follows the same naming standards as the AS/400, such as:

130-139 = Batch Processes

160-169 = Reports

Report Category Codes follow the same standards as the Form Design standards.

## Section Names

---

A section name within a report can be a maximum of 10 characters and should be formatted as *SzzzzzzzA*, such as S09800A, S30440B, and so on, where:

*S* = Report section name

*zzzzzzz* = Program name

*A* = A sequentially assigned letter

The tool set uses next numbers to automatically assign section names. Examples include S1, S2, S3, and so on.

The section description should include the section type, such as Batch Total Section, Payment Level Break Header Section.

Sections should be logically arranged in report rendering.

## Purge Table Program

---

Table Conversion-Batch Delete is the generic purge program in J.D. Edwards software that removes selected records from a table and stores the data in a backup file. To use this batch program, you must first create a table conversion in the Object Management Workbench (OMW), rather than a new version, for the table that you want to purge.

The purge table conversion name can be a maximum of eight characters and should be formatted as *Pxxxxxxp*, where:

*P* = The purge table

*xxxxxxp* = The table (file) name

---

### Note

In WorldSoftware, the purge program removes selected records and stores them in a designated backup. For each file that is purged, a new version is created with the new based-on table. The system does *not* create a new version; rather, you must create a table conversion.

---

### See Also

- ❑ *Creating a Batch Version* in the *Enterprise Report Writing Guide* for more information on batch versions
- ❑ *To save a report* in the *Enterprise Report Writing Guide* for information on how to save a report

### Versions

To indicate the purpose of the version, provide a description of up to 60 characters. The description indicates what the report does with a reference for setting processing options for that version.

---

### Note

XJDE versions are used for demo purposes and are typically batch applications.

---

When called from a menu, batch applications display the versions list so that clients can create production versions.

During an installation, XJDE versions are owned by J.D. Edwards, so J.D. Edwards may overwrite these versions.

ZJDE versions are used for default purposes and are typically interactive applications, or they are called from another application. You usually attach these versions to a menu. Clients can set these versions.

When called from a menu, interactive applications with a version are called with a blind execution based on predetermined processing option values.

Prior to release B73.3, during an installation, ZJDE versions are owned by J.D. Edwards. As of release B73.3, ZJDE versions are owned by the client and are not overwritten during an installation.

The installation replaces existing versions with the versions for Masters.

### **See Also**

- *Creating a Batch Version in the Enterprise Report Writing Guide*

## **Variables**

You define a variable to have one value until some condition is true, in which case you change the value of the variable. You can use a variable to control the flow of a function or statement; it allows you to check for certain conditions while your function progresses.

### **Batch Event Rule Variables**

An event rule variable name within a report should be formatted as *xxx\_yyzzzzzz\_AAAA*, where:

*xxx* = A prefix that the system automatically assigns, depending on the scope. For example:

*evt\_* (event scope)

*rpt\_* (report scope)

*sec\_* (section)

*yy* = Hungarian Notation for C variables, such as:

*c* - Character

*mn* - Math numeric

*sz* - String

*jd* - Julian date

*id* - Pointer

*zzzzzz* = A programmer-supplied variable name. Each word is capitalized.

*AAAA* = A data dictionary alias (all upper case).

For example, an item event rule variable would be *rpt\_mnItemNumber\_ITM*. Do not include any spaces.

If report global variables are used, global variables are defined in a conditional group section that is never called. This section is named Defined Global Variables. Global variables are placed in the section in logical groupings. Use constants to comment on the use of the global variables.

## Event Rule Variables

---

Event Rule variables are named similar to C variables and should be formatted as *xxx\_yyyyyyy\_AAAA*, where:

*xxx* = A prefix that varies depending on the scope. The system automatically assigns the prefix, such as:

*frm\_* (form scope)

*evt\_* (event scope)

*yy* = Hungarian Notation for C variables, including:

*c* - Character

*h* - Handle Request

*mn* - Math Numeric

*sz* - String

*jd* - Julian Date

*id* - Pointer

*yyyyyy* = A programmer-supplied variable name. Capitalize the first letter of each word.

*AAAA* = The data dictionary alias (all upper case).

For example, a branch/plant event rule variable would be *evt\_szBranchPlant\_MCU*. Do not include any spaces.

### Text Variables

The system automatically assigns a name using the format *TVyyyyyy*, where:

*TV* = Text Variable

*yyyyyy* = Programmer-supplied variable name

### See Also

- *Working with Event Rule Variables* in the *Development Tools Guide*

## Report Objects

---

A report must be defined as a UBE object type in the Object Librarian Master table (F9860). A report object must have at least a name, a description, and a product code to which the object is connected. After you have created the report object, you can save it and add additional specifications, such as the report format, at a later time.

### Default Settings for Reports

When you create a new report or another batch application, the system automatically applies certain standards for you. The J.D. Edwards development toolset automatically sets the following standards for you:

<b>Font</b>	7 point, Arial, regular font.
<b>Report name</b>	Appears in the upper-left corner of the report header (for example, such as R09800).
<b>Actual run date and run time values</b>	Appears on the right side of the first and second lines of the report header.
<b>Label Page, followed by the page number</b>	Appears in the upper-right corner of the report header.
<b>Report titles</b>	Centered at the top of the report header.
<b>Company name</b>	Appears on the first line of the report title in the report header.

### Creating a Report Object

J.D. Edwards software categorizes each report object in one of two ways: as a report template or as a batch version.

J.D. Edwards software offers two methods for creating report objects: the Report Design tool and the Object Management Workbench (OMW). You can also create batch versions with the Batch Versions tool. When you create a report object with Report Design, you create a new report template and, optionally, a batch version. This instance is the only time that you can use Report Design to create a batch version; any other batch versions that you need must be created with either the OMW or the Batch Versions tool.

You can also create a report template using OMW. OMW is a change management tool that allows you to create either a template or a batch version that is based on an already existing template.

#### See Also

- ❑ *Object Management Workbench* in the *Development Tools Guide* for more information on using the OMW
- ❑ *Batch Versions for Reports* in the *Enterprise Report Writing Guide* for more information on using the Batch Versions tool to create batch versions

## ► To create a report object with Report Design

---

*From the Report Writer menu (GH9111), choose Report Design Tool.*

1. On Report Design, click New.
2. On Create New Report, complete the following fields, and then click OK:
  - Report Name  
By default, the report name appears in the upper-left corner of the page header. The J.D. Edwards naming convention begins report names with the letter R, followed by the product code, and ending with a unique identifier.
  - Description  
The description appears in the center of the page header below the company name. J.D. Edwards recommends that you make this description into a useful identifier, such as G/L by Batch - Columnar.
  - Product Code  
Codes 55 - 59 are reserved for customers. Use these codes to ensure that your object remains unaltered by J.D. Edwards software upgrades.

The Report Design Director opens.

3. Continue with the Report Design Director to design the report. The option to create a version based on the report template you just created appears on the final Report Design Director form.

---

### **Note**

When you create a version, the system uses the current report level values. If you change the report level values after you create the version, the new report level values are not reflected in the version.

---

## ► To create a report template with OMW

---

*From the Cross Application Development Tools menu (GH902), choose Object Management Workbench (P98220).*

1. On Object Management Workbench, click Find.
2. On the project list, choose the project to which the new report object will be added, and then click Add.
3. On Add OneWorld Object to the Project, choose to create a Batch Application, and then click OK.
4. On Add Object, complete the following fields, and then click OK:
  - Object Name  
Object Name is the name of the report. By default, the name appears in the upper-left corner of the page header. The J.D. Edwards naming convention begins report names with the letter R, followed by the product code, and ending with a unique identifier.

- Description
 

The description appears in the center of the page header below the company name. J.D. Edwards recommends that you make this description into a useful identifier, such as G/L by Batch - Columnar.
  - Product Code
 

Codes 55 - 59 are reserved for customers. Use these codes to ensure that your object remains unaltered by J.D. Edwards software upgrades.
  - Product System Code
 

Use either the product code of the report or the business view.
  - Object Use
 

Depending on how you want to classify the report's use, you can use one of codes 160 - 166, which are all report-related classifications.
5. On Batch Application Design, click the Design Tools tab, and then click Start Report Design Aid.
- Continue with the Report Design Director to design your report.

► **To copy a report template with OMW**

---

*From the Cross Application Development Tools menu (GH902), choose Object Management Workbench (P98220)*

1. On Object Management Workbench, click find.
2. On the project list, highlight the report you want to copy and click Copy.
3. On Copy Object, complete the following fields, and then click OK:
  - Copy to
 

The name of the new report. By default the name appears in the upper-left corner of the page header. The J.D. Edwards naming convention begins report names with the letter R, followed by the product code, and ending with a unique identifier.
  - Description
 

The description appears in the center of the page header below the company name. J.D. Edwards recommends that you make this description into a useful identifier, such as G/L by Batch – Columnar.
  - Product Code
 

Codes 55 – 59 are reserved for customers. Use these codes to ensure that your object remains unaltered by J.D. Edwards software upgrades.
  - Product System Code
 

Use either the product code of the report or the business view.
  - Object Use
 

Depending on how you want to classify the report's use, you can use one of the report-related classification codes 160 – 166.

4. On Batch Application Design, click the Design Tools tab, and then click Start Report Design Aid.

Continue with the Report Design Director to design your report.

► **To create a batch version with OMW**

---

*From Cross Application Development Tools (GH902), choose Object Management Workbench.*

1. On Object Management Workbench, click Find.
2. On the project list, choose the project to which the new report object will be added, and then click Add.
3. On Add OneWorld Object to the Project, choose Batch Version, and then click OK.
4. On Adding a Version, enter the report template's name, or use the Search button to search for the report template, and then click OK.
5. On Version Add, complete the following fields, and then click OK:
  - Print Cover Page
  - Version
  - Version Title
  - Prompting Options  
This field is disabled if no processing options are associated with the report template.
  - Security
  - Job Queue
  - Version Detail

► **To copy a batch version using OMW**

---

*From Cross Application Development Tools (GH902), choose Object Management Workbench.*

1. On Object Management Workbench, click Find.
2. On the project list, choose the batch version to copy, and then click Copy.
3. On Version Copy, complete the following fields, and then click OK:
  - New Version
  - Security
  - Version Title
4. On Batch Version Design, click the Tools tab, and then click Report Design.  
Continue with Report Design to design your version.

## Deleting a Report Object

From time to time, you might need to delete report objects from your system. You can delete batch versions and report templates. If you delete a report template, all of its batch versions are deleted automatically.

You can delete a report object at three different levels:

- You can delete an object from the check-in server.
- You can delete an object from your local environment only.
- You can delete the object completely from the system.

---

### Note

You can delete report objects only if they are checked in, and you have the proper roles and permissions to delete them. For more information, see *Object Management Workbench* in the *Development Tools Guide*.

---

### See Also

- *Object Management Workbench* in the *Development Tools Guide* for information on checking in report object, and roles and permissions

---

### ► To delete a report object

---

*From the Cross Application Development Tools menu (GH902), choose Object Management Workbench.*

1. On Object Management Workbench, click Find.
2. On the project list, choose the object to delete, and then click Del (delete).
3. On Delete of, click one of the following options:
  - Delete Object from Server
  - Delete Object Locally
  - Remove Object from ALL Locations

4. Click OK.

Objects marked to be deleted completely are highlighted in bold text in the project display window. They are deleted when you close J.D. Edwards software.

## Opening an Existing Report

If you know the name of an existing report, you can open the report to make changes with Report Design. However, the first time that you try to open the report, you might receive an error message that tells you that the report does not exist on your workstation. You must then get the specifications from the server before you can work with the report.

You can open either a report template or a batch version. If you open and modify a report template, the changes that you make are reflected in the template's versions (unless prohibited by overrides in the batch versions). Open a batch version if you want to modify it or define overrides for it.

When you open an existing report, the Director is not available to assist with changes. Rather, the report template or batch version opens automatically to the Report Design form. You can open a report object with Report Design or OMW.

#### **See Also**

- ❑ *Object Management Workbench* in the *Development Tools Guide* for information on getting object specifications

#### **► To open a report object with OMW**

---

*From the Cross Application Development Tools menu (GH902), choose Object Management Workbench.*

1. On Object Management Workbench, click Find.
2. On the project list, choose the report object you want to open and click the Design button in the center column.

If the report object that you want to open is not in your project list, you must add it to one of your projects before you can work with it.

If you chose a report template, on Batch Application Design, click the Design Tools tab, and then click Start Report Design Aid.

If you chose a batch version, on Batch Version Design, click the Tools tab, and then click Report Design.

#### **See Also**

- ❑ *Object Management Workbench* in the *Development Tools Guide* for information on adding objects to your projects

## **Creating Detail Sections**

---

The Director guides you through the steps of creating a detail section. You might, however, need to modify an existing section or need to add one or more columnar, group, or tabular sections. Report Design provides features to help you accomplish these tasks.

To create an additional section using Report Design, forms similar to those displayed in the Director are available to help you design your section. This topic shows you how to add a detail section to a report.

### **Adding a Detail Section**

Report Design lets you manually create as many group, columnar, or tabular sections as are required for your report. You can design each detail section by choosing a business view and adding individual columns from it.

### ► To add a detail section

---

1. On Report Design, from the Section menu, choose Create.
2. From Create, choose one of the following:
  - Group
  - Columnar
  - Tabular

The Report Director appears to help you select a business view.

3. To create a new section, proceed through the director forms as they appear.

#### See Also

- See *Report Design Director* in the *Enterprise Report Writing Guide* for information about using the forms of the Report Design Director

## Selecting a Business View

Business views are the link between your report and the data in your J.D. Edwards software tables. A business view defines the data fields from one or more tables that a report uses. Report Design lets you limit your business column selection to only those columns that you need in your report.

### ► To select a business view

---

1. On Report Design, click inside the detail section.
2. From the Section menu, choose Select Business View.
3. On Business View Director, choose one of the following tabs; and then proceed to the appropriate instructions:
  - Select Business View
  - Favorite Business Views

#### See Also

See the following topics in the *Enterprise Report Writing Guide*:

- *To use the Select Business View tab to find a business view*
- *To use the Favorite Business Views tab to find a business view*

### ► To use the Select Business View tab to find a business view

---

1. On Business View Director, click the Select Business View tab.
2. On Select Business View, click Find or press Enter.

The form displays a list of all available business views. You can narrow your search by entering search criteria in the QBE line. Search for a business view using the following naming conventions:

The business view name starts with the letter V and is a maximum of 10 characters. It is formatted as follows: VxxzzzzzzA.

- xx = the product code (55-59 is reserved for clients).
  - zzzzzzz = the characters of the primary table.
  - A = the letter to designate the view. For example, V0101A is the first view over the table F0101, and V0101B is the second view over the same table.
3. Choose a business view, and then click OK

#### See Also

- *Business View Design* in the *Development Tools Guide* for more information about business views

#### ► To use the Favorite Business Views tab to find a business view

---

1. On Business View Director, click the Favorite Business Views tab.
2. From the Favorites list, choose the folder that contains the business view you want to use for your detail section. Click the + icons to expand the folders until you see the business view that you want to see.
3. Click the Description tab to see a brief description of the business view that you have chosen.
4. Click the Columns tab to see the data fields that are included in the business view which you have chosen.
5. When you have chosen the business view that you want to use, click OK.

Whether you chose a business view through the Select Business Views tab or Favorite Business Views, the title bars in the Report Tree and Report View windows now reflect the business view that you selected.

#### See Also

- *Setting up Business Views as Favorites* in the *Enterprise Report Writing Guide* for information about adding your own business views to this list

## Adding Business View Columns to a Detail Section

Business view is the link between your report and the data in your J.D. Edwards software tables. A business view defines the data field from one or more tables that a report uses. Report design lets you limit your business column selection to only those columns that you need in your report.

Based on the business view that you choose, you can add new business view columns to a detail section of your report.

#### ► To add business view columns to a detail section

---

1. On Report Design, click a detail section with an associated business view.
2. From the Section menu, choose Quick Section.  
The Quick Section form appears.

**BV Column 1**

**BV Column 3**

**BV Column 5**

**BV Column 2**

**BV Column 4**

**BV Column 6**

**Number of Columns = 2**

---

**BV Column 1**

**BV Column 4**

**BV Column 2**

**BV Column 5**

**BV Column 3**

**BV Column 6**

**Number of Columns = 3**

3. On Quick Section, from the Available Business View Columns, choose columns, and then do one of the following:
  - Click the right arrow to move one or more columns to Selected Columns.
  - Drag columns to Selected Columns.
  - Click the right double-arrow to move all columns to Selected Columns.
4. To remove a column from your report, from the Selected Columns list, choose the column, and then do one of the following:
  - Click the left arrow or press Delete to remove only the selected columns.
  - Click the left double-arrow to remove all columns.
5. To change the order that the columns appear on your report, from the Selected Columns list, choose the column, and then do one of the following:
  - Click the up or down arrow to move the selected column up or down one line in the list.
  - Drag a column to change its order.
  - Click the up or down double-arrows to move the selected column to the top or bottom of the list.

If you are creating a group section, the Number of Columns field appears below the Available Business View Columns list. This field determines how Report Design organizes the fields initially in the number of stacks it creates in the section. For example, if you have selected six business view columns and then set Number of Columns to 2, Report Director arranges the business view columns in two stacks, each three-business view columns deep. The first three appear in descending order in the first stack and the last three in descending order in the second. If you set Number of Columns to 3, however, it arranges the business view columns three across and two down. The default value is 2.

If you are creating a tabular section, the Description column is automatically added as a column on your report. This column appears in the Selected Columns list on the Section Layout form and appears as the first column on your report.

6. When you finish the layout of your section, click OK.

#### **See Also**

- *Adding Smart Fields to an Application Report* in the *Enterprise Report Writing Guide* for information about how to define smart fields
- *Working with Columns in Tabular Sections* in the *Enterprise Report Writing Guide* for information about how to define calculations

## **Defining Section Data Sequencing**

Data sequencing determines the order in which records are read from the database and displayed on the report. For example, you might want to order records by address book number and then by name.

Because J.D. Edwards software can sequence the records in the report by any column in the record (regardless of whether you choose to display the column in the report), the data sequencing columns that you choose in this task do not need to match the business view columns chosen on Section Layout.

### **► To define section data sequencing**

---

1. On Report Design, click the detail section for which you created the section layout in the previous task.
2. From the Section menu, choose Define Data Sequence.

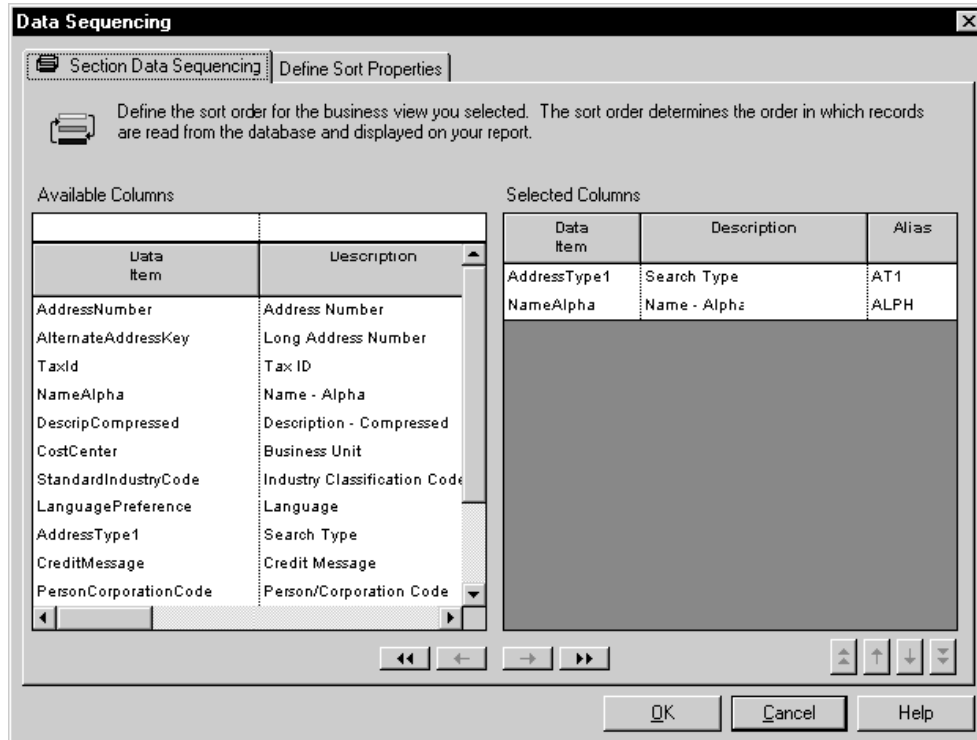

3. Click the Section Data Sequencing tab.
4. To choose columns for data sequencing, from the Available Columns list, choose columns, and then do one of the following:
  - Click the right arrow to move one or more columns to Selected Columns.
  - Drag columns to Selected Columns.
  - Click the right double-arrow to move all columns.
5. To remove a column from the Selected Columns list, choose the column, and then do one of the following:
  - Click the left arrow or press Delete to remove only the selected columns.
  - Click the left double-arrow to remove all columns.

---

### Caution

If you define a data sequencing column as a level break or page break (as explained in the next task), do not move that column from the Selected Columns list back to the Available Columns list.

---

6. To change the order that the business view columns appear on your report, from the Selected Columns list, choose the column, and then do one of the following:
  - Click the up or down arrow to move the selected column up or down one line in the list.
  - Drag a column to change its order.

- Click the up or down double-arrows to move the selected column to the top or bottom of the list.

When you finish determining the sequence order for your detail section, you can begin defining the sort properties.

## Defining Sort Properties

After you choose data fields to use for data sequencing, you can define sort properties for those data fields. The sort properties determine whether the rows are sorted in ascending or descending order, whether a level break should occur, and whether the level break should produce a page break. For example, you can sequence your information for Search Type in ascending order, designate Search Type as a level break, and have a new page begin for each Search Type.

### See Also

- *Working with Level-Break Header and Footer Sections in the Enterprise Report Writing Guide* for detailed information about working with level breaks

### ► To define sort properties

---

*From the Section menu, choose Define Data Sequence.*

1. On the Data Sequencing form, click the Define Sort Properties tab.

Define the properties for the sort columns you selected. These properties determine the type of sequencing (ascending/descending), whether a level break should occur, and if a level break should produce a page break. Click on a box to select a property.

Data Item	Description	Alias	Sort Order	Level Break	Page Break
AddressType1	Search Type	AT1		<input checked="" type="checkbox"/>	<input checked="" type="checkbox"/>
NameAlpha	Name - Alpha	ALPH	<input type="text" value="↕"/>	<input type="checkbox"/>	<input type="checkbox"/>

OK Cancel Help

2. On Define Sort Properties, complete the following fields, and then click OK:
  - Sort Order
  - Level Break
  - Page Break

---

**Note**

To set an object as a page break, you must first set the object as a level break.

---

## Defining Section Data Selection

Section data selection lets you define criteria whereby only specific, relevant records are included in your report.

The Section Data Selection form filters the data for one detail section only. If your report contains only one detail section, your report will display only the records that match the criteria entered on this form. If you add other detail sections to your report, you must define data selection for each section.

To limit the records retrieved from the J.D. Edwards software tables, specify data selection criteria, such as *is equal to* and *is less than* between the following:

- Data fields in the J.D. Edwards software tables
- Values that define the data in the data fields, such as ledger types, search types, or account numbers

### ► To define section data selection

---

1. On Report Design, click a detail section for which you have defined section data sequencing and sort properties.
2. From the Section menu, choose Define Data Selection.
3. On Section Data Selection, *Where* is the default value in the Operator column for the first set of criteria.

For subsequent statements, *And* and *Or* become the available values for the Operator column and are selected by double-clicking the appropriate one.

4. Click in the Left Operand column to display the list of available objects, and then perform one of the following:
  - Scroll through the list until you find the desired object, choose the object, and then double-click the object to populate the Left Operand column.
  - Type the first letters of the object name in the Left Operand field to bring you to the object in the list, and then double-click the highlighted object.

When you double-click the object for the Left Operand column, the list in the Comparison column automatically appears.

5. Select one of the following comparison operators:
  - is equal to
  - is greater than
  - is greater than or equal to
  - is less than
  - is less than or equal to
  - is not equal to
6. Click in the Right Operand column to display an available list of objects, special values, or variables. Your choices in this column depend on the choice you made in the Comparison column. Some of the following options could be available:

**Blank** Enters a blank (space) value

**Literal** Allows you to enter specific values (see the following step for information on entering specific values)

**Null** Indicates that no value is associated with the field

**Zero** Enters a value of zero

**BC** Indicates a business view column available for this report

**FI** Indicates a value passed through form interconnection to this report

**PC** Indicates the previous business view column

**PO** Indicates a processing option value for this report

**PV** Indicates the previous variable

**RC** Indicates a constant from this report

**RV** Indicates a variable from this report

**SV** Indicates a system variable

**SL** Indicates a system literal

**VA** Indicates an event rule variable

7. If you chose to enter a literal in the Right Operand column, the form that opens automatically enables you to enter the following:
  - Single value  
Enter a single value, and then click OK. For example, a value might be for a particular company.

- Range of values  
Enter a range of values, and then click OK. For example, a range of values might include companies from 00001 to 00060. Only *is equal to* and *is not equal to* are valid logical operators when using range of values.
- List of values  
To add values to or remove values from the list, do the following:
  - Type each value in the field, and then press Enter or click the Add button at the top of the form.
  - Repeat this process until your list of values is complete. For example, a list of values might include several user defined codes for search types such as C for Customers, E for Employees, and V for Vendors. Only *is equal to* and *is not equal to* are valid logical operators when you are using list of values.
  - Delete a value by choosing the value, and then click the Delete button at the top of the form.
  - Click OK when you are finished.

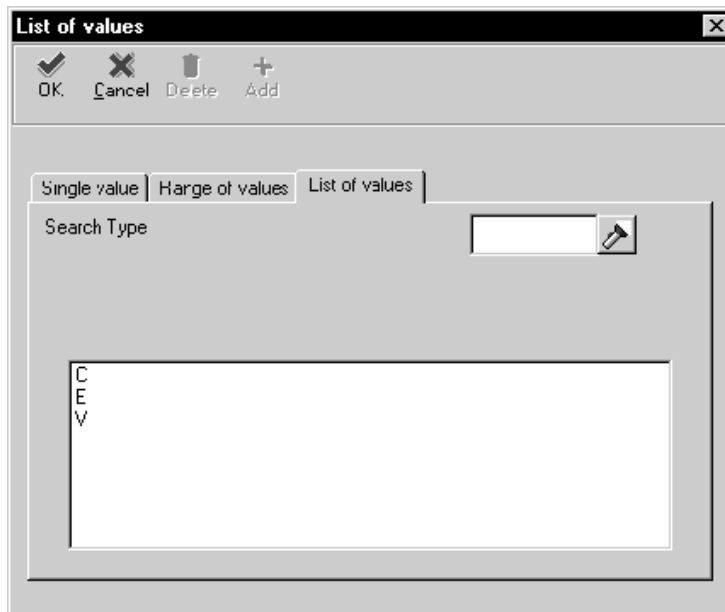

8. To delete a line of criteria on Section Data Selection, choose the row header to highlight the row, and then click the Delete button at the top of the form.
9. To change the order of the criteria, choose the row header to highlight the row, and then click the up or down button.

---

## Report Design Director

The Report Design Director (Director) gives a quick start to designing a report by leading you through a linear process to set up some basic elements. As you proceed through the Director, you answer simple questions, such as whether you want header and footer sections, what type of detail section to use, on what business view the data selection will be based, what columns to include in the report, and how to sequence and sort the records in your report. Based on your answers to these questions, the Director sets up a report and opens it in Report Design. You can then use Report Design to format and enhance the report and change anything set up through the Director.

The Director also includes director templates to help you create an application report. These templates contain default criteria, such as a recommended business view, a list of smart fields, data selection, and data sequencing options to include. When you choose one of the templates in the Director, the Director reads the template specifications (stored in J.D. Edwards software tables) and presents the default criteria through the Director forms. Several director templates are included with J.D. Edwards software. You can also create your own templates with the Smart Field Activation (P91420) and Report Director Templates (P91400) programs.

If you want to design your report without assistance of the Director, bypass the Director by clicking Finish or Cancel; then build your report, section by section, within Report Design.

### See Also

- ❑ *Working with Director Templates* in the *Enterprise Report Writing Guide* for more information about modifying and adding report director templates
- ❑ *Creating Detail Sections* in the *Enterprise Report Writing Guide* for information about creating sections by using Report Design rather than the Director

---

## Creating a Columnar Report

The columnar report is the simplest report that you can create by using the Report Design Director. It presents information from a business view in columns. Each data field is a column and each record is a row.

Use the Director to design a columnar report. The Director leads you through the process for creating a columnar report by asking you questions about the structure and content of the report. After you create the report, you can enhance it by using additional features of Report Design.

### See Also

See the following topics in the *Enterprise Report Writing Guide*:

- ❑ *Characteristics of a Columnar Section* for an overview of columnar sections and criteria for using them
- ❑ *Creating a Report Object* for information about starting the report design process and the Director

## Before You Begin

- ❑ Create a report object. The last step in creating a report object opens the Report Design Director automatically. See *Creating a Report Object* in the *Enterprise Report Writing Guide* for instruction on creating a report object.

### ► To choose report sections to include in the columnar report

#### Note

After you create a report object, Report Design Director starts with a Welcome form. The Director includes a Navigation Assistant pop-up box that shows you where you are in the report creation process. You can hide the Navigation Assistant by right-clicking it and choosing Hide.



1. On Welcome to the Report Design Director, click the following options for the headers and footers that you want to include in your report:
  - Report Header
  - Page Header
  - Page Footer
  - Report Footer

2. Click the Columnar option, and then click Next.

If you chose a page header, the Page Header Details form appears.

---

**Note**

If you did not choose a page header, the Business View Selection Option form appears. Go to one of the next tasks: *To choose from a list of favorite business views* or *To use Select Business View to find a business view*.

---

3. On Page Header Details, select one of the following options to automatically include the following standard data fields:
  - Automatically add the default informational fields shown below to my page header section.
  - Automatically add the default informational fields “Page n or Total” shown below to my page header section.

---

**Note**

After you complete the report using Report Director process, you can use Report Design to add or delete data fields from the page header.

If you do not select either of the options above, the Director creates an empty page header. You can manually add data fields to the page header from the Section menu on the Report Design form.

---

4. Click Next.

Business View Selection Option appears.

---

**► To choose from a list of favorite business views**

---

*After you choose the report sections for the report, Business View Selection Option appears.*

1. On Business View Selection Option, click the option under *I'd like help finding an appropriate business view*, and then click Next.
2. On Favorite Business Views, open the folder that contains the business view that you want to use for your report section. Click the + icons to expand the tree until you see the business view that you want.
3. Click the Description tab to see a brief description about the business view that you have chosen, if a description is available.

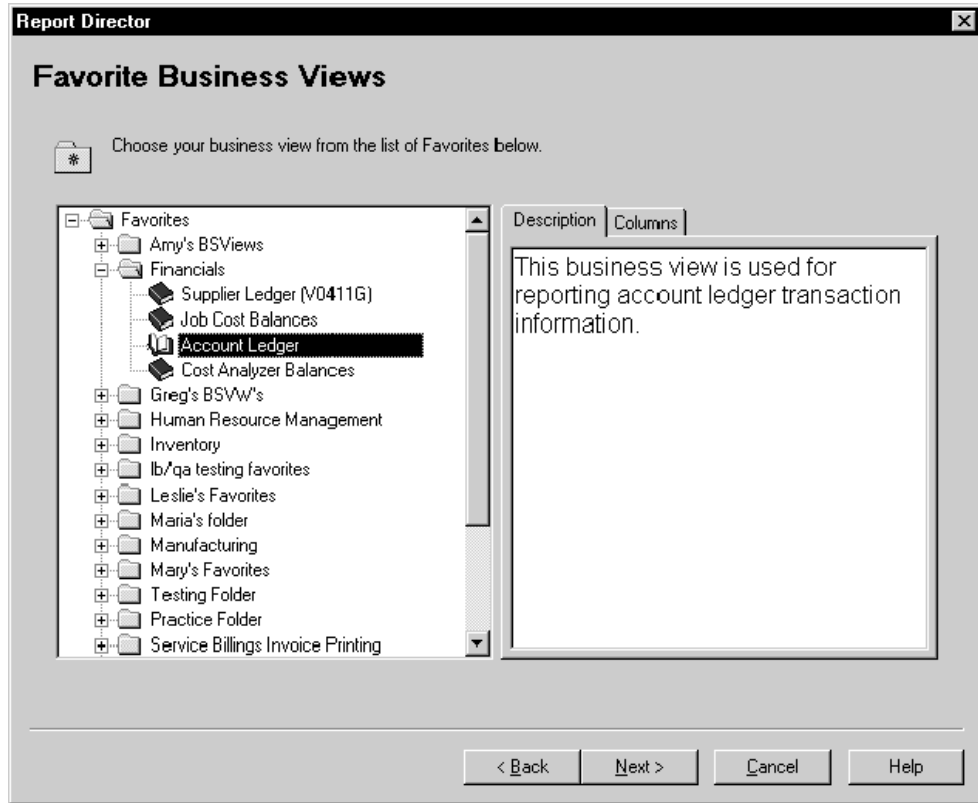

4. Click the Columns tab to see the data fields that are included in the business view that you have chosen.

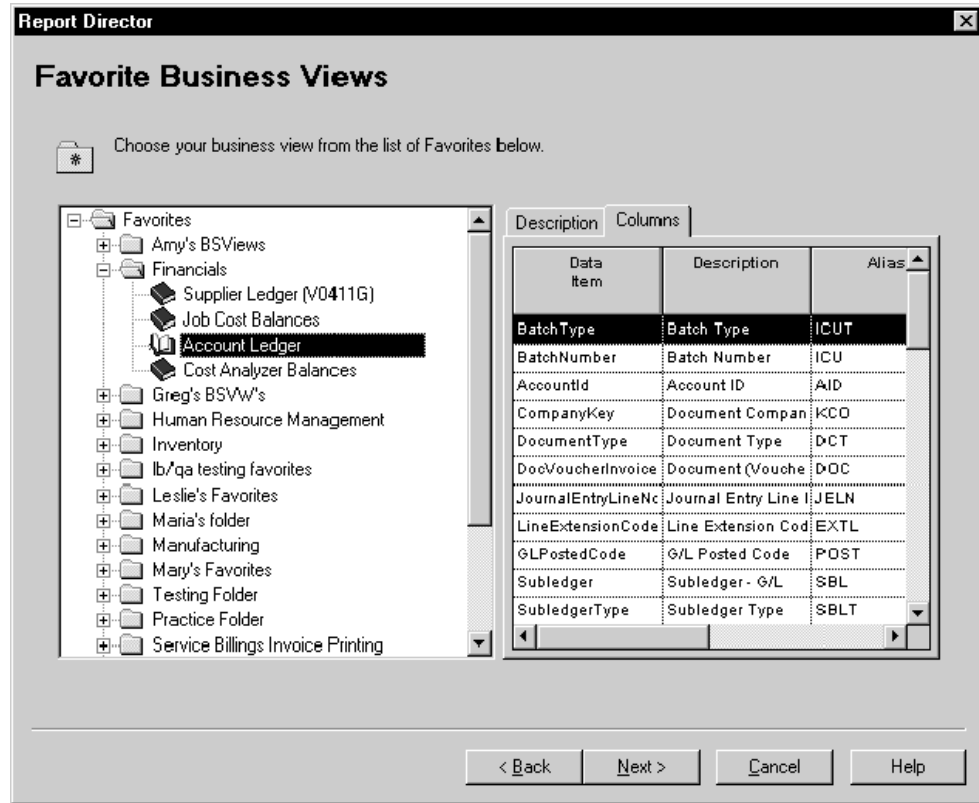

- When you have chosen the business view that you want to use, click Next to see Section Layout.

#### See Also

- Setting up Business Views as Favorites in the *Enterprise Report Writing Guide* for information about adding your own business views to this list

#### ► To use Select Business View to find a business view

After you choose the report sections for the report, *Business View Selection Option* appears.

- On Business View Selection Option, click the option under *I'll find a business view myself*.
- Click Next.
- On Select Business View, click Find or press Enter.

The form displays a list of all of the available business views. You can narrow your search by entering search criteria in the QBE row.

- Choose a business view, and then click Next to see Section Layout.

#### See Also

- Business View Design* in the *Development Tools Guide*

► **To add business view columns to the section**

---

*After you choose a business view as described in the previous task, Section Layout appears.*

1. From the Available Business View Columns list, choose the columns that you want in the report, and then click the arrow that is pointing to the right to move them to the Selected Columns list.

Alternately, you can drag each column individually into the Selected Columns list, or you can click the right double-arrow to move all of the columns from the Available Business View Columns list to the Selected Columns list.

The first item in the list appears as the left column in the report.

2. To remove a column from your report, choose a column in the Selected Columns list, and then click the arrow pointing to the left to move it to the Available Business View Columns list.

Alternately, you can click the left double-arrow to move all of the columns from the Selected Columns list to the Available Business View Columns list.

3. To change the order that the columns appear on your report, choose a column in the Selected Columns list, and then click the up or down arrow to move the selected column up or down one line in the list.

Alternately, you can drag a column to a new location in the list, or you can click the up or down double-arrows to move the selected column to the top or bottom of the list.

4. When you complete the layout of your section, click Next to see Section Data Sequencing.

► **To define section data sequencing for the section**

---

*After you select business view columns as described in the previous task, Section Data Sequencing appears.*

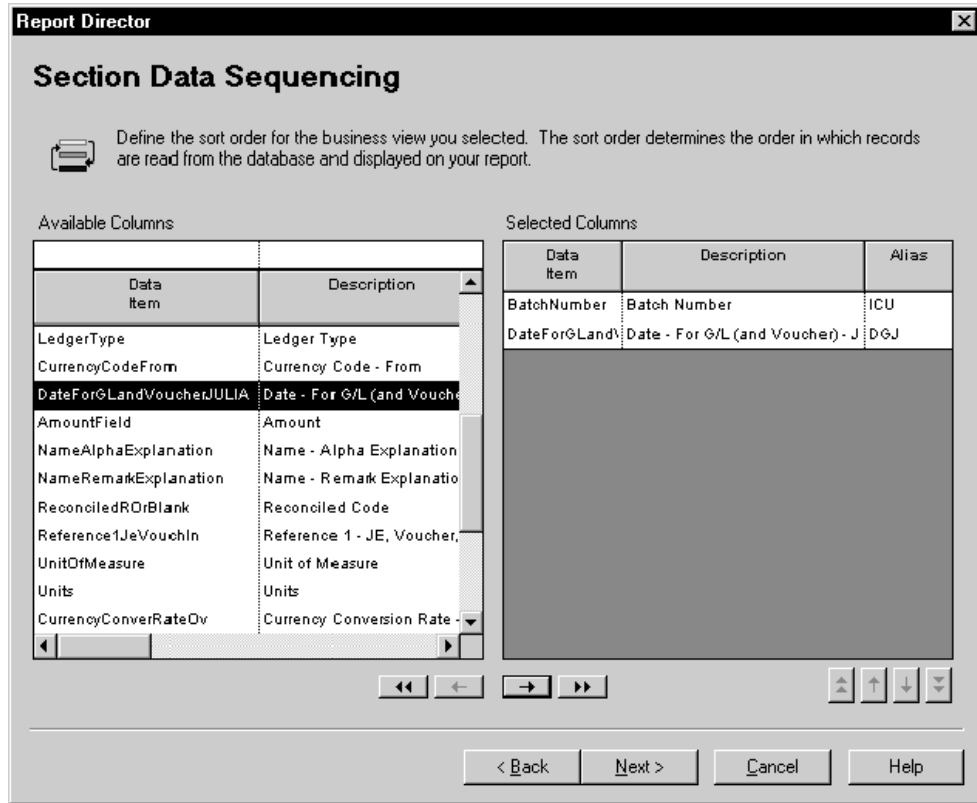

1. To select columns for section data sequencing, choose the columns from the Available Columns list, and then click the arrow that points to the right to move them to the Selected Columns list.

Alternately, you can drag each column individually into the Selected Columns list, or you can click the right double-arrow that is pointing to the right to move all of the columns from the Available Columns list to the Selected Columns list.

---

**Note**

To define sort properties in the next task, you must select the column on which you plan to sort in this task.

---

2. To remove a column from the Selected Columns list, choose a column in the Selected Columns list, and then click the arrow that points to the left to move it to the Available Columns list.

Alternately, you can click the left double-arrow to move all of the columns from the Selected Columns list to the Available Columns list.

3. To change the order of the columns that you selected for data sequencing, choose a column in the Selected Columns list, and then click the up or down arrow to move the selected column up or down one line in the list.

Alternately, you can drag a column to a new location in the list, or you can click the up or down double-arrows to move the selected column to the top or bottom of the list.

- When you finish the section data sequencing for your report, click Next to see Define Sort Properties.

### See Also

- Working with Level-Break Header and Footer Sections in the *Enterprise Report Writing Guide* for detailed information about working with level breaks

### ► To define sort properties for the section

---

After you define data sequencing as described in the previous task, *Define Sort Properties* appears.

**Report Director**

### Define Sort Properties

Define the properties for the sort columns you selected. These properties determine the type of sequencing (ascending/descending), whether a level break should occur, and if a level break should produce a page break. Click on a box to select a property.

**Sort Columns**

Data Item	Description	Alias	Sort Order	Level Break	Page Break
BatchNumber	Batch Number	ICU	↕		
DateForGLand	Date - For G/L (and Vou	DGL	↕		

< Back   **Next >**   Cancel   Help

- On Define Sort Properties, complete the following field:
  - Sort Order
- If you want to specify level and page breaks, complete the following fields:
  - Level Break

---

### Caution

If you define a section data sequencing column as a level break, returning to the Section Data Sequencing form and then moving that column from the Selected Columns list back to the Available Columns list could cause unpredictable results.

- Page Break

3. When completed, click Next to see Section Data Selection.

► **To select records to include in the section**

After you define sort properties for the section in the last task, the Section Data Selection form appears.

**Section Data Selection**

Define the subset of data your report will use when reading records from the database. In other words, filter the incoming data so that your report only processes certain records.

Operator	Left Operand	Comparison	Right Operand
Where	BC Amount (F0911)	is greater than	>'1,000.00"

< Back   Next >   Cancel   Help

1. On Section Data Selection, click in the Operator column and choose an operator. *Where* is the default value in the Operator column for the first set of criteria. For subsequent statements, *And* and *Or* become the available values for the Operator column, and are selected by double-clicking the appropriate word.
2. Click in the Left Operand column to display the list of available objects, and then perform one of the following actions:
  - Scroll through the list until you find the desired object, choose the object, and then double-click the object to populate the Left Operand column.
  - Type the first letters of the object name in the Left Operand field to display the object in the list, and then double-click the highlighted object.

When you double-click the object for the Left Operand column, the list in the Comparison column automatically appears.

3. Double-click one of the following comparison operators to select it:

- is equal to
- is greater than
- is greater than or equal to
- is less than
- is less than or equal to
- is not equal to

When you double-click the object for the Comparison column, the list in the Right Operand column automatically appears. The objects, special values, and variables that are available depend on the comparison operator that you choose.

4. Double-click a value from the list in the Right Operand column to select it.

Your choices in this column depend on the choice that you made in the Comparison column. Some of the following options could be available:

**Blank** Enters a blank (space) value

**Literal** Allows you to enter specific values, as described below

**Null** Indicates that no value is associated with the field

**Zero** Enters a value of zero

**BC** Indicates that a business view column is available for this report

**FI** Indicates that a value passed through form interconnection to this report

**PC** Indicates the previous business view column

**PO** Indicates a processing option value for this report

**PV** Indicates the previous value for the variable

**RC** Indicates a constant from this report

**RV** Indicates a variable from this report

**SV** Indicates a system variable

**SL** Indicates a system literal

**TV** Indicates a text variable

**VA** Indicates an event rule variable

If you chose Literal for the Right Operand column, the form that appears enables you to enter any of the value types that are described below.

5. Select one of the following tabs, define the values, and then click OK.

- Single value  
Enter a single value, and then click OK. For example, you might enter the address book number for a particular company.
- Range of values  
Enter a range of values, and then click OK. For example, a range of values might include companies from 00001 to 00060. Only *is equal to* and *is not equal to* are valid logical operators when using range of values.
- List of values  
To add values to or remove values from the list, perform the following:
  - Type each value in the field, and then press Enter or click the Add button at the top of the form.
  - Repeat this process until your list of values is complete. For example, a list of values might include several user-defined codes for search types, such as C for Customers, E for Employees, and V for Vendors. Only *is equal to* and *is not equal to* are valid logical operators when using a list of values.
  - Delete a value by choosing the value, and then clicking the Delete button at the top of the form.

6. Repeat steps 1 through 5 to define more selection criteria rows.
7. To delete a line of criteria on Section Data Selection, choose the row header to highlight the row, and then click the Delete button at the top of the form.
8. To change the order of the criteria, choose the row header to highlight the row, and then click the up or down button.
9. When you have completed defining selection criteria, click Next to see the Director's Finish form.

## ► To create a batch version of the report

---

After you define the data selection for the section, the Director's Finish form appears.

1. On the Finish form, click *Yes, create a version of this report* to automatically generate a batch version of the template.
2. Enter the version name in the field beneath *Yes, create a version of this report*.
3. To review your choices, click *Back* to move backwards through the Director forms, or click the form on the Navigation Assistant that you want to review.
4. When you are satisfied, click *Finish*.

---

### Caution

When you click *Finish*, you can no longer access the Director for this report. Prior to clicking *Finish*, you have one more opportunity to review your choices on all forms of the Director, as described in step 3.

---

Report Design - Report View appears.

### See Also

- ❑ *Object Management Workbench* in the *Development Tools Guide* for information on using OMW to create a batch version
- ❑ *Batch Versions for Reports* in the *Enterprise Report Writing Guide* for information on creating a batch version

## ► To save a report

---

After you click *Finish* on the Director's Finish form, the Report Design form appears.

On the Report Design form, perform one of the following actions:

- From the File menu, choose *Save*.
- Click the *Save* button on the toolbar.

### See Also

- ❑ *Object Management Workbench* in the *Development Tools Guide* for more information on checking in a report

See the following topics in the *Enterprise Report Writing Guide* for information about using Report Design to modify or enhance your report:

- ❑ *Basic Report Enhancements*
- ❑ *Advanced Report Enhancements*

## Reviewing the Results of the Director

When you click *Finish*, the Director process is complete. Based on the choices that you made during the process, Report Design displays the sections of your report and the data fields that you included in them. Each section includes the following:

- An icon that displays the section type
- Corner brackets enclosing each field within the section

- A title description

The title of the main detail section of the report uses a bold font to distinguish it from the titles of the other report sections.

### Example: Creating a Columnar Report with the Director

The sample columnar report below, used for an annual salary review, was created with the Director. It is based on the business view V060116A - Employee Master, and it uses the following columns from that business view:

- Address Number
- Name - Alpha
- Business Unit - Home
- Pay Class (H/S/P)
- Date - Original Employment
- Rate - Salary, Annual

R5607COL J.D. Edwards & Company 11/5/99 9:53:39

Employee Listing Page - 1

Address Number	Alpha Name	Home Business Unit	P C	Orig Start	Annual Salary
8002	Abbott, Dominique	9	S	4/10/99	39,000.00
8001	Allen, Ray	9	S	8/15/90	75,000.00
8014	Anderson, Jeanette	9	H	2/1/98	53,040.00
8832	Ato, Connie	9	S	2/15/97	39,000.00
7703	Bellas, Debbie	7071	S	3/15/97	53,000.00
8446	Bennett, Jody	M30	H	12/13/97	31,200.00
8447	Brown, Harvey J.	M30	H	8/2/97	41,600.00
5056	Carmichael, Bradley P.	5100	S	8/5/03	45,000.00
4802	Carol Fraser	6100	H	8/1/04	37,440.00
7584	Chamberlain, Carol M.	9	S	5/7/04	32,000.00
9200	Dobson, Jane	9	S	7/27/04	55,750.00
5127	Ebby, Chester	9	S	3/15/05	25,000.00
8012	Edwards, Angela	9	H	2/1/98	52,520.00
2479	Ellis, Jody A.	9	H	8/29/04	29,640.00
2428	Escalante, George	9	H	10/15/04	28,808.00
7550	Fuentes, Jason	5100	H	3/20/99	55,120.00
9400	Hawkins, Jack	30	S	1/15/03	34,750.00
7701	Holiday, Anthony	7071	H	8/1/03	23,400.00
2111	Ingram, Paul	9	S	3/15/05	22,250.00
2129	Jackson, John	5000	S	3/15/98	50,000.00
7704	Jacques Rivard	777	H	8/12/03	44,362.50
4803	Jeremy Beck	6100	H	3/22/00	45,000.80

A columnar report format was selected for this report because the information is best displayed in rows and columns of data since the listing is straightforward

#### ► To create the example columnar report

1. Launch the Report Design tool.
2. On Report Design, choose New from the File menu.
3. On Create New Report, complete the following fields, and then click OK.
  - Report Name
  - Description

- Product Code

The text that you enter in the Report Name field appears on the left side of the page header and the text that you enter in the Description field appears in the center of the page header under the company name.

4. On Welcome to the Report Design Director, choose Page Header and Columnar, and then click Next.
5. On Page Header Details, click Next.
6. On Business View Selection Option, click on the option under *I'll find a business view myself*, and then click Next.
7. On Select Business View, search for and choose the V060116A - Employee Master business view, and then click Next.
8. On Section Layout, use the horizontal arrow buttons to select the following columns and move them to the Select Columns column:
  - Address Number
  - Name - Alpha
  - Business Unit - Home
  - Pay Class (H/S/P)
  - Date - Original Employment
  - Rate - Salary, Annual
9. Ensure that the columns are ordered as listed above. Use the vertical buttons to change the order of the selected view, if necessary.

---

**Note**

Check the correlation between the order of the columns on this form and the order of the columns on the report illustration.

---

10. Click Next when the selected columns are arranged as shown in the example.
11. On Section Data Sequencing, use the horizontal arrow buttons to select and move the Name - Alpha column to the Selected Columns column, and then click Next.
12. On Define Sort Properties, ensure that the sort arrow points up (to alphabetize the report in ascending order by name), and then click Next.
13. On Section Data Selection, click Next.

No data selection is defined for this example.
14. On the Director's Finish form, enter the version name.
15. Click Finish.
16. On Report Design, click Save on the toolbar to save the report.
17. Click the Preview tab to see the report.
18. On Report Preview, click Yes.
19. Exit Report Design by selecting Exit from the File menu.

## Creating a Group Report

---

Group reports provide the greatest flexibility in arranging the data in a report. Each group on the report presents data from one record. They present data in groups of labeled data fields, called data items. Each data item displays data from a business view column.

You can specify how many of the data items that you selected should be listed vertically before the next vertical grouping begins. The default value is two. For example, if you selected six business view columns, they would appear initially as two across and three deep. If you changed the value to three, the columns would be arranged three across and two deep.

<b>BV Column 1</b>	<b>BV Column 4</b>
<b>BV Column 2</b>	<b>BV Column 5</b>
<b>BV Column 3</b>	<b>BV Column 6</b>

**Number of Columns = 2**

---

<b>BV Column 1</b>	<b>BV Column 3</b>	<b>BV Column 5</b>
<b>BV Column 2</b>	<b>BV Column 4</b>	<b>BV Column 6</b>

**Number of Columns = 3**

---

### Note

The term "business view column" might be confusing in relation to a group section because a group section is not organized in a columnar fashion. Remember, a business view column is simply a field; despite its name, it is not truly a column in and of itself. The business view column data can appear in columnar format, as it does in columnar and tabular sections, or in a free-floating field, as it does in group sections.

---

After you create a new report object, use the Director to design a group report. The Director leads you through a linear process for creating a group report by asking you questions about its structure and content. When you have completed creating the report, you can enhance it by using additional features of Report Design.

## See Also

- ❑ *Characteristics of a Group Section* in the *Enterprise Report Writing Guide* for an overview of group sections and criteria for using them

## Before You Begin

- ❑ Create a report object. The last step in creating a report object opens Report Design Director automatically. See *Creating a Report Object* in the *Enterprise Report Writing Guide* for information about starting the report design process and the Director.

## ► To choose report sections to include in the group report

*After you create a report object, the Director's Welcome form appears.*

The Director includes a Navigation Assistant in a pop-up box that shows you where you are in the report creation process. You can hide the Navigation Assistant by right-clicking it and choosing Hide.



1. On Welcome to the Report Design Director, click options for the headers and footers that you want to include in your report:
  - Report Header
  - Page Header
  - Page Footer

- Report Footer

2. Click the Group option, and then click Next.

If you chose a page header, Page Header Details appears.

If you did not choose a page header, Business View Selection Option appears. Go to the tasks that follow and describe how to select a business view.

3. On Page Header Details, click one of the following options to automatically include the following standard data fields:
- Automatically add the default informational fields shown below to my page header section.
  - Automatically add the default informational fields “Page n of Total” shown below to my page header section.

---

**Notes**

After you complete the report using Report Director, you can use Report Design to add or delete data fields from the page header.

If you turn both options off, the Director creates an empty page header. You can manually add data fields to the page header on the Report Design form.

---

4. Click Next to see Business View Selection Option.

► **To choose from a list of favorite business views**

---

*After you choose the report sections for the report, Business View Selection Option appears.*

1. On Business View Selection Option, click the option under *I'd like help finding an appropriate business view*, and then click Next.
2. On Favorite Business Views, open the folder that contains the business view that you want to use for your report section. Click the + icons to expand the tree until you see the business view that you want.
3. Click the Description tab to see a brief description about the business view that you have chosen, if a description is available.

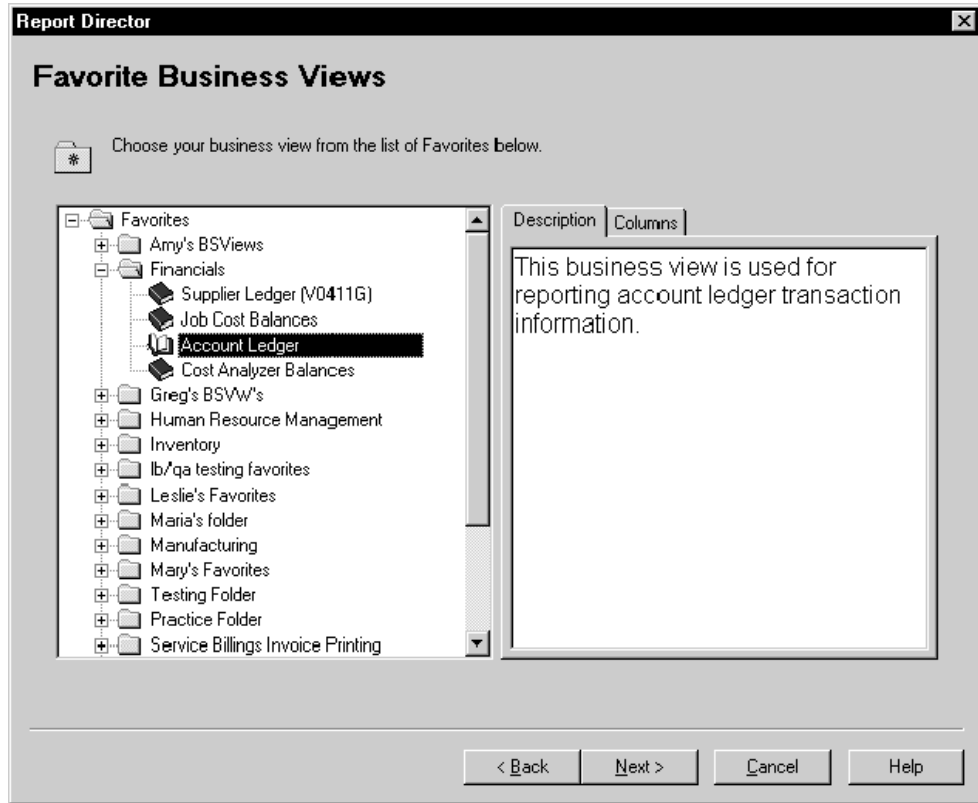

4. Click the Columns tab to see the data fields that are included in the business view that you have chosen.

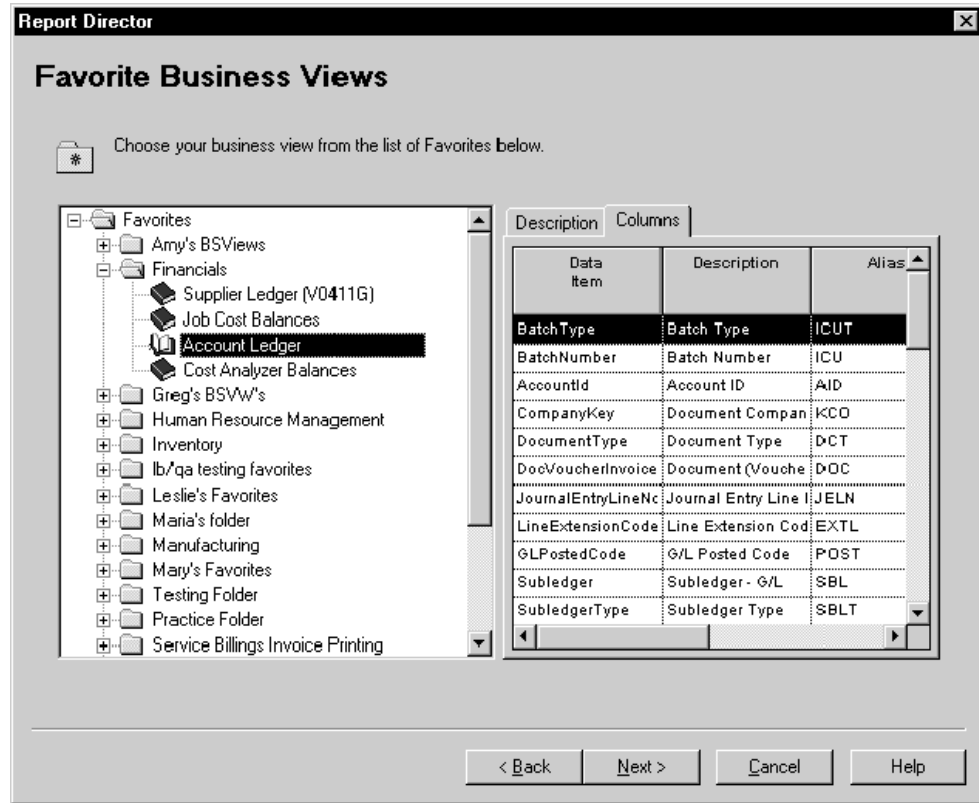

- When you have chosen the business view that you want to use, click Next to see Section Layout.

#### See Also

- Setting up Business Views as Favorites in the *Enterprise Report Writing Guide* for information about adding your own business views to this list

#### ► To use Select Business View to find a business view

After you choose the report sections for the report, *Business View Selection Option* appears.

- On Business View Selection Option, click the option under *I'll find a business view myself*.
- Click Next.
- On Select Business View, click Find or press Enter.

The form displays a list of all of the available business views. You can narrow your search by entering search criteria in the QBE row.

- Choose a business view, and then click Next to see Section Layout.

#### See Also

- Business View Design* in the *Development Tools Guide*

► **To add business view columns to the group section**

After you choose a business view as described in the previous task, Section Layout appears.

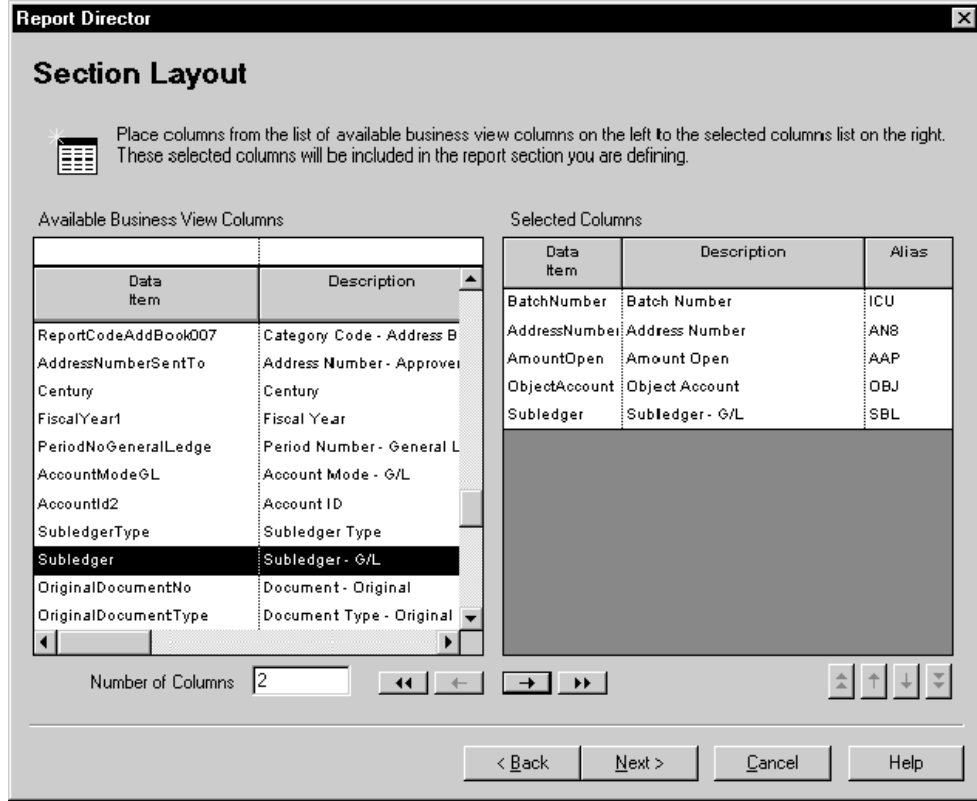

1. From the Available Business View Columns list, choose the columns that you want in the report, and then click the arrow that is pointing to the right to move them to the Selected Columns list.

Alternately, you can drag each column individually into the Selected Columns list, or you can click the double-arrow that is pointing to the right to move all of the columns from the Available Business View Columns list to the Selected Columns list.

The first item in the list appears as the left column in the report.

2. To remove a column from your report, choose a column in the Selected Columns list, and then click the arrow that is pointing to the left to move it to the Available Business View Columns list.

Alternately, you can click the double-arrow that is pointing to the left to move all of the columns from the Selected Columns list to the Available Business View Columns list.

- To change the order in which the columns appear on your report, choose a column in the Selected Columns list, and then click the up or down arrow to move the selected column up or down one line in the list.

Alternately, you can drag a column to a new location in the list, or you can click the up or down double-arrows to move the selected column to the top or bottom of the list.

- To change the initial number of vertical groupings in the report, enter the desired number in Number of Columns.
- When you finish the layout of your section, click Next to see Section Data Sequencing.

► **To define section data sequencing for the section**

*After you select business view columns as described in the previous task, Section Data Sequencing appears.*

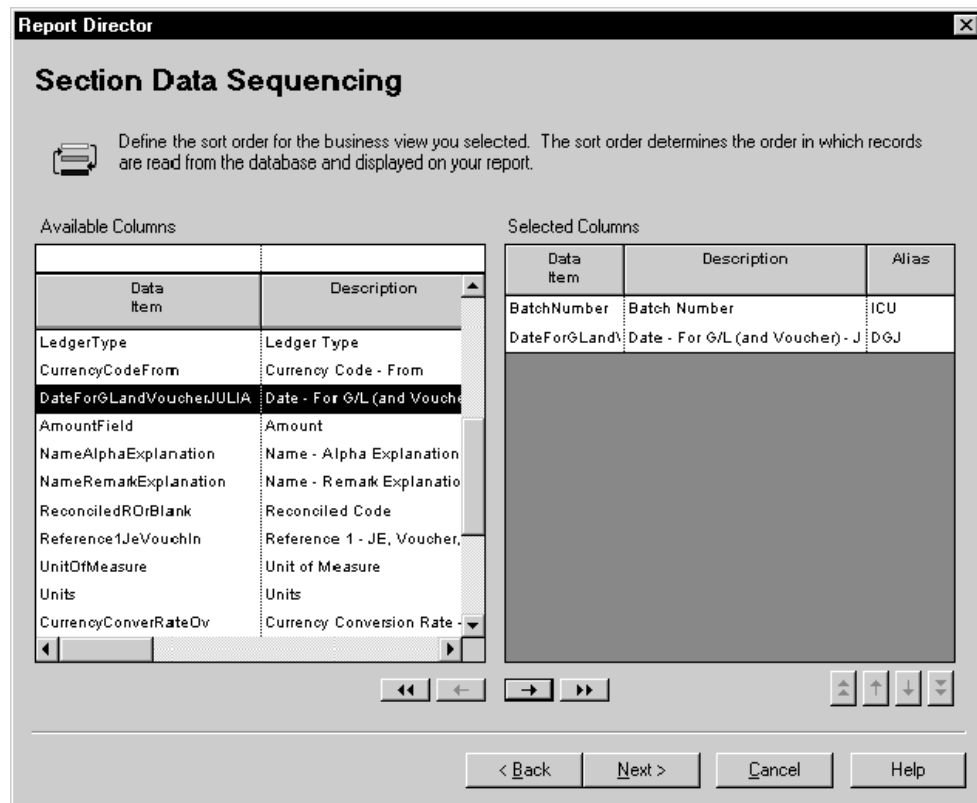

- To select columns for section data sequencing, choose the columns from the Available Columns list, and then click the arrow that points to the right to move them to the Selected Columns list.

Alternately, you can drag each column individually into the Selected Columns list, or you can click the right double-arrow that is pointing to the right to move all of the columns from the Available Columns list to the Selected Columns list.

---

**Note**

To define sort properties in the next task, you must select the column on which you plan to sort in this task.

---

2. To remove a column from the Selected Columns list, choose a column in the Selected Columns list, and then click the arrow that points to the left to move it to the Available Columns list.

Alternately, you can click the left double-arrow to move all of the columns from the Selected Columns list to the Available Columns list.

3. To change the order of the columns that you selected for data sequencing, choose a column in the Selected Columns list, and then click the up or down arrow to move the selected column up or down one line in the list.

Alternately, you can drag a column to a new location in the list, or you can click the up or down double-arrows to move the selected column to the top or bottom of the list.

4. When you finish the section data sequencing for your report, click Next to see Define Sort Properties.

---

**► To define sort properties for the section**

---

*After you define data sequencing as described in the previous task, Define Sort Properties appears.*

**Report Director**

### Define Sort Properties

Define the properties for the sort columns you selected. These properties determine the type of sequencing (ascending/descending), whether a level break should occur, and if a level break should produce a page break. Click on a box to select a property.

**Sort Columns**

Data Item	Description	Alias	Sort Order	Level Break	Page Break
BatchNumber	Batch Number	ICU	↕		
DateForGLand	Date - For G/L (and Vou	DGJ	↕		

< Back   **Next >**   Cancel   Help

1. On Define Sort Properties, complete the following field:
  - Sort Order
2. If you want to specify level and page breaks, complete the following fields:
  - Level Break

---

**Caution**

If you define a section data sequencing column as a level break, returning to the Section Data Sequencing form and then moving that column from the Selected Columns list back to the Available Columns list could cause unpredictable results.

---

- Page Break
3. When completed, click Next to see Section Data Selection.

► **To select records to include in the section**

---

*After you define sort properties for the section in the last task, the Section Data Selection form appears.*

**Report Director** [X]

### Section Data Selection

Define the subset of data your report will use when reading records from the database. In other words, filter the incoming data so that your report only processes certain records.

Operator	Left Operand	Comparison	Right Operand
Where	BC Amount (F0911)	is greater than	"1,000.00"

< Back   Next >   Cancel   Help

1. On Section Data Selection, click in the Operator column and choose an operator.  
*Where* is the default value in the Operator column for the first set of criteria. For subsequent statements, *And* and *Or* become the available values for the Operator column, and are selected by double-clicking the appropriate word.

2. Click in the Left Operand column to display the list of available objects, and then perform one of the following actions:

- Scroll through the list until you find the desired object, choose the object, and then double-click the object to populate the Left Operand column.
- Type the first letters of the object name in the Left Operand field to display the object in the list, and then double-click the highlighted object.

When you double-click the object for the Left Operand column, the list in the Comparison column automatically appears.

3. Double-click one of the following comparison operators to select it:

- is equal to
- is greater than
- is greater than or equal to
- is less than
- is less than or equal to
- is not equal to

When you double-click the object for the Comparison column, the list in the Right Operand column automatically appears. The objects, special values, and variables that are available depend on the comparison operator that you choose.

4. Double-click a value from the list in the Right Operand column to select it.

Your choices in this column depend on the choice that you made in the Comparison column. Some of the following options could be available:

**Blank** Enters a blank (space) value

**Literal** Allows you to enter specific values, as described below

**Null** Indicates that no value is associated with the field

**Zero** Enters a value of zero

**BC** Indicates that a business view column is available for this report

**FI** Indicates that a value passed through form interconnection to this report

**PC** Indicates the previous business view column

**PO** Indicates a processing option value for this report

**PV** Indicates the previous value for the variable

<b>RC</b>	Indicates a constant from this report
<b>RV</b>	Indicates a variable from this report
<b>SV</b>	Indicates a system variable
<b>SL</b>	Indicates a system literal
<b>TV</b>	Indicates a text variable
<b>VA</b>	Indicates an event rule variable

If you chose Literal for the Right Operand column, the form that appears enables you to enter any of the value types that are described below.

5. Select one of the following tabs, define the values, and then click OK.

- Single value

Enter a single value, and then click OK. For example, you might enter the address book number for a particular company.

- Range of values

Enter a range of values, and then click OK. For example, a range of values might include companies from 00001 to 00060. Only *is equal to* and *is not equal to* are valid logical operators when using range of values.

- List of values

To add values to or remove values from the list, perform the following:

- Type each value in the field, and then press Enter or click the Add button at the top of the form.
- Repeat this process until your list of values is complete. For example, a list of values might include several user-defined codes for search types, such as C for Customers, E for Employees, and V for Vendors. Only *is equal to* and *is not equal to* are valid logical operators when using a list of values.
- Delete a value by choosing the value, and then clicking the Delete button at the top of the form.

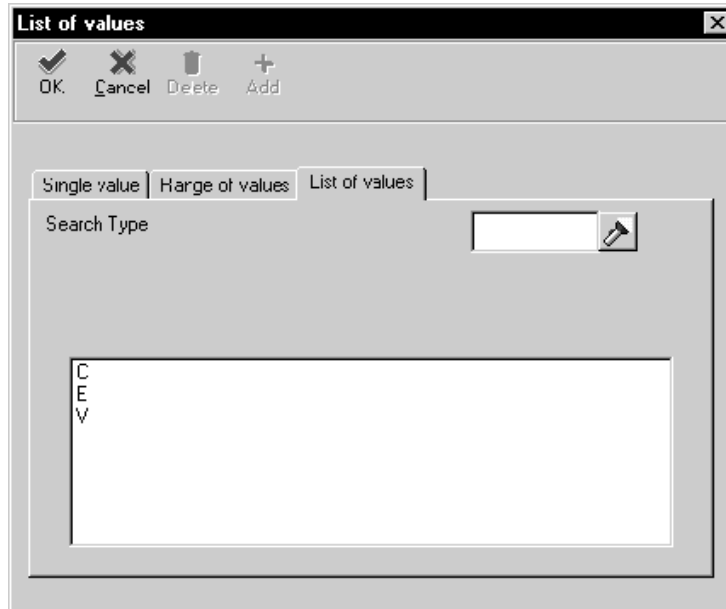

6. Repeat steps 1 through 5 to define more selection criteria rows.
7. To delete a line of criteria on Section Data Selection, choose the row header to highlight the row, and then click the Delete button at the top of the form.
8. To change the order of the criteria, choose the row header to highlight the row, and then click the up or down button.
9. When you have completed defining selection criteria, click Next to see the Director's Finish form.

### See Also

- *Working with Level-Break Header and Footer Sections in the Enterprise Report Writing Guide* for detailed information about working with level breaks

### ► To create a batch version of the report

---

*After you define the data selection for the section, the Director's Finish form appears.*

1. On the Finish form, click *Yes, create a version of this report* to automatically generate a batch version of the template.
2. Enter the version name in the field beneath *Yes, create a version of this report*.
3. To review your choices, click *Back* to move backwards through the Director forms, or click the form on the Navigation Assistant that you want to review.
4. When you are satisfied, click *Finish*.

---

**Caution**

When you click Finish, you can no longer access the Director for this report. Prior to clicking Finish, you have one more opportunity to review your choices on all forms of the Director, as described in step 3.

---

Report Design - Report View appears.

**See Also**

- ❑ *Object Management Workbench* in the *Development Tools Guide* for information on using OMW to create a batch version
- ❑ *Batch Versions for Reports* in the *Enterprise Report Writing Guide* for information on creating a batch version

**► To save a report**

---

*After you click Finish on the Director's Finish form, the Report Design form appears.*

On the Report Design form, perform one of the following actions:

- From the File menu, choose Save.
- Click the Save button on the toolbar.

**See Also**

- ❑ *Object Management Workbench* in the *Development Tools Guide* for more information on checking in a report

See the following topics in the *Enterprise Report Writing Guide* for information about using Report Design to modify or enhance your report:

- ❑ *Basic Report Enhancements*
- ❑ *Advanced Report Enhancements*

## Reviewing the Results of the Director

When you click Finish, the Director process is complete. Based on the choices that you made during the process, Report Design displays the sections of your report and the data fields that you included in them. Each section includes the following:

- An icon that displays the section type
- Corner brackets enclosing each field within the section
- A title description

The title of the main detail section of the report uses a bold font to distinguish it from the titles of the other report sections.

## Example: Creating a Group Report with the Director

The sample group report below was created with the Director. It is based on the business view V41021E - Item Location, Item Master Join; and it uses the following columns from that business view:

- Location
- Item Number - Short
- Primary Location (P/S)
- Category G/L
- Quantity on Hand - Primary units
- Quantity on Backorder
- Business Unit

Additionally, the report displays items from Business Unit 27 only.

R5641ILO		J.D. Edwards & Company			11/23/99	9:31:37
					Page -	1
Location		G/L Category	IN30	Business Unit	27	
Item Number (Short)	60011	Quantity on Hand				
Primary Location (P/S)	P	Quantity on Backorder				
Location		G/L Category	IN30	Business Unit	27	
Item Number (Short)	60020	Quantity on Hand				
Primary Location (P/S)	P	Quantity on Backorder				
Location		G/L Category	IN30	Business Unit	27	
Item Number (Short)	60038	Quantity on Hand				
Primary Location (P/S)	P	Quantity on Backorder				
Location		G/L Category	IN30	Business Unit	27	
Item Number (Short)	60062	Quantity on Hand				
Primary Location (P/S)	P	Quantity on Backorder				
Location		G/L Category	IN30	Business Unit	27	
Item Number (Short)	60071	Quantity on Hand				
Primary Location (P/S)	P	Quantity on Backorder				
Location		G/L Category	IN30	Business Unit	27	
Item Number (Short)	60177	Quantity on Hand				

### ► To create the example group report

---

1. Launch the Report Design tool.
2. On Report Design, choose New from the File menu.
3. On Create New Report, complete the following fields, and then click OK.
  - Report Name
  - Description
  - Product Code

The text that you enter in the Report Name field appears on the left side of the page header, and the text that you enter in the Description field appears in the center of the page header under the company name.

4. On the Director's Welcome form, choose Page Header and Group, and then click Next.
5. On Page Header Details, click Next.
6. On Business View Selection Option, choose the option under *I'll Find a business view myself*, and then click Next.
7. On Select Business View, search for and choose the V41021E - Item Location, Item Master Join business view; and then click Next to see Section Layout. .
8. On Section Layout, use the horizontal arrow buttons to select the following columns and move them to the Selected Columns column:
  - Location
  - Item Number - Short
  - Primary Location (P/S)
  - Category G/L
  - Quantity on Hand - Primary units
  - Quantity on Backorder
  - Business Unit
9. Ensure that the columns are ordered as listed above. Use the vertical buttons to change the order of the selected business columns, if necessary.

---

**Note**

Check the correlation between the order of the columns on this form and the order of the columns on the report illustration.

---

10. When the selected columns are arranged as shown, enter a 3 in the Number of Columns field, and then click Next.
11. On Section Data Sequencing, use the horizontal arrow buttons to select and move the Location and Item Number - Short columns to the Selected Columns column.
12. Ensure that the columns appear in the Selected Columns list as indicated in the figure above. Items on the report are sorted first by location and second, by item number.
13. Click Next when the selected columns are arranged as shown.
14. On Define Sort Properties, ensure the sort arrows point up (to alphabetize the report in ascending order in both categories), and then click Next to see Section Data Selection.

---

**Note**

Steps 15 and 16 limit the report to displaying records that are associated with Business Unit 27 only.

---

15. On the Section Data Selection form, fill out the grid fields as follows:

- Operator - Where
- Left Operand - Business Unit (F41021) (MCU) (BC)
- Comparison - is equal to
- Right Operand - <Literal>

When you double-click <Literal>, Single value appears.

16. Click the Single value tab, enter 27 in the Business Unit field, and click OK.

17. On the Section Data Selection form, click Next.

18. On the Finish form, enter the name of the version.

19. Click Finish.

20. On Report Design, click Save to save the report.

21. Click the Preview tab to see the report.

22. On Report Preview, click Yes.

The report should look similar to the sample report illustration at the beginning of this section.

23. Exit Report Design by clicking Exit from the File menu.

## Creating a Tabular Report

---

A tabular report looks a lot like a columnar report, but it provides several additional features. A tabular report automatically totals columns. It also allows you to link the data in a column to the data in the database so that users viewing the report can click on data and see the database entry. This process is especially helpful for auditors and other users who need to see how an amount was derived. This feature is called the drill-down feature.

After you create a new report object, use the Director to design a tabular report. The Director leads you through a linear process for creating a tabular report by asking you questions about its structure and content. When you have completed creating the report, you can enhance it by using additional features of Report Design.

### Before You Begin

- ❑ Create a report object. The last step in creating a report object opens Report Design Director automatically. See *Creating a Report Object* in the *Enterprise Report Writing Guide* for detailed instructions on creating a report object.

### See Also

- ❑ *Characteristics of a Tabular Section* in the *Enterprise Report Writing Guide* for an overview of tabular sections and criteria for using them

► **To choose report sections to include in the tabular report**

*After you create a report object, Welcome to the Report Design Director appears.*

The Director includes a Navigation Assistant pop-up box that shows you where you are in the report creation process. You can hide the Navigation Assistant by right-clicking it and choosing Hide.



1. On Welcome to the Report Design Director, click from the following headers and footers to include them in your report:
  - Report Header
  - Page Header
  - Page Footer
  - Report Footer
2. Click the Tabular option, and then click Next.

If you chose a page header, Page Header Details appears.

If you did not choose a page header, Business View Selection Option appears. Go to the next task.

3. On Page Header Details, click one of the following options:
  - Automatically add the default informational fields shown below to my page header section.
  - Automatically add the default informational fields “Page n of Total” shown below to my page header section.

---

**Notes**

After you complete the report using the Report Director process, you can use Report Design to add or delete data fields from the page header.

If you turn both options off, the Director creates an empty page header. You can manually add data fields to the page header from the Section menu on the Report Design form.

---

4. Click Next to see the Business View Selection Option.

► **To choose from a list of favorite business views**

---

*After you choose the report sections for the report, Business View Selection Option appears.*

1. On Business View Selection Option, click the option under *I'd like help finding an appropriate business view*, and then click Next.
2. On Favorite Business Views, open the folder that contains the business view that you want to use for your report section. Click the + icons to expand the tree until you see the business view that you want.
3. Click the Description tab to see a brief description about the business view that you have chosen, if a description is available.

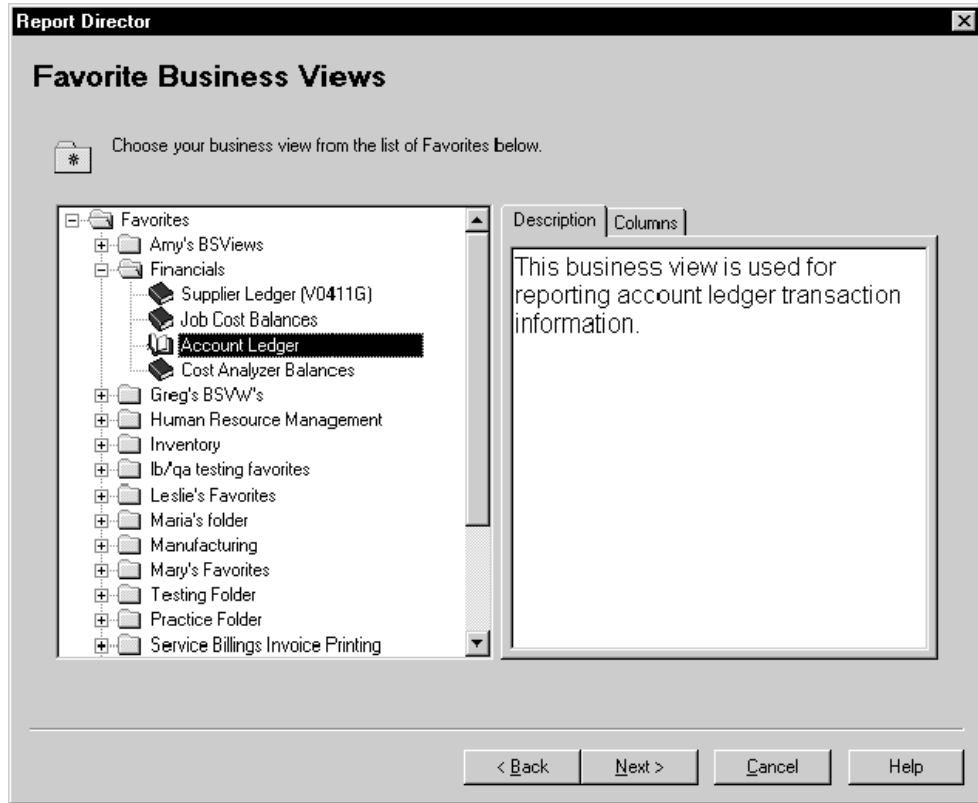

4. Click the Columns tab to see the data fields that are included in the business view that you have chosen.

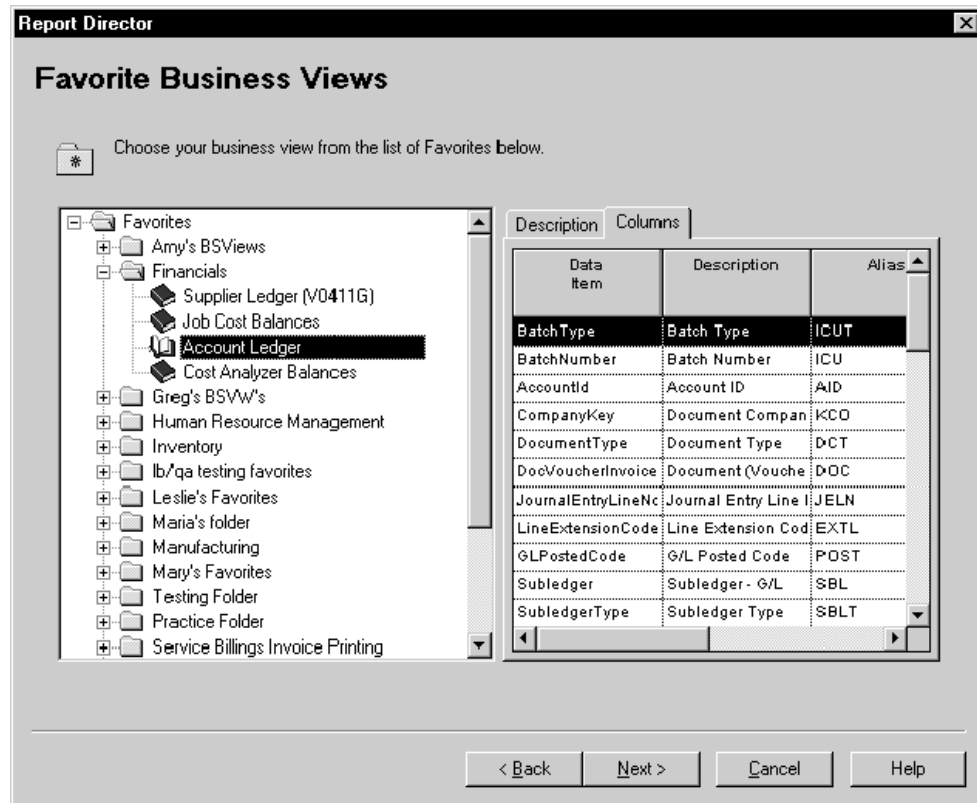

- When you have chosen the business view that you want to use, click Next to see Section Layout.

#### See Also

- Setting up Business Views as Favorites in the *Enterprise Report Writing Guide* for information about adding your own business views to this list

#### ► To use Select Business View to find a business view

After you choose the report sections for the report, *Business View Selection Option* appears.

- On Business View Selection Option, click the option under *I'll find a business view myself*.
- Click Next.
- On Select Business View, click Find or press Enter.

The form displays a list of all of the available business views. You can narrow your search by entering search criteria in the QBE row.

- Choose a business view, and then click Next to see Section Layout.

#### See Also

- Business View Design* in the *Development Tools Guide*

► **To add business view columns to the section**

---

*After you choose a business view as described in the previous task, Section Layout appears.*

1. From the Available Business View Columns list, choose the columns that you want in the report, and then click the arrow that is pointing to the right to move them to the Selected Columns list.

Alternately, you can drag each column individually into the Selected Columns list, or you can click the right double-arrow to move all of the columns from the Available Business View Columns list to the Selected Columns list.

The first item in the list appears as the left column in the report.

2. To remove a column from your report, choose a column in the Selected Columns list, and then click the arrow pointing to the left to move it to the Available Business View Columns list.

Alternately, you can click the left double-arrow to move all of the columns from the Selected Columns list to the Available Business View Columns list.

3. To change the order that the columns appear on your report, choose a column in the Selected Columns list, and then click the up or down arrow to move the selected column up or down one line in the list.

Alternately, you can drag a column to a new location in the list, or you can click the up or down double-arrows to move the selected column to the top or bottom of the list.

4. When you complete the layout of your section, click Next to see Section Data Sequencing.

► **To define section data sequencing for the section**

---

*After you select business view columns as described in the previous task, Section Data Sequencing appears.*

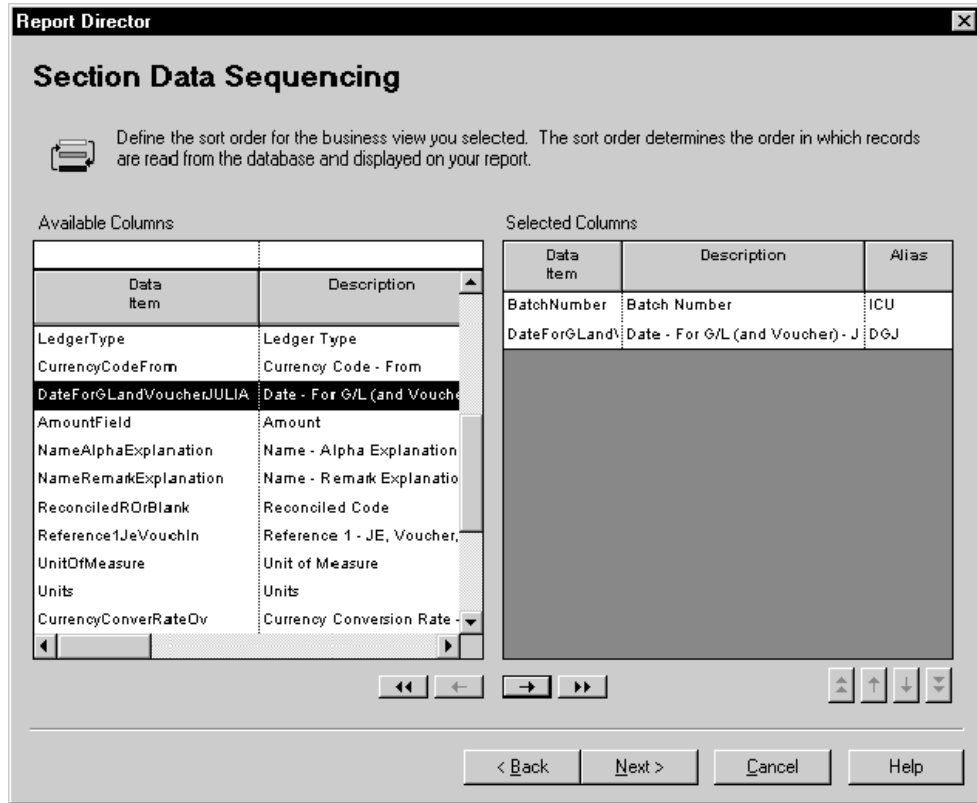

1. To select columns for section data sequencing, choose the columns from the Available Columns list, and then click the arrow that points to the right to move them to the Selected Columns list.

Alternately, you can drag each column individually into the Selected Columns list, or you can click the right double-arrow that is pointing to the right to move all of the columns from the Available Columns list to the Selected Columns list.

---

### Note

To define sort properties in the next task, you must select the column on which you plan to sort in this task.

---

2. To remove a column from the Selected Columns list, choose a column in the Selected Columns list, and then click the arrow that points to the left to move it to the Available Columns list.

Alternately, you can click the left double-arrow to move all of the columns from the Selected Columns list to the Available Columns list.

3. To change the order of the columns that you selected for data sequencing, choose a column in the Selected Columns list, and then click the up or down arrow to move the selected column up or down one line in the list.

Alternately, you can drag a column to a new location in the list, or you can click the up or down double-arrows to move the selected column to the top or bottom of the list.

4. When you finish the section data sequencing for your report, click Next to see Define Sort Properties.

► **To define sort properties for the section**

After you define data sequencing as described in the previous task, *Define Sort Properties* appears.

**Report Director**

### Define Sort Properties

Define the properties for the sort columns you selected. These properties determine the type of sequencing (ascending/descending), whether a level break should occur, and if a level break should produce a page break. Click on a box to select a property.

**Sort Columns**

Data Item	Description	Alias	Sort Order	Level Break	Page Break
BatchNumber	Batch Number	ICU	↗		
DateForGLand	Date - For G/L (and Vou	DGLJ	↗		

< Back   Next >   Cancel   Help

1. On Define Sort Properties, complete the following field:
  - Sort Order
2. If you want to specify level and page breaks, complete the following fields:
  - Level Break

---

**Caution**

If you define a section data sequencing column as a level break, returning to the Section Data Sequencing form and then moving that column from the Selected Columns list back to the Available Columns list could cause unpredictable results.

---

- Page Break
3. When completed, click Next to see Section Data Selection.

## See Also

- ❑ *Working with Level-Break Header and Footer Sections in the Enterprise Report Writing Guide* for detailed information about working with level breaks

### ► To select records to include in the section

After you define sort properties for the section in the last task, the Section Data Selection form appears.

	Operator	Left Operand	Comparison	Right Operand
	Where	BC Amount (F0911)	is greater than	"1,000.00"

1. On Section Data Selection, click in the Operator column and choose an operator. *Where* is the default value in the Operator column for the first set of criteria. For subsequent statements, *And* and *Or* become the available values for the Operator column, and are selected by double-clicking the appropriate word.
2. Click in the Left Operand column to display the list of available objects, and then perform one of the following actions:
  - Scroll through the list until you find the desired object, choose the object, and then double-click the object to populate the Left Operand column.
  - Type the first letters of the object name in the Left Operand field to display the object in the list, and then double-click the highlighted object.

When you double-click the object for the Left Operand column, the list in the Comparison column automatically appears.

3. Double-click one of the following comparison operators to select it:

- is equal to
- is greater than
- is greater than or equal to
- is less than
- is less than or equal to
- is not equal to

When you double-click the object for the Comparison column, the list in the Right Operand column automatically appears. The objects, special values, and variables that are available depend on the comparison operator that you choose.

4. Double-click a value from the list in the Right Operand column to select it.

Your choices in this column depend on the choice that you made in the Comparison column. Some of the following options could be available:

**Blank** Enters a blank (space) value

**Literal** Allows you to enter specific values, as described below

**Null** Indicates that no value is associated with the field

**Zero** Enters a value of zero

**BC** Indicates that a business view column is available for this report

**FI** Indicates that a value passed through form interconnection to this report

**PC** Indicates the previous business view column

**PO** Indicates a processing option value for this report

**PV** Indicates the previous value for the variable

**RC** Indicates a constant from this report

**RV** Indicates a variable from this report

**SV** Indicates a system variable

**SL** Indicates a system literal

**TV** Indicates a text variable

**VA** Indicates an event rule variable

If you chose Literal for the Right Operand column, the form that appears enables you to enter any of the value types that are described below.

5. Select one of the following tabs, define the values, and then click OK.
  - Single value
 

Enter a single value, and then click OK. For example, you might enter the address book number for a particular company.
  - Range of values
 

Enter a range of values, and then click OK. For example, a range of values might include companies from 00001 to 00060. Only *is equal to* and *is not equal to* are valid logical operators when using range of values.
  - List of values
 

To add values to or remove values from the list, perform the following:

    - Type each value in the field, and then press Enter or click the Add button at the top of the form.
    - Repeat this process until your list of values is complete. For example, a list of values might include several user-defined codes for search types, such as C for Customers, E for Employees, and V for Vendors. Only *is equal to* and *is not equal to* are valid logical operators when using a list of values.
    - Delete a value by choosing the value, and then clicking the Delete button at the top of the form.

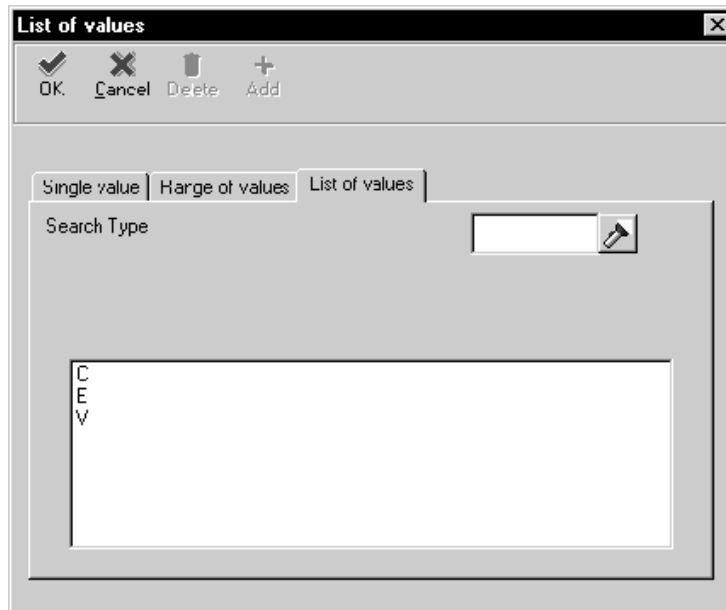

6. Repeat steps 1 through 5 to define more selection criteria rows.
7. To delete a line of criteria on Section Data Selection, choose the row header to highlight the row, and then click the Delete button at the top of the form.
8. To change the order of the criteria, choose the row header to highlight the row, and then click the up or down button.
9. When you have completed defining selection criteria, click Next to see the Director's Finish form.

## ► To create a batch version of the report

---

After you define the data selection for the section, the Director's Finish form appears.

1. On the Finish form, click *Yes, create a version of this report* to automatically generate a batch version of the template.
2. Enter the version name in the field beneath *Yes, create a version of this report*.
3. To review your choices, click *Back* to move backwards through the Director forms, or click the form on the Navigation Assistant that you want to review.
4. When you are satisfied, click *Finish*.

---

### Caution

When you click *Finish*, you can no longer access the Director for this report. Prior to clicking *Finish*, you have one more opportunity to review your choices on all forms of the Director, as described in step 3.

---

Report Design - Report View appears.

### See Also

- ❑ *Object Management Workbench* in the *Development Tools Guide* for information on using OMW to create a batch version
- ❑ *Batch Versions for Reports* in the *Enterprise Report Writing Guide* for information on creating a batch version

## ► To save a report

---

After you click *Finish* on the Director's Finish form, the Report Design form appears.

On the Report Design form, perform one of the following actions:

- From the File menu, choose *Save*.
- Click the *Save* button on the toolbar.

### See Also

- ❑ *Object Management Workbench* in the *Development Tools Guide* for more information on checking in a report

See the following topics in the *Enterprise Report Writing Guide* for information about using Report Design to modify or enhance your report:

- ❑ *Basic Report Enhancements*
- ❑ *Advanced Report Enhancements*

## Reviewing the Results of the Director

When you click *Finish*, the Director process is complete. Based on the choices that you made during the process, Report Design displays the sections of your report and the data fields that you included in them. Each section includes the following:

- An icon that displays the section type
- Corner brackets enclosing each field within the section

- A title description

The title of the main detail section of the report uses a bold font to distinguish it from the titles of the other report sections.

### Example: Creating a Tabular Report with the Director

The sample tabular report below was created with the Director. It shows the total amount in outstanding purchase orders for each business unit in a company. It is based on the business view V4311A - Purchase Order Detail Browse, and it uses the following columns from that business view:

- Business Unit
- Order Type
- Amount Open

The report is organized by company and displays item names. Also, it is filtered to display only those purchase orders (as opposed to items ordered by other methods, such as purchase requisitions) for stocked parts that have a balance and are not yet closed. While this stipulation might seem obvious, you must plan for and define this filter when you set up the report.

R5643POD		J.D. Edwards & Company		11/23/99	11:51:08
				Page -	1
Description	Business Unit	Or Ty	Amount Open		
Financial/Distribution Compa					
Mountain Bike, Red	40	OP	588,411.00		
Touring Bike, Green	20	OP	16,500.00		
Youth Sport Bike	30	OP	9,632.00		
Lid	30	OP	150.00		
Bottle	30	OP	450.00		
Bike Accessory Kit	30	OP	10,000.00		
Helmet	30	OP	1,100.00		
Helmet - HI Flow	30	OP	1,800.00		
Tire Repair Kit	30	OP	625.00		
250 mm Cro-Moly Tubing	30	OP	140.00		
500 mm Cro-Moly Tubing	30	OP	144.00		
160 mm Cro-Moly	30	OP	112.00		
500 mm Cro-Moly Bar	00	OP	240.00		
60 mm Cro-Moly Plate	30	OP	150.00		
Bolt - 6	30	OP	140.00		

A tabular report format was selected for this report because of the automatic totaling and Display Column features of tabular reports.

#### ► To create the example tabular report

*From the Report Writer menu (GH9111), choose Report Design Tool.*

1. On Report Design, choose New from the File menu.
2. On Create New Report, complete the following fields, and then click OK.
  - Report Name
  - Description
  - Product Code

The text that you enter in the Report Name field appears on the left side of the page header, and the text that you enter in the Description field appears in the center of the page header under the company name.

3. On Director's Welcome, choose Page Header and Tabular, and then click Next.
4. On Page Header Details, click Next.
5. On Business View Selection Option, choose the option under *I'll find a business view myself*, and then click Next.
6. On Select Business View, search for and choose the V4311A - Purchase Order Detail Browse business view, and then click Next to see Section Layout.

The Director has added a Description column for you already in Selected Columns.

7. On Section Layout, use the horizontal arrow buttons to select the following columns and move them to the Select Columns column:
  - Business Unit
  - Order Type
  - Amount - Open
8. Ensure that the columns are in the order that is listed above. Use the vertical buttons to change the order of the selected business columns, if necessary.

---

**Note**

Check the correlation between the order of the columns on this form and the order of the columns on the report illustration.

---

9. Click Next when the selected columns are arranged as shown.
10. On Section Data Sequencing, use the horizontal arrow buttons to select and move the Order Company (from table F4311) and 2nd Item Number columns to the Selected Columns column. Ensure that the columns are in the order that is shown below, and then click Next.

---

**Note**

Note that this report is sorted on business view columns that are not included for display in the report.

---

11. On Define Sort Properties, ensure the sort arrows point up (to alphabetize the report in ascending order by name) and that Level Break is selected for both business view columns. Then click Next.

If these two columns have level breaks, then the Description Column displays properly, and the system displays totals for open orders each time that the system displays a new record.

12. On Section Data Selection, filter data to appear on the report as follows, and then click Next. Note that each succeeding line of the filter is connected with an *And* operator. You must use *And* in this case because every data item must meet all of the criteria to be included in the report.
  - To include only purchase orders with a balance:

- Left Operand - Amount - Open (F4311)  
Although you select Amount - Open (F4311) from the drop-down list, the item appears as BC Amount - Open (F4311) (AOPN). BC is a code that indicates the item is a business column.
  - Comparison - is greater than
  - Right Operand - <Zero>  
Note that you cannot enter a value of zero as a literal value.
  - To include only purchase order items (purchase orders in the F4311 table are indicated by the code PO):
    - Operator - And
    - Left Operand - Order Type (F4311)
    - Comparison - is equal to
    - Right Operand - OP  
OP is a literal value. To insert it, select <Literal>. The Single value form appears. Click the Single value tab, enter OP in the Order Type field, and click OK.
  - To include only open purchase orders (indicated in the F4311 table by any code *except* 999):
    - Operator - And
    - Left Operand - Status Code - Next (F4311)
    - Comparison - is not equal to
    - Right Operand - 999  
999 is a literal value.
  - To include only stocked items (indicated in the F4311 table by a code of S):
    - Operator - And
    - Left Operand - Line Type (F4311)
    - Comparison - is equal to
    - Right Operand - S  
S is a literal value.
13. On Director's Finish, select *No, I will create a version of this report later*, and then click Finish.
  14. On Report Design, click Save to save the report.
  15. Click the Preview tab to see the report.
  16. Exit Report Design by choosing Exit from the File menu.

## Creating an Application Report with the Director

---

Application reports can be created only through the Director. It provides director templates to help you create specific reports for a J.D. Edwards software product, such as Financials, Fixed Assets, or Job Cost. J.D. Edwards software provides director templates that contain common default criteria for the type of reports that are created. When you choose one of the templates, the Director reads the template specifications and presents the default criteria through the Director forms. You can modify these templates or create your own templates.

Director templates allow you to use smart fields, which are data dictionary items (glossary group K) that are designed to retrieve and manipulate specific J.D. Edwards software table data. For example, by adding the smart field FINRPTAB - Account Balance to your report, you create a column that calculates the account balance as of a specified financial period and fiscal year.

Smart fields call business functions or named event rules. Business functions are programs that use data structures to do the following tasks:

- Request specific data from J.D. Edwards software tables.
- Return the data to the established parameters in the data structure.
- Perform some type of calculation or other manipulation on the data.
- Send the desired information, such as column headings and complex calculations, to your report.

A named event rule is a business function that is created by using the event-rules scripting language. This scripting language is platform-independent and stored in a database as a J.D. Edwards software object.

Because the smart fields have already been created for you, you can include complex logic in your report without having to do any programming.

For each smart field that you add to your report, you are prompted to define parameters that are specific to that smart field through a series of forms. Although the number and content of the forms vary, based on the smart field, the process occurs in three phases:

1. First, you are prompted to define how you want the column to appear in the report.
  2. Second, you are prompted to define parameters, such as period number offset, journal entry amount, fiscal year offset, and so on. Some smart fields have only one parameter and, therefore, only one form in this phase; others have multiple parameters that you specify through a series of forms in this phase.
- Third, you are prompted to limit the data that is returned by the report through data selection.

Application reports also allow you to define calculation columns. Calculation columns contain values that are the result of a calculation involving two or more smart field columns. You can also perform a calculation between calculation columns. In a report based on a director template, the Director is aware only of the smart fields that are attached to the template; therefore, data fields included in the business view cannot be used in a calculation. After you complete the Director process, you can use Report Design to add calculation columns, based on other columns in the report.

---

**Note**

Values in calculation columns are based on how the amounts appear on the report, not on how they are stored in the data tables.

---

In addition, application reports allow you to set additional properties. Additional properties provide the same functions as tabular section properties. They govern how the report runs and displays information. For example, if you do not want your report to display revenues as a negative value (-) and expenses as a positive value (+) as they appear in the database tables, you can choose to display them both as positive values. The additional properties that you can select can change, based on the selections that you made in the Report Director Templates program.

Because application reports templates are customized, not all forms described in the tasks below appear. Some forms might not be relevant for the report template that you select.

**See Also**

See the following topics in the *Enterprise Report Writing Guide*:

- ❑ *Working with Director Templates* for information about setting up templates to use when creating an application report
- ❑ *Creating a Report Object* for information about starting the report design process and the Director

**Before You Begin**

- ❑ Create a report object. The last step in creating a report object opens Report Design Director automatically. See *Creating a Report Object* in the *Enterprise Report Writing Guide* for detailed instructions on creating a report object.

**► To choose an application report template**

---

*After you create a report object, Welcome to the Report Design Director appears.*

The Director includes a Navigation Assistant pop-up box that shows you where you are in the report creation process. You can hide the Navigation Assistant by right-clicking it and choosing Hide.



1. On 'Welcome to the Report Design Director', click the following headers and footers that you want to include in your report:
  - Report Header
  - Page Header
  - Page Footer
  - Report Footer
2. Under the 'Application Reports' heading, click the down arrow to display a list of available director templates.
3. Choose the template that is most appropriate for the type of report that you are creating and click Next.

If you chose a page header, Page Header Details appears.

If you did not choose a page header, Business View Selection Option appears. Go to the next task.

4. On 'Page Header Details', click one of the following options:
  - Automatically add the default informational fields shown below to my page header section.
  - Automatically add the default informational fields "Page n of Total" shown below to my page header section.

---

## Notes

After you complete the report using the Report Director, you can use Report Design to add or delete data fields from the page header.

If you turn both options off, the Director creates an empty page header. You can manually add data fields to the page header from the Section menu on Report Design.

---

5. Click Next to see Business View Selection Option.

### ► To choose from a list of favorite business views

---

After you chose the report sections for the report, *Business View Selection Option* appears.

1. On Business View Selection Options, click the option under *I'd like help finding an appropriate business view*, and then click Next.
2. On Favorite Business Views, open the folder that contains the business view that you want to use for your report section. Click the + icons to expand the tree until you see the business view that you want to use.

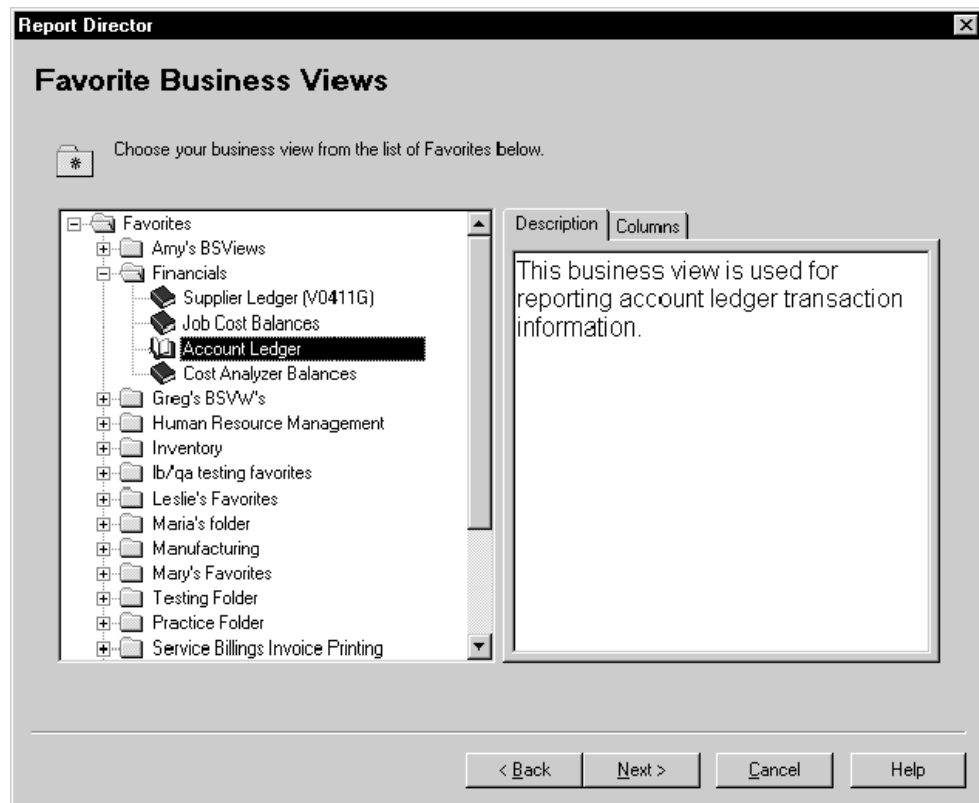

3. Click the Description tab, if one is available, to see a brief description about the business view you have chosen.

- Click the Column tab to see the data fields that are included in the business view that you have chosen.

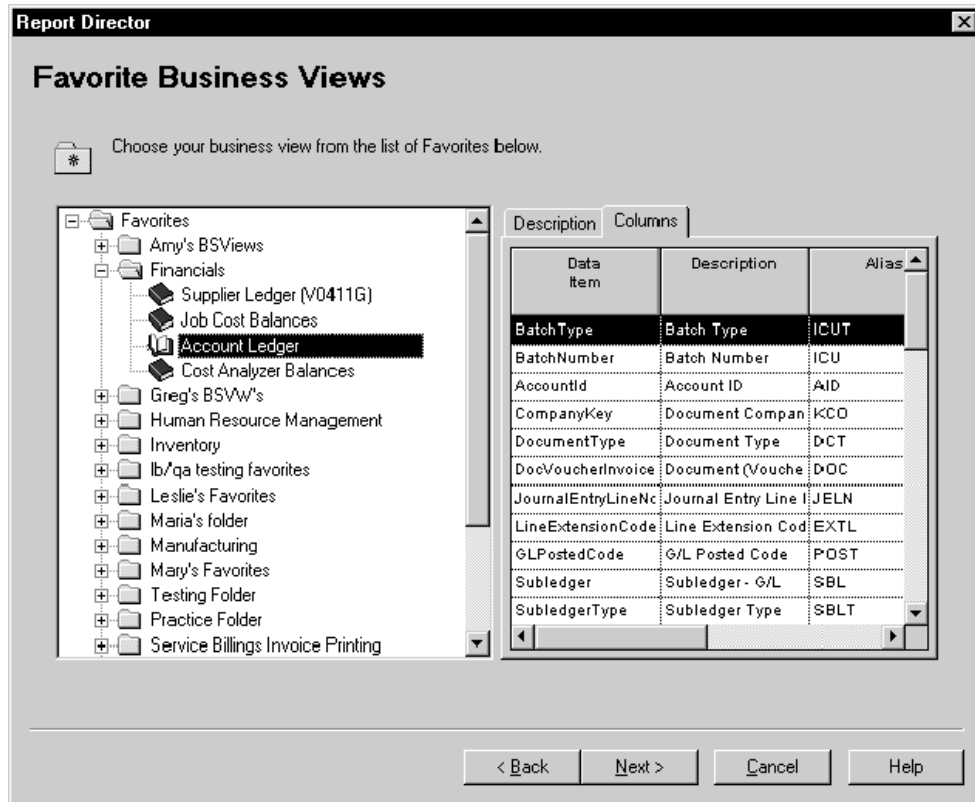

- When you have chosen the business view that you want to use, click Next to see Section Layout.

### Caution

The smart fields described in the task *To add smart fields to an application report* rely on business view columns in the default business view of the application report. If you select a business view other than the default, that business view must contain the business view columns that are required by the smart fields which you choose later; otherwise, the smart fields do not function properly.

### See Also

- ❑ *Business View Design* in the *Development Tools Guide* for information about creating your own business views
- ❑ *Setting up Business Views as Favorites* in the *Enterprise Report Writing Guide* for information about setting up folders to hold frequently used business views

### ► To use Select Business View to find a business view

After you chose the report sections for the report, *Business View Selection Option* appears.

1. On Business View Selection Option, click the option under *I'll find a business view myself*, and then click Next.
2. On Select Business View, click Find or press Enter.

The form displays a list of all of the available business views. You can narrow your search by entering search criteria in the QBE row.

3. Choose a business view, and then click Next.

### Caution

The smart fields described in the task *To add smart fields to an application report* rely on business view columns in the default business view of the application report. If you select a business view other than the default, that business view must contain the business view columns that are required by the smart fields which you choose later; otherwise the smart fields do not function properly.

Select Columns appears.

### See Also

- *Business View Design* in the *Development Tools Guide*

### ► To add smart fields to an application report

After you select a business view as described in the previous task, *Select Columns* appears.

Drag and drop columns from the list of available smart fields on the left to the selected columns list on the right. The selected columns will be included in the report section you are defining.

Available Smart Fields		Columns in Report Section		
Data Item	Description	Data Item	Description	Alias
FINRPTAB	Account Balance	Description	Description	DESC
FINRPTBA	Approved Budget			
FINRPTBO	Final Budget			
FINRPTBR	Requested Budget			
FINRPTIC	Inception to Date through Current Pe			
FINRPTIY	Inception to Date Year End			
FINRPTJE	Create Journal Entry			
FINRPTPA	Period Activity			

Buttons: Define Calculation, Define Smartfield, < Back, Next >, Cancel, Help

The Director automatically includes the Description column. After you finish the Director process, you can use Report Design to change its size, column heading name, and position on the report.

1. Drag the appropriate field from the Available Smart Fields list to the Columns in Report Section list.

Smart Field Name appears and marks the first phase of defining data for the smart field.

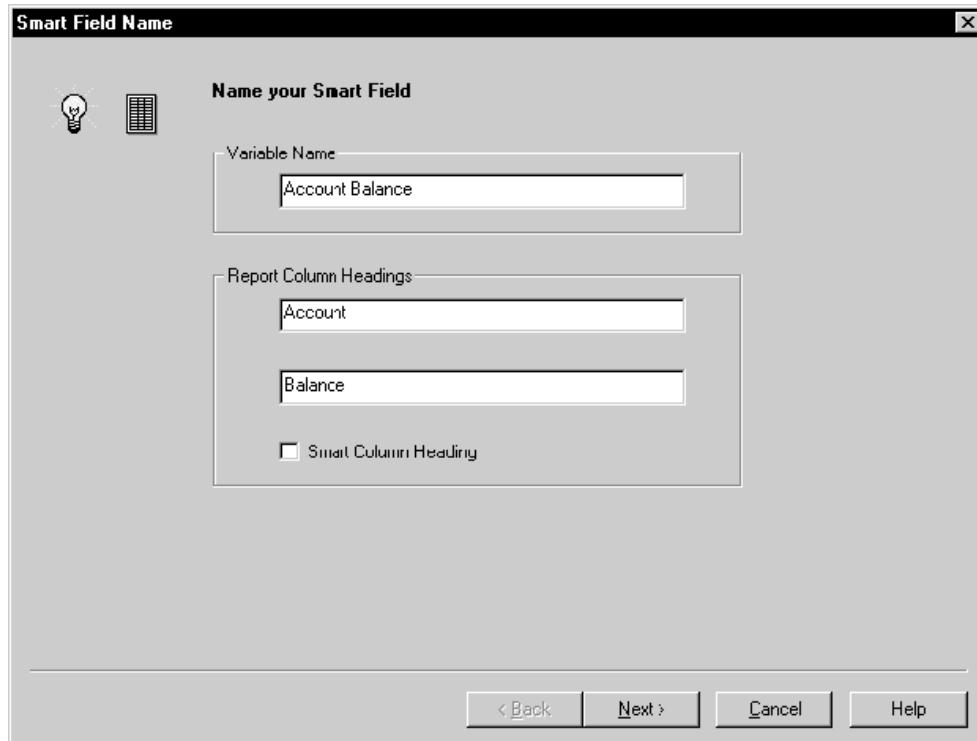

The image shows a dialog box titled "Smart Field Name" with a close button (X) in the top right corner. The dialog is titled "Name your Smart Field" and contains the following elements:

- A lightbulb icon and a grid icon on the left side.
- A section labeled "Variable Name" with a text input field containing "Account Balance".
- A section labeled "Report Column Headings" with two stacked text input fields. The top field contains "Account" and the bottom field contains "Balance".
- A checkbox labeled "Smart Column Heading" which is currently unchecked.
- At the bottom, there are four buttons: "< Back", "Next >", "Cancel", and "Help".

2. Complete the following fields, and then click Next:

- Variable Name

Give the smart field a unique variable name. If you attach event rules to this report or want to use the column in a calculation, and require this column to appear in the event or calculation, you can easily identify the column by what appears in this field.

- Report Column Headings

The Report Column Headings allows you to give the smart field a meaningful title as it appears on the report.

- Smart Column Heading

If this option is turned on, the report displays a name that corresponds to the specific value that is entered on the Smart Field Parameter - Column Heading form. For a financial smart field, this name might be the name of the period, such as June. If the option is not turned on, the report displays what you have indicated in the Report Column Headings.

One or more Smart Field Parameters forms might appear during the second phase of entering data for the smart field.

**Smart Field Parameters**

(a,b)

**Define Smart Field Parameters.**

Define Parameter for: COLUMN DATA

Period Number Offset

Description  
XXXXXXXX

The period number on which you want to base this column. Do one of the following actions: leave the field blank to use the current period, enter a specific period number, such as 6, or enter a number that is an offset to the current period number, such as +1 or -1.

Enter the Literal

-1

< Back   Next >   Cancel   Help

---

**Note**

The Smart Field Parameter forms vary, depending on which smart field you included. For example, if you chose the FINRPTAB smart field, the appropriate Smart Field Parameter forms appear.

---

3. Complete the following field, and then click Next:

- Enter the Literal

Leave the field blank to use the current year, enter a specific period number, or enter a number that is an offset to the current period number. For example, entering a 6 results in data for period 6 being retrieved. Entering a -1 results in data for the month prior to the current month being retrieved.

**Smart Field Parameters**

(a,b)

**Define Smart Field Parameters.**

Description  
XXXXXXXX

Fiscal Year Offset

The fiscal year on which you want to base this column. Do one of the following actions: leave the field blank to use the current period, enter the last two digits of a specific fiscal year, such as 98, or enter a number that is an offset to the current fiscal year, such as +1 or -1.

Enter the Literal

< Back   Next >   Cancel   Help



4. On Smart Field Parameters (Fiscal Year Offset), complete the following field, and then click Next:

- Enter the Literal

Leave the field blank to use the current year; enter the last 2 digits of a specific fiscal year, such as 98; or enter a number that is an offset to the current fiscal year, such as +1 or -1.

On Smart Field Data Selection, the fields vary, depending on the director template that you are using. This form marks the third phase of entering data for the smart field.

**Smart Field Data Selection**

  **Specify the data selection for your Smart Field.**

Ledger Type

Company

Business Unit

Object Account : From

Object Account : To

Advanced

  I'd like to setup smart field data selection myself.



< Back Finish Cancel Help

5. Complete the fields to define the data that you want retrieved for the smart field column, and then click Finish.

If the displayed fields do not meet your data selection criteria, you can define your own data selection by choosing the Advanced option. When you click Next, Column Data Selection appears. From this form, you can define the criteria by which records are included in your report.

**Column Data Selection**

Define the subset of data to be included in the column when reading records from the database. In other words, filter the incoming data so that the column only processes certain records.

	Operator	Left Operand	Comparison	Right Operand
	Where	BC Ledger Type (F0902)	is equal to	"AA"
	And	BC Business Unit (F0901)	is equal to	" 80"

< Back   Finish   Cancel   Help

- Repeat steps 1 - 5 for each smart field column that you want to include in the report. You can click the Define Smartfield button on Define Smartfields to revise choices that you made for any of the smart fields.

### See Also

See the following topics in the *Enterprise Report Writing Guide*:

- ❑ *Understanding the Description Column* for additional information about the Description column.
- ❑ *To performing manual data selection* for information about how to use Column Data Selection.

### ► To create calculation columns

---

- On Select Columns, click Define Calculation.
- On Define Calculation, complete the following field:
  - Calculation Name  
This field appears on the report as the column heading.

3. Choose one of the following calculation types:
  - Difference between
  - Percent variance between
  - Undefined
  - Total of
  - Product of
  
4. To define the Operands for your calculation column, perform one of the following tasks, and then click Finish:
  - If you chose *Difference between*, *Percent variance between*, or *Product of*, perform the following:
    - Under Operands, click the down arrow of the first operand field to display the existing columns, and then choose the column that you want to use as the first column in the calculation.
    - Under Operands, click the down arrow of the second operand field to display the existing columns, and then choose the column that you want to use as the second column in the calculation.
  - If you chose *Total of*, in the first Operands field, choose the columns that you want to include in your calculation total.  
 To choose multiple columns, click each column that you want included.  
  
 To remove a column from your calculation total, click the column to deselect it. It disappears from the Calculation Name field.
  - If you chose *Undefined*, a percent column is created without a calculation. You can define the percent calculation for the column after completing the steps of the Director and after rows have been created.
  
5. On the Select Columns, repeat steps 1 - 4 for each calculation column that you want to create.
  
6. When you have defined all of the calculation columns for your report, click Next on Select Columns to see Data Sequencing Help.

**See Also**

- *Defining a Percent Calculation in the Enterprise Report Writing Guide*

**► To define section data sequencing with the Advanced option off**

---

When you select a smart field or a calculation on the Select Columns form, the director guides you through the process of setting up the smart field or calculation.

*When the smart field or calculation setup is complete, click Finish, and the Select Columns form appears.*

1. From the Select Columns form, click Next.
2. On Data Sequencing Help, select the groups by which you wish to sequence the report, and then click Next.

---

**Note**

If Help with Section Data Selection appears, proceed with the task *To select records to include in an application report* in the *Enterprise Report Writing Guide*. This form appears if the Display Financial Criteria option is chosen on the Report Director Templates Revisions - Properties tab for the template that you chose.

If Section Data Selection appears, you can define the criteria by which records are included in your report. This form appears if the Display Generic Criteria option is chosen on the Report Director Templates Revisions - Properties tab for the template that you chose. Proceed with the task *To perform manual data selection* in the *Enterprise Report Writing Guide*.

---

**See Also**

See the following topics in the *Enterprise Report Writing Guide*:

- ❑ *Adding or Modifying Director Templates* for information about the Display Financial Criteria and Display Generic Criteria options
- ❑ *To perform manual data selection* for information about using Section Data Selection

---

**► To define section data sequencing with the Advanced option on**

---

When you select a smart field or a calculation on the Select Columns form, the director guides you through the process of setting up the smart field or calculation.

*When the smart field or calculation setup is complete, click Finish, and the Select Columns form appears.*

1. From the Select Columns form, click Next.
2. Perform one of the following tasks:
  - Turn the Advanced option on to further define the sequencing for default Report Grouping or Report Detail fields.
  - Turn the Advanced option on and deselect the fields in the Report Grouping or Report Detail lists so that you can select your own data sequencing and level breaking.
3. Click Next.

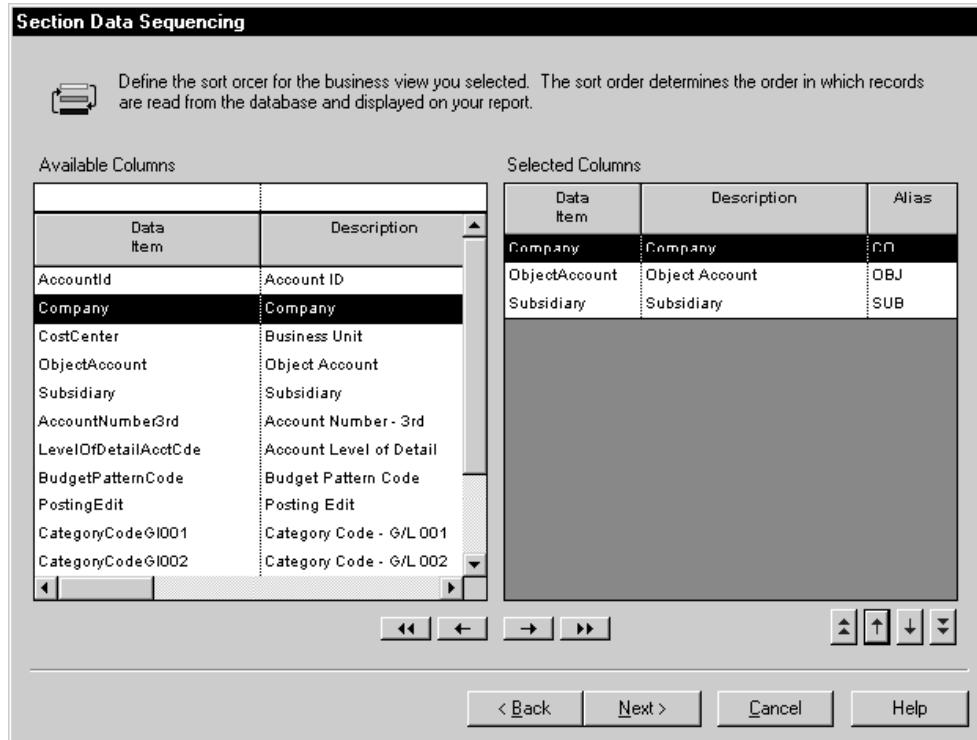

4. On Section Data Sequencing, to select columns for section data sequencing, choose the columns from the Available Columns list, and then click the arrow that is pointing to the right to move them to the Selected Columns list.

Alternately, you can drag each column individually into the Selected Columns list, or you can click the double-arrow that is pointing to the right to move all of the columns from the Available Columns list to the Selected Columns list.

5. To remove a column from the Selected Columns list, choose a column in the Selected Columns list, and then click the arrow that is pointing to the left to move it to the Available Columns list.

Alternately, you can click the double-arrow that is pointing to the left to move all of the columns from the Selected Columns list to the Available Columns list.

6. To change the order of the columns that you selected for data sequencing, choose a column in the Selected Columns list, and then click the up or down arrow to move the selected column up or down one line in the list.

Alternately, you can drag a column to a new location in the list, or you can click the up or down double-arrows to move the selected column to the top or bottom of the list.

7. When you have completed the section data sequencing for your report, click Next.

If you selected any columns in addition to the default columns, Define Sort Properties appears.

**Define Sort Properties**

Define the properties for the sort columns you selected. These properties determine the type of sequencing (ascending/descending), whether a level break should occur, and if a level break should produce a page break. Click on a box to select a property.

**Sort Columns**

Data Item	Description	Alias	Sort Order	Level Break	Page Break
Company	Company	CO	↑		
ObjectAccount	Object Account	OBJ	↗	✓	
Subsidiary	Subsidiary	SUB	↗	✓	

< Back   **Next >**   Cancel   Help

8. On Define Sort Properties, complete the following fields, and then click Next:

- Sort Order
- Level Break

Any report that includes a system-generated description column should sort on at least two columns, and the first two columns should be set as level breaks. Otherwise, the description column appear correctly.

- Page Break

---

**Note**

If Help with Section Data Selection appears, proceed with the task *To select records to include in an application report* in the *Enterprise Report Writing Guide*. This form appears if the Display Financial Criteria option is selected on the Report Director Templates Revisions - Properties tab for the template that you chose.

If Section Data Selection appears, you can define the criteria by which records are included in your report. This form appears if the Display Generic Criteria option is selected on the Report Director Templates Revisions - Properties tab for the template you chose. Proceed with the task *To perform manual data selection* in the *Enterprise Report Writing Guide*.

---

## See Also

See the following topics in the *Enterprise Report Writing Guide*:

- ❑ *Adding or Modifying Director Templates* for information about the Display Financial Criteria and Display Generic Criteria options
- ❑ *To select records to include in an application report* for information about data selection

### ► To select records to include in an application report

---

After defining section data sequencing using Data Sequencing Help or Section Data Sequencing, Help with Section Data Selection appears. This form appears only if the Display Financial Criteria option is selected on the Report Director Templates Revisions - Properties tab for the template that you chose.

*From Data Sequencing Help or Section Data Sequencing, click Next.*

On Help with Section Data Selection, perform one of the following tasks, and then click Next:

- To select data only from the balance sheet accounts, click *Select only BALANCE SHEET accounts from the automatic accounting instruction*. This selection includes data fields that are appropriate for a balance sheet—that is, the account range that is established in your company's General Purpose (GLGxx) automatic accounting instructions.  
The Additional Properties form appears.
- To select data only from the income statement accounts, click *Select only INCOME STATEMENT accounts from the automatic accounting instructions*. This selection includes data fields that are appropriate for an income statement—that is, the account range that is established in your company's General Purpose (GLGxx) automatic accounting instructions.  
The Additional Properties form appears.
- To base your data selection on the default balance-sheet data selection, but add your own criteria, click *Select only BALANCE SHEET accounts from the automatic accounting instructions*, and then click *I'll add my own data selection to the above balance sheet or income statement criteria*. This procedure provides the criteria for including balance sheet accounts while letting you define additional criteria as well.  
The Section Data Selection form appears.
- To base your data selection on the default income-statement data selection, click *Select only INCOME STATEMENT accounts from the automatic accounting instructions*, and then click *I'll add my own data selection to the above balance sheet or income statement criteria*. This option provides the criteria for including income statement accounts while letting you define additional criteria as well.  
The Section Data Selection form appears.
- To set up data selection manually, click *Set up data selection manually*. This option lets you define criteria for which records appear in your report.  
The Section Data Selection form appears.

## See Also

- ❑ *To perform manual data selection* in the *Enterprise Report Writing Guide* for information about using Section Data Selection
- ❑ *Understanding AAls for General Accounting* in the *General Accounting Guide* for more information about automatic accounting instructions

## ► To perform manual data selection

---

1. On Section Data Selection, click in the Operator column and choose an operator.  
*Where* is the default value in the Operator column for the first set of criteria. For subsequent statements, *And* and *Or* become the available values for the Operator column, and are selected by double-clicking the appropriate word.
2. Click in the Left Operand column to display the list of available objects, and then perform one of the following tasks:
  - Scroll through the list until you find the desired object, choose the object, and then double-click the object to populate the Left Operand column.
  - Type the first letters of the object name in the Left Operand field to display the object in the list, and then double-click the highlighted object.

When you double-click the object for the Left Operand column, the list in the Comparison column automatically appears.

3. Double-click one of the following comparison operators to select it:
  - is equal to
  - is greater than
  - is greater than or equal to
  - is less than
  - is less than or equal to
  - is not equal to

When you double-click the object for the Comparison column, the list in the Right Operand column automatically appears. The objects, special values, and variables that are available depend on the comparison operator that you choose.

4. Double-click a value from the list in the Right Operand column to choose it.

Your choices in this column depend on the choice that you made in the Comparison column. Some of the following options could be available:

**Blank** Enters a blank (space) value

**Literal** Allows you to enter specific values, described in step 5

**Null** Indicates that no value is associated with the field

**Zero** Enters a value of zero

**BC** Indicates that a business view column is available for this report

<b>FI</b>	Indicates that a value passed through form interconnection to this report
<b>PC</b>	Indicates the previous business view column
<b>PO</b>	Indicates a processing option value for this report
<b>PV</b>	Indicates the previous value for the variable
<b>RC</b>	Indicates a constant from this report
<b>RV</b>	Indicates a variable from this report
<b>SV</b>	Indicates a system variable
<b>SL</b>	Indicates a system literal
<b>TV</b>	Indicates a text variable
<b>VA</b>	Indicates an event rule variable

5. If you chose Literal for the Right Operand column, click one of the following tabs:

- Single value

Enter a single value, and then click OK. For example, you might enter the address book number for a particular company.

- Range of values

Enter a range of values, and then click OK. For example, a range of values might include companies from 00001 to 00060. Only *is equal to* and *is not equal to* are valid logical operators when using range of values.

- List of values

To add values to remove values from the list, perform the following tasks:

- Type each value in the field, and then press Enter or click the Add button at the top of the form.
- Repeat this process until your list of values is complete. For example, a list of values might include several user defined codes for search types, such as C for Customers, E for Employees, and V for Vendors. Only *is equal to* and *is not equal to* are valid logical operators when using a list of values.
- Delete a value by choosing the value, and then clicking the Delete button at the top of the form.

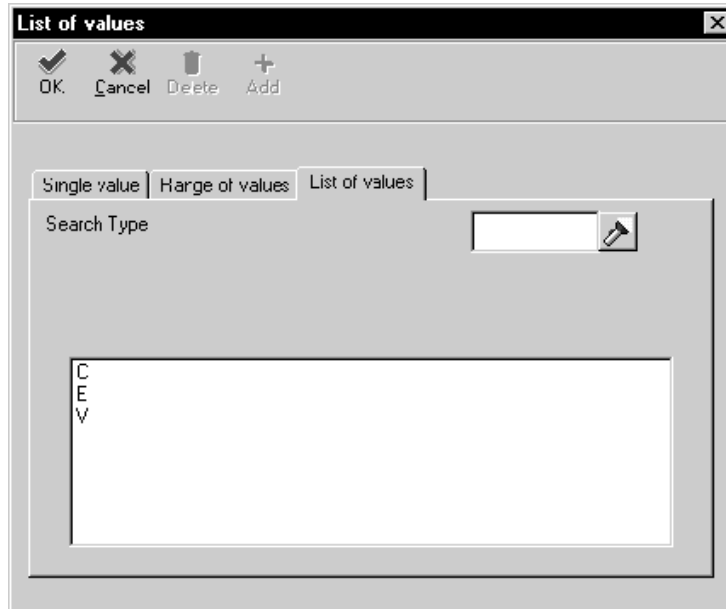

6. Click OK.
7. Repeat steps 1 through 6 to define more selection criteria rows.
8. To delete a line of criteria on Section Data Selection, choose the row header to highlight the row, and then click the Delete button at the top of the form.
9. To change the order of the criteria, choose the row header to highlight the row, and then click the up or down button.
10. When you have completed defining selection criteria, click Next to see Additional Properties.

► **To define additional properties for an application report**

---

*After you define data selection using Help With Section Data Selection or Section Data Selection, click Next.*

1. On Additional Properties, choose the following options, as applicable:
  - AAI (Automatic Accounting Instructions) Subtotaling, based on Financial Statement (FSxx) AAls
  - Reverse Sign For
  - Account Level of Detail Rollup
  - Drill Down
  - Zero Row Suppression

If you choose *Suppress Zero Detail Rows Only*, header accounts print even if the detail accounts have a zero balance.
2. Click Next to see Director's Finish.

## See Also

- ❑ *Understanding AAls for General Accounting* in the *General Accounting Guide* for more information about automatic accounting instructions

See the following topics in the *Enterprise Report Writing Guide*:

- ❑ *Working with Objects in Report Sections* for information about tabular section properties
- ❑ *Adding or Modifying Director Templates* for information about displaying all, some, or none of the additional properties

## ► To create a batch version of the report

---

*After you define the data selection for the section, the Director's Finish form appears.*

1. On the Finish form, click *Yes, create a version of this report* to automatically generate a batch version of the template.
2. Enter the version name in the field beneath *Yes, create a version of this report*.
3. To review your choices, click *Back* to move backwards through the Director forms, or click the form on the Navigation Assistant that you want to review.
4. When you are satisfied, click *Finish*.

---

### Caution

When you click *Finish*, you can no longer access the Director for this report. Prior to clicking *Finish*, you have one more opportunity to review your choices on all forms of the Director, as described in step 3.

---

Report Design - Report View appears.

## See Also

- ❑ *Object Management Workbench* in the *Development Tools Guide* for information on using OMW to create a batch version
- ❑ *Batch Versions for Reports* in the *Enterprise Report Writing Guide* for information on creating a batch version

## ► To save a report

---

*After you click Finish on the Director's Finish form, the Report Design form appears.*

On the Report Design form, perform one of the following actions:

- From the File menu, choose *Save*.
- Click the *Save* button on the toolbar.

## See Also

- ❑ *Object Management Workbench* in the *Development Tools Guide* for more information on checking in a report

See the following topics in the *Enterprise Report Writing Guide* for information about using Report Design to modify or enhance your report:

- ❑ *Basic Report Enhancements*
- ❑ *Advanced Report Enhancements*

## Reviewing the Results of the Director

When you click Finish, the Director process is complete. Based on the choices that you made during the process, Report Design displays the sections of your report and the data fields that you included in them. Each section includes the following:

- An icon that displays the section type
- Corner brackets enclosing each field within the section
- A title description

The title of the main detail section of the report uses a bold font to distinguish it from the titles of the other report sections.

---

## Basic Report Enhancements

After you create a report, either manually or through the Report Design Director, Report Design offers many features to help you refine the data, structure, and physical appearance of your report. You can add report sections and data fields; modify the properties of entire sections and individual data fields; add, move, or delete columns and rows; and perform calculations. You can also preview your report from the Report Design form as you make your changes.

The Report Design user interface provides you with various views of the report and its component objects, tools for creating those objects, and tools for configuring your design workspace. These tools can do the following:

- Preview reports.
- Add attachments or comments.
- View properties of report sections, fields, columns, and rows.
- Configure your design workspace.
- Add smart fields.
- Create header and footer sections.
- Work with level-break header and footer sections.
- Join subsections.
- Work with objects in report sections.
- Modify the appearance of report objects.

---

## Previewing a Report from Report Design

The Preview tab lets you see, while in design mode, how your report will appear when printed. Use the report preview to review your report for content and format as you make design changes.

---

### ► To preview a report from Report Design

*On the Report Design form, display the report template.*

1. Click the Preview tab.

The Report Preview form appears, asking if you want to run the preview.

To prevent this form from appearing prior to previewing your report, from the View menu, choose User Options. Turn the Prompt before Running Preview option off.

2. Click Yes on Report Preview.

If you made changes since you last saved your report, Report Design prompts you to save prior to previewing your report.

3. Click Yes to save the changes.

Report Design uses the Adobe Acrobat Reader to show the preview. You can use all of its functions to view the report.

4. Each time that you make changes to the report, you must refresh the preview. To refresh your preview, perform one of the following:
  - From the View menu, choose Refresh Preview Window.
  - If the View toolbar is displayed, click the Refresh Preview Window button.
  - Push F5 on your keyboard.
5. To change the number of table records to process and display in Preview mode, from the View menu, choose User Options.
6. On User Options, complete the following field to indicate how many table records to process in the preview:
  - Rows to preview

## **Adding Attachments or Comments**

---

You can attach media objects to reports and versions. A media object can be text, an image, a shortcut, or any file that conforms to the OLE (object linking and embedding) standard. For example, you can use attachments to provide generic help text about selected application reports that need to be made company-specific or to document changes that you made to a report. You cannot print attachments with a report; you can only view the attachments in Report Design.

In addition to adding attachments to reports, you can attach text-only comments to individual data fields within your report.

### **► To add or delete attachments to a report**

---

*On the Report Design form, display the report template.*

1. Click the Attachments tab.

The Attachments workspace is split into two panes. The left pane is the icon pane, and the right pane is the viewer pane.
2. To add text, type the desired text in the viewer pane.

You can use the formatting tools at the top of the viewer panel to format the text of your note.
3. If you want to add an object that is not text, right-click in the icon pane.
4. From the pop-up menu, choose New, and then choose one of the following:
  - Image
  - OLE
  - Shortcut
  - URL/File
5. To remove an object, right-click the object's icon in the icon pane and choose Delete from the pop-up menu.

## See Also

- ❑ *Working with Media Objects* in the *Foundation Guide* for more information about image, OLE, and shortcut attachments

### ► To add, modify, or delete comments to a data field

---

On the *Report Design* form, click the *Report* tab (or *Version* tab if you are working with a version).

1. Right-click the object to which you want to attach the comment, and then choose *Insert Comment*.

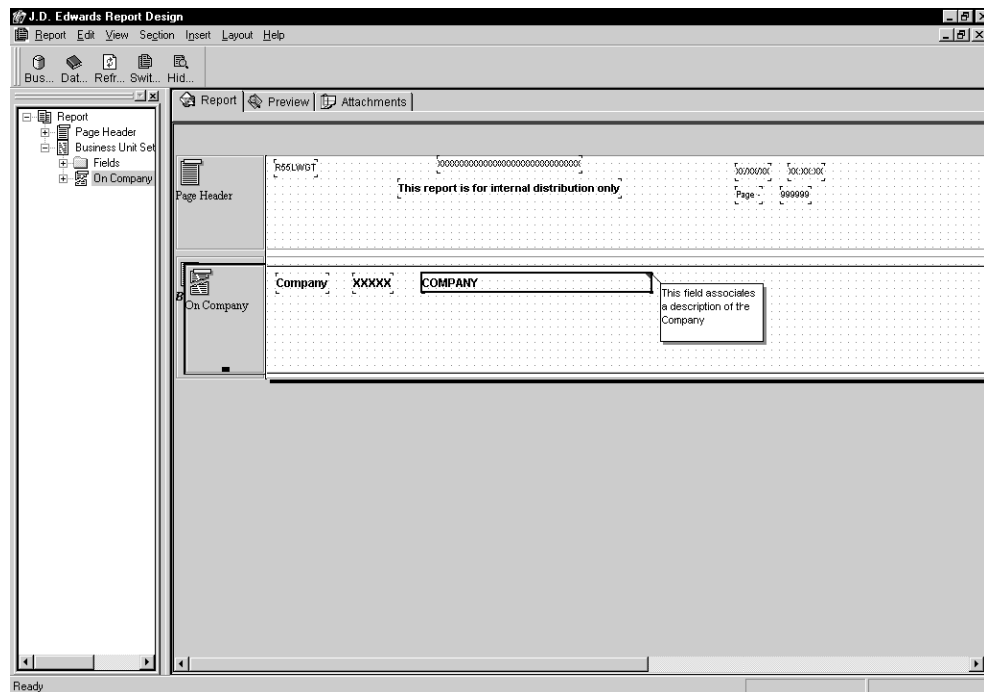

2. Type the text, and then click anywhere in the design workspace to close the text window.

A red flag appears in the upper right corner of the object to indicate that a comment is attached to this object.

3. To modify, delete, show, or hide the comment, right-click the object and choose the appropriate option from the pop-up menu.

## Viewing Properties for Report Sections, Fields, Columns, and Rows

---

Use Report Design to view the properties of a section, field, column, or row.

- Section properties that you can view include general, font, color, fields, and advanced. You can view section properties using either the menu method or the double-click method.
- Field properties that you can view include general properties, font, color, style, display, options, and advance properties. You can view data field properties using either the report section method or the double-click method.
- Columns (both the headings and the variables) are treated by Report Design as fields, so you can use the same methods of viewing column properties as you can for viewing field properties. In addition, Report Design offers a third way to view column properties: the column tab method.
- Rows exist in tabular sections only. You can view row properties by using either the report section method or row tab method.

Throughout the remainder of this guide, to access Section or Properties forms, you are instructed to use the double-click method. If you prefer the other methods, then substitute them as desired.

### ► To view a report section's properties using the menu method

---

*On the Report Design form, click the Report tab.*

1. Click the section for which you want to view properties.
2. From the Section menu, choose Section Properties.

Depending on the section type, the appropriate Section form appears.

### ► To view a report section's properties using the double-click method

---

*From the Report Design form, click the Report tab.*

Double-click the section for which you want to view properties.

Depending on the section type, the appropriate Section form appears.

### ► To view a data field's properties using the report section method

---

*From the Report Design form, click the Report tab.*

1. Double-click the section containing the data field for which you want to view properties.

Depending on the section type, the appropriate Section form appears.

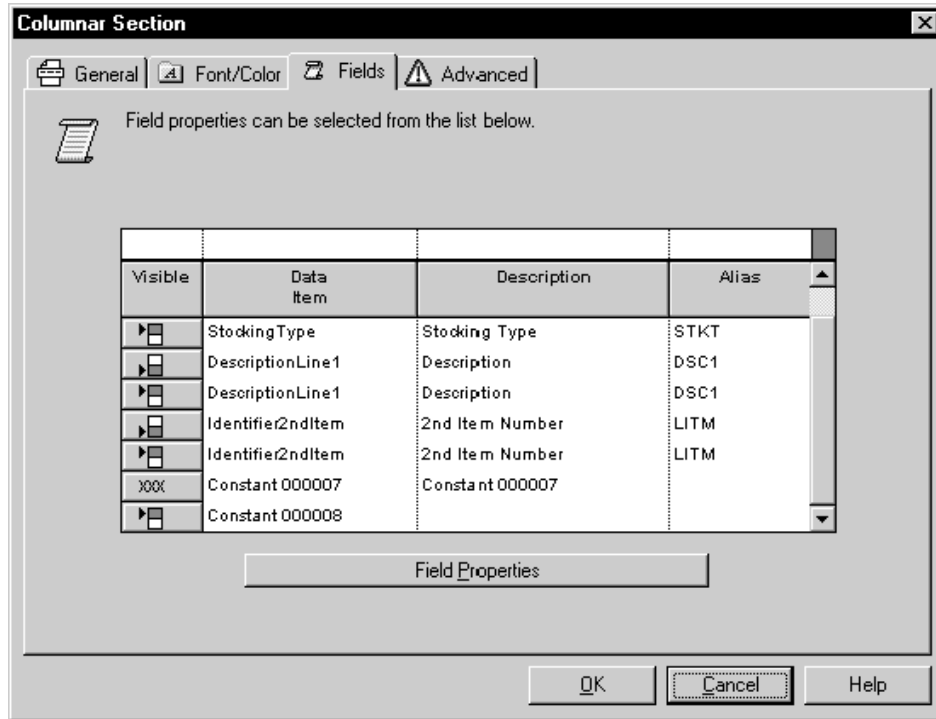

- Click the Fields tab.

The Fields tab lists all of the data fields in the section. The various field types are represented by different icons in the Visible column as follows:

- XXX. This icon represents a constant field.
- Dual-shaded box. This icon indicates a column object. If the arrow is pointing to the top section, the icon refers to the column header. If the arrow is pointing to the bottom section, the icon refers to the column variable.
- Gray, black, and white diamond. This icon represents a run-time field, such as report date, report time, page number, company title, or report title.
- Multicolored diamond. This icon represents a variable in a group section.

In all cases, if the data field is invisible, a circle with a line through it appears next to the icon. Double-click the icon to toggle the visible or invisible property.

---

**Note**

If a column header is invisible, its associated column variable is also invisible.

---

- Choose the data field for which you want to view properties and click Field Properties.

Depending on the field type, the appropriate Properties form appears.

► **To view a data field's properties using the double-click method**

---

*On the Report Design form, click the Report tab.*

Double-click the data field for which you want to view properties.

You can double-click data fields on the Report Design form and in the Report Tree form.

Depending on the field type, the appropriate Properties form appears.

► **To view a column's properties using the column tab method**

From the Report Design form, click anywhere within the tabular section for which you want to view column properties.

1. Click the Column tab.

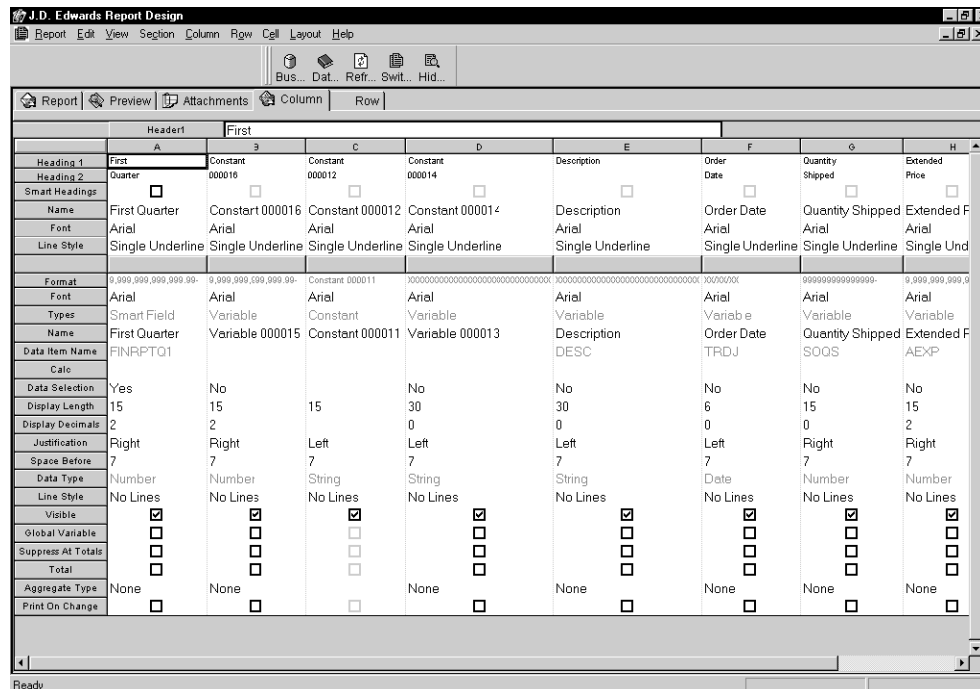

2. Right-click anywhere on the Column form grid.
3. Click Field Selection.
4. On Object Design Properties, use the Basic or Advanced tab to turn off or on any of the default field options, and then click OK.

This action lets you determine what fields are displayed on the Column tab grid.

5. To change a property, from the Column tab grid, double-click any field. Depending on the property that you are changing, an appropriate control appears.

► **To view a row's properties using the report section method**

On Report Design, click the Report tab.

1. Double-click the tabular section containing the row for which you want to view properties.

2. On Tabular Section, click the Row List tab.

The Row List tab lists all of the rows in the section. The various row types are represented by different icons in the Visible column.

In all cases, if the row is invisible, a circle with a line through it appears next to the icon. Double-click the icon to toggle the visible or invisible property.

3. Choose the row for which you want to view properties and click Row Properties. Depending on the row type, an appropriate Properties form appears.

► **To view a row's properties using the row tab method**

On Report Design, click the Row tab.

	Name	Description	Type	Calc	Data Selection	Data Selection	Reverse Sign	Visible	Page Break	Font Override
1	Revenue	Revenue	Text		No	6	<input type="checkbox"/>	<input checked="" type="checkbox"/>	<input type="checkbox"/>	
2	Object Sales	Object Sales	Inclusion		Yes	6	<input type="checkbox"/>	<input checked="" type="checkbox"/>	<input type="checkbox"/>	
3	Direct Costs	Direct Costs	Text		No	6	<input type="checkbox"/>	<input checked="" type="checkbox"/>	<input type="checkbox"/>	
4	Gross Margin	Revenue + Direct Costs	Calculation	[R2]+[TR Object Cos]	No	6	<input type="checkbox"/>	<input checked="" type="checkbox"/>	<input type="checkbox"/>	
5	Object Costs	Object Costs	Inclusion		Yes	6	<input type="checkbox"/>	<input checked="" type="checkbox"/>	<input type="checkbox"/>	
6	Sum 000024		Sum Calculation	Revenue - Revenue	No	10	<input type="checkbox"/>	<input checked="" type="checkbox"/>	<input type="checkbox"/>	
7	Underline 000025		Underline		No	6	<input type="checkbox"/>	<input checked="" type="checkbox"/>	<input type="checkbox"/>	

1. Right-click anywhere on the Row form grid.
2. Choose Field Selection.
3. On Object Design Properties, use the Basic or Advanced tab to turn off or on any of the default field options, and then click OK.

This action lets you determine what fields show on the Row tab grid.

The Row grid displays fields, such as Display Decimals and Display Length, that override column properties. These fields appear with no data if they are not overriding what was set at the column level.

4. If you want to change a property, from the Row tab grid, double-click any field. Depending on the property that you are changing, an appropriate control appears.

## Configuring Your Design Workspace

---

Report Design offers a variety of ways to configure your design workspace. Use Report Design to do the following tasks:

- Set user options.  
User options let you show or hide the elements of the user interface, such as rulers and tabs. You can also set user options to control the number of rows to process for preview.
- Set grid alignment.
- Show and hide the display tree.  
The display tree is a dockable window in Report Design that lists the fields of your report in a hierarchical tree structure.
- Show and hide the Business View Column Browser.  
The Business View Column Browser is a dockable window in Report Design that lists the business view columns you can use in your report.
- Show and hide the Data Dictionary Browser.  
The Data Dictionary browser is a dockable window in Report Design that allows you to search the data dictionary for fields to use in your report.

### ► To set user options

---

*On Report Design, from the View menu, choose User Options.*

1. On User Options, click any of the following options under the General heading, and then click Apply to see your changes immediately:
  - Show Invisible Sections at Startup
  - Show Section Titles  
This option displays the titles of sections to the left of each section.
  - Show Right Margin  
Showing the right margin is helpful when you change the orientation of your report because it enables you to see whether any fields fall outside the page's new margins.
  - Show Tabs  
This option displays the Report, Preview, Attachments, and other tabs at the top of the design workspace.
  - Show Navigational Assistant  
Compared to hiding the Navigation Assistant, which turns off the Navigation Assistant for the current report only, disabling the Navigation Assistant option turns off the Navigation Assistant for the current report as well as all o the reports that you create in the future.
  - Show Data Dictionary Text Overrides

This option displays a small triangle in the bottom right corner of the fields where the display name is not the same as the data dictionary name. The indicator appears in Report Design only; it does not print on the report.

- Allow Smart Field Template Selection
2. To show rulers at the top and side of the report, click the following option under the Rulers heading:
    - Show Rulers
  3. If you selected Show Rulers, complete the following field:
    - Ruler Units
  4. To display a prompt before running preview, click the following option under the Preview heading:
    - Prompt Before Running Preview
  5. If you selected Prompt Before Running Preview, complete the following field:
    - Rows to Preview
  6. Click OK.

#### See Also

- *Previewing a Report from Report Design* in the *Enterprise Report Writing Guide* for information on how to preview a report

#### ► To set the grid alignment

---

*On Report Design, choose Grid Alignment from the Layout menu.*

1. On Alignment Grid, change the following spacing fields:
  - Horizontal

---

#### Note

If you are exporting your output to a Comma Separated Values (CSV) file on the Printer Setup form, J.D. Edwards recommends that you set the Horizontal spacing to 52. This number corresponds to the default width of a column in Microsoft Excel. You should also turn on the Snap to Grid option.

---

- Vertical
- The spacing value represents pixels on the workstation that are used for designing the report. The value is converted to a workstation-independent measurement when it is saved. This action ensures that the report maintains the same proportions when it is displayed on a different workstation.
2. Choose the following options:
    - Display Grid

This option displays grid lines in the workspace.

  - Snap to Grid

This option aligns objects to the nearest grid line. The option functions whether the grid lines are visible or not.

3. Click OK.

### See Also

- ❑ *To export to Comma Separated Value (CSV) files in the Enterprise Report Writing Guide* for more information about the exporting to a CSV file

### ► To show and hide the display tree

---

*On Report Design, display the report.*

1. To toggle the display tree on or off, on Report Design, from the View menu, choose Report Tree View.

The display tree displays the sections that are included in the report as well as the objects which are associated with each section. Even invisible fields appear in the tree structure. The top-most component of the tree displays the name of the report. Under the report name, the first created section is displayed. Next to each component is a + or - sign.

2. Expand (+) and collapse (-) the Report Tree by clicking the + or - sign.

Expanding the first section displays a Fields folder. By expanding this folder, a list of objects that are included in this section appears (rows and cells do not appear in the Report Tree). If you expand a detail section and its Fields folder, two entries for each field appear. One entry represents the constant (header portion of field) and the other represents the variable (data portion of field).

3. To view or change an object's properties, double-click the object in the tree structure.

---

#### Note

The Report Tree shows only the structure of your report; it does not represent the processing flow for your report. You can use the Preview tab to see how your report will be formatted.

---

### ► To show and hide the Business View Column Browser

---

*On Report Design, click on a detail section in your report.*

1. To toggle on or off the browser, from the View menu, choose Business View Columns Browser.

---

#### Note

Because you can only add business view columns to detail sections, you can only access the browser when a detail section is active.

---

2. To add a business view column to your report, drag it from the Business View Column Browser and drop it where you want it.

---

► **To show and hide the Data Dictionary Browser**

---

*On Report Design, click on a detail section in your report.*

1. To toggle the browser on or off, from the View menu, choose Data Dictionary Browser.
2. To add a data dictionary item to your report, drag it from the Data Dictionary Browser and drop it where you want it.

---

## **Adding Smart Fields**

---

You can add smart fields to one or more detail sections of your report. Smart fields provide the ability to add complex, reusable calculations to your report. Smart fields are grouped by smart field templates. Therefore, before you can add a smart field, you must first attach a smart field template to the detail section.

Every smart field template is based on a particular business view. If you attach a smart field template to a section and the section's business view is different from the business view that is required by the smart field template, then the system provides you the opportunity to change the section's business view.

---

### **Caution**

If the business view attached to the section is not the same as the business view that is required by the smart field template, then any smart field which you add to the section might not function correctly.

---

### **See Also**

- *To add smart fields to an application report in the Enterprise Report Writing Guide for more information on using the Smart Field Director*

---

► **To choose a smart field template**

---

*On Report Design, choose User Options from the View menu.*

1. On User Options, choose the following option, and then click OK.
  - Allow Smart Field Template Selection
2. On Report Design, click the detail section to which you want to add a smart field.
3. From the Section menu, choose Section Properties.
4. On the Section form, click the General tab.
5. Choose a smart field template from the Smart Field Template field, and then click OK.

► **To add a smart field**

---

*On Report Design, choose Smart Field from the Insert menu.*

On Create New Smart Field, choose a smart field.

The Smart Field Director prompts you to set up the smart field.

## **Creating Header and Footer Sections**

---

Report header and footer sections and page header and footer sections are special-purpose sections that contain constant, variable, and run-time fields. Typical information to insert in headers and footers includes your company name, the name of your report, the date when the report is printed, and page numbers. Because header and footer sections typically provide commentary or system-related information rather than data from tables, they are not associated with business views.

When you create header and footer sections, they are added to the bottom of the report view in Report Design. However, when you print your report, the sections print in the order that is appropriate for the designated type of section.

A report can contain only one report header, which prints once at the beginning of the report. A report header might include the title of the report or any other special notation.

A report can contain only one report footer, which prints once at the end of a report. A report footer might include a legal disclaimer or some other text to conclude the report.

A report can contain only one page header, which prints once at the beginning of each page of the report. A page header might include such data items as a company name, date title, page number, and date.

A report can contain only one page footer, which prints once at the end of each page of the report. A page footer might include an explanation about what is found in the report.

The properties of report headers and footers and page headers and footers are similar to the properties of group sections.

### **See Also**

- *Working with Objects in Report Sections* in the *Enterprise Report Writing Guide* for more information about adding data fields to a section and about modifying properties

► **To create a report header**

---

*On Report Design, from the Section menu, choose Create, then Headers and Footers, and then Report Header.*

An icon is added to the Report Tree window and a frame is added to the Report View window for the report header.

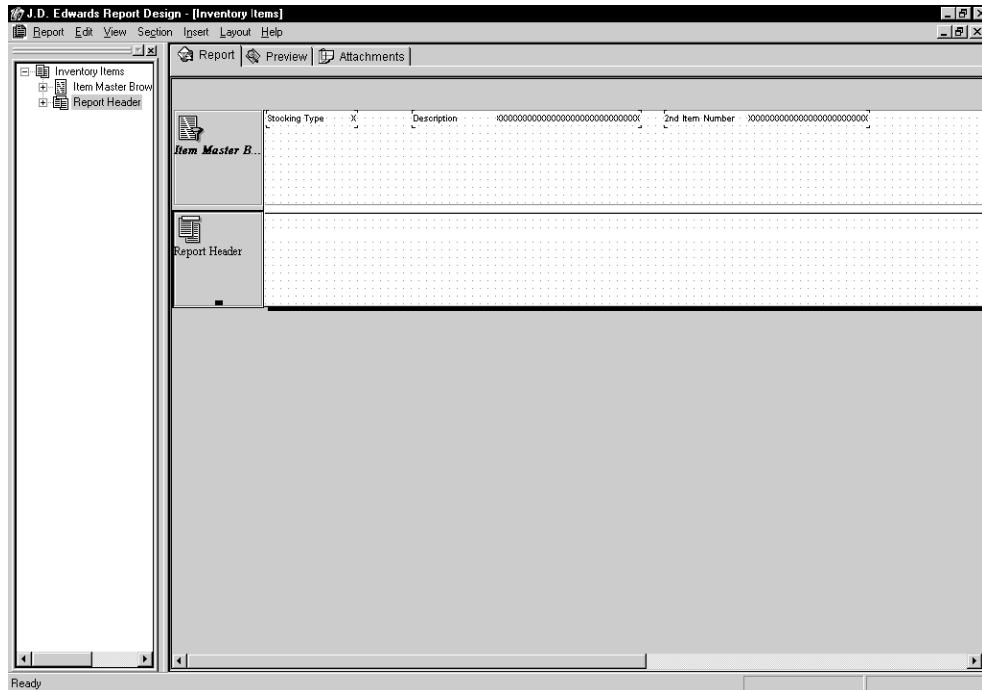

1. Click the report header.
2. Select fields from the Insert menu and add them to your section as needed by dropping them where you want them to appear. You can add any type of data field except business view columns; no business view is associated with this section.
3. From the Section menu, choose Section Properties or double-click in the Report Header section to open the Report Header form.

The Report Header form appears.

► **To create a report footer**

*On Report Design, from the Section menu, choose Create, Headers and Footers, and Report Footer.*

An icon is added to the Report Tree window and a frame is added to the report view window for the report footer.

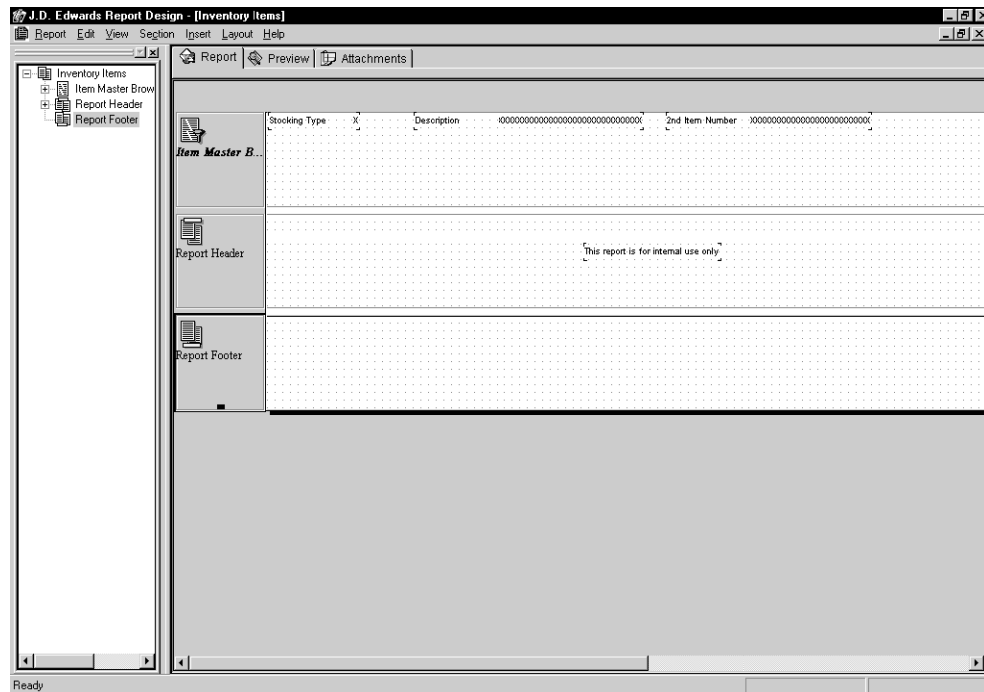

1. Click the report footer.
2. Select fields from the Insert menu and add them to your section as needed by dropping them where you want them to appear. You can add any type of data field except business view columns; no business view is associated with this section.
3. From the Section menu, choose Section Properties or double-click in the Report Footer section to open the Report Footer form.

### ► To create a page header

*On Report Design, from the Section menu, choose Create, Headers and Footers, Page Header, and then choose one of the following:*

- Section Only  
This choice creates a page header without any fields.
- Auto Create  
This choice creates a page header that includes the system date, page number, company name, title, and report name fields.

An icon is added to the Report Tree window, and a frame is added to the report view window for the page header.

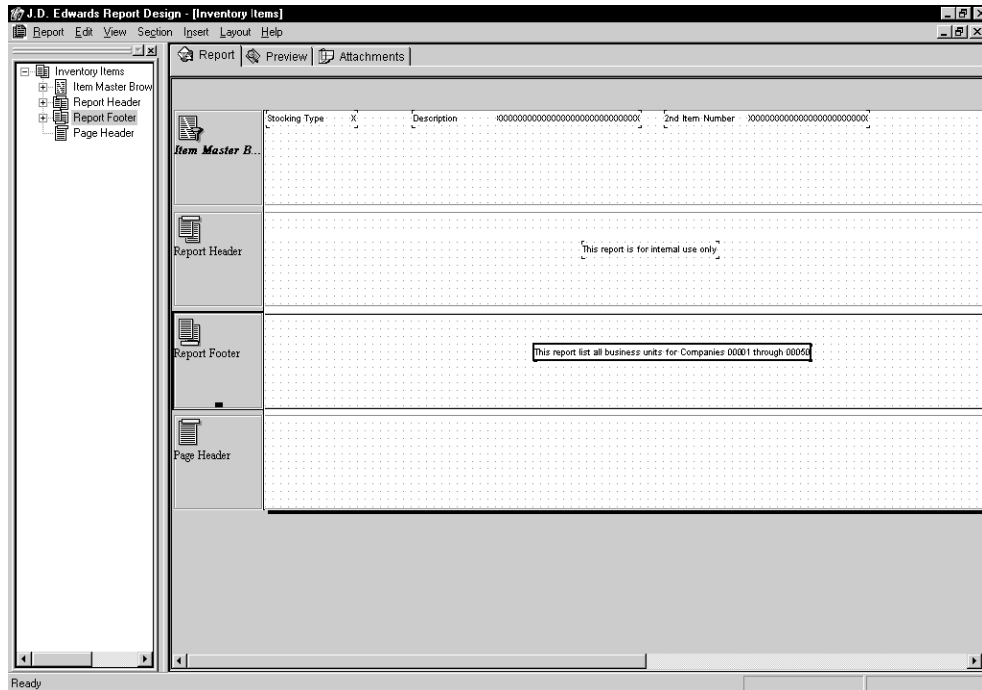

1. Click on the page header.
2. Select fields from the Insert menu and add them to your section as needed by dropping them where you want them to appear. You can add any type of data field except business view columns; no business view is associated with this section.
3. From the Section menu, choose Section Properties or double-click in the Page Header section to open the Page Header form.

The Page Header form appears.

---

**Note**

You can add extra white space between the report body and the header by placing a blank constant field below the header text.

---

► **To create a page footer**

---

*On Report Design, from the Section menu, choose Create, Headers and Footers, and Page Footer.*

An icon is added to the Report Tree window, and a frame is added to the report view window for the page footer.

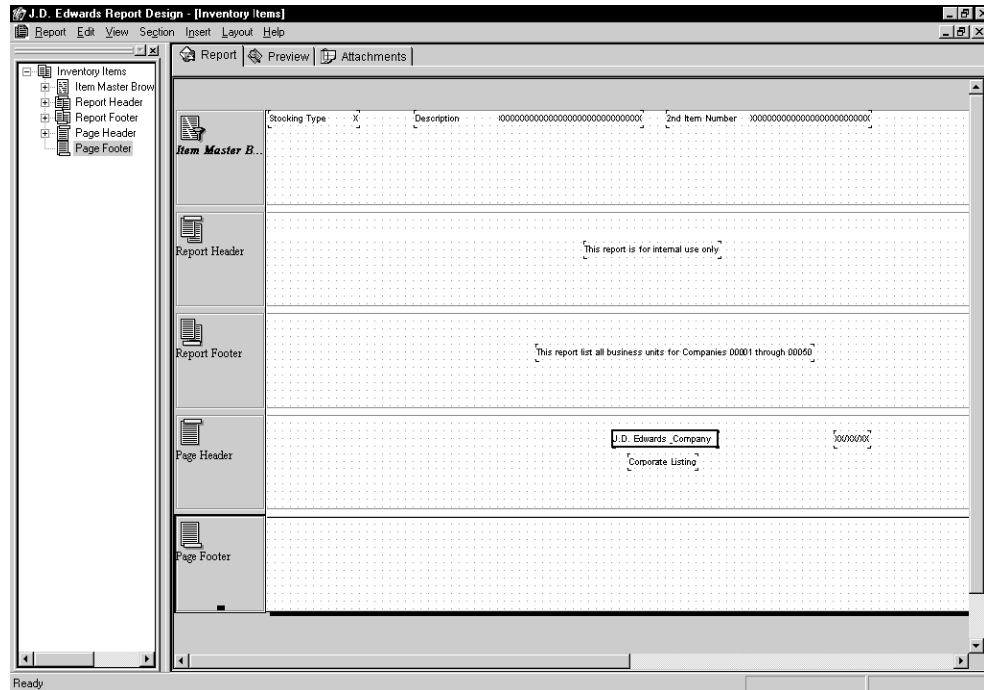

1. Click the page footer.
2. Select fields from the Insert menu and add them to your section as needed by dropping them where you want them to appear. You can add any type of data field except business view columns; no business view is associated with this section.
3. From the Section menu, choose Section Properties or double-click in the Page Footer section to open the Page Footer form.

---

**Note**

You can add extra white space between the report body and the footer by placing a blank constant field above the footer text.

---

## Working with Level-Break Header and Footer Sections

---

In a report, a set of records that has the same value for one of its fields is said to be in the same *level*. For example, in a report that is sorted by telephone numbers, all of the records having the same area code would be in the same level. When the value in that field changes, that is known as a *level break*.

Level breaks are useful because you can add processing when they occur. Two special report sections make adding processing to level breaks easy: the *level-break header* and *level-break footer* sections.

Associated with detail sections, level-break headers and footers are used to group large numbers of records into smaller, more manageable units. You can define any data field as a

level-break field. When the system processes the report, the level break triggers an event, such as the printing of a heading or total.

You can also designate the level break to cause a page break. For example, you could designate Company as a level-break field and have a new page begin each time the value in the Company field changes.

Level-break headers appear at the beginning of a level to define the information within a detail section. For example, if the level break is associated with telephone numbers, the level-break header announces the next group of phone numbers within a particular area code.

Level-break footers define the information that is presented after a level break has occurred in the preceding level. You could use a level-break footer in an employee listing to produce salary totals by department.

You can also make a level-break header or level-break footer section conditional so that it prints only if you tell it to print through a processing option. For example, you can create a report in which you want a total to print only when called by attaching the Hide Section system function to the level-break header or footer section in Event Rules. Then, in the Initialize Section event, you add an event rule for a processing option that shows or hides the section, depending on the user's preference.

By using Report Design, you can do the following:

- Add a level-break header.  
A level-break header presents a descriptive heading that you want to appear at the beginning of a level of records. For example, in a report in which the Company field is a level break, a level-break header could print the company number and its description at the beginning of each level of company. Because of their free-form layout, group sections are used for level-break headers.
- Hide a level-break header.  
If you add a level break header, you might have the same data field in both your level-break section (if you turned on the *Display selected columns as part of this section* option) and your detail section. However, to avoid having it print in both sections, you can hide the data field in the detail section.
- Associate a description with a level-break header.  
You might want to add a description to a field in your level-break header to make it more meaningful to the report reader. When you associate a description, the system displays the description that relates to the current level-break header record being read. For example, Company 00060 might have a description of Financial Reporting Company associated with it. When the level-break header is processed, this description prints along with the Company number.
- Add a level-break footer.  
A level-break footer presents information that appears after the level break. Often, fields within the level-break footer are used for accumulating totals. If you are using the level-break footer to accumulate totals, then the values in those fields are calculated dynamically at run time.
- Insert a description into a level-break footer.  
Add a description to the fields in your level-break footer to make it more meaningful to the report readers.

After you create a level-break header or footer, you can modify its properties. A level-break header is always a group section. A level-break footer might be either a group or columnar section.

### See Also

- *Working with Objects in Report Sections* in the *Enterprise Report Writing Guide* for more information about modifying section properties

### ► To create a level-break header

---

*On Report Design*, click the detail section to which you want to attach a level-break header.

1. From the Section menu, choose Create and then Level Break Header.
2. On Level Break, under the Show heading, choose one of the following options:
  - all columns  
This option displays a list of all available fields in the business view that are associated with the detail section which you created.
  - only existing sort columns  
This option displays the fields that you chose as your data sequencing fields when you created the detail section.
3. Choose one of the fields to designate it as a level-break field.
4. If you want the field chosen as the level break to appear in the level-break header on the report, turn the *Display selected column as part of this section* option on.
5. Click Finish.

You can designate another field as a level-break field by modifying the section properties of the level-break header.

In the report tree, the level-break header appears one branch below the section to which it is attached. In the report view, the level-break header appears within the detail section. The name of the level-break header usually begins with "On..." to indicate with which field of the section the level break is associated.

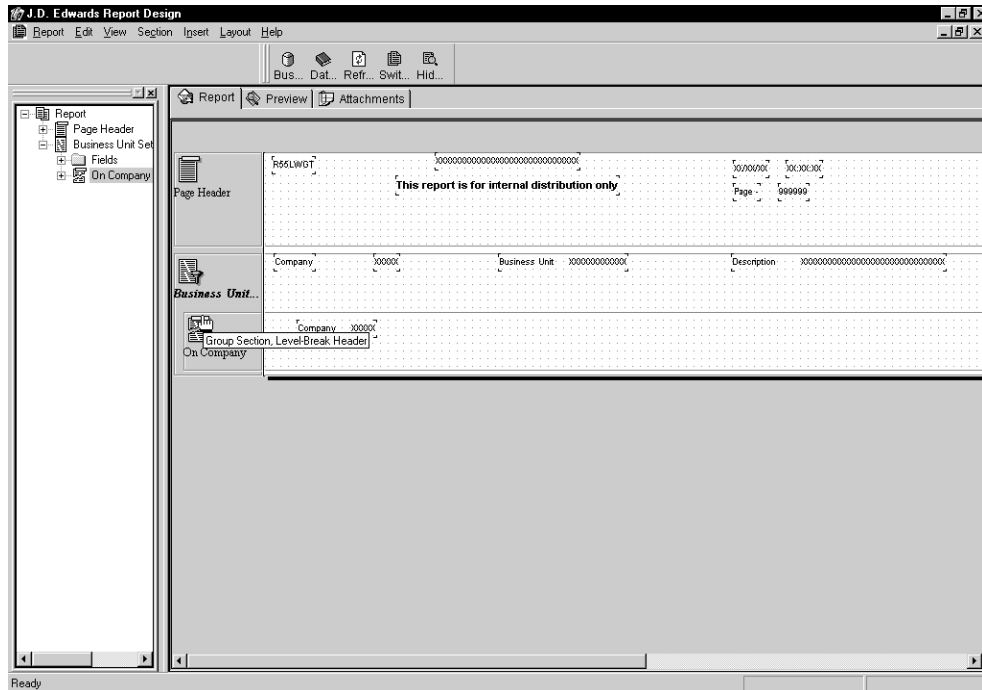

### ► To hide the level-break field in the detail section

*On Report Design, select the detail section containing the level-break field that you want to hide.*

1. Double-click the variable or column variable portion of the level-break field.
2. On Variable or Column Variable Properties, on the Advanced tab, turn the Visible option off.

If you ever need to make this field visible again, in the report tree, double-click the object and turn the Visible option on. Alternatively, you can display the Section Properties form by double-clicking the detail section, click on the Fields tab, and toggle Visible on.

### See Also

- ❑ *Configuring Your Design Workspace* in the *Enterprise Report Writing Guide* for more information about using the report tree window

### ► To associate a description with a level-break header

*On Report Design, click the variable portion of the level-break header field.*

1. From the Edit menu, choose Associate, and then choose Description.  
The cursor changes, allowing you to add the description to the level-break header.
2. Place the Description field anywhere within the level-break header. As with any field, you can drag it to a new location.

3. To change the properties of this field, double-click the field.
4. On Associated Description Properties, change options as required.

► **To create a level-break footer**

*On Report Design, click the detail section to which you want to attach a level-break footer.*

1. From the Section menu, choose Create and then Level Break Footer.
2. On Level Break Footer, click one of the following options, and then click OK:
  - Group Section
  - Columnar Section
3. On Level Break, under the Show heading, choose one of the following options:
  - all columns  
This option displays a list of all of the available fields in the business view that is associated with the detail section.
  - only existing sort columns  
This option displays the fields that you chose as your data sequencing fields when you created the detail section.
4. Choose one of the fields to designate it as a level-break field.
5. Click Next.

Aggregations

Define aggregations

Select operations and columns which you wish to aggregate

Operator	Operand
Average of	
Count of	
Maximum of	
Minimum of	
Total of	

Item display style

Single overline 9999

Double underline 9999

Reprint section at page break

< Back Finish Cancel Help

An *aggregate object* is an object that holds the result of a calculation on the values in other fields. For example, the calculation could be a sum of values, an average of values, or a count of how many records exist. After adding a level-break footer and assigning the totaling conditions to the aggregate object within the level-break footer, you might need to change the totaling conditions to meet other reporting requirements.

6. On Aggregations, define the Operator and Operand.

The Operator logic that you choose determines your choice of Operands. Choose one of the following Operators:

<b>Average of</b>	Reports the average of all the amounts in the column
<b>Count of</b>	Reports how many entries or records are in the column
<b>Maximum of</b>	Reports the maximum amount for a record in this column
<b>Minimum of</b>	Reports the minimum amount for a record in this column
<b>Total of</b>	Reports the sum of the values in this column

7. Click one of the following options under the Item display style heading:

- Single overline
- Double underline

8. Click the *Reprint section at page break* option, if necessary.

This option causes the last line from the previous page to be reprinted as the first line of the next page.

9. Click Finish.

Any time in the future, you can modify the aggregate object or add additional aggregate objects by clicking the level-break footer and choosing Add Aggregates from the Section menu.

In Report Design, hover the pointer over the aggregate object; the fields in the detail section upon which the aggregate's calculations are based change color.

In the report tree, the level-break footer appears one branch below the section to which it is attached. In the report view, the level-break footer appears within the detail section. The name of the level-break footer usually begins with "On..." to indicate the field of the section with which the level break is associated.

The level-break footer field appears below the column that it is totaling:

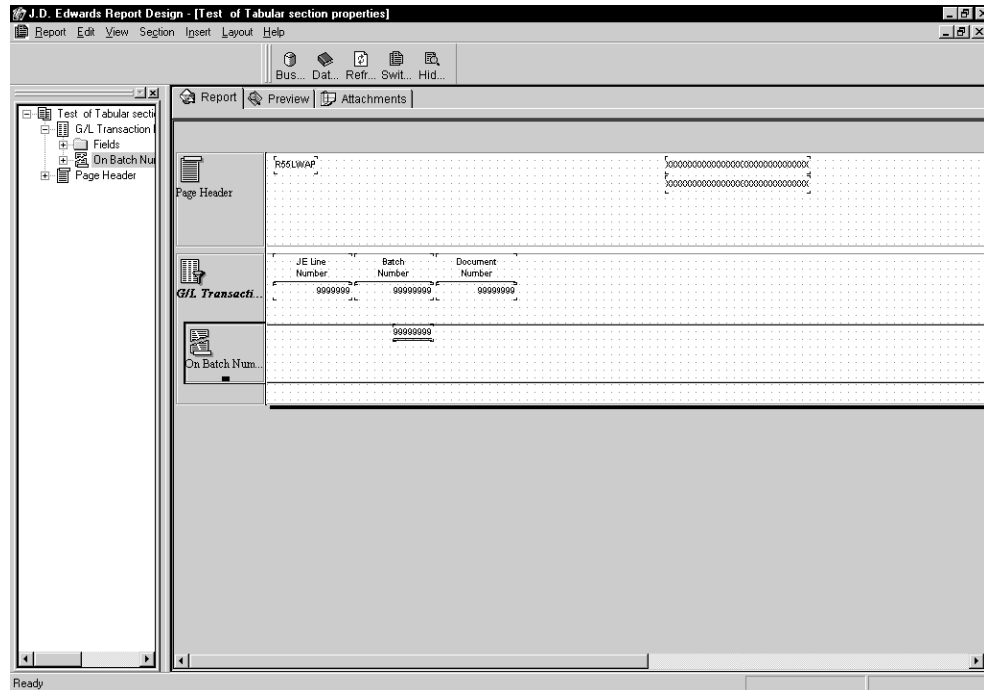

## See Also

- ❑ *To align fields or columns within or across report sections in the Enterprise Report Writing Guide for information about aligning the level-break field with columns in the detail section*

## ► To insert a description into a level-break footer

*On Report Design, click the level-break footer section.*

1. From the Insert menu, choose Constant Field.
2. Insert the constant field by clicking in the level-break footer where you want the object to appear.
3. Double-click the constant field.
4. On Constant Properties, change the Variable Name field to a meaningful description.

## See Also

- ❑ *Working with Objects in Report Sections in the Enterprise Report Writing Guide for more information about changing an object's associated text description*

## Example: Adding Level Breaks to a Detail Section

This example illustrates adding a level-break header and footer to an existing report.

### Note

For this example, you will modify the example report that was described in *Creating a Columnar Report*. See that task for information about creating the base report. The report below differs from that report in that a level-break header and footer is associated with the business unit field.

Even though an aggregate function is performed on one column (totaling the salaries), that field is not designated as a level break. Business unit is the level break for the footer because the report totals all of the salaries for each business unit.

Home Business Unit	Address Number	Alpha Name	P	Orig Start	Annual Salary
0	6002	Abbott, Dominique	S	4/10/99	38,000.00
	6044	Abrams, Brooke	S	4/15/98	60,000.00
	6001	Allen, Ray	S	8/15/90	75,000.00
	8014	Anderson, Jeanette	S	2/1/98	53,040.00
	6832	Ato, Connie	S	2/15/97	38,250.00
					<u>294,250.00</u>
6100	4803	Beck, Jeremy	H	3/22/00	45,000.80
					<u>45,000.80</u>
7071	7703	Bellas, Debbie	S	3/15/97	53,000.00
					<u>53,000.00</u>

### ► To add level breaks to a detail section

Launch the Report Design tool and open the R5607COL report.

1. To create the level-break header, from the Section menu, choose Create, and then choose Level Break Header.
2. On Level Break, choose Business Unit – Home, choose to display the data field in the header, and then click Finish.

Report Design displays the header section within the columnar section.

The sample report includes a description for Business Unit - Home as well as its number.

3. To include the description, click the variable part of the Business Unit - Home field and from the Edit menu, choose Associate Description.
4. Click in the header section to place the description field, and then move it next to the Business Unit - Home field.

The sample report does not repeat the Business Unit - Home column in the columnar section.

5. To hide the field, double-click Home Business Unit in the columnar section, click the Advanced tab on the resulting Properties form, and choose to make the field not visible.
6. Click OK.
7. To create the level-break footer, click the columnar section and from the Section menu, choose Create Level Break Footer.

The Level Break Footer form appears.

8. Because the columnar section is visible and the example lines up the salary totals with the salary columns, choose Group Section and click OK.
9. On Level Break, Choose Business Unit - Home and click Next.

The Aggregations form appears.

Define aggregations

Select operations and columns which you wish to aggregate

Operator	Operand
Total of	Rate - Salary, Annual

Item display style

Single overline     9999

Double underline     9999

Reprint section at page break

< Back   Finish   Cancel   Help

10. To sum the annual salaries for each business unit, set the Operator to Total of and set the Operand to Rate - Salary, Annual.

11. Choose a single overline and click Finish.

Report Design displays the footer section within the columnar section.

---

### Note

The order of the header and footer sections within the columnar section have no bearing on how they appear in the printed report.

---

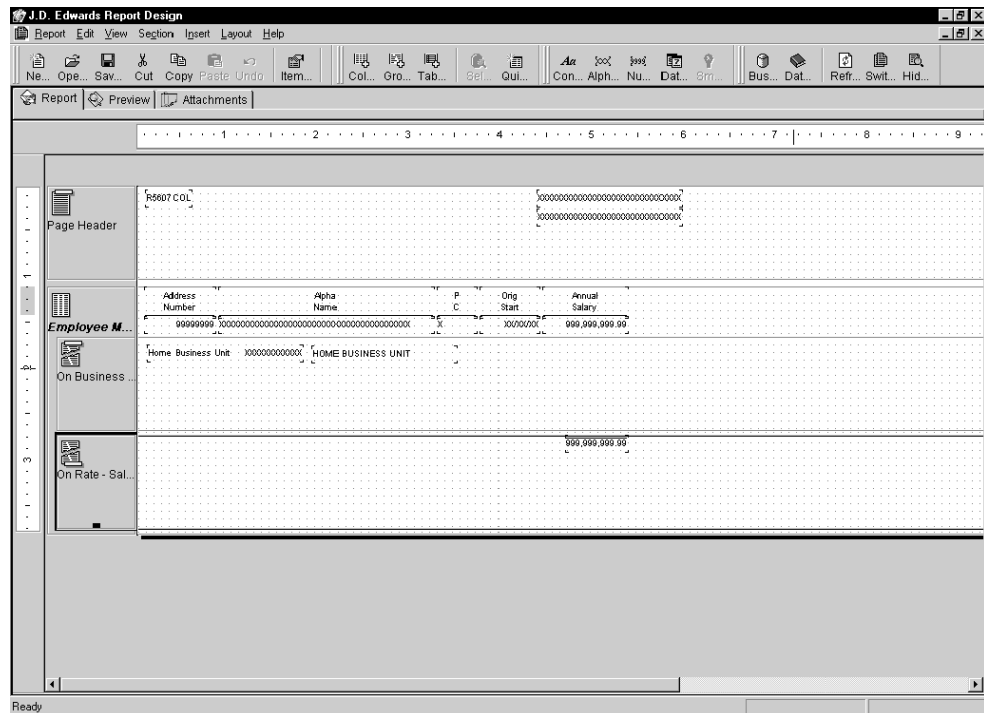

12. Click the Preview tab to see the report, which should look similar to the sample report illustration at the beginning of this section.

---

## Joining Subsections

---

Suppose you need to create a report, and none of the business views that are available have all of the data fields which are required for the report. Must you create your own business view to include all the required fields? Not necessarily. Rather, you can create two sections in your report with two different business views that share common fields. Then you can join these two sections by using a process called a *subsection join*. A link is established between the two sections by using the common fields that exist between the business views. The two sections are referred to as the *parent* (generally a master table) and *child* (generally a secondary table) sections. The parent section regulates the processing of the report. After each field in the parent section is processed, all of the corresponding records in the child section are processed.

For example, you can create a report to join A/P Voucher Details – PO Match (V0411V) information to G/L Transaction Detail Report (V0911G) information. Because the A/P Voucher and G/L Transaction business views both include the Document Type and Document Number fields, you can establish the subsection join based on these fields.

Using Report Design, you can do the following:

- Create a subsection join.
- Modify or sever a subsection join.

After creating a subsection join, some modification might be required. For example, you might need to change the fields on which the sections are joined. You can also choose to sever the join between the two sections.

- Join two existing detail sections.

If your report contains two detail sections that share common business view fields, you can create a subsection join between these two sections.

### **Before You Begin**

- This documentation assumes that the detail section to be used as the parent section has already been created. If this detail section has not been created, see *Creating Detail Sections* in the *Enterprise Report Writing Guide* for information about creating the parent section.

### **► To create a subsection join**

---

*On Report Design, click the columnar or group section to be used as the parent section.*

1. From the Section menu, choose Create, Sub-Section Join, and then one of the following options to create the child section:
  - Group
  - Columnar
2. On Business View Selection Option, choose the business view for the child section in the same way as you would for any detail section, and then click Next.

The business view that you choose for the child section must have at least one field that is also in the business view for the parent section.
3. On Favorite Business Views, choose the business view that you need, and then click Next. the Section Layout form appears.
4. On Section Layout, choose the business view columns to include in the child section, and then click Next.
5. On Sub Section Join, under the Parent heading, click the following field and choose the parent section to which you want to join the subsection:
  - Join to
6. Choose business view columns from the list boxes in the Child columns that are common with the business view columns in the Parent columns and variables.
7. Click the following option as necessary:
  - Join only at level breaks defined in the parent section

This option processes the records in the child section only after all of the records for defined level breaks in the parent section have first been processed. This action is critical when joining tables that have a many-to-many relationship-- for example, a detail file joined to a transaction file.

8. After you have completed entering columns in the child section to join with the parent section, click Finish.

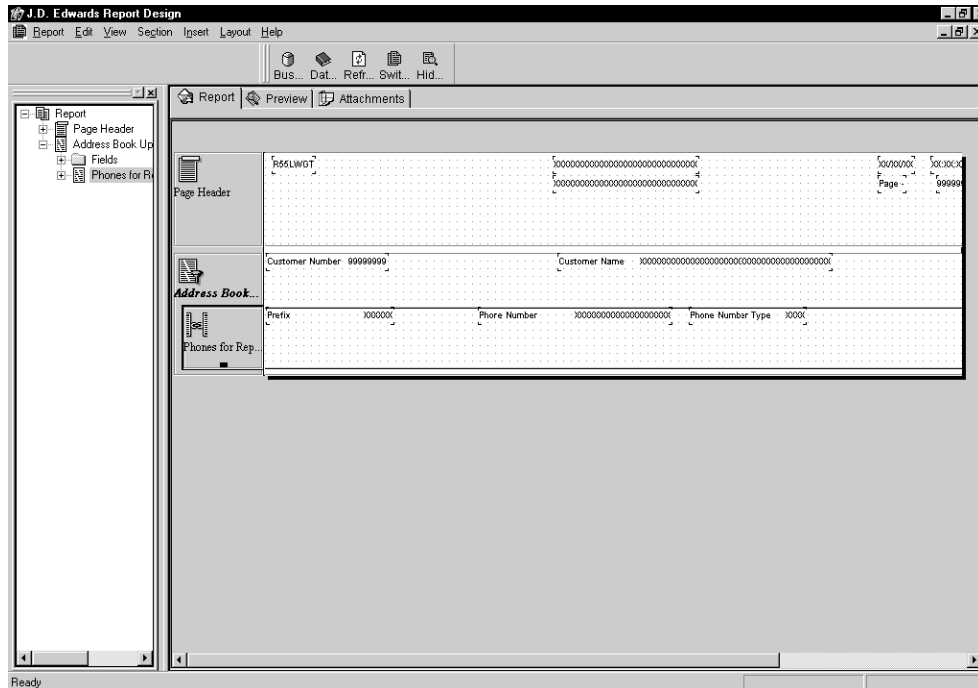

9. The child section has a chain-link icon, indicating that it is now joined to and resides within the borders of the parent section.
10. If necessary, define data sequencing for the child section by performing the following:
  - Click the child section.
  - From the Section menu, choose Define Data Sequence.
  - On Section Data Sequencing, choose any data fields that you want to use to sequence your report.
  - Click OK.
11. Modify the fields in the child section as necessary to enhance the report's appearance.

**See Also**

- *To select a business view in the Enterprise Report Writing Guide for more information about finding a business view*

## ► To modify or sever a subsection join

---

*Use one of the following navigations:*

*On Report Design, to make modifications to the subsection join, double-click the child section.*

*From the Section menu, choose Section Properties.*

The Columnar Section or Group Section form appears, depending on what section type you used to create the child section.

1. From the Sub Section Join tab, modify as necessary.
2. To sever a join, click the Sub Section Join tab, and click No Join.
3. Click OK.

The child section is now separated from the parent section.

## ► To join two existing detail sections

---

*On Report Design, click the detail section you want to join to another section in the report.*

This section will become the child section.

1. From the Section menu, choose Sub-Section Join.
2. On Define Sub-Section Join form, under the Parent heading, click the following field and choose the parent section to which you want to join:
  - Join To
3. Choose columns from the list boxes in the Child columns (data fields from the business view of the child section) that are common with the columns in the Parent columns and variables (data fields from the business view of the parent section).
4. Choose the following option as necessary:
  - Join only at level breaks defined in the parent section  
This option processes the records in the child section only after all records for defined level breaks in the parent section have first been processed. This action is critical when joining tables that have a many-to-many relationship-- for example, a detail file joined to a transaction file.
5. After you have completed entering columns in the child section to join with the parent section, click OK.
6. The child section has a chain-link icon, indicating that it is now joined to and resides within the borders of the parent section.

## Working with Objects in Report Sections

---

Report sections can contain numerous report objects. These objects are data fields. A specialized type of data field is a column. This section discusses the properties of various report objects, including:

- Business view columns
- Data fields
- Tabular sections

### See Also

- *Modifying the Appearance of Report Objects* in the *Enterprise Report Writing Guide* for information about changing a data field's size, font, color, and so on

## Working with Business View Columns

You can add business view columns to and remove them from any detail section that has a business view associated with it.

### ► **To add or remove a business view column in a detail section**

---

*On Report Design, click the detail section.*

1. From the View menu, choose Business View Columns Browser.  
The form that appears lists the columns in the business view that are associated with the section.
2. Drag one or more columns to your detail section.
3. To close the Business View Columns Browser, from the View menu, click Business View Columns Browser  
Alternatively, you can click the Close (X) button on the title bar of the form.
4. To move the column, drag it to the new location.
5. To remove a column, choose it (either the header or the body) and from the Edit menu, choose Delete.

## Understanding Data Fields

Residing in report sections, data fields are individual data containers. Page numbers, dates, and the name of the report are all examples of data fields. You can add data fields to any type of report section, although not every data field type can be added to every report section type. You might have already added some data fields such as report name, date, and so forth to the report when you created it.

After creating the report, you can do the following:

- Add data fields.
- Delete data fields.

- Change a data field's variable name.
- Change a column header's text.
- Disconnect a constant's text from its variable in a group section.

At times you might want to separate the text from the variable that it describes. For example, your report might contain a data field called Business Unit and another field called Description. Changing the constants of the two data fields to read Business Unit Number and Name might render the report easier to understand. By disconnecting the text from the variable, you can still retrieve the value for Business Unit from your J.D. Edwards software table; however, you can present the data to the reader with a more meaningful description.

- Perform in-section totaling.

Most of the time, when you perform a calculation on a column, you want to format and display the total so that the report is easy to read. In these cases, you typically perform the totaling in a level-break footer. Occasionally, you might not be concerned with how the calculation is displayed. For example, you might perform a calculation in one hidden section for use in another. When formatting is not an issue, you can perform calculations easily within a section. You can calculate a total, a grand total, or both.

- Change decimal scaling.

Decimal scaling allows you to simplify the way in which a report displays large numbers. You can change decimal scaling for a single field in a tabular section, for all fields in a tabular section, or for all fields in all detail sections.

The following table describes the data fields that you can insert directly:

<b>Constant Field</b>	A static item that is used to display a string of text, such as a company name inserted in the page header. Constant fields can be inserted into any report section.
<b>Alpha Variable</b>	A field that is used to hold alphanumeric information which is defined by an event rule. Alpha variables can be inserted into any report section.
<b>Numeric Variable</b>	A field that is used to hold numbers, typically with calculation columns. Numeric variables can be inserted into any report section.
<b>Date Variable</b>	A field that is used to hold dates. Date variables can be inserted into any report section.
<b>Report Date</b>	A run-time field that is used for the date when the report is run. Report dates can be inserted into any report section except columnar and tabular.
<b>Report Time</b>	A run-time field that is used for the time the report is run. Report times can be inserted into any report section except columnar and tabular.
<b>Page Number</b>	A run-time field that is used for the current report page number. Page numbers can be inserted into any report section except columnar and tabular.
<b>Page n of Total</b>	A run-time field that is used for the current report page number with the total number of pages in the report appended (such as "Page 4 of 10"). Page n of total can be inserted into page headers and footers only.

<b>Company Title</b>	A run-time field that is used for the name of the default company (company 00000). Company titles can be inserted into any report section except columnar and tabular.
<b>Report Title</b>	A run-time field that is used for the title of the report. A report title can be inserted into any report section except columnar and tabular.
<b>Data Dictionary Field</b>	A field from the data dictionary. Data dictionary fields can be inserted into any report section.
<b>Text Variable</b>	A field that is used to hold text. Text variables can be inserted into any report section.

Data fields inserted into columnar and tabular sections appear in columnar format. The heading is a constant and the body is a variable. The heading and body are linked so that if you move or delete one, Report Design moves or deletes the other.

In group sections, data fields are also made of a constant and a variable portion, although initially they appear side by side instead of in a columnar format. Unlike columnar and tabular sections, however, the two components can be moved independently of each other. Furthermore, by disconnecting the two, you can separate the constant from the variable and delete it without deleting the variable.

You can modify the appearance of a data field by changing its heading, moving it, changing its size, font, or color, or associating lines or a box with it. You can modify the behavior of a data field by associating an event rule with it.

### See Also

See the following topics in the *Enterprise Report Writing Guide*:

- ❑ *Modifying the Appearance of Report Objects* for information about changing a data field's size, font, color, and so on
- ❑ *Working with Event Rules* for information about creating event rules and associating them with a data field

### ► To add or remove a data field in a report section

---

*On Report Design, click the report section that you want to modify.*

1. From the Insert menu, choose the field you want to add.

Your data field choices vary, based on the report section that you selected.

In columnar and tabular sections, the data field is automatically inserted to the *right* of any column on which you are focused. If you did not focus on a specific column, the field is inserted to the *left* of the first column.

In group sections, you must click in the group section to place the data field after selecting it from the Insert menu.

2. To move the field or column, drag it to the new location.
3. To remove a data field, click it and choose Delete from the Edit menu.

► **To change a data field's variable name**

---

*On Report Design, double-click the data field that you want to change.*

An appropriate Properties form appears.

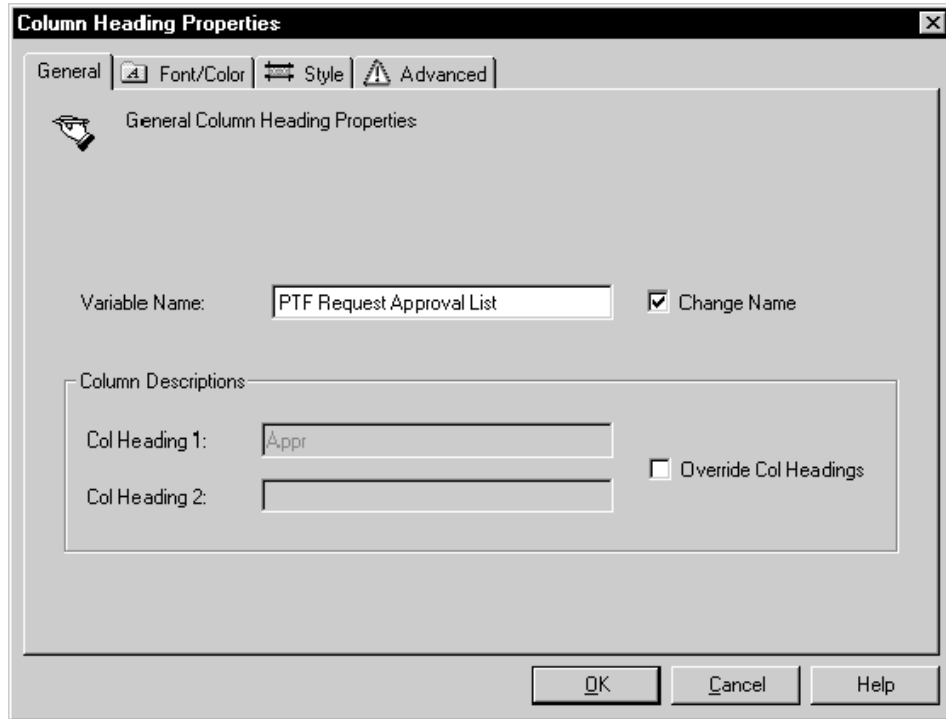

1. If the data field is based on a business view column, you must override the business view column name by clicking the one of the following options:

- Change Name
- Override Name

The Variable Name field is disabled until you click the Change Name or Override Name option.

2. Change the text in the Variable Name field and click OK.

---

**Note**

A change in the variable name of a constant field in any section, except columnar and tabular sections, is reflected on the report itself. All other variable name changes do not affect the data field's appearance directly. If you change a component's variable name, you should change its partner's variable name as well to make managing the data field easier (especially if you will be attaching event rules to the data field).

---

► **To change a column header's text**

---

*On Report Design, double-click the column header that you want to change.*

The Column Heading Properties form appears.

The screenshot shows a dialog box titled "Column Heading Properties" with a close button (X) in the top right corner. It features four tabs: "General", "Font/Color", "Style", and "Advanced". The "General" tab is selected, and the title of the active tab is "General Column Heading Properties". Below the tabs, there is a "Variable Name" field containing the text "Batch Type" and an unchecked "Change Name" checkbox. A section titled "Column Descriptions" contains two text input fields: "Col Heading 1" with the text "Bth" and "Col Heading 2" with the text "Ty". To the right of these fields is a checked "Override Col Headings" checkbox. At the bottom of the dialog are three buttons: "OK", "Cancel", and "Help".

1. If the column is based on a business view column, you must override the business view column names by clicking the following option:

- Override Col Headings.

The Column Description fields are disabled until you click Override Col Headings again.

2. Change the text in the Col Heading 1 and Col Heading 2 fields and click OK.

Columns can have two-line headings. Col Heading 1 corresponds to the top line of the column heading, and Col Heading 2 to the bottom.

---

**Note**

You should always change a data field's variable name to match its column name if you change its column name; this action makes managing the data field easier (especially if you will be attaching event rules to the data field).

---

---

► **To disconnect constant text from its variable in a group section**

---

**Caution**

After you disconnect the constant text from its variable, the two cannot be reconnected on the report. If necessary, you can delete the disconnected text and variable and then place the business view column on the report again. The new data field appears as it did originally with a constant field linked to its variable.

---

*Click the constant or its associated variable.*

1. From the Edit menu, choose Disconnect.
2. You can now move, format, or delete the text and the variable independently.

---

► **To perform in-section totaling**

---

*On Report Design, choose Report Properties from the File menu.*

1. On Properties, click the Report Properties tab.
2. Choose one or both of the following options, and then click OK:
  - Print Totals Only
  - Print Grand Totals
3. Double-click the variable portion of a numeric column for which you want to calculate a total.

---

**Note**

The variable portion of a numeric column is signified by a formatted series of "9"s; for example "99,999.99-".

---

4. On Column Variable Properties, click the Totaling tab.
5. Choose one or both of the following options:
  - Total
  - Grand Total

These two options correspond to the two options you selected in step two. You must choose Print Totals Only on the Properties form for the Total function to work correctly. Likewise, you must choose Print Grand Totals on the Properties form for the Grand Total function to work correctly.

6. Choose an aggregate function, and then click OK.

Depending on the options you selected, the system adds one or two lines to the bottom of each column before each section break. If you selected both Total and Grand Total, the Total line appears before the Grand Total line. The lines are not labeled; in fact, except for the column showing the total, information for each column is repeated in the total line.

You can suppress totals for fields you are not totaling and that you do not want to display on this line.

## Changing Decimal Scaling

Decimal scaling allows you to simplify how a report displays large numbers. For example, if your report is scaled to 1000, the report would show the following amounts:

Original Value	Displayed Value
100,000.42	100
10,041.62	10
1,021.75	1
1,512.69	1.5

### ► To change decimal scaling for a field in a tabular section

---

*On Report Design select the tabular section containing the column you wish to change,*

1. Double-click the variable portion of the numeric column that you want to change.
2. On Column Variable Properties, click the Decimal Scaling tab and select the level of decimal scaling that you want.

To return all of the section's fields to their default decimal scaling settings, click Defaults.

3. When finished, click OK.

### ► To change the decimal scaling for all fields in a tabular section

---

*On Report Design, double-click the tabular section that you want to change, or click the section and choose Section Properties from the Section menu.*

1. On the Section form, click the Decimal Scaling tab and select the level of decimal scaling that you want.

To return all of the the section's fields to their default decimal scaling settings, click Defaults.

Changes that you make on this form affect all of the numbers in the section, except for those fields that have been changed individually. To override individual settings and apply the changes to all fields in the section without exception, choose *Apply settings to all Objects*.

2. When finished, click OK.

### ► To change decimal scaling for all fields in all detail sections of a report

---

*On Report Design, from the File menu, choose Report Properties.*

1. On Properties, click the Decimal Scaling tab and select the level of decimal scaling that you want.

To return all of the report's fields to their default decimal scaling settings, click Defaults.

Changes that you make on this form affect all numbers in the report, except for those fields that have been changed individually. To override individual settings and apply the changes to all of the fields in the report without exception, choose *Apply settings to all Objects*.

2. When finished, click OK.

---

**Note**

Changes to properties at the report level are not reflected in the report's existing batch versions.

---

## Working with Tabular Sections

Tabular sections are a specialized type of columnar section that presents report data in columns, rows, and cells. When you include data fields that display numeric values, tabular sections automatically total the values in the fields. For example, if you include an object that displays Open Amounts, tabular sections calculate a grand total of all the Open Amounts in the section.

When you create a tabular section, observe the following guidelines for columns, rows, and cells:

<b>Defining columns only</b>	Define columns when you base the information for your report solely on the data that is contained in tables. When you define columns only, Report Design creates rows that are based on selection, sequence, and level break criteria that you provide.
<b>Defining columns and rows</b>	Row information is set up horizontally on your report. Define rows in addition to columns when you include details in your report, such as underlines, spaces, and blank lines, as well as special calculations, such as interim totals. Tabular sections are the only detail section for which you can define rows.
<b>Defining columns, rows, and cells</b>	A cell is the intersection of a column and row. Define cells if you want to override information that is defined by columns and rows in individual cells.

## Working with Columns in Tabular Sections

Although columnar and tabular sections both contain columnar data, tabular sections differ from columnar sections because they offer a variety of special-purpose columns as well. These columns include smart field columns, calculation columns, description columns, and percent calculation columns.

### Creating Smart Field Columns

Smart fields are data dictionary items (glossary group K) designed to retrieve and manipulate specific J.D. Edwards software table data. For example, by adding the smart field FINRPTAB - Account Balance to your report, you create a column that calculates the account balance as of the specified financial period and fiscal year.

Smart fields call business functions or named event rules. Business functions are programs that use data structures to do the following:

- Request specific data from J.D. Edwards software tables.
- Return the data to the established parameters in the data structure.
- Perform some type of calculation or other manipulation on the data.
- Send the desired information, such as column headings and complex calculations, to your report.

A named event rule is a business function that is created by using the event rules scripting language. This scripting language is platform independent and stored in a database as a J.D. Edwards software object.

Because the smart fields have already been created for you, you can include complex logic in your report without having to do any programming.

When you choose to create a smart field from the Column menu, the smart field director leads you through a series of forms to help you set up the smart field parameters and values. The option to create smart field columns is grayed out if no smart fields are associated with the attached business view.

#### ► To create or delete smart field columns

---

*On Report Design, click the section that you want to change.*

---

#### Note

When you create a smart field, you define what type of section it is used in. If you have not created a smart field for the type of section you are editing, the Smart Field option is not available in the Create menu. Because there are several predefined smart fields for application reports, smart fields are always available to the main section of an application report. For information on defining smart fields, see *Adding Smart Fields* in the *Enterprise Report Writing Guide*.

---

1. From the Column menu, choose Create and then Smart Field.  
The Create New Smart Field form appears with a list of smart fields included in the template associated with the section.
2. Choose the smart field that you want to work with, and then click Next.
3. Repeat steps 1-4 for each smart field column that you want to create.
4. To move the column, drag it to the new location.
5. To delete the column, click it and select Delete from the Edit menu.

### See Also

- *To add smart fields to an application report* in the *Enterprise Report Writing Guide* for information about working with the smart field forms that appear

### Defining Calculation Columns

Calculation columns contain values that are the result of a mathematical calculation. You can perform a calculation involving any number of columns or no columns. The columns that the calculations are performed on can include any columns in the business view, including columns that contain smart fields or other calculations.

---

### Caution

Calculation columns are based on the amount signs as they appear in the report, not the actual value (debit or credit).

---

The following instructions discuss:

- Defining calculation columns
- Removing a column calculation

### ► To define calculation columns

---

*On Report Design, select the tabular section in which you need to add a calculation column.*

1. Insert a field (usually a data dictionary or numeric variable field) to hold the calculated value.

---

### Note

For information on adding a variable field, see *To add or remove a data field in a report section* in the *Enterprise Report Writing Guide*.

---

2. To move the column, drag it to the new location.
3. Click the newly created column.
4. From the Column menu, choose Define Calculation.

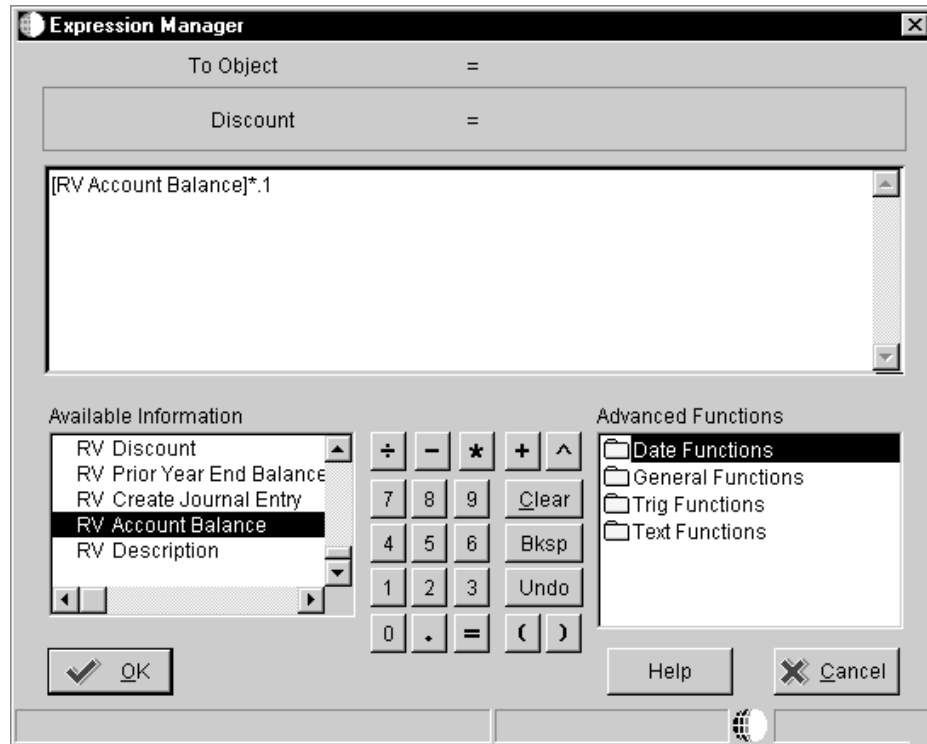

5. On Expression Manager, define your calculation by performing the following actions, and then click OK:
  - a. Double-click fields from the Available Information list.
  - b. Click the calculator functions to build your expression.
  - c. Repeat until your calculation expression is complete.

► **To remove a column calculation**

*On Report Design, click the Column variable that has a calculation attached.*

1. From the Column menu, choose Remove Calculation.

The Remove Calculation form appears, asking if you want to delete the calculation for this column.

2. Click Yes.

**See Also**

- *To create an event rule assignment in the Enterprise Report Writing Guide for information about attaching a calculation to a column*

## Understanding the Description Column

When you create a report using a tabular section, the Description column is automatically included. When the report prints, the data in this column is based on fields that are designated as level-break fields. If the system cannot retrieve a description for the field (the field must have a data dictionary trigger), the key for the field is printed instead. For example, if the level-break field is company 00001, the description Financial Reporting Company prints if a trigger exists. Otherwise, the key 00001 prints.

Except as noted below, at the lowest level break of a tabular section, this column becomes the row description. At higher level breaks, the Description column becomes level-break header or footer text.

The Description column has a special capability for level breaks that are associated with the Subledger, Cost Object, and Object Subsidiary fields. When a row of a tabular section prints due to a level break caused by a change in one of the following fields, the Description row automatically appears:

- Subledger and Subledger Type
- Cost Object and Cost Object Type
- Object Subsidiary and Object Subsidiary Type

### ► To create a Description column manually

---

*On Report Design, click the tabular section to which you need to add the Description column.*

From the Column menu, choose Create, and then choose Row Description Column.

The Description column appears. To move it, drag it to a new location.

### ► To delete the Description column

---

*On Report Design, select the Description column.*

From the Edit menu, select Delete.

## Defining a Percent Calculation

Sometime, you might need to present numbers in one column as a percent of their total in another column. This type of calculation is used in all reporting types but most often in standard income statements. When used in income statements, the percent calculation is referred to as the percent of revenue.

The following graphic illustrates how the rows and the Percent of Revenue column might appear on a report:

J.D. Edwards Report Design - [test of percent calc.]

Report Edit View Section Column Row Cell Layout Help

Report Preview Attachments Column Row

R55LW0605 J.D. Edwards & Company 6/5/99 11:24:45

Percent of Revenue Report

Description	Account Balance	Percent of Revenue
Revenue		
Class 1	955,000.00	78.86
Class 2	256,000.00	21.14
Total Revenue	1,211,000.00	100.00

Page 1 of 1 260% 11 x 8.5 in

Ready

## Before You Begin

- ❑ Do one of the following:
  - Create a percent calculation column in the Director. For example, if you are creating a financial report that is based on Account Balances, create a column called Percent of Revenue. See *Working with Columns in Tabular Sections* in the *Enterprise Report Writing Guide* for information about creating the column.
  - Create a numeric variable column from Report Design. See *Understanding Data Fields* in the *Enterprise Report Writing Guide* for additional information on creating a numeric variable column
- ❑ Add rows to your report. This step is necessary to create the 100% cell to use in the denominator. For example, add data rows to hold the revenue sales and a calculation row to hold the total revenue.

## ► To define a percent calculation

*From Report Design, after adding the appropriate rows to your tabular section, click the column that you created for the percent calculation.*

In this example, it would be the Percent of Revenue column.

1. From the Column menu, choose Define Calculation.
2. On Expression Manager, define the percent calculation.

For example, to get the Account Balance percent of each revenue class, divide the report variable (RV) Account Balance by the tabular cell [tabular cell (TC) Total Revenue: Account Balance \* 100].

The following illustration shows this calculation:

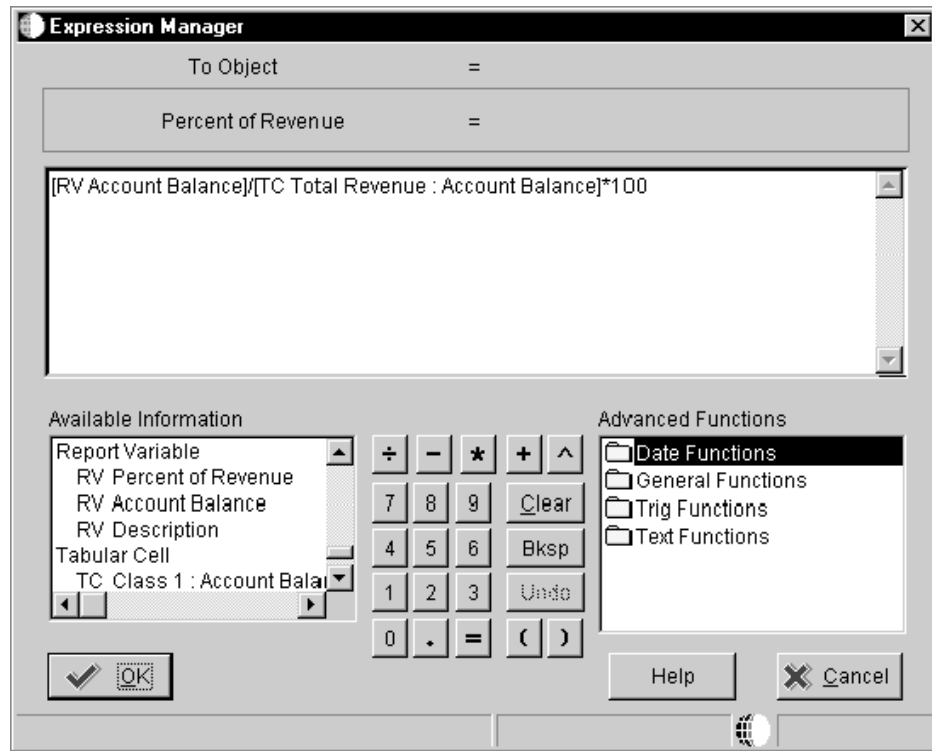

3. Click OK.

## Working with Rows in Tabular Sections

In a tabular section, a row consists of information that is set up horizontally. Typically, rows contain data that is read from individual database records; however, you can add rows to include details in your report such as underlines, blank lines, and special calculations. Tabular sections are the only detail sections for which you can define rows. In all cases, after creating a row, you can move it by dragging it to the desired location, or you can delete it by clicking it and selecting Delete from the Edit menu.

By using report design, you can add the following types of rows:

- **Data rows**  
Data rows contain data from J.D. Edwards software tables. They represent groups of data fields that are associated with the columnar amounts. For example, you could have a data row that tells you the Revenue (Column) for a certain range of items. In addition, you might add a row that tells you the direct costs for another range of fields. You must define the rows and identify the data from the business view that goes into them.
- **Calculation rows**  
Calculation rows contain amounts calculated from other rows. For example, you could calculate the gross margin of the Revenue and Direct Costs rows.

- **Sum rows**  
A sum row defines a special type of calculation. The calculation performs totaling for all numeric columns in a range of rows. The total can optionally include or exclude rows within the sum range that are themselves row calculations.
- **Underline rows**  
Underline rows let you create an underline to separate various rows in your report.
- **Constant rows**  
Constant rows contain text only. They are used to describe or label information on your report, such as identification information for a group of rows.
- **Automatically generated rows**  
In a tabular section, J.D. Edwards software can automatically generate rows that define a Chart of Accounts for a business unit or represent the merging of accounts from several business units. Additionally, you have the option to create rows that calculate account rollup totals at various levels of detail. For example, you might want J.D. Edwards software to automatically generate rows to create a balance sheet report that is based on a company's current month and its prior year account balance.

► **To add a data row**

---

*On Report Design, click a tabular section.*

1. From the Row menu, choose Create, and then choose Data.
2. On Data Row Properties, click the General tab and complete the following fields:
  - **Name**  
The Name appears in the Name field on the Tabular Section - Row List tab and on the Sum Row Properties form.
  - **Description**  
The Description appears on the report in the Description field on the Tabular Section - Row List tab, and in the Description field on the Sum Row Properties form. This description can be multiple lines to allow for as much description as needed. You must enter spaces in front of text to allow for indentation on the report.
3. Set other properties as desired on other tabs and click OK.
4. On Data Selection, define the specific criteria that you want applied to the data row, and then click OK.  
  
At any time in the future, you can modify the data selection by clicking this row and choosing Define Data Selection from the Row menu.
5. Add data rows as needed.  
  
To add rows directly beneath the last row you worked on, ensure that the last row is selected on your report section (indicated by a black box around the row).

## See Also

- ❑ *To select records to include in the section in the Enterprise Report Writing Guide for additional information about selecting data*

## ► To add a calculation row

---

*On Report Design, click a tabular section.*

1. From the Row menu, choose Create, and then choose Calculation.
2. On Calculation Row Properties, click the General tab and complete the following fields:
  - Name
  - Description
3. Set other properties as desired on other tabs and click OK.

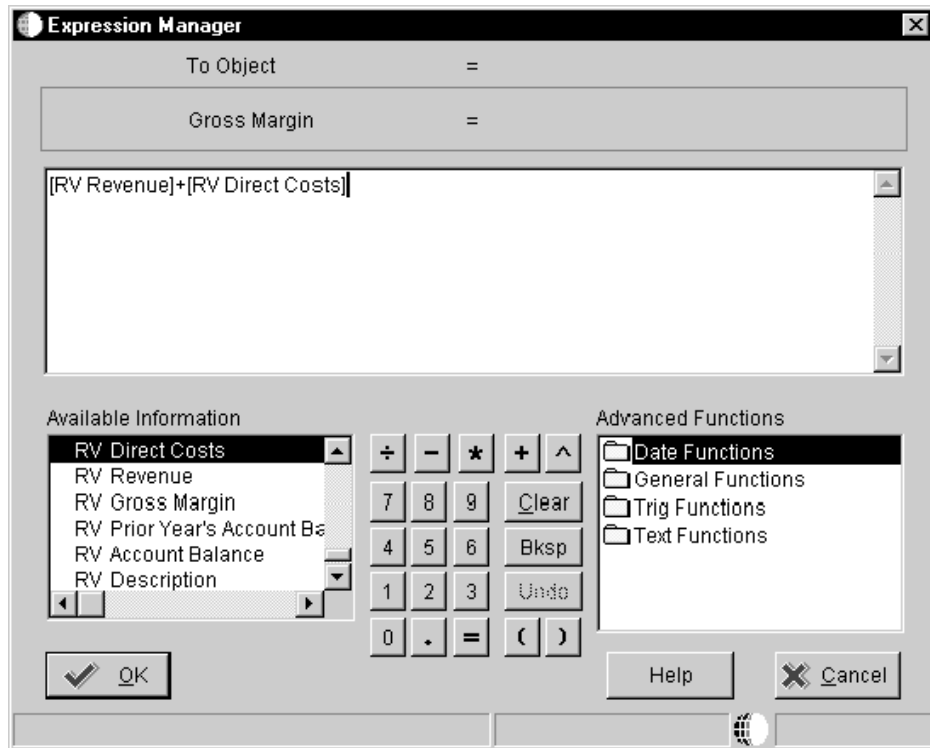

4. On Expression Manager, define your calculation, and then click OK.
5. Add calculation rows as needed.

To add rows directly beneath the last row you worked on, ensure that the last row is selected on your report section (indicated by a black box around the row).

## See Also

- ❑ *To create an event rule assignment in the Enterprise Report Writing Guide for information about attaching an expression to a calculation row*

► **To add a sum row**

*On Report Design, click your tabular section.*

1. From the Row menu, choose Create, and then choose Sum Row.

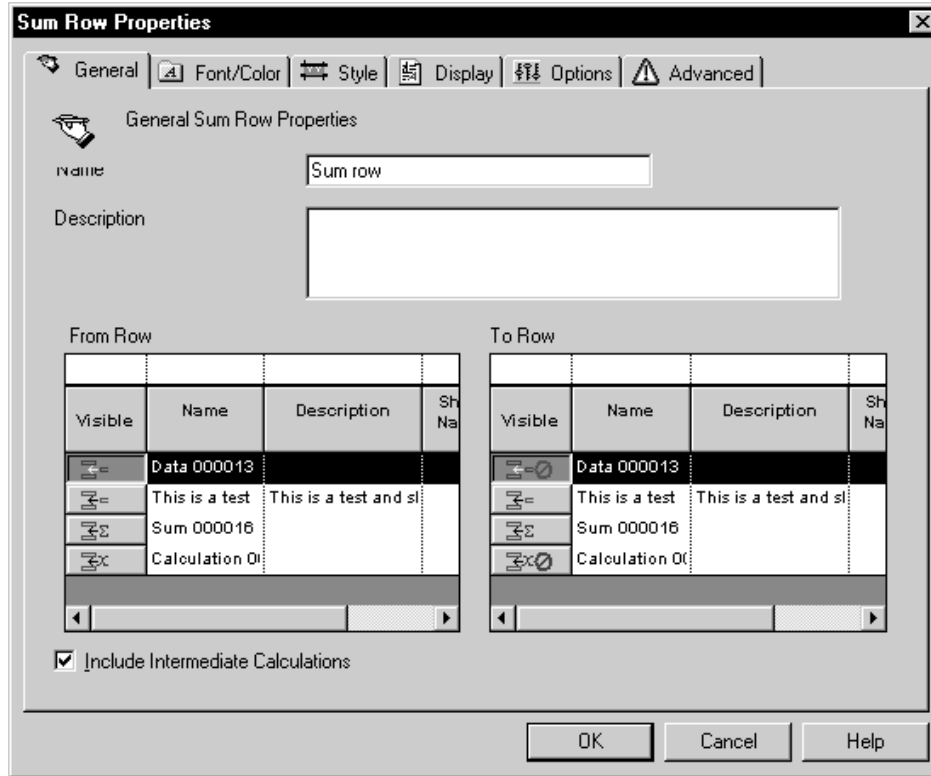

2. On Sum Row Properties, click the General tab and complete the following fields:

- Name
- Description

The Description appears on the report. This description can be multiple lines to allow for as much description as needed. You must enter spaces in front of text to allow for indentation on the report.

- From Row

From Row lists rows that can be used as the beginning row in a range of rows.

- To Row

To Row lists rows that can be used as the ending row in a range of rows.

- Include Intermediate Calculation

Choose whether interim calculation rows should be included in the sum.

3. Set other properties as desired on other tabs and click OK.

4. Add sum rows as needed.

To add rows directly beneath the last row you worked on, ensure that the last row is selected on your report section (indicated by a black box around the row).

► **To add an underline row**

---

*On Report Design, click your tabular section.*

1. From the Row menu, choose Create, and then choose Underline.
2. On Underline Row Properties, click the General tab and complete the following field:
  - Name
3. Set other properties as desired on other tabs (for example, click the Font/Color tab to modify the line's color; click the Options tab to modify the line's thickness and spacing).

4. Add underline rows as needed.

To add rows directly beneath the last row you worked on, ensure that the last row is selected on your report section (indicated by a black box around the row).

5. Click OK.

► **To add a constant row**

---

*On Report Design, click your tabular section.*

1. From the Row menu, choose Create, and then choose Constant.
2. On Constant Row Properties, click the General tab and complete the following fields:
  - Name
  - Description
3. Set other properties as desired on other tabs and click OK.

4. Add constant rows as needed.

To add rows directly beneath the last row you worked on, ensure that the row is selected on your report section (indicated by a black box around the row).

► **To generate rows automatically**

---

*On Report Design, click a tabular section.*

---

**Note**

This example illustrates a financial report with two smart field columns based on the FINRPTAB - Account Balance and FINRPTPC - Prior Year's Account Balance.

---

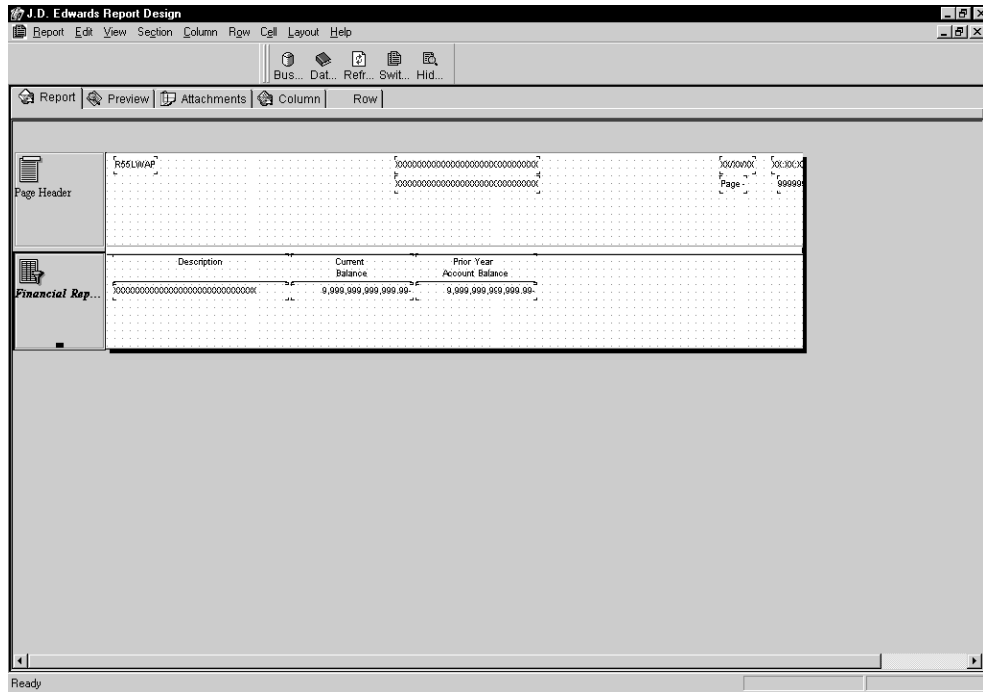

1. From the Row menu, choose Automatic Row Generation.

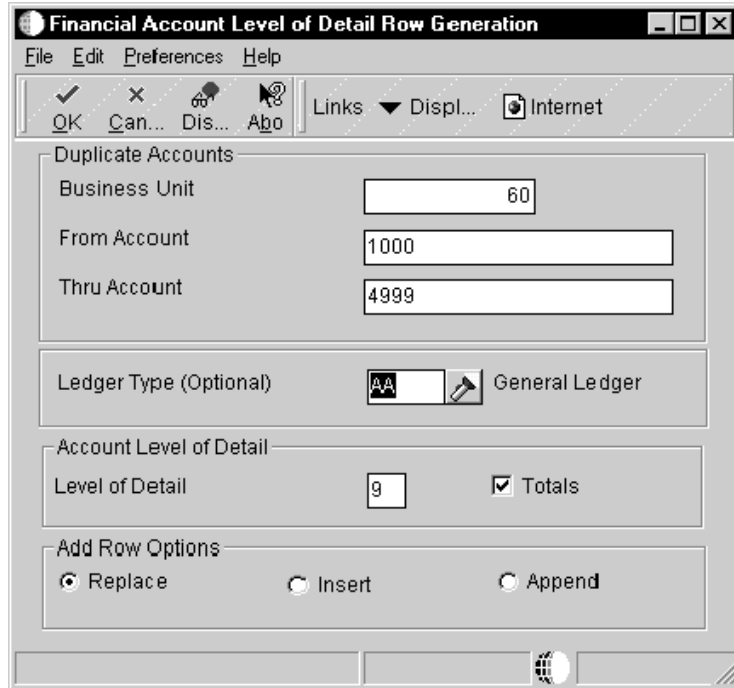

2. On Financial Account Level of Detail Row Generation, complete the following fields, and then click OK. Depending on how the section is designed, some fields might not appear on the form.
  - Business Unit

You can enter a business unit and an account range. Based on the Chart of Accounts that is defined for the business unit, the program generates all of the row specifications within that account range.
  - From Account

If you leave the From Account field blank, no accounts are generated.
  - Thru Account

If you leave the Thru Account field blank, no accounts are generated.
  - Ledger Type (Optional)

If specified, the ledger type is included in the data selection for that row.
  - Level of Detail

Optional account level of detail rows can be generated at level of detail breaks. The default is to generate total rows. The row amounts are based on account ranges that are specified through selection criteria.
  - Totals
3. Choose one of the following options under the Add Row Options heading:
  - Replace
  - Insert
  - Append

The range of rows that are generated are either appended to the bottom of existing rows or inserted after a selected row, or all previously defined rows are replaced. The default is to replace any existing rows. However, the append and insert options are useful for building hybrid account structures from several different business units.

## Overriding the Properties of Individual Cells

A cell contains information that is located at the intersection of a column and row. You can define cell overrides to override the information in the cell that is the result of the column and row specifications for the cell. For example, if you want to emphasize the data in a specific cell, you can override its properties, increase the size of the font, and make the font bold.

In Report Design, cells with cell overrides enabled are surrounded by a box with dashed lines. You can override variable cells in the following types of rows:

- Data rows
- Calculation rows
- Constant rows
- Underline rows

### ► To override a data row variable

---

*On Report Design, click a tabular section.*

1. From the Cell menu, choose Cell Mode.  
When Cell Mode is turned on, clicking on a variable encloses the cell in a solid black box. If Cell Mode is not turned on, clicking on a variable encloses the entire row in a solid black box.
2. Click the cell that contains the data row variable that you want to override.
3. From the Cell menu, choose Create Override, and then choose Data.
4. On Cell Properties, click the General tab and complete the following fields:
  - Name
  - Description
5. Set other properties as desired on other tabs, and then click OK.
6. On Data Selection, define the criteria that you want applied to the cell override.
7. Click OK to update the row in the tabular section.  
A dashed border around the cell indicates an override.

### See Also

- *Defining Section Data Selection in the Enterprise Report Writing Guide*

### ► To override a calculation row variable

---

*On Report Design, click a tabular section.*

1. From the Cell menu, choose Cell Mode.
2. Click the cell that contains the calculation row variable that you want to override.
3. From the Cell menu, choose Create Override, and then choose Calculation.
4. On Cell Properties, click the General tab and complete the following fields:
  - Name
  - Description
5. Set other properties as desired on other tabs, and then click OK.

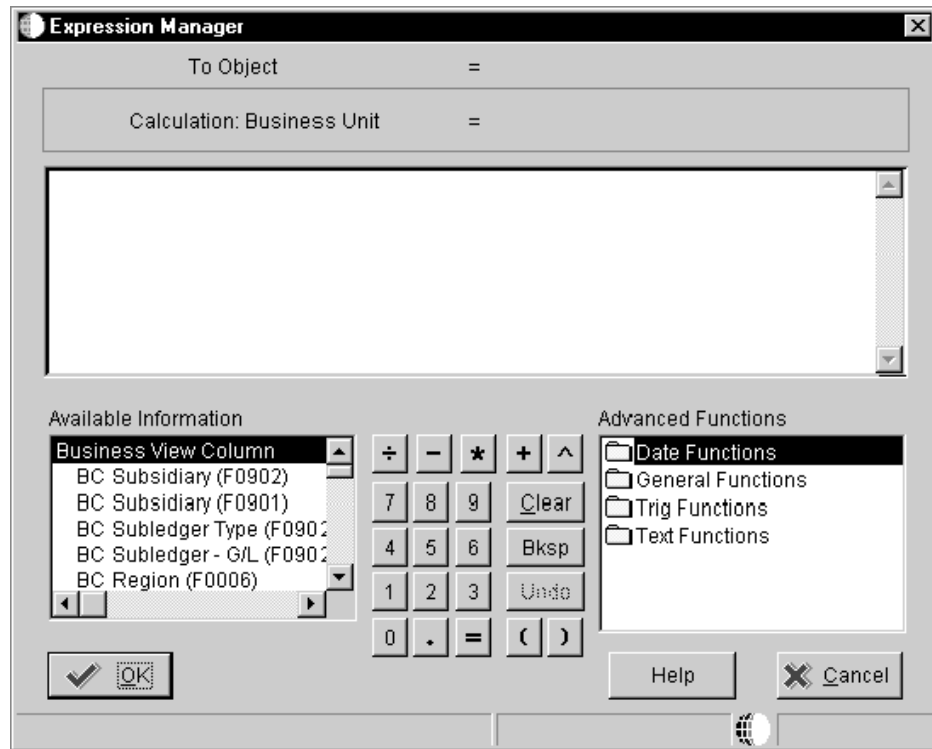

6. On Expression Manager, define your calculation by performing the following actions, and then click OK:
  - Double-click fields from the Available Information list.
  - Click the calculator functions to build your expression.
  - Repeat until your calculation expression is complete.

► **To override a constant row variable**

---

*On Report Design, click a tabular section.*

1. From the Cell menu, choose Cell Mode.
2. Click the cell that contains the constant row variable that you want to override.
3. From the Cell menu, choose Create Override, and then choose Constant.
4. On Cell Properties, click the General tab and complete the following fields:
  - Name
  - Description
5. Set other properties as desired on other tabs, and then click OK.

► **To override an underline row variable**

---

*On Report Design, click a tabular section.*

1. From the Cell menu, choose Cell Mode.
2. Click the cell that contains the underline row variable that you want to override.
3. From the Cell menu, choose Create Override, and then choose Underline.
4. On Cell Properties, click the General tab and complete the following fields:
  - Name
  - Description
5. Set other properties as desired on other tabs, and click OK.

## **Modifying the Appearance of Report Objects**

---

Every object in a report, such as a section, column heading, column variable, run-time field, or constant has its own properties. To modify how an object looks or behaves, you change those properties. For example, you can change the font size of a column heading or change the text to reflect company jargon. You can also modify the format of your report by changing column and row spacing and object alignment.

### **Changing Detail Section Descriptions**

You can change the name of a detail section as it appears on the Section Tile of Report Design.

► **To change a detail section's description**

---

*In the J.D. Edwards Windows environment, choose Report Design Tool from the Report Writer menu (GH9111).*

1. On Report Design, access your report in which you want to make a change.
2. Double-click the detail section that you want to change.
3. On Columnar Section, on the General tab, enter a new name in the Description field and then click OK.

### **Hiding Report Sections**

You can hide or display an entire report section outright, or you can set a detail section to appear or not based on certain criteria. To toggle displaying hidden report sections in Report Design (but not in the printed report), choose Hide/Show Invisible Sections from the View menu.

**See Also**

- *Working with Event Rules* in the *Enterprise Report Writing Guide* for more information on creating event rules

► **To hide or display a report section unconditionally**

---

*In the J.D. Edwards Windows environment, choose Report Design Tool from the Report Writer menu (GH9111).*

1. On Report Design, access the report in which you want to hide or display a section.
2. Double-click the report section you want to change.  
A Section form appears. The form and its name vary slightly, according to the type of section selected.
3. Click the Advanced tab.
4. Select the Visible option to display the report section or deselect the Visible option to hide the report section.
5. Click OK.

► **To display a detail section conditionally**

---

*In the J.D. Edwards Windows environment, choose Report Design Tool from the Report Writer menu (GH9111).*

1. On Report Design, access the report in which you want to display a detail section.
2. Click the section from which you want to launch the conditional section and choose Event Rules from the Edit menu.
3. Click the down arrow to open the pulldown menu in the toolbar and select the Do Section event rule.
4. From the Insert menu, select If/While and define the criteria for displaying the conditional section.
5. Position your cursor below the If/While statement and then select System Function from the Insert menu.
6. Under the Function Selection tab, from the Section folder, select Do Custom Section. The Parameter Mapping tab displays.
7. Double click the report section to display conditionally.  
The section displays in the Values column of the Parameters table.
8. Save the event rule.
9. On Report Design, double-click the report section you want to be the conditional section.  
Depending on the section type, an appropriate Section form appears.
10. Click the Advanced tab.
11. Select the Conditional option and click OK.

## Aligning Fields or Columns within or across Report Sections

When you create report sections, data fields or columns might not line up properly. Report Design (P00890) provides alignment options to let you precisely adjust the appearance of your report output.

When you align data fields, use the following guidelines:

- Clear your focus in all sections before you select the objects for alignment.
- Designate one object to act as an anchor to which other objects are aligned. The anchor is indicated by a black border; the objects to align with it are indicated by a gray border.
- The black border indicates the currently selected data field.
- The entire object must be selected for alignment, not just the constant text or its variable.
- The anchor can be a disconnected constant or variable object.
- The objects selected can be within the same or across sections.
- The fields themselves are aligned, not the text within the fields. This is especially noteworthy when you center-align fields, since the objects are centered based on field length and not on the length of the text within the fields.
- The alignment process cannot be used on tabular rows.

When you align columns with other columns or with data fields, use the following guidelines:

- To align tabular and columnar section columns with group section objects, the column in the tabular or columnar section must be the anchor for the alignment.
- To align tabular and columnar columns with columns in other columnar or tabular sections, you can only select one column in each tabular or columnar section to align.

### See Also

- *To change text justification for a report object in the Enterprise Report Writing Guide for information on aligning the text within data fields*

### ► To align fields or columns within or across sections

---

*In the J.D. Edwards Windows environment, choose Report Design Tool from the Report Writer menu (GH9111).*

1. On Report Design, access the report in which you want to align fields or columns.
2. Select an object you want to align with another.
3. Hold down the Ctrl key, and then click the objects that you want to align to each other.

As you select objects, they appear with a gray or black border. The object with the black border is the anchor. The *last* object you click is always the anchor.

4. From the Layout menu, choose Align.

5. On Align Objects, click one of the following options under the Left to Right heading:
  - Left Edges
  - Center
  - Right Edges
  - No Changes
6. Click one of the following options under the Top to Bottom heading:
  - Top Edges
  - Middle
  - Bottom Edges
  - No Changes

---

**Note**

These options are available only when you choose to apply changes to the current section.

---

7. Click one of the following options under the Apply to heading:
  - Current Section
  - All Sections
8. Click Apply.

Your changes appear immediately.
9. With Align Objects still open, click different options and click Apply until you are satisfied with how the objects are aligned.
10. When the objects are aligned the way you want, click OK.

## Changing Field Length and Column Width

You can change the length of most of the variable and system fields in your report. You can also change the width of column headers and their associated variables. In all cases, the system defaults to *text wrapping*; that is, if a field is too short to display its text, as much text as possible is placed in the space allowed and then is continued on succeeding lines. Turning this feature off is possible to display all of a field's text on a single line, despite the field length.

Changing a field's length and changing a column's width are not the same. To change a field's length is to change the number of characters the batch engine places in the field. To change a column's width is to change the amount of space allotted for display. If a field's length is 30 and the column's width is very small, you might only see five or six characters, but the batch engine has filled all 30 characters. Conversely, if a field's length is five and the column's width is very large, you see only five characters followed by a large amount of white space.

► **To change a field's length**

---

*In the J.D. Edwards Windows environment, choose Report Design Tool from the Report Writer menu (GH9111).*

1. On Report Design, access the report in which you want to change the length of a field.
2. Double-click the field you wish to change.
3. On the applicable Properties form, click the Display tab.  
If the Properties form does not have a Display tab, then you cannot change the field's length.
4. Enter a new length in the Display Length field, or use the arrow buttons to increase or decrease the length.
5. Click OK.

► **To change the width of a column**

---

*In the J.D. Edwards Windows environment, choose Report Design Tool from the Report Writer menu (GH9111).*

1. On Report Design, access the report in which you want to change the length of a field.
2. Click the column head.

---

**Note**

The small black box inside the selection box to the right indicates that you can manually resize the object.

---

3. Place your cursor over the small black box until the cursor changes to a horizontal line with an arrow on both ends.
4. Click and drag the black box until the column is the size you wish, and then release the mouse button.

► **To turn text wrapping on and off (Absolute Position)**

---

**Note**

You cannot toggle text wrapping for individual fields; instead, you must apply text wrapping to an entire report section. Furthermore, you cannot apply text wrapping to a column.

---

*In the J.D. Edwards Windows environment, choose Report Design Tool from the Report Writer menu (GH9111).*

1. On Report Design, access the report in which you want to change the length of a field.
2. Double-click the section for which you wish to toggle text wrapping.

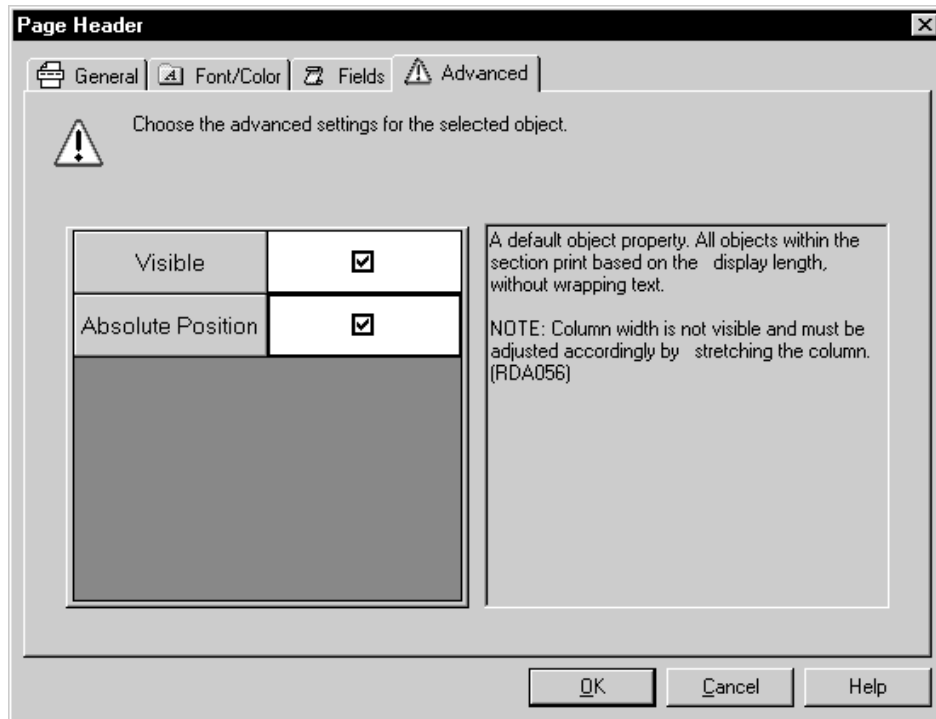

3. On the applicable Section form, click the Advanced tab.
4. Select the Absolute Position option to turn text wrapping off or deselect the Absolute Position option to turn text wrapping on.  
If the Advanced tab does not have an Absolute Position option, then you cannot turn text wrapping off for the section.
5. Click OK.

## Changing Column or Row Spacing

Column spacing (the space between columns) can be changed to create a larger or smaller spacing between all columns or to create a visible gap between individual columns (logical groups of data).

You can also change the spacing of rows to make the report look better.

### ► To change column spacing

*In the J.D. Edwards Windows environment, choose Report Design Tool from the Report Writer menu (GH9111).*

1. On Report Design, access the report in which you want to change the column spacing.
2. Click anywhere within the columnar or tabular section in which you want to modify column properties.

3. From the Layout menu, select Spacing.  
Depending on the section you chose, an appropriate Section Spacing form appears.
4. On the Column Spacing tab, perform one of the following to apply the spacing to columns:
  - Click the Select All Columns button to apply the spacing to all columns in the section
  - Choose specific columns from the grid to which you want to apply the spacing
5. In the Space before selected columns field, set the number of spaces you want to appear before the columns. The default is set at 5 spaces.
6. Click OK.

► **To change row spacing for a columnar section**

---

*In the J.D. Edwards Windows environment, choose Report Design Tool from the Report Writer menu (GH9111).*

1. On Report Design, access the report in which you want to change row spacing.
2. On Report Design, select the columnar section you want to change.
3. From the Layout menu, choose Spacing.
4. On Columnar Section Spacing, click the Row Spacing tab, then choose a Header to Detail option and a Detail to Detail option:
  - Single
  - Single + Half
  - Double

---

**Note**

Only Single spacing is supported for Comma Separated Values (CSV) files. Only Single and Double spacing is supported for line printers. See *Submitting a Report* in the *Enterprise Report Writing Guide* for more information about CSV files and printing to line printers.

---

- Single
  - Single + Half
  - Double
5. Click Apply, and then click OK.

► **To change row spacing for a tabular section with added rows**

---

*In the J.D. Edwards Windows environment, choose Report Design Tool from the Report Writer menu (GH9111).*

1. On Report Design, access the report in which you want to change row spacing.
2. Double-click on the row in your tabular section that you want to create a space above.

3. On Row Properties, click the Options tab.
4. Enter a value in the Space Before field and click OK.

## Changing Font Properties

A font is a set of print characters. Examples of font sets include Courier New and Arial. Typically, a font set includes variations such as bold and italic; properties such as alignment and spacing are not considered font variations and may be applied separately to any text in your report. You can use multiple fonts in a single report. Some fonts may be converted to PDF, PostScript, or PCL files; line printers are fairly limited in the types of fonts they can print.

Fonts can broadly be classified in two ways:

- Proportional Fonts
- Non-Proportional Fonts

A proportional font is one in which different characters have different *itches* (widths). In a proportionally spaced font, the letter *l* is narrower than the letter *q* and the letter *m* wider. Examples of fonts with proportional spacing are Arial and Times New Roman. While proportionally spaced fonts generally create a more visually pleasing document, it can be difficult to perform certain kinds of alignment because of the varying widths of data.

Non-Proportional fonts refer to fonts in which every character has the same width. Most typewriters and line printers use fixed-pitch fonts. An example of a non-proportional font is Courier New and MS Gothic.

Non-proportional Font: W i n d o w s

Proportional Font: W i n d o w s

The PDF generation, PostScript and PCL conversion can support any font size. For Line Printer, it is recommended to generate the PDF file with non-proportional fonts and font size of 10.

The base 14 fonts Report Design supports are shown in the following table where X is supported and blank is not supported:

Font Faces	Postscript	PCL	Line	PDF
Courier New	X		X	X
Courier New - Bold	X			X
Courier New - Italic				
Courier New - Bold Italic				
Arial	X	X		X
Arial - Bold	X			X
Arial - Italic				

Arial - Bold Italic

Symbol X

Times New Roman X X X

Times New Roman - Bold X X

Times New Roman - Italic

Times New Roman - Bold Italic

ZapfDingbats X

The base 14 fonts Report Design supports along with their valid printer types are shown in the following table:

<b>Font Faces</b>	<b>Postscript</b>	<b>PCL</b>	<b>Line</b>	<b>PDF</b>
Courier New	X		X	X
Courier New - Bold	X			
Courier New - Italic				
Arial				
Arial – Bold	X			X
Arial – Italic				
Arial – Bold Italic				
Symbol				X
Times New Roman	X	X		X
Times New Roman – Bold	X			X
Times New Roman – Italic				
Times New Roman – Bold Italic				
Zapf Dingbats				X

## Double Byte Fonts

In a double byte environment, fonts receive special treatment within UBE (Universal Batch Engine) and Output Management. In Report Design, you can select any font available to the system and assign it to the report, section, or object level. PDF will support one type of font with multiple font sizes in Simplified Chinese, Traditional Chinese, and Korean. However, in a double byte environment, only the fonts shown in the table below are supported when the PDF (Portable Document Format) file is generated:

Language	Font Name
Simplified Chinese	STSong-Light-Acro
Traditional Chinese	Mhei-Medium-Acro
Korean	HYGothic-Medium-Acro
Japanese	HeiseiMin-W3-Acro, MS Gothic (true type font)

The CJK languages (Japanese, Simplified Chinese, Traditional Chinese and Korean) do not support PCL.

## Bar code Fonts

Report Design supports Code 39 fonts for both PCL and PostScript conversion. The true type font name is *BC C39 3 to 1 Medium*. The barcode fonts can be seen in Report Design, previewed, and then printed. Since font vendors do not sell PCL fonts that can be scaled, only fixed-point size is supported for PCL.

The recommended point sizes that can be used for PostScript are between 8 and 24 points.

## Working with Bar Codes

You can use bar code fonts to create bar codes in your reports. Report Design provides base bar code functionality for your report and batch job output. You can use any true-type bar code font. Bar codes print on both PCL and postscript printers.

To specify a particular barcode, you must enter the encoding for that barcode in the constant properties. The encoding is a series of characters and numbers preceded and followed by a \* to let the system know this is a bar code.

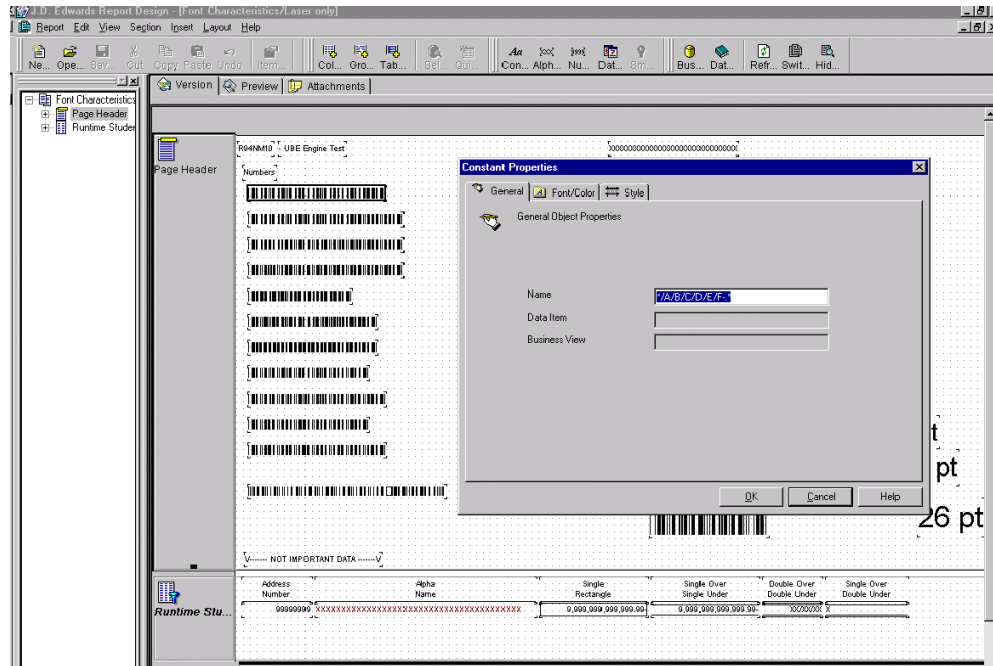

► **To create an object with a bar code font**

*On Report Design, double-click a constant.*

1. On Constant Properties, click the Font/Color tab
2. Complete the following fields:

- Font

The font is the bar code font name-- for example, the bar code font BC C39 3 to 1 Medium.

- Font Style
- Size

You can see a sample of what the font will look like in case you need to make changes.

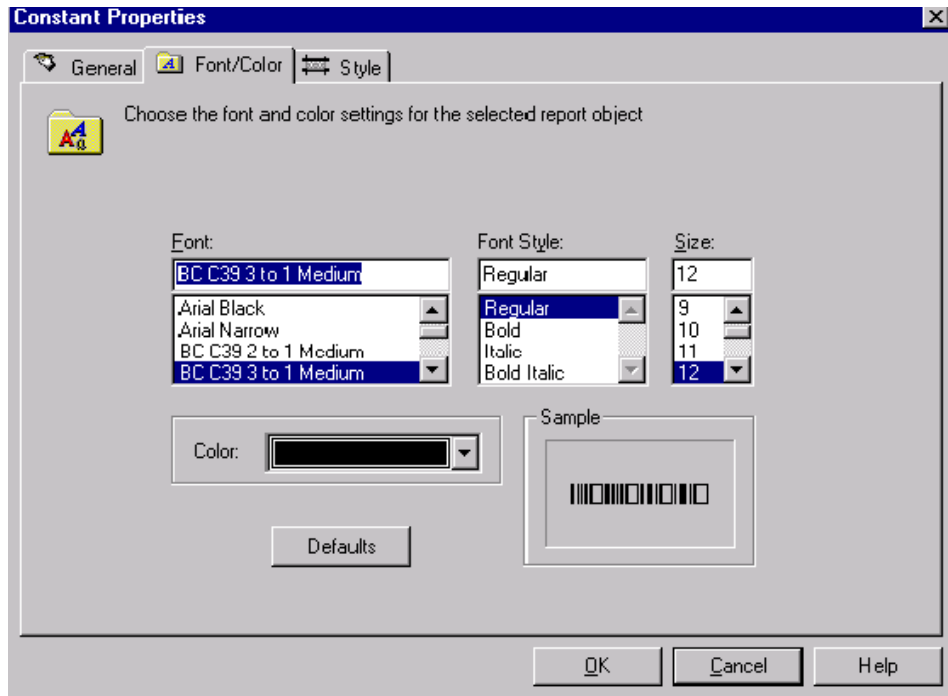

3. Click the General tab.

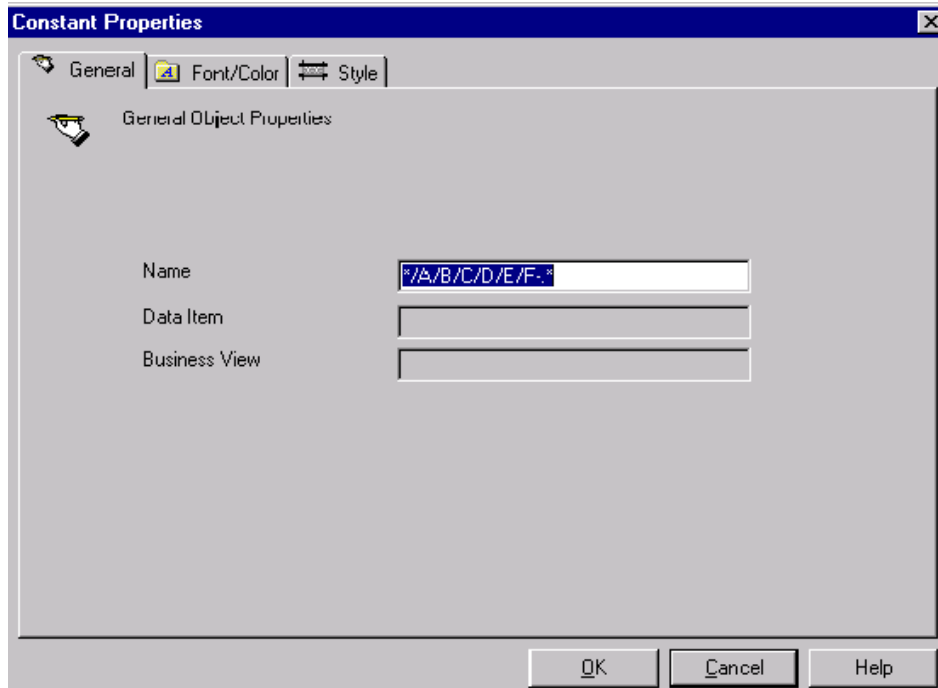

4. Enter the correct encoding sequence for the bar code in the following field and click OK.

- Name

You can see the bar codes in Report Design. They should look similar to the ones shown below.

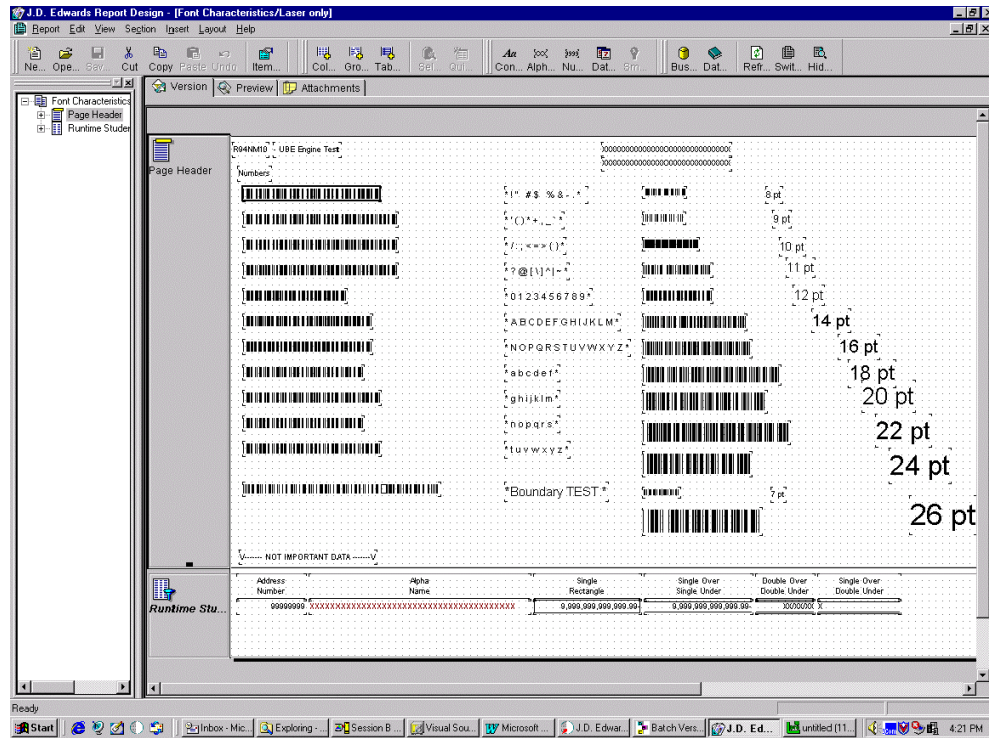

5. View the PDF file in Preview mode to display the bar codes.

When you submit your job, the Job Submission form should also display the bar codes properly.

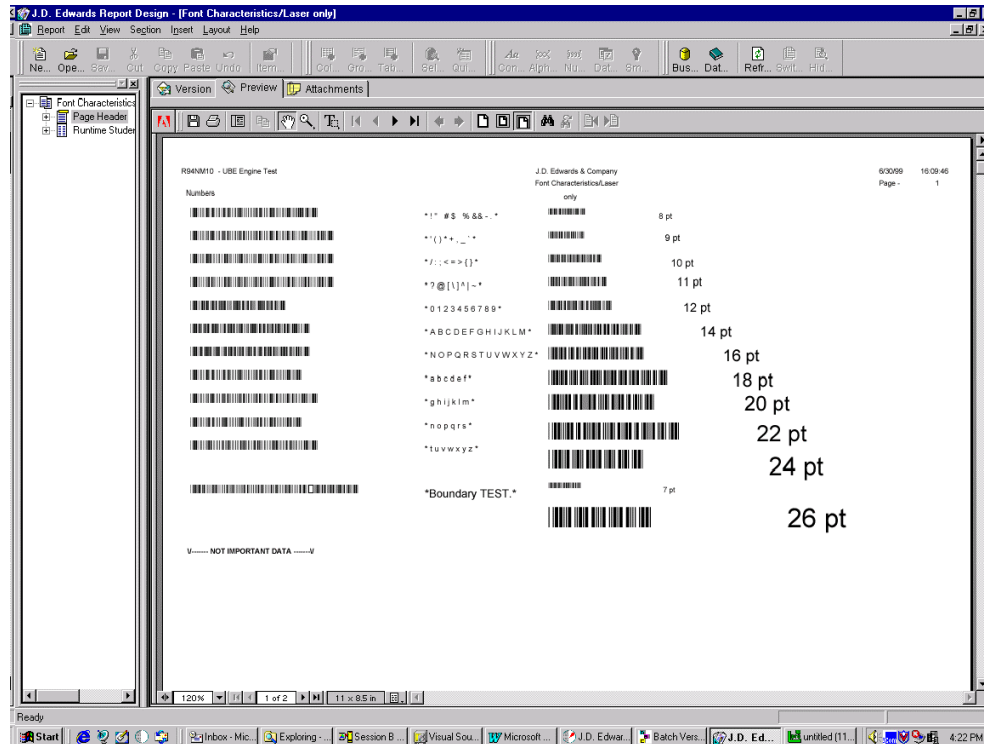

After you set up the bar code in your report, you must link the printer font name and the true type font name to a physical printer in the Bar Code Support application before you print to either a PostScript or PCL printer.

- From the Batch Processing Setup menu (GH9013), choose Bar Code Support, and complete the following fields:

- Printer Name
- True Type Font Name
- Printer Font Name

The printer font name comes from the font vendor, for example Code39Three.

- Printer Definition Language

If you are printing to a PCL printer you must also complete the following field:

- Symbol Set ID

---

### Note

Because font vendors do not sell scaleable PCL true-type bar-code fonts, only fixed-point size is supported for PCL. You should use point sizes between 8 and 24 for postscript.

---

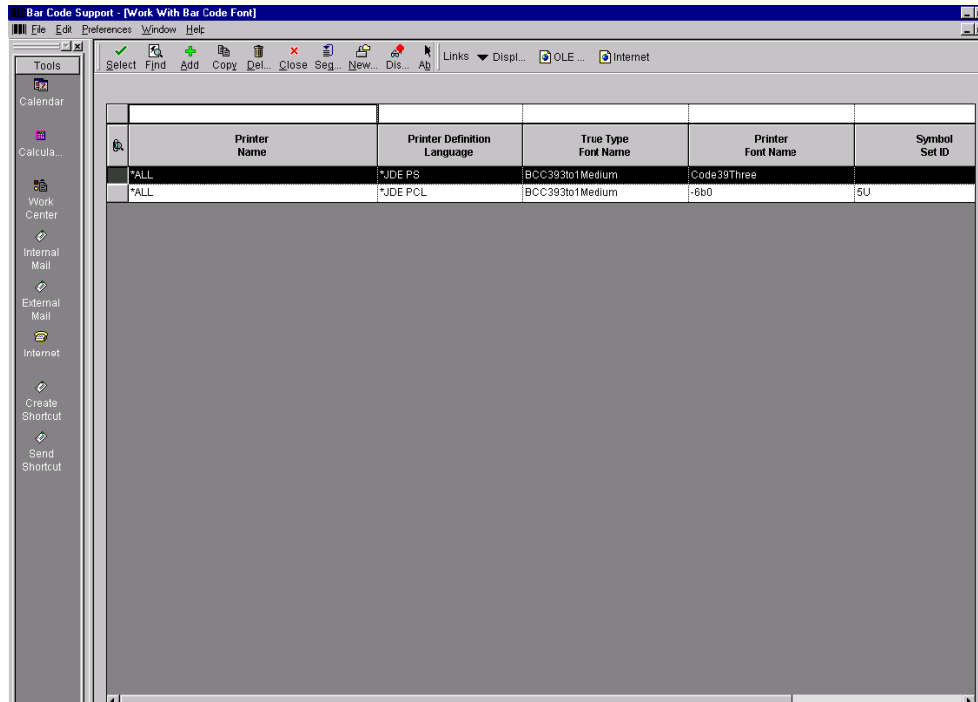

After you set up your bar code, you can use a scanner to test the bar code output.

## Color

Although you can choose any color from the Font dialog to display, for printing only 8 colors for PCL, 16 colors for PostScript and black for line printers are supported. Both PostScript and PDF generation use the *RGB model* for color and PCL uses the *Simple Color RGB model* that provides 8 colors only.

Refer to the Color Support Table below, where X is supported and blank is not supported:

Font Colors	PostScript	PCL	Line	PDF
Black	X	X	X	X
Blue	X	X		X
Cyan	X	X		X
Dark Blue	X			X
Dark Cyan	X			X
Dark Green	X			X
Dark Gray	X			X
Dark Magenta	X			X

Dark Red	X		X
Green	X	X	X
Light Gray	X		X
Magenta	X	X	X
Olive Green	X		X
Red	X	X	X
Yellow	X	X	X
White	X	X	X

**► To change the font properties for a field**

---

*In the J.D. Edwards Windows environment, choose Report Design Tool from the Report Writer menu (GH9111).*

1. On Report Design, access the report and select the field you want to change.
2. Right-click the field you want to change and select Properties from the resulting pop-up menu.

Depending on the field type, an appropriate Properties form appears.

3. Click the Font/Color tab and choose an option for the following headings:
  - Font
  - Font Style
  - Size
  - Color

To return all the section's fields to their default font settings, click Defaults.

4. After you are done making your selections, click OK.

**► To change the font properties for all fields in a report section**

---

*In the J.D. Edwards Windows environment, choose Report Design Tool from the Report Writer menu (GH9111).*

1. On Report Design, access the report and then double-click the report section that you want to change, or click the section and choose Section Properties from the Section menu.
2. On the applicable Section form, click the Font/Color tab and choose options for the following headings:
  - Font
  - Font Style
  - Size

- Color

To return all the section's fields to their default font settings, click Defaults.

Changes you make on this form affect all text in the section except for those fields that have been changed individually. To override individual settings and apply the changes to all fields in the section without exception, choose Apply settings to all Objects.

3. After you have made your selections, click OK.

### ► **To change the font properties for all fields in a report**

---

*In the J.D. Edwards Windows environment, choose Report Design Tool from the Report Writer menu (GH9111).*

1. On Report Design, access the report and then choose Report Properties from the File menu.
2. On Properties, click the Font/Color tab and choose options under the following headings:
  - Font
  - Font Style
  - Size
  - Color

To return all the report's fields to their default font settings, click Defaults.

Changes you make on this form affect all text in the report except for those fields that have been changed individually. To override individual settings and apply the changes to all fields in the report without exception, choose Apply settings to all Objects.

3. After you have made your selections, click OK.

## **Changing Text Justification**

Justification refers to how lines of text line up vertically in reference to each other. You can affect the alignment of text in columns and in most variables. You cannot set text justification for constants, however. In Report Design, you can align text in one of three ways:

- Right alignment
- Left alignment
- Center alignment

Justification is relative to the object's frame. For example, if you center align text, the text is centered within its frame instead of being centered on the page. The Batch Engine supports left and center alignment for all fonts and languages.

Out of the CJK (Chinese, Japanese, Korean) languages, right alignment is fully supported only for Japanese 7, 8 and 9-point size MS Gothic fonts. In the case of Chinese and Korean fonts, right alignment is not supported.

Bar codes must be left aligned in Report Design.

## See Also

- ❑ *Aligning Fields or Columns within or across Report Sections* in the *Enterprise Report Writing Guide* for information on aligning the report objects themselves

### ► To change text justification

---

*In the J.D. Edwards Windows environment, choose Report Design Tool from the Report Writer menu (GH9111).*

1. On Report Design, access the report and then double-click the field for which you want to specify its text justification.
2. On the applicable Properties form, click the Display tab.
3. Select the appropriate justification style, or click Defaults to return the object to its default justification style; then click OK.

## Changing Numerical Formatting

In Report Design, you can control the number of decimal places to be displayed. Through edit codes, you can control whether to use commas, how to display positive and negative values, and how to display monetary values.

---

### Note

You can also control the display of positive and negative numbers using processing options. Processing options override the settings entered using Report Design.

---

## See Also

- *Changing Decimal Scaling* in the *Enterprise Report Writing Guide* for information about changing decimal scaling

### ► To change how numbers are displayed

---

*In the J.D. Edwards Windows environment, choose Report Design Tool from the Report Writer menu (GH9111).*

1. On Report Design, access the report and then double-click the field for which you want to change the numerical formatting.
2. On the applicable Properties form, click the Display tab.
3. Enter the number of decimal places you wish to display in the Display Length field, or use the arrow buttons to increase or decrease the number of decimal places.

---

### Note

Setting display decimals is ineffective if currency has been enabled for the system.

---

4. If available, select the Edit Code field and use the Visual Assist to select a formatting style you want.
5. Click Defaults to return the object to its default style.
6. After you have made your selections, click OK.

#### See Also

- ❑ *Edit Code Table* in the *Enterprise Report Writing Guide* for a description of the edit code fields

## Associating Lines and Boxes

You can enclose most fields in a box. Additionally, you can include single and double lines above or below most fields. You cannot enclose columns or entire report sections in boxes.

### ► To associate lines and boxes

---

*In the J.D. Edwards Windows environment, choose Report Design Tool from the Report Writer menu (GH9111).*

1. On Report Design, access the report and then double-click the field you want to enclose in a box or attach lines to.
2. On the applicable Properties form, click the Style tab.
3. Deselect No Lines to activate the other options on the form.
4. To enclose the field in a box, select Single Rectangle. Otherwise, select the line style you desire.

The sample box on the form illustrates your selection.

5. After you make your selections, click OK.

## Inserting Page Breaks

In columnar and group sections, you can cause the last line printed on a page to be reprinted on the following page.

You can insert a manual page break (that is, cause the report to stop printing on the current page and start printing on the next) after detail sections and report headers. You cannot use these two features simultaneously, however.

### ► To print the last line on a page as the first on the succeeding page

---

*In the J.D. Edwards Windows environment, choose Report Design Tool from the Report Writer menu (GH9111).*

1. On Report Design, access the report and then double-click the group or columnar section that you want to affect.

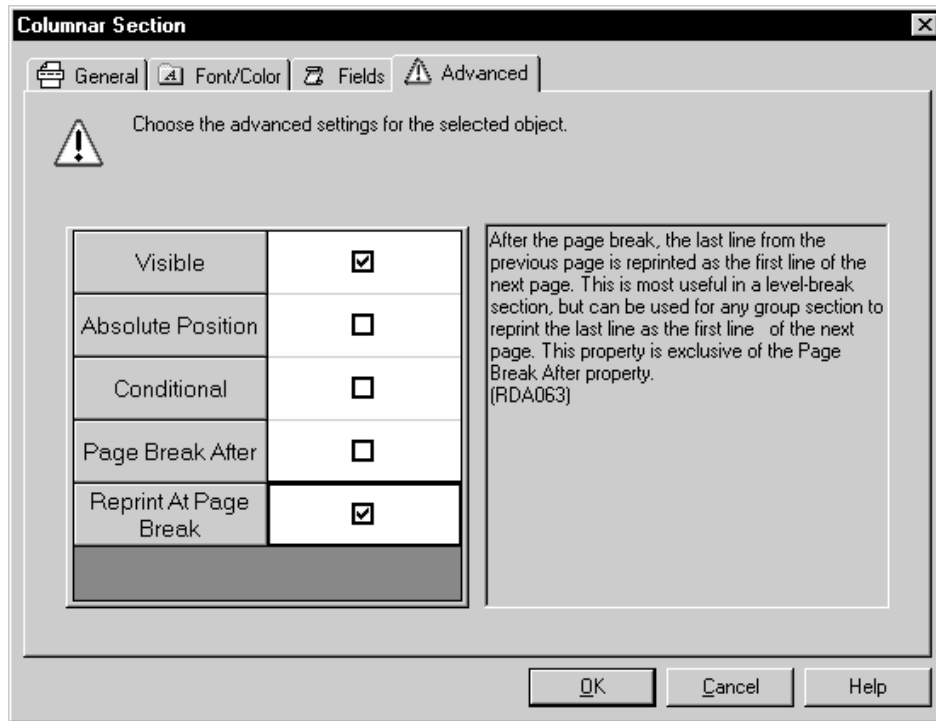

2. On the applicable Section form, click the Advanced tab.
3. Select Reprint At Page Break and click OK.

► **To insert a manual page break**

---

*In the J.D. Edwards Windows environment, choose Report Design Tool from the Report Writer menu (GH9111).*

1. On Report Design, access the report, and then double-click the detail or report header section that you want to affect.

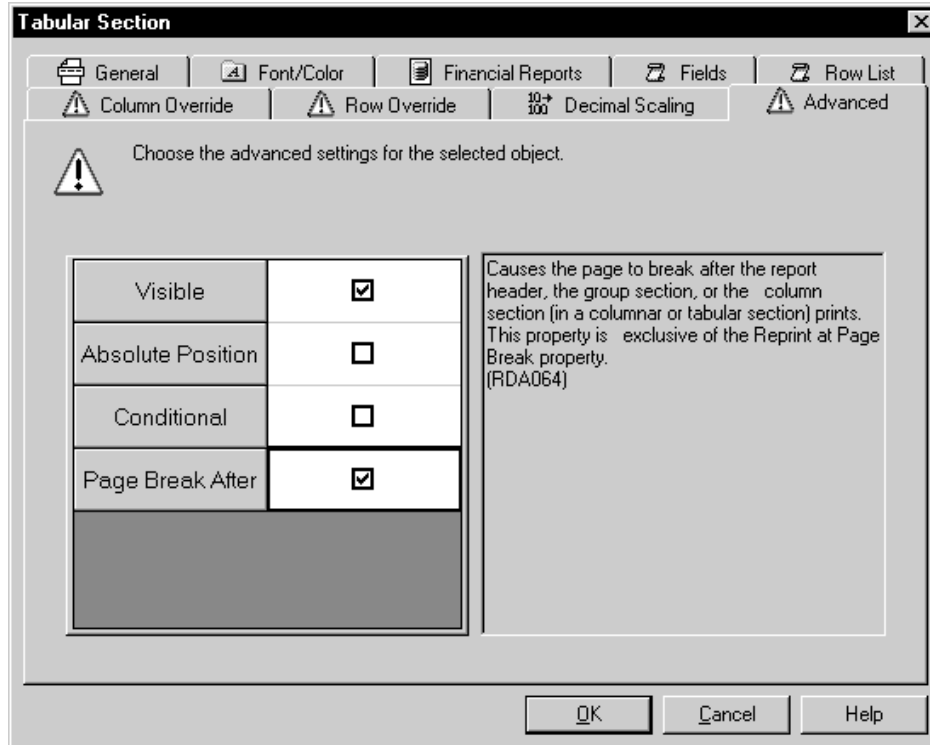

2. Click the Advanced tab.
3. Select Page Break After and click OK.

---

# Advanced Report Enhancements

In addition to the basic functional capabilities of Report Design, you can also use advanced features to create reports with greater depth of information and functions. The following table lists the available advanced features:

<b>Event Rules</b>	Event rules enable you to perform logical operations such as: <ul style="list-style-type: none"><li>• Processing conditional logic</li><li>• Moving values into or between objects</li><li>• Performing calculations and complex expressions</li><li>• Attaching existing business functions or system functions</li></ul>
<b>Date Titles</b>	For financial reports, a date title in the page header makes the report more meaningful. J.D. Edwards software includes commonly used date titles. The date title business function lets you choose the type of date title you want to display on your report.
<b>Drill Down</b>	The drill down feature creates a link to an interactive application. When you view a report using Adobe Acrobat Reader software, you can click a value in the report viewer to directly access the data in the report.
<b>Favorites</b>	A favorite is a simplified method that you can use to access information. In Report Design, favorites allow you to create a directory that contains only the business views that you require for your reporting needs.
<b>Processing Options Templates</b>	Processing options control how the system processes the data for a report or other batch application. They are version driven; therefore, different processing options can be specified for different versions of the same application.
<b>Director Templates</b>	The Director uses director templates to help you create application reports. These templates, included with J.D. Edwards software, contain default criteria. You can modify the J.D. Edwards software templates and create your own.
<b>Text Attachments</b>	You can add text attachments to records from the J.D. Edwards software interactive applications. In addition, you can design a report to include any text attachments that exist for a record.
<b>Report Properties</b>	Report Design lets you modify your report and version output by changing report properties.

## See Also

- ❑ *Smart Fields* in the *Enterprise Report Writing Guide*

See the following topics in the *Development Tools Guide*:

- ❑ *Changing Report Data Structures*
- ❑ *Working with Business Functions*
- ❑ *Creating a Table I/O Event Rule*
- ❑ *Creating Report Interconnections*

## Working with Event Rules

---

As a report is processed, the run-time engine pauses at certain points to process logic that has been attached. These points are called *events*, and you can use these events to insert custom logic for processing. Event rules are logic statements that you create and attach to an event without the difficult syntax that comes with most programming languages. Event rules process when an event, such as a page break, occurs. Events are attached to controls, such as a variable, a constant, a section, or a report.

The event to which you attach your event rule varies depending on the purpose of the event rule and the type of section in which the event occurs. For example, if you are adding an event rule to a columnar or group section, you might attach the event rule to the Do Section event. In a tabular section you might attach an event rule to the Do Tabular Break, Do Balance Auditor, or Column Inclusion events. Smart fields are automatically attached to the Column Inclusion event rule. If you are attaching an event rule to a variable, you might choose the Do Variable event.

Most event rules consist of two parts:

- An if/while statement
- An assignment

The if/while statement states the condition when an assignment should occur. Conditions include equal to, less than, greater than, not equal to, and combinations of these.

An assignment states what should happen when the condition of the if/while statement is met. All assignments take the form or “X equals Statement” where X is the variable being assigned a value, and Statement is the value assigned to the variable. Statement can be a simple value or a calculation.

### Example

Team C uses a different rating scale for employees than any other team. To be able to compare employees across teams, you need to multiply the employee ratings of Team C employees by 10. The if/while statement would be:

If Team is equal to C

The “is equal to” is the condition.

The assignment would be:

Rating equals Old Rating times 10

“Rating” is the variable being assigned a value. “Old Rating times 10” is the statement where that value is calculated.

### See Also

See the following topics in the *Development Tools Guide*:

- ❑ *Understanding Event Rules* for information on predefined events
- ❑ *Event Rules Design* for information about designing event rules and working with the event rule buttons
- ❑ *Creating Report Interconnections* for information about using event rules to use a report to launch other reports

See the following topics in the *Enterprise Report Writing Guide*:

- ❑ *Events* for information about which event rules are available for which sections
- ❑ *Defining Section Data Selection* for information about using the Criteria Design form for data selection

### Before You Begin

- ❑ Before you create an If/While statement, you might need to insert a field on your report to hold the result of the event rule. If the event rule will return text, you will most likely use a text variable. If your event rule is a calculation, you will need to decide between a numeric variable and a data dictionary item. See *Adding and Attaching Text Variables* in the *Enterprise Report Writing Guide* for more information about text variables.

### ► To create an If/While statement in an event rule

---

In the J.D. Edwards Windows environment, choose Report Design Tool from the Report Writer menu (GH9111).

1. On Report Design, access the report for which you want to create an if/while statement.
2. Click a section or the variable portion of a data field.
3. From the Edit menu, choose Event Rules.

Alternatively, you can click the right mouse button, and then choose Event Rules.

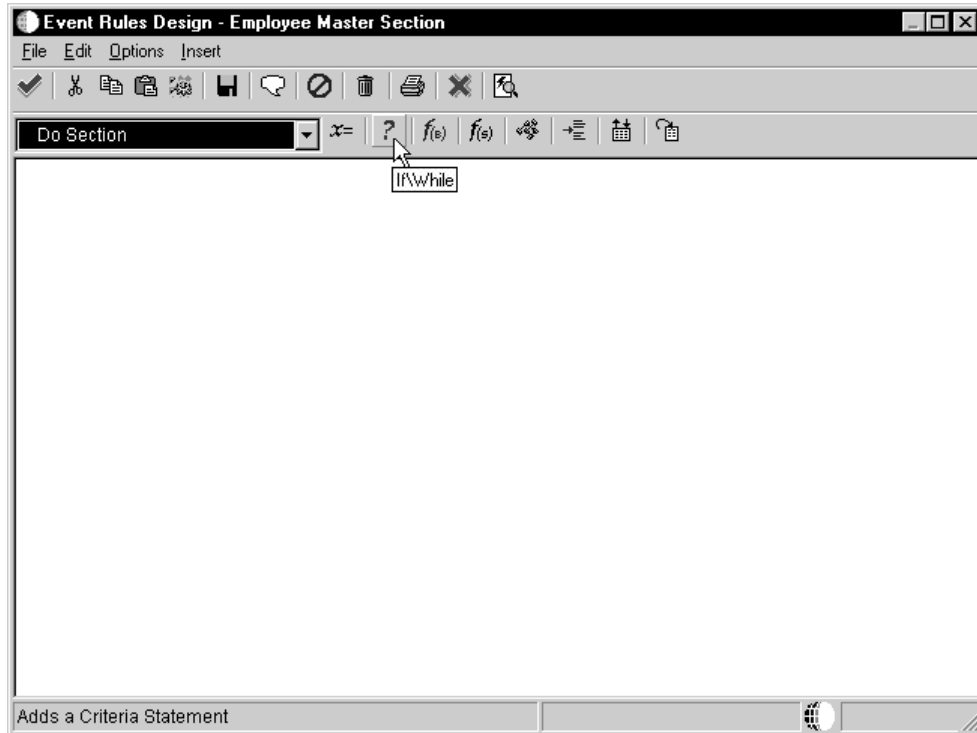

4. On Event Rules Design, from the pull-down menu of the Events list, choose an event.

For example, choose the Do Section event. This event is illustrated because it is the most commonly used event in columnar and group sections. When an event rule is written in the Do Section for a columnar or group section, multiple If statements with attached assignments or expressions can be written for multiple fields in that section.

5. Choose If/While from the Insert menu.

Alternatively, you can click the If/While button on the toolbar.

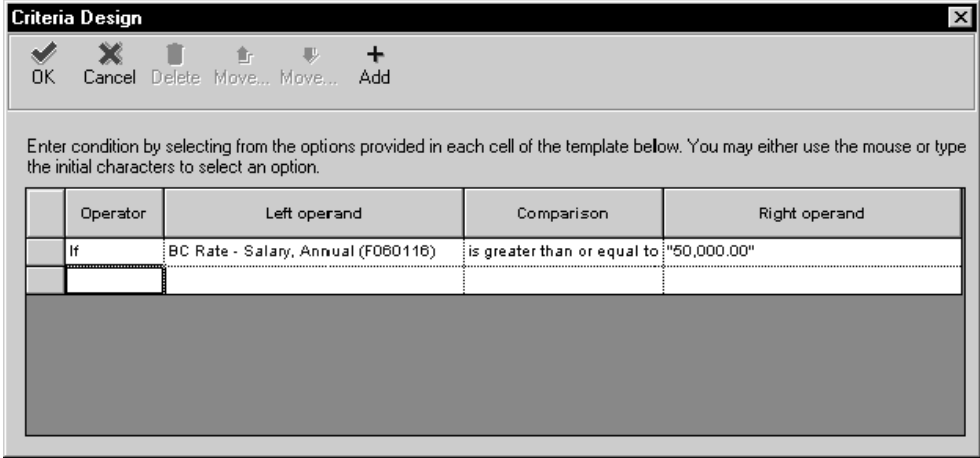

6. On Criteria Design, define the specific criteria you want applied to this event rule.
7. Click OK to save the If statement and return to Event Rules Design.

The If statement appears on Event Rules Design.

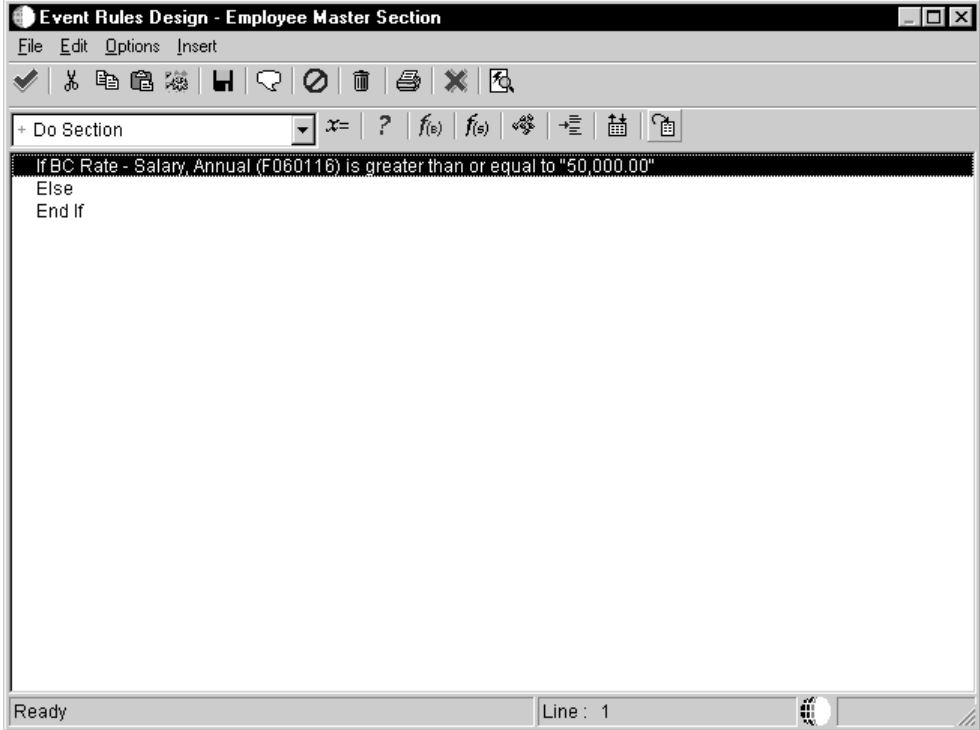

After creating the If statement, you can attach an event rule assignment to the If statement.

You can move an event rule line to a new location by selecting it and then dragging it to the desired position.

---

### Note

Changing the sequence of event rule statements can result in improper syntax. If you detect syntax errors, you can either disable the event rule and continue; or edit the event rule to eliminate the errors.

---

### ► To create an event rule assignment

---

*In the J.D. Edwards Windows environment, choose Report Design Tool from the Report Writer menu (GH9111).*

1. On Report Design, open the report in which you want to create an event rule assignment.
2. From the Edit menu, choose Event Rules.

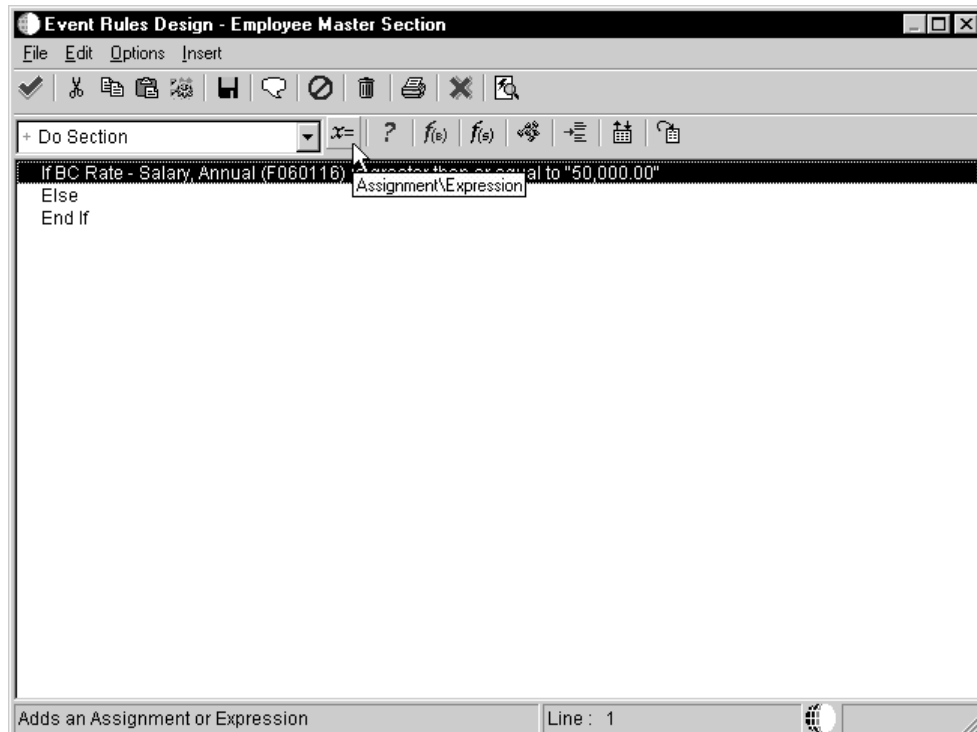

3. On Event Rules Design, click an If, Else, or End If statement that you want the conditions of the assignment to follow, and then choose Assignment/Expression from the Insert menu.

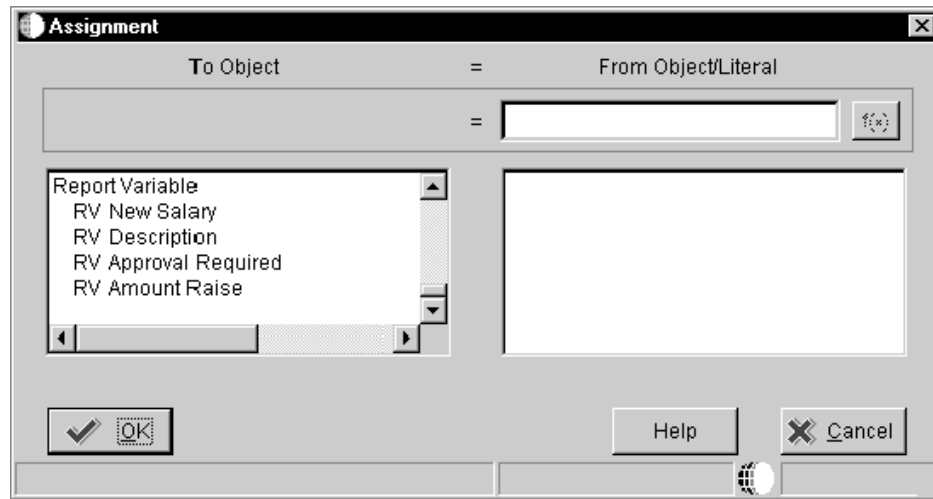

4. On Assignment, select the To Object by clicking on an available field from the list under the To Object heading. For example, the To Object might be the report variable (RV) from a column you inserted into the report to hold this value.

An available field is represented by a two-character, alphabetical code that characterizes the source of data and determines how the field data is used in an application at run time. The available fields could have the following prefixes:

**BC** A column in the business view. These columns are filled with values from the database when a fetch is performed and are the values that are saved when you add or update.

**PO** A value passed from a processing option.

**VA** Event rules variables. These objects represent any variables set up in the event rule. They are not manipulated by the system.

**RC** Report constant.

**RV** Report variable.

**RS** Report sections. These values may not be used when creating an event rule assignment.

The selected field appears in the gray area under the To Object heading. This field is the recipient of your assigned value.

5. To create a logical statement, choose an object from the From Object/Literal list on the right.

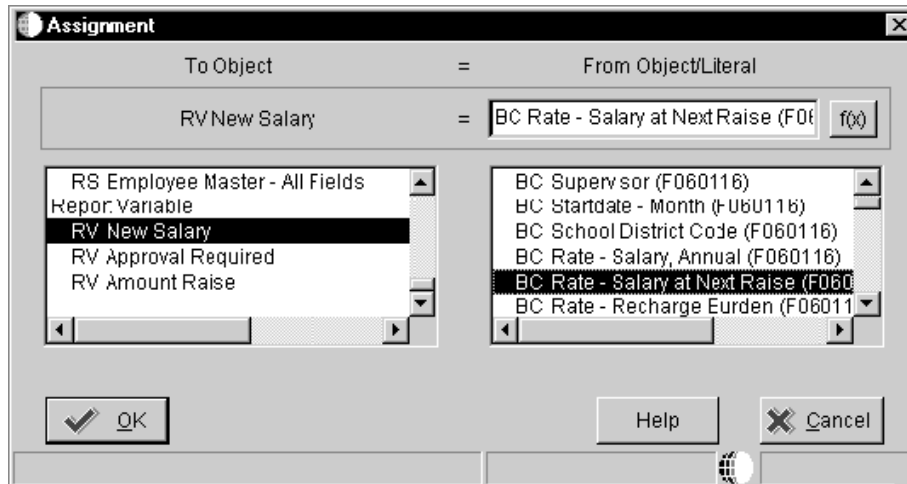

- To assign a literal statement for an alpha variable, enter a literal expression (such as a number or text) in the From Object/Literal.

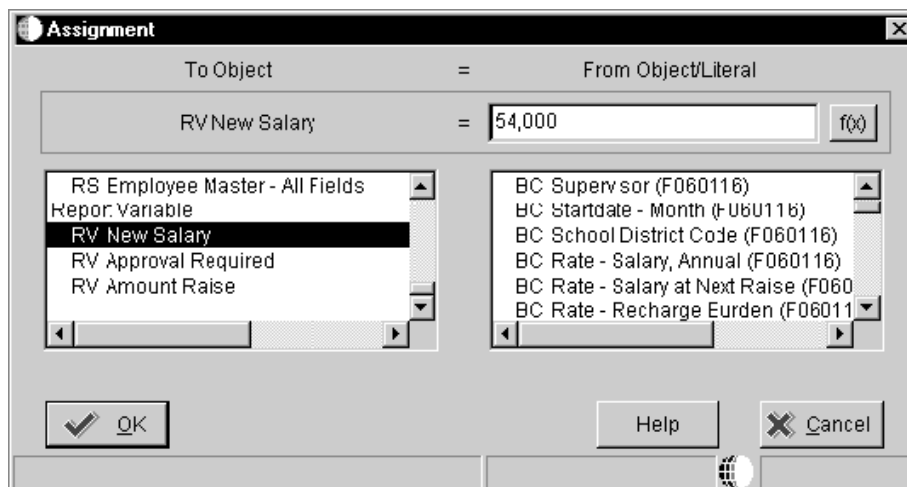

- To create an expression or mathematical function for a numeric variable, click the  $f(x)$  button.
- On Expression Manager, enter an expression and click OK.
- On Event Rules Design, choose Save from the File menu.  
Alternatively, you can click the check mark on the toolbar.

## Adding and Attaching Text Variables

In an event rule assignment, you may need a text variable (prefix TV ). Text variables are stored as strings and attached to your report through an event rule. They are used as an alternative to hard coding text strings in assignments. Because text variables are not hard-coded, they provide easier maintenance of event rules. Instead of changing each event rule where the text resides, you can simply change the text variable.

To use a text variable, you must first add it, and then attach it to the event rule.

The following graphic illustrates how text variables might appear on your report. The text string for the Required Approval column is a text variable. Based on the value in the Amount of Raise column, the report populates the column with the appropriate value, either "Director Approval" or "Manager Approval."

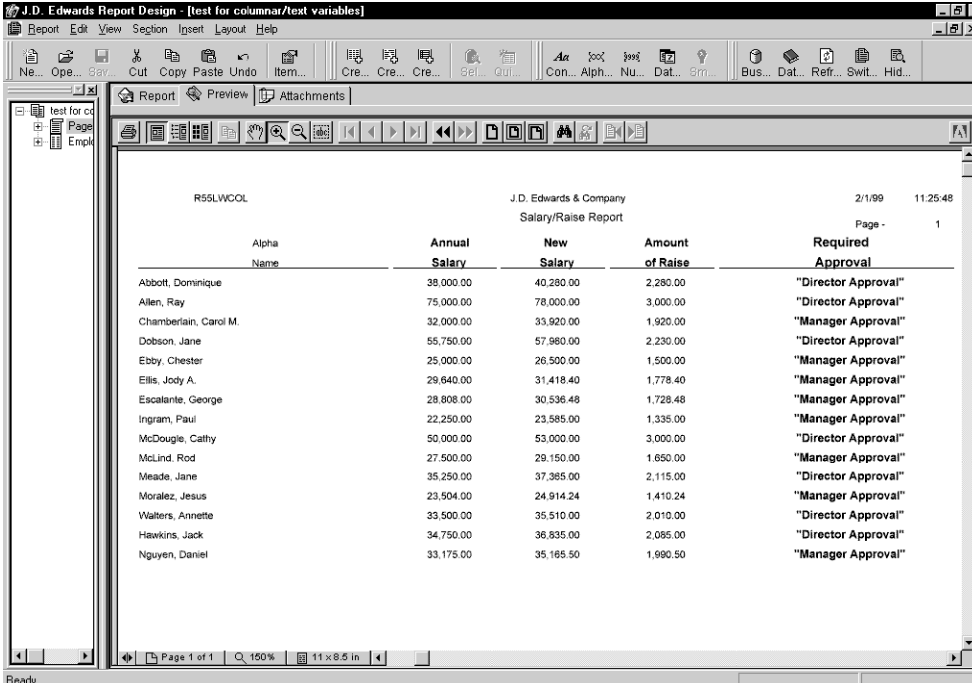

R55LWCOL J.D. Edwards & Company 2/1/99 11:25:48  
Salary/Raise Report Page - 1

Alpha Name	Annual Salary	New Salary	Amount of Raise	Required Approval
Abbott, Dominique	38,000.00	40,280.00	2,280.00	"Director Approval"
Allen, Ray	75,000.00	78,000.00	3,000.00	"Director Approval"
Chamberlain, Carol M.	32,000.00	33,920.00	1,920.00	"Manager Approval"
Dobson, Jane	55,750.00	57,960.00	2,230.00	"Director Approval"
Ebby, Chester	25,000.00	26,500.00	1,500.00	"Manager Approval"
Ellis, Jody A.	29,640.00	31,418.40	1,778.40	"Manager Approval"
Escalante, George	28,808.00	30,536.48	1,728.48	"Manager Approval"
Ingram, Paul	22,250.00	23,585.00	1,335.00	"Manager Approval"
McDougle, Cathy	50,000.00	53,000.00	3,000.00	"Director Approval"
McLind, Rod	27,500.00	29,150.00	1,650.00	"Manager Approval"
Meade, Jane	35,250.00	37,365.00	2,115.00	"Director Approval"
Morales, Jesus	23,504.00	24,914.24	1,410.24	"Manager Approval"
Walters, Annette	33,500.00	35,510.00	2,010.00	"Director Approval"
Hawkins, Jack	34,750.00	36,835.00	2,085.00	"Director Approval"
Nguyen, Daniel	33,175.00	35,165.50	1,990.50	"Manager Approval"

### ► To add text variables

*In the J.D. Edwards Windows environment, choose Report Design Tool from the Report Writer menu (GH9111).*

1. On Report Design, access the report for which you want to add text variables.
2. Click the detail section to which you want to add text variables and then choose Text Variables from the Section menu.
3. On Text Variables, type the text that you want to appear on your report under the Text String heading.

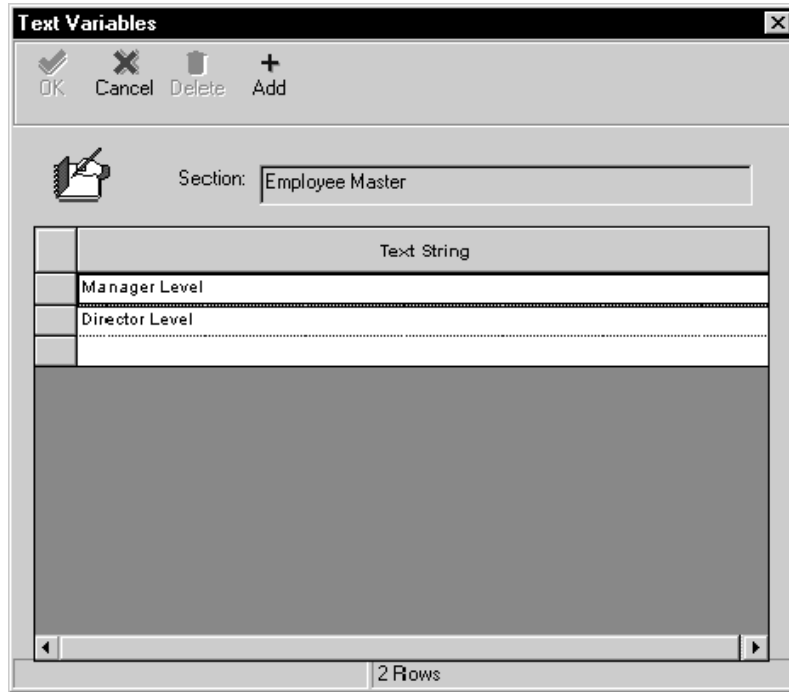

4. Press Enter or click Add.

You must press Enter after each entry for the Report Design tool to recognize your entry. When you press Enter, another blank line appears.

5. Repeat Steps 3 and 4 for all text strings required on your report, and then click OK.

► **To attach text variables to an event rule**

---

*In the J.D. Edwards Windows environment, choose Report Design Tool from the Report Writer menu (GH9111).*

1. On Report Design, access the report for which you want to attach text variables to an event rule.
2. Click the detail section to which you added the text variables, and then choose Event Rules from the Edit menu.

Alternatively, you can click the right mouse button and then choose Event Rules.

3. On Event Rules Design, choose the event to which you want to attach the text variables from the pull down events list.

This example uses the Do Section event.

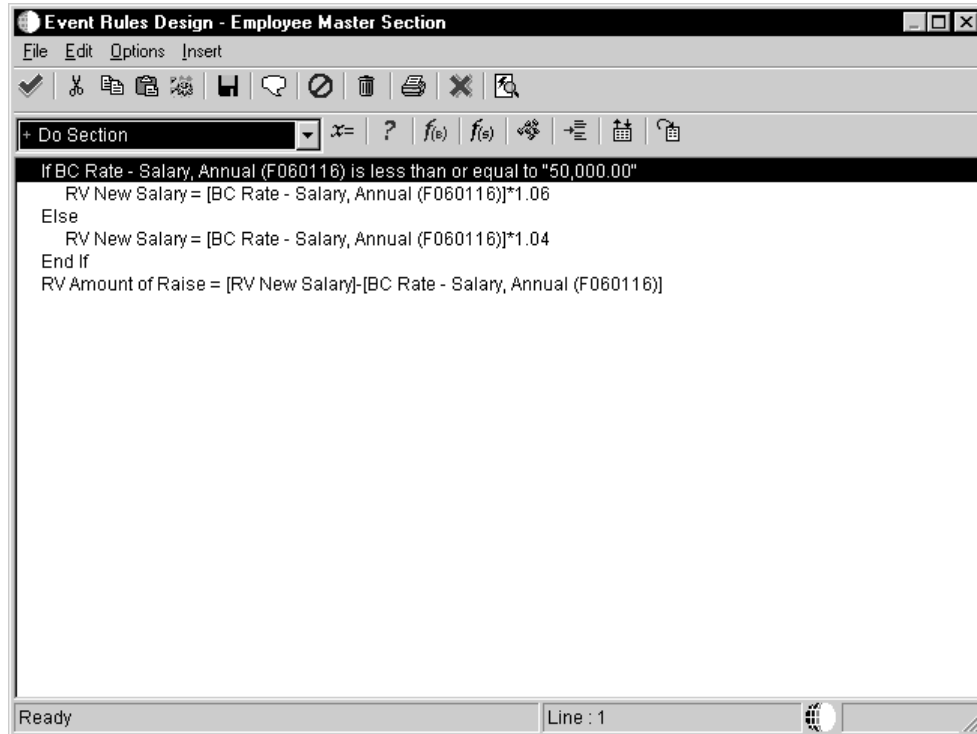

Events with associated event rules display a green plus sign (+).

4. Click the If, Else, or End If statement to which you want the conditions of the text variables to apply, and then choose Assignment/Expression from the Insert menu. Alternatively, you can click the x= button on the toolbar.

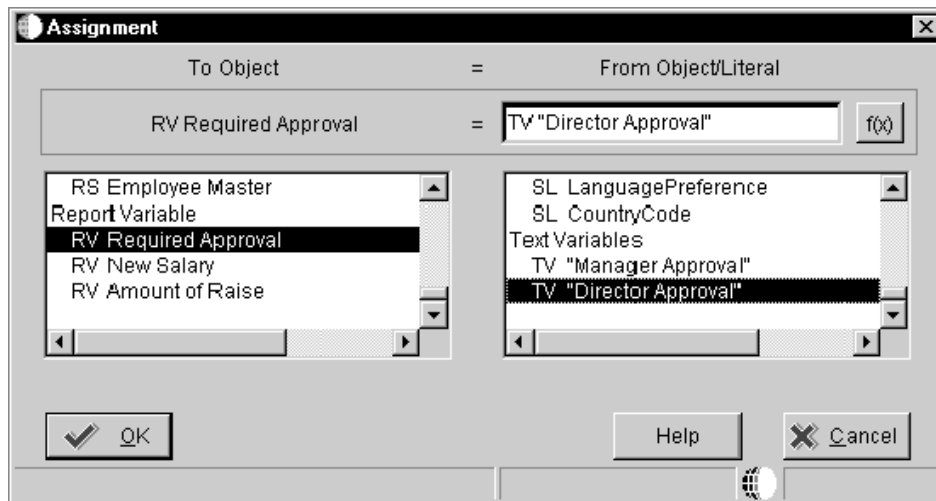

5. On Assignment, choose the To Object field (recipient of your text variable) by clicking on a field from the list under the To Object heading. For example, RV Required Approval.
6. Choose the From Object/Literal field by clicking a field with a TV (text variable) prefix from the list under the From Object/Literal heading. For example, click TV "Director Approval".
7. Click OK.

The Event Rules Design form appears with the If statement that now includes the text variable condition.

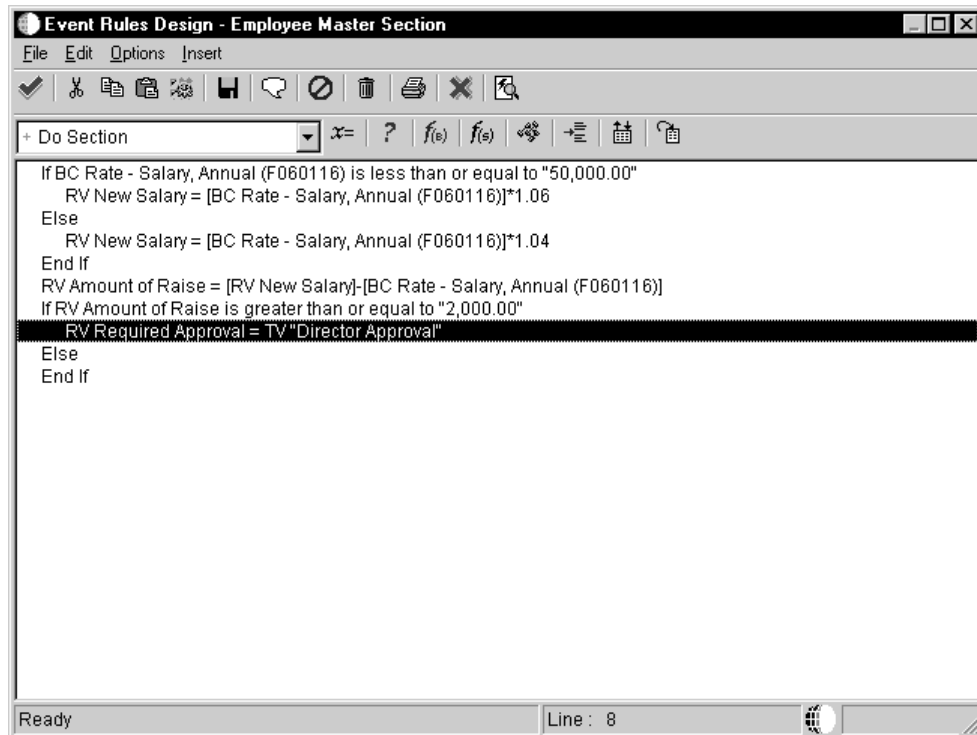

8. Repeat Steps 4-7 to add more text variables to the event rule, and then click the check mark on the toolbar to save and exit Event Rules Design.

## Attaching a System Function to an Event

Occasionally instead of using an assignment, you might need to use a J. D. Edwards system function if the condition stated in the if/while statement is met. System functions are predefined and allow you to perform complex calculations without adding code.

For example, you might need to hide one column heading on your report. You can do this task by attaching a system function to an event rule to hide this object.

► **To attach a system function to an event**

---

*In the J.D. Edwards Windows environment, choose Report Design Tool from the Report Writer menu (GH9111).*

1. On Report Design, access the report for which you want to attach a system function.
2. Click a section or the variable portion of a data field and then choose Event Rules from the Edit menu.

Alternatively, you can click the right mouse button, and then choose Event Rules.

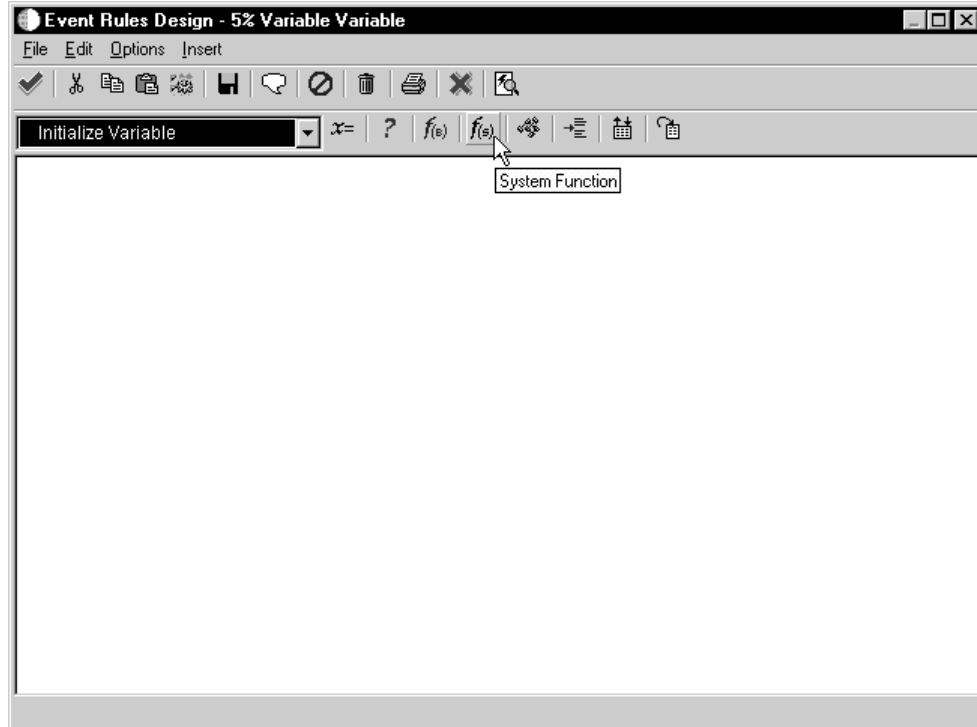

3. On Event Rules Design, choose an event from the pull-down events list.
4. Choose System Function from the Insert menu.  
Alternatively, you can click the  $f(s)$  button.

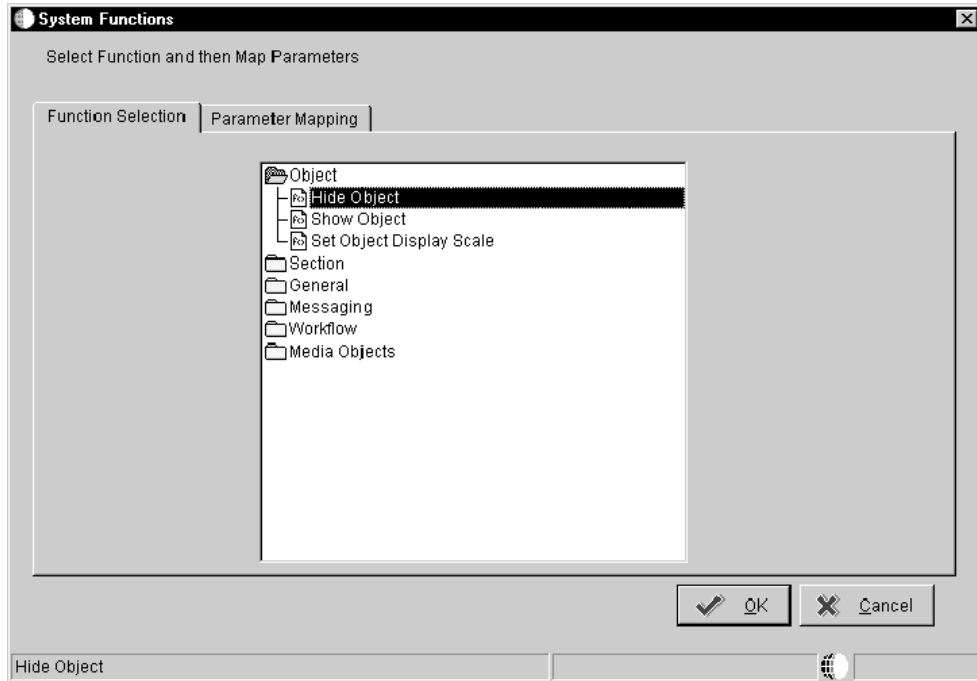

- On the Function Selection tab of the System Functions form, double-click the folder icon next to the system function to see all available functions within that category, and then choose a system function.
- Click the Parameter Mapping tab to define the parameters.  
For example, if you want to hide an object, you can open the Object folder and choose the Hide Object system function.

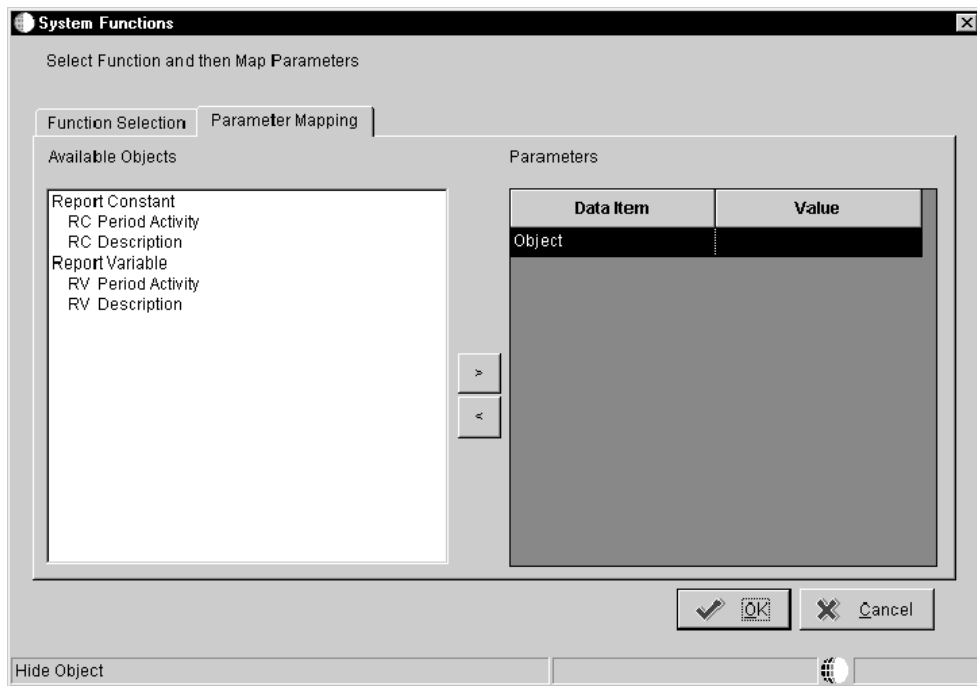

7. On the Parameter Mapping tab, choose a field from the Available Objects list, and then click the right arrow to move this value to the Parameters Value column.

In this example, you would choose the column you want to hide.

8. Click OK to return to Event Rules Design.
9. On Event Rules Design, click the check mark to save and return to Report Design.

## Creating an Event Rule Variable

An event rule variable (prefix VA) is a user-created object that inherits the characteristics of a selected data dictionary field. The variable is not, however, stored in the data dictionary. Rather, each variable exists only within the report where it was created. You determine whether the variable can be used for a specific event, for the section, or for the entire report. After you create a variable, it is added to the list of available fields used to create event rules.

### ► To create an event rule variable

*In the J.D. Edwards Windows environment, choose Report Design Tool from the Report Writer menu (GH9111).*

1. On Report Design, access the report for which you want to create an event rule variable.
2. Click the section to which you want to attach the event rule variable and choose Event Rules from the Edit menu.

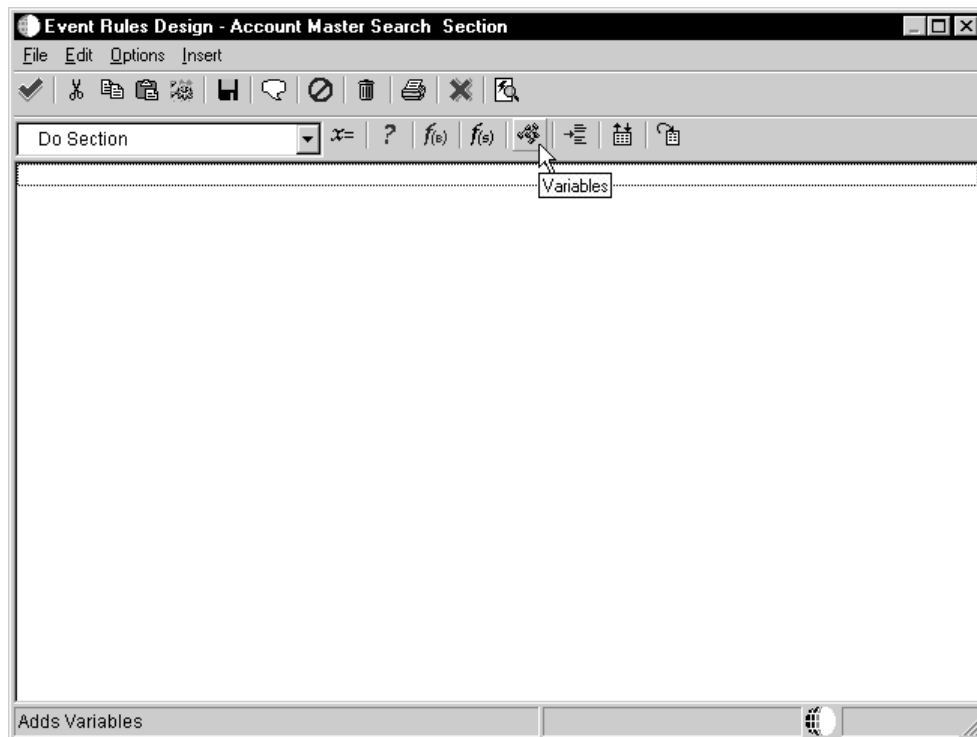

3. On Event Rules Design, choose an event from the pull-down events list.
4. Choose Variables from the Insert menu. Alternatively, you can click the Variables button.
5. On Event Rules Variables, click Add.
6. On Variable Item Selection, complete one of the following:
  - Click Find to display the valid data dictionary fields.
  - Use the QBE line to limit your search, and then click Find.
7. Choose the data item whose characteristics you want the variable to inherit, and then click Next.
8. On Variable Options Selection, click one of the following Scope options, depending on the purpose for which the variable is being created. For example, you can reference a report variable globally in the report, a section variable within the section, or an event variable only within the event where it was created.
  - Section
  - Report
  - Event
9. Type a meaningful name in the field provided, and then click Finish.

The Event Rules Variables form reappears displaying the event rule variable you just created.

The screenshot shows the 'Event Rules Variables' dialog box. The title bar reads 'Event Rules Variables' with a close button (X) on the right. The main area is divided into two sections. The top section contains a list box with one item, 'evt BatchQuantity'. To the right of the list box are three buttons: 'Add', 'Delete', and 'Edit'. Below the list box is a 'Properties' section with the following text: 'Data Item : #BQT', 'Data Type : MATH\_NUMERIC', 'Size : 15', 'Edit Rule :', and 'Display Decimals : 0'. At the bottom of the dialog are 'OK' and 'Cancel' buttons.

The variable is assigned one of the following prefixes based on the scope you specified.

- evt\_ (Event)
- rpt\_ (Report)
- sec\_ (Section)

An event rule variable cannot be modified after it is added. However, you can delete it and create a new event rule variable.

10. Click OK to return to Event Rules Design.
11. On Event Rules Design, click the check mark to save and return to Report Design.

## Column Inclusion Versus Do Section Event Rules

The most common event rule used for a tabular section is the Column Inclusion event rule. In a group or columnar section, the Do Section event is the most common. When a group or columnar section is processing data, the Do Section event occurs after each record is fetched. Because of the automatic totaling on a level break, tabular sections are processed differently. In a tabular section, the Do Section event is processed only at each level break. Therefore, the Column Inclusion event is used in a tabular section to process the data after each record is fetched, rather than waiting until the level break.

No matter the section type, do not use a Column Inclusion event rule when you are performing a calculation between columns (such as when calculating variance) or between variables within a column. For these situations, use a Do Section event.

When using the Column Inclusion event rule, you must attach individual event rules for each column in the section to which you want to attach logic.

### See Also

- *To create calculation columns in the Enterprise Report Writing Guide*

### ► To use the Column Event Rule

---

*In the J.D. Edwards Windows environment, choose Report Design Tool from the Report Writer menu (GH9111).*

1. On Report Design, access the report for which you want to use the column event rule.
2. Click the column in the tabular section to which you want to add the event rule. Ensure that you click the column itself and not its header.
3. From the Edit menu, choose Event Rules.

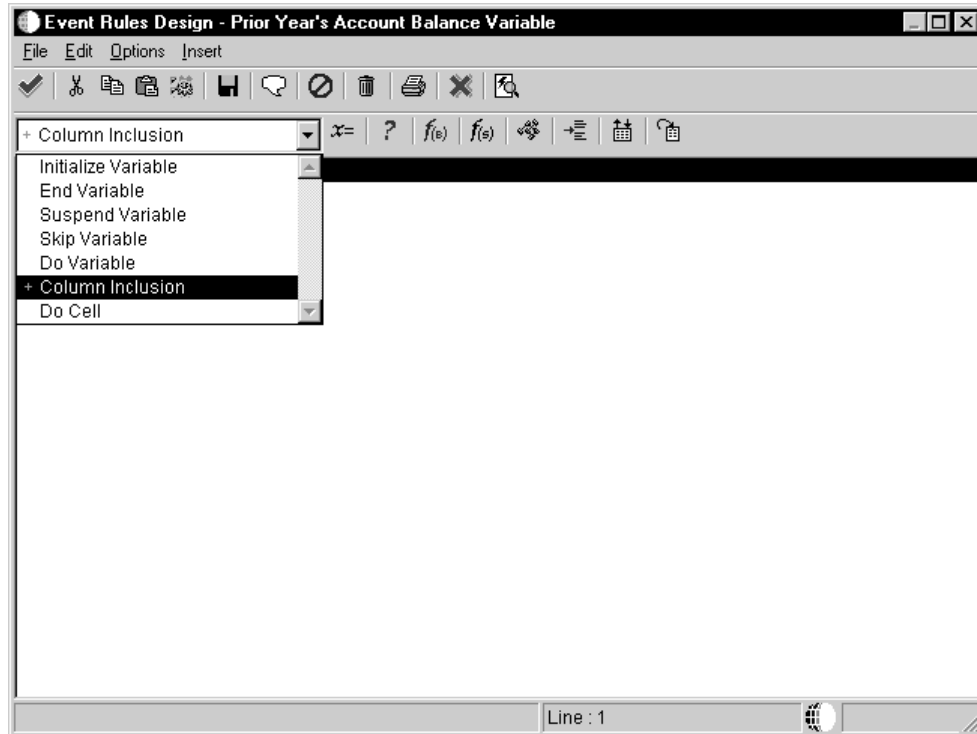

4. On Event Rules Design, choose Column Inclusion from the pull-down Events list.  
If you are working with a smart field column, this event could have a green + next to it. This plus sign indicates that an event rule already exists for this column.
5. The type of event rule you want to create determines which button you choose.  
For example, if you want to create an If/while statement, you would choose If/While from the Insert menu.
6. Perform Steps 1-5 for each column to which you want to add an event, and then click the check mark to save and return to Report Design.

## Creating Custom Sections

Custom sections allow you to control, through event rules, the information that prints on a report. You can use custom sections to force a page break by creating a custom section with no objects, and then activate Page Break After Print in that section's Section Properties. You can also use custom sections to print variable text, or for sections that present the same information, but are formatted differently. For example, you might use a custom section in a report that exists in two different modules, but depending on a user's needs, calls a different section that displays information specific to that particular module.

Another example of using a custom section is when you want to print additional information depending on certain criteria. For example, you might have an accounts receivable report that shows a customer's payment history, but you want the batch engine to print additional information if a customer is delinquent in his payments. In this case, you can create a custom section to display if the customer is 30, 60, or 90 days overdue, and then attach a processing option that calls that custom section. When the processing option is activated, and when the batch engine encounters a record that contains overdue information, the custom section prints; if no overdue information exists, the custom section does not print.

You can use the DO\_CUSTOM\_SECTION system function in columnar, group, or tabular sections to call the custom section. The number of custom sections you can use in a report is unlimited. Custom sections are allocated and treated like any other level-two section.

Custom sections can contain business view fields, variables, or data dictionary fields. Your report processes the same way regardless of the objects contained within it.

## Attaching Logic for a Custom Section

Custom sections are launched using a system function in Event Rules. You attach the logic for a custom section to the section preceding the custom section. For example, if you want a custom section to process before a columnar section, you call the custom section using the system function DO\_CUSTOM\_SECTION from the columnar section's DO\_SECTION event. Likewise, if you want a custom section to process before a level-break footer, you call the custom section using the system function DO\_CUSTOM\_SECTION from the INIT\_LEVEL\_BRK\_FOOTER event.

You can call a custom section event from any section. Furthermore, you can use any event rule logic along with a custom section, such as If and While statements, business functions, table I/O, and so on.

You can call a custom section from any event rule except INIT\_Section. If you try to call a custom section using INIT\_Section, your report will not process.

When you use a custom section, you specify the section as Conditional in Section Properties, then attach the system function event rule DO\_CUSTOM\_SECTION to the section preceding the custom section.

### ► To use a custom section

---

*In the J.D. Edwards Windows environment, choose Report Design Tool from the Report Writer menu (GH9111).*

1. On Report Design, access the report for which you want to use a customer section.
2. Click the section from which you want to call the custom section, and then choose Event Rules from the Edit menu.
3. Choose the event at which you want to process the custom section.
4. Click the System Function button.
5. On System Functions, choose Section from the System Functions tree view, and then choose Do Custom Section.

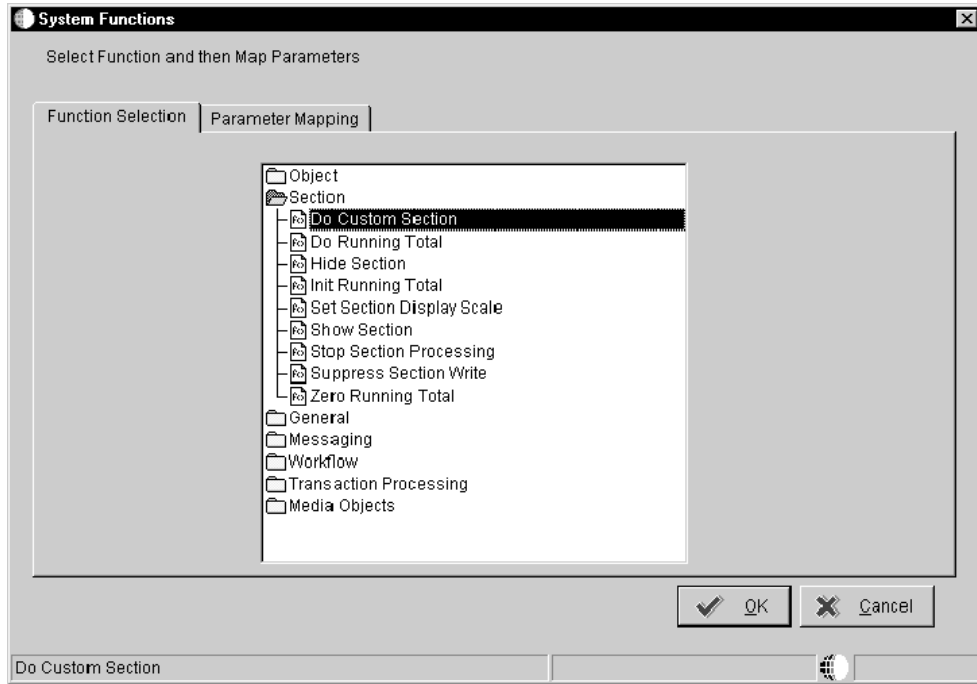

The system populates the Available Objects window with the sections in your report.

All of the sections in your report appear in the Available Objects window, not just the ones that you have specified as conditional.

- Click the Parameter Mapping tab, choose the conditional section you want to define as a custom section, and then click the right arrow to move it to the Parameters window.

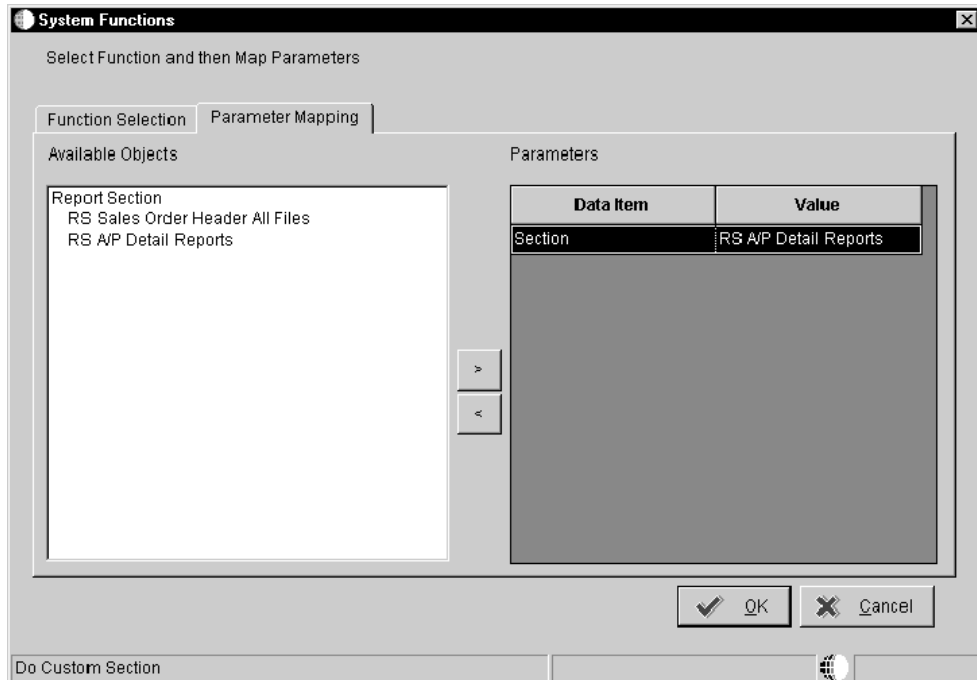

7. Click OK.

## Working with the Date Title for Financial Reports

---

For reports showing financial data, a date title in the page header makes the report more meaningful. J.D. Edwards software includes commonly used date titles. While a predefined date title lets you add a date title quickly, it might not be specific to your company's reporting needs. Therefore, you can add your own company-specific date title. By calling the User Defined Date Title business function (B8300007), you can add an existing date title to your report or create a date title specific to your reporting needs.

### Before You Begin

- See *Creating an Application Report with the Director* in the *Enterprise Report Writing Guide* for information about using the Financial Reports template to create a financial report to which you can add a date title.

## Adding a Date Title to a Financial Report

The following date titles are included with J.D. Edwards software:

<b>A (As of)</b>	"As of 03/31/05"
<b>B (Balance sheet)</b>	"As of March 31, 2005"
<b>P (Profit and Loss)</b>	"For the Three Months Ending March 31, 2005"
<b>S (Single period)</b>	"For the Month Ending March 31, 2005"

The User Defined Date Title business function (B8300007) uses the company number to determine the fiscal year. The company number is also used to determine the default reporting period if the processing option values for reporting month and year are blank.

### ► To add a date title to a financial report

---

*In the J.D. Edwards Windows environment, choose Report Design Tool from the Report Writer menu (GH9111).*

1. On Report Design, access the report to which you want to add a date title.
2. Click the Page Header section, and then choose Alpha Variable from the Insert menu.
3. Click to insert the field in the Page Header.
4. Double-click the alpha variable field that you just inserted.

5. On Variable Properties, on the Description tab, complete the following field:
  - Variable Name  
Label the variable so that you can identify it easily with a name such as DateTitle.
6. Click the Display tab and modify the following:
  - Justification  
Click Center.
  - Display Length  
Type 100. If the date title is over 100 characters, the date title will be truncated to fit the available space.
7. Click the Advanced tab and turn on the following option:
  - Global Variable  
Turning on this option makes the variable available in the Available Objects list (on the Business Functions form) for sections other than the one in which it is defined.
8. Click OK.
9. Align the object with the other objects in the section.
10. Click the detail section of your report (do not click the page header section), and then choose Event Rules from the Edit menu.
11. On Event Rule Design, click Yes to save your changes.
12. On Event Rules Design, choose Before Level Break from the pull-down Events list.
13. Choose Business Function from the Insert menu. Alternatively, you can click the  $f(b)$  (Business Function) button.
14. On Business Function Search, type B8300007 in the Source Module field of the QBE line, then press Enter or click Find.
15. Click Select.

The Business Functions form appears. You must assign values to each data item in the data structure. The remaining steps in this procedure show you how to assign these values. Refer to the illustration at the end of this procedure to see a complete data structure for the User Defined Date Title.

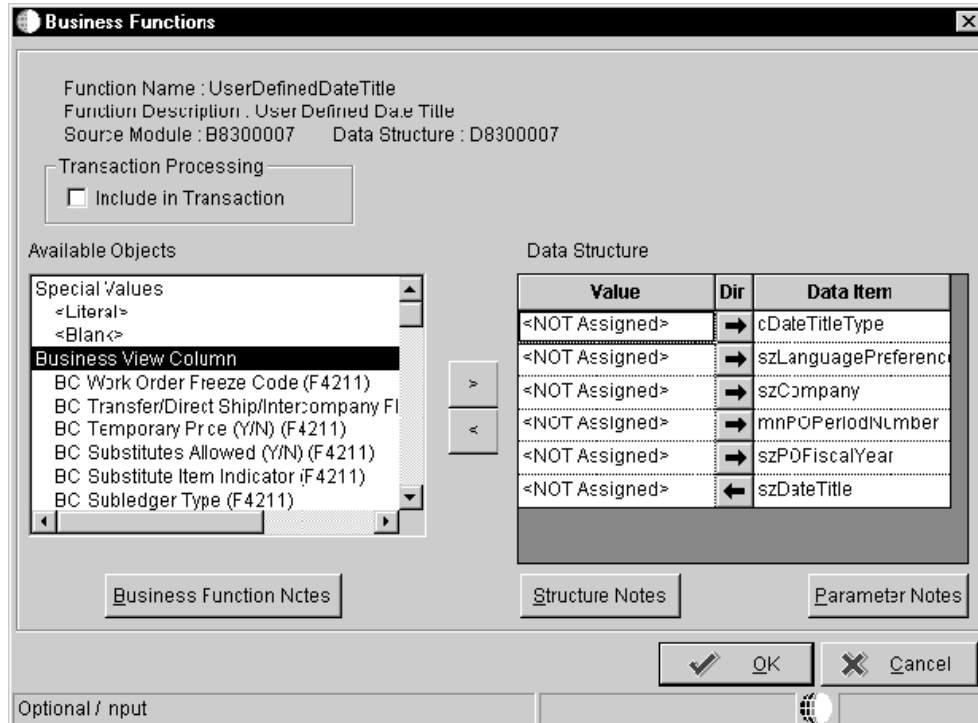

16. Click in the Value column next to the data item cDateTitleType, and then double-click <Literal> in the Available Objects list.
17. On Single value, click the visual assist button.
18. On Date Title Search, choose a value, and then click Select.
19. On Single value, click OK. The value you selected appears in the Value list.  
The Directional arrow is set automatically.
20. Click in the Value column next to the data item szLanguagePreference.
21. To have the date title print in the language of the user running the report, double-click SL LanguagePreference (system value for language preference in user profile) from the Available Objects list. If you do not have a language preference, skip to step 24.
22. To have the date title print in a specific language, regardless of the user preference of the user running the report, use the system double click <Literal> in the Available Objects List.
23. On Single value, click the visual assist button.
24. Choose a value, and then click Select.
25. On Single value, click OK. The value you selected appears in the Value list.  
The Directional arrow is set automatically.

26. Click in the Value column next to the data item szCompany, and then double-click <Literal> in the Available Objects list.
27. On Single value, enter the company number, or click the visual assist button to search for a company number to enter.
28. On Single value, click OK.

The company number you entered appears in the Value column and determines the fiscal date pattern.

The Directional arrow is set automatically.

29. Click in the Value column next to the data item mnPOPeriodNumber, and then double-click PO PeriodNoGeneralLedger in the Available Objects list to copy the object to the Value column.

This is the period number designated in the Financial Reports processing options (T83PO). This processing option will appear automatically at runtime to prompt the user for a value.

The Directional arrow is set automatically.

30. Click in the Value column next to the data item szPOFiscalYear, and then double-click PO szFiscalYear in the Available Objects list to copy the object to the Value column.

This is the fiscal year from the Financial Reports processing options (T83PO). This processing option will appear automatically at runtime to prompt the user for a value.

The Directional arrow is set automatically.

31. Click in the Value column next to the data item szDateTitle, and then double-click the report variable (RV) name (this is the name you assigned to the alpha variable inserted in the Page Header) in the Available Objects list to copy the object to the Value column.

The Directional arrow is set automatically.

After completing the szDateTitle parameter, the Business Functions form is complete with the following parameters in the Value and Data Item lists:

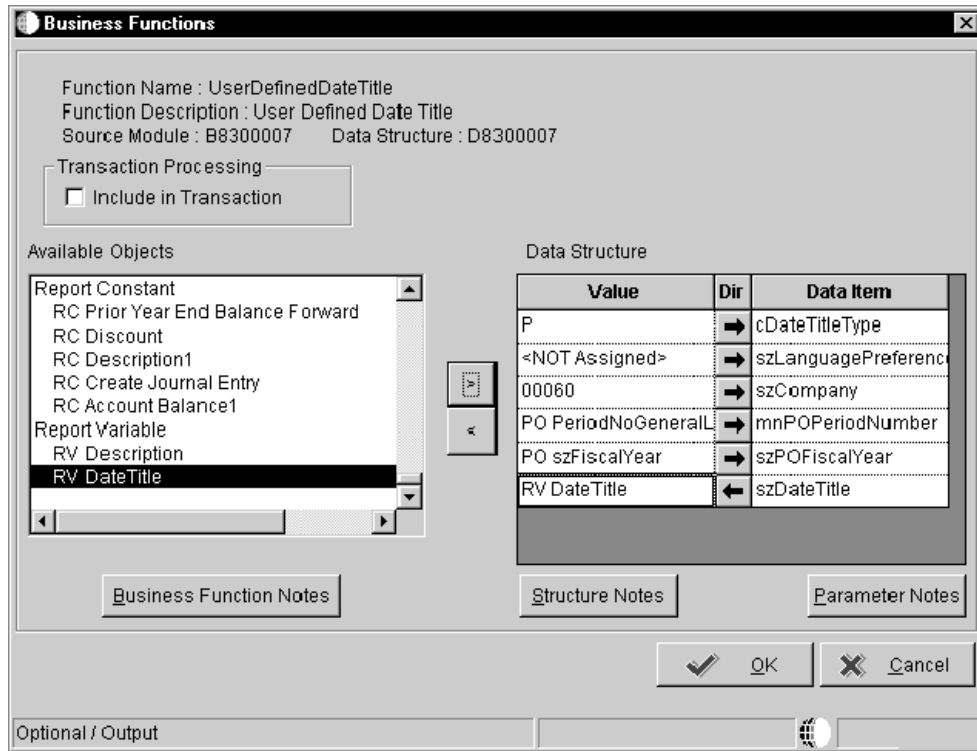

32. On Business Functions, click OK.
33. On Event Rules Design, click the check mark to save the User Defined Date Title event rule and return to Report Design.

**See Also**

- *To align fields or columns within or across sections in the Enterprise Report Writing Guide for information about aligning objects within a section*

## Customizing the Date Title

While a predefined date title is helpful, a company-specific date title could be more informative for users. Therefore, you can customize the date title by defining your own parameters to better suit your reporting needs. In addition, you can create the same date title in multiple languages. The date title parameters are stored in the Date Title table (F83100).

**See Also**

- *To assign your accounting periods to the column headings in the Enterprise Report Writing Guide for more information about defining the period names*

► **To set up a custom date title**

---

*From the Advanced Report Setup menu (GH9141), choose Date Titles.*

1. On Work With Date Titles, click Add.
2. On Date Title Revisions, complete the following fields:
  - Date Title Type
  - Description
  - Language

3. Complete the Elements fields.

The maximum length of a date title is 100 characters.

The maximum number of elements is 14, and each of these elements can be a literal text string or a text substitution parameter. The following lists the available text substitution parameters (stored in user defined code list 83/TS). These parameters are filled in at run time.

- @1: Period Name  
This value is assigned by defining the name of the period for a fiscal date pattern. This is generally the name of the month associated with the period. The information is stored in the Date Title table (F83110).
- @2: Day Period Ends  
This value is read from the Date Fiscal Patterns table (F0008). For example, this parameter would return 31 for a period that ends on the 31st of the month.
- @3: Century and Year  
For example, you might enter 2005 (the year the report is based upon).
- @4: Year  
For example, you might enter 05 (the year the report is based upon).
- @5: Text for Period Number  
These values are stored in and read from user defined code list 83/PT. This UDC holds text for the number of periods through the current period. For example, period 2 would retrieve two.
- @6: Date (06/30/05)

4. To revise the Text for Period Number (@5) values, choose Period Text from the Form menu.
5. On Date Title Revisions, click OK.

► **To preview a custom date title**

---

*From the Advanced Report Setup (GH9141) menu, choose Date Titles.*

1. On Work With Date Titles, click Find to bring up a list of valid date title types.
2. Choose the Date Title you want to preview, and then choose Preview from the Row menu.
3. On Date Title Preview, change or complete the following fields:
  - Date Title Type
  - Language
  - Company
  - Period Number  
If you leave this field blank, the value is retrieved from the Financial Reporting Date in the Company's application.
  - Fiscal Year  
If you leave this field blank, the value is retrieved from the Financial Reporting Date in the Company's application.
4. Choose Run Preview from the Form menu.

The date title appears on the form in the same format that it would appear in the report.

If the date title is over 100 characters, you will receive an error message, and the date title will be truncated to fit the available space.

If language-specific versions of the date title are not found, the date title appears in the default language.
5. Click OK.

## **Assigning Your Accounting Periods to the Column Headings**

Each fiscal date pattern type is assigned a name for each period, for example, Period One is equal to June. The name assigned to a period is used in the Date Title and in the Smart Column Headings associated with smart fields. Each Fiscal Date Pattern type can have its own period names to accommodate company-specific fiscal date patterns. For example, a fiscal date pattern that begins in October might have column heading October for Period 1, whereas a regular fiscal date pattern might have column heading January for Period 1.

### **See Also**

- *Smart Fields* in the *Enterprise Report Writing Guide* for additional information on Smart Column Headings

## ► To assign your accounting periods to the column headings

---

*From the Advanced Report Setup menu (GH9141), choose Column Headings.*

1. On Work With Column Headings, click Add.
2. On Column Headings Revisions, complete the following fields to set up a fiscal date pattern type, and then click OK:
  - Fiscal Date Pattern
  - Language
  - Period 1 - 14

## Working with the Drill Down Feature

---

In reports that show summary information, particularly financial reports, the report reader often needs to research beyond the summary information and into the detail from which the information was derived. For example, in a report that shows unpaid balances for customers, you might want to review each unpaid invoice that contributes to the total unpaid balance. You can design a report that uses the drill down feature to associate data on a report with a J.D. Edwards software interactive application. When reading an online report, a user can click data in the report, which automatically launches the J.D. Edwards software application.

When the J.D. Edwards software application opens, an audit trail is created that shows detail about the data on the report. The audit trail records are static. Therefore, the information in the audit trail might differ from the information in the records you are auditing. For example, if someone posts a transaction after you run a report and generate new audit trail data, the change is immediately reflected in the table, but it is not reflected in the audit trail. You cannot create an audit trail for tabular reports containing row or cell specifications or calculation fields.

---

### Caution

Because the drill down feature requires significant system resources, activate it only when necessary. In addition, the Balance Audit Work File table (F83UI001) does not automatically purge itself; therefore, you need to purge this work file periodically to improve processing time. The Drill Down program (P83001) is on the Advanced Report Setup menu (GH9141).

---

## Activating the Drill Down Feature

You can activate the drill down feature during the following activities:

- When you edit or revise the report using Report Design. This method will be described in the following task.
- When you create the report using the Report Design Director.
- When you are modifying or creating a report director template.

## See Also

- ❑ *To define additional properties for an application report in the Enterprise Report Writing Guide*
- ❑ *Adding or Modifying Director Templates in the Enterprise Report Writing Guide* for information about activating the drill down feature

## Before You Begin

- ❑ When enabling drill down in a batch version, override the specifications for the section layout and the event rules first. See *To override version specifications* in the *Enterprise Report Writing Guide* for instructions on overriding specifications.

## ► To activate the drill down feature

---

*In the J.D. Edwards Windows environment, choose Report Design Tool from the Report Writer menu (GH9111).*

1. On Report Design, access the report in which you want to activate the drill down feature.
2. Click in the tabular report section for which you want to activate the drill down feature.
3. Choose Section Properties from the Section menu.
4. On Tabular Section, click the Financial tab or the tab that relates to the director template-- for example, Financial Reports.
5. Click the following option, and then click Define:
  - Drill Down
6. On Work With Applications, click Find.

This form displays a list of all available applications. You can limit your search by entering search criteria in the QBE line.
7. Choose an application, and then click Select.

Choose an application to be called from the report. This is the application that you want to *drill* into to investigate balances.
8. On Work With Forms, choose a form, and then click Select.

Many J.D. Edwards software applications consist of multiple forms. Choose the form to open when you drill into the application.

If more than one version exists for a given form and application, the Work With Versions form appears.
9. On Work With Versions, do one of the following:
  - Choose a version, and then click Select.
  - Click Close to avoid choosing a specific version.

If the report has attached processing options, you are prompted to provide the parameters.

Form Interconnect Name: Call(App:P83001, Form: W83001A)      Version Name: XJDEU001

Available Objects

- Special Values
  - <Literal>
  - <Zero>
- Processing Option
  - PO PeriodNoGeneralLedger
- System Value
  - SL SectionNumber
  - SL ReverseSign
  - SL CurrentRow**
  - SL CurrentColumn
  - SL AgingDaysAR005

Data Structure

Value	Dir	Data Item
SL ReportName	→	szProgramID
SL VersionName	→	szVersionID
SL SectionNumber	→	mnSectionNumber
SL CurrentColumn	→	mnColumnNumber
SL CurrentRow	→	mnRowNumber

Structure Notes      Parameter Notes

OK      Cancel

- On Form Interconnections, from the Available Objects column, double-click the object in the Available Objects list that you want to pass to the Value column.

Data items come from the application that you just specified.

- Click the Directional arrow in the Dir column until it toggles to the right arrow icon (indicating that the data flows from the source to the target).

- Continue defining parameters for available objects.

Ensure that you move your cursor down to the next field in the data structure before choosing the next available object.

---

**Note**

Available objects vary, depending on the field type.

---

- After you have finished defining the form interconnection parameters, click OK.

- On Tabular Section, click OK to return to the Report Design form.

Proceed with the task of *Reviewing an Audit Trail*.

## Reviewing an Audit Trail

If you are viewing a report online that uses the drill down feature, you can click data in the report and automatically launch the J.D. Edwards software application. This establishes an audit trail whereby you can see detail about the data on the report.

### Before You Begin

- ❑ Run the report and view it online. See *To submit a report for batch processing* in the *Enterprise Report Writing Guide* for instructions on running a report and sending the output to your screen.

### ► To review an audit trail

---

*View your report online.*

1. On your online report, hover your cursor over the record you want to research until the cursor becomes a pointing index finger, then click.  
The Acrobat Reader displays a message asking if you want to launch the application.
2. On Acrobat Reader, click Yes to open the application form you want to research.  
The form that is associated with this report appears for that record.

Account Number	Account Description	Amount	Fiscal Year	Ledger Type	Subledger	Subledger Type	C
61.5100	Widget Sales-Class 1	1,965,000.00	5	AA			0000
62.5100	Widget Sales-Class 1	597,000.00	5	AA			0000
63.5100	Widget Sales-Class 1	302,000.00	5	AA			0000
	<b>TOTAL</b>	<b>2,864,000.00</b>					

3. Choose the record for which you want to display details, and then click Select.
4. The form that is associated with this report appears with details about the record which you are investigating.

**Financial Reporting Drill Down - [Work With Account Ledger]**

File Edit Preferences Form Row Window Help

Select Find Close Seg... New... Dis... Abo Links As-If... Internet

Account: 61.5100 Widget Sales-Class 1

Ledger Type 1: AA USD General Ledger From Date: 1/1/05

Ledger Type 2: Thru Date: 3/31/05

SubledgerType: Currency Code: \*

Posted  Unposted  All YTD: 449,000.00-

Subledger | Debit/Credit | Two Ledgers | Units

Do Ty	Doc Number	Doc Co	G/L Date	Explanation	LT 1 Amount	LT 1 Debit	P C	LT2 PC	LT 1 Credit
JE	1007	00060	1/1/05	January Units Entry			P		
JE	1004	00060	1/31/05	January Entries	156,000.00-		P		156,000.00-
JE	1009	00060	2/28/05	February Monthly Activity	148,000.00-		P		148,000.00-
JE	1020	00060	2/28/05	February Units Entry			P		
JE	1010	00060	3/31/05	March Monthly Activity	145,000.00-		P		145,000.00-
JE	1021	00060	3/31/05	March Units Entry			P		
				Column Total	449,000.00-				449,000.00-
				Ledger Total	449,000.00-				449,000.00-

Find records Row:1

- When you are finished with your evaluation of the form, click Close.
- When you are completely finished with your evaluation of the records, on Tabular Section - Financial tab, turn the Drill Down option off.

If you are creating an application report, the tab is named the same as the director template. For example, if you chose the Financial Reports template in the Director, the tab is named Financial Reports.

## Purging Drill Down Work Files

Each time that you activate the drill down feature in a report to review an audit trail, the system creates a work file which remains in the system until purged. Typically, a system administrator is responsible for purging drill down work files.

### ► To purge drill down work files

*From the Advanced Report Setup menu (GH9141), choose Drill Down Table Purge.*

- On Purge Financial Reporting Drill Down Work File, click Find.  
A list of all existing drill down work files appears in the grid.
- Choose a file, and then click Delete.

## Setting Up Business Views as Favorites

---

A business view *favorite* is a simplified method to access information. In Report Design, favorites allow you to create folders that contain only the business views that you require for your reporting needs. You can organize these business views in any logical grouping to simplify the selection process. For example, set up a group by reporting system, common functionality, or frequency of use.

During the report creation process, the Director allows you to choose business views from the favorites directory, but the Director interface is read-only. To modify the favorites, you must use the Favorites program, which you can access from the Advanced Report Setup menu (GH9141).

When setting up your favorites, you create a tree structure. The tree structure comprises folders and subfolders that allow you to logically categorize the business views that you designate as favorites. The tree structure appears in the left portion of the form, and any notes attached to the favorites appear in the right portion of the form. You can place subfolders directly into a predefined folder upon creation. The Work with Favorites form displays the information for favorites lists based on the user ID of the creator of the list.

You can also choose the language in which the text of the notes displays for your favorites.

### Creating a Favorites Folder or Subfolder

The folder is the top level of your favorites list. In the tree structure, your folders appear beneath the Favorites heading. You can place favorites directly into a folder and then create a subfolder to further categorize your favorites within that folder.

#### ► To create a favorites folder

---

*From the Advanced Report Setup menu (GH9141), choose Favorites.*

1. On Work With Favorites, click Add.
2. On Object Folder Revisions, complete the following fields and click OK:
  - Folder
  - Description
  - Folder Owner
  - Category Code 1
  - Category Code 2
  - Category Code 3
  - Category Code 4
  - Category Code 5
  - Category Code 6

► **To create a favorites subfolder**

---

**Note**

Because subfolders reside in folders, the folder in which you want to specify subfolders must already exist before you can add subfolders to it.

---

*From the Advanced Report Setup menu (GH9141), choose Favorites.*

1. On Work With Favorites, click the folder to which you want to add a subfolder, and then choose Add Subfolders from the Row menu.

The screenshot shows a dialog box titled "Favorites - [Object Folder Revisions]". It features a menu bar with "File", "Edit", "Preferences", "Window", and "Help". Below the menu bar is a toolbar with icons for "OK", "Can...", "Dis...", "Algo", "Links", "Displ...", "OLE...", and "Internet". The main content area is a form with the following fields:

- Folder:** Text box containing "Acc Rec".
- Description:** Text box containing "Accounts Receivable".
- Folder Owner:** Text box containing "7392" and "Accounts Receivable Department" to its right.
- Category Code 1-6:** Six empty text boxes stacked vertically.
- Parent:** Text box containing "Financials".
- Subfolder:** A checked checkbox.

2. On Object Folder Revisions, complete the following fields:
  - Folder
  - Description
  - Folder Owner
  - Category Code 1
  - Category Code 2
  - Category Code 3

- Category Code 4
  - Category Code 5
  - Category Code 6
3. Ensure that the Subfolder box has been selected, and then click OK.

## **Adding Business Views to a Favorites Folder or Subfolder**

After you add folders to a favorites list, you can add business views to the favorites folder. If you set up subfolders beneath your folders in your favorites list, you can also add business views to these subfolders.

### **► To add business views to a favorites folder or subfolder**

---

*From the Advanced Report Setup menu (GH9141), choose Favorites.*

1. On Work With Favorites, choose a folder or a subfolder.
2. From the Row menu, choose Revise Favorites.
3. On Favorites Revisions, click in the Object Name field, and then click the visual assist icon.
4. On Object Search, click Find to display a list of available business views.  
You can refine your search by entering search criteria in the QBE line.
5. Choose a business view in the detail area, and then click Select.
6. Repeat Steps 3-5 until you have added all the required business views to the folder or subfolder, and then click OK.

## **Using Notes with a Favorite, a Folder, or a Subfolder**

You can add notes to a favorite or a folder to describe its use or its contents. For example, you might include text that describes when to use a particular business view and the name of the business view.

### **► To add notes to a favorite, a folder, or a subfolder**

---

*From the Advanced Report Setup menu (GH9141), choose Favorites.*

1. On Work With Favorites, choose a favorite, folder, or subfolder.
2. From the Row menu, choose Note Revisions.

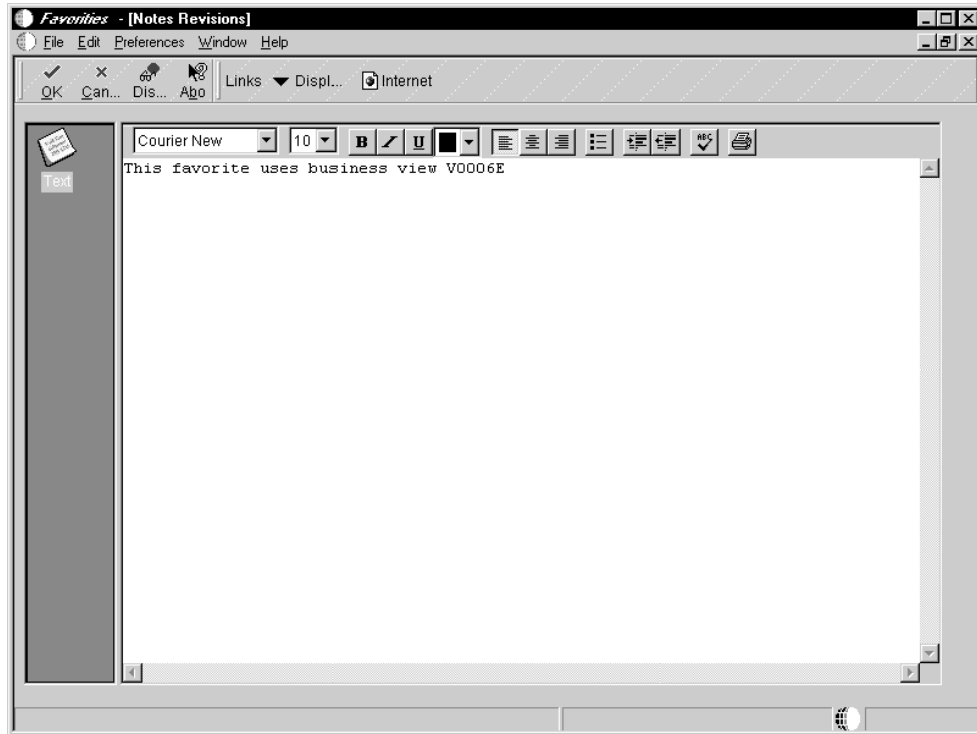

3. On Notes Revisions, type your note, and then click OK.

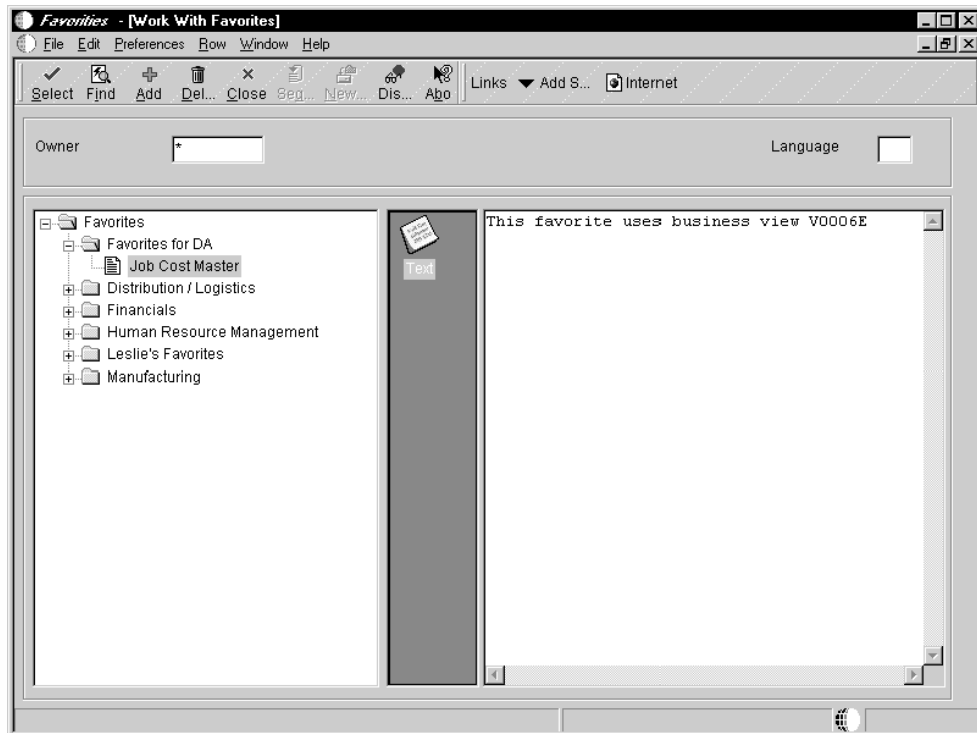

- On Work With Favorites, choose the appropriate item and notice that your note appears in the right portion of the form.

► **To delete notes from a favorite, a folder, or a subfolder**

From the Advanced Report Setup menu (GH9141), choose Favorites.

- On Work With Favorites, choose a favorite, a folder, or a subfolder.
- From the Row menu, choose Note Revisions.
- On Notes Revisions, delete the text, and then click OK.

## Translating Descriptions of Favorites

If you need to set up your system to handle multiple languages, you can enter alternate descriptions for your favorites to support the available languages. You can use the Favorites program (P91100) to include translations of items that appear in your favorites lists.

► **To set up favorites description translations**

From the Advanced Report Setup menu (GH9141), choose Favorites Description Translation.

- On Work With Favorites Description Translation, choose the language that you want to translate into from the grid, and then click Select.

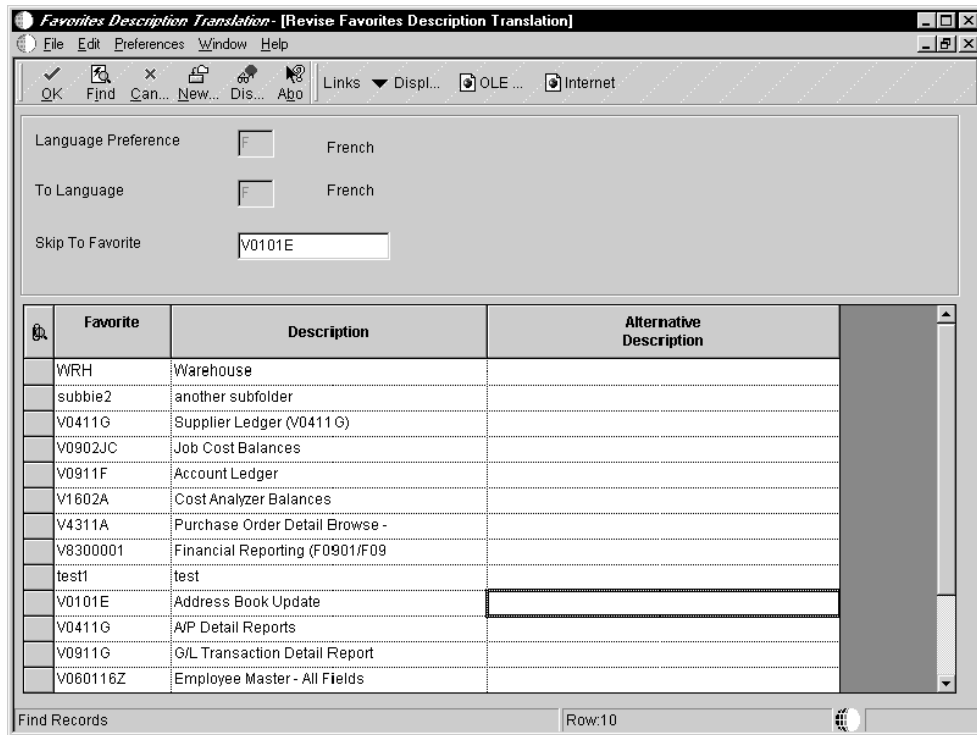

2. On Revise Favorites Description Translation, complete the following field, and then click Find:
  - Skip To Favorite
3. Type the Alternative Description in the detail area for the favorite you would like to translate, and then click OK.

► **To view a favorites list with alternative descriptions**

---

*From the Advanced Report Setup menu (GH9141), choose Favorites.*

On Work With Favorites, complete the following field, and then click Find:

- Language

If a favorite exists in the specified language, it displays; otherwise, the favorite displays in the domestic language.

Notice that the notes are blank to allow for notes to be entered in the translated language.

## **Working with Processing Options Templates**

---

Processing options control how a report or batch application processes data. They are version-driven; therefore, unique processing option values can be attached to different versions of the same report. Processing options for a report can be set to appear automatically at runtime to prompt the user for specific values. You can use processing options to:

- Control how a report processes data.
- Set up default values.
- Customize an application for different companies or even different users.
- Control the format of reports.
- Control page breaks for reports.
- Control totaling for reports.

A processing options template contains one or more processing options. Each processing option appears on a row within the template and is defined by its title, which includes its valid values if they exist.

The following overview outlines the process to create and use processing options templates:

1. Create processing options by building a list of parameters called a *template*.
2. Attach this template to a report and create event rules for the report to make use of these values.
3. Create versions of the report.
4. Specify how the processing options will be handled at run time by specifying different processing option values for different versions.
5. At run time, a processing option template displays a set of tabs within an area called a *page*. Each tab represents a category of processing options. When you click the

tab, the page changes to show the set of processing options for that category. At run time, depending on how you set up the report, one of the following occurs:

- The processing options appear, allowing the user to supply values.
- A versions list appears, with each version holding a preselected set of processing option values.
- The report runs with a preselected set of options, such as data selection and data sequencing, and with preselected processing option values.

This section contains detailed instructions for Steps 1 and 2 of the overview.

### **See Also**

See the following topics in the *Enterprise Report Writing Guide*:

- *To create a batch version* for information on creating versions of a report
- *To change processing options for batch versions* for information on specifying how processing options will be handled at run time
- *To submit a report for batch processing* for information on running a report

## **Designing Processing Options Templates**

You can create a processing options template that lists the values for data items passed to the report at run time. You can also add tabs to the processing options template.

### **► To create a processing options template**

---

*In the J.D. Edwards Widows environment, enter OMW in the fast path.*

1. On Object Management Workbench, click Add.
2. On Add J.D. Edwards Object to the Project, choose the following option and click OK.
  - Data Structure

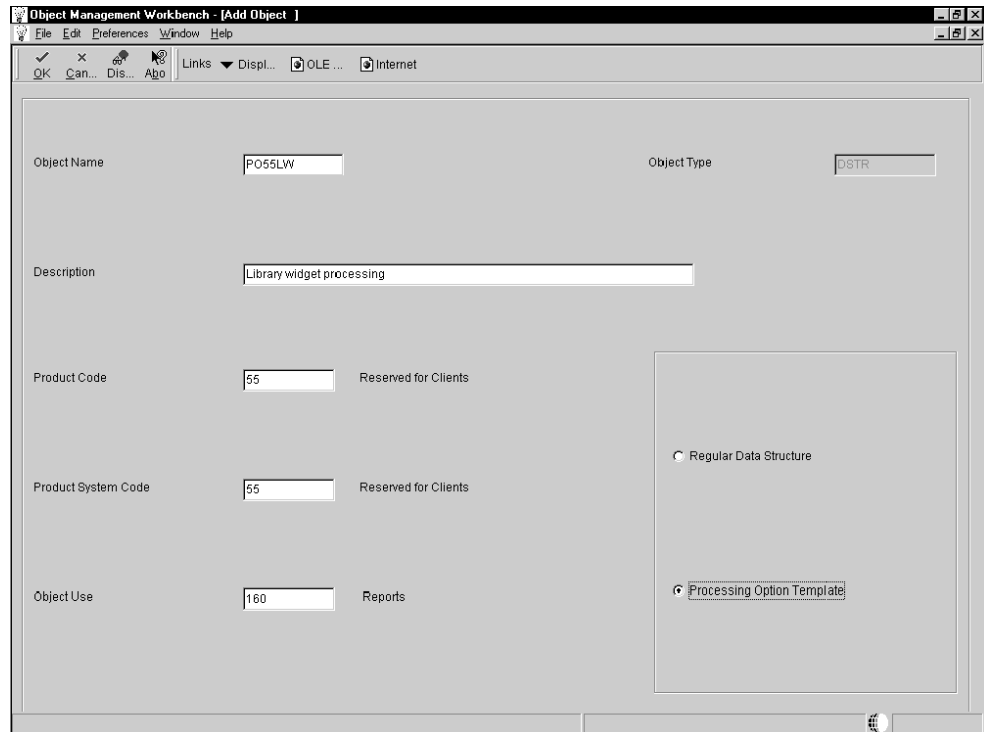

3. On Add Object, complete the following fields:

- Object Name
- Description
- Product Code
- Product System Code
- Object Use

Object Use should reflect the object being created. You can create your own valid value for Object Use. To do so, click the visual assist; then from the Form menu choose Revisions. On Work With User Defined Codes, click Add. On User Defined Codes, scroll to the bottom of the list to a blank row in the grid and enter a new code and description.

4. Choose Processing Option Template and click OK.

5. On Processing Option Design, click the Design Tools tab, and then click the Start the Processing Option Design Aid.

6. On Processing Options Design, click on the <New Tab>, right-click; and from the pop-up menu, choose Current Tab Properties.

7. On Tab Properties, complete the following fields, and then click OK:

- Short Name
- Long Name

8. To display data dictionary items on the Data Dictionary Browser form, perform one of the following:
  - Click the Search icon located directly beneath the Data Dictionary Browser heading.
  - Right-click on this form, and then choose Find.
  - Enter a value on the QBE line, and then press Enter.

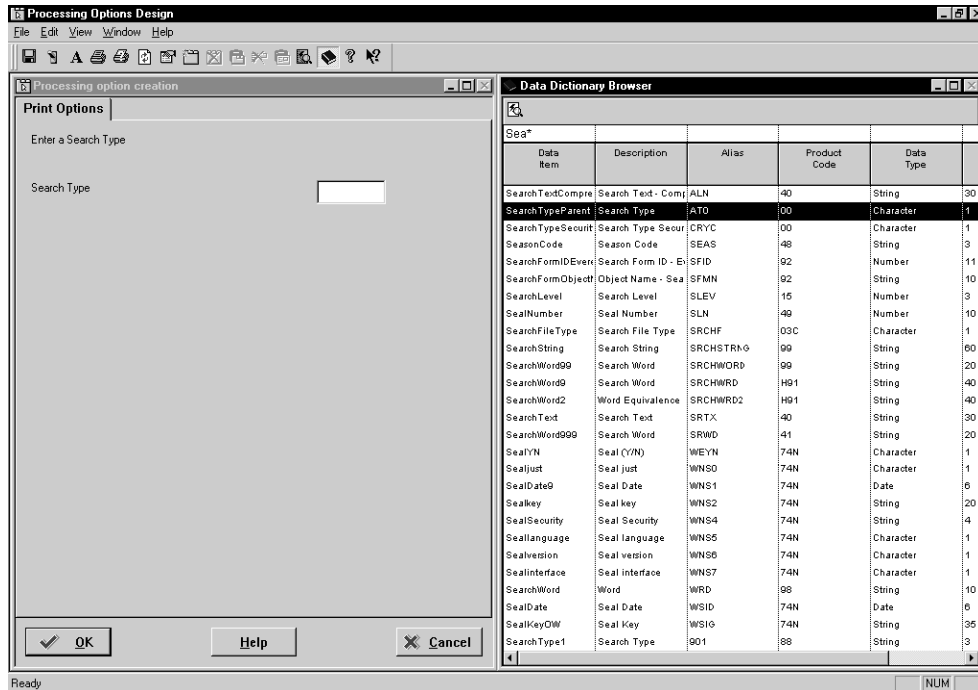

9. Use one of the following methods to select items that you want to add to your processing options:
  - Double-click the item in the Data Dictionary Browser. The item appears in the left side of the form under your tab.
  - Drag the item from the Data Dictionary Browser to the position you want it in on the tab.
10. To reposition an item on the tab, click the item and drag it to its new position.
 

The Processing Options tool automatically adjusts the size and position of data items to fit the width of the tab.
11. Double-click the text portion of the item to delete or overwrite it.
12. Right-click the data item and choose Properties from the resulting pop-up menu.
13. On JDE.DataItem Properties, on the General tab, change the Alias field, if necessary.
 

The Alias description must be a unique identifier.
14. Click the Help Override Data Item tab and modify the following field, if necessary:
  - Data Item Help Override Name
15. Click OK.

► **To add a tab to a processing options template**

*In the J.D. Edwards Windows environment, enter OMW in the fast path.*

1. On Object Management Workbench, click Add.
2. On Add J.D. Edwards Object to the Project, choose the following option and click OK:
  - Data Structure
3. On Add Object, complete the following fields and click OK:
  - Object Name
  - Description
  - Product Code
  - Product System Code
  - Object Use
4. On Processing Option Design, click the Design Tools tab, and then click Start the Processing Option Design Aid.
5. On Processing Options Design, click on the <New Tab>, right-click; then choose New Tab from the pop-up menu.

A second <New Tab> is added to the form, and the Tab Properties form appears.

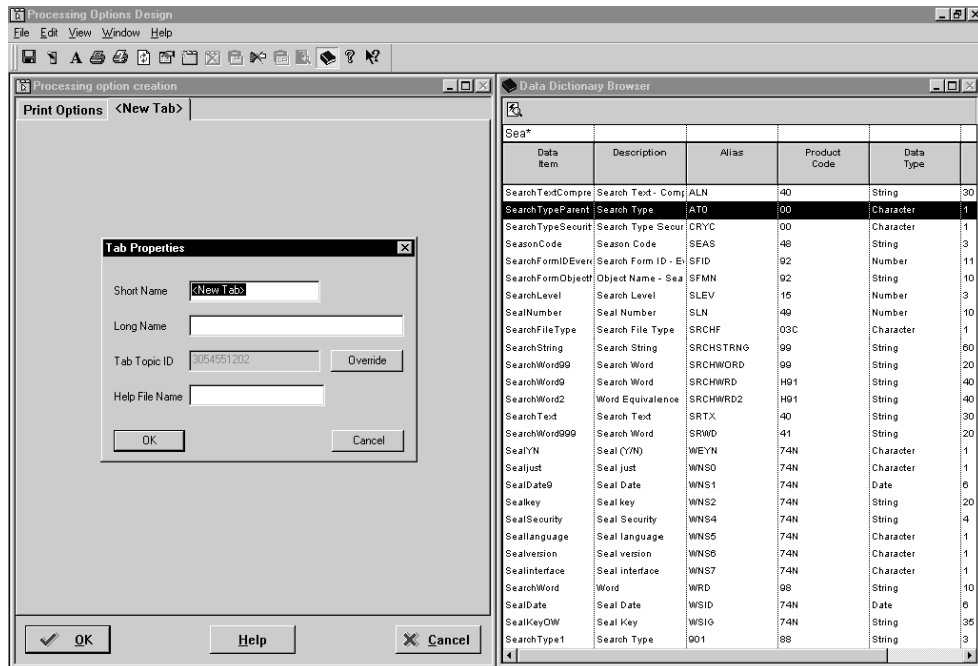

6. On Tab Properties, complete the following fields, and then click OK:
  - Short Name
  - Long Name
7. When your processing option is complete, you can choose Test from the Edit menu to see how it will display.

From this point, you can test the visual assist to ensure that you have chosen the correct data item for your processing option. You must save your changes before you exit.

## Attaching a Processing Options Template to a Report

You must attach a processing options template to a report to use the functionality at run time. Because the template exists as a separate object, you can attach the same template to multiple reports.

### ► To attach a processing options template to a report

---

*In the J.D. Edwards Windows environment, choose Report Design Tool from the Report Writer menu (GH9111).*

1. On Report Design, access your report to which you want to attach a processing options template.
2. Choose Select Processing Options from the File menu.
3. On Select Processing Option Template, choose the template you want to use, and then click OK.

A check mark appears next to Select Processing Options on the File menu, indicating that a processing options template is attached to this report.

4. To confirm that the correct processing options template is attached to the report, from the Report menu, choose Report Properties.

The Processing Options field indicates the processing options template that is attached to the report.

5. To remove an existing processing options template, choose Select Processing Options from the File menu.
6. On Select Processing Option Template, choose the template and click Remove.

## Working with Director Templates

---

The Report Director aids you in report design by helping you create a report object and guiding you step-by-step through the design process. In addition to creating a group, columnar, or tabular section through the Report Director, the Director uses director templates to help you create application reports, such as financial reporting, fixed assets, or job cost. These templates, included with J.D. Edwards software, contain default criteria. When you choose one of the templates in the Director, the Director program reads the template specifications (stored in J.D. Edwards software tables) and presents the default criteria through the Director forms. You can modify the J.D. Edwards software templates and create your own through the Smart Field Activation (P91420) and Report Director Templates (P91400) programs. For each director template you create, you must determine the following specifications:

- Which business view to use as the default view
- Which processing options to attach to the report
- Which Director forms to display
- Which smart fields to display for column selection
- The preferred smart field data selection
- The preferred data sequencing
- Which additional properties to include

The template specifications are stored in the following OneWorld tables:

<b>Report Director Templates (F91400)</b>	This table contains the default business view and processing option information.
<b>Report Director Templates Sequence Items (F91410)</b>	This table contains the information about the preferred data sequencing.
<b>Report Director Templates Smart Field Activation (F91420)</b>	This table contains the information about which smart fields to display.
<b>Smart Field Template Criteria (F91430)</b>	This table contains the information about smart field data selection.

## Working with Smart Field Templates

A smart field template lets you group smart fields so that you can include them collectively in a director template. For example, the smart field template called "S09001 - Financial Reporting" contains all the smart fields for financial reporting. J.D. Edwards' software includes predefined smart field templates. Through the Smart Field Activation program (P91420), you can add new or modify existing smart field templates to meet your reporting needs.

When you create a director template, you must attach a smart field template to the director template. The smart fields and data fields that are included in the smart field template determine which template you attach to the director template. For example, if you are creating a financial report, the smart field template called "S09001 - Financial Reporting" might contain all the smart fields and data fields that you require. Therefore, you could specify S09001 as the smart field template to attach to your director template. When you use the director template to create a report, the smart fields in the specified template appear in the Available Smart Fields area of the Select Column form of the Report Director. From this form, you can choose any of the fields to include in your report.

In addition to specifying which smart fields you want to include in the template, you can also include fields used for data selection within the smart field column. The fields chosen appear on the Smart Field Data Selection form of the Report Director.

### **Before You Begin**

- Before you can create a smart field template, the smart fields to include in that template must already exist. See *Attaching a Smart Field Trigger* in the *Development Tools Guide* to create smart fields.

### **► To create a new smart field template**

---

*From the Advanced Report Setup menu (GH9141), choose Smart Field Templates.*

1. On Work With Smart Field Templates, click Add.
2. On Smart Field Template Revisions, complete the following fields:
  - Smart Field Template
  - Description
3. Click in the Data Item field and click the Search button.
4. On Smart Field Search & Select, click the following option:
  - Smart Field
5. Click Find to display a list of all available Smart Fields.  
Use the QBE line to limit your search.
6. Choose a smart field, and then click Select.
7. Repeat Steps 3-7 until you have added all smart fields you want to include in the smart field template.
8. On Smart Field Template Revisions, click OK.  
The Smart Field Template Criteria Revisions form appears. This form lets you determine smart field data selection.
9. On Smart Field Template Criteria Revisions, click the visual assist icon in the Data Item field.

---

**Note**

The search form allows you to choose from all data items in the system. Select only those appropriate to your business views.

---

10. On Data Dictionary Search and Select by Alias, click Find to display a list of available data items.

Use the QBE line to refine your search.

11. Choose the data item, and then click Select.
12. On Smart Field Template Criteria Revisions, in the row of the data item that you selected, complete the following field:

Enter a 0 to indicate that the data item will have a single value only. Enter a 1 if you want a data item to accept a range of values, such as Object Account: From and Object Account: Thru. These data items appear on the Smart Field Data Selection form in the Director.

13. Repeat Steps 9-12 to select all data items for smart field data selection, and then click OK.
- 

**Note**

Only five data items are allowed. A range of values counts as two data items.

---

14. Use Display Sequences to determine the order in which you want the data items to appear on the Smart Field Data Selection form when you create an application report using the Report Director.

To use a smart field template, you must attach it to a director template.

**See Also**

- ❑ *Adding or Modifying Director Templates* in the *Enterprise Report Writing Guide* for information about connecting the smart field template to the director template

---

**► To modify an existing smart field template**

---

*From the Advanced Report Setup menu (GH9141), choose Smart Field Templates.*

1. On Work With Smart Field Templates, choose the template to be modified, and then click Select.
2. On Smart Field Template Revisions, add or delete smart fields from the template, and then click OK.
3. On Work With Smart Field Templates, choose Template Criteria from the Row menu to change the smart field data selection for the modified template.
4. On Smart Field Template Criteria Revisions, click the Data Item visual assist icon.
5. On Data Dictionary Search and Select by Alias, click Find to display a list of available data items.  
Use the QBE line to refine your search.
6. Choose the data item, and then click Select.

7. On Smart Field Template Criteria Revisions, in the row of the data item that you selected, complete the following field:
  - Range Values  
Enter a 0 to indicate that the data item will have a single value only. Enter a 1 if you want a data item to accept a range of values, such as Object Account: From and Object Account: Thru. These data items appear on the Smart Field Data Selection form in the Director.
8. Repeat Steps 4-7 to select all data items for smart field data selection, and then click OK.

---

**Note:**

Only five data items are allowed. A range of values counts as two data items.

---

9. Use Display Sequences to determine the order in which you want the data items to appear on the Smart Field Data Selection form when you create an application report using the Report Director.

To use a smart field template, you must attach it to a director template.

**See Also**

- ❑ *Adding or Modifying Director Templates* in the *Enterprise Report Writing Guide* for information about connecting the smart field template to the director template

## Adding or Modifying Director Templates

This section describes how to use the Report Director Templates program (P91400) to create and modify director templates. When created or modified, the templates are available to you on the Report Director's Welcome form.

---

**Caution**

Smart fields associated with a director template rely on business view columns in the template's associated business view. If you change the business view or select a different business view, the associated smart fields might not function correctly. Before making any such changes, ensure that you know which business view columns that the smart fields in question require.

---

**See Also**

See the following topics in the *Enterprise Report Writing Guide*:

- ❑ *To choose an application report template* for information about how the description appears on the Report Director's Welcome form
- ❑ *To define section data sequencing with the Advanced option off* or *To define section data sequencing with the Advanced option on* for information about the Data Sequencing Help form as it appears in the Report Director

## Before You Begin

- When you add a director template you will need to specify the name of a smart field template. If an existing smart field template does not contain the smart fields you need, you must create one suitable for your application. See *Working with Smart Field Templates* in the *Enterprise Report Writing Guide* for information about how to add or modify a smart field template.

### ► To add or modify a director template

---

*From the Advanced Report Setup menu (GH9141), choose Report Director Templates.*

1. On Work With Report Director Templates, click Add to add a director template.  
To modify an existing director template, click Find, choose the template to modify and click Select.
2. On Report Director Templates Revisions, complete the following fields:
  - Report Template/Description  
The description appears when you click the down arrow on the Report Director's Welcome form.
3. On the Building Blocks tab complete the following fields:
  - Section Type
  - Business View
  - Processing Options
  - Smart Field Template  
This field is active only if you chose to create a tabular section type.
4. Click in the Data Item field under the Default Sequence and Level Breaks column to display the Search button.
5. Click the Search button.
6. On Data Dictionary Search and Select by Alias, click Find to display a list of available data items.  
Use the QBE line to narrow your search.
7. Choose a data item in the detail area, and then click Select.
8. On Report Director Templates Revisions, click in the next Data Item field.  
The Description and Display Sequence form automatically appears for the data item selected in step 7.
9. Repeat steps 4-8 for every data item that you want to include on your report.  
The first two data item descriptions listed in the detail area are reflected in the Report Grouping column, and the subsequent data item descriptions are reflected in the Report Detail column on the Data Sequencing Help form of the Report Director.
10. On Report Director Templates Revisions, click the Properties tab.

11. Click the following options as necessary:

- Use Financial Description
- Display Level of Detail
- Display AAI Subtotal
- Display Adjust Sign
- Display Suppress Zero Rows
- Display Generic Criteria
- Display Financial Criteria

12. Click the Drill Down tab, and then click the Drill Down option.

By turning the Drill Down option on, the Drill Down option appears on the Additional Properties form of the Report Director. After designing your report with the Director, you can drill into the application, form, and version identified in the director template to see the detail of the data that appears on the report.

13. On Work With Applications, locate and choose the application to launch when the report reader wants to research report information.

14. Click Select.

15. On Work With Forms, choose a form, and then click Select.

If there are versions for a given form and application, the Work With Versions form appears.

16. On Work With Versions, choose a version, and then click Select.

17. On Report Director Templates Revisions, click OK.

## **Adding Text Attachments to a Report**

---

J.D. Edwards' software allows you to attach text to records in your database. For example, you might attach a comment to clarify a transaction, such as "Customer notified us that their payment was sent 02/01/99." Users can add text attachments to records from J.D. Edwards' software interactive applications.

You can design a report to show any text attachments that exist for a record. In this way, anyone who reads the report can see the same text attachments that are available in the interactive applications.

The following illustrates how a text attachment (shown under the Comments heading) might appear on your report:

R55LWGT		J. D. Edwards & Company		2/1/99	15:49:26
Voucher Detail					Page - 1
Document Number	Document Type	Invoice Date	Gross Amount	Comments	
1564	PV	6/5/05	1,500.0 0	Customer notified us that their payment was sent 2/1/99	
Document Number	Document Type	Invoice Date	Gross Amount	Comments	
1565	PVC	6/15/05	2,500.0 0	Voucher G9870 approved for payment by Jane Meade	

### See Also

- ❑ *To create an If/While statement in an event rule in the Enterprise Report Writing Guide for information about creating this criteria*

### Before You Begin

- ❑ This documentation assumes that text attachments already exist for the records to be included in the report. See *Media Object Attachments* in the *Foundation Guide* for information about adding text attachments.
- ❑ Access an existing report or create a new report that prints the records to which you have attached the text. See *Creating a Report Object* or *Report Design Director* in the *Enterprise Report Writing Guide* for information about accessing an existing report or creating a new report.
- ❑ J.D. Edwards software uses data structures to associate records with their text attachments. In this task you will need to specify the name of the data structure that the interactive application uses to associate records with their text attachments. You can use Object Management Workbench to see a list of all media object data structures (object type GT). See *Creating a Media Object Data Structure* in the *Development Tools Guide* for more information about media object data structures.

### ► To add text attachments to a report

*In the J.D. Edwards Windows environment, choose Report Design Tool from the Report Writer menu (GH9111).*

1. On Report Design, access the report and then select the detail section to which you want to add the text attachment.
2. From the Insert menu, choose Alpha Variable.
3. Insert the variable into the detail section.

4. Double-click the alpha variable field (the body, not the header) that you just inserted.  
An appropriate Variable Properties form appears.
5. On the Description tab, change the following field:
  - Variable Name  
Change the column or variable properties to a meaningful name-- for example, Comments.
6. Click the Display tab and modify the following field to a length that accommodates the text attachments that will appear in this field. If the text is longer than the display length, the text will wrap.
  - Display Length
7. Click OK.
8. Click anywhere in the detail section of your report to deselect the newly created alpha variable, and then choose Event Rules from the Edit menu.
9. On Event Rules Design, choose the Do Section event from the pull-down Events list.

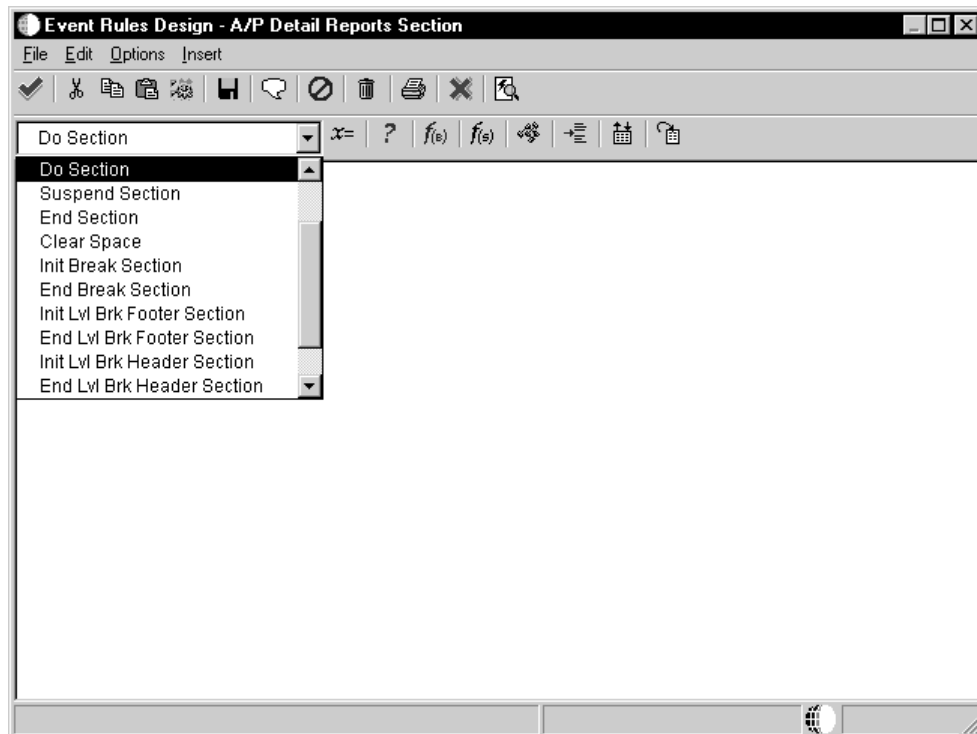

10. Choose System Function from the Insert menu.

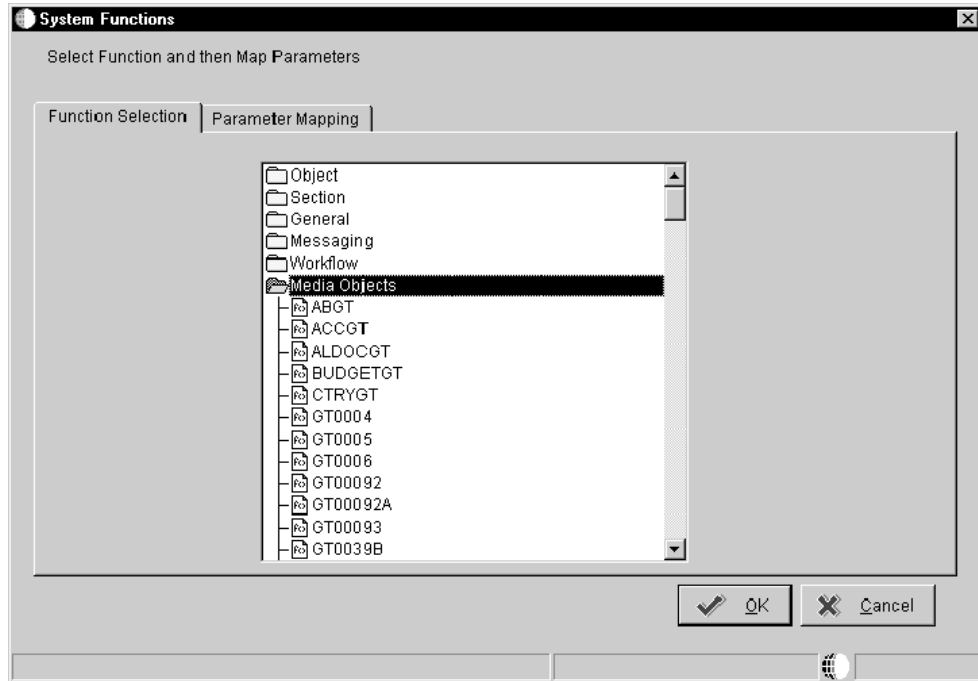

11. On System Functions, on the Function Selection tab, double-click the Media Objects folder to see all available functions.
12. Choose the media object data structure that was attached to the original application.
13. Click the Parameter Mapping tab.

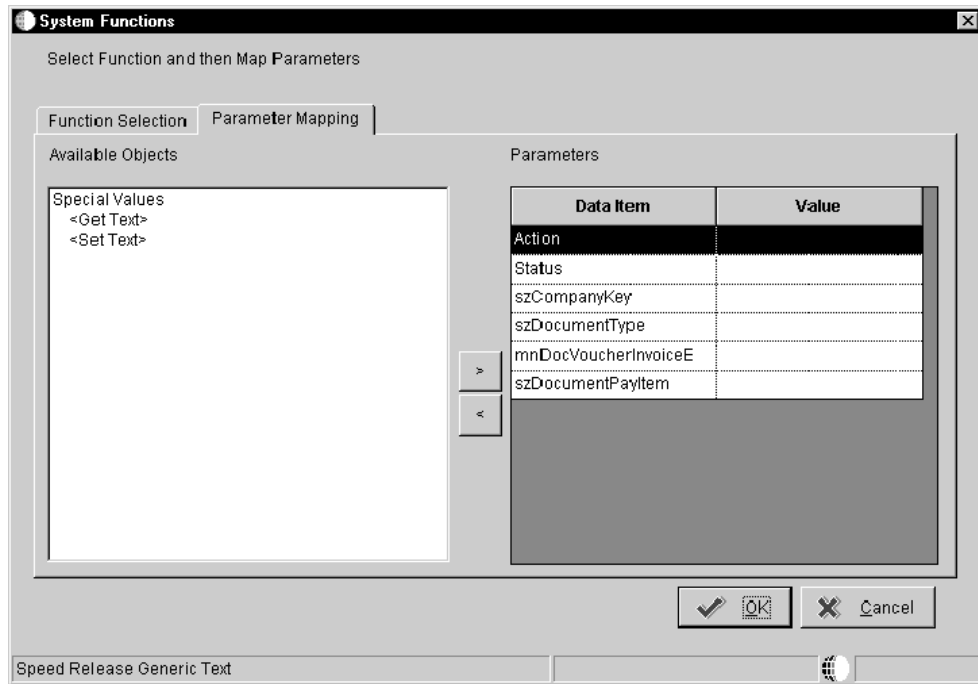

The parameters that appear on this screen, other than Action or Status, vary, depending on the criteria that you established.

14. Define the following two parameters:

- **Action**  
Choose <Get Text> from the Available Objects. This action calls a function to retrieve the generic text associated with the parameter.
- **Status**  
When you choose <Get Text> for the Action, this data item automatically changes to Text. Text designates the variable into which you input the retrieved text.

Choose RV Comments from the Available Objects.

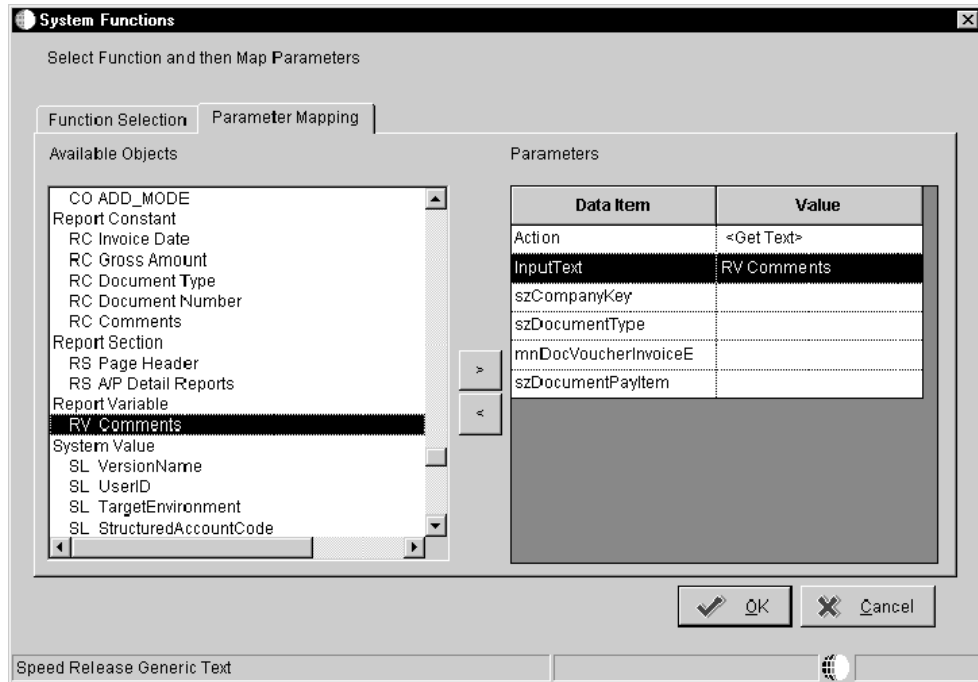

15. Define all other parameters using the available business view columns, and then click OK.

An event rule similar to the one below appears on the Event Rules Design form. This rule varies, depending on the criteria that you entered.

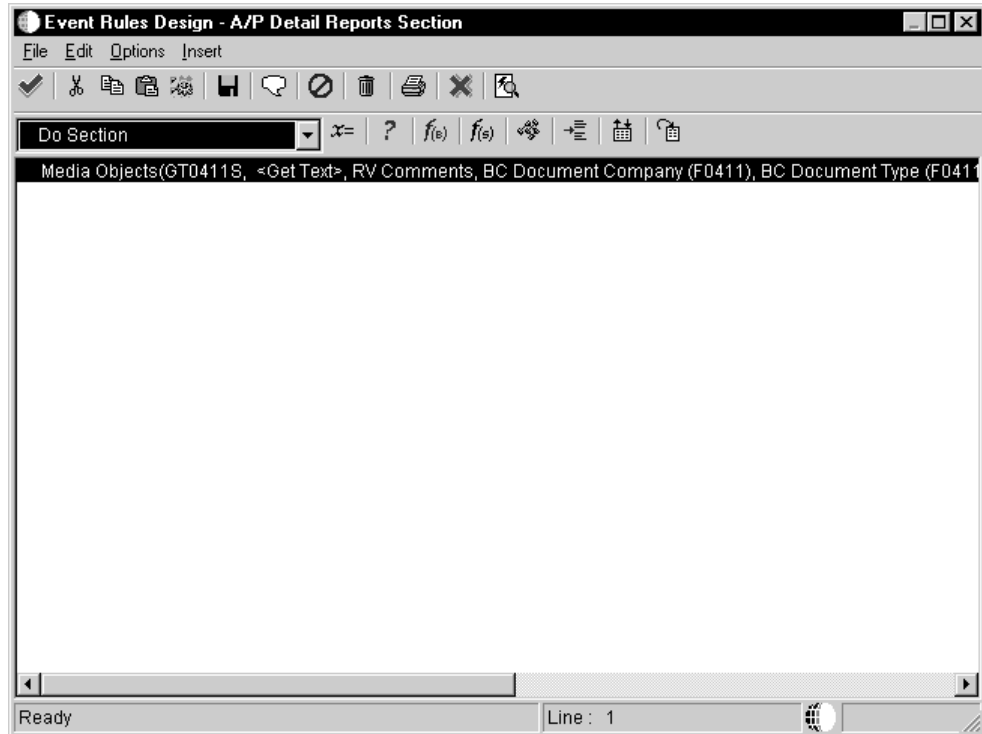

16. On Event Rules Design, click the check mark to save and return to Report Design.

17. Preview or run your report.

For any record that has generic text attached, the text prints where you placed the alpha variable on the report.

To see generic text for specific records, establish If/While criteria. If no generic text for the record exists or if the record is excluded by the If/While logic, no text prints in the alpha variable location.

## Working with Report Properties

---

Report Design lets you modify your report and version output by changing report properties. Report properties include details such as the report format, the number of records a report displays, various font types and colors, and more advanced properties.

You can also modify your report dimensions to support a custom form type. For example, if you want to print information on mailing labels, tax forms, or a preprinted check, you can define the dimensions of your report to match the dimensions of the hard-copy form type. Also, you can change the fonts on your report to print correctly on a line printer.

The properties that can be modified include report format and number of records displayed, default fonts and colors, cover page options, decimal scaling, and advanced properties.

### See Also

- *Transaction Processing* in the *Development Tools Guide* for additional information about using the Transaction Processing option

## ► To work with report properties

---

*In the J.D. Edwards Windows environment, choose Report Design Tool from the Report Writer menu (GH9111).*

1. On Report Design, access the report, and then choose Report Properties from the File menu.
2. On Properties, click the Report Properties tab, and click the following options as necessary:
  - Print Totals Only
  - Print Grand Totals
  - Suppress All Output
  - Limit Number of Primary Table Rows
3. Click the Font/Color tab.
4. Choose Apply settings to all Objects, click Defaults, or change other options.

Apply Settings to all Objects overrides any font/color choices you made at the individual field level.
5. Click the Cover Page Options tab.
6. Click the following options as necessary:
  - Print Cover Page

Cover pages provide information about the report or batch process including report properties, system properties, printer properties, and processing options. In addition, information is provided at the section level, including section properties, object properties, data selection and sequencing, and row properties. You can choose what level of detail your cover page will display for these properties.

If you choose Print Cover Page on Properties for the report template, a cover page does not print for the versions of the report. If you want to specify a cover page for a version, you need to turn this option on using Version Detail or Advanced Version Detail.

  - Report Properties
  - System Properties
  - Printer Properties
  - Processing Options
  - Section Properties
  - Data Selection
  - Data Sequencing
  - Object Properties
7. Click the Decimal Scaling tab and click one of the following options:
  - No Scaling
  - Scaling from 1 - 1,000,000,000
  - Apply settings to all Objects

8. Click the Advanced tab, and choose or update the following options and fields as necessary:
  - Subsystem
  - Wait Time (ms)
  - Custom
  - Enabled
  - Target
  - Source
  - Prompt for overrides at runtime
9. Click OK to save your changes.

## Using Dynamic Positioning

---

Dynamic positioning is a feature that:

- Allows you to designate a new font to be automatically applied when the report is printed on a line printer or in a foreign language
- Automatically adjusts the width of objects on a report so that they do not overlap when a font substitution occurs

This feature is most useful when you print reports in multiple languages. For example, you print a report in English, Greek, and Chinese. You might want to print the English reports in Arial; the Greek report, in Haettenschweiler; and the Chinese report, in SimSun. Since the German and Chinese fonts are wider than the English, the objects on the report are automatically repositioned to prevent overlap.

Dynamic positioning is also useful when you send many reports to a line printer and want them in different fonts so they will be easier to read. When sending reports to a line printer, you must use non-proportional fonts.

Dynamic positioning does not adjust for the height of report objects when you substitute fonts. If you are going to use font substitution for a report, space report object on different lines a little farther apart.

To use dynamic positioning, you must do the following:

- Turn dynamic positioning on for the machine where the reports are processed.
- Define font substitutions for languages and line printers.

Once you have turned dynamic positioning off for a machine, you should not turn it off. You can, however, turn dynamic positioning off for an individual report.

You can also view a report with font substitutions applied.

## Activating Dynamic Positioning for a Server or Client

You must enable dynamic positioning on the server or client that processes reports by inserting a line in the jde.ini file. If you run reports, to which you want to apply dynamic positioning, on more than one machine, you must enable dynamic positioning on each machine.

Once dynamic positioning is enabled, you should not disable it at the machine level. You can override it for an individual report.

### ► To activate dynamic positioning for a server or client

---

*Using Notepad, open jde.ini.*

1. In the [UBE] section, type the following line:

```
UBEDynamicPositioning=1
```

2. Save and close the jde.ini file.

## Defining Font Substitutions

Use the Bar Code font Support table (F986166) to tell the system which fonts to replace on a report when processing occurs. For example, if reports are created using the Arial font but you want them to print in Times Roman, you would enter this substitution on the font substitution table.

Font substitution is most useful for the following:

- To define fonts to be used when reports are sent to a line printer
- To define fonts to be used when a report is printed in a foreign language

The font substitution table allows you to indicate a new font, not a font size. When the font substitution is made, dynamic positioning automatically allows adjusts the position of items on the report to accommodate the width of the new font. It does not adjust the height of items on the report.

### ► To view font substitutions by language type

---

*From the Batch Processing Setup menu (GH9013), choose Font Substitution by Language Type.*

On Work with Font Substitution by Language Type, enter the language type in the QBE line and click Find.

The form displays all defined font substitutions for the language type that you entered.

### ► To define font substitutions for a language or line printer

---

*From the Batch Processing Setup menu (GH9013), choose Font Substitution by Language Type.*

1. On Work with Font Substitution by Language Type, click Add.

2. On Font Substitution by Language Revisions, complete the following fields and then click OK:
  - Language Type  
If you are defining a font substitution for a line printer, leave this field blank to select Domestic Language.
  - Original Font Name  
For a line printer, enter \*JDE LINE.
  - New Font Name  
For a line printer, you must use a non-proportional font, such as Courier New.

► **To change font substitutions by language type**

---

*From the Batch Processing Setup menu (GH9013), choose Font Substitution by Language Type.*

1. On Work with Font Substitution by Language Type, double-click the font substitution to edit.
2. On Font Substitution by Language Type Revisions, complete the following field and click OK:
  - New Font Name

## Turning On or Off Font Substitutions for a Report

If the report is already in the font you want, you can turn off font substitution for the report by selecting override. Once you turn off font substitution and save the report, font substitution remains disabled for the report. You must re-enable font substitution by deselecting override if you want font substitution in the future.

► **To turn font substitutions for an individual report on or off**

---

*In the J.D. Edwards Windows environment, choose Report Design Tool from the Report Writer menu (GH9111).*

1. On Report Design, access the report for which you wish to turn on or off font substitution.
2. From the File menu, choose Report Properties.
3. On Properties, click the Advanced tab.
4. In the System Language Font section, select Override.  
If Override is checked, font substitution is turned off. If Override is not checked, font substitution is turned on.
5. Click OK.

Once you have saved the report with the Override turned on, the system does not apply font substitutions to the report.

## Applying Font Substitutions to a Report Template

To view how a new font looks on a report before processing the report, you can apply the font substitution to the report template.

If the new font is also listed for substitution in the Font Substitution table, it will be replaced when you process the report. For example, if the Font Substitution table states that Arial should be replaced by Times New Roman and Times New Roman should be replaced by Courier and you apply the font substitution to an Arial report, the report appears on the report template in Times New Roman. If you then print the report, the system replaces the Times New Roman font with Courier. To prevent this replacement, turn off font substitution for the report after it appears in the font you want.

### ► To apply font substitutions to a report template

---

*In the J.D. Edwards Windows environment, choose Report Design Tool from the Report Writer menu (GH9111).*

1. On Report Design, access the report template to which you wish to apply font substitutions.
2. From the File menu, select Report Properties.
3. On Properties, click the Advanced tab.
4. In the System Language Font section, click Use System Language Font.

If a font substitution has been defined for the font currently used on the report, the system replaces the current font and dynamically positions items on the report to accommodate the new font.

## Using Business View V8300005 in Financial Row Reports

---

In ERP 9.0, a new business view, V8300005, was added to improve the system performance of Financial Row Reports. V8300005 is a simple join of the F0901, F0902, and F0006 tables. The output of a report using this business view will show only accounts with balances. It will not show header or title accounts. Use this business view in a financial row report where each row is individually defined.

If you did not receive V8300005 as part of ERP 9.0, but received it as part of an electronic software update (ESU), you need to manually change the report director template for financial row reports to use the new business view.

### ► To change the financial row reports director template to use business view V8300005

---

*From the Advanced Report Setup menu (GH9141), choose Report Director Templates.*

1. On Work With Report Director Templates, click Find to display the list of report director templates.
2. Choose S09003, Financial Row Reports and click Select.
3. On Report Director Templates Revisions, on the Building Blocks tab, change the value of the business view from V8300001 to V8300005, and then click OK.

PeopleSoft®

---

EnterpriseOne  
Enterprise Report Writing 8.9  
PeopleBook

---

2 of 2

**September 2003**



EnterpriseOne  
Enterprise Report Writing 8.9 PeopleBook  
SKU REL9EOR0309V2

Copyright 2003 PeopleSoft, Inc. All rights reserved.

All material contained in this documentation is proprietary and confidential to PeopleSoft, Inc. ("PeopleSoft"), protected by copyright laws and subject to the nondisclosure provisions of the applicable PeopleSoft agreement. No part of this documentation may be reproduced, stored in a retrieval system, or transmitted in any form or by any means, including, but not limited to, electronic, graphic, mechanical, photocopying, recording, or otherwise without the prior written permission of PeopleSoft.

This documentation is subject to change without notice, and PeopleSoft does not warrant that the material contained in this documentation is free of errors. Any errors found in this document should be reported to PeopleSoft in writing.

The copyrighted software that accompanies this document is licensed for use only in strict accordance with the applicable license agreement which should be read carefully as it governs the terms of use of the software and this document, including the disclosure thereof.

PeopleSoft, PeopleTools, PS/nVision, PeopleCode, PeopleBooks, PeopleTalk, and Vantive are registered trademarks, and Pure Internet Architecture, Intelligent Context Manager, and The Real-Time Enterprise are trademarks of PeopleSoft, Inc. All other company and product names may be trademarks of their respective owners. The information contained herein is subject to change without notice.

#### *Open Source Disclosure*

This product includes software developed by the Apache Software Foundation (<http://www.apache.org/>). Copyright (c) 1999-2000 The Apache Software Foundation. All rights reserved. THIS SOFTWARE IS PROVIDED "AS IS" AND ANY EXPRESSED OR IMPLIED WARRANTIES, INCLUDING, BUT NOT LIMITED TO, THE IMPLIED WARRANTIES OF MERCHANTABILITY AND FITNESS FOR A PARTICULAR PURPOSE ARE DISCLAIMED. IN NO EVENT SHALL THE APACHE SOFTWARE FOUNDATION OR ITS CONTRIBUTORS BE LIABLE FOR ANY DIRECT, INDIRECT, INCIDENTAL, SPECIAL, EXEMPLARY, OR CONSEQUENTIAL DAMAGES (INCLUDING, BUT NOT LIMITED TO, PROCUREMENT OF SUBSTITUTE GOODS OR SERVICES; LOSS OF USE, DATA, OR PROFITS; OR BUSINESS INTERRUPTION) HOWEVER CAUSED AND ON ANY THEORY OF LIABILITY, WHETHER IN CONTRACT, STRICT LIABILITY, OR TORT (INCLUDING NEGLIGENCE OR OTHERWISE) ARISING IN ANY WAY OUT OF THE USE OF THIS SOFTWARE, EVEN IF ADVISED OF THE POSSIBILITY OF SUCH DAMAGE.

PeopleSoft takes no responsibility for its use or distribution of any open source or shareware software or documentation and disclaims any and all liability or damages resulting from use of said software or documentation.



---

## Table of Contents

<b>Batch Versions for Reports</b>	<b>231</b>
Characteristics of Batch Versions .....	231
Batch Versions Created Using the Web Client.....	232
Working with Batch Versions.....	232
Running a Batch Version.....	233
Accessing the Work With Batch Versions Form.....	234
Changing the Design of a Batch Version .....	234
Changing Processing Options for Batch Versions .....	237
Accessing Data Selection and Sequencing for Batch Versions .....	239
Creating Reports of Processing Options .....	240
Accessing Properties for Table Conversion Versions .....	241
Working with Version Detail for Batch Versions .....	242
Copying a Batch Version .....	243
Creating a Batch Version.....	245
Checking Out or Checking In a Batch Version .....	246
Erasing the Check-Out Record of a Version .....	247
Changing Processing Options for the Batch Versions (P98305) Application.....	247
Moving Batch Version Specifications to an Enterprise Server .....	248
Overriding Version Specifications.....	249
Accessing BrowsER for a Report or Version.....	250
<b>Understanding Database Output</b>	<b>252</b>
<b>Report Processing</b>	<b>258</b>
Understanding Batch Processing .....	259
Report Sections .....	259
Understanding Section Processing .....	262
Processing Group and Columnar Sections .....	262
Processing Tabular Sections.....	264
Attaching Logic to Joined Sections.....	266
Data Selection and Sequencing .....	266
Understanding Custom Sections.....	267
Understanding Level-Break Processing .....	268
Level-Break Section Events .....	270
Understanding Batch Events.....	271
The Do Section Event.....	271
Additional Batch Events.....	271
System Functions within Batch Events.....	275
Understanding Batch Run-time Processing .....	276
Available Objects .....	276
Typical Event Flow for a Group Section .....	277
<b>Report Output</b>	<b>286</b>
Printing Properties in Report Design .....	286

Overriding a Designated Printer .....	286
Selecting Paper Type .....	287
Specifying Print Orientation .....	288
Exporting to Comma Separated Value (CSV) Files .....	289
Using System Function K2DolnitPrinter .....	290
Printing Properties at Report Submission .....	290
Resolving Printers.....	291
Selecting Paper Type .....	291
Specifying Print Orientation .....	292
Using the Print Immediate Option.....	292
Using the SavePDL (Printer Definition Language) File Option .....	292
Exporting to Comma Separated Value (CSV) Files .....	293
Storing and Passing Printer Information.....	293
Job Submission on Client .....	293
<b>Report Submission</b> .....	<b>295</b>
Submitting a Report.....	295
Submitting a Report for Batch Processing .....	295
Defining Processing Options .....	299
Overriding Data Selection and Data Sequencing.....	300
Using Advanced Option Overrides .....	302
Command Line Submission.....	303
Working with Submitted Reports .....	307
Checking Your Report Status .....	307
Viewing and Printing Your Report .....	308
Reviewing Errors .....	310
Holding and Releasing Reports on the Queue.....	310
Working with Your Report Output.....	311
Understanding Subsystem Jobs.....	312
Defining Subsystem Jobs.....	314
Adding an API Record to the Subsystem Table .....	315
Example: Subsystem Job Header File .....	315
<b>Report Printing Administration</b> .....	<b>319</b>
Understanding Printing.....	319
Running Reports on the Server .....	320
Running Reports on the Workstation.....	320
Print-Time Characteristics .....	321
Print Settings for the Workstation jde.ini.....	321
Working with the Printers Application.....	321
Generating and Retrieving Logs for Your Report .....	341
Setting Up a Null Pass-Through Print Filter .....	342
Designing Reports to Run on Line Printers .....	343
Setting Up a Printer to Use a Barcode Font.....	346
<b>Additional Information for Enterprise Report Writing</b> .....	<b>348</b>
Edit Code Table.....	348
Events .....	350

Events and Section Types .....	350
Available Objects .....	353
Report Examples .....	363
Report Techniques by Example .....	364
Printing Lists of Information .....	386
Printing Lists of Information Grouped by a Specific Field.....	388
Printing Totals and Auditing Numeric Data .....	392
Creating Journal Entries with Report Design .....	394
J.D. Edwards Reports .....	397
General Accounting .....	397
HR and Payroll Foundation .....	398
Inventory Management.....	398
Product Data Management.....	399
Smart Fields .....	399
Creating a Smart Field.....	400
Creating a Smart Field Template.....	413
Creating a Report Director Template.....	415
Creating a New Report Using Smart Fields .....	418
Understanding the Report .....	425
Output Stream Access .....	425
Creating and Associating OSA Interfaces .....	427
Creating an OSA Library .....	429



---

## Batch Versions for Reports

In J.D. Edwards software, a batch version is a user-defined set of specifications. These specifications control how batch processes run. Typically, batch versions are associated with reports or batch processes, and run as batch jobs on a J.D. Edwards software enterprise server.

Batch versions for reports are a predefined set of specifications contained in a file that is separate from the base report or batch specifications. These specifications control the logical functions and the appearance of the report. The version contains the processing instructions, which are a complete set of preselected processing options and additional characteristics specific to report design. Depending on how you assign security to your J.D. Edwards software applications, end users can choose or create different versions based on business requirements.

Versions are a powerful and convenient way to modify the behavior of reports. Typically, administrators control the creation, modification, and location of the initial batch version files. When you upgrade J.D. Edwards software or a specific application to a new release level, you can apply the existing batch versions without additional modification.

When you start a batch application (that is, when you submit a batch job) you must use a batch version. Depending on how the report was designed, you might have the option to override processing option values for the version. You also might be able to perform data sequencing and data selection, override default locations, or override the basic layout of the base report.

For example, suppose you have a report that prints the same financial information to two different audiences: an American subsidiary and a French subsidiary. You can create an American version, which shows financial information in dollars for a specific time period and formats the report for American-sized paper. You also can create a French version, which shows the financial information in francs for a different time period and formats the report for European-sized paper. For the French subsidiary, you also could display additional information on the report by adding data items in the French version.

---

## Characteristics of Batch Versions

A batch version is defined by the following characteristics:

- Data sequencing at the version level. For example, you can sort checks by date or by check number, you can sort address book records by employee or customer, or you can sort records alphabetically.
- Data selection at the version level. For example, you can specify which records to fetch, such as Business Unit 10-30 and 70, or all Address Book records with Category 1=North.
- Additions or overrides in the version at the section level. At the section level, report designers can use batch versions to add or override functionality using the report template. These section-level overrides differ from the version-level overrides in that they apply only to individual sections. At the section level, the report designer can override section layout, data selection, data sequencing, event rules, and database output. You cannot delete functionality if it exists in the base report.

- A specific set of processing option values. For example, you can set a processing option value to run G/L Post to print a different account number format on the report.

For batch versions, processing options do the following:

- Change functionality. For example, you can set a processing option to purge records to a history file after a report runs.
- Change input parameters. For example, you can set a processing option to specify which category code to use when processing a report.
- Define data. For example, you can set a processing option to define the fiscal year for which you want to run a report. You can also define the number of aging days in an Accounts Receivable aging report.

## **Batch Versions Created Using the Web Client**

---

If you use a Web client, you can create a new batch version of a report using the Add or Copy options on the Web client Work With Batch Versions - Available Versions form. The system indicates that these new batch versions are Web Only. To change the data selection, sequencing, or processing options of a Web Only version, choose the Data Selection, Data Sequencing, or Processing Options option from the Row menu.

To run a Web Only version in an environment other than the Web client, use Object Management Workbench to check the version out, and then check it in using the standard client. Object Management Workbench automatically converts the Web Only version to work on a standard client.

To permanently remove the Web Only flag, so that it becomes a standard version, generate the batch version using the eGenerator tool after converting the version. Since there must be specifications on the machine where the eGenerator tool is run, either run the conversion process on the same machine that runs the eGenerator tool, or use a "Get" within Object Management Workbench to bring the specification to the client running the eGenerator tool.

You cannot copy a batch version with a Web Only indicator.

### **See Also**

- *Generating OneWorld/ERP Serialized Objects in the Web Server Installation Guide* for instructions on using eGenerator

## **Working with Batch Versions**

---

For batch versions, J.D. Edwards software uses the same process as the Object Management Workbench to check in, check out, and erase checkouts for versions. You use this tool to control the movement of versions between the workstation and the server. Batch versions are submitted directly from the batch application.

Just like base report specifications, when you create a batch version, the specification records for that version exist only on your workstation. To make the version available to other users, you must check the version into the server. When you check in a version, J.D. Edwards software copies the version's specification records to the central objects data source (server) according to the path code of your current environment.

After you check in your version, you can still make specific changes to the version without checking it out. For example, when you make changes to the processing options, these changes are effective immediately, even if you have not checked in your local version. This is because a version's processing options are stored directly as a field in the version record that is stored in the server Version List table (F983051).

When you check a batch version into the central objects data source (server), anyone who installs and runs the version will be ensured of having the updated version. A version cannot be checked out by more than one user. The Version Detail form displays the user that has checked out a version.

You can create a new batch version that is not based on an existing version. For example, you might create a new version because you do not want to use the layout or data selection of the existing version. When you create a new version, you use the specifications provided by the base report.

If you make changes to the base (template) report, J.D. Edwards software automatically "pushes" any changes to all of the versions that exist for that base report, unless you created a version that contains overrides.

If you copy a version, the copied version inherits the same data selection and data sequencing as the existing version.

#### **See Also**

- ❑ *Changing the Design of a Batch Version* in the *Enterprise Report Writing Guide* for information about overrides

## **Running a Batch Version**

If batch versions are associated with a form, you can access them for viewing and printing from the form's Reports menu. Base reports and versions of those reports are available on menus as icons.

In most cases, you submit batch versions to an enterprise server, which can more efficiently handle the processing. The J.D. Edwards software environment that you log into specifies where your batch versions will run, although you can override this location when you submit a batch version. When you submit your batch job to the server, you can preview the report and use the Work With Servers program (P986116) to monitor the progress of your job in the queue.

When you submit a report to the enterprise server, if the report specifications do not currently reside on your workstation, the central objects data source (server) first performs JITI (just-in-time installation) to transfer the specifications to your workstation. After the JITI, your workstation continues with the submission of the report to the enterprise server, and J.D. Edwards software transfers the local version specifications (any changes you made to the version) to the enterprise server.

If a batch version is flagged as Web Only, and you are running the batch version on a fat client you must convert it into a flat client version before you can run it. To convert the web only batch version, use Object Management Workbench to check the batch version in, then check it out.

### See Also

- *Submitting a Report* in the *Enterprise Report Writing Guide* for complete information about running a batch version
- *The Work with Servers Program* in the *Configuration Planning and Setup: System Administration Guide* for information about the Work With Servers form

## Accessing the Work With Batch Versions Form

You can access the Work With Batch Versions - Available Versions form, which is the entry point to managing batch versions, in one of several ways.

### ► To access the Work With Batch Versions form

---

*Open J.D. Edwards Solution Explorer.*

From the Report Writer (GH9111) menu, choose Batch Versions (P98305).

The Work With Batch Versions – Available Versions form appears.

## Related Tasks

Other methods of accessing the Work With Batch Versions form include:

- From any menu with a batch application, choose the batch application and then, from the Edit menu, choose Prompt for Versions.
- From any menu with a batch application, right-click the batch application and then, from the pull-down menu that appears, choose Prompt for Versions. If no versions are associated with the batch application, you must copy or add a version and run that version as explained in this section.
- On the Menu bar, choose Tools and then Batch Versions.

## Changing the Design of a Batch Version

To change the specifications for a version, you do not need to change the base report template; instead, you can override the report specifications at the version level. The changes you make to the report specifications for the version do not affect any other version associated with the base report template. However, if you change the specifications at the report template level, those changes will not be pushed down to the version if an override has been applied to that specification type.

When you change the specifications at the version level, you should include a description of your modifications in the Version Detail field on the Version Detail form. The description should include any differences between the base report specifications and the version specifications.

The following can be changed in a report version:

- Section Layout
- Section Data Selection
- Section Event Rules
- Section Database Output
- Section Sort Sequence

---

**Note**

If you are using the Web client, you can only make run-time changes to a version if the version is not flagged as Web Only. Run-time changes do not persist.

---

**See Also**

- *Working with Version Detail for Batch Versions* in the *Enterprise Report Writing Guide*

**Before You Begin**

- Override specifications only at the version level. To copy or create a version to override, see *Copying a Batch Version* or *Creating a Batch Version* in the *Enterprise Report Writing Guide*.
- Check out the version before you access Report Design to create a version override; see *Checking Out or Checking In a Batch Version* in the *Enterprise Report Writing Guide*.
- Close the Report Design tool if it is open on your computer.

---

**► To change the design of a batch version**

---

Use the Batch Versions program (P98305) to locate and run versions of reports. In addition, you can modify version detail information, data selection, and data sequencing.

*In the J.D. Edwards Windows environment, choose Batch Versions from the System Administration Tools menu (GH9011).*

1. On Work With Batch Versions - Available Versions, complete the following field:
  - Batch ApplicationFor example, to locate a version for the One Line Per Address program, type R014021.
2. Click Find to locate the versions available on your workstation.
3. For alternate lists of versions in the J.D. Edwards Windows environment, from the Form menu, choose Display, and then choose one of the following:
  - Available Versions - for the versions available on your workstation
  - My Versions - for the versions you created
  - All Versions - for any version that exists for the batch application

When you view all versions, you can work only with versions that appear with black text.

You can delete any version (depending upon your application and user security) unless you are on a web client. If you are on a web client, you can only delete versions with a Web Only flag. If you try to delete a version that is not on your machine, a warning message appears.

4. In the detail area, choose a version with which you want to work.
5. From the Row menu, choose Advanced.

---

**Note**

Before you can complete the following steps, you must have already checked out a version of the report.

---

6. On Advanced Operations, choose Design Version from the Row menu.  
Report Design opens with the report specifications for the version.
7. On Report Design, click in a section and then choose Override Version Specifications from the Section menu.

You cannot make any changes to a section until you access the Override Version Specifications form and choose what you want to change.

Any overrides you make to a section are valid only for that section. You need to override additional sections individually.

8. Choose any of the following overrides, and then click OK:

---

**Note**

Remember that if you override any version specifications, those specifications are not updated if you then make changes to those specifications in the base report template. For example, if you turn on the Section Data Selection override and make changes to the version's data selection, and then later you change the data selection of the report template, the report template data selection changes will not be pushed to the version.

---

- **Section Layout**  
Select this override if you need to change section properties or to delete a column, add a new column, move a column, or change column headings on a report version.
- **Section Data Selection**  
Select this override if you need to have report versions that utilize specific data selection, such as a version for customer information only and a version for employee information only.
- **Section Event Rules**  
Select this override if you need a report version that utilizes a specific event rule, such as a version for employee information with a calculated percentage raise amount, date title, or Balance Auditor.

- Section Database Output  
Select this override if you need a report version that prints to a specific location other than the default printer location. If you want other sections, such as the page header, to also print to this location, you need to override the specifications to each of those sections as well.
  - Section Sort Sequence  
Select this override if you need a report version that is sorted differently than the base report. For example, you can have a version sort by name rather than by address number.
9. The changes you make affect only the version on your local workstation. To make these changes available to the enterprise, you must now check in the version. If you do not check in the version, verify that you erase your checkout so that others can check out this version.

#### See Also

- ❑ *Checking Out or Checking In a Batch Version* in the *Enterprise Report Writing Guide*
- ❑ *Erasing the Check-Out Record of a Version* in the *Enterprise Report Writing Guide*

## Changing Processing Options for Batch Versions

You can change the processing option settings for an existing batch version to suit your needs. For example, you can change the processing option values that direct the system to show or hide a field or you can change order activity rules. Not all batch versions have processing options associated with them; for example, a list of addresses might not require special prompting.

Processing option changes are stored for each UBE run. Unlike other changes to versions, changes to processing option values do not require you to check in or check out the version. Anyone who uses that version after you make the change will not be affected by the new processing option values.

If you are using a Web client, you can change the processing options of Web Only versions both at run time and within the version specifications. If the version is not marked Web Only, you can only change the processing options at run time. Run-time changes are not persistent.

---

#### Note

You should not modify J.D. Edwards demo versions, which contain ZJDE or XJDE prefixes. You should either copy these versions or create new versions to change any values, including the version number, version title, prompting options, security, and processing options.

---

#### Before You Begin

- ❑ If you access processing options from the Row menu of the Work With Batch Versions form, you must check out the version to your machine. See *Checking Out or Checking In a Batch Version* in the *Enterprise Report Writing Guide*.

## ► To change processing options for batch versions

---

*From the System Administration Tools menu (GH9011), choose Batch Versions (P98305).*

1. On Work With Batch Versions - Available Versions, type an application ID in the Batch Application field.  
For example, to locate a version for the One Line Per Address report, type R014021.
2. Click Find to locate the versions available on your workstation.  
Alternatively, on Work With Batch Versions - Available Versions, from the Form menu, choose Display and then click one of the following:
  - Available Versions  
All versions available on your workstation are shown.
  - My Versions  
Only the versions you created are shown.
  - All Versions  
All versions that exist for the batch application are shown. When you view All Versions, you can work only with versions that appear in black text.
3. In the detail area, choose the version with which you want to work.  
The Work With Batch Versions form shows only the versions available to your workstation, including any versions you create locally. Versions created on another machine must first be checked in to the central objects data source (server) before they appear on this form.
4. From the Row menu, choose Processing Options.  
If processing options do not exist for this version, or if you have been secured from changing processing options, a message box appears informing you of this; otherwise, the Processing Options form appears for the application. On this form, you can define the values that control how your report processes.  
  
You can also access the Processing Options form in the following ways:
  1. Choose a batch application, and then choose Prompt for Values from the Edit menu on J.D. Edwards Solution Explorer.
  2. Right-click the batch application name in J.D. Edwards Solution Explorer, and then choose Prompt for Values from the pull-down menu that appears.
5. Click each tab to view and change information on that tab.  
If multiple tabs exist and you cannot see all of them, left and right arrow buttons appear on the form. Click the arrow buttons to view the other tabs. You can also resize the Processing Options form by pointing to the edge of the form and dragging, or use the scroll bar to view additional processing options on a tab.
6. Change the processing option values as appropriate, and then click OK.

## Accessing Data Selection and Sequencing for Batch Versions

With batch versions, you can choose certain data values to narrow the range of your report. For example, you can choose to view only customers from New York. You can also sequence how you want your data presented in the report. For example, you can place your search type field first, followed by your address number and then the employee name.

You can select and sequence your data from one of two places, either from the Work With Batch Versions form, as explained here, or from the Version Prompting form.

If you are using a Web client, you can change the data selection and sequencing for Web Only versions both at run time and within the batch specifications. You can only change data selection and sequencing in non-Web Only versions at run time. Run-time changes are not persistent.

### See Also

- *Submitting a Report in the Enterprise Report Writing Guide*

### Before You Begin

- If you access data selection and sequencing from the Row menu of the Work With Batch Versions form, you must check out the version to your machine. See *Checking Out or Checking In a Batch Version* in the *Enterprise Report Writing Guide*.

### ► To access data selection and sequencing for batch versions

---

*From the System Administration Tools menu (GH9011), choose Batch Versions (P98305).*

1. On Work With Batch Versions – Available Versions, type an application ID in the Batch Application field. For example, to locate a version for the One Line Per Address report, type R014021.
2. Click Find to locate the versions available on your workstation.

Alternatively, on Work With Batch Versions - Available Versions, from the Form menu, choose Display and then click one of the following:

- Available Versions  
All versions available on your workstation are shown.
  - My Versions  
Only the versions you created are shown.
  - All Versions  
All versions that exist for the batch application are shown. When you view All Versions, you can work only with versions that appear in black text.
3. In the detail area, choose a version with which you want to work. The version must be checked out.
  4. From the Row menu, choose one of the following:
    - Data Selection  
The Data Selection form appears.

- Data Sequencing

The Selection Data Sequencing form appears.

When you are working with table conversion batch applications, J.D. Edwards software grays out the Data Selection and Data Sequencing menu items because they do not apply to table conversions.

5. To make these changes available to the enterprise, check in the version.

The changes that you make affect only the version on your local workstation. If you do not check in the version, ensure that you erase your check out so that others can check out this version.

#### See Also

- *Checking Out or Checking In a Batch Version* in the *Enterprise Report Writing Guide*
- *Erasing the Check-Out Record of a Version* in the *Enterprise Report Writing Guide*

## Creating Reports of Processing Options

This task explains how to create reports about processing options for interactive and batch application versions. This report shows the tab, text, and value of any processing option attached to an application's version (not all versions have processing options).

---

#### Caution

Run this process only locally (on your workstation).

---

#### ► To create reports of processing options

---

*From the System Administration Tools (GH9011), choose Batch Versions or choose Interactive Versions.*

1. On Work With Batch Versions – Available Versions, type an application ID in the Batch Application field or the Interactive Application field. For example, to locate a version for the General Journal by Batch report, type R09301 into the Batch Application field.
2. Click Find to locate the versions available on your workstation.
3. Do one of the following:
  - Choose a version and then choose Processing Options from the Row menu to view the version's default values.
  - Choose a version and then choose Print Options from the Row menu.
  - Without choosing a version, choose Print Options from the Form menu.
4. On Report Output Destination, choose one of the following options:
  - On Screen
  - To Printer

- Export to CSV
5. Choose the following option, if needed, and complete the associated field:
    - OSA Interface Name
  6. Click OK.

The system processes the report.

## Accessing Properties for Table Conversion Versions

This task is only for table conversion batch applications. You can access the version's properties from the Table Conversion Prompting form. You can also access properties directly from the Work With Batch Versions - Available Versions form.

### See Also

- *Submitting a Table Conversion* in the *Table Conversion Guide* for an explanation of the Table Conversion Prompting form

### ► To access properties for table conversion versions

---

*From the System Administration Tools menu (GH9011), choose Batch Versions.*

1. On Work With Batch Versions – Available Versions, type a table conversion application ID in the Batch Application field.
2. Click Find to locate the versions available on your workstation.

For alternate lists of versions, from the Form menu, choose Display, then choose one of the following:

- Available Versions - for the versions available on your workstation
- My Versions - for just the versions you created
- All Versions - for any version that exists for the batch application

When you view all versions, you can work only with versions that appear with black text.

3. In the detail area, choose a version with which you want to work. The version must be checked out.
4. From the Row menu, click Properties. This menu selection is enabled only for table conversions.

The system displays the Properties form.

5. The changes you make will affect only the version on your local workstation. To make these changes available to the enterprise, you must now check in the version. If you do not check in the version, make sure you erase your check out so that others can check out this version.

## See Also

- ❑ *Submitting a Table Conversion* in the *Table Conversion Guide* for information about changing table conversion properties
- ❑ *Checking Out or Checking In a Batch Version* in the *Enterprise Report Writing Guide* for information about checking in the version
- ❑ *Erasing the Check-Out Record of a Version* in the *Enterprise Report Writing Guide* for information about erasing a check-out record

## Working with Version Detail for Batch Versions

Use version detail to review information about a version, such as its title, the prompting options associated with it, or the security level. You can also specify whether to print a cover page on a report.

### Before You Begin

- ❑ Check out the version before you work with version detail. See *Checking Out or Checking In a Batch Version* in the *Enterprise Report Writing Guide*.

### ► To work with version detail for batch versions

---

*From the Report Writer menu (GH9111), choose Batch Versions.*

1. On Work With Batch Versions – Available Versions, type an application ID in the Batch Application field. For example, to locate a version for the One Line Per Address report, type R014021.
2. Click Find to locate the versions available on your workstation.

For alternate lists of versions, from the Form menu, choose Display, then choose one of the following:

- Available Versions - for the versions available on your workstation
- My Versions - for just the versions you created
- All Versions - for any version that exists for the batch application

When you view all versions, you can work only with versions that appear with black text.

3. Choose a version in the detail area with which you want to work. The version must be checked out.
4. From the Row menu, choose Version Detail.

The system displays the Version Detail form on which you can change information such as the title of the version, how the version uses processing options, and the security level for the version. You can also review background information about the report.

5. On Version Detail, modify or complete the following information:
  - Version Title
  - Prompting  
This option appears only if processing options are attached to the associated report template.
  - Security
  - Version Detail
  - Print Cover Page
  - Job Queue  
If you leave the Job Queue field blank, J.D. Edwards software reads the setting in the jde.ini on the enterprise server. If you submit the job to an AS/400, J.D. Edwards software looks to your user profile to determine the job queue.
  - Client Platform
6. Review the additional information that appears on the form as needed.
7. Click OK.
8. Check in this version to make it available to the enterprise.

**See Also**

- *Checking Out or Checking In a Batch Version* in the *Enterprise Report Writing Guide*

## **Copying a Batch Version**

You can copy an existing version, if it is not a Web Only version, and then tailor its information to fit your needs. The copied version inherits all the report template properties of the original version, including any overrides. If you are using a web client and copy a version, the new version you create is flagged Web Only. You cannot copy a Web Only version.

When you copy a batch version, you should add security to the new version. Security settings range from none, which means anyone has the authority to modify or run a version, to full security, in which only the person who last modified the version can modify and run the version. Version security is separate from Security Workbench, which allows you to set security for different J.D. Edwards software objects, such as applications.

**See Also**

- *Security* in the *System Administration Guide* for information about Security Workbench

## ► To copy a batch version

---

*In the J.D. Edwards Windows environment, choose Batch Versions from the Report Writer menu (GH9111).*

1. On Work With Batch Versions - Available Versions, type an application ID in the Batch Application field. For example, to locate a version for the One Line Per Address report, type R014021.
2. Click Find to locate the versions available on your workstation.

For alternate lists of versions, from the Form menu, choose Display, and then choose one of the following:

- Available Versions - for the versions available on your workstation
- My Versions - for just the versions you created
- All Versions - for any version that exists for the batch application

When you view all versions, you can work only with versions that appear with black text.

3. In the detail area, choose a version with which to work.
4. Click Copy on the toolbar.
5. On Version Copy, complete the following fields:

- New Version
- Security
- Version Title

6. Click OK.

The Batch Version Design form appears. On this form, you can select Revise Version to edit version information or you can select Run to run the new version.

7. On Batch Version Design, click OK to save your version.

When you click OK to copy a report version, if the version specifications do not currently reside on your workstation, the central objects data source (server) performs JITI (Just-in-time Installation) to transfer the specifications to your workstation.

8. Check in the new version to make this version available to the enterprise.

### See Also

- *Checking Out or Checking In a Batch Version in the Enterprise Report Writing Guide*

## Creating a Batch Version

You can create a new batch version that is based solely on the specification of the report template. Unlike copying a version, when you create a new batch version, the new version does not inherit any overrides.

If you are using a web client to create a new batch version, the new version is flagged Web Only.

When you create a batch version, you should add security to the new version. Security settings range from none, which means anyone has the authority to modify or run the version, to full security, in which only the person who last modified the version can modify and run the version. Refer to the Security field description for more information. Version security is separate from Security Workbench, which allows you to set security for different J.D. Edwards software objects, such as applications.

### See Also

- ❑ *Security* in the *System Administration Guide* for information about Security Workbench
- ❑ *Batch Versions Created Using the Web Client* in the *Enterprise Report Writing Guide* for information on Web-Only versions

### ► To create a batch version

---

*In the J.D. Edwards Windows environment, choose Batch Versions from the Report Writer menu (GH9111).*

1. On Work With Batch Versions - Available Versions, type the batch application upon which you want to base the new batch version in the following field:
  - Batch Application
2. Click Add to create a new version.
3. On Version Add, complete the following fields:
  - Version
  - Version Title
  - Prompting Options

If the batch application on which you base your version does not have any processing options attached, J.D. Edwards software leaves the Prompting Options field inactive. You can attach processing options only to a batch application template in Report Design.
  - Security
  - Job Queue
  - Version Detail

4. Choose the following option, if necessary:
  - Print Cover Page
5. Click OK to save your version.
6. Check in the new version to make this version available to the enterprise.

**See Also**

- *Checking Out or Checking In a Batch Version* in the *Enterprise Report Writing Guide*

## Checking Out or Checking In a Batch Version

To modify a report version using Report Design or to set data selection and sequencing using the options from the Row menu, you must first check out the report version. The check-out procedure copies the specification records from the central objects location to your workstation. This is based on your path code. Only versions in that central objects path code will be visible. You cannot access Report Design until you check out the version. A version cannot be checked out by more than one user at a time.

If you have checked out a version but are not going to make changes to it, erase the check-out record so others can check out that version. You need to check out a version to make changes that are overrides to the base (template) report. You do not need to check out a version if you make the following changes at the time you run the version: data selection, data sequencing, override location, or processing option values. However, if you make changes to data selection or data sequencing from the Work With Batch Versions - Available Versions form, you must check out and check in the version to save those changes and make them available to the enterprise.

Before you check in a version, make sure that you want to make permanent changes. When you check in a version, the system copies the report specifications back to the central objects location. These new specifications override the previous specifications for that version. The report specifications on your workstation remain intact.

To convert a Web Only version to run on a client other than a web client, you must check the version in and then check it out again. To permanently remove the Web Only indicator, generate the batch version using the eGenerator tool after converting the version.

You can check batch versions in or out with the Object Management Workbench program (P98220) or with the Batch Versions program (P98305) as described in the next task.

**See Also**

- The *J.D. Edwards Web Server Installation Guide* for instructions on using eGenerate

► **To check out or check in a batch version**

---

*In the J.D. Edwards Windows environment, choose Batch Versions from the Report Writer menu (GH9111).*

1. On Work With Batch Versions - Available Versions, type an application ID in the Batch Application field, and then click Find. For example, to locate a version for the One Line Per Address report, type R014021.
2. In the detail area, choose a version with which to work.

3. From the Row menu, choose Advanced.  
The Advanced Operations form appears. On this form, you can check in and check out versions, and erase the check out for a version, and enter design for the version.
4. On Advanced Operations, choose a version to check out or to check in.
5. From the Row menu, choose either Check Out Version or Check In Version.
6. Click OK.

## Erasing the Check-Out Record of a Version

Batch versions can be checked out by only one person at a time. Erasing the check out record allows another user to check out the version. After you have erased a check-out, you cannot check in that version. However, the report specifications on your workstation remain intact.

The Erase Check-Out procedure changes the status of the server-based record of version check-in and check-out. When you erase a check-out of a version, J.D. Edwards software updates the Checked Out field in the Versions List table (F983051) from a Y to an N. J.D. Edwards software also updates the version's Location field in the Versions List table. This value is changed from the location of the workstation that checked out the version to the machine name of the central object's server.

You can erase the check-out of batch versions using the Object Management Workbench program (P98220) or the Batch Versions program (P98305) as described in the next task.

### ► To erase the check-out record of a version

---

*In the J.D. Edwards Windows environment, choose Batch Versions from the Report Writer menu (GH9111).*

1. On Work With Batch Versions - Available Versions, type an application ID in the Batch Application field and click Find. For example, to locate a version for the One Line Per Address report, type R014021.
2. In the detail area, choose a version with which to work.
3. From the Row menu, choose Advanced.  
The Advanced Operations form appears. On this form, you can check in and check out versions and reports, erase the check out for a version, and enter the design for the version.
4. On Advanced Operations, choose the checked-out record that you want to erase.
5. From the Row menu, choose Erase Check Out.

## Changing Processing Options for the Batch Versions (P98305) Application

This task explains how to change the processing options for the Batch Versions program (P98305).

Processing option changes are stored for each UBE run. Unlike other changes to versions, changes to processing option values do not require you to check in or check out the version. Anyone who uses that version after you make the change will not be affected by the new processing option values.

## See Also

- ❑ *Changing Processing Options for Batch Versions* in the *Enterprise Report Writing Guide* for instructions on changing processing options for batch versions in general

### ► **To change Batch Versions (P98305) processing options**

---

*In the J.D. Edwards Windows environment, from the System Administration Tools menu (GH9011), right-click Batch Versions, choose Prompt For, and then choose Values.*

1. On Processing Options, complete the following fields:
  - **Confirmation Box**  
Enter a Y or 1 to enable, or enter N or 0 to disable the overwrite/delete local specifications confirmation box. If you enable the confirmation box, it appears when J.D. Edwards software is about to overwrite or delete specifications on your local machine. For example, when enabled, the confirmation box appears when you check out a batch version.
  - **Schedule Job**  
Enter a 0 (or leave the field blank) to not allow users to schedule when their batch versions run, meaning their batch version runs as soon as they submit it; enter a 1 to give the users the option of scheduling their batch versions; enter a 2 to force the users to always schedule their batch versions.
2. Click OK.

## See Also

- ❑ *Scheduling Jobs* in the *System Administration Guide* for complete information about how to schedule batch versions

## Moving Batch Version Specifications to an Enterprise Server

You can move batch version specifications to an enterprise server without actually running the batch version. You need to do this only when you have modified a batch version that is called by another batch version. After you modify the version, use this option to move its specifications to the same location as the batch version that calls it. This procedure ensures that the batch version calls the updated specifications, rather than obsolete specifications.

### ► **To move batch version specifications to an enterprise server**

---

*In the J.D. Edwards Windows environment, choose Batch Versions from the System Administration Tools menu (GH9011).*

1. On Work With Batch Versions - Available Versions, complete the following field, if necessary:
  - **Batch Application**
2. Click Find to display a list of versions based on the batch application you entered in the Batch Application field.
3. Choose the report version you want to submit, and then click Select.
4. On Version Prompting, choose Advanced from the Form menu.

5. On Advanced Version Prompting, choose the following options and click OK:
  - **Submit Version Specifications Only**  
Turn this option on to move batch version specifications to an enterprise server that you specify.
  - **Override Location**  
Turn this option on to access the JDE Data Sources form, which you use to specify the location of the enterprise server to which you want to move the batch version specifications.
6. On Version Prompting, click Submit.
7. On JDE Data Sources, choose the enterprise server to which you want to move the batch version specifications, and then click Select.

The batch version that you indicated will not run, but J.D. Edwards software moves the batch version specifications to the enterprise server that you specified. You can use the Work With Servers form to monitor the progress of your job on the queue.

#### **See Also**

- *Working with Servers* in the *System Administration Guide* for information about the Work With Servers form

## **Overriding Version Specifications**

Usually when you run a report version, the version specifications override the report template specifications. Occasionally you may want the report template specifications to override the versions specifications.

An example of when you would want to override the version specifications with the report template is when you have changed the report template and want that change pushed down to the version level. If you did not override the version specifications, the system would ignore the change at the version level.

---

### **Caution**

If a version contains information that is not displayed in the report template, this information will not be displayed if you override the version specifications.

---

### **► To override version specifications**

---

*In the J.D. Edwards Windows environment, choose Report Design Tool from the Report Writer menu (GH9111).*

1. On Report Design, select the section of the report for which you wish to override version specifications.

2. From the Section menu, choose Override Version Specifications.

Depending on the type of section you selected, the appropriate Section form appears.

3. Select from the following options and click OK:

- Section Layout
- Section Data Selection
- Section Event Rules
- Section Database Output
- Section Sort Sequence

Template specification now override version specifications.

## Accessing BrowsER for a Report or Version

BrowsER is an application you can use to view event rules and design layout for your reports and versions. BrowsER displays the structure of sections within a batch application. The sections are displayed in a hierarchical structure, with events and event rules for each section. You can enable or disable one or more event rules without extensive work in the design tools. This is useful for debugging specific event rules.

### See Also

- *BrowsER* in the *Development Tools Guide* for complete information about using BrowsER

### ► To access BrowsER for a report or version

---

*In the J.D. Edwards Windows environment, choose Batch Versions from the System Administration Tools menu (GH9011).*

1. On Work With Batch Versions - Available Versions, type an application ID in the Batch Application field. For example, to locate a version for the One Line Per Address report, type R014021.
2. Click Find to locate the versions available on your workstation.

For alternate lists of versions, from the Form menu, choose Display; and then choose one of the following:

- Available Versions - for the versions available on your workstation
- My Versions - for just the versions you created
- All Versions - for any version that exists for the batch application

When you view all versions, you can work only with versions that appear with black text.

3. In the detail area, choose a version with which you want to work.

4. From the Row menu, choose Advanced.

The Advanced Operations form appears. On this form, you can design report specifications for the version, check in and check out versions and reports, and erase the check out for a version.

5. On Advanced Operations, choose either Report BrowsER or Version BrowsER from the Form menu.

If you select Report BrowsER, you can enable or disable event rules for the report. If you select Version BrowsER, you can enable or disable event rules for a specific version of the report. When you are working with table conversion batch applications, J.D. Edwards software grays out the Version BrowsER button because it does not apply to table conversions.

---

## Understanding Database Output

You can use database output to update the database in conjunction with your report generation. You can attach a database output specification to any report section with a business view, but not a report or page header or footer.

You can use database output in Report Design to update, insert, or delete records in a table or text file. You can also use a special operation called "Insert or Update". This operation attempts to insert a record into a table. If a record with the same primary key exists, the insert fails and the existing record is updated.

You can use database output to output data to J.D. Edwards software tables or to text files. Text files can be specified as either comma delimited or fixed length text records. The comma delimited format is useful for transferring data to spreadsheets.

J.D. Edwards software provides several tools that you can use for batch database maintenance.

**Table Conversion** Use for high-performance SQL table-to-table processing. Allows access to non-J.D. Edwards software tables. No reporting.

**Database Output** Reporting and output must occur simultaneously. Source and destination tables can reside in different environments. Allows output to text files.

**Table I/O (in Event Rules)** Reporting and output must occur simultaneously. Input data must be transformed before it can be output.

Database output is performed for every row of data processed in the section. All database operations occur on a record-by-record basis using the standard JDE Base middleware APIs.

Defining database output involves defining the output and then overriding the specific environment.

### ► To define database output

---

*In the J.D. Edwards Windows environment, choose Report Design Tool from the Report Writer menu (GH9111).*

1. On a report section in Report Design, choose Database Output from the Section menu.

**Mapping Targets**

Select the OneWorld table or define flat files you want perform some type of table operation on.

Operation	Type	Name	Description
Insert only	OneWorld tab	F0006	Business Unit Master
Insert only			

< Back   Next >   Cancel   Help

2. On Mapping Targets, complete the following fields to define a list of output tables or files (targets).

- Operation

For a J.D. Edwards software table operations, can be Insert, Update, Delete, or Insert or Update. For text files, it must say Insert.

- Type

J.D. Edwards software table, comma delimited text file, or fixed record length text file.

- Name

Name of a valid J.D. Edwards software table or a valid file used for text file output.

You can double-click on the Operation and Type fields to see a list of available choices. Double-click on your choice to select it.

You can use the source target several times with different operations.

3. Click Next.

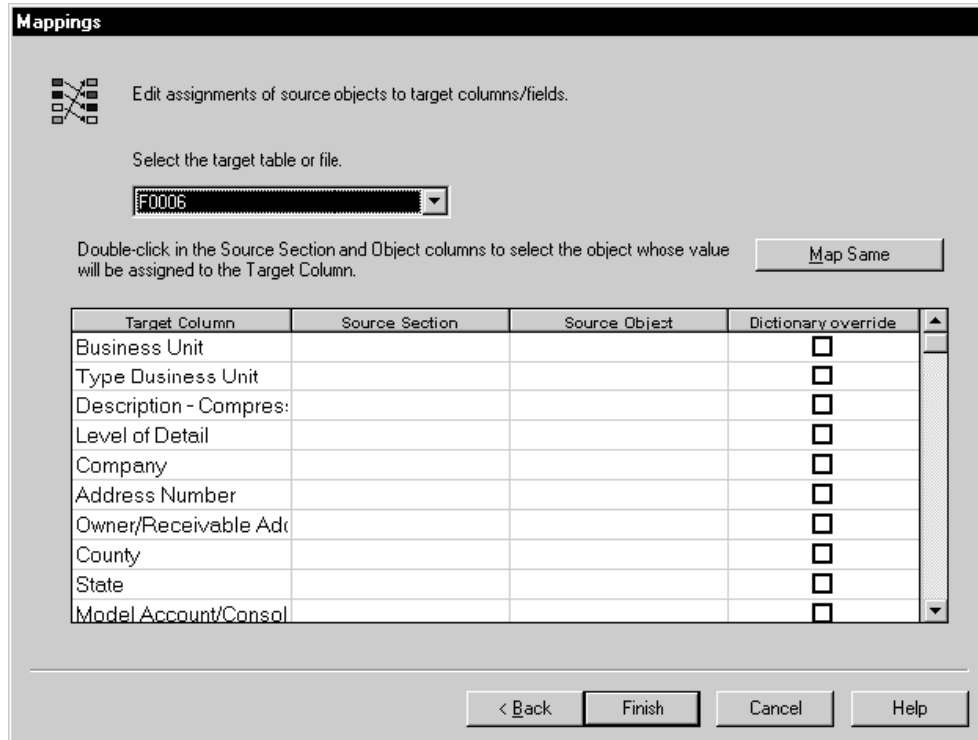

- On Mappings, for each target, specify which of the available section columns or variables should be assigned (mapped) to which column in the target. Double-click on a Source Section or a Source Object cell to display a list of options. You can also turn data dictionary overrides on and off here.

**Mappings**

 Edit assignments of source objects to target columns/fields.

Select the target table or file.

F0006

Double-click in the Source Section and Object columns to select the object whose value will be assigned to the Target Column. Map Same

Target Column	Source Section	Source Object	Dictionary override
Business Unit	Job Cost Master		<input type="checkbox"/>
Type Business Unit	Job Cost Master	[DC] Business Unit	<input checked="" type="checkbox"/>
Description - Compres:			<input type="checkbox"/>
Level of Detail			<input type="checkbox"/>
Company			<input type="checkbox"/>
Address Number			<input type="checkbox"/>
Owner/Receivable Ad			<input type="checkbox"/>
County			<input type="checkbox"/>
State			<input type="checkbox"/>
Model Account/Consol			<input type="checkbox"/>

- On Mappings, click Map Same if you need to map all columns.

**Mappings**

 Edit assignments of source objects to target columns/fields.

Select the target table or file.

F0006

Double-click in the Source Section and Object columns to select the object whose value will be assigned to the Target Column. Map Same

Target Column	Source Section	Source Object	Dictionary override
Business Unit	Job Cost Master	[BC] Business Unit	<input type="checkbox"/>
Type Business Unit	Job Cost Master	[DC] Business Unit Typ	<input type="checkbox"/>
Description - Compres:		[BC] Description - Com	<input type="checkbox"/>
Level of Detail	Job Cost Master	[BC] Level of Detail - Br	<input type="checkbox"/>
Company	Job Cost Master	[BC] Company	<input type="checkbox"/>
Address Number	Job Cost Master	[BC] Address Number	<input type="checkbox"/>
Owner/Receivable Ad	Job Cost Master	[BC] Address Number	<input type="checkbox"/>
County			<input type="checkbox"/>
State	Job Cost Master	[BC] State	<input type="checkbox"/>
Model Account/Consol	Job Cost Master	[BC] Model Accounts a	<input type="checkbox"/>

6. On Mappings, click Finish when you have finished your assignments.

### See Also

- ❑ *Triggers* in the *Development Tools Guide* guide for information on how to override and disable data dictionary triggers

### ► To override environments for database output

---

In the J.D. Edwards Windows environment, choose Report Design Tool from the Report Writer menu (GH9111).

1. On a report in Report Design, choose Report Properties from the File menu.
2. On Properties, click the Advanced tab.

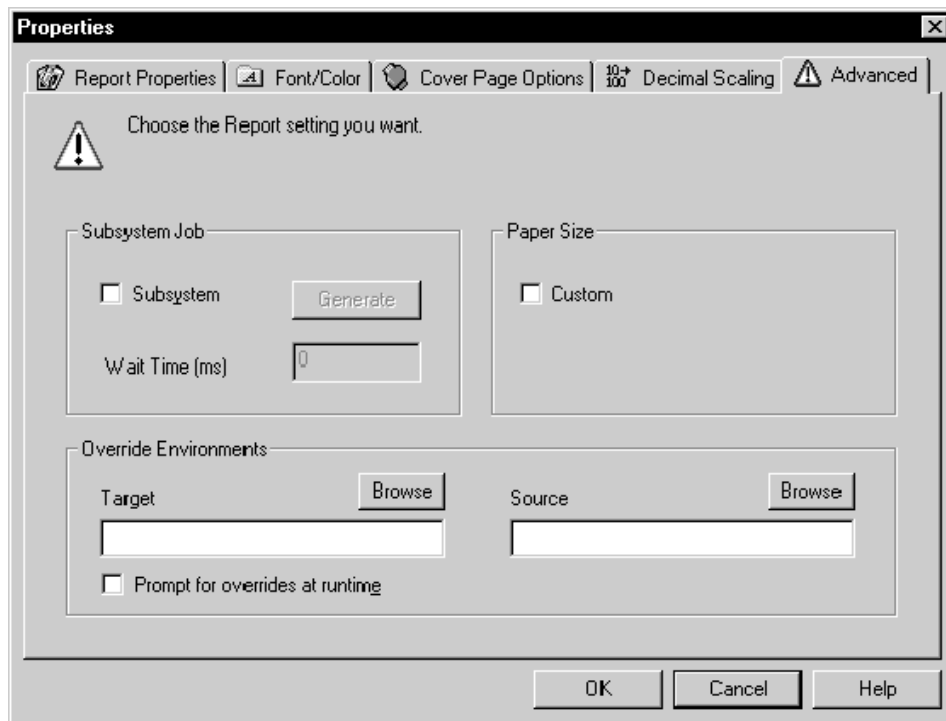

3. Complete the following field or click the Browse button to find the source environment:
  - Source
4. On Properties, click Prompt for overrides at runtime, if desired.
5. Complete the following field or click the Browse button to find the target environment:
  - Target

6. To suppress the database output features, choose between two options:
  - If you do not want database output for the entire report, then override the database output in the version and delete the mapping record.
  - If you do not want database output for specific rows of data, then use the Suppress Section Write system function. This system function suppresses not only printed output but also database mapping.
7. Click OK.

---

## Report Processing

Reports are processed via a batch process. A batch process is an application that processes automatically without user interaction.

The following graphic illustrates the flow of a batch process.

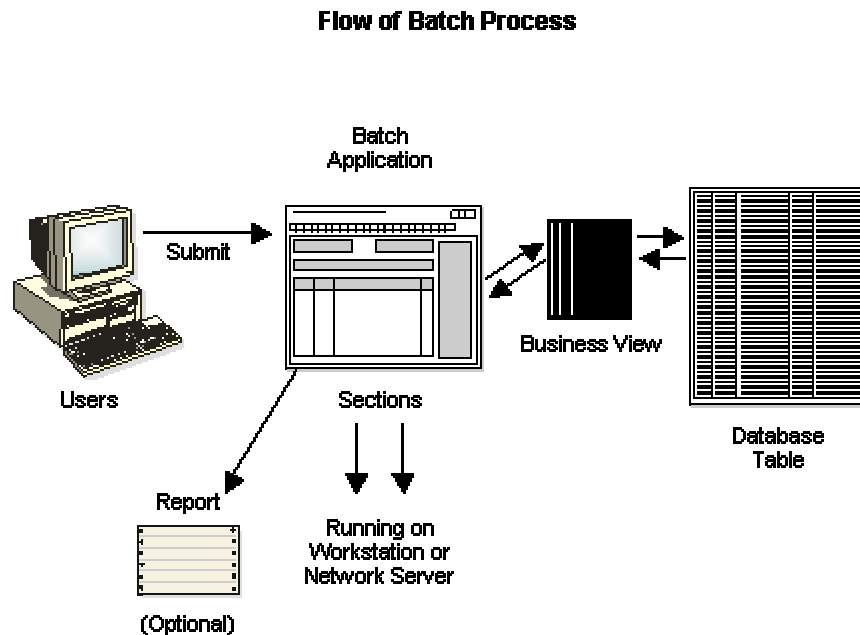

With interactive processes, the engine pauses at certain points and waits for the user's interaction or response. Based on the user's response, the program decides what to do next. There is no user interaction with batch processes. The engine executes the logic attached to the events within the report or process. After a batch process is launched, the user has no control over the flow of the logic within the batch process. If you need to change the flow of the logic within the process or report, you make those changes using Report Design.

Examples of batch processes include reports, subsystem jobs, database output, and table conversion.

Subsystem jobs are batch processes that constantly run in the background and offload processor resources. You can also use subsystem jobs to move activities along in a process, such as an escalation process in Workflow, which moves unanswered messages from one user to another after a certain period of time.

The database output function within Report Design allows you to update or insert records within tables. Table conversion transfers data from one table to one or more tables, changes the data or schema of a J.D. Edwards software table, and transfers data from a single business view to one or more tables.

This section describes some of the advanced features behind batch and report processing and is intended to give you an understanding of how the features of batch and report processes work.

## Understanding Batch Processing

---

You create reports and batch processes using the Report Design tool, and you use J.D. Edwards Solution Explorer to access the reports. You can also associate individual reports and batch processes with applicable menus. One difference between a batch process and a report is that a batch process does not usually print a report. You can use batch processes to update tables. You can also create a batch process that prints a report showing the results of the batch process.

J.D. Edwards software reports contain all the specifications for the report, including section and field layout, business views, event rules, data selection, sequencing, and database output. Reports are named with a unique identifier.

Each report contains one or more *sections*, which you create in Report Design. Sections are self-contained elements that are used as building blocks to construct a report. You can relate sections to one another or use them as stand-alone reports. Sections can also serve a special purpose, such as headers and footers.

### Report Sections

J.D. Edwards software sections include headers, footers, and detail sections (columnar, group, and tabular).

Independent (level-one) sections include:

- Group
- Columnar
- Tabular

Level-one sections can also be parent sections.

Dependent (level-two) sections include:

- Level-break headers
- Level-break footers
- Total sections (used in non-tabular reports)
- Subsections
- Custom

The following graphic illustrates how the batch engine processes sections within a report:

### Batch Engine Processing

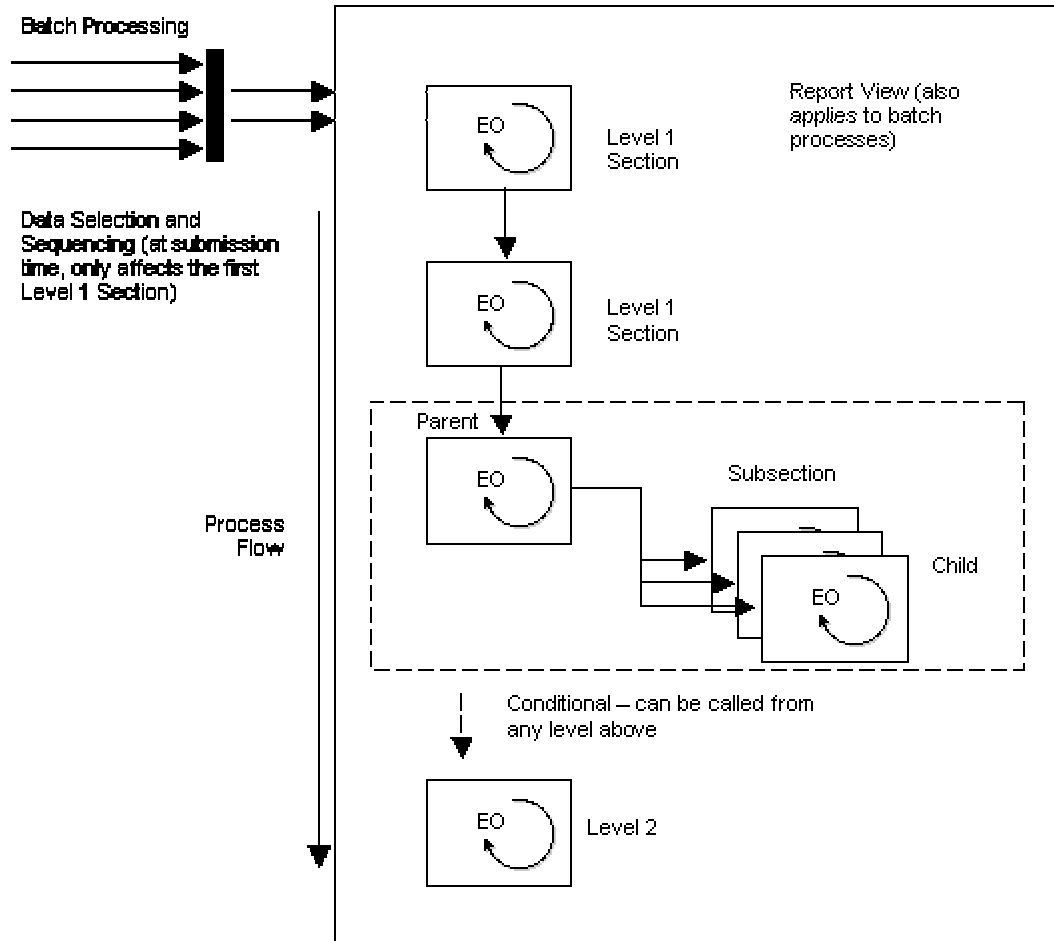

The report view within Report Design determines the flow of the report. For example, if you have multiple level-one sections within your report, each having their own business view, the first level one section (such as V0101E) is executed before the next level-one section (such as V4211A). Any level-two sections that exist between the level-one sections are processed when they are called from a level-one section or are connected to one. If the report contains a joined section (parent/child section) after the level-one sections, the parent/child section will be processed independently of the first two sections. Child sections are in subsection joins.

The system reads and processes all records in a section from beginning to end within a section based on its data selection. If you do not specify data selection, then all the records in the table will be read until the end of the file (EOF).

If your report contains a joined section (parent/child section) after a level-one section, the parent/child section is processed independently of the first section.

The parent/child section in the middle of the graphic illustrates the flow of a joined (parent/child) section. Parent/child sections can be called at any point within the process flow. Depending on how your sections are joined (one-to-one, one-to-many, or many-to-many), records are fetched from the child business view for each corresponding parent record. When all parent records have been processed, the system continues to the next section. If any database updates are performed in the first section over the V0101 business view, that change will be reflected when the records are fetched for the parent/child join section.

The last section shown in the graphic (the conditional section) can be called from any of the previous sections by using the system function Do Custom Section. A conditional section is considered a level-two section because you must call a conditional section from another section. Memory allocation occurs at the beginning of the section, so you must hide and show objects in the section as needed because memory is allocated and freed once, instead of each time a section is called. You can place conditional logic in your Initialize Section or End Section event to hide and show objects.

J.D. Edwards software processes all section types the same way, except for tabular sections. Tabular sections output to the report only when the system encounters a level break. In tabular sections, the system does not initialize the Do Section for each record. Instead, it summarizes the records to the lowest level-break level. Tabular sections are similar to level breaks in that the output to a report is similar to a level-break header section.

The flow of sections in a report or batch process depends on how you set up the sections in the report view in Report Design. In Report View, you can move sections up or down, which might affect the sequence of execution for the sections. Moving level 1 sections affects the sequence of execution. In report processing, the system processes all level-one sections in the order in which they appear. Moving conditional sections, subsections, level-break sections, page-headers, page-footers, and report headers will not affect the sequence of execution. Report execution takes place from top to bottom for sections, and top to bottom, left to right for objects within a section.

All level-two sections are processed as dependents of the level-one section. Custom sections appear as a level-one section in the report view, but are not processed unless explicitly called by the Do Custom Section system function.

Sections in themselves can be considered "mini reports," or batch processes, and each section can contain its own business view. Because other sections in your report might contain different business views, you must add any data sequencing and selection to the template for each section using Report Design.

---

**Note**

If a user sets up data sequencing and selection in the batch version at run time, sequencing and selection will affect only the first section of the report or batch process. Therefore, when you design a report or batch process, consider the impact on the users as they will not be able to change data selection and sequencing for any other sections.

Whether a level-one section has a business view attached to it or not, it will be executed at least once. This is important if you want to execute special event rule logic and you want to attach it to that section's Do Section event.

---

### See Also

- ❑ *Understanding Subsystem Jobs* in the *Enterprise Report Writing Guide* for information about how to create subsystem jobs
- ❑ *Understanding Database Output* in the *Enterprise Report Writing Guide* for more information about the database output function
- ❑ The *Table Conversion Guide* for information about how to create a table conversion using the table conversion tool
- ❑ *Creating Custom Sections* in the *Enterprise Report Writing Guide* for more information about custom sections

## Understanding Section Processing

---

When a report is processed, certain events occur. You can attach logic at these events. Your logic might be dependent on what happens before and after a particular event.

Several events can occur when a batch process or report is processed. You can determine at what point in the process you want to attach logic, because your logic could be dependent on what happens before and after a particular event.

The report header is processed before the section is processed, and the level-one section is initialized by the Initialize Section event. After Initialize Section, the system processes the Advance Section, Page Footer, Page Header, and so on. When the system finishes processing the first level-one section and all dependent sections associated with it, it repeats the process for the next level-one section.

### Processing Group and Columnar Sections

Group and columnar sections are alike in their processing because they both write to the output after each record is read, unlike tabular sections, which write to the output only when there is a level break. This output is determined by the data sequencing of that section.

The following diagram illustrates the typical event flow for group and columnar sections:

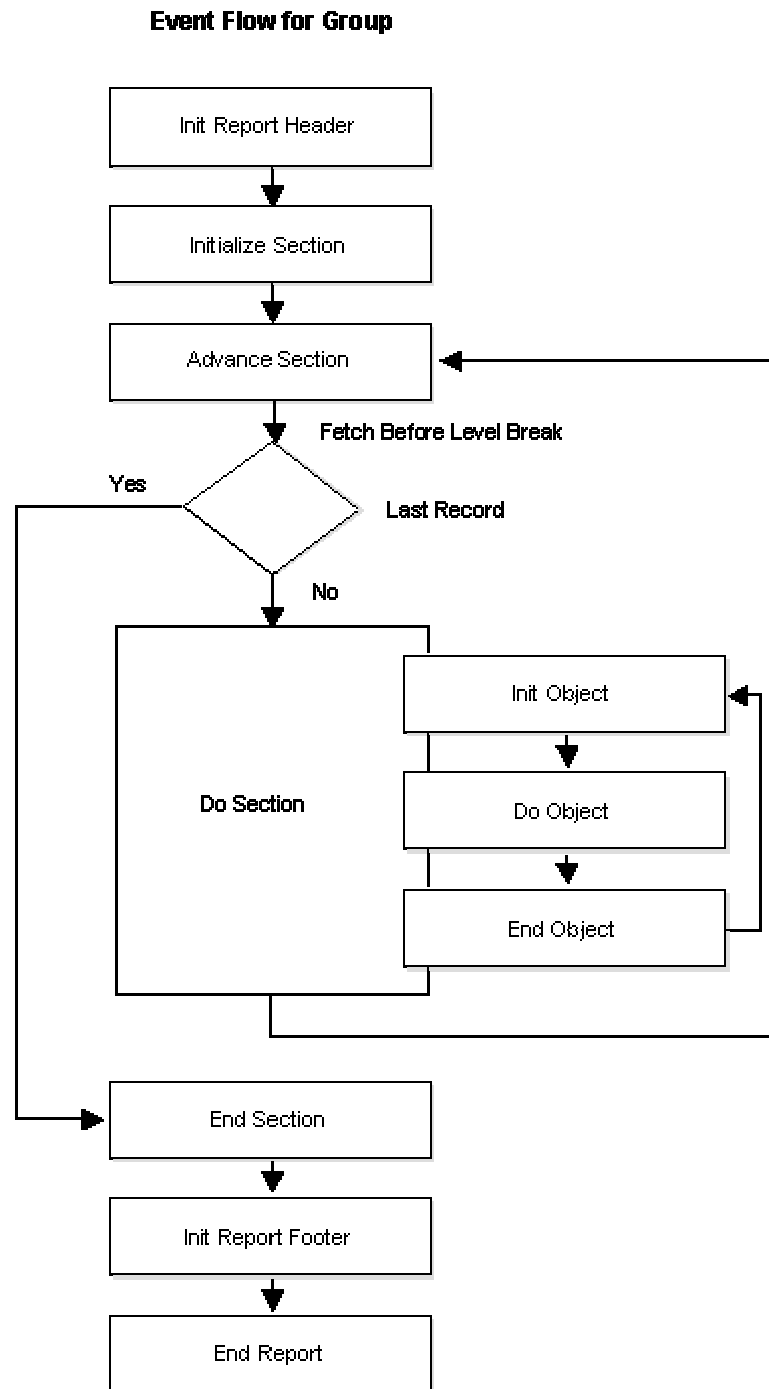

## Processing Tabular Sections

Tabular sections are comprised of columns, rows and cells. To define what information is contained in each column, row, or cell, you define inclusion rules or calculations. An inclusion rule is either a set of criteria, a business function, or a named event rule for that row or column. One advantage of tabular sections is that you do not have to define additional sections for level-break logic or processing as would have to be defined with a group or columnar section. However, you must set up the data sequencing correctly because the level-break part of the section is dependent on it.

The following diagram illustrates the typical event flow for tabular sections:

### Event Flow for Tabular Section

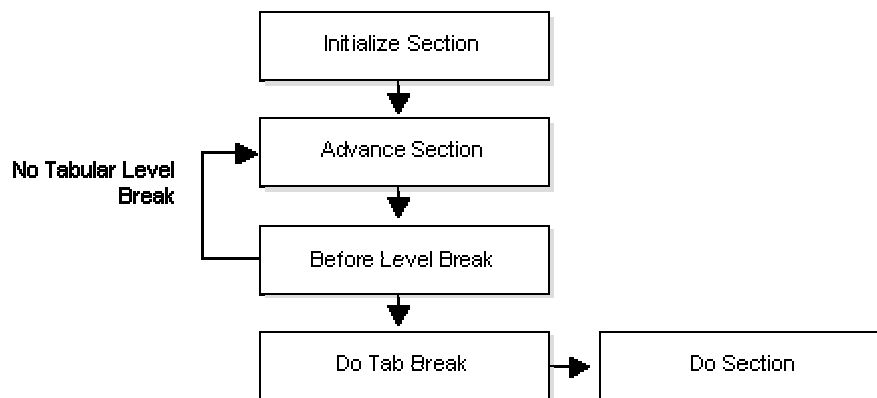

As shown in the following graphic, tabular sections summarize information and print only when there is a level break. Because level breaks are dependent on data sequencing, your report can be as detailed as your data sequencing allows or as general as is needed. For example, suppose you sequence your data in a tabular section by Company only, but you have the objects Object Account and Subsidiary included in your report as well. If you sequence by Company only, and only two company records exist, the tabular section prints only those two records on the report. If you sequence by Company and Object Account, the tabular section prints both Company and Object Account information. Likewise, if you sequence on Company, Object Account, and Subsidiary, the system prints information for all three objects. Therefore, the more data you sequence and level break in your report, the more detailed your report will be.

## Tabular Section Level

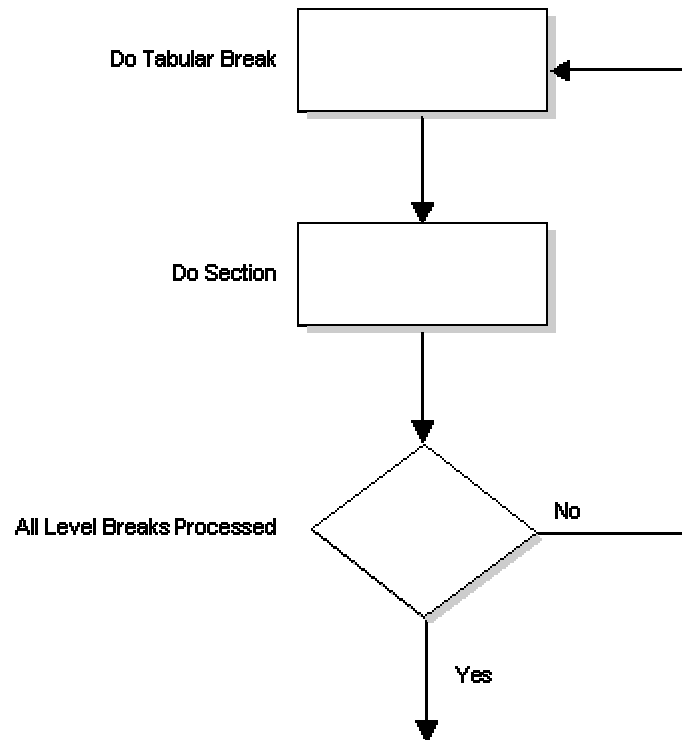

Other features in tabular sections include Drill Down, Account Level of Detail, a summarization feature, and automatic totaling. You can use Drill Down to provide a shortcut to an interactive application from the viewable output of a report. The interactive application shows the detail for the balances on the viewable output of your report. You can use the summarization feature (After Last Object Printed) to print or process logic after a section has been processed. The Automatic Totaling feature automatically totals any numeric values, regardless of what type of numeric values they are. However, keep in mind that the system may try to total any value in your report (numeric or otherwise). To keep the system from totaling a particular column, open that column's properties and choose the Suppress Printing at Totals option. Note that some items might be defined at the data dictionary level to prevent totaling.

You might have a situation in which you process a report using multiple sections or a combination of group and columnar sections. In this case, you might be able to use one tabular section in place of the multiple sections. An advantage of replacing multiple sections with a tabular section is that using a tabular section improves your system's performance. Instead of calling multiple sections, your system calls only one section.

### See Also

- ❑ *Understanding Batch Events* in the *Enterprise Report Writing Guide* for a discussion of the Do Section
- ❑ *Understanding Level-Break Processing* in the *Enterprise Report Writing Guide* for a discussion of the level break section

## Attaching Logic to Joined Sections

If you join sections and want to attach logic to the joined sections, you must attach it to the Refresh Section event, not the Initialize Section event, to ensure that the logic is processed every time the section is processed. When joined sections are processed, the system initializes the Initialize Section event the first time the parent/child section is processed, then initializes the Refresh Section event for all subsequent times the parent/child section is processed. Therefore, if you attach an event to Initialize Section, the logic is processed only once. If you attach it to the Refresh Section event, it is processed each time the section is processed.

## Data Selection and Sequencing

If your report or batch process takes a long time to process because it contains multiple sections, you might want to check the data selection for each section because the system will process all the records in the table unless you specify otherwise. If you want a level-one section to adopt the data selection and sequencing from another section, you can use the Use Data Sel/SeqFromASection system function. This system function propagates the data selection and sequencing to other sections. This functional capability affects only the level one sections in your report.

For example, in the Print Pick Slips program (R42520), you can choose from the hundreds of columns in the Sales Order Detail File table (F4211) for data selection. In the first section, which is hidden and has database output to the F4211 table, the report must first process commitments, which could add rows to the F4211 table. The next section in the report needs to display the modified and updated F4211 table to show the committed records. Possible solutions are to use a temporary file or to change the data selection on multiple sections. In this case, you would use the Use Data Sel/SeqFromASection system function, which adopts the data selection and sequencing from a previous level-one section.

The Use Data Sel/SeqFromASection system function allows a section to adopt the sequencing or data selection specifications from another section in the same report or from a section in an entirely different report. The target section can adopt the data selection criteria, the sequencing information, or both, from the source section. The selection or sequencing information from the source section replaces the information contained in the target section's specifications.

To use the Use Data Sel/SeqFromASection system function, access the event rules for the Initialize Section event of the target section. The Initialize Section event is the only event that should invoke this system function. Access the General folder to locate the Use Data Sel/SeqFromASection system function.

### See Also

- ❑ *Understanding Level-Break Processing* in the *Enterprise Report Writing Guide* for more information about level-break headers and footers and level-break events

## Understanding Custom Sections

---

Custom sections allow you to control, through event rules, the information that prints on a report. You can use custom sections to force a page break by creating a custom section with no objects, then activating Page Break After Print in that section's Section Properties. You can use custom sections to print variable text. Custom Sections can also be used for sections that present the same information, but are formatted differently. For example, a report that exists in two different modules, but depending on a user's needs, calls a different section that displays information specific to that particular module.

The following graphic illustrates the process flow for custom sections:

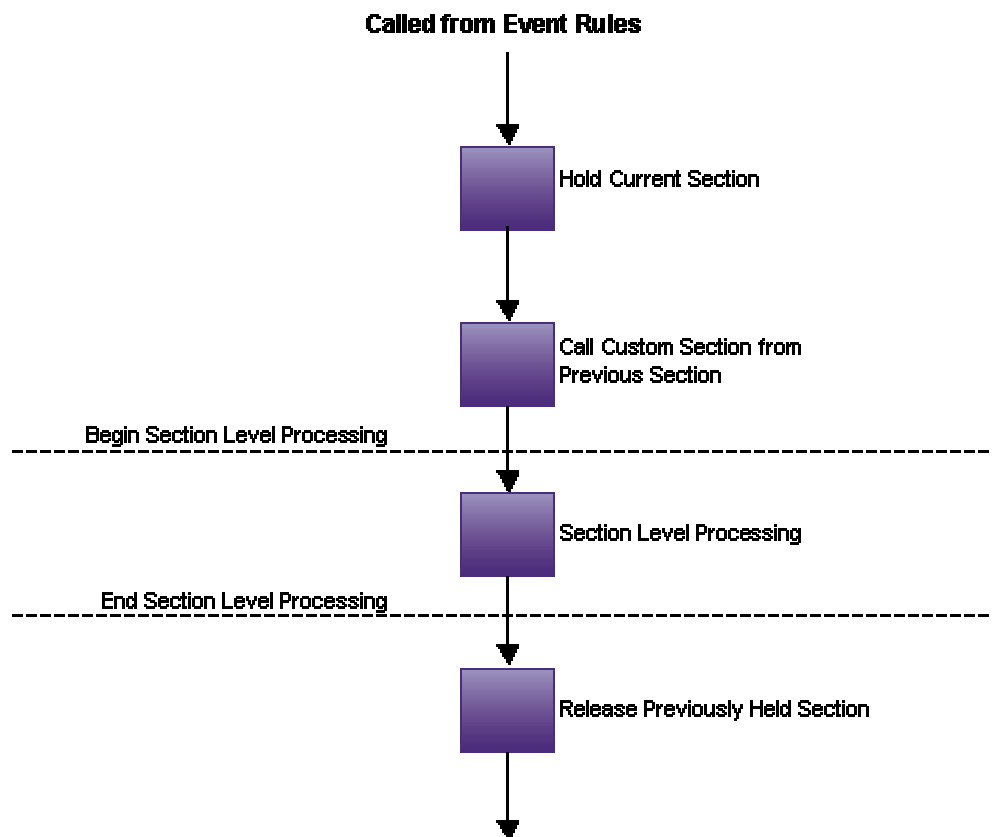

The batch engine stops processing the current section when it encounters a call for information contained within a custom section. After it processes the custom section, it returns to the previously held section.

The system stops processing the current section when it encounters a call for information contained within a custom section. After it processes the custom section, it returns to the previously held section.

When you run the report, the batch engine calls and processes each section until it encounters the system function for the custom section. The batch engine then retrieves the information for the custom section and processes it. When it finishes processing the custom section, it returns to the previous section unless instructed to do otherwise by another event rule.

You can call a custom section from any event rule except Initialize Section. If you try to call a custom section using Initialize Section, your report will not process.

The custom section process flow occurs in the same order as the type of section it is defined as, for example, group, columnar, or tabular.

## **Understanding Level-Break Processing**

---

You use level breaks to identify a change in a report or batch process's data by comparing the previous record to the current record. If there is a change between the records, a level break occurs. You can use level breaks to segregate large report listings into smaller, logical groups. For example, you could group telephone numbers by area code or employees by department. You can set up level breaks to initiate page breaks, totals, headers, or footers. Level breaks can be attached only to business view fields and not to any other variables in the report.

You can attach only one level-break header or level-break footer to one data item. If you try to attach more than one level-break header or footer to a data item, the batch system processes only the first level-break header or footer section that is attached to that item and ignores any other level-break sections that you have attached.

The following graphic illustrates level-break logic processing:

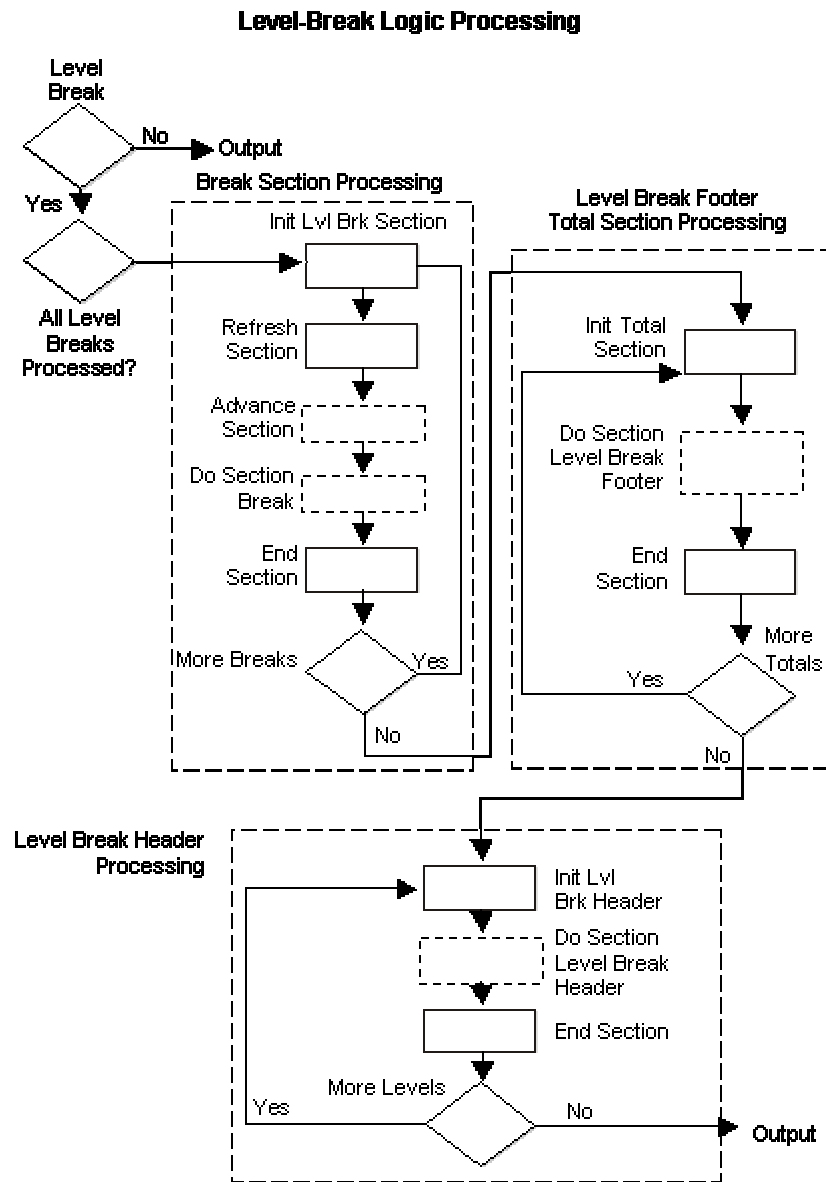

Before a level-break header or footer is processed, the batch system issues the Init Break Section event, which stops processing for the current section and moves to the level-break footer section. After the level-break footer section has been processed, the batch system processes the level-break header, if specified in the report.

**See Also**

- *Working with Level-Break Header and Footer Sections* in the *Enterprise Report Writing Guide* for more information about level-break headers and footers

## Level-Break Section Events

When you process a report that contains level-break headers and footers, J.D. Edwards software automatically calls the Init Lvl Brk Footer Section or Init Lvl Brk Header Section event. You can attach event rules to these events to control how the batch system processes them.

For example, if you want to create a report that summarizes information by company, you can design the report to read the detail file by company using a level-break footer. You set a level break on the Company data item, and when the company changes, the batch system calls the level-break footer for the detail section.

You can attach business functions, table I/Os, or other events to level-break section events.

### Init Lvl Brk Footer Section Event

When the batch system calls the Init Lvl Brk Footer Section event, the values in the previous section are accessed and are either summarized or totaled. For example, if you have a level-break footer set up to total the revenue for a company, the level-break footer inserts the total below all the records that have been processed in the previous section. The Init Lvl Brk Footer Section event is attached to the level-break footer section.

If you set up multiple level-break footers within a report, the batch system processes the footers starting from the lowest section up to the highest section.

If you need to attach logic to a level-break footer, attach it on the End Lvl Brk Footer Section event rather than on the End Section event.

### Init Lvl Brk Header Section Event

The Init Lvl Brk Header Section event is called after the previous section finishes processing. It is also called after the Init Lvl Brk Footer Section event, if you have set one up. The Init Lvl Brk Header Section event locates the header section associated with the current level and processes the information in the level-break header.

For example, if you have a level-break footer set up to create a grand total for a section, it will process before the level-break header for the next section, which might contain another company's revenues. The header section processes new records, or different data, from the previous section.

If you have set up multiple level-break headers within a report, the batch system processes the headers starting from the highest section down to the lowest section in the report.

### End Lvl Brk Header and Footer Section Events

After the Initialize Level Break events are processed, J.D. Edwards' software launches the End Lvl Brk Header or Footer Section event, which ends the level-break process and returns to the previous section. You can attach logic that calls a custom section to the End Lvl Brk Section event. For example, you might want to print text, such as a disclaimer, after information in a level-break footer. In this case, you can create a custom section that contains the information you want to print and attach the custom section logic to the End Lvl Brk Section event. When you process the report, the disclaimer appears below the level-break footer section.

## Understanding Batch Events

---

As a report or batch application is processed, the run-time engine pauses at certain points to process logic that has been attached. These points are called events, and you can use these events to insert custom logic for processing. J.D. Edwards software provides you with a set of predefined batch events. The basic flow of these events within a section is Initialize, Do, and then End.

The engine processes some events only if the appropriate type of section exists. For example, Init Report Header and End Report Header are initialized only if the report contains a report header section. Likewise, Init Lvl Brk Footer and End Lvl Bk Footer are processed only if a level-break footer exists.

### The Do Section Event

The Do Section event is invoked after the system has assigned new values to objects in the report and immediately prior to processing objects within a section. You most commonly attach logic to the Do Section event because it occurs before any objects are processed, and most often the logic you attach at this point will affect the objects in some way.

When the system processes the Do Section event, it processes the column headings first, then fetches the first line. For each object (column) in the line, it runs Init Object, Do Object, and End Object. After processing the last object, the system calls After Last Object Printed and then fetches the next line and repeats the process. When all lines have been fetched from the database, the system performs End Section.

The system processes the column headings first, then fetches the first line. For each object (column) in the line, it runs Init Object, Do Object, and End Object. After processing the last object, the system calls After Last Object Printed and then fetches the next line and repeats the process. When all objects have been fetched from the database, the engine runs End Section.

If the object will not fit on the page, the engine invokes Suspend Object, which moves the object to the next page.

If the object is a child section, such as in a joined section, the system invokes Initialize Section the first time it is processed. For any subsequent times that the child is processed, the engine invokes Refresh Section.

### Additional Batch Events

In addition to the basic batch events you typically use, other events can give you flexibility in your batch processes. These other events include the following:

- Report Level
- Section Level
- Page Header Section Level
- Page Footer Section Level
- Report Header Section Level
- Report Footer Section Level
- Constant and Variable

## Report Level Events

- Do Initialize Printer** Resolves and validates the printer name.
- Initialize Report** Resets global Report Variable and global Event Rule (ER) Variable values if the event point has no ER in a subsystem; preserves global variable values otherwise. The Initialize Report event is executed only once per report and is always the first event to be processed. If the report is a subsystem report, the ER on this event is executed once as the subsystem is starting before any subsystem triggers are processed.
- End Report** Executed once at the end of report processing and is always the last event to be processed. If the report is a subsystem, the ER on this event is executed only after the system processes an End Subsystem trigger and the subsystem is in the process or terminating.

## Section Level Events

- Advance Section** Occurs each time you do a fetch from the database. Use this event if you need to perform processing on objects before a fetch. If this section does not have a business view attached, then this event is processed once.
- After Last Object Printed** Occurs after a row is printed to an output file. Use this event to process information after a row has been output.
- Before Level Break** Use this event to do processing after a fetch but before any level breaks are checked.
- Do Balance Auditor** Valid only for tabular sections. Use this event for the drill down feature.
- Do Section** Occurs after Advance Section after values have been assigned to print out to a printer or an output file. This event occurs before any information for the current record is written to the PDF file. This event occurs before Do Cell (if Tabular cells exist) and before Do Variable/Do Constant.
- Do Tabular Break** Valid only for tabular sections. This event occurs when any of the business view fields set as level breaks change. Use this event to do processing that requires a change of values in any of the level break fields.
- End Break Section** Occurs after a level break finishes. Use this event to do processing immediately after a level break.
- End Lvl Brk Footer Section** Use this event to do processing immediately after a level break footer.

- End Lvl Brk Header Section** Use this event to do processing immediately after a level break header.
- End Section** Occurs after a batch process has completed processing the last set of section values. Use this event to do processing immediately after a section ends. This event is useful for last record and end-of-file procedures.
- Init Break Section** Occurs after a level break begins processing. This event initializes a child section that is joined to the parent section on a level break.
- Init Lvl Brk Footer Section** Use this event to do processing immediately before a level break footer.
- Init Lvl Brk Header Section** Use this event to do processing immediately before a level break header.
- Initialize Section** Occurs when a batch process encounters a section for the first time. Use this event to do processing immediately before a section begins. This event is useful for working with global variables or performing other preparatory procedures. For conditional sections, this event is processed each time the section is called.
- Refresh Section** The first time the UBE encounters a child section, it issues an initialize section event. Each subsequent time the child section is to be processed, the batch process uses Refresh Section. At this point, the internal structures and pointers for the child section have been established and the UBE is about to select a new group of records for the child section. This logic also works for the level break sections. Use this event to set the object values of level two sections based on the parent section. You can also use this event to reset or modify data selection and sequencing of the child section.
- Suspend Section** Processes when an overflow page break (that is, information exceeds the space available on the page) occurs. This event temporarily stops the section processing. Use this event to do processing when a page break occurs.

## Page Header Section Level Events

- Initialize Page Header** Occurs at the beginning of a report after any report header logic and before the page header section processes for the first time. It also processes every time a page break occurs. Use this event to initialize values that cannot be set until after the report header logic executes. This event is similar to Init Section for a normal group, columnar, or tabular section, except that it is processed only for a page header section.
- End Page Header** Occurs after the page header finishes processing. Use this event to do processing immediately after a page header.

## Page Footer Section Level Events

- Initialize Page Footer** Occurs at the beginning of the report after any report header logic and before the page header section processes for the first time. Use this event to initialize values to be printed in the current page footer section. These assignments typically depend on information processed so far on that page.
- End Page Footer** Occurs after the page header finishes processing. Use this event to do processing immediately after a page header.

## Report Header Section Level Events

- Initialize Report Header** Processes once at the very beginning of the report before anything else in the report processes. Use this event to initialize values at the beginning of a report. This event is similar to Init Section for a normal group, columnar, or tabular section, except that it processes only for a report header section.
- End Report Header** Occurs after the report header processes. Then the report processes the page header for a report. Use this event to do processing immediately after a report header.

## Report Footer Section Level Events

- Initialize Report Footer** Occurs once at the very end of a report after everything else processes and before the report footer prints. Use this event to initialize values to print in the report footer.
- End Report Footer** Occurs after the report footer processes. After processing finishes, the report terminates. Use this event to do processing immediately after a report footer.

## Constant and Variable Events

- Do Column Heading (constant)** Occurs when the column is initialized. Use this event to populate the column heading, based on event rule that is associated with a business function.
- Do Variable/Do Constant** Occurs just before the font and color are selected and before the value of the object is translated into a printable string of characters and is output to the page. Use this event to do processing after an object has been processed. This point is your last chance to manipulate the value or display attributes of the objects before output.
- End Variable/End Constant** Occurs immediately after an object processes even if the object is invisible or suppressed. Use this event to do processing after an object processes.

<b>Initialize Variable/Initialize Constant</b>	Occurs each time a report object or variable is to be processed. Use this event to do processing before an object processes. This event is useful to do processing that affects the calculation of an object's position because the object's position on the page has not yet been determined.
<b>Skip Variable/Skip Object (constant)</b>	Occurs when an object does not fit on the current page. The batch process issues a skip variable to bypass the object until the next page begins processing. Use this event to change the value of an object at the page break.
<b>Suspend Object (constant)</b>	If an object requires multiple text strings or column headings and if only part of the object fits on a page, then the batch process issues a suspend variable to halt processing of the object until the next page has been started. Use this event to modify the value at the page break. Because the value of the object has already been partially processed, this point is not a good time to manipulate that value.
<b>Column Inclusion</b>	Valid only for tabular sections, this event occurs after a record is fetched from the database. Use this event to perform calculations.
<b>Do Cell (Tabular)</b>	Occurs during Do Object after processing calculations for a cell. Use this event to manipulate cell data before displaying it. This event occurs before Do Variable/Do Constant. This event occurs during calculations.

## System Functions within Batch Events

Batch system functions give you flexibility and control over how your reports are processed. For example, you can use batch system functions to hide or show an object, to hide or show a section, to generate a message, and so on.

The batch system functions you might use consist of the following main categories:

<b>Object</b>	You can use Object system functions to do actions such as hide or show objects.
<b>Section</b>	You can use Section system functions to do actions such as hide or show sections or work with totals.
<b>General</b>	You can use general system functions to do actions such as work with selection and sequencing.
<b>Messaging</b>	You can use message system functions to do actions such as send, update, or delete messages.
<b>Workflow</b>	You can use workflow messages to do actions such as work with processes.
<b>Transaction Processing</b>	You can use transaction processing system functions to begin, commit, or roll back transactions.
<b>Media Objects</b>	You can use media object system functions to work with media objects.

Some general batch system functions that are commonly used are:

**Set Sequence Append Flag** This system function allows you to append or add the sequence for a section to the report's sequencing.

**Stop Section Processing** Stops processing the current section and moves to the next section. This system function is helpful for performance, especially when there is a large amount of event rule logic that remains to be performed. For example, if no more customers exist with a credit limit over a certain amount, the system stops processing that section and moves to the next section.

Stop Section Processing differs from Suppress Section Write in that Suppress Section Write suppresses only the current record, which causes the engine to process the same section for the next record.

**Hide Object** For group and columnar sections, when you hide objects using the Hide Object system function in Event Rules, be aware that even though it might be the only object on that line, the system still prints a blank line for it. The system has no way of knowing whether there are any other objects on that line that need to be printed. To keep the system from printing a blank line, place the object in its own conditional section and suppress the printing of that section using the Hide Object system function.

#### See Also

- *Events* in the *Enterprise Report Writing Guide* for a listing of events available in each report section and the order in which they are processed
- *ERP 9.0 APIs* on the Knowledge Garden for other system functions

## Understanding Batch Run-time Processing

---

The term *Batch run-time processing* refers to how events, such as initializing a section, and their attached event rule logic are evaluated at run time.

Run-time structures are blocks of memory that hold data as it is read, processed, and written to the database.

Report Design provides several different field types and event rules that are associated with run-time structures.

### Available Objects

An available object is represented by a two-character, alphabetical code that characterizes the source of data and determines how the object data is used in a report or batch process at run time.

During run-time processing, data is stored in memory in an internal data structure. Certain fields of the data structure temporarily store data during run time until it is no longer needed. Then data can be cleared to process another record.

The following available objects are defined for batch processing:

- BC** A column in the business view. Business view columns will appear in this list. These columns are filled with values from the database when a fetch is performed and are the values saved to the database during an add or update.
- PO** A value passed from a processing option. These values are passed into the application when it is started and can be accessed by any form in that application. These processing option values could have been entered by the user or set up in a particular version of an application.
- VA** Event rules variables. These objects represent variables set up by the developer in event rules. They are not manipulated by the system.
- SV** System variables. These objects represent some environment variables that have been made accessible to event rules.
- SL** System literals. These objects represent some constant system values that have been made accessible to event rules.
- TV** Text variable.
- RC** Report constant (UBE).
- RV** Report variable (UBE).
- PC** Previous business view column.
- PV** Previous report variable.

## Typical Event Flow for a Group Section

The run-time engine processes events in a certain order. The typical events for a group section and the order in which they are processed follow.

### Initialize Section

The following graphic illustrates what values are in the run-time structures after the following events occur.

- Initialize Section

This following example uses a group section for an Address Book report:

### Runtime Values Structure

RC		BC	
AN8	Address Number	AN8	
ALPH	Alpha Name	ALPH	

### Advance Section

The following graphic illustrates what values are in the run-time structures after the following events occur:

- Initialize Section
- Advance Section

### Runtime Values Structure

RC		BC	
AN8	Address Number	AN8	
ALPH	Alpha Name	ALPH	

## Before Level Break

The following graphic illustrates what values are in the run-time structures after the following events occur:

- Initialize Section
- Advance Section
- Before Level Break

### Runtime Values Structure

RC		BC	
AN8	Address Number	AN8	1
ALPH	Alpha Name	ALPH	Financial/Distribution Company

## Do Section

The following graphic illustrates what values are in the run-time structures after the following events occur:

- Initialize Section
- Advance Section
- Before Level Break
- Do Section

### Runtime Values Structure

RC		BC	
AN8	Address Number	AN8	1
ALPH	Alpha Name	ALPH	Financial/Distribution Company

## After Last Object

The following graphic illustrates what values are in the run-time structures after the following events occur and how the report looks at this point:

- Initialize Section
- Advance Section
- Before Level Break
- Do Section
- After Last Object

### Runtime Values Structure

RC		BC	
AN8	Address Number	AN8	1
ALPH	Alpha Name	ALPH	Financial/Distribution Company

Report	
Address Number	1
Alpha Name	Financial/Distribution Company

## Advance Section

The following graphic illustrates what values are in the run-time structures after the following events occur and how the report looks like at this point:

- Initialize Section
- Advance Section
- Before Level Break
- Do Section
- After Last Object
- Advance Section

### Runtime Values Structure

RC		BC	
ANS	Address Number	ANS	1
ALPH	Alpha Name	ALPH	Financial/Distribution Company

Report	
Address Number	1
Alpha Name	Financial/Distribution Company

## Before Level Break

The following graphic illustrates what values are in the run-time structures after the following events occur and how the report looks at this point:

- Initialize Section
- Advance Section
- Before Level Break
- Do Section
- After Last Object
- Advance Section
- Before Level Break

### Runtime Values Structure

RC		BC	
AN8	Address Number	AN8	27
ALPH	Alpha Name	ALPH	Eastern Area Distribution Center

Report	
Address Number	1
Alpha Name	Financial/Distribution Company

## Do Section

The following graphic illustrates what values are in the run-time structures after the following events occur and how the report looks at this point:

- Initialize Section
- Advance Section
- Before Level Break
- Do Section
- After Last Object
- Advance Section
- Before Level Break
- Do Section

### Runtime Values Structure

RC		EC	
AN8	Address Number	AN8	27
ALPH	Alpha Name	ALPH	Eastern Area Distribution Center

Report	
Address Number	1
Alpha Name	Financial/Distribution Company

## After Last Object

The following graphic illustrates what values are in the run-time structures after the following events occur and how the report looks at this point:

- Initialize Section
- Advance Section
- Before Level Break
- Do Section
- After Last Object
- Advance Section
- Before Level Break
- Do Section
- After Last Object

### Runtime Values Structure

RC		BC	
AN8	Address Number	AN8	27
ALPH	Alpha Name	ALPH	Eastern Area Distribution Center

Report	
Address Number	1
Alpha Name	Financial/Distribution Company
Address Number	27
Alpha Number	Eastern Area distribution Center

## Advance Section

The following graphic illustrates what values are in the run-time structures after the following events occur and how the report looks at this point:

- Initialize Section
- Advance Section
- Before Level Break
- Do Section
- After Last Object
- Advance Section
- Before Level Break
- Do Section
- After Last Object
- Advance Section

### Runtime Values Structure

RC		BC	
AN8	Address Number	AN8	27
ALPH	Alpha Name	ALPH	Eastern Area Distribution Center

Report	
Address Number	1
Alpha Name	Financial/Distribution Company
Address Number	27
Alpha Number	Eastern Area distribution Center

---

## Report Output

Reports are created using Report Design Tool in which certain printing properties can be defined for the report that can affect the resulting output. After the report is created and submitted, the Batch Engine can process the report on the various servers or on the client. After report processing is complete, Output Management handles output generation and printing. This topic describes printing properties during report creation, submission, output generation.

---

## Printing Properties in Report Design

Report Design incorporates printing properties that determine the format of output. In all cases, print properties set in Report Design override default properties established for batch processes. Setting print properties in a report version overrides the properties specified by the report template. Printer properties set in Report Design can be overridden at submission. This topic describes how to set print properties in Report Design.

---

### Note

Changes in print properties in a report template are not reflected in any of its already existing versions.

---

## Overriding a Designated Printer

A default printer is associated with batch processes. Default printers can also be associated with users; a user-associated printer overrides a batch process-associated printer. You can override both of these printers by selecting a printer when you design a report in Report Design. The printer you select is stored in the print specifications, causing the report to always print to that printer unless overridden at submission.

---

### ► To override a designated printer

*In the J.D. Edwards Windows environment, choose Report Design Tool from the Report Writer menu (GH9111).*

1. On Report Design, choose Print Setup from the File menu.
2. On Print Setup, click the Printer Name button.
3. On Printer Search & Select, choose the printer to which you wish the report to print, and then click Select.

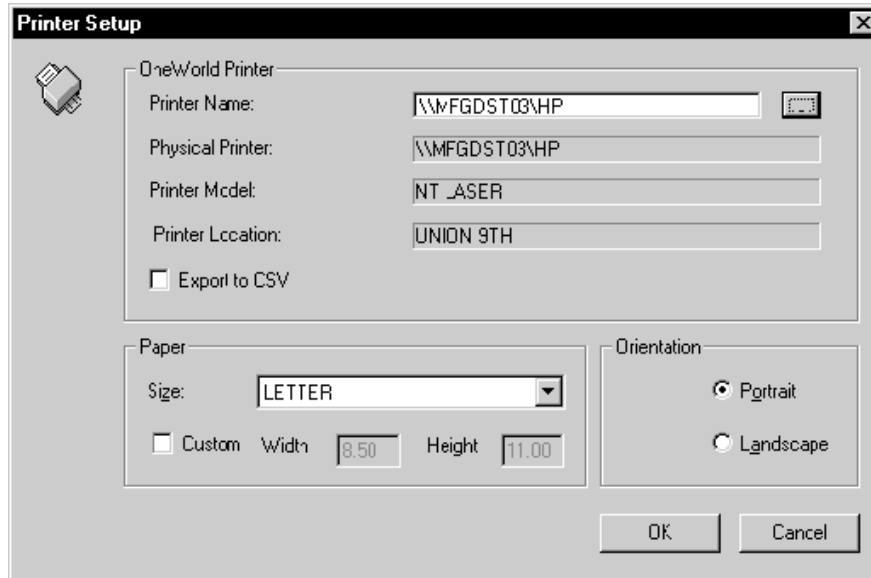

4. On Print Setup, choose other options as desired and click OK.

## Selecting Paper Type

You can select from a group of predefined paper sizes, or you can enter your own paper dimensions.

The standard predefined selections are A4, Legal, and Letter. Letter is the default paper type. The paper size used for PDF generation is the one defined in the Paper Definition table (F986162). Report Design inherits the paper size from the same table. Change this table to modify the predefined group.

Alternately, you can define paper size by width and height in inches. The minimum definable width is two inches, and the maximum is 21 inches. The minimum definable height is two inches, and the maximum is 24 inches.

### ► To select paper type

---

*In the J.D. Edwards Windows environment, choose Report Design Tool from the Report Writer menu (GH9111).*

1. On Report Design, choose Print Setup from the File menu.

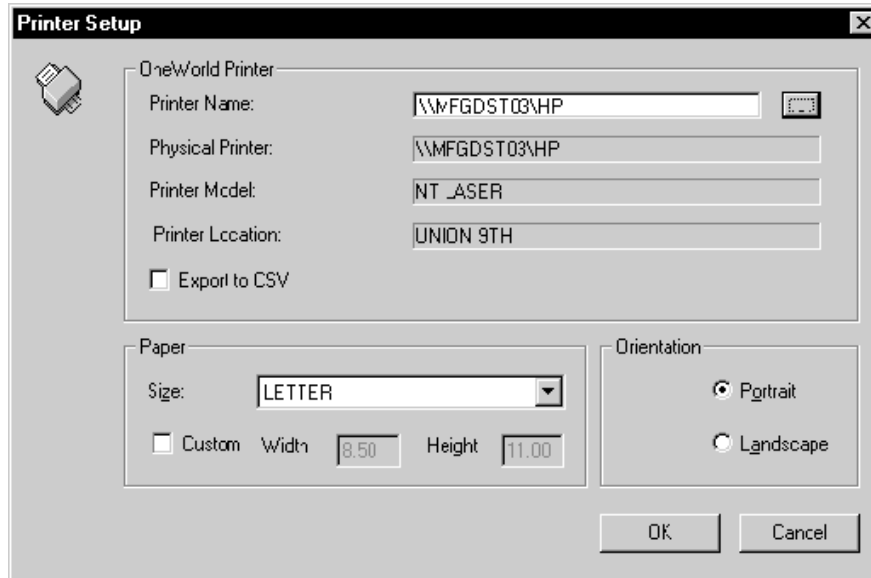

2. On Print Setup, select a predefined paper type from the drop-down menu in the Size field, or click Custom and indicate the paper width and size in inches.
3. Select other options as desired, and then click OK.

## Specifying Print Orientation

Orientation refers to how the paper is rotated when it is printed. A vertical orientation is called Portrait; a horizontal orientation is called Landscape. Orientation can be applied only to predefined paper sizes. The option is disabled for user-defined paper sizes.

In J.D. Edwards software, the default orientation is Landscape. When you are printing to line printers, a Portrait orientation is recommended. Orientation does not apply for CSV generation.

### ► To specify print orientation in Report Design

*In the J.D. Edwards Windows environment, choose Report Design Tool from the Report Writer menu (GH9111).*

1. On Report Design, choose Print Setup from the File menu.

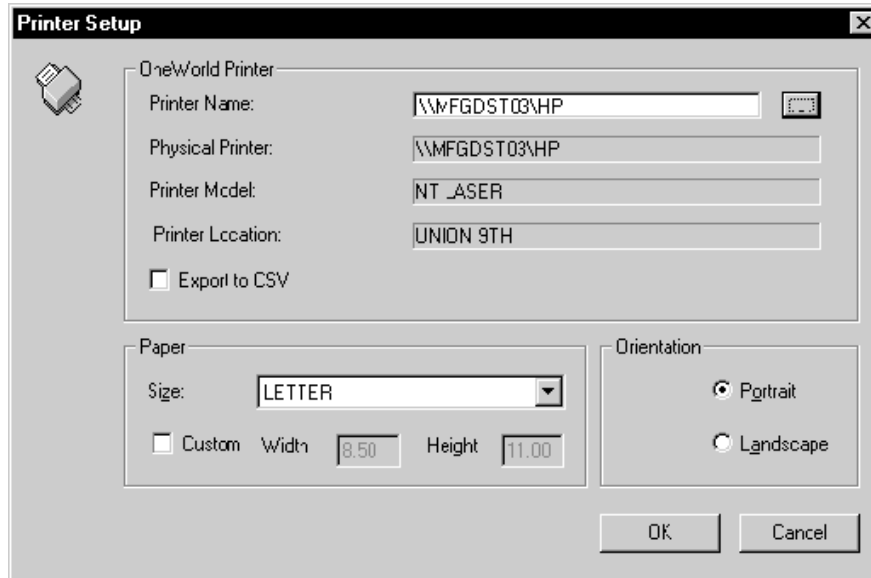

2. On Print Setup, click the desired orientation under the Orientation heading. Orientation options are deactivated if you have selected a custom paper size.
3. Select other options as desired, and then click OK.

## Exporting to Comma Separated Value (CSV) Files

To view report data in a spreadsheet programs such as Excel or Lotus, you must choose to export the data to a CSV file. Before exporting, J.D. Edwards recommends that no fields overlap and that the horizontal spacing be set to 52 (this spacing corresponds to the default width of a column in Excel). Also set the Snap to Grid options set in the grid alignment layout.

Both a .csv and a .pdf file are created in the Print Queue directory when the report is submitted to the screen or to the printer. Note that only single spacing and portrait orientation is supported for CSV files. Drill down links are ignored in CSV generation.

### ► To export to Comma Separated Value (CSV) files

*In the J.D. Edwards Windows environment, choose Report Design Tool from the Report Writer menu (GH9111).*

1. On Report Design, open the report you are exporting.
2. Check the layout of columns and fields.  
Ensure that no columns or fields overlap.
3. Click a report section, and from the Layout menu, select Grid Alignment.
4. On Alignment Grid, set the horizontal spacing to 52, choose the Snap to Grid option, and then click OK.

Report Design applies this value to the entire report.

- From the Report menu, select Print Setup.

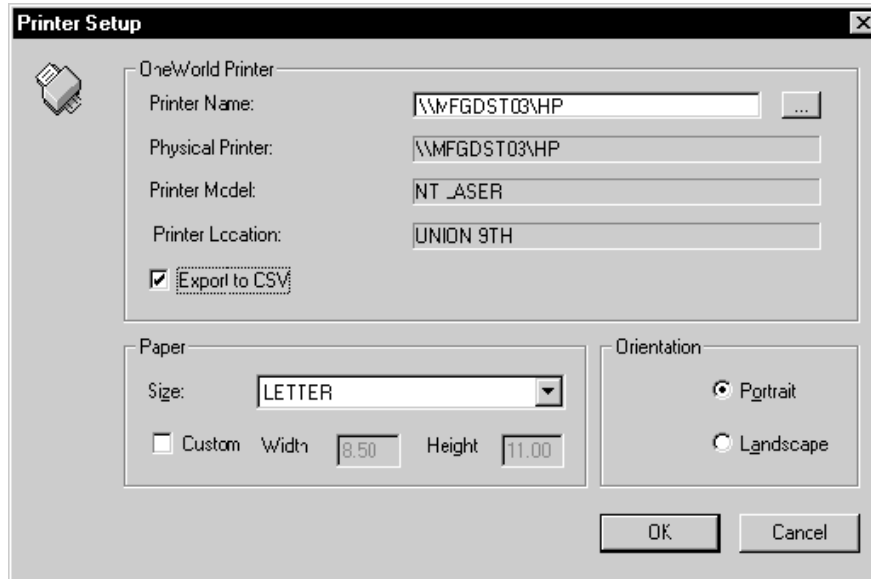

- On Print Setup, choose Portrait under the orientation heading.
- Choose Export to CSV, and then click OK.

#### See Also

- *Modifying the Appearance of Report Objects in the Enterprise Report Writing Guide* for information on altering field lengths and column widths

## Using System Function K2DoInitPrinter

You can use the Do Init Printer event to specify a printer when the batch application processes. In this way, you could print the same report to different printers based on other criteria that you specify. The event rule (ER) for this event is the first ER that is processed when the report is submitted. The system function resolves and validates the printer, and the Batch engine then uses the printer name (if valid) to obtain a printer device context. Portions of this device context can be overridden if certain flags in the report specification are set.

## Printing Properties at Report Submission

---

To submit a report, you must select the version of the report to be processed. You can submit the job in one of two ways:

- When a version is submitted locally, the client immediately launches the UBE process, giving you the option to view the output on screen or to print it to a printer.

- The version can also be submitted to an enterprise server that can handle the processing more efficiently than the client. When the version is submitted to the server for processing, the client packs the version specifications and other information necessary to run the report, (such as Processing Option values, Report Interconnect values, Printer Information), and sends a message to the server with all this information.

When a job is initiated on the server, it can be launched in one of the following ways:

- By another report or interactive application through a report interconnect. Report Interconnects can also be used to submit jobs locally.
- Through RUNUBE from the command line.

### See Also

- *Creating Report Interconnections in the Development Tools Guide*

## Resolving Printers

When a job is submitted on the client or server, the following applies:

- If a printer is selected at design time, the printer name is stored in the report specifications. On the client, the printer name is passed in at submission time to the Printer Selection dialog box.
- The user can override this printer.
- If no printer is selected at design time, then during submission the default printer for that user is used. The default printer is selected by user, OW environment, and host.
- Depending on the printer that was selected, the corresponding Printer Definition Language on the Advance tab will be enabled.

If a job was submitted through report interconnects, the child reports inherit the printer name from the parent report. At print time, for the child report, the user can override the printer from the Work With Servers program (P986116) once the job has completed.

When a job is submitted through RUNUBE, if a printer name was stored in the specifications it is used at print time; otherwise, the default printer for the user is used. At print time, the user can override the printer from the Work With Servers program when the job has completed.

## Selecting Paper Type

If custom paper size is used in Report Design to design the report, then at submission time the user will *not* have an option of changing the paper type.

The paper type defined for the printer is used during job submission. From the Print Property tab on the Printer Selection dialog box, the user can change the paper type. Depending on the printer that the user selects, the Paper Type field is automatically populated with the default paper type that is set for that printer.

## Specifying Print Orientation

The orientation selected in Report Design is stored in the report specifications. Orientation from the specifications is displayed in the Print Property tab of the Printer Selection dialog box at submission time. The user can, however, change the orientation at submission time (locally or on the server).

However, if custom paper size was selected at design time, the orientation control will be disabled in the Printer Selection dialog box. In the case of line printers, the CPI, CPP, LPI, and LPP that are defined for the line printer determine the orientation.

## Using the Print Immediate Option

On the server, if a job is marked for immediate printing (by setting the Print Immediate flag to TRUE in the client JDE.INI file under NETWORK QUEUE SETTINGS), the following is true:

- The job automatically prints without having to actually click the Print option on the Work With Servers program (P986116). The PrintImmediate option comes in checked on the Printer Selection dialog box. The user can override this setting.

[NETWORK QUEUE SETTINGS]

PrintImmediate=TRUE/FALSE

- For report interconnects, if the Print Immediate function is turned on then, the function is inherited by the child reports from the parent. In this case, the user does not have an option to override it.
- In the case of job submission through RUNUBE, Print Immediate can be passed as an argument from the command line. In this case, just like on the server, the job automatically prints if the PrintImmediate option is set to TRUE.

## Using the SavePDL (Printer Definition Language) File Option

If the JDE.INI file has the SavePDL option set to TRUE under NETWORK QUEUE SETTINGS, then at submission time the Printer Definition Language File option on the Document Setup tab is enabled. However, this option can be changed at submission time.

[NETWORK QUEUE SETTINGS]

SavePDL=TRUE/FALSE

Additionally, if the SavePDL option in the JDE.INI file is set to FALSE, the user has the option at submission time to select this option in order to save the intermediate temporary file created. The PDL file, when created, resides in the Print Queue directory. In the case of report interconnects, the child reports inherit this property from the parent.

At submission time the user has the option of modifying the Printer Definition Language File option and, depending on whether it is checked or unchecked, a PDF and a PDL file is created for that particular job only.

## Exporting to Comma Separated Value (CSV) Files

When you are submitting the job on the client, if the Export to CSV option was selected, the option is stored in the report specifications. This option from the specifications is displayed in the Report Output Destination dialog. The user can override this option by submitting the job To Printer or to On Screen.

If the user chooses to submit to the printer, the user has the option of overriding the Export to CSV option on the Document Setup tab of the Printer Selection form. A .csv and a .pdf file are created in the Print Queue directory when this option is selected.

When you are submitting the job to the server, if the Export to CSV option was stored in the report specifications at design time, then from the Work With Servers program (P986116), the user will have the opportunity to modify this option.

In the case of report interconnects, the export to CSV option is not inherited by the child report from the parent. Therefore, the option must be selected at design time to enable this option for the child or parent report.

## Storing and Passing Printer Information

When you launch a UBE on the client, the printer information is stored in the pUBEDs structure and this information is passed to the Batch Engine.

For submission of a job from client to server, the printer information that is obtained from the Printer Selection dialog box is stored in the F986110 (Job Control Status Master table) as a BLOB (Binary Large Object).

For job submission through report interconnects, the printer information for the child reports is inherited through the PRT\_GetInfoFromPreviousReport API from the parent report. The inherited values are Printer name, Print Immediate, SavePDL information, Paper Type and Printer flags, Number of Copies, and Paper Source, if any. If the child report in its specifications had a printer name defined or custom paper type set, then that would override the inherited values.

In the case of RUNUBE, the printer information, as well as information regarding Print Immediate and Save PDL, are packed and stored in the F986110 table.

## Job Submission on Client

A job can be submitted on the client in one of the following ways:

- To Printer
- On Screen (for viewing the PDF file)
- Export to CSV
- Export via OSA

When the job is submitted using the To Printer option, the Printer Selection dialog box is available to the user to modify output options.

When a job is submitted using the On Screen option on the Report Output Destination dialog box, the PDF file is displayed through the Acrobat Reader.

If the user submitted the job to the Export to CSV option, then the report will be automatically displayed through a default CSV viewer, such as Excel.

If the user submitted the job using the Output Stream Access (OSA) option, then the location of the output is determined by the OSA's interface functions. For example, the J.D. Edwards XML interface create an XML file in the same directories that are used for PDF and CSV output. An OSA library created by another company might store the OSA output in a different location.

## **Working with the Integrated File System (IFS) on the AS/400**

When you print a batch version on the AS/400® server, the resulting report is sent to the integrated file system (IFS) in portable document format (PDF). You can map to the reports using Windows Explorer.

The default PrintQueue directory is under the install directory. If you want to create your own PrintQueue directory, you need to define the PrintQueue using a valid IFS file name.

### **► To define the PrintQueue directory for the integrated file system (IFS)**

---

*Open the jde.ini file.*

1. Under [NETWORK QUEUE], change OutputDirectory = *system*, where *system* is the name of the PrintQueue directory.
2. Save and close the jde.ini file.

---

## Report Submission

When you submit a report, you can modify the data selection and data sequencing and select advanced version functions. You can also choose to view the report on screen, send it to the printer, export it to a Comma Separated Values (CSV) file, or use Output Stream Access (OSA) to export it to another software program.

---

## Submitting a Report

To submit a report, you must select a version of the report that you want to process. If you submit and process the report version on your workstation, you can specify whether to:

- View the report online.  
When you view the report online, the report is in a PDF format and is readable only with the Adobe Acrobat Reader.
- Print the report.
- Export the report to a generic Comma Separated Values (CSV) file  
A CSV file has all of the commas stripped from the data fields. When you export the report to a CSV file, the file can be viewed in a default CSV viewer, such as Microsoft Excel or Lotus 1-2-3. In addition to viewing the CSV file, you can manipulate report data after the report has finished processing.
- Export the report to a specific environment via Output Stream Access (OSA).  
Unlike the generic CSV file, you can direct to pass data to other software programs during batch processing, allowing the second software program to process and format the data concurrently. An OSA interface must already be defined before you can employ this option.

In most business environments, you submit your version to a designated enterprise server that manages the processing needs more efficiently than your workstation. Your system administrator determines whether the system automatically processes and prints your output, or places it on hold in the queue.

When you submit your version to the server for processing, it is sent to a job queue. Version specifications and information required to run the version are sent from the workstation to the servers. You can monitor the progress in the queue and preview the version when the processing is complete.

## Submitting a Report for Batch Processing

You can submit a report using various methods. For example, you can double-click a report icon from a menu, choose Batch Versions from the Report Writer (GH9111) menu, or choose Report Versions from the Tools menu in J.D. Edwards Solution Explorer. The following procedure describes the second method.

## ► To submit a report for batch processing

---

*In the J.D. Edwards Windows environment, choose Batch Versions from the Report Writer menu (GH9111).*

The forms that appear depend on whether you submit the report version to a workstation or a server.

1. On Work With Batch Versions - Available Versions, choose your report. Use the visual assist to more easily locate your report.

If the report version is new and has not been checked in, other users cannot run the version. If you modify the version and run the modified version, the *local* modified specifications will run. If the modified version is executed on the server, the updated version specifications will be used when you submit that version.

2. Click Select.
3. On Version Prompting, click Submit.

If your report version exists only on your workstation and you submit the version to the server, the Install Specifications form appears. You must first install the version and the report specifications to the server that processes the report.

4. On Install Specifications, click Yes.

The Remote Job form appears. Run a package install to put the report specifications and version information on the server to which the version will be submitted.

5. Click OK.

If you receive a communication failure message, resend the information to the server. If you continue to get a communication failure message, contact your system administrator.

If you are submitting a job to run locally, the Report Output Destination form appears.

6. On Report Output Destination, choose from the following options and click OK:

- On Screen
- To Printer
- Export to CSV
- OSA Interface Name

---

### **Note**

OSA runs in tandem with one of the first three choices. When you choose OSA Interface Name, you must also choose one of the other three options.

---

If you are submitting a job to run on a server and you have already installed the version and its specifications on the server, the Batch Versions - [Printer Selection] form appears. If a default printer has been defined for report processing, that printer's information appears on the Batch Versions - [Printer Selection] form. If you selected a different printer in RDA when designing your report, it overrides the default printer defined for the report processing.

7. On Printer Selection, on the Printer Selection tab, enter the number of copies of the report you wish to print.
8. Click the Print Property tab and select from the following override options as appropriate:
  - Portrait
  - Landscape
  - Number of Copies

This number reflects the number of copies entered on the Printer Selection tab. The default value is 1. Changing the value here changes the value on the Printer Selection tab to match. The option is valid only for post script and line printers; it is disabled for PCL printers.

If you are printing to an AS/400 line printer, you may need to modify your output queue description to enable this feature.
  - Paper Type
  - Paper Source

The default and maximum values are defined in the Printer Setup application. The option is only available for PostScript printers; it is disabled for PCL and line printers.

The options you select on this form override settings specified in the report itself, but apply to the current batch process only.
9. Click the Document Setup tab and choose from the following options as appropriate:
  - PDF(Portable Document Format)
  - Printer Definition Language File
  - Print Immediate
  - CSV(Comma Delimited)
  - OSA Interface Name
10. Click the Advanced tab and choose from the following options as appropriate:
  - PostScript
  - PCL
  - Line Printer
  - Custom
11. Click OK.

## See Also

See the following topics in the *Enterprise Report Writing Guide*:

- ❑ *Working with the Printers Application* for additional information on printers
- ❑ *Overriding Data Selection and Data Sequencing*
- ❑ *Using Advanced Option Overrides*
- ❑ *Setting Up a Printer for AS/400* in the *Server and Workstation Administration Guide*

## Comma Separated Values (CSV) Files

When you export a file to CSV, the following occurs:

- A CSV file is created in the print queue.
- A PDF file is created in the print queue.
- Your CSV file appears in Microsoft Excel, which launches automatically if you are running locally. If you are running on a server, from Work With Servers (P986116) choose View CSV to launch Excel and view the file.

You can also use the CSV file for other spreadsheet applications. Microsoft Excel can read a CSV file by default.

If you are running locally and you want to export a report to a CSV file for just a specific instance, do one of the following:

- Click the Export to CSV option when submitting your report.
- Click Export to CSV (Comma Delimited) on the Document Setup tab of the Printer Selection form.

If you always want a report to export to a CSV file, click Export to CSV in the Printer Setup in RDA so that the report specifications are set to export the report to a CSV file.

If you do not want the report to export to a CSV file for a single instance, even though it is set in the report specifications, click Export to CSV to remove the check when submitting your report.

Reports do not always export to other programs perfectly. For example, group sections with several one-character data fields might need some cleanup. Following are several points to consider when exporting to CSV files.

- The startup default column width in Excel is equivalent to about 52 units in Report Design, so for best results, set your horizontal grid alignment to 52 and turn on the snap to grid option.  
  
Each column you see in RDA is now equal to a column in Excel. Align the data so that the left edge of each data field is in a column. If a data field overlaps into the next column, the data in Excel will be in discrete columns. Since the text comes into Excel in one cell, you can then wrap the text in the calls in Excel. Delete unused columns in Excel and reformat information as needed.
- If data fields are vertically off, they appear in separate rows in Excel. If more than one data field with the same vertical and horizontal alignment appears in a column, only one of these fields will be in the CSV file. The first field to get output occupies the cell in Excel.

- Some countries use a comma as a decimal marker. In these countries, the decimal separator is recognized as a comma when the report exports and a tab-separated file with a .txt extension is created. Tabs are stripped out instead of commas.

The information transfers as flat text, so totaling columns just show text and you must set up totaling in Excel.

- After your report is designed to export into Excel cleanly, you can use the Auto Format feature in Excel to further format your report in Excel.
- Excel uses the same date format you use in your report.

## Output Stream Access (OSA) Files

When you use OSA to direct your output, J.D. Edwards software passes its output to another program for processing. The OSA interface must be predefined; several interfaces may exist for one program, depending on the report type and the desired output.

The benefits of OSA are that it can eliminate the task of manually formatting output (as you must do with CSV output) and that it can employ the processing power of the target software program.

OSA can use its own set of commands, or it can use an XML library. Because many software packages already use XML libraries for several functions, creating and using an XML library can simplify the interface.

### See Also

- *Creating and Associating OSA Interfaces* in the *Enterprise Report Writing Guide* for more information about defining OSA interfaces and libraries

## Defining Processing Options

Processing option values are stored for each report version in the Versions List table (F983051). This table is centrally located and can be accessed by all J.D. Edwards software users within a given environment. Any changes to processing option values are immediately visible to all other users working with the same report version. Jobs running on client machines and jobs running on servers all access the same table.

Processing option values that you enter during submission are used at execution. If there is no prompting, values that exist at submission are used at execution. Values that you enter during submission are saved in F983051 and will be seen the next time you submit that version.

Processing options that are defined by a particular user during submission of a report are saved for that user. This means that multiple users can run the same report with different processing option values and receive the output they desire based on their individual processing option values. For example, User A submits User Defined Codes Print (R0005P) to run on a server, changing the Language Preference processing option to E for English. The job goes to the server and waits in its queue. User B also submits R0005P, changing the Language Preference processing option from E to F for French. That job also goes to the server and waits. When User A's job gets to the top of the queue and becomes active, it will use the Language Preference value of E, even though User B changes the processing option value to F during submission.

Consider the following scenarios:

- Submitted on client, running on client.  
During report submission, the user might be prompted for data selection and sequencing values. The values that the user specifies during prompting are retained in memory, but are not saved to the local RDASPEC files. The values in memory are passed along to the job as it processes. If no prompting occurs, then the job will load selection and sequence values from the local RDASPEC files at execution.
- Submitted on client, running on server.  
The submission process begins in the same way as when a report is submitted and running on a client, but when the job is transferred to the server, the processing option values are also sent to the server, where they are stored in the Job Control Status Master table (F986110). When the job is executed, the processing option values are retrieved from F986110, instead of being loaded from F983051.

## Overriding Data Selection and Data Sequencing

From Version Prompting, you can change the data selection and data sequencing for your report. Every user (client machine) has a copy of a given version. Any changes made to a report version remain with the copy of the version that resides on that machine.

Data selection and sequencing values are stored in Report Design specification (RDASPEC) files, which can exist on the client as well as the server. In Terminal Server environments, multiple users share the same set of client RDASPEC files, so any change to specifications by one user are immediately visible to all other users of the same terminal server.

Values entered during submission are used for processing, but are not saved and will not be seen at the next report submission. If no prompting occurs, values that exist locally at submission are used during processing. Values entered in Version List or in Report Design are saved in the RDASPEC files.

Consider the following scenarios:

- Submitted on client, running on client.  
During report submission, you might be prompted for data selection and sequencing. The values that you specify during prompting are retained in memory, but are not saved to the local RDASPEC files. The values in memory are then passed along to the job as it processes. If no prompting occurs, the job will load selection and sequence values from the local RDASPEC files at execution time.
- Submitted on client, running on server.  
When a job is sent to a server, all of the specifications related to the version being submitted are copied into packed files that are sent to the server. When the job processes on the server, the information from the packed files is merged into the specifications on the server, which are then used to run the job. Every user gets his own copy of his report to run on the server.

If prompting for selection and sequencing values occurs during submission, the values retained in memory are copied into the packed files instead of the corresponding RDASPEC information, so the values from prompting will be used when the job eventually executes.

## Changing Data Selection

Data selection uses Boolean logic to determine which records to include in the report. Boolean logic uses operators such as *And* and *Or*.

Use *And* to include only the data that two or more fields in a record have in common. For example, suppose you need a list of customers who are located in New York City. You might use the two fields Location and Search Type with the following criteria:

Location = New York

*And*

Search Type = C (customer)

Use *Or* logic to search for records that include data items for either NYC *Or* C. For example, if you need to find any New York City record or any customer record, you would indicate the same information for Location and Search Type.

### ► To change data selection

---

*In the J.D. Edwards Windows environment, choose Batch Versions from the Report Writer menu (GH9111).*

1. On Work With Batch Versions - Available Versions, type an application ID in the Batch Application field. For example, to locate a version for the One Line Per Address report, type R014021.
2. Click Find to locate the versions available on your workstation.
3. Choose the report version you want to submit, and then click Select.
4. On Version Prompting, click the following option:
  - Data Selection
5. Click Submit.
6. On Data Selection, change the data selections as needed for your version.
7. Click OK.

If you are submitting a job to run locally, the Report Output Destination form appears.

### See Also

- *Defining Section Data Selection in the Enterprise Report Writing Guide*

## Changing Data Sequence

You can change the order in which the data in your report appears.

### ► To change data sequence

---

*In the J.D. Edwards Windows environment, choose Batch Versions from the Report Writer menu (GH9111).*

1. On Work With Batch Versions - Available Versions, type an application ID in the Batch Application field. For example, to locate a version for the One Line Per Address report, type R014021.
2. Click Find to locate the versions available on your workstation.
3. Choose the report version you want to submit, and then click Select.
4. On Version Prompting, click the following option:
  - Data Sequencing
5. Click Submit.
6. On Section Data Sequencing, change the data sequencing as needed for your version.
7. Click OK.

If you are submitting a job to run locally, the Report Output Destination form appears.

### See Also

- *Defining Section Data Sequencing in the Enterprise Report Writing Guide*

## Using Advanced Option Overrides

Advanced options allow you to override your processing location and use a variety of logging features.

### ► To use advanced option overrides

---

*In the J.D. Edwards Windows environment, choose Batch Versions from the System Administration Tools menu (GH9011).*

1. On Work With Batch Versions - Available Versions, type an application ID in the Batch Application field. For example, to locate a version for the One Line Per Address report, type R014021.
2. Click Find to locate the versions available on your workstation.
3. Choose the report version you want to submit, and then click Select.
4. On Version Prompting, choose Advanced from the Form menu.

If the menu bar does not appear at the top of Version Prompting, maximize the form.
5. On Advanced Version Prompting, click one or more of the following options, and then click OK:
  - Override Location

You must have authorization from your system administrator to override your location. If you select Override Location, the JDE Data Sources form appears when you click Submit from Version Prompting.

From this form, choose the enterprise server where you want to process your job, and then click Select to continue.

- Logging (JDE.log)
- Tracing (JDEDEBUG.log)
- UBE Logging Level

When you choose a high value to receive more technical information, you also receive all the information for the lower values. For example, when you enter a value of 3 (object level messages), you also receive information for 2 (section level messages), 1 (informative messages), and 0 (error messages).

- Submit Version Specifications Only

### See Also

- *Moving Batch Version Specifications to an Enterprise Server* in the *Enterprise Report Writing Guide* for information about working with the Submit Version Specifications Only option

## Command Line Submission

You can allow non-J.D. Edwards software applications to submit batch jobs for processing in J.D. Edwards software via a command line. J.D. Edwards software accepts two types of batch submission command lines:

- `runube` is a direct command line with which you can define which report and version to run, which job queue to use, how the queue is controlled, whether the report is printed or held, and where the report is output to. This command line requires no input files. It does not allow you to override or change processing options, data selection, or data sequencing from what has already been set using a J.D. Edwards software client.
- `runubexml` is a command line that uses an xml input file to specify to J.D. Edwards software about how to process the report. It is nearly as flexible as submitting a batch process directly within J.D. Edwards software, and it does allow you to override the settings in specifications for processing options, data selection, and data sequencing. However, you must have an xml input file available for each processing variation for each version of each report you want to run.

## Using `runube`

The format of the `runube` command line is as follows:

```
runube UID PWD ENV REP VER JQ B/I P/H S/D PTR
```

The following is a description of each of the command line components:

**`runube`** The name of the executable that submits the job.

**UID** A J.D. Edwards software user ID. You must have access to the report you want to run. If you do not enter a printer type and you have requested that the report be printed, the system uses the printer assigned as your default printer based on your user ID.

- PWD** The J.D. Edwards software password corresponding to the user ID.
- ENV** The J.D. Edwards software environment.
- REP** The system name of the report you want to process, such as R0006P.
- VER** The name of the version of the report you want to process; such as XJDE0001. You must enter a version; you cannot submit the template of a report.
- JQ** The name of the job queue to which the system should route the batch job, such as QBATCH.
- B/I** The processing mode. Enter B to use J.D. Edwards software's batch processing. In this case, the system uses the F986110 Job Control table to assign the report a place in the queue.  
Enter I for interactive mode which runs the report immediately outside of the J.D. Edwards software queuing mechanism.
- P/H** The hold code. Enter P to send the output to a printer immediately after the job completes.  
Enter H to hold the processed file without printing. You can print the job later using the Work With Servers program (P986116) located on the System Administration Tools menu (GH9011).
- S/D** The save code. Enter S to save the file after processing is complete. The delete option (D) is reserved for future functionality. Currently, the option is disabled.
- PTR** The printer ID. When printing the report, you may define which J.D. Edwards software printer to route it to. If you do not enter a printer type, the system uses the printer assigned as your default printer based on your user ID and environment.

---

### Caution

If you submit this line command in a UNIX environment, you should be aware of the possible security risk. Any user with access to the UNIX system can view this command line, including your password, while the runube command is processing.

---

### See Also

- *To define a default printer* in the *Enterprise Report Writing Guide* on the Printers Application program (P98616) on the Batch Processing Setup menu (GH9013)

### Using runubexml

To use runubexml, you must create an xml file which is used as input to provide J.D. Edwards software with batch processing instructions. If you will be routinely submitting the same reports with the same options for processing, you might consider creating several xml files for each report.

Create and submit an xml file that gives J.D. Edwards software your ID, password, and environment along with the name of the report and version you want to process. The system returns a new xml input file that defines the report version and its saved processing options. You can modify this input file and even create several variations of it to run.

You can run this input file as often as you wish. Note that changing the input file does not modify the report version as it is saved in J.D. Edwards software. The input file only provides the J.D. Edwards software batch processing engine with data; J.D. Edwards software does not maintain any connection between the xml input file and the report upon which it is based. If the report is changed in J.D. Edwards software and you want those changes to be reflected in the output you receive with the xml input file, you must either change the input file, or generate a new input file after the report has been altered in J.D. Edwards software.

You must use a file called jdeRequest.xml to instruct the system to create an xml input file based on a J.D. Edwards software report for you. If you do not have this file available, run the following command:

```
runubexml G CREATE_XML jdeRequest.xml
```

This command generates the jdeRequest.xml file, which looks like this example:

```
<?xml version='1.0' ?>
<jdeRequest type='ube' user='MYUNAME' pwd='MYPASS'
environment='MYENV' session=''>
  <!--This document is automatically generated by the J.D.Edwards
APIs-->
  <ACTION TYPE='CREATE_XML' TEMPLATE_TYPE='LAUNCH_JOB'>
    <REPORT_NAME VALUE='MYREPORT'/>
    <REPORT_VERSION VALUE='MYVERSION'/>
    <JARGON_SYSTEM_CODE VALUE='1'/>
    <COMMENTS VALUE='1'/>
    <DATA_TYPING VALUE='1'/>
    <BUSINESS_VIEW VALUE='0'/>
    <!-- Note that Printer Information cannot be overridden at
this time -->
    <PRINTER_INFORMATION VALUE='0'/>
    <POPULATED VALUE='1'/>
  </ACTION>
</jdeRequest>
```

Edit the jdeRequest.xml file based on the following explanations:

**user = 'MYUNAME'**

Substitute a J.D. Edwards software user name for MYUNAME.

**pwd = 'MYPASS'**

Substitute a J.D. Edwards software password for MYPASS. The password must be submitted in plain text; therefore, the jdeRequest.xml file should be kept in a secure location on your file system.

<b>environment = 'MYENV'</b>	Substitute a J.D. Edwards software environment for MYENV.
<b>REPORT_NAME VALUE = 'MYREPORT'</b>	Substitute the system name of the report, such as R0006P, that you want to base the parameters for the xml input file on.
<b>REPORT_VERSION VALUE = 'MYVERSION'</b>	Substitute the name of the batch version that you want to base the parameters for the xml input file on. This is a required value; you cannot base the xml input file on a report template, such as XJDE0001.
<b>JARGON_SYSTEM_CODE VALUE</b>	Enter 1 to use jargon overrides. Enter 0 to turn jargon off.
<b>COMMENTS VALUE</b>	Enter 1 to see xml comments in the xml file. Enter 0 to suppress comments.
<b>DATA_TYPING VALUE</b>	Enter 1 to see the data type (numeric, alpha, etc.) populating the fields. Enter 0 to suppress data type identification.
<b>BUSINESS_VIEW VALUE</b>	Enter 1 to see which business view columns are being used to generate the report. Enter 0 to suppress business view data.
<b>PRINTER INFORMATION VALUE</b>	Enter 1 to see information about the printer to which the report is to be routed. Enter 0 to suppress printer information.
	<b>Note</b>
	Even though print values are shown in both the jdeRequest.xml and the input xml file, you cannot override printer values with the xml input file.
<b>POPULATED VALUE</b>	Enter 1 to populate the resulting xml input file with the settings and options specified for the batch version. Enter 0 to generate a blank xml input file. Most of the time you will enter 1 in this field.

After you have edited and saved jdeRequest.xml, run the following command:

```
runubexml S jdeRequest.xml Filename.xml
```

This command submits the jdeRequest.xml file for processing and returns the input xml file you will need to run a batch job. Substitute the name you want to call this file for *Filename*. J.D. Edwards recommends naming the file after the report and version upon which it is based, such as R0006P\_XJDE0001.

At this point, you can edit *Filename.xml*, if you wish. For example, you can modify the processing options, data selection, or data sequencing. You might create several input files based on the same file with slightly different processing option values to save time if you will be running the variations on a regular basis.

---

### Caution

The input xml file is precisely formatted according to J.D. Edwards software input specifications. Altering the format of the file beyond modifying input values might result in errors when the file is run.

---

After creating, modifying, and saving the xml input file, use the following command line to process the batch application the file defines:

```
runubexml S Filename.xml jdeResponse.xml
```

This command submits your xml input file (substitute the filename for *Filename* in the above command line) for processing and returns the results (including error messages) in a file called *jdeResponse.xml*.

---

## Working with Submitted Reports

---

You can view the status of your submitted reports by accessing Work With Servers (P986116). You can change your job priority, the printer, and the job's queue.

### Checking Your Report Status

After you submit your report, you can review and modify its status.

---

#### ► To check your report status

---

*In the J.D. Edwards Windows environment, choose Work With Servers from the System Administration Tools menu (GH9011).*

1. On Work With Servers, click Find to display the list of available servers.  
If you use the Data Source column in the QBE line to search for the server, you must type the server name using uppercase letters for the system to recognize the server.
2. Choose the server, and then click Select.
3. On Submitted Job Search, the status of your report is shown in the following field:
  - StatusYour system administrator might have set up your configuration to automatically print reports. If the report does not automatically print, you can print it or view it online from this form.
4. If you need to check on another person's report or a different job queue, modify one or both of the following fields, and then click Find:
  - User ID
  - Job Queue

5. To review the job, choose the job, and then click Select.
6. On Job Maintenance, modify the following field as needed:
  - Job Priority  
If you have the proper administrative authority, you can change your job's priority on the job queue while your job is at a W (wait) status. You might choose to move more important jobs up in the queue and move those with less priority down in the queue.
7. Review the following fields for information about your report:
  - Job Status
  - Job Queue
  - Host
  - Environment
  - Server Job Number
  - User ID
  - Server Process ID
  - Origination Host Name
  - Date - Job Submitted
  - Time Job Submitted
  - Date - Last Task
  - Time - Last Task
8. Click OK.

## Viewing and Printing Your Report

After submitting your report and all processing is complete, you can print a version of the report from the Submitted Job Search form. Or, if you chose to submit your report to screen, the output will be in Portable Document Format (PDF) and can be viewed in Adobe Acrobat Reader. If you chose to export to a Comma Separate Value (CSV) file, you can view and manipulate the output through the default CSV viewer.

In addition to one of these three options, if you chose to use an Output Stream Access (OSA) interface, your ability to view the result depends on how the target program was instructed to process the data and the reviewing tools that the program supports.

After submitting your report to a server and all processing is complete, you can view an online version of the report from the Submitted Job Search form.

---

**Note**

If you are using an AS/400 client, the PDF is stored on the client in the integrated file system (IFS) folder you defined in the jde.ini file. See *Working with the Integrated File System (IFS)* in the *Enterprise Report Writing Guide* for information on defining the PrintQueue directory for the PDFs.

---

**Before You Begin**

- ❑ If you have not already done so, install Adobe Acrobat Reader on your workstation. See Adobe Acrobat Reader online help for more information about using Adobe Acrobat Reader.
- ❑ You must have a spreadsheet (for example, Microsoft Excel) or other application (for example, Lotus 1-2-3) available from which you can view a CSV file. See your default CSV viewer's online help for more information about using your CSV viewer.

---

**► To view and print your report**

---

*In the J.D. Edwards Windows environment, choose Work With Servers from the System Administration Tools menu (GH9011).*

1. On Work With Servers, click Find to display the list of available servers.

If you use the Data Source column in the QBE line to search for the server, you must type the server name using uppercase letters for the system to recognize the server.

2. Choose the server, and then click Select.
3. On Submitted Job Search, choose the report you want to view or print and from the Row menu, choose one of the following:
  - Print

Use this option for jobs with a status of E (error in processing) or D (processing is complete). Printing jobs with a status of E prints the error log, which helps you troubleshoot.

If you choose this option, the Printer Selection form appears.
  - View PDF

If you choose this option, the Portable Document Format (PDF) output will be downloaded from the server. You can view an online version of your report in Adobe Acrobat Reader. All of the Adobe Acrobat Reader functions are available to view and zoom the report.
  - View CSV

To use this option, you must have chosen the Export to CSV option on the Printer Setup form in Report Design or from the Advanced tab of the Printer Selection form. When you choose this option, the CSV output will be downloaded from the server and the output will display the CSV format in your default CSV viewer, such as Microsoft Excel or Lotus 1-2-3.

- View OSA

When you choose this option, if the OSA process used to process the report produces an output file and if the OSA process passes the location of the output to J.D. Edwards software, then the system will attempt to launch the software program associated with the output file. Otherwise, you will receive an error messaging informing you that output is unavailable.

If you choose the Print option, the Batch Versions - [Printer Selection] form appears.

### See Also

- ❑ *Troubleshooting the Workstation* and *Troubleshooting the Enterprise Server* in the *Server and Workstation Administration Guide* for more information about error logs and troubleshooting from these error logs
- ❑ *Working with the Printers Application* in the *Enterprise Report Writing Guide* for additional information
- ❑ *Submitting a Report* in the *Enterprise Report Writing Guide* for additional information

## Reviewing Errors

If your print job shows an E status, this indicates that an error occurred during the process. On the Submitted Job Search form, you can print or view the error online and remove the job. Printing a job with a status of E prints the error log, which can help you troubleshoot.

## Holding and Releasing Reports on the Queue

If you submit a report in a wait status (status of W) on the job queue, you can release it to run at a more appropriate time. This might be necessary if running a report impacts system resources. If you want to stop a report that is processing (status of P), you need to terminate it. The Terminate option does not delete the job; rather, it changes the status to E.

If you do not have authority to change your job queue, contact your system administrator.

### ► To review errors

---

*In the J.D. Edwards Windows environment, choose Work With Servers from the System Administration Tools menu (GH9011).*

1. On Work With Servers, click Find to display the list of available servers.  
If you use the Data Source column in the QBE line to search for the server, you must type the server name using uppercase letters for the system to recognize the server.
2. Choose the server, and then click Select.
3. On Submitted Job Search, choose the appropriate job, and then click Select.
4. To check your report, you can print or view it online.
5. To remove (delete) the record and the job from the outqueue, click the Delete button.  
You can use this option with jobs that have a status of E (error) or D (done).

## ► To hold and release reports on the queue

---

*In the J.D. Edwards Windows environment, choose Work With Servers from the System Administration Tools menu (GH9011).*

1. On Work With Servers, click Find to display the list of available servers.  
If you use the Data Source column in the QBE line to search for the server, you must type the server name using uppercase letters for the system to recognize the server.
2. Choose the server, and then click Select.
3. On Submitted Job Search, choose the appropriate job, and then click Select.
4. From the Row menu, choose Hold.  
The status changes to H (hold).
5. To release the job, choose Release from the Row menu.  
The H status is removed, and the job is sent to the queue.

## Working with Your Report Output

You can send your PDF report output as an attachment within an e-mail message or post your reports to the Worldwide Web. The J.D. Edwards software installation materials include Adobe Acrobat Reader to read report output in an e-mail message and Microsoft Internet Explorer, which enables you to read portable document format (PDF) files on the Worldwide Web.

In addition, you can select text and copy the unformatted text to other Windows applications that use the Clipboard. See your Adobe Acrobat Reader online help for more information.

You can view your CSV report output through a default CSV viewer such as Microsoft Excel or Lotus 1-2-3.

Where you submit or how you view your report output determines where the report is stored. Review the following:

- If you view your report output in PDF, CSV or OSA, the output is stored on your workstation. By default, your output will be in your \B7\PrintQueue subdirectory on the drive where J.D. Edwards software is installed. Contact your system administrator to find out the default location on your system. From this subdirectory, you can move, copy, and attach a file to an e-mail message.
- If you submit your report on an AS/400 server, your PDF or CSV file resides in the J.D. Edwards software system library. In this library, your PDF file resides in a member called Fxxxx, where xxxx represents your job number, in the PRINTQUEUE file. In this library your CSV file resides in a member called Cxxxx, where xxxx represents your job number, in the PRINTQUEUE file.
- For servers other than AS/400, the file resides in the PrintQueue subdirectory on the server. The location of the PrintQueue subdirectory depends on the path your system administrator sets in the jde.ini file. The following examples display possible settings for your jde.ini file:

- **Windows NT Server jde.ini**

[NETWORK QUEUE SETTINGS]

OutputPath=c:\PeopleSoft\output\PrintQueue

- **UNIX jde.ini**

[NETWORK QUEUE SETTINGS]

```
OutputPath=/usr/PeopleSoft/output/PrintQueue
```

In these examples, [NETWORK QUEUE SETTINGS] is the setting that determines the path to PrintQueue. For Windows NT Server, the full path for the setting is "c:\PeopleSoft\*output*\PrintQueue." For UNIX, the full path for the setting is "/usr/PeopleSoft/*output*/PrintQueue." The directory where PrintQueue resides for each example is *output*. This directory can be any valid directory on the server.

## Understanding Subsystem Jobs

---

Within J.D. Edwards software, subsystem jobs are batch processes that continually run independently of, but asynchronously with, J.D. Edwards software applications. These subsystem jobs function with the system's logical process or queue defined for the server platform. You can configure J.D. Edwards software to use one or more subsystems.

You use subsystem jobs to offload processor resources or to protect server processes. Examples of applications that are suited for use by subsystems include Distribution Warehousing, Inventory, and Sales Order Processing. For example, you might execute the Sales Order Entry application on a workstation and want to automatically print pick slips when all orders are entered. If you are using a version of pick slips that has the subsystem job function enabled in Report Properties, the request is executed by a subsystem job. The pick slip request is routed to and processed by the subsystem job on the defined enterprise server. As a result, no additional processing resources are required of the workstation.

When a J.D. Edwards software application issues a request for a job to run in a subsystem, it places a record in the Subsystem Job Master table (F986113). This record is identified by a subsystem job name and version, and contains status and operational indicators. Embedded in the record is key information that allows the subsystem to process the record without additional interaction with the requesting application. The continuously running subsystem monitors the records in this table. If the subsystem finds a record with its name, version, and appropriate status indicators, it processes the record and updates the status accordingly.

The following graphic illustrates how the system processes a subsystem job:

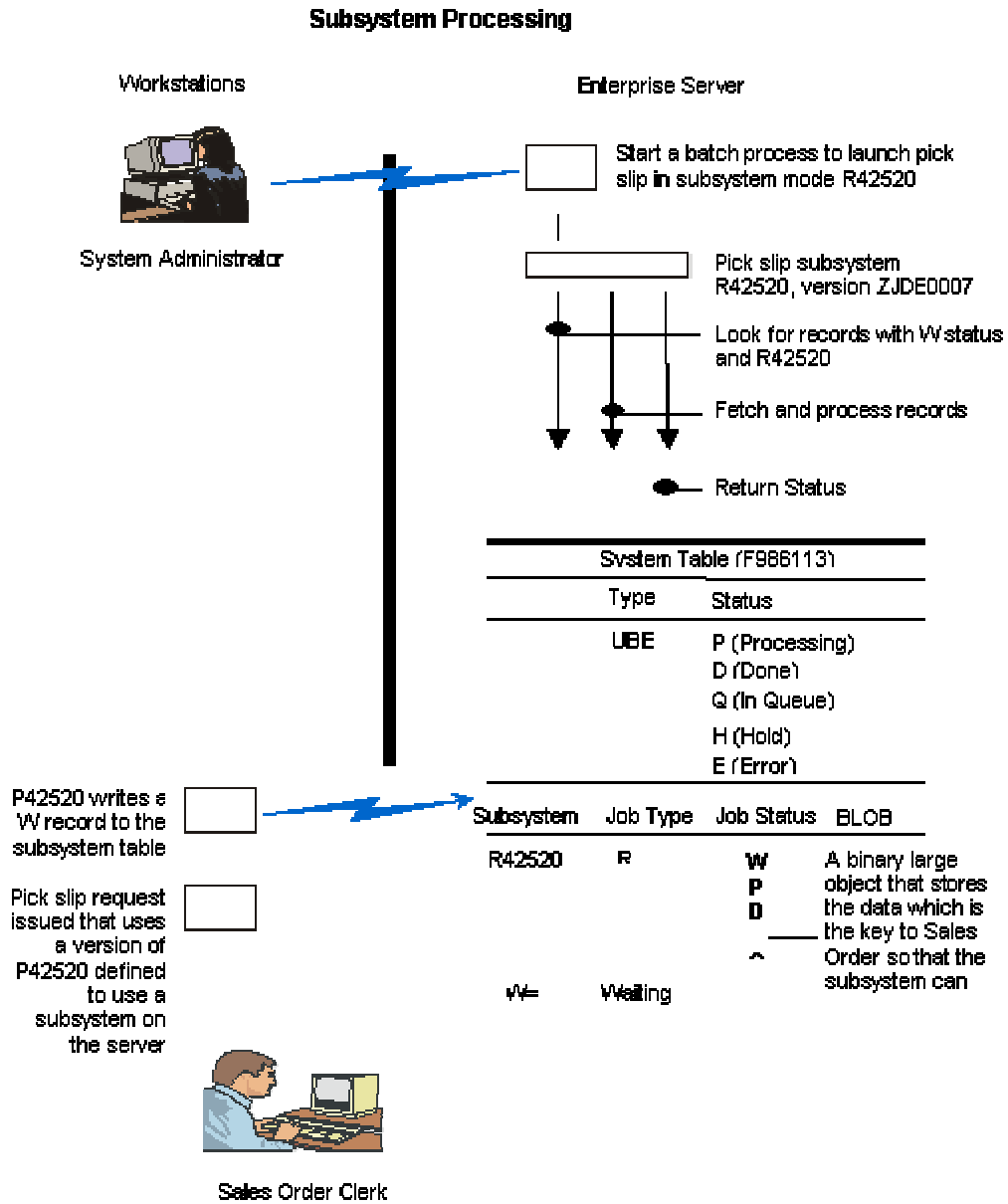

## Defining Subsystem Jobs

Subsystem jobs are continuous jobs, processing records from a data queue. This type of job runs until you request an end to the job. Subsystem jobs read records one at a time for a subsystem table, retrieve information from the particular record, and run a configurable processing engine for each record. At the end of the records, instead of ending the job, subsystem jobs wait for a specific period and then retrieve the information for each record once again. For each subsystem job, multiple records can exist in the subsystem table.

You start a subsystem job as you would a regular batch job. No difference exists between running a subsystem job and running a batch job.

Before processing, J.D. Edwards software ensures that limits for the subsystem job on the particular server have not been exceeded. If exceeded, the configurable processing engine does not process the subsystem job.

### ► To define subsystem jobs

*In the J.D. Edwards Windows environment, choose Report Design Tool from the Report Writer menu (GH9111).*

1. On Report Design open a report, and then choose Report Properties from the File menu.
2. On Properties, on the Advanced tab, choose the following options, and then click OK:
  - Subsystem
  - Wait Time (ms)  
The value in this field represents the time that the subsystem report will check the subsystem file for new records to process.
3. On Report Design, choose Report Data Structure from the File menu.

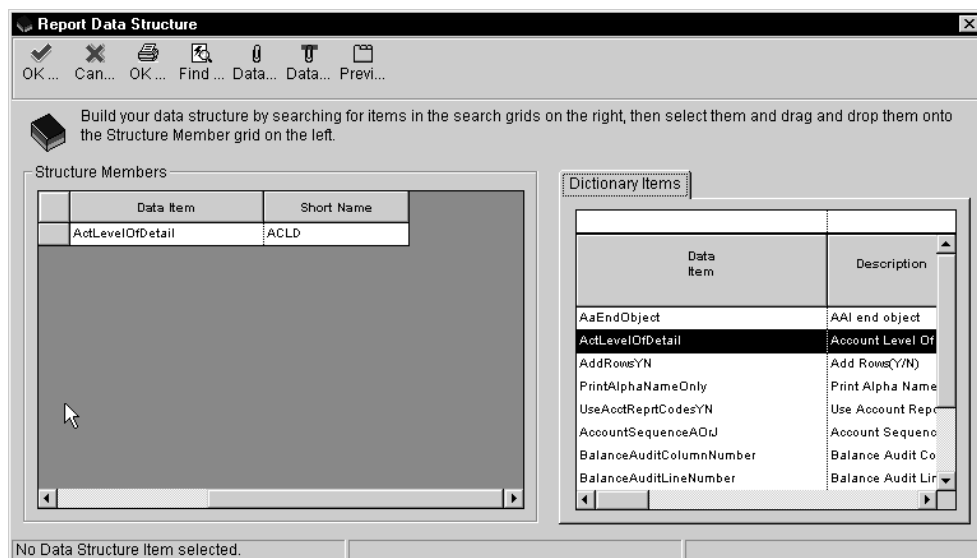

4. On Report Data Structure, click the Find button to display a list of data items.

5. From Dictionary Items, drag items into Structure Members, and then click OK.
6. On Report Design, choose Report Properties from the File menu.
7. On Properties, click the Advanced tab, and then click Generate to create a header file.

The header file takes the form of `Report_Name.h` under the `\B7\$environ\include` subdirectory. In an interactive application, from which you will send a record to process in the subsystem report, you can use this header file inside a business function to create a subsystem record.

For example, by clicking OK on Sales Order Entry (P4210), you can specify to call a business function that uses this report's data structure along with the subsystem's application programming interfaces (APIs) to trigger the subsystem report.

## Adding an API Record to the Subsystem Table

---

You add an API record to the subsystem table so that the subsystem job can perform the batch process. When you add a record to the subsystem table, you create a business function, then attach the header file that you generated to that business function using Microsoft Visual C++. After you attach the header file to the business function, you attach the business function to the event rule process of the program you want to call.

This API record retrieves data structure and user information from the cache. If the server name is not passed, the API finds Object Map Record from the Data Source Master table (F98611). If the record exists, it will use the record to send a JDENet Message to the server to add the record to the subsystem table on the server. However, if the user provides an Override Server name, the JDENet message is sent to that server instead.

### Before You Begin

- You must generate the header file using Report Data Structure to ensure that the API is called from the business function. See *Defining Subsystem Jobs* in the *Enterprise Report Writing Guide*.

### Example: Subsystem Job Header File

The following example shows what the subsystem job header file:

```
#include <jde.h>

/*****

* Report      : R98SSUBE
* ReportId    : 8123244
* DSTRId      : 380813
*
* Note:
* Do not edit the following typedef
* To make modifications, use the Report Design Aid Tool to
* Generate a revised version.
*****/
#ifndef REPORT_DS_380813
#define REPORT_DS_380813
```

```

typedef struct tagDS_RI_380813
{
    char                ProgramId[11];
} DSRI380813, *LPDSRI380813;
#define                IDERRProgramId_1
1L
#endif /* #define REPORT_DS_380813*/
#endif /* #define R98SSUBE H */

```

► **To add a record to the subsystem table**

*In J.D. Edwards software, create a new business function.*

1. In Microsoft Visual C++, open the business function include file and add the name of the header file that you generated.

In the following example, lines that you enter are underlined:

```

/*****
/* Table Header Inclusions
*****/

/*****
*/
External Business Function Header Inclusions
*****/
/
#include <R98SSUBE.h>

/*****
**
* Global Definitions
*****/
/

/*****
**
* Structure Definitions
*****/
/
* TYPEDEF for Data Structure
*   Template Name:      Report Interconnect Data Structure
*   Template ID:       D983059
*   Generated:         Wed Oct 18 14:01:22 1995

```

2. Open the business function source file in Visual C++ and declare the variable of this data structure type, then populate the members of the data structure.

```
#include <jde.h>

/*****
*****

* Variable declarations

*****/

HUSER hUser=NULL;

LPSTR szServer=NULL;

DSRI380813 dsRI; /* Declare the variable of type REPORT INTERCONNECT DATA
STRUCTURE */

BOOL bRet=FALSE;

JDEDEB_RESULT rcode;

/*****
*****

Declare structures

*****/

/*****
*****

Declare pointers

*****/

/*****
*****

Check for NULL pointers

*****/

if ((lpBhvrCom == NULL) ||
    (lpVoid == NULL) ||
    (lpDS == NULL))
```

3. In the source file, call the API to add the record.

```
*****
Main Processing
*****/
memset(&dsRI, 0, sizeof(DSRI380813));

/* Populate the members of the Report Interconnect Data Structure */
strcpy(dsRI.ProgramId,lpDS->szString01);

/* Call Subsystem API to add the record to the Subsystem Table */
/* Note : As Environment Name is set to NULL, this API will use OCMto find
the default Environment of this UBE */
bRet=jdeAddSubsystemRecord( hUser,/* User Handle */
"R98SSUBE", /* Name of the subsystem */
"XJDE0001", /* Name of the Subsystem Version*/
NULL, /* Name of the override env - not
used */
szServer, /* Name of the server */
&dsRI); /* Subsystem Connect DS */
/*****/
```

4. After you call the API to attach the record, attach the business function to the event rule process of the program you want to call. This program can be either an interactive or batch application.

#### See Also

- ❑ *Working with Business Functions in the Development Tools Guide*
- ❑ *Working with Event Rules Design in the Development Tools Guide*

---

## Report Printing Administration

The Printer Definition program (P98616) provides a single point of entry for configuring your report. The application allows you to define printers for workstations and enterprise servers. These definitions reside in J.D. Edwards' software tables that are maintained by the Printer Definition program.

In addition to creating your own reports, J.D. Edwards' software includes a number of predefined reports and report versions, which you can use and modify for your business needs. J.D. Edwards software uses the batch engine to create reports and generates these reports in Portable Document format (PDF). You can view the PDF files using the Adobe Acrobat Reader software.

Reports process as batch applications without user interaction. When a user submits a report for processing, the user makes choices, such as the selection and sequencing of data to include in the report, the location where the report will process, logging capabilities to monitor how the report processes, and the printer on which the report prints.

### See Also

- ❑ *Batch Versions for Reports* in the *Foundation Guide* for more information about submitting and printing a report

---

## Understanding Printing

When you submit a report, the batch engine generates a portable document format (PDF) file. The batch engine uses a device context to create the PDF file. This device context consists of information such as page size and the printable area of a page. J.D. Edwards software generates this information from the printer tables for all platforms.

J.D. Edwards software gives you the option of viewing the report (the PDF file) on your workstation, using Adobe Acrobat Reader, or sending the report directly to a printer. You can also print the report from the Adobe Acrobat Reader. When you send the report to a printer, J.D. Edwards software uses a conversion filter to transform the PDF file into one of three Page Description Language (PDL) formats: PCL, PostScript, or line-printer text, depending on the type of printer that prints the report.

The batch engine uses the following logical path to determine to which printer to send a report. If the first method does not return a valid printer name, the batch engine uses the subsequent method.

When the user submits the report:

1. The batch process triggers the Do Initialize Printer event from Report Design Aid (RDA). If this process retrieves a valid printer name, the following processes are ignored.
2. The user overrides the default printer name at the time that the report is submitted. If the user overrides the default printer with a valid printer name, the following processes are ignored.
3. The RDA specifications pass a printer name to the batch process. If this process retrieves a valid printer name, the following process is ignored.

4. J.D. Edwards software determines from the Printer Definition table (F98616) a valid default printer based upon the current user, the environment that the user is signed onto, and the host that processes the report.

## Running Reports on the Server

When you submit a report to the server, the engine prompts you for a printer name previously defined in the Default Location & Printers program (P400951). Then the server automatically creates a PDF file using the settings associated with the selected printer, unless event rules (ER) override those printer settings. You can, however, affect how your report prints on the server before you generate a PDF file by changing settings, such as the printer, page orientation, PDL, and paper type, on the Printer Selection dialog box. When you view the report on the server, J.D. Edwards' software copies the PDF file from the server to the local \b7\PrintQueue directory on your workstation.

---

### Note

When you are using an AS/400 client, the PDF file is stored on the client in the integrated file system (IFS). See *Working with the Integrated File System (IFS)* in the *Enterprise Report Writing Guide* for information on how to define the PrintQueue directory on the client.

---

When you run a report, you also have the option of turning on logging capabilities. You do so from the advanced form when you submit your report. When you view a log, your workstation stores the log file in the \b7\PrintQueue directory.

### See Also

- *Generating and Retrieving Logs for Your Report* in the *Enterprise Report Writing Guide* for more information about the location of the PrintQueue directory on a server

## Running Reports on the Workstation

When you choose to run a report and view the output on the screen, the engine tries to connect to the printer defined in Report Design. If the engine cannot connect or if there is no printer defined, the engine uses the default printer from the printer tables. Using the settings that it retrieves, the engine creates a PDF file and displays the report through Acrobat Reader. The PDF file is stored in your local \b7\PrintQueue directory.

When you run a report locally and send the output to a printer, the engine displays the Printer Selection dialog box, which gives you the option to change the printer, page orientation, PDL, paper type, and so on. The initial printer shown in this dialog box is the one defined in RDA or the default printer, if none was defined. The engine connects to the printer defined in the printer dialog box and retrieves the associated settings. Using these settings, the engine creates a PDF file, converts the PDF into a PDL file using the conversion filter, and sends the PDL file to a printer.

## Print-Time Characteristics

The user has the option of overriding the printer at a report's print time. This option is different from the option for overriding the printer when the user first submits the report. At submit time, the user can choose any valid enterprise printer. At print time, however, the user can override the printer only with another printer that supports the same platform, PDL, and paper type as the original printer because the batch engine has already created the PDF version of the report and has imbedded into the PDF file the platform, PDL, and paper type information.

## Print Settings for the Workstation jde.ini

The workstation jde.ini settings control whether a report prints immediately and whether J.D. Edwards' software saves the output after processing the report.

```
[NETWORK QUEUE SETTINGS]
PrintImmediate=TRUE/FALSE
SaveOutput=TRUE/FALSE
```

Setting	Description
<b>PrintImmediate</b>	Specifies whether the system automatically prints the report after processing is complete. Valid values are:  TRUE. The system processes the report on the server, generates a PDF file, converts the PDF to the appropriate PDL for the defined printer, and then prints the report.  FALSE. The system processes the report on the server, but does not automatically print the report. Users must use the Work with Servers application to manually print the report.
<b>SaveOutput</b>	Specifies whether the system saves or deletes the output after you view or print the job. Valid values are:  TRUE. The system saves the output after you have viewed or printed the job.  FALSE. The system deletes the output after you have viewed or printed the job.

## Working with the Printers Application

---

J.D. Edwards' software provides a single application that uses a director interface to help you set up your printer. From this director, you can add new printers, modify existing printers, and define default printers for a combination of a user, a host, and an environment. You can also add and modify the paper types and custom conversion programs that your printers use at the time that you add and modify printer settings.

---

### Note

You must set up printers for each server platform that you use in your enterprise.

---

## See Also

- ❑ *Understanding Printing* in the *Enterprise Report Writing Guide* for information about how J.D. Edwards software determines which printer to print to when a user submits a report

## ► To add a new printer

---

When you add a printer, J.D. Edwards' software provides a director to help you with each step of the process. Instructions appear on each form of the director to guide you through the printer addition process. The following procedure should be used in conjunction with the steps that appear on the Printer Setup Director form of the Printer Application program (P98616).

First-time users who are installing their first printer must complete this task and then the task *To define a default printer*.

---

## Note

You must complete all of the fields that appear on the director forms.

---

*In the J.D. Edwards Windows environment, choose Printers from the Batch Processing Setup menu (GH9013).*

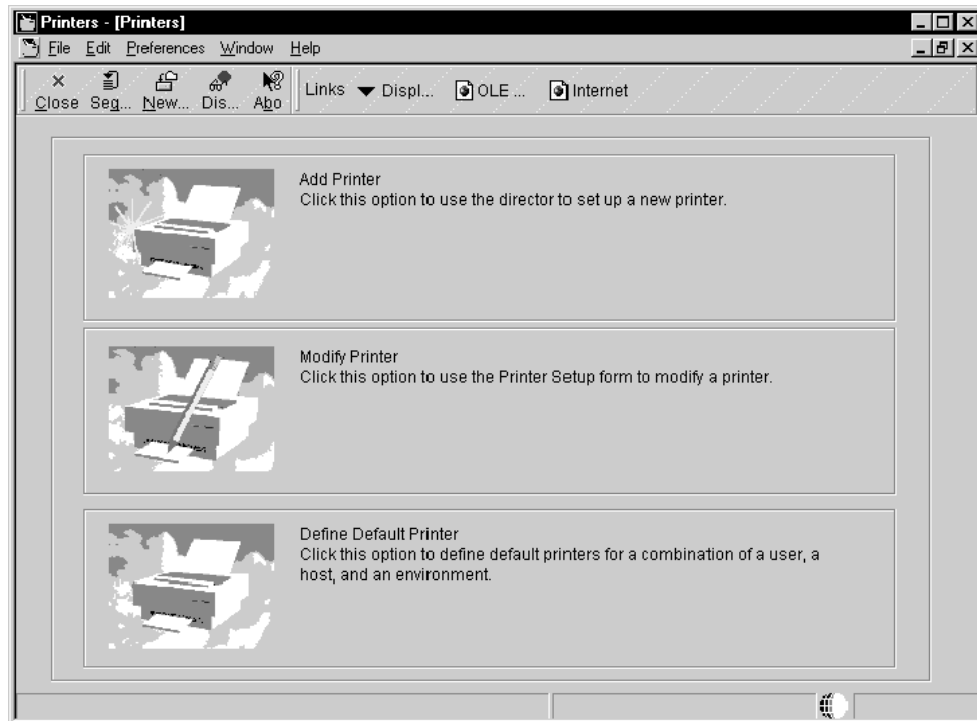

1. On Printers, click Add Printer.

The welcome page for the Printer Setup Director appears. This page describes the tasks that the director helps you to perform.

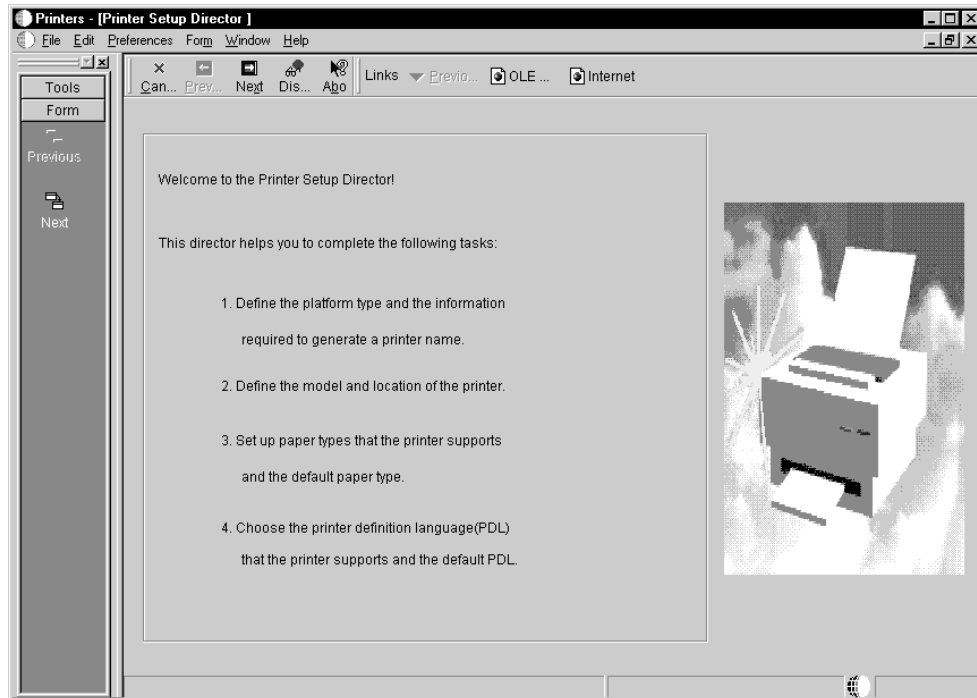

2. Review the welcome page and click the Next button.

The system displays the Platform Type depending on which operating system your J.D. Edwards' software is running on.

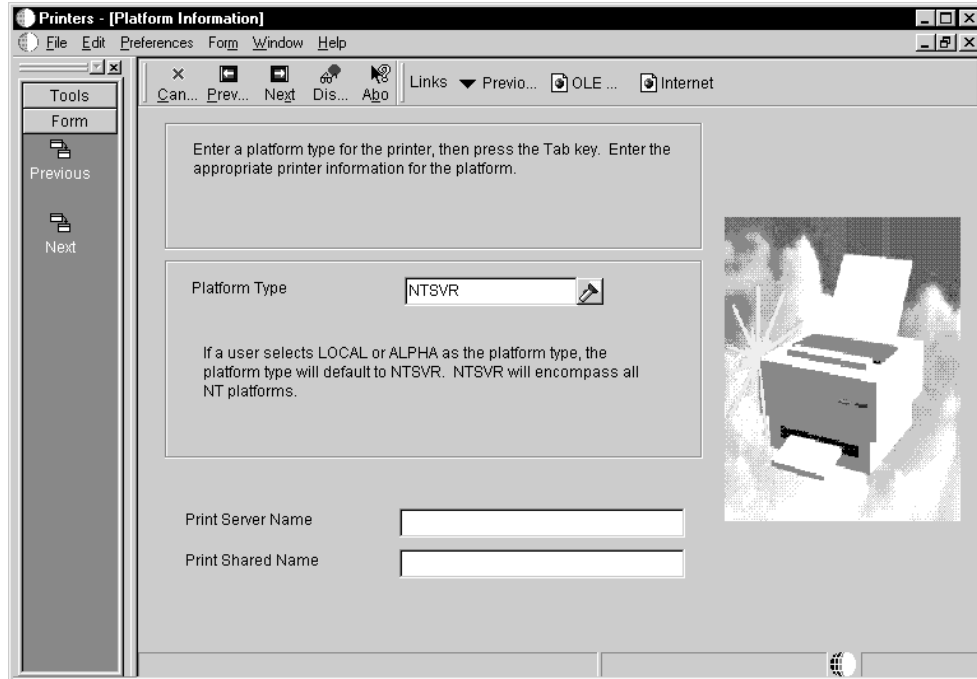

3. Complete the following fields and click Next:

- Print Server Name

Type the name of the print server for the printer that you are setting up. You cannot use spaces or special characters in this field. J.D. Edwards' software uses this name, along with the print shared name, to create the printer name, which appears grayed-out on the subsequent form.

- **AS/400:** *library name/outqueue name*

For the AS/400, the physical printer name must be the same as the outqueue name. If you use the default QGPL library to store your outqueues, you need only enter the outqueue name in this field. This information must be entered in upper case.

Example: DEVDES3A

If your outqueues reside in a library other than the default QGPL library, you need to enter the library name and the outqueue name in this field.

Example: QUSERSYS/DEVDES3A

---

**Note**

When you qualify your outqueue name with the library name, you avoid possible name conflicts that might result in the submission of your report at an unexpected outqueue.

---

- **Windows NT:** `\\server name\printer name`

Example: `\\corprts1\docprf2`

This information must be entered in lower case.

- **UNIX:** `printer name` (no slashes)

Example: `devprn16`

This information must be entered in lower case.

For printing reports to a non-network printer, leave this field blank.

- **Print Shared Name**

Type the share name of the printer that you are setting up. You cannot use spaces or special characters in this field. J.D. Edwards' software uses this name, along with the print server name, to create the printer name, which appears grayed-out on the subsequent form.

When you click Next, the Printer Setup form appears. Use this form to specify information for the printer such as the printer model, physical location of the printer, printer definition language, paper types, and encoding selection (AS/400 only).

---

**Note**

When you change an existing printer, you make your modifications to this page. See *To modify an existing printer* in the *Enterprise Report Writing Guide*.

---

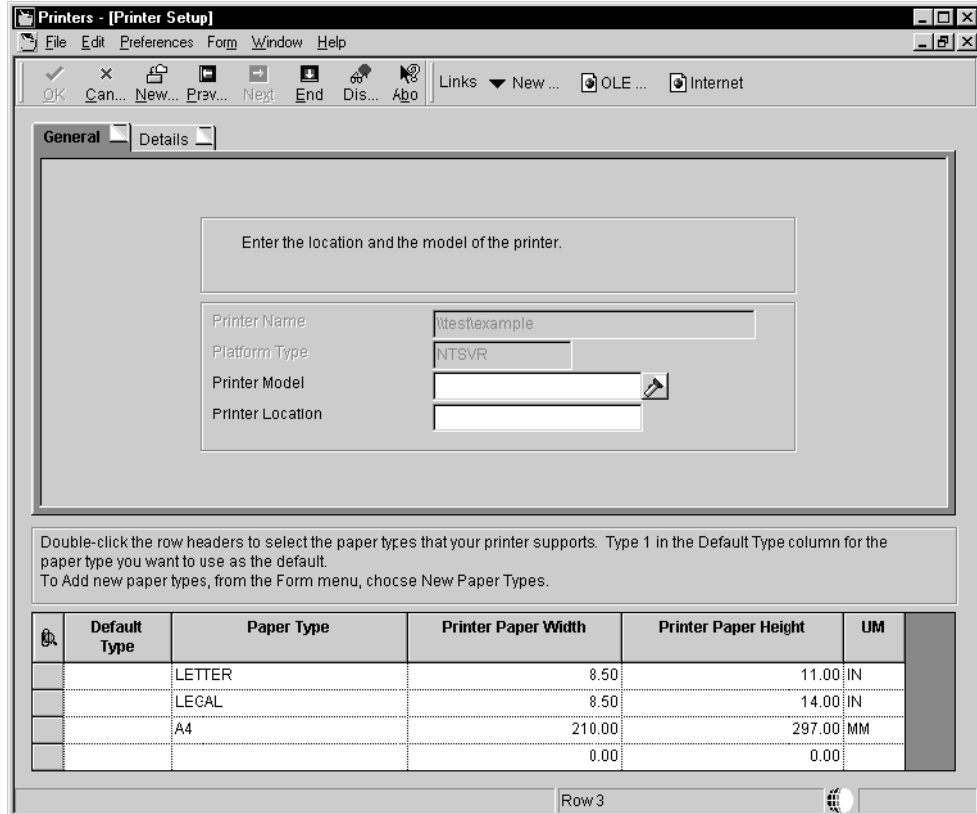

4. On Printer Setup, on the General tab, complete the following fields, and then click the Details tab:
- Printer Model
  - Printer Location

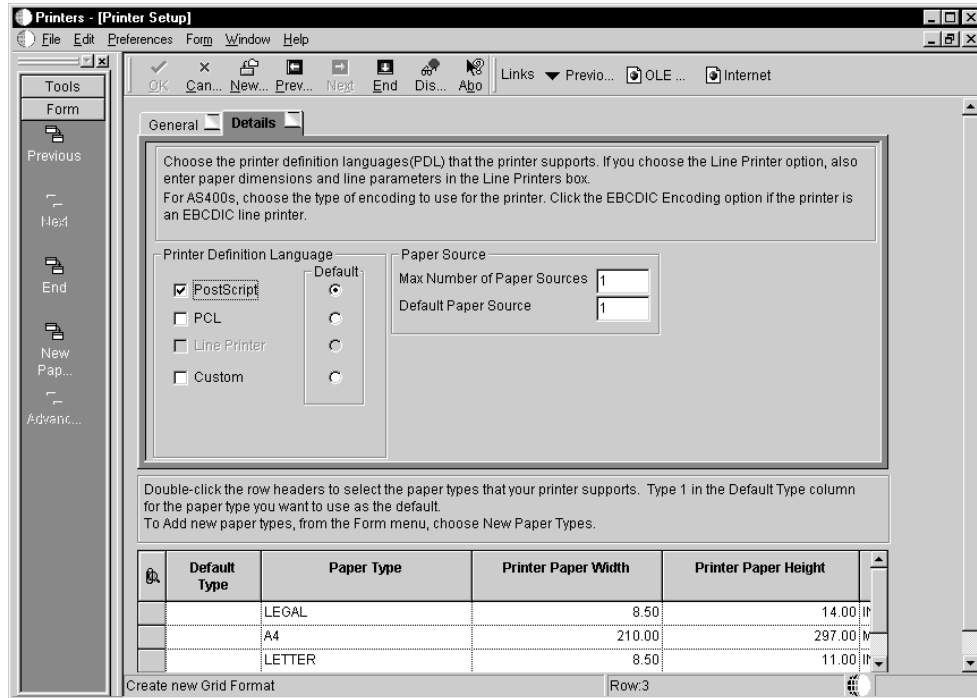

5. On the Details tab, inside the box labeled Printer Definition Language, choose any the following options:

- PostScript
- PCL
- Line Printer

When you choose the Line Printer option, the following events happens:

3. J.D. Edwards' software disables the detail area at the bottom of the form. Any paper types that you chose are cleared. J.D. Edwards software automatically provides a printer type of \*JDE LINE PAPER for the printer.
  4. Fields appear within a box labeled "Line Printers." You use these fields to set the paper dimensions and line parameters. This is fully explained in the following steps.
  5. When you choose the Line Printer option along with the AS/400 platform type, fields appear within a box labeled "AS400 Only." You use these fields to set the AS/400 encoding that your printer supports. This is fully explained in the following steps.
- Custom

---

**Caution**

The custom option uses an advanced feature of the Printers application. Only users with knowledge about building parameter strings for printers should use this option. This is fully explained in the following steps.

---

---

**Note**

If you choose PostScript or PCL from the left side of the box, J.D. Edwards' software disables the Line Printer option. If you choose the Line Printer option from the left side of the box, J.D. Edwards' software disables the PostScript and PCL options. You can choose multiple printer definition languages (PDLs) from the left side of the box, but only one default PDL under the Default label on the right side of the box. This sets the PDL that you want to specify as your default. You can override this PDL when a batch process is submitted.

---

6. On the Details tab, when you choose the PostScript option, the Paper Source box appears, from which you can change the following fields:
  - Max Number of Paper Sources  
Enter a numeric value in this field to indicate the number of paper trays that this printer has available.
  - Default Paper Source  
Enter a numeric value in this field to indicate the default tray number from which you want J.D. Edwards software to draw paper.
7. When you choose the Line Printer option, fields appear within the Line Printers box. You use these fields to set the paper dimensions and line parameters. Complete the following fields:

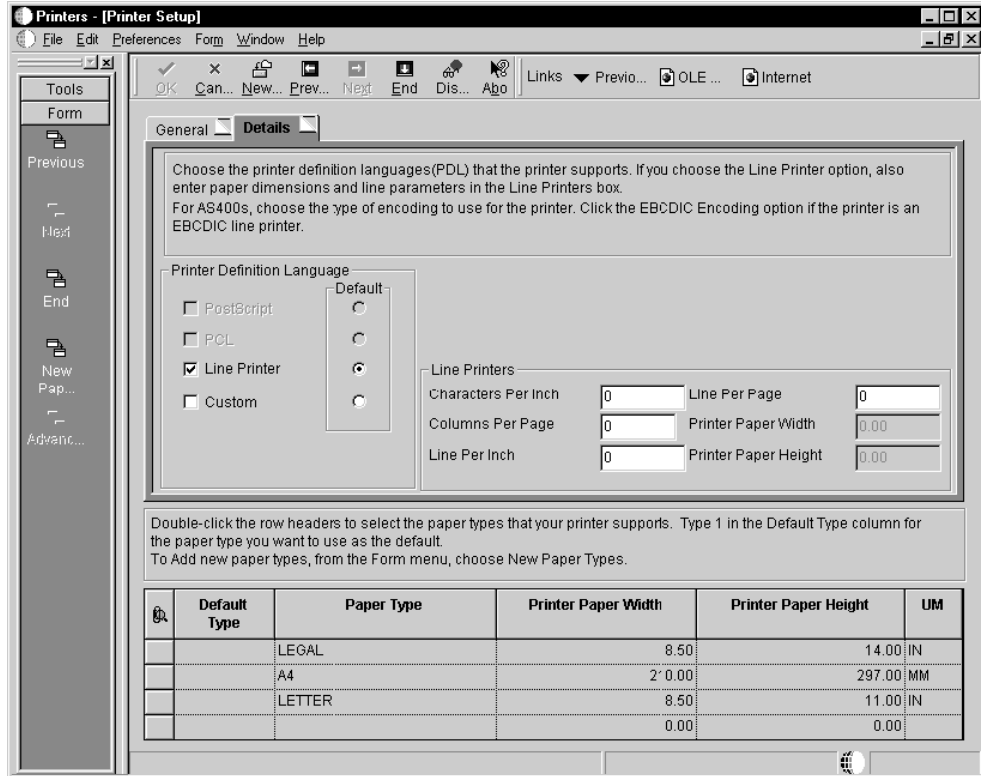

- **Characters Per Inch**  
The value that you enter in this field determines the number of characters that the physical printer allows in one horizontal inch.
- **Columns Per Page**  
The value that you enter in this field determines the number of characters that appear in one line of text in the given report.
- **Lines Per Inch**  
The value that you enter in this field determines the number of lines of text that the physical printer allows in one vertical inch.
- **Lines Per Page**  
The value that you enter in this field determines the number of lines of text that the physical printer allows on one printed page.
- **Printer Paper Width**  
The value in this field is calculated automatically, based on the numbers you enter in the Line Printers box.
- **Printer Paper Height**  
The value in this field is calculated automatically based on the numbers you enter in the Line Printers box.

8. When you choose the Line Printer option along with an AS/400 server, fields appear within a box labeled "AS400 Only." You use these fields to set the AS/400 encoding that your printer supports. Choose one of the following:

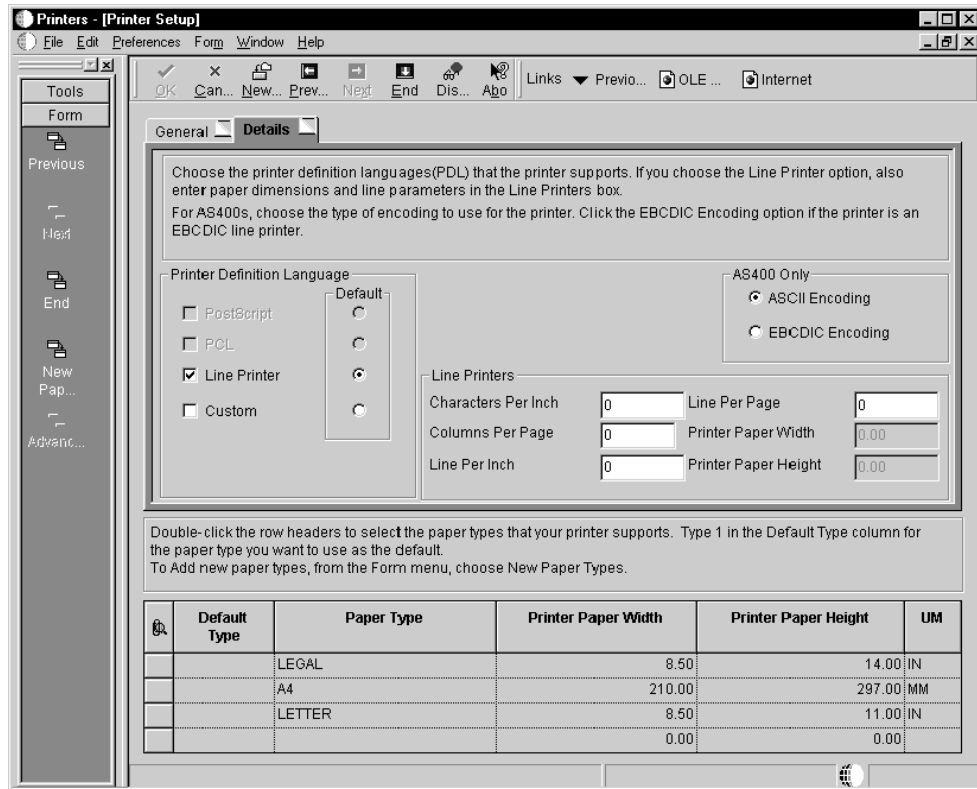

- ASCII Encoding
- EBCDIC Encoding

---

**Note**

If you choose a PostScript or PCL printer along with an AS/400 server, the ASCII Encoding option is automatically checked and the "AS400 Only" box is disabled.

---

9. To use the Custom option, complete the following:

---

**Note**

The custom option uses an advanced feature of the Printers application. Only users with knowledge about building parameter strings for printers should use this option.

---

- Click the Custom checkbox.  
A field appears beneath the Custom button.
- Enter the name of the conversion filter that you want to use.  
You can either type a conversion filter name into the field below the custom option, or you can use the Search button to select a filter.

- To change or add a conversion filter, choose Advanced from the form menu. This option is enabled only when Custom has been chosen.

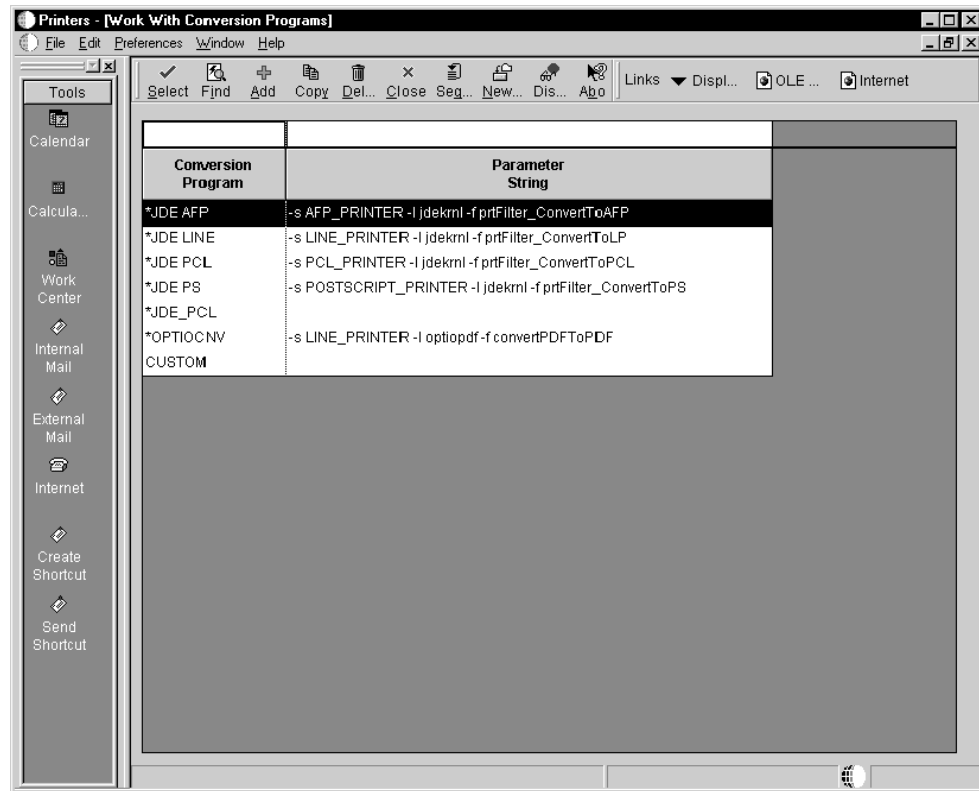

- On Work With Conversion Programs, either click Add, or choose one of the filters and click either Copy or Select.

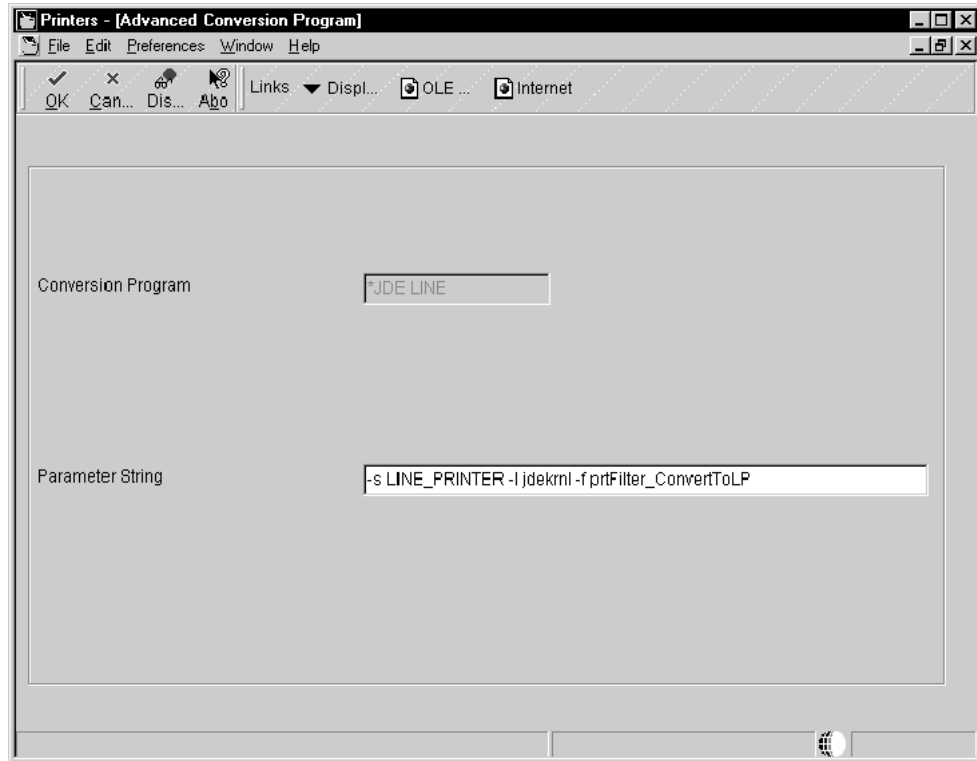

- On Advanced Conversion Program, change the following fields, and then click OK:
- Conversion Program
  - If you clicked Add or Copy on the previous form, the Conversion Program field is enabled. Enter the name of the conversion program that you want to add or copy. If you are making a copy, the string that you highlighted on the previous form appears in the Parameter String field.
- Parameter String
  - The parameter string is entered automatically. It is based on the host from which you are printing (AS/400, HP9000, etc.) and the type of printer (postscript, PCL, or line). For example:

```
-s string_name -l library_name -f convertPDFToPS
```

Where *-s* defines the string name, *-l* defines the library name (this value is the letter "l," not the number "1"), and *-f* defines the function name

10. In the detail area at the bottom of the Printer Setup form, double-click the row header for each paper type that your printer supports. A checkmark appears in the row header for each paper type that you choose.

---

**Note**

You can add new paper types as necessary. Instructions to do so are included later in this task.

---

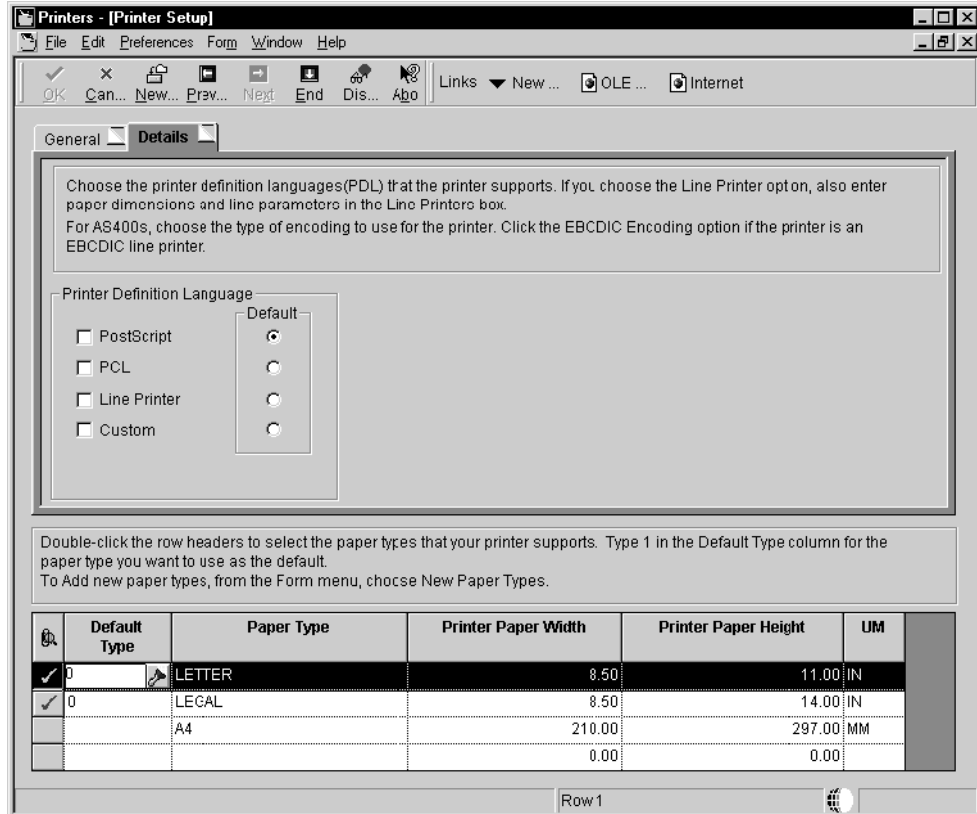

- In the Default Type column, type the numeral 1 in the row for the paper type that you want to use as the default. You can choose only one default paper type. You can override the default paper type when a batch process is submitted.

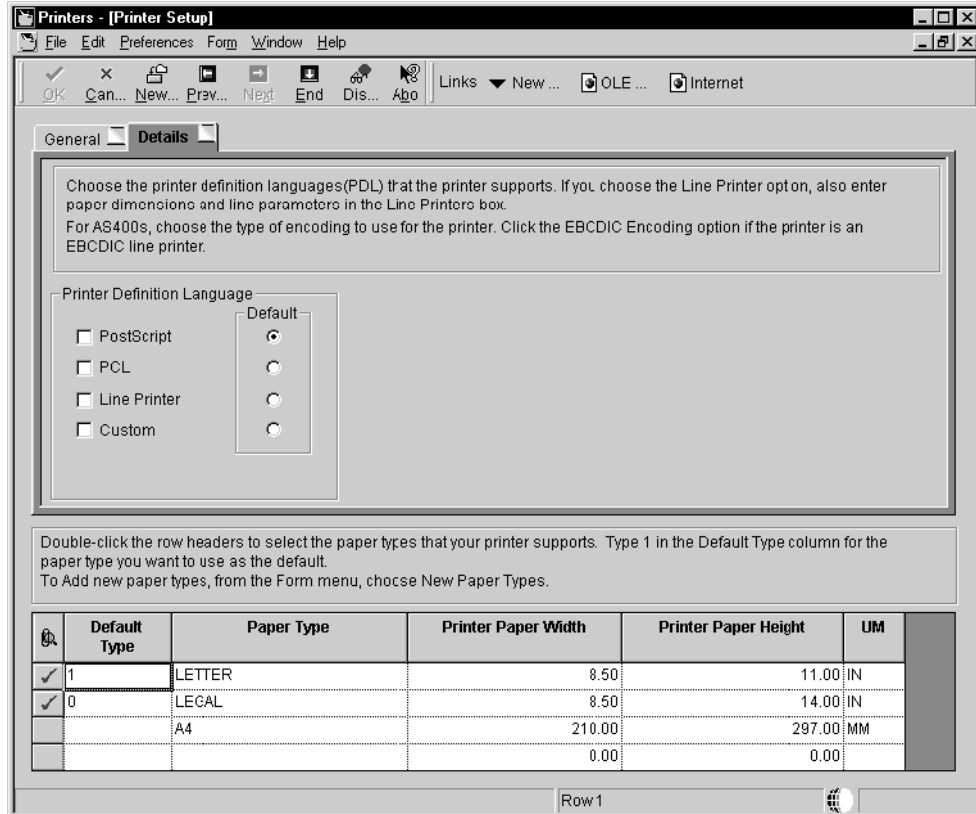

12. To add a new paper type, do the following:

- From the Form menu, choose New Paper Type.

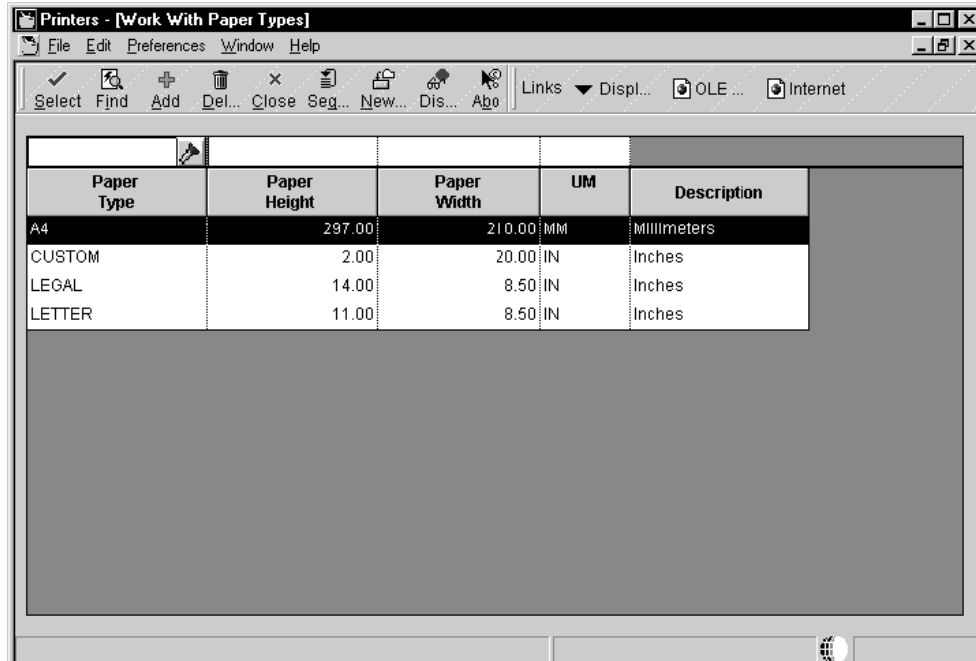

- On Work With Paper Types, click Add.

13. On Paper Type Revisions, complete the following fields, and click OK:

- Paper Type
- Paper Height
- Paper Width
- Unit of Measure

J.D. Edwards' software saves the new paper type and displays the Work With Paper Types form. After you close Work With Paper Types, the new paper type will be available in the Printer Setup detail area form. All previous paper type selections are cleared and would need to be chosen again if you want to reuse them.

14. When you finish entering information for the printer, click End.

J.D. Edwards' software saves the new printer and displays the Printers form.

► **To define a default printer**

---

*In the J.D. Edwards Windows environment, choose Printers from the Printers menu (GH9013).*

1. On Printers, click Define Default Printer.
2. On Work With Default Printers, click Add.

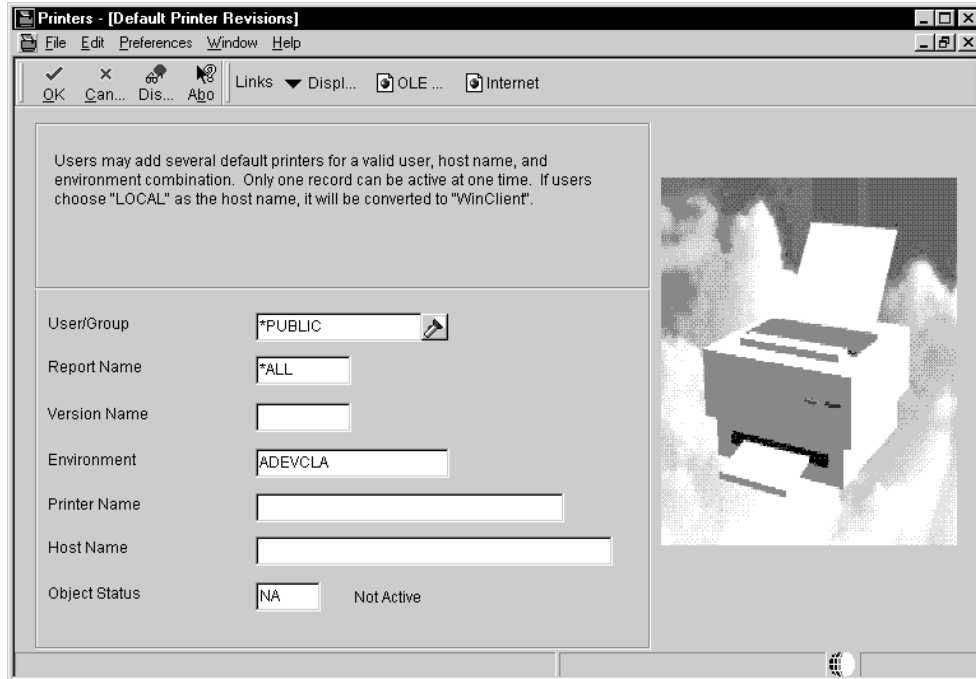

3. On Default Printer Revisions, complete the following fields, and then click OK.
- **User/Role**  
Click the visual assist to choose either a particular user for this printer or to choose an entire group. If the field is left blank, the default value is \*PUBLIC.
  - **Report Name**  
Click the visual assist to choose a specific report to print. If the field is left blank, the default value is \*ALL.
  - **Version Name**  
Click the visual assist to choose a specific version to run. If the field is left blank, the default value is \*ALL. If the Report Name is \*ALL, the version name will default to \*ALL and be disabled.
  - **Environment**  
J.D. Edwards' software automatically enters the name of the environment that you are currently signed onto. You can change this information.
  - **Printer Name**
  - **Host Name**  
Include the host server to where reports will run. The visual assist displays the appropriate host names, based on the printer name you select.

- Object Status

You can make this new printer the default printer by changing its status to active. If an error occurs, it means that another printer is currently the active default. You need to change the original default printer to inactive before you can activate the new printer. You can perform multiple status changes from the Work With Default Printers form as explained at the end of this task.

4. On Work With Default Printers, to change the status of a default printer from the Work With Default Printers form, click Find, choose a default record, and then from the Row menu, choose Change Status.

If another printer is already specified as the active default, an error occurs. To change the original default printer to inactive, choose it, and from the Row menu, choose Change Status. Then make the new printer the default.

► **To modify an existing printer**

*In the J.D. Edwards Windows environment, choose Printers from the Printers menu (GH9013).*

1. On Printers, choose the Modify Printer option.

Printer Name	Default Printer Definition Language	Platform Type	Printer Model
D/D6262	*JDE LINE	AS400	IBM 6262
QGPL/DEVDES3A	*JDE PS	AS400	LASER
QGPL/DEVPRN10	*JDE LINE	AS400	LINE PRINTER
QGPL/DEVPRN24	*JDE PS	AS400	IBM INFOPRINT
QGPL/LEXLINE	*JDE LINE	AS400	AS/400 LINE
QUSRSYS/D6262	*JDE LINE	AS400	IBM 6262
QUSRSYS/DEVPRN14	*JDE PS	AS400	HP DESKJET LASER PRIN
QUSRSYS/DEVPRN15	*JDE LINE	AS400	HP DESKJET LASER PRIN
QUSRSYS/DEVPRN16	*JDE LINE	AS400	HP DESKJET LASER PRIN
QUSRSYS/DEVPRN18	*JDE LINE	AS400	HP DESKJET LASER PRIN
QUSRSYS/DEVPRN21	*JDE PS	AS400	LEXMARK LASER
QUSRSYS/DEVPRN24	*JDE PCL	AS400	IBM INFOPRINT
QUSRSYS/JM952458	*JDE PCL	AS400	LEXMARK OPTRA 82455
QUSRSYS/LASERU7	*JDE PS	AS400	HP DESKJET LASER PRIN
QUSRSYS/QPRINTD	*JDE LINE	AS400	IBM 6262
TEST/AWAY	*JDE PS	AS400	AS/400 EBCDIC LASER
TEST/TEST1	*JDE PS	AS400	APPLE LASER

2. On Work With Printers, click Find, choose the printer that you want to modify, and then click Select.

The Printer Setup form appears. Use this form to change information for the printer, such as the printer model, physical location of the printer, printer definition language (PDL), and paper types.

Enter the location and the model of the printer.

Printer Name: QUSRSYS/DEVPRN14  
Platform Type: AS400  
Printer Model: KJDET LASER PRINTER  
Printer Location: DEN-83-4-260

Double-click the row headers to select the paper types that your printer supports. Type 1 in the Default Type column for the paper type you want to use as the default.  
To Add new paper types, from the Form menu, choose New Paper Types.

Default Type	Paper Type	Printer Paper Width	Printer Paper Height	UM
0	LEGAL	8.50	14.00	IN
0	A4	210.00	297.00	MM
	CUSTOM	20.00	2.00	IN

Row: 4

- On Printer Setup, modify the information for your printer as necessary and then click OK. You cannot modify the printer name and platform type. If you chose a line printer, the paper-type grid at the bottom of the form is disabled.

J.D. Edwards' software saves the new printer information and returns you to the Work With Printers form.

### ► To copy an existing printer

*In the J.D. Edwards Windows environment, choose Printers from the Printers menu (GH9013).*

- On Printers, choose the Modify Printer option.
- On Work With Printers, click Find, choose the printer that you want to copy, and then click Copy.
- On Printer Setup, complete the following fields:

- Printer Name

Enter the entire printer name, including the server path. For example, if printer docprf2 is on server corprts1, the printer name for a Windows NT printer would be: \\corprts1\docprf2. If you use multiple platforms, you must define a printer for each platform, using the following naming conventions:

- **AS/400:** library name/outqueue name

For the AS/400, the printer name must be the same as the outqueue name. If you use the default QGPL library to store your outqueues, you need only enter the outqueue name in this field. The information that you enter must be in upper case.

Example: DEVDES3A

If your outqueues reside in a library other than the default QGPL library, you need to enter the library name and the outqueue name in this field.

Example: QUSERSYS/DEVDES3A

---

**Note**

When you qualify your outqueue name with the library name, you avoid possible naming conflicts that might result in the submission of your report to an unexpected outqueue.

---

- **Windows NT:** *\\print server name\printer name*

Example: \\corprts1\docprf2

The information that you enter must be in lower case.

- **UNIX:** *printer name* (no slashes)

Example: devprn16

The information that you enter must be in lower case.

- **Platform Type**

Enter the platform that you are printing from, such as an AS/400 server.

4. Click the Details tab, change any information as needed, and then click OK.

---

**► To delete a printer**

---

*In the J.D. Edwards Windows environment, choose Printers from the Printers menu (GH9013).*

1. On Printers, choose the Modify Printer option.
2. On Work With Printers, click Find, choose a printer or choose multiple printers by holding down the Ctrl key, and then click Delete.

This task removes the printer definition.

---

**► To delete a paper type**

---

*In the J.D. Edwards Windows environment, choose Printers from the Printers menu (GH9013).*

1. On Printers, choose the Modify Printer option.
2. On Work With Printers, click Find, choose a printer, and then click Select.

3. On Printer Setup, choose New Paper Type from the Form menu.
4. On Work With Paper Types, choose a paper type and click Delete.
5. On Confirm Delete, click OK.

The paper type that you deleted no longer appears in the detail area.

#### ► **To search for incorrect printer records**

---

Use the following batch process to search the Printer Capability table (F986163) and list printer records that are incomplete, or that contain incorrect printer information. This task might be useful to users who are upgrading J.D. Edwards software from a release prior to B73.3.1 to release B73.3.2 or later. This report lists information that can help you correct your printing records.

*Enter BV in the fast path.*

1. On Work With Batch Versions - Available Versions, in the Batch Application field, type R9861602, and click Find.

The XJDE0001 version appears in the detail area.

2. Run the version as explained in *Submitting a Report* in the *Enterprise Report Writing Guide*.

The report lists reports that have a logical printer name. Use this information to change existing printer settings, since logical and physical printer names are no longer used in J.D. Edwards' software.

3. Go to the task *To modify an existing printer* in the *Enterprise Report Writing Guide*, and using the report, find the printer record and correct it.

#### ► **To determine logical printers attached to batch processes**

---

Use the following batch process to determine which of your batch processes, if any, are attached to printers. This task might be useful to users who are upgrading J.D. Edwards software from a release prior to B73.3.1 to release B73.3.2 or later.

*Enter BV in the fast path.*

1. On Work With Batch Versions - Available Versions, in the Batch Application field, type R9861601, and click Find.

The XJDE0001 version appears in the detail area.

2. Run the version as explained in *Submitting a Report* in the *Enterprise Report Writing Guide*.

The report lists reports that have a logical printer name. Use this information to change existing printer settings, since logical and physical printer names are no longer used in J.D. Edwards' software.

3. Use Report Design Aid (RDA) to attach a valid printer to those batch processes that had been attached to a logical printer.

Only someone familiar with RDA should attempt to attach a printer.

## Generating and Retrieving Logs for Your Report

---

When you run a report, you can specify whether you want to create logs for the report. The logs that you can create are the `jde.log` and the `jddebug.log`. These logs allow you to review how your reports process on the server. These logs reside in a specific directory on the server. Your `jde.ini` settings determine the location of this directory. Also, depending on the platform that you use, the `jde.ini` setting differs slightly. The following list provides sample `jde.ini` settings for the directory where your report logs reside:

- AS/400

```
[INSTALL]
DefaultSystem=B9SYS
Example path: B9SYS\PRINTQUEUE
```

- UNIX

```
[INSTALL]
B9=/usr/PeopleSoft/output
Example path: /usr/PeopleSoft/output/PrintQueue
```

- Windows NT Server

```
[INSTALL]
B9=d:\PeopeleSoft\output
Example path: d:\PeopleSoft\output\PrintQueue
```

The default directory for your log files is `PrintQueue`, which becomes a subdirectory to the directory that you designate in the `jde.ini` file. You can change the location of this directory as necessary.

---

### Note

These `jde.ini` settings also determine the location where your report output resides after processing. If you set your `jde.ini` to save the output for your reports, J.D. Edwards' software saves a PDF file for the report in the report output directory.

---

### ► To create logs for your report

---

*Enter BV in the fast path.*

1. On **Work With Batch Versions - Available Versions**, type an application ID in the **Batch Application** field and click **Find**. For example, to locate a version for the **One Line Per Address** report, type **R014021**.
2. Choose a version to submit, and then click **Select**.

The **Version Prompting** form appears. On this form, you can choose to change the data selection, change the data sequencing, and access the **Advanced Operations** form.

3. On Version Prompting, choose Advanced from the Form menu.  
The Advanced Version Prompting form appears. On this form, you can override the location where your report processes, activate the jde.log, activate the jdedebug.log, and modify the level of information that your logs include.
4. On Advanced Version Prompting, modify the following information and then click OK:
  - Logging (JDE.log)  
Turn on this option to activate a basic log that helps you determine when a fault occurs during a batch process.
  - Tracing (JDEDEBUG.log)  
Turn on this option to turn on advanced UBE logging that includes details about the batch process.
  - UBE Logging Level  
The value that you enter here, from 0-6, determines the level to which your batch process log shows errors ranging from error messages to object level messages and UBE function messages.

---

**Note**  
When you choose a high value to receive more technical information, you also receive all the information for the lower values. For example, when you enter a value of 6 (UBE function messages), you also receive information for values 0-5.

---
5. On Version Prompting, click Submit to run your report and create your logs.

## Setting Up a Null Pass-Through Print Filter

---

The null pass-through print filter allows you to send a portable document format (.pdf) directly to a print queue without converting it to a printer language format.

### ► To add a null pass-through print filter

---

*In the J.D. Edwards Windows environment, choose Printers from the Batch Processing Setup menu (GH9013).*

1. On Printers, click Add Printer  
The welcome page for the Printer Setup Director appears. This page describes the tasks that the director helps you to perform.
2. On Printer Setup Director, review the welcome page and click the Next button.  
The system displays the Platform Type depending on which operating system your J.D. Edwards software is running on.
3. On Platform Information, complete the following fields and click Next:
  - Print Server Name
  - Print Shared Name

4. On Printer Setup, click the Details tab.
5. In the Printer Definition Language field, select Custom.
6. From the Form menu, choose Advanced.
7. On Work With Conversion Programs, click Add.
8. On Advanced Conversion Program, type \*JDE PDF in the Conversion Program field.
9. In the Parameter String field, type -s POSTSCRIPT\_PRINTER.
10. Click OK.
11. On Work With Conversion Programs, click Close.
12. On Printer Setup, click the Visual Assist in the field under the Custom field.
13. On Conversion Program Search & Select, choose the \*JDE PDF conversion program and click Select.
14. On Printer Setup, click End.

J. D. Edwards' software saves the null pass-through print filter.

## **Designing Reports to Run on Line Printers**

---

When you run a report on a line printer, you must follow certain guidelines to ensure that the information contained in the report prints successfully. These guidelines include font family, font size, grid spacing, the width of the fields on the report, paper dimensions, and line parameters.

This section provides the information necessary to create line printer reports.

### **See Also**

- The following topics in the *Server and Workstation Administration Guide* for information on setting up printers on AS/400, UNIX, and Windows NT servers:
  - *Setting Up a Printer for AS/400*
  - *Setting Up a Printer for UNIX*
  - *Setting Up a Printer for Windows NT*

### **► To design a report to run on a line printer**

---

#### **Important**

In the Batch Versions program (P98305), create a version of the report to use only on line printers. Make the following modifications to this report version. Do not make these modifications at the report level. If you make these modifications at the report level, the information in your report might not appear properly on other printer platforms.

---

*From the Cross Application Development Tools menu (GH902), choose Report Design Aid.*

1. On Report Design, open the report with the version that you want to modify to support line printers.
2. From the Layout menu, choose Grid Alignment.

3. On Alignment Grid, set the value in the Vertical field to 16 to modify the vertical grid spacing for the report and click OK.
4. From the File menu, choose Report Properties.
5. On Properties, click the Font/Color tab, set the following font properties:
  - Change the font to Courier New.  
The Courier New font provides the best results; however, you can use other fixed-pitch fonts. For example, for reports that contain text in Japanese, users should use the fixed-pitch version of the MS-Gothic font.
  - Change the font size to 10.
6. Click the Apply settings to all objects option to make sure these settings apply to objects that may have individual font settings applied, and then click OK.
7. After you change the font properties, you might need to increase the width of some of the fields on your report.  
  
Widen fields as necessary to provide enough room for information to appear on your report. Reposition the sections of your report so that all the report objects appear in the detail area.
8. (Steps 7 through 10 apply to Group sections only.) If some data fields still do not properly align, press and hold the Ctrl key, then click on each field that you want to align.  
  
The last field that you choose is the field, the top edge of which you will use to align the other fields.
9. From the Layout menu, choose Align.
10. On Align Objects, click Current section in the Apply To box to enable the Top to Bottom box.
11. In the Top to Bottom box, click Top Edges, and then click OK.
12. When you complete the modifications to your report, save your report version.

► **To set up a line printer**

---

**Important**

The following steps provide information about the values at which you should set the paper dimensions for a line printer. These steps should be used as a supplement to the steps that describe how to set up a printer in *Working with the Printers Application* in the *Enterprise Report Writing Guide*.

---

*In the J.D. Edwards Windows environment, choose Printers from the Batch Processing Setup menu (GH9013).*

1. On Printers, click Modify Printer.
2. On Work With Printers, click Find. Available printers are listed in the detail area.
3. Choose the line printer from the detail area and click Select.
4. On Printer Setup, click the Details tab.
5. Click Line Printer.

6. Complete the following fields:

- Columns Per Page
- Characters Per Inch
- Line Per Page
- Line Per Inch

For an 8.5 x 77 inch piece of paper the values should be:

- Characters Per Inch: 10
- Columns Per Page: 85
- Lines Per Inch: 6
- Lines Per Page: 66

---

**Note**

You can use the following formula to calculate your paper dimensions:

$$\text{CPP} / \text{CPI} = \text{width in inches} \quad (85 / 10 = 8.5)$$

$$\text{LPP} / \text{LPI} = \text{height in inches} \quad (66 / 6 = 11)$$

---

7. Click OK to save these settings.

► **To print multiple copies to a remote AS/400 line printer**

---

This task is necessary only if the output queue for an AS/400 line printer does not support printing multiple copies. This task applies to remote output queues only. This task must be completed by a system administrator.

1. End the remote writer to which the output queue is connected.
2. Use the Change Output Queue (CHGOUTQ) command to change the Display Options (DSPOPT) parameter so that it contains the value "XAIX".
3. Restart the remote writer.

Your output queue should now be able to send multiple copies of your documents to the remote printer.

## Setting Up a Printer to Use a Barcode Font

---

J.D. Edwards' software supports the use of the BC C39 3 to 1 Medium barcode font. J.D. Edwards includes this barcode font with its software. After you set up your printers, you can assign a printer to use a barcode font for your reports. This section describes how to set a printer to support the barcode font BC C39.

---

### Note

Printers that support barcodes must use either the PostScript or PCL printer definition languages.

---

---

### ► To set up a printer to use a barcode font

---

*In the J.D. Edwards Windows environment, choose Bar Code Support from the Batch Processing Setup menu (GH9013).*

1. On Work With Bar Code Font, click Add.
2. On Bar Code Font Revisions, complete the following fields and options:
  - Printer Name  
Click the Search button for this field to access a list of printers.
  - PostScript or PCL  
Choose the appropriate option, depending on the printer definition language of the printer in the Printer Name field.
  - True Type Font  
Click this button to select the true type barcode font BC C39 3 to 1 Medium on the Font form.
  - Printer Font Name
  - (PCL only) Symbol Set ID  
This value defines the character and the character mapping for a particular symbol set. Contact your PCL printer font vendor to obtain this information.
3. After you finish entering information for a barcode-capable printer, click OK.

J.D. Edwards' software saves the information and clears the revision form. You can continue to enter information for other printers that support barcodes, or click Cancel to exit the form.

► **To modify barcode printer information**

---

*In the J.D. Edwards Windows environment, choose Bar Code Support from the Batch Processing Setup menu (GH9013).*

1. On Work With Bar Code Font, click Find.  
Printers previously set to support the barcode font appear in the detail area.
2. Choose the printer, the information for which you want to modify, and click Select.
3. On Bar Code Font Revisions, change the information on this form as necessary, and then click OK.

► **To copy barcode printer information for a new printer**

---

*In the J.D. Edwards Windows environment, choose Bar Code Support from the Batch Processing Setup menu (GH9013).*

1. On Work With Bar Code Font, click Find.  
Printers previously set to support the barcode font appear in the detail area.
2. Choose the printer, the information for which you want to copy, and click Copy.
3. On Bar Code Font Revisions, change the name of the printer.  
You can also change any other information on this form as necessary.
4. Click OK to save your information.

► **To delete barcode support information from a printer**

---

*In the J.D. Edwards Windows environment, choose Bar Code Support from the Batch Processing Setup menu (GH9013).*

1. On Work With Bar Code Font, click Find.  
Printers previously set to support the barcode font appear in the detail area.
2. Choose the printer that you want to delete, and click Delete.
3. On Confirm Delete, click OK.

---

## Additional Information for Enterprise Report Writing

This section provides useful information for creating reports by using Enterprise Report Writing. The following subjects are included:

- **Edit Code Table**  
Describes the edit codes that are available. Edit codes determine how data is formatted on a report.
- **Events**  
Describes the events that can occur during report processing.
- **Report Examples**  
Provides examples of reports that you can create and provides instructions for creating the example reports.
- **J.D. Edwards Reports**  
Provides a partial list of reports that are provided by J.D. Edwards.
- **Smart Fields**  
Describes how to create a smart field, define its data structure, define named mapping, perform calculations, create a data dictionary smart field item, create a smart field template, create a report director template, and create a new report by using smart fields.
- **Output Stream Access**  
Describes the uses of the output stream access (OSA) interface to trigger events during report processing.

---

### Edit Code Table

Edit codes are used by J.D. Edwards' software to determine how to display or format a particular value for a report. The default edit codes that pertain to reporting require particular attention because they account for a substantial amount of information.

To choose the appropriate default edit code for your report, review the Negative Amount Notation column in the following table and choose the appropriate option for your report figures. This narrows your search to four codes. For example, if you choose a trailing minus sign as your negative amount notation, your search is narrowed to a code of J, K, L, or M.

Review the Zero Balance column in the Default Edit Code table and determine whether you want to print zero balances. This narrows your search to two codes. For example, if you choose to print zero balances, your search is narrowed to a code of J or L.

Review the Commas column in the Default Edit Code table and determine whether you want commas to appear in the report figures on your report. For example, if you want commas in your report figures, choose J. If not, choose L.

The table shows the available edit codes and their characteristics:

<b>Code</b>	<b>Commas Y/N</b>	<b>Zero Balance Y/N</b>	<b>Negative Amount Notation</b>
A	Y	Y	Cr
B	Y	N	Cr
C	N	Y	Cr
D	N	N	Cr
J	Y	Y	- Trailing
K	Y	N	- Trailing
L	N	Y	- Trailing
M	N	N	- Trailing
N	Y	Y	- Preceding
O	Y	N	- Preceding
P	N	Y	- Preceding
Q	N	N	- Preceding
R	Y	Y	< >
S	Y	N	< >
T	N	Y	< >
U	N	N	< >
1	Y	Y	No sign
2	Y	N	No sign
3	N	Y	No sign
4	N	N	No sign

## Events

---

Events typically execute in a specific order. Additionally, most events have limitations. For example, some events are available only in specific sections.

### Events and Section Types

Certain events are available only in specific section types. The tables show in this section list events that are available for the following levels:

- Report
- Section
- Object

### Report Level Events

The following table shows the report level events that are available. X indicates the events that are shown in RDA and O indicates the events that are supported by UBE.

Event List	Report
Do Initialize Printer	XO

### Section Level Events

The following table shows the section level events available. X indicates the events that are shown in RDA and O indicates the events that are supported by UBE.

Event List	Report Header	Page Header	Columnar	Group	Tabular	Child/Custom (CG)	Level Break Header	Level Break Footer	Page Footer	Report Footer
Advance Section			XO	XO	XO	XO	XO			
After Last Object Printed	XO	XO	XO	XO	XO	XO	XO	XO	XO	XO
Before Level Break			XO	XO	XO	XO				
Do Balance Auditor					XO					
Do Section	XO	XO	XO	XO	XO	XO	XO	XO	XO	XO

Event List	Report Header	Page Header	Columnar	Group	Tabular	Child/Custom (CG)	Level Break Header	Level Break Footer	Page Footer	Report Footer
Do Tabular Break					XO					
End Break Section			XO	XO	XO	XO				
End Lvl Brk Footer Section								XO		
End Lvl Brk Header Section							XO			
End Page Header		XO								
End Report Header	XO									
End Report Footer										XO
End Section			XO	XO	XO	XO				
Init Break Section			XO	XO	XO	XO				
Init Lvl Brk Footer Section								XO		
Init Lvl Brk Header Section			XO	XO		XO	X			
Initialize Page Header		XO								
Initialize Page Footer									XO	
Initialize Report Header	XO									

Event List	Report Header	Page Header	Columnar	Group	Tabular	Child/Custom (CG)	Level Break Header	Level Break Footer	Page Footer	Report Footer
Initialize Report Footer										XO
Initialize Section			XO	XO	XO	XO	XO	XO		
Refresh Section						XO				
Suspend Section			XO	XO	XO	XO	XO	XO		

## Object Level Events

The tables under Variable Objects and Constant Objects show the events that are available at an object level.

### Variable Objects

The following table shows the events available at an object level. X indicates the events that are shown in RDA and O indicates the events that are supported by UBE.

Event List	Report Header	Page Header	Columnar	Group	Tabular	Level Break Header	Level Break Footer	Page Footer	Report Footer
Column Inclusion					XO				
Do Variable	XO	XO	XO	XO	XO	XO	XO	XO	XO
End Column (future)			XO	XO	XO				
End Variable	XO	XO	XO	XO	XO	XO	XO	XO	XO
Initialize Column (future)			XO	XO	XO				
Initialize Variable	XO	XO	XO	XO	XO	XO	XO	XO	XO

## Constant Objects

The following table shows the events available at an object level. X indicates the events that are shown in RDA and O indicates the events that are supported by UBE.

Event List	Report Header	Page Header	Columnar	Group	Tabular	Level Break Header	Level Break Footer	Page Footer	Report Footer
<b>Do Column Heading</b>			XO		XO		XO		
<b>Do Constant</b>	XO	XO	XO	XO	XO	XO	XO	XO	XO
<b>End Constant</b>	XO	XO	XO	XO	XO	XO	XO	XO	XO
<b>Initialize Const</b>	XO	XO	XO	XO	XO	XO	XO	XO	XO

## Available Objects

Some objects are available only for specific events. This topic contains tables that list the available objects for:

- Section level events
- Object level events
- Life span of objects in section level events

RVs are considered as the print buffers. They obtain their run-time values in the event when the user assigns the values to them.

RVs are printed to the report during the processing of the *Do Variable* event.

Values in the RVs are cleared before the processing of the *Advance Section* event. Before current RV values are cleared, these values are used to populate the PVs.

In B733 and prior releases, if an RV is derived from a BC, only the BC is shown through the event rules editor. In a nontabular section, accessing the BC has the same effect as accessing the RV. But in a tabular section, BCs are actually treated by the UBE engine as RVs, meaning the print buffer. Thus, the BCs contain cumulative values instead of the values of the record fetched from the database table. This BC/RV discrepancy will be addressed in the B81 release.

## Section Level Events

The tables in this section list the available objects for various section level events. The tables use the following abbreviations:

- BC - Business View Column
- TR - Tabular Row
- TC - Tabular Cell
- PC - Previous Business View Column
- PV - Previous Variable

### Report Header Section

	RV global	RV section
Initialize Report Header	x	x
Do Section	x	x
After Last Object Printed	x	x
End Report Header	x	x

### Page Header Section

	RV global	RV section
Initialize Page Header	x	x
Do section	x	x
After Last Object Printed	x	x
End Page Header	x	x

## Group Section

	<b>BC</b>	<b>RV global</b>	<b>RV section</b>	<b>PC</b>	<b>PV</b>
<b>Initialize Section</b>		x			x
<b>Refresh Section (Child)</b>		x	x	x	
<b>Advance Section</b>	x	x	x	x	x
<b>Before Level Break</b>	x	x	x	x	x
<b>Init Lvl Break Header Section</b>	x	x	x	x	
<b>Do Section</b>	x	x	x	x	x
<b>After Last Object Printed</b>	x	x	x	x	x
<b>Init Break Section(conditional)</b>	x	x	x	x	x
<b>End Break Section(conditional)</b>	x	x	x	x	x
<b>End Section</b>		x	x	x	x
<b>Suspend Section(conditional)</b>	x	x	x	x	x

## Columnar Section

	<b>BC</b>	<b>RV global</b>	<b>RV section</b>	<b>PC</b>	<b>PV</b>
<b>Initialize Section</b>		x			x
<b>Refresh Section (Child)</b>		x	x	x	
<b>Advance Section</b>	x	x	x	x	x
<b>Before Level Break</b>	x	x	x	x	x
<b>Init Lvl Break Header Section</b>	x	x	x	x	
<b>Do Section</b>	x	x	x	x	x
<b>After Last Object Printed</b>	x	x	x	x	x
<b>Init Break Section(conditional)</b>	x	x	x	x	x
<b>End Break Section(conditional)</b>	x	x	x	x	x
<b>End Section</b>		x	x	x	x
<b>Suspend Section(conditional)</b>	x	x	x	x	x

**Tabular Section**

	BC	RV global	RV section	TR	TC	PC	PV
<b>Initialize Section</b>							
<b>Advance Section</b>	x	x	x			x	x
<b>Before Level Break</b>	x	x	x			x	x
<b>Do Tabular Break</b>	x	x	x	x	x	x	x
<b>Do Section</b>	x	x	x	x	x	x	x
<b>Do Balance Auditor(conditional)</b>	x	x	x			x	x
<b>After Last Object Printed</b>	x	x	x	x	x	x	x
<b>Init Break Section</b>	x	x	x	x	x	x	x
<b>End Break Section</b>	x	x	x	x	x	x	x
<b>End Section</b>	x	x	x			x	x
<b>Suspend Section(conditional)</b>	x	x	x	x	x	x	x

**Level Break Header Section**

	BC	RV global	RV section	PC
<b>Initialize Section</b>		x		
<b>Do Section</b>	x	x	x	x
<b>After Last Object Printed</b>	x	x	x	x
<b>Advance Section</b>	x	x	x	x
<b>End Lvl Break Header Section</b>	x	x	x	x
<b>Suspend Section (conditional)</b>	x	x	x	x

### Level Break Footer Section

	BC	RV global	RV section	PC
Initialize Section		x		
Init Lvl Brk Footer Section	x	x	x	x
Do Section	x	x	x	x
After Last Object Printed	x	x	x	x
End Lvl Brk Footer Section	x	x	x	x
Suspend Section (conditional)	x	x	x	x

### Page Footer Section

	RV global	RV section
Initialize Page Footer	x	x
Do Section	x	x
After Last Object Printed	x	x

### Report Footer Section

	RV global	RV section
Initialize Report Footer	x	x
Do Section	x	x
After Last Object Printed	x	x
End Report Footer	x	x

## Object Level Events

The tables that follow list the available objects for object level events. The following list contains the abbreviations used in the tables:

- BC - Business View Column
- PC - Previous Business View Column
- PV - Previous Variable

### Report Header Section

	RV global	RV section
Initialize Variable	x	x
Do Variable	x	x
End Variable	x	x
Initialize Constant	x	x
Do Constant	x	x
End Constant	x	x

### Page Header Section

	RV global	RV section
Initialize Variable	x	x
Do Variable	x	x
End Variable	x	x
Initialize Constant	x	x
Do Constant	x	x
End Constant	x	x

## Group Section

	<b>BC</b>	<b>RV global</b>	<b>RV section</b>	<b>PC</b>	<b>PV</b>
<b>Initialize Column</b>		x			x
<b>Initialize Variable</b>	x	x	x	x	x
<b>Do Variable</b>	x	x	x	x	x
<b>End Variable</b>	x	x	x	x	x
<b>End Column</b>		x	x	x	x
<b>Initialize Constant</b>	x	x	x	x	x
<b>Do Constant</b>	x	x	x	x	x
<b>End Constant</b>	x	x	x	x	x

## Columnar Section

	<b>BC</b>	<b>RV global</b>	<b>RV section</b>	<b>PC</b>	<b>PV</b>
<b>Do Column Heading</b>	x	x	x	x	x
<b>Initialize Column</b>		x			x
<b>Initialize Variable</b>	x	x	x	x	x
<b>Do Variable</b>	x	x	x	x	x
<b>End Variable</b>	x	x	x	x	x
<b>End Column</b>		x	x	x	x
<b>Initialize Constant</b>	x	x	x	x	x
<b>Do Constant</b>	x	x	x	x	x
<b>End Constant</b>	x	x	x	x	x

### Tabular Section

	<b>BC</b>	<b>RV global</b>	<b>RV section</b>	<b>PC</b>	<b>PV</b>
<b>Do Column Heading</b>	x	x	x	x	x
<b>Initialize Column</b>					
<b>Column Inclusion</b>	x	x	x	x	x
<b>Initialize Variable</b>	x	x	x	x	x
<b>Do Variable</b>	x	x	x	x	x
<b>End Variable</b>	x	x	x	x	x
<b>End Column</b>	x	x		x	x
<b>Initialize Constant</b>	x	x	x	x	x
<b>Do Constant</b>	x	x	x	x	x
<b>End Constant</b>	x	x	x	x	x

### Level Break Header Section

	<b>BC</b>	<b>RV global</b>	<b>RV section</b>	<b>PC</b>
<b>Initialize Variable</b>	x	x	x	x
<b>Do Variable</b>	x	x	x	x
<b>End Variable</b>	x	x	x	x
<b>Initialize Constant</b>	x	x	x	x
<b>Do Constant</b>	x	x	x	x
<b>End Constant</b>	x	x	x	x

### Level Break Footer Section

	<b>BC</b>	<b>RV global</b>	<b>RV section</b>	<b>PC</b>
<b>Do Column Heading</b>	x	x	x	x
<b>Initialize Variable</b>	x	x	x	x
<b>Do Variable</b>	x	x	x	x
<b>End Variable</b>	x	x	x	x
<b>Initialize Constant</b>	x	x	x	x
<b>Do Constant</b>	x	x	x	x
<b>End Constant</b>	x	x	x	x

### Page Footer Section

	<b>RV global</b>	<b>RV section</b>
<b>Initialize Variable</b>	x	x
<b>Do Variable</b>	x	x
<b>End Variable</b>	x	x
<b>Initialize Constant</b>	x	x
<b>Do Constant</b>	x	x
<b>End Constant</b>	x	x

## Report Footer Section

	RV global	RV section
Initialize Variable	x	x
Do Variable	x	x
End Variable	x	x
Initialize Constant	x	x
Do Constant	x	x
End Constant	x	x

## Lifespan of Objects in Section Level Events

The following are common life ranges for section level events:

- BC/PC in Group and columnar section
- BC/PC in Column style tabular section
- BC/PC in Row style tabular section
- RV/PV Life Span

## Report Examples

---

Sometimes getting started is the most difficult part of creating a report. To help you get started, there are tasks which provide instructions for creating some typical reports. These include the following:

- Report techniques by example
- Printing lists of information
- Printing lists of information grouped by a specific field
- Printing totals and auditing numeric data
- Creating journal entries with Report Design

## Report Techniques by Example

This section provides several specific reports with a variety of features such as level-break sections, totaling, hidden controls, and so forth. Steps describing how to create each report follow each example, providing a contextual reference for using many of the features in Report Design.

### Printing Journal Entries by Batch Type

This example illustrates a report that shows journal entries by batch type for batch types K, V, W, and Z and for batches 1000-3000:

This report is confidential and proprietary to J. D. Edwards.  
R560001 J.D. Edwards & Company 1/19/00 14:32:27  
Page - 1 of 3

Listing by Batch Type

Batch Type K		A/P Checks (Automatic)					Amount
Batch Number	Co	Document Type	Document Number	G/L Date	Object Account		
2146	00050	PK	5002	6/30/05	1110	27,500.00-	
	00050	AE	5002	6/30/05	4110	27,500.00	
	00050	PK	5003	6/30/05	1110	394,966.48-	
	00050	AE	5003	6/30/05	4110	394,966.48	
	00050	PK	5004	6/30/05	1110	125,000.00-	
	00050	AE	5004	6/30/05	4110	125,000.00	
2147	00001	PK	2003	6/30/05	1110	144.64-	
	00001	PK	2003	6/30/05	1110	800.00-	
	00001	AE	2003	6/30/05	4110	800.00	
	00001	AE	2003	6/30/05	4110	144.64	
						.00	

10 Total entries for K

Batch Type V		Voucher Entry					Amount
Batch Number	Co	Document Type	Document Number	G/L Date	Object Account		
1028	00001	AE	1584	6/30/05	4110	1,500.00-	
	00001	PV	1584	6/30/05	8720	1,500.00	
	00001	AE	1585	6/30/05	4110	5,000.00-	
	00001	PV	1585	6/30/05	8605	5,000.00	
	00001	AE	1587	6/30/05	4110	1,000.00-	
	00001	PD	1587	6/30/05	8720	1,000.00-	
	00001	AE	1588	6/30/05	4110	2,500.00-	
	00001	AE	1588	6/30/05	4110	437.75-	

#### ► To create a report that contains a column section

*In the J.D. Edwards Windows environment, choose Report Design Tool from the Report Writer menu (GH9111).*

1. On Report Design, choose New from the File menu.
2. On Report Director, enter the following information:
  - Report Name: R560001
  - Description: G/L Transaction Detail
  - Product Code: 56

3. Choose the following options and then click Next:
  - Report Header
  - Page Header
  - Columnar
4. Choose the following option and then click Next:
  - Automatically add the default information fields shown below to my page header section
5. Choose the following option and then click Next:
  - I'll find a business view myself
6. Complete the following field with V0911G, click Find, and then click Next:
  - Object Name
7. Include the following business view columns in the following order and then click Next:
  - Batch Number (ICU)
  - Company (CO)
  - Document Type (DCT)
  - Document (DOC)
  - Date - For G/L (DGJ)
  - Object Account (OBJ)
  - Amount (AA)
  - Batch Type (ICUT)
8. Sequence the data based on the following business view columns in the following order and then click Next:
  - Batch Type (ICUT)
  - Batch Number (ICU)
  - Company (CO)
  - Document (DOC)
  - Object Account (OBJ)
9. Include a Level Break for Batch Type and click Next.
10. Define criteria to select only batch types K, V, W, and Z and batch numbers 1000-3000. The first is a literal list, the second a literal range.
11. Click Next.

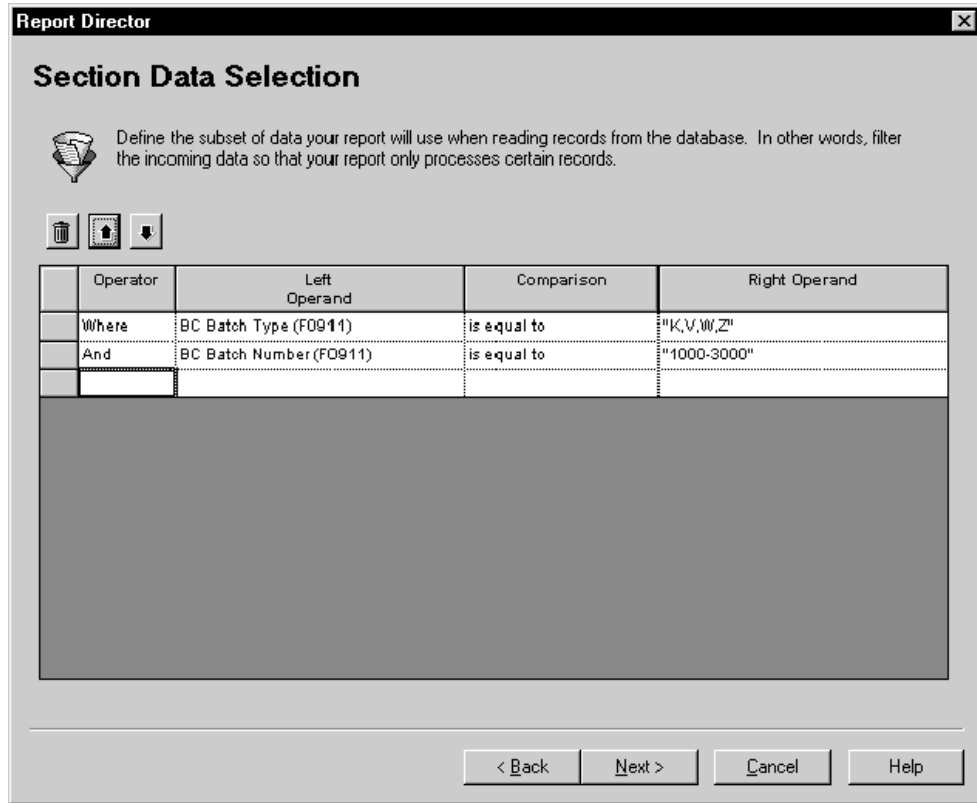

12. When you are finished defining the report parameters, choose the following option to create a report version and click Finish:

- No, I will create a Version of this report later

The system displays the report.

#### ► To change column spacing

*In the J.D. Edwards Windows environment, choose Report Design Tool from the Report Writer menu (GH9111).*

This process adds 25 pixels of space between each column to spread them evenly across the page. Furthermore, it adds 100 pixels of space before the first column to shift all of the columns to the right, thereby balancing the amount of white space to the left and right of the report body.

1. On Report Design, click the columnar section.
2. From the Layout menu, choose Spacing.

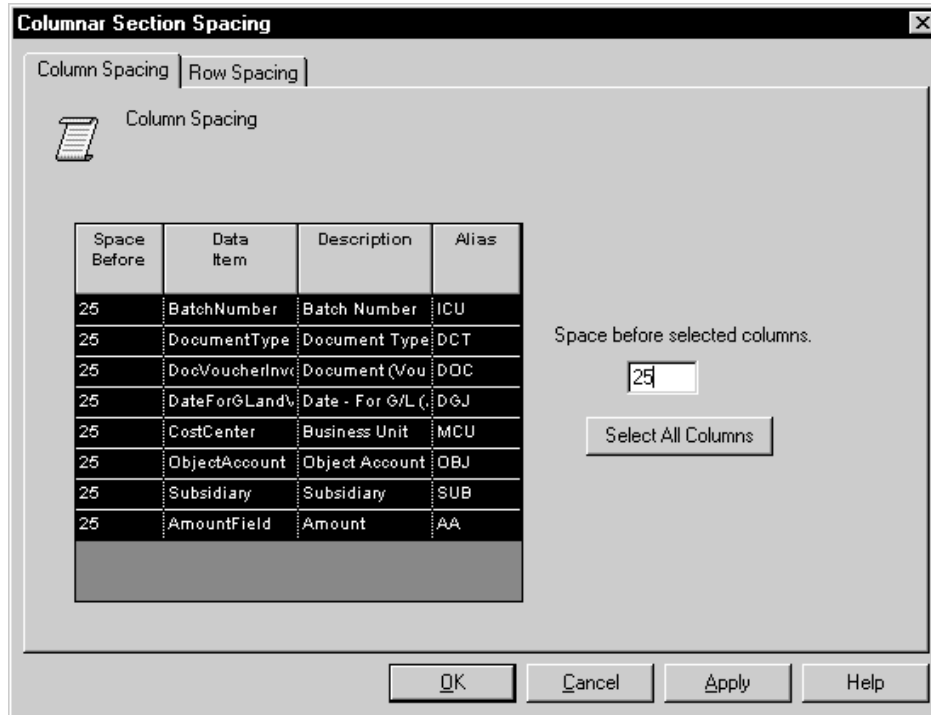

3. On Columnar Section Spacing, click Select All Columns.  
The system highlights all the columns on the form.
4. Type 25 in the following field and click Apply:
  - Space before selected columns
5. Choose Batch Number, type 100 in the following field, and then click OK:
  - Space before selected columns

► **To suppress redundant data**

*In the J.D. Edwards Windows environment, choose Report Design Tool from the Report Writer menu (GH9111).*

In this sample report, the data has been sequenced primarily by Batch Number. This process illustrates how to display the batch number only once per group, the first time it is encountered, that is, when Batch Number changes.

1. On Report Design, double-click the variable portion of the Batch Number column.
2. On Column Variable Properties, click the Advanced tab and choose the following options:
  - Visible (accept the default value)
  - Print on Change Only
3. Click OK.

► **To change column justification**

In this sample report, the Batch Number, Document Type and G/L Date columns are centered; the rest of the columns are right-justified. This process illustrates how to change column justification.

*In the J.D. Edwards Windows environment, choose Report Design Tool from the Report Writer menu (GH9111).*

1. On Report Design, click the columnar section and then click the Column tab.

The system displays the specifications for each column in the section.

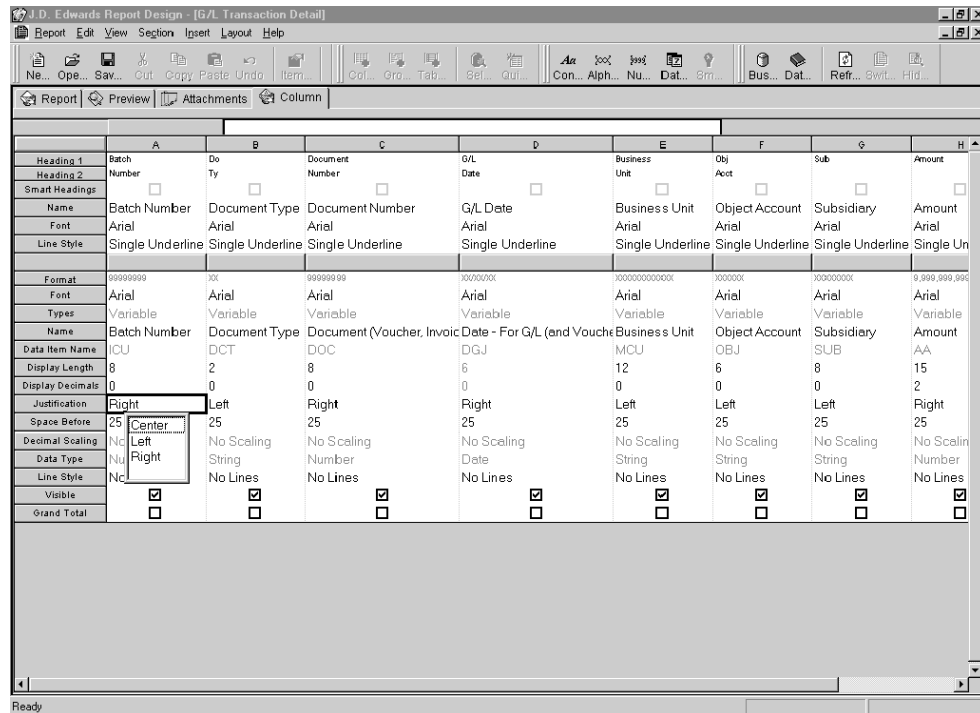

2. Double-click the justification option in the Batch Number column and double-click Center from the resulting drop-down menu.
3. Using this same technique, change the justification for the remaining columns.
4. Click the Report tab to return to the layout view of the report.

► **To change column titles**

In this sample report, two of the column titles have been changed from their default values as follows:

- Do Ty to Document Type
- Obj Acct to Object Account

This process illustrates how to change column titles.

*In the J.D. Edwards Windows environment, choose Report Design Tool from the Report Writer menu (GH9111).*

1. On Report Design, click the columnar section and then click the Column tab. The system displays the specifications for each column in the section.
2. Double-click Do in the Heading 1 cell and change it to Document.
3. Double-click Ty in the Heading 2 cell and change it to Type.
4. Using the same method, change the column titles for the Obj Acct column.
5. Click the Report tab to return to the layout view of the report.

► **To total and count columns in a level-break footer**

In this sample report, the Amount column is totaled for all of the items in each Batch Type. Additionally, the total entries displayed for each batch type is indicated. These values must be calculated and displayed in a level-break footer. Because a level break was attached to Batch Type, this process is possible. This process illustrates how to create a level-break footer and how to display an aggregate function for a column.

*In the J.D. Edwards Windows environment, choose Report Design Tool from the Report Writer menu (GH9111).*

1. Click the columnar section.
2. From the Section menu, choose Create, and then choose Level Break Footer.
3. On Level Break Footer, choose Group Section, and then click OK.

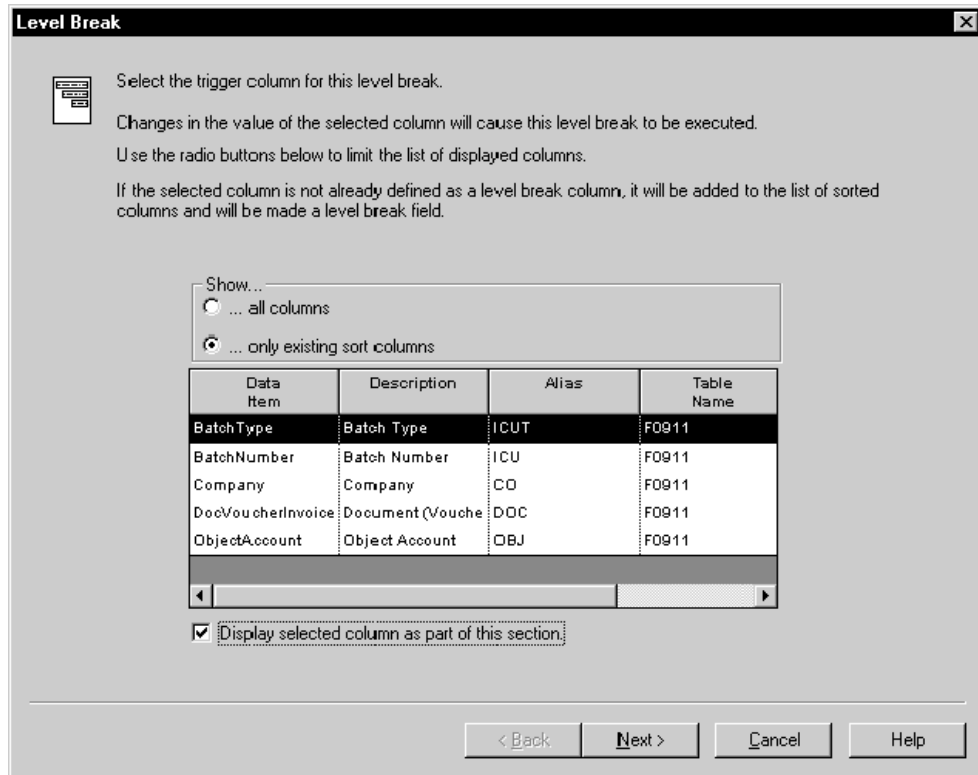

4. On Level Break, choose *only existing sort columns*, choose the Batch Type column, and then click Next.

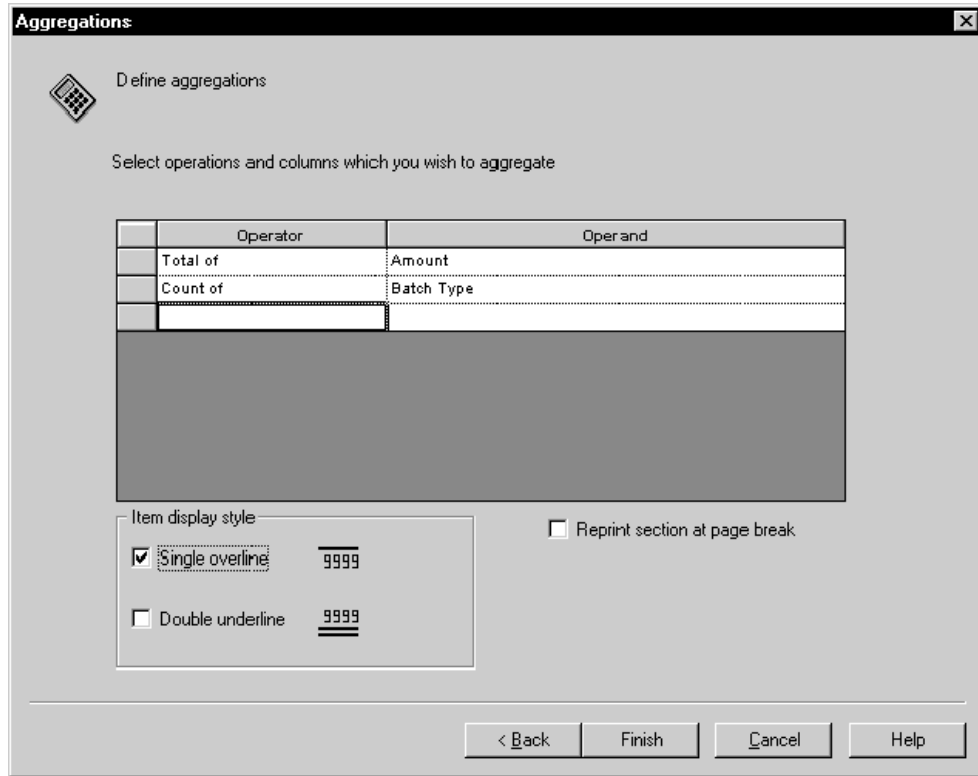

5. On Aggregations, double-click in the Operator column and double-click *Total of* from the resulting drop-down menu.
6. Double-click in the Operand column and double-click *Amount* from the resulting drop-down menu.
7. Double-click the next cell in the Operator column and double-click *Count of* from the resulting drop-down menu.
8. Double-click the next cell in the Operand column and double-click *Document Type* from the resulting drop-down menu.
9. Choose the Single overline option and click Finish.

The count variable does not have an overline in this sample report; you will remove the line from that report object later.

The level-break footer appears in the columnar section of the report.

#### ► To change the level-break footer

In this sample report, the count value at each level break has the text *Total entries for <batch type>* after it. Furthermore, the total values for account display zero rather than a blank if the value is zero. This process illustrates how to add text to the report section, how to write an event rule for a variable, and how to change how a numeric field displays numbers.

*In the J.D. Edwards Windows environment, choose Report Design Tool from the Report Writer menu (GH9111).*

1. On Report Design, click the level-break footer section.

2. From the Insert menu, choose Constant Field.  
When you move your cursor back into the level-break footer section, the cursor indicates that you can place the constant.
3. Move the cursor to the right of the Batch Type column and click to place the constant field.
4. Double-click the constant field.
5. On Constant Properties, on the Description tab, type "Total entries for" in the following field and click OK:
  - Variable Name
6. In the level-break footer, double-click the total field under the Amount column.
7. On Variable Properties, click the Display tab, type an R in the following field and then click OK.
  - Edit Code
8. In the level-break footer, click the constant component of the Batch Type control and choose Disconnect from the Edit menu.
9. Delete the now disconnected constant component of the Batch Type control.  
The variable component remains.
10. Double-click the variable field.
11. On Variable Properties, click the Advanced tab, deselect the Visible option, and click OK.  
Although you do not want it to appear, the Batch Type control must reside in the level-break footer so that the event rule created in the following steps will work properly.
12. From the Insert menu, choose Alpha Variable.  
When you move your cursor back into the level-break footer section, the cursor indicates that you can place the variable.
13. Move the cursor to the right of the Total entries for constant field and click to place the alpha variable.  
Because you are working so close to the report's edge and the default length for the alpha variable is so long, you might not be able to place the variable to the right of the constant field. If this is the case, place it below the constant field and then move it later after you have shortened the field length.
14. Double-click the alpha variable.
15. On Variable Properties, on the Description tab, change the variable name to Batch Type Variable.
16. Click the Display tab, change the display length to 1, and click OK.  
If necessary, reposition the variable on the report.
17. Save the report, click the alpha variable, and then choose Event Rules from the Edit menu.
18. On Event Rules Design, choose Do Variable from the drop-down field at the top of the form.

19. Click the Assignment/Expression button.
20. On Assignment, choose the RV Batch Type Variable from the To Object column and then choose the PC Batch Type from the From Object/Literal column.
21. Click OK.

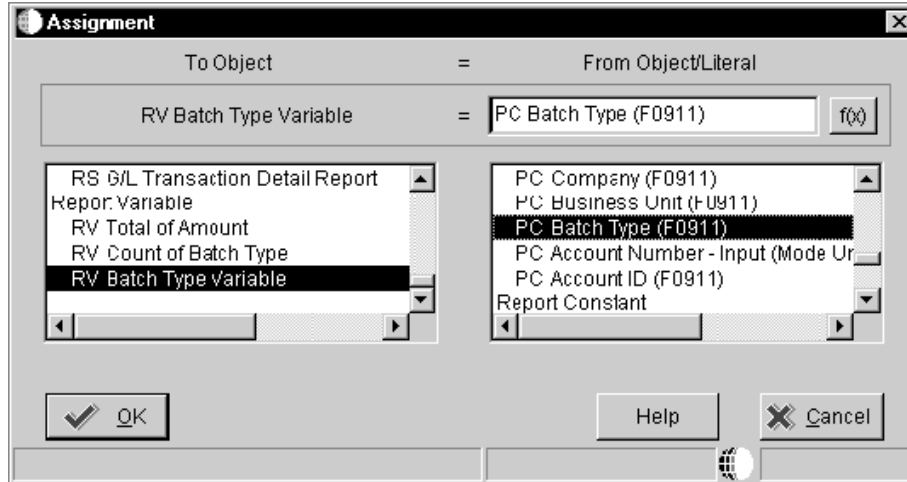

The Event Rules variable form reflects the event rule. You must set the variable equal to the previous value (rather than the current value) because of the way the report is processed.

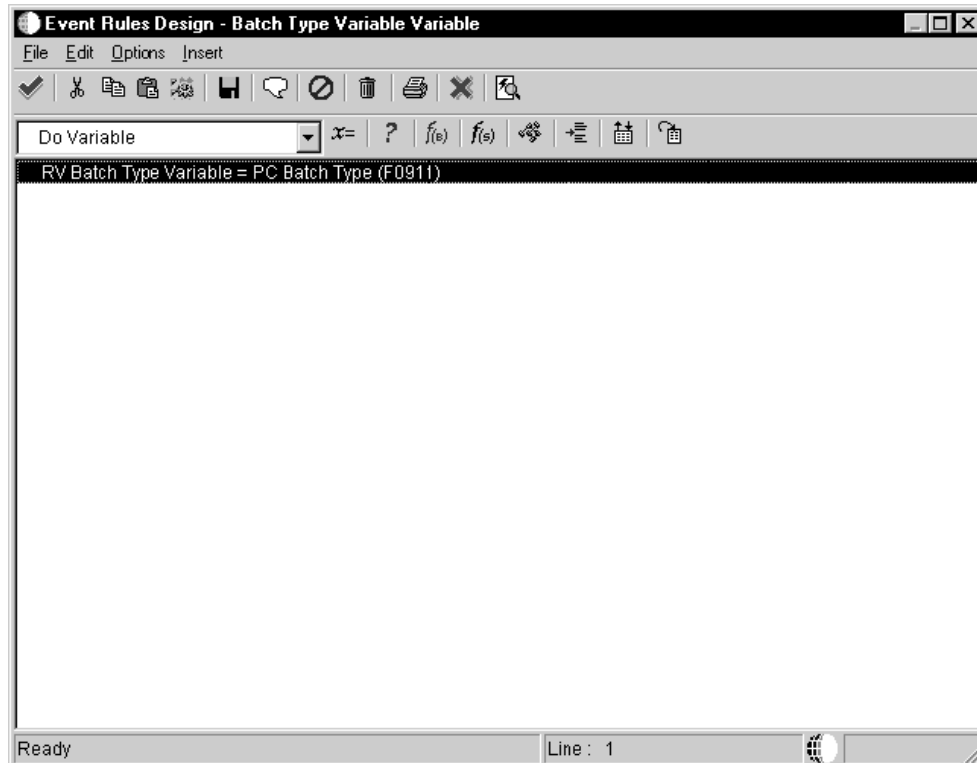

22. Click the Save and Exit button.

### ► To create a level-break header and hide objects

---

In this sample report, the batch type and its description appear at the top of every level break, but do not appear in the body of the report itself. This process illustrates how to add and format a level-break header and how to hide report objects.

*In the J.D. Edwards Windows environment, choose Report Design Tool from the Report Writer menu (GH9111).*

1. On Report Design, click the columnar section.
2. From the Section menu, choose Create, and then choose Level Break Header.
3. On Level Break, choose *only existing sort columns*, and then choose the Batch Type column.
4. Choose the following option and then click Finish:
  - Display selected column as part of the sectionThe level-break header appears in the columnar section of the report.
5. To display description text for the batch type, click the variable portion of the Batch Type control, and from the Edit menu choose Associate and then choose Description.  
When you move your cursor back into the level-break header section, the cursor indicates that you can place the constant.

*A control* is to a group section (level-break headers are always group sections) as a *column* is to a columnar or tabular section.

6. Move the cursor to the right of the Batch Type control and click to place the constant field.
7. Double-click the level-break header section.
8. On Associated Description Properties, click the Font/Color tab, and then choose Bold from the Font Style field and 10 from the Size field.
9. Opt to apply settings to all objects and click OK.  
The system changes all the fields in the level-break header section to 10-point bold. You might need to reposition the fields to prevent overlap.
10. In the columnar section, double-click the Batch Type column.
11. On the appropriate properties form, click the Advanced tab, deselect the Visible option, and then click OK.

The column disappears.

You can select either component of the column for this operation (the header or the variable); if you hide one component, the system automatically hides the other as well.

12. In the level-break footer section, double-click the variable that displays the batch type count.
13. On Variable Properties, click the Style tab, choose No Lines, and click OK.

## ► To add text to the report and page headers

---

In this sample report, the report header says "This report is confidential and proprietary to J.D. Edwards." Additionally, the page header displays "Listing by Batch Type" centered below the default text. This process illustrates how to add these phrases to these two sections.

*In the J.D. Edwards Windows environment, choose Report Design Tool from the Report Writer menu (GH9111).*

1. Click the Report Header and from the Insert menu, choose Constant Field.  
When you move your cursor back into the report header section, the cursor indicates that you can place the constant.
2. Move the cursor to approximately the center of the section and click to place the constant.
3. Double-click the constant field.
4. On Constant Properties, on the Description tab, enter the following in the Variable Name field, and then click OK:
  - This report is confidential and proprietary to J.D. Edwards.
5. Use the same technique to add a constant to the page header and name it Listing by Batch Type.
6. Shift-click the two constants that you just added and the two default constants in the middle of the page header.  
One of the two default constants should have a dark box around it; ensure that you click the constants you just created *first* to accomplish this. The formatting accomplished in the next steps occurs relative to the object with the dark box around it.
7. From the Layout menu, choose Align.
8. On Align Objects, click Center, then click Current Selection, and then click OK.  
The system centers the four constant fields.
9. In the Page Header section, choose the variable component of the page number control and delete it.
10. From the Insert menu, choose Runtime Field and then choose Page n of Total.  
When you move your cursor back into the page header section, the cursor indicates that you can place the run-time field.
11. Move the cursor to the right of the Page constant and click to place the run-time field.  
Note that this field is actually three fields placed closely together. If you want to reposition them, ensure that you select all three fields.

## Printing a Work Order Report

This example illustrates a report that lists work orders and their status:

R560002		J.D. Edwards & Company				12/17/99 14:58:25	
		Work Order Report				Page - 1	
<b>ACD Ultra Enterprise 2</b>							
Business Unit	830	Order Number and Type	451557 WM	W.O. Type and Status	0 E1	Asset Number	32731
		Unit Number		Quantity	1	Item	701333 7250
Business Unit	830	Order Number and Type	451741 SV	W.O. Type and Status	Y MC	Asset Number	32521
		Unit Number		Quantity	1	Item	701333 7250
<b>Forklift</b>							
Business Unit	M30	Order Number and Type	451717 WO	W.O. Type and Status	1 MJ	Asset Number	24600
		Unit Number	F7	Quantity	1	Item	701286 E200
<b>Machine Center</b>							
Business Unit	M38	Order Number and Type	400021 WO	W.O. Type and Status	1 MH	Asset Number	24731
		Unit Number	L2	Quantity		Item	
<b>Paint Booth II</b>							
Business Unit	M38	Order Number and Type	400012 WO	W.O. Type and Status	1 MH	Asset Number	24820
		Unit Number	PB2	Quantity	1	Item	
Business Unit	M30	Order Number and Type	451776 WM	W.O. Type and Status	0 E1	Asset Number	24820
		Unit Number	PB2	Quantity		Item	01532 REPLACE INTAKE FILTERS
Business Unit	M30	Order Number and Type	451784 WM	W.O. Type and Status	0 E1	Asset Number	24820
		Unit Number	PB2	Quantity	1	Item	01559 REPLACE DRYER FILTERS
Business Unit	M30	Order Number and Type	451792 WM	W.O. Type and Status	0 E1	Asset Number	24820
		Unit Number	PB2	Quantity	1	Item	01567 INSPECT EXHAUST FAN MOTOR
Business Unit	M30	Order Number and Type	451805 WM	W.O. Type and Status	0 MA	Asset Number	24820
		Unit Number	PB2	Quantity	1	Item	01575 LUBRICATE AIR COMPRESSOR

### ► To create a report that contains a group section

*In the J.D. Edwards Windows environment, choose Report Design Tool from the Report Writer menu (GH9111).*



1. On Report Design, choose New from the File menu.
2. On Create New Report, complete the following fields and click OK:
  - Report Name: R560002
  - Description: Work Order Report
  - Product Code: 56
3. On Report Director, choose the following options and click Next:
  - Page Header
  - Group
4. Choose the following option and click Next:
  - Automatically add the default informational fields shown below to my page header section
5. Choose the following option and click Next:
  - I'll find a business view myself
6. Enter V1201JE in the following field and click Find:
  - Object Name
7. Click Next.

8. Include the following business view columns in the following order and then click Next:
  - Business Unit (MCU)
  - Document (DOCO)
  - Order Type (DCTO)
  - Type - W.O. (TYP5)
  - Status Code W.O. (SRST)
  - Asset Item Number (NUMB)
  - Unit or Tag Number (APID)
  - Units - Order/Transaction Quantity (UORG)
  - Item Number - Short (ITM)
  - 2nd Item Number (LITM)
  - Description (DL01)
9. Sequence the data based on the following business view columns in the following order and then click Next:
  - Description (DL01)
  - Document (DOCO)
10. Click in the Level Break column for Description and click Next.
11. Define criteria to display information for Documents between 400,000 and 460,000 and click Next.

**Report Director** [X]

### Section Data Selection

 Define the subset of data your report will use when reading records from the database. In other words, filter the incoming data so that your report only processes certain records.

	Operator	Left Operand	Comparison	Right Operand
	Where	BC Document (Order No, Invoice, etc.)	is equal to	"400000-460000"

12. When you are finished defining the report parameters, choose the following option and click Finish:

- No, I will create a version of this report later

The system displays the report.

### ► To format the group section

---

In this sample report, the format of the group section varies from the default layout in these ways:

- Placement of controls
- Constant text of some controls
- Spacing between lines

A *control* is to a group section (level-break headers are always group sections) as a *column* is to a columnar or tabular section.

This process illustrates how to reformat the group section in these ways.

*In the J.D. Edwards Windows environment, choose Report Design Tool from the Report Writer menu (GH9111).*

1. On Report Design, choose Grid Alignment from the Layout menu.
2. On Alignment Grid, set the Horizontal Spacing to 20, ensure that Snap To Grid is enabled, and click OK.

With the snap to grid feature enabled, you can manually align report objects relative to the grid.

3. Click the Unit Number control and drag it out of the way.

---

#### **Note**

In a group section, you can select and move a variable and its constant text independently of each other. Clicking in the middle of the control selects both fields simultaneously.

---

4. Move the Order Number control to the right of the Business Unit control.
5. Double-click the constant field of the Order Number control.
6. On Constant Properties, choose the following option:
  - Override Name
7. Type Order Number and Type in the Variable Name field and then click OK.

You might need to move the variable field of the Order Number control to avoid overlap.
8. Click the constant field of the Order Type control and from the Edit menu, select Disconnect.

9. Delete the Order Type constant and move the remaining variable field to the right of the Order Number and Type control.

By disconnecting the constant from the variable, you can delete it without deleting the variable as well.

10. Repeat this process with the Type and Status controls, placing them to the right of the Order Number and Type control and changing the name of the Type control to W.O. Type and Status.
11. Move the Asset Number control to the right of the W.O. Type and Status control.
12. Move the Unit Number control directly below the Order Number and Type control.
13. Move the Quantity control directly below the W.O. Type and Status control.
14. Move the Item Number control directly below the Assent Number control, changing its name to Item.
15. Disconnect and delete the constant field of the 2nd Item Control, and then move it to the right of the Item control.
16. From the Insert menu, choose Constant Field.

When you move your cursor back into the group section, the cursor indicates that you can place the constant.

17. Place the constant and move the new control below the Unit Number control.
18. Double-click the constant control.
19. On Constant Properties, on the Description tab, delete the text from the Variable Name, and enter five spaces and click OK.

This empty constant field adds white space between each data set.

### ► **To create a level-break header and hide objects**

---

In this sample report, the description appears at the top of every level break, but does not appear in the body of the report itself. This process illustrates how to add and format a level-break header and how to hide report objects.

*In the J.D. Edwards Windows environment, choose Report Design Tool from the Report Writer menu (GH9111).*

1. On Report Design, click the columnar section.
2. From the Section menu, choose Create, and then choose Level Break Header.
3. On Level Break, choose *only existing sort columns*, and then choose the Description column.
4. Choose Display selected column as part of the section, and then click Finish.  
The level-break header appears in the columnar section of the report.
5. Disconnect and delete the constant field of the Description control.
6. Move the Description control to the upper left corner of the level-break header, and then double-click the control.
7. On Variable Properties, click the Font/Color tab, and then choose Bold from the Font Style field and 10 from the Size field.
8. Click the Style tab, click No Lines to unselect it and then choose Single Rectangle.

9. Click the Display tab, change the Display Length to 110 and then click OK.
10. In the columnar section, double-click the variable field of the Description control.
11. On Variable Properties, click the Advanced tab, deselect the Visible option, and then click OK.

The control disappears.

## Printing Outstanding Balance by Company

This example illustrates a report that displays amounts, by company, that are still outstanding. A grand total amount open for all companies appears at the end of the report.

R5501		J.D. Edwards & Company			12/17/99 8:14:50
Description	Or Ty	Address Number	Amount Open	Purchase Order Detail Report	Approval
Financial/Distribution Compa					
Mountain Bike, Red	CP	4343	588,411.00		
Touring Bike, Green	CP	6031	16,500.00	General Manager approval	
Youth Sport Bike	CP	4343	9,632.00	General Manager approval	
Lid	CP	4343	150.00	No approval required	
Bottle	CP	4343	400.00	No approval required	
Bike Accessory Kit	CP	4344	10,000.00	General Manager approval	
Helmet	CP	4343	1,100.00	General Manager approval	
Helmet - HI Flow	CP	4343	1,800.00	General Manager approval	
Tire Repair Kit	CP	4370	625.00	Purchase Manager approval	
250 mm Cro-Moly Tubing	CP	4343	140.00	No approval required	
500 mm Cro-Moly Tubing	CP	4343	144.00	No approval required	
160 mm Cro-Moly	CP	4343	112.00	No approval required	
500 mm Cro-Moly Bar	CP	4343	240.00	No approval required	
90 mm Cro-Moly Plate	CP	4343	150.00	No approval required	
Nut - 6	CP	4343	140.00	No approval required	
Nut - 6	CP	4343	867.50	Purchase Manager approval	
Steel Rod	CP	4343	165.00	No approval required	
Plastic Palette	CP	4344	75.00	No approval required	
Paint, Green	CP	4344	500.00	Purchase Manager approval	
Paint, Red	CP	4344	50.00	No approval required	
Paint, Blue	CP	4344	500.00	Purchase Manager approval	
Capacitor	CP	4343	48.00	No approval required	
Controller	CP	4343	588.00	Purchase Manager approval	
Resistor 5 ohm	CP	4343	24.00	No approval required	

### ► To create a report that contains a tabular section

*In the J.D. Edwards Windows environment, choose Report Design Tool from the Report Writer menu (GH9111).*

1. On Report Design, choose New from the File menu to create a new report object.
2. On Create New Report, complete the following fields and click OK:
  - Report Name: R5501
  - Description: Purchase Order Detail Report
  - Product Code: 55
3. On Report Director, choose the following options and click Next:
  - Page Header
  - Tabular
4. Choose the following option and click Next:
  - Automatically add the default informational fields shown below to my page header section

5. Choose the following option and click Next:
  - I'll find a business view myself
6. Enter V4311A in the following field and click Find:
  - Object Name
7. Click Next:
8. Include the following business view columns in the following order and click Next:
  - Order Type (DTCO)
  - Address Number (AN8)
  - Amount Open (AOPN)
9. Sequence the data based on the following business view columns in the following order and then click Next:
  - Order Company (KCOO)
  - 2nd Item Number (LITM)
10. Click in the level break column for both Order Company and 2nd Item Number and click Next.

Level breaks are critical to the appearance of tabular reports. The lowest level break defines the detail on the report. The higher level break defines subtotaling.
11. Define the following data selection criteria (join each criterion with an AND operator):
  - Amount Open is greater than 0
  - Order Type is equal to OP
  - Status Code - Next is not equal to 999
  - Line Type is equal to S

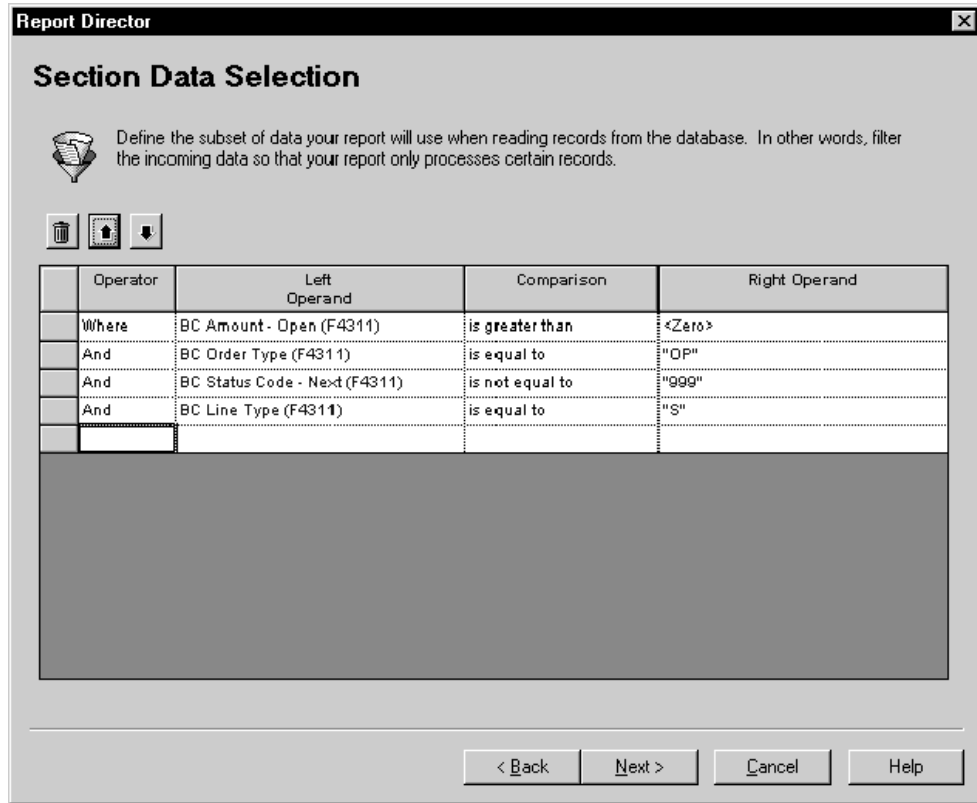

12. When you are finished defining the report parameters, choose the following option and then click Finish:

- No, I will create a version of this report later

The system displays the report.

#### ► To rename a column

The sample report does not include an Address Number column, but it does include a Supplier Number column. In actuality, the data is the address number, but it has been renamed for clarity. This procedure illustrates how to change a column's name.

*In the J.D. Edwards Windows environment, choose Report Design Tool from the Report Writer menu (GH9111).*

1. On Report Design, double-click the Address Number column heading.
2. On Column Heading Properties, change the text in the Variable Name field to Supplier Number.
3. Change the text in the Heading 1 field to Supplier
4. Change the text in the Heading 2 field to Number.
5. Click OK.

### ► To add an approval column

---

This sample report includes a column that indicates whether manager approval is required. The content of the column is assigned by an event rule. The first step in including this column in the report is to create the column itself.

*In the J.D. Edwards Windows environment, choose Report Design Tool from the Report Writer menu (GH9111).*

1. On Report Design, click the Amount Open column.
2. From the Column menu, choose Create, then Alpha Variable.  
The system adds the new column to the right of the Amount Open column.
3. Double-click the heading of the new column.
4. On Column Heading Properties, change the text in the Variable Name and Heading 1 fields to Approval.
5. Delete the text in the Heading 2 field and click OK.
6. Double-click the variable portion (the body beneath the heading) of the Approval column.
7. On Column Variable Properties, change the text in the Variable Name field to Approval and click OK.

J.D. Edwards recommends that you change the variable names of both column components as it simplifies identifying the column in later processes.

### ► To suppress printing columns at totals

---

Tabular sections automatically total all their columns. Non-numeric fields display the last business view value unless their data dictionary definitions instruct them to suppress totaling. In this sample report, only the Amounts column displays a total value. This process illustrates how to keep a total value from appearing for a column.

*In the J.D. Edwards Windows environment, choose Report Design Tool from the Report Writer menu (GH9111).*

1. On Report Design, double-click the variable portion (the body beneath the heading) of the Description column.
2. On Column Variable Properties, click the Advanced tab, choose the following options, and then click OK:
  - Visible (accept the default value)
  - Suppress At Totals
3. Use this technique to suppress printing at totals for all the columns except Amount Open.

► **To define and add event rules**

---

In this sample report, the Approvals column reads *General Manager approval* when the amount open exceeds 1000, *Purchase Manager approval* when the amount open is between 500 and 999, and *No approval required* when the amount open is less than 500. This process illustrates how to define and attach an event rule to display the appropriate text for each report line.

*In the J.D. Edwards Windows environment, choose Report Design Tool from the Report Writer menu (GH9111).*

1. On Report Design, click the Tabular Section.
2. From the Section menu, choose Text Variables.
3. On Text Variables, type the three phrases indicated at the beginning of this process, and then click OK.

Click Add between each phrase to move your cursor to the next grid line.

4. From the File menu, select Save.
5. Click the Tabular Section (ensure that no column in the section is active) and from the Edit menu, choose Event Rules.

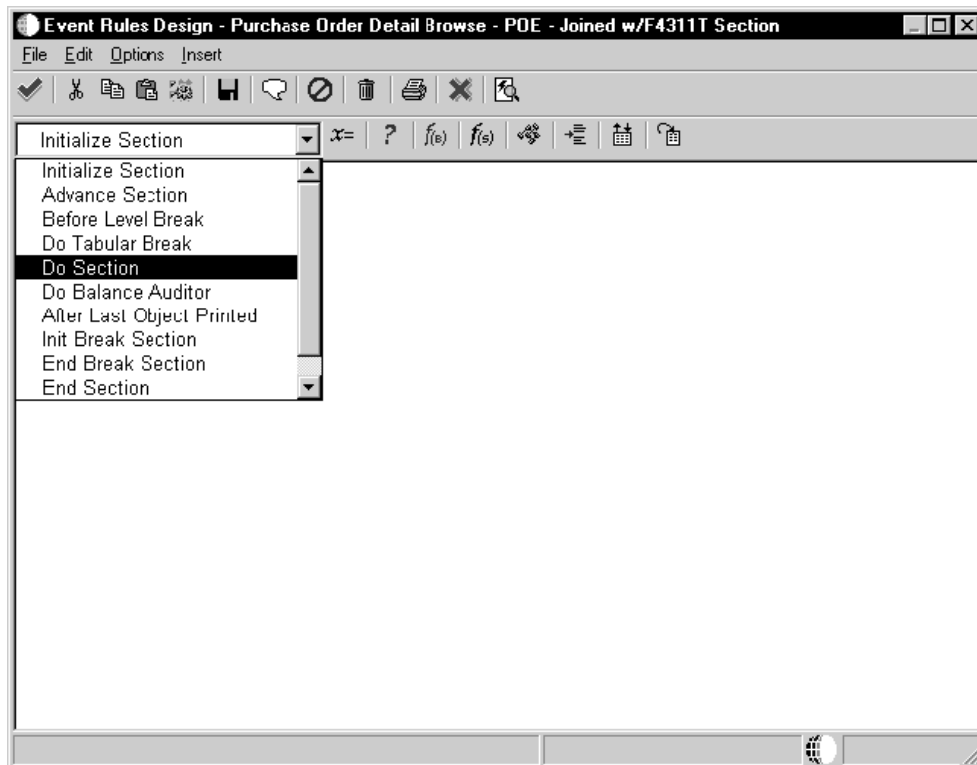

6. On Event Rules Design, choose the Do Section event from the event drop-down menu.

The system must apply the logic created in the following steps to each report row before it appears on the report. Do Section events are processed immediately after each record is fetched, but before it is written to the report.

7. Click the If/While button.  
Hold your cursor for a few seconds over a button to see its title.

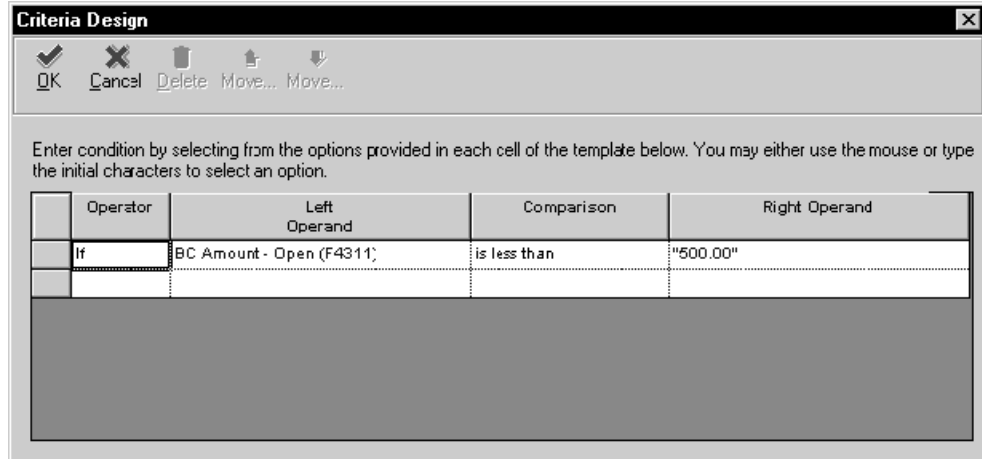

8. On Criteria Design, add the following event rule and click OK:
  - If BC Amount - Open is less than 500
 BC stands for Business Column.  
  
 The rule appears in the Event Rules Design form in an If/Then framework.
9. Click the line that says *If BC Amount - Open is less than "500"* and then click the Assignment/Expression button.

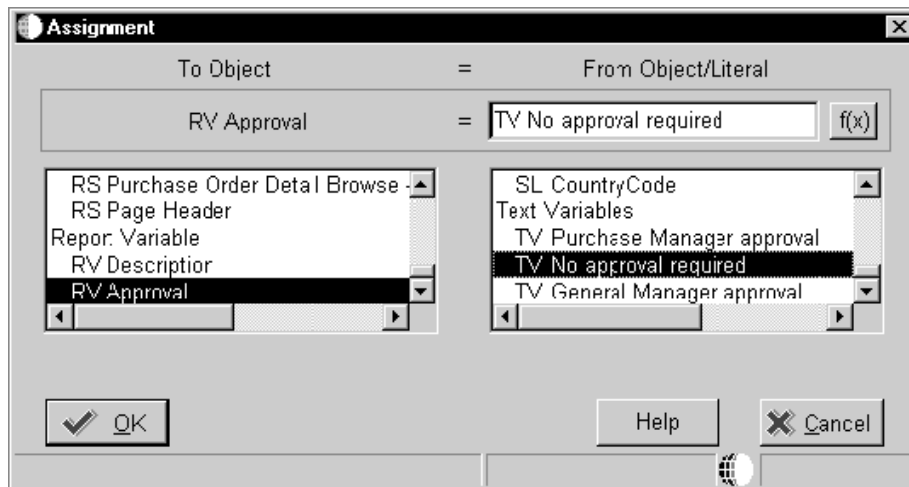

10. On Assignment, choose RV Approval from the To Object list.

11. Choose TV No approval required from the From Object/Literal list.  
RV stands for Report Variable; TV stands for Text Variable. Ensure that you select RV Approval and not RC Approval (RC stands for Report Constant). *Constant* represents the header portion of the column; *variable* represents the body portion of the column.
12. Click OK.  
The system adds the appropriate Then clause to the event rule.
13. Click the line that says *Else* and then click the If/While button.
14. On Criteria Design, add the following event rule and click OK:
  - If BC Amount - Open is greater than or equal to 500
  - And BC Amount - Open is less than 1000The rule appears in the Event Rules Design form in an If/Then framework.
15. Click the line you just created and then click the Assignment/Expression button.
16. On Assignment, choose RV Approval from the To Object list.
17. Choose TV Purchase manager approval from the From Object/Literal list and click OK.  
The system adds the appropriate Then clause to the event rule.
18. Click the next line down that says *Else* and then click the If/While button.
19. Add the following event rule and click OK:
  - If BC Amount - Open is greater than or equal to 1000The rule appears in the Event Rules Design form in an If/Then framework.
20. Click the line that you just created and then click the Assignment/Expression button.
21. On Assignment, from the To Object list, choose RV Approval.
22. From Object/Literal list, choose TV General manager approval and click OK.  
The system adds the appropriate Then clause to the event rule.

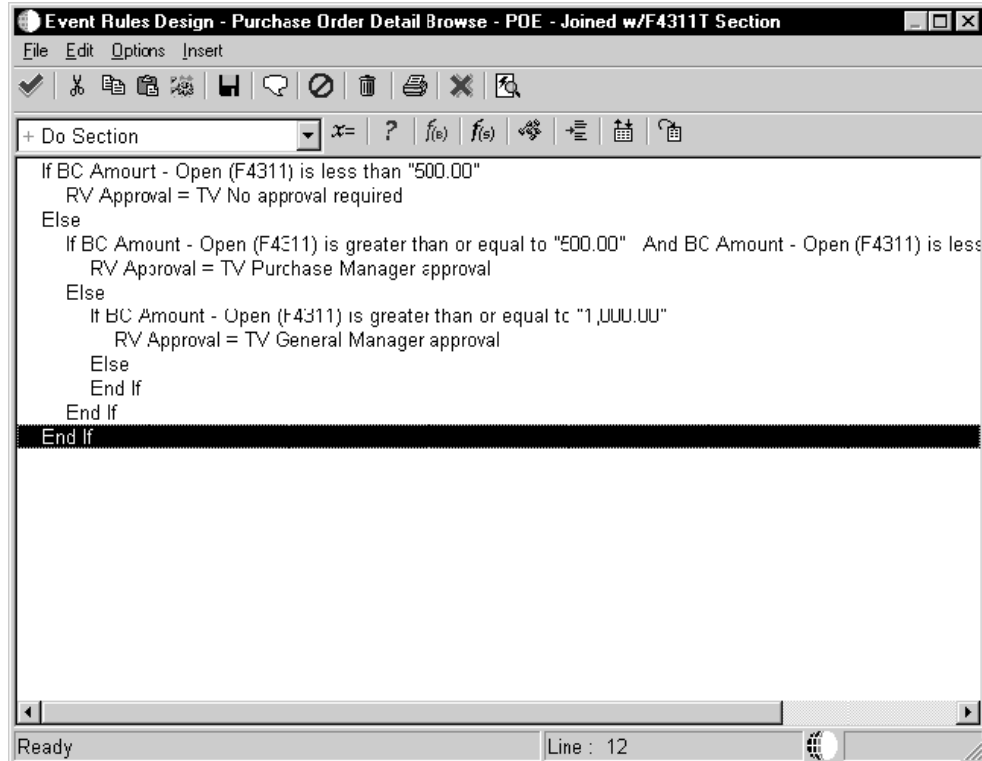

23. Click the Save and Exit button.

## Printing Lists of Information

Several types of reports that you could create to present lists of information are:

- Business units and descriptions for a company
- Inventory items by stocking type
- Address book information in a card file format
- Employee listing

### ► To print all business units and descriptions for a company

*In the J.D. Edwards Windows environment, choose Report Design Tool from the Report Writer menu (GH9111).*

1. On Report Design, create a report object called Company/Business Units/Descriptions Listing.
2. Create a group or columnar section.

The advantage of using a group section is the ability to rearrange your fields. This lets you control the placement of fields as they appear on the report. If you choose a columnar section, you cannot change the format of the column headings over the data fields.

3. Attach business view V0006D - Business Unit Setup.
4. Choose to include the following data fields on your report:
  - Company
  - Business Unit
  - Description01
5. Sequence the report on the following fields:
  - Company
  - Business Unit
6. Determine through data selection the records to appear on your report. For example, if you want to display the business units for all companies less than Company 00050, your data selection would be "Where Company is less than 00050."
7. On Report Design, format your report to enhance the appearance.

► **To print a list of inventory items by stocking type**

---

*In the J.D. Edwards Windows environment, choose Report Design Tool from the Reprot Writer menu (GH9111).*

1. On Report Design, create a report object called Inventory Item List.
2. Create a group or columnar section.
3. Attach business view V4101A - Item Master Browse.
4. Choose to include the following data fields on your report:
  - Stocking Type
  - Description
  - 2nd Item Number
5. Sequence the report on the following fields:
  - Stocking Type
  - Description
6. Sort both of these fields in ascending order.
7. Determine through data selection the records to appear on your report.

► **To print address book information in a card file format**

---

*In the J.D. Edwards Windows environment, choose Report Design Tool from the Reprot Writer menu (GH9111).*

1. On Report Design, create a report object called Address Book Information.
2. Create a group section.
3. Attach business view V0101B - Address Book One-Line report.
4. Choose to include the following data fields on your report:
  - Name - Alpha
  - Address Line 1

- City
  - State
  - Postal Code
5. Sequence the report on the following field:
    - Name - Alpha
  6. Sort this field in ascending order.
  7. Determine through data selection the records to appear on your report.
  8. On Report Design, arrange the fields to print Name on the first line, Address on the second, and City, State, and Postal Code on the third.
  9. Disconnect the Name, Address, City, State, and Zip Code constants from their variables, delete the constants, and print only the variable information on the report.

► **To print an employee listing**

---

*In the J.D. Edwards Windows environment, choose Report Design Tool from the Reprot Writer menu (GH9111).*

1. On Report Design, create a report object called Employee Listing Information.
2. Create a columnar section.
3. Attach business view V060116A - Employee Master.
4. Choose to include the following data fields on your report:
  - Name - Alpha
  - Business Unit - Home
  - Pay Class (H/S/P)
  - Date - Original Employment
  - Rate - Salary, Annual
5. Sequence the report on the following fields:
  - Business Unit - Home
  - Name - Alpha
6. Determine through data selection the records to appear on your report. For example, to list all employees on your report, your data selection could be "Where Search Type is equal to E."

### **Printing Lists of Information Grouped by a Specific Field**

Several types of reports that you could create to present lists of information grouped by a specific field are:

- Inventory items by stocking type
- Total the number of business units per company

## ► To group a list of inventory items by stocking type

---

Printing lists of information on a report might be more meaningful to the reader if a specific field, for example, Stocking Type, grouped the information. Adding a level-break header to a group or columnar section enables you to group information by a specific field.

*In the J.D. Edwards Windows environment, choose Report Design Tool from the Report Writer menu (GH9111).*

1. On Report Design, open your existing report called Inventory Item List.
2. Click the detail section to which you want to attach a level-break header.
3. From the Section menu, choose Create and then choose Level Break Header.  
If the Level Break Header selection is grayed out on the Section menu, you did not click on the detail section.
4. On Level Break, choose the following option under the Show heading:
  - only existing sort columns  
This option displays the fields you chose as your data sequencing fields when you created the detail section.
5. Choose the Stocking Type field to designate it as the level-break field.  
You can designate another field as a level-break field by modifying the section properties of the level-break header.
6. Turn the *Display selected column as part of this section* option on.
7. Click Finish.
8. Click the variable portion of the level-break header field.
9. From the Edit menu, choose Associate, and then choose Description.  
The cursor changes, allowing you to add the description to the level-break header.
10. Place the Description field anywhere within the level-break header. As with any field, you can drag it to a new location.
11. To change the properties of this field, double-click the field.
12. On Associated Description Properties, in the detail section, double-click the variable or column variable portion of the level-break field.
13. On Variable or Column Variable Properties, on the Advanced tab, turn the Visible option off.  
If you ever need to make this field visible again, you can turn the Visible option on.

### See Also

See the following topics in the *Enterprise Report Writing Guide*:

- ❑ *To create a level-break header* for additional information about level breaks
- ❑ *To associate a description with a level-break header* for additional information about adding a description field to a level-break header
- ❑ *To hide the level-break field in the detail section* for information about hiding the level-break field to prevent it from showing in both sections

## ► To total the number of business units per company

---

Printing lists of information might be more meaningful if the lists could be totaled to give critical information. For example, you might want to print out all business units and their descriptions for your companies and total the number of business units that exist for a specific company. Adding a level-break footer to a group or columnar section gives you this capability.

*In the J.D. Edwards Windows environment, choose Report Design Tool from the Reprot Writer menu (GH9111).*

1. On Report Design, open your existing report called Company/Business Units/Descriptions Listing.
2. Click the detail section to which you want to attach a level-break footer.
3. From the Section menu, choose Create, and then choose Level Break Footer.  
If the Level Break Footer selection is grayed out on the Section menu, you did not click the detail section.
4. On Level Break Footer, click the following options, and then click OK:
  - Group Section
5. On Level Break, choose the following option under the Show heading:
  - only existing sort columns  
This option displays the fields that you chose as your data sequencing fields when you created the detail section.
6. Choose the Company field to designate it as the level-break field.  
You can designate another field as a level-break field by modifying the section properties of the level-break footer.
7. Ensure that the *Display selected column as part of this section* option is turned off.
8. Click Next.

An *aggregate object* is one that holds the result of a calculation on the values in other fields. For example, you might want to know the total of business units for a specific company.

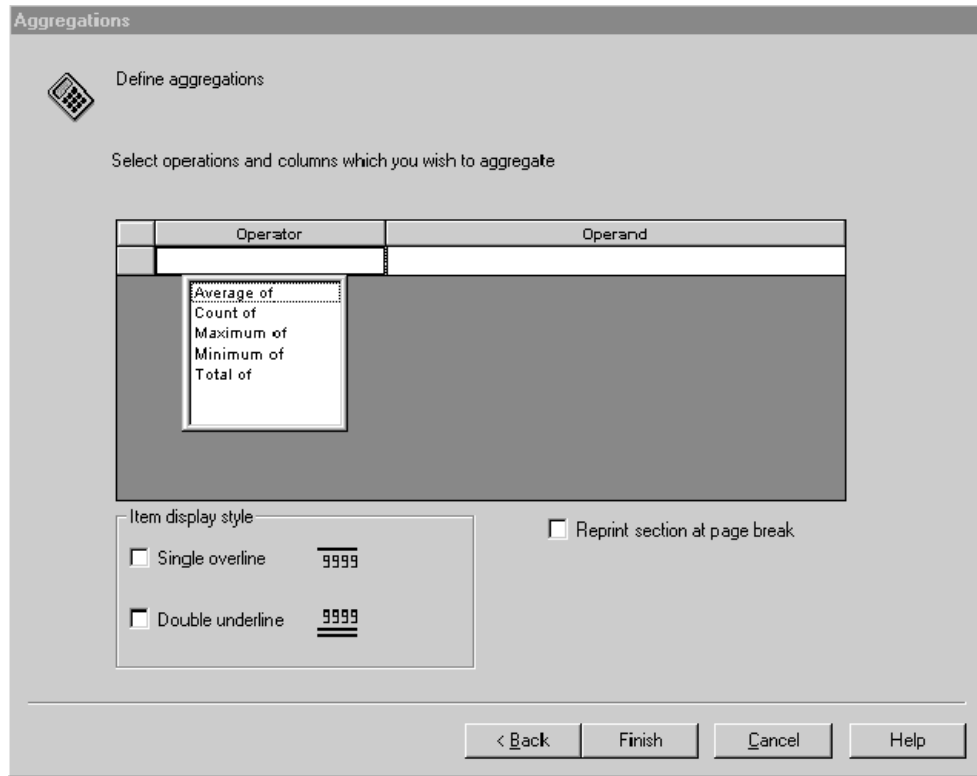

9. On Aggregations, choose the following option for the Operator:
  - Count of
10. Choose the following option for the Operand:
  - Business Unit
11. Click one of the following options under the Item display style heading:
  - Single overline
  - Double underline
12. Click *Reprint section at page break*, if necessary.
 

This option causes the last line from the previous page to be reprinted as the first line of the next page.
13. Click Finish.
 

At any time in the future, you can modify the aggregate object by clicking the level-break footer and choosing Add Aggregates from the Section menu.
14. Click the level-break footer section.
15. From the Insert menu, choose Constant Field.
16. Insert the constant field by clicking the level-break footer where you want the object to appear.
17. Double-click the constant field.
18. On Constant Properties, change the Name field to a meaningful description.

## See Also

- ❑ *To create a level-break footer in the Enterprise Report Writing Guide for additional information about adding a level-break footer to a report*
- ❑ *To insert a description into a level-break footer in the Enterprise Report Writing Guide for additional information about making a level-break footer more meaningful with a description*

## Printing Totals and Auditing Numeric Data

Suppose a report is needed to help put a new sales commission structure into place in your company. This report needs to show projected sales commissions to be paid on all current sales orders. The standard commission is 5% of the extended price. An additional 1% bonus is paid for high volume orders. The following example illustrates a report you could create with a tabular section to present totals and audit numeric data:

### ► To print totals and audit numeric data

---

*In the J.D. Edwards Windows environment, choose Report Design Tool from the Report Writer menu (GH9111).*

1. On Report Design, create a report object called Sales Order Detail.
2. Choose to create a tabular section.

Tabular sections provide automatic totaling for any field with a numeric value. If the total is meaningless, you might need to use the advanced options on a variable to suppress the totals. In addition to totaling, tabular sections let you drill into the application to view the source of any questionable data in your report.
3. Attach business view V4201C - Sales Order Header to Sales Order Detail - All.
4. Choose to include the following data fields on your report:
  - Description field (automatically added)

This field prints a description for each field selected as a level-break item.
  - Date - Order/Transaction
  - Quantity Shipped
  - Amount - Extended Price
5. Sequence the report on the following fields, and select these fields as level-break items:
  - Original Order Number
  - 2nd Item Number
6. Determine through data selection the records to appear on your report. For example, apply to each of the fields used for column selection the condition *greater than Zero*.
7. On Report Design, insert three Numeric Variables to the report to create columns to hold the calculations you are going to create.
8. Name the columns the following:
  - 5% Commission
  - High Volume 1% Bonus

- Total Commission
- Attach event rules to define 5% commission, High Volume 1% Bonus, and Total Commission.
  - Focus on the tabular report section for which you want to activate the drill down feature.
  - Do one of the following:
    - Double-click the report section.
    - From the Section menu, choose Section Properties.

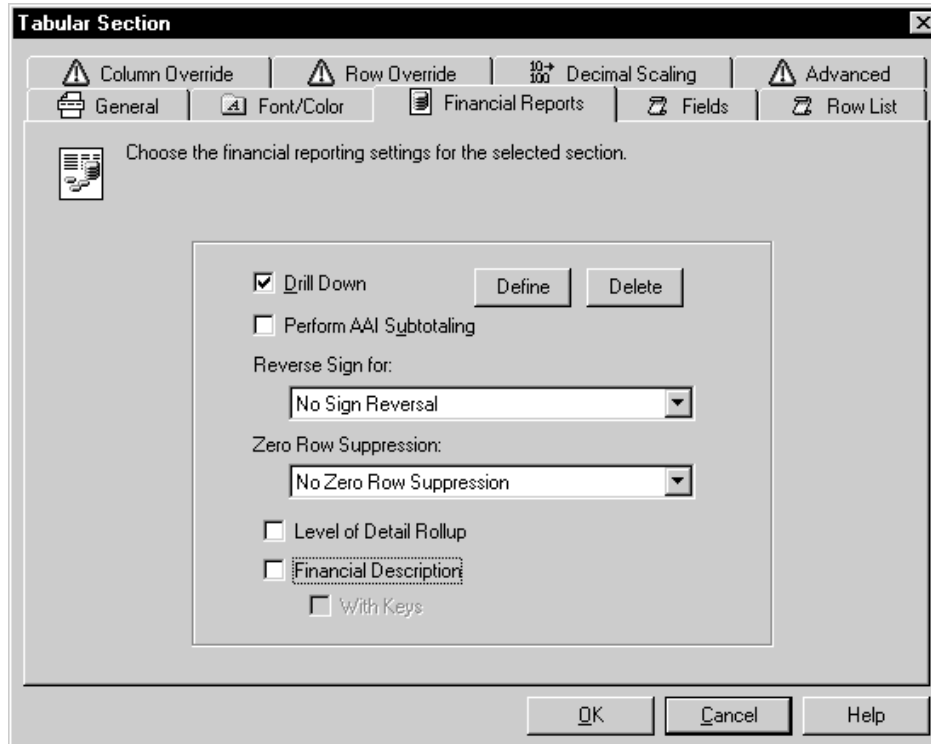

- On Tabular Section, click the Financial tab or the tab that relates to the director template, for example, Financial Reports.
- Click the following, and then click Define:
  - Drill Down
- On Work With Applications, click Find.
 

This form displays a list of all available applications. You can limit your search by entering search criteria in the QBE line.
- Choose an application, and then click Select.
 

Choose an application to be called from the report. This application is the one that you want to *drill* into to investigate balances. For this example, choose P4210 Sales Order Entry.
- On Work With Forms, choose a form, and then click Select.

Many J.D. Edwards software applications consist of multiple forms. Choose the form to open when you drill into the application. For this example, choose W4210A Sales Order Detail Revisions.

If versions for a given form and application exist, the Work With Versions form appears.

17. On Work With Versions, do one of the following:

- Choose a version, and then click Select.  
For this example, choose ZJDE0001 Sales Order Entry -SO Order Type.
- Click Close to avoid choosing a specific version.

18. On Form Interconnections, from the Available Objects column, double-click the object in the Available Objects list that you want to pass to the Value column.

The values to be passed are determined by the form you have specified in the drill down. If you access the form you will see what fields need to be populated to display data in the grid. These You need to include these values in your form interconnection data structure.

19. Click the Directional arrow until it toggles to the right arrow icon (indicating that the data flows from the source or report to the target or application) and then click OK.

20. On Tabular Section, click OK to return to the Report Design form.

21. On Report Design, sequence the report on the following fields:

- Company
- Business Unit

22. Determine through data selection the records to appear on your report. For example, if you want to display the business units for all companies less than Company 00050, your data selection would be *Where Company is less than or equal to 00050*.

23. On Report Design, format your report to enhance the appearance.

#### See Also

- *Reviewing an Audit Trail* in the *Enterprise Report Writing Guide* for information about viewing the detail about the data on the report

## Creating Journal Entries with Report Design

With Report Design, you can create a report that will create journal entries that can then be posted to the general ledger using the General Accounting system. For example, you might generate journal entries for budgeting purposes.

You can submit a version of your report in proof or final mode. Both modes produce a report. If applicable, Work Center error messages is created as well. In final mode, if no errors exist, the Account Ledger table (F0911) is created that can be posted to the general ledger. Prior to posting, these journal entries can be deleted through the General Accounting system, if necessary.

► **To create journal entries with Report Design**

---

*In the J.D. Edwards Windows environment, choose Report Design Tool from the Report Writer menu (GH9111).*

1. On Report Design, create a financial report to perform the required calculations; ensure that you create a version of the report.
2. Click the tabular section of the report; and from the Column menu, choose Create and then choose Smart Field.

If you have clicked one of the existing columns, the new smart field column appears to the right of that column. Otherwise, the new smart field column appears to the right of the last column in the report.

3. On Create New Smart Field, choose the data item FINRPTJE - Create Journal Entry and click Next.
4. On Smart Field Name, from the drop-down menu in the Select Report Variable field, select the column in the report upon which you want to base the journal entry on and then click Next.

The journal entry column must be based on another column. Because of this situation, the journal entry column is often hidden so that it does not appear on the report.

5. On Smart Field Parameters, enter your choices as appropriate and click Next to move to the next task. This director leads you through the steps required for setting up the smart field.

The report has two results that are based on the variable in the column you choose to be the balance column; the originating account is debited the balance amount, and the target account is credited the balance amount. For example, due to a clerk input error, you might want to transfer 100 U.S. dollars from the revenue account 61.5100 to the account 63.5100. The resulting journal entry would show values similar to the following:

<b>61.5100</b>	<b>63.5100</b>
100.00	0.00
100.00DB	
	100.00CR
0.00	100.00

6. On the final screen, click Finish.

Any values appearing on the Finish form have no effect on how the smart field functions.

The column you just created appears in the tabular section.

7. Save and close the report.

## ► To enter journal entry specifications

---

You must create journal entries with Report Design before you can enter your journal entry specifications.

*In the J.D. Edwards Windows environment, choose Report Versions from the Tools menu.*

1. On Work With Batch Versions - Available Versions, complete the following field with the report that you created and click Find:
  - Batch Application
2. Highlight the version for which you wish to enter journal entry specifications and select Processing Options from the Row menu.
3. Click the JE Creation tab.
4. Complete the following fields and click OK:
  - Report Journal Entry Creation Mode  
Both modes create a report and any applicable Work Center errors. In final mode, F0911 records are created if no errors are detected.
  - JE G/L Date  
This value can be different from the date that is used to base the report on.
  - Reverse Journal Entries
  - JE Document Type  
You should use a specific user-defined document type for Report Writer-created journal entries. In this way, journal entries created by Report Writer can be easily identified.
  - JE Name - Alpha Explanation
5. Submit the report either in proof or final mode.

When Report Writer creates journal entries, they must then be posted to the general journal using the General Accounting system. The journal entries can be deleted from the system before they are posted.
6. If you submit the report in final mode, you can examine the journal entries by checking the Report Writer JE Batches folder in your Workflow Center.

## **J.D. Edwards Reports**

---

J.D. Edwards provides many reports, including reports for:

- General Accounting
- HR and Payroll Foundation
- Inventory Management
- Product Data Management

You can use these reports as they are or you can modify them.

### **General Accounting**

The following lists the reports for the General Accounting system:

R00640 Supplemental Data by Data Type

R00650 Supplemental Data by Business Unit

R007011 Unposted Batches

R007021 Transactions To Batch Headers

R007031 Batch To Detail

R09130 Refresh Reconciliation File

R09301 General Journal by Batch Report

R093021 Indexed Comps Compute And Print Report

R093022 Variable Numerator Compute and Print

R09311 General Journal by Account

R09321 Transaction Journal

R09410 Trial Balance Report

R094121 Trial Balance By Object Report

R09415 Monetary Account Valuation

R09420 G/L by Business Unit

R09421 G/L by Object Account

R09470 General Ledger by Category Code

R09472 Debit/Credit T/B by Category Code

R097001 Companies in Balance

R097011 Intercompany Account Balance Integrity Report

R097021 Transaction w/o Account Master

R097031 Account Balance w/o Account Master

R09705 Compare Account Balances to Transactions

## **HR and Payroll Foundation**

The following lists the reports for the HR and Payroll Foundation systems:

R051450 Job Evaluation Factor Data

R05229 Payroll Journal Proof/Edit Proof

R053001 Time and Pay Entry Register

R058515 EE0-1 Report

R064011 Employee Roster

R064021 Employee Roster with Rate

R080400 Employee Report by Data Type

R080410 Employee Supplemental Data Report

R080423 Employee History Inquiry

R080424A Employee Salary History

R080430 Turnover Report

R080435 Workforce Analysis Report

## **Inventory Management**

The following lists the reports for the Inventory Management system:

R094121 Trial Balance By Object Account

R09421 G/L by Object Account

R41410A Print Cycle Count Sheets

R41411 Select Items for Count

R41510 Price Book

R4152 Buyers Guide

R41530 Stock Status

R41543 Item Ledger/Account Integrity

R41544 Item Balance/Ledger Integrity

R41560 Item Master Directory

R41580 Unit Cost Warnings

R41590 Inventory Valuation Analysis

R4164 ABC Analysis

R41700 Inventory Cost/Price Comparison

## Product Data Management

The following lists the reports for the Product Data Management system:

R30450 Kanban Size Calculation

R30460 Bill of Material Print

R30520 Where Used Bill of Material Update

## Smart Fields

---

Smart Fields are data dictionary items with attached business functions. The business functions include a named mapping that maps the source for each parameter of the business function data structure. This simplifies selecting a data item with particular capability. Instead of needing to know which business function to use and what parameters to pass, the user merely selects a data item that inherently has this information. Smart fields can be used for deriving column headings or to populate a value in a report section using the Report Design tool.

Smart fields are reusable objects that simplify using business functions in event rules. They are data dictionary items (group K) with business functions attached. The business function performs a specific task for the smart field such as a calculation.

For example, you can create a smart field to add sales values for period 1, period 2, and period 3 to calculate a First Quarter column in a report. This calculation will be performed by the business function for each row of data fetched into the report. Every time you use this smart field, it will perform this calculation. Report Design uses the smart field to do the calculation automatically.

With the use of this smart field, you will require only one column in your report that displays First Quarter sales. Without this smart field, your report would require four columns: one for each period and a quarterly amount column for the total. Additionally, you would need to write an event rule to add each period to populate the quarterly amount column. If you wanted to display a total for each quarter, you would need to write four event rules.

Smart fields can be created for any detail section. Each business function can be placed on any event that is valid at that point. In addition to defining the smart field, you must also define a column heading and data selection.

When the appropriate smart fields exist, you can create a smart field template to organize your smart fields. For example, existing J.D. Edwards' smart field templates are organized by usage in Financial Reports, Fixed Assets, and 52Period Accounting.

After the smart field is organized into an appropriate smart field template, a configurable director is created for all smart fields located in that template. You can use the configurable director to define report processing options, business views, and even the drill down feature in a tabular reporting section. Information included in this configurable director leads the report creator through the process of creating a report using this group of associated smart fields. The smart field template and configurable director allow you to organize and present your smart fields for ease of use in Report Design.

This topic uses the Quarter scenario described above to demonstrate how to create the following:

- Smart field
- Smart field template
- Report director template
- New report using smart fields

The result is an application report you can use in Report Design to create a report with quarterly total columns.

## Creating a Smart Field

The first step in making a smart field available to a user through the Director is to create the smart field. This topic demonstrates creating a smart field that will total sales values for period 1, period 2, and period 3 to calculate a First Quarter column in a report. The smart field will be named Quarterly Amount.

The basic components of a smart field are:

- A data dictionary item (user prompt)
- A data structure
- A named mapping
- A business function or named event rule
- A smart field data item

## Creating the Data Dictionary Item

The first component required for a smart field is a data dictionary item to be used as a user prompt. This item must be a standard data dictionary item using a D glossary group. This data item serves as a prompt for the report creator. When using the Quarterly Amount smart field, the report creator will be prompted for a value, which will represent the quarter for which sales totals should be displayed.

Therefore, if the report creator wanted to show a column for the first quarter, the smart field would then add period 1, period 2, and period 3 sales to display a total for the first quarter. If the report creator added a second sales column and chooses to use the Quarterly Amount smart field again for the second quarter, the smart field would then add period 4, period 5, and period 6 sales together to display a total for the second quarter.

This data dictionary item prompts the user for a value while creating the report with the Director. The form used to prompt the user in Report Design is called Smart Field Parameters. The name of the prompt appears on this form as well as in the help entered in the glossary.

When you create or copy and modify a data item to be used as a user prompt, be sure to enter the glossary text. The text should explain the purpose of the data item and will appear on the Smart Field Parameters form in Report Design. This text assists the user in determining which value to enter in the user prompt.

► **To create the data dictionary item**

---

*In the J.D. Edwards Windows environment, choose Object Management Workbench from the Cross Application Development Tools menu (GH902).*

1. On Object Management Workbench, highlight the project in which you wish to add the new data dictionary item and click Add.
2. On Add J.D. Edwards Object to the Project, select Data Item and click OK.
3. On Data Dictionary Item Type, click No.
4. On Data Item Specifications, complete the following fields with the indicated values:
  - Data Item  
QuarterlyAmount
  - Alias  
QUAMT
  - Glossary Group  
D
  - Description  
Quarterly Amount
  - Product Code  
55
  - Data Type  
9
  - Size  
1
  - Display Decimals  
0
  - Control Type  
4
  - Row Description  
Quarterly Amount
  - Column Title  
Top field: Quarterly  
Bottom field: Amount

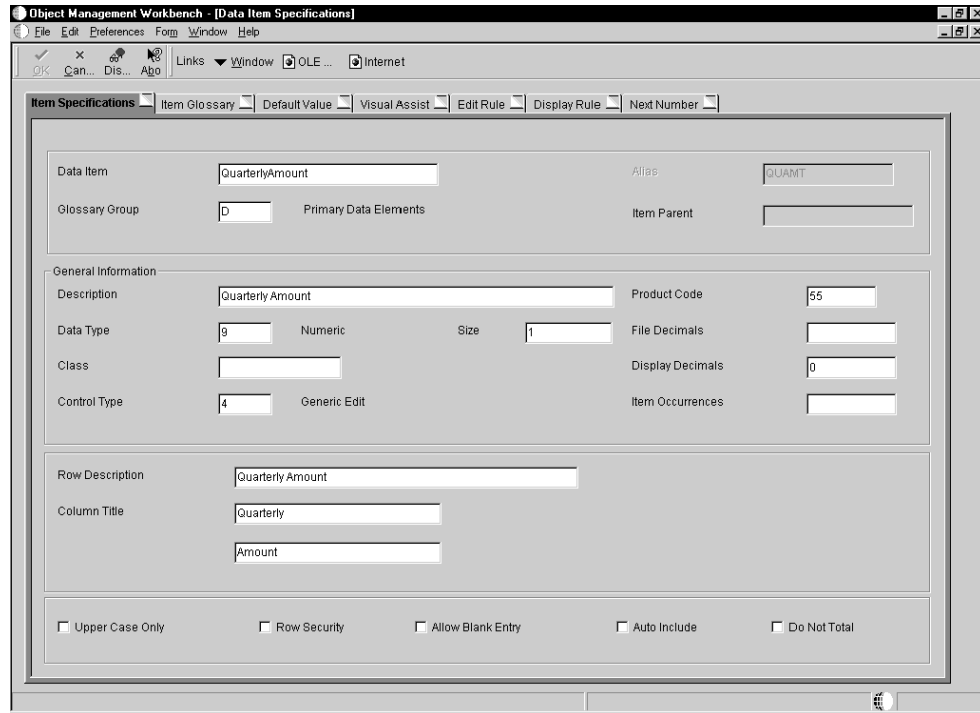

5. Click the Item Glossary tab and enter the following four text lines:  
Enter a 1 to display a total for first quarter data.  
  
Enter a 2 to display a total for second quarter data.  
  
Enter a 3 to display a total for third quarter data.  
  
Enter a 4 to display a total for fourth quarter data.

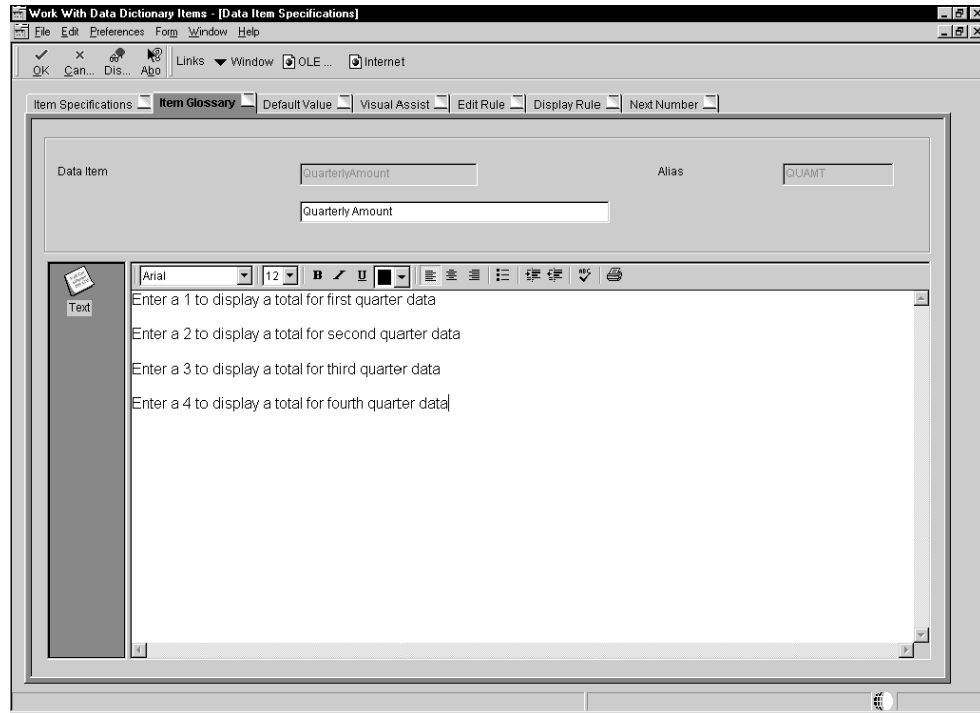

This text appears on the Smart Field Parameters form in Report Design to tell the report creator what the valid input values are.

6. Click OK.

### See Also

- ❑ *Defining a Data Item* in the *Development Tools Guide* for detailed instructions on creating a data item

## Defining the Data Structure

The second component required for a smart field is a data structure. A data structure is a list of parameters used to pass values between your report and the database tables, and it contains all data items required to complete the function of the smart field. The Quarterly Amount smart field requires twelve periods for use in calculating each quarter. It also requires a return value to hold the value that the smart field calculates for each quarter. Each of these data items must be added to the data structure for the smart field.

All data items added to this data structure must reside in the same business view. If you find that you need to add data items that are not included in single business view, you will need to create a business view with all of the required data items.

### See Also

- ❑ *Business View Design* in the *Development Tools Guide* for information about creating business views
- ❑ *Data Structures* in the *Development Tools Guide* for detailed information about creating data structures

► **To define the data structure**

*In the J.D. Edwards Windows environment, choose Object Management Workbench from the Cross Application Development Tools menu (GH902).*

1. On Object Management Workbench, highlight the project in which you wish to define the data structure and click Add.
2. On Add J.D. Edwards Object to the Project, select Data Structure, and then click OK.
3. On Add Object, create a new regular data structure named D55830001, and then click OK.
4. On Data Structure Design, on the Design Tools tab, click Data Structure Design.
5. In the Dictionary Item section of the data structure design tool, search for the data dictionary item QuarterlyAmount.
6. Drag the data dictionary item QuarterlyAmount to the left, and then rename the Structure Member Name to cQuarterlyAmount.
7. Make cQuarterlyAmount a required field and place a right-pointing arrow in its Input/Output column.
8. Search for the dictionary item AmountNetPosting\*.  
You must use the asterisk.
9. Drag the dictionary item AmountNetPosting001 to the left, and then rename the Structure Member Name to mnQuarterlyAmount.
10. Place a left-pointing arrow in the Input/Output column.
11. Drag the dictionary items AmountNetPosting001 through AmountNetPosting012 to the left and place a right-pointing arrow in the Input/Output column for each item.

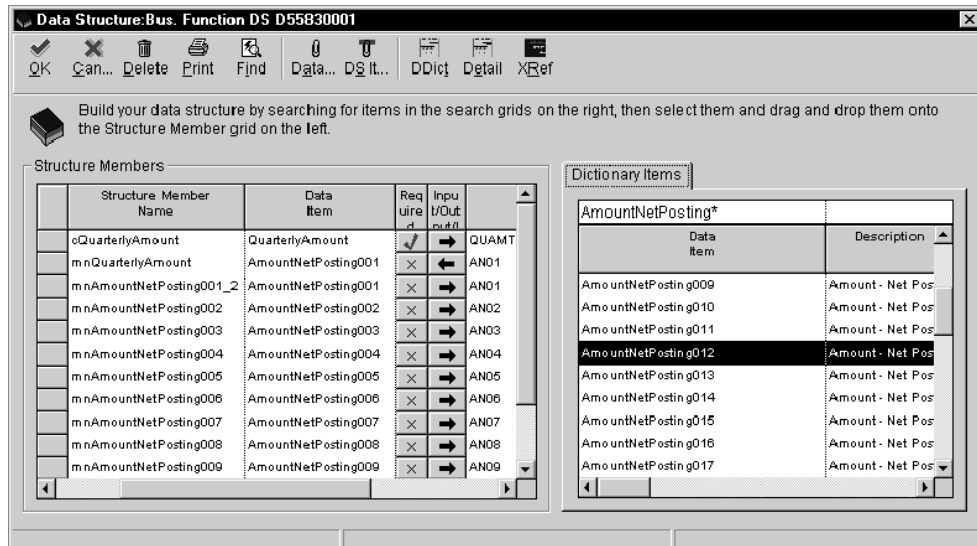

The Required field displays a check mark, which is the user prompt, for the Quarterly Amount data item.

Two AmountNetPosting001 data items are posted. The Structure Member Name has been changed on the first AmountNetPosting001 so that this data item can be used as the return value to hold the Quarterly Amount after it is calculated. The remaining AmountNetPosting data items represent each of the twelve months or periods needed to calculate each quarterly sales figure.

12. Click OK.

## Defining Named Mapping

The named mapping is a part of the data structure and is used only for smart fields. The named mapping defines each of the data items included in the data structure. It can also hold default values to be used for the business function so that the values do not need to be passed in the Report Design Tool.

The named mapping is used to map the source for each parameter (or data item) of the data structure. For example, source values are determined for the prompts, tables, and return values. Data structure data items can originate from one of several sources:

<b>Literal</b>	A literal is used to assign a specific value to the data item. If your calculation will need to use a tax rate for instance, enter the tax rate, in the value field.
<b>Prompt</b>	Specify the data item to be used as the prompt. In our example the Quarterly Amount data item is the prompt. In Report Design, the report creator will be prompted to enter the quarter to calculate for the report.
<b>Table</b>	Specify the data items that originate from a table. Browse to locate the table name and associate the data item in the data structure with a data item from the table.
<b>Data Dictionary Item</b>	Use this option if you will need to pass values from a processing option into your data structure. Some values used in smart fields might be known to a business function without requiring user input. For example, the desired fiscal year or period might already be specified in a processing option that can be passed into the data structure. If this is the case, the data item needs to be defined as a data dictionary item and a processing option in the named mapping.
<b>System Value</b>	Associate system value as the origin of the data item and browse for the appropriate system value. These system values, such as system date, are used throughout the system. System values are fetched from the F98VAR table.

### ► To define named mapping

---

*Immediately after creating a data structure, the Data Structure Design form appears.*

1. Double-click Named Mapping from the Design Tools tab.
2. On Named Mapping, click Add and add the Quarter scenario's data structure (M5583001) to the Named Mapping List.
3. Choose cQuarterlyAmount and click the Prompt option under Origin Types.

In the Quarter scenario's named mapping, the first data item in the data structure, Quarterly Amount, is a user prompt. In the named mapping, it must be defined as a prompt by performing this step. The user prompt should have been set as a required item in the actual data structure.

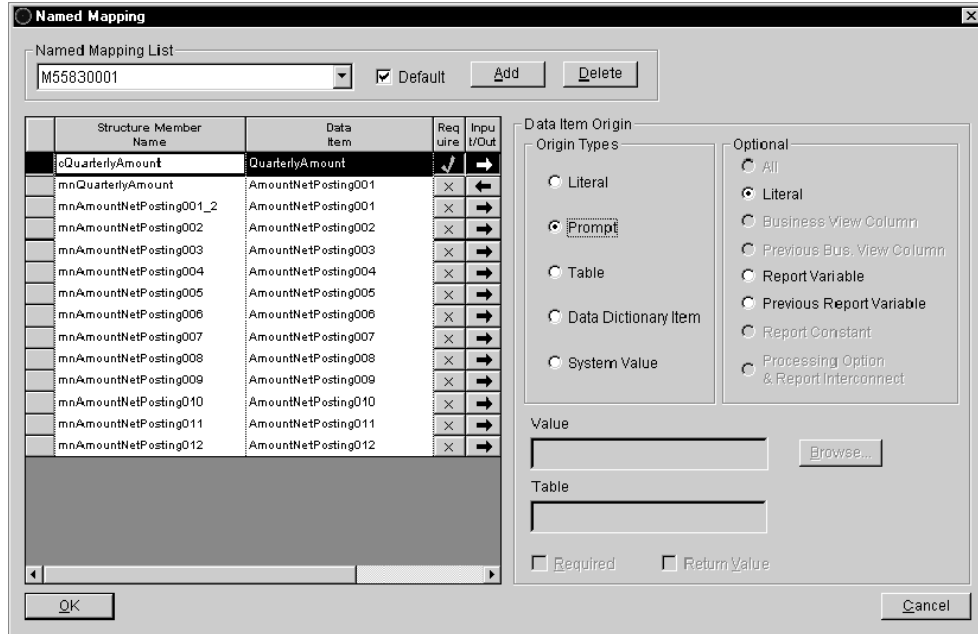

- Choose mnQuarterlyAmount and indicate that it is a returned value by clicking the Return Value field.

#### Note

The Required field is chosen automatically. You cannot inactivate the Required field for a Return Value.

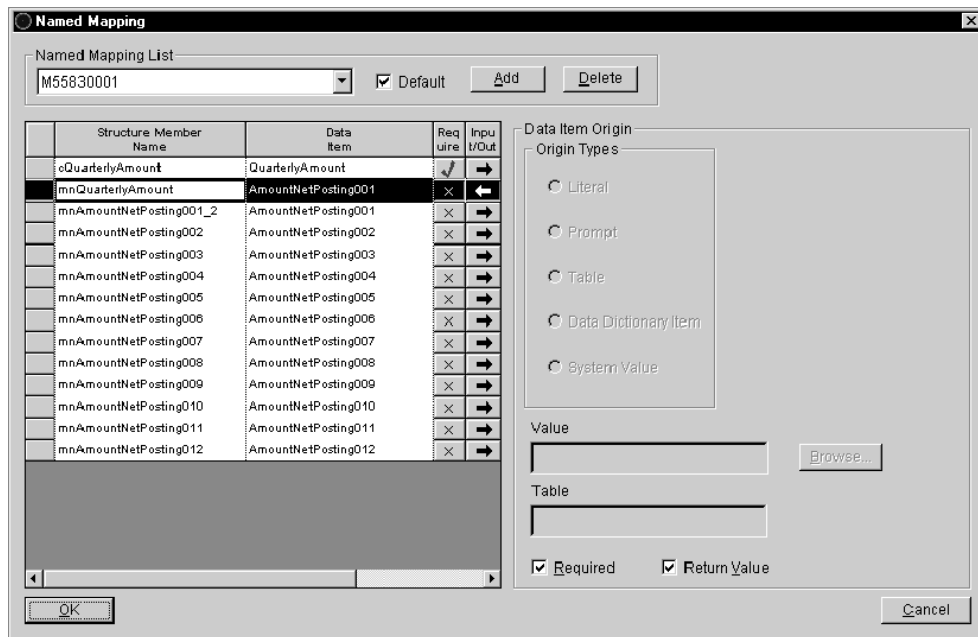

5. Choose mnAmountNetPosting001\_2 and click the Required field.
6. Define mnAmountNetPosting001\_2 as originating from a table by choosing the data item and then clicking the Table option under Origin Types.
7. Click Browse to bring up the Select a Table form.
8. Choose table F0902 and click Next.  
 This action indicates the table where the data item can be located. The last twelve data items in the Quarter scenario reside in table F0902.
9. Choose AmountNetPosting001 and click Finish.

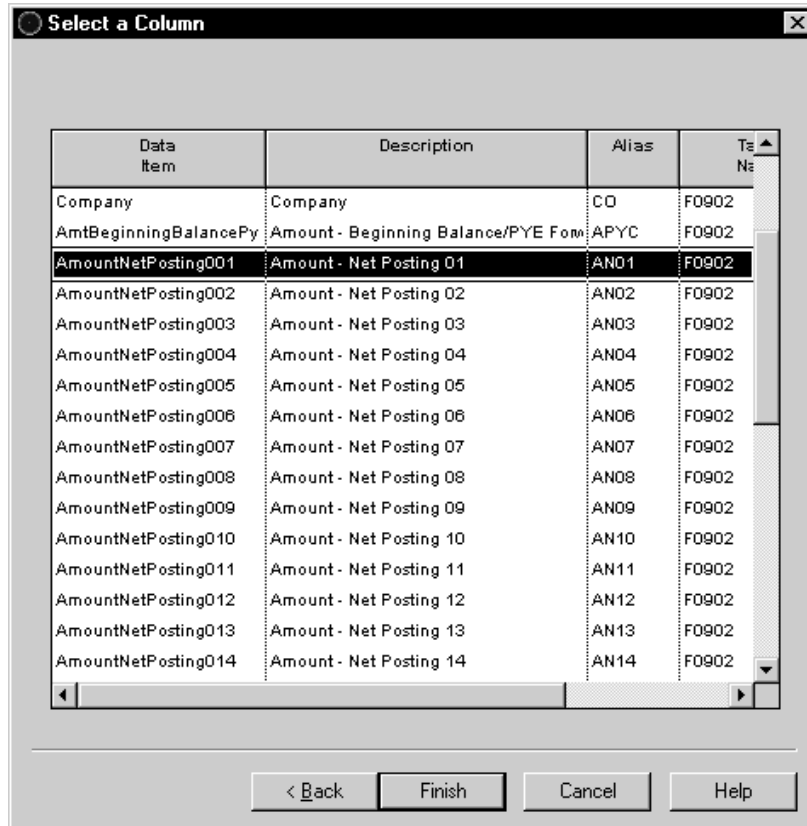

On Select a Column, you indicate which data item in the table will be the basis for the data item in the data structure. These data items must be defined as required by clicking the Required field.

10. Repeat steps 5-8 for the remaining 11 data items, mapping structure item mnAmountNetPosting002 to table item AmountNetPosting002, structure item mnAmountNetPosting003 to table item AmountNetPosting003, and so forth.

---

**Hint**

If you position the Select a Column form as shown below, you can reference which data item with which you are currently working.

---

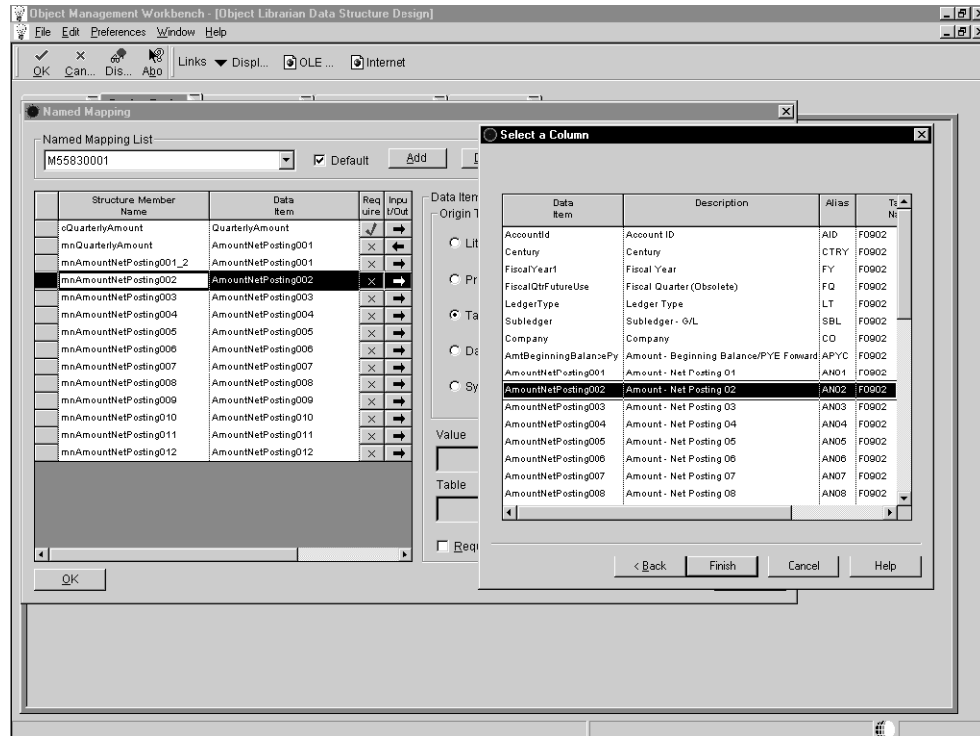

## Performing Calculations with Business Functions and Named Event Rules

You can use either a business function or a named event rule to set up the criteria for the smart field. Business functions are written in C language, while named event rules are written in scripting language using the J.D. Edwards software toolset.

The advantage of using a business function or named event rule is that they are reusable. The code is written once and can be used in multiple events and reports. In the Quarter scenario, without the named event rule, you would require four columns in your report: one column for each period, and a total column for the quarterly amount. You would then need to write an event rule to add each period to populate the quarterly amount column. If you need to display a total for each quarter you would need to write four different event rules. Instead, with the use of the named event rule, you can write the criteria once and reuse it for each of the four columns displaying quarterly amounts. This same named event rule can be used in other reports as well.

The next step in the Quarter scenario is to create a named event rule to perform the smart field's calculations. When a named event rule is created, a data structure is associated with it. For the Quarter scenario, you need to associate the Quarterly Amount data structure to this named event rule.

► **To perform calculations with a named event rule**

---

*In the J.D. Edwards Windows environment, choose Object Management Workbench from the Cross Application Development Tools menu (GH902).*

1. On Object Management Workbench, highlight the project to which you wish to add the named event rule and click Add.
2. On Add J.D. Edwards Object to the Project, select Business Function and click OK.
3. On Add Object, complete the following fields, select NER, and click OK.
  - Object Name
  - Description
  - Product Code
  - Product System Code
  - Object Use
4. On the Design Tools tab of the Business Function Design form, click Start Business Function Design Aid.
5. Create a function called QuarterlyAmount and associate the Quarterly Amount data structure with it.

QuarterlyAmount will become the name of the event rule.
6. Edit the function and enter the event rule as discussed below.

In the Quarter scenario, the named event rule will perform the following calculation to accumulate quarterly amounts:

```
Sales for Period 1 + Sales for Period 2 + Sales for Period 3
```

One item to define in the named event rule is what to do with the value that the user inputs. For example, if a user inputs a 1 in the user prompt, the user expects to see sales totals for the first quarter. Therefore, the named event rule must set up an If/While statement to that effect. An If statement will be added to the named event rule as follows:

```
If <user prompt> is equal to a 1
    Sales for Period 1 + Sales for Period 2 + Sales for Period 3
Else
```

Related information for each option for displaying data needs to be available to the user. Therefore, the following information must be included in the named event rule as well:

```
If <user prompt> is equal to a 2
    Sales for Period 4 + Sales for Period 5 + Sales for Period 6
Else
If <user prompt> is equal to a 3
```

```

Sales for Period 7 + Sales for Period 8 + Sales for Period 9
Else
If <user prompt> is equal to a 4
Sales for Period 10 + Sales for Period 11 + Sales for Period 12
End If
End If
End If
End If

```

When you are finished typing it, the event rule should appear as follows:

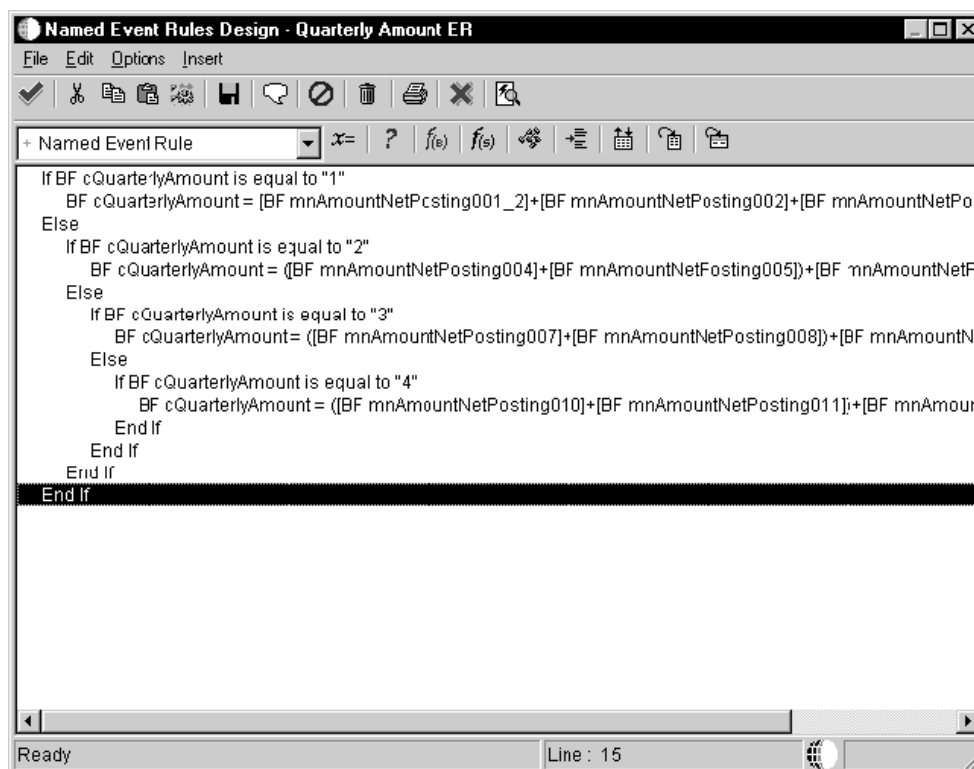

7. Save the event rule and click OK.
8. On Object Librarian Business Function Design, click the Design Tools tab, and then click Build Business Function.

### See Also

- ❑ *Business Functions* in the *Development Tools Guide*
- ❑ *Creating Business Function Event Rules* in the *Development Tools Guide* for detailed information about creating business functions and named event rules

## Creating a Data Dictionary Smart Field Item

The last component required for a smart field is a data dictionary smart field item. This data item defines the business function or named event rule and named mapping associated with the smart field. Smart field data dictionary items and any other data dictionary item differ in two ways: glossary group K and information in the Smart Field tab.

### Before You Begin

- Check in the data structure before creating the smart field data dictionary item so that the system can locate the named mapping.

### ► To create the data dictionary smart field item

---

*In the J.D. Edwards Windows environment, choose Object Management Workbench from the Cross Application Development Tools menu (GH902).*

1. On Object Management Workbench, highlight the project in which you wish to add the new data dictionary item and click Add.
2. On Add J.D. Edwards Object to the Project, select Data Item and click OK.
3. On Data Item Type, click No.
4. On Data Item Specifications, complete the following fields with the indicated values:
  - Data Item  
QuarterlySales
  - Alias  
QSALES
  - Glossary Group  
K
  - Description  
Quarterly Sales
  - Product Code  
55
  - Data Type  
9
  - Size  
15
  - Class  
CURRENCY
  - Display Decimals  
2

- Control Type  
4
- Row Description  
Quarterly Sales
- Column Title  
Top field: Quarterly  
Bottom field: Sales

The screenshot shows the 'Data Item Specifications' window in Object Management Workbench. The window title is 'Object Management Workbench - [Data Item Specifications]'. The menu bar includes File, Edit, Preferences, Form, Window, and Help. The toolbar has buttons for OK, Cancel, Dis..., and Abort. The main area is divided into several sections:

- Item Specifications:** Data Item: QuarterlySales, Alias: QSALES, Glossary Group: K, Smart Fields, Item Parent.
- General Information:** Description: Quarterly Sales, Product Code: 55, Data Type: 9 Numeric, Size: 15, File Decimals, Class: CURRENCY, Display Decimals: 2, Control Type: 4 Generic Edit, Item Occurrences.
- Row Description:** Row Description: Quarterly Sales, Column Title: Quarterly, Sales.
- Options:** Upper Case Only, Row Security, Allow Blank Entry, Auto Include, Do Not Total.

5. From the Form menu, select Smart Field to launch the Smart Field Criteria form.
6. Associate the QuarterlyAmount business function (the named event rule that you created in the last topic) with the smart field.
7. In the Event Name column, indicate from which event the smart field can be called.  
The Quarterly Amount smart field in the Quarter scenario will probably be used in financial reporting, which generally uses a tabular section. Therefore, the column inclusion event is a good choice for this smart field.
8. In the Named Mapping column, associate the named mapping you set up earlier with the smart field.  
The last step on this form is to associate the named mapping that this smart field will use.
9. As you did with the user prompt data dictionary item, enter help text using the Item Glossary tab for this smart field data item.

## See Also

- ❑ *Defining a Data Item* in the *Development Tools Guide* for detailed instructions about creating data items

## Creating a Smart Field Template

The smart field template is used to group smart fields that will be included in a single configurable director that prompts the report creator for data. Because you will define a business view and other reporting and processing components in this configurable director, the smart fields in a given template must be alike. For example: the Financial Report smart fields included in smart field template S09001 all use the same business view, processing options, and data sequencing and use the same configurable director.

### ► To create a smart field template

*From the Advanced Report Setup menu (GH9141), choose Smart Fields Templates.*

1. On Work With Smart Field Templates, click Add.
2. On Smart Field Template Revisions, complete the following fields:
  - Smart Field Template  
Type S55830001 in the Smart Field Template field.
  - Description  
Type Quarterly Smart Fields in the Description field.
3. Type QSALES in the following field and then click OK.
  - Data Item

The screenshot shows a dialog box titled "Smart Field Templates - [Smart Field Template Revisions]". The "Smart Field Template" field contains the text "S55830001" and the "Description" field contains "Quarterly Smart Fields". Below these fields is a table with two columns: "Data Item" and "Description". The table contains one row with "QSALES" in the "Data Item" column and "Quarterly Sales" in the "Description" column.

Data Item	Description
QSALES	Quarterly Sales

4. On Smart Field Template Criteria Revisions, indicate smart field data selection prompts by typing the following three data items in the Data Item field:
  - Fiscal Year (FY)
  - Ledger Type (LT)
  - Object Account (OBJ)

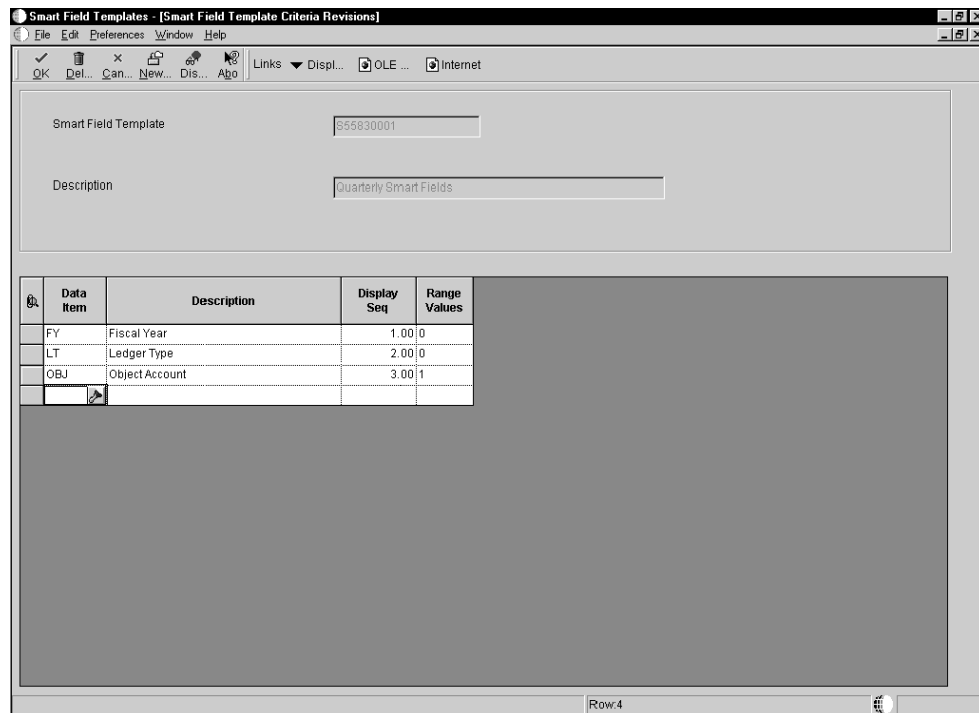

In the Quarter scenario, the report creator must be prompted to enter values for Fiscal Year, Ledger Type, and Object Account. Since Fiscal Year and Ledger Type do not require a range of values, the Range Values field can be set to 0. However, Object Account may include a range of accounts, so the Range Values Field must be set to 1.

The system prompts the report creator for these three values in the sequence shown via Smart Field Data Selection forms.

---

**Note**

Pre-determined data selection can be overridden in Report Design.

---

5. Click OK to save your changes.

**See Also**

- *Working with Smart Field Templates* in the *Enterprise Report Writing Guide* for more information about creating smart field templates

## Creating a Report Director Template

The report director template is used to create a director that leads the report creator through the steps of using the smart field. This director is similar to the Director that you use when creating a simple columnar or group report template.

### ► To create a Report Director template

---

*From the Advanced Report Setup menu (GH9141), choose Report Director Templates.*

1. On Work With Report Director Templates, click Add.
2. On Report Director Templates Revisions, complete the following fields:
  - Report Template/Description  
Type S55830001 in the template field and type Quarterly Smart Fields in the description field.

The J.D. Edwards naming convention is for the report director template to share the same name as the smart field template. This report director name appears in the Application Report drop-down list on the Report Design Director's Welcome form when creating the report in Report Design. The description appears on the Business View Selection Options form when creating a report template.

3. On the Building Blocks tab, type 46 in the following field to instruct the director that this smart field will be used in a tabular section:

- Section Type

Although you can use any detail section when setting up a report director template, the Quarter scenario uses a tabular section.

4. Type V8300001 in the following field:

- Business View

The business view you select must include all of the data items used in the data structure associated with the smart field. It is this business view that is used when the report creator selects the option, *I'll use the pre-defined business view* when using the Director in Report Design.

5. Type S55830001 in the following field:

- Smart Field Template

6. Add the following data items in the Default Sequence and Level Breaks grid:

- Company (CO)
- Business Unit (MCU)
- Object Account (OBJ)

The data items on this grid appear on the Director's Data Sequencing Help form. The first two data items entered in this grid are used as Level Break fields when using a tabular section. The remaining fields are used to sequence the data in the report. These choices can be overridden.

The Quarter scenario report template uses Company, Business Unit, and Object Account to sequence the data. Company and Business Unit are the level breaks.

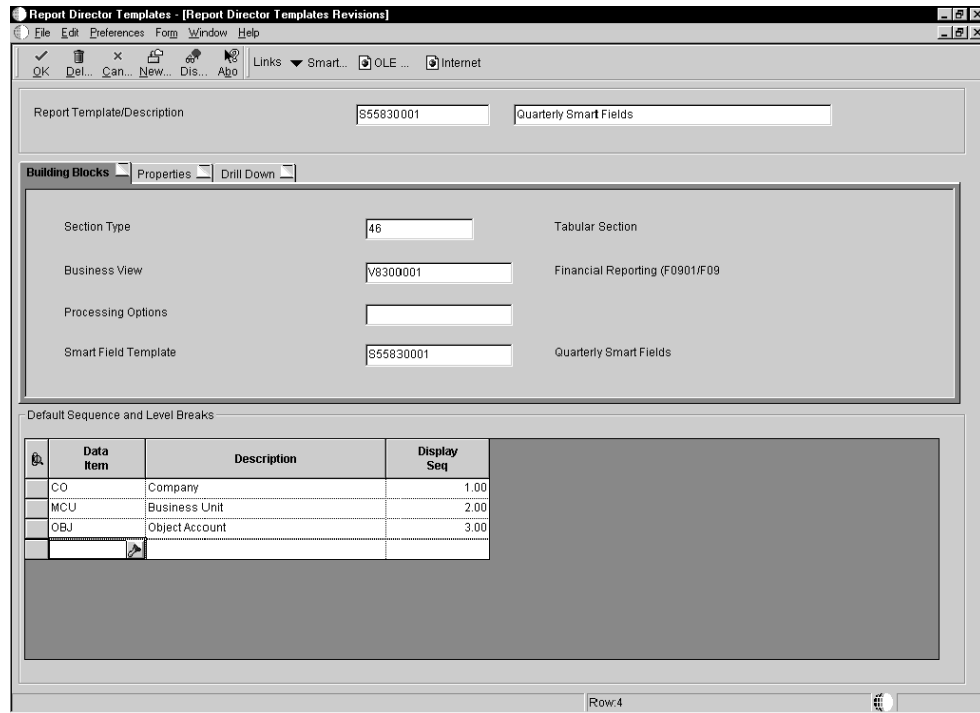

7. Click the Properties tab and select the following options:

- Use Financial Description
- Display Level of Detail
- Display Adjust Sign
- Display Suppress Zero Rows
- Display Financial Criteria

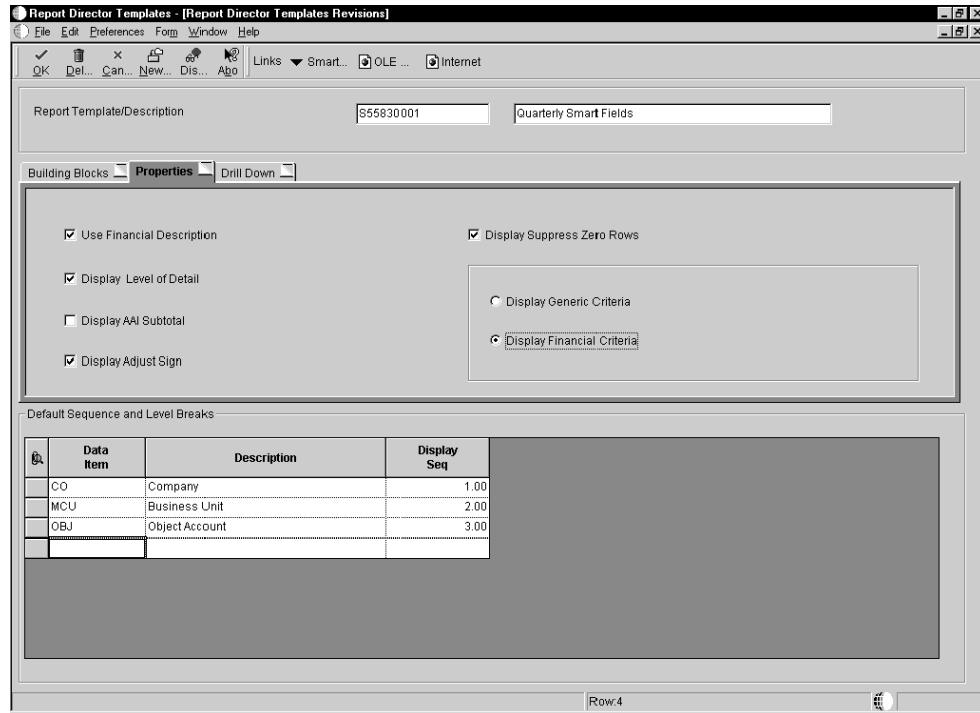

Many of these choices are specific to financial reporting. Even if you are creating a financial report director template, you might not want the report creator to have some of these options available to them. If you turn off the Display Level of Detail, for example, the report creator will be unable to choose that option when moving through the Director. The option in the section properties will be grayed out as well. Therefore, the report creator will be unable to control the level of detail in the report.

This tab is only available with a tabular section.

8. Click the Drill Down tab and choose the following option:
  - Drill Down
9. On Work With Applications, type P83001 in the Object Name field, click Find, and then click Select.
10. On Work With Forms, choose the W83001A form name and click Select.
11. On Work With Versions, choose the XJDE0001 version and click Select.

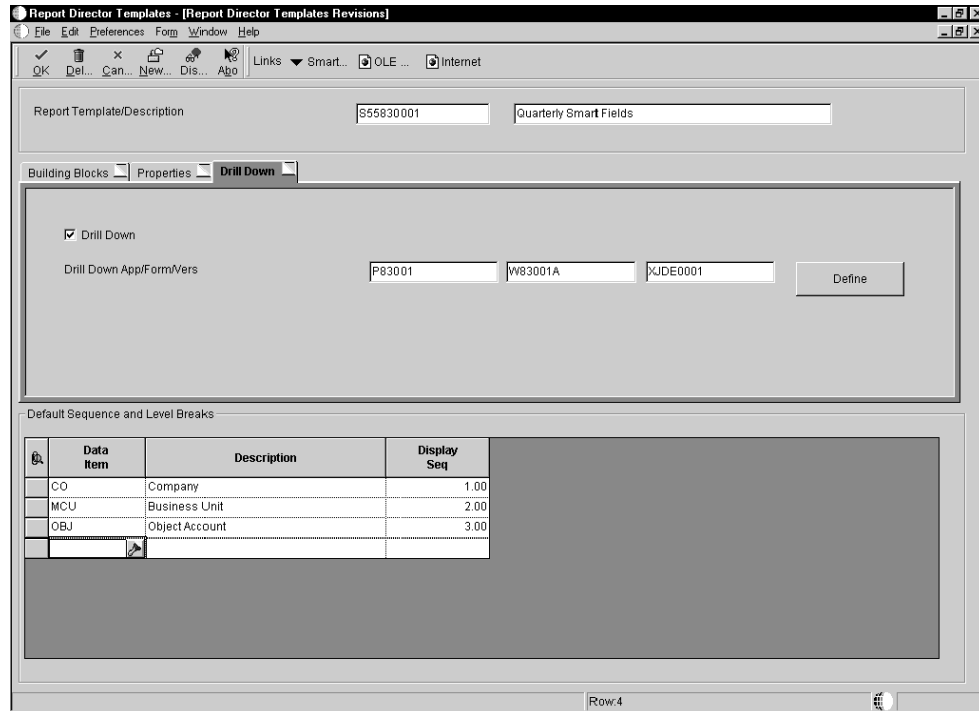

Remember that the drill down feature takes time and resources to process. The report creator is not required to enable drill down when creating the report. If drill down is requested, however, these settings become the default drill down values.

The Define button leads you through search and select forms to complete your application, form, and version choices. The actual form interconnect mapping must be accomplished when creating the report template itself.

This tab is only available in conjunction with a tabular section.

12. On Report Director Templates Revisions, click OK.

### See Also

- ❑ *Working with Smart Field Templates* in the *Enterprise Report Writing Guide* for more information about creating smart field templates
- ❑ *Working with the Drill Down Feature* in the *Enterprise Report Writing Guide* for more information about using drill down

## Creating a New Report Using Smart Fields

As the final step in this process, you should test the template. For this example, it is useful to look at how the Director displays all the information to the report creator so that you can see precisely from where the data originates and how the choices you made when setting up all of the objects to this point affect what the report creator sees.

### ► To create a new report using smart fields

---

*In the J.D. Edwards Windows environment, choose Report Design Tool from the Report Writer menu (GH9111).*

1. On Create New Report, complete the following fields and click OK:
  - Report Name
  - Description
  - Product Code



2. On Report Director, click Application Reports, choose Quarterly Smart Fields from the pull-down menu, and click Next.

The last item in the list is the Quarterly Smart Fields report director template you created. The name comes from the description you entered when you created the report director template.

3. On Page Header Details, accept the page header defaults and click Next.

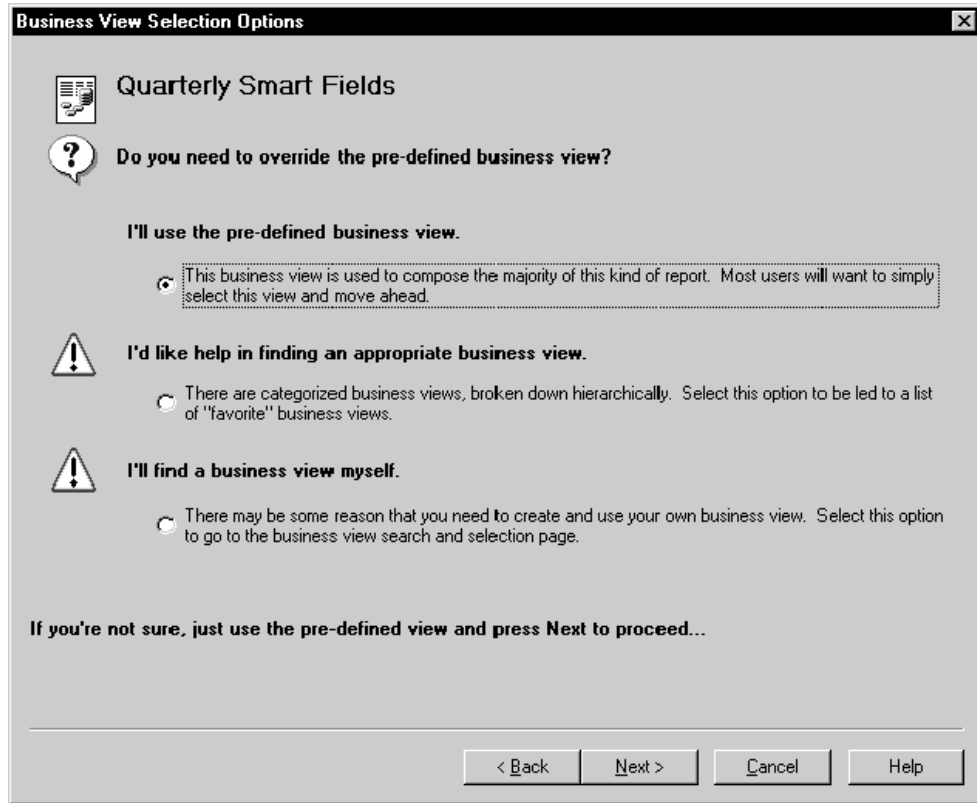

4. On Business View Selection Options, accept the pre-defined business view and click Next.

The name of the report director template that you created appears at the top of the Business View Selection Options form.

Displayed are three options for choosing a business view, one of which is to use the pre-defined business view, which is the business view V830001 that you entered on the Building Blocks tab of the report director template. It is set as the default but you can choose one of the other two options to override this default.

If the report creator accepts the pre-defined business view, the Director uses the business view V830001 that you indicated when you created the report director template. Of course, the report creator can select a different business view.

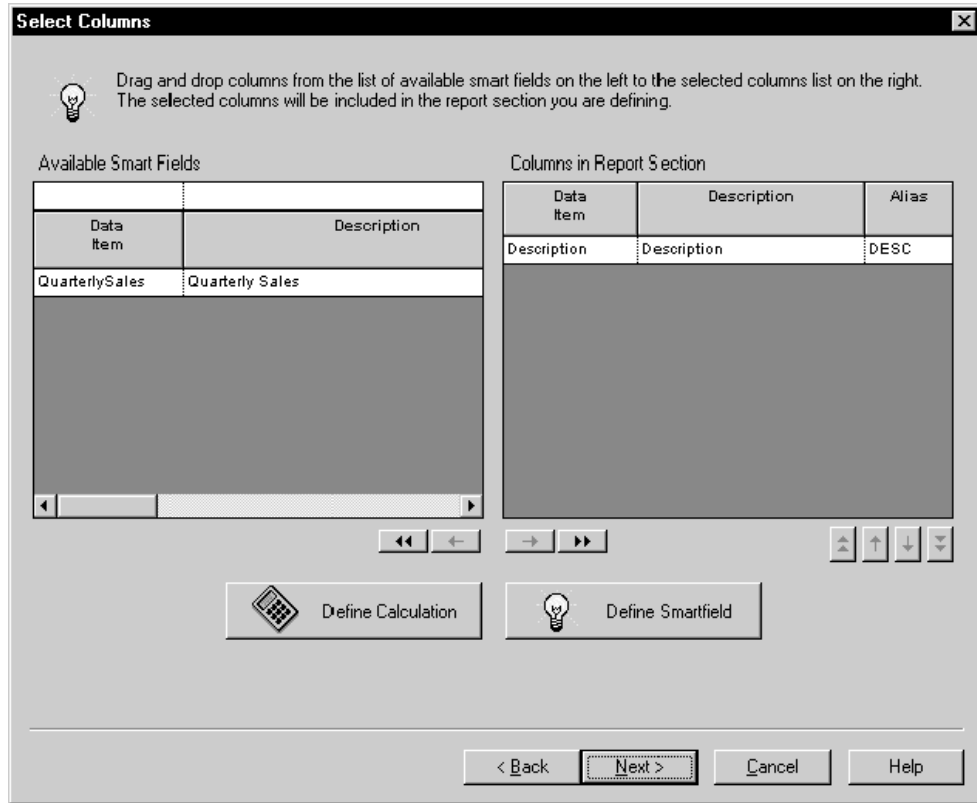

5. On Select Columns, drag the QuarterlySales smart field from the Available Smart Fields section to the Columns in Report Section.

This list comes from the smart field template you associated with the report director template. QuarterlySales is the name of the smart field that you created and associated with the template. Because you created only the one smart field, Quarterly Sales is the only smart field displayed.

The smart field director launches and displays a set of forms beginning with the Smart Field Name form.

6. Change the Variable Name field to First Quarter Sales and the first Report Column Headings field to First Quarter.

You set the default variable name and the names of the column when you created the smart field.

The Smart Field Parameters form appears, prompting you to enter the quarter for the column.

7. Enter a 1 in the field and click Next.

This prompt exists because of the data dictionary item QuarterlyAmount that you created. This is the data dictionary item created as a user prompt for the first component of this smart field. Furthermore, notice the item glossary text you entered when you created the data dictionary item appears here to tell the report creator what the applicable values are.

8. On Smart Field Data Selection, to display results for the year 2005 with a ledger type of actual amounts of the two accounts that hold sales data (Sales - Product Class 1 and Sales Product Class 2), type 05 in the Fiscal Year field, type AA in the Ledger Type field, type 5100 in the Object Account: From field, and type 5200 in the Object Account: To field.
9. Click Finish.

The items on this form come from the Smart Field Template where you attached the smart field data dictionary item and defined the data selection fields. In the smart field template you can include up to five data items. Object Account was set up as a range of values, so it takes up the space of two data items on this form.

An alternate way to use this smart field is to show trend information. For example, instead of having four columns, in your report each representing a quarter of the current year, you could have four columns where each column represents the first quarter of four consecutive years in order.

---

**Note**

If you intend to have the same data selection on each smart field column, you can leave this form blank and just fill in the data selection for the entire report.

---

Defining data selection for the columns might be unnecessary. For an income statement, if you set up only one smart field column, or if all of the smart field columns of this type use the same data selection (such as when you display a column for each quarter for the same year, ledger type, and account), it is more efficient to leave data selection blank at this point and then define data selection for the entire report later on.

The Select Columns form reappears. You can add additional Quarterly Sales columns to the report by repeating steps 6 through 8 for each new smart field column.

10. When finished adding columns to the report, click Next.

**Data Sequencing Help**

We'd like to help you sequence your report...

The grouping that you choose for your report determines what is output.

**Report Grouping**

Company  
Select the primary grouping

Business Unit  
You may want to specify a secondary grouping

**Report Detail**

Object Account

**Advanced**

I'd like to setup the sequencing and level breaking myself.

< Back   Next >   Cancel   Help

11. On Data Sequencing Help, click Next.

The Data Sequencing Help form displays the data sequence and level breaks that you defined in the report director template. Company and Business Unit were the first two fields entered into the grid in the report director template and will be the level breaks in this report. The third field, Object Account, was included in the report director template and will also be used for sequencing. You can define Object Account as a level break by clicking the text so that it will display in the field directly above the box where it currently resides.

If you would like to override the pre-defined data sequencing and level breaks, click the checkbox *I'd like to setup the sequencing and level breaking myself* located in the Advanced box. The Section Data Sequencing form appears so that you can set up your own data sequencing and level breaks. The fields listed in the Available Columns section are fields from the pre-defined business view. In this example, the pre-defined business view is V8300001

12. On Help with Section Data Selection, choose to create an income statement and to add your own data selection, and click Next.

Because you chose in the Properties tab in the report director template to display Financial Criteria, the next form asks what financial data you would like to see.

The Section Data Selection form appears with one line of data selection.

13. On Section Data Selection, change the Right Operand on the existing line to read 5100-5200, and add the following lines:
  - And Fiscal Year is equal to 5
  - And Ledger Type is equal to AA
  - And Company is equal to 60

**Section Data Selection**

Define the subset of data your report will use when reading records from the database. In other words, filter the incoming data so that your report only processes certain records.

Operator	Left Operand	Comparison	Right Operand
Where	BC Object Account (F0901)	is equal to	"5100-5200"
And	BC Fiscal Year (F0902)	is equal to	"5"
And	BC Ledger Type (F0902)	is equal to	"AA"
And	BC Company (F0901)	is equal to	"00060"

< Back    Next >    Cancel    Help

As stated previously, data selection for each smart field column might be unnecessary when the same smart field columns each have the same data selection in an income statement. If you do not define data selection for each column in that case, you must define it here as this step demonstrates. Defining data selection for the entire report as opposed to defining data selection for each smart field column is more efficient and might result in a faster-running report.

14. On Additional Properties, choose to show Revenue+, Expense- in the Reverse Sign for field and click Next.

This setting suppresses negative signs on the sales data in your report.

15. On Finish, click Finish and then save and preview your report.

## Understanding the Report

You can examine the smart field's event rules to see how the objects you created are implemented in the report. On Report Design, click the Report tab, and then click the variable portion of the smart field column. From the Edit menu, choose Event Rules, and then look at the Column Inclusion event rule. You wrote this event when you created the Quarterly Sales smart field data dictionary item.

Double-click the Quarterly Amount ER text to view the data structure. The named event rule information, as well as the data structure name, is displayed in the upper left corner of the Business Functions form. The data structure displays all of the mappings complete in the Data Structure section in the lower right section of the form.

Notice that the first data item, the Quarterly Amount, is the user prompt and is mapped to a 1. This number is the number that you input when you began creating your report and added the first smart field column. A 1 indicates that you wanted to display first quarter data.

The remainder of the parameters are passed according to the named mapping. None of these fields needs to be mapped in Report Design by the report creator. Without the use of this smart field, the report creator would have to know which business function to use and how to pass the values.

## Output Stream Access

---

A UBE application processes its components in a specific order. At different points during its execution, you can trigger an event via the Output Stream Access (OSA) interface.

These execution points are illustrated in the following diagram:

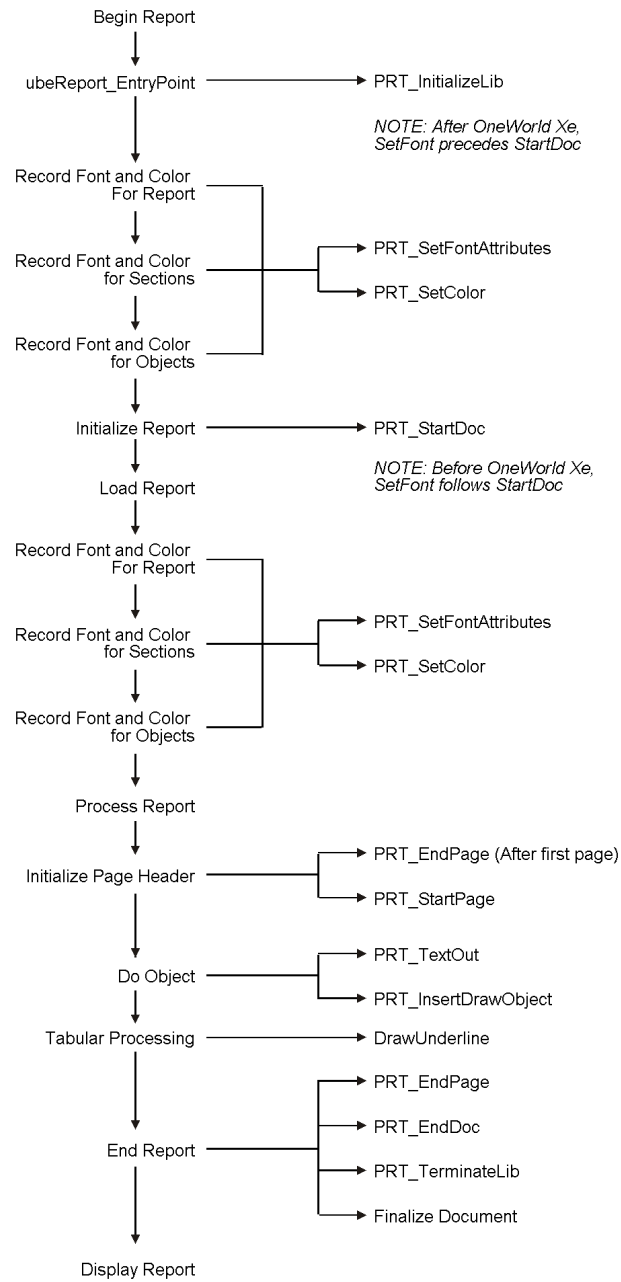

At each of these execution points, with the exception of PRT\_InitializeLib and PRT\_TerminateLib, you can call an OSA function. You can create your own functions, or you can use existing XML libraries and their functions.

## Creating and Associating OSA Interfaces

Before a report can be output using OSA, you must define the interface. Typically, once designed, OSAs are associated with targeted reports or batch versions; a user can override the default OSA at submission, however. A user can also output a report with any defined OSA at submission, although the results might vary depending on the robustness of the selected OSA. OSAs can also be associated with environments, hosts, and users or groups, in the same way that default printers can be assigned. Associating an OSA interface with an object is optional.

Depending on your output needs, you might need to define multiple interfaces.

### ► To create an OSA interface definition

---

*From the Batch Processing Setup menu (GH9013), choose Output Stream Access Setup.*

1. On Output Stream Access Setup, click Add or Modify the Output Stream Access Interface Definition.
2. On Work with Output Stream Access Interface Definition, click Add.
3. On Output Stream Access Interface Definition Revisions, enter a name for the OSA interface in the following field:
  - Output Stream Access Interface Name

---

#### **Note**

J.D. Edwards OSA interfaces begin with the letters JDE. J.D. Edwards recommends that you do not begin your interface names with JDE.

---

4. For each execution point where you want to trigger an event, enter the name of the desired function in the associated row.

Execution points with no associated function are ignored when the OSA interface executes.
5. When finished, click OK.

### ► To associate an OSA interface with an object

---

*From the Batch Processing Setup menu (GH9013), choose Output Stream Access Setup.*

1. On Output Stream Access Setup, click Add or modify the Output Stream Access Interface Usage specification.
2. On Work With Output Stream Access Interface Usage, click Add.
3. On Output Stream Access Interface Usage Revisions, enter the OSA interface name that you want to associate in the following field:
  - Output Stream Access Interface Name

You can also use the Search button for this field to find the interface name.
4. Associate the interface with the desired objects, and then click OK.

## How the System Resolves Priority Conflicts

The following table shows how the system resolves priority conflicts when you associate the interface with more than one object.

### Default OSA disambiguation, highest priority to lowest priority

User/Group	Report	Version	Environment	Host Type	
username	report	version	environment	hosttype	
	report	version	environment	*ALL	
	report	version	*ALL	hosttype	
	report	version	*ALL	*ALL	
	report	*ALL	environment	hosttype	
	report	*ALL	environment	*ALL	
	report	*ALL	*ALL	hosttype	
	report	*ALL	*ALL	*ALL	
	*ALL	*ALL	environment	hosttype	
	*ALL	*ALL	environment	*ALL	
	*ALL	*ALL	*ALL	hosttype	
	*ALL	*ALL	*ALL	*ALL	
	groupname	report	version	environment	hosttype
		report	version	environment	*ALL
report		version	*ALL	hosttype	
report		version	*ALL	*ALL	
report		*ALL	environment	hosttype	
report		*ALL	environment	*ALL	

	report	*ALL	*ALL	hosttype
	report	*ALL	*ALL	*ALL
	*ALL	*ALL	environment	hosttype
	*ALL	*ALL	environment	*ALL
	*ALL	*ALL	*ALL	hosttype
	*ALL	*ALL	*ALL	*ALL
*PUBLIC	report	version	environment	hosttype
	report	version	environment	*ALL
	report	version	*ALL	hosttype
	report	version	*ALL	*ALL
	report	*ALL	environment	hosttype
	report	*ALL	environment	*ALL
	report	*ALL	*ALL	hosttype
	report	*ALL	*ALL	*ALL
	*ALL	*ALL	environment	hosttype
	*ALL	*ALL	environment	*ALL

## Creating an OSA Library

A library is a collection of functions; a function must be included in a library before you can use the function. If necessary, you can create your own functions and libraries.

J.D. Edwards software includes an OSA library called OSASample. J.D. Edwards provides it, along with its source code, as an example of how to create an OSA library. The reference information following this topic is provided for developers who need to create their own libraries.

## Function Signatures

OSA functions are called using the function pointers defined in the JDEOSA file. Therefore, OSA functions should be defined using the same parameters and return values, as in the following example set of function prototypes:

```
void MyStartDoc (POSA_REPORT_INFO);
void MySetFont (POSA_REPORT_INFO, POSA_FONT_INFO);
void MySetColor (POSA_REPORT_INFO, unsigned long int);
void MyStartPage (POSA_REPORT_INFO);
void MyTextOut (POSA_REPORT_INFO, POSA_OBJECT_INFO);
void MyDrawObject (POSA_REPORT_INFO, POSA_OBJECT_INFO);
void MyUnderline (POSA_REPORT_INFO, POSA_OBJECT_INFO);
void MyEndPage (POSA_REPORT_INFO, POSA_LINK_INFO, unsigned long);
void MyEndDoc (POSA_REPORT_INFO, POSA_PAGEOF_INFO, unsigned long);
void MyFinalize (POSA_REPORT_INFO);
void MyStartDoc (POSA_REPORT_INFO);
void MySetFont (POSA_REPORT_INFO, POSA_FONT_INFO);
void MySetColor (POSA_REPORT_INFO, unsigned long int);
void MyStartPage (POSA_REPORT_INFO);
void MyTextOut (POSA_REPORT_INFO, POSA_OBJECT_INFO);
void MyDrawObject (POSA_REPORT_INFO, POSA_OBJECT_INFO);
void MyUnderline (POSA_REPORT_INFO, POSA_OBJECT_INFO);
void MyEndPage (POSA_REPORT_INFO, POSA_LINK_INFO, unsigned long);
void MyEndDoc (POSA_REPORT_INFO, POSA_PAGEOF_INFO, unsigned long);
void MyFinalize (POSA_REPORT_INFO);
```

## Definition File Structures

Definition file structures describe the following file structures:

- Report Information Structure
- Section Information Structure
- Item Information Structure
- Object Information Structure
- Font Information Structure
- Link Information Structure
- Page of Information Structure

## Report Information Structure

This structure definition is available in a common header file so that external applications can make use of it. It is loaded at the beginning of report processing and is passed by pointer to all OSA functions. It includes an External Data Pointer member, which can be used by OSA functions to retain and pass report level data between function calls. External applications can also return a log message and message severity from each execution point, which will be sent on to the UBELogMessage function.

```
struct tagOSA_REPORT_INFO
{
char szReport[11];
char szVersion[11];
char szMachineKey[16];
char szEnhv[11];
char szUser[21];
char szOneWorldRelease[11];
char szReportTime[12];
char szDateToday[11];
unsigned int nLocalCodePage;
unsigned int nRemoteCodePage;
int nLocalOperatingSystem;
int nRemoteOperatingSystem;
char szPrinter[256];
unsigned long ulPageSizeVertical;
unsigned long ulPageSizeHorizontal;
ulong ulNumberOfCopies;
ulong ulPaperSource;
unsigned short nPageOrientation;
unsigned short nPrinterLinesPerInch;
unsigned short nPrinterCharactersPerInch;
unsigned short nPrinterDefaultFontSize;
char szPDLProgram[11];
char szDecimalString[2];
char cThousandsSeparator;
char szDateFormat[5];
char cDateSeparator;
char *szReportTitle;
char szCompanyName[31];
unsigned long ulJobNum;
```

```

unsigned long ulCurrentPageNumber;
unsigned long ulActualCurrentPageNumber;
char szUBEFfileName[300];
char szOSAFileName[300];
unsigned long ulNumberOfSections;
OSA_SECTION_INFO *pOSASectionInfo;
void *pExternalDataPointer;
unsigned short *pnLogMessageSeverity;
char szLogMessage[256];
char szFutureUse[256];
};

```

### Section Information Structure

This structure definition is available in a common header file so that external applications can make use of it. An array of these structures is loaded at the beginning of report processing and the array pointer and counter is stored as part of the OSAReportInfo structure. This structure also includes an External Data Pointer member, which can be used by OSA functions to retain and pass section level data between function calls.

```

struct tagOSA_SECTION_INFO
{
char *szSectionName;
char szSectionType[50];
char szBusinessViewName[11];
unsigned long idSection;
unsigned long idParentSection;
unsigned long ulNumberOfObjects;
OSA_OBJECT_INFO *pOSAObjectInfo;
void *pExternalDataPointer;
char szFutureUse[256];
};

```

### Item Information Structure

This structure definition is available in a common header file so that external applications can make use of it. For each OSAObjectInfo structure, one OSALtemInfo structure is loaded prior to object level execution points, such as Text Out and Insert Draw Object.

```

struct tagOSA_ITEM_INFO
{
unsigned long ulOccurrenceCount;
};

```

```

unsigned long ulRecordFetchCount;
unsigned long ulNumPDFLines;
unsigned short nReprinting;
unsigned short nUnderlineThickness;
unsigned short nUnderlineMargin;
unsigned long int ColorRef;
OSA_FONT_INFO zFontInfo;
unsigned short nPointSize;
unsigned short nDisplayStyle;
float fObjectHorizontalPosition;
float fObjectVerticalPosition;
float fValueHorizontalPosition;
float fValueVerticalPosition;
float fValueEndingHorizontalPosition;
float fValueEndingVerticalPosition;
char *szValue;
char *szFullText;
};

```

### Object Information Structure

This structure definition is available in a common header file so that external applications can make use of it. For each section, an array of these structures is loaded at the beginning of report processing. Each SectionInfo structure contains a pointer to an array of ObjectInfo structures as well as a member indicating the number of elements contained in the array. However, for some execution points, an individual ObjectInfo structure is passed by pointer to the associated OSA function. Each OSAObjectInfo structure contains an OSAItemInfo structure which encapsulates the more dynamic pieces of object level data. This structure also includes an External Data Pointer member, which can be used by OSA functions to retain and pass object level data between function calls.

```

struct tagOSA_OBJECT_INFO
{
char szDataDictionaryAlias[41];
char szObjectName[31];
unsigned long idObject;
unsigned long idSection;
unsigned long idRow;
char szObjectType[3];
unsigned short nLength;
unsigned short idEverestType;
};

```

```

char cDataType;
OSA_ITEM_INFO zOSAItemInfo;
POSA_SECTION_INFO pOSASectionInfo;
void *pExternalDataPointer;
char szFutureUse[256];
};

```

### Font Information Structure

This structure definition is available in a common header file so that external applications can make use of it. This structure is loaded prior to execution of the appropriate OSA functions, as described below, and passed by pointer to such functions.

```

struct tagOSA_FONT_INFO
{
long int lfHeight;
long int lfWidth;
long int lfEscapement;
long int lfOrientation;
long int lfWeight;
unsigned char lfItalic;
unsigned char lfUnderline;
unsigned char lfStrikeOut;
unsigned char lfCharSet;
unsigned char lfOutPrecision;
unsigned char lfClipPrecision;
unsigned char lfQuality;
unsigned char lfPitchAndFamily;
unsigned char lfFaceName[32];
unsigned short nPointSize;
char szAdobeFontName[100];
};

```

## Link Information Structure

This structure definition is available in a common header file so that external applications can make use of it. An array of these structures is populated and sent at the End Page execution point whenever applicable.

```
struct tagOSA_LINK_INFO
{
float fLowerLeftHorizontal;
float fLowerLeftVertical;
float fUpperRightHorizontal;
float fUpperRightVertical;
char szApplication[11];
char szForm[11];
char *szParms;
};
```

## Page Of Information Structure

This structure definition is available in a common header file so that external applications can make use of it. An array of these structures is populated and sent at the End Document execution point.

```
struct tagOSA_PAGEOF_INFO
{
unsigned long ulBeginPage;
unsigned long ulEndPage;
unsigned long ulTotalPage;
};
```

## Function Parameters

Function parameters describe the following function parameters:

- Start Document Parameters
- Set Font Parameters
- Set Color Parameters
- Start Page Parameters
- Text Out Parameters
- Insert Draw Object Parameters
- Draw Underline Parameters
- End Page Parameters

- End Document Parameters
- Finalize Document Parameters

### Start Document Parameters

The OSA function that is associated with the Start Document execution point is called with the following parameter:

```
OSA_REPORT_INFO *pOSAReportInfo
OSA_REPORT_INFO *pOSAReportInfo
```

### Set Font Parameters

The OSA function that is associated with the Set Font execution point is called with the following parameters:

```
OSA_REPORT_INFO *pOSAReportInfo,
OSA_FONT_INFO *pOSAFontInfo
```

### Set Color Parameters

The OSA function that is associated with the Set Color execution point is called with the following parameters:

```
OSA_REPORT_INFO *pOSAReportInfo,
unsigned long int zColorRef
```

### Start Page Parameters

The OSA function that is associated with the Start Page execution point is called with the following parameter:

```
OSA_REPORT_INFO *pOSAReportInfo
```

### Text Out Parameters

The OSA function that is associated with the Text Out execution point is called with the following parameters:

```
OSA_REPORT_INFO *pOSAReportInfo,
OSA_OBJECT_INFO *pOSAObjectInfo
```

### Insert Draw Object Parameters

The OSA function that is associated with the Draw Lines execution point is called with the following parameters:

```
OSA_REPORT_INFO *pOSAReportInfo,
OSA_OBJECT_INFO *pOSAObjectInfo
```

### Draw Underline Parameters

The OSA function that is associated with the Draw Lines execution point is called with the following parameters:

```
OSA_REPORT_INFO *pOSAReportInfo,  
OSA_OBJECT_INFO *pOSAObjectInfo
```

### End Page Parameters

The OSA function that is associated with the End Page execution point is called with the following parameter:

```
OSA_REPORT_INFO pOSAReportInfo,  
OSA_LINK_INFO *pOSALinkInfo,  
unsigned long ulNumberOfLinks
```

### End Document Parameters

The OSA function that is associated with the End Document execution point is called with the following parameters:

```
OSA_REPORT_INFO *pOSAReportInfo,  
OSA_PAGEOF_INFO *pOSAPageOfInfo,  
unsigned long ulNumberOfPageOf
```

### Finalize Document Parameters

The OSA function that is associated with the Finalize Document execution point is called with the following parameter:

```
OSA_REPORT_INFO *pOSAReportInfo
```

### Retrieving OSA Documents

Within the OSAReportInfo structure, the szOSAFileName member allows external applications to specify the name of a file created by OSA functions. A member of the same name is added to the UBEVar structure. After the End Document execution point has been processed, any value that exists in the OSAReportInfo member for szOSAFileName is copied to the corresponding UBEVar member. When a job has finished processing, the UBEVar structure is updated into the Job Control Status Master file (F986110) for the job.

## Include File

The structure and function definitions required for functions interfacing through OSA are contained in the JDEOSA.H file, which is located in the system\include directory for ERP. The current contents of this file are as follows:

```

/*****
Header File Description
* JDEOSA.H Header file to support Output Stream Access functions
*
*****

Copyright (c) 1999 - 1999
J.D. Edwards & Company
*

This material is proprietary to J.D. Edwards & Company.
All rights reserved. The methods and techniques described herein are
considered trade secrets and/or confidential. Reproduction or
distribution, in whole or in part, is forbidden except by express
written permission of J.D. Edwards & Company.
*
*****/

#ifndef JDEOSA_H
#define JDEOSA_H

/** Page Of Information Structure **/
struct tagOSA_PAGEOF_INFO
{
unsigned long ulBeginPage;
unsigned long ulEndPage;
unsigned long ulTotalPage;
};

typedef struct tagOSA_PAGEOF_INFO OSA_PAGEOF_INFO,
*POSA_PAGEOF_INFO;

/** Link Information Structure **/
struct tagOSA_LINK_INFO
{
float fLowerLeftHorizontal;
float fLowerLeftVertical;
float fUpperRightHorizontal;

```

```

float fUpperRightVertical;
char szApplication[11];
char szForm[11];
char *szParms;
};
typedef struct tagOSA_LINK_INFO OSA_LINK_INFO, * POSA_LINK_INFO;
/** Font Information */
struct tagOSA_FONT_INFO
{
long int lfHeight;
long int lfWidth;
long int lfEscapement;
long int lfOrientation;
long int lfWeight;
unsigned char lfItalic;
unsigned char lfUnderline;
unsigned char lfStrikeOut;
unsigned char lfCharSet;
unsigned char lfOutPrecision;
unsigned char lfClipPrecision;
unsigned char lfQuality;
unsigned char lfPitchAndFamily;
char lfFaceName[32];
unsigned short nPointSize;
char szAdobeFontName[100];
};
typedef struct tagOSA_FONT_INFO OSA_FONT_INFO, * POSA_FONT_INFO;
/** Item Information */
struct tagOSA_ITEM_INFO
{
unsigned long ulOccurrenceCount;
unsigned long ulRecordFetchCount;
unsigned long ulNumPDFLines;
unsigned short nReprinting;
unsigned short nUnderlineThickness;
unsigned short nUnderlineMargin;
unsigned long int ColorRef;
};

```

```

OSA_FONT_INFO zFontInfo;
unsigned short nDisplayStyle;
float fObjectHorizontalPosition;
float fObjectVerticalPosition;
float fObjectEndingHorizontalPosition;
float fObjectEndingVerticalPosition;
float fValueHorizontalPosition;
float fValueVerticalPosition;
float fValueEndingHorizontalPosition;
float fValueEndingVerticalPosition;
char *szValue;
char *szFullText;
};

typedef struct tagOSA_ITEM_INFO OSA_ITEM_INFO, * POSA_ITEM_INFO;
/** Object Information **/
struct tagOSA_OBJECT_INFO
{
char szDataDictionaryAlias[41];
char szObjectName[31];
unsigned long idObject;
unsigned long idSection;
unsigned long idRow;
char szObjectType[3];
unsigned short nLength;
unsigned long idEverestType;
char cDataType;
OSA_ITEM_INFO zOSAItemInfo;
void *pOSASectionInfo;
void *pExternalDataPointer;
char szFutureUse[256];
};

typedef struct tagOSA_OBJECT_INFO OSA_OBJECT_INFO, *
POSA_OBJECT_INFO;
/** Section Information Structure **/
struct tagOSA_SECTION_INFO
{
char *szSectionName;

```

```

char szSectionType[50];
char szBusinessViewName[11];
unsigned long idSection;
unsigned long idParentSection;
unsigned long ulNumberOfObjects;
unsigned long ulRecordFetchCount;
OSA_OBJECT_INFO *pOSAObjectInfo;
void *pExternalDataPointer;
char szFutureUse[256];
};

typedef struct tagOSA_SECTION_INFO OSA_SECTION_INFO, *
POSA_SECTION_INFO;

/** Report Information Structure */
struct tagOSA_REPORT_INFO
{
char szReport[11];
char szVersion[11];
char szMachineKey[16];
char szEnhv[11];
char szUser[21];
char szOneWorldRelease[11];
char szReportTime[12];
char szDateToday[11];
unsigned int nLocalCodePage;
unsigned int nRemoteCodePage;
int nLocalOperatingSystem;
int nRemoteOperatingSystem;
char szPrinter[256];
unsigned long ulPageSizeVertical;
unsigned long ulPageSizeHorizontal;
unsigned long ulNumberOfCopies;
unsigned long ulPaperSource;
unsigned short nPageOrientation;
unsigned short nPrinterLinesPerInch;
unsigned short nPrinterCharactersPerInch;
unsigned short nPrinterDefaultFontSize;
char szPDLProgram[11];

```

```

char szDecimalString[2];
char cThousandsSeparator;
char szDateFormat[5];
char cDateSeparator;
char *szReportTitle;
char szCompanyName[31];
unsigned long ulJobNum;
unsigned long ulCurrentPageNumber;
unsigned long ulActualCurrentPageNumber;
char szUBEFileName[300];
char szOSAFileName[300];
unsigned long ulNumberOfSections;
OSA_SECTION_INFO *pOSASectionInfo;
void *pExternalDataPointer;
unsigned short *pnLogMessageSeverity;
char szLogMessage[256];
char szFutureUse[256];
};

typedef struct tagOSA_REPORT_INFO OSA_REPORT_INFO, *
POSA_REPORT_INFO;

/** Execution Point Identification Numbers **/
#define OSA_EXP_N_START_DOC 1
#define OSA_EXP_N_SET_FONT 2
#define OSA_EXP_N_SET_COLOR 3
#define OSA_EXP_N_START_PAGE 4
#define OSA_EXP_N_TEXT_OUT 5
#define OSA_EXP_N_DRAW_OBJECT 6
#define OSA_EXP_N_UNDERLINE 7
#define OSA_EXP_N_END_PAGE 8
#define OSA_EXP_N_END_DOC 9
#define OSA_EXP_N_FINALIZE_DOC 10

/** OSA Function Prototypes **/
typedef void (*FP_OSA_START_DOC) (POSA_REPORT_INFO);
typedef void (*FP_OSA_SET_FONT) (POSA_REPORT_INFO, POSA_FONT_INFO);
typedef void (*FP_OSA_SET_COLOR) (POSA_REPORT_INFO, unsigned long
int);
typedef void (*FP_OSA_START_PAGE) (POSA_REPORT_INFO);

```

```

typedef void (*FP_OSA_TEXT_OUT) (POSA_REPORT_INFO,
POSA_OBJECT_INFO);

typedef void (*FP_OSA_DRAW_OBJECT) (POSA_REPORT_INFO,
POSA_OBJECT_INFO);

typedef void (*FP_OSA_UNDERLINE) (POSA_REPORT_INFO,
POSA_OBJECT_INFO);

typedef void (*FP_OSA_END_PAGE) (POSA_REPORT_INFO, POSA_LINK_INFO,
unsigned long);

typedef void (*FP_OSA_END_DOC) (POSA_REPORT_INFO, POSA_PAGEOF_INFO,
unsigned long);

typedef void (*FP_OSA_FINALIZE_DOC) (POSA_REPORT_INFO);

#endif

```

## File Locations And Names

UBE performs the following steps to load an OSA Library:

If the library name, as defined in the OSA Interface Definition table (F986169), contains a period (.) character, UBE ignores the period and any characters that follow.

UBE adds prefixes, extensions, or both according to the platform on which UBE is executing, as follows:

### PLATFORM EXTENDED LIBRARY NAME

<b>PC</b>	libname + ".dll"
<b>HPUX</b>	"lib" + libname + ".sl"
<b>AIX, SUN</b>	"lib" + libname + ".so"
<b>AS/400</b>	libname

UBE passes the resulting library name to the LoadLibrary function, which, in turn, uses a standard search strategy to locate the desired library.

## OSA File Names

When J.D. Edwards software is retrieving an OSA file from the server, it makes some assumptions about the format of the OSA file name. For AS/400, it assumes that the file name will be stored in the format "LIBRARY/FILE(MEMBER)" and it stores the file on the client machine by using the name "MEMBER.FILE". For NT servers, J.D. Edwards software assumes that the file name is stored in the format "DIRECTORY\FILE.EXT". For all other platforms, J.D. Edwards software expects the file name in the format "DIRECTORY/FILE.EXT".

## OSASample Source Code

OSASample has three components:

- OSAStruct.h
- OSASample.h
- OSASample.c

### OSAStruct.h

```
#ifndef OSASAMPLE_DEF_HPP
#define OSASAMPLE_DEF_HPP
#define chAmpersand '&'
#define chOpenAngle '<'
#define chCloseAngle '>'
#define chDoubleQuote '"'
#define PAGEOF_TYPE "TP"
typedef struct tagOSASAMPLE_STRUCT
{
    unsigned short nCount;
    FILE *fpOutput;
} OSASAMPLE_STRUCT, *POSASAMPLE_STRUCT;
#endif
```

### OSASample.h

```
#ifndef __OSASAMPLE_H__
#define __OSASAMPLE_H__
#include <string.h>
#include <assert.h>
#include <stdio.h>
#include <jdeos.h>
#if defined (_WIN32)
#undef CDECL
#define CDECL _cdecl
#endif
#if defined(IAMOSASAMPLE)
#define APIEXPORT _declspec(dllexport)
#else
#define APIEXPORT _declspec(dllimport)
#endif
#endif
```

```

#else
#define CDECL
#define APIEXPORT
#endif
#define CLASSEXPOR APIEXPORT
#undef EXTERNC
#if defined(__cplusplus)
#define EXTERNC extern "C"
#else
#define EXTERNC
#endif
EXTERNC APIEXPORT void CDECL OSASample_StartDoc(POSA_REPORT_INFO
pOSAReportInfo);
EXTERNC APIEXPORT void CDECL OSASample_SetFont(POSA_REPORT_INFO
pOSAReportInfo, POSA_FONT_INFO pOSAFontInfo);
EXTERNC APIEXPORT void CDECL OSASample_SetColor(POSA_REPORT_INFO
pOSAReportInfo, unsigned long int zColorRef);
EXTERNC APIEXPORT void CDECL OSASample_EndDoc(POSA_REPORT_INFO
pOSAReportInfo,
POSA_PAGEOF_INFO pOSAPageofInfo,
unsigned long ulNumberOfStructs);
EXTERNC APIEXPORT void CDECL OSASample_StartPage(POSA_REPORT_INFO
pOSAReportInfo);
EXTERNC APIEXPORT void CDECL OSASample_EndPage(POSA_REPORT_INFO
pOSAReportInfo,
POSA_LINK_INFO pOsaLinkInfo,
unsigned long ulNumberOfLinks);
EXTERNC APIEXPORT void CDECL OSASample_TextOut(POSA_REPORT_INFO
pOSAReportInfo, POSA_OBJECT_INFO pOSAObjectInfo);
EXTERNC APIEXPORT void CDECL OSASample_DrawObject(POSA_REPORT_INFO
pOSAReportInfo, POSA_OBJECT_INFO pOSAObjectInfo);
EXTERNC APIEXPORT void CDECL OSASample_DrawUnderLine(POSA_REPORT_INFO
pOSAReportInfo, POSA_OBJECT_INFO pOSAObjectInfo);
EXTERNC APIEXPORT void CDECL OSASample_FinalizeDoc(POSA_REPORT_INFO
pOSAReportInfo);
#endif

```

## OSASAMPLE.c

```
/* Author: Kevin Reitz */
/* Date: 10/05/99 */
#include "OSASample.h"
#include "OSAstruct.h"
/*-----
 * Function Name: OSA_ReportInfoOut
 * Parameters: OSASAMPLE_STRUCT * Pointer to OSA Sample Structure
 * OSA_REPORT_INFO * Pointer to Report Info structure
 * Exceptions: None
 * Return Value: None
 * Description: Output data from the Report Info structure
 *-----
 */
void OSA_ReportInfoOut(POSASAMPLE_STRUCT pOSAStruct, POSA_REPORT_INFO
pOSAReportInfo)
{
/* Check for valid parameter values. If pointers are void, return. */
if (!pOSAStruct || !pOSAStruct->fpOutput || !pOSAReportInfo)
{
return;
}
/* Print values to the output file */
fprintf(pOSAStruct->fpOutput, "***** REPORT INFO *****\n\n");
fprintf(pOSAStruct->fpOutput, "Report: %s\n", pOSAReportInfo->szReport);
fprintf(pOSAStruct->fpOutput, "Version: %s\n", pOSAReportInfo->szVersion);
fprintf(pOSAStruct->fpOutput, "MachineKey: %s\n", pOSAReportInfo->szMachineKey);
fprintf(pOSAStruct->fpOutput, "Environment: %s\n", pOSAReportInfo->szEnhv);
fprintf(pOSAStruct->fpOutput, "User: %s\n", pOSAReportInfo->szUser);
fprintf(pOSAStruct->fpOutput, "Release: %s\n", pOSAReportInfo->szOneWorldRelease);
fprintf(pOSAStruct->fpOutput, "Time: %s\n", pOSAReportInfo->szReportTime);
fprintf(pOSAStruct->fpOutput, "Date: %s\n", pOSAReportInfo->szDateToday);
fprintf(pOSAStruct->fpOutput, "Local Code Page: %d\n", pOSAReportInfo->nLocalCodePage);
```

```

fprintf(pOSAstruct->fpOutput, "Remote Code Page: %d\n", pOSAReportInfo->nRemoteCodePage);

fprintf(pOSAstruct->fpOutput, "Local Operating System: %d\n",
pOSAReportInfo->nLocalOperatingSystem);

fprintf(pOSAstruct->fpOutput, "Remote Operating System: %d\n",
pOSAReportInfo->nRemoteOperatingSystem);

fprintf(pOSAstruct->fpOutput, "Printer: %s\n", pOSAReportInfo->szPrinter);

fprintf(pOSAstruct->fpOutput, "Page Height: %d\n", pOSAReportInfo->ulPageSizeVertical);

fprintf(pOSAstruct->fpOutput, "Page Width: %d\n", pOSAReportInfo->ulPageSizeHorizontal);

fprintf(pOSAstruct->fpOutput, "Number Of Copies: %d\n", pOSAReportInfo->ulNumberOfCopies);

fprintf(pOSAstruct->fpOutput, "Paper Source: %d\n", pOSAReportInfo->ulPaperSource);

fprintf(pOSAstruct->fpOutput, "Orientation: %d\n", pOSAReportInfo->nPageOrientation);

fprintf(pOSAstruct->fpOutput, "Lines Per Inch: %d\n", pOSAReportInfo->nPrinterLinesPerInch);

fprintf(pOSAstruct->fpOutput, "Default Font Size: %d\n", pOSAReportInfo->nPrinterDefaultFontSize);

fprintf(pOSAstruct->fpOutput, "Printer Type: %s\n", pOSAReportInfo->szPDLProgram);

fprintf(pOSAstruct->fpOutput, "Decimal Separator: %s\n", pOSAReportInfo->szDecimalString);

fprintf(pOSAstruct->fpOutput, "Thousands Separator: %c\n", pOSAReportInfo->cThousandsSeparator);

fprintf(pOSAstruct->fpOutput, "Date Format: %s\n", pOSAReportInfo->szDateFormat);

fprintf(pOSAstruct->fpOutput, "Date Separator: %c\n", pOSAReportInfo->cDateSeparator);

fprintf(pOSAstruct->fpOutput, "Report Title: %s\n", pOSAReportInfo->szReportTitle);

fprintf(pOSAstruct->fpOutput, "Company Name: %s\n", pOSAReportInfo->szCompanyName);

fprintf(pOSAstruct->fpOutput, "Job Number: %d\n", pOSAReportInfo->ulJobNum);

fprintf(pOSAstruct->fpOutput, "Current Page Number: %d\n", pOSAReportInfo->ulCurrentPageNumber);

fprintf(pOSAstruct->fpOutput, "Actual Page Number: %d\n", pOSAReportInfo->ulActualCurrentPageNumber);

fprintf(pOSAstruct->fpOutput, "UBE File Name: %s\n", pOSAReportInfo->szUBEFilename);

fprintf(pOSAstruct->fpOutput, "OSA File Name: %s\n", pOSAReportInfo->szOSAfilename);

```

```

fprintf(pOSAStruct->fpOutput, "Number of Sections: %d\n", pOSAStruct->ulNumberOfSections);
fprintf(pOSAStruct->fpOutput, "\n***** END REPORT INFO *****\n");
return;
}
/*-----
* Function Name: OSA_SectionInfoOut
* Parameters: OSASAMPLE_STRUCT * Pointer to OSA Sample Structure
* OSA_SECTION_INFO * Pointer to Section Info structure
* Exceptions: None
* Return Value: None
* Description: Output data from the Section Info structure
*-----
*/
void OSA_SectionInfoOut(POSASAMPLE_STRUCT pOSAStruct, POSA_SECTION_INFO
pOSAStruct->pSectionInfo)
{
/* Check for valid parameter values. If pointers are void, return. */
if (!pOSAStruct || !pOSAStruct->fpOutput || !pOSAStruct->pSectionInfo)
{
return;
}
fprintf(pOSAStruct->fpOutput, "\n\t***** SECTION INFO *****\n\n");
fprintf(pOSAStruct->fpOutput, "\tSection Name: %s\n", pOSAStruct->pSectionInfo->szSectionName);
fprintf(pOSAStruct->fpOutput, "\tSection Type: %s\n", pOSAStruct->pSectionInfo->szSectionType);
fprintf(pOSAStruct->fpOutput, "\tBusiness View Name: %s\n", pOSAStruct->pSectionInfo->szBusinessViewName);
fprintf(pOSAStruct->fpOutput, "\tSection ID: %d\n", pOSAStruct->pSectionInfo->idSection);
fprintf(pOSAStruct->fpOutput, "\tParent Section ID: %d\n", pOSAStruct->pSectionInfo->idParentSection);
fprintf(pOSAStruct->fpOutput, "\tNumber of Objects: %d\n", pOSAStruct->pSectionInfo->ulNumberOfObjects);
fprintf(pOSAStruct->fpOutput, "\tRecord Fetch Count: %d\n", pOSAStruct->pSectionInfo->ulRecordFetchCount);
fprintf(pOSAStruct->fpOutput, "\n\t***** END SECTION INFO *****\n");
return;
}

```

```

/*-----
* Function Name: OSA_ObjectInfoOut
* Parameters: OSASAMPLE_STRUCT * Pointer to OSA Sample Structure
* OSA_OBJECT_INFO * Pointer to Object Info structure
* unsigned short int Flag to control output of Item Info
* Exceptions: None
* Return Value: None
* Description: Output data from the Object Info and Item Info structures
*-----
*/
void OSA_ObjectInfoOut(POSASAMPLE_STRUCT pOSAStruct,
POSASAMPLE_STRUCT pOSAObjectInfo,
unsigned short int nPrintItemInfo)
{
/* Check for valid parameter values. If pointers are void, return. */
if (!pOSAStruct || !pOSAStruct->fpOutput || !pOSAObjectInfo)
{
return;
}
fprintf(pOSAStruct->fpOutput, "\n\t\t***** OBJECT INFO *****\n\n");
fprintf(pOSAStruct->fpOutput, "\t\tData Dictionary Item: %s\n",
pOSAObjectInfo->szDataDictionaryAlias);
fprintf(pOSAStruct->fpOutput, "\t\tObject Name: %s\n", pOSAObjectInfo->szObjectName);
fprintf(pOSAStruct->fpOutput, "\t\tObject ID: %d\n", pOSAObjectInfo->idObject);
fprintf(pOSAStruct->fpOutput, "\t\tSection ID: %d\n", pOSAObjectInfo->idSection);
fprintf(pOSAStruct->fpOutput, "\t\tRow ID: %d\n", pOSAObjectInfo->idRow);
fprintf(pOSAStruct->fpOutput, "\t\tObject Type: %s\n", pOSAObjectInfo->szObjectType);
fprintf(pOSAStruct->fpOutput, "\t\tObject Length: %d\n", pOSAObjectInfo->nLength);
fprintf(pOSAStruct->fpOutput, "\t\tOneWorld Data Type: %d\n",
pOSAObjectInfo->idEverestType);
fprintf(pOSAStruct->fpOutput, "\t\tGeneral Data Type: %c\n", pOSAObjectInfo->cDataType);
fprintf(pOSAStruct->fpOutput, "\n\t\t***** END OBJECT INFO *****\n");
/* Only output Item Info if the parameter indicates to do so */
if (nPrintItemInfo)

```

```

{
POSA_ITEM_INFO pOSAItemInfo = &(pOSAObjectInfo->zOSAItemInfo);
fprintf(pOSAstruct->fpOutput, "\n\t\t***** ITEM INFO *****\n\n");
fprintf(pOSAstruct->fpOutput, "\t\tOccurrence Count: %d\n", pOSAItemInfo->ulOccurrenceCount);
fprintf(pOSAstruct->fpOutput, "\t\tRecord Fetch Count: %d\n", pOSAItemInfo->ulRecordFetchCount);
fprintf(pOSAstruct->fpOutput, "\t\tNumber Of Lines: %d\n", pOSAItemInfo->ulNumPDFLines);
fprintf(pOSAstruct->fpOutput, "\t\tReprinting: %d\n", pOSAItemInfo->nReprinting);
fprintf(pOSAstruct->fpOutput, "\t\tUnderline Thickness: %d\n", pOSAItemInfo->nUnderlineThickness);
fprintf(pOSAstruct->fpOutput, "\t\tUnderline Margin: %d\n", pOSAItemInfo->nUnderlineMargin);
fprintf(pOSAstruct->fpOutput, "\t\tColor Reference: %d\n", pOSAItemInfo->ColorRef);
fprintf(pOSAstruct->fpOutput, "\t\tFont Face Name: %s\n", pOSAItemInfo->zFontInfo.lfFaceName);
fprintf(pOSAstruct->fpOutput, "\t\tFont Point Size: %d\n", pOSAItemInfo->zFontInfo.nPointSize);
fprintf(pOSAstruct->fpOutput, "\t\tAdobe Font Name: %s\n", pOSAItemInfo->zFontInfo.szAdobeFontName);
fprintf(pOSAstruct->fpOutput, "\t\tDisplay Style: %d\n", pOSAItemInfo->nDisplayStyle);
fprintf(pOSAstruct->fpOutput, "\t\tObject Start X: %f\n", pOSAItemInfo->fObjectHorizontalPosition);
fprintf(pOSAstruct->fpOutput, "\t\tObject Start Y: %f\n", pOSAItemInfo->fObjectVerticalPosition);
fprintf(pOSAstruct->fpOutput, "\t\tObject End X: %f\n", pOSAItemInfo->fObjectEndingHorizontalPosition);
fprintf(pOSAstruct->fpOutput, "\t\tObject End Y: %f\n", pOSAItemInfo->fObjectEndingVerticalPosition);
fprintf(pOSAstruct->fpOutput, "\t\tValue Start X: %f\n", pOSAItemInfo->fValueHorizontalPosition);
fprintf(pOSAstruct->fpOutput, "\t\tValue Start Y: %f\n", pOSAItemInfo->fValueVerticalPosition);
fprintf(pOSAstruct->fpOutput, "\t\tValue End X: %f\n", pOSAItemInfo->fValueEndingHorizontalPosition);
fprintf(pOSAstruct->fpOutput, "\t\tValue End Y: %f\n", pOSAItemInfo->fValueEndingVerticalPosition);
fprintf(pOSAstruct->fpOutput, "\t\tValue Text: %s\n", pOSAItemInfo->szValue);

```

```

fprintf(pOSAStruct->fpOutput, "\t\tFull Object Text: %s\n", pOSAItemInfo->szFullText);
fprintf(pOSAStruct->fpOutput, "\n\t\t***** END ITEM INFO *****\n");
}
else
{
fprintf(pOSAStruct->fpOutput, "\n\t\t***** No Item Info At This Point *****\n");
}
return;
}
/*-----
* Function Name: OSA_LinkInfoOut
* Parameters: OSASAMPLE_STRUCT * Pointer to OSA Sample Structure
* OSA_LINK_INFO * Pointer to array of Link Info structures
* unsigned long The number of elements in the Link Info array
* Exceptions: None
* Return Value: None
* Description: Output data from the Link Info structures, if any.
*-----
*/
void OSA_LinkInfoOut(POSASAMPLE_STRUCT pOSAStruct,
POSALINK_INFO pOSALinkInfo,
unsigned long ulNumberOfLinks)
{
unsigned short i =0;
/* Check for valid parameter values. If pointers are void, return. */
if (!pOSAStruct || !pOSAStruct->fpOutput)
{
return;
}
/* Check for valid parameter values. If pointer is void or array is empty,
output a message and return. */
if (!pOSALinkInfo || !ulNumberOfLinks)
{
fprintf(pOSAStruct->fpOutput, "\n** No Link Information **\n");
return;
}
}

```

```

fprintf(pOSAstruct->fpOutput, "\n***** LINK INFO *****\n\n");
for (i=0; i<ulNumberOfLinks; i++)
{
fprintf(pOSAstruct->fpOutput, "Lower Left X: %f\n",
pOSALinkInfo[i].fLowerLeftHorizontal);
fprintf(pOSAstruct->fpOutput, "Lower Left Y: %f\n",
pOSALinkInfo[i].fLowerLeftVertical);
fprintf(pOSAstruct->fpOutput, "Upper Right X: %f\n",
pOSALinkInfo[i].fUpperRightHorizontal);
fprintf(pOSAstruct->fpOutput, "Upper Right Y: %f\n",
pOSALinkInfo[i].fUpperRightVertical);
fprintf(pOSAstruct->fpOutput, "Application Name: %s\n",
pOSALinkInfo[i].szApplication);
fprintf(pOSAstruct->fpOutput, "Form Name: %s\n", pOSALinkInfo[i].szForm);
fprintf(pOSAstruct->fpOutput, "Parameter String: %s\n\n",
pOSALinkInfo[i].szParms);
}
fprintf(pOSAstruct->fpOutput, "\n***** END LINK INFO *****\n");
return;
}
/*-----
* Function Name: OSA_FontInfoOut
* Parameters: OSASAMPLE_STRUCT * Pointer to OSA Sample Structure
* OSA_FONT_INFO * Pointer to Font Info structure
* Exceptions: None
* Return Value: None
* Description: Output data from the Font Info structure
*-----
*/
void OSA_FontInfoOut(OSASAMPLE_STRUCT pOSAstruct,
POSA_FONT_INFO pFontInfo)
{
/* Check for valid parameter values. If pointers are void, return. */
if (!pOSAstruct || !pOSAstruct->fpOutput || !pFontInfo)
{
return;
}
fprintf(pOSAstruct->fpOutput, "\n***** FONT INFO *****\n\n");

```

```

fprintf(pOSAstruct->fpOutput, "Font Face Name: %s\n", pFontInfo->lfFaceName);

fprintf(pOSAstruct->fpOutput, "Font Point Size: %d\n", pFontInfo->nPointSize);

fprintf(pOSAstruct->fpOutput, "Adobe Font Name: %s\n", pFontInfo->szAdobeFontName);

fprintf(pOSAstruct->fpOutput, "\n***** END FONT INFO *****\n");

return;
}

/*-----
* Function Name: OSA_OpenOutputFile
* Parameters: OSA_REPORT_INFO * Pointer to Report Info Structure
* OSASAMPLE_STRUCT * Pointer to OSA Sample Structure
* Exceptions: None
* Return Value: None
* Description: Create the file which will contain the sample output
*-----
*/

void OSA_OpenOutputFile (POSA_REPORT_INFO pOSAReportInfo,
POSASAMPLE_STRUCT pOSAstruct)
{
/* Formulate the output file name based on information from Report Info. */
strcpy(pOSAReportInfo->szOSAFileName, pOSAReportInfo->szUBEFileName);
#ifdef JDENV_AS400
/* On AS/400, the UBE file name is of the form LIBRARY/PRINTQUEUE(F99999),
where 99999 is the job number. We will just switch an O for the F to
indicate an OSA file. */
pStrPtr = strrchr( pOSAReportInfo->szOSAFileName, 'F' );
*pStrPtr = 'O';

#else
/* On platforms other than AS/400, just replace the PDF file extension with
OSA. */
if( !strstr( pOSAReportInfo->szOSAFileName, ".pdf" ) )
{
/* If there is no .pdf extension, just tack on a .osa extension */
strcat( pOSAReportInfo->szOSAFileName, ".osa" );
}
}

```

```

else
{
    sprintf( strstr( pOSAReportInfo->szOSAFileName, ".pdf" ), ".osa");
}
#endif
/* Open the OSA file for output. */
pOSAStruct->fpOutput= fopen(pOSAReportInfo->szOSAFileName, "w+b");
if (!pOSAStruct->fpOutput)
{
    /* If the file could not be opened, send an error message back to the UBE
    log */
    if (pOSAReportInfo->pnLogMessageSeverity)
    {
        *(pOSAReportInfo->pnLogMessageSeverity) = 1;
    }
    sprintf(pOSAReportInfo->szLogMessage, "Could not open OSA file: %s\n",
    pOSAReportInfo->szOSAFileName);
    return;
}
return;
}
/*-----
*/
/* Name: OSASample_StartDoc */
/* Parameters: OSA_REPORT_INFO* */
/* Exceptions: None */
/* Return Value: None */
/* Description: Open the output file, */
/* Output Report, Section and Object */
/* properties. */
/*-----
*/
EXTERNC APIEXPORT void CDECL OSASample_StartDoc(OSA_REPORT_INFO*
pOSAReportInfo)
{
    POSASAMPLE_STRUCT pOSAStruct = NULL;
    POSA_SECTION_INFO pOSASectionInfo = NULL;
    POSA_OBJECT_INFO pOSAObjectInfo = NULL;

```

```

    char *pStrPtr = NULL;
unsigned long i = 0;
unsigned long j = 0;
if(!pOSAReportInfo )
{
return;
}
/* Allocate memory to hold severity value.
Deallocated in OSASample_EndDoc */
if (!pOSAReportInfo->pnLogMessageSeverity)
{
pOSAReportInfo->pnLogMessageSeverity = malloc(sizeof( unsigned short));
}
if (pOSAReportInfo->pnLogMessageSeverity)
{
pOSAReportInfo->pnLogMessageSeverity[0] = 0;
}
/* Create the common structure for passing values between functions,
if it has not been created before this point. */
if (!pOSAReportInfo->pExternalDataPointer)
{
pOSAstruct = malloc(sizeof( OSASAMPLE_STRUCT));
if (pOSAstruct)
{
memset(pOSAstruct, 0, sizeof(OSASAMPLE_STRUCT));
}
else
{
strcpy(pOSAReportInfo->szLogMessage, "OSA: Could not allocate External Data
Pointer.\n");
/* Set the correct severity to error message severity */
if (pOSAReportInfo->pnLogMessageSeverity)
{
*(pOSAReportInfo->pnLogMessageSeverity) = (unsigned short)1;
}
}
}
/* Record the pointer as the external data pointer in Report Info. */

```

```

pOSAReportInfo->pExternalDataPointer=pOSAstruct;
}
/* If the external data pointer does not exist execution
cannot go on. Set severity to the highest value, assign a message for the
log and return */
if(!pOSAReportInfo->pExternalDataPointer)
{
strcpy(pOSAReportInfo->szLogMessage, "OSA: No External Data Pointer at End
Doc.\n");
/* Set the correct severity to error message severity */
if (pOSAReportInfo->pnLogMessageSeverity)
{
*(pOSAReportInfo->pnLogMessageSeverity) = (unsigned short)1;
}
return;
}
pOSAstruct=pOSAReportInfo->pExternalDataPointer;
/* Create output file if it has not been created yet */
if (!pOSAstruct->fpOutput)
{
OSA_OpenOutputFile (pOSAReportInfo, pOSAstruct);
if (pOSAReportInfo->pnLogMessageSeverity[0] > 0)
return;
}
/* Identify the Execution Point */
fprintf(pOSAstruct->fpOutput, "***** START DOC EXECUTION POINT
*****\n\n");
/* Output Report Info to file. */
OSA_ReportInfoOut (pOSAstruct, pOSAReportInfo);
/* Output Section Info to file. */
if (!pOSAReportInfo->pOSASectionInfo || !pOSAReportInfo->ulNumberOfSections)
{
if (pOSAReportInfo->pnLogMessageSeverity)
{
*(pOSAReportInfo->pnLogMessageSeverity) = 2;
}
}
sprintf(pOSAReportInfo->szLogMessage, "No Section Info present.\n");

```

```

return;
}
pOSASectionInfo = pOSAReportInfo->pOSASectionInfo;
for (i=0; i<pOSAReportInfo->ulNumberOfSections; i++)
{
OSA_SectionInfoOut(pOSAstruct, pOSASectionInfo);
/* Output Object Info to file. */
if (!pOSASectionInfo->pOSAObjectInfo || !pOSASectionInfo->ulNumberOfObjects)
{
if (pOSAReportInfo->pnLogMessageSeverity)
{
*(pOSAReportInfo->pnLogMessageSeverity) = 3;
}
sprintf(pOSAReportInfo->szLogMessage,
"No Object Info present for Section %s.\n",
pOSASectionInfo->szSectionName);
return;
}
pOSAObjectInfo = pOSASectionInfo->pOSAObjectInfo;
for (j=0; j<pOSASectionInfo->ulNumberOfObjects; j++)
{
OSA_ObjectInfoOut(pOSAstruct, pOSAObjectInfo, 0); /* Do not print Item Info
at this time. */
pOSAObjectInfo++;
}
pOSASectionInfo++;
}
}
/*-----
*/
/* Name: OSASample_EndDoc */
/* Parameters: OSA_REPORT_INFO*, OSA_PAGEOF_INFO*, unsigned long */
/* Exceptions: None */
/* Return Value: None */
/* Description: Open the output file, */
/* Output Report, Section and Object */
/* properties. */

```

```

/*-----
*/
EXTERNC APIEXPORT void CDECL OSASample_EndDoc (OSA_REPORT_INFO*
pOSAReportInfo,
OSA_PAGEOF_INFO* pOSAPageofInfo,
unsigned long ulNumberOfStructs)
{
POSASAMPLE_STRUCT pOSAstruct = NULL;
/* If OSA does not provide the needed parameter (Highly unlikely), then
return */
if(!pOSAReportInfo )
{
return;
}
/* If the external data pointer does not exist execution
cannot go on. Set severity to the highest value, assign a message for the
log and return */
if(!pOSAReportInfo->pExternalDataPointer)
{
strcpy(pOSAReportInfo->szLogMessage, "OSA: No External Data Pointer at End
Doc.\n");
/* Set the correct severity to error message severity */
if (pOSAReportInfo->pnLogMessageSeverity)
{
*(pOSAReportInfo->pnLogMessageSeverity) = (unsigned short)1;
}
return;
}
/* Close Output File */
pOSAstruct=pOSAReportInfo->pExternalDataPointer;
/* Identify the Execution Point */
fprintf(pOSAstruct->fpOutput, "\n***** END DOC EXECUTION POINT *****");
if (pOSAstruct->fpOutput)
{
fclose (pOSAstruct->fpOutput);
}
/* Delete the structure created to hold the external data */
free (pOSAstruct);

```

```

if (pOSAReportInfo->pnLogMessageSeverity)
free(pOSAReportInfo->pnLogMessageSeverity);
pOSAReportInfo->pExternalDataPointer = NULL;
return;
}
/*-----
*/
/* Name: OSASample_StartPage */
/* Parameters: OSA_REPORT_INFO* */
/* Exceptions: None */
/* Return Value: None */
/* Description: Output Report Info to output file. */
/* */
/*-----
*/
EXTERNC APIEXPORT void CDECL OSASample_StartPage(OSA_REPORT_INFO*
pOSAReportInfo)
{
POSASAMPLE_STRUCT pOSAstruct = NULL;
/* If OSA does not provide the needed parameter (Highly unlikely), then
return */
if(!pOSAReportInfo )
{
return;
}
/* If the external data pointer does not exist execution
cannot go on. Set severity to the highest value, assign a message for the
log and return */
if(!pOSAReportInfo->pExternalDataPointer)
{
strcpy(pOSAReportInfo->szLogMessage, "OSA: No External Data Pointer at Start
Page.\n");
/* Set the correct severity to error message severity */
if (pOSAReportInfo->pnLogMessageSeverity)
{
*(pOSAReportInfo->pnLogMessageSeverity) = (unsigned short)1;
}
return;
}

```

```

}
/* Output Report Info */
pOSAStruct=pOSAReportInfo->pExternalDataPointer;
/* Check for valid file pointer */
if (!pOSAStruct->fpOutput)
{
strcpy(pOSAReportInfo->szLogMessage, "OSA: No Output File pointer at Start
Page.\n");
/* Set the correct severity to error message severity */
if (pOSAReportInfo->pnLogMessageSeverity)
{
*(pOSAReportInfo->pnLogMessageSeverity) = (unsigned short)1;
}
return;
}
/* Identify the Execution Point */
fprintf(pOSAStruct->fpOutput, "\n***** START PAGE EXECUTION POINT
*****\n");
OSA_ReportInfoOut (pOSAStruct, pOSAReportInfo);
return;
}
/*-----
*/
/* Name: OSASample_EndPage */
/* Parameters: OSA_REPORT_INFO*, OSA_LINK_INFO*, unsigned long */
/* Exceptions: None */
/* Return Value: None */
/* Description: Output Report Info and Link Info */
/* */
/*-----
*/
EXTERNC APIEXPORT void CDECL OSASample_EndPage (POSA_REPORT_INFO
pOSAReportInfo,
POSA_LINK_INFO pOSALinkInfo,
unsigned long ulNumberOfLinks)
{
POSASAMPLE_STRUCT pOSAStruct = NULL;

```

```

/* If OSA does not provide the needed parameter (Highly unlikely), then
return */
if(!pOSAReportInfo )
{
return;
}
/* If the external data pointer does not exist execution
cannot go on. Set severity to the highest value, assign a message for the
log and return */
if(!pOSAReportInfo->pExternalDataPointer)
{
strcpy(pOSAReportInfo->szLogMessage, "OSA: No External Data Pointer at End
Page.\n");
/* Set the correct severity to error message severity */
if (pOSAReportInfo->pnLogMessageSeverity)
{
*(pOSAReportInfo->pnLogMessageSeverity) = (unsigned short)1;
}
return;
}
/* Output Report Info */
pOSAStruct=pOSAReportInfo->pExternalDataPointer;
/* Check for valid file pointer */
if (!pOSAStruct->fpOutput)
{
strcpy(pOSAReportInfo->szLogMessage, "OSA: No Output File pointer at End
Page.\n");
/* Set the correct severity to error message severity */
if (pOSAReportInfo->pnLogMessageSeverity)
{
*(pOSAReportInfo->pnLogMessageSeverity) = (unsigned short)1;
}
return;
}
/* Identify the Execution Point */
fprintf(pOSAStruct->fpOutput, "\n***** END PAGE EXECUTION POINT *****\n");
OSA_ReportInfoOut (pOSAStruct, pOSAReportInfo);

```

```

/* Output Link Info */
OSA_LinkInfoOut (pOSAStruct, pOSALinkInfo, ulNumberOfLinks);
return;
}
/*-----
*/
/* Name: OSASample_SetFont */
/* Parameters: OSA_REPORT_INFO*, OSA_FONT_INFO* */
/* Exceptions: None */
/* Return Value: None */
/* Description: Output Font Info */
/* */
/*-----
*/
EXTERNC APIEXPORT void CDECL OSASample_SetFont (POSA_REPORT_INFO
pOSAReportInfo,
POSA_FONT_INFO pOSAFontInfo)
{
POSASAMPLE_STRUCT pOSAStruct = NULL;
/* If OSA does not provide the needed parameter (Highly unlikely), then
return */
if (!pOSAReportInfo )
{
return;
}
/* Allocate memory to hold severity value.
Deallocated in OSASample_EndDoc */
if (!pOSAReportInfo->pnLogMessageSeverity)
{
pOSAReportInfo->pnLogMessageSeverity = malloc(sizeof( unsigned short));
}
if (pOSAReportInfo->pnLogMessageSeverity)
{
pOSAReportInfo->pnLogMessageSeverity[0] = 0;
}
/* Create the common structure for passing values between functions,
if it has not been created before this point. */
if (!pOSAReportInfo->pExternalDataPointer)

```

```

{
pOSAstruct = malloc(sizeof( OSASAMPLE_STRUCT));
if (pOSAstruct)
{
memset(pOSAstruct, 0, sizeof(OSASAMPLE_STRUCT));
}
else
{
strcpy(pOSAReportInfo->szLogMessage, "OSA: Could not allocate External Data
Pointer.\n");
/* Set the correct severity to error message severity */
if (pOSAReportInfo->pnLogMessageSeverity)
{
*(pOSAReportInfo->pnLogMessageSeverity) = (unsigned short)1;
}
}
/* Record the pointer as the external data pointer in Report Info. */
pOSAReportInfo->pExternalDataPointer=pOSAstruct;
}
/* Output Report Info */
pOSAstruct=pOSAReportInfo->pExternalDataPointer;
/* Create output file if it has not been created yet */
if (!pOSAstruct->fpOutput)
{
OSA_OpenOutputFile (pOSAReportInfo, pOSAstruct);
if (pOSAReportInfo->pnLogMessageSeverity[0] > 0)
return;
}
/* Check for valid file pointer */
if (!pOSAstruct->fpOutput)
{
strcpy(pOSAReportInfo->szLogMessage, "OSA: No Output File pointer at Set
Font.\n");
/* Set the correct severity to error message severity */
if (pOSAReportInfo->pnLogMessageSeverity)
{
*(pOSAReportInfo->pnLogMessageSeverity) = (unsigned short)1;
}
}
}

```

```

}
return;
}
/* Identify the Execution Point */
fprintf(pOSAStruct->fpOutput, "\n***** SET FONT EXECUTION POINT *****\n");
OSA_FontInfoOut(pOSAStruct, pOSAFontInfo);
return;
}
/*-----
*/
/* Name: OSASample_SetColor */
/* Parameters: OSA_REPORT_INFO*, unsigned long int */
/* Exceptions: None */
/* Return Value: None */
/* Description: Output Color Reference Number */
/* */
/*-----
*/
EXTERNC APIEXPORT void CDECL OSASample_SetColor(POSA_REPORT_INFO
pOSAReportInfo,
unsigned long int zColorRef)
{
POSASAMPLE_STRUCT pOSAStruct = NULL;
/* If OSA does not provide the needed parameter (Highly unlikely), then
return */
if(!pOSAReportInfo )
{
return;
}
/* If the external data pointer does not exist execution
cannot go on. Set severity to the highest value, assign a message for the
log and return */
if(!pOSAReportInfo->pExternalDataPointer)
{
strcpy(pOSAReportInfo->szLogMessage, "OSA: No External Data Pointer at Set
Color.\n");
/* Set the correct severity to error message severity */
if (pOSAReportInfo->pnLogMessageSeverity)

```

```

{
*(pOSAReportInfo->pnLogMessageSeverity) = (unsigned short)1;
}
return;
}
/* Output Report Info */
pOSAstruct=pOSAReportInfo->pExternalDataPointer;
/* Check for valid file pointer */
if (!pOSAstruct->fpOutput)
{
strcpy(pOSAReportInfo->szLogMessage, "OSA: No Output File pointer at Set
Color.\n");
/* Set the correct severity to error message severity */
if (pOSAReportInfo->pnLogMessageSeverity)
{
*(pOSAReportInfo->pnLogMessageSeverity) = (unsigned short)1;
}
return;
}
/* Identify the Execution Point */
fprintf(pOSAstruct->fpOutput, "\n***** SET COLOR: %d *****\n", zColorRef);
return;
}
/*-----
*/
/* Name: OSASample_TextOut */
/* Parameters: OSA_REPORT_INFO*, OSA_OBJECT_INFO* */
/* Exceptions: None */
/* Return Value: None */
/* Description: Output Font Info */
/* */
/*-----
*/
EXTERNC APIEXPORT void CDECL OSASample_TextOut (POSA_REPORT_INFO
pOSAReportInfo,
POSA_OBJECT_INFO pOSAObjectInfo)
{
POSASAMPLE_STRUCT pOSAstruct = NULL;

```

```

/* If OSA does not provide the needed parameter (Highly unlikely), then
return */
if(!pOSAReportInfo )
{
return;
}
/* If the external data pointer does not exist execution
cannot go on. Set severity to the highest value, assign a message for the
log and return */
if(!pOSAReportInfo->pExternalDataPointer)
{
strcpy(pOSAReportInfo->szLogMessage, "OSA: No External Data Pointer at Text
Out.\n");
/* Set the correct severity to error message severity */
if (pOSAReportInfo->pnLogMessageSeverity)
{
*(pOSAReportInfo->pnLogMessageSeverity) = (unsigned short)1;
}
return;
}
/* Output Report Info */
pOSAStruct=pOSAReportInfo->pExternalDataPointer;
/* Check for valid file pointer */
if (!pOSAStruct->fpOutput)
{
strcpy(pOSAReportInfo->szLogMessage, "OSA: No Output File pointer at Text
Out.\n");
/* Set the correct severity to error message severity */
if (pOSAReportInfo->pnLogMessageSeverity)
{
*(pOSAReportInfo->pnLogMessageSeverity) = (unsigned short)1;
}
return;
}
/* Identify the Execution Point */
fprintf(pOSAStruct->fpOutput, "\n***** TEXT OUT EXECUTION POINT *****\n");
OSA_ObjectInfoOut(pOSAStruct, pOSAObjectInfo, 1);

```

```

return;
}
/*-----
*/
/* Name: OSASample_Underline */
/* Parameters: OSA_REPORT_INFO*, OSA_OBJECT_INFO* */
/* Exceptions: None */
/* Return Value: None */
/* Description: Output Font Info */
/* */
/*-----
*/
EXTERNC APIEXPORT void CDECL OSASample_DrawUnderline(POSA_REPORT_INFO
pOSAReportInfo,
POSA_OBJECT_INFO pOSAObjectInfo)
{
POSASAMPLE_STRUCT pOSAstruct = NULL;
/* If OSA does not provide the needed parameter (Highly unlikely), then
return */
if(!pOSAReportInfo )
{
return;
}
/* If the external data pointer does not exist execution
cannot go on. Set severity to the highest value, assign a message for the
log and return */
if(!pOSAReportInfo->pExternalDataPointer)
{
strcpy(pOSAReportInfo->szLogMessage, "OSA: No External Data Pointer at Draw
Underline.\n");
/* Set the correct severity to error message severity */
if (pOSAReportInfo->pnLogMessageSeverity)
{
*(pOSAReportInfo->pnLogMessageSeverity) = (unsigned short)1;
}
return;
}
/* Output Report Info */

```

```

pOSAStruct=pOSAReportInfo->pExternalDataPointer;
/* Check for valid file pointer */
if (!pOSAStruct->fpOutput)
{
strcpy(pOSAReportInfo->szLogMessage, "OSA: No Output File pointer at Draw
Underline.\n");
/* Set the correct severity to error message severity */
if (pOSAReportInfo->pnLogMessageSeverity)
{
*(pOSAReportInfo->pnLogMessageSeverity) = (unsigned short)1;
}
return;
}
/* Identify the Execution Point */
fprintf(pOSAStruct->fpOutput, "\n***** DRAW UNDERLINE EXECUTION POINT
*****\n");
OSA_ObjectInfoOut (pOSAStruct, pOSAObjectInfo, 1);
return;
}
/*-----
*/
/* Name: OSASample_DrawObject */
/* Parameters: OSA_REPORT_INFO*, OSA_OBJECT_INFO* */
/* Exceptions: None */
/* Return Value: None */
/* Description: Output Font Info */
/* */
/*-----
*/
EXTERNC APIEXPORT void CDECL OSASample_DrawObject (POSA_REPORT_INFO
pOSAReportInfo,
POSA_OBJECT_INFO pOSAObjectInfo)
{
POSASAMPLE_STRUCT pOSAStruct = NULL;
/* If OSA does not provide the needed parameter (Highly unlikely), then
return */
if (!pOSAReportInfo )
{

```

```

return;
}
/* If the external data pointer does not exist execution
cannot go on. Set severity to the highest value, assign a message for the
log and return */
if(!pOSAReportInfo->pExternalDataPointer)
{
strcpy(pOSAReportInfo->szLogMessage, "OSA: No External Data Pointer at Draw
Object.\n");
/* Set the correct severity to error message severity */
if (pOSAReportInfo->pnLogMessageSeverity)
{
*(pOSAReportInfo->pnLogMessageSeverity) = (unsigned short)1;
}
return;
}
/* Output Report Info */
pOSAstruct=pOSAReportInfo->pExternalDataPointer;
/* Check for valid file pointer */
if (!pOSAstruct->fpOutput)
{
strcpy(pOSAReportInfo->szLogMessage, "OSA: No Output File pointer at Draw
Object.\n");
/* Set the correct severity to error message severity */
if (pOSAReportInfo->pnLogMessageSeverity)
{
*(pOSAReportInfo->pnLogMessageSeverity) = (unsigned short)1;
}
return;
}
/* Identify the Execution Point */
fprintf(pOSAstruct->fpOutput, "\n***** DRAW OBJECT EXECUTION POINT
*****\n");
OSA_ObjectInfoOut (pOSAstruct, pOSAObjectInfo, 1);
return;
}

```