PeopleSoft Enterprise Asset Management 9.0 PeopleBook

September 2006

PeopleSoft Enterprise Asset Management 9.0 PeopleBook
SKU FSCM9AMP-B 0806
Copyright © 1992-2006, Oracle. All rights reserved.

The Programs (which include both the software and documentation) contain proprietary information; they are provided under a license agreement containing restrictions on use and disclosure and are also protected by copyright, patent, and other intellectual and industrial property laws. Reverse engineering, disassembly, or decompilation of the Programs, except to the extent required to obtain interoperability with other independently created software or as specified by law, is prohibited.

The information contained in this document is subject to change without notice. If you find any problems in the documentation, please report them to us in writing. This document is not warranted to be error-free. Except as may be expressly permitted in your license agreement for these Programs, no part of these Programs may be reproduced or transmitted in any form or by any means, electronic or mechanical, for any purpose.

If the Programs are delivered to the United States Government or anyone licensing or using the Programs on behalf of the United States Government, the following notice is applicable:

U.S. GOVERNMENT RIGHTS

Programs, software, databases, and related documentation and technical data delivered to U.S. Government customers are “commercial computer software” or “commercial technical data” pursuant to the applicable Federal Acquisition Regulation and agency-specific supplemental regulations. As such, use, duplication, disclosure, modification, and adaptation of the Programs, including documentation and technical data, shall be subject to the licensing restrictions set forth in the applicable Oracle license agreement, and, to the extent applicable, the additional rights set forth in FAR 52.227-19, Commercial Computer Software--Restricted Rights (June 1987). Oracle Corporation, 500 Oracle Parkway, Redwood City, CA 94065.

The Programs are not intended for use in any nuclear, aviation, mass transit, medical, or other inherently dangerous applications. It shall be the licensee’s responsibility to take all appropriate fail-safe, backup, redundancy and other measures to ensure the safe use of such applications if the Programs are used for such purposes, and we disclaim liability for any damages caused by such use of the Programs.

The Programs may provide links to Web sites and access to content, products, and services from third parties. Oracle is not responsible for the availability of, or any content provided on, third-party Web sites. You bear all risks associated with the use of such content. If you choose to purchase any products or services from a third party, the relationship is directly between you and the third party. Oracle is not responsible for: (a) the quality of third-party products or services; or (b) fulfilling any of the terms of the agreement with the third party, including delivery of products or services and warranty obligations related to purchased products or services. Oracle is not responsible for any loss or damage of any sort that you may incur from dealing with any third party.

Oracle, JD Edwards, PeopleSoft, and Siebel are registered trademarks of Oracle Corporation and/or its affiliates. Other names may be trademarks of their respective owners.

Open Source Disclosure

Oracle takes no responsibility for its use or distribution of any open source or shareware software or documentation and disclaims any and all liability or damages resulting from use of said software or documentation. The following open source software may be used in Oracle’s PeopleSoft products and the following disclaimers are provided.

Apache Software Foundation

This product includes software developed by the Apache Software Foundation (<http://www.apache.org/>). Copyright © 2000-2003. The Apache Software Foundation. All rights reserved. Licensed under the Apache License, Version 2.0 (the “License”); you may not use this file except in compliance with the License. You may obtain a copy of the License at <http://www.apache.org/licenses/LICENSE-2.0>.

Unless required by applicable law or agreed to in writing, software distributed under the License is distributed on an “AS IS” BASIS, WITHOUT WARRANTIES OR CONDITIONS OF ANY KIND, either express or implied. See the License for the specific language governing permissions and limitations under the License.

OpenSSL

Copyright © 1998-2005 The OpenSSL Project. All rights reserved.

This product includes software developed by the OpenSSL Project for use in the OpenSSL Toolkit (<http://www.openssl.org/>).

THIS SOFTWARE IS PROVIDED BY THE OpenSSL PROJECT “AS IS” AND ANY EXPRESSED OR IMPLIED WARRANTIES, INCLUDING, BUT NOT LIMITED TO, THE IMPLIED WARRANTIES OF MERCHANTABILITY AND FITNESS FOR A PARTICULAR PURPOSE ARE DISCLAIMED. IN NO EVENT SHALL THE OpenSSL PROJECT OR ITS CONTRIBUTORS BE LIABLE FOR ANY DIRECT, INDIRECT, INCIDENTAL, SPECIAL, EXEMPLARY, OR CONSEQUENTIAL DAMAGES (INCLUDING, BUT NOT LIMITED TO, PROCUREMENT OF SUBSTITUTE GOODS OR SERVICES; LOSS OF USE, DATA, OR PROFITS; OR BUSINESS INTERRUPTION) HOWEVER CAUSED AND ON ANY THEORY OF LIABILITY, WHETHER IN CONTRACT, STRICT LIABILITY, OR TORT (INCLUDING NEGLIGENCE OR OTHERWISE) ARISING IN ANY WAY OUT OF THE USE OF THIS SOFTWARE, EVEN IF ADVISED OF THE POSSIBILITY OF SUCH DAMAGE.

Loki Library

Copyright © 2001 by Andrei Alexandrescu. This code accompanies the book: Alexandrescu, Andrei. “Modern C++ Design: Generic Programming and Design Patterns Applied”. Copyright © 2001 Addison-Wesley. Permission to use, copy, modify, distribute and sell this software for any purpose is hereby granted without fee, provided that the above copyright notice appear in all copies and that both that copyright notice and this permission notice appear in supporting documentation.

Helma Project

Copyright © 1999-2004 Helma Project. All rights reserved. THIS SOFTWARE IS PROVIDED “AS IS” AND ANY EXPRESSED OR IMPLIED WARRANTIES, INCLUDING, BUT NOT LIMITED TO, THE IMPLIED WARRANTIES OF MERCHANTABILITY AND FITNESS FOR A PARTICULAR PURPOSE ARE DISCLAIMED. IN NO EVENT SHALL THE HELMA PROJECT OR ITS CONTRIBUTORS BE LIABLE FOR ANY DIRECT, INDIRECT, INCIDENTAL, SPECIAL, EXEMPLARY, OR CONSEQUENTIAL DAMAGES (INCLUDING, BUT NOT LIMITED TO, PROCUREMENT OF SUBSTITUTE GOODS OR SERVICES; LOSS OF USE, DATA, OR PROFITS; OR BUSINESS INTERRUPTION) HOWEVER CAUSED AND ON ANY THEORY OF LIABILITY, WHETHER IN CONTRACT, STRICT LIABILITY, OR TORT (INCLUDING NEGLIGENCE OR OTHERWISE) ARISING IN ANY WAY OUT OF THE USE OF THIS SOFTWARE, EVEN IF ADVISED OF THE POSSIBILITY OF SUCH DAMAGE.

Helma includes third party software released under different specific license terms. See the licenses directory in the Helma distribution for a list of these license.

Sarissa

Copyright © 2004 Manos Batsis.

This library is free software; you can redistribute it and/or modify it under the terms of the GNU Lesser General Public License as published by the Free Software Foundation; either version 2.1 of the License, or (at your option) any later version.

This library is distributed in the hope that it will be useful, but WITHOUT ANY WARRANTY; without even the implied warranty of MERCHANTABILITY or FITNESS FOR A PARTICULAR PURPOSE. See the GNU Lesser General Public License for more details.

You should have received a copy of the GNU Lesser General Public License along with this library; if not, write to the Free Software Foundation, Inc., 59 Temple Place, Suite 330, Boston, MA 02111-1307 USA.

ICU

ICU License - ICU 1.8.1 and later COPYRIGHT AND PERMISSION NOTICE Copyright © 1995-2003 International Business Machines Corporation and others. All rights reserved.

Permission is hereby granted, free of charge, to any person obtaining a copy of this software and associated documentation files (the "Software"), to deal in the Software without restriction, including without limitation the rights to use, copy, modify, merge, publish, distribute, and/or sell copies of the Software, and to permit persons to whom the Software is furnished to do so, provided that the above copyright notice(s) and this permission notice appear in all copies of the Software and that both the above copyright notice(s) and this permission notice appear in supporting documentation. THE SOFTWARE IS PROVIDED "AS IS," WITHOUT WARRANTY OF ANY KIND, EXPRESS OR IMPLIED, INCLUDING BUT NOT LIMITED TO THE WARRANTIES OF MERCHANTABILITY, FITNESS FOR A PARTICULAR PURPOSE AND NON-INFRINGEMENT OF THIRD PARTY RIGHTS. IN NO EVENT SHALL THE COPYRIGHT HOLDER OR HOLDERS INCLUDED IN THIS NOTICE BE LIABLE FOR ANY CLAIM, OR ANY SPECIAL INDIRECT OR CONSEQUENTIAL DAMAGES, OR ANY DAMAGES WHATSOEVER RESULTING FROM LOSS OF USE, DATA OR PROFITS, WHETHER IN AN ACTION OF CONTRACT, NEGLIGENCE OR OTHER TORTIOUS ACTION, ARISING OUT OF OR IN CONNECTION WITH THE USE OR PERFORMANCE OF THIS SOFTWARE. Except as contained in this notice, the name of a copyright holder shall not be used in advertising or otherwise to promote the sale, use or other dealings in this Software without prior written authorization of the copyright holder.

All trademarks and registered trademarks mentioned herein are the property of their respective owners.

Sun's JAXB Implementation – JSDK 1.5 relaxngDatatype.jar 1.0 License

Copyright © 2001, Thai Open Source Software Center Ltd, Sun Microsystems. All rights reserved.

THIS SOFTWARE IS PROVIDED BY THE COPYRIGHT HOLDERS AND CONTRIBUTORS "AS IS" AND ANY EXPRESS OR IMPLIED WARRANTIES, INCLUDING, BUT NOT LIMITED TO, THE IMPLIED WARRANTIES OF MERCHANTABILITY AND FITNESS FOR A PARTICULAR PURPOSE ARE DISCLAIMED. IN NO EVENT SHALL THE REGENTS OR CONTRIBUTORS BE LIABLE FOR ANY DIRECT, INDIRECT, INCIDENTAL, SPECIAL, EXEMPLARY, OR CONSEQUENTIAL DAMAGES (INCLUDING, BUT NOT LIMITED TO, PROCUREMENT OF SUBSTITUTE GOODS OR SERVICES; LOSS OF USE, DATA, OR PROFITS; OR BUSINESS INTERRUPTION) HOWEVER CAUSED AND ON ANY THEORY OF LIABILITY, WHETHER IN CONTRACT, STRICT LIABILITY, OR TORT (INCLUDING NEGLIGENCE OR OTHERWISE) ARISING IN ANY WAY OUT OF THE USE OF THIS SOFTWARE, EVEN IF ADVISED OF THE POSSIBILITY OF SUCH DAMAGE.

W3C IPR SOFTWARE NOTICE

Copyright © 2000 World Wide Web Consortium, (Massachusetts Institute of Technology, Institut National de Recherche en Informatique et en Automatique, Keio University). All Rights Reserved.

Note: The original version of the W3C Software Copyright Notice and License could be found at <http://www.w3.org/Consortium/Legal/copyright-software-19980720>.

THIS SOFTWARE AND DOCUMENTATION IS PROVIDED "AS IS," AND COPYRIGHT HOLDERS MAKE NO REPRESENTATIONS OR WARRANTIES, EXPRESS OR IMPLIED, INCLUDING BUT NOT LIMITED TO, WARRANTIES OF MERCHANTABILITY OR FITNESS FOR ANY PARTICULAR PURPOSE OR THAT THE USE OF THE SOFTWARE OR DOCUMENTATION WILL NOT INFRINGE ANY THIRD PARTY PATENTS, COPYRIGHTS, TRADEMARKS OR OTHER RIGHTS. COPYRIGHT HOLDERS WILL NOT BE LIABLE FOR ANY DIRECT, INDIRECT, SPECIAL OR CONSEQUENTIAL DAMAGES ARISING OUT OF ANY USE OF THE SOFTWARE OR DOCUMENTATION.

Contents

General Preface

About This PeopleBook Preface**xxiii**

PeopleSoft Enterprise Application Prerequisites.....xxiii

Application Fundamentals.....xxiii

Documentation Updates and Printed Documentation.....xxiv

 Obtaining Documentation Updates.....xxiv

 Downloading and Ordering Printed Documentation.....xxiv

Additional Resources.....xxv

Typographical Conventions and Visual Cues.....xxvi

 Typographical Conventions.....xxvi

 Visual Cues.....xxvii

 Country, Region, and Industry Identifiers.....xxvii

 Currency Codes.....xxviii

Comments and Suggestions.....xxviii

Common Elements Used in PeopleBooks.....xxviii

Preface

PeopleSoft Enterprise Asset Management Preface.....**xxxi**

PeopleSoft Products.....xxxi

PeopleSoft Application Fundamentals.....xxxii

Pages With Deferred Processing.....xxxii

Common Elements Used in This PeopleBook.....xxxii

Chapter 1

Getting Started With PeopleSoft Enterprise Asset Management.....**1**

PeopleSoft Asset Management Overview.....1

PeopleSoft Asset Management Business Processes.....2

PeopleSoft Asset Management Integration Touchpoints.....3

Implementing PeopleSoft Asset Management.....4

Chapter 2

Navigating in PeopleSoft Asset Management.....**15**

Using Custom Navigation Center Pages in PeopleSoft Asset Management.....15

Pages Used to Navigate in PeopleSoft Asset Management.....15

Chapter 3

Implementing Asset Management.....27
 Understanding Asset Management.....27
 Understanding the Asset Management Implementation Process.....28

Chapter 4

Converting to PeopleSoft Asset Management.....31
 Understanding Conversion to PeopleSoft Asset Management.....31
 Prerequisites.....32
 Converting with a Customized SQR.....32
 Running the Transaction Loader Edit Program.....34
 Pages Used to Run the Transaction Loader Edit Program.....34
 Using the Transaction Loader Edit Page.....34
 Viewing the Results of the Transaction Edit Program.....35
 Previewing and Approving Results.....36
 Populating Asset Management Tables with Asset Data.....36
 Using Transaction Loader Conversion Dates Options.....36
 Depreciating Converted Assets.....37
 Closing the Conversion Process.....38
 Page Used to Close the Conversion Process.....38
 Verifying the Conversion.....38
 Restoring Disk Space.....38
 Updating Security.....39
 Loading Retired Assets.....39
 Considerations for Retiring Assets.....39
 Populating Loader Tables.....40
 Reviewing Retired Asset Data.....40
 Converting Lease Information.....42
 Pages Used to Convert Lease Information.....43

Chapter 5

Adding and Maintaining Assets.....45
 Understanding Adding and Maintaining Assets.....45
 Adding and Maintaining Asset Information.....47
 Pages Used to Add or Change Asset Information.....48

| | |
|---|-----|
| Adding Asset Basic Information..... | 51 |
| Entering Asset Details..... | 57 |
| Entering Asset Acquisition Details..... | 61 |
| Viewing Tax Information..... | 64 |
| Entering Document Sequencing Information..... | 65 |
| Entering Location, Comments, and Attributes Information..... | 65 |
| Entering Manufacture, License, and Custodian Information..... | 66 |
| Entering Property Assets..... | 68 |
| Entering Property Taxes..... | 71 |
| Entering Asset Supplemental Data..... | 71 |
| Adding Attachments..... | 72 |
| Maintaining Asset Meters..... | 72 |
| Understanding Asset Meters..... | 73 |
| Pages Used to Maintain Asset Meters..... | 74 |
| Associating Meters with Assets..... | 74 |
| Entering Meter Readings..... | 75 |
| Reviewing Meter Reading History..... | 77 |
| Maintaining Warranties..... | 78 |
| Understanding Asset Warranties..... | 78 |
| Pages Used to Maintain Asset Warranties..... | 79 |
| Maintaining Asset Book Information..... | 79 |
| Pages Used to Maintain Asset Book Information..... | 80 |
| Identifying Asset Books and Other Depreciation Information..... | 80 |
| Adding Depreciation Details..... | 85 |
| Adding Tax Information for the Book..... | 86 |
| Adding Assets with the Asset ExpressAdd Component..... | 89 |
| Pages Used to Add Assets with the Asset ExpressAdd Component..... | 90 |
| Capitalizing Assets..... | 90 |
| Copying an Asset..... | 94 |
| Page Used to Copy an Asset..... | 94 |
| Copying an Asset..... | 94 |
| Viewing and Managing the Component Asset Hierarchy..... | 96 |
| Understanding Component Asset Hierarchies..... | 96 |
| Pages Used to View and Manage the Asset Component Hierarchy..... | 97 |
| Viewing the Asset Component Hierarchy..... | 97 |
| Managing the Asset Component Hierarchy..... | 98 |
| Creating Parent-Child Asset Relationships..... | 102 |
| Understanding Parent-Child Asset Relationships..... | 102 |
| Pages Used to Create Parent-Child Asset Relationships..... | 103 |
| Creating an Asset Parent..... | 103 |

| | |
|--|-----|
| Viewing Child Assets..... | 104 |
| Adding Parent and Child Component Assets..... | 104 |
| Using the Child Inherits Life of Parent Feature..... | 104 |
| Updating Parent-Child Basic Information..... | 105 |
| Selecting Child Assets..... | 105 |
| Viewing Parent and Child Assets..... | 107 |
| Calculating Asset Replacement Costs..... | 107 |
| Understanding Asset Replacement Cost..... | 107 |
| Page Used to Calculate Replacement Cost..... | 107 |
| Defining Asset Operational Information..... | 107 |
| Pages Used to Add and Maintain Asset Operational Information..... | 108 |
| Adding Operational Non-Financial Assets..... | 108 |
| Searching for Asset Information..... | 111 |
| Page Used to Search for Asset Information..... | 111 |
| Searching for an Asset..... | 111 |
| Printing Asset Information..... | 114 |
| Page Used to Print Asset Information..... | 114 |
| Adding Assets with the Excel to Component Interface Utility..... | 114 |
| Understanding How to Import Asset Information with the Excel to Component Interface Utility..... | 115 |
| Pages Used to Add Assets with the Excel to Component Interface Utility..... | 116 |
| Entering Data to Import Assets..... | 116 |
| Previewing the Data to Be Imported Through a Spreadsheet..... | 118 |

Chapter 6

| | |
|--|------------|
| Working with Asset Budgeting..... | 119 |
| Understanding Asset Budgeting..... | 119 |
| Understanding Capital Acquisition Planning..... | 119 |
| Defining New Capital Acquisition Plans..... | 120 |
| Pages Used to Define New Capital Acquisition Plans..... | 121 |
| Assigning Capital Acquisition Plan Name and ChartFields..... | 121 |
| Adjusting Capital Acquisition Plans..... | 123 |
| Linking Assets to Existing Capital Acquisition Plans..... | 123 |
| Viewing Capital Acquisition Plans..... | 123 |
| Pages Used to View Capital Acquisition Plans..... | 124 |
| Running Capital Acquisition Plan Reports..... | 125 |
| Page Used to Run Capital Acquisition Plan Reports..... | 125 |

Chapter 7

Working With Leased Assets.....127

Understanding Leased Assets.....127

 Capital and Operating Leases.....127

 Step Leases.....128

Defining Payment Schedules.....129

 Page Used to Define Payment Schedules.....129

 Defining Lease Payment Schedules.....129

Adding Capital and Operating Leases.....130

 Pages Used to Add Capital and Operating Leases.....131

 Creating a Lease.....131

 (Optional) Entering Information About Cost, ChartFields, and Depreciation.....139

 Viewing or Updating a Step-Lease Payment Schedule (Optional).....139

 Viewing or Updating a Lease Payment Schedule.....140

Creating Lease Expense Schedules.....141

 Page Used to Run the Lease Expense Schedule Process.....142

 Running the Lease Expense Schedule Process.....142

Transferring Operating Leases.....143

 Page Used to Transfer Operating Leases.....143

 Transferring an Operating Lease.....143

Retiring or Reinstating Leases.....144

Generating Lease Reports.....144

 Pages Used to Generate Lease Reports.....145

Chapter 8

Adjusting, Transferring, and Evaluating Assets.....147

Understanding Adjusting, Transferring, and Evaluating Assets.....147

Adjusting Cost and Transferring Assets.....148

 Understanding Cost Adjustments and Asset Transfers.....148

 Pages Used to Adjust Cost and Transfer Assets.....149

 Defining Asset Transactions.....150

 Entering Cost Information for Transactions.....152

 Specifying Transfer To/From Books Information.....158

 Marking Assets Up or Down.....161

 Selecting a Child Asset for Adjustment or Transfer.....161

 Entering Child Asset Details.....162

 Adding Advanced Transaction Details.....163

Transferring Parent-Child Assets to Other Business Units (InterUnit Transfers) In Mass.....163

 Page Used to Transfer Parent-Child Assets to Other Business Units In Mass.....163

| | |
|---|-----|
| Transferring Parent-Child Assets from One Business Unit to Another..... | 164 |
| Revaluing Assets Using the Revaluation Worksheet..... | 165 |
| Page Used to Revalue Assets Using the Revaluation Worksheet..... | 165 |
| Revaluing Assets Using the Revaluation Worksheet..... | 165 |
| Revaluing Assets In Mass..... | 171 |
| Page Used to Revalue Assets In Mass..... | 172 |
| Revaluing Assets Using Mass Revaluation..... | 172 |
| Capturing and Maintaining Asset Fair Market Value (FMV)..... | 173 |
| Page Used to Capture and Maintain Asset FMV..... | 174 |
| Capturing and Maintaining Asset FMV..... | 174 |
| Updating Noncapitalized Costs..... | 175 |
| Page Used to Update Noncapitalized Costs..... | 175 |
| Viewing Cost History and Summarizing Cost Rows..... | 175 |
| Understanding Cost History..... | 176 |
| Understanding Cost Summarization..... | 176 |
| Pages Used to View Cost History and Summarize Cost Rows..... | 177 |
| Generating Cost Summarizations..... | 177 |
| Updating the General Ledger with Adjustments and Transfers..... | 178 |
| Modifying or Deleting Pending Asset Transactions..... | 178 |
| Pages Used to Modify or Delete Pending Asset Transactions..... | 179 |
| Modifying or Deleting Pending Transactions..... | 179 |
| Viewing Asset Transaction Details..... | 179 |
| Updating Transaction Information..... | 180 |
| Adjusting for Asset Impairment..... | 180 |
| Understanding Impairment Testing..... | 180 |
| Pages Used to Make Impairment Adjustments..... | 182 |
| Working With the Impairment Worksheet..... | 182 |
| Running the CGU Impairment Batch Process..... | 186 |
| View and Report Impairment Losses and Reversals..... | 189 |

Chapter 9

| | |
|---|------------|
| Managing Asset Maintenance, Repair, Warranties, and Insurance..... | 191 |
| Understanding Asset Maintenance, Repair, Warranties, and Insurance..... | 191 |
| Checking Out Assets..... | 193 |
| Page Used to Check Out Assets..... | 193 |
| Checking Assets Out for Maintenance Events..... | 193 |
| Entering Asset Inspection Information..... | 194 |
| Page Used to Enter Asset Inspection Information..... | 194 |
| Entering Asset Maintenance Service and Repairs..... | 194 |

Pages Used to Enter Asset Service and Repair.....195

Describing Maintenance Events.....196

Entering Statistical Information for Repairs.....197

Entering Payment Information.....199

Tracking Asset Maintenance Contracts.....199

 Understanding Asset Maintenance Contracts.....199

 Pages Used to Track Asset Maintenance Contracts.....200

 Adding or Modifying Maintenance Contracts.....200

 Adding Maintenance Contract Terms.....200

Entering Warranty Information.....200

 Prerequisites.....201

 Pages Used to Enter Warranty Information.....201

 Entering Warranty Information.....201

 Applying Warranties from Template.....203

Entering Asset Insurance Information.....203

 Prerequisites.....203

 Page Used to Set Up Asset Insurance Information.....204

 Setting Up Asset Insurance.....204

Generating the Asset Warranties Report.....206

 Page Used to Generate the Asset Warranty Report.....206

Reviewing Asset Maintenance History.....206

 Page Used to View Asset Maintenance History Summaries.....206

Chapter 10

Using Group Asset Processing.....207

Understanding Group Asset Processing.....207

 Asset Transactions.....208

 Depreciated Group Assets.....208

 Retired Group Members.....208

 Strategy for Asset Grouping.....209

Prerequisites.....209

Adding Group Member Assets.....210

 Adding Group Member Assets with Background Processing.....211

 Adding Group Member Assets Online.....211

Adding Group Asset IDs with Background Processing.....212

Performing Transactions on Group Member Assets.....213

 Transferring Group Members Among Group Assets.....213

Consolidating Group Member Assets.....214

 Understanding Consolidation of Group Member Assets.....214

| | |
|--|-----|
| Pages Used to Consolidate Group Member Assets..... | 214 |
| Running the Group Asset Consolidation Process..... | 215 |
| Calculating Depreciation for Group Assets..... | 220 |
| Page Used to Calculate Depreciation for Group Assets..... | 220 |
| Running the Group Asset Depreciation Process..... | 220 |
| Running the Group Member Estimated Net Book Value Report..... | 220 |
| Understanding the Estimated Net Book Value Calculation..... | 220 |
| Page Used to Run the Group Member Estimated Net Book Value Report..... | 221 |
| Running the Group Member Estimated Net Book Value Report..... | 221 |
| Changing Rates Retroactively..... | 221 |
| Pages Used to Change Rates Retroactively..... | 221 |
| Processing Retroactive Rate Changes..... | 221 |
| Reviewing Asset Book History..... | 222 |
| Pages Used to Review Asset Book History..... | 222 |

Chapter 11

| | |
|--|------------|
| Using Composite Asset Processing..... | 223 |
| Understanding Composite Asset Processing..... | 223 |
| Adding a Composite Asset..... | 224 |
| Adding Composite Member Assets..... | 225 |
| Capitalizing Composite Members into Composite Assets..... | 225 |
| Retiring Composite Members from Composite Assets..... | 226 |
| Loading Composite Asset Transactions..... | 226 |
| Understanding the Effect of Capitalization into Composite..... | 226 |
| Understanding the Effect of Retirement from Composite..... | 227 |
| Performing Transactions on Composite Assets..... | 227 |
| Adjustments to Cost/Quantity..... | 227 |
| Recategorizations and Transfers..... | 228 |

Chapter 12

| | |
|--|------------|
| Performing Asset Physical Inventory..... | 229 |
| Understanding Physical Inventories..... | 229 |
| Prerequisites..... | 229 |
| Physical Inventory Processing Steps..... | 229 |
| Physical Inventory Terminology..... | 230 |
| Hardware and Software for Physical Inventory Processing..... | 231 |
| Setting Up a Physical Inventory..... | 233 |
| Page Used to Set Up a Physical Inventory..... | 233 |

Setting Up a Physical Inventory.....233

Defining the Extract Scope, the Scan Scope, and the Physical Inventory Controls.....234

 Understanding Extract Scopes and Scan Scopes.....235

 Pages Used to Define Extract Scopes, Scan Scopes, and Physical Inventory Controls.....236

 Defining the Extract Scope and the Scan Scope.....236

 Defining Physical Inventory Control Parameters.....237

 Defining the Physical Inventory Control Transaction Defaults.....238

 Setting Up Physical Inventory Schedule Information.....240

Processing a Physical Inventory.....240

 Pages Used to Process Physical Inventory.....242

 Extracting Asset Data (Step 1).....243

 Viewing the Results of the Extract.....243

 Creating an Extract File (Step 2).....244

 Loading Asset Inventory Data (Step 3).....245

 Finding Duplicate Tags.....245

 Finding Duplicate Serial Numbers.....246

 Generating Physical Inventory Results (Step 4).....247

 Reviewing Physical Inventory Results.....247

 Generating Physical Inventory Transactions (Step 5).....249

 Deleting Physical Inventory Transactions (Step 6).....250

 Deleting Physical Inventory Results (Step 7).....250

 Deleting Physical Inventory Scanned Data (Step 8).....250

 Deleting an Extract File (Step 9).....250

Viewing Physical Inventory History.....250

 Pages Used to View Physical Inventory History.....251

Chapter 13

Working with Joint Venture Asset Processing.....253

 Understanding Joint Venture Processing.....253

 Prerequisites for Joint Venture Processing.....255

 Adding and Maintaining Joint Venture Assets.....255

 Changing Ownership Allocations for Existing Joint Ventures.....256

 Defining a Mass Change for Joint Venture Processing.....256

 Loading Joint Venture Transactions.....258

Chapter 14

Processing Asset Depreciation.....259

 Prerequisites.....259

| | |
|--|------------|
| Understanding Depreciation Processing..... | 260 |
| Steps for Processing Depreciation..... | 261 |
| Understanding Depreciation of Group Assets..... | 262 |
| Processing Depreciation..... | 262 |
| Understanding Depreciation Processing..... | 263 |
| Pages Used to Process Depreciation..... | 263 |
| Running the Depreciation Calculation Process (AM_DEPR_CALC)..... | 263 |
| Reviewing Open Transactions..... | 264 |
| Changing Depreciation Attributes..... | 265 |
| Reviewing the Depreciation Processing Error Log..... | 266 |
| Expanding Depreciation by Period..... | 266 |
| Page Used to Expand Depreciation by Period..... | 266 |
| Expanding the Depreciation Period..... | 266 |
| Creating Pending Depreciation Transactions..... | 267 |
| Page Used to Create Pending Depreciation Transactions..... | 267 |
| Creating Open Depreciation Transactions..... | 267 |
| Viewing Depreciation-Related Information..... | 267 |
| Pages Used to View Depreciation-Related Information..... | 268 |
| Viewing Basic Asset Depreciation Information..... | 268 |
| Viewing Net Book Value and Depreciation..... | 268 |
| Viewing Period Depreciation..... | 269 |
| Viewing Child Asset Depreciation..... | 271 |
| Adjusting Accumulated Depreciation..... | 271 |
| Page Used to Adjust Accumulated Depreciation..... | 272 |
| Running Depreciation Reports..... | 272 |
| Understanding Depreciation Reports..... | 272 |
| Pages Used to Run Depreciation Reports..... | 273 |
| Loading the Depreciation Reporting Table..... | 273 |
| | |
| Chapter 15 | |
| Using User-Defined Asset Depreciation..... | 275 |
| Understanding User-Defined Depreciation..... | 275 |
| Creating or Selecting Variables..... | 276 |
| Page Used to Create or Select Variables..... | 278 |
| Creating or Selecting Variables..... | 278 |
| Creating a User-Defined Depreciation Method..... | 279 |
| Pages Used to Create a User-Defined Depreciation Method..... | 280 |
| Entering the User-Defined Depreciation Method..... | 280 |
| Generating a User-Defined Depreciation SQC Program..... | 282 |

Page Used to Generate a User-Defined Depreciation SQC Program.....283
 Using the User Defined Method Generate Page.....283
 Copying a User-Defined Depreciation Method.....283
 Page Used to Copy a User-Defined Depreciation Method.....284
 Copying a User-Defined Method.....284
 Selecting a User-Defined Depreciation Method for an Asset.....285

Chapter 16

Reviewing Asset Depreciation Calculation Results.....287
 Understanding What If Depreciation.....287
 Performing What If Depreciation.....287
 Pages Used to Perform What If Depreciation.....288
 Performing What If Depreciation.....288
 Viewing What If Depreciation Results.....289
 Loading the Net Book Value Depreciation Results Into a Spreadsheet Program.....289
 Page Used to Load the Net Book Value Depreciation Results into a Spreadsheet Program.....290
 Loading Depreciation Results Into a Spreadsheet Program.....290

Chapter 17

Allocating Asset Depreciation Expenses.....293
 Understanding the Depreciation Allocation Business Process.....293
 Processing Allocations With Fund Accounting.....293
 Prerequisites.....294
 Setting Up the Depreciation Allocation Business Process.....294
 Pages Used to Set Up the Depreciation Allocation Business Process.....295
 Entering the Allocation Basis Definition.....295
 Defining the Source and Destinations.....296
 Defining Allocations for Assets.....296
 Performing the Depreciation Allocation Business Process.....298
 Page Used to Run the Depreciation Allocation Business Process.....298
 Running the Depreciation Allocation Process.....298

Chapter 18

Creating PeopleSoft Asset Management Accounting Entries.....301
 Prerequisites.....301
 Understanding Asset Information Flow.....301
 Understanding Accounting Entry Setup.....303

| | |
|--|------------|
| Business Unit and Book Accounting Entry Options..... | 303 |
| Accounting Entry Templates..... | 304 |
| Depreciation Close Status..... | 311 |
| Creating Accounting Entries..... | 312 |
| Understanding the Depreciation Close Process..... | 312 |
| Common Elements Used in This Section..... | 314 |
| Pages Used to Create Accounting Entries..... | 315 |
| Requesting Accounting Entry Creation..... | 315 |
| Running the Depreciation Close Process..... | 316 |
| Closing Accounting Periods..... | 317 |
| | |
| Chapter 19 | |
| Retiring Assets..... | 319 |
| Understanding Asset Retirement..... | 319 |
| Retirement Types..... | 319 |
| Retiring Financial Assets..... | 320 |
| Pages Used to Retire Financial Assets..... | 320 |
| Retiring an Asset..... | 322 |
| Defining Other Retirement Options..... | 332 |
| Selecting Retirement Transactions by ChartField..... | 334 |
| Selecting Child Assets..... | 335 |
| Reviewing a Capital Gain Summary for Retirements..... | 336 |
| Integrating Retired Asset Information with PeopleSoft Billing..... | 336 |
| Specifying How VAT Is Calculated for Asset Retirement..... | 339 |
| Auto-Retiring Fully Depreciated Assets..... | 346 |
| Initiating Asset Retirement Using the Disposal Worksheet..... | 348 |
| Putting Assets Up for Auction..... | 351 |
| Retiring Non-Financial Assets..... | 352 |
| Page Used to Retire Non-Financial Assets..... | 352 |
| Retiring a Non-Financial Asset..... | 352 |
| Reinstating Assets..... | 353 |
| Understanding Reinstatement of Assets..... | 353 |
| Pages Used to Reinstate Assets..... | 353 |
| Reinstating an Asset..... | 353 |
| Running the Tax Retirement Capital Gains Report (AMTX3210)..... | 354 |
| Prerequisites..... | 354 |
| Pages Used to Run the Tax Retirement Capital Gains Report..... | 355 |

Chapter 20

| | |
|--|------------|
| Processing Asset Mass Changes..... | 357 |
| Understanding Mass Changes in Asset Management..... | 357 |
| Defining Mass Changes..... | 358 |
| Pages Used to Define Mass Changes..... | 359 |
| Adding or Updating Mass Change Definitions..... | 359 |
| Specifying Mass Change Criteria and Defaults..... | 360 |
| Specifying Mass Change Fields Specific to Asset Management..... | 362 |
| Generating Mass Change SQL Text..... | 362 |
| Running Mass Changes..... | 364 |
| Page Used to Run Mass Changes..... | 364 |
| Running Mass Changes..... | 364 |
| Verifying Data in the Loader Tables..... | 367 |
| Pages Used to Verify Data in the Loader Tables..... | 367 |
| Viewing Data in the Financial Loader Tables..... | 367 |
| Previewing Physical Load Data..... | 368 |
| Approving Changes..... | 369 |
| Pages Used to Approve Changes..... | 370 |
| Approving Financial Loader Data..... | 370 |
| Approving Physical Loader Data..... | 372 |
| Populating Asset Management Tables with Mass Change Data..... | 373 |
| Page Used to Populate Asset Management Tables with Mass Change Data..... | 373 |
| Populating Asset Management Tables Using the Transaction Loader Process..... | 373 |
| Depreciating Changed Assets..... | 374 |
| Reviewing Asset Management Mass Change Templates and Types..... | 374 |
| Understanding Mass Change Templates and Types..... | 375 |

Chapter 21

| | |
|---|------------|
| Using Asset Management Reporting Options..... | 383 |
| Understanding Asset Management Reporting Options..... | 383 |
| Prerequisites..... | 384 |
| Using Flexible Reporting and Formats..... | 385 |
| Pages Used to Run Reports With Format Templates..... | 385 |
| Running Flexible Reporting and Formats..... | 385 |
| Using Online Reporting..... | 387 |
| Page Used to Generate Online Reports..... | 387 |
| Generating Online Reports..... | 388 |
| Charting Financial Data..... | 390 |
| Page Used to Chart Financial Data..... | 390 |

Using Asset Management Financial Charts.....390

Chapter 22

Using Asset Management Self Service Web Components.....393
 Understanding Self Service Components in Asset Management.....393
 Security.....394
 Asset Management Roles.....394
 Prerequisites to Using Self Service Web Components.....394
 Using Self Service Application Pages.....395
 Pages Used to Use Self Service Application Pages.....396

Chapter 23

Using the Global Features of PeopleSoft Asset Management.....397
 Understanding PeopleSoft Asset Management in Global Settings.....397
 Prerequisites.....399
 (AUS) Using PeopleSoft Asset Management Options to Meet Australian Requirements.....402
 Pages Used to Meet Australian Requirements.....403
 Defining Asset R&D Categorization.....404
 Using the Australian Tax Credit Allowance.....405
 Tracking Changes in CCP.....406
 Reporting Changes in CCP.....408
 Calculating CGT.....408
 Calculation of CGT.....409
 Generating Asset Revaluation (Net Method).....409
 (CAN) Using Asset Management Options to Meet Canadian Requirements.....410
 Pages Used to Meet Canadian Requirements.....411
 Calculating CCA Reporting.....411
 Running the CCA Year-End Update Process.....411
 (FRA) Using PeopleSoft Asset Management Options to Meet French Requirements.....412
 Pages Used to Meet French Requirements.....413
 Reporting Business Tax.....413
 Depreciating Assets by Using the Derogatory Method.....413
 Revaluing Assets.....414
 Generating French Statutory Reports.....415
 (DEU) Using PeopleSoft Asset Management Options to Meet German Requirements.....415
 Pages Used to Meet German Requirements.....415
 Staffel Depreciation Method.....416
 Using a Half-Year Prorate Convention.....418

| | |
|--|-----|
| Using Geometric Digressive Depreciation..... | 419 |
| Processing Low-Value Assets..... | 419 |
| Special Depreciation Terms and Methods..... | 420 |
| (IND) Using PeopleSoft Asset Management Options to Meet Indian Requirements..... | 421 |
| Understanding Asset Depreciation Processing for India..... | 421 |
| Pages Used to Meet Indian Requirements..... | 422 |
| Processing India Tax Depreciation..... | 422 |
| (ITA) Using PeopleSoft Asset Management Options to Meet Italian Requirements..... | 426 |
| Page Used to Meet Italian Requirements..... | 426 |
| Generating the Fixed-Asset Register for Italy..... | 426 |
| (JPN) Using PeopleSoft Asset Management Options to Meet Japanese Requirements..... | 427 |
| Prerequisites..... | 427 |
| Pages Used to Meet Japanese Requirements..... | 427 |
| Using Japanese Depreciation Methods..... | 429 |
| Using Special Depreciation and Increased Depreciation..... | 431 |
| Using Advanced Depreciation..... | 433 |
| Using Composite Depreciation..... | 433 |
| Identifying Collateral Assets..... | 435 |
| Using Currency Rounding Options..... | 435 |
| Processing Local Tax Reports..... | 436 |
| Entering Consumption Tax..... | 440 |

Chapter 24

| | |
|---|------------|
| Archiving Asset Information..... | 441 |
| Understanding Archiving..... | 441 |
| Archiving Inactive Assets..... | 442 |
| Page Used to Archive Data..... | 442 |
| Running the Asset Archive Process..... | 442 |
| Viewing Archived Data..... | 443 |
| Pages Used to View Archived Data..... | 444 |
| Restoring Archived Data..... | 444 |
| Page Used to Restore Archived Data..... | 445 |
| Running the Asset Restore Process..... | 445 |
| Archiving From Transaction Table Details..... | 445 |

Appendix A

| | |
|--|------------|
| Understanding the Loader Table Data Dictionary..... | 449 |
| Understanding the Loader Tables..... | 449 |

| | |
|-----------------------------------|-----|
| Loader Table INTFC_FIN..... | 449 |
| Loader Table INTFC_PHY_A..... | 479 |
| Loader Table INTFC_PHY_B..... | 505 |
| Transaction Loader Inserts..... | 514 |
| From INTFC_FIN..... | 514 |
| From INTFC_PHY_A..... | 516 |
| From INTFC_PHY_B..... | 517 |
| Interface Types (Load Types)..... | 518 |

Appendix B

| | |
|---|------------|
| Understanding Depreciation Calculations..... | 525 |
| Understanding How PeopleSoft Asset Management Calculates Depreciation..... | 525 |
| Salvage Value..... | 525 |
| Tax Credits..... | 526 |
| Listed Property Assets..... | 526 |
| The Depreciation Calculation Process..... | 527 |
| Calculating the Begin Depreciation Date..... | 528 |
| Overriding the Begin Depreciation Field..... | 529 |
| Calculating Remaining Value..... | 529 |
| Remaining Value Calculation for Add Transactions..... | 529 |
| Life to Date Calculation for Add Transactions..... | 530 |
| Calculating Yearly Depreciation..... | 531 |
| Remaining Value Calculation for Add Transactions..... | 531 |
| Life to Date Calculation for Add Transactions..... | 532 |
| Calculating Period Allocation..... | 533 |
| Remaining Value Calculation for Add Transactions: Depreciate When In Service Off..... | 533 |
| Remaining Value Calculation for Add Transactions: Depreciate When In Service On..... | 534 |
| Life to Date Calculations for Add Transactions: Depreciate When in Service Off..... | 535 |
| Life to Date Calculation for Add Transactions: Calculate When in Service On..... | 536 |
| Calculating Prior Period Depreciation..... | 537 |
| Case 1: Add Transactions..... | 537 |
| Case 2: Add Transactions..... | 538 |
| Case 3: Add Transactions..... | 540 |
| Case 4: Add Transactions..... | 541 |
| Case 5: Add Transactions..... | 542 |
| Formula-Based Depreciation Methods..... | 544 |
| Straight Line..... | 544 |
| (IND) Straight Line Percent..... | 545 |
| Declining Balance with a Switch to Straight Line..... | 549 |

Declining Balance with Depreciation Limit.....550
 Declining Balance.....552
 Flat Rate.....553
 Sum of the Years' Digits.....554
 Calculating Depreciation When Salvage Value Exceeds Net Book Value (NBV).....556
 Stop Depreciation When Salvage Value Exceeds NBV.....556
 Allow Negative Depreciation.....558

Appendix C

PeopleSoft Asset Management Reports.....561
 PeopleSoft Asset Management Reports: A to Z.....561
 Asset Set Up Lists.....562
 Transaction Reports.....562
 Capital Acquisition Planning Reports.....563
 Depreciation Reports.....564
 Impairment Reports.....565
 Account Activity Reports.....566
 Accounting Entry Reports.....566
 Physical Inventory Reports.....567
 Lease Reports.....568
 Retirement Reports.....569
 U.S. Tax Reports.....569
 Global Reports.....571

Glossary of PeopleSoft Enterprise Terms.....575

Index601

About This PeopleBook Preface

PeopleSoft Enterprise PeopleBooks provide you with the information that you need to implement and use PeopleSoft Enterprise applications from Oracle.

This preface discusses:

- PeopleSoft Enterprise application prerequisites.
- Application fundamentals.
- Documentation updates and printed documentation.
- Additional resources.
- Typographical conventions and visual cues.
- Comments and suggestions.
- Common elements in PeopleBooks.

Note. PeopleBooks document only elements, such as fields and check boxes, that require additional explanation. If an element is not documented with the process or task in which it is used, then either it requires no additional explanation or it is documented with common elements for the section, chapter, PeopleBook, or product line. Elements that are common to all PeopleSoft Enterprise applications are defined in this preface.

PeopleSoft Enterprise Application Prerequisites

To benefit fully from the information that is covered in these books, you should have a basic understanding of how to use PeopleSoft Enterprise applications.

You might also want to complete at least one introductory training course, if applicable.

You should be familiar with navigating the system and adding, updating, and deleting information by using PeopleSoft Enterprise menus, pages, or windows. You should also be comfortable using the World Wide Web and the Microsoft Windows or Windows NT graphical user interface.

These books do not review navigation and other basics. They present the information that you need to use the system and implement your PeopleSoft Enterprise applications most effectively.

Application Fundamentals

Each application PeopleBook provides implementation and processing information for your PeopleSoft Enterprise applications.

For some applications, additional, essential information describing the setup and design of your system appears in a companion volume of documentation called the application fundamentals PeopleBook. Most product lines have a version of the application fundamentals PeopleBook. The preface of each PeopleBook identifies the application fundamentals PeopleBooks that are associated with that PeopleBook.

The application fundamentals PeopleBook consists of important topics that apply to many or all PeopleSoft Enterprise applications. Whether you are implementing a single application, some combination of applications within the product line, or the entire product line, you should be familiar with the contents of the appropriate application fundamentals PeopleBooks. They provide the starting points for fundamental implementation tasks.

Documentation Updates and Printed Documentation

This section discusses how to:

- Obtain documentation updates.
- Download and order printed documentation.

Obtaining Documentation Updates

You can find updates and additional documentation for this release, as well as previous releases, on Oracle's PeopleSoft Customer Connection website. Through the Documentation section of Oracle's PeopleSoft Customer Connection, you can download files to add to your PeopleBooks Library. You'll find a variety of useful and timely materials, including updates to the full line of PeopleSoft Enterprise documentation that is delivered on your PeopleBooks CD-ROM.

Important! Before you upgrade, you must check Oracle's PeopleSoft Customer Connection for updates to the upgrade instructions. Oracle continually posts updates as the upgrade process is refined.

See Also

Oracle's PeopleSoft Customer Connection, http://www.oracle.com/support/support_peoplesoft.html

Downloading and Ordering Printed Documentation

In addition to the complete line of documentation that is delivered on your PeopleBook CD-ROM, Oracle makes PeopleSoft Enterprise documentation available to you via Oracle's website. You can:

- Download PDF files.
- Order printed, bound volumes.

Downloading PDF Files

You can download PDF versions of PeopleSoft Enterprise documentation online via the Oracle Technology Network. Oracle makes these PDF files available online for each major release shortly after the software is shipped.

See Oracle Technology Network, <http://www.oracle.com/technology/documentation/psftent.html>.

Ordering Printed, Bound Volumes

You can order printed, bound volumes of selected documentation via the Oracle Store.

See Oracle Store, http://oraclestore.oracle.com/OA_HTML/ibeCCtpSctDspRte.jsp?section=14021

Additional Resources

The following resources are located on Oracle's PeopleSoft Customer Connection website:

| Resource | Navigation |
|---------------------------------------|--|
| Application maintenance information | Updates + Fixes |
| Business process diagrams | Support, Documentation, Business Process Maps |
| Interactive Services Repository | Support, Documentation, Interactive Services Repository |
| Hardware and software requirements | Implement, Optimize + Upgrade; Implementation Guide; Implementation Documentation and Software; Hardware and Software Requirements |
| Installation guides | Implement, Optimize + Upgrade; Implementation Guide; Implementation Documentation and Software; Installation Guides and Notes |
| Integration information | Implement, Optimize + Upgrade; Implementation Guide; Implementation Documentation and Software; Pre-Built Integrations for PeopleSoft Enterprise and JD Edwards EnterpriseOne Applications |
| Minimum technical requirements (MTRs) | Implement, Optimize + Upgrade; Implementation Guide; Supported Platforms |
| Documentation updates | Support, Documentation, Documentation Updates |
| PeopleBooks support policy | Support, Support Policy |
| Prerelease notes | Support, Documentation, Documentation Updates, Category, Release Notes |
| Product release roadmap | Support, Roadmaps + Schedules |
| Release notes | Support, Documentation, Documentation Updates, Category, Release Notes |
| Release value proposition | Support, Documentation, Documentation Updates, Category, Release Value Proposition |
| Statement of direction | Support, Documentation, Documentation Updates, Category, Statement of Direction |
| Troubleshooting information | Support, Troubleshooting |
| Upgrade documentation | Support, Documentation, Upgrade Documentation and Scripts |

Typographical Conventions and Visual Cues

This section discusses:

- Typographical conventions.
- Visual cues.
- Country, region, and industry identifiers.
- Currency codes.

Typographical Conventions

This table contains the typographical conventions that are used in PeopleBooks:

| Typographical Convention or Visual Cue | Description |
|--|--|
| Bold | Indicates PeopleCode function names, business function names, event names, system function names, method names, language constructs, and PeopleCode reserved words that must be included literally in the function call. |
| <i>Italics</i> | Indicates field values, emphasis, and PeopleSoft Enterprise or other book-length publication titles. In PeopleCode syntax, italic items are placeholders for arguments that your program must supply. We also use italics when we refer to words as words or letters as letters, as in the following: Enter the letter <i>O</i> . |
| KEY+KEY | Indicates a key combination action. For example, a plus sign (+) between keys means that you must hold down the first key while you press the second key. For ALT+W, hold down the ALT key while you press the W key. |
| Monospace font | Indicates a PeopleCode program or other code example. |
| “ ” (quotation marks) | Indicate chapter titles in cross-references and words that are used differently from their intended meanings. |
| . . . (ellipses) | Indicate that the preceding item or series can be repeated any number of times in PeopleCode syntax. |
| { } (curly braces) | Indicate a choice between two options in PeopleCode syntax. Options are separated by a pipe (). |

| Typographical Convention or Visual Cue | Description |
|--|---|
| [] (square brackets) | Indicate optional items in PeopleCode syntax. |
| & (ampersand) | <p>When placed before a parameter in PeopleCode syntax, an ampersand indicates that the parameter is an already instantiated object.</p> <p>Ampersands also precede all PeopleCode variables.</p> |

Visual Cues

PeopleBooks contain the following visual cues.

Notes

Notes indicate information that you should pay particular attention to as you work with the PeopleSoft Enterprise system.

Note. Example of a note.

If the note is preceded by *Important!*, the note is crucial and includes information that concerns what you must do for the system to function properly.

Important! Example of an important note.

Warnings

Warnings indicate crucial configuration considerations. Pay close attention to warning messages.

Warning! Example of a warning.

Cross-References

PeopleBooks provide cross-references either under the heading “See Also” or on a separate line preceded by the word *See*. Cross-references lead to other documentation that is pertinent to the immediately preceding documentation.

Country, Region, and Industry Identifiers

Information that applies only to a specific country, region, or industry is preceded by a standard identifier in parentheses. This identifier typically appears at the beginning of a section heading, but it may also appear at the beginning of a note or other text.

Example of a country-specific heading: “(FRA) Hiring an Employee”

Example of a region-specific heading: “(Latin America) Setting Up Depreciation”

Country Identifiers

Countries are identified with the International Organization for Standardization (ISO) country code.

Region Identifiers

Regions are identified by the region name. The following region identifiers may appear in PeopleBooks:

- Asia Pacific
- Europe
- Latin America
- North America

Industry Identifiers

Industries are identified by the industry name or by an abbreviation for that industry. The following industry identifiers may appear in PeopleBooks:

- USF (U.S. Federal)
- E&G (Education and Government)

Currency Codes

Monetary amounts are identified by the ISO currency code.

Comments and Suggestions

Your comments are important to us. We encourage you to tell us what you like, or what you would like to see changed about PeopleBooks and other Oracle reference and training materials. Please send your suggestions to your product line documentation manager at Oracle Corporation, 500 Oracle Parkway, Redwood Shores, CA 94065, U.S.A. Or email us at appsdoc@us.oracle.com.

While we cannot guarantee to answer every email message, we will pay careful attention to your comments and suggestions.

Common Elements Used in PeopleBooks

| | |
|-----------------------|--|
| As of Date | The last date for which a report or process includes data. |
| Business Unit | An ID that represents a high-level organization of business information. You can use a business unit to define regional or departmental units within a larger organization. |
| Description | Enter up to 30 characters of text. |
| Effective Date | The date on which a table row becomes effective; the date that an action begins. For example, to close out a ledger on June 30, the effective date for the ledger closing would be July 1. This date also determines when you can view and change the information. Pages or panels and batch processes that use the information use the current row. |

| | |
|------------------------------------|---|
| Once, Always, and Don't Run | <p>Select Once to run the request the next time the batch process runs. After the batch process runs, the process frequency is automatically set to Don't Run.</p> <p>Select Always to run the request every time the batch process runs.</p> <p>Select Don't Run to ignore the request when the batch process runs.</p> |
| Process Monitor | Click to access the Process List page, where you can view the status of submitted process requests. |
| Report Manager | Click to access the Report List page, where you can view report content, check the status of a report, and see content detail messages (which show you a description of the report and the distribution list). |
| Request ID | An ID that represents a set of selection criteria for a report or process. |
| Run | Click to access the Process Scheduler request page, where you can specify the location where a process or job runs and the process output format. |
| SetID | An ID that represents a set of control table information, or TableSets. TableSets enable you to share control table information and processing options among business units. The goal is to minimize redundant data and system maintenance tasks. When you assign a setID to a record group in a business unit, you indicate that all of the tables in the record group are shared between that business unit and any other business unit that also assigns that setID to that record group. For example, you can define a group of common job codes that are shared between several business units. Each business unit that shares the job codes is assigned the same setID for that record group. |
| Short Description | Enter up to 15 characters of text. |
| User ID | An ID that represents the person who generates a transaction. |

PeopleSoft Enterprise Asset Management Preface

This preface discusses:

- PeopleSoft application fundamentals.
- Pages with deferred processing.
- Common elements in this PeopleBook.

Note. This PeopleBook documents only page elements that require additional explanation. If a page element is not documented with the process or task in which it is used, then it either requires no additional explanation or is documented with the common elements for the section, chapter, or PeopleBook.

PeopleSoft Products

This PeopleBook makes reference to these products:

- PeopleSoft Enterprise Billing.
- PeopleSoft Enterprise Contracts.
- PeopleSoft Enterprise Customer Relationship Management Help Desk.
- PeopleSoft Enterprise General Ledger.
- PeopleSoft Enterprise Human Capital Management.
- PeopleSoft Enterprise IT Asset Management.
- PeopleSoft Enterprise Maintenance Management.
- PeopleSoft Enterprise Order Management.
- PeopleSoft Enterprise Payables.
- PeopleSoft Enterprise Project Costing.
- PeopleSoft Enterprise Purchasing.
- PeopleSoft Enterprise Real Estate Management.
- PeopleSoft Enterprise Resource Management.
- PeopleSoft Enterprise Strategic Sourcing.
- PeopleSoft Enterprise Supply Chain Management.

PeopleSoft Application Fundamentals

The *PeopleSoft Enterprise Asset Management PeopleBook* provides you with business process information for your Asset Management system. The *PeopleSoft Enterprise Asset Lifecycle Management Fundamentals PeopleBook* provides you with implementation and background information for your Asset Management system. However, additional, essential information describing the setup and design of your system resides in companion documentation. The companion documentation consists of important topics that apply to many or all PeopleSoft applications across the Financials, Enterprise Service Automation, and Supply Chain Management product lines. You should be familiar with the contents of these PeopleBooks.

The following companion PeopleBooks apply specifically to Asset Management.

- *PeopleSoft Enterprise Asset Lifecycle Management Fundamentals PeopleBook*
- *PeopleSoft Enterprise Application Fundamentals PeopleBook*
- *PeopleSoft Enterprise Setting Up Global Options and Reports*

Pages With Deferred Processing

Several pages in Asset Management operate in deferred processing mode. Most fields on these pages are not updated or validated until you save the page or refresh it by clicking a button, link, or tab. This delayed processing has various implications for the field values on the page—for example, if a field contains a default value, any value you enter before the system updates the page overrides the default. Another implication is that the system updates quantity balances or totals only when you save or otherwise refresh the page.

See the guidelines for designing pages in the *Enterprise PeopleTools 8.48 PeopleBook*, “*PeopleSoft Application Designer*”.

Common Elements Used in This PeopleBook

| | |
|-------------------------------------|---|
| Account | ChartField that identifies the nature of a transaction for corporate accounts. |
| Accounting Date | Date for accounting entries for an activity. |
| Affiliate | ChartField used to map transactions between business units when using a single interunit account. |
| Alt Acct (alternate account) | ChartField that identifies the nature of a transaction for statutory accounts. This field appears only if you enable the Alternate Account option for your organization and for the general ledger business unit. |
| As of Date | The last date for which a report or process includes data. |
| Business Unit | An identification code that represents a high-level organization of business information. You can use a business unit to define regional or departmental units within a larger organization. |
| Category | ChartField value that represents the category for a project transaction in Project Costing. A category further defines a source type. For example, if |

you have a source type of labor, you might have categories for architect labor, carpenter labor, and plumber labor. This field is available only if you have Project Costing.

| | |
|---|---|
| Chartfield 1 to Chartfield 3 | ChartFields that you configure to meet your organization's requirements. |
| Class | ChartField that identifies a particular appropriation when you combine it with a Fund, Department, Program Code, and Budget Reference. Group of customers in a trade, such as grocers or mass merchandisers. |
| Currency | Code that identifies the type of currency for an amount, such as USD or EUR. |
| Dept (department) | ChartField that indicates who is responsible for or affected by the transaction. |
| Description | Freeflow text up to 30 characters. |
| Document Sequence or Document Sequencing | Click to open a page where you can enter document sequencing information. This option is available only if you enable the document sequencing feature for the PeopleSoft General Ledger business unit. |
| Effective Date | Date on which a table row becomes effective; the date that an action begins. For example, if you want to close out a ledger on June 30, the effective date for the ledger closing would be July 1. This date also determines when you can view and change the information. Pages or panels and batch processes that use the information use the current row. |
| EmplID (employee ID) | Unique identification code for an individual associated with your organization. |
| Exchange Rate | Rate that is used for currency conversion. |
| Fund | ChartField that represents structural units for education and government accounting. Can also represent a divisional breakdown in your organization. |
| Journal | Created when you edit journal lines (accounting entries) online in PeopleSoft General Ledger or you run the Journal Generator process for subsystem, imported, or batch accounting entries. |
| Language or Language Code | The language in which you want the field labels and report headings of your reports to print. The field values appear as you enter them. Language also refers to the language spoken by an employee, applicant, or non-employee. |
| Oper Unit (operating unit) | ChartField that is used to identify a location, such as a distribution warehouse or sales center. |
| Process Frequency | Designates the appropriate frequency in the Process Frequency group box: <i>Once</i> executes the request the next time the batch process runs. After the batch process runs, the process frequency is automatically set to Don't Run. <i>Always</i> executes the request every time the batch process runs. <i>Don't Run</i> ignores the request when the batch process runs. |
| Process Monitor | This link takes you to the Process List page, where you can view the status of submitted process requests. |
| Product | ChartField that captures additional information that is useful for profitability and cash flow analysis by product sold or manufactured. |

| | |
|--------------------------|--|
| Program | ChartField that identifies groups of related activities, cost centers, revenue centers, responsibility centers, and academic programs. Tracks revenue and expenditures for programs. |
| Project | ChartField that captures information for project or grants accounting. |
| Report ID | The report identifier. |
| Report Manager | This link takes you to the Report List page, where you can view report content, check the status of a report, and see content detail messages (which show you a description of the report and the distribution list). |
| Request ID | A request identification that represents a set of selection criteria for a report or process. |
| Run | This button takes you to the Process Scheduler request page, where you can specify the location where a process or job runs and the process output format. |
| Run Control ID | A request identification that represents a set of selection criteria for a report or process. |
| SetID | An identification code that represents a set of control table information or TableSets. A TableSet is a group of tables (records) necessary to define your company's structure and processing options. |
| Short Description | Freeflow text up to 15 characters. |
| Source Type | ChartField value that represents the source type for a project transaction in Project Costing. A source type identifies the purpose of the transaction, for example labor. This field is available only if you have Project Costing. |
| Statistics Code | ChartField that identifies nonmonetary statistical amounts. |
| Status | Indicates if a row in a table is active or inactive. You cannot display inactive rows or pages or use them for running batch processes. Use inactive rather than delete data you no longer use in order to maintain an audit trail. |
| User ID | The system identifier for the individual who generates a transaction. |

See Also

Enterprise PeopleTools 8.48 PeopleBook, "PeopleSoft Process Scheduler," Understanding PeopleSoft Process Scheduler

Enterprise PeopleTools 8.48 PeopleBook, "Using PeopleSoft Applications," Working with Pages, Using Effective Dates

CHAPTER 1

Getting Started With PeopleSoft Enterprise Asset Management

This chapter provides an overview of PeopleSoft Enterprise Asset Management and discusses:

- PeopleSoft Asset Management business processes.
- PeopleSoft Asset Management integration touchpoints.
- Implementing PeopleSoft Asset Management.

PeopleSoft Asset Management Overview

This PeopleBook discusses the following functionality and business processes:

- Navigating in PeopleSoft Asset Management.
- Implementing PeopleSoft Asset Management.
- Converting to PeopleSoft Asset Management.
- Adding and maintaining assets.
- Working with asset budgeting.
- Working with leased assets.
- Adjusting, transferring and evaluating assets.
- Managing asset maintenance, warranties, repairs, and insurance.
- Using group asset processing.
- Using composite asset processing.
- Performing asset physical inventory.
- Working with joint venture assets.
- Processing depreciation.
- Using user-defined depreciation.
- Reviewing depreciation calculation results.
- Allocating depreciation expenses.
- Creating asset accounting entries.
- Retiring assets.
- Processing asset mass changes.

- Using PeopleSoft Asset Management reporting options.
- Using self-service web components.
- Using global features for asset management.
- Archiving asset information.
- Understanding depreciation calculations.
- Understanding the Loader Table Data Dictionary.
- PeopleSoft Asset Management reports.

PeopleSoft Asset Management Business Processes

The following graphic lists the PeopleSoft Asset Management business processes:

We cover these business processes in the business process chapters in this PeopleBook.

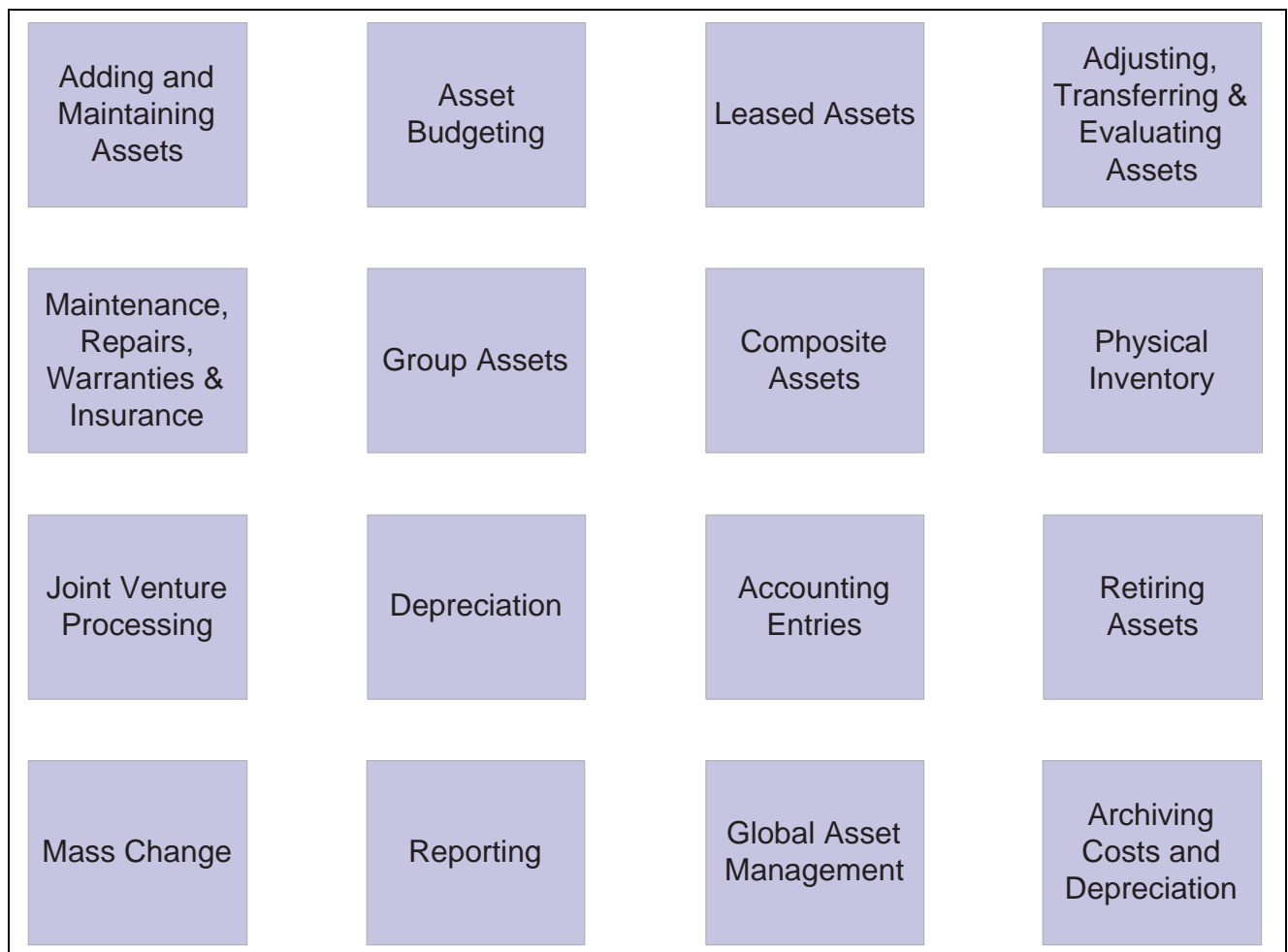

PeopleSoft Asset Management Business Processes

PeopleSoft Asset Management Integration Touchpoints

Asset Management is the core product of the PeopleSoft Enterprise Asset Lifecycle Management suite, which also includes:

- PeopleSoft Enterprise IT Asset Management
- PeopleSoft Enterprise Maintenance Management
- PeopleSoft Enterprise Real Estate Management

To use PeopleSoft Asset Management to full advantage, it is also important to understand the points of integration between PeopleSoft Asset Management and the other PeopleSoft applications that you have purchased, such as:

- PeopleSoft Enterprise General Ledger.
- PeopleSoft Enterprise Billing.
- PeopleSoft Enterprise Budgeting.
- PeopleSoft Enterprise Purchasing.
- PeopleSoft Enterprise Project Costing.
- PeopleSoft Enterprise Payables.
- PeopleSoft Enterprise Strategic Sourcing.
- Third-party applications for computer-aided facilities management, tax provider systems applications.

Because applications share information, you must plan to work closely with the implementation teams that install other PeopleSoft applications to ensure that PeopleSoft provides the full functionality and efficiency that your company requires.

We discuss integration considerations in the implementation chapters in this PeopleBook. Supplemental information about third-party application integrations is on the PeopleSoft Customer Connection web site:

PeopleSoft Asset Management integrates with these PeopleSoft applications:

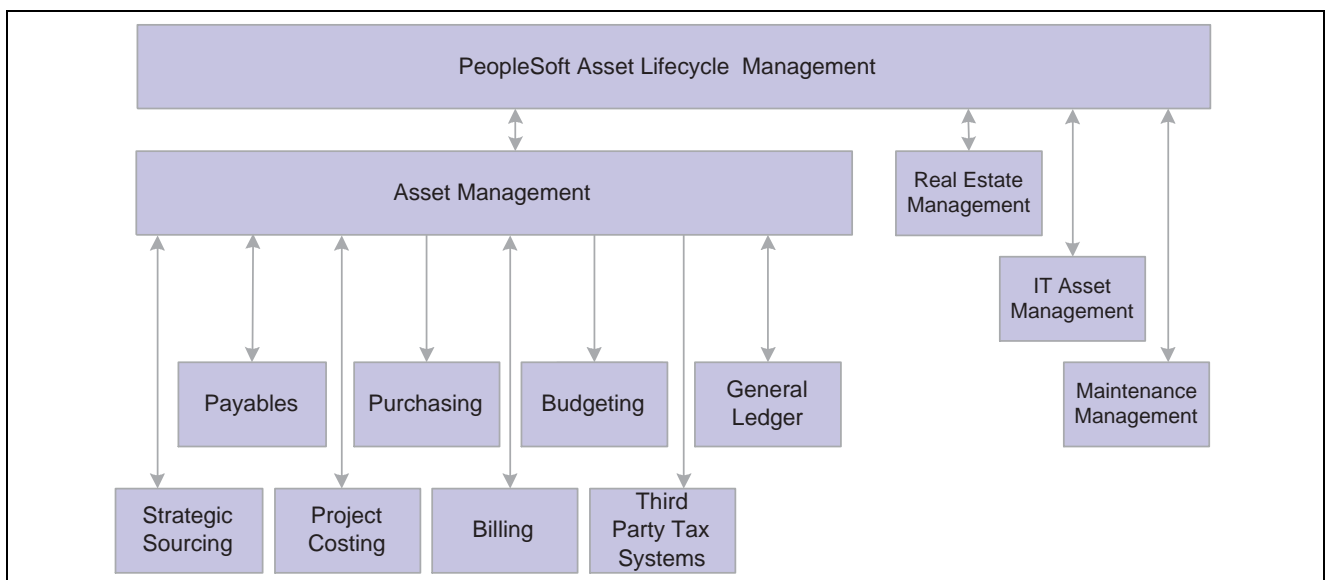

PeopleSoft Asset Management integration flow with other PeopleSoft applications

Implementing PeopleSoft Asset Management

PeopleSoft Setup Manager enables you to review a list of setup tasks for your organization for the products that you are implementing. The setup tasks include the components that you must set up, listed in the order in which you must enter data into the component tables, and links to the corresponding PeopleBook documentation.

PeopleSoft Financials also provides component interfaces to help you load data from your existing system into PeopleSoft tables. Use the Excel to Component Interface utility with the component interfaces to populate the tables.

| Component | Component Interface | Reference |
|--|---------------------|--|
| Agencies (AGENCY_DEFN) | | See <i>PeopleSoft Enterprise Asset Lifecycle Management Fundamentals 9.0 PeopleBook</i> , "Establishing Asset Processing," Pages Used to Define Asset Attributes. |
| Define AM Allocation Basis (ALLOC_BASIS_GRP) | | See <i>PeopleSoft Enterprise Asset Lifecycle Management Fundamentals 9.0 PeopleBook</i> , "Setting Up Depreciation Processing". |
| Area Definition (AM_AREA_TBL) | | See <i>PeopleSoft Enterprise Asset Lifecycle Management Fundamentals 9.0 PeopleBook</i> , "Establishing Asset Processing," Setting Up Area Definitions. |
| Define Criticality Code (AM_CRIT_LEVEL) | | See <i>PeopleSoft Enterprise Asset Lifecycle Management Fundamentals 9.0 PeopleBook</i> , "Establishing Asset Processing," Setting Up Criticality Codes. |
| Asset Indexes (AM_INDEX_TBL) | | See <i>PeopleSoft Enterprise Asset Lifecycle Management Fundamentals 9.0 PeopleBook</i> , "Setting Up Accounting Entry and Financial Processing for PeopleSoft Asset Management," Pages Used to Define Financial Processing. |
| AM Location Definition (AM_LOCATION) | | See <i>PeopleSoft Enterprise Asset Lifecycle Management Fundamentals 9.0 PeopleBook</i> , "Establishing Asset Processing," Pages Used to Define Asset Attributes. |
| Asset Owners (AM_OWNER_COMP) | | See <i>PeopleSoft Enterprise Asset Lifecycle Management Fundamentals 9.0 PeopleBook</i> , "Establishing Asset Processing," Establishing Asset Ownership. |

| Component | Component Interface | Reference |
|---|---------------------|--|
| Asset Owner Operators (AM_OWNER_OPR_COMP) | | See <i>PeopleSoft Enterprise Asset Lifecycle Management Fundamentals 9.0 PeopleBook</i> , “Establishing Asset Processing,” Establishing Asset Ownership. |
| Accounting Entry Template IDs (AMAE_TMPL_ID_PNL) | | See <i>PeopleSoft Enterprise Asset Lifecycle Management Fundamentals 9.0 PeopleBook</i> , “Setting Up Accounting Entry and Financial Processing for PeopleSoft Asset Management,” Defining Accounting Entries. |
| Asset Class (ASSET_CLASS) | ASSET_CLASS_CI | See <i>PeopleSoft Enterprise Asset Lifecycle Management Fundamentals 9.0 PeopleBook</i> , “Establishing Asset Processing,” Setting Up Asset Classes. |
| Asset Hazardous Code (ASSET_FSC_DFN) | ASSET_FSC_DEFN_CI | See <i>PeopleSoft Enterprise Asset Lifecycle Management Fundamentals 9.0 PeopleBook</i> , “Establishing Asset Processing,” Setting Up Hazardous-Material Codes. |
| Bus Tax Rate for Asset/Location (ASSET_LOC_RATE) | | See <i>PeopleSoft Enterprise Asset Lifecycle Management Fundamentals 9.0 PeopleBook</i> , “Setting Up Tax Processing and Tax Reporting,” (FRA) Defining Business Tax by Location. |
| Asset Thresholds (ASSET_THRESHOLDS) | | See <i>PeopleSoft Enterprise Asset Lifecycle Management Fundamentals 9.0 PeopleBook</i> , “Setting Up Tax Processing and Tax Reporting,” (AUS) Defining VAT Thresholds. |
| Define Asset Management Books (BOOK_DEFN1) | | See <i>PeopleSoft Enterprise Asset Lifecycle Management Fundamentals 9.0 PeopleBook</i> , “Establishing PeopleSoft Asset Management Business Units,” Defining Business Unit Processing Options. |
| BU Aggregate R&D Expenditure (BU_AGG_RD) | | See Chapter 23 , “Using the Global Features of PeopleSoft Asset Management,” Defining Asset R&D Categorization, page 404. |
| Asset Management Business Unit (BU_DEFN) | | See <i>PeopleSoft Enterprise Asset Lifecycle Management Fundamentals 9.0 PeopleBook</i> , “Establishing PeopleSoft Asset Management Business Units,” Creating PeopleSoft Asset Management Business Units. |

| Component | Component Interface | Reference |
|---|---------------------|--|
| Capital Acquisition Plan Type (CAP_TYPE) | | See <i>PeopleSoft Enterprise Asset Lifecycle Management Fundamentals 9.0 PeopleBook</i> , “Setting Up Accounting Entry and Financial Processing for PeopleSoft Asset Management,” Pages Used to Define Financial Processing. |
| Asset Category (CATEGORY_DEFN) | CATEGORY_DEFN_CI | See <i>PeopleSoft Enterprise Asset Lifecycle Management Fundamentals 9.0 PeopleBook</i> , “Setting Up Accounting Entry and Financial Processing for PeopleSoft Asset Management,” (Required) Defining Asset Categories. |
| Depr Convention Builder (CONV_BLDR_PNLG) | | See <i>PeopleSoft Enterprise Asset Lifecycle Management Fundamentals 9.0 PeopleBook</i> , “Setting Up Depreciation Processing,” Setting Up Depreciation Conventions. |
| Copy All Depr Conventions (CONV_COPY_ALL_COMP) | | See <i>PeopleSoft Enterprise Asset Lifecycle Management Fundamentals 9.0 PeopleBook</i> , “Setting Up Depreciation Processing,” Setting Up Depreciation Conventions. |
| Copy Depreciation Conventions (CONV_COPY_PNLG) | | See <i>PeopleSoft Enterprise Asset Lifecycle Management Fundamentals 9.0 PeopleBook</i> , “Setting Up Depreciation Processing,” Setting Up Depreciation Conventions. |
| Cost Types (COST_TYPE_DEFN) | | See <i>PeopleSoft Enterprise Asset Lifecycle Management Fundamentals 9.0 PeopleBook</i> , “Setting Up Accounting Entry and Financial Processing for PeopleSoft Asset Management,” Pages Used to Define Financial Processing. |
| Capitalization Limits Codes (DEPR_CAP_LIMIT) | | See <i>PeopleSoft Enterprise Asset Lifecycle Management Fundamentals 9.0 PeopleBook</i> , “Setting Up Accounting Entry and Financial Processing for PeopleSoft Asset Management,” Setting Up Capitalization Limits. |
| Depreciation Conventions (DEPR_CONVENTION) | | See <i>PeopleSoft Enterprise Asset Lifecycle Management Fundamentals 9.0 PeopleBook</i> , “Setting Up Depreciation Processing,” Setting Up Depreciation Conventions. |

| Component | Component Interface | Reference |
|--|-----------------------|--|
| Depreciation Limits (DEPR_LIMIT_DEFN) | | See <i>PeopleSoft Enterprise Asset Lifecycle Management Fundamentals 9.0 PeopleBook</i> , “Setting Up Depreciation Processing,” Defining Depreciation Limits. |
| Depreciation Schedules (DEPR_SCHEDULE_DEFN) | DEPR_SCHEDULE_DEFN_CI | See <i>PeopleSoft Enterprise Asset Lifecycle Management Fundamentals 9.0 PeopleBook</i> , “Setting Up Depreciation Processing,” Setting Up Depreciation Schedules. |
| Depreciation Terms Definition (DEPR_TERMS_DEFN) | DEPR_TERMS_DEFN_CI | See <i>PeopleSoft Enterprise Asset Lifecycle Management Fundamentals 9.0 PeopleBook</i> , “Setting Up Depreciation Processing,” Defining Depreciation Terms and Rates. |
| Accounting Entry Templates (DIST_TEMPLATE_DEFN) | | See <i>PeopleSoft Enterprise Asset Lifecycle Management Fundamentals 9.0 PeopleBook</i> , “Setting Up Accounting Entry and Financial Processing for PeopleSoft Asset Management,” Defining Accounting Entries. |
| FERC Code Definition (FERC_CD_DEFN) | | See <i>PeopleSoft Enterprise Application Fundamentals 9.0 PeopleBook</i> , “Defining Financials and Supply Chain Management Common Definitions,” Pages Used to Define Additional Common Information. |
| Financing Codes (FINANCE_CD) | | See <i>PeopleSoft Enterprise Asset Lifecycle Management Fundamentals 9.0 PeopleBook</i> , “Setting Up Accounting Entry and Financial Processing for PeopleSoft Asset Management,” Pages Used to Define Financial Processing. |
| Insurance Types (INSURANCE_TYPE) | | See <i>PeopleSoft Enterprise Asset Lifecycle Management Fundamentals 9.0 PeopleBook</i> , “Establishing Asset Processing,” Pages Used to Define Asset Attributes. |
| Inter Unit Transfer Definition (IU_TRF_DEFN_TBL) | IU_TRF_DEFN_TBL_CI | See <i>PeopleSoft Enterprise Asset Lifecycle Management Fundamentals 9.0 PeopleBook</i> , “Setting Up Accounting Entry and Financial Processing for PeopleSoft Asset Management,” Defining Accounting Entries. |

| Component | Component Interface | Reference |
|---|---------------------|---|
| Joint Venture BU Allocations (JV_BUS_ALLOC) | | See <i>PeopleSoft Enterprise Asset Lifecycle Management Fundamentals 9.0 PeopleBook</i> , “Establishing Asset Processing,” Defining Joint Venture Allocations. |
| Define Maintenance Types (MAINT_TYPE_DEFN) | | See <i>PeopleSoft Enterprise Asset Lifecycle Management Fundamentals 9.0 PeopleBook</i> , “Establishing Asset Processing,” Defining Maintenance Types. |
| Multi-Shift Definition (MULTI_SHIFT_DEFN) | | See <i>PeopleSoft Enterprise Asset Lifecycle Management Fundamentals 9.0 PeopleBook</i> , “Setting Up Depreciation Processing,” (DEU) Setting Up Multishift Codes. |
| Owner Information (OWNER_INFO_ DEFN) | | See <i>PeopleSoft Enterprise Asset Lifecycle Management Fundamentals 9.0 PeopleBook</i> , “Establishing Asset Processing,” Establishing Asset Ownership. |
| Physical Inventory Scheduling (PI_SCHEDULE) | | See Chapter 12, “Performing Asset Physical Inventory,” Setting Up a Physical Inventory, page 233. |
| Physical Inventory Sys Setup (PI_SYSTEM_SETUP) | | See Chapter 12, “Performing Asset Physical Inventory,” Setting Up a Physical Inventory, page 233. |
| Define Asset Profiles (PROFILE) | PROFILE_CI | See <i>PeopleSoft Enterprise Asset Lifecycle Management Fundamentals 9.0 PeopleBook</i> , “Establishing Asset Processing,” Setting Up Asset Profiles. |
| Lease Schedule (PYMNT_SCHED_ TBL) | | See <i>PeopleSoft Enterprise Asset Lifecycle Management Fundamentals 9.0 PeopleBook</i> , “Establishing Asset Processing,” Defining Lease Payment Schedules. |
| Qualified Investments (QIV) | | See <i>PeopleSoft Enterprise Asset Lifecycle Management Fundamentals 9.0 PeopleBook</i> , “Setting Up Tax Processing and Tax Reporting,” (USA) Defining Qualified Investment Codes. |
| Residual Rate Information (RESIDUAL_RATE_TBL) | | See <i>PeopleSoft Enterprise Asset Lifecycle Management Fundamentals 9.0 PeopleBook</i> , “Setting Up Tax Processing and Tax Reporting,” (JPN) Defining Residual Rates. |

| Component | Component Interface | Reference |
|---|---------------------|--|
| Return Information (RETURN_INFO_DEFN) | | See Chapter 23, “Using the Global Features of PeopleSoft Asset Management,” Processing Local Tax Reports, page 436. |
| Define Report Drilldown (RPT_DRILL_FLD_G) | | See <i>PeopleSoft Enterprise Asset Lifecycle Management Fundamentals 9.0 PeopleBook</i> , “Establishing Asset Processing,” Establishing Drill-Down Field Groups. |
| Book Class Security (SEC_BUBOOK_CLS) | | See <i>PeopleSoft Enterprise Application Fundamentals 9.0 PeopleBook</i> , “Securing Your System”. |
| Book Operator Security (SEC_BUBOOK_OPR) | | See <i>PeopleSoft Enterprise Application Fundamentals 9.0 PeopleBook</i> , “Securing Your System”. |
| Asset Tax Classes (TAX_CLASS_DEFN) | | See <i>PeopleSoft Enterprise Asset Lifecycle Management Fundamentals 9.0 PeopleBook</i> , “Setting Up Tax Processing and Tax Reporting,” (CAN, IND, and USA) Defining and Maintaining Tax Classes. |
| Tax Credit Status (TAX_CR_STATUS) | | See <i>PeopleSoft Enterprise Asset Lifecycle Management Fundamentals 9.0 PeopleBook</i> , “Setting Up Tax Processing and Tax Reporting,” Defining Tax Credits. |
| Tax Credits (TAX_CREDITS) | | See <i>PeopleSoft Enterprise Asset Lifecycle Management Fundamentals 9.0 PeopleBook</i> , “Setting Up Tax Processing and Tax Reporting,” Defining Tax Credits. |
| Retirement Basis Reduction (TRAN_EXCLUDE_TBL) | | See <i>PeopleSoft Enterprise Asset Lifecycle Management Fundamentals 9.0 PeopleBook</i> , “Setting Up Tax Processing and Tax Reporting,” Setting Up Retirement Basis Reduction Codes. |
| Transaction Groups (TRANS_PNL_GRP) | | See <i>PeopleSoft Enterprise Asset Lifecycle Management Fundamentals 9.0 PeopleBook</i> , “Setting Up Accounting Entry and Financial Processing for PeopleSoft Asset Management,” Defining Accounting Entries. |

| Component | Component Interface | Reference |
|--|---------------------|---|
| Define Transaction Codes (TRANSACTION_CODE) | | See <i>PeopleSoft Enterprise Asset Lifecycle Management Fundamentals 9.0 PeopleBook</i> , “Setting Up Accounting Entry and Financial Processing for PeopleSoft Asset Management,” Setting Up Transaction Codes. |
| User Defined Depreciation Rate (UD_DEPR_RATE) | UD_DEPR_RATE_CI | See <i>PeopleSoft Enterprise Asset Lifecycle Management Fundamentals 9.0 PeopleBook</i> , “Setting Up Depreciation Processing,” Defining Depreciation Terms and Rates. |
| User Defined Methods (UD_METHOD) | | See Chapter 15, “Using User-Defined Asset Depreciation,” Creating a User-Defined Depreciation Method, page 279. |
| User Defined Methods - Copy (UD_METHOD_COPY) | | See Chapter 15, “Using User-Defined Asset Depreciation,” Creating a User-Defined Depreciation Method, page 279. |
| User Defined Variables (UD_VARIABLE_DEFN) | | See Chapter 15, “Using User-Defined Asset Depreciation,” Creating or Selecting Variables, page 276. |
| Define Units of Production (UOP_DEFN) | | See <i>PeopleSoft Enterprise Asset Lifecycle Management Fundamentals 9.0 PeopleBook</i> , “Establishing Asset Processing,” Setting Up Units of Production Definitions. |
| Account (GL_ACCOUNT) | ACCOUNT_CF | See <i>PeopleSoft Enterprise Application Fundamentals 9.0 PeopleBook</i> , “Defining and Using ChartFields,” Adding Account Values. |
| Alternate Account (ALTACCT) | ALTACCT_CF | See <i>PeopleSoft Enterprise Application Fundamentals 9.0 PeopleBook</i> , “Defining and Using ChartFields,” Adding Alternate Account Values. |
| Operating Unit (OPERATING_UNIT) | OPER_UNIT_CF | See <i>PeopleSoft Enterprise Application Fundamentals 9.0 PeopleBook</i> , “Defining and Using ChartFields,” Adding Operating Unit Values. |
| Department (DEPARTMENT) | DEPT_CF | See <i>PeopleSoft Enterprise Application Fundamentals 9.0 PeopleBook</i> , “Defining and Using ChartFields,” Adding Department Values. |

| Component | Component Interface | Reference |
|--|----------------------------|---|
| Project ID (PROJECT) | PROJECT_CF | See <i>PeopleSoft Enterprise Application Fundamentals 9.0 PeopleBook</i> , "Defining and Using ChartFields," Adding Project Values and Grant Values. |
| Product (PRODUCT) | PRODUCT_CF | See <i>PeopleSoft Enterprise Application Fundamentals 9.0 PeopleBook</i> , "Defining and Using ChartFields," Adding Product Values. |
| Fund Code (FUND_DEFINITION) | FUND_CF | See <i>PeopleSoft Enterprise Application Fundamentals 9.0 PeopleBook</i> , "Defining and Using ChartFields," Adding Values for Expansion ChartFields 1, 2, and 3. |
| Chartfield 1 (CHARTFIELD1) | CHARTFIELD1 | See <i>PeopleSoft Enterprise Application Fundamentals 9.0 PeopleBook</i> , "Defining and Using ChartFields," Adding Values for Expansion ChartFields 1, 2, and 3. |
| Chartfield 2 (CHARTFIELD2) | CHARTFIELD2 | See <i>PeopleSoft Enterprise Application Fundamentals 9.0 PeopleBook</i> , "Defining and Using ChartFields," Adding Values for Expansion ChartFields 1, 2, and 3. |
| Chartfield 3 (CHARTFIELD3) | CHARTFIELD3 | See <i>PeopleSoft Enterprise Application Fundamentals 9.0 PeopleBook</i> , "Defining and Using ChartFields," Adding Values for Expansion ChartFields 1, 2, and 3. |
| InterUnit Template (IU_INTER_TMPLT) | IU_INTER_TMPLT | See <i>PeopleSoft Enterprise Application Fundamentals 9.0 PeopleBook</i> , "Using Interunit and Intraunit Accounting and ChartField Inheritance," Defining Interunit Templates. |
| IntraUnit Template (IU_INTRA_TMPLT) | IU_INTRA_TMPLT | See <i>PeopleSoft Enterprise Application Fundamentals 9.0 PeopleBook</i> , "Using Interunit and Intraunit Accounting and ChartField Inheritance," Defining Intraunit Templates. |
| InterUnit Pair Maintenance (IU_INTER_PR_BASIC) | IU_INTER_PR_BASIC | See <i>PeopleSoft Enterprise Application Fundamentals 9.0 PeopleBook</i> , "Using Interunit and Intraunit Accounting and ChartField Inheritance," Using Mass Maintenance for Interunit Pairs. |

| Component | Component Interface | Reference |
|---|----------------------------|---|
| Market Rates (RT_RATE_PNL) | | See <i>PeopleSoft Enterprise Global Options and Reports 9.0 PeopleBook</i> , “Processing Multiple Currencies,” Establishing Market Rates. |
| Market Rate Definition (MARKET_RATE_DEF) | | See <i>PeopleSoft Enterprise Global Options and Reports 9.0 PeopleBook</i> , “Processing Multiple Currencies,” Defining Market Rates. |
| Currency Quotation Method (CURR_QUOTE_PNL) | | See <i>PeopleSoft Enterprise Global Options and Reports 9.0 PeopleBook</i> , “Processing Multiple Currencies,” Defining Currency Quotations. |
| Ledgers for a Unit (BUSINESS_UNIT_LED) | EM_BUS_UNIT_LED | See <i>PeopleSoft Enterprise Application Fundamentals 9.0 PeopleBook</i> , “Setting Up Ledgers,” Defining Ledgers for a Business Unit. |
| Value Added Tax Code (TAX_CODE_VAT) | TAX_CODE_VAT | See <i>PeopleSoft Enterprise Global Options and Reports 9.0 PeopleBook</i> , “Working with VAT,” Setting Up VAT Authorities and Tax Codes. |
| VAT Accounts by Business Unit (TAX_BU_CODE_VAT) | TAX_BU_CODE_VAT | See <i>PeopleSoft Enterprise Global Options and Reports 9.0 PeopleBook</i> , “Working with VAT,” Defining VAT Accounts by General Ledger Business Unit (Optional). |
| VAT Entity (VAT_ENTITY_ID) | VAT_ENTITY_ID | See <i>PeopleSoft Enterprise Global Options and Reports 9.0 PeopleBook</i> , “Working with VAT,” Setting Up VAT Entities. |
| Vat Defaults CI Component (VAT_DEF_CI) | VAT_DEF_CI | See <i>PeopleSoft Enterprise Global Options and Reports 9.0 PeopleBook</i> , “Working with VAT,” Establishing VAT Defaults. |
| Customer Group Table (CUST_GROUP_TBL) | | See <i>PeopleSoft Enterprise Order to Cash Common Information 9.0 PeopleBook</i> , “Maintaining Additional Customer Information,” Establishing Customer Group Tables. |
| Contact Info (CONTACT_INFO) | | See <i>PeopleSoft Enterprise Order to Cash Common Information 9.0 PeopleBook</i> , “Maintaining Contacts”. |

| Component | Component Interface | Reference |
|--|---------------------|--|
| General Information (CUSTOMER_GENERAL) | | See <i>PeopleSoft Enterprise Order to Cash Common Information 9.0 PeopleBook</i> , “Maintaining General Customer Information”. |
| User Preferences (OPR_DEFAULT) | OPR_DEFAULT_FIN | See <i>PeopleSoft Enterprise Application Fundamentals 9.0 PeopleBook</i> , “Defining User Preferences”. |

Other Sources of Information

In the implementation planning phase, take advantage of all PeopleSoft sources of information, including the installation guides, data models, business process maps, and troubleshooting guidelines. A complete list of these resources is in the preface of the *About These PeopleBooks* with information on where to find the most up-to-date version of each.

See Also

Enterprise PeopleTools PeopleBook: PeopleSoft Setup Manager

Enterprise PeopleTools PeopleBook: PeopleSoft Component Interfaces

About These PeopleBooks

CHAPTER 2

Navigating in PeopleSoft Asset Management

This chapter discusses how to use custom Navigation Center pages in PeopleSoft Asset Management.

Using Custom Navigation Center Pages in PeopleSoft Asset Management

PeopleSoft Asset Management provides custom navigation center pages that contain groupings of folders that support a specific business process, task, or user role.

Note. In addition to the custom navigation center pages, PeopleSoft Asset Management provides menu navigation, standard navigation pages, and PeopleSoft Navigator.

Pages Used to Navigate in PeopleSoft Asset Management

This table lists the custom navigation Asset Definitions Center pages that are used to navigate implementation tasks in PeopleSoft Asset Management:

| Page Name | Navigation | Usage |
|--------------------------|---|--|
| Asset Management | Main Menu, Asset Management | Access primary PeopleSoft Asset Management menu options and activities. |
| Asset Definitions Center | Main Menu, Asset Management | Access primary PeopleSoft Asset Management Center menu options and activities. |
| Asset Transactions | Click Asset Transactions on the Asset Management menu page. | Access the Asset Transaction folder to administer financial and non-financial asset transactions, including adds, adjustments, transfers, and retirements. |
| Owned Assets | Click Owned Assets on the Asset Transactions menu page. | Access the Owned Assets folder to enter, copy, update, and display owned asset information. |
| Express Add | Click Express Add on the Owned Assets page. | Access the Express Add page to create a new asset with only financial data. |

| Page Name | Navigation | Usage |
|--------------------------------------|--|--|
| Basic Add | Click Basic Add on the Owned Assets page. | Access the Basic Add page to enter or update financial assets with physical and financial details. |
| View Component Hierarchy | Click View Component Hierarchy on the Owned Assets page. | Access the Asset Component Hierarchy page to display an asset hierarchy in a grid. |
| Manage Component Hierarchy | Click Manage Component Hierarchy on the Owned Assets page. | Access the Asset Component Hierarchy page to display an asset hierarchy in a grid as well as to insert and remove assets from the hierarchy. |
| Copy Existing Asset | Click Copy Existing Asset on the Owned Assets page. | Access Copy Existing Asset page to copy existing asset information to a new asset ID. |
| Calculate Replacement Cost | Click Calculate Replacement Cost on the Owned Assets page. | Access the Calculate Replacement Cost page to calculate and update indexed replacement costs. |
| Define Asset Operational Information | Click Define Asset Operational Info on the Owned Assets page. | Access the Define Asset Operational Information page to enter non-financial assets or update physical details of existing assets. |
| Leased Assets | Click Leased Assets on the Asset Transactions menu page. | Access the Leased Assets folder to enter and update leased asset information. |
| Express Add | Click Express Add on the Leased Assets page. | Access the Lease Express Add page to create capital or operating leases with appropriate payment and depreciation schedules. |
| Update Lease Information | Click Update Lease Information on the Leased Assets page. | Access the Update Lease Information page to enter or update leased assets with physical and financial details. |
| Create Expense Schedule | Click Create Expense Schedule on the Leased Assets page. | Access the Lease Expense Schedule page to generate new lease expense schedules. |
| Transfer Operating Lease | Click Transfer Operating Lease on the Leased Assets page. | Access the Transfer Operating Lease page to transfer an operating lease to a new ChartField. |
| Acquisition Details | Click Acquisition Details on the Asset Transactions menu page. | Access the Acquisition Details folder to review acquisition details from vouchers, purchase orders, and receipts. |

| Page Name | Navigation | Usage |
|--------------------------------|---|--|
| Review Purchase Orders | Click Review Purchase Orders on the Acquisition Details page. | Access the Review Purchase Orders page to review purchase order data such as business unit, PO ID, and related contracts. |
| Review Receivers | Click Review Receivers on the Acquisition Details page. | Access the Review Receivers page to review receiving details such as business unit, item ID, or vendor receipt quantities. |
| Review Vouchers | Click Review Vouchers on the Acquisition Details page. | Access the Review Vouchers page to review acquisition details from vouchers. |
| Asset Book Information | Click Asset Book Information on the Asset Transactions menu page. | Access the Asset Book Information component to review, add, or update asset books. |
| Define Tax/Depr Criteria | Click Define Tax/Depr Criteria on the Asset Book Information page. | Access the Define Tax/Depr Criteria page to define asset book and tax depreciation attributes. |
| Add/Copy Asset Book | Click Add/Copy Asset Book on the Asset Book Information page. | Access the Add/Copy Asset Book page to copy to a new book or convert book currency in mass. |
| Parent-Child Relationship | Click Parent-Child Relationship on the Asset Transactions menu page. | Access the Parent-Child Relationship folder to review parent-child relationships . |
| Create Parent | Click Create Parent on the Parent-Child Relationship page. | Access the Create Parent page to create umbrella parent asset; description only asset. |
| Parent-Child Basic Information | Click Parent-Child Basic Information on the Parent-Child Relationship page. | Access the Parent-Child Basic Information page to enter and update basic physical and financial data for parent or child assets. |
| Review Parent-Child | Click Review Parent-Child on the Parent-Child Relationship page. | Access the Review Parent-Child page to review parent assets and the associated child asset information. |
| Review Parent-Child NBV | Click Review Parent-Child NBV on the Parent-Child Relationship page. | Access the Review Parent-Child NBV page to view parent-child net book value; select and deselect included children. |
| InterUnit Parent-Child Trans | Click InterUnit Parent-Child Trans on the Parent-Child Relationship page. | Access the InterUnit Parent-Child Trans page to run the process for interunit parent-child transfers. |

| Page Name | Navigation | Usage |
|------------------------------|--|---|
| Capital Acquisition Planning | Click Capital Acquisition Planning on the Asset Transactions menu page. | Access the Capital Acquisition Planning folder to create and administer Capital Acquisition Plans (CAP). |
| Create (CAP) Plan | Click Create (CAP) Plan on the Capital Acquisition Planning page. | Access the Create (CAP) Plan page to define and update Capital Acquisition Plans (CAP). |
| Load Budgeting Asset Catalog | Click Load Budgeting Asset Catalog on the Capital Acquisition Planning page. | Access the Load Budgeting Asset Catalog page to load the budgeting asset catalog. |
| Send to Budgeting | Click Send to Budgeting on the Capital Acquisition Planning page. | Access the Send to Budgeting page to configure the interface for PeopleSoft Budgeting. |
| Run Report | Click Run Report on the Capital Acquisition Planning page. | Access the Run Report page to create Capital Acquisition Plan (CAP) reports. |
| Financial Transactions | Click Financial Transactions on the Asset Transactions menu page. | Access the Financial Transactions folder to perform financial asset maintenance transactions like adjustments and transfers. |
| Cost Adjust/Transfer Asset | Click Cost Adjust/Transfer Asset on the Financial Transactions page. | Access the Cost Adjust/Transfer Asset page to perform cost additions/adjustments, transfers, recategorizations, revaluations, markups, and InterUnit transfers. |
| CGU Impairment | Click CGU Impairment on the Financial Transactions page. | Access the CGU Impairment page to process CGU impairments. |
| Impairment Worksheet | Click Impairment Worksheet on the Financial Transactions page. | Access the Impairment Worksheet page to process impairments. |
| Revaluation Worksheet | Click Revaluation Worksheet on the Financial Transactions page. | Access the Revaluation Worksheet page to revalue assets using different methods. |
| Fair Market Value | Click Fair Market Value on the Financial Transactions page. | Access the Fair Market Value page to assign the fair market value for individual assets. |
| Revaluation in Mass | Click Revaluation in Mass on the Financial Transactions page. | Access the Revaluation in Mass page to collectively revalue assets. |
| Change/Delete Pending Trans | Click Change/Delete Pending Trans on the Financial Transactions page. | Access the Change/Delete Pending Trans page to update transactions in the Pending Transaction table before running depreciation processing. |

| Page Name | Navigation | Usage |
|--------------------------------|---|---|
| Cost Summarization | Click Cost Summarization on the Financial Transactions page. | Access the Cost Summarization page to process cost summarization. |
| Update Non-Capitalized Cost | Click Update Non-Capitalized Cost Asset on the Financial Transactions page. | Access the Update Non-Capitalized Cost page to update non-capitalized cost. |
| Asset Disposal | Click Asset Disposal on the Asset Transactions menu page. | Access the Asset Disposal folder to dispose of assets. |
| Retire/Reinstate Asset | Click Retire/Reinstate Asset on the Asset Disposal page. | Access the Retire/Reinstate Asset page to retire and reinstate financial assets. |
| Disposal Worksheet | Click Disposal Worksheet on the Asset Disposal page. | Access the Disposal Worksheet page to submit selected assets for disposal. |
| Approve Disposals | Click Approve Disposals on the Asset Disposal page. | Access the Approve Disposals page to approve pending asset disposal requests. |
| Auto-Retire Fully Depr Assets | Click Auto-Retire Fully Depr Assets on the Asset Disposal page. | Access the Auto-Retire Fully Depr Assets page to define auto-retire criteria to collectively retire fully depreciated assets. |
| Retire/Reinstate Non-Fin Asset | Click Retire/Reinstate Non-Fin Asset on the Asset Disposal page. | Access the Retire/Reinstate Non-Fin Asset page to retire and reinstate non-financial assets. |
| History | Click History on the Asset Transactions page. | Access the History folder to review book and cost history. |
| Review Book | Click Review Book on the History page. | Access the Review Book page to review book change history. |
| View Parent Component | Click View Parent Component on the History page. | Access the View Parent Component to view the Parent component. |
| Review Cost | Click Review Cost on the History page. | Access the Review Cost page to review capitalized and non-capitalized asset cost transactions. |
| Review Inflation | Click Review Inflation on the History page. | Access the Review Inflation page to review asset inflation history. |
| Archive Cost/Depreciation | Click Archive Cost/Depreciation on the History page. | Access the Archive Cost/Depreciation page to archive asset cost and depreciation information from production tables. |
| Restore Cost/Depreciation | Click Restore Cost/Depreciation on the History page. | Access the Restore Cost/Depreciation page to restore archived asset cost and depreciation data to production tables. |

| Page Name | Navigation | Usage |
|-------------------------------|---|--|
| Depreciation | Click Depreciation on the Asset Management menu page | Access the Depreciation folder to process and review regular and group asset depreciation. |
| Open Transactions | Click Open Transactions on the Depreciation page. | Access the Open Transactions page to create, review, and purge open transaction data. |
| Processing | Click Processing on the Depreciation page. | Access the Processing page to calculate depreciation and run depreciation-related processes. |
| Group Asset Depreciation | Click Group Asset Depreciation on the Depreciation page. | Access the Group Asset Depreciation page to consolidate, apply, and calculate group asset depreciation. |
| What-If Scenarios | Click What-If Scenarios on the Depreciation page. | Access the What-If Scenarios page to request and review what-if depreciation scenarios. |
| Review Depreciation Info | Click Review Depreciation Info on the Depreciation page. | Access the Review Depreciation Info page to review depreciation information. |
| Depreciation Process Log | Click Depreciation Process Log on the Depreciation page. | Access the Depreciation Process Log page to review depreciation processing results for errors. |
| Accounting Entries | Click Accounting Entries on the Asset Management menu page. | Access the Accounting Entries folder to process and close accounting activities. |
| Allocate Depreciation Expense | Click Cost and Depreciation Summary on the Accounting Entries page. | Access the Allocate Depreciation Expense component to allocate depreciation expense. |
| Create Accounting Entries | Click Create Accounting Entries on the Accounting Entries page. | Access the Create Accounting Entries page to create asset accounting entries. |
| Close Depreciation | Click Close Depreciation on the Accounting Entries page. | Access the Close Depreciation page to close period depreciation by generating accounting entries for the ledger. |
| Review Financial Entries | Click Review Financial Entries on the Accounting Entries page. | Access the Review Financial Entries page to review accounting entries. |
| Review Operating Leases | Click Review Operating Leases on the Accounting Entries page. | Access the Review Operating Leases page to review accounting entries for operating leases. |

| Page Name | Navigation | Usage |
|-------------------------------|--|--|
| Close Accounting Period | Click Close Accounting Period on the Accounting Entries page. | Access the Close Accounting Period page to close an accounting period to prevent accounting entries in that period. |
| Review Asset Journals | Click Review Asset Journals on the Accounting Entries page. | Access the Review Asset Journals page to review asset journal information. |
| Calculate Inflation | Click Calculate Inflation on the Accounting Entries page. | Access the Calculate Inflation page to run the process to calculate inflation amounts for assets. |
| Revalue AUS | Click Revalue AUS on the Accounting Entries page. | Access the Revalue AUS page to revalue assets (Australia). |
| Financial Reports | Click Financial Reports on the Asset Management menu page. | Access the Financial Reports folder to produce reports and load reporting tables. |
| Load Reporting Tables | Click Load Reporting Tables on the Financial Reports page. | Access the Load Reporting Tables folder to load PeopleSoft Asset Management reporting tables. |
| Asset Details | Click Asset Details on the Financial Reports page. | Access the Asset Details folder to create asset information reports. |
| Leased Assets | Click Leased Assets on the Financial Reports page. | Access the Leased Assets folder to create lease asset reports. |
| Accounting Entries | Click Accounting Entries on the Financial Reports page. | Access the Accounting Entries folder to generate account activity summaries, alternate account activity, reverse and reserve amounts, and statutory reports. |
| Cost and Depreciation | Click Cost and Depreciation on the Financial Reports page. | Access the Cost and Depreciation folder to create asset depreciation reports. |
| Retirement | Click Retirement on the Financial Reports page. | Access the Retirement folder to create asset retirement reports. |
| Cost and Depreciation Summary | Click Cost and Depreciation Summary on the Financial Reports page. | Access the Cost and Depreciation Summary page to review summarized depreciation activity, cost activity, and net book value. |
| Generate AM Charts | Click Generate AM Charts on the Financial Reports page. | Access the Generate AM Charts folder to generate PeopleSoft Asset Management charts. |

| Page Name | Navigation | Usage |
|-------------------------------|---|--|
| Send/Receive Information | Click Send/Receive Information on the Asset Management menu. | Access the Send/Receive Information folder to send and receive PeopleSoft Asset Management data and transactions. |
| Preview AP/PO Information | Click Preview AP/PO Information on the Send/Receive Information page. | Access the Preview AP/PO Information page to review the PeopleSoft Purchasing/Payables interface tables. |
| Retrieve Info from AP/PO | Click Retrieve Info from AP/PO on the Send/Receive Information page. | Access the Retrieve Info from AP/PO page to run pre-interface tables into the transaction loader. |
| Load Transactions | Click Load Transactions on the Send/Receive Information page. | Access the Load Transactions folder to load, consolidate, and unitize transactions to PeopleSoft Asset Management. |
| Load Interface | Click Load Interface on the Send/Receive Information page. | Access the Load Interface folder to send data to and receive data from PeopleSoft Asset Management tables. |
| Import Data via Spreadsheet | Click Import Data via Spreadsheet on the Send/Receive Information page. | Access the Import Data via Spreadsheet folder to import new assets from a spreadsheet using a Component Interface utility. |
| Approve Financial Information | Click Approve Financial Information on the Send/Receive Information page. | Access the Approve Financial Information folder to review and approve financial interface table transactions. |
| Approve Physical Information | Click Approve Physical Information on the Send/Receive Information page. | Access the Approve Physical Information folder to review and approve physical interface table A and B transactions. |
| Approve Lease Information | Click Approve Lease Information on the Send/Receive Information page. | Access the Approve Lease Information folder to review and approve lease interface table transactions. |
| Computer Aided Facility Mgmt | Click Computer Aided Facility Mgmt on the Send/Receive Information page. | Access the Computer Aided Facility Mgmt folder to integrate department, property, and employee information. |
| Taxes | Click Taxes on the Asset Management menu. | Access the Taxes folder to process and produce tax reports. |
| Update CCA | Click Update CCA on the Taxes page. | Access the Update CCA folder to update capital cost allowance balances. |

| Page Name | Navigation | Usage |
|----------------------------|---|--|
| Calculate Local Taxes | Click Calculate Local Taxes on the Taxes page. | Access the Calculate Local Taxes folder to update local tax information in local tax returns (Japan). |
| Depreciation | Click Depreciation on the Taxes page. | Access the Depreciation folder to calculate and update tax balances (India). |
| Reports | Click Reports on the Taxes page. | Access the Reports folder to create tax-related asset reports. |
| Asset Property Tax | Click Asset Property Tax on the Taxes page. | Access the Asset Property Tax page to enter asset property taxes. |
| Service and Maintenance | Click Service and Maintenance on the Asset Management menu. | Access the Service and Maintenance folder to create and maintain insurance and service/repair information . |
| Asset Insurance | Click Asset Insurance on the Service and Maintenance page. | Access the Asset Insurance page to define asset insurance information. |
| Asset Warranties | Click Asset Warranties on the Service and Maintenance page. | Access the Asset Warranties page to maintain asset warranty and service coverage information. |
| Maintenance Contract Terms | Click Maintenance Contract Terms on the Service and Maintenance page. | Access the Maintenance Contract Terms page to enter or update terms and coverage in maintenance contracts. |
| Review Maintenance History | Click Review Maintenance History on the Service and Maintenance page. | Access the Review Maintenance History page to review maintenance history. |
| Track Service and Repairs | Click Track Service and Repairs on the Service and Maintenance page. | Access the Track Service and Repairs page to enter or update asset service and repair information. |
| Asset Inspection | Click Asset Inspection on the Service and Maintenance page. | Access the Asset Inspection page to maintain asset inspection, cost, and coverage information. |
| Asset Checkout | Click Asset Checkout on the Service and Maintenance page. | Access the Asset Checkout page to check out assets for service and repair. |
| Asset Meter Information | Click Asset Meter Information on the Service and Maintenance page. | Access the Asset Meter Information folder to enter and update asset meter reading and to review meter reading history. |
| Reports | Click Reports on the Service and Maintenance page. | Access the Reports folder to create warranties and license information reports. |

| Page Name | Navigation | Usage |
|--------------------------------|--|--|
| Physical Inventory | Click Physical Inventory on the Asset Management menu. | Access the Physical Inventory folder to access asset physical inventory processing. |
| Physical Inventory/Mass Change | Click Physical Inventory/Mass Change on the Physical Inventory page. | Access the Physical Inventory/Mass Change page to define mass change parameters for physical inventory processing. |
| Create Schedules | Click Create Schedules on the Physical Inventory page. | Access the Create Schedules page to create a physical inventory schedule. |
| Create Extract Rules | Click Create Extract Rules on the Physical Inventory page. | Access the Create Extract Rules page to define physical inventory extract rules. |
| Define Inventory Occurrence | Click Define Inventory Occurrence on the Physical Inventory page. | Access the Define Inventory Occurrence page to establish physical inventory (PI) control ID and default PI asset transactions. |
| Load/Match/Reconcile PI Info | Click Load/Match/Reconcile PI Info on the Physical Inventory page. | Access the Load/Match/Reconcile PI Info page to export or import asset data to or from a bar code scanning device. |
| Process CSV Files | Click Process CSV Files on the Physical Inventory page. | Access the Process CSV Files page to create a comma-separated values (CSV) file. |
| Verify Duplicate Tags | Click Verify Duplicate Tags on the Physical Inventory page. | Access the Verify Duplicate Tags page to identify duplicate asset tags scanned by physical inventory counts. |
| Verify Duplicate Serial ID | Click Verify Duplicate Serial ID on the Physical Inventory page. | Access the Verify Duplicate Serial ID page to identify duplicate asset tags scanned during physical inventory counts. |
| Verify Scanned Data | Click Verify Scanned Data on the Physical Inventory page. | Access the Verify Scanned Data page to enter search criteria for physical inventory. |
| Review Matching Results | Click Review Matching Results on the Physical Inventory page. | Access the Review Matching Results page to review discrepancies between asset data and scanned physical inventory data. |
| Review Inventory History | Click Review Inventory History on the Physical Inventory page. | Access the Review Inventory History page to review assets' physical inventory history. |
| Review Extracted Data | Click Review Extracted Data on the Physical Inventory page. | Access the Review Extracted Data page to review asset extract information. |

| Page Name | Navigation | Usage |
|--------------------------------|--|--|
| Run Physical Inventory Reports | Click Run Physical Inventory Reports on the Physical Inventory page. | Access the Run Physical Inventory Reports page to create the Physical Inventory report. |
| Mass Change | Click Mass Change on the Asset Management menu. | Access the Mass Change folder to define Mass Change templates and process transactions. |
| Define Criteria | Click Define Criteria on the Mass Change page. | Access the Define Criteria page to define mass change selection criteria. |
| Run Request | Click Run Request on the Mass Change page. | Access the Run Request page to run the Mass Change process. |
| Print an Asset | Click Print an Asset on the Asset Management menu page. | Access the Print an Asset page to print asset detail information. |
| Search for an Asset | Click Search for an Asset on the Asset Management menu page. | Access the Search for an Asset page to locate an asset and view with drilldown detail functions. |
| Asset Definitions Center | Click Asset Definitions Center on the Asset Management menu. | Access the Asset Definitions Center folder to administer asset setup and configuration. |

See Also

Chapter 1, “Getting Started With PeopleSoft Enterprise Asset Management,” page 1

PeopleSoft Enterprise Asset Lifecycle Management Fundamentals 9.0 PeopleBook, “Navigating in PeopleSoft Asset Lifecycle Management”

CHAPTER 3

Implementing Asset Management

This chapter provides an overview of the steps to implement Asset Management

Understanding Asset Management

PeopleSoft provides a set of documentation components that complement each other to present all the information you need to implement Asset Management. Before you do, it is helpful to understand the various elements used in tandem with Asset Management.

Asset Management is the core financial product of the PeopleSoft Asset Lifecycle Management (ALM) Solution. The other products that compose the ALM product suite are:

- PeopleSoft Enterprise IT Asset Management.
- PeopleSoft Enterprise Maintenance Management.
- PeopleSoft Enterprise Real Estate Management.

The Asset Repository Manager (ARM) is the central feature used in common by these products. The asset repository is essentially the asset database, the core of asset processing. From the asset repository, assets are made available to other products in pursuance of their respective business processes.

See *PeopleSoft Enterprise Asset Lifecycle Management Fundamentals PeopleBook*, "Understanding the Asset Repository".

The products included in the ALM product suite also integrate directly with PeopleSoft Enterprise Human Capital Management.

Finally, Asset Management integrates with other Financials and Supply Chain Management products, including:

- PeopleSoft Enterprise Billing.
- PeopleSoft Enterprise Budgeting.
- PeopleSoft Enterprise General Ledger.
- PeopleSoft Enterprise Project Costing.
- PeopleSoft Enterprise Payables.
- PeopleSoft Enterprise Purchasing.
- PeopleSoft Strategic Sourcing.

Understanding the Asset Management Implementation Process

To implement Asset Management, you will find the information required to set up the tables and options used by Asset Management and the other ALM products in the following resources:

- PeopleSoft Enterprise Application Fundamentals PeopleBook.
- PeopleSoft Enterprise Asset Lifecycle Management Fundamentals PeopleBook
- PeopleSoft Enterprise IT Asset Management PeopleBook
- PeopleSoft Enterprise Maintenance Management PeopleBook
- PeopleSoft Enterprise Real Estate Management PeopleBook

Because the information you may need to fully implement Asset Management involves more than one PeopleSoft product, you need to refer to the *Getting Started* chapter in each PeopleBook for specific implementation and integration information.

Use the *PeopleSoft Enterprise Application Fundamentals PeopleBook* to find detailed information about the following functionality and processes:

- Defining Financials and Supply Chain Management common definitions.
- Setting installation options for PeopleSoft applications.
- Defining user preferences.
- Securing your system.
- Defining and using ChartFields.
- Editing ChartField combinations.
- Configuring ChartFields.
- Summarizing ChartFields using trees.
- Using entry events.
- Using alternate accounts.
- Defining accounting calendars.
- Setting up ledgers.
- Using journal generator.
- Using interunit and intraunit accounting and ChartField inheritance.
- Processing allocations.
- Setting up on-demand processing.

Use the *Asset Lifecycle Management Fundamentals PeopleBook* to find detailed information about the following functionality and processes:

- Establishing asset business units and cash generating units
- Establishing asset processing, including defining asset attributes, profiles, ownership and reporting options.
- Setting up accounting entry and financial processing.
- Setting up depreciation processing.

- Setting up tax processing and tax reporting.
- Integrating with other products.
- Using delivered workflows for assets.
- Configuring background processing for assets.
- Working with the Loader Table Data Dictionary.

See Also

PeopleSoft Enterprise Application Fundamentals 9.0 PeopleBook

PeopleSoft Enterprise Global Options and Reports 9.0 PeopleBook

PeopleSoft Enterprise Asset Lifecycle Management Fundamentals 9.0 PeopleBook

PeopleSoft Enterprise IT Asset Management 9.0 PeopleBook

PeopleSoft Enterprise Maintenance Management 9.0 PeopleBook

PeopleSoft Enterprise Real Estate Management 9.0 PeopleBook

PeopleSoft Enterprise Financials, Enterprise Service Automation, Asset Lifecycle Management Portal Packs 9.0 PeopleBook

PeopleSoft Enterprise Billing 9.0 PeopleBook

PeopleSoft Enterprise General Ledger 9.0 PeopleBook

PeopleSoft Enterprise Payables 9.0 PeopleBook

PeopleSoft Enterprise Project Costing 9.0 PeopleBook

PeopleSoft Enterprise Purchasing 9.0 PeopleBook

PeopleSoft Enterprise Strategic Sourcing 9.0 PeopleBook

CHAPTER 4

Converting to PeopleSoft Asset Management

This chapter provides an overview of converting to Asset Management and discusses how to:

- Convert with a customized Structured Query Report (SQR) .
- Run the Transaction Loader Edit program.
- Preview and approve results.
- Populate PeopleSoft Asset Management tables with asset data.
- Depreciate converted assets.
- Close the conversion process.
- Load retired assets.
- Convert lease information.

Understanding Conversion to PeopleSoft Asset Management

You can convert data using any number of methods that are available to you. You may want to generate a custom program after mapping records and fields from the existing database to the new PeopleSoft database; or you can perform the steps that are outlined in this chapter, using the application engine processes that are available from Oracle to convert the data.

The general tasks are:

1. Set up the database tables that will store accounting structure and asset information.
2. Transfer data from the existing system to PeopleSoft Asset Management.

No strict rules exist for performing these tasks. The pace and flow of the implementation will be guided by the requirements of your business environment, available personnel resources, and any unexpected events that you may encounter during the process.

If you use the PeopleSoft application engine processes that are described in this chapter to convert your data, Asset Management business units and books must be established before you transfer data into the loader tables. The sequence of other table setups are more flexible. You may want to partially complete the conversion before doing some table setup. For example, as you set up the Location table, you can refer to the record layout from your conversion file to determine how many different locations you need to establish and what they should be called. In general, however, you should complete the table setup that provides your system structure to begin building your asset management database. Your table setup must be complete before you can finish converting your asset data. The final conversion step, depreciating converted assets, cannot be carried out until all PeopleSoft Asset Management tables are set up. Setting up the database tables that provide your accounting structure and store asset information is discussed in previous chapters. Please refer to these for more details of the tasks involved.

Data validation is an important step as you plan and implement the conversion. Before you begin converting asset data from the current system, look closely at the existing data. Depending on the integrity of the source data, your first step should be to validate the existing data before you begin converting. At various intervals of the data conversion process, you will have the opportunity to examine the data. Create checks and balances as part of your conversion plan to test data that is being loaded into the PeopleSoft database.

Note. The Excel to CI PeopleTools spreadsheet utility enables you to use a PeopleSoft Asset Management template to upload asset data from another source to the PeopleSoft database. *You should not plan to use this utility to convert your initial database.* This utility is designed to assist in situations in which manual data entry would be tedious. Because the Excel to CI utility is limited to importing 65K rows of data at a time, large volumes of data cannot be uploaded. Because no automatic error checking is in the utility, you should carefully review all rows of data being uploaded and correct any problems as you discover them. Finally, the Asset Management template that is used for Excel to CI does not populate the INTFC_PHY_B tables. Data uploaded by this method may require additional manual data entry. Given these constraints, using the Excel to CI utility to convert legacy data to new PeopleSoft records is not recommended.

See Also

Appendix A, “Understanding the Loader Table Data Dictionary,” page 449

Prerequisites

Before proceeding with the data conversion, you must set up your business units and tables.

PeopleSoft strongly recommends that you add and depreciate some assets online *before* beginning the conversion process.

Performing these actions is a good test of your table setup. They enable you to test your Asset Profiles to ensure that they are working the way you intended, and you can see how the depreciation program works and how it is affected by different variables and conventions. Knowing what to expect from the PeopleSoft Asset Management application before you begin the conversion will assist you in making decisions for planning and carrying out the conversion.

Converting with a Customized SQR

To transfer data from an existing system into PeopleSoft Asset Management loader tables, you can write a custom SQR and use the delivered Asset Management application engines in this way:

1. Write and run a program that transfers data from the existing system into the Asset Management loader tables.

The following table describes the interim tables in Asset Management:

| Table | Description |
|-----------|--------------------------------|
| INTFC_FIN | Contains financial asset data. |

| Table | Description |
|-------------|-------------------------------|
| INTFC_PHY_A | Contains physical asset data. |
| INTFC_PHY_B | Contains physical asset data. |

Note. When writing this SQR, note that for load types of CN1 that use NEXT in the ASSET_ID field, each load line should have a unique INTFC_ID. This ensures that Asset IDs are generated correctly. In all other cases, you should use one INTFC_ID for each set of transactions with the same load type.

Note. The sample conversion program, AMCV1000.SQR, and its SQC links are not supported.

2. Run the Transaction Edit program (AMIFEDIT) to perform edit checks on the specified data fields to ensure that the information you load into PeopleSoft Asset Management is correct. The data fields that are edited include ChartFields, business units, and books.
3. Preview and approve data in the loader tables.

Use the Financials Transactions page, Physical Transactions A page, and Physical Transactions B page to see which data was loaded into the loader tables.

4. Use the Transaction Loader process (AMIF1000) to transfer information from the loader tables into your Asset Management tables.

This process reads data in the INTFC_FIN, INTFC_PHY_A and INTFC_PHY_B tables, and then populates the Asset Management tables with the asset data. This data appears in Asset Management as open transactions.

The AMIF1000 process has two options for populating open transaction accounting and transaction date fields with respect to how costs and accumulated depreciation are loaded. Search for RJS2-34 in AMIF1000 and choose the option that matches your business needs before running the program.

See [Chapter 4, “Converting to PeopleSoft Asset Management,” Using Transaction Loader Conversion Dates Options, page 36.](#)

5. Convert and depreciate the assets.

Note. When converting data from another system to PeopleSoft Asset Management, you should convert data as of the period *before* you want the system effective. You should calculate depreciation as of the *first period* that the system is effective.

For example, if you want the system to be effective on January 1, 2006, you should convert all your data as of December 31, 2005. The fiscal year, START_PD, and END_PD on the depreciation table should be 2005, 12, 12. The TRANS_DT and DTTM_STAMP should be December 31, 2005. However, you should calculate depreciation with OPEN_TRANS accounting and transaction dates of January 1, 2006.

The following diagram shows the Asset conversion process:

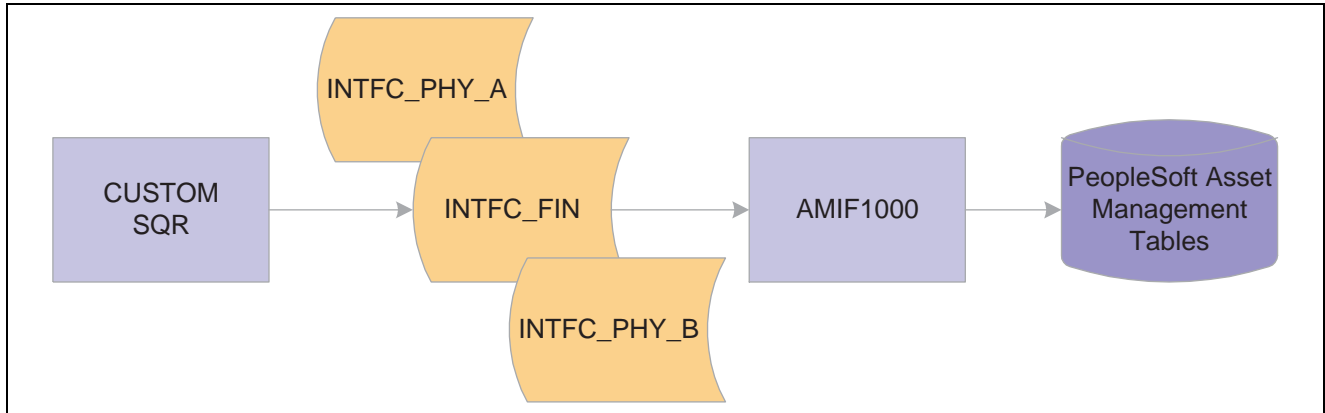

Asset conversion process

See Also

[Appendix A, “Understanding the Loader Table Data Dictionary,” page 449](#)

Running the Transaction Loader Edit Program

Before running the Transaction Loader (AMIF1000) program, you must run the Transaction Loader Edit (AMIFEDIT) program to check for valid values. The Transaction Loader Edit program edits the fields you specify, validates values, and marks those values that are in error. Using one or both of two available queries, you can check the results and view messages for those fields that are in error. This process helps ensure that the data is correct when it is entered by the Transaction Loader into PeopleSoft Asset Management tables.

This section discusses how to:

- Use the Transaction Loader Edit page.
- View the results of the Transaction Edit program.

Pages Used to Run the Transaction Loader Edit Program

| Page Name | Object Name | Navigation | Usage |
|-------------------------------|-----------------|---|--|
| Transaction Loader Edit | RUN_AMIFEDIT1 | Asset Management, Send/Receive Information, Load Transactions, Edit Transactions, Transaction Loader Edit | Run the Transaction Edit program. |
| BU Book Chartfields Summarize | AMIFEDIT_CF_SEC | Click the Chartfields link on the Transaction Loader Edit page. | Select ChartField summary options for the transaction loader edit process. |

Using the Transaction Loader Edit Page

Access the Transaction Loader Edit page.

Transaction Loader Edit

Run Control ID: CF_AUDIT [Report Manager](#) [Process Monitor](#) Run

Language: English

Run Control Parameters Find | View All | First 1 of 1 Last

Request ID: 1 Process Frequency: Once Language Code: English

Interface ID: 0 To Trans Load ID: 0 System Source:

Interface Edit Options

| | | |
|---|--|---|
| <input checked="" type="checkbox"/> Business Unit | <input checked="" type="checkbox"/> Depreciation/Retire Convention | <input checked="" type="checkbox"/> Location |
| <input checked="" type="checkbox"/> Book | <input checked="" type="checkbox"/> Depreciation Schedule | <input checked="" type="checkbox"/> Profile ID |
| <input checked="" type="checkbox"/> Category | <input checked="" type="checkbox"/> UD Method | <input checked="" type="checkbox"/> Asset Class |
| <input checked="" type="checkbox"/> Cost Type | <input checked="" type="checkbox"/> Currency Cd | <input checked="" type="checkbox"/> CAP Number/Sequence |
| Chartfields | <input checked="" type="checkbox"/> Depreciation Limit | <input checked="" type="checkbox"/> FERC Code |
| | <input checked="" type="checkbox"/> UOP ID | <input checked="" type="checkbox"/> Financing Code |
| | <input checked="" type="checkbox"/> Tax Class | <input checked="" type="checkbox"/> Vendor Code |

Find Trans Load ID (optional)

System Source: Load Type:

Load Status: Pending Financial Record Physical Records Search

Interface Information Customize | Find | View All | First 1-3 of 3 Last

| | Intfc ID | System Source | Load Type | Load Description | Load Status | Total Items in Query |
|---|----------|---------------|-----------|--------------------------|-------------|----------------------|
| 1 | 10000004 | BAM | RET | Asset Retirement | NEW | 4 |
| 2 | 90000001 | CNV | CN1 | Conversion of First Book | NEW | 1 |
| 3 | 90000002 | CNV | CN1 | Conversion of First Book | NEW | 1 |

Transaction Loader Edit page

Interface Edit Options

Select all the fields on which you want to perform the edit valuation. Cancel the selection of those fields that will have no values because you do not use the field, (that is, optional fields Category and Tax Class.)

Note. The default condition is to run edit checks on all of these fields. They are all selected when you first display the page. To prevent an edit check on a particular field, clear that check box.

Find Trans Load ID (transaction load ID)

System Source Generates the transactions that you want to edit.

Load Type A more detailed version of Trans Type. One trans type can generate several different load types.

Note. Whenever you rerun the Transaction Edit program, old message files from the previous run are deleted.

Viewing the Results of the Transaction Edit Program

To view results from the Transaction Edit program, run the following two queries:

- AM_INTFC_PHY_A_MSG (Interface Physical A Edit Messages) to see physical records.

- AM_INTFC_FIN_MSG (Interface Financial Edit Messages) to see financial records.

Previewing and Approving Results

After the asset data is in the loader tables, you will need to verify that the information in the loader tables is correct and approve all the load lines that you want to load into PeopleSoft Asset Management. This review and approval process is designed to prevent you from inadvertently loading massive amounts of invalid data into the system.

Use the Financials Transactions page, Physical Transactions A page, and Physical Transactions B page to see which data was loaded into INTFC_FIN, INTFC_PHY_A and INTFC_PHY_B. If you find errors, you can either correct them online using the SQL query tool or modify your custom SQR and run the program again.

See Also

PeopleSoft Enterprise Asset Lifecycle Management Fundamentals 9.0 PeopleBook, “Integrating PeopleSoft Asset Management with Other Products,” Previewing Data in the Loader Tables

Populating Asset Management Tables with Asset Data

This data conversion step populates PeopleSoft Asset Management database tables with the data that you just loaded into INTFC_FIN, INTFC_PHY_A, and INTFC_PHY_B by running the Transaction Loader Application Engine, AMIF1000.

The Transaction Loader is also used for mass transactions. After performing a mass change, run this Application Engine to create entries in Asset Management tables.

Note. You must run the Transaction Edit program (AMIFEDIT) before running the Transaction Loader, especially at conversion time. The Transaction Edit program performs edit checks on the data fields that you specify to help ensure that the information you load into PeopleSoft Asset Management is correct. Review the data that is loaded into INTFC_FIN, INTFC_PHY_A and INTFC_PHY_B and look carefully at the Transaction Loader Application Engine (AMIF1000) before you run it. You may need to change some of the data defaults that it contains.

See Also

PeopleSoft Enterprise Asset Lifecycle Management Fundamentals 9.0 PeopleBook, “Integrating PeopleSoft Asset Management with Other Products,” Running the Transaction Loader

Using Transaction Loader Conversion Dates Options

At conversion, you have two options when you use the Transaction Loader to populate open transaction accounting and transaction dates:

- Make the open transaction accounting and transaction dates the first day of the following period of the specified accounting date.
- Make the open transaction accounting and transaction date the same as the date that is specified in the Financial Interface table (INTFC_FIN).

First Day of the Following Accounting Period

To populate the open transaction accounting and transaction dates with the first day of the following accounting period, perform these steps.

1. Sign in to the Application Design.
2. Open Application Engine AMIF_FIN_PHY.
3. Scroll down to section 200120 and click the plus sign to expand the section.
4. Make sure that steps Step 100 and Step 120 are *Inactive* and step Step 130 is *Active*.

Populate Dates as Specified in INTFC_FIN

To populate the open transaction accounting and transaction dates with the date that is specified in the INTFC_FIN table, perform these steps:

1. Sign in to the Application Design.
2. Open Application Engine AMIF_FIN_PHY.
3. Scroll down to section 200120 and click the plus sign to expand the section.
4. Make sure that steps Step 100 and Step 120 are *Active* and Step 130 is *Inactive*.

Depreciating Converted Assets

The final step in converting to PeopleSoft Asset Management is to process all the open transactions that were created by the Transaction Loader. You will run the programs to:

- Calculate depreciation (AM_DEPR_CALC).
- Create accounting entries (AM_AMAEDIST).
- Close depreciation (AM_DPCLOSE).

Note. When converting data from the current system to PeopleSoft Asset Management, you should convert data as of the period *before* you want the system effective. You should calculate depreciation as of the *first period* that the system is effective.

For example, if you want the system to be effective on 01/01/06, you should convert all of the data as of 12/31/05. The fiscal year, START_PD and END_PD on the depreciation table, should be 2005, 12, 12, respectively. The TRANS_DT and DTTM_STAMP should be 12/31/05. However, you should calculate depreciation with OPEN_TRANS accounting and transaction dates of 01/01/06.

For converted assets and assets that are loaded through the Transaction Loader, the default is to book accumulated depreciation to the *previous* period. However, any accumulated depreciation is booked to the *current* period:

1. If you populate the START_PD, END_PD and FISCAL_YEAR fields in the Financial Loader table (INTFC_FIN) with values for the current period.
2. If the amount in the DEPR field is not 0.

Closing the Conversion Process

At this point, the conversion has created all the data in the system, and all assets are depreciated. Before you can move into full production, you must now close the conversion process:

- Verify the conversion to approve conversion results.
- Restore disk space by removing unnecessary tables from the system.
- Update security to restrict access to the conversion SQRs now that they are no longer needed.

Page Used to Close the Conversion Process

| Page Name | Object Name | Navigation | Usage |
|----------------------|--------------|---|--|
| Run Interface Loader | RUN_AMCV2000 | Asset Management, Send/Receive Information, Load Interface, Receive Conversion Data, Run Interface Loader | Run the Interface Loader program that can be used to delete data from the loader tables. |

Verifying the Conversion

You must run implementation checks to make sure that all the calculations used the correct values, followed the methods that you intended, and so forth. By balancing the conversion, you verify that the currency amounts in the system are those that you expect to see. If they are not, you need to verify your source system data and check the SQRs to determine where you might have inadvertently used the wrong depreciation method, an invalid date, or some other variable that affects calculations.

Restoring Disk Space

Access the Run Interface Loader page.

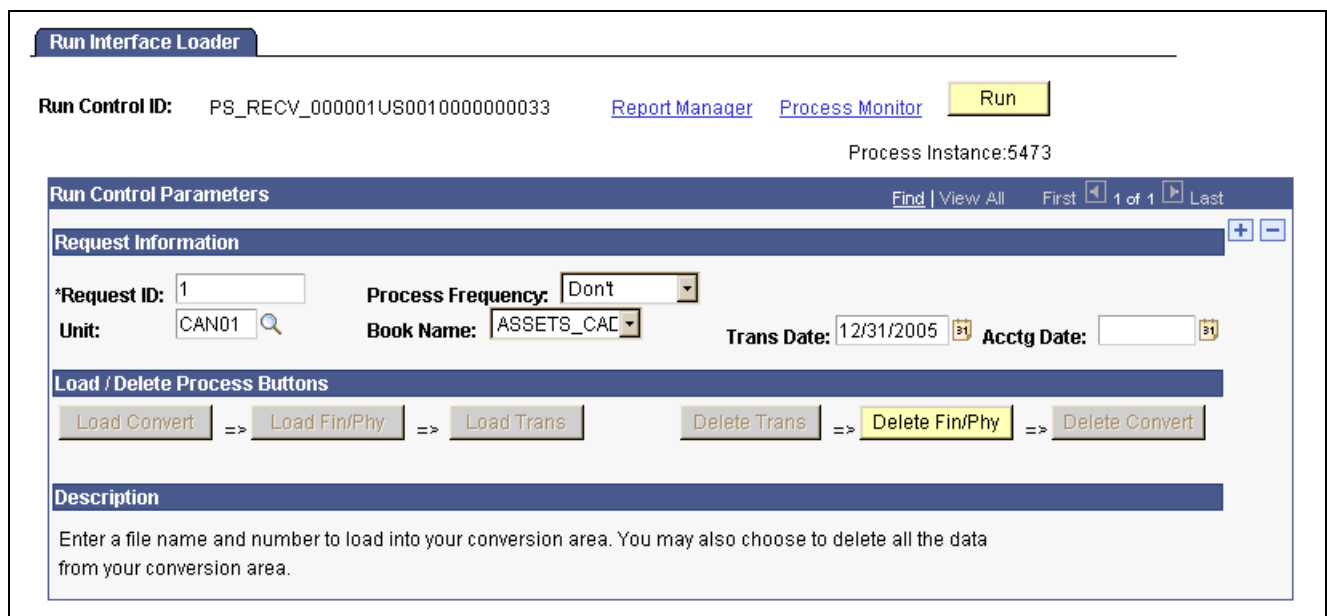

Run Interface Loader

Run Control ID: PS_REC_V_000001US0010000000033 [Report Manager](#) [Process Monitor](#)

Process Instance: 5473

Run Control Parameters Find | View All First 1 of 1 Last

Request Information + -

*Request ID: Process Frequency: Unit: Book Name: Trans Date: Acctg Date:

Load / Delete Process Buttons

=> => => =>

Description

Enter a file name and number to load into your conversion area. You may also choose to delete all the data from your conversion area.

Run Interface Loader page

When the conversion is complete, you will want to release the disk space that is occupied by all the interim tables that you used in the process. Working backwards, you can delete data from the tables that were populated by using the Interface Loader.

Load/Delete Process Buttons

Select Delete Fin/Phy and run this request. Process Scheduler runs the AMCV2000 process at user-defined intervals.

Updating Security

You may want to restrict access to the Interface Loader and Transaction Loader after the conversion is completed and approved. Review the system security page settings and make changes as warranted.

See Also

Enterprise PeopleTools 8.48 PeopleBook, "Security Administration".

Loading Retired Assets

You can add retired assets and asset history to the database. The load type *ARA* is used specifically for loading historical information for assets that are already retired.

For this load type, the Transaction Loader inserts records into Asset and, if applicable, Asset Custodian, Asset Location, Warranty, Attribute, License, Comments, PI Asset History, Parent Asset, and Acquisition Detail. It creates Book and Cost rows, as well as one row of accumulated depreciation for each book, all using the transaction type *ADD*. After modifying some of the values in INTFC_FIN and changing the transaction type to *RET*, the Transaction Loader inserts Cost and Retirement rows. The status of the assets is set to *D* (Disposed) for retired assets.

To load retired assets:

- Consider prerequisites for retiring assets.
- Populate loader tables.
- Review the retired asset data.

Considerations for Retiring Assets

Before loading retired assets, note these considerations:

- Assets should be fully depreciated and retired.
You can add partially retired assets, but the remaining cost basis will not be depreciated or processed in any way.
- The depreciation process (AM_DEPR_CALC) need not be run after the retired assets are loaded.
- After you add retired assets, you can reinstate them.

Note. The *ARA* interface type was designed to load fully depreciated, retired, or historical assets in cases for which AM_DEPR_CALC would never run and the assets would never be reinstated. To accommodate reinstatement of historical assets in this case, change the *ARA* interface type as needed.

Populating Loader Tables

To load retired assets using the *ARA* load type, follow these instructions to populate the loader tables:

- If you have a valid asset profile that is effective-dated correctly for your assets and your assets have the same amounts for cost, depreciation, gain/loss, and so on for each book (use the same depreciation conventions), you can load the retired assets with the `DEFAULT_PROFILE_SW` set to *Y*.

In this case, you should set `DEFAULT_PROFILE_SW` to *Y* on `INTFC_FIN` and `INTFC_PHY_A`, enter the valid profile ID in `INTFC_PHY_A`, and make only one entry in `INTFC_FIN` for each asset. Leave the `BOOK` field blank.

- *If this is not the case*, set the `DEFAULT_PROFILE_SW` to *N* and load one record for each book for each asset into `INTFC_FIN`. Consequently, if one asset reports to two books, you will load two records for the asset into `INTFC_FIN`.

Enter the accumulated depreciation into `INTFC_FIN.DEPR`, one entry for every ChartField combination. Each entry in `INTFC_FIN` corresponds to a row in `PS_DEPRECIATION`.

To simplify populating the load tables, one entry in `INTFC_FIN` is used to create both an *ADD* and a *RET* cost row for each book.

The key difference between the *ADD* and the *RET* rows is the `DTTM_STAMP`. The Transaction Loader loads the *ADD* row first, and then it increments the `DTTM_STAMP` by one day, sets the `RETIRE_SW` to *1*, and multiplies `COST` and `QUANTITY` by negative 1 (-1). It then loads this as the *RET* row.

Note that when the Transaction Loader finishes successfully, values in all the `INTFC_FIN` rows for *ARA* `INTFC_TYPE` and `INTFC_ID` will have changed. If you want to rerun the transaction using the same `INTFC_ID` entries:

- Subtract one day from `DTTM_STAMP`.
- Set `RETIRE_SW` back to *0*.
- Set the `LOAD_STATUS` to *New* (pending).
- Multiply the `COST` and `QUANTITY` by negative 1 (-1).

These actions restore the rows to their original values.

Reviewing Retired Asset Data

After you load retired assets, pay close attention to these `INTFC_FIN` fields:

| INTFC_FIN Field Name | Value |
|-----------------------------|---------------------------------------|
| DEPR | Accumulated depreciation. |
| INTFC_TYPE | ARA. |
| RETIREMENT_DT | The asset historical retirement date. |

| INTFC_FIN Field Name | Value |
|-----------------------------|--|
| DTTM_STAMP | Although you can set this to any value, we recommend that you set it to the earliest date/time stamp used for any of the assets that you are loading. This setting will ensure that it is earlier than all the retirement dates. |
| RETIRE_QUANTITY | Make sure it is a negative number. |
| RETIREMENT_AMT | Make sure it is a negative number. |
| FISCAL_YEAR | Represents the fiscal year (FY) of the accumulated depreciation. |
| START_PD | Starting period. |
| END_PD | Ending period. |
| GAIN_LOSS | Gain or loss. |
| END_DEPR_DT | Ending depreciation date. |
| BEGIN_DEPR_DT | Beginning depreciation date. |
| ACTIVITY_SW | 0 |
| RETIRE_SW | 0 (AMIF1000 handles the switch to 1 for the RET cost row). |
| RETIREMENT_RSV | Accumulated depreciation. |

Also pay close attention to these INTFC_PHY_A fields:

| INTFC_PHY_A Field Name | Value |
|-------------------------------|--|
| CAPITALIZATION_SW | 2 |
| PROFILE_ID | Must be valid in PROFILE_DET_TBL if you set DEFAULT_PROFILE_SW = Y in INTFC_FIN and INTFC_PHY_A. |

When using the Transaction Loader, you need not populate those fields that contain data in the PROFILE_DET_TBL if you provide a valid PROFILE_ID and set DEFAULT_PROFILE_SW to Y on both INTFC_FIN and INTFC_PHY_A.

Converting Lease Information

The interface load table INTFC_LEASE contains leased asset information for lease schedules that were already calculated. This lease interface table is used to add leases to PeopleSoft Asset Management tables using the Transaction Loader interface type *LAD* (Leased Asset Addition). The lease payment schedule information should be populated in the INTFC_LEASE table; it is not calculated by the Transaction Loader.

Before running the Transaction Loader, the INTFC_LEASE, INTFC_FIN and INTFC_PHY_A tables must be loaded with leased asset information. The new ASSET_IDs are calculated if the interface table ASSET_ID fields are set to *NEXT*. If *NEXT* ASSET_ID is used, each INTFC_LINE_NUM should represent one ASSET_ID, and the same INTFC_LINE_NUM should be used for all three interface tables.

These fields are required in INTFC_LEASE:

- PYMNT_DT
- PYMNT_SCHED_ID (do not populate this field with *NEXT*; it will not be assigned automatically)
- LEASE_TERM
- LEASE_TYPE
- IMPLICIT_RATE
- PV_MLP
- CAP_LEASE_AMT
- LEASE_DT
- MRP
- INTEREST_EXPENSE
- OBLIGATION_REDUCE
- EST_LIFE

These fields can have values of *zero* or *N*, or the default value from the profile (if you are using default profile switch = "Yes"):

- FMV
- BPO
- BPO_PAYMENT
- BORROW_RATE
- ACTUAL_RESIDUAL
- GUAR_RESIDUAL
- TSFR_OWNERSHIP_FLAG
- RENEWAL_OPTION
- ITC_AMT

- EXECUTORY_COSTS

If LEASE_TYPE = O (Operating Lease), then DEFAULT_PROFILE_SW must equal *N*. If it is an operating lease asset, then the BOOK field in the LEASE_OPER record will be populated with the DEFAULT_BOOK in the BUS_UNIT_TBL_AM record.

All of the preceding fields affect the LEASE_BOOK. The INTFC_FIN.LIFE on the LEASE_BOOK should be calculated as FREQUENCY × LEASE_TERM. For example, if the PYMNT_SCHED_ID is monthly and LEASE_TERM = 24, then LIFE = 24 and ESTIMATED LIFE = 24. The preceding data is needed for lease adjustments in Asset Management.

When the INTFC_LEASE table is populated, you can use the Load Preview-Lease page to review and correct lease data before uploading to the PeopleSoft Asset Management tables.

Pages Used to Convert Lease Information

| Page Name | Object Name | Navigation | Usage |
|-----------------------|------------------|---|--|
| Load Preview-Lease | INTFC_LEASE | Asset Management, Send/Receive Information, Approve Lease Information, Review | Review and, if necessary, correct lease data before uploading it to PeopleSoft Asset Management tables. |
| Load Approval - Lease | INTFC_LEASE_APPR | Asset Management, Send/Receive Information, Approve Lease Information, Approve | Approve lease data before uploading to PeopleSoft Asset Management tables. |

CHAPTER 5

Adding and Maintaining Assets

This chapter provides an overview of adding and maintaining assets and discusses how to:

- Add and maintain asset information.
- Maintain asset meters.
- Maintain warranties.
- Maintain asset book information.
- Add assets with the Asset ExpressAdd component.
- Copy an asset.
- View the component asset hierarchy.
- Manage the component asset hierarchy.
- Create parent-child asset relationships.
- Calculate asset replacement costs.
- Define asset operational information.
- Search for assets.
- Print asset information.
- Add assets with the Excel to Component Interface utility.

Understanding Adding and Maintaining Assets

PeopleSoft Asset Management stores the following types of asset information:

- *Financial information* includes details about cost, books, depreciation method and convention, and useful life.
- *Physical information* includes asset tag numbers, specifications, location, custodian, and manufacturer.

Oracle's PeopleSoft Asset Lifecycle Management (ALM) solution provides complete access to the entire asset portfolio, regardless of asset class, and featuring visibility into total cost of ownership by enabling cost tracking associated with acquisition as well as lifetime maintenance and performance.

Working with other products within the PeopleSoft ALM solution, including PeopleSoft IT Asset Management, PeopleSoft Maintenance Management and PeopleSoft Real Estate Management, PeopleSoft Asset Management provides functionality for the complete *plan to retire* business process, from the initial planning and acquisition of assets to the end-of-life disposal of assets.

PeopleSoft Asset Management provides a common Asset Repository Manager (ARM), accessible to all PeopleSoft ALM products and other PeopleSoft integrated products, which stores all asset data. The repository provides a single source for all physical, financial or operational asset data.

Adding Assets

After you establish PeopleSoft Asset Management foundation tables, you can add assets. This section discusses the different ways to add assets. The approach that you use depends on the needs of your organization and how much information is available when the assets are added.

To add assets, you can:

- Use Express Add to add assets using an asset profile for default book and depreciation information.
When assets are capitalized, most of the critical information is derived from the asset profile by default, and detailed physical information can be entered later.
- Use Basic Add when much of the physical information is readily available at the start. You can capitalize the asset immediately or later using the appropriate asset profile.
- Use Define Asset Operational Info to add non-financial assets.
- Use Excel to CI to add assets by uploading asset information from PeopleSoft's integrated Excel spreadsheet component interface. This process enables you to add multiple assets to generate PeopleSoft-formatted data from a predefined Excel asset template.

The PeopleSoft system enables asset receiving when you use PeopleSoft Purchasing, PeopleSoft Payables or PeopleSoft Project Costing. You can initially add an asset with only its physical information and then capitalize the asset when you receive financial information from the invoice. Conversely, you can initially add the asset's financial information when you order it and then add the physical information once it is received; or you can enter all the information at once.

You can also add assets through PeopleSoft Project Costing, along with all of the pertinent project information.

See *PeopleSoft Enterprise Project Costing 9.0 PeopleBook*, "Managing Assets," Setting Up and Using Express Capitalization.

PeopleSoft Asset Management enables you to use transaction currencies for multinational transactions. This allows you to maintain a base or local currency and conduct transactions with foreign entities by selecting a transaction currency for individual transactions. By establishing an exchange rate to convert the currencies, you can complete transactions in multiple currencies and convert them back to the base currency as needed.

Document Sequencing

Statutory requirements in some countries require that all financial transactions (documents) be classified into different transaction types, and that within each transaction type, all documents entered be numbered sequentially. The document sequencing feature helps you maintain established business practices by meeting both of these requirements.

Document sequencing is available for transactions that you create either online or through background (batch) processing. When you activate document sequencing, the system automatically assigns a sequence number to each document (invoice, voucher, journal, and so on) that you create. You can also enter sequence numbers manually. When you delete, change, or unpost a document, the system may generate additional document sequence numbers, as appropriate.

The document sequence page (AM_DOC_SEQ) is used throughout the PeopleSoft Asset Management application where a financial transaction occurs: Express Add, Basic Add, Cost Adjustment and Transfer, Leases, Copy Assets, Adjust Accumulated Depreciation, Update/Delete Pending Transactions, Impairment, and Retirement. Each page displays a document sequencing tab for the entry and allows you to view, enter or override document sequence information.

See *PeopleSoft Enterprise Asset Lifecycle Management Fundamentals 9.0 PeopleBook*, “Setting Up Accounting Entry and Financial Processing for PeopleSoft Asset Management,” Defining Document Sequencing.

Component Changeout

When you integrate PeopleSoft Asset Management with PeopleSoft Maintenance Management, component changeout functionality (swapping of older or broken components for newer replacement components) is enabled. The component changeout feature enables you to manage asset component swapping when failure or replacement is required to maintain an asset. A component is replaced with a “like-component” and the characteristics and attributes of the new component are associated with the overall larger asset. A component can be removed from one asset and marked for reuse in another asset. A component can also be served by parts. PeopleSoft Asset Management enables you to maintain an equipment parts list and associate it with an asset.

The Asset Repository manages the complete setup for component changeout functionality with predefined defaulting component hierarchy, and makes this information available to the work order operator to facilitate completion of the tasks associated with component changeout transactions.

The component changeout transaction installs, replaces, removes and disposes component assets within the Asset Repository. The process allows asset transfer and disposal transactions which are then passed to PeopleSoft Asset Management via the Transaction Loader process.

When the option to remove assets for reuse is selected, you map the ChartField accounts to be used for the transfer by entering the information on the Warehouse Mapping page via the Transaction Loader process. When the option to replace assets is selected, the transferred assets are updated with new replacement asset information via the Transaction Loader.

Meters and Warranties

Some assets are delivered with warranties or other maintenance contracts. As well, some assets may be insured where replacement of parts or service is covered under the insurance contract. PeopleSoft Asset Management enables you to track warranty, maintenance and insurance information associated with assets.

Some assets make use of meters to track usage for maintenance or billing purposes. Asset Management provides meter types and meter reading pages to monitor asset usage for these purposes.

See [Chapter 9, “Managing Asset Maintenance, Repair, Warranties, and Insurance,” page 191](#).

Adding and Maintaining Asset Information

This section discusses how to:

- Add asset basic information.
- Enter asset details.
- Enter asset acquisition details.
- View asset tax information.

- Enter document sequencing information.
- Enter asset location, comments and attributes information.
- Enter custodial, license, and manufacturer information.
- Enter property assets.
- Enter property taxes.
- Enter asset supplemental data.
- Enter attachments.

Pages Used to Add or Change Asset Information

| Page Name | Object Name | Navigation | Usage |
|------------------------|-------------------|---|--|
| General Information | ASSET_GENERAL_01 | Asset Management, Asset Transactions, Owned Assets, Basic Add | Add asset basic information manually, or modify existing asset information. |
| Asset R&D Information | ASSET_RD_SP | Click the Set R and D Info link on the General Information page. | Enter information about R&D (research and development) assets. In Australia, this information is used for tax reporting purposes; otherwise, it is informational only. |
| Warehouse Mapping | AM_WH_MAP_ASSET | Click the Asset Warehouse Mapping link on the General Information page. | Enter transfer information defaults for assets used in component changeout for PeopleSoft Maintenance Management. This page is used by PeopleSoft IT Asset Management and PeopleSoft Maintenance Management to transfer assets to a defined warehouse. Custodian, Location and Employee ID are also available. Custodian will inherit the ChartFields defined for the warehouse. |
| Fair Market Value | AM_FMV_DEFN | Click the Fair Market Value Details link on the General Information page. | Update fair market value (FMV) information for each asset. The data is stored on the AM_FMV record and is used for revaluation of the asset in accordance with statutory requirements. |
| (JPN) Local Tax Return | LTAX_ADD_INFO_SEC | Click the Local Tax Information link on the General Information page. | Enter local tax information when you acquire depreciable fixed assets. Note. Report local tax return information for Japan. |

| Page Name | Object Name | Navigation | Usage |
|--------------------------------|------------------|---|--|
| Operation/Maintenance | ASSET_GENERAL_02 | Asset Management, Asset Transactions, Owned Assets, Basic Add, Operation/Maintenance | Enter detailed physical information |
| Work Order Management | AM_WOM_OPT_ASSET | Click the Work Order Options for Components link on the Operation/Maintenance page. | Enter Work Order related information relevant to the asset. |
| Hazardous Asset Codes | ASSET_FSC | Click the Hazardous Code Info link on the Operation/Maintenance page. | When an asset is defined as hazardous, describe it by selecting at least one hazardous code from the list. |
| Asset Acquisition Detail | ASSET_ACQ_DETAIL | Asset Management, Asset Transactions, Owned Assets, Basic Add, Asset Acquisition Detail | Store information about how the asset was acquired and keep track of the separate costs and acquisition details of components that make up an asset. Note. If PeopleSoft Asset Management is integrated with PeopleSoft Payables, PeopleSoft Receivables, PeopleSoft Purchasing, or PeopleSoft Project Costing, these source systems will enter the information automatically. |
| Acquisition Details | ASSET_ACQ_DET_AP | Click the Interfaces Info link on the Acquisition Detail page. | View or enter information about assets acquired through other PeopleSoft applications. If Asset Management is integrated with other PeopleSoft applications, the source systems send the asset information via delivered interfaces. If not, you can add the information here. |
| Acquisition Detail Chartfields | ASSET_ACQ_DET_CF | Click the Acquisition Detail Chartfields link on the Asset Acquisition Detail page. | Enter acquisition ChartField details for the asset. |
| Doc Sequencing | AM_DOC_SEQ | Asset Management, Asset Transactions, Owned Assets, Basic Add, Doc Sequencing | Enter document sequencing information. |

| Page Name | Object Name | Navigation | Usage |
|----------------------------------|--------------------|---|--|
| Tax | ASSET_ACQ_DET_VAT | Click the Tax link on the Asset Acquisition Detail page. | Enter tax information for the asset. This feature is available only if the business unit is activated for VAT (value-added tax) processing. |
| Location/Comments/Attribute | ASSET_IMAGE□ | Asset Management, Asset Transactions, Owned Assets, Basic Add, Location/Comments/Attributes | Record the location and physical properties of the asset (such as color, height, weight) and store comments about it; view a stored image of the asset. |
| Assets by Location – Parameters | RUN_AMAS2200 | Asset Management, Financial Reports, Asset Details, By Location | Generate a report of assets sorted by location. |
| Manufacture/License/Custodia | ASSET_CUSTODIAN□ | Asset Management, Asset Transactions, Owned Assets, Basic Add, Manufacture/License/Custodian Or click the More Manufacturer Info link on the Operation/Maintenance page. | Record custodial information, maintain license information, and store manufacturer-related information. |
| License Address | ASSET_LIC_ADDR_SEC | Click the Address button on the Manufacture/License/Custodian page in the License Information group box. | Enter address information associated with an asset license. |
| License Information – Parameters | RUN_AMAS1700 | Asset Management, Service and Maintenance, Reports, License Information | Generate a report of asset licenses. |
| Asset Property | ASSET_PROPERTY | Asset Management, Asset Transactions, Owned Assets, Basic Add, Asset Property | Enter details to manage property assets and to maintain property specific attributes such as identifying information, asset hierarchy, area and occupancy, and legal descriptions. This page tab displays when the asset type of <i>Property</i> is selected; however, if Lease Administration is not a selected product within Installation Options and Space Management Installed is not selected within the Asset Management Installation Options, the Property page is disabled. |

| Page Name | Object Name | Navigation | Usage |
|-------------------------|----------------|--|---|
| Record Property Taxes | ASSET_PROP_TAX | Click Enter Property Taxes link from the Asset Property page. | Enter property tax details including due dates, taxing authorities and payments. |
| Asset Supplemental Data | AM_ASSET_SD | Asset Management, Asset Transactions, Owned Assets, Basic Add, Asset Supplemental Data | Record additional data based upon asset Business Unit, asset type, subtype, manufacturer and model. |
| Attachments | AM_ADD_ATTACH | Asset Management, Asset Transactions, Owned Assets, Basic Add, Attachments | Attach pertinent documents related to the asset. |

Adding Asset Basic Information

Access the General Information page.

The screenshot displays the 'General Information' page for an asset. At the top, there are tabs for 'General Information', 'Operation/Maintenance', 'Asset Acquisition Detail', and 'Location/Comments/Attributes'. Below the tabs, the 'Unit' is JPN01, 'Asset ID' is 000000000001, and 'Site 20' is selected. The 'Tag' is 'In Service'. The main section is titled 'Asset Information' and contains several fields and sections:

- Description:** Site 20
- Short Description:** Site 20
- CAP #:** [Empty field]
- Seq #:** [Empty field]
- Taggable Asset**
- Tag Number:** [Empty field]
- Asset Class:** [Empty field]
- Asset Type:** Property
- Asset Subtype:** [Empty field]
- *Asset Status:** In Service
- Acquisition Date:** 04/27/2006
- Placement Date:** 04/27/2006
- Collateral Asset:** [Empty field]
- *Acquisition Code:** Purchased
- FERC Code:** [Empty field]
- Financing Code:** [Empty field]
- Fair Market Value:** 0.000
- Appraisal Date:** [Empty field]
- Replacement Cost:** [Empty field]
- Last Update:** [Empty field]
- Index Name:** [Empty field]
- SubIndex Name:** [Empty field]
- Parent/Child:** None
- Parent ID:** [Empty field]
- Profile ID:** [Empty field]
- Reporting Life:** [Empty field]
- Schedule Type Code:** [Empty field]
- Last Review DT:** [Empty field]

Additional sections include 'Local Tax Information', 'Asset Warehouse Mapping', 'Auction Status: Not allowed to be Auctioned', 'Region Code: [Empty field]', 'Capitalized Asset' (unchecked), 'New Asset' (checked), 'Available For Use' (unchecked), 'Composite Asset' (unchecked), 'Composite Asset ID: [Empty field]', and 'Fair Market Value Details'.

General Information page

Unit Displays the business unit in which the asset is defined.

Asset ID Select the default *Next* to have the system automatically assign the next available number. You can also enter an alphanumeric value of your own.

| | |
|--|--|
| | <p>Note. When entering joint venture assets that are shared among several business units, it is recommended that you assign a unique asset ID. This ensures that the assets created at the participant level all have the same ID as the assets created at the joint venture business unit level. For example, you might use the prefix <i>JV</i>, which would generate an asset ID such as JV000022.</p> |
|--|--|

| | |
|--|--|
| Tag | Displays the tag number for assets already entered. |
| Asset Status | Displays of the current status of the asset, such as <i>In Service</i> . |
| Description and Short Description | Enter identifying and descriptive information about the asset. The Short Description can be an abbreviated description. |
| CAP # (capital acquisition plan number) and Seq # (sequence number) | Enter a CAP #(capital acquisition plan number) and associated sequence number, if applicable. The CAP # ties the asset to a Capital Acquisition Plan. Only valid numbers set up in the Capital Acquisition Plan table are accepted. The sequence number defines the detailed elements of the capital acquisition plan. |
| Taggable Asset and Tag Number | If you use tags to track assets, enter the Tag Number assigned to the asset. This automatically selects the Taggable Asset check box. Asset Management performs physical inventory using the asset tag number. If the business unit for this asset is set up to allow a default tag number based on the Asset ID, the default tag number appears here. |

| | |
|--|--|
| | <p>Note. You must use tag numbers to perform physical inventory with the Asset Management physical inventory application.</p> |
|--|--|

| | |
|--|---|
| | See Chapter 12, “Performing Asset Physical Inventory,” page 229 . |
|--|---|

| | |
|----------------------|--|
| Asset Class | If you use classifications to define assets within categories, enter the Asset Class code here. The Asset Class enables you to identify assets for reporting purposes. The asset class is also used as a VAT driver. |
| Asset Type | Select a value to indicate a type of asset. The available options are: <ul style="list-style-type: none"> <i>Equipment</i> <i>Facility</i> <i>Fleet</i> <i>Furniture</i> <i>Hardware</i> <i>Intangible</i> <i>Machinery</i> <i>Other</i> <i>Property</i> <i>Software</i> |
| Asset Subtype | Select a value to indicate a subset of asset type. Subtypes are optionally user-defined and directly related to the Asset Type. Only asset subtypes of the selected asset type are available when defining the asset. |

| | |
|--|---|
| Asset Status | <p>Select the appropriate Asset Status from the following options:</p> <ul style="list-style-type: none"> • <i>Budgeted</i>: Asset is budgeted but not placed in service. • <i>Work in Progress</i>: Asset is acquired for a project under way. • <i>Requisitioned</i>: Necessary paperwork has been completed for acquisition. • <i>Commitment</i>: Budget has been approved and the asset is being acquired. • <i>Received (not in service)</i>: Asset has been received but not yet placed in service. • <i>In Service</i>: Indicates the date the asset is available for use. The transaction date is the default. • <i>Disposed</i>: Asset has been disposed of. • <i>Transferred</i>: The Asset has been transferred from one business unit to another. • <i>Suspended</i>: Depreciation has been suspended for the asset. |
| Acquisition Date | Enter the date when the asset was acquired. This field is automatically populated if the asset was added from a feeder system, such as Purchasing or Payables. |
| Placement Date | Enter the date that the asset is placed in service for physical purposes. |
| (JPN) Collateral Asset | <p>Japanese accounting principles require that assets offered as collateral be treated according to financial reporting regulations under the commercial law. If this asset is such a collateral asset, select one of the available options that comply with Japanese requirements.</p> <p>See Chapter 23, “Using the Global Features of PeopleSoft Asset Management,” (JPN) Using PeopleSoft Asset Management Options to Meet Japanese Requirements, page 427.</p> |
| Acquisition Code | <p>The Acquisition Code indicates how you acquired the asset. Select one of the following options:</p> <ul style="list-style-type: none"> • <i>Donated</i>: Use for donated assets. • <i>Constructed</i>: Use for constructed assets. • <i>Leased</i>: Use to tie an asset to a capital or operating lease. You must also specify the capital or operating Lease Asset ID. • <i>Like Exchange</i>: This option is not valid for this page. You must add like exchanges in the Asset ExpressAdd component. • <i>Purchased</i>: This option is used for purchased assets. This is the default. • <i>Trade In</i>: This option is not valid for this page. You must add traded-in assets in the Asset ExpressAdd component. • <i>Transferred</i>: Transferred, either within the same business unit or to another business unit. |
| FERC Code (Federal Energy Regulatory Commission code) | The FERC Code is used to identify depreciation according to FERC guidelines. This field is used in the U.S., usually to identify group assets, such as telephone poles, highway signs, or other assets used in mass quantities. |

| | |
|--|---|
| Financing Code | Enter the code as you have defined it. Financing codes enable you to analyze debit and credit relationships for capital-intensive and government projects. |
| Fair Market Value | This display-only field indicates the fair market value (FMV) of the asset as updated from the Fair Market Value page. The FMV is used in the calculation of asset revaluation. |
| <hr/> | |
| Note. The Fair Market Value and related fields are not visible in Add mode. | |
| <hr/> | |
| Appraisal Date | This display-only field indicates the date when the current FMV was updated. When the asset is added to the database, the appraisal date is the same as the acquisition date by default. |
| Fair Market Value Details | Click to access the Fair Market Value page to update the fair market value details associated with an asset. |
| Replacement Cost | Indicates how much it would cost to replace the asset. When the asset is added to the database, the replacement cost is equal to the total base cost of the asset by default. The replacement cost can be derived by associating the asset to a cost index, such as the consumer price index (CPI) or inflation index. The association of the replacement cost index can be applied by default from the asset profile; the replacement cost is then calculated considering the base cost and the index amounts. The result is displayed here. |
| Last Update | If you are calculating the replacement cost using an index, the date that you performed the last update appears here. When the asset is added, this date the accounting date. |
| Index Name and Subindex Name | Enter the adjustment of the replacement cost using an index, such as the consumer price index. When you calculate the replacement cost, the original replacement cost is adjusted by the index and subindex that you specify. Enter valid codes. These are established on the Indexes page during implementation. |
| Parent/Child and Parent ID | For a parent or child asset, select the appropriate option in the Parent/Child field. If it is a child asset, enter the parent ID with which it is associated. The default is <i>None</i> . Parent and child assets cannot also be composite or group assets. |
| Profile ID | Enter a profile ID. Asset profiles are set up in the Asset Profile component. |
| (JPN) Reporting Life | Enter the reporting life for Japanese composite assets. This life is used for calculating average life of the Composite Asset |
| Set R and D Info (set research and development information) | Click to access the Asset R&D Information page, where you can enter identifying information for the asset. |
| (JPN) Local Tax Information | Click to access the Local Tax Return page. See Chapter 23, "Using the Global Features of PeopleSoft Asset Management," (JPN) Using PeopleSoft Asset Management Options to Meet Japanese Requirements, page 427. |
| Asset Warehouse Mapping | Click to access the Warehouse Mapping page. |
| Auction Status | Displays the status of an asset that has been submitted to Strategic Sourcing for auction. |

| | |
|---|---|
| Region Code | Select a region to categorize property assets by regions. Used for reporting. |
| Capitalized Asset | Indicates whether the asset has been capitalized. This check box is display-only. |
| New Asset | Select if this is a new asset. |
| Available For Use | Select if the asset is available to be used. |
| Composite Asset and Composite Asset ID | <p>Composite asset processing enables you to group assets so that their total cost is carried by one asset and depreciated that way. By selecting this option, you indicate that this single asset is a composite asset, and associated assets are known as composite members. This feature is frequently used by utility companies, and it meets the requirements to use the Japanese <i>Composite Depreciation Method</i>.</p> <p>When you select the Composite Asset check box on the Asset Information page, an Asset ID field appears. Associate the composite member by selecting the asset ID of a composite asset.</p> <p>See Chapter 11, “Using Composite Asset Processing,” page 223.</p> |
| (AUS) Schedule Type Code | If this is an Australian business unit, select a schedule type code. |
| (AUS) Calculate Last Date of Review | Click to generate the last date of mandatory review for the asset. |
| | <hr/> <p>Note. You cannot access the Schedule Type Code field, the Calculate Last Date of Review button or the Last Date of Mandatory Review field if the last date of mandatory review has already been calculated, <i>unless</i> you are in correction mode.</p> <hr/> |
| (AUS) Last Review DT | <p>Displays the last date of mandatory review for the asset. The last date of mandatory review is stored at the asset level.</p> <p>See Chapter 23, “Using the Global Features of PeopleSoft Asset Management,” (AUS) Using PeopleSoft Asset Management Options to Meet Australian Requirements, page 402.</p> |
| Book Page | Click to save the component and access the Book (ASSET_BOOK_01) page. |

(AUS) Identifying R&D Assets

Access the Asset R&D Information page.

Asset Management enables you to identify assets for the purpose of calculating research and development deductions.

| | |
|---|--|
| R and D Plant (research and development plant) | Select to identify the asset as specifically allocated for research and development. |
| R and D Start Date (research and development start date) | Enter the start date for the asset. |
| Use NBV (use net book value) | Select to use net book value for your tax reporting purposes. Click the OK button to return to the Asset Information page. |

See [Chapter 23, “Using the Global Features of PeopleSoft Asset Management,” \(AUS\) Using PeopleSoft Asset Management Options to Meet Australian Requirements, page 402.](#)

(JPN) Creating a Local Tax Return

Access the Local Tax Return page.

Asset Management enables you to calculate and run reports as required by Japanese local tax laws, including all required information for the local depreciable asset tax return. When the Localization Country field in Overall preferences is set to *Japan*, the Establish Business Units component for PeopleSoft Asset Management includes the Business Unit Info for Japan page. If you select Use JPN Local Tax on this page, you enable access to the Local Tax Return page from the General Information page.

Complete the fields as necessary to generate the Japanese local tax return.

See [Chapter 23, “Using the Global Features of PeopleSoft Asset Management,” \(JPN\) Using PeopleSoft Asset Management Options to Meet Japanese Requirements, page 427.](#)

Using Asset Warehouse Mapping

Access the Warehouse Mapping page.

Warehouse Mapping

Default Mapping from Asset

Operating Unit:

Fund Code:

Department:

Program Code:

Class Field:

Budget Reference:

Product:

Project:

Location Code

Custodian

EmplID

Warehouse Mapping

Default Mapping from Asset

Select to apply the asset ChartFields, location and custodian from the asset ID. The option displays as not selected (unchecked) by default. If the option is not selected, the system will use the ChartFields mapped at the business unit level.

Operating Unit, Fund Code, Department, Program Code, Class Field, Budget Reference, Product, Project

Displays the ChartField account codes to be used for the transferred component (asset). Only the active ChartFields for your system display.

| | |
|----------------------|---|
| Location Code | Select the Location Code where the replaced or transferred asset will be physically stored. |
| Custodian | Select the custodian or physical “owner” of the asset. |
| EmplID | Enter the employee ID assigned to the asset. |

Entering Asset Details

Access the Operation/Maintenance page.

| General Information | Operation/Maintenance | Asset Acquisition Detail | Location/Comments/Attributes |
|---|-----------------------|---|------------------------------|
| Unit: JPN01 Asset ID: JPN003 Computer Hardware | | Tag: In Service | |
| Asset Structure Asset Type: Hardware Asset Subtype: Component of: <input type="text"/> <input type="checkbox"/> Clustered Asset Work Order Options for Components | | Manufacturer Information Serial ID: <input type="text"/> Mfg ID: <input type="text"/> Model: <input type="text"/> Version: <input type="text"/> More Manufacturer Info... | |
| Asset Resource Information <input type="checkbox"/> Schedulable Charge Back: Default <input type="checkbox"/> Allow Overbooking WO Unit: <input type="text"/> <input type="checkbox"/> Use As Tool Shop: <input type="text"/> Crew: <input type="text"/> | | Maintenance Information <input type="checkbox"/> Repairable Repair Status: None Parts List: <input type="text"/> WO Location: <input type="checkbox"/> Offline Criticality: 02 Medium | |
| Other Information <input type="checkbox"/> Hazardous Asset Hazardous Code Info... <input type="checkbox"/> Non-Owned Asset <input type="checkbox"/> Replacement Asset Asset ID: <input type="text"/> <input type="checkbox"/> Asset is Available Contact: <input type="text"/> <input type="checkbox"/> Linear Asset Phone #: <input type="text"/> | | IT Asset Related information IP Address: <input type="text"/> CPU: <input type="text"/> | |

Operation/Maintenance page

Asset Structure

This section discusses how to define the asset structure. Assets may be catalogued as assets of a certain type, with sequential subtypes, assets that are components of a higher level asset, or clustered assets, multiple assets that combine to establish a whole asset.

| | |
|------------------------|---|
| Asset Type | Displays the asset type for this asset from a list of valid definitions. |
| Asset Subtype | Displays the asset subtype to this asset type. Only one asset subtype can be applied to an asset type. |
| Component Of | Enter the Asset ID that this asset is a component of. |
| Begin Date | Enter the date when the relationship begins. This field is only visible when a component is assigned or updated. |
| Clustered Asset | Select to indicate that the asset is part of a larger entity or cluster. A clustered asset is similar to a group asset. This field is used for reporting purposes only. |

Work Order Options for Components Go to the Work Order Options for Components page to define options for work orders.

Manufacturer Information

This section provides information to define asset manufacturer information.

Serial ID Enter the asset serial number ID, if available. Serial ID is required for asset type hardware.

Mfg ID Enter the asset manufacturing ID, if available.

Model Enter the asset model information or ID, if available.

Version Enter the asset version information or ID, if available.

More Manufacturer Info Select this link to go to the Asset Manufacture/License/Custodian (ASSET_CUSTODIAN) page.

Asset Resource Information

This section provides information to define the asset as a resource.

Schedulable Select if the asset can be scheduled by users. For example, a crane extension can be used on multiple cranes at multiple project sites. It may require separate inspections and certifications from the crane. It could be used to replace a similar extension in use on another crane that must be taken out of service for repairs or inspection. And since it can be used on more than one crane, it may be considered a schedulable asset. Only schedulable assets can be checked out using the asset checkout feature.

Allow Overbooking Select if the asset schedule of the asset can be overbooked.

Use As Tool Select if the asset is used as a tool in another event. This requires that an asset subtype be associated with the asset.

Charge Back Select if the asset can be charged back to a department, operating unit, project or other cost expensing entity.

WO Unit Enter the associated work order business unit accessing the asset. This option is available if PeopleSoft Maintenance Management is installed.

Shop This option is available if PeopleSoft Maintenance Management is installed. It is used for defaulting the location where the asset needs to be worked on during repair.

Crew Select the Crew name from the list of crews associated with the WO Unit and Shop that you previously selected.

Note. This option is available if PeopleSoft Maintenance Management is installed.

Maintenance Information

This section provides maintenance information about the assets.

Repairable Select if the asset can be repaired as needed.

| | |
|--|---|
| Repair Status | <p>Select a repair status of the asset. This field is available when the Repairable option is selected.</p> <p><i>Needs Repair, In Repair, and None.</i> Repair status can be updated from PeopleSoft Maintenance Management if the Repairable option is selected.</p> |
| Parts List | <p>Select a corresponding equipment parts lists (EPL) established for this asset. It is important to be sure that all the criteria match in order to assign an EPL template to the asset (Asset Type, Subtype, Manufacturer ID, Model and Product Version.)</p> |
| WO Location | <p>Select the Work Order location for the asset. This location designates where the repair will take place. The values are Asset, Shop or Other.</p> |
| Criticality | <p>Select the appropriate level of criticality for the asset. Criticality levels are defined on the Asset Criticality page (AM_CRIT_LVL) Set up Financials/Supply Chain, Product Related, Asset Management, Service and Repair, Criticality Code. You can establish meaningful levels of criticality for your organization when defining the Criticality Code and associated description.</p> <p>See <i>PeopleSoft Enterprise Asset Lifecycle Management Fundamentals 9.0 PeopleBook</i>, “Establishing Asset Processing,” Defining Asset Attributes.</p> |
| Offline | <p>Designate whether the asset is available or offline. (The field is informational only.)</p> |
| Other Information | |
| Hazardous Asset | <p>Select if the asset is considered a predominant or significant hazardous material.</p> <hr/> <p>Note. The federal government of the United States defines hazardous materials and waste to include: “Solid, liquid, or gaseous waste, or combination of these wastes, which because of its quantity, concentration or physical, chemical, or infectious characteristics may cause significantly to an increase in mortality or an increase in serious irreversible or incapacitating illness or pose a substantial present or potential hazard to human health or the environment when improperly treated, stored, transported, disposed of, or otherwise managed.”</p> <hr/> |
| Hazardous Code Info (hazardous code information) | <p>Click to access the Hazardous Code Information page, where you can indicate hazardous material information by selecting assigned codes. The PeopleSoft system is delivered with the U.S. Federal Supply Class (FSC) codes, or you can select from codes that are created during implementation to suit your specific needs.</p> <p>See <i>PeopleSoft Enterprise Asset Lifecycle Management Fundamentals 9.0 PeopleBook</i>, “Establishing Asset Processing,” Setting Up Hazardous-Material Codes.</p> |
| Non-Owned Asset | <p>Check if this asset is not owned.</p> |
| Replacement Asset and Asset ID | <p>Select if this is a replacement asset. When an asset (or asset component) has been replaced by another in PeopleSoft Maintenance Management, this field automatically displays the associated new asset ID.</p> |

Note. The asset ID displayed here shows the replaced asset ID. The new asset that replaced this asset has a new asset ID on the General Information page.

Asset is Available, Contact, and Phone #

Select and complete contact information if the asset is available for reassignment to another person.

Linear Asset

Identify an asset as linear within the Asset Repository. These are assets that have coordinates for their start and end points, such as a pipeline, train track or a highway. You can identify linear assets at the Asset Subtype level when defining subtypes. In this way, when you select a subtype for the asset, the Linear Assetcheck box automatically inherits the designation that was made for the asset subtype. You can, however, override the subtype linear designation here at the individual asset level.

Note. Identification of linear assets facilitates potential integrations with third-party products.

IT Asset Related Information

This section discusses how to define IT asset related information.

IP Address Enter the IP address of the asset.

CPU Enter the CPU identifier.

Using Work Order Options for Components

Access the Work Order Management page.

Work Order Management

Default Rules from Asset

- Retire Assets Components
- TRF Out Components for Reuse
- Transfer In Components

[Asset Warehouse Mapping](#)

InterUnit Transfer Defaults Options

| | | |
|--|--|---|
| <input type="checkbox"/> Asset Acquisition Info | <input type="checkbox"/> Asset Attributes Info | <input type="checkbox"/> Asset License/Register Info |
| <input type="checkbox"/> Asset Lease Info | <input type="checkbox"/> Asset Non Capitalized Cost | <input type="checkbox"/> Asset Maintenance Info |
| <input type="checkbox"/> Asset Comments | <input type="checkbox"/> Asset Warranty Info | <input type="checkbox"/> Asset Insurance Info |
| <input type="checkbox"/> Asset Inspection Info | <input type="checkbox"/> Asset Component History | <input type="checkbox"/> Asset Attribute Groups Info |

Work Order Management page

This page defines the transfer include and exclude rules for components swapped out and Interunit transfer options. It is available when PeopleSoft Maintenance Management is installed. It is also available on the business unit, asset type and subtype pages. You can define the rules at this level as an exception. If the Default Rules from Asset check box is not selected, the options are grayed out as the options will be taken from other levels unless you specifically check the option to use it at the asset level.

- Default Rules from Asset** Check to enable rules from asset. If you leave this check box unchecked, the system will take the default from a higher level and the other two fields will be grayed out.
- Retire Assets Components** Select to allow asset subcomponent disposal when the asset component is retired.
- Transfer Out Asset Components for Reuse** Select to allow transfer of subcomponents when the asset component is transferred.
- Asset Warehouse Mapping** Click to view the Warehouse Mapping page.
- InterUnit Transfer Defaults Options** Select the asset information to include with the transfer when there is an InterUnit transfer.

Using Hazardous Asset Codes

Access the Hazardous Asset Codes page.

| Hazardous Asset Codes | | | | |
|-----------------------|---------------------------|----------------|--|---|
| Hazardous Asset Codes | | | Customize Find View All [Grid Icon] First [Left Arrow] 1-2 of 2 [Right Arrow] Last | |
| | Hazardous Code | Hazardous Type | Items Contained | |
| 1 | 1375 <input type="text"/> | S | DEMOLITION MATERIALS | <input type="button" value="+"/> <input type="button" value="-"/> |
| 2 | 1370 <input type="text"/> | S | PYROTECHNICS | <input type="button" value="+"/> <input type="button" value="-"/> |

Hazardous Asset Codes page

When an asset is defined as hazardous, describe it by selecting at least one hazardous code from the list. This feature supports U.S. FSC codes, which are delivered with PeopleSoft Asset Management. When you mark an asset as hazardous and associate a descriptive code with it, you can also provide additional information about its location and custodian and other pertinent data (in the Basic Add component). You can use this information to generate a report to monitor or track hazardous assets.

- Hazardous Code** Select a code number.
- Hazardous Type and Items Contained** These fields display the values contained in the definition for the code from the Hazardous Codes table established at implementation.

Entering Asset Acquisition Details

Access the Asset Acquisition Detail page.

Asset Acquisition Detail page

Use the Asset Acquisition Detail page to enter costs before they have been approved for capitalization. Once they are approved, you can then capitalize them. The total capitalizable costs entered here appear by default in the Capitalize Information collapsible section.

Enter the following information for *each* acquisition detail line:

- System Source** Enter the source system from which the acquisition detail was derived for PeopleSoft Asset Management. The system source that you enter must be valid in the PeopleSoft Financials and Distribution Source table, and is typically Purchasing (PO), Payables (AP), or Project Costing (PC).
- Incentive ID** Investment incentives are derived from Project Costing. You can override amounts from Project Costing .
- Capitalize** Indicates whether this cost row has been capitalized. If it has not already been capitalized, you can assign it a status of *To be Capitalized* or *Never Capitalize*. PeopleSoft Asset Management enables you to associate books with non-capitalized assets with the *Never Capitalize* status. Based on the

option that you select, either the Capitalization Information section or the Non Capitalization Information section appears on the page.

Interfaces Info

Click to access a separate page where you can enter acquisition details information.

Acquisition Detail Chartfields

Click to access a separate page for storing ChartField information. Enter the operating unit, department, product, and project ID that you want to associate with the acquisition detail line.

Capitalization Information and Non Capitalization Information

Use the Capitalization Information section to capitalize assets using the book information provided by the asset profile. Enter cost information into asset books.

Use the Non Capitalization section to add non-capitalized costs associated with an asset at book level.

Local tax legislation may require capital gains tax in relation to the disposal of assets. Non-capitalized costs may need to be included in resultant capital gain (or loss) calculations.

Profile ID

Identifies a profile that is set up in the Asset Profile table. The current asset automatically displays all financial and tax depreciation information defined in that profile. You must enter a profile ID for each asset that you capitalize.

Accum Depr in Current Pd (accumulated depreciation in current period)

Select and add accumulated depreciation for the asset to be booked to the current period. Otherwise, accumulated depreciation is booked to the previous period. This check box appears only if you are capitalizing an asset.

Transaction Date and Accounting Date

By default, these fields display the current date or the dates specified as user defaults. Transactions in Asset Management are entered after they have occurred. The Transaction Date field reflects the accrual date that the event took place, while Accounting Date field reflects when it was booked or sent to accounting in the system. The transaction date must be earlier than or equal to the accounting date. For capitalized assets, note that any difference between accounting and transaction dates affects depreciation as well as posting or booking.

Transaction Code

Identifies which accounting entry template is used for the asset. The system accepts only a valid combination of asset category, transaction code, cost type, and transaction type for which accounting entry templates exist.

Capitalize

Click the Capitalize button to capitalize the asset and add cost rows for all books in the profile ID. The cost rows that appear by default equal the total of all capitalizable acquisition detail rows. You can change this amount. The Capitalize button is no longer present once you have clicked it.

Non-Capitalize

Select the Non-Capitalize button to add rows for all books in the profile ID. The cost rows that appear by default equal the total of all non-capitalizable acquisition detail rows. This button only appears when *Never Capitalize* is selected from the Capitalize options.

Amount left to be Capitalized

After capitalization, all capitalizable cost rows on the Asset Acquisition Detail page are marked as capitalized. Therefore, the amount left to be capitalized is 0 until you add more capitalizable cost rows to the Asset Acquisition Detail page.

Amount left to be Non-Capitalized

After capitalization, all non-capitalizable cost rows on the Asset Acquisition Detail page are marked as non-capitalized. Therefore, the amount left to be

non-capitalized is 0 until you add more non-capitalizable cost rows to the Asset Acquisition Detail page.

Accum Depr (accumulated depreciation) For capitalized assets, enter the amount of depreciation already recognized. If you are adding assets that have depreciation from prior years or prior periods, enter that amount in this field.

Note. As long as all acquisition detail lines are for the same set of ChartFields (Product, Project, Department) and for the same category and cost type, you can enter them all at once and capitalize them later by clicking the Capitalize button. However, if you enter acquisition detail lines for more than one set of ChartFields and for more than one category and cost type, you must enter and capitalize the acquisition detail lines for each set of ChartFields and for each category and cost type separately.

See Also

PeopleSoft Enterprise Asset Lifecycle Management Fundamentals 9.0 PeopleBook, “Establishing Asset Processing,” Setting Up Asset Profiles

Viewing Tax Information

Access the Tax page.

Tax

Transaction Type: Adjustment Date:

Currency: Base Currency:

| | | | |
|------------------|--------------------------------|------------------------------|--------------------------------|
| Merch amt: | <input type="text" value="0"/> | Merchandise Base Amount: | <input type="text" value="0"/> |
| Recoverable VAT: | <input type="text" value="0"/> | VAT Recovery Base Amount: | <input type="text" value="0"/> |
| Non-Recoverable: | <input type="text" value="0"/> | Non-Recoverable Base Amount: | <input type="text" value="0"/> |
| Total Tax: | <input type="text" value="0"/> | Total VAT Base Amount: | <input type="text" value="0"/> |

Optional

Tax Code Use Type

Tax Percent:

Eff Date: Taxable Act. %:

Tax page

Enter tax information for the asset.

Note. This information is optional except where VAT is applied. The system only validates the tax amounts entered; it does not store them.

See Also

PeopleSoft Enterprise Asset Lifecycle Management Fundamentals 9.0 PeopleBook, “Establishing PeopleSoft Asset Management Business Units,” Defining VAT Defaults

PeopleSoft Enterprise Global Options and Reports 9.0 PeopleBook , “Working with VAT”

Entering Document Sequencing Information

Access the Doc Sequencing page.

| | Asset Book Name | Document Type | Journal Code | Doc Sequence # | Doc Seq Date |
|---|-----------------|---------------|--------------|----------------|--------------|
| 1 | ASSETS_DEM | AM-ADD | | NEXT | |
| 2 | ASSETS_EUR | | | NEXT | |
| 3 | ASSETS_USD | | | NEXT | |

Document Sequencing page

Document sequencing is enabled at the general ledger business unit level. Rows are editable or not depending upon the Keep Ledgers in Sync option defined at ledger group level. If it is enabled, then only the primary ledger is editable; if it is not enabled, all the books that post entries to GL are editable.

See Also

PeopleSoft Enterprise Asset Lifecycle Management Fundamentals 9.0 PeopleBook, “Setting Up Accounting Entry and Financial Processing for PeopleSoft Asset Management,” Defining Document Sequencing

Entering Location, Comments, and Attributes Information

Access the Location/Comments/Attributes page.

Location/Comments/Attributes page 1 of 2

▼ Comments
Find | View All | First 1 of 1 Last

Date/Time: + -

Name:

Comment:

▼ Physical and Custom Attributes
Find | View All | First 1 of 1 Last

Effective Date: + -

Color:

Height: Cu Millim **Height Units:** 🔍

Width: **Width Units:** 🔍

Length: **Length Units:** 🔍

Weight: **Weight Units:** 🔍

Capacity: **Capacity Units:** 🔍

Power Rating: **Power Rating Units:** 🔍

Custom Attributes
Customize | Find | View All | First 1 of 1 Last

| Attribute | Attribute Name | Value | UOM | |
|-----------|----------------|----------------------|---|-----|
| 🔍 | | <input type="text"/> | <input type="text"/> 🔍 | + - |

▶ Detailed Description

▼ Image

Location/Comments/Attributes page 2 of 2

Record an asset’s location and physical properties (such as color, height, weight), enter comments, a detailed description, and associate user-defined custom attributes. You can also use this page to attach and view a stored image of the asset.

Entering Manufacture, License, and Custodian Information

Access the Manufacture/License/Custodian page.

| | | | | | |
|---|--|---------------------------------------|--|--|--|
| General Information | | Operation/Maintenance | Asset Acquisition Detail | Location/Comments/Attributes | |
| Unit: JPN01 | Asset ID: JPN0001 | Computer Hardware | Tag: | In Service | |
| Manufacturer Information | | | | | |
| Serial ID: | <input type="text" value="2FIN456789L"/> | | | | |
| Manufacturer ID: | <input type="text" value="APPLE"/> | | | | |
| Manufacturer Name: | <input type="text" value="Computer Hardware"/> | | | | |
| Model: | <input type="text"/> | | | | |
| Product Version: | <input type="text"/> | Production Date: | <input type="text"/> | | |
| Plant: | <input type="text"/> | Contact: | <input type="text"/> | | |
| VIN: | <input type="text"/> | SKU: | <input type="text"/> | | |
| License Information Find View All First 1 of 1 Last | | | | | |
| Supporting Doc Type: | <input type="text" value="License"/> | | | | |
| Agency ID: | <input type="text"/> | | | | |
| Vendor ID: | <input type="text"/> | | | | |
| Reg #: | <input type="text"/> | | | | |
| Issue Date: | <input type="text" value="04/26/2006"/> | Expiration Date: | <input type="text"/> | | |
| Renewal Date: | <input type="text"/> | | | | |
| Reg. Name: | <input type="text"/> | | | | |
| Address | <input type="text"/> | | | | |
| Comment: | <input type="text"/> | | | | |

Manufacture/License/Custodian page (1 of 2)

▼ Custodian Information
Find | View All | First 1 of 1 Last

Effective Date:
Effective Sequence:
 This Asset is Offsite

Custodian:

EmpID:

Authorization

Status:
Date:

Name:

Operating Unit:

Fund Code:

Department:

Program Code:

Class Field:

Budget Reference:

Product:

Project:

Manufacture/License/Custodian page (2 of 2)

Record custodial information, maintain license information, and keep track of manufacturer-related information.

Entering Property Assets

Access the Asset Property page.

| | | | | | | | | |
|-----------------------------|--|------------------------------|---------------------------|-------------------------------|----------------------|----------------|-----------------|----------------------|
| Asset Acquisition Detail | | Location/Comments/Attributes | | Manufacture/License/Custodian | | Asset Property | | |
| Unit: | US001 | Asset ID: | 000000000098 | HQ Bldg 1 | Tag: | In Service | | |
| Property Information | | | | | | | | |
| Property ID: | 0000000231 | | | | | | | |
| *Property Class: | Building | | | | | | | |
| Property Subclass: | <input type="text"/> | | | | | | | |
| *Property Name: | HQ Bldg 1 | | | | | | | |
| *Description: | HQ Bldg 1 | | | | | | | |
| Hierarchy | | | | | | | | |
| *Parent Property: | 0000000001 Corporate Headquarters Site | | | | | | | |
| *Site ID: | 0000000001 | Building ID: | 0000000231 | Floor ID: | <input type="text"/> | | Area ID: | <input type="text"/> |
| Attributes | | | | | | | | |
| *Total Area: | 46000.000 | | *Unit of Measure: | Square Feet | | | | |
| Occupancy: | Occupied | | Current Occupancy: | <input type="text"/> | | | | |
| Ownership: | Owned | | Maximum Occupancy: | <input type="text"/> | | | | |
| Description | | | | | | | | |
| Parcel Number: | 02235138006000 | | | | | | | |
| Lot Number: | 1460 | | | | | | | |
| Block Number: | 7704 | | | | | | | |
| Legal Description: | All the real property together with improvements, if any, situate, lying and being in the City and County of Denver and State of Colorado, described as follows: Lot 1460, Block 7704, Goldsmiths Addition to the city of Denver, third filing, City and County of Denver, | | | | | | | |

Asset Property page

Property Information

Property ID The property asset ID is displayed after the record is saved.

Property Class Select the property class from the available options. PeopleSoft delivers the following hierarchy of property classes:

Site

Building

Floor

Area

Space

Property Subclass Select the property subclass from the available user-defined options, if any.

Property Name and Description Enter the property name and descriptions. If these are entered on the General Information page, they will follow to this page.

Hierarchy

| | |
|------------------------|--|
| Parent Property | Select the parent property ID. Only the property asset IDs within this business unit are available. |
| Site ID | Enter the site property ID. |
| Building ID | Enter the building property ID. The field is available when the site property ID has been populated. The system performs an edit to check that higher level hierarchical fields are populated. |
| Floor ID | Enter the floor property ID. The field is available when the site property ID and the building property ID have been populated. The system performs an edit to check that higher level hierarchical fields are populated. |
| Area ID | Enter the area property ID. The field is available when the site property ID, building property ID, and floor property ID have been populated. The system performs an edit to check that higher level hierarchical fields are populated. |

Note. The last hierarchical definition for a property is *Space*. The space property ID is the same as the Property ID and is not displayed at this level.

Attributes

| | |
|--------------------------|--|
| Total Area | Enter the total measurement of the area of the property. |
| Unit of Measure | Enter the unit of measure for the total area. If this field is grayed out, the unit of measure is populated by default from the information selected when the asset was entered. |
| Occupancy | Select the occupancy status of the property from the available values: <i>Occupied</i> or <i>Vacant</i> . |
| Current Occupancy | Enter the current number of occupants for the property. |
| Ownership | Select the ownership status of the property from the available options: <i>Owned</i> or <i>Leased</i> . |
| Maximum Occupancy | Enter the maximum number of occupants for the property. This may be a legal definition. |

When no hierarchy is established, the default values for Unit of Measure is *Feet*, for Occupancy, *Occupied*, and for Ownership is *Owned*.

When a parent property ID is established, then Unit of Measure, Occupancy and Ownership values are inherited from the parent property.

When the parent property ID changes, however, only the Unit of Measure is inherited from the parent. This is because ownership and occupancy values do not usually change from parent to parent asset. For example, if Property A is leased but the parent ID changes, the property does not change ownership. It is still leased. Likewise, if a parent property changes, it does not automatically change from occupied to vacant.

Note. If you have defined custom attributes on the Asset Attributes page to be associated with an asset, the asset attributes will display with a unit of measure field. You may select the appropriate attributes from your user-defined attributes for this property as needed.

Description

This section is available only if the asset is a property defined as a Site or Building.

- Parcel Number** Enter the parcel number, usually provided within the grant or deed of trust.
- Lot Number** Enter the lot number, usually provided within the grant or deed of trust.
- Block Number** Enter the block number, usually provided within the grant or deed of trust.
- Legal Description** Enter the legal description, usually provided within the grant or deed of trust.

Entering Property Taxes

Access the Record Property Taxes page.

Record Property Taxes

Unit: US001 **Asset ID:** 000000000098 Sales Offices **Tag:** In Service

Property ID: 0000000231

Property Description: Sales Offices

Property Name: Sales Offices

Parcel Number: 657

Lot Number: 1460 **Block Number:** 15

Legal Description:

| Property Taxes | | | | | | | | | | Customize | Find | View All | First | 1-2 of 2 | Last | |
|----------------|---------------|-------------|------------|----------|--------------|---------|------------|-------|---|-----------|------|----------|-------|----------|------|--|
| *Tax Year | *Tax Due Date | *Delinquent | *Authority | *Tax | *Installment | *Amount | *Tax Basis | *Curr | | | | | | | | |
| 2003 | 06/30/2003 | 07/31/2003 | NYS | Property | 1 | 350.00 | 1.00 | USD | + | - | | | | | | |
| 2004 | 06/30/2004 | 07/30/2004 | NYS | Property | 2 | 350.00 | 1.00 | USD | + | - | | | | | | |

Record Property Taxes page

If the asset property is defined as *Site* or *Building*, the Enter Property Taxes link is available from the Asset Property page. Click on the link to display the Record Property Taxes page where informational data can be entered for taxes applicable to the property.

Entering Asset Supplemental Data

Access the Asset Supplemental Data page.

[Location/Comments/Attributes](#) | [Manufacture/License/Custodian](#) | **Asset Supplemental Data** | [Attachments](#)

Unit: US001 **Asset ID:** 000000000001 SOLARIS WORKSTATION **Tag:** In Service

Hardware Information

ADSL Modem **Processor:** Pentium I
 Cable Modem **RAM Memory:** 32.00
 Bluetooth **Type of Sound Card:** Offboard
Disk Space: 12.00
Type of Media:

Maintenance Information

Company: MS **Last Maint. Date:** 05/01/2000
Contact: SMITH,JOHN

Asset Supplemental Data page

Supplemental data is used within PeopleSoft Maintenance Management for additional asset attribute details. The attribute groups displayed for each asset depend upon the values that are selected for Asset Type, Asset Subtype, Manufacturer, Model and Business Unit. The attributes displayed are user-defined and reflect how the attribute groups work.

See *PeopleSoft Enterprise Asset Lifecycle Management Fundamentals 9.0 PeopleBook*, “Establishing Asset Processing,” Defining Asset Attributes.

See *PeopleSoft Enterprise Maintenance Management 9.0 PeopleBook*, “Using Supplemental Data”.

Adding Attachments

Access the Attachments page.

[Location/Comments/Attributes](#) | [Manufacture/License/Custodian](#) | [Asset Supplemental Data](#) | **Attachments**

Unit: US001 **Asset ID:** 000000000001 SOLARIS WORKSTATION **Tag:** In Service

Attachment Details Customize | Find | View All First 1 of 1 Last

| File Name | Description | User | Name | Date/Time Stamp | |
|--------------------------------|------------------------------|------|--------------------|------------------------|--------|
| AE-support.doc | Asset Supporting Information | VP1 | Kenneth Schumacher | 06/08/06 11:01:25PM | Delete |

[Add Attachment](#)

Attachments page

Maintaining Asset Meters

This section provides an overview of using asset meters and discusses how to maintain asset meters.

Understanding Asset Meters

Meters associated with assets are used to monitor asset usage and can trigger maintenance tasks based on the statistical units, such as mileage, measured by the meter. For example, a common asset meter is the odometer installed in a company vehicle that measures the number of miles the vehicle has traveled. For this type of asset, it is common for certain maintenance activities to be performed on it based on the number of miles traveled by the vehicle since the last maintenance event.

A less common, but familiar application, involves public utilities. State and local agencies use asset monitoring devices such as a water or electric meters attached to a home or commercial entity to measure the amount of water or electricity consumed by the entity. The units consumed are measured on a routine basis and the occupant is usually billed for the units consumed. The maintenance events associated with these types of meters may not have anything to do with the number of units measured since the meter was last read and other maintenance plans will have to be affected.

PeopleSoft uses meters to both measure asset usage and to trigger preventive maintenance tasks. Asset meter activities are performed within PeopleSoft Asset Management and PeopleSoft Maintenance Management applications. To enable meters, you must first define asset meter types. The meter types are associated with specific asset IDs.

Pages Used to Maintain Asset Meters

| Page Name | Object Name | Navigation | Usage |
|------------------------|----------------|---|--|
| Asset Meters | ASSET_METER | Asset Management, Service and Maintenance, Asset Meter Information, Establish Meter Reading, Asset Meters | Define asset meter by assigning meter types and associate the meter to assets. |
| Enter Meter Readings | AM_METER_READ1 | Asset Management, Service and Maintenance, Asset Meter Information, Enter Meter Readings | Enter meter readings for an asset. |
| Prior Reading | AM_METER_READ2 | Asset Management, Service and Maintenance, Asset Meter Information, Enter Meter Readings, Prior Reading | Enter prior meter reading information. |
| Update Meter Readings | AM_MTR_RD_UPD | Asset Management, Service and Maintenance, Asset Meter Information, Update Meter Readings | You can use the update Meter Readings page to correct prior meter readings. |
| Meter Reading Comments | AM_MTR_RD_CMT | Click on the Comment link from the Update Meter Readings page. | Enter comments relevant to meter reading updates. |
| Meter Reading History | AM_MTR_RD_HIS | Asset Management, Service and Maintenance, Asset Meter Information, Meter Reading History | View meter reading history for an asset. |
| Meter Reading Details | AM_MTR_RD_HID | Click on the Details link from the Meter Reading History page. | View details about the meter reading history for an asset including the date/time, source operator ID and daily average. |

Associating Meters with Assets

Access the Asset Meters page.

Asset Meters

Unit: US001
Asset ID: 000000000002 Gas/elec SUV - Fleet vehicle 1 **Tag:** P00000009001 In Service

| Meters | | | | | | | | Customize Find View All First 1-2 of 2 Last |
|-------------|--------|-------------------------------------|-----------------|--------------------------|-----------------|--------------------------|-----|---|
| *Meter Type | Status | Copy to Comp. | Est. Daily Avg. | Override Avg. | Act. Daily Avg. | Required for Work Order | | |
| 1 ODOMETER | Active | <input checked="" type="checkbox"/> | 25.0000 | <input type="checkbox"/> | 25.0000 | <input type="checkbox"/> | + - | |
| 2 THICKNESS | Active | <input type="checkbox"/> | 0.0000 | <input type="checkbox"/> | | <input type="checkbox"/> | + - | |

Asset Meters page

Meter Type

Select the meter type to be associated to this asset.

Copy to Comp. (copy to component)

Check if this meter should also be associated to any asset components associated with this asset (optional). This enables the component asset to use the same meter reading variations entered for its higher-level component assets.

The meter reading inheritance rules are as follows:

- The subcomponent inherits the reading from its immediately higher level component. If the higher component is also enabled to copy readings, the asset continues escalating to higher levels until finding the asset that is not enabled to inherit readings, or the parent asset. The inherited reading is derived from this asset.
- The inherited reading is recorded in the component when it is saved at the higher asset level.
- Components cannot inherit readings from upper levels if any intermediate level has its inherit reading option turned off. Example: assume three levels of components: grand parent, parent, child. All use an odometer as the meter ID type but the parent asset has the copy option unselected. In this example, the child cannot inherit its grand parent's odometer reading.

Note. The example is used to describe the physical inheritance rules of meter readings and has no relationship to the Parent-Child financial transaction in Asset Management.

- Components cannot inherit readings from upper levels if any intermediate level does not have the same meter type defined across the different levels.
For example: An asset has three levels of components, *A*, *B* and *C*. A meter type is associated with asset *A* and *C* but not *B*; in this case, *C* would not inherit its meter reading from *A*. As assets *B* and *C* are both components of asset *A*, then *B* must also inherit readings from *A* or neither asset *B* nor *C* may inherit readings from *A*.

Est. Daily Avg. (estimated daily average)

Displays the estimated average based on the actual readings taken when the number of readings specified to calculate the daily average has not been reached. The field is available when the meter type is enabled to maintain daily average. Estimated daily average is always a positive value.

Override Avg. (override average)

Select to override the actual daily average. The field is available when the meter type is enabled to override the actual daily average.

Act. Daily Avg. (actual daily average)

Displays the system calculated actual daily average. It can be zero or greater than zero. You can edit the value if the Override Avg. option is selected, but a new average is calculated when a new meter reading is entered. The field is available when Maintain Average option is enabled for the meter type.

Required for Work Order

Select to override a meter as required for any kind of work order as a condition to change its status to complete. This option defaults from the Meter Type Definition page and can be overridden here on the Asset Meters page. This field only displays if PeopleSoft Maintenance Management is installed.

Entering Meter Readings

Access the Enter Meter Readings page.

Enter Meter Readings
Prior Reading

Unit: US001

Asset ID: 000000000089 High Speed Copier **Tag:** In Service

| Current Reading | | | | | | | | | | | |
|-----------------|-----------|----------|-------------|----------|-----------|--------------------------|--------------------------|----------------|-----|--------------------------|---------------------|
| | | | | | | | | | | | Customize Find |
| | | | | | | | | | | | First 1-2 of 2 Last |
| | Date | Time | *Meter Type | Reading | Variation | Rollover | Replaced | Accum. Reading | UOM | Comments | |
| 1 | 02/10/200 | 5:46:38P | PAGES | 0.000000 | 0.0000 | <input type="checkbox"/> | <input type="checkbox"/> | | UNT | Comments | + - |
| 2 | 02/10/200 | 5:47:14P | | 0.000000 | 0.0000 | <input type="checkbox"/> | <input type="checkbox"/> | | | Comments | + - |

Enter Meter Readings page

Select the edit icon to activate entries for that row. Enter current reading information in the work area.

Date, Time

Enter the date and time of the meter reading. The system current date and time displays by default.

Meter Type

(Required) Select a valid meter type for this asset ID. Valid meter types are those that are associated with the asset and active.

Reading and Variation

(Required) Record the current meter reading.

Enter either the actual reading or variation from the last reading. If you had a reading of 12,000 km for an odometer and now you have 12,450 km, you can enter 450 in the variation field or 12,450 km in the Reading field above. The system automatically calculates the value for one field based on the entry made to the other field. The variation is used for the Copy to Components function. Variation is validated so that the reading does not fall outside the Low and High limits established for the meter when the Reading field is automatically calculated. Variation and Reading fields are both required when you have selected the Replaced option.

Rollover

Check this option if rollover is enabled AND should only be selected when the meter surpasses the upper limit. When selected, the meter resets to zero on the Assets Meters page once this reading is saved.

When the meter passes its established upper limit and begins a new cycle, the system keeps track of the accumulated usage. This applies only to *increasing* and *decreasing* meter types that also have enabled the Allow Rollover option.

Replaced

Select this option when the meter tool has been replaced. Both the Reading and Variation fields must be completed in this instance. This enables the system to calculate the total accumulated reading for the selected Meter Type. In the Reading field, enter the Actual Reading measured in terms of the new meter. In the Variation field, enter the difference between the last reading and the new one. These entries will be the basis to recalculate the accumulated meter reading when the page is saved.

Accum. Reading
(accumulated reading)

The last accumulated reading displays. If the Replaced option is selected, or if this is the first reading of the asset, this field is enabled for edit. Enter the new accumulated reading or complete the Reading and Variations fields to recalculate accumulated reading.

UOM (units of measure)

Displays the units of measure for this type of meter.

The following validations occur when the page is saved:

- The meter type entered cannot be duplicated for the same date and time or the system generates an error message.
- The reading/variation field must be completed or the system generates an error message.
- The accumulated reading or variation and the reading fields must be completed when the replaced option is selected or the system generates an error message.
- Readings must fall into the lower and upper limit range established at the meter type definition level or the system generates an error message.
- If the meter type is increasing or decreasing and the user enters a lower or greater reading than the prior reading, the system will generate an error message. If the meter type is increasing or decreasing *and* defined to allow rollover, the message warns that the rollover option must be selected before saving.

When you save the page, the meter readings entered become part of the meter history.

Using the Prior Reading tab, you can view the last entry made for the meter type. It also displays rollover or replacement activity from the prior meter reading.

You may enter comments related to a meter reading using the Comments link.

Updates to meter readings can be entered to modify existing readings. When making changes to meter readings, the change impacts not only the variation/reading of the changed meter reading but also the variation of the immediately following reading. You can modify the meter reading dates; this may cause meter readings that do not follow the rules of variations for increasing type of readings and conversely for decreasing type of readings as we have outlined on the enter readings page. Daily average will only be recalculated if the change affects the last n numbers of readings where n is the number of readings established at Meter Type definition level. Modifying meter reading dates could end up in having meters out of sequence that is, not entered and listed from the oldest to the newest). For auditing purposes, check the option to keep track of that out-of-sequence entries.



Reviewing Meter Reading History

Access the Meter Readings History page.

Meter Readings History

Business Unit: US001 **Asset ID:** 0000000000002

Meter Type:

Date From:  **To Date:** 

| Readings | | | | | | | | | |
|-------------------|------------|--------------------------|--------------------------|-------------|-----------|----------------|-----|------------------------|--|
| As of Date/Time | Meter Type | Rollover | Replaced | Reading | Variation | Accum. Reading | UOM | Detail | |
| 1 05/05/05 6:56PM | ODOMETER | <input type="checkbox"/> | <input type="checkbox"/> | 1500.000000 | | 1500.0000 | MIL | Detail | |
| 2 05/05/05 6:56PM | THICKNESS | <input type="checkbox"/> | <input type="checkbox"/> | 2.000000 | | 4.0000 | IN | Detail | |

Meter Readings History page

Search for and review meter readings history by business unit and asset ID. You can further refine the results by entering a meter type and date range. The results display the following information.

As of Date/Time Displays the date and time of the meter reading listed.

Meter Type Displays the type of meter associated to the asset and reading.

| | |
|--|--|
| Rollover | If checked, indicates a meter rollover occurred. |
| Replaced | If checked, indicates a replaced reading was entered, usually due to a rollover. |
| Reading | Displays the meter reading entered for the meter reading listed. |
| Variation | Displays the calculated change from the prior meter reading. |
| Accum. Reading (accumulated reading) | Displays the accumulated readings. |
| UOM (units of measure) | Displays the units of measure for the meter type. |

Maintaining Warranties

This section provides an overview of asset warranties and discusses how to associate warranties to assets.

Understanding Asset Warranties

Many assets are acquired with a standard manufacturer's warranty that the asset is free of defects and what remedies are available to you if the asset manifests a warranted defect during normal use, such as eligibility for a replacement asset, or a loaner while the warranted asset is repaired. The warranty often defines the period for which the asset is warranted, the maintenance and repair responsibilities of the owner, and the procedures for making a claim in the event a defect in the asset is discovered.

Warranties are sometimes available for extension. This may involve the issuance of a separate warranty that becomes active when the original warranty expires. Or it may warrant components of the asset that the standard warranty excludes. A warranty may contain different expiry dates for different components of the asset. It may provide for on-site repairs, may require return material authorizations (RMA), and may or may not be transferable.

PeopleSoft provides the ability to set up standard warranties and associate a warranty to an individual asset and provides warranty templates to apply a standard warranty to multiple assets at one time.

Pages Used to Maintain Asset Warranties

| Page Name | Object Name | Navigation | Usage |
|-------------------------------------|----------------|--|--|
| Asset Warranties | ASSET_WARRANTY | Asset Management, Service and Maintenance, Asset Warranties | Associate warranties to an asset ID and store warranty information including effective date, end date, coverage and contact information. . Multiple warranties may be applied to a single asset. |
| Search For Asset Warranty Templates | AM_WTMPL_SRH | Click the Apply Warranties from Templates e-link on the Asset Warranties page. | Search for warranty templates to apply to the asset. Templates are created by setID. Search parameters include asset type, asset subtype, vendor ID, Model and item ID. |

Maintaining Asset Book Information

Add books to assets either by entering the assets through the Asset ExpressAdd component or capitalizing them on the Asset Information page of the Asset Basic Information component.

The pages in the Asset Book Definition component enable you to enter book information that is *different* from that in your asset profile IDs.

This section discusses how to:

- Identify asset books and other depreciation information.
- Add depreciation details.
- Add tax information for the book.

Pages Used to Maintain Asset Book Information

| Page Name | Object Name | Navigation | Usage |
|---------------------------------|--------------------|--|---|
| Book - Depreciation | ASSET_BOOK_01 | Asset Management, Asset Transactions, Asset Book Information, Define Tax/Depr Criteria | Identify the asset's books and some of the information needed for calculating depreciation. An asset can be linked to any number of books. Typically, separate books are required for financial and tax purposes. |
| Depreciation Method Information | ASSET_DEPR_DETAILS | Select the Special Depreciation check box and then click the Special Terms link on the Book - Depreciation page. | Set special depreciation terms and select an accounting method for them. These are commonly used to meet depreciation requirements for specific countries. |
| Book - Tax | ASSET_BOOK_02 | Asset Management, Asset Transactions, Asset Book Information, Define Tax/Depr Criteria, Book - Tax | Specify property type, tax depreciation criteria and tax credit options. If the fields on this page are not available, the book was not set up as a tax book on the Business Unit/Book Definition page. |

Identifying Asset Books and Other Depreciation Information

Access the Book - Depreciation page.

| Book - Depreciation | | Book - Tax | |
|---|--|--|---|
| Unit: US001 | Asset ID: 000000000001 | SOLARIS WORKSTATION | Tag: In Service |
| Trans Date: 04/26/2006 | Accounting Date: 04/26/2006 | Profile ID: COMPUTERS | |
| Depreciation Attributes Find View All First 1 of 2 Last | | | |
| *Book Name: CORP Corporate | Base Currency: USD | | |
| Status: Depreciable | Total Cost: 7,500.00 | | |
| In Service Date: 05/01/2000 | <input type="checkbox"/> Depreciate When In Service | | |
| Begin Depr Date: | Adjust Conv: Actual Month | | |
| Convention: Actual Month | Retire Conv: | | |
| *Method: Sum of the Years | Calculation Type: Remaining Value | | |
| Percent: | Limit Pct: | Low Limit: | <input type="checkbox"/> Monthly |
| Useful Life: 36 | DB Pct: | UOP ID: | <input type="checkbox"/> Low Value |
| Schedule: | Method ID: | <input type="checkbox"/> Depr Pass Life | |
| End Date: | Future Depr Yrs: | *Avg Option: None | |
| <input type="checkbox"/> Special Depreciation Special Terms | | | |
| Depr Limit: | Cost Basis Limit: | | |
| Salvage %: | | | |
| Multi-Shift Code: | | | |
| <input type="checkbox"/> Child Inherits Parent's Life | | Go to Asset Basic Information | |
| <input type="checkbox"/> Impairment Process | | | |

Book - Depreciation page

In Service Date

Enter the date that the asset was made available for use from a financial standpoint. This date and the depreciation convention determine when depreciation starts for this book. This date is reflected in the Begin Depr Date field.

Depreciate When In Service

Select to allocate annual depreciation as of the date that you placed the asset in service. If you do not select this option, PeopleSoft Asset Management allocates annual distribution as of the date determined by the depreciation convention. This option is valid only in the year that the asset was acquired.

Convention

Enter the convention that the system uses to prorate depreciation for the asset. Asset Management is delivered with most standard depreciation conventions set up in the Depreciation Conventions table. The system derives the beginning depreciation date from the convention and the placed-in-service date. For example, if you began using an asset on May 3, 2006, and selected *Actual Month* as the depreciation convention, PeopleSoft Asset Management would begin depreciating this asset on May 1, 2006. If you selected *Following Month* as the convention, depreciation would begin on June 1, 2006.

Adjust Convention

Enter the adjustment convention that the system uses to prorate cost adjustments for the asset.

Retirement Convention Enter the retirement convention that the system uses to prorate retirement for the asset.

Select a depreciation method in the Depreciation Method field. Some depreciation methods require you to enter additional information. Depending on the method that you select, additional fields will display as needed, and as described in the following table:

| Method | Fields |
|---|---|
| <i>Declining Balance w/SL%/Limit</i> | DB Pct (declining balance percent) and Limit Pct (limit percent) |
| <i>Declining Balance w/SL%</i> | DB Pct |
| <i>Depreciation Schedule</i> | Schedule |
| <i>Declining Balance</i> | Percent, Low Limit, and Monthly |
| <i>Flat Rate %</i> | Percent, Low Limit, and Avg Option (averaging option) |
| <i>France Derogatory Balance</i> | DB Pct, Percent, Low Limit, and Depr Pass Life (depreciate past life) |
| <i>Germany Staffel Method</i> | DB Pct, Percent, Low Limit, and Depr Pass Life |
| <i>Japan - Intangible/Strt Line</i> | DB Pct, Percent, Low Limit, and Depr Pass Life |
| <i>Japan - Tangible / Declining Balance</i> | DB Pct, Percent, Low Limit, and Depr Pass Life |
| <i>Japan - Tangible/Strt Line</i> | DB Pct, Percent, Low Limit, and Depr Pass Life |
| <i>Japan -Changes DB to SL</i> | DB Pct, Percent, Low Limit, Depr Pass Life |
| <i>Japanese - Lease Depreciation</i> | No additional fields display. |
| <i>Manual Depreciation</i> | No additional fields display. The manual depreciation method enables you to adjust depreciation amounts using different method. To use manual depreciation, you must first create depreciation entries using another method. Once this has been done, you can make your adjustments. |
| <i>Straight Line</i> | No additional fields appear. |

| Method | Fields |
|------------------------------|---|
| <i>Straight Line Percent</i> | Percent |
| <i>Sum of the Years</i> | No additional fields appear. |
| <i>Units of Production</i> | UOP ID (units of production ID) |
| <i>User Defined Method</i> | Method ID, DB Pct, Percent, Low Limit, and Depr Pass Life |

The following table defines the additional fields:

| | |
|---|--|
| Limit Pct (limit percent) | Enter to specify a limit for depreciation as a percentage of cost. |
| UOP ID (units of production ID) | Enter the units-of -production ID, production information, and transaction information to use for the asset. |
| DB Pct (declining balance percent) | Enter the percentage of declining balance depreciation to be taken each year until the amount calculated by the straight line method is greater. |
| Percent | Enter the percentage of original basis to be taken in depreciation each year. |
| Low Limit | Enter an amount. When the asset basis reaches this limit, the remaining basis is taken in depreciation and the asset is fully reserved. Low limit is specific to group assets and flat rate. |
| Depr Pass Life (depreciate past useful life) | Select this if you want to continue to depreciate this asset past its useful life. This option is used for certain countries' governmental regulations and in utilities industries to depreciate an asset to the end of a depreciation calendar. |
| Method ID | Enter the user-defined method to use. |
| Schedule | Enter a schedule to use for depreciation. |
| Avg Option (average option) | Generally, this field is used by utility companies to depreciate composite assets. The averaging options are expressly designed to work with the flat rate depreciation method. |
| Monthly | Monthly averaging takes an average monthly asset balance and multiplies it by the annual depreciation rate. The result is then applied against a period allocation (1/12, 2/12, 3/12, and so on) to derive a year-to-date (YTD) depreciation amount. The difference between the newly calculated YTD depreciation and the previous YTD depreciation is the amount booked to the current period. This is applicable to the declining balance method only. |
| Yearly | Yearly averaging is similar to monthly averaging except that a yearly average balance is used. Because this amount is not known until the end of the year, it is usually estimated and adjusted periodically as the actual figures become available. |

Note. Using the flat rate depreciation method causes any depreciation to be posted to the end of the calendar. If this is not the intention, you must enter a low limit of *.01* when you first select the depreciation method in the Asset Book Definition component for the asset. If you have not already done this, update the Depreciation Method field by selecting *Flat Rate* and entering *.01* in the Low Limit field that appears.

| | |
|--|--|
| Calculation Type | Select <i>Remaining Value</i> to deduct any accumulated depreciation from the cost basis and depreciate the remaining value over the remaining life of the asset. Most assets are depreciated using this option. Use <i>Life-to-Date</i> to calculate the difference between the depreciation allowed and the depreciation taken. Typically, you use life-to-date calculations when there is a change in accounting principle, such as depreciation method. Changes of this type require an adjustment for the differences in accumulated depreciation to date. For example, if you took 20,000 USD depreciation over a two year period but the amount allowed was 24,000 USD, the difference of 4,000 USD would be expensed as an adjustment to accumulated depreciation in the current period. |
| Low Value | Select to identify assets with costs below a certain level for special depreciation processing. This is a requirement for Germany. |
| Useful Life | Enter the number of periods. This is used to perform the depreciation calculations for the financial books. |
| End Depr Date (end depreciation date) | Enter a value to have depreciation end at a particular time. At the ending depreciation date, the remaining asset basis is taken in depreciation and the asset is fully reserved. |
| Future Depr Yrs (future depreciation years) | Asset Management calculates and stores depreciation until the end of the asset's life. However, for optimal processing performance and greater table efficiency, you can specify a fixed number of years for which depreciation is calculated and stored. |
| <hr/> | |
| Note. It is strongly recommended that you use the Future Depreciation Years option for group assets and for a large number of assets. | |
| <hr/> | |
| Special Dpr or Special Terms | If you are working in a global environment and want to use special depreciation terms to meet specific country requirements, select the Special Dpr check box and click Special Terms to open the Depreciation Details page, where you can select special terms for depreciation. |
| Depr Limit Code (depreciation limit code) | Depreciation limits generally apply to tax books, but they can also be used for financial books. The TableSet delivered with Asset Management contains depreciation limits currently dictated by the U.S. Internal Revenue Service for luxury automobiles. |
| Cost Basis Limit | Enter the limit on the depreciable basis of this asset. If the actual cost of an asset is greater than its depreciable basis, the difference produces a gain when the asset is retired. |
| Salvage %Salvage Value | Enter the residual value of the asset subtracted from the cost to determine the depreciable basis used in depreciation calculations. You can enter it either as a flat rate or as a salvage percentage (a percentage of the asset's total cost). If you use a salvage percentage, the system recalculates the salvage value as you add additional costs for the asset. |

| | |
|-------------------------------------|---|
| (AUS) Multi-Shift Code | Enter rates by which depreciation should be increased based on the number of production shifts an asset is used. |
| Child Inherits Parent's Life | Select if the child asset inherits the parents remaining life. When you use parent-child component assets, all child assets have their own cost basis and depreciation attributes that are independent of the parent asset. Because the child's asset life may differ from the life of the parent asset, you may need to specify that a new child asset of a parent asset inherit the remaining life of the parent asset. |
| Impairment Process | Select to make asset available for impairment processing. See Chapter 8, "Adjusting, Transferring, and Evaluating Assets," Adjusting for Asset Impairment, page 180. |

See Also

PeopleSoft Enterprise Asset Lifecycle Management Fundamentals 9.0 PeopleBook, "Setting Up Depreciation Processing"

Adding Depreciation Details

Access the Depreciation Method Information page.

Select one of the following accounting method options:

| | |
|------------------|--|
| Allowance | Special depreciation amounts are not booked with the standard depreciation amounts. Journal entries are generated that include only the standard depreciation. PeopleSoft Asset Management does not support automatic generation of journal entries for the special depreciation <i>allowance</i> accounting method. You may need to run two reports—the Reserve for Special Depreciation report and the Reversal for Special Depreciation report—and then generate the journal entries manually into the General Ledger system. |
| Expense | Total amounts of special depreciation and standard depreciation are booked and journal entries are generated that include the total of the standard and special depreciation amounts. |
| Reserve | Special depreciation amounts are not booked with the standard depreciation amounts. Journal entries are generated that include only the standard depreciation. PeopleSoft Asset Management does not support automatic generation of journal entries for the special depreciation <i>reserve</i> accounting method. You may need to run two reports—the Reserve for Special Depreciation report and the Reversal for Special Depreciation report—and then generate the journal entries manually into PeopleSoft General Ledger. |

Additional fields are provided to comply with the depreciation methods used in countries other than the U.S. If your current depreciation method requires these fields, enter Special Terms, Accel Terms (accelerated terms), Initial Terms, and Incr Rate (increased rate).

When you use additional terms, they affect depreciation calculations as follows:

| Term | Depreciation |
|-------------|---------------------|
| Special | Depreciation × Rate |
| Accelerated | Depreciation × Rate |
| Initial | Cost × Rate |
| Increase | Depreciation × Rate |

The Year of Change field is available only if the depreciation method is *Japan-Change DB to SL*. Enter the year of the change in calculation methods.

See *PeopleSoft Enterprise Asset Lifecycle Management Fundamentals 9.0 PeopleBook*, “Setting Up Depreciation Processing,” Defining Depreciation Terms and Rates.

Adding Tax Information for the Book

Access the Book - Tax page.

Book - Depreciation
Book - Tax

Unit: US001 **Asset ID:** 000000000092 High Speed Copier **Tag:** In Service

Tax Find | View All First 1 of 2 Last

Book Name: CORP Corporate **Country:** USA **Currency:** USD

In Service Dt: 09/09/2003 **Useful Life:** 36 **Cost Basis:** 10,000.000 **Basis Red:**

Property Type: **Bus Tax Basis:**

Property Code: **Sec179** **179 Amt:**

Regulation: **Listed Property** **Listed Property Type:**

Recovery Life: **Business Tax** **Business Use %:**

Recovery SubType: **Corp. Sec.291** **Depreciation Bonus:**

Guideline Class: **Bonus Percent:**

Tax Credit Options Find | View All First 1 of 1 Last

Qualified Investment Code:

Tax Credit Type:

Tax Credit Code:

Basis Reduction Option:

Qualified Investment: % **Amount:**

Tax Credit: % **Amount:**

Cost Basis Reduction: % **Amount:**

Book - Tax page

Tax

Property Type and Property Code

These fields determine the amount of gain treated as ordinary income upon the disposition of the asset.

Regulation

Regulation is an indication of the tax system that you elect. Each tax system has an effective date that is validated against the asset's placed-in-service date. Select a regulation to identify the depreciation system elected for this asset. Options are:

- *A* (accelerated): Accelerated Cost Recovery System (ACRS).
- *D* (depreciation): Asset Depreciation Range (ADR).
- *F* (facts): Conventional Facts and Circumstances.
- *G* (guidelines): Asset Class Guideline.
- *M* (modified): Modified Accelerated Cost Recovery System (MACRS).

Recovery Life and Recovery SubType

For reporting purposes, you can further classify the asset by specifying the recovery life (expressed in years) and the recovery subtype. For example, the code for a 15-year life might be *15* and the code for low-income housing might be *LI*.

Guideline Class

All current U.S. classifications are set up in the Tax Class table in the delivered TableSet

Section 179

Select if you elect to expense all or a portion of the cost. You can expense assets up to an aggregate maximum of 200,000 USD per year, provided that the organization's gross income does not exceed the limitation specified by U.S. federal tax law. Investment credits are automatically calculated based on the criteria entered on the Tax Credit page.

Listed Property

Select the Listed Property box to define the asset as listed property and select its Listed Property Type. Listed property are certain kinds of assets that are conducive to mixed business and personal use, such as:

- Passenger automobiles under a certain weight.
- Any other property used for transportation such as trucks, buses, boats, airplanes, motorcycles, and other vehicles for transporting persons or goods.
- Any property of a type generally used for entertainment or recreation or amusement such as photographic, phonographic, communication, and video-recording equipment.
- Any computer and related peripheral equipment unless it is used only at a regular business establishment and owned or leased by the person operating the establishment.
- Any cellular telephone (or similar telecommunications equipment) placed in service or leased in a tax year beginning after 1989.

(FRA) Business Tax

Select to indicate that the business tax is applicable. This option enables you to calculate and report a business tax assessed on the gross value of fixed assets. This is a requirement in some countries.

Corp. Sec.291 (corporation section 291)

Select if the organization is a corporation. This check box must be selected if the company is a corporation in order for the Tax Retirement Capital Gains report (AMTX3210) to accurately reflect the correct Sec. 1231/Ordinary gains.

- (USA) Depreciation Bonus** Select to indicate if the asset qualifies for the depreciation bonus in the first year. The options you see depend on the effective date, the acquisition date and in service date of the asset as well as state or local application of the bonus depreciation allowance. Your choices are:
- *Gulf Opportunity Zone*: Select for certain types of property acquired in the hurricane zone (as defined in H.R. 4440) after August 28, 2005 and placed in service before December 31, 2007 (December 31, 2008 for non-residential real property or residential rental property) to apply a 50 percent depreciation bonus.
 - *New York Liberty Zone*: Select if the acquisition date and in service date is after September 10, 2001 and before December 31, 2007.
 - *None*: Select if the acquisition date and in service date of the asset is before September 10, 2001 or May 5, 2003.
 - *Section 101- Federal*: Select if the acquisition date and in service date is after September 10, 2001 and before December 31, 2005 to apply the 30 percent bonus. Select if the acquisition date and in service date is after May 5, 2003 and before December 31, 2005 to apply the 50 percent bonus.
 - *Section 101- Local*: Select if local or state allowance of the bonus depreciation should be applied.

Note. An asset is not eligible for the depreciation bonus if it is not within the eligible date ranges.

- (USA) Bonus Percent** Enter the percent amount of the depreciation bonus to be applied to the book(s) for this profile. This could be 30 percent to 50 percent depreciation bonus. The amount depends on the acquisition date and in service date of the asset as well as state or local application of the depreciation allowance. For example, if your state adopted the bonus depreciation as a percentage of the Federal percentage, the amount may be calculated as an amount other than the federally allowed 30 percent or 50 percent amounts.

Tax Credits Options

The rate and amount of the tax credit are based on federal tax law and determined by the qualified investment code, tax credit type, tax credit code, and the basis reduction option in Asset Management.

- Basis Red** (basis reduction) Displays the total reduction of the cost basis, if any. The total reduction amount is updated each time you change tax credit information.
- Qualified Investment Code** It corresponds to the option you enter in the Tax field.
- Tax Credit Type** Although the investment tax credit was essentially repealed on December 31, 1985, certain business incentive credits can still be taken. Currently, you can specify the following credits:
- *R* (rehabilitation): Building rehabilitation credit.
 - *E* (energy): Energy credit.
 - *I* (investment): Regular investment credit.
- Tax Credit Code** Enter a value in this field to further define the tax credit—for example, a 20 percent rehabilitation tax credit is available for certified historic buildings.

- Basis Reduction Option** Some credits require a corresponding reduction in the asset's cost basis. In this field, specify whether the basis needs to be reduced. Options are:
- *B* (basis): Reduction based on tax credit.
 - *P* (percentage): Reduction based on specified percentage.
 - *N* (no): No reduction required.

Asset Management calculates the percentage and computation amount based on the following calculations:

$(\text{Book Cost}) \times (\text{Qualified Investment Percentage}) = (\text{Amount Qualifying for Tax Credit})$

$(\text{Amount Qualifying}) \times (\text{Tax Credit Percentage}) = (\text{Amount of Tax Credit})$

$(\text{Amount of Tax Credit}) \times (\text{Basis Reduction Percentage}) = (\text{Amount That Basis Is Reduced})$

Adding Assets with the Asset ExpressAdd Component

The Asset ExpressAdd component is a series of pages that enable you to add owned assets quickly and efficiently. Assets added with the Asset ExpressAdd component are capitalized automatically when you save, and most of the information in the pages can be defaulted from an asset profile. This component also enables you to enter accumulated depreciation for assets.

When entering joint venture assets that are shared among several business units, it is best to assign a unique asset ID. This ensures that the assets created at the participant level have the same ID as the asset created at the joint venture business unit level. You can make these asset IDs easy to identify by including the prefix *JV*—for example, you might create the asset ID JV000022.

When entering assets that have a Parent/Child relationship, you must first enter a Parent ID on the Cost/Asset Information page before assigning the Profile ID default.

Add assets with the Asset ExpressAdd component as follows:

1. Enter information about how the asset will be capitalized. (If you are adding Parent/Child assets, you must specify the Parent ID in this step.)
2. Assign a profile ID.
3. Identify the asset's books and information needed for calculating depreciation.
4. Specify property type and tax depreciation criteria.

See Also

[Chapter 7, "Working With Leased Assets," page 127](#)

Pages Used to Add Assets with the Asset ExpressAdd Component

| Page Name | Object Name | Navigation | Usage |
|--------------------------|----------------|---|---|
| Cost / Asset Information | ASSET_ENTRY_00 | Asset Management, Asset Transactions, Owned Assets, Express Add | Enter information about how the asset will be capitalized. |
| Depreciation Information | ASSET_ENTRY_01 | Asset Management, Owned Assets, Express Add, Depreciation Information | If you set up book information in the asset profile, all book information appears by default. The Depreciation Information page identifies the asset's books and information needed for calculating depreciation. An asset can be linked to any number of books. Typically, separate books are required for financial and tax purposes. If you manage assets in multiple currencies, each currency can have its own book. |
| Tax Information | ASSET_ENTRY_02 | Asset Management, Owned Assets, Express Add, Tax Information | Specify property type and tax depreciation criteria and identify the investment credits that are taken for the current asset. If the fields on this page are unavailable, the book was not set up as a tax book. |

Capitalizing Assets

Access the Cost / Asset Information page.

Cost / Asset Information

Asset Information

Unit: US001 Asset ID: NEXT

Profile ID:

Description:

Location:

Tag Number:

Accum Depr in Current Pd

Trans Date: 07/04/2005

Acctg Date: 07/04/2005

Trans Code:

Currency: USD

Rate Type: CRRNT

Asset Cost Information

Find | View All First 1 of 1 Last

| Book Name | Quantity | Cost | Salvage |
|-----------|----------|----------|----------|
| CORP | 1.0000 | 0.00 USD | 0.00 USD |

| Category | Cost Type | Accum Depr | YTD Depr |
|----------------------|----------------------|------------|----------|
| <input type="text"/> | <input type="text"/> | 0.00 | 0.00 USD |

Default Profile

| Oper Unit | Fund | Dept | Program | Class | Bud Ref | Product | Project |
|----------------------|----------------------|----------------------|----------------------|----------------------|----------------------|----------------------|----------------------|
| <input type="text"/> | <input type="text"/> | <input type="text"/> | <input type="text"/> | <input type="text"/> | <input type="text"/> | <input type="text"/> | <input type="text"/> |

Asset Additional Information

Asset Type:

Asset Subtype:

CAP #: Seq #: [Set R and D Info...](#)

Serial ID:

Asset Class:

*Asset Status: In Service

FERC Code:

Acquisition Date: 07/04/2005 *Acquisition Code: Purchased

Collateral Asset:

Parent/Child: None Parent ID:

Hazardous Asset [Hazardous Code Info...](#)

Taggable Asset

Capitalized Asset

Composite Asset

Cost / Asset Information page

Asset Information

Accum Depr in Current Pd (accumulated depreciation in current period)

Select to have the system book accumulated depreciation for the asset to the current period. Otherwise, accumulated depreciation is booked to the previous period. If that is the case, you may need to reopen the period.

Trans Date (transaction date) and **Acctg Date** (accounting date)

Typically, the transaction date represents the date that you actually acquired the asset and the accounting date represents the date that the transaction is posted to the general ledger. The accounting date is validated against the FIN_OPEN_PERIOD table to determine the period to which the transaction is posted. The difference between the transaction date and the accounting date determines if any prior period depreciation needs to be calculated. For example, suppose that a computer was acquired and placed in service on March 15, 2001, but the information was not entered in PeopleSoft Asset Management until August 1, 2001. All general ledger periods prior to August are closed. In this case, PeopleSoft Asset Management automatically calculates depreciation starting in March and posts it to the general ledger in August.

| | |
|--------------------------------------|--|
| Location | Identify the asset location by selecting from a list of valid values. Identification of the asset location is required for managing hazardous material assets, which must often be monitored and reported on. This location is automatically populated with the ship from location for VAT-enabled business units. |
| Trans Code (transaction code) | Identify which accounting entry template is used for the asset, such as <i>Abandoned</i> , <i>Inventory</i> , or <i>Scrapped</i> . The system accepts only valid combinations of the category, cost type, transaction code, and transaction type for which accounting entry templates exist. |
| Currency and Rate Type | Select the currency and exchange rate type. |

Note. When working with Parent/Child assets, you must go to the Asset Additional Information section and enter the Parent ID before you select Default Profile.

Asset Cost Information

Enter one row of cost information before populating fields with the default information from the asset profile.

| | |
|--|---|
| Cost Type | Break down portions of the asset cost, and enter as many cost types as needed for each transaction. For example, the costs of constructing a building are often broken down into categories reflecting the type of cost, such as material, labor, permits, and so on. Only valid cost types are accepted. The cost types are user-defined during the system implementation. |
| Salvage | Displays the salvage value that is calculated based on the option defined at the asset profile level (either flat amount or percentage). Salvage value is prorated based on a ChartField's cost if a flat amount is used, and it appears as a percentage of cost if the percentage option is selected. |
| Accum Depr (accumulated depreciation) | Enter the amount of depreciation already recognized. If you are adding assets that have depreciation from prior years or prior periods, enter that amount in this field. |
| YTD Depr (year to date depreciation) | If any portion of the accumulated depreciation amount applies to the current fiscal year, enter the amount of that portion. |

Note. After you save this page, you cannot change the asset information here. To modify the information, you must use the Asset Cost Adjust/Transfer page or the Basic Add page. When working with Parent/Child assets, remember to designate the Parent ID before you continue.

Asset Additional Information

| | |
|-------------------|---|
| Asset Type | Select a value to indicate a type of asset. The available options are: <i>Equipment</i> <i>Facility</i> <i>Fleet</i> <i>Furniture</i> <i>Hardware</i> <i>Intangible</i> <i>Machinery</i> |
|-------------------|---|

| | |
|--|---|
| | <i>Other</i> |
| | <i>Property</i> |
| | <i>Software</i> |
| Asset Subtype | Select a value to indicate a subset of asset type. Subtypes are optionally user-defined and directly related to the Asset Type. Only asset subtypes of the selected asset type are available when defining the asset. |
| CAP # (capital acquisition plan number) and Seq #(sequence number) | The capital acquisition plan (CAP) number ties the asset to a CAP. Enter a valid number and sequence. You set up CAP numbers in the CAP table. |
| Serial ID | If applicable, enter the serial number for the asset. |
| Asset Class | This field is used to classify assets for reporting purposes. It can be used in combination with an asset category to refine asset classification. These fields can also be used for VAT purposes. |
| Asset Status | Indicate the status by selecting one of the following options: <ul style="list-style-type: none"> • <i>Budgeted</i>: Asset is budgeted but not placed in service. • <i>Commitment</i>: Budget has been approved and you are preparing to acquire the asset. • <i>Disposed</i>: Asset is no longer in service. • <i>In Service</i>: This is the date that the asset is available for use. The transaction date is the default. • <i>Received</i>: Asset was received but is not yet placed in service. • <i>Requisitiond</i> (requisitioned): Necessary paperwork has been completed for acquisition. • <i>Suspended</i>. Depreciation has been suspended for this asset • <i>Transferred</i>. This asset was transferred from another business unit. • <i>WIP</i> (work in progress): Asset is acquired for a project under way. |
| FERC Code | Select a FERC code if it applies. |
| Acquisition Date and Acquisition Code | Enter the date the asset was acquired and select an acquisition code: <i>Construct, Donated, Leased, Like Exch, Purchased, Trade In, Transfer</i> |
| Collateral Asset | Japanese accounting principles require that assets offered as collateral be treated according to financial reporting regulations under the commercial law. If the asset is a collateral asset, select one of the available options that comply with Japanese requirements. |
| Parent/Child and Parent ID | If you are adding a parent or child asset, select the parent-child asset option that applies. The default is <i>None</i> . If this is a child asset, enter the parent asset ID with which to associate it. |
| <hr/> | |
| Note. Parent and child assets cannot also be group assets or collateral assets. | |
| <hr/> | |
| Hazardous Asset | Check if the asset qualifies as hazardous. |
| Taggable Asset | Check if the asset can be physically assigned a tag number. |

- Capitalized Asset** This check box is display-only, and the status is determined automatically by the asset profile.

Non-capitalized assets have no cost or books and are not depreciated in Asset Management. Sometimes you need to track physical information only (such as location, physical specifications, number of units, and so forth), but you don't want information about the assets to appear in the general ledger.
- Composite Asset** Check if the asset is a composite asset.
- Set R and D Info** (set research and development information) Click this link to enter research and development information on the Asset R&D Information page. In Australia, this option is used for tax reporting purposes. Otherwise, this field is informational only.
- Hazardous Code Info** Click on this link to go to the Hazardous Asset Codes page and select a hazardous code to identify with and associate to this asset.

Copying an Asset

This section discusses how to copy an asset.

Page Used to Copy an Asset

| Page Name | Object Name | Navigation | Usage |
|---------------------|---------------|---|---|
| Create Asset Copies | ASSET_COPY_01 | Asset Management, Asset Transactions, Owned Assets, Copy Existing Asset | <p>Copy an existing asset if its financial and physical information is similar to that of a new asset that you want to create. Copy the existing asset and change only the financial and physical information that is different. The system automatically assigns the new asset a different asset ID. Alternatively, you can specify an asset ID.</p> <p>Note. If you copy a non-financial asset, the financial information will not be available.</p> |

Copying an Asset

Access the Create Asset Copies page.

Create Asset Copies

| | | | |
|---------------------------------------|-------------------|---|------------|
| Business Unit: | US001 | Trans Date: | 04/27/2006 |
| Original Asset ID: | MPK01 Mercedes SL | Acctg Date: | 04/27/2006 |
| Acquisition Date: | 04/27/2006 | Trans Code: | |
| *Currency: | USD | *Rate Type: | CRRNT |
| Num of Asset Copies to create: | 1 | Create Assets | |

Asset Copy Options

| | | | |
|--|---|---|---|
| <input checked="" type="checkbox"/> Asset Acquisition Info | <input checked="" type="checkbox"/> Asset Comments | <input checked="" type="checkbox"/> Asset License/Register Info | <input type="checkbox"/> Asset Non Capitalized Cost |
| <input checked="" type="checkbox"/> Asset Attributes Info | <input checked="" type="checkbox"/> Asset Lease Info | <input checked="" type="checkbox"/> Asset Maintenance Info | <input checked="" type="checkbox"/> Asset Warranty Info |
| <input checked="" type="checkbox"/> Asset Insurance Info | <input checked="" type="checkbox"/> Asset Inspection Info | <input checked="" type="checkbox"/> Asset Attribute Groups Info | |

Asset

| | | |
|--|---------------------|-------------------------------|
| *Asset ID: NEXT | Description: | Financial Parent ID: |
| <input checked="" type="checkbox"/> Taggable Asset | Tag Number: | Physical Component of: |
| | Serial ID: | |

Book

| | |
|-----------------------------|---------------------------|
| Book: CORP Corporate | Base Currency: USD |
| Cost | |

| Quantity | Cost | Salvage Value | Category | CT |
|----------|------------|---------------|----------|----|
| 1.0000 | 100,000.00 | USD 10,000.00 | USD AUTO | C |

Create Asset Copies page

Note. Child assets can be copied, but parent assets cannot.

Asset Copy Options

Select or deselect the data to be included in the copy

Asset

The next available Asset ID will be assigned. Enter the additional asset attributes for the copy.

Book

Quantity, Cost, Category, and CT (cost type) Displays the asset quantity, cost, category and cost type.

Salvage Value Displays a value that is calculated based on the selections for this field at the asset profile level (either flat amount or percentage). The salvage value is prorated based on a ChartField's cost if a flat amount is used. It appears as a percentage of cost if the Percentage option has been selected.

See Also

Chapter 5, "Adding and Maintaining Assets," Adding and Maintaining Asset Information, page 47

Copyright © 1992-2006, Oracle. All rights reserved.

95

Viewing and Managing the Component Asset Hierarchy

This section provides an overview of and discusses how to view and manage component asset hierarchies.

Understanding Component Asset Hierarchies

Assets can be considered as components of other assets of a higher level. For example, when you acquire specialized heavy duty equipment, such as cranes, tractors, or construction vehicles, it may be practicable to view specific elements of the asset as individual “sub-assets” that serve the overall asset it is a part of. A crane may use a specialized extension for larger projects, but the extension device must be attached to a crane before it is useful. In this case, the extension can be considered a component of the crane. It is, however, an expensive piece of equipment with a separate depreciable life from the crane and you would, therefore, want to maintain it as an asset rather than an expendable part of the crane.

In turn, the extension may also be used to support another component of itself, an optional set of hooks or lifters, for example. In such a case, the lifters are a component of the extension and the extension is a component of the crane. In this way, you may have multiple assets that serve one another as components of an asset at a higher level or that create a *component hierarchy*.

PeopleSoft Asset Management enables you to view and manage up to nine levels of asset component relationships from the Asset Component Hierarchy page. Move assets within the hierarchy as needed, view those changes through the Summary of Changes page and run a report to view changes within asset components for all assets, financial assets or non-financial assets.

Pages Used to View and Manage the Asset Component Hierarchy

| Page Name | Object Name | Navigation | Usage |
|-------------------------------------|--------------------|--|---|
| Asset Component Hierarchy | AM_HGRID | Asset Management, Asset Transactions, Owned Assets, View Component Hierarchy | View associated asset component relationships within the hierarchy (display only). |
| Asset Component Hierarchy | AM_HGRID | Asset Management, Asset Transactions, Owned Assets, Manage Component Hierarchy | Update associated asset component relationships by moving assets within the hierarchy. |
| Provide Reason for the Modification | AM_HGRID_REASN_SEC | Click the Comments icon from the Asset Component Hierarchy page. This icon is visible when a change is made to move an asset within the hierarchy. | Provide a reason and details for the modification. |
| Summary of Changes | AM_HGRID_DISP_CHG | Click the Review Changes link from the Asset Component Hierarchy page. | Review the summary of changes made within the asset hierarchy. |
| Asset Component Hierarchy Move | RUN_AMCH1000 | Asset Management, Financial Reports, Asset Details, Asset Component Hierarchy Move. | Run the Asset Component Hierarchy Move report to view a list of assets that were moved. Run this report for all assets, financial assets or non-financial assets. (SQR) |

Viewing the Asset Component Hierarchy

Access the Asset Component Hierarchy page from the View Component Hierarchy menu.

Asset Component Hierarchy

*Unit:

Asset ID: Serial ID:

Action:

[Expand All](#)

| Asset Component Information | | | | | | |
|-------------------------------------|--------------------------------|-----------------------|--------------|------------|---------|------------|
| General Information | | Operation/Maintenance | | | | |
| | Description | Asset ID | Tag Number | Asset Type | Subtype | Status |
| <input type="checkbox"/> | SS Process Complete | AMSS_C | | Fleet | | In Service |
| <input checked="" type="checkbox"/> | Gas/elec SUV - Fleet vehicle 1 | 000000000002 | P00000009001 | Fleet | AUTO | In Service |
| <input type="checkbox"/> | Gas/elec hybrid - fleet vehicl | 000000000004 | P00000009003 | Fleet | AUTO | In Service |

Asset Component Hierarchy page (View)

This page appears as display only. Review the details within the Asset Component Hierarchy.

- Action** After placing a check mark beside an asset, select one of the following actions and click the Go button:
- *Focus on Selected Row* - Refresh the grid using the selected row as the starting point of the hierarchy.
 - *Focus on Top Asset* - Refresh the grid using the highest asset as the starting point of the hierarchy.

Note. The View Component Hierarchy provides a subset of actions that are available within the Manage Component Hierarchy.

Managing the Asset Component Hierarchy

Access the Asset Component Hierarchy page from the Manage Component Hierarchy menu.

Asset Component Hierarchy

*Unit:

Asset ID: Serial ID:

Action: 1.....Choose Action

[Expand All](#)
[Review Changes](#)

| Asset Component Information | | | | | | | Find View All <input type="button" value="Grid"/> First 1-4 of 4 Last |
|-------------------------------------|------------------------------------|-----------------------|--------------|------------|---------|------------|---|
| General Information | | Operation/Maintenance | | | | | |
| | Description | Asset ID | Tag Number | Asset Type | Subtype | Status | |
| <input type="checkbox"/> | [-] SS Process Complete | AMSS_C | | Fleet | | In Service | |
| <input type="checkbox"/> | Gas/elec SUV - Fleet vehicle 1 | 000000000002 | P00000009001 | Fleet | AUTO | In Service | |
| <input type="checkbox"/> | [-] Gas/elec hybrid - fleet vehicl | 000000000004 | P00000009003 | Fleet | AUTO | In Service | |
| <input checked="" type="checkbox"/> | stereo | 000000000040 | P00030650 | Other | | In Service | |

Asset Component Hierarchy page (Manage)

Select component assets and move them within the hierarchy. The Asset Component Hierarchy page displays up to nine levels. If the hierarchy of asset components is more than nine levels deep, you can manipulate the whole hierarchy by focusing on specific branches of the component tree.

Note. Property asset types are not editable. When you enter a property type of asset, after pressing the Search button, the page will display as if the View Component Hierarchy was used.

- Action** Choose one of the following actions:
- *Insert Asset on Row Below* - Insert a row in the grid just below the selected row. When selecting the first row of the grid, the insert creates a child of the first row.
 - *Remove Asset from Hierarchy* - Remove the row from the grid and enter a reason for the removal on the secondary page that is provided.

- *Focus on Selected Row* - Refresh the grid using the selected row as the starting point of the hierarchy.
- *Focus on Top Asset* - Refresh the grid using the highest asset as the starting point of the hierarchy.



Indent Row

Select that asset and click the Indent Row icon. This action moves the selected asset down in the hierarchy so that it is a child of the prior row number (asset) in the grid.



Outdent Row

Click to move the selected asset up one level in the hierarchy.



Move Item Use Sequence Up

Click to move the indented asset up to a different parent. If the parent asset is moved, all of the child assets are moved with it.



Move Item Use Sequence Down

Click to move the selected asset down one row level.

Expand All link

Click to expand the entire hierarchy to view and manage all assets within the grid.

Review Changes link

Click to display a summary of changes made within the asset hierarchy (Summary of Changes page.)



Comments

Add a comment to explain the reason for the change on the Provide Reason for the Modification page.



Comment Warning

Upon save, this icon indicates that there have been no comments entered for the hierarchy change.



Warning

Upon save, this warning icon displays; mouse over text provides a detailed description of the warning for the following reasons:

- No comment provided. Click the comment icon to add or update a comment.
- Custodian information not updated. Click the Operation/Maintenance tab to add or update EmplID and/or Department.
- Location information not updated. Click the Operation/Maintenance tab to add or update Location and/or Area ID.



Row Deleted

Indicates that the row has been removed from the hierarchy.



Error

Indicates an invalid use of the Component field.



Asset Search

Click the Asset Search icon to search for an asset. The system searches PeopleSoft Maintenance Management (MM) assets if that product is installed. If MM is not installed, the search is directed to PeopleSoft Asset Management for retrieval.



Asset Details

Click to view asset details for the given asset. You will be directed to the Define Asset Operational Information page when PeopleSoft Maintenance Management is installed. When PeopleSoft Maintenance Management is not installed, you are directed to the Basic Add page for asset details.

Operation/Maintenance Tab

This page displays only if PeopleSoft Maintenance Management is installed. It provides the Operation/Maintenance details for the assets such as Custodian, Asset Criticality, Repairable Flag, Repair Status, VIN, Serial ID, EmplID, Department, Location Code, and Area ID.

Providing Comments

Provide comments with a detailed explanation of the change.



The screenshot shows a dialog box titled "Provide Reason for the Modification". Inside the dialog, there is a label "Comment:" followed by a large, empty text input field. Below the input field, there are two buttons: "OK" and "Cancel".

Provide Reason for the Modification page

When a component is removed from the hierarchy, you must indicate a reason for this action. This comment page is automatically displayed and contains a reason drop down list in addition to the comment entry field. Both Reason and Comment are mandatory in the case of a removal from the hierarchy.

Reviewing Changes Made to the Asset Hierarchy

Access the Summary of Changes page by clicking the Review Changes link.

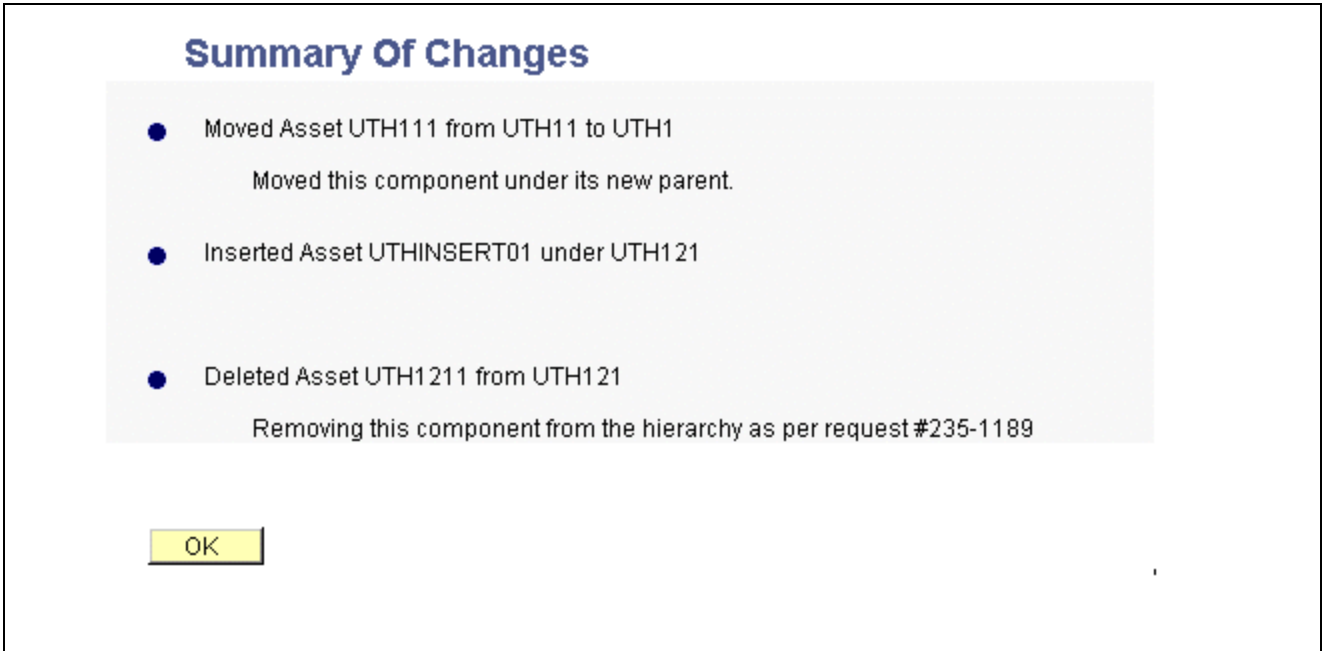

Summary of Changes page

Reporting Changes to the Hierarchy

Access the Asset Component Hierarchy Move run control page

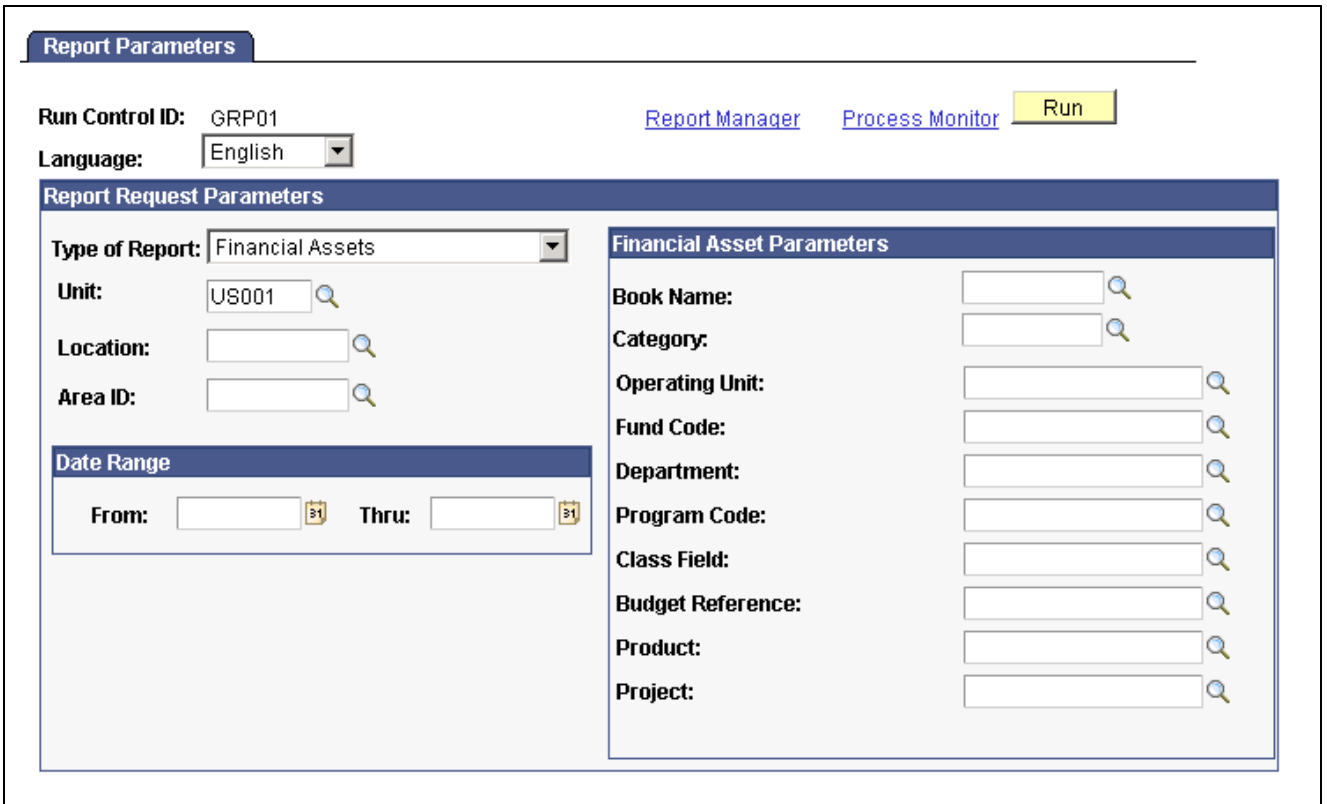

Asset Component Hierarchy Move - Report Parameters page

Type of Report

Select to run the report for *All* assets, *Financial Assets* or *Non Financial Assets*. When you select *Financial Assets*, the financial asset parameters appear.

Creating Parent-Child Asset Relationships

This section provides an overview of parent-child asset relationships and discusses how to:

- Create an asset parent.
- View child assets.
- Add parent and child component assets.
- Use the Child Inherits Life of Parent feature.
- Update parent-child basic information.
- Select child assets.
- View parent and child assets.

Understanding Parent-Child Asset Relationships

Some assets stand alone, while others are grouped together for ease of processing and reporting. Parent-child assets are assets that are grouped together. For example, a computer can be regarded as several separate assets such as a monitor, a CPU, and a printer.

Three approaches you might use to add the computer as an asset follow:

- Add the computer as a single asset.

You use this approach to capitalize the asset with one cost, depreciate it as a single unit, and physically track it as one item.

- Create a parent asset that is not an actual asset but rather a conceptual asset (for reporting purposes) that ties together the various asset components.

In Asset Management, this is referred to as a *parent only* asset. Use the asset ID to tie together all the components as child assets. Each component has its own cost basis, depreciation, and physical tracking information.

- Identify one of the asset's components as the parent when you enter it.

In PeopleSoft Asset Management, this is referred to as a *parent component* asset. Give it an asset ID, and use that ID to tie together the other components as child assets. Each component has its own cost basis, depreciation, and physical tracking information.

Note. Group assets or members cannot be used as parent-child assets.

Pages Used to Create Parent-Child Asset Relationships

| Page Name | Object Name | Navigation | Usage |
|------------------------------|--------------------|--|---|
| Asset Parent | ASSET_PARENT | Asset Management, Asset Transactions, Parent-Child Relationship, Create Parent, Asset Parent | Add an asset that is used only for reporting purposes as an umbrella for child assets. Add or delete comments. Link to a list of all child assets for a parent asset that has already been created. |
| Create Parent - Child Assets | CHILDASSETS_ALL | Click the Child Assets link on the Asset Parent page. | View child assets related to the parent asset. |
| Asset Information | ASSET_GENERAL_01 | Asset Management, Asset Transactions, Owned Assets, Basic Add, Asset Information | Add a parent asset or a child asset; select the appropriate parent asset for a child asset. |
| Cost/Asset Information | ASSET_ENTRY_00 | Asset Management, Asset Transactions, Owned Assets, Express Add, Cost/Asset Information | Add a parent asset or a child asset; select the appropriate parent asset for a child asset. |
| General Parent Info | ASSET_GEN_PAR_CHD | Asset Management, Asset Transactions, Parent-Child Relationship, Parent-Child Basic Information, General Parent Info | Update basic information about a parent asset. |
| Location | ASSET_LOCATION | Asset Management, Asset Transactions, Parent-Child Relationship, Parent-Child Basic Information, Location | Update location information about a parent asset. |
| Custodian/License | ASSET_CUSTODIAN | Asset Management, Asset Transactions, Parent-Child Relationship, Parent-Child Basic Information, Custodian/License | Update custodian or license information about a parent asset. |
| Child Assets | CHILD_ASSETS | Asset Management, Asset Transactions, Parent-Child Relationship, Parent-Child Basic Information, Child Assets | Select child assets to include in the update to a parent asset. |
| Parent and Child Assets | PARENT_CHILDASSETS | Asset Management, Asset Transactions, Parent-Child Relationship, Review Parent-Child | View an asset and any child assets associated with it. Use links associated with each child to access other components of Asset Management. |

Creating an Asset Parent

Access the Asset Parent page.

Parent assets created on this page cannot have associated costs and physical characteristics. Therefore, you cannot view them in the Parent-Child Basic Information component. Also, you cannot view them or perform transactions on them in the Asset Cost Adjust/Transfers component, the Asset Retirements component, or the Parent-Child NBV component. You can, however, view them on the Inquire - Parent and Child Assets page.

Viewing Child Assets

Access the Child Assets page.

You can use this page to view a child asset if you have added it with future transaction and accounting dates that have not yet passed. You cannot view such an asset on the Inquire - Parent and Child Assets page.

Adding Parent and Child Component Assets

You can add parent and child assets by using the Asset Basic Information component or the Asset ExpressAdd component. Before you can identify a child asset of a parent, you must first identify the parent asset.

Using the Child Inherits Life of Parent Feature

When you use parent-child component assets, all child assets have their own cost basis and depreciation attributes that are independent of the parent asset. Because the child's asset life may differ from the life of the parent asset, you may need to specify that a new child asset of a parent component asset inherit the remaining life of the parent asset. For example, suppose that a car is depreciated using a five-year life. After two years, a CD player is added as a child asset to the car (which is the parent asset). You can depreciate the CD player over the remaining depreciable life of the car—that is, three years. The child asset then takes on the remaining life of the parent component asset. You can also override the child's asset life with a different life, if necessary.

Setting Up the Child Inherits Life of Parent Feature

You must select the Child Inherits Parent's Life option on the following two pages before you can use it:

- On the Asset Management page of the Installation Options component.
- On the Business Unit/Book Feature page of the Asset Management Business Unit Definition component.

Applying the Child Inherits Life of Parent Feature to a Child Asset

To apply the Child Inherits Parent's Life feature to a child asset:

1. Add the child asset using the Cost / Asset Information page of the Asset ExpressAdd component, and enter the cost.
2. Expand the Asset Additional Information group box. From the Parent-Child drop-down list box, select *Child* to indicate that this is a child asset. Select an ID for the parent asset in the Parent ID field. You must enter a Parent ID before you select Default Profile.
3. From the Asset Cost Information group box, enter asset cost information for the child asset as it applies. Click the Default Profile button to capitalize the asset and create all the corresponding asset books.
4. When prompted, click Yes to have the system recalculate the book's asset life based on the parent's remaining life.
5. Access the Depreciation Information page, and click the Default Parent's Life button to view or recalculate the child asset's life.

The Default Parent's Depr Attributes page appears. The Parent Depreciation Attributes section shows the asset life information for the parent asset. The Child Depreciation Attributes section shows the asset life information for the child asset that Asset Management calculates from the remaining life of the parent asset.

6. Examine the calculated remaining life information, and either accept the remaining life for the child asset or change it by entering a new life

Note. Remember when working with Parent/Child assets, you must go to the Asset Additional Information section and enter the Parent ID before you select the Default Profile button.

Updating Parent-Child Basic Information

Use the pages within the Parent-Child Basic Information component to update basic information about a parent and its child assets.

Note. Parent assets created on the Asset Parent page (parent-only assets) do not have cost or basic information. They cannot be viewed in the Parent-Child Basic Information component. Also you cannot view them or perform transactions on them in the Cost Adjust/Transfer Asset component; the Retire/Reinstate Asset component; or the Review Parent-Child NBV component. If you want to use a parent asset as an umbrella asset for reporting purposes only and access these components to manipulate child assets in mass, you can create a 0-cost parent asset as opposed to a parent-only asset.

Any adjustments made to parent assets are not made to the associated child assets. To make a change to an associated child asset, select the child asset on the Child Assets page.

Details entered on the Location/Comment/Attributes page or the Manufacture/License/Custodian page are not automatically copied from a parent to its child assets.

See Also

[Chapter 5, "Adding and Maintaining Assets," Adding and Maintaining Asset Information, page 47](#)

Selecting Child Assets

Access the Child Assets page.

| General Parent Info Location Custodian/License Child Assets | | | | | | | | | |
|--|--------------|-------------------------------|----------------|----------------------|---------|----------|---------------------------|-----------------------------------|--|
| Unit: US001 | | Asset ID: EX_PARENT003 | | Executive Office Set | | | Status: In Service | | |
| Tag Number: | | | | | | | | | |
| <input type="button" value="Select All"/> | | | | | | | | | |
| Selected | Tag Number | Description | Child Asset ID | Asset Status | Cost | Currency | Acq Date | Asset Information | |
| <input type="checkbox"/> | P00000000501 | Desk | EX_CHILD0002 | In Service | 7500.00 | USD | 03/01/1999 | Asset Information | |
| <input type="checkbox"/> | P00000000506 | Bookcase | EX_CHILD0013 | In Service | 1500.00 | USD | 02/03/2000 | Asset Information | |
| <input type="checkbox"/> | P00000000507 | Chairs | EX_CHILD0014 | In Service | 5000.00 | USD | 02/03/2000 | Asset Information | |
| <input type="checkbox"/> | P00000000508 | Lamps | EX_CHILD0015 | In Service | 2500.00 | USD | 02/03/2000 | Asset Information | |
| | | | | | | | | | |
| | | | | | | | | | |
| | | | | | | | | | |
| | | | | | | | | | |
| | | | | | | | | | |
| | | | | | | | | | |

Child Assets page

To include a child asset, select the check box in the Selected column.

- Tag Number** Displays the tag assigned to the child asset. Parent and child assets may share the same tag number. You can sort child assets according to this field.
- Description** Displays the child asset description. You can sort child assets according to this field.
- Child Asset ID** Displays the asset ID assigned to the child asset. You can sort child assets according to this field.
- Cost** Displays the cost of the child asset. You can sort child assets according to this field.
- Currency** Displays the currency in which child asset costs are stored. You can sort child assets according to this field.
- Acq Date** (acquisition date) Displays the date that the asset was acquired. You can sort child assets according to this field.
- Asset Information** Click a link in this column to access another copy of the Asset Information page of the Asset Basic Information component. The component is populated with the child asset information.
- Include Parent Asset** Clearing this default setting enables you to update at once all or selected child assets while excluding the parent asset. However, the update details must be specified on the parent.

Note. If you select the Include Parent Asset check box and the transaction is complete, the pages continue to show the parent asset as retired, transferred, or recategorized. The retained parent values are not displayed until you save and exit the pages and then access the component again.

Viewing Parent and Child Assets

Access the Parent and Child Assets page.

If the status of a parent asset is Retired or Disposed and the asset has child assets that are still in service, the child assets are orphaned. If you have added a child asset and given it future transaction and accounting dates that have not yet passed, you cannot view that child asset on this page. However, you can view it by clicking the link for the child asset on Asset Parent page.

Calculating Asset Replacement Costs

This section provides an overview of asset replacement cost and discusses how to calculate replacement cost.

Understanding Asset Replacement Cost

Your tangible working assets are one of the greatest investments made in any enterprise. As certain assets approach the end of their useful lives, you need to be able to anticipate expenditures to replace these assets. You may need to get a replacement cost as you explore insurance coverage for property, equipment, computers and other assets. Likewise, you may need to replacement calculate the cost in the event of an unforeseen loss, such as when plants or equipment are destroyed in a fire or a natural disaster.

PeopleSoft Asset Management provides the Calculate Replacement Cost application engine (AMRCCAL) that will make a replacement cost calculation of all assets, assets with new activity, or a selected range of assets, based on an index that you apply to the equation, such as the consumer price index (CPI) or other indexes you maintain.

Page Used to Calculate Replacement Cost

| Page Name | Object Name | Navigation | Usage |
|----------------------------|-------------|--|-----------------------------------|
| Calculate Replacement Cost | RUN_AMRCCAL | Asset Management, Asset Transactions, Owned Assets, Calculate Replacement Cost | Calculate asset replacement cost. |

Defining Asset Operational Information

The Asset Operational Information component provides an efficient way to add and maintain non-financial assets. The operational and maintenance fields are available as they are in the Basic Add component but without the financial fields. From this component, however, you can access both financial and non-financial assets.

This component also provides a Maintenance Workbench to more easily access other areas of interest within the Service and Maintenance component. The Maintenance Workbench includes links to asset insurance, warranties, inspection, checkout, maintenance history, meter reading and service and repairs.

Note. Group Assets, Composite Assets and Parent/Child Assets are not created through this component.

Pages Used to Add and Maintain Asset Operational Information

| Page Name | Object Name | Navigation | Usage |
|--|-------------------|--|--|
| Define Asset Operational Information - Asset Information | AM_OM_ASSET_ADD | Asset Management, Asset Transactions, Owned Assets, Define Asset Operational Info, Asset Information | Add non-financial assets and corresponding details including asset type, manufacture, asset resource, location, custodian, license information, and physical attributes. Include an image of the asset and use the Maintenance Workbench to track service and repairs, warranties and other maintenance details. |
| Define Asset Operational Information - Asset Property | ASSET_PROPERTY | Asset Management, Asset Transactions, Owned Assets, Define Asset Operational Info, Asset Property | Enter details to manage non-financial property assets and to maintain property specific attributes such as identifying information, asset hierarchy, area and occupancy, and legal descriptions. This page tab displays when the asset type of <i>Property</i> is selected; however, if Lease Administration is not a selected product within Installation Options and Space Management Installed is not selected within the Asset Management Installation Options, the Property page is disabled. |
| Define Asset Operational Information - Customize Page Layout | AM_CUSTOMIZE_PAGE | Click the Customize Page Layout link from the Define Asset Operational Information page. | Customize the layout of the Asset Information page to hide, expand or collapse various sections on the page. |
| Asset Supplemental Data | AM_ASSET_SD | Asset Management, Asset Transactions, Owned Assets, Define Asset Operational Info, Asset Supplemental Data | Record additional data regarding hardware information and maintenance information for non-financial assets. |

Adding Operational Non-Financial Assets

Access the Define Asset Operational Information - Asset Information page.

Define Asset Operational Information

| | | | |
|------------------------------|---|-----------------------|---|
| Business Unit: | US001 | Asset ID: | 000000000001 |
| Tag Number: | <input type="text"/> | *Asset Status: | In Service <input type="button" value="v"/> |
| Short Desc: | SOLARIS WO | Profile ID: | COMPUTERS |
| Description: | SOLARIS WORKSTATION Customize Page Layout | | |
| Detailed Description: | SOLARIS WORKSTATION | | |

Asset Type

| | | | |
|---------------------|---|---|---|
| Asset Type | Hardware <input type="button" value="v"/> | Asset Subtype | <input type="text"/> <input type="button" value="Q"/> |
| Component of | <input type="text"/> <input type="button" value="Q"/> | Work Order Options for Components | |

Manufacture Information

| | | | |
|---------------------------|---|-------------------------|--|
| Serial ID: | 000000000001 | Manufacturer ID: | <input type="text"/> <input type="button" value="Q"/> |
| Manufacturer Name: | <input type="text"/> | | |
| Model: | <input type="text"/> <input type="button" value="Q"/> | Number of CPUs | <input type="text"/> |
| Product Version: | <input type="text"/> | Production Date: | <input type="text"/> <input type="button" value="B1"/> |
| Plant: | <input type="text"/> | Contact: | <input type="text"/> |
| VIN: | <input type="text"/> | SKU: | <input type="text"/> |

Asset Resource Information

Maintenance Information

| | | | | |
|--|-----------------------|---|---------------------|---|
| <input type="checkbox"/> Repairable | Repair Status: | None <input type="button" value="v"/> | Parts List: | <input type="text"/> <input type="button" value="Q"/> |
| <input type="checkbox"/> Offline | WO Location: | <input type="text"/> <input type="button" value="v"/> | Criticality: | 02 <input type="button" value="Q"/> Medium |

Define Asset Operational Information page (1 of 2)

| | | |
|---|--|----------------------------------|
| ▼ Additional Information | | |
| <input type="checkbox"/> Hazardous Asset | Hazardous Code Information | |
| <input type="checkbox"/> Non-Owned Asset | | |
| <input type="checkbox"/> Replacement Asset | Asset ID: <input type="text"/> | <input type="button" value="🔍"/> |
| <input type="checkbox"/> Asset is Available | Contact: <input type="text"/> | Phone #: <input type="text"/> |
| ▶ Location | | |
| ▶ Custodian Information | | |
| ▶ License Information | | |
| ▶ Physical and Custom Attributes | | |
| ▶ Comments | | |
| ▶ Image | | |
| ▼ Maintenance Workbench | | |
| Enter Meter Reading | Asset Inspection | |
| Asset Insurance | Asset Checkout | |
| Review Maintenance History | Track Service and Repairs | |
| Asset Warranties | | |

Define Asset Operational Information page (2 of 2)

The Define Asset Operational Information page provides an efficient way of capturing data for physical operators who do not handle financial information. However, you can review both financial and non-financial assets from this page. You can make changes to the attributes; however, there are no financial implications.

Any changes you make, such as custodian or location, appears as a new entry rather than an update to the existing entry. The effective date is the system date. The Profile ID is editable only when adding a new asset.

See [Chapter 5, “Adding and Maintaining Assets,” Adding Asset Basic Information, page 51](#).

Customizing the Asset Operational Information Page Layout

Access the Customize Page Layout page.

Customize Page Layout

| User ID | | | |
|---------------------------------------|-----------------------|----------------------------------|----------------------------------|
| | Hide Section | Collapse Section | Uncollapse Section |
| Manufacture Information | <input type="radio"/> | <input type="radio"/> | <input checked="" type="radio"/> |
| Asset Resource Information | <input type="radio"/> | <input type="radio"/> | <input checked="" type="radio"/> |
| Maintenance Information | <input type="radio"/> | <input type="radio"/> | <input checked="" type="radio"/> |
| Additional Information | <input type="radio"/> | <input type="radio"/> | <input checked="" type="radio"/> |
| Location Information | <input type="radio"/> | <input type="radio"/> | <input checked="" type="radio"/> |
| Custodian Information | <input type="radio"/> | <input type="radio"/> | <input checked="" type="radio"/> |
| License Information | <input type="radio"/> | <input checked="" type="radio"/> | <input type="radio"/> |
| Physical and Custom Attributes | <input type="radio"/> | <input checked="" type="radio"/> | <input type="radio"/> |
| Comments | <input type="radio"/> | <input checked="" type="radio"/> | <input type="radio"/> |
| Image | <input type="radio"/> | <input checked="" type="radio"/> | <input type="radio"/> |

Customize Page Layout page

Searching for Asset Information

This section discusses how to search for an asset.

Page Used to Search for Asset Information

| Page Name | Object Name | Navigation | Usage |
|---------------------|---------------|---------------------------------------|---|
| Search for an Asset | AM_LOOKUP_PNL | Asset Management, Search for an Asset | Search for an asset based on specified criteria. After you find assets that meet the criteria, you can view them in greater detail. Use links to quickly access other components in the system and perform transactions on selected assets. |

Searching for an Asset

Access the Search for an Asset page.

Asset Search Criteria

| | | | |
|--|---|---|--|
| Unit: <input type="text" value="US001"/> | Book: <input type="text"/> | Parent ID: <input type="text"/> | |
| Category: <input type="text"/> | Location: <input type="text"/> | Group ID: <input type="text"/> | |
| Asset ID: <input type="text"/> | Asset Status: <input type="text" value="In Service"/> | Impairment Processing: <input type="text"/> | |
| Tag Number: <input type="text"/> | Profile ID: <input type="text"/> | <input type="checkbox"/> Hazardous Asset | |
| Serial ID: <input type="text"/> | Additional Search Criteria | | Chartfield Search Criteria |

Acquisition Details

| | | | |
|-------------------------------|------------------------------------|-------------------------------|-----------------------------------|
| PO Unit: <input type="text"/> | Receipt Unit: <input type="text"/> | AP Unit: <input type="text"/> | PC Bus Unit: <input type="text"/> |
| PO No.: <input type="text"/> | Receipt No.: <input type="text"/> | Voucher: <input type="text"/> | Project ID: <input type="text"/> |

Retrieve

Cost Information
 Acquisition Information
 Location
 Non Capital Asset
 Custodian
 Lease
 [Hint](#)

 Drill-Down To:

Search Results - Select One Asset to Continue

| | | | | | |
|-----------------------------|----------------------------|---------------------|-----------------|------------------|---------|
| Customize Find View 100 | First 1-10 of 300 Last | | | | |
| Asset Information | Asset Cost Information | Acquisition Details | Owner/Custodian | Work Maintenance | More... |

| Unit | Asset ID | Description | Asset Type | Asset Subtype | Tag Number | Serial ID | Status |
|-----------------------|----------|---------------|--------------------------------|---------------|------------|---------------------------|------------|
| <input type="radio"/> | US001 | 0000000000001 | SOLARIS WORKSTATION | IT Hardware | | | In Service |
| <input type="radio"/> | US001 | 0000000000002 | Gas/elec SUV - Fleet vehicle 1 | Fleet | AUTO | P00000009001 666345234567 | In Service |
| <input type="radio"/> | US001 | 0000000000003 | Gas/elec car - fleet vehicle 2 | Fleet | AUTO | P00000009002 567345JPY5 | In Service |
| <input type="radio"/> | US001 | 0000000000004 | Gas/elec hybrid - fleet vehicl | Fleet | AUTO | P00000009003 123JPY345 | In Service |
| <input type="radio"/> | US001 | 0000000000005 | Fleet vehicle - Gas/Elec Hybri | Fleet | AUTO | P00000009005 PRIUS1234 | In Service |
| <input type="radio"/> | US001 | 0000000000006 | | Other | | P000038675 02716277 -3 | In Service |
| <input type="radio"/> | US001 | 0000000000007 | | Other | | P000041715 02736047 | In Service |
| <input type="radio"/> | US001 | 0000000000008 | | Other | | P00006375 SG57740753 | In Service |
| <input type="radio"/> | US001 | 0000000000009 | | Other | | P00007120 3433S22855 | In Service |
| <input type="radio"/> | US001 | 0000000000010 | | Other | | P00011408 SG51042341 | In Service |

Search for an Asset page

Note. The asset search utility includes searching by the Description field. If processing is very slow, PeopleSoft recommends that an index of the DESCR field be created for the ASSET table to improve performance.

Enhancing Search Performance

When an organization maintains a high volume of property assets, it is recommended that you create new indexes and alternate search keys to enhance search performance.

Alternate search keys should be created for the following fields:

1. Table ASSET_SITE change Record Definition to include PROPERTY_NM as an Alternate Search Key field.
2. Table ASSET_BLDG change Record Definition to include PROPERTY_NM as an Alternate Search Key field.
3. Table ASSET_FLOOR change Record Definition to include PROPERTY_NM as an Alternate Search Key field.
4. Table ASSET_AREA change Record Definition to include PROPERTY_NM as an Alternate Search Key field.

The following new indexes should be created on the ASSET_PROPERTY table:

1. PS_ASSET_PROPERTY(BUSINESS_UNIT,SITE_PROPERTY_ID).
2. PS_ASSET_PROPERTY(BUSINESS_UNIT,BLDG_PROPERTY_ID).

3. PS_ASSET_PROPERTY(BUSINESS_UNIT,FLOOR_PROPERTY_ID).
4. PS_ASSET_PROPERTY(BUSINESS_UNIT,AREA_PROPERTY_ID).
5. PS_ASSET_PROPERTY(IS_LEASED, BUSINESS_UNIT, SITE_PROPERTY_ID, BLDG_PROPERTY_ID, FLOOR_PROPERTY_ID, AREA_PROPERTY_ID).

Asset Search Criteria

Use the Asset Search Criteria, Acquisition Details, and Retrieve group boxes to establish the search criteria. Each group box enables you to confine the search to specific tables according to the following rules:

- Asset table information is always retrieved.
- Cost information is retrieved if any of the cost fields is used in the search criteria, or the Cost Information check box is selected.

For example, if you enter a category and the asset is capitalized, the cost information for the asset is retrieved regardless of whether the cost information check box is selected. However, if you don't populate any of the cost fields in the search criteria, you need to select the cost information check box. If you don't need to view cost data, leave the check box blank.

- Asset acquisition information is retrieved if any of the fields in the Acquisition Details group box are used in the search criteria, or if the Acquisition Information check box is selected.
- Location code is retrieved if the location field is used to retrieve asset information or if the Location check box is selected.
- The Non Capital Asset check box is used *only* when the Acquisition Information and Cost Information check boxes are selected, or when fields from the Asset Search Criteria and Acquisition Details group boxes are specified.

Click the Hint link for additional information when selecting criteria.

Search Results - Select One Asset to Continue

Search results display with details available from these tabs:

- Asset Information: This tab shows business unit, asset ID, description, asset type, asset subtype, tag number, serial ID and status.
- Asset Cost Information: This tab shows business unit, asset ID, description, ChartFields, cost type, quantity, cost and currency.
- Acquisition Detail: This tab shows business unit, asset ID, description, PO business unit, PO number, receiving business unit, receipt number, AP business unit, voucher ID, PC business unit, project ID, and activity.
- Owner/Custodian: This tab shows business unit, asset ID, description, employee ID, custodian, asset custodian department ID, and offsite status.
- Work Maintenance: This tab shows business unit, asset ID, description, use-as-tool option, schedulable option, capitalized asset option, overbooking option, work order location, work order business unit, work order shop, and VIN.
- More: This tab shows business unit, asset ID, description, profile ID, parent ID, group ID, location, lease end date, manufacturing ID, model, and replacement cost.

Display all columns by clicking the Show all Columns icon.

You can sort options to arrange the asset list order. For example, if you click Asset ID, assets are ordered according to the asset number assigned in either ascending or descending order.

Note. Some results may contain multiple ChartFields. To display them, click either the Asset Cost Information tab or the Show all Columns icon.

Drill-Down To

The drill-down functionality enables you to review detailed information about a selected asset within different Asset Management components. You can also use the drill-down functionality to copy or print an asset. Select one of the following options to view detailed asset information in a new window:

- *Asset Accounting Entries.*
- *Asset Basic Information.*
- *Asset Cost Adjust/Transfers.*
- *Asset Cost History.*
- *Asset Depreciation.*
- *Asset Retirements.*
- *Copy Asset.*
- *Define Tax/Depr Criteria* (define tax and depreciation criteria).
- *Print an Asset.*
- *View Component Hierarchy.*

Printing Asset Information

This section lists the page used to print asset information.

Page Used to Print Asset Information

| Page Name | Object Name | Navigation | Usage |
|-------------------------|-----------------|----------------------------------|--|
| Printable view of Asset | AM_LOOKUP_PRINT | Asset Management, Print an Asset | Generate a printed copy of the asset basic information, default book and depreciation attributes, and asset cost information for the default book. |

Adding Assets with the Excel to Component Interface Utility

The PeopleTools Excel to Component Interface utility enables you to add assets from a predefined spreadsheet template. You can use the utility to upload new asset information during a conversion or when adding assets acquired from an acquisition or merger. You can add financial data and physical data. Once the data is uploaded, it is available for the Transaction Loader process to process the asset additions as financial add transactions (FAD).

Note. The amount of data that can be uploaded from a spreadsheet is limited by the spreadsheet utility. Consequently, this method of conversion is inappropriate for large-volume data conversions.

This section provides an overview of how to import asset information with the Excel to Component Interface utility and discusses how to:

- Enter data to import assets.
- Preview the data to be imported through a spreadsheet.

See Also

Enterprise PeopleTools 8.48 PeopleBook, PeopleSoft Component Interfaces

Understanding How to Import Asset Information with the Excel to Component Interface Utility

The PeopleSoft system provides a template to import and add transactions financial data from the spreadsheet to Asset Management tables INTFC_FIN and INTFC_PHY_A with the Excel to Component Interface utility.

Here is an overview of the steps to add assets using import data from an Excel spreadsheet:

1. Connect to the database by entering the database connect information on the template Connect Information tab.
You need the PeopleSoft web server name, port, PeopleSoft Pure Internet Architecture or portal name, and default local node.
2. Select the predefined component interface (INTFC_FINPHY_SS_A) to populate the template on the Template tab.
3. Select the fields that are used to enter data.
Select New Data Input to format the Data Input tab with the selected data fields for the component interface.
4. Input data for all identified and selected record levels on the Data Input tab.
5. Stage the input data to the Stage & Submit Data tab.
6. Review the data that is ready for staging on the Stage & Submit Data tab.
Submit data for error-checking and transmission to the database, if successful.
7. Errors are returned to the Stage & Submit Data tab; select the Post Results option to return processing errors to the Data Input tab for reworking.
8. Submit data to the PeopleSoft Asset Management database as needed to successfully transmit all input data to Asset Management.
9. Preview the financial and physical data, using the menu option for importing data through a spreadsheet.
10. Run the Transaction Loader process to add assets to the database.

Pages Used to Add Assets with the Excel to Component Interface Utility

| Page Name | Object Name | Navigation | Usage |
|-----------------------------|-----------------|--|---|
| Import Data Via Spreadsheet | INTFC_FINPHY_SS | Asset Management, Send/Receive Information, Import Data via Spreadsheet, Financial and Physical, Import Data Via Spreadsheet | Preview data uploaded from ExcelToCI utility to import and add financial transaction data to Asset Management tables INTFC_FIN and INTFC_PHY_A before running the transaction loader. If you want to change any information, you must go back to the ExcelToCI utility to make changes. |

Entering Data to Import Assets

Access the Excel to Component Interface spreadsheet (ExcelToCI.xls).

Connect and select the component interface to be used for the asset upload: INTFC_FINPHY_SS_A. Select the data fields to be entered and format the Data Input tab by selecting New Data Input. Access the Input Data page of the Excel to Component Interface utility. The following table describes the entries for required fields to upload asset FAD transactions. Many other data fields are available to enter data through the template in addition to the ones described here; these are not required or key fields.

Record Level 000 identifies the common key field values to be shared by INTFC_FIN and INTFC_PHY_A. Record level 100 contains data fields for the INTFC_FIN table and record level 200 identifies the data fields for the INTFC_PHY_A table.

| Row Property | Input Description | Entry Required |
|--|--|----------------|
| Interface ID (INTFC_ID) | Use a unique previously unused INTFC_ID. Lock the Installation_AM table by updating the INTFC_ID to the next INTFC_ID. Use that INTFC for the CIS. | Required |
| Interface Line Number (INTFC_LINE_NUM) | The INTFC_LINE_NUM must be unique for each ASSET_ID. | Required |
| Business Unit (BUSINESS_UNIT) | | Required |
| Asset Identification (ASSET_ID) | This field can be NEXT. | Required |

| Row Property | Input Description | Entry Required |
|---|---|----------------|
| Asset Book Name (BOOK) | BOOK can be entered if the default profile SW (switch) = Y, but all the books need to be entered if the default profile SW = N (multiple lines for each asset, one line per book). | |
| Date/Time Stamp (DTTM_STAMP) | This field should be populated by the user. If left blank, the current time is entered for the row on which it is blank. If a different date-time stamp exists for the same asset, the asset cannot be created. | Required |
| Transaction Load Type (INTFC_TYPE) | Either FAD , ADD , CN1 & CN2 should be entered. If left blank , FAD is populated as the INTFC_TYPE | |
| System Source (SYSTEM_SOURCE) | Always populated as CIS. | |
| Interface Status (INTFC_STATUS) | Always populated as DON. | |
| Load Status (LOAD_STATUS) | Always populated as NEW. | |
| Default Books from Profile (DEFAULT_PROFILE_SW) | | Required |

Here is a portion of the input page:

| | A | B | C | D | E | F | G | H | I |
|----|--|------------------------------|----------------------|-----------------------------|------------------------|------------------------|-----------------------|-------------------|-----------------------|
| | Enter Connect Information >Create Template > Input Data > Stage & Submit Data | | | | | | | | |
| 1 | | | | | | | | | |
| 2 | Interface ID | Interface Line Number | Business Unit | Asset Identification | Asset Book Name | Date/Time Stamp | Operating Unit | Department | Asset Category |
| 3 | 73 | 1 | US001 | NEXT | CORP | 2003-02-11 10:59:36 | ILLINOIS | 10000 | AUTO |
| 4 | 73 | 1 | US001 | NEXT | FEDERAL | 2003-02-11 10:59:36 | ILLINOIS | 10000 | AUTO |
| 5 | 73 | 1 | US001 | NEXT | AMT | 2003-02-11 10:59:36 | ILLINOIS | 10000 | AUTO |
| 6 | 73 | 1 | US001 | NEXT | ACE | 2003-02-11 10:59:36 | ILLINOIS | 10000 | AUTO |
| 7 | 73 | 2 | US001 | NEXT | CORP | 2003-02-11 10:59:36 | ILLINOIS | 10000 | AUTO |
| 8 | 73 | 2 | US001 | NEXT | FEDERAL | 2003-02-11 10:59:36 | ILLINOIS | 10000 | AUTO |
| 9 | 73 | 2 | US001 | NEXT | AMT | 2003-02-11 10:59:36 | ILLINOIS | 10000 | AUTO |
| 10 | 73 | 2 | US001 | NEXT | ACE | 2003-02-11 10:59:36 | ILLINOIS | 10000 | AUTO |
| 11 | | | | | | | | | |

Example of Input Data page

When the data input is complete, stage the data to the Stage & Submit tab. Data is transmitted to the database from the Stage & Submit page.

Previewing the Data to Be Imported Through a Spreadsheet

Access the Import Data Via Spreadsheet page.

Select the FIN and PHY data to be uploaded from the Excel to Component Interface utility. Enter search criteria. You can search by interface ID, interface line number, business unit, transaction load type, system source, auto-approval status, load status, asset identification, and asset book name. Preview the data before running the Transaction Loader process. If you need to enter changes, you must return to the Excel to Component Interface utility to make them or update them in preview pages depending upon user permissions

CHAPTER 6

Working with Asset Budgeting

This chapter provides an overview of asset budgeting and capital acquisition planning, and discusses how to:

- Define new capital acquisition plans.
- Adjust capital acquisition plans.
- Link assets to existing capital acquisition plans.
- View capital acquisition plans.
- Run capital acquisition plan reports.

Understanding Asset Budgeting

Charting foreseeable acquisitions is sometimes straightforward, but can often involve assets with high levels of complexity. The capital acquisition planning functionality in PeopleSoft Asset Management and PeopleSoft Budgeting handles your plans when they involve a single asset, and also accommodates acquisitions that span several phases and involve many different components. For more complex acquisitions, PeopleSoft enables you to define a master plan with an unlimited number of subsidiary plans. As you acquire assets, you can associate them with the capital acquisition plan and maintain an up-to-date view as your business makes each expenditure included in the plan.

Each plan you set up is assigned a type. Types provide a categorization method you can use when you generate reports.

You can have as many capital acquisition plan types as you need to reflect the range of categories you want to track. Each time you design a capital acquisition plan, assign a type.

Before you work with capital acquisition planning, you must create business units and establish capital acquisition plan types.

See *PeopleSoft Enterprise Asset Lifecycle Management Fundamentals 9.0 PeopleBook*, “Integrating PeopleSoft Asset Management with Other Products,” Integrating with Budgeting.

Understanding Capital Acquisition Planning

The Asset Management and Budgeting products provide a straightforward page set for entering a plan, enabling you to link assets to that plan and to update cost and asset summaries so that you have an overview at a glance.

When you establish a new plan, you provide ChartField information to identify the project and you enter a cost estimate and cost limit. Plans consist of a single asset or multiple asset component in a large project. You can provide a text description and justification for the plan, and you can enter multiple authorizations for each asset within a plan.

Once you assign a plan to *Open* status, you can link assets to the plan as they are acquired. All associated assets appear on one summary page; cost summary information is provided on another. As the status of each asset changes, the summary totals reflect that progress; you can see how much of your acquisition amount is represented by assets in different life phases.

Note. You cannot link assets to a plan until the plan is assigned an *Open* status. You assign open status to a capital acquisition plan on the Capital Acquisition Planning - Details page.

Defining New Capital Acquisition Plans

To appropriate funds for a capital acquisition, you set up a capital acquisition plan by assigning a type; indicating the ChartFields affected; entering cost information; and providing a plan description, justification, and authorization.

Pages Used to Define New Capital Acquisition Plans

| Page Name | Object Name | Navigation | Usage |
|--|--------------------|---|--|
| Capital Acquisition Planning - Details | BD_CAP_DETAILS | Asset Management, Asset Transactions, Capital Acquisition Planning, Create (CAP) Plan | Add a new capital acquisition plan. |
| CAP Detail Long Description | BD_CAP_DET_SEC | Select the Sel (select) check box on the Capital Acquisitions Planning - Details page, and click Save. Click the Long Descr (long description) button. | Enter a long description for a selected item in the capital acquisition plan. |
| CAP Details - Annual Cost | BD_CAP_COST_SEC | Select the Sel (select) check box on the Capital Acquisitions Planning - Details page, and click Save. Click the Annual Cost button. | Enter and keep track of CAP annual cost for a selected item in the capital acquisition plan. Note. The values you enter on this page are for information only. The system does not use this information for any validation purposes. |
| CAP Details - Justification | BD_CAP_JUSTIFY_SEC | Select the Sel (select) check box on the Capital Acquisitions Planning - Details page, and click save. Click the Justification button. | Enter a detailed justification for a selected item in the capital acquisition plan. (optional) |
| CAP Details - Authorization | BD_CAP_AUTH_SEC | Select the Sel (select) check box on the Capital Acquisitions Planning - Details page, and click save. Click the Authorization button. | Authorize each item in the capitalization acquisition plan. |

Assigning Capital Acquisition Plan Name and ChartFields

Access the Capital Acquisition Planning - Details page.

Note. Column visibility and order for grids may vary by implementation. Use the scroll bar to view all the available columns.

CAP Class

Select a class:

- *Cost Reduction*
- *Expansion*
- *Necessity*
- *New*

Details

The Details group box can contain a single entry if the plan is for a standalone asset, or it can contain many assets that make up a larger project. For example, an expansion project for the Customer Service Department could have three CAP Seq # (sequence numbers), one each to build out a building wing, interior design plans, and furniture and fixtures.

Note. Since this is a new plan, the Original/Adjustment Switch should be set to *Original*. When you revise existing plans, be sure to select *Adjustment* instead.

| | |
|--|---|
| Description | Enter a description for the asset, which may be similar to the plan name if the plan contains only one sequence number. This description and the CAP Sequence number show on the other detail pages associated with capital acquisition planning for the asset. |
| CAP Type | Select a type. The available CAP types are those defined when you established asset processing. You can generate reports that segregate the assets by the CAP Type you assign here. |
| Status | Select a status from the options on the drop-down list. A CAP is considered open when the status is set to <i>Open</i> . You can only associate assets to a CAP that has an <i>Open</i> status. Conversely, you must set the status to <i>Closed</i> to close the CAP. The closing date entered in Est Comp does not also close the CAP status. Statuses are options for organizing information and are useful for reporting purposes or when you make adjustments to existing plans. |
| Est Comp (estimated completion) | Enter an estimated completion date to be used for tracking this plan. When all the items in this plan are acquired, access the page again and enter the Date Closed. Remember, you must also set the Status to <i>Closed</i> to keep assets from being added to this CAP after it is closed. |
| Requester | To ensure that the audit trail is accurate, enter a requester. |
| Estimated Cost | The cost you enter displays on the CAP Summary page. You can adjust the cost estimate as time passes by selecting the <i>Adjustment</i> option in the Original/Adjustment Switch field and specifying a different cost. The total of the adjustments and the updated cost estimate also display on the CAP Summary page. |
| % Over Allowed (percentage over allowed) | Specify a percentage to add a margin to your cost estimate. If you specify an amount, the system enables you to add an asset to the plan that pushes your acquisition costs above the limit you set. The system automatically calculates the Cost Limit based upon the estimated amount and the percentage over estimated amount that you specify. The disparity is reflected in the SQRs for capital acquisition planning. |

See Also

PeopleSoft Enterprise Asset Lifecycle Management Fundamentals 9.0 PeopleBook, “Establishing Asset Processing”

Adjusting Capital Acquisition Plans

Once a capital acquisition plan is established, there are a variety of revisions and additions you can make. All the information originally entered can be modified, and you have the option to change the original information or leave it intact and tag your changes as adjustments. The *Original* or *Adjustment* option on the Detail page reflects your categorization options.

You may not want to keep track of text changes you make to a plan, but you probably need to maintain the history of fluctuations in estimated costs and cost limits. The CAP Summary page separates the original cost estimate and cost limit from adjustments made to these amounts, so you can see the changing financial picture at a glance. You have these options:

- If you want the cost modifications to display separately, be sure that you select the *Adjustment* option on the Detail page before you enter cost information.
- If you want to change the original cost rather than make an adjustment, leave the *Original* option selected on the Detail page, and access pages by using Update/Display as the action.

Note. Keep in mind that the capital acquisition pages are not effective-dated, so you need to use the Adjustment option if you want to maintain a history of the changes you make to any plans.

Linking Assets to Existing Capital Acquisition Plans

One of the advantages of capital acquisition planning is that it gives you a measure against which you can chart capital expenditures to ensure that you stay within the projected budget. Once you have completed a capital acquisition plan, you want to ensure that the assets you acquire under that plan are associated with it so that you can view the totals as you approach the estimated cost or cost limit.

Each time you add an asset in PeopleSoft Asset Management, you have the option to assign it a capital acquisition plan number that links it to an open capital acquisition plan. This link can also be made in Purchasing when you create requisitions or purchase orders to purchase assets. Assets created using the interface from Purchasing are automatically associated with the CAP assigned on the requisition.

Note. The capital acquisition plan must have a status of *Open* to have assets associated with it. A capital acquisition plan that is still in approval phases cannot have assets linked to it.

Viewing Capital Acquisition Plans

PeopleSoft Asset Management and PeopleSoft Budgeting offer you a view of capital acquisition plans from different perspectives. You can see a list of all the assets that are linked to a particular plan, display any capital or operating lease payments associated with a particular plan, or view a summary of cost information.

Pages Used to View Capital Acquisition Plans

| Page Name | Object Name | Navigation | Usage |
|--|--------------------|---|--|
| Capital Acquisition Planning - Financial Assets | BD_CAP_ASSETS | Asset Management, Asset Transactions, Capital Acquisition Planning, Create (CAP) Plan, Financial Assets | View a list of financial assets associated with a plan. The link between an asset and a plan is made on the Asset Basic Information - Asset Entry page or the ExpressAdd Cost/Asset Information page when you add a new asset. The link between an asset and the plan can also be made when you create assets using the Purchasing/Assets interface for requisitions or purchase orders. Note. You must associate the asset with the capital acquisition plan by specifying the appropriate plan number on the Asset Basic Information - Asset Entry page, the ExpressAdd - Cost/Asset Information page, or the Purchasing/Asset interface. |
| Capital Acquisition Planning - Non-Financial Assets | BD_CAP_NF_ASSETS | Asset Management, Asset Transactions, Capital Acquisition Planning, Create (CAP) Plan, Non-Financial Assets | View a list of nonfinancial assets associated with a plan. The Non-Financial Assets page is populated by the CAP_ASSET_NF_VW view with nonfinancial assets that are not retired. |
| Capital Acquisition Planning - Capital Lease Payments | BD_CAP_LSE_PAY | Asset Management, Asset Transactions, Capital Acquisition Planning, Create (CAP) Plan, Capital Lease Payments | View a list of any capital lease payments associated with a capital acquisition plan. |
| Capital Acquisition Planning - Operating Lease Payments | BD_CAP_OPR_LSE_PAY | Asset Management, Asset Transactions, Capital Acquisition Planning, Create (CAP) Plan, Operating Lease Payments | View a list of any operating lease payments associated with a capital acquisition plan. The operating lease payment data is populated by the CAP_LSE_OPR_VW view, which pulls the schedule from the PS_LEASE_SCHED record. |

| Page Name | Object Name | Navigation | Usage |
|--|----------------|--|---|
| Capital Acquisition Planning - Summary | BD_CAP_SUMMARY | Asset Management, Asset Transactions, Capital Acquisition Planning, Create (CAP) Plan, Summary | Review cost information related to the plan. The system automatically totals the costs of both non-financial and financial assets associated with the capital acquisition plan and shows values by estimated costs, cost limits, and asset status categories. |

Running Capital Acquisition Plan Reports

Run the Capital Acquisition Planning report from the Capital Acquisition Planning - Parameters page.

Page Used to Run Capital Acquisition Plan Reports

| Page Name | Object Name | Navigation | Usage |
|---|--------------|--|---|
| Capital Acquisition Planning - Parameters | RUN_AMCP2000 | Asset Management, Asset Transactions, Capital Acquisition Planning, Run Report | Set parameters for the capital acquisition plan report. |

CHAPTER 7

Working With Leased Assets

This chapter provides an overview of leased assets, lists prerequisites, and discusses how to:

- Define payment schedules.
- Add or update capital and operating leases.
- Create lease expense schedules.
- Transfer operating leases.
- Retire or reinstate leases.
- Generate lease reports.

Understanding Leased Assets

PeopleSoft Asset Management incorporates full lease management functionality, including calculating and printing lease payment schedules, calculating leased asset revenues, and verifying leases as operating or capital leases, in accordance with the United States Financial Accounting Standards Board (FASB) Statement 13. It also provides the ability to define step leases.

In PeopleSoft Asset Management, you can retire and reinstate leased assets and track interim payments.

This section discusses:

- Capital and operating leases.
- Step leases.

Note. Your transactions are maintained with multiple currencies if you use them in conjunction with leased assets.

Capital and Operating Leases

There are two basic types of leases: capital leases and operating leases.

- A capital lease is treated as a financial asset.

It has a lease term and lease payment amount. The lease is carried on the balance sheet and is periodically depreciated.

- An operating lease is treated as a nonfinancial asset to which no cost information is associated. It is normally expensed and can include rent and monthly payments that are expensed periodically.

PeopleSoft Asset Management uses the lease classification rules for capital and operating leases as proscribed by the country requirements that were established during the setup of book location. For example, in the United States, leased assets are defined and governed by Financial Accounting Standards Board (FASB) Statement 13.

Note. The United States FASB 13 lease classification rules apply to all countries unless otherwise noted. For example, in Germany, the threshold for capitalization is 90 percent of the leased asset's economic life, as compared to 75 percent under the United States' generally accepted accounting principles. In Canada, the classification of capital or operating leases is the same as that defined in the United States FASB 13. PeopleSoft Asset Management supports the United States, Germany, Canada, and Australia for least type verification.

Step Leases

A step lease features variable payment amounts and variable timing over the term of the lease.

Examples of step leases include:

- Step-down leases with decreasing or declining lease payments.
- Step-up leases with increasingly larger lease payments during the lease term.
- Skip-payment leases in which payments are not required during certain periods.

This table provides an example of a step-down lease schedule:

| Number of Terms | Frequency | Payment Amount |
|-----------------|-----------|----------------|
| 6 | Monthly | \$400 |
| 18 | Monthly | \$350 |

This table provides an example of a quarterly step-lease payment schedule. It is suggested that you use three payment schedules with due dates as shown.

| Schedule | Due Dates |
|------------|----------------------------------|
| Schedule 1 | January, April, July, October |
| Schedule 2 | February, May, August, November |
| Schedule 3 | March, June, September, December |

For an annual step-lease payment schedule, it is suggested that you use 12 payment schedules, with one schedule for each of the 12 months as the payment due date.

Defining Payment Schedules

This section discusses how to add or modify payment schedules for leases.

Before you can add leased assets to your system, you must define at least one payment schedule to indicate when a lease starts and ends. Leases can share the same payment schedule ID.

Page Used to Define Payment Schedules

| Page Name | Object Name | Navigation | Usage |
|-------------------|--------------|--|---|
| Payment Schedules | LEASE_SCH_ID | Set Up Financials/Supply Chain, Product Related, Asset Management, Payment Schedules | Add or modify payment schedules for leases. |

Defining Lease Payment Schedules

Access the Payment Schedules page.

SetID: SHARE **Payment Schedule ID:** AN Annual Payment Schedule

Number of Payments Per Year:

Description: This payment schedule will be setup for annual lease calculations.

Generate Schedule Parameters

Begin Date: **Lease Term (Periods):**

End Date: **Payment Frequency:**

End Of Month Due Date

Payment Dates Customize | Find | View All | 1-8 of 24

| Payment Date | | |
|--|---|---|
| 01/01/1998 <input type="button" value="31"/> | + | - |
| 01/01/1999 <input type="button" value="31"/> | + | - |
| 01/01/2000 <input type="button" value="31"/> | + | - |
| 01/01/2001 <input type="button" value="31"/> | + | - |
| 01/01/2002 <input type="button" value="31"/> | + | - |
| 01/01/2003 <input type="button" value="31"/> | + | - |
| 01/01/2004 <input type="button" value="31"/> | + | - |
| 01/01/2005 <input type="button" value="31"/> | + | - |

Payment Schedules page

Complete the information about the begin date, end date, lease term, and payment frequency.

| | |
|------------------------------------|---|
| Number of Payments Per Year | Enter a value to determine the number of lease payments for the lease schedule. |
| End of Month Due Date | Select to always schedule a payment on the last day of the month. |
| Populate | After completing the fields about the payment schedule, click the Populate button to automatically populate the Payment Date column fields. |

Adding Capital and Operating Leases

This section discusses how to:

- Enter basic information about the lease and lease terms.
- (Optional) Enter information about cost, ChartFields, and depreciation.
- (Optional) View or update a step-lease payment schedule.
- View or update a lease payment schedule.

Pages Used to Add Capital and Operating Leases

| Page Name | Object Name | Navigation | Usage |
|--|-----------------|--|---|
| Express Add - Definition | ASSET_LEASE_01 | Asset Management, Asset Transactions, Leased Assets, Express Add | Create a capital lease or an operating lease. |
| Update Lease Information - Definition | ASSET_LEASE_01 | Asset Management, Asset Transactions, Leased Assets, Update Lease Information | Update a capital lease or an operating lease. |
| Express Add - Cost | ASSET_LEASE_02 | Asset Management, Asset Transactions, Leased Assets, Express Add, Cost | Enter cost, ChartField, and depreciation data for a leased asset. |
| Update Lease Information - Cost | ASSET_LEASE_02 | Asset Management, Asset Transactions, Leased Assets, Update Lease Information, Cost | Update cost, ChartField, and depreciation data for a leased asset. |
| Express Add - Step Lease Payment | ASSET_LEASE_05 | Asset Management, Asset Transactions, Leased Assets, Express Add, Step Lease Payment | Enter a step-lease payment schedule. |
| Update Lease Information - Step Lease Payment | ASSET_LEASE_05 | Asset Management, Asset Transactions, Leased Assets, Update Lease Information, Step Lease Payment | Update a step-lease payment schedule. |
| Express Add - Payment Schedule | ASSET_LEASE_03 | Asset Management, Asset Transactions, Leased Assets, Express Add, Payment Schedule | Create or view lease payment schedules. |
| Update Lease Information - Payment Schedule | ASSET_LEASE_03 | Asset Management, Asset Transactions, Leased Assets, Update Lease Information, Payment Schedule | Update lease payment schedules. |
| Update Lease Information - Operating ChartFields | ASSET_LEASE_06U | Asset Management, Asset Transactions, Leased Assets, Update Lease Information, Operating ChartFields | Update operating lease ChartField information. ASSET_LEASE_06 and ASSET_LEASE_06U are used to allocate operating lease payments to a particular set of ChartFields. |

Creating a Lease

Access the Express Add - Definition page.

| | | | | |
|--------------------------|------------------------------|---------------------|--------------------|------------------|
| Definition | | Cost | Step Lease Payment | Payment Schedule |
| Unit: | US001 | Asset ID: | NEXT | |
| Profile ID: | LEASED CAR | Trans Date: | 04/13/2005 | |
| Description: | Leased car for sales calls | Acctg Date: | 04/13/2005 | |
| CAP #: | | Seq #: | | |
| Asset Type: | Fleet | Subtype: | | Currency: USD |
| Serial ID: | | Tag Number: | | Rate Type: CRRNT |
| Lease Information | | | | |
| Lease ID: | P204956 | Acceptance Date: | | |
| *Description: | Leased car for sales calls | Receipt Date: | 01/03/2005 | |
| *Vendor ID: | USA0000004 Star Rental Group | Lease End Date: | 12/30/2005 | |
| Vendor Contact: | Ormsby,David | Display Alert Days: | | |
| *Responsibility: | Lattner,Kyle | | | |
| Comment: | | | | |

Express Add - Definition page (1 of 2)

| | |
|--|--|
| Lease Term | |
| Lease Term: | 4 Periods |
| Estimated Life: | 4 Periods |
| Interest Rate (%): | 6.000 |
| Borrowing Rate(%): | 8.000 |
| Payment Schedule ID: | Quarterly Payment Schedule |
| Fair Market Value: | 25,000.00 |
| Guaranteed Residual Value: | 15,000.00 |
| <input type="checkbox"/> BPO | |
| <input type="checkbox"/> BRO | |
| <input checked="" type="checkbox"/> Transfer Ownership end lease | |
| <input type="checkbox"/> Step lease | |
| Minimum Rental Payment (MRP): | 303.25 |
| Minimum Lease Payments (MLP): | 0.00 |
| Present Value Lease Payments: | 0.00 |
| Capitalized Lease Amount: | 298.77 |
| Interim Rent (Monthly): | 0.00 |
| <input type="checkbox"/> Capitalize Interim Rent | Calculate |
| Lease Payment Type | |
| <input type="radio"/> Advance | <input checked="" type="radio"/> Arrears |
| Lease Type | |
| <input checked="" type="radio"/> Capital | <input type="radio"/> Operating |
| | Verify |

Express Add - Definition page (2 of 2)

Profile ID

Enter an ID if you want to use the default information from an asset profile to define this asset. You must enter a profile ID for a capital lease because all depreciation information is stored in the profile ID. A profile ID is not required for an operating lease.

Trans Date (transaction date) and **Acctg Date** (accounting date)

Enter a transaction date and accounting date for the lease. For leases, the payment date is based on the transaction date. For example, if a lease begins in October and you need to start the payments in the same month, enter

a transaction date of October 1. The accounting date has no bearing on the payment date.

CAP#(capital acquisition planning number) and **Seq#**(sequence number)

Select the associated Capital Acquisition Plan number for this leased asset or look up the associated Asset ID Sequence number if one has been assigned.

Trans Code (transaction code)

Select the accounting entry template that is used for transactions relating to this asset.

Asset Type

Select the asset type from the available established values. You must enter Asset Type for operating leases if you do not enter a profile.

Subtype

Select the asset subtype from the available defined values for the selected Asset Type.

Currency

Select the currency for the transactions that are processed with this asset.

Serial ID

Enter the Serial ID that is associated with this asset. Serial IDs track physical inventory, especially for IT assets.

Tag Number

Enter the tag number that is associated with this asset. Tag numbers track physical inventory.

Note. To perform a physical inventory with PeopleSoft Asset Management, your assets must use tag numbers.

Rate Type

The exchange rate that is defined for the default book for the business unit appears by default in this field. You can select a different rate type.

Lease Information

Lease ID and Description

Select from the available lease IDs assign a new ID for this business unit and add a description of the lease. Description is required only if a Lease ID has been assigned.

Vendor ID and Vendor Contact

Select the Vendor ID from the list of available vendors for this asset and enter contact information. Vendor ID is required if Lease ID is assigned.

Responsibility

Enter the name of the person who is responsible for this leased asset. Required if Lease ID is entered.

Acceptance Date

Indicates the date that the lease contract is accepted (signed and returned to the lessor). If you complete the Interim Rent (Monthly) field in the Lease Term group box, you must enter an acceptance date that is earlier than the commencement date of the lease. Interim rent starts on the acceptance date and ends on the commencement date. You enter the amount of the interim rent in the Interim Rent (Monthly) field.

Receipt Date

Enter the date the leased asset is received. This is an information-only date fields for reporting purposes.

Lease End Date

Enter the date the leased asset is received. Lease End Date becomes required when a Lease ID is entered. This date is used for the Lease End Date report.

Display Alert Days

Enter the number of days in advance to receive the Lease End Date pagelet based on the Lease End Date.

| | |
|--|---|
| Commence Date and Expiration Date | These fields represent the first and last lease payment date (regardless of interim rent), and appear only after you save the page. |
| Inception Date | When viewing this page in Update/Display mode, this field display. The date displayed is the date of the original transaction. |
| Comment | Enter any comments to be noted for this leased asset. |
| Display Alert Days | The field Display Alert Days displays only if PeopleSoft IT Asset Management (ITAM) is installed. |

Note. If LEASE is entered and PeopleSoft ITAM is installed then Description, Lease End Date, Vendor Id and Responsibility are required fields.

Lease Term

| | |
|---|---|
| Lease Term | Enter the number of periods in this lease. |
| Estimated Life | The number of periods that you entered in Lease Term field appears by default. You can change this value. |
| Interest Rate (%) (interest rate percentage) | Enter the approximate percentage of profit the lessor gains by leasing the asset to you. This number must be an annual interest rate percentage in whole numbers. |
| Borrowing Rate (%) | Enter the interest rate that you would have incurred at the inception of the lease if you had borrowed the necessary funds to purchase the leased asset. This number must be an annual interest rate percentage in whole numbers. |
| Payment Schedule ID | If you want the system to define a lease payment schedule, enter a payment schedule ID. Capital leases must have a payment schedule ID. The values that you can select are set up on the Payment Schedule page when you specify the payment frequency and number of periods. |
| Fair Market Value | <p>Enter the fair market value. The system uses the fair market value to verify the lease type. It also records this value on the AM_FMV table to use in the asset revaluation process. The system calculates the capitalized lease amount using the lesser of the Present Value Lease Payments and Fair Market Value field values.</p> <p>If the present value of the lease payments is less than the fair market value, the capitalized lease amount equals the present value of the MLP.</p> <p>If the fair market value is less than the present value of lease payments, the capitalized lease amount equals the fair market value.</p> <p>You might want to change the interest rate so that the net present value equals the fair market value.</p> <p>If you do <i>not</i> enter a fair market value, the capitalized lease amount equals the present value of the MLP.</p> |
| Guaranteed Residual Value | Calculates depreciation based on the amount of the residual value of the leased asset that is guaranteed by the lessee to the lessor and considered as part of the minimum lease payments. |
| BPO (bargain purchase option) | Select if this lease includes a bargain purchase option, which represents a payment by the lessee to the lessor at the end of the lease term, allowing the lessee to obtain title to the leased property. |

| | |
|-------------------------------------|--|
| BRO (bargain renewal option) | Select if this lease includes a bargain renewal option, which requires a payment if the lease agreement grants the lessee the right to renew or extend the lease. If the agreement specifies that the lease must be renewed or extended, a penalty might be required for failure to renew. |
| Transfer Ownership end lease | Check if there is an ownership transfer of the asset at the end of the lease period. |
| Step lease | Select if the lease is a step lease. A step lease features variable payment amounts and/or variable timing over the term of the lease. |
| Minimum Rental Payment (MRP) | Enter the minimum rental payment. This field is not required for step leases. <hr/> Note. You must either enter a minimum rental payment here or complete the cost information on the Cost page. Otherwise, the system cannot calculate the lease payment schedule. <hr/> |
| Minimum Lease Payments (MLP) | Display a minimum lease payment. <ul style="list-style-type: none">• If there is no bargain purchase option (and you entered a bargain renewal option instead): $MLP = (MRP \times Lease\ Term \div 12\ periods\ per\ year \times number\ of\ payments\ per\ year) + Guaranteed\ Residual + BRO.$• If there is a bargain purchase option: $MLP = (MRP \times Lease\ Term \div 12\ periods\ per\ year \times number\ of\ payments\ per\ year) + BPO.$ |
| Present Value Lease Payments | Displays the present value of the lease payments for a step lease. The system uses two formulas to determine the present value of the total payment for a step lease. <ul style="list-style-type: none">• For the first payment in the schedule, the formula looks at the present value of an ordinary annuity for a series of payments of any amount: $P1 = Pymt \times ([1 - (1 + Intr) ^ -npymt] \div (intr))$ where: P1 = Present value of an ordinary annuity. Pymt = Periodic payment amount. Intr = Periodic interest rate. npymt = Number of payments.• For payments that are made after the first payment, the formula looks at the present value of a single future amount: $P2 = Single_Future_Pymt \times (1 \div (1 + intr) ^ nper)$ where: P2 = Present value of a single future amount. Single_Future_Pymt = Future amount. intr = Periodic interest rate. nper = Number of periods. |

The example illustrates the calculations using an interest rate of 7.2 percent.

| Number of Terms | Frequency | Payment Amount |
|-----------------|-----------|----------------|
| 6 | Monthly | 400 USD |
| 18 | Monthly | 350 USD |

PV1 equals Present value of the first payment in the schedule:

$$400 \text{ USD} \times ([1 - (1 + 0.01)^{-6}] \div (0.01)) = 2,350.40 \text{ USD}$$

PV2 equals Present value of the second payment in the schedule:

$$[350 \text{ USD} \times ([1 - (1 + 0.01)^{-18}] \div (0.01))] \times (1 \div 1.01^6) = 5,744.88 \text{ USD}$$

Present value of the total cash flow equals: $2,350.40 + 5,744.88 = 8,095.28 \text{ USD}$

Note. The lease term during the renewal period is considered part of the overall lease term.

Capitalized Lease Amount Enter the cost. The system uses the following method to calculate lease payments:

$$\text{Capitalized Lease Amount} - \text{Prior Obligation Reduction} = \text{Residual Capitalized Lease Amount}$$

$$\text{Residual Lease Amount} \times (\text{Annual Implicit Interest Rate} / \text{Number of Periods per Year}) = \text{Interest Expense per Period}$$

$$\text{Interest Expense per Payment} + \text{Obligation Reduction} = \text{MRP}$$

For example, this table illustrate a full payment schedule for a simple capital leased asset with a capitalized amount of 10,500 USD, an interest rate of 7 percent, a monthly payment of 908.53 USD, and 12 periods per year:

| Period | Residual Capitalized Lease Amount in USD | Obligation Reduction | Interest Expense | Payment in USD |
|--------|--|----------------------|------------------|----------------|
| 1 | 10,500.00 | 847.2800562 | 61.24994377 | 908.53 |
| 2 | 9,652.71 | 852.2225232 | 56.30747678 | 908.53 |
| 3 | 8,800.49 | 857.1938213 | 51.33617873 | 908.53 |
| 4 | 7,943.29 | 862.1941186 | 46.33588144 | 908.53 |
| 5 | 7,081.10 | 867.2235843 | 41.30641574 | 908.53 |

| Period | Residual Capitalized Lease Amount in USD | Obligation Reduction | Interest Expense | Payment in USD |
|--------|--|----------------------|------------------|----------------|
| 6 | 6,213.88 | 872.2823885 | 36.2476115 | 908.53 |
| 7 | 5,341.59 | 877.3707024 | 31.15929757 | 908.53 |
| 8 | 4,464.22 | 882.4886982 | 26.0413018 | 908.53 |
| 9 | 3,581.73 | 887.6365489 | 20.89345107 | 908.53 |
| 10 | 2,694.10 | 892.8144288 | 15.7155712 | 908.53 |
| 11 | 1,801.28 | 898.022513 | 10.50748703 | 908.53 |
| 12 | 903.26 | 903.2609776 | 5.26902237 | 908.53 |

Interim Rent (Monthly)

Enter the amount of monthly interim rent for a capital or operating lease. Interim rent is common for quarterly leases. Interim rent starts on the acceptance date and ends on the commencement date of the lease. Once the lease officially begins, the normal rental payment amount is tracked by the lease payment schedule.

PeopleSoft Asset Management prorates the first month of interim rent. You can see interim rent payments on the Express Add - Payment Schedule page (ASSET_LEASE_03).

Select Capitalize Interim Rent if you want to include these interim payments as part of your asset cost.

Note. You must post journal entries for interim rent each month by running the Depreciation Close process (AM_DPCLOSE).

Capitalize Interim Rent

Select this check box to capitalize. When selected, the interim rent is added to the cost of the leased asset.

Calculate

Click to have the system calculate the lease payment schedule.

Before the system can calculate the lease payment schedule, you must have:

- Defined a payment schedule.
- Entered (for leases other than step leases) the minimum rental payment on this page or entered cost information on the Express Add - Cost page.
- For step leases, entered payment information on the Express Add - Step Lease Payment page.

You can see the results of the calculation on the Express Add - Payment Schedule page.

Lease Payment Type

Select a payment type: Advance or Arrears. You can use either type for both capital leases and operating leases. More details on these two payment types are provided in this table:

| Calculation | Advance Payment Type | Arrears Payment Type |
|---|---|---|
| Present Value Factor | Total payment terms for present value factor excludes the term of the advance (or first) payment. | Total payment terms for present value factor equal the total terms of the lease. |
| Present Value of Minimum Lease Payments | Equals: (Present Value Factor \times Periodic Payment Amount) + Advance payment. | Equals: Present Value Factor \times Periodic Payment Amount. |
| Amortization Schedule | Period interest expense equals: Capitalized Amount \times the period interest rate. The Capitalized Amount used for the first period of the payment excludes the advance payment amount. | Period interest expense equals: Capitalized Amount \times the period interest rate. |

Advance

Select if an asset is leased with the first payment that is due before the lease begins. For advance payments, the interest expense is not calculated.

If the present value is calculated on a lease with 12 monthly payments of 100.00 USD and an interest rate of seven percent, then the calculated present value factor is 10.6254.

Calculated present value = 100 USD + 10.6254 \times 100 = 1,162.54 USD

Arrears

An arrears payment type means that an asset is leased with the payment due at the end of the period. This is the lease payment type by default. If the present value is calculated on a lease with 12 monthly payments of 100.00 USD and an interest rate of seven percent, then the calculated present value factor is 11.5571.

Calculated present value = 11.5571 \times 100 = 1,155.71 USD

Lease Type

When you select the lease type, you can verify that you have selected the correct lease type for a country. If you do not select either the Capital or the Operating options, the system selects the lease type for you. The system can verify the lease types for the U.S., Canada, Germany, and Australia. Canada uses the same criteria as the U.S. for classifying capital and operating leases. Germany uses a higher threshold for the lease term (90 percent instead of 75 percent).

Note. You cannot change a lease type from capital to operating or from operating to capital. If you must change the lease type, you must first retire the leased asset and then reenter the lease with the appropriate lease type.

Capital

Select if the lease is a capital lease.

According to FASB 13, a capital lease must meet one of the following criteria:

- There is an ownership transfer at the end of the lease.
- The lease contains a bargain purchase option (BPO).

- The lease term is 75 percent or more of the asset life.
In Germany, the lease term is 90 percent of the leased asset's economic life.
- The present value of the minimum lease payment is 90 percent or more of the fair market value of the asset.

Operating

Select if the lease is an operating lease.

Verify

Click this button to verify if the lease meets the criteria for a capital lease or an operating lease. If the lease type meets the criteria, the system displays a message confirming that the criteria for FASB Statement 13 has been met. If you do not select the Capital or Operating option before clicking the Verify button, the system looks at the information that you have entered on this page about the lease, including the country code, and selects the lease type for that country.

Note. This verification test is disabled for leased assets that use an Indian business unit; designation of capital or operating leases is manual for assets in India.

See [Chapter 23, “Using the Global Features of PeopleSoft Asset Management,” \(IND\) Using PeopleSoft Asset Management Options to Meet Indian Requirements, page 421.](#)

(Optional) Entering Information About Cost, ChartFields, and Depreciation

Access the Cost page.

| Quantity | Cost | Salvage Value | Category | CT |
|----------|------|---------------|----------|----|
| 1.0000 | 0.00 | 0.00 | USD | |

Cost page

If you did not enter a minimum rental payment (MRP) on the Definition (ASSET_LEASE-01) page, you must complete the cost information on this page.

The system uses the cost information on this page to calculate the lease payment schedule. Use the Cost, ChartFields, and Depreciation tabs to enter more details. Because the ChartFields are effective-dated, you can use them to track transfers.

Note. If you are working with a step lease, you do not have to enter any information on this page.

Viewing or Updating a Step-Lease Payment Schedule (Optional)

Access the Step Lease Payment page.

| Definition | Cost | Step Lease Payment | Payment Schedule | | | |
|--|-----------------------|---------------------------|------------------|--------|-----|-----|
| Unit: US001 | Asset ID: NEXT | Tag: | In Service | | | |
| Step Lease Customize Find View All First 1-2 of 2 Last | | | | | | |
| Line Number | Lease Term | Payment Frequency | Payment Amount | | | |
| 1 | 1.00 | 6 | Monthly | 400.00 | JPY | + - |
| 2 | 2.00 | 18 | Monthly | 350.00 | JPY | + - |

Step Lease Payment page

If you checked the Step lease check box on the Definition (ASSET_LEASE-01) page, you can use this page to change payment information.

Enter a line number, enter the lease term (number of periods), select a payment frequency, and enter a payment amount. For example, you could define a step lease that consists of six monthly payments of 400.00 JPY followed by 18 monthly payments of 350 JPY.

If you are defining a skip payment, enter a payment frequency, the number of lease terms, and a payment amount of zero (0.00).

Note. The line numbers must be in sequential order. For example, if you update a lease schedule and need to insert a row between lines 1 and 2, you can use a line number such as 1.2.

After you are done working with this page, you must return to the Definition (ASSET_LEASE-01) page and click the Calculate button to generate the lease payment schedule.

Viewing or Updating a Lease Payment Schedule

Access the Express Add - Payment Schedule page.

| Definition | Cost | Step Lease Payment | Payment Schedule | | | |
|--|-----------------------|---------------------------|-------------------------|----------------------|--------------|-----|
| Unit: US001 | Asset ID: NEXT | Status: In Service | | | | |
| Lease Book: CORP | Corporate | Currency: USD | | | | |
| Payment Schedule Customize Find View All First 1 of 1 Last | | | | | | |
| | Payment Date | Payment Total | Interest Expense | Obligation Reduction | Payment Type | |
| 1 | | 0.00 USD | 0.00 | 0.00 | | + - |

Payment Schedule page

The system calculates the payment schedule on this page when you click the Calculate button on the Express Add - Definition page.

You can update the information on this page as needed.

Note. In case of capitalizing the interim rent, payments are noted with a *C* rather than *I* next to the payment line. You can change this designation by modifying message number 8015,37, using the PeopleTools Message Catalog.

If you elect to process periodic depreciation accounting entries, the system creates the journal entries that are shown in the following table:

| Action | Debits | Credits |
|--------------|--|---|
| Add | <ul style="list-style-type: none"> AD Accumulated Depreciation FA Leased property under capital leases (capitalized lease amount) | <ul style="list-style-type: none"> DE Depreciation Expense LO Obligations under capital leases |
| Adjust | <ul style="list-style-type: none"> AD Accumulated Depreciation FA Leased property under capital leases (capitalized lease amount) | <ul style="list-style-type: none"> DE Depreciation Expense LO Obligations under capital leases |
| Transfer In | <ul style="list-style-type: none"> FA Leased property under capital leases (capitalized lease amount) DE Depreciation Expense | AD Accumulated Depreciation |
| Transfer Out | AD Accumulated Depreciation | <ul style="list-style-type: none"> FA Leased property under capital leases (capitalized lease amount) DE Depreciation Expense |
| Retire | <ul style="list-style-type: none"> CA Proceeds [Proceeds] LO Obligations under capital leases [Guaranteed Residual] AD Accumulated Depreciation [Current Reserve] LO Obligations under capital leases [Remaining Lease Payments] | <ul style="list-style-type: none"> LG Guaranteed Residual Payable [Guaranteed Residual] FA Leased property under capital leases [Current Cost] GL Gain/Loss on leased property [Remaining Payments + ((Proceeds – Removal Cost) + (Cost – Reserve))] |

Creating Lease Expense Schedules

This section discusses how to create lease expense schedules by running the Lease Expense Schedule process.

You must run this process:

- After setting up a step lease.
- After adjusting transactions in a step lease.
- Before running the depreciation close process.

Note. The purpose of running the lease expense schedule process is to prorate payment and interest expenses so that the proper amounts are sent to the general ledger (GL) according to the FASB. You must run this process for all leases that have non-monthly payment schedules.

AMLSESCH reads PS_LEASE_SCHEDULE and creates PS_LEASE_SCH2, which contains all the step-lease non-monthly payment information. AM_DPCLOSE reads PS_LEASE_SCH2 (through PS_LEASE_CHART3_vw) to distribute the payment and interest expenses to the GL.

The Lease Expense Schedule process spreads non-monthly lease payments (such as quarterly payments) throughout the year, dividing them into monthly amounts on the lease expense schedule. The results are different for capital leases and operating leases:

- For operating leases, the lease expense schedule allocates non-monthly payments to monthly amounts.
- For capital leases, the lease expense schedule allocates non-monthly interest expense to monthly amounts, and the payment amount is fully allocated on the date that the payment is due.

The following example uses an arrears type lease for a quarterly payment:

| Payment Date | Payment Amount | Interest Expense |
|--------------|----------------|------------------|
| 06/01/1998 | 300 | 33 |

The lease expense schedule allocates the payments as shown:

| Payment Date | Payment Amount | Interest Expense |
|--------------|----------------|------------------|
| 04/01/1998 | 0.00 | 11 |
| 05/01/1998 | 0.00 | 11 |
| 06/01/1998 | 300 | 11 |

If the general ledger period is closed, the allocation is carried forward to the next open period.

Note. Operating leases do not have interest expense on the payment schedule.

Page Used to Run the Lease Expense Schedule Process

| Page Name | Object Name | Navigation | Usage |
|------------------------|-----------------|--|---|
| Lease Expense Schedule | LEASE_SCH2_RQST | Asset Management, Asset Transactions, Leased Assets, Create Expense Schedule | Run the lease expense schedule process. |

Running the Lease Expense Schedule Process

Access the Lease Expense Schedule page.

Lease Expense Schedule page

Select Open Trans Range
(select open transaction range)

If you select this option, use the From Open Trans and To Open Transfields to select a range of transaction values.

Select Asset Range

If you select this option, use the From Asset and To Assetfields to select the asset range.

Transferring Operating Leases

This section describes how to transfer an operating lease.

Page Used to Transfer Operating Leases

| Page Name | Object Name | Navigation | Usage |
|-----------------------------|-------------------|---|---|
| Operating Lease Chartfields | LEASE_OPER_TFR_01 | Asset Management, Asset Transactions, Leased Assets, Transfer Operating Lease | Transfer an operating lease, for example, from one department to another. |

Transferring an Operating Lease

Access the Operating Lease Chartfields page.

| Operating Lease Chartfields | | | | | | | | |
|-------------------------------------|-------------------------------|----------------------------|----------------------|----------------------|----------------------|----------------------|----------------------|----------|
| Unit: US001 | Asset ID: 000000000097 | Sample data for Oper Lease | | | Tag: | In Service | | |
| Current Chartfields | | | | | | | | |
| Trans Date | Operating Unit | Fund Code | Department | Program Code | Class Field | Budget Reference | Product | Project |
| 12/14/2003 | | | 12000 | | | | | |
| New Chartfields | | | | | | | | |
| Operating Unit | Fund Code | Department | Program Code | Class Field | Budget Reference | Product | Project | Category |
| <input type="text"/> | <input type="text"/> | 12000 | <input type="text"/> | <input type="text"/> | <input type="text"/> | <input type="text"/> | <input type="text"/> | LCOMP |
| Edit Trans Dates... | | | | | | | | |

Operating Lease Chartfields page

This page displays the current ChartFields for the lease.

Use the New Chartfields section to change the Oper Unit(operating unit), Fund Code, Department, Program, Class Field, Budget Reference,Product, Project,and Category. The Category field is required for an operating lease.

Click the Edit Trans Dates button to change the transaction date.

Retiring or Reinstating Leases

Leased assets are retired or retired and reinstated using the same processes as all other assets. Review those sections of this PeopleBook for more information.

See Also

[Chapter 19, "Retiring Assets," page 319](#)

Generating Lease Reports

PeopleSoft Asset Management has several reports that you can use to view information about leases that is required to satisfy generally accepted accounting principles (GAAP) and to comply with FAS 13. You can use the lease reports provided to view when a lease expires, create an annual footnote disclosure report, view summary or detail information about a specific lease, or view a lease amortization schedule.

You may also review operating leases.

You must run the Lease Expense Schedule (LEASE_SCHED2) process before you run a lease report.

This section discusses how to generate the:

- Lease Expiration report.
- Lease Footnote Disclosure Summary and Lease Footnote Disclosure Detail reports.
- Lease Summary Information, Lease Detail Information, and Lease Amortization Schedule reports.

Note. PeopleSoft IT Asset Management also provides a report called Lease End Date.

Pages Used to Generate Lease Reports

| Page Name | Object Name | Navigation | Usage |
|---------------------------|-------------------------------|---|---|
| Lease Expiration | RUN_AMLE2400 | Asset Management, Financial Reports, Leased Assets, Lease Expiration | Define the run parameters for the Lease Expiration report (AMLE2400). Use the report to list leases that expire as of today's date, after a certain number of days from a specified date, or within a date range that you select. |
| Lease Footnote Disclosure | RUN_AMLE2300, RUN_AMLE2310 | Asset Management, Financial Reports, Leased Assets, Footnote Disclosure | Define the run parameters for a Lease Footnote Disclosure Detail and Lease Footnote Disclosure Summary reports (AMLE2300 and AMLE2310, respectively). Use at the end of each fiscal year to view all outstanding capital and operating lease commitments for the next five years. The report also provides the monthly lease payment and yearly totals. |
| Lease Information | RUN_AMLE2000 | Asset Management, Financial Reports, Leased Assets, Summary or Detail | Define the run parameters for the following reports: <ul style="list-style-type: none"> • Lease Summary Information (AMLE2000) • Lease Detail Information (AMLE2100) • Detail Amortization Schedule (AMLE2200) |

See Also

[Appendix C, "PeopleSoft Asset Management Reports," page 561](#)

CHAPTER 8

Adjusting, Transferring, and Evaluating Assets

This chapter provides an overview of adjusting, transferring, and evaluating assets and discusses how to:

- Adjust cost and transfer assets.
- Transfer parent-child assets to other business units in mass.
- Revalue assets using the Revaluation Worksheet.
- Revalue assets in mass.
- Capture and maintain asset fair market value (FMV).
- Update noncapitalized costs.
- View cost history and summarize cost rows.
- Update the general ledger with adjustments and transfers.
- Modify or delete pending asset transactions.
- Adjusting for asset impairments.

Understanding Adjusting, Transferring, and Evaluating Assets

Periodically, it is necessary to make changes to asset records to correct errors or add newly received information. You can modify any information that has been entered about assets, including cost, market value, quantity, depreciation rules, location, physical attributes, and so on.

Sometimes adjustment and transfer changes have a financial or tax impact. Changes to physical information about an asset, such as its weight, do not affect cost or depreciation. However, changing quantity, cost, depreciation attributes, or department affect your financial and tax books.

In compliance with accounting standards, many companies must carry assets at fair value. As a result, frequent revaluation of assets may be necessary, depending on requirements. PeopleSoft Asset Management provides a revaluation worksheet to facilitate potentially frequent revaluation of one or multiple assets using the Cost Based or Depreciation Write-off methods of revaluation. Additionally, you have the option of using the Revaluation in Mass process where the Net Method of revaluation is available, as well as the other two methods. These tools provide the capability to properly deal with the depreciation distribution between original cost and revalued basis

You must also be able to undertake an effective impairment test cycle for assets on at least an annual cycle at the balance sheet date depending on business industry and location. PeopleSoft Asset Management provides an impairment evaluation process that allows you to assess potential impairment of user-defined asset selections. The impairment worksheet enables you to enter recoverable amounts and automatically calculates potential impairment losses. Subsequent to this review, the impairment worksheet generates the associated accounting entries to enable you to recognize these adjustments in your accounting system. This process eliminates manual steps and minimizes accounting errors.

PeopleSoft supports the ability to maintain asset histories. Information on a per-asset basis is available within each record. Cost summary reporting and asset component hierarchy history reporting are both also available.

Adjusting Cost and Transferring Assets

This section provides an overview of cost adjustments and asset transfers and discusses how to:

- Define asset transactions.
- Enter cost information for transactions.
- Specify transfer to/from books information
- Mark assets up or down.
- Select a child asset for adjustment or transfer.
- Enter child asset details.
- Add advanced transaction details.

See Also

[Chapter 5, “Adding and Maintaining Assets,” Creating Parent-Child Asset Relationships, page 102](#)

Understanding Cost Adjustments and Asset Transfers

To adjust cost and transfer assets:

- Select the type of transaction, enter accounting and transaction dates, and specify the transaction data that is required to update the general ledger.
- Make the actual adjustments or cost entries.
- Select some, none, or all child assets to include in the transaction that you are performing. The Child Assets page appears only when the asset you are transacting against is a parent asset and the transaction type is a transfer. A separate Application Engine process is provided for transferring parent-child assets between business units.

Note. Adjustments to parents do not automatically filter down to the child assets; therefore, the Child Asset page does not appear for adjustments. Instead, add another child asset. A reminder message stating that child assets are associated with the parent asset that you are adjusting will appear.

- Use the Pending Transaction page for workflow processing.
- If you have changed information in a book that posts to your general ledger, PeopleSoft Asset Management generates the appropriate accounting entries when you run Create Accounting Entries (AM_AMAEDIST)

or Depreciation Close (AM_DPCLOSE). The asset account is updated when you generate and post the journal entries.

See Also

PeopleSoft Enterprise Asset Lifecycle Management Fundamentals 9.0 PeopleBook, “Setting Up Accounting Entry and Financial Processing for PeopleSoft Asset Management,” Defining Accounting Entries

Pages Used to Adjust Cost and Transfer Assets

| Page Name | Object Name | Navigation | Usage |
|-----------------------------|------------------|---|---|
| Main Transaction | ASSET_COST_01 | Asset Management, Asset Transactions, Financial Transactions, Cost Adjust/Transfer Asset | Identify the cost/adjust/transfer transaction that you want to perform. |
| Cost Information | ASSET_COST_01A | Click the GO! button on the Main Transaction page. | Enter or adjust cost information that is required by the transaction that you initiated from the Main Transaction page. |
| Asset Location Transfer | ASSET_COST_02_S2 | Click the Change Location link on the Cost Information page. | Change the location for an asset. |
| Asset Cost IU Transfer | ASSET_COST_02 | Click the InterUnit Transfer Options link on the Cost Information page. | Select the asset information that you want transferred with the asset. The link appears on the page only after you select <i>Fixed Price Markup</i> as the action on the Main Transaction page. |
| Asset Cost IU Book Transfer | ASSET_COST_02_S1 | Click the Transfer To/From Books link on the Cost Information page. | Specify how cost information for the transfer will be passed between business books. This link appears when you have selected <i>InterUnit Transfer</i> as the action on the Main Transaction page <i>and</i> when you have entered the business unit to transfer to. |
| InterUnit Proceeds | N/A | Click the Proceeds button on the Cost Information Page. This button appears on the page only when you select <i>Fixed Price Mark Up</i> as the action on the Main Transaction page. | Apply a markup or markdown to the asset that you are transferring. |

| Page Name | Object Name | Navigation | Usage |
|-------------------------------|-------------------|--|--|
| Child Assets | CHILD_ASSETS | Asset Management, Asset Transactions, Financial Transactions, Cost Adjust/Transfer Asset, Child Assets | Select child assets to include in the transfer or recategorization that you have initiated against the parent assets. |
| Child Asset TRF/RCT Overrides | AM_PARCHD_TRF_RCT | Click Child Details on the Asset Cost/Adjust Transfer Child Assets page. | Specify transaction overrides for a specific child asset. You can specify specific convention, quantity, cost, transaction percentage, transaction date and accounting date for the child asset on this page. |
| Parent Asset Adv Txn options | FULL_PART_SEC | Click the Advanced Txn Details link on the Asset Cost/Adjust Transfer Child Assets page. | Specify transaction overrides for all child assets at once. For example, you would use this page to specify that only 50 percent of the cost of all child assets be transferred between departments, while the parent asset is fully transferred. Select to apply as full transaction, actual percentage, or transaction amount. |

Defining Asset Transactions

Access the Main Transaction page.

Main Transaction

Unit: US001 **Asset ID:** 000000000091 Automobile **Tag:** In Service

Transaction Date: 04/14/2006

Accounting Date: 04/14/2006

Transaction Code:

Rate Type: CRRNT

Copy Changes to Other Books

Copy to Other Books Options

Transfer Other Books by: Amount

Adjust Other Books By: Amount

Include Convention: Exclude

Action:

Main Transaction page

Transaction Date and Accounting Date

Displays the current date or the dates that are specified as operator defaults. As a rule, transactions are entered in PeopleSoft Asset Management some time after they have occurred. Any difference between accounting and transaction dates will affect depreciation as well as posting.

See [Chapter 5, “Adding and Maintaining Assets,” Adding and Maintaining Asset Information, page 47.](#)

| | |
|------------------------------------|---|
| Transaction Code | (Optional) Select a code to help identify which accounting entry template to use for this transaction. |
| Rate Type | Enter the currency exchange rate type to use for this transaction. |
| Copy Changes to Other Books | Select to copy the changes that you make to other books. |
| Transfer Other Books by | Select to transfer the changes that you make to other books by <i>Amount</i> or <i>Percent</i> . |
| Adjust Other Books by | <p>Select to adjust the other books by <i>Amount</i> or <i>Percent</i>.</p> <p>Select <i>Percent</i> to transfer a percentage of the amount from subsequent books. For example, suppose you have an asset with two books, Corporate and Federal. The cost amount for Corporate is 5000.00 USD and is 4000.00 USD for Federal.</p> <p>If you transfer 2500.00 USD from the Corporate book, select Copy Changes to Other Books, and then specify the <i>Percent</i> option. 2500.00 USD will be transferred from the Corporate book and 2000.00 USD will be transferred from the Federal book.</p> <p>If you select <i>Amount</i>, a transfer of 2500.00 USD from both books will occur.</p> <p>If you have a multicurrency business unit, the <i>Amount</i> option will be overridden by <i>Percent</i> when you transfer or recategorize an asset.</p> <hr/> <p>Note. If you do not select the Copy Changes to Other Books option, when the book that you are changing is associated with a ledger group that contains multiple ledgers, and the Keep Ledgers In Synccheck box is selected for the ledger group, changes will be copied to other books that associated with the same ledger.</p> <hr/> |
| Include Convention | The options are to <i>Exclude</i> or <i>Include</i> a depreciation convention. The depreciation convention automatically displays <i>AM</i> (actual month) for all transactions (except for Adjustments, which invokes the convention specifically defined for adjustments.) If you choose to have the convention included, the convention will be copied to all books. If you choose to have the convention excluded, the convention will not be copied to all books. You can override each book separately at the transaction level also. |
| Action | <p>Select the financial transaction to be performed. Select an action and click the GO! button:</p> <ul style="list-style-type: none"> • <i>Addition:</i> <p>Adds an adjustment cost line with transaction type of <i>ADD</i> as a result of alternate or multiple funding sources, and so on. This option works the same as <i>Adjustment</i>, except that the transaction type in the cost table will be <i>ADD</i> instead of <i>ADJ</i>. If you use multiple currencies to track asset transactions, access to Transaction Currency fields for Adjust All Rows and Adjust Current Row By are available. When you click Apply, these fields are unavailable for entry. The transaction cost is converted to the base cost and added to the total cost of the asset. Exchange rates cannot be viewed from this component.</p> |

- *Adjustment*: Adjusts the cost or quantity of an existing row and adds a line with a transaction type of *ADJ*. If you use multiple currencies to track asset transactions, access to Transaction Currency fields for Adjust All Rows and Adjust Current Row By are available in this activity. When you click Apply, these fields are unavailable for entry. The transaction cost is converted to the base cost and added to the total cost of the asset. Exchange rates cannot be viewed from this component.
- *Fixed Price Markup*: Applies a markup to the asset that you are transferring. Transaction Currency fields are unavailable for enter for this activity.
- *InterUnit Transfer*: Transfers an asset from one business unit to another with different legal entities. Transaction Currency fields are unavailable for entry for this activity.
- *Recategorize*: Changes an asset category or cost type. Asset Categories classify assets by type for accounting entry purposes. Transaction Currency fields are unavailable for entry for this activity.
- *Revaluation*: Revalues an asset by percentage. Revaluation occurs as a result of a monetary revaluation or to account for inflation and is prescribed by a governmental entity. This value is used mostly in countries with high rates of inflation. Transaction Currency fields are unavailable for entry for this activity.

Note. Revaluation from this page is based upon the Cost of the assets disregarding the current Net Book Value, current Market Value and any prior Impairment made to the asset. For example, a revaluation adjustment of 15,000 USD means an increment in the asset's cost of that amount using the Cost type indicated for revaluation with no further calculations. If you want to calculate the revaluation considering the mentioned parameters, you must use the Revaluation Worksheet or the Revaluation in Mass process.

See [Chapter 8, "Adjusting, Transferring, and Evaluating Assets," Revaluing Assets Using the Revaluation Worksheet, page 165.](#)

See [Chapter 8, "Adjusting, Transferring, and Evaluating Assets," Revaluing Assets In Mass, page 171.](#)

- *Transfer*: Transfers an asset within the same business unit. For example, you can make a transfer between two departments or two operating units as an *intraunit* transaction as opposed to a transaction between two distinct and separate business units, or an *interunit* transaction. Transaction Currency fields are unavailable for this transaction.

Entering Cost Information for Transactions

Access the Cost Information page.

Main Transaction **Cost Information**

Unit: JPN01 Asset ID: JPN0002 Computer Hardware Tag: In Service

[Local Tax Info](#) [Change Location](#)

Book Find | View All First 1 of 3 Last

Book Name: LOCAL_JPY Local Book - JPY Base Currency: JPY Convention: Actual Month

Cost History

Edit Cost Information

Adjust All Rows By: Percent: Quantity: Cost: Curr: JPY Apply

| Quantity | Cost | Salvage | Category | Cost Type | Unit |
|----------|-------------|-----------|----------|-----------|-------|
| 1.0000 | 123,456,789 | 6,172,840 | COMP | A | JPN01 |

Oper Unit Fund Dept Program Class Bud Ref Product Project

Adjust Current Row By: JPY Apply

Cost Information page (1 of 2)

In this example, the page displays different fields and value options for addition, adjustment, recategorization, revaluation, and transfer activities.

Main Transaction **Cost Information**

Unit: JPN01 Asset ID: JPN0002 Computer Hardware Tag: In Service

InterUnit Transfer

Enter New Business Unit Information Find | View All First 1 of 1 Last

New Unit: New Asset ID: [InterUnit Transfer Options](#)

Profile ID: Trans Code: Use Profile

[Local Tax Info](#) [Change Location](#)

Book Find | View All First 1 of 3 Last

Book Name: LOCAL_JPY Local Book - JPY Base Currency: JPY Convention: Actual Month

Cost History

Edit Cost Information

| Quantity | Cost | Salvage | Category | Cost Type | Unit |
|----------|-------------|-----------|----------|-----------|-------|
| 1.0000 | 123,456,789 | 6,172,840 | COMP | A | JPN01 |

Oper Unit Fund Dept Program Class Bud Ref Product Project

Cost Information page (2 of 2)

In this example, the page displays interunit transfer or fixed-price markup-activity information.

Note. If you want to perform multiple transactions, complete one transaction, and then save and reenter the page to begin the next transaction. Doing so preserves the audit trail for each transaction.

Note. Transaction currency appears by default from the asset book base currency. Each line can reflect a different transaction currency, depending on the transaction. Balances are displayed in the base currency after the transaction currency is converted to the base currency.

| | |
|------------------------|--|
| Change Location | Click to change the asset's location. |
| Convention | Convention appears by default as <i>Actual Month</i> for all transactions, with the exception of Adjustments, which has its own convention. If you selected the Copy Changes to Other Books check box on the Main Transaction page and selected <i>Exclude</i> in the Include Convention check box, the convention will not be copied to all books. You need to override each book separately. |
| Cost History | Shows cost balance for the selected asset. You cannot update information here, but you can review cost rows and their associated ChartFields for an asset. |

We discuss the remaining fields on the Cost Information Page in the context of the transaction being performed. Some fields are available only for certain transactions.

Note. If the asset transactions that you want to adjust are still pending (depreciation has not yet been run), you may, depending on the transaction type, be able to delete or change them.

Cost History

Expand this group box to view cost history information.

The information displayed includes ChartField or Salvage Value, Category and Cost Type.

Edit Cost Information

Add new cost rows in the Edit Cost Information group box.

Cost, Percent, and Quantity Enter as necessary, and enter additions and adjustments for any appropriate ChartFields.

Adjusting Total Cost or Quantity

You can adjust the total cost of an asset by either a percentage of its original cost or by a specific cost amount.

Adjust All Rows By Enter the appropriate percentage or amount in the appropriate fields: Percent, Quantity, and Cost. The default is a positive adjustment. To make a negative adjustment, enter a negative percentage or amount. In a transaction, you can adjust the cost either by percent or cost, but not both.

You can adjust the total quantity of an asset by entering the Quantity adjustment. The default is a positive adjustment. If you want to make a negative adjustment, you must enter a negative quantity.

Apply Click to prorate the adjustment and add it to each cost row in cases of multi-chartfield asset. If the asset has one ChartField combination, the cost is added to the total cost. The system automatically calculates and displays the

adjusted total cost. If the cost that is entered is in a different currency than the base currency of your book, the cost is converted to the base currency before the cost rows are adjusted.

Note. Changes are applied only to the current book unless you select the Copy Changes to All Books check box on the Main Transaction page. If you select this option, your changes will be visible after you save the page and then restart it.

Note. Currency for Adjust by Percent is the same as the base currency of the book. However, Currency for Adjust by Cost can be any valid value.

Adjusting Cost or Quantity by Cost Row

Cost and Quantity

To adjust the cost or quantity for a particular cost row, enter the new field values directly into the cost row. You can adjust an asset's cost for individual cost rows by entering the new cost into the Cost field for each cost row that you'd like to change. To adjust the quantity for individual cost rows, enter the new quantity into the cost rows, not the number of units by which quantity will increase or decrease.

For example, if the quantity should be adjusted from 1 to 2, enter 2. This changes only the quantity, not the cost.

Note. To establish an audit trail, you should change cost information one field at a time. For example, if you need to change the department and adjust the cost, enter the new department and save your change, and then go back and adjust the cost.

Apply

Click to apply the adjustment to each cost row. The system automatically calculates and displays the adjusted total quantity.

Transferring Assets Within a Business Unit

Periodically, you need to transfer assets from one department, product, or project to another. In addition to physically relocating the assets, you may need to change some of the ChartField elements to correctly allocate asset cost and depreciation expense. You can perform full, partial, or retroactive transfers.

Note. This transaction describes transferring assets within a business unit.

See Transferring Assets to Other Business Units (InterUnit Transfers)

Full Transfers – Edit Cost Information

A full transfer requires you to transfer all units or the total cost of the asset.

Oper Unit (operating unit), **Dept** (department), **Program, Product,** and **Project** (and any other delivered or customized Chartfield)

Enter the new values into the appropriate fields.

Partial Transfers – Edit Cost Information

Partial transfers are useful when you want to assign an asset's cost and depreciation to two or more sets of ChartFields. To partially transfer an asset, you need to perform a separate transfer for each set of ChartFields.

Oper Unit (operating unit),
Dept (department), **Project**,
or **Product** (and any other
delivered or customized
Chartfield)

For each transfer, select the appropriate ChartFields, and enter quantity and amount in the Edit Cost Information group box.

For example, suppose department 43000 has two automobiles, worth a total of 60,000 JPY. You plan to transfer one car from department 43000 to 12000, and the other from department 43000 to 14000. Because the cost of the assets will eventually be allocated to two separate sets of ChartFields, you'll need to perform two separate transfers. Each transfer will move 30,000 JPY out of department 43000 and into departments 12000 and 14000.

Retroactive Transfers

You may want to transfer assets retroactively if they were transferred during a prior accounting period, but are not yet entered in PeopleSoft Asset Management. To do this, enter the transaction and accounting dates on the Main Transaction page and enter the appropriate cost information in the Edit Cost Information group box. The system will create correcting entries that back out depreciation from the original department for the period between the transaction date and the accounting date. Prior period depreciation for that same period will be posted for the new department.

Recategorizing Assets – Edit Cost Information

You may want to recategorize assets either because you entered the incorrect category or cost type, or because you have created a new category or cost type and want to transfer existing assets to the new reclassification.

Category and Cost Type Change the values as needed. Recategorizing an asset affects depreciation.

Revaluing Assets

Revaluation as defined here is based upon the original cost of the asset without consideration of any prior impairment nor taking into account the fair market value or net book value of the asset at the time of revaluation. For revaluation that includes these considerations, use the Revaluation Worksheet or the Revaluation in Mass process.

See [Chapter 8, "Adjusting, Transferring, and Evaluating Assets," Revaluing Assets Using the Revaluation Worksheet, page 165.](#)

See [Chapter 8, "Adjusting, Transferring, and Evaluating Assets," Revaluing Assets In Mass, page 171.](#)

Cost Type To revalue assets, select an action of revaluation, which will change the cost type to *R*, and enter the appropriate percentage in the Adjust All Rows By Percent field. Click Apply. The system will create an adjustment cost line with cost type of *R*.

Note. This action is only available if the revaluation process is enabled at the Installation Options and Business Unit/Book levels. The cost type that is used here depends upon the cost type for revaluation that is established at the Business Unit/Book level. The cost type, *R*, is the default value.

Note. Entering changes to cost information and transacting transfers, recategorizations and revaluations affect prior calculated depreciation and accounting entries. You must run both depreciation and accounting entry processing when you make these changes.

Transferring Assets to Other Business Units (InterUnit Transfers)

PeopleSoft Asset Management gives you full flexibility in performing InterUnit transfers. You can fully or partially transfer assets from one business unit to another, or from one business unit to many others. You can do full or partial transfers by cost, quantity, or percentage.

Note. You cannot perform interunit transfers on joint venture business units.

InterUnit processing is processed through the PeopleSoft Centralized Inter/IntraUnit Processor. It provides consistent setup and centralized processing to manage Inter/IntraUnit transactions.

Note. In cases in which you want to perform an InterUnit transfer between two asset management business units that report to different PeopleSoft General Ledger business units, you should retire the asset from the first business unit and add it to the second business unit. (Use an action of ADD instead of TRF). However, when both asset management business units report to the same general ledger business unit, InterUnit transfers automate transactions for you no matter which transaction you choose.

The procedures for performing interunit transfers that are discussed in this section do not apply to parent-child assets. You do InterUnit transfers for parent-child assets by using an application engine program.

Note. To transfer parent and child assets among business units in this application engine, you must set up the appropriate InterUnit Transfer Definitions.

In the New Unit field, select the business unit to which you are transferring the asset. The New Asset ID field is populated by default as *NEXT*. You can change this value if necessary. Do not enter an existing asset ID unless you want to transfer costs between the two assets.

Select a profile ID that is valid for the new business unit to set up book reporting. Trans Code (transaction code) identifies which accounting entry template to use for this transaction. Only valid combinations for accounting entry templates that exist are accepted.

Click the InterUnit Transfer Options link to access the InterUnit Transfer Options page, where you can select the asset information that you want transferred with the asset.

Click Transfer From/To Books to access the Transfer From/To Books page, where you specify the way in which cost information is passed between business unit books.

Use the fields in the Edit Cost Information group box to specify the cost and quantity to be transferred.

Use the Use Profile option to get profile attributes when New Profile ID has been enabled. If it is not enabled, the profile attributes are derived from the “from” or original asset profile.

Click Proceeds to open the InterUnit Proceeds page, where you can specify a markup value to be applied to the transferred assets in the receiving business unit. This feature is often used in European countries.

You can perform full interunit transfers from one business unit to another, or from one business unit to many others. You can also perform a partial interunit transfer in which the original business unit retains a portion of the asset but transfers part of it to another business unit.

Full InterUnit Transfers from One Business Unit to Another

Full interunit transfers from one business unit to another are the simplest transfers to perform. After you have completed the information in the Enter New Unit group box and its pages and saved the Cost Information page, all cost rows are transferred to the new business unit.

Full InterUnit Transfers from One to Many Business Units

You can transfer to as many business units as existing cost rows. To do this, enter one of the receiving business units in the New Unit field in the Enter New Unit group box. Complete the rest of the InterUnit transfer information. Review each cost row in the Edit Cost Information group box. All cost rows will show the new business unit that you entered in the New Unit field. Change the business unit for each cost row as appropriate. In this way, you can transfer all cost rows for an asset to multiple business units.

You can transfer part of an asset to a different business unit and enable the original business unit to retain a portion of it. To do this, enter the receiving business unit in the New Unit field in the Enter New Unit group box. Complete the rest of the InterUnit transfer information. Review each cost row in the Edit Cost Information group box. All cost rows will show the new business unit that you entered in the New Unit field. To retain some ownership of the asset with the original business unit, change the business unit on some cost rows back to the original unit.

Note. Transaction currency is supplied by default from the base currency of the book. Each line can reflect a different transaction currency depending on the transaction. Balances are displayed in the base currency after the transaction currency is converted to the base currency.

See Also

[Chapter 8, “Adjusting, Transferring, and Evaluating Assets,” Transferring Parent-Child Assets to Other Business Units \(InterUnit Transfers\) In Mass, page 163](#)

Specifying Transfer To/From Books Information

Access the Asset Cost IU Book Transfer page.

The transactions that are generated to pass book information for InterUnit transfers differ depending on how many *To* books a *From* book is passing information to, and whether it is passing the information using a Transfer Book action or an Add Book action.

Note. Assets that you transfer to new business units using the Add Book action will have a cost row of zero on the new business unit until you run the Depreciation Calculation application engine program (AM_DEPR_CALC). Running this program updates the asset’s cost row with its net book value from the *From* book.

Using a From Book Once

When you use a *From* book once only, an Add Book action generates a retirement for the *From* book and an add to the *To* book. A Transfer Book action generates a Transfer Out for the *From* book and a Transfer In for the *To* book.

The asset that is retired receives an asset status of *Disposed* on the *From* book.

These tables show that assets that you transfer between books using the action Transfer Book receive a status of Transferred.

| From Book | From Trans | To Book | To Trans | Action |
|-----------|--------------|-----------|-------------|---------------|
| CORPORATE | Transfer Out | CORPORATE | Transfer In | Transfer Book |
| FEDERAL | Transfer Out | FEDERAL | Transfer In | Transfer Book |

| From Book | From Trans | To Book | To Trans | Action |
|-----------|--------------|-----------|-------------|---------------|
| CORPORATE | Transfer Out | CORPORATE | Transfer In | Transfer Book |
| FEDERAL | Retire | FEDERAL | Add | Add Book |

| From Book | From Trans | To Book | To Trans | Action |
|-----------|------------|-----------|----------|----------|
| CORPORATE | Retire | CORPORATE | Add | Add Book |
| FEDERAL | Retire | FEDERAL | Add | Add Book |

Using a From Book for Two or More Transfers

When you use a From book for two or more Transfer Book actions, only one Transfer Out transaction is generated. Because this takes care of the cost on the From book, no additional Transfer Out transactions are generated for that book.

This table shows that assets that you transfer between books using the Transfer Book action receive a status of *Transferred*.

| From Book | From Trans | To Book | To Trans | Action |
|-----------|--------------|-----------|-------------|---------------|
| CORPORATE | Transfer Out | CORPORATE | Transfer In | Transfer Book |
| CORPORATE | | LOCAL | Transfer In | Transfer Book |

Using a From Book for Both Transfer and Add

When you use a From book for both a Transfer Book and an Add Book, a Transfer Out transaction is generated for the Transfer Book. Because this takes care of the cost on the From book, the Add Book does not generate a retirement for that book.

This tables shows that assets that you transfer between books using the Transfer Book action receive a status of *Transferred*.

| From Book | From Trans | To Book | To Trans | Action |
|-----------|--------------|-----------|-------------|---------------|
| CORPORATE | Transfer Out | CORPORATE | Transfer In | Transfer Book |
| CORPORATE | | LOCAL | Add | Add Book |

Using a From Book for Two or More Adds

When a From book is used for two or more Add Book actions, a retirement is generated for the first Add Book action. Because this takes care of the cost on the From book, no further retirements are generated for it.

This table shows that the asset that was retired receives a status of Disposed on the From book.

| From Book | From Trans | To Book | To Trans | Action |
|-----------|------------|-----------|----------|----------|
| CORPORATE | Retire | CORPORATE | Add | Add Book |
| CORPORATE | | LOCAL | Add | Add Book |

Retiring a Book

When an asset is transferred from a business unit with two books to a business unit with more than two books, the asset pulls the additional book's mapping from the InterUnit Business Unit/Book Definition page and profile.

For example, if you do a transfer from CAN01 (two books - ASSET-CAD/ASSET-USD) to US001, the mapping might be like this:

ASSETS-CAD -----> CORP

ASSETS-USD -----> FEDERAL

ASSETS-USD -----> ACE

ASSETS-USD -----> AMT

Some of the information such as life for the new business unit and book comes from the profile. The transfer amounts and so on are calculated from the FROM business unit or book, as previously outlined.

Note. When you transfer from a business unit with three books to a business unit with two books, the cost information on the extra From Book is automatically retired. You do not need to enter an action.

This table shows that assets that are retired receive a status of Disposed.

| From Book | From Trans | To Book | To Trans | Action |
|-----------|--------------|-----------|-------------|---------------|
| CORPORATE | Transfer Out | CORPORATE | Transfer In | Transfer Book |

| From Book | From Trans | To Book | To Trans | Action |
|-----------|--------------|---------|-------------|---------------|
| LOCAL | Transfer Out | LOCAL | Transfer In | Transfer Book |
| FEDERAL | Retire | | | |

Marking Assets Up or Down

Access the InterUnit Proceeds page.

You can transfer an asset from one business unit to another and have the receiving business unit receive the assets at a marked up cost by specifying either a fixed markup cost or a fixed markup percentage. To do so, enter the net markup price in InterUnit Proceeds or the net markup percentage in Mark Up/Down Percent. The default is a positive adjustment. If you want to decrease the price or percentage, you must enter a negative amount. Enter the number of assets in Transfer Quantity.

Note. If you were to enter both an InterUnit proceeds (Price) and a Mark Up/Down percent, the percent will override the price.

You can complete a partial transfer and a fixed price markup or markdown by using a two-step method. For example, you may want to do a partial transfer of four computers out of a total quantity of ten computers and mark up the price as well. The first step is to perform an InterUnit transfer for six computers. Complete this transaction, and then do a fixed price markup on the remaining four computers, and transfer them to the new business unit.

PeopleSoft Asset Management processes markups in the following ways:

- The markup percentage of the asset is specified on the cost of the asset.
- The cost of the asset is marked up or down for all the ChartFields in proportion to the original cost distribution of the asset.
- You can have the markup affect one or all of the asset's books during the transfer.

The Keep All Books in Sync option for the acquiring business unit controls whether the markup is done on one book or all the asset's books.

- The book information for the asset in the acquiring business unit comes from the asset profile that is specified at the time of the sale (on the Cost Information page).

This includes the depreciation method and convention, asset life, and so on.

- The selling business unit manages the markup price as proceeds.

Accumulated depreciation is not be passed on to the new business unit.

Selecting a Child Asset for Adjustment or Transfer

Access the Child Assets page.

Main Transaction Cost Information **Child Assets**

Unit: US001 **Asset ID:** MMFACTY0009 Air Conditioner Unit **Status:** In Service
Tag Number:

| Selected | Tag Number | Description | Child Asset ID | Asset Status | Cost | Currency | Acq Date | Child Details | Go To >> |
|----------------------------|------------|--------------|----------------|--------------|--------|----------|------------|-------------------------------|----------------------|
| 1 <input type="checkbox"/> | | AC Fan Motor | MMFACTY0010 | In Service | 400.00 | USD | 07/01/2004 | Child Details | <input type="text"/> |

Include Parent Asset [Advanced Txn Details](#)

Child Assets page

Note. Parent assets that are created on the Parent Asset page (parent-only assets) do not have cost or basic information. They cannot be viewed in the Parent-Child Basic Information component, nor can they be viewed or transacted against in the Asset Cost/Adjust Transfers component; the Asset Retirements component; or the Parent-Child NBV component. If you want to use a parent asset as a reporting umbrella only and access these pages to manipulate child assets in mass, you should create a zero cost parent asset instead of a parent only asset. Also, to transact against parent and child assets at once, parent and child must share the same asset profile.

Select All

Click Select All to include all child assets with the parent in the transaction that you have initiated.

To include some child assets, select the Selected check box on the specific rows.

Include Parent Asset

Select to include the parent asset in this transaction.



Note. Only child assets available for transfer based on the specified accounting date can be selected. The system compares the last accounting dates for the child assets as specified on the Book table with the accounting date of the current transaction to make this determination.

Entering Child Asset Details

Access the Child Details page.

Child Asset TRF/RCT Overrides

Child Asset Transfer/Recategorization Options

Convention: 
Quantity:
Cost:
Transaction Percentage:
Transaction Date: 
Accounting Date: 

Child Details page

Convention

Select a depreciation convention.

| | |
|---|---|
| Quantity or Cost | Enter the quantity or cost to use in this transaction for the child asset. For example, if you were transferring all costs for the parent from one department to another, but wanted to transfer only 500 USD for the child asset, you would enter 500 in Cost. |
| Transaction Percentage | You can specify a percentage of the child asset's cost to include by entering it in the Transaction Percentage field. |
| Transaction Date and Accounting Date | Enter a transaction date or an accounting date if you want it to differ from the dates that you entered for the parent's transaction. |

Adding Advanced Transaction Details

Access the Advanced Transaction Details page.

Select one of these options:

| | |
|---------------------------|--|
| Full Transaction | Applies the full transaction to all child assets. Select this check box when you are partially transferring the parent asset, for example, but want to fully transfer all associated child assets. |
| Actual Percentage | Enter the percentage of the costs of the child assets to apply to this transaction. For example, if you enter 50 percent, then 50 percent of the costs of all child assets will be included in the transaction even though a different percentage has been specified for the parent asset. |
| Transaction Amount | Enter a specific amount of the costs of the child assets to apply to this transaction. For example, if you enter 250, USD 250 of the costs of each child asset will be included in the transaction. |

Transferring Parent-Child Assets to Other Business Units (InterUnit Transfers) In Mass

Use the Parent-Child IU Transfer (AMPC_IUT_RQST) component to transfer parent-child assets from one business unit to another. The transfer process uses the application engine AM_PARCHD_IU.

This section discusses how to transfer parent-child assets from one business unit to another.

Page Used to Transfer Parent-Child Assets to Other Business Units In Mass

| Page Name | Object Name | Navigation | Usage |
|--------------------------|-----------------|---|--|
| Parent-Child IU Transfer | AMPARCHDIU_RQST | Asset Management, Asset Transactions, Parent-Child Relationship, InterUnit Parent-Child Trans | Run the AM_PARCHD_IU Application Engine process to transfer Parent-Child assets from one business unit to another. |

Transferring Parent-Child Assets from One Business Unit to Another

Access the Parent-Child IU Transfer page.

Parent-Child IU Transfer

Run Control ID: ALLOC [Report Manager](#) [Process Monitor](#) Run

*Request ID: Process Frequency: Status: Pending

*Unit: *Transaction Date:

*New Unit: *Accounting Date:

*Convention: Transaction Code:

*Parent Asset: Executive Office Set **Include Parent Asset**

*Profile ID: Select All

Select from the following Child Assets [Customize](#) | [Find](#) | [View All](#) | First 1-4 of 4 Last

| | Selected | Tag Number | Description | Child Asset ID | Asset Status | Cost | Curr | Acq Date |
|---|-------------------------------------|--------------|-------------|----------------|--------------|---------|------|------------|
| 1 | <input checked="" type="checkbox"/> | P00000000501 | Desk | EX_CHILD0002 | In Service | 7500.00 | USD | 03/01/1999 |
| 2 | <input checked="" type="checkbox"/> | P00000000506 | Bookcase | EX_CHILD0013 | In Service | 1500.00 | USD | 02/03/2000 |
| 3 | <input type="checkbox"/> | P00000000507 | Chairs | EX_CHILD0014 | In Service | 5000.00 | USD | 02/03/2000 |
| 4 | <input type="checkbox"/> | P00000000508 | Lamps | EX_CHILD0015 | In Service | 2500.00 | USD | 02/03/2000 |

Parent-Child IU Transfer page

- Unit** Select the business unit from which you are transferring assets.
- New Unit** Select the acquiring business unit.
- Convention** Select the depreciation convention.
- Transaction Date** Enter the transaction date.
- Accounting Date** Enter the accounting date for the transaction.
- Transaction Code** Identifies which accounting entry template to use for this transaction. Only valid combinations for which accounting entry templates exist are accepted.
- Parent Asset** Select the parent asset from which you are transferring assets.
- Profile ID** Select an ID that is valid for the new business unit to set up book reporting.

Include Parent Asset

Clear this check box to transfer all or selected child assets at once while leaving the parent asset out of the transaction.

Revaluing Assets Using the Revaluation Worksheet

This section lists the page used to revalue assets using the Revaluation Worksheet.

The Revaluation Worksheet allows you to revalue financial assets in accordance with International Accounting Standards (IAS 16) to reflect current fair market value, provided that the net book value (NBV) of an asset is less than its fair market value (FMV) at a given point.

Note. Since the NBV is required for determining the revaluation amount, the depreciation reporting table must be loaded prior to performing revaluation.

Page Used to Revalue Assets Using the Revaluation Worksheet

| Page Name | Object Name | Navigation | Usage |
|-----------------------|----------------|---|---|
| Revaluation Worksheet | AM_REVALUATION | Asset Management, Asset Transactions, Financial Transactions, Revaluation Worksheet | Search for financial assets using the desired criteria, mark them for revaluation, supplying the current fair market value amount and click the Save button. Changes take effect upon save as the Transaction Loader (AMIF1000) is automatically invoked, provided the Auto-Run Transaction Loader options within Asset Management - User Preferences are selected. |

Revaluing Assets Using the Revaluation Worksheet

Access the Revaluation Worksheet page.

Revaluation Worksheet

Asset Search Criteria

*Business Unit: *Book Name:

Asset Category: Location:

Profile ID: Cost Type:

Asset Class:

From Asset ID: To Asset ID: [Chartfield Search Criteria](#)

Revaluation Information

FMV Percentage(%): Copy Revaluation To Other Book

NBV Percentage(%): *Revalue Method:

*Accounting Date: Convention: [Revaluation Comments](#)

*Revaluation Date: Exclude Assets Revalue After:

Include current Period Depr. Frequency:

Revaluation Worksheet page (1 of 2)

use the buttons to mark assets for revaluating, updating FMV, or removing from the list.
The changes will take effect after you click "Save" button.

Mark to Revalue
 Mark to not Revalue

| Asset Search Results | | | | | | | | | | | | |
|--------------------------|--------------------|--------------|----------|--------------------------|----------------|-------------------|-------------|-----------------|------------------------|---------------------|-------------------------|--------------------------|
| Revaluation Information | | | | | | | | | | | | Asset Information |
| Mark | Revaluation Status | Asset ID | Cost | Accumulated Depreciation | Net Book Value | Fair Market Value | Revaluation | Cost Adjustment | Accum. Dep. Adjustment | Impairment Reversal | Carry Cost (Impairment) | Carry Cost (Revaluation) |
| <input type="checkbox"/> | | 000000000001 | 60000.00 | -19,000.00 | 41,000.00 | | | -60,000.00 | 19,000.00 | | | |
| <input type="checkbox"/> | | FT003 | 60000.00 | -18,366.69 | 41,633.31 | | | -60,000.00 | 18,366.69 | | | |
| <input type="checkbox"/> | | REVAL_01 | 60000.00 | 19,000.00 | 79,000.00 | 76,230.00 | | 16,230.00 | -19,000.00 | | | |
| <input type="checkbox"/> | | REVAL_02 | 60000.00 | -19,000.00 | 41,000.00 | 60,000.00 | 19,000.00 | | 19,000.00 | | | |
| <input type="checkbox"/> | | REVAL_03 | 60000.00 | -19,000.00 | 41,000.00 | 60,000.00 | 19,000.00 | | 19,000.00 | | | |

Revaluation Worksheet page (2 of 2)

- Business Unit** Select a business unit for your search criteria. This is a required field and displays only business units whose revaluation option is enabled.
- Book Name** Select a book for your search criteria. This is a required field and displays the default book for the business unit that you select in the Business Unit field.
- Cost Type** (Optional) Select a Cost Type to narrow your search criteria.
- Category** (Optional) Select a Category to narrow your search criteria.
- Location** (Optional) Select a Location to narrow your search criteria.
- Profile ID** (Optional) Select a Profile ID to narrow your search criteria.
- Asset Class** (Optional) Select an Asset Class to narrow your search criteria.

- From Asset ID/To Asset ID:** (Optional) Select an asset or a range of assets to further narrow your search criteria.
- ChartField Search Criteria** (Optional) Use this link to search assets by ChartField.
- FMV Percentage (%):** (Optional) Use a percentage that applies to all assets that appears in the search result section when the Retrieve button is pushed. Enter a value that is less than zero if there is a decrease from the original value. If both FMV percent and NBV percent exist, the system uses the FMV percent.
- For example, assume that Asset A has a Fair Market Value of 10,000 USD and the FMV has been effective for two years. If you enter a value of 25, it will change the FMV of the asset to 12,500 USD with the revaluation date when page is saved, which is 125 percent x Original FMV (125% x 10000 = 12500). The calculated FMV will appear in the result section.
- NBV Percentage (%):** (Optional) Use a percentage that applies to all assets that appears in the search result section when the Retrieve button is pushed. You must enter a value that is greater than zero in this field; otherwise, it will cause the FMV to be less than the NBV and no revaluation will occur.
- For example, assume that Asset B has a Fair Market Value of 9,000 USD and a Net Book Value of 10,000 USD. The FMV has been effective for two years. If you enter a value of 30, it will change the FMV to 13,000 USD (130% x 10,000) with the revaluation date when the page is saved. The calculated FMV will appear in the result section.
- Accounting Date** Enter the date that the revaluation is to be booked. This date must fall within the open period range and cannot be earlier than the revaluation date.
- Copy Revaluation to Other Book** Select this check box if you want the revaluation amount in a given book to populate other books whose revaluation process is enabled.
- PeopleSoft Asset Management copies the revaluation amount to other books in the ledger group as long as the Keep Ledgers in Sync (KLS) option is selected. If the option Copy Revaluation to Other Books is checked, PeopleSoft Asset Management copies the same amount to the books with the revaluation process selected for books that do not point to the ledger group. Depending on the selection of these options, when Copy Zero Impair/Revalue Rows is checked, the system copies zero revaluation data in all the remaining books.
- For example: Suppose you have a business unit with six books (A, B, C, D, E, F), with the first three books, A, B and C pointing to a ledger group, the ledger group is synchronized with the general ledger business unit and book B is pointing to the primary ledger. However, the other three books, D, E and F, do not point to general ledger and books A, B, C, and E have the revaluation option enabled. PeopleSoft Asset Management processes the revaluation against the primary book, B. The system then copies the revaluation adjustment to book A and book C because they are in the same ledger group, regardless of the status of the options Copy Revaluation to other books and Copy Zero Impair/Revalue Rows. If Copy Revaluation to other books is selected, the system copies the same revaluation adjustment to book E because the revaluation option is selected for that book. If the Copy Zero Impair/Revalue Rows option is selected, the system copies zero revaluation rows into book D and F. If the Copy Revaluation to other books option is not selected *and* the Copy Zero Impair/Revalue Rows option is selected, the system copies zero

impairment rows to books D and F. When both options are not selected, the system does not copy any impairment or revaluation row to books D, E and F.

Revalue Method

Select the method used to calculate the asset revaluation. This is a required field and includes the following two options:

- *Dpr Wt-Off* (depreciation write-off)

This option appears only if the Revaluation Write-off flag is turned on at the Business Unit/Book level. The depreciation write-off method writes off the accumulated depreciation as of the revaluation date. The asset value is increased to reflect the current fair market value and a revaluation surplus is recorded.

This table shows, at a high level, what happens with the depreciation write-off method when the original asset cost is 20,000 USD, the NBV is 19,000 USD and the FMV is 22,000 USD:

| Account | Debit / (Credit) | Description |
|--------------------------------------|------------------|--|
| Fixed Asset | 2,000 | FMV less Original Cost (22,000 - 20000) |
| Accumulated Depreciation (write-off) | 1,000 | Original Cost less NBV (20,000 - 19,000) |
| Revaluation Surplus | (3,000) | FMV less NBV (22,000 - 19,000) |

Note. With the previous accumulated depreciation written off, the adjusted basis of the asset is 22,000 USD and subsequent depreciation is calculated keeping, untouched the original depreciation amount, plus adjustments to fully depreciate the asset by the end of its useful life.

Note. If there is a remaining impairment processed previously for the asset, under the depreciation write-off method, the system first eliminates it and only the remaining value generates a revaluation surplus.

- *Cost Based*

This method leaves the accumulated depreciation to-date in tact and adjusts the asset cost by the difference between the asset NBV and the FMV.

This table shows, at a high level, what happens with the Cost Based method when the original asset cost is 20,000 USD, the NBV is 19,000 USD and the FMV is 22,000 USD:

| Account | Debit / (Credit) | Description |
|---------------------|------------------|--------------------------------|
| Fixed Asset | 3,000 | FMV less NBV (22,000 - 19,000) |
| Revaluation Surplus | (3,000) | FMV less NBV (22,000 - 19,000) |

Note. The total cost of the asset is now 23,000 USD with a remaining accumulated depreciation of 1,000. Subsequent depreciation is calculated based on the new total cost to fully depreciate the asset by the end of its useful life.

The actual accounting entries that are recorded as a result of these two revaluation methods are comprised of separate accounts so as to leave the original entries in tact. These accounts and corresponding distribution types are:

- Provision for Revaluation, (PR distribution type), is the Revaluation Surplus account and records the gain on the revaluation. This account is credited when creating the revaluation surplus and debited with the asset disposal.
- Reversal of Depreciation, (RD distribution type), is the realized gain during the usage of the asset and is credited periodically along with the asset depreciation.
- Provision for Revaluation Contra, (RC distribution type), is the depreciated amount of the Provision for Revaluation and is used for facilitating calculations at the moment of transferring or doing a recategorization. It acts for Provision for Revaluation as Accumulated Depreciation acts for the fixed asset account. It is debited periodically along with the asset depreciation and credited with the asset disposal.

See *PeopleSoft Enterprise Asset Lifecycle Management Fundamentals 9.0 PeopleBook*, “Setting Up Accounting Entry and Financial Processing for PeopleSoft Asset Management,” Defining Accounting Entries.

| | |
|--------------------------------------|--|
| Convention: | Enter the depreciation convention. The default value is <i>AM</i> (actual month). See <i>PeopleSoft Enterprise Asset Lifecycle Management Fundamentals 9.0 PeopleBook</i> , “Setting Up Depreciation Processing,” Setting Up Depreciation Conventions. |
| Revaluation Comments | Use this link to record transaction level details. |
| Revaluation Date: | Enter the date that the revaluation takes place. This is the transaction date and is used to determine the NBV and the FMV. |
| Include current Period Depr. | Select this option if the current period depreciation is to be accumulated. For example: if you perform the revaluation at the end of period 12 (the final period in the year) but you do not want to include period 12 depreciation to compare with FMV, you would not select this check box. |
| Exclude Assets Revalue After: | (Optional) Select a date that may assist you in retrieving assets that have not been revalued recently. |
| Frequency | Select the frequency of the revaluation. This is used for audit purposes. |
| Retrieve | Click the Retrieve button to retrieve the assets based on your search criteria. The Search section is collapsed and the revaluation information is visible but disabled. |

Asset Search Results

| | |
|----------------------------|---|
| Mark to Revalue | Click to revalue the selected assets. The revaluation status of the selected assets is changed to <i>Revalue</i> and when the page is saved, the asset is revalued. |
| Mark to not Revalue | Click to change the revaluation status of the selected assets to <i>Don't Revalue</i> . When the page is saved, the selected assets will not be revalued. A blank revaluation status is treated the same as the "Don't Revalue" asset; however, this designation marks the asset specifically as an asset that should not be revalued and the asset appears in the audit table. |
| Mark to Update FMV | Click to update the FMV in mass without performing a revaluation. The revaluation status will be <i>FMV</i> and implies only an update in the FMV table using the date of revaluation as the appraisal and effective date. The FMV is necessary for comparison purposes in the revaluation process and this provides a convenient way to update those values for in mass. |
| Remove From List | Click to remove the selected assets from the grid. This action does not generate a new Revaluation Status. |
| Refresh | Click to update changes in the revaluation calculation if you modify the FMV before saving the page. |
| Mark | Select those assets to which the action applies. |
| Revaluation Status | Displays the revaluation status of the asset. The values are: <ul style="list-style-type: none"> • <i>[blank]</i>: Default value. • <i>Revalue</i>: Displays when the Mark to Revalue button is selected. This inserts the new FMV into the FMV table, if applicable, and creates transaction rows in the financial interface table. • <i>Don't Revalue</i>: Displays when the Mark to not Revalue button is selected. No action is performed for the asset. • <i>FMV</i>: Displays the FMV when the Mark to Update FMV button is selected. • <i>Excluded</i>: The system assigns this status after saving the page if the FMV of the asset is less than the NBV and the revaluation status was set to <i>Revalue</i>. In this way, the system overrides the given status of an asset that should not be revalued by definition. |

Note. You can change the revaluation status until saving the page. Once you save the page, all data becomes unavailable for change.

| | |
|---------------------------------|--|
| Asset ID | Displays the asset identifier. |
| Cost | Displays the total cost of the asset in the base currency. |
| Accumulated Depreciation | Displays the total depreciation in the base currency of the asset up to the revaluation period or prior period based on the "Include Current Period Depr." option. |

Note. If the convention is *AD*, prior period means prior day.

| | |
|---|--|
| Net Book Value | Displays the asset NBV. This value is copied from the Depreciation Reporting table, which must be loaded before using the Revaluation Worksheet for revaluation. |
| Fair Market Value | Displays the FMV converted from its original currency to the book's base currency at the revaluation date rate. You can update the FMV in the book's base currency and at such time, a new entry is created in the FMV table at the time of save as long as the revaluation status is <i>Revalue</i> or <i>FMV</i> . If you modify the given FMV, click refresh button to update the revaluation amount. |
| Revaluation | Displays the revaluation adjustment amount. The system calculates the amount as follows: <ul style="list-style-type: none"> • Depreciation Write-Off Method: FMV less NBV less Carry Cost (Impairment) amount, if Revaluation is greater than zero. • Cost Based Method: FMV less NBV. |
| Cost Adjustment | Displays the cost adjustment amount. The system calculates this amount as follows: FMV less Cost. <ul style="list-style-type: none"> • Depreciation Write-Off Method: FMV less Cost. • Cost Based Method: FMV less NBV. |
| Accum. Depr. Adjustment(accumulated depreciation adjustment) | (Applies only when the Depreciation Write-off method is used.) Displays the amount of the accumulated depreciation adjustment due to revaluation. |
| Impairment Reversal | (Applies only when the Depreciation Write-off method is used.) Displays the impairment reversal amount. The system calculates this amount as follows: <ul style="list-style-type: none"> • If the Revaluation amount is greater than zero, the impairment reversal is the Carry Cost (Impairment) value. • If the Revaluation amount is less than zero, the impairment reversal is the FMV less the NBV. |
| Carry Cost (Impairment) | Displays the sum of the Impairment Loss and prior Impairment Reversal (in the base currency.) |
| Carry Cost (Revaluation) | Displays the sum of the prior Revaluation, Revaluation Reversal and Revaluation Write-off (in the base currency.) |

Note. Upon saving, an audit trail is stored in two tables: AM_REV_AUD_HDR and AM_REV_AUD_DTL.

Revaluing Assets In Mass

This section lists the page that you use to revalue assets in mass.

You can run the AMREVAL process (Cost Based method) to revalue assets in mass that meet the criteria that you specify. You can also run the AMAUSCAL process (Australian Revaluation or Net Method) or the AMDEPRWROFF process (Depreciation Write-Off) in mass. To revalue assets in mass, access the Mass Revaluation page.

Note. All three revaluation methods are available using the Mass Revaluation process: Cost Based (primarily French revaluation), Depreciation Write-Off and the Net Method (Australian revaluation). In contrast, the Revaluation Worksheet only allows the Cost Based and Depreciation Write-Off methods for revaluation.

When the NBV is required for determining the revaluation amount (as is always the case with the AMDEPRWRTOFF), the depreciation reporting table must be loaded prior to performing the revaluation. If you are using the Net Method, you do not need to load the depreciation reporting table prior to revaluation (AMAUSCAL.)

When using the Cost Based Method (AMREVAL), you should load the depreciation reporting table for all parameters except when using Cost Percentage. The Cost Percentage parameter does not require the depreciation reporting table.

Note. The Cost Based (AMREVAL) and the Depreciation Write-Off (AMDEPRWRTOFF) processes update the FMV of the revalued assets.

When calculating the revaluation amount, you may select from the following parameters: FMV, FMV Percentage, NBV Percentage, Cost Percentage or Amount. You may only select one parameter at a time and precedence takes place hierarchically from top to bottom in the order that the parameters appear on the Mass Revaluation run control page. Some parameters may not be available, depending upon the revaluation method that is selected.

Note. The revaluation method selected on the run control page must match the process name that is selected on the process scheduler request page.

See Also

[Chapter 23, “Using the Global Features of PeopleSoft Asset Management,” page 397](#)

Page Used to Revalue Assets In Mass

| Page Name | Object Name | Navigation | Usage |
|------------------|--------------|---|--|
| Mass Revaluation | AMREVAL_RQST | Asset Management, Asset Transactions, Financial Transactions, Revaluation in Mass, Mass Revaluation | Run a process to revalue, at once, all assets that meet the criteria that you specify. This process loads the interface tables and updates the FMV table if applicable; you must then use the Transaction Loader to populate all the asset tables. |

See Also

[Chapter 8, “Adjusting, Transferring, and Evaluating Assets,” Revaluing Assets Using the Revaluation Worksheet, page 165](#)

Revaluing Assets Using Mass Revaluation

Access the Mass Revaluation page.

Mass Revaluation

Run Control ID: AUSTRALIAN [Report Manager](#) [Process Monitor](#) Run

Revaluation In Mass
Find | View All
First 1 of 1 Last

*Request ID: Process Frequency:

*Business Unit: Book Name: Revaluation Method:

All Assets with this criteria Exclude Assets Revalue After:

A Range of Assets From Asset: To Asset:

Use Fair Market Value

FMV Percentage(%):

NBV Percentage(%):

Cost Percentage(%):

Amount: AUD

Convention:

*Acctg Date:

*Trans Date:

Frequency:

Include Current Period Depr.

Copy Revaluation To Other Book

Asset Selection Criteria

Category:

Profile ID:

Asset Class:

Cost Type:

Location:

Operating Unit:

Fund Code:

Department:

Program Code:

Class Field:

Budget Reference:

Product:

Project:

Mass Revaluation page

Capturing and Maintaining Asset Fair Market Value (FMV)

Fair Market Value is a key factor in establishing revaluation of assets. PeopleSoft Asset Management stores this information based on each asset and allows you to add a new fair market value (FMV) on a regular basis, leave it blank, or let it stay as original cost, depending upon your business requirements. FMV is not rolled up to the composite asset from its members. and the FMV history cannot be deleted for audit purposes.

FMV history cannot be deleted or updated for audit purposes unless you are authorized to edit within Correction Mode. Any changes made in this value after performing revaluation do not affect existing revaluations.

You can load market values in mass using the Excel to CI component interface.

See Chapter 5, “Adding and Maintaining Assets,” Adding Assets with the Excel to Component Interface Utility, page 114.

This section lists the page that you use to capture and maintain asset FMV.

Page Used to Capture and Maintain Asset FMV

| Page Name | Object Name | Navigation | Usage |
|-------------------|-------------|---|---|
| Fair Market Value | AM_FMV_DEFN | Asset Management, Asset Transactions, Financial Transactions, Fair Market Value | Capture and maintain the asset fair market value that is to be used in the revaluation process. |

Capturing and Maintaining Asset FMV

Access the Fair Market Value page.

Fair Market Value

Unit: US001 Asset ID: 000000000002 Gas/elec SUV - Fleet vehicle 1 Tag: P00000009001 In Service

Fair Market Value Detail. Find | View All First 1 of 1 Last

*Effective Date: 04/14/2006 Effective Sequence: 0

Appraisal Date: 04/14/2006 *Rate Type: CRRNT

Fair Market Value: 50,000 Currency: USD

Valuation Method: Depreciation Write-Off

Comment:

Fair Market Value page

- Effective Date** Enter the date that the revaluation process will use to find FMV at a specified point in time.
- Effective Sequence** The system populates this field and is incremented when a new row is inserted with the same effective date.
- Fair Market Value:** Enter the amount to be copied to the Basic Add page where the current fair market value is displayed.

Note. If the asset is a capital lease, synchronize the fair market value entered from the Lease Express Add page or the Update Lease Information page. The FMV entered on the lease page is inserted in the FMV table with the transaction date as the effective and appraisal dates. The valuation method is *Acquisition Amount*. The FMV becomes unavailable for edit on the FMV table, but you can modify it on the Lease Update page (ASSET_LEASE_01.) The system allows you to add/update other rows. On this page, you can change only the original FMV, and it is copied into the FMV table. A new row inserted on the FMV page will not impact on the FMV field on the Lease Update page.

See [Chapter 7, “Working With Leased Assets,” page 127](#).

| | |
|-------------------------|--|
| Currency | Enter the currency to be used to measure the FMV. This field value automatically populates from the default book currency. |
| Rate Type | Enter the rate type that will be used to convert FMV to base currency when it is used for revaluation. This field value automatically populates from the default book rate type. |
| Valuation Method | Enter the valuation method that is to be used for this asset. This is a text field and is used for informational and audit purposes. |

Updating Noncapitalized Costs

This section lists the page that you use to update noncapitalized costs for assets.

Page Used to Update Noncapitalized Costs

| Page Name | Object Name | Navigation | Usage |
|------------------------------|-------------------|---|---|
| Update Non-Capitalized Costs | ASSET_NON_CAP_UPD | Asset Management, Asset Transactions, Financial Transactions, Update Non-Capitalized Cost | Update noncapitalized costs for an asset. |

Viewing Cost History and Summarizing Cost Rows

Use the Review Cost (COST_HISTORY) component to review cost history for capitalized and noncapitalized assets.

Use the Cost Summarization (AM_COST_SUM_RUN) component to summarize cost rows.

This section provides overviews of cost history and cost summarization and discusses how to generate cost summarizations:

Understanding Cost History

PeopleSoft enables you to view cost history of assets online. You can view cost history for both capitalized and noncapitalized assets. Using the Cost History component, you can:

- View a history of an asset's transactions on the Cost History List page.
- View detail about a specific transaction on the Cost History Detail page.
- View a history of a noncapitalized asset's transactions on the Non Cap Cost History List page.
- View more detail about a specific transaction on the Non Cap Cost History Detail page.

Understanding Cost Summarization

Multiple transactions coming from PeopleSoft feeder systems rapidly create a large volume of cost history lines. PeopleSoft Asset Management provides the Cost Summarization process to summarize multiple cost lines that meet certain criteria into a single line. The process uses the Cost Summarization Run component (AM_COST_SUM_RUN). You should run the process only after calculating depreciation (AM_DEPR_CALC) and creating accounting entries (AM_AMAEDIST).

Cost summarization affects cost rows in the Cost table only. No changes are made to the Acquisition Detail table. The fields that are summarized are Cost, Transaction Cost, and Quantity. Cost summarization creates an audit table (AM_COST_SUM_AUD) that contains the original cost rows before summarization.

You can summarize cost rows that have matching values for:

- Business unit.
- Asset ID.
- Book.
- Category.
- Transaction type.
- Chart of accounts, or ChartField.
- Cost type.
- Transaction code.
- Accounting year and period.
- Transaction year and period.
- Depreciation convention.

Summarization updates the transaction date with the first day in the transaction period for all lines. It updates the accounting date with the last day in the accounting period for all lines. The summarization is then based on the new dates.

The only exception is the actual day (AD) convention.

When the transaction currency code or type differs, cost summarization uses the asset base currency as the transaction currency, and currency type is blank.

Note. You can run cost summarization in streamline mode during the create accounting entry process using the accounting entry component (AM_AMAEDIST).

Pages Used to View Cost History and Summarize Cost Rows

| Page Name | Object Name | Navigation | Usage |
|------------------------|-----------------|---|--|
| Cost History List | ASSET_TRANS_01 | Asset Management, Asset Transactions, History, Review Cost | View a history of an asset's transactions. |
| Cost History Detail | ASSET_TRANS_02 | <ul style="list-style-type: none"> Asset Management, Asset Transactions, History, Review Cost, Cost History List, Detail Click the Detail link on the Cost History List page. | View more detail about a specific transaction. |
| Non Cap History List | ASSET_TRANS_03 | Asset Management, Asset Transactions, History, Review Cost, Non Cap History List | View a history of a noncapitalized asset's transactions. |
| Non Cap History Detail | ASSET_TRANS_04 | <ul style="list-style-type: none"> Asset Management, Asset Transactions, History, Review Cost, Non Cap History List, Detail Click the Detail link on the Non Cap History List page. | View more detail about a specific transaction. |
| Cost Summarization | AM_COST_SUM_RUN | Asset Management, Asset Transactions, Financial Transactions, Cost Summarization | Generate cost summarizations. |

Generating Cost Summarizations

Access the Cost Summarization page.

| | |
|--------------------------------------|---|
| Business Unit | The business unit is required. |
| Book Name | If this field is blank, the cost summarization applies to all books. |
| Category | Select a category to apply summarization only to that category. Leave blank to include all categories. |
| From Asset ID and To Asset ID | Optionally enter a range of asset IDs to apply the summarization to specific assets. The assets that are available belong to the category when category is defined and that have accounting entries already generated. If the To Asset ID field is left blank, the summarization applies only to the asset ID that is specified in the From Asset ID field. |
| Accounting Date Range | The accounting date range is required for summarization. You can apply cost summarization to multiple books with different calendars. Define the date range according to the books that are selected. |

Note. When a line does not meet the criteria to summarize with other lines, no summarization occurs.

Cost summarization creates an audit table so that you can review the summarization details after you have processed the summary.

Updating the General Ledger with Adjustments and Transfers

When you make adjustments or changes that affect your general ledger, PeopleSoft Asset Management automatically creates corresponding journal entries that update the applicable accounts in your general ledger. Specifically, journal entries are created when your changes require recalculation or when an asset is transferred. The information that is used to create these journal entries comes from an Accounting Entry template that is set up for adjustments and transfers.

See Also

PeopleSoft Enterprise Asset Lifecycle Management Fundamentals 9.0 PeopleBook, “Setting Up Accounting Entry and Financial Processing for PeopleSoft Asset Management,” Defining Accounting Entries

PeopleSoft Enterprise General Ledger 9.0 PeopleBook, “Making General Ledger Journal Entries”

Modifying or Deleting Pending Asset Transactions

You can modify or delete financial asset transactions that are pending depreciation. (These are transactions on which depreciation has not yet been run.) You can modify or delete the following pending asset transactions:

- Adds
- Adjustments
- Transfers
- Recategorizations

Warning! You cannot modify or delete retirement transactions, leased asset transactions, group asset transactions, joint venture transactions, or parent/child asset transactions.

Note. Regarding the Copy Changes to Other Books option: when you delete an Add transaction, the deletion applies to all books to which the asset reports. However, when you delete Adjustments, Recategorizations, and Transfers transactions, you should review the delete at each book in the scroll area and click the Delete button on each book. Also, if you are using this page only to change the accounting date, transaction date, or transaction code, these changes will apply to all books to which the asset reports. To apply other types of updates to pending transactions, you need to scroll through each book that you want to affect with the modification. No other way is available to affect all books with an update.

Pages Used to Modify or Delete Pending Asset Transactions

| Page Name | Object Name | Navigation | Usage |
|---|--------------------|---|---|
| Pending Trans Update/Delete (pending transaction update and delete) | PEND_TRANS_UPD_DEL | Asset Management, Asset Transactions, Financial Transactions, Change/Delete Pending Trans | Update or delete transactions in Pending Transaction table prior to running depreciation processing (AM_DEPR_CALC). |
| Asset Addition | PEND_TRANS_A1_SP | Click the Update button or the Delete button on the Pending Trans Update/Delete page. | Review detail transaction information and then modify or delete the transaction. |
| Transaction Information | ASSET_TRNINFO4_SEC | Click the Edit Trans Info button on the Pending Trans Update/Delete page. | Modify the transaction or accounting date. |

Modifying or Deleting Pending Transactions

Access the Pending Trans Update/Delete page.

Review the information to make sure that this is the intended transaction that you want to modify or delete.

Click Update or Delete to review transaction information, and then either modify or delete it.

Click Edit Trans Info to edit the transaction date, accounting date, and the Transaction code.

Viewing Asset Transaction Details

Access the Asset Addition page.

Depreciation Status

You can change the status from *Depreciable* to *Non Depreciable*.

In Service Date

Captures when the asset was placed in service. You can modify this date.

Accum Depr in Current Pd (accumulate depreciation in current period)

Select if you want any accumulated depreciation for this asset to be booked to the current period. Do not select the check box if you want accumulated depreciation to be booked to the previous period, which you will probably have to reopen. The default setting for this option is disabled, or clear. If you use this check box, remember to select it for each book for the asset transaction that you are modifying.

Asset Transaction Detail

Modify the transaction directly in the cost row or rows.

Only certain fields are available for editing, based on the type of transaction that you are modifying:

Accum Depr (accumulated depreciation)

Add the amount of any depreciation that is already recognized for the asset. If you are adding assets that have depreciation from prior years or prior periods, you can enter the depreciation here if you forgot to enter it when you added the assets, or change it if you added depreciation before but want to change it now.

| Transaction Type | Fields You Can Update |
|------------------|--|
| ADD | Cost, Quantity, ChartFields, Category, Cost Type, In Service Date, Depreciation Status, Accumulated Depreciation |
| ADJ | Cost, Quantity |
| RCT | Category, Cost Type |
| TRF | ChartFields |

Updating Transaction Information

Access the Transaction Information page.

Trans Code (transaction code) is optional. It helps to identify which accounting entry template will be used for this transaction. You can select only those valid combinations for which accounting entry templates exist.

Adjusting for Asset Impairment

Use the Impairment (AM_IMPAIR) component or the CGU Impairment (AM_CGU_IMPAIR_RUN) component to perform impairment testing and create impairment adjustments to assets.

This section provides an overview of impairment testing, lists the pages used for impairment testing, and discusses how to:

- Work with the impairment worksheet.
- Run the CGU Impairment Batch process.
- View and report impairment losses and reversals.

Understanding Impairment Testing

PeopleSoft supports the requirements of International Accounting Standard (IAS) 36 by providing an impairment test worksheet.

A generally accepted principle is that long-lived assets should be subject to some form of recoverable amount constraint, that is, that the carrying amount of an asset does not exceed the amount that is recoverable from the future economic benefits that the asset is expected to generate. When the carrying amount of an asset exceeds its recoverable amount, the asset is described as *impaired* and the carrying value should be reduced to the recoverable amount. Therefore, assets should be subject to some type of impairment evaluation or test. The purpose of an impairment or recoverable amount test is to identify such assets and ensure that losses of future economic benefits are properly recognized in a timely manner (asset values are reduced in the statement of financial position, and expenses are recognized in the statement of financial performance).

In pursuance of this principle, the International Accounting Standards Board has defined IAS 36. This requires that you ensure that your assets are carried at no more than their recoverable value. IAS 36 provides a list of external and internal indicators of impairment as well as requirements for an impairment assessment strategy and frequency-of-asset impairment review. Only assets that are identified as 'potentially impaired' require an impairment assessment. If you have an indication that an asset may be impaired, then the enterprise is required to calculate the asset's recoverable amount.

Note. To assess whether any assets you have are subject to impairment review, consult the most current published IAS standards.

PeopleSoft also enables the definition of a Cash Generating Unit (CGU) and the association of CGUs with business units to further support impairment testing. Impairment losses can be allocated to individual assets on a CGU basis using the CGU Impairment utility. This batch process allocates CGU impairment data for each asset and stores the details in the INTFC_FIN table. You can also initiate the transaction loader (AMIF1000) to process and update asset tables automatically.

If an organization cannot determine recoverable value for an individual asset, it must identify the lowest aggregation of assets that generate largely independent cash flows. These aggregations of assets are called CGUs. CGUs are defined as the smallest identifiable group of assets that generates cash inflows from continuing use, and are largely independent of the cash inflows from other assets or groups of assets. CGU should be defined consistently from period to period. However, an asset that was previously part of a CGU but which is no longer used, should be excluded from the CGU and assessed for impairment separately.

If you are required to perform impairment evaluation, at a minimum, you should evaluate assets at each balance sheet date. You can test assets or CGUs for impairment at any time.

Impairment processing is enabled at the installation level. Impairments are then processed on assets that are contained within the business unit where impairment processing is selected. You can select asset categories, profiles, books, accounting entry template, CGUs, and individual asset IDs for impairment processing.

To process calculation of impairment, the system compares the following information:

- Carrying amount: The net book value (NBV) of the asset as it is currently recorded in the accounts.
- Recoverable amount: The higher of an asset's Net Selling Price (NSP) or its Value In Use (VIU):
 - The NSP is obtained from the sale of an asset in a bargained transaction between knowledgeable, willing parties with reference to the price of an active market and less the costs of disposal.
 - The VIU is the present value of estimated future cash flows that are expected to arise from the continuing use of an asset, and from its disposal at the end of its useful life, (for example, the sum of discounted cash flows).

The impairment worksheet can also apply an index to the carrying cost and calculates the potential NSP/VIU cost. The system compares the carrying amount value to the recoverable amount value to calculate the potential impairment. Any difference is the *impairment loss*.

An impairment reversal is required when a change has occurred in the estimates that are used to determine the impairment loss. In this case, the carrying amount of the asset is increased to the recoverable amount, where the recoverable amount does not exceed the original carrying amount.

You can also select impairment processing when running the Cost and Depreciation process.

To view impairment loss and reversal, use the Cost and Depreciation Summary page (AM_REPORT1). To generate reports of impairments, use the Asset Impairment report (AM_IMPAIR_RPT_RUN) component.

Note. Impairment testing prescribed by IAS 36 is not required in all countries.

See *PeopleSoft Enterprise Asset Lifecycle Management Fundamentals 9.0 PeopleBook*, “Establishing PeopleSoft Asset Management Business Units”.

Pages Used to Make Impairment Adjustments

| Page Name | Object Name | Navigation | Usage |
|---------------------------------|--------------------|---|---|
| Impairment Worksheet | AM_IMPAIR | Asset Management, Asset Transactions, Financial Transactions, Impairment | Select criteria to search for assets that can potentially be impaired, to process potential impairment, and to create loss adjustments automatically. |
| Cash Generating Unit Definition | AM_CGU_DEFN_01 | Click the CGU Details link from the Impairment Worksheet or from the CGU Impairment run control page to view (only) the CGU definition. | Review the CGU definition. |
| More Filter Options | AM_IMPAIR_CF_SEC | Click the ChartField Search Criteria link from the Impairment Worksheet page. | Filter search criteria by selecting ChartFields: Operating Unit, Fund Code, Department, Program, Class Field, Budget Reference, Product, and Project. |
| Impairment Comments | AM_IMPAIR_COMMENTS | Click the Impairment Comments link from the Impairment Worksheet OR from the CGU Impairment run control page. | Enter comments about this impairment. |
| CGU Impairment | AM_CGU_IMP_RUN_CTL | Asset Management, Asset Transactions, Financial Transactions, CGU Impairment | Allocate impairment losses to individual assets on a CGU basis. |
| Cost and Depreciation | AM_REPORT1 | Asset Management, Financial Reports, Cost and Depreciation Summary | View impairment losses and reversals online using the Cost and Depreciation online view. |
| Impaired Asset Value Report | AM_IMP_RPT_RUN_CTL | Asset Management, Financial Reports, Cost and Depreciation, Asset Impairment | Generate Crystal reports by category or CGU ID of impaired asset values. |

Working With the Impairment Worksheet

Access the Impairment Worksheet page.

Impairment Worksheet

▼ Asset Search Criteria

| | |
|---|---|
| *Business Unit: <input type="text" value="IMP01"/> | *Book Name: <input type="text" value="CORP"/> |
| Asset Category: <input type="text" value="ME"/> | Location: <input type="text" value="FRA01"/> |
| Cash Generating Unit: <input type="text"/> | Profile ID: <input type="text" value="MACHINERY"/> |

From Asset ID: **To Asset ID:**

▼ Impairment Information

| | |
|--|---|
| NSP Percentage(%): <input type="text" value="2.000000"/> | <input checked="" type="checkbox"/> Copy Impairment to other books |
| VLU Percentage(%): <input type="text" value="3.000000"/> | <input checked="" type="checkbox"/> Impairment Reversal |
| Accounting Date: <input type="text" value="03/31/2005"/> | Convention: <input type="text" value="FM"/> |
| *Impairment Strategy: <input type="text" value="Assets"/> | Frequency: <input type="text" value="Annually"/> |

***Impairment Date:** **Exclude Assets Impaired After:**

Impairment Worksheet page

Enter the asset search criteria and impairment information.

- Business Unit** Select the business unit (required). The business unit is supplied from the search dialog box.
- Book Name** Select the book name (required). The Book Name field is initially supplied by the default book (when the book is enabled for impairment processing). The valid values include only books for which impairment processing is enabled.
- Asset Category** Select the asset category to search for assets by category. The valid values include only categories for which impairment processing is enabled.
- Location** Select the asset location to search for assets by location. The valid values include only locations for which impairment processing is enabled.
- Cash Generating Unit** Select from the valid CGUs for this business unit, book, profile, or category if you want to impair at the CGU level.
- Profile ID** Select the asset profile ID to search for assets by profile. The valid values include only locations for which impairment processing is enabled.
- From Asset ID and To Asset ID** Select an asset ID or a range of asset IDs to be included.
- NSP Percentage (%)**(net selling price percentage) Apply and enter a net selling price percentage to determine the actual NSP. Net selling price is the amount that is obtainable from the sale of an asset in a bargained transaction (between knowledgeable, willing parties), less the costs of disposal.

For example, suppose the net book value of an asset is 10,000.00 USD. But the NSP is equal to 8,000.00 USD. The NSP percent is equal to 80 percent.
- Copy Impairment to other books** Select if you want the impairment carried over to other books.

| | |
|---|--|
| VIU Percentage (%) (value in use percentage) | <p>Enter the value in use percentage that you expect to determine the actual VIU amount.</p> <p>Value in use is the present value of estimated future cash flows that are expected to arise from the continuing use of an asset, and from its disposal at the end of its useful life.</p> <p>For example, suppose the net book value of an asset is 23,500.00 USD. But the VIU is unknown. You can apply a percentage that you expect , such as 70 percent, and the system will calculate the actual amount to be 16,450.00 USD.</p> |
| Impairment Reversal | <p>Select if the potential impairment is a reversal of a prior impairment adjustment.</p> <hr/> <p>Note. This option appears only if impairment reversal is enabled for the business unit.</p> <hr/> |
| Accounting Date | Enter the accounting date of the impairment. |
| Convention | Select the depreciation convention. The valid values are derived from those that are defined for the business unit. |
| Impairment Strategy | <p>Select the impairment strategy. Valid values are: <i>Asset</i> and <i>CGU</i>.</p> <ul style="list-style-type: none"> • <i>Asset</i>: If asset is selected, the system makes the impairment adjustment asset by asset. • <i>CGU</i>: If CGU is selected, the system calculates the adjustment to the whole CGU as a body. Impairment is based on all assets that are part of CGU definitions. If CGU is selected, then a cash generating unit must be provided. The CGU field in the search criteria section is only used to find out specific groups but it does not say what kind of impairment will apply to them. |
| Frequency | Select the frequency for performing the impairment test. the options include <i>Yearly</i> , <i>Semiannually</i> , <i>Quarterly</i> , <i>Monthly</i> , and <i>Other</i> |
| Impairment Date | <p>This is the transaction date on which the system calculates carrying cost (NBV). The depreciation for the impairment month is included in the NBV calculation. For example, if the impairment date is between December 12, 2003 and December 12, 2003, period 12 is included in the accumulated depreciation for the calculation:</p> $NBV = Cost - ACCUM$ |
| Exclude Assets Impaired After | Enter the dates to exclude more recently impaired assets. |

Retrieve Assets for Impairment

When you are finished entering search criteria and impairment information, initiate the retrieval process. On completion, the Search Criteria group box collapses. The Impairment Information group box is visible, but unavailable for entry. You can initiate a new search or refine search of your returned results.

The results of the assets matching the criteria that are entered are displayed in the Asset Search Results grid on the worksheet. The grid contains two tabs:

- Impairment Information
- Asset Details

Use the buttons to mark assets to be impaired and assets not to be impaired, to remove assets from the list, and to refresh the page.

Note. Selected assets must already have been processed for depreciation or included in the load depreciation report table process before they are available to be reported in the impairment worksheet.

Impairment Information

Access the Impairment Information tab.

This tab enables you to select or exclude selected assets for impairment.

| | |
|---|--|
| Mark  | When you click the Check button, you will select all assets in the list. Use Mark to select the line. |
| Mark to Impair | Click Mark to Impair and the system will set Impair Status to <i>Impair</i> for all selected rows. |
| Mark to Not Impair | Click Mark to Not Impair and the system will set Impair Status to <i>Don't Impair</i> for all selected rows. |
| Remove From List | Click Remove From List to remove selected rows from Asset Search Results. |
| Refresh | Click Refresh to recalculate all impairment information. |
| Impair Status | Displays the status of selected assets to be impaired or not to be impaired. Impaired assets will be inserted into INTFC_FIN table and Impairment audit tables. Not impaired assets will be inserted into the impairment audit tables. |
| Asset ID | Displays the asset ID for all assets meeting the search criteria. |
| Carry Cost (NBV) | Displays the current carry cost (net book value) of the asset. |
| NSP% | Displays the net selling price percentage that is applied to the carry cost. |
| NSP Amount | Displays the NSP as an amount in the base currency. |
| VIU% | Displays the value in use percentage that is applied to the carry cost. |
| VIU Amount | Displays the VIU as an amount in the base currency. |
| Impairment Loss | Displays the calculated impairment loss, usually the disposal cost. Impairment loss = NBV - (greater than NSP or VIU) |
| Revaluation Reversal | If this asset had a revaluation before, you need to reverse the revaluation before you allocate the loss. |
| Carry Cost (Impairment) | The remaining amount that is attributable to prior impairment loss. |
| Carry Cost (Revaluation) | The remaining amount that is attributable to prior impairment reversal. |

When you have reviewed and selected assets to be impaired, save the worksheet. The saving process performs the following tasks:

- The system creates a cost adjustment (with user define impairment loss cost type) for the impairment loss.
- The system creates a cost adjustment (user defined impairment reversal cost type) for the impairment revaluation reversal.
- The transaction date and the impairment date are inserted and is the same for this transaction.

- If you do not provide an accounting date, the system looks for the last day of the open period and books the transaction against that date. This date is validated against the open period.
- The system commits all validations at the time of the save.
- Upon saving the worksheet, the system places the actual adjustment in the staging table INTFC_FIN. The system loads the adjustment in the main asset tables when the transaction loader (AMIF1000) is run.
- The system automatically triggers the transaction loader (AMIF1000) to load the transactions if this option has been selected.
- The system validates that the impairment date is less than or equal to the accounting date.
- When the impairment reversal box is checked, the system processes impairment reversal instead of impairment loss.

Running the CGU Impairment Batch Process

Access the CGU Impairment page.

CGU Impairment

Run Control ID: CGU [Report Manager](#) [Process Monitor](#) Run

Request Find | View All | First 1 of 1 Last

*Request ID: *Process Frequency: + -

*Business Unit: *Book Name: Currency Code: USD

*CGU ID: [CGU Details](#)

Exclude Assets Impaired After: B1

Impairment Information

*Impairment Date: B1 Impairment Strategy: CGU Copy Impairment to other books

*Accounting Date: B1 *Impairment Frequency: Impairment Reversal

Convention: [Impairment Comments](#)

Carrying Values

Calculate

NBV:

Net Selling Price

NSP(%): Or

NSP Amount:

Value In Use

VIU(%): Or

VIU Amount:

Calculate Impairment Loss
Total Impairment Loss:

CGU Impairment page

Complete the applicable fields. When satisfied with the criteria, click Run. The batch process allocates CGU impairment data to each asset.

Request

| | |
|--------------------------------------|---|
| Business Unit | Select the business unit (required). The business unit is supplied from the search dialog box. |
| Book Name | Select the book name (required). The book is initially supplied by the default book (when the book is enabled for impairment processing). The valid values include only books for which impairment processing is enabled. |
| Currency Code | The currency code as defined for the Book. |
| CGU ID | Select from the valid CGUs for this business unit, book, profile, or category if you want to impair at the CGU level. |
| Exclude Assets Impaired After | Enter dates to exclude more recently impaired assets. |

Impairment Information

| | |
|---------------------------------------|---|
| Impairment Date | Enter the date of the asset impairment. This is the transaction date on which the system calculates carrying cost (NBV). The depreciation for the impairment month is included in the NBV calculation. The system uses the current date by default. |
| Impairment Strategy | <i>CGU</i> : Impairment based on all assets that are part of CGU definitions. The impairment strategy CGU appears by default when you are processing impairment in batch mode. |
| Copy Impairment to other books | Select if you want the impairment carried over to other books. PeopleSoft Asset Management copies the impairment amount to other books in the ledger group as long as the Keep Ledgers in Sync (KLS) option is selected. If the option Copy to Other Books is checked, PeopleSoft Asset Management copies the same amount to the books with impairment amount selected, for books that do not point to the ledger group. Depending on the selection of these options, when Copy Zero Impair/Revalue Rows is checked, then the system copies zero impairment data in all the remaining books. For example: Suppose you have a business unit with six books (A, B, C, D, E, F), with the first three books, A, B and C pointing to a ledger group, the ledger group is synchronized with the general ledger business unit and book B is pointing to the primary ledger. However, the other three books, D, E and F do not point to general ledger and books A, B, C, and E have the impairment option enabled. PeopleSoft Asset Management processes impairment loss against the primary book B. The system then copies the impairment loss to book A and book C because they are in the same ledger group regardless of the status of the options Copy Impairment to other books and Copy Zero Impair/Revalue Rows . If Copy Impairment to other books is selected, the system copies the same impairment loss to book E because the impairment option is selected for that book. If the Copy Zero Impair/Revalue Rows option is selected, the system copies zero impairment loss into book D and F. If the Copy Impairment to other books option is not selected <i>and</i> the Copy Zero Impair/Revalue Rows option is selected, the system copies zero impairment |

rows to books D and F. When both options are not selected, the system does not copy any impairment or revaluation row to books D, E and F.

See *PeopleSoft Enterprise Application Fundamentals 9.0 PeopleBook*, “Setting Installation Options for PeopleSoft Applications,” Defining Asset Management Installation Options.

See *PeopleSoft Enterprise Asset Lifecycle Management Fundamentals 9.0 PeopleBook*, “Establishing PeopleSoft Asset Management Business Units,” Creating PeopleSoft Asset Management Cash Generating Units.

| | |
|-----------------------------|--|
| Accounting Date | Enter the accounting date of the impairment. |
| Impairment Frequency | Select the frequency for performing the impairment test. The options include <i>Yearly</i> , <i>Semiannually</i> , <i>Quarterly</i> , <i>Monthly</i> , and <i>Other</i> |
| Impairment Reversal | Select for the system to process impairment reversal instead of impairment loss. Click the Calculate button to compute the net book value, prior impairment loss, and prior revaluation reversal. Click the Calculate Impairment Loss button to calculate the total impairment loss. |

Note. This option is available only if impairment reversal is enabled for the business unit.

| | |
|-------------------|---|
| Convention | Select the depreciation convention. The valid values are derived from those that are defined for the business unit. |
|-------------------|---|

Carrying Values

The NBV is the equivalent to the carrying value.

Click the Calculate button to retrieve the current NBV for the selected assets.

Net Selling Price

| | |
|--|---|
| NSP Percentage (%) (net selling price percentage) | Enter the net selling price percentage. For example, suppose the net book value of an asset is 10,000.00 USD. But the net selling price (NSP) is equal to 8,000.00. The NSP percent is equal to 80 percent. Net selling price is the amount obtainable from the sale of an asset in a bargained transaction (between knowledgeable, willing parties), less the costs of disposal. |
|--|---|

| | |
|---------------------------------------|-------------------------------------|
| NSP Amount (net selling price) | Enter the net selling price amount. |
|---------------------------------------|-------------------------------------|

Value In Use

| | |
|--|--|
| VIU % (value in use percentage) | Enter the value in use percentage. Value in use is the present value of estimated future cash flows that is expected to arise from the continuing use of an asset, and from its disposal at the end of its useful life. |
|--|--|

For example, suppose the net book value of an asset is 10,000.00 USD. But the VIU is equal to 7,200.00 USD. The VIU percent is equal to 72 percent.

VIU Amount

Enter the value in use amount. Value in use is the present value of estimated future cash flows that are expected to arise from the continuing use of an asset, and from its disposal at the end of its useful life.

Click the Calculate Impairment Loss button to compute total impairment loss.

View and Report Impairment Losses and Reversals

This section discusses how to view and report impairment losses and reversals.

Viewing Impairment Loss Online

Access the Cost and Depreciation page.

Cost and Depreciation

▼ Selection Criteria

| | | | | | |
|-----------------|-------|---|-------------|------|---|
| *Business Unit: | US001 | US001 NEW YORK OPERATIONS | | | |
| *Book Name: | CORP | Corporate | Currency: | USD | |
| *Fiscal Year: | 2004 | Period: <input style="width: 40px;" type="text"/> | Group Type: | None | ▼ |

▶ Secondary Selection Criteria

Cost and Depreciation by Period
Customize

Net Book Value
Depreciation Activity
Cost Activity
PDF

| Period | Drill-down To | Current Depr | YTD Depr | LTD Depr | Cost | Salvage Value | NBV |
|--------|------------------------|--------------|-----------|-----------|------------|---------------|------------|
| 8 | --- Select Field --- ▼ | 500.01 | 500.01 | 500.01 | 12,000.00 | | 11,499.99 |
| 9 | --- Select Field --- ▼ | 4,703.67 | 5,203.68 | 5,203.68 | 112,887.00 | | 107,683.32 |
| 10 | --- Select Field --- ▼ | 4,703.67 | 9,907.35 | 9,907.35 | 112,887.00 | | 102,979.65 |
| 11 | --- Select Field --- ▼ | 8,644.17 | 18,551.52 | 18,551.52 | 207,455.00 | | 188,903.48 |
| 12 | --- Select Field --- ▼ | 8,643.66 | 27,195.18 | 27,195.18 | 207,455.00 | | 180,259.82 |

Cost and Depreciation Summary

Use the Cost and Depreciation online view to review impairment transactions. Search by business unit required, book name, and fiscal year (all required) or search by selected secondary ChartField criteria.

Reporting Asset Impairment Activity

Access the Impaired Asset Value Report run control page.

Impaired Asset Value Report

Run Control ID: 1 [Report Manager](#) [Process Monitor](#) Run

Language: ▼

Report Request Parameters

| | |
|---|---|
| <p>*Business Unit: <input type="text" value="US001"/> 🔍</p> <p>*Impairment Strategy: <input type="text" value="Assets"/> ▼</p> <p>Impairment Date From: <input type="text"/> 📅</p> <p>As of Date: <input type="text" value="01/25/2005"/> 📅</p> | <p>Book Name: <input type="text"/> 🔍</p> <p>Category: <input type="text"/> 🔍</p> <p>Impairment Date To: <input type="text"/> 📅</p> |
|---|---|

Impaired Asset Value Report page

Enter the report criteria for the report. You can have the report output sorted by asset category or by asset CGU ID. You can see the Crystal report formats in the Reports appendix.

The business unit, impairment strategy and impairment date are required for the report.

Note. You *must* run the load depreciation report process for the dates on which you plan to evaluate the assets or CGU in order to perform the impairment.

See [Appendix C, “PeopleSoft Asset Management Reports,”](#) page 561.

CHAPTER 9

Managing Asset Maintenance, Repair, Warranties, and Insurance

This chapter provides an overview of managing asset maintenance, repair, warranties, and insurance, and describes how to:

- Enter maintenance details.
- Enter asset inspection information.
- Enter asset service and repair statistics.
- Track asset maintenance contracts.
- Enter warranty information.
- Enter insurance coverage information.
- Set up asset contract or warranty expiration notifications.
- Generate asset warranty reports.
- Review asset maintenance history.

Understanding Asset Maintenance, Repair, Warranties, and Insurance

All assets usually require some level of maintenance service or repair. Many are also acquired with accompanying insurance or warranties. PeopleSoft Asset Management provides features enabling you to manage and track these asset attributes.

Asset Checkout

PeopleSoft Asset Management provides the asset check out functionality in order to prepare, configure and maintain assets for use. This enables you to manage assets as they are moved around the enterprise for use in multiple settings. As well, the usage can be monitored and intervening maintenance or service events can be tracked while the asset is out of use.

Asset Maintenance, Service, and Inspection Management

At various intervals, all assets require some degree of maintenance, such as routine mechanics for company vehicles or repainting an office or building. Scheduling and tracking this type of maintenance provides a more complete picture of the true costs and revenues associated with these assets.

PeopleSoft Asset Management provides features to track the details of individual maintenance events by date and time, the person responsible for the maintenance, the vendor who issued the maintenance contract or warranty, and the cost.

Whenever an asset requires maintenance, you can track exactly when the maintenance takes place, how long it will take, and how it will affect cost and performance. Annual tune-ups may require that some automobiles are unavailable at certain times. Damages to machinery can result in large expenses due to unavailable equipment, as well as replacement and repair costs.

PeopleSoft Asset Management additionally provides the tools to view the maintenance history by type of maintenance performed or by the date that the maintenance was performed. Using inquiry pages, you can determine if any asset, or group of assets, requires a particular type of maintenance too often. For example, a vehicle that requires several quarts of oil more often than every 1,000 miles may have more severe underlying problems. Similarly, a piece of equipment that requires repeated repair or replacement of a particular part may be defective and should be replaced.

When you own assets that require expensive maintenance, you may acquire maintenance contracts with providers covering service and repair. While maintenance contracts do not necessarily have a one-to-one relationship with assets that require maintenance, you may still want to keep track of those contracts, the assets that they cover, the extent of coverage provided, and so forth. PeopleSoft Asset Management provides the tools to track such contracts and to determine repair and servicing costs, the time period covered in the contract, and the exact coverage specified by the contract.

Keeping detailed records of maintenance events helps manage the physical aspects of your assets. You can compare detailed repair estimates to actual costs and evaluate whether a warranty or maintenance contract on the asset can lower the costs that you may incur. Or a review of an asset maintenance history can help you make decisions about addressing underlying costs that are driving up the cost of production. Some assets additionally require routine inspections related to licensing or other validations or certifications. PeopleSoft Asset Management provides inspection and license tracking.

Asset Repair Data Management

In addition to tracking physical information about asset maintenance, it is useful to track detailed financial information. PeopleSoft Asset Management enables you to track:

- How long an asset will be unavailable for use.
- Hours required to service or repair the asset.
- Costs for labor and materials.
- Any other expenses that you may incur, such as rental of necessary replacement equipment.

This type of detail enables you to assess asset maintenance and repair costs. For instance, as equipment grows older, it may cost more to repair and service, especially if the parts are obsolete or out of stock. Tracking asset service and repair statistics helps you to see the financial picture more clearly and may be instrumental in helping you to decide when to retire or replace an asset.

Asset Warranty Management

Warranties can often lower the cost of repair and maintenance of your assets. Keep track of any warranties that you might have, which assets they cover, the period of coverage, the cost of the warranty, and so forth. Manufacturers often warrant an asset, or part of an asset, using specific terms and indicating specific conditions. Such information is easily accessible to all employees in your organization who might be responsible for the physical aspects of asset management.

Asset Insurance Management

PeopleSoft Asset Management enables you to enter asset-specific insurance coverage information, including key insured information, such as insured amount and insurer details. This provides immediate online access to asset insurance information associated with a specific asset ID, rather than maintaining this information in a separate database.

Checking Out Assets

This section discusses how to enter maintenance events and details.

Page Used to Check Out Assets

| Page Name | Object Name | Navigation | Usage |
|----------------|----------------|---|---|
| Asset Checkout | ASSET_CHECKOUT | Asset Management, Service and Maintenance, Asset Checkout | Check out an asset that can be scheduled from available assets. |

Checking Assets Out for Maintenance Events

Access the Asset Checkout page.

Asset Checkout

| | | | | | |
|--------------------------|---|---------------------------|----------------------|--|----------------------|
| Business Unit: | US001 | Asset ID: | EX_000000122 | Checkout ID: | 000000000002 |
| WO Business Unit: | MM001 | Work Order: | <input type="text"/> | Task No.: | <input type="text"/> |
| Checkout By: | Todman,Joe | | | | |
| Contact Info: | <input type="text" value="(925) 555-9090"/> | | | | |
| Location: | US001 | Shop: | <input type="text"/> | | |
| Deployed BU: | US001 | Deployed Asset ID: | <input type="text"/> | | |
| *Start Date: | 12/24/2004 | Start Time: | 6:18PM | | |
| End Date: | 12/29/2004 | End Time: | 3:15PM | <input type="checkbox"/> Checked In | |
| Usage Amount: | <input type="text"/> | Unit of Measure: | <input type="text"/> | | |

Asset Checkout page

- WO Business Unit** Select the business unit from which to select the work order for this asset.
- Work Order** Select the work order to associate with this asset checkout.
- Task No.** Select the task number associated with this checkout event.
- Checkout By** Select the person who checked out the asset.
- Contact Info** Enter any contact information regarding the checkout of this asset.
- Location** Select the location by business unit for the asset.
- Shop** Select the shop if applicable where the asset will be maintained.
- Deployed BU** Select the business unit to which the asset is deployed.
- Deployed Asset ID** Select the asset ID used when the asset is deployed.

| | |
|------------------------|---|
| Start Date | Enter the start date for the asset deployment. |
| Start Time | Enter the start time of the asset deployment |
| End Date | Enter the ending date of the asset deployment. |
| End Time | Enter the ending time of the asset deployment. |
| Checked In | Check this box when the deployed asset has been checked in. |
| Usage Amount | Enter the usage amount of the asset. For example, if the asset usage is tracked by a meter, a reading value can be entered. |
| Unit of Measure | Select the usage amount unit of measure type, such as miles, gallons, etc. |

Entering Asset Inspection Information

Use the Asset Inspection (ASSET_INSPECTION) component to enter information about required or other inspection for a given asset.

This section discusses how to enter asset inspections.

Page Used to Enter Asset Inspection Information

| Page Name | Object Name | Navigation | Usage |
|------------------|------------------|---|---|
| Asset Inspection | ASSET_INSPECTION | Asset Management, Service and Maintenance, Asset Inspection | Enter details pertaining to inspections performed for the asset. The inspection agency should be defined first. |

Entering Asset Maintenance Service and Repairs

Use the Track Service and Repairs (ASSET_MAINT_01) component to enter asset service and repair statistics. This section lists the pages used and discusses how to:

- Enter asset maintenance event information.
- Enter statistical information for repairs.
- Enter payment information.

Pages Used to Enter Asset Service and Repair

| Page Name | Object Name | Navigation | Usage |
|---|------------------|---|---|
| Asset Service/Repair - Event | ASSET_MAINT_01 | Asset Management, Service and Maintenance, Track Service and Repairs, Event | Provide the date and time of maintenance events and identify the type of maintenance, party responsible for the maintenance, and status of the maintenance. |
| Maintenance Details | ASSET_MAINT_01_S | Click the Maintenance Description link on the Asset Service/Repair Details - Event page. | Identify the type of maintenance, party responsible for the maintenance, and status of the maintenance. |
| Statistics | ASSET_MAINT_02 | Asset Management, Service and Maintenance, Service and Maintenance, Track Service and Repairs, Statistics | Enter detailed financial information pertaining to asset maintenance. |
| Related Meter Readings | ASSET_MAINT_05 | Click the Related Meter Readings link from the Statistics page. | Enter meter reading information relative to a maintenance event for this asset. This page enables you to enter and view related meter readings which may have influenced the maintenance event being tracked. <u>See Chapter 5, "Adding and Maintaining Assets," Entering Meter Readings, page 75.</u> |
| Meter Reading Details | AM_MTR_RD_HID3 | Click the Detail link from the Related Meter Readings page. | Use the details link to view asset meter reading details. <u>See Chapter 5, "Adding and Maintaining Assets," Reviewing Meter Reading History, page 77.</u> |
| Payment | ASSET_MAINT_03 | Asset Management, Service and Maintenance, Service and Maintenance, Track Service and Repairs, Payment | Enter information about a parts or services vendor. You can add any number of payment records. |
| Asset Service/Repair Details - Comments | ASSET_MAINT_04 | Asset Management, Service and Maintenance, Service and Maintenance, Track Service and Repairs, Comments | Enter problems encountered or recommendations for repair and service. You can maintain separate comments for each service/repair event or you can keep a running commentary covering all events. |

Describing Maintenance Events

Access the Track Service and Repairs Event page.

Event page

Date/Time Displays the date and time that each maintenance event was entered into PeopleSoft Asset Management.

Type Enter a valid maintenance type. This field is required to save the event.

Note. You can complete the rest of the fields on this page at any time.

Status Select the status of the maintenance event:

- Complete:* Maintenance and repairs are done and ready for inspection.
- Complete-Pickup:* Asset is ready for return to service.
- In Process:* Asset is undergoing maintenance or repairs.
- Inspected:* Maintenance and repairs have been approved.
- Scheduled:* Maintenance event has been planned and scheduled.
- Scheduled-Pickup:* Asset has been scheduled for pickup.

Problem ID If applicable, enter an ID for this maintenance event.

WO Unit Select the work order business unit from which to select the work order for this asset maintenance event.

Work Order ID Select the work order ID to associate with this asset.

| | |
|---------------------------------------|---|
| Task Number | Select the task number associated with this maintenance event. |
| Repair Code | Enter a repair code, if used. This field may be populated automatically when you have installed PeopleSoft Maintenance Management. See <i>PeopleSoft Enterprise Maintenance Management 9.0 PeopleBook</i> , “Setting Up and Generating Preventive Maintenance Work Orders”. |
| Responsibility | Enter the name of the person responsible for this asset, if used. This field may be populated automatically when you have installed Maintenance Management. See <i>PeopleSoft Enterprise Maintenance Management 9.0 PeopleBook</i> , “Setting Up and Generating Preventive Maintenance Work Orders”. |
| This Asset is Offsite | Check this box to indicate the asset is located off site. |
| Pickup Date and Pickup Contact | Enter the date the asset is scheduled for pickup and the contact name. |
| Ready Date Time | Enter the date and time the repaired asset is scheduled to be ready. |

See Also

PeopleSoft Enterprise Asset Lifecycle Management Fundamentals 9.0 PeopleBook, “Establishing Asset Processing”

Entering Statistical Information for Repairs

Access the Track Service and Repairs Statistics page.

| | | | | | | | |
|---|---------------------------------|--|---------------------------------|---|--|----------|--|
| Event | | Statistics | | Payment | | Comments | |
| Unit: US001 Asset ID: EX_000000122 Chairs | | | | Tag: P00000000122 In Service | | | |
| Maintenance Date and Time | | | | Find View All First ◀ 1 of 1 ▶ Last | | | |
| Date/Time: | | 06/23/2006 3:12PM | | | | | |
| Maintenance Event | | | | Find View All First ◀ 1 of 1 ▶ Last | | | |
| *Type: | MINOR | Minor Maintenance | | | | | |
| Currency: | USD | Related Meter Readings | | | | | |
| Down Hours: | <input type="text"/> | Estimated: | <input type="text"/> | | | | |
| Labor Hours: | 133.00 | Estimated: | 200.00 | | | | |
| Labor Cost: | <input type="text"/> \$1,000.00 | Estimated: | <input type="text"/> \$1,500.00 | | | | |
| Material Cost: | <input type="text"/> \$2,500.00 | Estimated: | <input type="text"/> \$2,600.00 | | | | |
| Tools Cost: | <input type="text"/> \$720.00 | Estimated: | <input type="text"/> \$1,000.00 | | | | |
| Purchase Cost: | <input type="text"/> \$0.00 | Estimated: | <input type="text"/> \$0.00 | | | | |
| Other Cost: | <input type="text"/> \$0.00 | Estimated: | <input type="text"/> \$0.00 | | | | |
| Total Cost: | \$4,220.00 | Estimated: | \$5,100.00 | | | | |

Statistics page

Typically, you enter estimates of the hours and monetary costs first. Then, as information becomes available or when the service is completed, you can go back and enter actual data in the following fields:

- Down Hours and Estimated** Enter the length of time that the asset is unavailable for service.
- Labor Hours and Estimated** Enter the length of time for repair and maintenance labor.
- Labor Cost and Estimated** Enter the monetary expense for repair or maintenance labor.
- Material Cost and Estimated** Enter the monetary expense for items used in repair or maintenance materials.
- Tools Cost and Estimated** Enter the monetary expense for items used in repair or maintenance tools.
- Purchase Cost and Estimated** Enter the purchase cost for items used in repair or maintenance.
- Other Cost and Estimated** Enter miscellaneous costs, such as subcontracting, replacement equipment, or rental equipment.

PeopleSoft Asset Management keeps a running total of both the actual Total Cost and Estimated total cost. Use this worksheet to compare your estimates with actual figures for determining if:

- The time and cost of maintaining the asset is within the expected margins.
- You must revise your estimates.
- You must find a more economical way to maintain your assets.

To view meter reading details for this asset, click on the Related Meter Readings link.

To view downtime details for this asset, click on the Downtime Detail link. Downtime detail is supported by PeopleSoft Maintenance Management.

Entering Payment Information

Access the Track Service and Repairs Payment page.

The screenshot shows the 'Payment' tab selected in a software interface. At the top, there are navigation tabs: 'Event', 'Statistics', 'Payment', and 'Comments'. Below these, the 'Unit' is 'US001', 'Asset ID' is '000000000001', and 'Tag' is 'SOLARIS WORKSTATION'. A 'Maintenance Event' section is visible, showing a date and time of '10/13/2003 1:11 PM'. Below this, there is a detailed form for a 'Maintenance Event' with the following fields: 'Type' (with expand/collapse buttons), 'Vendor ID' (BLG0000001, Multi Media Corp), 'Contract' (empty), 'PO No.' (empty), 'Voucher ID' (empty), 'Invoice' (101003-2900138), 'Reference' (KGK-2900138), and 'Invoice Date' (10/10/2003). A checkbox for 'Fixed Under Warranty' is checked.

Payment page

Enter information about asset parts or services, including vendor, purchase orders, and voucher IDs. You can also associate the payment with a contract ID. You can add any number of payment records.

Tracking Asset Maintenance Contracts

This section discusses how to:

- Add or modify maintenance contracts.
- Add maintenance contract terms.

Understanding Asset Maintenance Contracts

Use the Maintenance Contract Terms (MAINT_CONTRACT_01) component to track such contracts and to determine repair and servicing costs, the time period covered in the contract, and the exact coverage specified by the contract.

To track maintenance contracts:

- Add or modify maintenance contracts on the Maintenance Contracts - Detail page.
- Enter the terms of each maintenance contract and the coverage that it provides.

Note. You cannot set up maintenance contracts without first setting up a Vendor table. You need not set up all vendor tables, but you must at least set up a list of vendors.

Pages Used to Track Asset Maintenance Contracts

| Page Name | Object Name | Navigation | Usage |
|----------------------------------|-------------------|---|---|
| Maintenance Contracts - Detail | MAINT_CONTRACT_01 | Asset Management, Service and Maintenance, Maintenance Contract Terms | Add or modify maintenance contracts. |
| Maintenance Contracts - Coverage | MAINT_CONTRACT_02 | Asset Management, Service and Maintenance, Maintenance Contract Terms, Coverage | Enter the terms of each maintenance contract and the coverage that it provides. |

Adding or Modifying Maintenance Contracts

Access the Maintenance Contracts - Detail page.

You can add multiple records for any contract. By creating separate records with different dates in the Effective Date field, you can maintain a history of when the contract was first issued and any subsequent renewals. To identify the contract currently in use, make its Status *Active*.

The information in this page helps you to track maintenance contracts. You can enter when the contract was issued, when it expires, what you had to pay for it, and the vendor honoring the contract. You can also identify the person who is responsible for ensuring that the assets covered by this contract are maintained and repaired as required.

Adding Maintenance Contract Terms

Access the Maintenance Contract - Coverage page.

In the Coverage field, enter any information about the coverage provided under each maintenance contract, the cost of such coverage, or any other contract-related information.

Entering Warranty Information

Enter warranty information on the Asset Warranty (ASSET_WARRANTY) page.

This section lists prerequisites and discusses how to:

- Enter asset warranty information.
- Apply warranties from templates.

Prerequisites

Before entering asset warranty information, you can:

- Define standard warranty templates.
- Define asset warranty templates.

When these tables have been defined, the templates and defaults are available for assignment to asset warranties.

See Also

PeopleSoft Enterprise Asset Lifecycle Management Fundamentals 9.0 PeopleBook, “Establishing Asset Processing”

Pages Used to Enter Warranty Information

| Page Name | Object Name | Navigation | Usage |
|-------------------------------------|----------------|---|--|
| Asset Warranty | ASSET_WARRANTY | Asset Management, Service and Maintenance, Asset Warranties | Enter warranty information. |
| Search for Asset Warranty Templates | AM_WTMPL_SRH | Click the Apply Warranties from Template link on the Asset Warranties page. | Search to find a defined Standard Warranty Template to apply to the asset. |

Entering Warranty Information

Access the Asset Warranty page.

Asset Warranties

Unit: US001 **Asset ID:** 000000000005 Fleet vehicle - Gas/Elec Hybri **Asset Status:** In Service
Tag: P00000009005 **Serial ID:** PRIUS1234 **VIN:**

[Apply Warranties from Template](#)

Warranty Find | View All First 1 of 1 Last

Sequence: 1

Detail Find | View All First 1 of 1 Last

***Effective Date:** 07/03/2005 ***Status:** Active

Vendor ID: USA0000050 ABC Auto Supplies

Contact ID:

Warranty Number:

Warranty Name: 50,000 MILES WARRANTY

Warranty End Date:

Coverage:
 100% Parts and Materials

Asset Warranties page

Most of the information on this page helps you manage the repair of assets covered by manufacturer warranties.

- Sequence** The sequence value is determined by the order or *sequence* of warranty terms entered for this warranty. This system is enabled to support multiple warranties per asset.
- Effective Date and Status** Enter the effective date and status of the warranty. Use these fields to establish a history of when each warranty is first issued and any subsequent information that is relevant. You can add multiple warranty records for an asset. If the warranty is currently valid, select *Active* in the its Status field.
- Vendor ID** Select a vendor by ID from the list of those available for this business unit. Identifies the manufacturer. Only valid IDs set up in the Vendor Table are accepted.
- Contact ID** Select a warranty contact by ID from the list of those available for this vendor.
- Warranty Number** Enter the warranty number or ID.
- Warranty Name** Select a warranty name from the list of those available for this SetID.

| | |
|--------------------------|---|
| Warranty End Date | Enter the date the warranty expires. |
| Coverage | Specify the terms and conditions of each warranty in this memo field. |

Applying Warranties from Template

Access the Search for Asset Warranty Templates page.

Use this search page to find a defined standard warranty template and apply the warranty terms to this asset.

Enter search criteria to restrict template selections based on:

- Asset Type
- Asset Subtype
- Vendor ID
- Model
- Item ID

The valid warranty templates matching the search criteria appear, and you may select one to associated with this asset. Standard warranties are defined on the Standard Warranty Template.

See *PeopleSoft Enterprise Asset Lifecycle Management Fundamentals 9.0 PeopleBook*, “Establishing Asset Processing,” Setting Up Asset Warranties.

Entering Asset Insurance Information

This section lists prerequisites and discusses how to:

- Set up asset insurance vendors and types.
- Set up asset insurance.

Use the Asset Insurance (ASSET_INSURANCE) component to set up asset insurance.

The Asset Insurance page captures all of the information necessary to track the insurance coverage for an asset. The *Asset Insurance by Company* query is provided to enable viewing of the insurance by business unit and vendor ID.

Note. (JPN) This feature satisfies the Japanese requirement to link an insurance policy ID to an asset ID.

Prerequisites

The asset insurance pages use data stored in the Vendor table and the Insurance Type table. Before you can set up asset insurance, you must first define these tables and establish an asset ID. The asset ID is primary to the policy ID associated with the Asset Insurance page, which is subordinate to the asset ID.

To use the Asset Insurance page, you must first

- Establish insurance types.
- Set up asset insurance vendors.

| | |
|--|--|
| Asset ID | Displays the asset ID selected from the search criteria and with which this insurance information is associated. |
| Tag | Displays the asset tag number selected from the search criteria. |
| Policy ID | Displays the insurance policy ID if insurance information has previously been established or displays the ID entered when adding a new value. |
| Insurance Co (insurance company) | Displays the name of the insurance company for this coverage. The company must already be defined in the vendor file. |
| Insurance Type | Display or change the insurance type to correspond with this policy coverage. The available insurance types are defined during the setup process. |
| Insurance Information | |
| Effective Date | Indicates when the insurance coverage takes effect. If you want a history of changes, add new rows to the table and use effective dating to update insurance coverage, rather than making changes to the initial row. |
| Status | Refers to the status of the Effective Date row. |
| Descr (description) | Enter a description of the asset. |
| Long Descr (long description) | Enter a description of the asset. |
| Issue Date | Enter the insurance coverage issue date. |
| Expiration Dt (expiration date) | Enter the insurance coverage expiration date. |
| Valuation Type | Designate the insurance valuation calculation type used for this coverage. No processing takes effect as a result of this entry, but this entry identifies the appropriate calculating method in effect. The available insurance valuation types are: <ul style="list-style-type: none"> • <i>Curr Market Value at Mkt Rate</i> (current market value at market rate): Value at market rate. • <i>User Entered</i>: Enter a definition. • <i>Value as New and Insure</i>: Value as new and insure if repurchased. |
| Insurance Indicator | Designate the type of asset and risk associated with the asset: <i>On Loan</i> or <i>High Value</i> . Use this indicator to identify assets with any special insurance characteristics for reporting purposes. |
| Insured Value | Enter the amount of the insured asset value. |
| Policy Currency | Select the policy currency type. The value of this field is defaulted from the base currency of the business unit default book. |
| Current Value | Enter the current value of the asset. |
| Appraised Value | Enter the appraised value of the asset. |
| Min Insured Val (minimum insured value) | Enter the minimum amount of insurance for the asset. |

| | |
|--|--|
| Last Indexation Dt (last indexation date) | Enter the last date on which an indexation for the asset took place. |
| Premium Amount | Enter the amount of the premium in full or periodically. |
| Premium Frequency | Enter the type of premium schedule such as annual, quarter, month and so on. |
| Total Cost | Displays the total cost, which is derived from the COST table and reported in the base currency of the default book. |
| User Defined Amount | Corresponds to User Entered value. |
| Replacement Cost | Displays the replacement cost, which is derived from the replacement cost calculated for the asset and stored on the Basic Asset page. |
| Date of last update | Displays the date of the last update to the replacement cost. |
| Comments | Enter any comments. This is a free-text field. |

Generating the Asset Warranties Report

You can generate an asset warranty report to review asset warranty information. This section lists the page used to generate this report.

Page Used to Generate the Asset Warranty Report

| Page Name | Object Name | Navigation | Usage |
|-------------------------------|--------------|--|---|
| Asset Warranties - Parameters | RUN_AMAS1600 | Asset Management, Service and Maintenance, Reports, Warranties | Specify run control parameters to generate an asset warranty report. The warranties reports lists Asset ID, Description, Warranty, Vendor ID, End Date, Coverage. |

Reviewing Asset Maintenance History

This section lists the pages used to review asset maintenance history.

Page Used to View Asset Maintenance History Summaries

| Page Name | Object Name | Navigation | Usage |
|---|--------------------|--|--|
| Asset Service/Repair History - Maint History by Type (asset service/repair history - maintenance history by type) | ASSET_MAINT_SUM_01 | Asset Management, Service and Maintenance, Review Maintenance History, Maintenance History by Type | View a summary of asset maintenance by maintenance type. From the Work Order tab, you can link directly to the work order and review maintenance, cost and work order details. |

CHAPTER 10

Using Group Asset Processing

This chapter provides an overview of group asset processing and discusses how to:

- Add group member assets.
- Add group asset IDs with background processing.
- Perform transactions on group member assets.
- Consolidate group member assets.
- Calculate depreciation for group assets.
- Run the Group Member Estimated Net Book Value report.
- Change rates retroactively.
- Review asset book history.

Understanding Group Asset Processing

PeopleSoft Asset Management is fully equipped to handle group asset processing for organizations such as utility companies or other entities that support a communal infrastructure—such as federal, state, or municipal public utilities, highways, and roads—or other infrastructure that owns, leases, or uses depreciable assets.

Group assets are treated as a single entity for the purpose of depreciation but as multiple entities for all other purposes. These entities may reside in different locations, or they may be in different stages of their service lives. Nevertheless, you consolidate and depreciate their collective cost as if it were that of a single asset.

Some items commonly tracked as group assets include telephone poles, pipelines, and wire. Some of these group assets can be identified by the Federal Energy Regulatory Commission (FERC) code (delivered with the PeopleSoft system) and depreciated according to FERC guidelines. Group assets are added without cost information. The group member assets are added with associated cost information. Asset transactions, except depreciation and accounting entries, are performed on group member assets. After performing transactions against group members and before running depreciation against the group, the Group Asset Consolidation process is run, consolidating group member cost information at the group asset level. Depreciation is then run against the group asset, and the resulting accounting entries are made.

This section discusses:

- Asset transactions.
- Depreciated group assets.
- Retired group members.
- Strategy for asset grouping.

Asset Transactions

All transactions, except depreciation and accounting entries, are performed on the group asset's member assets. The member assets can be adjusted, transferred, recategorized, retired, reinstated, and so forth—just like any other asset. You can even transfer group member assets from one group asset to another.

The system applies asset transactions at the group member level. The resulting cost is then consolidated, and the total depreciable basis is depreciated at the group asset level.

Depreciated Group Assets

Each group asset is associated with an average service life that is usually set by the local regulatory agency. The system uses the asset's remaining service life to calculate a group depreciation rate. The group depreciation rate is usually calculated annually and remains fixed for the entire year. The system then applies this rate to the asset's depreciable basis (the sum of the depreciable bases of its group members) to calculate depreciation expense.

Depreciation expense is booked to general ledger by applying the depreciation rate either to an average account balance for the period (using an averaging option) or to actual activity for the period.

Average service life studies provide the basis for calculating average remaining life for a group of assets. Average service life studies are performed every three or four years, depending on the length of the local regulatory agency's rate cases.

Because depreciation rates are calculated by using remaining service life at the group asset level, and depreciation also takes place at the group asset level, it is not possible to over-depreciate group members.

Flat rate depreciation methods calculate depreciation until the calendar ends. Alternatively, if you don't want to calculate depreciation until the end of the associated calendar, you can specify the number of future years for which depreciation should be calculated when you add the asset.

Note. PeopleSoft Asset Management supports only the flat rate depreciation method for group asset processing.

Note. For optimal processing performance and greater table efficiency, you should specify the number of future years for which depreciation will be calculated rather than calculating it to the end of the calendar. Use the Future Depreciation Years option to do this.

See Also

[Chapter 5, "Adding and Maintaining Assets," page 45](#)

Retired Group Members

Retirements can be processed only against group members.

Because all group members of a group asset are generally depreciated as a single unit, and because the depreciation rate is based on a group average remaining life, all assets that are retired from within a group should be fully depreciated with no gain or loss.

However, not all assets that are managed by an organization are fully depreciated when they are retired. PeopleSoft Asset Management enables you to retire a group member as either fully depreciated or not fully depreciated. If not fully depreciated, gain or loss is calculated for the group member. Any accumulated depreciation is moved to the group asset.

Strategy for Asset Grouping

Before you set up group asset processing, consider how you want to group the assets. Asset grouping is not standardized; however, there are key components that apply almost universally. Assets can be grouped by FERC account or subaccount at the highest level. Vintage year and location are also commonly included in a grouping strategy.

Depreciation of group assets identified by the FERC code is usually calculated and booked to the general ledger at the FERC account level by using a group asset depreciation rate. Assets are summed by vintage year within the FERC account to provide statistics to support life studies and, subsequently, to derive the group rate for the FERC account and vintage year. Grouping by vintage year is also required to support reporting of deferred taxes. Regulatory agencies require reporting of assets by location or jurisdiction. Consequently, they require grouping by location.

Other factors that you should consider in determining how to group assets include depreciation policies, tax reporting requirements, jurisdictional reporting requirements, and corporate accounting procedures. Assets grouped together should have these attributes in common.

This diagram shows an asset grouping scheme:

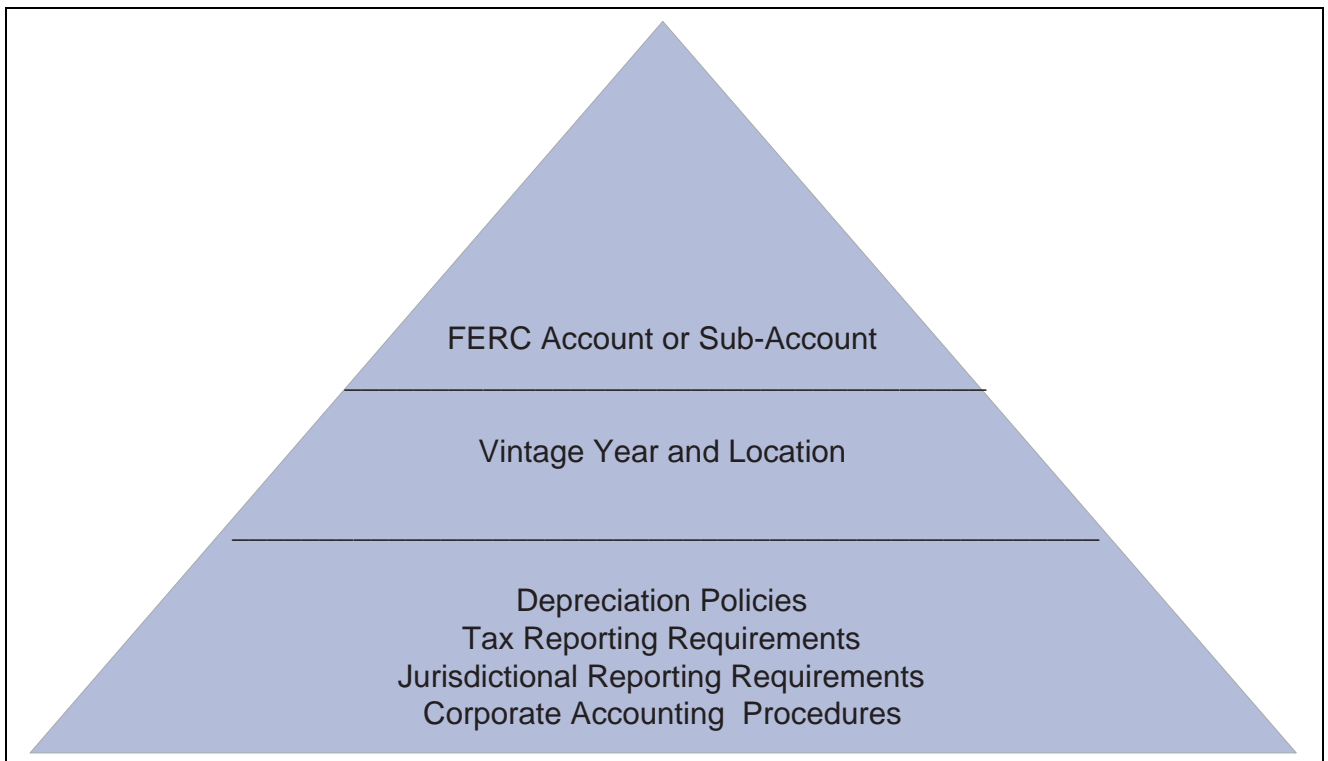

Asset grouping scheme

Note. All group asset processes are available for processing with multiple currency transactions enabled.

Prerequisites

To enable group asset processing, you must first set it up at the system and business unit book levels. To set up group asset processing:

1. Select Set Up Financials/Supply Chain, Install, Installation Options, Asset Management, and then select the Group Asset Processing check box.

2. Add or select a business unit and books for group asset processing.

You can use any book or business unit for group asset processing.

3. Associate the books with the business unit, and enable group asset processing at the business unit book level.

You must also select the ChartFields that the system will use to store depreciation records and subsequently charge with depreciation accounting entries.

Because group asset processing is enabled at the book level, a business unit might track assets in both a group asset processing book and another book that does not have group asset processing enabled. An asset would appear exactly the same in both books, but transactions would be processed differently. PeopleSoft Asset Management enables you to track assets in each of the books. Also, you can add a regular asset to the business unit that has group asset processing. The system prompts you to confirm that you want to add the asset as a regular asset.

Adding Group Member Assets

PeopleSoft Asset Management links each group asset to an asset profile. After the profile is linked to the asset, any group members that are added using that profile are automatically linked to that group asset. Much of the book information appears by default from the profile, as well.

Note. You cannot use group assets or members as parent-child assets.

To add group member assets:

1. Add a profile for the group member assets.

Be sure to associate this profile with the group asset processing books. Remember, each asset profile that you use for adding group member assets *must* be used by a single business unit. If you have multiple business units that perform group asset accounting, each one must have a unique set of asset profiles for adding group member assets. In this case, you may want to add a business unit identifier to the asset profile ID to facilitate recognition.

2. Using the ExpressAdd component, add a group asset ID.

Use the group asset profile to display the default book information for the asset. Do not add any cost information. Be sure to enter transaction and accounting dates that cover all group member assets. In the Group Flag field, select *Group ID*.

3. Link the group asset ID to the group member profile.

Return to the profile that you created. On the Depreciation page, select the Group Asset ID field. A list appears with all group assets for the business unit. Select the group asset (and all related group members) to link to this profile. You can override the default and enter a different group asset when you add the group members.

Next, add group member assets. Do this online or in a background process. It is recommended that you add group member assets using a background process. This reduces the likelihood of errors, frees up human resources, and saves time.

See Also

[Chapter 5, “Adding and Maintaining Assets,” Adding and Maintaining Asset Information, page 47](#)

PeopleSoft Enterprise Asset Lifecycle Management Fundamentals 9.0 PeopleBook, “Establishing Asset Processing,” Setting Up Asset Profiles

Adding Group Member Assets with Background Processing

Add group member assets by using background processing if the assets originated in another system. In that case, all asset data exists in either relational tables or a flat file format. To load the asset data into PeopleSoft Asset Management, you perform the steps discussed here.

To add group member assets with background processing:

1. Add a value for the PROFILE_ID field to each asset record.
2. Set the value of the PROFILE_ID field to equal the asset profile on which you want to base the group member assets.

Information in the profile populates the GROUP_ASSET_ID field and GROUP_ASSET_FLAG field in the Asset Management loader tables.

Note. The GROUP_ASSET_FLAG field must be set to *M*, and the GROUP_ASSET_ID field must be populated with the ID of a group asset. If these aren't set properly, group asset accounting does not work.

The next step depends on whether the data resides in relational tables or in flat files.

Relational Table Data

If the data resides in relational tables, write a Structured Query Report (SQR) to transfer the data to the PeopleSoft Asset Management loader tables. Then run the Transaction Loader process to transfer the load lines into PeopleSoft Asset Management as open transactions.

Note. Follow the same procedure outlined within the Custom SQR Conversion section in the Converting to PeopleSoft Asset Management chapter.

See Also

[Chapter 4, “Converting to PeopleSoft Asset Management,” page 31](#)

Adding Group Member Assets Online

Add group member assets online using the Asset ExpressAdd component.

When you add a group member asset online, remember that you must enter a group member profile ID for the asset. The group member profile automatically associates the group member with a particular group asset, flags it as a group member asset, and links it to a group asset processing book (or books). Remember, you must select a profile ID that is unique to the business unit.

Make sure that the Group Asset Flag field is set to *Grp Member* in the ExpressAdd component.

See Also

[Chapter 5, “Adding and Maintaining Assets,” Adding and Maintaining Asset Information, page 47](#)

Adding Group Asset IDs with Background Processing

Group asset IDs, like group member assets, can be loaded using a background process. In the Transaction Loader, you use the `Default_Profile_SW = "N"` option. Consequently, you must load one record for each book of each asset into `INTFC_FIN`.

Load these required fields into the `PS_INTFC_FIN` table when adding group asset IDs:

- `INTFC_ID`
- `INTFC_LINE_NUM`
- `BUSINESS_UNIT`
- `ASSET_ID`
This is the group asset ID.
- `BOOK`
- `DTTM_STAMP`
- `APPROVAL_SW`
- `LOAD_STATUS`
- `DEFAULT_PROFILE_SW = 'N'`
- `CATEGORY`
- `METHOD`
Set the method to *FL* (flat rate).
- `DEPR_PERCENT`
- `CONVENTION`
- `DEPR_AVG_OPTION`
- `IN_SERVICE_DT`
- `TRANS_DT`
- `CURRENCY_CD`

Load these fields into the `PS_INTFC_PHY_A` record when loading group asset IDs:

- `INTFC_ID`
- `INTFC_LINE_NUMBER`
- `BUSINESS_UNIT`
- `ASSET_ID`
This is the group asset ID.
- `DTTM_STAMP`
- `INTFC_TYPE`
- `SYSTEM_SOURCE`
- `APPROVAL_SW`
- `LOAD_STATUS`

- DEFAULT_PROFILE_SW
- ASSET_STATUS
- FINANCIAL_ASSET_SW
- PROFILE_ID
- GROUP_ASSET_FLAG
- CURRENCY_CD
- CUSTODIAN_EFFDT
- LOCATION_EFFDT

Note. You can include physical attribute data (asset location and asset custodian) for the group asset; however, the custodian and location effective-dated fields are required. The physical attribute data must be loaded into the PS_INTFC_PHY_A table.

Note. If a profile is already created for a group asset ID and you load the group asset ID in a background process, the system detects the profile ID in the PROFILE_DET_TBL table and returns an error.

See Also

[Chapter 5, “Adding and Maintaining Assets,” Pages Used to Add or Change Asset Information, page 48](#)

[Chapter 4, “Converting to PeopleSoft Asset Management,” page 31](#)

Performing Transactions on Group Member Assets

This section discusses how to transfer group members among group assets.

Although you depreciate grouped assets and make accounting entries at the group asset level, you perform all other transactions for grouped assets at the group member level. You can perform these transactions on group member assets:

- Adds
- Adjustments
- Transfers
- Recategorizations
- Retirements
- Reinstatements

You perform these transactions on group member assets the same way in which you perform these transactions on other assets.

Transferring Group Members Among Group Assets

Transfer a group member asset from one group asset to another by using the Asset Book Definition component.

To transfer group member assets:

1. Access the Asset Book Definition page.
2. Change the group asset ID to the new group that you want to associate with the member asset.
3. Enter the transaction date and accounting date.

Note. Enter a group asset ID for a group asset processing book only.

Consolidating Group Member Assets

This section provides an overview of consolidation of group member assets and discusses how to run the Group Asset Consolidation process (AMGRPCON).

Understanding Consolidation of Group Member Assets

PeopleSoft Asset Management provides the Group Asset Consolidation process, which consolidates (or summarizes) group member asset cost information at the group level, based on ChartFields that you specify. Once the process has been run, cost and depreciation information for all group members is stored at the group level. The process summarizes asset addition (ADD) and asset adjustment (ADJ) transactions. Other transactions such as transfers, retirements, and reinstatements are copied to the group asset level without consolidation because the system calculates reserve at the group member level. However, after you run depreciation for these transactions, they are consolidated at the group level the next time that you run the Group Asset Consolidation process.

The Group Asset Consolidation process uses the transaction period in which the ADD or ADJ transaction occurs, except when you use the actual-day depreciation convention. In that case, the process uses the actual transaction date. The period of the in-service date is also a factor when consolidating ADD transactions.

You must run the Group Asset Consolidation process before you depreciate group assets. When you next run the process to summarize new group member additions and adjustments, the process consolidates the new transactions with the previously summarized transactions for greater table efficiency.

Pages Used to Consolidate Group Member Assets

| Page Name | Object Name | Navigation | Usage |
|--------------------------------------|------------------|--|--|
| Group Asset Consolidation | AMGRPCON_RQST | Asset Management, Depreciation, Group Asset Depreciation, Consolidate, Group Asset Consolidation | Run the process that consolidates cost information for group member assets. The process summarizes cost information of group members at the group level, based on the ChartFields that you specify on the Business Unit/Book Definition page. Run this process before calculating depreciation for group assets. |
| Group Member Open Transaction Detail | AMGRPCON_DET_SEC | Click Open Trans for Group Members on the Group Asset Consolidation page. | Review open transactions for group members. |

Running the Group Asset Consolidation Process

Access the Group Asset Consolidation page.

Group Asset Consolidation

Run Control ID: [Report Manager](#) [Process Monitor](#) Run

Request

[Find](#) | [View All](#) | First ◀ 1 of 1 ▶ Last

| | | |
|--|---|---|
| *Request ID: <input style="width: 80%;" type="text" value="1"/> | Process Frequency: <input style="width: 80%;" type="text" value="Always"/> | + - |
| <input checked="" type="checkbox"/> Process in Parallel | Processing Sequence: <input style="width: 80%;" type="text" value="1"/> | |

Run Options

| | |
|--|---|
| Business Unit: <input style="width: 80%;" type="text" value="JPN01"/> | |
| Book Name: <input style="width: 80%;" type="text" value="ECDIV8"/> | Open Trans for Group Members |
| From Group Asset ID: <input style="width: 80%;" type="text"/> | To: <input style="width: 80%;" type="text"/> |

Group Asset Consolidation page

Note. Accumulated depreciation for group member assets is loaded at the member asset level, and the Group Asset Consolidation process consolidates at a group level.

Consolidation Example for Asset Additions

This example shows how group member cost information is consolidated for asset additions. In this example, Project ID and Category represent the ChartFields selected for summarization. The example is based on a monthly depreciation calendar.

This table shows the cost records for nine member assets that belong to one group asset before you run the Group Asset Consolidation process:

| Asset ID | Trans Date | Acct Date | In Svc Date | DprCnv | Oper Unit | Dept ID | Project ID | Category | Cost Type | Cost | Group Asset |
|----------|------------|-----------|-------------|--------|-----------|---------|------------|----------|-----------|-------|-------------|
| ASSET01 | 01/01/00 | 01/01/00 | 01/01/00 | AM | PLANT01 | 32000 | 0000000001 | AUTO | C | 1,000 | GRP1 |
| ASSET02 | 01/05/00 | 01/31/00 | 01/15/00 | AM | PLANT05 | 53000 | 0000000001 | AUTO | NA | 2,000 | GRP1 |
| ASSET03 | 01/31/00 | 01/31/00 | 01/01/00 | AM | NA | 53000 | 0000000001 | AUTO | M | 1,300 | GRP1 |
| ASSET04 | 01/20/00 | 01/20/00 | 01/15/00 | AM | PLANT06 | 10200 | 0000000002 | AUTO | C | 2,300 | GRP1 |
| ASSET05 | 01/25/00 | 01/31/00 | 01/20/00 | AM | NA | NA | 0000000002 | AUTO | NA | 4,300 | GRP1 |
| ASSET06 | 01/31/00 | 01/31/00 | 01/20/00 | FM | PLANT07 | 29321 | 0000000002 | AUTO | NA | 6,290 | GRP1 |
| ASSET07 | 12/31/99 | 01/06/00 | 01/01/00 | AM | PLANT01 | 32000 | 0000000001 | AUTO | C | 3,400 | GRP1 |
| ASSET08 | 01/15/00 | 01/15/00 | 12/15/99 | FM | PLANT01 | 32000 | 0000000001 | AUTO | C | 3,400 | GRP1 |
| ASSET09 | 01/31/00 | 01/31/00 | 12/31/99 | FM | PLANT01 | 53000 | 0000000001 | AUTO | C | 1,230 | GRP1 |

This table shows how the Group Asset Consolidation process consolidates the nine group member cost rows into five group asset cost rows:

| Group ID | Trans Date | Acct Date | In Svc Date | DeprConv | Project ID | Category | Cost |
|----------|------------|-----------|-------------|----------|------------|----------|----------|
| GRP1 | 01/01/00 | 01/31/00 | 01/01/00 | AM | 0000000001 | AUTO | 4,300.00 |
| GRP1 | 01/01/00 | 01/31/00 | 01/01/00 | AM | 0000000002 | AUTO | 6,600.00 |
| GRP1 | 01/01/00 | 01/31/00 | 01/01/00 | FM | 0000000002 | AUTO | 6,290.00 |
| GRP1 | 12/01/99 | 01/31/00 | 01/01/00 | AM | 0000000001 | AUTO | 3,400.00 |
| GRP1 | 01/01/00 | 01/31/00 | 12/01/99 | FM | 0000000001 | AUTO | 4,630.00 |

The cost rows are consolidated in this way:

- Group row 1 summarizes group member rows 1, 2, and 3.
- Group row 2 summarizes group member rows 4 and 5.
- Group row 3 summarizes group member row 6.
- Group row 4 summarizes group member row 7.
- Group row 5 summarizes group member rows 8 and 9.

Each of the group cost rows is then depreciated separately. In addition, the begin depreciation date for each asset is updated in this way:

| Asset ID (Group Members) | Updated Begin Depreciation Date |
|--------------------------|---------------------------------|
| ASSET01 | 01/01/00 |
| ASSET02 | 01/01/00 |
| ASSET03 | 01/01/00 |
| ASSET04 | 01/01/00 |
| ASSET05 | 01/01/00 |
| ASSET06 | 02/01/00 |
| ASSET07 | 01/01/00 |

| Asset ID (Group Members) | Updated Begin Depreciation Date |
|--------------------------|---------------------------------|
| ASSET08 | 01/01/00 |
| ASSET09 | 01/01/00 |

Consolidation Summary Levels

The consolidation summary levels are:

- Business unit.
- Book.
- Group asset ID.
- Depreciation convention.
- Transaction period (except when the actual-day convention is used; in that case, the actual transaction date is used instead of the period).
- Period of accounting date.
- Period of in-service date (ADD transactions only).
- Category ChartField (required).
- General ledger ChartFields and cost type (optional, depending on the settings on the Business Unit/Book Definition page).

Consolidation Example for Asset Adjustments

This example shows how group member cost information is consolidated for asset adjustments. In this example, Project ID and Category represent the ChartFields selected for summarization.

This table shows the cost records for nine member assets that belong to one group asset before you run the Group Asset Consolidation process:

| Asset ID | Trans Date | Acct Date | DeprConv | Oper Unit | Dept ID | Project ID | Category | Cost Type | Cost | Group Asset |
|----------|--------------|--------------|----------|-----------|---------|------------|----------|-----------|------|-------------|
| ASSET01 | 03/01 /00 | 05/01 /00 | AM | PLANT01 | 32000 | 0000000001 | AUTO | C | 200 | GRP1 |
| ASSET02 | 03/12 /00 | 05/12 /00 | AM | PLANT05 | 53000 | 0000000001 | AUTO | NA | 120 | GRP1 |
| ASSET03 | 03/15 /00 | 05/31 /00 | AM | NA | 53000 | 0000000001 | AUTO | M | 250 | GRP1 |
| ASSET04 | 03/31 /00 | 05/12 /00 | AM | PLANT06 | 10200 | 0000000002 | AUTO | C | 90 | GRP1 |

| Asset ID | Trans Date | Acct Date | DeprConv | Oper Unit | Dept ID | Project ID | Category | Cost Type | Cost | Group Asset |
|----------|--------------|--------------|----------|-----------|---------|------------|----------|-----------|------|-------------|
| ASSET05 | 03/20 /00 | 05/30/00 | AM | NA | 11000 | 0000000002 | AUTO | NA | 120 | GRP1 |
| ASSET06 | 04/30 /00 | 05/15 /00 | AM | PLANT07 | 29321 | 0000000002 | AUTO | NA | 75 | GRP1 |
| ASSET07 | 04/30 /00 | 06/01 /00 | AM | PLANT01 | 32000 | 0000000001 | AUTO | C | 200 | GRP1 |
| ASSET08 | 05/15 /00 | 06/14 /00 | AM | PLANT01 | 32000 | 0000000001 | AUTO | C | 430 | GRP1 |
| ASSET09 | 05/31 /00 | 06/30 /00 | AM | PLANT01 | 53000 | 0000000001 | AUTO | C | 892 | GRP1 |

This table shows how the Group Asset Consolidation process consolidates nine group member cost rows into five group asset cost rows:

| Group ID | Trans Date | Acct Date | DeprConv | Project ID | Category | Cost |
|----------|------------|-----------|----------|------------|----------|------|
| GRP1 | 03/01/00 | 05/31/00 | AM | 0000000001 | AUTO | 570 |
| GRP1 | 03/01/00 | 05/31/00 | AM | 0000000002 | AUTO | 210 |
| GRP1 | 04/01/00 | 05/31/00 | AM | 0000000002 | AUTO | 75 |
| GRP1 | 04/01/00 | 06/30/00 | AM | 0000000001 | AUTO | 200 |
| GRP1 | 05/01/00 | 06/30/00 | AM | 0000000001 | AUTO | 1322 |

The cost rows are consolidated in this way:

- Group row 1 summarizes group member rows 1, 2, and 3.
- Group row 2 summarizes group member rows 4 and 5.
- Group row 3 summarizes group member row 6.
- Group row 4 summarizes group member row 7.
- Group row 5 summarizes group member rows 8 and 9.

Calculating Depreciation for Group Assets

This section discusses how to run the Group Asset Depreciation process.

Page Used to Calculate Depreciation for Group Assets

| Page Name | Object Name | Navigation | Usage |
|--|--------------|--|--|
| Group Asset Depreciation Calc (group asset depreciation calculation) | RUN_AMDPCGRP | Asset Management, Depreciation, Group Asset Depreciation, Calculate, Group Asset Depreciation Calc | Run the depreciation calculation process for group assets. View the Asset Batch Process error log for information about problems that occurred during the process. |

Running the Group Asset Depreciation Process

Access the Group Asset Depreciation Calc page.

Select the parameters that this process will use to include assets in the calculation.

View the Asset Batch Process error log for information about problems that occurred during the process but did not terminate the process.

Indexing to Increase Processing Performance

To increase processing performance, PeopleSoft recommends that you create an index, as follows:

```
CREATE INDEX ON PS_OPEN_TRANS (BUSINESS_UNIT, GROUP_ASSET_ID, BOOK, TRANS_TYPE, DTTM =>
STAMP)
```

Running the Group Member Estimated Net Book Value Report

This section provides an overview of the estimated net book value calculation and discusses how to run the Group Member Estimated Net Book Value (NBV) report.

Understanding the Estimated Net Book Value Calculation

The Group Member Estimated Net Book Value (NBV) report enables you to estimate the net book value of an asset member before selling the asset. The report provides the estimated depreciation accumulation of the member by using the following formula:

$$\text{Cost of member (cost)} - \text{Estimated life to date depreciation of member, using historical rate of the group (expense)} = \text{Estimated net book value}$$

Note. The report provides only an estimate of the NBV.

Page Used to Run the Group Member Estimated Net Book Value Report

| Page Name | Object Name | Navigation | Usage |
|-------------------------------------|------------------|---|--|
| Group Member Estimated NBV, Request | RUN_AMDP2150_RPT | Asset Management, Financial Reports, Cost and Depreciation, Group Member Estimated NBV, Request | Estimate the net book value (NBV) of an asset member before selling the asset. |

Running the Group Member Estimated Net Book Value Report

Access the Group Member Estimated NBV, Request page.

Note. The business unit and book name must be associated with a group asset.

Changing Rates Retroactively

Utility companies often must use an interim depreciation rate pending FERC settlement of a rate case. The process of changing rates retroactively enables utility companies to retroactively recalculate group depreciation using a new rate.

This section discusses how to process retroactive rate changes.

Pages Used to Change Rates Retroactively

| Page Name | Object Name | Navigation | Usage |
|--------------------------------|-----------------|--|---|
| Group Asset Rate Change | AMGRPRRC_RQST | Asset Management, Depreciation, Group Asset Depreciation, Create New Group Rate, Group Asset Rate Change | Enter a new rate and initiate the Group Asset Rate Change process. |
| Group Asset Depreciation Calc | RUN_AMDPCGRP | Asset Management, Calculate Depreciation, Group Asset Depreciation, Calculate, Group Asset Depreciation Calc | Run the depreciation calculation process for group assets. This process picks up the retroactive rate change (RRC) open transaction records and recalculates depreciation as of the transaction date. |
| Run Depreciation Close Process | DEPR_CLOSE_RQST | Asset Management, Accounting Entries, Close Depreciation, Run Depreciation Close Process | Run the depreciation close process (AM_DPCLOSE) to pick up the prior period depreciation (PDP) entries and generate accounting entries. |

Processing Retroactive Rate Changes

To process retroactive rate changes:

1. On the Group Asset Rate Change page, enter the new rate, a range of assets to which the rate applies, and the transaction date on which the rate change retroactively became effective.
2. Run the Group Asset Rate Change process (AMGRPRRC).
The process updates the asset book and creates a book history entry with the new rate for the range of group assets that you specify. It also creates RRC open transaction records.
3. When you next run the Group Asset Depreciation process (AMDPCGRP), it picks up the RRC open transaction records and recalculates depreciation as of the transaction date.
The Group Asset Depreciation process also generates PDP entries in the depreciation table for the difference in the depreciation amounts.
4. When you next run the Depreciation Close process (AM_DPCLOSE), it picks up the PDP entries and generates accounting entries.

Reviewing Asset Book History

The Asset Book History component enables you to review a list of all book changes for an asset. You can use the Book History List page or view the details of a listed item on the Book History Detail page.

This section lists the pages used to review asset book history.

Pages Used to Review Asset Book History

| Page Name | Object Name | Navigation | Usage |
|-----------------------------|------------------|---|---|
| Asset Book History - List | ASSET_BOOK_HIST1 | Asset Management, Asset Transactions, History, Review Book, List | Review a list of book changes for an asset. |
| Asset Book History - Detail | ASSET_BOOK_HIST2 | Asset Management, Asset Transactions, History, Review Book, Detail Click a Detail link from Detail the Asset Book History - List page. | Review the details of a book change for an asset. |

CHAPTER 11

Using Composite Asset Processing

This chapter provides an overview of composite asset processing and discusses how to:

- Add a composite asset.
- Add a composite member asset.
- Capitalize composite members into composite assets.
- Retire composite members from composite assets.
- Load composite asset transactions.
- Perform transactions on composite assets.

Understanding Composite Asset Processing

Composite Asset Processing, frequently used by utility companies, is a way of grouping many assets so that their total cost is carried by, and depreciated as, one asset. This single asset is termed a *composite* asset, and associated assets are known as composite members.

In composite processing, no transaction detail is carried by individual composite members. All transaction detail, including any gain or loss accrued upon retirement, is rolled up to the composite asset level. Once this rollup occurs, no transaction detail is retained by composite members. Because depreciation occurs at the composite asset level, only the composite asset carries any information—such as book, depreciation method, prorate convention, or life—that relates to depreciation.

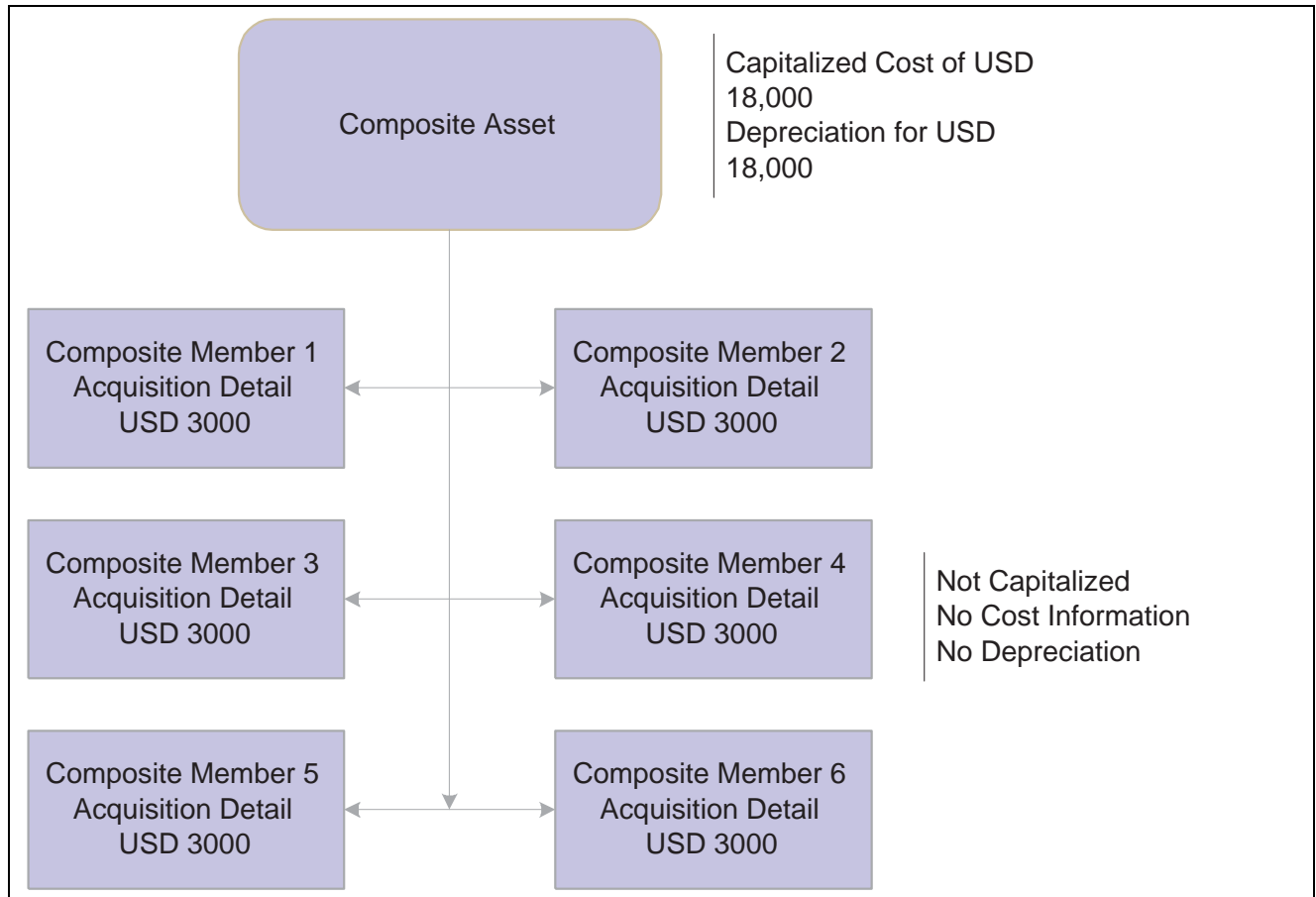

Composite asset processing

Because the composite asset carries all the cost for its associated composite members, it is a financial, or capitalized, asset. The composite asset can also carry its own cost information or not, as required, although no individual detail is retained once the total cost has been rolled up. Composite member assets, on the other hand, are non-financial assets, or not capitalized, and carry no cost information. Instead, they carry acquisition detail, which is summed up and capitalized at the composite asset level.

All transactions are performed at the composite asset level except for adjustments to acquisition detail. Adjustments are made at the composite member level and then rolled up to the composite level.

Note. The fair market value (FMV) of the asset does not roll up from the composite member to the composite level.

Summing up and adjusting cost information for composite assets is accomplished through a mass change that:

- Sums the acquisition detail for each ChartField combination contained in the affected Composite Member assets.
- Inserts one cost row into the Composite Asset for the total of each ChartField combination.

Adding a Composite Asset

Using Asset Basic Information, you must perform three steps to add a composite asset:

1. Select the Composite Asset check box on the General Information page.
After you save the asset, make note of its Asset ID.
2. Enter an asset Profile ID on the General Information page.
3. Capitalize the asset on the Asset Acquisition Detail page by selecting the Capitalize button.
You can enter cost information or not, as required.

See [Chapter 5, “Adding and Maintaining Assets,” Adding and Maintaining Asset Information, page 47.](#)

Adding Composite Member Assets

Using Asset Basic Information, you must perform these steps to enter composite member assets:

1. Associate the member with a composite asset.
Select the Composite Asset check box on the General Information page, and associate the composite member by selecting the Asset ID of a composite asset in the adjacent field.
2. On the Asset Acquisition Detail page, assign a Capitalize status of *To be Capitalized*.
The composite member is uncapitalized with no cost rows. You can use a Profile ID for composite member assets if you want. However, you must use a nonfinancial asset profile. A composite member asset may display an Amount left to Capitalize if it has any acquisition detail. This amount is displayed until the composite member is capitalized into its associated composite asset.
3. Add appropriate acquisition details to the composite member on the Asset Acquisition Detail page.

Note. A nonfinancial Asset Profile does not contain any book information. On the pages of the Asset Basic Information component, Capitalized Asset should not be selected.

4. Select an asset type (if no profile has been established).

See [Chapter 5, “Adding and Maintaining Assets,” page 45.](#)

See *PeopleSoft Enterprise Asset Lifecycle Management Fundamentals 9.0 PeopleBook*, “Establishing Asset Processing,” Setting Up Asset Profiles.

Capitalizing Composite Members into Composite Assets

To capitalize composite members into their associated composite asset, you need to create and run a mass change definition using the Mass Change Template *CC - Capitalize into Composite*.

In Execution Sequence 1, enter the composite asset ID into which you want to capitalize your composite members, the Business Unit to which the composite asset belongs, and the Composite Member Asset IDs you want to capitalize. You need not capitalize all composite member assets at one time.

In Execution Sequence 2, enter the Composite Member Asset ID and the Profile TableSet ID associated with that Business Unit. This information is required to improve system performance. There are no defaults to enter for this Mass Change Type.

Be sure to enter the Transaction Date and Accounting Date that are required by PeopleSoft Asset Management. You can also select the transaction currency as necessary.

See Also

[Chapter 20, “Processing Asset Mass Changes,” page 357](#)

Retiring Composite Members from Composite Assets

To retire composite members from their associated composite asset, you need to create and run a mass change definition using the Mass Change Template *CR - Composite Retirement*.

In Execution Sequence 1, enter the Composite Asset ID from which you want to retire your composite members, the business unit to which the composite asset belongs, and the Composite Member Asset IDs you want to retire. You need not retire all composite member assets at one time.

In Execution Sequence 2, enter the business unit associated with your composite asset and the Profile TableSet ID associated with that Business Unit. This information is required to improve system performance.

Enter the defaults for the retirement, including a Disposal Code, Retirement Type, and Retirement Convention, and indicate whether this is a *Voluntary* or *Involuntary Retirement*.

Be sure to enter the Transaction Date and Accounting Date that are required by PeopleSoft Asset Management.

See Also

[Chapter 20, “Processing Asset Mass Changes,” page 357](#)

Loading Composite Asset Transactions

After you have run a Composite Asset mass change, use the Transaction Loader to load results of the mass change into the PeopleSoft Asset Management tables.

The Load Type for *capitalize into composite* transactions is *CIC*. The Load Type for retire from composite transactions is either *PRT* or *RET*, depending on whether you are doing a partial or a full retirement.

See *PeopleSoft Enterprise Asset Lifecycle Management Fundamentals 9.0 PeopleBook*, “Integrating PeopleSoft Asset Management with Other Products,” Running the Transaction Loader.

Understanding the Effect of Capitalization into Composite

After your composite member assets are capitalized, they are designated *Already Capitalized* on the Asset Acquisition Detail page. The Capitalization Information group box is inactive. The Asset Acquisition Detail page no longer displays an amount or quantity that is left to capitalize.

The Composite Asset into which you capitalized will now contain one cost row for each ChartField combination represented in the acquisition detail of the composite members you just rolled up. To view this, select Asset Management, Asset Transactions, Financial Transactions, Cost Adjust/Transfer Asset, Cost Information.

Note. The Cost Information page appears after clicking the Search button.

Understanding the Effect of Retirement from Composite

After you retire a Composite Member from a Composite Asset, the cost row for the ChartField combination you retired will be decreased by the amount you retired. To view this, select Asset Management, Asset Transactions, Asset Disposal, Retire/Reinstate Asset, Retire Assets. You can also view this information on the Cost Information page.

Because Composite Member Assets carry no cost information, you will not see any change in them after retirement.

Performing Transactions on Composite Assets

All transactions on composite assets are performed at the composite asset level except adjustments to cost. Adjustments to cost/quantity are made at the composite member level as adjustments to acquisition detail, and then rolled up to the composite level and capitalized, where they are recognized as adjustments to total cost/quantity.

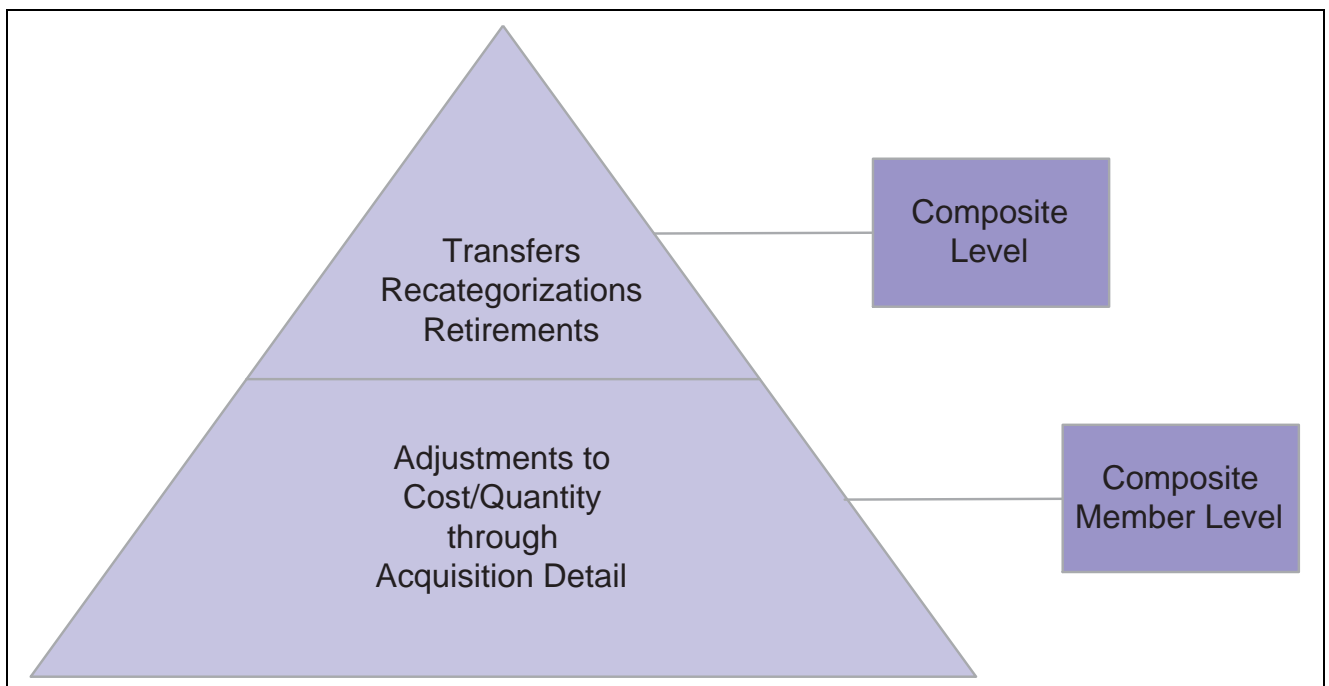

Performing transactions on composite assets

Adjustments to Cost/Quantity

Using Asset Basic Information, you must perform three steps to adjust the cost/quantity of a composite asset:

1. Add a row of acquisition detail to one of the associated Composite Members.

This row should equal the amount of the desired cost/quantity adjustment and contain the appropriate ChartField combination. The additional row is reflected in the Amount Left to Capitalize on the Asset Acquisition Detail page. If you want to add cost/quantity for more than one ChartField combination, enter additional rows.

2. Use Mass Change to capitalize the adjusted Composite Member into the Composite Asset.

3. Run the Transaction Loader.

Recategorizations and Transfers

Recategorizations and transfers on composite assets are performed at the composite level. Perform these transactions on composite assets as you would for any other asset by using the Asset Cost Adjust/Transfers component.

To transfer a composite asset:

1. Select Asset Management, Asset Transactions, Financial Transactions, Cost Adjust/Transfer Asset to access the Main Transaction page.
2. Select the Transaction Date, Accounting Date, Transaction Code, and Rate Type. Select *Transfer* in the Action drop-down list box. The Transaction Type for transfers is *TRF*.
3. Enter new ChartField information into the appropriate fields on the Cost Information page.

We recommend that you change information one field at a time to establish an audit trail. For example, if you need to change the department and project, first enter the new department and save the change. Then go back and change the project.

The Composite Asset may have several cost rows, each for a separate ChartField combination. These rows are the totals, by ChartField combination, of all the acquisition detail for the associated Composite Member Assets that have been capitalized into the Composite Asset.

4. Save your changes.

See [Chapter 8, “Adjusting, Transferring, and Evaluating Assets,” page 147](#).

CHAPTER 12

Performing Asset Physical Inventory

This chapter provides an overview of asset physical inventories and discusses how to:

- Set up a physical inventory.
- Define the extract scope, the scan scope, and the physical inventory controls.
- Process a physical inventory.
- View physical inventory history.

Understanding Physical Inventories

This section lists prerequisites and discusses:

- Physical inventory processing steps.
- Physical inventory terminology.
- Hardware and software for physical inventory processing.

Prerequisites

Before you can perform a physical inventory in PeopleSoft Asset Management, all assets must have tag numbers. They must also belong to a particular department or location, or you must have some other way to track their whereabouts.

Note. Assets with no cost records (such as expensed assets) are not included in a physical inventory.

Physical Inventory Processing Steps

These are the steps of physical inventory processing:

1. (Optional) Extract physical inventory asset data from PeopleSoft Asset Management.
PeopleSoft Asset Management provides a physical inventory system that enables you to extract asset data from the PeopleSoft Asset Management database into a sequential file and then load it into a bar code scanning device. You can also extract data from third-party information technology (IT) asset discovery tools. Such discovery tools belong to a class of software that you can use instead of bar coding for laptops, computers, and other IT equipment. These discovery tools poll the assets over a network and update a central database.
2. (Optional) Use the extracted physical inventory data to generate a sequential file that a bar code scanner or inventory device can use, and enter the file into the scanner.

Steps 1 and 2 are necessary only if you want to display data from your PeopleSoft Asset Management database as you scan each asset. The displayed information can include asset IDs, tag numbers, serial numbers, manufacturers, models, descriptions, departments, locations, and so forth. This asset data can provide instant information about an asset’s history.

3. After you scan assets, load the scanned data into PeopleSoft Asset Management and resolve any duplicate tag numbers and serial numbers.
4. After you match the physical inventory scan scope to the scanned data, generate physical inventory results for review.
5. Generate transactions based on the results.

You then load the transactions to reconcile the data in PeopleSoft Asset Management with the physical inventory results.

6. Delete the physical inventory transactions when you no longer need them.
7. Delete the physical inventory results when you no longer need them.
8. Delete the physical inventory scanned asset data when you no longer need it.
9. (Optional) If you created an extract file, delete that file when you no longer need it.

As an example of how physical inventory is processed, suppose that you are inventorying computer equipment. An IT discovery tool obtains the physical attributes of a workstation, along with the amount of installed memory, the type of monitor, the amount of free hard disk space, and the installed software on the computer. You then load physical inventory data and the physical information gathered by the discovery tool software into PeopleSoft Asset Management. The physical inventory processing determines the assets that have been added, transferred, or retired. Using these results, you perform matching and generate transactions to reconcile the data in PeopleSoft Asset Management with the results of the physical inventory.

This diagram shows the process flow of a physical inventory:

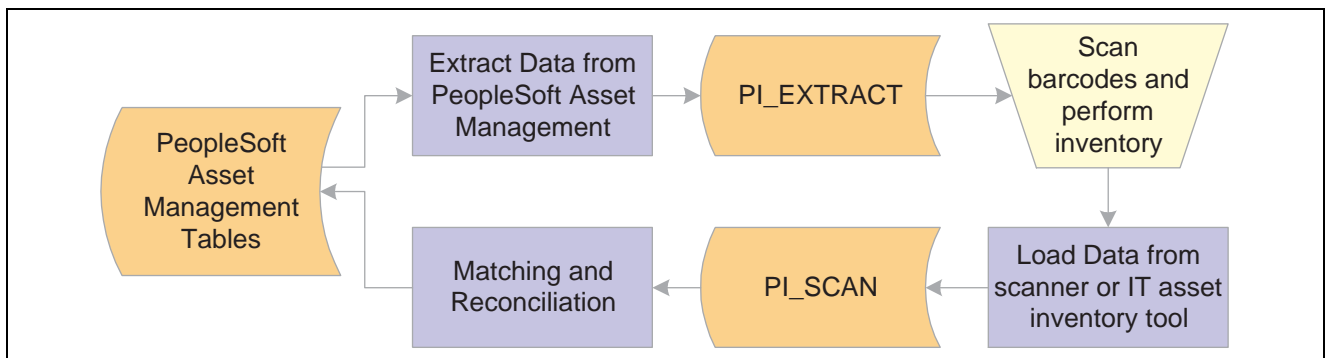

Physical inventory process

Physical Inventory Terminology

Some of the terms that relate to physical inventories may not be familiar to you. The following terms are integral to physical inventory processing and reconciliation.

Physical Inventory ID

A physical inventory control ID you assign within PeopleSoft Asset Management for each physical inventory that you perform.

Extract scope

Set of all assets that you might scan during a physical inventory. This set of assets is broader than the scan scope. It should include all possible locations or departments for the assets to be inventoried.

| | |
|--------------------------------------|--|
| Extract data | Data extracted from PeopleSoft Asset Management before you perform the physical inventory scan. This data should include all assets that you might scan during the physical inventory scan. |
| Extract file | PeopleSoft Asset Management creates a sequential file of the physical inventory data collected for each asset. The files are created as random access files when the user enters a tag or serial number. One is sorted by tag number and one that is sorted by serial number. |
| Physical inventory scan | Process of scanning assets with a bar code scanning device, such as a handheld Palm device that uses solutions from HighJump Software, Inc. |
| Physical inventory scan scope | Set of all assets that are defined in PeopleSoft Asset Management as belonging to a particular location or department to be scanned. |
| Physical inventory scan data | Data collected by the bar code scanning device during the physical inventory. |
| Mass Change Definition | PeopleSoft Asset Management Mass Change functionality is used to define the extract scope and the scan scope. The mass change definition is a user-defined extract scope and scan scope. The extract scope includes all assets that <i>might</i> be scanned during the inventory. The scan scope include the area of the <i>actual</i> scan. |

Hardware and Software for Physical Inventory Processing

To use the full range of the physical inventory functionality, you need additional hardware and software beyond the standard PeopleSoft system setup. These requirements are listed here.

Hardware

Here are the additional hardware requirements for physical inventory processing:

| | |
|---------------------------------------|---|
| Portable bar code reader | A handheld unit that you can use to collect asset data. |
| Bar code scanning wand | A device that you use to physically scan bar codes. The wand is usually purchased along with the bar code reader. |
| Thermal transfer label printer | A printer for printing labels. If you have a relatively large number of assets (more than 10,000), you should purchase a label printer. |

Note. You can integrate the Physical Inventory feature of PeopleSoft Asset Management with virtually any bar coding hardware. The Physical Inventory feature has been fully integrated, certified, and tested using a solution from HighJump Software, formerly called Data Collections Systems, Inc. (<http://www.highjumpsoftware.com>). Contact HighJump Software for information about integrated solutions that work with the Physical Inventory feature of PeopleSoft Asset Management.

Software

If you plan to print your own labels, you can use a Windows-based label-printing software package.

To view PeopleSoft Asset Management data on a scanning device while you scan assets, you need to develop your own application for the scanner or use the program that PeopleSoft Asset Management provides. This application reads data from the extract file, displays the data to the operator, and records any data that the operator enters. PeopleSoft has developed a sample application to run on a DOS-based bar code scanner. The program is written in Microsoft QuickBasic, and you can configure it easily. This application (which comprises the files PI.BAS and PI.EXE) is packaged with PeopleSoft Asset Management and resides in the \PI directory.

You need to transfer files between the computer and the bar code scanner. To do this, you can use any communications application transfers information from a computer to a scanning device.

In addition to (or in lieu of) bar coding, you can use an auto-discovery tool from any that are available on the market.

Asset Management comes with a number of programs (in the \PI directory) for physical inventory processing on DOS-based scanners. This table lists these programs:

| Program | Description |
|------------|--|
| PI.BAS | This is the BASIC source code for the scanner application that you use to perform the physical inventory. |
| PI.EXE | This is the compiled version of PI.BAS that runs on the scanner. You need a BASIC compiler to generate an executable file if you change this code. |
| PISORT.BAS | This is a BASIC source code program that sorts the sequential extract file that Asset Management creates. This application creates two random access files—one that is sorted by tag number (EXT.TAG) and one that is sorted by serial number (EXT.SER). These files are read by PI.EXE when the user enters a tag or serial number. |
| PISORT.EXE | This is the compiled version of PISORT.BAS. It is called from the batch file EXTCOPY.BAT. |

| Program | Description |
|--------------|--|
| EXTCOPY.BAT | <p>This batch file is used to download extract files to the scanner. Edit this file so that it:</p> <ul style="list-style-type: none"> • Calls the communications software to connect to the scanner. • Calls PISORT to sort the extract file. • Deletes EXT.TAG and EXT.SER from the scanner. • Downloads new versions of EXT.TAG and EXT.SER. <p>You may need to edit EXTCOPY.BAT if you want to copy files to the appropriate drive on the scanner. This requirement may vary among different scanning devices.</p> |
| SCANCOPY.BAT | <p>This batch file is used to upload the SCAN.DAT file from the scanner to \TEMP\SCAN.DAT. You can modify the program to copy the SCAN.DAT file from the appropriate drive on the scanner.</p> |

See Also

[Chapter 20, “Processing Asset Mass Changes,” page 357](#)

Setting Up a Physical Inventory

To set up a physical inventory in PeopleSoft Asset Management, use the Physical Inventory System Setup component (PI_SYSTEM_SETUP). This section provides an overview of setting up a physical inventory and discusses how to set up a physical inventory.

Page Used to Set Up a Physical Inventory

| Page Name | Object Name | Navigation | Usage |
|--------------------------|-----------------|--|---|
| Physical Inventory Setup | PI_SYSTEM_SETUP | Asset Management, Physical Inventory, Physical Inventory/Mass Change | <p>Review relationships between physical inventory fields and mass change definitions.</p> <p>Note. Unless you have altered the physical inventory system (for example, by adding fields), do not change information on this page.</p> |

Setting Up a Physical Inventory

Access the Physical Inventory Setup page.

| Physical Inventory Setup | | | |
|--|----------------------|----------------------|--------------------------|
| PI Scan Fieldname | PI Basis Record | PI Target Record | *Transaction Type |
| <input type="text"/> | <input type="text"/> | <input type="text"/> | Asset Non-Financial Add |
| *Mass Change Definition: <input type="text" value="PI5 - Physical Asset Adds"/> | | | |
| <input type="text"/> | <input type="text"/> | <input type="text"/> | Inventory History Insert |
| *Mass Change Definition: <input type="text" value="PI7 - Inventory History Insert"/> | | | |
| <input type="text"/> | <input type="text"/> | <input type="text"/> | Asset Retirement |
| *Mass Change Definition: <input type="text" value="PI4 - Retire Assets Not Found"/> | | | |

NOTE: Leave Scan Fieldname, Basis Record & Target Record blank for ADD and RET trans types; required otherwise!

Physical Inventory Setup page

When you perform step 5 of the physical inventory process (generating physical inventory results), the Structured Query Report (SQR) AMPI1000 uses data from this page to compare asset field values and determine the types of transactions that need to be generated. A physical inventory mass change process (AMIF1000) also uses this page to reload transactions into PeopleSoft Asset Management after the physical inventory is reconciled.

Note. The information on this page is prepopulated to work with the delivered physical inventory programs. Modify this page only if you have made alterations to the physical inventory system—for example, by creating new fields.

Defining the Extract Scope, the Scan Scope, and the Physical Inventory Controls

To define the extract and scanning scope, and set up the inventory controls for a physical inventory, use the Physical Inventory component. This section provides an overview of defining the extract scope, the scan scope, and the physical inventory controls and discusses how to:

- Define the extract scope and the scan scope.
- Define physical inventory control parameters.
- Define physical inventory control transaction defaults.
- Set up physical inventory schedule information.

Understanding Extract Scopes and Scan Scopes

Physical inventory matching and reconciliations are based on two separate sets of asset data that you define—the extract scope and the scan scope. Each of these sets is based on location, department, or both. The first set is the data that you originally extract from PeopleSoft Asset Management and load into a scanning device. The extract scope includes all possible locations and departments for the assets to be inventoried. This enables the bar code scanner to find PeopleSoft Asset Management data for most of the assets that it scans.

If you have not performed physical inventory in several years, define a broad extract scope. Because many assets may have been redistributed in the interim, the extract scope might even include the entire business unit.

Note. If you are using an IT asset discovery tool only, you do not need to define an extract scope.

The scan scope defines the scope of the actual physical inventory—that is, where the inventory actually occurs. For example, suppose that you plan to take inventory on the second floor of a five-floor building. Because the assets may have been redistributed since the last inventory, the extract scope might include assets on all five floors. However, the scan scope would include only assets on the second floor.

The system compares the scan scope with the actual scanned data when PeopleSoft Asset Management generates physical inventory results. Any assets that appear in the scan scope but not in the scanned data are called *unders*, and they create *retirements* when you generate transactions. Any assets that appear in the scanned data but not in the scan scope are *overs*, and they create *physical adds* when you generate transactions. Other differences between the scan scope and the scanned data create transfers and changes in the assets' non-financial information. These assets are assigned the status *inventoried*.

Pages Used to Define Extract Scopes, Scan Scopes, and Physical Inventory Controls

| Page Name | Object Name | Navigation | Usage |
|--|----------------|---|--|
| Physical Inventory Control - Definition | PI_CNTL_01 | Asset Management, Physical Inventory, Define Inventory Occurrence | Before you extract asset data, you must establish a physical inventory control ID within Asset Management for each physical inventory that you perform. Define the physical inventory ID here. |
| Physical Inventory Control - Transaction Defaults | PI_CNTL_02 | Asset Management, Physical Inventory, Define Inventory Occurrence, Transaction Defaults | Specify the defaults for any transactions and asset retirements that are generated from the physical inventory. |
| Scheduling | PI_SCHEDULE_01 | Asset Management, Physical Inventory, Create Schedules | Set up physical inventory schedule information. If several people perform physical inventories simultaneously at different locations, you may need to track the status of each inventory. |
| Asset Mass Change Definition - Description | MC_DEFN_00 | Asset Management, Mass Change, Define Criteria | Add or update a mass change definition. |
| Asset Mass Change Definition - Criteria and Defaults | MC_DEFN_01 | Asset Management, Mass Change, Define Criteria, Criteria and Defaults | Specify the mass change criteria for selecting rows, and identify the columns and values to be changed. |
| Asset Mass Change Definition - AM Specific Fields | MC_DEFN_AM | Asset Management, Mass Change, Define Criteria, AM Specific Fields | Complete mass change information that is unique to and required by Asset Management mass changes. |
| Asset Mass Change Definition - Generate SQL | MC_DEFN_02 | Asset Management, Mass Change, Define Criteria, Generate SQL | Generate and check the SQL text generated by a mass change definition before you run it. |
| Asset Mass Change Definition - Execution History | MC_DEFN_03 | Asset Management, Mass Change, Define Criteria, Execution History | Determine the last time a mass change definition was run and what the specific input parameters were. |

Defining the Extract Scope and the Scan Scope

Access the Asset Mass Change Definition - Description page.

Use this page to define the extract scope and the scan scope in PeopleSoft Asset Management. The extract scope should include all assets that *might* be scanned during the inventory. The scan scope should include the area of the actual scan.

Note. You must define a scan scope. An extract scope is necessary only if you want the scanning device to display asset data from the PeopleSoft Asset Management database as you scan each asset.

Because the Physical Inventory functionality of PeopleSoft Asset Management is based on mass changes, you use the Asset Mass Change functionality to define the extract scope and the scan scope, as described here:

- Access the Asset Mass Change Definition - Description page, by selecting *PI Extract* (physical inventory extract) or *PI Scan Scope* (physical inventory scan scope) as the Mass Change Template ID to specify the template on which to base this extract scope or scan scope.

The archive ID and archive date are optional on this page. The description that appears is derived from the mass change template that you select; you can modify the description.

- On the Asset Mass Change Definition - Criteria and Defaults page, select criteria for the inventory scope.

In the Criteria group box, enter the department or location (or both) from which to extract asset data or define a scan scope. Add rows to select additional departments and locations. You can define these values explicitly or by using SQL operators. If you leave either the Department or Location Field blank, you retrieve all possible values for that field.

- You do not need to use the Asset Mass Change Definition - AM Specific Fields page.

The additional parameters this page enables you to specify can be specified on the Physical Inventory pages.

- On the Asset Mass Change Definition - Generate SQL page, create a SQL statement that is based on the criteria that you set up on the Asset Mass Change Definition - Criteria and Defaults page.

After you complete the page, save the mass change definition, making sure that the Execute SQL Upon Saving check box is cleared. Because the Physical Inventory SQR program uses the physical inventory mass change definitions, they cannot be executed online.

See Also

[Chapter 20, "Processing Asset Mass Changes," page 357](#)

Defining Physical Inventory Control Parameters

Access the Physical Inventory Control - Definition page.

Definition
Transaction Defaults

Physical Inventory ID: PI2000 ***PI Name:**

Physical Inventory Parameters

| | | |
|--------------------|--|---|
| Unit: | <input style="width: 80%;" type="text" value="US001"/> | 🔍 |
| Start Date: | <input style="width: 80%;" type="text" value="08/08/2000"/> | |
| End Date: | <input style="width: 80%;" type="text" value="10/31/2000"/> | |
| Last Step: | 6 Transactions Loaded | |
| Extract ID: | <input style="width: 80%;" type="text" value="PI2000-US001-EXTR"/> | 🔍 |
| Scan ID: | <input style="width: 80%;" type="text" value="PI2000-SCANSCOPE"/> | 🔍 |

Comments

Physical Inventory Control - Definition page

Note. Each physical inventory occurrence must have a unique ID. Physical inventory IDs cannot contain spaces. Use an underscore instead of a space in a physical inventory ID.

| | |
|--------------------------------|---|
| Unit | Enter the business unit for which you want to conduct an inventory. If you are using an IT asset discovery tool, you can process all business units by leaving the Unit field blank, or you can process a single business unit by making a business unit selection. |
| Start Date and End Date | Enter dates for information purposes only; these are not used for processing the data. |
| Extract ID | Enter the mass change definition that the system uses to extract asset data from Asset Management. |
| Scan ID | Enter the mass change definition that the system uses to define the scope of this physical inventory—that is, the set of assets to be scanned. |

Note. This page indicates the last step that you performed in the current physical inventory. Refer to this page to ensure that you perform all steps in the proper sequence.

Defining the Physical Inventory Control Transaction Defaults

Access the Physical Inventory Control - Transaction Defaults page.

| Definition | | Transaction Defaults | |
|--|------------|---|--|
| Physical Inventory ID: PI2000 | | 2000 Inventory | |
| Auto Approval <input checked="" type="checkbox"/> Approve | | Transactions Enabled <input checked="" type="checkbox"/> Non-Financial Adds <input checked="" type="checkbox"/> Transfers <input checked="" type="checkbox"/> Asset Updates <input type="checkbox"/> Retirements <input checked="" type="checkbox"/> Physical Asset Changes | |
| Transaction Defaults | | | |
| * Transaction Date: | 11/01/2000 | * User ID: | DVP1 |
| * Accounting Date: | 11/01/2000 | * Interface ID: | 10000003 |
| Transaction Code: | | * Open Transaction ID: | 26 |
| Retirement Defaults | | | |
| * Disposal Code: | Sale | Voluntary Conversion | Type |
| * Retirement Convention: | FM | <input checked="" type="radio"/> Voluntary | <input checked="" type="radio"/> Ordinary |
| | | <input type="radio"/> Involuntary | <input type="radio"/> Extraordinary |

Physical Inventory Control - Transaction Defaults page

Auto Approval

Approve

Select this check box to have the system automatically approve the transactions that are generated from the inventory. PeopleSoft strongly recommends that you review and approve all transactions that are generated during the physical inventory process before you load them into PeopleSoft Asset Management.

Transactions Enabled

Use the check boxes in this group box to select the types of transactions that you want to generate. For instance, you may not want the results of the physical inventory to generate any financial transactions. In such cases, you would clear the Transfers and Retirements check boxes.

Transaction Defaults

Transaction Date, Accounting Date, and Transaction Code

The current date will display by default in the Transaction Date and Accounting Date fields. You may override these and enter a transaction code as needed.

User ID

Enter the user ID of the person who performs the physical inventory.

Interface ID and Open Transaction ID

By default, the system populates the Interface ID and Open Transaction ID fields with the next available values. When you process the generated transactions using the Transaction Loader, (AMIF1000) refer to the interface ID on this page. You can use the open transaction ID to locate depreciation open transactions that are created as a result of the physical inventory.

Retirement Defaults

Disposal Code

Select the method for retiring assets.

- Retirement Convention** Select to indicate how you want to prorate retired assets.
- Voluntary Conversion** Select to identify whether the retirement takes place for intended or unintended reasons. Options are Voluntary and Involuntary for the retirement default.
- Type** Select Ordinary or Extraordinary to define the types of retirements that you generate.

Setting Up Physical Inventory Schedule Information

Access the Scheduling page.

Scheduling page

- Schedule ID** Set up one Schedule ID or as many unique IDs as you like. For instance, if you have several branches, you might want a separate schedule for each branch. Enter an informative description for each Schedule ID.
- Start Date and End Date** You can leave the end date field blank until the inventory has actually been completed.
- PI ID**(physical inventory ID) and **PI Leader**(physical inventory leader) You can enter a code to identify the physical inventory by date, location, or some other identifier. You may also assign a physical inventory leader.

Note. Scheduling information is not used in any physical inventory processing. It is informational only.

Processing a Physical Inventory

This section discusses how to:

- (Optional) Extract asset data (step 1).
- (Optional) View the results of the extract.
- (Optional) Create an extract file (step 2).
- Load asset inventory data (step 3).
- Find duplicate tags.
- Find duplicate serial numbers.
- Generate physical inventory results (step 4).
- Review physical inventory results.
- Generate physical inventory transactions (step 5).

- Delete physical inventory transactions (step 6).
- Delete physical inventory results (step 7).
- Delete physical inventory scanned data (step 8).
- (Optional) Delete an extract file (step 9).

After you define the extract scope, the scan scope, the physical inventory control ID, and the physical inventory schedule, you can extract data from PeopleSoft Asset Management tables. When the extract is complete, you can use the extract data in subsequent steps of the physical inventory process.

In order to process physical inventory, you must execute each step in its proper order. For each step, enter the physical inventory ID and select the type of export or import output that you want—for example, comma-separated values (CSV) file, labels, or scanner file. If you are generating an output file, you also need to provide a file name.

Note. Because steps 2 and 3 require writing and reading files, you should run the AMPI1000 SQR process for these steps from the file location. For example, if you are writing and reading files from `c:\temp\file.txt` or `c:\temp\scan.dat`, you would run the process on the client. If you are writing and reading files from a directory on the PeopleSoft Internet Architecture server, run the process on that server.

Pages Used to Process Physical Inventory

| Page Name | Object Name | Navigation | Usage |
|--------------------|-----------------|--|---|
| Physical Inventory | RUN_AMPI1000 | Asset Management, Physical Inventory, Load/Match/Reconcile PI Info | Execute each step of the Physical Inventory process. We recommend that you add a new run control ID for each physical inventory control ID (PI ID). Also use this run control ID for subsequent steps within the same PI ID. |
| Extract Data | PI_EXTRACT_01 | Asset Management, Physical Inventory, Review Extracted Data | (Optional) View the results of the extract data one asset at a time. You can also search by PI line number, asset ID, department, tag number, serial ID, and location. The PI line number reflects the number of this asset in the extract sequence. For instance, the third asset that was extracted falls on PI Line Number 3. The system presents you with all the assets that match your criteria. Select the one you want to view. Note. You can run the report AMPI2000 to list all the information that has been extracted. Run this from the Physical Inventory Reports page. |
| Duplicate Tags | PI_SCAN_DUP_TAG | Asset Management, Physical Inventory, Verify Duplicate Tags | Conduct searches for finding and correcting physical inventory data. |
| Duplicate Serials | PI_SCAN_DUP | Asset Management, Physical Inventory, Verify Duplicate Serial ID | Conduct searches for finding and correcting physical inventory data. |
| Results | PI_RESULTS_01 | Asset Management, Physical Inventory, Review Matching Results | View the results of the matching process. |
| Details | PI_RESULTS_02 | Asset Management, Physical Inventory, Review Matching Results, Details | View the original and scanned data. Note. You can run reports that list inventoried assets (AMPI2200), unders (AMPI2210), and overs (AMPI2220). |

Extracting Asset Data (Step 1)

Access the Physical Inventory page.

The screenshot shows the 'Physical Inventory' page. At the top, there is a header 'Physical Inventory' and a 'Run Control ID: PhysInv-M04'. To the right are links for 'Report Manager' and 'Process Monitor', and a 'Run' button. Below this, there is a 'PI ID:' field with 'M04' and a search icon, and a 'File Name:' field with 'c:\temp\scan.dat'. To the right of these fields is an 'Export / Import' section with a 'Scanner File' dropdown menu. Below this is a 'Last PI Step Executed:' section with a sequence of buttons: 'Extract' => 'Gen Extr File' => 'Load Scan File' => 'Gen Results' => 'Gen Trans', and a reverse sequence: 'Delete Ext' <==== 'Delete Scan' <== 'Delete Res' <== 'Del Trans'. At the bottom is a 'Request Information' section with a text area containing the following text: 'Extract Data allows you to extract all your current PS/AM data into a format you may load into a Bar-code reader. If you accumulate PI Data in a Bar-code reader, you may run Load Data to get that data into the PS/AM PI system. Enter the filename you want to load. Once you have data in the PS/AM PI system, you may match that data to the current PS/AM data to help your reconciliation process.'

Physical Inventory page

This step executes the actual data extract from PeopleSoft Asset Management. When you extract data, you do not need to enter a file name or file type. The data is saved in a relational table called PI_EXTRACT. Click the Extract button and click the Run button. If you want to view the extract data before using it in subsequent steps, access the Extract Data page.

Viewing the Results of the Extract

Access the Extract Data page.

View the extract data one asset at a time. You can also search by PI line number, asset ID, department, tag number, serial ID, and location. The PI line number reflects the number of this asset in the extract sequence. For instance, the third asset that was extracted falls on PI Line Number 3. The system presents you with all the assets that match your criteria. Select the one you want to view.

| Extract Data | |
|-------------------------------|----------------------------|
| Physical Inventory ID: | PI2000 2000 Inventory |
| Extracted Data | |
| Asset ID: | EX_000000499 |
| Description: | Building B |
| Location: | US001 |
| Serial ID: | 6663123452805 |
| Cost: | 30,000,000.00 USD |
| Manufacturer: | |
| Tag Number: | |
| Model: | |
| EmplID: | |
| Category: | BLDG |
| Cost Type: | |
| Operating Unit: | NEWYORK |
| Fund Code: | |
| Department: | |
| Program Code: | |
| Class Field: | |
| Budget Reference: | |
| Product: | |
| Project: | |

Extract Data page

Creating an Extract File (Step 2)

Access the Physical Inventory page. This step creates an output file from the extract data.

Export/Import

Select *CSV* for a comma-separated values (CSV) file.

Select *Scanner File* as the import or export file type, and enter a file name (as well as any additional path information) for the file that you want to generate. The output file is formatted for loading into a bar code scanning device in preparation for performing physical inventory.

To create a file for printing labels rather than performing inventory, select *Generate Labels* as the export or import file type. A label file is created for the printer in a different format from the one used for a scanning device.

To generate files for both a scanning device and a printer, perform step 2 twice with a different output file type each time.

Gen Extr File (generate extract file)

Click this button and then click the Run button.

Note. The EXTCOPY.BAT file is configured to copy the extract file to the A:\ drive for demonstration or quick overview purposes. You need to modify EXTCOPY.BAT if you want to copy the extract file to the appropriate drive on a scanner.

Copy the scanner program (PI.EXE) and scanner file to the MS-DOS based scanning device. You can easily do this using a communications software package. You may wish to use the certified integration solution provided by HighJump Software. Consult the bar code scanning device manual and HighJump Software for more information.

Once you have loaded the extract file and scanner program into the inventory-scanning device, you can perform the physical inventory. Each time that you scan an asset that is included in the extract file, the scanner displays the asset's information, such as tag number, description, serial ID, asset ID, and custodian. For the asset that you scan, you can retain or modify the values displayed on the scanner.

While you are performing the physical inventory scan, the scanning device creates a sequential file that contains information on all the scanned assets. The next step is to load the scanned file into PeopleSoft Asset Management for review.

Note. The files EXTCOPY.BAT and PI.EXE reside in the \PI directory. EXTCOPY.BAT is no longer supported, but it may be useful for a quick overview of the process.

Review the section on hardware requirements for further information about bar code scanners and methods of moving data to and from scanning devices.

If you are using an IT asset discovery tool from a vendor such as MainControl, you need to run a gateway extract so that you have a file to load into PeopleSoft Asset Management.

Loading Asset Inventory Data (Step 3)

Access the Physical Inventory page.

After completing the physical inventory with the scanning system, download the scanner data into a workstation or network server so that it can be converted back into a PeopleSoft Asset Management table called PI_SCAN. You do this using a communications software package or by using the certified integration solution provided by HighJump Software. Consult the bar code scanning device manual or HighJump Software for more information.

Note. PeopleSoft Asset Management provides an unsupported file called SCANCOPY.BAT (found in the \PI directory) that can be edited to copy the SCAN.DAT file from the scanner to the computer. You may need to modify the copy statement in SCANCOPY.BAT so that it copies from the drive letter corresponding to the scanner's drive. This is similar to the modification that you may need to make to EXTCOPY.BAT.

Once the scanner files are available to load into Asset Management, you can run step 3 of the physical inventory process.

Enter the directory and file name of the inventory file. This is most likely \TEMP\SCAN.DAT. If located on the PeopleSoft Internet Architecture server, you can run the next process on the server.

Click the Load Scan File button and click the Run button to load the scan data into PeopleSoft Asset Management. You can load as many files as you need by renaming SCAN.DAT (during the bar code scanning process) with unique file names and loading each file separately.

Note. If you have written your own scanning program or modified PI.BAS to configure fields or field lengths, you need to update the file formats in AMPI1000.SQC to match.

Finding Duplicate Tags

Access the Duplicate Tags page.

It is very common for an asset to be scanned multiple times during physical inventory, thus creating more than one entry with the same tag or serial number. In order for PeopleSoft Asset Management to perform inventory reconciliation, each tag or serial number must be unique. Therefore, it is extremely important that you identify and resolve any duplicate entries. If any duplicate entries exist when results are generated, these entries are marked as errors and are not processed any further.

Duplicate Tags

Physical Inventory ID: PI2000 2000 Inventory

Unit: PSDEU Match Status: Over + -

Asset ID: NEXT Manual Review Required

Scanned By: MainControl

Scanned Data

| | | | |
|---------------|------------------------------|--------------|----------------|
| Tag Number: | P00005460 | Employee ID: | 3279 |
| Serial ID: | 03712928 | Custodian: | Natter,Andreas |
| Manufacturer: | Toshiba | Location: | GERMANY |
| Model: | 730 | Department: | 3100 |
| Description: | | IP Address: | |
| IP Alias: | ANATTER052099.peoplesoft.com | | |
| Comment: | | | |

Duplicate Tags page

You can search on a tag and a physical inventory line number. The physical inventory line number reflects the number of this asset in the scanning sequence. For instance, the third asset that was scanned falls on physical inventory line number 3.

If duplicates exist, the system displays a page on which you can correct or delete assets that have duplicate numbers.

The IP Alias and IP Address fields describe the internet protocol attributes of IT assets that are extracted from the IT discovery tools database.

Finding Duplicate Serial Numbers

Access the Duplicate Serials page.

Duplicate Serials

Physical Inventory ID: PI2000 2000 Inventory

Unit: **Match Status:**

Asset ID: **Manual Review Required**

Scanned By:

Scanned Data

| | |
|--|---|
| Tag Number: <input type="text" value="P00005460"/> | Employee ID: <input type="text" value="3279"/> |
| Serial ID: <input type="text" value="03712928"/> | Custodian: <input type="text" value="Natter,Andreas"/> |
| Manufacturer: <input type="text" value="Toshiba"/> | Location: <input type="text" value="GERMANY"/> |
| Model: <input type="text" value="730"/> | Department: <input type="text" value="3100"/> |
| Description: <input type="text"/> | IP Address: <input type="text"/> |
| IP Alias: <input type="text" value="ANATTER052099.peoplesoft.com"/> | |
| Comment: <input type="text"/> | |

Duplicate Serials page

The Duplicate Serial Number page is similar to the Duplicate Tags page except that you are reviewing created records that have a duplicate Serial ID number.

Generating Physical Inventory Results (Step 4)

Access the Physical Inventory page.

After the inventory data is loaded into Asset Management, you clean up the data. Then you can run step 4, which performs matching between a physical inventory scan scope and scanned data and creates physical inventory results for review.

Note. Before you generate results, you should use the Duplicate Tag page and Duplicate Serial Number page to clean up any possible errors in the scanned data.

| | |
|--|---|
| File Name | You can leave this field blank for this step. |
| Gen Results (generate results) and Run | Click the Gen Results button and click the Run button to initiate processing. Note that this step may take some time to complete due to the amount of information that must be processed. |
| | Because this step involves some complex processing, you may want to have your database administrator optimize the database before you execute the step. |

Reviewing Physical Inventory Results

Access the Results page.

Results
Details

Physical Inventory ID: PI2000 2000 Inventory

Asset ID:

PI Match Status:

Scanned By:

Manual Review Required
 Result In Error

Results Notification

Send Email
 Send Worklist

Description:

User ID:

Message Text:

Description:

Results page

The PI Match Status (physical inventory match status) field displays an asset’s physical inventory status when results are generated and matching is performed. An asset can have one of the following statuses:

| Status | Reason | Transactions Generated |
|--------------------|---|---|
| <i>Accel</i> | NA | NA |
| <i>All I, O, U</i> | | |
| <i>Discard</i> | | |
| <i>Initial</i> | | |
| <i>Inventory</i> | Asset was scanned during inventory as expected. | Transfers and physical changes (description, location, department, custodian, and so on). |
| <i>None</i> | | |
| <i>Over</i> | Asset was scanned but not expected. | Physical adds. |

| Status | Reason | Transactions Generated |
|----------------|-------------------------------------|------------------------|
| <i>Special</i> | | |
| <i>Under</i> | Asset was expected but not scanned. | Retirements. |

Manual Review Required

This check box is selected if the scanner operator requested a special review for this asset.

Results in Error

This check box is selected if the physical inventory processing cannot process a result further. Four error conditions may apply:

- Duplicate tags.

If any duplicate tags still exist in the scanned data, the results generated for those duplicates contain errors.

- Multiple sets of ChartFields.

If an asset has multiple sets of ChartFields (that is, the cost is divided between two departments), an error results. Physical inventory processing cannot handle such assets.

- Asset retired.

An asset recorded as *Retired* in Asset Management was scanned. Physical inventory processing doesn't process reinstatements automatically. Complete these in the Retiring Financial Assets component.

- InterUnit candidate.

A scanned tag was found for an asset in a business unit other than the one for which you're processing physical inventory. You should transfer it from that business unit to the physical inventory business unit. Physical inventory processing doesn't perform interunit transfers automatically. Complete these in the Asset Cost Adjust/Transfers component.

These errors are exceptions to the rule and should not occur frequently or in high volumes. Results that are in error do not generate transactions and should be resolved manually.

Results Notification

If you use Workflow, this section contains fields that are used in workflow processing to generate automatic physical inventory results notifications. These can be sent to a worklist, an email address, or both.

Generating Physical Inventory Transactions (Step 5)

Access the Physical Inventory page.

After matching is performed, you create physical inventory transactions that reconcile the data in Asset Management with the results of the physical inventory.

Enter the PI ID (physical inventory ID), click the Gen Trans (generate transactions) button, and click the Run button to begin generating the transactions.

Because this step involves some complex processing, you may want to have the database administrator optimize the database before you run it.

Note. This step takes the longest time to process, so be sure that you are satisfied with the generated results before you load the transactions. You can see the results of the matching process by reviewing the Results page and the Results Detail page.

After you have created, reviewed, and approved the reconciliation transactions, you load them by using the Interface Asset Information component and the Transaction Loader.

Deleting Physical Inventory Transactions (Step 6)

Access the Physical Inventory page.

When you no longer need your physical inventory transactions, click the Del Trans (delete transactions) button and click the Run button.

Deleting Physical Inventory Results (Step 7)

Access the Physical Inventory page.

When you no longer need your physical inventory results, click the Delete Res (delete results) button and click the Run button.

Deleting Physical Inventory Scanned Data (Step 8)

Access the Physical Inventory page.

When you no longer need your physical inventory scanned data, click the Delete Scan button and click the Run button.

Deleting an Extract File (Step 9)

Access the Physical Inventory page.

When you no longer need your physical inventory extract file, click the Delete Ext (delete extract) button and click the Run button.

Viewing Physical Inventory History

This section lists the pages used to view physical inventory history.

Pages Used to View Physical Inventory History

| Page Name | Object Name | Navigation | Usage |
|----------------------------|--------------------|--|---|
| Physical Inventory History | PI_ASSET_HIST1 | Asset Management, Physical Inventory, Review Inventory History | View a history of all the instances that an asset has been inventoried. |
| Physical Inventory Reports | RUN_AMP12000 | Asset Management, Physical Inventory, Run Physical Inventory Reports | Generate physical inventory reports. |

CHAPTER 13

Working with Joint Venture Asset Processing

This chapter provides an overview of joint venture processing and discusses how to:

- Add and maintain joint venture assets.
- Change ownership allocations for existing joint ventures.

Understanding Joint Venture Processing

The Joint Venture Processing feature of PeopleSoft Asset Management enables you to accurately track finances when two or more business units share in the ownership of an asset or a group of assets. To use this feature, you must set up a Joint Venture Business Unit, identify business units that participate in the joint venture, and associate all of the business units with their respective equities.

A Joint Venture Business Unit owns 100 percent of all joint venture assets. Participating business units are each assigned an equity percentage of the jointly owned assets. When you add, adjust, or retire an asset at the Joint Venture Business Unit level, similar transactions take place at the participant level, with cost and depreciation prorated according to each participant's equity percentage.

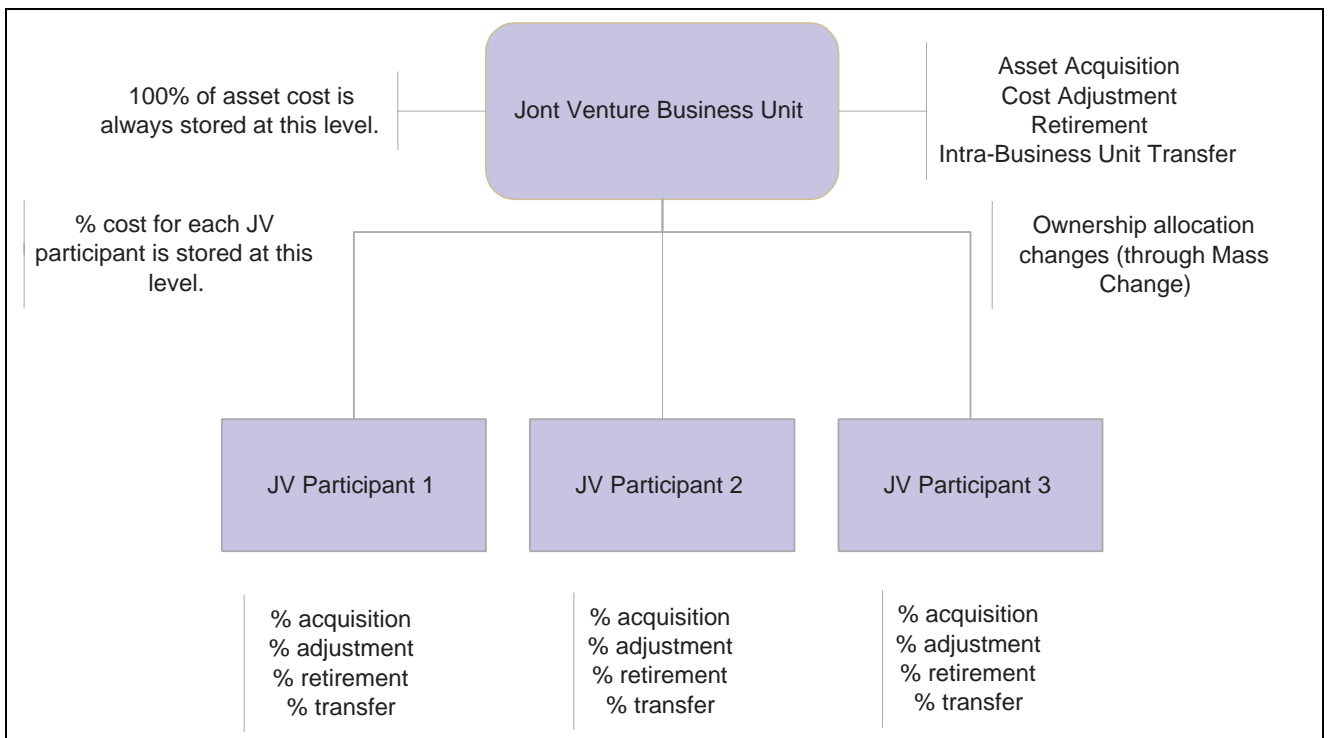

Joint venture processing

Equity percentages are defined in the Joint Venture Allocation table when you set up the PeopleSoft Asset Management tables. The sum of the participants' percentages must equal 100 percent. Equity percentages are allotted to participating business units according to the values you enter in the joint venture allocation table.

This allocation table sets up joint venture processing for Participants 1, 2, and 3, which own 60 percent, 20 percent, and 20 percent of the joint venture assets, respectively:

| Business Unit | Percentage |
|-----------------------------|-------------------|
| Joint Venture Business Unit | 100 |
| Participant 1 | 60 |
| Participant 2 | 20 |
| Participant 3 | 20 |

Most transactions on joint venture assets are performed at the Joint Venture Business Unit level. These transactions are automatically performed at the participant level as well, with cost, fair market and depreciation information prorated based on each participant's equity percentage.

For example, asset ID JV00022 was entered for the Joint Venture Business Unit. With USD 10,000 of remaining value and USD 2,000 in accumulated depreciation, these assets are created based on the previous allocation table:

| Unit | Asset ID | Book | Remaining Value | Accumulated Depreciation |
|-----------------------------|-----------------|-------------|------------------------|---------------------------------|
| Joint Venture Business Unit | JV00022 | CORP | 10,000 | 2,000 |
| NA | NA | FEDERAL | 10,000 | 2,000 |
| Participant 1 | JV00022 | CORP | 6,000 | 1,200 |
| | | FEDERAL | 6,000 | 1,200 |
| Participant 2 | JV00022 | CORP | 2,000 | 400 |
| | | FEDERAL | 2,000 | 400 |
| Participant 3 | JV00022 | CORP | 2,000 | 400 |
| | | FEDERAL | 2,000 | 400 |

Adds, Adjusts, and Retirements must take place at the Joint Venture Business Unit level. Changes in ownership allocation—such as additions and deletions of participants and reallocations of equity percentages—must be made at the Joint Venture Participant level.

Prerequisites for Joint Venture Processing

Joint Venture Processing requires setup steps that you need to follow to use this feature. These steps must be completed in the correct order so that subsequent options are available for selection.

To set up joint venture processing:

1. Select Set Up Financials/Supply Chain, Install, Installation Options, Asset Management and select the Joint Venture Processing check box on the Installation Options - Asset Management page.
2. Select Set Up Financials/Supply Chain, Business Unit Related, Assets, Asset Management Definition and define at least one Joint Venture Business Unit on the PeopleSoft Asset Management Business Unit Definition page.

The option to define a Joint Venture Business Unit is active only if you enabled Joint Venture Processing in step 1.

3. Create one business unit for each participant in the joint venture relationship to establish Joint Venture Processing.

These are standard business units and there are no additional steps to perform. Profiles for joint venture participant business units must have the same Profile ID as the joint venture business unit.

4. Associate the Joint Venture Participants with a particular Joint Venture Business Unit and define the percentage of asset ownership allocated to each participant to complete the last step in establishing Joint Venture Processing.

Do this by setting up a Joint Venture Allocation table for each Joint Venture Business Unit.

See Also

PeopleSoft Enterprise Asset Lifecycle Management Fundamentals 9.0 PeopleBook, “Establishing PeopleSoft Asset Management Business Units”

Adding and Maintaining Joint Venture Assets

Most transactions on joint venture assets are performed at the Joint Venture Business Unit level. These include asset acquisitions, cost adjustments, retirements, and intrabusiness unit transfers (for example, transfers from one department, product, project, or category to another within the same business unit).

Note. InterUnit transfer of joint venture assets is not available or supported.

Joint venture asset transactions are executed just as they are for any non-joint venture asset with no special steps to take. However, it is recommended that you establish a naming convention to distinguish assets that are shared by a joint venture. For example, you might assign a joint venture asset an asset ID that begins with the letters *JV*.

Joint venture asset transactions are automatically executed at the participant level as well, with cost and depreciation information prorated based on each participant's equity percentage. Acquisition detail table entries are not prorated. Any change in the ownership allocation of joint venture assets (ownership transfers) must be performed at the joint venture participant level.

Changing Ownership Allocations for Existing Joint Ventures

You must define and run a mass change to change the ownership allocation of assets in an existing joint venture. The Joint Venture Allocation table affects only newly added assets, which means that changes made to the allocation table do not affect existing joint venture assets.

Additions and deletions of participants and reallocations of equity percentages are recorded as sales transactions. This results in either a gain or a loss on the part of the selling participant. The value of the sale proceeds for the selling participants is recorded as the capital cost incurred by the buying participants.

PeopleSoft Asset Management processes these changes by retiring some portion of the equity percentage from the selling participant (to calculate gain/loss) and then transferring percentages between business units until the desired ownership ratio is achieved. The mass change transfers an established amount of the asset cost and quantity from one business unit to another (a one-to-one transfer). Because of this, you may need to run the mass change multiple times (up to the number of participating business units minus 1) to effect the desired change. For instance, if you have three original participants and want to add another, you might run the mass change three times: between business units 1 and 4, 2 and 4, and 3 and 4.

Defining a Mass Change for Joint Venture Processing

To change the ownership allocation of assets in an existing joint venture, PeopleSoft Asset Management is delivered with these joint venture mass change templates:

| Mass Change Template | Description |
|---------------------------------------|---|
| <i>JVA-Joint Venture BU Addition</i> | Adds a joint venture participant. |
| <i>JVP-Joint Vent BU Add (w/Prof)</i> | Adds a joint venture participant using book values from the new business unit's profile ID. |
| <i>JVR-Joint Venture BU Removal</i> | Removes a joint venture participant. |
| <i>JVT-JV Allocation Change</i> | Transfers the allocation percentages for a joint venture from one business unit to another. |

Note. After you run these changes, it is a good idea to update the allocation table to reflect the new equity percentages. Joint venture mass changes do not affect Joint Venture Allocation tables, and you must change these tables to reflect the updated joint ventures.

In addition to selecting the appropriate mass change template, make other selections that are specific to joint venture processing. PeopleSoft Asset Management requires a Transaction Date and an Accounting Date.

Depending on the joint venture mass change template you select, you may also need to select a set of default values for some or all of these fields:

| | |
|--|--|
| Joint Venture Business Unit to Add to | Value is inserted into INTFC_FIN table. |
| Percentage of Cost | Enter a decimal value—for example, enter 0.50 for 50 percent. |
| Disposal Code | Choose a disposal code from the available options. Disposal codes are fully described in Retiring Assets. |
| Total Proceeds | Enter 0 if there are none. |
| Percentage of Quantity | Enter a decimal value—for example, enter 0.50 for 50 percent. |
| Total Removal Cost | Enter 0 if there is none. |
| Retirement Type | Enter either Extraordinary or Ordinary to indicate how the gain or loss that results from a retirement should be reported. This is for information only. |
| Retirement Convention | Select a retirement convention. This indicates how depreciation will be calculated through retirement. |
| Voluntary/Involuntary | Enter either Voluntary or Involuntary to indicate the reason for a retirement. This is for information only. |

See [Chapter 20, “Processing Asset Mass Changes,”](#) page 357.

Adding a Joint Venture Participant

The Mass Change application engine program adds a joint venture participant business unit to an existing joint venture and performs these additional functions:

- Retires an established percentage of cost and quantity from one business unit and its books by using the defaults you specify for the retirement.
- Adds the same percentage of cost and quantity to the new business unit and its books by using the proceeds you specify for the retirement.

When defining the mass change, select *JVA-Joint Venture BU Addition* as the Mass Change Template used to add a joint venture participant. If you want to use book values from the profile ID of the new participant business unit, select the *JVP-Joint Vent BU Add (w/Prof)* mass change template.

In Execution Sequence 1, select the book or books from which you want to retire a portion of assets. Specify the Joint Venture Business Unit from which you want to retire assets so that these values can be applied to the new participant business unit.

In Execution Sequence 2, enter default values for the mass change.

Note. Before adding a business unit to an existing joint venture, that business unit must be fully established.

Removing a Joint Venture Participant

When Mass Change removes a joint venture participant business unit from an existing joint venture, it also performs these functions:

- Retires the total cost and quantity from one business unit and its books, using the defaults you specify for the retirement.

- Adds that cost and quantity to another business unit and its books, using the proceeds you specify for the retirement.

When defining the mass change, select *JVA-Joint Venture BU Removal* as the Mass Change Template used to remove a joint venture participant.

In Execution Sequence 1, select the book or books that you want to remove. Specify the Joint Venture Participant Business Unit you want to remove.

In Execution Sequence 2, enter default values for the mass change.

Changing Joint Venture Ownership Allocations

When the Mass Change process changes ownership allocations for an existing joint venture, it also performs these functions:

- Retires a percentage of the cost and quantity from one business unit and its books, using the defaults specified for the retirement.
- Adds that same percentage of cost and quantity to another business unit and its books, using the proceeds specified for the retirement.

When defining the mass change, select *JVT-JV Allocation Change* as the Mass Change Template used to change joint venture ownership allocations.

In Execution Sequence 1, select the department or departments from which you want to transfer joint venture assets. Specify the Joint Venture Business Unit from which you want to transfer assets.

In Execution Sequence 2, enter default values for the mass change.

Loading Joint Venture Transactions

After you run a joint venture mass change, use the Transaction Loader to load results of the mass change into the PeopleSoft Asset Management tables.

See *PeopleSoft Enterprise Asset Lifecycle Management Fundamentals 9.0 PeopleBook*, “Integrating PeopleSoft Asset Management with Other Products,” Running the Transaction Loader.

CHAPTER 14

Processing Asset Depreciation

This chapter lists prerequisites, provides overviews of depreciation processing and depreciation of group assets, and discusses how to:

- Process depreciation.
- Expand depreciation by period.
- Create pending depreciation transactions.
- View depreciation-related information.
- Adjust accumulated depreciation.
- Run depreciation reports.

Prerequisites

Before you begin to depreciate assets, you must set them up with required depreciation attributes.

You must set up the following attributes:

- Depreciation method.
- Prorate convention.
- Depreciable basis.
- Estimated useful life.
- Placed-in-service date.

See *PeopleSoft Enterprise Asset Lifecycle Management Fundamentals 9.0 PeopleBook*, “Establishing PeopleSoft Asset Management Business Units”.

See *PeopleSoft Enterprise Asset Lifecycle Management Fundamentals 9.0 PeopleBook*, “Establishing Asset Processing,” Setting Up Asset Profiles.

See *PeopleSoft Enterprise Asset Lifecycle Management Fundamentals 9.0 PeopleBook*, “Setting Up Depreciation Processing”.

See [Chapter 5, “Adding and Maintaining Assets,” page 45](#).

Understanding Depreciation Processing

PeopleSoft Asset Management can calculate depreciation for more than 18,000 different scenarios, depending on the depreciation attributes that you select. Most standard depreciation methods and prorate conventions are delivered, along with functionality for you to define your own depreciation methods and prorate conventions. In the United States, PeopleSoft Asset Management calculates tax credits and tax credit recapture. Standard depreciation reports are provided, as well as reports that enable you to comply with the U.S. Tax 40% Rule, the U.S. Alternative Minimum Tax (AMT), and the U.S. Adjusted Current Earnings (ACE). Outside the U.S., PeopleSoft Asset Management provides depreciation methods that are commonly used in Europe, Australia, India, and Japan, as well as other methods that are used globally.

PeopleSoft Asset Management calculates the annual depreciation based on the asset's life, depreciable cost basis, placed-in-service date, and any depreciation limits that you specify. You can set up required depreciation attributes on three levels: You can enter them in your business unit books, define them when you set up asset profiles, or specify them when you add assets to the system.

When you set up your business unit books, specify whether each book is a financial book, a tax book, or a financial book with tax information. This specification acts as a filter, enabling you to select options that correspond to the book type that you specified. For example, if you define a book as a tax book in the U.S., PeopleSoft Asset Management does not allow you to select depreciation attributes that aren't supported by U.S. federal tax code.

Asset profiles function as templates. They provide a quick way to enter asset information, especially depreciation criteria. Rather than enter the book, method, convention, life, and tax credit information each time that you add an asset, you can use the asset profile to supply that information by default. When you enter assets, specify the profile ID. If any depreciation information in the profile does not apply, you can override it.

You can also specify depreciation attributes as you add assets to PeopleSoft Asset Management. Do this if the asset profile does not contain the depreciation criteria that you want for the asset. If you use more than one book, specify the depreciation criteria for each book.

To ensure correct depreciation processing, the PeopleSoft detail calendar that you use must include at least five years prior to the life of the oldest asset. For example, if the life of the oldest asset began on January 1, 1990, your calendar must begin no later than January 1, 1985. These prior periods are required for correct depreciation processing.

Build detail calendars beyond the end depreciation date of the asset as well. When you do this, the system calculates depreciation over the longer period correctly for any added assets that have a longer than usual service life. If any short tax years are contained within this five-year period, create a calendar of more than five years to ensure correct depreciation.

If you use a depreciation method that relies on tables specifying the percentage of depreciation that is expensed for each period, review the delivered depreciation schedules. If you use depreciation schedules that are different from those delivered, you must add a schedule with the appropriate percentages for each in-service period for each year of life.

PeopleSoft Asset Management provides all standard prorate conventions. In addition, it enables you to build new conventions based on calendars and to copy conventions from one setID to another as appropriate.

Note. PeopleSoft Asset Management enables you to change both depreciation conventions and schedules as you deem necessary. If you change either the schedule or convention, you get a warning that the convention and the schedule do not agree. When you save your change, PeopleCode changes the convention or the schedule for you. The depreciation will calculate correctly whether you enter a change to schedule or convention and in either order.

Steps for Processing Depreciation

Follow these steps to process depreciation:

1. Run the Depreciation Calculation Application Engine process (AM_DEPR_CALC).
2. Review open transactions.
3. Change depreciation attributes and expand periods as needed.
4. Review the depreciation processing results for errors.
5. Create pending depreciation transactions.
6. Create period depreciation accounting entries.

When you have completed processing depreciation, you must go on to create accounting entries for the period depreciation. Before you create any accounting entries, check the processing options to determine whether the system runs processes automatically or whether you must schedule processing.

To create period depreciation accounting entries:

- Determine which periods are open to ensure that depreciation is expensed to the correct period.

To verify periods, use the Establish Business Units component, and access the Asset Management Definition page. Click the Update Open Periods link to review open and closed periods on the Open Period Update page.

If the open periods show that the current accounting period is open, you can create period depreciation accounting entries. If not, you must close the prior period manually and open the current period before creating period depreciation accounting entries.

- Account for any depreciation that is allowed for time during which an asset was not established in PeopleSoft Asset Management.

When you acquire assets (or place assets in service) during one accounting period but add them to PeopleSoft Asset Management during a different accounting period, you need to account for any depreciation that is allowed for the time during which the asset was not established in PeopleSoft Asset Management. You can do this by adjusting the transaction and accounting dates.

Typically, the transaction date represents the date that you actually acquired the asset and the accounting date represents the date that you want the transaction expensed. The accounting date is validated against the open periods for PeopleSoft Asset Management that are stored in the FIN_OPEN_PERIOD table to determine the period to which it is expensed. The difference between the transaction date and the accounting date determine whether any prior period depreciation needs to be calculated. For example, suppose that a computer was acquired and placed in service on March 15, 2005, but the information was not entered into PeopleSoft Asset Management until August 1, 2005. All periods prior to August are closed. PeopleSoft Asset Management automatically calculates depreciation starting in March, and it reflects this depreciation in the August period. When period depreciation accounting entries are created for August, they will reflect all depreciation activity since March.

Note. This is the only time life-to-date calculations take place without being selected.

- Create accounting entries for the amount that you enter during the *Add* process for assets with accumulated depreciation.

When you add an asset with accumulated depreciation, you can create accounting entries for the amount that you enter during the Add process. When the asset has been added, accumulated depreciation is updated each time that you create new period depreciation accounting entries.

- Set up the depreciation allocation calendar.

The amount of depreciation that you can expense for each period depends on how you set up your calendar. You can define the periods as months. When you set up your calendar, specify the year, the number of periods in each year, the beginning and ending date of each period, and the name of each period. For example, if you use a monthly calendar, the first period might be called January or April.

You also specify the portion of depreciation to be allocated for each period. For example, if you use a monthly calendar, you can specify that 1/12 of the annual depreciation amount is allocated to each period.

- Close accounting periods.

When you have created accounting entries for depreciation for an accounting period, you must close it.

See Also

[Chapter 18, “Creating PeopleSoft Asset Management Accounting Entries,” page 301](#)

[Chapter 18, “Creating PeopleSoft Asset Management Accounting Entries,” Running the Depreciation Close Process, page 316](#)

PeopleSoft Enterprise Asset Lifecycle Management Fundamentals 9.0 PeopleBook, “Establishing PeopleSoft Asset Management Business Units”

Understanding Depreciation of Group Assets

Group assets are treated differently from regular assets for depreciation purposes. Before you run depreciation on group assets, you must run a process that consolidates group member asset cost information at the group level. Then, you can depreciate group assets using the Group Asset Depreciation Calculation page. PeopleSoft Asset Management supports only the flat-rate depreciation method for group assets.

See Also

[Chapter 10, “Using Group Asset Processing,” page 207](#)

Processing Depreciation

This section provides an overview of processing depreciation and discusses how to:

- Run the Depreciation Calculation process (AM_DEPR_CALC).
- Review open transactions.
- Change depreciation attributes.
- Review the depreciation processing results for errors.

Understanding Depreciation Processing

You must run depreciation to account for every transaction that you perform on an asset. For example, when you transfer an asset, you may need to run depreciation to correctly reflect the new department that is using the asset. For some transactions (including adjustments, transfers, and recategorizations), the depreciation calculation process moves the stored depreciation amounts from department to department or category to category, depending on the transaction that you are performing and the ChartFields that you specify.

Pages Used to Process Depreciation

| Page Name | Object Name | Navigation | Usage |
|------------------------------|-------------------|---|---|
| Run Depreciation Calculation | RUN_AMDPCALC | Asset Management, Depreciation, Processing, Calculate | Run the Depreciation Calculation process. |
| Open Transaction Detail | OPEN_TRANS_DETAIL | Asset Management, Depreciation, Open Transactions, Review | Review detailed information about an open transaction. Note. You can view open tax transactions by using the same process when you select Asset Management, Taxes, Reports, Review Open Tax Transactions, Open Transactions- Tax. |
| Asset Processes Error Log | AM_ERROR_LOG | Asset Management, Depreciation, Depreciation Process Log | Review depreciation processing results for errors. |

Running the Depreciation Calculation Process (AM_DEPR_CALC)

Access the Run Depreciation Calculation page.

| | |
|--------------------------------------|---|
| Unit | Select a business unit from which to select a book or range of assets. |
| Book Name | Select a book to further narrow the assets to be included in processing. |
| From Asset ID and To Asset ID | Enter a range of assets to include in processing. |
| Process Frequency | Select the frequency for the process from these values: <i>Always</i> <i>Don't</i> <i>Once</i> |
| Delete Stage Row | Select the staged rows to delete: <i>All</i> <i>Current</i> <i>No</i> |

Note. Accumulated depreciation for group member assets is loaded at the member asset level.

See *PeopleSoft Enterprise Asset Lifecycle Management Fundamentals 9.0 PeopleBook*, “Configuring PeopleSoft Asset Lifecycle Management Background Processes”.

Reviewing Open Transactions

Access the Open Transaction Detail page.

You can review open transactions broadly—for example, by searching for them by business unit. Review open transactions more specifically by including more criteria in your search.

Open Transaction Searches

Use broad or narrow search criteria to identify a list of open transactions. In addition to business unit, you can specify asset identification, asset book name, transaction date, or accounting date. Alternatively, you can specify the action type of a pending transaction. Also, each open transaction can have a status, which you can use to further narrow the search criteria.

Actions of Open Transactions

Each pending transaction can have an action type associated with it. The following list shows the action types that are available:

- Asset Addition
- Asset Cost Adjustment
- Asset Recategorization
- Asset Reinstatement
- Asset Retirement
- Asset Transfer
- Book Adjustment
- Budgeted Depreciation
- Budgeted Lease Payments
- Depreciation
- Inflation Adjustment
- Lease Payment
- Manual Reserve Adjustment
- Prior Period Adjustment
- Resume Depreciation
- Retro Rate Change for Group Assets
- Suspend Depreciation

Depreciation Calc Status

Completed Depreciation has been calculated for the transaction.

| | |
|-----------------------------|---|
| Held For Transfer In | When you process InterUnit transfers, PeopleSoft Asset Management processes the out and in transactions at the same time. This status indicates that the transaction is being held until its corresponding transfer-out can be processed. |
| Never | The Depreciation Calculation process never includes the transaction. |
| Pending | Depreciation has not yet been calculated for the transaction. |
| In Process | Depreciation calculation is processing. |

Acctg Entry Creation Status

| | |
|------------------|--|
| Completed | The transaction has been sent to the general ledger. |
| Never | The distribution process never includes the transaction. |
| Pending | The transaction has not yet been sent to the general ledger. |

Group Consolidation Asset Status

| | |
|----------------------------|---|
| Completed | The summarization process has been completed on the transactions for group member assets. |
| Grouped | The asset is a group asset. |
| Member Depreciation | A book change has been made on a group member (such as changing its convention or in-service date). |
| Never | The transactions are never used by the summarization process. |
| Pending | The summarization process has not yet been completed on the transactions for group member assets. |

When you have searched for all open transactions based on specified criteria, you can view particular open transactions in detail.

Changing Depreciation Attributes

PeopleSoft Asset Management enables you to change depreciation attributes as necessary. You may find it necessary to:

- *Change the effective date.*

Changing the effective date of depreciation attributes may become necessary to accommodate changes in tax law or company policy. You can set up anticipated changes for future use by effective-dating them. You can also affect prior periods by changing the effective date.

- *Change the depreciation limit.*

Changing the depreciation limits on assets may change the amount of depreciation that you can expense on an asset in a given year. This, in turn, changes the depreciation amount that is allocated to each period. If necessary, the life of the asset is extended to depreciate the asset fully.

- *Change the status.*

Asset depreciation status is book-specific. Therefore, an asset can be depreciable for one book and non-depreciable for another. There is no limit to the number of times that an asset can have its depreciation suspended. Also, there is no limit on the length of time for which it can be suspended.

When you change the status of an asset from Depreciable to Nondepreciable, the system deletes future depreciation calculations. All transactions that are performed while the asset is suspended take into account only the depreciation that has occurred as of that time.

While an asset is in a suspended state (that is, has a status of Nondepreciable), you can still perform financial transactions on it. Those transactions generate appropriate accounting entries with a transaction date indicating when the transaction actually took place. Adjustments generate one accounting entry for the cost adjustment. Transfers generate two accounting entries—one for the cost transfer and one to transfer accumulated depreciation. Retirements generate accounting entries for cost, accumulated depreciation, and any gain or loss.

Note. You cannot perform InterUnit transfers on assets that have been suspended.

When you change a nondepreciable asset to a depreciable asset, PeopleSoft Asset Management performs a remaining value calculation and calculates depreciation based on all depreciation parameters. The time during which depreciation was suspended is not taken into account against the asset's life.

See [Appendix B, “Understanding Depreciation Calculations,” Calculating Depreciation When Salvage Value Exceeds Net Book Value \(NBV\), page 556.](#)

Reviewing the Depreciation Processing Error Log

Access the Asset Processes Error Log page.

You can review each processing instance for errors that may have occurred during processing. You can view the business unit, asset ID, and other information that is related to the error along with a message describing the problem. You can then correct the problem or continue.

Expanding Depreciation by Period

To maintain optimal table size and increase depreciation processing efficiency, store depreciation entries by fiscal year. However, if you need to store depreciation entries by period rather than by fiscal year, use the Expand Depreciation by Period page to expand fiscal year storage to period storage.

This section discusses how to expand the depreciation period.

Page Used to Expand Depreciation by Period

| Page Name | Object Name | Navigation | Usage |
|-------------------------------|---------------|--|---|
| Expand Depreciation by Period | AMDPEXPD_RQST | Asset Management, Depreciation, Processing, Expand by Period | Store depreciation entries by period. You can expand storage one fiscal year at a time. |

Expanding the Depreciation Period

Access the Expand Depreciation by Period page.

Enter a fiscal year and process frequency. You can run the process for only one fiscal year at a time.

Run Options

| | |
|--|--|
| Unit Option | Select a business unit option, either <i>All</i> or <i>One</i> . If you select <i>One</i> , select a business unit in the field that appears. |
| Book Option | Select either <i>All</i> or <i>One</i> . If you select <i>One</i> , select a book name in the field that appears. |
| GRP Asset Option (group asset option) | Select a book group asset option, either <i>All</i> or <i>Range</i> . If you specify a range, select values in the From Asset field and the To Asset ID field. |

Creating Pending Depreciation Transactions

This section discusses how to create open depreciation transactions.

Page Used to Create Pending Depreciation Transactions

| Page Name | Object Name | Navigation | Usage |
|--|----------------|---|---|
| Depr Recalc (depreciation recalculation) | AMOPNTRNS_RQST | Asset Management, Depreciation, Open Transactions, Create | Run a process that creates open transactions. |

Creating Open Depreciation Transactions

Access the Depr Recalc page.

Use this page to run a process that opens transactions. This is necessary when you have used the Future Depr Years (future depreciation years) option to limit depreciation calculations to a specific number of years rather than the asset's useful life. For example, if you had limited future depreciation years to two, and you were now entering the third year, you would run this process before running depreciation so that the depreciation calculations would account for all open transactions.

Run Options

Select an asset type. Options are:

| | |
|-------------------------------|---|
| <i>All Assets</i> | Recalculates depreciation for all assets. |
| <i>Group Asset</i> | Recalculates depreciation for all group assets. |
| <i>Non Group Asset</i> | Recalculates depreciation for all assets except group assets. |

Process Scheduler runs the Create Pending Depreciation Transactions (AMOPNTRNS) process at user-defined intervals.

Viewing Depreciation-Related Information

You can view depreciation-related information for both regular assets and parent-child assets online.

This section discusses how to:

- View basic asset depreciation information.
- View net book value and depreciation.
- View period depreciation.
- View child asset depreciation.

Pages Used to View Depreciation-Related Information

| Page Name | Object Name | Navigation | Usage |
|--|-----------------|---|--|
| Asset Depreciation - Asset | DEPR_ALL_MAIN | Asset Management, Depreciation, Review Depreciation Info, Asset Depreciation | View a summary of basic asset and depreciation information. |
| Asset Depreciation - Depreciation | DEPR_ALL_YEAR | Asset Management, Depreciation, Review Depreciation Info, Asset Depreciation, Depreciation | For regular assets, calculate an asset's net book value and view its depreciation information for the year. For parent-child assets, calculate net book value. Depreciation information by year does not appear. |
| Asset Depreciation - Period Depreciation | DEPR_ALL_PERIOD | Asset Management, Depreciation, Review Depreciation Info, Asset Depreciation, Depreciation, Period Depreciation | View depreciation for the periods that you specified when you entered the asset. |
| Child Assets | CHILD_ASSETS | Asset Management, Financial Management, Parent-Child Relationships, Review Parent-Child NBV, Child Assets | Specify child assets to include in a parent asset's net book value calculation. |

Viewing Basic Asset Depreciation Information

Access the Asset Depreciation - Asset page.

Parent assets that are created on the Parent Asset page (parent-only assets) do not have cost or basic information. They cannot be viewed in the Parent Child Basic Information component. Also, you cannot view them or perform transactions on them in the Asset Cost/Adjust Transfers component; the Asset Retirements component; or the Parent-Child NBV component. If you want to use a parent asset as an umbrella asset for reporting purposes only and access these components to manipulate child assets in mass, create a 0-cost parent asset as opposed to a parent only asset. Also, to transact against parent and child assets at once, parent and child must use the same asset profile.

Viewing Net Book Value and Depreciation

Access the Asset Depreciation - Depreciation page.

Asset Depreciation - Depreciation page (1 of 2)

Unit: AUS01 Asset ID: AM325 Automobiles Status: In Service

Book Name: ACCNT_AUD Accounting Book - AUD Currency: AUD Stop depr. when NBV < Salvage: N

Method: Straight Line Calc Type: Remaining Value In Service Dt: 07/10/2000

Useful Life: 120 Periods Convention: AM

Begin Date: 07/01/2000

Depr Status: Depreciate

Cost: 8,543.00 As Of Fiscal Year: 2006 Period: 3

Salvage Value: 0.00

Accum Depr: 4,912.22

Net Book Value: 3,630.78

Calculate NBV

Asset Depreciation - Depreciation page (1 of 2)

Asset Depreciation - Depreciation page (2 of 2)

| Year | Depreciation Amt | Oper Unit | Fund | Dept | Program | Class | Bud Ref | Product | Project | Category | Cost Type |
|------|------------------|-----------|------|------|---------|-------|---------|---------|---------|----------|-----------|
| 2000 | 427.15 | | | | | | | | | AUTO | |
| 2001 | 854.30 | | | | | | | | | AUTO | |
| 2002 | 854.30 | | | | | | | | | AUTO | |
| 2003 | 854.30 | | | | | | | | | AUTO | |
| 2004 | 854.30 | | | | | | | | | AUTO | |
| 2005 | 854.30 | | | | | | | | | AUTO | |
| 2006 | 854.30 | | | | | | | | | AUTO | |
| 2007 | 854.30 | | | | | | | | | AUTO | |
| 2008 | 854.30 | | | | | | | | | AUTO | |
| 2009 | 854.30 | | | | | | | | | AUTO | |
| 2010 | 427.15 | | | | | | | | | AUTO | |

Asset Depreciation - Depreciation page (2 of 2)

Net Book Value

To calculate the net book value of the asset, enter values in the As Of Fiscal Year field and the Period field, and click the Calculate NBV (calculate net book value) button. The system displays the cost, salvage value, accumulated depreciation, and net book value for the selected asset, fiscal year, and accounting period.

Yearly Depreciation

Displays depreciation amounts by year through the last year of the asset’s life.

Note. Yearly depreciation amounts are not shown for parent-child assets.

Viewing Period Depreciation

Access the Asset Depreciation - Period Depreciation page.

| Asset | | Depreciation | | Period Depreciation | | | | | | | |
|--|------------------|--------------------------------|-------|--|---------------------------|-------|---------|---------|---------|----------|-----------|
| Unit: | AUS01 | Asset ID: | AM325 | Automobiles | Status: In Service | | | | | | |
| Book Find View All First 1 of 3 Last | | | | | | | | | | | |
| Book Name: ACCNT_AUD Accounting Book - AUD | | Currency: AUD | | Stop depr. when NBV < Salvage: N | | | | | | | |
| Depreciation Attributes | | | | | | | | | | | |
| Net Book Value | | | | | | | | | | | |
| Cost: | 8,543.00 | As Of Fiscal Year: 2006 | | Period: 3 | | | | | | | |
| Salvage Value: | 0.00 | | | | | | | | | | |
| Accum Depr: | 4,912.22 | | | | | | | | | | |
| Net Book Value: | 3,630.78 | Calculate NBV | | | | | | | | | |
| Yearly Depreciation Customize Find View All First 1-11 of 11 Last | | | | | | | | | | | |
| Year | Depreciation Amt | Oper Unit | Fund | Dept | Program | Class | Bud Ref | Product | Project | Category | Cost Type |
| 2000 | 427.15 | | | | | | | | | AUTO | |
| 2001 | 854.30 | | | | | | | | | AUTO | |
| 2002 | 854.30 | | | | | | | | | AUTO | |
| 2003 | 854.30 | | | | | | | | | AUTO | |
| 2004 | 854.30 | | | | | | | | | AUTO | |
| 2005 | 854.30 | | | | | | | | | AUTO | |
| 2006 | 854.30 | | | | | | | | | AUTO | |
| 2007 | 854.30 | | | | | | | | | AUTO | |
| 2008 | 854.30 | | | | | | | | | AUTO | |
| 2009 | 854.30 | | | | | | | | | AUTO | |
| 2010 | 427.15 | | | | | | | | | AUTO | |

Asset Depreciation - Period Depreciation page

Get Period Depreciation

Expense Select to view depreciation expense for the year that is specified.

Accum (accumulated) Select to view accumulated depreciation for the year that is specified.

Note. If you do not select Expense, but you do select Accum, only the amounts that affected accumulated depreciation appear. The system does not show the expense for that year. For example, when an asset is added with accumulated depreciation, no corresponding expense amount exists. If you do not select Accum, but you do select Expense, the system displays the amounts that affected the expense account, but not the accumulated depreciation for that year.

Year Select a year to display its period depreciation entries.

Get Period Depr (get period depreciation) Click to have the system calculate depreciation that was allocated to each period for the year specified and display the information. You can change the period depreciation amounts. Note that when you modify the period depreciation, you change the depreciation method to manual depreciation.

Period Depreciation

Click the Depr. Accum Adjustment (depreciation accumulated adjustment) link to make adjustments to accumulated depreciation.

Note that if you perform two transfers on the same asset in the same accounting period (on the same set of ChartFields), the Asset Depreciation - Period Depreciation page displays only a *net* result of both transfers. For example, suppose that an asset with an Actual Month convention is added to department 12000 on August 31, 2006, with a cost of 10,000.00 JPY and a life of five years. On September 30, 2006, the asset is transferred to department 14000 using the same convention. The asset is then transferred again on the same day to department 21100. The Asset Depreciation - Period Depreciation page displays the following entries for the transfers:

```

12000  2006  8  DPR  166.66
12000  2006  9  TFR  -166.66
21100  2006  9  TFR  +166.66

```

No entry exists for the transfer in and out of department 14000 on the same day, as this is a net 0. Note, however, that the depreciation table has two additional rows for both transfer out and transfer in.

Viewing Child Asset Depreciation

Access the Child Assets page.

Click the Select All button to include all child assets with the parent in the net book value calculation.

To include particular child assets, select the Selected check box for a row.

| | |
|------------------------------------|---|
| Tag Number | Displays the tag that is assigned to the child asset. Parent and child assets can share the same tag number. |
| Description | Displays the child asset description. |
| Child Asset ID | Displays the asset ID that is assigned to the child asset. |
| Cost | Displays the cost of the child asset. |
| Currency | Displays the currency in which child asset costs are stored. |
| Acq Date (acquisition date) | Displays the date that the asset was acquired. |
| Asset Information | Click to open a new Asset page in the Asset Depreciation component. The page is populated with the child asset. |

The Include Parent Asset check box is selected by default. Clearing it enables you to calculate net book value at once for all or selected child assets while excluding the parent asset from the calculation.

Adjusting Accumulated Depreciation

Use the Depreciation Accumulated Adjustment page to adjust accumulated depreciation. After saving the page, click the Asset Depreciation link to view the adjustment.

Note. Each book has to be adjusted separately. If multiple books are associated with the same ledger group with KLS (Keep Ledgers in Synch) activated, the adjustment amount is converted and copied from the primary book to the secondary books if no adjustment amounts are entered in the secondary book.

This section lists the page that you use to adjust accumulated depreciation.

Page Used to Adjust Accumulated Depreciation

| Page Name | Object Name | Navigation | Usage |
|---|----------------|---|--|
| Depr Accum Adjustment (depreciation accumulated adjustment) | DEPR_ACCUM_ADJ | Asset Management, Depreciation, Processing, Adjusted Accumulated Depr | Make adjustments to accumulated depreciation. |

Running Depreciation Reports

This section provides an overview of depreciation reports and discusses how to load the depreciation reporting table.

Understanding Depreciation Reports

PeopleSoft Asset Management provides a full complement of depreciation-related reports. Before you can run depreciation reports, you must load the Depreciation Reporting table (PS_DEPR_RPT). The table stores life-to-date and year-to-date depreciation amounts. You should run the process once at the beginning of the year for all assets in your system, and on a monthly or other regular basis thereafter for new open transactions.

To run depreciation reports:

1. Load the Depreciation Reporting table.
2. Run the Depreciation by Period report.
3. Run the Depreciation by Fiscal Year report.
4. Run the Depreciation Activity report.

Pages Used to Run Depreciation Reports

| Page Name | Object Name | Navigation | Usage |
|---|---------------|---|---|
| Load Depr Reporting Table (load Depreciation Reporting table) | AMDPREPT_RQST | Asset Management, Financial Reports, Load Reporting Tables, Depr Reporting Table | Load the Depreciation Reporting table (PS_DEPR_RPT). Use this table for all depreciation reports. |
| Depreciation by Period - Parameters | RUN_AMDP2200 | Asset Management, Financial Reports, Cost and Depreciation, Depreciation by Period | Run the Depreciation by Period report. |
| Depreciation by Fiscal Year - Parameters | RUN_AMDP2300 | Asset Management, Financial Reports, Cost and Depreciation, Depreciation by Fiscal Year | Run the Depreciation by Fiscal Year report. |
| Depreciation Activity | RUN_AMDP2000 | Asset Management, Financial Reports, Cost and Depreciation, Depreciation Activity | Run the Depreciation by Activity report. |

Loading the Depreciation Reporting Table

Access the Load Depr Reporting Table page.

Load Depr Reporting Table

Run Control ID: DD [Report Manager](#) [Process Monitor](#) Run

Request Find | View All First ◀ 1 of 1 ▶ Last

*Request ID: Process Frequency: + -

Run Options

Use Open Trans Keep Other Fiscal Years

From Year: To Year:

Unit:

Book Name:

From Asset ID: To Asset ID:

Process Current Activity

Update Statistic

Check 'Update Statistics' if you want the process to Update Statistics at run time.
You need to update statistics if there is a huge difference between number of assets during this run and last run.

Load Depr Reporting Table page

Run Options

Use Open Trans (use open transactions) Select to pick up only new open transactions since you last ran the process.

Keep Other Fiscal Years Select to process a new year but retain other years in the table.

Note. The Depreciation Reporting table should be loaded only for the current fiscal year, or at most two fiscal years (depending on your reporting requirements).

You should run the AMDPREPT_RQST process throughout the year to account for new transactions that were created during the year by selecting the Use Open Trans check box.

CHAPTER 15

Using User-Defined Asset Depreciation

This chapter provides an overview of user-defined depreciation and discusses how to:

- Create a user-defined depreciation method.
- View user-defined variables.
- Review user-defined methods.
- Generate a user-defined depreciation SQC program.
- Copy a user-defined depreciation method.
- Select a user-defined depreciation method for an asset.

Understanding User-Defined Depreciation

PeopleSoft Asset Management enables you to create and use your own depreciation method. This section provides the information that you need to do so.

To create and use depreciation methods:

1. Review the variables available for use in your depreciation formula.

This section includes a table that lists the commonly used user-defined depreciation variables. Also included is an inquiry page, where you can review these variables within the system. Review the available variables, and then proceed to create depreciation formulae.

2. Define the formula that you want to use for depreciation.

Do this in a series of steps, and then review the steps on a summary page that we provide for this purpose.

3. Assign the user-defined method to assets.

You can do this on several different pages within the system.

4. Save the user-defined depreciation method.
5. Generate a user-defined method SQC program.

This SQC is called by the main depreciation calculation program, `AM_DEPR_CALC`, during depreciation calculations. It processes all user-defined depreciation methods by `setID`.

Creating or Selecting Variables

PeopleSoft provides a listing of the user-defined depreciation variables that are commonly used to construct the depreciation formula. The following table shows the variable name, the corresponding program variable, and whether a variable can be assigned a calculation result. Review this information to see if you can use it to construct your formula.

| Variable | Program Variable | Assign To Flag |
|-------------------------------|---------------------|----------------|
| ALLOC_LIFE | # ALLOC_LIFE | N |
| ALLOC_TOTAL | #ALLOC_TOTAL | N |
| ASSET_BASIS | #ASSET BASIS | N |
| ASSET_COST | #ASSET_COST | N |
| ASSET_COST_PER_ CHARTFIELD | #LINE_COST | N |
| ASSET_LIFE | #ASSET_LIFE | N |
| BEGIN_DEPR_PERIOD | #BEGIN_DEPR_PD | N |
| BEGIN_DEPR_YEAR | #BEGIN_DEPR_FY | N |
| CURRENT_YEAR | #SELECTED_FY | N |
| DB_PERCENT | #DB_PERCENT | N |
| DEPR | #DEPR | Y |
| DEPR_LOW_LIMIT | # DEPR_LOW_LIMIT | N |
| DEPR_PERCENT | #FLAT_PERCENT | N |
| LIFE_IN_YEARS | # LIFE_IN_YEARS | N |
| LIFE_REMAINING | #LIFE_REMAINING | N |
| LINE_COST_FRACTION | #LINE_COST_FRACTION | N |

| Variable | Program Variable | Assign To Flag |
|-----------------------|-------------------------|-----------------------|
| LTD_DEPR | #LTD_DEPR | N |
| NO_OF_PERIODS_IN_YEAR | #NUMBER_OF_PERIODS | N |
| NO_OF_PERIODS_TO_DEPR | #ALLOC | N |
| RESULT_A | #RESULT_A | Y |
| RESULT_B | #RESULT_B | Y |
| RESULT_C | #RESULT_C | Y |
| RESULT_D | #RESULT_D | Y |
| RESULT_E | #RESULT_E | Y |
| RESULT_F | #RESULT_F | Y |
| RESULT_G | #RESULT_G | Y |
| RESULT_H | #RESULT_H | Y |
| RESULT_I | #RESULT_I | Y |
| RESULT_J | #RESULT_J | Y |
| RESULT_K | #RESULT_K | Y |
| RESULT_L | #RESULT_L | Y |
| RESULT_M | #RESULT_M | Y |
| RESULT_N | #RESULT_N | Y |
| SALVAGE_VALUE | #SALVAGE_VALUE | N |
| TOTAL_PERIODS_DEPR | #PERIOD_COUNT_ACCUM | N |

| Variable | Program Variable | Assign To Flag |
|----------|------------------|----------------|
| UDX1 | #UDX1 | Y |
| UDX2 | #UDX2 | Y |
| UDX3 | #UDX3 | Y |
| UDX4 | #UDX4 | Y |
| UDX5 | #UDX5 | Y |
| UDX6 | #UDX6 | Y |

Page Used to Create or Select Variables

| Page Name | Object Name | Navigation | Usage |
|------------------------|------------------|--|---|
| User Defined Variables | UD_VARIABLE_DEFN | Set Up Financials/Supply Chain, Product Related, Asset Management, Depreciation, User Defined Variables | Create a new variable or select an existing variable. |
| User Defined Variables | UD_VARIABLE_INQ | Set Up Financials/Supply Chain, Product Related, Asset Management, Review User Defined Methods, User Defined Variables | View or select an existing variable. |

Creating or Selecting Variables

Access the User Defined Variables page.

Variable: ASSET_LIFE

Attributes

***Description:**

Assign to Variable **Initialize**

Program Variable:

Comment

Original Asset Life in periods.
 #Life = Number of Periods in Year * Asset Life in Year.
 Please note the difference between #Life and #Alloc_Life.

User Defined Variables page

| | |
|---------------------------|---|
| Assign To Variable | Indicates whether you can assign the resultant value to this variable. |
| Program Variable | Identifies and references the user-defined variable name with the corresponding internal AM_DEPR_CALC or AMDPCUDM program variable name. |
| Initialize | <p>Note. This check box appears only for variables that have the Assign To Variable selected.</p> <hr/> <p>Determines whether you can initialize the content of a variable during consecutive year calculation in order to use the variable content in the calculation for the subsequent years.</p> |

Creating a User-Defined Depreciation Method

Once you have designed the depreciation formula, you must enter it into PeopleSoft Asset Management. The User Defined Method component consists of three pages on which you define the custom depreciation formula, see a summary page of the formula that you entered, and add comments about the formula for reference as appropriate.

The User Defined Methods component (UD_METHOD) contains the pages to create and review custom depreciation formulas.

This section provides an overview of and discusses how to create and view user-defined depreciation methods, particularly how to:

- Enter the user-defined depreciation method.

- Summarize the user-defined method.
- Describe the user-defined method.

Pages Used to Create a User-Defined Depreciation Method

| Page Name | Object Name | Navigation | Usage |
|---|-------------------|---|---|
| User-Defined Method — Definition | UD_METHOD_DEFN | Set Up Financials/Supply Chain, Product Related, Asset Management, Depreciation, User Defined Methods | Create a user-defined depreciation method. Note. Method ID is the five-character identifier for the user-defined depreciation method that you create. |
| User Defined Methods - Definition (inquiry) | UD_METHOD_INQ | Set Up Financials/Supply Chain, Product Related, Asset Management, Review User Defined Methods, User Defined Methods | View the custom depreciation formula. |
| User Defined Methods - Summary | UD_METHOD_SUMMARY | <ul style="list-style-type: none"> • Set Up Financials/Supply Chain, Product Related, Asset Management, Depreciation, User Defined Methods, Summary • Set Up Financials/Supply Chain, Product Related, Asset Management, Review User Defined Methods, User Defined Methods, Summary | View a visual representation of the complete depreciation formula that you entered. |
| User Defined Methods - Comment | UD_METHOD_COMMENT | <ul style="list-style-type: none"> • Set Up Financials/Supply Chain, Product Related, Asset Management, Depreciation, User Defined Methods, Comment • Set Up Financials/Supply Chain, Product Related, Asset Management, Review User Defined Methods, User Defined Methods, Comment | Enter or view additional comments or explanations of this depreciation method. |

Entering the User-Defined Depreciation Method

Access the User Defined Methods - Definition page.

Definition Summary Comment

SetID: SHARE
Method ID: JDB ***Description:** Tangible/Declining Balance

Formula Sequence Find | View All First 1 of 12 Last

***Sequence:** 10 **Description:** Calculate Asset Cost

Condition
 None Then And
 If Else Or

End If

Operand 1
 Constant
 Variable
 ASSET_BASIS

Operation
 +

Operand 2
 Constant
 Variable
 SALVAGE_VALUE

Result
 RESULT_N

Sort Validate

User Defined Methods - Definition page

Formula Sequence

The system displays a sequence number. The sequence numbers are incremented by 10s (10, 20, and so on). You can change the sequence number if you like. Add a description of the sequence in the field provided.

For example, you can break the following depreciation formula into steps that you can enter as separate sequences on this page:

$$\text{Depreciation} = (\text{Asset Cost} / \text{Asset Life}) \times \text{Number of Periods to be Depreciated}$$

You can write the depreciation formula as two steps, or sequences:

- Step 1

$$\text{Result A} = \text{Asset Cost} / \text{Asset Life}$$

- Step 2

$$\text{Depreciation} = \text{Result A} \times \text{No. of periods to be depreciated}$$

Condition

| | |
|-------------|--|
| None | The default. |
| If | Indicates the beginning of an <i>If</i> statement within an If-Then-Else construct. |
| Then | Indicates the beginning of the <i>Then</i> statement within an If-Then-Else construct. |
| Else | Indicates the beginning of the <i>Else</i> statement within an If-Then-Else construct. |

- And** Indicates that you want to include both variables in the search.
- Or** Indicates that you want to include either variable in the search.

You can create and/or statements, if-then-else statements, and multiple if-then-else statements. You cannot use nested if statements.

Operand 1

- Constant** Select to indicate a value, and then enter the value.
- Variable** Select to indicate a user-defined variable.

Operation

Select the arithmetic operator.

Operand 2

- Constant** Select to indicate a value, and then enter the value.
- Variable** Select to indicate a user-defined variable.

Result

- Result** Specify a name for the result of this operation. The result can be any user-defined variable for which the Assign To Variable check box on the User Defined Variables page is selected.
- Validate** Click to ensure that the syntax that you entered is correct. The program performs a validation check and prompts you with an error message to correct any syntax mistakes.
- Sort** Click to redisplay the sequence of steps that you entered in ascending sequence order, if you have edited some steps into the formula.

End If

Select End If to indicate that this is the end of an If-Then-Else construct.

Generating a User-Defined Depreciation SQC Program

Once you have created a new user-defined depreciation method, you must regenerate the AMUDDEPR.SQC program that is called by the main depreciation calculation program AM_DEPR_CALC during the depreciation calculation process.

Page Used to Generate a User-Defined Depreciation SQC Program

| Page Name | Object Name | Navigation | Usage |
|-------------------------------|-----------------|--|--|
| Generate User Defined Methods | RUN_AMUD_METHOD | Set Up Financials/Supply Chain, Product Related, Asset Management, Depreciation, Generate User Defined Methods | Regenerate the AMUDEPR.SQC program that is called by the main depreciation calculation program AM_DEPR_CALC during the depreciation calculation process. |

Using the User Defined Method Generate Page

Access the Generate User Defined Methods page.

Run Control ID: GM [Report Manager](#) [Process Monitor](#) Run

Request Information

This process will generate a User Defined Method AMUDEPR.SQC to be called from AMDPCALC.SQR for all SetIDs.
 Make sure you do specify the output file as 'AMUDEPR.SQC' in the same directory where AMDPCALC.SQR is located.
 For example: C:\AMDVLSQR\AMUDEPR.SQC

Generate User Defined Methods page

The program automatically processes all user-defined depreciation method IDs that you created for that setID.

Note. Make sure that you copy the output file as AMUDEPR.SQC in the same directory where the AM_DEPR_CALC.SQR program is located.

If you receive any error messages when you run AM_DEPR_CALC, verify that you have copied the SQC properly to the directory where AM_DEPR_CALC is stored.

Process Scheduler runs the AMUDMTHD process at user-defined intervals.

Copying a User-Defined Depreciation Method

You can copy an existing user-defined depreciation formula when you define a new method that is similar to an existing one. You can copy the existing formula and modify it for the requirements of the new method, rather than defining it from scratch.

Page Used to Copy a User-Defined Depreciation Method

| Page Name | Object Name | Navigation | Usage |
|--------------------------------|----------------|--|---|
| User Defined Methods - Copy | UD_METHOD_COPY | Set Up Financials/Supply Chain, Product Related, Asset Management, Depreciation, User Defined Methods-Copy | Copy a user-defined depreciation method. Note. Enter the method ID of the user-defined depreciation method that you want to copy. |

Copying a User-Defined Method

Access the User Defined Methods - Copy page.

SetID: SHARE
Method ID: JDB Tangible/Declining Balance

Copy New Method

*New SetID:

*New Method ID:

*Description:

Comment

User Defined Methods — Copy page

New SetID Select the ID for the new depreciation method; it may be the same or different from the depreciation method from which you are copying.

New Method ID Enter an ID and a description for the new depreciation method. The description and Comment field appear by default from the old method; you can modify them.

After you have saved the new method, click the Go to Maintain User Defined Method Page link to modify the new copied method, if appropriate.

Note. You must save the new depreciation method before you can modify it.

Selecting a User-Defined Depreciation Method for an Asset

Once you have created a user-defined depreciation method and generated the SQC, the method is available for selection as the depreciation method to be used for an asset. You do this when you:

- Specify a user-defined depreciation method for the asset profile.
- Complete an Asset Book Definition.
- Add an asset with ExpressAdd.

See Also

PeopleSoft Enterprise Asset Lifecycle Management Fundamentals 9.0 PeopleBook, “Establishing Asset Processing,” Setting Up Asset Profiles

[Chapter 5, “Adding and Maintaining Assets,” page 45](#)

CHAPTER 16

Reviewing Asset Depreciation Calculation Results

This chapter provides an overview of *what if* depreciation and discusses how to:

- Perform what if depreciation modeling.
- Load the new book value depreciation results into a spreadsheet program.

Understanding What If Depreciation

PeopleSoft Asset Management provides you with the ability to perform what if depreciation simulation modeling and to load the net book value results into a spreadsheet program for analysis.

Using what if depreciation simulation modeling, you can determine, evaluate, and compare the depreciation amounts for assets if you were to change all or some of the depreciation parameters. For example, you may want determine the effect on depreciation if you change the prorate convention from mid-month to mid-quarter, or if you change the depreciation method from straight line to sum of the years digits. You can experiment with depreciation to determine what the effect on depreciation would be without changing the actual depreciation parameters for an asset.

Another useful benefit of the What If Depreciation feature is to project the depreciation if you add an asset and run the actual depreciation program. For example, you can create an asset and run the What If Depreciation program rather than running the *actual* depreciation program. You can then see what the depreciation amount for the asset would be, go back and modify the depreciation parameters accordingly, and then perform the actual depreciation.

To perform what if depreciation simulation, the assets must already exist in the system. Add at least one asset to perform the simulation. The What If Depreciation feature uses only Add and Transfer In transactions for modeling.

Performing What If Depreciation

To generate what if depreciation simulation:

- Perform what if depreciation.
- View what if depreciation results.

Pages Used to Perform What If Depreciation

| Page Name | Object Name | Navigation | Usage |
|------------------------------|---|--|---------------------------------------|
| Run What If Depreciation | RUN_AMDPCOMP | Asset Management, Depreciation, What If Scenarios, Request | Perform what if depreciation. |
| What If Depreciation Results | DEPR_ALL_PRD_COMP, DEPR_ALL_YEAR_COMP, DEPR_ALL_MAIN_COMP | Asset Management, Depreciation, What If Scenarios, Review | View results of what if depreciation. |

Performing What If Depreciation

Access the Run What If Depreciation page.

Run What If Depreciation

Run Control ID: ARUPDATE [Report Manager](#) [Process Monitor](#) Run

*Run ID: Delete Stage Row:

Selection Request Parameters

*Unit: Profile ID: Life:

Book Name: Method:

| Asset | Tag Number | In Service Date |
|---|----------------------------|---|
| From: <input type="text"/> <input type="button" value="🔍"/> | From: <input type="text"/> | From: <input type="text"/> <input type="button" value="📅"/> |
| To: <input type="text"/> <input type="button" value="🔍"/> | To: <input type="text"/> | To: <input type="text"/> <input type="button" value="📅"/> |

What-if Parameters

Method: Useful Life: Depr Pass Life

Convention: End Date: Monthly

UD Method: Low Limit: Low Value

Schedule: Depr Limit:

UOP ID: Shift Code:

Percent:

DB Pct:

Limit Pct:

| Calculation Type | Averaging Option | Transaction |
|---|--|--|
| <input type="radio"/> Remaining Value <input checked="" type="radio"/> Life-to-Date Reset | <input type="radio"/> Monthly <input type="radio"/> Yearly <input type="radio"/> None Reset | Trans Date: <input type="text"/> <input type="button" value="📅"/> Acctg Date: <input type="text"/> <input type="button" value="📅"/> |

Run What If Depreciation page

Save the what if depreciation changes that you make and run the program. If you want to run multiple modeling comparisons using the same range of assets, use different run control IDs.

The What If Depreciation page uses the AM_DEPR_COMP application engine program to run simulated depreciation instead of the actual depreciation program (AM_DEPR_CALC).

Process Scheduler runs the AM_DEPR_COMP application engine process at user-defined intervals.

Viewing What If Depreciation Results

Access the What If Depreciation Results page.

Asset | **What If Depreciation** | What If Period Depreciation

Unit: US001 **Asset ID:** EX01 Automobile **Status:** In Service

Book

Book Name: CORP Corporate **Run ID:** EX01 **Currency:** USD

▶ Depreciation Attributes

▼ Net Book Value

Cost: 12,000.00 *As Of Fiscal Year: 2006 **Period:** 8

Salvage Value: 2,000.00

Accum Depr: 5,555.57

Net Book Value: 6,444.43 Calculate NBV

What If Yearly Depreciation

| Year | Depreciation Amt | Operating Unit | Fund Code | Department | Program | Class Field | Bud Ref | Product | Project | Affiliate |
|----------------------|------------------|----------------|-----------|------------|---------|-------------|---------|---------|---------|-----------|
| 2005 | 3,333.33 | | | | | | | | | |
| 2006 | 3,333.34 | | | | | | | | | |
| 2007 | 3,333.33 | | | | | | | | | |

What If Depreciation Results page

You can view the results of what if depreciation through an inquiry page, or you can run a query to review results.

Using either method, examine the depreciation results to see the consequences of the depreciation parameter modifications that you made, or to see the projected depreciation if you ran depreciation for an asset. You can put the results of the query into a spreadsheet program. Go back and modify the depreciation results accordingly, and then run the actual depreciation program (AM_DEPR_CALC), if applicable.

Loading the Net Book Value Depreciation Results Into a Spreadsheet Program

You can load the net book value depreciation results into a spreadsheet program.

Page Used to Load the Net Book Value Depreciation Results into a Spreadsheet Program

| Page Name | Object Name | Navigation | Usage |
|--|--------------|--|--|
| Load Asset NBV Table (load asset net book value table) | RUN_AMLDNBVT | Asset Management, Financial Reports, Load Reporting Tables, Net Book Value Table | <p>Generate an online report of depreciation processing results, run a query to view them, and export the results into a spreadsheet program for manipulation.</p> <p>Note. You can run different modeling simulations for the same range of assets by giving each simulation a different Run Control ID. Net book value information is loaded to the Asset Net Book Value table (ASSET_NBV_TBL) and is available to view online.</p> |

Loading Depreciation Results Into a Spreadsheet Program

Access the Load Asset NBV Table page.

Load Asset NBV Table page

Specify the as of fiscal year (in the As Of FY field) and accounting period (in the Period field).

Once you have loaded the Net Book Value Table, you can run any of the following Crystal reports:

- Crystal Report - Asset NBV by ChartField (AMNB1000).
- Crystal Report - Asset NBV by Category (AMNB1010).
- Crystal Report - Asset NBV by Location (AMNB1030).

CHAPTER 17

Allocating Asset Depreciation Expenses

This chapter provides an overview of allocating depreciation expenses, describes the prerequisite tasks, and describes how to:

- Set up the depreciation allocation process.
- Run the allocation process.

Understanding the Depreciation Allocation Business Process

PeopleSoft Asset Management enables you to allocate depreciation expenses or asset costs across multiple departments or ChartField combinations. The allocation might be divided equally among all departments or selected ChartField combinations, or it might be calculated on a factor that is appropriate to your business, such as a prorata basis.

In some business environments, allocation of depreciation expenses to departments or ChartField combinations other than those assigned to an asset's cost might be required. For example, depreciation expenses for shared services assets such as HVAC (Heating, Ventilation, Air Conditioning) for a store in a mall might be needed to allocate the expenses across all departments using the service. The allocation might be spread evenly among all departments, or it might be calculated on a prorata basis based on the square footage of each department or some other factor.

PeopleSoft Asset Management enables you to create and process allocations before posting depreciation to the general ledger. Allocation amounts are derived in PeopleSoft Asset Management from the DIST_LN table, which is populated by accounting entry generation programs such as the Accounting Entry Creation process (AM_AMAEDIST) and the Depreciation Close process (AM_DPCLOSE). The allocation process must be run after running these programs and before journal generation. The allocation program takes unposted journal lines from the DIST_LN table, processes them according to the defined allocation, and creates new allocation entries. Also, lines that have already been sent to the general ledger by previous journal generation are available to allocate.

Processing Allocations With Fund Accounting

When an educational or governmental entity acquires a capital asset, the transaction is usually accounted for as a budgeted or funded acquisition. Other programs within PeopleSoft provide the tools to perform budget checking, such as in the Purchase Order and Accounts Payable transaction processing. After the transaction to acquire the asset is completed, PeopleSoft Asset Management creates ongoing depreciation transactions. It is important that the asset depreciation entries do not inherit the original budget reference during creation of period depreciation entries because the original budget reference is not appropriate for future year's depreciation.

For example, assume that the current financial year is 2006 with budget year of 2005. An asset was added on 01/01/2003 with a budget year of 2003. All of the depreciation rows for 2006 are created with the budget year of 2003. When the depreciation entries for 2006 are posted to the general ledger, they have an incorrect budget year of 2003.

To accommodate the use of budget or fund accounting in PeopleSoft Asset Management, it is recommended that you use the allocation process to reallocate the depreciation and other transactions to the active budget reference and year. This program is run after the accounting entry creation process and depreciation close process have been run.

Prerequisites

You must have already defined transaction groups to set up the allocation basis for asset costs and depreciation. If you use budget or fund accounting, it is recommended that you establish an asset or budget reallocation transaction group, such as *All* to include all transaction types that apply, such as ADD, DPR, PDP, RCT, RET, and TRF.

See Also

PeopleSoft Enterprise Asset Lifecycle Management Fundamentals 9.0 PeopleBook, “Establishing Asset Processing”

PeopleSoft Enterprise Asset Lifecycle Management Fundamentals 9.0 PeopleBook, “Setting Up Accounting Entry and Financial Processing for PeopleSoft Asset Management”

PeopleSoft Enterprise Asset Lifecycle Management Fundamentals 9.0 PeopleBook, “Setting Up Depreciation Processing”

Setting Up the Depreciation Allocation Business Process

Use the Allocation Basis Group component (ALLOC_BASIS_GRP) to set up the Depreciation Allocation business process:

- Define the allocation basis, which determines how and in what proportion the journal line amounts are distributed to various targets.
- Define the sources and destinations for the cost/depreciation to be allocated.
- Link assets to a defined allocation basis.

Pages Used to Set Up the Depreciation Allocation Business Process

| Page Name | Object Name | Navigation | Usage |
|---|------------------|---|--|
| Allocation Basis Definition - Definition | ALLOC_BASIS_PNL | Set Up Financials/Supply Chain, Product Related, Asset Management, Financials, Allocation Basis Definition | Define basic information for your allocation basis. |
| Allocation Basis Definition - Allocations | ALLOC_BASIS1_PNL | Set Up Financials/Supply Chain, Product Related, Asset Management, Financials, Allocation Basis Definition, Allocations | Specify the sources and destinations for the allocation. |
| Define Allocations for Asset | ALLOC_DEFN_PNL | Asset Management, Accounting Entries, Allocate Depreciation Expense, Asset Allocations | Associate assets with Allocation Basis IDs. |

Entering the Allocation Basis Definition

Access the Allocation Basis Definition - Definition page.

The screenshot displays the 'Definition' tab of the Allocation Basis Definition page. At the top, there are two tabs: 'Definition' and 'Allocations'. Below the tabs, the 'SetID' is 'SHARE' and 'Basis Id' is 'BUDGET2006'. A search bar contains 'Find | View All' and a page indicator shows '1 of 1'. The main form area includes the following fields and controls:

- *Description:** A text field containing 'Allocate 2005 to 2006' with '+' and '-' icons to its right.
- *Effective Date:** A date field containing '01/01/1900' with a calendar icon.
- *Transaction Group:** A dropdown menu showing 'DEPR'.
- *Allocation Type:** A dropdown menu showing 'Copy'.
- Unit of Measure:** A text field with a magnifying glass icon.
- Total Allocation Units:** A text field.
- Status:** A section with two radio buttons: 'Active' (selected) and 'Inactive'.

Allocation Basis Definition page

Transaction Group

Select a transaction group which combines depreciation types for allocating expenses. In the case of using budget or fund accounting, select the transaction group that is used for budget or fund reallocations.

Allocation Type

Select one:

- *Copy:* Select to override a value so that ownership can be assigned (for example, to one department while expense is charged to another department).

- *Evenly*: Select to distribute the Total Allocation Units equally among the allocation destinations.
- *Prorata*: Select to distribute the Total Allocation Units in the way you specify in the Destination group box on the Allocation Basis Definition - Allocations page.

Note. If you select *Prorata* as the allocation type, enter a Unit of Measure and the number of Total Allocation Units.

Unit of Measure

If you select *Prorata* as the allocation type, enter a unit of measure. This is the criteria you are going to use to do the allocation.

Total Allocation Units

The total quantity of your units of measure that are used to perform the allocation. You enter the allocation units for each destination to establish the allocation ratio for each destination.

Defining the Source and Destinations

Access the Allocation Basis Definition - Allocations page.

Allocation Basis Allocations page

Complete the applicable ChartField sources and destinations.

If you are using a prorata allocation, enter the Allocation Units for each destination in the Destination group box.

Defining Allocations for Assets

Access the Define Allocations for Asset page.

Define Allocations for Asset

Unit: US001 **Allocation Id:** BLDG_ALLOC

Find | View All First 1 of 1 Last

***Effective Date** **Status**

01/01/1900 Active Inactive + -

Book Name **Category** **Cost Type** **Allocation Basis Id**

 BLDG DEPT_ALLOC

Oper Unit **Fund** **Dept** **Program** **Class** **Bud Ref** **Product** **Project**

Customize | Find | View All First 1-3 of 3 Last

| *Asset ID | *Allocation Basis Id | Description | Tag Number |
|----------------|----------------------|-------------|------------|
| 1 EX_000000498 | DEPT_ALLOC | | + - |
| 2 EX_000000499 | DEPT_ALLOC | | + - |
| 3 EX_000000500 | DEPT_ALLOC | | + - |

Define Allocations for Asset page

Specify the criteria for the allocation by selecting the ChartFields to which you will associate the criteria. To generate proper search results for asset IDs, first populate one or all of the following fields:

- Book Name
- Category
- Cost Type
- Oper Unit
- Fund
- Dept (department)
- Program
- Class
- Bud Ref (budget reference)
- Product
- Project

Note. The system might not display all ChartFields. The available ChartFields are dependent upon the definitions that you have created during implementation.

Cost Type

Select the Cost Type to further narrow your search results.

Allocation Basis Id

Enter the Allocation Basis ID for this allocation; this is the default basis for this allocation.

Note. Use the upper Allocation Basis Id field to quickly establish the allocation basis value by default to each one of the selected asset IDs. Entering a value in the Allocation Basis Id field in this portion of the page *does not* narrow your search.

Within the group box on the page, you can also associate each Asset ID with an Allocation Basis Id .

When using budget or fund accounting, define the assets against which allocations should be run. For example, include all assets that pertain to the budget reference year 2001. After running the accounting entry generation process (AM_AMAEDIST) and the depreciation close (AM_DPCLOSE) process, the Depreciation Allocation (AMALLOC) process with the appropriate budget Allocation ID can be run for the applicable fiscal year and period.

Performing the Depreciation Allocation Business Process

You can create allocation entries in the DIST_LN table by running the Depreciation Allocation (AMALLOC) process.

Note. The allocations process calls the centralized processor to generate balanced Inter/IntraUnit entries.

See Also

PeopleSoft Enterprise Application Fundamentals 9.0 PeopleBook, “Using Interunit and Intraunit Accounting and ChartField Inheritance”

Page Used to Run the Depreciation Allocation Business Process

| Page Name | Object Name | Navigation | Usage |
|--|--------------|---|--|
| AM Period Allocation (asset management period allocation) | AMALLOC_RQST | Asset Management, Accounting Entries, Allocate Depreciation Expense, Process Allocation | Create allocation entries in the DIST_LN table. If necessary, the allocations process calls the IU Processor to create balanced entries. |

Running the Depreciation Allocation Process

Access the AM Period Allocation page.

AM Period Allocation

Run Control ID: ALLOC [Report Manager](#) [Process Monitor](#) Run

| | | | |
|------------------------|------------------------------------|----------------------------|---|
| *Request ID: | <input type="text" value="1"/> | | |
| *Business Unit: | <input type="text" value="US001"/> | *Allocation Id: | <input type="text" value="BLDG_ALLOC"/> |
| *Fiscal Year: | <input type="text" value="2006"/> | *Accounting Period: | <input type="text" value="12"/> |

Process Frequency

- Once
- Always
- Don't Run

AM Period Allocation page

Enter a Business Unit, Allocation Id, and Accounting Period to process allocations. Select a Process Frequency.

When processing for budget and fund accounting allocations, first run the accounting entry generation process (AM_AMAEDIST) and the depreciation close (AM_DPCLOSE) process. Then run the Depreciation Allocation (AMALLOC) process with the appropriate budget Allocation ID for the applicable fiscal year and period. These steps will change the entries to reflect the correct budget reference in the accounting entries for assets that were created in prior fiscal year and period.

CHAPTER 18

Creating PeopleSoft Asset Management Accounting Entries

This chapter lists prerequisites, provides overviews of asset information flow and accounting entry setup, and discusses how to create accounting entries.

Prerequisites

Before you initiate any processing, you should review your application options. Ensure that you have:

- Defined business unit and book accounting entry options.
- Established the accounting entry template IDs to be used for PeopleSoft Asset Management processing.
- Established the accounting entry templates to be used for PeopleSoft Asset Management processing.
- Determined the depreciation open and close status for periods.

Understanding Asset Information Flow

Each financial transaction that is entered into PeopleSoft Asset Management can be used to generate balanced accounting entries. These entries in turn can be summarized and written to a journal, which can then be rolled up and posted to the general ledger system.

Balanced accounting entries are generated from financial transactions and are the basis for creating journals that are posted to the general ledger. The primary sources of accounting entries within PeopleSoft Asset Management include:

- Accounting entries that are created from financial transactions such as asset additions, adjustments, allocations or retirements.
- Accounting entries that are created from depreciation close for a particular accounting period.
- Accounting entries that are created from lease payments.

Others include processing transactions to adjust for inflation and accounting entries that are created from an active integration with other PeopleSoft products such as Billing, Purchasing, and Payables.

Each time financial asset information is entered or adjusted, PeopleSoft Asset Management creates an open transaction. This transaction remains open until accounting entries are created or depreciation is calculated for the transaction. The process for accounting entry creation generates accounting entries for all financial transactions that are not related to depreciation. The Depreciation Close process (AM_DPCLOSE) generates accounting entries for depreciation in a particular accounting period.

Note.

To create accounting entries:

1. Enter asset transactions.

Based on the context of the transaction that you enter, the system creates an open transaction with a transaction type such as Add, Transfer, Adjust, Retire, and so forth. These open transactions form a list of accounting entry or depreciation tasks to be processed.

2. Calculate depreciation for open transactions.
3. Create asset transaction accounting entries by running the Accounting Entry Creation process (AM_AMAEDIST), which applies the appropriate accounting entry templates to the open transactions that were created in step 1.

Selection of an accounting entry template is determined by the accounting entry template ID, category, cost type, transaction type, and transaction code of the asset transaction. You can run this process at any interval. You should run the process more than once a month to prevent the process from being slowed at period close time. Use Process Scheduler to schedule and automatically initiate these processes.

4. At the end of each accounting period, create depreciation accounting entries by running the Depreciation Close process; the process applies the depreciation (DPR) and prior depreciation period (PDP) accounting entry templates to the asset depreciation table.

Run this process only once for each accounting period, and only after all of the transaction activity for the period has been completed.

5. Reverse accounting entries by running the Depreciation Close process with the option Reverse Posted Entries selected.

This option reverses only those journal entries that have been created and posted to the general ledger, and creates reversal entries.

This diagram shows the processes for creating accounting entries:

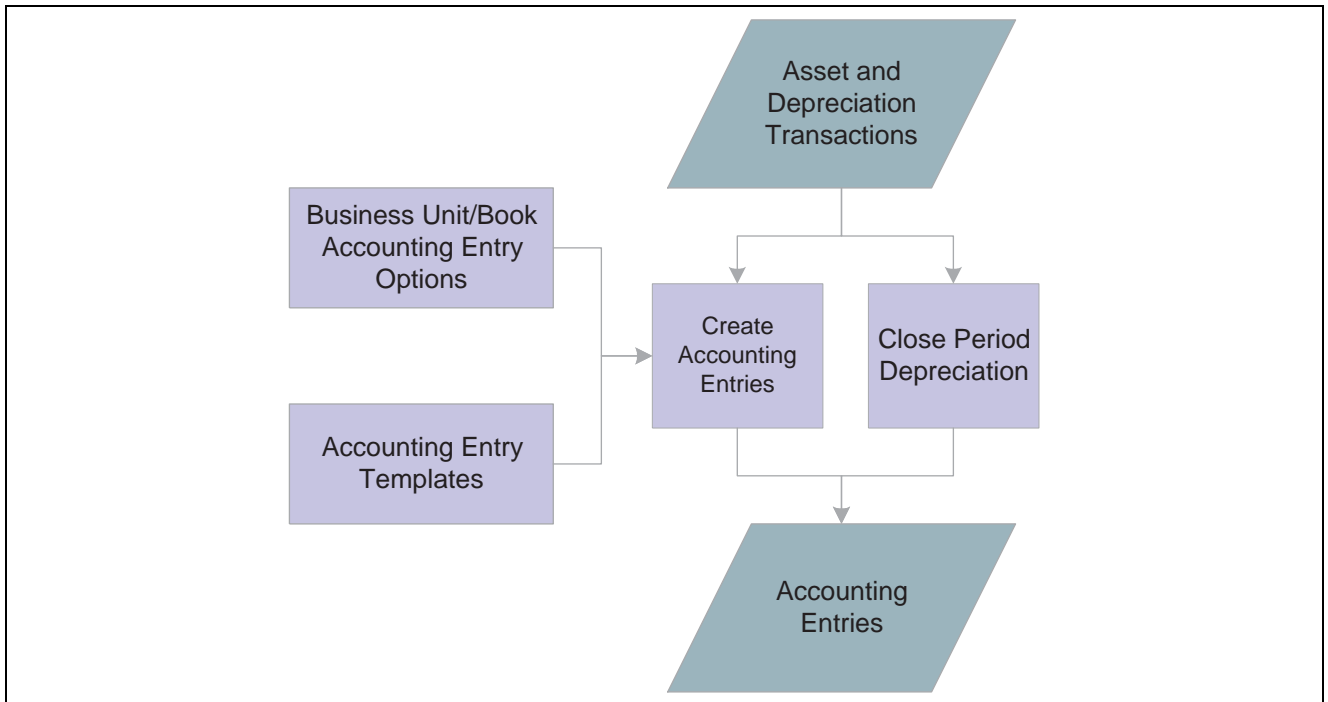

Processes for creating accounting entries

See *PeopleSoft Enterprise Asset Lifecycle Management Fundamentals 9.0 PeopleBook*, “Setting Up Accounting Entry and Financial Processing for PeopleSoft Asset Management”.

See *PeopleSoft Enterprise Asset Lifecycle Management Fundamentals 9.0 PeopleBook*, “Establishing Asset Processing”.

Understanding Accounting Entry Setup

This section discusses:

- Business unit and book accounting entry options.
- Accounting entry templates.
- Depreciation close status.

Business Unit and Book Accounting Entry Options

Business unit and book accounting entry options are defined in the Establish Business Units component, and they control which business unit book is used to create accounting entries. Select one book for each business unit to create accounting entries.

Note. When processing accounting entries, you should understand the relationship between PeopleSoft Asset Management business units and PeopleSoft General Ledger business units. If you are using different business units for the applications because you use multiple ledgers, you must be sure to specify the ledger. The ledger is required when you are searching on the Asset Journals page. Failing to enter the value generates an error, and the journal lines for business units that are different do not appear, even though the PeopleSoft Asset Management entries are generated and posted to the journal tables.

See *PeopleSoft Enterprise Asset Lifecycle Management Fundamentals 9.0 PeopleBook*, “Establishing PeopleSoft Asset Management Business Units”.

Accounting Entry Templates

The accounting entry template is the central table that the system uses to create accounting entries, which are the basis for general ledger journals. The accounting entry template defines accounting entry types based on asset category, cost type, transaction type, transaction code, and accounting entry template ID. For each accounting entry type, you specify:

- The accounts to use during accounting entry.
- The journal template to use for recording actual transactions.
- The budget journal template to use to record budget transactions.

When you add an accounting entry template in PeopleSoft Asset Management, the system populates it with standard accounting entry types (distribution types), based on the asset category, cost type, and action that is specified for all supported features that require accounting types.

If impairment and revaluation options are enabled at the installation level, you can specify within the cost type definition if you want to enable a given cost type for impairment or revaluation processing. If enabled, the system displays the appropriate impairment and revaluation related accounts at the Accounting Entry Template level.

Use the features within the Accounting Entry Template ID component to define accounting entry template IDs that include or exclude the appropriate accounting entry (distribution) types for each type of transaction. The accounting entry template IDs can be associated with business unit-level features such as the Book Code feature, the Derogatory Depreciation feature, the Like Kind Exchange feature, and the Revaluation feature.

Accounting entry types are delivered with the PeopleSoft system, and each asset event has an associated set of accounting entry types. For each combination of category, cost type, transaction code, and accounting entry template ID, you must set up an accounting entry template for the following transaction types:

| Transaction Type | Description |
|------------------|--|
| ADD | Additions. |
| ADJ | Adjustments. |
| TRF | Transfers. |
| RCT | Recategorizations. |
| DPR | Depreciation expense. |
| PDP | Prior period depreciation. |
| RET | Retirements (also used for processing reinstatements). |

| Transaction Type | Description |
|------------------|-----------------------|
| LPY | Lease payments. |
| INF | Inflation adjustment. |

Note. If you enter a transaction into the system with a combination of category, cost type, transaction code, and accounting entry template ID for which no accounting entry template exists, the accounting entry process will fail the next time it is run.

DPR and PDP transaction types are used only on an accounting entry template with a blank transaction code.

Accounting Entry Types (Distribution Types)

Asset Management creates accounting entries by using standard accounting entry types (distribution types), based on the asset category, cost type, and action that is specified for all supported features that require accounting entry types. The following tables list the accounting distribution types that are associated with each accounting entry feature.

Here are the distribution types for the ADD (addition) transaction type:

| Type | Description | Basic | Lease | Derogatory | Like Kind Exchange | Revaluation |
|------|-------------------------------------|-------|---------------------|------------|--------------------|-------------|
| AD | Accumulated Depreciation | X | Not applicable (NA) | NA | NA | X |
| AP | Contra Asset | X | NA | NA | NA | X |
| DD | Accumulated Derogatory Depreciation | NA | NA | X | NA | NA |
| DE | Depreciation Expense | X | NA | NA | NA | X |
| DR | Derogatory Depreciation Reversal | NA | NA | X | NA | NA |
| DX | Derogatory Depreciation Expense | NA | NA | X | NA | NA |
| FA | Fixed Asset | X | NA | NA | NA | X |
| LO | Lease Obligation | NA | X | NA | NA | NA |
| TI | Trade In | X | NA | NA | NA | X |
| UR | Unrecognized Gain/Loss | NA | NA | NA | X | X |

| Type | Description | Basic | Lease | Derogatory | Like Kind Exchange | Revaluation |
|------|---------------------------|-------|-------|------------|--------------------|-------------|
| RL | Recognized Loss | NA | NA | NA | X | X |
| PR | Provision for Revaluation | NA | NA | NA | NA | X |

Here are the distribution types for the ADJ (adjustment) transaction type:

| Type | Description | Basic | Lease | Derogatory | Like Kind Exchange | Revaluation |
|------|-------------------------------------|-------|-------|------------|--------------------|-------------|
| AD | Accumulated Depreciation | X | NA | NA | NA | X |
| AP | Contra Asset | X | NA | NA | NA | X |
| DD | Accumulated Derogatory Depreciation | NA | NA | X | NA | NA |
| DE | Depreciation Expense | X | NA | NA | NA | X |
| DR | Derogatory Depreciation Reversal | NA | NA | X | NA | NA |
| DX | Derogatory Depreciation Expense | NA | NA | X | NA | NA |
| FA | Fixed Asset | X | NA | NA | NA | X |
| LO | Lease Obligation | NA | X | NA | NA | NA |
| PR | Provision for Revaluation | NA | NA | NA | NA | X |
| RD | Reversal of Depreciation | NA | NA | NA | NA | X |
| IM | Impairment Loss | X | NA | NA | NA | X |
| IN | Impairment Contra | NA | NA | NA | NA | X |

Here are the distribution types for the TRF (transfer) transaction type:

| Type | Description | Basic | Lease | Derogatory | Like Kind Exchange | Revaluation |
|------|-------------------------------------|-------|-------|------------|--------------------|-------------|
| AD | Accumulated Depreciation | X | NA | NA | X | NA |
| DD | Accumulated Derogatory Depreciation | NA | NA | X | NA | NA |
| DR | Derogatory Depreciation Reversal | NA | NA | X | NA | NA |
| DX | Derogatory Depreciation Expense | NA | NA | X | NA | NA |
| FA | Fixed Asset | X | NA | NA | X | NA |
| PR | Provision for Revaluation | NA | NA | NA | NA | X |
| RC | Provision for Revaluation Contra | NA | NA | NA | NA | X |

Here are the distribution types for the RCT (recategorize) transaction type:

| Type | Description | Basic | Lease | Derogatory | Like Kind Exchange | Revaluation |
|------|-------------------------------------|-------|-------|------------|--------------------|-------------|
| AD | Accumulated Depreciation | X | NA | NA | X | NA |
| DD | Accumulated Derogatory Depreciation | NA | NA | X | NA | NA |
| DR | Derogatory Depreciation Reversal | NA | NA | X | NA | NA |
| DX | Derogatory Depreciation Expense | NA | NA | X | NA | NA |
| FA | Fixed Asset | X | NA | NA | X | NA |
| PR | Provision for Revaluation | NA | NA | NA | NA | X |
| RC | Provision for Revaluation Contra | NA | NA | NA | NA | X |

Here are the distribution types for the RET (retire) transaction type:

| Type | Description | Basic | Lease | Derogatory | Like Kind Exchange | Revaluation |
|------|-------------------------------------|-----------------------------|-------|------------|--------------------|-------------|
| AD | Accumulated Depreciation | X | NA | NA | NA | NA |
| AP | Contra Asset | NA | NA | NA | X | NA |
| BI | Proceeds to Billing Account | X (If Billing is installed) | NA | NA | NA | NA |
| CA | Proceeds | X | NA | NA | NA | NA |
| DD | Accumulated Derogatory Depreciation | NA | NA | X | NA | NA |
| DR | Derogatory Depreciation Reversal | NA | NA | X | NA | NA |
| DX | Derogatory Depreciation Expense | NA | NA | X | NA | NA |
| FA | Fixed Asset | X | NA | NA | NA | NA |
| GA | Gain | X | NA | NA | NA | NA |
| GL | Loss | X | NA | NA | NA | NA |
| LG | Lease Guarantee Contra | NA | X | NA | NA | NA |
| LO | Lease Obligation | NA | X | NA | NA | NA |
| LU | Lease Guarantee Obligation | NA | X | NA | NA | NA |
| MA | Mortgage - Others | NA | NA | NA | X | NA |
| ML | Mortgage - Comp | NA | NA | NA | X | NA |
| NV | Net Book Value | NA | NA | X | NA | NA |
| PR | Provision for Revaluation | NA | NA | NA | NA | X |

| Type | Description | Basic | Lease | Derogatory | Like Kind Exchange | Revaluation |
|------|----------------------------------|-------|-------|------------|--------------------|-------------|
| RC | Provision for Revaluation Contra | NA | NA | NA | NA | X |
| RD | Reversal of Depreciation | NA | NA | NA | NA | X |
| RG | Recognized Gain | NA | NA | NA | X | NA |
| RM | Removal Contra | X | NA | NA | NA | NA |
| SL | Sales of Fixed Asset | NA | NA | X | NA | NA |
| TI | Trade In | X | NA | NA | NA | NA |
| UG | Unrealized Gain | NA | NA | NA | X | NA |
| UL | Unrealized Loss | NA | NA | NA | X | NA |

Here are the distribution type for the DPR (depreciation) transaction type:

| Type | Description | Basic | Lease | Derogatory | Like Kind Exchange | Revaluation |
|------|-------------------------------------|-------|-------|------------|--------------------|-------------|
| AD | Accumulated Depreciation | X | NA | NA | NA | X |
| DD | Accumulated Derogatory Depreciation | NA | NA | X | NA | NA |
| DE | Depreciation Expense | X | NA | NA | NA | X |
| DR | Derogatory Depreciation Reversal | NA | NA | X | NA | NA |
| DX | Derogatory Depreciation Expense | NA | NA | X | NA | NA |

| Type | Description | Basic | Lease | Derogatory | Like Kind Exchange | Revaluation |
|------|----------------------------------|-------|-------|------------|--------------------|-------------|
| RC | Provision for Revaluation Contra | NA | NA | NA | NA | X |
| RD | Reversal of Depreciation | NA | NA | NA | NA | X |

Here are the distribution types for the PDP (prior period depreciation) transaction type:

| Type | Description | Basic | Lease | Derogatory | Like Kind Exchange | Revaluation |
|------|-------------------------------------|-------|-------|------------|--------------------|-------------|
| AD | Accumulated Depreciation | X | NA | NA | NA | NA |
| DD | Accumulated Derogatory Depreciation | NA | NA | X | NA | NA |
| DE | Depreciation Expense | X | NA | NA | NA | NA |
| DR | Derogatory Depreciation Reversal | NA | NA | X | NA | NA |
| DX | Derogatory Depreciation Expense | NA | NA | X | NA | NA |
| RC | Provision for Revaluation Contra | NA | NA | NA | NA | X |
| RD | Reversal of Depreciation | NA | NA | NA | NA | X |

Here are the distribution types for the LPY (lease payment) transaction type:

| Type | Description | Basic | Lease | Derogatory | Like Kind Exchange | Revaluation |
|------|-----------------------|-------|-------|------------|--------------------|-------------|
| LC | Lease Interest Contra | NA | X | NA | NA | NA |
| LI | Lease Interest | NA | X | NA | NA | NA |

| Type | Description | Basic | Lease | Derogatory | Like Kind Exchange | Revaluation |
|------|-------------------------|-------|-------|------------|--------------------|-------------|
| LO | Lease Obligation | NA | X | NA | NA | NA |
| LP | Lease Obligation contra | NA | X | NA | NA | NA |

Here are the distribution types for the INF (inflation) transaction type:

| Type | Description | Basic | Lease | Derogatory | Like Kind Exchange | Revaluation |
|------|---------------------------|-------|-------|------------|--------------------|-------------|
| IA | Inflation Accum Depr | X | NA | NA | NA | NA |
| IB | Inflation Accum Depr | X | NA | NA | NA | NA |
| IC | Inflation Cost Adjustment | X | NA | NA | NA | NA |
| ID | Inflation Cost Adjustment | X | NA | NA | NA | NA |
| IG | Inflation Gain | X | NA | NA | NA | NA |
| IL | Inflation Loss | X | NA | NA | NA | NA |
| IP | Inflation Period Depr | X | NA | NA | NA | NA |
| IQ | Inflation Period Depr | X | NA | NA | NA | NA |
| IY | Inflation YTD Depr | X | NA | NA | NA | NA |
| IZ | Inflation YTD Depr | X | NA | NA | NA | NA |

See *PeopleSoft Enterprise Asset Lifecycle Management Fundamentals 9.0 PeopleBook*, “Setting Up Accounting Entry and Financial Processing for PeopleSoft Asset Management,” Defining Accounting Entries.

See *PeopleSoft Enterprise Asset Lifecycle Management Fundamentals 9.0 PeopleBook*, “Establishing PeopleSoft Asset Management Business Units,” Creating PeopleSoft Asset Management Business Units.

Depreciation Close Status

You can run the Depreciation Close process only in an open period. You use the Business Unit/Book Definition page to determine which accounting periods have been closed. Select Depreciation Closed List to display all closed periods.

Note. Open and close accounting periods are maintained in General Ledger and migrated with the financial subsystems. Each subsystem application can either use the periods that are created in General Ledger or update the open and close periods at the application business unit level.

See *PeopleSoft Enterprise Application Fundamentals 9.0 PeopleBook*, “Defining Accounting Calendars,” Defining and Updating Open Periods and Adjustment Periods.

See *PeopleSoft Enterprise Asset Lifecycle Management Fundamentals 9.0 PeopleBook*, “Establishing PeopleSoft Asset Management Business Units,” Defining Open Periods.

Creating Accounting Entries

This section provides an overview of the Depreciation Close process, lists common elements, and discusses how to:

- Request accounting entry creation.
- Run the Depreciation Close process.
- Close accounting periods.

Understanding the Depreciation Close Process

The Depreciation Close process generates period depreciation accounting entries for all depreciable assets in a particular accounting period, including lease payments and offset accounts for the period. Run this process only for an accounting period that has not yet been closed. You can reverse or rerun this process if errors are detected in the results. The flexible run parameters allow processing to close the period, reversing the output of the last posting run, or reversal with reprocessing of the close entries.

Open and close accounting periods are maintained in General Ledger and migrated to the financial subsystems. Each subsystem application can either use the periods that are created in General Ledger or update the open and close periods at the application business unit level.

When you run the Depreciation Close process, you have two options: Rerun Depreciation Close and Reverse Posted Entries. The following examples demonstrate how these options affect processing.

Example of the Rerun Depreciation Close Option

With Rerun Depreciation Close enabled and the journal entries not yet created, the Depreciation Close process creates a new accounting entry, as shown in this table, and deletes the existing one (if any). If the journal entries have already been created, depreciation close will neither delete nor generate entries. No actions occur.

| DISTRIBUTION TYPE | DTTM_STAMP | AMOUNT | GL_DISTRIB_STATUS | REVERSE_STATUS | REVERSE_DTTM_STAMP | Journal ID | Journal Dttm Stamp |
|-------------------|------------------------|---------|-------------------|----------------|--------------------|------------|--------------------|
| AD | 2006-09-05 14:25:20 | -110.00 | N | | NULL | | NULL |
| DE | 2006-09-05 14:25:20 | 110.00 | N | | NULL | | NULL |

When the journal entries have been posted, the system updates the general ledger distribution status to *D* (done).

This table shows the results after the PeopleSoft General Ledger run:

| DISTRIBUTION TYPE | DTTM_ STAMP | AMOUNT | GL_DISTRIB_ STATUS | REVERSE_ STATUS | REVERSE_ DTTM_STAMP | Journal ID | Journal Dttm Stamp |
|----------------------|------------------------|---------|-----------------------|--------------------|------------------------|------------|-----------------------|
| AD | 2006-09-05 14:25:20 | -110.00 | D | | NULL | XX | Journal Dttmstamp |
| DE | 2006-09-05 14:25:20 | 110.00 | D | | NULL | XX | Journal Dttmstamp |

Example of the Reverse Posted Entries Option

When the Reverse Posted Entries option is selected and the journal entries have been created, the original entry is reversed with new rows inserted showing the reversed amounts. The new entries display the statuses *R* for reversal and *X* for reversed entries.

This table shows the original entry:

| DISTRIBUTION TYPE | DTTM_ STAMP | AMOUNT | GL_DISTRIB_ STATUS | REVERSE_ STATUS | REVERSE_ DTTM_STAMP | Journal ID | Journal Dttm Stamp |
|----------------------|------------------------|---------|-----------------------|--------------------|------------------------|------------|-----------------------|
| AD | 2006-09-05 14:25:20 | -110.00 | D | X | NULL | XX | Journal Dttmstamp |
| DE | 2006-09-05 14:25:20 | 110.00 | D | X | NULL | XX | Journal Dttmstamp |

This table shows the reversed entry:

| DISTRIBUTION TYPE | DTTM_ STAMP | AMOUNT | GL_DISTRIB_ STATUS | REVERSE_ STATUS | REVERSE_ DTTM_STAMP | Journal ID | Journal Dttm Stamp |
|----------------------|------------------------|---------|-----------------------|--------------------|------------------------|------------|-----------------------|
| AD | 2006-09-12 17:37:25 | 110.00 | N | R | 2003-09-05 14:25:20 | | |
| DE | 2006-09-12 17:37:25 | -110.00 | N | R | 2003-09-05 14:25:20 | | |

Example of Both the Rerun Depreciation Close and Reverse Posted Entries Options

When the Reverse Posted Entries and the Rerun Depreciation Close options are both selected, and the journal entries have been created, then the original entry is reversed as shown in the previous example, and a new accounting entry is created.

This table shows the original entry:

| DISTRIBUTION TYPE | DTTM_STAMP | AMOUNT | GL_DISTRIB_STATUS | REVERSE_STATUS | REVERSE_DTTM_STAMP | Journal ID | Journal Dttm Stamp |
|-------------------|------------------------|---------|-------------------|----------------|--------------------|------------|--------------------|
| AD | 2006-09-05 14:25:20 | -110.00 | D | X | NULL | XX | Journal Dttmstamp |
| DE | 2006-09-05 14:25:20 | 110.00 | D | X | NULL | XX | Journal Dttmstamp |

This table shows the reversed entry:

| DISTRIBUTION TYPE | DTTM_STAMP | AMOUNT | GL_DISTRIB_STATUS | REVERSE_STATUS | REVERSE_DTTM_STAMP | Journal ID | Journal Dttm Stamp |
|-------------------|------------------------|---------|-------------------|----------------|------------------------|------------|--------------------|
| AD | 2006-09-12 17:37:25 | 110.00 | N | R | 2003-09-05 14:25:20 | | |
| DE | 2006-09-12 17:37:25 | -110.00 | N | R | 2003-09-05 14:25:20 | | |

This table shows the results of the rerun with the new entry:

| DISTRIBUTION TYPE | DTTM_STAMP | AMOUNT | GL_DISTRIB_STATUS | REVERSE_STATUS | REVERSE_DTTM_STAMP | Journal ID | Journal Dttm Stamp |
|-------------------|------------------------|---------|-------------------|----------------|--------------------|------------|--------------------|
| AD | 2006-09-12 17:37:25 | -140.00 | N | | NULL | | NULL |
| DE | 2006-09-12 17:37:25 | 140.00 | N | | NULL | | NULL |

Common Elements Used in This Section

- Request ID** Displays the number of process requests that you have submitted.
- Unit** Enter the business unit for which transactions are processed.
- Book Name** Enter the book for which transactions are processed.
- Currency** Displays the currency in which the transactions are processed, based on the base currency for the selected book or business unit.

Pages Used to Create Accounting Entries

| Page Name | Object Name | Navigation | Usage |
|-----------------------------------|-------------------|--|---|
| Create Accounting Entries | AM_AMAEDIST_RQST | Asset Management, Accounting Entries, Create Accounting Entries | Set up and initiate a request or set of requests for accounting entry creation. |
| Run Depreciation Close Process | DEPR_CLOSE_RQST | Asset Management, Accounting Entries, Close Depreciation | Enter and initiate a depreciation close request or requests. |
| Close Asset Period | DEPR_CLOS_PD | Asset Management, Accounting Entries, Close Accounting Period | Close accounting periods to ensure that you do not make any new transactions in the period. |
| Review Financial Entries - List | ASSET_DIST_LIST | Asset Management, Accounting Entries, Review Financial Entries, List | Review accounting financial entries in summary list. Note. In the case where there are multiple "Future-dated" EFFDT, only the MAXIMUM effective-dated row will be displayed in the prompt for ACCOUNT in the Review Financial Entries component. |
| Review Financial Entries - Detail | ASSET_DIST_DETAIL | Asset Management, Accounting Entries, Review Financial Entries, Detail | Review accounting financial entries in detail. Note. In the case where there are multiple "Future-dated" EFFDT, only the MAXIMUM effective-dated row will be displayed in the prompt for ACCOUNT in the Review Financial Entries component. |
| Review Operating Leases - List | ASSET_NF_DIST_LN | Asset Management, Accounting Entries, Review Operating Leases, List | Review operating lease entries in summary list. |
| Review Operating Leases - Detail | LEASE_DIST_DETAIL | Asset Management, Accounting Entries, Review Operating Leases, Detail | Review operating lease entries in summary list. |
| Asset Journals | AM_GL_DRILL | Asset Management, Accounting Entries, Review Asset Journals | Review asset journal information. |
| Calculate Inflation - Request | DEPR_INF_RQST | Asset Management, Accounting Entries, Calculate Inflation | Run a process to calculate inflation for assets. |

Requesting Accounting Entry Creation

Access the Create Accounting Entries page.

| | |
|--------------------------------------|--|
| Cost Summarize | Select to create cost summary while creating accounting entries. |
| From Asset ID and To Asset ID | Enter the transaction range to process. |

Note. The system calls the Inter/IntraUnit central processor to create balanced accounting entries.

See *PeopleSoft Enterprise Application Fundamentals 9.0 PeopleBook*, “Using Interunit and Intraunit Accounting and ChartField Inheritance”.

Running the Depreciation Close Process

Access the Run Depreciation Close Process page.

| | |
|-------------------------------------|---|
| Fiscal Year and Period | Enter the appropriate fiscal year and open periods to be closed. |
| Rerun Depreciation Close | <p>Select to delete all existing accounting entries that haven't been generated as journal entries for depreciation expense and lease obligations for the specified business unit, book, fiscal year, and period. The system generates new entries.</p> <p>To generate new journal entries and to reverse a journal entry, run a request with both Rerun Depreciation Close and Reverse Posted Entries options selected.</p> <p>To rerun depreciation close for budgeted depreciation, run a request with both Rerun Depreciation Close and Create Budgeted Depreciation options selected.</p> |
| Reverse Posted Entries | <p>Select to reverse only those accounting entries that have been created and posted to the general ledger, including all existing accounting entries for depreciation expense and lease payments for the specified business unit, book, fiscal year, and period. The process creates reversal entries and marks the old entries with a status of <i>Reversed</i>. If journal entries have not been created, the entries marked <i>Reversed</i> are not used by the Journal Generator process.</p> <p>To reverse entries that are created and post them again, use Reverse Posted Entries in tandem with Rerun Depreciation Close. When you do this, the original journal entry is reversed and a new entry is created.</p> <p>When an entry has not been posted to the general ledger, use the rerun option. Reverse Posted Entries does not reverse unposted entries.</p> |
| Create Budgeted Depreciation | Displays the resulting accounting entries as budgeted depreciation and lease payments. These entries are posted to the budget ledger that is specified in the Business Unit Book options page when you run the Journal Generator process. |
| Process a Range of Assets | <p>Select to process a specific range of assets for a business unit, book, fiscal year, and period. Use this option to split up a large volume of assets for a particular business unit and book. Because the program AM_DPCLOSE commits its work after each request, selecting this option accelerates the process. You can also use this selection with the parallel option to take advantage of servers that have parallel processors. This speeds up processing for large volumes of data.</p> <p>For example, to increase throughput when creating depreciation accounting entries for 1,000,000 assets, you can enter 10 requests to process 100,000 assets each. Select Process in Parallel, and assign a processing sequence number to each process request. Processing sequence numbers must be unique.</p> |

Use care when specifying From asset ID and To asset ID processing parameters, as these parameters are inclusive. Overlapping can occur, and no edit is available to verify that you have set up inclusive asset ranges. For example, suppose that request 1 is processed from asset ID 0001 and to asset ID 0005. If request 2 is processed from asset ID 0005 and to asset ID 9999, asset 0005 is processed twice. You can use Query to verify ranges by counting the number of assets in total and number of assets per range.

Note. If you use the interface between PeopleSoft Asset Management and PeopleSoft Billing, accounting entries are created by these integrated transactions. How the entries are created is described in more detail in the PeopleSoft Billing documentation.

See *PeopleSoft Enterprise Asset Lifecycle Management Fundamentals 9.0 PeopleBook*, “Setting Up Accounting Entry and Financial Processing for PeopleSoft Asset Management,” Pages Used to Define Accounting Entry for PeopleSoft Asset Management.

See *PeopleSoft Enterprise Asset Lifecycle Management Fundamentals 9.0 PeopleBook*, “Integrating PeopleSoft Asset Management with Other Products”.

See *PeopleSoft Enterprise Asset Lifecycle Management Fundamentals 9.0 PeopleBook*, “Establishing PeopleSoft Asset Management Business Units,” Understanding Asset Management Business and Cash Generating Units.

See *PeopleSoft Enterprise General Ledger 9.0 PeopleBook*, “Making General Ledger Journal Entries”.

See *PeopleSoft Enterprise Billing 9.0 PeopleBook*, “Integrating with PeopleSoft Asset Management”.

Closing Accounting Periods

Access the Close Asset Period page.

Enter the year and period to be closed, and save the page. When a period has been closed, you cannot create additional depreciation-related accounting entries for that period.

See *PeopleSoft Enterprise General Ledger 9.0 PeopleBook*, “Managing Interim and Year End Closing”.

CHAPTER 19

Retiring Assets

This chapter provides an overview of asset retirement and discusses how to:

- Retire financial assets.
- Retire non-financial assets.
- Reinstate assets.
- Run the Tax Retirement Capital Gains report (AMTX3210).

Understanding Asset Retirement

PeopleSoft Asset Management enables you to fully or partially retire assets in the past, present, or future. Occasionally, a retirement transaction may require a reversal. In that case, you can reinstate a retired asset using the pages in the Asset Retirements component.

You retire assets when they are either disposed of or no longer in use. When you retire an asset, PeopleSoft Asset Management creates all the necessary journal entries. For example, when you sell an asset, the system calculates depreciation through the date of the sale, as well as any gain or loss. In addition, you can have the system create journal entries corresponding to each of these events. Gains and losses are booked to separate accounts, which provide flexibility in updating general ledger journals and balances.

An asset is retired by its book designation; therefore, you can retire an asset in one book, but it is still available for depreciation in others. You can reinstate retired assets at any time. When assets are reinstated, depreciation starts again for them if they are not fully depreciated.

Retirement Types

Assets are fully or partially retired by quantity or by cost. You can also enter retroactive retirement information for assets that were actually retired in a prior accounting period.

Full Retirement

When the full quantity and total cost of an asset are retired, the asset is considered fully retired. The asset is taken off the books after the retirement has been fully processed and accounting entries have been created. No further depreciation accrues.

Partial Retirement

You can partially retire an asset, and the system continues to process depreciation for the amount that remains. Two types of partial retirement are available:

- By quantity

You can partially retire assets by quantity. For example, if you have 250 computers, and you sell 50 of them to employees, you enter the 50 units as the quantity retired. PeopleSoft Asset Management calculates the corresponding cost.

- By cost

You can partially retire assets by cost. For example, suppose that you partially retire a computer for the price of the computer monitor, 400 USD, and you sell the monitor for 100 USD. The total cost of the computer is 1500 USD. The cost (400 USD) is the amount retired, and the 100 USD is the proceeds from the sale. PeopleSoft Asset Management automatically calculates the gain or loss based on these amounts.

Prior Period

To enter a retirement transaction for an asset that was actually retired in a prior accounting period, you must enter transaction and accounting dates that reflect the actual retirement and the accounting period in which you want the retirement posted. For example, suppose that an asset sold on April 30th was processed as a retirement in PeopleSoft Asset Management on June 30th. By the time the asset was entered as a retirement, depreciation expense for May and June had been posted to the general ledger. That posting resulted in overstated accumulated depreciation and an incorrect gain or loss. To correctly process this retirement, you would specify April 30th as the transaction date and—assuming all prior periods are closed—June 30th as the accounting date. PeopleSoft Asset Management then reverses the accumulated depreciation attributable for May and June and calculates the correct gain or loss on the asset.

Retiring Financial Assets

This section discusses how to:

- Retire an asset.
- Define other retirement options.
- Select retirement transactions by ChartField.
- Select child assets.
- Review a capital gain summary for retirements.
- Integrate retired asset information with PeopleSoft Billing.
- Specify how value-added tax (VAT) is calculated for asset retirement.
- Auto-retire fully depreciated assets.
- Initiate asset retirement using the disposal worksheet.
- Put assets up for auction.

Pages Used to Retire Financial Assets

| Page Name | Object Name | Navigation | Usage |
|---------------|-----------------|--|--|
| Retire Assets | ASSET_RETIRE_01 | Asset Management, Asset Transactions, Asset Disposal, Retire/Reinstate Asset | Retire or reinstate an asset. Click the appropriate button to access other fields based on your selection. |

| Page Name | Object Name | Navigation | Usage |
|---|------------------|---|---|
| Like Kind Exchange | LIKE_KIND_EXCH | Click the Like Kind Exchange Info (like-kind exchange information) link on the Retire Assets page. Select Retire As option <i>Like Kind Exchange</i> to display link. | Enter fair market values and descriptions for each asset to add multiple assets as part of a like-kind exchange. |
| General Info | CUST_GENERAL1 | Click the Customer General Info link from the Retire Assets page. | Search for and select customer information to add for retirements by sale or trade. |
| Retire/Reinstate Assets - Other Options | ASSET_RETIRE_02 | Asset Management, Asset Transactions, Asset Disposal, Retire/Reinstate Assets, Other Options | Select assets to be retired based on gain or loss and other options. |
| Retire/Reinstate Assets - By ChartField | ASSET_RETIRE_03 | Asset Management, Asset Transactions, Asset Disposal, Retire/Reinstate Assets, By Chartfield | Override PeopleSoft Asset Management calculations when shared assets are partially retired. |
| Child Assets | CHILD_ASSETS | Asset Management, Asset Transactions, Asset Disposal, Retire/Reinstate Asset, Child Assets | Select child assets to include in a retirement transaction that you have initiated against the parent on the Retire Assets page. |
| Child Asset Retirement Options | AM_PARCHD_RET01 | Click Child Details on the Child Assets page. | Specify retirement overrides for a specific child asset. For example, you might specify a different retirement disposal code for the child asset. |
| Advanced Transaction Details | FULL_PART_SEC | Click Child Details on the Child Assets page. | Specify transaction overrides for all child assets at once. |
| VAT | AM_VAT_TRANS_RET | Asset Management, Asset Transactions, Asset Disposal, Retire/Reinstate Asset, VAT | Specify options to use to calculate VAT on an asset retirement. |
| Auto-Retire Fully Depr Assets (automatically retire fully depreciated assets) | RUN_AMRETFDA | Asset Management, Asset Transactions, Asset Disposal, Auto-Retire Fully Depr Assets | Identify run-control parameters to initiate the Auto-Retire Fully Depreciated Assets process (RUN_AMRETFDA). |
| Auto-Retired Assets | RUN_AMRET001 | Asset Management, Financial Reports, Retirement, Auto-Retired Assets Report | Identify run-control parameters to generate the Auto-Retire Assets report. |

| Page Name | Object Name | Navigation | Usage |
|---|-------------------|--|--|
| Proceeds and Removal Cost | ASSET_RETIRE_SEC1 | Click the Base Amounts and Exchange Rate icon. | View the transaction in the base currency, alternate currency, and associated exchange rate. |
| Capital Gain | ASSET_RETIRE_05 | Asset Management, Asset Transactions, Asset Disposal, Retire/Reinstate Assets, Capital Gain | View the calculations for capital gains or losses for a retirement transaction. |
| Bill Information | ASSET_RETIRE_07 | Asset Management, Asset Transactions, Asset Disposal, Retire/Reinstate Assets, Bill Information | Define default values for PeopleSoft Billing. |
| AM/BI Interface (Asset Management-Billing interface) | RUN_AMBI_INTFC | Asset Management, Send/Receive Information, Load Interface, Interface AM to Billing | Run the PeopleSoft Asset Management-Billing interface. |
| Disposal Worksheet | AM_EXPRESS_RET1 | Asset Management, Asset Transactions, Asset Disposal, Disposal Worksheet | Identify and submit assets for disposal. |
| Asset Information,, Retirement Information,, Other Accounting Information | AM_DISPOSAL_00 | Click the Retrieve button on the Disposal Worksheet. | Retrieve assets per the search criteria entered; displays Asset Information, Retirement Information and Other Accounting Information tabs. |
| ChartField Search Criteria | AM_LOOKUP_CF_SEL | Asset Management, Asset Transactions, Asset Disposal, Disposal Worksheet Click the ChartField Search Criteria link. | Select ChartFields to use as search criteria. |
| Ownership Details | AM_DISPOSAL_01 | Asset Management, Asset Transactions, Asset Disposal, Disposal Worksheet Click the View Ownership Details link. | View the original asset owner selection attributes. |
| Approve Disposals | AM_DISP_APPR01 | Asset Management, Asset Transactions, Asset Disposal, Approve Disposals | Deny or approve a retirement disposal or place it on hold. |

Retiring an Asset

Access the Retire Assets page.

| Retire Assets | | Other Options | | By Chartfield | | Capital Gain | | VAT | | Bill Information | | | |
|---|------------|---------------------------------|------------|-----------------|--|--------------------|--|--------------------|------------|------------------|--|------------|--|
| Unit: | AUS01 | Asset ID: | AM325 | Automobiles | | | | Tag: | In Service | | | | |
| Trans Date: | 07/02/2005 | Acctg Date: | 07/02/2005 | Rate Type: | | | | CRRNT | | | | | |
| Book | | | | | | | | | | | | | |
| Book Name: | | ACCNT_AUD Accounting Book - AUD | | | | Base Currency: | | AUD | | As Of: | | 07/02/2005 | |
| Retire As: | | Retirement by Sale | | Go | | Reinstate | | Quantity: | | 1.0000 | | | |
| <input checked="" type="checkbox"/> Copy Changes to Other Books | | Cost: | | 8,543.00 | | | | | | | | | |
| Retirement | | | | | | | | | | | | | |
| *Disposal Code: | | Retirement by Sale | | Date/Time: | | 07/02/05 1:40:02PM | | Ret Status: | | | | New | |
| Quantity: | | -1.0000 | | Retirement Amt: | | -8,543.00 | | AUD | | | | | |
| Removal Cost: | | 200.00 | | RC Curr: | | AUD | | Base Removal Cost: | | 200.00 | | | |
| Proceeds: | | 2,000.00 | | Pr Curr: | | AUD | | Base Proceeds: | | 2,000.00 | | | |
| Convention: | | Actual Month | | Accum Depr: | | 0.00 | | | | | | | |
| Trans Code: | | Sale | | Gain/Loss: | | 0.00 | | | | | | | |
| Retire Option: | | Calculate Gain/Loss | | | | | | | | | | | |
| Customer/Ship from Information | | | | | | | | | | | | | |
| Ship from Loc: | | AUS01 | | | | | | | | | | | |
| Customer ID: | | AUS01 | | | | Maretec Ltd. | | Loc: | | 1 | | | |
| Sold To Customer: | | CANPP001 | | | | CAN PP 001 | | Sold Loc: | | 1 | | | |
| Ship To Customer: | | CANPP001 | | | | CAN PP 001 | | Ship Loc: | | 1 | | | |

Retire Assets page

Trans Date (transaction date)

The transaction date reflects the date that the retirement actually occurred. Usually, an actual transaction occurs before you enter it in PeopleSoft Asset Management. The transaction date and the prorate convention determine how much of the depreciation taken in PeopleSoft Asset Management must be recovered.

Acctg Date (accounting date)

The accounting date determines when the retirement transaction is posted to the general ledger.

Rate Type

Select an exchange rate type for the transaction if you use multiple currencies in processing and the retirement transaction is not in the base currency of the business unit.

Book

Book Name

Enter the book in which this asset retirement is recorded.

Retire As

Specify the type of retirement transactions to process by selecting from the list of disposal codes. Then, depending on the asset's status, click GO or Reinstate.. Until you click one of these buttons, you cannot enter information into other fields.

Note. To reinstate a specific retired transaction, scroll to the transaction and select the Reinstate check box before clicking the Reinstate button.

Copy Changes to Other Books

Selected by default, this option keeps all books in sync by copying this transaction to all other books that are defined for the asset. Clear the check box if you do not want to copy changes to other books.

Base Currency, As of, Quantity and Cost

These fields display the corresponding information as defined for this asset in the selected book before you save your changes. You can use this information as a reference when you enter quantity or amount information to partially retire an asset.

Note. If you process asset transactions in multiple currencies, the retirement transaction can be performed in a currency different from that of the asset base currency or the book currency. The Base Currency field is informational. It displays the default currency from the selected asset's business unit.

Disposal Codes

Disposal codes reflect the Retire As action that is selected to initiate the retirement transaction. PeopleSoft Asset Management calculates gain or loss amounts depending, in part, on the disposal code that you select. This table describes the available options in the Retire As field:

| Code | Usage | Gain/Loss |
|-------------------------------------|--|---|
| <i>Abandonment</i> | Select when the asset has no resale value and it is left behind. For example, consider leasehold improvements. At the end of the lease term, the improvements are generally left behind and no removal costs are incurred when you turn over the improvement to the lessor. | Gain/loss calculations are based on the asset net book value. |
| <i>Auto-Retire Fully Depr Asset</i> | Select when the asset is fully depreciated. | Gain/loss calculations are based on the asset net book value. |
| <i>Cannibalize for Other Assets</i> | Select when the asset has been dismantled and the parts are reused within the organization. For example, if an employee reuses a monitor that is part of an unused computer, you would retire the monitor as cannibalized. Typically, cannibalized assets are partially retired. They have no proceeds and no removal costs. | Gain/loss calculations are based on the asset net book value. |

| Code | Usage | Gain/Loss |
|----------------------------------|--|---|
| <i>Casualty Loss</i> | Select when an asset is unintentionally destroyed. If the asset cannot be sold, you may incur removal costs disposing of it. Retiring an asset as a casualty may have tax consequences if you have tax credits and the asset is not fully depreciated. | PeopleSoft Asset Management deducts the accumulated depreciation from the retirement amount and adds the removal costs to determine the amount of the casualty loss. |
| <i>Disappeared Assets</i> | Select when an asset cannot be located and you are not sure whether the asset was abandoned or stolen. Disappeared assets have no proceeds or removal costs. | Gain/loss calculations are based on the asset net book value. |
| <i>Disposal Due to Theft</i> | Select when an asset has been stolen. | Stolen assets have no proceeds and no removal costs. |
| <i>Donated to External Group</i> | Select when an asset is donated. You typically use this option when assets are donated to nonprofit organizations for tax purposes. | PeopleSoft Asset Management deducts the accumulated depreciation from the retirement amount, treating proceeds and removal costs as appropriate, to determine the gain or loss. Note. VAT is applicable for VAT business units. |
| <i>Like Kind Exchange</i> | Select to process like-kind exchanges under U.S. federal tax code. | See Like-Kind Exchange Processing later in this section. |
| <i>Missing Asset</i> | Select when an asset is missing. Missing assets have no proceeds and no removal costs. | Gain/loss calculations are based on the asset net book value. |
| <i>Retirement by Sale</i> | Select if you sell an asset. (If you sell the entity that owns the asset, you must retire all assets that are owned by the entity.) You can use the interface with PeopleSoft Billing to generate the bill. | The proceeds and removal cost from the sale, less the net book value of the asset, determines the gain or loss. Note. VAT is applicable for VAT business units. |

| Code | Usage | Gain/Loss |
|------------------------------------|--|---|
| <i>Returned to Inventory</i> | Select when the asset is returned to a common internal pool where it is available for others to use. | PeopleSoft Asset Management deducts the accumulated depreciation from the retirement amount, treating proceeds and removal costs as appropriate, to determine the gain or loss. Note. VAT is applicable for VAT business units. |
| <i>Scrapped Assets</i> | Select when the asset is no longer useful and has no resale value. | The gain/loss calculations include removal costs; accumulated depreciation is deducted and then the removal costs are added to derive the amount of the gain or loss. |
| <i>Traded In for Another Asset</i> | Use when you are trading one asset for another. See Processing Trade-Ins in this section. | PeopleSoft Asset Management deducts the accumulated depreciation from the retirement amount, treating proceeds and removal costs as appropriate, to determine the gain or loss. Note. VAT is applicable for VAT business units. |

Quantity

When you select a disposal code, the system automatically populates the Quantity field with the total number of units, and the Retirement Amount field with the total cost for all units. Adjust either the quantity or the cost for a partial retirement. If you adjust the number of units, the cost is recalculated. If you adjust the cost, the quantity is recalculated. When performing a full retirement, it is not necessary to adjust quantity or amount retired; enter any proceeds from the sale of this asset and any removal costs that you may have incurred. When performing a partial retirement, change either the quantity or cost that will be retired.

Removal Cost and RC Curr
(removal cost currency)

Enter the amount of any cost for removal and select the currency for the cost.

Proceeds and Pr Curr
(proceeds currency)

Enter the amount of the proceeds for the transaction and select the currency of the proceeds.



When you have transactions involving currencies other than base currency, click the Base Amounts and Exchange Rate icon to access the Proceeds and Removal Cost page. You can review base amounts and exchange rates. You cannot make changes on this page.

Convention

Specify the convention to use to calculate depreciation through retirement. Generally, the same depreciation convention is used to retire an asset as was used when the asset was in service. However, you can change the convention to manipulate depreciation processing. For example, assuming a calendar year, an asset retired on April 15th will be depreciated as follows:

| | |
|-------------------------|--|
| | <i>Actual Day:</i> (asset is depreciated through April 15) |
| | <i>Actual Month:</i> (asset is depreciated through March 31) |
| | <i>Following Month:</i> (asset is depreciated through April 30) |
| Transaction Code | Select to identify the reason for the retirement or reinstatement. |
| Retire Option | Select the retirement calculation options to be processed for the transaction. Options are: <ul style="list-style-type: none"> • <i>Calculate Gain/Loss</i> Select to calculate gain or loss that is associated with the retirement of an asset without fully depreciating the asset. Select if assets should not be fully depreciated at retirement so that the accounting entries passed to the general ledger would include gain or loss information. • <i>Fully Depr no Future Expense</i> Select to process the asset as fully depreciated with no future depreciation expenses, regardless of how much depreciation has actually been calculated. The accounting entries passed to the general ledger will not include gain and loss information. (This remains true as long as no proceeds or removal cost have been assigned for that particular asset.) This option is used generally within the utility industry for group assets and assumes that assets are fully depreciated at retirement regardless of how much depreciation has actually been calculated. Depreciation expense is debited for the full cost basis of the asset at the time of retirement, resulting in no gain or loss. Net book value (NBV) will remain, however. • <i>Fully Depr with Future Expense</i> Select to process the asset as fully depreciated, regardless of how much depreciation has actually been calculated, but future depreciation expenses may be created. The accounting entries passed to the general ledger will not include gain and loss information. (This remains true as long as no proceeds or removal cost have been assigned for that particular asset.) The depreciation close process (AM_DPCLOSE) generates the accounting entries for any remaining expense. |

Note. Fully depreciated assets are also called fully reserved assets.

For example, if you retire an asset with an original cost basis of 10,000 USD and accumulated depreciation of 8,000 USD, the NBV is 2,000 USD. When you run the Accounting Entry Creation process (AM_AMAEDIST) to create accounting entries, the system looks at the selection for the Retire Option field:

If you select *Calculate Gain/Loss*, the system creates the following accounting entries: Debit Accumulated Depreciation for 8,000 USD; Debit Loss for 2,000 USD; and Credit Fixed Asset for 10,000 USD.

If you select *Fully Depr no Future Expense*, no gain or loss is recorded, and the accounting entries are Debit Accumulated Depreciation for 10,000 USD and Credit Fixed Asset for 10,000 USD.

If you select *Fully Depr with Future Expense*, the accounting entries are Debit Accumulated Depreciation for 10,000 USD ; Credit Fixed Asset for 10,000

USD; Debit Depreciation Expense for 2,000 USD; and Credit Accumulated Depreciation for 2,000 USD.

Note. When you select *Fully Depr with Future Expense*, the first two rows are created by the Accounting Entry Creation process (AM_AMAEDIST.) The last two rows are created by the Depreciation Close process (AM_DPCLOSE.)

| | |
|--|---|
| Retirement Amt (retirement amount) | Displays the amount of the retirement transaction in the base currency. |
| Base Removal Cost | Displays the base removal cost, translated to the base currency. |
| Base Proceeds | Displays the base proceeds, translated to the base currency. |
| Accum Depr (accumulated depreciation) | Displays the accumulated depreciation for the asset, which is displayed after you have run the depreciation calculation process (AM_DEPR_CALC). |
| Gain/Loss | Displays the amount of the gain or loss on the transaction after you run the depreciation calculation process (AM_DEPR_CALC). |

Customer/Ship from Information

This section of the Retire Assets page enables you to retrieve customer information that is related to a retirement-by-sale transaction. The fields appear only when this value is selected as the retirement option or if the retirement option is *Traded In, Donated, or Returned to Inventory*, and the business unit is VAT enabled.

| | |
|---|---|
| Ship from Loc (ship from location) | The default ship-from location is the asset location. If no asset location is defined, the default is the business unit location. This field is required only for business units that are VAT-enabled. |
| Customer ID | Enter the customer ID for the customer who is billed for the transaction. The value that is entered determines VAT values. When you enter the customer ID, default values for customer location, bill-to-location, sold-to, and ship-to information are supplied automatically, if applicable. Click the Search button to view a list of the valid customer IDs for the business unit. When you enter a customer ID, the location is set to the default location and the ship-to and sold-to Customer IDs and locations are set to the same values. |
| Loc (location) | Enter the location ID for the customer location that is associated with the customer ID. |
| | <hr/> Note. Click the Search button to view a list of the valid customer location IDs for the business unit. <hr/> |
| Sold To Customer | Enter the customer ID for the customer that ordered and purchased the asset. This is not necessarily the same as the ID in the Customer ID field. |
| Sold Loc (sold location) | Enter the location ID for the customer that ordered or purchased the asset. This is not necessarily the same as the location in the Loc field. |
| Ship To Customer | Enter the customer ID where the assets will be shipped. Depending on the PeopleSoft Billing interface options that you have selected, this field appears when shipping information is associated with the selected customer ID. This is not necessarily the same as the ID in the Customer ID field. |

- Ship Loc** (Buyer Location) Enter the location ID associated with the ship-to customer. Customers can have several location addresses associated with them, each identified by a location number.
- Create Bill** Select to generate a PeopleSoft Billing invoice when the disposal is Retirement by Sale. This option does not appear if PeopleSoft Asset Management is not integrated with PeopleSoft Billing or if you did not enable the interface at implementation.

See *PeopleSoft Enterprise Billing 9.0 PeopleBook*, “Integrating with PeopleSoft Asset Management”.

See *PeopleSoft Enterprise Asset Lifecycle Management Fundamentals 9.0 PeopleBook*, “Integrating PeopleSoft Asset Management with Other Products,” Integrating with PeopleSoft Billing.

Customer General Info

Click the Customer General Info (customer general information) link to access the Customer General Information page. A new window opens and displays the page.

See *PeopleSoft Enterprise Order to Cash Common Information 9.0 PeopleBook*, “Maintaining General Customer Information”.

VAT

You can access the VAT page by clicking the link or by selecting the tab at the top of the page. This tab and link appear only for VAT-enabled business units.

Note. The VAT default values are automatically applied the first time that you access the page by clicking the link. However, if you change the customer, ship-from, or ship-to information after the VAT default values have been applied, the default values are not automatically updated. In this case, go to the VAT page and click the Reset All VAT Defaults button to redetermine all the defaults. This is not necessary if only the proceeds information has changed.

The fields that appear on the VAT page are specific to the transaction that is recorded. In addition to depending on proceeds, the VAT default values that appear depend on the customer ID, location, ship-to ID, ship-to location, and ship-from location (or the ship-to country, ship-to state, buyer’s registration country, and ship-from location if no customer information is available). The VAT drivers also determine which default values appear. The VAT drivers for assets are: (in descending order of precedence) asset class, customer location, customer, the PeopleSoft Asset Management business unit definition, VAT entity registration, and VAT country. The algorithm for the defaults selects information from asset class first, followed by customer location, followed by customer, and so on.

VAT is enabled based on the disposal code that is used in the transaction. VAT applies for the following disposal codes:

- *Retirement by Sale.*
- *Traded In for Another Asset.*
- *Donated to External Group.*
- *Returned to Inventory.*

See [Chapter 19, “Retiring Assets,” Specifying How VAT Is Calculated for Asset Retirement, page 339.](#)

Traded-In Asset Processing

To retire an asset by trading it for another asset:

1. Retire the asset using the disposal code in the Traded-In for Another Asset field.
2. Enter the amount that is gained through the trade-in into the Proceeds field.
3. Run depreciation to calculate the gain or loss amount.
4. Add the new asset by using the Asset ExpressAdd component and select *Trade-in* as the acquisition code.
5. Enter the asset ID of the asset that you traded into the Trade-in field.

Note. Be sure to run depreciation whenever you retire an asset. This process calculates the gain or loss amount. The proceeds are offset against the cost of the asset that is acquired as part of the exchange.

Like-Kind Exchange Processing

Access the Like Kind Exchange page.

PeopleSoft Asset Management supports 1031 Like-Kind Exchange regulations under the U.S. federal tax code. It enables you to:

- Retire an asset using a like-kind disposal code, recognize the gain that results, and roll the correct tax basis over to the newly acquired asset.
- Verify, through a comparison of the disposition date and the replacement date, that the 180-day exchange rule is met.
- Generate appropriate accounting entries for like-kind exchanges.
- Run reports that detail each like-kind transaction and show the carry forward of the tax basis from the old assets to the new assets.

Click the Like-Kind Exchange Info link to enter retirement information that is specific to a retirement transaction.

Like Kind Exchange

Unit: US001 **Asset ID:** EX_000000034 **Book:** CORP

| | | | |
|--------------------------------|-----------------------------------|--------------------------------|----------------------|
| Currency: | USD | Date/Time: | 11/06/2003 2:30:49PM |
| Transaction Information | | Base Information | |
| Cash: | <input type="text" value="0.00"/> | Base Cash: | 0.00 |
| FMV Like Kind: | <input type="text" value="0.00"/> | Base FMV Like Kind: | 0.00 |
| Net Liability: | <input type="text" value="0.00"/> | Base Net Liability: | 0.00 |
| FMV Non Like-Kind: | <input type="text" value="0.00"/> | Base FMV Non Like Kind: | 0.00 |
| Proceeds: | 0.00 | Base Proceeds: | 0.00 |
| | | Base Recognized G/L: | 0.00 |

One to Many Exchange

One to Many ID:

Trade-in List Customize | Find | View All | First 1 of 1 Last

| Transaction | Trade-In Value | Trade In Value | Description |
|-------------|----------------|----------------|--|
| | 0.00 | USD | 0.00 USD <input style="width: 100%;" type="text"/> |

Like Kind Exchange page

To process like-kind exchanges:

1. Retire an asset using the like-kind exchange disposal code.
 - Enter any cash that is received as part of the exchange in the Cash field. Cash that is received in a like-kind exchange is taxable and is often referred to as *boot*.
 - Enter the fair market value of the like asset that you will be adding in the FMV Like-Kind field.
For example, if you are retiring a building and adding another building that is valued at 60,000 USD, you enter 60,000 into the FMV Like-Kind field. If you plan to add more than one like asset, select One to Many to access the one-to-many list, where you can enter the values and descriptions of assets that you are adding.
 - If you will also receive non-like property as part of this exchange, enter its fair market value in the FMV Non Like-Kind field.
A gain that is realized through the acquisition of non-like property is taxable.
 - Enter the amount of your liability into the Net Liability field.
For example, if you are surrendering a building with a mortgage of 70,000 USD and acquiring a building with a mortgage of 30,000 USD, enter 40,000 USD as the net liability.

The system sums the values in the Cash, FMV and Net Liability fields and populates the Proceeds field with the result. You cannot change this amount.

PeopleSoft Asset Management prorates basis calculations when you perform a one-to-many exchange.
2. Run the Depreciation Calculation process, which calculates both the realized gain and the recognized gain.
You can view the result of this calculation in the Gain/Loss field on the Retire Assets page. Any realized loss is not recognized.
3. Add the new asset by using the Asset ExpressAdd component.
Select *Like-Kind Exchange* as the acquisition code, and select the asset ID of the retired asset.
The asset category automatically displays the category of the retired asset, and the cost fields are populated with the cost basis for the new asset. You cannot change either the category or the cost amounts.

Note. The FMV entered on the Like Kind Exchange page is not automatically assigned as the fair market value of the newly acquired asset.

See [Chapter 5, “Adding and Maintaining Assets,” Adding and Maintaining Asset Information, page 47](#).

Fair Market Values for a Like Kind Exchange

Access the One to Many page.

PeopleSoft Asset Management prorates basis calculations when you perform a one-to-many exchange.

One to Many ID Enter a one-to-many ID to identify the exchange.

Trade In Value/Description For each asset that you add, enter a trade-in value and description.

Like-Kind Exchange Example

If the owner of Building A wants to exchange it for Building B, Building A is retired using the like-kind disposal code and Building B is added through the Asset ExpressAdd component.

| Transaction | Building A (Retiring) | Building B (Adding) |
|--------------------------|-----------------------|---------------------|
| Cost | 85,000 USD | 60,000 USD |
| Liability (Mortgage) | 70,000 USD | 30,000 USD |
| Accumulated Depreciation | 10,000 USD | None |

PeopleSoft Asset Management calculates *boot*, which is any cash or non-like property that is involved in the transaction, like this:

$$(\text{Cash Received}) + (\text{FMV of Non-like Property Received}) + (\text{Liability Assumed}) = \text{Boot}$$

Note. Boot is money or other property that doesn't qualify for nonrecognition of gain.

In this example, boot is calculated like this: $0 + 0 + 40,000 = 40,000$.

When you run the Depreciation Calculation process, the process identifies the recognized gain as the lesser of the boot amount or the realized gain.

In this example, in which the boot amount is 40,000 and the realized gain is 25,000, the recognized gain is 25,000.

PeopleSoft Asset Management calculates the cost basis of the property exchanged (retired) like this:

$$(\text{Cost}) - (\text{Accumulated Depreciation}) = (\text{Cost Basis of Property Exchanged})$$

In this example, it is calculated like this: $85,000 - 10,000 = 75,000$.

PeopleSoft Asset Management calculates the cost basis of the added property added like this:

$$(\text{Basis of Retired Property}) - (\text{Boot Amount}) + (\text{Recognized Gain or Loss}) = (\text{Basis of the Added Property})$$

In this example, it is calculated like this: $75,000 - 40,000 + 25,000 = 60,000$.

Defining Other Retirement Options

Access the Retire/Reinstate Assets - Other Options page.

The screenshot displays the 'Retire Assets - Other Options' page. At the top, there are tabs for 'Retire Assets', 'Other Options', 'By Chartfield', 'Capital Gain', 'VAT', and 'Bill Information'. Below the tabs, the asset details are shown: Unit: AUS01, Asset ID: AM325, Description: Automobiles, and Tag: In Service. The page is divided into several sections:

- Book:** ACCNT_AUD. Includes 'Find | View All' and 'First 1 of 3 Last' navigation.
- Retirement:** Includes 'Find | View All' and 'First 1 of 1 Last' navigation.
 - Gain/Loss Calculations:** Three checkboxes: 'Use Original Cost', 'Recalc Cost Using Index', and 'Include Non Capitalized Cost'.
 - Conversion:** Radio buttons for 'Voluntary' and 'Involuntary'.
 - Type:** Radio buttons for 'Ordinary' and 'Extraordinary'.
 - Basis Reduction Code:** A small text input field.
 - Index Name:** A text input field.
 - SubIndex:** A text input field.
 - Reference Code:** A text input field.
 - Description:** A large text area with scrollbars.
 - Trade In Asset:** A checkbox labeled 'Auto-Retired'.

Retire/Reinstate Assets - Other Options page

Gain/Loss Calculations

PeopleSoft Asset Management provides three methods for calculating retirement gain or loss. You can use these methods separately or in combination. Select the appropriate check box in the Gain/Loss Calculations group box.

Use Original Cost and Basis Reduction Code

Select to exclude certain kinds of transactions from the calculation. Do this by selecting a basis reduction code (this is required when Use Original Cost is selected.) For example, if you had revalued an asset but wanted to exclude the revaluation from the gain/loss calculation at retirement, you would select the basis reduction code that you set up to exclude revaluations. PeopleSoft Asset Management reverses the revaluation and calculates gain/loss using the resulting net book value.

Note. For the Use Original Cost option to work correctly, any transaction types that you want to exclude must have distinct transaction codes.

Recalc Cost Using Index (recalculate cost using index), Index Name, and SubIndex

Select to adjust the cost of an asset, as well as any subsequent transactions, according to any index that you have set up in PeopleSoft Asset Management. For example, if you have set up an index to account for inflation, you can calculate gain/loss using the original cost and any subsequent transactions adjusted for inflation. This enables you to book the gain or loss adjusted for inflation. When you select this check box, you must enter an index and subindex to use in the recalculation.

Reference Code

Enter information to track the asset, such as retirement documentation or asset ID. This is optional.

Include Non-Capitalized Costs Select to include any noncapitalized costs in the net book value of an asset.

Trade In Asset Displays the ID of the new traded-in asset.

Auto-Retired Indicates that the asset was automatically retired by the Auto-Retire process (AMRETFDA).

Conversion

Voluntary and Involuntary Select one or the other to indicate whether this is a Voluntary or Involuntary retirement. This is for information only

Type

Ordinary and Extraordinary Select to indicate how the gain or loss that results from the retirement should be reported. This is informational.

Selecting Retirement Transactions by ChartField

Access the Retire/Reinstate Assets - By ChartField page.

Retire/Reinstate Assets - By ChartField page

Override the system selections by entering an amount in the Retire Amt (retire amount) field or the Quantity field. Typically, you use this page only when assets are split between departments or partially retired.

For example, suppose that the Sales and Marketing departments share 40 color monitors worth a total of 10,000 USD, and these assets are added to PeopleSoft Asset Management. Based on projected use, the Sales department is allocated 70 percent of the total cost and quantity and Marketing is allocated 30 percent. After a couple of years, all the color monitors are upgraded to flatscreen, resulting in the retirement of monitors with a total cost of 10,000 USD. Based on the original allocation of cost, the system fully retires the assets with 70 percent of the retirement amount allocated to Sales (department 21101) and 30 percent to Marketing (department 22001).

However, if Sales decides that some of their monitors are worth keeping, only 50 percent of the total cost is retired, rather than 70 percent. To make these changes, override the amount in the Retire Amt field with 5,000 USD allocated to the Sales department, or override the amount in the Quantity field with 20 allocated to Sales.

Note. When you perform a retirement by ChartField, for each ChartField combination you can retire only a cost or quantity that is less than or equal to the amount that was originally apportioned to that ChartField combination.

Selecting Child Assets

Access the Child Assets page.

Note. The Child Assets page appears in several different components of PeopleSoft Asset Management. Within the Asset Retirements component, use the Child Assets page to select child assets to include in the retirement transaction that you have initiated against its parent on the Retire Assets page. Also, you cannot view or perform transactions on child assets whose parent was created using the Asset Parent page.

Click Select All to include all child assets with the parent in the transaction that you have initiated.

Note. Parent assets created on the Parent Asset page (parent-only assets) do not have cost or basic information. They cannot be viewed in the Parent Child Basic Information component, nor can they be viewed or transacted against in the Asset Cost/Adjust Transfers component; the Asset Retirements component; or the Parent-Child NBV component. If you want to use a parent asset as a reporting umbrella only and access these pages for manipulating child assets in mass, we suggest creating a zero-cost parent asset as opposed to a parent-only asset. Also, for you to transact against parent and child assets at once, parent and child must use the same asset profile. Please also be aware that physical asset components will not be retired when the physical parent component is retired.

To include only some child assets, select the Selected check box for the appropriate rows.

| | |
|-------------------------|---|
| Acquisition Date | The date the asset was acquired. |
| Child Asset ID | The asset ID that is assigned to the child asset. |
| Cost | The cost of the child asset. |
| Currency | The currency in which child asset costs are stored. |
| Description | The child asset description. |
| Tag Number | The tag that is assigned to the child asset. Parent and child assets can share the same tag number. |

The Include Parent Asset check box is selected by default. Clearing it enables you to perform transactions on child assets while excluding the parent asset from the transactions. However, the transaction details must be specified on the parent.

Child Details

Click the Child Details link to access the Child Asset Retirement Overrides page where you can specify overrides for a specific child asset for the transaction.

Advanced Transaction Details

Click Advanced Transaction details to access the Advanced Transaction Details page where you can specify overrides that will be applied to all child assets at once.

Asset Information

Click the Asset Information link to access another copy of the Retire Assets page. The page will open populated with the child asset.

Reviewing a Capital Gain Summary for Retirements

Access the Capital Gain page.

| Retire Assets | Other Options | By Chartfield | Capital Gain | Bill Information |
|--|------------------------|--------------------------------|--------------|------------------|
| Unit: AUS01 | Asset ID: AM325 | Automobiles | Tag: | In Service |
| Book Find View All First 1 of 3 Last | | | | |
| Book Name: ACCNT_AUD Accounting Book - AUD Currency: AUD | | | | |
| Retirement Find View All First 1 of 1 Last | | | | |
| Date: 07/02/2005 2:10:31PM | | | | |
| Retire Amt: | -8,543.00 | Quantity: | -1.0000 | |
| Proceeds: | 2,000.00 AUD | Index Name: | | |
| Removal Cost: | 200.00 AUD | SubIndex Name: | | |
| Gain/Loss Calculation | | | | |
| Reduced Cost Basis: | | Capital Gains and Loss: | | |
| Accum Depr: | | Gain/Loss: | 0.00 | |

Capital Gain page

The Capital Gain tab displays when the business unit is enabled for Australian tax. A summary of the capital gains or losses for the retirement transaction are summarized on this page after retirement processes have been run.

Integrating Retired Asset Information with PeopleSoft Billing

Access the Bill Information page.

| Retire Assets | Other Options | By Chartfield | Capital Gain | Bill Information |
|--|------------------------|----------------------|------------------|------------------|
| Unit: AUS01 | Asset ID: AM325 | Automobiles | Tag: | In Service |
| Book Find View All First 1 of 3 Last | | | | |
| Book Name: ACCNT_AUD Accounting Book - AUD | | | | |
| Retirement Find View All First 1 of 1 Last | | | | |
| Date: | 07/02/2005 2:10:31PM | Cust ID: | Proceeds: | 2,000.00 AUD |
| Bill Data | | | | |
| BI Unit: | <input type="text"/> | Trans Status: | | |
| Invoice: | | Line Seq: | | |

Bill Information page

Note. Only assets that are retired with the disposal code *Retirement by Sale* are affected.

PeopleSoft Asset Management can be fully integrated with PeopleSoft Billing to automatically create bills when you retire assets using the *Retirement by Sale* disposal code. If you have implemented PeopleSoft Billing with PeopleSoft Asset Management and you have activated the PeopleSoft Asset Management-Billing interface for the processing business unit, this additional retirement tab is enabled.

| | |
|--|--|
| BI Unit (billing business unit) | Select the PeopleSoft Billing business unit that processes the asset sale to generate an invoice for the sale transaction. The PeopleSoft Billing business unit is defined at the business unit level, but it can be overridden at the asset level. |
| Trans Status (transaction status) | <p>Displays the transaction status of the invoice within the PeopleSoft Asset Management process. Values are:</p> <ul style="list-style-type: none"> • <i>Pending</i> When you have opted to generate an invoice through PeopleSoft Billing for a retirement transaction, the default status is <i>Pending</i> until the transaction is processed by the PeopleSoft Asset Management-Billing interface (AM_BI_INTFC). • <i>In Progress</i> When the PeopleSoft Asset Management-Billing interface is running, the transaction status is updated to <i>In Progress</i>. • <i>Complete</i> When the retirement transaction has been loaded into PeopleSoft Billing for processing, the transaction status is updated to <i>Complete</i>. • <i>Ignore</i> If you reinstate this asset before the PeopleSoft Asset Management-Billing interface is processed, the bill create and credit bill transactions appear in the interface. In this case, the PeopleSoft system cancels the initial retirement and the status of the billing request changes to <i>Ignore</i>. To proceed with the retirement, you must reenter the retirement transaction. You cannot generate a reinstatement until PeopleSoft Billing creates the invoice number (after BIIF0001 is run). If you reinstate this asset before the PeopleSoft Asset Management-Billing interface is processed but after running depreciation calculation for the retirement, the system cancels the initial retirement and the status of the billing request is changed to <i>Ignore</i>. |
| Invoice | When the transaction has been processed in PeopleSoft Billing, the invoice number that is assigned appears for future reference. |
| Line Seq (line sequence) | When the invoice for the sale transaction has been processed in PeopleSoft Billing, the line sequence number for this transaction appears. This identifies the invoice line number for the asset sale, and it appears when the invoice has been generated by PeopleSoft Billing. |

PeopleSoft Asset Management sends retirement information to the PeopleSoft Asset Management-Billing business unit (usually the one with the same general-ledger business unit) and then PeopleSoft Billing generates the invoice to the customer (also a general-ledger business unit). Depending on which PeopleSoft Payables business unit has been defined in the InterUnit billing definition (general ledger business unit definition), PeopleSoft Billing sends asset InterUnit information to PeopleSoft Payables, taking the vendor and location from the retired asset's general-ledger business unit.

If a retirement is processed due to an InterUnit transfer, the information is also sent to PeopleSoft Payables, including asset ID, asset profile, and cost type. When you are performing an InterUnit transaction, you must complete additional information.

| | |
|-------------------|--|
| AM Unit | Enter the business unit where the system adds or adjusts the asset through the interface with PeopleSoft Payables. |
| Asset ID | By default, the value is <i>Next</i> , but you can select another existing asset ID. |
| Profile ID | Select the profile for the asset. |
| Cost Type | (Optional) Select a cost type. |

When you click Save, the retirement-by-sale create bill transactions are assigned the transaction status *Pending*. Select the pending transactions to be included when you are ready to run the PeopleSoft Asset Management-Billing (AMBI_INTFC) interface.

Processing Retirement with Sale Transactions in the PeopleSoft Billing Interface

Access the AM/BI Interface page.

After you enter retirement transactions for assets that PeopleSoft Billing invoices, you can initiate the process to load the transactions for the AM/BI Interface process (RUN_AMBI_INTFC). Before you launch this process, the retirement entries must be generated.

Enter the run control ID to use or add a new one. Enter the business unit and the asset ID range to be processed, and click Run.

The process assembles the pending transactions that you have entered, attaches an interface ID, changes the transaction status to *In Progress*, and displays the transactions in a view page (PS_INTFC_BI). The transactions are loaded into PeopleSoft Billing for processing.

You can run the AM/Billing Transaction Status report to review the transactions that were processed. You can review accounting entries before or after the PeopleSoft Asset Management-Billing interface has been run.

Note. Reinstatements are processed according to two rules. First, if the reinstatement is performed before sending the retirement information to PeopleSoft Billing, neither transaction is processed by the PeopleSoft Asset Management-Billing interface. Second, reinstatements cannot be performed until the PeopleSoft Asset Management-Billing interface application (BIIF0001) has been run for the asset's previous retirement.

When transactions between PeopleSoft Asset Management and PeopleSoft Billing occur, the system provides a clearing account, Proceeds to Billing, which accumulates the income from the transactions and matches the transactions to the PeopleSoft Asset Management accounting entries. This maintains balanced accounting entries between the applications.

Running the AM/Billing Transaction Status Report

Access the AM/Billing Transaction Status page.

Enter the appropriate PeopleSoft Asset Management business unit, PeopleSoft Billing business unit, and range of dates for the transactions that you want to review. Click Run to generate and view the report.

Note. When processing a retirement-by-sale for a parent asset, you cannot generate an invoice for each child asset in the same transaction. You have to dispose of each child asset separately.

See Also

PeopleSoft Enterprise Asset Lifecycle Management Fundamentals 9.0 PeopleBook, “Integrating PeopleSoft Asset Management with Other Products,” Integrating with PeopleSoft Billing

Specifying How VAT Is Calculated for Asset Retirement

Access the VAT page.

| | | | | | | | | | | | |
|--|------------------------|-------------------------------|--|---------------------------------------|--|------------------------------|------------|------------|--|----------------------------------|--|
| Retire Assets | | Other Options | | By Chartfield | | Capital Gain | | VAT | | Bill Information | |
| Unit: AUS01 | Asset ID: AM325 | Automobiles | | | | Tag: | In Service | | | | |
| Book Find First 1 of 3 Last | | | | | | | | | | | |
| Book Name: ACCNT_AUD Accounting Book - AUD | | | | | | | | | | | |
| Retirement Find View All First 1 of 1 Last | | | | | | | | | | | |
| Date: 07/02/05 2:10:31PM | | Proceeds: 2,000.00 | | AUD | | | | | | | |
| Expand All Sections | | | | Collapse All Sections | | | | | | | |
| Physical Nature | | | | | | | | | | | |
| Physical Nature: | | | | | | | | | | | |
| VAT Locations | | | | | | | | | | | |
| Ship From Country: AUS | | | | Ship From State: | | | | | | | |
| Ship to Country: | | | | Ship to State: | | | | | | | |
| Vat Defaults | | | | | | | | | | | |
| VAT Registrations | | | | | | | | | | | |
| Reporting Country: AUS | | | | Defaulting State: | | | | | | | |
| Customer Registration Country: AUS | | | | Customer Registration ID: AU | | | | | | | |
| Customer Exception Type: | | | | Certificate ID: | | | | | | | |

VAT page (1 of 2)

| | | | |
|--|-------------------------|---|---|
| ▼ VAT Controls | | | |
| Calculate at Gross or Net: | Gross | | |
| <input checked="" type="checkbox"/> Recalculate at Payment | | | |
| Calculation Type: | Inclusive | | |
| Declaration Point: | Delivery | | |
| Declaration Date: | 07/02/2005 | | |
| Rounding Rule: | Nat Rnd | | |
| ▼ VAT Treatments | | | |
| Treatment: | Zero-Rated Goods Export | | |
| ▼ VAT Details | | | |
| Applicability: | Taxable | | |
| VAT Code: | AU1 | | |
| Transaction Type: | AOPU | | |
| ▼ Adjust/Reset VAT Defaults | | | |
| Adjust Affected VAT Defaults | | Click this button if you want the system to adjust the VAT Defaults on this page affected by changes you have made to this page. All changes you have made to VAT Defaults that affect other VAT Defaults will be retained. | |
| Levels: | This level only | Reset All VAT Defaults | Click this button if you want the system to reset all the VAT Defaults. All changes you have made to VAT Defaults will be lost. |
| ▼ VAT Calculations | | | |
| Transaction Amount: | 1818.18 AUD | Transaction Amount Base: | 1818.180 |
| Basis Amount: | 1818.18 AUD | Basis Amount Base: | 1818.180 |
| Tax Rate: | 10.0000 | | |
| Recorded Amount: | 181.82 AUD | Recorded Amount Base: | 181.820 |
| Recalculate | | | |

VAT page (2 of 2)

If asset transactions involve VAT, the Retire/Reinstate Assets component includes the VAT page.

You must complete the following tasks before you can access this page:

- Set up the VAT defaults.
 - Associate the business unit with a general ledger business unit that is associated with a VAT entity.
- Enter customer ship-from information.
- Enter a proceeds amount on the Retire Assets page.
- Select Create Accounting Entries on the Business Unit/Book Definition page.

When you retire an asset, the VAT information is recorded with a VAT account entry type of *VO* (VAT output). If you reinstate an asset that you have retired with VAT options, the reinstatement reverses the VAT entries. When you reinstate an asset, the reversal of the VAT is recorded with a VAT account entry type of *VORE* (VAT output reinstatement).

The VAT page contains several collapsible sections. Each section contains fields that are blank or that display default values. VAT entries are created for all books that generate accounting entries if the associated general ledger business unit is linked to a VAT entity.

The first collapsible section, **Book**, displays information that is supplied by default from the book that is associated with this asset.

The next section, **Retirement**, displays information that is supplied by default from the current retirement transaction that is being processed, or it contains blank fields. Within this section are several group boxes that contain blank and populated fields.

The final collapsible section, **VAT Calculations**, shows the calculated totals for the VAT transaction based on the values that are selected on the page. It also displays the default VAT information for the business unit, customer, and location.

Physical Nature

This collapsible section describes the physical nature of transactions. Options are *Goods* and *Services*. PeopleSoft Asset Management manages transactions for goods only.

Physical Nature Indicates whether an object is a good or a service. In many countries, you must report the sale or purchase of goods separately from services.

VAT Locations

You use location information to directly determine the reporting country, defaulting state, customer registration country, and treatment. This information is in turn used to determine customer exception type, VAT controls, and VAT details.

Ship From Country By default, this field displays the same value that is entered in the Ship from Loc field on the Retire Assets page. This is the asset location or the PeopleSoft Asset Management business-unit location.

Ship From State If the ship-from country is defined as tracking VAT by state or province, by default this field displays information (when available) based on the Ship from Loc field on the Retire Assets page.

Ship To Country By default, this field displays the customer's shipping address. This field always has an initial value.

Ship To State If the ship-to country is defined as tracking VAT by state or province, by default this field displays the information (when available) from the customer's shipping address. .

VAT Defaults

VAT Registrations The fields in this collapsible section are:

- **Reporting Country:** Displays the country for which this VAT is reported. This is the VAT entity's VAT registration country, and it determines many of the VAT defaults.
- **Customer Registration Country and Customer Registration ID:** Display the registration country and ID of the bill-to customer.
- **Customer Exception Type:** Displays the exception that is granted to the customer. Options are *None*, *Exonerated*, and *Suspended*. This value is specified for the bill-to customer.
- **Defaulting State:** If the reporting country requires that VAT be tracked by state or province, this field displays the state within the reporting country that is used to retrieve values from the VAT Defaults table.

VAT Controls

- **Certificate ID:** If applicable, displays the ID of the VAT exception certificate that may have been issued to the customer.
- **Calculate at Gross or Net:** Indicates how VAT is calculated. Options are:
 - *Gross:* The system calculates VAT before it applies any early payment discounts.
 - *Net:* The system calculates VAT after it deducts early payment discounts. If two percentage discounts exist, the system uses the larger of the two when it calculates VAT. The system does not use discount amounts, only discount percentages.

The default value comes from the VAT entity registration driver.

Note. PeopleSoft Asset Management does not manage payment discount. Consequently, net and gross produce the same result. When the retirement transaction is passed to PeopleSoft Billing and a prompt payment discount is available on the invoice, the final VAT that PeopleSoft Billing calculates differs from the estimated VAT that PeopleSoft Asset Management calculates.

- **Recalculate at Payment:** Select to enable the recalculation of VAT at payment time to allow for any early payment discounts if you are calculating VAT at gross. This causes the system to adjust the VAT amount at the time of payment if the discount has been taken. This is set by the VAT entity registration driver.

If you select *Net* as the VAT calculation method, recalculation at payment is not permitted.

You can select recalculation at payment if the entry is passed to PeopleSoft Billing.

- **Calculation Type:** The default value comes from the PeopleSoft Asset Management business unit driver. Options are:
 - *Exclusive:* VAT is not included in the proceeds. The VAT basis amount is equal to the proceeds amount. The system calculates the VAT amount by multiplying the VAT basis amount by the VAT rate.
 - *Inclusive:* VAT is included in the proceeds. First, the system calculates the VAT basis amount by dividing the proceeds amount by 1 plus the VAT rate. The system then calculates the VAT amount by taking the difference between the VAT basis amount and the proceeds amount.

Note. When the retirement transaction is passed to PeopleSoft Billing, only the *Exclusive* option is allowed.

- **Declaration Point:** Select to indicate when VAT transaction information is recognized for reporting purposes. Options are:
 - *Invoice:* VAT is recognized at time of invoice.
 - *Payment:* VAT is recognized at time of payment.
 - *Accounting:* VAT is recognized at the time of accounting.

- *Delivery*: VAT is recognized on delivery.

This value is set by the VAT entity registration driver and by the defaults in the VAT hierarchy (specifically the PeopleSoft Asset Management business unit, customer, and customer location).

Note. A VAT declaration point of payment is not valid in PeopleSoft Asset Management.

- **Declaration Date**: By default, displays the date of the retirement. You can override this to the actual delivery date.
- **Rounding Rule**: Displays the VAT rounding rule. The value comes from the VAT country driver or VAT entity registration driver definition. Values are:
 - *Natural Round*: Amounts are rounded normally (up or down) to the precision that is specified for the currency code. For example, for a currency that is defined with two decimal places, 157.4659 would round up to 157.47, but 157.4649 would round down to 157.46.
 - *Round Down*: Amounts are rounded down. For example, for a currency that is defined with two decimal places, 157.4699 would round down to 157.46.
 - *Round Up*: Amounts are rounded up with a rounding precision to one additional decimal place. For example, for a currency that is defined with two decimal places, 157.4659 would round up to 157.47, but 157.4609 would round down to 157.46.

VAT Treatments

Treatment: Displays the VAT treatment. Options for asset retirements are:

- *Domestic Goods Sale*: Sale of goods where the supplier and customer are located in the same country.
- *EU Distance Sale*: Sale of goods between European Union (EU) countries in which the supplier is registered in an EU country and the purchaser is not registered in an EU country. The VAT rate that is charged is the rate that applies in the supplier's country.
- *EU Goods Sale*: Sale of goods between EU countries.
- *EU Sale (Simplification)*: A transaction between an intermediary and the purchaser in which a sale of goods occurs between EU countries involving three parties: the purchaser, an intermediary (bill-from) supplier, and the actual goods supplier. Each party is located in a different EU country and registered in that country but not in either of the other two countries. This VAT treatment differs from normal EU sales in that the supplier is required to print a different message on the invoice referencing the statute that applies to triangulation, rather than the one that references the statute for normal EU sales.
- *No VAT Processing*: Sale does not require VAT processing.
- *Outside of Scope*: Sale is outside the scope of VAT.
- *Zero-rated Goods Export*: Export of goods is subject to 0-rated VAT.

Within the PeopleSoft system, detail VAT treatment values on the transaction lines are used to apply the precise defaults that apply to the transaction lines.

The treatment is determined based the rules that apply to the transaction. No VAT reporting or processing can take place without this value.

VAT Details

The fields in this collapsible section are:

- **Applicability:** Options are:
 - *Taxable:* VAT is chargeable. This may be at a 0 or non-0 rate.
 - *Exempt:* Item is nontaxable or exempt from VAT, and no VAT is charged.
 - *Exonerated:* Item is subject to exoneration from VAT.
 - *Outside of Scope of VAT:* Item is outside the scope of VAT, and no VAT is charged.
 - *Suspended:* This option is used when the purchasing organization has been granted suspension from paying VAT. This is the same as taxable at a 0 rate.
 - *VAT Only:* This option does not apply to PeopleSoft Asset Management; it applies in PeopleSoft Payables only when you are entering a third-party voucher and within General Ledger when you are entering a journal line against a VAT account.
 - *N/A (not applicable):* This is valid only for transactions that are completely non-VAT applicable.
- **VAT Code:** Displays the VAT code that defines the rate at which VAT is calculated for the line. These are established on the Tax Code VAT page. Select Set Up Financials/Supply Chain, Common Definitions, VAT and Intrastat, Value Added Tax.
- **Transaction Type:** Displays the code that categorizes and classifies the transaction for VAT reporting and accounting. These codes are established on the VAT Transaction Types page. Select Set Up Financials/Supply Chain, Common Definitions, VAT and Intrastat, Value Added Tax.

Adjust/Reset VAT Defaults

This collapsible section contains these elements:

- **Adjust Affected VAT Defaults:** When you change VAT defaults on this page, the VAT defaults might be associated with other unchanged VAT defaults on the page. For accuracy and consistency, click this button to have the system adjust the VAT defaults that are affected by those that you modified on this page. All changes to VAT defaults that affect other VAT defaults are retained.

Note. Always click the Adjust Affected VAT Defaults button after changing defaults on the VAT page.

- **Levels:** For asset retirement, you cannot select which levels to update. The Reset option always resets the defaults at this level only.
- **Reset All VAT Defaults:** Click to have the system reset the VAT defaults based on the value at this level only. All changes that you made to VAT defaults will be lost.



Click the Information button to list the fields that are adjusted when you select Adjust Affected VAT Defaults.

VAT Calculations

Transaction Amount Displays the amount of the transaction in the transaction currency. This is automatically calculated based on the proceeds amount.

Transaction Amount Base Displays the amount of the transaction in the base currency.

Basis Amount Displays the amount on which the VAT is calculated in the transaction currency. If VAT is calculated at net, this amount is net of any discounts.

Note. PeopleSoft Asset Management does not manage billing discount functionality.

Basis Amount Base Displays the amount on which the VAT is calculated in the base currency. If VAT is calculated at net, this amount is net of any discounts.

Tax Rate Displays the applicable VAT percentage.

Recorded Amount Displays the amount of VAT that is recorded for this transaction in the transaction currency. This is an estimated amount. If PeopleSoft Asset Management is integrated with PeopleSoft Billing, this value is called the *estimated amount*.

Recorded Amount Base Displays the amount of VAT that is recorded for the transaction in the base currency. If PeopleSoft Asset Management is integrated with PeopleSoft Billing, this value is called the *estimated amount*.

Recalculate Click to recalculate the VAT for the line.

All VAT edits are applied when you click Save.

Note. In PeopleSoft Asset Management, if you retire an asset and pass the information to PeopleSoft Billing, the VAT Transaction Loader process does not retrieve the VAT information from PeopleSoft Asset Management but from the bill that is created in PeopleSoft Billing. However, if the retirement transaction remains in PeopleSoft Asset Management, the VAT Transaction Loader process gets the VAT information from PeopleSoft Asset Management.

When you run the Accounting Entry Distribution process (AM_AMAEDIST), use the accounting entry template that you would normally use for asset retirements. To make the VAT entry, the system uses an account from the VAT accounting entry template, based on the combination of VAT code, VAT account type, and VAT transaction type that is specified for the retirement. The system first determines whether VAT ChartFields are defined by the VAT code and general-ledger business unit. If no VAT accounting information is found at that level, the system then checks for VAT ChartFields that are defined at the VAT code level. If the retirement is passed to PeopleSoft Billing, PeopleSoft Asset Management does not generate accounting entries in connection with VAT because PeopleSoft Billing creates them.

Note. If PeopleSoft Asset Management is *not* integrated with PeopleSoft Billing, note the following point: Although VAT is recorded when retiring an asset, PeopleSoft Asset Management does not generate a financial document such as a VAT invoice. If you also record the sale of an asset in PeopleSoft Billing or PeopleSoft Receivables, you might inadvertently record the applicable VAT a second time. In this case, you must ensure that the VAT is not reported on the VAT return twice.

Instead of using the VAT that is recorded in PeopleSoft Asset Management to generate the VAT return, you can use that information to enter the invoice for the sale of the asset in PeopleSoft Billing or PeopleSoft Receivables. In this case, you can copy the VAT into the VAT Transaction table. When running the VAT Transaction Loader process, do not run the process for all products and do not select Asset Management as a VAT transaction source.

Alternatively, you can exclude the PeopleSoft Asset Management VAT transactions from your VAT return. To do so, assign a specific VAT transaction type to asset retirement transactions. Then do not include that VAT transaction type on any line in the VAT report definition (or include it on an additional line in the VAT report definition but do not include the line in the Crystal report format).

See Also

PeopleSoft Enterprise Asset Lifecycle Management Fundamentals 9.0 PeopleBook, “Establishing PeopleSoft Asset Management Business Units,” Defining VAT Defaults

PeopleSoft Enterprise Global Options and Reports 9.0 PeopleBook , “Working with VAT”

PeopleSoft Enterprise General Ledger 9.0 PeopleBook, “Processing Value Added Tax (VAT) Transactions in General Ledger”

PeopleSoft Enterprise Billing 9.0 PeopleBook, “Calculating VAT in PeopleSoft Billing”

Auto-Retiring Fully Depreciated Assets

Access the Auto-Retire Fully Depr Assets page.

Auto-Retire Fully Depr Assets

Run Control ID: GBR [Report Manager](#) [Process Monitor](#) Run

Request

Find | View All First ◀ 1 of 1 ▶ Last

*Request ID: Process Frequency: + -

Selection Criteria

*Business Unit: 🔍

Book Name: ▼ Copy Changes to Other Books

Category: 🔍

From Asset: 🔍

To Asset: 🔍

Cost Limit: USD

Low Value Assets Only

Clustered Assets Only

Transaction

*Trans Date: 📅

*Acctg Date: 📅

Retirement Options

Disposal Code:

Convention: ▼

Transaction Code: ▼

Reference Code:

Auto-Retire Fully Depr Assets page

You can retire many assets without individually identifying them by running the Auto-Retire process (AMRETFDA). You enter selection criteria to qualify eligible assets for auto-retirement on the process request, and all selected assets are automatically retired by the process. Only fully depreciated assets can be retired by this process. Fully depreciated assets are assets with an end depreciation date that is less than or equal to the retirement transaction date.

Selection Criteria

| | |
|---|--|
| Business Unit | (Required) Select a business unit from the drop-down list. Only business units that have been enabled with the auto-retire feature appear. |
| Book Name | Select a business unit book from the drop-down list. Only books that have been enabled with the auto-retire feature appear. |
| Copy Changes to Other Books | Select to keep all books in sync. The system copies the transaction to all books that are set up for an asset. |
| Category, From Asset, and To Asset | Select as applicable to narrow the parameters by categories or by a range of asset IDs. |
| Cost Limit | Select assets that cost less than or equal to the cost limit. |
| Low Value Assets | Select to retrieve only low-value assets. |

| | |
|---|---|
| Clustered Assets | Select to retrieve only clustered assets. |
| Transaction Date and Accounting Date | Enter the applicable transaction or accounting date to define the selection criteria. |

Retirement Options

| | |
|-------------------------|---|
| Convention | Enter a retirement convention to override the asset profile default. |
| Transaction Code | Select a transaction code to identify the reason for the retirement. |
| Reference Code | (Optional) Enter information to track the asset, such as retirement documentation or an asset ID. |

Initiating Asset Retirement Using the Disposal Worksheet

PeopleSoft Asset Management provides the Disposal Worksheet page as a quick method to select assets to retire based on the following elements: ChartField combination, location, department, manufacturer, or other fields that are related to the assets.

Use of the worksheet depends on the establishment of asset-to-owner relationships as well as owner-to-operator relationships to enable the selection, review, and approval of asset disposal. When the Asset Owner and Asset Owner User links are defined, the asset owner can generate and submit a disposal worksheet for processing or approval. After the approval process has been established, an asset owner can review asset disposal requests from worklist entry notifications. Requests can be approved, denied, or designated as pending. Upon approval of the request, — you can submit the disposal worksheet for processing through the AMIF1000 transaction processor.

See *PeopleSoft Enterprise Asset Lifecycle Management Fundamentals 9.0 PeopleBook*, “Establishing Asset Processing,” Establishing Asset Ownership.

Generating the Disposal Worksheet

Access the Disposal Worksheet page.

The screenshot shows the 'Disposal Worksheet' page with the following fields and options:

- Asset Search Criteria:**
 - Unit: US001
 - Category: COMP
 - Asset ID: (empty)
 - Tag Number: (empty)
 - Serial ID: (empty)
 - Location: US003
 - Asset Status: In Service
 - Profile ID: COMPUTERS
 - [More Filter Options](#)
- Acquisition Details:**
 - PO Unit: (empty)
 - Receipt Unit: (empty)
 - AP Unit: (empty)
 - PC Bus Unit: (empty)
 - PO No.: (empty)
 - Receipt No.: (empty)
 - Voucher: (empty)
 - Project ID: (empty)
- Buttons and Options:**
 - Retrieve (button)
 - 100 Rows (text)
 - New Search (button)
 - [View Ownership Details](#) (link)

Disposal Worksheet page

This page provides numerous selection options to retrieve assets for retirement. Assets that are available for retrieval are determined by asset ownership and user ID.

You can search for assets using ChartField search criteria, and you can view asset ownership information by clicking the View Ownership Details link.

| | |
|------------------------------|---|
| Asset Search Criteria | Identify assets that are eligible for disposal based on the user's established asset ownership. Assets can be identified based on: <ul style="list-style-type: none"> • Unit • Serial ID • Category • Location • Asset ID • Asset Status • Tag Number • Profile ID • More Filter Options |
|------------------------------|---|

| | |
|----------------------------|--|
| Acquisition Details | To further identify assets for disposal, complete the following fields: <ul style="list-style-type: none"> • PO Unit (purchasing unit) • Receipt Unit • AP Unit(payables unit) • PC Bus Unit (projects business unit) • PO No.(PO number) • Receipt No(Receipt number) • Voucher • Project ID |
|----------------------------|--|

When you click Retrieve, the result set appears in the tabbed grid at the bottom of the disposal worksheet. You can begin again by pressing the New Search button, and use the link to view ownership details.

Asset Action

The system returns a list of assets that meet the search criteria. You can review and reselect options to create a new list of assets. To initiate a new search, click Clear and select new search criteria.

So that you can process assets for disposal, retirement information is specified to indicate the date and reason for an action.

| | |
|------------------------------------|---|
| Disposal Code | (Optional) Select the disposal code for all assets in the worksheet list to identify the reason for the disposal of the assets. |
| Retire Dt (retirement date) | Enter a retirement date, which can be retroactive or future-dated. This date is applied to all assets in the worksheet list. The default is the current date. |
| Accounting Date | Enter the accounting date to be recorded if different from the current date. This date is applied to all assets in the worksheet list. |
| Set All | Click to apply the retirement information to all assets in the list. |

The list is presented on three tabbed views: Asset Information, Retirement Information, and Optional Accounting Information (such as cost). The information may be hidden, depending on established permissions.

Asset Information

This tabbed view displays the asset ID, description, tag number, category, and serial ID.

Submit for Disposal, Select All, and Deselect All Select assets for disposal individually by selecting the Dispose check box, or select (or deselect) all.

Retirement Information

This tabbed view displays the asset ID, cost, quantity, retire quantity, proceeds, proceeds currency, removal cost, and removal cost currency.

Retire Qty Enter the number of assets to be retired.

Proceeds, PR Curr (proceeds currency),
Removal Cost, and RC Curr (removal cost currency) Enter any proceeds or removal cost along with the currency in which the proceeds or costs were incurred as applicable.

Disposal Code Select disposal codes for each asset individually by entering the code in this field.

Retire Dt Enter the retirement date.

Details Click to view the Asset Details (AM_DISPOSAL_02) page.

Optional Accounting Information

This tabbed view displays the asset ID and accounting date.

Accounting Date Enter the accounting date for the retirement transaction.

Trans Code Enter a transaction code to be applied to each asset individually.

Submit Asset Disposal Information

Click Submit for Disposal when you have completed the disposal worksheet. The disposal request is processed when you run the Transaction Loader process. It is routed for approval, if required, depending on the permissions that are established for the operator.

Approving Disposal Worksheet Requests

Access the Approve Disposals page.

Approve Disposals

Originator

Originator: VP2
Role User:
Date Submitted: 07/01/2005

Retirement Overrides

Retire Dt: 07/01/2005
Disposal Code:
Accounting Date: 07/01/2005

Disposals Pending Approval

Asset Information | Retirement Information | **Optional Accounting Info**
Customize | Find | View All | First 1 of 1 Last

| # | Approval Status | Unit | Asset ID | Accounting Date | Trans Code |
|---|-----------------|-------|--------------|--|-------------------------------|
| 1 | Pending | US001 | EX_000000091 | 07/01/2005 <input type="text" value="31"/> | <input type="text" value=""/> |

Approve Disposals page

The approval process is managed by the workflow settings for your organization. If the worksheet that you submit for disposal requires approval before being processed by the Transaction Loader process, a worklist entry is created and routed to the approver. Multiple assets can be associated with one worklist entry. The user who receives the worklist item approves or denies the disposal request.

The approver has the following three approval-status disposal options:

- | | |
|------------------------|--|
| <i>Denied</i> | The request is not approved and an email notification is sent to the disposal requestor. |
| <i>Approved</i> | The request is approved and the item is loaded to the Transaction Loader process for processing. |
| <i>Pending</i> | No action is taken on the item, and the request is placed on hold. |

The approver can then select Mark As Worked for the worklist item.

Putting Assets Up for Auction

When a bid is awarded through Strategic Sourcing, the bid price is returned to PeopleSoft Asset Management as proceeds for the asset that was sold. This updates the asset with the appropriate information completing the retirement transaction.

Note these points with regard to assets that are put up for auction:

- For you to enter an asset as a line item for sale in an auction event, the asset must have the PeopleSoft Asset Management statuses other than *Disposed* and *Transferred*. It must not be a Lease Asset, or a Hazardous Asset. The auction status is equal to *Allowed to be auctioned*.
- When you post the event, the PeopleSoft Asset Management auction status changes to *Sent to Auction*.
- The auction status remains at *Sent to Auction* until the event is awarded or canceled.

If the event is not approved or is not awarded, you must set the status to *Allowed to be Auctioned* to remove the *Sent to Auction* status for the asset. When the event has been awarded, Strategic Sourcing sends information to PeopleSoft Asset Management, and you have to run the Transaction Loader (AMIF1000) process to finalize the retirement. Strategic Sourcing changes the auction status to *Sold in Auction*.

Note. PeopleSoft Asset Management does not allow PeopleSoft Strategic Sourcing to access data for hazardous materials, intangible assets, or partial retirements. Assets with the status *Sent to Auction* are excluded from any transactions in PeopleSoft Asset Management until the status is changed by PeopleSoft Strategic Sourcing.

See Also

PeopleSoft Enterprise Strategic Sourcing 9.0 PeopleBook, “Creating Events”

Retiring Non-Financial Assets

This section discusses how to retire a non-financial asset.

Page Used to Retire Non-Financial Assets

| Page Name | Object Name | Navigation | Usage |
|----------------------|-----------------|--|------------------------------|
| Non-Financial Retire | ASSET_RET_NF_01 | Asset Management, Asset Transactions, Asset Disposal, Retire/Reinstate Non-Fin Asset | Retire non-financial assets. |

Retiring a Non-Financial Asset

Access the Non-Financial Retire page.

Non-Financial Retire

Unit: US001 **Asset ID:** 000000000005 Fleet vehicle - Gas/Elec Hybri **Tag:** P00000009005 In Service

Trans Date: **Trans Code:**

Retirement

Retire
 Reinstate
 Acq Code: Purchased **Date/Time:** 08/02/2006 3:20:58PM
***Ret Type:**

Lease Information

Lease ID: _____ **Inception Date:** 08/02/2006
Vendor ID: _____
Vendor Contact: _____

Non-Financial Assets page

Select a Trans Code and Ret Type type. Because the asset is a non-financial asset, there is no gain or loss calculation result.

To retire the non-financial asset, click Retire.

Note. Non-financial assets and operating leased assets do not have cost information. The retirement process therefore involves only changing the status of the asset to *Inactive* (or *Disposed*.) In the case of an operating lease, any future lease payments are stopped.

Reinstating Assets

This section provides an overview of asset reinstatement and discusses how to reinstate an asset.

Understanding Reinstatement of Assets

On occasion, you may need to reinstate an asset that has been retired.

When you reinstate an asset, all fields on the Retire Assets page become unavailable for data entry. If you want to subsequently retire this asset after reinstatement, you must access the page again.

Reinstatements generate credit lines in PeopleSoft Billing if the retirement has been passed to PeopleSoft Billing. You cannot generate a reinstatement until PeopleSoft Billing creates the invoice number (after the BIIF0001 process is run). If you reinstate an asset before the PeopleSoft Asset Management-Billing interface is processed but after running depreciation calculation for the retirement, the PeopleSoft system cancels the initial retirement and the status of the billing request changes to *G* (ignore). In the AM/Billing Transaction Status report, you can track the original invoice for each reinstatement.

Note. Reinstatement of non-financial assets involves merely changing the asset status to *In Service*; in the case of an operating lease, it involves restarting any future lease payments.

Pages Used to Reinstatement Assets

| Page Name | Object Name | Navigation | Usage |
|----------------------------|-----------------|--|---|
| Retire Assets | ASSET_RETIRE_01 | Asset Management, Asset Transactions, Asset Disposal, Retire/Reinstate Asset | Retire or reinstate an asset. |
| Non-Financial Asset Retire | ASSET_RET_NF_01 | Asset Management, Asset Transactions, Asset Disposal, Retire/Reinstate Non-Fin Asset | Retire or reinstate non-financial assets. |

Reinstating an Asset

Access the Retire Assets page.

Scroll through the retired transactions and select the Reinstatement check box for the retirement transaction that you want to reinstate for a financial asset. Then click the Reinstatement button. For a non-financial asset, from the Non Financial Asset Retirement page, select Reinstatement.

Note. Only one retired asset transaction can be reinstated at a time. If several retired assets transactions are selected for reinstatement, only the first selected transaction in the list is reinstated.

If no retirement transaction is selected for reinstatement and you click the Reinstatement button, the last retirement transaction against the assets is reinstated.

PeopleSoft Asset Management performs the reinstatement automatically. The Proceeds, Removal Costs, Accumulated Depreciation, and Gain/Loss fields are reset to 0, and the amount in the Retire Amt field is added back to the balance sheet (for financial assets only).

If depreciation has not been calculated for the gain/loss on retirement, selecting Reinstade causes the retirement rows that you previously created to be purged from the system.

All journal entries that were created by the retirement are reversed. To ensure that asset information posts correctly, the system generates a depreciation request when you reinstate assets. The transaction date is automatically set to the retirement date. If you accidentally or erroneously retired an asset in the wrong period, you have to deduct depreciation from the time the asset was actually retired. Any depreciation to which you were entitled during the accounting periods in which this asset was retired will be calculated and posted to the current accounting period as prior depreciation.

Running the Tax Retirement Capital Gains Report (AMTX3210)

This section lists prerequisites and lists the pages used to run the Tax Retirement Capital Gains report.

Prerequisites

Before you can run the Tax Retirement Capital Gains report, you must run the following two processes:

- Open Trans - Tax Report process.

This process assigns open transaction IDs for the transactions of assets that do not use straight-line depreciation.

- Depreciation Calculation Tax process.

This process calculates straight-line depreciation for all the pending assets in the process and marks the status as complete.

Pages Used to Run the Tax Retirement Capital Gains Report

| Page Name | Object Name | Navigation | Usage |
|---|------------------|--|--|
| Run Open Trans Tax (run open transaction tax) | RUN_AMTXOPEN | Asset Management, Depreciation, Processing, Process Open Trans for Tax | Run a process that assigns open transaction IDs to the transactions for assets that do not use the straight-line depreciation method. |
| Depreciation Calculation TAX | RUN_AMDPCALC_TAX | Asset Management, Depreciation, Processing, Calculate SL Depr for Tax | Run the process that calculates straight-line depreciation for all the pending assets in the AMTXOPEN process and mark the status as complete. Note. For corporations, you must select the Corporation Sec. 291 check box on the Book - Tax page to have the system calculate the ordinary gain and the Sec. 291 gain differently. |

CHAPTER 20

Processing Asset Mass Changes

This chapter provides an overview of mass changes in Asset Management and discusses how to:

- Define mass changes.
- Run mass changes.
- Verify data in the loader tables.
- Approve changes.
- Populate Asset Management tables with mass change data.
- Depreciate changed assets.
- Review Asset Management mass change templates and types.

Understanding Mass Changes in Asset Management

Regular business cycles sometime require you to make the same change to a large group of assets. In these situations, Asset Management provides Application Engine processes that you request from the processing menu within the application. In addition, the PeopleTools Mass Change application can be used for most processing needs. This section provides information about Mass Change and its uses in Asset Management.

Suppose a business restructuring requires you to transfer all assets from the marketing department to the corporate communications department. Transferring these assets manually would be onerous and likely to introduce errors. Mass Change, on the other hand, enables you to select a particular set of assets from the database, define the desired changes on those assets, and make those changes online or in the background using scheduled processing.

Because most businesses perform the same types of mass changes repeatedly, you can define mass changes using templates. These templates simplify mass change definition by storing information that enables you to select certain data from the database and modify it in specific ways. (Usually, you have to modify only selection and replacement values.) Asset Management is delivered with a full complement of Mass Change templates that serve the needs of most business applications. You can also create your own templates as needed.

Note. Because Mass Change can modify a large number of assets during scheduled processing, only the most experienced users should use Mass Change functionality. These users should have both a solid understanding of SQL and an extensive knowledge of Asset Management.

Processing mass changes with Asset Management consists of a definition phase and a processing phase. First, you define the selection criteria and changes to be made to the selected data, and then you run the Mass Change process (either online or in the background). You can run most types of mass changes online; however, there are a few types that you can run using only Process Scheduler.

To process mass changes in Asset Management:

1. Select a mass change template and use it to define a mass change.
Outline the criteria for selecting rows and identify the columns and values to modify.
2. Run the mass change process (RUN_MASSCHNG) to select, change, and transfer the data to the loader tables.
3. (Optional) Preview the data for suitability.
4. Run the Transaction Loader Application Engine process (AMIF1000) to load the data from the loader tables into Asset Management tables.
5. Run the batch depreciation program.

You must run depreciation when the mass change process is complete. You might also want to empty the INTFC_FIN, INTFC_PHY_A, and INTFC_PHY_B loader tables to free valuable disk space.

Note. The U.S. tax 40 percent rule states that if more than 40 percent of your total aggregate depreciable basis (other than residential property, nonresidential real property, and railroad grading and tunnel bores) is placed in service during the last three months of the year, all assets must be depreciated using the mid-quarter convention. Assets placed in service and disposed of during the same tax year are not taken into account. To comply with the U.S. tax 40 percent rule, you must write a report to select all eligible assets, calculate their aggregate basis, and divide this basis into your total asset aggregate basis. If the result is more than 40 percent, you then must run the mass change process on the eligible assets to change the depreciation convention to a mid-quarter convention, and recalculate life-to-date depreciation.

See Also

[Chapter 19, "Retiring Assets," page 319](#)

[Appendix A, "Understanding the Loader Table Data Dictionary," page 449](#)

Defining Mass Changes

Before you run the mass change process that transfers and alters data, you must provide information about the changes that you want to make. Use the pages in the Mass Change Definition (MC_DEFN) component to do so.

This section discusses how to:

- Add or update mass change definitions.
- Specify mass change criteria and defaults.
- Specify mass change fields specific to Asset Management.
- Generate mass change SQL text.

Pages Used to Define Mass Changes

| Page Name | Object Name | Navigation | Usage |
|--|-------------|---|---|
| Asset Mass Change Definition - Description | MC_DEFN_00 | Asset Management, Mass Change, Define Criteria | Add or update a mass change definition. |
| Asset Mass Change Definition - Criteria and Defaults | MC_DEFN_01 | Asset Management, Mass Change, Define Criteria, Criteria and Defaults | Specify the mass change criteria for selecting rows, and identify the columns and values to be changed. |
| Asset Mass Change Definition - AM Specific Fields (asset management specific fields) | MC_DEFN_AM | Asset Management, Mass Change, Define Criteria, AM Specific Fields | Complete mass change information that is unique to and required by Asset Management mass changes. |
| Asset Mass Change Definition - Generate SQL | MC_DEFN_02 | Asset Management, Mass Change, Define Criteria, Generate SQL | Generate and check the SQL text that is generated by a mass change definition before you run it. |
| Asset Mass Change Definition - Execution History | MC_DEFN_03 | Asset Management, Mass Change, Define Criteria, Execution History | Determine the last time that a mass change definition was run and identify the specific input parameters. |

Adding or Updating Mass Change Definitions

Access the Asset Mass Change Definition - Description page.

Description
Criteria and Defaults
AM Specific Fields
Generate SQL
Execution History
D

Mass Change Definition: PI2000-SCANSCOPE

***Mass Change Template:**

User ID: DVP1

Last Updated: 07/21/2000 2:17:00PM

Archive ID: **Archive Date:**

Description:

Physical Inventory Scan Scope MC

Asset Mass Change Definition - Description page

If this is a new mass change definition, select a mass change template. After you enter a template and move out of the Mass Change Template field, the field becomes unavailable for entry and the page is populated with data from the template.

Note. You may need to execute a group of mass changes in series. The mass change functionality makes it possible to define groups of mass changes and execute them all using one run control. Use the Mass Change Definition page to do this. No mass change groups are shipped with Asset Management.

See [famp] PeopleSoft Enterprise Asset Management 9.0 PeopleBook, Processing Asset Mass Changes, Reviewing Asset Management Mass Change Templates and Types.

Specifying Mass Change Criteria and Defaults

Access the Asset Mass Change Definition - Criteria and Defaults page.

Mass Change Definition: PI2000-SCANSCOPE

SQL Statement Find | View All First 1 of 1 Last

Execution Seq: 1 **Description:** Physical Inventory Scan Scope

Criteria Find | View All First 1-2 of 2 Last

| Field | Field Value |
|--------------------------------|----------------|
| Department(s) to Base Scope On | |
| Location(s) to Base Scope On | US001 CAN01 |

Defaults Customize | Find | View All First 1 of 1 Last

| Field Label | Mass Change Field Value |
|-------------|-------------------------|
| 1 | |

Asset Mass Change Definition - Criteria and Defaults page

Fields in the Criteria scroll area define the columns that are used as a basis for selecting data from the database. You must specify the operator and the value to which the column is to be compared.

For example, to select all the rows for department 21101, use the = operator and a value of 21101. To specify a range of values, use the *Between* operator and specify the two values, for example 12000 and 21000.

This table lists the values in the Operation drop-down list box, how they are used, and an example of each operator as used on a set of hypothetical business units, including M02, M04, M04A, M04B, M04C, M06, and M30:

| Operator | Meaning | Example | Result |
|------------------------------------|---|--------------------|------------------------------------|
| <i>Between Value A and Value B</i> | Between two values | BTW M04 BTW M06 | M04, M04A, M04B, M04C, M06 |
| <i>Equal To</i> | Equal to | = M06 | M06 |
| <i>Greater Than</i> | Greater than | > M06 | M30 |
| <i>Greater Than or Equal To</i> | Greater than or equal to | >= M06 | M06, M30 |
| <i>In Subset</i> | In a subset of | IN M04 IN M06 | M04, M06 |
| <i>Is Blank</i> | Equal to a space character. Used for character fields. | IS BLANK | NA |
| <i>Is Not Blank</i> | Not equal to a space character. Used for character fields. | NOT BLANK | M04, M04A, M04B, M04C, M06, M30 |
| <i>Is Not Null</i> | Not equal to no characters. Used for date fields. | NOT NULL | NA |
| <i>Is Null</i> | Equal to no characters. Used for date fields. | IS NULL | NA |
| <i>Less Than</i> | Less than | < M06 | M02, M04, M04B, M04C |
| <i>Less Than or Equal To</i> | Less than or equal to | <= M06 | M02, M04, M04B, M04C, M06 |
| <i>Like</i> | Used for wildcard searches. | LIKE MO% | M04, M04A, M04B, M04C, M06 |
| <i>Not Between</i> | Not between value A and value B | BTW M04 BTW M06 | M02, M30 |
| <i>Not Equal To</i> | Not equal to | <> M06 | M02, M04, M04B, M04C, M30 |

| Operator | Meaning | Example | Result |
|-----------------|---------------------------------|------------------|-------------------------------|
| <i>Not In</i> | Not in a subset of (complement) | IN M04 IN M06 | M02, M04A, M04B, M04C, M30 |
| <i>Not Like</i> | Used in wildcard searches. | NOT LIKE M0% | M30 |

Specifying Mass Change Fields Specific to Asset Management

Access the Asset Mass Change Definition - AM Specific Fields page.

Mass Change Definition: PI2000-SCANSCOPE

Additional Parameters

*Transaction Date: 07/21/2000 Auto Approval Status

*Accounting Date: 07/21/2000

Intfc ID: 10000002 New

Open Transaction ID: 25

User ID: VP1

Asset Mass Change Definition - AM Specific Fields page

- Transaction Date** Enter the date on which you made the change.
- Accounting Date** Enter the date on which you want this transaction posted to your general ledger.
- Intfc ID (interface ID) and Open Transaction ID** Displays the next available ID. You can change these values, but they must be unique.
- User ID** Appears automatically. You can change this value.

Note. If you reuse an existing mass change definition, be sure to insert a value in the Next Intfc ID field by clicking the New button. After you select New, Save the page, the system displays a new interface ID.

Generating Mass Change SQL Text

Access the Asset Mass Change Definition - Generate SQL page.

Mass Change Definition: PI2000-SCANSCOPE

Generate Clear Sw Execute SQL Upon Saving

SQL Statement Find | View All First 1 of 1 Last

Execution Seq: 1 **Description:** Physical Inventory Scan Scope

Sub Sequences Find | View All First 1 of 1 Last

```
INSERT INTO PS_PI_SCAN_SCOPE (ASSET_ID, BUSINESS_UNIT, PI_ID) SELECT DISTINCT PI_EXTRACT_VW.ASSET_ID,
PI_EXTRACT_VW.BUSINESS_UNIT, PI_CNTL.PI_ID FROM PS_MC_DEFN MC_DEFN, PS_MC_DEFN_AM MC_DEFN_AM,
PS_PI_CNTL.PI_CNTL, PS_PI_EXTRACT_VW PI_EXTRACT_VW, PS_RUN_CNTL_AM RUN_CNTL_AM WHERE
MC_DEFN.MC_DEFN_ID = 'PI2000-SCANSCOPE' AND MC_DEFN.MC_DEFN_ID = MC_DEFN_AM.MC_DEFN_ID AND
PI_CNTL.PI_ID = RUN_CNTL_AM.PI_ID AND PI_EXTRACT_VW.LOCATION IN ('US001', 'CAN01') AND
PI_CNTL.BUSINESS_UNIT = PI_EXTRACT_VW.BUSINESS_UNIT AND PI_EXTRACT_VW.TAGGABLE_SW = 'Y' AND
RUN_CNTL_AM.OPRID = $$$OPRID$$$ AND RUN_CNTL_AM.RUN_CNTL_ID = $$$RC$$$ AND PI_EXTRACT_VW.TAG_NUMBER
IN (SELECT PI_EXTRACT_VW2.TAG_NUMBER FROM PS_PI_EXTRACT_VW PI_EXTRACT_VW2 WHERE
PI_EXTRACT_VW2.BUSINESS_UNIT = PI_CNTL.BUSINESS_UNIT GROUP BY PI_EXTRACT_VW2.BUSINESS_UNIT,
PI_EXTRACT_VW2.TAG_NUMBER HAVING SUM (PI_EXTRACT_VW2.COST) >= PI_CNTL.MINIMUM_AMT)
```

Count Total rows to be 0

Asset Mass Change Definition - Generate SQL page

Note. Whenever you change a table, mass change type, or mass change template, you must regenerate the SQL text for any related mass change definitions.

Generate Click to generate the SQL text. Generating SQL might take several minutes.

Clear Sw(clear switch) Click to clear the SQL text for instances in which you want to change your mass change definition and regenerate the SQL. Clearing SQL might take several minutes.

SQL Statement

This scroll area lists the records on which a SQL statement operates and in what manner. Each record is processed in sequence. This scroll area also contains the SQL text for each statement, which you can view but not change. You can change statements only by altering the mass change type or template on which this definition is based, or by altering the field criteria and defaults on the Mass Change Definition page.

Execute SQL Upon Saving While online, select to run the SQL as soon as you save the page. Your user security determines whether you can run mass changes online. If you do not select this check box, you can save this mass change definition and then run it in the background using a run control.

Execution Seq (execution sequence) Indicates the order in which the SQL statements are run. Scroll through the execution sequences to view each statement.

Save Click this button when you are satisfied with the SQL text that is generated.

Note. If the SQL execution fails, the system rolls back all statements in the mass change definition. Commits to the database are made only when all statements have completed successfully.

Count

After you have generated and saved your SQL text, click to display the number of rows of data that were affected by this mass change. You can click this button only on mass changes that run online.

Some execution sequences are based on previous sequences that have inserted rows into an interim table. In these instances, clicking the Count button makes sense for only some execution sequences.

Running Mass Changes

You can run most mass changes either online or in the background, although you must run some through Process Scheduler using an application structured query report (SQR), such as the Physical Inventory SQR report.

This section discusses how to run mass changes.

Page Used to Run Mass Changes

| Page Name | Object Name | Navigation | Usage |
|-----------------|--------------|--|---|
| Run Mass Change | RUN_MASSCHNG | Asset Management, Mass Change, Run Request | Run a mass change or mass change group in the background. |

Running Mass Changes

There are three methods for running mass changes:

- Run mass changes online.
- Run mass changes with Process Scheduler.
- Run mass changes in the background.

Running Mass Changes Online

Use the Asset Mass Change Definition - Generate SQL page.

Running Mass Changes Using Process Scheduler

You must run mass changes that are based on the following mass change types through Process Scheduler using an application SQR:

| Mass Change Type | Description |
|--------------------------|--|
| PI Extract | Physical inventory extraction. |
| PI Scan Scope | Physical inventory scan scope. |
| PI1 - Asset Table Update | Physical inventory asset table update. |

| Mass Change Type | Description |
|--------------------------------|---|
| PI2 - Asset Location Changes | Physical inventory asset location changes update. |
| PI3 - Department Transfers | Physical inventory department transfers update. |
| PI4 - Retire Assets Not Found | Physical inventory retired assets not found update. |
| PI5 - Add Assets Found In PI | Physical inventory add assets found update. |
| PI6 - Asset Custodian Changes | Physical inventory asset custodian update. |
| PI7 - Inventory History Insert | Physical inventory history insert. |
| IUF-IU Transfer to Foreign BU | Interunit transfer to a foreign business unit. |
| PRC - Parent Recategorization | Parent and children category update. |

Process Scheduler runs the processes that you select at user-defined intervals.

You can run only those mass changes online that you are authorized to run online and that are based on authorized templates. Mass change user security grants permission to run mass changes online.

See *Enterprise PeopleTools 8.48 PeopleBook*, “Security Administration.”

See *Enterprise PeopleTools 8.48 PeopleBook*, “PeopleSoft Process Scheduler.”

Running Mass Changes in the Background

Access the Run Mass Change page.

Run Mass Change

Run Control ID: 1 [Report Manager](#) [Process Monitor](#) Run

Mass Change Run Type

Execute Single Mass Change
 Execute Mass Change Group
 Download File Preparation
 Download Table to a File
 UpLoad File Preparation
 Upload File to Table

Execution Parameters

Mass Change Definition:

Mass Change Group ID:

Download/Upload Data File:

MASSLAYO.SQC To Be Updated:

Run Mass Change page

Select a mass change run type. Each run type requires an additional execution parameter as described in this table:

| Run Type | Execution Parameter |
|-----------------------------|--------------------------|
| Execute single mass change. | Mass change definition. |
| Execute mass change group. | Mass change group ID. |
| Download file preparation. | Download data file name. |
| Download table to a file. | Download data file name. |
| Upload file preparation. | Upload data file name. |
| Upload file to a table. | Upload data file name. |

Verifying Data in the Loader Tables

You can see what data was loaded by the mass change process into the Asset Management loader tables (INTFC_FIN, INTFC_PHY_A, and INTFC_PHY_B). Viewing these tables provides the opportunity to preview the data that loads into Asset Management tables when you run the Transaction Loader process. If you find errors, you can either fix them online using your SQL query tool, or (preferably) modify the mass change definitions and run the mass change again.

This section discusses how to:

- View data in the financial loader tables.
- Preview physical load data.

Pages Used to Verify Data in the Loader Tables

| Page Name | Object Name | Navigation | Usage |
|-------------------------|--------------|--|---|
| Financial Transactions | INTFC_FIN_01 | Asset Management, Send/Receive Information, Approve Financial Information, Review | View data in the financial interface tables. Verify the financial data (which the Transaction Loader process uses when populating Asset Management tables) and change incorrect data. |
| Physical Transactions A | INTFC_PHY_A | Asset Management, Send/Receive Information, Approve Physical Information, Review-A | Preview the physical load data. View the data one row at a time and change incorrect data. |
| Physical Transactions B | INTFC_PHY_B | Asset Management, Send/Receive Information, Approve Physical Information, Review-B | Preview the physical load data. View the data one row at a time and change incorrect data. |
| Lease Transactions | INTFC_LEASE | Asset Management, Send/Receive Information, Approve Lease Information, Review | View records that you might have loaded for lease transactions (the INTFC_LEASE table). Use this page only if you're converting leases from a previous system. |

Viewing Data in the Financial Loader Tables

Access the Financial Transactions page.

| Financial Transactions | | | |
|------------------------------|--------------|---|----------------------------|
| Interface ID: | 10000003 | Interface Line Number: | 1 |
| PI ID: | PI2000 | Mass Change Definition: | PI3 - Department Transfers |
| Financial Information | | Find View All First 1 of 4 Last | |
| Unit: | US001 | <input checked="" type="checkbox"/> Auto Approval Status | |
| *Asset ID: | EX_000000072 | Trans Code: | |
| Book Name: | CORP | Load Type/Status: | TRF Loaded |
| Category: | OFFCE | Trans Date: | 11/01/2000 |
| Cost Type: | | Acctg Date: | 11/01/2000 |
| Operating Unit: | NEWYORK | Cost: | |
| Fund Code: | | Base Cost | -1,324.00 USD |
| Department: | 11000 | Quantity: | -1.0000 |
| Program Code: | | Depr Amt: | |
| Class Field: | | Proceeds: | |
| Budget Reference: | | Removal Cost: | |
| Product: | | | |
| Project: | | | |
| Error Message: | | | |

Financial Transactions page

The contents of the Financial Transactions table (INTFC_FIN) appear here, one row at a time, as populated by the mass change.

Errors normally involve assets that have recently undergone a financial transaction or transactions. The transaction date that is assigned to the mass change is compared with the transaction date of each asset on which that change is performed. If the asset transaction date occurs after the mass change transaction date, the system marks the load line as an error.

Auto Approval Status Selected if you previously selected the Auto Approval Status check box on the Asset Mass Change Definition - AM Specific Fields page.

Previewing Physical Load Data

Access the Physical Transactions A or Physical Transactions B page.

Physical Transactions A

Interface ID: 10000003 **Line Num:** 1
PI ID: **MC Defn ID:** PI1 - Asset Table Updates

Physical A Information

Find | View All First ◀ 1 of 1 ▶ Last

| | |
|---|---|
| <p>Unit: <input type="text" value="US001"/></p> <p>Asset ID: <input type="text" value="EX_000000072"/></p> <p>Description: <input type="text" value="Compaq DeskPro EN SFF PIII500"/></p> <p>Short Desc: <input type="text" value="Compaq Des"/></p> <p>Tag Number: <input type="text" value="P00000000072"/></p> <p>Serial ID: <input type="text" value="6663123456221"/></p> <p>Voucher ID: <input type="text"/></p> <p>Invoice: <input type="text"/></p> <p>Invoice Date: <input type="text"/></p> <p>PO No.: <input type="text"/></p> <p>Receipt No.: <input type="text"/></p> <p>Item ID: <input type="text"/></p> <p><input type="checkbox"/> Linear Asset</p> <p>Detailed Description:</p> <div style="border: 1px solid #ccc; height: 100px; width: 100%;"></div> | <p><input checked="" type="checkbox"/> Auto Approval Status</p> <p>Load Type: Asset Upd</p> <p>Load Status: <input type="text" value="Loaded"/></p> <p>System Source: AM Batch</p> <p>Profile ID: <input type="text" value="COMPUTERS"/></p> <p>Location: <input type="text"/></p> <p>Area ID: <input type="text"/></p> <p>EmplID: <input type="text"/></p> <p>Custodian: <input type="text"/></p> <p>Parent ID: <input type="text"/></p> <p>Project: <input type="text"/></p> <p>Quantity: <input type="text"/></p> <p>Amount: <input type="text"/></p> <p>VAT Inv: <input type="text"/></p> |
|---|---|

Physical Transactions A page

Auto Approval Status Selected if you previously selected the Auto Approval Status check box on the Asset Mass Change Definition - AM Specific Fields page.

Approving Changes

After you have run the mass change process and populated the loader tables, you might need to approve all changes before loading the resulting data into the Asset Management tables.

This section discusses how to:

- Approve financial loader data.
- Approve physical loader data.

Pages Used to Approve Changes

| Page Name | Object Name | Navigation | Usage |
|--------------------|------------------|---|---|
| Approve Financial | INTFC_FIN_APPR | Asset Management, Send/Receive Information, Approve Financial Information, Approve | View and approve the data in the financial loader table. |
| Approve Physical A | INTFC_PHY_APPR_A | Asset Management, Send/Receive Information, Approve Physical Information, Approve-A | View and approve all changes that are pending approval in the physical loader tables. These changes are grouped by transaction load ID and load type. A load type is similar to a transaction type, but at a greater level of detail. Each transaction type in Asset Management can generate several different load types. |
| Approve Physical B | INTFC_PHY_APPR_B | Asset Management, Send/Receive Information, Approve Physical Information, Approve-B | View and approve all changes that are pending approval in the physical loader tables. These changes are grouped by transaction load ID and load type. A load type is similar to a transaction type, but at a greater level of detail. Each transaction type in Asset Management can generate several different load types. |

Approving Financial Loader Data

Access the Approve Financial page.

The screenshot shows the 'Approve Financial' page with a table titled 'Interface Financial Approvals'. The table has columns for Intfc ID, Unit, Pl ID, Load Type, Amount Curr, Total Rows, and Approved. A single row is displayed with the following data: Intfc ID 10000004, Unit US001, Pl ID, Load Type RET, Amount Curr \$-20000.00, Total Rows 4, and Approved Y. There is a checkbox for 'Approval' which is currently unchecked. The page also shows navigation controls like 'Find', 'View All', 'First', '1 of 1', and 'Last'. Below the table, there is a section for 'Mass Change Definition:'.

Approve Financial page

The system groups financial transaction changes by transaction load ID and load type. A load type is similar to a transaction type, but at a greater level of detail. Each transaction type in Asset Management can generate several different load types.

Load types include the following (changes marked with an asterisk are uncommon):

| Load Type | Name | Financial or Physical Tables |
|------------------|-----------------------------------|-------------------------------------|
| <i>AAD</i> | Additional Cost Add | Financial |
| <i>ACQ</i> | Insert Acquisition Detail | Physical * |
| <i>ADD</i> | Asset Add | Financial |
| <i>ADJ</i> | Asset Cost Adjustment | Financial |
| <i>ADP</i> | Revaluation Write-off | Financial |
| <i>ADQ</i> | Adjust Cost & Acquisition Detail | Financial and physical * |
| <i>ARA</i> | Add Retired Asset | Financial and physical |
| <i>ASD</i> | Asset Deletion | Financial and physical |
| <i>AUP</i> | Asset Information Update | Physical |
| <i>BKD</i> | Book Deletion | Financial * |
| <i>BKS</i> | Book Change | Financial |
| <i>BSD</i> | Selective Book Delete | Financial * |
| <i>CAP</i> | Asset Capitalization | Financial |
| <i>CLC</i> | Custodian/Location Change | Physical * |
| <i>CIC</i> | Capitalize into Composite | Financial |
| <i>CNI</i> | Conversion of First Book | Financial and physical |
| <i>CN2</i> | Conversion of Subsequent Books | Financial |
| <i>FAD</i> | Financial and Physical Add | Financial |
| <i>IHI</i> | Physical Inventory History Insert | Physical |

| Load Type | Name | Financial or Physical Tables |
|------------|------------------------------|------------------------------|
| <i>IUI</i> | InterUnit Transfer, In Side | Financial and physical |
| <i>IUO</i> | InterUnit Transfer, Out Side | Financial |
| <i>LAD</i> | Leased Asset Add | Financial and physical * |
| <i>NAD</i> | Non-financial Add | Physical |
| <i>OPT</i> | Open Transaction Generator | NA * |
| <i>PHY</i> | Physical Asset Change | Physical |
| <i>PRT</i> | Partial Retirement | Financial |
| <i>RCT</i> | Asset Recategorization | Financial |
| <i>REI</i> | Asset Reinstatement | Financial |
| <i>RET</i> | Asset Retirement | Financial |
| <i>RNA</i> | Non-financial Retirement | Physical |
| <i>TRF</i> | IntraUnit Transfer | Financial |

You can approve or reject each load type by selecting or clearing the Approval check boxes. Use the scroll bar to move from one screen to the next.

Approving Physical Loader Data

Access the Approve Physical A or Approve Physical B page.

Approve Physical A

Load Approval Physical A Find | View All First ◀ 1 of 1 ▶ Last

| Intfc ID | Unit | PI ID | Physical Inventory Name | Load Type | Intfc Cnt | Appr |
|----------|-------|-------|-------------------------|-----------|-----------|---|
| 90000001 | US001 | | | CN1 | 1 | Y <input type="checkbox"/> Approve |

Mass Change Definition:

Approve Physical A page

Approve

Approve each load type by selecting its check box.

Populating Asset Management Tables with Mass Change Data

This section discusses how to populate Asset Management tables using the Transaction Loader process.

Page Used to Populate Asset Management Tables with Mass Change Data

| Page Name | Object Name | Navigation | Usage |
|------------------------|--------------|--|--|
| Run Transaction Loader | RUN_AMIF1000 | Asset Management, Send/Receive Information, Load Transactions, Load Transactions into AM | <p>Run the Transaction Loader process, which reads the loader tables and populates Asset Management tables with the data.</p> <p>Search for transactions to run based on system source, load type, load status, and whether transactions consist of physical or financial records. You can use as many or as few of these criteria as necessary. The more search criteria that you use, the narrower your search results become.</p> |

Populating Asset Management Tables Using the Transaction Loader Process

Access the Run Transaction Loader page.

The screenshot shows the 'Run Transaction Loader' page. At the top, there is a 'Run Control ID' field with the value '1' and a 'Run' button. Below this are links for 'Report Manager' and 'Process Monitor'. The main section is titled 'Run Control Parameters' and includes fields for 'Request ID' (1), 'Process Frequency' (Don't), 'Interface ID' (0), 'To Interface ID' (0), and 'System Source'. There is a checkbox for 'Process AM Integration'. Below this is a 'Find Trans Load ID (optional)' section with 'System Source', 'Load Type', and 'Load Status' (Pending) dropdowns, and radio buttons for 'Financial Record' and 'Physical Records'. A 'Search' button is present. At the bottom, there is an 'Interface Information' table with columns: Interface ID, System Source, Load Type, Load Description, Load Status, and Total Items in Query.

Run Transaction Loader page

Locate the Find Trans Load ID (find transaction loader ID) group box.

| | |
|---|--|
| System Source | If you do not know the transaction load IDs, enter the system source that generated the transactions that you want to load, such as <i>AM Batch</i> or <i>Strategic Sourcing</i> . Also, enter the load type. |
| Load Type | A load type is a more detailed version of a transaction type. One transaction type can generate several different load types. Specify the transactions to load, such as <i>Asset Add</i> or <i>Phys Add</i> (physical addition), if you know the range of transaction load IDs. You can specify transactions by system source, from transaction load ID, and to transaction load ID. |
| Financial Record or Physical Records | Select one depending on the type of transaction that you want to load. |
| Load Status | Select from the following values: <ul style="list-style-type: none"> • <i>Consolidat</i>: (consolidated): Transactions consolidated. • <i>Errored</i>: Transaction errors. • <i>In Process</i>: Transactions in process. • <i>Loaded</i>: Transactions loaded. • <i>On Hold</i>: Transaction on hold. • <i>Pending</i>: Transactions pending. • <i>Replaced</i>: Replaced by other interface records. • <i>Unitized</i>: Transactions unitized (will not be loaded). |

Depreciating Changed Assets

To ensure that all the entries in the loader tables `INTFC_FIN`, `INTFC_PHY_A`, and `INTFC_PHY_B` have been loaded, review the tables and check the load status of each entry. Each entry should have a load status of *DON* (done).

If any entries have a status of *ERR* (error), the entries have been marked as errors. You might need to complete them manually through the appropriate pages. Check the error message at the bottom of the Load Preview page to determine what action you should take.

After you have corrected the errors, all that remains for you to do in the mass change process is to run the depreciation calculation process. The financial changes that you made have created open transactions for each of the affected assets. Running the depreciation calculation process (`AM_DEPR_CALC`) identifies these changed assets and handles their depreciation appropriately.

Reviewing Asset Management Mass Change Templates and Types

This section provides an overview of mass change templates and types for Asset Management.

Understanding Mass Change Templates and Types

In most cases, the mass change template and the mass change type on which the template is based have the same ID. If the mass change type ID is different than the mass change template ID, the type ID is provided in parentheses under the template ID.

This table lists the mass change templates (and the mass change types on which the templates are based) that are delivered with Asset Management:

| Mass Change Template ID (Mass Change Type ID, If Different) | Mass Change Template Description / Asset Management |
|--|---|
| ADJ - Asset Cost Adjustment | Enables you to change the cost of a group of assets. |
| Archive Asset Depr Rpt Entries | This mass change type copies the specified DEPR_RPT entries into the DEPR_RPT_ARCH table. The system determines specified entries by the selection criteria of the mass change template with the same name (Archive Asset Depr Rpt entries). The system uses the Business Unit, Book, and Fiscal Year fields to select the data. |
| Archive NBV Entries | This mass change type copies the specified PS_ASSET_NBV_TBL entries into the PS_ASSET_NBV_ARCH table. PS_ASSET_NBV_ARCH stores the old net book value entries. You can also use this table to retrieve the entries into a sequential file. The system uses the Business Unit, Book, and As of Date fields to select the data. |
| Archive Asset Open Trans | Archives asset open transaction entries in the PS_OPEN_TRANS table. This template inserts entries into the Open Trans Archive table (PS_OPEN_TRANS_ARCH) and selects from the PS_OPEN_TRANS table. |
| Archive Assets Acctng Entries (Archive Asset Acctng Entries) | Helps archive asset accounting entries. This definition inserts rows into the PS_DIST_LN_ARCH table and selects from the production asset accounting entry table (PS_DIST_LN). You can use the PS_DIST_LN table to hold the old accounting entries and to unload the entries into a sequential file. |
| ASD - Asset Deletion | Inserts asset records into the INTFC_FIN table for deletion by Mass Change. |
| AUP - Asset Update | Changes certain fields that are stored on the asset table. Inserts rows into the INTFC_PHY_A table that the Transaction Loader process uses to update (not insert) the asset table. You may update all non key fields on the PS_ASSET table using this mass change definition. You may copy this template or modify it to update fields as necessary. |
| BA - Book Addition | Adds a new book to a business unit. You must add the asset profiles for the new book before running this mass change template, and the book you are adding must already exist for the business unit before processing. |

| Mass Change Template ID (Mass Change Type ID, If Different) | Mass Change Template Description / Asset Management |
|--|---|
| BC - Book Copy | <p>Copies the book and cost information from one book to another. You can use this process to perform a what-if analysis. You can also add a model book to a group of assets to do some reporting. This mass change template copies the data that you need from an existing book to your model book.</p> <p>The book to which you are copying must exist for the business unit before processing this mass change. Criteria for this mass change template must be entered twice; once for the non-retirement type transactions on the first execution sequence, and a second time for retirement transactions on the second execution sequence.</p> |
| BKD - Book Deletion | <p>Removes an entire book from a business unit. This template loads one row into the INTFC_FIN table with the business unit and book combination. The Transaction Loader process then deletes all rows for that business unit book from the following tables: BOOK, BOOK_TAX_CR, COST, DEPRECIATION, DIST_LN, OPEN_TRANS, and RETIREMENT.</p> |
| BKS - Asset Book Change | <p>Enables you to change depreciation methods, life, depreciation schedules, and convention combinations.</p> |
| BSD - Selective Book Delete | <p>Enables you to selectively delete books for a group of assets. You specify the business unit, book, and range of assets to delete. This differs from the mass change type BKD, which deletes information for an entire business unit/book combination.</p> |
| CC - Capitalize Into Comp DB2 | <p>Capitalizes acquisition detail amounts into composite assets specifically for the DB2 environment. This mass change template sums the uncapitalized acquisition detail line amounts for the assets that are associated with a composite asset.</p> |
| CC - Capitalize Into Composite | <p>Capitalizes acquisition detail amounts into composite assets. This mass change template sums the uncapitalized acquisition detail line amounts for the assets that are associated with a composite asset.</p> |
| CC - JPN Capitalize Comp DB2 | <p>Capitalizes Japanese acquisition detail amounts into composite assets specifically for the DB2 environment. This mass change template sums the uncapitalized acquisition detail line amounts for the assets that are associated with a composite asset.</p> |
| CC - JPN Capitalize Composite | <p>Capitalizes Japanese acquisition detail amounts into composite assets. This mass change template sums the uncapitalized acquisition detail line amounts for the assets that are associated with a composite asset.</p> |
| CR - Composite Retirement | <p>Retires acquisition detail amounts from composite assets. This mass change template inserts the retirement cost for each set of ChartFields into INTFC_FIN.</p> |

| Mass Change Template ID (Mass Change Type ID, If Different) | Mass Change Template Description / Asset Management |
|---|--|
| Delete Asset Acctg Entries (Delete Archived DIST_LN) | Deletes entries from the PS_DIST_LN table after they have been archived. |
| Delete Asset Depr Rpt Entries | Deletes the DEPR_RPT, DEPR_RPT_CF_SUM, and DEPR_RPT_PD_SUM specified entries that are determined by the selection criteria of the mass change template that you use. To delete archived entries, enter the same selection criteria that you used for the mass change archive of DEPR_RPT entries. To purge DEPR_RPT entries, use the Business Unit, Book, and Fiscal Year fields as selection criteria when you run the mass change. |
| Delete Asset NBV Entries | Deletes the entries from the Asset Net Book Value table (PS_ASSET_NBV_TBL). To delete archived entries, enter the same selection criteria that you used for the mass change archive of Asset NBV entries. To purge Asset Net Book Value entries, use the Business Unit, User ID, and As of Date fields as selection criteria when you run the mass change |
| Delete Asset Open Trans | Deletes open transaction entries from the PS_OPEN_Trans table after they have been archived. |
| EURO1 - InterUnit Trf – New Book | <p>Performs mass interunit asset transfers from one book to another within the same business unit. The new book might have a different currency code. An example might be if you are changing from a 13- to a 12-period calendar. You must enter the business unit, the from book twice, and a blank, which transfers all assets.</p> <p>Note. If you copy this mass change template or use it as a basis to create your template, and you are changing currencies, you must populate the INTFC_FIN.MC_DEFN_ID field with the words <i>Currency Conversion</i> (mixed case) on the transfer IN row. It does not matter what you enter in the transfer OUT row; the name of the mass change suffices or you can leave the row blank.</p> |

| Mass Change Template ID (Mass Change Type ID, If Different) | Mass Change Template Description / Asset Management |
|---|---|
| InterUnit RET/Add w/Curr Conv | <p>Performs financial asset transfers from one business unit to another, especially when the business units have different currencies and books. Assets are retired in the <i>from</i> business unit and added in the <i>to</i> business unit. This mass change template differs from others in that IUF does not perform currency conversions.</p> <p>Note. New setIDs for the <i>to</i> business unit are assigned by the Transaction Loader process, not by Mass Change. If you preview the load transactions prior to running the Transaction Loader process, you see that the <i>to</i> business unit assets have the <i>from</i> business unit asset IDs. The Transaction Loader process assigns new IDs when adding the assets to the <i>to</i> business unit.</p> <p>Note. To perform currency conversion when moving assets from one business unit to another, use the default profile option in the Transaction Loader process. This means that the profile IDs on the <i>To</i> business unit must exist for the assets that are being moved from the <i>From</i> business unit, and they must be the same profile IDs that were used in the <i>From</i> business unit. Books that are associated with the profile ID may be different.</p> <p>Note. You cannot perform interunit transfers [retire/add] on group assets.</p> |
| InterUnit TRF w/Attrib, War, Lic | <p>Performs mass interunit transfers when asset attributes, warranty and license information also need to be transferred. Two Physical A and two Financial transactions are created, one for the <i>From</i> business unit and one for the <i>To</i> business unit. Entries are also created in Physical B for attribute, warranty, and license information transfers.</p> |
| InterUnit TRF w/Currency Conv (InterUnit TRF w/Curr Conv) | <p>Performs financial asset transfers from one business unit to another, especially when the business units have different currencies and books. This mass change template performs currency conversion when business unit and book currency codes are different in the <i>From</i> and <i>To</i> business units.</p> <p>Note. New asset IDs for the <i>To</i> business unit are assigned by the Transaction Loader process, not by Mass Change. If you preview the load transactions prior to running the Transaction Loader process, you see that the <i>To</i> business unit assets contain the <i>From</i> business unit asset IDs. The Transaction Loader process assigns new IDs when you add the assets to the <i>To</i> business unit.</p> <p>Note. To perform currency conversion when moving assets from one business unit to another, the default profile option in the Transaction Loader process is used. This means that the profile IDs on the <i>To</i> business unit must exist for the assets that are being moved from the <i>From</i> business unit, and they must be the same profile IDs that are used in the <i>From</i> business unit. Books that are associated with the profile ID may be different.</p> <p>Note. You cannot perform interunit transfers (retire/add) on group assets.</p> |
| IRC - Increase Rate Change | <p>Performs mass change for increase in special rates and accelerated depreciation.</p> |

| Mass Change Template ID (Mass Change Type ID, If Different) | Mass Change Template Description / Asset Management |
|--|---|
| IUF - IU Transfer to Another BU | <p>Performs financial asset transfers from one business unit to another.</p> <p>This template does not perform currency conversion. You can also refer to the definition for the InterUnit RET/Add w/Curr Conv template.</p> |
| IUT - Inter-Unit Transfer | <p>Performs mass interunit transfers of assets. You cannot perform interunit transfers on group assets. This mass change type does not perform currency conversion. Refer also to the definition for the InterUnit RET/Add w/Curr Conv template.</p> |
| JVA - Joint Venture BU Addition | <p>Adds a new business unit to a joint venture using the joint venture's profiles.</p> |
| JVP - Joint Venture BU Add (w/Prof) | <p>Adds a new business unit to a joint venture with the participant's profile. Book table values that can be populated with default values from the profile detail table are obtained from the profile ID for the new business unit. This mass change type is similar to the JVA mass change type, except that JVP uses the joint venture participant's profiles.</p> |
| JVR - Joint Venture BU Removal | <p>Removes joint venture business units.</p> |
| JVT - JV Allocation Change | <p>Transfers the allocation percentage from one business unit to another.</p> |
| PAD - Parent Asset Cost Adjust | <p>Changes the cost of a parent asset and all of its children.</p> |
| Parent Retire w/Pro/RC Absolut | <p>Retires parent assets and their children. The system sets the proceeds and removal cost for each asset as equal to the proceeds and removal cost that were entered by the user.</p> |
| Parent Retire w/Pro/RC Distrib | <p>Retires parent assets and their children. The system proportionally distributes proceeds and removal costs by retirement amount.</p> |
| Partial Parent Asset Transfer | <p>Performs partial asset transfers for a specific parent and all of its children assets. The system transfers a percentage of cost and quantity between the specified ChartFields.</p> |
| Partial Retire Parent Proc Abs | <p>Partially retires parent assets and all of their children assets (children that are financial assets). The percentage of retirement is specified by the user.</p> <p>The system sets the proceeds and removal costs for each asset as equal to the proceeds and removal cost that were entered by the user.</p> |

| Mass Change Template ID (Mass Change Type ID, If Different) | Mass Change Template Description / Asset Management |
|--|---|
| Partial Retire Parent Proc Dis | Partially retires parent assets and all of their children assets. The percentage of retirement is specified by the user. The system proportionally distributes proceeds and removal costs for each asset based on the cost of each asset that is retired over the total cost of all assets that are retired. |
| Partial Retire Proceeds Absolu | Partially retires assets. The user specifies the percentage of retirement. The system sets proceeds and removal costs for each asset as equal to the proceeds and removal cost that were entered by the user. |
| Partial Retire Proceeds Dist (Part. Retirement Proceeds Dist) | Partially retires assets. Do not use this mass change type to do a full retirement. The system proportionally distributes proceeds by retirement amount. |
| PHY - Physical Asset Changes | Changes the physical side of assets, such as asset location and custodian. |
| PI Extract | Extracts asset data from multiple Asset Management tables into one physical inventory extract table. |
| PI Scan Scope | Scans scope for physical inventory mass change. |
| PI1 - Asset Table Updates (PI1 - Asset Table Update) | Processes scanned inventory data and places it in updates to the asset table. |
| PI2 - Asset Location Changes | Changes the location table for an asset. |
| PI3 - Department Transfers | Transfers departments for assets (used in physical inventory). |
| PI4 - Asset Retirements (PI4 - Retire Assets Not Found) | Retires assets that are not found during physical inventory processing. |
| PI5 - Physical Asset Adds (PI5 - Add Assets Found in PI) | Adds the “overs” into Asset Management, which are assets that were scanned in physical inventory but were not originally in Asset Management. These assets are entered as a physical add only, not financial. |
| PI6 - Asset Custodian Changes | Changes an asset’s custodian (used in physical inventory). |

| Mass Change Template ID (Mass Change Type ID, If Different) | Mass Change Template Description / Asset Management |
|--|---|
| PI7 - Inventory History Insert | <p>Inserts records into the Physical Inventory Asset History table at the close of physical inventory for every asset in the Results table with a status of <i>Inventory</i>.</p> <p>Note. You cannot run Mass Changes PI1 - PI18, PI Extract, and PI Scan Scope online. They are used only by the Physical Inventory SQR.</p> |
| PRC - Parent Recategorization | Moves the cost of an asset from one asset category to another for a parent asset and all of its children. |
| PTF - Parent Asset Transfer | Transfers the cost of a parent asset and all of its children out of the <i>from</i> values and into the <i>to</i> values. |
| PTR - Partial Transfer by Dept (PTR- Partial Asset Transfer) | Performs partial asset transfers; which is where the system transfers a percentage of the cost and quantity of an asset between the ChartFields specified. |
| RCT – Recategorization | Moves the cost of an asset from one asset category to another. |
| REI - Reinstatement Assets (REI - Reinstatement) | Reinstates retired assets. |
| REP - Reinstatement Parent Assets | Reinstates retired parent assets and all of their children. |
| Retire w/Proceeds/RC Absolute | Retires assets. The system sets proceeds and removal cost for each asset as equal to the proceeds and removal cost that were entered by the user. |
| Retire w/Proceeds/RC Distribut | Retires assets. The system proportionally distributes proceeds and removal cost for each asset based on the cost of each asset that is retired over the total cost of all assets that are retired. |
| TM - Acctg Entry Template Copy | Copies accounting entry templates from one setID to another. |
| TM - Actg Ent Tmpl Copy w/in Set (TM - Acctg Entry Template Copy) | <p>Differs from the TM - Acctg Entry Template Copy template in that this template copies from one category to another within the same setID. The TM - Acctg Entry Template Copy template copies accounting entry templates from one setID to another setID.</p> <p>This mass change empties the temporary tables, dumps the template rows of the source setID and category into temporary tables, and copies the temporary rows over to the permanent accounting entry template tables for the target category that is specified.</p> <p>Note. The system uses the temporary tables PS_DIST_TMPL_TMP and PS_DIST_TMPLLN_TMP.</p> |

| Mass Change Template ID (Mass Change Type ID, If Different) | Mass Change Template Description / Asset Management |
|--|---|
| TRF - Full Transfer by Dept (TRF - Asset Transfer) | Transfers assets from current ChartField values to the to values that are entered by the user. The Cost Balance view gives the current cost at a ChartField level and enables you to change those values. |
| Unload DIST_LN_ARCH to file (Archive DIST_LN_ARCH to file) | Archives the PS_DIST_LN_ARCH table to a sequential file. |
| Unload Open Trans to file (Unload Open Trans Archive) | Unloads entries from the Asset Open Transaction Archive table to a sequential file. |
| Upload Asset Acctng Entries (Load Archived DIST_LN) | Loads the production asset accounting entry table (PS_DIST_LN) from the accounting entry archive table (PS_DIST_LN_ARCH). |
| Upload Asset Open Trans (Upload Archive Open Trans) | Uploads open transactions into the PS_OPEN_TRANS table from the PS_OPEN_TRANS_ARCH table. |

CHAPTER 21

Using Asset Management Reporting Options

This chapter provides an overview of Asset Management reporting options and discusses how to use:

- Flexible reporting and formats
- Online reports.
- Charting for financial data.

Understanding Asset Management Reporting Options

PeopleSoft delivers several kinds of report options within Asset Management. This section discusses:

- Reporting and formatting options.
- Online reporting via inquiry pages.
- Asset management financial chart generation.

Reporting and Formats

Asset Management reports are generated as the result of an asset management process or in response to an ad hoc request for asset information. Processes and reports can be generated as part of scheduled batch activities or as one-time requests, all of which are handled through the Process Scheduler. The type of report that is generated is usually the result of how the data is to be presented or of the kind of processing that is required to produce the desired results.

Asset Management provides reports to aid in tracking and reconciling asset transactions, capital acquisition planning, depreciation, account activity, accounting entries, physical inventory, asset disposal and retirement, and to meet tax reporting requirements. Reports supporting these same asset management activities on the global level as well as statutory requirements are also available for Australia, Canada, France, Germany, Italy, India, and Japan. All of the available reports that are associated with asset management are listed in Appendix: Asset Management Reports in this PeopleBook.

Most of the reports that are used for different functions within Asset Management make use of the same data but report it from a different perspective. For example, depreciation is often reviewed by ChartField activity. It is, however, also useful to review depreciation based on a category or location. To that end, you may use a report template that enables you to define the reporting-by method to be used.

PeopleSoft delivers a report template that can be shared by all users but that can be defined by you to include or exclude information of your choosing. The template controls the report title, Report By field name, sort order, field length to display, field label overrides, amount field length, and sub-totaling. To accommodate the varying needs of many users, the report can be generated using Report By as the key, with a report suffix added to the report ID to indicate what value is used for Report By.

Asset Management also provides the tools to produce reports in user-defined formats. Using report IDs or user IDs as keys to reporting templates, multiple groups or individuals use the same general information provided in a report but receive it in a dynamically defined format addressing the particular needs of the group or individual.

Online Reporting

Asset Management provides online inquiries of the depreciation reporting table (DEPR_RPT), which displays high level summary data for a period with details available via drill down functions that are defined at the business unit/book definition level. When enabled for online reporting, selection criteria includes Business Unit, Book, Fiscal Year, Period, Asset Category, Profile ID and ChartFields. The drill down feature provides the option to view the data presented to the lowest level available.

Asset Management Charts

Asset Management provides the ability to display some financial data in 2-D, or stacked bar charts. This option is available for generating data comparisons (for example, depreciation per operating units or by book). By selecting the values to be compared, a full color coded chart is generated, which provides an at-a-glance depiction of financial data.

Prerequisites

To use Asset Management reporting options, you must have:

- Established business units and book definitions.

The online reporting option is established at the business unit/book definition level. You must have enabled this option for each business unit and each book that is associated with that business unit for which you want to view online inquiries with drill down capability.

- Established ChartFields.

Report suffix is appended to the run control ID for a report and defaults to a ChartField order. If additional ChartFields are to be defined, the new ChartFields must be included.

Online reporting selects data based on ChartFields:

- Defined drill down fields.

Online reporting enables users to view details of costs and depreciation from high level summary views to the lowest reporting level available for reporting periods. Once you have defined the drill down fields, you can view the details in finer granularity.

See Also

PeopleSoft Enterprise Asset Lifecycle Management Fundamentals 9.0 PeopleBook, “Establishing PeopleSoft Asset Management Business Units”

PeopleSoft Enterprise Asset Lifecycle Management Fundamentals 9.0 PeopleBook, “Establishing Asset Processing”

PeopleSoft Enterprise Application Fundamentals 8.9 PeopleBook, *Defining and Using ChartFields*.

Using Flexible Reporting and Formats

PeopleSoft enables you to generate reports and print them using your report format templates for the following reports:

- Cost Activity (RUN_AMAS2000)
- Depreciation Activity (RUN_AMDP2000)
- Asset Net Book Value (RUN_AMDP2100)
- Asset Reclassifications (RUN_AMAS240)
- Asset Transfers (RUN_AMAS2300)
- Asset Acquisitions (RUN_AMAS2100)

See Also

PeopleSoft Enterprise Asset Lifecycle Management Fundamentals 9.0 PeopleBook, “Establishing Asset Processing,” Setting Up Reporting Options

Pages Used to Run Reports With Format Templates

| Page Name | Object Name | Navigation | Usage |
|------------------------|------------------|---|---|
| Parameters | RUN_* | Asset Management, Financial Reports | Select a report and apply a report format template in the Report Print Options group box or update or add a report format template. |
| Report Format Template | RPT_FMT_TMPL_SBP | Click the Update/Add Template link in the Report Print Options group box. | Update or add new report format templates. |

Running Flexible Reporting and Formats

Select Asset Management, Financial Reports, then select the report to be generated. Select the Run Control ID associated with your report or create a new one.

Parameters

Run Control ID: Asset_NBV [Report Manager](#) [Process Monitor](#) Run

Language: English

▼ Report Print Options

Report By: Title Override:

Template Id: [Update/Add Template](#) Amount Length:

Report Request Parameters

| | | |
|---|--|--|
| <p>Unit: </p> <p>Book Name: </p> <div style="background-color: #4F81BD; color: white; padding: 2px 5px; font-weight: bold;">Fiscal Year/Period</div> <p>As Of Fiscal Year: Period: </p> <p style="text-align: center;">OR</p> <div style="background-color: #4F81BD; color: white; padding: 2px 5px; font-weight: bold;">Date Range</div> <p>As of Date: </p> <div style="background-color: #4F81BD; color: white; padding: 2px 5px; font-weight: bold;">Type of Report</div> <p><input checked="" type="radio"/> Detail <input type="radio"/> Summary</p> <div style="background-color: #4F81BD; color: white; padding: 2px 5px; font-weight: bold;">Stopped depreciation options</div> <p><input type="checkbox"/> Assets with negative NBV only</p> <p><input type="checkbox"/> Assets with NBV < Salvage</p> | <p><input checked="" type="checkbox"/> Include Transfers</p> <p>Location: </p> <p>Category: </p> <p>Operating Unit: </p> <p>Fund Code: </p> <p>Department: </p> <p>Program Code: </p> <p>Class Field: </p> <p>Budget Reference: </p> <p>Product: </p> <p>Project: </p> | <p><input checked="" type="checkbox"/> Include Retirements</p> |
|---|--|--|

Parameters page

Access the run control page for the report to be formatted with user-defined parameters and expand the Report Print Options group box.

Note. Not all Asset Management reports are enable with the flexible report format template feature.

Report Print Options

Report By

Select from the valid Report By values by which data is to be reported for this report type. For example, the report may use ChartFields and the information in the report can be presented by any ChartField value. If you select DEPTID, the data is grouped by department ID. If you select ACCOUNT, the same information is retrieved but is grouped by account. The purpose or audience for your report drives your selection.

Template Id

Select the template ID for this report from the saved templates by clicking the drop down arrow. Click the Update/Add Template link to go to the Report Format Template page where you can add a new template or update an existing template. The template contains the report format you have defined. For example, perhaps you need a list of departments and expense totals for a period. You can limit your report to include only the relevant fields for your task and save the selected options as a template for future use.

Note. To add a new template ID, the Template Id field must be blank before you select the Update/Add Template link.

Title Override

Enter the title for the report. This field enables you to enter a meaningful report title for this run of the report. If you do not enter a title, the system selects a default value from the string table value of the technical value for the report. Instead, it is useful to name your report based on the current reason, date, or requester for the report.

Amount Length

Enter the maximum number of spaces that are required for the Amount fields to display. The default is 23 digits.

Update/Add Template

Click this link to update or add a new report format template.

Report Format Template

Access the Report Format Template page.

Report Format Template

Report ID: AMAS2100

Template Id: [Add Template](#)

| Field Name | Field Order | Display Length | Label Override | Include in Report | Print subtotals |
|------------|----------------------|----------------------|----------------------|--------------------------|--------------------------|
| | <input type="text"/> | <input type="text"/> | <input type="text"/> | <input type="checkbox"/> | <input type="checkbox"/> |

Report Format Template page

See Also

[Appendix C, “PeopleSoft Asset Management Reports,” page 561](#)

Enterprise PeopleTools 8.48 PeopleBook: PeopleSoft Process Scheduler

Using Online Reporting

To use online reporting in Asset Management, you must first enable the option on the Asset Management Business Unit/Book Definition page. You may optionally use drill down features and link group IDs to user IDs to use with online reporting.

Page Used to Generate Online Reports

| Page Name | Object Name | Navigation | Usage |
|-----------------------|-------------|--|--|
| Cost and Depreciation | AM_REPORT1 | Asset Management, Financial Reports, Cost and Depreciation Summary | View summarized depreciation activity, cost activity and net book value from reporting tables and drill down to details. |

Generating Online Reports

You can define the drill down functions for online inquiries of the depreciation reporting table (DEPR_RPT). The report displays high level summary data for a period with details available for drill down to the lowest available level. The drill down definition is set up at the business unit, book definition level in the Financial Reports component.

Access the Cost and Depreciation page.

Cost and Depreciation

▼ Selection Criteria

| | | | |
|------------------------|----------------------------------|--------------------|---|
| *Business Unit: | US001 US001 NEW YORK OPERATIONS | Currency: | USD |
| *Book Name: | CORP Corporate | Group Type: | None ▼ |
| *Fiscal Year: | 2005 | Period: | <input type="text"/> |

▼ Secondary Selection Criteria

| | | |
|-------------------------------|----------------------|--|
| Account - Accum Depr: | <input type="text"/> | |
| Account - Fixed Asset: | <input type="text"/> | |
| Asset Category: | <input type="text"/> | |
| Asset Profile ID: | <input type="text"/> | |
| Budget Reference: | <input type="text"/> | |
| Class Field: | <input type="text"/> | |
| Cost Type: | <input type="text"/> | |
| Department: | <input type="text"/> | |
| Fund Code: | <input type="text"/> | |
| Operating Unit: | <input type="text"/> | |
| Product: | <input type="text"/> | |
| Program Code: | <input type="text"/> | |
| Project: | <input type="text"/> | |

Cost and Depreciation by Period Customize

| <input type="button" value="Net Book Value"/> | <input type="button" value="Depreciation Activity"/> | <input type="button" value="Cost Activity"/> | <input checked="" type="button" value="Special Terms"/> | <input type="button" value="EBE"/> | | |
|---|--|--|---|------------------------------------|----------------|---------------|
| Period | Drill-down To | Special Depr | Initial Depr | Accelerat Depr | Increased Depr | Standard Depr |
| | | | | | | |

Cost and Depreciation page

Selection Criteria

Business Unit, Book Name, Fiscal Year, and Currency

All of these values are required.

The business unit is based on the user ID options.

The book name is the default book for the business unit, if the business unit is not blank.

The fiscal year uses today's date from the calendar table, if the book name is not blank.

Currency The system uses the business unit, book name base currency for the default currency.

| | |
|-------------------|---|
| Period | Enter the period when the expected data is of high volume and selection criteria is entered. If you leave the field blank, all periods display after performing your search. |
| Group Type | This field is used only when the business unit/book name uses group assets. If group assets is not defined at the installation level, Group Type will not display. Select <i>Group Asset</i> , <i>Group Member</i> , or <i>None</i> . |

Secondary Selection Criteria

Select any secondary criteria to further narrow the report results. The available options reflect the ChartFields, asset category, asset profile ID, and cost type.

After you have entered the selection criteria and performed the search, the resulting data is summarized by period. You can now drill down on any asset to the lowest level of data that can be viewed. This option is set when you create the group ID definition. Drill down enables bidirectional summary data, so that you can drill down and go back to a previous level of data. The system displays *breadcrumbs* to manage your drill down layers.

Related amounts are grouped and viewed in separate tabs.

Net Book Value

Net book value includes period depreciation, year-to-date (YTD) depreciation, LTD depreciation, cost, salvage value and net book value.

- Special term depreciation

Includes special depreciation, accelerated depreciation, increase depreciation, standard depreciation, and initial depreciation.

Note. When no special term depreciation is tracked, this tab is hidden.

- ChartFields

Includes ChartFields that are available for drill down when the *All Assets* option is selected.

- Other Information

Includes profile ID, location, fixed asset account, and accumulated depreciation account when the *All Assets* option is selected.

Depreciation Activity

Depreciation activity includes accumulated depreciation for additions, transfers, re-categorization, retirements, reinstatements, and prior depreciation.

Note. When the group type *Group Member* is selected, depreciation activity is hidden.

Cost Activity

Cost activity includes cost addition, adjustment, transfer, re-categorization, retirement, and reinstatement.

Note. When Group Type is *Group Asset*, Cost Activity is hidden.

Charting Financial Data

When using Asset Management charting features, you select your criteria and view the resulting online chart output.

Page Used to Chart Financial Data

| Page Name | Object Name | Navigation | Usage |
|--------------------|-------------|---|--|
| Selection Criteria | AMCHART1 | Asset Management, Financial Reports, Generate AM Charts | Select criteria and create and view online charts of financial data. |

Using Asset Management Financial Charts

Access the Selection Criteria page.

Selection Criteria
Chart Image

*Unit: Book Name:

Compare Data

*Compare:

Value1: USD

vs.

Value2: USD

Cost
 Accumulated Depr
 Net Book Value

ChartField Selection Criteria
Customize | Find | First 1 of 1 Last

| | Name | Value | To Value | | |
|---|----------------------|---|---|----------------------------------|----------------------------------|
| 1 | <input type="text"/> | <input type="text"/> <input type="button" value="🔍"/> | <input type="text"/> <input type="button" value="🔍"/> | <input type="button" value="+"/> | <input type="button" value="-"/> |

From Year: To Year:

Search Results
Customize | Find | First 1-2 of 2 Last

| | Fiscal Year | AUTO Cost | FF Cost | AUTO Net Book Value | FF Net Book Value |
|---|-------------|------------|------------|---------------------|-------------------|
| 1 | 2005 | 461,963.00 | 273,678.96 | 253,324.93 | 273,678.96 |
| 2 | 2006 | 461,963.00 | 273,678.96 | 217,749.93 | 273,678.96 |

Chart Type:

Selection Criteria page

The Selection Criteria page defines the parameters for the chart. Values are derived to compare business units, books, ChartFields, and totals for cost, accumulated depreciation, and net book value, and are depicted in the resulting chart.

Compare Data

Compare Select the values you want to compare in the chart. For example, if business unit is selected, you must select the business units to compare. The chart depicts the comparison between the business unit values that you enter.

Cost, Accumulated Depr, (accumulated depreciation), Net Book Value Select the summary totals to be compared. For example, to create a what-if scenario of business units for Germany and France operations, select Accumulated Depr to compare that value for each business unit. You must select at least one summary total to compare or any combination of the three.

Note. When using reporting functions that report multiple currencies, the comparison is always reported in the *from* business unit currency.

ChartField Selection Criteria Further define the chart to display subtotals by ChartField.

From Year and To Year Enter the range of fiscal years to include in the chart.

Chart Type Select the type of chart you want to assemble. The valid choices are *2-D Horizontal Bar* or *Stacked Bar*.

When you have selected all the appropriate criteria, gather the data by clicking the Search button. The data summary totals display, with one row for each fiscal year requested and one column for each field and value selected. Before you can view the chart, you must press the Generate Chart button.

The chart image displays automatically on a second page tab. A legend is included in the chart for each color-coded bar in the chart. A summary of the chart totals displays in the Chart Creation Data group box.

This illustration depicts a summary of the chart totals:

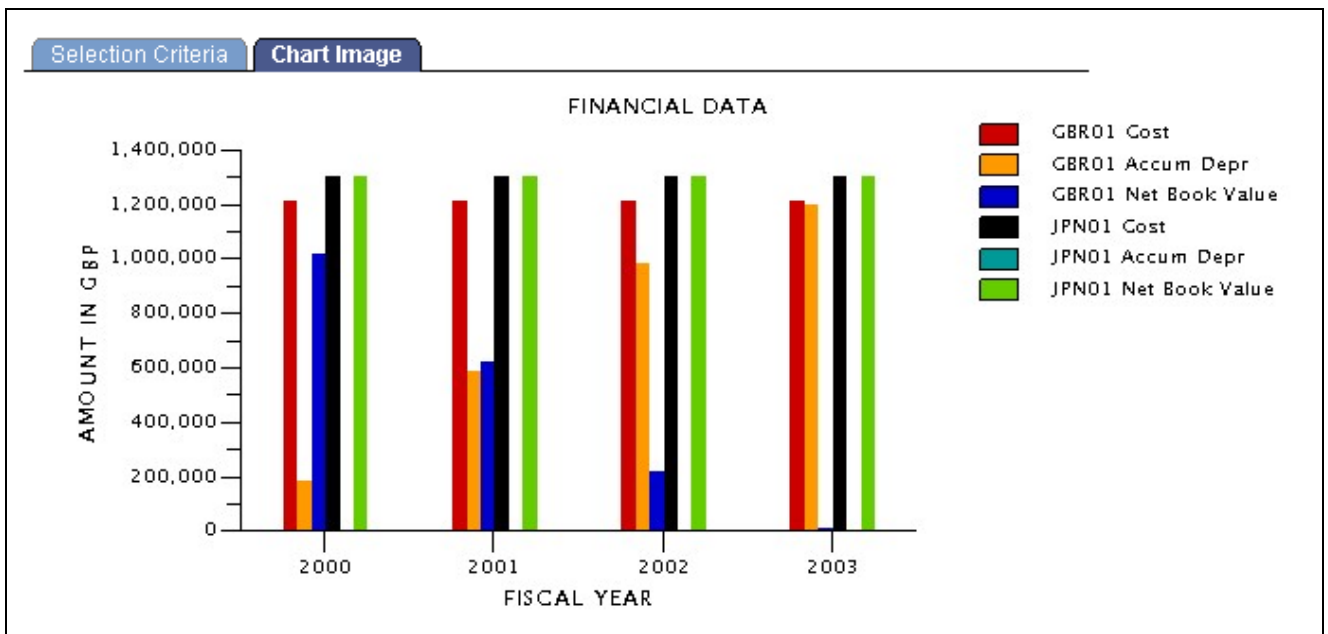

Example: Chart Image page

| Chart Creation Data | | | | Customize | Find | First | 1-24 of 24 | Last |
|---------------------|------|----------------------|--------------|-----------|------|-------|------------|------|
| | Year | Description | Amount | | | | | |
| 1 | 2000 | GBR01 Cost | 1,216,009.00 | | | | | GBP |
| 2 | 2000 | GBR01 Accum Depr | 191,610.61 | | | | | GBP |
| 3 | 2000 | GBR01 Net Book Value | 1,024,398.39 | | | | | GBP |
| 4 | 2000 | JPN01 Cost | 1,306,524.64 | | | | | GBP |
| 5 | 2000 | JPN01 Accum Depr | 0.00 | | | | | GBP |
| 6 | 2000 | JPN01 Net Book Value | 1,306,524.64 | | | | | GBP |
| 7 | 2001 | GBR01 Cost | 1,216,009.00 | | | | | GBP |
| 8 | 2001 | GBR01 Accum Depr | 590,875.98 | | | | | GBP |
| 9 | 2001 | GBR01 Net Book Value | 625,133.02 | | | | | GBP |
| 10 | 2001 | JPN01 Cost | 1,306,524.64 | | | | | GBP |
| 11 | 2001 | JPN01 Accum Depr | 0.00 | | | | | GBP |
| 12 | 2001 | JPN01 Net Book Value | 1,306,524.64 | | | | | GBP |
| 13 | 2002 | GBR01 Cost | 1,216,009.00 | | | | | GBP |
| 14 | 2002 | GBR01 Accum Depr | 990,141.35 | | | | | GBP |
| 15 | 2002 | GBR01 Net Book Value | 225,867.65 | | | | | GBP |
| 16 | 2002 | JPN01 Cost | 1,306,524.64 | | | | | GBP |
| 17 | 2002 | JPN01 Accum Depr | 0.00 | | | | | GBP |
| 18 | 2002 | JPN01 Net Book Value | 1,306,524.64 | | | | | GBP |
| 19 | 2003 | GBR01 Cost | 1,216,009.00 | | | | | GBP |
| 20 | 2003 | GBR01 Accum Depr | 1,201,590.53 | | | | | GBP |
| 21 | 2003 | GBR01 Net Book Value | 14,418.47 | | | | | GBP |
| 22 | 2003 | JPN01 Cost | 1,306,524.64 | | | | | GBP |
| 23 | 2003 | JPN01 Accum Depr | 0.00 | | | | | GBP |
| 24 | 2003 | JPN01 Net Book Value | 1,306,524.64 | | | | | GBP |

Example: Chart Summary Totals

CHAPTER 22

Using Asset Management Self Service Web Components

This chapter provides an overview of Asset Management self service web components and describes:

- Prerequisites to use Asset Management self service web components.
- Using self service application pages.

Understanding Self Service Components in Asset Management

Self-service web applications provide your employees secure and convenient access to information. For many people, self-service applications provide an improved alternative to automated telephone prompting systems. In addition, they can help ease the workload for internal support staff.

PeopleSoft delivers several self-service web components as templates. You can use the PeopleTools Application Designer to modify these Web components just as you would any application components.

Asset Management provides four self-service web components:

| Component | Description |
|-------------------------|--|
| Assets | Provides details for an individual asset, including the reference information (ID, tag number, and serial number), location, department, model, manufacturer, and custodian. |
| Asset Transfer Request | An employee can create and submit a request to indicate an asset has been lost, stolen, inappropriately assigned, or relocated to another department. |
| Asset Transfer Approval | A manager can approve, deny, or hold an asset transfer request that is submitted by an employee. |
| Department Assets | Provides a list of all assets that are assigned to a particular department for which the manager is responsible. |

The information displayed in these pages derives directly from the tables in Asset Management.

Security

The user profile that is created for each individual who accesses the self-service web application determines the pages the user can access. Create user profiles in the User Profiles - General page within the User Profile component. Assign a role to each user profile and link roles to permission lists. Each permission list identifies the pages that individuals assigned to a role can access. To modify the access for specific web pages for each role, modify the permission list for the user's role.

Note. If a permission list is modified, it changes the access for all users who are assigned to roles to which the permission list is linked.

Use the user profile to define to which data the user has access. For example, you can associate the user profile for an employee with a specific employee ID. When employees sign on to the self-service web application, they only receive access to asset management information for the employee that is assigned to that employee ID. As another example, you can associate the user profile for a manager with a specific employee ID. The manager receives access to asset management information for assets to which they are assigned.

See Also

Enterprise PeopleTools 8.48 PeopleBook, "Security Administration"

Asset Management Roles

Asset Management provides self-service Web pages for the following roles:

- Employees
- Managers

PeopleSoft delivers definitions for each of these roles. You assign permission lists to each role.

Employees have access to self-service web pages where they can perform the following tasks:

- View asset details.
- Create asset transfer requests.

Managers have access to self-service web pages where they can perform the following tasks:

- View asset details.
- View assets by department.
- Approve, deny, or hold asset transfer requests.

See Also

Enterprise PeopleTools 8.48 PeopleBook, "Security Administration"

Prerequisites to Using Self Service Web Components

Before using Asset Management, you must set up the product application.

To use employee and manager data, you must also transfer data from the Human Resources database to the Financials database. When using Human Capital Management applications, the system uses application messaging to retrieve data from the Human Capital Management tables to the Financials tables. The application messages that provide the data needed for Asset Management Self Service web components are PERSON_BASIC_SYNC and PERSON_BASIC_FULL_SYNC.

Additionally, you must define user or employee IDs, user profiles, roles, and permission lists.

See Also

PeopleSoft Enterprise Asset Lifecycle Management Fundamentals 9.0 PeopleBook, “Establishing PeopleSoft Asset Management Business Units”

PeopleSoft Enterprise Asset Lifecycle Management Fundamentals 9.0 PeopleBook, “Establishing Asset Processing”

PeopleSoft Enterprise Application Fundamentals 9.0 PeopleBook

Enterprise PeopleTools 8.48 PeopleBook, “Security Administration”

Enterprise PeopleTools 8.48 PeopleBook, “Integration Tools”

Using Self Service Application Pages

This section describes the web pages that employees or managers can access to view or modify information for Asset Management. The information that appears on the page and the use of the page might differ, depending on the user’s role. Both employees and managers can review asset information and submit asset transfer requests. However, only managers can approve, hold, or deny asset transfer requests.

Note. Approvals on the self-service web application pages do not automatically generate transactions in Asset Management. An email or a work list is sent to a corresponding employee to enter the action manually in Asset Management.

Pages Used to Use Self Service Application Pages

| Page Name | Object Name | Navigation | Usage |
|------------------------|--------------------|--|---|
| My Assets | AM_MY_ASSET | Employee Self-Service, Assets, View/Transfer Assets | Employees view a list of assets that are assigned to them, access asset detail information, and submit asset transfer requests. |
| Asset Information | AM_MY_ASSET_DETAIL | Click the Asset link on the My Assets page | Employees and managers view asset detail information and submit asset transfer requests. |
| Asset Transfer Request | AM_MY_ASSET_RQST1 | Click the Transfer button on the My Assets page | Employees submit an Asset Transfer Request to a manager. The Asset Transfer Request displays asset detail and transfer request information. |
| My Departments | AM_MY_DEPT | Manager Self-Service, Assets, My Departments | Managers view a list of departments that are assigned to them and access department's asset information. |
| My Department | AM_MY_DEPT_ASSET | Manager Self-Service, Assets, View Department Assets | Managers view a list of assets that are assigned to their departments, access asset detail information, and submit asset transfer requests. |
| Approve Asset Transfer | AM_MY_ASSETS_RQST2 | Manager Self-Service, Assets, Approve Asset Transfer | Managers approve, deny, or hold asset transfer requests submitted by themselves or their employees. |

CHAPTER 23

Using the Global Features of PeopleSoft Asset Management

PeopleSoft Asset Management provides enhanced enterprise-wide global support. This chapter provides an overview of Asset Management in global settings and discusses how to:

- (AUS) Use PeopleSoft Asset Management options to meet Australian requirements.
- (CAN) Use PeopleSoft Asset Management options to meet Canadian requirements.
- (FRA) Use PeopleSoft Asset Management options to meet French requirements.
- (DEU) Use PeopleSoft Asset Management options to meet German requirements.
- (IND) Use PeopleSoft Asset Management options to meet Indian requirements.
- (ITA) Use PeopleSoft Asset Management options to meet Italian requirements.
- (JPN) Use PeopleSoft Asset Management options to meet Japanese requirements.

Note. You must have established the correct international options at implementation to display and use these pages.

See Also

PeopleSoft Enterprise Asset Lifecycle Management Fundamentals 9.0 PeopleBook, “Getting Started with PeopleSoft Enterprise Asset Lifecycle Management Fundamentals”

[Chapter 1, “Getting Started With PeopleSoft Enterprise Asset Management,” page 1](#)

PeopleSoft Enterprise Asset Lifecycle Management Fundamentals 9.0 PeopleBook, “Establishing PeopleSoft Asset Management Business Units”

Understanding PeopleSoft Asset Management in Global Settings

Requirements for asset tracking and the subsequent taxing and reporting on assets vary around the world. This chapter provides the information necessary to implement country-specific options to meet local tracking, taxation, and reporting requirements for Asset Management.

Using PeopleSoft Asset Management in Australia

PeopleSoft Asset Management provides the options to identify assets for and calculate deductions of expenditures on assets for research and development (R&D) based on aggregate values.

The system provides options to manage Australian tax credit allowances related to capital investment projects that include provisions for rebates (often referred to as credits).

The system provides the options to track and report on the usage of assets requiring changes in creditable purpose (CCP), assets that may be subject to goods and services tax (GST) or value-added tax (VAT), and capital gains taxes (CGT).

The system provides the functionality to perform “net-method” asset revaluation in accordance with AASB1010 and AASB1041 accounting standards, which require crediting to related asset accounts the balance of accumulated depreciation at the date on which an asset is revalued.

Using PeopleSoft Asset Management in Canada

PeopleSoft Asset Management enables you to calculate depreciation for tax purposes in Canada under the terms of the Capital Cost Allowance (CCA) Reporting. In Canada, all depreciation is calculated on the pool or class of assets by using the rate that is prescribed by the Income Tax Act.

The CCA calculation consists of several components. To calculate CCA, the undepreciated capital cost (UCC) of assets at the beginning of the taxation year is determined, and acquisitions and dispositions during the year are added and subtracted to obtain the balance that can be depreciated. A percentage depreciation and CCA rate is applied to this UCC balance to determine the maximum amount that can be claimed. The CCA that is claimed is deducted from the beginning UCC to calculate the UCC at the end of the year. The final balance is used at the beginning of the following year.

Using PeopleSoft Asset Management in France

PeopleSoft Asset Management supports the specialized derogatory depreciation methods commonly used in France.

The system provides the reporting features necessary to track and report the French business tax at the asset book level and the asset profile level.

The system provides the functionality to perform asset revaluation as necessary.

Using PeopleSoft Asset Management in Germany

PeopleSoft Asset Management supports commonly used practices in Germany, including Staffel depreciation, a half-year prorate convention, geometric digressive depreciation, a parameter-driven automatic retirement process, and management of capitalization limits for low-value assets. In addition, PeopleSoft Asset Management provides reports to meet German statutory requirements.

Using PeopleSoft Asset Management in India

PeopleSoft Asset Management provides asset processing features that correspond to the tax reporting requirements established by the Indian Tax Depreciation Act of 1961. This local standard requires that assets are grouped within a defined *tax block*. Currently India identifies four asset tax blocks: buildings, furniture and fixtures, machinery and plant, and intangibles. Each block of assets is further assigned a *tax group* or class, and each class maintains an individual tax rate. The Indian *tax year* is a fixed fiscal calendar starting April 1 and ending March 31. Tax depreciation is reported annually at the fiscal year to the tax authority per asset block.

The system takes into account the rules regarding the treatment of capital and operating leases by enabling you to designate them.

The system provides the Straight Line Percent depreciation method for India, which calculates depreciation based on rates, and useful life is calculated on cost, salvage value, and depreciation rate combined.

The system provides the India Asset Tax Register, which reports all booked transactions to show the cost, depreciation, and net book value of assets, as well as tax depreciation reporting options.

Using PeopleSoft Asset Management in Italy

PeopleSoft Asset Management enables you to produce a fixed-asset book, required by Italian article 16, D.P.R. 600/73, to record information regarding depreciable fixed assets. The fixed-asset book lists information that is relevant to fixed assets, including the date of purchase, original cost, accumulated depreciation (beginning of year balance), depreciation rate, year-to-date (YTD) depreciation (current year activity), retirement and disposal information, ending balance, and any revaluation and devaluation information in a particular fiscal year for either the economic or fiscal book. Most Italian business entities use an economic book to record depreciation that is not subject to fiscal constraints and a fiscal book to record specific rules and depreciation methods that are regulated by fiscal authorities.

Using PeopleSoft Asset Management in Japan

PeopleSoft Asset Management supports commonly used practices in Japan, including depreciation methods for fixed and leased assets, composite depreciation, and collateral assets. In addition, PeopleSoft Asset Management provides reports to satisfy tax reporting requirements.

Prerequisites

Before you can perform some of the functions discussed in this chapter, you must have already performed some or all of the following country-specific tasks:

| Country | Task |
|-----------------|--|
| VAT countries | Set up the appropriate value-added-tax (VAT) defaults and reporting options, and associate these defaults and options with business units or VAT-driven entities. <i>See PeopleSoft Enterprise Asset Lifecycle Management Fundamentals 9.0 PeopleBook, "Establishing PeopleSoft Asset Management Business Units," Defining VAT Defaults.</i> <i>See PeopleSoft Enterprise Global Options and Reports 9.0 PeopleBook, "Working with VAT".</i> |
| (AUS) Australia | |

| Country | Task |
|---|---|
| <p>Before processing asset revaluations, ensure that these conditions have been set up for Australia:</p> | <ul style="list-style-type: none"> • Select the Create Accounting Entries check box for the accounting book that you are using on the Business Unit/Book Definition page in the Asset Management Business Unit Definition component. <i>See PeopleSoft Enterprise Asset Lifecycle Management Fundamentals 9.0 PeopleBook, “Establishing PeopleSoft Asset Management Business Units”.</i> • Set up the appropriate book definition for Australia on the Assets Books page. <i>See PeopleSoft Enterprise Asset Lifecycle Management Fundamentals 9.0 PeopleBook, “Establishing PeopleSoft Asset Management Business Units,” Defining Business Unit Processing Options.</i> • Verify that cost type <i>R</i> (revaluation) is available on the Cost Types page and set as the Revaluation process. <i>See PeopleSoft Enterprise Asset Lifecycle Management Fundamentals 9.0 PeopleBook, “Establishing Asset Processing,” Defining Asset Attributes.</i> • Add new accounts for <i>Provision for Revaluation (Equity)</i> and <i>Reversal of Depreciation (Expense)</i>. Do this on the Accounts page in the Design ChartFields component. <i>See PeopleSoft Enterprise Application Fundamentals 9.0 PeopleBook, “Defining and Using ChartFields”.</i> • Define a set of accounting entry template IDs for each setID that is affected by revaluation, and define accounting entry templates for each category of asset that is affected by the revaluation using cost type <i>R</i> on the Accounting Entry Template page. These are necessary to generate accounting entries. <i>See PeopleSoft Enterprise Asset Lifecycle Management Fundamentals 9.0 PeopleBook, “Setting Up Accounting Entry and Financial Processing for PeopleSoft Asset Management,” Defining Accounting Entries.</i> • Run the detailed Net Book Value report by category (AMDP2100). This is not required, but is recommended. |
| (CAN) Canada | |
| <p>Set up the following conditions to calculate CCA reporting for Canada:</p> | <ul style="list-style-type: none"> • Set up or modify CCA tax classes on the Tax Class page and specify the CCA percentage rate. Asset pools or classes and CCA rates are set by governmental regulations. In the year that assets are acquired, use 50 percent of the normal rate. The value that you enter for an asset tax class for the CCA rate percent is used later when you run a process to calculate the CCA rate. • On the Asset Book Definition - Book Tax page, select the tax guideline class that reflects the CCA tax class to which the asset belongs. <i>See PeopleSoft Enterprise Asset Lifecycle Management Fundamentals 9.0 PeopleBook, “Setting Up Tax Processing and Tax Reporting,” (CAN, IND, and USA) Defining and Maintaining Tax Classes.</i> |
| (FRA) France | |

| Country | Task |
|--|---|
| Set up the following conditions for France: | <ul style="list-style-type: none"> • Establish your statutory book in the Business Unit/Book definition component. <i>See PeopleSoft Enterprise Asset Lifecycle Management Fundamentals 9.0 PeopleBook, “Establishing PeopleSoft Asset Management Business Units”.</i> • To create accounting entries that include the derogatory accounts required by France, set up an accounting entry template ID with the derogatory feature selected. • Define asset profiles as business tax applicable by selecting the Business Tax check box in the Asset Profile component. • Define asset books as business tax applicable by selecting the Business Tax check box in the Asset Book Definition component. <p><i>See PeopleSoft Enterprise Asset Lifecycle Management Fundamentals 9.0 PeopleBook, “Setting Up Tax Processing and Tax Reporting”.</i></p> |
| (DEU) Germany | |
| Set up the following tables to process tax and depreciation for Germany: | <ul style="list-style-type: none"> • Establish capitalization limit codes for low-value assets. • Create a user-defined Staffel depreciation method. • Define special depreciation terms for accelerated depreciation and associate the terms at the asset or book level. <p><i>See PeopleSoft Enterprise Asset Lifecycle Management Fundamentals 9.0 PeopleBook, “Setting Up Tax Processing and Tax Reporting”.</i></p> <p><i>See PeopleSoft Enterprise Asset Lifecycle Management Fundamentals 9.0 PeopleBook, “Setting Up Depreciation Processing”.</i></p> |
| (IND) India | |
| Set up the following tables to process tax and depreciation for India: | <ul style="list-style-type: none"> • Asset blocks Define assets blocks that are equivalent to the <i>tax block</i> in India. • Tax classes Set up or modify India tax classes on the Tax Class page and specify the asset block and the tax percentage rate. Tax class is used to define tax rates by group for processing tax and depreciation in India. The tax group is a subcategory of the tax block in India. • Tax/report entities Define the tax/report entity. The tax/report entity comprises one or more business units. Tax reporting is disclosed per entity for India. <p><i>See PeopleSoft Enterprise Asset Lifecycle Management Fundamentals 9.0 PeopleBook, “Setting Up Tax Processing and Tax Reporting”.</i></p> <p><i>See PeopleSoft Enterprise Application Fundamentals 9.0 PeopleBook, “Defining User Preferences,” Defining Overall User Preferences.</i></p> |

| Country | Task |
|--|--|
| (JPN) Japan | |
| Set up the following tables to process tax and depreciation for Japan: | <p>Set up the overall options for user preferences (OPR_DEF_TABLE_FS1) in the Common Definitions component:</p> <p>Set the Localization Country value to <i>JPN</i> (Japan), which enables the JPN Info (Japan information) link in the Define Business Units component for Asset Management.</p> <p>See <i>PeopleSoft Enterprise Asset Lifecycle Management Fundamentals 9.0 PeopleBook</i>, “Establishing PeopleSoft Asset Management Business Units”.</p> |

(AUS) Using PeopleSoft Asset Management Options to Meet Australian Requirements

This section discusses how to:

- Define asset R&D categorization.
- Use the Australian tax credit allowance.
- Track changes in CCP.
- Report changes in CCP.
- Calculate CGT.
- Generate asset revaluation (net method).

Pages Used to Meet Australian Requirements

| Page Name | Object Name | Navigation | Usage |
|---|------------------|--|--|
| Asset Unit Aggregate RD (asset unit aggregate research and development) | BU_AGG_RD | Set Up Financials/Supply Chain, Business Unit Related, Assets, Asset Unit Aggregate RD | Calculate research and development tax deductions for R&D plant assets. |
| Asset Profile | PROFILE_DEFN | Set Up Financials/Supply Chain, Product Related, Asset Management, Profiles, Asset Profiles | Define asset profiles. |
| Asset Information | ASSET_GENERAL_01 | Asset Management, Owned Assets, Basic Add | Add asset basic information manually, or add or change existing asset information. Also access the Set R&D Info page. |
| Cost/Asset Information | ASSET_ENTRY_00 | Asset Management, Owned Assets, ExpressAdd | Enter information about how this asset will be capitalized. Also access the Set R&D Info page. |
| Asset R&D Information (asset research and development information) | ASSET_RD_SP | Click the Set R&D Info link from the Asset Information page or from the Asset Additional Information section on the Cost/Asset Information page in ExpressAdd. | Enter information about R&D assets. For Australian customers, use this page for tax reporting purposes. For others, this page is informational only. |
| Tax Information | ASSET_ENTRY_02 | Asset Management, Owned Assets, ExpressAdd, Tax Information | Specify property type and tax depreciation criteria to identify which investment credits are taken for the current asset. If the fields on this page are unavailable, you are working with a book that was not set up as a tax book. |
| RD Deductions - AUS (research and development deductions - Australia) | RUN_AMTX10AU | Asset Management, Taxes, Reports, RD Deductions - AUS | Run a report to view the number of R&D concessions that can be claimed. |
| Tax Credits - AUS | RUN_AMTX20AU | Asset Management, Taxes, Reports, Tax Credits - AUS | Run the Tax Credit Allowance Structured Query Report (SQR) to produce a report of total tax credits by business units. |
| Australia CCP Report (Australia changes in creditable purpose report) | RUN_AMTX30AU | Asset Management, Taxes, Reports, Tax CCP | Report the apportionment of recoverable versus nonrecoverable VAT on invoices. |

Defining Asset R&D Categorization

Enable R&D calculations and define assets as R&D eligible assets from the following pages:

- Asset Unit Aggregate RD page.
- Asset Profiles - Definition page.
- Set R and D Info page.

Enabling R&D Calculations

Access the Asset Unit Aggregate RD page.

To calculate the amount of deductions that it is possible to claim, enter the aggregate R&D amount for each fiscal year. Enter the fiscal year, expenditure, and description for the business unit.

Defining an Asset as R&D Eligible on the Asset Profile Page

Asset profiles that are defined with R&D options selected indicate that all assets that are added to your system by using this profile are used for R&D and are entitled to R&D tax concessions.

| | |
|--|---|
| R&D Plant Asset (research and development plant asset) | Select if this asset is used for R&D and is entitled to R&D tax concessions. |
| R&D Start Date (research and development start date) | Enter the date on which the asset was first used exclusively for R&D. If you leave this field blank, the in-service date from the business unit's tax book is used as the start date. The start date determines the first year in which you can claim R&D concessions. |
| Use NBV for R&D (use net book value for research and development) | Select if you want to base the R&D concessions calculation on the net book value of the asset (at the R&D start date) instead of the book cost. This is useful when an asset previously being depreciated as a non-R&D asset subsequently becomes eligible for R&D concessions. |

Defining an Asset as R&D Eligible on the Set R&D Information Page

Assets that are added to your system through either the Basic Add, Asset Information page or the ExpressAdd, Cost/Asset Information page with R&D options selected identify that the asset is used for R&D and therefore entitled to R&D tax concessions.

Access the Set R&D Info page.

| | |
|---|---|
| R&D Plant (research and development plant) | Select if you want to identify the asset as specifically allocated for R&D. |
| R&D Start Date (research and development start date) | Enter the R&D start date for this asset. |
| Use NBV (use net book value) | Select if appropriate for your tax reporting purposes. Click the OK button to return to the Asset Information or Cost/Asset Information page. |

See Also

PeopleSoft Enterprise Asset Lifecycle Management Fundamentals 9.0 PeopleBook, “Establishing Asset Processing”

PeopleSoft Enterprise Asset Lifecycle Management Fundamentals 9.0 PeopleBook, “Setting Up Depreciation Processing”

PeopleSoft Enterprise Asset Lifecycle Management Fundamentals 9.0 PeopleBook, “Setting Up Tax Processing and Tax Reporting”

[Chapter 5, “Adding and Maintaining Assets,” page 45](#)

Using the Australian Tax Credit Allowance

Australia tax law provides certain tax credit allowances related to capital investment projects that include provisions for rebates (often referred to as credits). Unlike allowable deductions, the tax credits are not part of the calculation of taxable income.

The tax credit allowance is calculated in this way:

Tax credit cost basis = book cost x basis reduction rate (%)

Tax credit = tax credit cost basis x tax credit (%)

To use this feature:

- Set up your own credit tables or modify the existing tables on the Tax Credits page.
- Assign a status to the defined tax credits.

The status enables you to classify assets when reporting credits. Use the Tax Credit Status page to enter or modify a tax credit status.

- Enter tax credits against assets.

Use the Asset Profiles, Asset Book Definition, or Asset ExpressAdd component.

See *PeopleSoft Enterprise Asset Lifecycle Management Fundamentals 9.0 PeopleBook*, “Setting Up Tax Processing and Tax Reporting,” Defining Tax Credits.

Entering Tax Credits Against an Asset

Tax credits are entered against an asset in the Asset Book Definition or Asset ExpressAdd component, or at the asset profile level by using the Asset Profile Tax Credits page. You can enter tax credits against leased assets by using the Asset Book Definition page after the asset has been entered through Leased Asset Entry.

See *PeopleSoft Enterprise Asset Lifecycle Management Fundamentals 9.0 PeopleBook*, “Establishing PeopleSoft Asset Management Business Units,” Creating PeopleSoft Asset Management Business Units.

See [Chapter 7, “Working With Leased Assets,” page 127](#).

Entering Tax Credits in the Asset Book Definition Component

The Tax Credit Options region on the Tax page (PROFILE_BK_03) of the Asset Profiles component provides you with the options to identify which investment credits are taken for a selected asset. You must specify the tax criteria before you can enter tax credits.

After you enter the tax credit code, PeopleSoft Asset Management retrieves the percentage figures that are specified for the tax credit and calculates the computation amount using the following formula:

Book cost x basis reduction percentage = amount qualifying for the tax credit

Amount qualifying x tax credit percentage = amount of tax credit

The sum of all tax credits that are defined in the current book appears in the Tax Credit field. The total tax credit amount is updated each time that you change tax credit information.

See *PeopleSoft Enterprise Asset Lifecycle Management Fundamentals 9.0 PeopleBook*, “Establishing Asset Processing,” Setting Up Asset Profiles.

Entering Tax Credits in the Asset ExpressAdd Component

The Asset ExpressAdd component enables you to identify which investment credits are taken for a selected asset from the Tax Credit Options region on the Tax Information page (ASSET_ENTRY_02). You must specify the tax criteria before you can enter tax credits.

Access the Tax Credit Options group box on the Tax Information page.

Enter the tax credit code. You can optionally enter a tax credit status.

After you enter the tax credit code, PeopleSoft Asset Management retrieves the percentage figures that are specified for the tax credit and calculates the computation amount by using the following formula:

Book cost x basis reduction percentage = amount qualifying for the tax credit

Amount qualifying x tax credit percentage = amount of tax credit

The sum of all tax credits that are defined in the current book appears in the Tax Credit field. The total tax credit amount is updated each time that you change tax credit information.

If you change the cost information on the Cost/Asset Information page of the Asset ExpressAdd component after you have entered tax credits, click the Calculate Credit button to recalculate the amount of the credits. This reloads the percentage figures from the Tax Credit table and then recalculates the amounts for all tax credits that are defined for the current asset.

See [Chapter 5, “Adding and Maintaining Assets,” Adding Assets with the Asset ExpressAdd Component, page 89](#).

Tracking Changes in CCP

Australian financial services organizations are required to track the usage of fixed assets that are used in making input tax supply. Input tax that is not creditable is capitalized in the value of the asset and depreciated accordingly. Creditable tax is eligible for refund and is not included in the value of the asset. Because a single asset can be used by a business entity in multiple activities, some of which may be taxable or GST-free and some of which may be input taxed, the full amount of GST that is paid must be recorded and apportioned creditable and noncreditable based upon usage. Over the life of an asset, this apportionment must be reviewed annually and adjusted to reflect the asset’s current usage. The time period during which an asset is subject to this review is determined by the cost of the asset. Review periods are maintained in the Asset Threshold-VAT table referenced when assigning the last date of mandatory review.

Recording GST in Payables and Passing GST on to Asset Management

To track the apportionment of GST that is relevant to an asset, four fields are passed to Asset Management from Payables using the Run Load Assets process (INTFAPAM):

- Asset ID
- Merchandise Amount

- Non Recoverable VAT
- Total VAT

Payables validates the information that you entered on the invoice before passing it to Asset Management.

Note. The invoice information must be validated in PeopleSoft Payables before it is passed to PeopleSoft Asset Management. Invoice information cannot be rejected once it has reached PeopleSoft Asset Management.

This diagram illustrates the interface process:

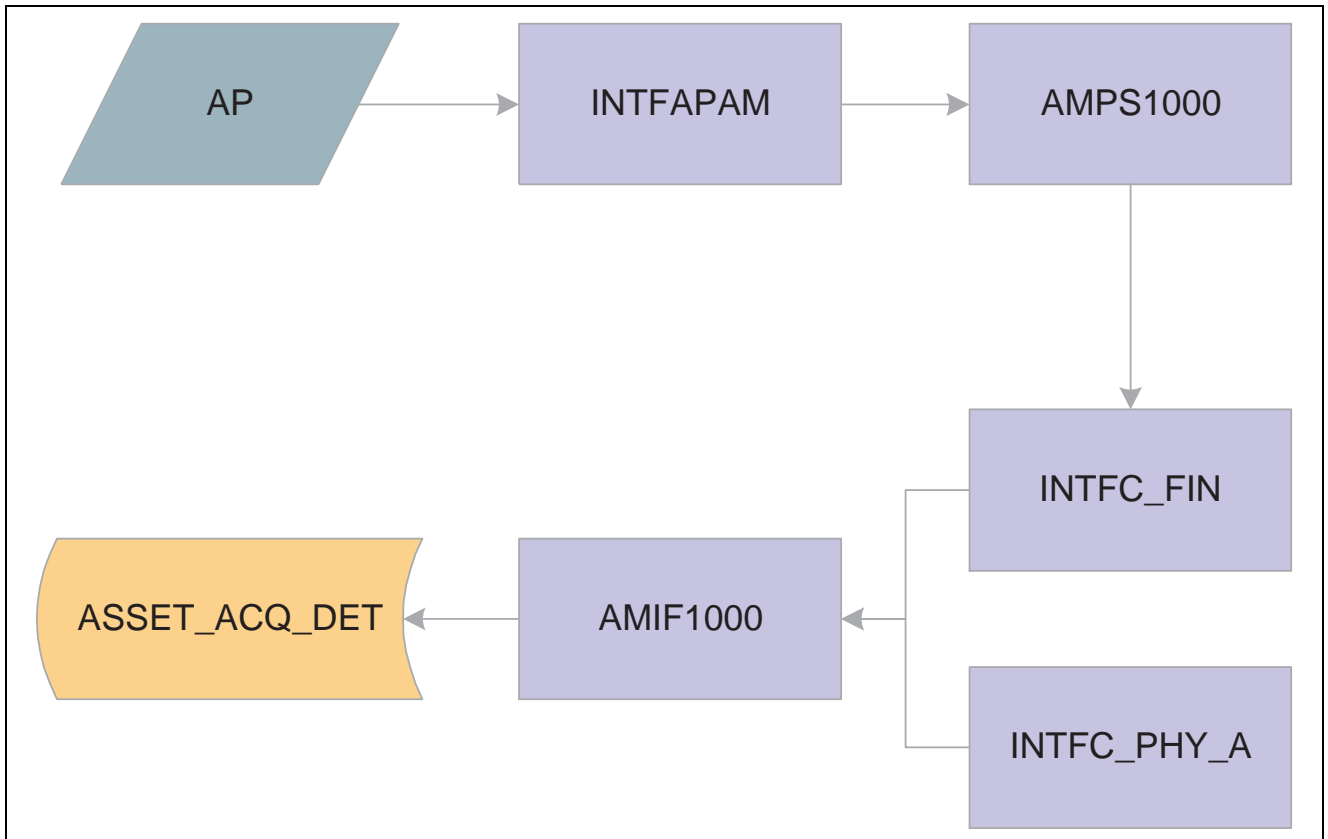

PeopleSoft Payables to PeopleSoft Asset Management GST process

See *PeopleSoft Enterprise Payables 9.0 PeopleBook*, “Processing Value Added Tax (VAT) in PeopleSoft Payables”.

Adding GST Online in Asset Management

You can enter GST information directly into Asset Management when entering an asset online through the Asset Basic Information component. Use the Tax link on the Asset Acquisition Detail page to enter tax amounts that are charged to the asset.

Changes in CCP are recorded on the same page that you use to enter an asset’s GST amounts manually and to designate recoverable and nonrecoverable amounts. When changing the usage percentage of an existing asset, select the transaction type *Adjustment* rather than *Addition*; otherwise, the entry process is the same.

When working in a business unit that is identified for Australia, the Calculate Last Date of Review button appears on the Asset Information page. Select a schedule type code, and click the Calculate Last Date of Review button to generate the last date of mandatory review for the asset. The last date of mandatory review is stored on the Asset Basic Information page.

See Also

Chapter 5, “Adding and Maintaining Assets,” Adding and Maintaining Asset Information, page 47

Reporting Changes in CCP

Some organizations must track fixed assets that are used in making input tax supply. You can track the change in the extent to which a fixed asset is used to make taxable supply from reporting period to reporting period, and you can make adjustments for any change. For instance, in Australia, Australian financial services organizations require a solution to record the apportionment of recoverable versus nonrecoverable VAT on invoices. This information is then sent to PeopleSoft Asset Management for capital assets.

Access the Australia CCP Report page (RUN_AMTX30AU) to generate the report.

Calculating CGT

CGT legislation in Australia requires payment of tax on certain capital gains that are realized at the time of an asset’s sale, net of inflation, of all components of the cost basis. Tax deductions can also be realized in certain circumstances for losses. PeopleSoft Asset Management provides pages on which you designate the applicability of a gain or loss calculation for specific assets or for all of the assets in a book. When an asset on which gain or loss has been designated as applicable is retired, the system calculates the gain or loss and stores the results for later reporting. The gain or loss calculation is split into an assessable gain or loss and a capital gain or loss amount.

Specifying Capital Gain or Loss Options for an Asset

There are multiple components where you can indicate that an asset is CGT-applicable if you want the capital gain or loss calculated for an asset upon retirement:

- Asset Book Definition - Book Tax page (if the CGT calculation is applicable for assets on a book level).
- Asset Profile.
- ExpressAdd.

To be prompted to identify an asset as CGT-applicable, you must associate the book for the asset with the country (Australia) on the Asset Book Definition page.

If CGT is applicable for this asset, select the CGT Applicable check box on any of these pages.

Run the Australian Retirements reports to view the results of CGT-applicable assets. Use these calculations:

Capital gain or loss = asset proceeds – indexed revalued amount or original price – removal amount

Assessable gain/loss = asset proceeds or original price – net book value – removal amount

These calculations use existing indexing tables containing local consumer price indexes (CPI). A logical extension of this calculation is to determine the actual amount of tax to be paid, or in the case of a loss, the tax credit that you can later net against a future capital gain.

See Also

PeopleSoft Enterprise Asset Lifecycle Management Fundamentals 9.0 PeopleBook, “Establishing Asset Processing,” Setting Up Asset Profiles

Chapter 5, “Adding and Maintaining Assets,” page 45

Calculation of CGT

Here are the elements that are used in the calculation of a capital gain or capital loss on the disposal of an asset:

- The cost base of the asset, which is used to determine the amount of a capital gain if the disposal of the asset occurs within 12 months of the taxpayer's acquisition of the asset.
- The indexed cost base of the asset, which is used to calculate the amount of a capital gain if the taxpayer disposes of the asset 12 months or more after the date of its acquisition.
- The reduced cost base of the asset, which is used to calculate the amount of a capital loss that arises on the disposal of the asset.

Using the Asset Retirements page, you can view the CGT that is calculated upon retirement for each asset by book.

The Retirement reports also contain CGT information.

Generating Asset Revaluation (Net Method)

Asset Management supports asset revaluations in accordance with AASB1010 and AASB1041 accounting standards, which require crediting to related asset accounts a balance of accumulated depreciation at the date on which an asset is revalued.

Processing Revaluations

The net method of revaluation cannot be run from the Revaluation worksheet. You must use the process described here.

To process asset revaluations:

- Run the Australian Revaluation process (AMAUSCAL) from Asset Management, Asset Transactions, Financial Transactions, Revaluation in Mass
 - Select the net method as the revaluation method, define the run control parameters and click the Run button on the Process request page.

If you select the Include Current Period Depr (include current period depreciation) option, the process includes the depreciation in the revaluation accounting entries.

Note. Not all of the parameters that are normally available from the run control page are available for this revaluation method.

- Select the Australian Revaluation check box.

The process updates the Financial Loader table (PS_INTFC_FIN) with four rows for each asset included in the process request: one for retirement (RET) with the total cost, one for reinstatement (REI) with the total cost, one for an adjustment (ADJ) reflecting the difference between the original cost and the cost calculated with revaluation parameters, and one for book change (BKS).

- (Optional) Preview the data in the Financial Loader table by using an online page.
- Run the Transaction Loader process (AMIF1000) to load the retirement transactions that are created by revaluation.

Use the load type *RET* to find the load ID to process.

- Run the Depreciation Calculation process (AM_DEPR_CALC) to account for the retirement transactions.

- Run Transaction Loader (AMIF1000) to load the reinstatement transactions that are created by the revaluation.
Use the load type *REI*.
- Run the Revaluation Australia process (AMAUSUPD) to update depreciation and distribution status for retirement and reinstatement transactions.
- Run Transaction Loader (AMIF1000) to load the adjustment transactions that are created by the revaluation.
Use the load type *ADJ*.
- Run Depreciation Calculation (AM_DEPR_CALC) to account for the adjustment transactions.
- Run Transaction Loader (AMIF1000) to load the adjustment transactions created by the revaluation.
Use the load type *BKS*.
- Run the Depreciation Calculation process (AM_DEPR_CALC) to account for the book change transactions.
- Run the Accounting Entry Creation process (AM_AMAEDIST) to generate accounting entries.
- Run the Detail Net Book Value Report by Category (AMDP2110).

See Also

PeopleSoft Enterprise Asset Lifecycle Management Fundamentals 9.0 PeopleBook, “Integrating PeopleSoft Asset Management with Other Products,” Previewing Data in the Loader Tables

PeopleSoft Enterprise Asset Lifecycle Management Fundamentals 9.0 PeopleBook, “Integrating PeopleSoft Asset Management with Other Products,” Running the Transaction Loader

Chapter 8, “Adjusting, Transferring, and Evaluating Assets,” Revaluing Assets In Mass, page 171

Chapter 18, “Creating PeopleSoft Asset Management Accounting Entries,” page 301

(CAN) Using Asset Management Options to Meet Canadian Requirements

This section discusses how to:

- Calculate CCA reporting.
- Run the CCA Year-End Update process.

Pages Used to Meet Canadian Requirements

| Page Name | Object Name | Navigation | Usage |
|--|--------------------------------|---|--|
| Beginning of Year | CCA_UCC_BEGIN | Asset Management, Taxes, Update CCA, Identify CCA Begin Yr | (Optional) Change UCC beginning of year amounts or CCA amounts. |
| CCA Year End Updates (capital cost allowance year end updates) | AMCCAUPD_RQST | Asset Management, Taxes, Update CCA, Update CCA Year End | Run the CCA Year End Updates process (AMCCAUPD_RQST) to extract the components necessary for CCA calculation, and populate the CCA_YR_END_TBL. This process uses the extracted data to calculate all CCA amounts that are required by the CCA report. |
| CCA Yr End - Canada Rpt (capital cost allowance year end - Canada report) | RUN_AMTX10CA, RUN_AM_TX11CA | Asset Management, Financial Reports, Accounting Entries, CCA Year End CAN | Create the Revenue Canada Year End report. Also generate the CCA Year End Extract report. |

Calculating CCA Reporting

Asset Management enables you to calculate and report CCA amounts as required by Schedule 8 of Revenue Canada.

To calculate the CCA:

- Set up or modify CCA tax classes on the Tax Class page, and specify the CCA percentage rate.
Asset pools or classes and CCA rates are set by governmental regulations. In the year that assets are acquired, 50 percent of the normal rate should be used. The value that you enter for an asset tax class for the CCA rate percent is used later when you run a process to calculate the CCA rate.
- On the Asset Book Definition - Book Tax page, select the tax guideline class that reflects the CCA tax class to which the asset belongs.
- For each reporting fiscal year, associate a CCA UCC beginning year value with a CCA tax class.
- Run the CCA Year End Update process that extracts the data that is necessary for CCA calculation, populates the CCA_YR_END_TBL table, and calculates all amounts that are required by the CCA report.
- Run the CCA Year End reports.

See Also

PeopleSoft Enterprise Asset Lifecycle Management Fundamentals 9.0 PeopleBook, “Setting Up Tax Processing and Tax Reporting,” (CAN, IND, and USA) Defining and Maintaining Tax Classes

Running the CCA Year-End Update Process

Access the CCA Year End Updates Request page.

Enter the business unit, CCA book name, and applicable fiscal year. Select a process frequency. This process is iterative. Run it as many times as necessary to complete CCA reporting. To run the process for multiple business units, leave the Unit field blank.

The CCA Year End Update process populates the CCA_YEAR_END_TBL table with these values:

| Business Unit | Acquisitions |
|---------------|---------------|
| Book | Adjustments |
| Fiscal Year | Transfers |
| CCA Tax Class | Net Proceeds |
| Currency Code | Capital Gains |

The process calculates CCA amounts according to the following formula:

$$UCC = UCC \text{ beginning of year} + \text{additions} \pm \text{adjustments} - \text{retirements}$$

$$CCA = UCC - (50\% * \text{addition}) * CCA \text{ rate}$$

$$UCC \text{ end of year} = UCC - CCA$$

(FRA) Using PeopleSoft Asset Management Options to Meet French Requirements

PeopleSoft Asset Management supports asset management practices that are commonly used in France. This section discusses how to:

- Report business tax.
- Depreciate assets by using the derogatory method.
- Revalue assets.
- Generate French statutory reports.

Pages Used to Meet French Requirements

| Page Name | Object Name | Navigation | Usage |
|---------------------|----------------|--|---|
| Business Tax Report | RUN_AMBT1000 | Asset Management, Taxes, Reports, Business Tax | Run the Business Tax report or the Business Tax by Alternate Account report. |
| 2054 2055 Reports | EU_AM_RUNCNTRL | Asset Management, Taxes, Reports, Statutory Report 2054/2055 | Obtain information on the asset, its cost and net book value, and all transactions that occurred in the specified reporting year, including depreciation and yearly depreciation. |

Reporting Business Tax

To calculate and report a business tax that is assessed on the gross value of fixed assets:

- Define the business tax rates by country, year, and location.
- Define asset profiles as business tax applicable by selecting the Business Tax check box in the Asset Profile component.
- Define asset books as business tax applicable by selecting the Business Tax check box in the Asset Book Definition component.
- Run the Business Tax reports: Business Tax by Account or Business Tax by Alternate Account.

See Also

PeopleSoft Enterprise Asset Lifecycle Management Fundamentals 9.0 PeopleBook, “Establishing Asset Processing,” Setting Up Asset Profiles

[Chapter 5, “Adding and Maintaining Assets,” Maintaining Asset Book Information, page 79](#)

Depreciating Assets by Using the Derogatory Method

PeopleSoft Asset Management supports derogatory depreciation and enables you to generate appropriate accounting entries.

To use the derogatory method:

- Set up rates for use with the derogatory method by using the Depreciation Rate - User Defined page in the Establishing Asset Processing component.
- Define appropriate reporting books for France.

In the statutory book, select *France Derogatory Balance* as the depreciation method.

Creating Accounting Entries for Derogatory Depreciation

By setting up the appropriate accounting entry information using an accounting entry template, you can generate accounting entries and see the difference between depreciation that is reflected in the economic book and the statutory book.

To set up appropriate accounting entries:

- Define the economic and statutory books at the business unit level.

Select the Derogatory Depreciation check box on the Business Unit/Book Definition page for the statutory book.

- Add assets.

Identification of derogatory depreciation processing is defined at the business unit or book level.

- Select the Derogatory Accounting entries check box when setting the accounting entry template ID *Derogatory* to define the accounting treatment for derogatory depreciation.
- Run the Depreciation Calculation process (AM_DEPR_CALC) for both books.
- Run the Accounting Entry Creation process (AM_AMAEDIST).
- Review depreciation entries on the Asset Depreciation - Period Depreciation page.
- Review accounting entries for each book in the Asset Accounting Entries component.

The pages in this component provide the accounting date, transaction type, account, and amount of each entry.

- Run the French Net Book Value by Account report (AMFR2120) on the Report - Asset Net Book Value page.
- After you specify parameters for the report and click the Run button, select the French Net Book Value by Account check box from the process list that appears.
- Run the French Net Book Value by Alternate Account report (AMFR2121) on the Report - Alt Acct Activity Detail page.
- After you specify parameters for the report and click the Run button, select the French Net Book Value by Alternate Account check box from the process list that appears.

See Also

PeopleSoft Enterprise Asset Lifecycle Management Fundamentals 9.0 PeopleBook, “Establishing PeopleSoft Asset Management Business Units”

PeopleSoft Enterprise Asset Lifecycle Management Fundamentals 9.0 PeopleBook, “Setting Up Accounting Entry and Financial Processing for PeopleSoft Asset Management,” Defining Accounting Entries

Revaluing Assets

PeopleSoft Asset Management enables you to revalue assets as a whole by using an Application Engine process. You can also revalue one or more assets at one time using the Revaluation Worksheet page. The system enables you to track and report on the revalued amount separately.

Distribution types to support accounting entries for asset revaluation are available. When setting up accounting entry templates, you can use the *Derogatory* accounting entry template ID and select *Asset Adjustments and Transfers*. In the Accounting Entries column, Asset Management provides two entries: *Provision for Revaluation* and *Reversal of Depreciation*.

See Also

PeopleSoft Enterprise Asset Lifecycle Management Fundamentals 9.0 PeopleBook, “Setting Up Accounting Entry and Financial Processing for PeopleSoft Asset Management,” Defining Accounting Entries

Chapter 8, “Adjusting, Transferring, and Evaluating Assets,” Revaluing Assets In Mass, page 171

Generating French Statutory Reports

French statutory reports EU_2054 and EU_2055 are attachments to the annual balance sheet and provide information about the history and activity of assets during the specified fiscal year. Asset categories on both reports are based on the French statutory chart of accounts. The system provides a reporting option to generate both of these statutory reports for France.

Access the 2054 2055 Reports page.

(DEU) Using PeopleSoft Asset Management Options to Meet German Requirements

This section provides an overview of commonly used German depreciation methods and discusses how to:

- Use a half-year prorate convention.
- Use geometric digressive depreciation.
- Process low-value assets.

Pages Used to Meet German Requirements

| Page Name | Object Name | Navigation | Usage |
|--------------------------------------|-----------------|---|---|
| User-Defined Method | UD_METHOD_DEFN | Set Up Financials/Supply Chain, Product Related, Asset Management, Depreciation, User Defined Methods | Create a user-defined Staffel depreciation method. |
| Auto-Retire Fully Depreciated Assets | RUN_AMRETFDA | Asset Management, Send/Receive Information, Financial Transactions, Auto-Retire Fully Depr Assets | Identify run control parameters to automatically retire fully depreciated assets. |
| Capitalization Limit CD | DEPR_CAP_LIMIT | Set Up Financials/Supply Chain, Product Related, Asset Management, Financials, Capitalization Limits | Specify asset value minimums and associate warning or error actions with assets whose values fall below those limits. |
| Depreciation Terms | DEPR_TERMS_DEFN | Set Up Financials/Supply Chain, Product Related, Asset Management, Depreciation, Terms Definition | Define special depreciation terms for accelerated depreciation and associate the terms at the asset or book level. |

| Page Name | Object Name | Navigation | Usage |
|---|------------------|--|---|
| Load History Report Table | LOAD_AM_HIST_TBL | Asset Management, Reports, Load Reporting Tables, Load Asset History Table | Run one of two SQR processes that load asset data into tables where it can be used for reports. <ol style="list-style-type: none"> 1. The AMLDDPHI.SQR process loads depreciation history data into a table where it can be used to run the Depreciation History reports. 2. The AMASHIST.SQR process loads asset history data into a table where it can be used by Asset History reports. <p>Note. Before running this process, you must run a process to load the depreciation report table.</p> |
| Asset History Reports | RUN_AMDE1000 | Asset Management, Reports, Owned Assets, Asset History Sheet | Run the Asset History Sheet reports that are attached to annual balance sheets and provide information about the history of an asset and its transactions. |
| Reconciliation AP/AM (reconciliation accounts payable/asset management) | RUN_AMDE5000 | Asset Management, Reports, Cost and Depreciation, Reconciliation AP/AM | Run a report to help you reconcile accounts payable asset vouchers with Asset Management asset transaction information. |

Staffel Depreciation Method

The Staffel depreciation method is used for depreciating buildings in Germany and other countries. The Staffel depreciation method can be characterized as a “step straight line.” For example, for a building with an acquisition cost of \$100,000 and a life of 25 years, the depreciation calculation is 10 percent (\$10,000) per year for years one through four, 5 percent (\$5,000) per year for years five through seven, and 2.5 percent (\$2,500) per year for years eight through twenty-five. These percentages vary due to legislation and the acquisition date of the building.

Three Staffel Depreciation Methods

There are three common Staffel depreciation methods.

The first Staffel method is for domestic buildings that are used by an organization for non-habitational purposes (for example, production buildings within Germany) and where the request to build was submitted to the local construction authorities after March 31, 1985, but before February 28, 1989:

| Year | Percentage |
|------------|----------------|
| Years 1–4 | 10% each year |
| Years 5–7 | 5% each year |
| Years 8–25 | 2.5% each year |

Non-habitational buildings that do not fulfill the preceding criteria are depreciated according to this criteria:

| Year | Percentage |
|-------------|-----------------|
| Years 1–8 | 5% each year |
| Years 9–14 | 2.5% each year |
| Years 15–50 | 1.25% each year |

Exceptions (all buildings that are used for habitational use and where the request to build was submitted to local construction authorities after February 28, 1989) are depreciated according to this criteria:

| Year | Percentage |
|-------------|-----------------|
| Years 1–4 | 7% each year |
| Years 5–10 | 5% each year |
| Years 11–16 | 2% each year |
| Years 17–40 | 1.25% each year |

Depreciation periods in Germany are based on calendar years (January 1 – December 31). Because not all buildings are completed or purchased on January 1, if you activate an asset in a different month, you must prorate the depreciation for the first year, *including* the month of asset addition. For example, the depreciation amount for the first year is 36,000 EU if activated on January 1. But if the asset was activated on August 12, the depreciation amount for the first year is 15,000 EU, reflecting the months August through December.

Also, you must prorate the depreciation in the year of asset retirement (or sale) *excluding* the month in which it is retired. For example, the depreciation for the last year is 60,000 EU if the asset is retired at the end of the year. But if the asset was retired or sold on August 12, then the depreciation amount must be adjusted to 35,000 EU, reflecting the months January through July.

Creating a User-Defined Staffel Depreciation Method

To calculate depreciation by using the Staffel method, you can create a user-defined depreciation method for this formula. For example, in this case:

- The asset basis of the building is \$100,000 (EU).
- The asset life is 25 years (300 periods).
- The depreciation convention is AM (actual month).
- The user-defined depreciation method name is Staffel.

To create a Staffel user-defined depreciation method, use the User-Defined Method page. Enter a description for the method ID.

You must define the following four variables to create a Staffel user-defined depreciation method:

Result A = ALLOC_LIFE – Total Periods Depr

This calculation results in the number of remaining periods in weeks:

Result D = Result A / 52

This is the number of remaining periods in years.

Result C = No Periods to Depr / Alloc Total

This provides the number of periods for the year to be depreciated / total periods for the year, for example, 6 / 12 for the first year.

Result B = Asset basis x Percentage

This result is:

Asset basis – Salvage value x Appropriate Staffel Percentage

Finally, to calculate the depreciation proration for the first year and the year of retirement, specify the following in the formula:

Depreciation = Result B x Result C

See Also

[Chapter 15, “Using User-Defined Asset Depreciation,” page 275](#)

Using a Half-Year Prorate Convention

PeopleSoft Asset Management supports the German half-year convention. The German half-year convention differs from the U.S. half-year convention in that an asset takes a full year’s depreciation if it was acquired in the first half of the year. This convention is delivered in the tables shipped, but you can modify it as necessary to suit a specific requirement.

See Also

PeopleSoft Enterprise Asset Lifecycle Management Fundamentals 9.0 PeopleBook, “Setting Up Depreciation Processing,” Setting Up Depreciation Conventions

Using Geometric Digressive Depreciation

Geometric digressive depreciation calculates depreciation up to three times the annual straight-line depreciation with a maximum of 30 percent of the asset cost per year. Asset Management supports this depreciation method by providing the declining balance with a *Switch to Straight Line* depreciation method option. To depreciate assets by using this method, select *DB w/SL By Limit%* on the Book-Tax page in the Asset Book Definition component, the Depreciation page in the Asset Profiles component, or the Depreciation Information page in the Asset ExpressAdd component. Specify 300 as the declining balance percent and 30 as the limit percent.

See Also

[Appendix B, “Understanding Depreciation Calculations,” Declining Balance with Depreciation Limit, page 550](#)

Processing Low-Value Assets

PeopleSoft Asset Management supports low-value asset processing by providing a capitalization limit table where you can specify asset value minimums and associate warning or error actions with assets whose values fall below those limits. Additionally, you can set the limit at which an asset is marked as a low-value asset.

Access the Capitalization Limits Cd page.

Capitalization Limit Cd

SetID: SHARE

Cost Limit Code: GERMANY *Currency Code: DEM Mark

Description: Germany Depreciation Limits

| | Amount | Low Value Switch | Message Severity | | |
|---|--------|-------------------------------------|------------------|---|---|
| 1 | 100.00 | <input type="checkbox"/> | Error | + | - |
| 2 | 800.00 | <input checked="" type="checkbox"/> | Warning | + | - |

Capitalization Limits Cd page

After you have set up the necessary capitalization limits, select Table Lim (table limit) and the correct code as the capitalization limit method on the Business Unit/Book Definition page in the Establish Business Units - Asset Management Definition component.

When you add assets to that business unit and book combination, Asset Management checks the capitalization limits against the amounts that are stored by code in the capitalization limit table.

In Germany, assets marked as low value should be depreciated in one year.

PeopleSoft Asset Management provides the *PROG WG* asset profile that is defined with depreciation attributes that are appropriate for German low-value asset processing. These include depreciation using the straight-line method and a useful life of 12 periods. Also, Asset Management provides the German First Day Last Period depreciation convention that you can use to generate one accounting entry for the annual depreciation for a low-value asset.

Low-value assets can be retired in mass using the Auto-Retire feature to satisfy the requirement that low-value assets be fully depreciated and retired after the first year of service.

See Also

PeopleSoft Enterprise Asset Lifecycle Management Fundamentals 9.0 PeopleBook, “Establishing PeopleSoft Asset Management Business Units,” Creating PeopleSoft Asset Management Business Units

PeopleSoft Enterprise Asset Lifecycle Management Fundamentals 9.0 PeopleBook, “Setting Up Accounting Entry and Financial Processing for PeopleSoft Asset Management,” Setting Up Capitalization Limits

PeopleSoft Enterprise Asset Lifecycle Management Fundamentals 9.0 PeopleBook, “Setting Up Depreciation Processing,” Setting Up Depreciation Conventions

PeopleSoft Enterprise Asset Lifecycle Management Fundamentals 9.0 PeopleBook, “Establishing Asset Processing,” Setting Up Asset Profiles

Special Depreciation Terms and Methods

Access the Depreciation Terms page.

PeopleSoft Asset Management supports special depreciation methods that are used in Germany, such as accelerated depreciation, by enabling you to define special terms and associate them at the asset and book level.

Depreciation Terms

SetID: SHARE **Depreciation Special Terms:** SONDER_AFA

Find | View All
First ◀ 1 of 1 ▶ Last

***Effective Date:**

***Description:**

| Special Terms | | Customize Find View All | First ◀ | 1-2 of 4 | ▶ Last |
|---------------|--------------------------------|---------------------------------------|---------|----------|--------|
| | *Year of Life | Depreciation Percent (%) | | | |
| 1 | <input type="text" value="1"/> | <input type="text" value="5.000000"/> | + | | - |
| 2 | <input type="text" value="2"/> | <input type="text" value="5.000000"/> | + | | - |

Depreciation Terms page

After you have defined special terms, associate them with an asset or book by selecting the Special Depreciation check box on the Depreciation Information page in the Asset ExpressAdd component.

See Also

PeopleSoft Enterprise Asset Lifecycle Management Fundamentals 9.0 PeopleBook, “Establishing Asset Processing”

PeopleSoft Enterprise Asset Lifecycle Management Fundamentals 9.0 PeopleBook, “Setting Up Depreciation Processing”

Chapter 5, “Adding and Maintaining Assets,” page 45

(IND) Using PeopleSoft Asset Management Options to Meet Indian Requirements

PeopleSoft Asset Management addresses issues related to fixed-asset accounting in India. This section provides an overview of asset depreciation processing for India and discusses how to process tax depreciation.

Understanding Asset Depreciation Processing for India

PeopleSoft Asset Management provides asset processing features that correspond to the tax reporting requirements established by the Indian Tax Depreciation Act of 1961. The Indian Tax Depreciation Act (Indian Income Tax Act 1961) does not recognize depreciation on individual assets. Instead, it groups similar pools of assets under a prescribed *tax block*. There are only four tax blocks of assets provided for under the tax act: buildings, furniture and fixtures, machinery and plant, and intangibles. Further, each tax block of assets comprises *tax groups*, and each tax group has its own individual tax rate. The Indian tax *year* is fixed on a fiscal year calendar that runs from April 1 through March 31. Annual tax depreciation is reported to the tax authority per tax block per fiscal year .

To meet these requirements, PeopleSoft Asset Management allows for the grouping of assets by *asset blocks* for accumulating and reporting depreciation and taxes. Each asset block can have as many depreciation rates associated with it as necessary to delineate Indian tax groups. To meet reporting requirements, a *tax entity* is defined, associated with a specific book, and has as many business units and asset books associated with it as necessary.

The Straight Line Percent method of depreciation in PeopleSoft Asset Management uses the asset useful life to calculate the depreciation rate. India calculates useful life based on the depreciation rate guidelines published by the governmental finance authority. The rates established depreciate 95 percent of the cost over the useful life of the asset, at minimum: accelerated depreciation is allowed. India calculates depreciation based on the rates rather than useful life. In addition, these rates also consider the residual or salvage value at the end of the asset useful life. To determine useful life of an asset in India, the straight line percent method multiplies the depreciation rate by cost and this results in the useful life. Further, there are two different ways to calculate depreciation adjustments under the Indian Straight Line Percent method: *remaining value* and *life-to-date*. All transactions use an actual day (AD) convention for calculating depreciation. Assets are depreciated when they are placed in service. Processing for leased assets is included.

During the end-of-year processing of depreciation and taxes for India, assets are grouped into blocks based on the tax entity and asset profile definition in place for the asset. The opening written down value (WDV) is retrieved from the prior year WDV for the corresponding tax entity, asset block, and rate.

Asset Management provides these reporting processes to manage Indian tax and depreciation requirements:

- Produce the Asset Register - India: Reports an historical record of assets over the fiscal year period.

- Produce the Depreciation Balance - IND report: Displays the calculated opening WDV balance and reports depreciation during the year.
- Calculate and Update Depreciation Balance - IND processes: Calculates depreciation balances for India and provides an online update of balances (depending on your setup options).

The system provides functionality to process operating and capital leases when manually specified.

Pages Used to Meet Indian Requirements

| Page Name | Object Name | Navigation | Usage |
|--|---------------|---|--|
| Tax Depreciation Request | AM_DEPR_TAX | Asset Management, Taxes, Depreciation, Calculate Balances IND | Calculate tax depreciation balances for India. |
| Tax Depr Bal (tax depreciation balances) | TAX_DEPR_BAL | Asset Management, Taxes, Depreciation, Update Balances IND | Displays tax depreciation balance for India that you can update. |
| Assets Register - IND | RUN_AMDP2510 | Asset Management, Financial Reports, Cost and Depreciation, Assets Register - IND | Reports historical depreciation for the fiscal year. |
| Depreciation Balance - IND | TAX_DEPR_RQST | Asset Management, Taxes, Reports, Depreciation Balance IND | Generate tax depreciation balance report for the tax period. |

Processing India Tax Depreciation

When you accumulate assets subject to India's depreciation and tax guidelines, you must first assign an asset block, a guideline (tax) class, and a tax entity to each asset. Also, you should set up each asset to depreciate when in service. These attributes are defined in the Book Definition component and the Book - Depreciation (ASSET_BOOK_01) and Book - Tax (ASSET_BOOK_02) pages. When depreciation and tax processing commences, the system retrieves these designated assets for processing.

See [Chapter 5, "Adding and Maintaining Assets," page 45](#).

To process and report on depreciation and tax for India:

1. To process depreciation for India, request the depreciation calculation process (AM_DEPR_CALC).
See [Chapter 14, "Processing Asset Depreciation," page 259](#).
2. To calculate depreciation balances for India for the tax period, request the process to calculate balances for India (AMTX2000).
3. To update depreciation balances for India for the tax period, request the process to update balances for India (TAX_DEPR_BAL).
4. To review the asset register for India, request the assets register for India (AMDP2510).

Calculating Tax Depreciation Balances for India

Access the Tax Depreciation Request page.

Tax Depreciation Request

Run Control ID: amdpcalci [Report Manager](#) [Process Monitor](#) Run

Tax/Reporting Entity

| | |
|--|---|
| <p>*Request ID: <input type="text" value="1"/></p> <p>*Tax/Reporting Entity: <input type="text" value="INDIA"/> </p> <p>*Entity Book: <input type="text" value="TAX"/> </p> <p>*Fiscal Year: <input type="text" value="2002"/></p> | <div style="background-color: #4F81BD; color: white; padding: 2px; margin-bottom: 5px;">Process Frequency</div> <p><input type="radio"/> Process Once</p> <p><input checked="" type="radio"/> Always Process</p> <p><input type="radio"/> Don't Run</p> |
|--|---|

Tax Depreciation Request page

Tax/Reporting Entity Select the tax and reporting entity for this process. The available tax entities are defined by the asset blocks, tax class tax rates, setID calendar, and business unit/books that are associated with it.

Entity Book Select the entity book for this process. The entity book defines how to group the tax or reporting information.

See *PeopleSoft Enterprise Asset Lifecycle Management Fundamentals 9.0 PeopleBook*, “Setting Up Tax Processing and Tax Reporting,” (IND) Defining Tax Entities and Tax Options.

Updating Depreciation Balances for India

Access the Tax Depr Bal page.

Tax Depr Bal

Tax/Rpt Entity: INDIA **Entity Book:** TAX **Asset Block:** BUILDING **Fiscal Year:** 2002

Customize | Find |
First 1-3 of 3 Last

| Calculated Values | Depreciation and WDV | | | |
|-------------------|----------------------|--------------------|-------------------|--------------|
| Guide Cls | Opening Balance | Add/Adj (50% Rule) | Add/Adj (Regular) | Net Proceeds |
| BU10% | 0.00 | 0.00 | 0.00 | 10,000.00 |
| BU100% | 0.00 | 0.00 | 0.00 | 0.00 |
| BU5% | 0.00 | 3,000.00 | 3,000.00 | 0.00 |

Tax Depr Bal page (1 of 2)

| Tax Depr Bal | | | | | | |
|-----------------------|-------------------|---------------------|------------------------|-----------------------|-----------------|-------------------|
| Tax/Rpt Entity: INDIA | | Entity Book: TAX | | Asset Block: BUILDING | | Fiscal Year: 2002 |
| Guide Cls | Manual Adjustment | Depreciation Amount | Depreciation Amt - 50% | Rate% | Closing Balance | |
| BU10% | 0.00 | -1,000.00 | 0.00 | 10.000 | -9,000.00 | INR |
| BU100% | 0.00 | 0.00 | 0.00 | 100.000 | 0.00 | INR |
| BU5% | 0.00 | 150.00 | 75.00 | 5.000 | 5,775.00 | INR |

Tax Depr Bal page (2 of 2)

If your setup options have enabled manual adjustments to depreciation balances, you can access calculated balances and enter adjustments in the Manual Adjustment column. No recalculations are processed on the basis of any manual adjustment entered, but the values are added to the WDV.

Generating the Asset Register India

Access the Assets Register - IND page.

| Assets Register - IND | |
|---|--|
| Run Control ID: VP1 | Report Manager Process Monitor Run |
| Language: English | |
| Selection Request Parameters | |
| Report By: Report Entity | |
| Report Entity: INDIA | |
| Entity Book: TAX | |
| Fiscal Year | |
| As Of Fiscal Year: 2002 | |
| Type of Report | |
| <input checked="" type="radio"/> Detail | <input type="radio"/> Summary |

Assets Register - IND page

Selection Request Parameters

Define the parameters for the asset register to report by business unit or report entity. Complete these fields as dictated by your needs:

- Unit.
- Book.
- Report Entity.
- Entity Book.
- As of Fiscal Year.

- Detail or Summary (available only when you select to report by report entity).

Processing Rules

When calculating the annual tax depreciation balances, the following rules apply:

- Tax depreciation is calculated for each tax group per the tax group tax rate.
- Opening balance (WDV) is required for each tax group each year.
The opening balance in the conversion year is entered; in subsequent years, the opening balance is processed by Asset Management and is equal to the ending balance of the previous year.

- Additions and adjustments for the fiscal year are lumped together.

However, these are subgrouped separately to include assets that have been in use for more than 180 days and those that have been in use for less than 180 days. For assets in use for less than 180 days, only 50 percent of the normal depreciation rate is allowed (per Section 32).

To determine the assets that fall in the category of Additions/Adjustments more than 180 days, the system calculates the difference between the fiscal year end date (March 31) and the in-service date for *ADD* and *ADJ* transaction types. For additions less than 180 days, the system calculates the difference between the year end (March 31) and the in-service date for *ADD* and *ADJ* transaction types. If the in-service date is in the current year but the acquisition date is in prior years, the asset is depreciated at the regular rate rather than at 50 percent of the prescribed rate.

- Proceeds for the assets sold during the year are calculated.
- Use the formula for calculating WDV depreciation, where:
 - A = Opening WDV/Balance.
 - B = Proceeds from sale of an asset.
 - C = Additions/Adjustments > 180 days.
 - D = Additions/Adjustments < 180 days.
 - E = Rate of Depreciation, Depr Value.

$$(A-B+C) \times E + (D \times E / 2) = \text{Depreciation Value } (F)$$

$$\text{Closing WDV} = A - B + C + D - F$$

In case the entire tax block of assets ceases to exist (for example, all of the assets are sold or transferred), the net income is taxed as short term capital gain. In this case, the opening WDV of all the tax groups in this block becomes zero for the subsequent year.

See Also

PeopleSoft Enterprise Asset Lifecycle Management Fundamentals 9.0 PeopleBook, “Establishing Asset Processing”

PeopleSoft Enterprise Asset Lifecycle Management Fundamentals 9.0 PeopleBook, “Setting Up Tax Processing and Tax Reporting”

[Chapter 5, “Adding and Maintaining Assets,” page 45](#)

(ITA) Using PeopleSoft Asset Management Options to Meet Italian Requirements

This section discusses how to generate the fixed-asset register for Italy.

Page Used to Meet Italian Requirements

| Page Name | Object Name | Navigation | Usage |
|----------------------|--------------|---|---|
| Fixed Asset Register | RUN_AMDP2500 | Asset Management, Financial Reports, Cost and Depreciation, Assets Register - ITA | Specify report request parameters to generate the Assets Register - ITA report. |

Generating the Fixed-Asset Register for Italy

Access the Fixed Assets Register Rpt page.

Fixed Assets Register Rpt

Run Control ID: amdpcalci [Report Manager](#) [Process Monitor](#) Run

Language: English ▼

Report Request Parameters

| | |
|---|--|
| <p>Unit: <input type="text" value="ITLE1"/> 🔍</p> <p>Book: <input type="text" value="CORP"/> 🔍</p> <p>From Asset ID: <input type="text" value="000000000001"/> 🔍</p> <p>To Asset ID: <input type="text" value="000000000001"/> 🔍</p> <div style="background-color: #4a7ebb; color: white; padding: 5px; margin-top: 10px;">Fiscal Year Period</div> <p>As Of Fiscal Year: <input type="text" value="2003"/> Period: <input type="text" value="2"/></p> <p style="text-align: center;">OR</p> <div style="background-color: #4a7ebb; color: white; padding: 5px; margin-top: 10px;">Date</div> <p>As of Date: <input type="text" value="09/22/2003"/> 📅</p> | <div style="background-color: #4a7ebb; color: white; padding: 5px; margin-bottom: 10px;">Anticipated Depreciation</div> <p><input type="radio"/> None <input type="radio"/> Accelerated Depr</p> <p><input type="radio"/> Special Depr <input type="radio"/> Initial Depr</p> <p>Category: <input type="text"/> 🔍</p> <p>Operating Unit: <input type="text"/> 🔍</p> <p>Fund Code: <input type="text"/> 🔍</p> <p>Department: <input type="text"/> 🔍</p> <p>Program Code: <input type="text"/> 🔍</p> <p>Class Field: <input type="text"/> 🔍</p> <p>Budget Reference: <input type="text"/> 🔍</p> <p>Product: <input type="text"/> 🔍</p> <p>Project: <input type="text"/> 🔍</p> |
|---|--|

Fixed Assets Register Rpt page

Define the parameters to generate the register.

(JPN) Using PeopleSoft Asset Management Options to Meet Japanese Requirements

This section lists prerequisites and discusses how to:

- Use Japanese depreciation methods.
- Use special depreciation and increased depreciation.
- Use advanced depreciation.
- Use composite depreciation.
- Identify collateral assets.
- Use currency rounding options.
- Process local tax reports.
- Enter consumption tax.

Prerequisites

Many of the features for processing assets for Japan are dependent on the business unit information definitions established at the business unit level. You must establish these business unit definitions in order to complete processing for Japanese requirements.

Access the Business Unit Info for Japan page from the AM Business Unit Definition component. Click the JPN Info link.

| | |
|--|---|
| Corporate Book for Japan | Select the corporate book for Japan. |
| Tax Book for Japan | Select the tax book for Japan. |
| Advanced Depreciation | Select if advanced depreciation is used. |
| Japan Composite | Select if composite assets are used. |
| Use JPN Local Tax (use Japan local tax) | Select if local tax reporting is enabled. |

See *PeopleSoft Enterprise Asset Lifecycle Management Fundamentals 9.0 PeopleBook*, “Establishing PeopleSoft Asset Management Business Units,” (JPN) Defining Business Unit Information for Japan.

Pages Used to Meet Japanese Requirements

| Page Name | Object Name | Navigation | Usage |
|-----------------------|--------------|---|---|
| Advanced Depreciation | RUN_AMAD1000 | Asset Management, Financial Reports, Cost and Depreciation, Advanced Depreciation | Specify report request parameters to generate the advanced Depreciation Amount or Advanced Depreciation Reversal Schedule report. |

| Page Name | Object Name | Navigation | Usage |
|------------------------------------|-------------------|---|---|
| Owner Information | OWNER_INFO_DEFN | Set Up Financials/Supply Chain, Product Related, Asset Management, Owner Information Definition | Enter owner information that is printed on the Depreciable Asset Tax Return (Tax Roll) report. |
| Depreciation Rate-User Defined | UD_DEPR_RATE_TBL | Set Up Financials/Supply Chain, Product Related, Asset Management, Depreciation, Rate-User Defined | Set up useful life and depreciation rate tables. |
| Life and Rate Information | MR_AM_LIFERATE | Set Up Financials/Supply Chain, Product Related, Asset Management, Depreciation, Rate-User Defined, Life and Rate Information | Set up useful life and depreciation rate tables. |
| Return Information | RETURN_INFO_DEFN1 | Set Up Financials/Supply Chain, Product Related, Asset Management, Return Information Definition | Enter information that is required for the Depreciable Asset Tax Return (Tax Roll) report. |
| Local Tax Return | LTAX_ADD_INFO_SEC | Asset Management, Asset Transactions, Owned Assets, Asset ExpressAdd Asset Management, Asset Transactions, Owned Assets, Asset Basic Add | Enter local tax information when you acquire depreciable fixed assets. |
| Criteria and Defaults | MC_DEFN_01 | Asset Management, Mass Change, Define Criteria, Criteria and Defaults | Use the Mass Change component to process composite depreciation for Japan. |
| NBV - Assessment Calculation | AMLTPROC_RQST | Asset Management, Taxes, Calculate Local Taxes, Calculate Amounts JPN | Run an SQR process to load asset data and calculate the theoretical net book value and assessment value for each asset. |
| Local Tax Information - Adjustment | LTAX_ADJ_01 | Asset Management, Taxes, Calculate Local Taxes, Adjust Amounts JPN | Change the theoretical net book value and assessment value. |
| Local Tax Report | RUN_LTAXPROCESS | Asset Management, Taxes, Reports, Local Tax Returns | Run local tax reports for Japan. |
| Local Tax Information | LTAX_COST_01 | Asset Management, Taxes, Calculate Local Taxes, Change Local Tax JPN | Change the local tax office where the return is filed and the asset return type. |

| Page Name | Object Name | Navigation | Usage |
|--------------|--------------|--|--|
| National Tax | RUN_AMNT1000 | Asset Management, Taxes, Reports, National Tax | Run a report of the depreciation calculation details to be reported to the Japanese Tax Office. The report includes all required information for the National Depreciable Asset Tax Return Beppyo 16(1), (2) in Japan. |

Using Japanese Depreciation Methods

PeopleSoft Asset Management supports depreciation methods that are used in Japan for both fixed assets and leased assets.

Fixed Assets

This table shows depreciation methods, the calculations used by the methods, and the types of assets to which these methods are applied:

| Asset Depreciation Methods | Depreciation Calculation Method |
|---|---|
| Intangible/Straight Line | Acquisition cost * straight line depreciation rate based on useful life (years) |
| Tangible/Straight Line | (Acquisition cost – 10% of acquisition cost) * straight line depreciation rate based on useful life (years) |
| Tangible/Declining Balance | Beginning net book value * declining balance depreciation rate based on useful life (years) |
| Change Declining Balance to Straight Line | <p>(Beginning net book value at method change – 10% of acquisition cost) * straight line depreciation rate based on useful life (years)</p> <p>The only method to adapt the depreciation rate based on useful life (years), this method is determined by regulations instead of the rate based on useful life for salvage year.</p> |

Depreciation Rate

PeopleSoft Asset Management supports useful life in years as specified for Japan. This is applied from the Rate-User Defined table (UD_DEPR_RATE_TBL, MR_AM_LIFERATE) in the Depreciation Rate-User Defined component. To apply the appropriate depreciation rates, use the five delivered depreciation methods for Japan or add new ones as needed.

Access the Depreciation Rate-User Defined page.

Select a setID and a depreciation method code matching the depreciation method to be used. Enter the effective date, and click the Life and Depreciation Information button. The Useful Life/Rate page displays.

Effective Date: 01/01/1900

| Useful Life/Rate | | Find | First | 1-99 of 99 | Last |
|------------------|---------------------------------|--------|--------------------------------------|----------------------------------|----------------------------------|
| *Useful Life: | <input type="text" value="2"/> | *Rate: | <input type="text" value="0.68400"/> | <input type="button" value="+"/> | <input type="button" value="-"/> |
| *Useful Life: | <input type="text" value="3"/> | *Rate: | <input type="text" value="0.53600"/> | <input type="button" value="+"/> | <input type="button" value="-"/> |
| *Useful Life: | <input type="text" value="4"/> | *Rate: | <input type="text" value="0.43800"/> | <input type="button" value="+"/> | <input type="button" value="-"/> |
| *Useful Life: | <input type="text" value="5"/> | *Rate: | <input type="text" value="0.36900"/> | <input type="button" value="+"/> | <input type="button" value="-"/> |
| *Useful Life: | <input type="text" value="6"/> | *Rate: | <input type="text" value="0.31900"/> | <input type="button" value="+"/> | <input type="button" value="-"/> |
| *Useful Life: | <input type="text" value="7"/> | *Rate: | <input type="text" value="0.28000"/> | <input type="button" value="+"/> | <input type="button" value="-"/> |
| *Useful Life: | <input type="text" value="8"/> | *Rate: | <input type="text" value="0.25000"/> | <input type="button" value="+"/> | <input type="button" value="-"/> |
| *Useful Life: | <input type="text" value="9"/> | *Rate: | <input type="text" value="0.22600"/> | <input type="button" value="+"/> | <input type="button" value="-"/> |
| *Useful Life: | <input type="text" value="10"/> | *Rate: | <input type="text" value="0.20600"/> | <input type="button" value="+"/> | <input type="button" value="-"/> |
| *Useful Life: | <input type="text" value="11"/> | *Rate: | <input type="text" value="0.18900"/> | <input type="button" value="+"/> | <input type="button" value="-"/> |
| *Useful Life: | <input type="text" value="12"/> | *Rate: | <input type="text" value="0.17500"/> | <input type="button" value="+"/> | <input type="button" value="-"/> |
| *Useful Life: | <input type="text" value="13"/> | *Rate: | <input type="text" value="0.16200"/> | <input type="button" value="+"/> | <input type="button" value="-"/> |
| *Useful Life: | <input type="text" value="14"/> | *Rate: | <input type="text" value="0.15200"/> | <input type="button" value="+"/> | <input type="button" value="-"/> |

Depreciation Rate-User Defined - Useful Life/Rate page

Enter the useful life and corresponding rate as determined by regulations issued from the Ministry of Finance.

Note. Useful Life rates also use the Residual Rate Definition.

See *PeopleSoft Enterprise Asset Lifecycle Management Fundamentals 9.0 PeopleBook*, "Setting Up Depreciation Processing".

Leased Assets

PeopleSoft Asset Management supports the Declining Balance Depreciation Method - Finance Lease (excluding transfer of ownership) 10/9 method, which is calculated in this way:

Declining balance depreciation calculation resultx10/9

Use the Depreciation Rate-User Defined - Useful Life/Rate page to modify rates for the lease depreciation method.

Example Values

This table shows the values used in an example using the Declining Balance Depreciation Method - Finance Lease (excluding transfer of ownership) 10/9 method:

| | |
|-------------------|------------------|
| Acquisition Cost | <i>1,000,000</i> |
| Useful Life | <i>5 years</i> |
| Depreciation Rate | <i>0.369</i> |

Calculation Results for Example Values

Using the values from the previous table and applying the Declining Balance Depreciation Method - Finance Lease (excluding transfer of ownership) 10/9 method, the results are:

| Year | Depreciation Amount by Declining Balance Method | Depreciation Amount by 10/9 Method |
|-------|---|------------------------------------|
| 1 | 369,000 | 410,000 |
| 2 | 232,839 | 258,710 |
| 3 | 146,921 | 163,245 |
| 4 | 92,707 | 103,007 |
| 5 | 58,588 | 65,038 |
| Total | 900,000 | 1,000,000 |

Select the example depreciation methods on the Book-Tax page in the Asset Book Definition component, the Depreciation page in the Asset Profiles component, or the Depreciation Information page in the Asset ExpressAdd component.

Using Special Depreciation and Increased Depreciation

PeopleSoft Asset Management supports special depreciation (initial and accelerated) and increased depreciation used in Japan. This table shows the types of special depreciations and their associated accounting methods, depreciation calculations, and additional notes as appropriate:

| Depreciation Method | Type | Accounting Method | Depreciation Calculation | Notes |
|---------------------|-------------|-------------------|--|--|
| Special | Initial | Expense | Acquisition cost * special depreciation rate | Book the initial special depreciation amount as the depreciation amount, and add it to the standard depreciation amount. |
| Special | Initial | Reserve/Allowance | Acquisition cost * special depreciation rate | Do <i>not</i> add the initial special depreciation amount to the standard depreciation amount. |
| Special | Accelerated | Expense | Standard depreciation amount * accelerated depreciation rate | Book the accelerated depreciation amount as the depreciation amount, and add it to the standard depreciation amount. |
| Special | Accelerated | Reserve/Allowance | Standard depreciation amount * accelerated depreciation rate | Do <i>not</i> add the accelerated depreciation amount to the standard depreciation amount. |
| Increased | NA | NA | Standard Depreciation Amount * Increased Depreciation Rate Standard depreciation amount * increased depreciation rate | |

For the initial special depreciation and accelerated depreciation rate, specify the useful life in years and the depreciation rate on the Depreciation Terms Definition page.

For the increased depreciation rate, enter the specific rate on the Depreciation Details page.

See [Chapter 14, "Processing Asset Depreciation," page 259](#).

See [Appendix B, "Understanding Depreciation Calculations," page 525](#).

Using Advanced Depreciation

You can also use advanced depreciation for Japan. This table shows the accounting methods that you can use with advanced depreciation:

| Accounting Method | Action |
|-------------------|--|
| Expense | Adds a cost line to the Corporate and Tax book for the advanced depreciation amount and enters a negative (–) cost as a compressed amount on the Asset/Cost Adjust Transfer page. |
| Allowance | Adds a cost line to the Corporate and Tax book for the advanced depreciation amount and enters a negative (–) cost as a compressed amount on the Asset Cost/Adjust Transfer page. You must select <i>A</i> (allowance) as the cost type. |
| Reserve | Adds a cost line to the Corporate and Tax book for the advanced depreciation amount and enters a negative (–) cost as a compressed amount on the Asset Cost Adjust/Transfer page. You must select <i>R</i> (reserve) as the reserve method. |

Advanced Depreciation Reports

When you adopt the advanced depreciation method by using the Allowance or Reserve method, you can verify the allowance or reserve amount for the compressed amount by using the Advanced Depreciation Amount of Advanced Depreciation Reversal Schedule report.

Using Composite Depreciation

Composite depreciation, as practiced in Japan, is supported by calculating the useful life in years or by using the 5 percent retirement method.

Use the Mass Change component to process composite depreciation.

Note. To use the Composite Depreciation method for Japan, you must specify the Corporate and Tax book for Japan and select *Japan Composite* when you establish asset management business units.

You can add composite depreciable assets and individual assets by using the Asset Basic Information page. When you add composite depreciable assets, you must enter a profile ID, transaction date, and accounting date, and then click the Capitalize button on the Asset Acquisition Details page. When you add individual assets, you must enter the Reporting Life in periods on the Asset Information page.

After adding composite depreciable assets and individual assets for composite assets, you must capitalize by using the Mass Change template CC-JPN Capitalize Composite.

Calculating the Automatic Useful Life in Years for Composite Depreciable Assets

The total acquisition cost includes the acquisition cost of each composite member asset divided by its respective useful life, calculating the depreciation amount for each composite member asset.

The acquisition costs of each composite member asset are then summed, and the total is divided by the summed depreciation amounts for each composite member asset.

This table displays the depreciation values calculated to find the total depreciation for 20,000,000 of asset costs:

| Assets | Acquisition Cost (A) | Useful Life (B) | Depreciation Amount (A)/(B) |
|--------|----------------------|-----------------|-----------------------------|
| Asset1 | 1,000,000 | 4 years | 250,000 |
| Asset2 | 3,000,000 | 5 years | 600,000 |
| Asset3 | 4,000,000 | 4 years | 1,000,000 |
| Asset4 | 7,000,000 | 10 years | 700,000 |
| Asset5 | 5,000,000 | 8 years | 625,000 |
| Totals | 20,000,000 | NA | 3,175,000 |

The calculation of composite depreciation useful life is then:

$$20,000,000 / 3,175,000 = 6.29 \text{ or } 6 \text{ years (composite depreciation useful life)}$$

Using the 5 Percent Retirement Method

When using this method, depreciable composite member assets are retired, and the book value is 5 percent of the acquisition cost of each member asset retired.

Access the Mass Change page, and add the Mass Change Definition JPN Composite Retirement. Composite member assets can be retired by using the mass change template CR-JPN Composite Retirement.

Criteria and Defaults | AM Specific Fields | Generate SQL | Execution History | Mc Defn Wrk1

Mass Change Definition: JPN Composite Retirement

SQL Statement Find | View All First 1 of 3 Last

Execution Seq: 1 **Description:** Composite Retirement Step 1

Criteria Find | View All First 1 of 3 Last

| Field | Field Value |
|--------------------|-----------------------------|
| Composite Asset ID | Value: <input type="text"/> |
| Operation: | |
| Equal To | |

Defaults Customize | Find | View All First 1 of 1 Last

| Field Label | Mass Change Field Value |
|-------------|-------------------------|
| 1 | <input type="text"/> |

Mass Change Definition page

Enter the composite asset ID to be retired in the Value field. Specify *Retire as Fully Depreciated* in the Mass Change Field Value field. Generate the SQR, and run the mass change.

See [Chapter 20, “Processing Asset Mass Changes,” page 357](#).

Identifying Collateral Assets

Japanese accounting principles require that assets that are offered as collateral be treated according to financial reporting regulations under commercial law. Collateral assets are identified on the Cost/Asset Information page in the Asset ExpressAdd component as one of these types in compliance with Japanese reporting requirements:

- Factory Foundation Mortgage.
- Fixed Mortgage.
- Mortgage.
- Other.

See [Chapter 5, “Adding and Maintaining Assets,” Adding Assets with the Asset ExpressAdd Component, page 89](#).

Using Currency Rounding Options

Rounding options are applied to depreciation calculations and asset salvage values. You can select rounding options to be used for depreciation calculations on the Business Unit/Book Definition page in the Establish Business Units - Asset Management Definition component, and for salvage value calculations on the Depreciation page in the Asset Profiles component.

Select a rounding rule, which determines the type of rounding that is performed. Select the *Currency* rounding type.

Select the rounding precision, rounding factor, and truncation. Round precision is the number of places to the right or left of the decimal point to which the amount or number is rounded. Rounding factor is the number to which the amount is rounded.

See *PeopleSoft Enterprise Asset Lifecycle Management Fundamentals 9.0 PeopleBook*, “Establishing PeopleSoft Asset Management Business Units,” Creating PeopleSoft Asset Management Business Units.

See *PeopleSoft Enterprise Asset Lifecycle Management Fundamentals 9.0 PeopleBook*, “Establishing Asset Processing,” Setting Up Asset Profiles.

Processing Local Tax Reports

Asset Management supports reporting requirements defined by Japanese local tax laws. The system provides these reports, including all required information for the local depreciable asset tax return:

- Depreciable Asset Tax Return (Tax Roll or Depreciable Assets) report (AMLT1000).
- Asset Detail (Increased Assets/All Assets) report (AMLT1100).
- Asset Detail (Decreased Assets) report (AMLT1200).

To set up local tax reporting:

1. Define the localization country as Japan.

This enables the business unit information link for Japan. The link appears in the Establish Business Units component. Use the User Preferences component, and set the overall preferences localization country to *JPN*.

See *PeopleSoft Enterprise Application Fundamentals 9.0 PeopleBook*, “Defining User Preferences,” Defining Overall User Preferences.

2. Define business unit information for Japan.

This defines the corporate and tax default books for Japan, as well as enables advanced depreciation, composite asset functionality, and local tax usage. Specify the corporate and tax book that you use for Japan when you establish asset management business units, and select the Use JPN Local Tax check box.

See *PeopleSoft Enterprise Asset Lifecycle Management Fundamentals 9.0 PeopleBook*, “Establishing PeopleSoft Asset Management Business Units,” Creating PeopleSoft Asset Management Business Units.

3. Define owner information definition for Japanese assets.

This defines the information needed to process your local tax return.

See *PeopleSoft Enterprise Asset Lifecycle Management Fundamentals 9.0 PeopleBook*, “Establishing Asset Processing,” Establishing Asset Ownership.

4. Define local tax information in the Asset Information component.

See [Chapter 5, “Adding and Maintaining Assets,” Maintaining Asset Book Information, page 79](#).

5. Define the local tax return processing information.

To run the reports:

- Process the theoretical net book value and assessment value calculation.
- Process local tax reports.

Defining Local Tax Return Information

Access the Return Information page.

The screenshot displays the 'Return Information' page with the following details:

- SetID:** SHARE **Local Tax Office:** JAPAN
- Return Information** (Page Header)
- Effective Date:** 01/01/1900 **Status:** Active
- Owner ID:** [] **Owner Code:** [] **Capital of Amount:** []
- Recipient Name:** [] **Year of Date:** Year: [] Month: []
- Business Category:** []
- Address:** Address Line 1: [] Address Line 2: [] Address Line 3: []
- General Tax Information:**
 - Tax Exception Special/Advanced Depreciation Tax Free Asset
 - Life Reduction Increase Depreciation Notice Blue Returns
 - Tax Acct Depr:** [] **Building Category:** []
- Contact:**
 - Reply Person:** [] **Telephone:** []
 - Licensed Tax Accountant:** [] **Telephone:** []
 - Rental Asset
 - Lessor Name:** [] **Telephone:** []
- Notes:** []

Return Information page

Select an owner ID. Enter an owner code, capital amount (in millions of yen), recipient name of the taxation office where the return is filed, business category, and the year and month that the company commenced business.

Enter address information for up to three branch offices within the same city, district, or town (place of tax payment).

Note. If a branch office is located at the same address that is defined on the Owner Information page, you can leave these fields blank.

Tax Exception

Select if you have assets to apply to the special treatment of the taxation standard.

Special/Advanced Depreciation

Select if you have assets to be applied to special depreciation under the Special Taxation Measures Law, or to be applied to advanced depreciation under

| | |
|---|--|
| | Articles 42 to 50 and Article 142 of the Corporation Tax Law, or from Article 42 to 44 and Article 165, or Article 58 of the Tax on Income Law. |
| Tax Free Asset | Select if you have assets without taxation. |
| Life Reduction | Select if you have assets that have been applied a shorter useful life approved by the Director or the District Tax Office under the Corporate Tax Law – Govt. Order 57-1 and Tax on Income – Govt. Order 130-1. |
| Increase Depreciation Notice | Select if you have assets that have been submitted on a detailed statement for increased depreciation to the tax office under the Corporation Tax Law – Govt. Order 60 and Tax on Income Law – Govt. Order 133. |
| Blue Returns | Select if you file a blue return under the Corporation Tax Law, Article 122. |
| Tax Acct Depr (tax account depreciation) | Select a depreciation method in tax accounting. |
| Building Category | Select the possession classification of the building for the business place. |
| Reply Person | Enter the name and telephone number of the accounting representative. |
| Licensed Tax Accountant | Enter the name and telephone number of the licensed tax accountant. |
| Rental Asset | Select if you have rental assets. |
| Lessor Name and Telephone | Enter the name and telephone number of the lessor. |

Use the Notes region to add any relevant descriptions, such as appendixes or remarks, or to identify any attachments.

Entering Asset Local Tax Return Information

Access the Local Tax Return Information page.

Define the asset as *New* or *Used*, and select a local tax office.

Select one of these asset return type options:

- *Structure*
- *Machinery*
- *Ship*
- *Airplane*
- *Vehicle*
- *Tool*

Specify a numerator and denominator for the exception rate.

Specify a theoretical net book value and an assessment value for your information.

Note. The Theoretical Net Book Value and the Assessment Value fields are not required when you add a newly acquired asset in the current year, but you must enter the asset's theoretical net book value and assessment value reported in the *previous* year if you acquired assets in the previous year but added them to Asset Management for the first time.

Calculating Theoretical Net Book Value and Assessment Value

Access the Theoretical NBV and Assessment Value page.

Note. Enter the same local tax office code in both fields when you are reporting to a single tax office.

The results of this process populate the LTAX_INFO1_TBL.

Running Local Tax Reports

Select a range of local tax office codes to be declared for the theoretical net book value and assessment value.

Note. Enter the same local tax office code in both fields when you are reporting to a single tax office.

Specify a return year.

Select one of the Request Local Tax Return options:

- | | |
|-----------------|--|
| All | Include all assets. |
| Increase | Include assets added and received by transfer in this fiscal year. |

Changing the Local Tax Office and Asset Return Type

Enter the transaction date on which to change the local tax office and asset return type. Enter the new local tax office code for filing the return.

Select one of these new asset return types:

- *Structure*
- *Machinery*
- *Ship*
- *Airplane*
- *Vehicle*
- *Tool*

Changing the Local Tax Office and Asset Return Type While Transferring Assets

When you transfer assets, the operation process varies according to the transfer scenario. This table displays the various operation processes:

| Transfer Scenario | Operation Process |
|---|--|
| Asset is partially transferred to another local tax office, or the asset return type is changed, or both. | Use <i>InterUnit Transfer</i> to change the local tax office, or the asset return type, or both. |

| Transfer Scenario | Operation Process |
|--|---|
| Asset is fully transferred to another department ID and the local tax office where the return is filed, and the asset return type has changed. | Use <i>Transfer</i> to change the local tax office or asset return type. |
| Asset is partially transferred to another department ID and the local tax office where the return is filed, and the asset return type has changed. | Use <i>InterUnit Transfer</i> to change the local tax office and asset return type. |

Entering Consumption Tax

Asset Management supports Japanese consumption tax on asset sales by using VAT functionality on the asset Retirement page. In addition to entering VAT information, you can enter customer information for asset sales.

See [Chapter 19, “Retiring Assets,” Specifying How VAT Is Calculated for Asset Retirement, page 339](#).

See *PeopleSoft Enterprise Asset Lifecycle Management Fundamentals 9.0 PeopleBook*, “Establishing PeopleSoft Asset Management Business Units”.

CHAPTER 24

Archiving Asset Information

This chapter provides an overview of removing inactive asset information from your system and describes how to:

- Archive cost and depreciation data.
- View archived data.
- Restore archived data.

Understanding Archiving

The tables that store asset information accumulate large volumes of data over time. Eventually some of this data is no longer needed on a routine basis. You can use PeopleSoft Asset Management to archive inactive data on the cost and depreciation of assets, and if that data is ever needed again, you can use PeopleSoft Asset Management to restore the data that you archived. The benefits of archiving inactive data include improving the performance of reports and processes and reducing the space that your system needs to store asset data.

Before you archive inactive asset information, you should keep these general guidelines in mind. You cannot archive:

- Retired assets.
- Group assets.
- Assets with depreciation based on schedules.

You can archive active assets one at a time or by using a range of asset IDs. You must archive each asset book by book. The fiscal year must be closed before an asset can be archived. The archive period automatically defaults to the last period of the specified fiscal year.

You can archive an asset more than one time. If you archive an asset multiple times and later decide to restore the data, you will need to restore each archive one by one. For example, if you archive an asset two times, you will need to restore the asset information two times, one for each archive that was run.

The process that archives data actually moves application data from the application tables to the archive tables. The process then deletes data from the application tables.

The archive tables are just like other application tables. You can back up these archive tables using another disk or tape for storage and then manually delete the contents of the archive tables if desired. This approach allows you to use tools, such as PS/Query or Crystal Reports, to report and review the contents of the archived files. The data in the archived files can also be joined to the application tables to provide a complete picture of activity including active and archived data.

After you archive an asset, you cannot perform a transaction or a transfer involving that asset before the archival date unless you restore the archived asset. For example, if the asset has been archived through December 31 of the previous year, you will not be able to perform any transactions on the asset in the previous year.

All historical data showing transaction costs in multiple currencies is supported in the archive and restore processes. You can save transactions with multiple currencies just as they occurred and restore them as well.

You can archive, delete, and retrieve archived data, accumulated by a process that updates high volume asset management transaction tables: ASSET_NBV_TBL, DEPR_RPT, OPEN_TRANS, and DIST_LN. Using the Mass Change component, you can define mass change criteria and use the delivered template for each transaction table to archive, delete, or view archived transaction details. This method enables improved performance for day-to-day transactions while maintaining historical data for reporting and audit purposes.

See Also

[Chapter 20, “Processing Asset Mass Changes,” page 357](#)

Archiving Inactive Assets

This section describes how to run a process that archives depreciation, cost, and book data.

Use the Archive Cost/Depreciation (AM_ARCHIV) component to archive asset management cost and depreciation transactions.

Page Used to Archive Data

| Page Name | Object Name | Navigation | Usage |
|-------------|-------------|--|--|
| Run Archive | RUN_ARCHIVE | Asset Management, Asset Transactions, History, Archive Cost/Depreciation | Run the Asset Archive process (AMDPARCH) to archive inactive cost and depreciation data. |

Running the Asset Archive Process

Access the Run Archive page.

Run Archive

Run Control ID: LBM [Report Manager](#) [Process Monitor](#) Run

Report Request Parameters

| | | | |
|-----------------------|---------------------------------------|---------------------------|---------------------------------------|
| *Unit: | <input type="text" value="AUS01"/> | | |
| Book Name: | <input type="text" value="CORP_USD"/> | | |
| From Asset ID: | <input type="text" value="0"/> | To Asset ID: | <input type="text" value="ZZZZZZZZ"/> |
| Fiscal Year: | <input type="text" value="2003"/> | Process Frequency: | <input type="text" value="Once"/> |
| Archive ID: | <input type="text" value="00000001"/> | | |

Run Archive page

| | |
|--------------------------------------|---|
| Unit | Select the business unit from which records will be archived. |
| Book Name | You must archive an asset using each book it is associated with. |
| From Asset ID and To Asset ID | Use these fields to archive a range of asset IDs. To archive one asset, enter the asset ID in the From Asset field. |
| Fiscal Year | By default, the process will archive data up to the last period of the fiscal year you enter here. The fiscal year must be closed before an asset can be archived. |
| Archive ID | When you run the process, the system populates this field with the run control ID and stores the archive ID in the <i>ARCHIVE_NO</i> field on the depreciation table. You must keep a record of this archive ID if you want to restore archived data. |

The Asset Archive Application Engine (AM_CSDP_ARCH) process copies inactive data from the application tables to archive tables. This process then deletes the archived data from the application tables and consolidates the rows that are left.

For cost rows, the Asset Archive process consolidates multiple cost rows of data into one row.

For depreciation rows, all the depreciation rows prior to the *Fiscal Year* are summed up to create one *ADD* row for accumulated depreciation. The archived records are stored in the depreciation history table.

Viewing Archived Data

You can use inquiry pages to look up different levels of information about archived data.

You can also use the following queries:

- PS_COST_ARCHIVE
- PS_DEPR_ARCHIVE

- PS_BOOK_ARCHIVE

Use the Review Book (ASSET_BOOK_HIST) and the Review Cost (COST_HISTORY) components to view archived asset data.

Pages Used to View Archived Data

| Page Name | Object Name | Navigation | Usage |
|------------------------|------------------|---|---|
| Review Book – List | ASSET_BOOK_HIST1 | Asset Management, Asset Transactions, History, Review Book, List | Review book change history. |
| Review Book – Detail | ASSET_BOOK_HIST2 | Asset Management, Asset Transactions, History, Review Book, Detail | Review detailed book change history. |
| Cost History List | ASSET_TRANS_01 | Asset Management, Asset Transactions, History, Review Cost, Cost History List | View a history of an asset's transactions, including assets that have been archived as an ADD transaction. For archived assets, the total cost includes the sum of the costs consolidated into one cost row. |
| Cost History Detail | ASSET_TRANS_02 | Asset Management, Asset Transactions, History, Review Cost, Cost History Detail Select Detail from the Cost History List page. | View more detail about a specific transaction. |
| Non-Cap History List | ASSET_TRANS_03 | Asset Management, Asset Transactions, History, Review Cost, Non-Cap History List | View a history of a non-capitalized asset's transactions, including assets that have been archived as an ADD transaction. For archived assets, the total cost includes the sum of the costs consolidated into one cost row. |
| Non-Cap History Detail | ASSET_TRANS_04 | Asset Management, Asset Transactions, History, Review Cost, Non-Cap History Detail Select Detail from the Non-Cap History List page. | View more detail about a specific transaction for a non-capitalized asset. |

Restoring Archived Data

This section describes how to run a process that restores archived data.

Use the Restore Cost/Depreciation (AM_RESTORE) component to restore archived asset cost and depreciation transactions.

Page Used to Restore Archived Data

| Page Name | Object Name | Navigation | Usage |
|-------------|-------------|---|--|
| Run Restore | RUN_RESTORE | Asset Management, Asset Transactions, History, Restore Cost/Depreciation, Run Restore | Run the Asset Restore (AM_CD_RESTO) Application Engine process that copies data stored in the archive tables back to the application tables. |

Running the Asset Restore Process

Access the Cost/Depreciation Restore page.

| | |
|--------------------------------------|--|
| Unit | Select the business unit from which records will be restored. |
| Book Name | You must restore an asset in each book associated with the asset. |
| From Asset ID and To Asset ID | Use these fields to restore a range of archived asset IDs. To restore one archived asset, enter the asset ID in the From Asset field. |
| Archive ID | Enter the run control ID that the system generated when the data was archived. By default, the system displays the most recent run control ID for the Asset Archive process. |

The Asset Restore process restores the archived data by deleting the summed row in the application tables and replacing it with the multiple rows of data stored in the archive tables.

Archiving From Transaction Table Details

PeopleSoft provides the templates for the Mass Change component to archive, delete, and retrieve data from high-volume transaction detail tables. The tables available for this process are:

- ASSET_NBV_TBL: Accumulates detail lines from net book value processing.
- DEPR_RPT: Accumulates detail lines from depreciation reporting.
- OPEN_TRANS: Accumulates detail lines from open transactions.
- DIST_LN: Accumulates information from creating accounting entries.

The transaction detail lines can also be deleted from the tables once they have been archived, or without archive if the transactions are set to be purged. Data that is archived is also available for retrieval as needed for reporting or audit purposes.

The steps for archiving, deleting or retrieving transaction detail from tables are:

1. Run Calculate Depreciation (AM_DEPR_CALC) process to generate depreciation calculations.
2. Run Depreciation Reporting (AMDPREPT) process and Load Net Book Value (AMLDNBVT) process to collect the information provided by AM_DEPR_CALC. (If you are working with the OPEN_TRANS or DIST_LN tables, you do not need to run these processes.)

3. Run the archive mass change using the appropriate template for the table from which transactions are pulled.
4. Run the delete mass change using the appropriate template for the table from which transactions are pulled.
5. Run the retrieve archived data mass change using the appropriate template for the table from which transactions are to be viewed.

When you are ready to define the parameters of your archive mass change, access the Mass Change component, Define Criteria (MC_DEFN_00) page.

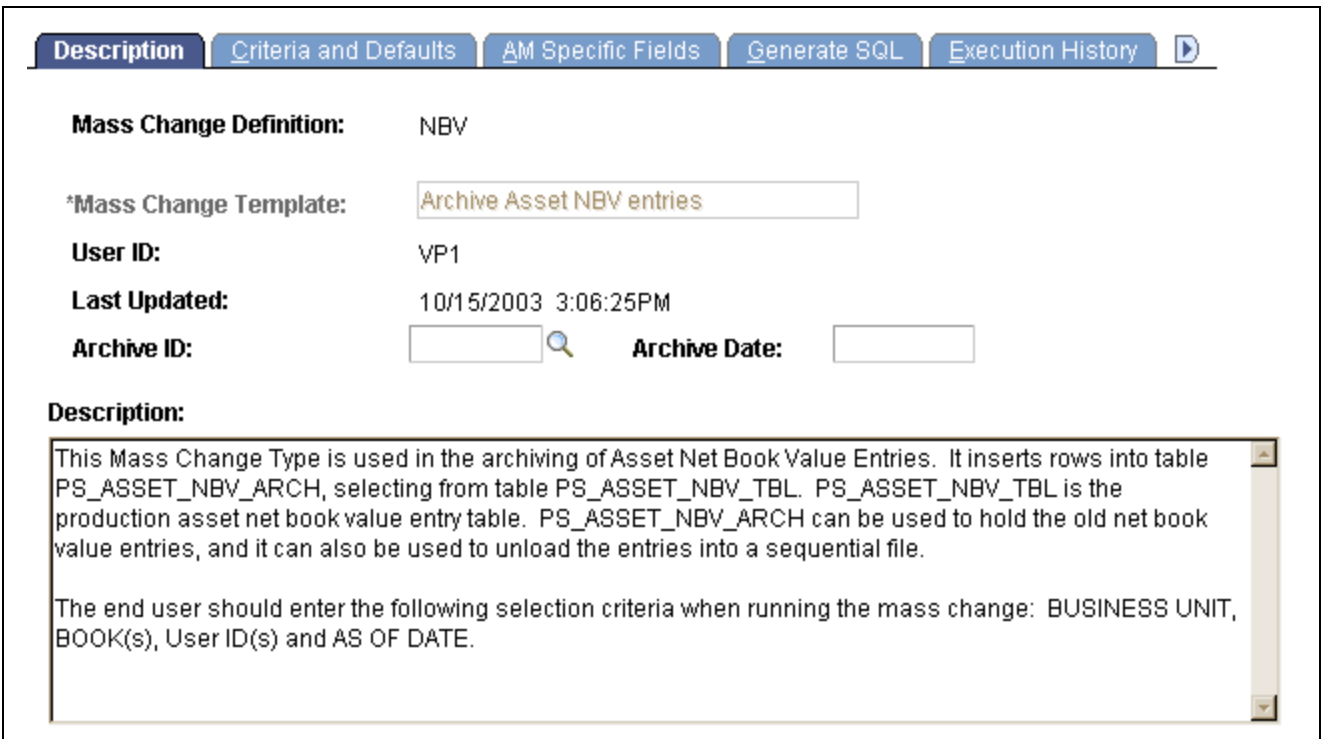

Mass Change Definition: NBV

***Mass Change Template:** Archive Asset NBV entries

User ID: VP1

Last Updated: 10/15/2003 3:06:25PM

Archive ID:

Archive Date:

Description:

This Mass Change Type is used in the archiving of Asset Net Book Value Entries. It inserts rows into table PS_ASSET_NBV_ARCH, selecting from table PS_ASSET_NBV_TBL. PS_ASSET_NBV_TBL is the production asset net book value entry table. PS_ASSET_NBV_ARCH can be used to hold the old net book value entries, and it can also be used to unload the entries into a sequential file.

The end user should enter the following selection criteria when running the mass change: BUSINESS UNIT, BOOK(s), User ID(s) and AS OF DATE.

Archive – Mass Change, Define Criteria page

Add a new mass change and select the template that corresponds to the table and archive activity you want to perform. The templates to archive, delete and retrieve detail are:

- *Archive Asset Depr Rpt entries:* This mass change type copies the specified DEPR_RPT entries into the DEPR_RPT_ARCH table. Specified entries are determined by the selection criteria of the mass change template with the same name (Archive Asset Depr Rpt entries). The following fields will be used to select the data:
 - Business Unit: If entered, mass change selects the specified business unit. If not entered, mass change selects all business units.
 - Book: If entered, mass change selects the specified book. If not entered, mass change selects all books
 - Fiscal Year: It is recommended that you enter a fiscal year; mass change selects the specified value.
- *Archive Asset NBV entries:* This mass change type copies the specified PS_ASSET_NBV_TBL entries into the PS_ASSET_NBV_ARCH table. PS_ASSET_NBV_ARCH is used to store the old net book value entries, and it can also be used to retrieve the entries into a sequential file. The following fields will be used to select the data:
 - Business Unit: If entered, mass change selects the specified business unit. If not entered, mass change selects all business units.

- Book: If entered, mass change selects the specified book. If not entered, mass change selects all books
- As of Date: It is recommended that you enter an As of Date; mass change selects the specified value.
- *Archive Asset Open Trans:* This mass change type is used to archive Asset Open Transaction (PS_OPEN_TRANS table) details. It inserts the selected entries into the Open Trans Archive table (PS_OPEN_TRANS_ARCH). The following fields are used to select the data:
 - Business Unit: If entered, mass change selects the specified business unit. If not entered, mass change selects all business units.
 - Book: If entered, mass change selects the specified book. If not entered, mass change selects all books
 - Accounting Date: It is recommended that you enter an accounting date; mass change selects the specified value.
- *Archive Asset Acctng Entries* This mass change template is used in the archiving of Asset Accounting Entries (PS_DIST_LN table). It inserts selected rows into table PS_DIST_LN_ARCH. PS_DIST_LN_ARCH is to archive the old accounting entries, and it can also be used to retrieve the archived entries into a sequential file. The following fields are used to select the data:
 - Business Unit: If entered, mass change selects the specified business unit. If not entered, mass change selects all business units.
 - Book: If entered, mass change selects the specified book. If not entered, mass change selects all books
 - Accounting Date: It is recommended that you enter an accounting date; mass change selects the specified value.
- *Delete Asset Acctng Entries* This mass change template is used to delete entries from the assets accounting entry table (PS_DIST_LN) that have been archived. Enter the deletion selection criteria for:
 - Business Unit: If entered, mass change selects the specified business unit. If not entered, mass change selects all business units.
 - Book: If entered, mass change selects the specified book. If not entered, mass change selects all books
 - Accounting Date: It is recommended that you enter an accounting date; mass change selects the specified value.
- *Delete Asset Depr Rpt entries:* This mass change type deletes the DEPR_RPT, DEPR_RPT_CF_SUM and DEPR_RPT_PD_SUM specified entries that are determined by the selection criteria of the mass change template you use. You should enter the same selection criteria used for the mass change archive of DEPR_RPT entries if you want to delete archived entries. If you want to purge DEPR_RPT entries, you should enter the following selection criteria when running the mass change:
 - Business Unit: If entered, mass change selects the specified business unit. If not entered, mass change selects all business units.
 - Book: If entered, mass change selects the specified book. If not entered, mass change selects all books
 - Fiscal Year: It is recommended that you enter a fiscal year; mass change selects the specified value.
- *Delete Asset NBV entries:* This mass change type deletes the entries from the Asset Net Book Value table (PS_ASSET_NBV_TBL). You should enter the same selection criteria used for the mass change archive of Asset NBV entries if you want to delete archived entries. If you want to purge Asset Net Book Value entries, you should enter the following selection criteria when running the mass change:
 - Business Unit: If entered, mass change selects the specified business unit. If not entered, mass change selects all business units.
 - Book: If entered, mass change selects the specified book. If not entered, mass change selects all books

- User ID: If entered, mass change selects the specified User ID. If not entered, mass change selects all User IDs.
- As of Date: It is recommended that you enter an accounting date; mass change selects the specified value.
- *Delete Asset Open Trans*: This mass change type deletes Open Transaction entries from table PS_OPEN_TRANS. It should be used after they have been archived. Enter the:
 - Business Unit: If entered, mass change selects the specified business unit. If not entered, mass change selects all business units.
 - Book: If entered, mass change selects the specified book. If not entered, mass change selects all books
 - As of Date: It is recommended that you enter an as of date; mass change selects the specified value.
- *Unload DIST_LN_ARCH to file*

This mass change template is used to retrieve details from the archive table PS_DIST_LN_ARCH to a sequential file. Enter the selection criteria:

 - Archive ID
 - Archive Date
- *Unload Open Trans to File*

This Mass Change Type is used to unload entries from the Asset Open Transaction Archive table to a sequential file. Enter the Archive ID and Archive Date to be used as selection criteria.
- *Upload Asset Open Trans*

This Mass Change Type is used to upload Open Transactions into table PS_OPEN_TRANS from table PS_OPEN_TRANS_ARCH. Enter the Archive ID and Archive Date to be used as selection criteria.
- *Upload Asset Acctng Entries*

This Mass Change Type is used to load the production asset accounting entry table (PS_DIST_LN) from the accounting entry archive table (PS_DIST_LN_ARCH). Enter the Archive ID and Archive Date as selection criteria for loading.

APPENDIX A

Understanding the Loader Table Data Dictionary

This chapter provides an overview of understanding the loader tables and discusses how to:

- Use loader table INTFC_FIN.
- Use loader table INTFC_PHY_A.
- Use loader table INTFC_PHY_B.
- Use transaction loader inserts.
- Use interface types (load types)

Understanding the Loader Tables

This document contains descriptions and explanations of the usage of the fields on the PeopleSoft Asset Management loader tables: INTFC_FIN, INTFC_PHY_A, and INTFC_PHY_B. This document, in conjunction with the listing of these records in the Application Designer, provides all the information required to load data into PeopleSoft Asset Management using these tables. Information about records in the Application Designer includes the field type, size, valid values, and other technical details. The field names used in this document match the field names in any table. For example, the field name for Interface ID in any table is always INTFC_ID.

If these fields are modified on the application tables, then they must also be modified on the loader tables if you will be using the Transaction Loader.

Loader Table INTFC_FIN

The following table describes information found in the Loader Table INTFC_FIN.

| Field Name | Long Name | Use and Processing Considerations | Tables Updated | Required for Conversion |
|----------------|-----------------------|--|--|-------------------------|
| INTFC_ID | Interface ID | <p>Key to this table. An interface ID is typically assigned to a group of transactions with the same load type.</p> <p>Use a unique, previously unused INTFC_ID for each set of transactions with the same load type.</p> <p>When using a load type of CN1 and NEXT in the ASSET_ID field, you'll need to use a unique INTFC_ID for each asset.</p> <p>For FADs and Conversions, if INTFC_ID is the same for multiple lines for an asset, increment the INTFC_LINE_NUM for each individual line.</p> | Used internally. | Y |
| INTFC_LINE_NUM | Interface Line Number | <p>Key to this table. Interface Line Number is used as a key for multiple lines for the same Interface ID for transactions with similar keys (for example, multiple acquisition details, such as CAP).</p> <p>For FADs and Conversions, if INTFC_ID is the same for multiple lines for an asset, increment the INTFC_LINE_NUM for each individual line.</p> | Used Internally. | Y |
| BUSINESS_UNIT | Business Unit | Identifies the business unit of the financial transaction to be processed. (You should never have more than one business unit per interface ID.) | BOOK, COST, DEPRECIATION, RETIREMENT, OPEN_TRANS | Y |
| ASSET_ID | Asset Identification | Identifies the asset ID of the financial transaction to be processed. For add interface types (ADD, NAD, FAD, CN1, etc.), if this field contains the value 'NEXT' then Transaction Loader will assign the next asset ID for this business unit. | BOOK, COST, DEPRECIATION, RETIREMENT, OPEN_TRANS | Y |

| Field Name | Long Name | Use and Processing Considerations | Tables Updated | Required for Conversion |
|------------|-----------------|--|--|-----------------------------------|
| BOOK | Asset Book Name | <p>Identifies the asset book to be processed. All financial transactions must be assigned a book if the DEFAULT_PROFILE_SW = 'N'.</p> <p>The financial information for an asset (book, cost, depreciation, retirements) addition can be entered by creating transactions manually. This is done by putting one row into the INTFC_FIN table for each book that an asset reports to.</p> <p>This information can also be defaulted via the profile. The Transaction Loader will then populate the financial tables for all books specified in the profile from the one row in INTFC_FIN. When the DEFAULT_PROFILE_SW is set to 'Y', book can be left blank (" "). Books will default in from the profile, which is populated in INTFC_PHY_A.</p> <p>If you're doing a CN1, set the DEFAULT_PROFILE_SW to 'N'.</p> | BOOK, COST, DEPRECIATION, RETIREMENT, OPEN_TRANS | Y when Default Profile Switch = N |

| Field Name | Long Name | Use and Processing Considerations | Tables Updated | Required for Conversion |
|----------------|-----------------|---|--|-------------------------|
| DTTM_STAMP | Date/Time Stamp | <p>Used to populate the key field of datetime stamp on many tables. Represents the date/time that this transaction was added to the system. While Date/Time Stamp can be set to any value, we recommend that you set it to the date of the conversion. This ensures that it will be earlier than the date of any further transactions.</p> <p>It's used as a key because INTFC_LINE_NUM isn't always incremented (for example, when creating transactions via Mass Change). Making this a key is a safeguard against getting a duplicate insert.</p> <p>If you have multiple cost rows for one asset, you may want to increment this field by one second for each subsequent row to prevent duplicate inserts into PS_COST.</p> | COST, DEPRECIATION, RETIREMENT, OPEN_TRANS | Y |
| OPERATING_UNIT | Operating Unit | A ChartField, which can be customized. See the online ChartField customization topic for further discussion. | COST, DEPRECIATION | |
| DEPTID | Department | A ChartField, which can be customized. See the online ChartField customization topic for further discussion. | COST, DEPRECIATION | |
| PRODUCT | Product | A ChartField, which can be customized. See the online ChartField customization topic for further discussion. | COST, DEPRECIATION | |
| FUND_CODE | Fund Code | A ChartField, which can be customized. See the online ChartField customization topic for further discussion. | COST, DEPRECIATION | |

| Field Name | Long Name | Use and Processing Considerations | Tables Updated | Required for Conversion |
|------------------|--------------------------|--|-----------------------|-------------------------|
| CLASS_FLD | Class Field | A ChartField, which can be customized. See the online ChartField customization topic for further discussion. | COST, DEPRECIATION | |
| PROGRAM_CODE | Program Code | A ChartField, which can be customized. See the online ChartField customization topic for further discussion. | COST, DEPRECIATION | |
| BUDGET_REF | Budget Reference | A ChartField, which can be customized. See the online ChartField customization topic for further discussion. | COST, DEPRECIATION | |
| AFFILIATE | Affiliate | A ChartField, which can be customized. See the online ChartField customization topic for further discussion. | COST, DEPRECIATION | |
| AFFILIATE_INTRA1 | Fund Affiliate | A ChartField, which can be customized. See the online ChartField customization topic for further discussion. | COST, DEPRECIATION | |
| AFFILIATE_INTRA2 | Operating Unit Affiliate | A ChartField, which can be customized. See the online ChartField customization topic for further discussion. | COST, DEPRECIATION | |
| CHARTFIELD1 | ChartField 1 | A ChartField, which can be customized. See the online ChartField customization topic for further discussion. | COST, DEPRECIATION | |
| CHARTFIELD2 | ChartField 2 | A ChartField, which can be customized. See the online ChartField customization topic for further discussion. | COST, DEPRECIATION | |
| CHARTFIELD3 | ChartField 3 | A ChartField, which can be customized. See the online ChartField customization topic for further discussion. | COST, DEPRECIATION | |

| Field Name | Long Name | Use and Processing Considerations | Tables Updated | Required for Conversion |
|------------|----------------------------|--|-----------------------|-------------------------|
| PROJECT_ID | Project | A ChartField, which can be customized. See the online ChartField customization topic for further discussion. | COST, DEPRECIATION | |
| CATEGORY | Asset Category | An asset ChartField that is used to derive the GL accounts for any given financial transaction (used in conjunction with Cost Type, Trans Type, and Trans Code - see the topic on accounting entries). | COST, DEPRECIATION | Y |
| COST_TYPE | Cost Type | An asset ChartField that is used to derive the GL accounts for any given financial transaction (used in conjunction with Cost Type, Trans Type, and Trans Code - see the topic on accounting entries). | COST, DEPRECIATION | |
| CF_SEQNO | Chartfield Sequence Number | Internal Use. Every combination of Chartfield values at the Asset/Book level has a unique ChartField sequence number (CF_SEQNO) and every ChartField sequence number value at the Asset/Book level represents one combination of ChartField values. The values of this field are not shared among assets. When the cost of the asset is transferred to a new combination of ChartFields, the ChartField sequence number is assigned a new value. | COST, DEPRECIATION | |
| VOUCHER_ID | Voucher ID | Identifies the voucher associated with the financial transaction. This is used in AP integration. This field can be used for PeopleSoft or non-PeopleSoft integration. This field is on this table so that the INTFC_FIN transactions can be easily queried by voucher. This should be populated if the transaction is voucher related. | Used internally. | |

| Field Name | Long Name | Use and Processing Considerations | Tables Updated | Required for Conversion |
|----------------------|---------------------------------------|--|------------------|-------------------------|
| VOUCHER_ LINE_NUM | Voucher Line Number | Identifies the voucher line number associated with the financial transaction. This is used in AP integration. This field can be used for PeopleSoft or non-PeopleSoft integration. | Used internally. | |
| DISTRIB_LINE_ NUM | Distribution Line Number | Identifies the voucher line distribution number associated with the financials transaction. This is used in AP integration. This field can be used for PeopleSoft or non-PeopleSoft integration. | Used internally. | |
| INTFC_TYPE | Interface Type, also called Load Type | Identifies the type of transaction this is. Transaction Loader will process this transaction based upon this field. A list of interface types and their usage is included at the end of this table. | Used internally. | Y default CN1 or CN2 |
| SYSTEM_ SOURCE | System Source | The source system that created this transaction. Valid values are listed in the translate table. This field is used extensively by AM to drill back to source systems. Feel free to add valid values to the translate table for your external systems (or use EXT). You can run Transaction Loader selectively for specific values of system source. | Used internally. | Y default CNV |
| APPROVAL_SW | Auto-approval Status | Identifies whether the transaction is approved or not. Transaction Loader will only load approved transactions. Valid values are 'Y' for approved and 'N' for not approved. | Used internally. | Y |
| PI_ID | Physical Inventory ID | Used for internal processing. Do not populate. The physical inventory ID that was entered when defining physical inventory is used here. | Used internally. | |

| Field Name | Long Name | Use and Processing Considerations | Tables Updated | Required for Conversion |
|---------------|--------------------------------|---|------------------|-------------------------|
| INTFC_STATUS | Interface Status | Used for internal processing. Default this field to 'DON'. | Used internally. | Y default DON |
| LOAD_STATUS | Load Status | <p>Identifies the status of this transaction. Updated by the Transaction Loader. Valid values are:</p> <ul style="list-style-type: none"> • NEW Not processed. • ERR An error exists on this transaction and it will not be processed. • DON The transaction has been successfully processed. • CON The transaction has been consolidated into a different transaction and it will not be loaded. • UNI The transaction has been unitized into a different transaction and it will not be loaded. • HLD The transaction is on hold. This is used to prevent or delay the processing of an entry. • INP The transaction is in process. This is the status while the application engine is working with the row. | Used internally. | Y NEW |
| ORIG_INTFC_ID | Original Interface ID | Used for internal processing. Do not populate. | Used internally. | |
| ORIG_LINE_NUM | Original Interface Line Number | Used for internal processing. Do not populate. | Used internally. | |

| Field Name | Long Name | Use and Processing Considerations | Tables Updated | Required for Conversion |
|--------------------|----------------------------|--|------------------|-------------------------|
| DEFAULT_PROFILE_SW | Default Books from Profile | <p>Identifies whether a profile will be used for an asset add or capitalization by the Transaction Loader. When this switch is set to Y the fields in the BOOK table are defaulted from the profile tables rather than the loader tables (INTFC_). When this switch is set to Y, the category and group asset ID on the COST table, group asset ID on the OPEN_TRANS table, a few fields on the ASSET and ASSET_ACQ_DET tables, and the retirement convention on the RETIREMENT table will also be defaulted from the profile tables. The profile_id is identified on the INTFC_PHY_A table.</p> <p>When this switch is set to C, the category from the interface row is retained. If the switch is set to G, the group is retained. If the switch is set to B, both the category and the group are retained.</p> <p>When performing a CN1, you must set the DEFAULT_PROFILE_SW to N.</p> <p>The default value of DEFAULT_PROFILE_SW in INTFC_FIN must match the status of DEFAULT_PROFILE_SW in INTFC_PHY_A.</p> <p>The section on Setting Up Asset Profiles in the topic entitled Establishing Asset Processing, explains profile processing, including which fields default from a profile. Remember, the values from a profile always override the values on this table if profile processing has been chosen.</p> | Used internally. | Y |

| Field Name | Long Name | Use and Processing Considerations | Tables Updated | Required for Conversion |
|--------------|--------------------|---|-----------------------|-------------------------|
| TRANS_CODE | Transaction Code | <p>Used to identify special accounting treatment for the transaction. The category, cost type, transaction type, and transaction code together identify the accounting entry template that will be used for a given transaction. The transaction code allows you to specify an alternative template to be used for a transaction.</p> <p>If you add or modify a TRANS_CODE, you must set up an Accounting Entry Template for each additional Category/Cost Type/Trans Code/Trans Type combination it generates. For more information on Transaction Codes and Accounting Entry Templates, refer to Establishing Asset Processing.</p> | COST, DEPRECIATION | |
| TRANS_IN_OUT | Transaction In/Out | <p>Used to identify which side of a transfer or recategorization this transaction represents. Every such transaction contains two transactions. The <i>outside</i> of the transaction adjusts the asset being transferred/recategorized from. The <i>inside</i> of the transaction adjusts the asset being transferred/recategorized to. Valid values are 'O' and 'I'.</p> | COST, DEPRECIATION | |

| Field Name | Long Name | Use and Processing Considerations | Tables Updated | Required for Conversion |
|---------------|------------------|---|--------------------------------|-------------------------|
| TRANS_DT | Transaction Date | <p>Denotes the date this transaction occurred. Example: An asset was purchased and placed into service on 15 April, 1997, but was added to the system on 5 June, 1997. The company wanted the add to hit the general ledger for period 5 (May). In this example the transaction date would be 15 April, 1997. The accounting date most likely would be 31 May, 1997.</p> <p>During conversion it is important that this field represent the last period for which depreciation has been calculated.</p> <p>For CN1 load types, the system increments the TRANS_DT and ACCOUNTING_DT you enter into INTFC_FIN by one day. So if you enter 05/31/95 as your transaction and accounting dates, the system will use 06/01/95.</p> | COST, DEPRECIATION, OPEN_TRANS | Y |
| ACCOUNTING_DT | Accounting Date | <p>Denotes the date this transaction was accounted for. This is the date that will be passed to the general ledger. It is the difference between the transaction date and the accounting date that identifies a retroactive transaction. Remember, the accounting date must always be greater than or equal to the transaction date.</p> <p>See the example of transaction date for an illustration.</p> <p>For CN1 load types, the system increments the TRANS_DT and ACCOUNTING_DT you enter into INTFC_FIN by one day. So if you enter 05/31/95 as your transaction and accounting dates, the system will use 06/01/95.</p> | COST, OPEN_TRANS | Y |

| Field Name | Long Name | Use and Processing Considerations | Tables Updated | Required for Conversion |
|--------------------|----------------------------|--|----------------|-------------------------|
| IN_SERVICE_DT | In Service Date | The date the asset was placed in service. This field is used in conjunction with the convention to determine the begin depreciation date. This field only relates to depreciable assets. | BOOK | Y |
| IN_SERVICE_PD | In Service Period | The calendar period in which the in service date falls. If this field is not populated, the depreciation calculation program will calculate it. | BOOK | |
| IN_SERVICE_FY | In Service Fiscal Year | The calendar fiscal year in which the in service date falls. If this field is not populated, the depreciation calculation program will calculate it. | BOOK | |
| DEPR_IN_SERVICE_SW | Depreciate When in Service | This field marks whether the yearly depreciation in the year of acquisition should be spread from the in service date through the end of the year or from the begin depreciation date as calculated using the convention and the in service date. Example: In service date = 1 April 1997, convention = half year, begin depreciation date = 1 July, 1997, 1997 Depreciation = \$1,000. If this field = 'Y' then the \$1,000 will be spread from 1 April to 31 December. If this field = 'N' then the \$1,000 will be spread from 1 July to 31 December. | BOOK | Y default N |
| BEGIN_DEPR_DT | Begin Depreciation Date | The date the asset begins depreciating. This field is typically calculated by the depreciation calculation program (AM_DEPR_CALC) using the in service date and the convention, so you should leave this field blank. | BOOK | |

| Field Name | Long Name | Use and Processing Considerations | Tables Updated | Required for Conversion |
|------------------|-------------------------------------|--|----------------|-------------------------|
| BEGIN_DEPR_PD | Begin Depreciation Period | Used for internal processing. Do not populate. | BOOK | |
| BEGIN_DEPR_FY | Begin Depreciation Fiscal Year | Used for internal processing. Do not populate. | BOOK | |
| BEGIN_FRACTION | Begin Depreciation Period Fraction | Used for internal processing. Do not populate. | BOOK | |
| DEPR_CALC_SW | Depreciation Calculation Switch | Used for internal processing. Do not populate. | BOOK | |
| BEGIN_CALC_DT | Begin Depreciation Calculation Date | Used for internal processing. Do not populate. | BOOK | |
| BEGIN_CALC_PD | Begin Calculation Period | Used for internal processing. Do not populate. | BOOK | |
| BEGIN_CALC_FY | Begin Calculation Fiscal Year | Used for internal processing. Do not populate. | BOOK | |
| CALCULATION_TYPE | Calculation Type | <p>The type of depreciation calculation that will be performed by the depreciation calculation program (AM_DEPR_CALC). The valid values are 'R' for remaining value and 'L' for Life-to-Date. Most conversions will use a remaining value type. For a more detailed discussion of these calculation types, please refer to Appendix C: Understanding Depreciation Calculations.</p> <p>In general, if the Remaining Value option is selected, depreciation will be calculated from the Transaction Date. If the Life-to-Date option is selected, depreciation will be calculated from the Begin Depreciation Date.</p> | BOOK | Y |

| Field Name | Long Name | Use and Processing Considerations | Tables Updated | Required for Conversion |
|-------------------|-------------------------------------|---|----------------|-------------------------|
| LAST_CALC_TYPE | Last Calculation Type | Used for internal processing. Do not populate. | BOOK | |
| RSV_FRACTION | Reserve Fraction (RSV/Cost) | Used for internal processing. Do not populate. | BOOK | |
| RECALC_RSV_SW | Recalculate RSV Fraction (RSV/Cost) | Used for internal processing. Do not populate. | BOOK | |
| SCHED_FRACTION | Fraction of Schedule Elapsed | Used for internal processing. Do not populate. | BOOK | |
| YEAR_REM_FRACTION | Year Remaining Fraction | Used for internal processing. Do not populate. | BOOK | |
| DEPR_STATUS | Depreciation Status | <p>Marks the asset book as depreciable or non-depreciable. The valid values are 'D' for depreciable and 'N' for non-depreciable. If an asset is marked non-depreciable, then the depreciation calculation program (AM_DEPR_CALC) will not process it and no depreciation will be posted. It can still be capitalized, however, and Cost and Book record rows will be tracked.</p> <p>If you mark an asset book as non-depreciable, you must still enter a life and convention for it.</p> | BOOK | Y |
| REGULATION | Depreciation Regulation | Identifies the U.S. tax regulation that covers this asset book. Valid values are in the translate table. | BOOK | |
| RECOVERY_LIFE | Recovery Life | Identifies the U.S. tax recovery life for this asset book. | BOOK | |
| RECOVERY_SUBTYPE | Recovery Sub-type | Identifies the U.S. tax recovery sub-type for this asset book. | BOOK | |

| Field Name | Long Name | Use and Processing Considerations | Tables Updated | Required for Conversion |
|----------------|---------------------|--|----------------|--|
| CONVENTION | Prorate Convention | <p>Identifies the depreciation prorate convention to be used with this asset book. The convention is applied to the in service date to calculate the begin depreciation date for the asset book. The valid values must be set up on the convention table prior to implementation. PeopleSoft ships a 'MODEL' set of conventions with the system that can be shared by your business units.</p> <p>Note. If you are using a calendar other than a standard, 12 period calendar, it may be necessary to modify the 'MODEL' set of conventions or create new convention definitions to match the calendar(s) you're using.</p> | BOOK | Y |
| LIFE | Life | Identifies the depreciable life of this asset book. If the asset is using a depreciation method that uses life (such as straight line, schedule, declining balance switching to straight line, etc.) then life is a required field. Life is measured in periods. If you are using a calendar that is 12 periods, and the life of the asset is 5 years, then the life field would contain 60. | BOOK | Y for most methods |
| LIFE_REMAINING | Remaining Life | Used for internal processing. Do not populate. | BOOK | |
| TAX_CLASS_AM | Guideline Tax Class | Identifies the U.S. tax class associated with this asset book. | BOOK | |
| DEPR_PERCENT | Percent | Identifies the percent to be used. This field is only used when the depreciation method is flat rate or declining balance. | BOOK | Y for flat rate declining balance depreciation |

| Field Name | Long Name | Use and Processing Considerations | Tables Updated | Required for Conversion |
|---------------|----------------------------|---|----------------|--|
| DB_PERCENT | Declining Balance Percent | Identifies the declining balance percent. This field is only used when the depreciation method is declining balance with switch to straight line. | BOOK | Y for declining balance w/ a straight line switch depreciation |
| METHOD | Depreciation Method | Identifies the depreciation method to be used. Valid values are in the translate table. | BOOK | Y |
| DEPR_SCHED_CD | Depreciation Schedule Code | Identifies the depreciation schedule to be used. This field is only used if the depreciation method is schedule. This field must reference a valid depreciation schedule. The schedules are defined by the user in the Establish Asset Processing window. PeopleSoft ships a number of sample schedules in the 'MODEL' TableSet. Note. Life is a key field on the Depreciation Schedule Code table. Verify that the Depreciation Schedule Code selected is valid and life corresponds to the value entered in the life field. | BOOK | Y for depreciation method Schedule |
| DEPR_LIMIT_CD | Depreciation Limit Code | Identifies the depreciation limits to be used. Depreciation limits are used to limit the amount of depreciation expense that can be taken in a given fiscal year. This field must reference a valid depreciation limit. The limits are defined by the user in the Establish Asset Processing window. PeopleSoft ships a number of sample limits in the 'MODEL' TableSet. | BOOK | |
| PROPERTY_CD | Property Code | Identifies what code of property the asset book falls into for U.S. tax processing purposes. Valid values are '1' for section 1245 property and '2' for section 1250 property. | BOOK | |

| Field Name | Long Name | Use and Processing Considerations | Tables Updated | Required for Conversion |
|-----------------|---------------------------|--|-----------------------|-------------------------|
| PROPERTY_TYPE | Property Type | Identifies the type of property the asset book represents. Valid values are 'R' for real property and 'P' for personal property. | BOOK | |
| SALVAGE_VALUE | Salvage Value | The salvage or residual value that is to be used in the depreciation calculation for this asset book. It is subtracted from the cost to determine the depreciable basis in depreciation calculations. | COST | |
| TAX_CREDIT_SW | Tax Credit Switch | Used for internal processing. Do not populate. | BOOK | |
| BASIS_RED_TOTAL | Basis Reduction Total | The total amount of the reduction in the cost basis for this asset book. | BOOK | |
| BASIS_RED_RECAP | Basis Reduction Recapture | The total amount of the recapture of the basis reduction for this asset book. | BOOK | |
| SEC179_TAKEN_SW | Section 179 Taken Switch | Identifies whether the asset book has qualified under the U.S. Tax regulation section 179. Valid values are 'Y' for yes and 'N' for no. | BOOK | |
| SEC179_AMT | Section 179 Taken Amount | If the asset book qualified for section 179 expense, how much was taken? | BOOK | |
| ACTIVITY_SW | Activity Switch | Identifies whether this transaction reflects an active ChartField combination for an asset. This is a numeric field. When the sum of the activity switch for a ChartField combination for an asset = 0 then this ChartField combination is active. For asset adds, this field will always be 0. | COST, DEPRECIATION | |

| Field Name | Long Name | Use and Processing Considerations | Tables Updated | Required for Conversion |
|-------------------|------------------------|---|------------------|-------------------------|
| RETIRE_SW | Retirement Switch | Identifies whether this ChartField combination for the asset book has been retired (fully) or not. This is a numeric field and works the same as the activity switch. | COST | |
| QUANTITY | Asset Quantity | Represents the quantity of this transaction. Remember, each transaction's quantity is summed to provide a balance at a given point in time. | COST | |
| COST | Cost | Represents the cost of this transaction. Remember, each transaction's cost for an asset book is summed to provide a balance at a given point in time. | COST | Y |
| CURRENCY_CD | Currency Code | This field represents the transaction currency. This field is used to determine the currency conversion that will occur when populating each asset book, which may be in a different currency. | COST, RETIREMENT | Y |
| TRANSFER_BU | Transfer Business Unit | For an interunit asset transfer to transaction (transaction type='TRF' and Transaction in/out switch='I') this represents the business unit the asset was transferred from. For an interunit asset transfer from transaction (transaction type='TRF' and Transaction in/out switch='O') this represents the business unit the asset was transferred to. | COST | |
| TRANSFER_ASSET_ID | Transfer Asset ID | This field works just like the Transfer Business Unit, only it represents the asset ID used in the transfer transaction. | COST | |
| TRANSFER_BOOK | Transfer From Book | This field works just like the Transfer Business Unit, only it represents the book used in the transfer transaction. | COST | |

| Field Name | Long Name | Use and Processing Considerations | Tables Updated | Required for Conversion |
|-------------|---------------------------|--|------------------|---|
| OPRID | Operator ID | The operator ID that initiated this transaction. | COST, OPEN_TRANS | |
| FISCAL_YEAR | Fiscal Year | Represents the fiscal year in which the depreciation was taken. When converting depreciation you must identify the time period the depreciation covers. If converting an asset for which depreciation has been calculated through June 1997, then the fiscal year would be 1997, the start period would be 6 and the end period would be 6. | DEPRECIATION | Y if the asset has accumulated depreciation |
| START_PD | Start Period | Represents the start period for which the depreciation was taken. See the example above. | DEPRECIATION | Y if the asset has accumulated depreciation |
| END_PD | End Period | Represents the end period for which the depreciation was taken. See the example above. | DEPRECIATION | Y if the asset has accumulated depreciation |
| YTD_FLAG | Original Reserve | Set value to 'N' for Depreciation Amount that represents accumulated depreciation as of the conversion date. Default to 'Y' for other depreciation transactions. | DEPRECIATION | Y if the asset has accumulated depreciation |
| DEPR | Depreciation Amount | The depreciation amount of this transaction. | DEPRECIATION | Y if the asset has accumulated depreciation |
| DEPR_YTD | Year-to-Date Depreciation | Populate with Year To Date Depreciation | DEPRECIATION | Y if Method is Sum of Years, Declining Balance, Declining Balance with Switch to Straight line and you are doing a mid-year conversion. |

| Field Name | Long Name | Use and Processing Considerations | Tables Updated | Required for Conversion |
|-------------------|-----------------------|---|----------------|-------------------------|
| RETIREMENT_DT | Retirement Date | The retirement date of the transaction. This field is used for retirement transactions only. | RETIREMENT | |
| RETIRE_CONVENTION | Retirement Convention | Represents the convention used for the retirement transaction. The convention is used to determine the end depreciation date for this asset book. This field is used for retirement transactions only. | RETIREMENT | |
| END_DEPR_DT | End Depreciation Date | The end depreciation date for this retirement transaction. This represents the date that depreciation will stop for this asset. The depreciation for that period is then prorated to determine the amount of accumulated depreciation being retired. This field is used for retirement transactions only. | RETIREMENT | |
| DISPOSAL_CODE | Disposal Code | Represents a memo field detailing the method that was used to dispose of this asset. The valid values for this field are in the translate table. This field is used for retirement transactions only. | RETIREMENT | |
| RETIREMENT_TYPE | Retirement Type | Represents whether this retirement transaction was ordinary or extraordinary according to U.S. Tax code. This field is used for retirement transactions only. | RETIREMENT | |
| RETIREMENT_STATUS | Retirement Status | Represents the status of the retirement transaction. The valid values are in the translate table. The initial value should be 'N' for a new retirement. This field is used for retirement transactions only. | RETIREMENT | |

| Field Name | Long Name | Use and Processing Considerations | Tables Updated | Required for Conversion |
|--------------------|-------------------------------|--|----------------|-------------------------|
| VOLUNTARY | Voluntary Conversion | Represents whether the retirement was voluntary or involuntary. This is required by U.S. tax code. The valid values are in the translate table. This field is used for retirement transactions only. | RETIREMENT | |
| TRADE_IN_ASSET_ID | Asset ID Bought with Trade In | Represents the asset ID that was bought using this asset as a trade-in. This field is only used for retirement transactions. | RETIREMENT | |
| TRADE_IN_DTTM_STMP | Trade In Date /Time Stamp | Represents the date/time stamp of the asset add transaction for the asset that was bought This field is only used for retirement transactions. | RETIREMENT | |
| TRADE_IN_AMT | Trade In Amount | The amount received for the trade-in of an asset. This field is only used for retirement transactions. | RETIREMENT | |
| TRADE_IN_VALUE | Trade In value | To retire an asset by trading it for another asset. | RETIREMENT | Y |
| CASH | Cash Received /Paid | "Cash received in a like-kind exchange is taxable and is often referred to as "boot". " | RETIREMENT | Y |
| REFERENCE | Reference Code | A memo field that can be used to tie this retirement transaction to a reference document. This field is only used for retirement transactions. | RETIREMENT | |
| LIABILITY_ASSUMED | Liabilities Assumed | "If you are surrendering a building with a mortgage of USD 70,000 and acquiring a building with a mortgage of USD 30,000, you would enter 40,000 as the net liability. " | RETIREMENT | Y |
| NON_LIKE_KIND | FMV Non Like Kind Property | Fair Market Value for Non Like Kind Property. | RETIREMENT | Y |

| Field Name | Long Name | Use and Processing Considerations | Tables Updated | Required for Conversion |
|-----------------------|-----------------------------|--|----------------|-------------------------|
| RETIRE_ QUANTITY | Retirement Quantity | The quantify of the asset book being retired by this transaction. This field is only used for retirement transactions. | RETIREMENT | |
| RETIREMENT_ AMT | Retirement Amount | The amount of cost for the asset book being retired by this transaction. This field is only used for retirement transactions. | RETIREMENT | |
| PROCEEDS | Retirement Proceeds | The proceeds received for this asset. This is used in the depreciation calculation program to derive the gain/loss amount. This field is only used for retirement transactions. | RETIREMENT | |
| REMOVAL_ COST | Removal Cost | The cost of removal for this asset. This is used in the depreciation calculation program to derive the gain/loss amount. This field is only used for retirement transactions. | RETIREMENT | |
| RETIREMENT_ RSV | Reserve Retired | The accumulated depreciation being retired by this transaction. This is calculated by the depreciation calculation program. This field is only used for retirement transactions. | RETIREMENT | |
| GAIN_LOSS | Retirement Gain/Loss | The gain/loss amount for this retirement transaction. This is calculated by the depreciation calculation program. This field is only used for retirement transactions. | RETIREMENT | |
| LEASE_REM_ PAYMNTS | Lease Remaining Payments | The number of payments remaining at the time of the retirement. This field is calculated by the program AM_DEPR_CALC and does not have to be populated. This field is only used for retirement transactions. | RETIREMENT | |

| Field Name | Long Name | Use and Processing Considerations | Tables Updated | Required for Conversion |
|------------------|---------------------|--|----------------|-------------------------|
| OPEN_TRANS_ID | Open Transaction ID | <p>The ID (key) for the OPEN_TRANS table. The OPEN_TRANS table is a “to do” list for several programs, such as AM_DEPR_CALC and AM_AMAEDIST. If this transaction requires processing by these programs, an entry is made to the OPEN_TRANS table.</p> <p>For performance reasons, this field should be populated for conversions. A single unique OPEN_TRANS_ID can be used for a group of the same transaction types, for example, CN1s.</p> | OPEN_TRANS | Y |
| CALC_DEPR_STATUS | Depreciation | <p>This field is used to determine whether depreciation needs to be calculated on this transaction. Only financial transactions need depreciation calculated. An open transaction (OPEN_TRANS) is created for those transactions that will have depreciation calculated. The OPEN_TRANS entry is then used by AM_DEPR_CALC as a “to do” list of transactions to process.</p> <p>Transaction Loader will populate this field. It can be left blank.</p> <p>Note. Open Transactions are still generated for non-depreciable assets.</p> | OPEN_TRANS | |

| Field Name | Long Name | Use and Processing Considerations | Tables Updated | Required for Conversion |
|------------------|-------------------------------|---|-----------------|-------------------------|
| CALC_DIST_STATUS | Distribution | This field is used to determine whether accounting entries need to be created for this transaction. Only financial transactions on a book marked for accounting entry creation need to have accounting entries created. An open transaction (OPEN_TRANS) is created for those transactions that will have accounting entries created. The OPEN_TRANS table entry is then used by AM_AMAEDIST as a “to do” list of transactions to process. Transaction Loader will populate this field. It can be left blank. | OPEN_TRANS | |
| MESSAGE_SET_NBR | Message Set Number | Used for internal processing. Do not populate. | Used internally | |
| MESSAGE_NBR | Message Number | Used for internal processing. Do not populate. | Used internally | |
| BUSINESS_UNIT_JV | Joint Venture Business Unit | The “parent” JV business unit, if the asset is part of a joint venture. | Used internally | |
| LIFE_END_DT | Useful Life End Date | This field represents the end date of the useful life on the asset book. This field can be used as an alternate to the life field. Life and life end date are mutually exclusive. When you specify the life end date, the depreciation calculation program will calculate the life field and store it on the BOOK table. | BOOK | |
| DEPR_LOW_LIMIT | Depreciation Low Limit Amount | This field represents the low amount that net book value must reach before an asset stops depreciating. This field is only used by the declining balance depreciation method. Since the declining balance method does not use a life, the low limit is the way to specify when an asset should become fully reserved. | BOOK | |

| Field Name | Long Name | Use and Processing Considerations | Tables Updated | Required for Conversion |
|-------------------|-----------------------------|---|--------------------------------------|-------------------------|
| SUSPEND_STATUS | Suspend Status | Indicates whether the book is currently "mothballed". Default value for this field is blank. If the book is "mothballed", enter a value of 'Y' in this field. | BOOK | |
| SUSPEND_DT | Suspend Date | The date that depreciation was suspended. | BOOK | |
| RESUME_DT | Resume Date | The date that depreciation was resumed after a suspension. | BOOK | |
| SUSPENDED_PERIODS | Number of Suspended Periods | The number of periods that depreciation was suspended for. | BOOK | |
| COST_BASIS_LIMIT | Cost Basis Limit | The maximum amount that can be capitalized for this asset book. | BOOK | |
| DEPR_AVG_OPTION | Averaging Option | A special option that applies only to the flat rate depreciation method. Valid values are 'M' (Monthly), 'Y' (Yearly), or 'N' (None). If you're doing a conversion (CN1), you must set this field to a value, no matter what depreciation method you're using. | BOOK | Y default N |
| UOP_ID | Units of Production ID | Represents the ID of the Units of Production control table that specifies the units of production for this asset book. | BOOK | |
| IU_MAP_KEY | InterUnit Map Key | Used for InterUnit transfers. | Appears on COST. | |
| MC_DEFN_ID | Mass Change ID | Used for internal processing. Do not populate. | Used internally. | |
| GROUP_ASSET_ID | Group Asset ID | Used to identify which group asset group members report to. | BOOK, COST, DEPRECIATION, OPEN_TRANS | |

| Field Name | Long Name | Use and Processing Considerations | Tables Updated | Required for Conversion |
|-------------------|------------------------------|--|----------------|--|
| UD_METHOD_ID | Method ID | Identifies the user-defined depreciation method to be used. This field must reference a valid user-defined depreciation method. The user defined methods are specified in the Establish Asset Processing window. | BOOK | Y for depreciation method user-defined |
| INCLUDE_CAP_GAINS | CGT Applicable | A flag which determines whether or not capital gains tax should be included in the gain/loss of a book. The INCLUDE_CAP_GAINS is for Australian customers. | BOOK | |
| REDUCED_COST | Reduced Cost Basis | Amount used in calculating gain/loss for Australian Customers. | RETIREMENT | |
| CAPITAL_G_L | Capital Gains and Loss | Amount used in calculating gain/loss for Australian Customers. | RETIREMENT | |
| RET_NON_CAP_AM2 | Non-Capitalized CGT amount. | Amount used in calculating gain/loss for Australian Customers. | RETIREMENT | |
| AM_BK_UD_CHAR1 | User-Defined character field | | BOOK | |
| AM_BK_UD_CHAR2 | User-Defined character field | | BOOK | |
| AM_BK_UD_DATE1 | User-Defined date field | | BOOK | |
| AM_BK_UD_NUM1 | User-Defined numeric field | | BOOK | |
| AM_BK_UD_NUM2 | User-Defined numeric field | | BOOK | |

| Field Name | Long Name | Use and Processing Considerations | Tables Updated | Required for Conversion |
|-------------------|-------------------------------------|---|----------------|-------------------------|
| INCREASE_RATE | Increased Rate | Used to calculate special depreciation amount. You can enter a rate and the standard depreciation will be modified by this percentage along all the life of the asset. This is a Japanese Requirement but can be used for any country. | BOOK | |
| FULLY_DEPR_SW | Retire as Fully Depreciated | Used to retire assets as fully depreciated. | RETIREMENT | |
| ACCOUNTING_MTHD | Accounting Method | Supports 3 different accounting methods in Japan. In Expense method, the standard depreciation is modified with the special depreciation. The accounting entries in this method have standard + special depreciation in the same accounts. In Allowance and Reserve Method, the information must be in separate accounts. | BOOK | |
| FUTURE_DEPR_YEARS | Number of Future Depreciation Years | Number of future years of depreciation to create when AM_DEPR_CALC runs. For example: if value was 3 and accounting fiscal year is 2000, AM_DEPR_CALC will create years: 2000, 2001 and 2002. If left zero, AM_DEPR_CALC will create all years of the life of the asset. | BOOK | |
| SALVAGE_VAL | Salvage Value | Used to populate an absolute amount in COST.SALVAGE_VALUE by Book on future transactions – used only when default profile switch = No | BOOK | |
| SALVAGE_PCT | Salvage Percent | Used to calculate COST.SALVAGE_VALUE as a percentage of the cost by asset book on future transactions - used only when default profile switch = No | BOOK | |

| Field Name | Long Name | Use and Processing Considerations | Tables Updated | Required for Conversion |
|------------------|--------------------------------|-----------------------------------|--------------------------------|-------------------------|
| AUTO_RETIRE_SW | Auto-Retired Fully Depreciated | Internal | RETIREMENT | |
| RATE_DIV | Rate Divisor | Currency Conversion | RETIREMENT, COST, DEPRECIATION | Y |
| RATE_DIV_2 | Rate Divisor | Currency Conversion | RETIREMENT, COST, DEPRECIATION | Y |
| RATE_MULT | Rate Multiplier | Currency Conversion | RETIREMENT, COST, DEPRECIATION | Y |
| RATE_MULT_2 | Rate Multiplier | Currency Conversion | RETIREMENT, COST, DEPRECIATION | Y |
| RT_EFFDT | Rate Effective Date | Currency Conversion | RETIREMENT, COST, DEPRECIATION | Y |
| RT_TYPE | Rate Type | Currency Conversion | RETIREMENT, COST, DEPRECIATION | Y |
| BILL_TO_CUST_ID | Customer | Bill to Information. | RETIREMENT | Y |
| ADDRESS_SEQ_NUM | Address Sequence Number | Bill to Information. | RETIREMENT | Y |
| SHIP_TO_CUST_ID | Ship To Customer | Ship to Information. | RETIREMENT | Y |
| SHIP_TO_ADDR_NUM | Ship To Address Sequence Num | Ship to Information. | RETIREMENT | Y |
| SHIP_FROM_LOC | Ship From Location | Ship to Information. | RETIREMENT | Y |

| Field Name | Long Name | Use and Processing Considerations | Tables Updated | Required for Conversion |
|--------------------|-------------------------------|---|-----------------|-------------------------|
| SOLD_TO_CUST_ID | Sold To Customer | Sold to Information. | RETIREMENT | Y |
| SOLD_TO_ADDR_NUM | Sold To Address Sequence Num | Sold to Information. | RETIREMENT | Y |
| BILL_SOURCE_ID | Bill Source | Billing Source. | AMBI_INTFC_BILL | Y |
| TOT_OBLIGATION | Lease Total Obligation | Leasing Obligation. | BOOK | Y |
| TXN_CASH | Transaction Cash | Cash in transaction currency. | COST | Y |
| TXN_COST | Transaction Cost | Cost in transaction currency. | COST | Y |
| TXN_CURRENCY_CD | Transaction Currency | Transaction Currency. | COST | Y |
| TXN_CURRENCY_CD2 | Transaction Currency Display | Transaction Currency. | COST | Y |
| TXN_LIAB_ASSUMED | Transaction Liability Assumed | Liab Assumed in transaction currency. | RETIREMENT | Y |
| TXN_NON_LIKE_KIND | FMV Non Like-Kind | Non Like Kind in transaction currency. | RETIREMENT | Y |
| TXN_PROCEEDS | Transaction Proceeds | Used to populate an amount for Billing – Asset Management transactions. | | |
| TXN_REMOVAL_COST | Transaction Removal Cost | Removal Cost in transaction currency. | RETIREMENT | Y |
| TXN_TRADE_IN_VALUE | Transaction Trade-In Value | Trade in value in transaction currency. | RETIREMENT | Y |

| Field Name | Long Name | Use and Processing Considerations | Tables Updated | Required for Conversion |
|-------------------|----------------------------|---|----------------|-------------------------|
| DEPR_BONUS_SW | Depreciation Bonus | Depreciation Bonus Switch for Depreciation Calculation. | BOOK | Y |
| DEPR_BONUS_PCT | Depreciation Bonus Percent | Depreciation Bonus Percentage for Depreciation Calculation. | BOOK | Y |
| PROCESS_INSTANCE | Process Instance | Internal field / Informational. | | |
| SPECIAL_DEPR_SW | Special Depreciation | Depreciation Calculation. | BOOK | Y |
| ACCELERATED_TERMS | Accelerated Terms | Depreciation Calculation. | BOOK | Y |
| INITIAL_TERMS | Initial Terms | Depreciation Calculation. | BOOK | Y |
| SPECIAL_TERMS | Special Terms | Depreciation Calculation. | BOOK | Y |
| YEAR_CHANGE | Year of Change | Depreciation Calculation. | BOOK | Y |
| LIFE_IN_YRS | Life in Years | Depreciation Calculation. | BOOK | Y |
| MULTI_SHIFT_CODE | Multi-Shift Code | Depreciation Calculation. | BOOK | Y |
| MULTI_SHIFT_NBR | Shift Factor Number | Depreciation Calculation. | BOOK | Y |
| DEPR_LIMIT_PCT | Depreciation Limit Percent | Depreciation Calculation. | BOOK | Y |
| DEPR_PASS_LIFE_SW | Depreciate Pass Life SW | Depreciation Calculation. | BOOK | Y |
| DEROGATORY_SW | Derogatory Depreciation | Depreciation Calculation. | BOOK | Y |

| Field Name | Long Name | Use and Processing Considerations | Tables Updated | Required for Conversion |
|-------------------|-----------------------------|--|----------------|-------------------------|
| ACCEL_DEPR | Accelerated Depreciation | Depreciation Calculation. | BOOK | Y |
| INCREASE_DEPR | Increased Depreciation | Depreciation Calculation. | BOOK | Y |
| INITIAL_DEPR | Initial Depreciation | Depreciation Calculation. | BOOK | Y |
| SPEC_DEPR | Special Depreciation | Depreciation Calculation. | BOOK | Y |
| STANDARD_DEPR | Standard Depreciation | Depreciation Calculation. | BOOK | Y |
| IMPAIR_FLG | Impairment Process | Impairment Processing Switch. | BOOK | Y |
| CC_FLAG | Component Changeout Old/New | Internal Use | | |
| ADJUST_CONVENTION | Adjust Convention | Adjustment transaction convention populated with values from the CONV_TBL table. | BOOK, COST | |

Loader Table INTFC_PHY_A

The PeopleSoft platform has a limitation on the maximum number of columns allowed in a table. Because of this limitation, PeopleSoft created two physical interface tables. INTFC_PHY_A contains the most frequently used physical interface fields, and INTFC_PHY_B contains the least frequently used physical interface fields.

The following table contains information found in the Loader Table INTFC_PHY_A.

| Field Name | Long Name | Use and Processing Considerations | Tables Updated | Required for Conversion |
|----------------|-----------------------|--|--|-------------------------|
| INTFC_ID | Interface ID | <p>Key to this table. An interface ID is typically assigned to a group of transactions with the same load type.</p> <p>Use a unique, previously unused INTFC_ID for each set of transactions with the same load type.</p> <p>When using a load type of CN1 and NEXT in the ASSET_ID field, you'll need to use a unique INTFC_ID for each asset.</p> <p>For FADs and Conversions, if INTFC_ID is the same for multiple lines for an asset, increment the INTFC_LINE_NUM for each individual line.</p> | Used internally. | Y |
| INTFC_LINE_NUM | Interface Line Number | <p>Key to this table. Interface Line Number is used as a key for multiple lines for the same Interface ID for transactions with similar keys (ex., multiple acquisition details, such as CAP).</p> <p>For FADs and Conversions, if INTFC_ID is the same for multiple lines for an asset, increment the INTFC_LINE_NUM for each individual line.</p> | Used internally. | Y |
| BUSINESS_UNIT | Business Unit | The business unit that identifies the asset to be processed. This field is required | ASSET, ASSET_ACQ_DET, ASSET_CUSTODIAN, ASSET_LOCATION, PARENT_ASSET | Y |

| Field Name | Long Name | Use and Processing Considerations | Tables Updated | Required for Conversion |
|------------------|----------------------|---|--|-------------------------|
| ASSET_ID | Asset Identification | The asset ID that identifies the asset to be processed. This field is required. If this field contains the value 'NEXT' and the interface type is FAD or CN1 then Transaction Loader will assign the next asset ID for this business unit. | ASSET, ASSET_ACQ_DET, ASSET_CUSTODIAN, ASSET_LOCATION, and many others | Y |
| ASSET_TYPE | Asset Type | Asset Classification. | ASSET | Y |
| ASSET_SUBTYPE | Asset Subtype | Asset Classification. | ASSET | Y |
| DTTM_STAMP | Date/Time Stamp | Used to populate the key field of datetime stamp on many tables. Represents the date/time that this transaction was added to the system. During conversion it is important that this field represent the period through which depreciation has been calculated | | Y |
| VOUCHER_ID | Voucher ID | Identifies the voucher associated with the financial transaction. This is used in AP integration. This field can be used for PeopleSoft or non-PeopleSoft integration. This field is on this table so that the INTFC_FIN transactions can be easily queried by voucher. This should be formatted if the transaction is voucher related. | Used internally. ASSET_ACQ_DET | |
| VOUCHER_LINE_NUM | Voucher Line Number | Identifies the voucher line number associated with the financial transaction. This is used in AP integration. This field can be used for PeopleSoft or non-PeopleSoft integration. | Used internally. ASSET_ACQ_DET | |

| Field Name | Long Name | Use and Processing Considerations | Tables Updated | Required for Conversion |
|----------------------|---------------------------------------|--|---------------------------------------|-------------------------|
| DISTRIB_ LINE_NUM | Distribution Line Number | Identifies the voucher line distribution number associated with the financials transaction. This is used in AP integration. This field can be used for PeopleSoft or non-PeopleSoft integration. | Used internally. ASSET_ACQ_ DET | |
| INTFC_TYPE | Interface Type, also called Load Type | Identifies the type of transaction this is. Transaction loader will process this transaction based upon this field. Valid values are listed in the translate table. | Used internally. | Y |
| MC_DEFN_ID | Mass Change ID | Used for internal processing. Do not populate. | Used internally. | |
| SYSTEM_ SOURCE | System Source | The source system that created this transaction. Valid values are listed in the translate table. This field is used extensively by AM to drill back to source system. Feel free to add valid values to the translate table for your external systems. You can run Transaction Loader selectively for specific values of system source. | ASSET_ACQ_ DET | Y default CNV |
| APPROVAL_ SW | Auto Approval Status | Identifies whether the transaction is approved or not. Transaction Loader will only load approved transactions. Valid values are 'Y' for approved and 'N' for not approved. | Used internally. | y |
| INTFC_STATUS | Interface Status | Used for internal processing. Default this field to 'DON'. | Used internally. | Y default DON |

| Field Name | Long Name | Use and Processing Considerations | Tables Updated | Required for Conversion |
|--------------------|--------------------------------|---|------------------|-------------------------|
| LOAD_STATUS | Load Status | Identifies the status of this transaction. Valid values are 'NEW' = not processed; 'ERR' = an error exists on this transaction and it will not be processed; 'DON' = the transaction has been successfully processed. CON = transaction has been consolidated into a different transaction and it will not be loaded. UNI = transaction has been unitized into a different transaction and it will not be loaded. | Used internally. | Y default NEW |
| ORIG_INTFC_ID | Original Interface ID | Used for internal processing. Do not populate. | Used internally. | |
| ORIG_LINE_NUM | Original Interface Line Number | Used for internal processing. Do not populate. | Used internally. | |
| DEFAULT_PROFILE_SW | Default Books from Profile | Identifies whether a profile will be used for an asset add by the Transaction Loader. When this switch is set to 'Y' the BOOK table will have its fields defaulted from the profile tables rather than the load tables (INTFC...). The category on the cost table will also be defaulted from the profile tables. The profile_ID is identified on the INTFC_PHY_A table. When performing a CN1, you must set the DEFAULT_PROFILE_SW to 'N'. The value of DEFAULT_PROFILE_SW in INTFC_FIN must match the value of DEFAULT_PROFILE_SW in INTFC_PHY_A. | Used internally. | Y (Set = N for CN1) |

| Field Name | Long Name | Use and Processing Considerations | Tables Updated | Required for Conversion |
|--------------------|-------------------------------|---|----------------------------|-------------------------|
| TRANS_IN_OUT | Transaction In/Out | Used to identify which side of a transfer or recategorization this transaction represents. Every such transaction contains two transactions. The <i>outside</i> of the transaction adjusts the asset being transferred/recategorized from. The <i>inside</i> of the transaction adjusts the asset being transferred/recategorized to. | Used internally. | |
| PARENT_ID | Parent Asset ID | Used to identify the parent of this asset. Parent/Child relationships can be built using the Parent ID. A parent can be an existing asset (the parent ID is the asset ID of another asset) or a "virtual" asset (the parent ID is not an actual asset ID). In any case the parent ID should be a valid entry on the record Parent_Asset. If an entry does not exist on Parent_Asset for the parent ID, then Transaction Loader will create one. | ASSET, PARENT_ ASSET | |
| PARENT_DESCR | Parent Asset Description | The description of the parent asset that will be entered on the table parent_asset if an entry does not exist. | PARENT_ ASSET | |
| PARENT_DESCRLONG50 | Parent Asset Long Description | The long description of the parent asset that will be entered on the table parent_asset if an entry does not exist. | PARENT_ ASSET | |
| COMPONENT_OF_ID | Component of Asset | Used to establish Asset Components Structure. | ASSET | Y |
| ASSET_ASSIGNED_TO | Asset Assigned To | "Was to be used by REM. Lease Administration wanted to assign Chairs and other assets to the offices/asset. However, I believe that they agreed to not do that after all " | ASSET | Y |

| Field Name | Long Name | Use and Processing Considerations | Tables Updated | Required for Conversion |
|--------------------|-----------------------|---|----------------|-----------------------------|
| TAGGABLE_SW | Taggable Asset Switch | Indicates whether the asset is taggable or not. Valid values are 'Y' or 'N'. A tag is the physical tag that is affixed to an asset. | ASSET | |
| TAG_NUMBER | Tag Number | The tag number that is assigned to this asset. | ASSET | |
| DESCR | Description | A description of the asset. 30 characters. | ASSET | |
| DESCRSHORT | Short Description | A short description of the asset. 10 characters. | ASSET | |
| ASSET_STATUS | Asset Status | The status of the asset. The valid values are in the translate table. This field is generally for information purposes only. No accounting events are tied to this status. | ASSET | Y default to I (in service) |
| FINANCIAL_ASSET_SW | Capitalized Asset | Identifies whether this asset has been capitalized. Valid values are 'Y' for yes and 'N' for no. If an asset has not been capitalized, there can be no financial information or transactions for the asset (BOOK, COST, DEPRECIATION, RETIREMENT, OPEN_TRANS, etc.). However, there can be acquisition detail information (ASSET_ACQ_DET). Since acquisition detail is not tied to accounting events - it is an audit trail, you can store as much expense information as you would like. | ASSET | Y |
| REPLACE_SW | Replacement Asset | Identifies whether this is a replacement asset. | ASSET | |
| REPLACE_ASSET_ID | Replaced Asset ID | If this is a replacement asset, what is the Asset ID of the asset that was replaced. | ASSET | |

| Field Name | Long Name | Use and Processing Considerations | Tables Updated | Required for Conversion |
|------------------|-----------------------|--|------------------|-------------------------|
| CONVERSION_ID | Old Asset ID | Identifies the ID in an old system for this asset. We recommend that you do not try to convert your Asset IDs from your old system to AM. Since Asset ID is only an internal key to our system, it is better to let AM assign Asset IDs to your assets. You can then store the ID from the old system in this field. | ASSET | |
| NEW_ASSET_SW | New Asset | Was this asset acquired new? Valid values are 'Y' or 'N'. | ASSET | Y |
| AVAIL_SW | Asset is Available | Is this asset available for resale? Valid values are 'Y' or 'N'. When marked 'Y' this field can be queried to identify assets that are not being used by their custodians and are available for resale or internal transfer. A PS/Query is shipped with Asset Management as an example. | ASSET | Y |
| AVAIL_CONTACT | Availability Contact | If the asset is available, who should be contacted if someone is interested in the asset. | ASSET | |
| AVAIL_PHONE | Availability Phone | Phone number of the contact above. | ASSET | |
| ACQUISITION_CD | Acquisition Code | Identifies how this asset was acquired. The valid values are in the translate table. | ASSET | |
| ACQUISITION_DT | Acquisition Date | Identifies the acquisition date of this asset. This is a memo only field and is not used for any calculations. | ASSET | Y |
| FINANCING_CD | Financing Code | User defined financing code. Should be a valid value on the FINANCE_CD_TBL. | ASSET | |
| ASSET_DTTM_STAMP | Asset Date/Time Stamp | Used for internal processing. Do not populate. | Used internally. | |

| Field Name | Long Name | Use and Processing Considerations | Tables Updated | Required for Conversion |
|---------------|---------------------------------|--|----------------|-------------------------|
| PROFILE_ID | Asset Profile ID | Identifies the profile to be used to default the book information on an asset add. This field is only used if the INTFC_FIN.DEFAULT_PROFILE_SW = 'Y'. When that field is set to 'Y' then Profile ID must be populated with a valid, effective-dated Profile ID on the PROFILE_DET_TBL. | ASSET | Y |
| ASSET_CLASS | Asset Class | Identifies the asset class that this asset falls into. This is just another way to categorize your assets. This field must be a valid value on the ASSET_CLASS_TBL. This table is maintained in the Establish Asset Processing menu online. | ASSET | |
| CAP_NUM | Capital Acquisition Plan Number | Combined with CAP_SEQUENCE this field identifies the C.A.P. that this asset is associated with. Capital Acquisition Planning (C.A.P.) is a way of specifying asset budgets or appropriations. | ASSET | |
| MFG_ID | Manufacturer ID | Manufacturer Id of the Asset. | ASSET | Y |
| MANUFACTURER | Manufacturer Name | Manufacturer of the asset. | ASSET | |
| MODEL | Model | Model of the asset. | ASSET | |
| PROD_VERSION | Product Version | Product version of the asset. | ASSET | |
| SERIAL_ID | Serial ID | Serial number of the asset. | ASSET | |
| PRODUCTION_DT | Production Date | Production date of the asset. | ASSET | |
| PLANT | Manufacturing Plant | Plant that manufactured the asset. | ASSET | |

| Field Name | Long Name | Use and Processing Considerations | Tables Updated | Required for Conversion |
|--------------------|-----------------------------|--|-----------------|-------------------------|
| MANUFACTUR_CONTACT | Manufacturing Contact | Contact at the plant that manufactured the asset. | ASSET | |
| CAP_SEQUENCE | C.A.P. Sequence | Combined with CAP_NUM this field identifies the C.A.P. that this asset is associated with. Capital Acquisition Planning (C.A.P.) is a way of specifying asset budgets or appropriations. | ASSET | |
| REPLACEMENT_COST | Replacement Cost | Estimated replacement cost of the asset. This field can be processed by the Indexing feature in Asset Management. The indexing feature only updates replacement cost. It does not perform the initial population of this field. | ASSET | |
| LEASE_ASSET_ID | Lease Asset ID | If this is a non-capitalized asset and is associated with a lease, this is the Asset ID of that lease. This field must identify a capitalized asset ID with an acquisition code of leased. | ASSET | |
| BUSINESS_UNIT_JV | Joint Venture Business Unit | The "parent" JV business unit, if the asset is part of a joint venture. | Used internally | |
| INDEX_NAME | Index Name | Identifies which index to use in revaluing asset cost. | ASSET | |
| INDEX_DETAIL_NAME | Index Detail Name | Same as INDEX_NAME. | ASSET | |
| LAST_INDEX_VALUE | Last Index Value | Last index value used to revalue assets, such as the Consumer Price Index. | ASSET | Y |

| Field Name | Long Name | Use and Processing Considerations | Tables Updated | Required for Conversion |
|-------------------|----------------------------|---|----------------|-------------------------|
| COMPOSITE_SW | Composite Asset | Used to indicate whether the asset is a composite asset. Similar to parent/child assets except that a composite asset is not a “virtual” asset. The composite asset exists as a standard asset record within the Asset Management system. | ASSET | |
| COMPOSITE_ID | Composite Asset ID | If applicable, enter the Asset ID of the composite asset that is associated with this asset record. | ASSET | |
| FERC_CD | FERC Code | Identifies the FERC code associated with this asset. The valid values must be set up on the FERC Code table prior to implementation. PeopleSoft ships a ‘MODEL’ set of FERC codes with the system that can be shared by your business units. | ASSET | |
| SEQUENCE_NBR_6 | Sequence | Used to sequence the acquisition detail table. This field must be incremented for each acquisition detail row for an asset. The Transaction Loader does not increment this field, it must be assigned correctly on the INTFC_PHY_A table. This means that the feeder system must set this field. For the Payables and Purchasing interface this field is set by AMPS1000. | ASSET_ACQ_DET | |
| ACQUISITION_DESCR | DESCR field for ACQ_DETAIL | A description for the acquisition detail for this transaction. | ASSET_ACQ_DET | |
| CAPITALIZATION_SW | Capitalized | Identifies whether this particular transaction should be capitalized. Valid values are on the translate table. This must be set to 1, 2, 3, or 4 in order for acquisition detail records to be inserted. | ASSET_ACQ_DET | |

| Field Name | Long Name | Use and Processing Considerations | Tables Updated | Required for Conversion |
|------------------|-----------------------------|--|----------------|-------------------------|
| BUSINESS_UNIT_AP | AP Business Unit | The business unit from Accounts Payable that generated this transactions. | ASSET_ACQ_DET | |
| TXN_CURRENCY_CD | Transaction Currency | Transaction Currency Code | ASSET_ACQ_DET | Y |
| CURRENCY_CD | Currency Code | Represents the currency of the transaction. | ASSET_ACQ_DET | Y |
| RATE_DIV | Rate Divisor | Currency Conversion. | ASSET_ACQ_DET | Y |
| RATE_MULT | Rate Multiplier | Currency Conversion. | ASSET_ACQ_DET | Y |
| RT_TYPE | Rate Type | Currency Conversion. | ASSET_ACQ_DET | Y |
| BUSINESS_UNIT_PO | PO Business Unit | The business unit from Purchasing that is associated with this transaction. | ASSET_ACQ_DET | |
| PO_ID | Purchase Order Number | The PO number from Purchasing that is associated with this transaction. | ASSET_ACQ_DET | |
| PO_LINE_NBR | Purchase Order Line Number | The PO line number from Purchasing that is associated with this transaction. | ASSET_ACQ_DET | |
| SCHED_NBR | Schedule Number | The schedule number from Purchasing that is associated with this transaction. | ASSET_ACQ_DET | |
| PO_DIST_LINE_NUM | PO Distribution Line Number | The distribution line number from Purchasing that is associated with this transaction. | ASSET_ACQ_DET | |
| REFERENCE_ID | Reference Number | A general reference number associated with the acquisition of this asset. | ASSET_ACQ_DET | |

| Field Name | Long Name | Use and Processing Considerations | Tables Updated | Required for Conversion |
|----------------|-------------------------------|---|----------------|-------------------------|
| INVOICE_DT | Invoice Date | Represents the date of the invoice associated with this transaction. | ASSET_ACQ_DET | |
| VENDOR_ID | Vendor ID | The vendor ID from Accounts Payable or Purchasing that is associated with this transaction. | ASSET_ACQ_DET | |
| VENDOR_NAME | Vendor Name | The name of the vendor associated with this transaction. This would only be used when an external purchasing or payable system is used. | ASSET_ACQ_DET | |
| INVOICE_ID | Invoice Number | The invoice number of the invoice associated with this transaction. | ASSET_ACQ_DET | |
| TXN_AMOUNT | Transaction Amount | Amount in Transaction Currency. | ASSET_ACQ_DET | |
| AMOUNT | Amount | The amount of this transaction. This is the amount that will be capitalized if that is what has been requested. Note that this field is NOT used by Transaction Loader for inserting cost. It is the amount field on Acq Detail. It should match the COST field on INTFC_FIN. | ASSET_ACQ_DET | |
| QUANTITY | Quantity | The quantity of this transaction. This is the quantity that will be capitalized if that is what has been requested. Note that this field is NOT used by Transaction Loader for inserting cost. It is the quantity field on Acq Detail. It should match the QUANTITY field on INTFC_FIN. | ASSET_ACQ_DET | |
| SALETX_AMT | Sales Tax Distribution Amount | The amount of sales tax associated with this transaction. | ASSET_ACQ_DET | |
| SALETX_AMT_BSE | Base Sales Tax Amount | Sale Tax Amount in Transaction Currency | ASSET_ACQ_DET | |

| Field Name | Long Name | Use and Processing Considerations | Tables Updated | Required for Conversion |
|--------------------|-----------------------------------|--|----------------|-------------------------|
| SALETX_CD | Sales Tax Code | The code representing the sales taxing authority associated with this transaction. | ASSET_ACQ_DET | |
| USETAX_AMT | Use Tax Distribution Amount | The amount of use tax associated with this transaction. | ASSET_ACQ_DET | |
| USETAX_AMT_BSE | Base Use Tax Amount | Use Tax Amount in Transaction Currency. | ASSET_ACQ_DET | |
| USETAX_CD | Use Tax Code | The code representing the use taxing authority associated with this transaction. | ASSET_ACQ_DET | |
| FREIGHT_AMT | Freight Amount | The amount of freight associated with this transaction. | ASSET_ACQ_DET | |
| FREIGHT_AMT_BSE | Base Freight Amount | Freight Amount in Transaction Currency. | ASSET_ACQ_DET | |
| BUSINESS_UNIT_RECV | Business Unit Receive | Identifies the Purchasing receiving business unit that this transaction is associated with. | ASSET_ACQ_DET | |
| RECEIVER_ID | Receiver ID | Identifies the Purchasing receiving receiver ID that this transaction is associated with. | ASSET_ACQ_DET | |
| RECV_LN_NBR | Receiver Line Number | Identifies the Purchasing receiving line number that this transaction is associated with. | ASSET_ACQ_DET | |
| RECV_SHIP_SEQ_NBR | Receiver Shipping Sequence Number | Identifies the Purchasing receiving shipping sequence number that this transaction is associated with. | ASSET_ACQ_DET | |
| RECV_DIST_LINE_NUM | Receiver Distribution Line Number | Identifies the Purchasing receiving distribution line number that this transaction is associated with. | ASSET_ACQ_DET | |

| Field Name | Long Name | Use and Processing Considerations | Tables Updated | Required for Conversion |
|-----------------|------------------------------|---|----------------|-------------------------|
| DISTRIB_SEQ_NUM | Distribution Sequence Number | Identifies the Purchasing receiving distribution sequence number that this transaction is associated with. | ASSET_ACQ_DET | |
| INV_ITEM_ID | Inventory Item ID | Identifies the inventory item ID that this transaction is associated with. | ASSET_ACQ_DET | |
| OPERATING_UNIT | Operating Unit | The operating unit (ChartField) associated with this transaction. This field should be the same as the corresponding ChartField on the INTFC_FIN table. See the online ChartField customization topic for further discussion. | ASSET_ACQ_DET | |
| DEPTID | Department | The department (ChartField) associated with this transaction. This field should be the same as the corresponding ChartField on the INTFC_FIN table. | ASSET_ACQ_DET | |
| PRODUCT | Product | The product (ChartField) associated with this transaction. This field should be the same as the corresponding ChartField on the INTFC_FIN table. | ASSET_ACQ_DET | |
| FUND_CODE | Fund Code | A ChartField, which can be customized. See the online ChartField customization topic for further discussion. | ASSET_ACQ_DET | Y |
| CLASS_FLD | Class Field | A ChartField, which can be customized. See the online ChartField customization topic for further discussion. | ASSET_ACQ_DET | Y |
| PROGRAM_CODE | Program Code | A ChartField, which can be customized. See the online ChartField customization topic for further discussion. | ASSET_ACQ_DET | Y |

| Field Name | Long Name | Use and Processing Considerations | Tables Updated | Required for Conversion |
|------------------|--------------------------|--|----------------|-------------------------|
| BUDGET_REF | Budget Reference | A ChartField, which can be customized. See the online ChartField customization topic for further discussion. | ASSET_ACQ_DET | Y |
| AFFILIATE | Affiliate | A ChartField, which can be customized. See the online ChartField customization topic for further discussion. | ASSET_ACQ_DET | Y |
| AFFILIATE_INTRA1 | Fund Affiliate | A ChartField, which can be customized. See the online ChartField customization topic for further discussion. | ASSET_ACQ_DET | Y |
| AFFILIATE_INTRA2 | Operating Unit Affiliate | A ChartField, which can be customized. See the online ChartField customization topic for further discussion. | ASSET_ACQ_DET | Y |
| CHARTFIELD1 | ChartField 1 | A ChartField, which can be customized. See the online ChartField customization topic for further discussion. | ASSET_ACQ_DET | Y |
| CHARTFIELD2 | ChartField 2 | A ChartField, which can be customized. See the online ChartField customization topic for further discussion. | ASSET_ACQ_DET | Y |
| CHARTFIELD3 | ChartField 3 | A ChartField, which can be customized. See the online ChartField customization topic for further discussion. | ASSET_ACQ_DET | Y |
| PROJECT_ID | Project ID | The project (ChartField) associated with this transaction This field should be the same as the corresponding ChartField on the INTFC_FIN table. | ASSET_ACQ_DET | |
| CATEGORY | Asset Category | The category associated with this transaction. This field should be the same as the category on the INTFC_FIN table. | ASSET_ACQ_DET | Y |

| Field Name | Long Name | Use and Processing Considerations | Tables Updated | Required for Conversion |
|-------------------|------------------------|---|----------------|-------------------------|
| COST_TYPE | Cost Type | The cost type associated with this transaction. This field should be the same as the cost type on the INTFC_FIN table. | ASSET_ACQ_DET | |
| BUSINESS_UNIT_PC | Projects Business Unit | The business unit in Projects that generated this asset transaction. Can also come from Purchasing/Payables integration. | ASSET_ACQ_DET | |
| MASTER_PROJECT | Master Project | The master project in Projects that generated this asset transaction. | ASSET_ACQ_DET | |
| ACTIVITY_ID | Activity ID | The activity ID in Projects that generated this asset transaction. Can also come from Purchasing/Payables integration. | ASSET_ACQ_DET | |
| RESOURCE_TYPE | Resource Type | The resource type in Projects that generated this asset transaction. Can also come from Purchasing/Payables integration. | ASSET_ACQ_DET | |
| RESOURCE_SUB_CAT | Resource subcategory | The resource subcategory from Projects, Purchasing or Payables. | ASSET_ACQ_DET | |
| ANALYSIS_TYPE | Resource Analysis type | The resource analysis type in Projects that generated this asset transaction. Can also come from Purchasing/Payables integration. | ASSET_ACQ_DET | |
| RESOURCE_CATEGORY | Resource category | The resource category in Projects that generated this asset transaction. Can also come from Purchasing/Payables integration. | ASSET_ACQ_DET | |

| Field Name | Long Name | Use and Processing Considerations | Tables Updated | Required for Conversion |
|--------------------|--------------------------------|---|-----------------|-------------------------|
| CUSTODIAN_EFFDT | Asset Custodian Effective Date | The date the custodian of this asset became effective. If the transaction is an add, the date should be the same as the trans_dt. It is very important that this field be formatted with a valid date on an add transaction, whether or not the custodian is known. Transaction loader uses this when inserting custodian entries. If it is null, no custodian entry is loaded. | ASSET_CUSTODIAN | Y |
| EFFSEQ | Effective Sequence | The sequence number of the custodian. This will be zero unless the asset has had more than one custodian for a given effective date. | ASSET_CUSTODIAN | |
| CUSTODIAN | Custodian | The name of the custodian of this asset. | ASSET_CUSTODIAN | |
| EMPLID | Asset Custodian Employee ID | The employee ID of the custodian of this asset. | ASSET_CUSTODIAN | |
| CUSTODIAN_DEPTID | Asset Custodian Department | The department of the custodian of this asset. | ASSET_CUSTODIAN | |
| CUSTODIAN_PROJECT | Asset Custodian Project | The project associated with the custodian of this asset. | ASSET_CUSTODIAN | |
| OFFSITE_SW | This Asset is Offsite | Is this asset offsite? Valid values are 'Y' or 'N'. | ASSET_CUSTODIAN | |
| AUTH_STATUS | Authorization Status | The status of the authorization for this asset to be assigned to this custodian. | ASSET_CUSTODIAN | |
| AUTHORIZATION_NAME | Authorization Name | The name of the person who has authorized this asset to be assigned to this custodian. | ASSET_CUSTODIAN | |
| AUTHORIZATION_DT | Authorization Date | The date of the authorization for this asset to be assigned to this custodian. | ASSET_CUSTODIAN | |

| Field Name | Long Name | Use and Processing Considerations | Tables Updated | Required for Conversion |
|---------------------|-------------------------------------|--|--------------------|-------------------------|
| LOCATION_ EFFDT | Location Effective Date | The date the location of this asset became effective. If the transaction is an add, the date should be the same as the trans_dt. It is very important that this field be formatted with a valid date on an add transaction, whether or not the location is known. Transaction loader uses this when inserting location entries. If it is null, a location entry is not loaded. | ASSET_ LOCATION | Y |
| LOCATION_ EFFSEQ | Location Effective Sequence | The sequence number of the location. This will be zero unless the asset has been in more than one location for a given effective date. | ASSET_ LOCATION | |
| LOCATION | Location | The location of this asset. Should be a valid value on the LOCATION_TBL. | PI_ASSET_ HIST | |
| PI_ID | Physical Inventory ID | Used for internal processing. Do not populate. The physical inventory ID that was entered when defining physical inventory is used here. | ASSET_ LOCATION | |
| INVENTORY_ DT | Last Inventory Date | The last date that this asset was inventoried at this location. | PI_ASSET_ HIST | |
| PERFORMED_ BY | Performed By | The name of the person who performed the last inventory. | PI_ASSET_ HIST | |
| DOCUMENT_ ID | Document | A reference document ID associated with this asset. | ASSET_ LOCATION | |
| LOC_AUTH_ STATUS | Location Authorization Status | The authorization status for this asset at this location. | ASSET_ LOCATION | |
| LOC_AUTH_ NAME | Location Authorization Name | The name of the person who authorized this asset to be at this location. | ASSET_ LOCATION | |

| Field Name | Long Name | Use and Processing Considerations | Tables Updated | Required for Conversion |
|------------------|-----------------------------|--|--------------------------------------|-------------------------|
| LOC_AUTH_DT | Location Authorization Date | The date the authorization was given for this asset to be at this location. | ASSET_LOCATION | |
| REPLACE_COST_DT | Replacement Cost Date | Same as INDEX_NAME. | ASSET | |
| GROUP_ASSET_FLAG | Group Asset Flag | Used for Group Asset Processing. | ASSET | |
| GROUP_ASSET_ID | Group Asset ID | Used to identify which group asset group members report to. | BOOK, COST, DEPRECIATION, OPEN_TRANS | |
| RD_PLANT_ASSET | R&D Plant Asset | Flag to indicate this asset is used for R&D. | ASSET | |
| RD_START_DATE | R&D Start Date | Date asset became used for R&D. | ASSET | |
| RD_USE_NBV | Use NBV for R&D | Use net book value in gain/loss calculations for R&D assets. | ASSET | |
| LAST_INDEX_VALUE | Last Index Value | Last index value used to revalue assets, such as the Consumer Price Index. | ASSET | |
| INCENTIVE_ID | Incentive ID | An incentive ID, as would be assigned to a grant. Assigned in Projects and sent to Asset Management. | ASSET_ACQ_DET | |
| IP_ADDRESS | IP Address | The Internet Protocol address of an asset, such as a computer or printer. Can be uploaded from Tangram's Asset Insight during Physical Inventory. | ASSET | |
| IP_ALIAS | IP Alias | May be used to capture the name of a user associated with an asset, since IP addresses may be dynamic. Can be uploaded from Tangram's Asset Insight during Physical Inventory. | ASSET | |

| Field Name | Long Name | Use and Processing Considerations | Tables Updated | Required for Conversion |
|-------------------|------------------------------------|--|----------------|-------------------------|
| MERCH_AMT_BSE | Merchandise amount | Used in Payables/Assets integration. | ASSET_ACQ_DET | |
| VAT_INV_AMT | VAT Invoice Amount | Vat Invoice in Transaction Currency. | ASSET_ACQ_DET | Y |
| VAT_INV_AMT_BSE | VAT invoice amount | Used in Payables/Assets integration. | ASSET_ACQ_DET | |
| VAT_NRCVR_AMT | VAT Non Recoverable Amount | Vat Non Recoverable in Transaction Currency. | ASSET_ACQ_DET | Y |
| VAT_NRCVR_AMT_BSE | VAT Nonrecoverable amount | Used in Payables/Assets integration. | ASSET_ACQ_DET | |
| VAT_RCVRY_AMT | VAT Recovery Amt | Vat Recoverable in Transaction Currency. | ASSET_ACQ_DET | Y |
| VAT_RCVRY_AMT_BSE | VAT recovery amount | Used in Payables/Assets integration. | ASSET_ACQ_DET | |
| MISC_AMT | Misc Charge Amount | Miscellaneous Charges in transaction Currency. | ASSET_ACQ_DET | Y |
| MISC_AMT_BSE | Base Misc. Amount | Used in Payables/Assets integration. | ASSET_ACQ_DET | Y |
| AM_AST_UD_CHAR1 | User-defined Asset character field | | ASSET | |
| AM_AST_UD_CHAR2 | User-defined Asset character field | | ASSET | |
| AM_AST_UD_DATE1 | User-defined Asset date field | | ASSET | |
| AM_AST_UD_NUM1 | User-defined Asset numeric field | | ASSET | |

| Field Name | Long Name | Use and Processing Considerations | Tables Updated | Required for Conversion |
|-------------------|----------------------------------|--|----------------|-------------------------|
| AM_AST_UD_NUM2 | User-defined Asset numeric field | | ASSET | |
| PROCESS_INSTANCE | Process Instance | Internal | | |
| MERCHANDISE_AMT | Merchandise Amt | Merchandise Amount in Transaction Currency. | ASSET_ACQ_DET | Y |
| SKU | Stock Keeping Unit | Used to identify IT Software | ASSET | |
| UPC_ID | Uniform Product Code ID | Used to identify IT Software | ASSET | |
| VIN | VIN | Vehicle Identification Number | ASSET | |
| ASSET_RESOURCE_SW | Asset Resource Switch | Used by Maintenance Management. Indicates if Asset is "used as a tool". | ASSET | |
| ALLOW_OVERBOOK_SW | Allow Overbooking | Used by Maintenance Management to check if an asset can be double booked for scheduling. MM passes this to RM for Scheduling | ASSET | |
| CHARGE_BACK_SW | Charge Back Switch | Used by Maintenance Management. Allow chargebacks - this is one of the default levels for chargebacks | ASSET | |
| SCHEDULABLE_SW | Schedulable Switch | Used by Maintenance Management. Asset to be used in WO is able to be scheduled for maintenance. | ASSET | |
| EPL_TMPL_ID | Parts List Template | Used by Maintenance Management. Equipment and Parts list. | ASSET | |
| REPAIRABLE_FLG | Repairable Flag | Used by Maintenance Management. Asset is repairable. | ASSET | |

| Field Name | Long Name | Use and Processing Considerations | Tables Updated | Required for Conversion |
|-------------------|---------------------|--|----------------|-------------------------|
| REPAIR_STATUS | Repair Status | Used by Maintenance Management. Field values are: None, Needs Repair, In Repair. | ASSET | |
| BUSINESS_UNIT_WO | Business Unit | Used by Maintenance Management. The Business Unit of the Work Order where this asset could be used. | ASSET | |
| SHOP_ID | Shop | Used by Maintenance Management. hop/Location where the work order tasks are to be done. The shop for which this asset is used. | ASSET | |
| UNOWNED_FLG | Non-Owned Asset | Used by Maintenance Management. Asset not owned by the organization | ASSET | |
| WO_LOCATION_FLG | Work Order Location | Used by Maintenance Management. This field is used to determine what Location should be defaulted to the Work Location field on the Work Order Task, it contains 3 values: 'Asset' would default the Asset's Location as specified in the Asset definition; 'Shop' would default the Shop's Location; 'Other' will leave the Work Location blank for user entry. | ASSET | |
| OFFLINE_FLG | Asset Offline | Used by Maintenance Management. An indicator to indicate whether it needs to be taken offline for maintenance. | ASSET | |
| ASSET_CRITICALITY | Asset Criticality | Used by Maintenance Management. Indicator of how critical the asset is to help managers identify the priority of maintenance. | ASSET | |

| Field Name | Long Name | Use and Processing Considerations | Tables Updated | Required for Conversion |
|--------------------|----------------------|---|----------------|-------------------------|
| CREW_ID | Crew | Used by Maintenance Management to represent the Crew definition associated with the asset. | ASSET | |
| AVAIL_FOR_USE | Available For Use | Used by Maintenance Management. Asset is available to be used by a Work Order request. | ASSET | |
| PROPERTY_ID | Property I | Used by Real Estate Management. Identifier for an asset property | ASSET_PROPERTY | |
| PROPERTY_DESCR | Property Description | Used by Real Estate Management. Description of asset property | ASSET_PROPERTY | |
| PROPERTY_NM | Property Name | Used by Real Estate Management. Name of the asset property. | ASSET_PROPERTY | |
| PROPERTY_CLASS | Property Class | Used by Real Estate Management. Indicator that the property is a SITE, BUILDING, FLOOR, AREA, or SPACE. | ASSET_PROPERTY | |
| PROPERTY_SUBCLASS | Property Subclass | Used by Real Estate Management. Subcategory of Property Class. | ASSET_PROPERTY | |
| PARENT_PROPERTY_ID | Parent Property ID | Used by Real Estate Management. Parent Asset of the property. | ASSET_PROPERTY | |
| SITE_PROPERTY_ID | Site ID | Used by Real Estate Management. Property ID of the SITE for the asset's property hierarchy. | ASSET_PROPERTY | |
| BLDG_PROPERTY_ID | Building ID | Used by Real Estate Management. Property ID of the SITE for the asset's property hierarchy. | ASSET_PROPERTY | |

| Field Name | Long Name | Use and Processing Considerations | Tables Updated | Required for Conversion |
|-------------------|-----------------------|---|----------------|-------------------------|
| FLOOR_PROPERTY_ID | Floor ID | Used by Real Estate Management. Property ID of the BUILDING for the asset property hierarchy. | ASSET_PROPERTY | |
| AREA_PROPERTY_ID | Area ID | Used by Real Estate Management. Property ID of the BUILDING for the asset property hierarchy. | ASSET_PROPERTY | |
| SPACE_PROPERTY_ID | Space ID | Used by Real Estate Management. Property ID of the AREA for the asset's property hierarchy. | ASSET_PROPERTY | |
| PARCEL_NUMBER | Parcel Number | Used by Real Estate Management. Property ID of the SPACE for the asset's property hierarchy. | ASSET_PROPERTY | |
| LOT | Lot Number | Used by Real Estate Management. Used to record legal description from surveyors when recorded in Lots and Blocks. | ASSET_PROPERTY | |
| BLOCK | Block Number | Used by Real Estate Management. Used to record legal description from surveyors when recorded in Lots and Blocks. | ASSET_PROPERTY | |
| TOTAL_AREA | Total Area | Used by Real Estate Management. Total measurement in sq. ft or sq. meters for the asset. | ASSET_PROPERTY | |
| SPACE_UOM | Space Unit of Measure | Used by Real Estate Management. Used in conjunction with Total Area. Indicates Sq. Ft and Sq. Meters. | ASSET_PROPERTY | |
| CURRENT_OCCUPANCY | Current Occupancy | Used by Real Estate Management. Number of people currently occupying the asset property. | ASSET_PROPERTY | |

| Field Name | Long Name | Use and Processing Considerations | Tables Updated | Required for Conversion |
|------------------|------------------------------|--|-----------------|-------------------------|
| MAX_OCCUPANCY | Maximum Occupancy | Used by Real Estate Management. Max number of people that can be assigned to the asset property. | ASSET_PROPERTY | |
| OCCUPANCY_STATUS | Occupancy Status | Used by Real Estate Management. Indicates whether it is "occupied" or "unoccupied". | ASSET_PROPERTY | |
| OWNERSHIP_STATUS | Ownership Status | Used by Real Estate Management. Indicates whether it is "owned" or "leased". | ASSET_PROPERTY | |
| LEGAL_DESCR | Legal Description | Used by Real Estate Management. Legal description of asset property using metes and bounds. | ASSET_PROPERTY | |
| IT_UD_CHAR1 | IT User Defined Char Field 1 | ITAM User Defined Fields | ASSET | |
| IT_UD_CHAR2 | IT User Defined Char Field 2 | ITAM User Defined Fields | ASSET | |
| IT_UD_DATE1 | IT User Defined Date Field | ITAM User Defined Fields | ASSET | |
| IN_SERVICE_DT | In Service Date | Used to determine if the asset is still under warranty. | ASSET | |
| REGION_CD | Region Code | Used by Real Estate Management for Space Utilization metrics. Prompt allows for values for RPT Region Types. | | |
| CC_FLAG | Component Changeout Old/New | Internal | | |
| DESCR_LONG | Description | Long description for informational purposes. | ASSET | |
| AREA_ID | Area ID | A more granular level of the asset location used to identify areas. | ASSET, LOCATION | |

| Field Name | Long Name | Use and Processing Considerations | Tables Updated | Required for Conversion |
|-----------------|-----------------|--|----------------|-------------------------|
| LINEAR_ASSET_SW | Linear Asset | Identify linear assets and facilitate potential third-party integrations | ASSET | |
| NBR_OF_CPU | Number of CPU's | Used by ITAM. Identifies the number of CPU's in servers and desktop computers. A separate software license is needed for each CPU. | ASSET | |

Loader Table INTFC_PHY_B

When used, INTFC_PHY_B fields are most commonly loaded at conversion. They are not currently interfaced from Purchasing, Payables, or Projects, but could be with some customization.

Note. This table does not need to be inserted for conversion. But if you insert any values into it, the ones marked Y are required

| Field Name | Long Name | Use and Processing Considerations | Tables Updated | Required for Conversion |
|------------|--------------|--|------------------|-------------------------|
| INTFC_ID | Interface ID | <p>Key to this table. An interface ID is typically assigned to a group of transactions with the same load type.</p> <p>Use a unique, previously unused INTFC_ID for each set of transactions with the same load type.</p> <p>When using a load type of CN1 and NEXT in the ASSET_ID field, you'll need to use a unique INTFC_ID for each asset.</p> <p>For FADs and Conversions, if INTFC_ID is the same for multiple lines for an asset, increment the INTFC_LINE_NUM for each individual line.</p> | Used internally. | Y |

| Field Name | Long Name | Use and Processing Considerations | Tables Updated | Required for Conversion |
|----------------|---------------------------------------|---|---|-------------------------|
| INTFC_LINE_NUM | Interface Line Number | <p>Key to this table. Interface Line Number is used as a key for multiple lines for the same Interface ID for transactions with similar keys (ex., multiple acquisition details, such as CAP).</p> <p>For FADs and Conversions, if INTFC_ID is the same for multiple lines for an asset, increment the INTFC_LINE_NUM for each individual line.</p> | Used Internally. | Y |
| BUSINESS_UNIT | Business Unit | Identifies the business unit of the transaction to be processed. This field is required. | ASSET_ATTRIBUTE, ASSET_COMMENTS, ASSET_LICENSE, ASSET_WARRANTY | Y |
| ASSET_ID | Asset ID | Identifies the asset ID of the transaction to be processed. This field is required. If this field contains the value 'NEXT' and the interface type is FAD then Transaction Loader will assign the next asset ID for this business unit. | ASSET_ATTRIBUTE, ASSET_COMMENTS, ASSET_LICENSE, ASSET_WARRANTY | Y |
| INTFC_TYPE | Interface Type, also called Load Type | Identifies the type of transaction this is. Transaction loader will process this transaction based upon this field. Valid values are listed in the translate table. | Used internally. | Y |
| SYSTEM_SOURCE | System Source | The source system that created this transaction. Valid values are listed in the translate table. This field is used extensively by AM to drill back to source system. Feel free to add valid values to the translate table for your external systems. You can run Transaction Loader selectively for specific values of system source. | Used internally. | Y |

| Field Name | Long Name | Use and Processing Considerations | Tables Updated | Required for Conversion |
|-----------------|--------------------------------|---|------------------|-------------------------|
| MC_DEFN_ID | Mass Change ID | Used for internal processing. Do not populate. | Used internally. | |
| APPROVAL_SW | Auto Approval Status | Identifies whether the transaction is approved or not. Transaction Loader will only load approved transactions. Valid values are 'Y' for approved and 'N' for not approved. | Used internally. | Y |
| INTFC_STATUS | Interface Status | Used for internal processing. Do not populate. | Used internally. | |
| LOAD_STATUS | Load Status | Identifies the status of this transaction. Valid values are 'NEW' = not processed; 'ERR' = an error exists on this transaction and it will not be processed; 'DON' = the transaction has been successfully processed. 'CON' = transaction has been consolidated into a different transaction and it will not be loaded. 'UNI' = transaction has been unitized into a different transaction and it will not be loaded. | Used internally. | Y enter NEW |
| ATTRIBUTE_EFFDT | Asset Attribute Effective Date | <p>These next fields relate to the Asset_Attributes record. This is optional information. If you do not populate these fields then a row of asset attribute information will not be created for the asset (thus saving space). You can populate the asset attributes on as many (or as few) assets as you like. It is not an all or nothing proposition. If you are not planning on tracking attributes (color, weight, height, width, length, capacity, power rating) for an asset, then do not populate these fields for that asset.</p> <p>The effective date of the attributes of this asset. If the asset is being added, this should be the same as the trans_dt.</p> | ASSET_ATTRIBUTE | |

| Field Name | Long Name | Use and Processing Considerations | Tables Updated | Required for Conversion |
|----------------|--------------------------------|---|-----------------|-------------------------|
| ASSET_COLOR | Asset Color | The color of the asset. | ASSET_ATTRIBUTE | |
| ASSET_WEIGHT | Asset Weight | The weight of the asset. | ASSET_ATTRIBUTE | |
| WEIGHT_UM | Asset Weight Unit of Measure | The unit of measure used for the asset weight. Should be a valid unit of measure defined on the units of measure table. | ASSET_ATTRIBUTE | |
| ASSET_HEIGHT | Asset Height | The height of the asset. | ASSET_ATTRIBUTE | |
| HEIGHT_UM | Asset Height Unit of Measure | The unit of measure used for the asset height. Should be a valid unit of measure defined on the units of measure table. | ASSET_ATTRIBUTE | |
| ASSET_WIDTH | Asset Width | The width of the asset. | ASSET_ATTRIBUTE | |
| WIDTH_UM | Asset Width Unit of Measure | The unit of measure used for the asset width. Should be a valid unit of measure defined on the units of measure table. | ASSET_ATTRIBUTE | |
| ASSET_LENGTH | Asset Length | The length of the asset. | ASSET_ATTRIBUTE | |
| LENGTH_UM | Asset Length Unit of Measure | The unit of measure used for the asset length. Should be a valid unit of measure defined on the units of measure table. | ASSET_ATTRIBUTE | |
| ASSET_CAPACITY | Asset Capacity | The capacity of the asset. | ASSET_ATTRIBUTE | |
| CAPACITY_UM | Asset Capacity Unit of Measure | The unit of measure used for the asset capacity. Should be a valid unit of measure defined on the units of measure table. | ASSET_ATTRIBUTE | |

| Field Name | Long Name | Use and Processing Considerations | Tables Updated | Required for Conversion |
|--------------------|------------------------------------|--|-----------------|-------------------------|
| POWER_RATING | Asset Power Rating | The power rating of the asset. | ASSET_ATTRIBUTE | |
| POWER_RATING_UM | Asset Power Rating Unit of Measure | The unit of measure used for the asset power rating. Should be a valid unit of measure defined on the units of measure table. | ASSET_ATTRIBUTE | |
| COMMENT_DTTM_STAMP | Asset Comments Date/Time Stamp | The date/time stamp of the comments for this asset. This is used as a key to the Asset_Comments record. | ASSET_COMMENTS | |
| NAME | Name | The name of the person who entered the comments. | ASSET_COMMENTS | |
| COMMENTS50 | Comments 50 Characters | The comments for the assets. This field is long on the Asset_Comments record, but is a 50 byte character field here due to database restrictions. You can load additional comments online that can be up to 32k in length. | ASSET_COMMENTS | |

| Field Name | Long Name | Use and Processing Considerations | Tables Updated | Required for Conversion |
|-------------------|-------------------------|--|----------------|-------------------------|
| AGENCY_ID | Agency ID | <p>These next fields relate to the Asset_License record. It is used to track the license or registration of an asset with a given agency or vendor. An example may be a vehicle registration with the state or software registration with a vendor (like PeopleSoft!). This is optional information. If you do not populate these fields then a row of asset license information will not be created for the asset (thus saving space). You can populate asset license information on as many (or as few) assets as you like. It is not an all or nothing proposition. If you are not planning on tracking license information for an asset, then do not populate these fields for that asset.</p> <p>This field is the agency that the asset is registered with and is mutually exclusive of the asset license vendor ID. Should be a valid value on the Agency_Tbl record.</p> | ASSET_LICENSE | |
| LICENSE_VENDOR_ID | Asset License Vendor ID | This is the vendor that the asset is registered with and is mutually exclusive with the agency ID. Should be a valid value on the VNDR_FS record. | ASSET_LICENSE | |
| REGISTRATION_NO | Registration Number | The registration number for the asset. | ASSET_LICENSE | |
| INSPECTION_SW | Inspection Required | Is an inspection of the asset required? Valid values are 'Y' or 'N'. | ASSET_LICENSE | |
| LIC_START_DT | License Effective Date | The effective date of the license or registration. | ASSET_LICENSE | |
| LIC_END_DT | License Expiration Date | The expiration date of the license or registration. | ASSET_LICENSE | |

| Field Name | Long Name | Use and Processing Considerations | Tables Updated | Required for Conversion |
|---------------|-----------------|---|------------------------|-------------------------|
| REGISTER_NAME | Name | The name of the person under which the asset is registered. | ASSET_LICENSE | |
| COUNTRY | Country | The country in which the asset is registered. | ASSET_LICENSE, COUNTRY | |
| ADDRESS1 | Address 1 | The address line 1 under which the asset is registered. | ASSET_LICENSE | |
| ADDRESS2 | Address 2 | The address line 2 under which the asset is registered. | ASSET_LICENSE | |
| ADDRESS3 | Address 3 | The address line 3 under which the asset is registered. | ASSET_LICENSE | |
| ADDRESS4 | Address 4 | The address line 4 under which the asset is registered. | ASSET_LICENSE | |
| CITY | City | The city under which the asset is registered. | ASSET_LICENSE | |
| NUM1 | Number 1 | | ASSET_LICENSE | |
| NUM2 | Number 2 | | ASSET_LICENSE | |
| HOUSE_TYPE | House Type | The type of house, for example houseboat, trailer. | ASSET_LICENSE | |
| ADDR_FIELD1 | Address Field 1 | Address Field | ASSET_LICENSE | |
| ADDR_FIELD2 | Address Field 2 | Address Field | ASSET_LICENSE | |
| ADDR_FIELD3 | Address Field 3 | Address Field | ASSET_LICENSE | |
| COUNTY | County | The county under which the asset is registered. | ASSET_LICENSE | |

| Field Name | Long Name | Use and Processing Considerations | Tables Updated | Required for Conversion |
|-------------------------|--------------------------------------|---|----------------|-------------------------|
| STATE | State | The state under which the asset is registered. | ASSET_LICENSE | |
| POSTAL | Postal Code | The postal code under which the asset is registered. | ASSET_LICENSE | |
| GEO_CODE | Tax Vendor Geographical Code | The tax vendor geographical code. | ASSET_LICENSE | |
| IN_CITY_LIMIT | In City Limit | Is vendor within city limit? | ASSET_LICENSE | |
| LICENSE_COMMENTS50 | Asset License Comments 50 Characters | Comments about the license or registration for the asset. | ASSET_LICENSE | |
| WARRANTY_EFFECTIVE_DATE | Warranty Effective Date | <p>The following fields relate to the Asset_Warranty record. This is optional information. If you do not populate these fields then a row of asset warranty information will not be created for the asset (thus saving space). You can populate asset warranty information on as many (or as few) assets as you like. It is not an all or nothing proposition. If you are not planning on tracking warranty information for an asset, then do not populate these fields for that asset.</p> <p>This field represents the date the warranty for this asset became effective.</p> | ASSET_WARRANTY | |
| EFF_STATUS | Status as of Effective Date | The status of the warranty as of the effective date. Valid values are 'A' for active, or 'I' for inactive. | ASSET_WARRANTY | |
| WARRANTY_VENDOR_ID | Warranty Vendor ID | The vendor ID that has provided the warranty. This should be a valid value on the VNDR.FS record. | ASSET_WARRANTY | |

| Field Name | Long Name | Use and Processing Considerations | Tables Updated | Required for Conversion |
|-------------------|---------------------------------------|---|----------------|-------------------------|
| WARRANTY_NUM | Warranty Number | The number of the warranty. | ASSET_WARRANTY | |
| WARRANTY_DURATION | Warranty Duration (Months) | The duration of the warranty in months. | ASSET_WARRANTY | |
| COVERAGE50 | Asset Warranty Coverage 50 Characters | The comments on the coverage of the warranty. This field is a long field on the Asset_Warranty record, but is only 50 characters here. Online you can enter up to 32K of information into this field. | ASSET_WARRANTY | |
| JURISDICTION | Jurisdiction | Identifies the municipal authority of which it is a part. Could be used by property tax to identify taxing authority. | ASSET_LICENSE | |
| AM_AST_UD_CHAR1 | User Defined Char Field 1 | User defined. | ASSET | |
| AM_AST_UD_CHAR2 | User Defined Char Field 2 | User defined. | ASSET | |
| AM_AST_UD_DATE1 | User Defined Date Field 1 | User defined. | ASSET | |
| AM_AST_UD_NUM1 | User Defined Number Field 1 | User defined. | ASSET | |
| AM_AST_UD_NUM2 | User Defined Number Field 2 | User defined. | ASSET | |
| PROCESS_INSTANCE | Process Instance | Internal | | |

When converting a blank character field (a character field with a null value), you should assign it a value of a *single* space, regardless of the field length. For example, to convert a blank character field with a length of five characters, you should give it a value of one space, *not* five spaces. This is particularly important for ChartFields.

When converting character fields, do not add any trailing spaces to the field value. For example, the value in Book should be *CORP* not *CORP* .

When loading rows into any interface tables, the `intfc_id`, `intfc_line_num`, and `dtm_stamp` must be the same across all used loader tables (that is, `INTFC_FIN`, `INTFC_PHY_A`)

Transaction Loader Inserts

Depending on what Transaction Type you are processing, and which loader table it is reading, the Transaction loader inserts field values into various Asset Management tables and performs any additional processing noted in the table. It inserts all those fields that the target table and the loader table have in common.

From INTFC_FIN

The following table contains information inserted from `INTFC_FIN`.

| Transaction Type | Inserts into These Tables | Additional Processing |
|------------------|---|--|
| FAD | Book * Book Profile # Cost * Cost Profile # Depreciation * Depreciation Profile # Open Trans * Open Trans Profile # | |
| ADD | Book * Book Profile # Cost * Cost Profile # Depreciation * Depreciation Profile # Open Trans * Open Trans Profile # | |
| CN1 | Book * Book Profile # Cost * Cost Profile # Depreciation * Depreciation Profile # | Process Conversion Open Trans 1 |
| CN2 | Book * Book Profile # Cost * Cost Profile # Depreciation * Depreciation Profile # | Process Conversion Open Trans 1 |
| CAP | Book * Book Profile # Cost * Cost Profile # Depreciation * Depreciation Profile # Open Trans * Open Trans Profile # | |
| CIC | Book * Book Profile # Cost * Cost Profile # Open Trans * Open Trans Profile # | Validate Distribution Templates |
| AAD | Cost * Cost Profile # Open Trans * Open Trans Profile # | |
| IUI | Book * Cost # Open Trans * | Set Trans Type to TRF Set Trans_In_Out to 1 Validate Distribution Templates Process IUI Asset ID |

| Transaction Type | Inserts into These Tables | Additional Processing |
|------------------|---|---|
| IUO | Cost * Open Trans * | Set Trans Type to TRF Set Trans_In_Out to O Validate Distribution Templates |
| TRF | Cost (positive amount for transfer in) * Cost (negative amount for transfer out) * Open Trans * | |
| ADJ | Cost * Open Trans * | |
| RCT | Cost * Open Trans * | |
| RET | Cost * Retirement Open Trans * | Set Asset Status to Disposed |
| PRT | Cost * Retirement Open Trans * | |
| REI | Cost * Retirement Open Trans * | Update Asset Status to In Service |
| BKS | Open Trans * | Update Book Processing |
| BKD | | Delete Book |
| BSD | | Delete only BU/Book/Asset ID combinations |
| OPT | Open Trans * | |
| ASD | Deletes from all base tables | Check DIST_LN Delete Asset Processing |
| ADQ | Cost * Cost Profile # Open Trans * Open Trans Profile # | |
| ARA | Book * Book Profile # Cost * Cost Profile # Depreciation * Depreciation Profile # Retirement * Retirement Profile # | |

| Transaction Type | Inserts into These Tables | Additional Processing |
|------------------|--|-----------------------|
| LAD | Book * Book Profile # Cost * Cost Profile # Depreciation * Depreciation Profile # Retirement * Retirement Profile # Open Trans * | |
| ADP | Depreciation * Open Trans | |

* When Default Profile Switch = N

When Default Profile Switch = Y and PHY_A.PROFILE_ID is valid in the profile detail table, the system gets book, cost, depreciation, and open trans information from the profile detail table rather than INTFC_FIN.

From INTFC_PHY_A

The following table contains information inserted from INTFC_PHY_A.

| Transaction Type | Inserts into These Tables | Additional Processing |
|------------------|--|-------------------------------------|
| FAD | Asset, Asset Acquisition Detail, Asset Custodian, Asset Location | |
| NAD | Asset, Asset Acquisition Detail, Asset Custodian, Asset Location | |
| IUI | Asset, Asset Acquisition Detail, Asset Custodian, Asset Location | |
| CN1 | Asset, Asset Acquisition Detail, Asset Custodian, Asset Location | |
| AUP | | Update Asset |
| PHY | Asset Acquisition Detail Asset Custodian Asset Location | |
| CAP | Asset Acquisition Detail | Capitalize Asset Acquisition Detail |
| ACQ | Asset Acquisition Detail | |
| ADQ | Asset Acquisition Detail | |
| CLC | Asset Custodian Asset Location | |

| Transaction Type | Inserts into These Tables | Additional Processing |
|------------------|---|---|
| LAD | Asset, Asset Custodian, Asset Location | |
| CIC | | Update Asset Acquisition Detail = CIC |
| IHI | Physical Inventory History | |
| RAQ | Asset Acquisition Detail | Replace Acquisition Detail - Used solely by AMPS1000 and AMIF1000 |
| ARA | Asset Custodian, Asset Location, Physical Inventory History, Parent Asset | |

From INTFC_PHY_B

The following table contains information inserted from INTFC_PHY_B.

| Transaction Type | Inserts into These Tables | Additional Processing |
|------------------|---|-----------------------|
| FAD | Asset Attribute Asset Comments Asset License Asset Warranty | |
| NAD | Asset Attribute Asset Comments Asset License Asset Warranty | |
| PHY | Asset Attribute Asset Comments Asset License Asset Warranty | |
| CN1 | Asset Attribute Asset Comments Asset License Asset Warranty | |
| ARA | Asset Attribute Asset Comments Asset License Asset Warranty | |
| LAD | Asset Attribute Asset Comments Asset License Asset Warranty | |

Interface Types (Load Types)

The following table defines Interface Types.

| Interface Type | Long Name | Usage | Tables Updated |
|----------------|------------------------------------|--|--|
| AAD | Additional Cost Add | Rarely used. Used to add additional cost information to an asset. Mainly used for joint venture and composite rollups. Inserts into cost and open trans. | Cost, Open Trans |
| ACQ | Insert Acquisition Detail | Inserts into Acquisition Detail. | Acquisition Detail |
| ADD | Asset Add | Asset add - Financial only. Inserts into book, cost, depr, and open trans. For details see load type CN2. | Book, Cost, Depr, Open Trans |
| ADJ | Asset Cost Adjustment | To adjust the cost of an existing asset. | Cost, Open Trans |
| ADP | Asset Depreciation | Inserts depreciation information created by the revaluation in mass programs. | Depreciation, Open Trans |
| ADQ | Adjust Cost and Acquisition Detail | To adjust the cost and acquisition details of an existing asset. | Acquisition Detail, Cost, Open Trans |
| ARA | Add Retired Asset | To add an asset that has been fully reserved and retired. | Book, Cost, Depr, Asset, and if applicable Custodian, Asset Location, Warranty, Attribute, License, Comments, and Acquisition Detail |

| Interface Type | Long Name | Usage | Tables Updated |
|----------------|---------------------------|--|---|
| ASD | Asset Deletion | To delete an existing asset. This will only delete assets that have not been used to generate any journals. | Asset, Acquisition Detail, Asset Fair Market Value, Attribute, Comments, Custodian, Location, Maintenance, Warranty, Book, Book Tax Credit, Cost, Depr, Dist Line, Open Trans, Retirement, Lease, Lease Schedule, PI Asset History, |
| AUP | Asset Information Update | To update the asset table only. Rarely used except in physical inventory. | Asset, Component of Asset History |
| BKD | Book Deletion | To delete a book for an asset or business unit. For example, this can be used to delete any dummy books used for performing 'what if' analyses. | Book, Book Tax Credit, Depr, Dist Line, Retirement, Open Trans |
| BKS | Book Change | To make any change to an asset book. | Book, Open Trans |
| BSD | Selective Book Delete | To delete a book from a range of asset IDs. Very similar to BKD. | Book, Book Tax Credit, Depr, Dist Line, Retirement, Open Trans |
| CAP | Asset Capitalization | To add a line of acquisition detail and capitalize it. If the acquisition detail line is originally uncapitalized, the interface will insert book, cost, and open trans as well as acquisition detail. If it is originally capitalized, the book information will not be inserted. | Acquisition Detail, Book, Cost, Open Trans |
| CIC | Capitalize into Composite | Used to capitalize composite assets. Similar to CAP. | Acquisition Detail, Book, Cost, Open Trans |
| CLC | Custodian/Location Change | Updates custodian/location information. | Custodian, Location |

| Interface Type | Long Name | Usage | Tables Updated |
|----------------|-----------------------------------|--|---|
| CN1 | Conversion of First Book | Used during conversion to convert the first asset book. Inserts into all asset tables, as well as financial tables. | Book, Cost, Depr, Open Trans, Asset, Acquisition Detail, Location, PI Asset History, Component of Asset History, Parent Asset, Attribute, Comments, License, Warranty |
| CN2 | Conversion of Subsequent Books | Used during conversion to convert any subsequent books. Inserts only into financial tables. | Book, Cost, Depr, Component of Asset History, Open Trans |
| FAD | Financial and Physical Add | Used for adding assets with both physical and financial information. This is the Interface Type most commonly used for adding assets. | Book, Cost, Depr, Open Trans, Asset, Acquisition Detail, Location, PI Asset History, Component of Asset History, Parent Asset, Attribute, Comments, License, Warranty |
| IHI | Physical Inventory History Insert | Used by the Physical Inventory SQR (AMPI1000). | PI Asset History |
| IUI | InterUnit Transfer, In Side | <p>Used for the IN side of an InterUnit Transfer. Valid values for ACTIVITY_SW include:</p> <p>1 Full Transfer 0 Active ChartField combination -1 Reactivated ChartField combination</p> <p>For example, one ChartField combination is fully transferred out of a department (ACTIVITY_SW = 1) and an identical ChartField combination is transferred in to the same department (ACTIVITY_SW = -1). The activity switch values for the two transactions then cancel each other out, resulting in an active ChartField combination (ACTIVITY_SW = 0).</p> | Asset, Book, Cost, Asset Fair Market Value, Open Trans, Component of Asset History |

| Interface Type | Long Name | Usage | Tables Updated |
|----------------|------------------------------|---|---|
| IUO | InterUnit Transfer, Out Side | <p>Used for the OUT side of an InterUnit Transfer. Valid values for ACTIVITY_SW include:</p> <p>1 Full Transfer 0 Active ChartField combination -1 Reactivated ChartField combination</p> <p>For example, one ChartField combination is fully transferred out of a department (ACTIVITY_SW = 1) and an identical ChartField combination is transferred in to the same department (ACTIVITY_SW = -1). The activity switch values for the two transactions then cancel each other out, resulting in an active ChartField combination (ACTIVITY_SW = 0).</p> | Cost, Open Trans |
| LAD | Leased Asset Add | Used to add leased assets. | Lease, Lease Schedule, Book, Cost, Depr, Open Trans, Asset, Acquisition Detail, Asset Fair Market Value, Location, PI Asset History, Parent Asset, Attribute, Comments, License, Warranty |
| NAD | Non-financial Add | Used to add an asset with only physical information. | Asset, Custodian, Location, PI Asset History, Component of Asset History, Parent Asset, Attribute, Comments, License, Warranty, Open Trans |
| OPT | Open Transaction Generator | Used to create open transactions for a set of assets. Rarely used. | Open Trans |
| PHY | Physical Asset Change | Used to perform inserts to any physical asset tables other than the Asset Table, for example, location, custodian, or manufacturer. | Acquisition Detail, Custodian, Location, Attribute, Comments, License, Warranty |

| Interface Type | Long Name | Usage | Tables Updated |
|----------------|----------------------------|---|-------------------------------------|
| PRT | Partial Retirement | Used to perform partial retirements. | Cost, Retirement, Open Trans, Asset |
| RAQ | Replace Acquisition Detail | Used by AMPS1000 and AMIF1000 | Acquisition Detail |
| RCT | Asset Recategorization | Used to perform recategorizations. | Cost, Open Trans |
| REI | Asset Reinstatement | Used to perform reinstatements. | Cost, Retirement, Open Trans, Asset |
| RET | Asset Retirement | Used to perform full retirements. | Cost, Retirement, Open Trans, Asset |
| RNA | Non-Financial Retirements | Used to perform retirements of non-financial assets. | Asset, Asset Retirement |
| TRF | IntraUnit Transfer | <p>Used to perform transfers within the same business unit. Valid values for ACTIVITY_SW include:</p> <p>1 Full Transfer 0 Active ChartField Combination -1 Reactivated ChartField Combination</p> <p>For example, one ChartField combination is fully transferred out of a department (ACTIVITY_SW = 1) and an identical ChartField combination is transferred in to the same department (ACTIVITY_SW = -1). The activity switch values for the two transactions then cancel each other out, resulting in an active ChartField combination (ACTIVITY_SW = 0).</p> | Cost, Open Trans |

See Also

PeopleSoft Enterprise Asset Lifecycle Management Fundamentals 9.0 PeopleBook, “Integrating PeopleSoft Asset Management with Other Products,” Previewing Data in the Loader Tables

PeopleSoft Enterprise Asset Lifecycle Management Fundamentals 9.0 PeopleBook, “Integrating PeopleSoft Asset Management with Other Products,” Running the Transaction Loader

APPENDIX B

Understanding Depreciation Calculations

This appendix provides an overview of depreciation calculations and discusses how PeopleSoft Asset Management calculates:

- The begin depreciation date.
- Remaining value and remaining life.
- Yearly depreciation.
- Period allocation.
- Prior period depreciation.
- Formula-based depreciation methods.
- Depreciation when salvage value exceeds net book value.

Understanding How PeopleSoft Asset Management Calculates Depreciation

PeopleSoft Asset Management determines depreciation amounts using either tables or formulas. If you have a large number of assets, you will probably want to use formula-based depreciation, because this is considerably faster and uses less storage space. To help you more fully understand how PeopleSoft Asset Management calculates depreciation, this appendix includes a discussion of how formulas are used.

When you add an asset to PeopleSoft Asset Management, you decide the cost basis that you want to depreciate—you can include the basic cost of the asset as well as any freight and taxes that were paid. If you do not want to include freight and tax charges in the depreciable cost basis, you can still track these charges in the Acquisition Detail page.

If allowed by the depreciation method, the cost basis is reduced by either salvage value or tax credits.

Salvage Value

You can enter the salvage value as a percentage of the cost or the actual amount. Typically, you specify salvage value when you add the asset in PeopleSoft Asset Management. If allowed, salvage value is deducted from the cost basis for depreciation calculations. When the salvage value changes after depreciation begins, PeopleSoft Asset Management automatically adjusts the cost basis and depreciation from that time forward to reflect the change.

See [Appendix B, “Understanding Depreciation Calculations,” Calculating Depreciation When Salvage Value Exceeds Net Book Value \(NBV\), page 556.](#)

Tax Credits

Tax methods such as ACRS and MACRS determine which tax credits are available in PeopleSoft Asset Management. When you specify a Qualified Investment Code, PeopleSoft Asset Management uses this code to determine which tax credits apply to your assets. If you fail to specify a Qualified Investment Code for any reason, PeopleSoft Asset Management deduces the applicable code from the tax method that you elect.

If you do not specify a tax system, PeopleSoft Asset Management considers the date that the assets were placed in service to determine which method applies. Based on the tax method that you select and the recovery life, PeopleSoft Asset Management derives the corresponding qualified investment code and the tax credits that are available under that code, and elects the applicable tax credits for you.

If a Basis Reduction Percentage applies, the depreciable basis of the asset is reduced. The calculation is based on the Qualified Investment Code, the Tax Credit, and the Basis Reduction Percentage.

Calculating Tax Credits

PeopleSoft Asset Management uses the Qualified Investment Code, together with the Recovery Life and in-service date, to determine the Qualified Investment Percentage—the rate that is applied to the book cost—to determine the amount that qualifies for tax credits.

The Tax Credit Percentage is derived from the Tax Credit Type, Tax Credit Code, Recovery Life, and in-service date.

The amount of the tax credit is based on the following calculations:

Book Cost x Qualified Investment Percentage = Amount qualifying for the tax credit

Amount qualifying x Tax Credit Percentage = Amount of tax credit

Cost Basis Reduction

After the amount of the tax credit is calculated, a corresponding reduction in the basis is calculated as required:

Amount of tax credit x Basis Reduction Percentage = Amount the basis will be reduced

If you dispose of the asset before it has completely depreciated, PeopleSoft Asset Management calculates the recapture of the credit and adds it to the depreciable cost basis.

Section 179 Expense

If you elect to expense all or a portion of the cost, you should select the Section 179 Expense Taken check box on the Asset Book Definition - Tax page. You can expense assets up to an aggregate maximum of 200,000 USD per year, provided your company's gross income does not exceed the limitation that is specified by Federal tax law. Investment credits are automatically calculated based on the criteria that you enter in the Asset Book Definition - Tax Credit page.

Listed Property Assets

If an asset is considered a listed property asset for tax purposes, then the allowable depreciable basis is reduced by the percentage of business use. For example:

Business Use % = 75%

Cost = 10,000 USD

Depreciable basis = 7500 USD

Listed property is certain kinds of assets that are conducive to mixed business and personal use such as:

- Passenger automobiles under a certain weight.
- Any other property that is used for transportation such as trucks, buses, boats, airplanes, motorcycles, and any other vehicles for transporting persons or goods.
- Any property of a type that is generally used for entertainment, recreation, or amusement such as photographic, phonographic, communication, and video recording equipment.
- Any computer and related peripheral equipment unless it is used only at a regular business establishment and owned or leased by the person operating the establishment.
- Any cellular telephone (or similar telecommunications equipment) placed in service or leased in a tax year beginning after 1989.

The Depreciation Calculation Process

PeopleSoft Asset Management performs five basic steps to calculate depreciation for an asset. It calculates:

1. The asset's *beginning depreciation date*.
2. The asset's *remaining life* and *remaining value*.
3. The asset's yearly depreciation.
4. The asset's period depreciation allocation.
5. The asset's prior period depreciation.

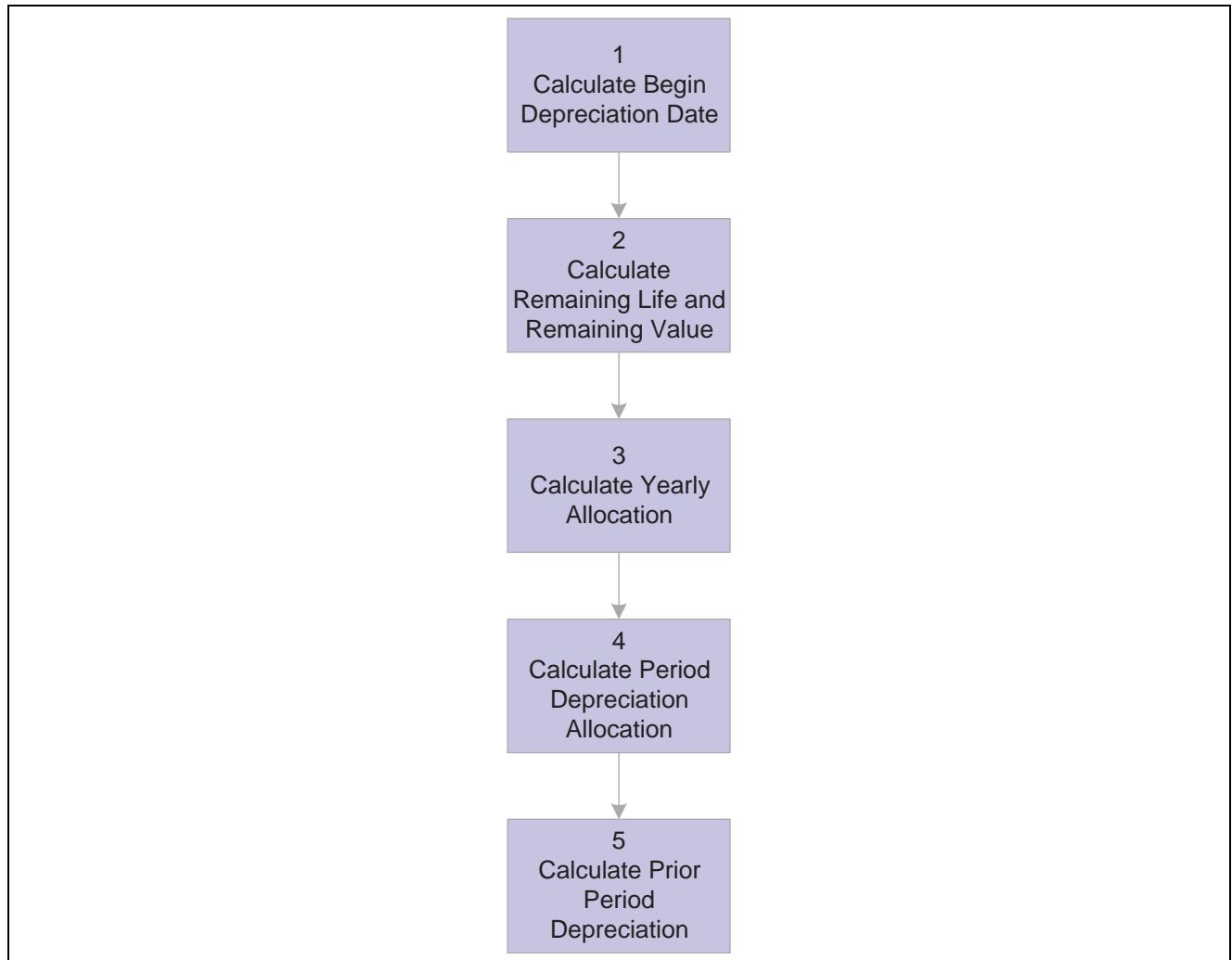

How PeopleSoft Asset Management calculates depreciation

The following sections provide illustrative examples of how PeopleSoft Asset Management handles all of these calculations in a variety of different scenarios.

Note. PeopleSoft Asset Management calculates depreciation yearly, not by month or by period. It then allocates yearly depreciation among the year's periods, except when you select the Declining Balance depreciation method or the Declining Balance method with a switch to the Straight Line method *and* the monthly depreciation option is selected.

Calculating the Begin Depreciation Date

PeopleSoft Asset Management uses two asset attributes to begin calculating depreciation:

- In-service date.
- Convention.

The combination of the in-service date and the prorated convention is the factor that actually determines when depreciation begins.

Overriding the Begin Depreciation Field

When you use the *Depreciate When in Service* date option, PeopleSoft Asset Management allocates depreciation based on the date that the asset was placed in service. This option is valid only in the year that the asset is acquired.

Calculating Remaining Value

PeopleSoft Asset Management calculates remaining value and remaining life using five asset attributes:

- Begin Depr Date
- Transaction Date
- Life
- Cost
- Accumulated Depreciation

Calculations differ depending on which calculation type is used and the relationship between the beginning depreciation date and the transaction date. The following examples show how the calculation is performed for each method.

Remaining Value Calculation for Add Transactions

The following table shows data that is used in the calculation examples that follow it.

| Attributes | Data |
|-----------------------------------|-----------------|
| Transaction Date | 10/1/2006 |
| Accounting Date | 10/1/2006 |
| In-Service Date | 3/1/2006 |
| Life | 60 periods |
| Cost | 6,000 USD |
| Accumulated Depreciation | 500 USD |
| Calculation Type | Remaining Value |
| Convention | Half-Year |
| Method | Straight-Line |
| Depreciate When In Service Switch | N |
| Begin Depr Date | 7/1/2006 |

| Attributes | Data |
|-----------------|------------|
| Remaining Value | 5,500 USD |
| Remaining Life | 60 periods |

Remaining Value

The following example illustrates remaining value:

$$\text{Remaining Value} = \text{Cost} - \text{Accumulated Depreciation}$$

$$6,000 \text{ USD cost} - 500 \text{ USD accumulated depreciation} = 5,500 \text{ USD remaining value}$$

Life to Date Calculation for Add Transactions

The following table shows data that is used in the calculation example that follows it.

| Attributes | Data |
|-----------------------------------|---------------|
| Transaction Date | 10/1/2006 |
| Accounting Date | 10/1/2006 |
| In-Service Date | 3/1/2006 |
| Life | 60 periods |
| Cost | 6,000 USD |
| Accumulated Depreciation | 500 USD |
| Calculation Type | Life to Date |
| Convention | Half-Year |
| Method | Straight-Line |
| Depreciate When In Service Switch | N |
| Begin Depr Date | 7/1/2006 |
| Remaining Value | 6,000 USD |
| Remaining Life | 60 periods |

Remaining Value

The following example illustrates remaining value:

$$\text{Remaining Value} = \text{Cost}$$

$$6,000 \text{ USD cost}$$

Calculating Yearly Depreciation

PeopleSoft Asset Management calculates yearly depreciation using two asset attributes:

- Begin Depr Date
- Depreciation Method

Other information that is used in this calculation includes the following information:

- Adj Trans Date
- Remaining Life
- Remaining Value

Calculations differ depending on which calculation type is used: *Remaining Value* or *Life to Date*. The following examples show how this calculation is performed for each method. The base information is the same in both cases.

Remaining Value Calculation for Add Transactions

The following table introduces the data used in the calculation example that follow it.

| Attributes | Data |
|-----------------------------------|-----------------|
| Transaction Date | 10/1/2006 |
| Accounting Date | 10/1/2006 |
| In-Service Date | 3/1/2006 |
| Life | 60 periods |
| Cost | 6,000 USD |
| Accumulated Depreciation | 500 USD |
| Calculation Type | Remaining Value |
| Convention | Half-Year |
| Method | Straight-Line |
| Depreciate When In Service Switch | N |
| Begin Depr Date | 7/1/2006 |
| Remaining Value | 5,500 USD |
| Remaining Life | 60 periods |
| Yearly Depreciation (First year) | 550 USD |

Yearly Depreciation for 2006

Here is yearly depreciation for 2006 using the Remaining Value calculation type:

```

Number of Periods in Year = Year End - Begin Depr Date
6 = 12/31/2006 - 7/01/2006
Percentage Depreciation for Year = Number of Periods in Year/Remaining Life
10% = 6 / 60
Yearly Depreciation = Percentage Depreciation for Year x Remaining Value
550 USD = 10% x 5500 USD

```

Life to Date Calculation for Add Transactions

The following table introduces the data that is used in the calculation example that follow it.

| Attributes | Data |
|-----------------------------------|---------------|
| Transaction Date | 10/1/2006 |
| Accounting Date | 10/1/2006 |
| In-Service Date | 3/1/2006 |
| Life | 60 periods |
| Cost | 6,000 USD |
| Accumulated Depreciation | 500 USD |
| Calculation Type | Life to Date |
| Convention | Half-Year |
| Method | Straight-Line |
| Depreciate When In Service Switch | N |
| Begin Depr Date | 7/1/2006 |
| Remaining Value | 6,000 USD |
| Remaining Life | 60 periods |
| Yearly Depreciation (First year) | 600.00 USD |

Yearly Depreciation for 2006

Here is yearly depreciation for 2006 using the Life to Date calculation type:

```

Number of Periods in Year = Year End - Begin Depr Date
6 = 12/31/2006 - 7/01/2006
Percentage Depreciation for Year = Number of Periods in Year/Remaining Life
10% = 6 / 60
Yearly Depreciation = Percentage Depreciation for Year x Remaining Value

```

$$600 \text{ USD} = 10\% \times 6000 \text{ USD}$$

Calculating Period Allocation

PeopleSoft Asset Management calculates period allocation using three asset attributes:

- In-Service Date
- Begin Depr Date
- Transaction Date

Other information that is used in this calculation includes the following, derived from previous calculations:

- Calculation Type
- Adjusted Transaction Date
- Yearly Depreciation
- Number of Periods in Year

Life to Date calculations differ depending on whether the Depreciate When in Service option is set to *N* or *Y*. The following examples illustrate how PeopleSoft Asset Management calculates period allocation using the *Remaining Value* and *Life to Date* calculations. All examples use the same base information.

When a remaining balance exists due to rounding in the year, PeopleSoft Asset Management allocates that amount to the last period of the fiscal year. For example, 2000 USD to be allocated over 12 periods, periods 1 through 11 will have 166.67 each and period 12 will have 166.63 USD (2000 USD - (166.67 x 11)).

| 1 | 2 | 3 | 4 | 5 | 6 | 7 | 8 | 9 | 10 | 11 | 12 | Periods |
|--------|--------|--------|--------|--------|--------|--------|--------|--------|--------|--------|--------|---------|
| 166.67 | 166.67 | 166.67 | 166.67 | 166.67 | 166.67 | 166.67 | 166.67 | 166.67 | 166.67 | 166.67 | 166.63 | Amounts |

Remaining Value Calculation for Add Transactions: Depreciate When In Service Off

The following table shows data that is used in the calculation.

| Attributes | Data |
|--------------------------|-----------------|
| Transaction Date | 10/1/2006 |
| Accounting Date | 10/1/2006 |
| In-Service Date | 3/1/2006 |
| Life | 60 periods |
| Cost | 6,000 USD |
| Accumulated Depreciation | 500 USD |
| Calculation Type | Remaining Value |

| Attributes | Data |
|-----------------------------------|---------------|
| Convention | Half-Year |
| Method | Straight-Line |
| Depreciate When In Service Switch | N |
| Begin Depr Date | 7/1/2006 |
| Remaining Value | 5,500 USD |
| Remaining Life | 60 periods |
| Yearly Depreciation (First year) | 550 USD |
| Period Allocation (First year) | 91.66 USD |

Period Depreciation Allocation

Here is the period depreciation allocation:

Period Depreciation Allocation = Yearly Depreciation / Number of Periods Remaining⇒
in Year

550 USD Yearly Depreciation / 6 periods = 91.66 USD per period

Remaining Value Calculation for Add Transactions: Depreciate When In Service On

The following table shows data that is used in the calculation example that follows it.

| Attributes | Data |
|-----------------------------------|-----------------|
| Transaction Date | 10/1/2006 |
| Accounting Date | 10/1/2006 |
| In-Service Date | 3/1/2006 |
| Life | 60 periods |
| Cost | 6,000 USD |
| Accumulated Depreciation | 500 USD |
| Calculation Type | Remaining Value |
| Convention | Half-Year |
| Method | Straight-Line |
| Depreciate When In Service Switch | Y |

| Attributes | Data |
|----------------------------------|------------|
| Begin Depr Date | 7/1/2006 |
| Remaining Value | 5,500 USD |
| Remaining Life | 60 periods |
| Yearly Depreciation (First year) | 550 USD |
| Period Allocation (First year) | 55 USD |

Period Depreciation Allocation

Here is the period depreciation allocation:

$$\text{Period Depreciation Allocation} = \frac{\text{Yearly Depreciation}}{\text{Periods from In-Service Date}}$$

$$\text{Periods from In-Service Date} = \text{Year End} - \text{In-Service Date}$$

$$550 \text{ USD Yearly Depreciation} / 10 \text{ periods from In-Service Date} = 55 \text{ USD per period}$$

Life to Date Calculations for Add Transactions: Depreciate When in Service Off

The following table shows data that is used in the calculation example that follows it.

| Attributes | Data |
|-----------------------------------|---------------|
| Transaction Date | 5/1/2006 |
| Accounting Date | 5/1/2006 |
| In-Service Date | 3/1/2006 |
| Life | 60 periods |
| Cost | 6,000 USD |
| Accumulated Depreciation | 500 USD |
| Calculation Type | Life to Date |
| Convention | Half-Year |
| Method | Straight-Line |
| Depreciate When In Service Switch | N |
| Begin Depr Date | 7/1/2006 |
| Remaining Value | 6,000 USD |
| Remaining Life | 60 periods |

| Attributes | Data |
|----------------------------------|------------|
| Yearly Depreciation (First year) | 600.00 USD |
| Period Allocation (First year) | 100 USD |

Period Depreciation Allocation

Here is the period depreciation allocation:

$$\text{Period Depreciation Allocation} = \text{Yearly Depreciation} / \text{Number of Periods in Year}$$

$$600 \text{ USD Yearly Depreciation} / 6 \text{ periods} = 100 \text{ USD per period}$$

Life to Date Calculation for Add Transactions: Calculate When in Service On

The following table shows data that is used in the calculation example that follows it.

| Attributes | Data |
|-----------------------------------|---------------|
| Transaction Date | 3/1/2006 |
| Accounting Date | 3/1/2006 |
| In-Service Date | 3/1/2006 |
| Life | 60 periods |
| Cost | 6,000 USD |
| Accumulated Depreciation | 500 USD |
| Calculation Type | Life to Date |
| Convention | Half-Year |
| Method | Straight-Line |
| Depreciate When In Service Switch | Y |
| Begin Depr Date | 7/1/2006 |
| Remaining Value | 6,000 USD |
| Remaining Life | 60 periods |
| Yearly Depreciation (First year) | 600.00 USD |
| Period Allocation (First year) | 60 USD |

Depreciation Results

The following table shows yearly depreciation by period for 2006.

| 1 | 2 | 3 | 4 | 5 | 6 | 7 | 8 | 9 | 10 | 11 | 12 | Periods |
|---|---|----|----|----|----|----|----|----|----|----|----|---------|
| | | 60 | 60 | 60 | 60 | 60 | 60 | 60 | 60 | 60 | 60 | Amount |

Remaining life is 60 periods; remaining value is 6,000 USD; yearly depreciation for 2006 is 600 USD.

Calculating Prior Period Depreciation

Prior period depreciation is generally calculated only for *Life to Date* calculations. In *Remaining Value* calculations, prior period depreciation is calculated only if the accounting date occurs after transaction date.

Prior period depreciation is keyed by a derived beginning calculation date. For remaining value calculations in which the accounting date occurs after the transaction date, the beginning calculation date equals the transaction date. For life to date calculations, the beginning calculation date depends on a combination of the following items:

- Transaction Date
- Begin Depr Date

Note. One overriding factor that is used to derive the beginning calculation date is that it can never occur before the beginning depreciation date. If according to all calculations it should, it is automatically made to equal the beginning depreciation date.

PeopleSoft Asset Management calculates prior period depreciation using the derived beginning calculation date as well as the following items:

- Period Depreciation Allocation
- Accumulated Depreciation

The following examples illustrate how PeopleSoft Asset Management calculates prior period depreciation.

Case 1: Add Transactions

The following table shows data that is used in the calculation example that follows it.

| Attributes | Data |
|--------------------------|--------------|
| Transaction Date | 10/1/2006 |
| Accounting Date | 10/1/2006 |
| In-Service Date | 3/1/2006 |
| Life | 60 periods |
| Cost | 6,000 USD |
| Accumulated Depreciation | |
| Calculation Type | Life to Date |

| Attributes | Data |
|-----------------------------------|---------------|
| Convention | Half-Year |
| Method | Straight-Line |
| Depreciate When In Service Switch | N |
| Begin Depr Date | 7/1/2006 |
| Begin Calc Date | 7/1/2006 |
| Remaining Value | 6,000 USD |
| Remaining Life | 60 periods |
| Yearly Depreciation (First year) | 600.00 USD |
| Period Allocation (First year) | 100 USD |
| Prior Period Depreciation | 300 USD |

Depreciation Results

The following table shows yearly depreciation by period for 2006. Prior period depreciation occurred in periods 7 through 9.

| 1 | 2 | 3 | 4 | 5 | 6 | 7 | 8 | 9 | 10 | 11 | 12 | Periods |
|---|---|---|---|---|---|-----|-----|-----|-----|-----|-----|------------|
| | | | | | | 100 | 100 | 100 | | | | Allowed |
| | | | | | | | | | 100 | 100 | 100 | Taken |
| | | | | | | 100 | 100 | 100 | | | | Difference |

Prior Period Depreciation

Here is the prior period depreciation:

```

Difference Per Period = Period Depreciation Allocation (allowed) - Depreciation
    Taken
Example Period 7: 100 USD - 0 = 100 USD
Begin Calc Date = Begin Depr Date
Periods from Begin Calc Date to Accounting Date = 7, 8, 9 = Periods within 7/1⇒
/2006 to 10/1/2006
Prior Period Depreciation = Sum of Difference Per Period for all periods within⇒
    Begin Calc Date to Accounting Date
$300 = $100 + $100 + $100
    
```

Case 2: Add Transactions

The following table shows data that is used in the calculation example that follows it.

| Attributes | Data |
|-----------------------------------|---------------|
| Transaction Date | 10/1/2006 |
| Accounting Date | 10/1/2006 |
| In-Service Date | 3/1/2006 |
| Life | 60 periods |
| Cost | 6,000 USD |
| Accumulated Depreciation | 500 USD |
| Calculation Type | Life to Date |
| Convention | Half-Year |
| Method | Straight-Line |
| Depreciate When In Service Switch | N |
| Begin Depr Date | 7/1/2006 |
| Begin Calc Date | 7/1/2006 |
| Remaining Value | 6,000 USD |
| Remaining Life | 60 periods |
| Yearly Depreciation (First year) | 600.00 USD |
| Period Allocation (First year) | 100 USD |
| Prior Period Depreciation | (200) USD |

Depreciation Results

The following table shows yearly depreciation by period for 2006. Prior period depreciation occurred in periods 7 through 9.

| 1 | 2 | 3 | 4 | 5 | 6 | 7 | 8 | 9 | 10 | 11 | 12 | Periods |
|---|---|---|---|---|-------|-----|-----|-----|-----|-----|-----|------------|
| | | | | | | 100 | 100 | 100 | 100 | 100 | 100 | Allowed |
| | | | | | 500 | | | | 100 | 100 | 100 | Taken |
| | | | | | (500) | 100 | 100 | 100 | | | | Difference |

Prior Period Depreciation

Here is the prior period depreciation:

$$\text{Difference Per Period} = \text{Period Depreciation Allocation (allowed)} - \text{Depreciation} \Rightarrow$$

Taken
 Example Period 7: 100 USD - 0 = 100 USD
 Begin Calc Date = Begin Depr Date
 Periods from Begin Calc Date to Accounting Date =
 7, 8, 9 = Periods within 7/1/2006 to 10/1/2006
 Prior Period Depreciation = Sum of Difference Per Period for all periods within⇒
 Begin Calc Date to Accounting Date - Accumulated Depreciation
 (200) USD = (500)USD + 100 USD + 100 USD + 100 USD

Case 3: Add Transactions

The following table shows data that is used in the calculation example that follows.

| Attributes | Data |
|-----------------------------------|---------------|
| Transaction Date | 10/1/2006 |
| Accounting Date | 10/1/2006 |
| In-Service Date | 3/1/2006 |
| Life | 60 periods |
| Cost | 6,000 USD |
| Accumulated Depreciation | |
| Calculation Type | Life to Date |
| Convention | Half-Year |
| Method | Straight-Line |
| Depreciate When In Service Switch | Y |
| Begin Depr Date | 7/1/2006 |
| Begin Calc Date | 7/1/2006 |
| Remaining Value | 6,000 USD |
| Remaining Life | 60 periods |
| Yearly Depreciation (First year) | 600.00 USD |
| Period Allocation (First year) | 60 USD |
| Prior Period Depreciation | 420 USD |

Depreciation Results

The following table shows yearly depreciation by period for 2006. Prior period depreciation occurred in periods 3 through 9.

| 1 | 2 | 3 | 4 | 5 | 6 | 7 | 8 | 9 | 10 | 11 | 12 | Periods |
|---|---|----|----|----|----|----|----|----|----|----|----|------------|
| | | 60 | 60 | 60 | 60 | 60 | 60 | 60 | 60 | 60 | 60 | Allowed |
| | | | | | | | | | 60 | 60 | 60 | Taken |
| | | 60 | 60 | 60 | 60 | 60 | 60 | 60 | | | | Difference |

Prior Period Depreciation

Here is the prior period depreciation:

Difference Per Period = Period Depreciation Allocation (allowed) - Depreciation⇒
Taken

Example Period 7: 60 USD - 0 = 60 USD

Begin Calc Date = Begin Depr Date

Periods from In Service Date to Accounting Date =

7, 8, 9, 10= Periods within 3/1/2006 to 10/1/2006

Prior Period Depreciation = Sum of Difference Per Period for all periods within In
Service Date to Accounting Date

420 USD = 60 USD + 60 USD + 60 USD + 60 USD + 60 USD + 60 USD + 60 USD

Case 4: Add Transactions

The following table shows data that is used in the calculation example that follows it.

| Attributes | Data |
|-----------------------------------|---------------|
| Transaction Date | 10/1/2006 |
| Accounting Date | 10/1/2006 |
| In-Service Date | 3/1/2006 |
| Life | 60 periods |
| Cost | 6,000 USD |
| Accumulated Depreciation | 500 USD |
| Calculation Type | Life to Date |
| Convention | Half-Year |
| Method | Straight-Line |
| Depreciate When In Service Switch | Y |
| Begin Depr Date | 7/1/2006 |
| Begin Calc Date | 7/1/2006 |
| Remaining Value | 6,000 USD |

| Attributes | Data |
|----------------------------------|------------|
| Remaining Life | 60 periods |
| Yearly Depreciation (First year) | 600.00 USD |
| Period Allocation (First year) | 60 USD |
| Prior Period Depreciation | (80) USD |

Depreciation Results

The following table shows yearly depreciation by period for 2006. Prior period depreciation occurred in periods 3 through 9.

| 1 | 2 | 3 | 4 | 5 | 6 | 7 | 8 | 9 | 10 | 11 | 12 | Periods |
|---|---|----|----|----|-------|----|----|----|----|----|----|------------|
| | | 60 | 60 | 60 | 60 | 60 | 60 | 60 | 60 | 60 | 60 | Allowed |
| | | | | | 500 | | | | 60 | 60 | 60 | Taken |
| | | 60 | 60 | 60 | (440) | 60 | 60 | 60 | | | | Difference |

Prior Period Depreciation

Here is the prior period depreciation:

Difference Per Period = Period Depreciation Allocation (allowed) - Depreciation⇒
Taken

Example Period 7: 60 USD - 0 = 60 USD

Begin Calc Date = Begin Depr Date

Periods from In Service to Accounting Date =

3, 4, 5, 6, 7, 8, 9 = Periods within 3/1/2006 to 10/1/2006

Prior Period Depreciation = Sum of Difference Per Period for all periods within In Service Date to Accounting Date

(80) USD = 60 USD + 60 USD + 60 USD + (440) USD + 60 USD + 60 USD + 60 USD

Case 5: Add Transactions

The following table shows data that is used in the calculation example that follows it.

| Attributes | Data |
|------------------|------------|
| Transaction Date | 3/1/2006 |
| Accounting Date | 10/1/2006 |
| In-Service Date | 3/1/2006 |
| Life | 60 periods |
| Cost | 6,000 USD |

| Attributes | Data |
|-----------------------------------|-----------------|
| Accumulated Depreciation | |
| Calculation Type | Remaining Value |
| Convention | Half-Year |
| Method | Straight-Line |
| Depreciate When In Service Switch | N |
| Begin Depr Date | 7/1/2006 |
| Begin Calc Date | 7/1/2006 |
| Remaining Value | 6,000 USD |
| Remaining Life | 60 periods |
| Yearly Depreciation (First year) | 600.00 USD |
| Period Allocation (First year) | 100 USD |
| Prior Period Depreciation | 300 USD |

Depreciation Results

The following table shows yearly depreciation by period for 2006. Prior period depreciation occurred in periods 7 through 9.

| 1 | 2 | 3 | 4 | 5 | 6 | 7 | 8 | 9 | 10 | 11 | 12 | Periods |
|---|---|---|---|---|---|-----|-----|-----|-----|-----|-----|------------|
| | | | | | | 100 | 100 | 100 | 100 | 100 | 100 | Allowed |
| | | | | | | | | | 100 | 100 | 100 | Taken |
| | | | | | | 100 | 100 | 100 | | | | Difference |

Prior Period Depreciation

Here is the prior period depreciation:

Difference Per Period = Period Depreciation Allocation (allowed) - Depreciation⇒
Taken

Example Period 7: 100 USD - 0 = 100 USD

Begin Calc Date = Begin Depr Date

Periods from Begin Calc Date to Accounting Date =

7, 8, 9 = Periods within 7/1/2006 to 10/1/2006

Prior Period Depreciation = Sum of Difference Per Period for all periods within⇒
Begin Calc Date to Accounting Date

300 USD = 100 USD + 100 USD + 100 USD

Formula-Based Depreciation Methods

PeopleSoft Asset Management is equipped to use the following different formula-based depreciation methods:

- Straight Line
- (IND) Straight Line Percent
- Declining Balance with a Switch to Straight Line
- Declining Balance with Depreciation Limit
- Declining Balance
- Flat Rate
- Sum of the Year's Digits

PeopleSoft Asset Management can calculate depreciation for each of the first six methods using either a schedule or a formula. The formulas that it uses to calculate yearly depreciation for each of these methods are explained in the following pages.

Straight Line

Yearly Straight Line depreciation is calculated using the following formula:

$$NBV \times (\text{Number of Periods to Depreciate} / \text{Remaining Life})$$

Straight Line Depreciation Example

The following table shows data that is used in the depreciation example that follows.

| Attributes | Data |
|----------------|--------------------------------------|
| Asset Cost | 11,000.00 USD |
| Salvage Value | 1,000.00 USD |
| Asset Basis | 10,000.00 USD (Cost - Salvage Value) |
| Life | 60 periods (5 years) |
| Begin Depr Dt. | 07/01/2006 |

Depreciation Results

The following table shows yearly depreciation and the calculation that is used to produce the result.

| Year | Depreciation Calculation | Depreciation Expense |
|------|--------------------------|----------------------|
| 2006 | 10,000 x (6/60) | = 1000.00 |
| 2007 | 9000 x (12/54) | = 2000.00 |
| 2008 | 7000 x (12/42) | = 2000.00 |
| 2009 | 5000 x (12/30) | = 2000.00 |

| Year | Depreciation Calculation | Depreciation Expense |
|------|--------------------------|----------------------|
| 2010 | 3000 x (12/18) | = 2000.00 |
| 2011 | 1000 x (6/6) | = 1000.00 |

(IND) Straight Line Percent

The Straight Line Percent method that is used in India differs from the Straight Line method. Depreciation is calculated based on rates rather than useful life. In addition, the rates also consider the residual or salvage value at the end of the asset useful life. In India the following assumptions are made:

- Assets are depreciated as of the in-service date.
- The minimum rates that are established by statute depreciate 95 percent of the asset cost over the asset useful life.
- An entity is entitled to depreciate at a higher rate, but not lower.

When using Straight Line Percent as the method, you complete the Percent field with the depreciation rate. The Useful Life field is unavailable. Other fields are ignored for this depreciation calculation. Although residual value is included in the rate, you have to enter salvage value.

Salvage Value acts as a limit. When the NBV reaches this amount, it automatically allocates the rest of the depreciable amount to the last period. Life in Years reflects both years and fractions, such as 8.4. Useful Life and Life in Years are displayed after you save or refresh the page. AM_DEPR_CALC recalculates these fields when it runs. Those assets that are coming from batch processes will calculate only Useful Life and Life in Years when you run AM_DEPR_CALC.

The formula to calculate Useful Life is:

$$(Cost - Salvage Value) / (Cost \times Depr Rate)$$

For example, an asset that is worth \$1,000 and a salvage value of \$50, with a 4.75% annual depreciation rate, using the actual month convention, will have a useful life of 20 years or 240 periods. Sometimes useful life may result in fractional periods.

| Year | NBV Begin | Rate | Depr | NBV End |
|------|-----------|--------|-------|---------|
| 2001 | 1,000.00 | 0.0475 | 47.50 | 952.50 |
| 2002 | 952.50 | 0.0475 | 47.50 | 905.00 |
| 2003 | 905.00 | 0.0475 | 47.50 | 857.50 |
| 2004 | 857.50 | 0.0475 | 47.50 | 810.00 |
| 2005 | 810.00 | 0.0475 | 47.50 | 762.50 |
| 2006 | 762.50 | 0.0475 | 47.50 | 715.00 |
| 2007 | 715.00 | 0.0475 | 47.50 | 667.50 |
| 2008 | 667.50 | 0.0475 | 47.50 | 620.00 |
| 2009 | 620.00 | 0.0475 | 47.50 | 572.50 |

| Year | NBV Begin | Rate | Depr | NBV End |
|------|-----------|---------------------------|---------------|---------|
| 2010 | 572.50 | 0.0475 | 47.50 | 525.00 |
| 2011 | 525.00 | 0.0475 | 47.50 | 477.50 |
| 2012 | 477.50 | 0.0475 | 47.50 | 430.00 |
| 2013 | 430.00 | 0.0475 | 47.50 | 382.50 |
| 2014 | 382.50 | 0.0475 | 47.50 | 335.00 |
| 2015 | 335.00 | 0.0475 | 47.50 | 287.50 |
| 2016 | 287.50 | 0.0475 | 47.50 | 240.00 |
| 2017 | 240.00 | 0.0475 | 47.50 | 192.00 |
| 2018 | 192.00 | 0.0475 | 47.50 | 145.00 |
| 2019 | 145.00 | 0.0475 | 47.50 | 97.50 |
| 2020 | 97.50 | 0.0475 | 47.50 | 50.00 |
| | | <i>Total Depreciation</i> | <i>950.00</i> | |

Remaining Value and Life to Date

Two different ways are available to calculate depreciation adjustments under Indian Straight Line Percent Method:

- Remaining Value
- Life to Date

For instance, in the preceding example, suppose that in the sixth year, the rate must change to 5.28 percent because the government adopts a new rate according to Schedule XIV. Using Remaining Value, the system calculates the useful life. It takes into account the new rate on the original cost. It calculates depreciation based on the NBV minus any residual value over the remaining new useful life, where remaining new useful life means the new useful life minus periods that are already depreciated.

Revised Useful Life:

$$(Cost - Salvage Value) / (Cost \times Depr Rate) \text{ Revised Useful Life: } (1000 - 50) / (1000 \times .0528) = 17.992424$$

Rounded up to 18 years or 216 months.

New Depreciation Amount:

$$(Net Book Value - Limiting Value) / (Revised useful life - Years Depreciated)$$

New Depreciation Amount:

$$(762.5 - 50) / (18 - 5) = 54.8076$$

In the last period, the remaining value will be residual value.

The following table shows the depreciation with the adjustment in the sixth year.

| Yearly Start Date | Original Cost | Schedule XIV Rates | Effective Depreciation | Net Book Value | Number of Years |
|-------------------|---------------|--------------------|------------------------|----------------|-----------------|
| 01 JAN 2003 | 1000.00 | 0.0475 | 47.50 | 952.50 | 1 |
| 01 JAN 2004 | 952.50 | 0.0475 | 47.50 | 905.00 | 2 |
| 01 JAN 2005 | 905.00 | 0.0475 | 47.50 | 857.50 | 3 |
| 01 JAN 2006 | 857.50 | 0.0475 | 47.50 | 810.00 | 4 |
| 01 JAN 2007 | 810.00 | 0.0475 | 47.50 | 762.50 | 5 |
| 01 JAN 2008 | 762.50 | 0.0528 | 54.81 | 707.69 | 6 |
| 01 JAN 2009 | 707.69 | 0.0528 | 54.81 | 652.88 | 7 |
| 01 JAN 2010 | 652.88 | 0.0528 | 54.81 | 598.08 | 8 |
| 01 JAN 2011 | 598.08 | 0.0528 | 54.81 | 543.27 | 9 |
| 01 JAN 2012 | 543.27 | 0.0528 | 54.81 | 488.46 | 10 |
| 01 JAN 2013 | 488.46 | 0.0528 | 54.81 | 433.65 | 11 |
| 01 JAN 2014 | 433.65 | 0.0528 | 54.81 | 378.85 | 12 |
| 01 JAN 2015 | 378.85 | 0.0528 | 54.81 | 324.04 | 13 |
| 01 JAN 2016 | 324.04 | 0.0528 | 54.81 | 269.23 | 14 |
| 01 JAN 2017 | 269.23 | 0.0528 | 54.81 | 214.42 | 15 |
| 01 JAN 2018 | 214.42 | 0.0528 | 54.81 | 159.62 | 16 |
| 01 JAN 2019 | 159.62 | 0.0528 | 54.81 | 104.81 | 17 |
| 01 JAN 2020 | 104.82 | 0.0528 | 54.81 | 50.00 | 18 |

In the case of Life to Date, the useful life is again recalculated. This method takes into account the new rate on the original cost. Depreciation is based on what the system had calculated if the rate would have been the new rate from the beginning. An adjustment to the prior depreciation amounts is required in this method to reflect the change retroactively. It consists of summarizing all depreciation amounts until the change and comparing with the amount that would have been obtained if the asset had always been calculated based on the new rate.

Useful Life:

$$(Cost - Salvage Value) / (Cost \times Depr Rate)$$

Useful Life:

$$(1000 - 50) / (1000 \times .0528) = 17.992424$$

Rounded up to 18 years or 216 months.

The following table depicts the depreciation if the rate had always been 5.28 percent.

| Yearly Start Date | Original Cost | Schedule XIV Rates | Effective Depreciation | Net Book Value | Number of Years | Total Depreciation |
|-------------------|---------------|--------------------|------------------------|----------------|-----------------|--------------------|
| 01 JAN 2003 | 1000.00 | 0.0528 | 52.80 | 947.20 | 1 | |
| 01 JAN 2004 | 947.20 | 0.0528 | 52.80 | 894.40 | 2 | |
| 01 JAN 2005 | 894.40 | 0.0528 | 52.80 | 841.60 | 3 | |
| 01 JAN 2006 | 841.60 | 0.0528 | 52.80 | 788.80 | 4 | |
| 01 JAN 2007 | 788.80 | 0.0528 | 52.80 | 736.00 | 5 | 264.00 |
| 01 JAN 2008 | 736.00 | 0.0528 | 52.80 | 683.20 | 6 | |
| 01 JAN 2009 | 683.20 | 0.0528 | 52.80 | 630.40 | 7 | |
| 01 JAN 2010 | 630.40 | 0.0528 | 52.80 | 577.60 | 8 | |
| 01 JAN 2011 | 577.60 | 0.0528 | 52.80 | 524.80 | 9 | |
| 01 JAN 2012 | 524.80 | 0.0528 | 52.80 | 472.00 | 10 | |
| 01 JAN 2013 | 472.00 | 0.0528 | 52.80 | 419.20 | 11 | |
| 01 JAN 2014 | 419.20 | 0.0528 | 52.80 | 366.40 | 12 | |
| 01 JAN 2015 | 366.40 | 0.0528 | 52.80 | 313.60 | 13 | |
| 01 JAN 2016 | 313.60 | 0.0528 | 52.80 | 260.80 | 14 | |
| 01 JAN 2017 | 260.80 | 0.0528 | 52.80 | 208.00 | 15 | |
| 01 JAN 2018 | 208.00 | 0.0528 | 52.80 | 155.20 | 16 | |
| 01 JAN 2019 | 155.20 | 0.0528 | 52.80 | 102.40 | 17 | |
| 01 JAN 2020 | 102.40 | 0.0528 | 52.40 | 50.00 | 18 | |

Compare the preceding table that shows what the amount would have been with a constant rate of 5.28 percent versus the following table that shows what the amounts are with a change and an adjustment in the sixth year.

| Yearly Start Date | Original Cost | Schedule XIV Rates | Effective Depreciation | Net Book Value | Number of Years | Adjustment |
|-------------------|---------------|--------------------|------------------------|----------------|-----------------|------------|
| 01 JAN 2003 | 1000.00 | 0.0475 | 47.50 | 952.50 | 1 | |
| 01 JAN 2004 | 952.50 | 0.0475 | 47.50 | 952.50 | 2 | |
| 01 JAN 2005 | 905.00 | 0.0475 | 47.50 | 905.00 | 3 | |
| 01 JAN 2006 | 857.50 | 0.0475 | 47.50 | 857.50 | 4 | |
| 01 JAN 2007 | 810.00 | 0.0475 | 47.50 | 762.50 | 5 | 237.50 |

| Yearly Start Date | Original Cost | Schedule XIV Rates | Effective Depreciation | Net Book Value | Number of Years | Adjustment |
|-------------------|---------------|--------------------|------------------------|----------------|-----------------|------------|
| 31 DEC 2007 | | | 26.50 | 736.00 | | 264.00 |
| 01 JAN 2008 | 736.00 | 0.0528 | 52.77 | 683.23 | 6 | |
| 01 JAN 2009 | 683.23 | 0.0528 | 52.77 | 630.46 | 7 | |
| 01 JAN 2010 | 630.46 | 0.0528 | 52.77 | 577.69 | 8 | |
| 01 JAN 2011 | 577.69 | 0.0528 | 52.77 | 524.92 | 9 | |
| 01 JAN 2012 | 524.92 | 0.0528 | 52.77 | 472.15 | 10 | |
| 01 JAN 2013 | 472.15 | 0.0528 | 52.77 | 419.38 | 11 | |
| 01 JAN 2014 | 419.38 | 0.0528 | 52.77 | 366.62 | 12 | |
| 01 JAN 2015 | 366.62 | 0.0528 | 52.77 | 313.85 | 13 | |
| 01 JAN 2016 | 313.85 | 0.0528 | 52.77 | 261.08 | 14 | |
| 01 JAN 2017 | 261.08 | 0.0528 | 52.77 | 208.31 | 15 | |
| 01 JAN 2018 | 208.31 | 0.0528 | 52.77 | 155.54 | 16 | |
| 01 JAN 2019 | 155.54 | 0.0528 | 52.77 | 102.77 | 17 | |
| 01 JAN 2020 | 102.77 | 0.0528 | 52.77 | 50.00 | 18 | |

Adjustment PDP:

Total Depreciation at new rate – Total Depreciation at former rate

Adjustment PDP:

$264 - 237.50 = 26.50$ for the first 5 years.

New Depreciation Amount:

(Net Book Value – Adj PDP - Limiting Value) / (Revised useful life – Years Depreciated)

New Depreciation Amount:

$(762.5 - 26.5 - 50) / (18 - 5) = 52.7692$

Declining Balance with a Switch to Straight Line

Declining Balance with a Straight Line Switch performs two simultaneous equations to calculate yearly depreciation. One equation calculates declining balance depreciation and the other calculates straight line depreciation. PeopleSoft Asset Management then compares the two yearly depreciation amounts and applies whichever is greater.

Note that in this type of calculation the asset's net book value is multiplied by the declining balance percentage times the straight line depreciation percentage.

$NBV \times ((\text{Number of Periods to Depreciate} / \text{Life}) \times \text{DB}\%)$

Declining Balance with a Switch to Straight Line Example

The following table shows data that is used in the depreciation example that follows it.

| Attributes | Data |
|---------------------|----------------------|
| Asset Cost | 10,000.00 USD |
| Life | 60 periods (5 years) |
| Begin Depr Dt. | 07/01/2006 |
| Declining Balance % | 200% |

Depreciation Results

The following table shows yearly depreciation and the calculation that is used to produce the result.

| Year | Depreciation Calculation | Depreciation Expense |
|-------------|---|----------------------|
| 2006 | $10,000 \times ((6/60) \times (200/100))$ | = 2000.00 |
| 2007 | $8000 \times ((12/60) \times (200/100))$ | = 3200.00 |
| 2008 | $4800 \times ((12/60) \times (200/100))$ | = 1920.00 |
| 2009 | $2880 \times ((12/60) \times (200/100))$ | = 1152.00 |
| 2010 x (SL) | $1728 \times (12/18)$ | = 1152.00 |
| 2011 x (SL) | $576 \times (6/6)$ | = 576.00 |

In this example, in 2010, the straight line depreciation is greater than the declining balance depreciation. Therefore, switch to straight line depreciation. The declining balance calculation for 2010 is $1728 \times ((12/60) \times (200/100)) = 691.20$. In 2011, the straight line depreciation is equal to the declining balance depreciation.

Declining Balance with Depreciation Limit

This calculation type enables you to specify annual depreciation limits based on a percentage of an asset's cost. This method supports asset management practices that are commonly used in some European countries. In environments in which this is legally acceptable, the advantage to this method is that it provides greater decreases in value in the first years of an asset's service. In some environments, a company may use this depreciation method initially and then switch to straight-line when that method provides a greater write-off.

This method runs three calculations and performs comparisons between the results.

First, it calculates using the formula that is already documented for Declining Balance with a Switch to Straight Line:

$NBV \times ((\text{Number of Periods to Depreciate}/\text{Life}) \times \text{DB}\%)$

(See DB column in the table provided with the following example.)

It then calculates using the specified limit percentage of original cost or bet book value:

$NBV \times \text{Limit}\%$

(See MAX column in the table provided with the following example.)

The results of these two calculations are compared and the system determines which amount is lesser. (See Comparison 1 column in the table provided with following example.)

Finally, it calculates using the Straight Line formula:

$NBV \times (\text{Number of Periods to Depreciate}/\text{Remaining Life})$

(See SL column in the table provided with following example.)

Results of the Straight Line calculation are compared with the lesser amount from the first comparison. (Column SL compared with column Comparison 1 in the following table. Comparison 2 column shows when the Straight Line method produces the greater result.)

The greater amount between this final comparison is the annual depreciation amount. (See Depr column in the table after the following table.)

Declining Balance with Depreciation Limit Example

The following table shows data that is used in the depreciation example that follows it.

| Attributes | Data |
|---------------------|----------------------|
| Asset Cost | 10,000.00 USD |
| Life | 96 periods (8 years) |
| Begin Depr Dt. | 01/01/2006 |
| Declining Balance % | 300% |
| Limit % | 30% |

Depreciation Results

The following table shows yearly depreciation and the calculation that is used to produce the result.

| Year | NBV | DB | Max (Limit%) | Comparison 1 | SL | Comparison 2 | Depr. |
|--------|--------|-------|--------------|--------------|-------|--------------|-------|
| Year 1 | 100000 | 37500 | 30000 | 30000 | 12500 | | 30000 |
| Year 2 | 70000 | 26250 | 21000 | 21000 | 10000 | | 21000 |
| Year 3 | 49000 | 18375 | 14700 | 14700 | 8167 | | 14700 |
| Year 4 | 34300 | 12862 | 10290 | 10290 | 6860 | | 10290 |
| Year 5 | 24010 | 9004 | 7203 | 7203 | 6003 | | 7203 |
| Year 6 | 16807 | 6303 | 5042 | 5042 | 5602 | SW | 5602 |

| Year | NBV | DB | Max (Limit%) | Comparison 1 | SL | Comparison 2 | Depr. |
|--------|-------|------|--------------|--------------|------|--------------|-------|
| Year 7 | 11205 | 4201 | 3361 | 3361 | 5602 | SW | 5602 |
| Year 8 | 5602 | 2101 | 1681 | 1681 | 5602 | SW | 5602 |

Declining Balance

For this type of calculation, the declining balance percentage represents a percentage of NBV.

$$NBV \times DB\%$$

When you are depreciating an asset with a declining balance method, the life of the asset is irrelevant. Note that if you used this method alone, an asset would never be fully depreciated. To fully depreciate an asset using the Declining Balance method, you must enter either a book low limit or an end depreciation date. When an asset's NBV reaches its book low limit or end depreciation date, the remaining value is taken in depreciation for that year.

Declining Balance Example

The following table shows data that is used in the depreciation example that follows it.

| Attributes | Data |
|---------------------|---|
| Asset Cost | 10,000.00 USD |
| Salvage Value | 1,000.00 USD (not used for calculating asset basis) |
| Asset Basis | 10,000.00 USD |
| Life | 60 periods (5 years) |
| Begin Depr Dt. | 01/01/94 |
| Declining Balance % | 20% |

Depreciation Results

The following table shows yearly depreciation and the calculation that is used to produce the result.

| Year | Depreciation Calculation | Depreciation Expense |
|------|--------------------------|----------------------|
| 1994 | 10,000 x (20/100) | = 2000.00 |
| 1995 | 8000 x (20/100) | = 1600.00 |
| 1996 | 6400 x (20/100) | = 1280.00 |
| 1997 | 5120 x (20/100) | = 1024.00 |
| 1998 | 4096 x (20/100) | = 819.20 |

| Year | Depreciation Calculation | Depreciation Expense |
|------|--------------------------|----------------------|
| 1999 | 3276.80 x (20/100) | = 655.54 |
| 2000 | 2621.21 x (20/100) | = 524.24 |

Calculations continue in this manner until the book low limit or end depreciation date is reached. If no book low limit or end depreciation date is specified, the asset never fully depreciates.

Flat Rate

The formula for calculating Flat Rate depreciation is simple.

$$\text{Basis} \times \text{Flat \%}$$

Flat Rate with an Averaging Option

You can combine the Flat Rate depreciation method with either a monthly or yearly averaging option. These options are typically used by utility companies to depreciate composite assets. When these options are used, PeopleSoft Asset Management uses up to three separate formulas to calculate depreciation for adjustments—one for calculating current period depreciation, one for calculating following period depreciation, and one for calculating depreciation for all subsequent periods.

These formulas are used only for calculating additional depreciation resulting from adjustments to the average balance. And these adjustments are applied only to the current year. For all subsequent years, as well as the first time it is done, the system calculates depreciation by applying the flat rate percentage to the average balance and allocating this amount among the periods.

Because of the averaging option, all adjustment transactions must take effect from the beginning of the year to its end. Therefore, current period depreciation is calculated after each transaction on a year-to-date basis.

As adjustments are made, additional depreciation is posted for each period that is affected.

Note. Using the flat rate depreciation method causes any depreciation to be posted to the end of the calendar. If this is not your intention, you must enter a low limit of .01 when you first select the depreciation method on the Asset Book Definition page group for this asset. If you have not already done this, update the Depreciation Method field on the General 2 page by selecting *Flat Rate* and entering .01 in the Low Limit additional field that appears.

Monthly Averaging Option

Review the following examples of monthly averaging calculations resulting from a \$2000 adjustment made in period 3. The asset is depreciated at 12%.

$$((\text{Adjustment Amount} / 2) \times \text{Flat Rate \%}) \times \text{Period Allocation}$$

Calculation for the current period (YTD):

$$((2,000 \text{ USD} / 2) \times 12\%) \times 3/12 = 30 \text{ USD}$$

$$\text{Current Period Depreciation} + ((\text{Adjustment Amount} \times \text{Flat Rate \%}) \times \text{Period Allocation})$$

Calculation for the following period:

$$30 \text{ USD} + ((2,000 \text{ USD} \times 12\%) \times 1/12) = 50 \text{ USD}$$

$$(\text{Adjustment Amount} \times \text{Flat Rate \%}) \times \text{Period Allocation}$$

Calculation for Subsequent Periods:

$$(2,000 \text{ USD} \times 12\%) \times 1/12 = 20 \text{ USD}$$

Note. The only exception to this rule occurs when the following period crosses into another fiscal year. When this is the case, all periods but the current one are calculated using the full value of the transaction. Current Period depreciation is not added to the following period depreciation.

Yearly Averaging Option

When using the yearly averaging option, you'll want to estimate financial activity for the year. The original estimate should be posted as an add transaction in the first period of the year and subsequently adjusted as the actual figures become available.

Review the following example of the yearly averaging option using the same 2,000 USD adjustment in Period 3. The asset is depreciated at 12 percent.

$$((\text{Adjustment Amount} / 2) \times \text{Flat Rate \%}) \times \text{Period Allocation}$$

Calculation for the current period (YTD):

$$((2,000 \text{ USD} / 2) \times 12\%) \times 3/12 = 30 \text{ USD}$$

$$((\text{Adjustment Amount} / 2) \times \text{Flat Rate \%}) \times \text{Period Allocation}$$

Calculation for all subsequent periods:

$$((2,000 \text{ USD} / 2) \times 12\%) \times 1/12 = 10 \text{ USD}$$

Sum of the Years' Digits

Yearly Sum of the Years' Digits depreciation is calculated using the following formula:

$$((\text{Remaining Years of Life} / \text{Sum of Years Remaining}) \times \text{NBV}) \times \% \text{ of Year to Depreciate}$$

Sum of the Years Digits Example

The following table shows data that is used in the depreciation example that follows it.

| Attributes | Data |
|----------------|----------------------|
| Asset Cost | 3700.00 |
| Salvage Value | 100.00 |
| Asset Basis | 3600.00 |
| Life | 36 periods (3 years) |
| Begin Depr Dt. | 07/01/2006 |

Depreciation Results

The following table shows yearly depreciation and the calculation that is used to produce the result.

| Year | Depreciation Calculation | Depreciation Expense |
|------|--|----------------------|
| 2006 | $3600 \times (3/(1+2+3)) \times (6/12)$ | = 900.00 |
| 2007 | $2700 \times (2.5/(1+2+3/2)) \times (12/12)$ | = 1500.00 |
| 2008 | $1200 \times (1.5/(1+2/2)) \times (12/12)$ | = 900.00 |
| 2009 | $300 \times (0.5/(1/2)) \times (6/6)$ | = 300.00 |

Calculation for the first year Sum of Years Remaining = $3/(1+2+3)$

Units of Production

Units of production depreciation differs from other methods in that it does not depreciate an asset based on its periods of life, but rather on its production detail. In this method, an asset is assumed to have a fixed lifetime production capacity—a maximum number of units it can produce. Thus, a fixed amount of depreciation is allotted to each unit of production. The net book value of the asset is then multiplied by the number of units that are produced in a period over the remaining units to be produced to determine how much depreciation to take for that period.

$NBV \times (\text{Units Produced} / \text{Units Remaining})$

Production detail for the asset is entered into the Units of Production table (Set Up Financials/Supply Chain, Product Related, Asset Management, Depreciation, Units of Production). Each time new detail is added to this table, open transactions are created for each asset that is associated with it. You should recalculate depreciation each time you add to or change the detail in the Units of Production table.

Units of Production Example

The following table shows data that is used in the depreciation example that follows it.

| Attributes | Data |
|----------------------------------|---------------|
| Asset Cost | 10,000.00 USD |
| Total Estimated Production Units | 40,000 |
| Production Units for each month | 10,000 |

Depreciation Results

The following table shows yearly and monthly depreciation and the calculation that is used to produce the result.

| Year, Month | Depreciation Calculation | Depreciation Expense |
|-----------------|---------------------------------|----------------------|
| Year 1, Month 1 | $10,000 \times (10,000/40,000)$ | = 2500.00 |
| Year 1, Month 2 | $7500 \times (10,000/30,000)$ | = 2500.00 |
| Year 1, Month 3 | $5000 \times (10,000/20,000)$ | = 2500.00 |
| Year 1, Month 4 | $2500 \times (10,000/10,000)$ | = 2500.00 |

Note. Units remaining are calculated by summing the production units for all remaining periods that are set up on the Units of Production page (Set Up Financials/Supply Chain, Product Related, Asset Management, Depreciation, Units of Production).

Calculating Depreciation When Salvage Value Exceeds Net Book Value (NBV)

There are instances when the residual value (salvage value) of an asset may increase to an amount equal to or greater than the asset's carrying amount (NBV.) If that situation arises, PeopleSoft provides the following treatments for depreciation calculation, depending upon statutory requirements:

- Stop depreciation calculation when salvage value exceeds NBV.
- Allow negative depreciation when salvage value exceeds NBV.

Stop Depreciation When Salvage Value Exceeds NBV

In compliance with International Accounting Standards (IAS) and Generally Accepted Accounting Principles (GAAP), PeopleSoft provides the option to stop the depreciation calculation in the event the salvage value of an asset exceeds that of its NBV.

See *PeopleSoft Enterprise Asset Lifecycle Management Fundamentals 9.0 PeopleBook*, "Setting Up Depreciation Processing," Enabling Options to Stop Negative Depreciation.

Stop Depreciation Example

The following table shows data that is used in the depreciation example that follows it:

| Attributes | Data |
|---|-----------------|
| Transaction Date | January 1, 2006 |
| Accounting Date | January 1, 2006 |
| In Service Date | January 1, 2006 |
| Calculation Type | Life to Date |
| Convention | Actual Month |
| Method | Straight Line |
| Asset Cost | 75,000.00 |
| Salvage Value (Increased from 0 to 50,000 on January 1, 2008) | 50,000.00 |
| Accumulated Depreciation (24 months in service) | 30,000.00 |
| Net Book Value at January 1, 2008 | 45,000.00 |
| Asset Useful Life | 60 months |

Depreciation Result - Stop Depreciation

The following table shows the result of the depreciation calculation when the Stop Depr option is selected:

| Year | Depreciation Calculation | Depreciation Expense |
|-------------------------------------|--------------------------|----------------------|
| January 1 through December 31, 2006 | 75,000 x (12/60 months) | 15,000.00 |
| January 1 through December 31, 2007 | 60,000 x (12/48 months) | 15,000.00 |
| January 1 through December 31, 2008 | Depreciation stopped | 0 |
| January 1 through December 31, 2009 | Depreciation stopped | 0 |
| January 1 through December 31, 2010 | Depreciation stopped | 0 |

Stop Depreciation Example with Additional Adjustment of Salvage Value

The following table shows data that is used in the depreciation example that follows it:

| Attributes | Data |
|---|-----------------|
| Transaction Date | January 1, 2006 |
| Accounting Date | January 1, 2006 |
| In Service Date | January 1, 2006 |
| Calculation Type | Life to Date |
| Convention | Actual Month |
| Method | Straight Line |
| Asset Cost | 75,000.00 |
| Salvage Value (Increased from 0 to 50,000 at January 1, 2008) | 50,000.00 |
| Accumulated Depreciation (24 months in service) | 30,000.00 |
| Net Book Value at January 1, 2008 | 45,000.00 |
| New Salvage Value - (Reduced to zero at January 1, 2009) | 0 |
| Asset Useful Life | 60 months |

Depreciation Result - Stop Depreciation with Additional Adjustment of Salvage Value

The following table shows the result of the depreciation calculation when the Stop Depr option is selected and there is an additional adjustment of salvage value:

| Year | Depreciation Calculation | Depreciation Expense |
|--|--|----------------------|
| January 1 through December 31, 2006 | 75,000 x (12/60 months) | 15,000.00 |
| January 1 through December 31, 2007 | 60,000 x (12/48 months) | 15,000.00 |
| January 1 through December 31, 2008 | Depreciation stopped | 0 |
| January 1 through December 31, 2009 (salvage value reduced to zero at January 1, 2009) | (NBV - Salvage Value = 45,000) (45,000 - 0 = 45,000) 45,000 x (12/24 months) | 22,500.00 |
| January 1 through December 31, 2010 | 22,500 x (12/12 months) | 22,500.00 |

Allow Negative Depreciation

The alternate approach to handling an asset when the NBV becomes less than the salvage value is to allow the system to generate negative depreciation until the NBV equals the salvage value at the end of the asset's useful life. To use this approach, simply do not select the Stop Depr when NBV < Salvage options.

Allow Negative Depreciation

The following table shows data that is used in the depreciation example that follows it:

| Attributes | Data |
|---|-----------------|
| Transaction Date | January 1, 2006 |
| Accounting Date | January 1, 2006 |
| In Service Date | January 1, 2006 |
| Calculation Type | Life to Date |
| Convention | Actual Month |
| Method | Straight Line |
| Asset Cost | 75,000.00 |
| Salvage Value (Increased from 0 to 50,000 at January 1, 2008) | 50,000.00 |
| Accumulated Depreciation (24 months in service) | 30,000.00 |
| Net Book Value at January 1, 2008 | 45,000.00 |
| Asset Useful Life | 60 months |

Depreciation Result - Allow Negative Depreciation

The following table shows the result of the depreciation calculation when the Stop Depr option is not selected:

| Year | Depreciation Calculation | Depreciation Expense |
|---|---|----------------------|
| January 1 through December 31, 2006 | $75,000 \times (12/60 \text{ months})$ | 15,000.00 |
| January 1 through December 31, 2007 | $60,000 \times (12/48 \text{ months})$ | 15,000.00 |
| January 1 through December 31, 2008 (Salvage Value increase on January 1, 2008) | $(\text{NBV} - \text{Salvage Value}) \times (12/36 \text{ months})$ $(45,000 - 50,000) \times (12/36 \text{ months})$ | - 1,666.67 |
| January 1 through December 31, 2009 | $(\text{NBV} - \text{Salvage Value}) \times (12/24 \text{ months})$ $(46,666.67 - 50,000) \times (12/24 \text{ months})$ | - 1,666.67 |
| January 1 through December 31, 2010 | $(\text{NBV} - \text{Salvage Value}) \times (12/12 \text{ months})$ $(48,333.33 - 50,000) \times (12/12 \text{ months})$ | - 1,666.67 |

Allow Negative Depreciation with Additional Adjustment of Salvage Value

The following table shows data that is used in the depreciation example that follows it:

| Attributes | Data |
|---|-----------------|
| Transaction Date | January 1, 2006 |
| Accounting Date | January 1, 2006 |
| In Service Date | January 1, 2006 |
| Calculation Type | Life to Date |
| Convention | Actual Month |
| Method | Straight Line |
| Asset Cost | 75,000.00 |
| Salvage Value (Increased from 0 to 50,000 at January 1, 2008) | 50,000.00 |
| Accumulated Depreciation (24 months in service) | 30,000.00 |
| Net Book Value at January 1, 2008 | 45,000.00 |
| New Salvage Value - (Reduced to zero at January 1, 2009) | 0 |
| Asset Useful Life | 60 months |

Depreciation Result - Allow Negative Depreciation with Additional Adjustment to Salvage Value

The following table shows the result of the depreciation calculation when the Stop Depr option is not selected and there is an additional adjustment to salvage value:

| Year | Depreciation Calculation | Depreciation Expense |
|--|--|-----------------------------|
| January 1 through December 31, 2006 | $75,000 \times (12/60 \text{ months})$ | 15,000.00 |
| January 1 through December 31, 2007 | $60,000 \times (12/48 \text{ months})$ | 15,000.00 |
| January 1 through December 31, 2008 (Salvage value increase on January 1, 2008) | $(\text{NBV} - \text{Salvage Value}) \times (12/36 \text{ months})$ $(45,000 - 50,000) \times (12/36 \text{ months})$ | - 1,666.67 |
| January 1 through December 31, 2009 (Salvage value reduced to zero on January 1, 2009) | $(\text{NBV} - \text{Salvage Value}) \times (12/24 \text{ months})$ $(46,666.67 - 0) \times (12/24 \text{ months})$ | 23,333.34 |
| January 1 through December 31, 2010 | $(\text{NBV} - \text{Salvage Value}) \times (12/12 \text{ months})$ $(23,333.33 - 0) \times (12/12 \text{ months})$ | 23,333.33 |

APPENDIX C

PeopleSoft Asset Management Reports

This appendix provides an overview of PeopleSoft Asset Management reports, lists common elements, and enables you to:

- View summary tables of all reports.
- View report details and tables accessed.

Note. For samples of these reports, see the Portable Document Format (PDF) fields that are published on CD-ROM with your documentation.

See Also

Enterprise PeopleTools 8.48 PeopleBook, “Process Scheduler”

PeopleSoft Asset Management Reports: A to Z

These tables list the PeopleSoft Asset Management reports, sorted alphanumerically by report ID. If you need more information about a report, refer to the report details at the end of this appendix.

This section discusses:

- Asset lists.
- Transaction reports.
- Capital acquisition planning reports.
- Depreciation reports.
- Impairment Reports
- Account activity reports.
- Accounting entry reports.
- Physical inventory reports.
- Lease reports.
- Retirement reports.
- U.S. tax reports.
- Global reports.

Asset Set Up Lists

| Report ID and Report Name | Description | Navigation | Run Control Page |
|--|--|--|------------------|
| AMBU1000 Asset Management Units/Books | Lists all valid business units and asset books. (Crystal) | Set Up Financials/Supply Chain, Business Unit Related, Reports, Asset Management Units/Books | RUN_AMBU1000 |
| AMAE1000 List of Accounting Entry Templates | Lists all accounting entry templates by category. (Crystal) | Set Up Financials/Supply Chain, Product Related, Asset Management, Reports, Accounting Entry Templates | RUN_AMAE1000 |
| AMAE1100 Book Code Discrepancy Report | Lists book code discrepancies where accounting entry templates do not meet the book code validations for pairs distribution types. (SQR) | Set Up Financials/Supply Chain, Product Related, Asset Management, Reports, Accounting Entry Templates | RUN_AMAE1000 |
| AMAS1100 Asset Categories | Lists Asset Categories (Crystal) | Set Up Financials/Supply Chain, Product Related, Asset Management, Reports, Asset Categories | RUN_AMAS1100 |

Transaction Reports

| Report ID and Report Name | Description | Navigation | Run Control Page |
|--|---|--|------------------|
| AMAS1600 Asset Warranties | Lists all of the warranties that are in place for a specified business unit as of a date that you select. (Crystal) | Asset Management, Service and Maintenance, Reports, Warranties | RUN_AMAS1600 |
| AMAS1700 Asset Licenses | Lists asset licenses. (Crystal) | Asset Management, Service and Maintenance, Reports, License Information | RUN_AMAS1700 |
| AMAS2000 Cost Activity | Sorts cost activity by ChartField, by Category, or by Account (SQR). Use the PeopleSoft Asset Management report formatting features to include/exclude data and append suffixes to identify report types. | Asset Management, Financial Reports, Cost and Depreciation, Cost Activity Report | RUN_AMAS2000 |
| AMAS2100 Asset Acquisitions by ChartField | Lists asset information and also includes Cost, LTD and YTD Depreciation and Net Book Value with ChartField, Book and Report totals. (SQR) | Asset Management, Financial Reports, Asset Details, Acquisitions | RUN_AMAS2100 |

| Report ID and Report Name | Description | Navigation | Run Control Page |
|---|--|---|------------------|
| AMAS2110 Asset Acquisitions by In Service Date | Lists asset information and also includes Cost, LTD and YTD Depreciation and Net Book Value with ChartField, In-service Period/Year, Book and Report totals. (SQR) | Asset Management, Financial Reports, Asset Details, Acquisitions | RUN_AMAS2100 |
| AMAS2200 Assets by Location | Lists information on assets by location. (SQR) | Asset Management, Financial Reports, Asset Details, By Location | RUN_AMAS2200 |
| AMAS2210 Assets by Asset ID | Lists assets by Asset ID. (SQR) | Asset Management, Financial Reports, Asset Details, By Location | RUN_AMAS2200 |
| AMAS2300 Asset Transfers by ChartField | Lists asset transfers transactions ordered by ChartField. (SQR) | Asset Management, Financial Reports, Cost and Depreciation, Asset Transfers | RUN_AMAS2300 |
| AMAS2400 Asset Reclassifications | Lists asset recategorizations ordered by ChartField. (SQR) | Asset Management, Financial Reports, Cost and Depreciation, Asset Reclassifications | RUN_AMAS2400 |
| AMAS2201 Hazardous Assets by Location | List assets designated as hazardous, sorted by location. (SQR) | Asset Management, Financial Reports, Asset Details, Hazardous Assets by Location | RUN_AMAS2201 |
| AMCH1000 Asset Component Hierarchy Move | List asset component hierarchy moves made through the Manage Component Hierarchy transaction (SQR) | Asset Management, Financial Reports, Asset Details, Asset Component Hierarchy Move | RUN_AMCH1000 |

Capital Acquisition Planning Reports

| Report ID and Report Name | Description | Navigation | Run Control Page |
|---|---|--|------------------|
| AMCP2000 Capital Acquisition Plans | Lists capital acquisition planning information. (SQR) | Asset Management, Asset Transactions, Capital Acquisition Planning, Run Report | RUN_AMCP2000 |
| AMCP2010 Capital Acquisition Plans by Department | Lists capital acquisition planning by department. (SQR) | Asset Management, Asset Transactions, Capital Acquisition Planning, Run Report | RUN_AMCP2000 |
| AMCP2100 Capital Acquisition Planning Assets | Lists capital acquisitions planning by asset ID. (SQR) | Asset Management, Asset Transactions, Capital Acquisition Planning, Run Report | RUN_AMCP2000 |

Depreciation Reports

| Report ID and Report Name | Description | Navigation | Run Control Page |
|--|--|--|-------------------|
| AMDP2000 Depreciation Activity | Sorts cost activity by ChartField. (SQR), by Category, or by Account. Use the PeopleSoft Asset Management report formatting features to include/exclude data and append suffixes to identify report types. | Asset Management, Financial Reports, Cost and Depreciation, Depreciation Activity | RUN_AMDP2000 |
| AMDP2021 Depreciation Activity by Alternate Account | Sorts depreciation activity by alternate account. (SQR) | Asset Management, Financial Reports, Accounting Entries, Alt Account Activity Detail, Depreciation Activity by Alt Account | RUN_AMDP2000 |
| AMDP2100 Net Book Value | Sorts cost activity by ChartField, by Category, Location, or by Account (SQR). Use the PeopleSoft Asset Management report formatting features to include/exclude data and append suffixes to identify report types. This report also provides options for assets that have had their depreciation stopped. | Asset Management, Financial Reports, Cost and Depreciation, Asset Net Book Value | RUN_AMDP2100 |
| AMDP2121 Asset Net Book Value by Alternate Account | Sorts asset net book value information by alternate account. (SQR) | Asset Management, Financial Reports, Accounting Entries, Alt Account Activity Detail, Net Book by Alt Account | RUN_AMDP2100 |
| AMDP2150 Group Member Estimated NBV | Lists estimated depreciation accumulation of the member. (SQR) | Asset Management, Financial Reports, Cost and Depreciation, Group Member Estimated NBV | RUN_AMDP2150_RQST |
| AMDP2200 Depreciation by Period | Sorts assets by period depreciation at asset, category, department, book, or project levels. (SQR) Use the PeopleSoft Asset Management report formatting features to include/exclude data. | Asset Management, Financial Reports, Cost and Depreciation, Depreciation by Period | RUN_AMDP2200 |

| Report ID and Report Name | Description | Navigation | Run Control Page |
|---|---|---|-------------------|
| AMDP2300 Depreciation by Fiscal Year | Sorts assets by fiscal year depreciation at asset, category, project, department, or book levels. (SQR) Use the PeopleSoft Asset Management report formatting features to include/exclude data. | Asset Management, Financial Reports, Cost and Depreciation, Depreciation by Fiscal Year | RUN_AMDP2300 |
| AMGL1000 Crystal - AM to GL Reconciliation by Department | Reconciles AM to GL by ChartField. (Crystal) | Asset Management, Financial Reports, Cost and Depreciation, AM/GL and NBV Reports | RUN_RPT_TBLS_REPS |
| AMGL1010 Crystal - AM to GL Reconciliation by Category | Reconciles AM to GL by category. (Crystal) | Asset Management, Financial Reports, Cost and Depreciation, AM/GL and NBV Reports | RUN_RPT_TBLS_REPS |
| AMNB1000 Crystal - Asset NBV by ChartField | Sorts net book value by ChartField. (Crystal) | Asset Management, Financial Reports, Cost and Depreciation, AM/GL and NBV Reports | RUN_RPT_TBLS_REPS |
| AMNB1010 Crystal - Asset NBV by Category | Lists net book value related amounts sorted by category. (Crystal) | Asset Management, Financial Reports, Cost and Depreciation, AM/GL and NBV Reports | RUN_RPT_TBLS_REPS |
| AMNB1030 Crystal - Asset NBV by Location | Lists net book value related amounts sorted by location. (Crystal) | Asset Management, Financial Reports, Cost and Depreciation, AM/GL and NBV Reports | RUN_RPT_TBLS_REPS |

Impairment Reports

| Report ID and Report Name | Description | Navigation | Run Control Page |
|---|---|---|--------------------|
| AMIMP001 Impaired Asset Value Report by Category | Lists impaired asset values summarized by asset category. (Crystal) | Asset Management, Financial Reports, Cost and depreciation, Asset Impairment, Impaired Asset Value Report by Category | AM_IMP_RPT_RUN_CTL |
| AMIMP002 Impaired Asset Value Report by CGU | Lists impaired asset values summarized by asset CGU. (Crystal) | Asset Management, Financial Reports, Cost and depreciation, Asset Impairment, Impaired Asset Value Report by CGU | AM_IMP_RPT_RUN_CTL |

Account Activity Reports

| Report ID and Report Name | Description | Navigation | Run Control Page |
|--|---|--|------------------|
| AMAS2030 Account Activity Summary - Cost | Lists cost and related transaction amounts per account with ChartFields, book, and report totals. (SQR) | Asset Management, Financial Reports, Accounting Entries, Account Activity Summary | RUN_AMAE2000 |
| AMDP2030 Account Activity Summary - Depreciation | Lists depreciation and related transaction amounts per account with ChartFields, book, and report totals. (SQR) | Asset Management, Financial Reports, Accounting Entries, Account Activity Summary | RUN_AMAE2000 |
| AMDP2130 Account Activity Summary - Net Book Value | Lists cost balance, YTD, LTD, depreciation and NBV amount per account. (SQR) | Asset Management, Financial Reports, Accounting Entries, Account Activity Summary | RUN_AMAE2000 |
| AMAS2031 AltAccount Activity Summary - Cost | Lists cost and related transaction amounts per account with ChartFields, book, and report totals. (SQR) | Asset Management, Financial Reports, Accounting Entries, Alt Accounting Entry Detail | RUN_AMAE2001 |
| AMAS2021 Cost Activity by Alt Account | Sorts cost activity by Alternate Account. (SQR) | Asset Management, Financial Reports, Cost and Depreciation, Cost Activity Report | RUN_AMAS2000 |
| AMDP2031 AltAccount Activity Summary - Depreciation | Lists depreciation and related transaction amounts per account with ChartFields, book, and report totals. (SQR) | Asset Management, Financial Reports, Accounting Entries, Alt Accounting Entry Detail | RUN_AMAE2001 |
| AMDP2131 AltAccount Activity Summary - Net Book Value | Lists cost, depreciation and net book value amounts per account with ChartFields, book, and report totals. This report is similar to the Account Activity Summary Report. (SQR) | Asset Management, Financial Reports, Accounting Entries, Alt Accounting Entry Detail | RUN_AMAE2001 |

Accounting Entry Reports

| Report ID and Report Name | Description | Navigation | Run Control Page |
|--|---|--|------------------|
| AMAE2100 Accounting Entry Detail | Lists accounting entry details. (SQR) | Asset Management, Financial Reports, Accounting Entries, Account Entry | RUN_AMAE2100 |
| AMAE2101 Alternate Account Entry Detail | Retrieves alternate account entry information with ChartField, alternate account and report totals. (SQR) | Asset Management, Reports, Accounting Entries, Alt Account Entry | RUN_AMAE2101 |

| Report ID and Report Name | Description | Navigation | Run Control Page |
|--|--|---|------------------|
| AMAE2110 Accounting Entry Detail - Cost | Lists cost and related transaction amounts per asset, with ChartFields, book, and report totals. (SQR) | Asset Management, Financial Reports, Accounting Entries, Account Activity Summary | RUN_AMAE2000 |
| AMAE2120 Accounting Entry Detail - Depreciation | Lists depreciation and related transaction amounts per asset, with ChartFields, book, and report totals. (SQR) | Asset Management, Financial Reports, Accounting Entries, Account Activity Summary | RUN_AMAE2000 |
| AMAE2130 Accounting Entry Detail - Net Book Value | Lists cost balance, YTD, and LTD depreciation and NBV amounts per asset. (SQR) | Asset Management, Financial Reports, Accounting Entries, Account Activity Summary | RUN_AMAE2000 |
| AMAE2111 Alt Acct Entry Detail – All | Gather alternate account entry detail information. Lists cost beginning and ending balance with related transaction amounts. (SQR) | Asset Management, Financial Reports, Accounting Entries, Alt Account Entry Detail | RUN_AMAE2001 |
| AMAE2121 Alt Acct Entry Detail – Depr | Gather alternate account entry detail information. Lists cost beginning and ending balance with related transaction amounts. (SQR) | Asset Management, Financial Reports, Accounting Entries, Alt Account Entry Detail | RUN_AMAE2001 |
| AMAE2131 Alt Acct Entry Detail – NBV | Lists Cost Balance, YTD, and LTD Depreciation and NBV amount per asset. (SQR) | Asset Management, Financial Reports, Accounting Entries, Alt Account Entry Detail | RUN_AMAE2001 |

Physical Inventory Reports

| Report ID and Report Name | Description | Navigation | Run Control Page |
|--|---------------------------------------|--|------------------|
| AMPI2000 Physical Inventory Extract | Gathers PI extract data. (SQR) | Asset Management, Physical Inventory, Run Physical Inventory Reports | RUN_AMPI2000 |
| AMPI2100 Physical Inventory Scan Data | Gathers PI scan data. (SQR) | Asset Management, Physical Inventory, Run Physical Inventory Reports | RUN_AMPI2000 |
| AMPI2200 Physical Inventory Results - INVENTORIED | Gathers PI inventoried results. (SQR) | Asset Management, Physical Inventory, Run Physical Inventory Reports | RUN_AMPI2000 |
| AMPI2210 Physical Inventory Results - UNDER | Gathers PI unders results. (SQR) | Asset Management, Physical Inventory, Run Physical Inventory Reports | RUN_AMPI2000 |
| AMPI2220 Physical Inventory Results - OVER | Gathers PI overs results. (SQR) | Asset Management, Physical Inventory, Run Physical Inventory Reports | RUN_AMPI2000 |

| Report ID and Report Name | Description | Navigation | Run Control Page |
|---|---|--|------------------|
| AMDE4001 Inventory Report (Detail Version) | Lists detailed information about assets within inventory. (Crystal) | Asset Management, Financial Reports, Asset Details, By Location, Inventory Report (Detail Version) | RUN_AMAS2200 |
| AMDE4002 Inventory Report (Short Version) | Lists summarized information about assets within inventory. (Crystal) | Asset Management, Financial Reports, Asset Details, By Location, Inventory Report (Short Version) | RUN_AMAS2200 |

Lease Reports

| Report ID and Report Name | Description | Navigation | Run Control Page |
|---|--|--|------------------|
| AMLE2000 Lease Summary Information | Lists lease summary information. (SQR) | Asset Management, Financial Reports, Leased Assets, Summary or Detail | RUN_AMLE2000 |
| AMLE2100 Lease Detail Information | Lists lease detail information. (SQR) | Asset Management, Financial Reports, Leased Assets, Summary or Detail | RUN_AMLE2000 |
| AMLE2200 Lease Amortization Schedule | Lists lease detail information. (SQR) | Asset Management, Financial Reports, Leased Assets, Summary or Detail | RUN_AMLE2200 |
| AMLE2310 Lease Footnote Disclosure Summary | Lists all outstanding lease commitments for five years and provides the monthly lease payment and yearly totals. (SQR) | Asset Management, Financial Reports, Leased Assets, Lease Footnote Disclosure | RUN_AMLE2300 |
| AMLE2300 Lease Footnote Disclosure Detail | Lists all outstanding lease commitments for five years and provides the monthly lease payment and yearly totals. (SQR) | Asset Management, Financial Reports, Reports, Leased Assets, Lease Footnote Disclosure | RUN_AMLE2300 |
| AMLE2400 Lease Expiration | Lists all leases expiring in a certain number of days from a specified date, or leases expiring within a date range that you select. (SQR) | Asset Management, Financial Reports, Leased Assets, Lease Expiration | RUN_AMLE2400 |

Retirement Reports

| Report ID and Report Name | Description | Navigation | Run Control Page |
|---|--|--|------------------|
| AMRT2000 Retirement by ChartField | Sorts retirement information by ChartField. (SQR) | Asset Management, Financial Reports, Retirement, Retirement Information Report | RUN_AMRT2000 |
| AMRT2010 Retirement by In Service Date | Lists retirement information with totals per in service year/period. (SQR) | Asset Management, Financial Reports, Retirement, Retirement Information Report | RUN_AMRT2000 |
| AMRT2100 Retirement Activity | Lists retirement related information. (SQR) | Asset Management, Financial Reports, Retirement, Retirement Activity Report | RUN_AMRT2100 |
| AMBI1000 AM/Billing Transaction Status | Create the Assets Pending to Bill and Invoiced report. Lists the status of the transactions sent to Billing. | Asset Management, Financial Reports, Retirement, AM/Billing Transaction Status | RUN_AMBI1000 |
| AMRET001 Auto-Retired Assets | Lists all auto-retired assets. (SQR) | Asset Management, Financial Reports, Retirement, Auto-Retired Assets | RUN_AMRET001 |

U.S. Tax Reports

| Report ID and Report Name | Description | Navigation | Run Control Page |
|--|---|--|------------------|
| AMTX3000 Tax Acquisitions | Lists acquisition information for tax purposes. (SQR) Note. This report can be run in detail or summary mode. | Asset Management, Taxes, Reports, Gain/Loss Report | RUN_AMTX3000 |
| AMTX3100 Tax Adjustments | Lists adjustment information for tax purposes. (SQR) | Asset Management, Taxes, Reports, Gain/Loss Report | RUN_AMTX3000 |
| AMTX3200 Tax Retirements | Lists adjustment information for tax purposes. (SQR) This report can be run in detail or summary mode. | Asset Management, Taxes, Reports, Gain/Loss Report | RUN_AMTX3000 |
| AMTX3210 Tax Retirement Capital Gains | Lists retirement capital gains information for tax purposes. (SQR) | Asset Management, Taxes, Reports, Gain/Loss Report | RUN_AMTX3000 |
| AMTX3220 Like Kind Exchanges Activity | Use this report to review LKE activity. (SQR). | Asset Management, Taxes, Reports, Gain/Loss Report | RUN_AMTX3000 |
| AMTX3500 Tax Depreciation | Gathers depreciation information for tax purposes. (SQR) | Asset Management, Taxes, Reports, Gain/Loss Report | RUN_AMTX3000 |

| Report ID and Report Name | Description | Navigation | Run Control Page |
|---|--|---|------------------|
| AMTX3610 Tax Depreciation for Current Year Assets | Similar to Tax Depreciation report, ordered by fiscal year/period or date range. (SQR) | Asset Management, Taxes, Reports, Gain/Loss Report | RUN_AMTX3000 |
| AMTX3620 Tax Depreciation for Prior Year Assets | Similar to Tax Depreciation report, ordered by fiscal year/period or date range. (SQR) | Asset Management, Taxes, Reports, Gain/Loss Report | RUN_AMTX3000 |
| AMTX3630 Tax Depreciation – Listed Property | Gathers depreciation information relevant to listed property. (SQR) | Asset Management, Taxes, Reports, Gain/Loss Report | RUN_AMTX3000 |
| AMTX3640 Generate Bonus Depreciation Tax Reports | This report is used in conjunction with the bonus depreciation allowed per the U.S. Job Creation and Worker Assistance Act. Use to review bonus depreciation amounts for Non-Listed Property. | Asset Management, Taxes, Reports, Gain/Loss Report | RUN_AMTX3000 |
| AMTX3650 Generate Bonus Depreciation Tax Reports | This report is used in conjunction with the bonus depreciation allowed per the U.S. Job Creation and Worker Assistance Act. Use to review bonus depreciation amounts for Listed Property with business use over 50%. | Asset Management, Taxes, Reports, Gain/Loss | RUN_AMTX3000 |
| AMTX4000 Alternative Minimum Tax (AMT) | Gathers alternative minimum tax information. (SQR) Note. This report can be run in detail or summary mode. | Asset Management, Taxes, Reports, Tax AMT/ACE USA | RUN_AMTX4000 |
| AMTX4100 Adjusted Current Earnings Worksheet (ACE) | Lists adjusted current earnings information. (SQR) | Asset Management, Taxes, Reports, Tax AMT/ACE USA | RUN_AMTX4000 |
| AMTX4200 40% Rule Analysis Report | Run to comply with the US Tax 40% Rule. (SQR) Note. If you add over 40% of your assets in the 4 th quarter, you must update the convention from mid-year to mid-quarter under certain US requirements. This report can be run in detail or summary mode. | Asset Management, Taxes, Reports, 40% Rule Analysis | RUN_AMTX4200 |
| AMTX4300 AMT Retirements | Gathers alternative minimum tax information from retirements. (SQR) | Asset Management, Taxes, Reports, Tax AMT/ACE USA | RUN_AMTX4000 |
| AMTX4400 ACE Retirements | Gathers adjusted current earnings information from retirements. (SQR) | Asset Management, Taxes, Reports, Tax AMT/ACE USA | RUN_AMTX4000 |

Global Reports

| Report ID and Report Name | Description | Navigation | Run Control Page |
|---|---|--|------------------|
| AMTX10AU AUS RD Tax Deductions | View the amount of research and development concessions that can be claimed. (SQR) | Asset Management, Taxes, Reports, RD Deductions AUS | RUN_AMTX10AU |
| AMTX20AU Tax Credits by Category (Australia) | Lists total tax credits by business unit. (SQR) | Asset Management, Taxes, Reports, Tax Credits AUS | RUN_AMTX20AU |
| AMRT10AU Retirement Activity (AUS) | Lists retirement related information relevant to Australian Retirements for a business unit and book. (SQR) | Asset Management, Financial Reports, Retirement, AUS Retirement Activity | RUN_AMRT10AU |
| AMRT20AU Retirement Detail by ChartField (Australia) | Lists assets that have been partially or fully retired in the periods specified for Australia sorted by ChartField. (SQR) | Asset Management, Financial Reports, Retirement, AUS Retirement Information | RUN_AMRT20AU |
| AMTX10CA CCA Year End Updates CAN | (CAN) Creates and prints columns of information required by Revenue Canada and CCA year end results. (Crystal) | Asset Management, Financial Reports, Accounting Entries, CCA Year End CAN | RUN_AMTX10CA |
| AMTX11CA CCA Report | (CAN) Creates and prints columns of information required by Revenue Canada and CCA year end results. (Crystal) | Asset Management, Financial Reports, Accounting Entries, CCA Year End CAN | RUN_AMTX10CA |
| AMTX30AU Tax CCP – AUS | Monitors CCP adjustments and the review process. (SQR) | Asset Management, Taxes, Reports, Tax CCP AUS | RUN_AMTX30AU |
| AMFR2100 French Retirement Activity | Lists retirement related information relevant to French Retirements. (SQR) | Asset Management, Financial Reports, Retirement, Retirement Activity, French Retirement Activity | RUN_AMDP2100 |
| AMFR2120 French Net Book Value Account | Reports French asset net book value information. | Asset Management, Financial Reports, Cost and Depreciation, Asset Net Book Value, French Net Book Value Account | RUN_AMDP2100 |
| AMFR2121 French Net Book Value by Alternate Account | Similar to Asset Net Book Value by Alternate Account, listing French depreciation related information. (SQR) | Asset Management, Financial Reports, Accounting Entries, Alt Account Activity Detail, French Net Book by Alt Account | RUN_AMDP2100 |

| Report ID and Report Name | Description | Navigation | Run Control Page |
|--|--|--|------------------|
| AMDE1000 Asset History Sheet by Category | (DEU) Shows the original asset cost beginning in year 2 of the asset's life. (Crystal) | Asset Management, Financial Reports, Asset Details, History, Asset History Sheet by Category | RUN_AMDE1000 |
| AMDE1001 Asset History Sheet by Account | (DEU) Shows the original Asset Cost beginning in year 2 of the asset's life. (Crystal) | Asset Management, Financial Reports, Asset Details, History, Asset History Sheet by Account | RUN_AMDE1000 |
| AMDE1002 Asset History Sheet Summary | (DEU) Shows the original Asset Cost beginning in year 2 of the asset's life. (Crystal) | Asset Management, Financial Reports, Asset Details, History, Asset History Sheet Summary | RUN_AMDE1000 |
| AMDE1101 Depreciation History | (DEU) Lists chronological history of asset depreciation, including any extraordinary depreciation. (Crystal) | Asset Management, Financial Reports, Asset Details, History, Depreciation History | RUN_AMDE1000 |
| AMDE1102 Extraordinary Depreciation History | (DEU) Lists chronological detailed history of extraordinary asset depreciation. (Crystal) | Asset Management, Financial Reports, Asset Details, History, Extraordinary Depreciation History | RUN_AMDE1000 |
| AMDE5001 Reconciliation AP/AM | (DEU) Reconciles AP Asset Vouchers with AM asset transaction information. (Crystal) | Asset Management, Financial Reports, Cost and Depreciation, Reconciliation AP/AM | RUN_AMDE5000 |
| AMBT1000 Business Tax | (JPN) Gathers business tax information on a specific account and location. (SQR) | Asset Management, Taxes, Reports, Business Tax | RUN_AMBT1000 |
| AMBT1010 Business Tax by Alternate Account | (JPN) Gathers business tax information on a specific alternate account and location. (SQR) | Asset Management, Taxes, Reports, Business Tax | RUN_AMBT1000 |
| AMAD1000 Advanced Depreciation Amount | Obtains the advanced depreciation amount for the specified asset ID range. (Crystal) | Asset Management, Financial Reports, Cost and Depreciation, Advanced Depreciation | RUN_AMAD1000 |
| AMAD1010 Advanced Depreciation Reverse Amount | Obtains reversal amounts for the specified asset ID range. (Crystal) | Asset Management, Financial Reports, Cost and Depreciation, Advanced Depreciation | RUN_AMAD1000 |
| AMIMP001 Imp Asset Value Report by Category | Review impairment asset values by category. (Crystal). | Asset Management, Financial Reports, Cost and Depreciation, Asset Impairment, Imp Asset Value Report by Category | RUN_AMIMP001 |
| AMIMP002 Imp Asset Value Report by CGU | Review impairment asset values by CGU. (Crystal). | Asset Management, Financial Reports, Cost and Depreciation, Asset Impairment, Imp Asset Value Report by Category | RUN_AMIMP001 |

| Report ID and Report Name | Description | Navigation | Run Control Page |
|--|---|---|-------------------------|
| AMSP1000 Reserve Detail by Asset ID | Obtains reversal amounts for the specified Asset ID range. (Crystal) | Asset Management, Financial Reports, Accounting Entries, Reserve and Reverse Amounts | RUN_AMSP1000 |
| AMSP1010 Reserve Summary by Category | Lists reserve amounts and details for fiscal years by asset ID. (Crystal) | Asset Management, Financial Reports, Accounting Entries, Reserve and Reverse Amounts | RUN_AMSP1000 |
| AMSP1020 Reverse Detail by Asset ID | Lists reverse amounts and details for fiscal years by Asset ID. (Crystal) | Asset Management, Financial Reports, Accounting Entries, Reserve and Reverse Amounts | RUN_AMSP1000 |
| AMSP1030 Reverse Summary by Category | Lists summarized reverse information by category. (Crystal) | Asset Management, Financial Reports, Accounting Entries, Reserve and Reverse Amounts | RUN_AMSP1000 |
| EU_2054 2054ab Reports by Account | (FRA) View information on the asset, its cost and net book value, information on all transactions that occurred in the specified reporting year, including depreciation and yearly depreciation. (Crystal) | Asset Management, Financial Reports, Accounting Entries, Statutory Report 2054/2055 | EU_AM_RUNCNTRL |
| EU_2055A 2055a Reports by Account | (FRA) View information on the asset, its cost and net book value, information on all transactions that occurred in the specified reporting year, including depreciation and yearly depreciation. (Crystal) | Asset Management, Financial Reports, Accounting Entries, Statutory Report 2054/2055 | EU_AM_RUNCNTRL |
| EU_2055B 2055b Reports by Account | (FRA) View information on the asset, its cost and net book value, information on all transactions that occurred in the specified reporting year, including depreciation and yearly depreciation. (Crystal) | Asset Management, Financial Reports, Accounting Entries, Statutory Report 2054/2055 | EU_AM_RUNCNTRL |
| EU_205x1 2054ab Reports by Alt Account | (FRA) View information on the asset, its cost and net book value, information on all transactions that occurred in the specified reporting year, including depreciation and yearly depreciation. (Crystal) | Asset Management, Financial Reports, Accounting Entries, Statutory Report 2054/2055 | EU_AM_RUNCNTRL |

| Report ID and Report Name | Description | Navigation | Run Control Page |
|--|---|---|------------------|
| EU_205x2 2054a Reports by Alt Account | (FRA) View information on the asset, its cost and net book value, information on all transactions that occurred in the specified reporting year, including depreciation and yearly depreciation. (Crystal) | Asset Management, Financial Reports, Accounting Entries, Statutory Report 2054/2055 | EU_AM_RUNCNTRL |
| EU_205x3 2054b Reports by Alt Account | View information on the asset, its cost and net book value, information on all transactions that occurred in the specified reporting year, including depreciation and yearly depreciation. (Crystal) | Asset Management, Financial Reports, Accounting Entries, Statutory Report 2054/2055 | EU_AM_RUNCNTRL |
| AMLT1000 Japanese Local Tax Roll | (JPN) Local tax report. (SQR) | Asset Management, Taxes, Reports, Local Tax Returns | RUN_AMLT1000 |
| AMLT1100 Japanese Local Tax Increase All Asset List | (JPN) Local tax increase report. (SQR) | Asset Management, Taxes, Reports, Local Tax Returns | RUN_AMLT1100 |
| AMLT1200 Japanese Local Tax Decrease All Asset List | (JPN) Local tax decrease report. (SQR) | Asset Management, Taxes, Reports, Local Tax Returns | RUN_AMLT1100 |
| AMNT1000 Japanese National Tax | (JPN) List depreciation calculation details to be reported to the Japanese Tax Office. The report includes all required information for the National Depreciable Asset Tax Return called Beppyo 16(1),(2) in Japan. (SQR) | Asset Management, Taxes, Reports, National Tax | RUN_AMNT1000 |
| AMDP2500 Fixed Assets Register Report | (ITA) Run to comply with Italian article 16, D.P.R. 600/73. The fixed asset book lists information relevant to fixed assets. (SQR) | Asset Management, Financial Reports, Cost and Depreciation, Assets Register (ITA) | RUN_AMDP2500 |
| AMDP2510 Assets Register INDIA | (IND) Run to generate an historical record of assets over the fiscal year period to comply with The Indian Tax Depreciation Act (Indian Income Tax Act 1961). Can generate by business unit or tax/reporting entity. (SQR). | Asset Management, Financial Reports, Cost and Depreciation, Assets Register (IND) | RUN_AMDP2510 |
| AMTX2000 Depreciation Balance IND | (IND) Calculate the annual tax depreciation balances for India. (Crystal). | Asset Management, Taxes, Reports, Depreciation Balance IND | RUN_AMTX2000 |

Glossary of PeopleSoft Enterprise Terms

| | |
|------------------------------|---|
| absence entitlement | This element defines rules for granting paid time off for valid absences, such as sick time, vacation, and maternity leave. An absence entitlement element defines the entitlement amount, frequency, and entitlement period. |
| absence take | This element defines the conditions that must be met before a payee is entitled to take paid time off. |
| academic career | In PeopleSoft Enterprise Campus Solutions, all course work that a student undertakes at an academic institution and that is grouped in a single student record. For example, a university that has an undergraduate school, a graduate school, and various professional schools might define several academic careers—an undergraduate career, a graduate career, and separate careers for each professional school (law school, medical school, dental school, and so on). |
| academic institution | In PeopleSoft Enterprise Campus Solutions, an entity (such as a university or college) that is independent of other similar entities and that has its own set of rules and business processes. |
| academic organization | In PeopleSoft Enterprise Campus Solutions, an entity that is part of the administrative structure within an academic institution. At the lowest level, an academic organization might be an academic department. At the highest level, an academic organization can represent a division. |
| academic plan | In PeopleSoft Enterprise Campus Solutions, an area of study—such as a major, minor, or specialization—that exists within an academic program or academic career. |
| academic program | In PeopleSoft Enterprise Campus Solutions, the entity to which a student applies and is admitted and from which the student graduates. |
| accounting class | In PeopleSoft Enterprise Performance Management, the accounting class defines how a resource is treated for generally accepted accounting practices. The Inventory class indicates whether a resource becomes part of a balance sheet account, such as inventory or fixed assets, while the Non-inventory class indicates that the resource is treated as an expense of the period during which it occurs. |
| accounting date | The accounting date indicates when a transaction is recognized, as opposed to the date the transaction actually occurred. The accounting date and transaction date can be the same. The accounting date determines the period in the general ledger to which the transaction is to be posted. You can only select an accounting date that falls within an open period in the ledger to which you are posting. The accounting date for an item is normally the invoice date. |
| accounting split | The accounting split method indicates how expenses are allocated or divided among one or more sets of accounting ChartFields. |
| accumulator | You use an accumulator to store cumulative values of defined items as they are processed. You can accumulate a single value over time or multiple values over time. For example, an accumulator could consist of all voluntary deductions, or all company deductions, enabling you to accumulate amounts. It allows total flexibility for time periods and values accumulated. |
| action reason | The reason an employee's job or employment information is updated. The action reason is entered in two parts: a personnel action, such as a promotion, termination, or change from one pay group to another—and a reason for that action. Action reasons are used by PeopleSoft Enterprise Human Resources, PeopleSoft Enterprise Benefits |

| | |
|--------------------------------|--|
| | Administration, PeopleSoft Enterprise Stock Administration, and the COBRA Administration feature of the Base Benefits business process. |
| action template | In PeopleSoft Enterprise Receivables, outlines a set of escalating actions that the system or user performs based on the period of time that a customer or item has been in an action plan for a specific condition. |
| activity | <p>In PeopleSoft Enterprise Learning Management, an instance of a catalog item (sometimes called a class) that is available for enrollment. The activity defines such things as the costs that are associated with the offering, enrollment limits and deadlines, and waitlisting capacities.</p> <p>In PeopleSoft Enterprise Performance Management, the work of an organization and the aggregation of actions that are used for activity-based costing.</p> <p>In PeopleSoft Enterprise Project Costing, the unit of work that provides a further breakdown of projects—usually into specific tasks.</p> <p>In PeopleSoft Workflow, a specific transaction that you might need to perform in a business process. Because it consists of the steps that are used to perform a transaction, it is also known as a step map.</p> |
| address usage | In PeopleSoft Enterprise Campus Solutions, a grouping of address types defining the order in which the address types are used. For example, you might define an address usage code to process addresses in the following order: billing address, dormitory address, home address, and then work address. |
| adjustment calendar | In PeopleSoft Enterprise Campus Solutions, the adjustment calendar controls how a particular charge is adjusted on a student's account when the student drops classes or withdraws from a term. The charge adjustment is based on how much time has elapsed from a predetermined date, and it is determined as a percentage of the original charge amount. |
| administrative function | In PeopleSoft Enterprise Campus Solutions, a particular functional area that processes checklists, communication, and comments. The administrative function identifies which variable data is added to a person's checklist or communication record when a specific checklist code, communication category, or comment is assigned to the student. This key data enables you to trace that checklist, communication, or comment back to a specific processing event in a functional area. |
| admit type | In PeopleSoft Enterprise Campus Solutions, a designation used to distinguish first-year applications from transfer applications. |
| agreement | In PeopleSoft Enterprise eSettlements, provides a way to group and specify processing options, such as payment terms, pay from a bank, and notifications by a buyer and supplier location combination. |
| allocation rule | In PeopleSoft Enterprise Incentive Management, an expression within compensation plans that enables the system to assign transactions to nodes and participants. During transaction allocation, the allocation engine traverses the compensation structure from the current node to the root node, checking each node for plans that contain allocation rules. |
| alternate account | A feature in PeopleSoft Enterprise General Ledger that enables you to create a statutory chart of accounts and enter statutory account transactions at the detail transaction level, as required for recording and reporting by some national governments. |
| analysis database | In PeopleSoft Enterprise Campus Solutions, database tables that store large amounts of student information that may not appear in standard report formats. The analysis database tables contain keys for all objects in a report that an application program can use to reference other student-record objects that are not contained in the printed report. For instance, the analysis database contains data on courses that are considered |

for satisfying a requirement but that are rejected. It also contains information on courses captured by global limits. An analysis database is used in PeopleSoft Enterprise Academic Advisement.

| | |
|-------------------------------|---|
| Application Messaging | PeopleSoft Application Messaging enables applications within the PeopleSoft Enterprise product family to communicate synchronously or asynchronously with other PeopleSoft Enterprise and third-party applications. An application message defines the records and fields to be published or subscribed to. |
| AR specialist | Abbreviation for <i>receivables specialist</i> . In PeopleSoft Enterprise Receivables, an individual in who tracks and resolves deductions and disputed items. |
| arbitration plan | The arbiter when multiple price rules match the transaction. This plan determines the order in which the price rules are applied to the transaction base price. |
| assessment rule | In PeopleSoft Enterprise Receivables, a user-defined rule that the system uses to evaluate the condition of a customer's account or of individual items to determine whether to generate a follow-up action. |
| asset class | An asset group used for reporting purposes. It can be used in conjunction with the asset category to refine asset classification. |
| attribute/value pair | In PeopleSoft Enterprise Directory Interface, relates the data that makes up an entry in the directory information tree. |
| auction event | In PeopleSoft Strategic Sourcing, a sourcing event where bidders actively compete against one another to achieve the best price or score. |
| audience | In PeopleSoft Enterprise Campus Solutions, a segment of the database that relates to an initiative, or a membership organization that is based on constituent attributes rather than a dues-paying structure. Examples of audiences include the Class of '65 and Undergraduate Arts & Sciences. |
| authentication server | A server that is set up to verify users of the system. |
| base time period | In PeopleSoft Enterprise Business Planning, the lowest level time period in a calendar. |
| benchmark job | In PeopleSoft Enterprise Workforce Analytics Solution, a benchmark job is a job code for which there is corresponding salary survey data from published, third-party sources. |
| bid response | In PeopleSoft Strategic Sourcing, the response by a bidder to an event. |
| billing career | In PeopleSoft Enterprise Campus Solutions, the one career under which other careers are grouped for billing purposes if a student is active simultaneously in multiple careers. |
| bio bit or bio brief | In PeopleSoft Enterprise Campus Solutions, a report that summarizes information stored in the system about a particular constituent. You can generate standard or specialized reports. |
| book | In PeopleSoft Enterprise Asset Management, used for storing financial and tax information, such as costs, depreciation attributes, and retirement information on assets. |
| branch | A tree node that rolls up to nodes above it in the hierarchy, as defined in PeopleSoft Tree Manager. |
| budgetary account only | An account used by the system only and not by users; this type of account does not accept transactions. You can only budget with this account. Formerly called "system-maintained account." |

| | |
|----------------------------------|--|
| budget check | In commitment control, the processing of source transactions against control budget ledgers, to see if they pass, fail, or pass with a warning. |
| budget control | In commitment control, budget control ensures that commitments and expenditures don't exceed budgets. It enables you to track transactions against corresponding budgets and terminate a document's cycle if the defined budget conditions are not met. For example, you can prevent a purchase order from being dispatched to a vendor if there are insufficient funds in the related budget to support it. |
| budget period | The interval of time (such as 12 months or 4 quarters) into which a period is divided for budgetary and reporting purposes. The ChartField allows maximum flexibility to define operational accounting time periods without restriction to only one calendar. |
| business activity | The name of a subset of a detailed business process. This might be a specific transaction, task, or action that you perform in a business process. |
| business event | In PeopleSoft Enterprise Receivables, defines the processing characteristics for the Receivable Update process for a draft activity. In PeopleSoft Enterprise Sales Incentive Management, an original business transaction or activity that may justify the creation of a PeopleSoft Enterprise Incentive Management event (a sale, for example). |
| business process | A standard set of 17 business processes are defined and maintained by the PeopleSoft Enterprise product families and are supported by the Business Process Engineering group. An example of a business process is Order Fulfillment, which is a business process that manages sales orders and contracts, inventory, billing, and so forth. <i>See also detailed business process.</i> |
| business unit constraints | In PeopleSoft Strategic Sourcing, these constraints apply to a selected Strategic Sourcing business unit. Spend is tracked across all of the events within the selected Strategic Sourcing business unit. |
| business task | The name of the specific function depicted in one of the business processes. |
| business unit | A corporation or a subset of a corporation that is independent with regard to one or more operational or accounting functions. |
| buyer | In PeopleSoft Enterprise eSettlements, an organization (or business unit, as opposed to an individual) that transacts with suppliers (vendors) within the system. A buyer creates payments for purchases that are made in the system. |
| buy event | In PeopleSoft Strategic Sourcing, for event creators, the purchase of goods or services, most typically associated with a request for quote, proposal, or reverse auction. For bidders, the sale of goods or services. |
| campus | In PeopleSoft Enterprise Campus Solutions, an entity that is usually associated with a distinct physical administrative unit, that belongs to a single academic institution, that uses a unique course catalog, and that produces a common transcript for students within the same academic career. |
| cash drawer | A repository for monies and payments taken locally. |
| catalog item | In PeopleSoft Enterprise Learning Management, a specific topic that a learner can study and have tracked. For example, "Introduction to Microsoft Word." A catalog item contains general information about the topic and includes a course code, description, categorization, keywords, and delivery methods. A catalog item can have one or more learning activities. |
| catalog map | In PeopleSoft Enterprise Catalog Management, translates values from the catalog source data to the format of the company's catalog. |

| | |
|------------------------------------|--|
| catalog partner | In PeopleSoft Enterprise Catalog Management, shares responsibility with the enterprise catalog manager for maintaining catalog content. |
| categorization | Associates partner offerings with catalog offerings and groups them into enterprise catalog categories. |
| category | In PeopleSoft Enterprise Campus Solutions, a broad grouping to which specific comments or communications (contexts) are assigned. Category codes are also linked to 3C access groups so that you can assign data-entry or view-only privileges across functions. |
| channel | In PeopleSoft MultiChannel Framework, email, chat, voice (computer telephone integration [CTI]), or a generic event. |
| ChartField | A field that stores a chart of accounts, resources, and so on, depending on the PeopleSoft Enterprise application. ChartField values represent individual account numbers, department codes, and so forth. |
| ChartField balancing | You can require specific ChartFields to match up (balance) on the debit and the credit side of a transaction. |
| ChartField combination edit | The process of editing journal lines for valid ChartField combinations based on user-defined rules. |
| ChartKey | One or more fields that uniquely identify each row in a table. Some tables contain only one field as the key, while others require a combination. |
| checkbook | In PeopleSoft Enterprise Promotions Management, enables you to view financial data (such as planned, incurred, and actual amounts) that is related to funds and trade promotions. |
| checklist code | In PeopleSoft Enterprise Campus Solutions, a code that represents a list of planned or completed action items that can be assigned to a staff member, volunteer, or unit. Checklists enable you to view all action assignments on one page. |
| claimback | In the wholesale distribution industry, a contract between supplier and distributor, in which monies are paid to the distributor on the sale of specified products or product groups to targeted customers or customer groups. |
| class | In PeopleSoft Enterprise Campus Solutions, a specific offering of a course component within an academic term. See also <i>course</i> . |
| Class ChartField | A ChartField value that identifies a unique appropriation budget key when you combine it with a fund, department ID, and program code, as well as a budget period. Formerly called <i>sub-classification</i> . |
| clearance | In PeopleSoft Enterprise Campus Solutions, the period of time during which a constituent in PeopleSoft Enterprise Contributor Relations is approved for involvement in an initiative or an action. Clearances are used to prevent development officers from making multiple requests to a constituent during the same time period. |
| clone | In PeopleCode, to make a unique copy. In contrast, to <i>copy</i> may mean making a new reference to an object, so if the underlying object is changed, both the copy and the original change. |
| cohort | In PeopleSoft Enterprise Campus Solutions, the highest level of the three-level classification structure that you define for enrollment management. You can define a cohort level, link it to other levels, and set enrollment target numbers for it. See also <i>population</i> and <i>division</i> . |

| | |
|--|---|
| collection | To make a set of documents available for searching in Verity, you must first create at least one collection. A collection is set of directories and files that allow search application users to use the Verity search engine to quickly find and display source documents that match search criteria. A collection is a set of statistics and pointers to the source documents, stored in a proprietary format on a file server. Because a collection can only store information for a single location, PeopleTools maintains a set of collections (one per language code) for each search index object. |
| collection rule | In PeopleSoft Enterprise Receivables, a user-defined rule that defines actions to take for a customer based on both the amount and the number of days past due for outstanding balances. |
| comm key | See <i>communication key</i> . |
| communication key | In PeopleSoft Enterprise Campus Solutions, a single code for entering a combination of communication category, communication context, communication method, communication direction, and standard letter code. Communication keys (also called <i>comm keys</i> or <i>speed keys</i>) can be created for background processes as well as for specific users. |
| compensation object | In PeopleSoft Enterprise Incentive Management, a node within a compensation structure. Compensation objects are the building blocks that make up a compensation structure's hierarchical representation. |
| compensation structure | In PeopleSoft Enterprise Incentive Management, a hierarchical relationship of compensation objects that represents the compensation-related relationship between the objects. |
| component interface | A component interface is a set of application programming interfaces (APIs) that you can use to access and modify PeopleSoft Enterprise database information using a program instead of the PeopleSoft client. |
| condition | In PeopleSoft Enterprise Receivables, occurs when there is a change of status for a customer's account, such as reaching a credit limit or exceeding a user-defined balance due. |
| configuration parameter catalog | Used to configure an external system with PeopleSoft Enterprise. For example, a configuration parameter catalog might set up configuration and communication parameters for an external server. |
| configuration plan | In PeopleSoft Enterprise Incentive Management, configuration plans hold allocation information for common variables (not incentive rules) and are attached to a node without a participant. Configuration plans are not processed by transactions. |
| constituents | In PeopleSoft Enterprise Campus Solutions, friends, alumni, organizations, foundations, or other entities affiliated with the institution, and about which the institution maintains information. The constituent types delivered with PeopleSoft Enterprise Contributor Relations Solutions are based on those defined by the Council for the Advancement and Support of Education (CASE). |
| constraint | A business policy or rule that affects how a sourcing event is awarded. There are three types of constraints: business, global, and event. |
| content reference | Content references are pointers to content registered in the portal registry. These are typically either URLs or iScripts. Content references fall into three categories: target content, templates, and template pagelets. |
| context | In PeopleCode, determines which buffer fields can be contextually referenced and which is the current row of data on each scroll level when a PeopleCode program is running. In PeopleSoft Enterprise Campus Solutions, a specific instance of a comment or communication. One or more contexts are assigned to a category, which you link to |

3C access groups so that you can assign data-entry or view-only privileges across functions.

In PeopleSoft Enterprise Incentive Management, a mechanism that is used to determine the scope of a processing run. PeopleSoft Enterprise Incentive Management uses three types of context: plan, period, and run-level.

| | |
|--------------------------------|---|
| control table | Stores information that controls the processing of an application. This type of processing might be consistent throughout an organization, or it might be used only by portions of the organization for more limited sharing of data. |
| cost plus contract line | A rate-based contract line associated with a fee component of Award, Fixed, Incentive, or Other. Rate-based contract lines associated with a fee type of None are not considered cost-plus contract lines. |
| cost plus pricing | In PeopleSoft Enterprise Pricer, a pricing method that begins with cost of goods as the basis. |
| cost profile | A combination of a receipt cost method, a cost flow, and a deplete cost method. A profile is associated with a cost book and determines how items in that book are valued, as well as how the material movement of the item is valued for the book. |
| cost row | A cost transaction and amount for a set of ChartFields. |
| counter sale | A face-to-face customer transaction where the customer typically selects items from the storefront or picks up products that they ordered ahead of time. Customers pay for the goods at the counter and take the goods with them instead of having the goods shipped from a warehouse. |
| course | In PeopleSoft Enterprise Campus Solutions, a course that is offered by a school and that is typically described in a course catalog. A course has a standard syllabus and credit level; however, these may be modified at the class level. Courses can contain multiple components such as lecture, discussion, and lab. See also <i>class</i> . |
| course share set | In PeopleSoft Enterprise Campus Solutions, a tag that defines a set of requirement groups that can share courses. Course share sets are used in PeopleSoft Enterprise Academic Advisement. |
| current learning | In PeopleSoft Enterprise Learning Management, a self-service repository for all of a learner's in-progress learning activities and programs. |
| data acquisition | In PeopleSoft Enterprise Incentive Management, the process during which raw business transactions are acquired from external source systems and fed into the operational data store (ODS). |
| data cube | In PeopleSoft Analytic Calculation Engine, a data cube is a container for one kind of data (such as Sales data) and works with in tandem with one or more dimensions. Dimensions and data cubes in PeopleSoft Analytic Calculation Engine are unrelated to dimensions and online analytical processing (OLAP) cubes in PeopleSoft Cube Manager. |
| data elements | Data elements, at their simplest level, define a subset of data and the rules by which to group them. For Workforce Analytics, data elements are rules that tell the system what measures to retrieve about your workforce groups. |
| dataset | A data grouping that enables role-based filtering and distribution of data. You can limit the range and quantity of data that is displayed for a user by associating dataset rules with user roles. The result of dataset rules is a set of data that is appropriate for the user's roles. |

| | |
|-----------------------------------|--|
| delivery method | <p>In PeopleSoft Enterprise Learning Management, identifies the primary type of delivery method in which a particular learning activity is offered. Also provides default values for the learning activity, such as cost and language. This is primarily used to help learners search the catalog for the type of delivery from which they learn best. Because PeopleSoft Enterprise Learning Management is a blended learning system, it does not enforce the delivery method.</p> <p>In PeopleSoft Enterprise Supply Chain Management, identifies the method by which goods are shipped to their destinations (such as truck, air, and rail). The delivery method is specified when creating shipment schedules.</p> |
| delivery method type | In PeopleSoft Enterprise Learning Management, identifies how learning activities can be delivered—for example, through online learning, classroom instruction, seminars, books, and so forth—in an organization. The type determines whether the delivery method includes scheduled components. |
| detailed business process | A subset of the business process. For example, the detailed business process named Determine Cash Position is a subset of the business process called Cash Management. |
| dimension | <p>In PeopleSoft Analytic Calculation Engine, a dimension contains a list of one kind of data that can span various contexts, and it is a basic component of an analytic model. Within the analytic model, a dimension is attached to one or more data cubes.</p> <p>In PeopleSoft Cube Manager, a dimension is the most basic component of an OLAP cube and specifies the PeopleSoft metadata to be used to create the dimension's rollup structure. Dimensions and data cubes in PeopleSoft Analytic Calculation Engine are unrelated to dimensions and OLAP cubes in PeopleSoft Cube Manager.</p> |
| direct receipt | Items shipped from a warehouse or vendor to another warehouse. |
| direct ship | Items shipped from the vendor or warehouse directly to the customer (formerly referred to as <i>drop ship</i>). |
| directory information tree | In PeopleSoft Enterprise Directory Interface, the representation of a directory's hierarchical structure. |
| division | <p>In PeopleSoft Enterprise Campus Solutions, the lowest level of the three-level classification structure that you define in PeopleSoft Enterprise Recruiting and Admissions for enrollment management. You can define a division level, link it to other levels, and set enrollment target numbers for it.</p> <p>See also <i>population</i> and <i>cohort</i>.</p> |
| document sequencing | A flexible method that sequentially numbers the financial transactions (for example, bills, purchase orders, invoices, and payments) in the system for statutory reporting and for tracking commercial transaction activity. |
| dynamic detail tree | A tree that takes its detail values—dynamic details—directly from a table in the database, rather than from a range of values that are entered by the user. |
| edit table | A table in the database that has its own record definition, such as the Department table. As fields are entered into a PeopleSoft Enterprise application, they can be validated against an edit table to ensure data integrity throughout the system. |
| effective date | A method of dating information in PeopleSoft Enterprise applications. You can predate information to add historical data to your system, or postdate information in order to enter it before it actually goes into effect. By using effective dates, you don't delete values; you enter a new value with a current effective date. |
| EIM ledger | Abbreviation for <i>Enterprise Incentive Management ledger</i> . In PeopleSoft Enterprise Incentive Management, an object to handle incremental result gathering within the scope of a participant. The ledger captures a result set with all of the appropriate traces to the data origin and to the processing steps of which it is a result. |

| | |
|----------------------------------|--|
| elimination set | In PeopleSoft Enterprise General Ledger, a related group of intercompany accounts that is processed during consolidations. |
| entry event | In PeopleSoft Enterprise General Ledger, Receivables, Payables, Purchasing, and Billing, a business process that generates multiple debits and credits resulting from single transactions to produce standard, supplemental accounting entries. |
| equitization | In PeopleSoft Enterprise General Ledger, a business process that enables parent companies to calculate the net income of subsidiaries on a monthly basis and adjust that amount to increase the investment amount and equity income amount before performing consolidations. |
| equity item limit | In PeopleSoft Enterprise Campus Solutions, the amounts of funds set by the institution to be awarded with discretionary or gift funds. The limit could be reduced by amounts equal to such things as expected family contribution (EFC) or parent contribution. Students are packaged by Equity Item Type Groups and Related Equity Item Types. This limit can be used to assure that similar student populations are packaged equally. |
| event | <p>A predefined point either in the Component Processor flow or in the program flow. As each point is encountered, the event activates each component, triggering any PeopleCode program that is associated with that component and that event. Examples of events are FieldChange, SavePreChange, and RowDelete.</p> <p>In PeopleSoft Enterprise Human Resources, also refers to an incident that affects benefits eligibility.</p> |
| event constraints | In PeopleSoft Strategic Sourcing, these constraints are associated with a specific sourcing event. Spend is tracked within the selected event. |
| event propagation process | In PeopleSoft Enterprise Sales Incentive Management, a process that determines, through logic, the propagation of an original PeopleSoft Enterprise Incentive Management event and creates a derivative (duplicate) of the original event to be processed by other objects. PeopleSoft Enterprise Enterprise Sales Incentive Management uses this mechanism to implement splits, roll-ups, and so on. Event propagation determines who receives the credit. |
| exception | In PeopleSoft Enterprise Receivables, an item that either is a deduction or is in dispute. |
| exclusive pricing | In PeopleSoft Enterprise Order Management, a type of arbitration plan that is associated with a price rule. Exclusive pricing is used to price sales order transactions. |
| fact | In PeopleSoft Enterprise applications, facts are numeric data values from fields from a source database as well as an analytic application. A fact can be anything you want to measure your business by, for example, revenue, actual, budget data, or sales numbers. A fact is stored on a fact table. |
| financial aid term | In PeopleSoft Enterprise Campus Solutions, a combination of a period of time that the school determines as an instructional accounting period and an academic career. It is created and defined during the setup process. Only terms eligible for financial aid are set up for each financial aid career. |
| financial sanctions | <p>For U.S. based companies and their foreign subsidiaries, a federal regulation from the Office of Foreign Assets Control (OFAC) requires that vendors be validated against a Specially Designated Nationals (SDN) list prior to payment.</p> <p>For PeopleSoft Payables, eSettlements, Cash Management, and Order to Cash, you can validate your vendors against any financial sanctions list (for example, the SDN list, a European Union list, and so on).</p> |
| forecast item | A logical entity with a unique set of descriptive demand and forecast data that is used as the basis to forecast demand. You create forecast items for a wide range of uses, but they ultimately represent things that you buy, sell, or use in your organization and for which you require a predictable usage. |

| | |
|-----------------------------|---|
| fund | In PeopleSoft Enterprise Promotions Management, a budget that can be used to fund promotional activity. There are four funding methods: top down, fixed accrual, rolling accrual, and zero-based accrual. |
| gap | In PeopleSoft Enterprise Campus Solutions, an artificial figure that sets aside an amount of unmet financial aid need that is not funded with Title IV funds. A gap can be used to prevent fully funding any student to conserve funds, or it can be used to preserve unmet financial aid need so that institutional funds can be awarded. |
| generic process type | In PeopleSoft Process Scheduler, process types are identified by a generic process type. For example, the generic process type SQR includes all SQR process types, such as SQR process and SQR report. |
| gift table | In PeopleSoft Enterprise Campus Solutions, a table or so-called <i>donor pyramid</i> describing the number and size of gifts that you expect will be needed to successfully complete the campaign in PeopleSoft Enterprise Contributor Relations. The gift table enables you to estimate the number of donors and prospects that you need at each gift level to reach the campaign goal. |
| GDS | Abbreviation for <i>Global Distribution System</i> . Broad-based term to describe all computer reservation systems for making travel plans. |
| GL business unit | Abbreviation for <i>general ledger business unit</i> . A unit in an organization that is an independent entity for accounting purposes. It maintains its own set of accounting books. See also <i>business unit</i> . |
| GL entry template | Abbreviation for <i>general ledger entry template</i> . In PeopleSoft Enterprise Campus Solutions, a template that defines how a particular item is sent to the general ledger. An item-type maps to the general ledger, and the GL entry template can involve multiple general ledger accounts. The entry to the general ledger is further controlled by high-level flags that control the summarization and the type of accounting—that is, accrual or cash. |
| GL Interface process | Abbreviation for <i>General Ledger Interface process</i> . In PeopleSoft Enterprise Campus Solutions, a process that is used to send transactions from PeopleSoft Enterprise Student Financials to the general ledger. Item types are mapped to specific general ledger accounts, enabling transactions to move to the general ledger when the GL Interface process is run. |
| global constraints | In PeopleSoft Strategic Sourcing, these constraints apply across multiple Strategic Sourcing business units. Spend is tracked across all of the events from the multiple Strategic Sourcing business units. |
| group | In PeopleSoft Enterprise Billing and Receivables, a posting entity that comprises one or more transactions (items, deposits, payments, transfers, matches, or write-offs). In PeopleSoft Enterprise Human Resources Management and Supply Chain Management, any set of records that are associated under a single name or variable to run calculations in PeopleSoft business processes. In PeopleSoft Enterprise Time and Labor, for example, employees are placed in groups for time reporting purposes. |
| ideal response | In PeopleSoft Strategic Sourcing, a question that requires the response to match the ideal value for the bid to be considered eligible for award. If the response does not match the ideal value, you can still submit the bid, but it will be disqualified and ineligible for award. |
| incentive object | In PeopleSoft Enterprise Incentive Management, the incentive-related objects that define and support the PeopleSoft Enterprise Incentive Management calculation process and results, such as plan templates, plans, results data, and user interaction objects. |

| | |
|----------------------------|---|
| incentive rule | In PeopleSoft Enterprise Sales Incentive Management, the commands that act on transactions and turn them into compensation. A rule is one part in the process of turning a transaction into compensation. |
| incur | In PeopleSoft Enterprise Promotions Management, to become liable for a promotional payment. In other words, you owe that amount to a customer for promotional activities. |
| initiative | In PeopleSoft Enterprise Campus Solutions, the basis from which all advancement plans are executed. It is an organized effort targeting a specific constituency, and it can occur over a specified period of time with specific purposes and goals. An initiative can be a campaign, an event, an organized volunteer effort, a membership drive, or any other type of effort defined by the institution. Initiatives can be multipart, and they can be related to other initiatives. This enables you to track individual parts of an initiative, as well as entire initiatives. |
| inquiry access | In PeopleSoft Enterprise Campus Solutions, a type of security access that permits the user only to view data. See also <i>update access</i> . |
| institution | In PeopleSoft Enterprise Campus Solutions, an entity (such as a university or college) that is independent of other similar entities and that has its own set of rules and business processes. |
| integration | A relationship between two compatible integration points that enables communication to take place between systems. Integrations enable PeopleSoft Enterprise applications to work seamlessly with other PeopleSoft Enterprise applications or with third-party systems or software. |
| integration point | An interface that a system uses to communicate with another PeopleSoft Enterprise application or an external application. |
| integration set | A logical grouping of integrations that applications use for the same business purpose. For example, the integration set <code>ADVANCED_SHIPPING_ORDER</code> contains all of the integrations that notify a customer that an order has shipped. |
| item | In PeopleSoft Enterprise Inventory, a tangible commodity that is stored in a business unit (shipped from a warehouse). In PeopleSoft Enterprise Demand Planning, Inventory Policy Planning, and Supply Planning, a noninventory item that is designated as being used for planning purposes only. It can represent a family or group of inventory items. It can have a planning bill of material (BOM) or planning routing, and it can exist as a component on a planning BOM. A planning item cannot be specified on a production or engineering BOM or routing, and it cannot be used as a component in a production. The quantity on hand will never be maintained. In PeopleSoft Enterprise Receivables, an individual receivable. An item can be an invoice, a credit memo, a debit memo, a write-off, or an adjustment. |
| item shuffle | In PeopleSoft Enterprise Campus Solutions, a process that enables you to change a payment allocation without having to reverse the payment. |
| itinerary | In PeopleSoft Expenses, a collection of travel reservations. Itineraries can have reservations that are selected and reserved with the travel vendor. These itineraries are not yet paid for and can be referred to as <i>pending reservations</i> . Reservations that have been paid for are referred to as <i>confirmed reservations</i> . |
| joint communication | In PeopleSoft Enterprise Campus Solutions, one letter that is addressed jointly to two people. For example, a letter might be addressed to both Mr. Sudhir Awat and Ms. Samantha Mortelli. A relationship must be established between the two individuals in the database, and at least one of the individuals must have an ID in the database. |

| | |
|-----------------------------|---|
| keyword | In PeopleSoft Enterprise Campus Solutions, a term that you link to particular elements within PeopleSoft Enterprise Student Financials, Financial Aid, and Contributor Relations. You can use keywords as search criteria that enable you to locate specific records in a search dialog box. |
| KPI | An abbreviation for <i>key performance indicator</i> . A high-level measurement of how well an organization is doing in achieving critical success factors. This defines the data value or calculation upon which an assessment is determined. |
| KVI | Abbreviation for <i>Known Value Item</i> . Term used for products or groups of products where the selling price cannot be reduced or increased. |
| landlord | In PeopleSoft Real Estate Management, an entity that owns real estate and leases the real estate to tenants. |
| LDIF file | Abbreviation for <i>Lightweight Directory Access Protocol (LDAP) Data Interchange Format file</i> . Contains discrepancies between PeopleSoft Enterprise data and directory data. |
| learner group | In PeopleSoft Enterprise Learning Management, a group of learners who are linked to the same learning environment. Members of the learner group can share the same attributes, such as the same department or job code. Learner groups are used to control access to and enrollment in learning activities and programs. They are also used to perform group enrollments and mass enrollments in the back office. |
| learning components | In PeopleSoft Enterprise Learning Management, the foundational building blocks of learning activities. PeopleSoft Enterprise Learning Management supports six basic types of learning components: web-based, session, webcast, test, survey, and assignment. One or more of these learning component types compose a single learning activity. |
| learning environment | In PeopleSoft Enterprise Learning Management, identifies a set of categories and catalog items that can be made available to learner groups. Also defines the default values that are assigned to the learning activities and programs that are created within a particular learning environment. Learning environments provide a way to partition the catalog so that learners see only those items that are relevant to them. |
| learning history | In PeopleSoft Enterprise Learning Management, a self-service repository for all of a learner's completed learning activities and programs. |
| lease | In PeopleSoft Real Estate Management, a legally binding agreement between a landlord and a tenant, where the tenant rents all or part of a physical property from the landlord. |
| lease abstract | In PeopleSoft Real Estate Management, a summarized version of the complete lease contract with only the important terms. The lease abstract usually fits on one page and does not include legal terminology. |
| ledger mapping | You use ledger mapping to relate expense data from general ledger accounts to resource objects. Multiple ledger line items can be mapped to one or more resource IDs. You can also use ledger mapping to map dollar amounts (referred to as <i>rates</i>) to business units. You can map the amounts in two different ways: an actual amount that represents actual costs of the accounting period, or a budgeted amount that can be used to calculate the capacity rates as well as budgeted model results. In PeopleSoft Enterprise Warehouse, you can map general ledger accounts to the EW Ledger table. |
| library section | In PeopleSoft Enterprise Incentive Management, a section that is defined in a plan (or template) and that is available for other plans to share. Changes to a library section are reflected in all plans that use it. |
| line | In PeopleSoft Strategic Sourcing, an individual item or service upon which there can be a bid. |

| | |
|-------------------------------|---|
| linked section | In PeopleSoft Enterprise Incentive Management, a section that is defined in a plan template but appears in a plan. Changes to linked sections propagate to plans using that section. |
| linked variable | In PeopleSoft Enterprise Incentive Management, a variable that is defined and maintained in a plan template and that also appears in a plan. Changes to linked variables propagate to plans using that variable. |
| LMS | Abbreviation for <i>learning management system</i> . In PeopleSoft Enterprise Campus Solutions, LMS is a PeopleSoft Enterprise Student Records feature that provides a common set of interoperability standards that enable the sharing of instructional content and data between learning and administrative environments. |
| load | In PeopleSoft Enterprise Inventory, identifies a group of goods that are shipped together. Load management is a feature of PeopleSoft Enterprise Inventory that is used to track the weight, the volume, and the destination of a shipment. |
| local functionality | In PeopleSoft Enterprise HRMS, the set of information that is available for a specific country. You can access this information when you click the appropriate country flag in the global window, or when you access it by a local country menu. |
| location | Locations enable you to indicate the different types of addresses—for a company, for example, one address to receive bills, another for shipping, a third for postal deliveries, and a separate street address. Each address has a different location number. The primary location—indicated by a <i>1</i> —is the address you use most often and may be different from the main address. |
| logistical task | In PeopleSoft Enterprise Services Procurement, an administrative task that is related to hiring a service provider. Logistical tasks are linked to the service type on the work order so that different types of services can have different logistical tasks. Logistical tasks include both preapproval tasks (such as assigning a new badge or ordering a new laptop) and postapproval tasks (such as scheduling orientation or setting up the service provider email). The logistical tasks can be mandatory or optional. Mandatory preapproval tasks must be completed before the work order is approved. Mandatory postapproval tasks, on the other hand, must be completed before a work order is released to a service provider. |
| market template | In PeopleSoft Enterprise Incentive Management, additional functionality that is specific to a given market or industry and is built on top of a product category. |
| mass change | In PeopleSoft Enterprise Campus Solutions, mass change is a SQL generator that can be used to create specialized functionality. Using mass change, you can set up a series of Insert, Update, or Delete SQL statements to perform business functions that are specific to the institution. See also <i>3C engine</i> . |
| match group | In PeopleSoft Enterprise Receivables, a group of receivables items and matching offset items. The system creates match groups by using user-defined matching criteria for selected field values. |
| MCF server | Abbreviation for <i>PeopleSoft MultiChannel Framework server</i> . Comprises the universal queue server and the MCF log server. Both processes are started when <i>MCF Servers</i> is selected in an application server domain configuration. |
| merchandising activity | In PeopleSoft Enterprise Promotions Management, a specific discount type that is associated with a trade promotion (such as off-invoice, billback or rebate, or lump-sum payment) that defines the performance that is required to receive the discount. In the industry, you may know this as an offer, a discount, a merchandising event, an event, or a tactic. |

| | |
|----------------------------|---|
| meta-SQL | Meta-SQL constructs expand into platform-specific SQL substrings. They are used in functions that pass SQL strings, such as in SQL objects, the SQLExec function, and PeopleSoft Application Engine programs. |
| metastring | Metastrings are special expressions included in SQL string literals. The metastrings, prefixed with a percent (%) symbol, are included directly in the string literals. They expand at run time into an appropriate substring for the current database platform. |
| multibook | In PeopleSoft Enterprise General Ledger, multiple ledgers having multiple-base currencies that are defined for a business unit, with the option to post a single transaction to all base currencies (all ledgers) or to only one of those base currencies (ledgers). |
| multicurrency | The ability to process transactions in a currency other than the business unit's base currency. |
| national allowance | In PeopleSoft Enterprise Promotions Management, a promotion at the corporate level that is funded by nondiscretionary dollars. In the industry, you may know this as a national promotion, a corporate promotion, or a corporate discount. |
| NDP | Abbreviation for <i>Non-Discountable Products</i> . Term used for products or groups of products where the selling price cannot be decreased. |
| need | In PeopleSoft Enterprise Campus Solutions, the difference between the cost of attendance (COA) and the expected family contribution (EFC). It is the gap between the cost of attending the school and the student's resources. The financial aid package is based on the amount of financial need. The process of determining a student's need is called <i>need analysis</i> . |
| node-oriented tree | A tree that is based on a detail structure, but the detail values are not used. |
| Optimization Engine | A PeopleTools component that Strategic Sourcing leverages to evaluate bids and determine an ideal award allocation. The award recommendation is based on maximizing the value while adhering to purchasing and company objectives and constraints. |
| pagelet | Each block of content on the home page is called a pagelet. These pagelets display summary information within a small rectangular area on the page. The pagelet provide users with a snapshot of their most relevant PeopleSoft Enterprise and non-PeopleSoft Enterprise content. |
| participant | In PeopleSoft Enterprise Incentive Management, participants are recipients of the incentive compensation calculation process. |
| participant object | Each participant object may be related to one or more compensation objects. See also <i>compensation object</i> . |
| partner | A company that supplies products or services that are resold or purchased by the enterprise. |
| pay cycle | In PeopleSoft Enterprise Payables, a set of rules that define the criteria by which it should select scheduled payments for payment creation. |
| payment shuffle | In PeopleSoft Enterprise Campus Solutions, a process allowing payments that have been previously posted to a student's account to be automatically reapplied when a higher priority payment is posted or the payment allocation definition is changed. |
| pending item | In PeopleSoft Enterprise Receivables, an individual receivable (such as an invoice, a credit memo, or a write-off) that has been entered in or created by the system, but hasn't been posted. |

| | |
|--|--|
| PeopleCode | PeopleCode is a proprietary language, executed by the PeopleSoft Enterprise component processor. PeopleCode generates results based on existing data or user actions. By using various tools provided with PeopleTools, external services are available to all PeopleSoft Enterprise applications wherever PeopleCode can be executed. |
| PeopleCode event | See <i>event</i> . |
| PeopleSoft Pure Internet Architecture | The fundamental architecture on which PeopleSoft 8 applications are constructed, consisting of a relational database management system (RDBMS), an application server, a web server, and a browser. |
| performance measurement | In PeopleSoft Enterprise Incentive Management, a variable used to store data (similar to an aggregator, but without a predefined formula) within the scope of an incentive plan. Performance measures are associated with a plan calendar, territory, and participant. Performance measurements are used for quota calculation and reporting. |
| period context | In PeopleSoft Enterprise Incentive Management, because a participant typically uses the same compensation plan for multiple periods, the period context associates a plan context with a specific calendar period and fiscal year. The period context references the associated plan context, thus forming a chain. Each plan context has a corresponding set of period contexts. |
| person of interest | A person about whom the organization maintains information but who is not part of the workforce. |
| personal portfolio | In PeopleSoft Enterprise Campus Solutions, the user-accessible menu item that contains an individual's name, address, telephone number, and other personal information. |
| phase | A level 1 task, meaning that if a task had subtasks, the level 1 task would be considered the phase. |
| pickup quantity | The product quantity that the customer is taking with them from the counter sales environment. |
| plan | In PeopleSoft Enterprise Sales Incentive Management, a collection of allocation rules, variables, steps, sections, and incentive rules that instruct the PeopleSoft Enterprise Incentive Management engine in how to process transactions. |
| plan context | In PeopleSoft Enterprise Incentive Management, correlates a participant with the compensation plan and node to which the participant is assigned, enabling the PeopleSoft Enterprise Incentive Management system to find anything that is associated with the node and that is required to perform compensation processing. Each participant, node, and plan combination represents a unique plan context—if three participants are on a compensation structure, each has a different plan context. Configuration plans are identified by plan contexts and are associated with the participants that refer to them. |
| plan template | In PeopleSoft Enterprise Incentive Management, the base from which a plan is created. A plan template contains common sections and variables that are inherited by all plans that are created from the template. A template may contain steps and sections that are not visible in the plan definition. |
| planned learning | In PeopleSoft Enterprise Learning Management, a self-service repository for all of a learner's planned learning activities and programs. |
| planning instance | In PeopleSoft Enterprise Supply Planning, a set of data (business units, items, supplies, and demands) constituting the inputs and outputs of a supply plan. |
| population | In PeopleSoft Enterprise Campus Solutions, the middle level of the three-level classification structure that you define in PeopleSoft Enterprise Recruiting and |

Admissions for enrollment management. You can define a population level, link it to other levels, and set enrollment target numbers for it.

See also *division* and *cohort*.

| | |
|------------------------------|---|
| portal registry | In PeopleSoft Enterprise applications, the portal registry is a tree-like structure in which content references are organized, classified, and registered. It is a central repository that defines both the structure and content of a portal through a hierarchical, tree-like structure of folders useful for organizing and securing content references. |
| predecessor task | A task that you must complete before you start another task. |
| price breaks | In PeopleSoft Strategic Sourcing, a price discount or surcharge that a bidder may apply based on the quantity awarded. |
| price components | In PeopleSoft Strategic Sourcing, the various components, such as material costs, labor costs, shipping costs, and so on that make up the overall bid price. |
| price list | Enables you to select products and conditions for which the price list applies to a transaction. During a transaction, the system either determines the product price based on the predefined search hierarchy for the transaction or uses the product's lowest price on any associated, active price lists. This price is used as the basis for any further discounts and surcharges. |
| price rule | The conditions that must be met for adjustments to be applied to the base price. Multiple rules can apply when conditions of each rule are met. |
| price rule conditions | Conditions that select the price-by fields, the values for the price-by fields, and the operator that determines how the price-by fields relate to the transaction. |
| price rule key | The fields that are available to define price rule conditions (which are used to match a transaction) on the price rule. |
| primacy number | In PeopleSoft Enterprise Campus Solutions, a number that the system uses to prioritize financial aid applications when students are enrolled in multiple academic careers and academic programs at the same time. The Consolidate Academic Statistics process uses the primacy number indicated for both the career and program at the institutional level to determine a student's primary career and program. The system also uses the number to determine the primary student attribute value that is used when you extract data to report on cohorts. The lowest number takes precedence. |
| primary name type | In PeopleSoft Enterprise Campus Solutions, the name type that is used to link the name stored at the highest level within the system to the lower-level set of names that an individual provides. |
| process category | In PeopleSoft Process Scheduler, processes that are grouped for server load balancing and prioritization. |
| process group | In PeopleSoft Enterprise Financials, a group of application processes (performed in a defined order) that users can initiate in real time, directly from a transaction entry page. |
| process definition | Process definitions define each run request. |
| process instance | A unique number that identifies each process request. This value is automatically incremented and assigned to each requested process when the process is submitted to run. |
| process job | You can link process definitions into a job request and process each request serially or in parallel. You can also initiate subsequent processes based on the return code from each prior request. |

| | |
|----------------------------|--|
| process request | A single run request, such as a Structured Query Report (SQR), a COBOL or Application Engine program, or a Crystal report that you run through PeopleSoft Process Scheduler. |
| process run control | A PeopleTools variable used to retain PeopleSoft Process Scheduler values needed at runtime for all requests that reference a run control ID. Do not confuse these with application run controls, which may be defined with the same run control ID, but only contain information specific to a given application process request. |
| product | A PeopleSoft Enterprise or third-party product. PeopleSoft organizes its software products into product families and product lines. Interactive Services Repository contains information about every release of every product that PeopleSoft sells, as well as products from certified third-party companies. These products appear with the product name and release number. |
| product adds | The pricing functionality where buying product A gets product B for free or at a price (formerly referred to as <i>giveaways</i>). |
| product bidding | In PeopleSoft Strategic Sourcing, the placing of a bid on behalf of the bidder, up or down to the bidder's specified amount, so that the bidder can be the leading bidder. |
| product category | In PeopleSoft Enterprise Incentive Management, indicates an application in the PeopleSoft Enterprise Incentive Management suite of products. Each transaction in the PeopleSoft Enterprise Incentive Management system is associated with a product category. |
| product family | A group of products that are related by common functionality. The family names that can be searched using Interactive Service Repository are Oracle's PeopleSoft Enterprise, PeopleSoft EnterpriseOne, PeopleSoft World, and third-party, certified partners. |
| product line | The name of a PeopleSoft Enterprise product line or the company name of a third-party certified partner. Integration Services Repository enables you to search for integration points by product line. |
| programs | In PeopleSoft Enterprise Learning Management, a high-level grouping that guides the learner along a specific learning path through sections of catalog items. PeopleSoft Enterprise Learning Systems provides two types of programs—curricula and certifications. |
| progress log | In PeopleSoft Enterprise Services Procurement, tracks deliverable-based projects. This is similar to the time sheet in function and process. The service provider contact uses the progress log to record and submit progress on deliverables. The progress can be logged by the activity that is performed, by the percentage of work that is completed, or by the completion of milestone activities that are defined for the project. |
| project transaction | In PeopleSoft Enterprise Project Costing, an individual transaction line that represents a cost, time, budget, or other transaction row. |
| promotion | In PeopleSoft Enterprise Promotions Management, a trade promotion, which is typically funded from trade dollars and used by consumer products manufacturers to increase sales volume. |
| prospects | In PeopleSoft Enterprise Campus Solutions, students who are interested in applying to the institution. In PeopleSoft Enterprise Contributor Relations, individuals and organizations that are most likely to make substantial financial commitments or other types of commitments to the institution. |
| proxy bidding | In PeopleSoft Strategic Sourcing, the placing of a bid on behalf of the bidder, up or down to the bidder's specified amount, so that the bidder can be the leading bidder. |

| | |
|--------------------------------|--|
| publishing | In PeopleSoft Enterprise Incentive Management, a stage in processing that makes incentive-related results available to participants. |
| rating components | In PeopleSoft Enterprise Campus Solutions, variables used with the Equation Editor to retrieve specified populations. |
| record group | A set of logically and functionally related control tables and views. Record groups help enable TableSet sharing, which eliminates redundant data entry. Record groups ensure that TableSet sharing is applied consistently across all related tables and views. |
| record input VAT flag | Abbreviation for <i>record input value-added tax flag</i> . Within PeopleSoft Enterprise Purchasing, Payables, and General Ledger, this flag indicates that you are recording input VAT on the transaction. This flag, in conjunction with the record output VAT flag, is used to determine the accounting entries created for a transaction and to determine how a transaction is reported on the VAT return. For all cases within Purchasing and Payables where VAT information is tracked on a transaction, this flag is set to Yes. This flag is not used in PeopleSoft Enterprise Order Management, Billing, or Receivables, where it is assumed that you are always recording only output VAT, or in PeopleSoft Enterprise Expenses, where it is assumed that you are always recording only input VAT. |
| record output VAT flag | Abbreviation for <i>record output value-added tax flag</i> . See <i>record input VAT flag</i> . |
| recname | The name of a record that is used to determine the associated field to match a value or set of values. |
| recognition | In PeopleSoft Enterprise Campus Solutions, the recognition type indicates whether the PeopleSoft Enterprise Contributor Relations donor is the primary donor of a commitment or shares the credit for a donation. Primary donors receive hard credit that must total 100 percent. Donors that share the credit are given soft credit. Institutions can also define other share recognition-type values such as memo credit or vehicle credit. |
| reference data | In PeopleSoft Enterprise Sales Incentive Management, system objects that represent the sales organization, such as territories, participants, products, customers, and channels. |
| reference object | In PeopleSoft Enterprise Incentive Management, this dimension-type object further defines the business. Reference objects can have their own hierarchy (for example, product tree, customer tree, industry tree, and geography tree). |
| reference transaction | In commitment control, a reference transaction is a source transaction that is referenced by a higher-level (and usually later) source transaction, in order to automatically reverse all or part of the referenced transaction's budget-checked amount. This avoids duplicate postings during the sequential entry of the transaction at different commitment levels. For example, the amount of an encumbrance transaction (such as a purchase order) will, when checked and recorded against a budget, cause the system to concurrently reference and relieve all or part of the amount of a corresponding pre-encumbrance transaction, such as a purchase requisition. |
| regional sourcing | In PeopleSoft Enterprise Purchasing, provides the infrastructure to maintain, display, and select an appropriate vendor and vendor pricing structure that is based on a regional sourcing model where the multiple ship to locations are grouped. Sourcing may occur at a level higher than the ship to location. |
| relationship object | In PeopleSoft Enterprise Incentive Management, these objects further define a compensation structure to resolve transactions by establishing associations between compensation objects and business objects. |
| remote data source data | Data that is extracted from a separate database and migrated into the local database. |

| | |
|-----------------------------|---|
| REN server | Abbreviation for <i>real-time event notification server</i> in PeopleSoft MultiChannel Framework. |
| requester | In PeopleSoft Enterprise eSettlements, an individual who requests goods or services and whose ID appears on the various procurement pages that reference purchase orders. |
| reservations | In PeopleSoft Expenses, travel reservations that have been placed with the travel vendor. |
| reversal indicator | In PeopleSoft Enterprise Campus Solutions, an indicator that denotes when a particular payment has been reversed, usually because of insufficient funds. |
| RFI event | In PeopleSoft Strategic Sourcing, a request for information. |
| RFx event | In PeopleSoft Strategic Sourcing, a request for proposal or request for a quote event when bidders submit their overall best bids and during which bidders do not actively compete against one another. |
| role | Describes how people fit into PeopleSoft Workflow. A role is a class of users who perform the same type of work, such as clerks or managers. Your business rules typically specify what user role needs to do an activity. |
| role user | A PeopleSoft Workflow user. A person's role user ID serves much the same purpose as a user ID does in other parts of the system. PeopleSoft Workflow uses role user IDs to determine how to route worklist items to users (through an email address, for example) and to track the roles that users play in the workflow. Role users do not need PeopleSoft user IDs. |
| roll up | In a tree, to roll up is to total sums based on the information hierarchy. |
| run control | A run control is a type of online page that is used to begin a process, such as the batch processing of a payroll run. Run control pages generally start a program that manipulates data. |
| run control ID | A unique ID to associate each user with his or her own run control table entries. |
| run-level context | In PeopleSoft Enterprise Incentive Management, associates a particular run (and batch ID) with a period context and plan context. Every plan context that participates in a run has a separate run-level context. Because a run cannot span periods, only one run-level context is associated with each plan context. |
| saved bid | In PeopleSoft Strategic Sourcing, a bid that has been created but not submitted. Only submitted bids are eligible for award. |
| score | In PeopleSoft Strategic Sourcing, the numerical sum of answers (percentages) to bid factors on an event. Scores appear only to bidders on auction events. |
| SCP SCBM XML message | Abbreviation for <i>Supply Chain Planning Supply Chain Business Modeler Extensible Markup Language message</i> . Supply Chain Business Modeler uses XML as the format for all data that it imports and exports. |
| search query | You use this set of objects to pass a query string and operators to the search engine. The search index returns a set of matching results with keys to the source documents. |
| search/match | In PeopleSoft Enterprise Campus Solutions and PeopleSoft Enterprise Human Resources Management Solutions, a feature that enables you to search for and identify duplicate records in the database. |
| seasonal address | In PeopleSoft Enterprise Campus Solutions, an address that recurs for the same length of time at the same time of year each year until adjusted or deleted. |

| | |
|--------------------------------|---|
| section | In PeopleSoft Enterprise Incentive Management, a collection of incentive rules that operate on transactions of a specific type. Sections enable plans to be segmented to process logical events in different sections. |
| security event | In commitment control, security events trigger security authorization checking, such as budget entries, transfers, and adjustments; exception overrides and notifications; and inquiries. |
| sell event | In PeopleSoft Strategic Sourcing, for event creators, the sale of goods or services most typically associated with forward auctions. For bidders, the purchase of goods or services. |
| serial genealogy | In PeopleSoft Enterprise Manufacturing, the ability to track the composition of a specific, serial-controlled item. |
| serial in production | In PeopleSoft Enterprise Manufacturing, enables the tracing of serial information for manufactured items. This is maintained in the Item Master record. |
| service impact | In PeopleSoft Enterprise Campus Solutions, the resulting action triggered by a service indicator. For example, a service indicator that reflects nonpayment of account balances by a student might result in a service impact that prohibits registration for classes. |
| service indicator | In PeopleSoft Enterprise Campus Solutions, indicates services that may be either withheld or provided to an individual. Negative service indicators indicate holds that prevent the individual from receiving specified services, such as check-cashing privileges or registration for classes. Positive service indicators designate special services that are provided to the individual, such as front-of-line service or special services for disabled students. |
| session | <p>In PeopleSoft Enterprise Campus Solutions, time elements that subdivide a term into multiple time periods during which classes are offered. In PeopleSoft Enterprise Contributor Relations, a session is the means of validating gift, pledge, membership, or adjustment data entry . It controls access to the data entered by a specific user ID. Sessions are balanced, queued, and then posted to the institution's financial system. Sessions must be posted to enter a matching gift or pledge payment, to make an adjustment, or to process giving clubs or acknowledgements.</p> <p>In PeopleSoft Enterprise Learning Management, a single meeting day of an activity (that is, the period of time between start and finish times within a day). The session stores the specific date, location, meeting time, and instructor. Sessions are used for scheduled training.</p> |
| session template | In PeopleSoft Enterprise Learning Management, enables you to set up common activity characteristics that may be reused while scheduling a PeopleSoft Enterprise Learning Management activity—characteristics such as days of the week, start and end times, facility and room assignments, instructors, and equipment. A session pattern template can be attached to an activity that is being scheduled. Attaching a template to an activity causes all of the default template information to populate the activity session pattern. |
| setup relationship | In PeopleSoft Enterprise Incentive Management, a relationship object type that associates a configuration plan with any structure node. |
| share driver expression | In PeopleSoft Enterprise Business Planning, a named planning method similar to a driver expression, but which you can set up globally for shared use within a single planning application or to be shared between multiple planning applications through PeopleSoft Enterprise Warehouse. |
| short-term customer | A customer not in the system who is entered during sales order entry using a template. |

| | |
|------------------------------|--|
| single signon | With single signon, users can, after being authenticated by a PeopleSoft Enterprise application server, access a second PeopleSoft Enterprise application server without entering a user ID or password. |
| source key process | In PeopleSoft Enterprise Campus Solutions, a process that relates a particular transaction to the source of the charge or financial aid. On selected pages, you can drill down into particular charges. |
| source transaction | In commitment control, any transaction generated in a PeopleSoft Enterprise or third-party application that is integrated with commitment control and which can be checked against commitment control budgets. For example, a pre-encumbrance, encumbrance, expenditure, recognized revenue, or collected revenue transaction. |
| sourcing objective | For constraints, the option to designate whether a business rule is required (mandatory) or is only recommended (target). |
| speed key | See <i>communication key</i> . |
| SpeedChart | A user-defined shorthand key that designates several ChartKeys to be used for voucher entry. Percentages can optionally be related to each ChartKey in a SpeedChart definition. |
| SpeedType | A code representing a combination of ChartField values. SpeedTypes simplify the entry of ChartFields commonly used together. |
| staging | A method of consolidating selected partner offerings with the offerings from the enterprise's other partners. |
| standard letter code | In PeopleSoft Enterprise Campus Solutions, a standard letter code used to identify each letter template available for use in mail merge functions. Every letter generated in the system must have a standard letter code identification. |
| statutory account | Account required by a regulatory authority for recording and reporting financial results. In PeopleSoft Enterprise, this is equivalent to the Alternate Account (ALTACCT) ChartField. |
| step | In PeopleSoft Enterprise Sales Incentive Management, a collection of sections in a plan. Each step corresponds to a step in the job run. |
| storage level | In PeopleSoft Enterprise Inventory, identifies the level of a material storage location. Material storage locations are made up of a business unit, a storage area, and a storage level. You can set up to four storage levels. |
| subcustomer qualifier | A value that groups customers into a division for which you can generate detailed history, aging, events, and profiles. |
| Summary ChartField | You use summary ChartFields to create summary ledgers that roll up detail amounts based on specific detail values or on selected tree nodes. When detail values are summarized using tree nodes, summary ChartFields must be used in the summary ledger data record to accommodate the maximum length of a node name (20 characters). |
| summary ledger | An accounting feature used primarily in allocations, inquiries, and PS/nVision reporting to store combined account balances from detail ledgers. Summary ledgers increase speed and efficiency of reporting by eliminating the need to summarize detail ledger balances each time a report is requested. Instead, detail balances are summarized in a background process according to user-specified criteria and stored on summary ledgers. The summary ledgers are then accessed directly for reporting. |
| summary time period | In PeopleSoft Enterprise Business Planning, any time period (other than a base time period) that is an aggregate of other time periods, including other summary time periods and base time periods, such as quarter and year total. |

| | |
|-------------------------|---|
| summary tree | A tree used to roll up accounts for each type of report in summary ledgers. Summary trees enable you to define trees on trees. In a summary tree, the detail values are really nodes on a detail tree or another summary tree (known as the <i>basis</i> tree). A summary tree structure specifies the details on which the summary trees are to be built. |
| syndicate | To distribute a production version of the enterprise catalog to partners. |
| system function | In PeopleSoft Enterprise Receivables, an activity that defines how the system generates accounting entries for the general ledger. |
| system source | <p>The system source identifies the source of a transaction row in the database. For example, a transaction that originates in PeopleSoft Enterprise Expenses contains a system source code of BEX (Expenses Batch).</p> <p>When PeopleSoft Enterprise Project Costing prices the source transaction row for billing, the system creates a new row with a system source code of PRP (Project Costing pricing), which represents the system source of the new row. System source codes can identify sources that are internal or external to the PeopleSoft Enterprise system. For example, processes that import data from Microsoft Project into PeopleSoft Enterprise applications create transaction rows with a source code of MSP (Microsoft Project).</p> |
| TableSet | A means of sharing similar sets of values in control tables, where the actual data values are different but the structure of the tables is the same. |
| TableSet sharing | Shared data that is stored in many tables that are based on the same TableSets. Tables that use TableSet sharing contain the SETID field as an additional key or unique identifier. |
| target currency | The value of the entry currency or currencies converted to a single currency for budget viewing and inquiry purposes. |
| task | A deliverable item on the detailed sourcing plan. |
| tax authority | In PeopleSoft Enterprise Campus Solutions, a user-defined element that combines a description and percentage of a tax with an account type, an item type, and a service impact. |
| template | A template is HTML code associated with a web page. It defines the layout of the page and also where to get HTML for each part of the page. In PeopleSoft Enterprise, you use templates to build a page by combining HTML from a number of sources. For a PeopleSoft Enterprise portal, all templates must be registered in the portal registry, and each content reference must be assigned a template. |
| tenant | In PeopleSoft Real Estate Management, an entity that leases real estate from a landlord. |
| territory | In PeopleSoft Enterprise Sales Incentive Management, hierarchical relationships of business objects, including regions, products, customers, industries, and participants. |
| third party | A company or vendor that has extensive PeopleSoft Enterprise product knowledge and whose products and integrations have been certified and are compatible with PeopleSoft Enterprise applications. |
| tiered pricing | Enables different portions of a schedule to be priced differently from one another. |
| time span | A relative period, such as year-to-date or current period, that various PeopleSoft General Ledger functions and reports can use when a rolling time frame, rather than a specific date, is required. |
| total cost | In PeopleSoft Strategic Sourcing, the estimated dollar cost (sum of real price dollars and potential “soft” or non-price dollars) of a particular award approach. |

| | |
|------------------------------------|---|
| travel group | In PeopleSoft Expenses, the organization's travel rules and policies that are associated with specific business units, departments, or employees. You must define at least one travel group when setting up the PeopleSoft Expenses travel feature. You must define and associate at least one travel group with a travel vendor. |
| travel partner | In PeopleSoft Expenses, the travel vendor with which the organization has a contractual relationship. |
| 3C engine | Abbreviation for <i>Communications, Checklists, and Comments engine</i> . In PeopleSoft Enterprise Campus Solutions, the 3C engine enables you to automate business processes that involve additions, deletions, and updates to communications, checklists, and comments. You define events and triggers to engage the engine, which runs the mass change and processes the 3C records (for individuals or organizations) immediately and automatically from within business processes. |
| 3C group | Abbreviation for <i>Communications, Checklists, and Comments group</i> . In PeopleSoft Enterprise Campus Solutions, a method of assigning or restricting access privileges. A 3C group enables you to group specific communication categories, checklist codes, and comment categories. You can then assign the group inquiry-only access or update access, as appropriate. |
| trace usage | In PeopleSoft Enterprise Manufacturing, enables the control of which components will be traced during the manufacturing process. Serial- and lot-controlled components can be traced. This is maintained in the Item Master record. |
| transaction allocation | In PeopleSoft Enterprise Incentive Management, the process of identifying the owner of a transaction. When a raw transaction from a batch is allocated to a plan context, the transaction is duplicated in the PeopleSoft Enterprise Incentive Management transaction tables. |
| transaction state | In PeopleSoft Enterprise Incentive Management, a value assigned by an incentive rule to a transaction. Transaction states enable sections to process only transactions that are at a specific stage in system processing. After being successfully processed, transactions may be promoted to the next transaction state and "picked up" by a different section for further processing. |
| Translate table | A system edit table that stores codes and translate values for the miscellaneous fields in the database that do not warrant individual edit tables of their own. |
| tree | The graphical hierarchy in PeopleSoft Enterprise systems that displays the relationship between all accounting units (for example, corporate divisions, projects, reporting groups, account numbers) and determines roll-up hierarchies. |
| tuition lock | In PeopleSoft Enterprise Campus Solutions, a feature in the Tuition Calculation process that enables you to specify a point in a term after which students are charged a minimum (or <i>locked</i>) fee amount. Students are charged the locked fee amount even if they later drop classes and take less than the normal load level for that tuition charge. |
| unclaimed transaction | In PeopleSoft Enterprise Incentive Management, a transaction that is not claimed by a node or participant after the allocation process has completed, usually due to missing or incomplete data. Unclaimed transactions may be manually assigned to the appropriate node or participant by a compensation administrator. |
| universal navigation header | Every PeopleSoft Enterprise portal includes the universal navigation header, intended to appear at the top of every page as long as the user is signed on to the portal. In addition to providing access to the standard navigation buttons (like Home, Favorites, and signoff) the universal navigation header can also display a welcome message for each user. |
| update access | In PeopleSoft Enterprise Campus Solutions, a type of security access that permits the user to edit and update data. |

See also *inquiry access*.

| | |
|--------------------------------|---|
| user interaction object | In PeopleSoft Enterprise Sales Incentive Management, used to define the reporting components and reports that a participant can access in his or her context. All PeopleSoft Enterprise Sales Incentive Management user interface objects and reports are registered as user interaction objects. User interaction objects can be linked to a compensation structure node through a compensation relationship object (individually or as groups). |
| variable | In PeopleSoft Enterprise Sales Incentive Management, the intermediate results of calculations. Variables hold the calculation results and are then inputs to other calculations. Variables can be plan variables that persist beyond the run of an engine or local variables that exist only during the processing of a section. |
| VAT exception | Abbreviation for <i>value-added tax exception</i> . A temporary or permanent exemption from paying VAT that is granted to an organization. This term refers to both VAT exoneration and VAT suspension. |
| VAT exempt | Abbreviation for <i>value-added tax exempt</i> . Describes goods and services that are not subject to VAT. Organizations that supply exempt goods or services are unable to recover the related input VAT. This is also referred to as exempt without recovery. |
| VAT exoneration | Abbreviation for <i>value-added tax exoneration</i> . An organization that has been granted a permanent exemption from paying VAT due to the nature of that organization. |
| VAT suspension | Abbreviation for <i>value-added tax suspension</i> . An organization that has been granted a temporary exemption from paying VAT. |
| warehouse | A PeopleSoft Enterprise data warehouse that consists of predefined ETL maps, data warehouse tools, and DataMart definitions. |
| weight or weighting | In PeopleSoft Strategic Sourcing, how important the line or question is to the overall event. Weighting is used to score and analyze bids. For RFx and RFI events, weightings may or may not appear to bidders. |
| work order | In PeopleSoft Enterprise Services Procurement, enables an enterprise to create resource-based and deliverable-based transactions that specify the basic terms and conditions for hiring a specific service provider. When a service provider is hired, the service provider logs time or progress against the work order. |
| worker | A person who is part of the workforce; an employee or a contingent worker. |
| workset | A group of people and organizations that are linked together as a set. You can use worksets to simultaneously retrieve the data for a group of people and organizations and work with the information on a single page. |
| worksheet | A way of presenting data through a PeopleSoft Enterprise Business Analysis Modeler interface that enables users to do in-depth analysis using pivoting tables, charts, notes, and history information. |
| worklist | The automated to-do list that PeopleSoft Workflow creates. From the worklist, you can directly access the pages you need to perform the next action, and then return to the worklist for another item. |
| XML link | The XML Linking language enables you to insert elements into XML documents to create a links between resources. |
| XML schema | An XML definition that standardizes the representation of application messages, component interfaces, or business interlinks. |
| XPI | Abbreviation for <i>eXtended Process Integrator</i> . PeopleSoft XPI is the integration infrastructure that enables both real-time and batch communication with JD Edwards EnterpriseOne applications. |

yield by operation

In PeopleSoft Enterprise Manufacturing, the ability to plan the loss of a manufactured item on an operation-by-operation basis.

zero-rated VAT

Abbreviation for *zero-rated value-added tax*. A VAT transaction with a VAT code that has a tax percent of zero. Used to track taxable VAT activity where no actual VAT amount is charged. Organizations that supply zero-rated goods and services can still recover the related input VAT. This is also referred to as exempt with recovery.

Index

Numerics/Symbols

- 2054 2055 Reports page 413, 415
- 40% rule analysis report 570

A

- account activity summary reports 566
- accounting entries
 - common field definitions 314
 - creating 301, 312
 - reversing 302
 - sources in Asset Management 301
 - understanding 301
- Accounting Entries component 21
- Accounting Entry
 - set up 303
- Accounting Entry Creation process 302
- accounting entry detail reports 566
- Accounting Entry Distribution
 - process 345
- Accounting Entry Generation process 299
- accounting entry templates 304
- accounting entry templates report 562
- accounting entry types 305
- accounting periods
 - closing 317
 - viewing closed periods 311
- accumulated depreciation 261
- ACE retirements report 570
- acquisition codes 53
- acquisition costs 61
- Acquisition Details page 48
- Add/Copy Asset Book page 17
- addition transactions 214
- additional documentation xxiv
- adjusted current earnings worksheet (ACE)
 - report 570
- adjustment transactions 214
- advance payments 138
- advanced depreciation 433
- advanced depreciation reports 572
- Advanced Transaction Details page 321
- Allocation Basis Definition component
 - Allocations page 295, 296
 - Definition page 295
- allocation table 256
- allocations 293
 - depreciation expenses 293
 - running the depreciation allocation process 298
 - setting up 294
 - specifying criteria 296
- Allocations page — Allocation Basis Definition 295, 296
- ALM
 - overview 1
- altaccount activity summary reports 566
- alternate account entry detail reports 566
- alternative minimum tax (AMT)
 - report 570
- AM Period Allocation page 298
- AM Specific Fields page — Asset Mass Change Definition 236, 237, 362
- AM Specific Fields page - Asset Mass Change Definition 359
- AM to GL reconciliation by category
 - report 565
- AM to GL reconciliation by Department
 - report 565
- AM/BI Interface page 322, 338
- AM/Billing Transaction Status page 338
- AM/Billing Transaction Status report 569
- AM_DEPR_CALC
 - running 263
- AMDPARCH process 442
- AMT retirements report 570
- AMTX3210 report 87
- AMUDEPR.SQC program 282
- Annual Cost page — CAP Details 121
- application fundamentals xxiii
- Approve Asset Transfer page 396
- Approve Disposal page 350
- Approve Disposals page 19, 322
- Approve Financial Information
 - component 22
- Approve Financial page 370
- Approve Lease Information
 - component 22
 - Load Approval page 43
 - Load Preview page 43
- Approve Physical A or B page 372

- Approve Physical Information component 22
- Archive Cost/Depreciation page 19
- archiving
 - inactive assets 442
 - restoring data 444
 - understanding 441
 - using mass change 445
 - viewing results 443
- arrears payments 138
- Asset Acquisition Detail page 48, 61
- asset acquisitions by ChartField report 562
- asset acquisitions by in service date report 563
- Asset Addition page 179
- Asset Archive process 442
- Asset Archive process (AMDPARCH) 442
- asset blocks 421
- Asset Book History - Detail page 222
- Asset Book History - List page 222
- asset books
 - maintaining 79
- asset budgeting
 - linking to capital acquisition plans 123
 - overview 119
- asset categories report 562
- Asset Checkout page 23
- asset classes
 - assigning 52, 93
- Asset Component Hierarchy Move report 97
- asset component hierarchy page 97
- Asset Component Hierarchy page 16, 97
- asset components
 - work order options 60
- Asset Cost Adjust/Transfers component
 - Cost Information page 152
 - Main Transaction page 150
- Asset Cost IU Book Transfer page 149, 158
- Asset Cost IU Transfer page 149
- Asset Definitions
 - navigation 15
- Asset Depreciation component
 - Asset page 268
 - Depreciation page 268
 - Period Depreciation page 268, 269
- asset details
 - entering 57
- Asset Details component 21
- Asset ExpressAdd 89
- Asset Information page 103, 396
- asset inspection
 - tracking 194
- Asset Inspection page 23
- Asset Insurance page 23, 204
- asset licenses report 562
- Asset Location Transfer page 149
- asset maintenance
 - scheduling and tracking 193
 - tracking financial information 194
- asset management units/books report 562
- Asset Mass Change Definition component
 - AM Specific Fields page 236, 237, 359, 362
 - Criteria and Defaults page 236, 237, 359, 360
 - Description page 236, 359
 - Execution History page 236, 359
 - Generate SQL page 236, 237, 359, 362
- Asset Meter Information component 23
- asset meters
 - associating to assets 74
 - maintaining 72
- Asset Meters page 74
- asset NBV by category report 565
- asset NBV by ChartField report 565
- asset NBV by location report 565
- Asset NBV reports 290
- asset net book value by alternate account report 564
- Asset Operational Information
 - non-financial assets 107
- Asset page — Asset Depreciation 268
- Asset Parent page 103
- asset profiles
 - composite assets 225
 - setting up for group assets 210
- Asset Property page 50
- Asset Property Tax page 23
- Asset R&D Information page 48, 55
- asset reclassifications report 563
- Asset Restore process (AMDPREST) 445
- Asset Service/Repair Details component
 - Maintenance Details page 195
 - Payment page 199
- Asset Service/Repair History component
 - Maint History by Type page 206

- Asset Set Up Lists 562
- asset supplemental data
 - entering 71
- Asset Supplemental Data page 71, 108
- Asset Transfer Request page 396
- asset transfers by ChartField report 563
- Asset Unit Aggregate RD page 403, 404
- asset warranties
 - entering 201
- Asset Warranties component —
 - Parameters 206
- Asset Warranties page 23
- asset warranties report 562
- Asset Warranties report 206
- Asset Warranty page 201
- assets
 - copying 94
 - assets by asset ID report 563
 - Assets by Location — Parameters page 48
 - assets by location report 563
 - Assets Register - IND page 422, 424
 - assets register INDIA reports 574
 - assets, creating and maintaining 45
 - adding using Excel to Component Interface (ExcelToCI) utility 114
 - basic information 51
 - changing depreciation rates 221
 - changing group asset ID 213
 - defining parent-child relationships 102
 - defining status 53, 93
 - entering capitalization information 63
 - entering location and custom attributes 65
 - insurance information 203
 - manufacture, license, and custodian information 66
 - tracking costs 194
 - using Asset ExpressAdd 89
 - using Basic Add 47
- assets, depreciation 80, 85
 - listed property assets 526
 - salvage value 525
 - tax credits 526
- assets, printing 114
- assets, processing
 - group assets 207
- assets, recategorizing 156
- assets, reinstating 353
- assets, retiring 319, 320
 - group members 208
- like-kind exchanges 330
 - non-financial 352
 - putting up for auction 351
 - traded-in assets 329
 - using the disposal worksheet 348
- assets, revaluing
 - France 414
 - net method 409
 - processing 409
 - setting up 402
- assets, searching 111
- assets, transferring
 - adjusting costs or quantity 154
 - between business units 157
 - books 158
 - children 161
 - cost adjustments and transfers 148
 - retroactive transfers 156
 - within business units 155
- assets, viewing
 - book history 222
 - inventory data 243
 - maintenance history 206
- attachments
 - adding 72
- Attachments page 72
- auctions 351
- AUS RD Tax Deductions report 571
- Australia CCP Report page 403, 408
- Australia support
 - asset revaluations 399, 409
 - CCP 408
 - CGT calculation 408
 - defining R&D asset eligibility 404
 - defining R&D assets 404
 - enabling R&D calculations 404
 - overview 397
 - recording goods and services tax (GST) 406, 407
 - setting up revaluations 402
 - tax credit allowance 405
 - tracking changes in CCP 406
- Australian reports 571
 - retirement activity report 571
 - retirement detail by ChartField report 571
- Australian Revaluation process 409
- Authorization page — CAP Details 121
- auto approval 239
- auto-discovery tool 231

Auto-Retire Fully Depr Assets page 19
 Auto-Retire Fully Depreciated Assets
 page 321, 346
 Auto-Retired Assets page 321
 auto-retired assets report 569

B

bar charts 391
 bar code scanning devices 231
 Basic Add 47, 104
 Basic Add -O&M 108
 Basic Add page 16
 Beginning of Year page 411
 Bill Information page — Retire/Reinstate
 Assets 322, 336
 Billing
 processing reinstatements 353
 processing retired assets 336
 retired assets 336
 Book - Depreciation page 80
 Book - Tax page 80, 86
 book code discrepancy report 562
 books
 defining 80, 85, 86, 209
 estimated net value calculation 220
 maintaining 79
 retiring 160
 reviewing changes 222
 budgeting
 capital acquisition planning 119
 buildings
 depreciation 416
 business processes 2
 business tax for France 87
 Business Tax Report page 413
 business units
 setting up for joint ventures 253, 255
 By ChartField page — Retire/Reinstate
 Assets 321, 334

C

Calculate Inflation page 21
 Calculate Local Taxes component 23
 Calculate Replacement Cost page 16
 Canada support 410
 CCA Reporting 411
 overview 398
 running CCA year end update
 process 411

 setting up CCA reporting 400
 Canadian reports 571
 CAP, *See* capital acquisition plans (CAP)
 CAP Detail Long Description page 121
 CAP Details component
 Annual Cost page 121
 Authorization page 121
 Justification page 121
 Capital Acquisition Planning
 Capital Lease Payments page 124
 Financial Assets page 124
 Non-Financial Assets page 124
 Operating Lease Payments page 124
 Summary page 125
 capital acquisition planning assets
 report 563
 Capital Acquisition Planning component
 CAP Detail Long Description page 121
 Details page 121
 Parameters page 125
 capital acquisition plans (CAP)
 adjusting costs 123
 assigning names and ChartFields 121
 defining 120
 defining class 121
 developing 119
 leased assets 133
 linking assets to 52, 93, 123
 reporting 125
 understanding 119
 viewing 123
 capital acquisition plans by department
 report 563
 capital acquisition plans report 563
 capital cost allowance (CCA)
 calculating and reporting 411
 running year end update 411
 Capital Gain page — Retire/Reinstate
 Assets 322, 336
 capital gains tax (CGT)
 calculating for Australia 408, 409
 specifying assets 408
 capital investment projects
 defining for Australia 405
 Capital Lease Payments page — Capital
 Acquisition Planning 124
 capital leases 127, 138
 capitalization information 63, 90
 Capitalization Limit Cd page 419
 capitalize status

- defining for composite member
 - assets 225
- capitalized assets
 - composite members 226
 - creating composite assets 224
 - understanding composite assets 223
 - viewing costs 175
- Cash Generating Unit Definition page 182
- CCA, *See* capital cost allowance (CCA)
- CCA report 571
- CCA Year End Updates page 411
- CCA Year End UpdatesCAN report 571
- CCA Yr End - Canada Rpt page 411
- CCP
 - reporting 408
 - tracking changes 406
- Centralized Inter/IntraUnit Processor 157
- CGT, *See* capital gains tax (CGT)
- CGU impairment batch process
 - running 186
- CGU Impairment page 18, 182
- Change/Delete Pending Trans page 18
- changes in creditable purpose 406
 - See Also See* CCP
- Chart Image page — Generate AM Charts 391
- ChartField Search Criteria page 322
- Charting Financial Data 390
- Child Asset Retirement Options page 321
- Child Asset TRF/RCT Overrides page 150
- child assets
 - copying 94
- Child Assets page 103, 105, 150, 161, 268, 271
- Child Assets page — Retire/Reinstate Assets 321, 335
- Child Details page 162
- Child Inherits Parent's Life option 104
- classes
 - capital acquisition plans 121
 - defining for assets 52, 93
- Close Accounting Period page 21
- Close Asset Period page 317
- Close Depreciation page 20
- closed accounting periods 317
- collateral assets 435
- Comment page — User Defined Methods 280
- Comments page 195
- comments, submitting xxviii
- common elements xxviii
- common fields xxxii
- companion documentation xxxii
- component asset hierarchy
 - view 96
- composite assets 223
 - See Also* group assets
 - adding 224, 225
 - adjusting cost or quantity 227
 - adjusting costs or quantity 227
 - capitalizing members 225, 226
 - performing transactions 226, 227
 - retiring 226, 227
 - transferring and recategorizing 228
 - understanding 223
- composite depreciation 433
- Computer Aided Facility Mgmt component 22
- Consolidation process
 - example of asset additions 215
 - example of asset adjustments 218
 - summary levels 218
- contact information xxviii
- conversion
 - date options 36
 - deleting interim data 38
 - depreciating converted assets 37
 - leased assets 42
 - loading retired assets 39
 - overview 31
 - prerequisites 32
 - reviewing retired asset data 40
 - running Transaction Edit 34
 - running Transaction Loader (AMIF1000) 33
 - verifying 38
 - viewing results of Transaction Edit 35
 - writing a custom SQR 32
- Copy Existing Asset page 16
- corporation section 291 87
- Cost / Asset Information page 90
- cost activity by alt account report 566
- cost activity report 562
- Cost Adjust/Transfer Asset component
 - Main Transaction page 228
- Cost Adjust/Transfer Asset page 18
- Cost and Depreciation 21
- Cost and Depreciation page 182, 388

- Cost and Depreciation Summary
 - component 20
 - Cost and Depreciation Summary page 21
 - Cost History Detail page 177, 444
 - Cost History List page 177, 444
 - Cost Information page 149
 - Cost page - Lease Express Add 131, 139
 - Cost page - Update Lease Information 131
 - cost summarization
 - generating 177
 - Cost Summarization page 19
 - Cost/Asset Information page 90, 103
 - Cost/Depreciation Restore page 445
 - costs
 - adjusting and transferring assets 148
 - adjusting composite assets 227
 - consolidating for group assets 215
 - entering transfer information 152
 - leases 136
 - maintenance details 197
 - viewing archived data 444
 - viewing history 175
 - coverage 203
 - Coverage page — Maintenance Contracts 200
 - Create (CAP) Plan page 18
 - Create Accounting Entries page 20, 315
 - Create Asset Copies page 94
 - Create Event page 351
 - Create Extract Rules page 24
 - Create Parent - Child Assets page 103, 104
 - Create Parent page 17
 - Create Schedules page 24
 - Criteria and Defaults page — Asset Mass Change Definition 236, 237, 360
 - Criteria and Defaults page - Asset Mass Change Definition 359
 - cross-references xxvii
 - currency rounding
 - options for Japan 435
 - custodian information 66
 - Custodian/License page — Parent Child Basic Information 103
 - Customer Connection website xxiv
- D**
- Declining Balance with a Straight Line Switch depreciation 549
 - Declining Balance with Depreciation Limit 550
 - Define Allocations for Asset page 295, 296
 - Define Asset Operational Information - Asset Information page 108
 - O&M Basic Add 108
 - Define Asset Operational Information - Asset Property page 108
 - Define Asset Operational Information - Customize Page Layout page 108
 - Define Asset Operational Information page 16
 - Define Criteria page 25
 - Define Inventory Occurrence page 24
 - Define Tax/Depr Criteria page 17
 - Definition page — Allocation Basis Definition 295
 - Definition page — Lease Express Add 131
 - Definition page — Physical Inventory Control 236, 237
 - Definition page — User Defined Methods 280
 - Definition page - Lease Express Add 131
 - Definition page - Update Lease Information 131
 - Depr Recalc page 267
 - depreciation
 - changing rates 221
 - converted assets 37
 - group assets 208
 - maintaining book information 80
 - retiring assets 346
 - retiring group assets 208
 - updating attributes 265
 - viewing 267
 - viewing by period 269
 - viewing child asset depreciation 271
 - viewing net book value and yearly depreciation 268
 - what if simulation modeling 287
 - depreciation accounting entries
 - accumulated depreciation 261
 - adjusting for prior periods 261
 - creating 261
 - creating for a period 316
 - leased assets 141
 - depreciation activity by alternate account report 564

- Depreciation Activity page 273
- depreciation activity report 564
- depreciation allocation 294
- Depreciation Allocation (AMALLOC)
 - process 298
- Depreciation Balance - IND page 422
- depreciation balance (IND) report 574
- depreciation begin date 528
- Depreciation by Activity report 273
- depreciation by fiscal year report 565
- Depreciation by Fiscal Year report 273
- depreciation by period report 564
- Depreciation by Period report 273
- Depreciation Calculation process 263, 527
- Depreciation Calculation Tax page 355
- depreciation calculations
 - formula-based methods 544
 - group assets 220
 - life to date calculation 530, 532
 - listed property assets 526
 - NBV < Salvage 556
 - prior period 537
 - remaining value and life 529
 - salvage value 525
 - status 264
 - tax 354
 - tax credits 526
 - understanding 525
 - yearly 531
- depreciation close
 - understanding 312
- Depreciation Close page 221
- Depreciation Close process 221, 299, 316
- Depreciation component 23
- depreciation expenses
 - allocation 293
 - setting up allocations 294
- Depreciation Information page 90
- Depreciation Method Information
 - page 80, 85
- depreciation methods 82
 - assigning user-defined methods 285
 - declining balance 552
 - declining balance switching to straight line 549
 - declining balance with depreciation limit 550
 - flat rate 553
 - geometric digressive 419
 - straight line 544
 - sum of the years digits 554
 - units of production 555
 - user-defined 275, 279, 282, 283
- depreciation methods (France)
 - derogatory method 413
- depreciation methods (Germany)
 - Staffel 416
 - user-defined Staffel 418
- depreciation methods (India)
 - straight line percent 545
- depreciation methods (Japan)
 - 5 percent retirement 434
 - composite depreciation 433
 - declining balance 430
- Depreciation page — Asset Depreciation 268
- Depreciation Process Log page 20
- depreciation processing 262
 - creating pending transactions 267
 - India 421
 - overview 260
 - storing entries by period 266
- depreciation rate
 - useful life for Japan 429
- depreciation reporting 272
 - loading report table 273
 - US reports 260
- depreciation results
 - loading into a spreadsheet 289
- Depreciation Terms page 420
- depreciation variables 276
- derogatory depreciation
 - creating accounting entries 413
- Description page — Asset Mass Change Definition 236, 359
- Description page - Asset Mass Change Definition 359
- Detail page — Maintenance Contracts 200
- Detail page — Review Book 444
- Details page — Capital Acquisition Planning 121
- Details page — Inventory Results 242
- Details page - Capital Acquisition Planning 121
- (DEU) asset history sheet by account report 572
- (DEU) asset history sheet reports 572
- (DEU) depreciation history report 572

(DEU) extraordinary depreciation history report 572
 (DEU) reconciliation AP/AM report 572
 disposal codes 324
 disposal worksheet
 retiring assets 348
 Disposal Worksheet page 19, 322, 348
 distribution types 305
 associated with addition (ADD)
 transactions 305
 associated with adjustment (ADJ)
 transactions 306
 associated with depreciation (DPR)
 transactions 309
 associated with inflation (INF)
 transactions 311
 associated with lease payment (LPY)
 transactions 310
 associated with prior period depreciation (PDP) transactions 310
 associated with recategorize (RCT)
 transactions 307
 associated with retire (RET)
 transactions 308
 associated with transfer (TRF)
 transactions 306
 document sequencing
 entering 65
 documentation
 printed xxiv
 related xxiv
 updates xxiv
 drilldown functions
 using with depreciation reporting table 388
 Duplicate Serials page 242
 Duplicate Tags page 242, 245

E

employee self-service 394, 395
 errors
 assets retired 249
 duplicate tags 249
 interunit candidate 249
 multiple ChartFields 249
 physical inventory processing 249
 EU_2054 and EU_2055 reports 415
 Event page 195, 196
 Excel to Component Interface (ExcelToCI) utility 32

adding assets 114
 example spreadsheet 117
 template for Asset Management 115
 exchanging assets 330
 Execution History page — Asset Mass Change Definition 236
 Execution History page - Asset Mass Change Definition 359
 Expand Depreciation by Period page 266
 Express Add component
 Cost/Asset Information page 90
 creating group member assets 211
 defining parent-child assets 104
 Express Add page 15
 extract and scan scope 234
 Extract Data page 242, 243
 extracting data
 creating an output file 244
 physical inventory 243

F

Fair Market Value 174
 fair market value (FMV) 134, 331
 Fair Market Value page 18, 174
 Federal Energy Regulatory Commission (FERC)
 codes for group assets 53, 207
 codes to group assets 209
 FERC, *See* Federal Energy Regulatory Commission (FERC)
 financial assets
 composite assets 223
 creating composite assets 224
 Financial Assets page — Capital Acquisition Planning 124
 Financial Transactions page 367
 fixed asset register
 reporting for Italy 426
 Fixed Asset Register page 426
 flat rate depreciation 553
 averaging option 553
 monthly averaging option 553
 yearly averaging option 554
 FMV, *See* fair market value (FMV)
 (FRA) Statutory French 2054a Reports by Alt Account 574
 (FRA) Statutory French 2054ab Reports by Account 573
 (FRA) Statutory French 2054ab Reports by Alt Account 573

- (FRA) Statutory French 2054b Reports by Alt Account 574
- (FRA) Statutory French 2055a Reports by Account 573
- (FRA) Statutory French 2055b Reports by Account 573
- France support
 - overview 398
 - setting up 400
- French net book value account report 571
- French net book value by alternate account report 571
- French Net Book Value reports 413
- French reports 571
- French retirement activity report 571
- French support 412
 - depreciating assets using the derogatory method 413
 - reporting business tax 413
 - revaluing assets 414
 - statutory reporting 415

G

- General Information page 48, 51
- General Ledger
 - updating for adjustments and transfers 178
- general ledger journals
 - accounting entry templates 304
- General Parent Info page — Parent-Child Basic Information 103
- Generate AM Charts 21
- Generate AM Charts component
 - Chart Image page 391
 - Selection Criteria page 390
- generate bonus depreciation tax reports 570
- Generate SQL page — Asset Mass Change Definition 236, 237, 362
- Generate SQL page - Asset Mass Change Definition 359
- Generate User Defined Methods page 283
- geometric digressive depreciation 419
- German reports 571, 572
- Germany support 415
 - creating a user defined Staffel depreciation method 418

- first day last period depreciation convention 419
- geometric digressive depreciation 419
- half year prorate convention 418
- overview 398
- processing low value assets 419
- setting up tax and depreciation 401
- special depreciation terms and methods 420
- Staffel depreciation method 416
- glossary 575
- goods and services tax (GST)
 - adding online 407
 - recording 406
- goods and services tax (VAT) 406
- Group Asset Consolidation page 214, 215
- Group Asset Consolidation process 214, 215
- Group Asset Depreciation page 20, 220, 221
- Group Asset depreciation process 220
- Group Asset Depreciation process 221
- Group Asset Rate Change page 221
- Group Asset Rate Change process 221
- group assets 207, 223, 253
 - See Also* composite assets; joint ventures consolidating 214, 215
 - depreciation 208, 220
 - estimated net book value report 220
 - member transactions 213
 - processing 221
 - retiring 208
 - setting up 209, 210, 211, 212
 - transferring members 213
- Group Member Estimated NBV page 221
- group member estimated NBV report 220, 564
- Group Member Open Transaction Details page 214
- grouping assets
 - defining parent-child relationships 102

H

- half-year prorate
 - German convention 418
- Hazardous Asset Codes page 61
- hazardous assets
 - defining 61

HighJump Software 231, 245

I

impaired asset value report by
category 565
impaired asset value report by CGU 565
impairment asset value report by
category 572
impairment asset value report by CGU
(cash generating unit) 572
Impairment Comments page 182
impairment losses and reversals
reports 189
view online 189
impairment worksheet 180
working with 182
Impairment Worksheet page 18, 182
implementation 4
Import Data via Spreadsheet
component 22
India support 421
asset depreciation 421
overview 398
processing and reporting
depreciation 422
setting up tax and depreciation 401
straight line percent depreciation 545
updating depreciation balance 423
Indian reports 571, 574
inquiries 388
insurance
entering asset information 203
entering policy ID 205
entering valuation types 205
integration
overview diagram 3
interest and borrowing rates 134
Interface Loader page 38
interface types 518
InterUnit Parent-Child Trans page 17
InterUnit Proceeds page 149, 161
interunit transfers 157
inventory, *See* physical inventory
inventory report (detail version) 568
inventory report (short version) 568
Inventory Results component
Details page 242
Results page 242, 247
involuntary retirements 226
IT asset discovery tools 229

(ITA) fixed assets register report 574
Italian reports 571, 574
Italy support 426
overview 399

J

Japan support 427
5 percent retirement method 434
advanced depreciation 433
advanced depreciation reports 433
asset insurance 203
calculating theoretical NBV and
assessment value 439
changing the local tax office and asset
return type 439
composite depreciation 433
currency rounding options 435
defining local tax returns 437
depreciation methods 429, 431
entering consumption tax 440
entering local tax return
information 438
identifying collateral assets 435
local tax reports 436
overview 399
running local tax reports 439
setting up tax and depreciation 402
Japanese reports 571, 574
joint venture assets
adding business units 257
changing ownership 256, 258
defining allocations 255
loading transactions 258
mass change templates 256
naming conventions 255
removing business units 257
setting up 255
transaction processing 255
understanding 253
(JPN) business tax by alternate account
report 572
(JPN) business tax report 572
(JPN) Japanese Local Tax Decrease All
Asset List 574
(JPN) Japanese Local Tax Increase All
Asset List 574
(JPN) Local Tax Return page 56
(JPN) local tax roll reports 574
(JPN) national tax report 574
Justification page — CAP Details 121

L

- label files 244
- lease amortization schedule report 568
- Lease Expense Schedule 142
- Lease Expense Schedule page 16
- Lease Expense Schedule process 141
- Lease Expiration page 145
- lease expiration report 568
- Lease Express Add component
 - Cost page 131, 139
 - Definition page 131
 - Payment Schedule page 131, 140
 - Step Lease Payment page 131, 139
- Lease Express Add page 16
- Lease Footnote Disclosure page 145
- lease footnote disclosure reports 568
- Lease Information page 145
- lease information reports 568
- lease interface table 42
- Lease Transactions page 367
- leased assets 127
 - capital and operating leases 127
 - conversion 42
 - creating 130, 131
 - creating expense schedules 141
 - declining balance depreciation method 430
 - defining payment schedules 129
 - entering fair market value (FMV) 134
 - entering lease information 133
 - entering lease term 134
 - entering lease type 138
 - entering payment type 138
 - entering payments 135
 - entering residual values 134
 - overview 127
 - reporting 144
 - retiring or reinstating 144
 - running expense schedule 142
 - step leases 128
 - transferring 143
 - verifying mass changes 367
- Leased Assets component 21
- License Address page 48
- license information 66
- License Information – Parameters page 50
- life to date calculation 530, 532, 535
- Like Kind Exchange page 321, 330

- like-kind exchanges
 - example 331
 - processing 330
- List page — Review Book 444
- listed property assets 526
- Load Approval page — Approve Lease Information 43
- Load Asset NBV Table page 290
- Load Asset Net Book Value query 290
- Load Budgeting Asset Catalog page 18
- Load Depr Reporting Table page 273
- Load Interface component 22
- Load Preview page — Approve Lease Information 43
- Load Reporting Tables component 21
- Load Transactions component 22
- load types 226, 370, 518
- Load/Match/Reconcile PI Info page 24
- loader tables
 - financial information table (INTFC_FIN) 449
 - physical A table (INTFC_PHY_A) 479
 - physical B table (INTFC_PHY_B) 505
 - understanding 449
 - verifying mass change data 367
- Local Tax Return page 48
- Location page — Parent-Child Basic Information 103
- Location/Comments/Attributes page 48, 65
- low-value assets
 - processing for Germany 419

M

- Main Transaction page — Asset Cost Adjust/Transfers 149, 150
- Maint History by Type page — Asset Service/Repair History 206
- maintain warranties 78
- maintaining assets
 - checking out 193
- maintenance
 - entering payment information 199
 - event status 196
 - viewing history 206
- Maintenance Contract Terms page 23
- maintenance contracts
 - tracking 199
- Maintenance Contracts component
 - Coverage page 200

- Detail page 200
- Maintenance Details page — Asset
 - Service/Repair Details 195
- manager self-service 394, 395
- Manufacture/License/Custodian page 48, 66
- manufacturer information 66
- Mass Change
 - archiving and restoring data 445
 - background processing 365
 - depreciating assets 374
 - executing 364
 - physical inventory 234
 - populating Asset Management tables 373
 - processing overview 357
 - U.S. tax 40 percent rule 358
 - understanding 357
 - using Process Scheduler 364
 - verifying results 367
- Mass Change definitions 358, 359, 360, 362
- Mass Change templates 374
- Mass Change, approval
 - financial data 370
 - physical data 372
- Mass Change, composite assets
 - capitalizing members 225
 - loading results 226
 - processing JPN composite retirement 434
 - retiring members 226
- Mass Change, joint venture assets 256
 - adding business units 257
 - changing allocations 258
 - removing business units 257
 - templates 256
- Mass Revaluation page 172
- meter reading
 - history 77
- Meter Reading Details page 195
- meter reading history
 - reviewing 77
- meter readings
 - entering 75
 - prior readings 75
- mixed use assets 526
- My Assets page 396
- My Department page 396
- My Departments page 396

N

- navigation 15
 - Asset Definitions 15
- net book value
 - calculating 268
 - loading depreciation results 289
- net book value report 564
- Non Cap History Detail page 177
- Non Cap History List page 177
- non capitalization information 63
- Non-Cap History Detail page 444
- Non-Cap History List page 444
- non-capitalized assets
 - viewing archived data 444
 - viewing costs 175
- non-financial assets
 - composite member assets 225
- Non-Financial Assets page — Capital Acquisition Planning 124
- Non-Financial Retire page 352
- notes xxvii

O

- One to Many page 331
- Open Transaction Detail page 264
- open transactions 301
 - creating 267
 - reviewing 264
 - searching for 264
- Open Transactions page 20
- Operating ChartFields 131
- Operating Lease Chartfields page 143
- Operating Lease Payments page — Capital Acquisition Planning 124
- operating leases 127, 138
- Operation/Maintenance page 48, 57
- Other Options page — Retire/Reinstate Assets 321, 332
- Ownership Details page 322

P

- Parameters page — Asset Warranties 206
- Parameters page — Capital Acquisition Planning 125
- Parameters page — Depreciation by Fiscal Year 273
- Parameters page — Depreciation by Period 273
- Parent and Child Assets page 103, 107

- Parent Asset Adv Txn options page 150
- parent-child assets
 - calculating net book value 267
 - creating 103, 104
 - defining 104
 - maintaining 105
 - retiring 335
 - transferring or recategorizing 161, 162, 163, 164
 - understanding relationships 102
 - viewing 104, 107
- Parent-Child Basic Information
 - component 105
 - Child Assets page 103, 105
 - Custodian/License page 103
 - General Parent Info page 103
 - Location page 103
- Parent-Child Basic Information page 17
- Parent-Child IU Transfer page 163
- partial transfers 156
- payables
 - interface to Asset Management 407
 - tracking goods and services tax (GST) 406
- Payables
 - interface to Asset Management 407
 - tracking goods and services tax (GST) 406
- Payment page 195
- Payment page — Asset Service/Repair Details 199
- Payment Schedule page — Lease Express Add 131
- Payment Schedule page - Lease Express Add 140
- Payment Schedule page - Update Lease Information 131
- Payment Schedules page 129
- Pending Trans Update/Delete page 179
- Pending Transaction Update/Delete page 179
- pending transactions
 - deleting or modifying 178
 - viewing details 179
- PeopleBooks
 - ordering xxiv
- PeopleCode, typographical conventions xxvi
- PeopleSoft Customer Connection web site 3
- PeopleSoft Enterprise Billing, *See* Billing
- PeopleSoft Enterprise General Ledger, *See* General Ledger
- PeopleSoft Enterprise IT Asset Management, *See* IT Asset Management
- PeopleSoft Enterprise Maintenance Management, *See* Maintenance Management
- PeopleSoft Enterprise Payables, *See* Payables
- PeopleSoft Enterprise Project Costing, *See* Project Costing
- PeopleSoft Enterprise Purchasing, *See* Purchasing
- PeopleSoft Enterprise Real Estate Management, *See* Real Estate Management
- PeopleSoft Enterprise Strategic Sourcing, *See* Strategic Sourcing
- period depreciation allocation
 - calculations 533, 535
- Period Depreciation page — Asset Depreciation 268, 269
- Physical Inventory Control component
 - Definition page 236, 237
 - Transaction Defaults page 236, 238
- physical inventory extract report 567
- Physical Inventory History page 251
- Physical Inventory page 242, 243, 244, 245, 249, 250
- Physical Inventory Reports page 251
- physical inventory results reports 567
- physical inventory scan data report 567
- Physical Inventory Setup page 233
- physical inventory, processing
 - deleting extract files 250
 - deleting inventory results 250
 - deleting reconciliation transactions 250
 - deleting scanned data 250
 - errors 249
 - flow diagram 230
 - generating reconciliation transactions 249
 - generating results 247
 - identifying duplicate tags 245
 - loading inventory data 245
 - Mass Change process 234
 - overview 229, 240
 - viewing extract data 243
 - viewing results 247
- physical inventory, reporting 250

- physical inventory, requirements
 - hardware 231
 - programs for scanners 231
 - software 231
 - physical inventory, scheduling 240
 - physical inventory, setting up 229, 233
 - extract scope 236
 - scope and control parameters 234
 - transactions 239
 - physical inventory, terminology 230
 - Physical Inventory/Mass Change page 24
 - Physical Transactions A and B pages 368
 - using during conversion 36
 - PI Match status 248
 - prerequisites xxiii, 394
 - Preview AP/PO Information page 22
 - Print an Asset page 25
 - Printable view of Asset page 114
 - printed documentation xxiv
 - prior period depreciation 537
 - Proceeds and Removal Cost page 322
 - Process CSV Files page 24
 - processing depreciation
 - errors 266
 - Processing page 20
 - property assets
 - entering 68
 - property taxes
 - recording 71
 - Provide Reason for the Modification page 97
- Q**
- queries
 - archived data 443
- R**
- R&D, *See* research and development (R&D)
 - rates 134
 - RD Deductions — AUS page 403
 - reconciliation 249
 - Record Property Taxes page 51, 71
 - recovery information 87
 - reinstatements 353
 - related documentation xxiv, xxxii
 - Related Meter Readings page 195
 - remaining value and life calculations 529, 531
 - replacement cost
 - calculate 107
 - Report Format Template page 387
 - reports 383, 561
 - account activity 566
 - accounting entry 566
 - bar charts 384
 - capital acquisition plans (CAP) 125, 563
 - depreciation 564
 - generating 385
 - global 571
 - impairments 565
 - lease 568
 - online 387
 - online inquiries 384
 - physical inventory 567
 - retirement 569
 - transactions 562
 - U.S.A tax 569
 - viewing financial charts 390
 - Reports component 23
 - research & development (R&D)
 - enabling calculations 404
 - research and development (R&D)
 - defining asset profiles 404
 - defining assets 55, 404
 - reserve detail by Asset ID report 573
 - reserve summary by Category report 573
 - residual values 134
 - Restore Cost/Depreciation page 19
 - restoring archived data 444, 445
 - Results page — Inventory Results 242, 247
 - Retire Assets page 320, 322, 353
 - Retire/Reinstate Asset page 19
 - Retire/Reinstate Assets component
 - Bill Information page 322, 336
 - By Chartfield page 334
 - By ChartField page 321
 - Capital Gain page 322, 336
 - Child Assets page 321, 335
 - Other Options page 321, 332
 - VAT page 321, 329, 339
 - Retire/Reinstate Non-Fin Asset page 19
 - Retirement 21
 - retirement activity (Australia) report 571
 - retirement activity report 569
 - retirement by ChartField report 569
 - retirement by in service date report 569

- retirement detail by ChartField (Australia)
 - report 571
 - retirement types 319
 - retirements
 - automating 346
 - books 160
 - calculating gains or losses 333
 - calculating VAT 339
 - composite assets 226, 227
 - during inventory 239
 - joint venture assets 256
 - leased assets 144
 - loading retired assets during
 - conversion 39
 - non-financial assets 352
 - options 327
 - overview 319
 - parent-child assets 335
 - processing like-kind exchanges 330
 - processing traded assets 329
 - reporting capital gains 354
 - selling assets by auction 351
 - using the disposal worksheet 348
 - viewing gains or losses 336
 - Retrieve Info from AP/PO page 22
 - retroactive changes
 - depreciation rates 221
 - Return Information page 437
 - Revaluation in Mass page 18
 - revaluation worksheet 165
 - Revaluation Worksheet 165
 - Revaluation Worksheet page 18, 165
 - revaluations 156
 - processing multiple assets 171
 - Revalue AUS page 21
 - reverse detail by Asset ID report 573
 - reverse summary by Category report 573
 - reversing accounting entries 302, 316
 - Review Asset Journals page 21
 - Review Book component
 - Detail page 444
 - List page 444
 - Review Book page 19
 - Review Cost page 19
 - Review Depreciation Info page 20
 - Review Extracted Data page 24
 - Review Financial Entries page 20
 - Review Inflation page 19
 - Review Inventory History page 24
 - Review Maintenance History page 23
 - Review Matching Results page 24
 - Review Operating Leases page 20
 - Review Parent-Child NBV page 17
 - Review Parent-Child page 17
 - Review Purchase Orders page 17
 - Review Receivers page 17
 - Review Vouchers page 17
 - rounding
 - VAT calculations 343
 - rounding options
 - Japan 435
 - Run Archive page 442
 - Run Depreciation Calculation page 263
 - Run Depreciation Close Process page 316
 - Run Mass Change page 364, 365
 - Run Open Trans Tax page 355
 - Run Physical Inventory Reports page 25
 - Run Report page 18
 - Run Request page 25
 - Run Transaction Loader page 373
 - Run What If Depreciation page 288
- S**
- salvage value 525
 - scan scope, *See* extract and scan scope
 - scanning devices
 - loading asset data 244
 - Scheduling page 236, 240
 - Search for an Asset page 25, 111
 - search for assets 111
 - indexes and alternate search keys 112
 - Section 179 Expense 526
 - security
 - reviewing after conversion 39
 - self-service 394
 - Selection Criteria page — Generate AM Charts 390
 - Self Service Web Components
 - self service application pages 393
 - self-service Web components 393, 395
 - roles 394
 - security 394
 - setting up 394
 - Send to Budgeting page 18
 - serial numbers
 - identifying duplicates 246
 - servicing
 - scheduling and tracking 194
 - viewing history 206
 - servicing and repairs

- assets 194
- Set R&D Info page 404
- shared assets, *See* joint venture assets
- simulations
 - depreciation 287
- SQR
 - using for conversion 32
- Staffel depreciation methods 416
- Statistics page 195, 197
- Step Lease Payment page - Lease Express Add 131, 139
- Step Lease Payment page - Update Lease Information 131
- step leases 128
- Stop Depr 556
- straight line depreciation 544
- straight line percent depreciation 545
- Strategic Sourcing
 - selling assets 351
- suggestions, submitting xxviii
- Summary of Changes page 97
- Summary page — Capital Acquisition Planning 125
- Summary page — User Defined Methods 280

T

- tags
 - identifying duplicates 245
- tax
 - reporting for France 413
- tax acquisitions report 569
- tax adjustments report 569
- Tax CCP – AUS report 571
- tax credits 88
 - calculating 526
 - using in depreciation calculations 526
- Tax Credits — AUS page 403
- tax credits (AUS)
 - capital investment projects 405
 - entering in Asset ExpressAdd 406
 - entering in the Asset Book Definition 405
 - specifying assets 405
- tax credits by category (Australia) report 571
- Tax Depr Bal page 422, 423
- tax depreciation reports 569, 570
- Tax Depreciation Request page 422
- Tax Information page 90

- Tax page 48, 64
- Tax Retirement Capital Gains Report 354
- tax retirements reports 569
- taxes
 - defining for books 86
 - entering online 64
- templates
 - defining report formats 387
- terms 575
- Theoretical NBV and Assessment Value page 439
- Track Service and Repairs component
 - Comments page 195
 - Event page 195, 196
 - Meter Reading Details page 195
 - Payment page 195
 - Related Meter Readings page 195
 - Statistics page 195, 197
- Track Service and Repairs page 23
- Transaction Defaults page — Physical Inventory Control 236, 238
- Transaction Edit (AMIFEDIT) program 34
 - viewing results 35
- Transaction Information page 179, 180
- transaction loader
 - creating group assets 212
 - inserts from Financial Information table (INTFC_FIN) 514
 - inserts from physical A table (INTFC_PHY_A) 516
 - inserts from physical B table (INTFC_PHY_B) 517
 - inserts into Asset Management tables 514
 - interface types 518
 - running during conversion 33, 36
 - using with mass changes 373
- Transaction Loader Edit page 34
- transaction types
 - transfers 228
- Transfer Operating Lease page 16
- transfers
 - between business units 157
 - between group assets 213
 - child assets 161
 - composite assets 228
 - entering book information 158
 - entering cost information 152
 - marking up or down 161

- overview 148
- partial transfers 156
- retroactive 156
- within business units 155

typographical conventions xxvi

U

- U.S.A support
 - tax 40 percent rule 358
 - tax reports 569
- uncapitalized assets
 - composite member assets 225
- United States Financial Accounting Standards Board (FASB) Statement 13 127
- units of production 555
- Update CCA component 22
- Update Lease Information component
 - Cost page 131
 - Definition page 131
 - Payment Schedule page 131
 - Step Lease Payment 131
- Update Lease Information page 16
- Update Non-Capitalized Cost page 19
- Update Non-Capitalized Costs page 175
- Useful Life/Rate page 429, 430
- User Defined Methods - Copy page 284
- User Defined Methods component
 - Comment page 280
 - Definition page 280
 - Summary page 280
- User Defined Variables page 278
- user-defined depreciation
 - assigning to assets 285
 - copying methods 283
 - creating a depreciation method 279
 - generating 283
 - SQC program 282
 - understanding 275
 - variables 276

V

- valuations
 - insurance information 205
- value added tax (VAT)
 - calculating for asset retirements 339
 - defaults 341
 - defining for assets 64
 - locations 341

- physical nature 341
- rounding rules 343
- variables
 - creating 278
- VAT, *See* value added tax (VAT)
- VAT page — Retire/Reinstate Assets 321, 329, 339
- Verify Duplicate Serial ID page 24
- Verify Duplicate Tags page 24
- Verify Scanned Data page 24
- View Parent Component page 19
- visual cues xxvii
- voluntary retirements 226

W

- warnings xxvii
- warranties
 - entering information 200
 - reporting on 206
- What If Depreciation
 - performing 287
 - viewing results 289
- What If Depreciation Results page 289
- What-If Scenarios page 20
- workflow
 - approving disposals 350
 - physical inventory results 249

Y

- yearly depreciation
 - calculating 531

