

Oracle® Retail Merchandising

Batch Schedule

Release 14.1.2

October 2015

Copyright © 2015, Oracle. All rights reserved.

Primary Author: Nathan Young

This software and related documentation are provided under a license agreement containing restrictions on use and disclosure and are protected by intellectual property laws. Except as expressly permitted in your license agreement or allowed by law, you may not use, copy, reproduce, translate, broadcast, modify, license, transmit, distribute, exhibit, perform, publish, or display any part, in any form, or by any means. Reverse engineering, disassembly, or decompilation of this software, unless required by law for interoperability, is prohibited.

The information contained herein is subject to change without notice and is not warranted to be error-free. If you find any errors, please report them to us in writing.

If this is software or related documentation that is delivered to the U.S. Government or anyone licensing it on behalf of the U.S. Government, then the following notice is applicable:

U.S. GOVERNMENT END USERS: Oracle programs, including any operating system, integrated software, any programs installed on the hardware, and/or documentation, delivered to U.S. Government end users are "commercial computer software" pursuant to the applicable Federal Acquisition Regulation and agency-specific supplemental regulations. As such, use, duplication, disclosure, modification, and adaptation of the programs, including any operating system, integrated software, any programs installed on the hardware, and/or documentation, shall be subject to license terms and license restrictions applicable to the programs. No other rights are granted to the U.S. Government.

This software or hardware is developed for general use in a variety of information management applications. It is not developed or intended for use in any inherently dangerous applications, including applications that may create a risk of personal injury. If you use this software or hardware in dangerous applications, then you shall be responsible to take all appropriate fail-safe, backup, redundancy, and other measures to ensure its safe use. Oracle Corporation and its affiliates disclaim any liability for any damages caused by use of this software or hardware in dangerous applications.

Oracle and Java are registered trademarks of Oracle and/or its affiliates. Other names may be trademarks of their respective owners.

Intel and Intel Xeon are trademarks or registered trademarks of Intel Corporation. All SPARC trademarks are used under license and are trademarks or registered trademarks of SPARC International, Inc. AMD, Opteron, the AMD logo, and the AMD Opteron logo are trademarks or registered trademarks of Advanced Micro Devices. UNIX is a registered trademark of The Open Group.

This software or hardware and documentation may provide access to or information about content, products, and services from third parties. Oracle Corporation and its affiliates are not responsible for and expressly disclaim all warranties of any kind with respect to third-party content, products, and services unless otherwise set forth in an applicable agreement between you and Oracle. Oracle Corporation and its affiliates will not be responsible for any loss, costs, or damages incurred due to your access to or use of third-party content, products, or services, except as set forth in an applicable agreement between you and Oracle.

Value-Added Reseller (VAR) Language

Oracle Retail VAR Applications

The following restrictions and provisions only apply to the programs referred to in this section and licensed to you. You acknowledge that the programs may contain third party software (VAR applications) licensed to Oracle. Depending upon your product and its version number, the VAR applications may include:

(i) the **MicroStrategy** Components developed and licensed by MicroStrategy Services Corporation (MicroStrategy) of McLean, Virginia to Oracle and imbedded in the MicroStrategy for Oracle Retail Data Warehouse and MicroStrategy for Oracle Retail Planning & Optimization applications.

(ii) the **Wavelink** component developed and licensed by Wavelink Corporation (Wavelink) of Kirkland, Washington, to Oracle and imbedded in Oracle Retail Mobile Store Inventory Management.

(iii) the software component known as **Access Via**™ licensed by Access Via of Seattle, Washington, and imbedded in Oracle Retail Signs and Oracle Retail Labels and Tags.

(iv) the software component known as **Adobe Flex**™ licensed by Adobe Systems Incorporated of San Jose, California, and imbedded in Oracle Retail Promotion Planning & Optimization application.

You acknowledge and confirm that Oracle grants you use of only the object code of the VAR Applications. Oracle will not deliver source code to the VAR Applications to you. Notwithstanding any other term or condition of the agreement and this ordering document, you shall not cause or permit alteration of any VAR Applications. For purposes of this section, "alteration" refers to all alterations, translations, upgrades, enhancements, customizations or modifications of all or any portion of the VAR Applications including all reconfigurations, reassembly or reverse assembly, re-engineering or reverse engineering and recompilations or reverse compilations of the VAR Applications or any derivatives of the VAR Applications. You acknowledge that it shall be a breach of the agreement to utilize the relationship, and/or confidential information of the VAR Applications for purposes of competitive discovery.

The VAR Applications contain trade secrets of Oracle and Oracle's licensors and Customer shall not attempt, cause, or permit the alteration, decompilation, reverse engineering, disassembly or other reduction of the VAR Applications to a human perceivable form. Oracle reserves the right to replace, with functional equivalent software, any of the VAR Applications in future releases of the applicable program.

Contents

Send Us Your Comments	vii
Preface	ix
Audience	ix
Related Documents.....	ix
Customer Support.....	ix
Review Patch Documentation.....	x
Improved Process for Oracle Retail Documentation Corrections	x
Oracle Retail Documentation on the Oracle Technology Network.....	x
Conventions.....	x
1 Introduction to Merchandising Batch Processing	1
Batch Processing.....	1
Types of Batch Programs	1
Batch Window	2
Batch Schedule and Phases.....	2
Merchandising Batch Schedule.....	2
Program List	3
RMS, ReIM, RTM Section	4
prepost Program	5
Modifications to the Batch Schedule	6
2 Program List	7
3 Interface Diagrams for RMS and RPAS	25
RMS Pre/Post Extract Diagrams	26
RMS Foundation Data Extract Diagrams	27
RMS Fact Data Extract Diagrams.....	29
RPAS-RMS Fact Load Diagram	30
4 Interface Diagrams for RMS and MFP	31
RMS Pre/Post Extract Diagrams	32
RMS Foundation Data Extract Diagrams	33
RMS Fact Data Extract Diagrams.....	35
5 Interface Diagrams for RMS and AIP	37
RMS Pre/Post Extract Diagrams	39
RMS Foundation Data Extract Diagrams	40
6 Interface Diagrams for Allocation, AP and SPO	45

Send Us Your Comments

Oracle Retail Merchandising Batch Schedule, Release 14.1.2

Oracle welcomes customers' comments and suggestions on the quality and usefulness of this document.

Your feedback is important, and helps us to best meet your needs as a user of our products. For example:

- Are the implementation steps correct and complete?
- Did you understand the context of the procedures?
- Did you find any errors in the information?
- Does the structure of the information help you with your tasks?
- Do you need different information or graphics? If so, where, and in what format?
- Are the examples correct? Do you need more examples?

If you find any errors or have any other suggestions for improvement, then please tell us your name, the name of the company who has licensed our products, the title and part number of the documentation and the chapter, section, and page number (if available).

Note: Before sending us your comments, you might like to check that you have the latest version of the document and if any concerns are already addressed. To do this, access the new Applications Release Online Documentation CD available on My Oracle Support and www.oracle.com. It contains the most current Documentation Library plus all documents revised or released recently.

Send your comments to us using the electronic mail address: retail-doc_us@oracle.com

Please give your name, address, electronic mail address, and telephone number (optional).

If you need assistance with Oracle software, then please contact your support representative or Oracle Support Services.

If you require training or instruction in using Oracle software, then please contact your Oracle local office and inquire about our Oracle University offerings. A list of Oracle offices is available on our Web site at www.oracle.com.

Preface

This batch schedule document details the integrated cyclical processing schedules for the Oracle Retail Merchandising applications:

- Oracle Retail Merchandising System (RMS)
- Oracle Retail Invoice Matching (ReIM)
- Oracle Retail Price Management (RPM)
- Oracle Retail Sales Audit (ReSA)
- Oracle Retail Trade Management (RTM)
- Oracle Retail Allocation

This guide describes the periodic and ad hoc phases of batch processing, as well as pre- and post-processing dependencies.

Audience

The audiences for this guide are as follows:

- Systems analysts and system operations personnel who need information about Merchandising processes, internally or in relation to systems across the enterprise
- Integrators and implementation staff who have the overall responsibility for implementing the Merchandising applications in their enterprise

Related Documents

For more information, see the following documents for the Oracle Retail Merchandising products:

- *Oracle Retail Invoice Matching Operations Guide*
- *Oracle Retail Merchandising System Operations Guide*
- *Oracle Retail Price Management Operations Guide*
- *Oracle Retail Sales Audit Operations Guide*

Customer Support

To contact Oracle Customer Support, access My Oracle Support at the following URL:

<https://support.oracle.com>

When contacting Customer Support, please provide the following:

- Product version and program/module name
- Functional and technical description of the problem (include business impact)
- Detailed step-by-step instructions to re-create
- Exact error message received
- Screen shots of each step you take

Review Patch Documentation

When you install the application for the first time, you install either a base release (for example, 14.1) or a later patch release (for example, 14.1.1). If you are installing the base release or additional patch releases, read the documentation for all releases that have occurred since the base release before you begin installation. Documentation for patch releases can contain critical information related to the base release, as well as information about code changes since the base release.

Improved Process for Oracle Retail Documentation Corrections

To more quickly address critical corrections to Oracle Retail documentation content, Oracle Retail documentation may be republished whenever a critical correction is needed. For critical corrections, the republication of an Oracle Retail document may at times **not** be attached to a numbered software release; instead, the Oracle Retail document will simply be replaced on the Oracle Technology Network Web site, or, in the case of Data Models, to the applicable My Oracle Support Documentation container where they reside.

This process will prevent delays in making critical corrections available to customers. For the customer, it means that before you begin installation, you must verify that you have the most recent version of the Oracle Retail documentation set. Oracle Retail documentation is available on the Oracle Technology Network at the following URL:

<http://www.oracle.com/technetwork/documentation/oracle-retail-100266.html>

An updated version of the applicable Oracle Retail document is indicated by Oracle part number, as well as print date (month and year). An updated version uses the same part number, with a higher-numbered suffix. For example, part number E123456-02 is an updated version of a document with part number E123456-01.

If a more recent version of a document is available, that version supersedes all previous versions.

Oracle Retail Documentation on the Oracle Technology Network

Documentation is packaged with each Oracle Retail product release. Oracle Retail product documentation is also available on the following Web site:

<http://www.oracle.com/technetwork/documentation/oracle-retail-100266.html>

(Data Model documents are not available through Oracle Technology Network. These documents are packaged with released code, or you can obtain them through My Oracle Support.)

Documentation should be available on this Web site within a month after a product release.

Conventions

Navigate: This is a navigate statement. It tells you how to get to the start of the procedure and ends with a screen shot of the starting point and the statement “the Window Name window opens.”

This is a code sample

It is used to display examples of code

Introduction to Merchandising Batch Processing

This chapter is a brief introduction to Oracle Retail batch processing. It defines basic terms and concepts, describes batch processing phases, and explains how to interpret the batch schedule program list.

Batch Processing

Batch processing is the execution of a group of batch programs (jobs). The results are returned without user intervention. Batch programs are commonly used for the following reasons:

- To process large volumes of transaction data
- To interface with external systems
- To perform internal maintenance

Batch programs can process very large quantities of data quickly and efficiently. Batch programs can perform some updates that could be performed through online transactions, but much more quickly and with less impact on system performance. Batch processing is usually scheduled for times when systems are idle or least busy.

Batch programs can be run automatically using batch scheduler software. The batch scheduler allows batch jobs to be set up in a specific order, with restrictions attached to any program as needed. If an error occurs with a batch program, an administrator must correct the error and manually rerun the batch program that failed.

Types of Batch Programs

Oracle Retail batch programs are of several types:

- Upload programs bring data from external systems into the Oracle Retail database. For example, the sales upload program uploads daily transactions that occur at the point of sale (POS) for processing by the Oracle Retail Management System (RMS).
- Download programs extract data from RMS and format it so it can be used by external systems. For example, the posdnld program extracts new and changed information about an item/location for downloading to the point of sale.
- System maintenance programs perform tasks such as updating the system date. For example, the dtesys program increments the system date at the end of each batch cycle.
- Functional maintenance programs process data specific to a functional area. For example, the mrt.pc program creates individual transfers for an approved Mass Return Transfer.

Batch Window

Because of the impact on production systems, it is not always possible to run batch programs during business hours; however, there is a window of opportunity during each day or night when online systems are not being used. This time frame is the *batch window*. For example, a retailer with stores throughout the continental U.S. might require its online systems to be available from 8 AM Eastern Standard Time, when its East Coast offices open, until 9 PM Pacific Standard Time, when its West Coast stores close. This allows an eight-hour batch window for processing all batch jobs.

Batch Schedule and Phases

Order is critical when running batch programs. Some tasks need to be performed before others. A batch schedule ensures that every time batch processing is performed, the correct tasks are performed in the proper order.

The batch schedule is a program list with batch phases and pre/post dependencies for each batch job. For each individual user, the schedule is a suggested starting point for the installation. Some programs are specific to products that may not be installed, so these programs may not be used at all.

The total batch schedule is divided into phases. Each phase must be completed before the next phase can begin. Within a phase, there may also be programs that depend on the completion of another program within that phase, so programs within each phase may need to be run in a particular order.

Merchandising Batch Schedule

The integrated Merchandising batch schedule combines the batch schedules of all Merchandising applications into a single schedule program list. The batch program list (later in this document) shows the batch dependencies among the Merchandising applications.

The integrated Merchandising batch schedule combines the batch modules for the following applications:

- Oracle Retail Merchandising System (RMS)
- Oracle Retail Trade Management (RTM)
- Oracle Retail Sales Audit (ReSA)
- Oracle Retail Invoice Matching (ReIM)
- Oracle Retail Price Management (RPM)
- Oracle Retail Allocation

Program List

The columns of the program list provide details about each batch program, as follows:

Column	Description
Program name	Name of the program or script
Functional area	Functional area of the application for which the batch program is run
Threaded	Whether the program is threaded (Y/N)
Driver	Program driver
Phase	Phase during which the program is run
Pre-dependency	Programs that must be completed before the program can be run
Post-dependency	Programs that must be run after the program completes successfully
Timing	How often the program is run (for example, daily, weekly, monthly, ad hoc)
Restart/Recovery	Whether the program uses restart/recovery (R=Yes, N=No)
Run Parameters for Program	Command syntax to run the program

For example, the following shows the information in the program list about an RMS phase 3 program named dealday:

Program Name	dealday
Functional Area	Deals
Threaded	Y
Driver	Location
Phase	3
Pre-dependency	dealinc, dealfinc, prepost dealday pre
Post-dependency	prepost dealday post, salmnth
Timing	Monthly
Restart/Recovery	R
Usage	dealday userid/passwd

The program list is grouped in the following order:

- RMS, RTM, and ReSA programs
- RPM programs
- ReIM programs
- Allocation programs
- RMS extracts for Retail Predictive Application Server (RPAS)

The extracts for RPAS are programs that are part of the RMS application.

RMS, ReIM, RTM Section

The first section diagrams the RMS, ReIM, and RTM programs and their dependencies. This section is further divided into phases 0 through 8, ad hoc, and date set batch.

Each phase must be completed before the next phase can begin. Also, a phase may contain programs that depend on other programs within the phase. Programs within each phase may need to run in a particular sequence.

The following are brief descriptions of the Merchandising batch processing phases. Depending on your implementation, some programs and phases may not apply.

[^]Note - Ad hoc processes are not strictly constrained to one phase of the batch cycle.

Ad hoc jobs may be run multiple times per day in parallel with other operations.

Ad hoc jobs can have dependencies on specific jobs in phases. In these cases, it is presumed that if a transaction misses the current run of the ad hoc job, it will be picked up by the next run.

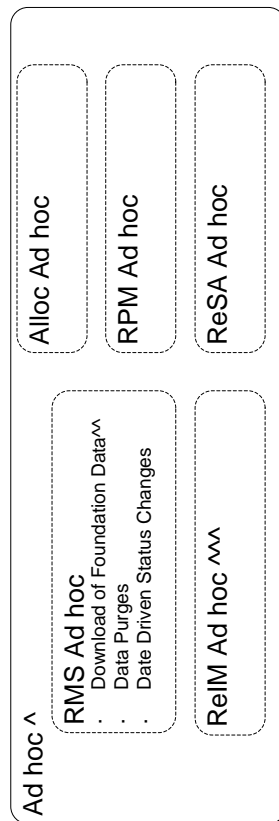

Integrated Merch Batch Cycle Phase Overview

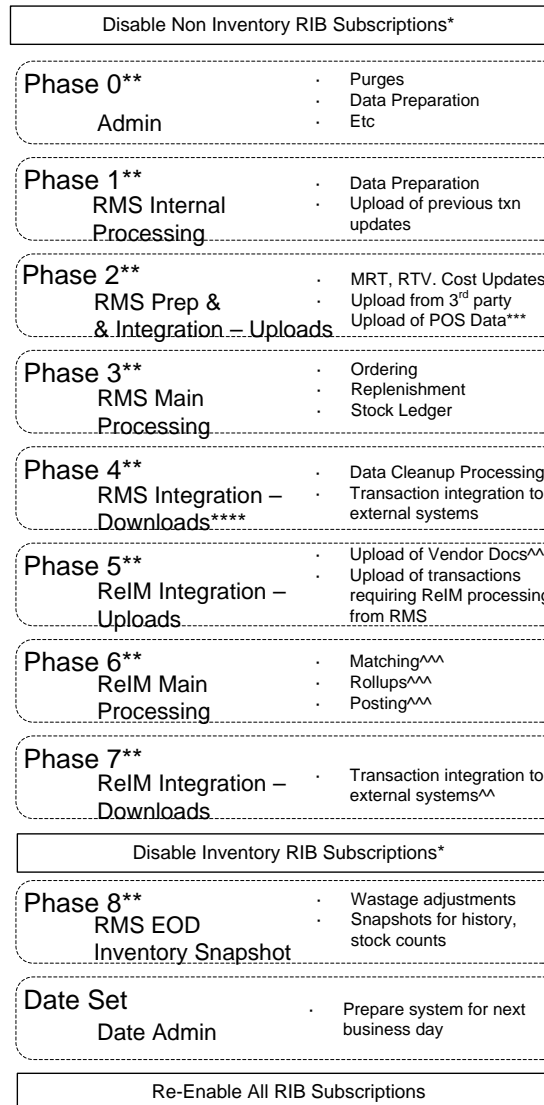

* Note - See 24x7 Inventory Availability whitepaper in the Merchandising Functional Library (Doc ID: 1585843.1). for more information about which subscriptions are inventory vs non inventory.

** Note - All jobs that belong to a phase must finish before any jobs in the next phase begin.

***Note - POS data can be uploaded throughout the day via trickle polling.

If the client does not trickle poll, this is the main POS upload slot.

If the client does trickle poll, sales trickled in after this point may or may not affect inventory related processing like replenishment, depending on when the transactions trickle in. It is assumed that if trickle polling, the vast majority of daily sales have been loaded at this point, resulting in reasonable calculated results.

^^Note - Integration of foundation data can occur ad hoc, but integration of transactions occurs after the RMS batch processes that create transactions

^^^ Note - Most ReIM jobs can be run both ad hoc and in their scheduled phases.

ReIM jobs should be run at a minimum in these scheduled phase positions. Running in these positions ensures that all order, receipt and invoice information from the day is considered.

But some can also be run ad hoc. Running ad hoc during the day or prior to these positions may match/post/etc many documents prior to the batch cycle.

Abbreviations

In the diagram, abbreviations in parentheses that follow program names have the following meanings:

Abbreviation	Meaning
(perl)	The module is a Perl script.
(FIF)	The module is related to the Financials application.
(sqlldr)	There is a sqlloader process to load/ftp the output files.
(rebuild all)	There is a rebuild process inside the application.
(IM)	The module is related to Invoice Matching but owned by RMS.
(RMS)	The module belongs to RMS.
(RMS)	(Bold type) The RMS module is executed externally to that phase.
(ReSA)	The module belongs to ReSA.
(ReSA)	(Bold type) The ReSA module is executed externally to that phase.
(ReIM)	The module belongs to ReIM.
(RTM)	The module belongs to RTM.
(Weekly)	The module is executed weekly.
(Monthly)	The module is executed monthly.
(Forms Auditing)	This is an online forms auditing process related to ReSA.

prepost Program

The prepost program facilitates multi-threading by allowing general system administration functions (such as table deletions or mass updates) to be completed after all threads of a particular program have been processed. The prepost program must be run before, after, or both before and after, programs that require specific processing to run or complete successfully.

In the batch schedule program list, the prepost program is indicated by “pre” and “post” entries, as in the following examples.

Modifications to the Batch Schedule

The integrated Merchandising batch schedule shows the dependencies for all the programs that *could* be run by a retailer. Based on many factors, there will always be some programs that a retailer does not run. Determining which programs, or groups of programs, are not required is a job that should be performed at implementation time.

One major factor involves the applications that the retailer has purchased and wants to install:

- For example, a retailer may have purchased RMS, but not ReIM; in this case, the ReIM programs would not be run.
- Another example is that a retailer may not want to use some functionality within an application. Perhaps a retailer purchased RMS but did not purchase the MFP application. In this case, the retailer may not want to run the programs that extract RMS data to be used later by the MFP application.

These major configuration choices also affect whether some programs are used:

- Whether the Retail Integration Bus (RIB) is used
For more information about configuring the RIB for Merchandising applications, see “Configuring RPM without the RIB” in the “Backend System Administration and Configuration” chapter of the *Oracle Retail Price Management Operations Guide*.
- Whether full-featured or simplified RTM is used
For more information about configuring simplified RTM, see the “Oracle Retail Trade Management Batch” chapter in Volume 1 of the *Oracle Retail Merchandising System Operations Guide*.
- Whether 24x7 processing is used

RMS,RTM,ReSA Program Dependency and Scheduling

Catalog ID	Job Name	Functional Area	Type	Driver	Phase	Program Pre-dependency	Program Post-dependency	Dependency/Run Notes	Frequency	Run Parameters for Programs
RMS175	allocbt.ksh	Inventory		Warehouse	ad hoc	N/A	N/A	N/A	As needed	allocbt.ksh [-p <# parallel threads>] <connect> <# parallel threads> is the number of threads to run in parallel. The default is the value on RESTART_CONTROL.NUM_THREADS.
RMS119	ang_prcqtydnl.ksh	Item Maintenance	Integration	Store	ad hoc	N/A	N/A	Should be run after RPM price change, clearance and promotion processing	Daily	
RMS120	ang_proddnl.ksh	Item Maintenance	Integration	Dept	ad hoc	dlyprg.pc	N/A		Daily	
RMS162	ang_saplgen.ksh	Oracle Retail	Integration	Store	ad hoc	N/A	N/A	N/A	Daily	
RMS121	ang_stdnl.ksh	Sales Audit	Integration	N/A	ad hoc	N/A	N/A		Daily	
RMS180	async_job_status_retry_cleanup.ksh	Foundation Data	Admin	N/A	ad hoc	N/A	N/A		As needed	async_queue_cleanup.ksh [-t <# days>] <connect> async_job_status_retry_cleanup.ksh <-t #hours> <connect> <-t #hours> represents how old the entries to be cleaned up. Suggested is 72 hours old.
RMS181	async_queue_cleanup.ksh	Administration		N/A	4	N/A	N/A	N/A	As needed	auditprg /@Batch_Alias_Name
RMS182	auditprg	Administration		N/A	ad hoc	N/A	N/A	N/A	As needed	auditsys /@Batch_Alias_Name
RMS183	auditsys	Administration		N/A	ad hoc	N/A	N/A	N/A	As needed	batch_alloctsfupd.ksh [-p <# parallel threads>] <connect> <# parallel threads> is the number of threads to run in parallel. The default is the value on RESTART_CONTROL.NUM_THREADS.
RMS184	batch_alloctsfupd.ksh	Foundation Data	Processing	Allocation and Tr	2	batch_compeffupd.ksh	prepost batch_costcompupd post	If none of the Cost Component Updates batch are to be run then, prepost batch_costcompupd post.	daily	batch_compeffupd.ksh <connect>
RMS185	batch_compeffupd.ksh	Foundation Data	Processing	NA	2	NA	prepost batch_costcompupd post	If none of the Cost Component Updates batch are to be run then, prepost batch_costcompupd post.	daily	batch_compeffupd.ksh <connect>
RMS186	batch_depchrgupd.ksh	Foundation Data	Processing	N/A	2	batch_compeffupd.ksh	prepost batch_costcompupd post	Updates batch are to be run then, prepost	daily	batch_depchrgupd.ksh <connect>
RMS187	batch_ditinsrt.ksh	Deals		N/A	1	N/A	orddscnt	Run either batch_ditinsrt.ksh or ditinsrt.pc. See detailed program documents for more information	daily	batch_depchrgupd.ksh <connect>
RMS188	batch_expprofupd.ksh	Foundation Data	Processing	N/A	2	batch_compeffupd.ksh	prepost batch_costcompupd post	If none of the Cost Component Updates batch are to be run then, prepost batch_costcompupd post.	daily	batch_expprofupd.ksh <connect> batch_itmcostcompupd.ksh [-p <# parallel threads>] <connect> <# parallel threads> is the number of threads to run in parallel. The default is the value on RESTART_CONTROL.NUM_THREADS.
RMS189	batch_itmcostcompupd.ksh	Foundation Data	Processing	Location, Supplie	2	batch_compeffupd.ksh prepost batch_ordcostcompupd prebatch_compeffupd.ksh	prepost batch_costcompupd post prepost batch_ordcostcompupd post	Updates batch are to be run then, prepost batch_costcompupd post.	daily	ch_ordcostcompupd.ksh [-p <# parallel threads>] <connect> <# parallel threads> is the number of threads to run in parallel. The default is the value on RESTART_CONTROL.NUM_THREADS.
RMS190	batch_ordcostcompupd.ksh	Foundation Data	Processing	Order	2	prepost batch_ordcostcompupd pre	prepost batch_costcompupd post	If none of the Cost Component Updates batch are to be run then, prepost batch_costcompupd post.	daily	batch_orpos_extract.ksh /@Batch_Alias_Name [-p <no. of threads>] [DIR - location where extracts are to be generated]
RMS19	batch_orpos_extract.ksh	Integration - Oracle Retail POS Suite		Store	4	RPM - RPMtoORPOSPublishExport.sh salesprocess.ksh	prepost batch_orpos_extract post	If RPM pricing info is reqd then run after extraction script 'RPMtoORPOSPublishExport.sh'	daily	

RMS192	batch_reqext.ksh	Replenishment		Partition (Item)	3	rplatupd repladj prepost replroq pre replroq.ksh	prepost reqext post	Run either batch_reqext.ksh or reqext.pc. See detailed program documents for more information	daily	batch_reqext.ksh /@Batch_Alias_Name
RMS193	batch_rfmvcurconv.ksh	Foundation Data		NA	ad hoc	prepost reqext pre NA	rplex NA		daily	partition_position batch_rfmvcurconv.ksh <connect> batch_rplapprvgtax.ksh [-p <# parallel threads>] <connect> <# parallel threads> is the number of threads to run in parallel. The default is the value on RESTART_CONTROL.NUM_THREADS.
RMS194	batch_rplapprvgtax	Replenishment		Order	3	rplapprv prepost rplex pre rplatupd rilmaint repladj reqext	N/A prepost rplex post supsplit cntrprss ibcxpl ibcalc	cntrordb and cntrprss are dependencies if contracting is used. They are not dependencies of the client does not use contractign	daily	
RMS195	batch_rplex.ksh	Replenishment		Dept	3	cntrordb	rplbld	Run either batch_rplex.ksh or rplex.pc. See detailed program	daily	batch_rplex.ksh /@Batch_Alias_Name
RMS196	ccprg	Cost Change		N/A	ad hoc	N/A	N/A		monthly	ccprg /@Batch_Alias_Name
RMS53	cednld	Trade		Broker	2	N/A	N/A		daily	cednld /@Batch_Alias_Name broker file_name
RMS198	cmpprg	Competitive Pricing		N/A	ad hoc	N/A	N/A		daily	cmpprg /@Batch_Alias_Name
RMS61	cmpupld	Competitive Pricing		N/A	ad hoc	N/A	N/A	All RPM batch modules should run after this job All Replenishment modules should run after this program (and all replenishment is later than phase 0)	As needed	cmpupld /@Batch_Alias_Name input_file reject_file
RMS200	cntrmain	Contracts	Processing	N/A	0	N/A	N/A		daily	cntrmain /@Batch_Alias_Name
RMS201	cntrordb	Contracts		Contract	3	rpladj	prepost cntrordb post		daily	cntrordb /@Batch_Alias_Name
RMS202	cntrprss	Contracts		Dept	3	rplex	rplbld		daily	cntrprss /@Batch_Alias_Name
RMS203	costeventprg.pc	Future Cost	Admin	Event Type	0	N/A	N/A		daily	costeventprg /@Batch_Alias_Name
RMS204	cremhierdly	Foundation Data		N/A	4	N/A	reclsdly		daily	cremhierdly /@Batch_Alias_Name
RMS205	customer_order_purge.ksh	Purchase Orders		N/A	ad hoc	N/A	N/A		monthly	customer_order_purge.ksh /@Batch_Alias_Name
						salstage prepost dealact_nor pre prepost dealact_po pre prepost dealact_sales pre prepost dealact_nor pre prepost dealact_po pre				
					TBD?					
RMS206	dealact	Deals		Deal Id	3	prepost dealact_sales pre	N/A		daily	dealact /@Batch_Alias_Name
RMS207	dealcls	Deals		N/A	3	N/A	prepost dealcls post		daily	dealcls /@Batch_Alias_Name
RMS208	dealday	Deals		Location	3	dealinc prepost dealday pre	prepost dealday post salmnth		monthly	dealday /@Batch_Alias_Name dealact /@Batch_Alias_Name [Y/N - EOM processing ind]
RMS209	dealact	Deals		Deal Id	3	prepost dealact pre	salmth dealact dealday salmth		daily	
RMS65	dealfinc	Integration - General Ledger	Integration	Deal Id	3	dealact dealact	salmth is a post dependency at EOM		weekly/ as needed	dealfinc /@Batch_Alias_Name dealinc /@Batch_Alias_Name [Y/N -EOM processing ind]
RMS211	dealinc	Deals		Deal Id	3	prepost dealinc pre	salmth		monthly	
RMS212	dealprg	Deals		N/A	ad hoc	N/A	N/A		monthly	dealprg /@Batch_Alias_Name
RMS42	dealupld	Deals	Integration	File-based	0	N/A	N/A	All other deals programs, which will occur as all deals batch is in later phases of the cycle. (SQL*Load the output file)	daily	dealupld /@Batch_Alias_Name input_file reject_file
RMS214	dfrtbld	Foundation Data		Dept	8	uploadsales_all.ksh			daily	dfrtbld /@Batch_Alias_Name outfile
RMS215	discotbapply	Deals		Dept	4	orddscnt	N/A		daily	discotbapply /@Batch_Alias_Name
RMS216	distropcpub	Transfers, Allocations, and RTV		Store	4	PriceEventExecutionBatch	N/A	Predepeny is an RPM batch process	daily	distropcpub /@Batch_Alias_Name
RMS217	ditinsrt	Deals		N/A	1	N/A	orddscnt	Run either batch_ditinsrt.ksh or ditinsrt.pc. See detailed program documents for more information	daily	ditinsrt /@Batch_Alias_Name (P or S)
RMS218	dlyprg	Administration	Admin	N/A	0	N/A	prepost dlyprg post		daily	dlyprg /@Batch_Alias_Name

RMS219	docclose	Transfers, Allocations, and RTV	Business Processing	N/A	ad hoc	prepost docclose pre tsfclose	wfordcls wfretcls tsfprg ordprg	daily	docclose /@Batch_Alias_Name
RMS220	dtesys	Administration Transfers, Allocations, and RTV		N/A	date_set	sastdycr		daily	dtesys /@Batch_Alias_Name [indate--YYYYMMDD format]
RMS221	dummyctn			N/A	ad hoc	N/A	N/A	daily	dummyctn /@Batch_Alias_Name
RMS44	edidladd	Foundation Data		N/A	ad hoc	N/A	N/A	As needed	edidladd /@Batch_Alias_Name ediadd_output
RMS45	edidlcon	Contracts		N/A	ad hoc	N/A	N/A	As needed	ediadd_catalog
RMS127	edidlinv	Invoice Matching	Integration	Location	4	N/A	N/A	Daily	edidlcon /@Batch_Alias_Name edidlcon_outfile
RMS46	edidlord	Purchase Orders		N/A	4	ordrev	N/A	As needed	edidlinv /@Batch_Alias_Name output_filename
RMS47	edidlprd	Inventory		N/A	8	prepost edidlprd pre	prepost edidlprd post	As needed	edidlord /@Batch_Alias_Name filename
RMS217	ediprg	Item Maintenance		N/A	ad hoc	N/A	N/A	monthly	edidlprd /@Batch_Alias_Name filename (Towards the end of the batch cycle)
RMS48	ediupack	Purchase Orders		N/A	1	N/A	N/A	As needed	ediprg /@Batch_Alias_Name
RMS49	ediupadd	Foundation Data		File-based	2	N/A	prepost ediupadd post	daily	ediupack /@Batch_Alias_Name data_file reject_file
RMS50	ediupavl	Contracts		File-based	1	N/A	N/A	As needed	ediupadd /@Batch_Alias_Name input_file reject_file
RMS222	elcexcprg	Foundation Data		N/A	2	N/A	N/A	As needed	ediupcat /@Batch_Alias_Name edi_data_file error_file
RMS223	fcexec	Future Cost Franchise Management		Cost Event Proc	2	prepost fcexec pre	N/A	daily/ as needed	elcexcprg /@Batch_Alias_Name
RMS224	fcosttmplprocess.ksh	Franchise Management		N/A	ad hoc	fcosttmplupld.ksh	N/A	daily	fcexec /@Batch_Alias_Name
RMS225	fcosttmplpurge.ksh	Franchise Management		N/A	ad hoc	N/A	N/A	daily	fcosttmplprocess.ksh
RMS125	fcosttmplupld.ksh	Franchise Management	Integration	N/A	ad hoc	N/A	fcosttmplupld.ksh	daily	fcosttmplpurge.ksh
RMS227	fcstprg	Integration - Planning		Domain Id	ad hoc	prepost fcstprg pre	prepost fcstprg post	daily	fcstprg /@Batch_Alias_Name domain
RMS228	fcstrbld	Integration - Planning		Domain Id	3	N/A	prepost fcstrbld post	weekly	fcstrbld /@Batch_Alias_Name
RMS229	fcstrbld_sbc	Integration - Planning		Domain Id	3	prepost fcstrbld post	N/A	weekly daily/ as needed	fcstrbld_sbc /@Batch_Alias_Name
RMS230	fcthreadexec	Future Cost Integration - General Ledger		Cost Event Proc	2	batch_itmcostcompupd.ksh salstage	N/A	as needed	fcthreadexec /@Batch_Alias_Name
RMS66	fifgldn1	Integration - General Ledger	Integration	Dept	3		salapnd	daily	fifgldn1 /@Batch_Alias_Name
RMS67	fifgldn2	Integration - General Ledger	Integration	Dept	3	salstage	salapnd	daily	fifgldn2 /@Batch_Alias_Name
RMS68	fifgldn3	Integration - General Ledger	Integration	Store/Wh	3	salmth	N/A	monthly	fifgldn3 /@Batch_Alias_Name
RMS15	ftmednld	Integration - Planning	Integration	N/A	ad hoc	N/A	N/A	As needed	ftmednld /@Batch_Alias_Name
RMS43	gcupld	Foundation Data		N/A	ad hoc	N/A	N/A	As needed	gcupld <username/password@environment> <infile>
RMS237	genpreiss	Purchase Orders		Supplier	ad hoc	N/A	N/A	As needed	<outfile>
RMS133	gradupld	Integration - Planning		File-based	ad hoc	N/A	N/A	As needed	genpreiss /@Batch_Alias_Name
RMS239	hstbld	Sales History	Business Process	Location	8	salesprocess.ksh prepost hstbld pre (for rebuild all)	prepost hstbld post (for rebuild all)	weekly	gradupld /@Batch_Alias_Name input_file rej_file
RMS240	hstbld_diff	Sales History	Business Processing	N/A	8	hstbld	N/A	weekly	hstbld /@Batch_Alias_Name level(weekly/rebuild)
RMS241	hstbldmth	Sales History	Business Processing	Dept	8	salesprocess.ksh	prepost hstbldmth post	Monthly	hstbld_diff /@Batch_Alias_Name
RMS242	hstbldmth_diff	Sales History	Business Processing	N/A	ad hoc	N/A	prepost hstbld post	monthly	hstbldmth /@Batch_Alias_Name level(monthly/rebuild)
RMS158	hstmthupd	Sales History	Business Processing	Location	8	refeodinventory.ksh	Run SQL*Loader using the control file hstmthupd.ctl to load data from the output file written by hstmthupd.pc for non-existent records on ITEM_LOC_HIST_MTH.	Monthly	hstbldmth_diff /@Batch_Alias_Name The program should be run on the last day of the month. refeodinventory.ksh must run successfully prior to execution to ensure that ITEM_LOC_SOH_EOD is up-to-date. (The program should be run on the last day of the month).

RMS244	hstprg	Sales History	Admin	N/A	ad hoc	N/A	N/A		Monthly	hstprg /@Batch_Alias_Name
RMS245	hstprg_diff	Sales History	Admin	N/A	ad hoc	N/A	N/A	Should be run after hstbld_diff.pc.	Monthly	hstprg_diff /@Batch_Alias_Name
RMS159	hstwkupd	Sales History Oracle Retail Trade	Business Processing	Store/Wh	8	refeodinventory.ksh	N/A	Run SQL*Loader using the control file hstwkupd.ctl to load data from the output file written by hstwkupd.pc for non-existent records on ITEM_LOC_HIST. refeodinventory.ksh must run successfully prior to execution to ensure that ITEM_LOC_SOH_EOD is up-to-date.	Weekly	hstwkupd /@Batch_Alias_Name (out_file)
RMS247	hts_240_to_2400	Management		N/A	ad hoc	N/A	htsupld		As needed	
RMS41	htsupld	Oracle Retail Trade Management		File-based	ad hoc	hts240_to_2400 ushts2rms prepost htsupld pre ibexpl replex	N/A	Hts240_to_2400 and Ushts2rms are file transformation perl scripts used to create the appropriate upload files	As needed	htsupld /@Batch_Alias_Name input_file reject_file country_id ; perl hts_240_to_2400 inputfile outputfile ; perl ushts2rms inputfile outputfile rejectfile
RMS249	ibcalc	Replenishment	Processing	Dept	3	prepost ibcalc pre	rplbld		As needed	ibcalc /@Batch_Alias_Name
RMS250	ibexpl	Replenishment		N/A	3	rplext	ibcalc		As needed	ibexpl /@Batch_Alias_Name
RMS251	invaprg	Inventory		N/A	ad hoc	N/A	N/A		As needed	invaprg /@Batch_Alias_Name
RMS252	invclshp	Invoice Matching	Business Processir	N/A	2	N/A	N/A	doc says adhoc/daily, schedule says phase 2/as needed - chqanging both to phase 2 daily	Daily	invclshp /@Batch_Alias_Name
RMS253	invprg	Invoice Matching Oracle Retail Trade	Admin	N/A	ad hoc	ordprg	N/A	The program should run after ordprg.pc	monthly	invprg /@Batch_Alias_Name
RMS57	lcadnld	Management		N/A	4	N/A	lcmt700		daily	lcadnld /@Batch_Alias_Name output_file
RMS255	lclrbld	Foundation Data Oracle Retail Trade		N/A	ad hoc	N/A	N/A	lcmt707 (perl script)	monthly	lclrbld /@Batch_Alias_Name
RMS56	lcmdnld	Management Oracle Retail Trade		N/A	4	N/A	lcmt707		daily	lcmdnld /@Batch_Alias_Name output_file.
RMS136	lcmt700	Management Oracle Retail Trade	Integration	N/A	4	lcadnld	N/A		daily	
RMS137	lcmt707	Management Oracle Retail Trade	Integration	N/A	4	lcmdnld	N/A		daily	
RMS138	lcmt730	Management Oracle Retail Trade	Integration	N/A	2	N/A	lcupld		daily	
RMS139	lcmt798	Management Oracle Retail Trade	Integration	N/A	2	N/A	lcmt798		daily	
RMS54	lcup798	Management Oracle Retail Trade		N/A	2	lcmt798	N/A		daily	lcup798 /@Batch_Alias_Name input_file rej_file
RMS55	lcupld	Management		N/A	2	lcmt730	N/A		daily	lcupld /@Batch_Alias_Name input_file rej_file
RMS150	lifstkup	Stock Count Transfers, Allocations, and RTV	Integration	File-based	1	WMS job (inv_bal_upload.sh)	stockcountupload.ksh stockcountprocess.ksh		daily	lifstkup /@Batch_Alias_Name input_file output_file
RMS273	mrt	Transfers, Allocations, and RTV		Warehouse	2	N/A	mtrtrv mrtupd		daily	mrt /@Batch_Alias_Name
RMS274	mrtprg	Transfers, Allocations, and RTV		Warehouse	ad hoc	N/A	N/A		As needed	mrtprg /@Batch_Alias_Name
RMS275	mtrtrv	Transfers, Allocations, and RTV		Warehouse	2	mrt	mrtupd		As needed	mtrtrv /@Batch_Alias_Name
RMS276	mrtupd	Transfers, Allocations, and RTV		Warehouse	2	mtrtrv	N/A		As needed	mrtupd /@Batch_Alias_Name
RMS277	nwppurge	Stock Ledger	Admin	N/A	ad hoc	N/A	N/A	Only required in specific markets (e.g. Germany)	Annually	nwppurge /@Batch_Alias_Name

RMS278	nwpyearend	Stock Ledger	Business Processing	Location	8	refeodinventory.ksh	N/A	run on last day of year in specific markets (e.g. Germany)	Annually	nwpyearend /@Batch_Alias_Name
RMS128	onictext	Integration - Planning		Transfer	4	onordext	onorddnld		weekly	onictext /@Batch_Alias_Name datefile
RMS12	onorddnld	Integration - Planning	Integration	Store/Wh	4	onictext	N/A		daily	onorddnld /@Batch_Alias_Name
RMS129	onordext	Integration - Planning		Order	4	prepost onordext pre	onictext		daily	onordext /@Batch_Alias_Name datefile
RMS282	ordautcl	Purchase Orders		N/A	ad hoc	N/A	N/A		daily	ordautcl /@Batch_Alias_Name
RMS283	orddscent	Purchase Orders		Supplier	4	reclsdly	discotbapply dealcls		daily	orddscent /@Batch_Alias_Name
RMS113	ordinvupld	Inventory		File-based	2	saordinvexp	N/A		daily	lock_file
RMS285	ordprg	Purchase Orders		N/A	ad hoc	N/A	invprg wfrmprg		monthly	ordprg /@Batch_Alias_Name
RMS286	ordrev	Purchase Orders		N/A	4	orddscent	edidlord		daily	ordrev /@Batch_Alias_Name
RMS287	ordupd	Purchase Orders		N/A	4	sccect	otbdlord	After RPM pricing change extraction batch	daily	ordupd /@Batch_Alias_Name
RMS13	otbdlord	Open To Buy	Integration	N/A	4	ordupd	N/A	This program must be run after ORDUPD (order upload.) It also must be run after SALWEEK for the week just ended. This program and OTBDNLD can run anytime after SALWEEK, but SALDLY cannot run between OTBDNLD, OTBDLSAL and OTBDLORD.	daily	otbdlord /@Batch_Alias_Name output_file
RMS16	otbdlsal	Stock Ledger	Integration	N/A	4	ordupd, salweek	N/A		Weekly	otbdlsal /@Batch_Alias_Name output_file
RMS130	otbdnld	Open To Buy		N/A	4	ordupd	N/A		daily	otbdnld /@Batch_Alias_Name output_file
RMS291	otbprg	Open To Buy		N/A	ad hoc	N/A	N/A		monthly	otbprg /@Batch_Alias_Name
RMS131	otbupfwd	Open To Buy		File-based	ad hoc	N/A	N/A		daily	/@Batch_Alias_Name input_file reject_file
RMS133	otbupld	Open To Buy		File-based	ad hoc	N/A	N/A		daily	otbupld /@Batch_Alias_Name input_file reject_file
RMS69	poscdnld	Integration - 3rd Party POS	Integration	N/A	4	posdnld	prepost poscdnld post		daily	poscdnld /@Batch_Alias_Name outputfile
RMS70	posdnld	Integration - 3rd Party POS	Integration	Store	ad hoc	N/A	prepost posdnld post		daily	posdnld /@Batch_Alias_Name output_filename
RMS147	posgpdlld	Integration - 3rd Party POS	Integration	N/A	4	reclsdly	N/A		daily	posgpdlld /@Batch_Alias_Name output_file
RMS148	posrefresh	Integration - 3rd Party POS	Integration	N/A	ad hoc	N/A	N/A		As needed	posrefresh /@Batch_Alias_Name output_file store
RMS298	prchstprg.pc	Foundation Data		partition	ad hoc	N/A	N/A	Recommend this is run prior to phase 3 to improve phase 3 performance Refer to AIP Operations and Installation Guides	daily	prchstprg /@Batch_Alias_Name
RMS159	pre_rmse_aip.ksh	Integration - AIP	Integration	N/A	ad hoc	N/A	N/A		daily	N/A
RMS160	pre_rmse_rpas.ksh	Integration - Planning	Integration	N/A	ad hoc	N/A	N/A	This is a pre setup script	daily	N/A
RMS302	reclsdly	Foundation Data		Reclass no	4	cremhierdly prepost reclsdly pre	prepost reclsdly post	N/A	daily	reclsdly /@Batch_Alias_Name process_mode
RMS303	refeodinventory	Inventory		N/A	8	N/A	N/A		daily	refeodinventory.ksh /@Batch_Alias_Name
RMS304	refmv110nentity	Foundation Data	Admin	N/A	ad hoc	N/A	N/A		As needed	refmv110nentity /@Batch_Alias_Name
RMS305	refmvlocprimaddr	Foundation Data		N/A	ad hoc	N/A	N/A		As needed	refmvlocprimaddr /@Batch_Alias_Name
RMS306	repl_wf_order_sync.ksh	Replenishment		N/A	3	rplapprv	N/A		daily	repl_wf_order_sync.ksh /@Batch_Alias_Name
RMS307	repladj	Replenishment		Dept	3	rplatupd	reqext rplext		daily	repladj /@Batch_Alias_Name
RMS308	replroq.ksh	Replenishment		N/A	3	prepost replroq pre repladj	N/A		As needed	replroq.ksh /@Batch_Alias_Name <last run of day>
RMS309	replsizeprofile	Replenishment		N/A	ad hoc	prepost replsizeprofile pre	N/A		As needed	<restart_ind> replsizeprofile /@Batch_Alias_Name Y/N. (Y/N indicator indicates if allocations is installed or not, if installed pre job for this program has to be run prepost replsizeprofile pre)
RMS310	reqext	Replenishment		Partition (Item)	3	salesprocess.ksh rplatupd repladj prepost replroq pre replroq.ksh prepost reqext pre	prepost reqext post rplext	Run either batch_reqext.ksh or reqext.pc. See detailed program documents for more information	daily	reqext /@Batch_Alias_Name partition_position

RMS311	rilmaint	Replenishment	Location	3	sccext rplatupd prepost rilmaint pre	prepost rilmaint post repladj		Refer to AIP Operations and Installation Guides	daily	rilmaint username/password
RMS20	rmse_aip_alloc_in_well.ksh	Integration - AIP	Integration	N/A	ad hoc	pre_rmse_aip.ksh	N/A	Refer to AIP Operations and Installation Guides	daily	N/A
RMS27	rmse_aip_banded_item.ksh	Integration - AIP	Integration	N/A	ad hoc	pre_rmse_aip.ksh, dlyprg	N/A tsfprg ordprg	Refer to AIP Operations and Installation Guides	daily	N/A
RMS21	rmse_aip_cl_po.ksh	Integration - AIP	Integration	N/A	ad hoc	pre_rmse_aip.ksh		Refer to AIP Operations and Installation Guides	daily	N/A
RMS28	rmse_aip_future_delivery_alloc.ksh	Integration - AIP	Integration	N/A	ad hoc	pre_rmse_aip.ksh	N/A	Refer to AIP Operations and Installation Guides	daily	N/A
RMS22	rmse_aip_future_delivery_order.ksh	Integration - AIP	Integration	N/A	ad hoc	pre_rmse_aip.ksh vrplbld cntrordb	N/A	Refer to AIP Operations and Installation Guides	daily	N/A
RMS29	rmse_aip_future_delivery_tsf.ksh	Integration - AIP	Integration	N/A	ad hoc	pre_rmse_aip.ksh reqext	N/A	Refer to AIP Operations and Installation Guides	daily	N/A
RMS23	rmse_aip_item_loc_traits.ksh	Integration - AIP	Integration	N/A	ad hoc	pre_rmse_aip.ksh dlyprg	N/A	Refer to AIP Operations and Installation Guides	daily	N/A
RMS30	rmse_aip_item_master.ksh	Integration - AIP	Integration	N/A	ad hoc	pre_rmse_aip.ksh reclsdly	N/A	Refer to AIP Operations and Installation Guides	daily	N/A
RMS24	rmse_aip_item_retail.ksh	Integration - AIP	Integration	N/A	ad hoc	pre_rmse_aip.ksh dlyprg	N/A	Refer to AIP Operations and Installation Guides	daily	N/A
RMS31	rmse_aip_item_sale.ksh	Integration - AIP	Integration	N/A	ad hoc	pre_rmse_aip.ksh sitmain	N/A	Refer to AIP Operations and Installation Guides	daily	N/A
RMS25	rmse_aip_item_supp_country.ksh	Integration - AIP	Integration	N/A	ad hoc	pre_rmse_aip.ksh dlyprg	N/A	Refer to AIP Operations and Installation Guides	daily	N/A
RMS32	rmse_aip_merchier.ksh	Integration - AIP	Integration	N/A	ad hoc	pre_rmse_aip.ksh dlyprg	N/A	Refer to AIP Operations and Installation Guides	daily	N/A
RMS26	rmse_aip_orghier.ksh	Integration - AIP	Integration	N/A	ad hoc	pre_rmse_aip.ksh dlyprg	N/A	Refer to AIP Operations and Installation Guides	daily	N/A
RMS33	rmse_aip_rec_qty.ksh	Integration - AIP	Integration	N/A	ad hoc	pre_rmse_aip.ksh vrplbld cntrordb reqext	N/A	Refer to AIP Operations and Installation Guides	daily	N/A
RMS40	rmse_aip_store.ksh	Integration - AIP	Integration	N/A	ad hoc	pre_rmse_aip.ksh dlyprg	N/A	Refer to AIP Operations and Installation Guides	daily	N/A
RMS38	rmse_aip_substitute_items.ksh	Integration - AIP	Integration	N/A	ad hoc	pre_rmse_aip.ksh	N/A	Refer to AIP Operations and Installation Guides	daily	N/A
RMS37	rmse_aip_suppliers.ksh	Integration - AIP	Integration	N/A	ad hoc	pre_rmse_aip.ksh	N/A	Refer to AIP Operations and Installation Guides	daily	N/A
RMS36	rmse_aip_tsf_in_well.ksh	Integration - AIP	Integration	N/A	ad hoc	pre_rmse_aip.ksh reqext	N/A	Refer to AIP Operations and Installation Guides	daily	N/A
RMS35	rmse_aip_wh.ksh	Integration - AIP	Integration	N/A	ad hoc	pre_rmse_aip.ksh dlyprg	N/A	Refer to AIP Operations and Installation Guides	daily	N/A
RMS106	rmse_mfp_inventory.ksh	Integration - Planning	Integration	N/A	ad hoc	pre_rmse_rpas.ksh		Refer to MFP Operations guide	Weekly	Note: I - 'Initial load W-'Weekly load
RMS107	rmse_mfp_onorder.ksh	Integration - Planning	Integration	N/A	ad hoc	pre_rmse_rpas.ksh		Refer to MFP Operations guide	Weekly	N/A
RMS149	rmse_rpas.ksh	Integration - Planning	Integration	N/A	ad hoc	pre_rmse_rpas.ksh	N/A	Refer to RPAS Operations guide	daily	N/A
RMS01	rmse_rpas_attributes.ksh	Integration - Planning	Integration	N/A	ad hoc	pre_rmse_rpas.ksh saldly	N/A	Refer to RPAS Operations guide	daily	N/A
RMS08	rmse_rpas_daily_sales.ksh	Integration - Planning	Integration	N/A	ad hoc	pre_rmse_rpas.ksh	N/A	Refer to RPAS Operations guide	daily	N/A
RMS06	rmse_rpas_domain.ksh	Integration - Planning	Integration	N/A	ad hoc	N/A sitmain	N/A	Refer to RPAS Operations guide	daily	N/A
RMS05	rmse_rpas_item_master.ksh	Integration - Planning	Integration	N/A	ad hoc	pre_rmse_rpas.ksh reclsdly dlyprg	N/A	Refer to RPAS Operations guide	daily	N/A
	rmse_rpas_merchier.ksh	Integration - Planning	Integration	N/A	ad hoc	pre_rmse_rpas.ksh reclsdly dlyprg	N/A	Refer to RPAS Operations guide	daily	N/A
RMS10	rmse_rpas_merchier.ksh	Integration - Planning	Integration	N/A	ad hoc	pre_rmse_rpas.ksh	N/A	Refer to RPAS Operations guide	daily	N/A

RMS04	rmse_rpas_orghier.ksh	Integration - Planning	Integration	N/A	ad hoc	dlyprg	N/A	Refer to RPAS Operations guide	daily	N/A
	rmse_rpas_orghier.ksh	Integration - Planning		N/A	ad hoc	pre_rmse_rpas.ksh	N/A	Refer to RPAS Operations guide	daily	N/A
RMS07	rmse_rpas_stock_on_hand.ksh	Integration - Planning	Integration	N/A	ad hoc	stkdiy	N/A	Refer to RPAS Operations guide	daily	N/A
	rmse_rpas_store.ksh	Integration - Planning		N/A	ad hoc	dlyprg	N/A	Refer to RPAS Operations guide	daily	N/A
RMS02	rmse_rpas_store.ksh	Integration - Planning	Integration	N/A	ad hoc	pre_rmse_rpas.ksh	N/A	Refer to RPAS Operations guide	daily	N/A
RMS11	rmse_rpas_suppliers.ksh	Integration - Planning	Integration	N/A	ad hoc	N/A	N/A	Refer to RPAS Operations guide	daily	N/A
RMS09	rmse_rpas_weekly_sales.ksh	Integration - Planning	Integration	N/A	ad hoc	hstwkupd salweek pre_rmse_rpas.ksh	N/A	Refer to RPAS Operations guide	daily	N/A
RMS03	rmse_rpas_wh.ksh	Integration - Planning	Integration	N/A	ad hoc	dlyprg pre_rmse_rpas.ksh pre_rmse_aip.ksh	N/A	Refer to RPAS Operations guide	daily	N/A
RMS39	rmse_store_cur_inventory.ksh	Integration - AIP		Item_loc_soh (n	ad hoc	stkvar wasteadj salstage reqext salesprocess.ksh pre_rmse_aip.ksh rmse_store_cur_inventory.ksh	N/A	Refer to AIP Operations and Installation Guides	daily	D - single -threaded delta extract F - multi-threaded full extract if ITEM_LOC is partitioned; single-threaded full extract if ITEM_LOC is not partitioned
RMS34	rmse_wh_cur_inventory.ksh	Integration - AIP	Warehouse		ad hoc	stkvar wasteadj salstage reqext	N/A	rmse_store_cur_inventory.ksh (if running delta extract) Refer to AIP Operations and Installation Guides	daily	D - single -threaded delta extract F - multi-threaded full extract if ITEM_LOC is partitioned; single-threaded full extract if ITEM_LOC is not partitioned
RMS134	rmsl_rpas_forecast.ksh	Integration - Planning		N/A	ad hoc	pre_rmse_rpas.ksh	N/A	Refer to RPAS Operations guide	daily	rmsl_rpas_forecast.ksh daily or weekly
RMS161	rmsl_rpas_update_retl_date.ksh	Integration - Planning		N/A	ad hoc	pre_rmse_rpas.ksh rmse_rpas.ksh rmse_rpas_attributes.ksh rmse_rpas_daily_sales.ksh rmse_rpas_domain.ksh rmse_rpas_item_master.ksh rmse_rpas_merchhier.ksh rmse_rpas_orghier.ksh rmse_rpas_stock_on_hand.ksh rmse_rpas_store.ksh rmse_rpas_suppliers.ksh rmse_rpas_weekly_sales.ksh	N/A	This should be the last RMS/Planning System Integration RETL scripts	daily	rmsl_rpas_update_retl_date.ksh CLOSED_ORDER or RECEIVED_QTY
RSA13	rmst_saimptlog_promo	Oracle Retail Sales Audit	Integration	N/A	ad hoc	RPM program prmdtlex.ksh	saimptlog or saimptogi		Daily	
	rplapprv	Replenishment		N/A	3	rplsplsplit supcnstr prepost rplapprv pre	batch_rplapprvgtax		daily	rplapprv /@Batch_Alias_Name rplathistprg /@Batch_Alias_Name (This batch may be run only if repl_attr_hist_retention_weeks in system_options table is set)
RMS312	rplathistprg	Replenishment		N/A	ad hoc	N/A	N/A	prepost rplatupd post repladj rplext reqext	As needed	
RMS313	rplatupd	Replenishment	Location		3	prepost rplatupd pre			daily	rplatupd /@Batch_Alias_Name

RMS314	rplbld	Replenishment		Supplier	3	ibcalc rplext cntrprss vrplbld ibexpl supsplit	supcnstr	daily	rplbld username/password
						prepost rplext pre rplatupd rilmaint repladj reqext cntrordb	prepost rplext post supsplit cntrprss ibcxpl ibcalc rplbld	daily	cntroordb and cntrprss are dependencies if contracting is used. They are not dependencies of the client does not use contractign
RMS315	rplext	Replenishment		Dept	3			daily	rplext /@Batch_Alias_Name dept
RMS316	rplprg	Replenishment		N/A	ad hoc	N/A	N/A	daily	rplprg /@Batch_Alias_Name
RMS317	rplprg_month	Replenishment		N/A	ad hoc	N/A	N/A	monthly	rplprg_month /@Batch_Alias_Name
RMS318	rplsplit	Replenishment		Supplier	3	supcnstr	rplapprv	daily	rplsplit /@Batch_Alias_Name
RMS319	rpmovavg	Sales History Transfers, Allocations, and RTV	Business Processing	Store	3	salstage	N/A	daily	rpmovavg /@Batch_Alias_Name business_date(YYYYMMDD) store(optional)
RMS320	rtvprg	Oracle Retail		N/A	ad hoc	N/A	N/A	monthly	rtvprg /@Batch_Alias_Name
RSA05	saescheat	Sales Audit	Integration	N/A	ad hoc	satotals sarules	saexpim sapurge	Monthly	saescheat /@Batch_Alias_Name
									Runs from saescheat and does not need to be seperately scheduled.
RSA25	saescheat_nextesn	Oracle Retail Sales Audit	Admin	N/A	ad hoc	N/A	N/A	monthly	
RSA03	saexpach	Oracle Retail Sales Audit	Integration	N/A	ad hoc	satotals sarules sapreexp	N/A	daily	saexpach /@Batch_Alias_Name
RSA02	saexpdw	Oracle Retail Sales Audit	Integration	Store	ad hoc	satotals sarules sapreexp	resa2dw	daily	saexpdw /@Batch_Alias_Name ; perl resa2dw inputfile outputfile
									resa2dw is a file transformation perl script
RSA09	saexpgl	Oracle Retail Sales Audit	Integration	N/A	ad hoc	satotals sarules sapreexp	N/A	daily	saexpgl /@Batch_Alias_Name
RSA04	saexpim	Oracle Retail Sales Audit	Integration	N/A	ad hoc	saescheat satotals sarules	N/A	daily	saexpim /@Batch_Alias_Name
RSA01	saexprms	Oracle Retail Sales Audit	Integration	Store	ad hoc	satotals sarules sapreexp	saprepost saexprms post	daily	saexprms /@Batch_Alias_Name
									resa2sim is a file transformation perl script
RSA14	saexpsim	Oracle Retail Sales Audit	Integration	Store	ad hoc	satotals sarules sapreexp	post resa2sim	daily	saexpsim /@Batch_Alias_Name ; perl resa2sim inputfile outputfile
RSA06	saexpuar	Oracle Retail Sales Audit	Integration	N/A	ad hoc	satotals sarules sapreexp	N/A	daily	saexpuar /@Batch_Alias_Name sagetref /@Batch_Alias_Name itemfile wastefile ref_itemfile prim_variantfile varupcfile storedayfile codesfile errorfile ccvalfile storeposfile tendertypefile merchcodesfile partnerfile supplierfile employeefile bannerfile currencyfile promfile whfile invstatusfile (To prevent a file from being written, place a '-' in its place. Note: Item files must all be written together).
RSA00	sagetref	Oracle Retail Sales Audit	Integration	N/A	ad hoc	sastdycr	saimptlog or saimptlogi	daily	
RSA07	saimpadj	Oracle Retail Sales Audit	Integration	N/A	ad hoc	saimptlogfin	satotals	daily	saimpadj /@Batch_Alias_Name input_file rej_file saimptlog user/pw infile badfile itemfile wastefile ref_itemfile primvariantfile varupcfile storedayfile promfile codesfile errorfile ccvalfile storeposfile tendertypefile merchcodefile partnerfile supplierfile employeefile bannerfile currencyfile whfile invstatusfile max_tran_gap(optional)
							saprepost saimptlog post		Clients can use either saimptlog & SQL loader or saimptlogi.
RSA11a	saimptlog	Oracle Retail Sales Audit	Integration	Store/Day	ad hoc	sagetref saprepost saimptlog pre saprepost saimptlog/i post	post	daily	Use sql Loader to load data into ReSA tables
RSA18	saimptlogfin	Oracle Retail Sales Audit	Integration	N/A	ad hoc	saimptlog savouch	satotals saprepost saimptlogi	daily	saimptlogfin /@Batch_Alias_Name store_day_file
RSA11b	saimptlogi	Oracle Retail Sales Audit	Integration	Store/Day	ad hoc	sagetref saprepost saimptlogi pre	post		Clients can use either saimptlog & SQL loader or saimptlogi. This program should be run before running saimptlog/saimptlogi if any Store-Day's have been deleted.
RSA19	saimptlogtdup_upd	Oracle Retail Sales Audit	Admin		ad hoc		saimptlog/saimptlogi	As needed	

RMS335	salapnd	Stock Ledger		N/A	3	salstage fifgldn1 fifgldn2	N/A	daily	salapnd /@Batch_Alias_Name
RMS336	saldly	Stock Ledger		Store/Wh	3	salstage	salweek (on end of week day)	daily	saldly /@Batch_Alias_Name
RMS337	saleoh	Stock Ledger		Dept	3	salmth prepost saleoh pre	N/A	half yearly	saleoh /@Batch_Alias_Name
RMS338	salesgenrej.ksh	Sales Posting		N/A	2	salesprocess.ksh	N/A	As needed	Must be run in at least phase 2. Can also be run ad hoc to trickle poll sales. Must be run in at least phase 2. Can also be run ad hoc to trickle poll sales.
RMS151	salesprocess.ksh	Sales Posting	Integration	N/A	2	uploadsales.ksh	salesgenrej.ksh	As needed	./salesprocess.ksh \$UP
RMS340	salesuploadarch.ksh	Sales Posting	Admin	N/A	ad hoc	salesgenrej.ksh	salesuploadpurge.ksh	As needed	./salesuploadarch.ksh \$UP
RMS341	salesuploadpurge.ksh	Sales Posting		N/A	ad hoc	salesuploadarch.ksh	N/A	As needed	./salesuploadpurge.ksh \$UP <retention period>
RMS342	salmaint	Stock Ledger		N/A	ad hoc	N/A	N/A	half yearly	salmaint /@Batch_Alias_Name pre_or_post
RMS343	salmth	Stock Ledger		Dept	3	salweek	prepost salmth post	monthly	salmth /@Batch_Alias_Name
RMS344	salprg	Stock Ledger		N/A	ad hoc	N/A	N/A	daily	salprg /@Batch_Alias_Name
							saldly salapnd salweek dealact rpmovavg fifgldn1 fifgldn2		
RMS345	salstage	Stock Ledger		N/A	3	salesprocess.ksh saldly stkdiy salapnd prepost salweek pre dealact dealinc vendinvc vendinvf	N/A	daily	salstage /@Batch_Alias_Name
RMS346	salweek	Stock Ledger Oracle Retail	Business Process	Dept	3		salmth prepost salweek post	weekly	salweek /@Batch_Alias_Name
RSA12	saordinvexp	Sales Audit	Integration	Store	2	N/A	N/A	daily	saordinvexp /@Batch_Alias_Name
							saexpach saexppl saexpim saexpdw saexpsim saexprms saexpuar		Should run before any SA export processes
RSA20	sapreexp	Oracle Retail Sales Audit		N/A	ad hoc	sarules		daily	sapreexp /@Batch_Alias_Name
RSA26	saprepost	Oracle Retail Sales Audit		N/A	ad hoc	N/A	N/A	daily	saprepost /@Batch_Alias_Name program pre_or_post
RSA21	sapurge	Oracle Retail Sales Audit		Store	ad hoc	saprepost sapurge pre	saprepost sapurge post	daily	sapurge /@Batch_Alias_Name deleted_items_file [optional list of store days to be deleted]
RSA18	sarules	Oracle Retail Sales Audit		N/A	ad hoc	satotals	saescheat	daily	sarules /@Batch_Alias_Name store_no
									(It should run before the DTESYS batch program and before the next store/day's transactions are received)
RSA15	sastdycr	Oracle Retail Sales Audit		N/A	date_set	N/A	dtesys	daily	sastdycr /@Batch_Alias_Name [YYYYMMDD]
RSA16	satotals	Oracle Retail Sales Audit		N/A	ad hoc	saimptlogfin	sarules	daily	satotals /@Batch_Alias_Name store_no savouch /@Batch_Alias_Name infile rejfile
RSA08	savouch	Oracle Retail Sales Audit		N/A	ad hoc	saimptlog/saimptlogi	saimptlogfin	daily	tendertype_file
RMS355	sccext	Cost Change		N/A	3	N/A	prepost sccext post	daily	sccext /@Batch_Alias_Name
RMS356	schedprg	Foundation Data		N/A	ad hoc	N/A	N/A	monthly	schedprg /@Batch_Alias_Name
RMS357	sitmain	Item Maintenance		N/A	ad hoc	lclrbld	N/A	As needed	sitmain /@Batch_Alias_Name
RMS115	soutdnld	Integration - Planning		Domain Id	4	N/A	N/A	daily	soutdnld /@Batch_Alias_Name
RMS359	stkdiy	Stock Count		Dept	3	stkvar	salweek	daily	stkdiy /@Batch_Alias_Name
RMS360	stkprg	Stock Count		N/A	ad hoc	N/A	prepost stkprg post	monthly	stkprg /@Batch_Alias_Name
RMS361	stkschedxpld	Stock Count	Processing	Location	0	N/A	stkxpdl	daily	stkschedxpld /@Batch_Alias_Name
RMS362	stkupd	Stock Count	Processing	Location	8	prepost stkupd pre stkxpdl		daily	stkupd /@Batch_Alias_Name
RMS363	stkvar	Stock Count		Dept	1	N/A	N/A	daily	stkvar /@Batch_Alias_Name [report_file_name]
RMS364	stxpld	Stock Count		Dept	8	stkschedxpld wasteadj	stkupd	daily	stxpld /@Batch_Alias_Name

RMS17	stlgdnld	Stock Ledger	Integration	Dept	4	Should have some dependency on weekly processes.	N/A	Normal weekly run is phase 4. Additionally, can be run ad hoc for historic data	weekly	stlgdnld /@Batch_Alias_Name input_file
RMS366	stockcountprocess.ksh	Stock Count		Dept	1	lifstkup	N/A		daily	stockcountprocess.ksh /@Batch_Alias_Name
RMS153	stockcountupload.ksh	Stock Count	Integration	Dept	1	lifstkup	N/A		daily	stockcountupload.ksh /@Batch_Alias_Name input_file
RMS368	supcnstr	Purchase Orders		N/A	3	rplbld	rplsplit		daily	<reject_file>
RMS369	supmth	Foundation Data		Dept	3	N/A	prepost supmth post		monthly	supcnstr /@Batch_Alias_Name
RMS370	supsplit	Replenishment Transfers, Allocations, and RTV		Item	3	rplext	prepost supsplit pre	rplbld	daily	supmth /@Batch_Alias_Name
RMS371	tamperctn	Integration - 3rd Party POS Administration		N/A	ad hoc	N/A	N/A	N/A	As needed	supsplit /@Batch_Alias_Name
RMS372	taxdnld	Party POS		Store	ad hoc	N/A	N/A	N/A	As needed	tamperctn /@Batch_Alias_Name
RMS373	taxevntprg	Administration		N/A	ad hoc	N/A	N/A	N/A	As needed	taxdnld /@Batch_Alias_Name output_filename
RMS59	tcktdnld	Foundation Data Integration - 3rd Party POS		N/A	ad hoc	N/A	N/A	N/A	daily	taxevntprg /@Batch_Alias_Name no_of_days
RMS116	tifposdn	Party POS		N/A	4	txrposdn	prepost tifposdn post		daily	tcktdnld /@Batch_Alias_Name filename print_online_ind
RMS376	trandataload	Stock Ledger	Integration Business Processing	N/A	3	N/A	trandataprocess	N/A	daily	days_in_advance [location]
RMS377	trandataprocess	Stock Ledger Oracle Retail Trade Management		N/A	3	trandataload	salstage	N/A	daily	tifposdn /@Batch_Alias_Name output_file
RMS378	tranupld	Allocations, and RTV Transfers, Allocations, and RTV		File-based	ad hoc	N/A	N/A	N/A	daily	trandataload.ksh /@Batch_Alias_Name <file load indicator> <input file>
RMS379	tsfclose	Integration - 3rd Party POS		Transfer	ad hoc	N/A	docclose		daily	trandataprocess.ksh /@Batch_Alias_Name <num threads>
RMS380	tsfprg	Integration - 3rd Party POS		N/A	ad hoc	prepost tsfprg pre	prepost tsfprg post	wfrtnprg	monthly	tranupld /@Batch_Alias_Name infile
RMS152	txrposdn	Foundation Data	Integration	N/A	4	N/A	tifposdn		daily	tsfclose /@Batch_Alias_Name
RMS58	txrtupld	Foundation Data		N/A	4	N/A	N/A		As needed	tsfprg /@Batch_Alias_Name
RMS157	uploadsales_all.ksh	Sales Posting	Integration Processing	N/A	2	saexprms	N/A	Must be run in at least phase 2. Can also be run ad hoc to trickle poll sales.	As needed	txrposdn /@Batch_Alias_Name
RMS384	vatdtxpl	Item Maintenance		Vat Region	0	N/A	prepost vatdtxpl post		daily	txrtupld username/password input_file reject_file
RMS122	vendinvc	Deals	Integration	Deal Id	3	dealact salstage(if daily) prepost vendinvc pre	prepost vendinvc post	salweek is a post dependency at EOW samth is a dependency at EOM	daily	./uploadsales_all.ksh \$UP<optional directory parameter>
RMS123	vendinvf	Deals	Integration	Deal Id	3	salstage(if daily) prepost vendinvf pre	prepost vendinvf post	salweek is a post dependency at EOW samth is a dependency at EOM	daily	vatdtxpl /@Batch_Alias_Name
RMS387	vrplbld	Purchase Orders		Supplier	2	ediupack	prepost vrplbld post		daily	uploadsales_all.ksh \$UP<optional directory parameter>
RMS388	wasteadj	Inventory Franchise Management		Store	8	N/A	stkupld		daily	vatdtxpl /@Batch_Alias_Name
RMS389	wf_apply_supp_cc.ksh	Franchise Management		N/A	ad hoc	fcexec	scxext		daily	./uploadsales_all.ksh \$UP<optional directory parameter>
RMS156	wfbillex.ksh	Franchise Management	Integration	Store	ad hoc	N/A	N/A		daily	vatdtxpl /@Batch_Alias_Name
RMS391	wfordcls	Franchise Management		Franchise Order	ad hoc	docclose	wfordprg		daily	./uploadsales_all.ksh \$UP<optional directory parameter>
RMS392	wfordprg	Franchise Management		Franchise Order	ad hoc	wfordcls	wfrtnprg		monthly	vatdtxpl /@Batch_Alias_Name
RMS60	wfordupld.ksh	Franchise Management		File-based	ad hoc	prepost wfordupld pre	N/A		As needed	./uploadsales_all.ksh \$UP<optional directory parameter>
RMS394	wfretcls	Franchise Management		Franchise RMA I	ad hoc	docclose	wfrtnprg		daily	./uploadsales_all.ksh \$UP<optional directory parameter>
RMS154	wfretupld.ksh	Franchise Management	Integration	File-based	ad hoc	prepost wfretupld pre	N/A		As needed	./uploadsales_all.ksh \$UP<optional directory parameter>
RMS396	wfrtnprg	Franchise Management		Franchise RMA I	ad hoc	ordprg	wfordprg		monthly	./uploadsales_all.ksh \$UP<optional directory parameter>
RMS397	wfslsupld.ksh	Franchise Management	Integration	File-based	ad hoc	N/A	N/A		daily	./uploadsales_all.ksh \$UP<optional directory parameter>
RMS398	whstrasg	Foundation Data		N/A	3	rplapprv	prepost whstrasg post		daily	./uploadsales_all.ksh \$UP<optional directory parameter>

RMS399	ushts2rms	Oracle Retail Trade Management	N/A	ad hoc	N/A	htsupld	As needed
RMS400	prepost rpl pre			3?			
RMS401	prepost salweek post	Stock Ledger		3?	salweek		
RMS402	prepost salmth post				salmth	N/A	
RMS403	prepost rplapprv pre			3?			
RMS404	prepost rplatupd pre			3?			
RMS405	prepost rplatupd post			3?			
RMS406	prepost rilmaint pre			3?			
RMS407	prepost rilmaint post			3?			
RMS408	prepost supmth post			3?			
RMS409	prepost sccext post			3?			
RMS410	prepost hstbld pre			8?			
RMS411	prepost hstbld post			8?			
RMS412	prepost posdnl post			ad hoc			
RMS413	prepost edidlprd post			8?			
RMS414	prepost edidlprd pre			8?			
RMS415	prepost fcstrbld post			3?			
RMS416	prepost vrplbld post			2?			
RMS417	prepost cntrordb post			3?			
RMS418	prepost fsadnld post			TBD?			
RMS419	prepost btchcycl			TBD?			
RMS420	prepost whstrasg post			3?			
RMS421	prepost poscdnld post			4?			
RMS422	prepost tifposdn post			4?			
RMS423	prepost htupld pre			ad hoc			
RMS424	prepost onordext pre			4?			
RMS425	prepost reclsdly pre			4?			
RMS426	prepost reclsdly post			4?			
RMS427	prepost ibcalc pre	Replenishment	Processing	3?			
RMS428	prepost fcstprg pre	Integration - Planning		ad hoc		fcstprg	
RMS429	prepost fcstprg post	Integration - Planning		ad hoc	fcstprg		
RMS430	prepost reqext pre	Replenishment		3?		reqext	
RMS431	prepost reqext post	Replenishment		3?	reqext		
RMS432	prepost stkupd pre	Stock Count	Processing	8?		stkupd	
RMS433	prepost replroq pre	Replenishment		3?		replroq.ksh	
RMS434	prepost rplext post	Replenishment		3?	rplatupd	supsplit	
RMS435	prepost posupld post			TBD?	rilmaint	cntrprss	
RMS436	prepost vatdtxpl post		Processing	0	repladj	ibcxpl	
RMS438	prepost saleoh pre			3?	reqext	ibcalc	
					cntrordb ??	rplbld ??	
					still needed		
					dealfct		
					dealinc		
					vendinvc		
					vendinvf		
					saldly		
					stkdly		
RMS440	prepost salweek pre	Stock Ledger		3?	salapnd		
RMS441	prepost dealinc pre	Deals		3?		dealinc	
RMS442	prepost dealday pre	Deals		3?		dealday	
RMS443	prepost dealday post	Deals		3?	dealday	salmth	
RMS444	prepost dealact_nor pre			TBD?		dealact	
RMS445	prepost dealact_po pre			TBD?		dealact	
RMS446	prepost dealact_sales pre			TBD?		dealact	
RMS447	prepost dealfct pre	Deals		3?	dealinc?	dealfct	
RMS448	prepost dealcls post	Deals		3?	dealcls		
RMS449	prepost hstbldmth post	Sales History		8?	hstbldmth		
					dealact		
RMS450	prepost vendinvc pre	Deals		3?	salstage(if daily)	vendinvc	
RMS451	prepost vendinvf pre	Deals		3?	salstage(if daily)	vendinvf	
						salweek	
RMS452	prepost vendinvc post	Deals		3?	vendinvc	salmth	
						salweek	
RMS453	prepost vendinvf post	Deals		3?	vendinvf	salmth	

RMS454	prepost docclose pre	Transfers, Allocations, and RTV			ad hoc?			
RMS455	prepost stkprg post	Stock Count Franchise			ad hoc?	stkprg		
RMS456	prepost wfordupld pre	Management Franchise			ad hoc?		wfordupld.ksh	
RMS457	prepost wfretupld pre	Management Replenishment			ad hoc?		wfretupld.ksh	
RMS458	prepost replsizeprofile pre	Replenishment			ad hoc?		replsizeprofile	
RMS459	prepost supsplit pre	Replenishment Integration - Oracle Retail POS Suite			3??	rplext??	supsplit	
RMS460	prepost batch_orpos_extract post	Foundation Data			4?	batch_orpos_extract.ksh		
RMS461	prepost batch_ordcostcompupd pre	Foundation Data			2?			
RMS462	prepost batch_ordcostcompupd post	Foundation Data			2?			
RMS463	prepost batch_costcompupd post	Foundation Data			2?			
RMS464	prepost ediupadd post	Foundation Data			2?			
RMS465	prepost dlyprg post	Administration			0?	dlyprg		
RMS466	prepost tsfprg pre	Transfers, Allocations, and RTV			ad hoc	N/A	tsfprg	
RMS467	prepost tsfprg post	Transfers, Allocations, and RTV			ad hoc	tsfprg	wftrnprg	
RMS468	prepost fcexec pre	Future Cost			2?	fcthreadexec	fcexec	
RMS469	prepost start_batch pre	Administration	Admin		0			
RMS470	prepost end_batch post	Administration	Admin		date_set			
RMS112	uploadsales.ksh	Sales Posting	Integration		ad hoc	saexprms	N/A	daily
RMS117	cfastgload.ksh	CFAS	Integration	N/A	ad hoc			As Needed
RMS126	fcustomerupload.ksh	Integration			ad hoc	N/A		
RMS141	orposcouponitemdnld	Integration - Oracle Retail POS Suite	Integration		4?			not clear about prepost job if run seperately
RMS142	orposcouponpricednld	Integration - Oracle Retail POS Suite	Integration		4?			not clear about prepost job if run seperately
RMS143	orpositemsdnld	Integration - Oracle Retail POS Suite	Integration		4?			not clear about prepost job if run seperately
RMS144	orposmerchdnld	Integration - Oracle Retail POS Suite	Integration		4?			not clear about prepost job if run seperately
RMS145	orposcustsegdnld	Integration - Oracle Retail POS Suite	Integration		4?			not clear about prepost job if run seperately
RMS146	orposstorednld	Integration - Oracle Retail POS Suite	Integration		4?			not clear about prepost job if run seperately
RMS118	rmse_aip_batch.ksh	Integration - AIP	Integration	N/A	ad hoc			
RMS471	cfagen.ksh	CFAS	Admin		ad hoc			As needed
RMS472	cfamigrate.ksh	CFAS	Admin		ad hoc			As needed
RMS473	loadods.ksh	Administration	Admin					
RSA27	saprepost saexprms post	ReSA						
RSA28	saprepost saexpdw post	ReSA						
RSA29	saprepost saordinvexp post	ReSA						
RSA30	saprepost saexpsfm post	ReSA						
RSA31	saprepost saexpsim post	ReSA						
RSA32	saprepost saimptlog saimptlogi pre	ReSA						
RSA33	saprepost saimptlog saimptlogi post	ReSA						
RSA34	saprepost sapurge pre	ReSA						
RSA35	saprepost sapurge post	ReSA						
RSA36	resa2sim	ReSA						
RSA37	resa2dw	ReSA						

RPM Program Dependency and Scheduling Details

Product	Program Name	Functional Area	Threaded	Driver	Phase	Program Pre-dependency	Program Post-dependency	Dependency Notes	Timing	Uses Restart/Recovery	Run Parameters for Programs
RPM	ItemReclassBatch	Future Retail	N	N/A	N/A	recsdly(RMS)	NewItemLocBatch		daily/ad hoc	N	itemReclassBatch.sh rpm-batch-user-alias
RPM	NewItemLocBatch	Future Retail	N	N/A	N/A	ItemReclassBatch	LocationMoveBatch		daily/ad hoc	N	NewItemLocBatch.sh rpm-batch-user-alias [status [error-commit-count]]
RPM	LocationMoveScheduleBatch	Zone Structure/Future Retail	Y	Location move	N/A	NewItemLocBatch	PriceEventExecutionBatch		daily, adhoc	N	locationMoveScheduleBatch.sh rpm-batch-user-alias
RPM	LocationMoveBatch	Zone Structure/Future Retail	Y	Location move	N/A	NewItemLocBatch	LocationMoveBatch		daily	N	locationMoveBatch.sh rpm-batch-user-alias
RPM	PriceEventExecutionBatch	Price Change/Clearance/Promc	Y	Pricing event	N/A	LocationMoveBatch	PriceEventExecutionRMSBatch		daily	N	priceEventExecutionBatch.sh rpm-batch-user-alias
RPM	PriceEventExecutionRMSBatch	Price Change/Clearance/Promc	Y	Pricing event	N/A	PriceEventExecutionBatch	PriceEventExecutionDealsBatch		daily	N	priceEventExecutionRMSBatch.sh rpm-batch-user-alias
RPM	PriceEventExecutionDealsBatch	Price Change/Clearance/Promc	Y	Pricing event	N/A	PriceEventExecutionRMSBatch	MerchExtractKickOffBatch		daily	N	priceEventExecutionDealsBatch.sh rpm-batch-user-alias
RPM	FutureRetailRollUpBatch	Future Retail	Y	N/A	N/A	N/A	N/A		ad hoc	N	FutureRetailRollUpBatch.sh <username> <password> [dept=<deptId> class=<classId> subclass=<subclassId>]
RPM	PriceStrategyCalendarBatch	Price Strategy	N	N/A	N/A	N/A	MerchExtractKickOffBatch		daily	N	priceStrategyCalendarBatch.sh rpm-batch-user-alias
RPM	WorksheetAutoApproveBatch	Pricing Worksheet	Y	Price strategy	N/A	N/A	MerchExtractKickOffBatch		daily	N	worksheetAutoApproveBatch.sh rpm-batch-user-alias
RPM	MerchExtractKickOffBatch	Pricing Worksheet	Y	Price strategy	N/A	PriceEventExecutionBatch WorksheetAutoApproveBatch	Wholesale Item Catalog Report (RMS)		daily	N	merchExtractKickOffBatch.sh rpm-batch-user-alias
RPM	PurgeBulkConflictCheckArtifacts	Conflict Checking	N	N/A	N/A	PriceStrategyCalendarBatch wfcostcalc (RMS)	N/A		daily	N	purgeBulkConflictCheckArtifacts.sh rpm-batch-user-alias
RPM	RPMtoORPOSPublishBatch.sh	Price Change/Clearance/Promc	N	N/A	N/A	WorksheetAutoApproveBatch	N/A		daily	N	ksh RPMtoORPOSPublishBatch.sh </@tns-user-name> <log path> <error path>
RPM	RPMtoORPOSPublishExport.sh	Price Change/Clearance/Promc	Y	Location	N/A	RPMtoORPOSPublishBatch.sh	N/A		daily	N	ksh RPMtoORPOSPublishExport.sh </@tns-user-name > <Numberof slots> <logpath> <error path> <Export path>
RPM	RegularPriceChangePublishBatch	Regular Price Changes	Y	Price event (item	N/A	WorksheetAutoApproveBatch	RegularPriceChangePublishExport		daily/ad hoc	N	regularPriceChangePublishBatch.sh rpm-batch-user-alias
RPM	regularPriceChangePublishExport	Regular Price Changes	N	Price event (item	N/A	RegularPriceChangePublishBatch			daily/ad hoc	N	regularPriceChangePublishExport.sh /@tns-user-name [export-path]
RPM	ClearancePriceChangePublishBatch	Clearances	Y	Price event (item	N/A	WorksheetAutoApproveBatch	ClearancePriceChangePublishExport		daily/ad hoc	N	clearancePriceChangePublishBatch.sh rpm-batch-user-alais
RPM	ClearancePriceChangePublishExport	Clearances	N	Price event (item	N/A	ClearancePriceChangePublishBatch			daily/ad hoc	N	clearancePriceChangePublishExport.sh /@tns-user-name [export-path]
RPM	processPendingChunksBatch	Price Change/Clearance/Promc	Y	N/A	N/A	N/A	N/A		ad hoc	N	processPendingChunksBatch.sh rpm-batch-user-alias
RPM	PromotionPriceChangePublishBatch	Promotions	Y	Price event (item	N/A	WorksheetAutoApproveBatch	PromotionPriceChangePublishExport		daily/ad hoc	N	promotionPriceChangePublishBatch.sh rpm-batch-user-alias
RPM	PromotionPriceChangePublishExport	Promotions	N	Price event (item	N/A	PromotionPriceChangePublis	N/A		daily/ad hoc	N	promotionPriceChangePublishExport.sh /@tns-user-name [export-path]
RPM	PriceChangeAutoApproveResultsPurge	Purge	N	N/A	N/A	N/A	N/A		daily	N	priceChangeAutoApproveResultsPurgeBatch.sh rpm-batch-user-alias
RPM	PriceChangePurgeBatch	Purge	N	N/A	N/A	N/A	N/A		daily	N	priceChangePurgeBatch.sh rpm-batch-user-alias
RPM	PriceChangePurgeWorkspaceBatch	Purge	N	N/A	N/A	N/A	N/A		daily	N	priceChangePurgeWorkspaceBatch.sh rpm-batch-user-alias
RPM	priceEventItemlistPurgeBatch.sh	Purge	N	N/A	N/A	N/A	N/A		daily/ad hoc	N	priceEventItemlistPurgeBatch connect_string logpath errpath
RPM	primaryZoneModificationsBatch	Future Retail	Y	PZG definition up	N/A	N/A	N/A		ad hoc	N	primaryZoneModificationsBatch <userid/password@sid> <log path> <error path>
RPM	promotionArchiveBatch.sh	Promotin	N	N/A	N/A	N/A	N/A		daily	N	
RPM	PromotionPurgeBatch	Purge	N	N/A	N/A	N/A	N/A		daily	N	promotionPurgeBatch.sh rpm-batch-user-alias
RPM	PurgeExpiredExecutedOrApprovedClearancesBatch	Purge	N	N/A	N/A	N/A	N/A		daily	N	purgeExpiredExecutedOrApprovedClearancesBatch.sh rpm-batch-user-alias
RPM	PurgeUnusedAndAbandonedClearancesBatch	Purge	N	N/A	N/A	N/A	N/A		daily	N	purgeUnusedAndAbandonedClearancesBatch.sh rpm-batch-user-alias
RPM	PurgeLocationMovesBatch	Purge	N	N/A	N/A	N/A	N/A		daily	N	purgeLocationMovesBatch.sh rpm-batch-user-alias
RPM	ZoneFutureRetailPurgeBatch	Purge	N	N/A	N/A	N/A	N/A		daily	N	zoneFutureRetailPurgeBatch.sh rpm-batch-user-alias
RPM	ItemLocDeleteBatch	Purge	N	N/A	N/A	N/A	N/A		daily	N	itemLocDeleteBatch.sh rpm-batch-user-alias
RPM	priceChangeAreaDifferentialBatch	Price Change	Y	N/A	N/A	N/A	N/A		ad hoc	N	priceChangeAreaDifferentialBatch rpm-batch-user-alias password [status=<status>] [event_type=<event_type>]
RPM	InjectorPriceEventBatch	Price Change/Clearance/Promc	Y	Item/Location	N/A	N/A	PriceEventExecutionDealsBatch		ad hoc	N	InjectorPriceEventBatch.sh rpm-batch-user-alias <location> [date(YYYYMMdd)]
RPM	refreshPosDataBatch	Price Event	Y	N/A	N/A	N/A	N/A		ad hoc	N	refreshPosDataBatch.sh <rpm-batch-user-alias> <location> [date(YYYYMMdd)]
RPM	purgePayloadsBatch	purge	N	Price event	N/A	RegularPriceChangePublishExport, ClearancePriceChangePublishExport, PromotionPriceChangePublishExport			ad hoc	N	purgePayloads.sh </@tns-user-name> <publish-status>
RPM	taskPurgeBatch.sh	Purge	N	N/A	N/A	N/A	N/A		daily	N	taskPurgeBatch.sh <rpm-batch-user-alias> [<purgeDays>] [Y/N]
RPM	priceEventPayloadPopulationBatch	Payload	Y	Price Event	N/A	N/A	RPMtoORPOSPublishBatch.sh, RegularPriceChangePublishBatch, ClearancePriceChangePublishBatch, PromotionPriceChangePublishBatch		ad hoc	N	priceEventPayloadPopulationBatch.sh </@tns-user-name> <slots> <status> <logpath> <errpath>

ReIM Program Dependency and Scheduling Details

Product	Program Name	Functional Area	Threaded	Driver	Phase	Program Pre-dependency	Program Post-dependency	Dependency Notes	Timing	Uses Restart/R recovery	Run Parameters for Programs
RelM	reimaccountworkspacepurge	Invoice Matching (RelM)	N	N/A	N/A	N/A	N/A		Daily	R	batch-user-alias
RelM	reimautomatch	Invoice Matching (RelM)	Y	N/A	6	NA	reimrollup		Daily	R	batch-user-alias
RelM	reimpurge	Invoice Matching (RelM)	N	N/A	0	N/A	reimposting		Daily	R	batch-user-alias PURGE ALL TABLE_NAME [COMMIT NOCOMMIT]
RelM	reimcomplexdealupload	Invoice Matching (RelM)	Y	N/A	5	vendinvc(RMS), vendinvf(RMS)	reimautomatch		Daily	R	batch-user-alias BlockSize PartitionNo [PartitionSize]
RelM	reimcreditnoteautomatch	Invoice Matching (RelM)	Y	N/A	6	N/A	reimrollup		Daily	R	batch-user-alias
RelM	reimdiscrepancy	Invoice Matching (RelM)	N	N/A	1	N/A	reimposting		Daily	R	batch-user-alias PURGE ALL TABLE_NAME [COMMIT NOCOMMIT]
RelM	reimediinjector	Invoice Matching (RelM)	Y	N/A	5	edidlinv(RMS)	reimautomatch, reimcreditnoteautomatch		Daily	R	batch-user-alias "EDI input file with path" "EDI reject file with path"
RelM	reimediinvdownload	Invoice Matching (RelM)	N	N/A	7	reimposting	N/A		Daily	R	batch-user-alias "EDI output file with path"
RelM	reimfixeddealupload	Invoice Matching (RelM)	Y	N/A	5	vendinvf(RMS)	reimautomatch		Daily	R	batch-user-alias BlockSize PartitionNo [PartitionSize]
RelM	reimrollup	Invoice Matching (RelM)	N	N/A	6	reimautomatch, reimcreditnot	reimposting		Daily	R	batch-user-alias
RelM	reimreceiptwriteoff	Invoice Matching (RelM)	N	N/A	6	reimautomatch	N/A		Daily	R	batch-user-alias
RelM	reimposting	Invoice Matching (RelM)	Y	N/A	6	reimrollup	N/A		Daily	R	batch-user-alias

Allocation Program Dependency and Scheduling Details

Product	Program Name	Functional Area	Threaded	Driver	Phase	Program Pre-dependency	Program Post-dependency	Dependency Notes	Timing	Uses Restart/R recovery	Run Parameters for Programs
Allocation	AllocSchedulerBatch.ksh	Scheduled Allocation	Y	N/A	N/A		None		daily	N	batch-user-alias
Allocation	alct_plan.ksh	Integration - Planning	N	N/A	N/A		alcl_plan.ksh		daily	N	
Allocation	alcl_plan.ksh	Integration - Planning	N	N/A	N/A	alct_plan.ksh			daily	Y	plan_data_input_file [thread_number]
Allocation	alct_receipt_plan.ksh	Integration - Planning	N	N/A	N/A		alcl_receipt_plan.ksh		daily	N	
Allocation	alcl_receipt_plan.ksh	Integration - Planning	N	N/A	N/A	alct_receipt_plan.ksh			daily	Y	reciept_data_input_file [thread_number]
Allocation	alct_size_profile	Integration - Planning	N	N/A	N/A		alcl_size_profile		daily	N	
Allocation	alcl_size_profile	Integration - Planning	N	N/A	N/A	alct_size_profile.ksh		The Allocation snapshot programs can functionally run concurrently. However, they use parallel processing so depending on database resources it may make sense to limit how many run concurrently.	daily	Y	input_file [thread_number]
Allocation	AlcSnapshotSOH.ksh	Snapshots	N	N/A	8	reclsdly.pc(RMS)		The Allocation snapshot programs can functionally run concurrently. However, they use parallel processing so depending on database resources it may make sense to limit how many run concurrently.	daily	N	batch-user-alias
Allocation	AlcSnapshotOnOrder.ksh	Snapshots	N	N/A	8	reclsdly.pc(RMS)		The Allocation snapshot programs can functionally run concurrently. However, they use parallel processing so depending on database resources it may make sense to limit how many run concurrently.	daily	N	batch-user-alias
Allocation	AlcSnapshotAllocIn.ksh	Snapshots	N	N/A	8	reclsdly.pc(RMS)		The Allocation snapshot programs can functionally run concurrently. However, they use parallel processing so depending on database resources it may make sense to limit how many run concurrently.	daily	N	batch-user-alias
Allocation	AlcSnapshotCrosslink.ksh	Snapshots	N	N/A	8	reclsdly.pc(RMS)		The Allocation snapshot programs can functionally run concurrently. However, they use parallel processing so depending on database resources it may make sense to limit how many run concurrently.	daily	N	batch-user-alias
Allocation	AlcSnapshotAllocOut.ksh	Snapshots	N	N/A	8	reclsdly.pc(RMS)		The Allocation snapshot programs can functionally run concurrently. However, they use parallel processing so depending on database resources it may make sense to limit how many run concurrently.	daily	N	batch-user-alias
Allocation	AlcSnapshotCustomerOrder.ksh	Snapshots	N	N/A	8	reclsdly.pc(RMS)		The Allocation snapshot programs can functionally run concurrently. However, they use parallel processing so depending on database resources it may make sense to limit how many run concurrently.	daily	N	batch-user-alias
Allocation	AlcDailyCleanup.ksh	Admin	N	N/A	N/A	AllocSchedulerBatch.ksh			daily	N	

Interface Diagrams for RMS and RPAS

Because RMS is the retailer's central merchandising transactional processing system, it is the principle source of the foundation data needed in some of the Oracle Retail suite of products. RMS provides foundation data to RPAS, and RPAS provides planning data to RMS.

This chapter presents flow diagrams for data processing from sources. The source system's program or output file is illustrated, along with the program or process that interfaces with the source. After initial interface processing of the source, the diagrams illustrate the flow of the data.

Before setting up a program schedule, familiarize yourself with the functional and technical constraints associated with each program. Refer to the *Oracle Retail Merchandising System Operations Guide* for more information about these interface programs.

RMS Pre/Post Extract Diagrams

RMS Pre RETL Extract Maintenance

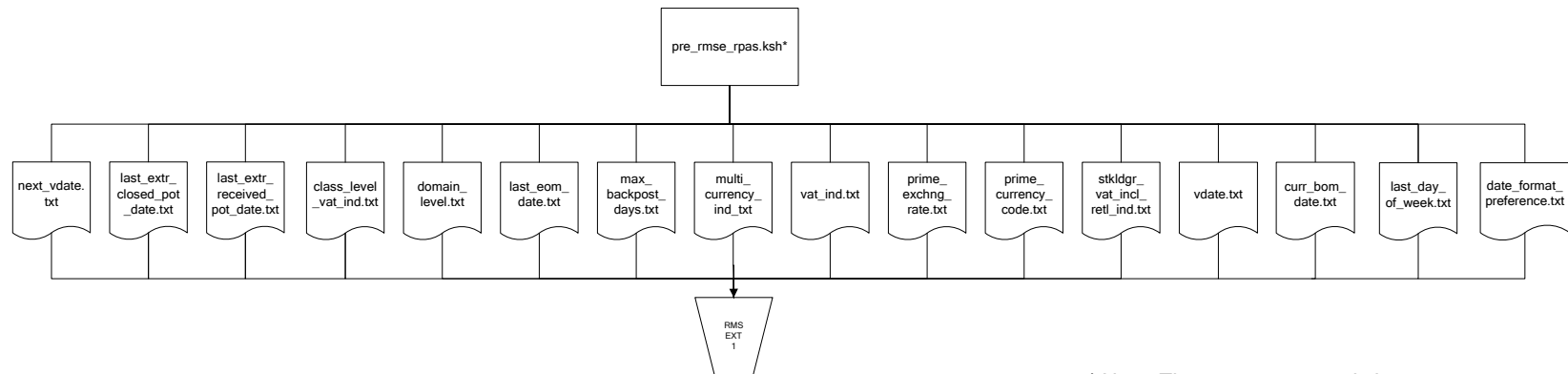

* Note: The `pre_rmse_rpas.ksh` program checks for existing `.txt` output files. Because of this validation, retailers running the program for the first time should include an optional `-c` parameter. This parameter allows the program to run successfully without pre-existing `.txt` output files.

RMS Foundation Data Extract Diagrams

Merchandise Hierarchy for RPAS

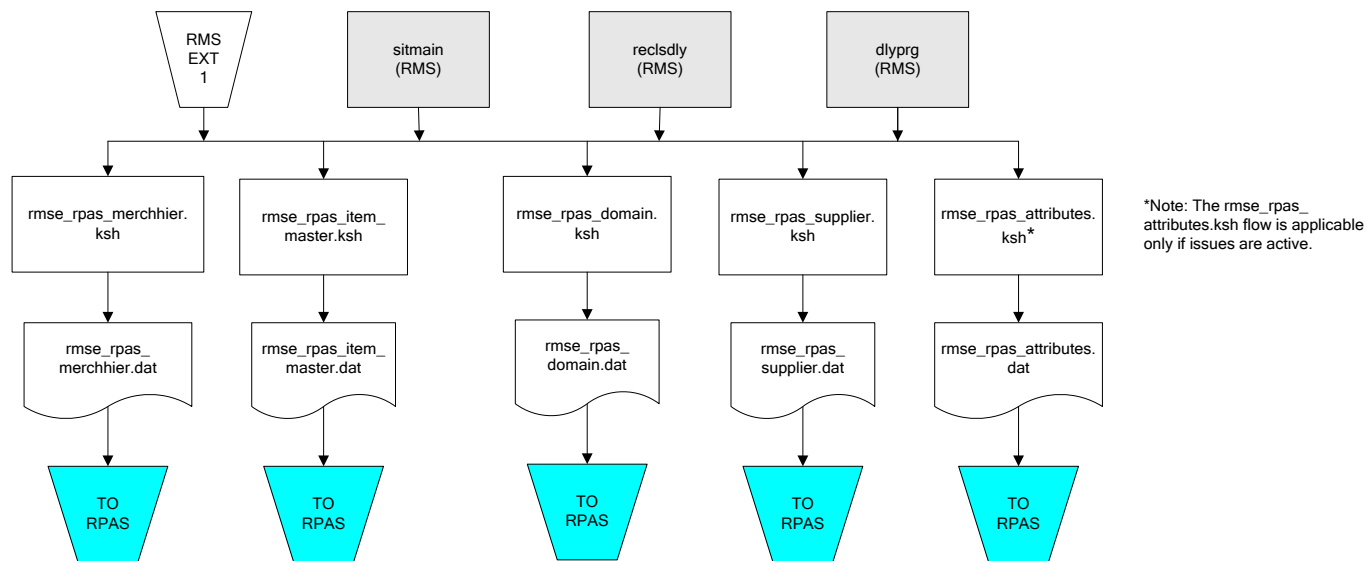

Organization Hierarchy for RPAS

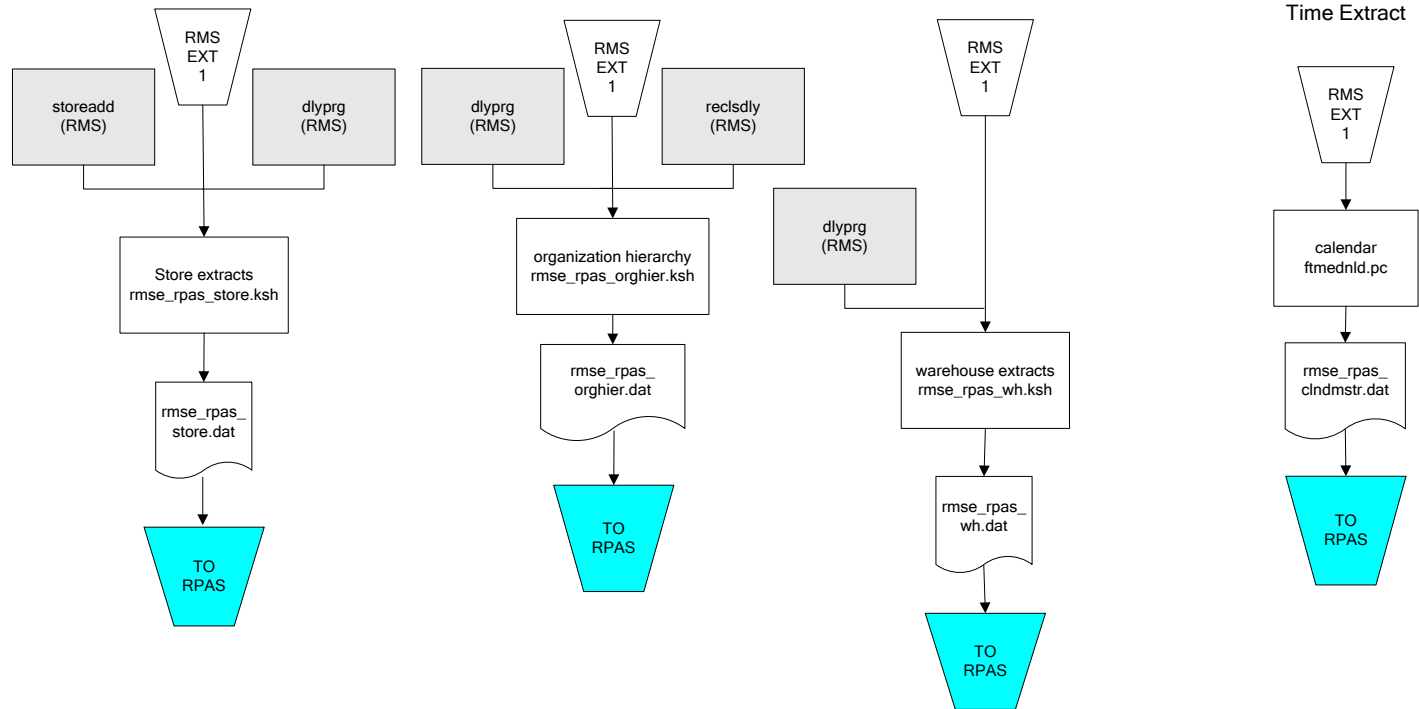

RMS Fact Data Extract Diagrams

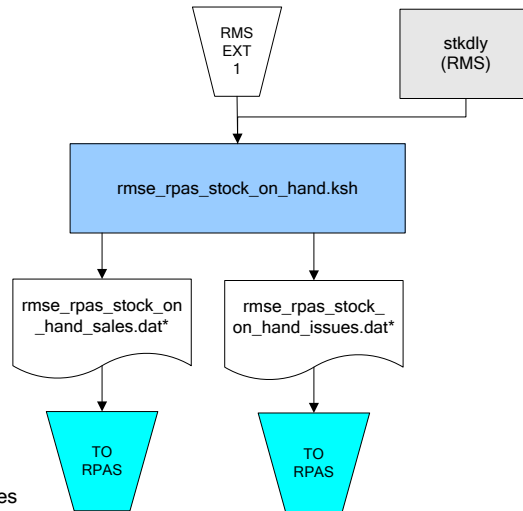

* Note:
 If issues are active, the following two files result from the rmse_rpas_stock_on_hand.ksh flow:
 rmse_rpas_stock_on_hand_issues.dat
 rmse_rpas_stock_on_hand_sales.dat

If issues are not active, the following file results from the rmse_rpas_stock_on_hand.ksh flow:
 rmse_rpas_stock_on_hand_sales.dat

Sales Extracts For RPAS

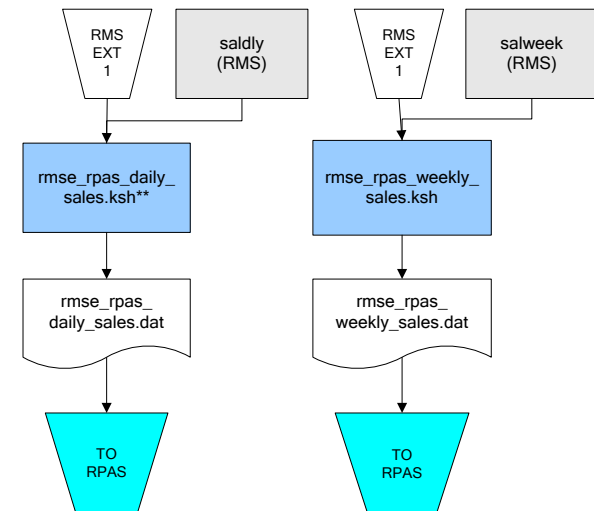

** Note:
 Depending upon the configuration of rmse_rpas_daily_sales.ksh, the data can be pulled from TRAN_DATA_HISTORY or TRAN_DATA.

RPAS-RMS Fact Load Diagram

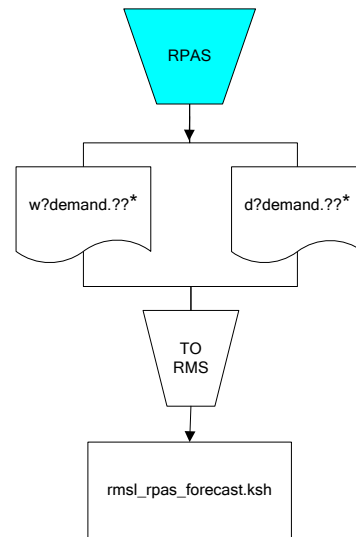

*Note:

? can represent the following:

- i (for issues)
- s (for stores)

?? represents domain 01-99.

Interface Diagrams for RMS and MFP

Because RMS is the retailer's central merchandising transactional processing system, it is the principle source of the foundation data needed in some of the Oracle Retail suite of products. RMS provides foundation data to RPAS, and RPAS provides planning data to RMS.

This chapter presents flow diagrams for data processing from sources. The source system's program or output file is illustrated, along with the program or process that interfaces with the source. After initial interface processing of the source, the diagrams illustrate the flow of the data.

Before setting up a program schedule, familiarize yourself with the functional and technical constraints associated with each program. Refer to the *Oracle Retail Merchandising System Operations Guide* for more information about these interface programs.

RMS Pre/Post Extract Diagrams

RMS Pre RETL Extract Maintenance

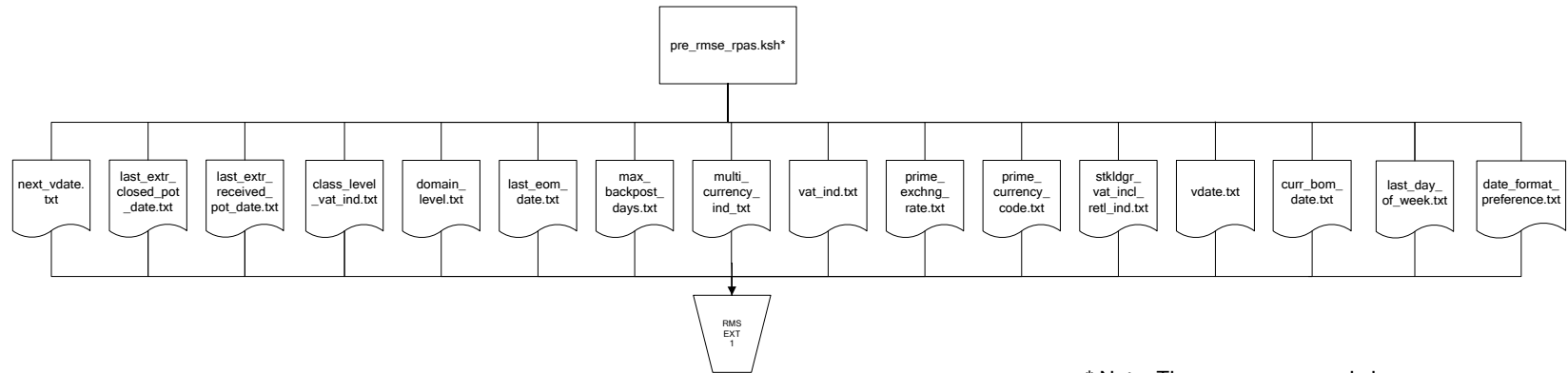

* Note: The pre_rmse_rpas.ksh program checks for existing .txt output files. Because of this validation, retailers running the program for the first time should include an optional -c parameter. This parameter allows the program to run successfully without pre-existing .txt output files.

RMS Foundation Data Extract Diagrams

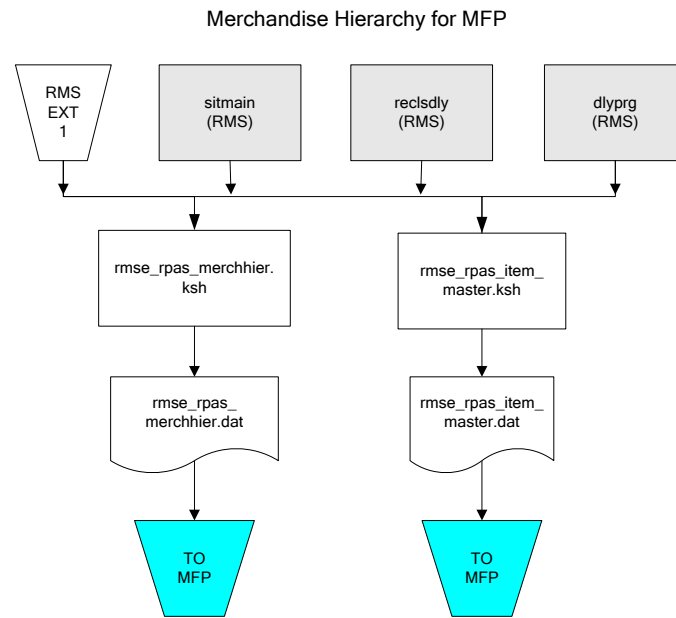

Organization Hierarchy for MFP

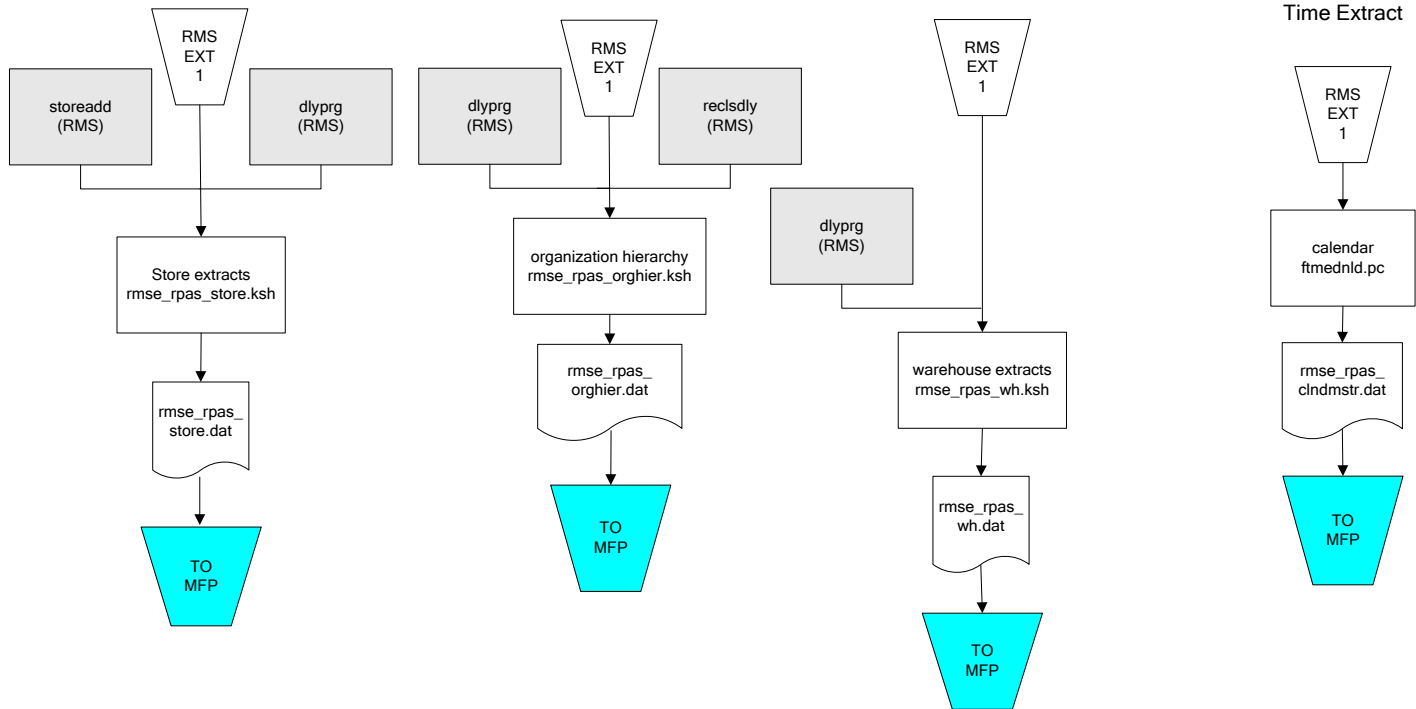

RMS Fact Data Extract Diagrams

Integration Extracts for MFP

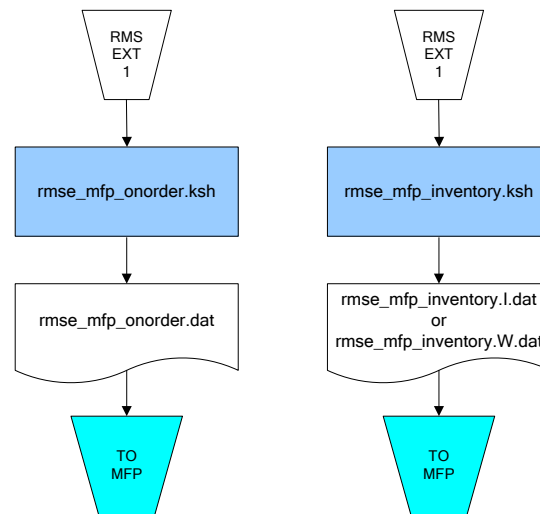

Note:
I is for initial load and W is
for weekly load..

Interface Diagrams for RMS and AIP

This chapter presents flow diagrams for RETL extract data processing from RMS to AIP. The RMS program or output file is illustrated, along with the program or process that interfaces with the source. The diagrams illustrate the flow of the data after initial interface processing of the source.

Before setting up a program schedule, familiarize yourself with the functional and technical constraints associated with each program. See the *Oracle Retail Merchandising System Operations Guide Volume 1—Batch Overviews and Designs* for more information about the modules shown in the following diagrams.

RMS Pre/Post Extract Diagrams

RMS Pre RETL Extract Maintenance

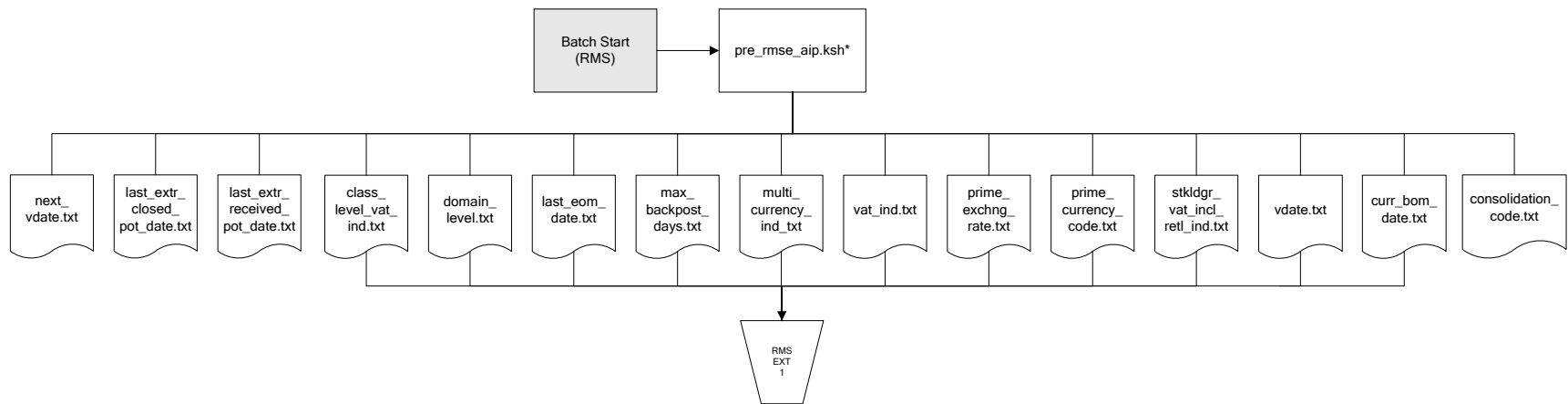

RMS Foundation Data Extract Diagrams

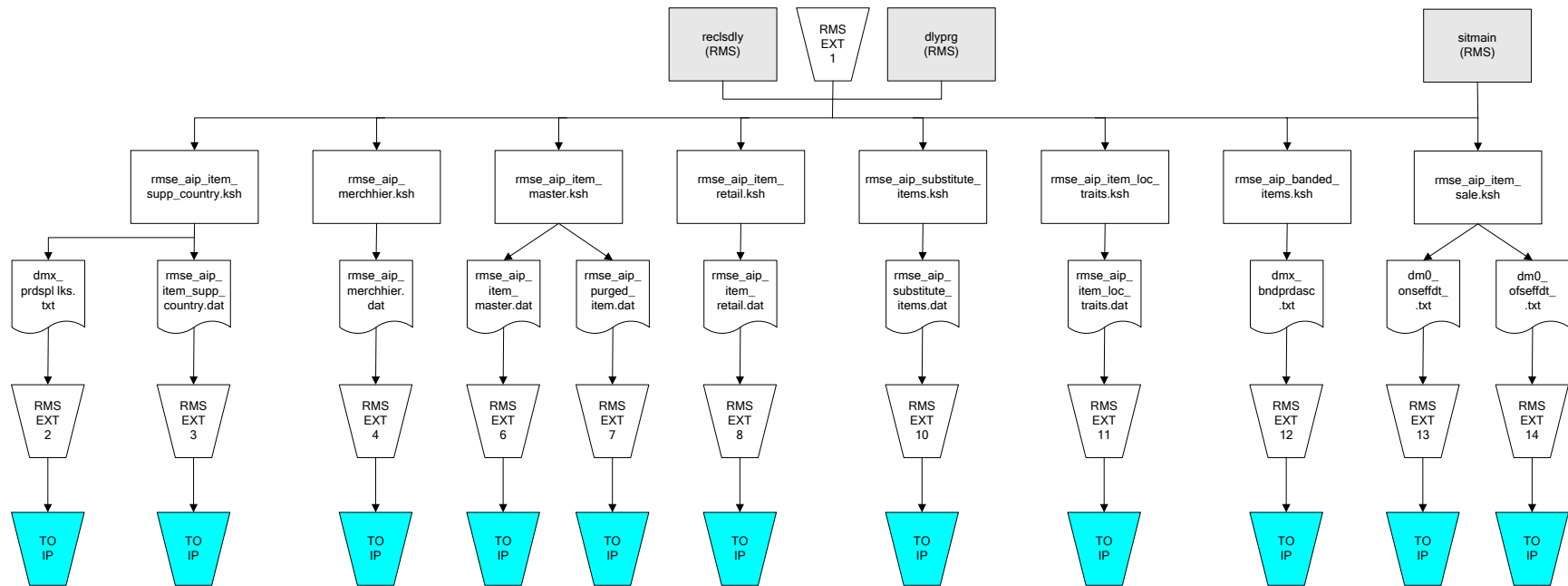

IP = Time-phased inventory planning tool

Organization Hierarchy for IP

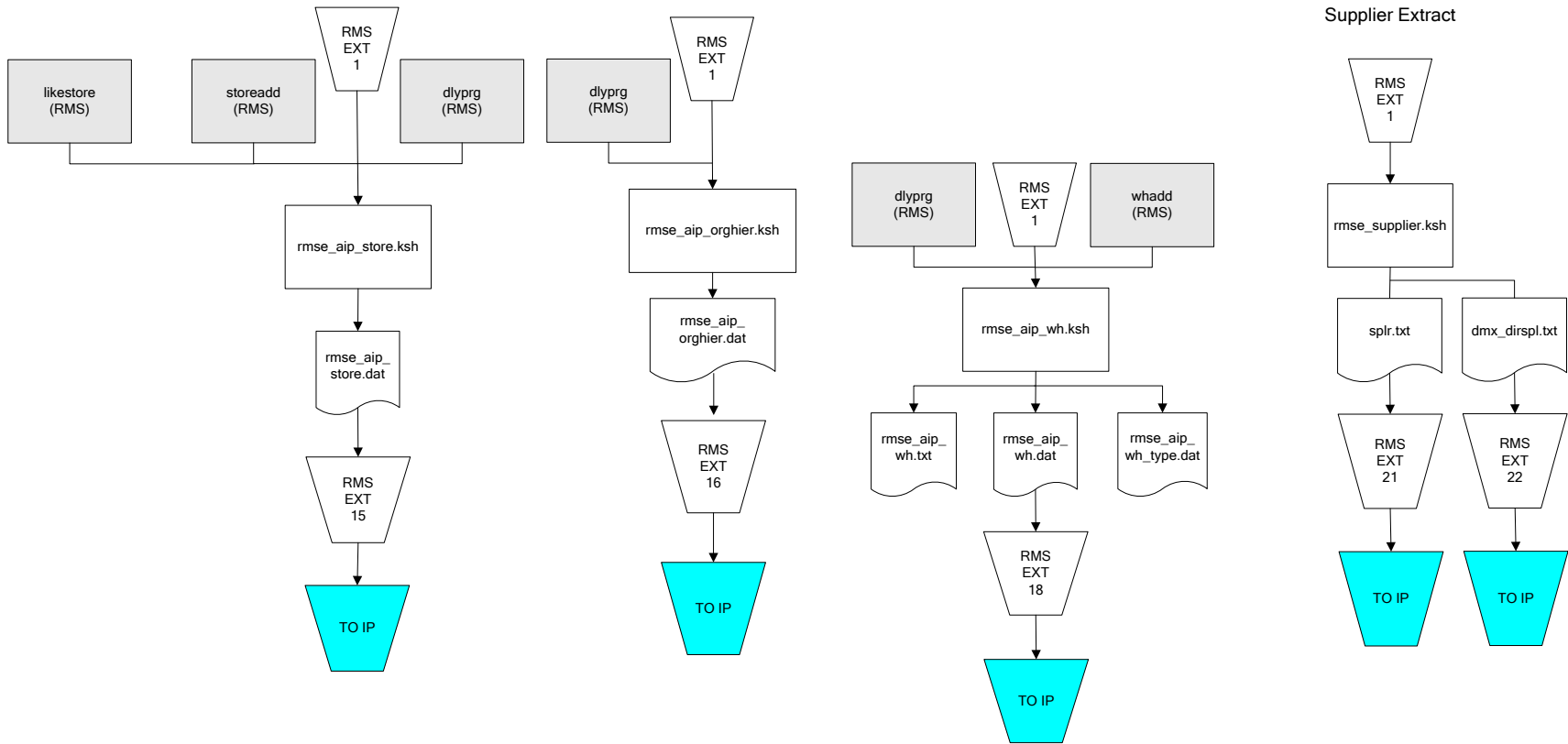

IP = Time-phased inventory planning tool

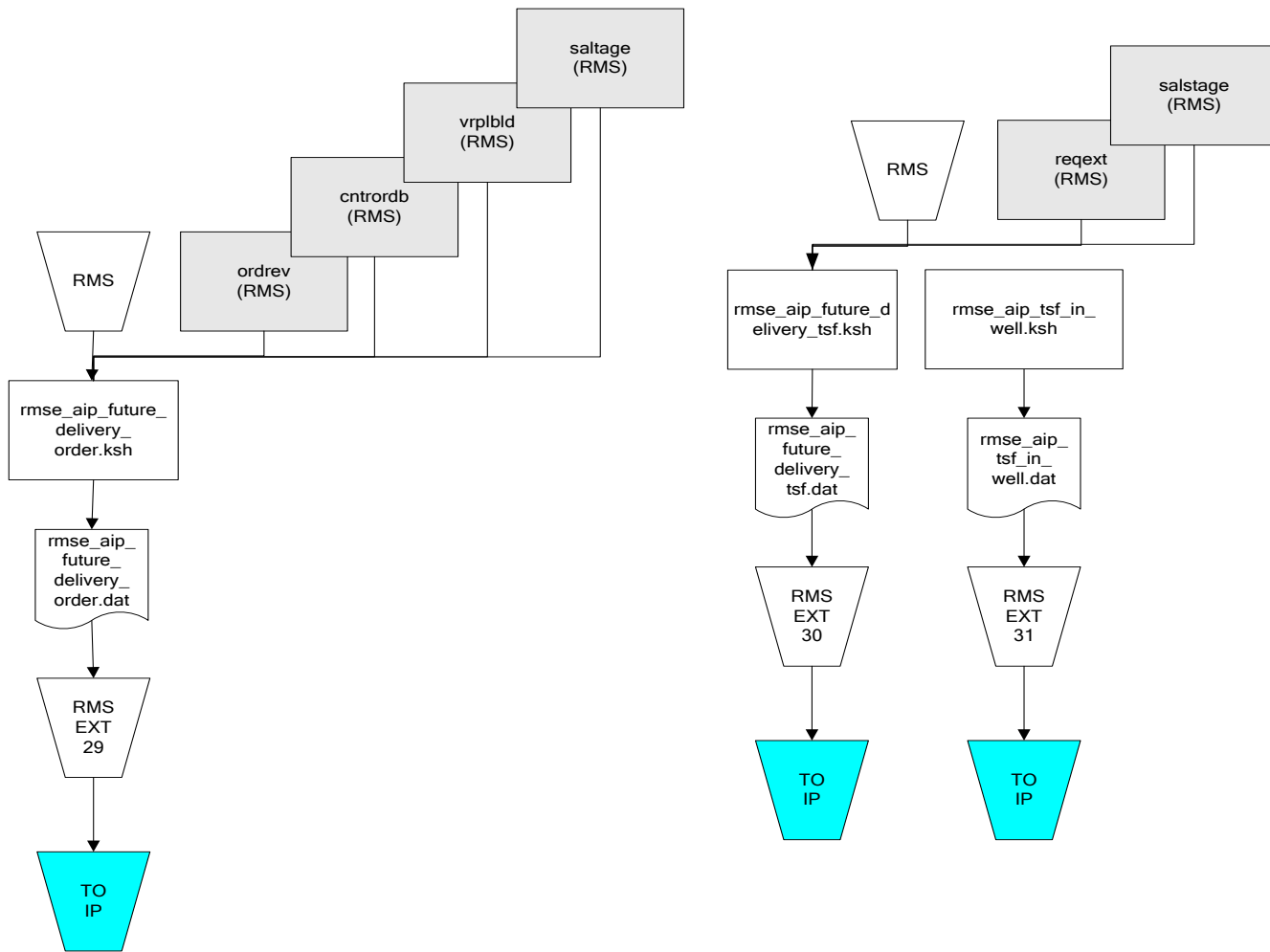

IP = Time-phased inventory planning tool

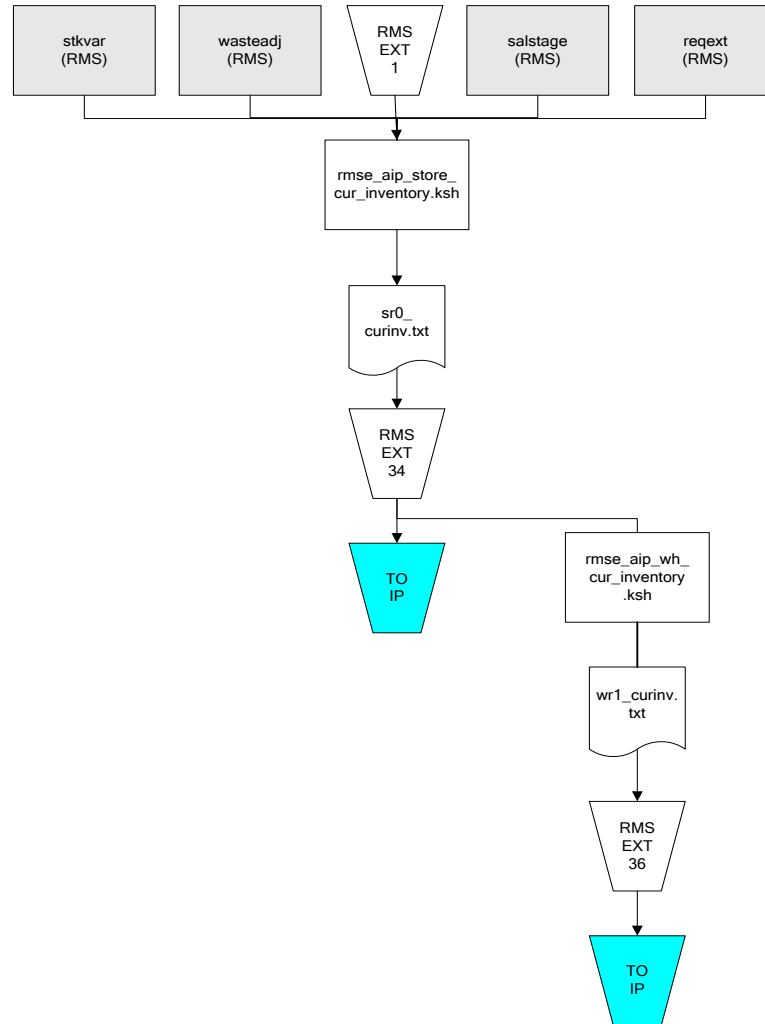
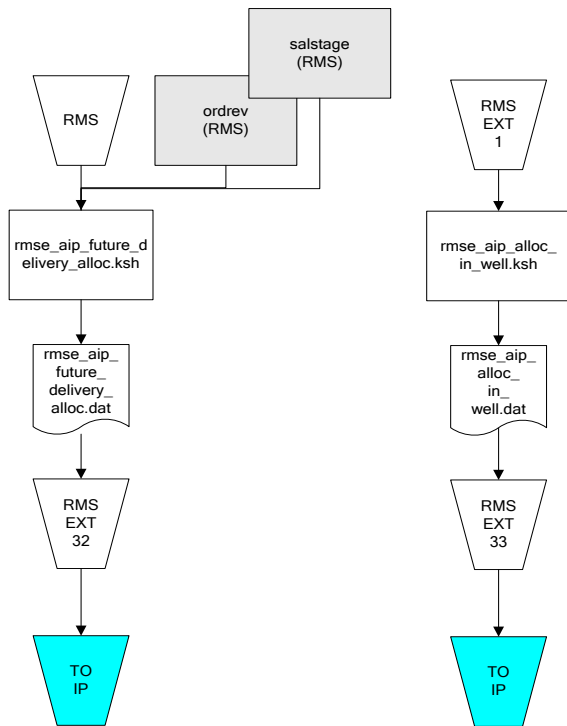

IP = Time-phased inventory planning tool

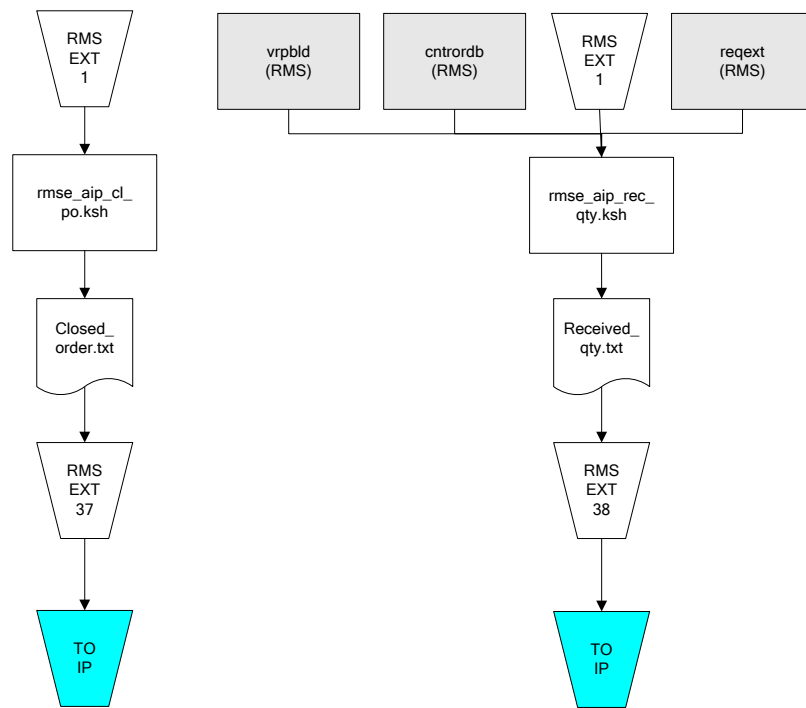

IP = Time-phased inventory planning tool

Interface Diagrams for Allocation, AP and SPO

This chapter presents flow diagrams for RETL extract data processing from Assortment Planning (AP) and Size Profile Optimization (SPO) to Allocation. The Allocation program or output file is illustrated, along with the program or process that interfaces with the source. The diagrams illustrate the flow of the data after initial interface processing of the source.

Before setting up a program schedule, familiarize yourself with the functional and technical constraints associated with each program. See the *Oracle Retail Allocation Operations Guide* for more information about the modules shown in the following diagrams.

Integration Extracts for Allocation

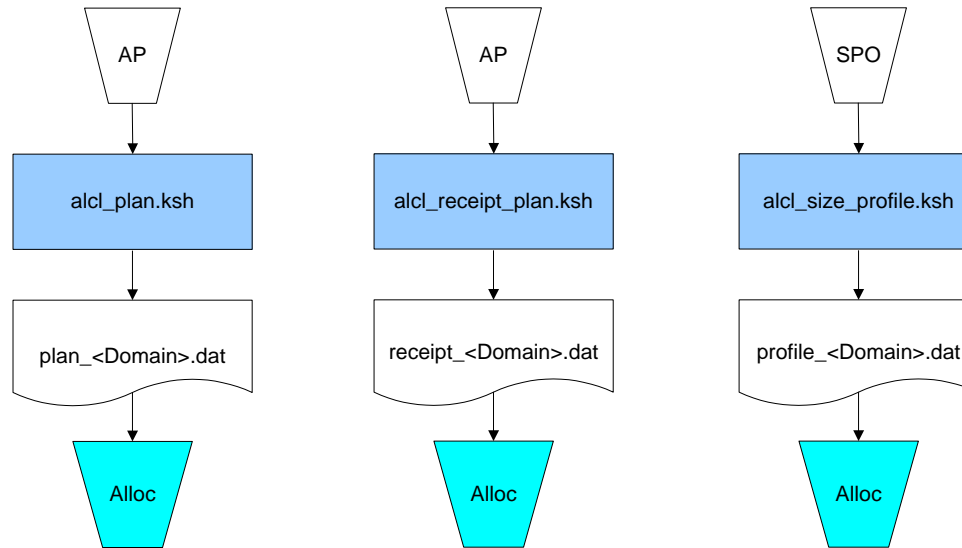

Note: See Allocation version-specific documentation to determine which of these programs apply to your version of Allocation.