

**SeeBeyond™ eBusiness Integration Suite**

# e\*Way Intelligent Adapter for BroadVision User's Guide

*Release 4.5.2*



The information contained in this document is subject to change and is updated periodically to reflect changes to the applicable software. Although every effort has been made to ensure the accuracy of this document, SeeBeyond Technology Corporation (SeeBeyond) assumes no responsibility for any errors that may appear herein. The software described in this document is furnished under a License Agreement and may be used or copied only in accordance with the terms of such License Agreement. Printing, copying, or reproducing this document in any fashion is prohibited except in accordance with the License Agreement. The contents of this document are designated as being confidential and proprietary; are considered to be trade secrets of SeeBeyond; and may be used only in accordance with the License Agreement, as protected and enforceable by law. SeeBeyond assumes no responsibility for the use or reliability of its software on platforms that are not supported by SeeBeyond.

e\*Gate, e\*Insight, e\*Way, e\*Xchange, e\*Xpressway, iBridge, Intelligent Bridge, IQ, SeeBeyond, and the SeeBeyond logo are trademarks and service marks of SeeBeyond Technology Corporation. All other brands or product names are trademarks of their respective companies.

© 1999–2002 by SeeBeyond Technology Corporation. All Rights Reserved. This work is protected as an unpublished work under the copyright laws.

**This work is confidential and proprietary information of SeeBeyond and must be maintained in strict confidence.**

Version 20020307094740.

# Contents

---

<b>Preface</b>	<b>8</b>
Intended Reader	8
Organization	8
Nomenclature	9
Online Viewing	9
Writing Conventions	9
<hr/>	
<b>Chapter 1</b>	
<b>Introduction</b>	<b>10</b>
Overview	10
Interaction with BroadVision	11
e*Gate to BroadVision	11
BroadVision to e*Gate	12
The BroadVision Converter	13
e*Way Components	14
<hr/>	
<b>Chapter 2</b>	
<b>Installation</b>	<b>15</b>
System Requirements	15
Supported Operating Systems	15
External System Requirements	16
Installing the e*Way	17
Windows Systems	17
Subdirectories and Files	19
Environment Configuration	20
UNIX Systems	21
Subdirectories and Files	22
Environment Configuration	23
Optional Example Files	24
Installation Procedure	24

Subdirectories and Files	25
<hr/>	
<b>Chapter 3</b>	
<b>System Implementation</b>	<b>26</b>
Overview	26
Implementation Sequence	27
The e*Gate Enterprise Manager	28
Creating a Schema	29
Creating Event Types	30
Creating Event Type Definitions	31
Using the ETD Editor's Build Tool	31
The BroadVision Converter Wizard	33
Assigning ETDs to Event Types	34
Defining Collaborations	35
Creating Intelligent Queues	36
Sample Schema	36
BV_Orders_Post	37
Collaboration: BV_Orders_Post	38
BV_Products	39
Collaboration: BV_Products	40
<hr/>	
<b>Chapter 4</b>	
<b>Setup Procedures</b>	<b>41</b>
Overview	41
Setting Up the e*Way	42
Creating the e*Way	42
Modifying e*Way Properties	43
Configuring the e*Way	44
Using the e*Way Editor	45
Section and Parameter Controls	46
Parameter Configuration Controls	46
Command-line Configuration	47
Getting Help	47
Changing the User Name	48
Setting Startup Options or Schedules	48
Activating or Modifying Logging Options	50
Activating or Modifying Monitoring Thresholds	51
Starting and Running the e*Way	52
Starting the e*Way Manually	52
Troubleshooting the e*Way	53
Configuration Problems	53
System-related Problems	54

---

Chapter 5

<b>Operational Overview</b>	<b>55</b>
<b>BroadVision e*Way Architecture</b>	<b>55</b>
<b>Basic e*Way Processes</b>	<b>57</b>
Initialization Process	58
Connect to External Process	59
Data Exchange Process	60
Disconnect from External Process	63
Shutdown Process	63

---

Chapter 6

<b>Configuration Parameters</b>	<b>64</b>
<b>Overview</b>	<b>64</b>
<b>General Settings</b>	<b>65</b>
Journal File Name	65
Max Resends Per Message	65
Max Failed Messages	65
Forward External Errors	66
<b>Communication Setup</b>	<b>67</b>
Start Exchange Data Schedule	67
Stop Exchange Data Schedule	67
Exchange Data Interval	67
Down Timeout	68
Up Timeout	68
Resend Timeout	68
Zero Wait Between Successful Exchanges	68
<b>Monk Configuration</b>	<b>69</b>
Specifying Function or File Names	69
Specifying Multiple Directories	69
Load Path	69
Additional Path	70
Auxiliary Library Directories	70
Monk Environment Initialization File	70
Startup Function	71
Process Outgoing Message Function	71
Exchange Data with External Function	72
External Connection Establishment Function	73
External Connection Verification Function	74
External Connection Shutdown Function	74
Positive Acknowledgment Function	75
Negative Acknowledgment Function	75
Shutdown Command Notification Function	76
<b>BroadVision Settings</b>	<b>78</b>
Version	78
Store Name	78
Agent Name	78
Desired State	78
New State	79
Maximum Order Count	79
Maximum Content Count	79

Content Status	79
Predefined States	80

---

## Chapter 7

<b>API Functions</b>	<b>81</b>
<b>Overview</b>	<b>81</b>
<b>BroadVision Orders Functions</b>	<b>82</b>
bv-order-complete-fulfill	82
bv-order-get-accountname	83
bv-order-get-ordernumber	83
bv-order-get-orderprop-ordernumber	84
bv-order-get-orders	84
bv-order-get-useralias	85
bv-order-get-userid	85
bv-order-partial-fulfill	86
bv-order-set-configured-state	86
bv-order-start	87
bv-order-struct-create	87
bv-order-struct-update	88
<b>BroadVision General Functions</b>	<b>89</b>
bv-startup	89
bv-connect	90
bv-verify-connect	90
bv-ack	91
bv-nak	91
bv-category-create	92
bv-category-delete	92
bv-category-get-cat-entry	93
bv-category-move	94
bv-category-rename	94
bv-cnt-delete	95
bv-cnt-get-productname	95
bv-cnt-sql-select	96
bv-cnt-struct-create	97
bv-cnt-struct-update	97
bv-content-ref-create	98
bv-content-ref-delete	98
bv-content-ref-list	99
bv-date-to-sap-date	100
ewbv-init	100
ewbv-shutdown	101
sap-date-to-bv-date	101
<b>Generic e*Way Functions</b>	<b>103</b>
event-commit-to-egate	103
event-rollback-to-egate	104
event-send-to-egate	104
event-send-to-egate-ignore-shutdown	105
event-send-to-egate-no-commit	105
get-logical-name	106
insert-exchange-data-event	106
send-external-up	107
send-external-down	107
shutdown-request	108
start-schedule	108
stop-schedule	109
waiting-to-shutdown	109

---

Index

# Preface

This Preface contains information regarding the User's Guide itself.

---

## P.1 Intended Reader

The reader of this guide is presumed to be a developer or system administrator with responsibility for maintaining the SeeBeyond™ e\*Gate™ Integrator system, and have a working knowledge of:

- Windows NT/2000 and/or UNIX operations and administration
- Windows-style GUI operations
- BroadVision One-To-One applications

---

## P.2 Organization

This User's Guide is organized roughly into two parts. The first part, consisting of Chapters 1-4, introduces the e\*Way and describes the procedures for installing the e\*Way and implementing a working system incorporating the e\*Way. Chapter 3 also contains descriptions of the sample schemas provided with the product. These can be used to test your system following installation and, if appropriate, as templates you can modify to produce your own custom schemas. This part should be of particular interest to a System Administrator or other user charged with the task of getting the system up and running.

The second part, consisting of Chapters 5-7, describes the architecture and internal functionality of the e\*Way. This part should be of particular interest to a Developer involved in customizing the e\*Way for a specific purpose. Information contained in this part that is necessary for the initial setup of the e\*Way is cross-referenced in the first part of the guide, at the appropriate points in the procedures.



---

## P.3 Nomenclature

Note that for purposes of brevity, the e\*Way Intelligent Adapter for BroadVision is frequently referred to as the BroadVision e\*Way, or simply the e\*Way.

---

## P.4 Online Viewing

This User's Guide is provided in Adobe Acrobat's Portable Document Format (PDF). As such, it can be printed out on any printer or viewed online. When viewing online, you can take advantage of the extensive hyperlinking imbedded in the document to navigate quickly throughout the Guide.

Hyperlinking is available in:

- The Table of Contents
- The Index
- Within the chapter text, indicated by **blue print**

Existence of a hyperlink *hotspot* is indicated when the hand cursor points to the text. Note that the hotspots in the Index are the *page numbers*, not the topics themselves. Returning to the spot you hyperlinked from is accomplished by right-clicking the mouse and selecting **Go To Previous View** on the resulting menu.

---

## P.5 Writing Conventions

The writing conventions listed in this section are observed throughout this document.

### Monospaced (Courier) Font

Computer code and text to be typed at the command line are set in Courier as shown below.

```
Configuration forBOB_Promotion  
java -jar ValidationBuilder.jar
```

Variables within a command line, or attributes within a function signature, are set within brackets <> as shown below:

```
stcregutl -rh <host-name> -un <user-name> -up <password> -sf
```

### Bold Sans-serif Font

- User Input: Click **Apply** to save, or **OK** to save and close.
- File Names and Paths: In the **Open** field, type **D:\setup\setup.exe**.
- Parameter, Function, and Command Names: The default parameter **localhost** is usually used only for testing; the Monk function **iq-put** places an Event into an IQ.

# Introduction

This chapter provides a brief introduction to the SeeBeyond e\*Way Intelligent Adapter for BroadVision.

## 1.1 Overview

The e\*Way Intelligent Adapter for BroadVision enables the e\*Gate system to exchange data with BroadVision One-To-One business applications. The e\*Way can operate in either inbound-to or outbound-from-BroadVision mode, at near-real-time speed.

**Figure 1** BroadVision e\*Way Process Flow

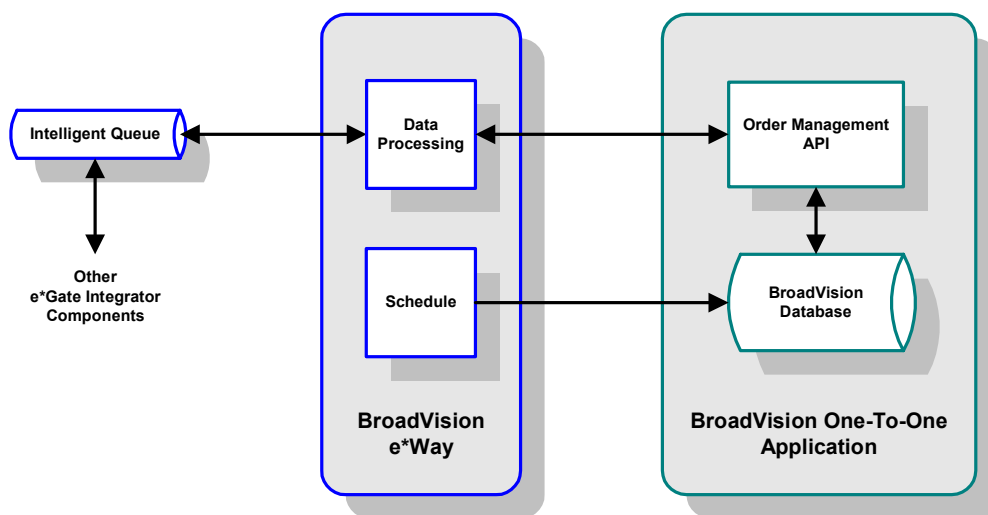

The BroadVision e\*Way interacts with BroadVision's Order Management API to pass data to and from the BroadVision database. When operating in BroadVision-outbound mode, the e\*Way polls the BroadVision database directly according to a user-configured schedule. By defining the polling interval to be very short (e.g., seconds), the response approximates that of an event-driven system.

## 1.2 Interaction with BroadVision

### 1.2.1 e\*Gate to BroadVision

Figure 2 e\*Gate-to-BroadVision Process Flow

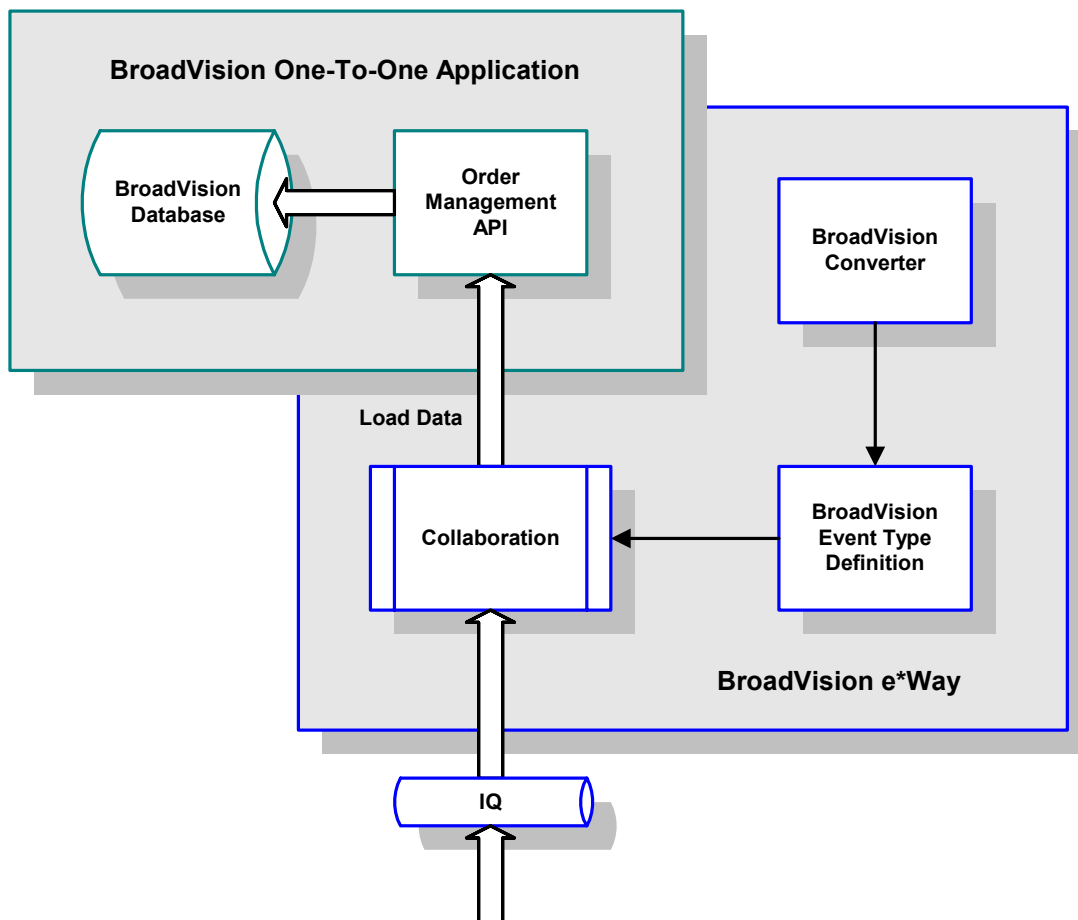

- 1 The BroadVision e\*Way extracts data from an Intelligent Queue for processing.
- 2 The e\*Way processes the information following a Collaboration incorporating an ETD created previously using the BroadVision Converter.
- 3 The e\*Way loads data into the BroadVision database by means of the BroadVision Order Management API.

## 1.2.2 BroadVision to e\*Gate

Figure 3 BroadVision-to-e\*Gate Process Flow

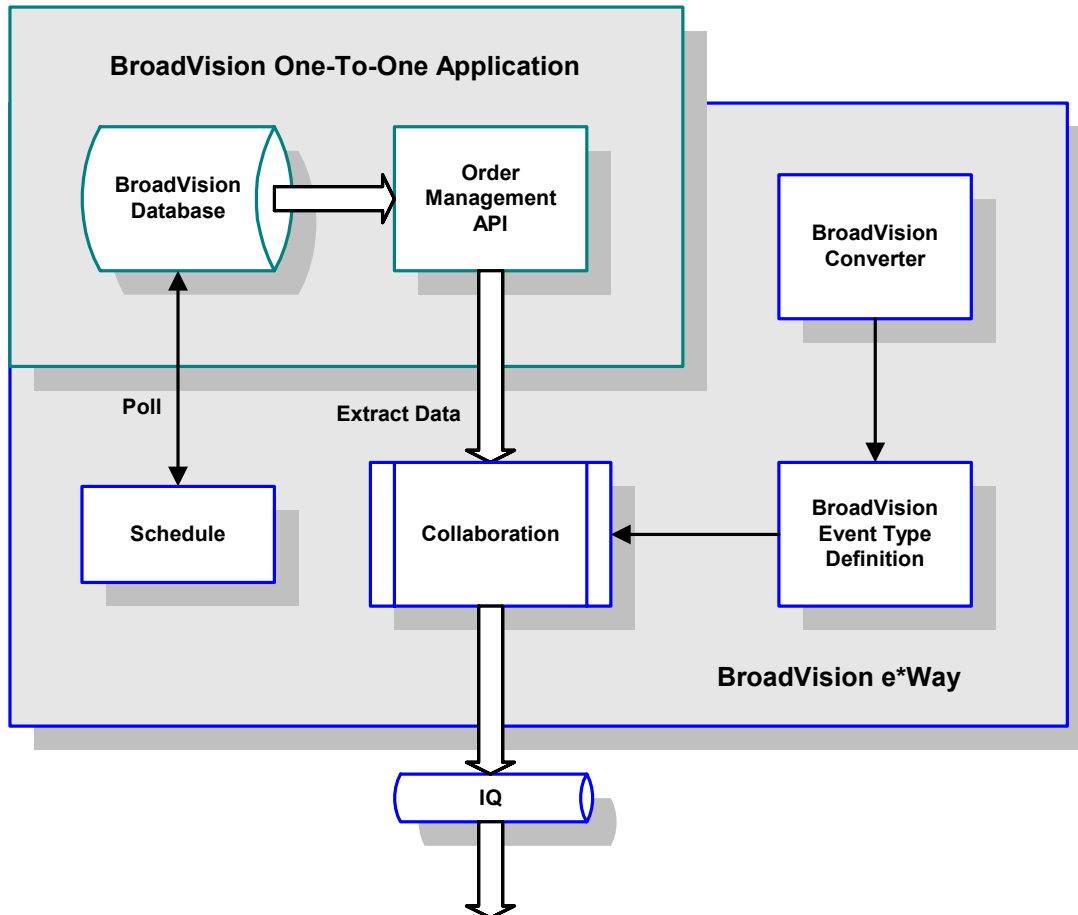

- 1 The BroadVision e\*Way polls the BroadVision database according to a predefined schedule.
- 2 The e\*Way extracts new data from BroadVision by means of the BroadVision Order Management API.
- 3 The e\*Way processes the information following a Collaboration incorporating an ETD created previously using the BroadVision Converter.
- 4 The e\*Way sends the processed data to an Intelligent Queue for further processing and/or routing to another application.

## 1.3 The BroadVision Converter

Event Type Definitions (and ultimately Collaborations) are prepared using the BroadVision Converter, which is integrated with the ETD Editor. The BroadVision Converter has two basic components: the Java Wizard (front end) and the BroadVision C-based converter (back end). For the majority of installations, the front end is on an NT platform and the back end—which has to be on the same host as the BroadVision web server—is usually on a UNIX machine.

**Figure 4** BroadVision Converter

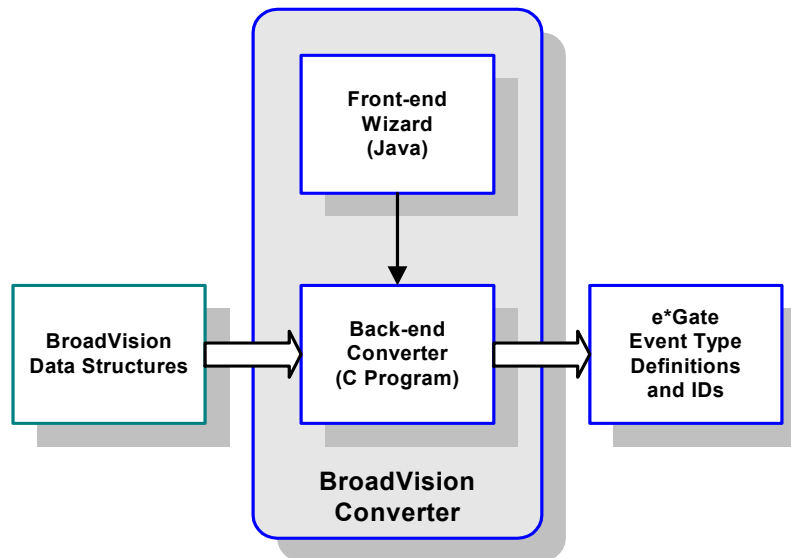

Java's Remote Method Invocation (RMI) is used to invoke the back-end converter remotely. RMI also has two parts: the Java RMI registry (`rmiregistry.exe`) and the required BV Java RMI Converter Server classes.

For Windows, both parts are run as services, and are installed automatically by InstallShield. For UNIX, however, you need to add a file to the system initialization directory manually, and also modify some environment settings. Instructions are found in [Environment Configuration](#) on page 23.

---

## 1.4 e\*Way Components

The BroadVision e\*Way incorporates the following:

- An executable file, `stcewgenericmonk.exe`, installed as part of e\*Gate Integrator
- Dynamic load libraries, `stc_ewbv.dll` and `stc_ewbv55.dll`, which extend the Generic e\*Way Kernel to form the BroadVision e\*Way
- A default configuration file, `ewbv.def`
- Monk function scripts and library files, discussed in [Chapter 7](#)
- The BroadVision Converter, `stcbvconvert.exe` and `stcbv55convert.exe`, used to build Event Type Definitions
- Example schema, discussed in [Sample Schema](#) on page 36

For a list of installed files, see [Chapter 2](#).

# Installation

This chapter describes the requirements and procedures for installing the e\*Way Intelligent Adapter for BroadVision. Once you have installed this e\*Way, you must configure it for your system and incorporate it into a schema by defining and associating the appropriate Collaborations, Collaboration Rules, IQs, and Event Types. See [Chapter 3](#) for information on implementing a working system.

---

## 2.1 System Requirements

To use the e\*Way Intelligent Adapter for BroadVision, you need the following:

- 1 An e\*Gate Participating Host, version 4.5.1 or later.
- 2 A TCP/IP network connection
- 3 Sufficient free disk space to accommodate e\*Way files:
  - ♦ Approximately 15 MB on Windows systems
  - ♦ Approximately 28 MB on Solaris systems
  - ♦ Approximately 19 MB on HP-UX systems

**Note:** *Additional disk space is required to process and queue the data that this e\*Way processes; the amount necessary varies, based on the type and size of the data being processed, and any external applications performing the processing.*

### 2.1.1 Supported Operating Systems

**Note:** *The BroadVision e\*Way must be installed on the BroadVision system host computer. The e\*Gate Enterprise Manager GUI runs only on the Windows operating system.*

The e\*Way Intelligent Adapter for BroadVision is available on the following operating systems:

- Windows 2000, Windows 2000 SP1, and Windows 2000 SP2
- Windows NT 4.0 SP 6a
- Solaris 2.6, Solaris 7, and Solaris 8
- HP-UX 11.0

## Japanese

- Windows 2000, Windows 2000 SP1, and Windows 2000 SP2
- Windows NT 4.0 SP 6a
- Solaris 2.6, Solaris 7, and Solaris 8
- HP-UX 11.0

### 2.1.2 External System Requirements

The e\*Way Intelligent Adapter for BroadVision supports the following applications:

- BroadVision One-To-One Enterprise 4.1 or 5.5

**Note:** *The BroadVision RMI Registry requires jre 1.3 or later.*



## 2.2 Installing the e\*Way

### 2.2.1 Windows Systems

**Note:** *The installation utility detects and suggests the appropriate installation directory. Use this directory unless advised otherwise by SeeBeyond. You must have Administrator privileges to install this e\*Way.*

To install the e\*Way on a Windows NT or Windows 2000 system

- 1 Log in as an Administrator on the workstation on which you want to install the e\*Way.
- 2 Exit all Windows programs and disable any anti-virus applications before running the setup program.
- 3 Insert the e\*Way installation CD-ROM into the CD-ROM drive.
- 4 If the CD-ROM drive's Autorun feature is enabled, the setup application should launch automatically. Otherwise, use the Windows Explorer or the Control Panel's **Add/Remove Applications** feature to launch the file **setup.exe** on the CD-ROM drive.
- 5 The InstallShield setup application launches. Follow the on-screen instructions until you come to the **Choose Product** screen.

**Figure 5** Choose Product Dialog

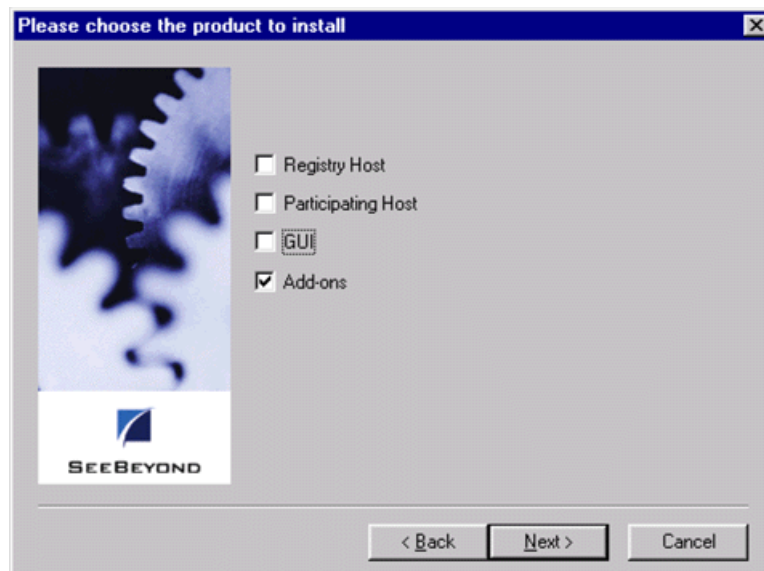

- 6 Check **Add-ons**, then click **Next**. Again follow the on-screen instructions.
- 7 When the **Select Components** dialog box appears, highlight—but do not check—**eWays** and then click **Change**.

Figure 6 Select Components Dialog

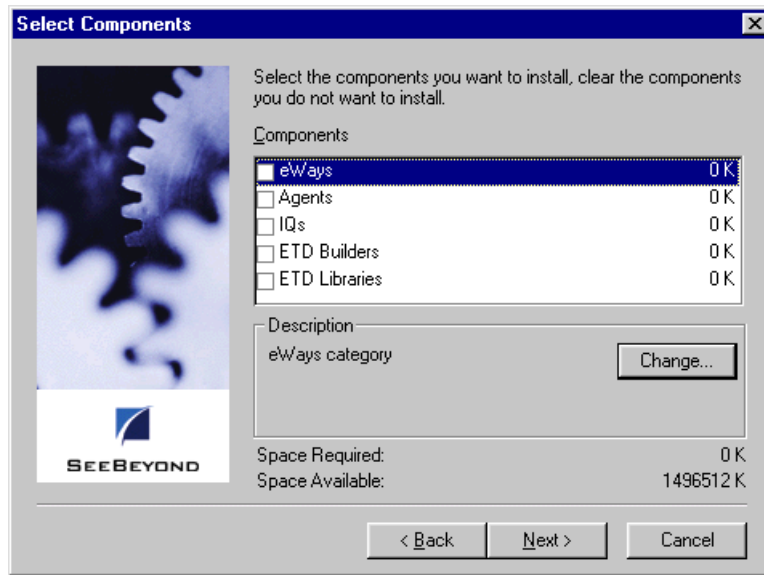

- 8 When the **Select Sub-components** dialog box appears, check the **BroadVision e\*Way**.

Figure 7 Select e\*Way Dialog

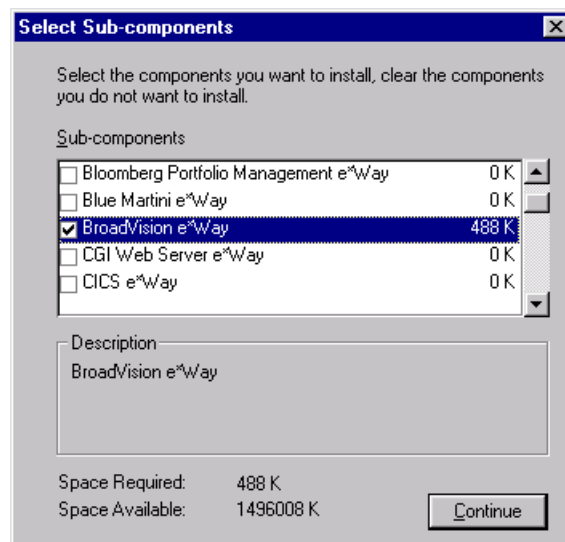

- 9 Click **Continue**, and the **Select Components** dialog box reappears.
- 10 Click **Next** and continue with the installation.

## Subdirectories and Files

By default, the InstallShield installer creates the following subdirectories and installs the following files within the \eGate\client tree on the Participating Host, and the \eGate\Server\registry\repository\default tree on the Registry Host.

**Table 1** Participating Host & Registry Host

Subdirectories	Files
\bin\	stc_ewbv.dll stc_ewbv55.dll stcbvconvert.exe stcbv55convert.exe stcsvcinstd.exe
\configs\stcewgenericmonk\	ewbv.def
\monk_library\	ewbv.gui
\monk_library\ewbv\	bv-category-create.monk bv-category-delete.monk bv-category-get-cat-entry.monk bv-category-move.monk bv-category-rename.monk bv-cnt-delete.monk bv-cnt-get-productname.monk bv-cnt-internal.monk bv-cnt-sql-select.monk bv-cnt-struct-create.monk bv-cnt-struct-update.monk bv-content-ref-create.monk bv-content-ref-delete.monk bv-content-ref-list.monk bv-order-complete-fulfill.monk bv-order-get-accountname.monk bv-order-get-ordernumber.monk bv-order-get-orderprop-ordernum.monk bv-order-get-orders.monk bv-order-get-useralias.monk bv-order-get-userid.monk bv-order-internal.monk bv-order-partial-fulfill.monk bv-order-set-state.monk bv-order-struct-create.monk bv-order-struct-update.monk bv-util.monk bv.monk ewbv-init.monk ewbv-shutdown.monk

By default, the InstallShield installer also installs the following file within the \eGate\Server\registry\repository\default tree on the Registry Host.

**Table 2** Registry Host Only

Subdirectories	Files
\	stcewbv.ctf

## Environment Configuration

The BroadVision starting process automatically appends the directories `bv1to1\bin` and `bv1to1\orbix\bin` to the Path environment variable.

For the BroadVision e\*Way to run as a Windows NT/2000 Service, any environment variables required by BroadVision should be set at the System level. These include:

BV_DB_DATABASE	ORACLE_HOME
BV_DB_USER	ORACLE_SID
BV_DB_PASSWD	IT_DAEMON_PORT
BV_DB_SERVER	BV1TO1
BV_DB_VENDOR	BV1TO1_VAR

Follow the path **Start > Settings > Control Panel > System > Environment** to display the System variables settings.

For the BroadVision Converter, specific settings variables need to be modified according to the your environment on the Participating Host, as shown in Table 3, below.

**Table 3** Settings Variables Requiring Modification

Variable	Description
BVUSER	BroadVision user name
EGATEDIR	Base directory of e*Gate installation
JREHOME	Base directory of Java Runtime Environment (JRE) installation

*Note:* See also [Starting and Running the e\\*Way](#) on page 52.

## 2.2.2 UNIX Systems

**Note:** You do not need root privileges to install this e\*Way, but you do to set up the RMI service. You can log in under the user name that you wish to own the e\*Way files, if the user has sufficient privilege to create files in the e\*Gate directory tree.

To install the BroadVision e\*Way on a UNIX system:

- 1 Log in on the workstation containing the CD-ROM drive and, if necessary, mount the drive.
- 2 Insert the e\*Way installation CD-ROM into the CD-ROM drive.
- 3 At the shell prompt, type
 

```
cd /cdrom
```
- 4 Start the installation script by typing:
 

```
setup.sh
```
- 5 A menu appears, displaying several options. Select the **Install e\*Way** option, and follow any additional on-screen instructions.

**Note:** Be sure to install the e\*Way and BroadVision Converter files in the **BVUSER** directory on the Participating Host.

- 6 The file **S99stcsvcinstdx** can be found on the installation CD under the **utils\bvstaging\** subdirectory. This file should be copied into the appropriate host directory, as listed in Table 4, below. All else in the subdirectory should be left untouched.

**Table 4** S99stcsvcinstdx Location

HPUX 11	Others
/sbin/rc3.d/	/etc/rc3.d/

To set up the RMI service

- 1 Ensure that the files **egate.jar** and **stcjs.jar** are located in **egate\client\classes**.
- 2 As the *root user*, copy this file to the appropriate directory listed in [Table 4 on page 21](#).
- 3 Modify **S99stcsvcinstdx** to have the correct entries, for example:

```
BVUSER=bv
EGATEDIR=/export/home/bv/egate/client
JREHOME=/opt/Java/JDK-1_1
JEXE=jre
```

- 4 Start the service by typing the following at the command line:

```
S99stcsvcinstdx start
```

- 5 If the service has been started correctly you should see the message:

```
RMI service <BVtoETD> is available and the rmi process should be running.
```

## Subdirectories and Files

The preceding installation procedure creates the following subdirectories and installs the following files within the /eGate/client tree on the Participating Host, and the /eGate/Server/registry/repository/default tree on the Registry Host.

**Table 5** Participating Host & Registry Host

Subdirectories	Files
/	S99stcsvcinstdx instbv.sh
/bin/	stc_ewbv.dll stc_ewbv55.dll stcbvconvert stcbv55convert
/configs/stcewgenericmonk/	ewbv.def
/monk_library/	ewbv.gui
/monk_library/ewbv/	bv-category-create.monk bv-category-delete.monk bv-category-get-cat-entry.monk bv-category-move.monk bv-category-rename.monk bv-cnt-delete.monk bv-cnt-get-productname.monk bv-cnt-internal.monk bv-cnt-sql-select.monk bv-cnt-struct-create.monk bv-cnt-struct-update.monk bv-content-ref-create.monk bv-content-ref-delete.monk bv-content-ref-list.monk bv-order-complete-fulfill.monk bv-order-get-accountname.monk bv-order-get-ordernumber.monk bv-order-get-orderprop-ordernum.monk bv-order-get-orders.monk bv-order-get-useralias.monk bv-order-get-userid.monk bv-order-internal.monk bv-order-partial-fulfill.monk bv-order-set-state.monk bv-order-struct-create.monk bv-order-struct-update.monk bv-util.monk bv.monk ewbv-init.monk ewbv-shutdown.monk

The preceding installation procedure also installs the following file only within the /eGate/Server/registry/repository/default tree on the Registry Host.

**Table 6** Registry Host Only

Subdirectories	Files
/	stcewbv.ctf

## Environment Configuration

The BroadVision starting process automatically appends the directories `bv1to1\bin` and `bv1to1\orbix\bin` to the Path environment variable.

For the BroadVision e\*Way to run as a UNIX Service, any environment variables required by BroadVision should be set at the System level. These include:

BV_DB_DATABASE	ORACLE_HOME
BV_DB_USER	ORACLE_SID
BV_DB_PASSWD	IT_DAEMON_PORT
BV_DB_SERVER	BV1TO1
BV_DB_VENDOR	BV1TO1_VAR

For the BroadVision Converter, specific settings variables need to be modified according to the your environment on the Participating Host, as shown in Table 7, below.

**Table 7** Settings Variables Requiring Modification

Variable	Description
BVUSER	BroadVision user name
EGATEDIR	Base directory of e*Gate installation
JREHOME	Base directory of Java Runtime Environment (JRE) installation

*Note:* See also [Starting and Running the e\\*Way](#) on page 52.

## 2.3 Optional Example Files

The installation CD contains two sample schemas, **BV\_Orders\_Post**, and **BV\_Products**, located in the **samples\ewbv** directory. To use a schema, you must load it onto your system using the following procedure. See **Sample Schema** on page 36 for descriptions of the sample schema and instructions regarding its use.

**Note:** *The BroadVision e\*Way must be properly installed on your system before you can run the sample schema.*

### 2.3.1 Installation Procedure

To load a sample schema

- 1 Invoke the **Open Schema** dialog box and select **New** (see Figure 8).

**Figure 8** Open Schema Dialog

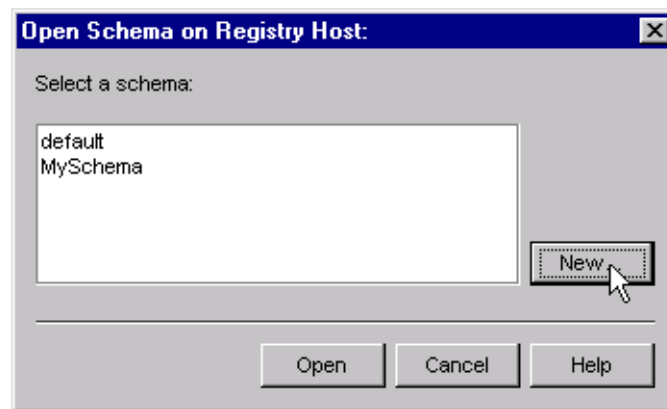

- 2 Type the name you want to give to the schema (for example, **Orders.Sample**)
- 3 Select **Create from export** and navigate to the directory containing the sample schema by clicking the **Find** button (see Figure 9).

**Figure 9** New Schema Dialog

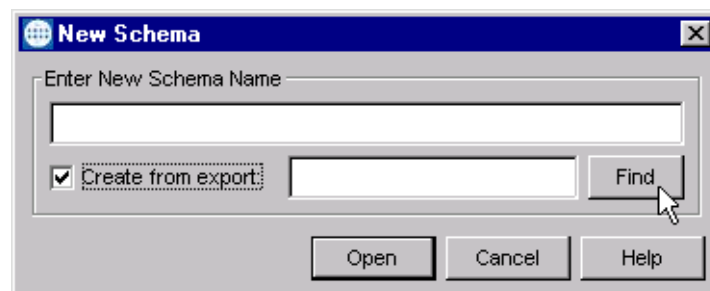

- 4 Select the desired archive file (\*.zip) and click **Open**.



**Note:** The schema installs with the host name **localhost** and control broker name **localhost\_cb**. If you want to assign your own names, copy the file \*.zip to a local directory and extract the files. Using a text editor, edit the file \*.exp, replacing all instances of the name **localhost** with your desired name. Add the edited .exp file back into the .zip file.

## 2.3.2 Subdirectories and Files

The preceding process creates the following subdirectories and installs the following files within the \eGate\client\eGateImport tree on the Participating Host. These files also are committed to their own schemas on the Registry Host.

**Table 8** Subdirectories and Files - BV\_Orders\_Post Schema

Subdirectories	Files
\	BV_Orders_Post.ctl BV_Orders_Post.exp
\BV_Orders_Post\runtime\configs\stcewfile\	orders_feeder.cfg orders_feeder.sc
\BV_Orders_Post\runtime\configs\stcewgenericmonk\	ewBVOrdersPost.cfg ewBVOrdersPost.sc
\BV_Orders_Post\runtime\data\Bv\	bv_orders.dat
\BV_Orders_Post\runtime\monk_scripts\common\	BV_Orders_Post.tsc BVSALESORDER.ssc

**Table 9** Subdirectories and Files - BV\_Products Schema

Subdirectories	Files
\	BV_Products.ctl BV_Products.exp
\BV_Products\runtime\configs\stcewfile\	feeder.cfg feeder.sc
\BV_Products\runtime\configs\stcewgenericmonk\	BV_Products.cfg BV_Products.sc
\BV_Products\runtime\data\Bv\	bv_products.dat
\BV_Products\runtime\monk_scripts\common\	BV_Products.ssc BV_Products.tsc BV_Products_Input.ssc

# System Implementation

In this chapter we summarize the procedures required for implementing a working system incorporating the BroadVision e\*Way. Please refer to the *e\*Gate Integrator User's Guide* for additional information.

---

## 3.1 Overview

This e\*Way provides a specialized transport component for incorporation in an operational schema. The schema also contains Collaborations, linking different data or Event types, and Intelligent Queues. Typically, other e\*Way types also are used as components of the schema.

One or more sample schema, included in the software package, are described at the end of this chapter. These can be used to test your system following installation and, if appropriate, as a template that you can modify to produce your own schema.

The topics discussed in this chapter include the following:

[The e\\*Gate Enterprise Manager](#) on page 28

[Creating a Schema](#) on page 29

[Creating Event Type Definitions](#) on page 31

[Defining Collaborations](#) on page 35

[Creating Intelligent Queues](#) on page 36

[Sample Schema](#) on page 36

### 3.1.1 Implementation Sequence

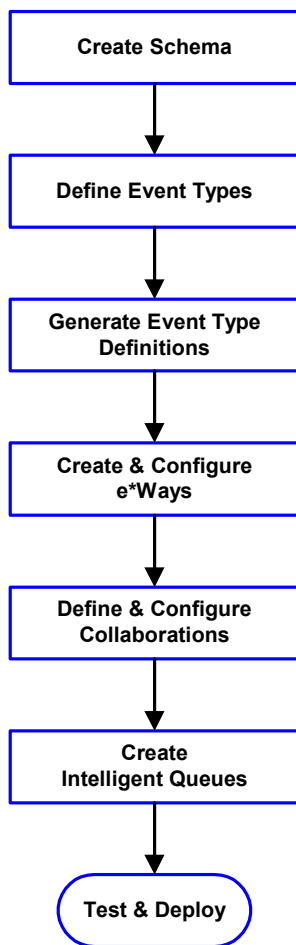

- 1 The first step is to create a new Schema—the subsequent steps apply only to this Schema (see [Creating a Schema](#) on page 29).
- 2 The second step is to define the Event Types you are transporting and processing within the Schema (see [Creating Event Types](#) on page 30).
- 3 Third, you need to associate the Event Types created in the previous step with Event Type Definitions (ETDs) derived from the applicable Business Rules (see [Creating Event Type Definitions](#) on page 31).
- 4 The fourth step is to create and configure the required e\*Ways (see [Chapter 4](#)).
- 5 Next is to define and configure the Collaborations linking the Event Types from step 2 (see [Defining Collaborations](#) on page 35).
- 6 Now you need to create Intelligent Queues to hold published Events (see [Creating Intelligent Queues](#) on page 36).
- 7 Finally, you must test your Schema. Once you have verified that it is working correctly, you may deploy it to your production environment.

## 3.2 The e\*Gate Enterprise Manager

First, here is a brief look at the e\*Gate Enterprise Manager. The general features of the e\*Gate Enterprise Manager window are shown in Figure 10. See the *e\*Gate Integrator User's Guide* for a detailed description of the features and use of the Enterprise Manager.

**Figure 10** e\*Gate Enterprise Manager Window (Components View)

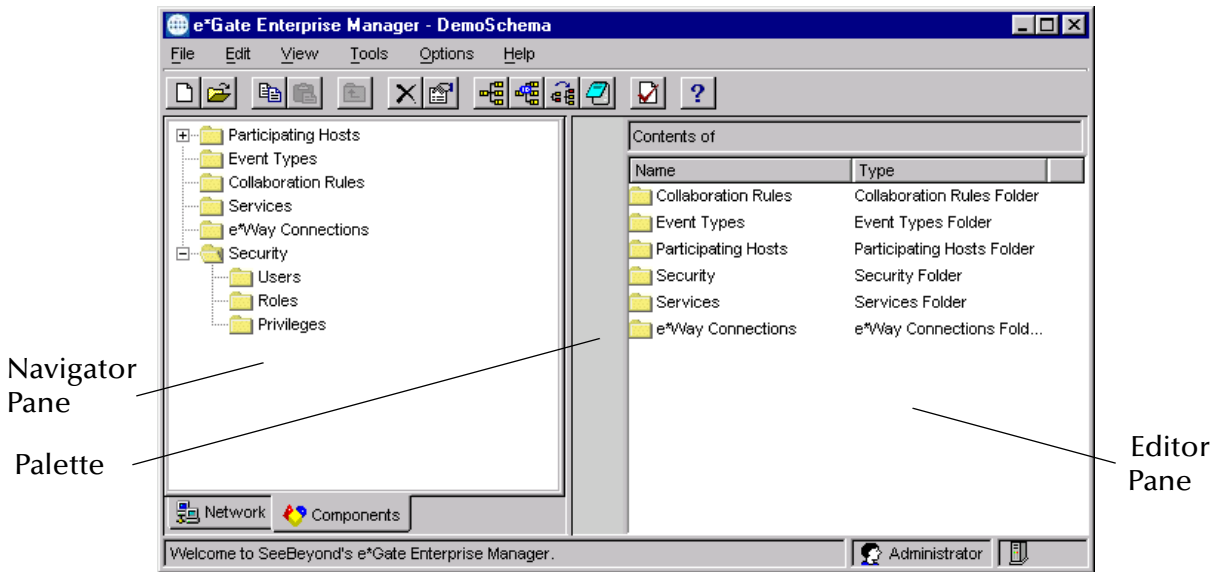

Use the Navigator and Editor panes to view the e\*Gate components. Note that you may only view components of a single schema at one time, and that all operations apply only to the current schema. All procedures in this chapter should be performed while displaying the Components Navigator pane.

## 3.3 Creating a Schema

A schema is the structure that defines e\*Gate system parameters and the relationships between components within the e\*Gate system. Schemas can span multiple hosts.

Because all setup and configuration operations take place within an e\*Gate schema, a new schema must be created, or an existing one must be started before using the system. Schemas store all their configuration parameters in the e\*Gate Registry.

To select or create a schema

- 1 Invoke the **Open Schema** dialog box and **Open** an existing schema or click **New** to create a new schema.

**Figure 11** Open Schema Dialog

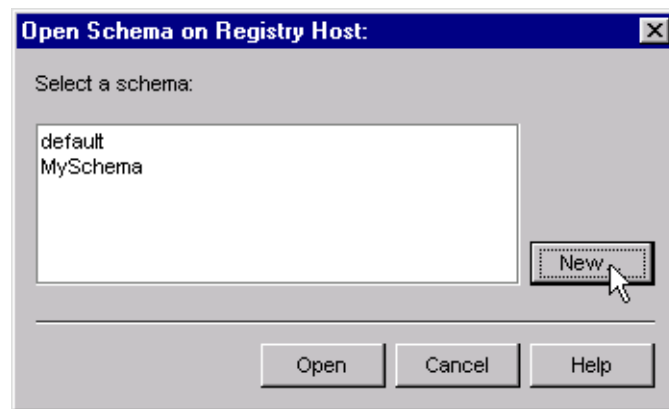

- 2 Enter a new schema name and click **Open**.
- 3 The e\*Gate Enterprise Manager then opens under your new schema name.
- 4 From the **Options** menu, click on **Default Editor** and select **Monk**.
- 5 Select the **Components** tab, found at the bottom of the Navigator pane of the e\*Gate Enterprise Manager window.
- 6 You are now ready to begin creating the necessary components for this new schema.

---

## 3.4 Creating Event Types

Within e\*Gate, messages and/or packages of data are defined as Events. Each Event must be categorized into a specific Event Type within the schema.

### To define the Event Types

- 1 In the e\*Gate Enterprise Manager's Navigator pane, select the Event Types folder.
- 2 On the Palette, click the New Event Type button .
- 3 In the New Event Type Component box, enter the name for the input Event Type and click **Apply**. Use this method to create all required Event Types, for example:
  - ◆ InboundEvent
  - ◆ ValidEvent
  - ◆ InvalidEvent
- 4 After you have created the final Event Type, click **OK**.

## 3.5 Creating Event Type Definitions

Before e\*Gate can process any data to or from a BroadVision system, you must create an Event Type Definition to package and route that data within the e\*Gate system. See the *e\*Gate Integrator User's Guide* for additional information about Event Type Definitions and the e\*Gate ETD Editor.

### 3.5.1 Using the ETD Editor's Build Tool

The Event Type Definition Editor's Build tool automatically creates an Event Type Definition file based upon sample data. Use this procedure to create an Event Type Definition based upon the data your installation requires.

**Note:** Be sure to set the Default Editor to Monk, from the Options menu in the e\*Gate Enterprise Manager.

To create an Event Type Definition using the Build tool

- 1 Launch the ETD Editor by clicking  in the e\*Gate Enterprise Manager tool bar.
- 2 On the ETD Editor's tool bar, click **Build**.

The *Build an Event Type Definition* dialog box opens.

**Figure 12** Build Event Type Definition Dialog

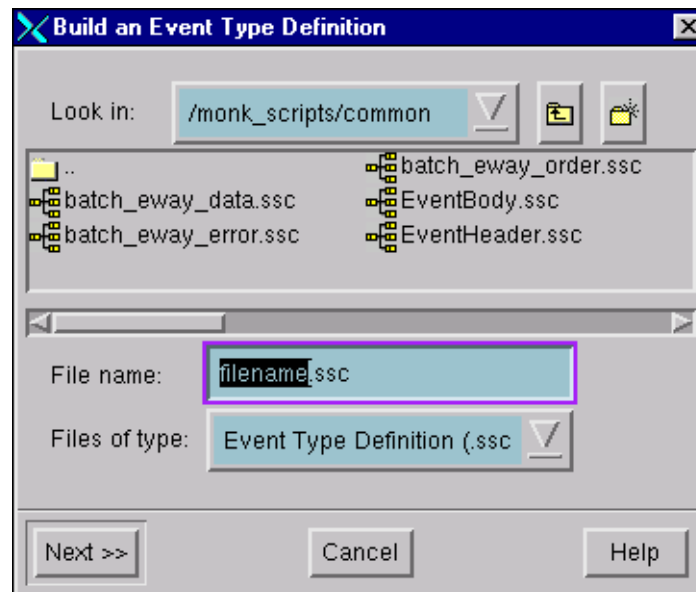

- 3 In the *File name* box, type the name of the ETD file you want to build.

**Note:** The Editor automatically supplies the .ssc extension.

- 4 Click **Next**. A new dialog box appears, as shown in Figure 13.

**Figure 13** Building the ETD

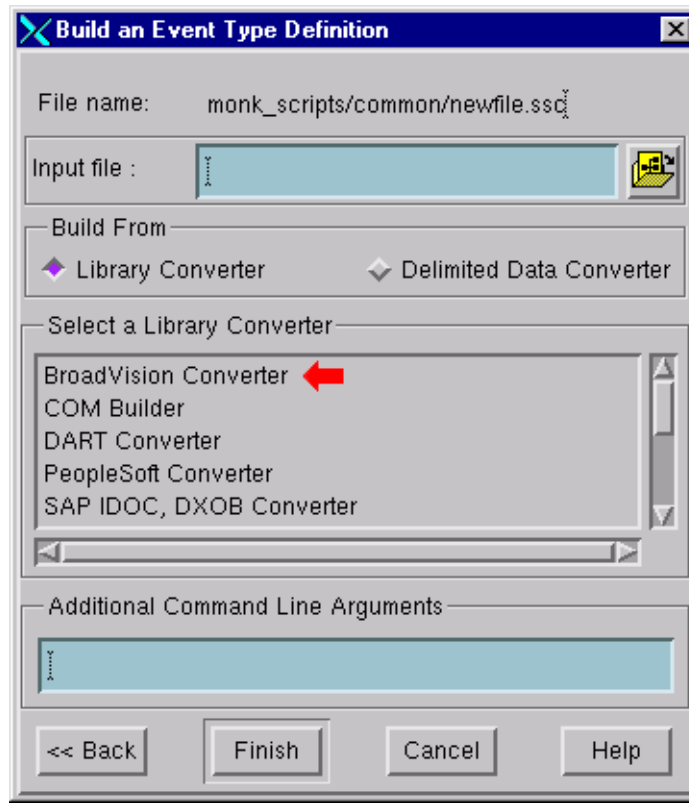

- 5 Under *Build From*, select **Library Converter**.
- 6 Under *Select a Library Converter*, select **BroadVision Converter**.
- 7 In the *Additional Command Line Arguments* box, type any additional arguments, if desired.
- 8 Click **Finish**, and the BroadVision Converter Wizard appears.
- 9 Follow the Wizard's instructions to finish building the ETD file.



## 3.5.2 The BroadVision Converter Wizard

Figure 14 BroadVision Converter Wizard (1)

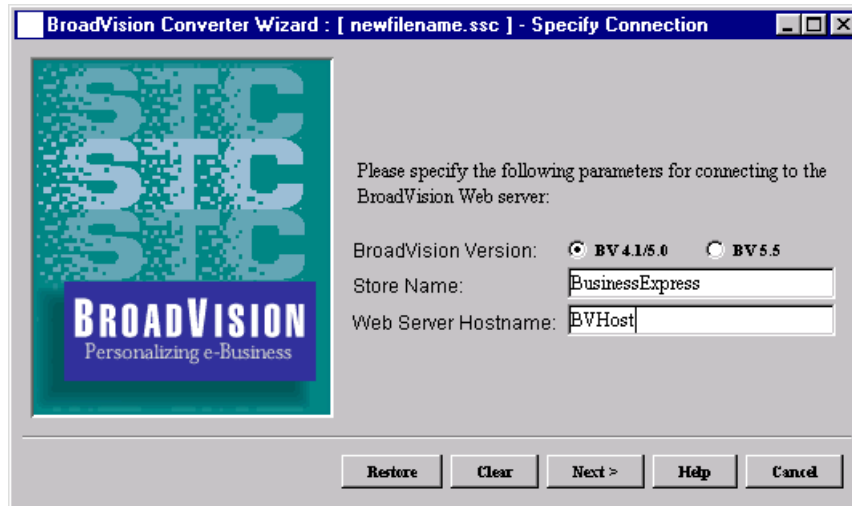

- 1 Select whether you are using BroadVision 4.1 or 5.0, or BroadVision 5.5.
- 2 Type in the Store Name and Web Server Hostname, and click Next.

Figure 15 BroadVision Converter Wizard (2)

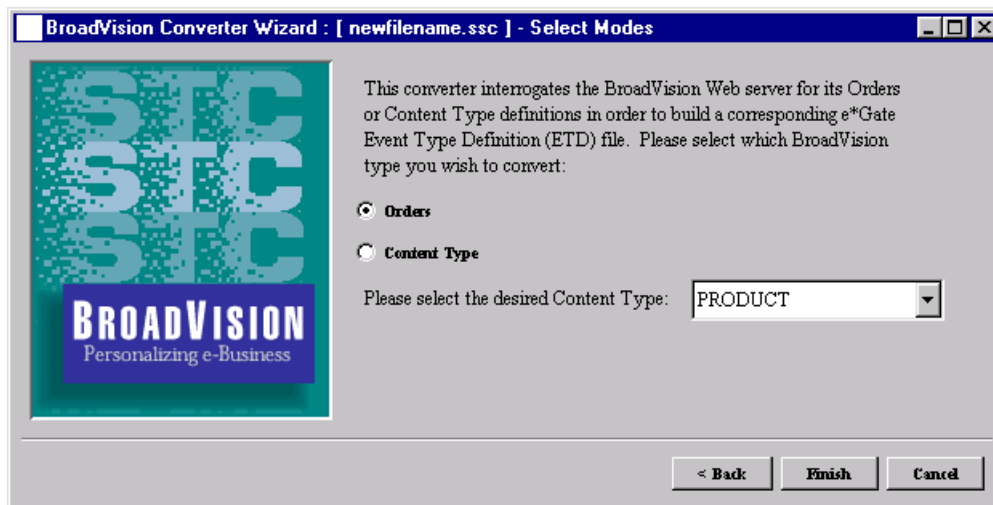

- 3 On the second Wizard screen, select which BroadVision type you want to convert, Orders or Content Type.
- 4 If you select Content Type, you also need to select the specific one from the scroll box.
- 5 Click Finish.
- 6 The Converter now runs and, when processing is completed, you are presented with the Editor screen.

### 3.5.3 Assigning ETDs to Event Types

After you have created the e\*Gate system's ETD files, you can assign them to Event Types you have already created.

To assign ETDs to Event Types

- 1 In the Enterprise Manager window, select the **Event Types** folder in the Navigator/Components pane.
- 2 In the Editor pane, select one of the Event Types you created.
- 3 Right-click on the Event Type and select **Properties** (or click  in the toolbar). The Event Type Properties dialog box appears. See Figure 16.

**Figure 16** Event Type Properties Dialog Box



- 4 Under Event Type Definition, click **Find**, and the Event Type Definition Selection dialog box appears (it is similar to the Windows Open dialog box).
- 5 Open the **monk\_scripts** folder, then select the desired file name (.ssc). It is usually found in the **common** sub-folder, but may be in a sub-folder specific to the e\*Way.
- 6 Click **Select**. The file populates the Event Type Definition field.

- 7 To save any work in the properties dialog box, click **Apply** to enter it into the system.
- 8 When finished assigning ETDs to Event Types, click **OK** to close the properties dialog box and apply all the properties.

Each Event Type is now associated with the specified Event Type Definition.

## 3.6 Defining Collaborations

After you have created the required Event Type Definitions, you must define a Collaboration to transform the incoming Event into the desired outgoing Event.

Collaborations are e\*Way components that receive and process Event Types, then forward the output to other e\*Gate components. Collaborations consist of the Subscriber, which “listens” for Events of a known type or from a given source, and the Publisher, which distributes the transformed Event to a specified recipient. The same Collaboration cannot be assigned to more than one e\*Gate component.

**Figure 17** Collaborations

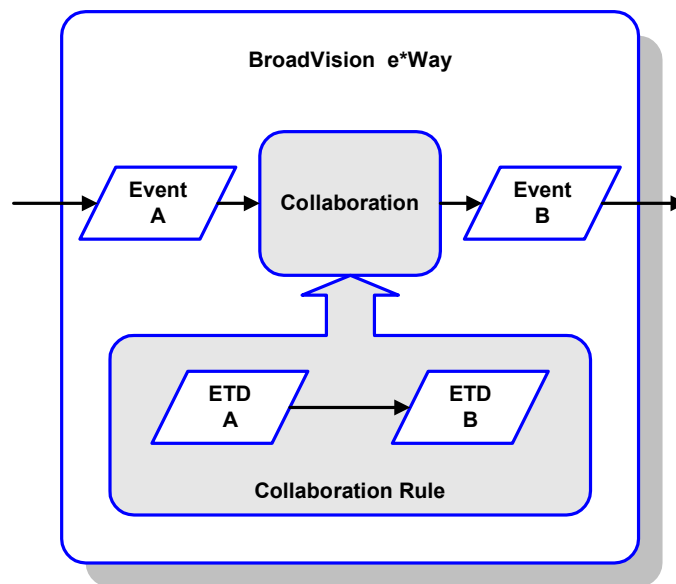

The Collaboration is driven by a Collaboration Rules script, which defines the relationship between the incoming and outgoing ETDs. You can use an existing Collaboration Rules script, or use the Monk programming language to write a new Collaboration Rules script. Once you have written and successfully tested a script, you can then add it to the system’s run-time operation.

Collaborations are defined using the e\*Gate Monk Collaboration Rules Editor. See the *e\*Gate Integrator User’s Guide* for instructions on using this Editor. The file extension for Monk Collaboration Rules is **.tsc**.

---

## 3.7 Creating Intelligent Queues

IQs are components that provide nonvolatile storage for Events within the e\*Gate system as they pass from one component to another. IQs are *intelligent* in that they are more than just a “holding tank” for Events. They actively record information about the current state of Events.

Each schema must have an IQ Manager before you can add any IQs to it. You must create at least one IQ per schema for published Events within the e\*Gate system. Note that e\*Ways that publish Events externally do not need IQs.

For more information on how to add and configure IQs and IQ Managers, see the *e\*Gate Integrator System Administration and Operations Guide*. See the *e\*Gate Integrator Intelligent Queue Services Reference Guide* and the *SeeBeyond JMS Intelligent Queue User’s Guide* for complete information on working with IQs.

---

## 3.8 Sample Schema

Sample implementations are available in the `\samples\ewbv\` directory of the e\*Gate CD-ROM.

- `BV_Orders_Post` - example for Sales Orders data (only)
- `BV_Products` - example for Product data (only)

These samples can be used to test your system following installation and, if appropriate, as a template you can modify to produce your own schema.

See [Optional Example Files](#) on page 24 for installation instructions.

### 3.8.1 BV\_Orders\_Post

The e\*Gate-to-BroadVision example, **BV\_Orders\_Post**, sets up a single instance of the BroadVision e\*Way and also of the File e\*Way, having the logical names shown in the following table.

e*Way Type	Logical Name
BroadVision e*Way	ewBVOrdersPost
File e*Way	orders_feeder

It also sets up an Intelligent Queue, with the logical name **BVOrders\_IQ**.

The process within e\*Gate Integrator is diagrammed in Figure 21.

**Figure 18** BV\_Products Schema

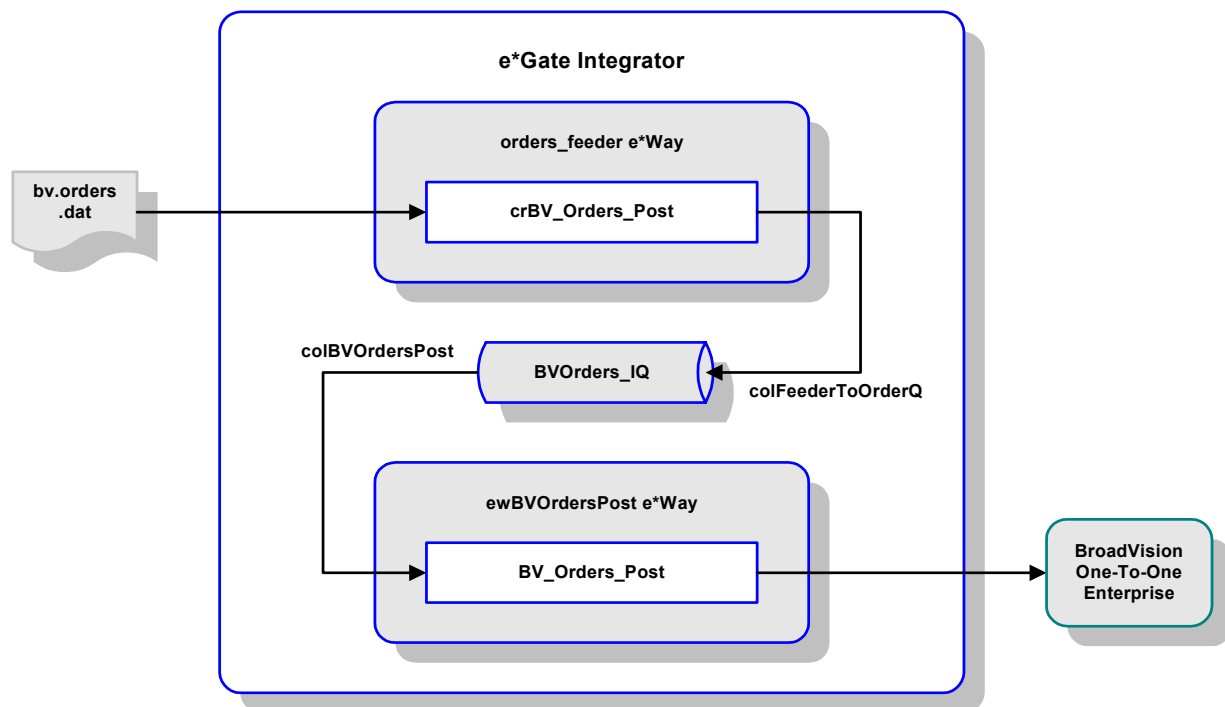

- 1 The File e\*Way `orders_feeder` receives a data file, `bv.orders.dat`, from an external source.
- 2 Using the Pass-Through Collaboration `crBV_Orders_Post`, the e\*Way `orders_feeder` then publishes the data to the IQ as `colFeederToOrderQ`.
- 3 The BroadVision e\*Way `ewBVOrdersPost` subscribes to the data from the IQ as `colBVOrdersPost`.
- 4 Using the Collaboration `BV_Orders_Post`, the e\*Way `ewBVOrdersPost` transforms and sends the data to BroadVision in the required format.

## Collaboration: BV\_Orders\_Post

This Collaboration is based on the Monk script BV\_Orders\_Post.tsc, whose source and destination ETDs are both BVORDERSPOST.ssc (see Figure 19 and Figure 20).

Figure 19 Source ETD

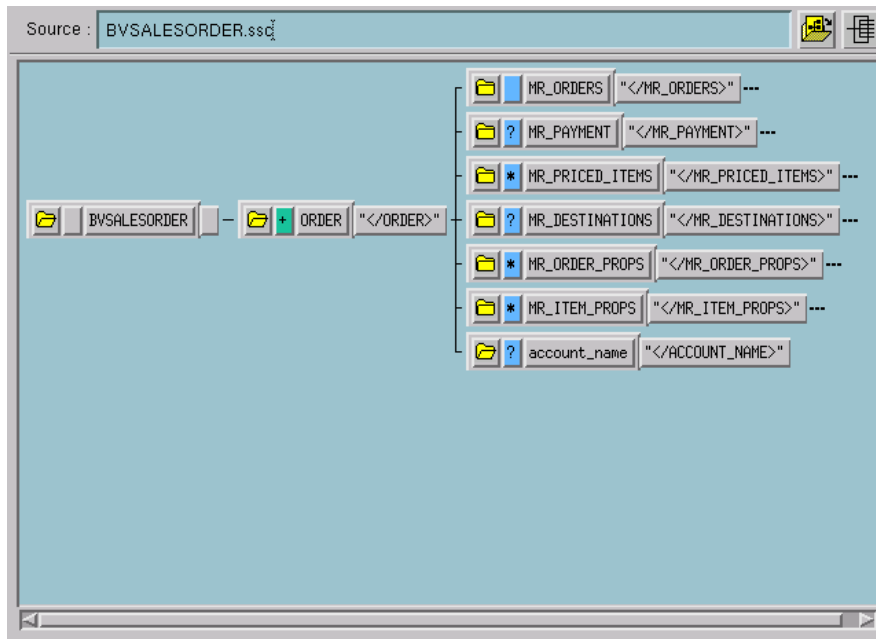
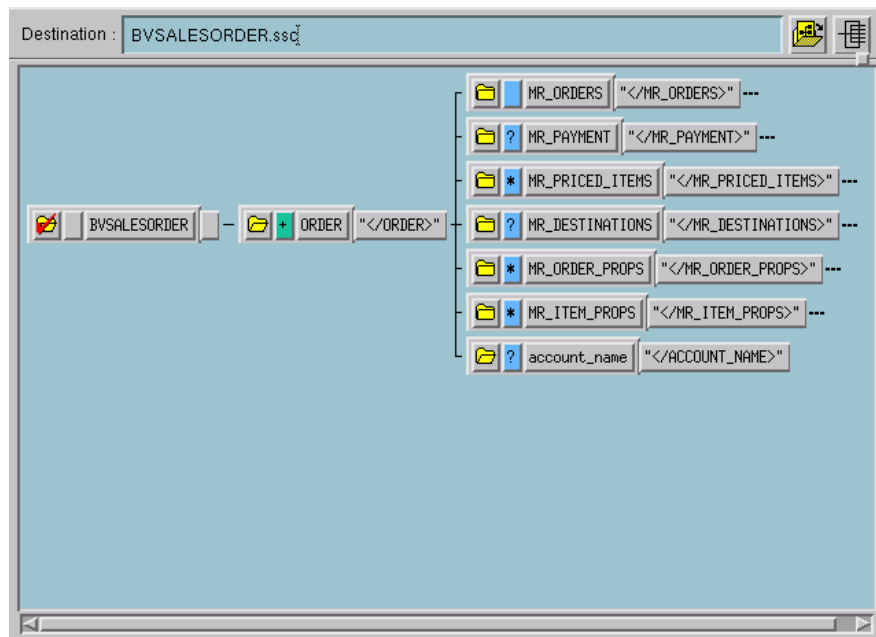

Figure 20 Destination ETD



### 3.8.2 BV\_Products

The e\*Gate-to-BroadVision example, **BV\_Products**, sets up a single instance of the BroadVision e\*Way and also of the File e\*Way, having the logical names shown in the following table.

e*Way Type	Logical Name
BroadVision e*Way	BV_Products
File e*Way	Feeder

It also sets up an Intelligent Queue, with the logical name **BV\_Products\_IQ**.

The process within e\*Gate Integrator is diagrammed in Figure 21.

**Figure 21** BV\_Products Schema

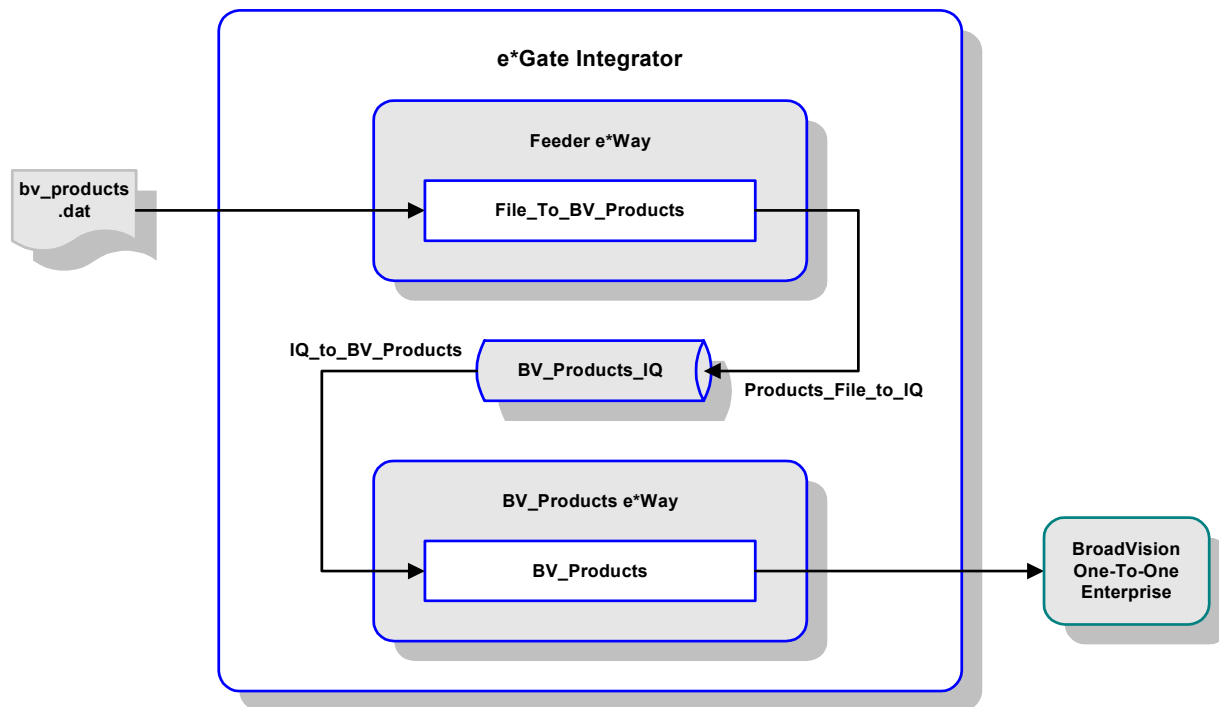

- 1 The File e\*Way Feeder receives a data file, **bv\_products.dat**, from an external source.
- 2 Using the Pass-Through Collaboration **File\_To\_BV\_Products**, the e\*Way Feeder then publishes the data to the IQ as **Products\_File\_to\_IQ**.
- 3 The BroadVision e\*Way **BV\_Products** subscribes to the data from the IQ as **IQ\_To\_BV\_Products**.
- 4 Using the Collaboration **BV\_Products**, the e\*Way **BV\_Products** transforms and sends the data to BroadVision in the required format.

## Collaboration: BV\_Products

This Collaboration is based on the Monk script `BV_Products.tsc`, whose source ETD is `BV_Products_Input.ssc` (see Figure 22) and destination ETD is `BV_Products.ssc` (see Figure 23).

Figure 22 Source ETD

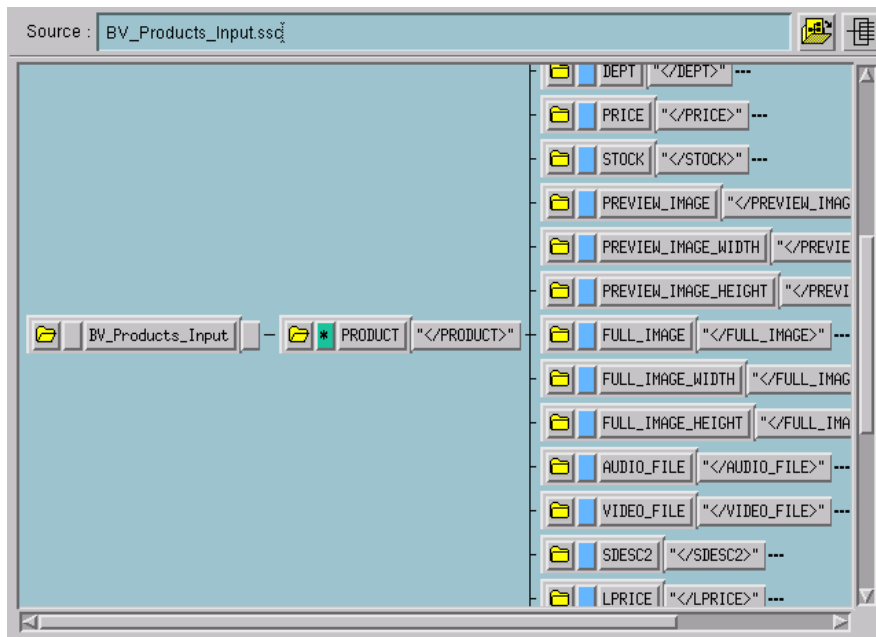
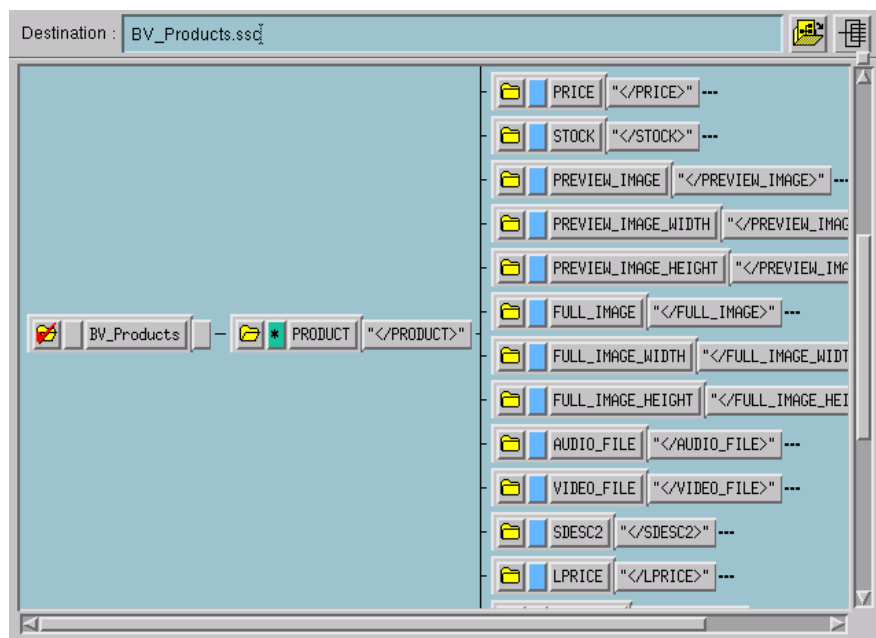

Figure 23 Destination ETD





# Setup Procedures

This chapter describes the procedure for customizing the BroadVision e\*Way to operate with your system.

---

## 4.1 Overview

After installing the BroadVision e\*Way, you must perform an initial setup for it to work with your system. A wide range of setup options allow the e\*Way to conform to your system's operational characteristics and your facility's operating procedures.

The topics discussed in this chapter include the following:

### Setting Up the e\*Way

[Creating the e\\*Way](#) on page 42

[Modifying e\\*Way Properties](#) on page 43

[Configuring the e\\*Way](#) on page 44

[Changing the User Name](#) on page 48

[Setting Startup Options or Schedules](#) on page 48

[Activating or Modifying Logging Options](#) on page 50

[Activating or Modifying Monitoring Thresholds](#) on page 51

### Starting and Running the e\*Way

[Starting the e\\*Way Manually](#) on page 52

### Troubleshooting the e\*Way

[Configuration Problems](#) on page 53

[System-related Problems](#) on page 54

## 4.2 Setting Up the e\*Way

**Note:** The e\*Gate Enterprise Manager GUI runs only on the Windows operating system.

### 4.2.1 Creating the e\*Way

The first step in implementing an e\*Way is to define the e\*Way component using the e\*Gate Enterprise Manager.

To create an e\*Way

- 1 Open the schema in which the e\*Way is to operate.
- 2 Select the e\*Gate Enterprise Manager Navigator's Components tab.
- 3 Open the host on which you want to create the e\*Way.
- 4 Select the Control Broker you want to manage the new e\*Way.

**Figure 24** e\*Gate Enterprise Manager Window (Components View)

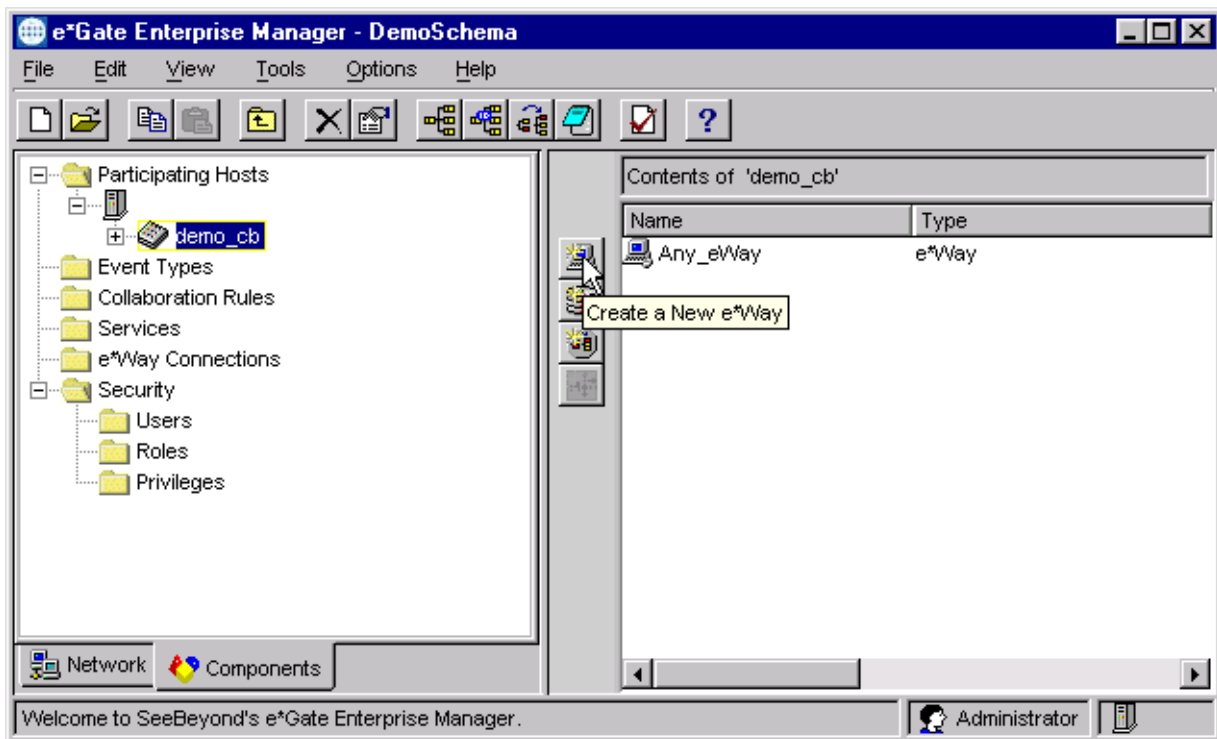

- 5 On the Palette, click Create a New e\*Way.
- 6 Enter the name of the new e\*Way, then click OK.
- 7 All further actions are performed in the e\*Gate Enterprise Manager Navigator's Components tab.

## 4.2.2 Modifying e\*Way Properties

To modify any e\*Way properties

- 1 Right-click on the desired e\*Way and select **Properties** to edit the e\*Way's properties. The properties dialog opens to the **General** tab (shown in Figure 25).

**Note:** The executable and default configuration files used by this e\*Way are listed in **e\*Way Components** on page 14.

**Figure 25** e\*Way Properties (General Tab)

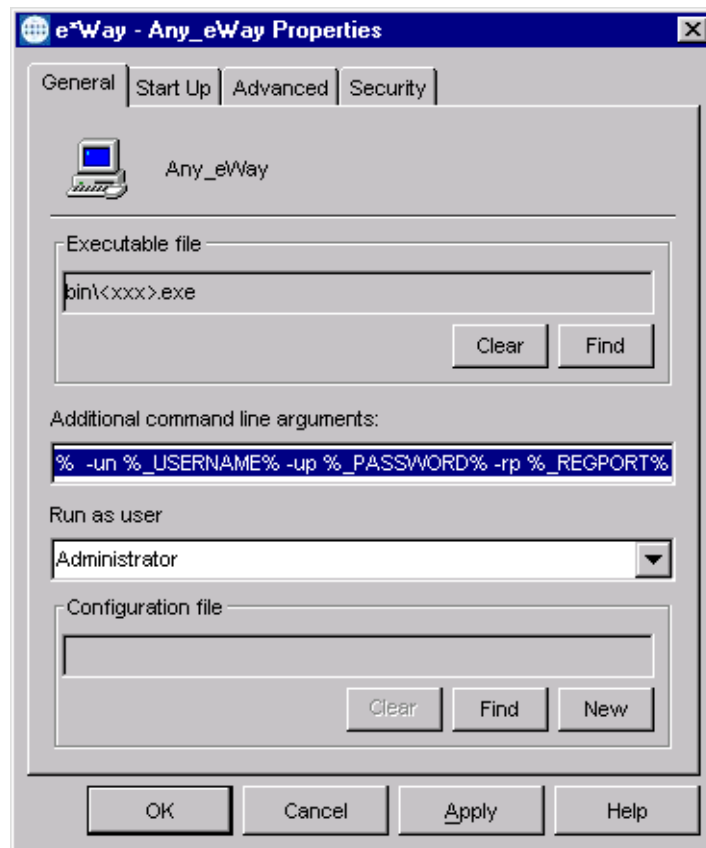

- 2 Make the desired modifications, then click **OK**.

### 4.2.3 Configuring the e\*Way

The e\*Way's default configuration parameters are stored in an ASCII text file with a .def extension. The e\*Way Editor provides a simple graphical interface for viewing and changing those parameters to create a working configuration (.cfg) file.

To change e\*Way configuration parameters

- 1 In the e\*Gate Enterprise Manager's Component editor, select the e\*Way you want to configure and display its properties.

**Note:** The executable and default configuration files used by this e\*Way are listed in [e\\*Way Components](#) on page 14.

**Figure 26** e\*Way Properties - General Tab

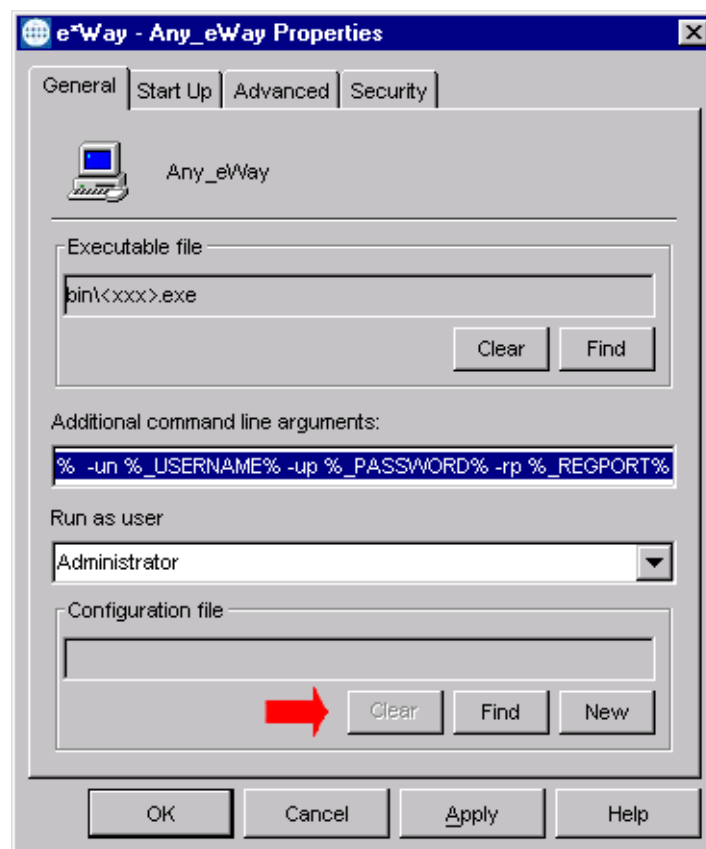

- 2 Under Configuration File, click New to create a new file or Find to select an existing configuration file. If you select an existing file, an Edit button appears. Click this button to edit the currently selected file.
- 3 You are now in the e\*Way Configuration Editor.

## 4.2.4 Using the e\*Way Editor

Figure 27 The e\*Way Configuration Editor

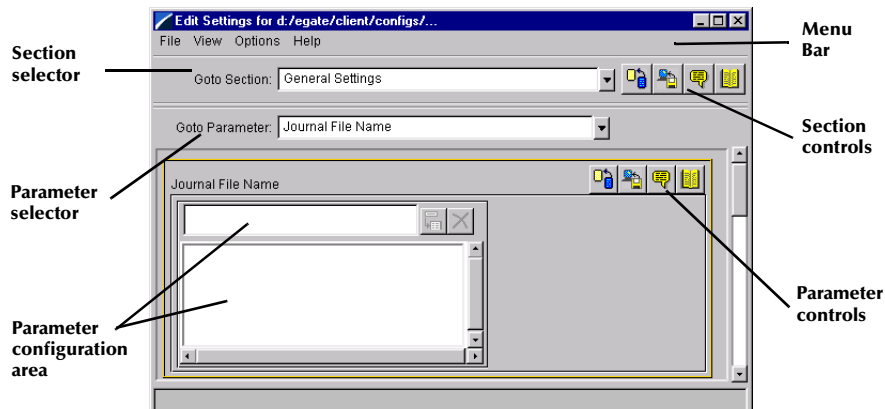





The e\*Way Editor controls fall into one of six categories:

- The **Menu bar** allows access to basic operations (e.g., saving the configuration file, viewing a summary of all parameter settings, and launching the Help system)
- The **Section selector** at the top of the Editor window enables you to select the category of the parameters you wish to edit
- **Section controls** enable you to restore the default settings, restore the last saved settings, display tips, or enter comments for the currently selected section
- The **Parameter selector** allows you to jump to a specific parameter within the section, rather than scrolling
- **Parameter controls** enable you to restore the default settings, restore the last saved settings, display tips, or enter comments for the currently selected parameter
- **Parameter configuration controls** enable you to set the e\*Way's various operating parameters

## Section and Parameter Controls

The section and parameter controls are shown in Table 10 below.

**Table 10** Parameter and Section Controls

Button	Name	Function
	<b>Restore Default</b>	Restores default values
	<b>Restore Value</b>	Restores saved values
	<b>Tips</b>	Displays tips
	<b>User Notes</b>	Enters user notes



*Note: The section controls affect all parameters in the selected section, whereas the parameter controls affect only the selected parameter.*

## Parameter Configuration Controls

Parameter configuration controls fall into one of two categories:

- Option buttons
- Selection lists, which have controls as described in Table 11

**Table 11** Selection List Controls

Button	Name	Function
	<b>Add to List</b>	Adds the value in the text box to the list of available values.
	<b>Delete Items</b>	Displays a “delete items” dialog box, used to delete items from the list.

---

## Command-line Configuration

In the **Additional Command Line Arguments** box, type any additional command line arguments that the e\*Way may require, taking care to insert them *at the end* of the existing command-line string. Be careful not to change any of the default arguments unless you have a specific need to do so.

---

## Getting Help

To launch the e\*Way Editor's Help system

From the **Help** menu, select **Help** topics.

To display tips regarding the general operation of the e\*Way

From the **File** menu, select **Tips**.

To display tips regarding the selected Configuration Section

In the **Section Control** group, click .

To display tips regarding the selected Configuration Parameter

In the **Parameter Control** group, click .

**Note:** *“Tips” are displayed and managed separately from the Help system that launches from the Toolbar's Help menu. You cannot search for Tips within the Help system, or view Help system topics by requesting Tips.*

For detailed descriptions and procedures for using the e\*Way Configuration Editor, see the *e\*Gate Integrator User's Guide*.

## 4.2.5 Changing the User Name

Like all e\*Gate executable components, e\*Ways run under an e\*Gate user name. By default, all e\*Ways run under the **Administrator** user name. You can change this if your site's security procedures so require.

To change the user name

- 1 Display the e\*Way's properties dialog.
- 2 On the **General** tab, use the **Run as user** list to select the e\*Gate user under whose name this component is to run.

See the *e\*Gate Integrator System Administration and Operations Guide* for more information on the e\*Gate security system.

## 4.2.6 Setting Startup Options or Schedules

SeeBeyond e\*Ways can be started or stopped by any of the following methods:

- The Control Broker can start the e\*Way automatically whenever the Control Broker starts.
- The Control Broker can start the e\*Way automatically whenever it detects that the e\*Way terminated execution abnormally.
- The Control Broker can start or stop the e\*Way on a schedule that you specify.
- Users can start or stop the e\*Way manually using an interactive monitor.

You determine how the Control Broker starts or shuts down an e\*Way using options on the e\*Way properties **Start Up** tab (see Figure 28). See the *e\*Gate Integrator System Administration and Operations Guide* for more information about how interactive monitors can start or shut down components.



**Figure 28** e\*Way Properties (Start-Up Tab)

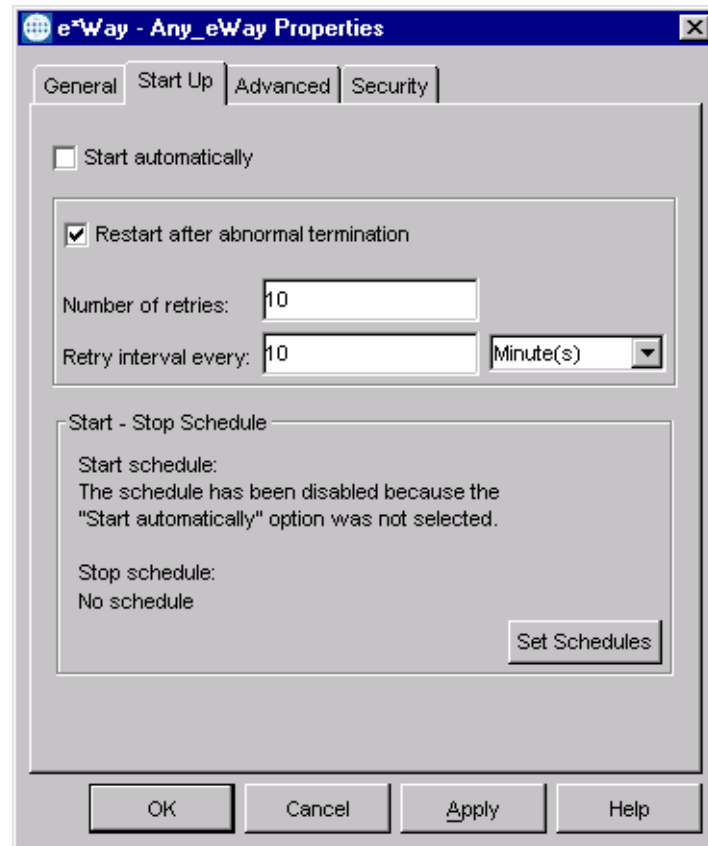

To set the e\*Way's startup properties

- 1 Display the e\*Way's properties dialog.
- 2 Select the Start Up tab.
- 3 To have the e\*Way start automatically when the Control Broker starts, select the Start automatically check box.
- 4 To have the e\*Way start manually, clear the Start automatically check box.
- 5 To have the e\*Way restart automatically after an abnormal termination:
  - A Select Restart after abnormal termination.
  - B Set the desired number of retries and retry interval.
- 6 To prevent the e\*Way from restarting automatically after an abnormal termination, clear the Restart after abnormal termination check box.
- 7 Click OK.

## 4.2.7 Activating or Modifying Logging Options

Logging options enable you to troubleshoot problems with the e\*Way and other e\*Gate components.

To set the e\*Way debug level and flag

- 1 Display the e\*Way's Properties dialog.
- 2 Select the **Advanced** tab.
- 3 Click **Log**. The dialog window appears (see Figure 29).

**Figure 29** e\*Way Properties (Advanced Tab - Log Option)

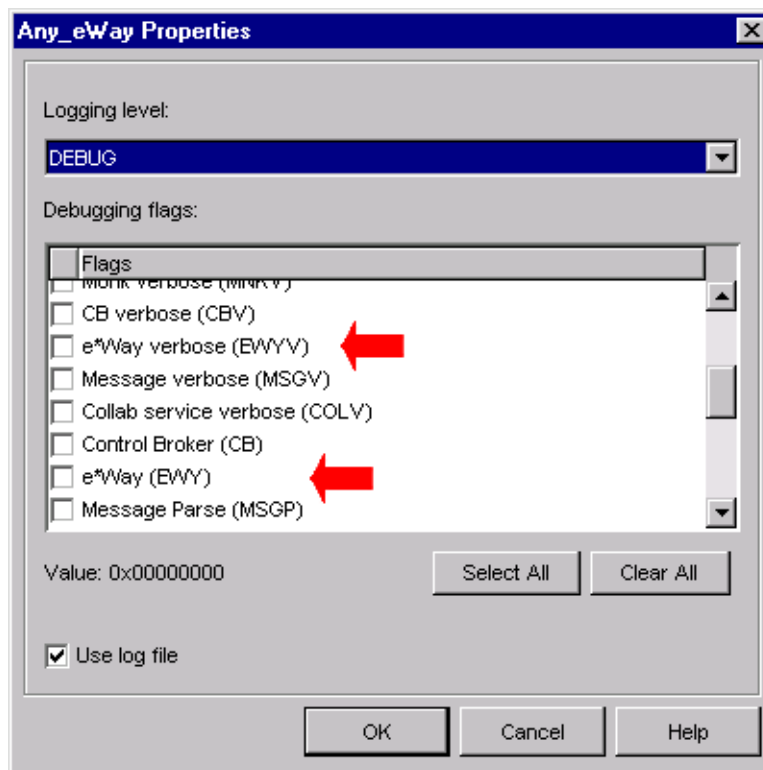

- 4 Select **DEBUG** for the **Logging level**.
- 5 Select either **e\*Way (EWY)** or **e\*Way Verbose (EWYV)** for the **Debugging flag**. Note that the latter has a significant negative impact on system performance.
- 6 Click **OK**.

The other options apply to other e\*Gate components and are activated in the same manner. See the *e\*Gate Integrator Alert and Log File Reference* for additional information concerning log files, logging options, logging levels, and debug flags.

## 4.2.8 Activating or Modifying Monitoring Thresholds

Monitoring thresholds enable you to monitor the throughput of the e\*Way. When the monitoring thresholds are exceeded, the e\*Way sends a Monitoring Event to the Control Broker, which routes it to the e\*Gate Monitor and any other configured destinations.

- 1 Display the e\*Way's properties dialog.
- 2 Select the **Advanced** tab.
- 3 Click **Thresholds**.
- 4 Select the desired threshold options and click **OK**.

See the *e\*Gate Integrator Alert and Log File Reference* for more information concerning threshold monitoring, routing specific notifications to specific recipients, or for general information about e\*Gate's monitoring and notification system.

---

## 4.3 Starting and Running the e\*Way

The BroadVision e\*Way must be run on the same machine as BroadVision One-To-One Enterprise (or Business Commerce). You should start the BroadVision One-To-One application *before* starting the e\*Way, so that the e\*Way can bind to the BroadVision One-To-One services. Note that BroadVision One-To-One Enterprise and Business Commerce are started manually, and the BroadVision starting process automatically appends the directories `bv1to1\bin` and `bv1to1\orbix\bin` to the Path environment variable.

### 4.3.1 Starting the e\*Way Manually

The BroadVision One-To-One Enterprise or Business Commerce for Windows NT/2000 installation includes the MKS Kit, which is a Windows-based Korn shell application. Both the e\*Way and the Control Broker can be launched manually from the Korn shell window, and the environment can be accessed by typing `env`. The Korn shell window can be launched from the **Start > Program** menu by running the file `bv1to1.sh` in the BroadVision One-To-One application folder.

---

## 4.4 Troubleshooting the e\*Way

In the initial stages of developing your e\*Gate Integrator system administration system, most problems with e\*Ways can be traced to configuration.

### 4.4.1 Configuration Problems

#### In the Enterprise Manager

- Does the e\*Way have the correct Collaborations assigned?
- Do those Collaborations use the correct Collaboration Services?
- Is the logic correct within any Collaboration Rules script employed by this e\*Way's Collaborations?
- Do those Collaborations subscribe to and publish Events appropriately?
- Are all the components that "feed" this e\*Way properly configured, and are they sending the appropriate Events correctly?
- Are all the components that this e\*Way "feeds" properly configured, and are they subscribing to the appropriate Events correctly?

#### In the e\*Way Editor

- Check that all configuration options are set appropriately.
- Check that all settings you changed are set correctly.
- Check all required changes to ensure they have not been overlooked.
- Check the defaults to ensure they are acceptable for your installation.

#### On the e\*Way's Participating Host

- Check that the Participating Host is operating properly, and that it has sufficient disk space to hold the IQ data that this e\*Way's Collaborations publish.
- Check that the PATH (on Windows) or LD\_LIBRARY\_PATH (on UNIX) environmental variable includes a path to the PeopleSoft dynamically-loaded libraries.

#### In the BroadVision Application

- Check that the application is configured correctly, is operating properly, and is sending or receiving the correct data appropriately.

## 4.4.2 System-related Problems

- Check that the connection between the external application and the e\*Way is functioning appropriately.
- Once the e\*Way is up and running properly, operational problems can be due to:
  - ♦ External influences (network or other connectivity problems).
  - ♦ Problems in the operating environment (low disk space or system errors)
  - ♦ Problems or changes in the data the e\*Way is processing.
  - ♦ Corrections required to Collaboration Rules scripts that become evident in the course of normal operations.

One of the most important tools in the troubleshooter's arsenal is the e\*Way log file. See the *e\*Gate Integrator Alert and Log File Reference Guide* for an extensive explanation of log files, debugging options, and using the e\*Gate monitoring system to monitor operations and performance.

# Operational Overview

This chapter contains an overview of the architecture and basic internal processes of the BroadVision e\*Way.

## 5.1 BroadVision e\*Way Architecture

*Note:* This section describes functionality that is common to all e\*Ways based on the Generic e\*Way Kernel. Not all of this common functionality is used routinely by the BroadVision e\*Way.

Conceptually, an e\*Way can be viewed as a multi-layered structure, consisting of one or more layers that handle communication with the external application, built upon an e\*Way Kernel layer that manages the processing of data and subscribing or publishing to other e\*Gate components (see Figure 30).

**Figure 30** BroadVision e\*Way Architecture

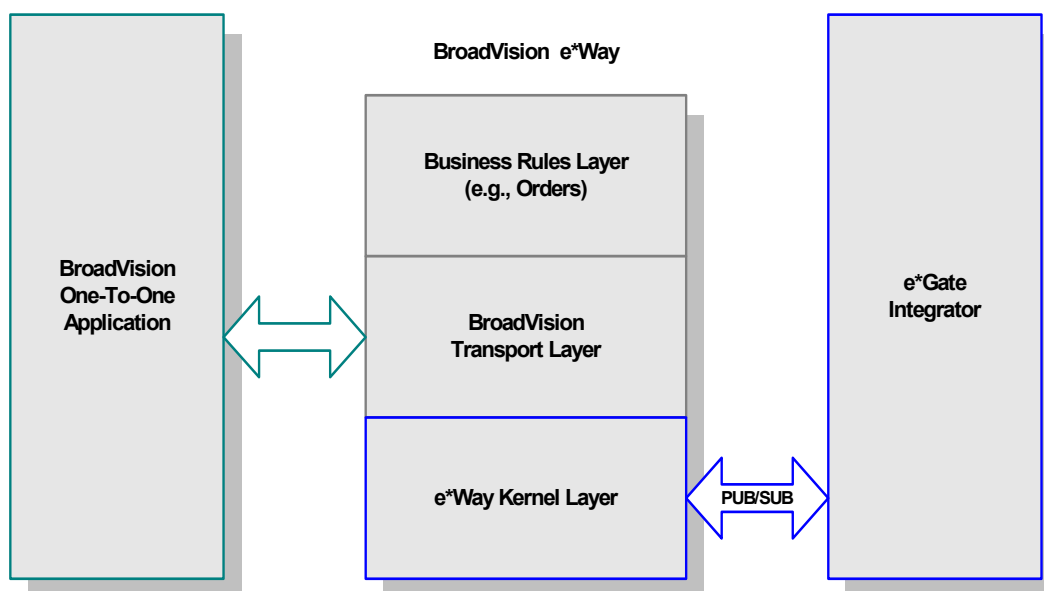

The upper layers of the e\*Way use Monk functions to perform Business Process modeling and ETD mapping, package data as e\*Gate *Events*, send those Events to

Collaborations, and manage interaction with the external system. These layers are built upon an e\*Way Kernel layer that manages the basic operations of the e\*Way, data processing, and communication with other e\*Gate components.

The communication layers of the e\*Way are single-threaded. Functions run serially, and only one function can be executed at a time. Processing layers are multi-threaded, with one executable thread for each Collaboration. Each thread maintains its own Monk environment; therefore, information such as variables, functions, path information, and so on cannot be shared between threads.

Collaborations execute the business logic that enable the e\*Way to do its intended work. In turn, each Collaboration executes a Collaboration Rule, containing the actual instructions to execute the business logic. Each Collaboration that publishes its processed Events internally (within e\*Gate Integrator) requires one or more IQs to receive the Events, as shown in Figure 31. Any Collaboration that publishes its processed Events only to an external system does *not* require *any* IQs.

**Figure 31** Collaborations

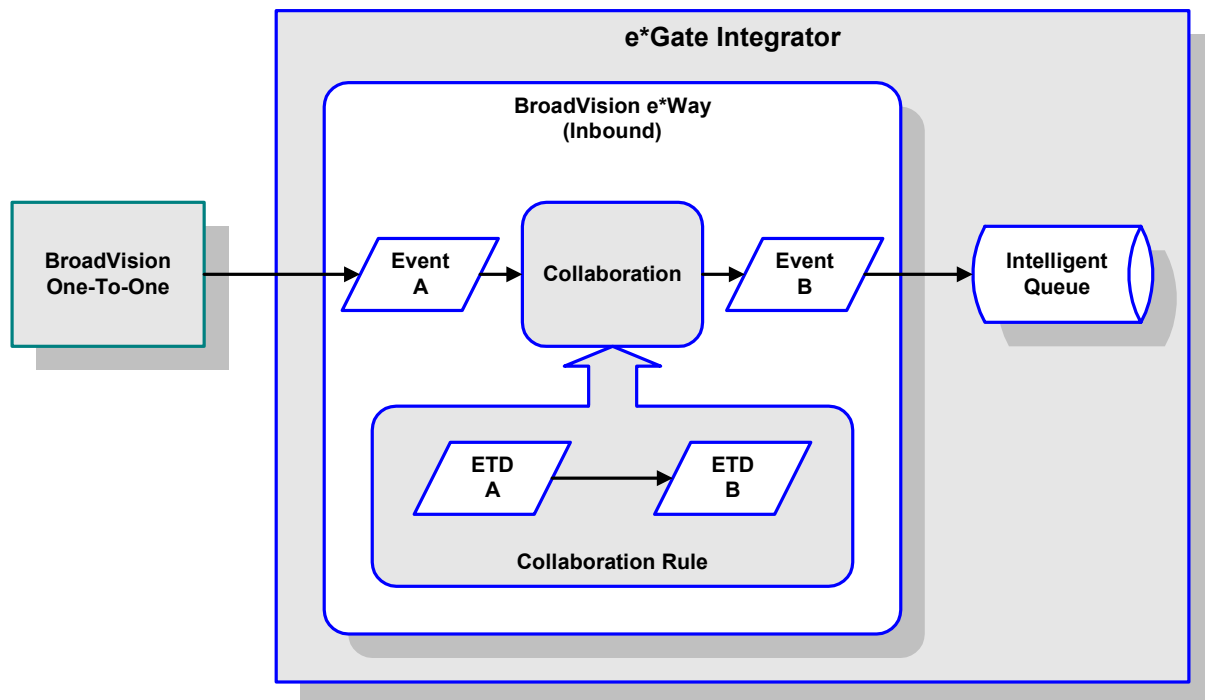

Configuration options that control the Monk environment and define the Monk functions used to perform various e\*Way operations are discussed in [Chapter 6](#). You can create and modify these functions using the SeeBeyond Collaboration Rules Editor or a text editor (such as *Microsoft Word* or *Notepad*, or UNIX *vi*). The available set of e\*Way API functions is described in [Chapter 7](#). Generally, e\*Way Kernel Monk functions should be called directly only when there is a specific need not addressed by higher-level Monk functions, and should be used only by experienced developers.

For more information on defining Collaborations, defining IQs, assigning Collaborations to e\*Ways, or configuring Collaborations to publish Events, see the *e\*Gate Integrator User's Guide*.



## 5.2 Basic e\*Way Processes

**Note:** This section describes the basic operation of a typical e\*Way based on the Generic e\*Way Kernel. Not all functionality described in this section is used routinely by this e\*Way.

The most basic processes carried out by an e\*Way are listed in Figure 32. In e\*Ways based on the Generic Monk e\*Way Kernel (using `stcewgenericmonk.exe`), these processes are controlled by the listed Monk functions. Configuration of these functions is described in the referenced sections of this User's Guide.

**Figure 32** Basic e\*Way Processes

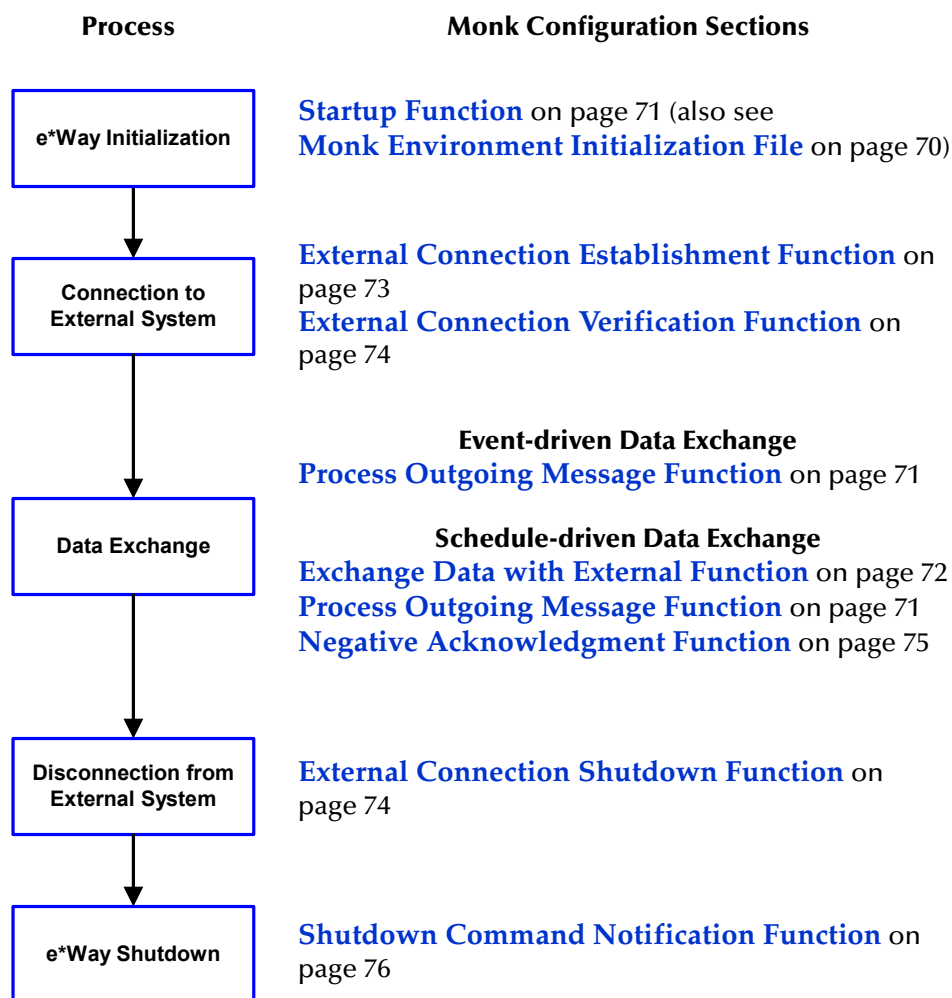

A series of diagrams on the next several pages illustrate the interaction and operation of these functions during the specified processes. Configuring the parameters associated with these functions is covered in [Chapter 6](#), while the functions themselves are described in [Chapter 7](#).

## Initialization Process

Figure 33 illustrates the e\*Way's initialization process, using the **Monk Environment Initialization File** and **Startup Function**.

**Figure 33** Initialization Process

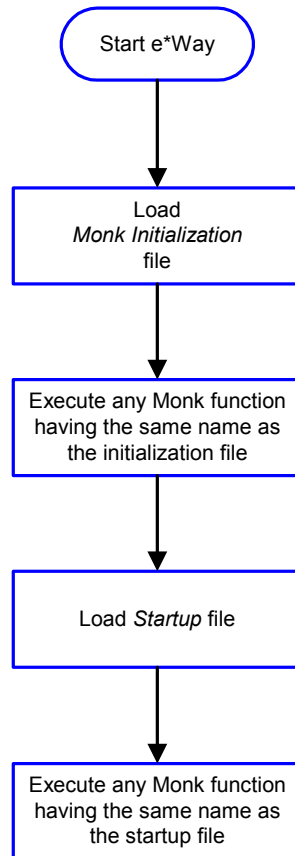

## Connect to External Process

Figure 34 illustrates how the e\*Way connects to the external system, using the **External Connection Establishment Function** and **External Connection Verification Function**.

**Figure 34** Connection Process

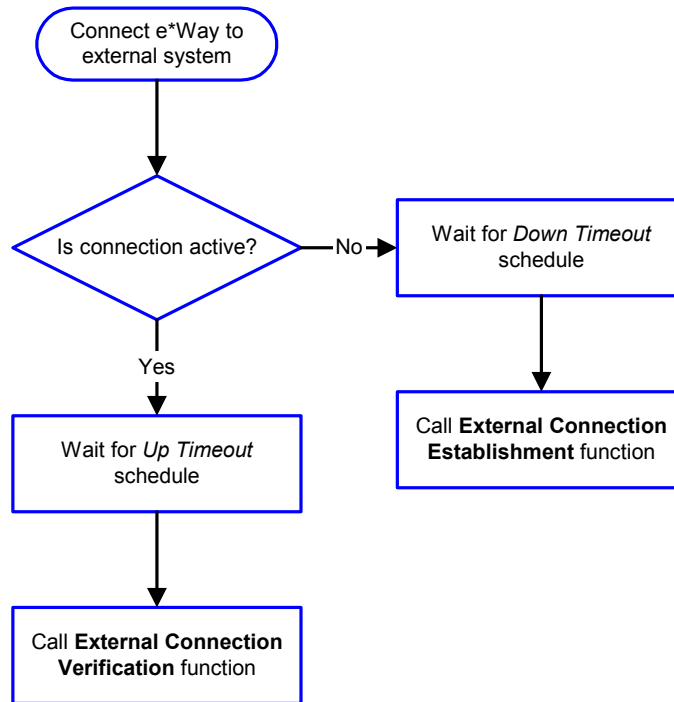

**Note:** The e\*Way selects the connection function based on an internal **up/down** flag rather than a poll to the external system. See [Figure 36 on page 61](#) and [Figure 35 on page 60](#) for examples of how different functions use this flag.

User functions can manually set this flag using Monk functions. See [send-external-up](#) on page 107 and [send-external-down](#) on page 107 for more information.

## Data Exchange Process

### Event-driven

Figure 35 illustrates how the e\*Way's event-driven data exchange process works, using the **Process Outgoing Message Function**.

The e\*Way periodically checks the *Failed Message* counter against the value specified by the **Max Failed Messages** parameter. When the *Failed Message* counter exceeds the specified maximum value, the e\*Way logs an error and shuts down.

After the function exits, the e\*Way waits for the next outgoing Event.

**Figure 35** Event-Driven Data Exchange Process

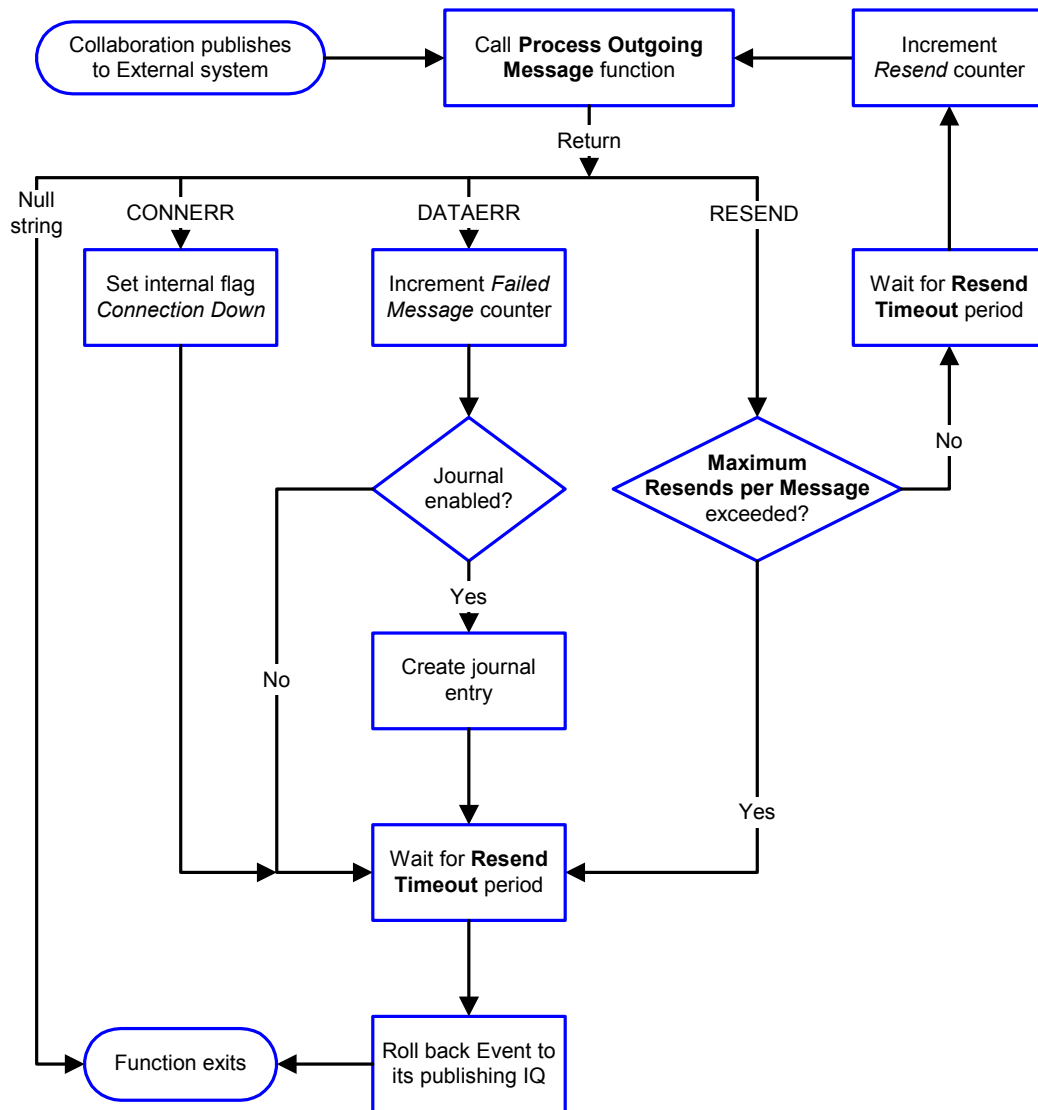

Schedule-driven

Figure 36 illustrates how the e\*Way’s schedule-driven data exchange process works for incoming data, using the **Exchange Data with External Function, Positive Acknowledgment Function**, and **Negative Acknowledgment Function**.

**Figure 36** Schedule-Driven Data Exchange Process

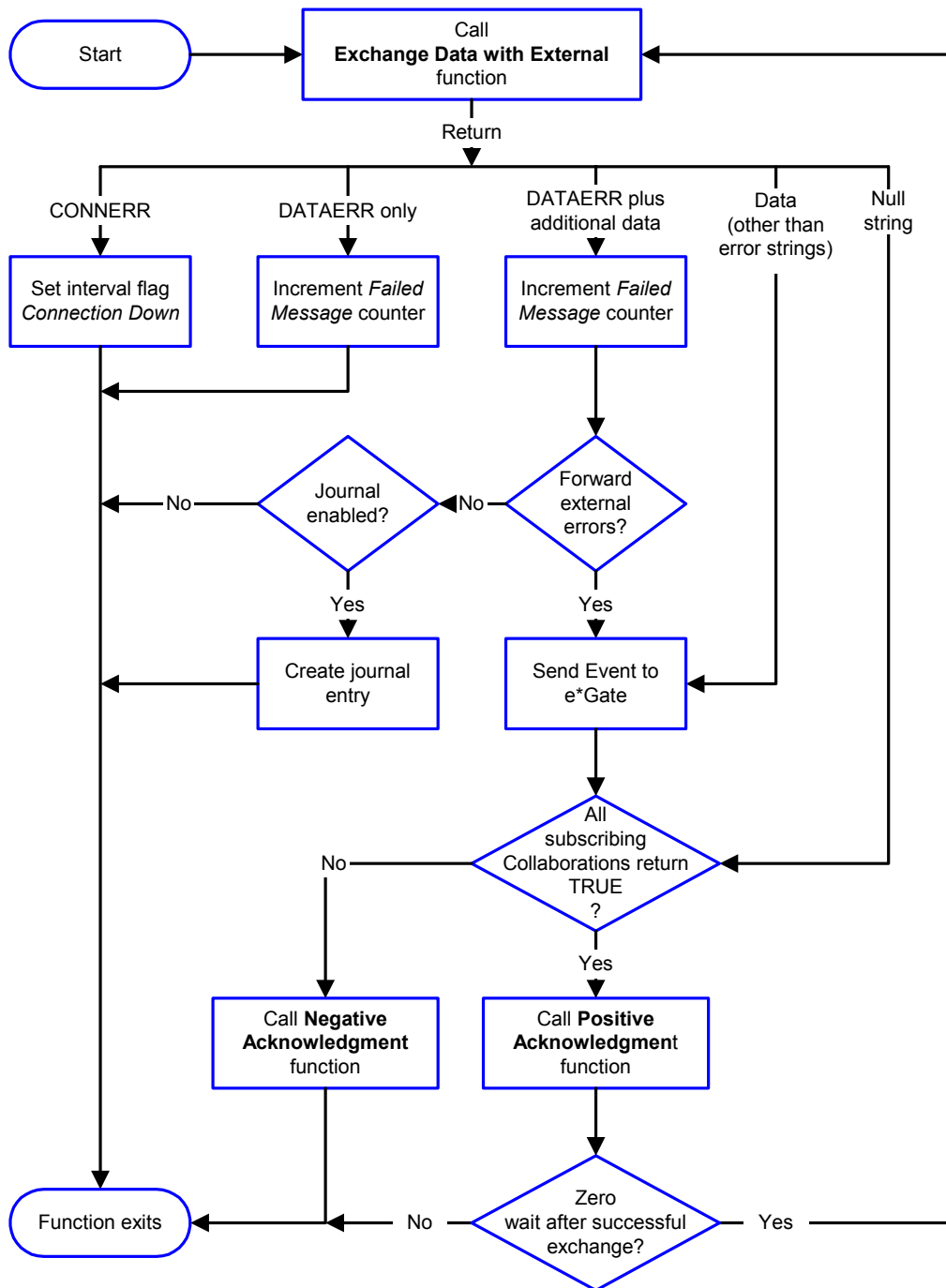

*Start* can occur in any of the following ways:

- *Start Data Exchange* time occurs
- Periodically during data-exchange schedule (after *Start Data Exchange* time, but before *Stop Data Exchange* time), as set by **Exchange Data Interval**
- The **start-schedule** Monk function is called

*Send Events to e\*Gate* can be implemented using any of the following Monk functions:

- **event-send-to-egate**
- **event-send-to-egate-ignore-shutdown**
- **event-send-to-egate-no-commit**

The last of these is used when confirmation of correct transmission is required from the external system. In this case, the e\*Way sends information back to the external system after receiving data. Depending upon whether the acknowledgment is positive or negative, you subsequently use one of the following functions to complete the process (see Figure 37):

- **event-commit-to-egate**
- **event-rollback-to-egate**

**Figure 37** Send Event to e\*Gate with Confirmation

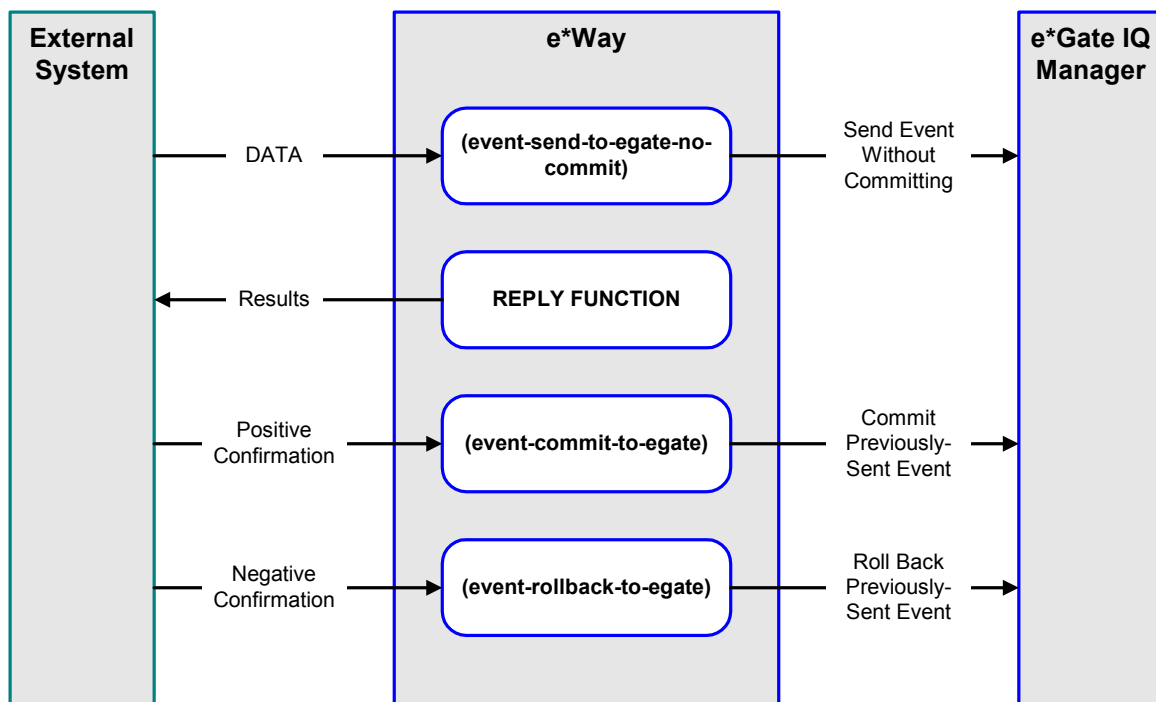

After the function exits, the e\*Way waits for the next *Start* time or command.

## Disconnect from External Process

Figure 38 illustrates how the e\*Way disconnects from the external system, using the **External Connection Shutdown Function**.

**Figure 38** Disconnect Process

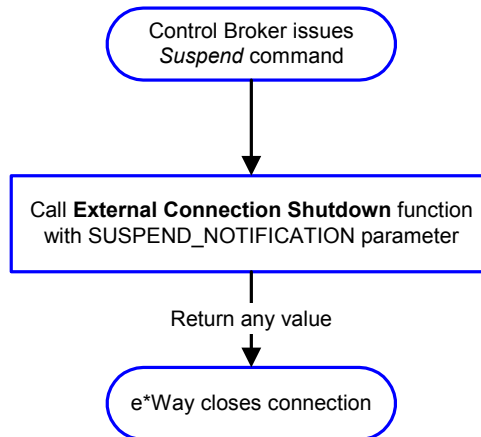

## Shutdown Process

Figure 39 illustrates how the e\*Way shuts itself down, using the **Shutdown Command Notification Function**.

**Figure 39** Shutdown Process

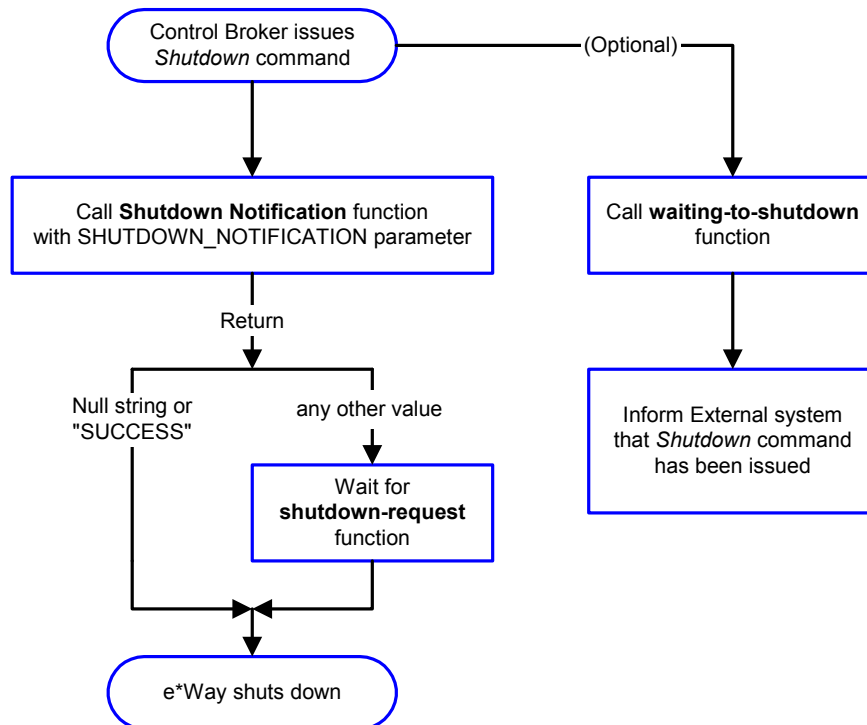

# Configuration Parameters

This chapter describes the configuration parameters for the e\*Way Intelligent Adapter for BroadVision.

---

## 6.1 Overview

The e\*Way's configuration parameters are set using the e\*Way Editor; see [Configuring the e\\*Way](#) on page 44 for procedural information. The BroadVision e\*Way's configuration parameters are organized into the following sections. The default configuration is provided in `ewbv.def`.

[General Settings](#) on page 65

[Communication Setup](#) on page 67

[Monk Configuration](#) on page 69

[BroadVision Settings](#) on page 78



---

## 6.2 General Settings

The General Settings control basic operational parameters.

---

### Journal File Name

#### Description

Specifies the name of the journal file.

#### Required Values

A valid filename, optionally including an absolute path (for example, `c:\temp\filename.txt`). If an absolute path is not specified, the file is stored in the e\*Gate SystemData directory. See the *e\*Gate Integrator System Administration and Operations Guide* for more information about file locations.

#### Additional Information

An Event is Journalled for the following conditions:

- When the number of resends is exceeded (see [Max Resends Per Message](#) below)
  - When its receipt is due to an external error, but [Forward External Errors](#) is set to No
- 

### Max Resends Per Message

#### Description

Specifies the number of times the e\*Way attempts to resend a message (Event) to the external system after receiving an error. When this maximum is reached, the e\*Way waits for the number of seconds specified by the [Resend Timeout](#) parameter, and then rolls back the Event to its publishing IQ.

#### Required Values

An integer between 1 and 1,024. The default is 5.

---

### Max Failed Messages

#### Description

Specifies the maximum number of failed Events that the e\*Way allows. When the specified number of failed Events is reached, the e\*Way shuts down and exits.

#### Required Values

An integer between 1 and 1,024. The default is 3.

---

---

## Forward External Errors

### Description

Selects whether or not error messages received from the external system that begin with the string "DATAERR" is queued to the e\*Way's configured queue. See [Exchange Data with External Function](#) on page 72 for more information.

### Required Values

Yes or No. The default value, No, specifies that error messages are not to be forwarded. See [Data Exchange Process](#) on page 60 for more information about how the e\*Way uses this function.

---

## 6.3 Communication Setup

The Communication Setup parameters control the schedule by which the e\*Way obtains data from the external system.

***Note:** The schedule that you set using the e\*Way's properties in the e\*Gate Enterprise Manager controls when the e\*Way executable runs. The schedule that you set within the parameters discussed in this section (using the e\*Way Editor) determines when data are exchanged. Be sure that you set the "exchange data" schedule to fall within the "run the executable" schedule.*

---

### Start Exchange Data Schedule

#### Description

Establishes the schedule to invoke the e\*Way's **Exchange Data with External Function**.

#### Required Values

One or more schedules. The schedule can specify a date, time, or frequency (such as yearly, weekly, monthly, daily, or every *n* seconds).

**Also required:** If you set a schedule using this parameter, you must also define all three of the following:

- **Exchange Data with External Function**
- **Positive Acknowledgment Function**
- **Negative Acknowledgment Function**

If you do not do so, the e\*Way terminates execution when the schedule attempts to start.

---

### Stop Exchange Data Schedule

#### Description

Establishes the schedule to stop data exchange.

#### Required Values

One or more schedules. The schedule can specify a date, time, or frequency (such as yearly, weekly, monthly, daily, or every *n* seconds).

---

### Exchange Data Interval

#### Description

Determines the number of seconds the e\*Way waits between Event exchange attempts.

#### Required Values

An integer between 1 and 86,400. The default is 10.

---

## Down Timeout

### Description

Specifies the number of seconds that the e\*Way waits between calls to the [External Connection Establishment Function](#).

### Required Values

An integer between 1 and 86,400. The default is 15.

---

## Up Timeout

### Description

Specifies the number of seconds the e\*Way waits between calls to the [External Connection Verification Function](#).

### Required Values

An integer between 1 and 86,400. The default is 15.

---

## Resend Timeout

### Description

Specifies the number of seconds the e\*Way waits between attempts to resend an Event to the external system, after receiving an error message.

### Required Values

An integer between 1 and 86,400. The default is 10.

---

## Zero Wait Between Successful Exchanges

### Description

Specifies whether or not to initiate data exchange after the [Exchange Data Interval](#), or immediately after a successful previous exchange.

### Required Values

Yes or No. The default is No.

If this parameter is set to Yes, the e\*Way immediately invokes the [Exchange Data with External Function](#) if the previous exchange function returned an Event.

If this parameter is set to No, the e\*Way always waits the number of seconds specified by [Exchange Data Interval](#) between invocations of the [Exchange Data with External Function](#).

## 6.4 Monk Configuration

The parameters in this section help you set up the information required by the e\*Way to utilize Monk for communication with the external system. The *functions* that you specify within this section are Monk functions that the e\*Way calls automatically as part of its normal operations. The functions are not called under user control.

All the configuration options in this section—the functions or variables defined, and the additional path information—are loaded into a separate Monk environment than is used by the e\*Way's Collaborations and its Collaboration Rules scripts. You cannot access any of these functions, variables, or path information from Collaboration Rules scripts.

### Specifying Function or File Names

For those parameters that accept a file or the name of a Monk function, the e\*Way presumes that the name of the file is the same as the name of the function to be executed, plus a `.monk` extension. For example, the file `startup.monk` should contain the definition for the function `startup`. If path information is specified, that path is appended to the **Load Path**.

If you specify a file name, be sure that the file has one of the following extensions:

- `.monk`
- `.tsc`
- `.dsc`

### Specifying Multiple Directories

To specify multiple directories, manually enter the directory names rather than selecting them with the **File Selection** button. Directory names must be separated with semicolons, and you can mix absolute paths with relative e\*Gate paths. For example:

```
monk_scripts\my_dir;c:\my_directory
```

The internal e\*Way function that loads this path information is called only once, when the e\*Way first starts up.

### Load Path

The Monk *load path* is the path Monk uses to locate files and data (set internally within Monk). The default load paths are determined by the **SharedExe** and **SystemData** settings in the `.egate.store` file. See the *e\*Gate Integrator System Administration and Operations Guide* for more information about this file.

---

## Additional Path

### Description

Specifies a path to be appended to the **Load Path**. A directory specified here is searched *after* searching the default load path.

### Required Values

A pathname, or a series of paths separated by semicolons. There is no default value for this parameter.

*Note:* This parameter is optional and may be left blank.

### Additional information

The internal e\*Way function that loads this path information is called only once, when the e\*Way first starts up.

---

## Auxiliary Library Directories

### Description

Specifies a path to auxiliary library directories. Any **.monk** files found within those directories is automatically loaded into the e\*Way's Monk environment.

### Required Values

A pathname, or a series of paths separated by semicolons. The default value is **monk\_library/ewbv**.

*Note:* This parameter is optional and may be left blank.

---

## Monk Environment Initialization File

### Description

Specifies a file that contains environment initialization functions, which is loaded after the **Auxiliary Library Directories** are loaded.

### Required Values

A filename within the **Load Path**, or filename plus path information (relative or absolute). If path information is specified, that path is appended to the load path. The default value is **ewbv-init**.

*Note:* This parameter is optional and may be left blank.

### Returns

The string "FAILURE" indicates that the function failed, and the e\*Way exits; any other string, including a *null string*, indicates success.

### Additional information

- Use this feature to initialize the e\*Way's Monk environment (for example, to define Monk variables that are used by the e\*Way's function scripts); it is good practice to initialize any global Monk variables that may be used by any other Monk Extension scripts
- The internal function that loads this file is called once when the e\*Way first starts up
- The e\*Way loads this file and try to invoke a function of the same base name as the file name

---

## Startup Function

### Description

Specifies a Monk function that the e\*Way loads and invokes upon startup or whenever the e\*Way's configuration is reloaded. It is called after the e\*Way loads the specified **Monk Environment Initialization File** and any files within the specified **Auxiliary Library Directories**. This function accepts no input, and must return a string.

This function should be used to initialize the external system before data exchange starts.

### Required Values

The name of a Monk function or the name of a file containing a Monk function. The default value is **bv-startup**.

*Note:* This parameter is optional and may be left blank.

### Returns

The string "FAILURE" indicates that the function failed, and the e\*Way exits; any other string (including a *null string*) indicates success.

---

## Process Outgoing Message Function

### Description

Specifies the Monk function responsible for sending outgoing messages (Events) from the e\*Way to the external system. This function is event-driven, rather than schedule-driven). The function requires a non-null string as input (i.e., the outgoing Event to be sent), and must return a string.

### Required Values

The name of a Monk function or the name of a file containing a Monk function. There is no default value for this parameter.

*Note:* This parameter is **required**, and must **not** be left blank.

## Returns

- A *null string* ("" ) indicates that the Event was published successfully to the external system
- A string beginning with **RESEND** indicates that the Event should be resent
- A string beginning with **CONNERR** indicates that there is a problem with the connection to the external system, and causes a rollback of the Event
- A string beginning with **DATAERR** indicates that there is a problem with the message (Event) data itself, and causes a rollback of the Event
- A string beginning with **SHUTDOWN** indicates that the e\*Way must exit immediately
- If any string other than one of the preceding is returned, the e\*Way creates an entry in the log file indicating that an attempt has been made to access an unsupported function

## Additional Information

- The e\*Way invokes this function when one of its Collaborations publishes an Event to an *external* destination (as specified within the e\*Gate Enterprise Manager).
- Once this function has been called with a *non-null string*, the e\*Way does not process another Event until the current Event has been completely processed.

**Note:** *If you wish to use **event-send-to-egate** to enqueue failed Events in a separate IQ, the e\*Way must have an inbound Collaboration (with appropriate IQs) configured to process those Events.*

---

## Exchange Data with External Function

### Description

Specifies a Monk function that initiates the transmission of data from the external system to the e\*Gate system and forwards that data as an inbound Event to one or more e\*Gate Collaborations. This function is invoked automatically by the **Start Exchange Data Schedule** or manually by the **start-schedule** Monk function, and is responsible for either sending data to or receiving data from the external system. If this function returns data, it is queued to e\*Gate in an inbound Collaboration. The e\*Way must have at least one Collaboration configured suitably to process the inbound Event, as well as any required IQs.

### Required Values

The name of a Monk function or the name of a file containing a Monk function. There is no default value for this parameter.

**Note:** *This parameter is **conditional** and must be supplied only if the **Exchange Data Interval** is set to a non-zero value.*



## Returns

- A *null string* ("" ) indicates that the data exchange was completed successfully, but with no resultant data sent back to the e\*Gate system
- A string beginning with **CONNERR** indicates that there is a problem with the connection to the external system
- A string beginning with **DATAERR** indicates that there is a problem with the message (Event) data itself. If the error string contains data beyond the keyword, the entire string is queued to e\*Gate if an inbound Collaboration is so configured and **Forward External Errors** is set to **Yes**. Queuing, however, is performed without the subsequent sending of a **ACK** or **NAK** to the external system.
- Any other string indicates that the contents of the string are packaged as an inbound Event

## Additional Information

- Data can be queued directly to e\*Gate by using the **event-send-to-egate** Monk function or, if a two-phase approach is required, by using **event-send-to-egate-no-commit** and then **event-commit-to-egate** or **event-rollback-to-egate** to commit or rollback the enqueued events, as appropriate

*Note:* Until an Event is committed, it is not revealed to subscribers of that Event.

---

## External Connection Establishment Function

### Description

Specifies a Monk function that the e\*Way calls (repeatedly) when it has determined that the connection to the external system is down. The function accepts no input and must return a string.

This function is executed according to the interval specified within the **Down Timeout** parameter, and is called *only* according to this schedule. Once the e\*Way has determined that its connection to the external system is up, it calls the **External Connection Verification Function** (see next).

### Required Values

The name of a Monk function or the name of a file containing a Monk function. The default value is **bv-connect**.

*Note:* This parameter is **required**, and must **not** be left blank.

### Returns

- A string beginning with **SUCCESS** or **UP** indicates that the connection was established successfully
- A string beginning with **DOWN** indicates that the connection was not established successfully
- Any other string, including a *null string*, indicates that the attempt to establish the connection failed and the external state is unknown

---

## External Connection Verification Function

### Description

Specifies a Monk function that the e\*Way calls when its internal variables show that the connection to the external system is up. It is executed according to the interval specified within the **Up Timeout** parameter, and is called *only* according to this schedule.

### Required Values

The name of a Monk function or the name of a file containing a Monk function. The default value is **bv-verify-connect**.

*Note:* This parameter is optional and may be left blank.

### Returns

- “SUCCESS” or “UP” indicates that the connection was established successfully
- Any other string (including the null string) indicates that the attempt to establish the connection failed

### Additional Information

If this function is not specified, the e\*Way executes the **External Connection Establishment Function** in its place. This latter function also is called when the e\*Way has determined that its connection to the external system is down.

---

## External Connection Shutdown Function

### Description

Specifies a Monk function that the e\*Way calls to shut down the connection to the external system. This function is invoked only when the e\*Way receives a *suspend* command from a Control Broker.

### Required Values

The name of a Monk function or the name of a file containing a Monk function. The default value is **ewbv-shutdown**.

*Note:* This parameter is **required**, and must **not** be left blank.

### Input

A string indicating the purpose for shutting down the connection.

- “SUSPEND\_NOTIFICATION” - the e\*Way is being suspended or shut down
- “RELOAD\_NOTIFICATION” - the e\*Way is being reconfigured

### Returns

A string, the value of which is ignored. Any return value indicates that the *suspend* command can proceed and that the connection to the external system can be broken immediately.

**Note:** Include in this function any required “clean up” operations that must be performed as part of the shutdown procedure, but before the e\*Way exits.

---

## Positive Acknowledgment Function

### Description

This function is loaded during the initialization process and is called when all data received from the external system has been processed and enqueued successfully.

### Required Values

The name of a Monk function or the name of a file containing a Monk function. The default value is **bv-ack**.

**Note:** This parameter is **conditional** and must be supplied only if the **Exchange Data with External Function** is set to a non-zero value.

### Required Input

A string, the inbound Event to e\*Gate.

### Returns

- The string beginning with CONNERR indicates a problem with the connection to the external system; when the connection is re-established, the function is called again, with the same input data
- Any other string, including a *null string*, indicates that the acknowledgement has been sent to the external system successfully

### Additional Information

- After the **Exchange Data with External Function** returns a string that is transformed into an inbound Event, the Event is handed off to one or more Collaborations for further processing. The e\*Way executes this function only if the Event’s processing is completed successfully by *all* the Collaborations to which it was sent; otherwise, the e\*Way executes the **Negative Acknowledgment Function**.
- This function can return data to be queued, but the e\*Way will *not* acknowledge the data with an ACK or NAK.

**Note:** If you configure the acknowledgment function to return a non-null string, you must configure a Collaboration (with appropriate IQs) to process the returned Event.

---

## Negative Acknowledgment Function

### Description

This function is loaded during the initialization process and is called when the e\*Way fails to process or enqueue data received from the external system successfully.

### Required Values

The name of a Monk function or the name of a file containing a Monk function. The default value is **bv-nak**.

**Note:** *This parameter is **conditional** and must be supplied only if the **Exchange Data with External Function** is set to a non-zero value.*

### Required Input

A string, the inbound Event to e\*Gate.

### Returns

- The string beginning with CONNERR indicates a problem with the connection to the external system; when the connection is re-established, the function is called again, using the same input data
- Any other string, including a *null string*, indicates that the acknowledgement has been sent to the external system successfully

### Additional Information

- This function is called only during the processing of inbound Events. After the **Exchange Data with External Function** returns a string that is transformed into an inbound Event, the Event is handed off to one or more Collaborations for further processing. The e\*Way executes this function if the Event's processing is not completed successfully by *all* the Collaborations to which it was sent; otherwise, the e\*Way executes the **Positive Acknowledgment Function**.
- This function can return data to be queued, but the e\*Way will *not* acknowledge the data with an ACK or NAK.

**Note:** *If you configure the acknowledgment function to return a non-null string, you must configure a Collaboration (with appropriate IQs) to process the returned Event.*

---

## Shutdown Command Notification Function

### Description

The e\*Way calls this Monk function automatically to notify the external system that it is about to shut down. This function also can be used to shut down the connection with the external. The function accepts a string as input and must return a string.

### Required Values

The name of a Monk function or the name of a file containing a Monk function. There is no default value for this parameter.

**Note:** *This parameter is **required**, and must **not** be left blank.*

### Input

When the Control Broker issues a shutdown command to the e\*Way, the e\*Way calls this function with the string "SHUTDOWN\_NOTIFICATION" passed as a parameter.

### Returns

- A *null string* or “SUCCESS” indicates that the shutdown can occur immediately
- Any other string indicates that shutdown must be postponed; once postponed, shutdown does not proceed until the Monk function **shutdown-request** is executed

### Additional Information

If you postpone a shutdown using this function, be sure to use the **shutdown-request** function to complete the process in a timely manner.

---

## 6.5 BroadVision Settings

These configuration parameters set up the BroadVision application.

---

### Version

#### Description

The version of BroadVision One-To-One Enterprise being used.

#### Required Values

Either of the following:

- BV4.1/5.0 (default)
  - BV5.5
- 

### Store Name

#### Description

Name of store or business.

#### Required Values

String. Default: (none).

---

### Agent Name

#### Description

The Agent name for this e\*Way for the purpose of accessing the BroadVision system.

#### Required Values

String. Default: (none).

---

### Desired State

#### Description

Desired state for order retrieval from BroadVision (only orders in the desired state are retrieved by the e\*Way).

#### Required Values

Number between 0 and 999 (see [Predefined States](#) on page 80).

Default: 1

---

## New State

### Description

After orders in the desired state are read from BroadVision and sent to the IQ, the order state is updated to the new state.

### Required Values

Number between 0 and 999 (see [Predefined States](#) on page 80).

Default: 3

---

## Maximum Order Count

### Description

The maximum number of orders to get with a single poll to the BroadVision system.

### Required Values

Range: 1-84,600

Default: 1

---

## Maximum Content Count

### Description

The maximum number of content references to get from the BroadVision system.

### Required Values

Range: 1-84,600

Default: 1

---

## Content Status

### Description

Specifies whether to list *all* contents, or only *online* contents from the BroadVision system.

### Required Values

Either ALL or ONLINE; the default is ALL.

## Predefined States

Number	Name	Message String
0	UnknownOrderState	"Unknown Order State"
1	OrderNew	"New Order"
2	BeingAuthorized	"Payment is being Authorized"
3	WaitFulfillment	"Order is waiting to be Fulfilled"
4	BeingFulfilled	"Order is being Fulfilled"
5	OrderFulfilled	"Order is completely fulfilled"
6	OrderPartiallyFulfilled	"Order is partially fulfilled"
7	WaitReturn	"Payment is waiting to be return/credit back"
8	BeingFullySettled	"Payment is being fully settled"
9	BeingPartiallySettled	"Payment is being partially settled"
10	BeingReturnSettled	"Payment is being return settled"
11	OrderComplete	"Order is complete (fully settled)"
12	OrderPartiallyComplete	"Order is partially complete/settled"
13	OrderReturnComplete	"Payment return/credit complete successfully"
14	OrderCancelled	"Order is cancelled"
101	AuthorizationError	"Cannot authorize payment"
102	FulfillmentError	"Cannot fulfill order"
103	SettlementError	"Cannot settle order"
104	OrderReturnError	"Payment return/credit back failed"
999	UnknownError	"Unknown Error"



# API Functions

---

## 7.1 Overview

As stated earlier, the e\*Way can be viewed as a three-layered structure, consisting of a:

- Business Rules Layer
- BroadVision Transport Layer
- e\*Way Kernel Layer

Each layer contains Monk scripts and/or functions, and makes use of lower-level Monk functions residing in the layer beneath. Developers primarily make use of the functions residing in the upper (BroadVision) layers.

The BroadVision e\*Way's Monk functions fall into the following categories:

- **BroadVision Orders Functions** on page 82
- **BroadVision General Functions** on page 89
- **Generic e\*Way Functions** on page 103

---

## 7.2 BroadVision Orders Functions

These Monk functions have been developed specifically to support the **Orders** business process of a BroadVision One-To-One application.

- [bv-order-complete-fulfill](#) on page 82
- [bv-order-get-accountname](#) on page 83
- [bv-order-get-ordernumber](#) on page 83
- [bv-order-get-orderprop-ordernumber](#) on page 84
- [bv-order-get-orders](#) on page 84
- [bv-order-get-useralias](#) on page 85
- [bv-order-get-userid](#) on page 85
- [bv-order-partial-fulfill](#) on page 86
- [bv-order-set-configured-state](#) on page 86
- [bv-order-start](#) on page 87
- [bv-order-struct-create](#) on page 87
- [bv-order-struct-update](#) on page 88

---

### **bv-order-complete-fulfill**

#### Description

Used to *completely* fill the specified order.

#### Signature

(bv-order-complete-fulfill <order\_number\_string>)

#### Parameters

Name	Type	Description
order_number_string	String	BroadVision order number.

#### Returns

Boolean true (#t) upon success; otherwise, false (#f).

#### Throws

None

#### Location

`bv-order-complete-fulfill.monk`

---

## bv-order-get-accountname

### Description

Used to get the `account_name` that corresponds to the given `user_id`.

### Signature

```
(bv-order-get-accountname <user_id_number>)
```

### Parameters

Name	Type	Description
<code>user_id_number</code>	Num	User ID.

### Returns

Upon success, a string representing the account name that corresponds to the given user ID.

Upon failure, a Boolean false (`#f`).

### Throws

None

### Location

`bv-order-get-accountname.monk`

---

## bv-order-get-ordernumber

### Description

Looks up the BroadVision order number based on the SAP order number property.

### Signature

```
(bv-order-get-ordernumber <sap_order_number_string>)
```

### Parameters

Name	Type	Description
<code>sap_order_number_string</code>	String	SAP order number.

### Returns

Upon success, a string containing the BroadVision order number.

Upon failure, a Boolean false (`#f`).

### Throws

None

### Location

`bv-order-get-ordernumber.monk`

---

## bv-order-get-orderprop-ordernumber

### Description

Looks up the BroadVision order number based on the property name and property value.

### Signature

(bv-order-get-orderprop-ordernumber <prop\_name>\_<prop\_value>)

### Parameters

Name	Type	Description
prop_name	String	Corresponds to PROP_NAME in the MR_ORDER_PROPS table.
prop_value	String	Corresponds to PROP_VALUE in the MR_ORDER_PROPS table.

### Returns

Upon success, a string containing the BroadVision order number.

Upon failure, a Boolean false (#f).

### Throws

None

### Location

bv-order-get-orderprop-ordernumber.monk

**Note:** The property name-value combination must be *unique* to obtain the correct BV order number.

## bv-order-get-orders

### Description

Gets orders corresponding to the desired state. Both the state and the maximum number of orders to get are configured through the GUI.

### Signature

(bv-order-get-orders)

### Parameters

None.

### Returns

Upon success, a string containing the contents of order (empty string is returned when there is no order of the desired state).

Upon failure, a Boolean false (#f).

**Throws**

None

**Location**

`bv-order-get-orders.monk`

---

## bv-order-get-useralias

**Description**

Used to get the user aliases for the given `user_id`.

**Signature**

`(bv-order-get-useralias <user_id_number>)`

**Parameters**

Name	Type	Description
<code>user_id_number</code>	Integer	User ID.

**Returns**

Upon success, returns a string containing user aliases for the given `user_id`.

Upon failure, a Boolean false (`#f`).

**Throws**

None

**Location**

`bv-order-get-useralias.monk`

---

## bv-order-get-userid

**Description**

Used to get a list of user IDs for the given account.

**Signature**

`(bv-order-get-userid <account_name_string>)`

**Parameters**

Name	Type	Description
<code>account_name_string</code>	String	Account name.

**Returns**

Upon success, a vector representing the user IDs associated with the account are returned in a vector of strings.

Upon failure, a Boolean false (#f).

**Throws**

None

**Location**

`bv-order-get-userid.monk`

## bv-order-partial-fulfill

**Description**

Used to *partially* fill the specified order.

**Signature**

`(bv-order-partial-fulfill <order_number_string>)`

**Parameters**

Name	Type	Description
order_number_string	String	BroadVision order number.

**Returns**

Boolean true (#t) upon success; otherwise, false (#f).

**Throws**

None

**Location**

`bv-order-partial-fulfill.monk`

## bv-order-set-configured-state

**Description**

Sets a new state (as configured through the GUI) for the given order number.

**Signature**

`(bv-order-set-configured-state <order_number_string>)`

**Parameters**

Name	Type	Description
order_number_string	String	BroadVision order number.

**Returns**

Boolean true (#t) if the new state is set successfully; otherwise, false (#f).

### Throws

None

### Location

`bv-order-set-state.monk`

---

## bv-order-start

### Description

Prepares to create/update an order.

### Signature

```
(bv-order-internal <ordernumber_string>)
```

### Parameters

Name	Type	Description
ordernumber_string	String	

### Returns

Boolean true (**#t**) upon success; otherwise, false (**#f**).

### Throws

None

### Location

`bv-order-internal.monk`

---

## bv-order-struct-create

### Description

Creates an order with the specified fields in **node-path**.

### Signature

```
(bv-order-struct-create <node-path>)
```

### Parameters

Name	Type	Description
node-path	Path	Path to node containing specified field.

### Returns

Upon success, the order number for the new object.

Upon failure, a Boolean false (**#f**).

### Throws

None

### Location

**bv-order-struct-create.monk**

*Note: Only those fields whose MAP subfield has a value of 1 are used.*

---

## bv-order-struct-update

### Description

Modifies an order with the specified fields in **node-path**.

### Signature

(bv-order-struct-update <node-path>)

### Parameters

Name	Type	Description
node-path	Path	Path to node containing specified field.

### Returns

Upon success, the order number for the new object.

Upon failure, a Boolean false (#f).

### Throws

None

### Location

**bv-order-struct-update.monk**

*Note: Only those fields whose MAP subfield has a value of 1 are used.*



---

## 7.3 BroadVision General Functions

These Monk functions have been developed specifically to control communications between the BroadVision e\*Way and the BroadVision One-To-One application, and are external to the e\*Way kernel.

- [bv-startup](#) on page 89
- [bv-connect](#) on page 90
- [bv-verify-connect](#) on page 90
- [bv-ack](#) on page 91
- [bv-nak](#) on page 91
- [bv-category-create](#) on page 92
- [bv-category-delete](#) on page 92
- [bv-category-get-cat-entry](#) on page 93
- [bv-category-move](#) on page 94
- [bv-category-rename](#) on page 94
- [bv-cnt-delete](#) on page 95
- [bv-cnt-get-productname](#) on page 95
- [bv-cnt-sql-select](#) on page 96
- [bv-cnt-struct-create](#) on page 97
- [bv-cnt-struct-update](#) on page 97
- [bv-content-ref-create](#) on page 98
- [bv-content-ref-delete](#) on page 98
- [bv-content-ref-list](#) on page 99
- [bv-date-to-sap-date](#) on page 100
- [sap-date-to-bv-date](#) on page 101
- [ewbv-init](#) on page 100
- [ewbv-shutdown](#) on page 101

---

### **bv-startup**

#### **Description**

A dummy **STARTUP** function.

#### **Signature**

(bv-startup)

### Parameters

None.

### Returns

The string "SUCCESS" indicates success, "FAILURE" indicates failure.

### Throws

None

### Location

bv.monk

---

## bv-connect

### Description

Initializes a connection to the BroadVision system; for example, initializing an order manager.

### Signature

(bv-connect)

### Parameters

None.

### Returns

The string "UP" indicates connection is up (operational); "DOWN" indicates connection is down (non-operational).

### Throws

None.

### Location

bv.monk

---

## bv-verify-connect

### Description

Verifies the connection with the BroadVision system.

### Signature

(bv-verify-connect)

### Parameters

None.

### Returns

The string "UP" indicates connection is up (operational); "DOWN" indicates connection is down (non-operational).

**Throws**

None

**Location**

**bv.monk**

---

**bv-ack**

**Description**

A dummy ACK function.

**Signature**

(bv-ack)

**Parameters**

None.

**Returns**

An empty string.

**Throws**

None

**Location**

**bv.monk**

---

**bv-nak**

**Description**

A dummy NAK function.

**Signature**

(bv-nak)

**Parameters**

None.

**Returns**

An empty string.

**Throws**

None

**Location**

**bv.monk**

## bv-category-create

### Description

Creates a new (child) category under the specified parent category, having the specified name.

### Signature

```
(bv-category-create <cat_name> <parent_oid> <store_id> <content_type>
<status>)
```

### Parameters

Name	Type	Description
cat_name	String	Category name.
parent_oid	Integer	Object ID of parent category.
store_id	Integer	Store ID number.
content_type	Integer	Type of content.
status	Integer	Status.

### Returns

Upon success, returns an integer representing the object ID.

Upon failure, a Boolean false (#f).

### Throws

If you create a category that already exists, you get a Monk exception.

### Location

`bv-category-create.monk`

### Examples

```
(display (bv-category-create "Printers" 0 101 0 1)) (newline) -8012
```

## bv-category-delete

### Description

Deletes a category having an object ID of “categorical”.

### Signature

```
(bv-category-delete <category_oid>)
```

### Parameters

Name	Type	Description
category_oid	OID	Object ID of desired category.

### Returns

Boolean true (#t) if the category deletes successfully; otherwise, false (#f).

### Throws

None

### Location

**bv-category-delete.monk**

### Examples

```
(display (bv-category-delete -8048)) (newline)
```

## bv-category-get-cat-entry

### Description

Gets the category entry for the named category.

### Signature

```
(bv-category-get-cat-entry <category_name>)
```

### Parameters

Name	Type	Description
category-oid	OID	Object ID of desired category.

### Returns

A vector of 8 items from **bv\_category** table:

```
#(oid type parent_oid store_id content_type status deleted always_0)
```

If category doesn't exist, it returns a vector of all zeros:

```
#(0 0 0 0 0 0 0 0)
```

### Throws

None

### Location

**bv-category-get-cat-entry.monk**

### Examples

```
(display (bv-category-get-cat-entry "Computers")) (newline) #(-8047 2  
0 101 0 1 0 0)
```

```
(display (vector-ref (bv-category-get-cat-entry "Computers") 0)) -  
8047
```

## bv-category-move

### Description

Moves the specified category to a new branch, giving it the new object ID.

### Signature

```
(bv-category-move <old_oid> <new_oid>)
```

### Parameters

Name	Type	Description
old_oid	Integer	Current object ID of desired category.
new_oid	Integer	New object ID for specified category.

### Returns

Boolean true (**#t**) if the function concludes successfully; otherwise, false (**#f**).

### Throws

None

### Location

bv-category-move.monk

### Examples

```
(display (bv-category-move -8043 -8047)) (newline)
```

*Note:* Supported only by BroadVision release 5.5 and above.

## bv-category-rename

### Description

Renames the category having the specified object ID with the specified name.

### Signature

```
(bv-category-rename <category_oid> <new_name>)
```

### Parameters

Name	Type	Description
category_oid	OID	Object ID of category to be renamed.
new_name	String	New name for category having object ID of category_oid.

### Returns

Boolean true (#t) if the category is renamed successfully; otherwise, false (#f).

### Throws

None

### Location

`bv-category-rename.monk`

### Examples

```
(display (bv-category-rename -8047 "NewCategoryName")) (newline)
```

---

## bv-cnt-delete

### Description

Used to delete the content object indicated by the content key value.

### Signature

```
(bv-cnt-delete <content_type_name_string> <cnt_key_value_string>)
```

### Parameters

Name	Type	Description
content-type-name-string	String	Content type name.
cnt-key-value-string	String	Content key value.

### Returns

Boolean true (#t) if the category deletes successfully; otherwise, false (#f).

### Throws

None

### Location

`bv-cnt-delete.monk`

---

## bv-cnt-get-productname

### Description

Used to get the name of the product whose `prod_id` is specified.

### Signature

```
(bv-cnt-get-productname <prod_id_string>)
```

### Parameters

Name	Type	Description
prod_id	String	Product ID.

### Returns

Upon success, a string representing the name of the specified product.

Upon failure, a Boolean false (#f).

### Throws

None

### Location

bv-cnt-get-productname.monk

## bv-cnt-sql-select

### Description

Used to query the database with the following SQL statement:

```
SELECT <field_name> FROM <table_name> WHERE <condition>.
```

### Signature

```
(bv-cnt-sql-select <field_name_string> <table_name_string>  
 <condition_string>)
```

### Parameters

Name	Type	Description
field_name	String	Name of data field.
table_name	String	Name of table in which the data field is located.
condition	String	Location of table.

### Returns

Upon success, a vector of Monk strings. Elements of this vector are values of the specified field, returned as strings.

Upon failure, a Boolean false (#f).

### Throws

None

### Location

bv-cnt-sql-select.monk



## bv-cnt-struct-create

### Description

Creates a content-type object with the specified fields in `node-path`. Note that the `user_id` defaults to 0, as recommended by BroadVision.

### Signature

(bv-cnt-struct-create <node-path>)

### Parameters

Name	Type	Description
node-path	String	Path to node containing specified field.

### Returns

Upon success, an integer representing the object ID number for the newly created object.

Upon failure, a Boolean false (#f).

### Throws

None

### Location

bv-cnt-struct-create.monk

*Note:* Only those fields whose MAP subfield has a value of 1 are used.

## bv-cnt-struct-update

### Description

Updates the fields of a content-type object whose key value is `cnt_key_value_string`.

### Signature

(bv-cnt-struct-update <node\_path> <cnt\_key\_value\_string>)

### Parameters

Name	Type	Description
node_path	String	Path to node containing specified field.
cnt_key_value_string	String	Key value of the object whose fields are to be updated.

### Returns

Boolean true (#t) if the fields update successfully; otherwise, false (#f).

### Throws

None

### Location

**bv-cnt-struct-update.monk**

*Note:* Only those fields whose MAP subfield has a value of 1 are used.

## bv-content-ref-create

### Description

Assigns a list of content references to a category.

### Signature

```
(bv-content-ref-create <parent_oid> <oid_list>)
```

### Parameters

Name	Type	Description
parent_oid	Integer	Object ID of parent category.
oid_list	List	List of object IDs for categories containing desired content.

### Returns

Boolean true (#t) if the function concludes successfully; otherwise, false (#f).

### Throws

None

### Location

**bv-content-ref-create.monk**

### Example

```
(display (bv-content-ref-create -8043 1 2 3 4 5)) (newline)
```

### Additional Information

- 1 Make sure that the products exist before creating content references.
- 2 If a content reference already exists, it is not created again—but the function still returns #t.
- 3 The list of object IDs can have any number of elements, but *must* have at least one.

## bv-content-ref-delete

### Description

Removes a list of content references from the parent\_oid.

### Signature

```
(bv-content-ref-delete <parent_oid> <oid_list>)
```

### Parameters

Name	Type	Description
parent_oid	Integer	Object ID of parent category.
oid_list	List	List of object IDs for categories containing desired content.

### Returns

Boolean true (#t) if the function concludes successfully; otherwise, false (#f).

### Throws

None

### Location

`bv-content-ref-delete.monk`

### Example

```
(display (bv-content-ref-create -8043 1 2 3 4 5)) (newline)
```

### Additional Information

- 1 Make sure that the products exist before removing content reference.
- 2 If you attempt to remove a non-existent content reference, nothing is removed, but the function still returns #t.
- 3 The list of object IDs can have any number of elements, but *must* have at least one.

## bv-content-ref-list

### Description

Retrieves a list of contents belonging to a category, according to the configured parameters.

You can specify “all” or “online” categories.

**BroadVision Settings > Content Status: ALL or ONLINE**

You can specify the maximum number to retrieve.

**BroadVision Settings > Maximum Content Count: range: 1 - 86400, default: 1.**

### Signature

```
(bv-content-ref-list <oid>)
```

### Parameters

Name	Type	Description
oid	Integer	Object ID of desired category.

### Returns

Upon success, a vector of OIDs belonging to the category, for example:  **#(8204 8580)**

### Throws

None

### Location

**bv-content-ref-list.monk**

### Example

```
(display (bv-content-ref-list -8047)) (newline)
```

---

## bv-date-to-sap-date

### Description

Converts BroadVision date format **mm/dd/yy hh:mm:ss** to SAP date format **yyyymmdd**.

### Signature

```
(bv-date-to-sap-date <bv_date_string> <decade>)
```

### Parameters

Name	Type	Description
bv_date_string	String	Date in BroadVision format.
decade	String	Determines 20th or 21st Century.

### Returns

A string representing the date in SAP format.

### Throws

None

### Location

**bv-util.monk**

---

## ewbv-init

### Description

Reads in the configuration parameters and establishes the Monk environment.

### Signature

```
(ewbv-init)
```

### Parameters

None.

### Returns

The string "SUCCESS" indicates success, "FAILURE" indicates failure.

### Throws

None

### Location

ewbv-init.monk

---

## ewbv-shutdown

### Description

Shuts down the BroadVision e\*Way.

### Signature

(ewbv-shutdown)

### Parameters

None.

### Returns

An empty string.

### Throws

None.

### Location

ewbv-shutdown.monk

---

## sap-date-to-bv-date

### Description

Converts SAP date format `yyyymmdd` to BroadVision date format `mm/dd/yyyy`.

### Signature

(sap-date-to-bv-date <sap\_date\_string>)

### Parameters

Name	Type	Description
sap_date_string	String	Date in SAP format.

### Returns

A string representing the date in BroadVision format.

### Throws

None

## Location

`bv-util.monk`

## 7.4 Generic e\*Way Functions

The functions described in this section control the e\*Way's most basic operations, and can only be used by the functions defined within the e\*Way's configuration file. None of these functions is available to Collaboration Rules scripts executed by the e\*Way.

The current set of basic Monk functions is:

- [event-commit-to-egate](#) on page 103
- [event-rollback-to-egate](#) on page 104
- [event-send-to-egate](#) on page 104
- [event-send-to-egate-ignore-shutdown](#) on page 105
- [event-send-to-egate-no-commit](#) on page 105
- [get-logical-name](#) on page 106
- [insert-exchange-data-event](#) on page 106
- [send-external-up](#) on page 107
- [send-external-down](#) on page 107
- [shutdown-request](#) on page 108
- [start-schedule](#) on page 108
- [stop-schedule](#) on page 109
- [waiting-to-shutdown](#) on page 109

---

### event-commit-to-egate

#### Description

Commits the Event sent previously to the e\*Gate system using [event-send-to-egate-no-commit](#).

#### Signature

```
(event-commit-to-egate <string>)
```

#### Parameters

Name	Type	Description
string	string	The data to be sent to the e*Gate system.

#### Returns

Boolean true (**#t**) if the data is committed successfully; otherwise, false (**#f**).

#### Throws

None.

---

## event-rollback-to-egate

### Description

Rolls back the Event sent previously to the e\*Gate system using **event-send-to-egate-no-commit**, following receipt of a rollback command from the external system.

### Signature

(event-rollback-to-egate <string>)

### Parameters

Name	Type	Description
string	string	The data to be rolled back to the e*Gate system.

### Returns

Boolean true (#t) if the data is rolled back successfully; otherwise, false (#f).

### Throws

None.

---

## event-send-to-egate

### Description

Sends data that the e\*Way has already received from the external system into the e\*Gate system as an Event.

### Signature

(event-send-to-egate <string>)

### Parameters

Name	Type	Description
string	string	The data to be sent to the e*Gate system

### Returns

A Boolean true (#t) if the data is sent successfully; otherwise, a Boolean false (#f).

### Throws

None.

### Additional information

This function can be called by any e\*Way function when it is necessary to send data to the e\*Gate system in a blocking fashion.



See also

[event-send-to-egate-ignore-shutdown](#) on page 105

[event-send-to-egate-no-commit](#) on page 105

## event-send-to-egate-ignore-shutdown

### Description

Sends data that the e\*Way has already received from the external system into the e\*Gate system as an Event—but ignores any pending shutdown issues.

### Signature

```
(event-send-to-egate-ignore-shutdown <string>)
```

### Parameters

Name	Type	Description
string	string	The data to be sent to the e*Gate system.

### Returns

Boolean true (#t) if the data is sent successfully; otherwise, false (#f).

### Throws

None.

See also

[event-send-to-egate](#) on page 104

[event-send-to-egate-no-commit](#) on page 105

## event-send-to-egate-no-commit

### Description

Sends data that the e\*Way has received from the external system to the e\*Gate system as an Event—but without Committing, pending confirmation from the external system of correct transmission of the data.

### Signature

```
(event-send-to-egate-no-commit <string>)
```

### Parameters

Name	Type	Description
string	string	The data to be sent to the e*Gate system.

### Returns

Boolean true (#t) if the data is sent successfully; otherwise, false (#f).

### Throws

None.

### See also

[event-commit-to-egate](#) on page 103

[event-rollback-to-egate](#) on page 104

[event-send-to-egate](#) on page 104

[event-send-to-egate-ignore-shutdown](#) on page 105

---

## get-logical-name

### Description

Returns the logical name of the e\*Way.

### Signature

(get-logical-name)

### Parameters

None.

### Returns

The name of the e\*Way (as defined by the e\*Gate Enterprise Manager).

### Throws

None.

---

## insert-exchange-data-event

### Description

While the [Exchange Data with External Function](#) is still active, this function can be called to initiate a repeat call to it—whether or not data was queued to e\*Gate via the function's return mechanism following the initial call.

### Signature

(insert-exchange-data-event)

### Parameters

None.

### Returns

None.

### Throws

None.

### See also

[Exchange Data Interval](#) on page 67

[Zero Wait Between Successful Exchanges](#) on page 68

---

## send-external-up

### Description

Informs the e\*Way that the connection to the external system is up.

### Signature

(send-external-up)

### Parameters

None.

### Returns

None.

### Throws

None.

---

## send-external-down

### Description

Informs the e\*Way that the connection to the external system is down.

### Signature

(send-external-down)

### Parameters

None.

### Returns

None.

### Throws

None.

---

## shutdown-request

### Description

Completes the e\*Gate shutdown procedure that was initiated by the Control Broker but was interrupted by returning a non-null value within the [Shutdown Command Notification Function](#). Once this function is called, shutdown proceeds immediately.

### Signature

(shutdown-request)

### Parameters

None.

### Returns

None.

### Throws

None.

### Additional Information

Once interrupted, the e\*Way's shutdown cannot proceed until this Monk function is called. If you do interrupt an e\*Way shutdown, we recommend that you complete the process in a timely fashion.

---

## start-schedule

### Description

Requests that the e\*Way execute the [Exchange Data with External Function](#) specified within the e\*Way's configuration file. Does not affect any defined schedules.

### Signature

(start-schedule)

### Parameters

None.

### Returns

None.

### Throws

None.

---

## stop-schedule

### Description

Requests that the e\*Way halt execution of the [Exchange Data with External Function](#) specified within the e\*Way's configuration file. Execution is stopped when the e\*Way concludes any open transaction. Does not effect any defined schedules, and does not halt the e\*Way process itself.

### Signature

(stop-schedule)

### Parameters

None.

### Returns

None.

### Throws

None.

---

## waiting-to-shutdown

### Description

Informs the external application that a shutdown command has been issued.

### Signature

(waiting-to-shutdown)

### Parameters

None.

### Returns

Boolean true (**#t**) if successful; otherwise, false (**#f**).

### Throws

None.

# Index

## A

Additional Path parameter 70  
 Agent Name parameter 78  
 APIs - see functions, Monk  
 Assigning ETDs to Event Types 34  
 Autorun 17  
 Auxiliary Library Directories parameter 70

## B

BroadVision Converter 12  
 bv-ack function 91  
 bv-category-create function 92  
 bv-category-delete function 92  
 bv-category-get-cat-entry function 93  
 bv-category-move function 94  
 bv-category-rename function 94  
 bv-cnt-delete function 95  
 bv-cnt-get-produstname function 95  
 bv-cnt-sql-select function 96  
 bv-cnt-struct-create function 97  
 bv-cnt-struct-update function 97  
 bv-connect function 90  
 bv-content-ref-create function 98  
 bv-content-ref-delete function 98  
 bv-content-ref-list function 99  
 bv-date-to-sap-date function 100  
 bv-nak function 91  
 bv-order-complete-fulfill function 82  
 bv-order-get-accountname function 83  
 bv-order-get-ordernumber function 83  
 bv-order-get-orderprop-ordernumber function 84  
 bv-order-get-orders function 84  
 bv-order-get-useralias function 85  
 bv-order-get-userid function 85  
 bv-order-partial-fulfill function 86  
 bv-order-set-configured-state function 86  
 bv-order-start function 87  
 bv-order-struct-create function 87  
 bv-order-struct-update function 88  
 bv-startup function 89  
 bv-verify-connect function 90

## C

Changing the User Name 48  
 Collaboration 35, 53, 54, 56  
   Rules 56  
 configuration  
   BroadVision Settings 78–80  
   Communication Setup 67–68  
   General Settings 65–66  
   Monk Configuration 69–77  
 configuration parameters  
   Additional Path 70  
   Agent Name 78  
   Auxiliary Library Directories 70  
   Desired State 78  
   Down Timeout 68  
   Exchange Data With External Function 72  
   Exchange Event Interval 67  
   External Connection Establishment Function 73  
   External Connection Shutdown Function 74  
   External Connection Verification Function 74  
   Forward External Errors 66  
   Journal File Name 65  
   Max Failed Events 65  
   Max Resends Per Event 65  
   Maximum Content Count 79  
   Maximum Order Count 79  
   Monk Environment Initialization File 70  
   Negative Acknowledgment Function 75  
   New State 79  
   Positive Acknowledgement Function 75  
   Process Outgoing Event 71  
   Resend Timeout 68  
   Shutdown Command Notification Function 76  
   Start Exchange Data Schedule 67  
   Startup Function 71  
   Stop Exchange Data Schedule 67  
   Store Name 78  
   Up Timeout 68  
   Version 78  
   Zero Wait Between Successful Exchanges 68  
 configuration procedures 44  
 conventions, writing in document 9  
 Converter, BroadVision 12  
 Creating an e\*Way 42

## D

Desired State parameter 78  
 Down Timeout parameter 68

## E

e\*Way

- configuration 44
- creating 42
- Installation 17
- Properties 43
- Schedules 48
- Startup Options 48
- troubleshooting 53
- Enterprise Manager 28
- Event Type 34
- Event Type Definition (ETD) 31, 34
- event-commit-to-egate function 103
- event-rollback-to-egate function 104
- Events 55
- event-send-to-egate function 104
- event-send-to-egate-ignore-shutdown function 105
- event-send-to-egate-no-commit function 105
- ewbv-init function 100
- ewbv-shutdown function 101
- Exchange Data with External Function parameter 72
- Exchange Event Interval parameter 67
- External Connection Establishment Function parameter 73
- External Connection Shutdown Function parameter 74
- External Connection Verification Function parameter 74

## F

- File e\*Way 37, 39
- Forward External Errors parameter 66
- functions (see also functions, Monk)
  - BroadVision General 89–102
  - BroadVision Orders 82–88
  - Generic 103–109
- functions, Monk
  - bv-ack 91
  - bv-category-create 92
  - bv-category-delete 92
  - bv-category-get-cat-entry 93
  - bv-category-move 94
  - bv-category-rename 94
  - bv-cnt-delete 95
  - bv-cnt-get-productname 95
  - bv-cnt-sql-select 96
  - bv-cnt-struct-create 97
  - bv-cnt-struct-update 97
  - bv-connect 90
  - bv-content-ref-create 98
  - bv-content-ref-delete 98
  - bv-content-ref-list 99
  - bv-date-to-sap-date 100
  - bv-nak 91
  - bv-order-complete-fulfill 82

- bv-order-get-accountname 83
- bv-order-get-ordernumber 83
- bv-order-get-orderprop-ordernumber 84
- bv-order-get-orders 84
- bv-order-get-useralias 85
- bv-order-get-userid 85
- bv-order-partial-fulfill 86
- bv-order-set-configured-state 86
- bv-order-start 87
- bv-order-struct-create 87
- bv-order-struct-update 88
- bv-startup 89
- bv-verify-connect 90
- event-commit-to-egate 103
- event-rollback-to-egate 104
- event-send-to-egate 104
- event-send-to-egate-ignore-shutdown 105
- event-send-to-egate-no-commit 105
- ewbv-init 100
- ewbv-shutdown 101
- get-logical-name 106
- insert-exchange-data-event 106
- sap-date-to-bv-date 101
- send-external down 107
- send-external-up 107
- shutdown-request 108
- start-schedule 108
- stop-schedule 109
- waiting-to-shutdown 109

## G

- Generic e\*Way Functions 103–109
- get-logical-name function 106

## I

- implementation 26
- insert-exchange-data-event function 106
- Installation procedure
  - e\*Way (UNIX) 21
  - e\*Way (Windows) 17
  - sample schema 24
- InstallShield 17
- Intelligent Queue (IQ) 11, 12, 36

## J

- Journal File Name parameter 65

## L

- Load Path, Monk 69

logging options 50

## M

Max Failed Events parameter 65  
Max Resends Per Event parameter 65  
Maximum Content Count parameter 79  
Maximum Order Count parameter 79  
monitoring thresholds 51  
Monk Configuration

- Load Path 69
- Specifying File Names 69
- Specifying Function Names 69
- Specifying Multiple Directories 69

Monk Environment Initialization File parameter 70  
Monk functions - see functions, Monk

## N

Negative Acknowledgment Function parameter 75  
New State parameter 79

## O

Order Management API 11, 12

## P

Participating Host 53  
Positive Acknowledgment Function parameter 75  
Predefined State Table 80  
procedures

- configuration 44
- installation 17

Process Outgoing Event Function parameter 71  
Properties, e\*Way 43

## Q

Queue - see Intelligent Queue (IQ)

## R

Resend Timeout parameter 68

## S

sample schema

- descriptions 36
- installation 24

sap-date-to-bv-date function 101  
Schedules 48  
send-external down function 107

send-external-up function 107  
Setting Startup Options or Schedules 48  
Shutdown Command Notification Function parameter 76  
shutdown-request function 108  
Start Exchange Data Schedule parameter 67  
start-schedule function 108  
Startup Function parameter 71  
Startup Options 48  
States, Predefined 80  
Stop Exchange Data Schedule parameter 67  
stop-schedule function 109  
Store Name parameter 78

## T

TCP/IP 15  
troubleshooting the e\*Way 53

## U

UNIX installation procedure 21  
Up Timeout parameter 68  
User name 48  
Using the e\*Gate Enterprise Manager 28

## V

Version parameter 78

## W

waiting-to-shutdown function 109  
Windows installation procedure 17

## Z

Zero Wait Between Successful Exchanges parameter 68