



Sun Fire™ B1600 Blade System Chassis DIMM Replacement Guide For The B200x Blade

Sun Microsystems, Inc.
4150 Network Circle
Santa Clara, CA 95054 U.S.A.
650-960-1300

Part No. 817-3434-10
July 2003, Revision A

Send comments about this document to: docfeedback@sun.com

Copyright 2003 Sun Microsystems, Inc., 4150 Network Circle, Santa Clara, California 95054, U.S.A. All rights reserved.

Sun Microsystems, Inc. has intellectual property rights relating to technology embodied in the product that is described in this document. In particular, and without limitation, these intellectual property rights may include one or more of the U.S. patents listed at <http://www.sun.com/patents> and one or more additional patents or pending patent applications in the U.S. and in other countries.

This document and the product to which it pertains are distributed under licenses restricting their use, copying, distribution, and decompilation. No part of the product or of this document may be reproduced in any form by any means without prior written authorization of Sun and its licensors, if any.

Third-party software, including font technology, is copyrighted and licensed from Sun suppliers.

Parts of the product may be derived from Berkeley BSD systems, licensed from the University of California. UNIX is a registered trademark in the U.S. and in other countries, exclusively licensed through X/Open Company, Ltd.

Sun, Sun Microsystems, the Sun logo, AnswerBook2, docs.sun.com, Netra, Netra ft, Sun Fire, and Solaris are trademarks or registered trademarks of Sun Microsystems, Inc. in the U.S. and in other countries.

All SPARC trademarks are used under license and are trademarks or registered trademarks of SPARC International, Inc. in the U.S. and in other countries. Products bearing SPARC trademarks are based upon an architecture developed by Sun Microsystems, Inc. The Energy Star logo is a registered trademark of EPA.

The OPEN LOOK and Sun™ Graphical User Interface was developed by Sun Microsystems, Inc. for its users and licensees. Sun acknowledges the pioneering efforts of Xerox in researching and developing the concept of visual or graphical user interfaces for the computer industry. Sun holds a non-exclusive license from Xerox to the Xerox Graphical User Interface, which license also covers Sun's licensees who implement OPEN LOOK GUIs and otherwise comply with Sun's written license agreements.

Use, duplication, or disclosure by the U.S. Government is subject to restrictions set forth in the Sun Microsystems, Inc. license agreements and as provided in DFARS 227.7202-1(a) and 227.7202-3(a) (1995), DFARS 252.227-7013(c)(1)(ii) (Oct. 1998), FAR 12.212(a) (1995), FAR 52.227-19, or FAR 52.227-14 (ALT III), as applicable.

DOCUMENTATION IS PROVIDED "AS IS" AND ALL EXPRESS OR IMPLIED CONDITIONS, REPRESENTATIONS AND WARRANTIES, INCLUDING ANY IMPLIED WARRANTY OF MERCHANTABILITY, FITNESS FOR A PARTICULAR PURPOSE OR NON-INFRINGEMENT, ARE DISCLAIMED, EXCEPT TO THE EXTENT THAT SUCH DISCLAIMERS ARE HELD TO BE LEGALLY INVALID.

Copyright 2003 Sun Microsystems, Inc., 4150 Network Circle, Santa Clara, California 95054, Etats-Unis. Tous droits réservés.

Sun Microsystems, Inc. a les droits de propriété intellectuelle relatants à la technologie incorporée dans le produit qui est décrit dans ce document. En particulier, et sans la limitation, ces droits de propriété intellectuelle peuvent inclure un ou plus des brevets américains énumérés à <http://www.sun.com/patents> et un ou les brevets plus supplémentaires ou les applications de brevet en attente dans les Etats-Unis et dans les autres pays.

Ce produit ou document est protégé par un copyright et distribué avec des licences qui en restreignent l'utilisation, la copie, la distribution, et la décompilation. Aucune partie de ce produit ou document ne peut être reproduite sous aucune forme, par quelque moyen que ce soit, sans l'autorisation préalable et écrite de Sun et de ses bailleurs de licence, s'il y en a.

Le logiciel détenu par des tiers, et qui comprend la technologie relative aux polices de caractères, est protégé par un copyright et licencié par des fournisseurs de Sun.

Des parties de ce produit pourront être dérivées des systèmes Berkeley BSD licenciés par l'Université de Californie. UNIX est une marque déposée aux Etats-Unis et dans d'autres pays et licenciée exclusivement par X/Open Company, Ltd.

Sun, Sun Microsystems, le logo Sun, AnswerBook2, docs.sun.com, Netra, Netra ft, Sun Fire, et Solaris sont des marques de fabrique ou des marques déposées de Sun Microsystems, Inc. aux Etats-Unis et dans d'autres pays.

Toutes les marques SPARC sont utilisées sous licence et sont des marques de fabrique ou des marques déposées de SPARC International, Inc. aux Etats-Unis et dans d'autres pays. Les produits portant les marques SPARC sont basés sur une architecture développée par Sun Microsystems, Inc.

L'interface d'utilisation graphique OPEN LOOK et Sun™ a été développée par Sun Microsystems, Inc. pour ses utilisateurs et licenciés. Sun reconnaît les efforts de pionniers de Xerox pour la recherche et le développement du concept des interfaces d'utilisation visuelle ou graphique pour l'industrie de l'informatique. Sun détient une licence non exclusive de Xerox sur l'interface d'utilisation graphique Xerox, cette licence couvrant également les licenciés de Sun qui mettent en place l'interface d'utilisation graphique OPEN LOOK et qui en outre se conforment aux licences écrites de Sun.

LA DOCUMENTATION EST FOURNIE "EN L'ÉTAT" ET TOUTES AUTRES CONDITIONS, DECLARATIONS ET GARANTIES EXPRESSES OU TACITES SONT FORMELLEMENT EXCLUES, DANS LA MESURE AUTORISEE PAR LA LOI APPLICABLE, Y COMPRIS NOTAMMENT TOUTE GARANTIE IMPLICITE RELATIVE A LA QUALITE MARCHANDE, A L'APTITUDE A UNE UTILISATION PARTICULIERE OU A L'ABSENCE DE CONTREFAÇON.



Replacing DIMMs in the Sun B200x Blade

This document provides the procedures for installing DIMMs in the Sun Fire B200x blade, and contains the following sections:

- “Before You Start” on page 1
 - “Replacing the DIMM” on page 2
 - “Installing the Blade” on page 8
-

Before You Start

Check that either the blue ‘Ready to Remove’, or amber ‘service required’ LED is lit on the blade you want to remove from the system chassis.

Note – Do not remove the blade until one of these LED states is displayed.

See the *Sun Fire B1600 Blade System Chassis Administration Guide* for details of how to shut down the blade safely.



Caution – Operating the system chassis with empty blade slots might disrupt airflow through the system chassis and will compromise EMC compliance.

Replacing the DIMM

This section provides the following procedures:

- “To Remove the Existing DIMM” on page 2
- “To Install the New DIMM” on page 5

▼ To Remove the Existing DIMM



Caution – Use proper ESD grounding techniques when handling components. Wear an antistatic wrist strap and use an ESD-protected mat. Store ESD-sensitive components in antistatic bags before placing them on any surface.

1. Remove the blade cover screws (FIGURE 1).

Use a Phillips No. 2 screwdriver to remove the screws.

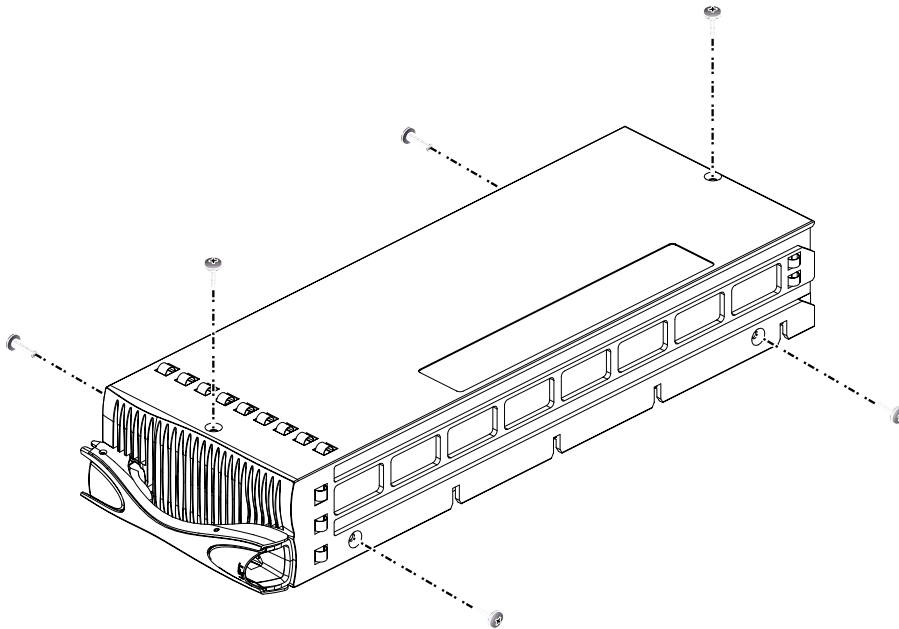

FIGURE 1 Removing the Blade Cover Screws

2. Lift the blade cover away from the blade (FIGURE 2).

Slide the cover off and then lift it away from the blade body.

Caution – Lift the blade cover perpendicularly away from the blade to ensure that the integrity of the blade EMI fingers is not affected.

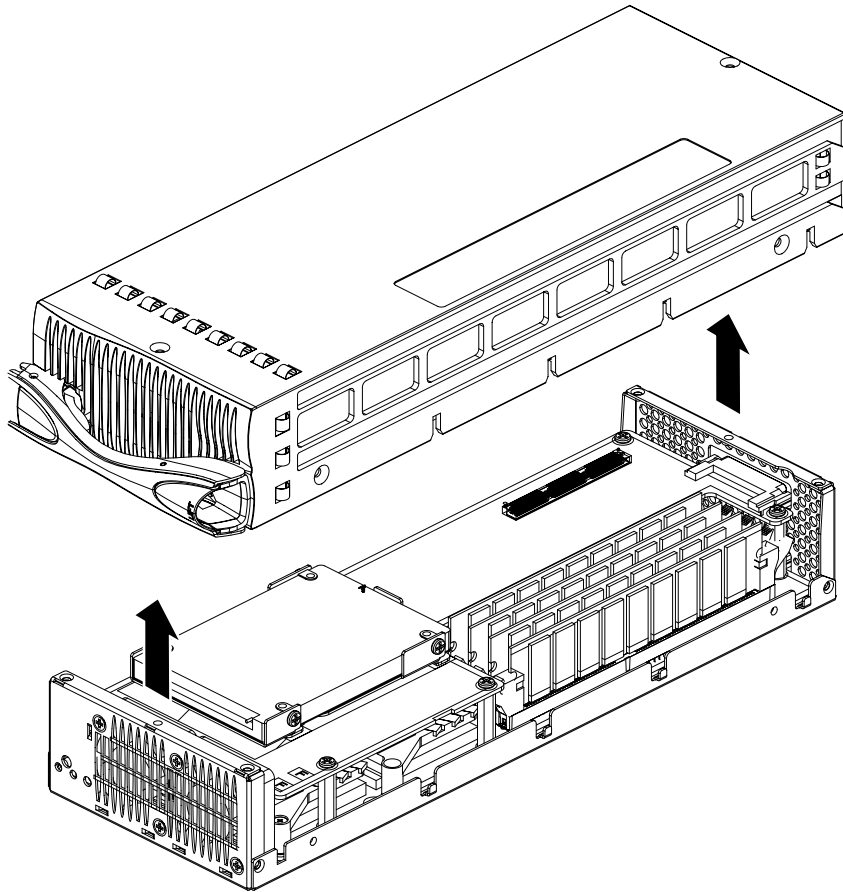

FIGURE 2 Lifting the Blade Cover Away From the Blade

3. Remove the DIMMs by pressing the DIMM ejectors firmly (FIGURE 3).

Note – You must remove the front DIMMs if you require access to the back DIMMs.



Caution – Do not use a screwdriver to lever the ejectors. The use of excessive force might cause damage to both the ejector and other blade components.

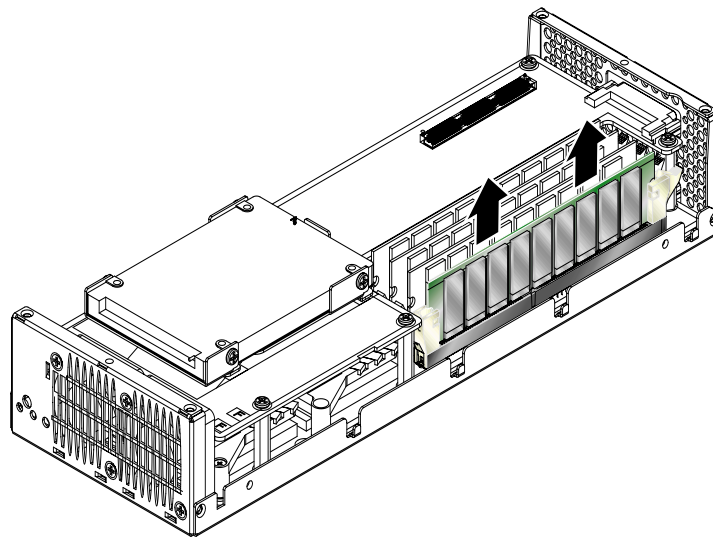
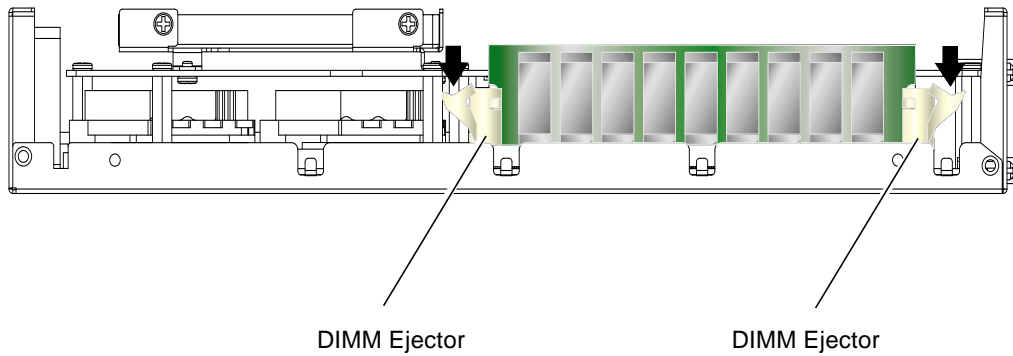

FIGURE 3 Removing the Existing DIMM

▼ To Install the New DIMM

The B200x blade has four DIMM slots. In a standard configuration, slots 2A and 2B are populated. Additional DIMM pairs should be installed in slots 1A and 1B.

Note – DIMMs should be replaced in pairs. A DIMM pair must be of the same size, type and manufacturer.

Note – DIMM slot 2A must always be populated.

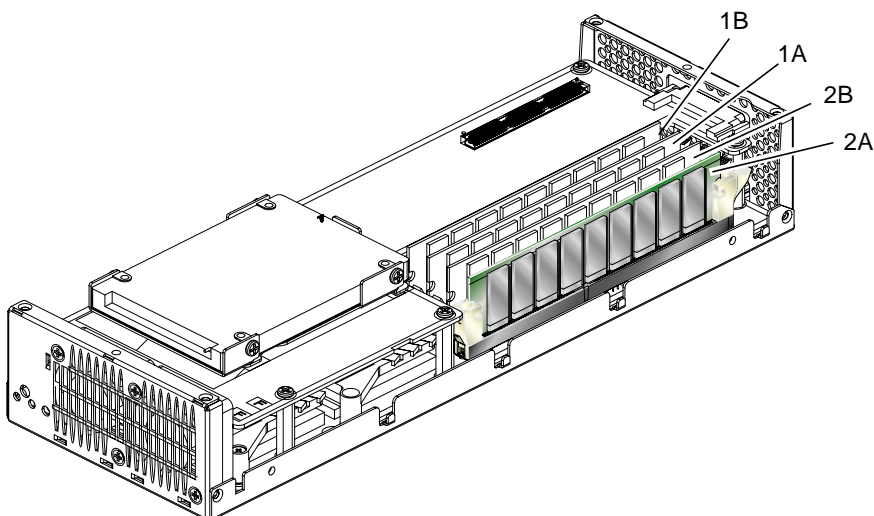

1. **Unpack the replacement DIMM.**
2. **Insert the DIMM into the vacant DIMM slot.**
3. **Press the DIMM until the DIMM ejectors engage on the edges of the DIMM (FIGURE 4).**

Note – The DIMM ejectors might not engage fully. Press the top of the DIMM firmly to until each ejector is in place.



Caution – Do not use a screwdriver to lever the ejectors in place. The use of excessive force might cause damage to both the ejector and other blade components.

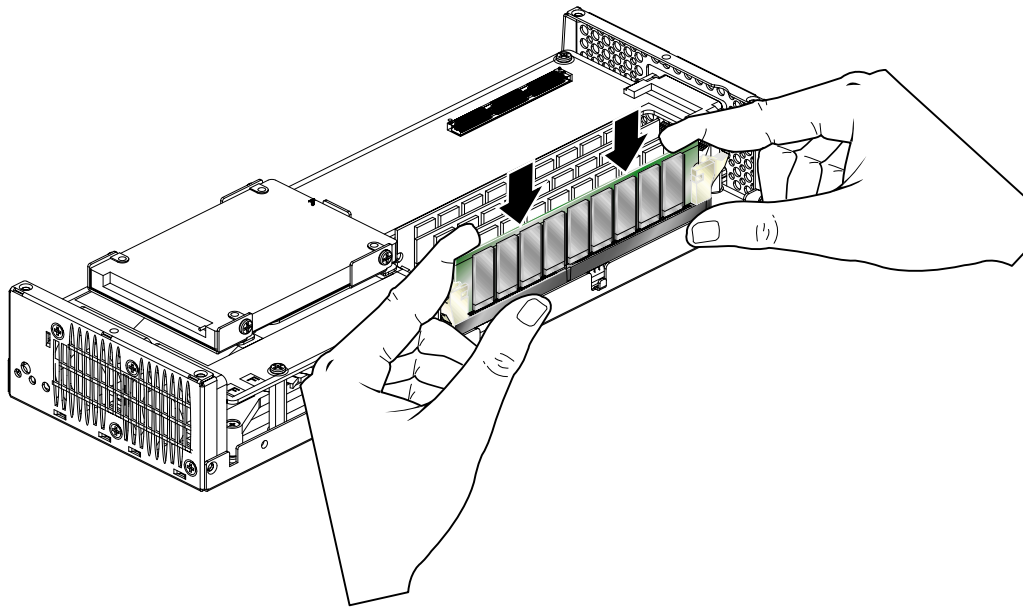
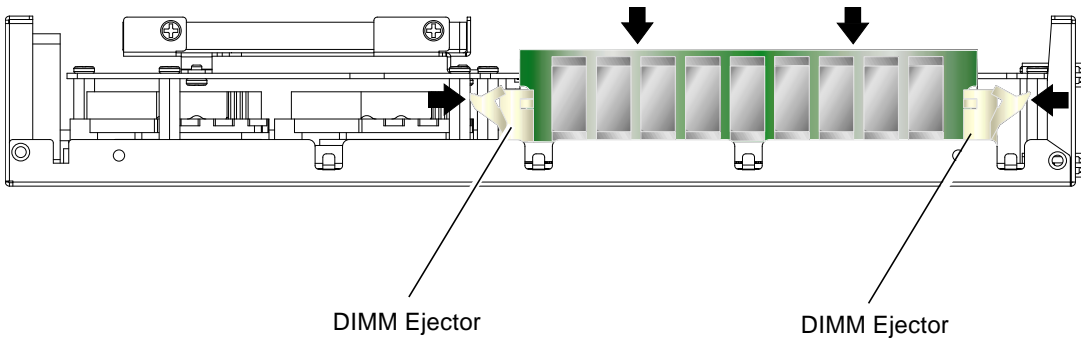

FIGURE 4 Engaging the DIMM Ejectors

4. Place the blade cover on to the blade (FIGURE 5).

Keep the blade cover level with the blade chassis and slide the cover in position. Check that the bottom retention lugs of the chassis engage in the blade cover.

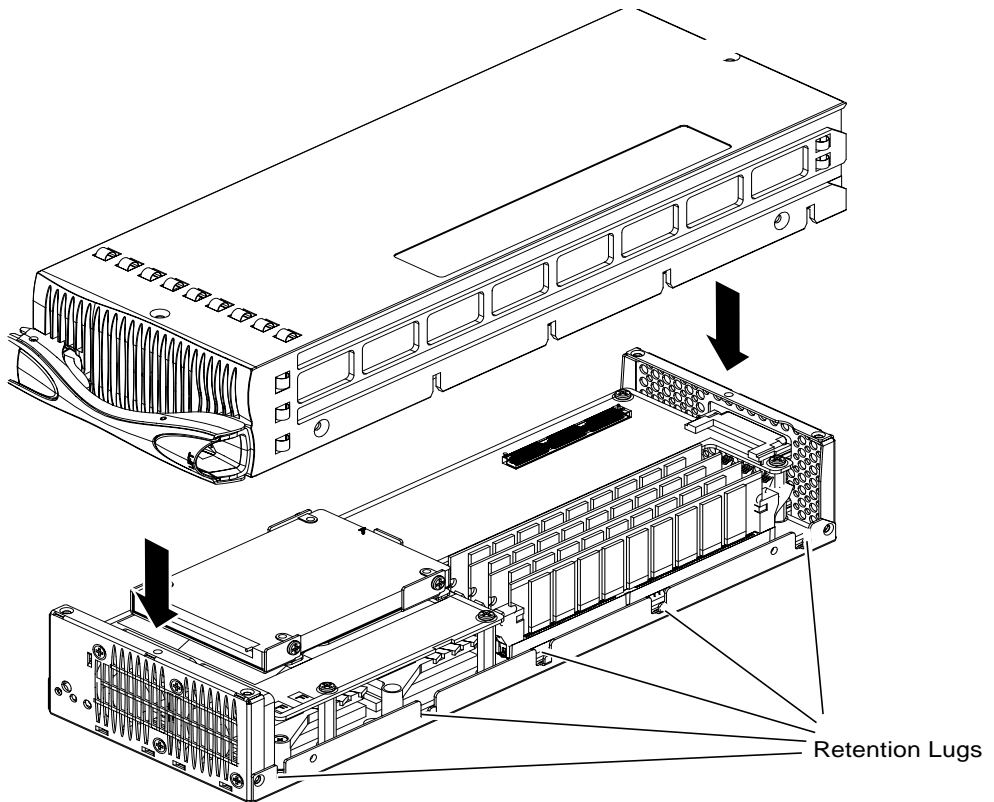

FIGURE 5 Lowering the DIMM Cover on to The Blade Enclosure

5. Attach the blade cover to the blade enclosure with the blade cover screws.

Installing the Blade

The system chassis is designed to operate with all blade slots populated with either blades and/or filler panels.



Caution – Operating the system chassis with empty blade slots might disrupt airflow through the system chassis and will compromise EMC compliance.

See the *Sun Fire B200x Server Blade Installation and Setup Guide* for details of how to install the blade into the system chassis, and how to bring the blade online.