

Sun Blade™ X6250 Server Module Service Manual

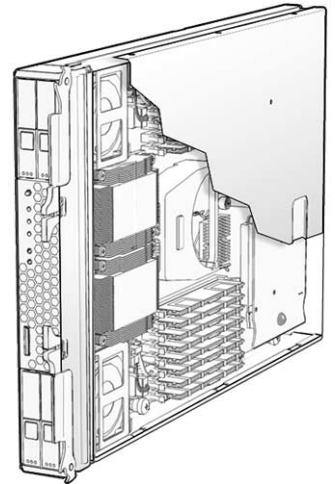

Sun Microsystems, Inc.
www.sun.com

Part No. 820-1185-17
May 2009, Revision A

Submit comments about this document by clicking the Feedback[+] link at: <http://docs.sun.com>

Copyright © 2009 Sun Microsystems, Inc., 4150 Network Circle, Santa Clara, California 95054, U.S.A. All rights reserved.

This distribution may include materials developed by third parties.

Sun, Sun Microsystems, the Sun logo, Java, Netra, Solaris, Sun Ray and Sun Blade X6250 Server Module are trademarks or registered trademarks of Sun Microsystems, Inc., or its subsidiaries, in the U.S. and other countries.

Intel® is a trademark or registered trademark of Intel Corporation or its subsidiaries in the United States and other countries. Intel® Xeon® is a trademark or registered trademark of Intel Corporation or its subsidiaries in the United States and other countries. Intel Inside® is a trademark or registered trademark of Intel Corporation or its subsidiaries in the United States and other countries.

This product is covered and controlled by U.S. Export Control laws and may be subject to the export or import laws in other countries. Nuclear, missile, chemical biological weapons or nuclear maritime end uses or end users, whether direct or indirect, are strictly prohibited. Export or reexport to countries subject to U.S. embargo or to entities identified on U.S. export exclusion lists, including, but not limited to, the denied persons and specially designated nationals lists is strictly prohibited.

Use of any spare or replacement CPUs is limited to repair or one-for-one replacement of CPUs in products exported in compliance with U.S. export laws. Use of CPUs as product upgrades unless authorized by the U.S. Government is strictly prohibited.

Copyright © 2009 Sun Microsystems, Inc., 4150 Network Circle, Santa Clara, California 95054, Etats-Unis. Tous droits réservés.

Cette distribution peut inclure des éléments développés par des tiers.

Sun, Sun Microsystems, le logo Sun, Java, Netra, Solaris, Sun Ray et Sun Blade X6250 Server Module sont des marques de fabrique ou des marques déposées de Sun Microsystems, Inc., ou ses filiales, aux Etats-Unis et dans d'autres pays.

Intel® est une marque de fabrique ou une marque déposée de Intel Corporation ou de sa filiale aux Etats-Unis et dans d'autres pays . Intel® Xeon® est une marque de fabrique ou une marque déposée de Intel Corporation ou de sa filiale aux Etats-Unis et dans d'autres pays . Intel Inside® est une marque de fabrique ou une marque déposée de Intel Corporation ou de sa filiale aux Etats-Unis et dans d'autres pays

Ce produit est soumis à la législation américaine sur le contrôle des exportations et peut être soumis à la réglementation en vigueur dans d'autres pays dans le domaine des exportations et importations. Les utilisations finales, ou utilisateurs finaux, pour des armes nucléaires, des missiles, des armes biologiques et chimiques ou du nucléaire maritime, directement ou indirectement, sont strictement interdites. Les exportations ou reexportations vers les pays sous embargo américain, ou vers des entités figurant sur les listes d'exclusion d'exportation américaines, y compris, mais de manière non exhaustive, la liste de personnes qui font objet d'un ordre de ne pas participer, d'une façon directe ou indirecte, aux exportations des produits ou des services qui sont régis par la législation américaine sur le contrôle des exportations et la liste de ressortissants spécifiquement désignés, sont rigoureusement interdites.

L'utilisation de pièces détachées ou d'unités centrales de remplacement est limitée aux réparations ou à l'échange standard d'unités centrales pour les produits exportés, conformément à la législation américaine en matière d'exportation. Sauf autorisation par les autorités des Etats-Unis, l'utilisation d'unités centrales pour procéder à des mises à jour de produits est rigoureusement interdite.



Please
Recycle



Adobe PostScript

Contents

Preface xiii

1. Introduction to the Sun Blade X6250 Server Module 1-1

1.1 Features of the Servers 1-1

1.2 Sun Blade X6250 Server Module Orientation 1-2

1.2.1 Server Module Front Panel 1-2

1.2.2 Server Module Components 1-4

1.3 Using a Dongle Cable for Testing 1-4

▼ To Use a Dongle Cable for Testing 5

1.4 Accessory Kits 1-6

1.5 Additional Options and Replaceable Components 1-7

1.6 Customer Replaceable Units (CRUs) and Field Replaceable Units (FRUs)
1-7

2. Powering On and Configuring BIOS Settings 2-1

2.1 Powering On the Server 2-1

▼ To Power On the Server 2

2.2 Powering Off the Server 2-3

2.3 Configuring BIOS Settings 2-4

2.3.1 Changing the Configuration of a BIOS Menu Item 2-5

2.3.2 BIOS Considerations 2-5

- 2.3.2.1 PCI Card Slot Booting Priority 2-6
- 2.3.2.2 Ethernet Port Device and Driver Naming 2-6
- 2.3.2.3 Ethernet Port (NIC) Booting Priority 2-7
- 2.3.2.4 BIOS Option ROM Size Limitation 2-7
- 2.3.3 Descriptions of the BIOS Setup Utility Screens 2-7
- 2.3.4 BIOS Setup Utility Menu Screens 2-9
 - 2.3.4.1 BIOS Main Menu Screen 2-9
 - 2.3.4.2 Advanced Settings 2-10
 - 2.3.4.3 CPU Configuration 2-11
 - 2.3.4.4 Memory Configuration 2-12
 - 2.3.4.5 IDE Configuration 2-13
 - 2.3.4.6 Primary IDE Master 2-14
 - 2.3.4.7 Secondary IDE Master 2-15
 - 2.3.4.8 Super I/O Configuration 2-16
 - 2.3.4.9 Trusted Computing 2-17
 - 2.3.4.10 USB Configuration 2-18
 - 2.3.4.11 PCI Configuration 2-19
 - 2.3.4.12 MPS Configuration 2-20
 - 2.3.4.13 Event Log Configuration 2-21
 - 2.3.4.14 Boot Menu 2-22
 - 2.3.4.15 Hard Disk Drives 2-23
 - 2.3.4.16 Boot Settings 2-24
 - 2.3.4.17 Boot Device Priority 2-25
 - 2.3.4.18 Server 2-26
 - 2.3.4.19 AST2000 LAN Configuration 2-27
 - 2.3.4.20 IP Address 2-28
 - 2.3.4.21 MAC Address 2-29
 - 2.3.4.22 Subnet Mask 2-30

2.3.4.23	Remote Access Configuration	2–31
2.3.4.24	Security Settings	2–32
2.3.4.25	Exit	2–33
2.4	Resetting the BIOS Password and Clearing CMOS	2–34
2.5	Resetting the Service Processor Password Using the BIOS Setup Utility	2–36
▼	To Reset the SP Password Using the BIOS Setup Utility	37
2.6	Updating the BIOS	2–37
2.7	Power-On Self-Test (POST)	2–38
3.	Maintaining the Server	3–1
3.1	Monitoring System Components	3–2
3.1.1	Monitoring System Components Through the Service Processor	3–2
3.1.2	Monitoring System Components Through System Status LED	3–2
3.1.2.1	External Status Indicator LEDs	3–2
3.1.2.2	Internal Status Indicator LEDs	3–5
3.2	Tools and Supplies Needed	3–6
3.3	Removing the Server Module From the Chassis and Removing the Cover	3–7
3.3.1	Removing the Server Module From the Chassis	3–7
3.3.2	Removing the Main Cover	3–9
3.4	Locations of Replaceable Components	3–10
3.5	Replaceable Component Procedures	3–11
3.5.1	Replacing the Coin Battery	3–11
▼	To Replace the Coin Battery	11
3.5.2	Replacing the Compact Flash Module	3–13
▼	To Replace the Compact Flash Module	13
3.5.3	Replacing Memory Modules (DIMMs)	3–14
3.5.3.1	DIMM Population Rules	3–15

- ▼ To Replace DIMMs 16
 - 3.5.3.2 Error Correction and Parity 3–18
- 3.5.4 Replacing a CPU and Heatsink 3–18
 - ▼ To Replace a CPU and Heatsink 18
- 3.5.5 Replacing the Motherboard 3–25
 - ▼ To Replace the Motherboard 25
- 3.5.6 Replacing a Hard Disk 3–26
 - 3.5.6.1 RAID Configuration 3–27
 - 3.5.6.2 Solid State Drives (SSDs) 3–27
 - 3.5.6.3 HD Replacement Procedure 3–28
 - ▼ To Replace a Hard Disk 28
- 3.5.7 Adding or Replacing a RAID Expansion Module 3–31
 - ▼ To Add, Remove or Replace a REM Board 31
- 3.5.8 Restoring an Existing RAID Array After Changing the REM 3–34
 - ▼ To Restore a RAID Array After Replacing a REM Card 35
- 3.5.9 Changing the Sun Blade RAID 5 Expansion Module Battery 3–35
- 3.5.10 Replacing a Fabric Expansion Module 3–37
 - ▼ To Install Fabric Expansion Module 37
 - ▼ To Remove a Fabric Expansion Module 40

4. Performing Diagnostic Tests 4-1

- 4.1 Pc-Check Diagnostics Overview 4-1
 - ▼ To Access the Pc-Check Diagnostics 2
- 4.2 System Information Menu 4-3
- 4.3 Advanced Diagnostics 4-4
- 4.4 Hard Disk Testing 4-6
 - ▼ To Select and Test a Hard Disk 6
- 4.5 Burn-In Testing 4-8
 - 4.5.1 Performing Immediate Burn-In Testing 4-8

- ▼ To Perform Immediate Burn-in Testing 8
 - 4.5.2 Performing Deferred Burn-In Testing 4-10
 - ▼ To Perform Deferred Burn-in Testing 10
 - 4.6 Diagnostic Partition 4-11
 - 4.7 Show Results Summary 4-11
 - 4.8 Print Results Report 4-12
 - 4.9 About Pc-Check 4-12
 - 4.10 Exit 4-13
- 5. Updating the ELOM Firmware 5-1**
 - 5.1 Updating BIOS, CPLD and the SP 5-1
 - ▼ To Update BIOS, CPLD and the SP 1
 - 5.2 Updating the CPLD 5-2
 - ▼ To Update CPLD (Common Programmable Logic Device) on the Motherboard 3
 - 5.3 Updating the REM Firmware 5-3
 - ▼ To Update the REM Firmware from a DOS-Bootable USB Thumb Drive 3
- A. System Specifications A-1**
 - A.1 Server Module Specifications A-1
- B. BIOS Power-On Self-Test (POST) Codes B-1**
 - B.1 Introduction B-1
 - B.2 How BIOS POST Memory Testing Works B-2
 - B.3 Redirecting Console Output B-2
 - ▼ To Redirect Console Output 2
 - B.4 Changing POST Options B-4
 - ▼ To Change POST Options 4
 - B.5 POST Codes B-5

Index Index-1

Figures

- FIGURE 1-1 Server Module Front Panel 1–3
- FIGURE 1-2 Server Module Replaceable Component Locations 1–4
- FIGURE 1-3 Dongle Cable Connections 1–5
- FIGURE 2-1 Power Button and Power/OK LED Location 2–3
- FIGURE 2-2 Ethernet Port Chassis Labeling Designations 2–6
- FIGURE 2-3 Server Module NIC Naming 2–6
- FIGURE 2-4 Server Module BIOS Setup Utility Menu Tree 2–8
- FIGURE 2-5 Location of Jumpers J19 and J23 2–36
- FIGURE 3-1 External LED Location 3–3
- FIGURE 3-2 Fault Indicator Button 3–6
- FIGURE 3-3 Removing a Server Module 3–8
- FIGURE 3-4 Removing the Main Cover 3–9
- FIGURE 3-5 Location of CPU Components 3–10
- FIGURE 3-6 Removing the Battery 3–13
- FIGURE 3-7 Replacing the Compact Flash 3–14
- FIGURE 3-8 DIMM Slots and Fault Indicator Button 3–16
- FIGURE 3-9 Removing a DIMM 3–17
- FIGURE 3-10 Fault Remind Button 3–19
- FIGURE 3-11 CPU Locations 3–20
- FIGURE 3-12 Removing the Heatsink and CPU 3–21

- FIGURE 3-13 Replacing the CPU 3–23
- FIGURE 3-14 Applying Thermal Grease 3–24
- FIGURE 3-15 Designation of Hard Disk Disks 3–27
- FIGURE 3-16 Removing the Hard Disk Drive After Removing the Server Module 3–29
- FIGURE 3-17 Removing the Hard Disk Drive Without Removing the Server Module 3–30
- FIGURE 3-18 Inserting the REM 3–32
- FIGURE 3-19 HD Backplane Connectors 3–34
- FIGURE 3-20 REM Battery Screws and Connectors 3–37
- FIGURE 3-21 Removing the Connector Cap 3–38
- FIGURE 3-22 Installation of a Fabric Expansion Module 3–39
- FIGURE 3-23 Removing a Fabric Expansion Module 3–41

Tables

TABLE 1-1	Summary Comparison of Features	1–2
TABLE 1-2	DB9 Port Pinouts	1–6
TABLE 1-3	Accessory Kit	1–6
TABLE 1-4	CRU and FRU List	1–8
TABLE 2-1	BIOS Setup Utility Screens Summary	2–7
TABLE 3-1	Front Panel LED Functions	3–4
TABLE 3-2	Internal LED Functions	3–6
TABLE 3-3	DIMM Slots and Locations	3–15
TABLE 4-1	System Information Menu Options	4–3
TABLE 4-2	Advanced Diagnostics Test Menu Options	4–5
TABLE 4-3	Continuous Burn-In Testing Options	4–9
TABLE A-1	Server Module Physical Specifications	A–1
TABLE A-2	Server Module Environmental Specifications	A–1
TABLE B-1	Error Messages and Responses	B–5

Preface

This *Sun Blade™ X6250 Server Module Service Manual* contains information and procedures for maintaining and upgrading the Sun Blade X6250 server module.

Related Documentation

For a description of the document set for the Sun Blade X6250 modular server, see the *Where to Find Documentation* sheet that is packed with your system and also posted at:

<http://docs.sun.com>

This web site provides translated versions of some of these documents in French, Simplified Chinese, Traditional Chinese, Korean, and Japanese. English documentation is revised more frequently and might be more up-to-date than the translated documentation.

For all Sun hardware documentation:

<http://docs.sun.com>

Sun Welcomes Your Comments

Sun is interested in improving its documentation and welcomes your comments and suggestions. You can submit your comments by going to:

<http://www.sun.com/hwdocs/feedback>

Please include the title and part number of your document with your feedback:

Sun Blade X6250 Server Module Service Manual, 820-1185-17

Introduction to the Sun Blade X6250 Server Module

This chapter contains overviews of the Sun Blade X6250 server module. It contains the following sections:

- [Section 1.1, “Features of the Servers” on page 1-1](#)
- [Section 1.2, “Sun Blade X6250 Server Module Orientation” on page 1-2](#)
- [Section 1.3, “Using a Dongle Cable for Testing” on page 1-4](#)
- [Section 1.4, “Accessory Kits” on page 1-6](#)
- [Section 1.5, “Additional Options and Replaceable Components” on page 1-7](#)
- [Section 1.6, “Customer Replaceable Units \(CRUs\) and Field Replaceable Units \(FRUs\)” on page 1-7](#)

1.1 Features of the Servers

The Sun Blade X6250 server module is designed to fit into the Sun Blade 6000 chassis system. The Sun Blade X6250 server module supports two Intel Xeon 5000 series processors and embedded I/O that provides PCI-Express, SAS, and Gigabit Ethernet interfaces to the Sun Blade 6000 chassis midplane, and four SAS (with RAID Expansion Module) or SATA drive interfaces at the front of the server module. Server monitoring is performed by an onboard IPMI 2.0 compliant service processor with Integrated Lights Out Manager (iLOM) or an Embedded Lights Out Manager (ELOM).

[TABLE 1-1](#) summarizes the features of the server module.

TABLE 1-1 Summary Comparison of Features

Feature or Component	Specifications
CPU	Up to two Intel Xeon 5000 series dual-core or quad-core processors
Memory	Up to 8 fully buffered ECC DIMMs per CPU (up to 64 GB capacity using 4 GB DIMMs)
Hard Disks (HDs)	Four Serial-Attached SCSI (SAS) or Serial ATA (SATA) HDs (2.5 inch) or four Solid State Drives (SSDs)
Service Processor	Onboard IPMI 2.0 compliant service processor (SP) with Integrated Lights Out Manager or Embedded Lights Out Manager. One 10/100 Management Ethernet Port to Midplane Remote Keyboard/Video/Mouse (KVMs) over IP
RAID options	Four-channel SAS RAID disk controller
Midplane I/O	<ul style="list-style-type: none">• Four 8-lane PCI-Express, one per Network Express Module (NEM)• Two 10/100/1000 Gigabit Ethernet, one per NEM• 10/100 Ethernet management port to the Chassis Control Module (CMM), which serves as the service processor for the Sun Blade 6000 chassis
Front Panel I/O	Dongle connector that interfaces to: <ul style="list-style-type: none">• VGA Graphics• Serial Console to SP• Dual USB ports (keyboard/mouse)
Compact Flash	IDE Compact Flash Module Interface

1.2 Sun Blade X6250 Server Module Orientation

This section contains illustrations that you can use to become familiar with the components of the Sun Blade X6250 server module.

1.2.1 Server Module Front Panel

[FIGURE 1-1](#) shows the features of the front panel.

FIGURE 1-1 Server Module Front Panel

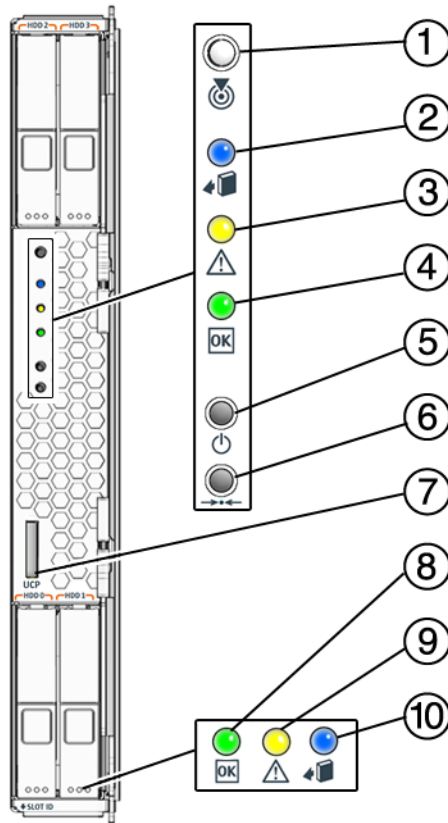

Figure Legend

-
- 1 Locate button/indicator (white)
 - 2 Ready to Remove indicator (blue)
 - 3 Service Action Required / Fault (amber)
 - 4 System Status Indicator (green)
 - 5 Power on/standby button
 - 6 For service use only
 - 7 UCP (universal connector port) to connect dongle cable
 - 8 HD OK/Activity Indicator (green)
 - 9 HD Fault/Locate Indicator (amber)
 - 10 HD Ready to Remove Indicator (blue)
-

1.2.2 Server Module Components

FIGURE 1-2 shows the locations of the server module replaceable components, with the top cover removed.

FIGURE 1-2 Server Module Replaceable Component Locations

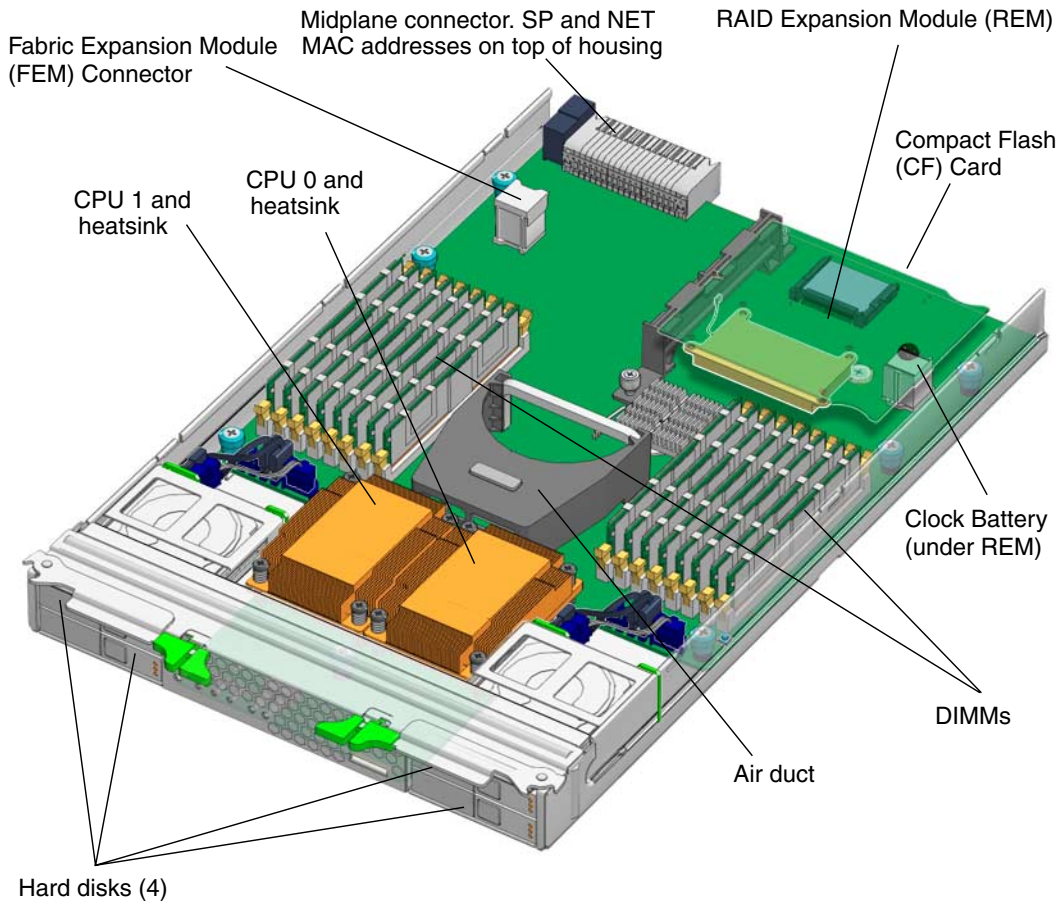

1.3 Using a Dongle Cable for Testing

Your chassis ships with a dongle cable that allows you to plug devices directly into the front of the server.

The dongle cable has either three or four connectors. [FIGURE 1-3](#) shows a dongle with four connectors.

▼ To Use a Dongle Cable for Testing

1. Insert the dongle cable into the universal connector port (UCP) on the server module front panel. See [FIGURE 1-1](#) and [FIGURE 1-3](#).
2. Connect the dongle cable connections as appropriate.

FIGURE 1-3 Dongle Cable Connections

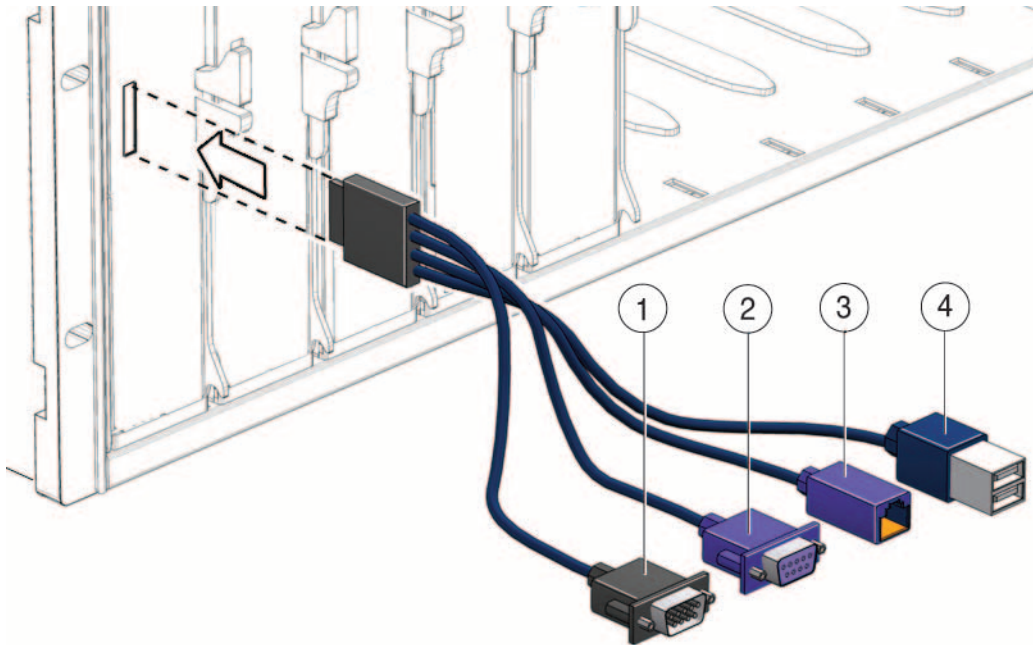

Figure Legend

-
- | | |
|---|---|
| 1 | DB-9 serial connector |
| 2 | VGA video connector. Note: this connector is not present on a three-connector dongle |
| 3 | RJ-45 connector.
- On a three-connector dongle, this connector provides serial access to the service processor.
- On a four-connector dongle, this connector is unused. |
| 4 | Dual USB connectors |
-



Caution – Disconnect the multi-port dongle cable when you are finished using the cable. Otherwise, the cable, blade, or chassis could be damaged when the chassis door is closed or the cable abruptly pulled.

TABLE 1-2 lists the pinouts of the DB9 port.

TABLE 1-2 DB9 Port Pinouts

Pin	Signal Description	Status
6	COM DSR	Not supported
2	COM SIN	Supported
7	COM RTS	Supported
3	COM SOUT	Supported
8	COM CTS	Supported
4	COM DTR	Supported
1	COM DCD	Supported
9	COM RI	Not supported



Caution – Disconnect the dongle cable when you are done with it. Otherwise, the cable could be damaged. Also, the server might exceed RFI specifications while the dongle is connected.

1.4 Accessory Kits

TABLE 1-3 lists the contents of the accessory kit that is shipped with the servers.

TABLE 1-3 Accessory Kit

Item	Part Number
Sun Blade X6250 Server Module Tools and Drivers CD	707-0093

TABLE 1-3 Accessory Kit

Item	Part Number
<i>Sun Blade X6250 Server Module Installation Guide</i> (printed documentation)	820-1182
<i>Where to Find Sun Blade X6250 Server Module Documentation</i> (printed sheet)	820-1187
Additional safety and license documentation	

1.5 Additional Options and Replaceable Components

Supported components and their part numbers are subject to change over time. For the most up-to-date list of replaceable components for these servers, go to:

http://sunsolve.sun.com/handbook_pub/Systems/

1. Click the name and model of your server.
2. On the product page that opens for the server, click on **Full Components List** for the list of components.

Note – These servers are fully compliant with the Reduction of Hazardous Substances (RoHS) Directive.

1.6 Customer Replaceable Units (CRUs) and Field Replaceable Units (FRUs)

Customer Replaceable Units (CRUs) are designed to be changed by customers. Field Replaceable Units (FRUs) must be changed by Sun service personnel.



Caution – Changing FRUs can damage your equipment and void your warranty.

TABLE 1-4 lists the CRUs and FRUs.

TABLE 1-4 CRU and FRU List

Part	CRU or FRU
FRU, Blade, No CPU/Memory (motherboard)	FRU
CPU chip - quad core, 3.50 GHz, 1333 MHz (Xeon X5270)	FRU
CPU chip - quad core, 3.33 GHz, 1333 MHz (Xeon X5470)	FRU
CPU chip - quad core, 2.66 GHz, 1333 MHz (Xeon L5430)	FRU
CPU chip - quad core, 2.50 GHz, 1333 MHz (Xeon E5420)	FRU
CPU chip – quad-core, 1.86 GHz, 1066MHz (Xeon E5320)	FRU
CPU chip – quad-core, 1.60 GHz, 1066MHz (Xeon L5310)	FRU
CPU chip – quad-core, 2.33 Ghz, 1333MHz (Xeon E5345)	FRU
CPU chip – quad-core, 2.66 GHz, 1333MHz (Xeon X5355)	FRU
CPU chip – dual-core, 3.0 GHz, 1333 MHz (Xeon X5160)	FRU
CPU chip – quad-core, 3.0 GHz, 1333 MHz (Xeon X5365)	FRU
CPU chip – dual-core, 3.33 GHz, 1333 MHz (Xeon X5260)	FRU (see Note)
CPU chip – quad-core, 2.5 GHz, 1333 MHz (Xeon L5420)	FRU (see Note)
CPU chip – quad-core, 2.33 GHz, 1333 MHz (Xeon E5410)	FRU (see Note)
CPU chip – quad-core, 2.83 GHz, 1333 MHz (Xeon E5440)	FRU (see Note)
CPU chip – quad-core, 3.16 GHz, 1333 MHz (Xeon X5460)	FRU (see Note)
CPU chip - quad core, 3.00 GHz 1333 MHz (Xeon E5450)	FRU (see Note)
2 x 1 GB, DIMM kit	CRU
2 x 2 GB, DIMM kit	CRU
2 x 4 GB, DIMM kit	CRU
80 GB SFF SATA disk drive	CRU
73 GB 10K SFF SAS disk drive	CRU
73 GB 15K SFF SAS disk drive	CRU
146 GB SFF SAS disk drive	CRU
200 GB SFF SATA disk drive	CRU
300 GB 10K SFF SAS disk drive	CRU
Sun Blade RAID 5 Expansion Module (REM) (with or without battery)	CRU
Battery for Sun Blade RAID 5 Expansion Module	CRU
Sun Blade 10 GigabitEthernet Fabric Expansion Module (FEM)	CRU

TABLE 1-4 CRU and FRU List *(Continued)*

Part	CRU or FRU
PCIe Pass Through Fabric Expansion Module (FEM)	CRU
CR2032 coin battery	CRU
Cable kit	CRU

Note – In servers with these CPUs, the Solaris 10 U4 OS requires patch 127112-05 or later, which must be added when the operating system is installed, as the server cannot boot without it. Servers with the Red Hat Linux must have RHEL 4.6 or newer.

Powering On and Configuring BIOS Settings

This chapter contains the following procedures and information:

- Section 2.1, “Powering On the Server” on page 2-1
- Section 2.2, “Powering Off the Server” on page 2-3
- Section 2.3, “Configuring BIOS Settings” on page 2-4
- Section 2.4, “Resetting the BIOS Password and Clearing CMOS” on page 2-34
- Section 2.5, “Resetting the Service Processor Password Using the BIOS Setup Utility” on page 2-36
- Section 2.6, “Updating the BIOS” on page 2-37
- Section 2.7, “Power-On Self-Test (POST)” on page 2-38

2.1 Powering On the Server

Note – Before powering on your server for the first time, follow the installation instructions provided in the *Sun Blade X6250 Modular Server Installation Guide*, (820-1182.)



Caution – Do not operate the server without all component heatsinks, air baffles, and covers installed. Severe damage to server components can occur if the server is operated without adequate cooling mechanisms.

▼ To Power On the Server

1. **When you insert your server module into a chassis that is powered on, it comes up to standby power mode.**

When the server module is in standby power mode, the green Power/OK LED on the front panel blinks, indicating that the service processor (SP) is working and the system is ready to be fully powered on to main power mode. See [FIGURE 2-1](#) for the LED location.

Note – See your chassis documentation for information about powering on the chassis.

2. **Use a non-conducting pointed object, such as a stylus to press and release the recessed Power button on the server front panel.** See [FIGURE 2-1](#) for the Power button location.

When main power is applied to the full server, the green Power/OK LED next to the Power button lights and remains lit.

[FIGURE 2-1](#) shows the location of the power button.

You can also use the SP to turn on main power.

- From the the ILOM or ELOM CLI, enter **start /SYS**.
- From the ILOM or ELOM web interface, use the Remote Power Control screen. See the corresponding SP documentation for details.

FIGURE 2-1 Power Button and Power/OK LED Location

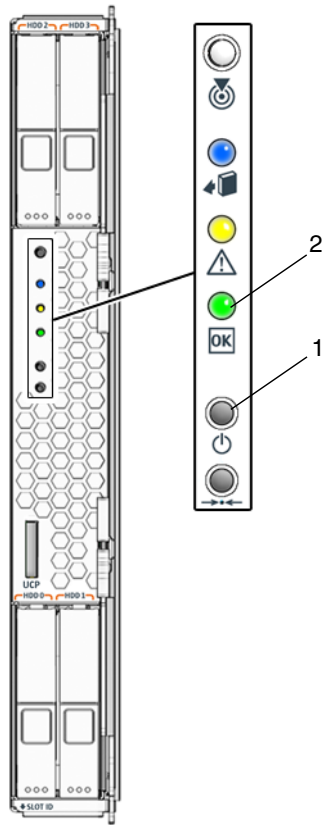

Figure Legend

-
- | | |
|---|--|
| 1 | Power on/standby button |
| | System Status/OK Indicator (green) |
| | - Steady ON = system OK |
| | - Standby blink = 0.1 second on / 2.9 seconds off |
| 2 | - Transition blink = 1 Hz on/off at 50% duty cycle during SP boot and POST |
-

2.2 Powering Off the Server

You can use one of two methods for shutting down the server from main power mode to standby power mode.

1. **Graceful shutdown:** Use a non-conducting pointed object, such as a stylus to press and release the Power button on the front panel. This causes Advanced Configuration and Power Interface (ACPI) enabled operating systems to perform an orderly shutdown of the operating system and place it in standby power mode. Servers not running ACPI-enabled operating systems will shut down to standby power mode immediately.
2. **Emergency shutdown:** Press and hold the Power button for four seconds to force main power off and enter standby power mode.
3. **ELOM or ILOM web interface:** Log in to the web interface and use the Remote Power Control screen to perform a graceful power off of the server.
4. **ELOM or ILOM command-line interface (CLI):** Log in to the ELOM or ILOM CLI and use the following command:

```
-> stop /SYS
```

For more information about controlling server power from the web interface or CLI, see the corresponding SP documentation collection.



Caution – When you use the Power button to enter standby power mode, power is still directed to the service processor and power supply fans, indicated when the Power/OK LED is blinking (0.1 seconds on, 2.9 seconds off).

5. To completely power off the server, you must remove it from the chassis. See [Section 3.3.1, “Removing the Server Module From the Chassis”](#) on page 3-7 for details.

When main power is off, the Power/OK LED on the front panel blinks, indicating that the server is in standby power mode.

2.3 Configuring BIOS Settings

This section describes how to view and modify the BIOS settings.

The Basic Input/Output System (BIOS) has a setup utility stored in the BIOS flash memory. The setup utility reports system information and can be used to configure the BIOS settings. The configured data is provided with context-sensitive Help and is stored in the system's battery-backed CMOS RAM. If the configuration stored in the CMOS RAM is invalid, the BIOS settings will default to optimal values specified in the BIOS.

Use the left and right arrow keys to move sequentially back and forth through the seven screens. Fields that can be reconfigured are displayed in color. All other fields are nonconfigurable. Use the up and down arrows, on the keyboard, to scroll through a screen's menu. Use the Tab key to move back and forth across columns.

2.3.1 Changing the Configuration of a BIOS Menu Item

You can change the BIOS configuration using several different interfaces:

- Use a USB keyboard and mouse, and a VGA monitor connected directly to the server dongle.
 - Use the remote video console of the Service Processor and redirect the server's console output. Refer to the *Embedded Lights Out Manager Administration Guide* or the *Sun Integrated Lights Out Manager 2.0 User's Guide* for more information.
 - Use a terminal (or terminal emulator connected to a computer) through the serial port on the server dongle.
1. **To change the system parameters, enter the BIOS Setup Utility by pressing the F2 key while the system is performing the power-on self-test (POST).**

The first BIOS Setup menu screen is displayed.

POST testing is indicated when the Power/OK LEDs on the front and back panels go into slow-blink mode.

2. **Highlight the field to be modified using the arrow keys and Tab key.**
3. **Press Enter to select the field.**

A dialog box appears. The dialog box presents you with the options available for the setup field that you have chosen.
4. **Modify the setup field and close the screen.**
5. **If you need to modify other setup parameters, use the arrow keys and Tab key to navigate to the desired screen and menu item, then repeat Steps 1 through 4. Otherwise, go to Step 6.**
6. **Press and release the right arrow key until the Exit menu screen is displayed.**
7. **Follow the instructions on the Exit menu screen to save your changes and exit the Setup utility.**

2.3.2 BIOS Considerations

This section contains information and considerations regarding the system BIOS.

2.3.2.1 PCI Card Slot Booting Priority

The slots for the PCI cards are detected by the BIOS during startup in this order: PCI EM BLx.1 and PCI EM BLx.0. For example, if the server module is in slot 3, the BIOS boot priority will be 3.1. 3.0.

2.3.2.2 Ethernet Port Device and Driver Naming

The Sun Blade X6250 server modules have up to two 10/100/1000BASE-T Gigabit Ethernet ports provided by the NEMs installed in the Sun Blade 6000 chassis. The lower NEM port provides NET 0 and the upper NEM port provides NET 1. The numbers correspond to the slot number, as shown in [FIGURE 2-2](#) (*N* represents the slot number).

FIGURE 2-2 Ethernet Port Chassis Labeling Designations

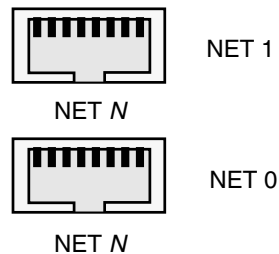

Server Module NIC Naming

[FIGURE 2-3](#) shows how various operating systems and interfaces name the NICs shown in [FIGURE 2-2](#).

FIGURE 2-3 Server Module NIC Naming

BIOS	Solaris 10	Red Hat Linux	SUSE Linux	Windows 2003/2008
slot 800A	e1000 g1	eth1	eth1	net2
slot 000A	e1000 g0	eth0	eth0	net

2.3.2.3 Ethernet Port (NIC) Booting Priority

The order in which the BIOS detects the Ethernet ports during bootup, and the corresponding drivers that control those ports are listed below:

1. NET 0 (INTEL NIC 0)
2. NET 1 (INTEL NIC 1)

2.3.2.4 BIOS Option ROM Size Limitation

The BIOS Option ROM is 128 KB. Of these 128 KB, approximately 80 KB are used by the VGA controller, and the network interface card. Approximately 48 KB remain for the Option ROM.

2.3.3 Descriptions of the BIOS Setup Utility Screens

[TABLE 2-1](#) provides summary descriptions of the seven top-level BIOS setup screens.

TABLE 2-1 BIOS Setup Utility Screens Summary

Screen	Description
Main	General system information.
Advanced	Configuration interface for the CPUs, Memory, IDE, SuperIO, Trusted Computing, USB, PCI, MPS, and Event Log.
Boot	Configure the boot device priority (CD/DVD, Removable, Hard Disks, Networks).
Server	IPMI 2.0 service processor information.
Security	Install or change the user and supervisor passwords.
Exit	Save or discard changes.

[FIGURE 2-4](#) summarizes the BIOS Setup Utility menu tree, with differences between models of the server noted. See [Section 2.3.4, “BIOS Setup Utility Menu Screens”](#) on [page 2-9](#) for examples of each of these screens.

FIGURE 2-4 Server Module BIOS Setup Utility Menu Tree

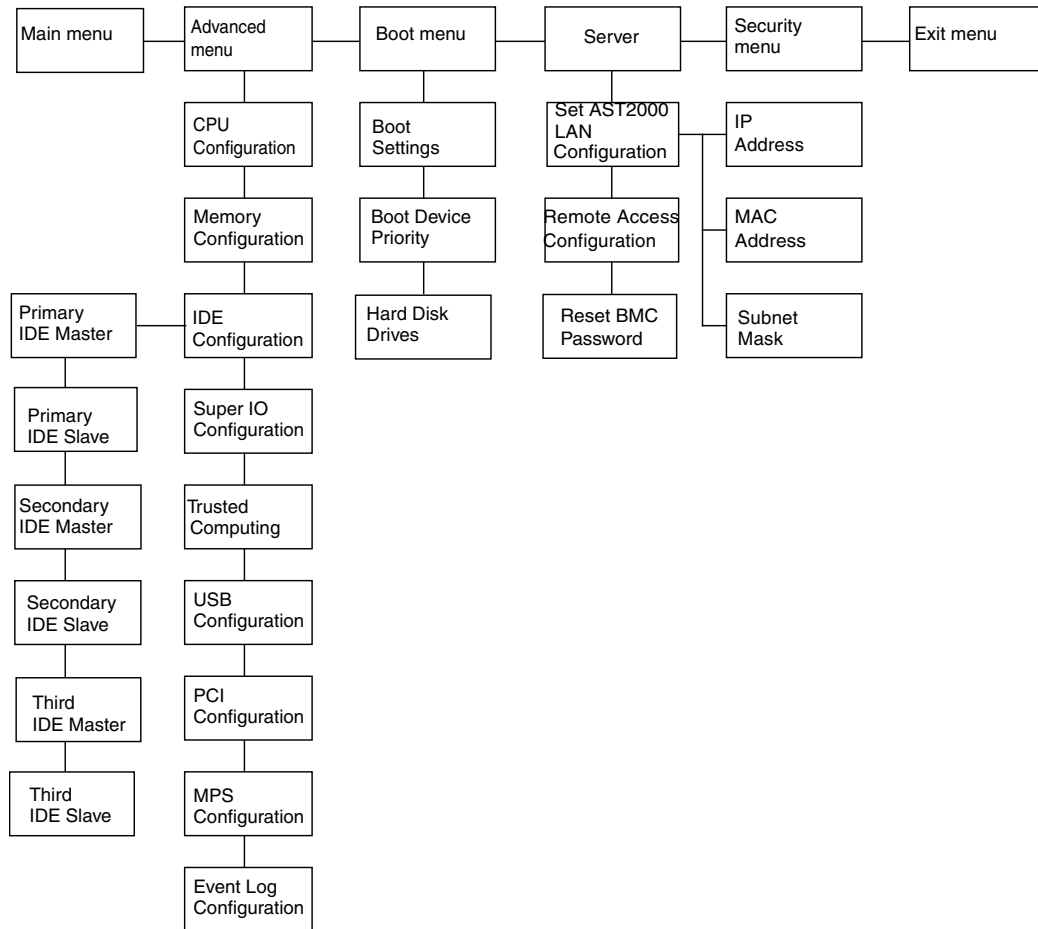

2.3.4 BIOS Setup Utility Menu Screens

The following figures show sample BIOS setup menu screens.

Note – The screens shown are examples. The version numbers and the screen items and selections shown are subject to change over the life of the product.

2.3.4.1 BIOS Main Menu Screen

```
Main      Advanced      Boot      Server      Security      Exit
*****
* System Overview                                     ** Use [ENTER], [TAB]   *
* ***** or [SHIFT-TAB] to                          *
* AMIBIOS                                           ** select a field.   *
* Version      :08.00.14                             **                  *
* Build Date:04/23/07                               ** Use [+] or [-] to  *
* ID           :1ADPI017                             ** configure system Time.*
*                                                     **                  *
* Product Name      : Sun Blade X6250 Server Modul**                  *
* Board Serial Number : 2029QTF8717MW0141          **                  *
* BMC Firmware Version : 00 00.26                  **                  *
* CPLD Revision      : 140                          **                  *
* Processor                                     * *      Select Screen *
* Intel(R) Xeon(R) CPU           E5320 @ 1.86GHz  * **      Select Item   *
* Speed      :1866MHz                * +-      Change Field  *
* Count      :1                       * Tab     Select Field  *
*                                                     * F1      General Help *
* System Memory                                     * F10     Save and Exit *
* Size       :2048MB                             * ESC     Exit         *
*                                                     *                  *
**System Time           [08:11:54]                *****
* System Date           [Mon 04/09/2007]          **                  *
**System Time           [08:12:14]                *****
*****
v02.61 (C)Copyright 1985-2007, American Megatrends, Inc.
```

2.3.4.2 Advanced Settings

```

Main      Advanced      Boot      Server      Security      Exit
*****
* Advanced Settings                                     * Configure CPU.      *
* ***** *
* WARNING: Setting wrong values in below sections      *
*           may cause system to malfunction.           *
*
* * CPU Configuration                                   *
* * Memory Configuration                                *
* * IDE Configuration                                   *
* * SuperIO Configuration                               *
* * Trusted Computing                                   *
* * USB Configuration                                   *
* * PCI Configuration                                   *
* * MPS Configuration                                   *
* * Event Log Configuration                             *
*
*
*
*
*
*
*
*
*
*
*****
v02.61 (C)Copyright 1985-2007, American Megatrends, Inc.
```

2.3.4.3 CPU Configuration

Advanced

```
*****
* Configure advanced CPU settings                               * This should be enabled *
* *****                                                    * in order to enable or *
* Intel(R) Xeon(R) CPU          E5320 @ 1.86GHz              * disable the Hardware  *
* CPUID          :6F7                                         * Prefetcher Disable   *
* Stepping       :B-3                                         * Feature.              *
* Frequency      :1.86GHz                                     *                       *
* FSB Speed      :1066MHz                                     *                       *
* Cache L1       :128 KB                                     *                       *
* Cache L2       :8192 KB                                    *                       *
* Ratio Status:Unlocked (Max:07, Min:06)                     *                       *
* Ratio Actual Value:7                                       *                       *
*                                                         *                       *
* Hardware Prefetcher          [Enabled]                    * *   Select Screen    *
* Adjacent Cache Line Prefetch [Enabled]                    * **  Select Item      *
* Max CPUID Value Limit        [Disabled]                   * +-   Change Option   *
* Vanderpool Technology        [Enabled]                    * F1   General Help    *
* Execute Disable Bit          [Enabled]                    * F10  Save and Exit    *
* Core Multi-Processing        [Enabled]                    * ESC  Exit              *
* Intel(R) SpeedStep(tm) tech. [Disabled]                   *                       *
*                                                         *                       *
*****
v02.61 (C)Copyright 1985-2007, American Megatrends, Inc.
```

2.3.4.4 Memory Configuration

Advanced

```
*****
* System Memory Settings                               * Rank Interleave:      *
* *****                                           * interleaves in the   *
* *                                               * same branch.         *
* *                                               * Branch Interleave:  *
* MCH Branch Mode [Branch Interleave] * Branch Interleave:  *
* Branch 0 Specific Sparing [Disabled] * interleaves between *
* Branch 1 Specific Sparing [Disabled] * branche 0 and 1.    *
* *                                               * Mirroring:          *
* *                                               * mirrors branch space *
* *                                               * between branches.   *
* *                                               *                     *
* *                                               * * Select Screen     *
* *                                               * ** Select Item      *
* *                                               * +- Change Option    *
* *                                               * F1 General Help     *
* *                                               * F10 Save and Exit   *
* *                                               * ESC Exit            *
* *                                               *                     *
* *                                               *                     *
*****
```

v02.61 (C) Copyright 1985-2007, American Megatrends, Inc.

2.3.4.6 Primary IDE Master

Advanced

```
*****
* Primary IDE Master                               * Select the type      *
* *****                                         * of device connected *
* Device      :Hard Disk                          * to the system.     *
* Vendor      :FUJITSU MHV2080BSSUN80G 07011255M0 *                   *
* Size        :80.0GB                             *                   *
* LBA Mode    :Supported                          *                   *
* Block Mode  :16Sectors                          *                   *
* PIO Mode    :4                                  *                   *
* Async DMA   :MultiWord DMA-2                   *                   *
* Ultra DMA   :Ultra DMA-5                       *                   *
* S.M.A.R.T. :Supported                          *                   *
* *****                                         *                   *
* Type                [Auto]                     * *   Select Screen   *
* LBA/Large Mode      [Auto]                     * **  Select Item     *
* Block (Multi-Sector Transfer) [Auto]           * +-  Change Option   *
* PIO Mode            [Auto]                     * F1  General Help    *
* DMA Mode            [Auto]                     * F10 Save and Exit   *
* S.M.A.R.T.          [Auto]                     * ESC Exit            *
* 32Bit Data Transfer [Enabled]                  *                   *
*                                                           *                   *
*****
v02.61 (C)Copyright 1985-2007, American Megatrends, Inc.
```

2.3.4.7 Secondary IDE Master

Advanced

```
*****
* Secondary IDE Master                               * Select the type          *
* *****                                           * of device connected     *
* Device      :Hard Disk                             * to the system.         *
* Vendor      :FUJITSU MHV2080BSSUN80G 063412554N  *                       *
* Size        :80.0GB                               *                       *
* LBA Mode    :Supported                             *                       *
* Block Mode  :16Sectors                             *                       *
* PIO Mode    :4                                     *                       *
* Async DMA   :MultiWord DMA-2                       *                       *
* Ultra DMA   :Ultra DMA-5                           *                       *
* S.M.A.R.T. :Supported                               *                       *
* *****                                           *                       *
* Type                [Auto]                         * *   Select Screen      *
* LBA/Large Mode      [Auto]                         * **  Select Item        *
* Block (Multi-Sector Transfer) [Auto]               * +-  Change Option      *
* PIO Mode            [Auto]                         * F1  General Help       *
* DMA Mode            [Auto]                         * F10 Save and Exit      *
* S.M.A.R.T.          [Auto]                         * ESC Exit                *
* 32Bit Data Transfer [Enabled]                      *                       *
*                                                              *
*****
v02.61 (C)Copyright 1985-2007, American Megatrends, Inc.
```

2.3.4.9 Trusted Computing

Advanced

```
*****
* Trusted Computing                               * Enable/Disable TPM *
* *****                                       * TCG (TPM 1.1/1.2) supp *
* TCG/TPM SUPPORT                               [No]          * in BIOS             *
*                                               *                   *
*                                               *                   *
*                                               *                   *
*                                               *                   *
*                                               *                   *
*                                               *                   *
*                                               *                   *
*                                               *                   *
*                                               *                   *
*                                               *                   *
*                                               * *   Select Screen  *
*                                               * **   Select Item   *
*                                               * +-   Change Option *
*                                               * F1   General Help  *
*                                               * F10  Save and Exit *
*                                               * ESC  Exit           *
*                                               *                   *
*                                               *                   *
*****
```

v02.61 (C) Copyright 1985-2007, American Megatrends, Inc.

2.3.4.10 USB Configuration

Advanced

```
*****
* USB Configuration                               * Enables support for *
* *****                                         * legacy USB. AUTO   *
* Module Version - 2.24.2-13.4                   * option disables   *
*                                                 * legacy support if  *
* USB Devices Enabled :                          * no USB devices are *
*   2 Keyboards, 2 Mice, 1 Hub                   * connected.        *
*                                                 *                   *
* Legacy USB Support                             [Auto]              *
* Port 64/60 Emulation                           [Disabled]         *
* USB Functions                                  [6 USB Ports]      *
* USB 2.0 Controller                             [Enabled]         *
*                                                 *                   *
*                                                 * *   Select Screen  *
*                                                 * **  Select Item    *
*                                                 * +-  Change Option  *
*                                                 * F1   General Help  *
*                                                 * F10  Save and Exit *
*                                                 * ESC  Exit           *
*                                                 *                   *
*                                                 *                   *
*****
v02.61 (C)Copyright 1985-2007, American Megatrends, Inc.
```

2.3.4.12 MPS Configuration

Advanced

```
*****
* MPS Configuration                               *      Select MPS      *
* *****                                       *      Revision       *
* MPS Revision                                  [1.4]          *
*                                                                 *
*                                                                 *
*                                                                 *
*                                                                 *
*                                                                 *
*                                                                 *
*                                                                 *
*                                                                 *
*                                                                 *
*                                                                 *
* *      Select Screen                             *
* **     Select Item                               *
* +-     Change Option                             *
* F1     General Help                              *
* F10    Save and Exit                             *
* ESC    Exit                                       *
*                                                                 *
*****
v02.61 (C) Copyright 1985-2007, American Megatrends, Inc.
```

2.3.4.13 Event Log Configuration

Advanced

```
*****
* Event Logging details                               * Discard all events *
* *****                                           * in the Event Log. *
* View Event Log                                     *                 *
* Mark all events as read                             *                 *
* Clear Event Log                                     *                 *
*                                                     *                 *
*                                                     *                 *
*                                                     *                 *
*                                                     *                 *
*                                                     *                 *
*                                                     *                 *
*                                                     *                 *
*                                                     *                 *
* *          Select Screen                            *                 *
* **         Select Item                              *                 *
* Enter Go to Sub Screen *                           *                 *
* F1        General Help                             *                 *
* F10       Save and Exit                             *                 *
* ESC       Exit                                      *                 *
*                                                   *                 *
*                                                   *                 *
*****
```

v02.61 (C) Copyright 1985-2007, American Megatrends, Inc.

2.3.4.15 Hard Disk Drives

```

Main      Advanced      Boot      Server      Security      Exit
*****
* Hard Disk Drives                                     * Configure Settings *
* *****                                             * during System Boot. *
* *1st Drive                                           * [RAID:ASR-5445 PCI-] *
*                                                       *                       *
*                                                       *                       *
*                                                       *                       *
*                                                       *                       *
*                                                       *                       *
*                                                       *                       *
*                                                       *                       *
*                                                       *                       *
*                                                       * *      Select Screen *
*                                                       * **      Select Item  *
*                                                       * Enter Go to Sub Screen *
*                                                       * F1      General Help  *
*                                                       * F10     Save and Exit *
*                                                       * ESC     Exit          *
*                                                       *                       *
*                                                       *                       *
*****
v02.61 (C)Copyright 1985-2007, American Megatrends, Inc.
```

2.3.4.16 Boot Settings

Boot

```
*****
* Boot Settings Configuration                               * Allows BIOS to skip *
* *****                                                * certain tests while *
* Quick Boot [Enabled]                                    * booting. This will *
* Quiet Boot [Disabled]                                   * decrease the time *
* AddOn ROM Display Mode [Force BIOS]                   *                    *
* Bootup Num-Lock [On]                                    * system.            *
* Wait For 'F1' If Error [Enabled]                       *                    *
* Hit 'F2' Message Display [Enabled]                    *                    *
* Interrupt 19 Capture [Enabled]                        *                    *
*                                                         *                    *
*                                                         *                    *
*                                                         * *   Select Screen  *
*                                                         * **  Select Item   *
*                                                         * +-  Change Option *
*                                                         * F1  General Help  *
*                                                         * F10 Save and Exit *
*                                                         * ESC Exit          *
*                                                         *                    *
*                                                         *                    *
*****
v02.61 (C)Copyright 1985-2007, American Megatrends, Inc.
```

2.3.4.18 Server

```

Main      Advanced  Boot      Server    Security  Exit
*****
* IPMI Information                                     ** InPut for Set LAN      *
* ***** Configuration command. *
* Status Of BMC                                     Working                ** See IPMI 1.5 Spec,   *
* IPMI Specification Version                       2.0                    ** table 19.1          *
* BMC Firmware Version                            00 00.21               ** NOTE:-              *
*                                                                 **      Each question in *
* NIC1 Mac Address                               [00-16-36-F1-66-9A]    ** this group may take  *
* NIC2 Mac Address                               [00-16-36-F1-66-9B]    ** considerable amount of *
*                                                                 ** time.                 *
* * Set AST2000 LAN Configuration                  **                       *
* * Remote Access Configuration                  **                       *
*                                                                 **                       *
* Restore on AC Power Loss                       [Last State]          ** *   Select Screen    *
* External Serial Port                           [System]              ** **   Select Item      *
*                                                                 ** Enter Go to Sub Screen *
* Event Control Interface                        **                       *
* *****                                          **                       *
* View BMC System Event Log                      **                       *
* Clear BMC System Event Log                     ** *   Select Screen    *
*                                                                 ** *                       *
* Event Logging                                  [Enabled]             ** +-   Change Option     *
* ECC Event Logging                              [Enabled]             ** F1   General Help      *
* PCI Error Logging                              [Enabled]             ** F10  Save and Exit       *
* NB FSB Error Logging                           [Enabled]             ** ESC  Exit              *
* NB Internal Error Logging                      [Enabled]             **                                           *
* NMI on Error                                   [Fatal]               **                                           *
*                                                                 **                                           *
* Reset BMC Password                             **                                           *
*****
v02.61 (C)Copyright 1985-2007, American Megatrends, Inc.

```

Note – With ILOM 3.0 it is possible to delete the default user account, root. If it has been deleted, nothing changes when you select Reset BMC Password.

Tip – Use the web interface or the CLI to create a backup root account with administrator privileges. See the ILOM 3.0 documentation for details.

2.3.4.19 AST2000 LAN Configuration

Server

```
*****
* AST2000 LAN Configuration.                               * Enter channel number *
* *****                                                * for SET LAN Config  *
* Channel Number           [01]                          * Command.           *
* Channel Number Status:   Channel number is OK         * Proper value below 16. *
* * IP Address              *                             *
* * MAC Address             *                             *
* * Subnet Mask             *                             *
*                           *                             *
*                           *                             *
*                           *                             *
*                           *                             *
*                           *                             *
*                           * *   Select Screen      *
*                           * **   Select Item        *
*                           * Enter Update           *
*                           * F1   General Help       *
*                           * F10  Save and Exit      *
*                           * ESC   Exit              *
*                           *                             *
*                           *                             *
*****
```

v02.61 (C) Copyright 1985-2007, American Megatrends, Inc.

2.3.4.20 IP Address

```
Server
*****
* IP Address Configuration.                               * Enter IP address in *
* *****                                                * decimal in the form of *
* Parameter Selector           [03]                      * XXX.XXX.XXX.XXX      *
* IP Address                   [010.006.072.150]         * (XXX less than 256   *
* Current IP address in BMC:   010.006.072.150         * and in decimal only). *
*                               *                          *
*                               *                          *
*                               *                          *
*                               *                          *
*                               *                          *
*                               *                          *
*                               *                          *
*                               * *   Select Screen      *
*                               * **  Select Item        *
*                               * F1   General Help      *
*                               * F10  Save and Exit     *
*                               * ESC   Exit              *
*                               *                          *
*                               *                          *
*                               *                          *
*****
v02.61 (C)Copyright 1985-2007, American Megatrends, Inc.
```

2.3.4.22 Subnet Mask

Server

```
*****
* Subnet Mask Configuration.                               * Enter Subnet Mask in *
* *****                                                * decimal in the form of *
* Parameter Selector           [06]                       * XXX.XXX.XXX.XXX      *
* Subnet Mask                  [255.255.252.000]          * (XXX less than 256   *
* Current Subnet Mask in BMC:  255.255.252.000          * and in decimal only). *
*                                                                     *
*                                                                     *
*                                                                     *
*                                                                     *
*                                                                     *
*                                                                     *
*                                                                     *
*                                                                     *
* *      Select Screen                                         *
* **     Select Item                                           *
* F1     General Help                                          *
* F10    Save and Exit                                         *
* ESC    Exit                                                  *
* ESC                                         *
*                                                                     *
*                                                                     *
*****
```

v02.61 (C) Copyright 1985-2007, American Megatrends, Inc.

2.3.4.23 Remote Access Configuration

```

Main      Advanced    Boot      Server    Security  Exit
*****
* IPMI Information                                     ** Configure Remote *
* *****                                             *
* Remote Access           [Enabled]                *
*                                                                 *
* Serial port number     [COM1]                       *
*   Base Address, IRQ    [3F8h, 4]                     *
* Serial Port Mode       [09600 8,n,1]                 *
* Flow Control           [None]                        *
*                                                                 *
*                                                                 *
*                                                                 *
*                                                                 *
*                                                                 *
* * Select Screen                                       *
* ** Select Item                                       *
* F1 General Help                                       *
* F10 Save and Exit                                     *
* ESC Exit                                              *
* ESC                                                  *
*                                                                 *
*                                                                 *
*****
v02.61 (C)Copyright 1985-2007, American Megatrends, Inc.
```

2.3.4.24 Security Settings

```

Main      Advanced  Boot      Server    Security  Exit
*****
* Security Settings                                     * Install or Change the *
* *****                                             * password.             *
* Supervisor Password :Not Installed                  *                   *
* User Password       :Not Installed                  *                   *
*                                                             *                   *
* Change Supervisor Password                          *                   *
* Change User Password                                *                   *
*                                                             *                   *
* Boot Sector Virus Protection    [Disabled]          *                   *
*                                                             *                   *
*                                                             *                   *
*                                                             *                   *
*                                                             * *   Select Screen   *
*                                                             * **   Select Item   *
*                                                             * Enter Change       *
*                                                             * F1   General Help  *
*                                                             * F10  Save and Exit  *
*                                                             * ESC  Exit           *
*                                                             *                   *
*                                                             *                   *
*****
v02.61 (C)Copyright 1985-2007, American Megatrends, Inc.
```

2.3.4.25 Exit

```

Main      Advanced  Boot      Server    Security  Exit
*****
* Exit Options                                     * Exit system setup *
* *****                                         * after saving the  *
* Save Changes and Exit                           * changes.         *
* Discard Changes and Exit                         *                 *
* Discard Changes                                  * F10 key can be used *
*                                                    * for this operation.*
* Load Optimal Defaults                           *                 *
* Load Failsafe Defaults                           *                 *
*                                                    *                 *
*                                                    *                 *
*                                                    *                 *
*                                                    *                 *
* *          Select Screen                          *                 *
* **         Select Item                            *                 *
* Enter Go to Sub Screen *                         *                 *
* F1         General Help                           *                 *
* F10        Save and Exit                          *                 *
* ESC        Exit                                    *                 *
*                                                    *                 *
*                                                    *                 *
*****
v02.61 (C)Copyright 1985-2007, American Megatrends, Inc.
```

Note – Do not use failsafe mode unless it is recommended by Sun service personnel.

2.4 Resetting the BIOS Password and Clearing CMOS

Jumper J23 allows you to reset the BIOS passwords and clear CMOS. Because the SP password is in CMOS, this resets it to the factory default.

1. **Shut down the server to standby power mode by using a non-conducting pointed object, such as a stylus to press and release the recessed Power button on the front panel.**

See [Section 2.2, “Powering Off the Server”](#) on page 2-3.



Caution – Before handling components, attach an ESD wrist strap to the grounding post that is built into the rear of the chassis. The printed circuit boards and hard disks contain components that are extremely sensitive to static electricity.

2. **Remove the server from the chassis.** See [Section 3.3.1, “Removing the Server Module From the Chassis”](#) on page 3-7.
3. **Remove the main cover from the server.** See [Section 3.3.2, “Removing the Main Cover”](#) on page 3-9.
4. **Change jumpers on J23 as follows:**
 - To clear the BIOS password, move the jumper from pins 4 and 6 to pins 2 and 4.
 - To clear the CMOS, move the jumper from pins 3 and 5 to pins 1 and 3.

[FIGURE 2-5](#) shows the location of the jumper block, and the pin numbers.
5. **Install the server main cover.**
6. **Install the server into the chassis.**
7. **Return the server to main power mode by using a non-conducting pointed object, such as a stylus to press and release the recessed Power button on the front panel.**

Note – You must allow the entire server, not just the SP, to reboot to main power mode to complete the password reset. This is because the state of this jumper cannot be determined without the host CPU running. Wait until the end of POST, when you see the CMOS password cleared by jumper message, after which both the BIOS and SP passwords are reset.

- If you reset the BIOS password, the BIOS resets the password by a separate operation performed by the BIOS when it discovers the presence of this jumper. The BIOS password is not reset to *changeme*, it is removed so that there is no longer a BIOS password set. If you had a BIOS password set, you are no longer prompted for one.
- If you cleared the CMOS, the contents of CMOS are cleared.

8. Repeat Steps 1 through 7 to return the jumpers to their original locations.



Caution – You must return the CMOS jumper to pins 3 and 5 before you can use the server module. If you do not return the BIOS password jumper to pins 4 and 6, you will be unable to enter a BIOS password.

Note – If you have an ELOM service processor, jumper J19 is used to recover from a corrupt service processor, as described in the *Embedded Lights Out Manager Administration Guide* (820-1253). It appears in [FIGURE 2-5](#).

FIGURE 2-5 Location of Jumpers J19 and J23

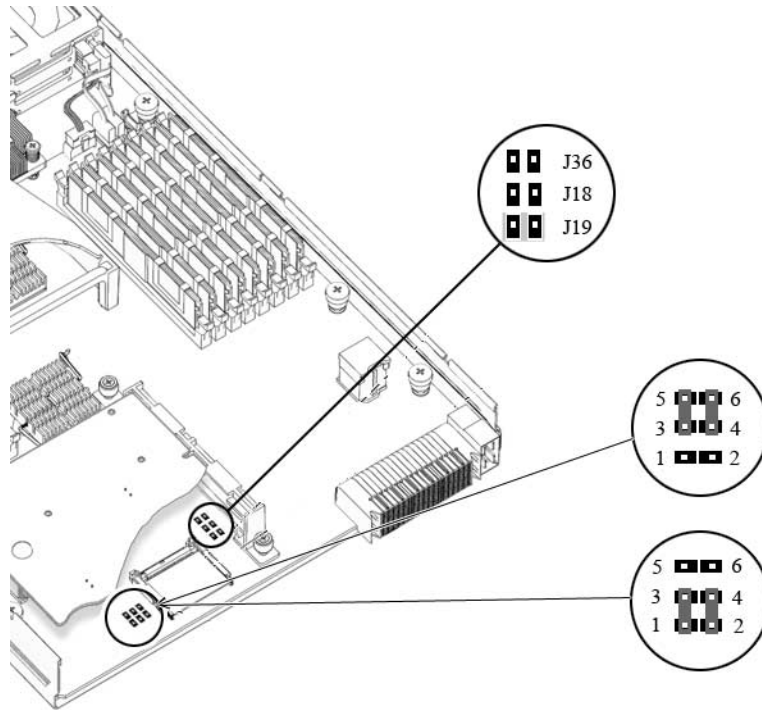

2.5 Resetting the Service Processor Password Using the BIOS Setup Utility

Use the following procedure to reset the SP password.

▼ To Reset the SP Password Using the BIOS Setup Utility

- 1. Setup the server module so that you can view POST messages and access the BIOS Setup Utility.**
 - You can connect the multi-port dongle cable to the UCP on the front of the server and attach a KVM to the dongle cable (see the *Sun Blade X6250 Server Module Installation Guide*).
 - or-
 - You can use the SP's Remote Console application, and configure the server module to boot to BIOS. See the *Sun Blade X6250 Server Module Embedded Lights Out Manager Administrative Guide* or the *Sun Integrated Lights Out Manager 2.0 User's Guide*.
- 2. Reboot the server module, and watch the display for the prompt to press F2.**

If you are using a Remote Console application, the server boots directly into the BIOS Setup Utility, and you can skip to [Step 4](#).
- 3. When prompted, press F2 to enter the BIOS Setup Utility.**

The BIOS Setup Utility appears.
- 4. Use the arrow keys to navigate to the Server screen.**

The Server screen appears.
- 5. Use the down arrows to select the Reset Password option.**
 - On systems with an ELOM, select Reset BMC Password.
 - On systems with an ILOM, select Reset ILOM Password.
- 6. Press Enter.**

The Reset Password Now? pop-up appears.
- 7. Use the arrow keys to highlight OK, and press enter.**

The password is reset to the default, "changeme."

2.6 Updating the BIOS

The BIOS is updated whenever you update the service processor firmware. For instructions on updating the firmware, refer to the *Embedded Lights Out Manager Administration Guide* or the *Sun Integrated Lights Out Manager Supplement for Sun Blade X6250 Server Module*.

2.7 Power-On Self-Test (POST)

For information about BIOS POST testing, POST codes, POST code checkpoints, and console redirection, see [Appendix B](#).

Maintaining the Server

This chapter contains information and procedures for servicing your modular server hardware, including component removal and replacement procedures.

The following topics are covered in this section:

- [Section 3.1, “Monitoring System Components” on page 3-2](#)
- [Section 3.2, “Tools and Supplies Needed” on page 3-6](#)
- [Section 3.3, “Removing the Server Module From the Chassis and Removing the Cover” on page 3-7](#)
- [Section 3.4, “Locations of Replaceable Components” on page 3-10](#)
- [Section 3.5, “Replaceable Component Procedures” on page 3-11](#)

3.1 Monitoring System Components

You can monitor the status of system components through the service processor and the system status LEDs.

3.1.1 Monitoring System Components Through the Service Processor

The following component information is available through the system service processor.

- Viewing replaceable component information
- Viewing sensors and LED indicators
- Viewing Indicators (LEDs) and Controlling the Locate LED
- Managing alerts
- Viewing and clearing the system event log

See the *Embedded Lights Out Manager Administration Guide* or the corresponding ILOM documentation collection for more information.

3.1.2 Monitoring System Components Through System Status LED

Your server module has external and internal system status LEDs.

3.1.2.1 External Status Indicator LEDs

[FIGURE 3-1](#) shows the locations of the external status indicator LEDs.

FIGURE 3-1 External LED Location

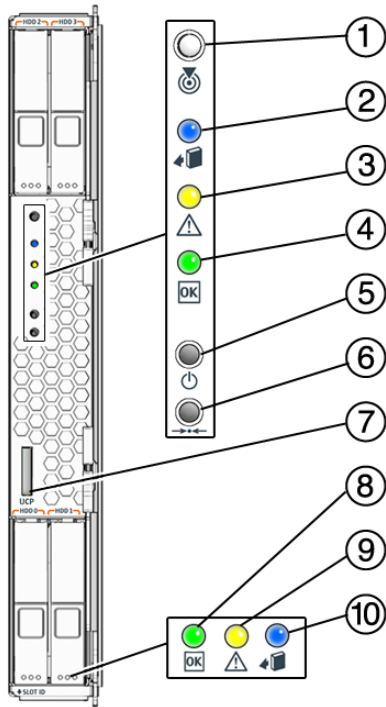

Refer to [TABLE 3-1](#) for descriptions of the LED behavior.

TABLE 3-1 Front Panel LED Functions

LED Name	Description
Locate button/LED–White	<p>This LED helps you to identify which system you are working on.</p> <p>The following actions activate it:</p> <p>Push and release this button, or use service processor commands to make the Locate LED blink for 30 minutes.</p> <ul style="list-style-type: none">• From the ILOM web interface:<ol style="list-style-type: none">1) Navigate to System Monitoring -> Indicators.2) Highlight Sys/Locate.3) select Turn LED Off or Set LED to Fast Blink from the pull down menu.• From the ILOM CLI, enter: /SYS/LOCATE value=FastBlink or /SYS/LOCATE value=Off <p>Hold down this button for 5 seconds to initiate a “lamp test” mode that illuminates other LEDs for 15 seconds.</p>
Ready to Remove LED–Blue	<p>The server module is ready to be removed from the chassis.</p> <ul style="list-style-type: none">• For ELOM or ILOM 2.0, this LED is switched on by the service processor when the server module main power is off.• For ILOM 3.0, this LED can only be switched on and off by using the ILOM web interface or CLI.
Service Action Required LED–Amber	<p>On systems equipped with an ELOM service processor, this LED has three states:</p> <ul style="list-style-type: none">• Off: Normal operation.• Slow Blinking: A new (unacknowledged) event requiring a service action has been detected.• On: The event has been acknowledged, but the problem still requires attention. <p>On systems equipped with an ILOM service processor, this LED has two states:</p> <ul style="list-style-type: none">• Off: Normal operation.• On: Fault detected.
Power/OK LED–Green	<p>Off – Server main power and standby power are off.</p> <p>Standby Blinking (.1 sec On, 2.9 sec Off) – Standby power.</p> <p>On – Server is in main power mode.</p>
ELOM and ILOM 2.0 Startup	<p>The blue, amber, and green LEDs blink at 1 second intervals until the ILOM services are running.</p>

TABLE 3-1 Front Panel LED Functions (*Continued*)

LED Name	Description
ILOM 3.0 Startup	The blue, amber, green, and white LEDs blink three times, at one second intervals (.5 sec On, .5 sec Off). After the three blinks, the green LED goes to fast blink while the ILOM performs power calculations (.125 sec On, .125 sec Off). When the system is ready to turn on, the green LED stays On for 3 seconds. You can now press the Power button to power on the host (go to main power mode). Otherwise it goes to standby blink (.1 sec On, 2.9 sec Off).

3.1.2.2 Internal Status Indicator LEDs

These servers have internal status indicator LEDs for the DIMM slots and the CPUs.

When the server module is removed from the chassis and the top cover removed, a fault indicator button can be pressed to view the location of the DIMM or CPU that has failed.

- See [Section 3.3, “Removing the Server Module From the Chassis and Removing the Cover”](#) on page 3-7 for instructions to remove the server module from the chassis and remove the top cover.
- [FIGURE 3-2](#) shows the fault indicator button and internal status indicator LEDs.

FIGURE 3-2 Fault Indicator Button

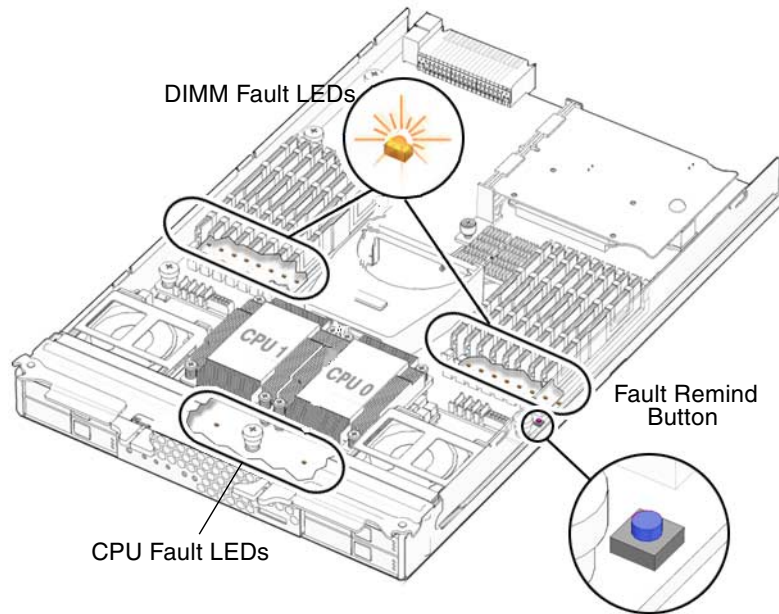

TABLE 3-2 Internal LED Functions

LED Name	Description
DIMM Fault LED	This LED is OFF when DIMM is operating properly and Amber when the system has detected a fault with the DIMM.:
CPU Fault LED	This LED is Off when the CPU is operating properly and Amber when the system has detected a fault with the CPU.

The DIMM and CPU Fault LEDs only light when the Fault Remind Button is pressed AND the Fault Remind circuit's charge capacitor is charged. If in doubt about a DIMM or CPU fault, reinsert the blade into the chassis for 5 minutes to recharge this capacitor, then remove the blade and try again (pressing the Fault Remind Button).

3.2 Tools and Supplies Needed

The server can be serviced with the following items:

- No. 2 Phillips screwdriver
- Adjustable-setting torque driver (5–20 in-lbs)

- Antistatic wrist strap
- A non-conducting pointed object, such as a stylus, to press the recessed Power button

3.3 Removing the Server Module From the Chassis and Removing the Cover

Use the preparatory procedures in this section when you are referred to them from the removal and replacement procedures.

3.3.1 Removing the Server Module From the Chassis

To replace components for the Sun Blade X6250 server module, with the exception of the hard disks, you need to remove the server module from the chassis. If you are only removing hard disks, you can skip this section and go to [Section 3.5.6, “Replacing a Hard Disk”](#) on page 3-26.

1. **Choose a method for shutting down the server from main power mode to standby power mode. See [FIGURE 3-1](#) for the location of the power button.**
 - **Graceful shutdown:** Use a non-conducting pointed object, such as a stylus, to press and release the recessed Power button on the front panel. This causes Advanced Configuration and Power Interface (ACPI) enabled operating systems to perform an orderly shutdown of the operating system. Servers not running ACPI-enabled operating systems shutdown to standby power mode immediately.
 - **Service Processor Shutdown: Use the ELOM or ILOM CLI or web interface to power off the system.**

From the ELOM or ILOM command prompt, type:

```
-> stop /SYS
```

See the *Embedded Lights Out Manager Administration Guide* or the *Sun Integrated Lights Out Manager 2.0 User's Guide* for more information.

When main power is off, the Power/OK LED on the front panel blink, indicating that the server is in standby power mode.



Caution – When you use the Power button to enter standby power mode, power is still directed to service processor and power supply fans, indicated when the Power/OK LED is blinking .01 seconds on, 2.9 seconds off. To completely power off the server, you must remove the server module from the midplane.

2. Turn off any peripheral devices connected to the dongle and disconnect the dongle from the server.

FIGURE 3-3 Removing a Server Module

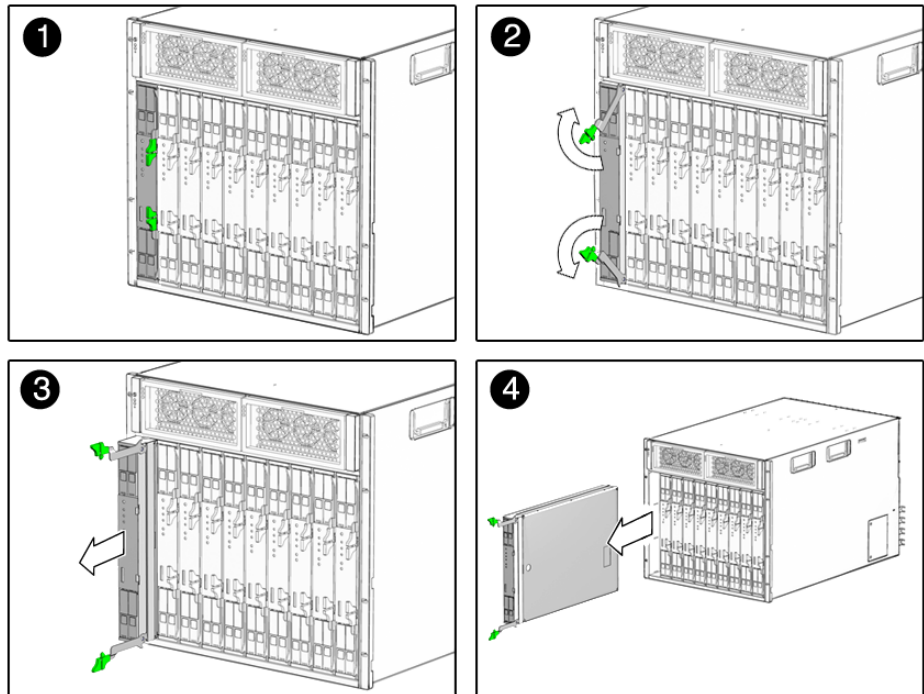

3. Remove the server module from the chassis. See [FIGURE 3-3](#).
 - a. Press together and hold green ejector buttons.
 - b. Open the ejector levers by rotating them out from the server module
 - c. Pull the server module out from the chassis by the ejector levers until you are able to grasp the module with both hands to pull it out of the chassis.



Caution – The server module is heavy. Use two hands to remove it from the chassis, and be prepared to support the weight when it clears the chassis.

4. Set the server module on an antistatic surface.



Caution – Before handling internal components of the server module, attach an electrostatic-discharge (ESD) wrist strap to the grounding post that is built into the rear of the chassis. The system's printed circuit boards and hard disks contain components that are extremely sensitive to static electricity.



Caution – Do not operate the system with empty slots. Always insert a filler into an empty slot to reduce the possibility of module shutdown.

3.3.2 Removing the Main Cover

1. Press down on the cover release button and, using the indent for leverage, slide the main cover toward the rear of the chassis approximately 0.5 inch (12 mm). See [FIGURE 3-4](#).
2. Grasp the cover by its rear edge and lift it straight up from the chassis.

FIGURE 3-4 Removing the Main Cover

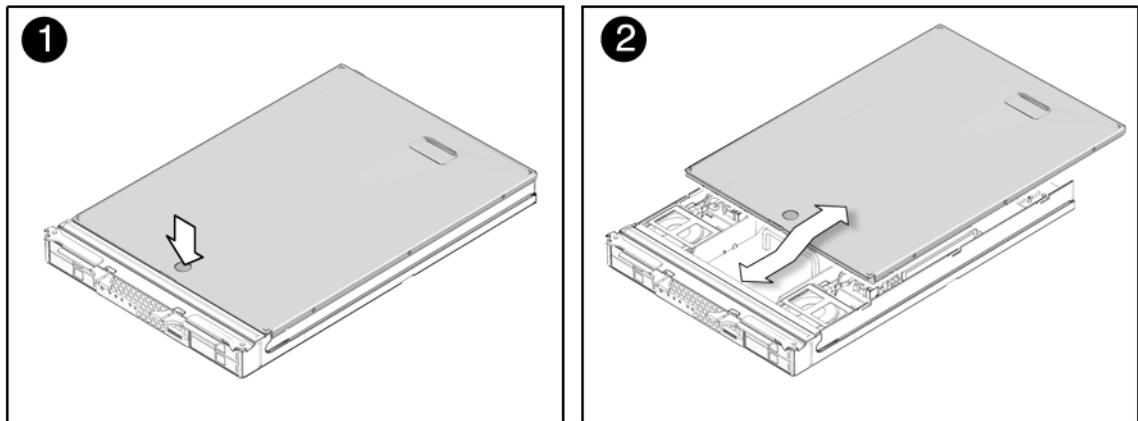

3.4 Locations of Replaceable Components

FIGURE 3-5 shows the locations of the replaceable components that are documented in this chapter.

FIGURE 3-5 Location of CPU Components

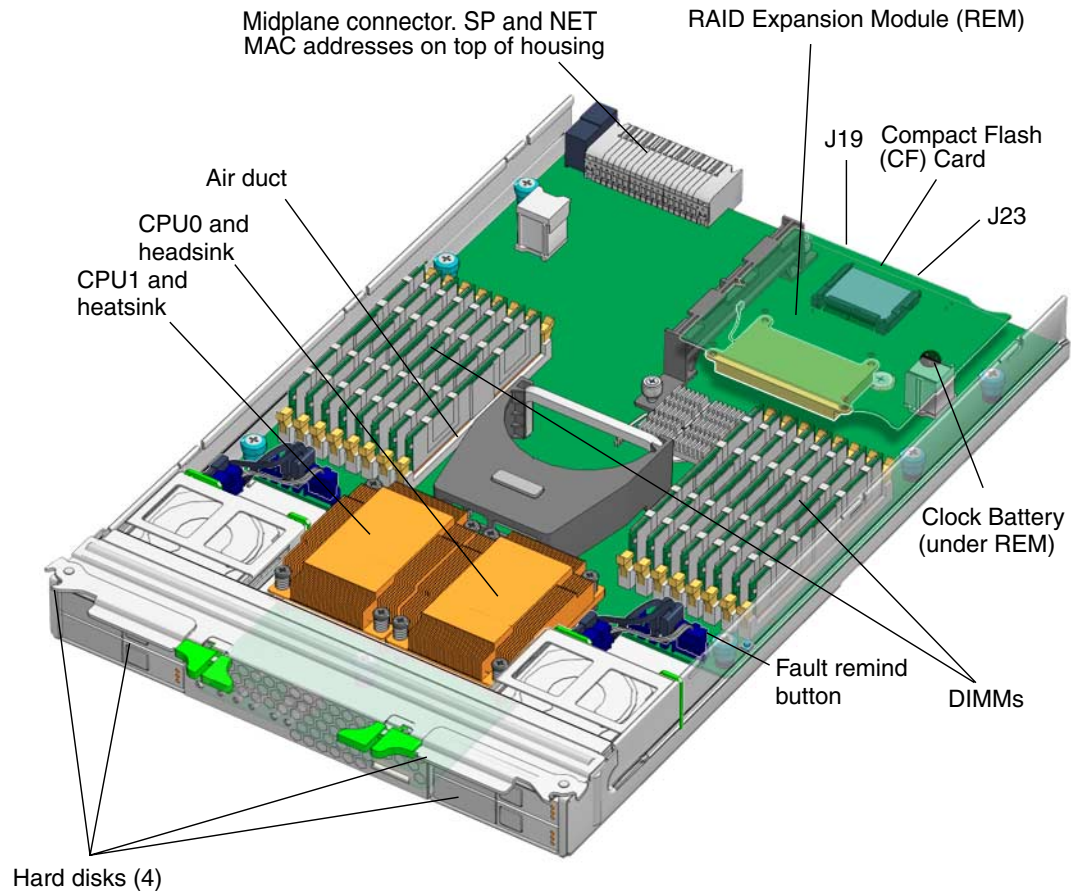

3.5 Replaceable Component Procedures

Note – Some of the procedures in this section are for customer-replaceable units (CRUs) and some are for field-replaceable units (FRUs), as noted in the procedures and in the list below. FRU components should be replaced *only* by trained service technicians. Contact your Sun Service representative for assistance with FRU replacements.

This section contains procedures for replacing the following components:

- [Section 3.5.1, “Replacing the Coin Battery” on page 3-11 \(CRU\)](#)
- [Section 3.5.2, “Replacing the Compact Flash Module” on page 3-13 \(CRU\)](#)
- [Section 3.5.3, “Replacing Memory Modules \(DIMMs\)” on page 3-14 \(CRU\)](#)
- [Section 3.5.4, “Replacing a CPU and Heatsink” on page 3-18](#)
- [Section 3.5.5, “Replacing the Motherboard” on page 3-25 \(FRU\)](#)
- [Section 3.5.6, “Replacing a Hard Disk” on page 3-26 \(CRU\)](#)
- [Section 3.5.7, “Adding or Replacing a RAID Expansion Module” on page 3-31 \(CRU\)](#)
- [Section 3.5.8, “Restoring an Existing RAID Array After Changing the REM” on page 3-34](#)
- [Section 3.5.9, “Changing the Sun Blade RAID 5 Expansion Module Battery” on page 3-35 \(CRU\)](#)



Caution – Before handling components, attach an ESD wrist strap to the grounding post that is built into the rear of the chassis. The system’s printed circuit boards and hard disks contain components that are extremely sensitive to static electricity.

3.5.1 Replacing the Coin Battery

▼ To Replace the Coin Battery

Note – This component is a CRU and can be replaced by anyone.

Supported components and their part numbers are subject to change over time. For the most up-to-date list of replaceable components for these servers, visit:

http://sunsolve.sun.com/handbook_pub/Systems/

1. Click on the name and model of your server.
2. On the product page that opens for the server, click on **Full Components List** for the list of components.

Use the following procedure to replace this component.

1. **Power off the server and remove the server module from the chassis as described in Section 3.3.1, “Removing the Server Module From the Chassis” on page 3-7.**



Caution – Do not operate the system with empty slots. Always insert a filler into an empty slot to reduce the possibility of module shutdown.

2. **Remove the main cover as described in Section 3.3.2, “Removing the Main Cover” on page 3-9.**

Note – Note the orientation (polarity) of the battery in its holder before removing it. The positive polarity, marked with a “+” symbol, should be facing up.

3. **If a RAID expansion module is present, lift it out of the way.**

The battery is under the RAID expansion module. See [FIGURE 3-6](#).

See [Section 3.5.7, “Adding or Replacing a RAID Expansion Module”](#) on page 3-31 if required for additional information.

4. Remove the battery by gently pulling the clip away from the battery face and lifting the battery straight up. See [FIGURE 3-6](#).

FIGURE 3-6 Removing the Battery

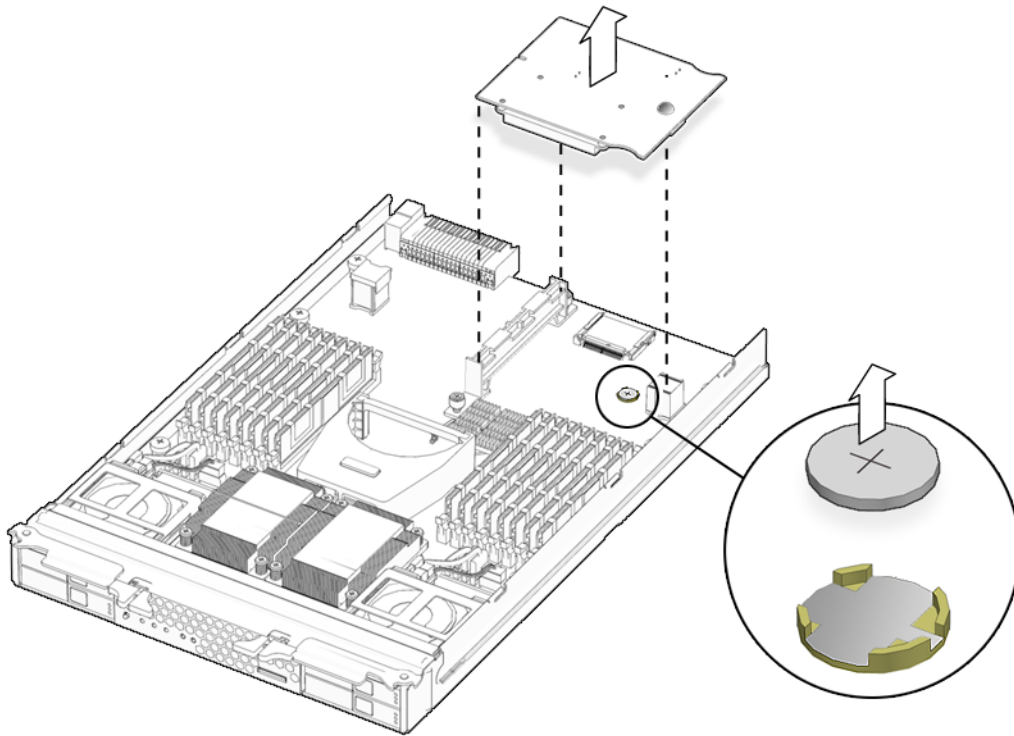

To install the battery, reverse [Step 1](#) through [Step 4](#).

Note – Install the new battery in the holder with the same orientation (polarity) as the battery that you removed. The positive polarity, marked with a “+” symbol, should be facing toward the chassis center.

3.5.2 Replacing the Compact Flash Module

▼ To Replace the Compact Flash Module

1. If necessary, back up any data that is contained on the compact flash module.

2. Power off the server and remove the server module from the chassis as described in Section 3.3.1, “Removing the Server Module From the Chassis” on page 3-7.



Caution – Do not operate the system with empty slots. Always insert a filler into an empty slot to reduce the possibility of module shutdown.

3. Remove the main cover as described in Section 3.3.2, “Removing the Main Cover” on page 3-9.
4. Locate the compact flash module under the REM at the back of the server module. See FIGURE 3-7.

FIGURE 3-7 Replacing the Compact Flash

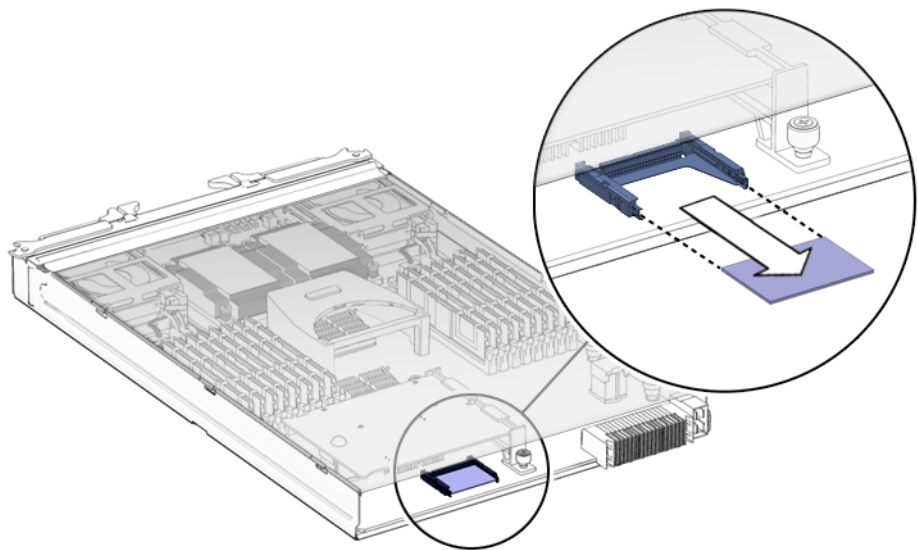

5. Grasp the module and pull it out.
Installation is the reverse of this procedure.

3.5.3 Replacing Memory Modules (DIMMs)

This section describes how to replace DIMMs. It provides the rules for populating DIMMs, and a procedure to replace them.

3.5.3.1 DIMM Population Rules

The DIMM population rules for the modular server are listed here:

- The server module can support a maximum of 16 DDR2 DIMMs.
- Two DIMMs within each pair must be identical (same manufacturer, size, and speed).
- The DIMM slots are paired. The DIMMs must be installed in pairs (0 and 1, 2 and 3, etc). The slots for the first two pairs are white; all others are black.

TABLE 3-3 shows the relationships. The branches and slots, and the order in which they must be installed, appear in FIGURE 3-8.

TABLE 3-3 DIMM Slots and Locations

Number of DIMMs	Pairs/Slots	Branch
2	A0, B0	0
4	C0, D0	1
6	A1, B1	0
8	C1, D1	1
10	A2, B2	0
12	C2, D2	1
14	A3, B3	0
16	C3, D3	1

Note – A DIMM is a CRU and can be replaced by anyone.

Supported components and their part numbers are subject to change over time. For the most up-to-date list of replaceable components for these servers, see the following URL:

http://sunsolve.sun.com/handbook_pub/Systems/

1. Click the name and model of your server.
2. On the product page that opens for the server, click on **Full Components List** for the list of components.

▼ To Replace DIMMs

1. Power off the server and remove the server module from the chassis as described in Section 3.3.1, “Removing the Server Module From the Chassis” on page 3-7.



Caution – Do not operate the system with empty slots. Always insert a filler into an empty slot to reduce the possibility of module shutdown.

2. Remove the main cover as described in Section 3.3.2, “Removing the Main Cover” on page 3-9.
3. Press the fault remind button on the motherboard to illuminate the LED for the DIMMs that have failed.

Note – The DIMM Fault LEDs and the CPU Fault LEDs are powered by capacitors that retain their charge for about 30 minutes after the server module is removed from the chassis. To recharge the capacitor, place the server module in a powered chassis for five minutes.

FIGURE 3-8 DIMM Slots and Fault Indicator Button

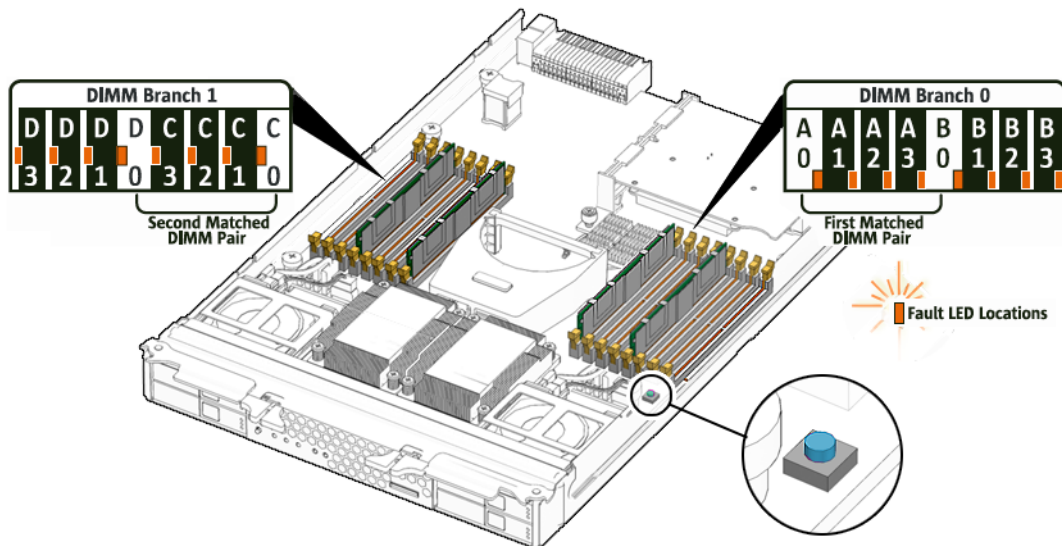

4. Locate the DIMM slot on the motherboard to which you will install or replace a DIMM.

LEDs next to the DIMMs indicate a faulty DIMM:

- If the corresponding LED is off, the DIMM is operating properly.
- If the corresponding LED is on (amber), the DIMM is faulty and should be replaced.

5. Before continuing with the next step, review the guidelines in [Section 3.5.3.1, “DIMM Population Rules”](#) on page 3-15.

6. To remove a DIMM:

- a. Rotate both DIMM slot ejectors outward as far as they will go.

The DIMM is partially ejected from the socket. See [FIGURE 3-9](#).

- b. Carefully lift the DIMM straight up to remove it from the socket.

FIGURE 3-9 Removing a DIMM

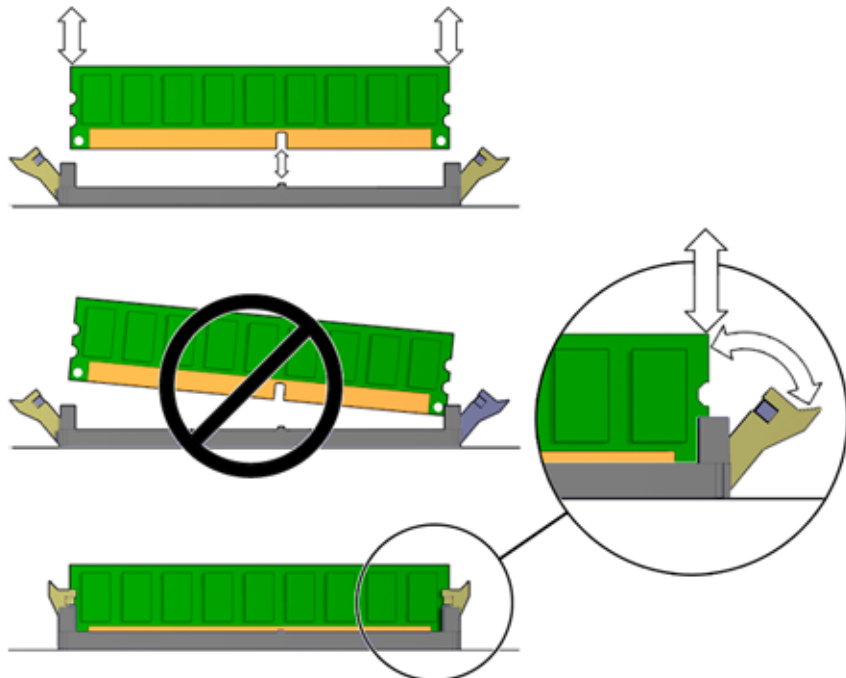

7. To install a DIMM:

- a. Ensure that the DIMM slot ejectors at each end of the memory socket are fully open (rotated outward) to accept the new DIMM.

- b. **Align the notch in the bottom edge of the DIMM with the key in the DIMM socket. See [FIGURE 3-9](#).**
- c. **Press down evenly on both top corners of the DIMM until the ejectors snap over the cutouts in the left and right edges of the DIMM.**

3.5.3.2 Error Correction and Parity

The Intel Xeon processor on the Sun Blade X6250 server module provides parity protection on its internal cache memories and error-correcting code (ECC) protection of the data. The system can detect and log to the system event log (SEL) the following types of errors:

- Correctable and uncorrectable memory ECC errors
- SP correctable memory ECC errors
- Correctable and uncorrectable CPU internal errors
- Faults in the chassis shared infrastructure, including fan and power supply faults

Advanced ECC corrects up to 4 bits in error on nibble boundaries, as long as they are all in the same DRAM. If a DRAM fails, the DIMM continues to function.

3.5.4 Replacing a CPU and Heatsink

▼ To Replace a CPU and Heatsink

1. **Power off the server and remove the server module from the chassis as described in [Section 3.3.1, “Removing the Server Module From the Chassis”](#) on [page 3-7](#).**



Caution – Do not operate the system with empty slots. Always insert a filler into an empty slot to reduce the possibility of module shutdown.

2. **Remove the main cover as described in [Section 3.3.2, “Removing the Main Cover”](#) on [page 3-9](#).**
3. **Press the fault remind button on the motherboard to illuminate the LED for the CPU that has failed.**

Note – The DIMM Fault LEDs and the CPU Fault LEDs are powered by capacitors that retain their charge for about 30 minutes after the server module is removed from the chassis. To recharge the capacitor, place the server module in a powered chassis for five minutes.

FIGURE 3-10 Fault Remind Button

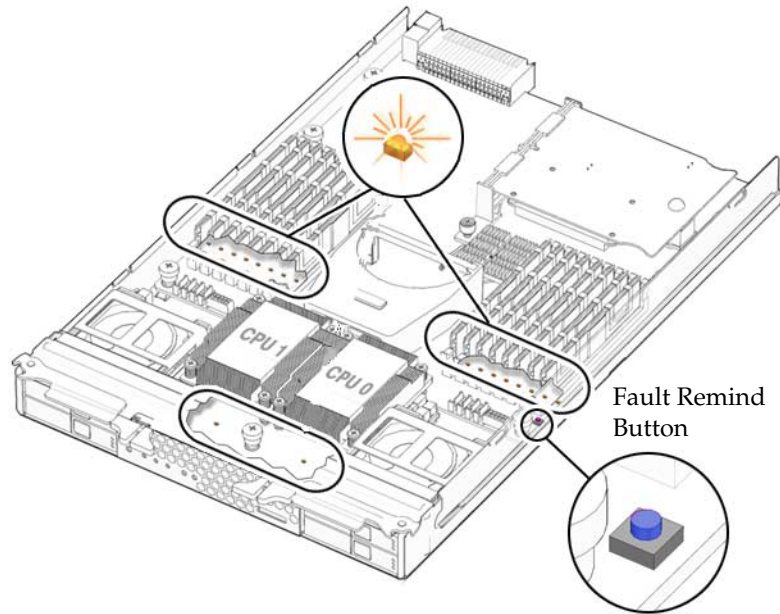

4. Identify which CPU and heatsink you are replacing.

The internal designation of the two CPUs in the server is shown in [FIGURE 3-10](#). There is a fault LED on the motherboard for each CPU:

- LED is off: CPU is OK.
- LED is lit (amber): Indicates a fatal error with the corresponding CPU.

FIGURE 3-11 CPU Locations

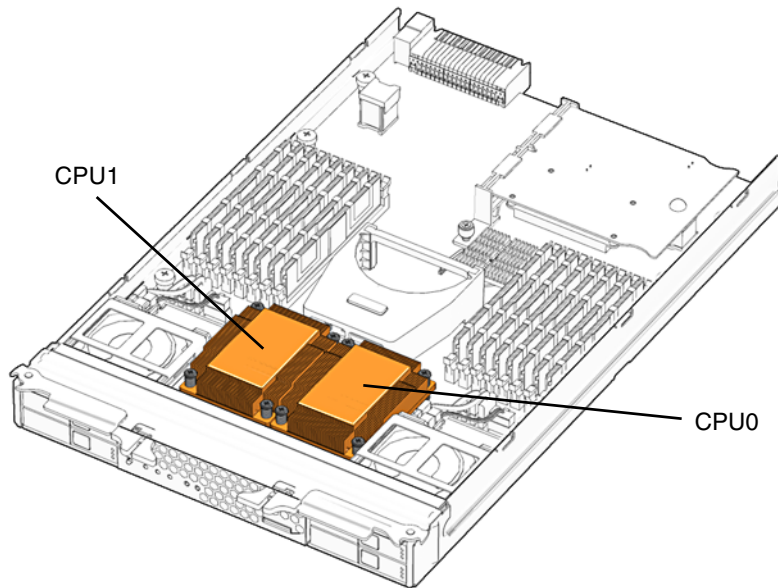

5. Remove the heatsink from the motherboard:

- a. Hold down on the top of the heatsink to prevent it from tipping unevenly while you alternately loosen the four spring-loaded mounting screws that secure the heatsink to the motherboard. Turn the screws 180 degrees at a time, then remove the screws when they are detached. See [FIGURE 3-12](#).

- c. Open the hinged plate that covers the CPU until it is in the fully open position.
- d. Lift the CPU out of the socket, leaving the lever and plate in the open position.

7. Install the new CPU, or reinstall the existing CPU (see [FIGURE 3-13](#)):

Note – Mixing CPU speeds is not supported. Use two identical CPUs in your server.

- a. If you are reinstalling the existing CPU, use an alcohol pad to clean all the old thermal grease from the component surface.

You will need to apply new thermal grease when you reinstall the heat sink in [Step 8](#).

- b. Ensure that the CPU socket release lever and retainer plate are in the fully open position.
- c. Align the CPU in the socket.



Caution – Use the alignment keys in the CPU socket to match the alignment notches on the sides of the CPU. The keys must be properly aligned to seat the CPU properly and to avoid damaging it.

- d. Gently set the CPU onto the pins in the socket.
- e. When the CPU is fully seated in the socket, pivot the hinged retainer plate down onto the top of the CPU.
- f. Pivot the release lever down and into the locked position, at the side of the socket.

The release lever must lock down the retainer plate as you close the lever.

8. Install the heat sink:

- a. Using one syringe of thermal grease (500 mg [0.2 ml]), carefully apply grease to the top of the CPU in an X pattern as shown in [FIGURE 3-14](#).

FIGURE 3-13 Replacing the CPU

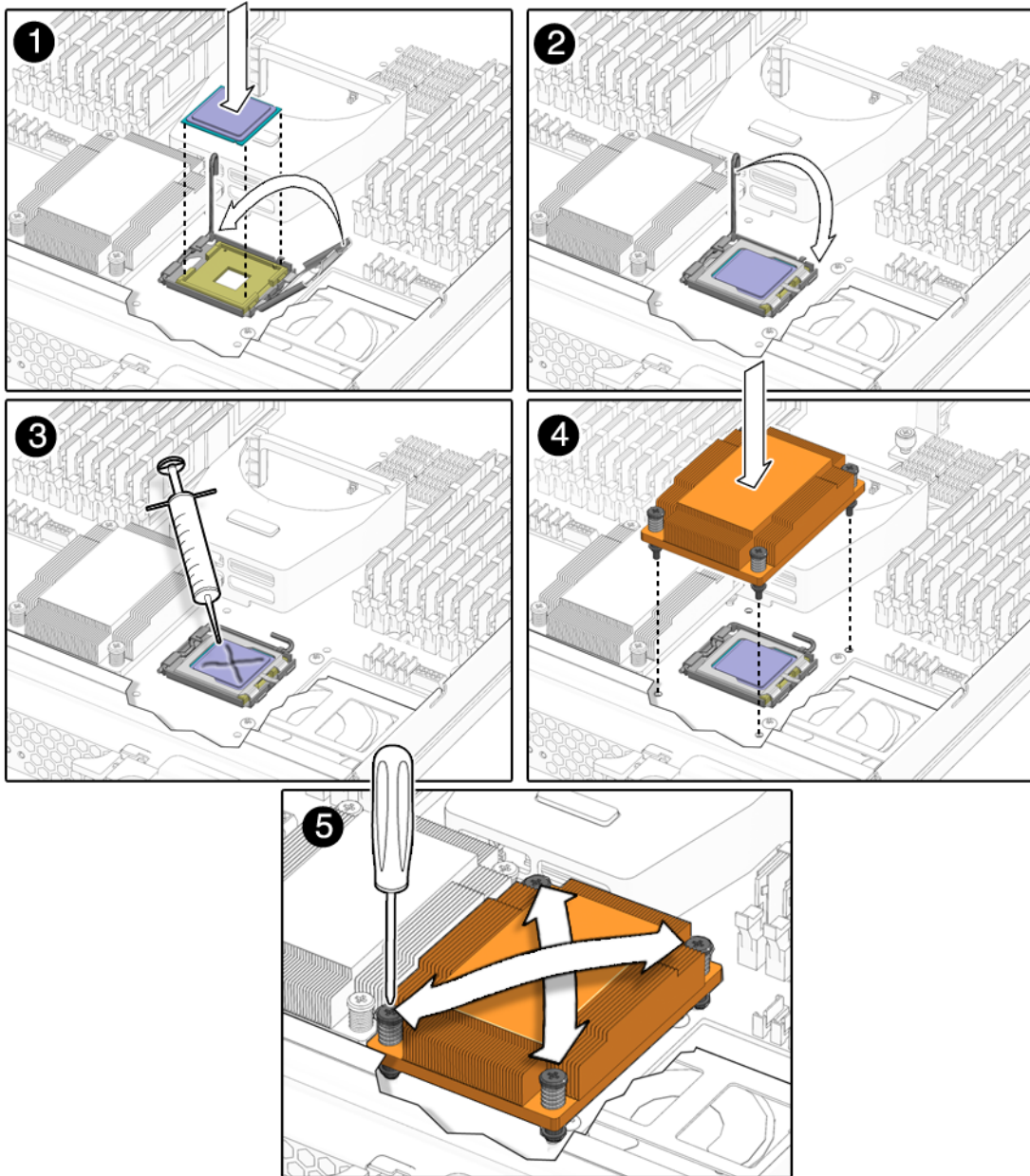
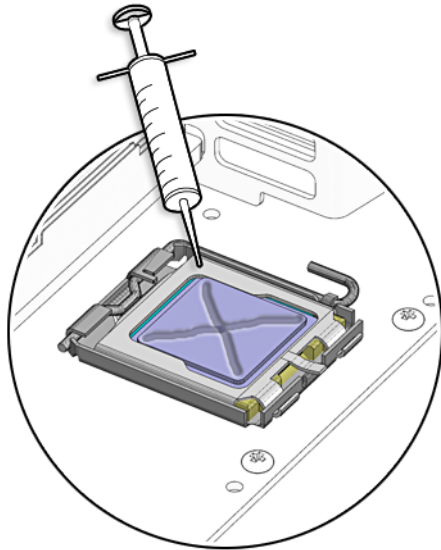

FIGURE 3-14 Applying Thermal Grease



- b. If you are reinstalling an existing heatsink, use an alcohol pad to clean all the old thermal grease from the component surface. Also, clean the dust from the heatsink fins.

Note – System cooling might be affected by dust and contaminant build-up. Therefore, you should open and check systems approximately every six months (or more often in dirty operating environments). Check system heatsinks, fans, and air openings. If necessary, clean systems by carefully brushing, blowing, or vacuuming contaminants from the system.

- c. Turn the heatsink upright and reinsert the four springs and mounting screws.



Caution – Avoid moving the heatsink after it has contacted the top of the CPU. Too much movement could disturb the layer of thermal grease, leading to component damage.

- d. Carefully position and align the heatsink over the CPU.
- e. Lower the heatsink onto the CPU, aligning the mounting screws with their holes on the motherboard.
- f. Using an adjustable torque driver, alternately tighten the two heatsink mounting screws, 180 degrees at a time, until each spring is completely compressed. Tighten screws to 8 in-lbs (0.8 Nm).



Caution – After replacing the CPU, you must update the BIOS and SP firmware, as described in [Section 5.1, “Updating BIOS, CPLD and the SP”](#) on page 5-1.

3.5.5 Replacing the Motherboard

The motherboard is always shipped with the enclosure. You should never separate the motherboard from the enclosure.

Note – This component is an FRU and should be replaced *only* by qualified service technicians. Contact your Sun Service representative for assistance.

Supported components and their part numbers are subject to change over time. For the most up-to-date list of replaceable components for these servers, visit:

http://sunsolve.sun.com/handbook_pub/Systems/

1. Click the name and model of your server.
2. On the product page that opens for the server, click on `Full Components List` for the list of components.

▼ To Replace the Motherboard

1. **Power off the server and remove the server module from the chassis as described in [Section 3.3.1, “Removing the Server Module From the Chassis”](#) on page 3-7.**



Caution – Do not operate the system with empty slots. Always insert a filler into an empty slot to reduce the possibility of module shutdown.

2. **Remove the main cover as described in [Section 3.3.2, “Removing the Main Cover”](#) on page 3-9.**
3. **Remove the following components from the motherboard and place them on an antistatic surface.**
 - DIMMs: See [Section 3.5.3, “Replacing Memory Modules \(DIMMs\)”](#) on page 3-14.
 - CPU and heatsink: See [Section 3.5.4, “Replacing a CPU and Heatsink”](#) on page 3-18.
 - Hard disks: See [Section 3.5.6, “Replacing a Hard Disk”](#) on page 3-26.

You must return each HD to the bay from which it was removed. Use an adhesive note or another method to temporarily label the HDs after you remove them.

- RAID expansion module (optional) - [Section 3.5.7, “Adding or Replacing a RAID Expansion Module” on page 3-31.](#)
 - Fabric expansion module (optional) - [Section 3.5.10, “Replacing a Fabric Expansion Module” on page 3-37.](#)
 - Compact flash module (optional) - [Section 3.5.2, “Replacing the Compact Flash Module” on page 3-13.](#)
4. **Install the components you removed from the old motherboard onto the new.**
- DIMMs: See [Section 3.5.3, “Replacing Memory Modules \(DIMMs\)” on page 3-14.](#)
 - CPU and heatsink: See [Section 3.5.4, “Replacing a CPU and Heatsink” on page 3-18.](#)
 - Hard disks: See [Section 3.5.6, “Replacing a Hard Disk” on page 3-26.](#)

You must return each HD to the bay from which it was removed. Use an adhesive note or another method to temporarily label the HDs after you remove them.

3.5.6 Replacing a Hard Disk

The server module includes four HD bays on the front panel.

Note – HDs are hot-swappable CRUs that can be replaced by anyone.

The internal system software designation of the HDs is shown in [FIGURE 3-15](#).

Supported components and their part numbers are subject to change over time. For the most up-to-date list of replaceable components for these servers, see:

http://sunsolve.sun.com/handbook_pub/Systems/

1. Click the name and model of your server.
2. On the product page that opens for the server, click on `Full Components List` for the list of components.

FIGURE 3-15 Designation of Hard Disk Disks



3.5.6.1 RAID Configuration

For information about the implementation and configuration of RAID on this server, see the *Sun Intel Adaptec BIOS RAID Utility User's Manual*.



Caution – Possible data loss: If you insert an HD that has been configured with a RAID volume into a server that did not previously have its HDs configured with RAID volumes, the existing HDs in the server are converted to RAID volumes during automatic synchronization, and any existing data on the existing HDs in the server is erased. Before permanently removing an HD that is part of an active RAID volume, use the Configuration Utility to delete the RAID volume from the HD to avoid causing this problem. See the *Sun Intel Adaptec BIOS RAID Utility User's Manual* for more information about the Configuration Utility.

3.5.6.2 Solid State Drives (SSDs)

The X6250 server module supports installing SSDs in the HD bays. Each SSD provides 32Gb of SATA capacity.

The following conditions apply:

- You cannot mix SSD and other disk drives in a single RAID volume.
- You cannot mix SAS SSD and SATA SSD drives in a single RAID volume.
- You CAN create multiple volumes where each volume contains a different type of disk drives.

- NO mixing of SAS SSD and SATA SSD in a single RAID volume is allowed. For example, one volume could contain SAS SSD drives, and the other could contain SATA SSD drives.
- When drives are hot plugged, or when a drive fails and a Hot Spare is activated, the firmware determines that the new drive meets the above conditions before integrating it into the array.

3.5.6.3 HD Replacement Procedure

Follow these steps to remove and replace a hard disk (HD).

▼ To Replace a Hard Disk

1. Observe the LEDs on the faces of the HDs and identify the defective HD:

- Middle LED on (amber): The disk is faulty and should be replaced.
- Left LED on (green): The disk is operating properly.
- Right LED on (blue): This indicates that the disk is ready to remove. This can be useful if you are replacing a disk that hasn't failed.

Note – When you replace the HDs, you must return each HD to the bay from which it was removed. Use an adhesive note or another method to temporarily label the HDs when you remove them.

The server module HDs are hot-swappable, so you can remove an HD either when server module is installed in the chassis or when it is out of the chassis. See [FIGURE 3-16](#).

FIGURE 3-16 Removing the Hard Disk Drive After Removing the Server Module

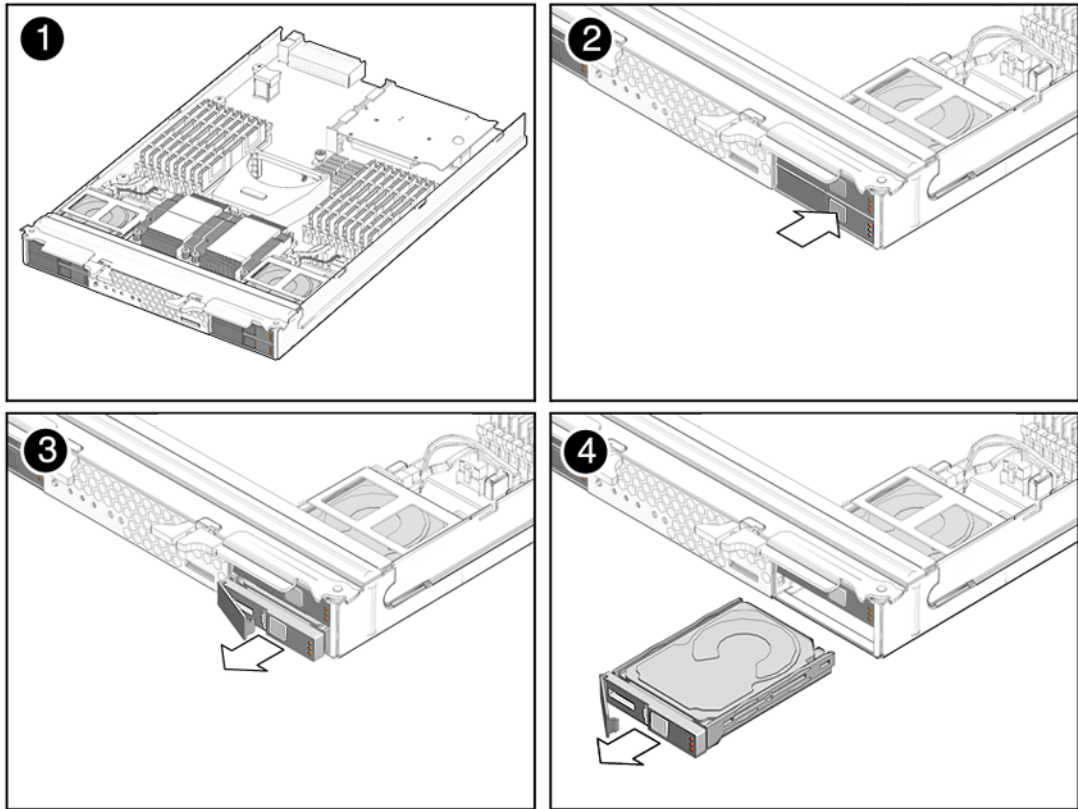
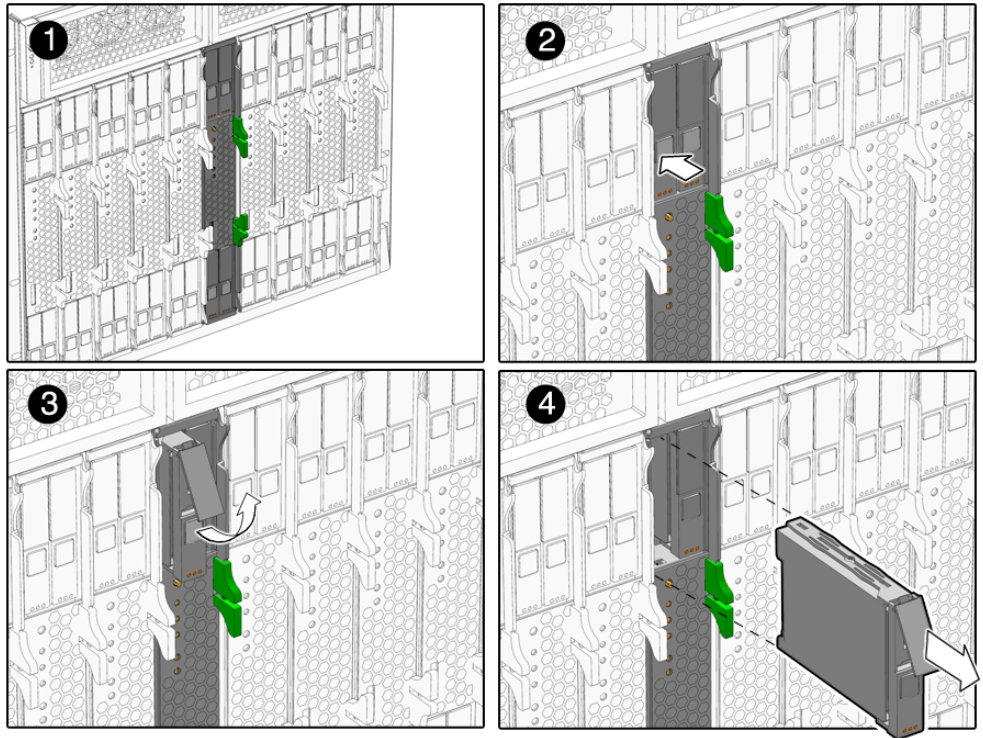

FIGURE 3-17 Removing the Hard Disk Drive Without Removing the Server Module



2. Press the button on the face of the HD to release the spring-loaded securing latch. See [FIGURE 3-17](#).
3. Grasp the securing latch and remove the HD from the disk bay.

Installation is the reverse of this procedure.

Note – When you install an HD, open its securing latch before you push the disk into the bay. Push the HD into the bay until it stops, then close the securing latch to fully engage the connector on the HD backplane.

Note – If the HDs were previously configured as a mirrored RAID 1 array, an automatic resynchronization is invoked and the contents are automatically rebuilt from the rest of the array with no need to reconfigure the RAID parameters. If the bad HD was configured as a hotspare, the new HD is automatically configured as a new hotspare.

3.5.7 Adding or Replacing a RAID Expansion Module

The Sun Blade RAID 5 Expansion Module (REM) enables RAID functionality.

If you are adding a Sun Blade RAID 5 Expansion Module to a system, you must have a set of SAS HDs to replace the existing SATA HDs. This will effectively remove the operating system, and any data from your system.

When the Sun Blade RAID 5 Expansion Module is installed, SAS disks can be installed in disk slots 0 through 3. These disks can be configured as RAID 0, 1, 1E, 10, 5, or 6 with global or dedicated hot spares, as described in the *Sun Intel Adaptec BIOS RAID Utility User's Manual*.

To update the REM firmware, see [Section 5.3, “Updating the REM Firmware”](#) on page 5-3.

The Sun Blade RAID 5 Expansion Module includes a battery. For instructions, see [Section 3.5.9, “Changing the Sun Blade RAID 5 Expansion Module Battery”](#) on page 3-35.



Caution – Backup all data to an external site before adding a REM to server without one.



Caution – If you change a REM on a system with an existing RAID array, to preserve the array configuration and the data in the array, use the procedure in [Section 3.5.8, “Restoring an Existing RAID Array After Changing the REM”](#) on page 3-34.

▼ To Add, Remove or Replace a REM Board

1. **Ensure that your REM has a battery, and that the cable is connected to the REM.**
 - If the battery is not already connected to the REM board, connect it as described in [Section 3.5.9, “Changing the Sun Blade RAID 5 Expansion Module Battery”](#) on page 3-35.
 - If the cable is disconnected, connect it.
2. **Power off the server and remove the server module from the chassis as described in [Section 3.3.1, “Removing the Server Module From the Chassis”](#) on page 3-7.**



Caution – Do not operate the system with empty slots. Always insert a filler into an empty slot to reduce the possibility of module shutdown.

3. Remove the main cover as described in [Section 3.3.2, “Removing the Main Cover”](#) on page 3-9.
4. Remove the existing REM board or the cap from the REM connector if either is present.
The cap should only be present if you are adding a REM board to a server module without one.
5. Slide the REM board at an angle into the support bracket, then press it carefully into the connector. See [FIGURE 3-13](#).

Note – For information about the implementation and configuration of RAID on this server, see the Disk Controller Documentation collection. .

FIGURE 3-18 Inserting the REM

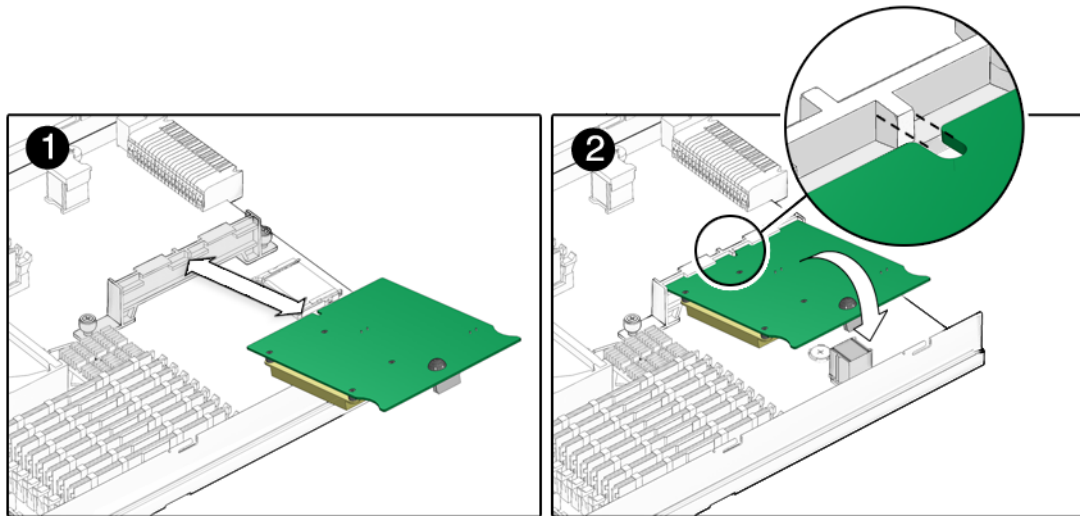

Note – If you are replacing an existing REM, you are done. If you are adding a REM to a system without a REM, continue.



Caution – The following steps will remove all data from the system. Back up your data to an external site before proceeding.

6. **Remove the hard disks.** See [Section 3.5.6, “Replacing a Hard Disk”](#) on page 3-26.
7. **To change the disk controller type from SATA to SAS, move the disk control cables on the motherboard.**

The server has two HD backplanes positioned behind HD 0 and 1, and behind HD 2 and 3 respectively. Each backplane connector has two cables that connect to the motherboard. The connectors on the HD backplane are labeled HD 1/3 and HD 0/2.

Move the cables on the motherboard as follows:

HD Bay	HD Backplane Connectors	Motherboard Connectors
HD 0 and 1	HD 0/2	Move from SATA0 to SAS0
	HD 1/3	Move from SATA1 to SAS1
HD 2 and 3	HD 0/2	Move from SATA2 to SAS2
	HD 1/3	Move from SATA3 to SAS3

[FIGURE 3-19](#) shows the HD backplane to motherboard cables.

FIGURE 3-19 HD Backplane Connectors

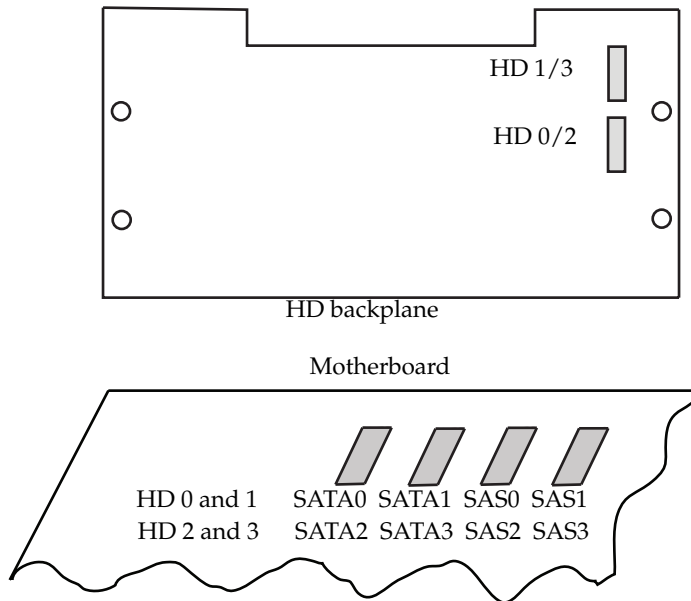

8. Place the new SAS disks in the disk bays.

See [Section 3.5.6, “Replacing a Hard Disk”](#) on page 3-26.

Unless you have pre-loaded software on the SAS disks, your server will not have an operating system, or any data. You will need to restore your data from backups, and install the operating system:

- To install the Solaris OS or Linux, see the *Sun Blade X6250 Server Module Operating System Installation Guide*.
- To install the Windows OS, see the *Sun Blade X6250 Server Module Windows Operating System Installation Guide*.

3.5.8 Restoring an Existing RAID Array After Changing the REM

When you change the REM on a server module with an existing RAID array, when you restart the server module, the new controller probes the disks, and downloads information about the array. It then offers a selection to restore the existing array.

Use the following procedure to preserve an existing RAID array and the data in it.

▼ To Restore a RAID Array After Replacing a REM Card

1. **After changing the REM, restart the server module.**

The startup messages include a message from the RAID controller utility offering to restore the original array.

2. **Accept the option to restore the existing array.**

The RAID controller utility restores the existing array.



Caution – Declining this option could cause you to lose the array configuration, and the data in the array.

Note – Alternatively, if you open the RAID controller utility, it offers a selection to restore the existing array. Accept the option to restore the existing array.

For information, see the disk controller collection.

3.5.9 Changing the Sun Blade RAID 5 Expansion Module Battery

The Sun Blade RAID 5 Expansion Module has a battery that should be replaced when indicated in the *Sun Intel Adaptec BIOS RAID Utility User's Manual* .

If you are adding a Sun Blade RAID 5 Expansion Module to a server module without one, connect the battery to the Sun Blade RAID 5 Expansion Module, as described in [Step 5](#).

Note – The shipping container might include extra cables. Do not use them.

1. **Power off the server and remove the server module from the chassis as described in [Section 3.3.1, “Removing the Server Module From the Chassis” on page 3-7](#).**



Caution – Do not operate the system with empty slots. Always insert a filler into an empty slot to reduce the possibility of module shutdown.

2. **Remove the main cover as described in [Section 3.3.2, “Removing the Main Cover” on page 3-9](#).**

3. **Remove the Sun Blade RAID 5 Expansion Module as described in [Section 3.5.7, “Adding or Replacing a RAID Expansion Module”](#) on page 3-31.**
4. **Remove the battery:**
 - a. **Turn the Sun Blade RAID 5 Expansion Module board over.**

The battery is located underneath the REM board.
 - b. **Disconnect the battery cable from the Sun Blade RAID 5 Expansion Module.**

See [FIGURE 3-20](#).
 - c. **Remove the four screws that secure the battery to the Sun Blade RAID 5 Expansion Module board.**
 - d. **Lift the battery away from the Sun Blade RAID 5 Expansion Module board.**
5. **Install the new battery:**
 - a. **Attach the battery to the Sun Blade RAID 5 Expansion Module using the four screws.**

See [FIGURE 3-20](#).
 - b. **Connect the cable on the battery to the connector on the Sun Blade RAID 5 Expansion Module.**

Note – Dispose of the old battery correctly. Do not place it in the trash.

FIGURE 3-20 REM Battery Screws and Connectors

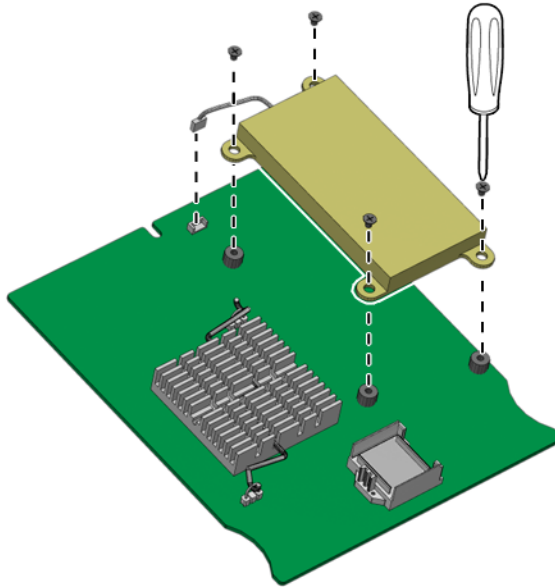

3.5.10 Replacing a Fabric Expansion Module

The procedures in this section describe how to install and remove an optional Fabric Expansion Module (FEM).

The module is installed on the left side of the center mounting bracket.

▼ To Install Fabric Expansion Module

1. Power off the server and remove the server module from the chassis as described in [Section 3.3.1, “Removing the Server Module From the Chassis”](#) on [page 3-7](#).



Caution – Do not operate the system with empty slots. Always insert a filler into an empty slot to reduce the possibility of module shutdown.

2. Remove the main cover as described in [Section 3.3.2, “Removing the Main Cover”](#) on [page 3-9](#).

3. Remove the protective cap from the fabric expansion module connector (see [FIGURE 3-21](#)).

The fabric expansion module connector is located on the left side of the center support bracket.

FIGURE 3-21 Removing the Connector Cap

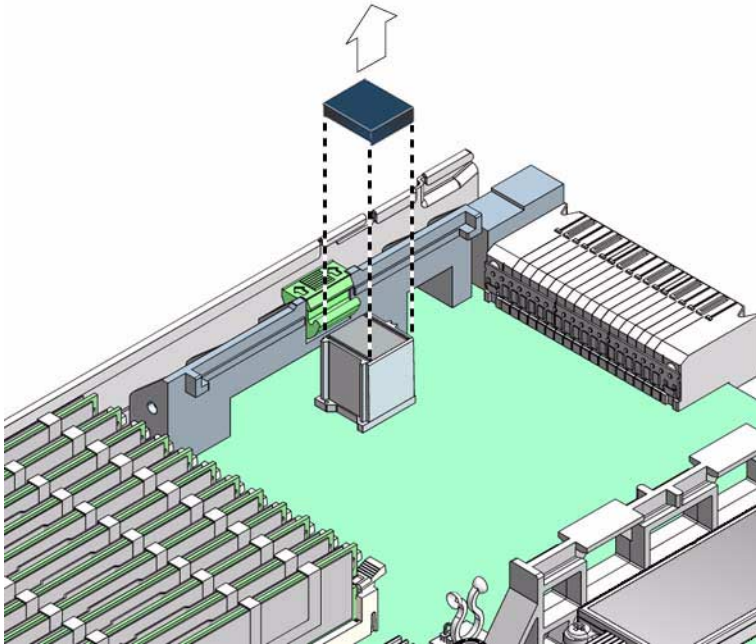

4. Position the fabric expansion module (connector side down) over the fabric expansion module connector on the motherboard, and insert the (opposite) edge of the fabric expansion module into the slots on the center support bracket (see [FIGURE 3-22](#)).

FIGURE 3-22 Installation of a Fabric Expansion Module

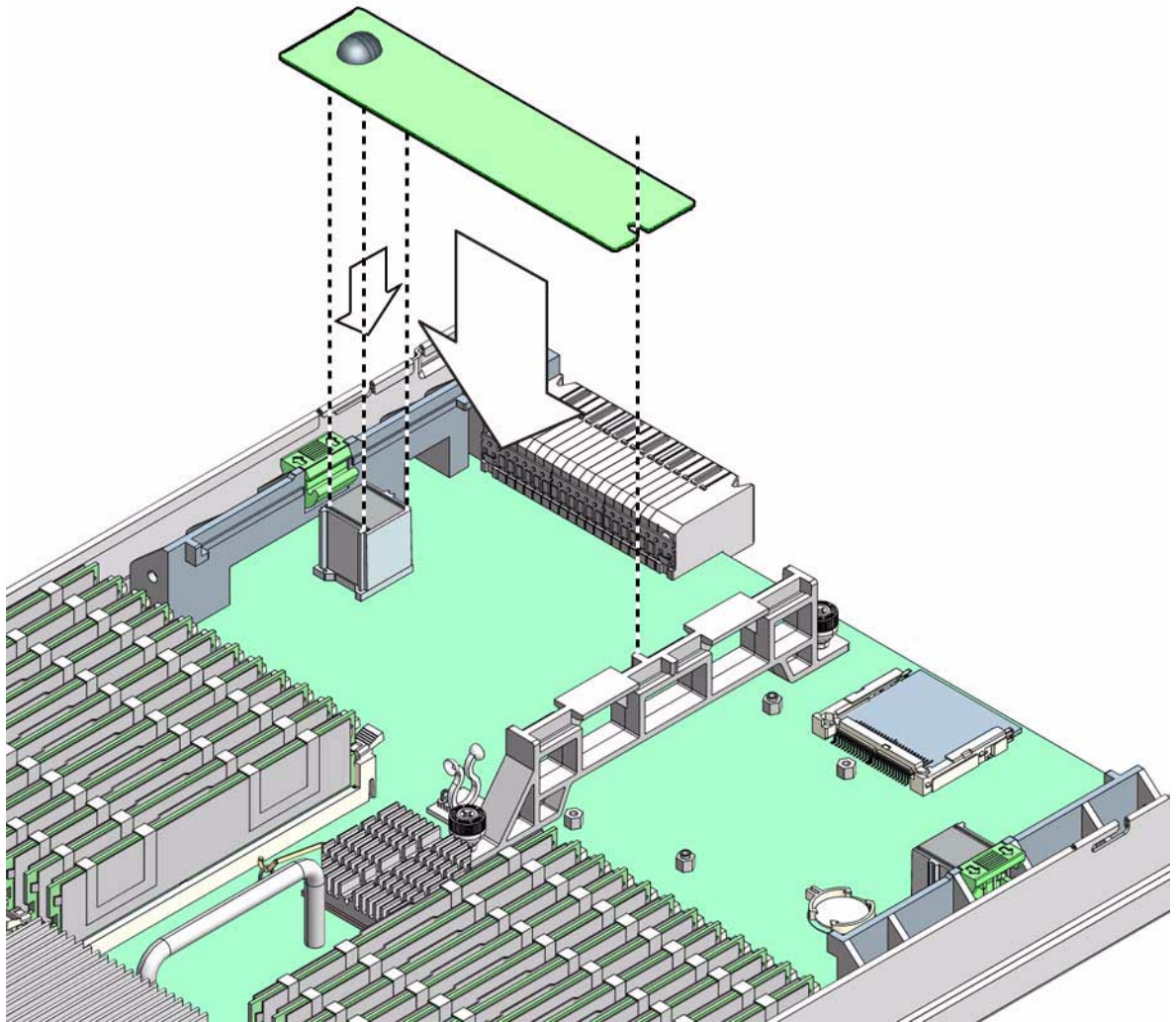

5. Gently press the connector on the underside of the module onto the connector on the motherboard, until the edge of the board is secured by the ejector clip on the left-side support bracket.

The module is installed.

▼ To Remove a Fabric Expansion Module

1. **Power off the server and remove the server module from the chassis as described in Section 3.3.1, “Removing the Server Module From the Chassis” on page 3-7.**



Caution – Do not operate the system with empty slots. Always insert a filler into an empty slot to reduce the possibility of module shutdown.

2. **Remove the main cover as described in Section 3.3.2, “Removing the Main Cover” on page 3-9.**

The fabric expansion module connector is located on the left side of the center support bracket.

3. **Press down on the ejector lever to unlock the edge of the fabric expansion module.**

The ejector lever is located on the left-side support bracket. Unlocking the module allows you to disconnect the module from the motherboard.

4. **To disconnect, gently lift the edge of the module off the connector on the motherboard.**

The other end of the module is secured under clips on the center support bracket (see [FIGURE 3-23](#)).

FIGURE 3-23 Removing a Fabric Expansion Module

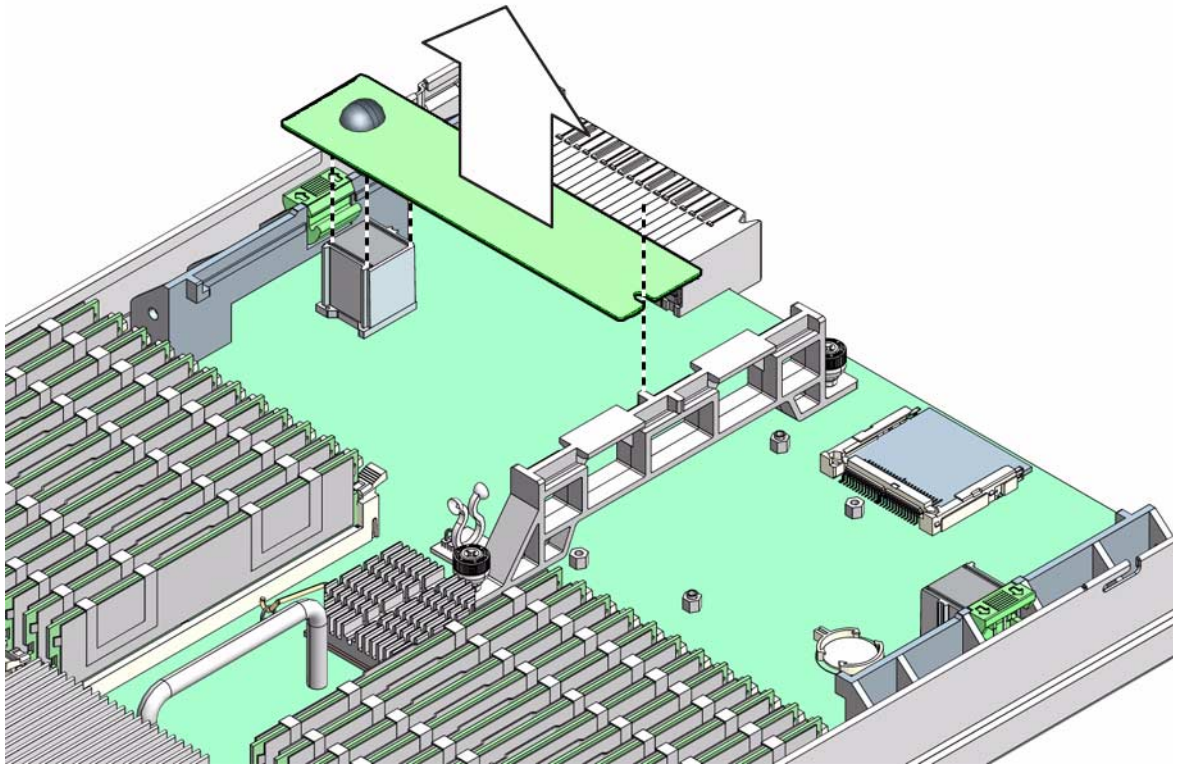

5. When the fabric expansion module is disconnected, pull the card away from the center support bracket, and remove it from the server.

Performing Diagnostic Tests

This chapter describes how to use the Pc-Check diagnostic tests, provided on the service processor (ILOM or ELOM). If you are having a problem with your system, use the diagnostics to diagnose and solve it.

This chapter contains the following sections:

- [Section 4.1, “Pc-Check Diagnostics Overview” on page 4-1](#)
- [Section 4.2, “System Information Menu” on page 4-3](#)
- [Section 4.3, “Advanced Diagnostics” on page 4-4](#)
- [Section 4.4, “Hard Disk Testing” on page 4-6](#)
- [Section 4.5, “Burn-In Testing” on page 4-8](#)
- [Section 4.6, “Diagnostic Partition” on page 4-11](#)
- [Section 4.7, “Show Results Summary” on page 4-11](#)
- [Section 4.8, “Print Results Report” on page 4-12](#)
- [Section 4.9, “About Pc-Check” on page 4-12](#)
- [Section 4.10, “Exit” on page 4-13](#)

4.1 Pc-Check Diagnostics Overview

The Pc-Check diagnostics can test and detect problems on all motherboard components, drives, ports, and slots. This program can be accessed and executed only from the service processor.

Normally, if you encounter any hardware-related error message (such as memory errors or hard disk errors) on your workstation, you will run one of the following selections from the Diagnostics main menu:

- Use *Immediate Burn-In Test* to run a test script. Sun provides three diagnostic scripts designed to test a full range of system resources.
- Use *Advanced Diagnostics Test* to test a specific hardware component, for example, a CPU or a hard disk.

Other selections on the Diagnostics main menu display information about the system, create disk partitions and display test results.

▼ To Access the Pc-Check Diagnostics

1. Shut down the server.

For instructions, see [Section 2.2, “Powering Off the Server”](#) on page 2-3.

2. Start the service processor and access the web interface.

3. Start the diagnostic program.

- On the ELOM:

a. **Select Remote Control => Remote Power Control => Boot from PCCheck.**

b. **Select Submit.**

The system boots to the Pc-Check main menu.

- On the ILOM:

a. **Select Remote Control => Diagnostics.**

b. **Select an option from the drop-down menu.**

- Choose `Manual` to run diagnostics in manual mode. This causes the system to boot to the Pc-Check main menu.
- Choose `Disabled` to turn off Pc-Check.

Note – Choose `Enabled` or `Extended` only when requested by Sun support personnel.

c. **Restart the system.**

The system boots to the Pc-Check main menu,

The Pc-Check main menu offers the following selections:

- System Information Menu
- Advanced Diagnostics Tests
- Immediate Burn-In Testing
- Deferred Burn-In Testing

- Create Diagnostic Partition
- Show Results Summary
- Print Results Report
- About PC-CHECK
- Exit

Use the arrow keys on the keyboard to navigate through the diagnostics software, the Enter key to select a menu item, and the ESC key to exit a menu. Navigation instructions appear at the bottom of each screen.

To test a specific hardware component, select “Advanced Diagnostics Test.” See [Section 4.3, “Advanced Diagnostics” on page 4-4](#) for details.

To run a test script, select “Immediate Burn-In Testing.” Sun provides three scripts that include a full test of all possible devices (`full.tst`), a quick test of devices (`quick.tst`), and a test that requires no user interaction (`noinput.tst`). See [Section 4.5.1, “Performing Immediate Burn-In Testing” on page 4-8](#) for details.

To create your own test script, select “Deferred Burn-In Testing.” See [Section 4.5.2, “Performing Deferred Burn-In Testing” on page 4-10](#) for details.

The following sections in this chapter describe the menu items and tests in detail.

4.2 System Information Menu

Clicking System Information in the Diagnostics main menu causes the System Information menu to appear. Select items in this menu to see detailed information.

[TABLE 4-1](#) describes the selections in the System Information menu.

TABLE 4-1 System Information Menu Options

Option	Description
System Information Menu	Includes basic information about your system, motherboard, BIOS, processor, memory cache, drives, video, modem, network, buses, and ports.
Hardware ID Image Menu	Enables you to create an XML or <code>.txt</code> document showing your system’s hardware ID.
System Management Info	Provides information about the BIOS type, system, motherboard, enclosure, processors, memory modules, cache, slots, system event log, memory array, memory devices, memory device mapped addresses, and system boot.

TABLE 4-1 System Information Menu Options (*Continued*)

Option	Description
PCI Bus Info	Includes details about specific devices from <code>pci-config</code> space within the system, similar to the System Management Information section.
IDE Bus Info	Displays information about the IDE bus.
Interrupt Vectors	Displays a list of interrupt vectors.
IRQ Information	Shows hardware interrupt assignments.
Device Drivers	Shows device drivers loaded under Open DOS.
APM Information	Enables you to test and configure the Advanced Power Management (APM) capabilities of the system. You can choose to change the power state, view the power status, indicate CPU usage, get a power management event, or change the interface mode.
I/O Port Browser	Shows the I/O port assignment for the hardware devices on the system.
Memory Browser	Enables you to view the mapped memory for the entire system.
Sector Browser	Reads sector information from the hard disks sector by sector.
CPU Frequency Monitor	Tests the processor speed.
CMOS RAM Utilities	Shows the CMOS settings of the system.
Text File Editor	Opens a file editor.
Start-Up Options	Enables you to set up startup options for diagnostics testing.

4.3 Advanced Diagnostics

Advanced diagnostics are used to test an individual device on the system. Most of the selections on this menu display information about the corresponding devices, and then offer a menu of testing options. For example, to test CPU 0, you can select Advanced Diagnostics => Processor => CPU0.

Note – If you do not know which device to test, see [Section 4.5, “Burn-In Testing” on page 4-8](#).

[TABLE 4-2](#) gives the name and a brief description of the selections in the Advanced Diagnostics Tests menu.

Note – Some of the tests in [TABLE 4-2](#) might be irrelevant for certain systems. Ignore any that are not relevant to your hardware configuration.

TABLE 4-2 Advanced Diagnostics Test Menu Options

Option	Description
Processor	Displays information about the processors and includes a Processor Tests menu.
Memory	Displays information about the memory, and includes tests for the different types of system memory.
Motherboard	Displays information about the motherboard, and includes a Motherboard Tests menu.
Floppy Disks	Not relevant.
Hard Disks	Displays information about the hard disk and includes a Hard Disk Tests menu. Refer to Section 4.4, “Hard Disk Testing” on page 4-6 , for detailed information about scripts and about testing hard disks.
CD-ROM/DVD	Displays a CD-ROM/DVD menu to test DVD devices on the system.
ATAPI Devices	Displays information about devices attached to the IDE controllers on the system other than a DVD or hard disks (for example, zip drives).
ATA	Includes an ATA test menu. Select the parallel ATA driver to test.
USB	Displays information about the USB devices on the system and includes a USB Tests menu.
Network	Performs network register controller tests.
System Stress Test	Exercises and checks the CPU, memory, and hard disk.
Keyboard	Includes a Keyboard Test menu with options for performing different tests on the keyboard.
Mouse	Displays information about the mouse and includes a menu to test the mouse on the system.

TABLE 4-2 Advanced Diagnostics Test Menu Options (*Continued*)

Option	Description
Audio	Displays information about the audio devices on the system and includes an Audio Tests menu to test audio device information. A PCI audio card is required to run this test.
Video	Displays information about the video card. Initially, the monitor might flicker, but then it brings up a Video Test Options menu that enables you to perform various video tests.
Firmware –ACPI	Displays information about Advanced Configurable Power Interface (ACPI) and includes an ACPI Tests menu.

4.4 Hard Disk Testing

Use these tests to select and test a hard disk. Before starting the test, you can set the parameters using the Test Settings option.

▼ To Select and Test a Hard Disk

- 1. From the main menu, choose Advanced Diagnostics Tests.**
- 2. From the Advanced Diagnostics Tests menu, choose Hard Disks.**
- 3. From the Select Drive menu, choose the hard disk you need to test.**

The Hard Disk Diagnostics dialog opens. It displays information about the selected hard disk and the Hard Disk Tests menu, which includes the following options:

- Select Drive
- Test Settings
- Read Test
- Read Verify Test
- Non-Destructive Write Test
- Destructive Write Test
- Mechanics Stress Test
- Internal Cache Test
- SMART Immediate Test

- View Error Log
- Utilities Menu
- Exit

4. Click Select Drive to select a hard disk to test.

5. Click Test Settings, if desired, to select options for that test.

This enables you to change the following parameters:

- Number of Retries
Selects the number of times to retry testing a device before terminating the test.
- Maximum Errors
Selects the number of errors allowed before terminating the test.
- Check SMART First
Selects Smart Monitoring Analysis Reporting Test (SMART).
- HPA Protection
Selects Host Protected Area (HPA) protection.
- Media Test Settings
Selects the test time duration, the percentage of the hard disk to test, and the sectors to be tested on the hard disk.
- Device Test Settings
Selects the test time durations of the devices and the test level.

6. Select a test to begin execution.

The Read Test, Read Verify Test, the Non-Destructive Write Test, and the Destructive Write Test test the actual media on the physical disk.

The Mechanics Stress Test and the Internal Cache Test test non media-related parts of the hard disk hardware.



Caution – Running the Destructive Write Test destroys any data on the disk.

4.5 Burn-In Testing

Burn-In testing enables you to run test scripts and to create new scripts.

The Diagnostics main menu provides two burn-in selections, Immediate Burn-In Testing and Deferred Burn-In Testing.

- Immediate Burn-In enables you to run an existing script and to select configuration options.
- Deferred Burn-In enables you to create a new script.

Sun provides three ready-made scripts designed to test the general health of the devices on your system. These scripts include:

- `quick.tst` – This script performs a series of tests that require the user to interact with the test software. When they require a user interaction, they stop and do not time out. These tests are faster than the `full.tst` but they are less thorough. For example, they do not run all the tests associated with a DIMM.
- `noinput.tst` – This script performs a non-detailed test of most hardware components, excluding those components that require user input (keyboard, mouse, sound, and video). This test does not require user input. It is normally the first test performed for hardware-related problems.
- `full.tst` – This script performs a detailed and comprehensive test on all hardware components, including those that require user input. It includes external port tests and requires loopback connectors on COM ports, parallel ports and USB ports. You must interact with the test utility to progress through these interactive tests.

Tip – Each of these scripts tests the operating status of your entire system. To test specific disks independently of the rest of the system, use the procedures in [Section 4.4, “Hard Disk Testing”](#) on page 4-6.

4.5.1 Performing Immediate Burn-In Testing

Use Immediate Burn-In Testing to run test scripts.

▼ To Perform Immediate Burn-in Testing

1. **From the Diagnostics main menu, select Immediate Burn-In Testing.**

The screen displays a list of settings shown in [TABLE 4-3](#) and a Burn-In menu.

2. From the menu, select Load Burn-In Script.

A text box appears.

3. Type the name of the script you want to run.

- `quick.tst`, `noinput.tst`, or `full.tst`
- If you have created and saved your own script, type `d:\testname.tst` where *testname* is the name of the script that you have created.

4. To change any of the options, at the bottom of the screen, select Change Options.

This opens the Burn-In Options menu, which enables you to modify the options listed in [TABLE 4-3](#) for the currently loaded test script.

5. Select Perform Burn-In Tests.

The diagnostics software executes the test script as configured.

TABLE 4-3 Continuous Burn-In Testing Options

Option	Default – General	Default Using quick.tst, noinput.tst, or full.tst Script	All Possible Choices
Pass Control	Overall Time	Overall Passes	Individual Passes, Overall Passes, or Overall Time
Duration	01:00	1	Enter any number to choose the time duration of the test
Script File	N/A	quick.tst, noinput.tst, or full.tst	quick.tst, noinput.tst, or full.tst
Report File	None	None	User defined
Journal File	None	D:\noinput.jrl, D:\quick.jrl, or D:\full.jrl	User defined
Journal Options	Failed Tests	All Tests, Absent Devices, and Test Summary	Failed Tests, All Tests, Absent Devices, and Test Summary
Pause on Error	N	N	Y or N
Screen Display	Control Panel	Control Panel	Control Panel or Running Tests

TABLE 4-3 Continuous Burn-In Testing Options (*Continued*)

Option	Default – General	Default Using quick.tst, noinput.tst, or full.tst Script	All Possible Choices
POST Card	N	N	Y or N
Beep Codes	N	N	Y or N
Maximum Fails	Disabled	Disabled	1–9999

4.5.2 Performing Deferred Burn-In Testing

Use Deferred Burn-In Testing to create scripts.

▼ To Perform Deferred Burn-in Testing

1. From the Diagnostics main menu, select Deferred Burn-In Testing.

The screen displays a list of settings shown in [TABLE 4-3](#) and a Burn-In menu.

2. Use the menu to configure the following selections:

■ **Change Options**

Opens the Burn-In Options menu, which enables you to modify the options listed in [TABLE 4-3](#) for the currently loaded test script.

■ **Select Tests**

Opens a listing of the tests available for your workstation configuration and the currently loaded test script.

3. When you are done, select Save Burn-In Script and type the name for the new script.

Enter `d:\testname.tst`

Where *testname* is the name of the script that you have created.

4. To run the newly created script, go to Immediate Burn-In Testing in [Section 4.5.1, “Performing Immediate Burn-In Testing”](#) on page 4-8, and run the script *testname.tst*.

4.6 Diagnostic Partition

A diagnostic partition is required for the test scripts to write their log files. Without a diagnostic partition, the only output is the display on the diagnostic screens.

The diagnostic partition is preinstalled on the Sun Blade X6250 server module. You do not need to reinstall the diagnostic partition unless you have removed it.

To change partitions, see the instructions for your operating system.

If you have RAID, you can use the instructions in the *Sun StorageTek RAID Manager Software User's Guide*, 820-1177 and the *Uniform Command-Line Interface User's Guide*, 820-2145.

4.7 Show Results Summary

Selecting Show Results Summary on the Diagnostics main menu displays the tests that have been run and lists the results, which can be Pass, Fail, or N/A.

The following list describes all the tests that are available with the Tools and Drivers CD. If your system does not have the corresponding option, the results will show as N/A in the Show Results Summary list.

- Processor

This section shows the following tests conducted against the processor: Core Processor Tests, AMD 64-Bit Core Tests, Math Co-Processor Tests – Pentium Class FDIV and Pentium Class FIST, MMX Operation, 3DNow! Operation, SSE Instruction Set, SSE2 Instruction Set, and MP Symmetry.

- Motherboard

This section shows the following tests conducted against the motherboard: DMA Controller Tests, System Timer Tests, Interrupt Test, Keyboard Controller Tests, PCI Bus Tests, and CMOS RAM/Clock Tests.

- Memory, Cache Memory, and Video Memory

This section shows the following tests conducted against the various types of memory: Inversion Test Tree, Progressive Inv. Test, Chaotic Addressing Test, and Block Rotation Test.

- Input Device

This section shows the following tests conducted against the input device: Verify Device, Keyboard Repeat, and Keyboard LEDs.

- Mouse

This section shows the following tests conducted against the mouse: Buttons, Ballistics, Text Mode Positioning, Text Mode Area Redefine, Graphics Mode Positions, Graphics Area Redefine, and Graphics Cursor Redefine.

- Video

This section shows the following tests conducted against the video: Color Purity Test, True Color Test, Alignment Test, LCD Test, and Test Cord Test.

- ATAPI Devices

This section shows the following tests conducted against ATAPI devices: Linear Read Test, Non-Destructive Write, and Random Read/Write Test.

- Hard Disk

This section shows the following tests conducted against the hard disk: Read Test, Read Verify Test, Non-Destructive Write Test, Destructive Write Test, Mechanics Stress Test, and Internal Cache Test.

- USB

This section shows the following tests conducted against the USB: Controller Tests and Functional Tests.

- Hardware ID

The compare test is used to determine the machine ID for the system. This test is not available for the Sun Blade X6250 server module.

4.8 Print Results Report

The Print Results Report option enables you to print results of the diagnosis of your system.

Ensure that your workstation is connected to a printer, and then enter the required information to print the results.

4.9 About Pc-Check

The About Pc-Check window includes general information about the Pc-Check software, including resident and nonresident components, such as mouse devices.

4.10 Exit

The Exit option exits the Pc-Check software and reboots the server module.

Updating the ELOM Firmware

This chapter describes how to update the SP using the ELOM web interface.

This chapter contains the following sections:

- Section 5.1, “Updating BIOS, CPLD and the SP” on page 5-1
- Section 5.2, “Updating the CPLD” on page 5-2
- Section 5.3, “Updating the REM Firmware” on page 5-3

5.1 Updating BIOS, CPLD and the SP

Use this procedure for updating the ELOM.

- For ILOM 2.0, see the *Sun Integrated Lights Out Manager 2.0 Supplement for Sun Blade X6250 Server Module*.
- For ILOM 3.0, see the *Sun Integrated Lights Out Manager 3.0 Supplement for Sun Blade X6250 Server Module* and the ILOM 3.0 documentation collection.

▼ To Update BIOS, CPLD and the SP

1. **Download the Tools and Driver CD ISO image from**
<http://www.sun.com/servers/blades/downloads.jsp>.
2. **Burn a CD or mount the ISO image and locate the combined firmware image file:**
Use `firmware/bmc/x6250v*.rom`
where * is a variable that identifies the file version number.
3. **Save the file to your hard disk.**

4. Navigate your browser to:

`http://SP-ip-address`

5. Log in to the SP web interface:

Login: **root**

Password: **changeme**

6. Select Remote Control, then Remote Power Control.

7. Power off the system. Select Power Off, then click the Submit button.

8. Select Maintenance, then click Enter Upgrade Mode.

9. Locate the firmware upgrade file.

a. Click Browse.

A browser-type window opens.

b. Browse for the `x6250v*.rom` file.

c. Select the file then click Open.

The browser closes.

10. Select Start Upgrade.

The firmware upgrade process updates the BIOS and the SP. After the upgrade is complete, the SP reboots and the web session is restarted.

Proceed to [Section 5.2, “Updating the CPLD”](#) on page 5-2

5.2 Updating the CPLD

The following procedure is rarely used, and should not be done unless instructed by Sun Service personnel.

This procedure is used for server modules equipped with ELOM service processors only.

- For ILOM 2.0, see the *Sun Integrated Lights Out Manager 2.0 Supplement for Sun Blade X6250 Server Module*.
- For ILOM 3.0, see the *Sun Integrated Lights Out Manager 3.0 Supplement for Sun Blade X6250 Server Module* and the ILOM 3.0 documentation collection.

▼ To Update CPLD (Common Programmable Logic Device) on the Motherboard

1. **Download the Tools and Driver CD ISO image from**
<http://www.sun.com/servers/blades/downloads.jsp>.
2. **Burn a CD or mount the ISO image and locate the combined firmware image file**
`firmware/bmc/CPLD_V*.jbc`.
3. **Save the `CPLD_V*.jbc` file to a location on your hard disk.**
4. **Ensure that the host operating system is shut down.**
5. **Login to the ELOM web interface.**
6. **To power off the system, select Power Off, then click the Submit button.**
7. **Select Maintenance and click Enter Upgrade Mode.**
8. **Click Browse and select the `CPLD_V*.jbc` file.**
where * is a variable that identifies the file version number.
9. **Select Upgrade to upgrade the CPLD.**
10. **Wait until the upgrade is finished.**
11. **Power cycle or reset the server to enable the new CPLD to take effect.**

5.3 Updating the REM Firmware

The following procedure describes how update the firmware in the Raid Expansion Module (REM) from a DOS-bootable USB thumb drive.

You can also update the REM firmware using the procedures in the *Sun StorageTek RAID Software Manager User's Guide*.

▼ To Update the REM Firmware from a DOS-Bootable USB Thumb Drive

1. **Download the Tools and Driver CD ISO image from**
<http://www.sun.com/servers/blades/downloads.jsp>.
2. **Burn a CD or mount the ISO image and locate the Adaptec firmware file:**
`firmware/REM`

3. Copy all the files there to the DOS-bootable USB thumb drive.
4. Connect a dongle cable, keyboard, monitor, and USB thumb drive to the server module.
5. Boot the USB thumb drive to DOS.
 - a. Restart the server module.
 - b. When BIOS is booting press F8.

After some messages, the software prompts you to select a boot device.
 - c. Select USB boot device, then press Enter.

The server module boots to DOS and displays the DOS prompt.

```
A: \>
```
6. Navigate to the directory where you placed the Adaptec files.
7. Enter the command `afu`.

The Adaptec Flash Utility window appears.
8. Select Update the Flash Image, then press Enter.

The utility displays a message:

```
Please insert disk lebeled "Sun STK RAID REM Firmware Disk."
```
9. Press OK to select the file.

The utility displays a similar message for the next file.
10. As the utility loops through the files on the USB thumb drive one-by-one, press OK until all the files are selected.

When all the files are selected, the utility displays a message:

```
"AFU is about to update firmware..."
```
11. Select OK.

The utility asks you to wait, and displays a number of messages. This can take several minutes.

When it is done, the utility displays a message:

```
Flash image was updated and verified successfully. Press any key to continue.
```
12. Press any key.

The utility displays a message "Please restart the computer" then offers another list of selections.
13. Select Exit, and confirm by selecting Yes.

The utility exits to DOS.

- 14. Press Alt-Ctrl-Del to reboot the server module.**
The server module reboots.

System Specifications

This appendix contains physical, power, environmental, and acoustic noise emission specifications for the Sun Blade X6250 server modules.

A.1 Server Module Specifications

TABLE A-1 Server Module Physical Specifications

Specification	Value
Width	17 inches (432 mm)
Height	1.7 inches (44 mm)
Depth	24 inches (610 mm)
Weight	17 pounds (8 kg)

TABLE A-2 Server Module Environmental Specifications

Specification	Value
Temperature (operating)	41- 95° F 5 - 35° C
Temperature (storage)	-40 - 158° F -40 - 70° C
Humidity	10%- 90% non-condensing
Operating altitude	0 - 10,000 feet (0 - 3048 m)

BIOS Power-On Self-Test (POST) Codes

This appendix provides the following sections:

- [Section B.1, “Introduction” on page B-1](#)
- [Section B.2, “How BIOS POST Memory Testing Works” on page B-2](#)
- [Section B.3, “Redirecting Console Output” on page B-2](#)
- [Section B.4, “Changing POST Options” on page B-4](#)
- [Section B.5, “POST Codes” on page B-5](#)

B.1 Introduction

The system BIOS provides a rudimentary power-on self-test. The basic devices required for the server to operate are checked, memory is tested, the controller and attached disks are probed and enumerated, and the two Intel dual-gigabit Ethernet controllers are initialized.

The progress of the self-test is indicated by a series of POST codes.

These codes are displayed at the bottom right corner of the system’s VGA screen when the self-test has progressed far enough to initialize the video monitor. However, the codes are displayed as the self-test runs and scroll off of the screen too quickly to be read. An alternate method of displaying the POST codes is to redirect the output of the console to a serial port (see [Section B.3, “Redirecting Console Output” on page B-2](#)).

The message, BMC Responding is displayed at the end of POST.

B.2 How BIOS POST Memory Testing Works

The BIOS POST memory testing is performed as follows:

1. The first megabyte of DRAM is tested by the BIOS before the BIOS code is shadowed (that is, copied from ROM to DRAM).
2. Once executing out of DRAM, the BIOS performs a simple memory test (a write/read of every location with the pattern 55aa55aa).

Note – This memory test is performed only if Quick Boot is *not* enabled from the Boot Settings Configuration screen. Enabling Quick Boot causes the BIOS to skip the memory test. See [Section B.4, “Changing POST Options”](#) on page B-4 for more information.

3. The BIOS polls the memory controllers for both correctable and uncorrectable memory errors and logs those errors into the service processor.

B.3 Redirecting Console Output

Use these instructions to access the service processor and redirect the console output so that the BIOS POST codes can be read.

▼ To Redirect Console Output

1. **Connect a dongle cable to the server module UCP port.**
2. **Connect a monitor to the dongle cable video port and a keyboard to a USB port.**
3. **Power cycle or power on the server.**
4. **Initialize the BIOS Setup utility by pressing the F2 key while the system is performing the power-on self-test (POST).**
The BIOS Main Menu screen appears.
5. **Select Server.**
The Server screen appears.

6. Select AST2000 LAN Configuration.

The LAN Configuration screen appears.

7. Select the IP Address menu item.

The service processor's IP address is displayed

8. Start a web browser and type the service processor's IP address in the browser's URL field.

■ If you have an ELOM service processor:

a. Type a user name and password as follows:

User name: **root**

Password: **changeme**

b. The ELOM Service Processor interface screen appears.

c. Click the Remote Control tab.

d. Click the Redirection tab.

e. Click on the Start Redirection button.

The javaRConsole window appears and prompts you for your user name and password again.

f. When you are prompted, type a user name and password as follows:

User name: **root**

Password: **changeme**

The current POST screen is displayed.

■ If you have an ILOM service processor:

a. Type a user name and password as follows:

User name: **root**

Password: **changeme**

b. Click the Remote Control tab.

The Remote Control screen appears.

c. Click the Launch Redirection button.

The ILOM remote console appears.

d. When you are prompted, type a user name and password as follows:

User name: **root**

Password: **changeme**

The current POST screen is displayed.

Note – If the server module has an older version of the Linux operating system, or VMware with an older Linux kernel, you might need to change the mouse mode from absolute to relative. See the Sun Integrated Lights Out Manager 2.0 User’s Guide for details.

B.4 Changing POST Options

These instructions are optional, but you can use them to change the operations that the server performs during POST testing.

▼ To Change POST Options

1. **Initialize the BIOS Setup utility by pressing the F2 key while the system is performing the power-on self-test (POST).**

The BIOS Main Menu screen appears.

2. **Select the Boot menu.**

The Boot Settings screen appears.

3. **Select Boot Settings Configuration.**

The Boot Settings Configuration screen appears.

4. **On the Boot Settings Configuration screen, there are several options that you can enable or disable:**

- **Hit 'F2' Message Display:** Displays “Press F2 to run Setup” in POST. This option is enabled by default.
- **Quick Boot:** This option is enabled by default. The BIOS skips certain tests while booting, such as the extensive memory test. This decreases the time it takes for the system to boot.
- **Quiet Boot:** This option is disabled by default. If you enable this option, the Sun Microsystems logo is displayed instead of POST codes.
- **Add On ROM Display Mode:** This option is set to Force BIOS by default. This option takes effect only if you have also enabled the Quiet Boot option, but it controls whether output from the Option ROM is displayed. The two settings for this option are as follows:
 - **Force BIOS:** Remove the Sun logo and display Option ROM output.
 - **Keep Current:** Do not remove the Sun logo. The Option ROM output is not displayed.

- **Boot Num-Lock:** This option is On by default (keyboard Num-Lock is turned on during boot). If you set this option off, the keyboard Num-Lock is not turned on during boot.
- **Wait for F1 if Error:** This option is enabled by default. The system pauses if an error is found during POST and only resumes when you press the F1 key.
- **Interrupt 19 Capture:** This option is reserved for future use. Do not change.

B.5 POST Codes

TABLE B-1 contains descriptions of each of the POST codes, listed in the same order in which they are generated. These POST codes appear as a four-digit string that is a combination of two-digit output from primary I/O port 80 and two-digit output from secondary I/O port 81. In the POST codes listed in TABLE B-1, the first two digits are from port 81 and the last two digits are from port 80.

The Response column describes the action taken by the system on encountering the corresponding error. The choices are:

- **Warning or Not an Error** – The message is displayed on the screen. An error record is logged to the system event log (SEL). The system continues booting with a degraded state. The user might want to replace the unit.
- **Pause** – The message is displayed on the screen, an error is logged to the SEL, and user input is required to continue. The user can take immediate corrective action or choose to continue booting.
- **Halt** – The message is displayed on the screen, an error is logged to the SEL, and the system cannot boot unless the error is resolved. The user needs to replace the faulty part and restart the system.

TABLE B-1 Error Messages and Responses

Error Code	Error Message	Response
0000	Timer Error	Pause
0003	CMOS Battery Low	Pause
0004	CMOS Settings Wrong	Pause
0005	CMOS Checksum Bad	Pause
000B	CMOS memory size Wrong	Pause
000C	RAM R/W test failed	Pause
000E	A: Driver Error	Pause
000F	B: Driver Error	Pause

TABLE B-1 Error Messages and Responses *(Continued)*

Error Code	Error Message	Response
0012	CMOS Date/Time Not Set	Pause
0040	Refresh Timer Test Failed	Halt
0041	Display Memory Test Failed	Pause
0042	CMOS Display Type WrongPause	Pause
0043	~<INS> Pressed	Pause
0044	DMA Controller Error	Halt
0045	DMA-1 Error	Halt
0046	DMA-2 Error	Halt
0047	Unknown BIOS error. Error code = 0047	Halt
0048	Password Check Failed	Halt
0049	Unknown BIOS error. Error code = 0049	Halt
004A	Unknown BIOS error. Error code = 004A	Pause
004B	Unknown BIOS error. Error code = 004B	Pause
005E	Password Check Failed	Pause
005D	S.M.A.R.T. Command Failed S.M.A.R.T. Status BAD, Backup and Replace	Pause
0060	Primary Master Hard Disk Error	Pause
0061	Primary Slave Hard Disk Error	Pause
0062	Secondary Master Hard Disk Error	Pause
0063	Secondary Slave Hard Disk Error	Pause
0080	Primary Master Drive – ATAPI Incompatible	Pause
0081	Primary Slave Drive – ATAPI Incompatible	Pause
0082	Secondary Master Drive – ATAPI Incompatible	Pause
0083	Secondary Slave Drive – ATAPI Incompatible	Pause
00FF		Not an Error
0101	Warning! This system board does not support the power requirements of the installed processor. The processor will be run at a reduced frequency, which will impact system performance.	Pause
0102	Error! The CPU Core to Bus ratio or VID configuration has failed! Please enter BIOS Setup and re-config it.	Pause
0120	Thermal Trip Failure	Pause

TABLE B-1 Error Messages and Responses *(Continued)*

Error Code	Error Message	Response
0121	Thermal Trip Failure	Pause
0122	Thermal Trip Failure	Pause
0123	Thermal Trip Failure	Pause
0124	Thermal Trip Failure	Pause
0125	Thermal Trip Failure	Pause
0126	Thermal Trip Failure	Pause
0127	Thermal Trip Failure	Pause
0150	Processor Failed BIST	Pause
0151	Processor Failed BIST	Pause
0152	Processor Failed BIST	Pause
0153	Processor Failed BIST	Pause
0154	Processor Failed BIST	Pause
0155	Processor Failed BIST	Pause
0156	Processor Failed BIST	Pause
0157	Processor Failed BIST	Pause
0160	Processor missing microcode	Pause
0161	Processor missing microcode	Pause
0162	Processor missing microcode	Pause
0163	Processor missing microcode	Pause
0164	Processor missing microcode	Pause
0165	Processor missing microcode	Pause
0166	Processor missing microcode	Pause
0167	Processor missing microcode	Pause
0180	BIOS does not support current stepping	Pause
0181	BIOS does not support current stepping	Pause
0182	BIOS does not support current stepping	Pause
0183	BIOS does not support current stepping	Pause
0184	BIOS does not support current stepping	Pause
0185	BIOS does not support current stepping	Pause
0186	BIOS does not support current stepping	Pause

TABLE B-1 Error Messages and Responses *(Continued)*

Error Code	Error Message	Response
0187	BIOS does not support current stepping	Pause
0194	CPUID, Processor family are different	Pause
0196	CPUID, Processor Model are different	Pause
0193	CPUID, Processor stepping are different	Pause
0192	L2 cache size mismatch	Pause
0197	Processor speeds mismatched	Pause
0195	Front side bus mismatch. System halted.	Pause
5120	CMOS cleared by jumper	Pause
5121	Password cleared by jumper	Pause
5180	Unsupported Memory Vendor : DIMM_A0	Warning
5181	Unsupported Memory Vendor : DIMM_A1	Warning
5182	Unsupported Memory Vendor : DIMM_A2	Warning
5183	Unsupported Memory Vendor : DIMM_A3	Warning
5184	Unsupported Memory Vendor : DIMM_B0	Warning
5185	Unsupported Memory Vendor : DIMM_B1	Warning
5186	Unsupported Memory Vendor : DIMM_B2	Warning
5187	Unsupported Memory Vendor : DIMM_B3	Warning
5188	Unsupported Memory Vendor : DIMM_C0	Warning
5189	Unsupported Memory Vendor : DIMM_C1	Warning
518A	Unsupported Memory Vendor : DIMM_C2	Warning
518B	Unsupported Memory Vendor : DIMM_C3	Warning
518C	Unsupported Memory Vendor : DIMM_D0	Warning
518D	Unsupported Memory Vendor : DIMM_D1	Warning
518E	Unsupported Memory Vendor : DIMM_D2	Warning
518F	Unsupported Memory Vendor : DIMM_D3	Warning
5190	Unsupported AMB Vendor : DIMM_A0	Warning
5191	Unsupported AMB Vendor : DIMM_A1	Warning
5192	Unsupported AMB Vendor : DIMM_A2	Warning
5193	Unsupported AMB Vendor : DIMM_A3	Warning
5194	Unsupported AMB Vendor : DIMM_B0	Warning

TABLE B-1 Error Messages and Responses *(Continued)*

Error Code	Error Message	Response
5195	Unsupported AMB Vendor : DIMM_B1	Warning
5196	Unsupported AMB Vendor : DIMM_B2	Warning
5197	Unsupported AMB Vendor : DIMM_B3	Warning
5198	Unsupported AMB Vendor : DIMM_C0	Warning
5199	Unsupported AMB Vendor : DIMM_C1	Warning
519A	Unsupported AMB Vendor : DIMM_C2	Warning
519B	Unsupported AMB Vendor : DIMM_C3	Warning
519C	Unsupported AMB Vendor : DIMM_D0	Warning
519D	Unsupported AMB Vendor : DIMM_D1	Warning
519E	Unsupported AMB Vendor : DIMM_D2	Warning
519F	Unsupported AMB Vendor : DIMM_D3	Warning
51A0	Memory Configuration Error	Pause
8101	Warning! USB Host Controller not found at the specified address!!!	Warning
8102	Error! USB device failed to initialize !!!	Warning
8103	Warning! Unsupported UBS device found and disabled !!!	Warning
8104	Warning! Port 60h/64h emulation is not supported by this USB Host Controller !!!	Warning
8105	Warning! EHCI controller disabled. It requires 64bit data support in the BIOS.	Pause
8301	Not enough space in Runtime area!!. SMBIOS data will no be available.	Warning
8302	Not enough space in Runtime area!!. SMBIOS data will no be available.	Pause
8601	Error: BMC Not Responding	Pause
8701	Insufficient Runtime space for MPS data. !!. System may operate in PCI or Non-MPS mode.	Pause

Index

A

- accessory kit contents, 1-6
- Advanced Configurable Power Interface (ACPI), testing, 4-6
- ATA, diagnosing, 4-5
- ATAPI devices
 - diagnosing, 4-5
 - display information about, 4-5
 - tests against, 4-12
- audio devices, testing, 4-6
- available options, 1-7

B

- battery replacement, 3-11
- BIOS
 - configuring, 2-4
 - menu tree, 2-8
 - Option ROM size, 2-7
 - overview, 2-4
 - PCI-X slot priority, 2-6
 - POST codes, B-5
 - POST options, B-4
 - POST overview, B-1
 - redirecting console output for POST, B-2
 - sample setup menu screens, 2-9
 - setup screens summary, 2-7
 - special considerations, 2-5
 - updating, 2-37
- burn-in testing, 4-3

C

- cache

- testing, 4-7

- CD-ROM/DVD, 4-5

- coin battery replacement, 3-11

- comments and suggestions, -xiii

- component overview figure, 1-4

- configuring BIOS, 2-4

- console output, redirecting, B-2

- CPU

- fault LED, 3-6

D

- data loss, 4-7

- Destructive Write Test, running, 4-7

- diagnostics

- advanced diagnostics option, 4-4

- hard disk testing, 4-6

- main menu options, 4-1

- Pc-Check information, viewing, 4-12

- print results reports option, 4-12

- show results summary option, 4-11

- shut down option, 4-13

- system information menu options, 4-3

- DIMMs

- fault LEDs, 3-6

- population rules, 3-17

- documentation, related, -xiii

- dongle cable, 1-4, 1-5

E

- ELOM

- powering off the server, using, 2-4

- emergency shutdown, 2-3
- environmental specs, A-1
- external LEDs, 3-2

F

- Fabric Expansion Module
 - removing, 3-40
- Fabric Expansion Module (FEM)
 - installing, 3-37
- feature summary, 1-1
- figure, 3-10
- firmware, testing, 4-6
- front panel, 1-2
- full.tst script, 4-8

G

- graceful shutdown, 2-3

H

- hard disk
 - diagnosing, 4-5
 - replacement, 3-26
 - testing, 4-6
 - tests against, 4-12

I

- ILOM
 - powering off the server using, 2-4
- input device
 - testing, 4-11
- internal LEDs, 3-5

J

- Jumper J19, 2-35

K

- keyboard
 - testing, 4-5

L

- LEDs
 - CPU fault, 3-6
 - DIMM fault, 3-6
 - external, 3-2
 - internal, 3-5
 - Locate, 3-4

- Power/OK, 3-4
 - Service Action Required, 3-4
- limitations of Option ROM size, 2-7
- Locate LED and button, 3-4

M

- memory
 - diagnosing, 4-5
 - tests against, 4-11
- menu tree, BIOS setup screens, 2-8
- motherboard
 - components
 - testing, 4-1
 - diagnosing, 4-5
 - tests against, 4-11
- motherboard replacement, 3-25
- mouse
 - testing, 4-5
 - tests against, 4-12

N

- network
 - testing, 4-5
- noinput.tst script, 4-8

O

- Option ROM size, 2-7
- options available, 1-7

P

- Pc-Check
 - utility, 4-1
 - viewing information on, 4-12
- PCI-X
 - slot BIOS priority, 2-6
- physical specs, A-1
- POST
 - changing options, B-4
 - codes table, B-5
 - overview, B-1
 - redirecting console output, B-2
- power
 - standby, 2-4
- Power/OK LED, 3-4
- powering off the server, 2-3
- powering on the server, 2-1

power-on self-test, See POST

processor

- diagnosing, 4-5
- tests against, 4-11

Q

quick.tst script, 4-8

R

redirecting console output, B-2

related documentation, -xiii

replaceable component locations, 3-10

replaceable components list, 1-7

S

sample BIOS setup screens, 2-9

scripts, for testing components, 4-8

server features list, 1-1

Service Action Required LED, 3-4

shutting down the server, 2-3

special considerations, BIOS, 2-5

specs, system, A-1

standby power, 2-4

summary of features, 1-1

system specs, A-1

T

testing

- ATAPI devices, 4-12

- burn-in, 4-3

- cache, 4-7

- hard disk, 4-12

- memory, 4-11

- motherboard, 4-11

- motherboard components, 4-1

- mouse, 4-12

- processor, 4-11

- USB, 4-12

- using a dongle cable, 1-4

- video, 4-12

thermal grease application, 3-22, 3-23

tools required, 3-6

U

USB

- device connection, 1-5

devices, diagnosing, 4-5

tests against, 4-12

V

video

- devices, testing, 4-6

- memory tests, 4-11

- tests, 4-12

