



# Sun Fire™ E25K/E20K Systems

---

## Site Planning Guide

Sun Microsystems, Inc.  
www.sun.com

Part No. 817-4137-13  
March 2007, Revision A

Submit comments about this document at: <http://www.sun.com/hwdocs/feedback>

Copyright 2007 Sun Microsystems, Inc., 4150 Network Circle, Santa Clara, California 95054, U.S.A. All rights reserved.

Sun Microsystems, Inc. has intellectual property rights relating to technology that is described in this document. In particular, and without limitation, these intellectual property rights may include one or more of the U.S. patents listed at <http://www.sun.com/patents> and one or more additional patents or pending patent applications in the U.S. and in other countries.

This document and the product to which it pertains are distributed under licenses restricting their use, copying, distribution, and decompilation. No part of the product or of this document may be reproduced in any form by any means without prior written authorization of Sun and its licensors, if any.

Third-party software, including font technology, is copyrighted and licensed from Sun suppliers.

Parts of the product may be derived from Berkeley BSD systems, licensed from the University of California. UNIX is a registered trademark in the U.S. and in other countries, exclusively licensed through X/Open Company, Ltd.

Sun, Sun Microsystems, the Sun logo, AnswerBook2, docs.sun.com, Sun Fire, Sun Fireplane interconnect, Java, and Solaris are trademarks or registered trademarks of Sun Microsystems, Inc. in the U.S. and in other countries.

All SPARC trademarks are used under license and are trademarks or registered trademarks of SPARC International, Inc. in the U.S. and in other countries. Products bearing SPARC trademarks are based upon an architecture developed by Sun Microsystems, Inc.

The OPEN LOOK and Sun™ Graphical User Interface was developed by Sun Microsystems, Inc. for its users and licensees. Sun acknowledges the pioneering efforts of Xerox in researching and developing the concept of visual or graphical user interfaces for the computer industry. Sun holds a non-exclusive license from Xerox to the Xerox Graphical User Interface, which license also covers Sun's licensees who implement OPEN LOOK GUIs and otherwise comply with Sun's written license agreements.

U.S. Government Rights-Commercial use. Government users are subject to the Sun Microsystems, Inc. standard license agreement and applicable provisions of the FAR and its supplements.

DOCUMENTATION IS PROVIDED "AS IS" AND ALL EXPRESS OR IMPLIED CONDITIONS, REPRESENTATIONS AND WARRANTIES, INCLUDING ANY IMPLIED WARRANTY OF MERCHANTABILITY, FITNESS FOR A PARTICULAR PURPOSE OR NON-INFRINGEMENT, ARE DISCLAIMED, EXCEPT TO THE EXTENT THAT SUCH DISCLAIMERS ARE HELD TO BE LEGALLY INVALID.

---

Copyright 2007 Sun Microsystems, Inc., 4150 Network Circle, Santa Clara, Californie 95054, Etats-Unis. Tous droits réservés.

Sun Microsystems, Inc. a les droits de propriété intellectuels relatants à la technologie qui est décrit dans ce document. En particulier, et sans la limitation, ces droits de propriété intellectuels peuvent inclure un ou plus des brevets américains énumérés à <http://www.sun.com/patents> et un ou les brevets plus supplémentaires ou les applications de brevet en attente dans les Etats-Unis et dans les autres pays.

Ce produit ou document est protégé par un copyright et distribué avec des licences qui en restreignent l'utilisation, la copie, la distribution, et la décompilation. Aucune partie de ce produit ou document ne peut être reproduite sous aucune forme, par quelque moyen que ce soit, sans l'autorisation préalable et écrite de Sun et de ses bailleurs de licence, s'il y en a.

Le logiciel détenu par des tiers, et qui comprend la technologie relative aux polices de caractères, est protégé par un copyright et licencié par des fournisseurs de Sun.

Des parties de ce produit pourront être dérivées des systèmes Berkeley BSD licenciés par l'Université de Californie. UNIX est une marque déposée aux Etats-Unis et dans d'autres pays et licenciée exclusivement par X/Open Company, Ltd.

Sun, Sun Microsystems, le logo Sun, AnswerBook2, docs.sun.com, Sun Fire, Sun Fireplane interconnect, Java, et Solaris sont des marques de fabrique ou des marques déposées de Sun Microsystems, Inc. aux Etats-Unis et dans d'autres pays.

Toutes les marques SPARC sont utilisées sous licence et sont des marques de fabrique ou des marques déposées de SPARC International, Inc. aux Etats-Unis et dans d'autres pays. Les produits portant les marques SPARC sont basés sur une architecture développée par Sun Microsystems, Inc.

L'interface d'utilisation graphique OPEN LOOK et Sun™ a été développée par Sun Microsystems, Inc. pour ses utilisateurs et licenciés. Sun reconnaît les efforts de pionniers de Xerox pour la recherche et le développement du concept des interfaces d'utilisation visuelle ou graphique pour l'industrie de l'informatique. Sun détient une licence non exclusive de Xerox sur l'interface d'utilisation graphique Xerox, cette licence couvrant également les licenciées de Sun qui mettent en place l'interface d'utilisation graphique OPEN LOOK et qui en outre se conforment aux licences écrites de Sun.

LA DOCUMENTATION EST FOURNIE "EN L'ÉTAT" ET TOUTES AUTRES CONDITIONS, DECLARATIONS ET GARANTIES EXPRESSES OU TACITES SONT FORMELLEMENT EXCLUES, DANS LA MESURE AUTORISÉE PAR LA LOI APPLICABLE, Y COMPRIS NOTAMMENT TOUTE GARANTIE IMPLICITE RELATIVE A LA QUALITE MARCHANDE, A L'APTITUDE A UNE UTILISATION PARTICULIERE OU A L'ABSENCE DE CONTREFAÇON.

# Contents

---

**Preface ix**

**1. Physical Specifications 1-1**

- 1.1 System Components 1-2
- 1.2 System Cabinet Physical Specifications 1-4
- 1.3 Raised Floor Installations 1-10
- 1.4 Non-Raised Floor Installation 1-10
- 1.5 Cabinet Floor Caster Weight Load 1-12
- 1.6 Planning Your Access Route 1-13

**2. Environmental Requirements 2-1**

- 2.1 Environmental Requirements 2-1
  - 2.1.1 Suggested Ambient Temperatures 2-2
  - 2.1.2 Suggested Ambient Relative Humidity 2-2
- 2.2 Basic Cooling Requirements 2-3
- 2.3 Computer Room Layout 2-6

**3. Facility and System Requirements 3-1**

- 3.1 Facility Power Requirements 3-1
- 3.2 Cabinet Grounding Requirements 3-6

- 4. Network Planning 4-1**
  - 4.1 Network Connections 4-1
  - 4.2 System Setup Information 4-2
  - 4.3 Network Configurations 4-3
    - 4.3.1 HA Network Configuration 4-4
    - 4.3.2 Non-HA Network Configuration 4-5
  - 4.4 System Setup Worksheets 4-6
    - 4.4.1 Platform Name 4-6
    - 4.4.2 Internal Networks 4-6
      - 4.4.2.1 I1 Network 4-7
      - 4.4.2.2 I2 Network 4-8
    - 4.4.3 External Networks 4-8
      - 4.4.3.1 System Controller 4-9
      - 4.4.3.2 Domains 4-10
  
- 5. Site Planning Checklists 5-1**
  - 5.1 System Components 5-1
  - 5.2 Miscellaneous 5-1
  - 5.3 Environmental Requirements 5-2
  - 5.4 Physical Specifications 5-3
  - 5.5 Network Planning 5-3
  - 5.6 Planning Your Access Route 5-4
  - 5.7 Installation Schedule 5-5
  
- A. Power and Cooling, and System Setup Worksheets A-1**

# Figures

---

- [FIGURE 1-1](#) Site Preparation Process 1–1
- [FIGURE 1-2](#) Sun Fire E25K/E20K Systems Cabinet Sample Configurations 1–3
- [FIGURE 1-3](#) Sun Fire E25K/E20K Systems Shipping Crate Dimensions 1–7
- [FIGURE 1-4](#) Sun Fire E25K/E20K Systems Cabinet Dimensions 1–8
- [FIGURE 1-5](#) Sun Fire E25K/E20K Systems Cabinet Clearance Dimensions 1–9
- [FIGURE 1-6](#) Sun Fire E25K/E20K Systems Floor Cutout and Base Dimensions Diagram 1–11
- [FIGURE 2-1](#) Sun Fire E25K/E20K Systems Air Flow 2–5
- [FIGURE 2-2](#) Proposed Sun Fire E25K/E20K Systems Configuration 2–7
- [FIGURE 2-3](#) Proposed Sun Fire E25K/E20K Systems—Multiple Configuration 2–8
- [FIGURE 3-1](#) Sun Fire E25K/E20K Systems Power Connections—Redundant Power, Double Power Source (Power Source A and B) 3–3
- [FIGURE 3-2](#) Sun Fire E25K/E20K Systems Power Connections—High-Reliability Power, Single Power Source (One Power Source) 3–4
- [FIGURE 3-3](#) Sun Fire E25K/E20K Systems Power Connections—Basic Single Power, Single Power Source (One Power Source, No Redundancy, Not Advisable) 3–5
- [FIGURE 3-4](#) Ground Cable Attachment Point at System Cabinet 3–7
- [FIGURE 4-1](#) Highly Available Network Configuration 4–4
- [FIGURE 4-2](#) Dense Network Configuration 4–5



# Tables

---

TABLE 1-1	Physical Specifications for System Cabinets	1–4
TABLE 1-2	System Weight by Components Worksheet	1–5
TABLE 1-3	Sun Fire E25K/E20K Systems Load on Building Structure	1–12
TABLE 2-1	Environmental Requirements	2–2
TABLE 2-2	Sun Fire E25K/E20K Systems Cabinet Power and Cooling Requirements	2–3
TABLE 2-3	System Power and Cooling Requirements Worksheet	2–4
TABLE 3-1	Facility Power Requirements	3–2
TABLE 3-2	Facility Power Cable Requirements Worksheet	3–2
TABLE 3-3	Power Configuration Summary	3–6
TABLE 4-1	Sun Fire E25K/E20K Systems Network	4–1
TABLE 4-2	Sun Fire E25K/E20K Systems Network Interfaces	4–2
TABLE 4-3	Sun Fire E25K/E20K Systems Platform Name Worksheet	4–6
TABLE 4-4	IP Networks Subnet Masks for Internal Network Worksheet	4–6
TABLE 4-5	Host Name IP Addresses for the I1 Network Worksheet	4–7
TABLE 4-6	Host Name IP Addresses for the I2 Network Worksheet	4–8
TABLE 4-7	IP Networks Subnet Masks for External Networks Worksheet	4–8
TABLE 4-8	Community Host Name IP Addresses for the System Controllers Worksheet	4–9
TABLE 4-9	Host Name IP Addresses for the SC Logical Interface Worksheet	4–9
TABLE 4-10	Community Host Name IP Addresses for the Domain Worksheet	4–10





# Preface

---

This site planning guide provides site preparation guidelines and checklists for you prior to installing the Sun Fire™ E25K/E20K systems. This document details information necessary to locate and plan a controlled environment for your new system. This information assists in the installation planning process. Worksheets to calculate system requirements are provided along with environmental and power specifications needed for this planning.

---

## How This Book Is Organized

Chapter 1 provides recommended network configuration and worksheets for site-planning setups.

Chapter 2 details the basic computer room layout and cooling requirements.

Chapter 3 defines the facility power requirements for the Sun Fire E25K/E20K systems. A power cable requirements worksheet and system power connections diagrams are included.

Chapter 4 describes security and network planning with domain setup information.

Chapter 5 provides a site planning checklist.

---

## Related Documentation

**TABLE P-1** Related Documentation

<b>Application</b>	<b>Title</b>
Service	<i>Sun Fire E25K/E20K Systems Read Me First</i>
Service	<i>Sun Fire E25K/E20K Systems Getting Started</i>
Service	<i>Sun Fire E25K/E20K Systems Unpacking Guide</i>
Service	<i>Sun Fire E25K/E20K Systems Site Planning Guide</i>
Service	<i>Sun Fire E25K/E20K Systems Hardware Installation and Uninstallation Guide</i>
Service	<i>Sun Fire E25K/E20K Systems Service Manual</i>
Service	<i>Sun Fire E25K/E20K Systems Service Reference I—Nomenclature</i>
Service	<i>Sun Fire E25K/E20K Systems Service Reference II—Component Numbering</i>
Service	<i>Sun Fire E25K/E20K Systems Carrier Plate Configurations</i>
Service	<i>Sun Fire High-End Server Systems Cable Management Guide</i>
Service	<i>Sun Fire Link System Overview</i>
Service	<i>Task Map for Getting Started With Sun Fire Link Networks</i>
Service	<i>Sun Fire Link Hardware Installation Guide</i>
Service	<i>Sun Fire Link Service Manual</i>
Service	<i>Sun Fire Link Site Planning Guide</i>
Service	<i>Sun Fire Link Software Installation Guide</i>
Service	<i>Sun Fire Link Fabric Administrator's Guide</i>
Service	<i>Sun Fire Link Switch Installation and Service Manual</i>

---

---

## Accessing Sun Documentation

You can view, print, or purchase a broad selection of Sun documentation, including localized versions, at:

<http://www.sun.com/documentation>

---

## Contacting Sun Technical Support

If you have technical questions about this product that are not answered in this document, go to:

<http://www.sun.com/service/contacting>

---

## Sun Welcomes Your Comments

Sun is interested in improving its documentation and welcomes your comments and suggestions. You can submit your comments by going to:

<http://www.sun.com/hwdocs/feedback>

Please include the title and part number of your document with your feedback:

*Sun Fire E25K/E20K Systems Site Planning Guide*, part number 817-4137-13

---

## United States Export Control Laws Notice

Products covered by and information contained in this site planning guide are controlled by U.S. Export Control laws and might be subject to the export or import laws in other countries. Nuclear, missile, chemical biological weapons, or nuclear maritime end uses or end users, whether direct or indirect, are strictly prohibited. Export or re-export to countries subject to U.S. embargo or to entities identified on U.S. export exclusion lists, including but not limited to the denied persons and specially designated nationals lists, is strictly prohibited. Use of any spare or replacement CPUs is limited to repair or one-for-one replacement of CPUs in products exported in compliance with U.S. export laws. Use of CPUs as product upgrades unless authorized by the U.S. Government is strictly prohibited.



# Physical Specifications

This chapter details the physical requirements for Sun Fire E25K/E20K systems. Review the site preparation process flow diagram shown in [FIGURE 1-1](#) as you begin to evaluate the needed requirements before your system installation.

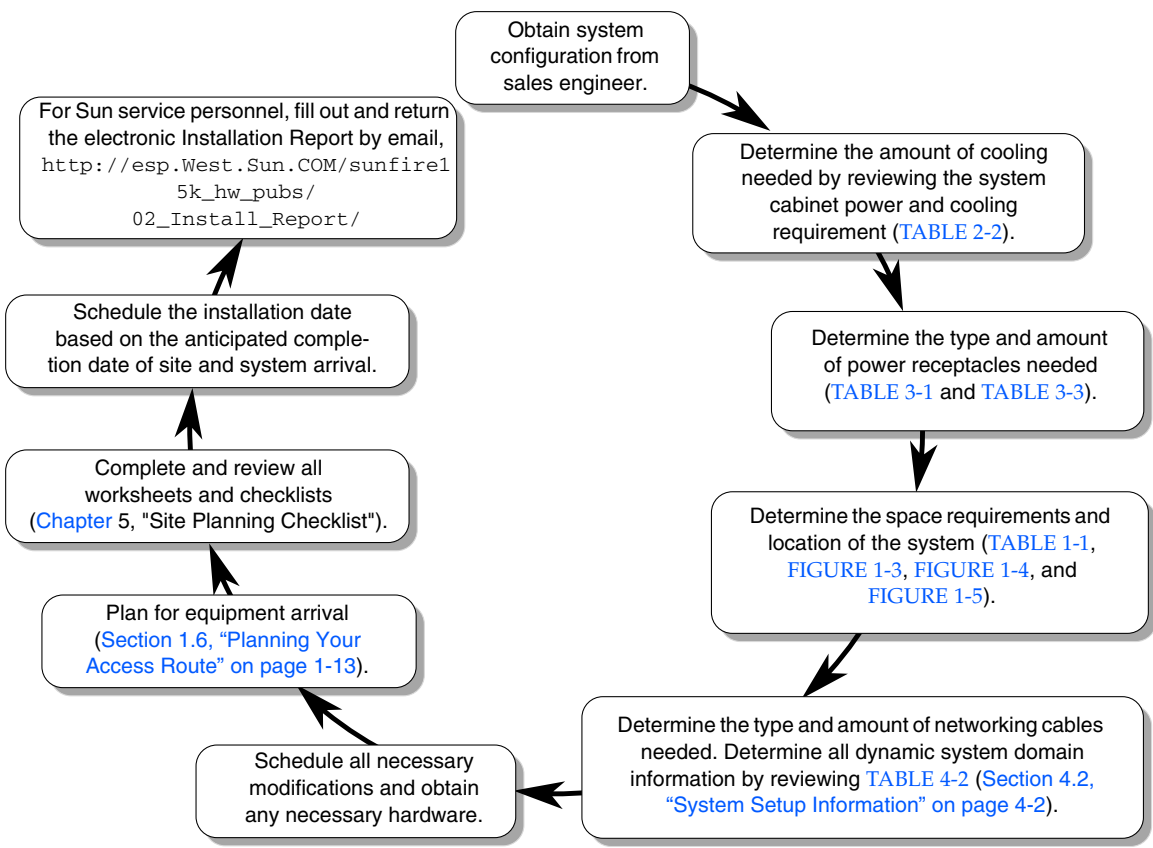

FIGURE 1-1 Site Preparation Process

---

# 1.1 System Components

Sun Fire E25K/E20K systems consist of two or more air-cooled cabinets that are configured to meet customer-specified requirements. Minimum configurations use one system cabinet, which houses system components and one customer-selected I/O expansion rack. System components include:

- CPU boards (up to 18)
- I/O (minimum of one assembly and up to 18 additional I/O assemblies)
- Sun™ Fireplane interconnect
- System Control (SC) boards (2)
- SC peripheral boards (2)
- Power and cooling subsystems

All systems ordered are configured with a full complement of fan trays and power supplies, two System Control boards, and two SC peripheral boards. Processor and I/O assemblies are then ordered per the customer's specific system requirements.

Multiple cabinet configurations ([FIGURE 1-2](#)) would include additional customer-selected I/O expansion racks with I/O cabling (customer-specified length). Customer-selected I/O expansion racks house additional I/O disk or tape subsystems. Additionally, each I/O expansion rack contains AC distribution subsystems for use with the I/O subsystems.

Multiple cabinets may be placed side-by-side as long as the environmental specifications in Chapter 2 are met.

When determining the space, cooling, and power requirements, determine what system and I/O components will be used in your system. To begin the process of preparing your site for your Sun Fire E25K/E20K systems, record your configuration on the worksheet in [TABLE 2-3](#).

The system cabinet may be located in any position within the system configuration.

Additional customer-selected I/O expansion racks may be used, provided I/O cable length requirements are not compromised.

---

**Note** – Evaluate the system weight on both the raised floor system and the building structural system (see [Section 1.3, “Raised Floor Installations”](#) on page 1-10). The Sun Fire E25K system cabinet has a concentrated load weight of 726 lb (329.3 kg) per caster (within the allowable load for a typical computer room raised floor that is generally made of steel construction). The Sun Fire E20K system cabinet has a concentrated load weight of 635 lb (288 kg).

---

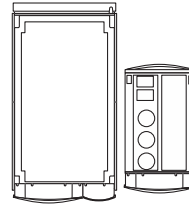
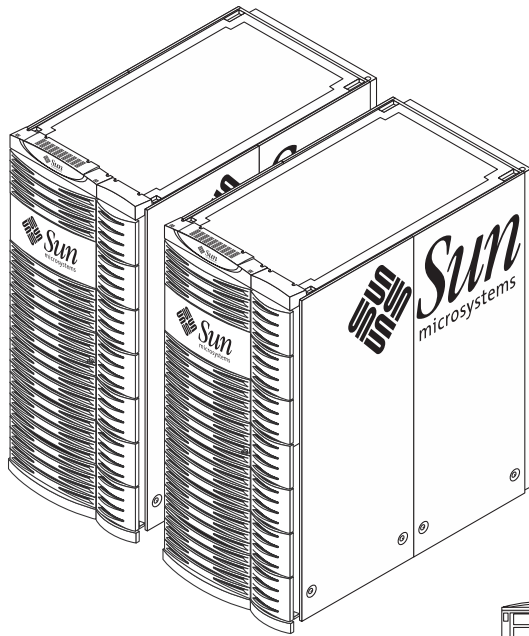

Sample configuration A - Top view

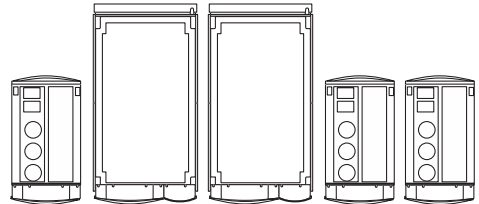

Sample configuration B - Top view

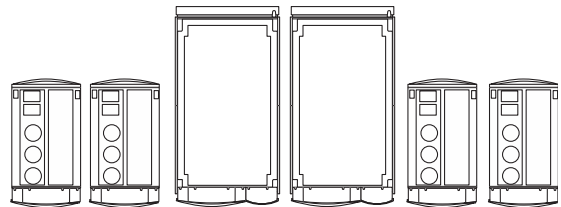

Sample configuration C - Top view

**FIGURE 1-2** Sun Fire E25K/E20K Systems Cabinet Sample Configurations

## 1.2 System Cabinet Physical Specifications

[TABLE 1-1](#) lists the physical specifications for Sun Fire E25K/E20K systems. Use [TABLE 1-2](#) to calculate the weight of your system as various components are added.

**TABLE 1-1** Physical Specifications for System Cabinets

Characteristic	Sun Fire E25K System Cabinet	Sun Fire E20K System Cabinet
Shipping height	80.0 in. (203.2 cm)	80.0 in. (203.2 cm)
Shipping width	48.0 in. (121.9 cm)	48.0 in. (121.9 cm)
Shipping depth	75.5 in. (191.8 cm)	75.5 in. (191.8 cm)
Shipping weight (maximum):	3,110.1 lb (1,410.7 kg)	2,745.9 lb (1,245.5 kg)
Cabinet:		
E25K:	2,904.1 lb (1,317.3 kg)	
E20K:	2,539.9 lb (1,152.1 kg)	
Shipping kit & Pallet:	206 lb (93.4 kg)	
Height	75.5 (191.8 cm)	75.5 (191.8 cm)
Width (with panels)	33.3 in. (84.6 cm)	33.3 in. (84.6 cm)
Width (without panels)	32.0 in. (81.3 cm)	32.0 in. (81.3 cm)
Depth (with doors)	64.5 in. (163.8 cm)	64.5 in. (163.8 cm)
Depth (without doors)	56.25 in. (142.9 cm)	56.25 in. (142.9 cm)
Depth (with door hinges and without doors)	61.0 in. (155.0 cm)	61.0 in. (155.0 cm)
Weight (maximum)	2,889.82 lb (1,310.8 kg)	2,380.77 lb (1079.9 kg)
Access requirement for front and rear ( <a href="#">FIGURE 1-6</a> )	44.0 in. (111.8 cm) 22.0 in. (55.9 cm) minimum	44.0 in. (111.8 cm) 22.0 in. (55.9 cm) minimum



**TABLE 1-2** System Weight by Components Worksheet

System Component	Qty.	Single Qty. Weight	Total Weight	Purch. Qty.	E25K System Calculated Actual Weight	E20K System Calculated Actual Weight
Base system cabinet (power module, power centerplane, fan backplane, cables, side panels, kick plate, EMI filters, air filters, pushbars and extension included)	1 X	963.6 lb (437 kg)	= 963.6 lb (437 kg)		963.6 lb (437 kg)	963.6 lb (437 kg)
Power supply	6 X	42.2 lb (19.2 kg)	= 253.2 lb (115.1 kg)		253.2 lb (115.1 kg)	253.2 lb (115.1 kg)
Fan trays	8 X	25.1 lb (11.4 kg)	= 200.8 lb (91.2 kg)		200.8 lb (91.2 kg)	200.8 lb (91.2 kg)
Sun Fireplane (centerplane)	1 X	30.1 lb (13.7 kg)	= 30.1 lb (13.7 kg)		30.1 lb (13.7 kg)	30.1 lb (13.7 kg)
Centerplane support board	2 X	5.2 lb (2.4 kg)	= 10.4 lb (4.7 kg)		10.4 lb (4.7 kg)	10.4 lb (4.7 kg)
Centerplane support board carrier plate	2 X	19.0 lb (8.6 kg)	= 38.0 lb (17.3 kg)		38.0 lb (17.3 kg)	38.0 lb (17.3 kg)
System Control board	2 X	14.3 lb (6.5 kg)	= 28.6 lb (13 kg)		28.6 lb (13 kg)	28.6 lb (13 kg)
System control peripheral board	2 X	16.5 lb (7.5 kg)	= 33.0 lb (15.0 kg)		33.0 lb (15.0 kg)	33.0 lb (15.0 kg)
Expander carrier plate (14 for E25K System, 7 for E20K System)	X	14.3 lb (6.5 kg)	= 14.3 lb (6.5 kg)	X___ =	_____	_____
Expander carrier plate (with air dam), center (4 for E25K System, 2 for E20K System)	X	17.8 lb (8.1 kg)	= 17.8 lb (8.1 kg)	X___ =	_____	_____
CPU board (up to 18 for E25K system, up to 9 for E20K system)	1 X	27.4 lb (12.4 kg)	= 27.4 lb (12.4 kg)	X___ =	_____	_____
Expander board (up to 18 for E25K system, up to 9 for E20K system)	1 X	6.0 lb (2.7 kg)	= 6.0 lb (2.7 kg)	X___ =	_____	_____
Options:						
hsPCI-X/hsPCI+ assembly plus four (4) cassettes (up to 18 for E25K system, up to 9 for E20K system)	1 X	19.5 lb (8.9 kg)	= 19.5 lb (8.9 kg)	X___ =	_____	_____
CPU filler panel (9 minimum for E20K system)	1 X	6.2 lb (2.8 kg)	= 6.2 lb (2.8 kg)	X___ =	_____	_____

**TABLE 1-2** System Weight by Components Worksheet (Continued)

System Component	Qty.	Single Qty. Weight	Total Weight	Purc h. Qty.	E25K System Calculated Actual Weight	E20K System Calculated Actual Weight
I/O filler panel (9 minimum for E20K system)	1 X	5.2 lb (2.4 kg)	= 5.2 lb (2.4 kg)	X__ =	_____ _____	_____ _____
<b>Systems with 2-doors (1 in front, 1 in rear)</b>						
Door, front (with torque drivers)	1 X	44.2 lb (20.7 kg)	= 44.2 lb (20.7 kg)		44.2 lb (20.7 kg)	44.2 lb (20.7 kg)
Door, rear	1 X	39 lb (17.7 kg)	= 39 lb (17.7 kg)		39 lb (17.7 kg)	39 lb (17.7 kg)
<b>Systems with 4-doors (2 in front, 2 in rear)</b>						
Door, front right (with torque drivers)	1 X	20.5 lb (9.3 kg)	= 20.5 lb (9.3 kg)		20.5 lb (9.3 kg)	20.5 lb (9.3 kg)
Door, front left	1 X	29.0 lb (13.2 kg)	= 29.0 lb (13.2 kg)		29.0 lb (13.2 kg)	29.0 lb (13.2 kg)
Door, rear right	1 X	14.0 lb (6.4 kg)	= 14.0 lb (6.4 kg)		14.0 lb (6.4 kg)	14.0 lb (6.4 kg)
Door, rear left	1 X	17.5 lb (8.0 kg)	= 17.5 lb (8.0 kg)		17.5 lb (8.0 kg)	17.5 lb (8.0 kg)
Total weight						

FIGURE 1-3 shows the dimensions of the Sun Fire E25K/E20K systems cabinet crate.

FIGURE 1-4 shows the dimensions of the Sun Fire E25K/E20K systems cabinet.

**Note** – There might be slight variances in some component weights depending on customer configurations.

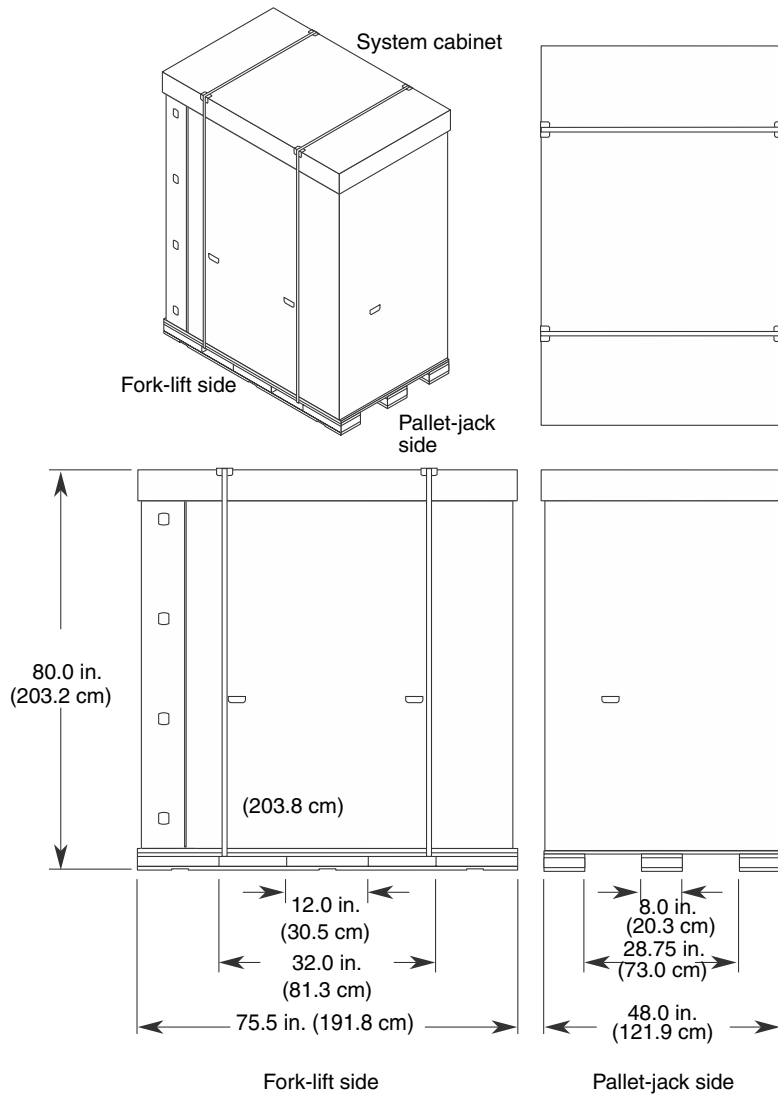

**FIGURE 1-3** Sun Fire E25K/E20K Systems Shipping Crate Dimensions

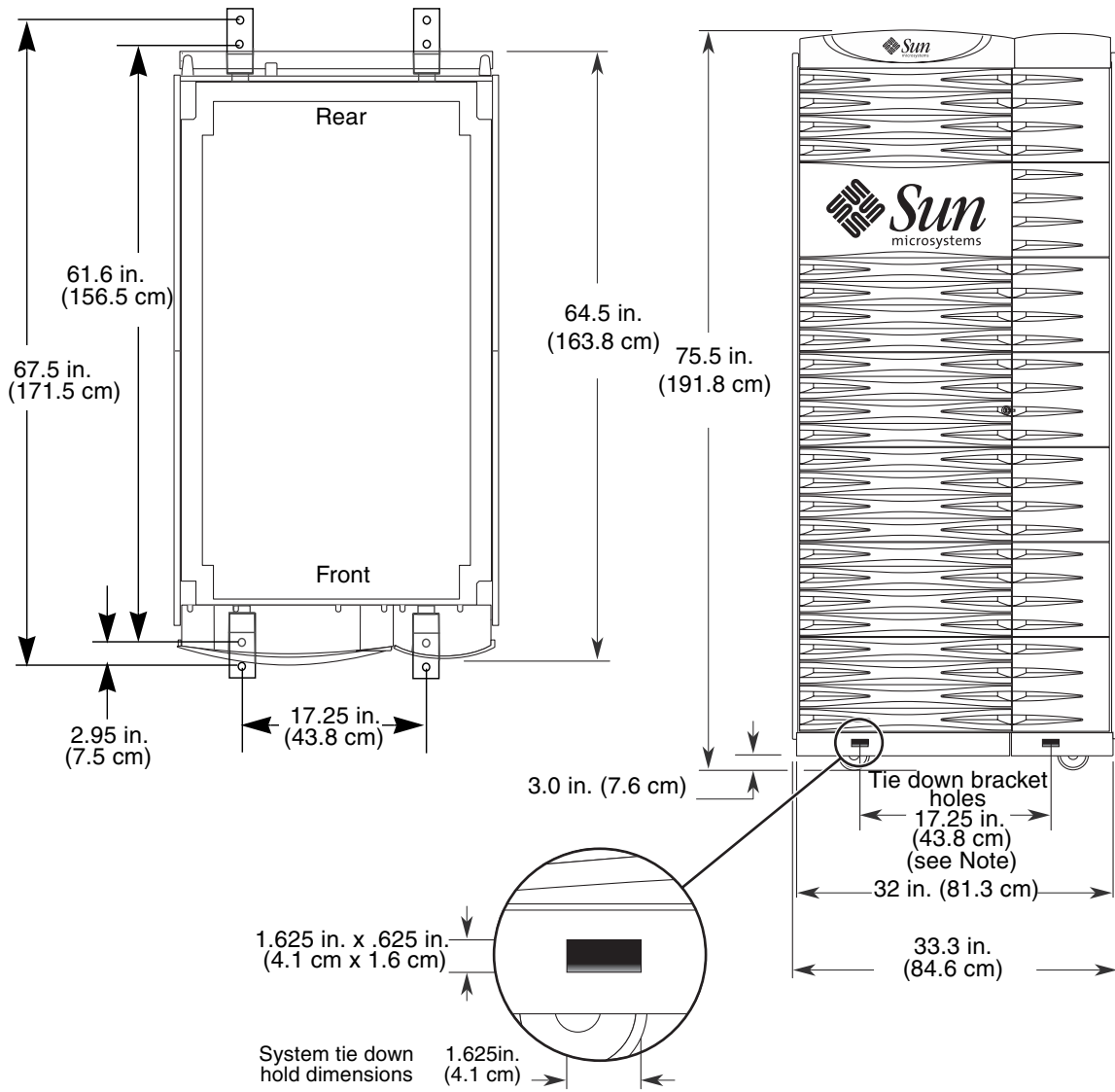

**FIGURE 1-4** Sun Fire E25K/E20K Systems Cabinet Dimensions

**Note** – The shipping pallet tie-down bracket holes in the front and rear of the lower chassis can also be used to hold-down or secure the system frame to the floor of your facility.

FIGURE 1-5 shows the clearance dimensions of the Sun Fire E25K/E20K systems cabinet. These dimensions apply to both 4-door and 2-door systems.

For system cabinet electrical specifications and receptacle information, see TABLE 3-1.

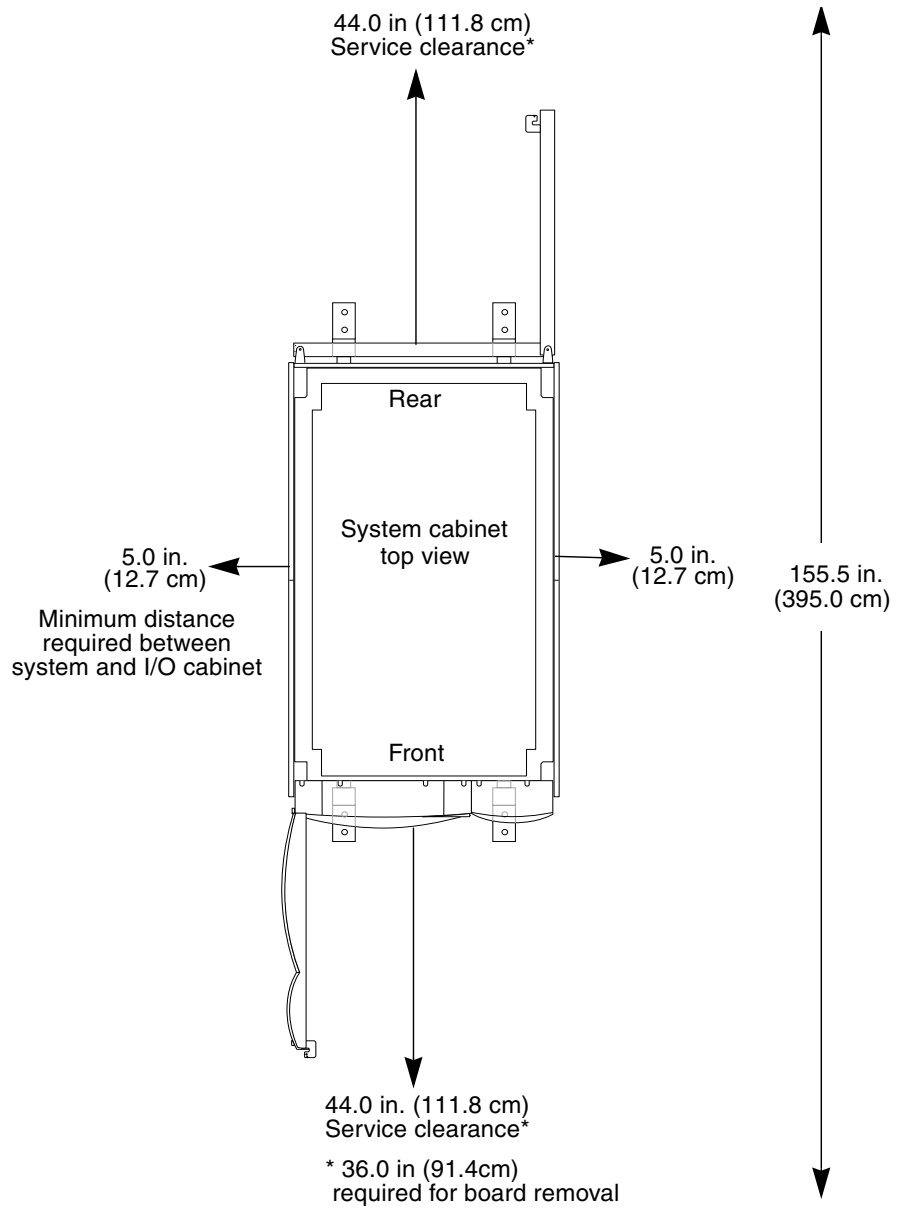

FIGURE 1-5 Sun Fire E25K/E20K Systems Cabinet Clearance Dimensions

---

## 1.3 Raised Floor Installations

A raised floor system provides a convenient way to duct cooling air and to route power and communication cabling. Sun strongly recommends that the system be installed on a raised floor to ensure that optimal cooling is available to the system.

The computer room floor must be able to support the weight of the system cabinets (defined previously in [TABLE 1-1](#)). Each cabinet rests on four casters and four feet that concentrate the weight of the cabinet on a small surface area.

Place perforated floor panels or floor grilles near or directly under the base of the system. [FIGURE 1-6](#) illustrates the floor cutouts for cables. Suggested locations for perforated floor panels or floor grilles are shown in [FIGURE 2-2](#). Use the floor layout diagram of the proposed location for the system shown in [FIGURE 1-6](#) to determine the exact area required for your system. Ensure cabinets are positioned so all casters and leveling feet are on solid raised-floor tiles.

Sun Microsystems recommends a minimum raised floor height of 24–36 in. (61.0–91.5 cm).

---

## 1.4 Non-Raised Floor Installation

If you are not installing your system on a raised floor, ensure the cooling requirements specified in [TABLE 2-2](#) can be met. Also ensure that the intake air to the system meets the requirements specified in [TABLE 2-1](#). Use cable covers to protect personnel from injury and protect cables from damage.

---

**Note** – If the cooling to the system is inadequate, automatic system shutdown can result.

---

**Note** – Older systems have eye bolts using M12 x 1.75 bolts. These eyebolts are not to be used for lifting the system.

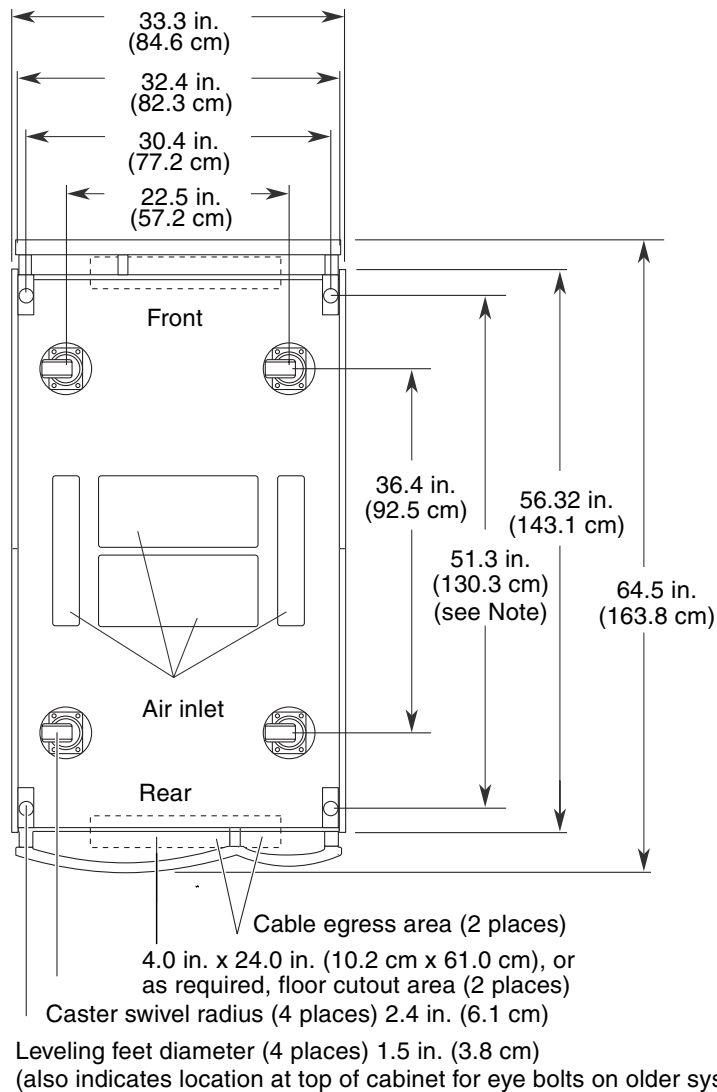

**FIGURE 1-6** Sun Fire E25K/E20K Systems Floor Cutout and Base Dimensions Diagram

**Note** – In addition to the standard 4.0 in. X 24.0 in. (10.2 cm x 61.0 cm) floor cutout area (see dotted lines), any unused cable opening should be filled with a suitable material to block airflow.

---

## 1.5 Cabinet Floor Caster Weight Load

The cabinet has a concentrated load weight of 728.5 lb (330.44 kg) per three-inch caster (within the allowable load for a typical computer room raised floor) and contact pressures of 1460 psi. Review your facility floor weight requirements prior to moving Sun Fire E25K/E20K systems to the new location.

---

**Note** – When lowering the cabinet leveling feet, extend each leveler at the base of each corner with an additional one-quarter turn to ensure stability for the cabinet. The levelers should *not* raise the casters off the floor.

---

You can have various loads on a floor: static (concentrated, uniform, ultimate) or dynamic loads (rolling and impact). Midrange floating floors can handle approximately 1500 lb (680.38 kg) of concentrated load, 250 lb (113.6 kg) of uniform load, 2500 lb (1136.4 kg) of ultimate load, and 1000 lb (454.6 kg) of rolling load. These loads are estimates applied to a one-square-inch area. Review [TABLE 1-3](#) for the Sun Fire E25K/E20K systems information on pounds per square foot on a building structure.

**TABLE 1-3** Sun Fire E25K/E20K Systems Load on Building Structure

	<b>E25K System Cabinet</b>	<b>E20K System Cabinet</b>
<b>Building Structure Pounds Per Square Foot (psf)</b>	<b>2,904.1 lb, 33.3 in. x 56.3 in. 1,160.6 kg, 84.6 cm x 143.0 cm)</b>	<b>2,211.2 lb, 33.3 in. x 56.3 in. 1005.1 kg, 84.6 cm x 143.0 cm)</b>
Equipment footprint	223.1 psf (1089.1 kg/m <sup>2</sup> )	195.1 psf (952.49 kg/m <sup>2</sup> )

There are also tiles that can take up to 2500 lb of concentrated load. If you have any questions concerning the structural capabilities of any floor, contact a qualified structural engineer.



---

## 1.6 Planning Your Access Route

For best performance, place the cabinet over perforated floor tiles as indicated in Chapter 2, "Environmental Requirements", and in accordance with the proposed configurations shown in [FIGURE 2-2](#).



---

**Caution** – To prevent damage to the cabinet and injury to personnel, a 60-in. pallet jack can only be used at the narrow end of the pallet and a forklift can only be used at the wide side of the pallet.

---

If your existing loading dock meets height or ramp requirements for a standard freight carrier truck, you can use a standard 60-inch pallet jack (at narrow end of pallet) to unload the system. Trucks can be between 48 ft (14.6 meters) and 61 ft (18.6 meters) long, 8.5 ft (2.6 meters) wide, and 14 ft (4.3 meters) high. If your loading dock does not meet these requirements, use a standard forklift (at wide side of pallet) or other means to unload the system, or request the system to be shipped in a truck with a lift gate. A standard forklift has a maximum outside tine dimension of 27 in. (68.6 cm) and a minimum inside tine dimension of 15 in. (38.1 cm).

An illustration of the system cabinet shipping crate and its dimensions are shown in [FIGURE 1-3](#). A pallet jack is required to move each shipping crate to the system location.

Sun Microsystems recommends that you leave each system cabinet in its shipping crate until it reaches its unpacking destination. If the system does not fit through the planned access route, it can be partially disassembled after the unit has been removed from the crate. To accommodate the tight space availability, the side panels can be removed. This reduces the width of the system cabinet to 32.0 in. (81.3 cm) from its original width of 33.3 in. (84.6 cm).

---

**Note** – There is a maximum cabinet threshold height of one inch with the kick plate installed and a maximum height of three inches when the kick plate is removed.

---

The entire access route to your computer room should be free of raised patterns that can cause vibration. In addition, the strength of the perforated tiles should be verified. It is common to see damaged floor tiles in delivery paths because of the repeated rolling loads. It is recommended that the entire raised-floor delivery path be protected with material such as heavy particle board or another material of similar strength.

---

**Note** – Any path in the access route must not have an incline more than 10 degrees.

---



# Environmental Requirements

---

This chapter details the temperature and humidity requirement for Sun Fire E25K/E20K systems.

---

## 2.1 Environmental Requirements

The design of the environmental control system (such as computer room air conditioning units) must ensure that intake air to the system meets the requirements specified in this section. Air enters the cabinet through the access panels and through an air intake that is located underneath the system cabinet. The heated air is exhausted out of the top of the system cabinet. Overheating can occur if warm air is directed underneath a cabinet or toward the access panels. [TABLE 2-1](#) provides the environmental requirements for Sun Fire E25K/E20K systems and the customer-selected I/O expansion racks. If the system is significantly colder (40 °F [4 °C] or colder) than the environment in which you will install it, leave the system in its shipping crate at its final destination for 24 hours to prevent thermal shock and condensation.

**TABLE 2-1** Environmental Requirements

<b>Environmental Factor</b>	<b>Operating</b>	<b>Nonoperating</b>	<b>Suggested Operating Range</b>
Temperature	50–95°F (10–35°C) derated 2° for every 1 km up to 3 km. Temperature ramp rate not to exceed 59°F (15°C) per hour, humidity ramp rate not to exceed 30% relative humidity per hour. Derated 3C for every 1km up to 2km with UltraSPARC IV+ 1.8/1.95 GHz CPU/Memory boards.	-4–140°F (-20°C–60°C) Temperature ramp rate not to exceed 68°F (20°C per hour), humidity ramp rate not to exceed 20% relative humidity per hour. Derated 3C for every 1km up to 2km with UltraSPARC IV+ 1.8/1.95 GHz CPU/Memory boards.	70–74°F (21–23°C)
Humidity	20%–80% (noncondensing) 81°F (27°C) max wet bulb	Up to 93%	45%–50%
Altitude	Up to 10,000 ft (3,047 m) Up to 7,000 ft (2,134 m) with UltraSPARC IV+ 1800/1950 GHz CPU/Memory boards.	Up to 40,000 ft (12,188 m)	

## 2.1.1 Suggested Ambient Temperatures

The ambient temperature range of 70 degrees F to 74 degrees F (21 degrees C to 23 degrees C) is optimal for system reliability and operator comfort levels. Most computer equipment can operate within a wide temperature range, but a level near 72 degrees F (22 degrees C) is desirable because it is easier to maintain safe associated relative humidity levels at this temperature. Operating in this temperature range provides a safety buffer just in case the environmental support systems go down for a period of time. Though individual standards vary slightly, 70 degrees F to 74 degrees F (21 degrees C to 23 degrees C) should be used as an optimal temperature choice.

## 2.1.2 Suggested Ambient Relative Humidity

The ambient relative humidity levels between 45% and 50% are the most suitable for safe data processing operations. Under certain circumstances, most processing equipment can operate within a fairly wide environmental range (20% to 80%), but the optimal goal should be between 45% to 50% because this range:

- Helps protect computer systems from corrosive problems associated with high humidity levels.
- Provides the greatest operating time buffer in the event of environmental control system failure.
- Helps avoid failures or temporary malfunctions caused by intermittent interference from static discharges that occur when relative humidity is too low.

Electrostatic discharge (ESD) is easily generated and less easily dissipated in areas where the relative humidity is below 35%, and becomes critical when levels drop below 30%. The 5% relative humidity range might seem unreasonably tight when compared to the guidelines used in typical office environments or other loosely controlled areas, but it is not so difficult to maintain in a data center because of the high efficiency vapor barrier and low rate of air changes normally present.

## 2.2 Basic Cooling Requirements

TABLE 2-2 and TABLE 2-3 provide air conditioning information for Sun Fire E25K/E20K systems components based upon the maximum system configuration. Use the worksheet in TABLE 2-3 (see Appendix A for an expanded form to use and retain for your records) to determine your system power and cooling requirements. This worksheet will assist you in calculating your total system power consumption in power (watts) and the total system air conditioning required in British thermal units (BTUs/hrs). The amount of air conditioning required depends upon your configuration.

**TABLE 2-2** Sun Fire E25K/E20K Systems Maximum Power and Cooling Requirements

Sun Fire System	Quantity of System Slots Occupied	Power (VA)	Air Conditioning (BTU/Hr)
E20K	Up to 9	16,655	56,629
E25K	Up to 18	28,701	97,538

The dynamics of the Sun Fire E25K/E20K systems power dissipation depends on the application and configuration. This manual accounts for these dynamics and is based on a rigorous code condition set that has been verified in a lab environment. During these tests, all measurements were taken with the latest-technology, high-speed current probe connected to the 48-volt side. The numbers were then changed to account for efficiency loss and power factor correction.

Once the system configuration (based on the number of system boards and I/O configuration) is determined, the environmental cooling requirements must be calculated. It is important that the site is able to accommodate the appropriate environmental requirements. The numbers in this manual account for these requirements.

To facilitate future upgrades, always provide environmental cooling, not merely limited to the purchased configuration of system and I/O assemblies, but for the anticipated growth, or maximum power dissipation and cooling needs.

For example, although all cabinets are normally configured with a full-capacity power system, the actual system power dissipation might be much less than the maximum available, and will vary depending upon the number and type of configured components. Therefore, in the design phase of facility development, provide enough power and cooling capacity for the maximum configuration anticipated. When upgrading, system power dissipation will increase, which might require new site planning for power and cooling.

**TABLE 2-3** System Power and Cooling Requirements Worksheet

	Components	System Power		Air Conditioning	
		Qty. x AC Power (VA)	Total (VA)		BTU/Hr
<b>System Cabinet</b>					
Base system	System Control (2)	2 x 182	364	x 3.4 =	1237.6
	SC peripheral (2)	2 x 55	110	x 3.4 =	374.0
	Fan trays (8)	8 x 289	2309	x 3.4 =	7849.9
	Centerplane support (2)	2 x 18	36	x 3.4 =	122.4
	Sun Fireplane (1)	1 x 204	204	x 3.4 =	693.6
Expander	Expander (up to 18)	__ x 88		x 3.4 =	
Slot 0	1950Mhz USIV+ Uniboards	__ x 1148		x 3.4 =	
	1800Mhz & under USIV / USIV+ Uniboards	__ x 1088		x 3.4 =	
	USIII / USIII+ Uniboards	__ x 993		x 3.4 =	
Slot 1	hsPCI-X/hsPCI+ (up to 18)	__ x 94		x 3.4 =	
I/O adapters	PCI (up to 72)	__ x 24		x 3.4 =	
TOTAL			—		—

FIGURE 2-1 demonstrates the directions of the air flow within the system cabinet.

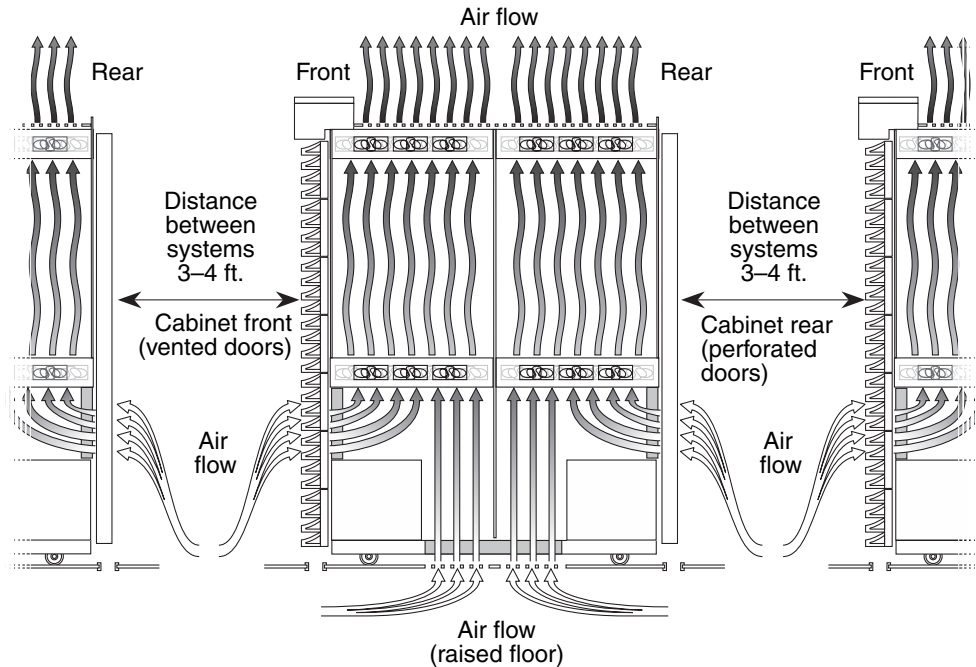

Sun Fire E25K/E20K systems cabinet air flow ratios: 62% front and rear  
38% bottom

FIGURE 2-1 Sun Fire E25K/E20K Systems Air Flow

---

## 2.3 Computer Room Layout

The fan tray redundancy in Sun Fire E25K/E20K systems provide enough air flow for adequate system performance on a flat floor. A raised floor is recommended for optimal system performance. Air enters the cabinet through the front and rear doors and through the air intake panels underneath the cabinet. Review the recommended floor plan layout sample for a fully configured system in [FIGURE 2-2](#) for planning your solid and perforated tile floor configuration. This floor plan is based on floor tiles delivering 600 cubic feet per minute (cfm) cooling for each tile.

[FIGURE 2-3](#) shows a floor plan layout for multiple Sun Fire E25K/E20K systems.

---

**Note** – In higher power consumption configurations, some perforated tiles might be required adjacent to the server or the customer-selected I/O expansion racks. These tiles will restrict the use of adjacent space, and this restriction should be clearly identified.

---

The maximum cable distance between the Sun Fire E25K system and the I/O rack is 157.5 in. (400 cm). If you are using a single-ended SCSI device for this connection, the connection cannot be made from the farthest rear corner of the system to the front top of the I/O rack, even if the rack is placed at the minimum distance requirement of 5.0 in (12.7 cm).



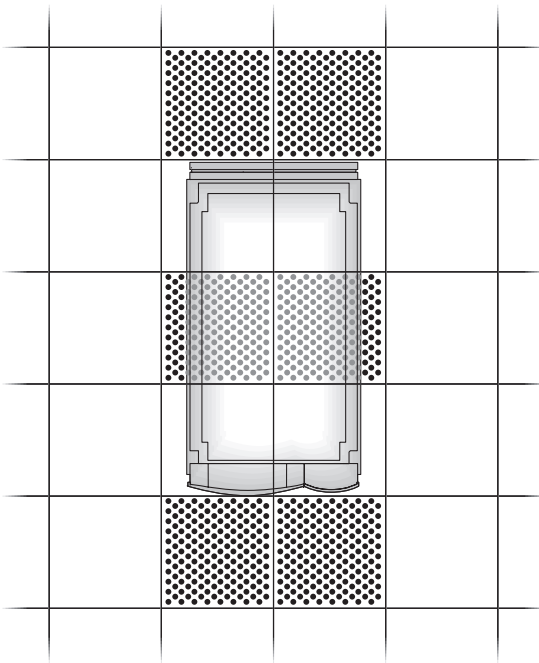

Suggested floor plan:  
 - Fully configured system  
 - 24 kW load  
 - Six (6) perforated tiles required

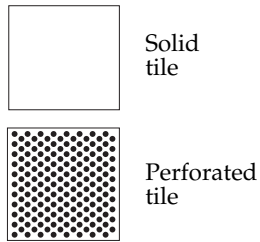

**FIGURE 2-2** Proposed Sun Fire E25K/E20K Systems Configuration

**Note** – Casters and leveling feet, located at the corners of each cabinet, are to be positioned only on solid floor tiles.

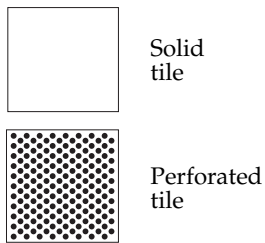
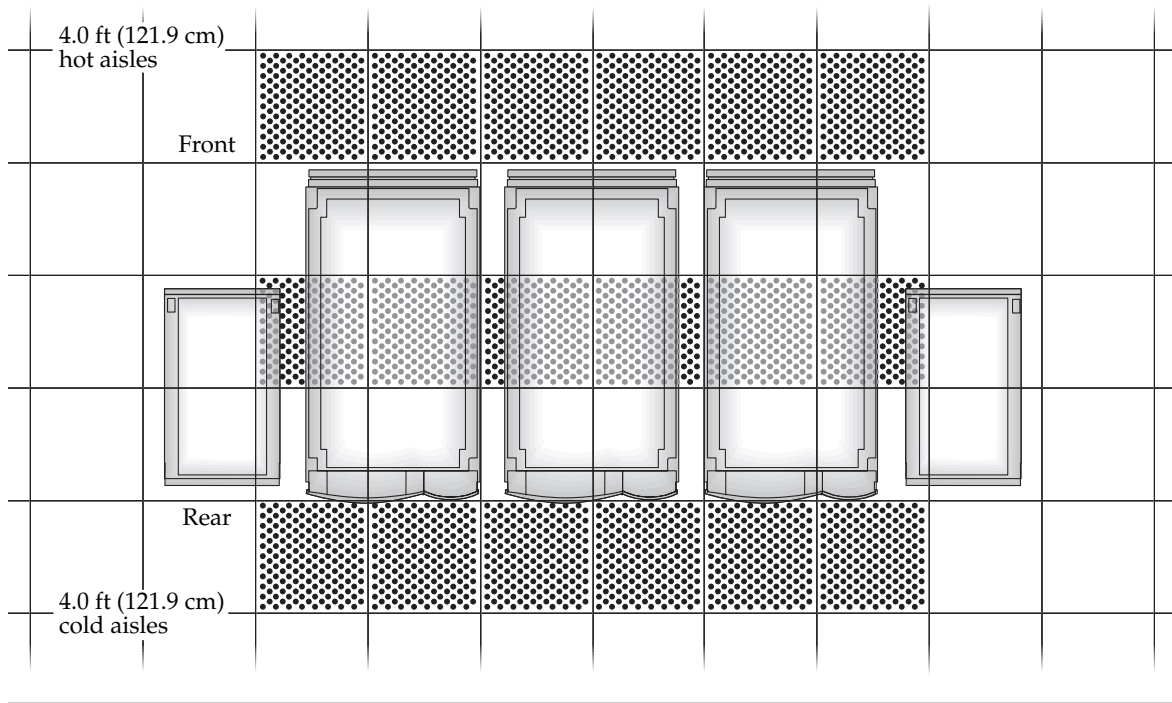

**FIGURE 2-3** Proposed Sun Fire E25K/E20K Systems—Multiple Configuration

**Note** – The system power cables are 157.5 in. (400.1 cm) long. Consider the maximum distance to a power receptacle when positioning the system.

# Facility and System Requirements

---

This chapter details the power and grounding requirements for Sun Fire E25K/E20K systems.

---

## 3.1 Facility Power Requirements

To prevent catastrophic failures, the design of the power system ensures adequate power is provided to Sun Fire E25K/E20K systems. *Sun Microsystems recommends that all power circuits supplying power to the Sun Fire E25K/E20K systems be derived from dedicated electrical distribution panels.* Electrical work and installations must comply with applicable local, state, or national electrical codes.



---

**Caution** – System earth fault protection relies on the building circuit.

---

Sun Microsystems makes every effort to minimize the effects of power failures and interruptions to the hardware. Sun Fire E25K/E20K systems have dual, redundant, current-sharing power supply inputs, and are designed to use two independent power sources. However, if the system is subjected to repeated power interruptions and fluctuations, it is susceptible to a higher component failure rate than it would be with a stable power source. Provide a stable power source, such as an uninterruptible power system (UPS), to reduce the possibility of component failures.

The power supplies of Sun Fire E25K/E20K systems incorporate an inrush current limitation after the first power on. The maximum inrush current is 55 amperes peak, during hot or cold start (after the AC has been removed for 60 seconds) and 35 amperes root mean square, hot or cold, when measured over one line cycle. The inrush current decays to its normal operating current in less than 200 milliseconds.

Every Sun Fire E25K/E20K system cabinet and customer-selected I/O expansion rack requires its own customer-supplied circuit breakers and receptacles. Ensure the power receptacles are within 14 feet (427 cm cable length) of the system cabinet and

each customer-selected I/O expansion rack location.

[TABLE 3-1](#) lists the electrical specifications for the system cabinet. Use [TABLE 3-2](#) to record the power cable requirements (see Appendix A for an expanded form to use and retain for your records). [TABLE 3-3](#) provides a summary of features of the three power configurations. [FIGURE 3-1](#), [FIGURE 3-2](#), and [FIGURE 3-3](#) illustrate the possible system power connections.

- It is recommended that the system cabinet utilize a redundant power, double power source as shown in [FIGURE 3-1](#).
- It is recommended that the system cabinet utilize twelve single-phase receptacles. See [TABLE 3-1](#).
- An International Electrotechnical Commission 309 (IEC 309) connector, or NEMA L6-30P, supplied by Sun Microsystems, connects power to the system.

Sun Fire E25K/E20K systems can operate while one power supply is being serviced and with two independent power sources as in [FIGURE 3-1](#) as long as the systems stay under 20,000W DC power consumption as measured by the SMS command `showenvironment -p powers`.

Sun Fire E25K/E20K systems equipped entirely with 300-1705 (A196) power supplies add the capability to operate while one power supply is being serviced above 20,000 W but not coincident with a loss of one power source. Sun Fire E20K/E25K systems equipped entirely with 300-1813 (A211) power supplies add the capability to operate with 1950Mhz USIV+Uniboards.

Sun Fire E25K/E20K systems configured as in [FIGURE 3-3](#) cannot operate above 20,000W DC power consumption while one power supply is being serviced.

**TABLE 3-1** Facility Power Requirements

Electrical Service	Specification
<b>System and I/O expansion racks require:</b>	
Voltage	200–240 VAC, single phase
Power factor	.99
Frequency	47–63 Hz
Circuit breaker:	Size for 24A maximum input per line cord according to local regulations
Volt-Ampere rating:	28,701 VA (Max Load)
Power cords (15 ft maximum)	15 ft (457 cm) connector-compatible drop cord
Receptacle: North America and Japan	AC input power cable, Harting Han 6HsB to NEMA L6-30P or equivalent (P/N 180-1943) AC Power Cord, Han 6HsB to NEMA L6-30P (US) 4M (P/N 180-1954) Power Cord, Blue 30A Watertight IEC 309 to Han 6HsB (P/N 180-2058) Power Cord, Blue 32A Watertight IEC 309 to Han 6HsB (P/N 180-2059)
Receptacle: International	AC input power cable, Harting Han 6HsB to IEC 309 (P/N 180-1944) AC Power Cord, Han 6HsB to Blue 32A IEC309 (Intl) (P/N 180-1955) Power Cord, Blue 30A Watertight IEC 309 to Han 6HsB (P/N 180-2063) Power Cord, Blue 32A Watertight IEC 309 to Han 6HsB (P/N 180-2064)

**TABLE 3-2** Facility Power Cable Requirements Worksheet

Frame Type	Number of Cabinets	Number of Poles	Number * of Cords	Single Phase	3 Phase
System Cabinet (Single Phase)	___	x 2	x ___	= ___	n/a
Total number of poles required				<input type="text"/>	<input type="text"/>

\* Contact a Sun Microsystems System Engineer for power cord quantity/receptacle information to ensure the receptacle prepared matches the power cord that was ordered.

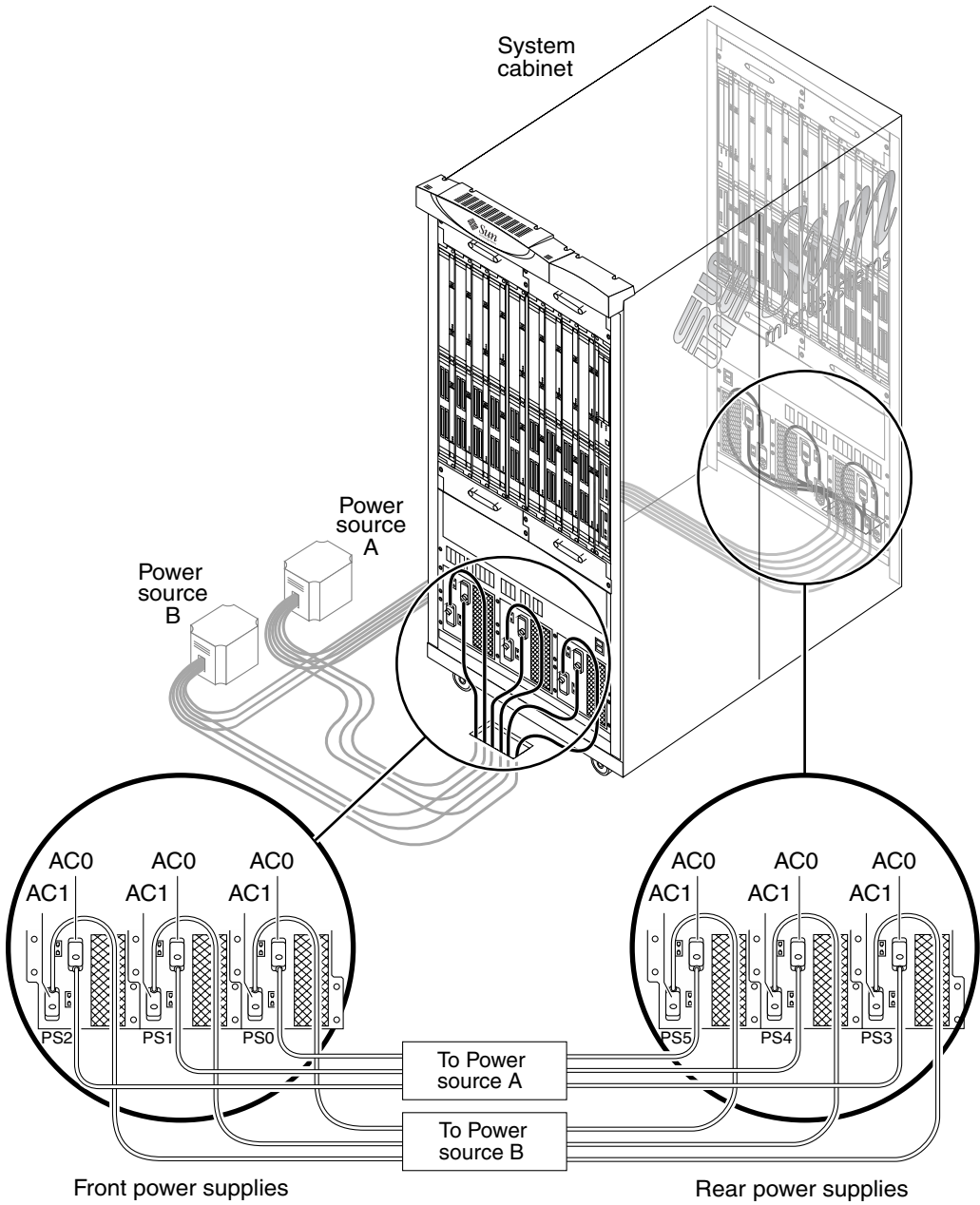

**FIGURE 3-1** Sun Fire E25K/E20K Systems Power Connections—Redundant Power, Double Power Source (Power Source A and B)

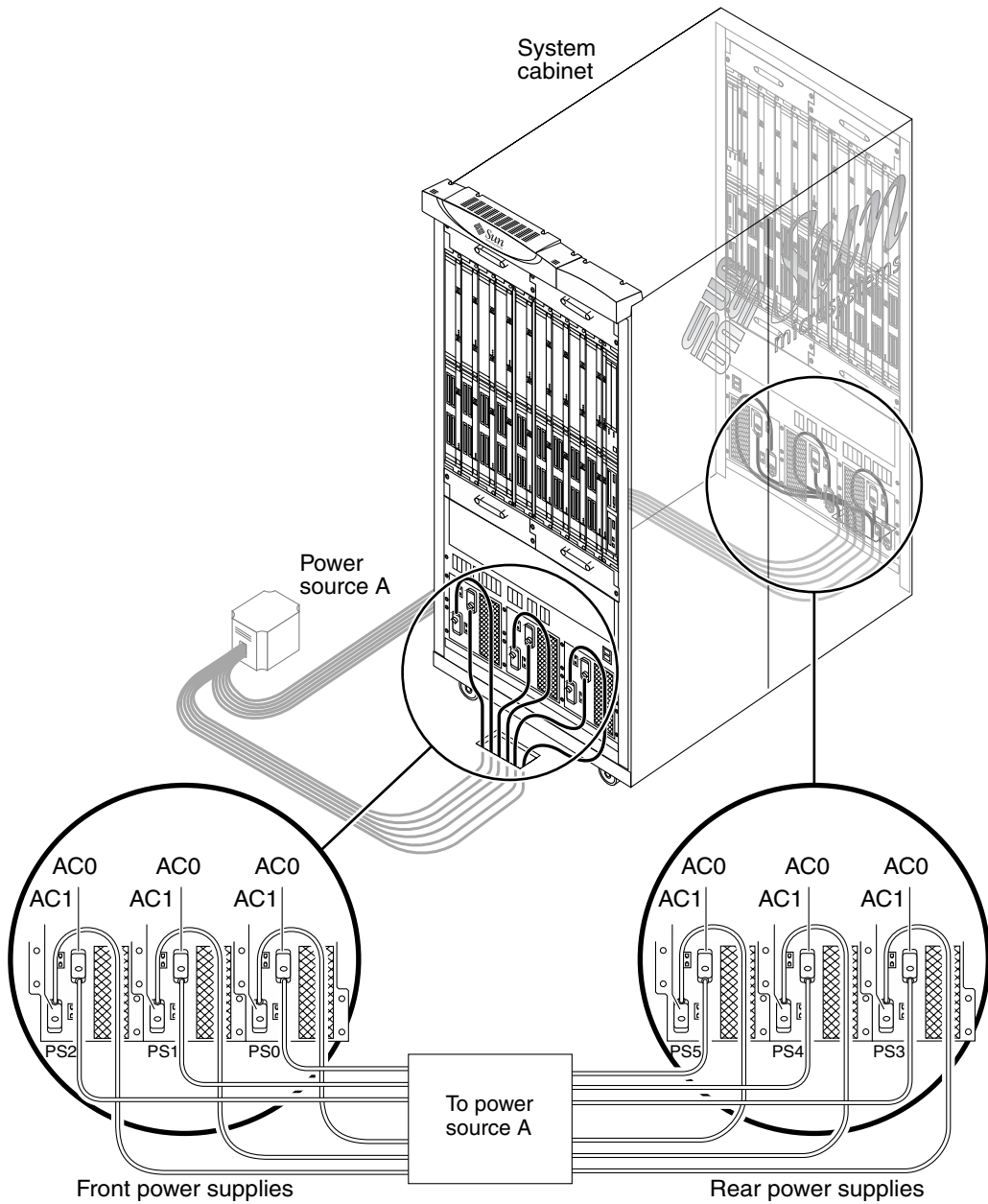

**FIGURE 3-2** Sun Fire E25K/E20K Systems Power Connections—High-Reliability Power, Single Power Source (One Power Source)

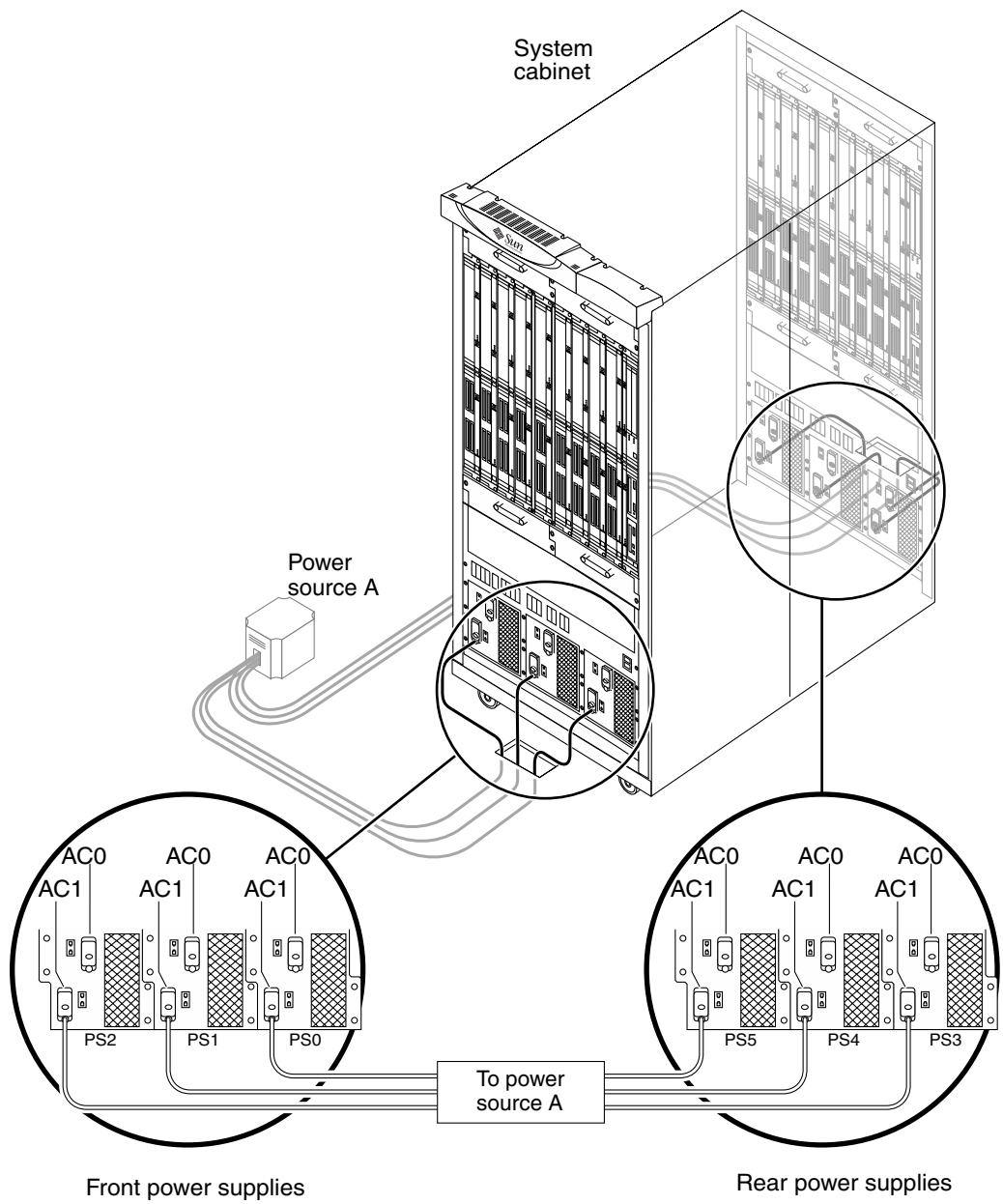

**FIGURE 3-3** Sun Fire E25K/E20K Systems Power Connections—Basic Single Power, Single Power Source (One Power Source, No Redundancy, Not Advisable)



**TABLE 3-3** Power Configuration Summary

Configuration	Protection From Loss of Internal Power Supply	Protection From Loss of External Source of Power
Redundant (FIGURE 3-1)	Yes	Yes, one of two sources
High reliability (FIGURE 3-2)	Yes	No, only one source
Basic (FIGURE 3-3)	Yes	No, only one source

---

## 3.2 Cabinet Grounding Requirements

The Sun Fire E25K/E20K systems achieve earth ground through the power cords. For this reason, a grounding cable is not provided with the system. The power cords have three prongs: two for current and one for ground. At the AC input module, the ground prong and system chassis are connected. Final chassis ground is achieved when the power cord is connected to a receptacle, where the ground prong contacts the power receptacle. For successful grounding, the customer must provide properly grounded power receptacles so the power distribution unit (PDU) ground is earth ground.

A ground cable may be affixed to the system. While not required, the additional ground point allows leakage current to dissipate more efficiently. It is important to note that power cords are grounded through the receptacle and the ground cable must reference a common earth ground. Otherwise, a difference in ground potential can be introduced.



---

**Caution** – If the customer is unsure of the facility PDU receptacle grounding, **do not install** a ground cable until a proper PDU receptacle grounding has been confirmed. If a difference in ground potential is apparent, *corrective action must be taken*.

---

Use the following procedures to properly ground the Sun Fire E25K/E20K systems.

---

**Note** – You can use the A-series circuit breaker (Carlingswitch, part number: AF3-X0-06-184-X13-D, or equivalent) if a PDU is used between the Sun Fire E25K/E20K systems and the facility power system.

---

1. Ensure the customer has properly grounded PDUs in the data center. The PDU must be earth ground.
2. Ensure all grounding points (raised floors and power receptacles) reference PDU ground.

---

**Note** – The customer needs to procure the grounding cable. A grounding cable is not shipped with the system.

---

3. Attach the ground cable to the system, behind the kick plate, at the bottom of the frame base as shown in [FIGURE 3-4](#).

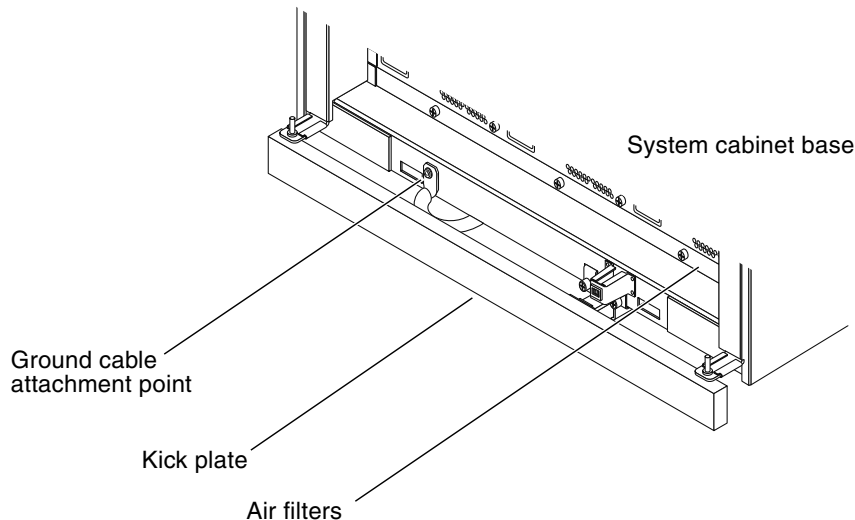

**FIGURE 3-4** Ground Cable Attachment Point at System Cabinet

4. The ground cable attaching area might be a painted surface. Ensure metal-to-metal solid contact is made for this installation.

# Network Planning

This section provides recommended network configurations and worksheets for planning system and domain setups.

## 4.1 Network Connections

The Sun Fire E25K/E20K systems require 10BASE-T or 100BASE-TX Ethernet connections for each System Control (SC) board.

There are several networks to plan and set up for Sun Fire E25K/E20K systems. Two networks are internal to the platform, the others are external and require cabling. The networks are defined in [TABLE 4-1](#).

**TABLE 4-1** Sun Fire E25K/E20K Systems Network

Network Designation	Description
I1 <sup>1</sup>	Domain-to-SC management network. Domains A–R communicate with the SC over this network. This network is internal to the platform and does not require cabling. By default, IP forwarding on the I1 network is disabled. Forwarding should not be enabled.
I2	SC-to-SC management network. Each SC communicates with the other over this network. There is no domain traffic on this network. This network is internal to the platform and does not require cabling. By default, IP forwarding on the I2 network is disabled. Forwarding should not be enabled.

**TABLE 4-1** Sun Fire E25K/E20K Systems Network (Continued)

Network Designation	Description
Cx <sup>2</sup>	<p>External customer-provided network for access to the SC and domains A–R. Each C network represents a user community, which might or might not share network traffic. Cabling, network equipment, and domain-side interface cards must be provided by the customer.</p> <p>Additionally, each C network cabled to the SC has a logical IP address. This address is logical and does not require cabling.</p>

<sup>1</sup> IPv4 must be used on the I1 network if network installation/booting domains across I1 are required.

<sup>2</sup> A maximum of two user communities can be cabled to the SC. This restriction does not apply to domains.

## 4.2 System Setup Information

The information in the sections below must be determined prior to the installation of Sun Fire E25K/E20K systems. Most system information is network related and must be provided by the customer. [TABLE 4-2](#) identifies the network interfaces available and their function.

**TABLE 4-2** Sun Fire E25K/E20K Systems Network Interfaces

Interface Designation	Description
SC-I1	Connection to the internal network I1 from the master SC. There is only one address assigned for the pair of SCs. Only the master SC accesses the I1 network.
D[A-R]-I1	Connection to the internal network I1 from domains A–R.
SC[0,1]-I2	Connection to the internal network I2 from SC0 and SC1.
SC[0,1]-Cx	Connection to the external network Cx from SC0 and SC1.
SC[0,1]-PCx	Pathgroup specific failover address for each Cx pathgroup. PCx interfaces remain local to the SC <sup>1</sup> .
F-Cx	Logical interface for each C network on the SC. The interface is reachable through the appropriate Cx network. F-Cx interfaces are only present on the main SC.
D[A-R]-Cx	Connection to the external network Cx from domains A–R.

<sup>1</sup> Only present for pathgroups with  $\geq 2$  NICs.

All external connections to the SC should be through the user community logical interface L-Cx, so clients are always directed to the main SC.

---

## 4.3 Network Configurations

For the System Controller, there are two types of network configurations: high availability (HA) and non HA. In either of the network configurations, the following is true:

- The domains can connect to any number of user communities. The limitation of two is for the SC only.
- The domains might or might not be cabled to the same user communities as the System Controllers. This is driven by the security policy of the site.
- The main SC and the spare SC must have identical network cabling.
- For HA configurations, redundancy can be further increased within each user community by deploying multiple switches or hubs.
- If the SC loses all connections to any one user community, an SC failover (switch over) is triggered (affecting all user communities attached to the SC).
- Access to the platform itself is highly available. Outages due to a catastrophic SC-centric failure are averted by failing over to the spare SC.

---

**Note** – The cPCI slot in the SC is not currently supported and is not available for network connections.

---

Network configurations for the domains are not discussed and are left to the specific requirements of the customer and application.

## 4.3.1 HA Network Configuration

HA network configuration is shown in [FIGURE 4-1](#).

*Advantages:*

- Each SC has two redundant connections to a user community network.
- A failure of any single network connection to the system controller does not induce an SC failover.

*Disadvantages:*

- Limited to a single-user community cabled to the system controller

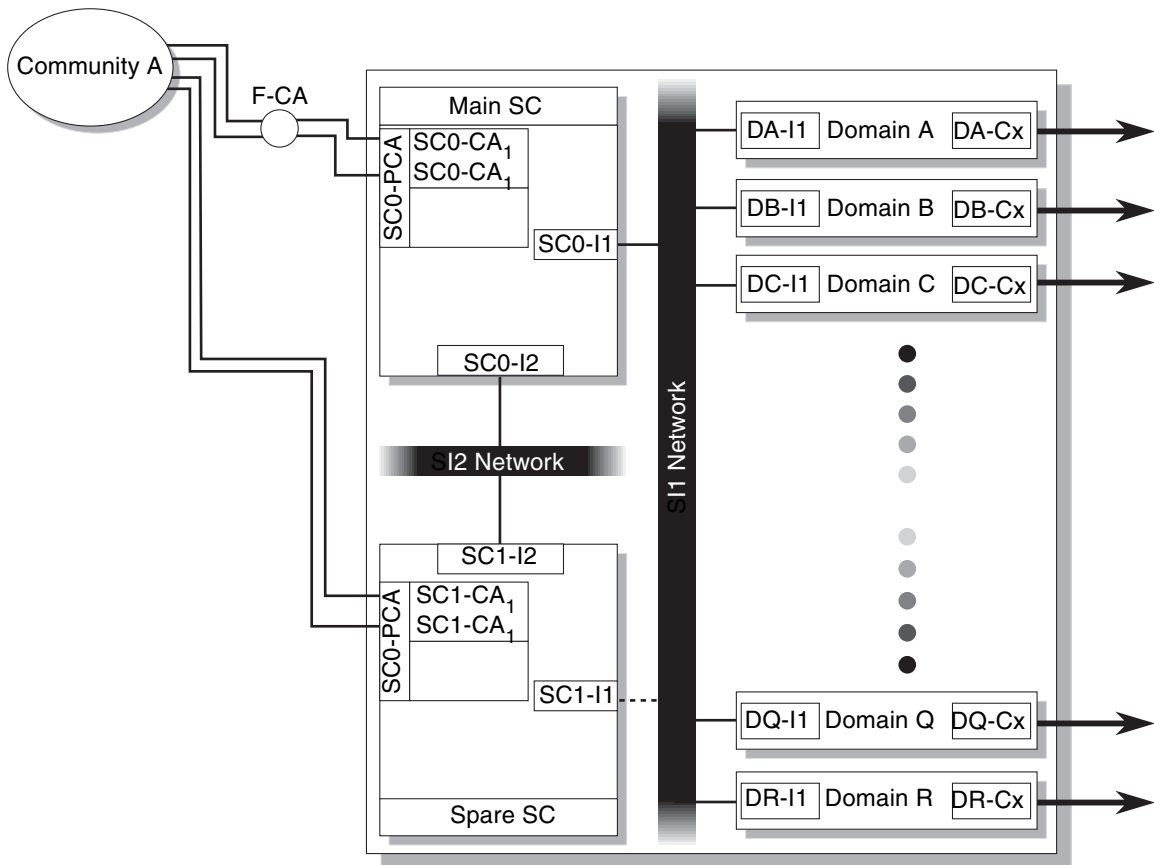

**FIGURE 4-1** Highly Available Network Configuration

## 4.3.2 Non-HA Network Configuration

A non-HA network configuration is shown in [FIGURE 4-2](#).

*Advantages:*

- Up to two user community connections to the System Controller.

*Disadvantages:*

- A failure of any single network connection induces an SC failover.

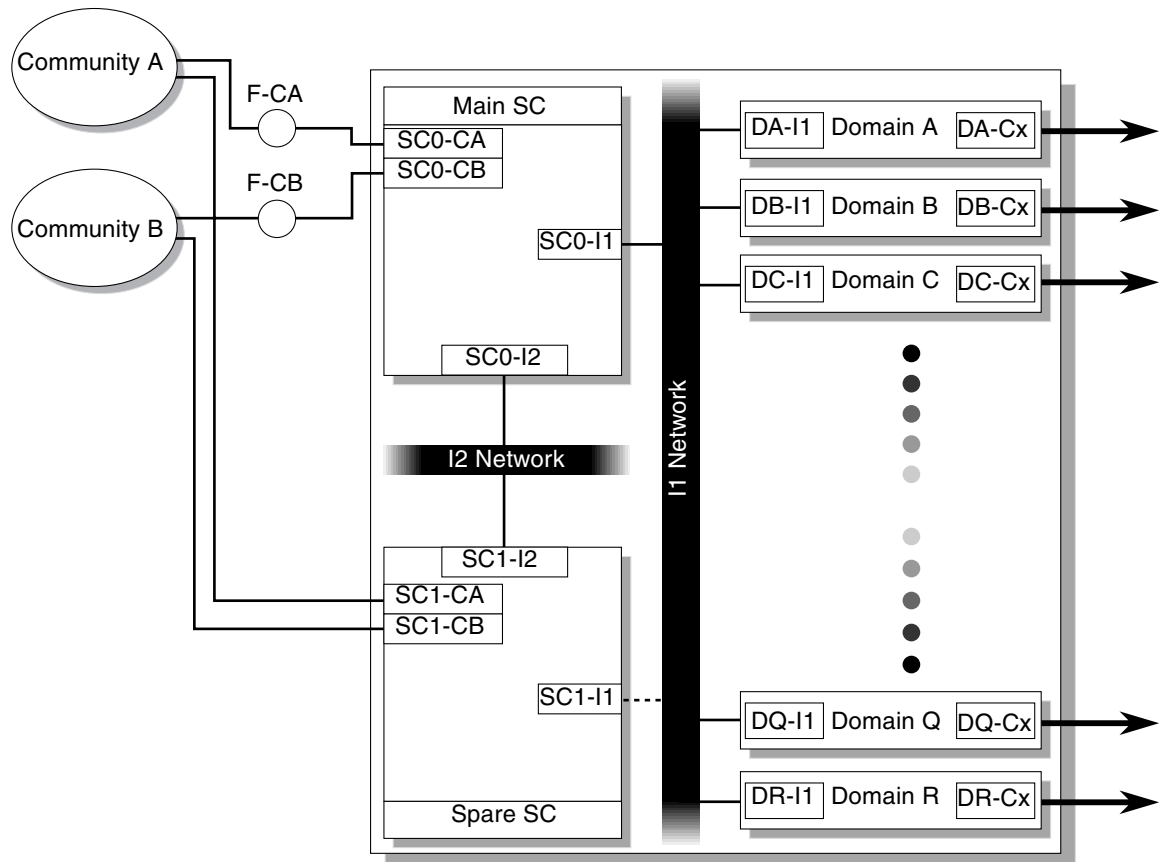

**FIGURE 4-2** Dense Network Configuration

---

## 4.4 System Setup Worksheets

Host names, networks, internet protocol (IP) addresses, and subnet masks for the System Controllers are required. Domain OS installation also requires host names, IP addresses, and subnet masks for the domain external connections. Multiple user communities may also be involved. The worksheets that follow are designed to help organize this information before the installation.

### 4.4.1 Platform Name

Sun Fire E25K/E20K systems require a platform name. The platform name, globally unique within the network, is a logical name given to an entire system and does not correspond to any host on the network. The platform name is used as the default prefix for host names of internal network interfaces, see [Section 4.4.2, "Internal Networks" on page 4-6](#). This platform name must consist of alphanumeric characters using an alpha character first. Record the platform name in the space provided in [TABLE 4-3](#) (see Appendix A for an expanded form to use and retain for your records).

**TABLE 4-3** Sun Fire E25K/E20K Systems Platform Name Worksheet

Platform Name

### 4.4.2 Internal Networks

Enter the IP networks and subnet masks in the worksheet provided in [TABLE 4-4](#) (see Appendix A for an expanded form to use and retain for your records). The subnets for the internal networks are fixed. As neither I1 nor I2 are routed, the IP networks can be taken from the IP private pool. Networks should be unique within the customer network.

**TABLE 4-4** IP Networks Subnet Masks for Internal Network Worksheet

Network	IP Network	Subnet Mask
I1		255.255.255.224
I2		255.255.255.252



## 4.4.2.1 I1 Network

Host names and IP addresses are required for the I1 network. For the System Controller, only one host name and IP address is assigned to the I1 network. Only the main SC actively connects to the I1 network.

The host names and IP addresses can be automatically assigned by `smsconfig(1M)` during installation. For example, if the platform name is `Name1`, domain A I1 host name becomes `Name1-a`. IP assignments are made based on the IP network subnet mask provided from lowest to highest starting with the SC and ending with domain R.

---

**Note** – Automatic assignment of a host name IP address for the I1 network is highly recommended.

---

If performing a manual installation, record the host names and IP addresses for the I1 interfaces in the worksheet provided in [TABLE 4-5](#).

**TABLE 4-5** Host Name IP Addresses for the I1 Network Worksheet

I1 Network		
Interface	Host Name	IP Address
System Control board (SC-I1)	<i>platform-sc-i1</i>	
Domain A (DA-I1)	<i>platform-a</i>	
Domain B (DB-I1)	<i>platform-b</i>	
Domain C (DC-I1)	<i>platform-c</i>	
Domain D (DD-I1)	<i>platform-d</i>	
Domain E (DE-I1)	<i>platform-e</i>	
Domain F (DF-I1)	<i>platform-f</i>	
Domain G (DG-I1)	<i>platform-g</i>	
Domain H (DH-I1)	<i>platform-h</i>	
Domain I (DI-I1)	<i>platform-i</i>	
Domain J (DJ-I1)	<i>platform-j</i>	
Domain K (DK-I1)	<i>platform-k</i>	
Domain L (DL-I1)	<i>platform-l</i>	
Domain M (DM-I1)	<i>platform-m</i>	
Domain N (DN-I1)	<i>platform-n</i>	
Domain O (DO-I1)	<i>platform-o</i>	
Domain P (DP-I1)	<i>platform-p</i>	

**TABLE 4-5** Host Name IP Addresses for the I1 Network Worksheet (*Continued*)

I1 Network		
Interface	Host Name	IP Address
Domain Q (DQ-I1)	<i>platform-q</i>	
Domain R (DR-I1)	<i>platform-r</i>	

## 4.4.2.2 I2 Network

Each System Controller maintains an active link to the I2 network, regardless of the SC role (main or spare). As with the I1 network, the I2 host name names and IP addresses can be automatically assigned during installation by `smsconfig(1M)`.

**Note** – Automatic assignment of a host name IP address for the I2 network is highly recommended.

If performing a manual installation, record the host names and IP addresses for the I2 interfaces in the worksheet provided in [TABLE 4-6](#).

**TABLE 4-6** Host Name IP Addresses for the I2 Network Worksheet

Interface	Host Name	IP Address
SC0-I2	<i>platform-sc0-i2</i>	
SC1-I2	<i>platform-sc1-i2</i>	

## 4.4.3 External Networks

Enter the IP networks and subnet masks in the worksheet provided in [TABLE 4-7](#). Each subnet must be unique within the network. The System Controller can connect to a maximum of two user communities.

**TABLE 4-7** IP Networks Subnet Masks for External Networks Worksheet

User Community Network	IP Network	Subnet Mask
Community A		
Community B		

### 4.4.3.1 System Controller

IP addresses are required for every interface on the System Controller that is cabled to a user community. The SC has two built-in Ethernet ports (labeled “Ethernet” and “Ext Ethernet”). Use the worksheet in [TABLE 4-8](#) to record this information.

**TABLE 4-8** Community Host Name IP Addresses for the System Controllers Worksheet

Cx Network		
Interface	User Community	IP Address
System Controller 0, Ethernet		
System Controller 0, Ext Ethernet		
System Controller 1, Ethernet		
System Controller 1, Ext Ethernet		

Additionally, for each user community, a logical interface is required for the System Controllers. Logical interfaces are only present on the main SC. SC pathgroup-specific IP addresses are also required when using the HA configuration. Use the worksheet in [TABLE 4-9](#) to record this information.

**TABLE 4-9** Host Name IP Addresses for the SC Logical Interface Worksheet

User Community	Logical Host Name	Logical IP Address	SC0 Pathgroup IP Address	SC1 Pathgroup IP Address
User Community A				
User Community B				

**Note** – The logical and pathgroup-specific IP address for a community must use the same IP network and subnet as the physical NIC(s) in that community.

## 4.4.3.2

### Domains

Host names and IP addresses are also required for the domain connections to a user community. The worksheet in [TABLE 4-10](#) assumes that each domain connects to only one user community. If a domain connects to multiple user communities, or user communities not previously defined, record that information on a separate sheet of paper.

**TABLE 4-10** Community Host Name IP Addresses for the Domain Worksheet

<b>Cx Network</b>			
<b>Interface</b>	<b>User Community</b>	<b>Host Name</b>	<b>IP Address</b>
Domain A (DA-Cx)			
Domain B (DB-Cx)			
Domain C (DC-Cx)			
Domain D (DD-Cx)			
Domain E (DE-Cx)			
Domain F (DF-Cx)			
Domain G (DG-Cx)			
Domain H (DH-Cx)			
Domain I (DI-Cx)			
Domain J (DJ-Cx)			
Domain K (DK-Cx)			
Domain L (DL-Cx)			
Domain M (DM-Cx)			
Domain N (DN-Cx)			
Domain O (DO-Cx)			
Domain P (DP-Cx)			
Domain Q (DQ-Cx)			
Domain R (DR-Cx)			

## Site Planning Checklists

---

Prior to the Sun Fire E25K/E20K systems installation, confirm that the following requirements have been met.

---

### 5.1 System Components

- o Has the system configuration been determined?
- o Total number of cabinets \_\_\_\_.

---

### 5.2 Miscellaneous

- o Have system administrators and operators been enrolled in the necessary Sun Microsystems training course, ES-421, Sun Fire E25K/E20K Systems Server Administration?
- o Is a security clearance required for this site? If so, has local Sun Microsystems Enterprise Services Management been notified of the required security level?  
Note: Clearances can take months to obtain, so timely notification is important.
- o Was the *Sun Fire E25K/E20K Systems Site Planning Guide* provided to all appropriate members of the customer staff including the facility planning and operations team for review during the site planning process?

---

## 5.3 Environmental Requirements

- o Does the computer room environment meet the Sun Microsystems specifications for temperature and humidity listed in [TABLE 2-1](#)?
- o Confirm there is sufficient unused cooling capacity supporting the computer area to handle the increase in load from this system. Redundant capacity should not be considered. See [TABLE 2-1](#).
- o Verify the number of circuit breaker pole positions are available to connect the systems properly.
- o Determine the source of power for the proposed systems. Are the sources of power consistent with the intended power connection configurations shown in [FIGURE 3-1](#), [FIGURE 3-2](#), or [FIGURE 3-3](#)?
- o Is the computer room voltage between 200–240 VAC?
- o Have sufficient power receptacles been ordered for the system cabinet and each customer-selected I/O expansion rack ([TABLE 3-2](#))?
- o Ensure the power receptacles are within 14 ft (427 cm cable length) of the system cabinet and each customer-selected I/O expansion rack location.
- o Are the circuit breakers for the system cabinet and each customer-selected I/O expansion rack properly installed and labeled?

---

## 5.4 Physical Specifications

- o Has the system location been established?
- o Does the equipment floor layout meet the equipment maintenance access requirements? See [Section 2.3, “Computer Room Layout”](#) on page 2-6.
- o Confirm the equipment is positioned so that the minimum distance from the discharge of a heat-rejecting device meets the recommendations in [FIGURE 2-1](#).
- o Are the floor cutouts for the system cabinet and each customer-selected I/O expansion rack in place?
- o Are recommended perforated floor panels in place? See [Section 2.3, “Computer Room Layout”](#) on page 2-6.
- o Confirm the raised-floor system and the raised-floor tiles are rated for the loads imposed by the system.
- o Is the system positioned to correspond to the precise edge of raised-floor tile locations shown in the *Sun Fire E25K/E20K Systems Site Planning Guide*? See [Section 2.3, “Computer Room Layout”](#) on page 2-6. *Casters and leveling feet must be on solid raised-floor tiles.*
- o Have you had a structural engineer evaluate the building structure for the anticipated weight of the system?

---

## 5.5 Network Planning

- o Have the Ethernet connections in [TABLE 4-1](#) been considered for the customer network?
- o Have all networking cables been ordered to arrive prior to installation?
- o Have all network connections for each configured network controller been ordered?
- o Have all IP addresses for each configured network controller been assigned?
- o Are the Ethernet connections available to the user’s network?

---

## 5.6 Planning Your Access Route

- o Has a 60-inch pallet jack been obtained for transporting the system cabinet on the pallet? (Refer to the *Sun Fire E25K/E20K Systems Unpacking Guide*.)
- o Has an access route to the final system location been identified?
- o Does the access route satisfy the access requirements outlined in [TABLE 1-1](#)?
- o Have provisions been made to cover irregular or engraved floor patterns along the access route to reduce vibration?
- o Have personnel been allocated to unload the system during delivery? (Refer to the *Sun Fire E25K/E20K Systems Unpacking Guide*.)
- o Does the loading dock meet the standard freight-carrier truck requirements? Trucks can be between 48 ft (14.6 meters) and 61 ft (18.6 meters) long, 8.5 ft (2.6 meters) wide, and 14 ft (4.3 meters) high.
- o If the loading dock does not meet the standard freight-carrier truck requirements, has a forklift been allocated for delivery? (Refer to the *Sun Fire E25K/E20K Systems Unpacking Guide*.)
- o Is a truck with a lift gate that can accommodate the crated system needed? See [TABLE 1-1](#) of this site planning guide for physical specifications.
- o Does the access route meet the floor-loading requirements for the system?
- o Do the pallet-jack fork dimensions meet requirements for the shipping crate? See [Section 1.6, “Planning Your Access Route”](#) on page 1-13.
- o Are the elevator and elevator door dimensions adequate ([TABLE 1-1](#))?
- o Is the elevator weight capacity adequate ([TABLE 1-1](#))?
- o Does each ramp incline in the access route have an incline that is less than 10 degrees? Refer to the *Sun Fire E25K/E20K Systems Unpacking Guide*.
- o Has a crate unloading area next to the raised floor been identified?
- o Have you protected the raised floor along the delivery path?
- o Is each door opening along the delivery path wide and tall enough to accommodate the system?



---

## 5.7 Installation Schedule

- o Has an installation date been determined? Date: \_\_\_\_\_
- o Who is the customer contact for shipment?

Name: \_\_\_\_\_

Phone: \_\_\_\_\_

Email: \_\_\_\_\_



# Power and Cooling, and System Setup Worksheets

---

A larger version of the worksheets within the various tables of this document have been provided in this appendix for your use. These worksheets from Chapter 1, Chapter 2, Chapter 3, and Chapter 4 are listed below.

---

**Chapter and Table Number**

---

**Chapter 1**

TABLE 1-2 "System Weight by Components Worksheet"

**Chapter 2**

TABLE 2-3 "System Power and Cooling Requirements Worksheet"

**Chapter 3**

TABLE 3-2 "Facility Power Cable Requirements Worksheet"

**Chapter 4**

TABLE 4-3 "Sun Fire E25K/E20K Systems Platform Name Worksheet"

TABLE 4-4 "IP Networks Subnet Masks for Internal Network Worksheet"

TABLE 4-5 "Host Name IP Addresses for the I1 Network Worksheet"

TABLE 4-6 "Host Name IP Addresses for the I2 Network Worksheet"

TABLE 4-7 "IP Networks Subnet Masks for External Networks Worksheet"

TABLE 4-8 "Community Host Name IP Addresses for the System Controllers Worksheet"

TABLE 4-9 "Host Name IP Addresses for the SC Logical Interface Worksheet"

TABLE 4-10 "Community Host Name IP Addresses for the Domain Worksheet"

---

Use these pages and retain them for your records.



# System Weight by Components Worksheet

Record Date \_\_\_\_\_

System Component	Qty.	Single Qty. Weight	=	Total Weight	Purch. Qty.	=	E25K System Calculated Actual Weight	E20K System Calculated Actual Weight
Base system cabinet (power module, power centerplane, fan backplane, cables, side panels, kick plate, EMI filters, air filters, pushbars and extension included)	1 X	963.6 lb (437 kg)	=	963.6 lb (437 kg)		=	963.6 lb (437 kg)	963.6 lb (437 kg)
Power supply	6 X	42.2 lb (19.2 kg)	=	253.2 lb (115.1 kg)		=	253.2 lb (115.1 kg)	253.2 lb (115.1 kg)
Fan trays	8 X	25.1 lb (11.4 kg)	=	200.8 lb (91.2 kg)		=	200.8 lb (91.2 kg)	200.8 lb (91.2 kg)
Sun Fireplane (centerplane)	1 X	30.1 lb (13.7 kg)	=	30.1 lb (13.7 kg)		=	30.1 lb (13.7 kg)	30.1 lb (13.7 kg)
Centerplane support board	2 X	5.2 lb (2.4 kg)	=	10.4 lb (4.7 kg)		=	10.4 lb (4.7 kg)	10.4 lb (4.7 kg)
Centerplane support board carrier plate	2 X	19.0 lb (8.6 kg)	=	38.0 lb (17.3 kg)		=	38.0 lb (17.3 kg)	38.0 lb (17.3 kg)
System Control board	2 X	14.3 lb (6.5 kg)	=	28.6 lb (13 kg)		=	28.6 lb (13 kg)	28.6 lb (13 kg)
System control peripheral board	2 X	16.5 lb (7.5 kg)	=	33.0 lb (15.0 kg)		=	33.0 lb (15.0 kg)	33.0 lb (15.0 kg)
Expander carrier plate (14 for E25K System, 7 for E20K System)	X	14.3 lb (6.5 kg)	=	200.2 lb (91.0 kg)	X ____	=	_____	_____
Expander carrier plate (with air dam), center (4 for E25K System, 2 for E20K System)	X	17.8 lb (8.1 kg)	=	71.2 lb (32.4 kg)	X ____	=	_____	_____
CPU board (up to 18 for E25K system, up to 9 for E20K system)	1 X	27.4 lb (12.4 kg)	=	27.4 lb (12.4 kg)	X ____	=	_____	_____
Expander board (up to 18 for E25K system, up to 9 for E20K system)	1 X	6.0 lb (2.7 kg)	=	6.0 lb (2.7 kg)	X ____	=	_____	_____
Options: hsPCI-X/hsPCI+ assembly plus four (4) cassettes (up to 18 for E25K system, up to 9 for E20K system)	1 X	19.5 lb (8.9 kg)	=	19.5 lb (8.9 kg)	X ____	=	_____	_____

System Component	Qty.	Single Qty. Weight	=	Total Weight	Purch. Qty.	=	E25K System Calculated Actual Weight	E20K System Calculated Actual Weight
CPU filler panel (9 minimum for E20K system)	1 X	6.2 lb (2.8 kg)	=	6.2 lb (2.8 kg)	X ___	=	_____	_____
I/O filler panel (9 minimum for E20K system)	1 X	5.2 lb (2.4 kg)	=	5.2 lb (2.4 kg)	X ___	=	_____	_____
<b>Systems with 2-doors (1 in front, 1 in rear)</b>								
Door, front (with torque drivers)	1 X	44.2 lb (20.7 kg)		44.2 lb (20.7 kg)			44.2 lb (20.7 kg)	44.2 lb (20.7 kg)
Door, rear	1 X	39 lb (17.7 kg)		39 lb (17.7 kg)			39 lb (17.7 kg)	39 lb (17.7 kg)
<b>Systems with 4-doors (2 in front, 2 in rear)</b>								
Door, front right (with torque drivers)	1 X	20.5 lb (9.3 kg)	=	20.5 lb (9.3 kg)			20.5 lb (9.3 kg)	20.5 lb (9.3 kg)
Door, front left	1 X	29.0 lb (13.2 kg)	=	29.0 lb (13.2 kg)			29.0 lb (13.2 kg)	29.0 lb (13.2 kg)
Door, rear right	1 X	14.0 lb (6.4 kg)	=	14.0 lb (6.4 kg)			14.0 lb (6.4 kg)	14.0 lb (6.4 kg)
Door, rear left	1 X	17.5 lb (8.0 kg)	=	17.5 lb (8.0 kg)			17.5 lb (8.0 kg)	17.5 lb (8.0 kg)

# System Power and Cooling Requirements Worksheet

Record Date \_\_\_\_\_

	Components	System Power		Air Conditioning	
		Qty. x AC Power (VA)	Total (VA)		BTU/Hr
<b>System Cabinet</b>					
Base system	System Control (2)	2 x 182	364	x 3.4 =	1237.6
	SC peripheral (2)	2 x 55	110	x 3.4 =	374.0
	Fan trays (8)	8 x 289	2309	x 3.4 =	7849.9
	Centerplane support (2)	2 x 18	36	x 3.4 =	122.4
	Sun Fireplane (1)	1 x 204	204	x 3.4 =	693.6
Expander	Expander (up to 18)	__ x 88		x 3.4 =	
Slot 0	1950Mhz USIV+ Uniboards	__ x 1148		x 3.4 =	
	1800Mhz & under USIV / USIV+ Uniboards	__ x 1088		x 3.4 =	
	USIII / USIII+ Uniboards	__ x 993		x 3.4 =	
Slot 1	hsPCI-X/hsPCI+ (up to 18)	__ x 94		x 3.4 =	
I/O adapters	PCI (up to 72)	__ x 24		x 3.4 =	
TOTAL			_____		_____





# Facility Power Cable Requirements Worksheet

Record Date \_\_\_\_\_

Frame Type	Number of Cabinets	Number of Poles	Number * of Cords	Single Phase	3 Phase
System Cabinet (Single Phase)	_____	x 2	x _____ = _____		n/a
Total number of poles required					

\* Contact a Sun Microsystems System Engineer for power cord quantity/receptacle information to ensure the receptacle prepared matches the power cord that was ordered..



# Sun Fire E25K/E20K Systems Platform Name Worksheet

Record Date \_\_\_\_\_

Platform Name	
---------------	--



# IP Networks Subnet Masks for Internal Network Worksheet

Record Date \_\_\_\_\_

Network	IP Network	Subnet Mask
I1		255.255.255.224
I2		255.255.255.252



# Host Name IP Addresses for the I1 Network Worksheet

Record Date \_\_\_\_\_

I1 Network		
Interface	Hostname	IP Address
System Control board (SC-I1)	<i>platform-sc-i1</i>	
Domain A (DA-I1)	<i>platform-a</i>	
Domain B (DB-I1)	<i>platform-b</i>	
Domain C (DC-I1)	<i>platform-c</i>	
Domain D (DD-I1)	<i>platform-d</i>	
Domain E (DE-I1)	<i>platform-e</i>	
Domain F (DF-I1)	<i>platform-f</i>	
Domain G (DG-I1)	<i>platform-g</i>	
Domain H (DH-I1)	<i>platform-h</i>	
Domain I (DI-I1)	<i>platform-i</i>	
Domain J (DJ-I1)	<i>platform-j</i>	
Domain K (DK-I1)	<i>platform-k</i>	
Domain L (DL-I1)	<i>platform-l</i>	
Domain M (DM-I1)	<i>platform-m</i>	
Domain N (DN-I1)	<i>platform-n</i>	
Domain O (DO-I1)	<i>platform-o</i>	
Domain P (DP-I1)	<i>platform-p</i>	
Domain Q (DQ-I1)	<i>platform-q</i>	
Domain R (DR-I1)	<i>platform-r</i>	





# Host Name IP Addresses for the I2 Network Worksheet

Record Date \_\_\_\_\_

Interface	Hostname	IP Address
SC0-I2	<i>platform-sc0-i2</i>	
SC1-I2	<i>platform-sc1-i2</i>	



# IP Networks Subnet Masks for External Networks Worksheet

Record Date \_\_\_\_\_

User Community Network	IP Network	Subnet Mask
Community A		
Community B		



# Community Host Name IP Addresses for the System Controller Worksheet

Record Date \_\_\_\_\_

Cx Network		
Interface	User Community	IP Address
System Controller 0, Ethernet		
System Controller 0, Ext Ethernet		
System Controller 1, Ethernet		
System Controller 1, Ext Ethernet		



# Host Name IP Addresses for the SC Logical Interface Worksheet

Record Date \_\_\_\_\_

User Community	Logical Host Name	Logical IP Address	SC0 Pathgroup IP Address	SC1 Pathgroup IP Address
User Community A				
User Community B				





# Community Host Name IP Addresses for the Domain Worksheet

Record Date \_\_\_\_\_

Cx Network			
Interface	User Community	Hostname	IP Address
Domain A (DA-Cx)			
Domain B (DB-Cx)			
Domain C (DC-Cx)			
Domain D (DD-Cx)			
Domain E (DE-Cx)			
Domain F (DF-Cx)			
Domain G (DG-Cx)			
Domain H (DH-Cx)			
Domain I (DI-Cx)			
Domain J (DJ-Cx)			
Domain K (DK-Cx)			
Domain L (DL-Cx)			
Domain M (DM-Cx)			
Domain N (DN-Cx)			
Domain O (DO-Cx)			
Domain P (DP-Cx)			
Domain Q (DQ-Cx)			
Domain R (DR-Cx)			

