



# Sun Fire™ E25K/E20K Systems

---

## Service Manual

Sun Microsystems, Inc.  
[www.sun.com](http://www.sun.com)

Part No. 817-4138-15  
April 2008, Revision A

Submit comments about this document at: <http://www.sun.com/hwdocs/feedback>

Copyright 2008 Sun Microsystems, Inc., 4150 Network Circle, Santa Clara, California 95054, U.S.A. All rights reserved.

Sun Microsystems, Inc. has intellectual property rights relating to technology that is described in this document. In particular, and without limitation, these intellectual property rights may include one or more of the U.S. patents listed at <http://www.sun.com/patents> and one or more additional patents or pending patent applications in the U.S. and in other countries.

This document and the product to which it pertains are distributed under licenses restricting their use, copying, distribution, and decompilation. No part of the product or of this document may be reproduced in any form by any means without prior written authorization of Sun and its licensors, if any.

Third-party software, including font technology, is copyrighted and licensed from Sun suppliers.

Parts of the product may be derived from Berkeley BSD systems, licensed from the University of California. UNIX is a registered trademark in the U.S. and in other countries, exclusively licensed through X/Open Company, Ltd.

Sun, Sun Microsystems, the Sun logo, AnswerBook2, docs.sun.com, Sun Fire, OpenBoot, SunVTS, Sun Fireplane interconnect, Netra, Java, and Solaris are trademarks or registered trademarks of Sun Microsystems, Inc. in the U.S. and in other countries.

All SPARC trademarks are used under license and are trademarks or registered trademarks of SPARC International, Inc. in the U.S. and in other countries. Products bearing SPARC trademarks are based upon an architecture developed by Sun Microsystems, Inc.

The OPEN LOOK and Sun™ Graphical User Interface was developed by Sun Microsystems, Inc. for its users and licensees. Sun acknowledges the pioneering efforts of Xerox in researching and developing the concept of visual or graphical user interfaces for the computer industry. Sun holds a non-exclusive license from Xerox to the Xerox Graphical User Interface, which license also covers Sun's licensees who implement OPEN LOOK GUIs and otherwise comply with Sun's written license agreements.

U.S. Government Rights-Commercial use. Government users are subject to the Sun Microsystems, Inc. standard license agreement and applicable provisions of the FAR and its supplements.

DOCUMENTATION IS PROVIDED "AS IS" AND ALL EXPRESS OR IMPLIED CONDITIONS, REPRESENTATIONS AND WARRANTIES, INCLUDING ANY IMPLIED WARRANTY OF MERCHANTABILITY, FITNESS FOR A PARTICULAR PURPOSE OR NON-INFRINGEMENT, ARE DISCLAIMED, EXCEPT TO THE EXTENT THAT SUCH DISCLAIMERS ARE HELD TO BE LEGALLY INVALID.

---

Copyright 2008 Sun Microsystems, Inc., 4150 Network Circle, Santa Clara, Californie 95054, Etats-Unis. Tous droits réservés.

Sun Microsystems, Inc. a les droits de propriété intellectuels relatants à la technologie qui est décrit dans ce document. En particulier, et sans la limitation, ces droits de propriété intellectuels peuvent inclure un ou plus des brevets américains énumérés à <http://www.sun.com/patents> et un ou les brevets plus supplémentaires ou les applications de brevet en attente dans les Etats-Unis et dans les autres pays.

Ce produit ou document est protégé par un copyright et distribué avec des licences qui en restreignent l'utilisation, la copie, la distribution, et la décompilation. Aucune partie de ce produit ou document ne peut être reproduite sous aucune forme, par quelque moyen que ce soit, sans l'autorisation préalable et écrite de Sun et de ses bailleurs de licence, s'il y en a.

Le logiciel détenu par des tiers, et qui comprend la technologie relative aux polices de caractères, est protégé par un copyright et licencié par des fournisseurs de Sun.

Des parties de ce produit pourront être dérivées des systèmes Berkeley BSD licenciés par l'Université de Californie. UNIX est une marque déposée aux Etats-Unis et dans d'autres pays et licenciée exclusivement par X/Open Company, Ltd.

Sun, Sun Microsystems, le logo Sun, AnswerBook2, docs.sun.com, Sun Fire, OpenBoot, SunVTS, Sun Fireplane interconnect, Netra, Java, et Solaris sont des marques de fabrique ou des marques déposées de Sun Microsystems, Inc. aux Etats-Unis et dans d'autres pays.

Toutes les marques SPARC sont utilisées sous licence et sont des marques de fabrique ou des marques déposées de SPARC International, Inc. aux Etats-Unis et dans d'autres pays. Les produits portant les marques SPARC sont basés sur une architecture développée par Sun Microsystems, Inc.

L'interface d'utilisation graphique OPEN LOOK et Sun™ a été développée par Sun Microsystems, Inc. pour ses utilisateurs et licenciés. Sun reconnaît les efforts de pionniers de Xerox pour la recherche et le développement du concept des interfaces d'utilisation visuelle ou graphique pour l'industrie de l'informatique. Sun détient une licence non exclusive de Xerox sur l'interface d'utilisation graphique Xerox, cette licence couvrant également les licenciées de Sun qui mettent en place l'interface d'utilisation graphique OPEN LOOK et qui en outre se conforment aux licences écrites de Sun.

LA DOCUMENTATION EST FOURNIE "EN L'ÉTAT" ET TOUTES AUTRES CONDITIONS, DECLARATIONS ET GARANTIES EXPRESSES OU TACITES SONT FORMELLEMENT EXCLUES, DANS LA MESURE AUTORISEE PAR LA LOI APPLICABLE, Y COMPRIS NOTAMMENT TOUTE GARANTIE IMPLICITE RELATIVE A LA QUALITE MARCHANDE, A L'APTITUDE A UNE UTILISATION PARTICULIERE OU A L'ABSENCE DE CONTREFAÇON.

# Contents

---

## **Preface** xxiii

### **1. Guidelines, Indicators, and Nomenclature** 1-1

- 1.1 System Component Hot-Swap Guidelines 1-1
- 1.2 Configuration Rules 1-2
- 1.3 Testing the System 1-3
- 1.4 Reviewing System Temperatures 1-4
- 1.5 Reviewing System Power 1-5
- 1.6 Hardware Indicators 1-6
- 1.7 Field-Replaceable Units (FRU)—Mean Time to Repair (MTTR) 1-7
- 1.8 Safety Precautions 1-12
- 1.9 Special Tools and Shipping Kit Items 1-13
- 1.10 System Block Diagrams 1-14

### **2. TopCap and Extension Replacement Procedures** 2-1

- 2.1 TopCap Replacement 2-2
  - 2.1.1 Removing the TopCap 2-2
  - 2.1.2 Installing the TopCap 2-2
- 2.2 TopCap Extension Replacement 2-2
  - 2.2.1 Removing the TopCap Extension 2-2

2.2.2 Installing the TopCap Extension 2-3

### **3. System Power 3-1**

3.1 Power Module Replacement Procedures 3-1

3.1.1 Power Module Replacement 3-1

3.1.2 Powering Off for Power Module Removal 3-2

3.1.3 Removing a Power Module 3-3

3.1.4 Installing a Power Module 3-5

3.1.5 Powering On After Power Module Installation 3-6

3.2 4 kW Dual AC-DC Power Supply Replacement Procedures 3-7

3.2.1 4 kW Dual AC-DC Power Supply LEDs 3-8

3.2.2 4 kW Dual AC-DC Power Supply Replacement 3-9

3.2.2.1 Isolating a Failed Power Supply 3-9

3.2.2.2 Powering Off a 4 kW Dual AC-DC Power Supply 3-10

3.2.2.3 Removing a 4 kW Dual AC-DC Power Supply 3-10

3.2.2.4 Installing a 4 kW Dual AC-DC Power Supply 3-11

3.2.2.5 Powering On a 4 kW Dual AC-DC Power Supply 3-12

3.2.2.6 Verifying a 4 kW Dual AC-DC Power Supply 3-13

### **4. Fan Trays 4-1**

4.1 Fan Tray LEDs 4-2

4.2 Fan Tray Replacement Procedures 4-3

4.2.1 Isolating a Failed Fan Tray 4-3

4.2.2 Powering Off a Fan Tray 4-4

4.2.3 Removing a Fan Tray 4-4

4.2.4 Installing a Fan Tray 4-5

4.2.5 Verifying a Fan Tray 4-6

### **5. System Controller CPU Board for the System Control (SC) Board 5-1**

- 5.1 System Control (SC) Board System Controller CPU Board Replacement Procedures 5-2
  - 5.1.1 Powering Off the SC Board 5-2
  - 5.1.2 Removing the SC Board. 5-2
  - 5.1.3 Removing the System Control (SC) Board System Controller CPU Board 5-3
- 5.2 System Controller CPU Board Memory Board Installation Procedures 5-3
  - 5.2.1 Installing Memory Boards on the System Controller CPU Board 5-3
  - 5.2.2 Verifying the Switch Positions on the System Controller CPU Board 5-5
  - 5.2.3 Installing the System Controller CPU Board 5-6
  - 5.2.4 Installing the System Control (SC) Board 5-6
  - 5.2.5 Verifying the Memory Boards on the System Controller CPU Board 5-7
- 6. System Control (SC) Board 6-1**
  - 6.1 System Control (SC) Board Replacement 6-1
    - 6.1.1 System Control Board LEDs 6-1
    - 6.1.2 System Control Board (SC) Replacement Procedures 6-4
      - 6.1.2.1 Isolating a Failed System Control Board 6-4
      - 6.1.2.2 Powering Off a System Control (SC) Board 6-4
      - 6.1.2.3 Removing a System Control (SC) Board 6-6
      - 6.1.2.4 Installing a System Control (SC) Board 6-8
      - 6.1.2.5 Verifying a System Control (SC) Board 6-9
- 7. System Control (SC) Peripheral Board 7-1**
  - 7.1 System Control Peripheral Board LEDs 7-2
  - 7.2 System Control Peripheral Board Replacement Procedures 7-5
    - 7.2.1 Isolating a Failed System Control (SC) Peripheral Board 7-5
    - 7.2.2 Powering Off a System Control (SC) Peripheral Board 7-5

- 7.2.3 Removing a System Control (SC) Peripheral Board 7-5
- 7.2.4 Installing a System Control (SC) Peripheral Board 7-7
- 7.2.5 Powering On a System Control (SC) Peripheral Board 7-8
- 7.2.6 Verifying a System Control (SC) Peripheral Board 7-8
- 7.3 DVD Component Replacement Procedures 7-9
  - 7.3.1 Removing the DVD Component From the System Control (SC) Peripheral Board 7-9
  - 7.3.2 Installing the DVD Component on the System Control (SC) Peripheral Board 7-10
  - 7.3.3 Powering On a DVD Component 7-11
  - 7.3.4 Verifying a DVD Component 7-11
- 7.4 Hard Drive Replacement Procedures 7-11
  - 7.4.1 Removing the Failed Hard Drive From the System Control (SC) Peripheral Board 7-11
  - 7.4.2 Installing the Hard Drive on the System Control (SC) Peripheral Board 7-14
  - 7.4.3 Powering On a Hard Drive 7-14
  - 7.4.4 Verifying a Hard Drive 7-14
- 7.5 Digital Audio Tape (DAT) Replacement Procedures 7-15
  - 7.5.1 Removing the Failed DAT From the System Control (SC) Peripheral Board 7-15
  - 7.5.2 Installing the DAT on the System Control (SC) Peripheral Board 7-16
  - 7.5.3 Powering On a Digital Audio Tape (DAT) 7-17
  - 7.5.4 Verifying a Digital Audio Tape (DAT) 7-17

## **8. CPU (Slot 0) Board 8-1**

- 8.1 CPU (Slot 0) Board LEDs 8-2
- 8.2 CPU (Slot 0) Board Replacement Procedures 8-3
  - 8.2.1 Isolating a Failed CPU (Slot 0) Board 8-3
  - 8.2.2 Powering Off a CPU (Slot 0) Board 8-4

- 8.2.3 Removing a CPU (Slot 0) Board 8–5
- 8.2.4 Installing a CPU (Slot 0) Board 8–7
- 8.2.5 Verifying a CPU (Slot 0) Board 8–8
- 8.3 CPU (Slot 0) Board DIMM Replacement Procedures 8–8
  - 8.3.1 Removing the CPU DIMMs 8–9
  - 8.3.2 Installing the CPU DIMMs 8–11
- 8.4 CPU (Slot 0) Filler Panel Replacement Procedures 8–12
  - 8.4.1 Removing a CPU (Slot 0) Filler Panel 8–12
  - 8.4.2 Installing a CPU (Slot 0) Filler Panel 8–12
- 9. I/O (Slot 1) Assemblies 9–1**
  - 9.1 I/O Assembly 9–2
    - 9.1.1 I/O Assembly LEDs 9–2
    - 9.1.2 I/O Assembly Replacement Procedures 9–3
      - 9.1.2.1 Isolating a Failed I/O Assembly 9–3
      - 9.1.2.2 Powering Off an I/O Assembly 9–4
      - 9.1.2.3 Removing an I/O Assembly 9–5
      - 9.1.2.4 Installing an I/O Assembly 9–6
      - 9.1.2.5 Powering On an I/O Assembly 9–7
      - 9.1.2.6 Verifying an I/O Assembly 9–7
  - 9.2 PCI Cassette Replacement Procedures 9–7
    - 9.2.1 PCI Cassette Replacement 9–8
      - 9.2.1.1 Removing the PCI Cassette 9–8
      - 9.2.1.2 Installing the PCI Cassette 9–9
  - 9.3 PCI Cassette Card Replacement Procedures 9–10
    - 9.3.1 PCI Cassette Card Replacement 9–10
      - 9.3.1.1 Removing the PCI Card from the Cassette 9–10
      - 9.3.1.2 Installing the PCI Card into the Cassette 9–10
  - 9.4 I/O Filler Panel Replacement Procedures 9–11

9.4.1 Removing an I/O Filler Panel 9–11

9.4.2 Installing an I/O Filler Panel 9–11

## **10. Board Set Carrier Plates 10–1**

10.1 Inserting a Board Set Carrier Plate 10–2

10.2 Carrier Plate Configuration Modification and Replacement 10–5

10.2.1 Two-In-One Carrier Plate FRU Modification Contents 10–6

10.2.2 Carrier Plate Replacement for Standard Configuration of Slots 1, 2, 3, 6, 7, 8, 10, 11, 12, 15, 16, and 17 10–6

10.2.3 Carrier Plate Configuration and Replacement for Slots 0 and 9 10–7

10.2.4 Carrier Plate Replacement for Standard Configurations of Slots 4, 5, 13, and 14 10–8

## **11. System Control Expander Board Set 11–1**

11.1 Centerplane Support Board Replacement 11–2

11.1.1 Centerplane Support Board LEDs 11–2

11.2 Centerplane Support Board Replacement Procedures 11–3

11.2.1 Isolating a Failed Centerplane Support Board 11–4

11.2.2 Powering Off a Centerplane Support Board 11–4

11.2.3 Removing a Centerplane Support Board 11–5

11.2.4 Installing a Centerplane Support Board 11–7

11.2.5 Powering On a Centerplane Support Board 11–8

11.2.6 Verifying a Centerplane Support Board 11–9

## **12. System Expander Board Set 12–1**

12.1 System Expander Board LEDs 12–2

12.2 Expander Board Replacement Procedures 12–3

12.2.1 Isolating a Failed Expander Board 12–3

12.2.2 Powering Off an Expander Board 12–4

12.2.3 Removing an Expander Board 12–5



- 12.2.4 Installing an Expander Board 12–7
- 12.2.5 Powering On an Expander Board 12–8
- 12.2.6 Verifying an Expander Board 12–8
  
- 13. Sun Fireplane Interconnect Replacement Procedure 13–1**
  - 13.1 Determining a Capacity on Demand (COD) System 13–2
  - 13.2 Isolating a Failed Sun Fireplane Interconnect 13–3
  - 13.3 Setting Up the System Prior to Replacing the Sun Fireplane Interconnect 13–4
  - 13.4 Powering Off the System for Sun Fireplane Interconnect Replacement 13–6
  - 13.5 Removing the Sun Fireplane Interconnect From the Chassis 13–7
  - 13.6 Installing the Sun Fireplane Interconnect into the Chassis 13–10
  - 13.7 Powering on the System After the Sun Fireplane Interconnect Installation 13–12
    - 13.7.1 Powering on the System Controllers 13–12
    - 13.7.2 Powering on the Centerplane Support Board 13–12
    - 13.7.3 Starting the Domains 13–13
  - 13.8 Restarting Capacity on Demand (COD) After Sun Fireplane Interconnect Installation 13–14
  
- 14. Fan Backplane Replacement Procedure 14–1**
  - 14.1 Powering Off a Fan Backplane 14–2
  - 14.2 Removing a Fan Backplane 14–3
  - 14.3 Installing a Fan Backplane 14–5
  - 14.4 Powering On a Fan Backplane 14–6
  
- 15. Power Centerplane Replacement Procedure 15–1**
  - 15.1 Powering Off the System for Power Centerplane Replacement 15–2
  - 15.2 Removing the Power Centerplane 15–3
  - 15.3 Installing the Power Centerplane Assembly into the Chassis 15–6

15.4 Powering On the System After Power Centerplane Installation 15-9

## **16. Cable Replacement Procedures 16-1**

16.1 AC Power Cord 16-9

16.2 Internal Cabinet Cable Replacement Procedures 16-9

16.2.1 Powering Off the System for Cable Replacement 16-10

16.2.2 48 VDC Power Cable Replacement 16-11

16.2.2.1 Removing the 48 VDC Power Cable 16-11

16.2.2.2 Installing the 48 VDC Power Cable 16-12

16.2.3 Power Shelf I2C or TopCap Cable Replacement 16-13

16.2.3.1 Removing the Power Shelf I2C or TopCap Cable 16-13

16.2.3.2 Installing the Power Shelf I2C or TopCap Cable 16-13

16.2.4 Power Crossover Cable Replacement 16-14

16.2.4.1 Removing the Power Crossover Cable 16-14

16.2.4.2 Installing the Power Crossover Cable 16-14

16.2.5 Fan Tray Power Cable Replacement 16-15

16.2.5.1 Removing the Fan Tray Power Cable 16-15

16.2.5.2 Installing the Fan Tray Power Cable 16-16

16.2.6 Internal Cable Harness Set Replacement 16-17

16.2.6.1 Removing the Internal Cable Harness Set 16-17

16.2.6.2 Installing the Internal Cable Harness Set 16-19

16.2.7 TopCap Cable Replacement 16-20

16.2.7.1 Removing the TopCap Cable 16-20

16.2.7.2 Installing the TopCap Cable 16-21

16.3 Powering On the System 16-22

## **17. Mechanical Components Replacement Procedures 17-1**

17.1 Side Panel Replacement 17-1

17.1.1 Removing a Side Panel 17-2

|            |   |             |
|------------|---|-------------|
| 17.1.2     | Installing a Side Panel   | 17-2        |
| 17.2       | Access Door Replacement   | 17-2        |
| 17.2.1     | Removing an Access Door   | 17-2        |
| 17.2.2     | Installing an Access Door   | 17-2        |
| 17.3       | Kick Plate Assembly Replacement                                   | 17-3        |
| 17.3.1     | Removing a Kick Plate Assembly                                    | 17-3        |
| 17.3.2     | Installing a Kick Plate Assembly                                  | 17-4        |
| <b>18.</b> | <b>Periodic Maintenance</b>                                       | <b>18-1</b> |
| 18.1       | Installing the Service Cable Straps                               | 18-2        |
| 18.1.1     | Systems With Four Doors (Two in Front)                            | 18-2        |
| 18.1.1.1   | For the Front of the System                                       | 18-2        |
| 18.1.1.2   | For the Rear of the System  | 18-4        |
| 18.1.2     | Systems With Two Doors (One in Front)                             | 18-5        |
| 18.1.2.1   | For the Front of the System                                       | 18-5        |
| 18.1.2.2   | For the Rear of the System  | 18-6        |
| 18.2       | Using the Cable Straps  | 18-7        |
| 18.3       | Uninstalling the Service Cable Straps                             | 18-7        |
| 18.3.1     | Systems With Four Doors (Two in Front)                            | 18-7        |
| 18.3.1.1   | For the Front of the System                                       | 18-7        |
| 18.3.1.2   | For the Rear of the System  | 18-8        |
| 18.3.2     | Systems With Two Doors (One in Front)                             | 18-8        |
| 18.3.2.1   | For the Front of the System                                       | 18-8        |
| 18.3.2.2   | For the Rear of the System  | 18-9        |
| 18.4       | Cleaning the Air Plenum Panel Air-Intake Screens                  | 18-10       |
| 18.4.1     | Air Plenum Panel Air-Intake Screen for Sun Fire E25K/E20K Systems | 18-10       |
| 18.4.2     | Cleaning the Air Plenum Air-Intake Screens                        | 18-11       |
| 18.5       | Air Filter Replacement  | 18-11       |

18.5.1 Replacing an Air Filter 18–12

**A. Component Serial Number Worksheet A–1**

**B. System Labels B–1**

- B.1 ESD GROUND and Top Fan Tray Component Number Labels B–1
- B.2 System Chassis and Carrier Plate Labels B–2
- B.3 Fan Tray Labels B–4
  - B.3.1 Fan Tray Removal Label B–4
  - B.3.2 Bottom Fan Tray Component Number Labels B–5
- B.4 Board Carrier Slot Component Number Labels B–5
  - B.4.1 Front Component Number Labels B–5
  - B.4.2 Rear Component Number Labels B–6
- B.5 Expander Label B–6
- B.6 Centerplane Support Label B–6
- B.7 Sun Fireplane Interconnect Label B–7
- B.8 Power Supply Labels B–7
  - B.8.1 Power Supply Component Labels B–7
  - B.8.2 External Power Supply Handle-Instruction Label B–7
  - B.8.3 Power Supply Weight-Information Label B–8
  - B.8.4 Power Supply CAUTION Label B–8

**C. Sun Fire E25K/E20K Systems Field-Replaceable Units (FRU) C–1**

- C.1 Access Doors and Side Panels C–2
- C.2 TopCap Assembly C–3
- C.1 Kick Plate Assembly C–3
- C.3 System Board Assemblies and Carrier Plates C–4
- C.4 Fan Tray Cooling Components C–12
- C.5 Power Supplies and Air Filters C–13
- C.2 System Cables C–15

**Index Index-1**



# Figures

---

- FIGURE 1-1 Sun Fire E25K/E20K Systems Component Numbering—Front 1–8
- FIGURE 1-2 Sun Fire E25K System Component Numbering—Rear 1–9
- FIGURE 1-3 Sun Fire E20K System Component Numbering—Rear 1–10
- FIGURE 1-4 Cassette Component Numbering—Sun Fire E25K Front and Rear, and Sun Fire E20K Front 1–11
- FIGURE 1-5 System Architecture Block Diagram 1–14
- FIGURE 1-6 Control Distribution Block Diagram 1–15
- FIGURE 1-7 Power Distribution Block Diagram 1–16
- FIGURE 3-1 Air-Plenum Cover 3–4
- FIGURE 3-2 Power Module 3–5
- FIGURE 3-3 Sun Fire E25K/E20K Systems Power Supply 3–7
- FIGURE 3-4 4 kW Dual AC–DC Power Supply LEDs 3–9
- FIGURE 3-5 AC Power Cord Installation 3–12
- FIGURE 4-1 Fan Tray 4–1
- FIGURE 4-2 Fan Tray LEDs 4–3
- FIGURE 5-1 System Controller CPU Board Memory Board Installation 5–4
- FIGURE 5-2 System Controller CPU Board Switch Positions 5–5
- FIGURE 5-3 System Controller CPU Board (CP-2140) Switch Positions 5–6
- FIGURE 6-1 System Control Board LEDs (3U to 6U Conversion Board Option) 6–3
- FIGURE 6-2 System Control Board 6–8
- FIGURE 7-1 System Control Peripheral Board LEDs 7–3

|             |  |       |
|-------------|--|-------|
| FIGURE 7-2  | SC Peripheral Board and Center Access Panel—Exploded                     | 7-7   |
| FIGURE 7-3  | SC Peripheral Board DVD Component Removal and Access Panel—Exploded      | 7-10  |
| FIGURE 7-4  | SC Peripheral Board Hard Drive Removal and Access Panel—Exploded         | 7-13  |
| FIGURE 7-5  | SC Peripheral Board DAT Removal and Access Panel—Exploded                | 7-16  |
| FIGURE 8-1  | CPU Board LEDs   | 8-3   |
| FIGURE 8-2  | CPU Board Components   | 8-6   |
| FIGURE 8-3  | CPU Board Memory DIMM Locations  | 8-10  |
| FIGURE 8-4  | CPU DIMM Removal   | 8-11  |
| FIGURE 9-1  | I/O Assembly LEDs  | 9-3   |
| FIGURE 9-2  | PCI Cassette Removal   | 9-9   |
| FIGURE 10-1 | System Carrier Plates  | 10-3  |
| FIGURE 10-2 | Standard Configuration Carrier Plate                                     | 10-5  |
| FIGURE 10-3 | Removing the T-Rail Guide  | 10-7  |
| FIGURE 10-4 | Securing the Center Guide Bracket After the T-Rail Guide Removal         | 10-8  |
| FIGURE 11-1 | Centerplane Support Board LEDs   | 11-3  |
| FIGURE 11-2 | Centerplane Support Board and Carrier Plate                              | 11-6  |
| FIGURE 12-1 | System Expander Board LEDs   | 12-3  |
| FIGURE 12-2 | Expander Board and Carrier Plate—Exploded                                | 12-6  |
| FIGURE 13-1 | Sun Fireplane Interconnect—Front and Rear View                           | 13-9  |
| FIGURE 13-2 | Sun Fireplane Interconnect Tightening Pattern                            | 13-11 |
| FIGURE 14-1 | Fan Backplane Locations—Front  | 14-4  |
| FIGURE 14-2 | Fan Backplane Connections  | 14-5  |
| FIGURE 15-1 | Power Centerplane Power Control Connections                              | 15-4  |
| FIGURE 15-2 | Voltage-and-Return Reference Designation Labels—Front and Rear           | 15-7  |
| FIGURE 16-1 | Sun Fire E25K/E20K Systems Internal Cable Connections                    | 16-2  |
| FIGURE 16-2 | System Cable Layout Diagram—Typical for Front (Side 0) and Rear (Side 1) | 16-3  |
| FIGURE 16-3 | Fan Tray Backplane FRU Cable Diagram—Top Front, Side 0                   | 16-4  |
| FIGURE 16-4 | Fan Tray Backplane FRU Cable Diagram—Top Front, Side 1                   | 16-4  |
| FIGURE 16-5 | Power Centerplane Cable Diagram—Bottom Front, Side 0                     | 16-5  |
| FIGURE 16-6 | Power Centerplane Cable Diagram—Bottom Rear, Side 1                      | 16-6  |



|              |   |       |
|--------------|---|-------|
| FIGURE 16-7  | Cable Schematic Diagram for Interface Connectors—Side 0                   | 16-6  |
| FIGURE 16-8  | Cable Schematic Diagram for Interface Connectors—Side 1                   | 16-7  |
| FIGURE 16-9  | DC Power Distribution Cables—Side 0 and Side 1                            | 16-7  |
| FIGURE 16-10 | 48 VDC Power Cables   | 16-12 |
| FIGURE 16-11 | Fan Tray Power Cable  | 16-16 |
| FIGURE 16-12 | Internal Cable Harness Set  | 16-18 |
| FIGURE 16-13 | TopCap Cable  | 16-21 |
| FIGURE 17-1  | Kick Plate Assembly   | 17-3  |
| FIGURE 18-1  | Front Door Maintenance Straps   | 18-3  |
| FIGURE 18-2  | Rear door maintenance strap   | 18-4  |
| FIGURE 18-3  | Installing the Maintenance Brackets and Straps                            | 18-6  |
| FIGURE 18-4  | Air Plenum Panel and Air-Intake Screen for the Sun Fire E25K/E20K Systems | 18-10 |
| FIGURE 18-5  | Filter Replacement—Front and Rear   | 18-13 |
| FIGURE B-1   | ESD GROUND and Top Fan Tray Component Number Labels                       | B-2   |
| FIGURE B-2   | System Chassis and Carrier Plate Label—Carrier Plate Installation         | B-3   |
| FIGURE B-3   | Carrier Plate Warning Label   | B-4   |
| FIGURE B-4   | Fan Tray Removal Label  | B-4   |
| FIGURE B-5   | Bottom Fan Tray Component Number Labels                                   | B-5   |
| FIGURE B-6   | Front Component Number Labels   | B-5   |
| FIGURE B-7   | Rear Component Number Labels  | B-6   |
| FIGURE B-8   | Expander Label  | B-6   |
| FIGURE B-9   | Centerplane Support Label   | B-6   |
| FIGURE B-10  | Sun Fireplane Interconnect Label  | B-7   |
| FIGURE B-11  | Power Supply Component Labels   | B-7   |
| FIGURE B-12  | External Power Supply Label   | B-7   |
| FIGURE B-13  | Power Supply Weight-Information Label                                     | B-8   |
| FIGURE B-14  | Power Supply CAUTION Label  | B-8   |
| FIGURE C-1   | System FRU Component Categories   | C-1   |
| FIGURE C-2   | Access Doors and Side Panels  | C-2   |
| FIGURE C-3   | TopCap Assembly Components  | C-3   |

|             |  |      |
|-------------|--|------|
| FIGURE C-4  | Kick Plate Assembly Components                             | C-3  |
| FIGURE C-5  | Centerplane Support Board                                  | C-5  |
| FIGURE C-6  | System Controller Carrier Plate                            | C-5  |
| FIGURE C-7  | System Expander Carrier Plate (With Air Dam)               | C-6  |
| FIGURE C-8  | System Control Board—3U to 6U Conversion Board Option      | C-6  |
| FIGURE C-9  | System Control Peripheral Board                            | C-7  |
| FIGURE C-10 | System Expander Board                                      | C-7  |
| FIGURE C-11 | System Expander Carrier Plate (With or Without Air Dam)    | C-8  |
| FIGURE C-12 | CPU Board  | C-8  |
| FIGURE C-13 | I/O Assembly   | C-9  |
| FIGURE C-14 | I/O Filler Panel (Used as Required)                        | C-9  |
| FIGURE C-15 | CPU Filler Panel (Used as Required)                        | C-10 |
| FIGURE C-16 | Sun Fireplane Interconnect                                 | C-10 |
| FIGURE C-17 | Power Centerplane  | C-11 |
| FIGURE C-18 | Fan Backplane  | C-11 |
| FIGURE C-19 | Fan Tray Cooling Component                                 | C-12 |
| FIGURE C-20 | Power Supply   | C-14 |
| FIGURE C-21 | Power Module   | C-14 |
| FIGURE C-22 | Air Filter   | C-15 |
| FIGURE C-23 | AC Power Cable, Domestic                                   | C-17 |
| FIGURE C-24 | AC Power Cable, Domestic 2                                 | C-17 |
| FIGURE C-25 | AC Power Cable, International                              | C-18 |
| FIGURE C-26 | AC Power Cable, International 2                            | C-18 |
| FIGURE C-27 | Fan Power Cable  | C-19 |
| FIGURE C-28 | Fan I2C Cable, Front Upper                                 | C-21 |
| FIGURE C-29 | Fan I2C Cable, Front Lower                                 | C-21 |
| FIGURE C-30 | Fan I2C Cable, Rear Upper                                  | C-22 |
| FIGURE C-31 | Fan I2C Cable, Rear Lower                                  | C-22 |
| FIGURE C-32 | Power Module to Connector Bulkhead, 48 VDC Power           | C-23 |
| FIGURE C-33 | Connector Bulkhead to Connector Bulkhead, 48 VDC Crossover | C-24 |

- FIGURE C-34 Power Module to Connector Bulkhead, I2C Signals C-24
- FIGURE C-35 Control 0 Cable, Front C-25
- FIGURE C-36 Control 1 Cable, Front C-25
- FIGURE C-37 Control 0 Cable, Rear C-26
- FIGURE C-38 Control 1 Cable, Rear C-26
- FIGURE C-39 Power Control Cable, Front C-27
- FIGURE C-40 Power Control Cable, Rear C-27
- FIGURE C-41 TopCap Power Cable, Internal C-27
- FIGURE C-42 TopCap Power Cable, External C-27
- FIGURE C-43 RS-232 Cable, Internal C-29
- FIGURE C-44 RS-232 Cable, External C-29
- FIGURE C-45 SC-CPU Cable C-30



# Tables

---

|           |  |      |
|-----------|--|------|
| TABLE 1-1 | Temperature Levels   | 1–4  |
| TABLE 1-2 | Ambient Thermal Levels   | 1–4  |
| TABLE 1-3 | Voltage and Current Limits                                     | 1–5  |
| TABLE 1-4 | LEDs   | 1–6  |
| TABLE 1-5 | Customer Availability and Mean Time to Repair                  | 1–7  |
| TABLE 1-6 | Safety Precautions   | 1–12 |
| TABLE 1-7 |  | 1–13 |
| TABLE 3-1 | 4 kW Dual AC–DC Power Supply Components                        | 3–8  |
| TABLE 3-2 | 4 kW Dual AC–DC Power Supply Valid LED Status                  | 3–8  |
| TABLE 4-1 | Fan Tray Components  | 4–2  |
| TABLE 4-2 | Fan Tray Valid LED Status                                      | 4–2  |
| TABLE 6-1 | System Control Board Components                                | 6–1  |
| TABLE 6-2 | System Control Board Valid LED Status                          | 6–2  |
| TABLE 6-3 | System Control CPU Board Indicator Function Descriptions       | 6–2  |
| TABLE 7-1 | System Control (SC) Peripheral Board Components                | 7–2  |
| TABLE 7-2 | System Control (SC) Peripheral Board Valid LED Status          | 7–2  |
| TABLE 7-3 | System Control DVD Indicator Function Descriptions             | 7–3  |
| TABLE 7-4 | System Control Tape Peripheral Indicator Function Descriptions | 7–4  |
| TABLE 8-1 | CPU Board Components   | 8–2  |
| TABLE 8-2 | CPU Board Valid LED Status                                     | 8–2  |

|            |   |      |
|------------|---|------|
| TABLE 9-1  | I/O Assembly Components   | 9-2  |
| TABLE 9-2  | I/O Assembly Valid LED Status   | 9-2  |
| TABLE 10-1 | Carrier Plate FRU Modification Contents                                       | 10-6 |
| TABLE 11-1 | Centerplane Support Board Components  | 11-2 |
| TABLE 11-2 | Centerplane Support Board Valid LED Status                                    | 11-2 |
| TABLE 12-1 | Expander Board Components   | 12-2 |
| TABLE 12-2 | Expander Board Valid LED Status   | 12-2 |
| TABLE 13-1 | Component Serial Numbers Worksheet  | 13-5 |
| TABLE 16-1 | Cable Termination Table   | 16-7 |
| TABLE C-1  | Access Doors and Side Panels  | C-2  |
| TABLE C-2  | TopCap Assembly Components  | C-3  |
| TABLE C-3  | Kick Plate Assembly Components  | C-3  |
| TABLE C-4  | System Board Assemblies   | C-4  |
| TABLE C-5  | System Board Carrier Plates   | C-4  |
| TABLE C-6  | Fan Tray Cooling Components   | C-12 |
| TABLE C-7  | Power Supplies and Air Filters  | C-13 |
| TABLE C-8  | System Cables   | C-15 |
| TABLE C-9  | AC Power Cable, Domestic, Wire List   | C-17 |
| TABLE C-10 | AC Power Cable, Domestic 2, Wire List   | C-17 |
| TABLE C-11 | AC Power Cable, International, Wire List                                      | C-18 |
| TABLE C-12 | AC Power Cable, International 2, Wire List                                    | C-18 |
| TABLE C-13 | Fan Power Cable (Side 0) Termination Table 0                                  | C-19 |
| TABLE C-14 | Fan Power Cable (Side 1) Termination Table 1                                  | C-20 |
| TABLE C-15 | Power Module to Connector Bulkhead Cable, 48 VDC Power, Termination Table     | C-23 |
| TABLE C-16 | Connector Bulkhead to Connector Bulkhead, 48 VDC Crossover, Termination Table | C-24 |
| TABLE C-17 | TopCap Power Cable, External, Termination Specifications                      | C-28 |
| TABLE C-18 | RS-232 Cable, External, Termination Specifications                            | C-29 |
| TABLE C-19 | SC-CPU Cable Termination Specifications                                       | C-30 |

# Preface

---

The *Sun Fire E25K/E20K Systems Service Manual* provides guidelines and detailed instructions for replacing field-replaceable components on the Sun Fire™ E25K/E20K Systems.

---

## How This Book Is Organized

Chapter 1 provides component replacement guidelines, indicator descriptions, and hardware nomenclature.

Chapter 2 details the replacement procedures for the TopCap assembly and the TopCap extension.

Chapter 3 details the replacement procedures for the system power module and the 4 kW dual AC–DC power supplies.

Chapter 4 details the replacement procedures for the system fan trays.

Chapter 5 details the replacement procedures for the System Control (SC) CPU board and installation of the cPCI memory.

Chapter 6 details the replacement procedures for the System Control (SC) board.

Chapter 7 details the replacement procedures for the System Control peripheral board containing the DVD, DAT drive, and hard drive peripherals.

Chapter 8 details the replacement procedures for the CPU (slot 0) board.

Chapter 9 details the replacement procedures for the I/O (slot 1) assemblies.

Chapter 10 details the replacement procedures for the board set carrier plate and identifies the carrier-plate configurations.

Chapter 11 details the replacement procedures for the centerplane support board of the system control expander board set.

Chapter 12 details the replacement procedures for the expander board of the system expander board set.

Chapter 13 details the replacement procedures for the Sun™ Fireplane interconnect assembly.

Chapter 14 details the replacement procedures for the fan backplane.

Chapter 15 details the replacement procedures for the power centerplane.

Chapter 16 details the replacement procedures for the system cables.

Chapter 17 details the replacement procedures for the mechanical components.

Chapter 18 provides procedures for the system components requiring periodic maintenance.

Appendix A provides a component serial number worksheet.

Appendix B details the information and safety labels used in the Sun Fire E25K/E20K systems.

Appendix C provides a pictorial review of the Sun Fire E25K/E20K systems components.

---

## Using UNIX Commands

This document may not contain information on basic UNIX® commands and procedures such as shutting down the system, booting the system, and configuring devices.

See the following for this information:

- Documentation for the Solaris™ Operating System, which is at:  
<http://docs.sun.com>
- Other software documentation that you received with your system



---

# Typographic Conventions

**TABLE P-1** Typographic Conventions

| Typeface         | Meaning  | Examples  |
|------------------|--|---|
| AaBbCc123        | The names of commands, files, and directories; on-screen computer output | Edit your <code>.login</code> file.<br>Use <code>ls -a</code> to list all files.<br>% You have mail.                              |
| <b>AaBbCc123</b> | What you type, when contrasted with on-screen computer output            | % <b>su</b><br>PASSWORD:  |
| <i>AaBbCc123</i> | Book titles, new words or terms, words to be emphasized                  | Read Chapter 6 in the <i>User's Guide</i> .<br>These are called <i>class</i> options.<br>You <i>must</i> be superuser to do this. |
|                  | Command-line variable; replace with a real name or value                 | To delete a file, type <code>rm filename</code> .   |

---

# Shell Prompts

**TABLE P-2** Shell Prompts

| Shell                       | Prompt       |
|-----------------------------|--------------|
| System Control (SC) Command | sc%          |
| SC superuser, main SC       | sc#          |
| Domain superuser            | domain_name# |
| SC superuser, spare SC      | sc_spare#    |

---

# Related Documentation

**TABLE P-3** Related Documentation

| Application | Title  |
|-------------|--|
| Service     | <i>Sun Fire E25K/E20K Systems Read Me First</i>                                  |
| Service     | <i>Sun Fire E25K/E20K Systems Getting Started</i>                                |
| Service     | <i>Sun Fire E25K/E20K Systems Unpacking Guide</i>                                |
| Service     | <i>Sun Fire E25K/E20K Systems Site Planning Guide</i>                            |
| Service     | <i>Sun Fire E25K/E20K Systems Hardware Installation and Uninstallation Guide</i> |
| Service     | <i>Sun Fire E25K/E20K Systems Service Manual</i>                                 |
| Service     | <i>Sun Fire E25K/E20K Systems Service Reference I—Nomenclature</i>               |
| Service     | <i>Sun Fire E25K/E20K Systems Service Reference II—Component Numbering</i>       |
| Service     | <i>Sun Fire E25K/E20K Systems Carrier Plate Configurations</i>                   |

---

## Accessing Sun Documentation

You can view, print, or purchase a broad selection of Sun documentation, including localized versions, at:

<http://www.sun.com/documentation>

---

## Contacting Sun Technical Support

If you have technical questions about this product that are not answered in this document, go to:

<http://www.sun.com/service/contacting>

---

## Sun Welcomes Your Comments

Sun is interested in improving its documentation and welcomes your comments and suggestions. You can submit your comments by going to:

<http://www.sun.com/hwdocs/feedback>

Please include the title and part number of your document with your feedback:

*Sun Fire E25K/E20K Systems Service Manual*, part number 817-4138-15

---

# United States Export Control Laws Notice

Products covered by and information contained in this service manual are controlled by U.S. Export Control laws and may be subject to the export or import laws in other countries. Nuclear, missile, chemical biological weapons, or nuclear maritime end uses or end users, whether direct or indirect, are strictly prohibited. Export or re-export to countries subject to U.S. embargo or to entities identified on U.S. export exclusion lists, including but not limited to the denied persons and specially designated nationals lists, is strictly prohibited. Use of any spare or replacement CPUs is limited to repair or one-for-one replacement of CPUs in products exported in compliance with U.S. export laws. Use of CPUs as product upgrades unless authorized by the U.S. Government is strictly prohibited.

# Guidelines, Indicators, and Nomenclature

---

This chapter provides the following introductory information for the Sun Fire E25K/E20K systems:

- Section 1.1, “System Component Hot-Swap Guidelines” on page 1-1
- Section 1.2, “Configuration Rules” on page 1-2
- Section 1.3, “Testing the System” on page 1-3
- Section 1.4, “Reviewing System Temperatures” on page 1-4
- Section 1.5, “Reviewing System Power” on page 1-5
- Section 1.6, “Hardware Indicators” on page 1-6
- Section 1.7, “Field-Replaceable Units (FRU)—Mean Time to Repair (MTTR)” on page 1-7
- Section 1.8, “Safety Precautions” on page 1-12
- Section 1.9, “Special Tools and Shipping Kit Items” on page 1-13
- Section 1.10, “System Block Diagrams” on page 1-14

---

## 1.1 System Component Hot-Swap Guidelines

In the Sun Fire E25K/E20K systems, hot-swapping a component refers to physically removing and replacing a component while the remaining system components are operational.

---

**Note** – The System Management Software (SMS) requires 30 seconds to recognize the removal of a hot-swappable component. The user should wait for a system response before installing a new replacement board.

---

The hot-swappable components in the system are listed as follows.

- System Control board
- Centerplane support board
- CPU board
- I/O assembly
- System expander board
- Fan trays
- Power supplies
- System control peripheral board

---

## 1.2 Configuration Rules

The following rules apply when configuring components of the Sun Fire E25K/E20K systems:

- Every system must be equipped with two centerplane support boards (CSB) in order to utilize full-width data, address, and response paths. If one CSB fails, there is an interruption in service. However, SMS recovers the domains and the remaining CSB runs in a degraded mode.
- Every system must be equipped with two System Control (SC) boards.
- Every system must be equipped with two SC peripheral boards.
- Every system must be equipped with eight fan trays.
- Every system must be equipped with six power supplies.

The following rules apply when configuring components on the CPU board:

---

**Note** – The CPU/Memory board field-replaceable unit (FRU) is for maintenance use only. FRUs must not be used to upgrade CPU performance in systems. Usage as such can violate United States export regulations.

---

The United States government sets limits as to the server configuration exportable to certain destinations or certain customers. Server CPU upgrades must be ordered as standalone CPU upgrade options rather than spares. All upgrades must first be

approved by Sun International Trade Services to ensure the system does not exceed the legal limit for the destination (customer). The following message appears on the label on all CPU FRUs to alert all concerned that this FRU is for maintenance of the system only and should not be used to upgrade a system:

**This assembly is for maintenance use only.  
Not to be used to upgrade systems.  
Use as system upgrades could violate  
United States export regulations.**

- All CPU modules must be the same speed.
- All external cache modules must be the same size.
- When configuring memory:
  - All sockets within a bank must be fully populated.
  - All DIMM sizes within a bank must be equal.

---

## 1.3 Testing the System

The Sun Fire E25K/E20K systems use `setkeyswitch` to diagnose system problems by running `hpost(1M)` when posting a domain. The `hpost(1M)` diagnostic probes, configure and test the domain hardware, preparing the system to run OpenBoot™ PROM and subsequently the Solaris OS.

The Sun VTS™ diagnostics suite can be used as a verification of a dynamic system domain or an SC. To use the `sunvts(1M)` command, you must be logged into the host as superuser. Information about `sunvts(1M)` is located in `/opt/share/man/man1m`.

Verify the SMS is up and running by typing:

```
sc% showfailover -r
MAIN
```

This command explains the role of the SC. The value returned should be `MAIN` indicating that this SC is providing all resources for the Sun Fire E25K/E20K systems. If you do not get this value, consult the *SMS Administration Guide*.

## 1.4 Reviewing System Temperatures

The temperature status can be checked at any time by using Sun™ Management Center software or the `showenvironment` command. At the command line type:

```
sc% showenvironment -p temps
```

See the `showenvironment(1M)` man page for further details.

**TABLE 1-1** Temperature Levels

| Component     |  | Optimum | High Warning      | High Critical   | Overlimit |
|---------------|--|---------|-------------------|-----------------|-----------|
| ASICs         |  |         |                   |                 |           |
| Category I:   | AR, SDC, DX, SBBC,<br>CBH: IOA           | < 80°C  | > 85°C to<br>95°C | > 95°C to 105°C | > 105°C   |
| Category II:  | PROC                                     | < 80°C  | > 85°C to<br>90°C | > 90°C to 95°C  | > 95°C    |
| Category III: | SDI, AXQ, RMX,<br>AMX, DMX, WCI,<br>DARB | < 65°C  | > 70°C to<br>80°C | > 80°C to 85°C  | > 85°C    |
|               | Power supplies                           | < 65°C  | > 70°C to<br>75°C | > 75°C to 80°C  | > 80°C    |
|               | Proximity sensors                        | < 40°C  | > 45°C to<br>50°C | > 50°C to 55°C  | > 55°C    |

**TABLE 1-2** Ambient Thermal Levels

| Component | Low Critical | Low Warning   | Optimum         | High Warning   | High Critical | Overlimit |
|-----------|--------------|---------------|-----------------|----------------|---------------|-----------|
| Ambient   | ≤ 5°C        | > 5°C to 15°C | > 20°C to 25°C* | > 25°C to 35°C | > 35°C        | > 40°C    |

\* Fan reset point



## 1.5 Reviewing System Power

- Check the power status by using Sun Management Center software or the `showenvironment` command. To review, at the command line type:

```
sc% showenvironment -p volts
```

See the `showenvironment(1M)` man page for further details.

**TABLE 1-3** Voltage and Current Limits

| Voltage and Current | Low-Minimum    | Acceptable Range  | High-Maximum   |
|---------------------|----------------|---|----------------|
| PROC Core           | -5%            | Core voltage*   | +5%            |
| +1.5 V              | $x \leq +1.4$  | $+1.4 < x < +1.6$   | $+1.6 \leq x$  |
| +2.5 V              | $x \leq +2.3$  | $+2.3 < x < +2.7$   | $+2.7 \leq x$  |
| +3.3 V              | $x \leq +3.0$  | $+3.0 < x < +3.5$   | $+3.5 \leq x$  |
| +3.3 HK             | $x \leq +3.0$  | $+3.0 < x < +3.5$   | $+3.5 \leq x$  |
| +5.0 V              | $x \leq +4.75$ | $+4.75 < x < +5.25$   | $+5.25 \leq x$ |
| +12 V               | $x \leq +11.4$ | $+11.4 < x < +12.6$   | $+12.6 \leq x$ |
| -12 V               | $x \leq -12.6$ | $-12.6 < x < -11.4$   | $-11.4 \leq x$ |
| +5 V current        |                | Each component must be within $\pm 50\%$ of the average of all components in the group. |                |
| +3.3 V current      |                | Each component must be within $\pm 50\%$ of the average of all components in the group. |                |
| +1.5 V converter    |                | Each component must be within $\pm 50\%$ of the average of all components in the group. |                |




\* Core voltage is processor-version dependent.

---

## 1.6 Hardware Indicators

The LED indicators provide current status information about the component directly associated with the indicator array. Indicators are arranged in a straight line, horizontal or vertical, with the green LED on the left or top ([TABLE 1-4](#)).

**TABLE 1-4** LEDs

| Symbol  | LED Color     | Indication           | Operation  |
|---|---------------|----------------------|--|
|  | Green         | Activation indicator | Component is powered on.                               |
|  | Amber         | Service indicator    | Service indicator is only used during initial startup. |
|  | Amber or blue | Removal indicator    | Component may be removed.                              |

## 1.7 Field-Replaceable Units (FRU)—Mean Time to Repair (MTTR)

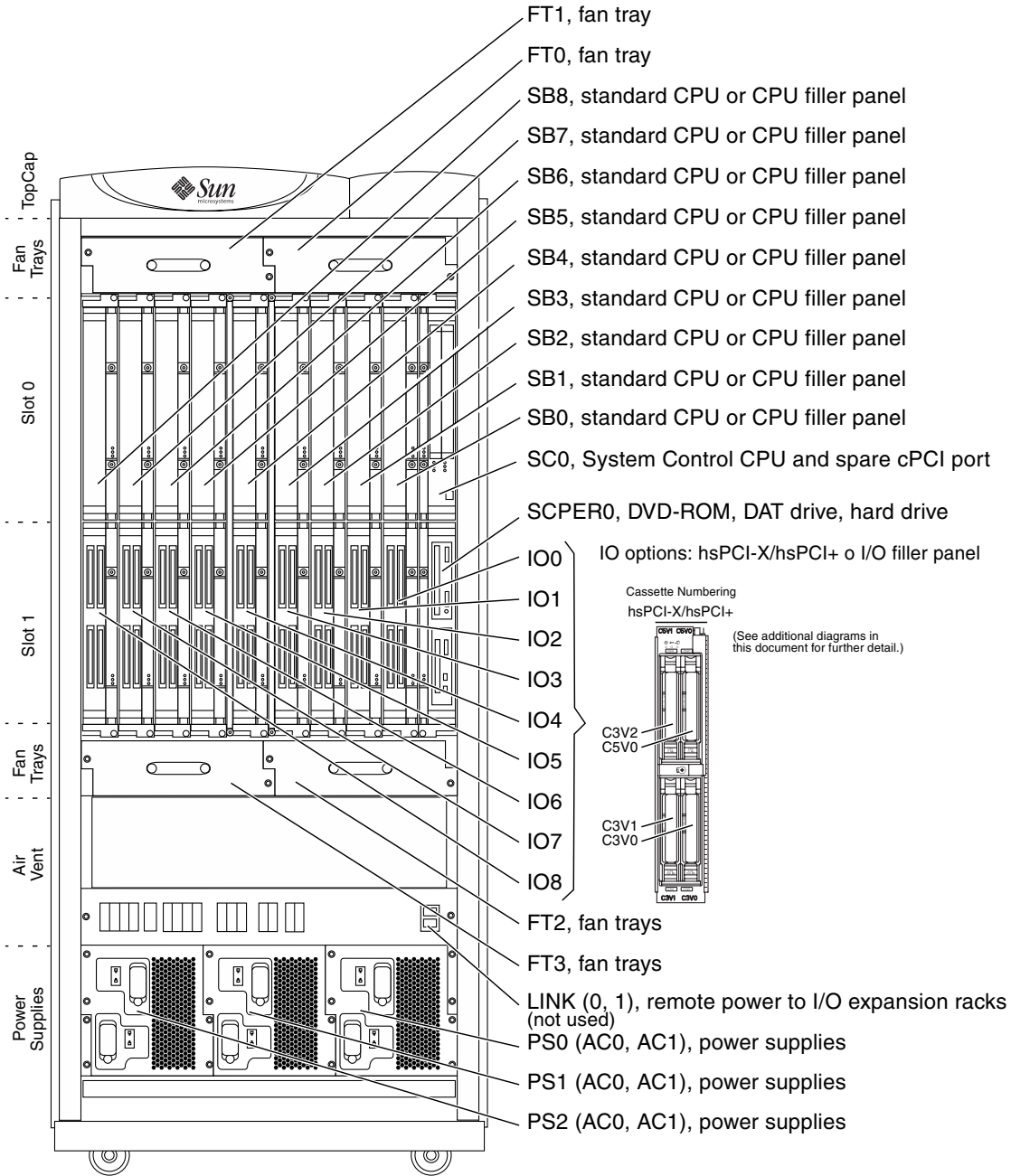
TABLE 1-5 lists the estimated time required for replacement of the FRUs in the Sun Fire E25K/E20K systems. These times assume the new component is on site and properly configured. They do not include any time required by software for system reconfiguration or the shutdown and bring-up time required for the non-concurrent service items.

**TABLE 1-5** Customer Availability and Mean Time to Repair

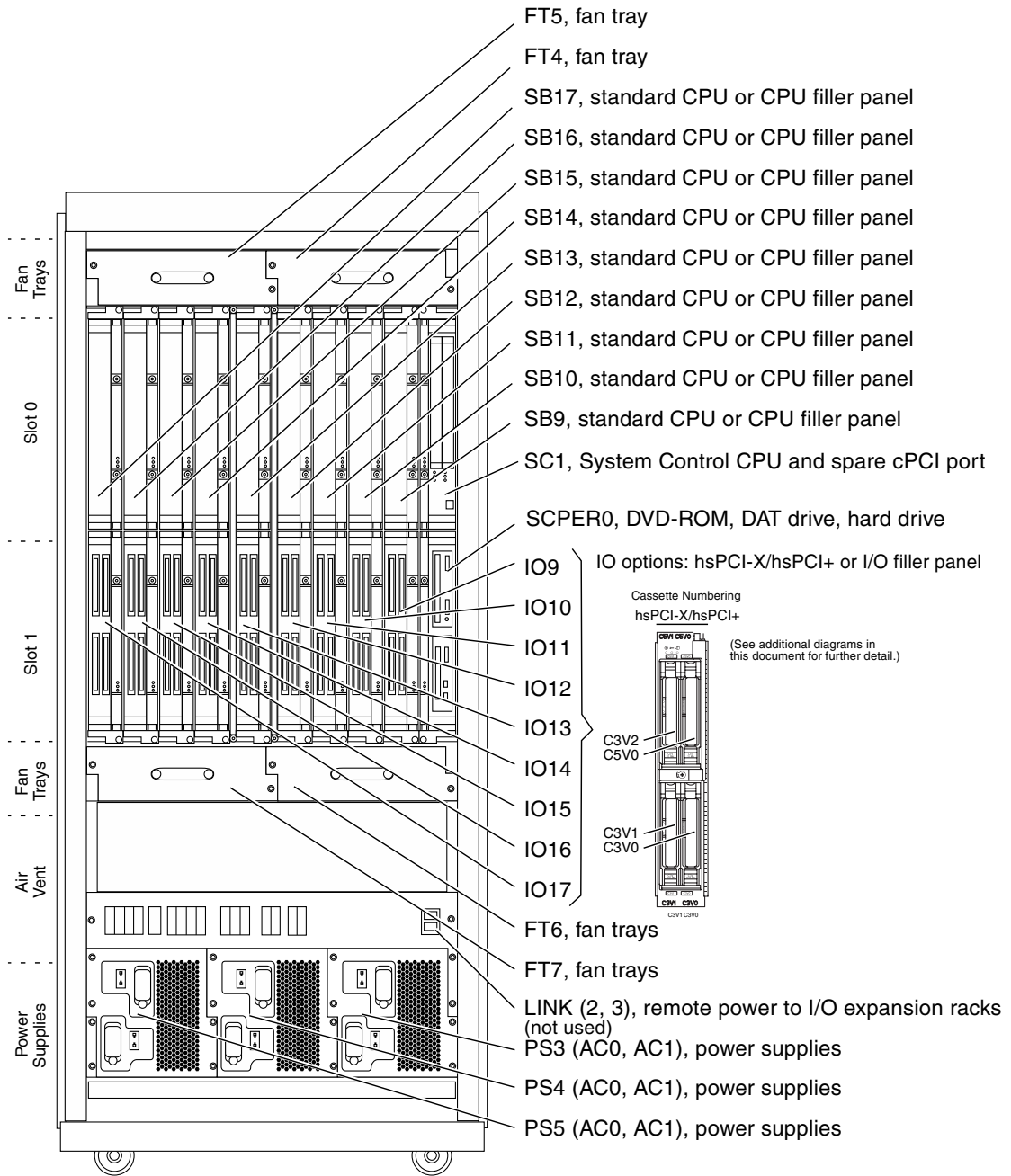
| FRU                               | MTTR    | Online Service |
|-----------------------------------|---------|----------------|
| 4 kW dual AC–DC power supply      | 10 min  | Yes            |
| Fan tray                          | 10 min  | Yes            |
| Centerplane support board         | 30 min  | Yes            |
| System Control board              | 10 min  | Yes            |
| SC CPU board                      | 10 min  | Yes            |
| SC peripheral board               | 10 min  | Yes            |
| Expander board                    | 30 min  | Yes            |
| Dual in-line memory module (DIMM) | 10 min  | Yes            |
| CPU board                         | 10 min  | Yes            |
| I/O assembly                      | 10 min  | Yes            |
| Sun Fireplane interconnect        | 90 min  | No             |
| Power centerplane                 | 180 min | No             |
| Fan backplane                     | 70 min  | No             |
| I/O cables                        | 15 min  | Yes            |
| Power module                      | 60 min  | No             |
| TopCap                            | 10 min  | Yes            |
| Side panel                        | 5 min   | Yes            |
| Access doors                      | 5 min   | Yes            |
| Air filter                        | 5 min   | Yes            |
| AC power cord                     | 5 min   | Yes            |

See the front and rear system component numbering ([FIGURE 1-1](#), [FIGURE 1-2](#) and [FIGURE 1-3](#)). See [FIGURE 1-4](#) for cassette component numbering.

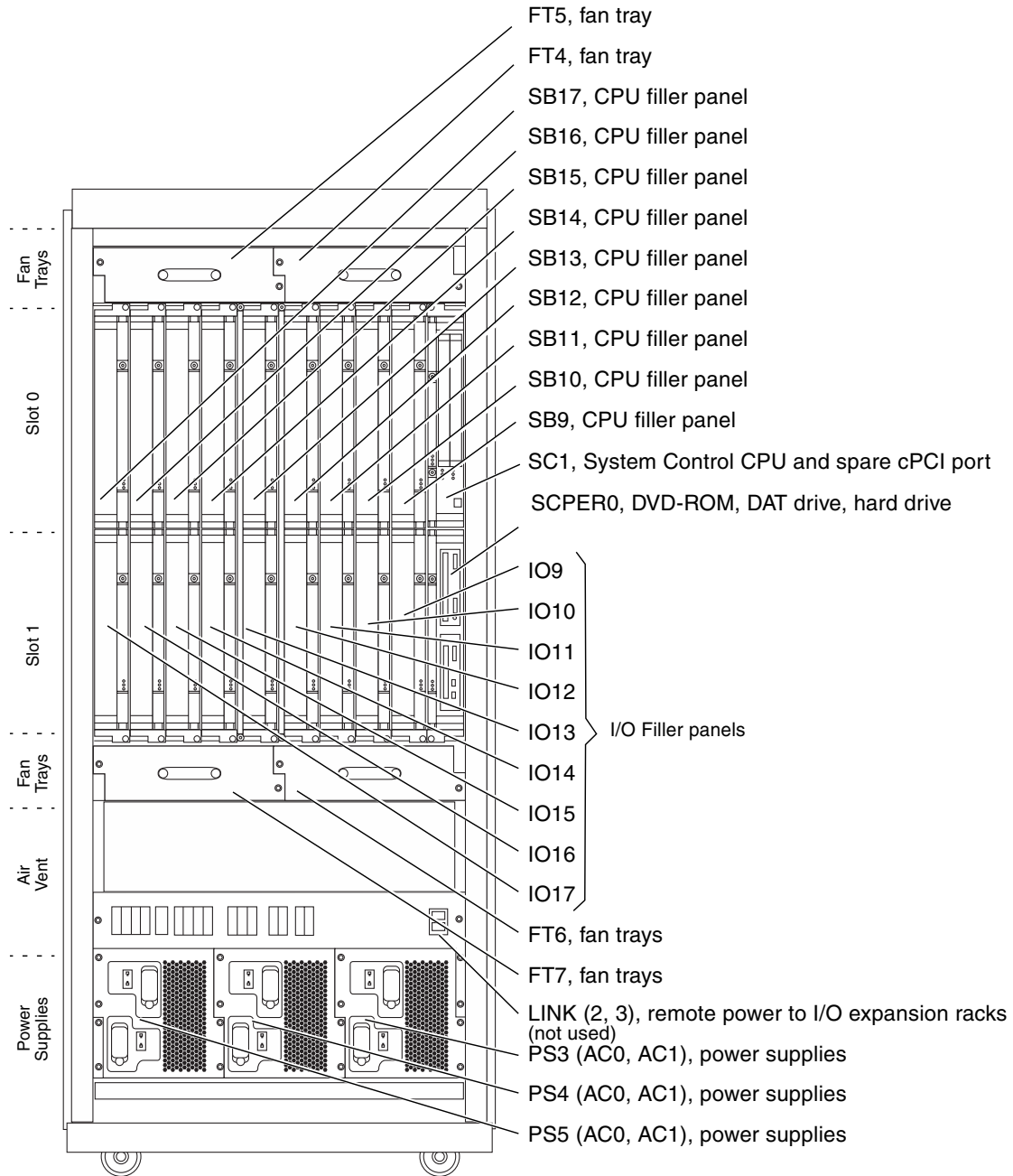
**FIGURE 1-1** Sun Fire E25K/E20K Systems Component Numbering—Front



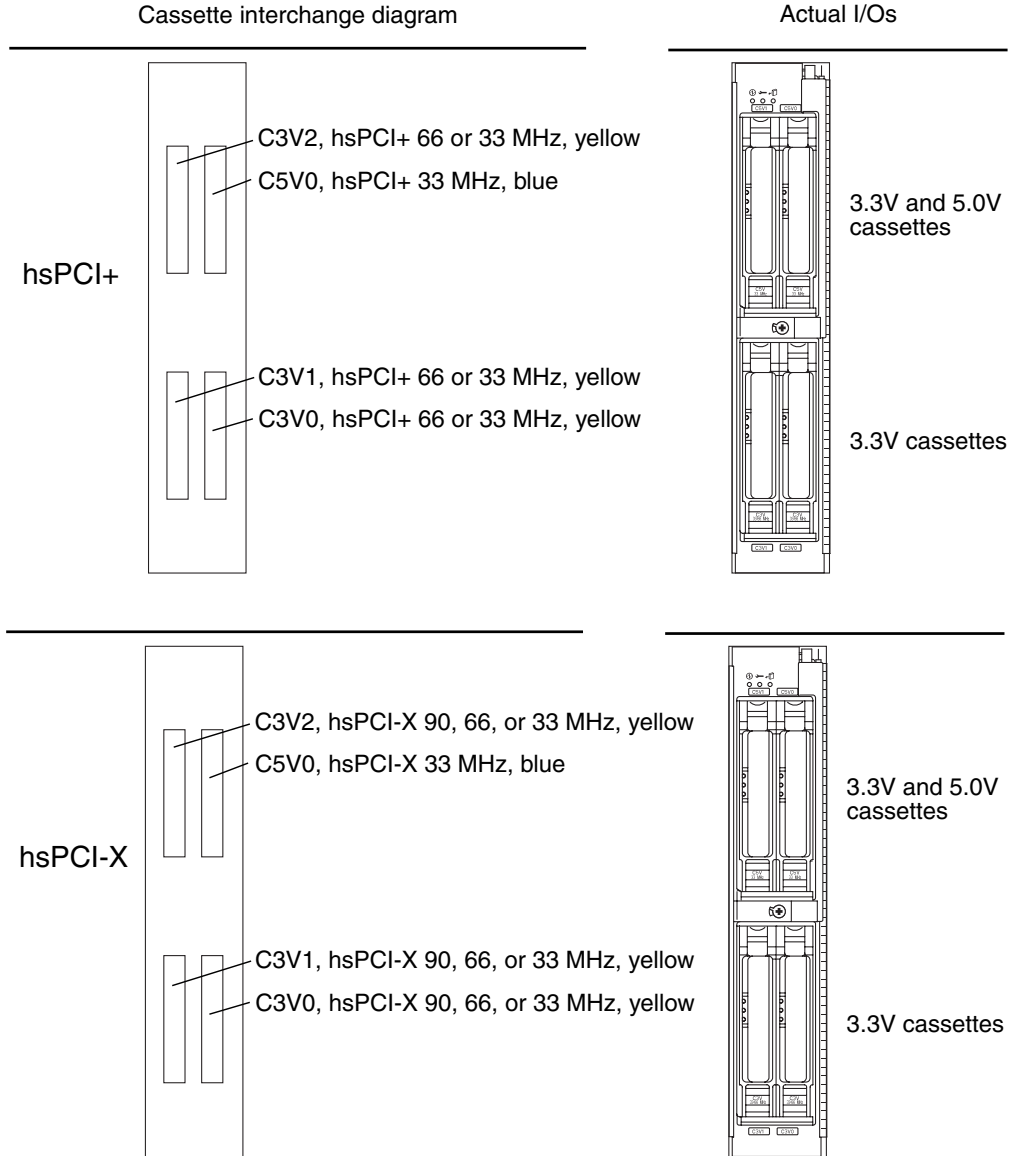
**FIGURE 1-2** Sun Fire E25K System Component Numbering—Rear



**FIGURE 1-3** Sun Fire E20K System Component Numbering—Rear



**FIGURE 1-4** Cassette Component Numbering—Sun Fire E25K Front and Rear, and Sun Fire E20K Front



**Note** – The 3.3V cassette positions are interchangeable and the 5.0V cassette positions are interchangeable.

---

## 1.8 Safety Precautions

For your protection, observe the following safety precautions when setting up your equipment:

- Follow all cautions and instructions marked on the equipment.
- Never push objects of any kind through openings in the equipment as they might touch dangerous voltage points or short out components that could result in fire or electric shock.
- Refer servicing of equipment to qualified personnel.

To protect both yourself and the equipment, observe the safety precautions outlined in [TABLE 1-6](#).

**TABLE 1-6** Safety Precautions

| <b>Item</b>     | <b>Problem</b>                 | <b>Precaution</b>  |
|-----------------|--------------------------------|--|
| ESD wrist strap | Electro-Static Discharge (ESD) | There are four ground points on the system cabinet, two at the front top left and top right, and two at the rear top left and top right.   |
| ESD mat         | ESD                            | An approved ESD mat provides protection from static damage when used with a wrist strap. The mat also cushions and protects parts that are attached to the printed circuit boards. |



---

## 1.9 Special Tools and Shipping Kit Items

The following list represents the special tools and items supplied in the shipping kit box at the time of system delivery:

**TABLE 1-7**

---

**Special Tools and Shipping Kit Items**

---

**Special Tools in Front Door**

Two (2) preset 18 in.-lbs (2.2 Nm) torque screwdrivers

**Special Tools in Shipping Kit:**

Two (2) system control console cables

One (1) 11 in. (27.9 cm) magnetic, replaceable-tip screwdriver

One (1) No. 1 Phillips head bit

One (1) No. 2 Phillips head bit

**Other Shipping Kit Items:**

I/O cable labels

Power cable labels

Velcro straps for I/O cables

ESD Kit with large mat:

Wrist strap

Static mat, 24 in. (61.0 cm) x 24 in. (61.0 cm)

Envelope, plastic bag

ESD kit instructions

---

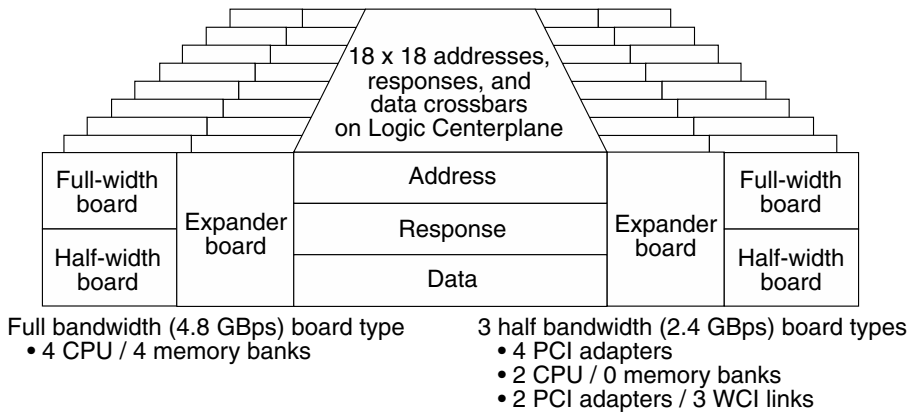
# 1.10 System Block Diagrams

FIGURE 1-5 defines the Sun Fire E25K/E20K systems architecture.

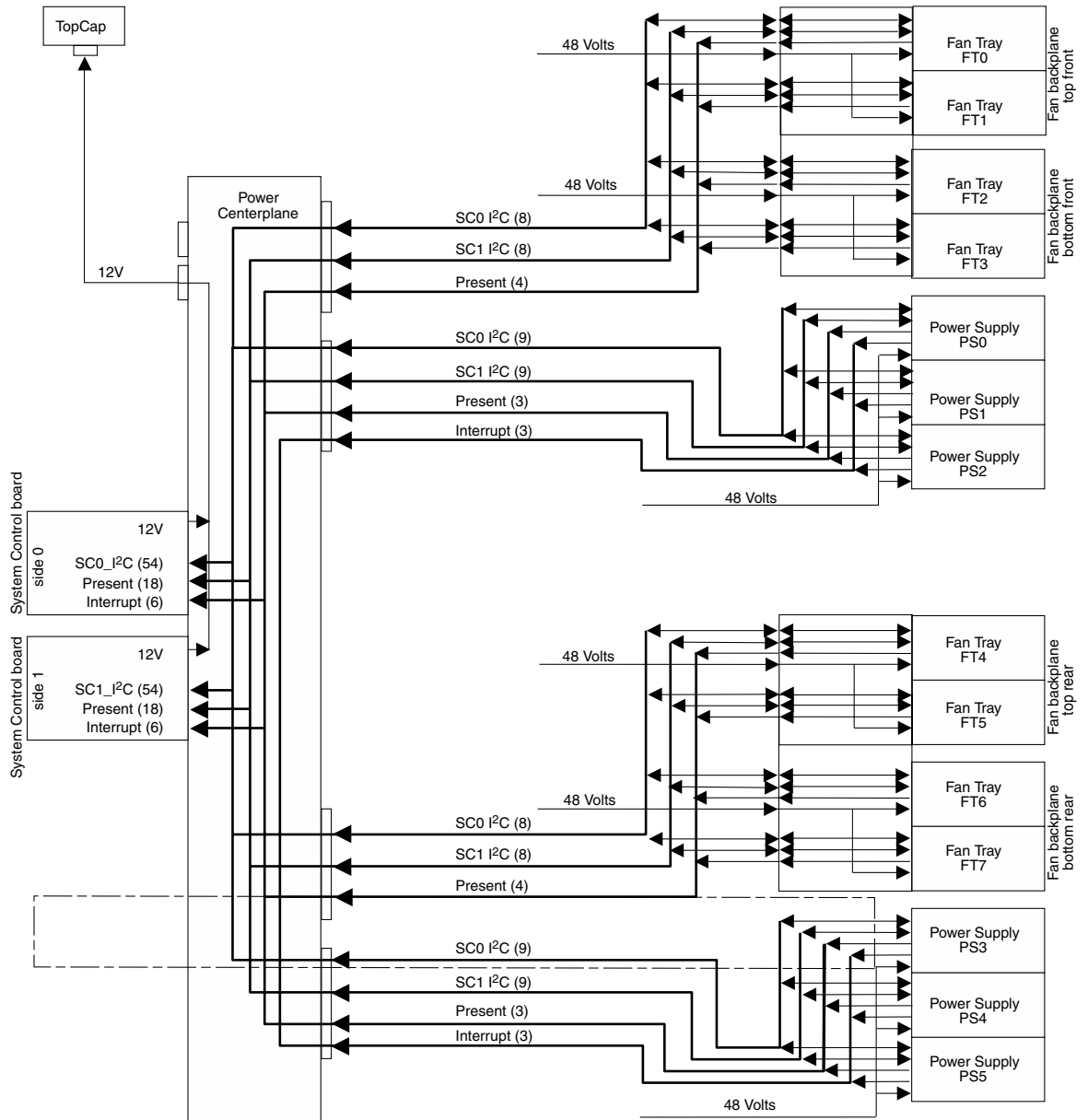
FIGURE 1-6 defines the power control system circuitry from the System Control boards to the individual power supplies and the fan trays.

FIGURE 1-7 defines the power distribution circuitry. This diagram represents the 48 VDC power distribution from the individual power supplies to the various boards through the designated circuit breakers.

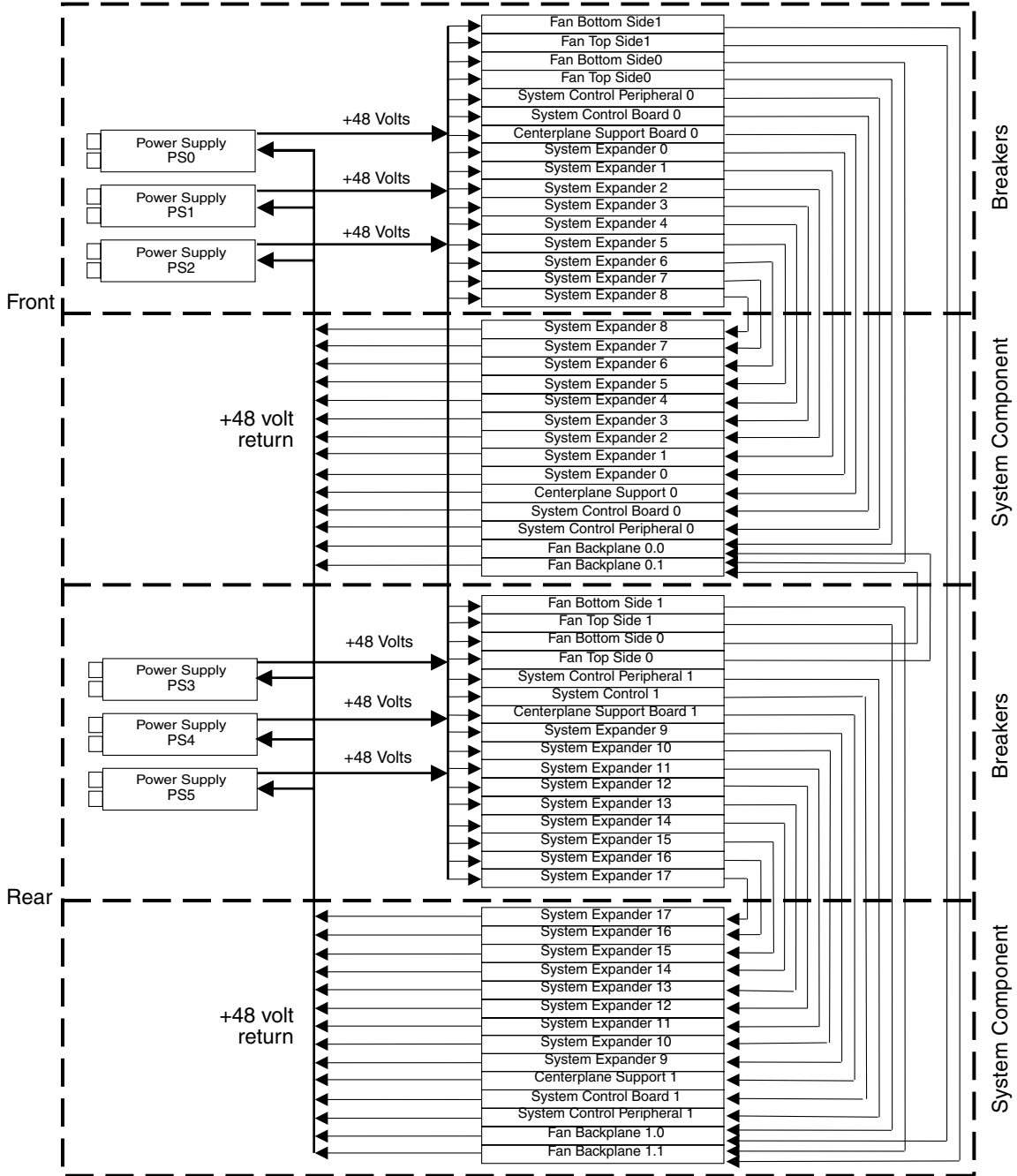
FIGURE 1-5 System Architecture Block Diagram



**FIGURE 1-6** Control Distribution Block Diagram



**FIGURE 1-7** Power Distribution Block Diagram



# TopCap and Extension Replacement Procedures

---

This chapter contains the replacement procedures for the TopCap assembly and extension.

The chapter contains the following sections:

- [Section 2.1, “TopCap Replacement” on page 2-2](#)
- [Section 2.2, “TopCap Extension Replacement” on page 2-2](#)

For your protection, observe the following safety precautions:

- Follow all cautions and instructions marked on the equipment.
- Always use proper ESD equipment and procedures when handling boards and components.
- Never push objects of any kind through openings in the equipment as they might touch dangerous voltage points or short out components that can result in fire or electric shock.
- Refer servicing of equipment to qualified personnel.

---

## 2.1 TopCap Replacement

### 2.1.1 Removing the TopCap



---

**Caution** – Be sure you are properly grounded before you begin the hardware removal and installation. There are ground points at the top left and top right of the cabinet in both front and rear.

---

1. Remove the four (4) M4x12 panhead screws securing the TopCap assembly.
2. Disconnect the 12V cable connector from the rear of the TopCap assembly.
3. Remove the TopCap assembly.

### 2.1.2 Installing the TopCap

1. Install a new TopCap assembly.
2. Connect the 12V cable connector to the rear of the TopCap assembly.
3. Secure the TopCap assembly with four (4) M4x12 panhead screws.

---

## 2.2 TopCap Extension Replacement

### 2.2.1 Removing the TopCap Extension

1. Remove the two (2) M4x12 panhead screws securing the TopCap extension.
2. Remove the TopCap extension.

## 2.2.2 Installing the TopCap Extension

1. Install the new TopCap extension.
2. Secure the TopCap extension with two (2) M4x12 panhead screws.





# System Power

---

The Sun Fire E25K/E20K systems have two power modules, each holding three hot-swappable power supplies. One module is on the front of the system and the other module is on the rear of the system. This chapter contains the replacement procedures for the power modules and the 4 kW dual AC–DC power supplies.

This chapter contains the following sections:

- [Section 3.1, “Power Module Replacement Procedures” on page 3-1](#)
- [Section 3.2, “4 kW Dual AC–DC Power Supply Replacement Procedures” on page 3-7](#)

For your protection, observe the following safety precautions:

- Follow all cautions and instructions marked on the equipment.
- Always use proper ESD equipment and procedures when handling boards and components.
- Never push objects of any kind through openings in the equipment as they might touch dangerous voltage points or short out components that can result in fire or electric shock.
- Refer servicing of equipment to qualified personnel.

---

## 3.1 Power Module Replacement Procedures

### 3.1.1 Power Module Replacement

The Sun Fire E25K/E20K systems have two power modules, each holding three power supplies. One module is on the front of the system and the other module is on the rear of the system. See [FIGURE 3-2](#).

## 3.1.2 Powering Off for Power Module Removal



---

**Caution** – The power module is NOT a hot-swappable component. This procedure requires a complete shutdown of the domains and SCs, and disconnection of all AC power to the system.

---

There are four ground points on the system cabinet, two at the front top left and top right, and two at the rear top left and top right.



---

**Caution** – The seven (7) power cables and the two (2) control cables MUST BE REMOVED from the side of the system where the power module is being removed.

---

1. As a superuser on the domains, systematically shut down all running domains by typing:

```
domain_name# shutdown -y -g seconds -i 0
```

where *seconds* is the amount of time before shutdown.

2. On the main SC, power off the domain hardware by typing:

```
sc% poweroff
```

This command powers off the entire system with the exception of the power supplies, fans, and the SCs. Refer to `poweroff(1M)` for more information.

3. Shut down the System Control boards by doing the following:

- As a superuser on the spare SC, shut down the spare SC by typing:

```
sc_spare# shutdown -y -g seconds -i 0
```

where *seconds* is the amount of time before shutdown.

- On the main SC, power off the spare SC by typing:

```
sc% poweroff SCx
```

where *x* is 0 or 1, dependent upon which SC is the spare.

- As a superuser on the main SC, shutdown the main SC by typing:

```
sc# shutdown -y -g seconds -i 0
```

where *seconds* is the amount of time before shutdown.

#### 4. Open the cabinet door.

---

**Note** – All DC circuit breakers are to remain in the on position at all times.

---

#### 5. Power off the AC0 and AC1 circuit breakers for all power supplies in the system.

---

**Note** – Observe the following warning message displayed at the right side of the circuit breakers on the circuit breaker panel above the AC power supplies:

WARNING  
FAN TRAYS HAVE REDUNDANT DC POWER SOURCES.  
CIRCUIT BREAKERS ON BOTH SIDES, FRONT AND REAR,  
MUST BE OPERATED TO TURN OFF FAN TRAYS.

POWER SUPPLIES HAVE DUAL AC INPUTS.  
BOTH CIRCUIT BREAKERS, AC0 AND AC1 MUST BE  
OPERATED TO TURN OFF A POWER SUPPLY.

---

### 3.1.3 Removing a Power Module



---

**Caution** – Be sure you are properly grounded before you begin the hardware removal and installation of the board. There are ground points at the top left and top right of the cabinet in both front and rear.

---

#### 1. Route I/O cables away from the power module, ensuring not to disconnect any cables.

See [Section 18.1, “Installing the Service Cable Straps”](#) on page 18-2.

#### 2. Label and disconnect the twelve (12, six per side) AC power cords with the labels provided in the shipping kit.

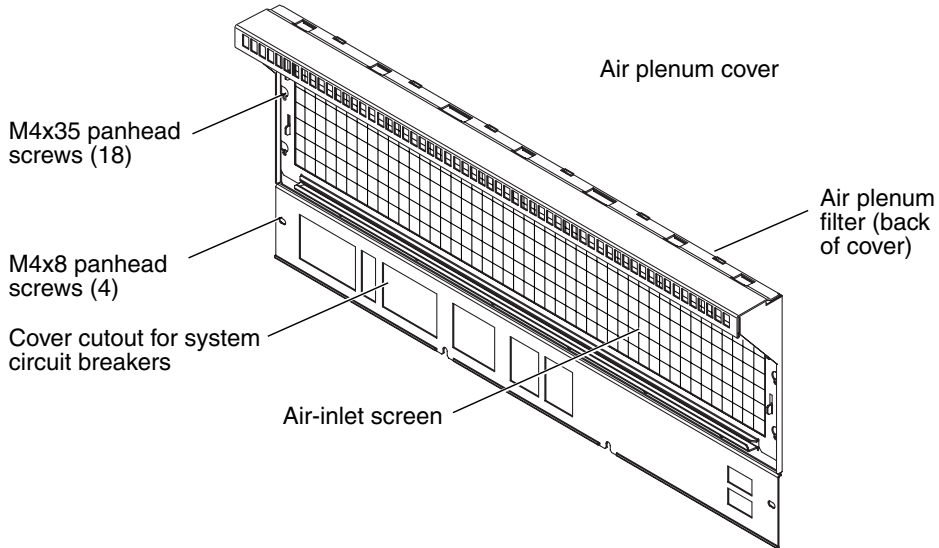
#### 3. Remove the power supplies from the power module.

See [Section 3.2.2.3, “Removing a 4 kW Dual AC–DC Power Supply”](#) on page 3-10.

#### 4. Remove the air-plenum cover by removing the eighteen (18) M4x35 panhead screws from the top, sides, and bottom of the air-inlet screen ([FIGURE 3-1](#)).

#### 5. Remove the four (4) M4x8 panhead screws from the side and bottom of the air plenum panel, at the circuit breaker level.

**FIGURE 3-1** Air-Plenum Cover



---

**Caution** – Handle the EMI honeycomb panel carefully to prevent damage to the screen.

---

6. Remove the air plenum cover and its air-inlet EMI honeycomb panel and air filter and place them on a flat sturdy surface.



---

**Caution** – The seven (7) power cables and the two (2) control cables **MUST BE REMOVED** from the system chassis on both the front and rear sides of the system prior to removing the power module.

---

7. With a flat-blade screwdriver (if needed), loosen the jackscrews on the seven (7) 8W8 Combo-D 8-pin DC power connectors (on the left side) and the two (2) DB-25 control connectors (on the right side).
8. Disconnect the cables from the mounting bulkhead of the system chassis.
9. Remove the four (4) M4x10 panhead screws attaching the power module front flanges to the system chassis, as shown in [FIGURE 3-2](#).



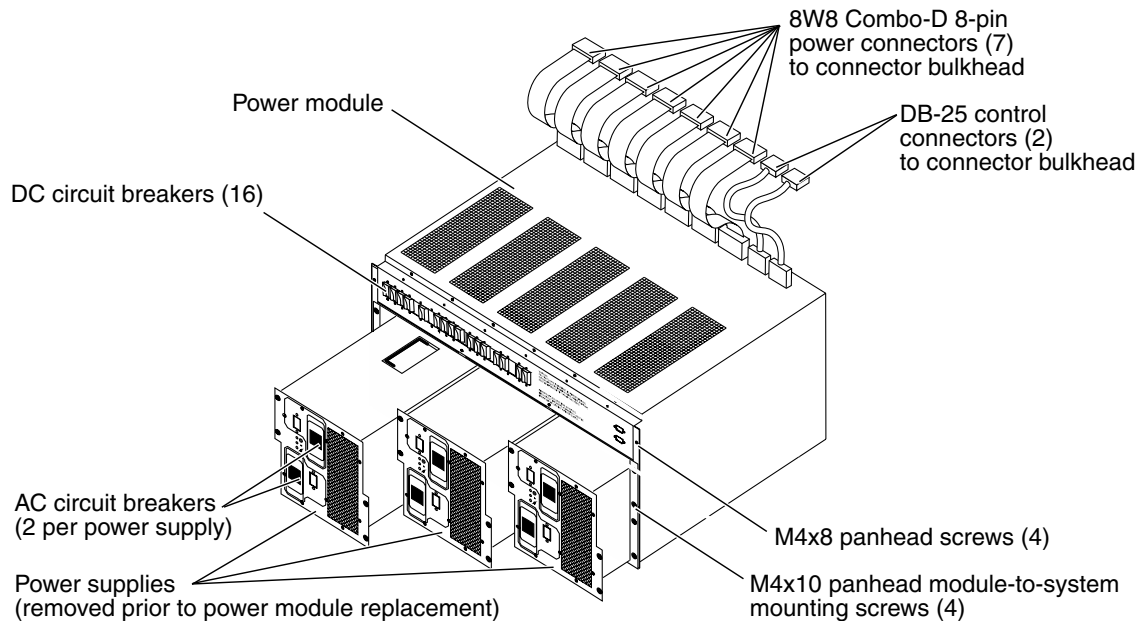
---

**Caution** – The power module weighs 48 lb (21.82 kg). Although the unit can be lifted by one person, it is suggested that two people, one on each side, maneuver the power module into position. Use proper heavy-lifting procedures when removing this unit.

---

10. With one person on each side of the power module, grasp the front (at the power supply opening) and the bottom and slide the power module outward from the cabinet.
11. Place the power module on a flat sturdy surface.
12. From the top rear of the power module, loosen the seven (7) 8W8 Combo-D 8-pin DC power connectors (on the left side) and the two (2) DB-25 control connectors (on the right side).
13. Disconnect the cables, and set them aside.

**FIGURE 3-2** Power Module



### 3.1.4 Installing a Power Module

1. Connect and hand tighten the jackscrews of the seven (7) 8W8 Combo-D 8-pin DC power connectors on the left side and the two (2) DB-25 control connectors on the right side (FIGURE 3-2).

The jack screws are found at the top rear of the power module.

---

**Note** – The power module weighs 48 lb (21.82 kg). Although the unit can be lifted by one person, it is suggested that two people, one on each side, maneuver the power module into position. Use proper heavy-lifting procedures when installing this unit.

---

2. With one person on each side of the power module, grasp the front (at the power supply opening) and the bottom and slide the power module into the system chassis.
3. Secure the power module to the system chassis with the four (4) M4x10 panhead module-to-system mounting screws, as shown in [FIGURE 3-2](#).
4. Connect the seven (7) 8W8 Combo-D 8-pin DC power connectors (on the left side) and the two (2) DB-25 control connectors (on the right side) to the mounting bulkhead of the system chassis, as shown in [FIGURE 3-2](#), and hand tighten the jackscrews.



---

**Caution** – Handle the EMI honeycomb panel carefully to prevent damage to the screen.

---

5. Install the air-plenum cover and its air-inlet EMI honeycomb panel and air filter.
6. Secure with the eighteen (18) M4x35 panhead screws at the top, sides, and bottom around the air-inlet screen, and the four (4) M4x8 panhead screws at the side and bottom of the air plenum panel, at the circuit breaker level.

---

**Note** – All power supply units are fully interchangeable.

---

7. Install the 4 kW dual AC input power supplies.  
See [Section 3.2.2.4, “Installing a 4 kW Dual AC–DC Power Supply”](#) on page 3-11.
8. Ensure that all DC circuit breakers are in the on position.
9. Ensure that all AC circuit breakers are in the off position.
10. Restore the I/O cables to their original location.  
See [Section 18.3, “Uninstalling the Service Cable Straps”](#) on page 18-7.

## 3.1.5 Powering On After Power Module Installation

1. Connect the AC power cords to the 4 kW dual AC–DC power supplies.

2. Power on the AC0 and AC1 circuit breakers for all power supplies in the system.
3. Close the cabinet door.
4. Once the main SC is booted, start the domain(s) by typing:

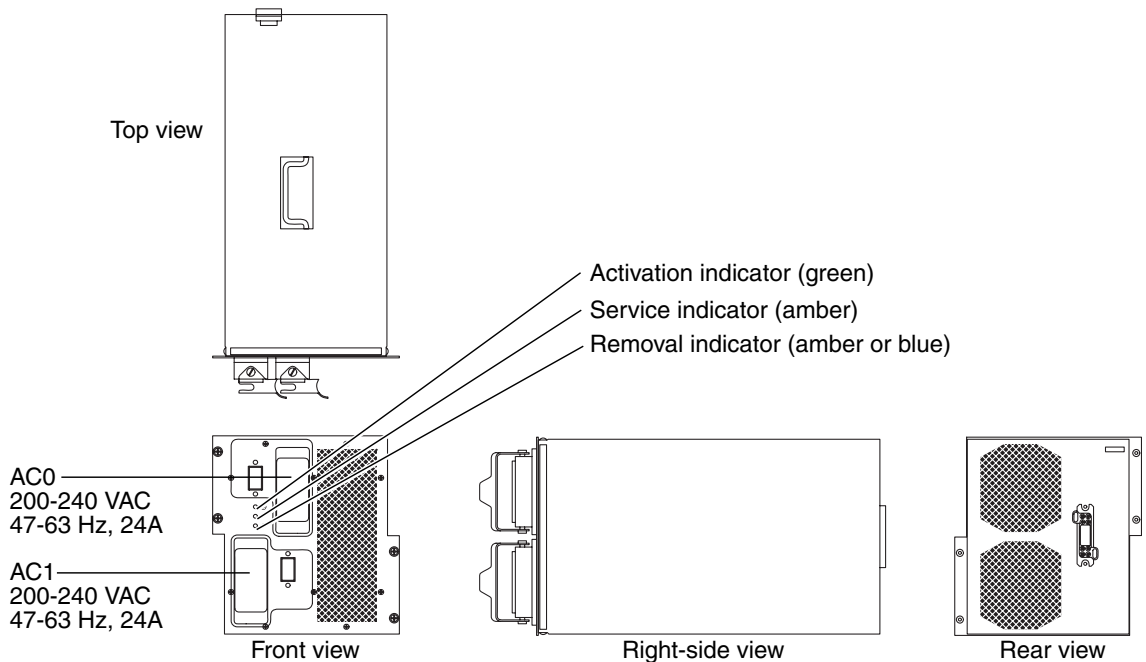
```
sc% setkeyswitch -d domain_id on
```

where *domain\_id* is the domain letter A-R. Execute one `setkeyswitch` command for each domain to be started.

## 3.2 4 kW Dual AC-DC Power Supply Replacement Procedures

The Sun Fire E25K/E20K systems have three 4 kW dual AC-DC hot-swappable power supplies at the front of the system and three at the rear of the system. See [FIGURE 3-3](#).

**FIGURE 3-3** Sun Fire E25K/E20K Systems Power Supply



## 3.2.1 4 kW Dual AC–DC Power Supply LEDs

4 kW Dual AC–DC power supply components and LEDs are listed in [TABLE 3-1](#) and [TABLE 3-2](#).

**TABLE 3-1** 4 kW Dual AC–DC Power Supply Components

| Total Number of Power Supplies Per System | Total Number of LEDs Per Power Supply |
|---|---------------------------------------|
| 6   | 3                                     |

**TABLE 3-2** 4 kW Dual AC–DC Power Supply Valid LED Status

| LEDs after Insertion or Initial System Power On |         |        | LEDs After PRESENCE is Detected |         |        | Component Powered On* |         |        | Component Powered Off† |         |        |
|---|---------|--------|---------------------------------|---------|--------|-----------------------|---------|--------|------------------------|---------|--------|
| Active  | Service | Remove | Active                          | Service | Remove | Active                | Service | Remove | Active                 | Service | Remove |
| on  | off     | off    | off                             | off     | on     | on                    | off     | off    | off                    | off     | on     |

\* ON = AC0\_FAIL\_L = H or AC1\_FAIL\_L = H

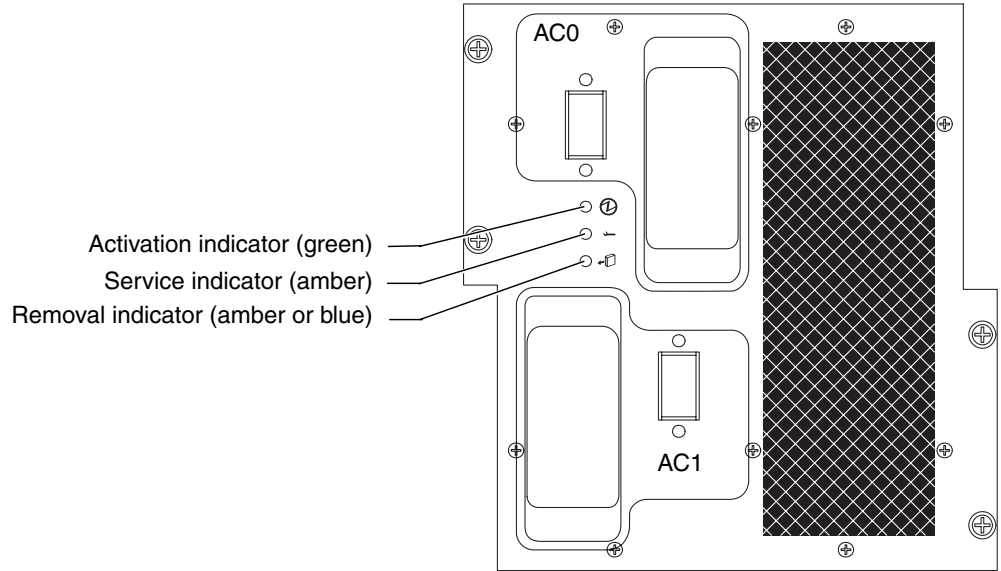
† OFF = AC0\_FAIL\_L = L and AC1\_FAIL\_L = L

Failure of the active LED to transition from ON to OFF within 60 seconds after insertion indicates a power-status control fault.

[FIGURE 3-4](#) illustrates the power supply and the LED locations.



**FIGURE 3-4** 4 kW Dual AC–DC Power Supply LEDs



## 3.2.2 4 kW Dual AC–DC Power Supply Replacement

### 3.2.2.1 Isolating a Failed Power Supply

1. Check that the power supply fans are on.
2. Verify the status of the LEDs.
3. Confirm that the power supply is properly seated.
4. Check the power status by using the Sun Management Center or by typing the following SMS command:

```
sc% showenvironment -p powers
```

5. On the SC, check for error messages in  
`/var/opt/SUNWSMS/adm/platform/messages.`

### 3.2.2.2 Powering Off a 4 kW Dual AC–DC Power Supply

- Power off the AC–DC power supply by using the Sun Management Center or by typing the following SMS command:

```
sc% poweroff psx
```

where *x* is the power supply 0-5. Refer to `poweroff(1M)` for more information.

This should cause the AC0 and AC1 circuit breakers to go into the off position.

### 3.2.2.3 Removing a 4 kW Dual AC–DC Power Supply



---

**Caution** – Be sure you are properly grounded before you begin the hardware removal and installation. There are four ground points on the system cabinet, two at the front top left and top right, and two at the rear top left and top right.

---

1. Open the cabinet door.



---

**Caution** – Before removing the power supply from the system, the green activation LED must be off and the amber or blue removal OK LED must be on. See [Section 3.2.2.2, “Powering Off a 4 kW Dual AC–DC Power Supply” on page 3-10](#).

---

**Note** – Observe the following warning message displayed at the right of the circuit breakers on the circuit breaker panel above the AC power supplies.

WARNING  
FAN TRAYS HAVE REDUNDANT DC POWER SOURCES.  
CIRCUIT BREAKERS ON BOTH SIDES, FRONT AND REAR,  
MUST BE OPERATED TO TURN OFF FAN TRAYS.

POWER SUPPLIES HAVE DUAL AC INPUTS.  
BOTH CIRCUIT BREAKERS, AC0 AND AC1 MUST BE  
OPERATED TO TURN OFF A POWER SUPPLY.

- 
2. Ensure power is off at the circuit breakers, AC0 (top breaker) and AC1 (bottom breaker), on the front panel of the power supply.
- 

**Note** – Ensure all AC power cords are labeled before removing.

---

3. Route I/O cables away from the power supply, ensuring not to disconnect any cables.

See [Section 18.1, “Installing the Service Cable Straps”](#) on page 18-2.

4. Label and remove both AC power cords from the front panel of the power supply.



---

**Caution** – The power supply unit weighs 42.2 lb (19.2 kg). Use proper heavy-lifting procedures when removing this unit.

---

5. Use a Phillips No. 2 screwdriver to loosen the four (4) front panel captive fasteners.
6. To pull out the 4 kW dual AC–DC power supply, use the power connector insert-ejector bracket as a handle and slide the power supply forward until the handle on the top of the power supply is exposed.
7. Use one hand to hold the power supply by the handle as you pull it the rest of the way out of the power module.
8. Place the power supply on a flat, sturdy, ESD-protected surface.

#### 3.2.2.4

### Installing a 4 kW Dual AC–DC Power Supply



---

**Caution** – The power supply unit weighs 42.2 lb (19.2 kg). Use proper heavy-lifting procedures when removing this unit.

---

1. Insert the 4 kW dual AC–DC power supply into its appropriate location in the power module.
2. Slide the power supply smoothly inward to a point where contact is made with the power module connector.
3. Secure the power supply with the four (4) front panel captive fasteners.

---

**Note** – Failure of the active LED to transition from on to off within 60 seconds after insertion indicates a power-status control fault.

---

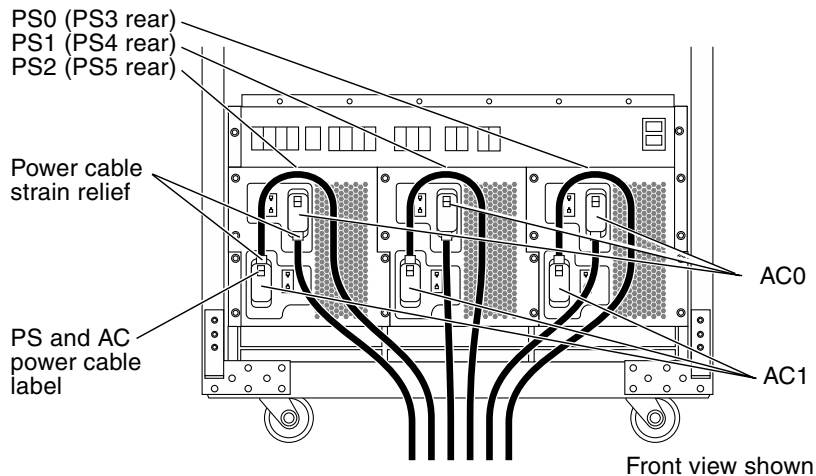
4. Verify the LED status per [TABLE 3-2](#).

**5. Connect the AC power cords into their appropriate AC connectors on the front panel of the power supply.**

See [FIGURE 3-5](#) to determine the proper part number and orientation for connection.

- The strain relief for the AC0 power cable housing is positioned downward when connected.
- The strain relief for the AC1 power cable housings is positioned upward when connected.
- Power source A cord will normally connect into AC0.
- Power source B cord will normally connect into AC1.

**FIGURE 3-5** AC Power Cord Installation



**6. Affix the appropriate power supply component label to the back of the power cable connector housing.**

**7. Restore the I/O cables to their original location.**

See [Section 18.3, “Uninstalling the Service Cable Straps”](#) on page 18-7.

### 3.2.2.5 Powering On a 4 kW Dual AC–DC Power Supply

- 1. Power on the circuit breakers, AC0 (top breaker) and AC1 (bottom breaker), on the front panel of the power supply.**
- 2. Close the cabinet door.**

### 3.2.2.6 Verifying a 4 kW Dual AC–DC Power Supply

1. On the SC, check for error messages in `/var/opt/SUNWSMS/adm/platform/messages`.
2. Check the power supply status by using the Sun Management Center or by typing the following SMS command:

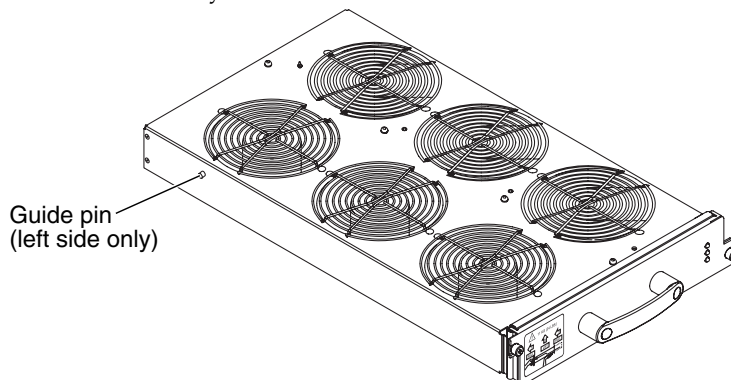
```
sc% showenvironment -p powers
POWER      UNIT      AC0      AC1      DC0      DC1      FAN0      FAN1
-----
PS0        OK        OK        OK        ON        ON        OK        OK
...
```



## Fan Trays

The Sun Fire E25K/E20K systems have eight hot-swappable fan trays. Each fan tray has two layers of six fans for a total of twelve fans per tray. There are two fan trays at the top and two fan trays at the bottom on both the front and rear of the system. See [FIGURE 4-1](#). This chapter contains the replacement procedures for the fan trays.

**FIGURE 4-1** Fan Tray



All fan trays are interchangeable.

This chapter contains the following sections:

- [Section 4.1, “Fan Tray LEDs” on page 4-2](#)
- [Section 4.2, “Fan Tray Replacement Procedures” on page 4-3](#)

For your protection, observe the following safety precautions:

- Follow all cautions and instructions marked on the equipment.
- Always use proper ESD equipment and procedures when handling boards and components.
- Never push objects of any kind through openings in the equipment as they might touch dangerous voltage points or short out components that can result in fire or electric shock.

- Refer servicing of equipment to qualified personnel.

## 4.1 Fan Tray LEDs

Fan tray components and LEDs are listed in [TABLE 4-1](#) and [TABLE 4-2](#).

**TABLE 4-1** Fan Tray Components

| Total Number of Fan Trays Per System Per Side | Total Number of Fan Trays Per Fan Shelf Per Side | Number of LEDs Per Fan Tray | Number of Fans Per Fan Tray |
|---|--|-----------------------------|-----------------------------|
| 4   | 2  | 3                           | 12                          |

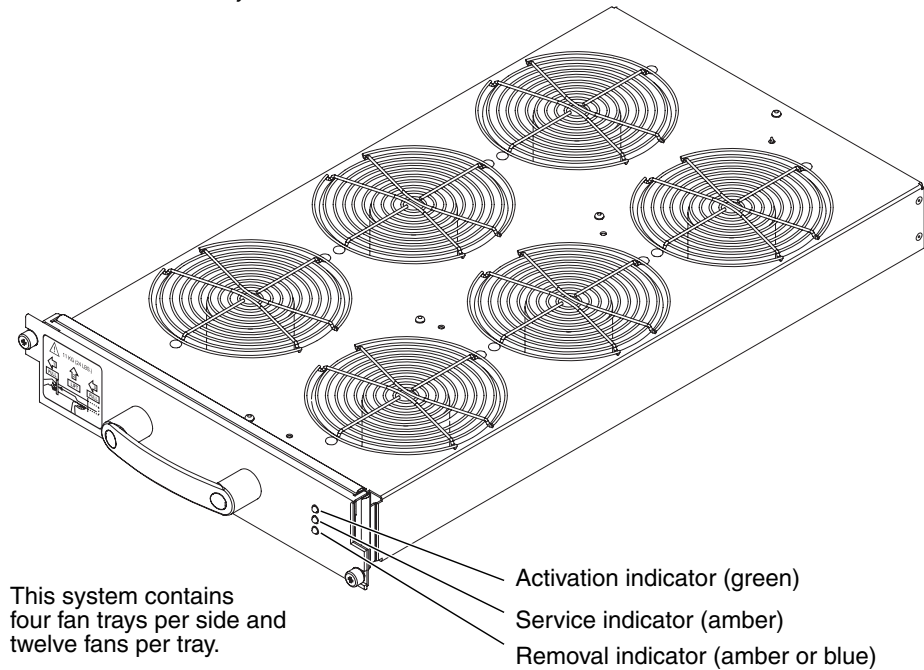
**TABLE 4-2** Fan Tray Valid LED Status

| LEDs After Insertion or Initial System Power On |         |        | LEDs After Presence is Detected |         |        | Component Powered On |         |        | Component Powered Off |         |        |
|---|---------|--------|---------------------------------|---------|--------|----------------------|---------|--------|-----------------------|---------|--------|
| Active  | Service | Remove | Active                          | Service | Remove | Active               | Service | Remove | Active                | Service | Remove |
| on  | off     | off    | on                              | off     | off    | on                   | off     | off    | off                   | off     | on     |

[FIGURE 4-2](#) illustrates the fan tray and the LED locations.



FIGURE 4-2 Fan Tray LEDs



---

## 4.2 Fan Tray Replacement Procedures

### 4.2.1 Isolating a Failed Fan Tray

1. Check that the fans are on.
2. Verify the status of the LEDs.
3. Check the fan status by using the Sun Management Center or by typing the following SMS command:

```
sc% showenvironment -p fans
```

4. Check the `/var/opt/SUNWSMS/adm/platform/messages` file for fan error messages.

## 4.2.2 Powering Off a Fan Tray



---

**Caution** – To maintain adequate system cooling during fan tray replacement, limit the amount of time a fan is off. Do NOT remove a failed fan tray from the system until the replacement tray is ready for installation.

---

- **Power off a fan tray by using the Sun Management Center or by typing the following SMS command:**

```
sc% poweroff ftx
```

where *x* is the Fan Tray 0-7. Refer to `poweroff(1M)` for more information.

## 4.2.3 Removing a Fan Tray



---

**Caution** – Be sure you are properly grounded before you begin the hardware removal and installation. There are ground points at the top left and top right of the cabinet in both front and rear.

---

---

**Note** – When removing the upper fan trays, remember the bottom system kick plate is NOT a step. DO NOT use the kick plate to gain access to the top fan trays. Obtain a proper stool if required. Excessive weight on the kick plate will bend the door support brackets.

---

1. **Open the cabinet door.**



---

**Caution** – Before removing the fan tray from the system, the green activation LED must be off and the amber or blue removal OK LED must be on. See [Section 4.2.2, “Powering Off a Fan Tray”](#) on page 4-4.

---

2. **Route I/O cables away from the fan tray, ensuring not to disconnect any cables.**

See [Section 18.1, “Installing the Service Cable Straps”](#) on page 18-2.

3. **Loosen the two (2) fan tray front panel No. 2 Phillips captive screw fasteners.**



---

**Caution** – The fan tray weighs 25.1 lb (11.4 kg). Use proper heavy-lifting procedures when removing this unit.

---

**4. Grasp the handle and pull the fan tray outward.**

As the tray slides forward, the guide pin on the left side of the tray comes up to a 45-degree upward angle on the bi-level groove approximately 3/4ths of the way out. This is a safety feature alerting you to stop pulling and to place the other hand *under* the fan tray.

**5. Continue lifting up and pulling outward on the guide rail pulling the fan tray out with both hands away from the system chassis.**

**6. Place the fan tray on a flat sturdy surface.**

## 4.2.4 Installing a Fan Tray



---

**Caution** – The fan tray weighs 25.1 lb (11.4 kg). Use proper heavy-lifting procedures when removing this unit.

---

**1. Grasp the fan tray by the handle with one hand and support the bottom of the fan tray with the other hand.**

**2. Insert the fan tray into the system chassis aligning the guide pin on the left side of the tray with the left guide rail of the angled guide ramp and slide the fan tray into the chassis.**

It will go in approximately one fourth of the way and drop down about 0.2 in. (.5 cm).

**3. Slide the fan tray inward until it connects with the connector of the fan backplane.**

**4. Using firm, steady pressure, insert the fan tray until it is fully seated with the fan backplane connector.**

**5. Secure the two (2) front panel captive screw fasteners.**

---

**Note** – Failure of the service LED to transition from on to off within 60 seconds after insertion indicates a power-status control fault.

---

**6. Verify the LED status per [TABLE 4-2](#).**

**7. Restore the I/O cables to their original location.**

See [Section 18.3, “Uninstalling the Service Cable Straps”](#) on page 18-7.

**8. Close the cabinet door.**

## 4.2.5 Verifying a Fan Tray

1. On the SC, check for error messages in `/var/opt/SUNWSMS/adm/platform/messages`.
2. Check the fan tray status by using the Sun Management Center or by typing the following SMS command:

```
sc% showenvironment -p fans
FANTRAY  POWER  SPEED  FAN0  FAN1  FAN2  FAN3  FAN4  FAN5  FAN6
-----  -
FT0      ON      HIGH   OK    OK    OK    OK    OK    OK    OK
...
```

## System Controller CPU Board for the System Control (SC) Board

---

The System Control (SC) board (slot 0) for the Sun Fire E25K/E20K systems support the system controller CPU board, Netra™ CP2140 CompactPCI, and its memory board(s). This chapter contains the removal and replacement procedures for the system controller CPU board and its memory board(s).

This chapter contains the following sections:

- [Section 5.1, “System Control \(SC\) Board System Controller CPU Board Replacement Procedures” on page 5-2](#)
- [Section 5.2, “System Controller CPU Board Memory Board Installation Procedures” on page 5-3](#)

For your protection, observe the following safety precautions:

- Follow all cautions and instructions marked on the equipment.
- Always use proper ESD equipment and procedures when handling boards and components.
- Never push objects of any kind through openings in the equipment as they might touch dangerous voltage points or short out components that can result in fire or electric shock.
- Refer servicing of equipment to qualified personnel.

---

## 5.1 System Control (SC) Board System Controller CPU Board Replacement Procedures



---

**Caution** – Be sure you are properly grounded before you begin the hardware removal and installation. There are ground points at the top left and top right of the cabinet in both front and rear.

---



---

**Caution** – The Sun Fire E25K/E20K systems do not support the Netra CP2140 CompactPCI as a hot-swappable component.

---

The system controller CPU board is not a hot-swappable component. Damage can occur to the board if all power down procedures are not followed as detailed in this manual.



---

**Caution** – Before removing a board from the system, the green activation LED must be off and the amber or blue removal OK LED must be on. See [Section 6.1.2.2, “Powering Off a System Control \(SC\) Board”](#) on page 6-4.

---

### 5.1.1 Powering Off the SC Board

- **Power off the SC board.**  
See [Section 6.1.2.2, “Powering Off a System Control \(SC\) Board”](#) on page 6-4.

### 5.1.2 Removing the SC Board.

- **Remove the SC board.**  
See [Section 6.1.2.3, “Removing a System Control \(SC\) Board”](#) on page 6-6.

### 5.1.3 Removing the System Control (SC) Board System Controller CPU Board

1. Loosen the two (2) captive screws holding the system controller CPU to the SC board.
2. Remove the system controller CPU board by using the insert-eject levers on the board, and place the board on a flat sturdy ESD-protected surface with the component side up.

---

## 5.2 System Controller CPU Board Memory Board Installation Procedures

---

**Note** – Prior to installation, Sun Microsystems technicians need to reference Infodoc 72037 for the required system controller CPU upgrade information.

---

Inspect the new board before inserting it into the Sun Fire E25K/E20K systems.

1. Remove the connector protective cover from the board being installed and inspect the connector for any damage or gaps between the pins.
2. Ensure the board alignment tabs are not bent.
3. Inspect the mating connector before inserting the new board.



---

**Caution** – Do not force any board into a slot; it can cause damage to the board and the system. The board should insert and seat smoothly. If it binds, remove the board and inspect the card cage slot for any obvious obstructions.

---

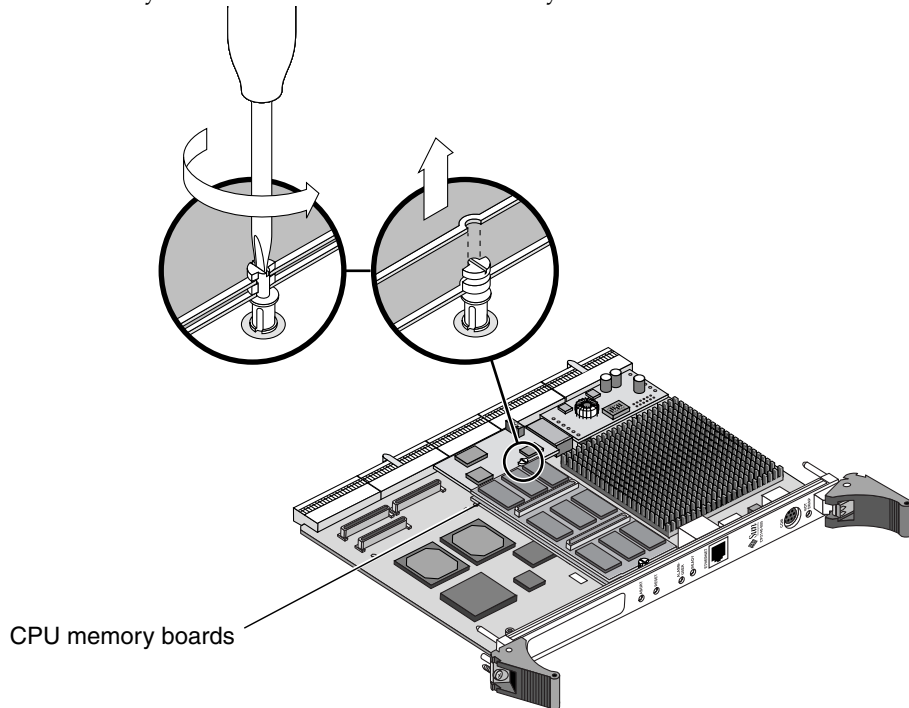
### 5.2.1 Installing Memory Boards on the System Controller CPU Board

The system controller CPU board can support up to two memory boards, each with a 512 MByte configuration. The first memory board is installed directly onto the system controller CPU board. The second memory board is installed directly on top of the first memory board.

1. Determine if one or two memory boards are being installed for this installation.

FIGURE 5-1 shows the system controller CPU board with the double memory board configuration.

FIGURE 5-1 System Controller CPU Board Memory Board Installation



2. Using a screwdriver, set the two memory board plastic support fasteners to their open position with the slots away from the board.
3. Align the two bottom memory board connectors (P3 and P4) above the memory board connector sockets (J0601 and J0602), located at the center of the system controller CPU board, and press down firmly, ensuring the two connectors are properly seated.

---

**Note** – To avoid microfracture damage to the system controller CPU board, do not apply excessive pressure on any of the connectors.

---

---

**Note** – If you are installing the single memory board configuration, skip Step 4 and continue with Step 5 below.

---

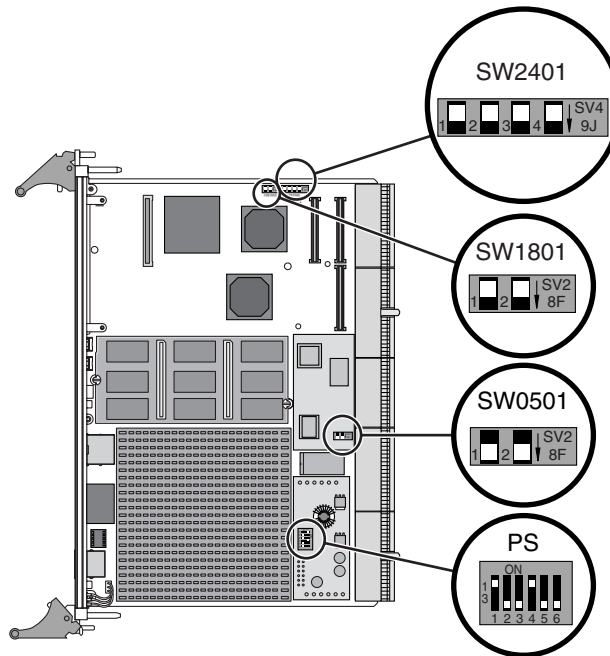


4. For the second memory board, align the two bottom connectors (P3 and P4) on top of the first memory board connector sockets (P1 and P2) and press down firmly, ensuring the two connectors are properly seated in the first memory board.
5. Using a screwdriver, set the two memory board plastic support fasteners to the locked position by turning the fastener 180 degrees.

## 5.2.2 Verifying the Switch Positions on the System Controller CPU Board

Verify all switch positions are set as follows prior to rebooting the system controller CPU board (FIGURE 5-2).

FIGURE 5-2 System Controller CPU Board Switch Positions

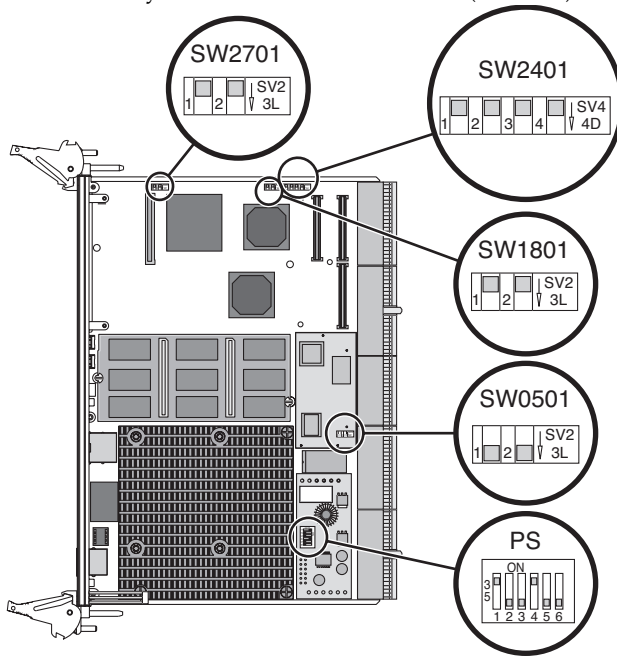



---

**Note** – Switch SW-2701 appears on recent CP-2140 board (501-6772-xx). This switch is not used and should be set to OPEN by default.

---

**FIGURE 5-3** System Controller CPU Board (CP-2140) Switch Positions



1. Ensure the system management controller (SMC) switches (SW0501-1 and SW0501-2) are in the down (off) position.
2. Ensure power module configuration (PS) switches 1 and 4 are in the up (on) position, and PS 2, 3, 5, and 6, are in the down (off) position.
3. Ensure the SW1801 and SW2401 switches are in the up position.

## 5.2.3 Installing the System Controller CPU Board

1. Install the correctly configured system controller CPU board and lock the insert-eject levers into position.
2. Secure the system controller CPU board to the SC board with the two (2) captive screws.

## 5.2.4 Installing the System Control (SC) Board

1. Install the SC board.  
See [Section 6.1.2.4, "Installing a System Control \(SC\) Board"](#) on page 6-8.

2. Reconnect all I/O cables.
3. Power on the SC board by using the Sun Management Center or from the main SC by typing the following SMS command:

```
sc% resetsc
```

```
About to reset other SC. Are you sure you  
want to continue? (yes/no)? yes
```

## 5.2.5 Verifying the Memory Boards on the System Controller CPU Board

1. Verify the SC board.

See [Section 6.1.2.5, “Verifying a System Control \(SC\) Board”](#) on page 6-9.

---

**Note** – Memory failure might occur due to the installation of an incorrect memory board, memory board failure, or improper installation.

---

2. After the installation of the SC board, the system goes through SCPOST and OpenBoot PROM (OBP). Review the messages on the console.

The memory configuration is recognized in groups indicated as Group 0, Group 1, Group 2, and Group 3. For two memory boards, 128 Mbytes double-sided, single-stuffed, the OBP displays the following configuration information:

```
Memory Group #0, 64 + 64 : 128 Megabytes  
Memory Group #1, 0 + 0 : 0 Megabytes  
Memory Group #2, 64 + 64 : 128 Megabytes  
Memory Group #3, 0 + 0 : 0 Megabytes
```

3. If an error message is displayed, check the following for a solution:

- Ensure the correct memory board is installed in the proper slot and that it is properly seated.
- If two memory boards are installed, ensure each board is installed in the proper position.
- Ensure the total memory on the memory board(s) does not exceed the total memory limit for the processor board.



## System Control (SC) Board

---

The System Control (SC) board for the Sun Fire E25K/E20K systems is a hot-swappable board at SC0 (front) and SC1 (rear). This chapter contains the replacement procedures for the SC board.

For your protection, observe the following safety precautions:

- Follow all cautions and instructions marked on the equipment.
- Always use proper ESD equipment and procedures when handling boards and components.
- Never push objects of any kind through openings in the equipment as they might touch dangerous voltage points or short out components that can result in fire or electric shock.
- Refer servicing of equipment to qualified personnel.

---

## 6.1 System Control (SC) Board Replacement

### 6.1.1 System Control Board LEDs

System Control (SC) board components and LEDs are listed in [TABLE 6-1](#) and [TABLE 6-2](#).

**TABLE 6-1** System Control Board Components

| Total Number of System Control Boards Per System | Total Number of System Control Boards Per side | Number of LEDs Per System Control Board |
|--|--|---|
| 2  | 1  | 9                                       |

**TABLE 6-2** System Control Board Valid LED Status

| LEDs After Insertion<br>or Initial<br>System Power On |             |        | LEDs After Presence<br>is Detected |             |        | Component Powered On |         |            | Component Powered Off |             |        |
|---|-------------|--------|------------------------------------|-------------|--------|----------------------|---------|------------|-----------------------|-------------|--------|
| Activ<br>e  | Servic<br>e | Remove | Activ<br>e                         | Servic<br>e | Remove | Activ<br>e           | Service | Remov<br>e | Active                | Servic<br>e | Remove |
| on  | on          | off    | on                                 | off         | off    | on                   | off     | off        | off                   | off         | on     |

The SC CPU slot and SC 6U/3U spare slot on the SC board do not have unique bits, referred to as *presence* bits. Failure of the service LED to transition from ON to OFF within 60 seconds after insertion indicates a power-status control fault.

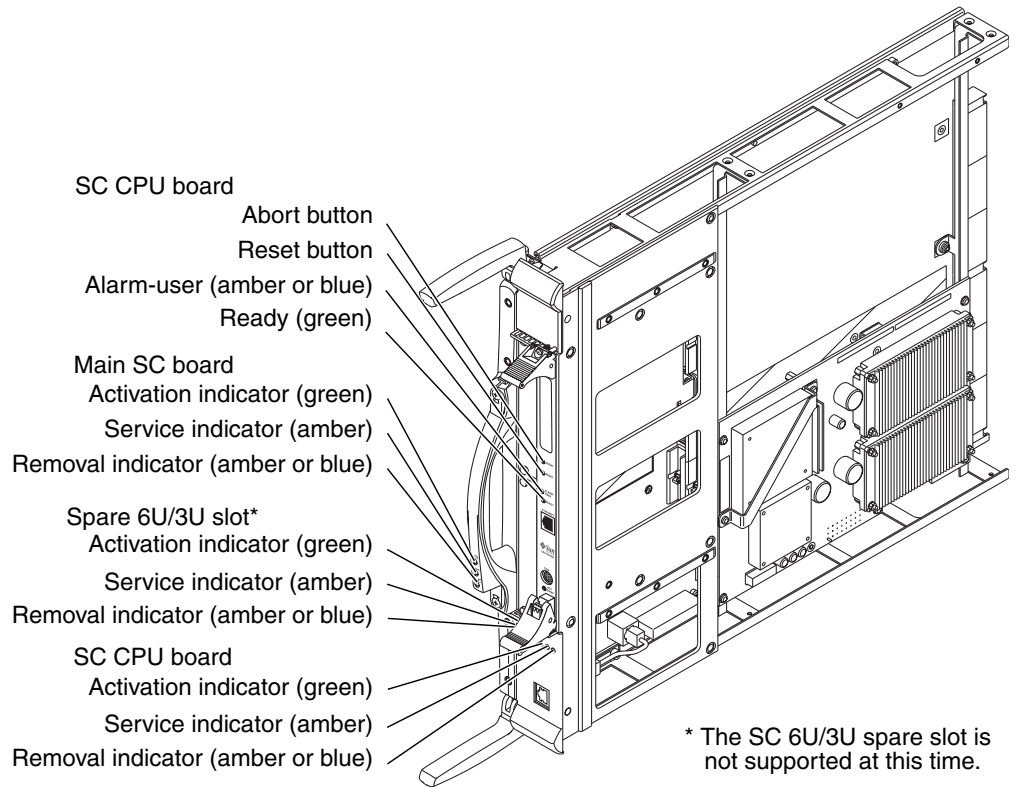
TABLE 6-3 describes the SC CPU board indicator functions.

**TABLE 6-3** System Control CPU Board Indicator Function Descriptions

| Indicator Functions | Description  |
|---------------------|--|
| Alarm               | Not used   |
| Ready               | Component ON and board is READY                    |
| Reset button        | Global reset to the SC CPU and PCI reset to the SC |
| Abort button        | Resets the CPU                                     |

FIGURE 6-1 illustrates the System Control board and the LED locations.

**FIGURE 6-1** System Control Board LEDs (3U to 6U Conversion Board Option)



**Caution** – Using the SC CPU reset and SC CPU abort hardware buttons might corrupt the operating system disk if the operating system has not been properly shut down.

■ **SC CPU Reset Button**

When the RESET button on the front panel of the SC CPU board is pressed, a Power-on-reset (POR) is generated to the SC CPU board and a peripheral component interconnect (PCI) reset is generated to the PCI devices on the SC main board. This results in a general clearing of the SC CPU board to a power on state, and a reset of the PCI bus on the SC main board.

Using the RESET button will reboot the operating system on the SC if the appropriate OpenBoot PROM (OBP) environment variables have been set.

■ **SC CPU Abort Button**

When the ABORT button on the front panel of the SC CPU board is pressed, an external initiated reset (XIR) is generated to the CPU module, returning the CPU to a known start-up state. No other devices are affected by this reset.

## 6.1.2 System Control Board (SC) Replacement Procedures

### 6.1.2.1 Isolating a Failed System Control Board

**1. Check for any error messages during SCPOST.**

SCPOST messages are output to an SMS console. To read SC SMS console messages, you must attach a console cable and terminal to the SC.

**2. On the SC, check for any error messages in `/var/adm/messages` and `/var/opt/SUNWSMS/adm/platform/messages`.**

**3. Use `adb` to examine any core files in `/var/crash/sc_name`.**

### 6.1.2.2 Powering Off a System Control (SC) Board

**1. If the System Control board is to be replaced in the spare SC, go to [Step 6](#), as follows. If the System Control board is to be replaced in the main SC, ensure the spare SC is available. Synchronize the main SC to the spare SC by typing:**

```
sc% setdatasync backup
```

If no messages are reported in `/var/opt/SUNWSMS/adm/platform/messages` and the command completes, the `setdatasync backup` was successful.

**2. As a superuser on the main SC, make a backup copy of the SMS configuration:**

```
sc# smsbackup directory
```

This `smsbackup` file can be used to recover the SMS configuration in the event of another failure during the replacement.

**3. From the main SC, failover (switch over) to the spare SC by typing:**

```
sc% setfailover force
```



4. Monitor the SMS log at `/var/opt/SUNWSMS/adm/platform/messages` on the spare SC for messages similar to the following:

CODE EXAMPLE 6-1

```
sc% tail /var/opt/SUNWSMS/adm/platform/messages
Jul 25 11:14:20 2001 xc12-scl fomd[378]: [8570 351292396349 NOTICE
FailoverMgr.cc 1846] Reset the remote SC
Jul 25 11:14:20 2001 xc12-scl fomd[378]: [8573 351293425787 NOTICE
FailoverMgr.cc 1860] Taking over the main role because the remote SC (current
Main) has a fault - Forced Failover
Jul 25 11:14:21 2001 xc12-scl ssd[322]: [1304 351936455728 NOTICE
StartupManager.cc 2146] software component start-up initiated: name=pcd
Jul 25 11:14:21 2001 xc12-scl ssd[322]: [1304 351990720428 NOTICE
StartupManager.cc 2146] software component start-up initiated: name=tmd
Jul 25 11:14:21 2001 xc12-scl ssd[322]: [1304 352013091113 NOTICE
StartupManager.cc 2146] software component start-up initiated: name=esmd
.
.
.
Jul 25 11:14:27 2001 xc12-scl esmd[2401]: [6143 357922367375 ERR
Slot0PowerControl.cc 957] Failed to get SCM Console Bus port configuration
setting, status = 1173 on CPU at SB12
Jul 25 11:14:27 2001 xc12-scl hwad[340]: [1173 358098116693 ERR PciComm.cc 205]
console bus illegal access error at address 5c000000
Jul 25 11:14:27 2001 xc12-scl esmd[2401]: [1173 358098116693 ERR PciComm.cc 205]
console bus illegal access error at address 5c000000
Jul 25 11:14:27 2001 xc12-scl esmd[2401]: [6143 358099878028 ERR
Slot0PowerControl.cc 957] Failed to get SCM Console Bus port configuration
setting, status = 1173 on CPU at SB15
Jul 25 11:14:30 2001 xc12-scl fomd[378]: [8576 361695126570 NOTICE
FailoverMgr.cc 1963] SC configured as Main
```

This indicates that the failover operation has completed successfully. The spare SC is now the main SC.

5. On the main SC, verify that it has assumed the main role and that failover is disabled by typing:

```
sc% showfailover -r
MAIN
sc% showfailover
SC Failover Status:    DISABLED
```

If failover is disabled, go to [Step 8](#).

6. On the main SC, disable the failover mechanism by typing:

```
sc% setfailover off
```

7. Verify the failover is DISABLED by typing:

```
sc% showfailover
SC Failover Status:  DISABLED
```

8. If the spare SC is running Solaris software, as superuser, shut down the spare (inactive) SC by typing:

```
sc_spare# shutdown -y -g seconds -i 0
```

where *seconds* is the amount of time before shutdown.

9. Power off the spare (inactive) SC by using the Sun Management Center or from the main SC by typing the following SMS command:

```
sc% poweroff scx
```

where *x* is 0 or 1. Refer to `poweroff(1M)` for more information.

The `poweroff` command will query the user to continue.

---

**Note** – The `poweroff` command only supports `poweroff` of the other SC (`poweroff` SC0 at SC1 or SC1 at SC0). If the user executes `poweroff` of SC0 from SC0, the command will fail.

---

### 6.1.2.3

## Removing a System Control (SC) Board



---

**Caution** – Be sure you are properly grounded before you begin the hardware removal and installation. There are ground points at the top left and top right of the cabinet in both front and rear.

---

1. Open the cabinet door.



---

**Caution** – Before removing a board from the system, the green activation LED must be off and the amber or blue removal OK LED must be on. See [Section 6.1.2.2, “Powering Off a System Control \(SC\) Board”](#) on page 6-4.

---

2. Label and remove the I/O cables from the SC board.

3. Insert a Phillips No. 1 screwdriver into the pawl latches turning counterclockwise to release the lever and lift the carrier insert-eject lever.

4. Apply equal pressure to both insert-eject levers in the unlocking direction and pull the board outward to release it from the centerplane support board. (FIGURE 6-2).
5. Use the front handle to extract the SC board, supporting the bottom with the other hand, and place it on a flat, sturdy, ESD-protected surface with the component side up.
6. Review the platform message log to verify SMS has received the message that the component has been removed, by typing:

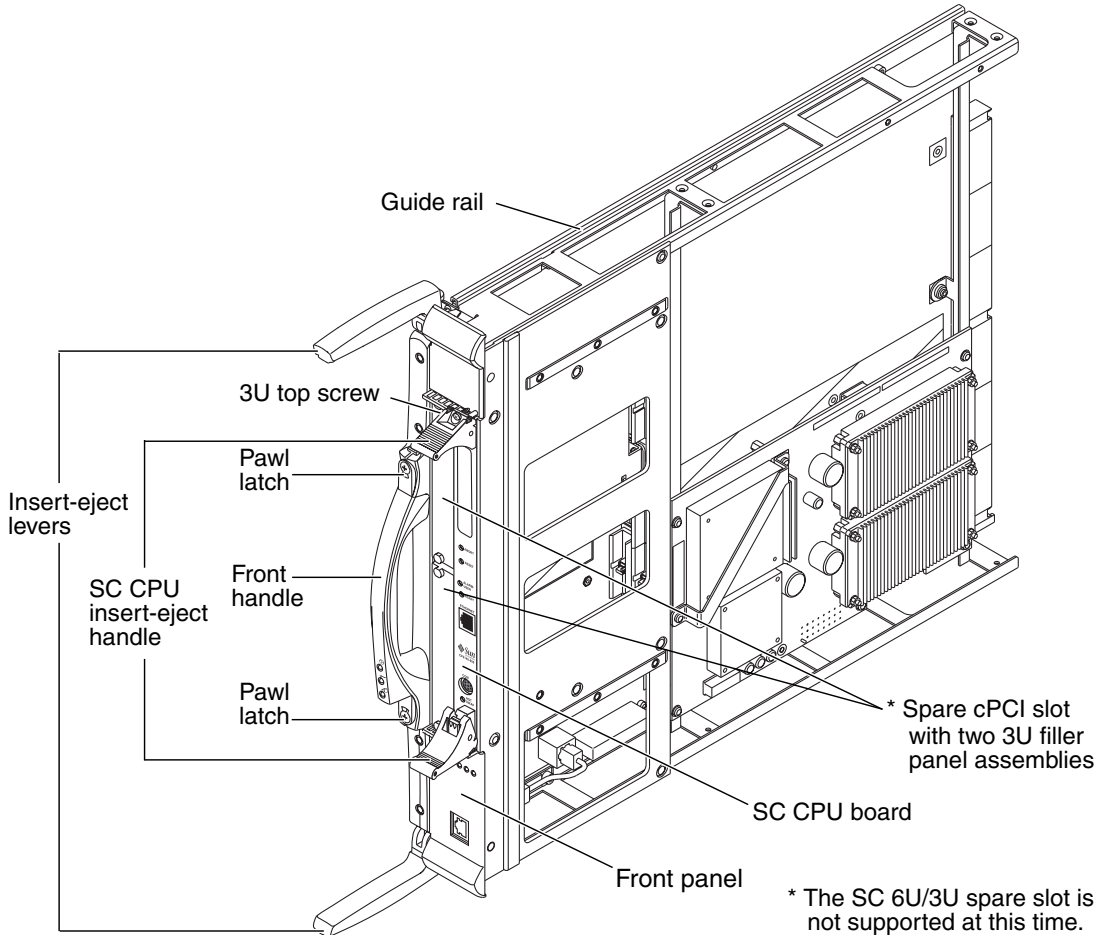
```
sc% showlogs -F
```

Review the board removal message. You will see a message similar to the one below.

```
Jun 16 14:28:05 2003 sun15-sc0: esmd[7167]: [0 4824421445907014  
NOTICE Boards.cc 1646] SC at IOx removed
```

where  $x$  is the SC assembly 0 or 1.

**FIGURE 6-2** System Control Board



### 6.1.2.4 Installing a System Control (SC) Board

Inspect the new board before inserting it into the Sun Fire E25K/E20K systems.

1. Remove the connector protective cover from the board being installed and inspect the connector for any damaged or gaps between the pins.
2. Ensure any board alignment tabs are not bent.
3. Inspect the mating connector before inserting the new board.



---

**Caution** – Do not force any board into a slot; it can cause damage to the board and the system. The board should insert and seat smoothly. If it binds, remove the board and inspect the card cage slot for any obvious obstructions.

---

4. **To install a System Control board, firmly grasp the board by the front handle, supporting the bottom with the other hand, and position it onto the carrier rail.**

For proper installation of the SC Board, the SC board carrier plate must be completely installed.

5. **Align the guide rails on the SC control carrier with the guide rails on the SC board carrier plate.**
6. **Apply firm pressure on the front panel of the SC control carrier to connect with the connector on the centerplane support board.**
7. **Apply pressure to the top and bottom insert-eject levers simultaneously to ensure the board is properly seated.**

When the board is fully seated, both insert-eject levers will simultaneously lock into place automatically.

Failure of the service LED to transition from on to off within 60 seconds after insertion indicates a power-status control fault.

The SC board is powered on upon insertion; therefore, power-on commands are not required.

8. **Verify the LED status per [TABLE 6-2](#).**
9. **Review the platform message log to verify SMS has received the message that the component has been inserted, by typing:**

```
sc% showLogs -F
```

Review the board insertion message. You will see a message similar to the one as follows.

```
Jun 16 14:30:05 2003 sun15-sc0: esmd[7167]: [0 4824421445907014  
NOTICE Boards.cc 1646] SC at IOx inserted
```

where  $x$  is the SC assembly 0 or 1.

10. **Close the cabinet door.**

### 6.1.2.5 Verifying a System Control (SC) Board

1. **Monitor SSCPOST for any error messages.**

SSCPOST messages are output to an SMS console. To read SC SMS console messages, you must attach a console cable and terminal to the SC.

---

**Note** – SSCPOST might not be present if a new SC CPU board has been installed.

---

2. Confirm that SMS sees the SC when powered on by using the Sun Management Center or by typing the following SMS command:

|     |    |    |       |   |   |
|-----|----|----|-------|---|---|
| SC0 | On | SC | Spare | - | - |
| SC1 | On | SC | Main  | - | - |

3. Ensure the SC boots properly and no errors are reported to the SMS console or /var/adm/messages.

An example message is displayed below.

```
...
Oct 10 19:40:12 2001 Print services started.
Oct 10 19:40:16 2001 volume management starting.
Oct 10 19:40:17 2001 The system is ready.
```

#### 4. Check that the SC CPU board flash PROMs match the level on the disk:

```
sc% flashupdate -f /opt/SUNWSMS/firmware/SCOBPimg.di SC0/FP0

Current SC FPROM Information
=====
SC at SC0, FPROM 0:
Name: SSCOBP-dropins, Version: 1.1
Size: 144, Check Sum: 52295
Date Flashed: 09/17/01
Date Created: 09/17/01

SC Flash Image Information
=====
Name: SSCOBP-dropins, Version: 1.1
Size: 144, Check Sum: 52795
Date Flashed: 08/23/01
Date Created: 08/23/01

Do you wish to update the SC User FPROM (yes/no)?

sc% flashupdate -f /opt/SUNWSMS/firmware/SSCPOST.di SC0/FP1

Current SC FPROM Information
=====
SC at SC0, FPROM 1:
Name: ExtPOST, Version: 1.15
Size: 207169, Check Sum: 44872
Date Flashed: 09/17/01
Date Created: 09/17/01

SC Flash Image Information
=====
Name: ExtPOST, Version: 1.15
Size: 207161, Check Sum: 62276
Date Flashed: 08/23/01
Date Created: 08/23/01

Do you wish to update the SC User FPROM (yes/no)?
```

- If different, answer yes to update the PROM(s).
- If the PROM(s) are updated, reboot the SC.

**5. Ensure SMS starts properly and no errors are reported in**

`/var/opt/SUNWSMS/adm/platform/messages.`

Check the platform message log for any errors. Once the SMS starts, the following message is displayed:

```
Oct 12 11:58:11 2001 star7scl fomd[348]: [8577 118844134283  
NOTICE  
FailoverMgr.cc 2785] SC configured as Spare
```

The spare could be either `Spare` or `Main`, depending on the state of the opposite SC.

**6. Re-enable failover on the main SC by typing:**

```
sc% setfailover on
```

**7. Verify failover is enabled by typing:**

```
sc% showfailover  
SC Failover Status:  ACTIVE
```



## System Control (SC) Peripheral Board

---

The System Control (SC) hot-swappable peripheral board (slot 1) for the Sun Fire E25K/E20K systems support the DVD-ROM, DAT drive and hard drive peripherals. This chapter contains the replacement procedures for the SC peripheral board, and peripherals.

This chapter contains the following sections:

- [Section 7.1, “System Control Peripheral Board LEDs” on page 7-2](#)
- [Section 7.2, “System Control Peripheral Board Replacement Procedures” on page 7-5](#)
- [Section 7.3, “DVD Component Replacement Procedures” on page 7-9](#)
- [Section 7.4, “Hard Drive Replacement Procedures” on page 7-11](#)
- [Section 7.5, “Digital Audio Tape \(DAT\) Replacement Procedures” on page 7-15](#)

For your protection, observe the following safety precautions

- Follow all cautions and instructions marked on the equipment.
- Always use proper ESD equipment and procedures when handling boards and components.
- Never push objects of any kind through openings in the equipment as they might touch dangerous voltage points or short out components that can result in fire or electric shock.
- Refer servicing of equipment to qualified personnel.

# 7.1 System Control Peripheral Board LEDs

System Control (SC) peripheral board components and LEDs are listed in [TABLE 7-1](#) and [TABLE 7-2](#).

**TABLE 7-1** System Control (SC) Peripheral Board Components

| Total Number of System Control Peripheral Boards Per System | Total Number of System Control Peripheral Boards Per Side | Number of LEDs Per System Control Peripheral Board |
|---|---|--|
| 2   | 1   | 6  |

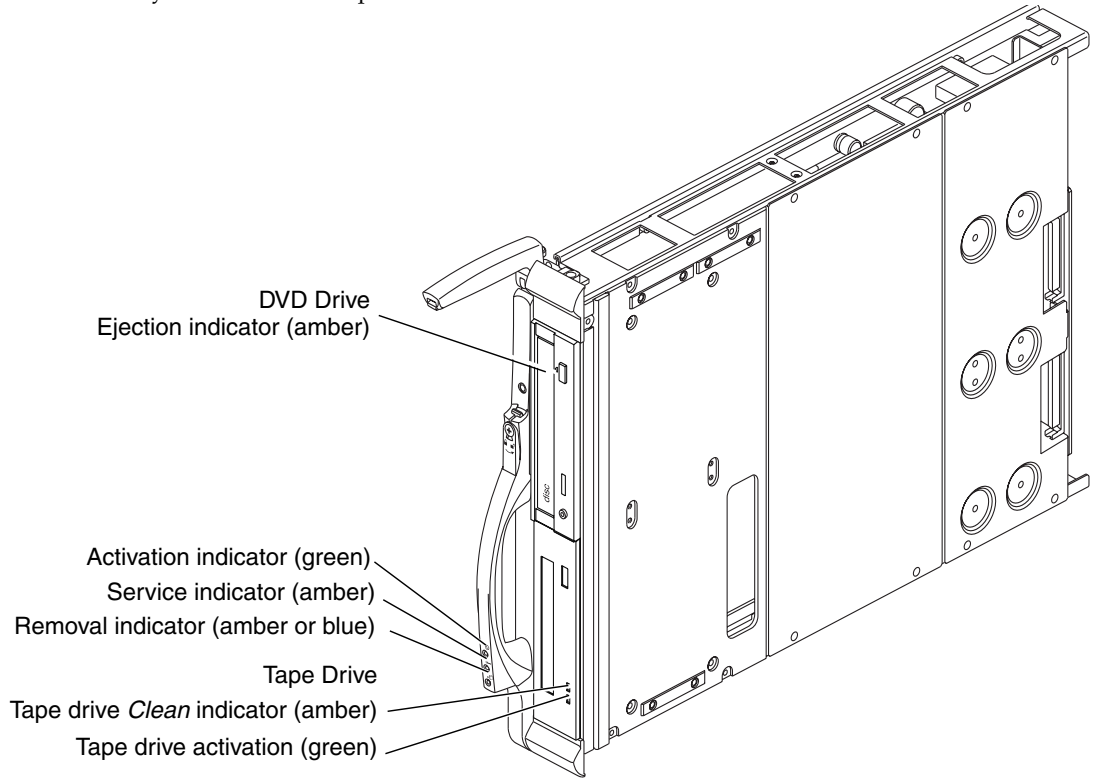
**TABLE 7-2** System Control (SC) Peripheral Board Valid LED Status

| LEDs After Insertion or Initial System Power On |         |        | LEDs After Presence is Detected |         |        | Component Powered On |         |        | Component Powered Off |         |        |
|---|---------|--------|---------------------------------|---------|--------|----------------------|---------|--------|-----------------------|---------|--------|
| Active  | Service | Remove | Active                          | Service | Remove | Active               | Service | Remove | Active                | Service | Remove |
| on  | on      | off    | on                              | off     | off    | on                   | off     | off    | off                   | off     | on     |

System Control must be present and powered on before the SC peripheral board can be powered on. Failure of the service LED to transition from ON to OFF within 60 seconds after insertion indicates a power-status control fault.

[FIGURE 7-1](#) illustrates the System Control peripheral board and the LED locations.

**FIGURE 7-1** System Control Peripheral Board LEDs



[TABLE 7-3](#) describes the DVD indicator function, and [TABLE 7-4](#) describes the tape indicator functions.

**TABLE 7-3** System Control DVD Indicator Function Descriptions

| Indicator Functions             | Description    |
|---------------------------------|----------------|
| Blinking (0.8 second intervals) | Busy           |
| OFF                             | Idle           |
| OFF                             | No disk        |
| ON                              | Error          |
| Blinking (1.6 second intervals) | Audio playback |
| ON                              | Data transfer  |

**TABLE 7-4** System Control Tape Peripheral Indicator Function Descriptions

| <b>Indicator Functions</b>                  | <b>Description</b>                                    |
|---|---|
| <b>Tape Indicator</b>                       |   |
| Green flashing and amber OFF                | Loading or unloading                                  |
| Green fast flashing and amber OFF           | Reading and writing                                   |
| Green ON and amber OFF                      | Tape is loaded and ready                              |
| Green ON or OFF and amber flashing          | Clean tape drive                                      |
| Green ON or OFF and amber ON                | Error   |
| <b>Cleaning Mode</b>                        |   |
| Green fast flashing and amber OFF           | Cleaning in progress                                  |
| <b>Firmware Upgrade Mode</b>                |   |
| Green fast flashing and amber fast flashing | Firmware is downloading (auto ejection when complete) |

---

## 7.2 System Control Peripheral Board Replacement Procedures

The system control peripheral board is a hot-swap component board. The following sections provide instructions for removing and installing the peripheral board and the DVD, DAT drive, and hard drive peripheral components:

### 7.2.1 Isolating a Failed System Control (SC) Peripheral Board

**1. Check for any error messages during SCPOST.**

SCPOST messages are output to an SMS console. To read SC SMS console messages, you must attach a console cable and terminal to the SC.

**2. On the SMS, check for any error messages in `/var/adm/messages` and `/var/opt/SUNWSMS/adm/platform/messages`, specifically those dealing with the onboard peripherals (disk, tape).**

### 7.2.2 Powering Off a System Control (SC) Peripheral Board

● **Power off the SC Board.**

See [Section 6.1.2.2, “Powering Off a System Control \(SC\) Board”](#) on page 6-4.

### 7.2.3 Removing a System Control (SC) Peripheral Board



---

**Caution** – Be sure you are properly grounded before you begin the hardware removal and installation. There are ground points at the top left and top right of the cabinet in both front and rear.

---

**1. Open the cabinet door.**



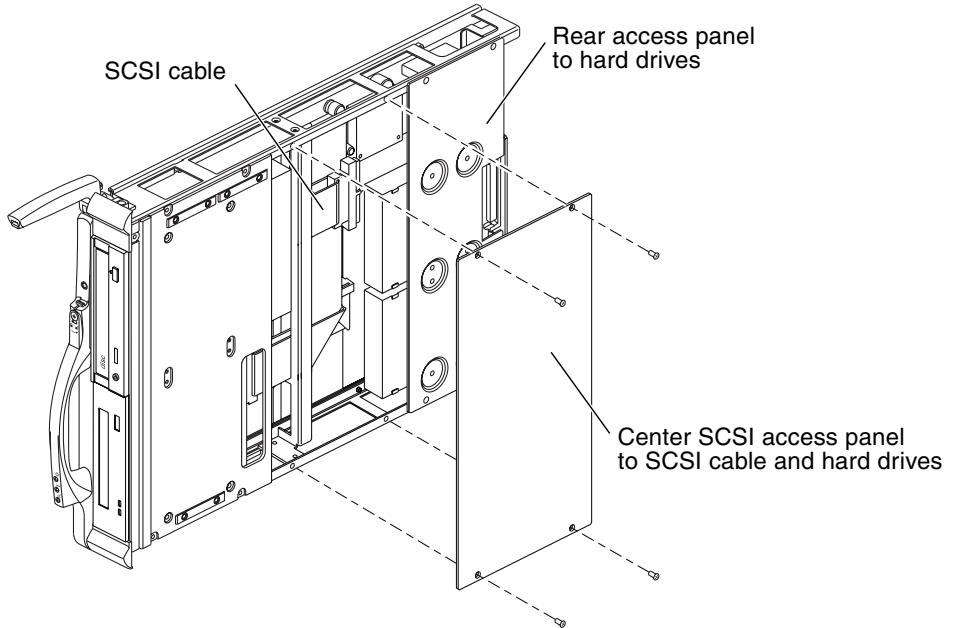
---

**Caution** – Before removing a board from the system, the green activation LED must be off and the amber or blue removal OK LED must be on. See [Section 7.2.2, “Powering Off a System Control \(SC\) Peripheral Board”](#) on page 7-5.

---

2. Insert a Phillips No. 1 screwdriver into the pawl latches turning counterclockwise to release the lever and lift the carrier insert-eject lever.
3. Use the front handle to extract the SC peripheral board, supporting the bottom with the other hand, and place it on a flat, sturdy, ESD-protected surface with the component side up.
4. To access the internal components of the SC peripheral board, remove the four (4) M3x6 flathead screws from the center SCSI access panel, as shown in [FIGURE 7-2](#).

**FIGURE 7-2** SC Peripheral Board and Center Access Panel—Exploded



## 7.2.4 Installing a System Control (SC) Peripheral Board

Inspect the new board before inserting it into the Sun Fire E25K/E20K systems.

1. Remove the connector protective cover from the board being installed and inspect the connector for any damaged or gaps between the pins.
2. Ensure board alignment tabs are not bent.
3. Inspect the mating connector before inserting the new board.



---

**Caution** – Do not force any board into a slot; it can cause damage to the board and the system. The board should insert and seat smoothly. If it binds, remove the board and inspect the card cage slot for any obvious obstructions.

---

4. To install a SC peripheral board, firmly grasp the board by the front handle, supporting the bottom with the other hand, and position it onto the carrier rail.
5. With the insert-eject lever extended, slide the board into the slot until it begins to connect with the centerplane support board connector.
6. Apply firm pressure to the face plate to fully seat the board with the connector.

7. Fold the insert-eject lever inward to fully seat the board ensuring the lever is nested within the front handle.

Failure of the service LED to transition from on to off within 60 seconds after insertion indicates a power-status control fault.

8. Verify the LED status per [TABLE 7-2](#).
9. Close the cabinet door.

## 7.2.5 Powering On a System Control (SC) Peripheral Board

- Power on the SC by using the Sun Management Center or from the main SC by typing the following SMS command:

```
sc% resetsc
```

```
About to reset other SC. Are you sure you  
want to continue? (yes/no)? yes
```

## 7.2.6 Verifying a System Control (SC) Peripheral Board

1. Monitor SCPOST for any error messages during SC boot.

SCPOST messages are output to an SMS console. To read SC SMS console messages, you must attach a console cable and terminal to the SC.

2. Ensure that Solaris software can communicate to all the peripheral devices.

- For the DVD-ROM, insert a CD and ensure it mounts properly.
- For hard disks, check that the `/dev/dsk` and `/dev/rdisk` entries are correct and that the Solaris software can access the disks (`format`, `prtvtoc`).
- For the DAT drive, check that the `/dev/rmt` entries are correct and that the Solaris software can access the tape device (`mt status`).

3. Verify the SC Board.

See [Section 6.1.2.5, "Verifying a System Control \(SC\) Board"](#) on page 6-9.



---

## 7.3 DVD Component Replacement Procedures

All backup procedures and any other customer administrative procedures must be completed by the responsible system administrator prior to DVD replacement by field personnel.

### 7.3.1 Removing the DVD Component From the System Control (SC) Peripheral Board



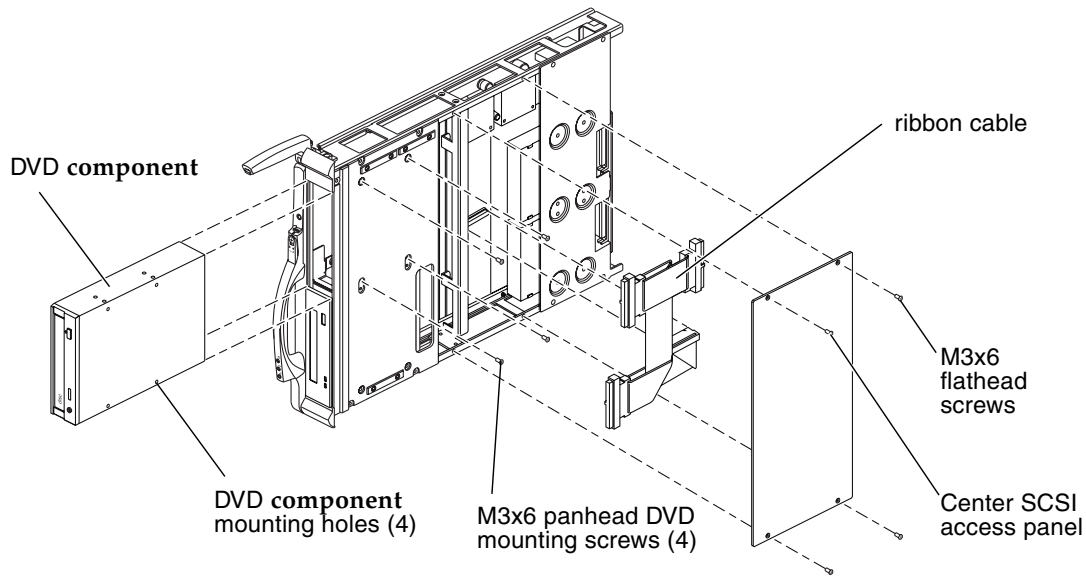
---

**Caution** – Be sure you are properly grounded before you begin the hardware removal and installation. There are ground points at the top left and top right of the cabinet in both front and rear.

---

1. **Open the cabinet door.**
2. **Power off the SC board.**  
See [Section 6.1.2.2, “Powering Off a System Control \(SC\) Board”](#) on page 6-4.
3. **Remove the SC peripheral board.**  
See [Section 7.2.3, “Removing a System Control \(SC\) Peripheral Board”](#) on page 7-5.
4. **At the center SCSI access panel, remove the four (4) M3x6 flathead screws and remove the panel.**
5. **Disconnect the ribbon cable connector and the DVD component power connector from the DVD.**  
Some DVD components may use an IDE ribbon connected to and IDE to SCSI converter.
6. **To access the internal DVD component of the SC peripheral board, remove the four (4) M3x6 panhead screws from the forward mounting panel, as shown in [FIGURE 7-3](#).**

**FIGURE 7-3** SC Peripheral Board DVD Component Removal and Access Panel—Exploded



7. From the front of the SC peripheral board, pull out the DVD component and place it on an ESD-protected surface.

## 7.3.2 Installing the DVD Component on the System Control (SC) Peripheral Board

1. With the SC peripheral board in horizontal position, insert a new DVD component into the top bay with the mounting holes aligned upward.
2. Push the DVD component inward until the front-panel bezel meets the SC peripheral board housing.
3. Align the four (4) holes of the side-panel sheet metal with the four (4) holes of the DVD component.
4. Secure the DVD component to the SC peripheral board housing with the four (4) M3x6 panhead screws.
5. Connect the DVD component power cable and the ribbon cable connectors. Some DVD components may use an IDE ribbon connected to an IDE to SCSI converter.
6. Install the center SCSI access panel and secure with the four (4) M3x6 flathead screws.

7. Install the SC peripheral board.

See [Section 7.2.4, “Installing a System Control \(SC\) Peripheral Board”](#) on page 7-7.

8. Close the cabinet door.

### 7.3.3 Powering On a DVD Component

- Power on the SC by using the Sun Management Center or from the main SC by typing the following SMS command:

```
sc% resetsc
```

```
About to reset other SC. Are you sure you  
want to continue? (yes/no)? yes
```

### 7.3.4 Verifying a DVD Component

- Verify the DVD component.

See [Section 7.2.6, “Verifying a System Control \(SC\) Peripheral Board”](#) on page 7-8.

---

## 7.4 Hard Drive Replacement Procedures

All backup procedures and any other customer administrative procedures must be completed by the responsible system administrator prior to hard drive peripheral replacement by field service personnel.

### 7.4.1 Removing the Failed Hard Drive From the System Control (SC) Peripheral Board



---

**Caution** – Be sure you are properly grounded before you begin the hardware removal and installation. There are ground points at the top left and top right of the cabinet in both front and rear.

---

1. Open the cabinet door.

**2. Power off the SC board.**

See [Section 6.1.2.2, “Powering Off a System Control \(SC\) Board”](#) on page 6-4.

**3. Remove the SC peripheral board.**

See [Section 7.2.3, “Removing a System Control \(SC\) Peripheral Board”](#) on page 7-5.

**4. At the center SCSI access panel, remove the four (4) M3x6 flathead screws and remove the panel (FIGURE 7-4).**

**5. To access the internal hard drive(s) component, remove the four (4 per drive) 6-32 2A UNC screws holding the hard drive(s) to the rear panel of the SC peripheral.**



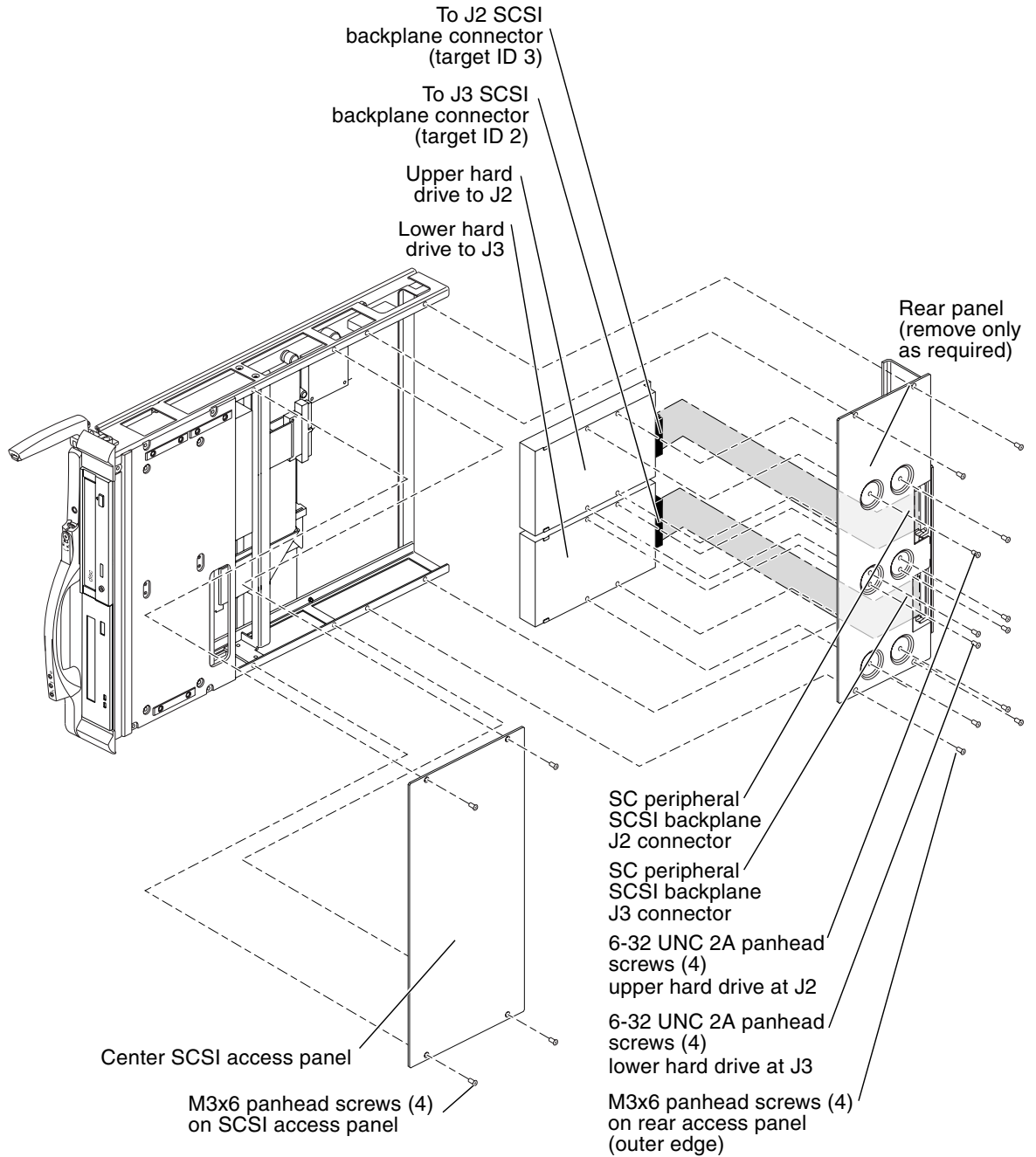
---

**Caution** – Support the hard drive during removal to prevent damage to the SC peripheral board and its components.

---

**6. Holding the front end of the failed hard drive, pull outward to disconnect the J2 (upper drive), or J3 (lower drive), connector of the SCSI backplane from the back of the rear panel. Pull outward and up to clear the rear panel.**

**FIGURE 7-4** SC Peripheral Board Hard Drive Removal and Access Panel—Exploded



## 7.4.2 Installing the Hard Drive on the System Control (SC) Peripheral Board



---

**Caution** – Support the hard drive during installation to prevent damage to the SC peripheral board and its components.

---

1. Holding the front end of the new hard drive(s), insert under the rear panel and connect to the J2 (upper drive), or J3 (lower drive), connector of the SC peripheral SCSI backplane.
2. Secure the hard drive(s) to the SC peripheral board with the four (4 per drive) 6-32 2A UNC screws.
3. Replace the SCSI access panel and secure with the four (4) M3x6 flathead screws.
4. Install the SC peripheral board.  
See [Section 7.2.4, “Installing a System Control \(SC\) Peripheral Board”](#) on page 7-7.
5. Close the cabinet door.

## 7.4.3 Powering On a Hard Drive

- Power on the SC by using the Sun Management Center or from the main SC by typing the following SMS command:

```
sc% resetsc
```

```
About to reset other SC. Are you sure you  
want to continue? (yes/no)? yes
```

## 7.4.4 Verifying a Hard Drive

- Verify the hard drive.  
See [Section 7.2.6, “Verifying a System Control \(SC\) Peripheral Board”](#) on page 7-8.

---

## 7.5 Digital Audio Tape (DAT) Replacement Procedures

All backup procedures and any other customer administrative procedures must be completed by the responsible system administrator prior to DAT replacement by Field Service personnel.



---

**Caution** – Before removing a board from the system, the green activation LED must be off and the amber or blue removal OK LED must be on. See [Section 7.2.2, “Powering Off a System Control \(SC\) Peripheral Board”](#) on page 7-5.

---

### 7.5.1 Removing the Failed DAT From the System Control (SC) Peripheral Board



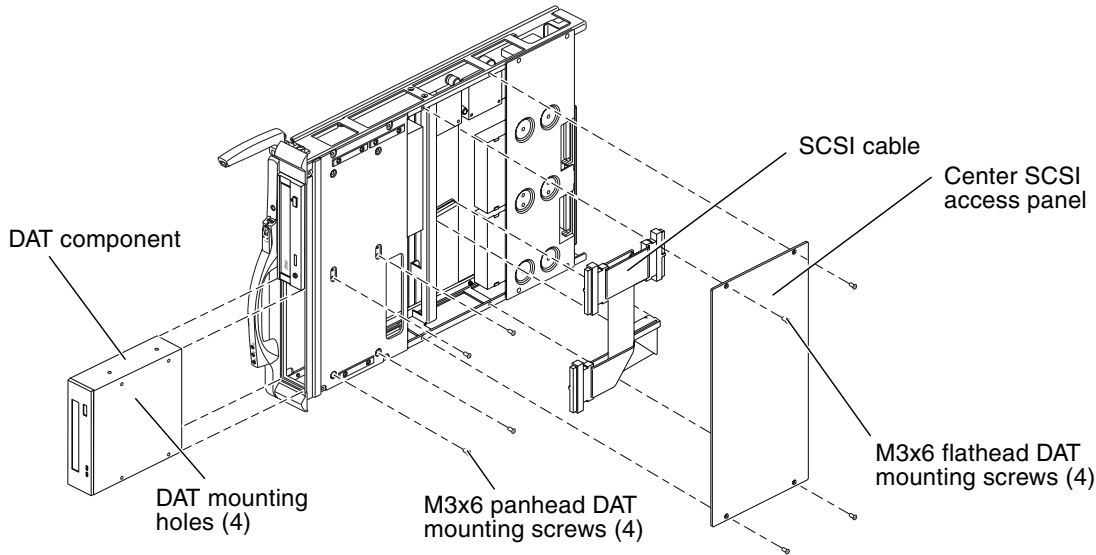
---

**Caution** – Be sure you are properly grounded before you begin the hardware removal and installation. There are ground points at the top left and top right of the cabinet in both front and rear.

---

1. **Open the cabinet door.**
2. **Power off the SC Board.**  
See [Section 6.1.2.2, “Powering Off a System Control \(SC\) Board”](#) on page 6-4.
3. **Remove the SC Peripheral board.**  
See [Section 7.2.3, “Removing a System Control \(SC\) Peripheral Board”](#) on page 7-5.
4. **At the center SCSI access panel, remove the four (4) M3x6 flathead screws and remove the access panel.**
5. **Disconnect the SCSI ribbon cable connector and the DAT PWR cable connector from the DAT peripheral.**
6. **To access the internal DAT component of the SC peripheral board, remove the four (4) M3x6 panhead screws from the forward mounting panel, as shown in [FIGURE 7-5](#).**
7. **From the front of the SC peripheral board, pull out the failed DAT and place on an ESD-protected surface.**

**FIGURE 7-5** SC Peripheral Board DAT Removal and Access Panel—Exploded



## 7.5.2 Installing the DAT on the System Control (SC) Peripheral Board

1. With the SC peripheral board in horizontal position, insert a new DAT into the bottom bay with the mounting holes aligned upward.
2. Push the DAT inward until the front-panel bezel meets the SC peripheral board housing.
3. Align the four (4) holes of the side-panel sheet metal with the four (4) holes of the DAT.
4. Secure the DAT to the SC peripheral board with the four (4) M3x6 panhead screws.
5. Connect the DAT power cable and the SCSI ribbon cable connectors.
6. Install the center SCSI access panel and secure with the four (4) M3x6 flathead screws.
7. Install the SC peripheral board.  
See [Section 7.2.4, "Installing a System Control \(SC\) Peripheral Board"](#) on page 7-7.
8. Close the cabinet door.



## 7.5.3 Powering On a Digital Audio Tape (DAT)

- Power on the SC by using the Sun Management Center or from the main SC by typing the following SMS command:

```
sc% resetsc
```

```
About to reset other SC. Are you sure you  
want to continue? (yes/no)? yes
```

## 7.5.4 Verifying a Digital Audio Tape (DAT)

- Verify the DAT.

See [Section 7.2.6, “Verifying a System Control \(SC\) Peripheral Board”](#) on page 7-8.



## CPU (Slot 0) Board

---

The standard hot-swappable CPU boards or CPU filler panels for the Sun Fire E25K/E20K systems are inserted into slot 0, expander 0 through 8 (front), and slot 0, expander 9 through 17 (rear). This chapter contains the replacement procedures for the standard CPU board, the CPU board DIMMs, and the CPU filler panels.

This chapter contains the following sections:

- Section 8.1, “CPU (Slot 0) Board LEDs” on page 8-2
- Section 8.2, “CPU (Slot 0) Board Replacement Procedures” on page 8-3
- Section 8.3, “CPU (Slot 0) Board DIMM Replacement Procedures” on page 8-8
- Section 8.4, “CPU (Slot 0) Filler Panel Replacement Procedures” on page 8-12

For your protection, observe the following safety precautions:

- Follow all cautions and instructions marked on the equipment.
- Always use proper ESD equipment and procedures when handling boards and components.
- Never push objects of any kind through openings in the equipment as they might touch dangerous voltage points or short out components that can result in fire or electric shock.
- Refer servicing of equipment to qualified personnel.

The following configuration rules apply when configuring components of the Sun Fire E25K/E20K systems:

---

**Note** – The CPU/Memory board field-replaceable unit (FRU) is for maintenance use only. FRUs must not be used to upgrade CPU performance in systems. Usage as such can violate United States export regulations.

---

- All CPU modules must be the same speed.
- All external cache modules must be the same size.
- When configuring memory:

- All sockets within a bank must be fully populated.
- All DIMM sizes within a bank must be equal.

## 8.1 CPU (Slot 0) Board LEDs

CPU Board components and LEDs are listed in [TABLE 8-1](#) and [TABLE 8-2](#).

**TABLE 8-1** CPU Board Components

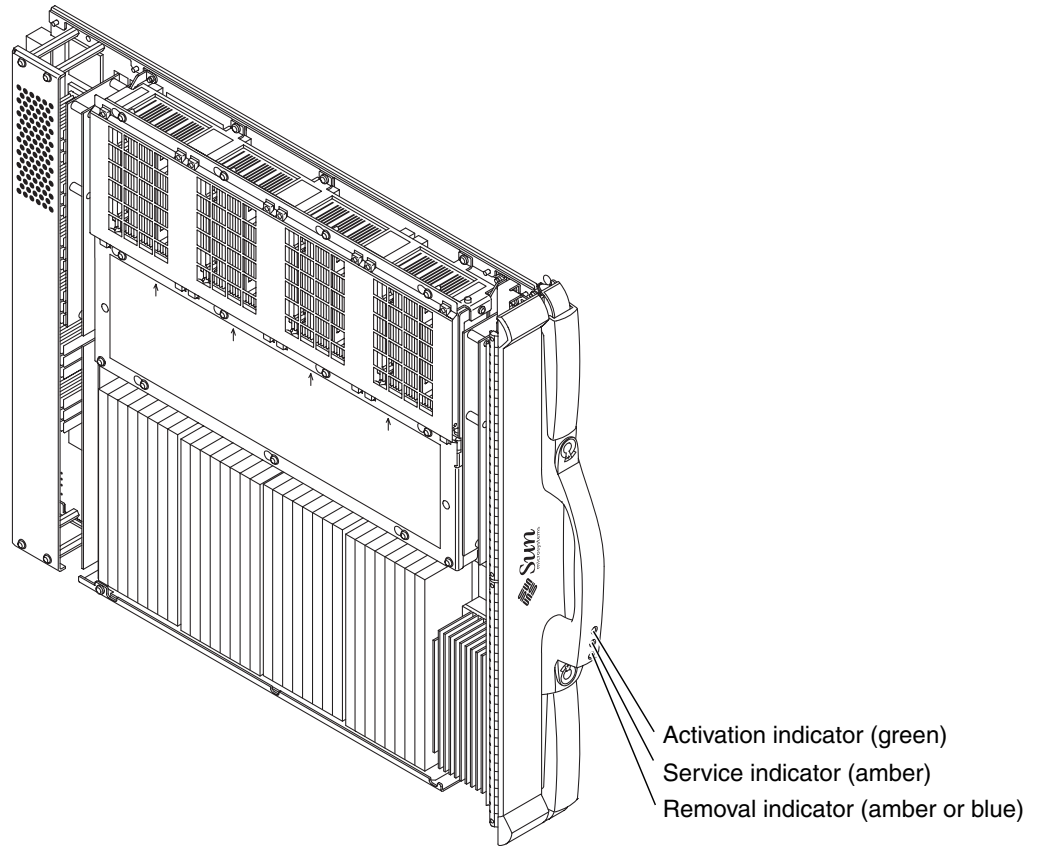
| Total Number of CPU Boards Per System | Total Number of CPU Boards Per Side | Number of LEDs Per CPU Board |
|---------------------------------------|-------------------------------------|------------------------------|
| 1-18                                  | 0-9                                 | 3                            |

**TABLE 8-2** CPU Board Valid LED Status

| LEDs After Insertion or Initial System Power On |         |        | Component Powered On |         |        | Component Powered Off |         |        |
|---|---------|--------|----------------------|---------|--------|-----------------------|---------|--------|
| Active  | Service | Remove | Active               | Service | Remove | Active                | Service | Remove |
| off   | off     | on     | on                   | off     | off    | off                   | off     | on     |

[FIGURE 8-1](#) illustrates the CPU board and the LED locations.

**FIGURE 8-1** CPU Board LEDs



---

## 8.2 CPU (Slot 0) Board Replacement Procedures

### 8.2.1 Isolating a Failed CPU (Slot 0) Board

1. Check for any error messages during POST.
2. On the SC, check for any error messages in `/var/opt/SUNWSMS/adm/platform/messages` and `/var/opt/SUNWSMS/adm/domain_id/messages`, where *domain\_id* is the domain letter.

If available, examine any DStop or RStop files located in  
`/var/opt/SUNWSMS/adm/domain_id/dump.`

where *domain\_id* is the domain letter.

3. On the specific domain(s), use `adb` to examine any core files in  
`/var/crash/hostname.`

## 8.2.2 Powering Off a CPU (Slot 0) Board

1. Check the power state of the board to be removed by typing:

```
sc% showboards | grep SBx
```

where *x* is the CPU board 0-17.

- If the board is powered `off`, go to [Section 8.2.3, “Removing a CPU \(Slot 0\) Board” on page 8-5.](#)
- If the power state is `On` and the board status is `Isolated` and not part of the domain, power off the CPU board by using the Sun Management Center or by typing the following SMS command:

```
sc% poweroff SBx
```

where *x* is the CPU Board 0-17. Go to [Section 8.2.3, “Removing a CPU \(Slot 0\) Board” on page 8-5.](#)

2. If the board is part of a multi-board domain or a single-board domain, do the following:
  - For a multi-board domain, use dynamic reconfiguration to deconfigure the CPU from the running domain by using the Sun Management Center or by typing the following SMS command:

```
sc% deleteboard SBx
```

where *x* is the CPU Board 0-17. Go to [Section 8.2.3, “Removing a CPU \(Slot 0\) Board” on page 8-5.](#)

- If you have a single-board domain and the operating system is up, log into the domain as the domain administrator and shut down the operating system by typing the following sequence:

```
domain_name# shutdown -y -g seconds -i 0
```

where *seconds* is the amount of time before shutdown.

- Power off the hardware associated with the domain by typing:

```
sc% setkeyswitch -d domain_id off
```

## 8.2.3 Removing a CPU (Slot 0) Board



---

**Caution** – Be sure you are properly grounded before you begin the hardware removal and installation. There are ground points at the top left and top right of the cabinet in both front and rear.

---



---

**Caution** – After the board is removed, carry the board to a work area holding it vertically by the front handle with the connector downward. Lift the board and place the other hand under the bottom, or back, of the board placing the bottom, or back, on an ESD-protected surface. Never place the weight of a board on its connector as it is easily damaged.

---

### 1. Open the cabinet door.



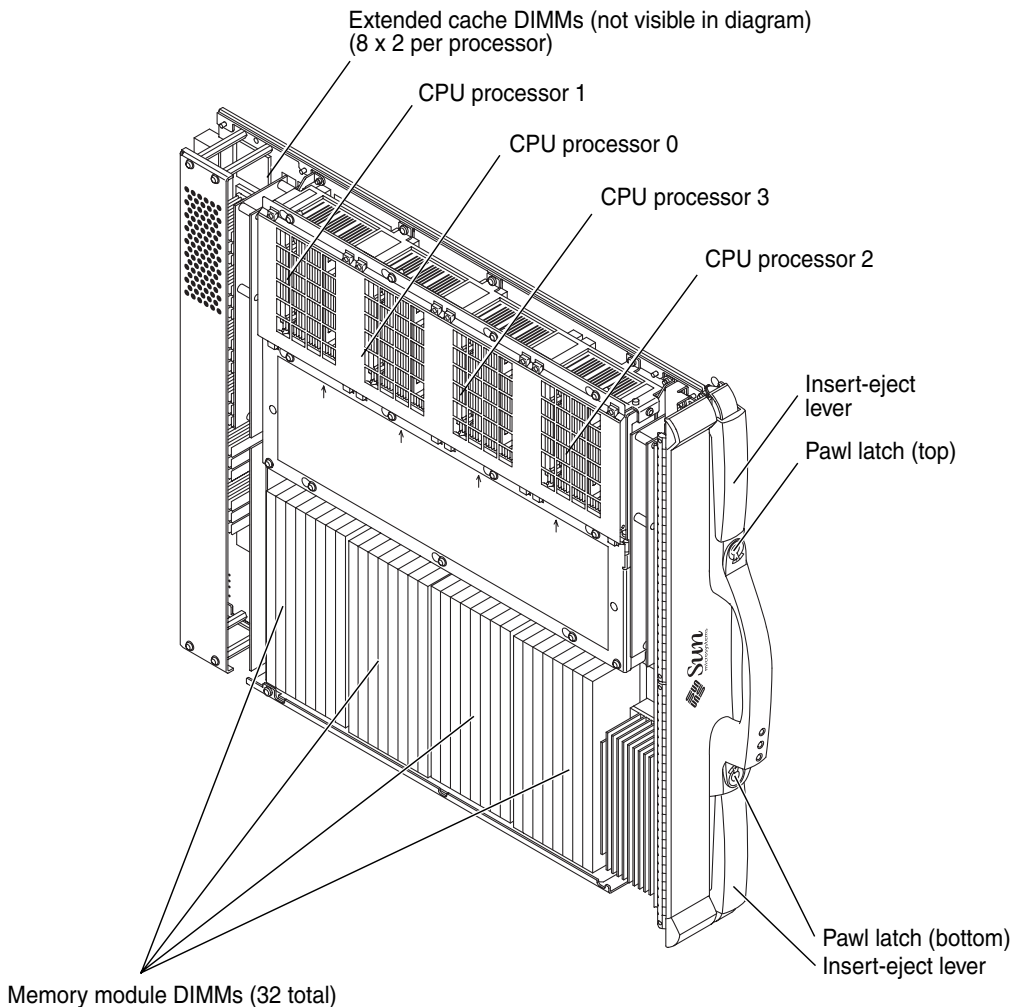
---

**Caution** – Before removing a board from the system, the green activation LED must be off and the amber or blue removal OK LED must be on. See [Section 8.2.2, “Powering Off a CPU \(Slot 0\) Board”](#) on page 8-4.

---

2. Insert a Phillips No. 1 screwdriver into top and bottom pawl latches turning counterclockwise to release the levers operating the two (2) board carrier insert-eject levers simultaneously ([FIGURE 8-2](#)).
3. Use the front handle to extract the CPU board, supporting the bottom with the other hand, and place it on a flat, sturdy, ESD-protected surface with the component side up.

**FIGURE 8-2** CPU Board Components



4. Review the platform message log to verify SMS has received the message that the component has been removed, by typing:

```
sc% showlogs -F
```

Review the board removal message. You will see a message similar to the one below.

```
Jun 16 14:28:05 2003 sun15-sc0: esmd[7167]: [0 4824421445907014  
NOTICE Boards.cc 1646] CPU at SBxx removed
```



where *xx* is the CPU assembly 0-17.

**5. Remove the memory module DIMMs from the board and set aside.**

See [Section 8.3.1, “Removing the CPU DIMMs”](#) on page 8-9.

## 8.2.4 Installing a CPU (Slot 0) Board

Inspect the new board before inserting it into the Sun Fire E25K/E20K systems.

- 1. Remove the connector protective cover from the board being installed and inspect the connector for any damage or gaps between the pins.**
- 2. Ensure board alignment tabs are not bent.**
- 3. Inspect the mating connector before inserting the new board.**



---

**Caution** – Do not force any board into a slot; it can cause damage to the board and the system. The board should insert and seat smoothly. If it binds, remove the board and inspect the card cage slot for any obvious obstructions.

---

**4. Install the memory module DIMMs removed from the board.**

See [Section 8.3.2, “Installing the CPU DIMMs”](#) on page 8-11.

**5. To install a CPU (slot 0) board, firmly grasp the board by the front handle, supporting the bottom with the other hand, and position it onto the carrier rail.**

See [FIGURE 8-2](#) detailing the CPU board components.

**6. With the insert-eject levers extended, slide the board into the slot until it begins to connect with the expander connector.**

**7. Apply firm pressure to the face plate to fully seat the board with the expander connector.**

**8. Use the insert-eject lever to fully seat and automatically lock the board into position.**

The usual failure of the service LED to transition from on to off within 60 seconds after insertion, indicating a power-status control fault, does not apply for the CPU board.

**9. Verify the LED status per [TABLE 8-2](#).**

10. Review the platform message log to verify SMS has received the message that the component has been inserted, by typing:

```
sc% showlogs -F
```

Review the board insertion message. You will see a message similar to the one below.

```
Jun 16 14:30:05 2003 sun15-sc0: esmd[7167]: [0 4824421445907014  
NOTICE Boards.cc 1646] CPU at SBxx inserted
```

where *xx* is the CPU assembly 0-17.

11. Close the cabinet door.

## 8.2.5 Verifying a CPU (Slot 0) Board

1. Using dynamic reconfiguration, configure the CPU board into the domain(s) by using the Sun Management Center or by typing the following SMS command:

```
sc% addboard -d domain_id SBx
```

where *x* is the CPU Board 0-17.

*domain\_id* is the letter A-R of the target domain(s) for the component.

OR

If the domain was shut down prior to the expander replacement, start the domain by typing:

```
sc% setkeyswitch -d domain_id on
```

2. Examine the POST messages reported by the `addboard` or `setkeyswitch` for any errors. Also monitor the message logs on the SC, specifically  
`/var/opt/SUNWSMS/adm/platform/messages` and  
`/var/opt/SUNWSMS/adm/domain_id/messages`.

---

## 8.3 CPU (Slot 0) Board DIMM Replacement Procedures

## 8.3.1 Removing the CPU DIMMs



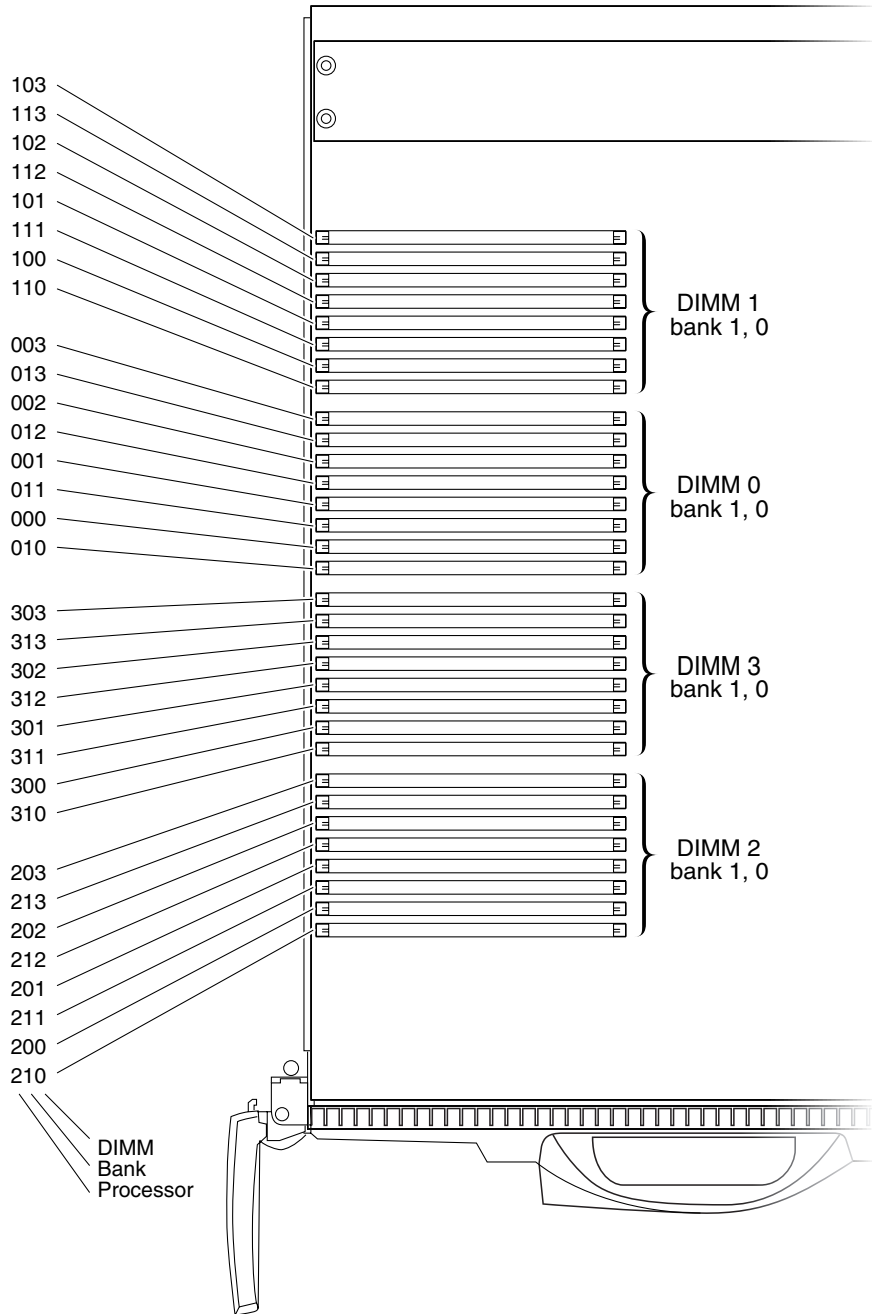
---

**Caution** – Be sure you are properly grounded before you begin the hardware removal and installation. There are four ground points on the system cabinet, two at the front top left and top right, and two at the rear top left and top right.

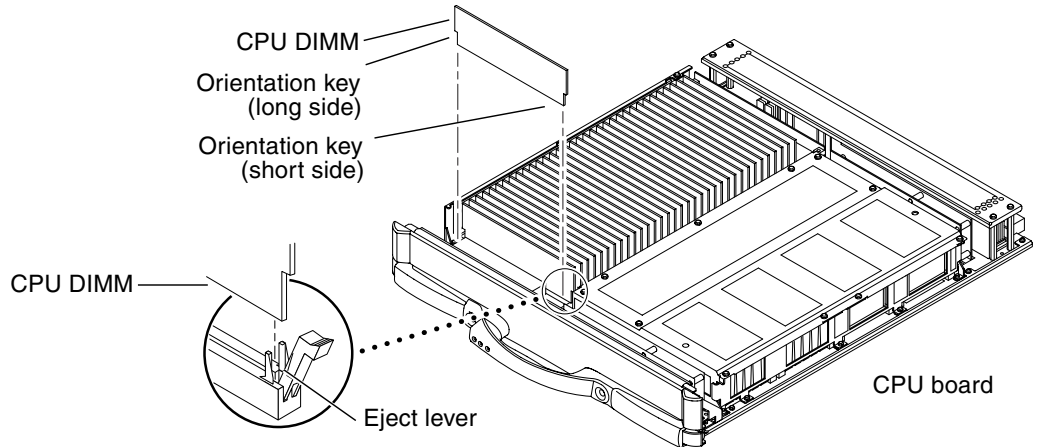
---

1. Open the cabinet door.
2. Remove the CPU board requiring a DIMM replacement by following the procedures in:
  - [Section 8.2.2, “Powering Off a CPU \(Slot 0\) Board”](#) on page 8-4
  - [Section 8.2.3, “Removing a CPU \(Slot 0\) Board”](#) on page 8-5
3. Locate the slot for the CPU DIMM requiring replacement. DIMM location numbers are shown in [FIGURE 8-3](#).
4. Eject the faulty CPU DIMM by pressing down on the ejection levers on both sides of the DIMM connector as shown in [FIGURE 8-4](#).
5. Remove the CPU DIMM by holding the edges and place on an ESD-protected surface.

**FIGURE 8-3** CPU Board Memory DIMM Locations



**FIGURE 8-4** CPU DIMM Removal



## 8.3.2 Installing the CPU DIMMs



---

**Caution** – Be sure you are properly grounded before you begin the hardware removal and installation. There are ground points at the top left and top right of the cabinet in both front and rear.

---

1. Ensure the CPU board is on an ESD-protected surface.
2. Carefully remove the new CPU DIMM from its protective packaging and place it on an ESD-protected surface.

---

**Note** – Install one bank completely on each board before installing the remaining banks. All banks must have the same size DIMMs. DIMMs from different manufacturers are interchangeable in a single bank if the DIMMs have the same capacity and speed. Sort the DIMMs into banks by DIMM size.

---

3. Press down on the ejector levers at both ends of the DIMM connector slot to set them in the insert-ready position.
4. Align the short-side and the long-side orientation key of the CPU DIMM with the short side and long side orientation position of the DIMM connector (FIGURE 8-4).
5. Push firmly on the top edge of the CPU DIMM to insert into the DIMM connector.
6. Install the remaining new CPU DIMMs.

7. After installation of the new CPU DIMMs, follow the procedures in:
  - [Section 8.2.4, “Installing a CPU \(Slot 0\) Board” on page 8-7](#)
  - [Section 8.2.5, “Verifying a CPU \(Slot 0\) Board” on page 8-8](#)
8. Close the cabinet door.

---

## 8.4 CPU (Slot 0) Filler Panel Replacement Procedures

### 8.4.1 Removing a CPU (Slot 0) Filler Panel



---

**Caution** – Be sure you are properly grounded before you begin the hardware removal and installation. There are ground points at the top left and top right of the cabinet in both front and rear.

---

1. Open the cabinet door.
2. Insert a Phillips No. 1 screwdriver into the top and bottom pawl latches turning counterclockwise to release the levers operating the two (2) board carrier insert-eject levers simultaneously.
3. Use the front handle to extract the CPU filler panel, supporting the bottom with the other hand, and place on a flat, sturdy, surface.

### 8.4.2 Installing a CPU (Slot 0) Filler Panel

1. Firmly grasp the CPU filler panel by the front handle, supporting the bottom with the other hand, and position it onto the carrier rail.
2. With the insert-eject levers extended, slide the panel into the slot until it is even with the other boards.
3. Use the front handle to fully seat the board.
4. Lock the CPU filler panel by sliding the insert-eject levers into position until they are fully nested with the front handle.
5. Close the cabinet door.

## I/O (Slot 1) Assemblies

---

The I/O assemblies and I/O filler panels are inserted into slot 1, expander 0 through 8 (front), and slot 1, expander 9 through 17 (rear). This chapter contains the replacement procedures for the I/O assemblies (hsPCI-X/hsPCI+), the I/O filler panels and the PCI Cassettes that go in them.

This chapter contains the following sections:

- [Section 9.1, “I/O Assembly” on page 9-2](#)
- [Section 9.2, “PCI Cassette Replacement Procedures” on page 9-7](#)
- [Section 9.3, “PCI Cassette Card Replacement Procedures” on page 9-10](#)
- [Section 9.4, “I/O Filler Panel Replacement Procedures” on page 9-11](#)

For your protection, observe the following safety precautions:

- Follow all cautions and instructions marked on the equipment.
- Always use proper ESD equipment and procedures when handling boards and components.
- Never push objects of any kind through openings in the equipment as they might touch dangerous voltage points or short out components that can result in fire or electric shock.
- Refer servicing of equipment to qualified personnel.

---

**Note** – For I/O assembly maintenance, all cable management straps should remain in place. Any disconnected cable set will hang from the black cable hanger strap at the air plenum cutout.

---

# 9.1 I/O Assembly

## 9.1.1 I/O Assembly LEDs

I/O assemblies and LEDs are listed in [TABLE 9-1](#) and [TABLE 9-2](#).

**TABLE 9-1** I/O Assembly Components

| Total Number of Assemblies Per System | Total Number of Assemblies Per Side | Number of LEDs Per Assembly |
|---------------------------------------|-------------------------------------|-----------------------------|
| 1-18                                  | 0-9                                 | 15                          |

**TABLE 9-2** I/O Assembly Valid LED Status

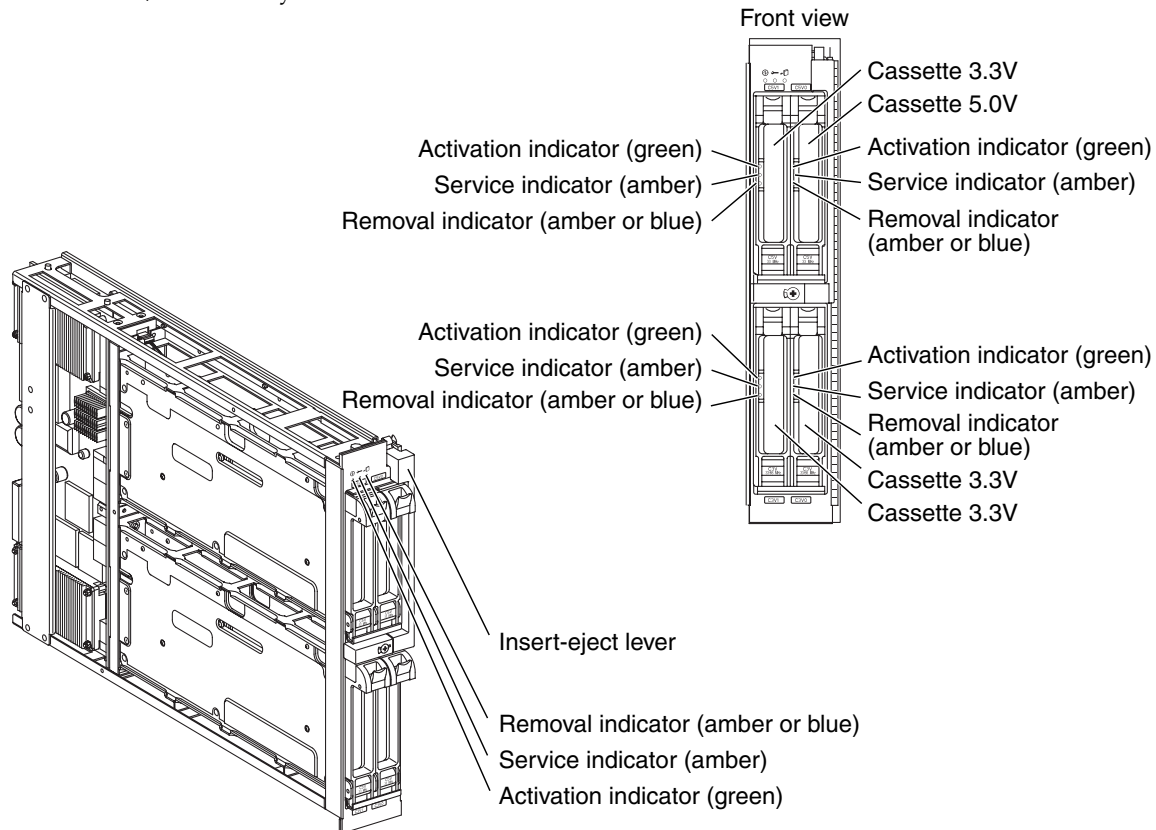
| LEDs After Insertion or Initial System Power On |         |        | LEDs After Presence is Detected |         |        | Component Powered On |         |        | Component Powered Off |         |        |
|---|---------|--------|---------------------------------|---------|--------|----------------------|---------|--------|-----------------------|---------|--------|
| Active  | Service | Remove | Active                          | Service | Remove | Active               | Service | Remove | Active                | Service | Remove |
| off   | on      | on     | off                             | off     | on     | on                   | off     | off    | off                   | off     | on     |

Failure of the service LED to transition from ON to OFF within 60 seconds after insertion indicates a power-status control fault.

[FIGURE 9-1](#) illustrates the I/O assembly and the LED locations.



**FIGURE 9-1** I/O Assembly LEDs



## 9.1.2 I/O Assembly Replacement Procedures

All I/O assemblies (hsPCI-X/hsPCI+) have identical replacement instructions.

### 9.1.2.1 Isolating a Failed I/O Assembly

1. **Check for any error messages during POST.**
2. **On the SC, check for any error messages in**  
`/var/opt/SUNWSMS/adm/platform/messages` and  
`/var/opt/SUNWSMS/adm/domain_id/messages`.  
where *domain\_id* is the domain letter.

3. If available, examine any DStop or RStop files located in `/var/opt/SUNWSMS/adm/domain_id/dump`, where `domain_id` is the domain letter.
4. On the specific domain(s), use `adb` to examine any core files in `/var/crash/hostname`.

## 9.1.2.2 Powering Off an I/O Assembly

1. Check the power state of the board to be removed by typing:

```
sc% showboards | grep IOx
```

where `x` is the I/O assembly 0-17.

- If the board is powered off, go to [Section 9.1.2.3, “Removing an I/O Assembly” on page 9-5](#).
- If the power state is On and the board status is Isolated and not part of the domain, power off the I/O assembly by using the Sun Management Center or by typing the following SMS command:

```
sc% poweroff IOx
```

where `x` is the I/O assembly 0-17, and go to [Section 9.1.2.3, “Removing an I/O Assembly” on page 9-5](#).

2. If the assembly is part of a multi-board domain or a single-board domain, do the following:
  - Terminate all input/output device operations associated with the I/O assembly to be deconfigured.
  - For multi-board domain, using dynamic reconfiguration, deconfigure the I/O assembly from the running domain by using the Sun Management Center or by typing the following SMS command:

```
sc% deleteboard IOx
```

where `x` is the I/O assembly 0-17, and go to [Section 9.1.2.3, “Removing an I/O Assembly” on page 9-5](#).

- If you have a single-board domain and the operating system is running, log into the domain as the domain administrator and shut down the operating system by typing the following sequence:

```
domain_name# shutdown -y -g seconds -i 0
```

where *seconds* is the amount of time before shutdown.

- Power off the hardware associated with the domain by typing:

```
sc% setkeyswitch -d domain_id off
```

### 9.1.2.3 Removing an I/O Assembly



---

**Caution** – Be sure you are properly grounded before you begin the hardware removal and installation. There are ground points at the top left and top right of the cabinet in both front and rear

---



---

**Caution** – After the board is removed, carry the board to a work area holding it vertically by the front handle with the connector downward. Lift the board and place the other hand under the bottom, or back, of the board placing the bottom, or back, on an ESD-protected surface. Never place the weight of a board on its connector as it is easily damaged.

---

#### 1. Open the cabinet door.



---

**Caution** – Before removing a board from the system, the green activation LED must be off and the amber or blue removal OK LED must be on. See [Section 9.1.2.2, “Powering Off an I/O Assembly”](#) on page 9-4.

---

2. Label and remove the I/O cables from the hsPCI assembly.
3. Insert a Phillips No. 1 screwdriver into the pawl latches turning counterclockwise to release the lever and lift the carrier insert-eject lever.
4. Use the front handle to extract the hsPCI (slot 1) assembly, supporting the bottom with the other hand, and place it on a flat, sturdy, ESD-protected surface with the component side up.

5. Review the platform message log to verify SMS has received the message that the component has been removed, by typing:

```
sc% showlogs -F
```

Review the board removal message. You will see a message similar to the one below.

```
Jun 16 14:28:05 2003 sun15-sc0: esmd[7167]: [0 4824421445907014  
NOTICE Boards.cc 1646] HPCI at IOxx removed
```

where *xx* is the I/O assembly 0-17.

### 9.1.2.4 Installing an I/O Assembly

1. To install a I/O assembly, firmly grasp the board assembly, supporting the bottom with the other hand, and position it onto the carrier rail.
2. With the insert-eject lever extended, slide the board into the slot until it begins to connect with the expander connector.
3. Apply firm pressure to the face plate to properly seat the board with the expander connector.
4. Use the insert-eject lever to fully seat and automatically lock the board into position.  
Failure of the service LED to transition from on to off within 60 seconds after insertion indicates a power-status control fault.
5. Verify the LED status per [TABLE 9-2](#).
6. Install all I/O cables.
7. Review the platform message log to verify SMS has received the message that the component has been inserted, by typing:

```
sc% showlogs -F
```

Review the board insertion message. You will see a message similar to the one below.

```
Jun 16 14:30:05 2003 sun15-sc0: esmd[7167]: [0 4824421445907014  
NOTICE Boards.cc 1646] HPCI at IOxx inserted
```

where *xx* is the I/O assembly 0-17.

8. Close the cabinet door.

### 9.1.2.5 Powering On an I/O Assembly

- Power on the I/O assembly by using the Sun Management Center or by typing the following SMS command:

```
sc% poweron IOx
```

where *x* is the I/O assembly 0-17.

### 9.1.2.6 Verifying an I/O Assembly

1. Using dynamic reconfiguration, configure the I/O assembly into the domain by using the Sun Management Center or by typing the following SMS command:

```
sc% addboard -d domain_id IOx
```

where *x* is the I/O assembly 0-17.

*domain\_id* is the letter A-R of the target domain(s) for the board.

OR

**If the domain was shut down prior to the expander replacement, start the domain by typing:**

```
sc% setkeyswitch -d domain_id on
```

2. Examine the POST messages reported by the `addboard/setkeyswitch` for any errors. Also monitor the message logs on the SC, specifically  
`/var/opt/SUNWSMS/adm/platform/messages` and  
`/var/opt/SUNWSMS/adm/domain_id/messages`.

---

## 9.2 PCI Cassette Replacement Procedures

The cassettes in the I/O assembly are also hot-swap components.

## 9.2.1 PCI Cassette Replacement

### 9.2.1.1 Removing the PCI Cassette



---

**Caution** – Before removing a cassette, the green activation LED must be off and the amber or blue removal OK LED must be on. See [TABLE 9-2](#) for I/O LED descriptions.

---

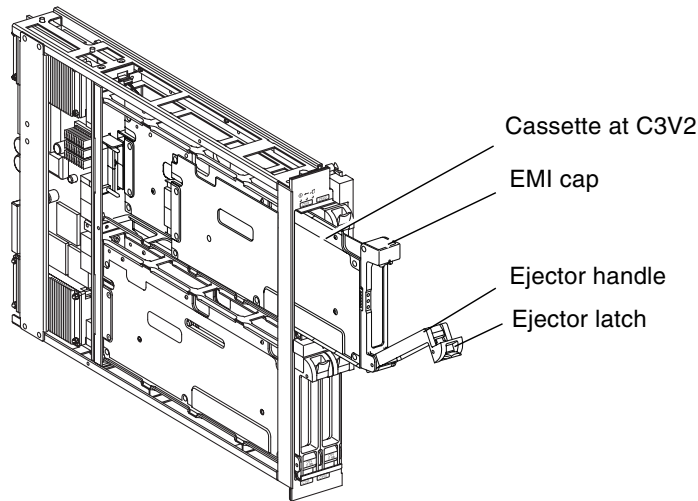
1. Open the cabinet door.
2. Ensure that the adapter in the cassette to be removed has terminated all input/output operations. Refer to the man pages for `ifconfig` or `umount` for more information.
3. The customer domain administrator should power off the cassette by typing the following `rcfgadm` command:

```
sc% rcfgadm -d domain_id -c disconnect ap_id
```

where *ap\_id* is a DR attachment point identifier for the PCI cassette. Refer to the `rcfgadm` man page for attachment point identifier details.

4. Wait for the amber or blue removal indicator LED to illuminate.
5. Label and remove the I/O cables from the cassette.
6. Press down the ejector latch at the top front of the cassette to release the ejector handle ([FIGURE 9-2](#)) and carefully remove the cassette.

**FIGURE 9-2** PCI Cassette Removal



7. Grab the handle and pull forward to release the cassette from the I/O assembly.

### 9.2.1.2 Installing the PCI Cassette

1. Insert the PCI cassette into the appropriate slot (C5V0, C3V0, C3V1, or C3V2).
2. Push the cassette inward and push the eject handle upward into position seating the cassette into the connector.
3. Reconnect the I/O cables to the cassette.
4. To power on the board, the customer domain administrator should type:

```
sc% rcfgadm -d domain_id -c configure ap_id
```

where *ap\_id* is a DR attachment point identifier for the PCI cassette. Refer to the `rcfgadm` man page for attachment point identifier details.

5. Verify that the activation LED is green.
6. Close the cabinet door.

---

## 9.3 PCI Cassette Card Replacement Procedures

### 9.3.1 PCI Cassette Card Replacement

#### 9.3.1.1 Removing the PCI Card from the Cassette

1. Open the cabinet door.
2. Remove the 3.3v or 5.0v PCI card cassette.
3. To access the PCI slot, remove the two (2) M3x5 flathead screws and remove the EMI cap.
4. Remove the one (1) M3x4 panhead screw securing the PCI card to the front panel.



---

**Caution** – Avoid damaging components on the PCI card when removing.

---

5. From the top of the cassette, carefully grab each edge of the PCI card at the notches provided on the PCB board, avoid the components, and pull to release the card from the connector.

#### 9.3.1.2 Installing the PCI Card into the Cassette

1. To access the PCI slot, remove the two (2) M3x5 flathead screws and remove the EMI cap.
2. For a new PCI card installation, remove the one (1) M3x4 panhead screw and discard the filler panel.
3. Install the new PCI card, inserting vertically into the PCI slot of the cassette. Push firmly until the PCI card is fully seated with the connector.
4. Reinstall the EMI cap.
5. Secure the PCI card with the two (2) M3x5 flathead screws.
6. Insert the PCI cassette into the hsPCI assembly.



7. Close the cabinet door.

---

## 9.4 I/O Filler Panel Replacement Procedures

### 9.4.1 Removing an I/O Filler Panel



---

**Caution** – Be sure you are properly grounded before you begin the hardware removal and installation. There are four ground points on the system cabinet, two at the front top left and top right, and two at the rear top left and top right.

---

1. Open the cabinet door.
2. Insert a Phillips No. 1 screwdriver into the pawl latches, turning counterclockwise to release the lever, and lift the carrier insert-eject lever.
3. Use the front handle to extract the I/O filler panel, supporting the bottom with the other hand, and place on a flat, sturdy, surface.

### 9.4.2 Installing an I/O Filler Panel

1. Firmly grasp the I/O filler panel by the front handle, supporting the bottom with the other hand, and position it onto the carrier rail.
2. With the insert-eject lever extended, slide the panel into the slot until it is even with the other boards.
3. Use the front handle to fully position the panel.
4. Lock the I/O filler panel by sliding the insert-eject lever into position until it is fully nested with the front handle.
5. Close the cabinet door.



## Board Set Carrier Plates

---

The board set carrier plates inside the Sun Fire E25K/E20K systems require special handling. There are also three different configuration setups depending on the board sets the carrier plate is assigned to carry. For increased thermal control, a carrier plate with an air dam has been designed for slots 4, 5, 13, and 14. This chapter contains the replacement procedures for these three configurations.

This chapter contains the following sections:

- [Section 10.1, “Inserting a Board Set Carrier Plate” on page 10-2](#)
- [Section 10.2, “Carrier Plate Configuration Modification and Replacement” on page 10-5](#)

For your protection, observe the following safety precautions:

- Follow all cautions and instructions marked on the equipment.
- Always use proper ESD equipment and procedures when handling boards and components.
- Never push objects of any kind through openings in the equipment as they might touch dangerous voltage points or short out components that can result in fire or electric shock.
- Refer servicing of equipment to qualified personnel.

---

## 10.1 Inserting a Board Set Carrier Plate

The following are general guidelines for inserting a board carrier into the system. To reduce the risk of damage to the connectors, take the following precautions:

- Thoroughly inspect the male and female connectors before making connections.
  - Look for damage to the plastic housings.
  - Look for foreign material in the plastic housings.
  - Look for bent or damaged pins or ground shields.

---

**Note** – If any of these conditions exist, do not try to repair or replace parts unless you have been trained to do so.

---

- **NEVER:**
  - Set or bump a connector against another surface.
  - Place the weight of a board on its connector as it is easily damaged.
  - Insert or remove carrier plates with any slot 0 and slot 1 boards installed.
  - Try to force a connector using an insertion/ejection mechanism if the carrier becomes cocked or jammed.
  - Use damaged components.
- See [Section 10.2, “Carrier Plate Configuration Modification and Replacement” on page 10-5](#) for additional details regarding removal and installation of carriers.



---

**Caution** – It is **critical** that careful handling and seating of the carrier plate is maintained during the insertion process. It is imperative that the simultaneous insertion of the ejector screws be followed to avoid damage to the Sun Fireplane interconnect connectors.

---

When inserting a carrier plate into the card cage:



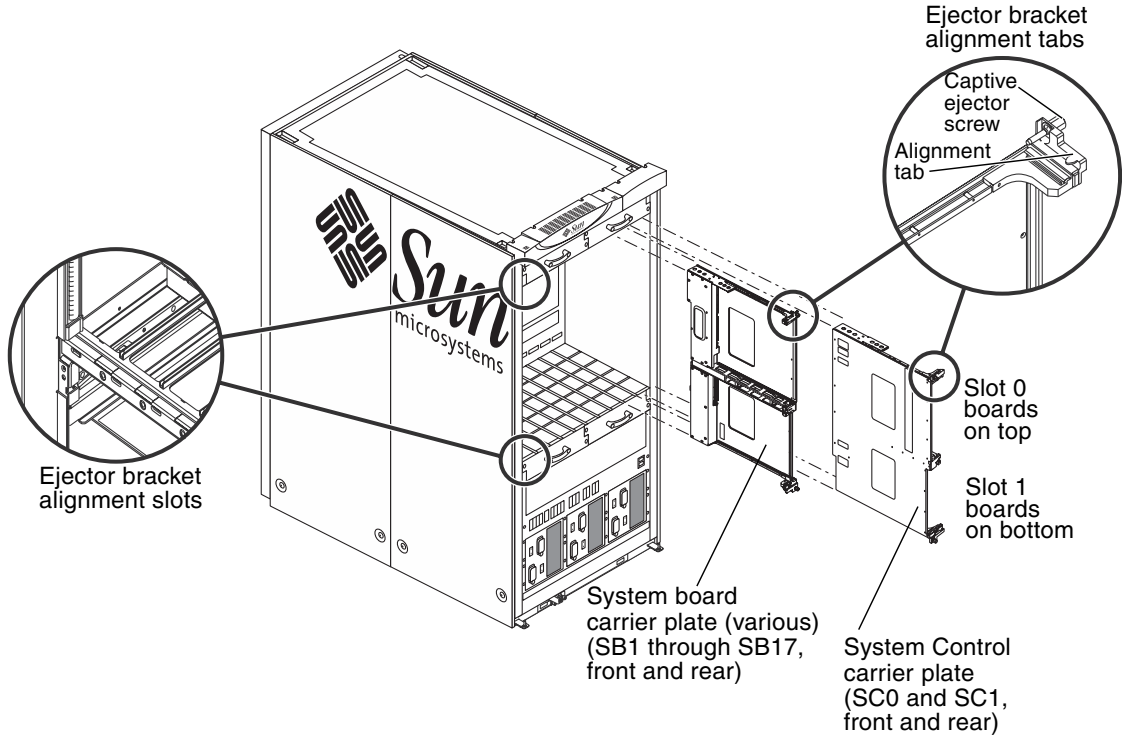
---

**Caution** – Use **extreme caution** when inserting the board set into the card cage of the system. The top-right leading edge of the board set must be aligned properly in the card guide before insertion into the system. This prevents any component parts from being damaged if hit by the edge of the carrier plate, which can result in catastrophic failures to the system operation.

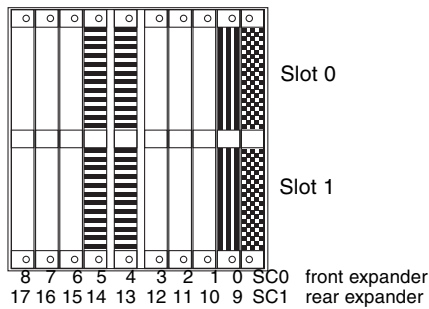
---

1. Hold the bottom edge of the carrier plate and insert it into the bottom of the card guide, aligning with the top card guide to avoiding any angled insertion of the carrier plate ([FIGURE 10-1](#)).

**FIGURE 10-1** System Carrier Plates

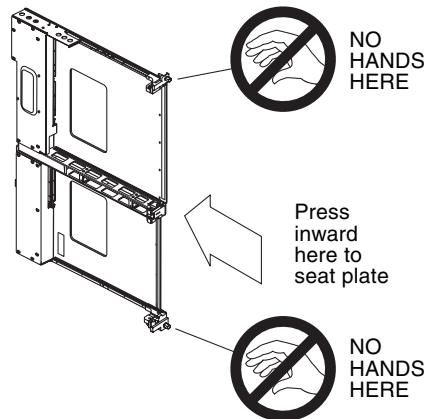


**Carrier Plate Location Placement**



- part number 541-0119
- ▨ part number 541-0120
- ▧ part number 541-0121
- ▩ part number 540-3993

**CAUTION**  
AVOID ANGLED INSERTION



2. Torque the carrier plate captive ejector screws until the driver clicks or slips (equal to 18.0 in.-lbs or 2.2 Nm).

Two (2) 0.5 in. hex socket-fixed torque drivers are provided in the torque tool holder brackets on the inside of the front door. Ensure the torque drivers are returned to the torque tool holder brackets after use.

3. Press the carrier plate inward, with evenly distributed pressure at the center edge, until the captive ejection screws seat against the card cage and the top and bottom alignment tabs on the carrier plate are inserted into the top and bottom alignment slots on the chassis.

If you feel resistance, check for proper alignment of the tabs and the slots (FIGURE 10-1).



---

**Caution** – DO NOT use the torque drivers to secure the carrier plate until the hand insertion process has been completed.

---

4. Secure the captive ejector screws into the threaded inserts of the top and bottom of the card cage.

The screws should be turned by hand simultaneously. The screws should be tightened until the back of the captive ejector screws meet the top and bottom face plate of the carrier plate.

5. Firmly press inward at the center edge of the carrier plate to manually seat the carrier plate again.
6. Manually secure the captive ejector screws simultaneously until the back of the screws meet the face plate.
7. Repeat this process several times until the carrier plate is fully seated and the top and bottom carrier plate ejector bracket alignment tabs (not visible from the front) are evenly set.
8. Use two (2) 0.5 in. hex socket-fixed torque drivers to secure the carrier plate captive ejector screws. Simultaneously secure the top and bottom captive ejector screws until the connector is fully seated and the ejector brackets are flush with the card cage.

The Sun Fire E25K/E20K systems hold various carrier plate types. The System Control carrier plate is part number 540-3993. The system board carrier plates are different depending upon their location within the system, part number 541-0119, 541-0120, and 541-0121. Review the location placement in FIGURE 10-1. For slots 4, 5, 13, and 14, there is also a carrier plate with an air dam, part number 540-5736.

---

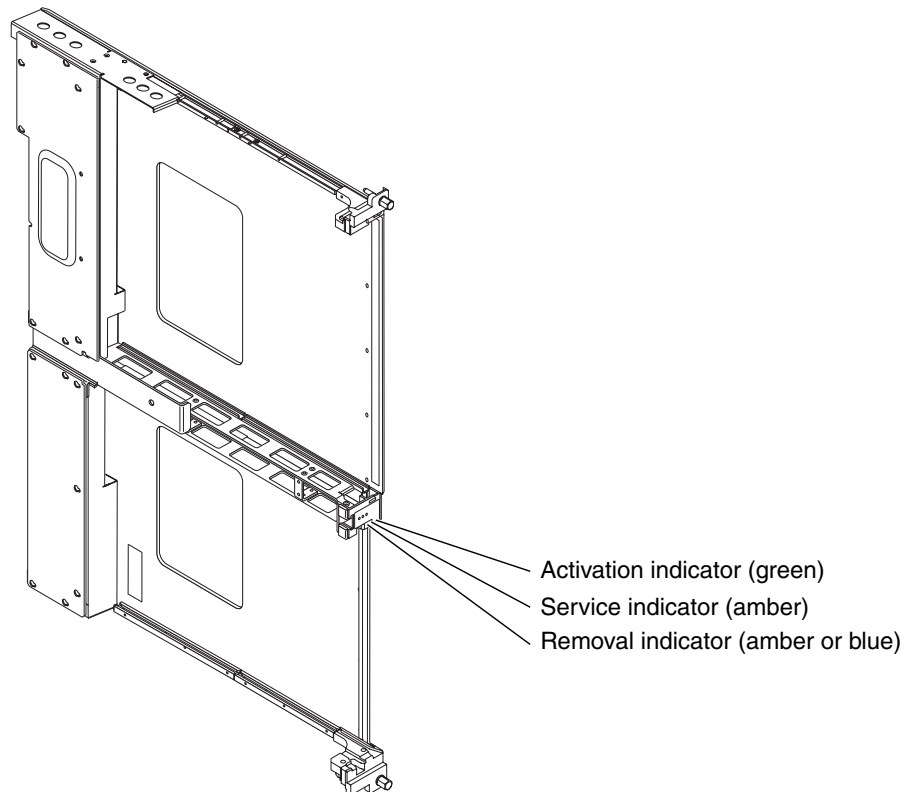
## 10.2 Carrier Plate Configuration Modification and Replacement

The Sun Fire E25K/E20K systems have three varieties of system carrier plate configurations to accommodate the connector locations on the Sun Fireplane interconnect. This field-replaceable unit (FRU) contains the reconfigurable parts to be used with the standard carrier plate for the three types of carrier plate slots ([FIGURE 10-2](#)).

- Standard configuration for slots 1-3, 6-8, 10-12, and 15-17, part number 541-0119
- Configuration modification for system slots 0 and 9, part number 541-0120
- Standard configuration for system slots 4, 5, 13, and 14, part number 541-0121

Review [Section 10.1, “Inserting a Board Set Carrier Plate”](#) on page 10-2 prior to handling the system carrier plates.

**FIGURE 10-2** Standard Configuration Carrier Plate





---

**Caution** – Be sure you are properly grounded before you begin the hardware removal and installation. There are ground points at the top left and top right of the cabinet in both front and rear.

---

## 10.2.1 Two-In-One Carrier Plate FRU Modification Contents

TABLE 10-1 lists the contents of the FRU package.

TABLE 10-1 Carrier Plate FRU Modification Contents

| Part Number | Qty. | Description  |
|-------------|------|--|
| 817-4141    | 1    | FRU Service Document for Carrier Plate Configurations                        |
| 541-0119    | 1    | Carrier plate assembly carrier plate at slots 1,2,3,6,7,8, 10,11,12,15,16,17 |
| 240-4363    | 1    | M3x8 mm flathead screw, plastic coated                                       |

## 10.2.2 Carrier Plate Replacement for Standard Configuration of Slots 1, 2, 3, 6, 7, 8, 10, 11, 12, 15, 16, and 17

1. Remove the carrier plate from the system.

---

**Note** – Follow the instructions in [Section 12.2.3, “Removing an Expander Board”](#) on page 12-5 and [Section 12.2.4, “Installing an Expander Board”](#) on page 12-7.

---

2. Remove the expander board from the carrier plate, as required, and set aside. No modifications are required for standard carrier plate configurations.

---

**Note** – The Sun Fire E25K system has an expander board installed on each carrier plate. The Sun Fire E20K system only has an expander installed on the slot 0 through slot 8 carrier plates. Slots 9 through 17 are filled with filler panels.

---

3. Re-install the expander board, as required, on the new carrier plate.
4. Install the new carrier plate into the system.



5. Discard any remaining hardware supplied with the FRU package.

## 10.2.3 Carrier Plate Configuration and Replacement for Slots 0 and 9

This configuration is for the slots on the left sides of the System Controllers.

1. Remove the carrier plate from the system.

---

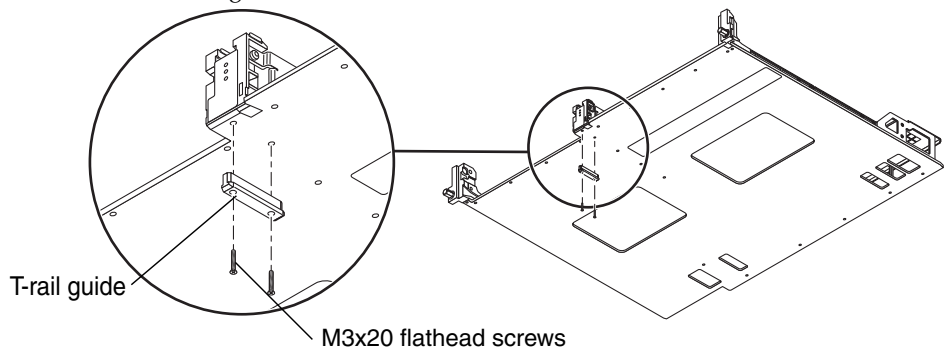
**Note** – Follow the instructions in [Section 12.2.3, “Removing an Expander Board”](#) on page 12-5 and [Section 12.2.4, “Installing an Expander Board”](#) on page 12-7.

---

2. Remove the expander board from the carrier plate, as required, and set aside.  
No changes are required for standard carrier plate configurations.
3. Remove the two (2) M3x20 flathead screws securing the T-rail guide of the new carrier plate to the center guide bracket of the new carrier plate and discard ([FIGURE 10-3](#)).

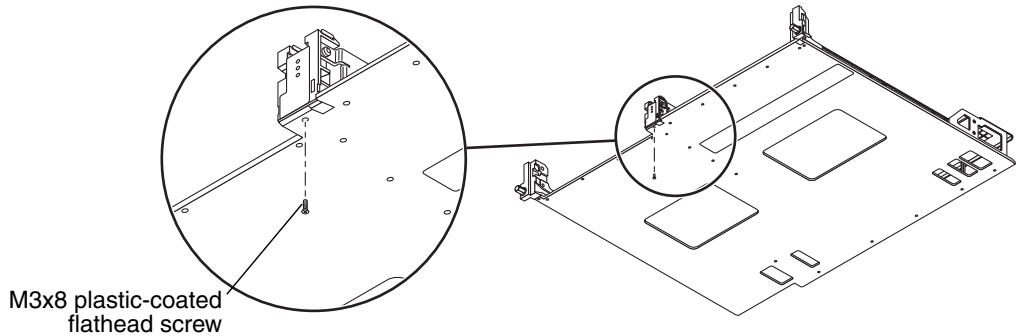
These items are not needed for this configuration.

**FIGURE 10-3** Removing the T-Rail Guide



4. Install one (1) M3x8 flathead plastic-coated screw from the FRU package to secure the center guide bracket to the new carrier plate ([FIGURE 10-4](#)).
5. Re-install the expander board, as required, on the new carrier plate.
6. Install the carrier plate into the system.

**FIGURE 10-4** Securing the Center Guide Bracket After the T-Rail Guide Removal



7. Discard any remaining hardware supplied with the FRU package.

## 10.2.4 Carrier Plate Replacement for Standard Configurations of Slots 4, 5, 13, and 14

1. Remove the carrier plate from the system.

---

**Note** – Follow the instructions in [Section 12.2.3, “Removing an Expander Board”](#) on page 12-5 and [Section 12.2.4, “Installing an Expander Board”](#) on page 12-7.

---

2. Remove the expander board from the carrier plate, as required, and set aside.  
No modifications are required for this standard carrier plate configuration.

---

**Note** – The Sun Fire E25K system has an expander board installed on each carrier plate (with air dam) at slots 4, 5, 13 and 14. The Sun Fire E20K system only has an expander installed on the slot 4 through slot 5 carrier plates. Slot 13 and slot 14 are filled with filler panels.

---

3. Re-install the expander board, as required, on the new carrier plate.
4. Install the new carrier plate into the system.

## System Control Expander Board Set

---

The system control expander board set for the Sun Fire E25K/E20K systems consists of a carrier plate that holds the hot-swappable centerplane support board and the hot-swappable System Control (SC) board at SC0 (front) and SC1 (rear). This chapter contains the replacement procedures for the centerplane support board. See [Chapter 6](#) for the SC replacement procedures.

This chapter contains the following sections:

- [Section 11.1, “Centerplane Support Board Replacement”](#) on page 11-2
- [Section 11.2, “Centerplane Support Board Replacement Procedures”](#) on page 11-3

For your protection, observe the following safety precautions:

- Follow all cautions and instructions marked on the equipment.
- Always use proper ESD equipment and procedures when handling boards and components.
- Never push objects of any kind through openings in the equipment as they might touch dangerous voltage points or short out components that can result in fire or electric shock.
- Refer servicing of equipment to qualified personnel.

# 11.1 Centerplane Support Board Replacement

## 11.1.1 Centerplane Support Board LEDs

Centerplane support board (CSB) components and LEDs are listed in [TABLE 11-1](#) and [TABLE 11-2](#).

**TABLE 11-1** Centerplane Support Board Components

| Total Number of Centerplane Support Boards Per System | Total Number of Centerplane Support Boards Per Side | Number of LEDs Per Centerplane Support Board |
|---|---|--|
| 2   | 1   | 3  |

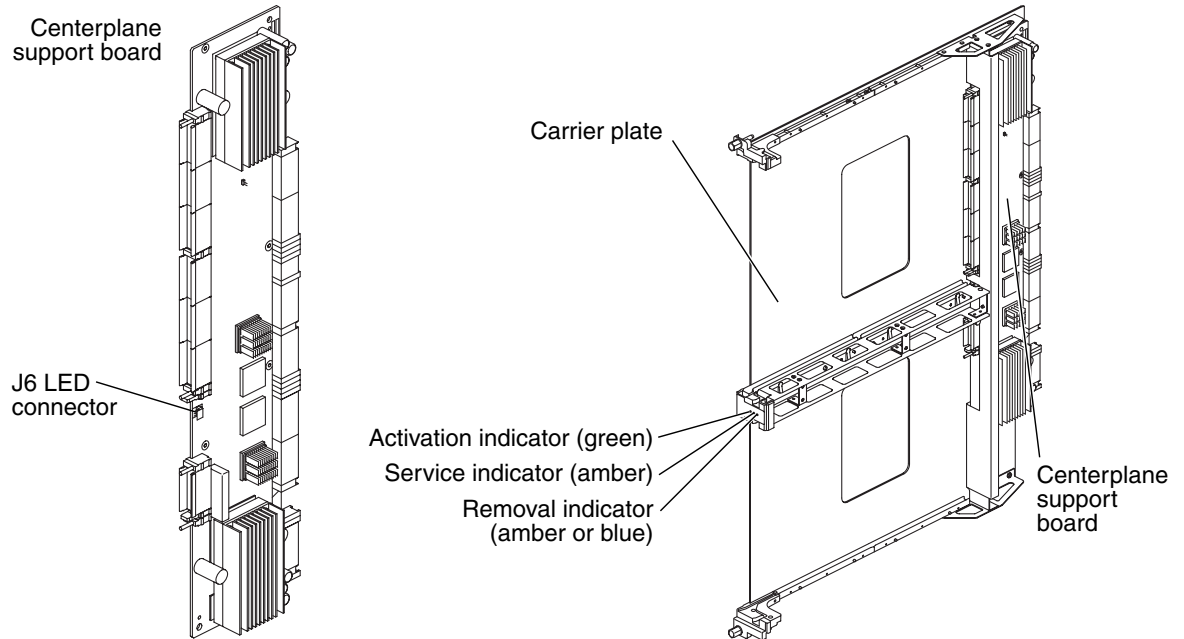
**TABLE 11-2** Centerplane Support Board Valid LED Status

| LEDs After Insertion or Initial System Power On |         |        | LEDs After Presence is Detected |         |        | Component Powered On |         |        | Component Powered Off |         |        |
|---|---------|--------|---------------------------------|---------|--------|----------------------|---------|--------|-----------------------|---------|--------|
| Active  | Service | Remove | Active                          | Service | Remove | Active               | Service | Remove | Active                | Service | Remove |
| off   | on      | on     | off                             | off     | on     | on                   | off     | off    | off                   | off     | on     |

Failure of the service LED to transition from ON to OFF within 60 seconds after insertion indicates a power-status control fault.

FIGURE 11-1 illustrates the centerplane support board and the LED locations.

FIGURE 11-1 Centerplane Support Board LEDs



---

## 11.2 Centerplane Support Board Replacement Procedures



---

**Caution** – The centerplane support board and mounting system (carrier plate) are also used as the electrical interface and mounting mechanism for the system controller. Therefore, prior to removal of the centerplane support board, the System Control board and System Control peripheral modules *must be* deconfigured, powered off, and *removed*. The references to those procedures are included in the following steps.

---

## 11.2.1 Isolating a Failed Centerplane Support Board

1. Check for any error messages during POST.
2. On the SC, check for any error messages in `/var/opt/SUNWSMS/adm/platform/messages`.  
On the SC, if available, examine any DStop dump files or record stop dump files located in `/var/opt/SUNWSMS/adm/domain_id/dump`, where *domain\_id* is the domain letter.
3. On the SC, check the environment by using the Sun Management Center or by typing the following SMS command:

```
sc% showenvironment -p temps | grep CP
```

4. Save this output to a file for later use.

## 11.2.2 Powering Off a Centerplane Support Board

Powering off a centerplane support board also powers off one-half of the Sun Fireplane interconnect assembly.

1. Use dynamic bus reconfiguration to specify the Sun Fireplane interconnect assembly half that will remain active. Failure to do so will DStop all running domains. Type the following command:

```
sc% setbus -c x
```

where *x* is CS0 or CS1. This represents the centerplane support board that will remain powered on (or the one that will not be powered off).

2. Power off a centerplane support board by using the Sun Management Center or by typing the following SMS command:

```
sc% poweroff csx
```

where *x* is 0 or 1. Refer to `poweroff(1M)` for more information.

## 11.2.3 Removing a Centerplane Support Board

Remove boards by pulling outward using the front handle with one hand and placing the other hand underneath the bottom guide rail for additional support. Carry the board to a work area holding vertically, with the connector downward, by the front handle. Lift the board and place the other hand under the bottom, or back, of the board placing the bottom, or back, on an ESD-protected surface.

---

**Note** – Never place the weight of a board on its connector as it is easily damaged.

---



---

**Caution** – Be sure you are properly grounded before you begin the hardware removal and installation. There are ground points at the top left and top right of the cabinet in both front and rear.

---

### 1. Open the cabinet door.



---

**Caution** – Before removing a board from the system, the green activation LED must be off and the amber or blue removal OK LED must be on. See [Section 11.2.2, “Powering Off a Centerplane Support Board”](#) on page 11-4.

---

### 2. Power off and remove the SC.

See [Section 6.1.2.2, “Powering Off a System Control \(SC\) Board”](#) on page 6-4.

See [Section 6.1.2.3, “Removing a System Control \(SC\) Board”](#) on page 6-6.

### 3. Remove the SC peripheral board that occupies the same carrier plate as the centerplane support board being replaced.

See [Section 7.2.3, “Removing a System Control \(SC\) Peripheral Board”](#) on page 7-5.



---

**Caution** – Never remove the carrier plate while it contains slot 0 or slot 1 boards as this will cause *severe damage to the connector* system. Review [Section 10.1, “Inserting a Board Set Carrier Plate”](#) on page 10-2.

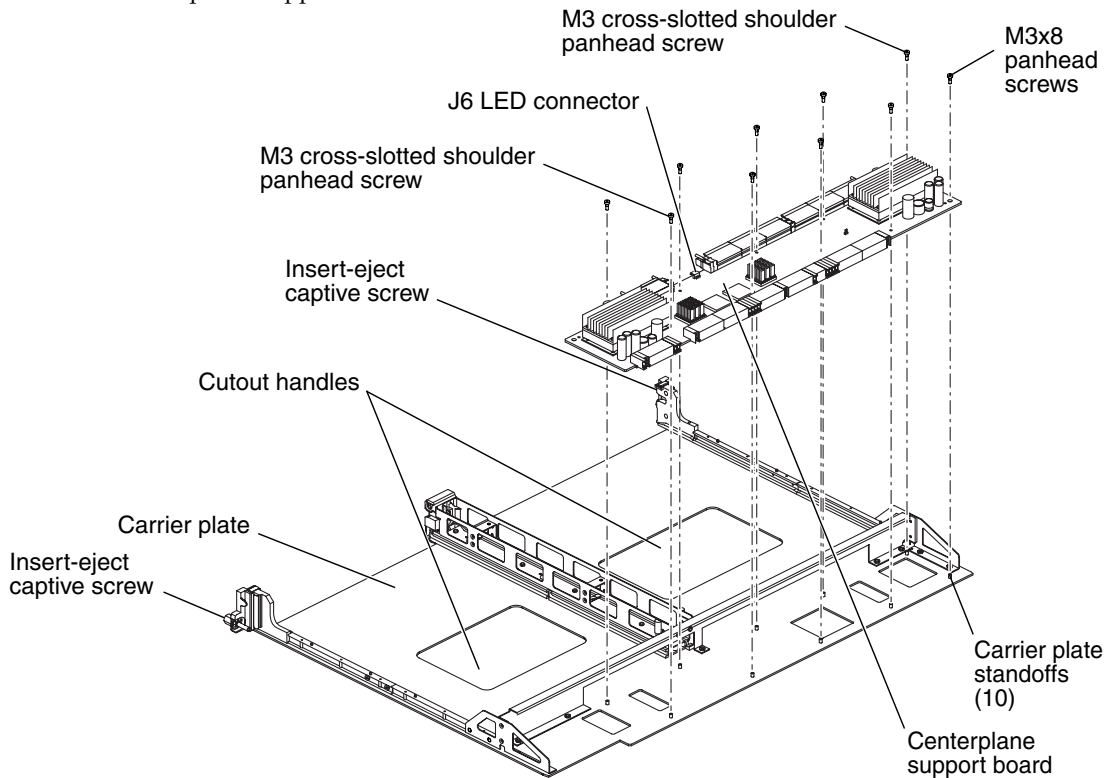
---

### 4. Be sure to read the label on the inside corner trims of the chassis and then use the two (2) 0.5 in. (13 mm) nut drivers to loosen the carrier plate captive ejector screws simultaneously until they are fully disengaged.

### 5. Use the front handle to extract the carrier plate, supporting the bottom with the other hand, and place it on a flat, sturdy, ESD-protected surface with the component side up.

6. Disconnect the LED ribbon cable from the connector (J6) on the centerplane support board.
7. Using a Phillips No. 2 screwdriver, remove the two (2) M3 cross-slotted shoulder panhead screws.
8. Remove the eight (8) M3x8 panhead screws.
9. Firmly grasp the centerplane support board lifting upward and pulling out away from the carrier plate standoffs (FIGURE 11-2).

**FIGURE 11-2** Centerplane Support Board and Carrier Plate





## 11.2.4 Installing a Centerplane Support Board

1. Holding the centerplane support board close to the carrier plate, connect the LED cable into the connector (J6) on the centerplane support board.
2. Install the centerplane support board, aligning the mounting holes with the standoffs.
3. Using a Phillips No. 2 screwdriver, loosely secure the centerplane support board with the two (2) M3 cross-slotted shoulder panhead screws through the board and into the standoffs on the carrier plate, until the board is evenly positioned with the screws.
4. Secure the eight (8) M3x8 panhead screws.
5. Firmly secure the centerplane support board to the carrier plate with the two (2) M3 cross-slotted shoulder panhead screws.
6. Install the carrier plate.  
See [Section 10.1, “Inserting a Board Set Carrier Plate”](#) on page 10-2.
7. Verify the LED status per [TABLE 11-2](#).  
Failure of the service LED to transition from on to off within 60 seconds after insertion indicates a power-status control fault.

---

**Note** – Wait for 15 minutes after inserting CSB, so the new component acclimates to the temperature of the frame before continuing to Step 8.

---

8. Install the SC.  
See [Section 6.1.2.4, “Installing a System Control \(SC\) Board”](#) on page 6-8.
9. Install the SC peripheral.  
See [Section 7.2.4, “Installing a System Control \(SC\) Peripheral Board”](#) on page 7-7.  
Inserting the SC peripheral board should power on the SC with the CSB still powered off.
10. Verify that both SCs are running. See [Section 6.1.2.5, “Verifying a System Control \(SC\) Board”](#) on page 6-9. If inserting the SC peripheral board did not boot the SC than boot the SC manually.

---

**Note** – If the SCs are not running correctly when `thermcal` is run you will have to wait an additional 15 minutes before re-running `thermcal`.

---

11. Close the cabinet door.

## 11.2.5 Powering On a Centerplane Support Board

1. Power on the centerplane support board and calibrate its temperature by typing the following SMS command from the main SC:

```
sc% thermal -w scx
```

Wait for SCx to boot up completely before proceeding to the next step.

2. Update the system SEEPROMs by typing the following service command from the main SC:

```
sc% updates EEPROM platformtype value
```

The values for platform type are not case sensitive. The values are: e25k, e20k, sunfiree25k, sunfiree20k.

3. Stop SMS from the main SC by typing:

```
sc% /etc/init.d/sms stop
```

4. Restart SMS from the main SC by typing:

```
sc% /etc/init.d/sms start
```

5. Type the following command from the main SC to get temperature information:

```
sc% showenvironment -p temps | grep CP
```

6. Compare temperature output from Step 5 above to the file created in [Step 4 of Section 11.2.1, "Isolating a Failed Centerplane Support Board"](#) on page 11-4 and verify that the newly calibrated information is being reflected.
7. If previously deconfigured, use the dynamic bus reconfiguration to enable both halves of the Sun Fireplane interconnect assembly.

```
sc% setbus -c cs0,cs1
```

## 11.2.6 Verifying a Centerplane Support Board

- Address any errors reported by `setbus` and confirm the centerplane support board is powered on by using the Sun Management Center or by typing the following SMS command:

|     |    |     |   |   |   |
|-----|----|-----|---|---|---|
| CS0 | On | CSB | - | - | - |
| CS1 | On | CSB | - | - | - |



## System Expander Board Set

---

The system expander board set for the Sun Fire E25K/E20K systems consists of a carrier plate that holds the hot-swappable system expander board and optional system boards or I/O filler panels. This board set is inserted at I/O expander 0 through 8 (front) and I/O expander 9 through 17 (rear). This chapter contains the replacement procedures for the expander board.

This chapter contains the following sections:

- [Section 12.1, “System Expander Board LEDs” on page 12-2](#)
- [Section 12.2, “Expander Board Replacement Procedures” on page 12-3](#)

For your protection, observe the following safety precautions:

- Follow all cautions and instructions marked on the equipment.
- Always use proper ESD equipment and procedures when handling boards and components.
- Never push objects of any kind through openings in the equipment as they might touch dangerous voltage points or short out components that can result in fire or electric shock.
- Refer servicing of equipment to qualified personnel.

## 12.1 System Expander Board LEDs

System expander board components and LEDs are listed in [TABLE 12-1](#) and [TABLE 12-2](#).

**TABLE 12-1** Expander Board Components

| Total Number of System Expander Boards Per System (front-rear) | Total Number of System Expander Boards Per Side | Number of LEDs Per System Expander Board |
|--|---|--|
| 1-18   | 0-9   | 3  |

**TABLE 12-2** Expander Board Valid LED Status

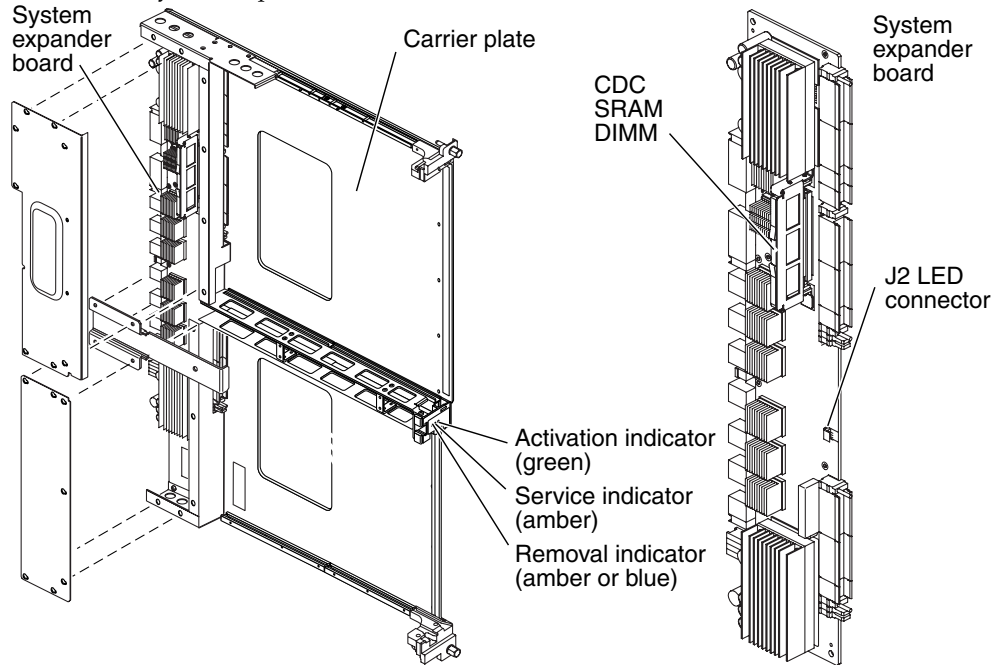
| LEDs After Insertion or Initial System Power On |         |        | LEDs After Presence is Detected |         |        | Component Powered On |         |        | Component Powered Off |         |        |
|---|---------|--------|---------------------------------|---------|--------|----------------------|---------|--------|-----------------------|---------|--------|
| Active  | Service | Remove | Active                          | Service | Remove | Active               | Service | Remove | Active                | Service | Remove |
| off   | on      | on     | off                             | off     | on     | on                   | off     | off    | off                   | off     | on     |

Failure of the service LED to transition from ON to OFF within 60 seconds after insertion indicates a power-status control fault.

[FIGURE 12-1](#) illustrates the expander board and the LED locations.

Any slot 0 or slot 1 board present in the expander being replaced must be deconfigured, powered off, and removed prior to removing or replacing the expander. If the expander is configured as a split slot, up to two domains can be affected.

**FIGURE 12-1** System Expander Board LEDs



---

## 12.2 Expander Board Replacement Procedures

### 12.2.1 Isolating a Failed Expander Board

1. Check for any error messages during POST.
2. On the SC, check for any error messages in `/var/opt/SUNWSMS/platform/adm/messages` and `/var/opt/SUNWSMS/adm/domain_id/messages`, where *domain\_id* is the domain letter.
3. If available, examine any DStop or RStop files located in `/var/opt/SUNWSMS/adm/domain_id/dump`, where *domain\_id* is the domain letter.

4. On the specific domain(s), use `adb` to examine any core files in `/var/crash/hostname`.

## 12.2.2 Powering Off an Expander Board

1. Check the power state of the expander to be removed by typing:

```
sc% showboards -v | grep EXx
```

where *x* is the expander number 0-17.

If the expander is powered off, go to [Section 12.2.3, “Removing an Expander Board” on page 12-5](#).

2. If the expander board is part of a multi-board domain(s), use dynamic reconfiguration to deconfigure the slot 0 and slot 1 boards by using the Sun Management Center or by typing the following SMS commands:

```
sc% deleteboard SBx
sc% deleteboard IOx
sc% poweroff EXx
```

where *x* is the expander number 0-17 and go to [Section 12.2.3, “Removing an Expander Board” on page 12-5](#).

3. If the expander board is part of a single-board domain(s), as a superuser on the domain, shut down the operating system by typing:

```
domain_name# shutdown -y -g seconds -i 0
```

where *seconds* is the amount of time before shutdown.

---

**Note** – You might need to shut down more than one domain if the expander is part of a split-slot domain.

---

4. Power off the hardware associated with the domain(s) by typing:

```
SC% setkeyswitch -d domain_id off
```

---

**Note** – You might need to power off more than one domain if the expander is part of a split-slot domain.

---



## 12.2.3 Removing an Expander Board



---

**Caution** – Be sure you are properly grounded before you begin the hardware removal and installation. There are ground points at the top left and top right of the cabinet in both front and rear.

---



---

**Caution** – The expander board and mounting system (carrier plate) are used as the electrical interface and mounting mechanism for the slot 0 and slot 1 modules or filler panels. Therefore, prior to removal of the expander board, the slot 0 and slot 1 modules *must be* deconfigured, powered off, and *removed*. The references to those procedures are included in the following steps:

---

1. Open the cabinet doors.



---

**Caution** – Before removing a board from the system, the green activation LED must be off and the amber or blue removal OK LED must be on. See [Section 12.2.2, “Powering Off an Expander Board”](#) on page 12-4.

---

2. Remove any slot 0 boards, slot 1 boards, or filler panels following the appropriate directions for each board type.



---

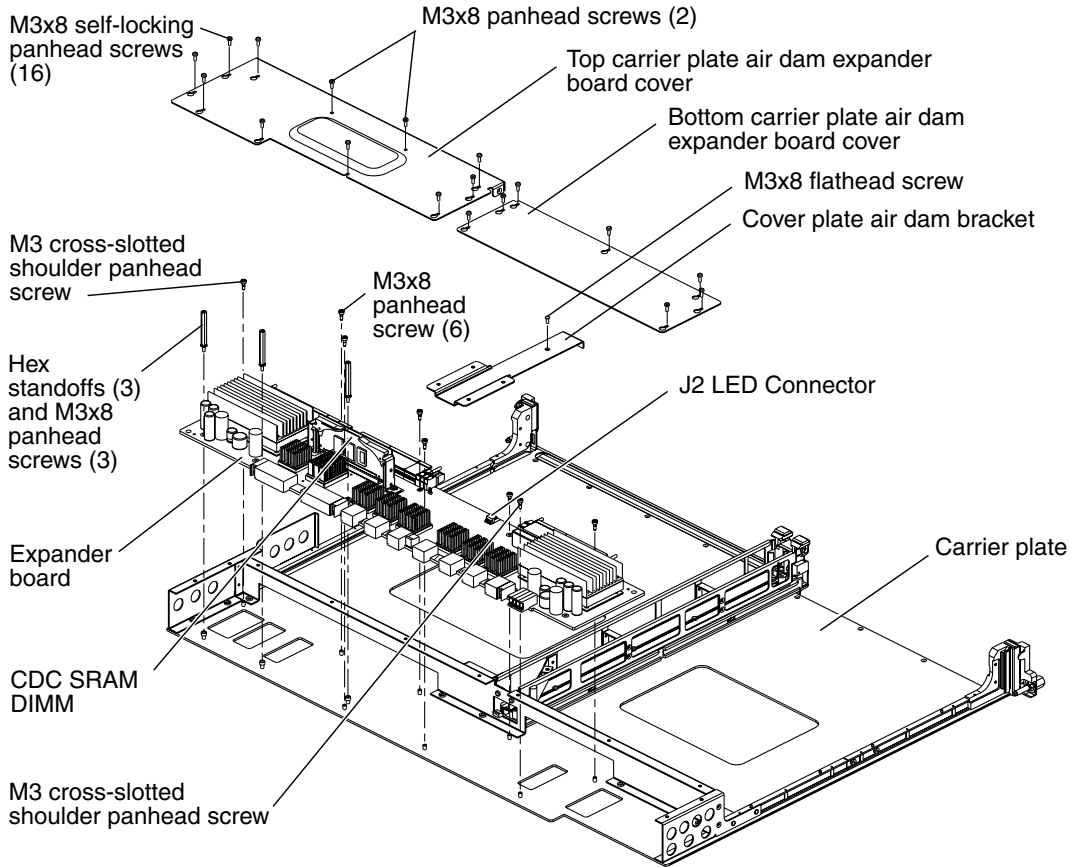
**Caution** – Never remove the carrier plate while it contains slot 0 or slot 1 boards as this will cause *severe damage to the connector system*.

---

3. Using two (2) 0.5 in. (13 mm) nut drivers, simultaneously loosen the carrier plate captive ejector screws until they are fully disengaged.
4. Remove the carrier plate and place it on an ESD-protected surface.
5. Using a Phillips No. 2 screwdriver, remove the two (2) M3x8 panhead screws on the top expander cover that are not common to the rest of the slotted holes.
6. Remove the one (1) M3x8 flathead screw and remove the cover plate air dam bracket located near the center of the assembly.
7. Loosen the remaining sixteen (16) M3x8 self-locking panhead screws and remove the top, bottom, and center covers and set them aside.
8. Disconnect the LED ribbon cable (P2) from the connector (J2) on the expander board.
9. Use a 0.25 in. (6mm) nut driver to remove the three (3) threaded hex standoffs.

10. Remove the two (2) M3 cross-slotted shoulder screws from the expander.
11. Remove the six (6) M3x8 panhead screws from the expander.
12. Firmly grasp the expander board lifting upward and pulling out away from the carrier plate standoffs (FIGURE 12-2).

**FIGURE 12-2** Expander Board and Carrier Plate—Exploded



13. Place the expander board on an ESD-protected surface, component side up.

14. Review the platform message log to verify SMS has received the message that the component has been removed, by typing:

```
sc% showlogs -F
```

Review the board removal message. You will see a message similar to the one as follows.

```
Jun 16 14:28:05 2003 sun15-sc0: esmd[7167]: [0 4824421445907014  
NOTICE Boards.cc 1646] EXB at EXxx removed
```

where *xx* is the expander assembly 0-17.

## 12.2.4 Installing an Expander Board

1. Position the expander board onto the carrier plate aligning the eleven (11) mounting holes with the eleven (11) mounting standoffs on the carrier plate.  
The expander board should be oriented with the components upward and the LED connector toward the LED board of the carrier plate.
2. Install the two (2) M3 cross-slotted shoulder screws to the expander.
3. Secure the expander with the six (6) M3x8 panhead screws.
4. Use the 0.25 in. (6 mm) nut driver to install the three (3) threaded hex standoffs.
5. Connect the LED ribbon cable (P2) into the connector (J2) on the expander board.
6. Install the center cover plate air dam bracket with the one (1) M3x8 flathead screw.
7. Install the top and bottom expander covers and secure with the sixteen (16) M3x8 self-locking panhead screws.
8. Install the two (2) M3x8 self locking flathead screws into the two non-slotted holes in the top expander cover.
9. Install the carrier plate.  
See [Section 10.1, "Inserting a Board Set Carrier Plate"](#) on page 10-2.
10. Verify the LED status per [TABLE 12-2](#).
11. Install any slot 0 boards, slot 1 boards, or filler panels previously removed. Follow the appropriate directions for each board type as outlined in later sections of this document.

12. Review the platform message log to verify SMS has received the message that the component has been inserted, by typing:

```
sc% showlogs -F
```

Review the board insertion message. You will see a message similar to the one as follows.

```
Jun 16 14:30:05 2003 sun15-sc0: esmd[7167]: [0 4824421445907014  
NOTICE Boards.cc 1646] EXB at EXxx inserted
```

where *xx* is the expander assembly 0-17.

13. Close the cabinet doors.

## 12.2.5 Powering On an Expander Board

- Power on the expander by using the Sun Management Center or by typing the following SMS command:

```
sc% poweron EXx
```

where *x* is the expander number 0-17.

## 12.2.6 Verifying an Expander Board

1. Using dynamic reconfiguration, configure the slot 0 and slot 1 boards occupying the expander into the domain(s) by using the Sun Management Center or by typing the following SMS command:

```
sc% addboard -d domain_id SBx  
sc% addboard -d domain_id IOx
```

where *SB* is for slot 0 boards.

*IO* is for slot 1 boards.

*x* is the expander number 0-17.

*domain\_id* is the letter A-R of the target domain(s) for the component.

OR

If the domain(s) were shut down prior to the expander replacement, start the domain(s) with:

```
sc% setkeyswitch -d domain_id on
```

---

**Note** – You might need to use `setkeyswitch` for more than one domain if the expander is part of a split-slot domain.

---

- 2. Examine the POST messages reported by the `addboard/setkeyswitch` for any errors. Also monitor the message logs on the SC, specifically `/var/opt/SUNWSMS/adm/platform/messages` and `/var/opt/SUNWSMS/adm/domain_id/messages`.**



# Sun Fireplane Interconnect Replacement Procedure

---

The Sun Fireplane interconnect is designed with a coherent shared-memory protocol and resides in the center of the Sun Fire E25K/E20K systems. This chapter contains the replacement procedures for the Sun Fireplane interconnect.

This chapter contains the following sections:

- [Section 13.1, “Determining a Capacity on Demand \(COD\) System” on page 13-2](#)
- [Section 13.2, “Isolating a Failed Sun Fireplane Interconnect” on page 13-3](#)
- [Section 13.3, “Setting Up the System Prior to Replacing the Sun Fireplane Interconnect” on page 13-4](#)
- [Section 13.4, “Powering Off the System for Sun Fireplane Interconnect Replacement” on page 13-6](#)
- [Section 13.5, “Removing the Sun Fireplane Interconnect From the Chassis” on page 13-7](#)
- [Section 13.6, “Installing the Sun Fireplane Interconnect into the Chassis” on page 13-10](#)
- [Section 13.7, “Powering on the System After the Sun Fireplane Interconnect Installation” on page 13-12](#)
- [Section 13.8, “Restarting Capacity on Demand \(COD\) After Sun Fireplane Interconnect Installation” on page 13-14](#)
- [Section 13.8, “Restarting Capacity on Demand \(COD\) After Sun Fireplane Interconnect Installation” on page 13-14](#)

For your protection, observe the following safety precautions:

- Follow all cautions and instructions marked on the equipment.
- Always use proper ESD equipment and procedures when handling boards and components.

- Never push objects of any kind through openings in the equipment as they might touch dangerous voltage points or short out components that can result in fire or electric shock.
- Refer servicing of equipment to qualified personnel.

---

## 13.1 Determining a Capacity on Demand (COD) System

A COD system is one that runs SMS software, minimum version 1.3, and has the COD option. Before you install a Sun Fireplane interconnect, you need to determine whether your system is running the Capacity on Demand (COD) system option.

To ensure you have the latest COD licensing information, refer to the *System Management Services (SMS) Administrator Guide* at <http://docs.sun.com>.

You must have platform administration privileges to run the SMS commands in this procedure. When you replace a COD Sun Fireplane interconnect board, all existing COD licenses must be replaced.

1. **Start SMS.**
2. Display all currently installed COD right-to-use (RTU) licenses:

```
sc0:sms-user:> showcodlicense -v
```

If COD licenses are listed, the system is running COD.

3. **Save the command output to use in Step 3 in the section [Section 13.8, "Restarting Capacity on Demand \(COD\) After Sun Fireplane Interconnect Installation"](#) on page 13-14.**
4. Determine if any COD CPU/Memory boards are installed:

```
sc0:sms-user:> showboards -v
```

If the message COD appears in the Type of Board column, the system is running COD.

5. **Do one of the following:**
  - If the system is not a COD system, skip to ["Isolating a Failed Sun Fireplane Interconnect"](#) on page 3.



- If the system is running COD, obtain the current Chassis hostID of the system by typing:

```
sc0:sms-user:> showplatform -p cod
```

You will need the Chassis hostID information later.

6. **Contact the Sun License Center using email, fax, or telephone to request new COD licenses.**
  - a. **Go to** <http://www.sun.com/licensing>.
  - b. **Explain that you are replacing the Sun Fireplane interconnect and request a transfer of the existing licenses to the new Chassis hostID**
7. **Provide the following information to the Sun License Center:**
  - The current Chassis hostID, which you can obtain by typing:

```
sc0:sms-user:> showplatform -p cod
```

- The new Chassis hostID which is the serial number of the new Sun Fireplane interconnect.
8. **Ask the License Center to email the COD licenses to you and your customer.**

Continue with the subsequent steps while waiting for the licenses.

---

## 13.2 Isolating a Failed Sun Fireplane Interconnect



---

**Caution** – The Sun Fireplane interconnect assembly is NOT a hot-swappable component. This procedure requires powering off the AC power to the system.

---

1. **Check for any error messages during POST.**
2. **On the SC, check for any error messages in**  
`/var/opt/SUNWSMS/adm/platform/messages.`
3. **If available, examine any DStop or RStop files located in**  
`/var/opt/SUNWSMS/adm/domain_id/dump.`  
where `domain_id` is the domain letter.

4. On the SC, check the environment by using the Sun Management Center or by typing the following SMS command:

```
sc% showenvironment -p temps | grep CP
```

5. Save this output to a file for later use.

---

## 13.3 Setting Up the System Prior to Replacing the Sun Fireplane Interconnect

1. Locate all required tools; two Phillips screwdrivers (No. 1 and No. 2), one small flat-bladed screwdriver, and one small flashlight.
2. Secure or remove all loose clothing, jewelry, and watches that might get caught on internal mechanical components.
3. Verify that all I/O cables are properly labeled.
4. Set up an ESD-protected surface for all control expander board sets and system expander board sets.
5. Attach a wrist strap.

---

**Note** – System Control boards, System Control peripheral boards, system expander boards, I/O assemblies, CPU boards, centerplane support boards, and the Sun Fireplane interconnect assembly are all very susceptible to static. Therefore, all possible precautions should be taken to protect these boards against static damage. Transport board assemblies on an ESD static-protected cart whenever possible. Use a static wrist strap when handling.

---

6. Open and remove both cabinet doors.
7. Use the following *Component Serial Numbers Worksheet* to note the serial numbers and locations of the existing boards as well as the serial number and revision of the new Sun Fireplane interconnect assembly (TABLE 13-1). A larger version of this table is located in [Appendix A](#) for use during component replacement.

**TABLE 13-1** Component Serial Numbers Worksheet

| Expander | S/N | Slot 0     |     | Slot 1     |     |
|----------|-----|------------|-----|------------|-----|
|          |     | Board Type | S/N | Board Type | S/N |
| CSB0     |     |            |     |            |     |
| EXB0     |     |            |     |            |     |
| EXB1     |     |            |     |            |     |
| EXB2     |     |            |     |            |     |
| EXB3     |     |            |     |            |     |
| EXB4     |     |            |     |            |     |
| EXB5     |     |            |     |            |     |
| EXB6     |     |            |     |            |     |
| EXB7     |     |            |     |            |     |
| EXB8     |     |            |     |            |     |
| CSB1     |     |            |     |            |     |
| EXB9     |     |            |     |            |     |
| EXB10    |     |            |     |            |     |
| EXB11    |     |            |     |            |     |
| EXB12    |     |            |     |            |     |
| EXB13    |     |            |     |            |     |
| EXB14    |     |            |     |            |     |
| EXB15    |     |            |     |            |     |
| EXB16    |     |            |     |            |     |
| EXB17    |     |            |     |            |     |

New Sun Fireplane interconnect assembly S/N:

Rev:

**8. Review the documentation that accompanies the replacement FRU prior to removal and replace of the Sun Fireplane interconnect.**

---

## 13.4 Powering Off the System for Sun Fireplane Interconnect Replacement



---

**Caution** – The Sun Fireplane interconnect is NOT a hot-swappable component. This procedure requires a complete shutdown of the domains and SCs, and disconnection of all AC power to the system.

---

1. As a superuser on the domains, systematically shut down all running domains by typing:

```
domain_name# shutdown -y -g seconds -i 0
```

where *seconds* is the amount of time before shutdown.

2. On the main SC, power off the domain hardware by typing:

```
sc% poweroff
```

This command powers off the entire system with the exception of the power supplies, fans, and the SCs. Refer to `poweroff(1M)` for more information.

3. Shut down the System Control boards by doing the following:

- As a superuser on the spare SC, shut down the spare SC by typing:

```
sc_spare# shutdown -y -g seconds -i 0
```

where *seconds* is the amount of time before shutdown.

- On the main SC, power off the spare SC by typing:

```
sc% poweroff SCx
```

where *x* is 0 or 1, dependent upon which SC is the spare.

- As a superuser on the main SC, shutdown the main SC by typing:

```
sc# shutdown -y -g seconds -i 0
```

where *seconds* is the amount of time before shutdown.

---

**Note** – All DC circuit breakers are to remain in the on position at all times.

---

4. Power off the AC0 and AC1 circuit breakers for all power supplies in the system.
5. Label and disconnect the twelve (12, six per side) AC power cords with the labels provided in the ship kit.
6. Label and disconnect all I/O cables from the front and rear of the system and set aside.

---

## 13.5 Removing the Sun Fireplane Interconnect From the Chassis

The Sun Fireplane interconnect assembly can only be removed from the front of the Sun Fire E25K/E20K systems. Follow the front and rear notations in this procedure carefully.



---

**Caution** – The Sun Fireplane interconnect assembly weighs 30.1 lb (13.7 kg). Use proper heavy-lifting procedures when removing this unit.

---

- From the rear of the system:



---

**Caution** – Be sure you are properly grounded before you begin the hardware removal and installation. There are ground points at the top left and top right of the cabinet in both front and rear.

---

1. Remove all slot 0 and slot 1 boards and place each on an ESD-protected surface.



---

**Caution** – Never remove the carrier plate while it contains slot 0 or slot 1 boards as this will cause *severe damage to the connector system*.

---

2. Remove all system expander boards and the centerplane support board carrier assemblies from the connectors by pulling each carrier plate forward approximately six inches.

- From the front of the system:

1. Remove all slot 0 and slot 1 boards and place on an ESD-protected surface.
2. Remove all centerplane support boards carrier assemblies and the system expander boards from the connectors by pulling each carrier plate forward and place each on an ESD-protected surface following the procedures in:

- Section 11.2.3, “Removing a Centerplane Support Board” on page 11-5
- Section 12.2.3, “Removing an Expander Board” on page 12-5



---

**Caution** – The Sun Fireplane interconnect has *sharp edges* at the top guide rails. When the board is fully installed, the top guide rails are at head-level for the average person. Use care when working inside the cabinet chassis to avoid hitting the rails and causing bodily injury.

---

**3. Loosen the twenty-two (22) Phillips captive screws from the perimeter of the Sun Fireplane interconnect assembly stiffener (FIGURE 13-1).**

After the Sun Fireplane interconnect assembly is moved away from the chassis guide pins, the assembly will slightly drop and hang by the Sun Fireplane interconnect assembly sheet metal guide brackets to ride along the sheet metal guide rails in the system chassis.



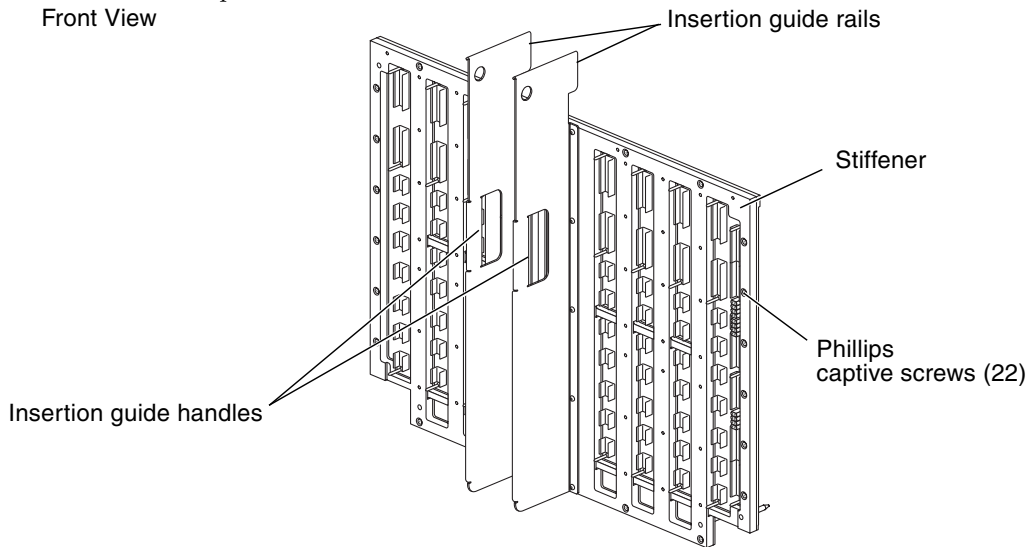
---

**Caution** – The Sun Fireplane interconnect assembly weighs 30.1 lb (13.7 kg). Use proper heavy-lifting procedures when removing this unit.

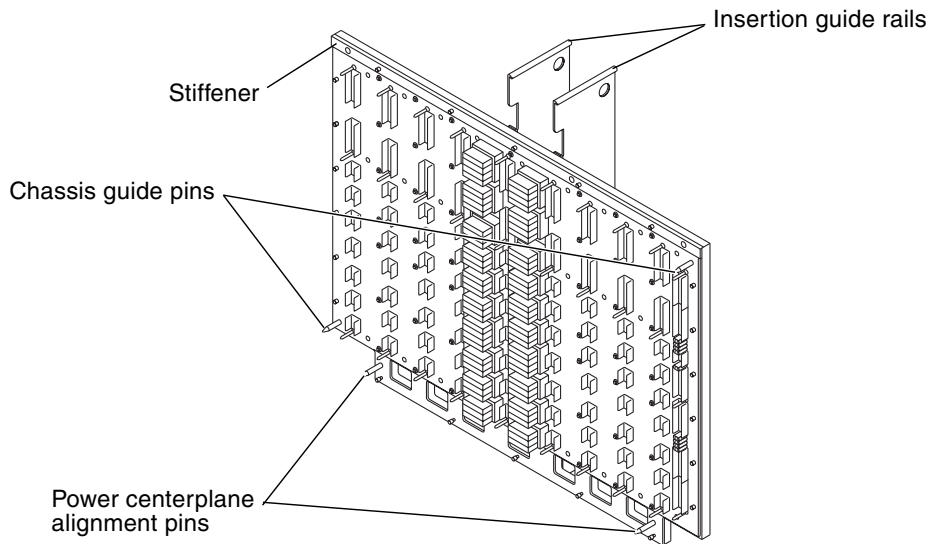
---

- 4. Grasp the Sun Fireplane interconnect assembly by pulling the sheet metal insertion guide handles (located in the center of the Sun Fireplane interconnect assembly) and gently slide the assembly forward along the top sheet metal guide rails of the card cage.**
- 5. After the assembly drops onto the sheet metal guide rails, continue to slide the Sun Fireplane interconnect assembly forward.**
- 6. To remove the Sun Fireplane interconnect assembly from the system card cage, lift and tilt the assembly to the bottom left to release the top guide bracket from the guide rail at the top of the card cage. Continue to pull the assembly forward to clear the system chassis.**

**FIGURE 13-1** Sun Fireplane Interconnect—Front and Rear View



Rear View



**Caution** – The ASICs on the Sun Fireplane interconnect assembly are easily damaged. Be careful when placing the assembly on an ESD-protected surface.

---

## 13.6 Installing the Sun Fireplane Interconnect into the Chassis

The Sun Fireplane interconnect assembly can only be installed into the front of the system. Follow the front and rear notations in this procedure carefully.



---

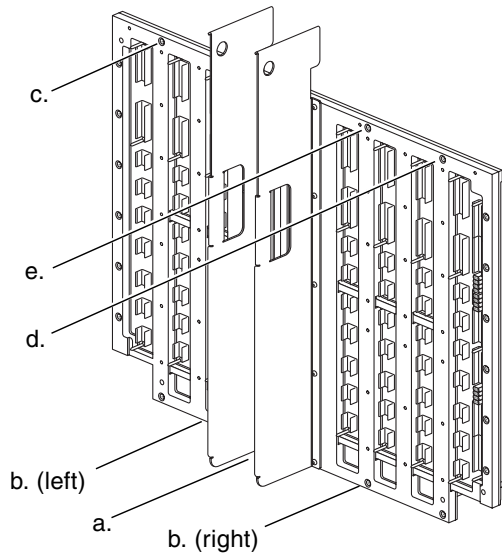
**Caution** – The Sun Fireplane interconnect assembly weighs 30.01 lb (13.7 kg). Use proper heavy-lifting procedures when removing this unit.

---

- From the front of the system:
  1. Place the top of the Sun Fireplane interconnect assembly sheet metal guide brackets onto the sheet metal guide rail at the top center of the card cage.
  2. Use the sheet metal insertion guide handles to slide the Sun Fireplane interconnect assembly into the card cage aligning the two (2) chassis guide pins and two (2) power centerplane alignment pins (FIGURE 13-1) through the center mid-plane panel of the system chassis.
  3. Ensure the edges are flush against the chassis and secure the Sun Fireplane interconnect assembly with the twenty-two (22) Phillips captive screws around the perimeter of the Sun Fireplane interconnect assembly stiffener. Follow the tightening pattern shown in FIGURE 13-2.



**FIGURE 13-2** Sun Fireplane Interconnect Tightening Pattern



- a. Secure the bottom center captive screw.
  - b. Secure the immediate right and left of bottom center captive screw.
  - c. Secure the upper top left corner captive screw.
  - d. Secure the upper top right corner captive screw.
  - e. Secure the remaining screws going around the perimeter in a counterclockwise direction.
4. Install all centerplane support boards and system expander boards by following the procedures in:
    - [Section 11.2.4, “Installing a Centerplane Support Board”](#) on page 11-7
    - [Section 12.2.4, “Installing an Expander Board”](#) on page 12-7
  5. Install all slot 0 and slot 1 boards. See the *Component Serial Number Worksheet*, [TABLE 13-1](#), used to verify board position.
    - From the rear of the system:
      1. Seat the system expander boards and the centerplane support board into the Sun Fireplane interconnect assembly.
      2. Install all slot 0 and slot 1 boards.  
See the *Component Serial Number Worksheet*, [TABLE 13-1](#), used to verify board position.

---

## 13.7 Powering on the System After the Sun Fireplane Interconnect Installation

### 13.7.1 Powering on the System Controllers

---

**Note** – Wait for 15 minutes so the new component acclimates to the temperature of the frame before powering on the system.

---

1. **Connect the AC power cords to the 4 kW dual AC-DC power supplies.**
2. **Connect all I/O cables referencing the cable label for proper identification.**
3. **Power on the AC0 and AC1 circuit breakers for all power supplies in the system.**

This should boot the System Controllers.

4. **Verify that both SCs are running.**

See [Section 6.1.2.5, “Verifying a System Control \(SC\) Board”](#) on page 6-9. If one of the SCs is not running try removing and reseating the SC.

---

**Note** – If the SCs are not running correctly when `thermcal` is run to power on the centerplane you will have to wait an additional 15 minutes before re-running `thermcal`.

---

5. **Close the cabinet door.**

### 13.7.2 Powering on the Centerplane Support Board

1. **Power on the centerplane support board and calibrate its temperature by typing the following SMS command from the main SC:**

```
sc% thermcal -w scx
```

Wait for SC $x$  to boot completely before proceeding to the next step.

2. Update the system SEEPROMs by typing the following service command from the main SC:

```
sc% updateseeprom platformtype value
```

The values for platform type are not case sensitive. The values are: e25k, e20k, sunfiree25k, sunfiree20k.

3. Stop SMS from the main SC by typing:

```
sc% /etc/init.d/sms stop
```

4. Restart SMS from the main SC by typing:

```
sc% /etc/init.d/sms start
```

5. Type the following command from the main SC to get temperature information:

```
sc% showenvironment -p temps | grep CP
```

6. Compare temperature output from Step 5 above to the file created in [Step 4 of Section 13.2, “Isolating a Failed Sun Fireplane Interconnect”](#) on page 13-3 and verify that the newly calibrated information is being reflected. A hardware issue should show up in the platform logs as a I2C error. If the temperature output does not match and there are no errors in the platform logs wait 15 minutes and retry [Step 1](#).

7. If previously deconfigured, use the dynamic bus reconfiguration to enable both halves of the Sun Fireplane interconnect assembly.

```
sc% setbus -c cs0,cs1
```

## 13.7.3 Starting the Domains

1. Start the domain(s) by typing:

```
sc% setkeyswitch -d domain_id on
```

where *domain\_id* is the domain letter A-R.

2. Verify all required components are on by typing:

```
sc% showboards -v
```

3. Execute one `setkeyswitch` command for each domain to be started.

---

## 13.8 Restarting Capacity on Demand (COD) After Sun Fireplane Interconnect Installation

Any current COD licenses are no longer valid because they were tied to the original Chassis hostID of the system.

1. Check your email for messages from the Sun License Center.

Each message should contain a new COD license key and password to replace the previous COD licenses.

2. Wait at least one minute and verify that the new Chassis hostID of the system is the same as the serial number of the Sun Fireplane interconnect:

```
sc0:sms-user:> showplatform -p cod
```

3. Run the `deletecodlicense` command to delete each COD license you saved in Step 2 in the section, [Section 13.1, "Determining a Capacity on Demand \(COD\) System"](#) on page 13-2.

For details on deleting COD licenses, refer to the "Capacity on Demand" chapter of the *System Management Services (SMS) Administration Guide*.

4. Run the `addcodlicense` command to add the new COD license keys provided in the email from the Sun License Center.

For details on adding COD licenses, refer to the "Capacity on Demand" chapter of the *System Management Services (SMS) Administration Guide*.

5. Verify the new COD licenses have been recorded:

```
sc0:sms-user:> showcodlicense -v
```

The new COD licenses should be listed. You can now use the COD CPU/Memory boards. If the new COD licenses are not listed try again to be certain a typo did not occur. If the problem is a typo at the license center than a new license will be needed.

# Fan Backplane Replacement Procedure

---

There are four fan backplanes mounted above the Sun Fireplane interconnect and four below the power centerplane. The fan backplane provides the power distribution to the eight fan trays in the Sun Fire E25K/E20K systems. This chapter contains the replacement procedures for the fan backplanes.

This chapter contains the following sections:

- [Section 14.1, “Powering Off a Fan Backplane” on page 14-2](#)
- [Section 14.2, “Removing a Fan Backplane” on page 14-3](#)
- [Section 14.3, “Installing a Fan Backplane” on page 14-5](#)
- [Section 14.4, “Powering On a Fan Backplane” on page 14-6](#)

For your protection, observe the following safety precautions:

- Follow all cautions and instructions marked on the equipment.
- Always use proper ESD equipment and procedures when handling boards and components.
- Never push objects of any kind through openings in the equipment as they might touch dangerous voltage points or short out components that can result in fire or electric shock.
- Refer servicing of equipment to qualified personnel.

---

## 14.1 Powering Off a Fan Backplane



---

**Caution** – Be sure you are properly grounded before you begin the hardware removal and installation. There are ground points at the top left and top right of the cabinet in both front and rear.

---



---

**Caution** – The fan backplane is NOT a hot-swappable component. This procedure requires a complete shutdown of the domains and SCs, and disconnection of all AC power to the system.

---

Since the system must be powered off, the operating system and all of the domains must be systematically brought down and then halted.

1. As a superuser on the domains, systematically shut down all running domains by typing:

```
domain_name# shutdown -y -g seconds -i 0
```

where *seconds* is the amount of time before shutdown.

2. On the main SC, power off the domain hardware by typing:

```
sc% poweroff
```

This command powers off the entire system with the exception of the power supplies, fans, and the SCs. Refer to `poweroff(1M)` for more information.

3. Shut down the System Control boards by doing the following:

- As a superuser on the spare SC, shut down the spare SC by typing:

```
sc_spare# shutdown -y -g seconds -i 0
```

where *seconds* is the amount of time before shutdown.

- On the main SC, power off the spare SC by typing:

```
sc% poweroff SCx
```

where *x* is 0 or 1, dependent upon which SC is the spare.

- As a superuser on the main SC, shutdown the main SC by typing:

```
sc# shutdown -y -g seconds -i 0
```

where *seconds* is the amount of time before shutdown.

#### 4. Open the system cabinet door.

---

**Note** – All DC circuit breakers are to remain in the on position at all times.

---

#### 5. Power off the AC0 and AC1 circuit breakers for all power supplies in the system.

#### 6. Label and disconnect the twelve (12, six per side) AC power cords with the labels provided in the ship kit.

---

## 14.2 Removing a Fan Backplane

There are two fan backplanes on the front of the Sun Fire E25K/E20K systems and two on the rear. The front fan backplane locations are shown in [FIGURE 14-1](#).

---

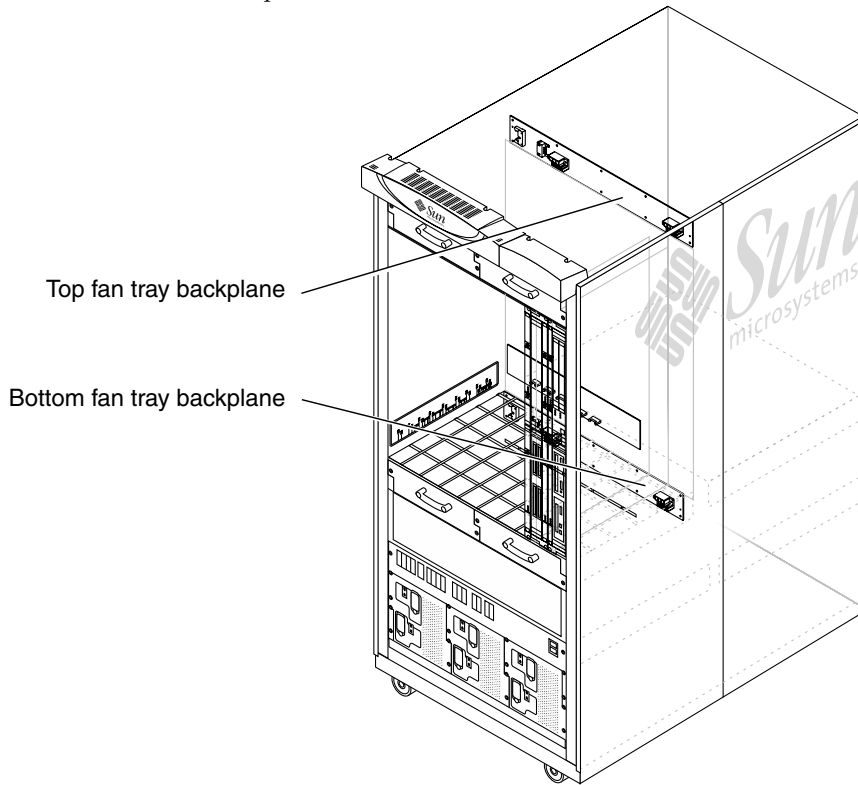
**Note** – All DC circuit breakers are to remain in the on position at all times.

---

Take care when removing the carrier plates. Ensure proper temporary storage for the carrier plates.

1. Power off the AC circuit breakers on the power supply front panel.
2. Disconnect the AC power cords.
3. Remove the two fan trays connected to the fan backplane being removed.  
See [Section 4.2.3, “Removing a Fan Tray”](#) on page 4-4.

**FIGURE 14-1** Fan Backplane Locations—Front



---

**Note** – Boards should be removed by pulling outward using the front handle with one hand and placing the other hand underneath the bottom guide rail for additional support. Carry the board by the front handle to a work area holding it vertically, with the connector downward. Lift the board and place the other hand under the bottom, or back, of the board placing the bottom, or back, on an ESD-protected surface. Never place the weight of a board on its connector as it is easily damaged.

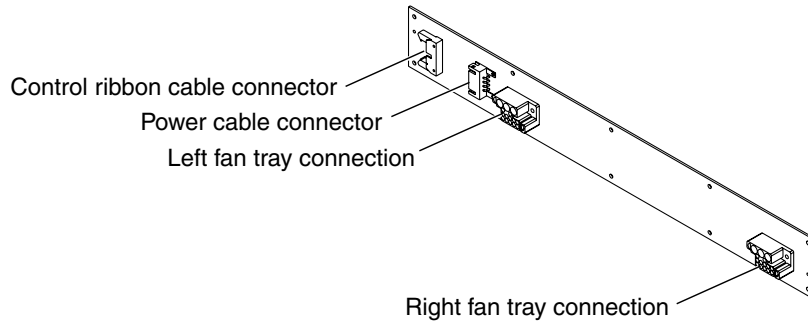
---

4. To gain additional access to the power cable, remove board sets and carrier plates from slots 5, 6, 7, and 8 front (side 0) or slots 14, 15, 16, and 17 rear (side 1). Remove additional carrier plates, as needed.



5. Disconnect the power cable connector and the control ribbon cable connector from the fan backplane. See [FIGURE 14-2](#).

**FIGURE 14-2** Fan Backplane Connections



---

**Note** – Avoid dropping screws into system cabinet during removal.

---

6. Remove the ten (10) M4x6 panhead screws by using a Phillips No. 2 extra long (11 in. (27.9 cm) minimum) magnetic tip screwdriver, provided in the shipping kit.
7. From the left side of the card cage, grasp the left fan tray connector and pull forward and angle the backplane around the fan tray slots.
8. Remove the fan backplane from the cabinet.

---

## 14.3 Installing a Fan Backplane

---

**Note** – When removing the upper fan trays, remember the bottom system kick plate is NOT a step. Do NOT use the kick plate to gain access to the top fan trays. Obtain a proper stool if required. Excessive weight on the kick plate will bend the door support brackets.

---

1. Orient the fan backplane with the power connector and the control connector on the left ([FIGURE 14-2](#)) and insert it at an angle into the cabinet around the fan tray slot separator (center of the double fan tray location) then set into position over the mounting holes.

---

**Note** – Avoid dropping screws into system cabinet during installation.

---

2. Secure the fan backplane with the ten (10) M4x6 panhead screws by using a Phillips No. 2 extra long (11 in. (27.9 cm) minimum) magnetic-tip screwdriver, provided in the shipping kit.
3. Connect the power cable connector and the control ribbon cable connector to the fan backplane. See [FIGURE 14-2](#).
4. Install the boards and carrier plates in slots 5, 6, 7, and 8 front (side 0) or 14, 15, 16, and 17 rear (side 1), and any additional boards removed for access.
5. Install the two fan trays.  
See [Section 4.2.4, "Installing a Fan Tray" on page 4-5](#).
6. Connect the AC power cables.
7. Power on the AC circuit breakers at the power supply front panel.

---

## 14.4 Powering On a Fan Backplane

1. Ensure all DC circuit breakers are in the on position.
2. Connect the AC power cords to the 4 kW dual AC-DC power supplies.
3. Power on the AC0 and AC1 circuit breakers for all power supplies in the system.
4. Close the cabinet door.
5. Once the main SC is booted, start the domain(s) by typing:

```
sc% setkeyswitch -d domain_id on
```

where *domain\_id* is the domain letter A-R. Execute one `setkeyswitch` command for each domain to be started.

# Power Centerplane Replacement Procedure

---

Power is distributed to all board sets through the power centerplane which is located beneath the Sun Fireplane interconnect. The power centerplane can be removed only from the front of the Sun Fire E25K/E20K systems. Access must be obtained by also removing all boards from the rear. Follow the front and rear notations in this procedure carefully. This chapter contains the replacement procedures for the power centerplane.

---

**Note** – The Sun Fireplane interconnect assembly overlaps the top of the power centerplane; therefore, the Sun Fireplane interconnect assembly must be removed first.

---

This chapter contains the following sections:

- [Section 15.1, “Powering Off the System for Power Centerplane Replacement” on page 15-2](#)
- [Section 15.2, “Removing the Power Centerplane” on page 15-3](#)
- [Section 15.3, “Installing the Power Centerplane Assembly into the Chassis” on page 15-6](#)
- [Section 15.4, “Powering On the System After Power Centerplane Installation” on page 15-9](#)

For your protection, observe the following safety precautions

- Follow all cautions and instructions marked on the equipment.
- Always use proper ESD equipment and procedures when handling boards and components.
- Never push objects of any kind through openings in the equipment as they might touch dangerous voltage points or short out components that can result in fire or electric shock.
- Refer servicing of equipment to qualified personnel.

---

## 15.1 Powering Off the System for Power Centerplane Replacement



---

**Caution** – The power centerplane is NOT a hot-swappable component. This procedure requires a complete shutdown of the domains and SCs, and disconnection of all AC power to the system.

---

Since the system must be powered off, the operating system and all of the domains must be systematically brought down and then halted.

1. As a superuser on the domains, systematically shut down all running domains by typing:

```
domain_name# shutdown -y -g seconds -i 0
```

where *seconds* is the amount of time before shutdown.

2. On the main SC, power off the domain hardware by typing:

```
sc% poweroff
```

This command powers off the entire system with the exception of the power supplies, fans, and the SCs. Refer to `poweroff(1M)` for more information.

3. Shut down the System Control boards by doing the following:

- As a superuser on the spare SC, shut down the spare SC by typing:

```
sc_spare# shutdown -y -g seconds -i 0
```

where *seconds* is the amount of time before shutdown.

- On the main SC, power off the spare SC by typing:

```
sc% poweroff SCx
```

where *x* is 0 of 1, dependent upon which SC is the spare.

- As a superuser on the main SC, shutdown the main SC by typing:

```
sc# shutdown -y -g seconds -i 0
```

where *seconds* is the amount of time before shutdown.

4. Open the cabinet doors.

---

**Note** – All DC circuit breakers are to remain in the on position at all times.

---

5. Power off the AC0 and AC1 circuit breakers for all power supplies in the system.
6. Label and disconnect the twelve (12, six per side) AC power cords with the labels provided in the ship kit.
7. Label and disconnect all I/O cables from the front and rear of the system and set aside.

---

## 15.2 Removing the Power Centerplane



---

**Caution** – Be sure you are properly grounded before you begin the hardware removal and installation. There are ground points at the top left and top right of the cabinet in both front and rear.

---

The actual removal of the power centerplane is from the front of the system but the initial removal procedures starts at the rear of the system.

- From the rear of the system:

---

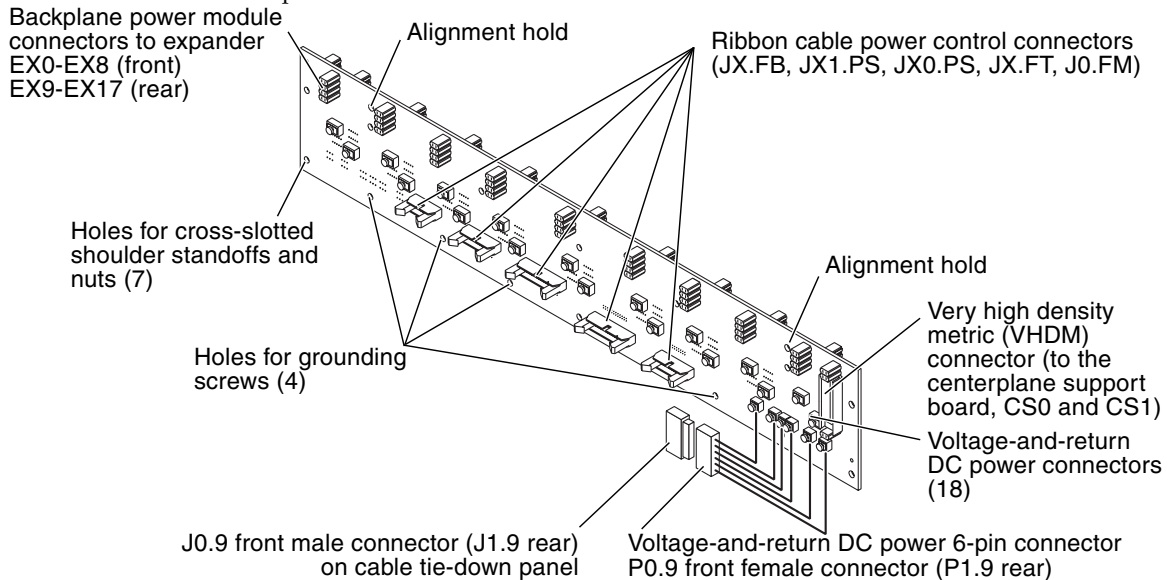
**Note** – Boards should be removed by pulling outward using the front handle with one hand and placing the other hand underneath the bottom guide rail for additional support. Carry the board to a work area holding vertically, with the connector downward, by the front handle. Lift the board and place the other hand under the bottom, or back, of the board placing the bottom, or back, on an ESD-protected surface. Never place the weight of a board on its connector as it is easily damaged.

---

1. Remove all system expander and the centerplane support board sets by following the procedures in:
  - [Section 12.2.3, “Removing an Expander Board” on page 12-5](#)
  - [Section 11.2.3, “Removing a Centerplane Support Board” on page 11-5](#)

2. Remove the Sun Fireplane interconnect prior to removing the power centerplane.  
See [Section 13.5, “Removing the Sun Fireplane Interconnect From the Chassis”](#) on page 13-7.
3. Remove fan tray F7, to access the two (2) lower M4x8 Phillips screws of the DC cable cover, and place on a flat, sturdy, surface.  
See [Section 4.2.3, “Removing a Fan Tray”](#) on page 4-4.
4. Remove the DC cable cover by removing the nine (9) M4x8 Phillips screws from the DC cable cover.
5. Remove the five (5) ribbon cable power control connectors from the power centerplane ([FIGURE 15-1](#)).

**FIGURE 15-1** Power Centerplane Power Control Connections



6. Disconnect the P1.9 six-wire friction-fit 48V power connector from J1.9 by depressing the end clips.  
The P1.9 six-wire friction-fit 48V power connector is found at the cable tie-down panel beneath the power centerplane.
7. Remove the eighteen (18) voltage-and-return DC power cables from the power centerplane by loosening the captive screw of each cable while pulling back on the lug.

8. Remove the seven (7) cross-slotted shoulder standoff nuts from the power centerplane.
  - From the front of the system:
    1. Remove all system expander boards and the centerplane support board by following the procedures in:
      - [Section 12.2.3, “Removing an Expander Board”](#) on page 12-5
      - [Section 11.2.3, “Removing a Centerplane Support Board”](#) on page 11-5
    2. Remove fan tray F3, to access the lower two (2) remaining M4x8 Phillips screws of the DC cable cover, and place on a flat sturdy surface.  
See [Section 4.2.3, “Removing a Fan Tray”](#) on page 4-4.
    3. Remove the DC cable cover by removing the nine (9) M4x8 Phillips screws.
    4. Remove the five (5) ribbon cable power control connections from the power centerplane. See [FIGURE 15-1](#).
    5. Disconnect the P0.9 six-wire friction-fit 48V power connector from J0.9 by depressing the end clips.  
The P0.9 six-wire friction-fit 48V power connector is found at the cable tie-down panel beneath the power centerplane.
    6. Remove the eighteen (18) voltage-and-return DC power cables from the power centerplane by loosening the captive screw of each cable while pulling back on the lug.
    7. Remove the four (4) M4x10 panhead grounding screws from the power centerplane.  
  
The four grounding screws are only on the front side of the power centerplane.
    8. Remove the seven (7) cross-slotted shoulder standoff screws from the front of the power centerplane.
    9. Remove the power centerplane and place on an ESD-protected surface.

---

## 15.3 Installing the Power Centerplane Assembly into the Chassis



---

**Caution** – Be sure you are properly grounded before you begin the hardware removal and installation. There are ground points at the top left and top right of the cabinet in both front and rear.

---

■ From the front of the system:

**1. Install the power centerplane and attach it with the seven (7) cross-slotted shoulder standoff screws.**

The power centerplane floats on the shoulder standoff until the four remaining screws secure it into position after the installation of the Sun Fireplane interconnect in [Step 8](#) as follows.

---

**Note** – Securing of the ground screws at this time (after installation of the power centerplane and the cross-slotted shoulder screws) is not advised until after the installation of the Sun Fireplane interconnect, in [Step 7](#) as follows. Do not secure the ground screws at this time.

---

---

**Note** – Verify the red wires are installed in the top row and the black wires are installed in the bottom row.

---

**2. Install the eighteen (18) voltage-and-return DC power cables to the power centerplane.**

See [Section 16.2.2, “48 VDC Power Cable Replacement”](#) on page 16-11.

[FIGURE 15-2](#) shows the voltage-and-return reference designations on the internal cabinet label. These labels are located inside the chassis above the lower fan trays on the left side, respectively.

**3. Connect the P0.9 six-wire friction-fit 48V power connector of the power centerplane to J0.9 on the cable tie-down panel.**

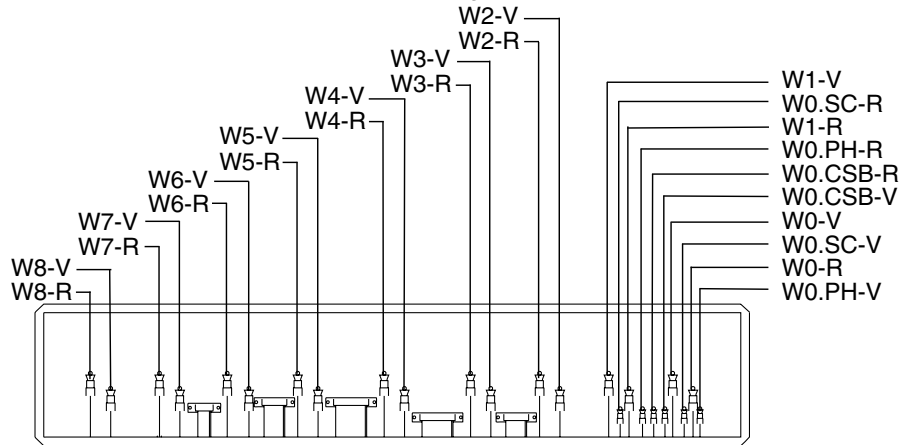
**4. Connect the five (5) ribbon cable connectors to the power centerplane.**

**5. Install the DC cable cover and secure with nine (9) M4x8 Phillips screws.**

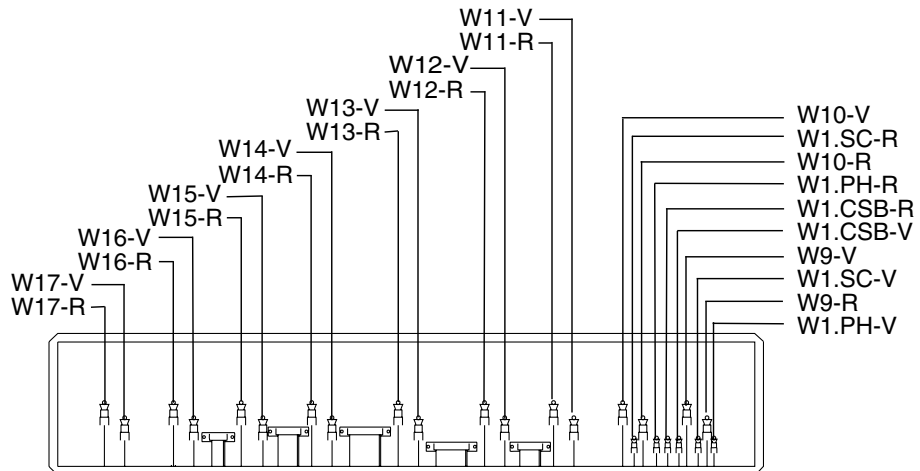


**FIGURE 15-2** Voltage-and-Return Reference Designation Labels—Front and Rear

Internal label of power centerplane voltage-and-return connection—front



Internal label of power centerplane voltage-and-return connections—rear



**6. Reinstall fan tray F3.**

See [Section 4.2.4, “Installing a Fan Tray”](#) on page 4-5.

**7. Install the Sun Fireplane interconnect assembly, if not previously installed.**

See [Section 13.6, “Installing the Sun Fireplane Interconnect into the Chassis”](#) on page 13-10.



---

**Caution** – Ensure the Sun Fireplane interconnect assembly is installed prior to securing the four (4) grounding screws.

---

8. **Secure the power centerplane into position with the four (4) M4x10 panhead grounding screws to the power centerplane.**
9. **Install all system expander and the centerplane support board sets by following the procedures in:**
  - [Section 12.2.4, “Installing an Expander Board” on page 12-7](#)
  - [Section 11.2.4, “Installing a Centerplane Support Board” on page 11-7](#)
  - From the rear of the system:
    1. **Install the seven (7) cross-slotted standoff nuts onto the male threads of the cross-slotted shoulder standoff screws.**
    2. **Connect the eighteen (18) voltage-and-return AC power cables to the power centerplane.**  
See [Section 16.2.2, “48 VDC Power Cable Replacement” on page 16-11.](#)
    3. **Connect the P1.9 six-wire friction-fit 48V power connector at the power centerplane to J1.9 on the cable tie-down panel.**
    4. **Connect the five (5) ribbon cable connectors to the power centerplane.**
    5. **Install the DC cable cover and secure with nine (9) M4x8 Phillips screws.**
    6. **Reinstall fan tray F7.**  
See [Section 4.2.4, “Installing a Fan Tray” on page 4-5.](#)
    7. **Install all system expander and the centerplane support board sets by following the procedures in:**
      - [Section 12.2.4, “Installing an Expander Board” on page 12-7](#)
      - [Section 11.2.4, “Installing a Centerplane Support Board” on page 11-7](#)

---

## 15.4 Powering On the System After Power Centerplane Installation

1. Connect the AC power cords to the 4 kW dual AC-DC power supplies.
2. Connect all I/O cables referencing the cable label for proper identification.
3. Power on the AC0 and AC1 circuit breakers for all power supplies in the system.
4. Close the cabinet doors.
5. Once the main SC is booted, start the domain(s) by typing:

```
sc% setkeyswitch -d domain_id on
```

where *domain\_id* is the domain letter A-R.

6. Execute one `setkeyswitch` command for each domain to be started.



## Cable Replacement Procedures

---

FIGURE 16-1 shows the locations of the internal system cable connections for the Sun Fire E25K/E20K systems. Cable functions are further defined in the diagrams shown in FIGURE 16-2. FIGURE 16-3, FIGURE 16-4, FIGURE 16-5, FIGURE 16-6, FIGURE 16-7, FIGURE 16-8 and FIGURE 16-9 that identify the silkscreen numbers on the cabinet that corresponds to the cable connections. Review TABLE 16-1 for cable termination wire color definitions. This chapter contains the replacement procedures specifically for the internal cabinet cables.

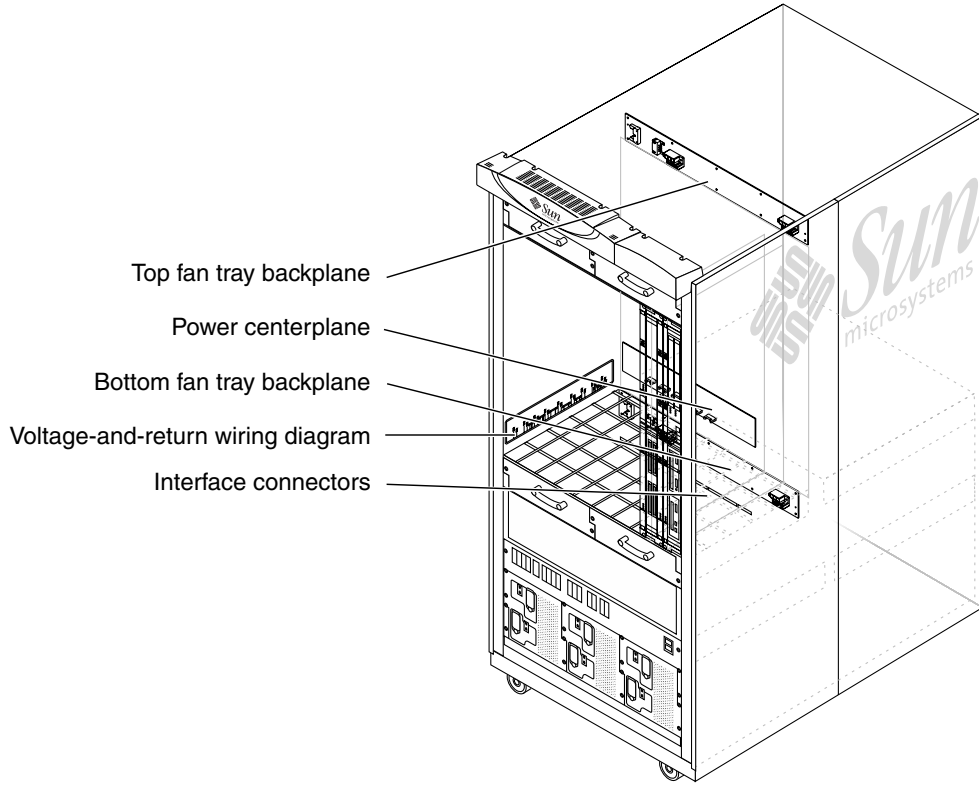
This chapter contains the following sections:

- Section 16.1, “AC Power Cord” on page 16-9
- Section 16.2, “Internal Cabinet Cable Replacement Procedures” on page 16-9
- Section 16.3, “Powering On the System” on page 16-22

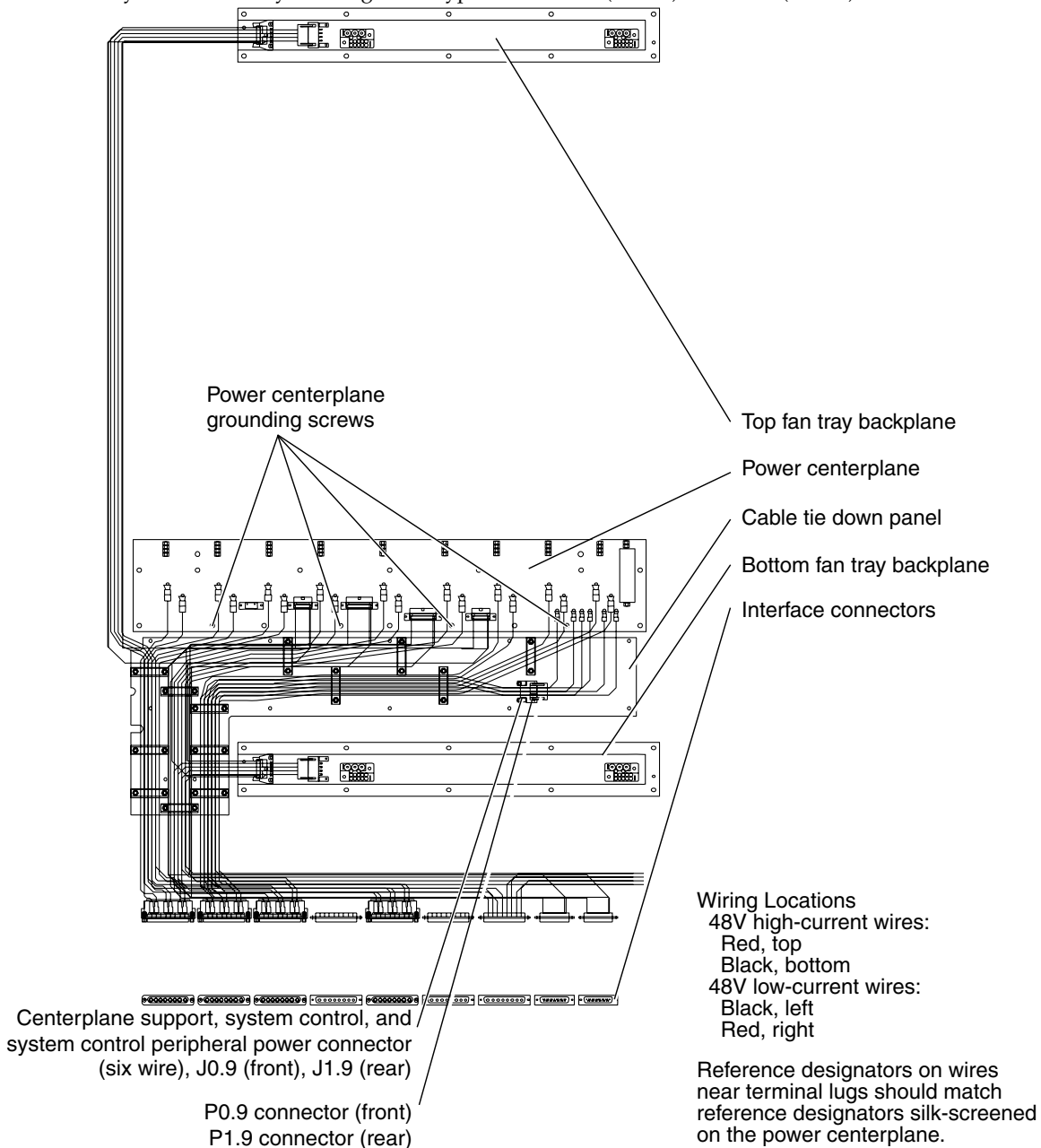
For your protection, observe the following safety precautions:

- Follow all cautions and instructions marked on the equipment.
- Always use proper ESD equipment and procedures when handling boards and components.
- Never push objects of any kind through openings in the equipment as they might touch dangerous voltage points or short out components that can result in fire or electric shock.
- Refer servicing of equipment to qualified personnel.

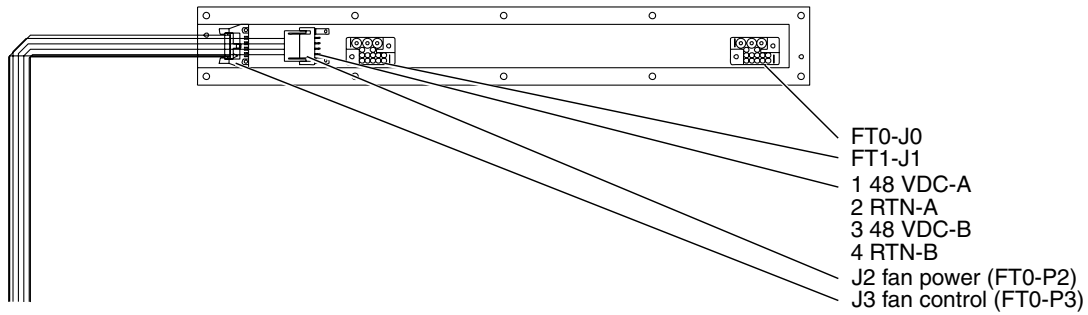
**FIGURE 16-1** Sun Fire E25K/E20K Systems Internal Cable Connections



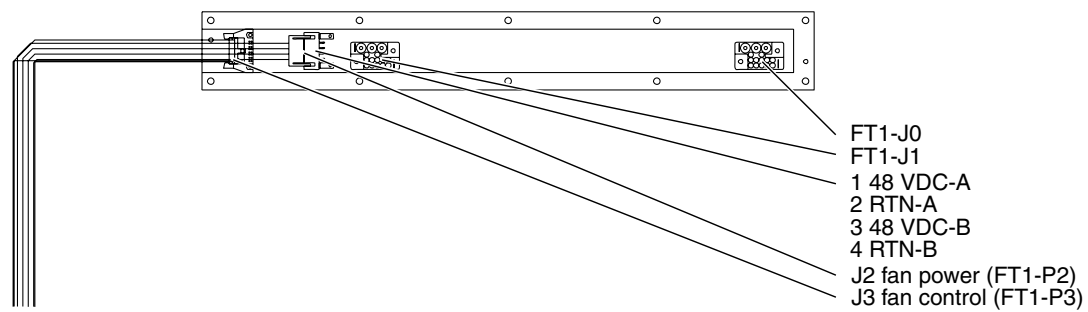
**FIGURE 16-2** System Cable Layout Diagram—Typical for Front (Side 0) and Rear (Side 1)



**FIGURE 16-3** Fan Tray Backplane FRU Cable Diagram—Top Front, Side 0

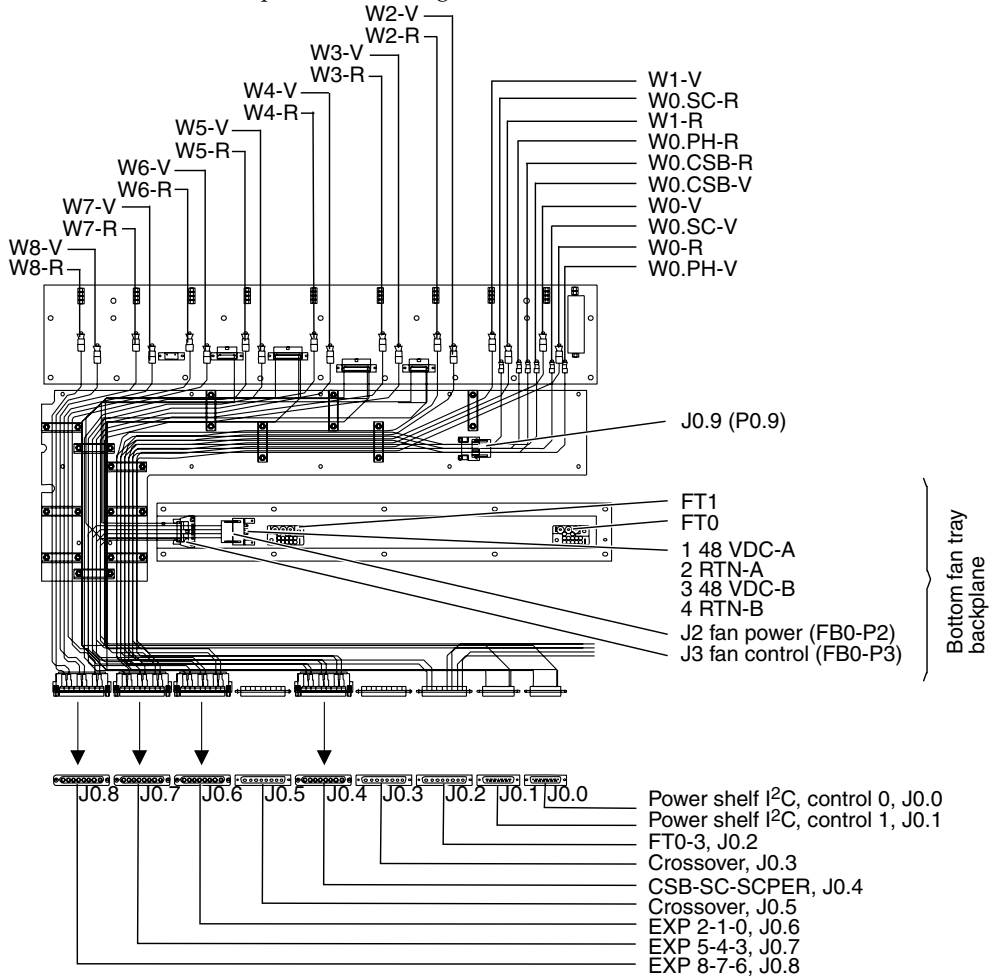


**FIGURE 16-4** Fan Tray Backplane FRU Cable Diagram—Top Front, Side 1

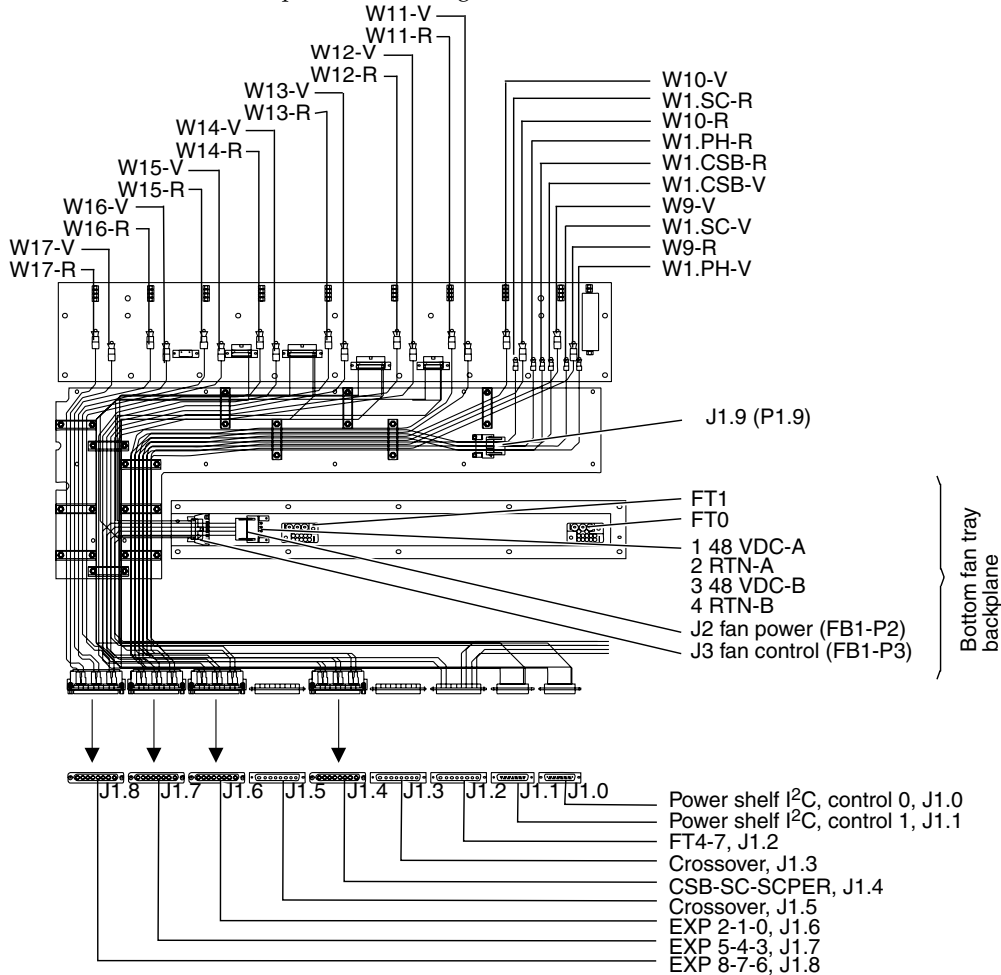




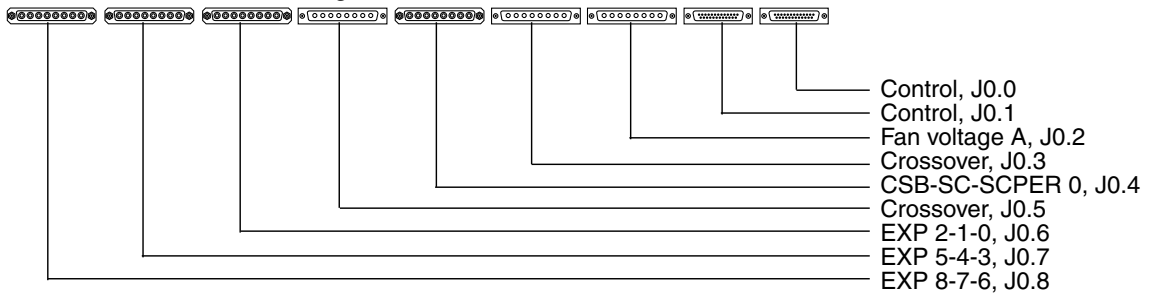
**FIGURE 16-5** Power Centerplane Cable Diagram—Bottom Front, Side 0



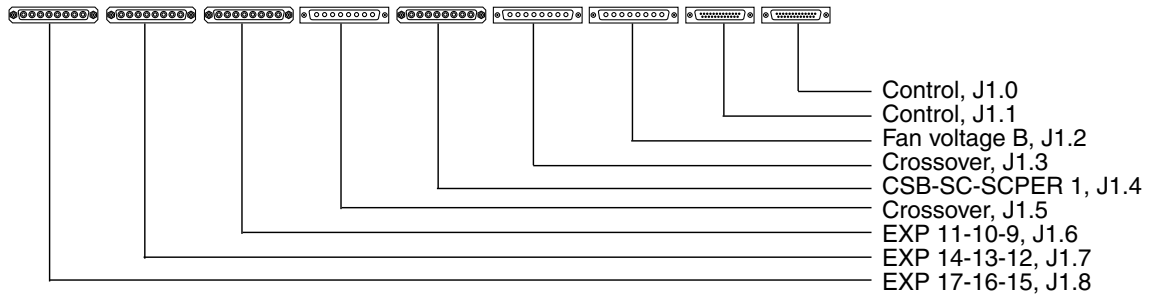
**FIGURE 16-6** Power Centerplane Cable Diagram—Bottom Rear, Side 1



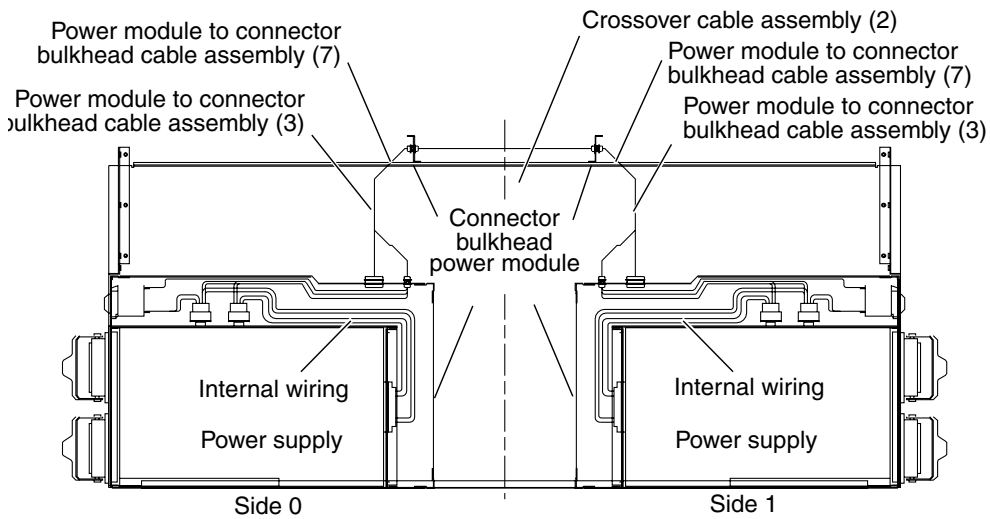
**FIGURE 16-7** Cable Schematic Diagram for Interface Connectors—Side 0



**FIGURE 16-8** Cable Schematic Diagram for Interface Connectors—Side 1



**FIGURE 16-9** DC Power Distribution Cables—Side 0 and Side 1



**TABLE 16-1** Cable Termination Table

| From Power C P | To Interface | AWG & Color | Function      | From Power CP | To Interface | AWG & Color | Function      |
|----------------|--------------|-------------|---------------|---------------|--------------|-------------|---------------|
| FRONT (SIDE 0) |              |             |               | REAR (SIDE 1) |              |             |               |
| W8-R           | J0.8-8       | 10 BLK      | EXP 8 RETURN  | W17-R         | J1.8-8       | 10 BLK      | EXP 17 RETURN |
| W8-V           | J0.8-7       | 10 RED      | EXP 8 48VDC   | W17-V         | J1.8-7       | 10 RED      | EXP 17 48VDC  |
| NC             | J0.8-6       |             | NO CONNECTION | NC            | J1.8-6       |             | NO CONNECTION |
| W7-R           | J0.8-5       | 10 BLK      | EXP 7 RETURN  | W16-R         | J1.8-5       | 10 BLK      | EXP 16 RETURN |
| W7-V           | J0.8-4       | 10 RED      | EXP 7 48VDC   | W16-V         | J1.8-4       | 10 RED      | EXP 16 48VDC  |

**TABLE 16-1** Cable Termination Table (Continued)

| <b>From Power C P</b> | <b>To Interface</b> | <b>AWG &amp; Color</b> | <b>Function</b>     | <b>From Power CP</b> | <b>To Interface</b> | <b>AWG &amp; Color</b> | <b>Function</b>     |
|-----------------------|---------------------|------------------------|---------------------|----------------------|---------------------|------------------------|---------------------|
| NC                    | J0.8-3              |                        | NO CONNECTION       | NC                   | J1.8-3              |                        | NO CONNECTION       |
| W6-R                  | J0.8-2              | 10 BLK                 | EXP 6 RETURN        | W15-R                | J1.8-2              | 10 BLK                 | EXP 15 RETURN       |
| W6-V                  | J0.8-1              | 10 RED                 | EXP 6 48VDC         | W15-V                | J1.8-1              | 10 RED                 | EXP 15 48VDC        |
| W5-R                  | J0.7-8              | 10 BLK                 | EXP 5 RETURN        | W14-R                | J1.7-8              | 10 BLK                 | EXP 14 RETURN       |
| W5-V                  | J0.7-7              | 10 RED                 | EXP 5 48VDC         | W14-V                | J1.7-7              | 10 RED                 | EXP 14 48VDC        |
| NC                    | J0.7-6              |                        | NO CONNECTION       | NC                   | J1.7-6              |                        | NO CONNECTION       |
| W4-R                  | J0.7-5              | 10 BLK                 | EXP 4 RETURN        | W13-R                | J1.7-5              | 10 BLK                 | EXP13 RETURN        |
| W4-V                  | J0.7-4              | 10 RED                 | EXP 4 48VDC         | W13-V                | J1.7-4              | 10 RED                 | EXP13 48VDC         |
| NC                    | J0.7-3              |                        | NO CONNECTION       | NC                   | J1.7-3              |                        | NO CONNECTION       |
| W3-R                  | J0.7-2              | 10 BLK                 | EXP 3 RETURN        | W12-R                | J1.7-2              | 10 BLK                 | EXP 12 RETURN       |
| W3-V                  | J0.7-1              | 10 RED                 | EXP 3 48VDC         | W12-V                | J1.7-1              | 10 RED                 | EXP 12 48VDC        |
| W2-R                  | J0.6-8              | 10 BLK                 | EXP 2 RETURN        | W11-R                | J1.6-8              | 10 BLK                 | EXP 11 RETURN       |
| W2-V                  | J0.6-7              | 10 RED                 | EXP 2 48VDC         | W11-V                | J1.6-7              | 10 RED                 | EXP 11 48VDC        |
| NC                    | J0.6-6              |                        | NO CONNECTION       | NC                   | J1.6-6              |                        | NO CONNECTION       |
| W1-R                  | J0.6-5              | 10 BLK                 | EXP 1 RETURN        | W10-R                | J1.6-5              | 10 BLK                 | EXP 10 RETURN       |
| W1-V                  | J0.6-4              | 10 RED                 | EXP 1 48VDC         | W10-V                | J1.6-4              | 10 RED                 | EXP 10 48VDC        |
| NC                    | J0.6-3              |                        | NO CONNECTION       | NC                   | J1.6-3              |                        | NO CONNECTION       |
| W0-R                  | J0.6-2              | 10 BLK                 | EXP 0 RETURN        | W9-R                 | J1.6-2              | 10 BLK                 | EXP 9 RETURN        |
| W0-V                  | J0.6-1              | 10 RED                 | EXP 0 48VDC         | W9-V                 | J1.6-1              | 10 RED                 | EXP 9 48VDC         |
| W0-CSB-R              | P0.9-1              | 16 BLK                 | CP SUPT BD 0 RETURN | W1-CSB-R             | P1.9-1              | 16 BLK                 | CP SUPT BD1 RETURN  |
| J0.9-1                | J0.4-8              | 16 BLK                 | CP SUPT BD 0 RETURN | J1.9-1               | J1.4-8              | 16 BLK                 | CP SUPT BD 1 RETURN |
| W0-CSB-V              | P0.9-6              | 16 RED                 | CP SUPT BD 0 48VDC  | W1-CSB-V             | P1.9-6              | 16 RED                 | CP SUPT BD 1 48VDC  |
| J0.9-6                | J0.4-7              | 16 RED                 | CP SUPT BD 0 48VDC  | J1.9-6               | J1.4-7              | 16 RED                 | CP SUPT BD 1 48VDC  |
| NC                    | J0.4-6              |                        | NO CONNECTION       | NC                   | J1.4-6              |                        | NO CONNECTION       |
| W0.SC-R               | P0.9-3              | 16 BLK                 | SYST CNTLR 0 RETURN | W1.SC-R              | P1.9-3              | 16 BLK                 | SYST CNTLR 1 RETURN |
| J0.9-3                | J0.4-5              | 16 BLK                 | SYST CNTLR 0 RETURN | J1.9-3               | J1.4-5              | 16 BLK                 | SYST CNTLR 1 RETURN |
| W0.SC-V               | P0.9-5              | 16 RED                 | SYST CNTLR 0 48VDC  | W1.SC-V              | P1.9-5              | 16 RED                 | SYST CNTLR 1 48VDC  |
| J0.9-5                | J0.4-4              | 16 RED                 | SYST CNTLR 0 48VDC  | J1.9-5               | J1.4-4              | 16 RED                 | SYST CNTLR 1 48VDC  |
| NC                    | J0.4-3              |                        | NO CONNECTION       | NC                   | J1.4-3              |                        | NO CONNECTION       |

**TABLE 16-1** Cable Termination Table (*Continued*)

| From Power C P | To Interface | AWG & Color | Function               | From Power CP | To Interface | AWG & Color | Function               |
|----------------|--------------|-------------|------------------------|---------------|--------------|-------------|------------------------|
| W0.PH-R        | P0.9-2       | 16 BLK      | SYST CNTLR PER 0 RET   | W1.PH-R       | P1.9-2       | 16 BLK      | SYST CNTLR PER1 RET    |
| J0.9-2         | J0.4-2       | 16 BLK      | SYST CNTLR PER 0 RET   | J1.9-2        | J1.4-2       | 16 BLK      | SYST CNTLR PER 1 RET   |
| W0.PH-V        | P0.9-4       | 16 RED      | SYST CNTLR PER 0 48VDC | W1.PH-V       | P1.9-4       | 16 RED      | SYST CNTLR PER 1 48VDC |
| J0.9-4         | J0.4-1       | 16 RED      | SYST CNTLR PER 0 48VDC | J1.9-4        | J1.4-1       | 16 RED      | SYST CNTLR PER 1 48VDC |

## 16.1 AC Power Cord

To hot-swap an AC power cord, see [Section 3.2.2.3, “Removing a 4 kW Dual AC–DC Power Supply”](#) on page 3-10.

## 16.2 Internal Cabinet Cable Replacement Procedures

If a failure is in the cable harness set (includes the front and rear cable tie-down panels), the complete harness set should be replaced. See [Section 16.2.6, “Internal Cable Harness Set Replacement”](#) on page 16-17.



**Caution** – The internal cabinet cables are NOT hot-swap components. These procedures require turning off the AC power to the system prior to cable replacement.

## 16.2.1 Powering Off the System for Cable Replacement



---

**Caution** – The cable harness set is NOT a hot-swap component. This procedure requires a complete shutdown of the domains and SCs, and disconnection of all AC power to the system.

---

1. As a superuser on the domains, systematically shut down all running domains by typing:

```
domain_name# shutdown -y -g seconds -i 0
```

where *seconds* is the amount of time before shutdown.

2. On the main SC, power off the domain hardware by typing:

```
sc% poweroff
```

This command powers off the entire system with the exception of the power supplies, fans, and the SCs. Refer to `poweroff(1M)` for more information.

3. Shut down the System Control boards by doing the following:

- As a superuser on the spare SC, shut down the spare SC by typing:

```
sc_spare# shutdown -y -g seconds -i 0
```

where *seconds* is the amount of time before shutdown.

- On the main SC, power off the spare SC by typing:

```
sc% poweroff SCx
```

where *x* is 0 or 1, dependent upon which SC is the spare.

- As a superuser on the main SC, shutdown the main SC by typing:

```
sc# shutdown -y -g seconds -i 0
```

where *seconds* is the amount of time before shutdown.

4. Open the cabinet doors.

---

**Note** – All DC circuit breakers are to remain in the on position at all times.

---

5. Power on the AC0 and AC1 circuit breakers for all power supplies in the system.

6. Label and disconnect the twelve (12, six per side) AC power cords with the labels provided in the ship kit.

## 16.2.2 48 VDC Power Cable Replacement

### 16.2.2.1 Removing the 48 VDC Power Cable



---

**Caution** – Be sure you are properly grounded before you begin the hardware removal and installation. There are four ground points on the system cabinet, two at the front top left and top right, and two at the rear top left and top right.

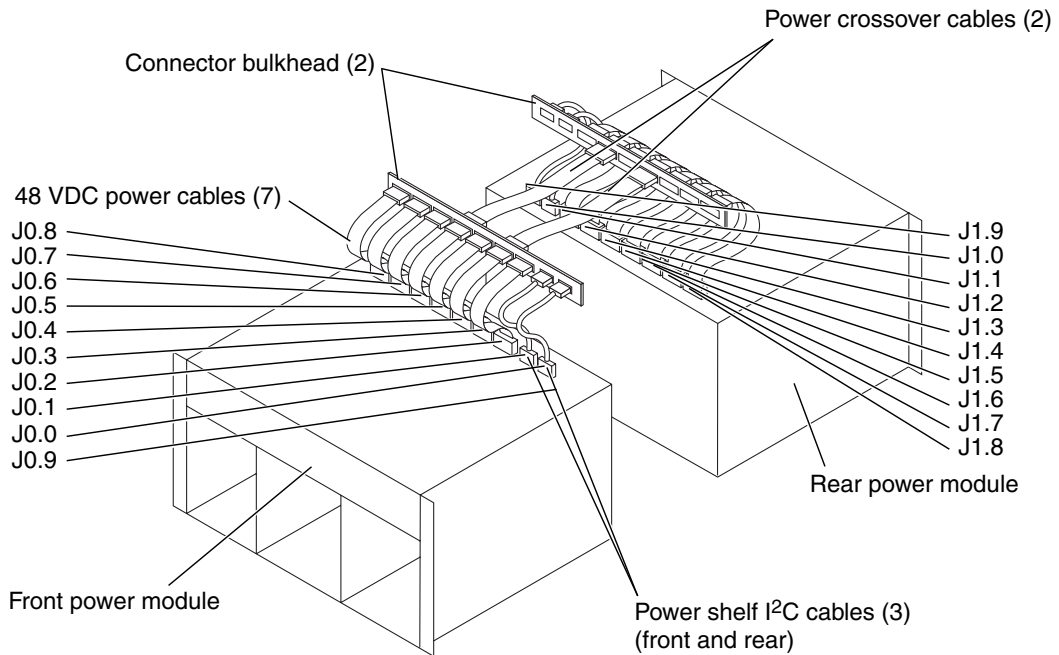
---

1. **Power off the system.**

See [Section 16.2.1, “Powering Off the System for Cable Replacement”](#) on page 16-10.

2. **Remove the twenty-two (22) M4x30 panhead screws retaining the air plenum cover, and remove both the plenum cover and the honeycomb EMI filter panel.**
3. **Reach inside the system, below the fan trays, and release the four (4 per cable) male jackscrews holding the 48 VDC cable assemblies to both the top of the power shelf assembly and the cable retaining bracket (FIGURE 16-10).**

**FIGURE 16-10** 48 VDC Power Cables



4. Remove the cable(s).

### 16.2.2.2 Installing the 48 VDC Power Cable

1. Install the new cable.
2. Secure the four (4 per cable) jackscrews holding the 48 VDC cable assemblies to both the top of the power shelf assembly and the cable retaining bracket.
3. Install the honeycomb EMI Filter panel and air plenum cover and secure with the twenty-two (22) M4x30 panhead screws.
4. Power on the system.

See [Section 16.3, "Powering On the System"](#) on page 16-22.



## 16.2.3 Power Shelf I<sup>2</sup>C or TopCap Cable Replacement



---

**Caution** – Be sure you are properly grounded before you begin the hardware removal and installation. There are four ground points on the system cabinet, two at the front top left and top right, and two at the rear top left and top right.

---

### 16.2.3.1 Removing the Power Shelf I<sup>2</sup>C or TopCap Cable

**1. Power off the system.**

See [Section 16.2.1, “Powering Off the System for Cable Replacement”](#) on page 16-10.

**2. Remove the twenty-two (22) M4x30 panhead screws retaining the air plenum cover, and remove both the plenum cover and the honeycomb EMI filter panel.**

**3. Release the four (4 per cable) male jackscrews holding the power shelf I<sup>2</sup>C cable assemblies to both the top of the power shelf assembly and the cable retaining bracket.**

The jackscrews are located inside the system, below the fan trays.

**4. Remove the cable.**

### 16.2.3.2 Installing the Power Shelf I<sup>2</sup>C or TopCap Cable

**1. Install the new cable.**

**2. Secure the four (4 per cable) male jackscrews holding the power shelf I<sup>2</sup>C cable assemblies to both the top of the power shelf assembly and the cable retaining bracket.**

**3. Install the honeycomb EMI Filter panel and air plenum cover and secure with the twenty-two (22) M4x30 panhead screws.**

**4. Power on the system.**

See [Section 16.3, “Powering On the System”](#) on page 16-22.

## 16.2.4 Power Crossover Cable Replacement

### 16.2.4.1 Removing the Power Crossover Cable



---

**Caution** – Be sure you are properly grounded before you begin the hardware removal and installation. There are ground points at the top left and top right of the cabinet in both front and rear.

---

**1. Power off the system.**

See [Section 16.2.1, “Powering Off the System for Cable Replacement”](#) on page 16-10.

**2. Remove the twenty-two (22) M4x30 panhead screws retaining the air plenum cover, and remove both the plenum cover and the honeycomb EMI filter panel.**

**3. Remove at least three (3) center system board components and their associated carrier plate assemblies from both the front and the rear of the system to allow access to the cables below the lower card guide assembly.**

Review the board set carrier plate instructions for proper handling. See [Section 10.1, “Inserting a Board Set Carrier Plate”](#) on page 10-2.

**4. Remove the two (2) lower fan trays and set aside.**

See [Section 4.2.3, “Removing a Fan Tray”](#) on page 4-4.

**5. Reach inside the system, below the fan trays, and release the four (two (2) per connector) male jackscrews (front and rear) holding the 48 VDC power cable assemblies (two (2) per side) to the two (2) power crossover cables. [FIGURE 16-10](#).**

**6. Using a 3/16 inch nut driver, carefully remove the four (4) female jack screws (two (2) per connector) holding the crossover cable connectors to the horizontal connector bracket.**

**7. Reaching through the lower card guide assembly, remove the cable(s).**

### 16.2.4.2 Installing the Power Crossover Cable

**1. Install the new cable(s).**

**2. Secure the four (4) female jack screws (two per connector) holding the crossover cable connectors to the horizontal connector bracket by using a 3/16 inch nut driver.**

**3. Secure the four (4) (two per connector) jackscrews holding the 48 VDC power cable assemblies (front and rear) to the two (2) power crossover cables.**

4. **Install the lower fan trays.**  
See [Section 4.2.4, “Installing a Fan Tray”](#) on page 4-5.
5. **Install the center system board components and their associated carrier plate assemblies to both the front and the rear of the system previously removed to enable access to the cables below the lower card guide assembly.**  
Review the board set carrier plate instructions for proper handling. See [Section 10.1, “Inserting a Board Set Carrier Plate”](#) on page 10-2.
6. **Install the honeycomb EMI Filter panel and air plenum cover and secure with the twenty-two (22) M4x30 panhead screws.**
7. **Power on the system.**  
See [Section 16.3, “Powering On the System”](#) on page 16-22.

## 16.2.5 Fan Tray Power Cable Replacement

### 16.2.5.1 Removing the Fan Tray Power Cable



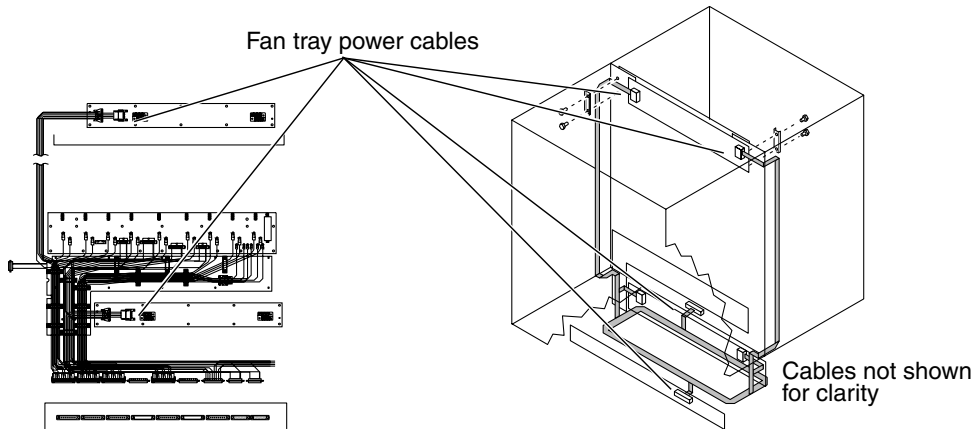
---

**Caution** – Be sure you are properly grounded before you begin the hardware removal and installation. There are ground points at the top left and top right of the cabinet in both front and rear.

---

1. **Power off the system.**  
See [Section 16.2.1, “Powering Off the System for Cable Replacement”](#) on page 16-10.
2. **Remove the system board modules and their associated carrier plate assemblies from the front and rear of the system.**
3. **Remove the twenty-two (22) M4x30 panhead screws retaining the air plenum cover, and remove both the plenum cover and the honeycomb EMI filter panel.**
4. **Reach inside the system, below the fan tray, and release the four (4) (two per connector) male jackscrews holding the 48 VDC power cable assemblies to the two (2) fan tray power cable connectors attached to the connector bracket.** See [FIGURE 16-11](#).

**FIGURE 16-11** Fan Tray Power Cable



5. Using a 3/16 inch nut driver, carefully remove the four (4) female jack screws (two (2) per connector) holding the fan tray cable connectors to the horizontal connector bracket on the front and rear of the system.
6. Remove the sixteen (16) M4x6 panhead screws (eight (8) per cover) holding the vertical cable wireway covers on the front and rear of the system.
7. Remove the two (2) upper cable clamps (each with two (2) locknuts (one (1) per side) from the front and rear of the system.
8. Remove the thirty-eight (38) (nineteen (19) per side) M4x6 panhead screws retaining the black plastic cable cover attached to the center bulkhead on the front and rear of the system.
9. Reach through the upper and lower card guide assembly and remove the blue colored connectors attaching the fan power cable to the four (4) fan backplanes.
10. Remove the fan power cable assembly from the system.

### 16.2.5.2 Installing the Fan Tray Power Cable

1. Install the new cable(s), carefully routing the cable(s) as originally installed.
2. Replace the blue colored connectors attaching the fan power cable to the four (4) fan backplanes.  
See [FIGURE 16-3](#) and [FIGURE 16-4](#) for reference designators.
3. Secure the black plastic cable covers, on the front and rear of the system, to the center bulkhead with the thirty-eight (38) (nineteen (19) per side) M4x6 panhead screws.

4. Replace the two (2) upper cable clamps (each with two (2) locknuts on the front and rear of the system).
5. Secure the vertical cable wireway covers, on the front and rear of the system, with the sixteen (16) M4x6 panhead screws (eight (8) per cover).
6. Secure the four (4) female jack screws (two (2) per connector) holding the fan tray cable connectors to the horizontal connector bracket by using a 3/16 inch nut driver.
7. Secure the four (two (2) per connector) jackscrews holding the 48 VDC power cable assemblies to the two (2) fan tray power cable connectors on the front and rear of the system.
8. Install the honeycomb EMI Filter panel and air plenum cover and secure with the twenty-two (22) M4x30 panhead screws.
9. Install the system board modules and their associated carrier plate assemblies into the front and rear of the system.
10. Power on the system.  
See [Section 16.3, “Powering On the System”](#) on page 16-22.

## 16.2.6 Internal Cable Harness Set Replacement

### 16.2.6.1 Removing the Internal Cable Harness Set



---

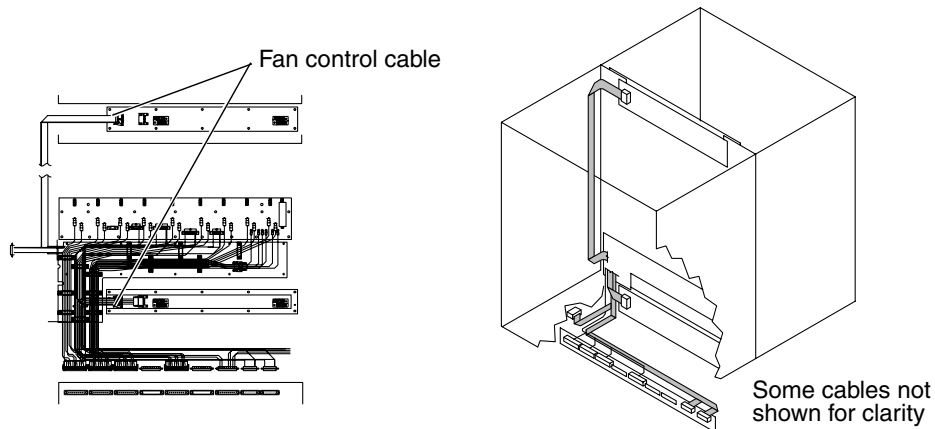
**Caution** – Be sure you are properly grounded before you begin the hardware removal and installation. There are ground points at the top left and top right of the cabinet in both front and rear.

---

1. Power off the system.  
See [Section 16.2.1, “Powering Off the System for Cable Replacement”](#) on page 16-10.
2. Remove the system board modules and their associated carrier plate assemblies from the front and rear of the system.
3. Remove the upper and lower fan trays from the front and rear of the system.
4. Remove the twenty-two (22) M4x30 panhead screws retaining the air plenum cover, and remove both the plenum cover and the honeycomb EMI filter panel from the front and rear of the system.

5. With a flat-blade screwdriver (if needed), loosen the jackscrews on the seven (7) 8W8 Combo-D 8-pin DC power connectors (on the left side of the power module) and the two (2) DB-25 control connectors (on the right side) on the front and rear of the system.
6. Using a 3/16 inch nut driver, carefully remove the two (2) nut screws and the vertical bracket holding the internal harness set connectors to the fan backplane on the front and rear of the system.
7. Unlock and remove the connector at J3 of the upper and lower fan backplane from the front and rear of the system.
8. Depress the top and bottom clamp to remove the connector at J2 of the upper and lower fan backplane from the front and rear of the system.
9. Remove the cable wireway cover by removing the sixteen (16) M4x6 panhead screws (eight (8) per cover), on the front and rear of the system.
10. Remove the thirty-eight (38) (nineteen (19) per side) M4x6 panhead screws retaining the black plastic cable cover attached to the center bulkhead on the front and rear of the system.
11. Reach through the upper and lower card guide assembly and remove the grey colored connectors attaching the I<sup>2</sup>C fan cable to the four (4) fan backplanes (FIGURE 16-12).

**FIGURE 16-12** Internal Cable Harness Set



12. Disconnect all forty-eight (48) (twenty-four (24) per side) discrete screw lugs and ten (10) (five (5) per side) ribbon cable connectors from the power centerplane at the front and rear of the system.
13. Remove the twelve (12) jack screws holding the cable harness set to the chassis and carefully remove from the system.

## 16.2.6.2 Installing the Internal Cable Harness Set

1. Install the new internal cable harness set assembly into the system and secure with the twelve (12) jack screws.
2. Install the forty-eight (48) (twenty-four (24) per side) discrete screw lugs and ten (10) (five (5) per side) ribbon cable connectors to the power centerplane at the front and rear of the system.
3. Replace the grey colored connectors attaching the I2C fan cable to the four (4) fan backplanes.  
See [FIGURE 16-5](#) and [FIGURE 16-6](#) for reference designators.
4. Secure the black plastic cable cover to the center bulkhead with the thirty-eight (38) (nineteen (19) per side) M4x6 pan head screws to the front and rear of the system.
5. Secure the cable wireway cover with the sixteen (16) (eight (8) per cover) M4x6 panhead screws on the front and rear of the system.
6. Insert and lock the connector at J3 of the upper and lower fan backplane to the front and rear of the system.
7. Insert the connector at J2 of the upper and lower fan backplane to the front and rear of the system.
8. With the 3/16 nut driver, secure the vertical bracket with the two (2) nut screws to holds the internal harness set connectors to the fan backplane on the front and rear of the system.
9. With the jack screws, install the seven (7) 8W8 Combo-D 8-pin DC power connectors (on the left side of the power module) and the two (2) DB-25 control connectors (on the right side) on the front and rear of the system.
10. Replace the honeycomb EMI filter panel onto the air plenum cover and install with the twenty-two (22) M4x30 panhead screws on the front and rear of the system.
11. Replace the upper and lower fan trays at the front and rear of the system.
12. Install the system board modules and their associated carrier plate assemblies into the front and rear of the system.
13. Power on the system.

See [Section 16.3, "Powering On the System"](#) on page 16-22.

## 16.2.7 TopCap Cable Replacement

### 16.2.7.1 Removing the TopCap Cable



---

**Caution** – Be sure you are properly grounded before you begin the hardware removal and installation. There are four ground points on the system cabinet, two at the front top left and top right, and two at the rear top left and top right.

---

**1. Power off the system.**

See [Section 16.2.1, “Powering Off the System for Cable Replacement”](#) on page 16-10.

**2. Remove the three (3) M4x12 panhead screws holding the TopCap to the chassis.**

**3. Disconnect the 12V power cable from the rear of the TopCap.**

**4. Loosen the lower captive screws on the right-rear external side panel a quarter turn, and lift upward off to remove the panel from the chassis.**

**5. Remove the four (4) M4x12 panhead screws holding the four (4) cable clamps that secure the TopCap cable to the chassis.**

**6. At the rear of the system, remove the twenty-two (22) M4x30 panhead screws retaining the air plenum cover, and remove both the plenum cover and the honeycomb EMI filter panel.**

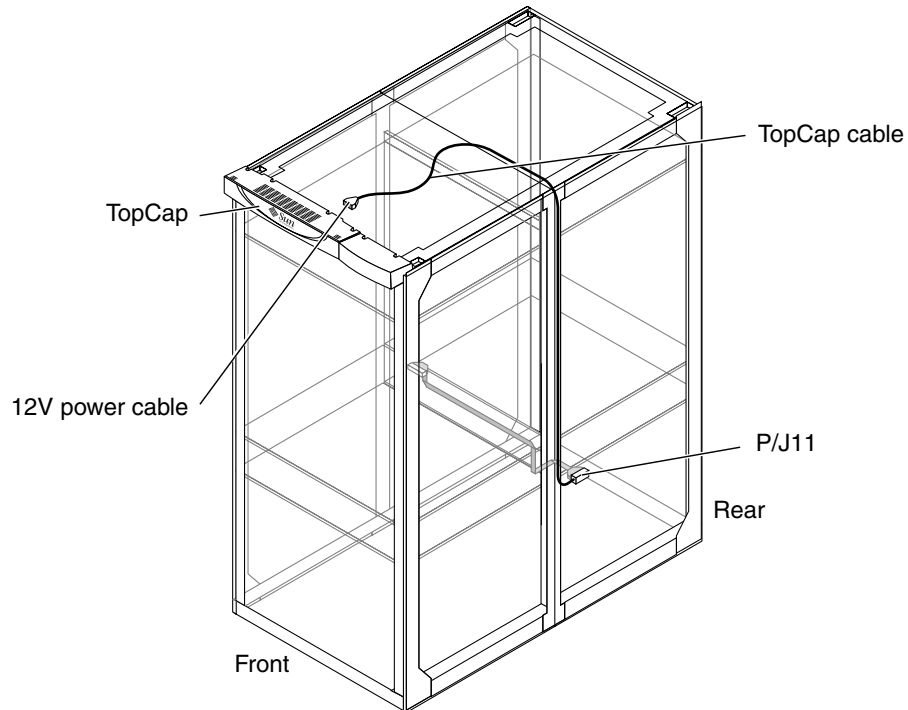
**7. Reach inside the air plenum and release the two (2) male jackscrews holding the internal cable connector to the internal chassis side panel.**

**8. To remove the right-angle connector, release the two (2) female jack screws using a 3/16-inch nut driver.**

**9. Remove the external right-angle connector (P/J11) from the chassis side panel ([FIGURE 16-13](#)).**



**FIGURE 16-13** TopCap Cable



10. Remove the TopCap cable.

### 16.2.7.2 Installing the TopCap Cable

1. Place the new TopCap cable on top of the system.
2. Install the external right-angle connector (P/J11) at the end of the cable to the chassis side panel.
3. Secure the right-angle connector with the two (2) female jack screws using a 3/16-inch nut driver.
4. Secure the two (2) jackscrews that hold the internal TopCap cable to the bulkhead on the internal chassis side panel.
5. Install the honeycomb EMI Filter panel and air plenum cover and secure with the twenty-two (22) Mx30 panhead screws at the rear of the system.
6. Secure the four (4) cable clamps with the four (4) M4x12 panhead screws to mount the TopCap cable to the chassis.

7. Install the external side panel by placing the panel on the turn-screw and setting the panel into its proper position.
8. Connect the 12V power cable to the connector on the rear of the TopCap.
9. Secure the TopCap to the chassis with three (3) M4x12 panhead screws.
10. Power on the system.  
See [Section 16.3, "Powering On the System"](#) on page 16-22.

---

## 16.3 Powering On the System

1. Connect the AC power cords to the 4 kW dual AC-DC power supplies.
2. Connect all I/O cables referencing the cable label for proper identification.
3. Power on the AC0 and AC1 circuit breakers for all power supplies in the system.
4. Close the cabinet doors.
5. Once the main SC is booted, start the domain(s) by typing:

```
sc% setkeyswitch -d domain_id on
```

where *domain\_id* is the domain letter A-R.

6. Execute one **setkeyswitch** command for each domain to be started.

# Mechanical Components Replacement Procedures

---

The mechanical components of the Sun Fire E25K/E20K systems consist of the side panels, the front and rear access doors, the six air filters, and the two kick plate assemblies. This chapter contains the replacement procedures for these mechanical components.

This chapter contains the following sections:

- [Section 17.1, “Side Panel Replacement” on page 17-1](#)
- [Section 17.2, “Access Door Replacement” on page 17-2](#)
- [Section 17.3, “Kick Plate Assembly Replacement” on page 17-3](#)

For your protection, observe the following safety precautions:

- Follow all cautions and instructions marked on the equipment.
- Always use proper ESD equipment and procedures when handling boards and components.
- Never push objects of any kind through openings in the equipment as they might touch dangerous voltage points or short out components that can result in fire or electric shock.
- Refer servicing of equipment to qualified personnel.

---

## 17.1 Side Panel Replacement

The Sun Fire E25K/E20K systems have four panels, two per side.

## 17.1.1 Removing a Side Panel

1. Release the two (2) spring-loaded captive fasteners by pushing inward and making a counterclockwise turn.
2. Using both hands, firmly grasp the panel on each side, near the top, and lift straight up and then outward to remove the panel away from the cabinet.

## 17.1.2 Installing a Side Panel

1. Using both hands, firmly grasp the panel on each side, near the top.
2. Lift the panel holding at an angle, approximately one (1) foot out from the base.
3. Hang the panel on the side skin-hanger features at the left outer corner and right inner post (or right outer corner and left inner post for other panel, depending on which panel is being replaced) of the chassis.

---

## 17.2 Access Door Replacement

The Sun Fire E25K/E20K systems will have either four (two in front) or two (one in front) access doors. All access doors are removed and replaced the same way.

### 17.2.1 Removing an Access Door

1. At the top of the door, pull up the spring-loaded pin and remove the peg of the door from the top hinge bracket of the cabinet.
2. Lift the bottom peg out of the bottom hinge bracket and remove the door from the cabinet.

### 17.2.2 Installing an Access Door

1. Insert the door onto the bottom peg of the bottom hinge bracket of the cabinet.
2. At the top of the door, pull down the spring-loaded pin and insert the peg of the door into the top hinge bracket of the cabinet.

## 17.3 Kick Plate Assembly Replacement

The kick plate assembly may be formed to match the curve of the doors or straight as shown in [FIGURE 17-1](#).

---

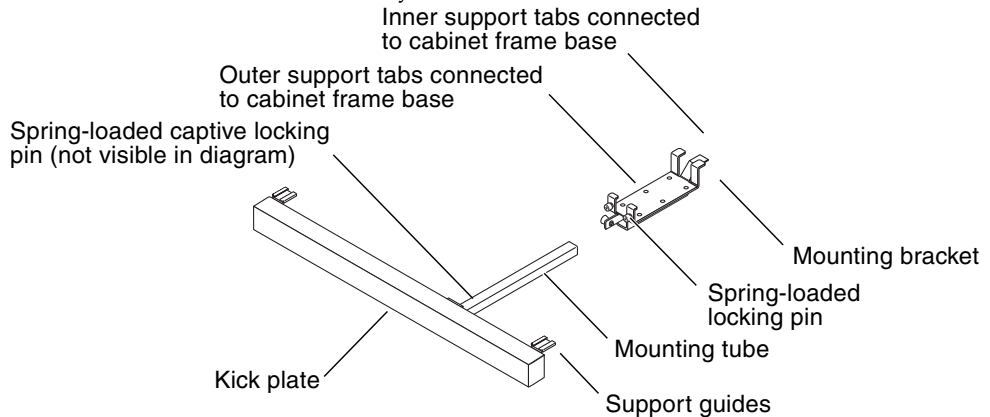
**Note** – The bottom system kick plate is NOT a step. Do NOT use the kick plate to gain access to the high-level components. Obtain a proper stool if required. Excessive weight on the kick plate bends the door support brackets.

---

### 17.3.1 Removing a Kick Plate Assembly

1. Use a pull-turn motion to release the spring-loaded captive locking pin on the left side of the mounting tube and pull the kick plate assembly outward from the mounting bracket ([FIGURE 17-1](#)).

**FIGURE 17-1** Kick Plate Assembly



2. Loosen the two captive panel fasteners of the kick plate mounting bracket assembly.
3. Remove the kick plate assembly by pulling forward and tipping downward to release the inner support tabs from their mounting holes at the cabinet frame base.

## 17.3.2 Installing a Kick Plate Assembly

1. Insert the inner support tabs of the kick plate mounting bracket at the base of the cabinet.
2. Align the two outer tabs at the front mounting holes of the cabinet frame and slide the bracket inward to align the inner support tabs into the two mounting holes of the horizontal support structure under the cabinet.
3. Secure the mounting bracket with the two captive panel fasteners.
4. Insert the square mounting tube of the kick plate mounting bracket assembly until it is flush with the cabinet.
5. Secure the kick plate with the spring-loaded captive locking pin at the left side of the mounting tube.

## Periodic Maintenance

---

This chapter contains the procedures for using the Cable Management system and for the routine cleaning of Air Plenum Panel Air-Intake Screens and Air Filter Replacement.

This chapter contains the following sections:

- [Section 18.1, “Installing the Service Cable Straps” on page 18-2](#)
- [Section 18.2, “Using the Cable Straps” on page 18-7](#)
- [Section 18.3, “Uninstalling the Service Cable Straps” on page 18-7](#)
- [Section 18.4, “Cleaning the Air Plenum Panel Air-Intake Screens” on page 18-10](#)
- [Section 18.5, “Air Filter Replacement” on page 18-11](#)

For your protection, observe the following safety precautions when setting up your equipment:

- Follow all cautions and instructions marked on the equipment.
- Always use proper ESD equipment and procedures when handling boards and components.
- Never push objects of any kind through openings in the equipment as they might touch dangerous voltage points or short out components that can result in fire or electric shock.
- Refer servicing of equipment to qualified personnel.

---

## 18.1 Installing the Service Cable Straps

Green maintenance straps are for service only and should not be left in the system. A location should be determined and the straps stored at the site. This section describes the procedures for installing the green maintenance straps for:

- [Systems With Four Doors \(Two in Front\)](#)
- [Systems With Two Doors \(One in Front\)](#)

For I/O assembly maintenance, all cable management straps should remain in place. Any disconnected cable set will hang from the black cable hanger strap (No. 4) at the air plenum cutout.

---

**Note** – If the cable management system I/O bundle straps were not installed during installation see the *Sun Fire E25K/E20K Systems Hardware Installation and Uninstallation Manual* or the *Cable Management Guide for Sun Fire High End Server Systems* for installation instructions.

---

### 18.1.1 Systems With Four Doors (Two in Front)

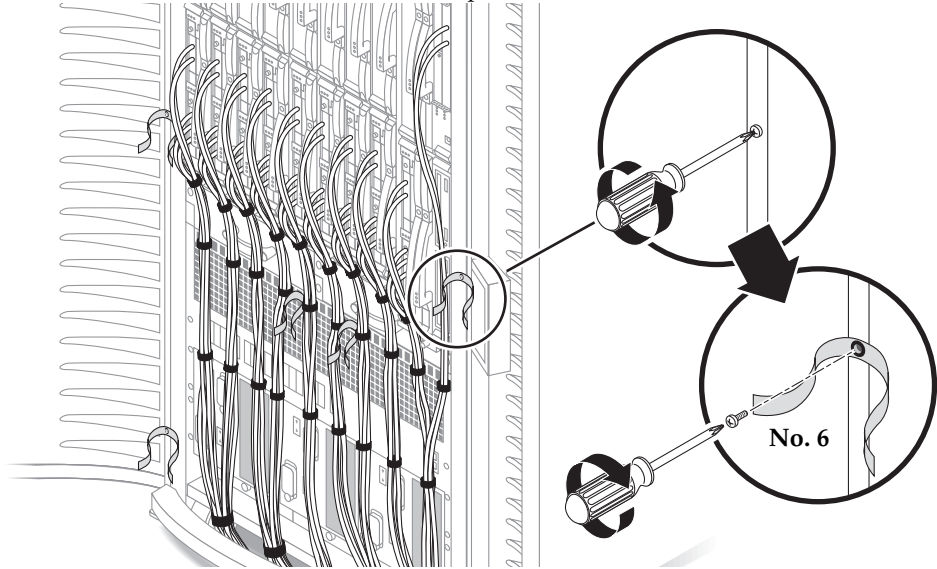
#### 18.1.1.1 For the Front of the System

1. Remove the screws located second from the bottom and eleventh from the bottom of the cabinet door on the left.
2. Use the screws recovered from [Step 1](#) to secure two green cable straps (No. 6) to the holes opened in [Step 1](#) ([FIGURE 18-1](#)).

The screws should be turned no more than 3.0 revolutions to prevent the stripping of the internal door material.



**FIGURE 18-1** Front Door Maintenance Straps



3. Remove the screws located second from the bottom and tenth from the bottom of the cabinet door on the right.
4. Use the screws recovered from [Step 3](#) to secure two green cable straps (No. 6) to the holes opened in [Step 3](#) ([FIGURE 18-1](#)).

### 18.1.1.2 For the Rear of the System

The buckle end of the green buckle strap (No. 2) that is used at the top crossbar of each rear door measures approximately 17.0 in. (43.2 cm). The other end that used to hold the cables measures approximately 12.0 in. (30.5 cm).

**1. Attach the green buckle strap (No. 2) to the top crossbar on the hinged side of the cabinet door on the left (FIGURE 18-2).**

a. Insert the 17.0 in. (43.2 cm) end of the strap, buckle facing toward you, underneath and over the crossbar, and insert the end through the buckle.

**b. Loosely secure the strap.**

This strap should be pushed close to the hinged side of the door to retain proper tension when the cables are held during maintenance.

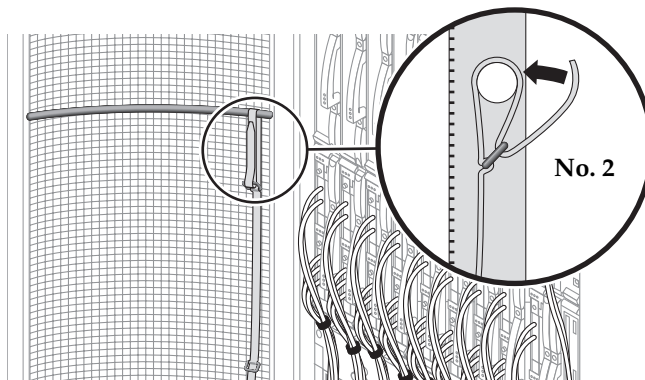
**2. Attach the green buckle strap (No. 2) to the top crossbar on the hinged side of the cabinet door on the right (FIGURE 18-2).**

a. Insert the 17.0 in. (43.2 cm) end of the strap, buckle facing toward you, underneath and over the crossbar, and insert the end through the buckle.

**b. Loosely secure the strap.**

This strap should be pushed close to the hinged side of the door to retain proper tension when the cables are held during maintenance.

**FIGURE 18-2** Rear door maintenance strap



## 18.1.2 Systems With Two Doors (One in Front)

### 18.1.2.1 For the Front of the System

1. Remove the pushbar (if it's still attached)
2. Remove the screws located second from the bottom and eleventh from the bottom on the cabinet door.
3. Use the screws recovered from [Step 2](#) to secure two green cable straps (No. 6) to the holes opened in [Step 2](#) ([FIGURE 18-3](#)).

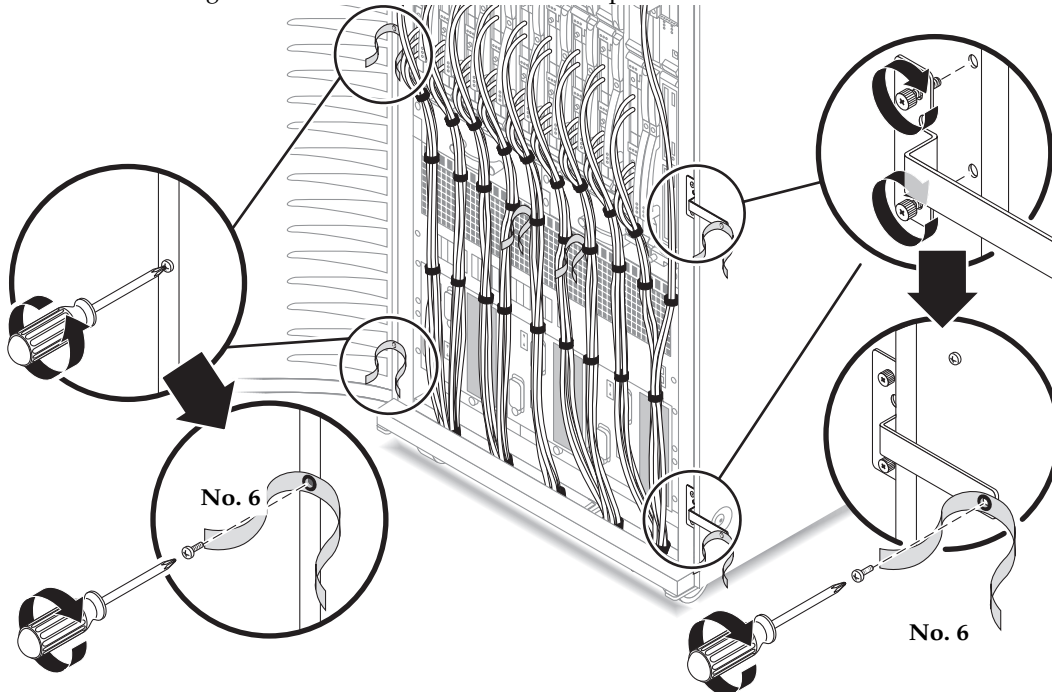
The screws should be turned no more than 3.0 revolutions to prevent the stripping of the internal door material.

4. Secure the two cable management brackets to the holes on the right side of the cabinet ([FIGURE 18-3](#)).

The brackets have captive fasteners that can be tightened by hand.

5. Use the included phillips screws to secure a green cable strap (No. 6) to the holes at the end of each of the cable management brackets ([FIGURE 18-3](#)).

**FIGURE 18-3** Installing the Maintenance Brackets and Straps



### 18.1.2.2 For the Rear of the System

The buckle end of the green buckle strap (No. 2) that is used at the top crossbar of the door measures approximately 17.0 in. (43.2 cm). The other end that used to hold the cables measures approximately 12.0 in. (30.5 cm).

1. **Attach the green buckle strap (No. 2) to the top crossbar on the hinged side of the door (FIGURE 18-2).**

a. **Insert the 17.0 in. (43.2 cm) end of the strap, buckle facing toward you, underneath and over the crossbar, and insert the end through the buckle.**

b. **Loosely secure the strap.**

This strap should be pushed close to the hinged side of the door to retain proper tension when the cables are held during maintenance.

2. **Secure the two cable management brackets to the holes on the right side of the cabinet (FIGURE 18-3).**

The brackets have captive fasteners that can be tightened by hand.

3. Use the included phillips screws to secure a green cable strap (No. 6) to the holes at the end of each of the cable management brackets (FIGURE 18-3).

---

## 18.2 Using the Cable Straps

1. Release the I/O cable bundles from the black cable hanger straps of the air plenum (No. 4) and lift the cable bundles upward to obtain cable slack from beneath the tile floor.



---

**Caution** – Avoid excessive strain on the I/O cable connectors.

---

2. Secure the I/O cable bundles with the green maintenance straps.

Ensure the cables are held tight and that ample room is provided to gain access to the air plenum panel.

3. Perform maintenance on the system.

Refer to the system service manual for the component maintenance procedures.

---

## 18.3 Uninstalling the Service Cable Straps

Green maintenance straps are for service only and should not be left in the system. A location should be determined and the straps stored at the site. This section describes the uninstallation procedures for:

- [Systems With Four Doors \(Two in Front\)](#)
- [Systems With Two Doors \(One in Front\)](#)

### 18.3.1 Systems With Four Doors (Two in Front)

#### 18.3.1.1 For the Front of the System

1. Release the I/O cable bundles from the green maintenance strap and resecure them to their former black cable hanger straps on the air plenum.

2. Remove the two screws that secure the green cable straps (No. 6) to the cabinet door on the left and store the green straps for future use.
3. Remove the two screws that secure the green straps (No. 6) to the cabinet door on the right and store the green straps for future use.
4. Secure the four screws in their original locations on the cabinet doors.
5. Close the cabinet doors.

### 18.3.1.2 For the Rear of the System

The buckle end of the green buckle strap (No. 2) that is used at the top crossbar of the door measures approximately 17.0 in. (43.2 cm). The other end that used to hold the cables measures approximately 12.0 in. (30.5 cm).

1. Release the I/O cable bundles from the green buckle straps (No. 2) and resecure them to their former black cable hanger straps on the air plenum.
2. Release the buckle and remove the green buckle strap (No. 2) from the top crossbar on the hinged side of the cabinet door on the left (FIGURE 18-2).
3. Release the buckle and remove the green buckle strap (No. 2) from the top crossbar on the hinged side of the cabinet door on the right (FIGURE 18-2).
4. Close the cabinet doors.

## 18.3.2 Systems With Two Doors (One in Front)

### 18.3.2.1 For the Front of the System

1. Release the I/O cable bundles from the green maintenance strap and resecure them to their former black cable hanger straps on the air plenum.
2. Remove the two screws that secure the green cable straps (No. 6) to the cabinet door on the left and store the green straps for future use.
3. Secure the two screws in their original locations.
4. Remove the two screws that secure the green cable straps (No. 6) to the cable management brackets and store the straps and screws for future use.
5. Remove the cable management brackets and store them for future use (FIGURE 18-3).

The brackets have captive fasteners that can be loosened by hand.

6. Close the cabinet doors.

### 18.3.2.2 For the Rear of the System

The buckle end of the green buckle strap (No. 2) that is used at the top crossbar of the door measures approximately 17.0 in. (43.2 cm). The other end that used to hold the cables measures approximately 12.0 in. (30.5 cm).

1. Release the I/O cable bundles from the green maintenance strap and resecure them to their former black cable hanger straps on the air plenum.
2. Release the buckle and remove the green strap from the top crossbar on the hinged side of the cabinet door (FIGURE 18-2).
3. Remove the two screws that secure the green cable straps (No. 6) to the cable management brackets and store the straps and screws for future use.
4. Remove the cable management brackets and store them for future use (FIGURE 18-3).

The brackets have captive fasteners that can be loosened by hand.

5. Close the cabinet doors.

---

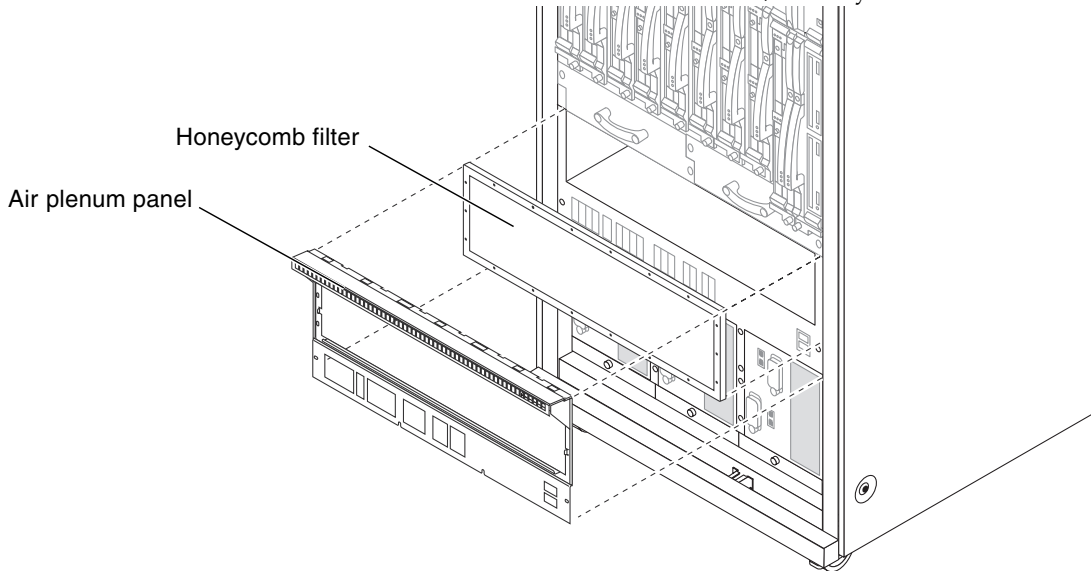
## 18.4 Cleaning the Air Plenum Panel Air-Intake Screens

You can clean the air intake screens by using various methods. The front and back side of the screen can be vacuumed using a brush attachment on a vacuum cleaner. Take care not to damage the honeycomb of the screen. If this does not clean the screen enough, use a high pressure air hose with a nozzle attachment for blowing air.

### 18.4.1 Air Plenum Panel Air-Intake Screen for Sun Fire E25K/E20K Systems

The air plenum of the air-intake screens of the Sun Fire E25K/E20K systems is located below the bottom fan trays on the front and rear of the system ([FIGURE 18-4](#)).

**FIGURE 18-4** Air Plenum Panel and Air-Intake Screen for the Sun Fire E25K/E20K Systems





## 18.4.2 Cleaning the Air Plenum Air-Intake Screens

1. Open the cabinet door.
2. Route I/O cables away from the Air Plenum, ensuring not to disconnect any cables.  
See [Section 18.1, “Installing the Service Cable Straps”](#) on page 18-2.
3. Remove the twenty-two (22) M4x30 panhead screws from the air plenum panel to access the honeycomb filter air-intake screen at the front or rear of the system.
4. Remove the old honeycomb filter air-intake screen from the system.
5. Clean the honeycomb filter air-intake screen.  
See [Section 18.4, “Cleaning the Air Plenum Panel Air-Intake Screens”](#) on page 18-10.
6. Install the clean air plenum air-intake screen and the air plenum panel.
7. Secure the air plenum panel to the system with the twenty-two (22) M4x30 screws.
8. Restore the I/O cables to their original location.  
See [Section 18.3, “Uninstalling the Service Cable Straps”](#) on page 18-7.
9. Close the cabinet door.
10. Repeat Step 1 through Step 9 for the rear of the system.

---

## 18.5 Air Filter Replacement

The Sun Fire E25K/E20K systems have three front and three rear air filters, which allow approximately 3500 CFMs per system, that require periodic cleaning or replacing. To prevent restricted air flow and possible equipment failure, perform this procedure when the filters contain trapped particles, or every three months.

## 18.5.1 Replacing an Air Filter



---

**Caution** – Be sure you are properly grounded before you begin the hardware removal and installation. There are ground points at the top left and top right of the cabinet in both front and rear.

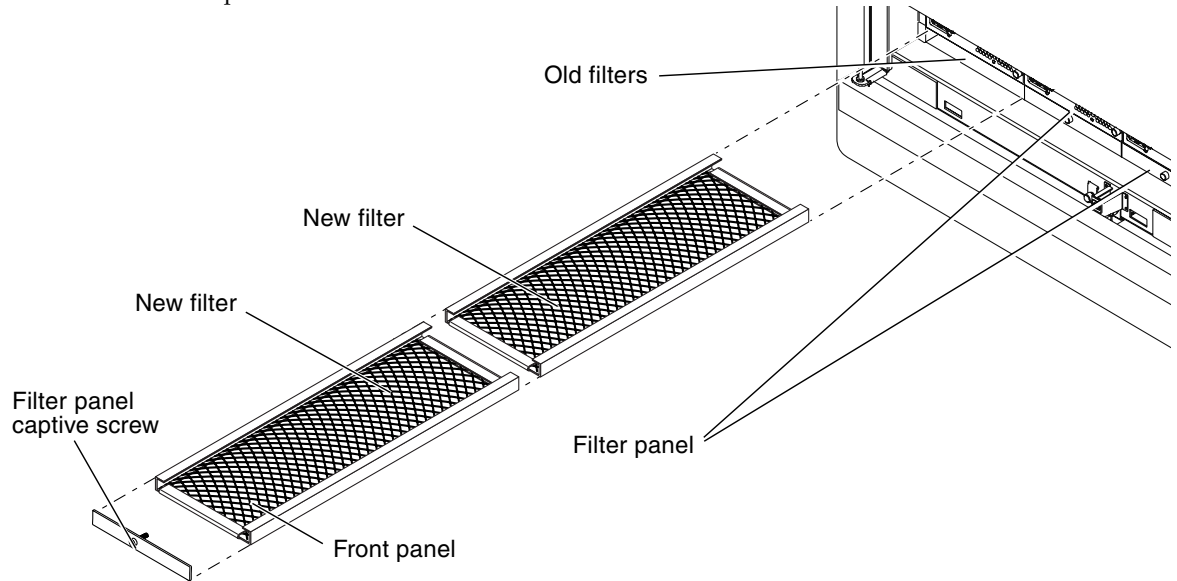
---

1. **Open the cabinet doors.**
2. **Route I/O cables away from the filter being replaced, ensuring not to disconnect any cables. Do this on both the front and rear of the chassis.**  
See [Section 18.1, “Installing the Service Cable Straps”](#) on page 18-2.
3. **Remove the face plates by loosening the front panel captive thumbscrew from both the front and rear of the three filter chambers on the power chassis.**

There are three front and three rear face plates for each of the three filter chambers.

4. **Take two (2) new filters and insert one behind the other in one of the filter chambers, pushing the old filters out through the other side of the chassis.**  
Bend the power cable upward and out of the way on one side of the chassis to gain access and on the other side to provide space for the filter to slide outward, as necessary ([FIGURE 18-5](#)).

**FIGURE 18-5** Filter Replacement—Front and Rear



Replacing filters in this manner prevents an unfiltered area from opening up through which debris can be ingested into the powered up system.

5. Repeat [Step 3](#), and [Step 4](#) for the two remaining filter chambers.
6. After the six (6) new filters have been replaced, install the faceplates and tighten the captive screws.
7. Restore the I/O cables to their original location.  
See [Section 18.3, “Uninstalling the Service Cable Straps”](#) on page 18-7.
8. Close the cabinet doors.
9. Place the dirty filters on a flat surface away from air vents that might dislodge the dust particles which can become airborne.
10. If the filters are to be reused, vacuum both sides by using a brush and vacuum cleaner equipped with a crevice tool. If filters are not to be reused, discard the filters.

For reused filters, it is suggested that an additional set of six be acquired in order to replace the filters as described in this procedure and ensure debris does not get into the powered up system while cleaning the filters.



# Component Serial Number Worksheet

---

A larger version of the Component Serial Number Worksheet, introduced in [Chapter 13, Section TABLE 13-1, "Component Serial Numbers Worksheet" on page 13-5](#) of this document has been provided in this appendix on page A-3. You can use this page to record your serial numbers for retention for your records.



# Component Serial Number Worksheet

Record Date \_\_\_\_\_

| Expander | S/N | Slot 0 Board Type | S/N | Slot 1 Board Type | S/N |
|----------|-----|-------------------|-----|-------------------|-----|
| CSB0     |     |                   |     |                   |     |
| EXB0     |     |                   |     |                   |     |
| EXB1     |     |                   |     |                   |     |
| EXB2     |     |                   |     |                   |     |
| EXB3     |     |                   |     |                   |     |
| EXB4     |     |                   |     |                   |     |
| EXB5     |     |                   |     |                   |     |
| EXB6     |     |                   |     |                   |     |
| EXB7     |     |                   |     |                   |     |
| EXB8     |     |                   |     |                   |     |
| CSB1     |     |                   |     |                   |     |
| EXB9     |     |                   |     |                   |     |
| EXB10    |     |                   |     |                   |     |
| EXB11    |     |                   |     |                   |     |
| EXB12    |     |                   |     |                   |     |
| EXB13    |     |                   |     |                   |     |
| EXB14    |     |                   |     |                   |     |
| EXB15    |     |                   |     |                   |     |
| EXB16    |     |                   |     |                   |     |
| EXB17    |     |                   |     |                   |     |

New Sun Fireplane interconnect S/N:

Rev:





## System Labels

---

Various labels appear on the Sun Fire E25K/E20K systems to reference a specific component by its assigned component number. There are also caution and instruction labels that are visible inside the access doors as well as internally within the system. The following paragraphs provide a description and indicate the physical location for these labels:

---

### B.1 ESD GROUND and Top Fan Tray Component Number Labels

The four (4) electrostatic device (ESD) grounding connections and the top fan tray component numbers (FT0, FT1, FT4, and FT5, right-to-left) are combined into one label for each of the four top positions ([FIGURE B-1](#)).

**FIGURE B-1** ESD GROUND and Top Fan Tray Component Number Labels

Front left



Front right



Rear left



Rear right

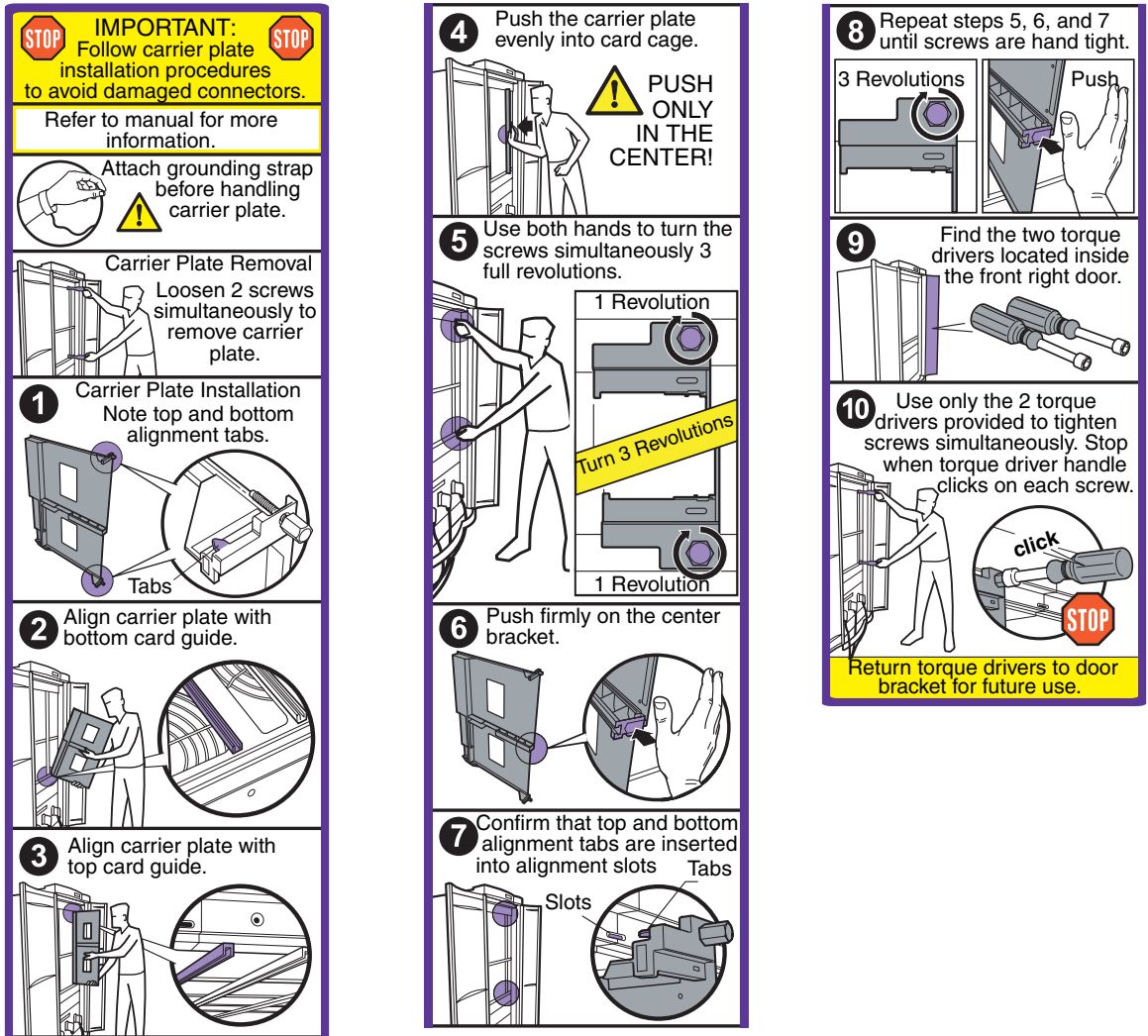


---

## B.2 System Chassis and Carrier Plate Labels

The label in [FIGURE B-2](#) is displayed on the inside left and right side of the frame of the chassis inside the doors on the front and rear sides of the system. It may also appear on some carrier plates. **FOLLOW THESE DIRECTIONS CAREFULLY TO AVOID DAMAGED CONNECTORS.** See [Section 10.1, “Inserting a Board Set Carrier Plate” on page 10-2](#) for complete instructions on the handling of the system carrier plates.

**FIGURE B-2** System Chassis and Carrier Plate Label—Carrier Plate Installation



The warning label, shown in [FIGURE B-3](#), is located on each carrier plate.

**FIGURE B-3** Carrier Plate Warning Label



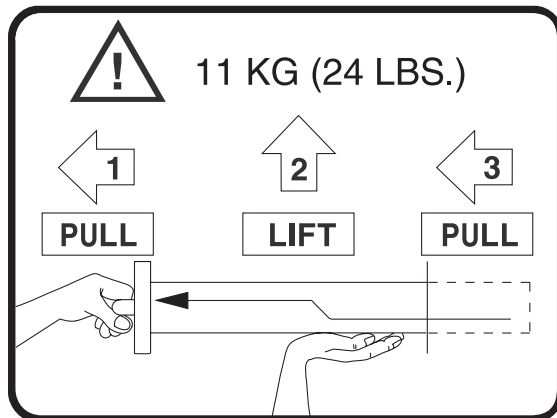
---

## B.3 Fan Tray Labels

### B.3.1 Fan Tray Removal Label

The fan tray removal label, shown in [FIGURE B-4](#), is located at the upper-left outside front corner of each of the four (4) fan trays.

**FIGURE B-4** Fan Tray Removal Label



## B.3.2 Bottom Fan Tray Component Number Labels

The bottom fan tray component number labels (FT2, FT3, FT6, and FT7, right-to-left), have been placed on the I/O cable retention bracket ([FIGURE B-5](#)).

**FIGURE B-5** Bottom Fan Tray Component Number Labels



---

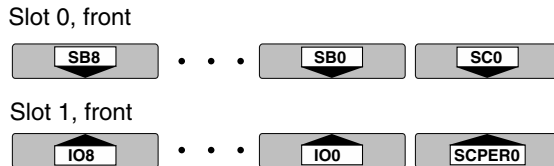
## B.4 Board Carrier Slot Component Number Labels

The system and I/O boards are numbered sequentially right-to-left. See [FIGURE 1-1](#) and [FIGURE 1-2](#) in [Chapter 1](#) for more details.

### B.4.1 Front Component Number Labels

The labels shown in [FIGURE B-6](#) indicate the system CPU boards SB0 through SB8 (left-to right) and the System Control board SC0 for slot 0; and the I/O boards IO0 through IO8 (right-to-left) and the system control peripheral board SCPER0 for slot 1.

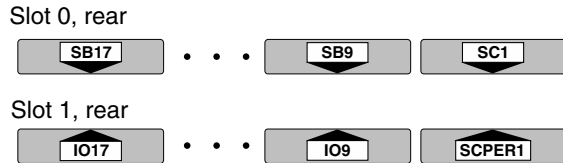
**FIGURE B-6** Front Component Number Labels



## B.4.2 Rear Component Number Labels

The labels shown in [FIGURE B-7](#) indicate the system CPU boards SB9 through SB17 (left-to right) and the System Control board SC1 for Slot 0; and the I/O boards IO9 through IO17 (right-to-left) and the System Control peripheral board SCPER1 for slot 1.

**FIGURE B-7** Rear Component Number Labels

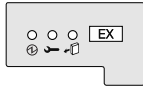


---

## B.5 Expander Label

The expander label (EX), shown in [FIGURE B-8](#), is located at the center bracket for each eighteen (18) expander carrier panels on the front and rear of the system.

**FIGURE B-8** Expander Label

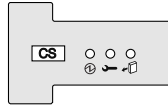


---

## B.6 Centerplane Support Label

The centerplane support (CS) label, shown in [FIGURE B-9](#), is located at the center bracket for the two (2) centerplane support carrier panels on the front and rear of the system.

**FIGURE B-9** Centerplane Support Label



---

## B.7 Sun Fireplane Interconnect Label

Two (2) identical Sun Fireplane interconnect labels, shown in [FIGURE B-10](#), are located on the lower right side of each Sun Fireplane interconnect insertion handle visible from the rear of the system.

**FIGURE B-10** Sun Fireplane Interconnect Label



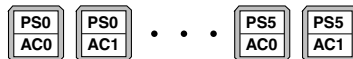
---

## B.8 Power Supply Labels

### B.8.1 Power Supply Component Labels

The six power supplies (PS0 through PS5) each have two AC power connections (AC0 and AC1) with labels as shown in [FIGURE B-11](#).

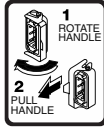
**FIGURE B-11** Power Supply Component Labels



### B.8.2 External Power Supply Handle-Instruction Label

An external power supply label providing handle rotation and forward pull instructions, as shown in [FIGURE B-12](#), appears at the upper left corner of each of the six (6) power supplies.

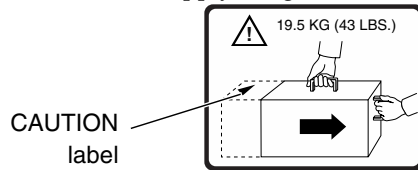
**FIGURE B-12** External Power Supply Label



## B.8.3 Power Supply Weight-Information Label

The power supply weight-information label, shown in [FIGURE B-13](#), is placed at the internal top-front of each of the six (6) power supply units.

**FIGURE B-13** Power Supply Weight-Information Label



## B.8.4 Power Supply CAUTION Label

A CAUTION label, indicating *APPROACHING END OF UNIT!* (due to extensive weight), is located internally at the top end of the power supply unit ([FIGURE B-14](#)).

**FIGURE B-14** Power Supply CAUTION Label





# Sun Fire E25K/E20K Systems Field-Replaceable Units (FRU)

---

The illustrations and tables in this chapter supplement the removal and replacement procedures described in previous chapters. [FIGURE C-1](#) identifies the FRU replacement categories listed in this chapter.

For information about additional capacity drives and other replacement options, contact your sales representative.

**FIGURE C-1** System FRU Component Categories

## FRU Categories

- Access doors and side panels
- TopCap assembly
- System board assemblies and carrier plates
- Fan tray cooling components
- Power supplies and air filters
- System Cables
- Options



System cabinet

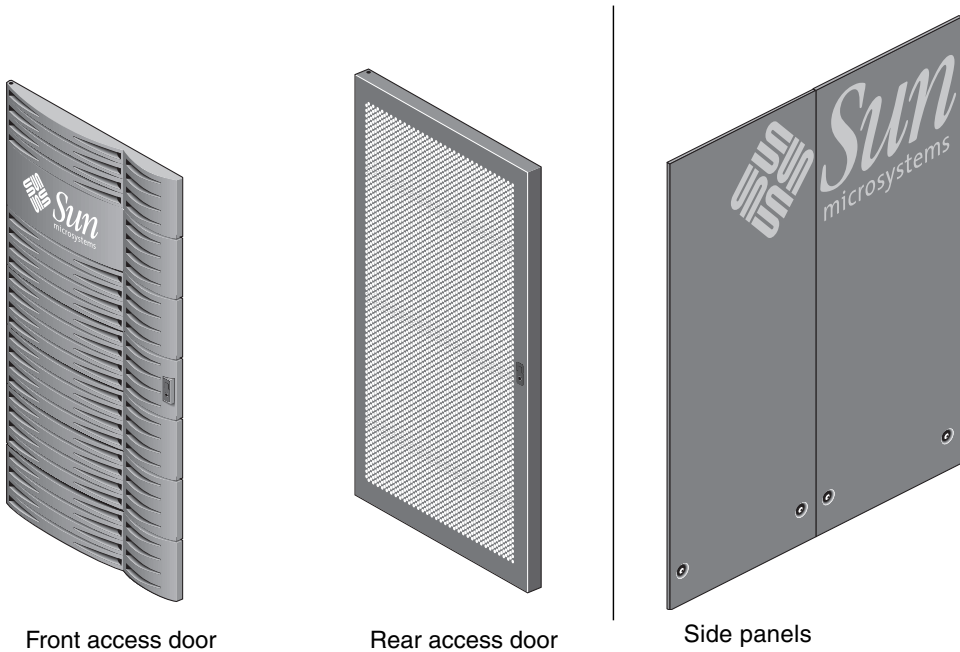
# C.1 Access Doors and Side Panels

TABLE C-1 lists the Sun Fire E25K/E20K systems front and rear access doors and side panels. FIGURE C-2 illustrates each item.

TABLE C-1 Access Doors and Side Panels

| Description       |
|-------------------|
| Front access door |
| Rear access door  |
| Side panel        |

FIGURE C-2 Access Doors and Side Panels



---

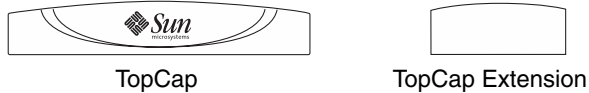
## C.2 TopCap Assembly

TABLE C-2 lists the Sun Fire E25K/E20K systems TopCap assembly parts. FIGURE C-3 illustrates each item.

TABLE C-2 TopCap Assembly Components

| Description      |
|------------------|
| TopCap           |
| TopCap extension |

FIGURE C-3 TopCap Assembly Components



---

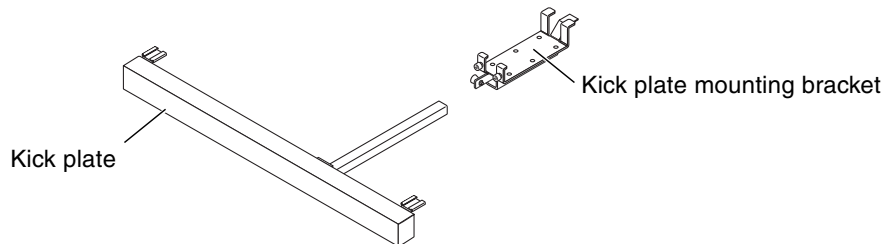
## C.1 Kick Plate Assembly

TABLE C-3 lists the Sun Fire E25K/E20K systems kick plate assembly. FIGURE C-4 illustrates this item.

TABLE C-3 Kick Plate Assembly Components

| Description                 |
|-----------------------------|
| Kick plate                  |
| Kick plate mounting bracket |

FIGURE C-4 Kick Plate Assembly Components



## C.3 System Board Assemblies and Carrier Plates

[TABLE C-4](#) lists the Sun Fire E25K/E20K systems board assemblies and filler panels. [TABLE C-5](#) lists the system board assembly carrier plates with part numbers. [FIGURE C-5](#) through [FIGURE C-18](#) illustrate each component.

**TABLE C-4** System Board Assemblies

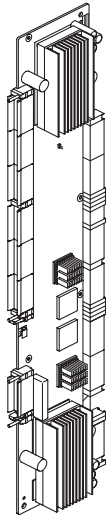
| Description   |
|---|
| Centerplane support board   |
| System controller carrier plate ( <a href="#">TABLE C-5</a> )                   |
| System Control board  |
| System control peripheral board   |
| System expander board   |
| System and modified system expander carrier plate ( <a href="#">TABLE C-5</a> ) |
| CPU board   |
| I/O assembly  |
| I/O filler panel (used as required)   |
| CPU filler panel (used as required)   |
| Sun Fireplane interconnect  |
| Power centerplane   |
| Fan backplane   |

**TABLE C-5** System Board Carrier Plates

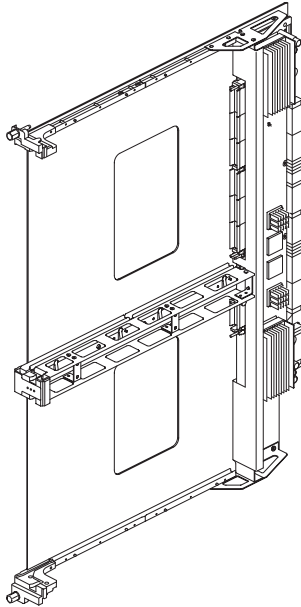
| Description   | Part Number |
|---|-------------|
| System controller carrier plate at SC0 (front) and SC1 (rear)                           | 540-3993    |
| System expander carrier plate at slots 1,2,3,6,7,8 (front) and 10,11,12,15,16,17 (rear) | 541-0119    |
| Modified system expander carrier plate at slots 4,5 (front) and 13,14 (rear)            | 541-0121    |
| Modified system expander carrier plate at slots 0 (front) and 9 (rear)                  | 541-0120    |
| System expander carrier plate (with air dam) at slots 4, 5, 13, and 14                  | 540-5736    |

See the carrier plate location placement diagram in [FIGURE 10-1](#).

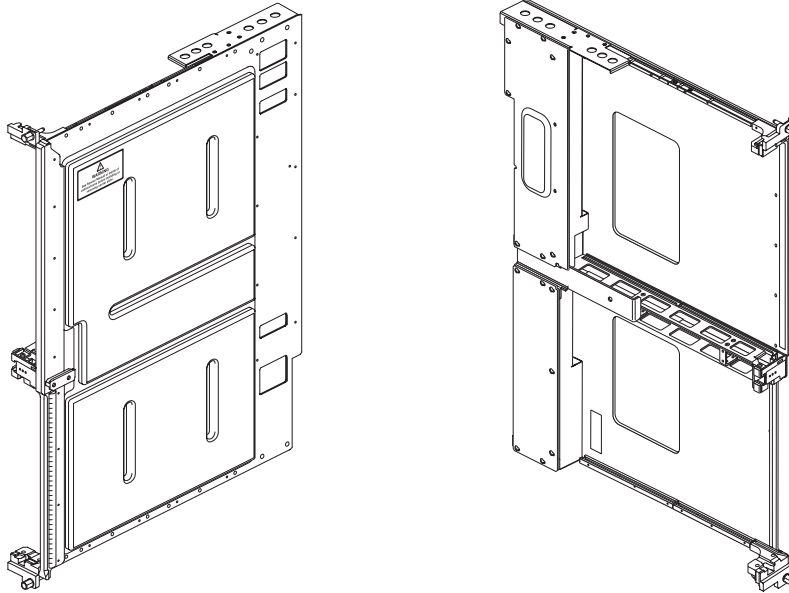
**FIGURE C-5** Centerplane Support Board



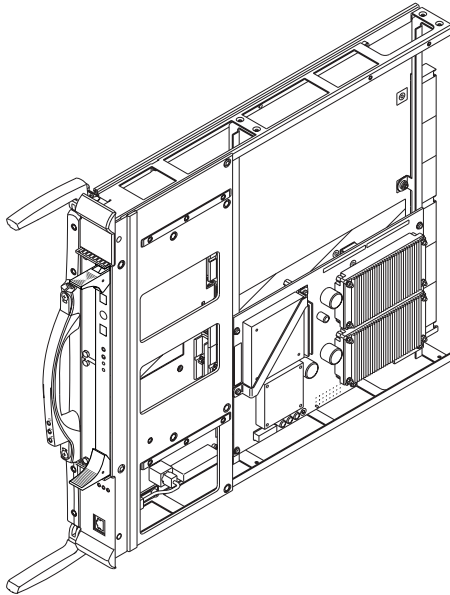
**FIGURE C-6** System Controller Carrier Plate



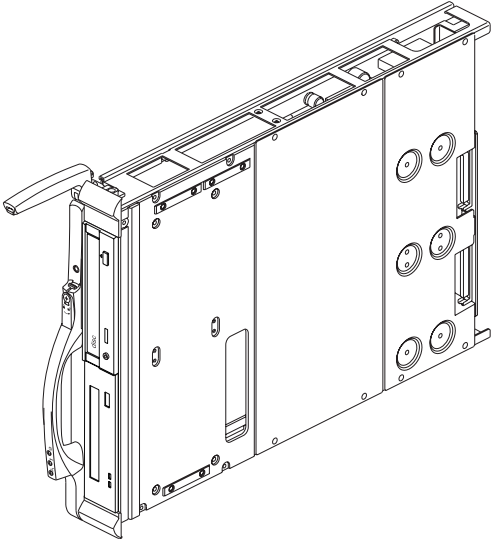
**FIGURE C-7** System Expander Carrier Plate (With Air Dam)



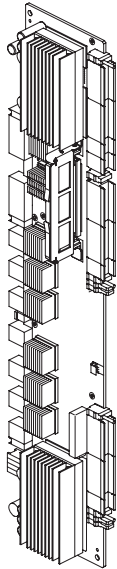
**FIGURE C-8** System Control Board—3U to 6U Conversion Board Option



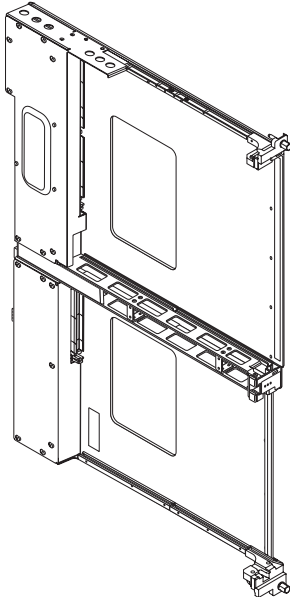
**FIGURE C-9** System Control Peripheral Board



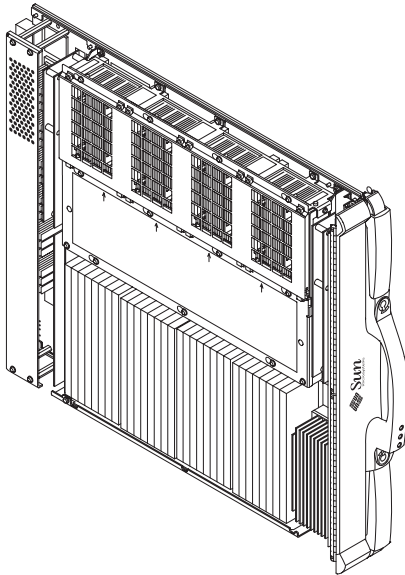
**FIGURE C-10** System Expander Board



**FIGURE C-11** System Expander Carrier Plate (With or Without Air Dam)

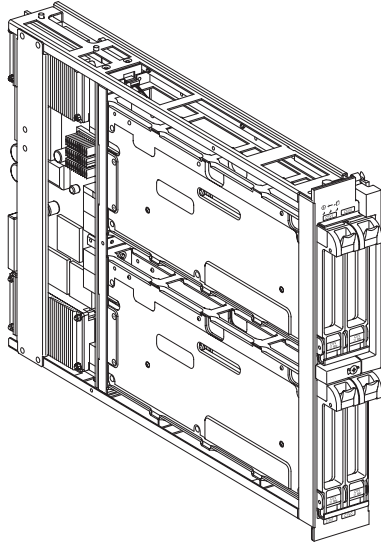


**FIGURE C-12** CPU Board

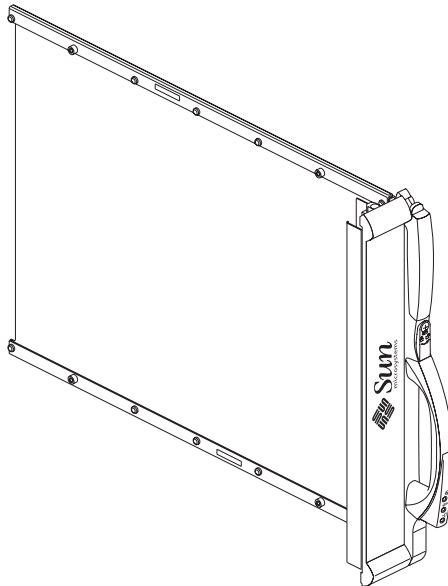




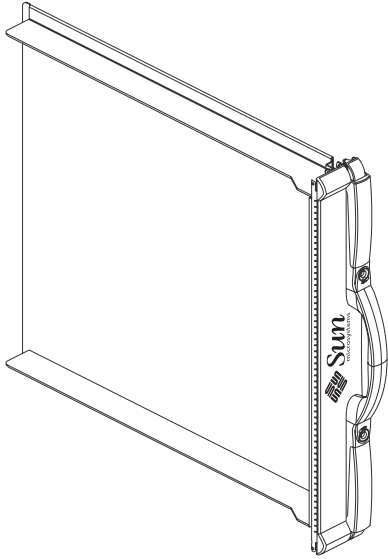
**FIGURE C-13** I/O Assembly



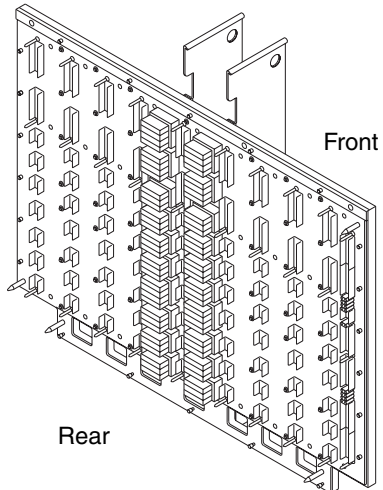
**FIGURE C-14** I/O Filler Panel (Used as Required)



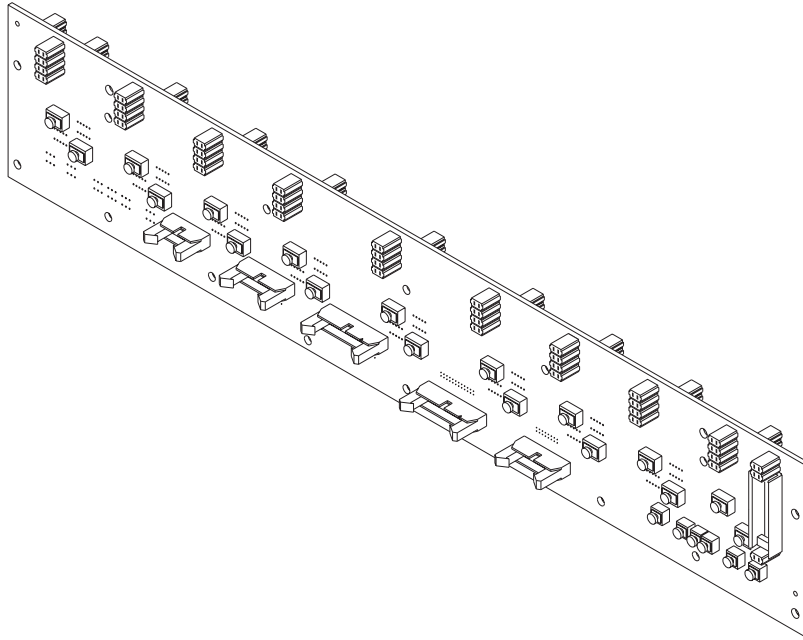
**FIGURE C-15** CPU Filler Panel (Used as Required)



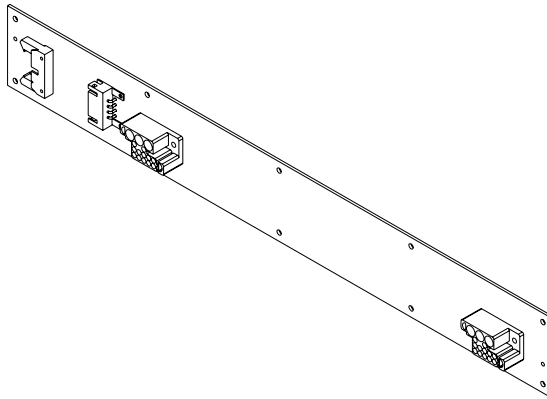
**FIGURE C-16** Sun Fireplane Interconnect



**FIGURE C-17** Power Centerplane



**FIGURE C-18** Fan Backplane



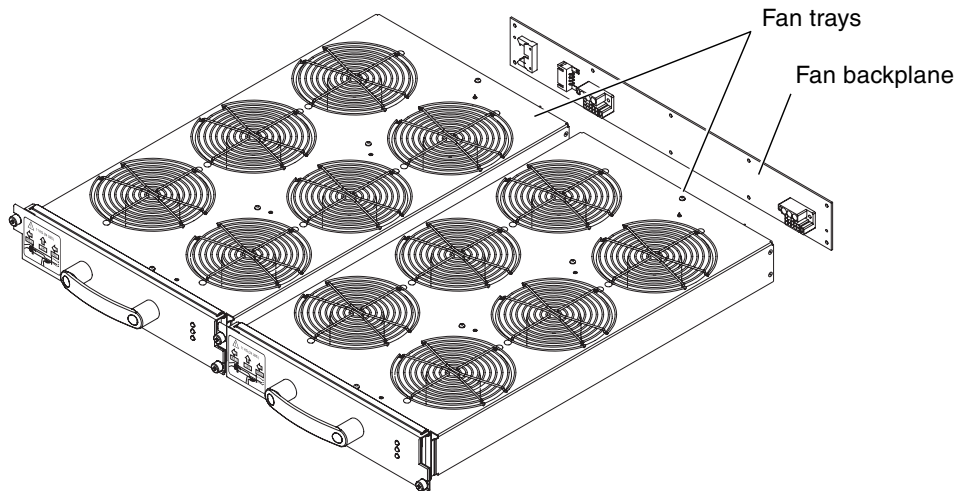
## C.4 Fan Tray Cooling Components

TABLE C-6 lists the Sun Fire E25K/E20K systems fan tray components. FIGURE C-19 illustrates each item.

TABLE C-6 Fan Tray Cooling Components

| Description   |
|---------------|
| Fan tray      |
| Fan backplane |

FIGURE C-19 Fan Tray Cooling Component



---

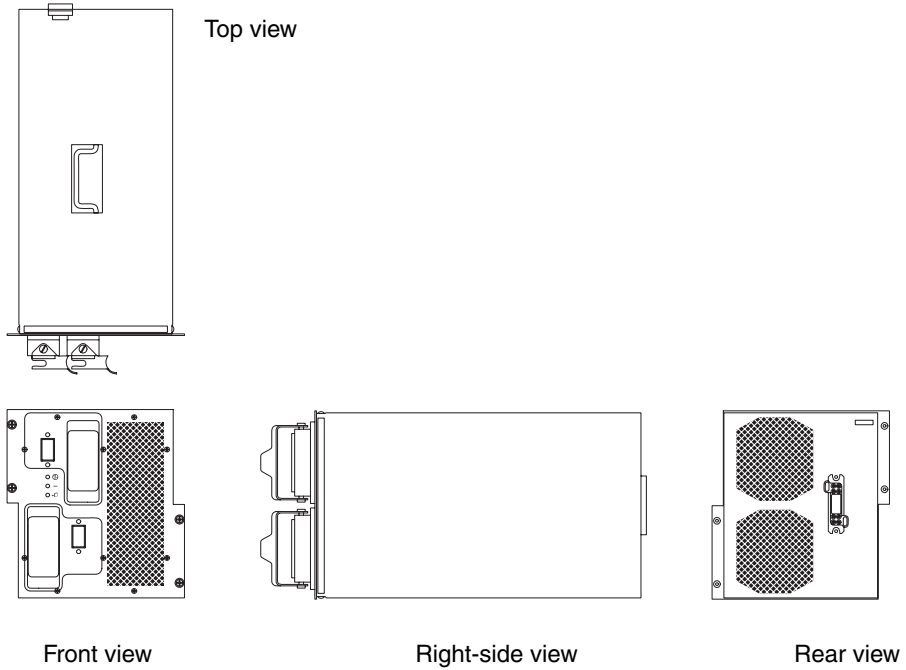
## C.5 Power Supplies and Air Filters

[TABLE C-7](#) lists the Sun Fire E25K/E20K systems power supply components and air filters. [FIGURE C-20](#), [FIGURE C-21](#), and [FIGURE C-22](#) illustrate each item.

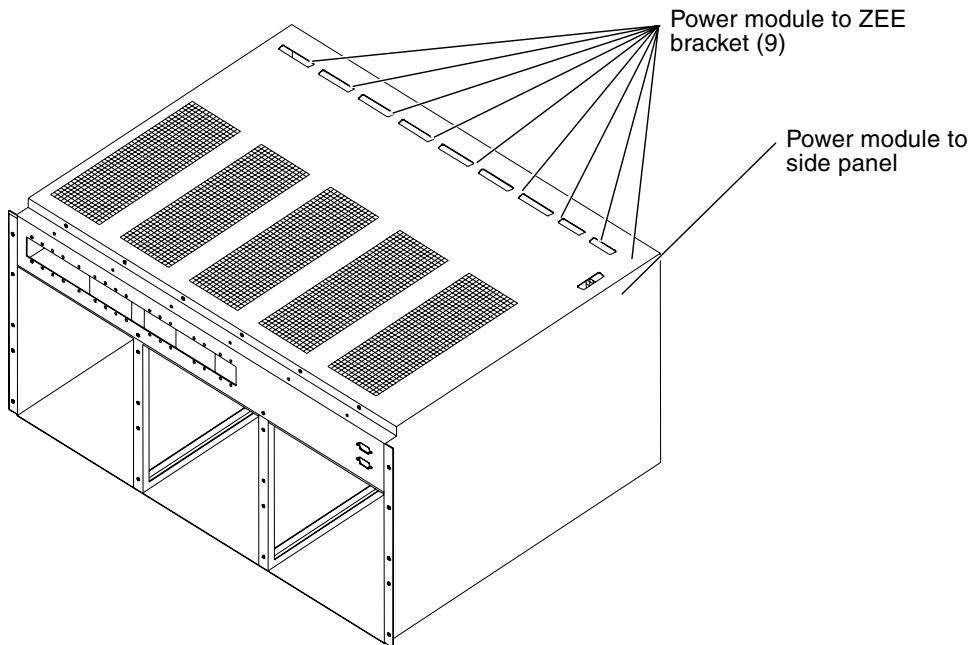
**TABLE C-7** Power Supplies and Air Filters

| Description  |
|--------------|
| Power supply |
| Power module |
| Air filter   |

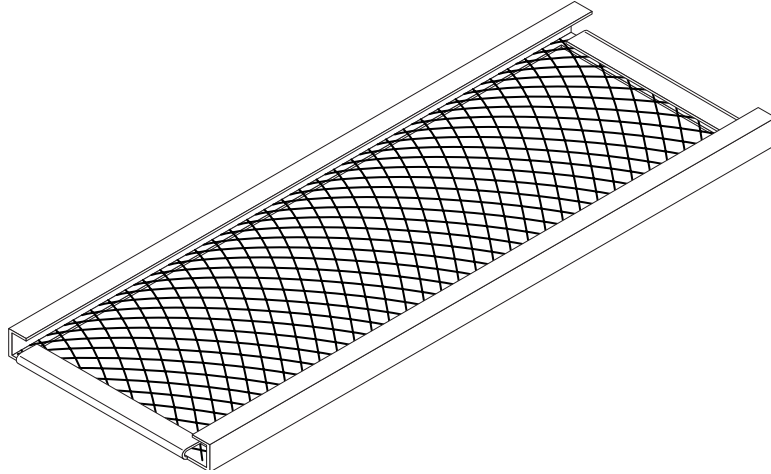
**FIGURE C-20** Power Supply



**FIGURE C-21** Power Module



**FIGURE C-22** Air Filter



---

## C.2 System Cables

**TABLE C-8** lists the Sun Fire E25K/E20K systems cables. **FIGURE C-23** through **FIGURE C-45**, on the following pages, illustrate each item:

**TABLE C-8** System Cables

---

| Description |
|-------------|
|-------------|

---

AC power cable, domestic

AC power cable, domestic 2

AC power cable, international

AC power cable, international 2

Fan power cable

Fan I<sup>2</sup>C cable, front upper

Fan I<sup>2</sup>C cable, front lower

Fan I<sup>2</sup>C cable, rear upper

Fan I<sup>2</sup>C cable, rear lower

Power module to connector bulkhead, 48 VDC power

Connector bulkhead to connector bulkhead, 48 VDC crossover

Power module to connector bulkhead, I<sup>2</sup>C signals

---

**TABLE C-8** System Cables

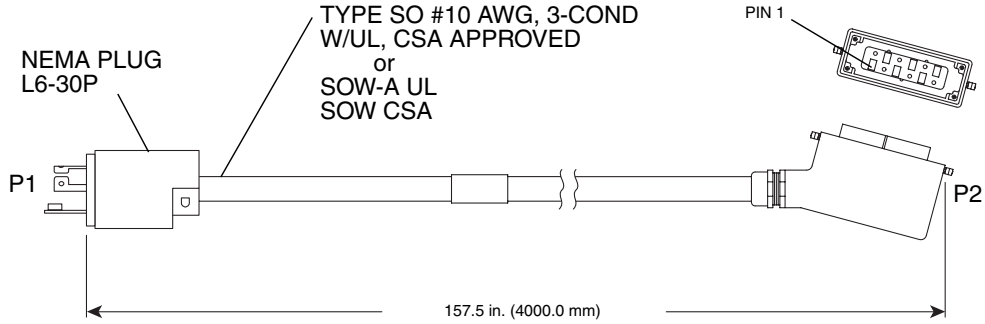
---

| <b>Description</b>           |
|------------------------------|
| Control 0 front cable        |
| Control 1 front cable        |
| Control 0 rear cable         |
| Control 1 rear cable         |
| Power control front cable    |
| Power control rear cable     |
| TopCap power cable, internal |
| TopCap power cable, external |
| RS-232 cable, internal       |
| RS-232 cable, external       |
| SC-CPU cable                 |
| SC-laptop cable              |

---



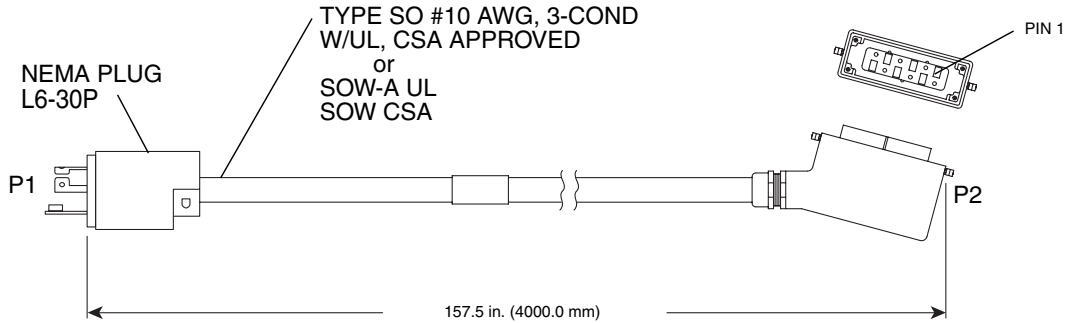
**FIGURE C-23** AC Power Cable, Domestic



**TABLE C-9** AC Power Cable, Domestic, Wire List

| Wire # | Color | From | To   | Signal |
|--------|-------|------|------|--------|
| 1      | BLK   | P1-X | P2-2 | Line 1 |
| 2      | WHT   | P1-Y | P2-4 | Line 2 |
| 3      | GRN   | P1-G | P2-3 | Earth  |

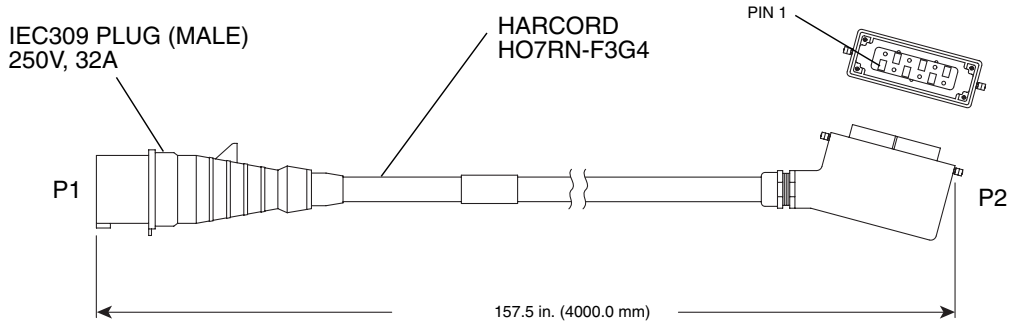
**FIGURE C-24** AC Power Cable, Domestic 2



**TABLE C-10** AC Power Cable, Domestic 2, Wire List

| Wire # | Color | From | To   | Signal |
|--------|-------|------|------|--------|
| 1      | BLK   | P1-X | P2-2 | Line 1 |
| 2      | WHT   | P1-Y | P2-4 | Line 2 |
| 3      | GRN   | P1-G | P2-3 | Earth  |

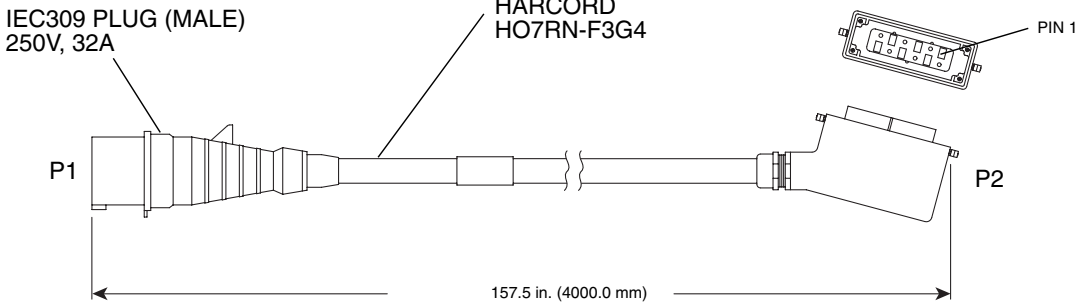
**FIGURE C-25** AC Power Cable, International



**TABLE C-11** AC Power Cable, International, Wire List

| Wire # | Color   | From   | To   | Signal |
|--------|---------|--------|------|--------|
| 1      | BLK     | P1-L   | P2-2 | Line   |
| 2      | WHT     | P1-N   | P2-4 | NEU    |
| 3      | YEL/GRN | P1-GND | P2-3 | Earth  |

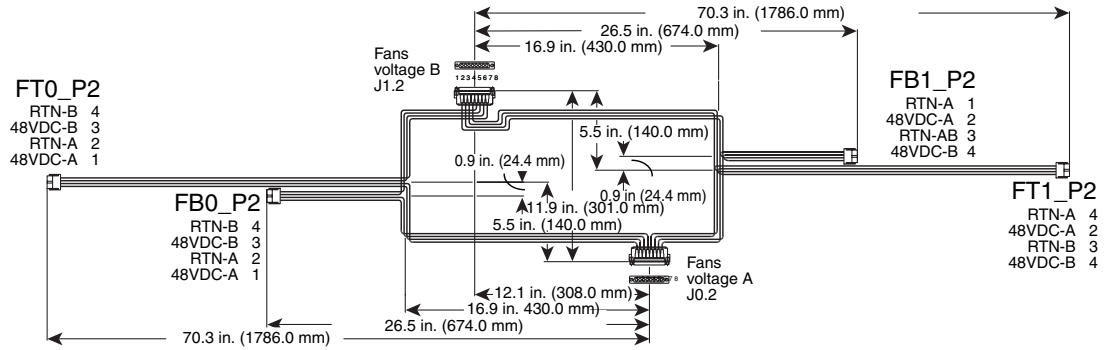
**FIGURE C-26** AC Power Cable, International 2



**TABLE C-12** AC Power Cable, International 2, Wire List

| Wire # | Color   | From   | To   | Signal |
|--------|---------|--------|------|--------|
| 1      | BLK     | P1-L   | P2-2 | Line   |
| 2      | WHT     | P1-N   | P2-4 | NEU    |
| 3      | YEL/GRN | P1-GND | P2-3 | Earth  |

**FIGURE C-27** Fan Power Cable



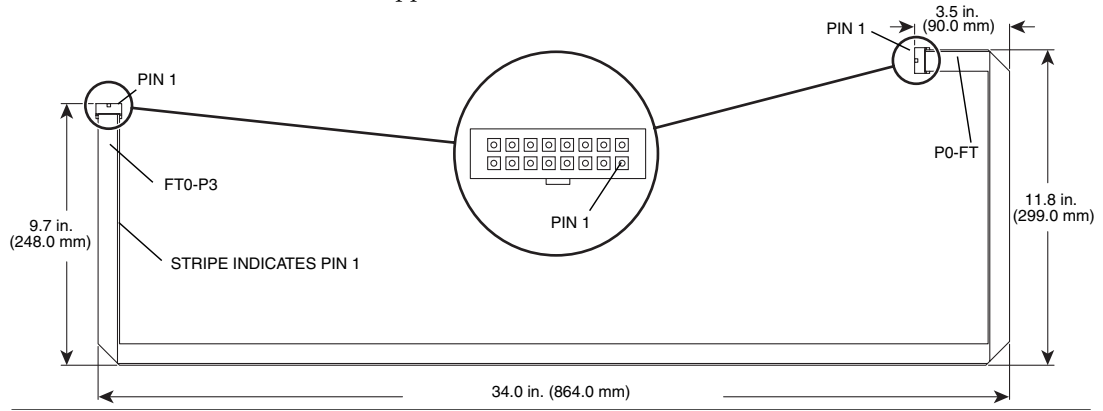
**TABLE C-13** Fan Power Cable (Side 0) Termination Table 0

| From Connector<br>Bulkhead Side 0<br>Voltage A | To<br>Fan BP | Wire Size AWG &<br>Color<br>UL1213 | Function                           |
|--|--------------|------------------------------------|------------------------------------|
| J0.2-8   | FT0_P2-2     | 14 BLK                             | Fan trays, top side 0, return A    |
| J0.2-7   | FT0_P2-1     | 14 RED                             | Fan trays, top side 0, 48VDC-A     |
| J0.2-6   | FB0_P2-2     | 14 BLK                             | Fan trays, bottom side 0, return A |
| J0.2-5   | FB0_P2-1     | 14 RED                             | Fan trays, bottom side 0, 48VDC-A  |
| J0.2-4   | FT1_P2-2     | 14 BLK                             | Fan trays, top side 1, return A    |
| J0.2-3   | FT1_P2-1     | 14 RED                             | Fan trays, top side 1, 48VDC-A     |
| J0.2-2   | FB1_P2-2     | 14 BLK                             | Fan trays, bottom side 1, return A |
| J0.2-1   | FB1_P2-1     | 14 RED                             | Fan trays, bottom side 1, 48VDC-A  |

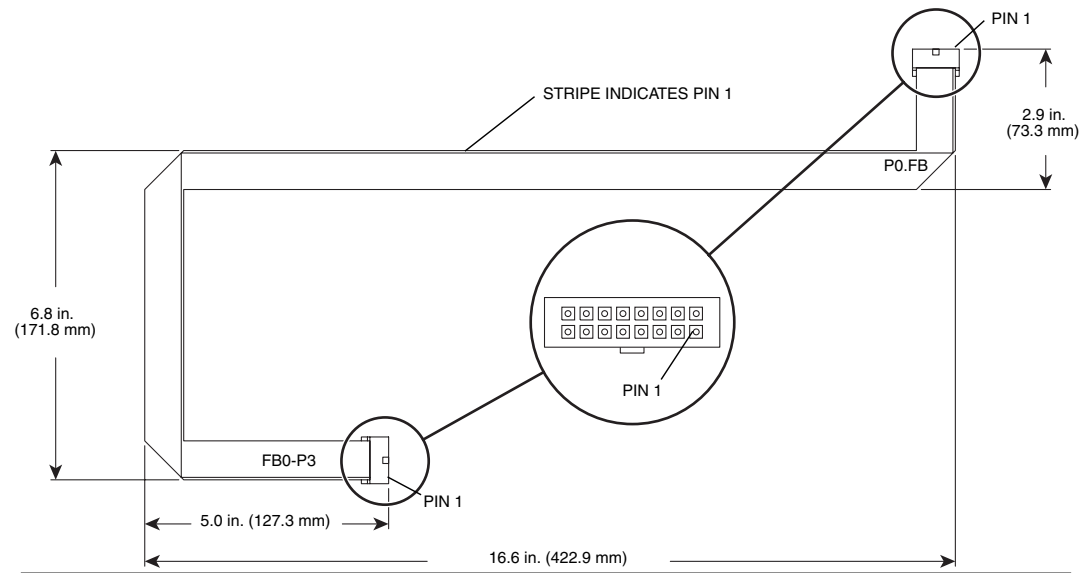
**TABLE C-14** Fan Power Cable (Side 1) Termination Table 1

| <b>From Connector<br/>Bulkhead Side 1<br/>Voltage B</b> | <b>To<br/>Fan BP</b> | <b>Wire Size AWG &amp;<br/>Color<br/>UL1213</b> | <b>Function</b>                        |
|---|----------------------|---|--|
| J1.2-8  | FT0_P2-<br>4         | 14 BLK  | Fan trays, top side 0, return B        |
| J1.2-7  | FT0_P2-<br>3         | 14 RED  | Fan trays, top side 0, 48VDC-B         |
| J1.2-6  | FB0_P2-<br>4         | 14 BLK  | Fan trays, bottom side 0, return B     |
| J1.2-5  | FB0_P2-<br>3         | 14 RED  | Fan trays, bottom side 0, 48VDC-B      |
| J1.2-4  | FT1_P2-<br>4         | 14 BLK  | Fan trays, top side 1, return B        |
| J1.2-3  | FT1_P2-<br>3         | 14 RED  | Fan trays, top side 1, 48 VDC-B        |
| J1.2-2  | FB1_P2-<br>4         | 14 BLK  | Fan trays, bottom side 1, return B     |
| J1.2-1  | FB1_P2-<br>3         | 14 RED  | Fan trays, bottom side 1, 48 VDC-<br>B |

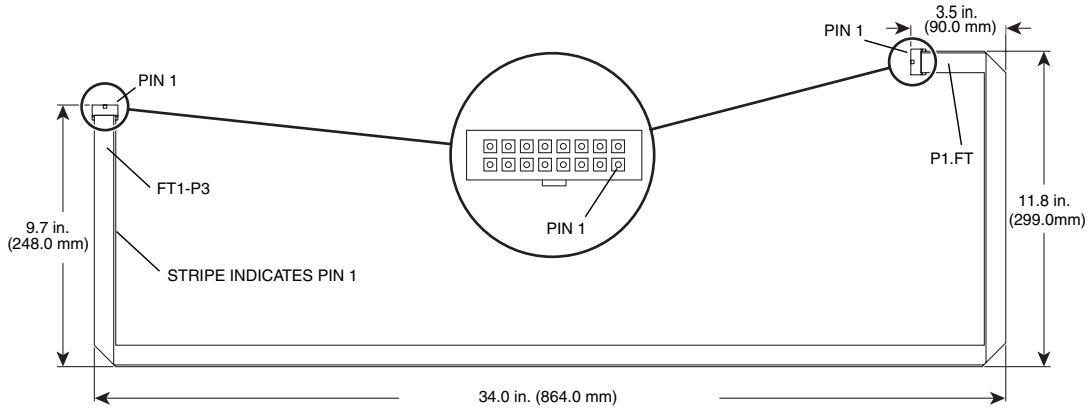
**FIGURE C-28** Fan I<sup>2</sup>C Cable, Front Upper



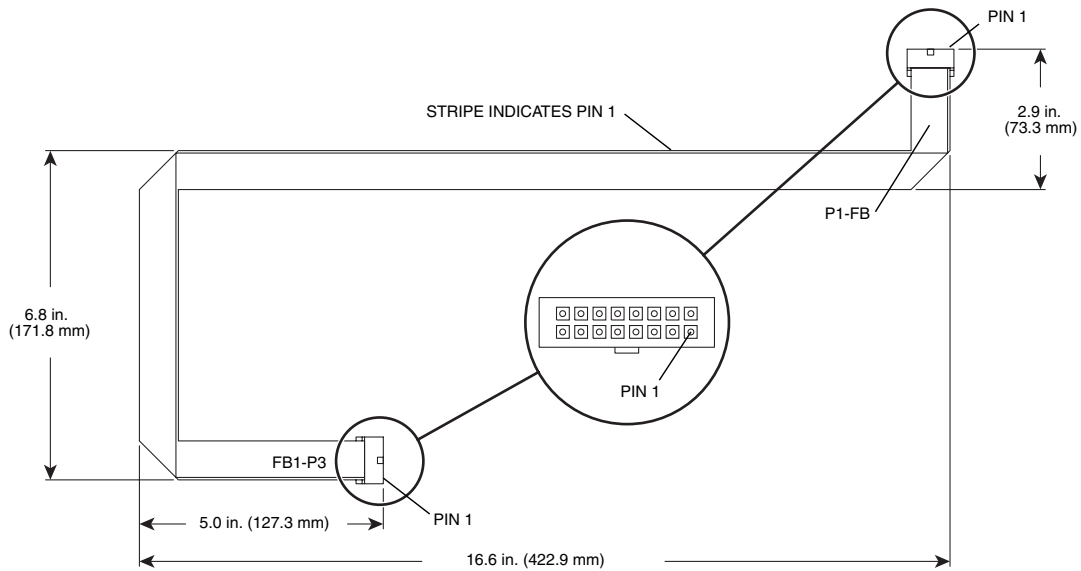
**FIGURE C-29** Fan I<sup>2</sup>C Cable, Front Lower



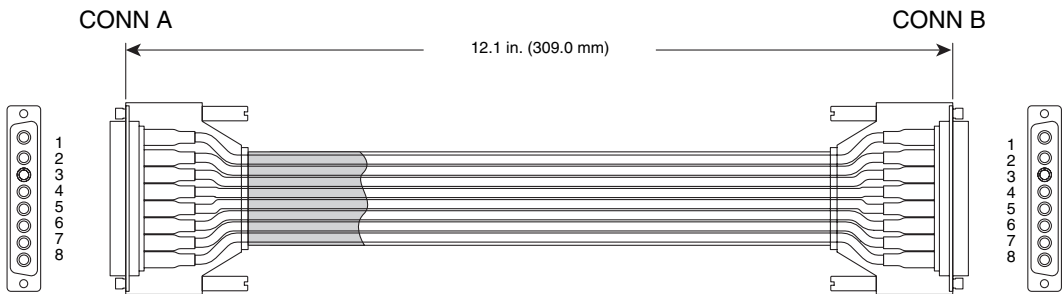
**FIGURE C-30** Fan I<sup>2</sup>C Cable, Rear Upper



**FIGURE C-31** Fan I<sup>2</sup>C Cable, Rear Lower



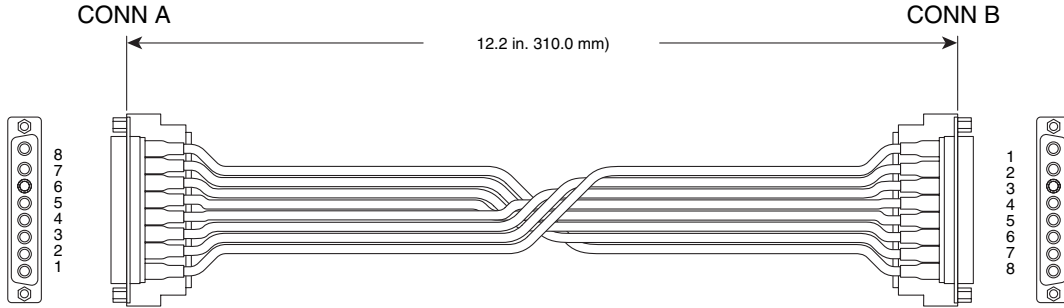
**FIGURE C-32** Power Module to Connector Bulkhead, 48 VDC Power



**TABLE C-15** Power Module to Connector Bulkhead Cable, 48 VDC Power, Termination Table

| From CONN A | To CONN B |
|-------------|-----------|
| 1           | 1         |
| 2           | 2         |
| 3           | 3         |
| 4           | 4         |
| 5           | 5         |
| 6           | 6         |
| 7           | 7         |
| 8           | 8         |

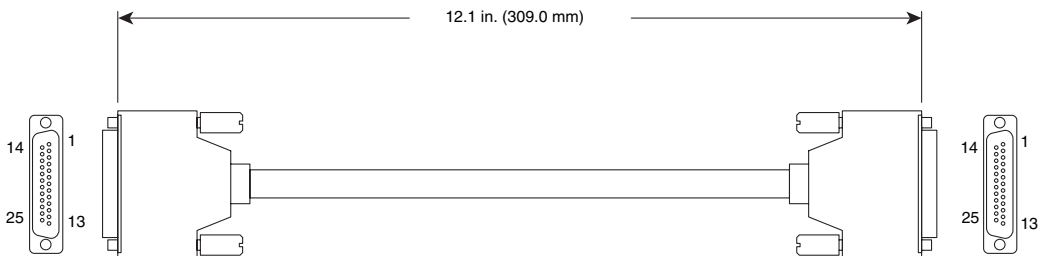
**FIGURE C-33** Connector Bulkhead to Connector Bulkhead, 48 VDC Crossover



**TABLE C-16** Connector Bulkhead to Connector Bulkhead, 48 VDC Crossover, Termination Table

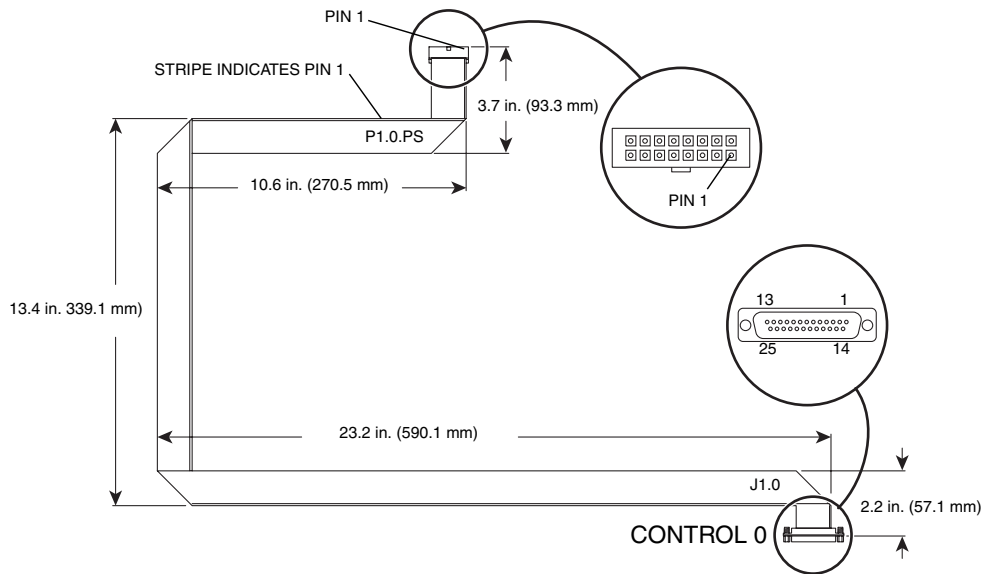
| From CONN A | To CONN B | Wire Color |
|-------------|-----------|------------|
| 1           | 1         | RED        |
| 2           | 2         | BLK        |
| 3           | 3         | RED        |
| 4           | 4         | BLK        |
| 5           | 5         | RED        |
| 6           | 6         | BLK        |
| 7           | 7         | RED        |
| 8           | 8         | BLK        |

**FIGURE C-34** Power Module to Connector Bulkhead, I<sup>2</sup>C Signals

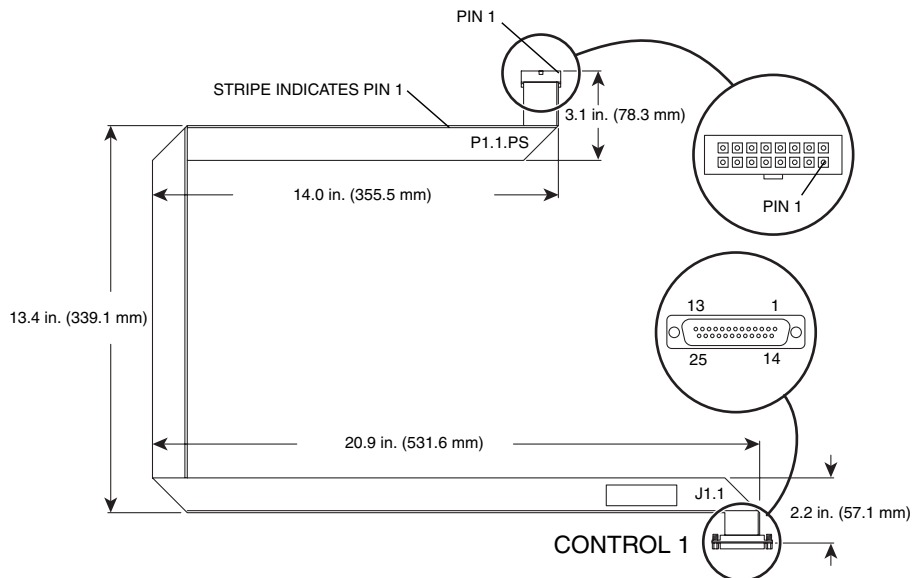




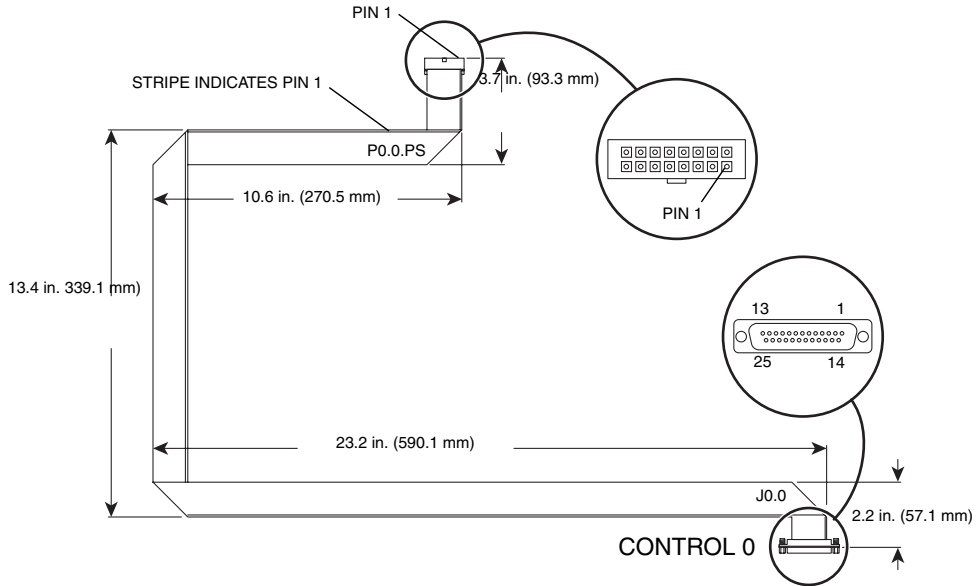
**FIGURE C-35** Control 0 Cable, Front



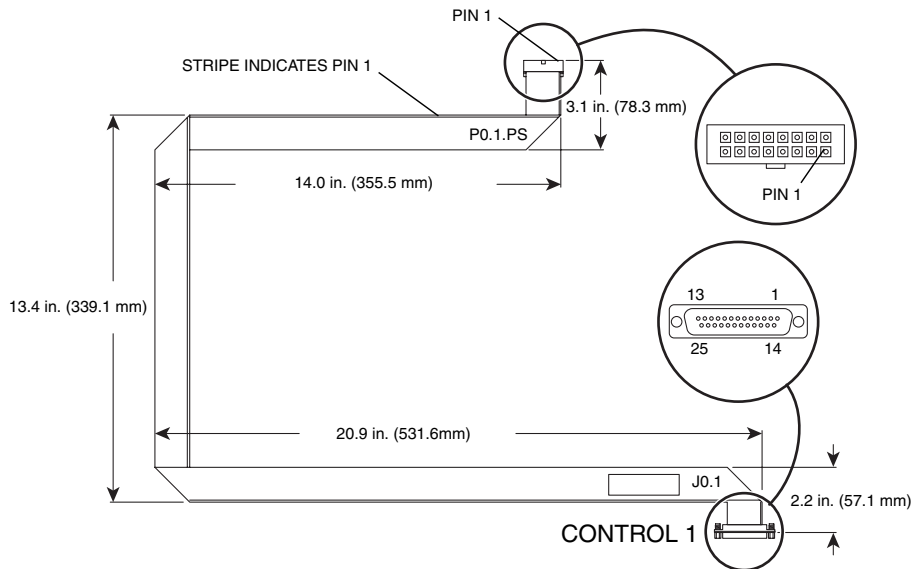
**FIGURE C-36** Control 1 Cable, Front



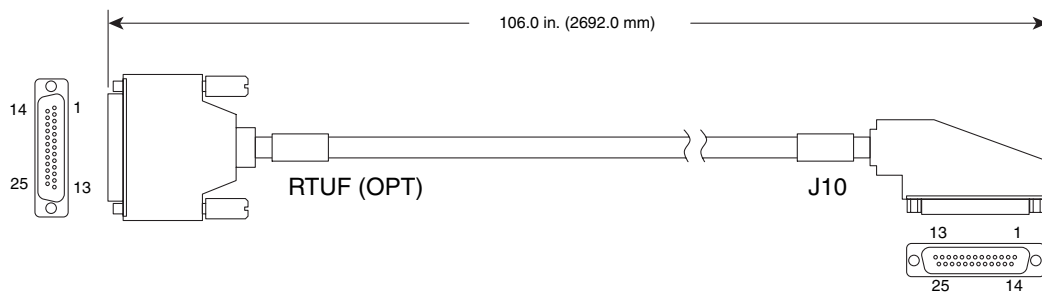
**FIGURE C-37** Control 0 Cable, Rear



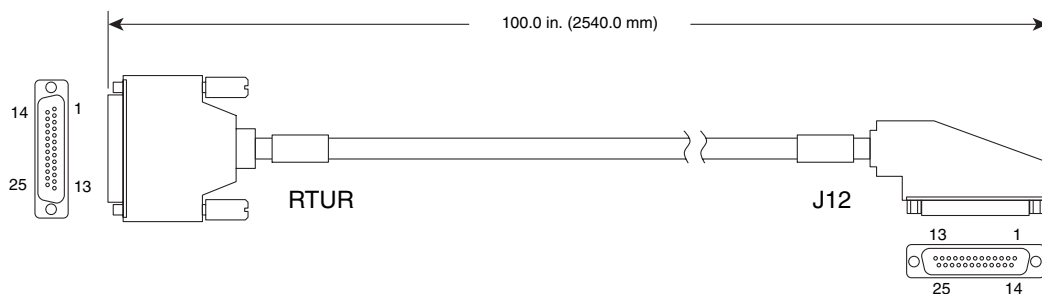
**FIGURE C-38** Control 1 Cable, Rear



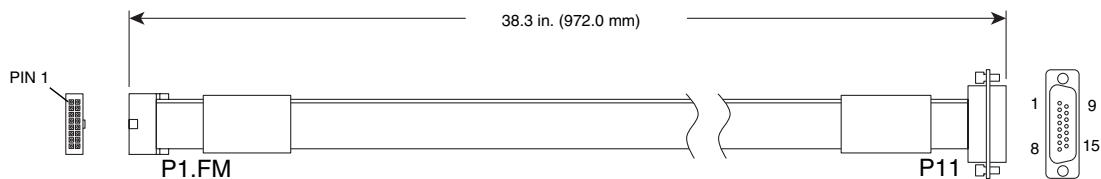
**FIGURE C-39** Power Control Cable, Front



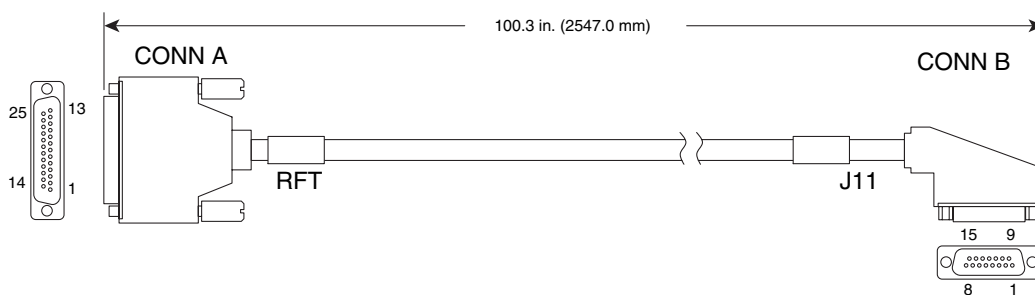
**FIGURE C-40** Power Control Cable, Rear



**FIGURE C-41** TopCap Power Cable, Internal



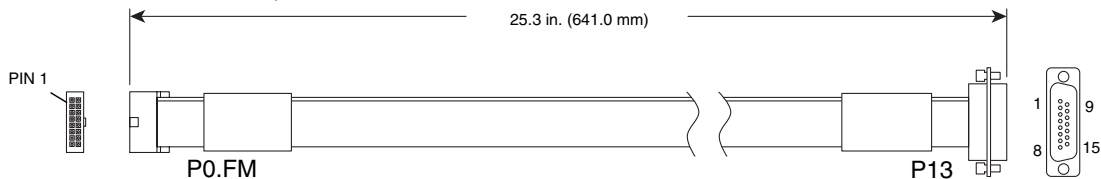
**FIGURE C-42** TopCap Power Cable, External



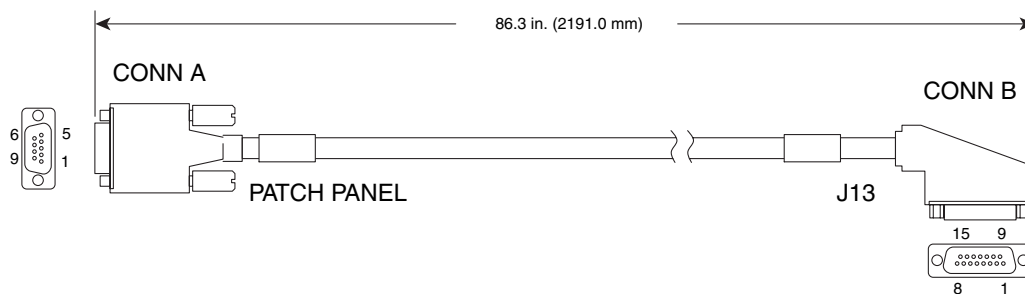
**TABLE C-17** TopCap Power Cable, External, Termination Specifications

| <b>From CONN A (DB25P)</b> | <b>To CONN B (DB-15P)</b> |
|----------------------------|---------------------------|
| 1                          | 1                         |
| 2                          | 2                         |
| 3                          | 3                         |
| 4                          | 4                         |
| 5                          | 5                         |
| 6                          | 6                         |
| 7                          | 7                         |
| 8                          | 8                         |
| 14                         | 9                         |
| 15                         | 10                        |
| 16                         | 11                        |
| 17                         | 12                        |
| 18                         | 13                        |
| 19                         | 14                        |
| 20                         | 15                        |

**FIGURE C-43** RS-232 Cable, Internal



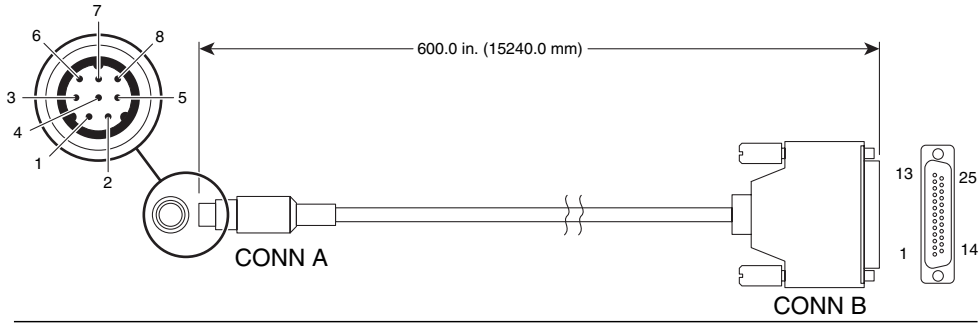
**FIGURE C-44** RS-232 Cable, External



**TABLE C-18** RS-232 Cable, External, Termination Specifications

| From CONN A (DB9S) | To CONN B (DB-15P) |
|--------------------|--------------------|
| 1                  | 1                  |
| 2                  | 2                  |
| 3                  | 3                  |
| 4                  | 4                  |
| 5                  | 5                  |
| 6                  | 9                  |
| 7                  | 10                 |
| 8                  | 11                 |
| 9                  | 12                 |

**FIGURE C-45** SC-CPU Cable



**TABLE C-19** SC-CPU Cable Termination Specifications

| From CONN A (Mini DIN-8P) | To CONN B (DB-25P) |
|---------------------------|--------------------|
| 1                         | 6, jumper to 8     |
| 2                         | 20                 |
| 3                         | 3                  |
| 4                         | 7                  |
| 5                         | 2                  |

# Index

---

## A

- access door
  - installation, 17-2
  - removal, 17-2
- air filter, C-15
- air filter replacement, 18-12

## B

- board insertion, 10-2

## C

- cables
  - connections, 16-2
  - layout diagram, 16-3
  - replacement, internal to cabinet, 16-9
- carrier plate insertion, 10-2
- caution
  - power supply, B-8
  - remove components, 10-2, 10-4
- centerplane support board, C-5
  - configuration rules, 1-2
  - installation, 11-7
  - power off, 11-4
  - power on, 11-8
  - removal, 11-5
- component
  - configuration rules, 1-2, 8-1
  - numbering
    - back, 1-9, 1-10
    - front, 1-8
  - removal, caution, 10-2, 10-4
- configuration

- memory, 1-3, 8-1
- rules, 1-2

## CPU

- board
  - installation, 8-7
  - power off, 8-4
  - removal, 8-5
- filler panel
  - installation, 8-12
  - removal, 8-12

CPU board, C-8

CPU filler panel, C-10

## D

- diagnostics, SunVTS, 1-3

## E

- expander board
  - installation, 12-7
  - power off, 12-4
  - power on, 12-8
  - removal, 12-5

## F

- fan backplane, C-11
  - installation, 14-5
  - power on, 14-6
  - removal, 14-2
- fan tray
  - installation, 4-5
  - power off, 4-4
  - removal, 4-4

fan tray cooling components, C-12  
field replaceable units (FRU), C-1

## H

hsPCI I/O board, C-9  
hsPCI+ assembly  
  installation, 9-6  
  power off, 9-4  
  removal, 9-5

## I

I/O filler panel, C-9  
  installation, 9-11  
  removal, 9-11  
insertion  
  board set, 10-2  
  carrier plate, 10-2  
install  
  access door, 17-2  
  centerplane support board, 11-7  
  CPU  
    board, 8-7  
    filler panel, 8-12  
  expander board, 12-7  
  fan backplane, 14-5  
  fan tray, 4-5  
  hsPCI+ assembly, 9-6  
  I/O filler panel, 9-11  
  power  
    centerplane, 15-6  
    module, 3-5  
    supply, 48-volt, 3-11  
  side panel, 17-2  
  Sun Fireplane Interconnect, 13-10  
  system  
    control board, 6-8  
    control peripheral board, 7-7  
  TopCap, 2-2  
  TopCap extension, 2-3

## K

Kick Plate assembly, C-3  
kick plate assembly component, C-3

## M

memory, configuration, 1-3, 8-1

## N

nomenclature, 1-1

## P

power centerplane, C-10, C-11  
  installation, 15-6  
  power off, 15-2  
  power on, 15-9  
power module, C-14  
  installation, 3-5  
power off  
  48-volt power supply, 3-10  
  centerplane support board, 11-4  
  CPU board, 8-4  
  expander board, 12-4  
  fan tray, 4-4  
  hsPCI+ assembly, 9-4  
  power centerplane, 15-2  
  Sun Fireplane Interconnect, 13-6  
  system control board, 6-4  
  system control peripheral board, 7-5  
power on  
  centerplane support board, 11-8  
  expander board, 12-8  
  fan backplane, 14-6  
  power centerplane, 15-9  
  power supply 48-volt, 3-12  
  system, 13-12  
power supply, C-14  
  48-volt  
    installation, 3-11  
    power off, 3-10  
    power on, 3-12  
    removal, 3-10  
  caution label, B-8  
powering on the system, 16-22

## R

remove  
  access door, 17-2  
  centerplane support board, 11-5  
  CPU  
    board, 8-5  
    filler panel, 8-12  
  expander board, 12-5  
  fan backplane, 14-2  
  fan tray, 4-4



- hsPCI+ assembly, 9-5
- I/O filler panel, 9-11
- power supply, 48-volt, 3-10
- side panel, 17-2
- Sun Fireplane Interconnect, 13-7
- system control board, 6-6
- system control peripheral board, 7-5
- TopCap, 2-2
- TopCap extension, 2-2
- replacement
  - air filter, 18-12
  - Sun Fireplane Interconnect, 13-4
- rules, configuration, 1-2

## **S**

- setup, Sun Fireplane Interconnect replacement, 13-4
- side panel
  - installation, 17-2
  - removal, 17-2
- Sun Fireplane Interconnect
  - installation, 13-10
  - power off, 13-6
  - removal, 13-7
  - replacement setup, 13-4
- Sun Fireplane interconnect, C-10
- SunVTS diagnostics, 1-3
- system
  - power on, 13-12
  - testing, 1-3
- system control board, C-6
  - installation, 6-8
  - power off, 6-4
  - removal, 6-6
- system control peripheral board, C-7
  - installation, 7-7
  - power off, 7-5
  - removal, 7-5
- system expander board, C-7
- system expander carrier plate (with or without air dam), C-8

## **T**

- testing, system, 1-3
- TopCap
  - installation, 2-2
  - removal, 2-2
- TopCap assembly components, C-3

- TopCap extension
  - installation, 2-3
  - removal, 2-2

