



Solstice X.25 9.2 PAD User's Guide

Sun Microsystems, Inc.
901 San Antonio Road
Palo Alto, CA 94303-4900
U.S.A.

Part No: 806-1236-10
October 1999

Copyright 1999 Sun Microsystems, Inc. 901 San Antonio Road, Palo Alto, California 94303-4900 U.S.A. All rights reserved.

This product or document is protected by copyright and distributed under licenses restricting its use, copying, distribution, and decompilation. No part of this product or document may be reproduced in any form by any means without prior written authorization of Sun and its licensors, if any. Third-party software, including font technology, is copyrighted and licensed from Sun suppliers.

Parts of the product may be derived from Berkeley BSD systems, licensed from the University of California. UNIX is a registered trademark in the U.S. and other countries, exclusively licensed through X/Open Company, Ltd.

Sun, Sun Microsystems, the Sun logo, docs.sun.com, AnswerBook, AnswerBook2, Solstice, SunLink, SunNet, SunNet Manager and Solaris are trademarks, registered trademarks, or service marks of Sun Microsystems, Inc. in the U.S. and other countries. All SPARC trademarks are used under license and are trademarks or registered trademarks of SPARC International, Inc. in the U.S. and other countries. Products bearing SPARC trademarks are based upon an architecture developed by Sun Microsystems, Inc.

The OPEN LOOK and Sun™ Graphical User Interface was developed by Sun Microsystems, Inc. for its users and licensees. Sun acknowledges the pioneering efforts of Xerox in researching and developing the concept of visual or graphical user interfaces for the computer industry. Sun holds a non-exclusive license from Xerox to the Xerox Graphical User Interface, which license also covers Sun's licensees who implement OPEN LOOK GUIs and otherwise comply with Sun's written license agreements.

RESTRICTED RIGHTS: Use, duplication, or disclosure by the U.S. Government is subject to restrictions of FAR 52.227-14(g)(2)(6/87) and FAR 52.227-19(6/87), or DFAR 252.227-7015(b)(6/95) and DFAR 227.7202-3(a).

DOCUMENTATION IS PROVIDED "AS IS" AND ALL EXPRESS OR IMPLIED CONDITIONS, REPRESENTATIONS AND WARRANTIES, INCLUDING ANY IMPLIED WARRANTY OF MERCHANTABILITY, FITNESS FOR A PARTICULAR PURPOSE OR NON-INFRINGEMENT, ARE DISCLAIMED, EXCEPT TO THE EXTENT THAT SUCH DISCLAIMERS ARE HELD TO BE LEGALLY INVALID.

Copyright 1999 Sun Microsystems, Inc. 901 San Antonio Road, Palo Alto, California 94303-4900 Etats-Unis. Tous droits réservés.

Ce produit ou document est protégé par un copyright et distribué avec des licences qui en restreignent l'utilisation, la copie, la distribution, et la décompilation. Aucune partie de ce produit ou document ne peut être reproduite sous aucune forme, par quelque moyen que ce soit, sans l'autorisation préalable et écrite de Sun et de ses bailleurs de licence, s'il y en a. Le logiciel détenu par des tiers, et qui comprend la technologie relative aux polices de caractères, est protégé par un copyright et licencié par des fournisseurs de Sun.

Des parties de ce produit pourront être dérivées du système Berkeley BSD licenciés par l'Université de Californie. UNIX est une marque déposée aux Etats-Unis et dans d'autres pays et licenciée exclusivement par X/Open Company, Ltd.

Sun, Sun Microsystems, le logo Sun, docs.sun.com, AnswerBook, AnswerBook2, Solstice, SunLink, SunNet, SunNet Manager et Solaris sont des marques de fabrique ou des marques déposées, ou marques de service, de Sun Microsystems, Inc. aux Etats-Unis et dans d'autres pays. Toutes les marques SPARC sont utilisées sous licence et sont des marques de fabrique ou des marques déposées de SPARC International, Inc. aux Etats-Unis et dans d'autres pays. Les produits portant les marques SPARC sont basés sur une architecture développée par Sun Microsystems, Inc.

L'interface d'utilisation graphique OPEN LOOK et Sun™ a été développée par Sun Microsystems, Inc. pour ses utilisateurs et licenciés. Sun reconnaît les efforts de pionniers de Xerox pour la recherche et le développement du concept des interfaces d'utilisation visuelle ou graphique pour l'industrie de l'informatique. Sun détient une licence non exclusive de Xerox sur l'interface d'utilisation graphique Xerox, cette licence couvrant également les licenciés de Sun qui mettent en place l'interface d'utilisation graphique OPEN LOOK et qui en outre se conforment aux licences écrites de Sun.

CETTE PUBLICATION EST FOURNIE "EN L'ETAT" ET AUCUNE GARANTIE, EXPRESSE OU IMPLICITE, N'EST ACCORDEE, Y COMPRIS DES GARANTIES CONCERNANT LA VALEUR MARCHANDE, L'APTITUDE DE LA PUBLICATION A REpondre A UNE UTILISATION PARTICULIERE, OU LE FAIT QU'ELLE NE SOIT PAS CONTREFAISANTE DE PRODUIT DE TIERS. CE DENI DE GARANTIE NE S'APPLIQUERAIT PAS, DANS LA MESURE OU IL SERAIT TENU JURIDIQUEMENT NUL ET NON AVENU.



Contents

Preface ix

1. Overview 1

Packet Assembler Disassembler (PAD) 1

The PAD Protocols 2

Command Mode and Call Mode 3

The PAD Hosts Database 3

Echoing 3

Terminal Type 4

PAD Parameters 4

2. Making PAD Calls 5

Before you Start 5

Finding out your Terminal Type 5

Displaying the PAD Hosts Database 6

Address Formats 7

Address Extensions 7

Link Numbers 7

Calling a Host 8

Starting the pad Program in Call Mode 8

Starting the pad Program in Command Mode 10

	Calls Using Address Extensions	11
	Ending a PAD Call	11
	Setting PAD Parameters	12
3.	PAD Commands	15
	Getting Help	16
	Making Calls	17
	Remote Host Call Commands	17
	Displaying Information	21
	Local and Remote Configuration	21
	Setting Parameters	22
	Using a Profile	23
	Setting Parameters Numerically	23
	Setting Parameters using Commands	23
	Index	29

Tables

TABLE P-1	Typographic Conventions	ix
TABLE P-2	Shell Prompts	x
TABLE 2-1	Address Extensions	7
TABLE 3-1	Address Extensions	18

Figures

Figure 1-1	PAD Summary	1
Figure 1-2	Outgoing and Incoming PAD call	2

Preface

This guide describes the ways you can use Solstice™ X.25 9.2 to communicate with devices on other networks. It does not describe how to install, configure or administer Solstice X.25. If you need information about any of these tasks, refer to the installation instructions and *Solstice X.25 9.2 Administration Guide*.

How This Book Is Organized

This book contains the following chapters:

Chapter 1 is an overview of the `pad` program.

Chapter 2 explains the basic use of the `pad` program.

Chapter 3 details the use of PAD commands to parameters to be used when making PAD calls.

What Typographic Changes Mean

The following table describes the typographic changes used in this book.

TABLE P-1 Typographic Conventions

Typeface or Symbol	Meaning	Example
AaBbCc123	The names of commands, files, and directories; on-screen computer output	Edit your <code>.login</code> file. Use <code>ls -a</code> to list all files. <code>machine_name% You have mail.</code>
AaBbCc123	What you type, contrasted with on-screen computer output	<code>machine_name% su</code> Password:
<i>AaBbCc123</i>	Command-line placeholder: replace with a real name or value	To delete a file, type <code>rm filename</code> .
<i>AaBbCc123</i>	Book titles, new words or terms, or words to be emphasized	Read Chapter 6 in <i>User's Guide</i> . These are called <i>class</i> options. You <i>must</i> be root to do this.

Shell Prompts in Command Examples

The following table shows the default system prompt and superuser prompt for the C shell, Bourne shell, and Korn shell.

TABLE P-2 Shell Prompts

Shell	Prompt
C shell prompt	<code>machine_name%</code>
C shell superuser prompt	<code>machine_name#</code>
Bourne shell and Korn shell prompt	<code>\$</code>
Bourne shell and Korn shell superuser prompt	<code>#</code>

Overview

With Solstice X.25 installed on your workstation or server, you can make connections with devices on remote networks across a Packet Switched Data Network (PSDN) and access their resources as if they were local.

Packet Assembler Disassembler (PAD)

A Packet Assembler Disassembler (PAD) forms part of the Solstice X.25 software. It allows you to make standard terminal connections to remote machines that support any standard implementation of X.25.

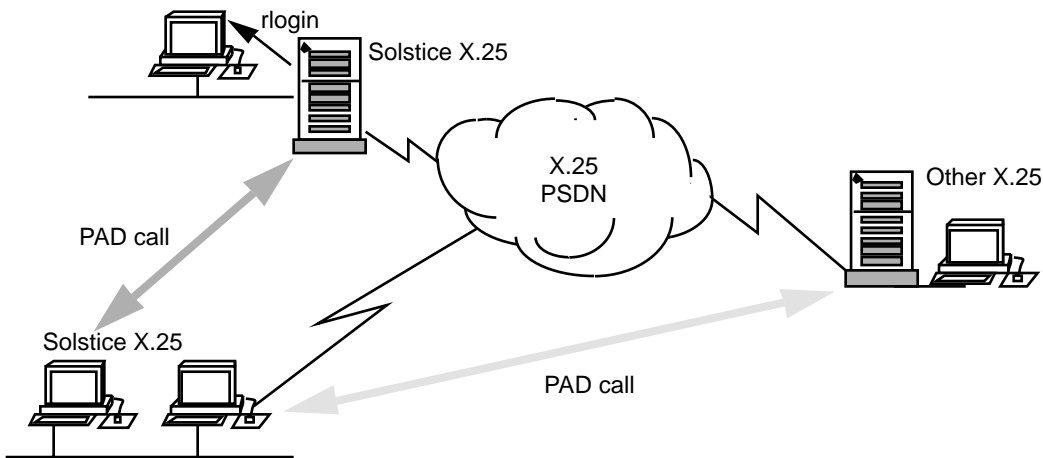

Figure 1-1 PAD Summary

Figure 1-1 shows some of the ways you can use Solstice X.25 to make connections with remote devices:

- PAD calls from Sun workstations running Solstice X.25 to Sun workstations and servers running Solstice X.25 and to remote systems running other implementations of X.25.
- PAD calls from one X.25 device to another, from where the user can `rlogin` to a non-X.25 IP host.

Note - All of the connections shown in the diagram are made across the X.25 Packet Switched Data Network.

A PAD program allows a terminal to communicate with an X.25 PSDN. It does this by assembling characters generated by an asynchronous terminal into packets for forwarding across the PSDN, and by disassembling packets received from a PSDN into a character stream that can be read by a terminal.

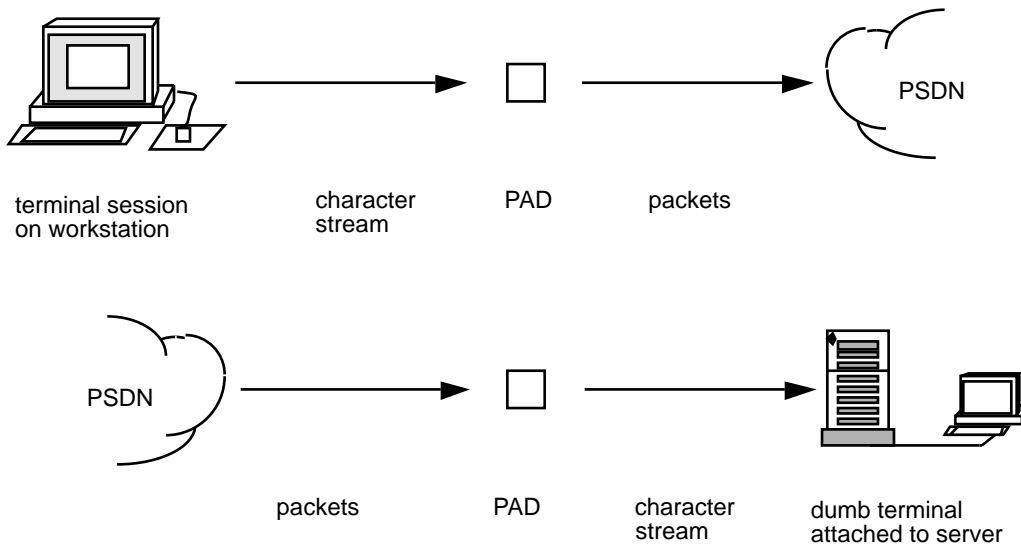

Figure 1-2 Outgoing and Incoming PAD call

The PAD program that forms part of Solstice X.25 lets you make PAD calls using a terminal session on a workstation, or using a physical terminal attached to a server. Workstations and servers can receive PAD calls from Sun and non-Sun machines, as long as they use a standard implementation of X.25 and the PAD protocols.

The PAD Protocols

The way a PAD operates is defined by a set of protocols, described in three ITU-T recommendations:

- X.3 defines the way the PAD program itself works.
- X.28 defines the way that interaction between the PAD and the terminal is handled.
- X.29 defines the way that interaction between the PAD and the PSDN is handled.

These three standards are often referred to together as *triple X*. This is sometimes written *XXX*.

Command Mode and Call Mode

The `pad` program operates in two modes:

- In *command mode*, you communicate with the `pad` program. Use command mode to enter commands specifying the way you want the `pad` program to work, for example to change the way echoing is handled.
- In *call mode*, you communicate with the remote host.

The PAD Hosts Database

The PAD hosts database is a list of remote hosts with associated parameters created by the System Administrator using the Solstice X.25 configuration tool `x25tool`. You can make PAD calls to remote hosts that are in the PAD hosts database simply by referring to them by name. You can also make PAD calls to remote hosts that are not in the PAD hosts database, but in this case you must specify parameters before connecting to the remote host.

By default, when you issue the `pad` command, the `pad` program will check the PAD Hosts Database to see if the specified host matches one of the alias defined in the database. If there is a match, the `pad` program will use the parameters defined in the database to establish a connection.

If you use the `-noaddrparse` option with the `pad` program, the PAD program will not search the PAD Hosts Database.

Echoing

Echoing refers to the mechanism used to display characters typed on the keyboard on the terminal screen. The Solstice X.25 `pad` program supports the following echo modes:

<i>message mode</i>	This is the default. The PAD echoes the characters you type and handles line-editing. The <code>pad</code> program stores all of the characters in a line, until you either press Return or
----------------------------	---

type the 81st character. Then the PAD sends the line to the remote host. This is the most appropriate type of echoing to use when you are using the operating system functions of the remote host. Using the PAD to handle echoing and line-editing minimizes the burden placed on the network and the remote host.

native mode

The remote host echoes the characters you type and handles line-editing. This is the appropriate mode to use for many screen-oriented applications. Using native mode places a high burden on both the network and remote host.

transparent mode

The PAD echoes the characters you type, but does not format them. Transparent mode is not often used.

Your System Administrator should have configured the most appropriate echo mode for your system. If you need to, you can over-ride this setting on a per-call basis.

Terminal Type

Hosts running the Solaris operating environment require you to specify the type of terminal you are using when you log in using a PAD call. This is because the X.29 protocol does not require the transfer of this information. If you are logging into non-Sun machines, check with the System Administrator to find out if you need to specify the terminal type.

PAD Parameters

Your System Administrator should have configured the appropriate PAD parameters for your local system. If you need to change or override them, refer to *Solstice X.25 9.2 Administration Guide*.

Making PAD Calls

If your System Administrator has made an entry for a remote host in the PAD Hosts Database, you can call it by name. If not, you must call it by the address. Before calling a host, make sure you have all the information you need.

Before you Start

Before you can make a PAD call, you need to know the following information:

- the type of terminal you are using
- whether the remote host is in the PAD hosts database

If the host you are calling turns out not to be in the PAD hosts database, you also need to know

- its exact address
- which link to call it over

You also need to find out what parameters, if any, you need to set. You are very unlikely to need to set parameters if you are calling a host that is in the PAD Hosts Database. You may need to set parameters if you are calling a host that is not in the PAD Hosts Database.

Finding out your Terminal Type

To find out your terminal type, enter the following command:

```
localhost% set | grep term
```

You system will display the terminal type, like this:

```
term sun-cmd
```

Make a note of the terminal type, as you will need it once you have established a PAD connection.

Displaying the PAD Hosts Database

If you are not sure whether the host you want to call is in the PAD hosts database, you can use the `pad` program in command mode to find out.

1. Start the `pad` program, by entering:

```
localhost% /opt/SUNWconn/bin/pad
```

The system displays the `PAD:` prompt:

```
PAD:
```

This tells you that you are in command mode.

2. Enter the `hosts` command to display the PAD hosts database:

```
PAD: hosts
```

The system displays the PAD hosts database:

```
PAD: hosts
      HOSTS AVAILABLE
      -----
Name: host1
Name: host2
Name: host3
```

Note - Starting the `pad` program is more convenient if `/opt/SUNWconn/bin` is in your `PATH`. If it is not, ask your System Administrator to add it. Once this is done, you only need to type `pad` to start the `pad` program.

Address Formats

If there is no entry for a host in the PAD Hosts Database, you must use its address to make a call to it. The type of address you use depends on the type of network you are making the call across.

- PSDN

If you are making a call across a Packet Switched Data Network, you must enter the remote host's X.121 address. This is almost certainly a DTE address and can be up to 15 decimal digits long.

- LAN

If you are making a call to a host that is on the same LAN as you, you must enter its LSAP address. This is 14 hexadecimal digits long and is made up of the host's 12 digit MAC address, followed by a 2 digit SAP address. The default SAP address for X.25 systems is 7e. For example, if the remote host's MAC address was 080020092186, its LSAP address would be 0800200921867e.

If you are not sure of a remote host's address, ask your System Administrator.

Address Extensions

You can specify additional components to a numeric address. Each must be preceded by an identifier to tell the software what kind of extension this is. The available components and identifiers are:

TABLE 2-1 Address Extensions

Extension	Identifier
OSI NSAP address	.N.
Non-OSI address extension	.X.
Call User Data	<space>~

Link Numbers

A link is an association between a physical line, for example a serial cable or a phone line, and a hardware port on your machine. You must specify the link number when you specify the address if the following are all true:

- you have multiple links on your machine
- you are using a numeric address rather than a name or alias
- your system administrator has not set up the Solstice X.25 routing feature
- you are calling over a link other than link 0, the default link

Calling a Host

You can call a host by name if it is in the PAD hosts database. Otherwise, you must specify its address.

If you have already started the `pad` program in command mode, for example to look at the PAD Hosts Database, you need to switch to call mode to call the host.

Alternatively, if you have not already started the `pad` program, you can start it up in call mode.

Starting the `pad` Program in Call Mode

To start the `pad` program in call mode and call a host:

1. **Start the `pad` program as follows, specifying either the name of the host you want to call, as it appears in the PAD Hosts Database or its address:**

```
localhost% /opt/SUNWconn/bin/pad hostname/address
```

If you need to give the link number, put it before the hostname or address, followed by a period:

```
localhost% /opt/SUNWconn/bin/pad linknumber.address
```

The system responds with the break-in sequence, then tells you that it is trying to establish a connection, then displays a login prompt.

```
localhost% /opt/SUNWconn/bin/pad host1  
  
Break-in sequence is '^Pa'  
  
Connecting...  
Connected
```

(continued)

```
Solstice X.29 Terminal Service  
login:
```

Make a note of the break-in sequence as you need it to close the connection.

2. Log into the remote system as normal, entering your password if the system prompts for one.

For security reasons, the password is not echoed on the screen.

```
login: username  
Password: password  
term: Undefined variable  
remotehost%
```

3. Set your terminal type.

You need to do this if you are connecting to a host running the Solaris environment. You may also need to do so for some other operating systems. If in doubt, check with the person responsible for the remote host.

If the remote host is running the Solaris 2.x environment and the Bourne shell, the default, set the terminal type like this:

```
remotehost% set TERM=terminal type  
remotehost% export TERM  
remotehost% /usr/bin/tput reset
```

If the remote host is running the Solaris 1.x environment and the Bourne shell, set the terminal type like this:

```
remotehost% set TERM=terminal type
remotehost% export TERM
remotehost% /usr/bin/tset reset
```

Once you have established a connection with the remote host, as shown above, you can work as normal.

Starting the pad Program in Command Mode

To start the pad program in command mode, enter:

```
localhost% /opt/SUNWconn/bin/pad
```

The system displays the PAD: prompt:

```
PAD:
```

This tells you that you are in command mode.

Optionally, if you run the pad command with the f option and a user configuration file as a parameter, this will be executed first before the PAD: prompt appears.

Switch to call mode by calling a host. Enter the command call followed by the name or address of the remote host at the PAD: prompt, then continue as described in steps 2 and 3, above, like this:

```
PAD: call hostname/address
Break-in sequence is '^Pa'

Connecting...
Connected
Solstice X.29 Terminal Service
login: username
Password: password
term: Undefined variable
remotehost%
remotehost% set TERM=terminal type
remotehost% export TERM
remotehost% /usr/bin/tput reset
```

Calls Using Address Extensions

You can specify the following additional components of a numeric address: an OSI NSAP address, a non-OSI address extension, and Call User Data.

To specify an OSI NSAP address, enter a period, an N (uppercase only) and a period before the NSAP address:

```
PAD: call 21521122334455.N.4910002233
```

To specify a non-OSI address extension, enter a period, an X (uppercase only), and another period:

```
PAD: call 21521122334455.X.7777
```

Specify Call User Data by preceding the data with space followed by a tilde (~). For example:

```
PAD: call 21521122334455 ~cud
```

The `pad` program automatically adds the X.29 protocol identifier (01000000) to the front of the data you specify.

If you enter a `pad` command using call user data in a `c` shell, you must escape the tilde by preceding it with a back-slash “\”:

```
> pad 21521122334455 \~cud
```

You can also specify Call User Data in conjunction with an OSI or non-OSI address extension. For example:

```
PAD: call 21521122334455.N.4910002233 ~cud
```

Ending a PAD Call

To end a PAD call:

1. **Log out from the remote host. To do this, enter the appropriate log out command for the remote host's environment.**

For a Solaris 2.x environment using the Bourne shell, the command is `logout`:

```
remotehost% logout
Call Cleared
PAD:
```

2. **Close the connection with the remote host.**

If `Call Cleared` appears when you enter `logout`, as shown above, you do not need to do this. Otherwise, enter `clear` to close down the connection:

```
remotehost% logout
PAD: clear
Call Cleared
PAD:
```

3. **Exit from the pad program.**

To do this, enter `quit` at the `PAD:` prompt:

```
PAD: quit
localhost%
```

Setting PAD Parameters

You are unlikely to need to set parameters for hosts that are included in the PAD hosts database, as the System Administrator should have set them when making the database entry. When calling hosts that are not in the PAD Hosts Database, the Solstice X.25 `pad` program's default values are appropriate in the majority of cases.

You must be in command mode to set parameters. You can either set them before making a call, or drop out of call mode in order to do so.

To switch from call mode to command mode, enter the Break-in sequence that was displayed when you made the call. In the example above, this is `<Ctrl-p><a>`. To return to Command Mode, resuming the connection with the remote host, press Return on an empty line. The example below shows how this works:

```
remotehost% <Ctrl-p><a>
PAD: native
PAD:

[Connection resumed]

remotehost%
```

Note - The escape sequence is not echoed when you type it. It is shown in the example for clarity.

You can also use the `pad -f` command to specify the name of a file containing parameters.

PAD Commands

This chapter describes the commands that are available when you are using the `pad` program. “Making Calls” on page 17 describes the commands you need to use to establish, manage and close PAD calls. “Displaying Information” on page 21 describes the commands you use to set PAD parameters for the duration of a call. You should only use the commands described in this section if you have been told you need to change the PAD parameters, as in most cases the defaults are suitable. You should not need to change the PAD parameters to make calls to hosts in the PAD Hosts Database.

You need to be in command mode to use the commands described in this chapter.

To start the `pad` program in command mode, enter:

```
localhost% /opt/SUNWconn/bin/pad
```

The system displays the `PAD:` prompt:

```
PAD:
```

This tells you that you are in command mode.

To switch from call mode to command mode, enter the Break-in sequence that was displayed when you made the call. In the example, this is `<Ctrl-p>a`:

```
remotehost% <Ctrl-p>a  
PAD: native
```

Getting Help

To display a summary of the available commands, enter `help` or a question mark (?) at the `PAD:` prompt. The display looks like this:

```
PAD: help
BREAK          (or B)          - send break signal to the host
BREAKACTION [n] (or BRA)       - set breakaction
BREAKIN        (or B)          - set PAD recall character
CALL host      (or C)          - set up a connection to the named host
CLEAR          (or CLR)       - close the current connection
ECHO [on|off]  (or E)          - enable/disable terminal echo
EMASK [kk]     (or EM)        - set terminal echo mask to kk
FLOW [on|off]  (or F)          - enable/disable terminal flow control
FORWARD [n]    (or FOR)       - set data forwarding conditions
HELP           (or ?)         - display help information
HOSTS          (or H)         - list all the hosts available
INT            (or I)          - transmit an interrupt packet
LFINSERT [n]   (or LF)        - set linefeed insertion action
LOGHOST [on|off] (or LOG)     --- display incoming X.29 messages
MESSAGE        (or MES)       - enable Message mode of operation
NATIVE         (or NAT)       - enable Native mode of operation
PAGEWAIT [n]   (or PW)        - set page wait to n lines
PARAM          (or PAR)       - display current X.3 parameters
PAR?           (or P)         - request current values of specified params
PRINTER        (or PRT)       - define terminal as hardcopy device
PROFILE [p]    (or PROF)      - sets terminal profile
QUIT           (or Q)         - exit the PAD session
RESET          (or RST)       - reset the current call
RPAR?         (or R)         - display remote parameters
RSET?         (or R)         - set remote parameters
SET           (or S)         - set specified parameters to given values
SET? list     (or S)         - set & read specified params to given values
STATUS [all]   (or STAT)     - displays the status of the connection
TRANSPARENT    (or TRA)       - enable Transparent mode of operation
VDU           (or V)         - define terminal as display device
WIDTH [n]     (or WID)       - set terminal width to be n characters
PAD:
```

Making Calls

Remote Host Call Commands

This section describes the commands you use when making calls to a remote host. They are listed in alphabetical order.

`break`

The `break` command sends a break signal to the remote host. The effect of the break signal depends on the setting you make using `breakaction`. By default it sends an interrupt signal and an indication of break to the remote host.

`call`

The `call` command makes a call to a remote host. You must enter it followed by at least one parameter—the name or address of the host you want to call. You can also enter other parameters to specify extended addressing and facilities.

The available parameters are:

hostname/alias

This is the hostname or alias configured for this destination by your System Administrator in the PAD Hosts Database. If this is the only parameter you enter, the `pad` program uses the parameters set in the PAD Hosts Database.

address

If you are making a call across a Packet-Switching Data Network, you must enter the remote host's X.121 address. This is almost certainly a DTE address and can be up to 15 decimal digits long.

If you are making a call to a host on the same LAN as you, you must enter its LSAP address. This is 14 decimal digits long and is made up of the host's 12 digit MAC address, followed by a 2 digit SAP address. The default SAP address for X.25 systems is 7e. For example, if the remote host's MAC address was 080020092186, its LSAP address would be 0800200921867e.

address extensions

You can specify additional components to a numeric address. Each must be preceded by an identifier to tell the software what kind of extension this is. The available components and identifiers are:

TABLE 3-1 Address Extensions

Extension	Identifier
OSI NSAP address	.N.
Non-OSI address extension	.X.
Call User Data	<space>~

facilities

You can use this parameter to override the facilities set by the System Administrator in the PAD Hosts Database, or to set facilities for a call to a host that is not in the PAD Hosts Database. The facilities you can set are:

- incoming and outgoing packet sizes—syntax: *pnumber/number*
- incoming and outgoing window sizes—syntax: *wnumber/number*
- fast select—syntax *f*
- reverse charge—syntax *r*

To specify a packet size, use powers of two, for example *p7/7* means 2 to the power of 7, that is 128 for incoming and outgoing packets. The example below shows setting packet sizes to 256, window sizes to 2, using fast select and reverse charging:

```
PAD: call address p8/8w2/2fr
```

Closed User Group

If the host you are calling is a member of a Closed User Group, enter its CUG number. If it is a multi-user CUG, precede the number with a *G*. If it is a bilateral CUG, precede it with a *B*.

Network User Identifier

If the remote host is attached to a PSDN that requires you to provide an NUI for security reasons, enter it, preceded by an N.

Recognized Private Operating Agency

You can enter a 4-digit RPOA number to provide additional routing information, if this is relevant to your network. To enter multiple ROPA numbers, enter them as a single string of digits.

`clear`

The `clear` command closes the current connection to the host. Some hosts automatically close the connection for you when you log out. In this case you do not need to use the `clear` command.

`hosts`

The `hosts` command displays a list of the hosts in the PAD Hosts Database. These are the hosts you can call by name.

`int`

The `int` command sends an interrupt packet to the remote host.

`loghost`

The `loghost` command displays the incoming and outgoing X.29 messages between the pad program and the remote host on the screen. You may be asked to use the `loghost` command and report the output if you contact your support organization with a question.

The `loghost` display looks like this:

```
PAD: loghost on
PAD: call host1
Break-in sequence is '^Pa'

Connecting...
Connected
X29 RX 2 : 03 7E 04 00 07 00 0A 50 0D 04 0F 01 10 7F 11 18
X29 RX 4
```

(continued)

```
X29 TX 0 : 01 01 02 01 03 7E 04 00 05 00 06 01 07 00 08 00 09 00 0A
50 0B 0E 0C 01 0D 04 0E 00 0F 01 10 7F 11 18 12 12
Solstice X.29 Terminal Service
login: user1
X29 RX 2 : 01 01 02 00 03 7E 04 00 05 00 06 01 07 05 08 00 09 00 0A
50 0C 01 0D 00 0E 00 0F 01 10 7F 11 15 12 12
X29 TX 4
Password: X29 RX 2 : 02 01 02 01 03 7E 04 00 05 00 05 01 07 05 08
00 09 00 0A 50 0C 01 0D 0E 04 00 0F 01 10 71 11 1f 12 12
X29 TX 46

remotehost%
```

quit

The `quit` command closes the connection to the remote host, exits the `pad` program and returns you to your local system prompt.

reset

The `reset` command sends a Reset Request to the currently connected host.

status

The `status` command tells you whether you are currently in Call or Command Mode and gives the name of the remote host you are connected to.

`status all` also tells you which parameters apply to this call:

```
PAD: status all

Break-in sequence is '^Pa'

Echo = ON, Echomask = 192, Flow = ON, Lfinsert = 4, Breakaction = 5
Pagewait = 0, Width = 80, Forward = 126, Timeout = 0, Message Mode
Profile = V5, Vdu, Loghost = ON

Call Status: Call Connected
Host      hostname
PAD:
```

width

The `width` command lets you specify the width, in columns of the terminal or window you are using for this call. The valid range is 20 - 255. The default width is 80. If you enter `width` without a parameter, the current setting is displayed.

Displaying Information

Local and Remote Configuration

The commands in this section display information about the local and remote configuration.

`par`

To display a single, or group, of local parameters values, enter `par?` followed by the relevant parameter number(s), like this:

```
PAD: par? 3
PAR 3:126
PAD:
```

`param`

To display the current X.3 parameters used by the local machine in numerical format, enter `param`. The output looks like this:

```
PAD: param
1:1, 2:1, 3:126, 4:0, 5:0, 6:1, 7:5, 8:0, 9:0, 10:80, 11:14, 12:1,
13:4, 14:0, 15:1, 16:127, 17:21, 18:18
PAD:
```

`rpar?`

To display the current X.3 parameters used by the remote machine in numerical format, enter `rpar?`. The output looks like this:

```
PAD: rpar?
1:1, 2:1, 3:126, 4:0, 5:0, 6:1, 7:5, 8:0, 9:0, 10:80, 11:14, 12:1,
13:4, 14:0, 15:1, 16:127, 17:21, 18:18
PAD:
```

To display a single, or group of remote parameter values, enter `rpar?` followed by the relevant parameter number(s), like this:

```
PAD: rpar? 4,7
PAR 4:0, 7:5
PAD:
```

status

To display local parameter values verbosely, enter `status all`:

```
PAD: status all

Break-in sequence is '^Pa'

Echo = ON, Echomask = 192, Flow = ON, Lfinsert = 4, Breakaction = 5
Pagewait = 0, Width = 80, Forward = 126, Timeout = 0, Message Mode
Profile = V5, Vdu, Loghost = ON

Call Status: Call Connected
Host    hostname
PAD:
```

Setting Parameters

You may occasionally need to set some of the PAD X.3 parameters for a particular call.

The Solstice X.25 `pad` program provides two methods of changing the X.3 parameters.

- Using the `set` command specifies the parameter number together with the numeric value representing the parameter setting you want. Use `set` if your network provider sends you information in this format.

- Using the remaining commands to set parameters.

Using a Profile

`profile`

Solstice X.25 pad program is delivered with a set of pre-defined profiles, that set suitable X.3 parameters for a variety of networks. Check with your System Administrator to find out whether there is a profile for your network. To use a profile, enter `profile`, followed by the name of the profile you want.

Setting Parameters Numerically

Some network providers supply information about which parameters to set to which values numerically. For example, you might be told to set parameter 3 to 126.

`set`

Use the `set` command to set local values like this. Specify the parameter number, followed by a colon and the parameter setting. To set multiple parameters, separate them with commas or spaces. For example:

```
PAD: set 2:1, 10:7, 13:4
```

`rset?`

Set remote parameters in the same way, using `rset?`. For example:

```
PAD: rset? 2:1, 10:7, 13:4
```

Setting Parameters using Commands

The commands in this section all let you set local X.3 parameter values. They are listed in alphabetical order, and the X.3 parameter number for each one is given.

breakaction

The `breakaction` command sets X.3 parameter 7.

This decides what action is taken when you use the `break` command. Possible values are:

Value	Meaning
0	No action
1	Send an interrupt packet
2	Send a reset packet
5	The default value. Send an interrupt packet and an indication of break
8	Exit Call Mode for Command Mode
21	Send an interrupt packet and an indication of break, then discard output from the host.

Entering `breakaction` with no argument displays the current setting.

echo

The `echo` command sets X.3 parameter 2.

Use `echo` to turn the `pad` program's echoing on or off. By default, echoing is on. This means that as well as processing characters it receives, the `pad` program echoes them back to the terminal.

emask

The `emask` command sets X.3 parameter 20.

It lets you decide which characters are not echoed to the screen. Possible values are:

Mask Value	Characters Not Echoed
1	CR
2	LF
4	VT, HT, FF

Mask Value	Characters Not Echoed
8	BEL, BS
16	ESC, ENQ
32	ACK, NAK, STX, SOX, EOT, ETB, ETX
64	DEL, CAN, DC2
128	All other control characters

To set more than one value, add them together. For example the default value is 192, which means 128 plus 64.

flow

The `flow` command sets X.3 parameter 5.

It enables or disables local flow control processing of XON and XOFF characters. Switching flow control on, using `flow on`, lets you use `Ctrl-s` to halt terminal output and `Ctrl-q` to restart it. If you are using an application that needs to use these control characters for other purposes, for example an EMACS-type editor, turn flow control `off`. By default, flow control is on.

Entering `flow` without a parameter displays the current setting.

forward

The `forward` command sets X.3 parameter 3.

`forward` allows you to select the character sequence you want to use to tell the pad program that it has received a complete character sequence that it should assemble and forward.

Possible values are:

Value	Data-forwarding characters
1	alphanumeric characters
2	CR
4	ESC, BEL, ENQ, ACK
8	DEL, CAN, DC2

Value	Data-forwarding characters
16	ETX, EOT
32	HT, LF, VT, FF
64	all other control characters, except XON, XOFF, DEL, CAN, DC2

To enter a combination of values, add them together, for example, the default value is 48, that is 16 plus 32.

If you do not specify a value, `forward` displays the current setting.

linefeed

The `linefeed` command sets X.3 parameter 13.

This determines whether the PAD will set a Line Feed character when transferring data. Possible values are:

Value	Effect
0	No line feed insertion
1	add LF after a CR in data from the host
2	add LF after a CR in data to the host
4	add LF after echoing a CR

The `linefeed` setting has no effect in native mode, unless echoing is on. In this case, setting 4 is valid.

In transparent mode, setting 1 has no effect.

To use more than one value, add them together. For example the default value is 6, 2 plus 4.

Entering `linefeed` without a value displays the current setting.

message

The `message` command sets X.3 parameters 2, 4, 10 and 15.

The effect of this is that the `pad` program echoes the characters you type and handles line-editing. This is the most appropriate type of echoing to use when you are using

the operating system functions of the remote host. Using the `pad` to handle echoing and line-editing minimizes the burden placed on the network and the remote host.

Enter `message` without a parameter to change to message mode.

`native`

The `native` command sets X.3 parameters 2, 4, 10 and 15.

The effect of this is that the remote host echoes the characters you type and handles line-editing. This is the appropriate mode to use for many screen-oriented applications. Using native mode places a high burden on both the network and remote host.

Enter `native` without a parameter to change to native mode.

`pagewait`

The `pagewait` command sets X.3 parameter 22.

`pagewait` tells the display to pause after the number of lines you specify. The default value is 0, meaning that the display does not pause.

Enter `pagewait` without a value to display the current setting.

`printer`

The `printer` command sets X.3 parameter 19.

`printer` notifies the `pad` program that you are using a hardcopy terminal.

`transparent`

The `transparent` command sets X.3 parameters 2, 4, 10 and 15.

The effect of setting transparent mode is that the `pad` echoes the characters you type, but does not format them.

`vdu`

The `vdu` command sets X.3 parameter 19.

`vdu` notifies the `pad` program that you are using a video terminal.

Index

A

address, 17
address extensions, 7, 11, 18
address formats, 7
alias, 17
asynchronous terminal, 2

B

break, 17
break-in sequence, 8
breakaction, 24

C

call, 17
call mode, 3, 10
Call User Data, 11
calls, making, 17
character stream, 2
clear, 19
Closed User Group, 18
command mode, 3, 8, 10, 16

E

echo, 24
echo modes, 3
emask, 24

F

facilities, 18
flow, 25

forward, 25

H

help, 16
hostname, 17
hosts, 19

I

int, 19

L

LAN, 7
linefeed, 26
link number, specifying in a PAD command
line, 7
loghost, 19
login prompt, 8
LSAP address, 7

M

making calls, 17
message, 26
message mode, 4

N

native, 27
native mode, 4
Network User Identifier, 19
noaddrparse, using with pad command, 3

O

OSI NSAP address, specifying as an address extension, 11

P

Packet Switched Data Network, 2

PAD

- overview, 2
- parameters, 4
- protocols, 2
- starting in call mode, 8
- starting in command mode, 6

PAD call

- ending, 11
- making, 5

PAD hosts database, 3, 6

pagewait, 27

par, 21

param, 21

parameters, setting, 13

printer, 27

profile, 23

PSDN, 2, 7

Q

quit, 20

R

Recognized Private Operating Agency, 19

reset, 20

rpar?, 21

rset?, 23

S

set, 23

setting parameters, 13

status, 20, 22

T

terminal session, 2

terminal type, 4, 5, 9

transparent, 27

transparent mode, 4

V

vdu, 27

W

width, 21

X

X.28, 3

X.29, 3

X.3, 3

XXX, 3