

# Sun StorEdge™ A7000 Installation Guide

---



THE NETWORK IS THE COMPUTER™

**Sun Microsystems, Inc.**  
901 San Antonio Road  
Palo Alto, CA 94303-4900 USA  
650 960-1300 Fax 650 969-9131

Part No. 805-4632-12  
September 1999, Revision A

Send comments about this document to: [docfeedback@sun.com](mailto:docfeedback@sun.com)

Copyright 1999 Sun Microsystems, Inc., 901 San Antonio Road • Palo Alto, CA 94303 USA. All rights reserved.

This product or document is protected by copyright and distributed under licenses restricting its use, copying, distribution, and decompilation. No part of this product or document may be reproduced in any form by any means without prior written authorization of Sun and its licensors, if any. Third-party software, including font technology, is copyrighted and licensed from Sun suppliers.

Parts of the product may be derived from Berkeley BSD systems, licensed from the University of California. UNIX is a registered trademark in the U.S. and other countries, exclusively licensed through X/Open Company, Ltd.

Sun, Sun Microsystems, the Sun logo, AnswerBook, Java, the Java Coffee Cup logo, StorEdge, Intelligent Storage Server, and Solaris are trademarks, registered trademarks, or service marks of Sun Microsystems, Inc. in the U.S. and other countries. All SPARC trademarks are used under license and are trademarks or registered trademarks of SPARC International, Inc. in the U.S. and other countries. Products bearing SPARC trademarks are based upon an architecture developed by Sun Microsystems, Inc.

The OPEN LOOK and Sun™ Graphical User Interface was developed by Sun Microsystems, Inc. for its users and licensees. Sun acknowledges the pioneering efforts of Xerox in researching and developing the concept of visual or graphical user interfaces for the computer industry. Sun holds a non-exclusive license from Xerox to the Xerox Graphical User Interface, which license also covers Sun's licensees who implement OPEN LOOK GUIs and otherwise comply with Sun's written license agreements.

**RESTRICTED RIGHTS:** Use, duplication, or disclosure by the U.S. Government is subject to restrictions of FAR 52.227-14(g)(2)(6/87) and FAR 52.227-19(6/87), or DFAR 252.227-7015(b)(6/95) and DFAR 227.7202-3(a).

DOCUMENTATION IS PROVIDED "AS IS" AND ALL EXPRESS OR IMPLIED CONDITIONS, REPRESENTATIONS AND WARRANTIES, INCLUDING ANY IMPLIED WARRANTY OF MERCHANTABILITY, FITNESS FOR A PARTICULAR PURPOSE OR NON-INFRINGEMENT, ARE DISCLAIMED, EXCEPT TO THE EXTENT THAT SUCH DISCLAIMERS ARE HELD TO BE LEGALLY INVALID.

Copyright 1999 Sun Microsystems, Inc., 901 San Antonio Road • Palo Alto, CA 94303 Etats-Unis. Tous droits réservés.

Ce produit ou document est protégé par un copyright et distribué avec des licences qui en restreignent l'utilisation, la copie, la distribution, et la décompilation. Aucune partie de ce produit ou document ne peut être reproduite sous aucune forme, par quelque moyen que ce soit, sans l'autorisation préalable et écrite de Sun et de ses bailleurs de licence, s'il y en a. Le logiciel détenu par des tiers, et qui comprend la technologie relative aux polices de caractères, est protégé par un copyright et licencié par des fournisseurs de Sun.

Des parties de ce produit pourront être dérivées des systèmes Berkeley BSD licenciés par l'Université de Californie. UNIX est une marque déposée aux Etats-Unis et dans d'autres pays et licenciée exclusivement par X/Open Company, Ltd.

Sun, Sun Microsystems, le logo Sun, AnswerBook, Java, le logo Java Coffee Cup, StorEdge, Intelligent Storage Server, et Solaris sont des marques de fabrique ou des marques déposées, ou marques de service, de Sun Microsystems, Inc. aux Etats-Unis et dans d'autres pays. Toutes les marques SPARC sont utilisées sous licence et sont des marques de fabrique ou des marques déposées de SPARC International, Inc. aux Etats-Unis et dans d'autres pays. Les produits portant les marques SPARC sont basés sur une architecture développée par Sun Microsystems, Inc.

L'interface d'utilisation graphique OPEN LOOK et Sun™ a été développée par Sun Microsystems, Inc. pour ses utilisateurs et licenciés. Sun reconnaît les efforts de pionniers de Xerox pour la recherche et le développement du concept des interfaces d'utilisation visuelle ou graphique pour l'industrie de l'informatique. Sun détient une licence non exclusive de Xerox sur l'interface d'utilisation graphique Xerox, cette licence couvrant également les licenciés de Sun qui mettent en place l'interface d'utilisation graphique OPEN LOOK et qui en outre se conforment aux licences écrites de Sun.

CETTE PUBLICATION EST FOURNIE "EN L'ETAT" ET AUCUNE GARANTIE, EXPRESSE OU IMPLICITE, N'EST ACCORDEE, Y COMPRIS DES GARANTIES CONCERNANT LA VALEUR MARCHANDE, L'APTITUDE DE LA PUBLICATION A REpondre A UNE UTILISATION PARTICULIERE, OU LE FAIT QU'ELLE NE SOIT PAS CONTREFAISANTE DE PRODUIT DE TIERS. CE DENI DE GARANTIE NE S'APPLIQUERAIT PAS, DANS LA MESURE OU IL SERAIT TENU JURIDIQUEMENT NUL ET NON AVENU.



Adobe PostScript

## Declaration of Conformity

Compliance ID: 1660  
Product Name: Sun StorEdge A7000

### EMC

European Union  
This equipment complies with the following requirements of the EMC Directive 89/336/EEC:

EN55022 / CISPR22 (1985)		Class A
EN50082-1	IEC801-2 (1991)	4 kV (Direct), 8 kV (Air)
	IEC801-3 (1984)	3 V/m
	IEC801-4 (1988)	1.0 kV Power Lines, 0.5 kV Signal Lines

### Safety

This equipment complies with the following requirements of Low Voltage Directive 73/23/EEC:

EC Type Examination Certificates:

EN60950/IEC950

EN60950 w/ Nordic Deviations

### Supplementary Information:

This product was tested and complies with all the requirements for the CE Mark.

/ S /

Dennis P. Symanski    DATE  
Manager, Product Compliance

/ S /

John Shades                    DATE  
Quality Assurance Manager

Sun Microsystems, Inc.  
901 San Antonio Road, M/S UMPK15-102  
Palo Alto, CA 94303, USA  
Tel: 650-786-3255  
Fax: 650-786-3723

Sun Microsystems Scotland, Limited  
Springfield, Linlithgow  
West Lothian, EH49 7LR  
Scotland, United Kingdom  
Tel: 0506 670000  
Fax: 0506 760011



## Declaration of Conformity

Compliance ID: 1660Exp  
Product Name: Sun StorEdge A7000

### EMC

European Union  
This equipment complies with the following requirements of the EMC Directive 89/336/EEC:

EN55022 / CISPR22 (1985)		Class A
EN50082-1	IEC801-2 (1991)	4 kV (Direct), 8 kV (Air)
	IEC801-3 (1984)	3 V/m
	IEC801-4 (1988)	1.0 kV Power Lines, 0.5 kV Signal Lines

### Safety

This equipment complies with the following requirements of Low Voltage Directive 73/23/EEC:

EC Type Examination Certificates:

EN60950/IEC950

EN60950 w/ Nordic Deviations

### Supplementary Information:

This product was tested and complies with all the requirements for the CE Mark.

/ S /

Dennis P. Symanski     DATE  
Manager, Product Compliance

/ S /

John Shades             DATE  
Quality Assurance Manager

Sun Microsystems, Inc.  
901 San Antonio Road, M/S UMPK15-102  
Palo Alto, CA 94303, USA  
Tel: 650-786-3255  
Fax: 650-786-3723

Sun Microsystems Scotland, Limited  
Springfield, Linlithgow  
West Lothian, EH49 7LR  
Scotland, United Kingdom  
Tel: 0506 670000  
Fax: 0506 760011



## Safety Agency Compliance Statements

Read this section before beginning any procedure. The following text provides safety precautions to follow when installing a Sun Microsystems product.

### Safety Precautions

For your protection, observe the following safety precautions when setting up your equipment:

- Follow all cautions and instructions marked on the equipment.
- Ensure that the voltage and frequency of your power source match the voltage and frequency inscribed on the equipment's electrical rating label.
- Never push objects of any kind through openings in the equipment. Dangerous voltages may be present. Conductive foreign objects could produce a short circuit that could cause fire, electric shock, or damage to your equipment.

### Symbols

The following symbols may appear in this book:



**Caution** – There is risk of personal injury and equipment damage. Follow the instructions.



**Caution** – Hot surface. Avoid contact. Surfaces are hot and may cause personal injury if touched.



**Caution** – Hazardous voltages are present. To reduce the risk of electric shock and danger to personal health, follow the instructions.



**On** – Applies AC power to the system.

Depending on the type of power switch your device has, one of the following symbols may be used:



**Off** – Removes AC power from the system.



**Standby** – The On/Standby switch is in the *standby* position.

### Modifications to Equipment

Do not make mechanical or electrical modifications to the equipment. Sun Microsystems is not responsible for regulatory compliance of a modified Sun product.

### Placement of a Sun Product



**Caution** – Do not block or cover the openings of your Sun product. Never place a Sun product near a radiator or heat register. Failure to follow these guidelines can cause overheating and affect the reliability of your Sun product.

### SELV Compliance

Safety status of I/O connections comply to SELV requirements.

### Power Cord Connection



**Caution** – Sun products are designed to work with single-phase power systems having a grounded neutral conductor. To reduce the risk of electric shock, do not plug Sun products into any other type of power system. Contact your facilities manager or a qualified electrician if you are not sure what type of power is supplied to your building.



**Caution** – Not all power cords have the same current ratings. Household extension cords do not have overload protection and are not meant for use with computer systems. Do not use household extension cords with your Sun product.



**Caution** – Your Sun product is shipped with a grounding type (three-wire) power cord. To reduce the risk of electric shock, always plug the cord into a grounded power outlet.

The following caution applies only to devices with a **Standby** power switch:



**Caution** – The power switch of this product functions as a standby type device only. The power cord serves as the primary disconnect device for the system. Be sure to plug the power cord into a grounded power outlet that is nearby the system and is readily accessible. Do not connect the power cord when the power supply has been removed from the system chassis.

## Lithium Battery



**Caution** – On Sun CPU boards, there is a lithium battery molded into the real-time clock, SGS No. MK48T59Y, MK48TXXB-XX, MK48T18-XXXPCZ, M48T59W-XXXPCZ, MK48T08, M48T02-200PC1, or M48T02-XXXPCZ. Batteries are not customer replaceable parts. They may explode if mishandled. Do not dispose of the battery in fire. Do not disassemble it or attempt to recharge it.

## System Unit Cover

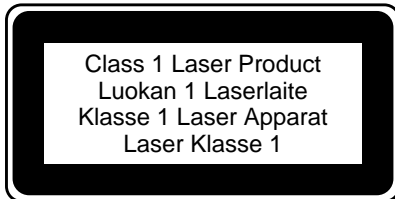
You must remove the cover of your Sun computer system unit in order to add cards, memory, or internal storage devices. Be sure to replace the top cover before powering up your computer system.



**Caution** – Do not operate Sun products without the top cover in place. Failure to take this precaution may result in personal injury and system damage.

## Laser Compliance Notice

Sun products that use laser technology comply with Class 1 laser requirements.



## CD-ROM



**Caution** – Use of controls, adjustments, or the performance of procedures other than those specified herein may result in hazardous radiation exposure.

## Einhaltung sicherheitsbehördlicher Vorschriften

Auf dieser Seite werden Sicherheitsrichtlinien beschrieben, die bei der Installation von Sun-Produkten zu beachten sind.

### Sicherheitsvorkehrungen

Treffen Sie zu Ihrem eigenen Schutz die folgenden Sicherheitsvorkehrungen, wenn Sie Ihr Gerät installieren:

- Beachten Sie alle auf den Geräten angebrachten Warnhinweise und Anweisungen.

- Vergewissern Sie sich, daß Spannung und Frequenz Ihrer Stromquelle mit der Spannung und Frequenz übereinstimmen, die auf dem Etikett mit den elektrischen Nennwerten des Geräts angegeben sind.
- Stecken Sie auf keinen Fall irgendwelche Gegenstände in Öffnungen in den Geräten. Leitfähige Gegenstände könnten aufgrund der möglicherweise vorliegenden gefährlichen Spannungen einen Kurzschluß verursachen, der einen Brand, Stromschlag oder Geräteschaden herbeiführen kann.

## Symbole

Die Symbole in diesem Handbuch haben folgende Bedeutung:



**Achtung** – Gefahr von Verletzung und Geräteschaden. Befolgen Sie die Anweisungen.



**Achtung** – Hohe Temperatur. Nicht berühren, da Verletzungsgefahr durch heiße Oberfläche besteht.



**Achtung** – Gefährliche Spannungen. Anweisungen befolgen, um Stromschläge und Verletzungen zu vermeiden.



**Ein** – Setzt das System unter Wechselstrom.

Je nach Netzschaltertyp an Ihrem Gerät kann eines der folgenden Symbole benutzt werden:



**Aus** – Unterbricht die Wechselstromzufuhr zum Gerät.



**Wartezustand** (Stand-by-Position) - Der Ein-/Wartezustand-Schalter steht auf Wartezustand. Änderungen an Sun-Geräten.

Nehmen Sie keine mechanischen oder elektrischen Änderungen an den Geräten vor. Sun Microsystems, übernimmt bei einem Sun-Produkt, das geändert wurde, keine Verantwortung für die Einhaltung behördlicher Vorschriften



## Aufstellung von Sun-Geräten



**Achtung** – Um den zuverlässigen Betrieb Ihres Sun-Geräts zu gewährleisten und es vor Überhitzung zu schützen, dürfen die Öffnungen im Gerät nicht blockiert oder verdeckt werden. Sun-Produkte sollten niemals in der Nähe von Heizkörpern oder Heizluftklappen aufgestellt werden.

## Einhaltung der SELV-Richtlinien

Die Sicherung der I/O-Verbindungen entspricht den Anforderungen der SELV-Spezifikation.

## Anschluß des Netzkabels



**Achtung** – Sun-Produkte sind für den Betrieb an Einphasen-Stromnetzen mit geerdetem Nulleiter vorgesehen. Um die Stromschlaggefahr zu reduzieren, schließen Sie Sun-Produkte nicht an andere Stromquellen an. Ihr Betriebsleiter oder ein qualifizierter Elektriker kann Ihnen die Daten zur Stromversorgung in Ihrem Gebäude geben.



**Achtung** – Nicht alle Netzkabel haben die gleichen Nennwerte. Herkömmliche, im Haushalt verwendete Verlängerungskabel besitzen keinen Überlastungsschutz und sind daher für Computersysteme nicht geeignet.



**Achtung** – Ihr Sun-Gerät wird mit einem dreidradigen Netzkabel für geerdete Netzsteckdosen geliefert. Um die Gefahr eines Stromschlags zu reduzieren, schließen Sie das Kabel nur an eine fachgerecht verlegte, geerdete Steckdose an.

Die folgende Warnung gilt nur für Geräte mit Wartezustand-Netzschalter:



**Achtung** – Der Ein/Aus-Schalter dieses Geräts schaltet nur auf Wartezustand (Stand-By-Modus). Um die Stromzufuhr zum Gerät vollständig zu unterbrechen, müssen Sie das Netzkabel von der Steckdose abziehen. Schließen Sie den Stecker des Netzkabels an eine in der Nähe befindliche, frei zugängliche, geerdete Netzsteckdose an. Schließen Sie das Netzkabel nicht an, wenn das Netzteil aus der Systemeinheit entfernt wurde.

## Lithiumbatterie



**Achtung** – CPU-Karten von Sun verfügen über eine Echtzeituhr mit integrierter Lithiumbatterie (Teile-Nr. MK48T59Y, MK48TXXB-XX, MK48T18-XXXPCZ, M48T59W-XXXPCZ, MK48T08, M48T02-200PC1, oder M48T02-XXXPCZ). Diese Batterie darf nur von einem qualifizierten Servicetechniker ausgewechselt werden, da sie bei falscher Handhabung explodieren kann. Werfen Sie die Batterie nicht ins Feuer. Versuchen Sie auf keinen Fall, die Batterie auszubauen oder wiederaufzuladen.

## Gehäuseabdeckung

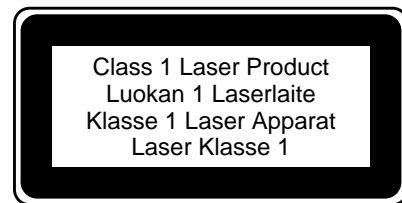
Sie müssen die obere Abdeckung Ihres Sun-Systems entfernen, um interne Komponenten wie Karten, Speicherchips oder Massenspeicher hinzuzufügen. Bringen Sie die obere Gehäuseabdeckung wieder an, bevor Sie Ihr System einschalten.



**Achtung** – Bei Betrieb des Systems ohne obere Abdeckung besteht die Gefahr von Stromschlag und Systemschäden.

## Einhaltung der Richtlinien für Laser

Sun-Produkte, die mit Laser-Technologie arbeiten, entsprechen den Anforderungen der Laser Klasse 1.



## CD-ROM



**Warnung** – Die Verwendung von anderen Steuerungen und Einstellungen oder die Durchführung von Prozeduren, die von den hier beschriebenen abweichen, können gefährliche Strahlungen zur Folge haben.

## Conformité aux normes de sécurité

Ce texte traite des mesures de sécurité qu'il convient de prendre pour l'installation d'un produit Sun Microsystems.

## Mesures de sécurité

Pour votre protection, veuillez prendre les précautions suivantes pendant l'installation du matériel :

- Suivre tous les avertissements et toutes les instructions inscrites sur le matériel.
- Vérifier que la tension et la fréquence de la source d'alimentation électrique correspondent à la tension et à la fréquence indiquées sur l'étiquette de classification de l'appareil.
- Ne jamais introduire d'objets quels qu'ils soient dans une des ouvertures de l'appareil. Vous pourriez vous trouver en présence de hautes tensions dangereuses. Tout objet conducteur introduit de la sorte pourrait produire un court-circuit qui entraînerait des flammes, des risques d'électrocution ou des dégâts matériels.

## Symboles

Vous trouverez ci-dessous la signification des différents symboles utilisés :



**Attention** : risques de blessures corporelles et de dégâts matériels. Veuillez suivre les instructions.



**Attention** : surface à température élevée. Evitez le contact. La température des surfaces est élevée et leur contact peut provoquer des blessures corporelles.



**Attention** : présence de tensions dangereuses. Pour éviter les risques d'électrocution et de danger pour la santé physique, veuillez suivre les instructions.



**MARCHE** – Votre système est sous tension (courant alternatif).

Un des symboles suivants sera peut-être utilisé en fonction du type d'interrupteur de votre système:



**ARRÊT** – Votre système est hors tension (courant alternatif).



**VEILLEUSE** – L'interrupteur Marche/Veilleuse est en position « Veilleuse ».

## Modification du matériel

Ne pas apporter de modification mécanique ou électrique au matériel. Sun Microsystems n'est pas responsable de la conformité réglementaire d'un produit Sun qui a été modifié.

## Positionnement d'un produit Sun



**Attention** : pour assurer le bon fonctionnement de votre produit Sun et pour l'empêcher de surchauffer, il convient de ne pas obstruer ni recouvrir les ouvertures prévues dans l'appareil. Un produit Sun ne doit jamais être placé à proximité d'un radiateur ou d'une source de chaleur.

## Conformité SELV

Sécurité : les raccordements E/S sont conformes aux normes SELV.

## Connexion du cordon d'alimentation



**Attention** : les produits Sun sont conçus pour fonctionner avec des alimentations monophasées munies d'un conducteur neutre mis à la terre. Pour écarter les risques d'électrocution, ne pas brancher de produit Sun dans un autre type d'alimentation secteur. En cas de doute quant au type d'alimentation électrique du local, veuillez vous adresser au directeur de l'exploitation ou à un électricien qualifié.



**Attention** : tous les cordons d'alimentation n'ont pas forcément la même puissance nominale en matière de courant. Les rallonges d'usage domestique n'offrent pas de protection contre les surcharges et ne sont pas prévues pour les systèmes d'ordinateurs. Ne pas utiliser de rallonge d'usage domestique avec votre produit Sun.



**Attention** : votre produit Sun a été livré équipé d'un cordon d'alimentation à trois fils (avec prise de terre). Pour écarter tout risque d'électrocution, branchez toujours ce cordon dans une prise mise à la terre.

L'avertissement suivant s'applique uniquement aux systèmes équipés d'un interrupteur VEILLEUSE:



**Attention** : le commutateur d'alimentation de ce produit fonctionne comme un dispositif de mise en veille uniquement. C'est la prise d'alimentation qui sert à mettre le produit hors tension. Veuillez donc à installer le produit à proximité d'une prise murale facilement accessible. Ne connectez pas la prise d'alimentation lorsque le châssis du système n'est plus alimenté.

## Batterie au lithium



**Attention** : sur les cartes CPU Sun, une batterie au lithium (référence MK48T59Y, MK48TXXB-XX, MK48T18-XXXPCZ, M48T59W-XXXPCZ, MK48T08, M48T02-200PC1, ou M48T02-XXXPCZ.) a été moulée dans l'horloge temps réel SGS. Les batteries ne sont pas des pièces remplaçables par le client. Elles risquent d'exploser en cas de mauvais traitement. Ne pas jeter la batterie au feu. Ne pas la démonter ni tenter de la recharger.

## Couvercle

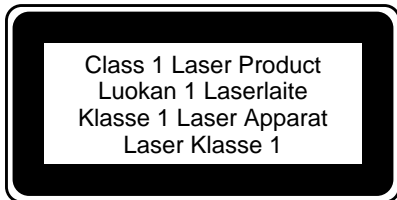
Pour ajouter des cartes, de la mémoire, ou des unités de stockage internes, vous devrez démonter le couvercle de l'unité système Sun. Ne pas oublier de remettre ce couvercle en place avant de mettre le système sous tension.



**Attention** : il est dangereux de faire fonctionner un produit Sun sans le couvercle en place. Si l'on néglige cette précaution, on encourt des risques de blessures corporelles et de dégâts matériels.

## Conformité aux certifications Laser

Les produits Sun qui font appel aux technologies lasers sont conformes aux normes de la classe 1 en la matière.



## CD-ROM



**Attention** - L'utilisation de contrôles, de réglages ou de performances de procédures autre que celle spécifiée dans le présent document peut provoquer une exposition à des radiations dangereuses.

## Normativas de seguridad

El siguiente texto incluye las medidas de seguridad que se deben seguir cuando se instale algún producto de Sun Microsystems.

## Precauciones de seguridad

Para su protección observe las siguientes medidas de seguridad cuando manipule su equipo:

- Siga todas las avisos e instrucciones marcados en el equipo.
- Asegúrese de que el voltaje y la frecuencia de la red eléctrica concuerdan con las descritas en las etiquetas de especificaciones eléctricas del equipo.
- No introduzca nunca objetos de ningún tipo a través de los orificios del equipo. Pueden haber voltajes peligrosos. Los objetos extraños conductores de la electricidad pueden producir cortocircuitos que provoquen un incendio, descargas eléctricas o daños en el equipo.

## Símbolos

En este libro aparecen los siguientes símbolos:



**Precaución** - Existe el riesgo de lesiones personales y daños al equipo. Siga las instrucciones.



**Precaución** - Superficie caliente. Evite el contacto. Las superficies están calientes y pueden causar daños personales si se tocan.



**Precaución** - Voltaje peligroso presente. Para reducir el riesgo de descarga y daños para la salud siga las instrucciones.



**Encendido** - Aplica la alimentación de CA al sistema.

Según el tipo de interruptor de encendido que su equipo tenga, es posible que se utilice uno de los siguientes símbolos:



**Apagado** - Elimina la alimentación de CA del sistema.



**En espera** - El interruptor de Encendido/En espera se ha colocado en la posición de *En espera*.

## Modificaciones en el equipo

No realice modificaciones de tipo mecánico o eléctrico en el equipo. Sun Microsystems no se hace responsable del cumplimiento de las normativas de seguridad en los equipos Sun modificados.

## Ubicación de un producto Sun



**Precaución** – Para asegurar la fiabilidad de funcionamiento de su producto Sun y para protegerlo de sobrecalentamientos no deben obstruirse o taparse las rejillas del equipo. Los productos Sun nunca deben situarse cerca de radiadores o de fuentes de calor.

## Cumplimiento de la normativa SELV

El estado de la seguridad de las conexiones de entrada/salida cumple los requisitos de la normativa SELV.

## Conexión del cable de alimentación eléctrica



**Precaución** – Los productos Sun están diseñados para trabajar en una red eléctrica monofásica con toma de tierra. Para reducir el riesgo de descarga eléctrica, no conecte los productos Sun a otro tipo de sistema de alimentación eléctrica. Póngase en contacto con el responsable de mantenimiento o con un electricista cualificado si no está seguro del sistema de alimentación eléctrica del que se dispone en su edificio.



**Precaución** – No todos los cables de alimentación eléctrica tienen la misma capacidad. Los cables de tipo doméstico no están provistos de protecciones contra sobrecargas y por tanto no son apropiados para su uso con computadores. No utilice alargadores de tipo doméstico para conectar sus productos Sun.



**Precaución** – Con el producto Sun se proporciona un cable de alimentación con toma de tierra. Para reducir el riesgo de descargas eléctricas conéctelo siempre a un enchufe con toma de tierra.

La siguiente advertencia se aplica solamente a equipos con un interruptor de encendido que tenga una posición "En espera":



**Precaución** – El interruptor de encendido de este producto funciona exclusivamente como un dispositivo de puesta en espera. El enchufe de la fuente de alimentación está diseñado para ser el elemento primario de desconexión del equipo. El equipo debe instalarse cerca del enchufe de forma que este último pueda ser fácil y rápidamente accesible. No conecte el cable de alimentación cuando se ha retirado la fuente de alimentación del chasis del sistema.

## Batería de litio



**Precaución** – En las placas de CPU Sun hay una batería de litio insertada en el reloj de tiempo real, tipo SGS Núm. MK48T59Y, MK48TXXB-XX, MK48T18-XXXPCZ, M48T59W-XXXPCZ, MK48T08, M48T02-200PC1, o M48T02-XXXPCZ. Las baterías no son elementos reemplazables por el propio cliente. Pueden explotar si se manipulan de forma errónea. No arroje las baterías al fuego. No las abra o intente recargarlas.

## Tapa de la unidad del sistema

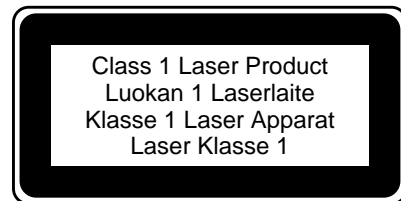
Debe quitar la tapa del sistema cuando sea necesario añadir tarjetas, memoria o dispositivos de almacenamiento internos. Asegúrese de cerrar la tapa superior antes de volver a encender el equipo.



**Precaución** – Es peligroso hacer funcionar los productos Sun sin la tapa superior colocada. El hecho de no tener en cuenta esta precaución puede ocasionar daños personales o perjudicar el funcionamiento del equipo.

## Aviso de cumplimiento con requisitos de láser

Los productos Sun que utilizan la tecnología de láser cumplen con los requisitos de láser de Clase 1.



## CD-ROM

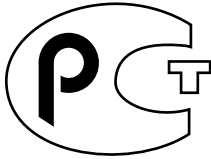


---

**Precaución** – El manejo de los controles, los ajustes o la ejecución de procedimientos distintos a los aquí especificados pueden exponer al usuario a radiaciones peligrosas.

---

## GOST-R Certification Mark



## Nordic Lithium Battery Cautions

### Norge



---

**A D V A R S E L** - Litiumbatteri — Eksplosjonsfare. Ved utskifting benyttes kun batteri som anbefalt av apparatfabrikanten. Brukt batteri returneres apparatleverandøren.

---

### Sverige



---

**WARNING** - Explosionsfara vid felaktigt batteribyte. Använd samma batterityp eller en ekvivalent typ som rekommenderas av apparattillverkaren. Kassera använt batteri enligt fabrikantens instruktion.

---

### Danmark



---

**ADVARSEL!** - Litiumbatteri — Eksplosionsfare ved fejlagtig håndtering. Udsiftning må kun ske med batteri af samme fabrikat og type. Levér det brugte batteri tilbage til leverandøren.

---

### Suomi



---

**VAROITUS** - Paristo voi räjähtää, jos se on virheellisesti asennettu. Vaihda paristo ainoastaan laitevalmistajan suosittelemaan tyyppiin. Hävitä käytetty paristo valmistajan ohjeiden mukaisesti.

---



# Regulatory Compliance Statements

Your Sun product is marked to indicate its compliance class:

- Federal Communications Commission (FCC) — USA
- Industry Canada Equipment Standard for Digital Equipment (ICES-003) - Canada
- Voluntary Control Council for Interference (VCCI) — Japan
- Bureau of Standards Metrology and Inspection (BSMI) — Taiwan

Please read the appropriate section that corresponds to the marking on your Sun product before attempting to install the product.

## FCC Class A Notice

This device complies with Part 15 of the FCC Rules. Operation is subject to the following two conditions:

This device may not cause harmful interference.

1. This device must accept any interference received, including interference that may cause undesired operation.

**Note:** This equipment has been tested and found to comply with the limits for a Class A digital device, pursuant to Part 15 of the FCC Rules. These limits are designed to provide reasonable protection against harmful interference when the equipment is operated in a commercial environment. This equipment generates, uses, and can radiate radio frequency energy, and if it is not installed and used in accordance with the instruction manual, it may cause harmful interference to radio communications. Operation of this equipment in a residential area is likely to cause harmful interference, in which case the user will be required to correct the interference at his own expense.

**Shielded Cables:** Connections between the workstation and peripherals must be made using shielded cables to comply with FCC radio frequency emission limits. Networking connections can be made using unshielded twisted-pair (UTP) cables.

**Modifications:** Any modifications made to this device that are not approved by Sun Microsystems, Inc. may void the authority granted to the user by the FCC to operate this equipment.

## FCC Class B Notice

This device complies with Part 15 of the FCC Rules. Operation is subject to the following two conditions:

This device may not cause harmful interference.

2. This device must accept any interference received, including interference that may cause undesired operation.

**Note:** This equipment has been tested and found to comply with the limits for a Class B digital device, pursuant to Part 15 of the FCC Rules. These limits are designed to provide reasonable protection against harmful interference in a residential installation. This equipment generates, uses and can radiate radio frequency energy and, if not installed and used in accordance with the instructions, may cause harmful interference to radio communications. However, there is no guarantee that interference will not occur in a particular installation. If this equipment does cause harmful interference to radio or television reception, which can be determined by turning the equipment off and on, the user is encouraged to try to correct the interference by one or more of the following measures:

- Reorient or relocate the receiving antenna.
- Increase the separation between the equipment and receiver.
- Connect the equipment into an outlet on a circuit different from that to which the receiver is connected.
- Consult the dealer or an experienced radio/television technician for help.

**Shielded Cables:** Connections between the workstation and peripherals must be made using shielded cables in order to maintain compliance with FCC radio frequency emission limits. Networking connections can be made using unshielded twisted pair (UTP) cables.

**Modifications:** Any modifications made to this device that are not approved by Sun Microsystems, Inc. may void the authority granted to the user by the FCC to operate this equipment.

## ICES-003 Class A Notice - Avis NMB-003, Classe A

This Class A digital apparatus complies with Canadian ICES-003.

Cet appareil numérique de la classe A est conforme à la norme NMB-003 du Canada.

## ICES-003 Class B Notice - Avis NMB-003, Classe B

This Class B digital apparatus complies with Canadian ICES-003.

Cet appareil numérique de la classe B est conforme à la norme NMB-003 du Canada.

## VCCI 基準について

### 第一種 VCCI 基準について


第一種 VCCI の表示があるワークステーションおよびオプション製品は、第一種情報装置です。これらの製品には、下記の項目が該当します。

この装置は、第一種情報装置(商工業地域において使用されるべき情報装置)で商工業地域での電波障害防止を目的とした情報処理装置等電波障害自主規制協議会(VCCI)基準に適合しております。したがって、本製品を、住宅地域または住宅地域に隣接した地域でご使用になりますと、ラジオ、テレビジョン受信機等に受信障害を与えることがあります。

取り扱い説明書に従って正しくお取り扱いください。



## 第二種VCCI基準について

第二種VCCIの表示  があるワークステーションおよびオプション製品は、第二種情報装置です。これらの製品には、下記の項目が該当します。

この装置は、第二種情報装置(住宅地域または住宅地域に隣接した地域において使用されるべき情報装置)で住宅地域での電波障害防止を目的とした情報処理装置等電波障害自主規制協議会(VCCI)基準に適合しております。しかし、本製品を、ラジオ、テレビジョン受信機に近接してご使用になりますと、受信障害の原因となることがあります。

取り扱い説明書に従って正しくお取り扱いください。

## BSMI Class A Notice

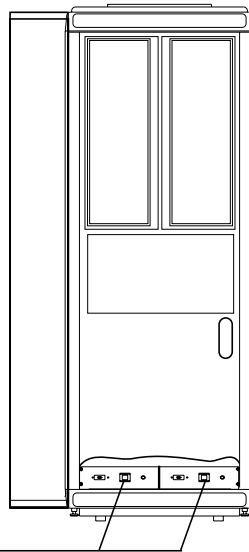
The following statement is applicable to products shipped to Taiwan and marked as Class A on the product compliance label.

警告使用者：  
這是甲類的資訊產品，在居住的環境中使用時，可能會造成射頻干擾，在這種情況下，使用者會被要求採取某些適當的對策。



**WARNING: AVERTISSEMENT: ACHTUNG:**

- No AC disconnect switch in equipment. A disconnect device must be provided on the wall.
  - L'appareil ne comporte pas d'interrupteur c.a. Un interrupteur doit être installé au mur.
  - Kein ausschaltbarer Ws-Schalter am Gerät. Ein solcher Schalter muß in der Installation angebracht werden.
- Versorgungsspannung:
- Kein Netzschalter am Gerät, CB in der Installation öffnet bei Gefahr.
  - An die Anschlußleitung muß ein JEC Stecker Tye B angeschlossen werden.



- Shown are the main disconnect switches for this equipment. All other switches with "IO" markings power down individual components.
- L'interrupteur principal de cet appareil est illustré. Les autres interrupteurs marqués "IO" coupent l'alimentation aux composants individuels.
- Dargestellt ist der Hauptschalter dieses Geräts. Alle anderen mit "IO" versehenen Schalter schalten die einzelnen Komponenten aus.



# Contents

---

**Preface xxxiii**

How This Book Is Organized xxxiii

Graphical User Interface Terms xxxv

Typographic Conventions xxxvi

Shell Prompts xxxvii

Related Documentation xxxvii

Sun Documentation on the Web xxxvii

Sun Welcomes Your Comments xxxviii

**1. Safety Information and Installation Overview 1-1**

1.1 Safety Procedures and Practices 1-2

1.2 Electrostatic Discharge Protection 1-4

1.3 Electromagnetic Interference 1-5

1.4 Installation Overview 1-5

1.5 Preparing for the Installation 1-7

1.5.1 Tools and Test Equipment Needed 1-8

1.5.2 Inventorying the Equipment 1-9

1.5.3 Preparing the Site 1-9

- 2. Unpacking the A7000 and PCU 2-1**
  - 2.1 Unpacking and Positioning the Equipment 2-2
    - 2.1.1 Positioning the A7000 Before Unpacking 2-2
    - 2.1.2 Unpacking and Positioning the A7000 2-3
    - 2.1.3 Removing the Packing Material - Front 2-8
    - 2.1.4 Removing the HDSA Shipping Brackets 2-10
    - 2.1.5 Removing the Packing Material - Rear 2-12
    - 2.1.6 Unpacking and Positioning the PCU 2-13
  - 2.2 Inspecting the Equipment 2-13
    - 2.2.1 Inspecting for Physical Damage 2-14
    - 2.2.2 Inspecting Power Switches 2-14
    - 2.2.3 Inspecting Switches and Connectors in I/O Bay 2-14
    - 2.2.4 Inspecting Components in Rear of Cabinet 2-16
    - 2.2.5 Reporting Damaged or Missing Equipment 2-17
  - 2.3 Connecting the Internal ESCON Cables 2-17
- 3. Installing the StorEdge A7000 and PCU 3-1**
  - 3.1 Performing the Electrical Installation 3-2
    - 3.1.1 Connecting the HDSA Expansion Cabinet (Optional) 3-3
    - 3.1.2 Performing Safety Checks 3-4
    - 3.1.3 Power Plugs, Cables, and Hardwiring 3-4
    - 3.1.4 Connecting the PCU to the Bypass Switch 3-4
    - 3.1.5 Grounding the A7000 and PCU 3-8
  - 3.2 Connecting the Data Cables 3-14
- 4. Installing the Disk Drives and System Console 4-1**
  - 4.1 Leveling the Cabinet Before Disk Installation 4-2
  - 4.2 Unpacking and Installing Disk Drives 4-4
    - 4.2.1 How the Disk Drives Are Labeled 4-5
    - 4.2.2 To Open the HDSA Drawer Manually (Without Power) 4-6
    - 4.2.3 Unpacking the Disk Drives 4-7

- 4.2.4 Installing the Disk Drives 4-8
- 4.3 Leveling the Cabinet After Disk Installation 4-14
- 4.4 Installing the System Console 4-14
  - 4.4.1 Unpacking and Installing the System Console 4-14
  - 4.4.2 Completing an International System Console Installation 4-15
- 5. Powering On 5-1**
  - 5.1 Powering on the PCU 5-2
  - 5.2 Checking and Programming the PCU Input and Output Voltage 5-4
    - 5.2.1 Testing PCU Output Voltage 5-4
    - 5.2.2 Checking (and Calibrating, if necessary) Nominal Output Voltage: Parameter 05 5-5
    - 5.2.3 Checking (and Calibrating, if necessary) PCU Input Voltmeter: Parameter 27 5-6
    - 5.2.4 Checking (and Calibrating, if necessary) PCU Output Voltmeter: Parameter 28 5-7
  - 5.3 Setting the PCU Date and Time 5-8
    - 5.3.1 Setting the User Password 5-8
    - 5.3.2 Checking PCU Firmware Revision Level (Parameter 128) 5-9
    - 5.3.3 Setting the Current Time, Date, and Year, Firmware Revision Level 1.06 or Above (Parameters 89, 90, 91) 5-9
    - 5.3.4 Setting the Current Time and Date, Firmware Revision Level 1.05 or Below (Parameters 89, 90, 91) 5-10
  - 5.4 Powering on the Cabinet and Checking Switches 5-12
    - 5.4.1 Powering on the Cabinet 5-12
    - 5.4.2 Checking the AC Relay Switch 5-12
    - 5.4.3 Checking Other Switches: 5-13
  - 5.5 Adjusting the HDSA Drawer 5-17
  - 5.6 Completing the Power On Procedure 5-19
    - 5.6.1 Powering on the System Console 5-19
    - 5.6.2 Opening Windows Into the A7000 Subsystems 5-20
    - 5.6.3 Powering on the Subsystems and Check DC Voltage 5-21

- 5.6.4 Saving the ROM Monitor NVRAM Data 5-23
- 5.6.5 Powering on the HDSA Power Supplies 5-23

## **6. Completing the Installation 6-1**

- 6.1 Connecting the Internal Power Conditioning Unit (PCU) Data Cables 6-2
- 6.2 Installing Channel Interface Cables 6-4
  - 6.2.1 Installing the Block Multiplexer Channel (BMC) Cables 6-5
  - 6.2.2 Installing the ESCON Cables 6-8
  - 6.2.3 Installing the SCSI Target Cables 6-9
- 6.3 Analyzing the Acceptance Test Procedure (ATP) Results and Error Report (errpt) 6-9
- 6.4 Configuring the A7000 to Phone Home 6-12
  - 6.4.1 Following RSS Naming Conventions 6-13
  - 6.4.2 Entering Customer Information into MCD 6-14
  - 6.4.3 Configuring RSS and Entering Service Support Telephone Number 6-17
  - 6.4.4 Checking File Information 6-19
  - 6.4.5 Disabling or Enabling the RSS Paging Feature 6-20
- 6.5 Configuring Modem Files (International Installation Only) 6-21
- 6.6 Testing the Phone-Home Feature 6-22
  - 6.6.1 Testing the Remote Support System Phone-Home Feature 6-22
  - 6.6.2 Creating a Link if the Phone-Home Test Fails 6-25
- 6.7 Entering the Date, Time, and Timezone 6-25
  - 6.7.1 Setting Up a Subsystem 6-25
  - 6.7.2 Setting Up the System Console 6-27
- 6.8 Starting the PCU Software 6-28
  - 6.8.1 Editing the PCU Configuration Files 6-28
  - 6.8.2 Enabling the PCU Start and Stop Daemons 6-30
  - 6.8.3 Completing the PCU Software Setup 6-30
  - 6.8.4 Performing a Manual Start or Stop 6-31



- 6.9 Checking the PCU Battery 6-32
  - 6.10 Setting the A7000 Password 6-33
  - 6.11 Configuring the Operating System Software for Remote Dual Copy 6-33
  - 6.12 Checking the Master Configuration Data (MCD) 6-37
  - 6.13 Backing Up Important System Files 6-38
- A. Setting Up the PCU Dirty Power A-1**
    - A.1 Setting the Service Password A-1
    - A.2 Setting Dirty Power Parameter Values (Parameters 09, 78, 85, 86, 87) A-2
- B. Installing the HDSA Expansion Cabinet B-1**
    - B.1 Required Tools List B-4
    - B.2 Before You Begin... B-4
    - B.3 Power Off the StorEdge A7000 B-5
      - B.3.1 Open the System Console Carrier Tray and Cover B-5
      - B.3.2 Stop the DataShare Facilities (Optional) B-6
      - B.3.3 Stop the SCSI Target Emulation Software (Optional) B-6
      - B.3.4 Stop the Simulation Software (Optional) B-6
      - B.3.5 Shut Down All Subsystems B-6
      - B.3.6 Abort the System Reboot (Optional) B-8
      - B.3.7 Shut Down the System Console B-9
      - B.3.8 Power Off the System Console B-9
      - B.3.9 Open the Front Cabinet Door B-10
      - B.3.10 Power Off the Subsystems B-10
      - B.3.11 Check Other Switches B-10
      - B.3.12 Power Off the HDSA Supplies B-10
      - B.3.13 Power Off the Cabinet Power Supply B-11
      - B.3.14 Power Off the PCU B-11
    - B.4 Preparing the Cabinets B-12
    - B.5 Feed Cables Into the System Cabinet B-16
    - B.6 Install or Connect the SCSI Expander Cards and Cables B-16

B.6.1	Connect the SCSI Expander Cables	B-19
B.7	Install the SCSI Controller Cards	B-22
B.8	Connect the SCSI Controller Cables	B-22
B.9	Physically Connecting the Cabinets	B-24
B.10	Connect the HDSA Drawer Interlock Cables	B-28
B.11	Completing the Installation	B-30
B.12	Updating the Master Configuration Database	B-30

**Glossary** GL-1

**Index** 1

# Figures

---

- FIGURE 1-1 Steps to Install the StorEdge A7000 1-6
- FIGURE 2-1 StorEdge A7000 Cabinet Front Door Lock and Tray Latches 2-9
- FIGURE 2-2 Removing the Foam Shipping Brace 2-10
- FIGURE 2-3 HDSA Shipping Brackets 2-11
- FIGURE 2-4 Removing the Foam HDSA Shipping Material 2-12
- FIGURE 2-5 StorEdge A7000 Power Switches 2-15
- FIGURE 2-6 Inside Rear of A7000 2-16
- FIGURE 2-7 ESCON Controller and Cable 2-19
- FIGURE 3-1 Typical Electrical Installation 3-3
- FIGURE 3-2 PCU Keyswitch and Circuit Breaker Switch 3-5
- FIGURE 3-3 AC Input to PCU and AC Output from PCU for Domestic (NAFO) Installations 3-7
- FIGURE 3-4 AC Input to PCU and AC Output from PCU for Many International Installations 3-8
- FIGURE 3-5 PCU and StorEdge A7000 Common Ground Point Connection 3-12
- FIGURE 3-6 Ground Cables Connected to A7000's Ground Point 3-13
- FIGURE 3-7 Ground Cables Connected to Ground Clamp 3-14
- FIGURE 3-8 StorEdge A7000 Circuit Breaker Location 3-15
- FIGURE 4-1 Leveling the Cabinet 4-3
- FIGURE 4-2 Disk Drive Slot Layout and Labeling 4-5
- FIGURE 4-3 HDSA Drawer Retractor Pin 4-7

FIGURE 4-4	9-Gbyte Disk Drive	4-9
FIGURE 4-5	18-Gbyte Disk Drive	4-10
FIGURE 4-6	18-Gbyte Disk Drive Chassis	4-11
FIGURE 4-7	HDSA Disk Drive Slot Location Reference Labels, Single Drawer (Example)	4-13
FIGURE 4-8	System Console Tray Location	4-16
FIGURE 4-9	System Console Connection Block Diagram (Domestic Installation)	4-17
FIGURE 4-10	System Console Connection Block Diagram (International Installation)	4-18
FIGURE 4-11	System Console Installation	4-19
FIGURE 4-12	Modem Connector Assembly in I/O Bay Cabinet	4-20
FIGURE 4-13	Serial Communications Subsystem	4-21
FIGURE 4-14	System Console/Serial Communications System Cable Connections	4-22
FIGURE 5-1	PCU Keyswitch and Circuit Breaker Switch	5-3
FIGURE 5-2	50A Maringo CS8269 Power Output Receptacle	5-4
FIGURE 5-3	PCU Front Panel Used to Program PCU Output Voltage	5-6
FIGURE 5-4	HDSA Drawer Open/Close and Power Switches Inside Cabinet Front	5-14
FIGURE 5-5	LAD/SCSI Expander Power Switch Location	5-15
FIGURE 5-6	AC Box Power Switches	5-16
FIGURE 5-7	HDSA Drawer Channel Guide Adjustment Diagram	5-18
FIGURE 5-8	Serial Communications Subsystem Power Supply LEDs	5-19
FIGURE 5-9	Subsystem Power Supply and HDSA On/Off Switches	5-24
FIGURE 6-1	Inside Rear of A7000	6-2
FIGURE 6-2	Processor Card Adaptor Board Front Panel	6-3
FIGURE 6-3	PCU Data Cable, StorEdge A7000 Internal Connection	6-4
FIGURE 6-4	Quad-Channel BMC Interface Panel	6-5
FIGURE 6-5	I/O Bay Cabinet, BMC Interface Panels, ESCON Interface Panels	6-7
FIGURE 6-6	ESCON Interface Panel	6-8
FIGURE 6-7	Disk Select LEDs, HDSA Drawer	6-10
FIGURE 6-8	MCD Choose Class menu	6-15

FIGURE 6-9	MCD System window	6-16
FIGURE 6-10	Connectors Inside I/O Bay Cabinet	6-24
FIGURE 6-11	System Console Application Menu Bar	6-28
FIGURE 6-12	PCU Front Panel	6-32
FIGURE B-1	StorEdge A7000 With Expansion Cabinet	B-2
FIGURE B-2	Expansion Cabinet Installation Flowchart	B-3
FIGURE 6-13	Shutdown Pulldown Menu and Window	B-7
FIGURE B-3	LAD/SCSI Expander Power Switch Location	B-11
FIGURE B-4	Cabinet Orientation	B-12
FIGURE B-5	Side Skin Panel Removal	B-13
FIGURE B-6	RFI Connector Frame Bolts	B-14
FIGURE B-7	System Cabinet Front, Bolt Access Plate and Screws	B-15
FIGURE B-8	Dual SCSI Expander Chassis	B-17
FIGURE B-9	SCSI Expander Card Connectors and Jumpers, Both Card Types	B-18
FIGURE B-10	SCSI Expander and Controller Cards Connection and Labeling Example	B-19
FIGURE B-11	SCSI Controller Port Labeling	B-23
FIGURE B-12	Pushing Cabinets Together	B-24
FIGURE B-13	HDSA Drawer Retractor Pin	B-26
FIGURE B-14	Attachment Bolt and Washer Locations	B-27
FIGURE B-15	Drawer Motor Connectors	B-28
FIGURE B-16	Drawer Interlock Connection Diagram	B-29



# Tables

---

TABLE P-1	Graphical User Interface Terms	xxxv
TABLE P-2	Typographic Conventions	xxxvi
TABLE P-3	Shell Prompts	xxxvii
TABLE P-4	Related Documentation	xxxvii
TABLE 3-1	Input Voltage Needed for PCU	3-6
TABLE 5-1	Temperatures and Voltages at Installation	5-22
TABLE 6-1	PCU Data Cable, Internal Connections	6-4
TABLE 6-2	Worldwide Support Center Telephone Numbers	6-19
TABLE 6-3	PCU Configuration	6-29
TABLE A-1	PCU Dirty Power Parameters	A-3
TABLE B-1	SCSI Expander Card Labeling	B-20
TABLE B-2	System and HDSA Expansion Cabinet Disk Labeling	B-21





# Preface

---

This installation guide is intended for Sun Microsystems, Inc. personnel and other trained Field Engineers (FEs) responsible for installing Sun StorEdge™ A7000 hardware.

---

## How This Book Is Organized

This guide shows and describes installation procedures in a checklist or “cookbook” format, listing the steps for each installation task. Use it with the Acceptance Test Procedure (ATP) that is included with each storage server.

When you finish each installation task, sign and date the guide in the box at the end of each task’s section.

Read and become completely familiar with this guide before installing the A7000 system.

**Chapter 1** contains information on safety, provides an overview of the installation process, and describes getting started.

**Chapter 2** describes how to unpack the A7000 and power conditioning unit (PCU), position the equipment in the computer room, install leveler feet, connect internal Enterprise System Connection (ESCON) cables, and inspect the system.

**Chapter 3** describes how to perform the electrical installation and connect the data cables of the A7000 and PCU.

**Chapter 4** describes how to install the disk drives in the High-Density Storage Array (HDSA) drawer and how to install the System Console.

**Chapter 5** describes how to power on the PCU, A7000 cabinet, subsystems, System Console, and HDSA drawer; it also describes how to check the PCU voltage and subsystem power supplies.

**Chapter 6** describes final installation procedures: connecting cables, testing features, setting the system password, and others.

**Appendix A** describes the other options available for PCUs used with A7000 systems.

**Appendix B** describes HDSA installation procedures; notes in Chapters 1 through 6 refer you to this appendix if necessary.

**Appendix C** describes how to install a bypass switch.

---

# Graphical User Interface Terms

**TABLE P-1** Graphical User Interface Terms

<b>Verb</b>	<b>Action</b>	<b>Example</b>
Choose	To open a menu or initiate a command.	Choose New from the File menu.
Click	To press and release a mouse button without moving the pointer.	Click the left mouse button.
Double-click	To click a mouse button twice quickly without moving the pointer.	Double-click on the File Manager icon to re-open the program.
Drag	To move the pointer or an object by sliding the mouse with one or more buttons pressed.	Drag the Applications Menu Bar to the left corner of the screen.
Point	To move the mouse pointer to a specific location on the screen with no mouse buttons pressed.	Point to the Trash icon and click to select it.
Press	To push a mouse button down and continue to hold it.	Press the left mouse button on the OK button.
Release	To let up on a mouse button to initiate an action.	Release the left mouse button when the Print button is highlighted.
Select	To highlight an entire window or data in a window.	Select the Applications Menu bar. Select the dsp1 window.

# Typographic Conventions

TABLE P-2 Typographic Conventions

Typeface or Symbol	Meaning	Examples
AaBbCc123	The names of commands, files, and directories; on-screen computer output.	Edit your <code>.login</code> file. Use <code>ls -a</code> to list all files. % You have mail.
<b>AaBbCc123</b>	What you type, when contrasted with on-screen computer output.	% <b>su</b> Password:
<i>AaBbCc123</i>	Book titles, new words or terms, words to be emphasized. Command-line variable; replace with a real name or value.	Read Chapter 6 in the <i>User's Guide</i> . These are called <i>class</i> options. You <i>must</i> be <code>root</code> to do this. To delete a file, type <code>rm filename</code> .
<b>Keyname-Keyname</b>	A hyphen between the names of keys or mouse buttons indicates simultaneous use of two keys or a key and a mouse button.	<b>Ctrl-W</b>
Underlined letter in menu title or item	An underlined letter in a menu title is a menu shortcut (mnemonic). This means that simultaneously pressing the Alt key and the key for that letter makes that menu appear.	<u>F</u> ile means to press the Alt and F keys at the same time to show the File menu
Menu item→Menu item	An arrow between the names of menu items indicates a cascading menu.	Utilities→service
.	In examples, a vertical ellipsis indicates that information was omitted.	Testing Backplane Cards . . . Term set to: vt100 <CR>= default>

---

# Shell Prompts

TABLE P-3 Shell Prompts

Shell	Prompt
C shell	<i>machine_name%</i>
C shell superuser	<i>machine_name#</i>
Bourne shell and Korn shell	\$
Bourne shell and Korn shell superuser	#

---

# Related Documentation

TABLE P-4 Related Documentation

Application	Title	Part Number
Service	<i>StorEdge A7000 Service Manual</i>	805-6489
Planning	<i>StorEdge A7000 Physical Planning Manual</i>	805-4878
Users	<i>CommandCenter Master Configuration Data (MCD) User's Guide</i>	805-4886
Installation	<i>Best Power Technology UNITY/I Installation Manual (shipped with PCU)</i>	N/A

---

# Sun Documentation on the Web

The `docs.sun.com` web site enables you to access Sun technical documentation on the Web. You can browse the `docs.sun.com` archive or search for a specific book title or subject at:

`http://docs.sun.com`

---

# Sun Welcomes Your Comments

We are interested in improving our documentation and welcome your comments and suggestions. You can email your comments to us at:

`docfeedback@sun.com`

Please include the part number of your document in the subject line of your email.

# Safety Information and Installation Overview

---

This chapter introduces you to the StorEdge A7000 installation process. Topics include:

- Safety Procedures and Practices—page 1-2
- Electrostatic Discharge Protection—page 1-4
- Electromagnetic Interference—page 1-5
- Installation Overview—page 1-5
- Preparing for the Installation—page 1-7

---

## 1.1

# Safety Procedures and Practices



---

**Caution** – Do not move or attempt to move the StorEdge A7000 cabinet with the HDSA drawer extended or open in any way. The cabinet could become unbalanced and topple if you try to move it incorrectly. Make sure the cabinet is properly level at all times. Chapter 4 and Chapter 5 describe how to level the cabinet. Do not remove or retract the main cabinet leveler feet if the HDSA drawer contains disk drives.

---

---

**Note** – All physical requirements, electrical requirement, environmental requirements, and other requirements for installing the StorEdge A7000 must be defined and satisfied as described in *StorEdge A7000 Physical Planning Manual* before the A7000 is installed.

---

To ensure your personal safety and that of your co-workers, follow these safety precautions at all times:

- Before turning any power on or off, check that no one is working on or around the equipment. Be sure to look for any tags indicating work-in-progress on the equipment. Verify that the AC feature of your digital voltmeter (DVM) is functional.
- Ensure that the equipment is properly powered off before turning off the power (circuit breakers or switch). Always use a reliable voltmeter to verify that power is actually off after using power-off switches. Most power supplies have bleeder resistors to drain the capacitor charge when power is removed. As a precaution, use a meter to check all capacitors before you attempt maintenance. A defective bleeder resistor could create an unexpected hazard. If the equipment has a battery backup feature installed, the output from the battery backup must also be de-energized or disconnected (refer to the battery backup equipment maintenance manual).
- Turn off the energy-isolating device or power disconnect that controls the equipment on which you will be working. (This may be at the customer power distribution panel, the system main power disconnects, or the frame level disconnects. If power needs to be turned off at the customer panel, have the customer turn off the appropriate switch or circuit breaker.) Do not rely on logic controls to power off equipment.
- Perform only necessary tasks on equipment. Double check your work for any errors.
- Replace all protective covers or other safeguards that were removed.
- Again, check to see that no one is working on or around equipment, and ensure that all tools and foreign objects are removed from the immediate work area.



- Do not work alone when working on systems supplied with AC or DC power greater than 50 volts. Use the buddy system. The buddy can be a customer, employee, or other vendor employee.
- Observe customer safety regulations at all times.
- To prevent injury to your back, use your leg muscles to lift equipment. Always get someone to help you with loads that are difficult for you to lift safely.
- Verify that all appropriate AC and DC power is off before you:
  - Remove or assemble major components.
  - Work on or near power supplies.
  - Perform mechanical inspections.
  - Install electrical or mechanical devices.
- When you must work on equipment with the power on, take these precautions:
  - Arrange for another person familiar with the power-off controls to be in the immediate vicinity.
  - Remove all rings, wrist watches, chains, necklaces, and bracelets.
  - Use only insulated tools.
  - Keep one hand in your pocket.
  - Avoid contacting ground potential, such as metal floor strips or machine frames.
- Avoid wearing loose garments. High-speed, electromechanical devices (such as fans and drive belts) can seize articles of clothing.
- During maintenance, practice good housekeeping to reduce safety hazards in your work area. When you are finished, put tools, parts, and work materials in a safe, secure place. Also, clean up debris and return the work area to its original condition.
- Put all safety devices such as guards, shields, and ground wires back in place when you finish.
- Use grounding straps to protect components from electrostatic discharge.
- Check and replace worn or broken tools on a continuing basis.
- Wear eye protection when:
  - Soldering or cutting wire.
  - Using solvents, sprays, or cleaners to clean parts.
  - Using power tools.

---

## 1.2 Electrostatic Discharge Protection

Moving paper, plastic, rubber, or a leather shoe against itself, on a carpet, or vinyl flooring, generates large amounts of static electricity that discharge through you to whatever you touch. This electricity is called Electrostatic Discharge (ESD).

If you are holding or wearing any of these materials and then touch any equipment sensitive to static electricity, that equipment can be damaged. You must bring static-sensitive equipment to the same ground potential as the machine you are installing, deinstalling, or working on — which means grounding all static electricity that is present by following these general rules:

- Do not touch, or allow a static-sensitive component to touch any item that is not properly grounded.
- Never set a component on a surface that is not grounded.
- Use antistatic ground mats to temporarily hold components that are being removed or reattached.
- Always wear a properly grounded wrist strap when handling static-sensitive components. Once you are wearing a grounded wrist strap, you may touch any static-sensitive device or component without causing damage.
- Always ship static-sensitive devices and components in approved containers. Use the packaging and shipping container from a replacement component to carry and/or return the component. Packaging material and shipping containers used alone do not completely shield static-sensitive devices from damage. Repeated tests have shown that, although containers prevent static charge buildup on their contents, they do not shield their contents from damage caused by external static discharge.

Observe these guidelines when packaging and shipping Printed Circuit Boards (PCBs):

- Always use a grounded wrist strap when handling PCBs.
- When packaging individual PCBs for local or short distance shipments, put the PCBs into conductive grid bags first, and then put them into protective bags.
- When packaging individual PCBs for customer or long distance shipments, put the PCBs into conductive grid bags first, then into protective bags, and then place them into a padded shipping container.

---

## 1.3 Electromagnetic Interference

Electromagnetic interference (EMI) is radiated electrical energy that causes interference in digital or analog equipment. EMI is also known as Radio Frequency Interference (RFI).

EMI/RFI is present in varying strengths around AC-driven electric motors, electrostatic copiers, and X-ray machines. Hand-held electric power tools, air dehumidifiers, refrigerators, and air-conditioning units are other sources of EMI/RFI.

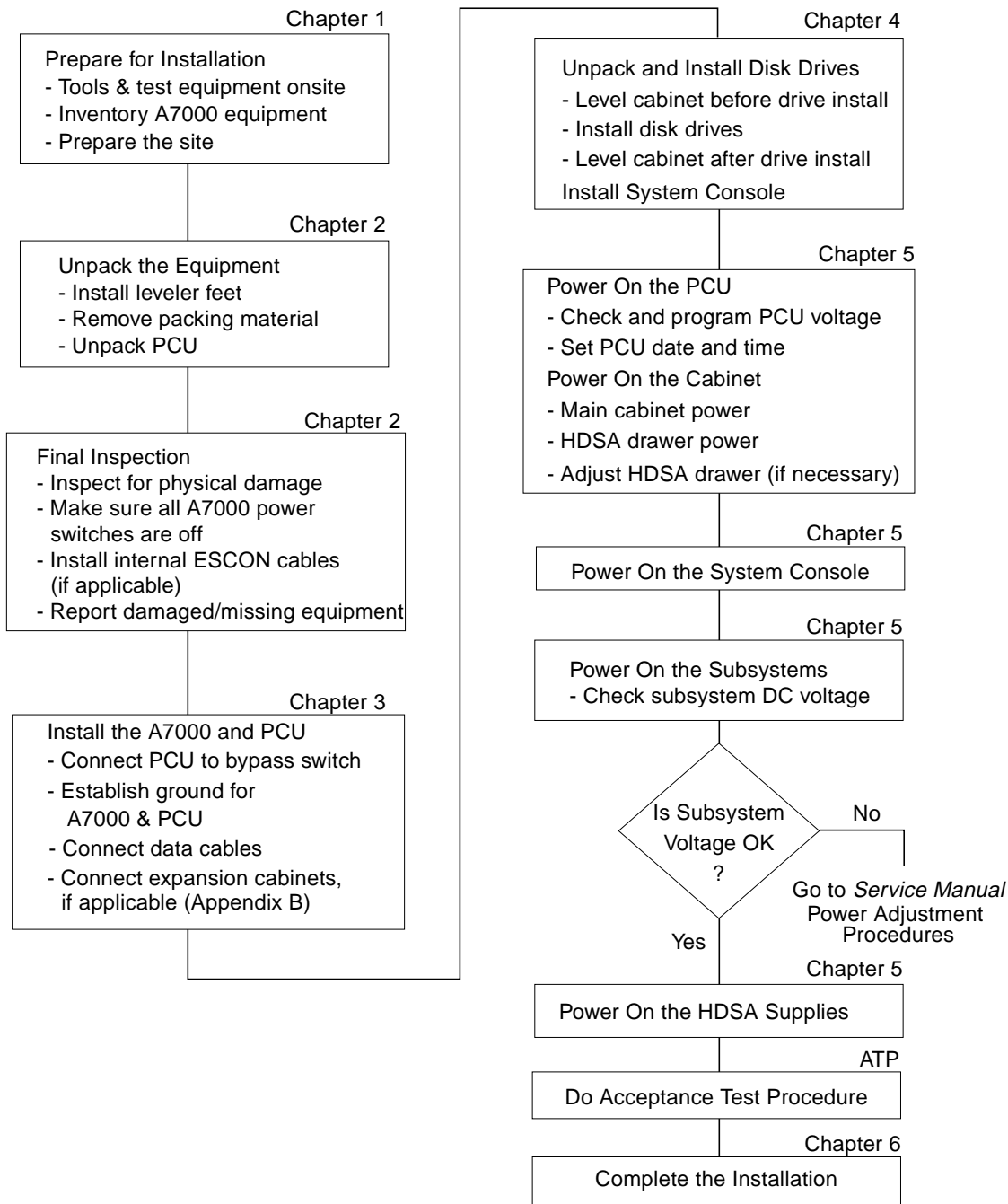
Make sure the test system is properly grounded and has all its shields in place. Pay special attention to the finger stock on all doors, interframe connections, and panels. Make sure they are all correctly in place and are connected to the system ground.

Static, or noise generated by this equipment, travels along AC power cords to the junction box that is the source of its power. Do not connect any EMI/RFI-sensitive subsystems to power sources that are shared with EMI/RFI generating devices. Use isolated or single-line power sources when performing diagnostic testing before deinstallation.

---

## 1.4 Installation Overview

The flowchart in FIGURE 1-1 shows the steps you have to complete to install the StorEdge A7000.



**FIGURE 1-1** Steps to Install the StorEdge A7000

---

## 1.5 Preparing for the Installation

This section describes the following steps which you must perform before installing the A7000:

1. Ensure that you have all the necessary special installation tools and test equipment.
2. Inventory the items on the shipper list. All items must be available before you begin the installation
3. Prepare the site.

These additional steps are discussed in Chapter 2:

4. Unload and unpack the equipment.
5. Check the A7000 for damage and missing components.

## 1.5.1 Tools and Test Equipment Needed

You need the following tools to unpack and install the A7000:

- Wheel chocks to prevent the cabinet from moving during installation
- English-unit socket wrench set with sockets up to and including 3/4 inch
- English-unit open end wrench set with wrenches up to and including 3/4 inch or an adjustable wrench that can be adjusted up to 2 cm.
- Side cutters
- Phillips screwdriver
- Common-point/flat-blade screwdriver
- Utility knife
- Two pairs of utility or slip-joint pliers
- Carpenter's level or an equivalent one-foot-long leveling tool
- Stepladder (for HDSA adjustment only)
- Digital voltmeter
- Jumpers
- Block mux controller (BMC) loopback Bus connector and loopback Tag connector. These parts may be obtained through the following vendor:

Mold-Tech Inc.  
20 Elberta Road  
Painesville, Ohio 44077

Phone Number: (440) 357-1161  
Fax Number: (440) 357-1248

The vendor part numbers are MT95070038 for the BMC loopback Tag connector and MT95070039 for the BMC loopback Bus connector.

- Can of lubricant spray, such as WD-40
- Ammonia-based window cleaner
- Paper towels
- Claw hammer (optional)
- Portable Maintenance Box

If you plan to connect an HDSA expansion cabinet, see Appendix B for the tools required for that task.

## 1.5.2 Inventorying the Equipment

After you receive the A7000, use the accompanying shipping documentation to:

1. **Check the shipment manifest and bill of materials for the correct number of items received.**
2. **Check the System ID Number on the packing slips against the serial numbers on the shipping boxes.**
3. **Check for evidence of fire, water, or impact damage to the A7000. Write a description of all damage on the shipment manifest.**
4. **Indicate the delivery date here: \_\_\_\_\_.**
5. **Repeat steps 1 to 4 for each crate, package, and box in the shipment.**
6. **Place the packing slip and manifest into the ATP binder sleeve.**

## 1.5.3 Preparing the Site

If your computer room has a raised floor with removable tiles, perform the following before unpacking:

1. **Set the cable entry floor tile(s) in their respective location(s).**
2. **Make sure that the BMC, ESCON, and/or SCSI target cables (cables that link the A7000 to the mainframe computer system or other host), AC input power cable, and telephone line are positioned where the A7000 will be installed.**
3. **Make sure an electrician is available for the installation of the 8KVA power conditioning unit (PCU) and bypass switch (see Appendix C).**
4. **Make sure all AC power inputs are connected to the same AC phase in all the A7000 and expansion cabinet installation configurations.**
5. **Make sure that a customer common ground point has been established for grounding the A7000 and PCU(s). The grounding cables provided with the A7000 are 1.83 meters (6 feet) long. If the customer common ground point is further than 1.83 meters (6 feet) from the A7000 and PCU(s), obtain longer cables.**





## Unpacking the A7000 and PCU

---



---

**Caution** – *Do not move or attempt to move the Storedge A7000 cabinet with the HDSA drawer extended or open in any way. The cabinet could become unbalanced and topple if you try to move it incorrectly. Make sure the cabinet is properly level at all times. Chapter 4 describes how to level the cabinet. Do not remove or retract the system cabinet leveler feet if the HDSA drawer contains disk drive modules.*

---

This chapter describes how to unpack the A7000 and the power conditioning unit (PCU). Topics include:

- Unpacking and Positioning the Equipment—page 2-2
  - Positioning the A7000 Before Unpacking—page 2-2
  - Unpacking and Positioning the A7000—page 2-2
  - Removing the Packing Material - Front—page 2-8
  - Removing the HDSA Shipping Brackets—page 2-10
  - Removing the Packing Material - Rear—page 2-12
  - Unpacking and Positioning the PCU—page 2-13
- Inspecting the Equipment—page 2-13
  - Inspecting for Physical Damage—page 2-14
  - Inspecting Power Switches—page 2-14
  - Inspecting Switches and Connectors in I/O Bay—page 2-14
  - Inspecting Components in Rear of Cabinet—page 2-16
  - Reporting Damaged or Missing Equipment—page 2-17
- Connecting the Internal ESCON Cables—page 2-17

---

## 2.1 Unpacking and Positioning the Equipment



---

**Caution** – Top-heavy equipment (with a high center of gravity) can tip over easily. Two people are needed to move the equipment.

---

---

**Note** – *Unpack equipment within 15 days of its arrival.* This step is important since the full extent of any shipping damage may not be determined until final inspection.

---

Ground shipments are transported with the A7000 cabinet wrapped in corrugated board, packing foam, and a protective bag. You may need moving equipment such as a forklift truck for the pallet, boxes, and crates. The moving equipment is usually provided by the mover.

### 2.1.1 Positioning the A7000 Before Unpacking

Before starting to unpack the A7000, make sure you:

- Orient the A7000 properly in the unpacking area. The front of the A7000 is located on the side of the packing box to which the shipping label is affixed. However, the A7000 will roll off the shipping pallet right-side first (that is, I/O Bay first), not front first.
- Have enough room around the pallet to work. In its shipping package, the A7000 is 1.3 m (51 in.) wide, 2.21 m (87 in.) high, and 1.2 m (47 in.) deep.)
- Have enough room in front of the pallet to position the ramp and roll the A7000 off the pallet. The ramps, which are stowed on the pallet under the A7000, are approximately 1.2 m (47 in.) long.
- Place the pallet on a flat, level surface.

For more information about the space requirements for an A7000 installation and about the physical configuration of the A7000, refer to the *Sun Storage A7000 Physical Planning Manual*.

---

**Note** – The System Console and disk drives are packed separately from the system cabinet. Their unpacking procedures are described as part of their installation.

*Also, place the boxes containing the disk drives in the room where the A7000 is to be installed. This lets the drives adjust to the computer room climate.*

---

## 2.1.2 Unpacking and Positioning the A7000

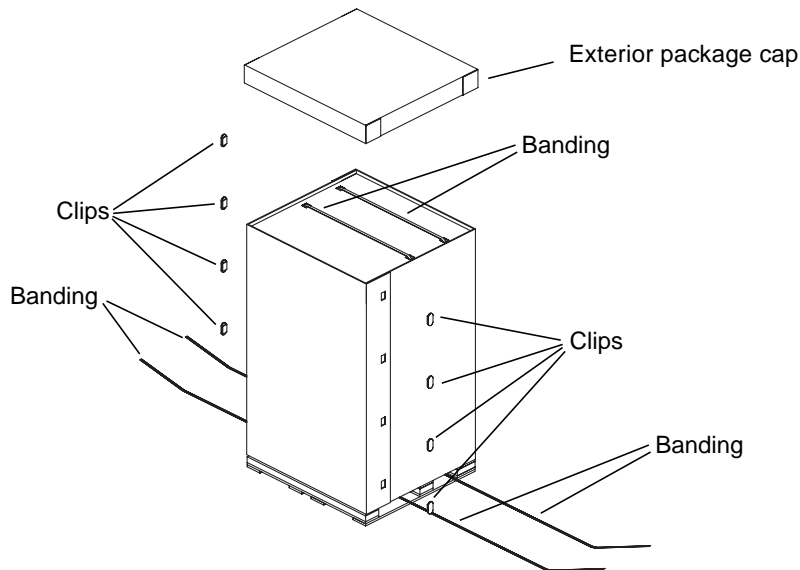


---

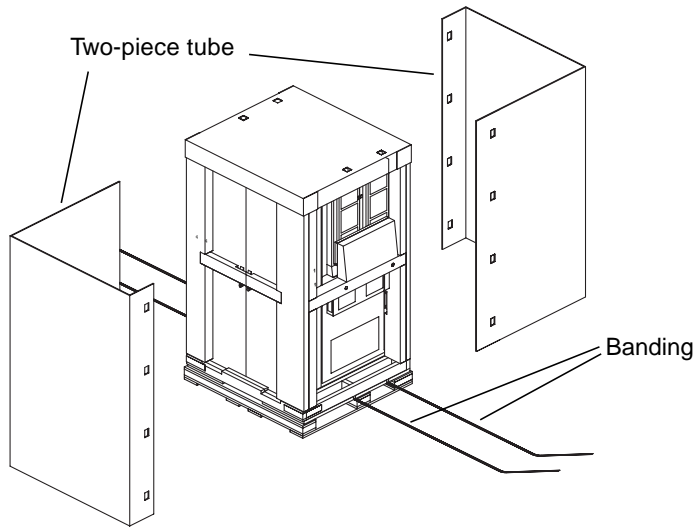
**Caution** – Be careful when removing the bands in the following steps. The bands can spring uncontrollably after being cut, causing personal injury. Using the method in Step 1 will keep both ends of the band under control.

---

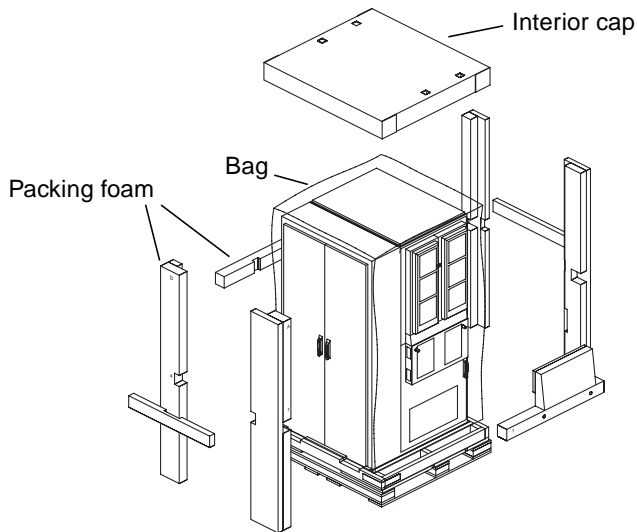
1. **Remove exterior package cap, clips, and banding. To break the banding:**
  - a. **Hold one pair of pliers in each hand and clamp onto one of the bands.**
  - b. **Position the pliers so that the sides of the jaws are against each other.**
  - c. **Twist the pliers in opposite directions to break the band.**



**2. Remove the two-piece tube and its banding.**



**3. Remove the interior cap, packing foam, and bag around the A7000.**



4. **Inspect the outside panels for damage and verify the system ID on the label on the back of the cabinet.**

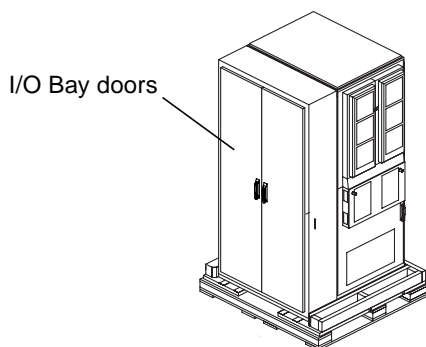


---

**Caution** – The bottom opening to the StorEdge A7000's I/O Bay does not provide enough clearance for the AC power cords' plugs to pass through after the A7000 has been taken off the pallet. Unless floor tiles can be removed to pass these plugs through after the A7000 is in place in the computer room, they must be passed through the bottom of the I/O Bay before the A7000 is moved off the pallet. *Failure to do so may result in damage to the A7000 or injury to installation personnel.*

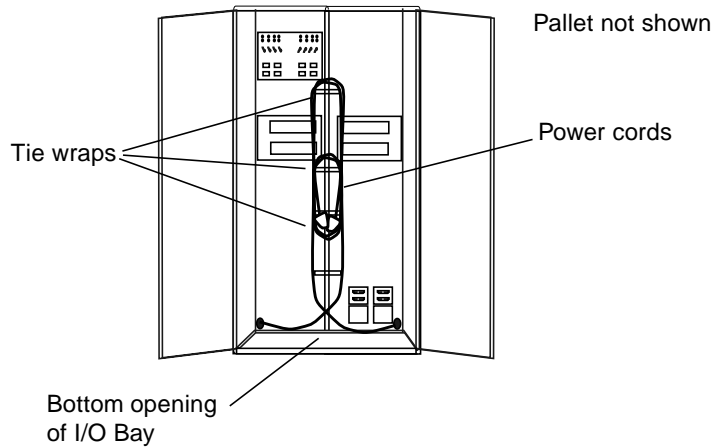
---

5. **Before attempting to move the A7000 off the pallet, bring the AC power cords through the bottom opening of the I/O Bay.**
  - a. **Open I/O Bay doors.**



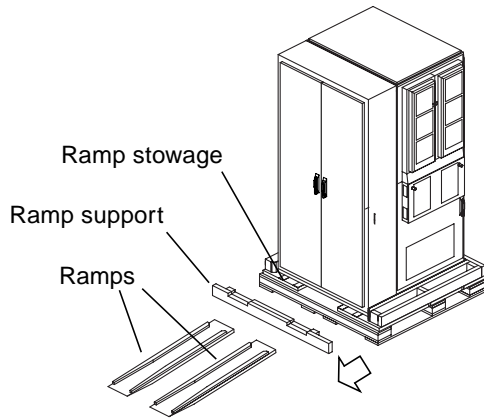
- b. **A plastic bag containing black plastic leveler feet is secured one of the AC power cords inside the I/O Bay. Remove this plastic bag and set in aside. The leveler feet will be installed later, in Step 10 of this unpacking procedure.**

- c. The AC power cords are secured to the interior of the I/O Bay with tie wraps. Cut tie wraps securing AC power cords.



- d. Pull the AC power cord through the bottom of the I/O Bay cabinet. Pull each AC power cord to the side of the pallet nearest it.
- e. Position the power cords so that they:
- allow the I/O Bay doors to close completely
  - are out of the path the A7000 will take as it rolls off the ramp
  - will present no danger to personnel or equipment as the A7000 is moved off the pallet
- f. Close I/O Bay doors.

**6. Remove the ramps and ramp support from their stowage area under the A7000.**



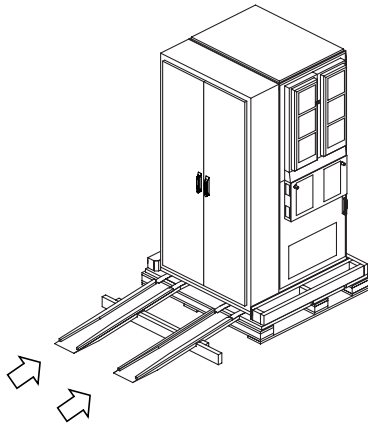
**7. Place the ramp in front of the pallet. Align the ramp with the wheel path of the cabinet. Align the wide black line on each ramp with the ramp support. Fasten the ramps to the ramp support with the Velcro strips attached to each.**



---

**Caution** – The ramps must be fastened securely with the Velcro strips before moving the A7000.

---



---

**Caution** – Make sure the leveler legs are fully retracted before moving the A7000 down the ramps.

---



---

**Caution** – In the next step, move the cabinet slowly so that it does not pick up momentum as it rolls down the ramp. Two people must perform the next step.

---

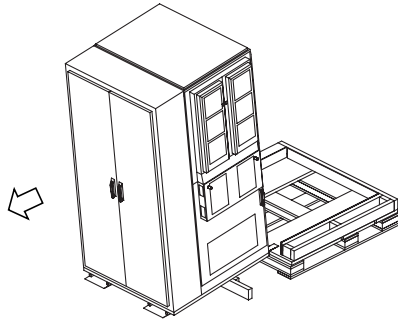


---

**Caution** – If the cabinet begins to tip over, do not attempt to right it. Move out of the way. Serious injury could occur otherwise.

---

**8. Slowly roll the cabinet down the ramp.**



9. Move the A7000 to the computer room. Place the A7000 in its predetermined location, selected prior to installation as specified in the *Sun StorEdge Physical Planning Manual*.
10. Get the black plastic leveler feet you removed from inside the I/O Bay in Step 5b on page 2-3. Close the I/O Bay door.
11. Use wheel chocks placed in front of the cabinet wheels to keep the cabinet from moving.
12. Align the leveler feet to the leveler legs and screw down the leveler legs until the legs snap into the feet.

## 2.1.3 Removing the Packing Material - Front

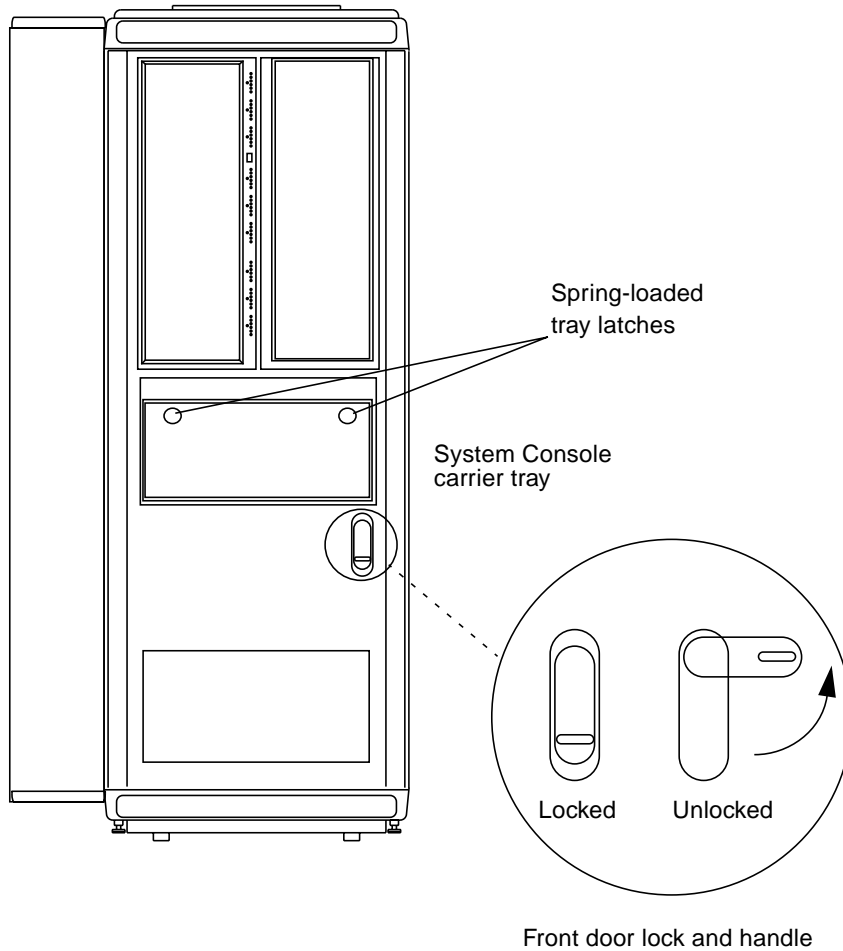
Packing material is inside the front of the A7000 cabinet. The front cabinet door is located at the lower half of the A7000 cabinet (the upper half holds the HDSA drawers). To open the front cabinet door:

1. Insert a flat-blade screwdriver into the door lock and turn it clockwise. See

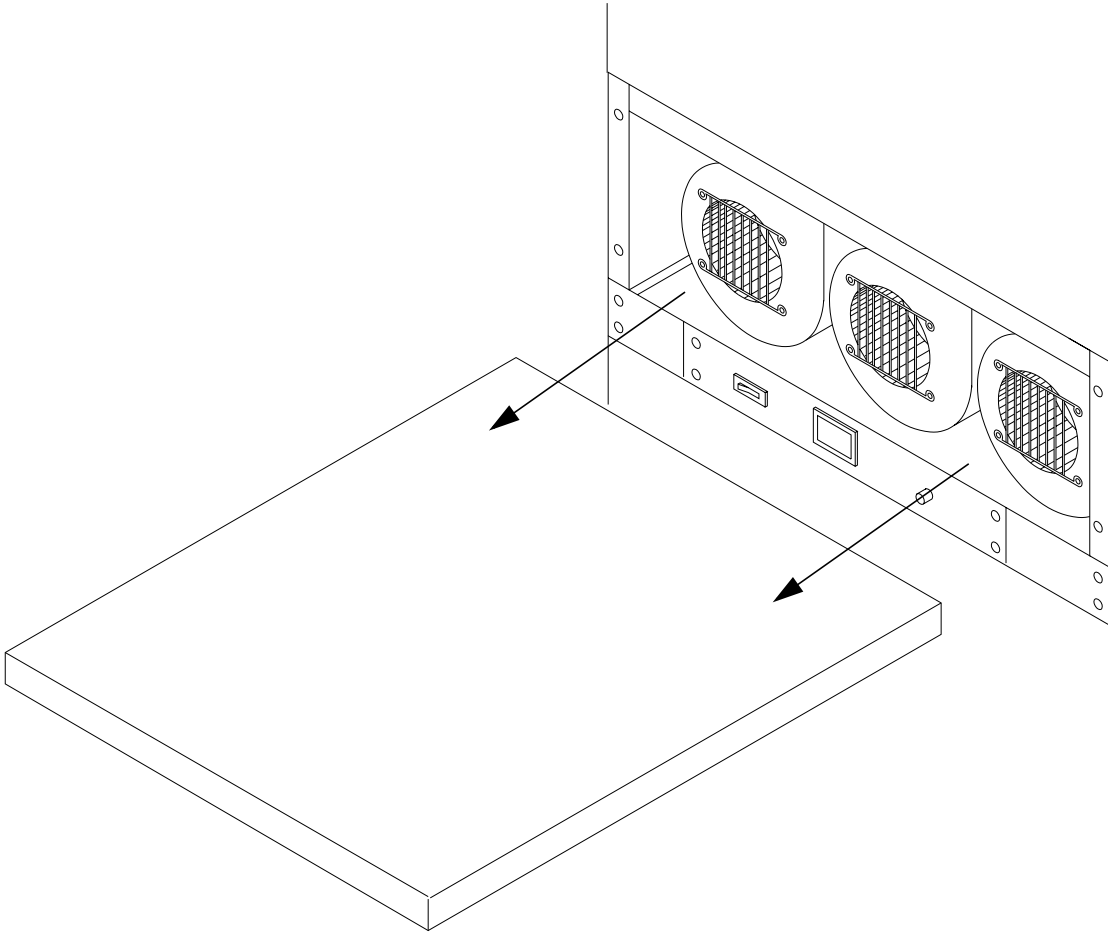
FIGURE 2-1.



2. Pull the bottom of the latch out and turn the latch assembly counterclockwise.
3. Pull the latch to open the door.
4. At the bottom of the cabinet, locate the foam shipping brace under the blower fan assembly and remove it. See FIGURE 2-2.



**FIGURE 2-1** StorEdge A7000 Cabinet Front Door Lock and Tray Latches



**FIGURE 2-2** Removing the Foam Shipping Brace

## 2.1.4 Removing the HDSA Shipping Brackets

The High Density Storage Array (HDSA) shipping brackets are just inside the rear door.

---

**Caution** – The hardware that secures the shipping brackets is loose, not captive. Remove it carefully.

---

1. Locate the HDSA shipping brackets from the side assembly as shown in FIGURE 2-3. Using a Philips screwdriver, remove the screws holding the brackets. Remove all washers.
2. Remove the brackets. Store the brackets, washers, and screws in a spare parts locker or other place onsite, along with items shipped with the server (manuals, tapes, other items).

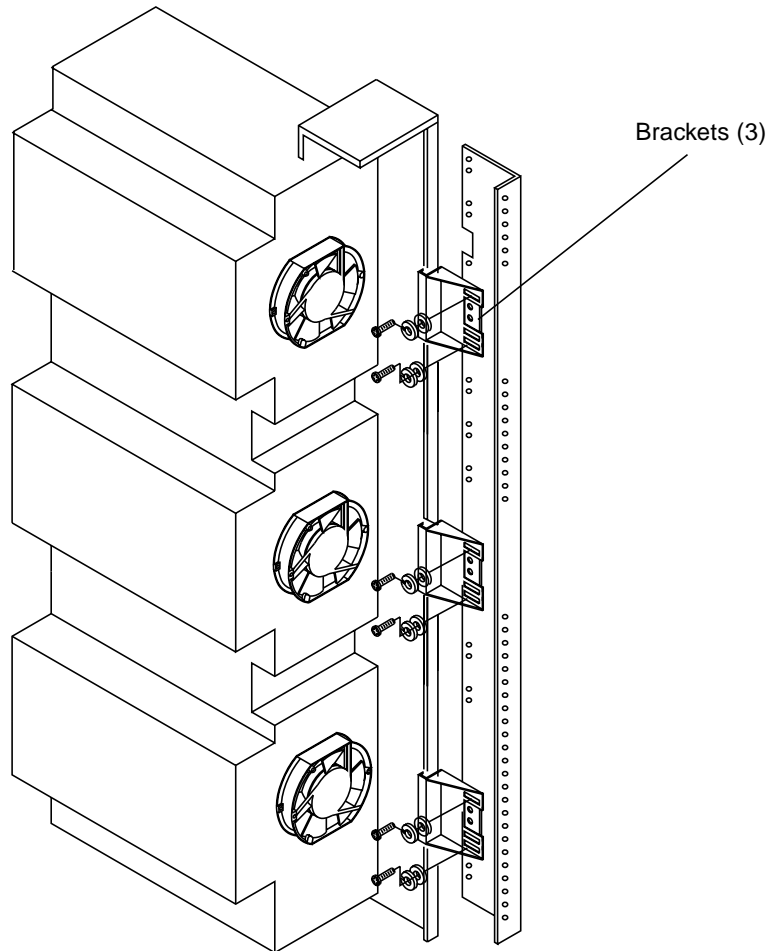


FIGURE 2-3 HDSA Shipping Brackets

## 2.1.5 Removing the Packing Material - Rear

1. At the rear door, slide the black latch covering the door lock sideways to expose the lock.
2. Insert a flat-blade screwdriver into the door lock and turn it clockwise.
3. Pull the bottom of the latch out and turn the latch assembly clockwise.
4. Pull the latch to open the door.
5. Locate the foam packing material behind the HDSA cable tracks and carefully remove it. See FIGURE 2-4.

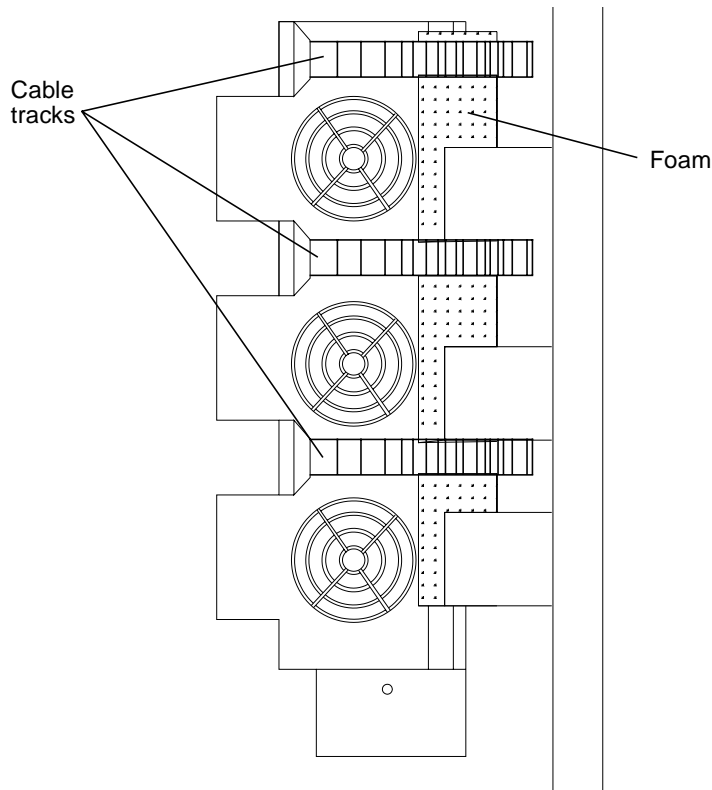


FIGURE 2-4 Removing the Foam HDSA Shipping Material

## 2.1.6 Unpacking and Positioning the PCU

The PCU is shipped in a carton on a pallet separate from the A7000; the shipping materials also include a ramp. This carton also includes vendor documentation for the specific model of PCU. Save this documentation.

---

**Note** – Complete and return the PCU warranty cards found in the PCU documentation.

---

1. **Unpack the PCU and move it down the ramp as described the vendor documentation shipped with it.**
2. **Move the PCU to the computer room. Place the PCU in its predetermined location, selected prior to installation as specified in the *Sun StorEdge Physical Planning Manual*.**
3. **Lower the PCU leveler feet.**

---

## 2.2 Inspecting the Equipment

The following paragraphs tell you how to inspect the A7000 and report any damage found during the final inspection. Damage must be reported within 15 days of delivery or you may waive all rights to file a damage claim with the carrier. Do not move damaged equipment until the insurance company has completed its investigation and granted permission.



---

**Caution** – Always wear a properly grounded wrist strap when working inside the A7000 cabinet and handling static-sensitive components. Chapter 1 describes more electrostatic discharge (ESD) precautions.

---

## 2.2.1 Inspecting for Physical Damage

1. **Inspect for interior and exterior shipment damage:**
  - Check how doors interlock and check other exterior parts for appearance and fit.
  - Check that the nameplate and all switches are intact.
  - Check that printed circuit boards (PCBs), connector plugs, and other components are not loose, missing, or damaged.
2. **Report all damage as described in “Reporting Damaged or Missing Equipment” on page 2-17.**

## 2.2.2 Inspecting Power Switches

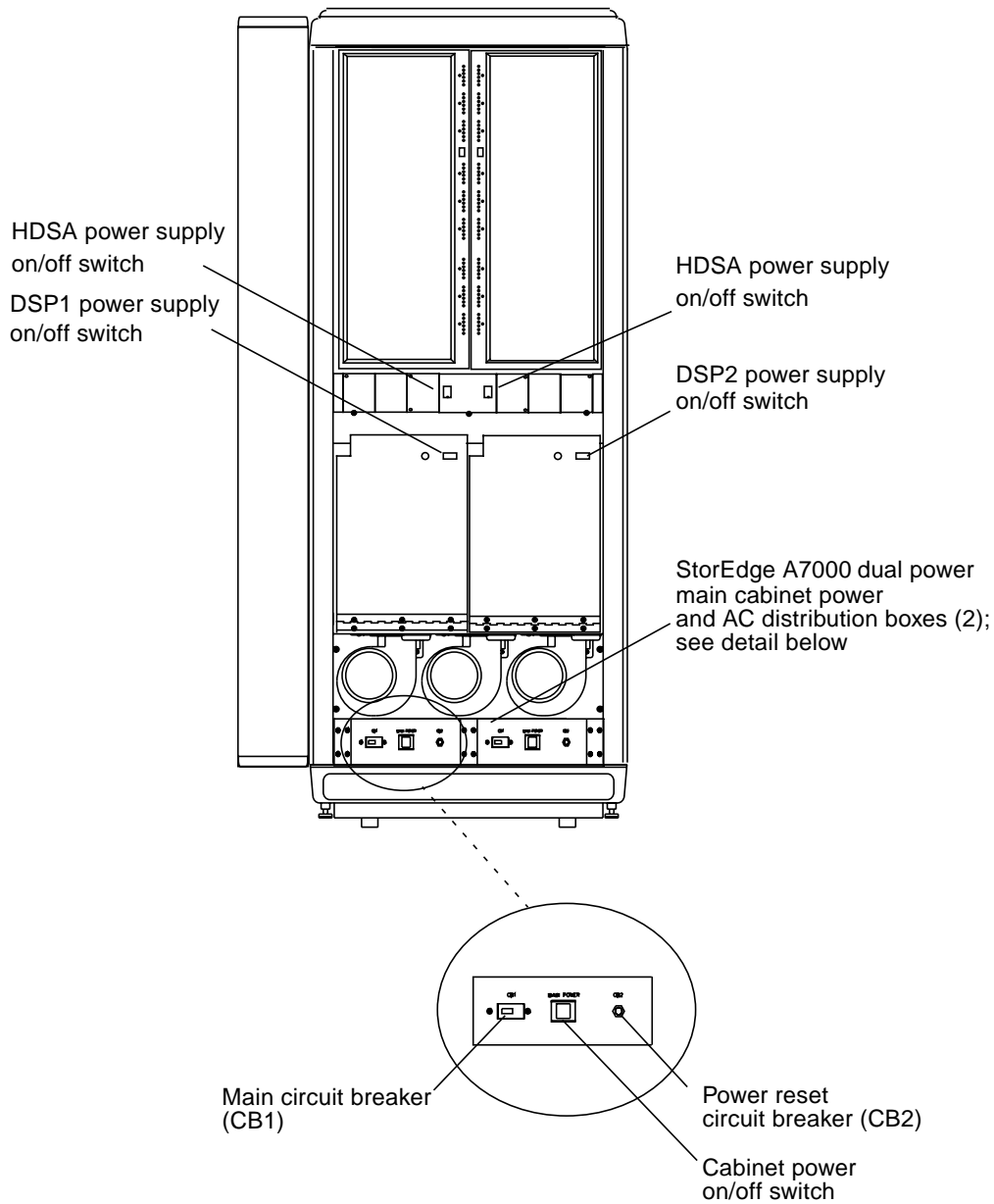
Open the front doors of the A7000 cabinet to reveal all A7000 power switched. FIGURE 2-5 shows the locations of the power switches. Check all power switches and verify that:

1. **Circuit Breaker 1 (CB1) is thrown to the left, in the OFF position.**
2. **HDSA power supply (DC power) is in the OFF (0) position.**
3. **Power supplies for dsp1 and dsp2 are in the OFF (0) position.**

## 2.2.3 Inspecting Switches and Connectors in I/O Bay

Open the I/O Bay doors and verify that:

1. **All BMC, ESCON, or other interface panels in the I/O Bay cabinet have their online/offline switches in the ONLINE position. These switches are spring-loaded—pull out and hold the top of the switch, move it to ONLINE, and then release it.**
2. **Inspect BMC Bus and Tag connectors in the I/O Bay cabinet; make sure the connector pins are not bent.**
3. **Report all damage as described in “Reporting Damaged or Missing Equipment” on page 2-17.**



**FIGURE 2-5** StorEdge A7000 Power Switches

## 2.2.4 Inspecting Components in Rear of Cabinet

Open the rear doors of the A7000 cabinet. FIGURE 2-6 shows the rear of the A7000 with the doors open.

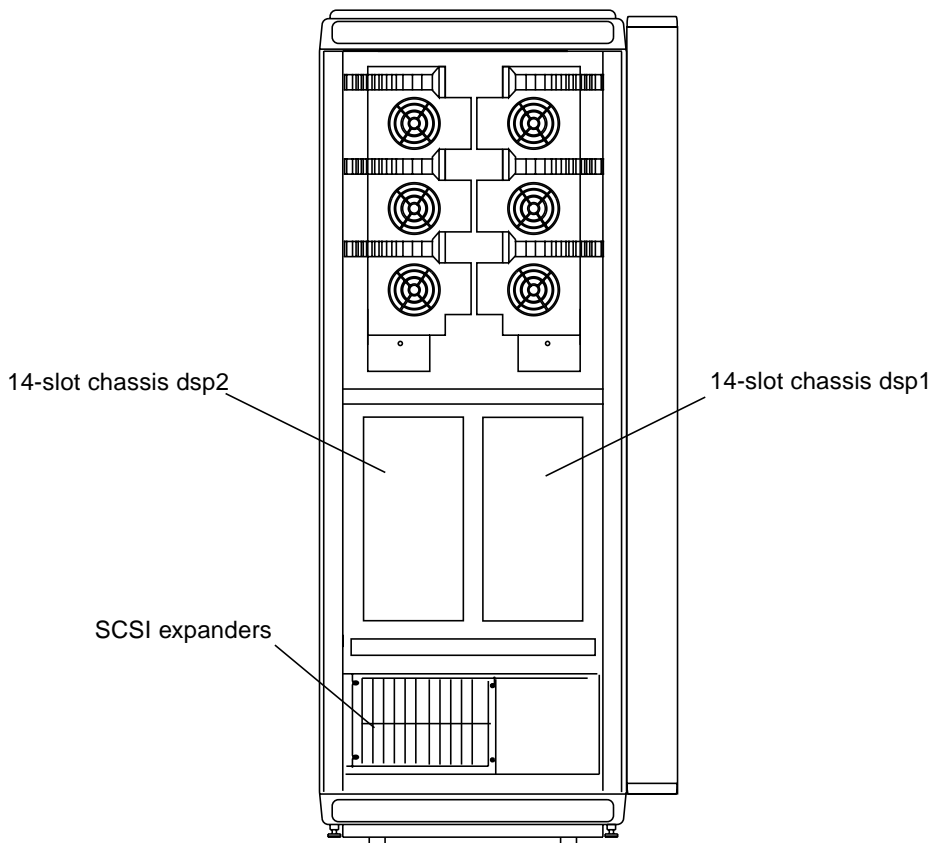


FIGURE 2-6 Inside Rear of A7000

Check all A7000 components and verifying that:

4. All chassis cards (like the processor card and SCSI controller) are secured to the chassis; check that the card hold-down screws are tight (these screws are at the top and bottom of each card's faceplate). *Do not overtighten* these screws.
5. All internal cable connections, except ESCON cables, are firmly seated and locked.



6. For systems including ESCON, ESCON cables inside the cabinet are shipped uninstalled. If this system includes ESCON, verify the ESCON cables are present and undamaged.
7. All front and rear cables to the SCSI Expander cards (also known as SCSI splitter or ATTO cards) are firmly seated. These cards and cables are in the bottom rear of the cabinet.
8. Report all damage as described in “Reporting Damaged or Missing Equipment” on page 2-17.

## 2.2.5 Reporting Damaged or Missing Equipment

If any equipment is damaged, report it as follows:

1. Describe the extent of the damage on the Quality Feedback Report (QFR) that the customer and Sun representative will retain.
2. Notify the field manager and the customer account representative of the damage.

If any equipment is missing, report it as follows:

1. Mark the unaccounted items as missing on the QFR that the customer and Sun representative will retain.
2. Report the loss to the field manager and the customer account representative.

---

## 2.3 Connecting the Internal ESCON Cables

For systems that include the VME to ESCON controller, ESCON cables inside the cabinet are shipped uninstalled. The controller card ships with protective cover plugs installed in each channel connector. Refer to FIGURE 2-7.

1. Open the rear cabinet door.
2. Inside the rear of the A7000, locate the VME to ESCON controller cards for dsp1 and dsp2 in each dsp’s 14-slot chassis. See the depiction of the card front panel in FIGURE 2-7.
3. At the controller card channel connectors, remove the protective cover plugs by squeezing the top and bottom of each plug.
4. On each ESCON cable connector, grab the spring-loaded top segment and pull it back; hold it. Remove the protective fiber plugs. Release the top segment.



---

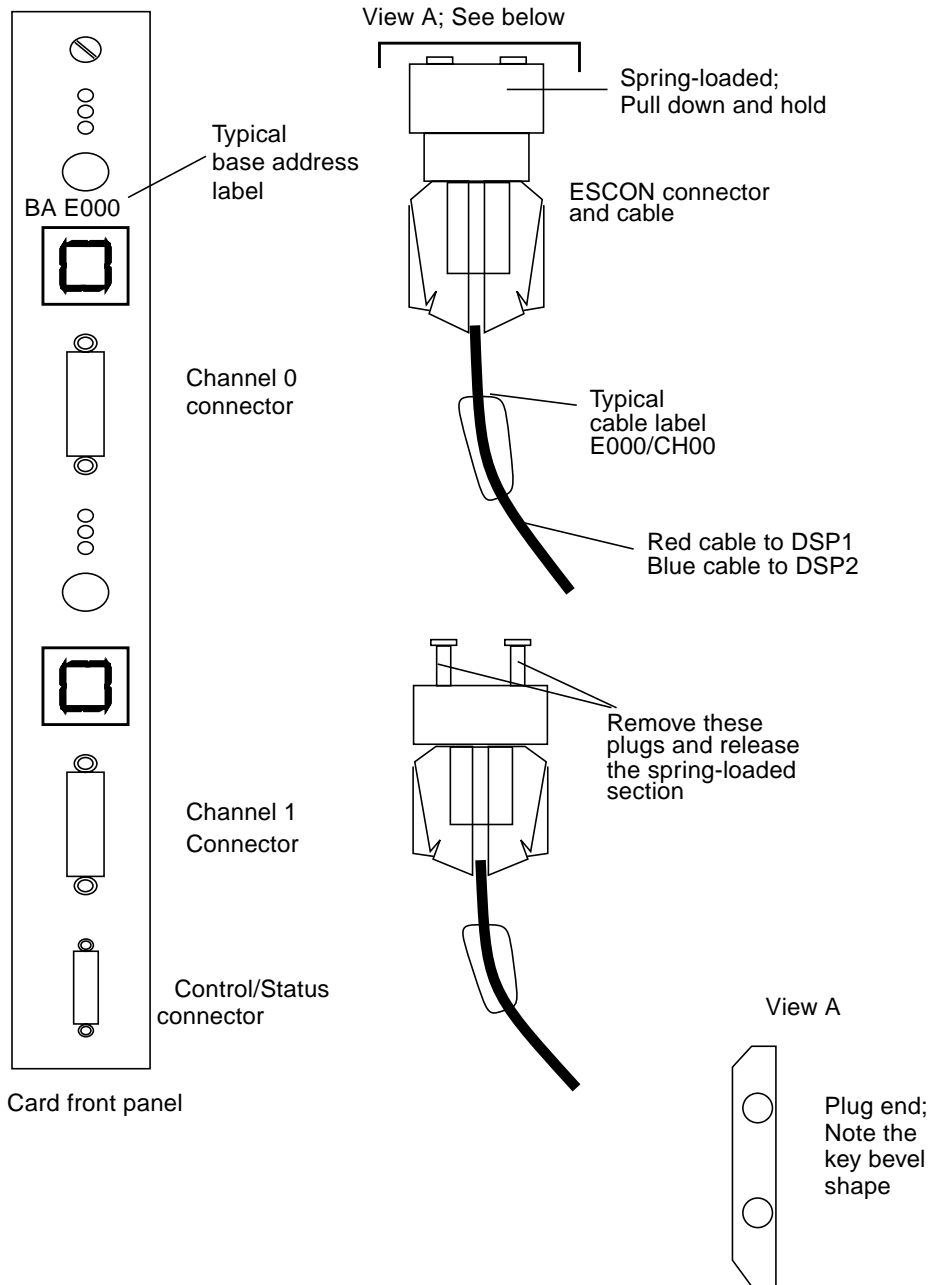
**Caution** – Do not bend the ESCON cables tightly.

---

- 5. Install the ESCON cables on each VME to ESCON controller. Note that each cable connector is keyed—do not force the connector; it should glide into place.**

Each cable is colored red or blue. Red cables go to ESCON controllers in chassis `dsp1`; blue cables go to chassis `dsp2`.

Each card and cable is labeled; for example, a red-cabled connector labeled `E000/CH00` installs on the first controller card channel 0 in the `dsp1` chassis. This card would be labeled with a base address `E000`; each card has two channels.



**FIGURE 2-7** ESCON Controller and Cable



# Installing the StorEdge A7000 and PCU



---

**Caution** – *Do not move or attempt to move the StorEdge A7000 cabinet with the HDSA drawer extended or open in any way. The cabinet could become unbalanced and topple if you try to move it incorrectly. Make sure the cabinet is properly level at all times. Chapter 4 describes how to level the cabinet. Do not remove or retract the system cabinet leveler feet if the HDSA drawer contains disk drive modules.*

---

---

**Note** – All physical requirements, electrical requirement, environmental requirements, and other requirements for installing the StorEdge A7000 must be defined and satisfied as described in *Sun StorEdge A7000 Physical Planning Manual* before attempting to install the A7000.

---

This chapter describes how to install the A7000 and the power conditioning unit (PCU). Topics include:

- Performing the Electrical Installation—page 3-2
  - Connecting the HDSA Expansion Cabinet (Optional)—page 3-4
  - Performing Safety Checks—page 3-4
  - Power Plugs, Cables, and Hardwiring—page 3-4
  - Connecting the PCU to the Bypass Switch—page 3-4
  - Grounding the A7000 and PCU—page 3-9
- Connecting the Data Cables—page 3-15

---

## 3.1 Performing the Electrical Installation

Before performing the electrical installation, ensure that the electrical pre-installation has been performed as described in the *Sun StorEdge A7000 Physical Planning Manual*.

FIGURE 3-1 shows a typical electrical installation. If an HSDA expansion cabinet were part of the installation, it would have its own bypass switch, PCU and junction box containing a pair of Maringo CS8269 receptacles.

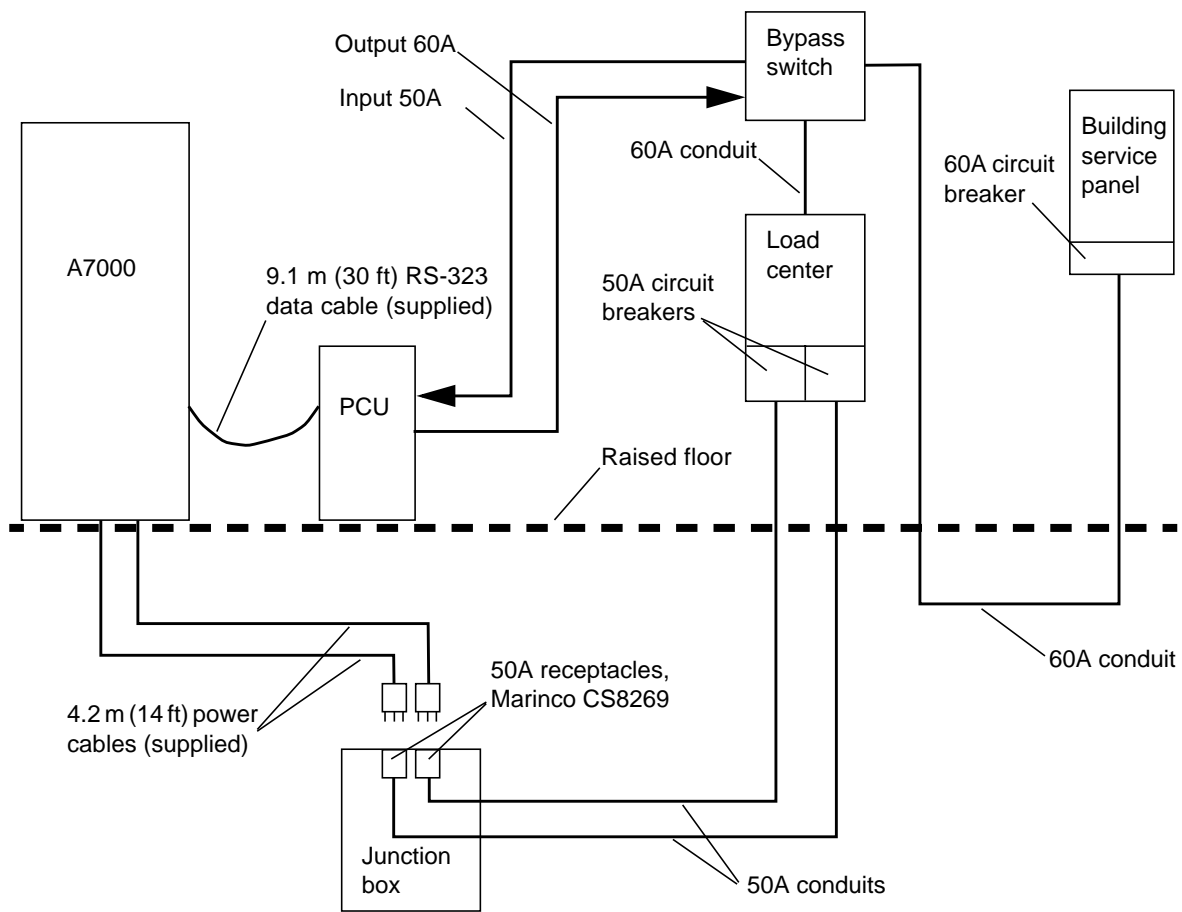
The following tasks must be completed before beginning the electrical installation. A licensed electrician must perform the electrical pre-installation:

- Install bypass switch(es) and connect it to the building service panel.
- Connect a load center(s) to the bypass switch(es).
- Install the Maringo CS8269 receptacles for the AC power plugs of the A7000 (and optional HSDA expansion cabinet) in junction box(es) and connect them to the load center(s).

---

**Note** – Both input power cords for the StorEdge A7000 must be wired to the same AC phase. This is required for single power grid, dual power grid, and any alternate power source that may be available. Do not supply power to the A7000 from separate power sources, including backup sources such as house UPS or generators, unless phase synchronization can be guaranteed at all times.

---



**FIGURE 3-1** Typical Electrical Installation

### 3.1.1 Connecting the HDSA Expansion Cabinet (Optional)

If you are installing an A7000 with an HDSA expansion cabinet, see Appendix B for instructions on how to connect it to the A7000. Power to the expansion cabinet is supplied through a bypass switch connected to a PCU, like power to the A7000. The PCU dedicated to the expansion cabinet is connected and grounded as described in page 3-4 through page 3-9.

### 3.1.2 Performing Safety Checks

Before beginning the electrical installation, perform the following safety checks

- Make sure that the bypass switches are turned off.
- Let everyone involved in the installation know the location of the main power distribution wall circuit breaker.
- Label the wall panel power distribution circuit breaker serving the A7000 PCU.

### 3.1.3 Power Plugs, Cables, and Hardwiring

The A7000 is manufactured with two power cables and ships with two 50 ampere plugs. The HDSA expansion cabinet is also manufactured with two power cables. A total of four AC power cables are supplied with a dual cabinet configuration. The cables are 4.27 meters (14 feet) long (from the cabinet exit).

The PCU device is not supplied with a power cable or plug; it must be hardwired. The PCU hardwiring:

- Must be performed by a qualified electrician
- Must meet all applicable codes
- Requires a 50-ampere circuit breaker (minimum) for each PCU device
- Requires appropriate wire size, depending on location of PCU and length of wire

### 3.1.4 Connecting the PCU to the Bypass Switch



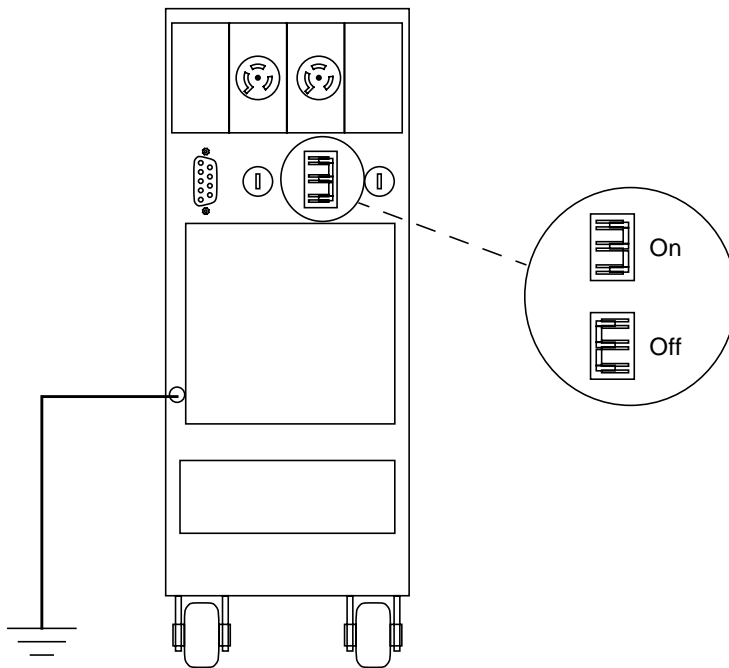
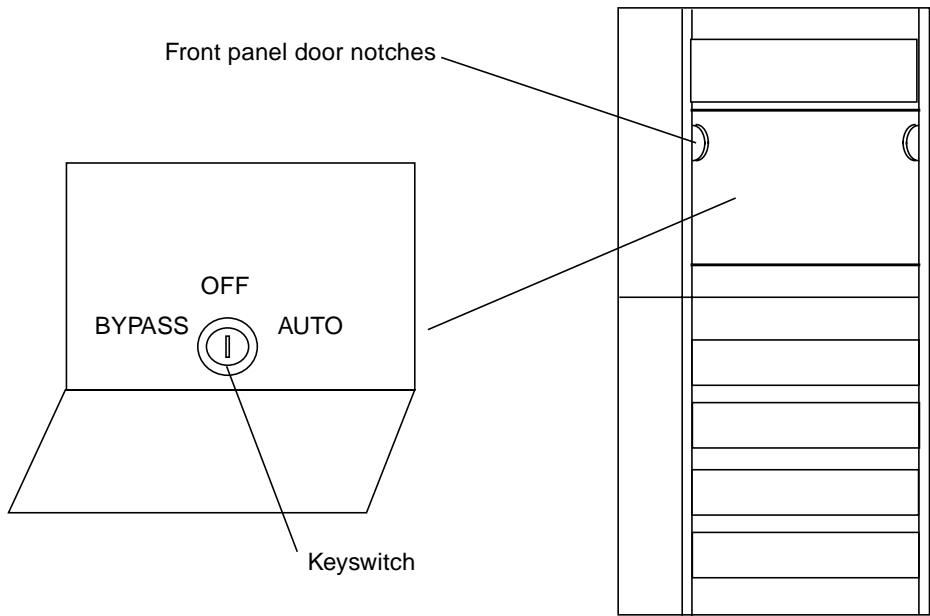
---

**Caution** – The PCU can generate fatal voltages with or without input power. Use extreme care when measuring live power.

---



- 1. Make sure the PCU is off. At the front of the PCU, put the keyswitch in the OFF position. The keyswitch is behind the front panel; pull it down by the notches. See FIGURE 3-2. At the rear of the PCU, put the circuit breaker switch in the OFF position.**
- 2. Remove the PCU cover panels. Remove the two screws on each side near the back of the PCU and the three screws along the top. Lift the panel straight up and off.**



**FIGURE 3-2** PCU Keyswitch and Circuit Breaker Switch

3. **Connect AC power input from the bypass switch to the PCU. A licensed electrician must perform this step.**
  - a. **Remove the AC input knockout at the rear of the PCU.**
  - b. **Hardwire the PCU power cable to the PCU through this knockout; secure the cable with a metal strain-type collar.**
  - c. **Hardwire the other end of the PCU power cable to the bypass switch.**

Refer to the *Best Power Technology UNITY/I Installation Manual* for more details.
4. **Make sure that the terminal block inside the PCU has black output wires connected to terminals X1 and X5 (ground is X3). See FIGURE 3-3 and FIGURE 3-4 for a typical domestic and international installation.**
5. **With a digital voltmeter (DVM), measure the AC voltage between the phases (L1 and L2) and between ground (N) and each phase. See FIGURE 3-3 and FIGURE 3-4. Make sure the voltages are in the range listed in TABLE 3-1.**

Measure the AC voltages. The voltages must match those specified in TABLE 3-1. The best place to measure the power to the PCU is where the power connects to the PCU: at the terminal block inside the PCU.

**TABLE 3-1** Input Voltage Needed for PCU

Measure Between...	AC Voltage Should Be...	International or Domestic...
Ground and X phase	120 VAC +/- 10%	Domestic
Ground and Y phase	120 VAC +/- 10%	Domestic
X phase and Y phase	190 to 250 VAC	Domestic
N phase and L1 phase	230 VAC +/- 10%	International

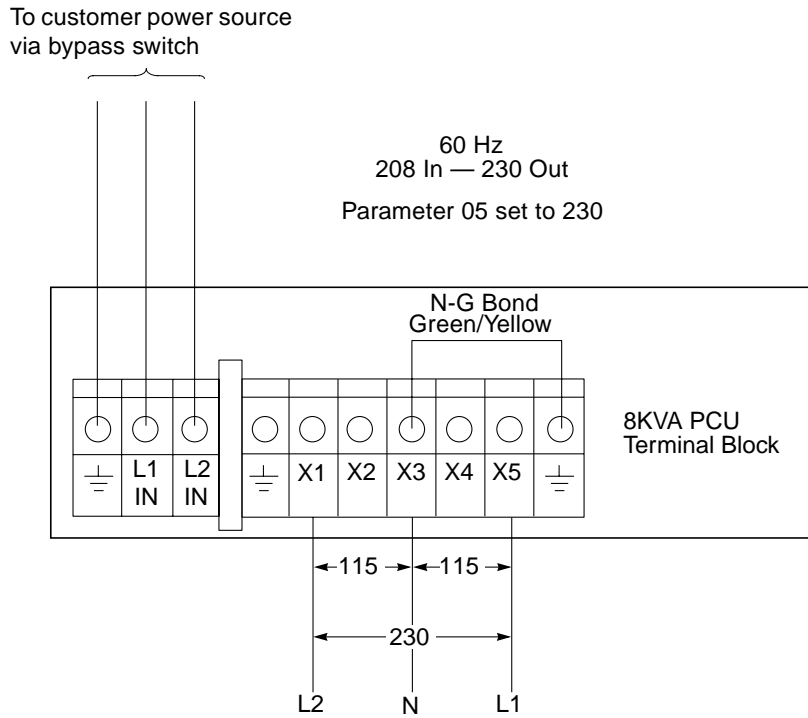
6. **Connect the AC power output from the PCU to the bypass switch. A licensed electrician must perform this step.**
  - a. **Remove the AC output knockout at the rear of the PCU.**
  - b. **Hardwire the PCU power cable to the PCU through this knockout; secure the cable with a metal strain-type collar.**
  - c. **Hardwire the other end of the PCU power cable to the bypass switch.**

Refer to the *Best Power Technology UNITY/I Installation Manual* for more details.
7. **Replace the PCU cover panels.**

---

**Note** – If the installation requires setting up the PCU for noisy or dirty power, see Appendix A for instructions.

---

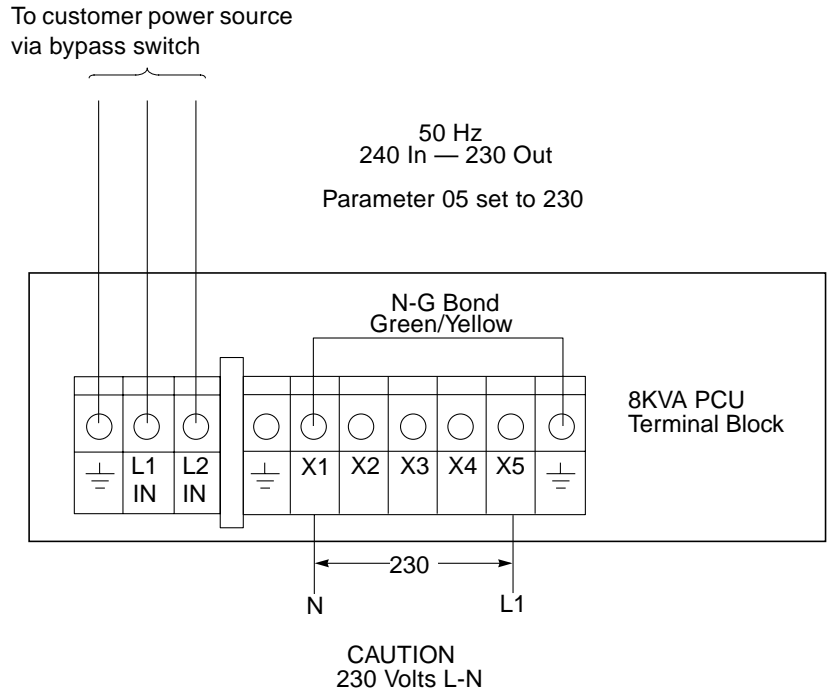


**FIGURE 3-3** AC Input to PCU and AC Output from PCU for Domestic (NAFO) Installations

---

**Note** – For both domestic and international installations, connect the PCUs’ green an yellow neutral-to-ground wire (N-G bond) to the output terminal indicated.

---



**FIGURE 3-4** AC Input to PCU and AC Output from PCU for Many International Installations

---

**Note** – For both domestic and international installations, connect the PCUs' green and yellow neutral-to-ground wire (N-G bond) to the output terminal indicated.

---

### 3.1.5 Grounding the A7000 and PCU




---

**Caution** – Do not power on the A7000 or PCU(s) at this time.

---

This section describes how to connect the A7000 and the PCU(s) to establish a ground connection. You need this ground connection to safely install the disk drives, described in Chapter 4.

This section explains how to:

- Prepare for grounding:
  - Confirm that the selected customer common ground point is appropriate for grounding—page 3-10.
  - Measure and record the differentials between the various points of grounding—page 3-10.
- Perform grounding:
  - Install the ground clamp—page 3-12.
  - Install a ground cable to the A7000—page 3-12.
  - Install ground cables to PCUs—page 3-12.
  - Connect ground cables to the ground clamp—page 3-12.

### 3.1.5.1 Preparing for Grounding

The customer common ground point is typically the raised-floor tile metal support post of a ground raised floor system. If this type of ground point is not available or no metal support post is within 1.83 meters (6 feet) of the A7000 and PCU, use the appropriate gauge of ground cable connected from the common ground point to the Sun ground strap (part number 530-1619-xx). The ground cable gauge must be one gauge size larger than the AC power input cable to the PCU. For example, if the AC power input cable to the PCU is 6 gauge, use 4 gauge ground cable.

The resistance between the customer common ground point and the earth ground reference must be no more than 0.1 ohms. This resistance level should have been measured and established as no more than 0.1 ohms during the physical planning stage, as described in *Sun StorEdge A7000 Physical Planning Manual*. However, it should be confirmed at this time as part of the grounding preparation.

Before beginning any grounding procedures, measure the differentials between the various points of grounding. Record these values in the table provided at the end of this section.

1. **With a DVM, measure the resistance in ohms from the selected customer common ground point to the earth ground reference.**
  - a. **Confirm that the resistance between the customer common ground point and the earth ground reference is no more than 0.1 ohms.**
  - b. **If the resistance between the customer common ground point and the earth ground reference is more than 0.1 ohms, it does not qualify as grounded and a new ground point must be established.**
  - c. **If the resistance between the customer common ground point and the earth ground reference is no more than 0.1 ohms, record this value in the table provide at the end of this section.**

2. Measure the resistance in ohms and the AC voltage in millivolts from the selected ground point to the A7000 chassis and record these values in the table provide at the end of this section.
3. Measure the resistance in ohms and the AC voltage in millivolts from the customer common ground point to the PCU and record these values in the table provide at the end of this section.
4. Measure the resistance in ohms from and the AC voltage in millivolts the A7000 chassis to the PCU chassis and record these values in the table provide at the end of this section.
5. For configurations that include an HSDA expansion cabinet, repeat Step 3 to Step 4 for the expansion cabinet's PCU.

Record the differential values is the space provide in this table:

Points of Measurement	Resistance (in ohms)	AC Voltage (in millivolts)
Customer Common Ground Point to Earth Ground Reference		N/A
A7000 to Ground Point		
A7000's PCU to Ground Point		
Expansion Cabinet's PCU to Ground Point		

### 3.1.5.2 Grounding

To perform the grounding procedures, you need:

- Ground clamp of the following type or equivalent:
  - Harger No. BGC4 Ground Clamp (Sun part number 240-3484-xx); available from:  
Harger Lightning Protection  
301 Ziegler Lake Drive  
Grayslake, IL 60030  
1-800-842-7437
- One Sun ground cable (part number 530-1619-xx) for each system component: A7000 system cabinet and PCU

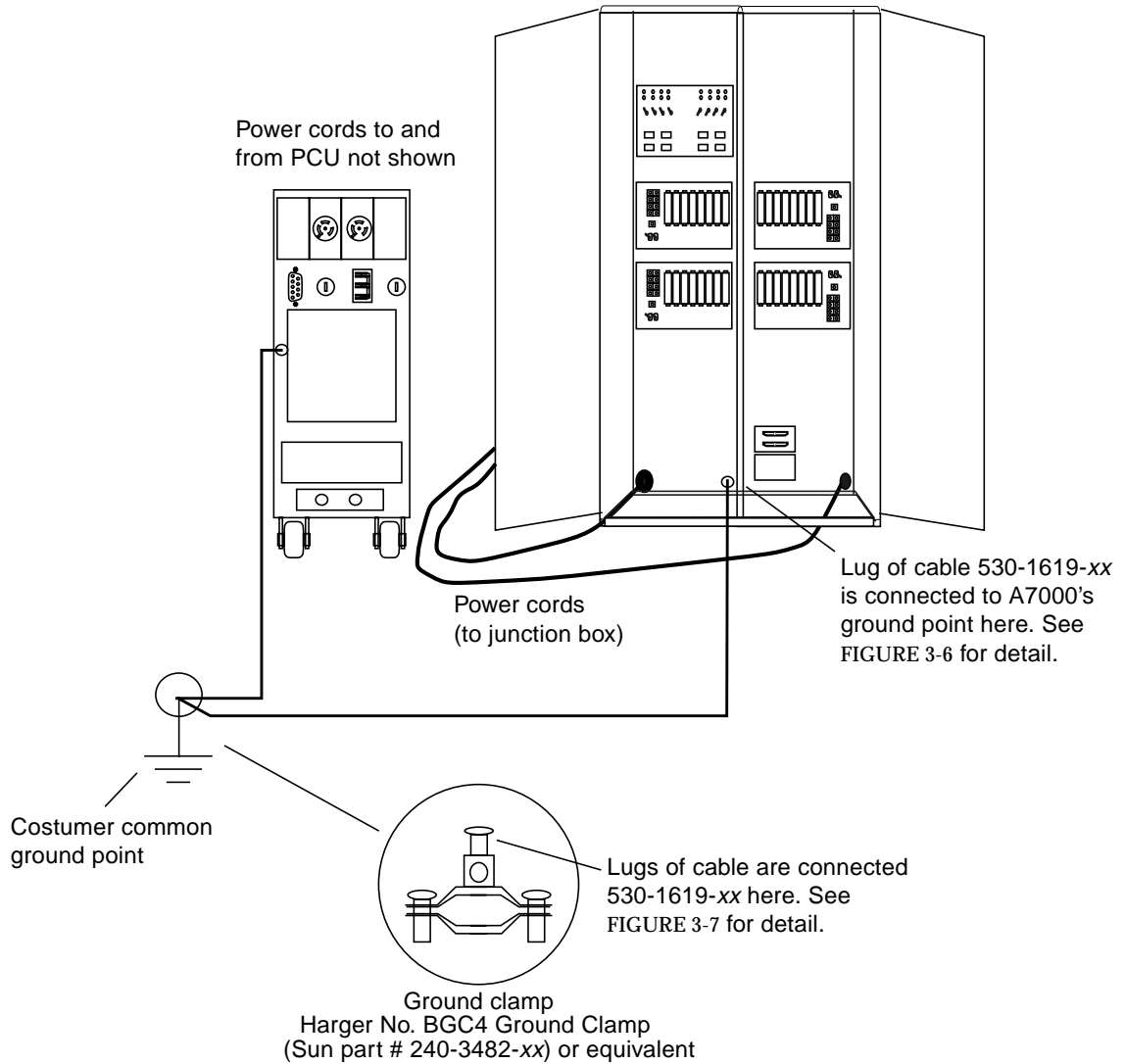
---

**Note** – The customer common ground point is typically the raised-floor tile metal support post of a ground raised floor system. This section assumes the customer has this type of ground point.

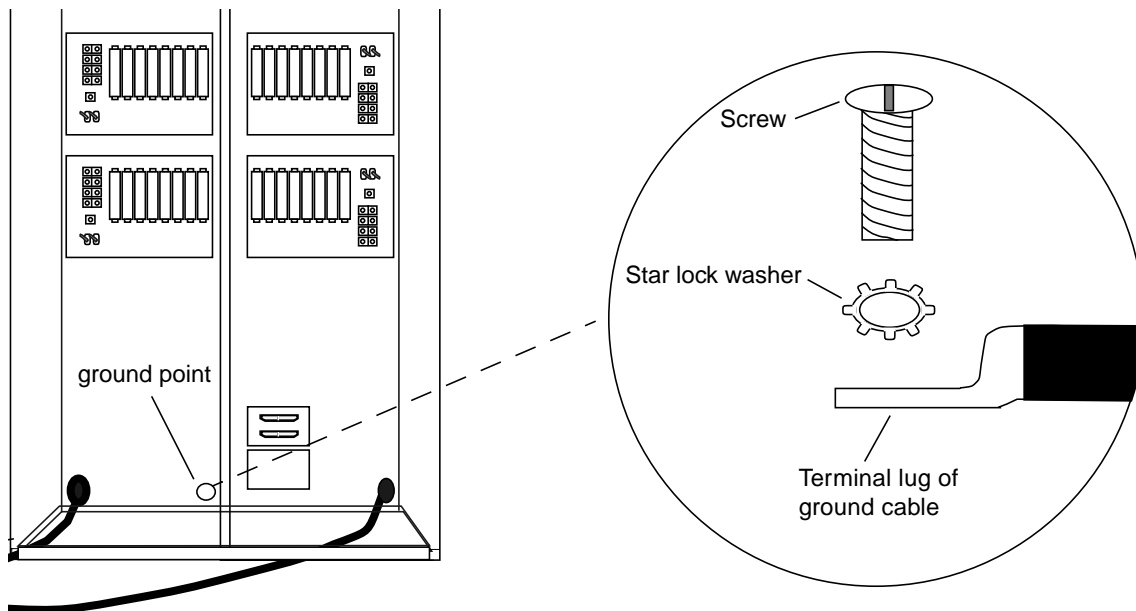
---

- 1. Remove one raised-floor tile within 1.83 meters (6 feet) of the StorEdge A7000 and PCU.**
- 2. Install a ground clamp on the floor metal support post.**
- 3. Install one end of one Sun ground cable to the A7000 system cabinet. This cable is approximately 1.8 meters (6 feet) long with terminal lugs on both ends. To connect the ground cable to the A7000's ground point:**
  - a. Locate the A7000's ground point. The A7000's ground point is located just near the bottom center of the I/O Bay cabinet. See FIGURE 3-5 and FIGURE 3-6.**
  - b. Remove the hardware on the A7000's ground point. This hardware should include a screw and a star lock washer. Save these to use in connecting the ground cable.**
  - c. Screw the ground cable terminal lug to the A7000's ground point, placing a star lock washer above the terminal lug. See FIGURE 3-6.**
- 4. Route the ground strap under the floor tiles (if possible).**
- 5. Install one end of one Sun ground cable to the PCU. The PCU's ground point is the bolt at the left rear of the PCU. See FIGURE 3-5.**
- 6. For configurations that include an HSDA expansion cabinet, repeat for the expansion cabinet's PCU.**
- 7. Connect the free ends of the installed ground cables to the ground clamp. See FIGURE 3-5 and FIGURE 3-7. Screw the ground cable terminal lugs to the ground clamp, placing a star lock washer above each terminal lug as shown in FIGURE 3-7.**
- 8. Replace the raised-floor tile.**



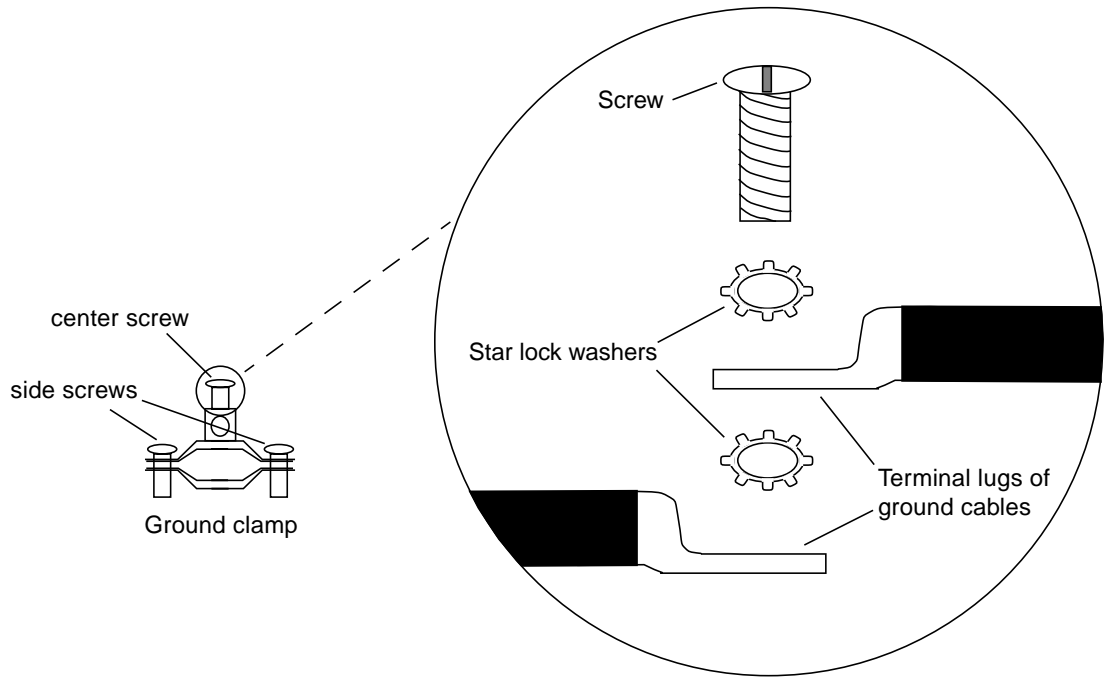


**FIGURE 3-5** PCU and StorEdge A7000 Common Ground Point Connection



A7000 cabinet  
(lower portion of I/O Bay shown)

**FIGURE 3-6** Ground Cables Connected to A7000's Ground Point



**FIGURE 3-7** Ground Cables Connected to Ground Clamp

---

**Note** – FIGURE 3-7 shows two ground cables connected to the ground clamp using the center screw. Fewer or more ground cables may be connected to the ground clamp. If all the ground cables required will not fit on the center screw, connect all ground cables to one of the side screws. Always place a star lock washer above each ground cable terminal lug, as shown

---

---

## 3.2 Connecting the Data Cables

The PCU model shipped with the A7000 includes a 9-meter (30-foot) data cable to connect from the A7000 to the PCU and an 2.5-meter (8-foot) Y-cable to internally connect the subsystem Processor cards to the DB9 connector panel inside the I/O Bay cabinet.

---

**Note** – The 2.5-meter (8-foot) Y-cable is installed internally, with one end connected to the internal connector on the DB9 connector panel. *As shipped, the other end is not connected to the Processor boards' serial port.* Do not connect the cable to the serial ports at this time. Chapter 6 describes how to connect this cable.

---

1. **Make sure the A7000 cabinet main circuit breaker CB1 is OFF (thrown to the left).** See FIGURE 3-8.

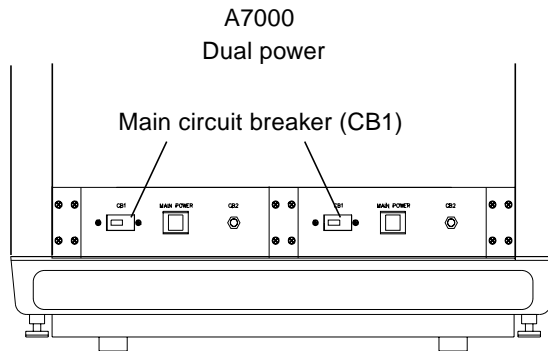


FIGURE 3-8 StorEdge A7000 Circuit Breaker Location

2. **At the front of the PCU, turn the key switch inside the front panel to OFF. To open the panel, pull it down at the notches.** See FIGURE 3-2.
3. **At the rear of the PCU, put the power circuit breaker in the OFF position.** See FIGURE 3-2.
4. **Inside the A7000's I/O Bay cabinet doors, locate the DB9 connector panel.**
5. **Connect one end of the 9.14-meter (30-foot) data cable to the DB9 connector panel in the A7000's I/O Bay.**
6. **Locate the RS232-EPO cable (part number 370-3827-xx). This is a small Y-cable shipped with the PCU.**
7. **One end of the RS232-EPO cable is labeled UPS or PCU. Connect this end to the DB9 connector located on the rear of the PCU. EPO functionality is present even if it is not required.**
8. **Connect the free end of the 9-meter (30-foot) data cable to the PCU through the RS232-EPO cable that is now connected to the PCU. Connect it to the DB9 connector on the RS232-EPO cable that is labeled RS-232.**

# Installing the Disk Drives and System Console

---



**Caution** – *Do not move or attempt to move the StorEdge A7000 cabinet with the HDSA drawer extended or open in any way. The cabinet could become unbalanced and topple if you try to move it incorrectly. Make sure the cabinet is properly level at all times. This chapter describes how to level the cabinet. Do not remove or retract the system cabinet leveler feet if the HDSA drawer contains disk drives.*

---

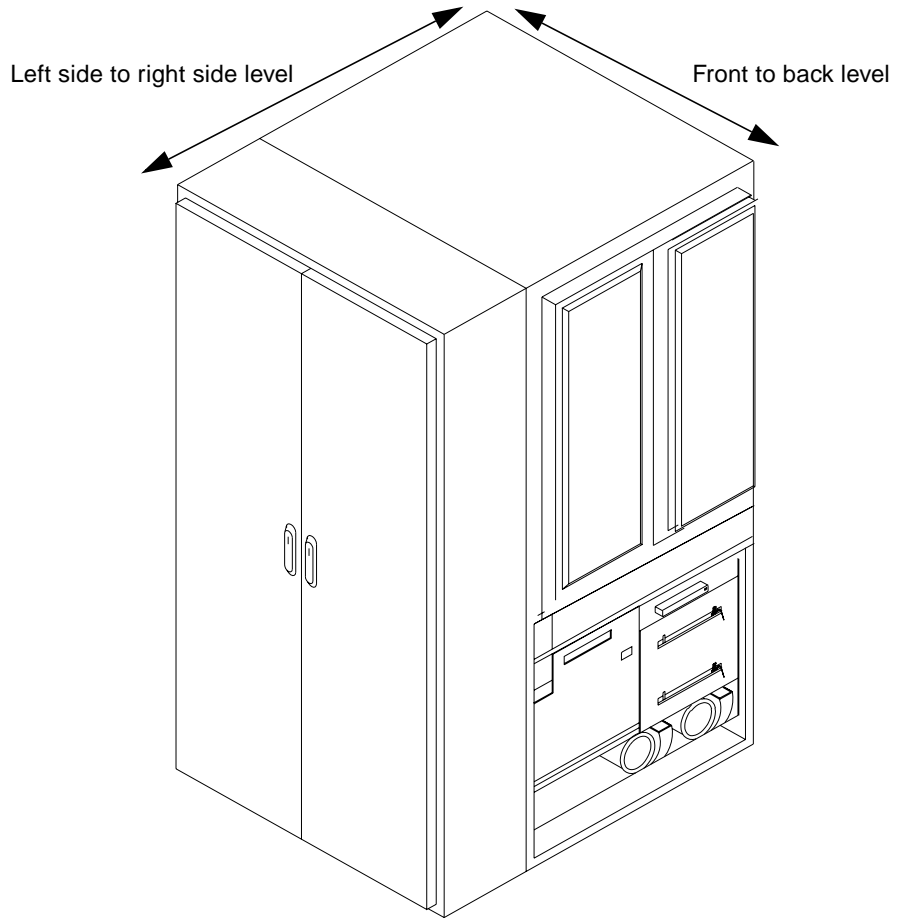
- Leveling the Cabinet Before Disk Installation—page 4-2
- Unpacking and Installing Disk Drives—page 4-4
- Leveling the Cabinet After Disk Installation—page 4-14
- Installing the System Console—page 4-14

---

## 4.1 Leveling the Cabinet Before Disk Installation

Before you install the disk drives in the HDSA (described in “Installing the Disk Drives” on page 4-8), you must level the cabinet. The leveling legs are located under each corner of the cabinet. Level the cabinet again, after installing the disk drives (described in “Leveling the Cabinet After Disk Installation”). See FIGURE 4-1.

1. **Use an adjustable wrench or an open end 7/16-inch wrench to screw down the front cabinet leveling legs until contact with the floor is made.**
2. **Extend each front cabinet leveling leg one additional turn.**
3. **Unscrew the rear cabinet leveling legs until contact with the floor is made.**
4. **Extend each rear cabinet leveling leg one additional turn.**
5. **Adjust the appropriate leveling legs to set the cabinet’s “front to back” at true level. Use a carpenter’s level or an equivalent leveling tool.**
6. **Adjust the leveling legs to set the cabinet’s “left side to right side” at true level.**
7. **Use an adjustable wrench or an open end 7/16-inch wrench to screw down the two I/O Bay cabinet legs until contact with the floor is made. Do not use these legs to level the cabinet; they are for support only.**



**FIGURE 4-1** Leveling the Cabinet

---

## 4.2 Unpacking and Installing Disk Drives

The following paragraphs describe how to unpack and install the disk drives. These steps include opening the HDSA drawer, where you install the disk drives.

- Each six-drive shipping carton is labeled with the address corresponding to the drive location in the HDSA drawer. Refer to “How the Disk Drives Are Labeled” on page 4-5 for more information.
- When possible, the disk drive cartons are packed and shipped on a pallet dedicated to an HDSA drawer. For example, all drives for HDSA drawer 1 are on one pallet, and all drives for HDSA drawer 2 are on another pallet. This packing depends on the A7000 configuration shipped to your site.



## 4.2.1 How the Disk Drives Are Labeled

The six drives in each carton make a bundle and are dedicated to a specific, labeled six-drive chassis in the HDSA. Each disk drive label indicates the slot and chassis for correct placement. The shelf under each six-drive chassis in the HDSA has a corresponding label. See FIGURE 4-2.

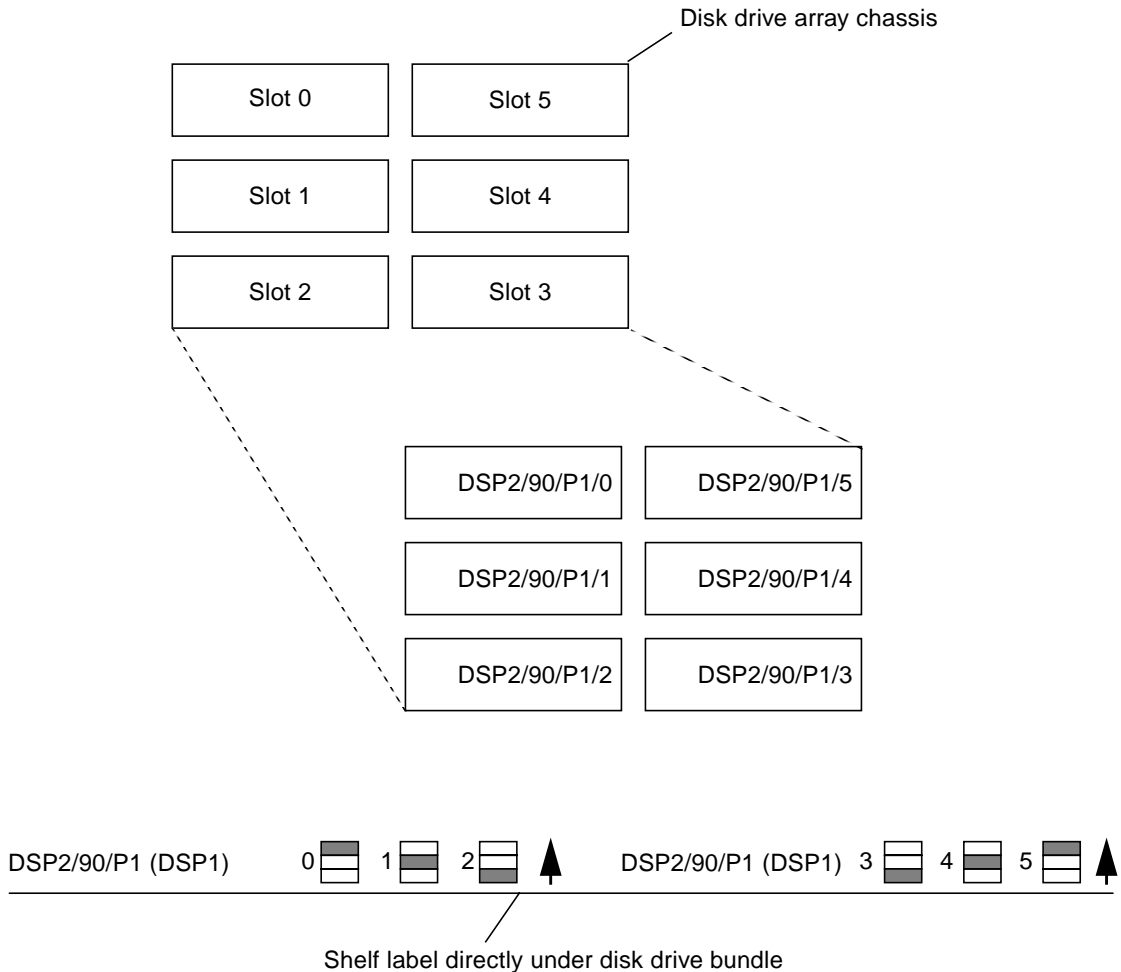


FIGURE 4-2 Disk Drive Slot Layout and Labeling

## 4.2.2

# To Open the HDSA Drawer Manually (Without Power)



---

**Caution** – In the procedure below, remove only one pin at a time to move a drawer. Never remove both pins at the same time. The cabinet can become unbalanced and tip, threatening personal safety.

---

A metal pin installed at the rear of the cabinet near the bottom HDSA cable track prevents the drawer from moving manually. See FIGURE 4-3.

1. **Remove the pin; the drawer may slide forward a bit.**
2. **Go to the front of the cabinet and pull the drawer forward until fully extended.**
3. **When you finish installing the disk drives as described in “Installing the Disk Drives” on page 4-8, retract the drawer by pushing it back in gently and replace the pin.**
4. **Repeat steps 1, 2, and 3 for each HDSA drawer.**

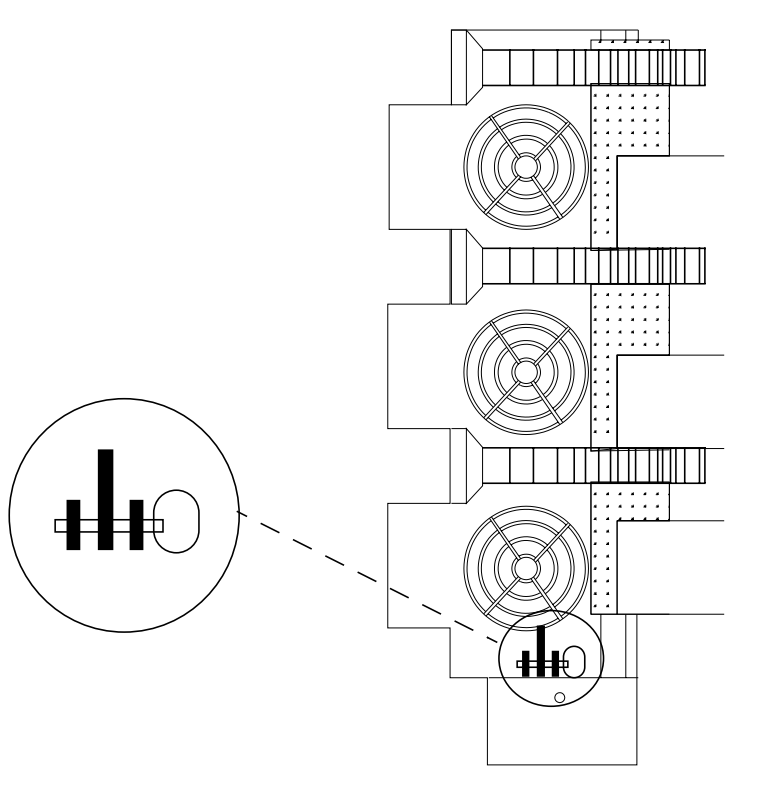


FIGURE 4-3 HDSA Drawer Retractor Pin

## 4.2.3 Unpacking the Disk Drives



---

**Caution** – Take electrostatic discharge (ESD) precautions when unpacking the disk drives, such as wearing an ESD wrist strap.

---

When the A7000 is delivered, the HDSA drawer is empty of disk drives. The disk drives are shipped in cartons to the installation site, six drives to a carton. To unpack the disk drives from each carton:

1. **Open the carton and remove the top pad.**

2. Each disk drive module is packed in an antistatic plastic bag. Pull a disk drive module out and remove it from the bag.
3. Remove the foam connector protector on the rear of the disk drive module.
4. Install the disk drive as described in “Installing the Disk Drives” on page 4-8.
5. Repeat Step 1 to Step 4 until all disk drives have been unpacked and installed.

---

**Note** – After unpacking the disk drives, inspect them for signs of damage. Record the serial number found on the identification label of all damaged disk drives. Notify the field manager and the customer account representative of the damage.

---

## 4.2.4 Installing the Disk Drives

---

**Note** – Ensure that the disk drives are in their proper slots—each slot and drive is labeled. If the StorEdge A7000 configuration includes an HDSA expansion cabinet, install the disk drives in the system cabinet first, and then install the drives in the HDSA expansion cabinet, starting with drawer 3. See Appendix B, FIGURE B-1.

---



---

**Caution** – Take electrostatic discharge (ESD) precautions, such as wearing an ESD wrist strap, when unpacking and installing the disk drives.

---



---

**Caution** – If the StorEdge A7000 configuration includes an HDSA expansion cabinet, install the disk drives in the lower two drawers (drawers 3 and 4 as shown in Appendix B, FIGURE B-1) first before installing disk drives in the upper two drawers (drawers 5 and 6). To ensure the stability of the cabinet when an upper drawer is extended, never install more disk drives in the upper drawers than are installed in the lower drawers. For example, if each lower drawer contains seven six-pack bundles (42 drives total), the maximum number of drives you can install in each upper drawer is 42.

---

StorEdge A7000 storage servers may include 9-Gbyte disk drives or 18-Gbyte disk drives. Each type of drive fits in its own type of six-drive chassis and has its own installation procedure.

## 4.2.4.1 Installing a 9-Gbyte Disk Drive

FIGURE 4-4 shows a 9-Gbyte disk drive. The two LEDs on the faceplate of each drive indicate the following:

- **POWER**—when yellow and steady, the drive is powered on
- **SAFE TO REMOVE**—when green, the drive can be removed from its storage bundle slot

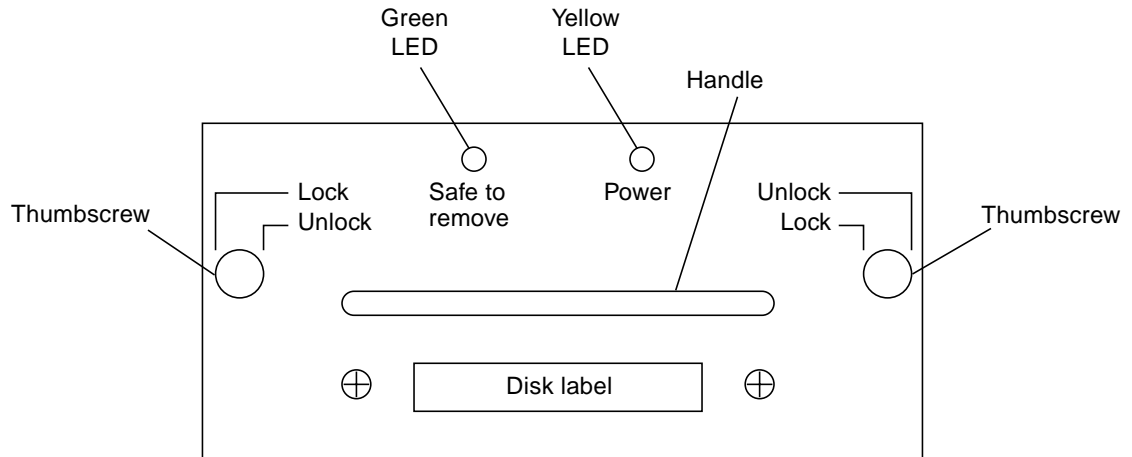


FIGURE 4-4 9-Gbyte Disk Drive

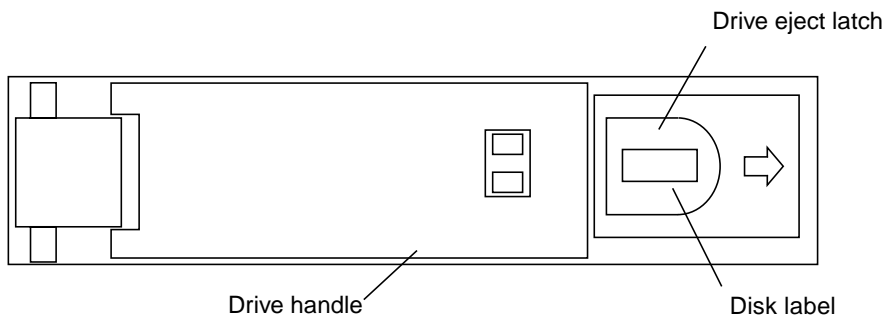
1. **Locate the labeled slot corresponding to the label on the front of the disk drive module.** FIGURE 4-7 shows an example of labeled locations for a single drawer.
2. **Make sure the thumbscrews on the front of the disk drive are turned completely counterclockwise.** See FIGURE 4-4.
3. **Slide the disk drive into its corresponding slot. Push it to engage the backplane connector.**
4. **Turn the drive's locking/unlocking thumbscrews clockwise to secure the drive in the slot.**
5. **Repeat unpacking steps 3 and 4 in paragraph "Unpacking the Disk Drives" on page 4-7, and installation steps 1 through 4 above for the remaining drives in the carton.**
6. **Repeat all steps in the above paragraphs for each carton and each 9-Gbyte drive in the cartons.**

## 4.2.4.2 Installing an 18-Gbyte Disk Drive

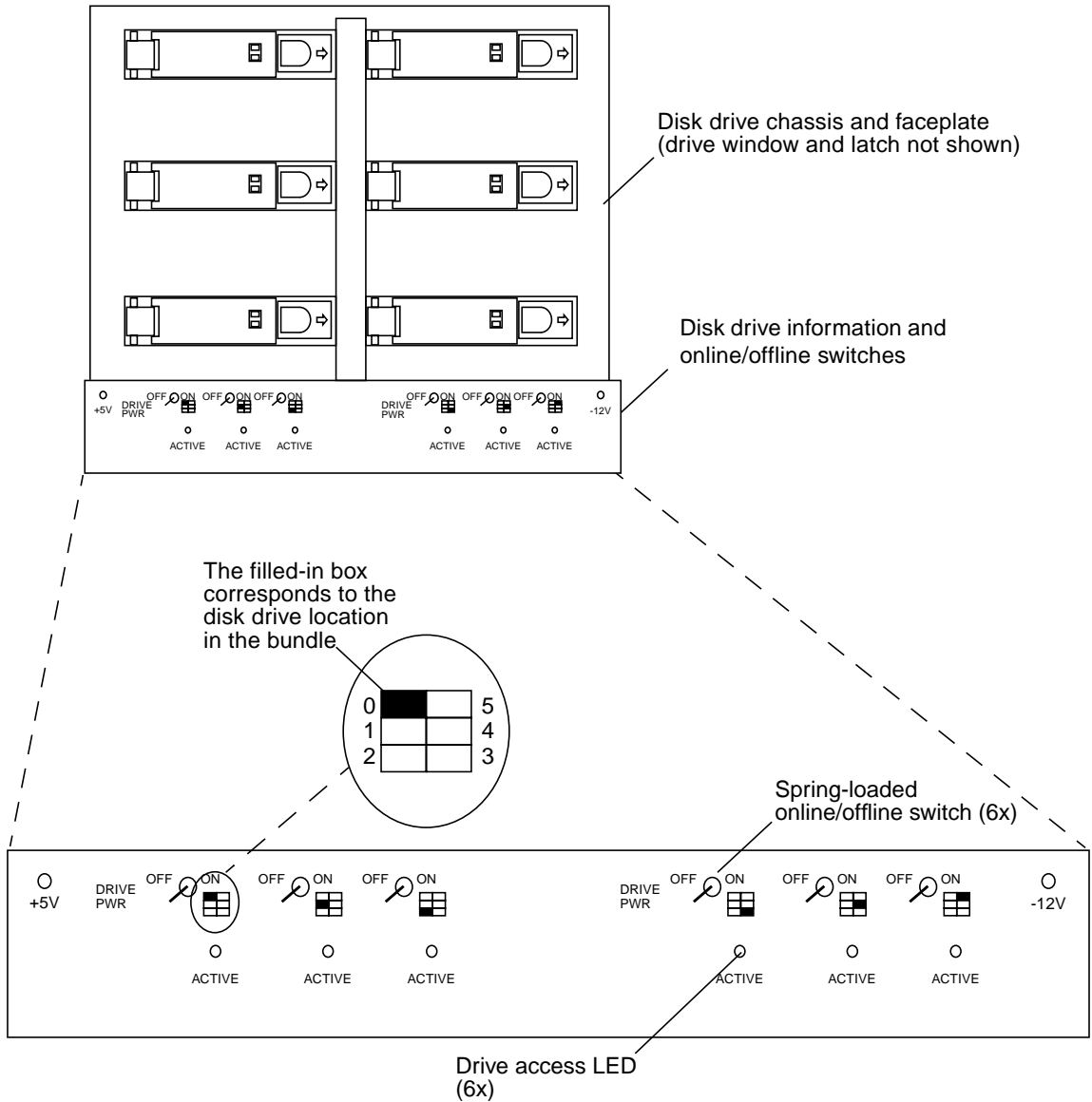
FIGURE 4-5 shows the an 18-Gbyte disk drive. FIGURE 4-6 shows a six-drive chassis for 18-Gbyte drives. Spring-loaded online/offline switches for each drive and LEDs indicating power and activeness for the drives are on the lower front portion of the faceplate of the six-drive chassis.

The three LEDs on the front panel of the 18-Gbyte disk drive chassis indicate the following:

- +5V—when green and steady, the +5V power is on
- -12V—when green and steady, the -12V power is on
- ACTIVE—when green, the drives are being accessed



**FIGURE 4-5** 18-Gbyte Disk Drive



**FIGURE 4-6** 18-Gbyte Disk Drive Chassis

1. A clear plexiglas window covers the front of the 18-Gbyte disk drive chassis. It has a latch in the center of it. Flip the drive window latch up, pull it, and open the drive window.
2. Locate the labeled slot corresponding to the label on the front of the disk drive module. FIGURE 4-7 shows an example of labeled locations for a single drawer.
3. Ensure that the slot in which the disk drive will be installed is offline.
  - a. Find the appropriate disk drive location as indicated on the lower portion of the drive chassis faceplate. See FIGURE 4-6.
  - b. Place this disk drive location offline by pulling the spring-loaded switch out and throwing it to the OFF position. See FIGURE 4-7.
4. Push the drive eject latch to the right to release the disk drive handle. See FIGURE 4-5.
5. Slide the disk drive into its corresponding slot. Push it to engage the backplane connector and close the handle.
6. Repeat unpacking steps 3 and 4 in paragraph “Unpacking the Disk Drives” on page 4-7 and installation Step 2 to Step 5 above until all six drives are installed in the chassis.
7. Close the drive window and push the window latch down to lock it.
8. Repeat all steps in the above paragraphs for each carton and each 18-Gbyte drive in the cartons.
9. Place all disk drives online by placing all the disks spring-loaded online/offline switches to the ON position (see FIGURE 4-7) before closing the drive drawers.



FIGURE 4-7 HDSA Disk Drive Slot Location Reference Labels, Single Drawer (Example)



HDSA drawer (side view)

\* Shelf labels include this disk module indicator for disks 0, 1, & 2.



\*\* Shelf labels include this disk module indicator for disks 5, 4, & 3.



---

## 4.3 Leveling the Cabinet After Disk Installation

After you install all disk drives and close the HDSA drawer(s), level the cabinet again. Use the same procedure described in “Leveling the Cabinet Before Disk Installation” on page 4-2.

---

## 4.4 Installing the System Console

---

**Note** – For some international installations, the A7000 System Console uses its serial port, shipped with an installed cable that connects to a connector panel assembly with DB9 connector. This panel assembly is inside the I/O Bay cabinet. Installations at international sites must obtain a modem conforming to local regulation.

---

The following paragraphs describe how to install the System Console for the A7000.

### 4.4.1 Unpacking and Installing the System Console

The System Console and PCMCIA cards are packaged separately and need to be installed. All System Console and PCMCIA card cables are already installed inside the carrier tray.

FIGURE 4-9 and FIGURE 4-10 are System Console connection block diagrams. FIGURE 4-13 shows the serial communications subsystem inside the rear of the cabinet; FIGURE 4-14 is an schematic of internal cable hookup, for reference only. All cables and connections inside the cabinet are pre-installed.

To install the System Console:

1. **Remove the System Console from its vendor packaging.**
2. **Open the carrier tray by turning the spring-loaded knobs on the tray clockwise to release the tray. See FIGURE 4-8.**
3. **Fold down the front door tray. You will see a cabling harness holding connectors wrapped in antistatic foam.**
4. **The System Console is held in place by snap-type Velcro strips. See FIGURE 4-11.**

5. **There is one PCMCIA dual-connector slot on the side of the System Console. This connector slot holds an Ethernet card (bottom connector) and modem card (top connector). Plug the modem and Ethernet PCMCIA cards into this slot.**



---

**Caution** – Each PCMCIA card has slot-eject buttons on each side; do not touch these buttons when the System Console is powered on.

---

6. **Remove the foam from the connectors and connect the following:**
  - Power cable from the AC/DC converter power supply to the power cable connector at the rear of the System Console notebook
  - Cable connector labeled DSP1/DSP2 to console parallel port connector
  - RJ-11 telephone cable connector to modem card (domestic installations); cable is labeled MODEM
  - DB9 serial connector to serial port (international installations; see FIGURE 4-10)
  - Ethernet connector to Ethernet card

Do not connect the external phone line until RSS has been configured. For more information of connecting the external phone line, see “Testing the Remote Support System Phone-Home Feature” on page 6-22 of Chapter 6 in this manual.

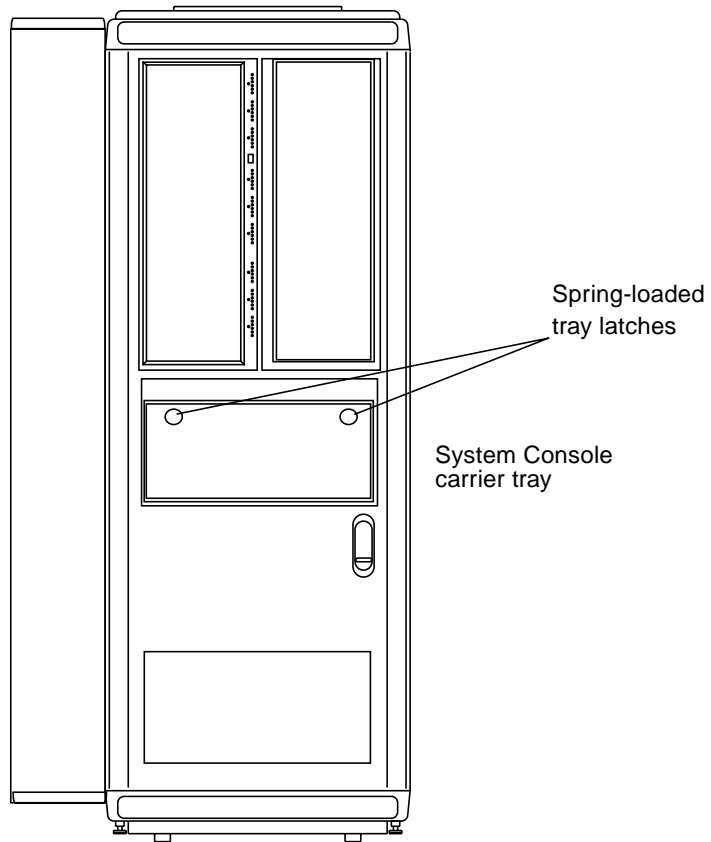
7. **Place the System Console snugly on the Velcro strips. Ensure the notebook is attached to the Velcro.**

This completes the domestic installation. Continue to “Completing an International System Console Installation” on page 4-15 if this is an international installation.

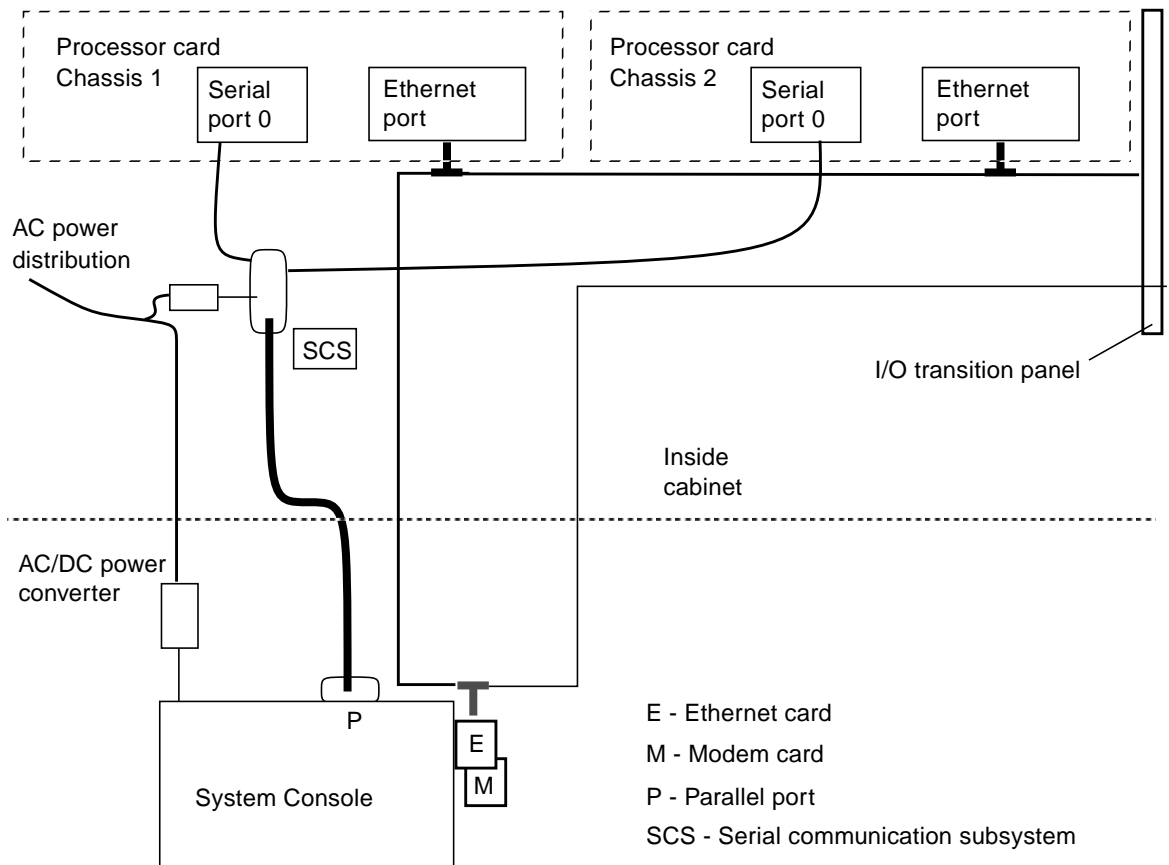
## 4.4.2 Completing an International System Console Installation

8. **Connect the serial cable to the System Console serial port (see FIGURE 4-11).**
9. **The I/O Bay cabinet contains a connector panel assembly with a DB9 connector labeled SERIAL. This connector is for the external modem used in the international installation.**
10. **Cable the external modem to this DB9 connector.**

Chapter 6, “Configuring Modem Files (International Installation Only)”, describes how to configure modem files for use internationally.



**FIGURE 4-8** System Console Tray Location



**FIGURE 4-9** System Console Connection Block Diagram (Domestic Installation)

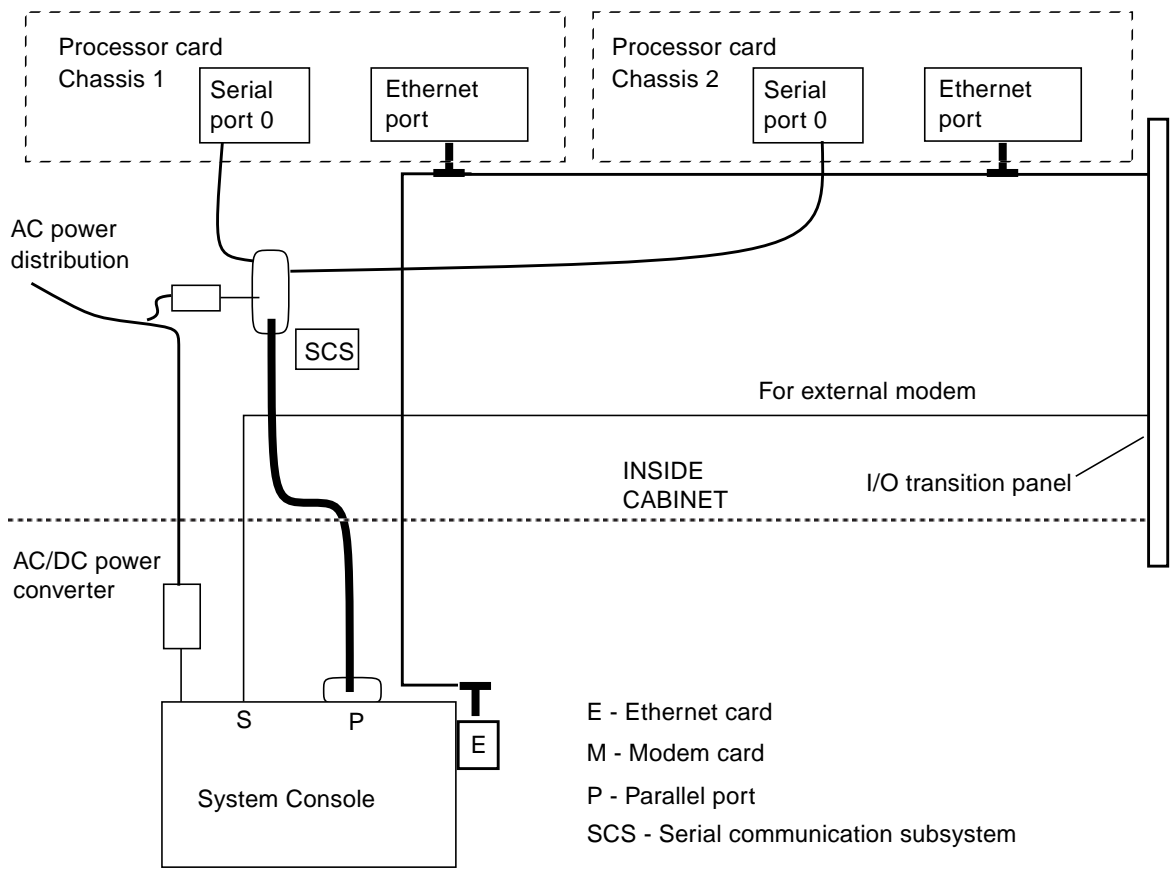
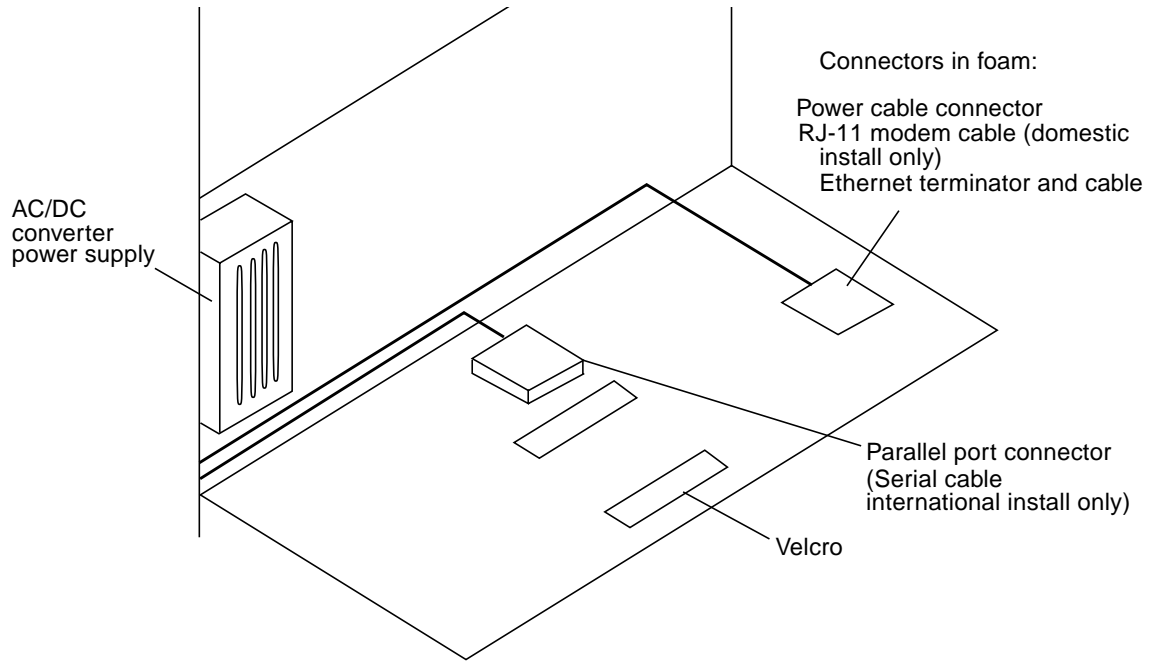
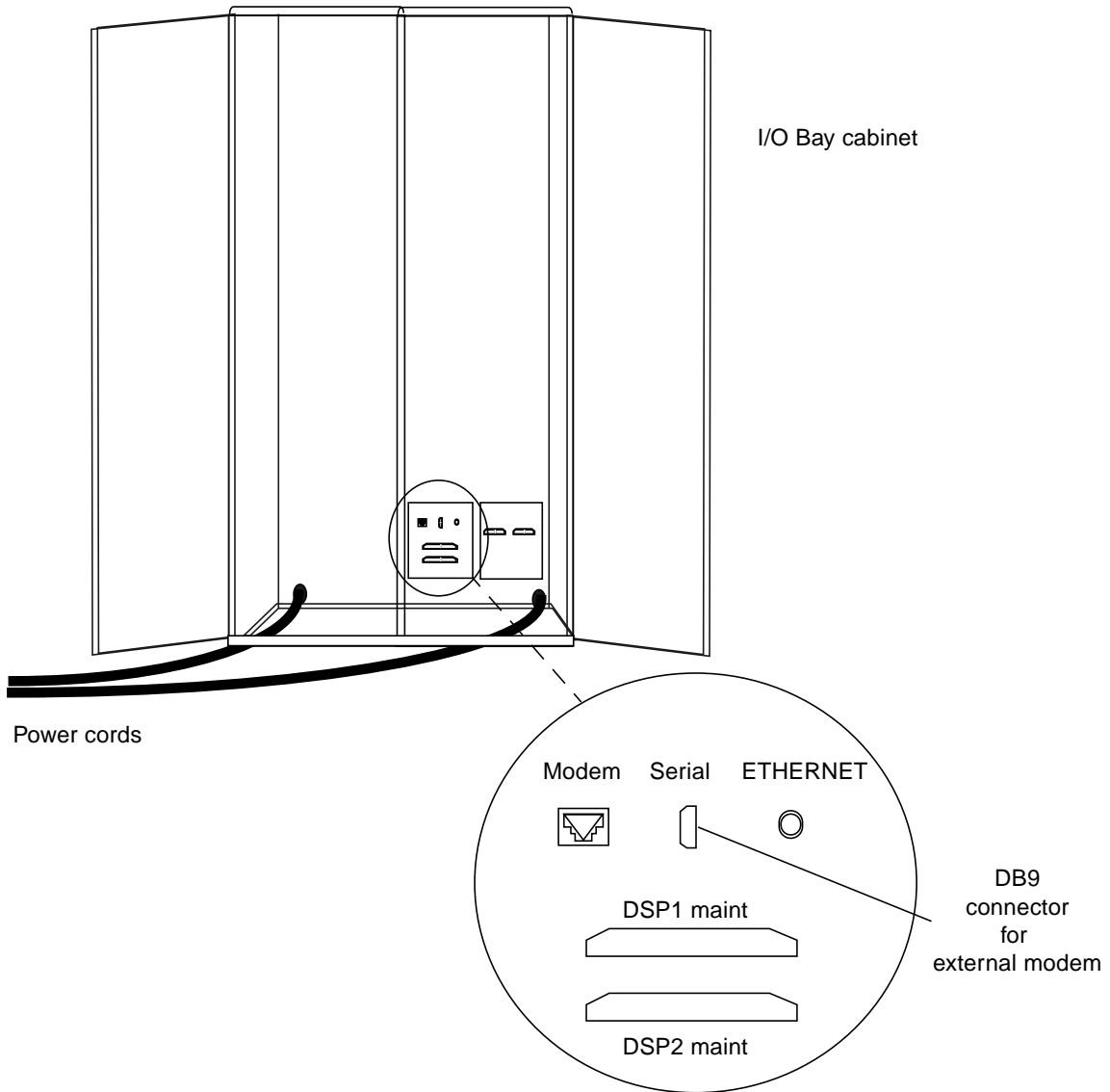


FIGURE 4-10 System Console Connection Block Diagram (International Installation)



**FIGURE 4-11** System Console Installation



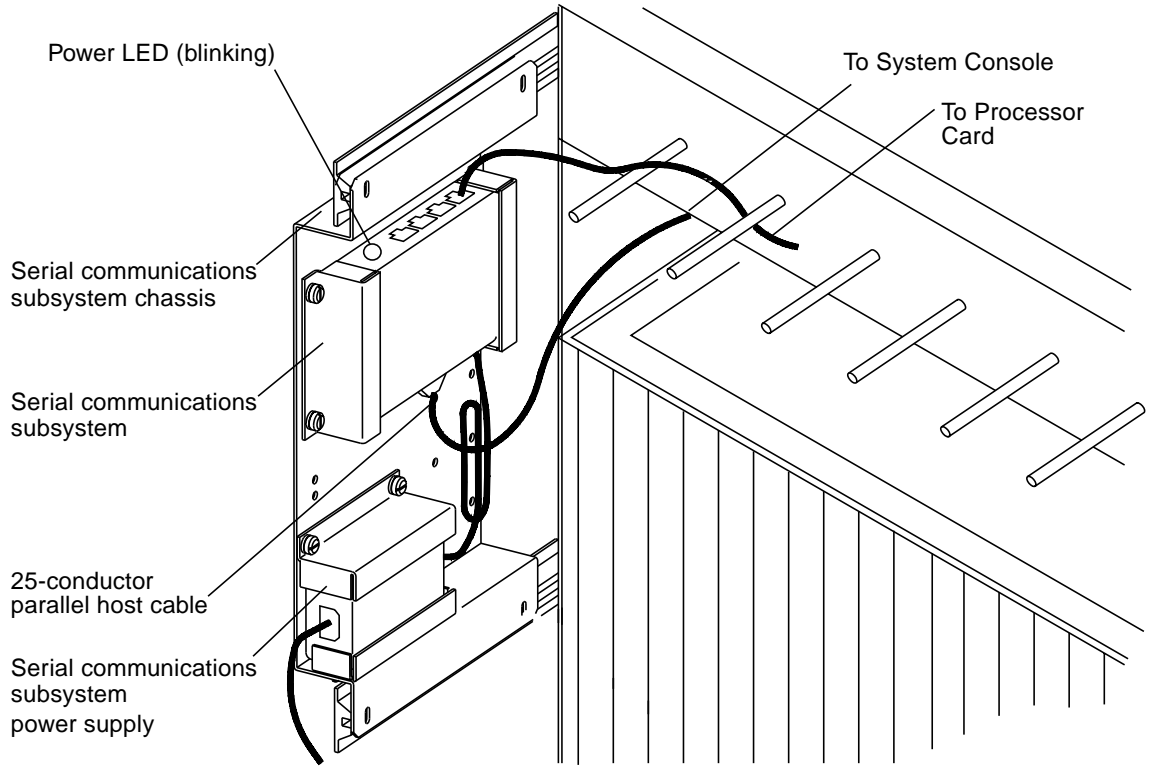
**FIGURE 4-12** Modem Connector Assembly in I/O Bay Cabinet

---

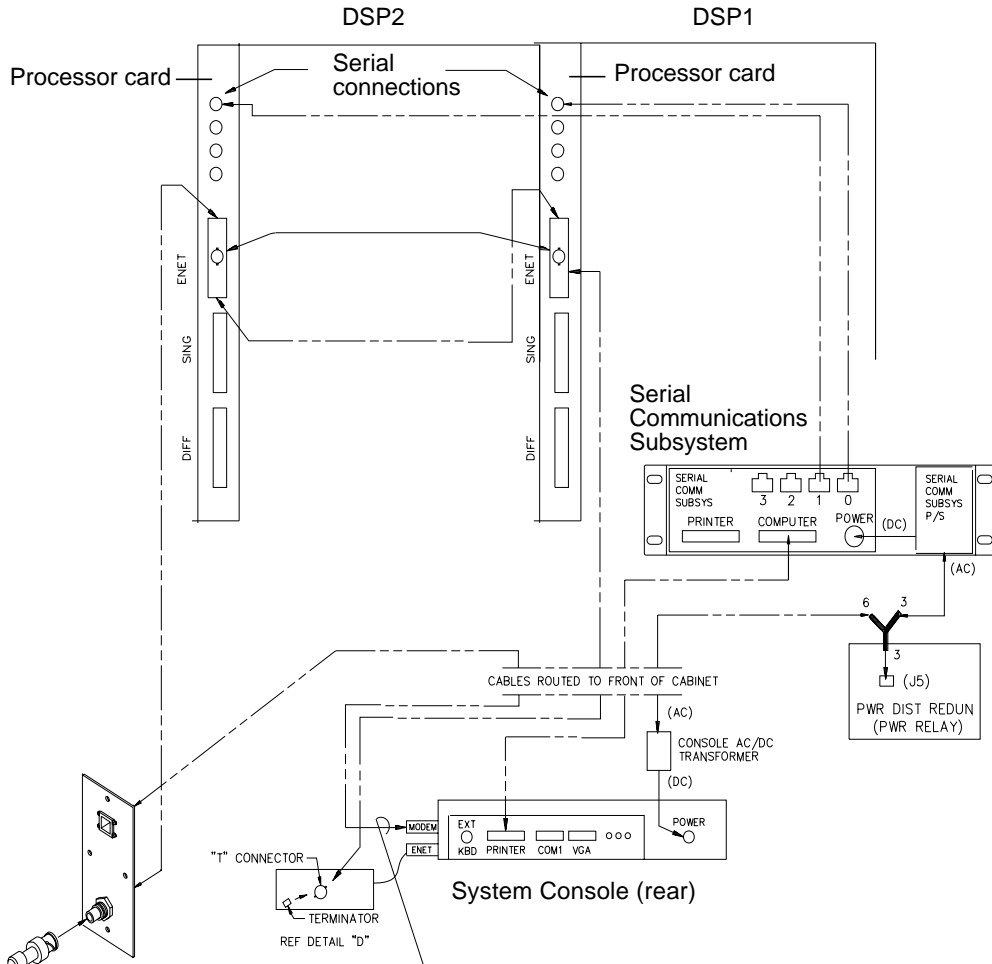
**Note** – Do not connect the external phone line until RSS has been configured. For more information of connecting the external phone line, see “Testing the Remote Support System Phone-Home Feature” on page 6-22 of Chapter 6 in this manual.

---





**FIGURE 4-13** Serial Communications Subsystem



If configured for international shipments, remove RJ11 cable from here and connect DB9 cable to COM1 port of System Console.

FIGURE 4-14 System Console/Serial Communications System Cable Connections

## Powering On

---



---

**Caution** – *Do not move or attempt to move the StorEdge A7000 cabinet with the HDSA drawer extended or open in any way. The cabinet could become unbalanced and topple if you try to move it incorrectly. Make sure the cabinet is properly level at all times. Chapter 4 describes how to level the cabinet. Do not remove or retract the main cabinet leveler feet if the HDSA drawer contains disk drives.*

---

This chapter describes how to power on the power conditioning unit (PCU), A7000 cabinet, subsystems, System Console, and HDSA drawer; it also describes how to check the PCU voltage and subsystem power supplies.

- Powering on the PCU—page 5-2
- Checking and Programming the PCU Input and Output Voltage—page 5-4
- Setting the PCU Date and Time—page 5-8
- Powering on the Cabinet and Checking Switches—page 5-12
- Adjusting the HDSA Drawer—page 5-17
- Completing the Power On Procedure—page 5-19
  - Powering on the System Console—page 5-19
  - Powering on the Subsystems and Check DC Voltage—page 5-21
  - Powering on the HDSA Power Supplies—page 5-23

---

## 5.1 Powering on the PCU

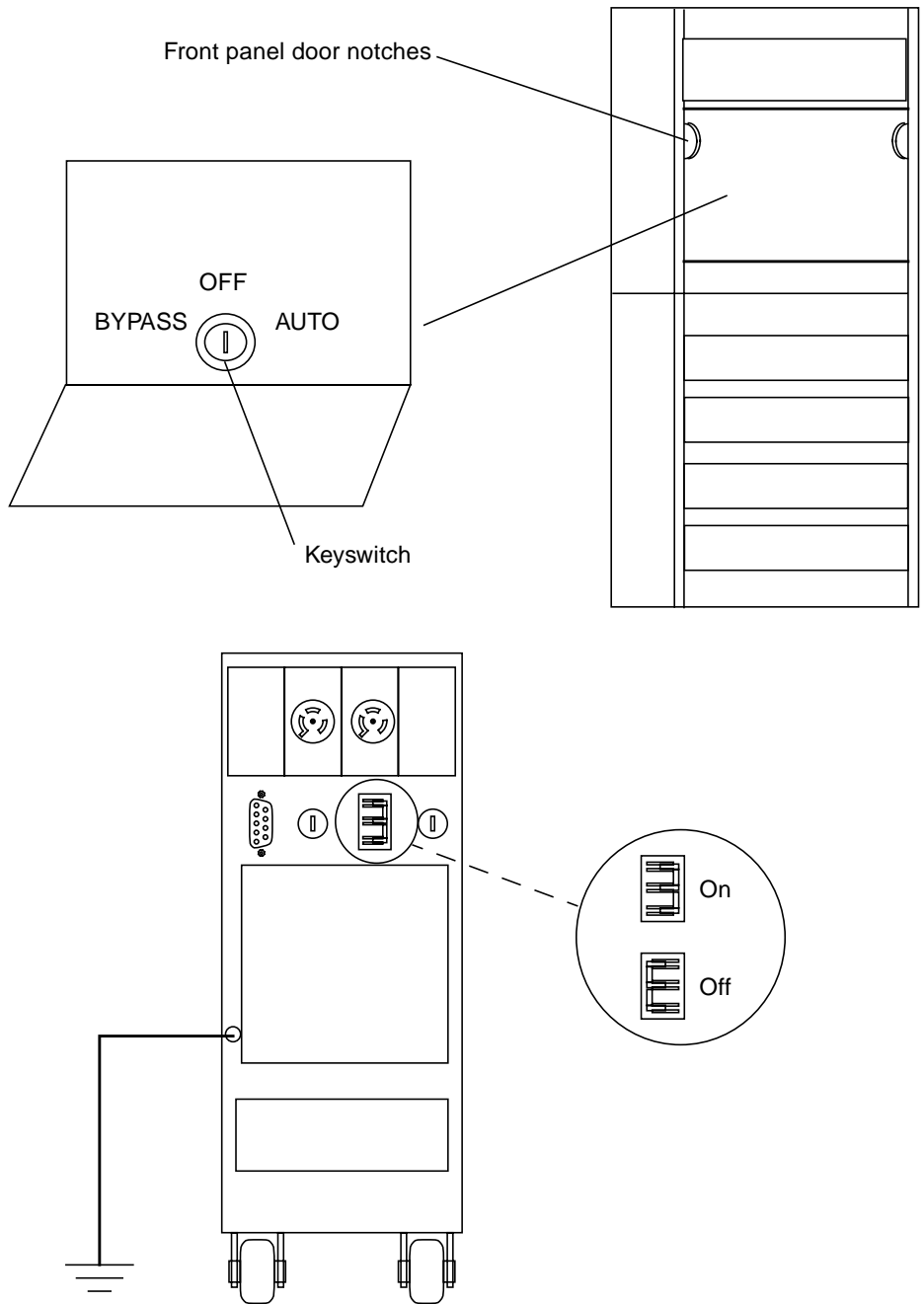


---

**Caution** – Unplug the A7000 power cords from their power output receptacles now.

---

1. **Turn on power to the PCU at the bypass switch.**
2. **At the front of the PCU, turn the key switch inside the front panel to AUTO. To open the panel, pull it down at the notches.**
3. **At the rear of the PCU, put the power circuit breaker in the ON position.**



**FIGURE 5-1** PCU Keyswitch and Circuit Breaker Switch

---

## 5.2 Checking and Programming the PCU Input and Output Voltage

---

**Note** – The following procedure assumes a licensed electrician has connected the PCU to a bypass switch, but *that the A7000 is not receiving power through the PCU*.

---



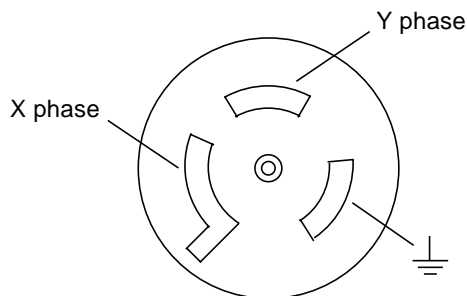
---

**Caution** – Some of the following steps are performed with the PCU powered. The PCU can generate fatal voltages with or without input power. Use extreme care when measuring live power.

---

### 5.2.1 Testing PCU Output Voltage

1. **Make sure the A7000 is not plugged into the PCU. Make sure the PCU is powered on.**
2. **With a digital voltmeter (DVM), check that the PCU output voltage is 230 VAC, +/- 4 VAC. Measure the voltage at the 50A Marincó CS8269 power output receptacles built into the junction box (refer to FIGURE 3-1 on page 3-3). See FIGURE 5-2.**



**FIGURE 5-2** 50A Marincó CS8269 Power Output Receptacle

X phase voltage to ground should be 90 to 125 VAC; Y phase voltage to ground should be 90 to 125 VAC. X phase to Y phase voltage should be 227 to 233 VAC.

Go to the next section, “Checking (and Calibrating, if necessary) Nominal Output Voltage: Parameter 05”.

## 5.2.2 Checking (and Calibrating, if necessary) Nominal Output Voltage: Parameter 05

Use the PCU front panel to verify that Parameter 05 is 230. The front panel of the PCU has five buttons used to program its output voltage; an LED display to the left of the buttons shows the programming results. See FIGURE 5-3.

1. Power the PCU on.
2. At the PCU front panel, press and hold the CANCEL and RUNTIME buttons at the same time for more than two seconds. Release the buttons when the display shows P-00.
3. Press the CANCEL button. The display shows 0.
4. Press and hold the %LOAD button until the display shows 377, and then release it. (If you press the button and it increments past 377, press the VOUT button to go back.)
5. Press the RUNTIME button. The display shows 1.
6. Press the CANCEL button. The display shows P-00.
7. Press and hold the %LOAD button until the display shows P-05, and then release it. (If you press the button and it increments past P-05, press the VOUT button to go back.)
8. Press the CANCEL button. If the display shows the correct voltage [230 VAC], press the VLINE button twice to quit this programming procedure.  
If the display shows incorrect voltage (other than 230 VAC), continue this procedure.
9. To change the voltage setting, press the %LOAD button to increase it and press the VOUT button to decrease it. The correct setting is 230.
10. With the display showing the correct voltage, press the RUNTIME button.
11. Press the CANCEL button twice to verify the new value in P-05.
12. Press the VLINE button twice to quit the programming procedure.

Go to the next section, "Checking (and Calibrating, if necessary) PCU Input Voltmeter: Parameter 27".



---

**Caution** – Uncalibrating or incorrectly calibrating the PCU voltmeters can cause actual output voltage to exceed safe levels for load equipment.

---

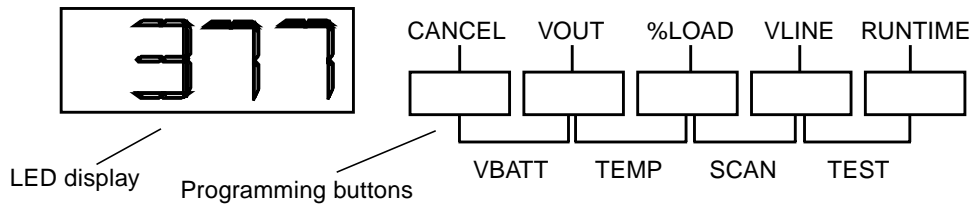


FIGURE 5-3 PCU Front Panel Used to Program PCU Output Voltage

### 5.2.3 Checking (and Calibrating, if necessary) PCU Input Voltmeter: Parameter 27

In this step, measure the input voltage to the PCU and make sure it matches PCU Parameter 27.

1. **With a DVM, measure the input voltage (L1 phase to L2 phase) and record it; measure the voltage at the terminal block where the AC power connects to the PCU, inside the PCU cabinet:\_\_\_\_\_ VAC**
2. **At the PCU front panel, press and hold the CANCEL and RUNTIME buttons at the same time for more than two seconds. Release when the display shows P-00.**
3. **Press and hold the %LOAD button until the display shows P-27, and then release it.**
4. **Press the CANCEL button once to show the P-27 parameter.**  
If the parameter is within the measurement of Step 1(+/- 2 VAC), go to Step 13.  
If the parameter is not within the measurement of Step 1, continue this procedure.
5. **Press the CANCEL button. Press the VOUT button to go to parameter P-00. Press the CANCEL button; the display shows 0.**
6. **Press and hold the %LOAD button to increase the value to 2639.**
7. **With the display showing the correct value, press the RUNTIME button. The display shows 2.**
8. **Press the CANCEL button. The display shows P-00.**
9. **Press and hold the %LOAD button until the display shows P-27, and then release it.**
10. **Press the CANCEL button once to show the P-27 parameter value.**



11. To change the voltage setting, press the %LOAD button to increase it and the VOUT button to decrease it. The correct setting is the value you measured in Step 1.
12. With the display showing the correct voltage, press the RUNTIME button.
13. Press the CANCEL button twice to verify the new value in P-27.
14. Press the VLINE button twice to quit the programming procedure.
15. Verify that the actual input voltage matches VLINE.  
Go to the next section, "Checking (and Calibrating, if necessary) PCU Output Voltmeter: Parameter 28".

## 5.2.4 Checking (and Calibrating, if necessary) PCU Output Voltmeter: Parameter 28

In this step, measure the output voltage of the PCU and make sure it matches PCU Parameter 28.

1. With a DVM, measure the output voltage (X phase to Y phase) and record it. Measure the voltage at the 50A power output receptacles built into the junction box. \_\_\_\_ VAC
2. At the PCU front panel, press and hold the CANCEL and RUNTIME buttons at the same time for more than two seconds.
3. Press and hold the %LOAD button until the display shows P-28, and then release it.
4. Press the CANCEL button once to show the P-28 parameter.  
If the parameter is within the measurement of Step 1 (+/- 4 VAC), go to Step 13; if not, continue this procedure.
5. Press the VOUT button to go to parameter P-00. Press the CANCEL button; the display shows 0.
6. Press and hold the %LOAD button to increase the value to 2639.
7. With the display showing the correct value, press the RUNTIME button. The display shows 2.
8. Press the CANCEL button. The display shows P-00.
9. Press and hold the %LOAD button until the display shows P-28, and then release it.

10. Press the CANCEL button once to show the P-28 parameter value. Compare this value to the value in Step 1, +/- 4 VAC.
11. To change the voltage setting, press the %LOAD button to increase it and the VOUT button to decrease it. The correct setting is the value you measured in Step 1.
12. With the display showing the correct voltage, press the RUNTIME button.
13. Press the CANCEL button twice to verify the new value in P-28.
14. Press the VLINE button twice to quit the programming procedure.
15. Verify that the actual output voltage matches VOUT; press the VOUT button. Measure the voltage at the 50A connector at the rear of the PCU again.
16. Power off the PCU and replace the cover panels.

---

## 5.3 Setting the PCU Date and Time



---

**Caution** – Make sure the A7000 is not plugged into the PCU.

---

In this procedure, you set the PCU user password, set the current date and time, and check these values. Depending on the PCU firmware revision level, some PCU date and time parameter numbers (P-xx) are different from others; “Checking PCU Firmware Revision Level (Parameter 128)” tells how to check the firmware revision level of the PCU you are setting.

### 5.3.1 Setting the User Password

1. Power the PCU on.
2. At the PCU front panel, press and hold the CANCEL and RUNTIME buttons at the same time for more than two seconds. Release the buttons when the display shows P-00.
3. Press the CANCEL button. The display shows 0.
4. Press and hold the %LOAD button until the display shows 377, and then release it. (If you press the button and it increments past 377, press the VOUT button to go back.)
5. Press the RUNTIME button. The display shows 1.

## 5.3.2 Checking PCU Firmware Revision Level (Parameter 128)

1. Press the CANCEL button. The display shows P-00.
2. Press and hold the %LOAD button until the display shows P-128, and then release it. (If you press the button and it increments past P-128, press the VOUT button to go back.)
3. Press the CANCEL button. If the display shows 1.06 or above, go to “Setting the Current Time, Date, and Year, Firmware Revision Level 1.06 or Above (Parameters 89, 90, 91)”. If the display shows 1.05 or below, go to “Setting the Current Time and Date, Firmware Revision Level 1.05 or Below (Parameters 89, 90, 91)” — page 5-10.

## 5.3.3 Setting the Current Time, Date, and Year, Firmware Revision Level 1.06 or Above (Parameters 89, 90, 91)

1. Press the CANCEL button. The display shows P-128.
2. TIME: Press and hold the VOUT button until the display shows P-89, and then release it. (If you press the button and the display value goes below P-89, press the %LOAD button to increase the value.)
3. Press the CANCEL button to show the value for the hours and minutes, in the format *hh:mm*, where *hh* is hours and *mm* is minutes. The clock for the PCU is a 24-hour type (for example, 11:00 PM is 23:00).
4. To change the value, press the %LOAD button to increase it and press the VOUT button to decrease it. The range for the time is 00:00 to 23:59.
5. When the display shows the correct time, press the RUNTIME button.
6. Press the CANCEL button twice to verify the new value in P-89.
7. DATE: Press the CANCEL button. The display shows P-89.
8. Press the %LOAD button once, until the display shows P-90, and then release it. (If you press the button and it increments past P-90, press the VOUT button to go back.)
9. Press the CANCEL button to show the value for the date, in the format *mm.dd*, where *mm* is the month and *dd* is the day.

10. To change the value, press the %LOAD button to increase it; press the VOUT button to decrease it. The range for date is 01/01 to 12/31.
11. With the display showing the correct date, press the RUNTIME button.
12. Press the CANCEL button twice to verify the new value in P-90.
13. YEAR: Press the CANCEL button. The display shows P-90.
14. Press the %LOAD button once until the display shows P-91, and then release it. (If you press the button and it increments past P-91, press the VOUT button to go back.)
15. Press the CANCEL button to show the value for the current year, in the format *yyyy*, where *yyyy* is the year.
16. To change the value, press the %LOAD button to increase it; press the VOUT button to decrease it.
17. Press the CANCEL button twice to verify the new value in P-91.
18. Press the VLINE button twice to quit the programming procedure.

### 5.3.4 Setting the Current Time and Date, Firmware Revision Level 1.05 or Below (Parameters 89, 90, 91)

1. Press the CANCEL button. The display shows P-128.
2. TIME, Seconds: Press and hold the VOUT button until the display shows P-89, and then release it. (If you press the button and the display value goes below P-89, press the %LOAD button to increase the value.)
3. Press the CANCEL button to show the value for the minutes and seconds, in the format *mm:ss*, where *mm* is minutes and *ss* is seconds. You cannot change the minutes now; the PCU uses the minutes you will set in parameter P-90.
4. To change the value, press the %LOAD button to increase it and press the VOUT button to decrease it. The range for seconds is 00 to 59.
5. With the display showing the correct time, press the RUNTIME button.
6. Press the CANCEL button twice to verify the new value in P-89.
7. TIME, Hours and Minutes: Press the %LOAD button once until the display shows P-90, and then release it. (If you press the button and it increments past P-90, press the VOUT button to go back.)

8. Press the CANCEL button to show the value for the hours and minutes, in the format *hh:mm*, where *hh* is hours and *mm* is minutes. The clock for the PCU is a 24-hour type (for example, 11:00 PM is 23:00).
9. To change the value, press the %LOAD button to increase it and press the VOUT button to decrease it. The range for the time is 00:00 to 23:59.
10. With the display showing the correct time, press the RUNTIME button.
11. Press the CANCEL button twice to verify the new value in P-90.
12. DATE, Week and Day: Press the CANCEL button. The display shows P-90.
13. Press the %LOAD button once until the display shows P-91, and then release it. (If you press the button and it increments past P-91, press the VOUT button to go back.)
14. Press the CANCEL button to show the value for the date, in the format *w.dd*, where *w* is the week of the month and *dd* is the day of the week.
15. To change the value, press the %LOAD button to increase it and press the VOUT button to decrease it. The range for date is 1.01 to 4.07.
16. With the display showing the correct date, press the RUNTIME button.
17. Press the CANCEL button twice to verify the new value in P-91.
18. Press the VLINE button twice to quit the programming procedure.

---

## 5.4 Powering on the Cabinet and Checking Switches

The following procedures describe how to power on the cabinet and check the AC relay and other switches.

### 5.4.1 Powering on the Cabinet

1. **Make sure the PCU is off.**
2. **Plug the A7000 power cords into their power output receptacles.**
3. **Power the PCU on.**
4. **Open the front door—Pull the bottom of the latch out and turn the latch assembly counterclockwise. Pull the latch to open the door.**
5. **At the left AC distribution box, throw the main circuit breaker switch CB1 to the right (ON). See FIGURE 5-4.**
6. **Press the cabinet power switch to turn on power to the cabinet. Make sure the switch lights.**
7. **Repeat the above steps for the right AC distribution box.**
8. **Listen for the blower fans; this indicates power has been applied to the cabinet.**

### 5.4.2 Checking the AC Relay Switch

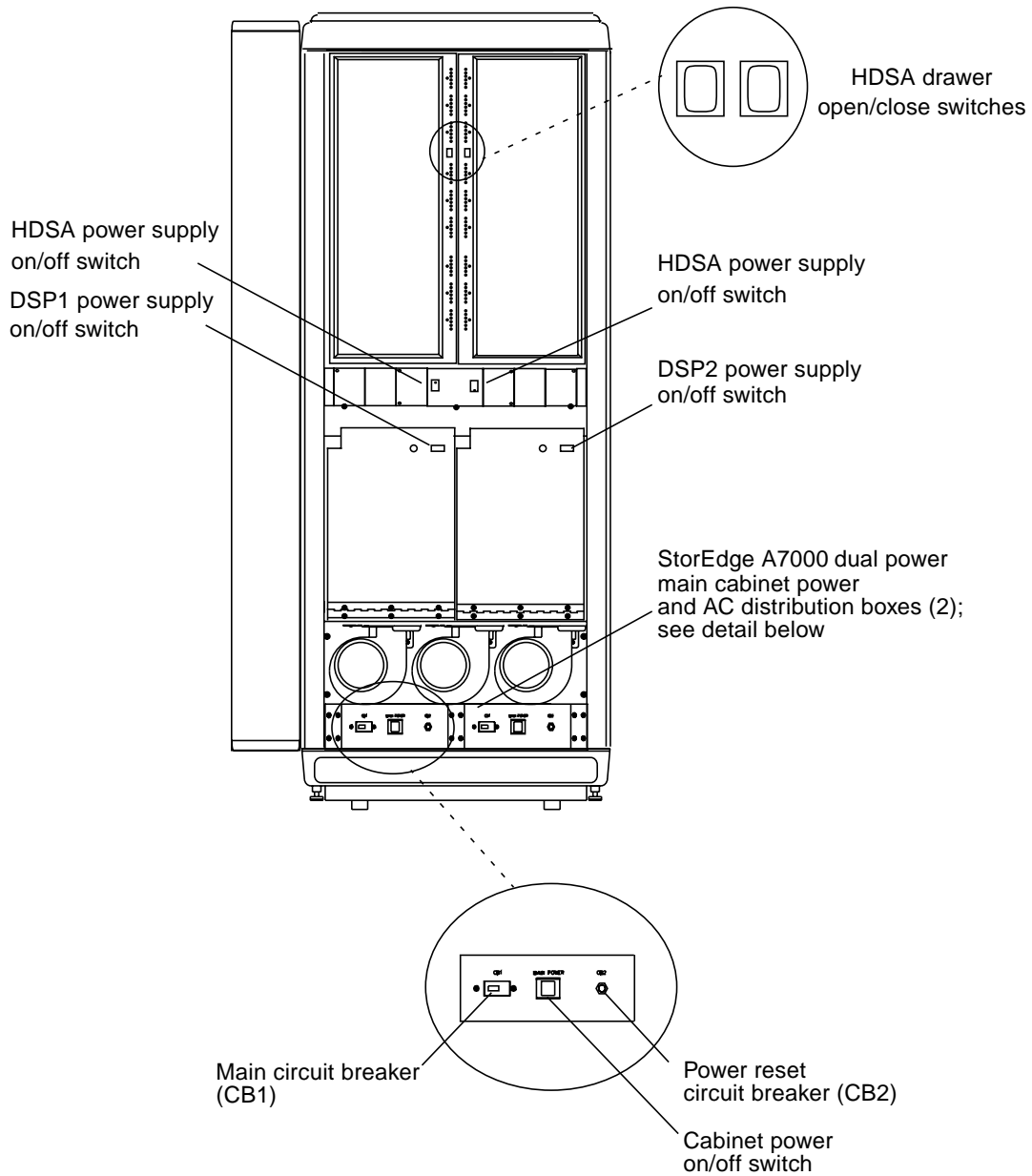
These steps verify that the AC relay switch is operating.

9. **Make sure you have performed Step 5 and Step 6 for both AC boxes.**
10. **At the AC box you first powered on (for DSP1), turn off the cabinet power switch and make sure its light is off. Verify that all three blower fans continue to operate.**
11. **Press the cabinet power switch on. Verify that power is restored by seeing that the switch lights.**

12. At the AC box for DSP2, turn off the cabinet power switch and make sure its light is off. Verify that all three blower fans continue to operate.
13. Press the cabinet power switch on. Verify that power is restored by seeing that the switch lights.

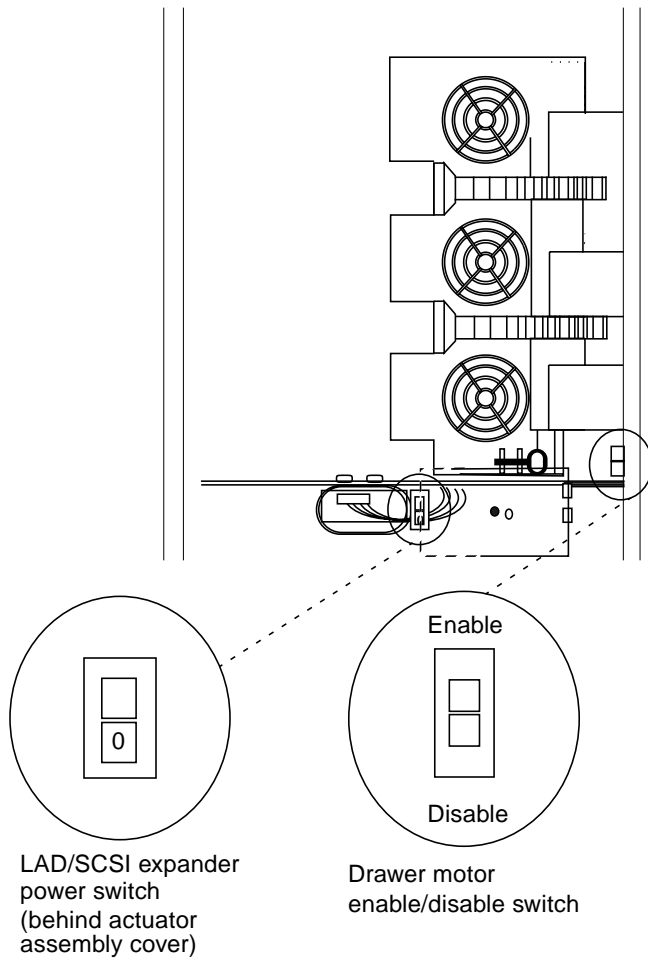
### 5.4.3 Checking Other Switches:

1. Power on the LAD/SCSI Expander power supply. Verify that the power switch LED is on. See FIGURE 5-5 for switch location at the rear of the cabinet.
2. Open the I/O Bay cabinet doors.
3. Just above the right power cord are two switches labeled DSP1 and DSP2. Press the top of the switch to throw these to ON. See FIGURE 5-6. These supply power to the dual DC supplies for each subsystem. The LED in each switch will light.



**FIGURE 5-4** HDSA Drawer Open/Close and Power Switches Inside Cabinet Front





**FIGURE 5-5** LAD/SCSI Expander Power Switch Location

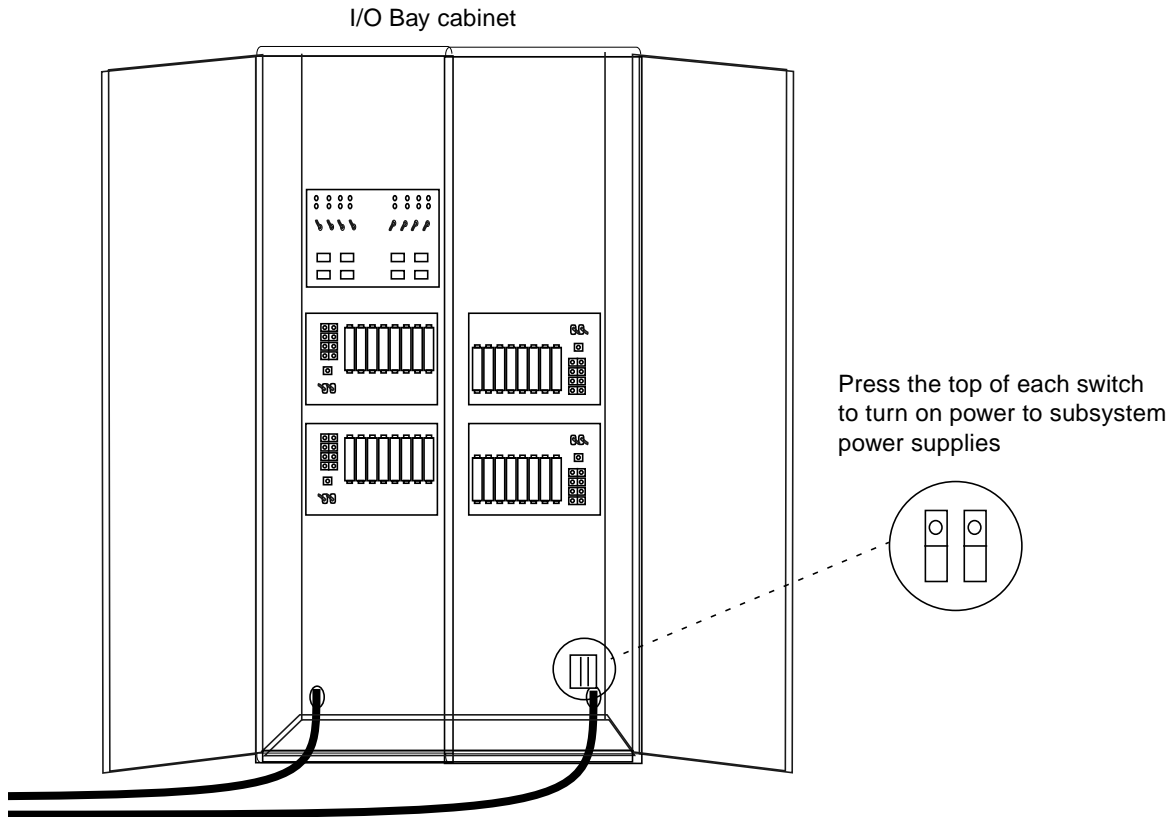


FIGURE 5-6 AC Box Power Switches

---

## 5.5 Adjusting the HDSA Drawer

---

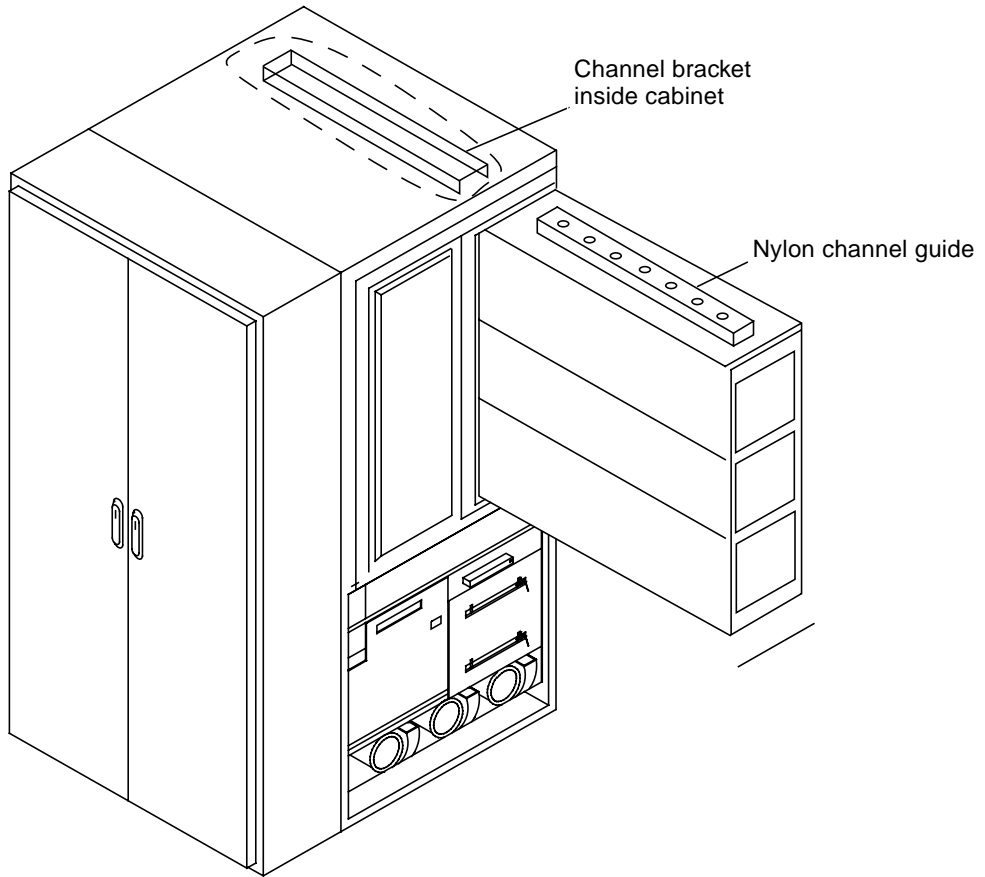
**Note** – Perform this step only if the HDSA drawer is not retracting or extending smoothly. First check that the cabinet is level, according to procedures in Chapter 4.

You will need a stepladder to reach the top of the drawer.

---

The HDSA drawer is adjusted at the factory; it may need readjustment because of flooring differences between the factory and customer site.

1. **Open the HDSA cabinet door and put the drawer motor enable/disable switch at the rear of the cabinet in the ENABLE position.**
2. **Press the HDSA drawer open/close switch a few times to check that the drawer travels in and out smoothly. If it is not smooth, continue to Step 3.**
3. **If the drawer will not extend on its own, gently pull it all the way forward.**
4. **At the top of the drawer is the nylon channel guide, shown in FIGURE 5-7. Seven screws hold the channel guide in place. Loosen all seven screws. Note that the channel guide moves side to side.**
5. **Center the channel guide to the channel bracket. Tighten the rearmost screw only.**
6. **Press the HDSA drawer open/close switch so that it only partially closes just before the next (second to the rear) screw. (To stop the drawer, press the switch.) Adjust and center the channel guide to the channel bracket again.**
7. **Repeat Step 6 until the channel guide is adjusted and all screws are tight.**



**FIGURE 5-7** HDSA Drawer Channel Guide Adjustment Diagram

---

## 5.6 Completing the Power On Procedure

The following paragraphs describe the remaining steps to complete the A7000 power on procedures.

### 5.6.1 Powering on the System Console

The System Console is mounted in the carrier tray in the front door. To power it on:

1. **Make sure the cabinet is powered on, according to “Powering on the Cabinet and Checking Switches” on page 5-12. Make sure the System Console power supply power LED is on; this power supply is located to the left of the System Console. If the A7000 includes the Serial Communications Subsystem (inside the cabinet rear door), make sure its power LED is blinking. See FIGURE 5-8.**

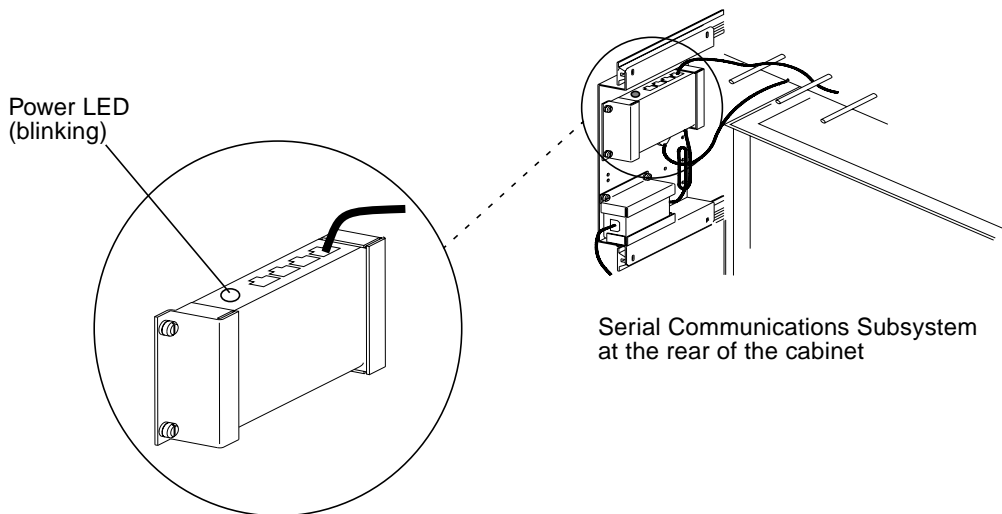


FIGURE 5-8 Serial Communications Subsystem Power Supply LEDs

2. **Power on the System Console.**
3. **Remove protective plastic from the System Console display (if applicable).**
4. **Watch the startup process (“boot”) messages for any warnings or failures.**

5. **The System Console operating system and environment boots automatically. Subsystem windows open automatically; make sure one window opens for each subsystem. Each subsystem window will be titled `dsp1` and `dsp2`.**

If subsystem windows do not open, refer to “Opening Windows Into the A7000 Subsystems” on page 5-20.

## 5.6.2 Opening Windows Into the A7000 Subsystems

---

**Note** – The System Console is factory-configured so that subsystem windows automatically open upon completion of System Console power on. Use the following procedures if windows are not or do not open after power on.

---

The A7000 has two subsystems named `dsp1` and `dsp2`. When powered on, each subsystem sends initialization and powerup messages to the System Console; you must open windows to see these messages.

To open windows corresponding to the two A7000 subsystems:

1. **Use the trackball/trackpad mouse or pointing device and move the mouse pointer to Windows at the Menu Bar.**

---

**Note** – On the System Console with trackpad mouse or pointing device, move the pointer by putting your finger on the trackpad; the pointer moves as your finger moves over the trackpad.

---

2. **Press the left mouse button. A menu is displayed.**
3. **Drag the mouse pointer to `dsp1`. This is the A7000 subsystem 1.**
4. **Release the mouse button. Window `dsp1` is displayed and shows any communication occurring through the Processor board’s serial port 0.**
5. **Repeat Step 1 to Step 4 for `dsp2`.**

An alternate method to open these two windows is as follows:

1. **Move the mouse pointer to Windows at the Menu Bar.**
2. **Press the Alt-W keys. A menu is displayed.**
3. **Using the Down arrow key, move the mouse pointer to `dsp1`. This is the A7000 subsystem 1.**
4. **Press the Enter key. Window `dsp1` is displayed and shows any communication occurring through the Processor board’s serial port 0.**

5. Repeat Step 1 to Step 4 for dsp2.

### 5.6.3 Powering on the Subsystems and Check DC Voltage

FIGURE 5-9 shows the subsystem power supply on/off switches. These slide switches move left to right to show a 1 (on) or right to left to show a 0 (off). As shown in FIGURE 5-9, the A7000 has two subsystems, dsp1 and dsp2, with a power supply switch for each.

1. Open the front cabinet door.
2. Slide the subsystem power supply on/off switches to the right.
3. Close the door partially and go to the System Console. CPU startup messages start to appear in each subsystem window, and finish by displaying the following prompt:

```
ROM >>
```

4. Put the cursor in the subsystem window. The mouse pointer turns into a cursor (|). Click the left mouse button to select the window. The window border changes color.
5. Reset the subsystem:

```
ROM >> reset node
```

**6. Check the subsystem DC voltages by typing the following command at the ROM>> prompt:**

```
ROM >> environ
```

Text like the following is displayed:

```
Temperature: Inlet: 28.21 c Exhaust: 48.92 c  
Voltage +5V: +5.00 v  
Voltage +12V: +11.99 v / -12V: -12.03 v
```

The voltages should be in the following ranges. If not, you must adjust them, according to procedures in the *StorEdge A7000 Service Manual*.

+5 Volt Supply: +4.95 VDC to +5.01 VDC

+12 Volt Supply: +11.85 VDC to +12.05 VDC

-12 Volt Supply: -11.85 VDC to -12.05 VDC

**7. Record the displayed temperatures and voltages in the Value column shown in TABLE 5-1.**

**8. Repeat Step 4 through Step 7 for all subsystems.**

**TABLE 5-1** Temperatures and Voltages at Installation

Subsystem	Item	Value
dsp1	Intake Temperature	
	Exhaust Temperature	
	+5 VDC Supply	
	+12 VDC Supply	
	-12 VDC Supply	
dsp2	Intake Temperature	
	Exhaust Temperature	
	+5 VDC Supply	
	+12 VDC Supply	
	-12 VDC Supply	



## 5.6.4 Saving the ROM Monitor NVRAM Data

1. Open an xterm window:
  - a. Put the mouse pointer in any open area on the root window display area.
  - b. Press the left mouse button. A menu appears. Drag the mouse pointer to **NEW WINDOW**. Release the mouse button.
  - c. An xterm window is displayed. Move the mouse pointer to the xterm window.
2. Save the NVRAM data on dsp1:

```
# nvram_save dsp1
```

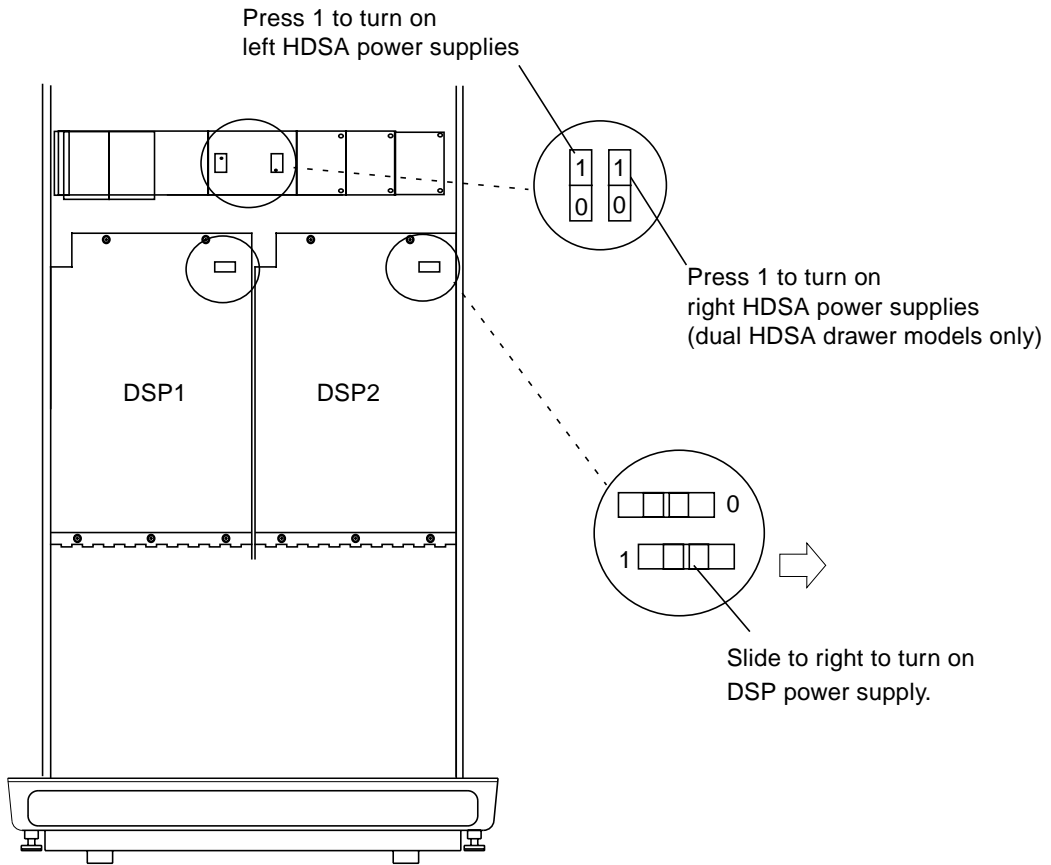
3. Save the NVRAM data on dsp2:

```
# nvram_save dsp2
```

## 5.6.5 Powering on the HDSA Power Supplies

In the middle of the cabinet front just under the HDSA drawer(s) are the HDSA power supply switches. See FIGURE 5-9. These snap switches are labelled with a 0 and 1. The 0 position is OFF and the 1 position is ON.

1. Place the left HDSA power supply switch in the 1 position.
2. Dual HDSA drawer models only: Place the right HDSA power supply switch in the 1 position.
3. Make sure all HDSA power supply LEDs light.
4. Listen to make sure all front and rear HDSA drawer blower fans turn on. Open the rear doors to check rear fan operation.
5. Make sure that no disk drive select LEDs on the front of the HDSA drawers remain lighted.
6. Close the front door.



**FIGURE 5-9** Subsystem Power Supply and HDSA On/Off Switches

---

**Note** – Go to the Acceptance Test Procedure (ATP) document. After completing the ATP, return to this Guide’s Chapter 6 to complete the installation.

---

# Completing the Installation

---

---

**Note** – Perform the procedures here only after you have completed the Acceptance Test Procedure (ATP), as instructed in Chapter 5.

---

This chapter describes how to complete the StorEdge A7000 installation.

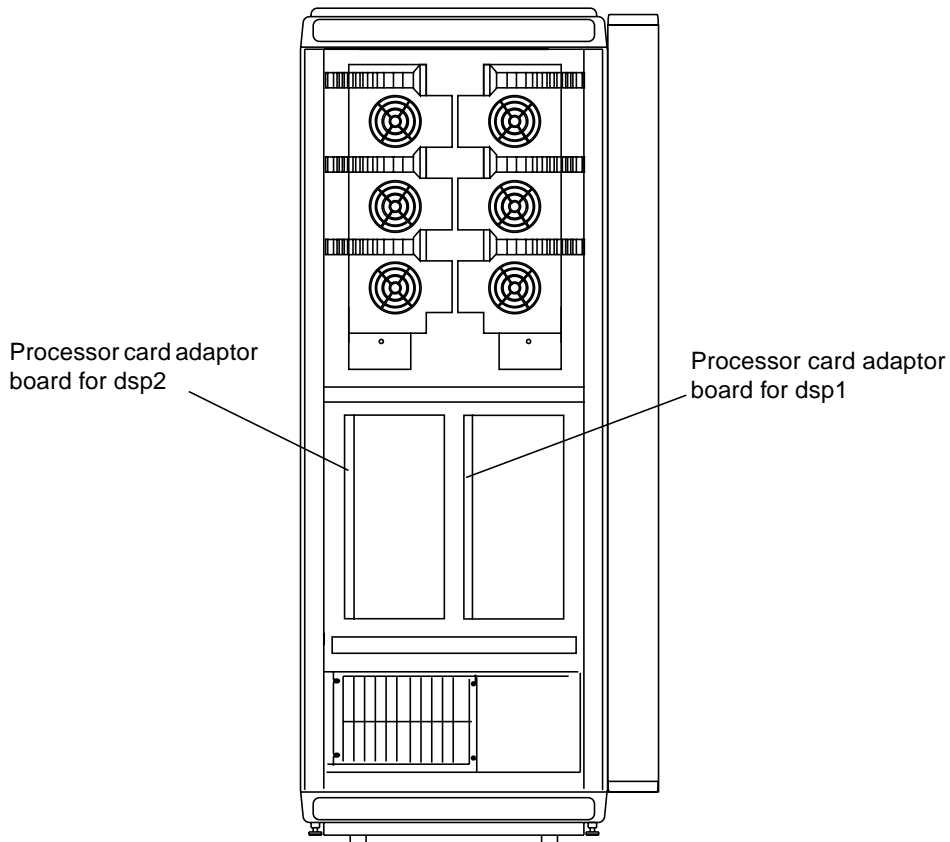
- Connecting the Internal Power Conditioning Unit (PCU) Data Cables—page 6-2
- Installing Channel Interface Cables—page 6-4
- Analyzing the Acceptance Test Procedure (ATP) Results and Error Report (errpt)—page 6-9
- Configuring the A7000 to Phone Home—page 6-12
  - Entering Customer Information into MCD—page 6-14
  - Configuring RSS and Entering Service Support Telephone Number—page 6-17
- Testing the Phone-Home Feature—page 6-22
- Entering the Date, Time, and Timezone—page 6-25
- Starting the PCU Software—page 6-28
- Checking the PCU Battery—page 6-32
- Setting the A7000 Password—page 6-33
- Configuring the Operating System Software for Remote Dual Copy—page 6-33
- Checking the Master Configuration Data (MCD)—page 6-37
- Backing Up Important System Files—page 6-38
- Configuring Modem Files (International Installation Only)—page 6-21

---

## 6.1 Connecting the Internal Power Conditioning Unit (PCU) Data Cables

After successfully powering the A7000 on and running the ATP, you can now connect the internal PCU data cable.

1. **Open the rear cabinet door.**
2. **Inside the rear of the A7000, locate the processor card adaptor boards for dsp1 and dsp2. Each processor card adaptor board is in the first slot of the dsp's 14-slot chassis. See FIGURE 6-1.**



**FIGURE 6-1** Inside Rear of A7000

3. Remove the loopback cable connected to each Processor card's serial ports 1, 2, and 3. See FIGURE 6-2.

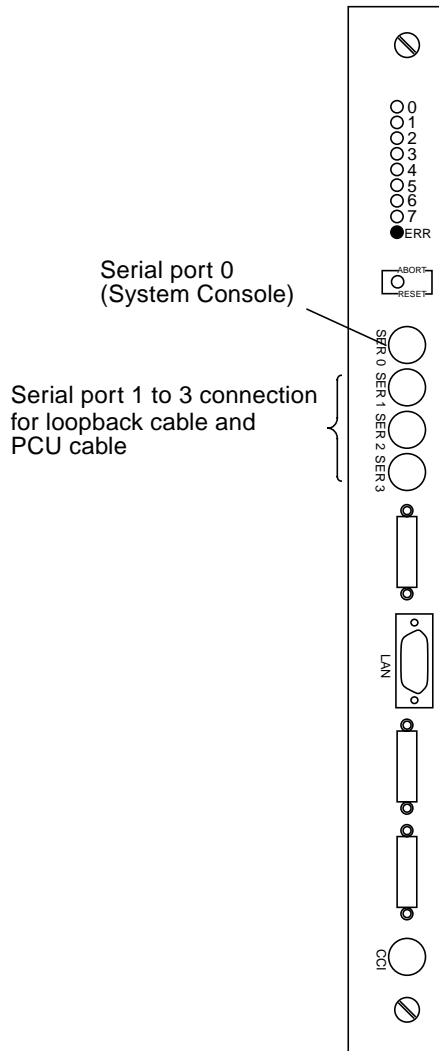


FIGURE 6-2 Processor Card Adaptor Board Front Panel

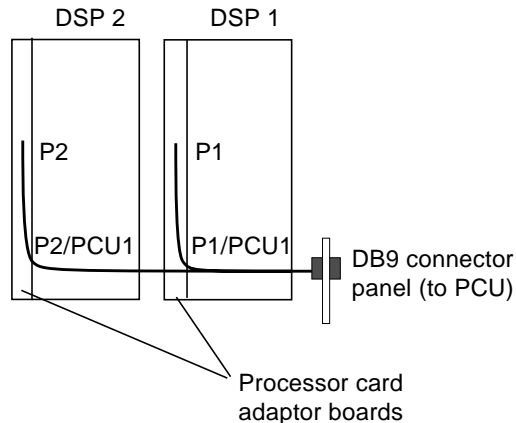
**4. Refer to TABLE 6-1 for cable connections.**

**TABLE 6-1** PCU Data Cable, Internal Connections

Y-Cable Connector Labeled...	Connects to Processor Card Adaptor Board...
P2/PCU1 or DSP2/SER3/UPS (P2 connector on cable)	serial port 3, DSP2 chassis
P1/PCU1 or DSP1/SER3/UPS (P1 connector on cable)	serial port 3, DSP1 chassis

**5. Remove foam protectors from all cables to be used.**

**6. Connect the PCU data cables to serial port 3 on the appropriate processor card adaptor board. See FIGURE 6-3.**



**FIGURE 6-3** PCU Data Cable, StorEdge A7000 Internal Connection

## 6.2 Installing Channel Interface Cables

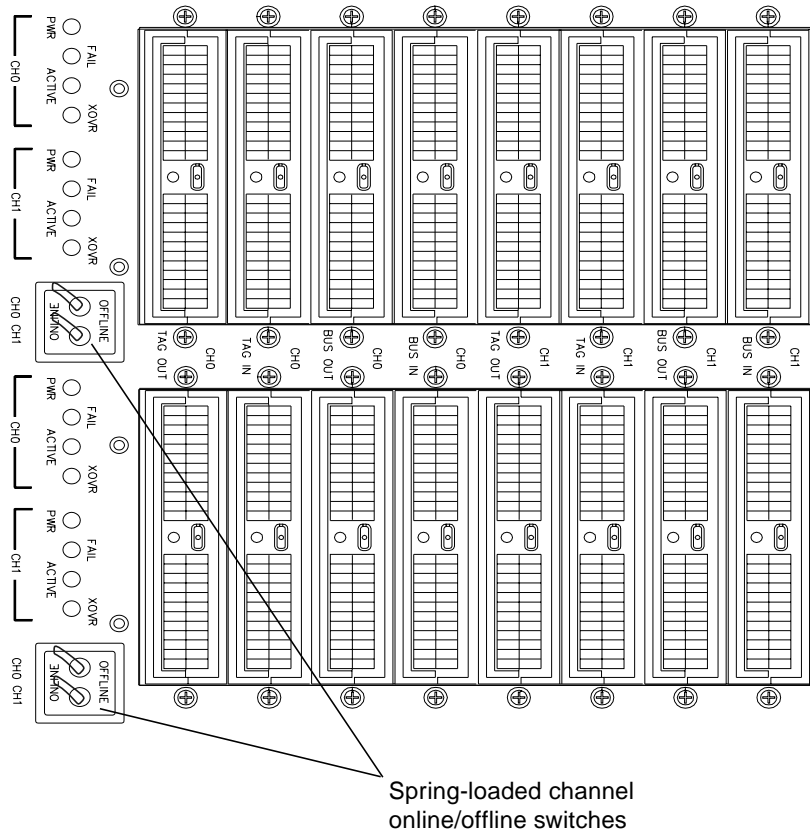
The following paragraphs describe how to install the channel interface cables for:

- Block multiplexer (MUX)—page 6-5
- ESCON—page 6-8
- SCSI target emulation (STE)—page 6-9

Depending on the configuration, one or more of these options may be installed.

## 6.2.1 Installing the Block Multiplexer Channel (BMC) Cables

If the configuration includes BMC cards, at least four BMC channel interface panels are inside the I/O Bay cabinet. (There will be more if more channels are configured in your system). There is one panel type, shown in FIGURE 6-4.

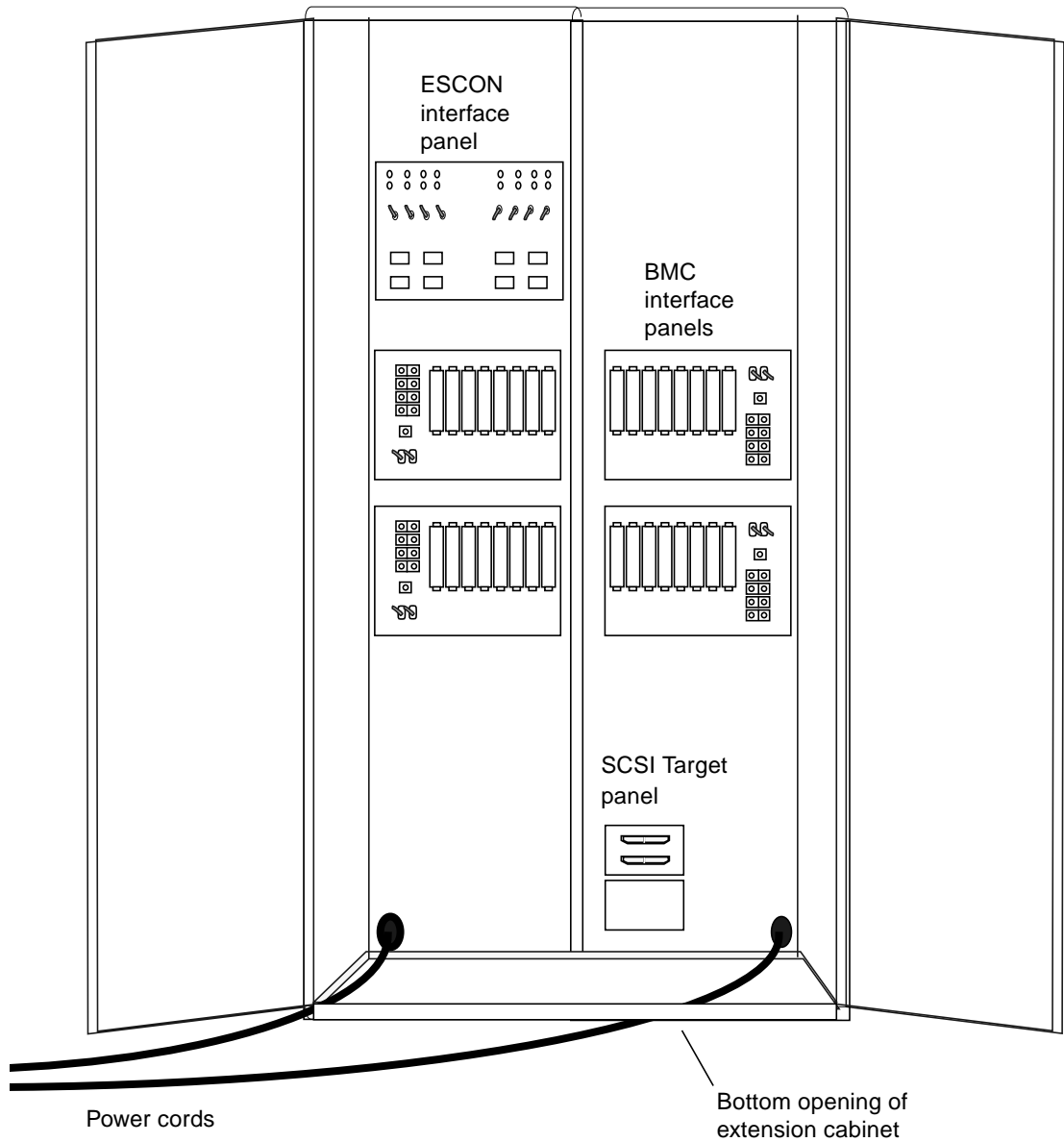


**FIGURE 6-4** Quad-Channel BMC Interface Panel

Note that the right two panels are upside down (also see FIGURE 6-5). Each panel includes one online toggle switch for each channel. Each interface panel is clearly marked with labels similar to DSP1/EB00, where DSP1 is the chassis where the BMC card resides, and EB00 is the BMC card's base address as set on the PCB. To install the BMC cables:

- 1. Run the cables through the opening in the bottom of the extension cabinet, as shown in FIGURE 6-5.**
- 2. Each channel has two Bus connectors (Bus In and Bus Out) and two Tag connectors (Tag In and Tag Out). Connect the Bus and Tag cables from the mainframe to the appropriate connector slot. Be careful when seating cables. Improper seating can cause bent or broken connector pins.**
- 3. To secure the connectors to the slots, locate the securing screw in the center of each connector and screw down each connector with a flat-blade screwdriver. Do not overtighten. If the screw is hard to turn, reseal the connector and try again.**
- 4. Put each interface panel channel online by placing each toggle switch in the online (1) position. These switches are spring-loaded—pull out and hold the top of the switch, move it to online, and then release it.**





**FIGURE 6-5** I/O Bay Cabinet, BMC Interface Panels, ESCON Interface Panels

## 6.2.2 Installing the ESCON Cables

Inside the I/O Bay cabinet is at least one Enterprise System Connection (ESCON) channel transition interface panel. (There will be more if more channels are configured in your system).

Each panel includes one online toggle switch for each channel. Each interface panel is clearly marked with labels similar to CH1, where CH1 is channel 0 of the dsp1 dual-channel ESCON to VME interface card, CH2 is channel 1 of the dsp2 dual-channel ESCON to VME interface card, and so on. See FIGURE 6-6.

To install the ESCON cables:

1. **Run the cables through the opening in the bottom of the extension cabinet. See FIGURE 6-5.**
2. **Each channel has one connector. Connect the cables from the mainframe to the appropriate connector slot. Be careful when seating cables.**
3. **Put each channel online by placing each toggle switch in the online (1) position. These switches are spring-loaded—pull out and hold the top of the switch, move it to online, and then release it.**

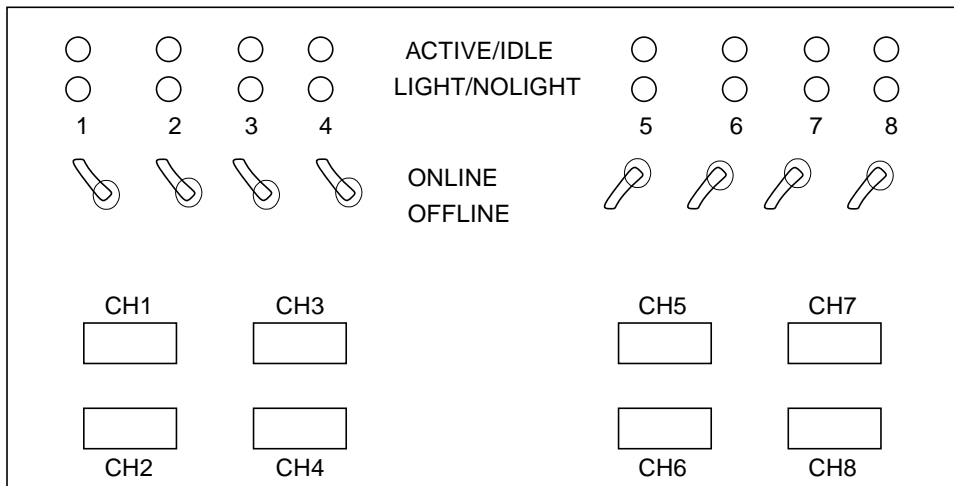


FIGURE 6-6 ESCON Interface Panel

## 6.2.3 Installing the SCSI Target Cables

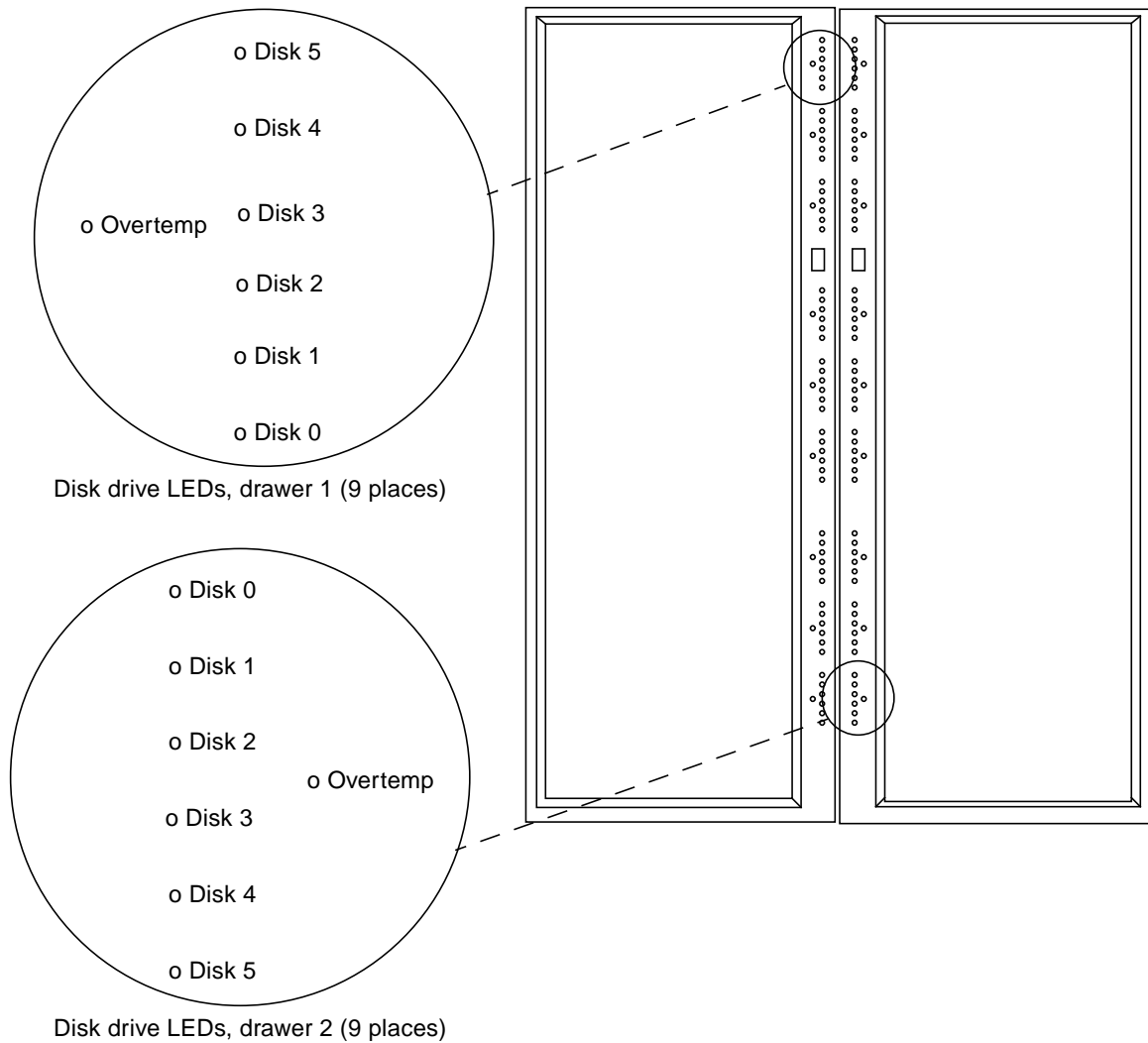
Inside the I/O Bay cabinet is at least one Small Computer Systems Interface (SCSI) target channel transition interface. See FIGURE 6-5. (There will be more if more channels are configured in your system). There are two connectors per panel.

1. **Connect the SCSI cable from the host computer.**
2. **Secure it with the mounting screws on the sides of the SCSI target female connector.**

---

## 6.3 Analyzing the Acceptance Test Procedure (ATP) Results and Error Report (errrpt)

During the ATP, the disk drive select LEDs at the front of the HDSA drawer flash on and off. FIGURE 6-7 shows the LEDs. When the LEDs stop flashing and are not lighted, the ATP is complete.



**FIGURE 6-7** Disk Select LEDs, HDSA Drawer

The next step is to analyze the ATP results. Perform the following steps for each subsystem.

1. During the ATP, any messages from the subsystems are displayed on the System Console in the dsp1 and dsp2 subsystem windows, which open automatically at power on. Take corrective action, if needed, for these messages before continuing.
2. The analyze command displays the directory path of ATP test results. Type the following:

```
# cd /usr/install/stp
# ./analyze ATP
```

3. The last message displayed is the test results directory path. Change to that directory:

```
# cd /usr/install/stp/RESULTS/ATP_date_time
```

where *ATP\_date\_time* is the date and time that ATP test ran.

4. The aborts file contains test results for any test that aborted abnormally. (If the test ran successfully, there will be no aborts file.) Find and display this file; take corrective action, if needed:

```
# ls -l aborts
# pg aborts
```

5. Tests generating errors create a file named *testname.errors*, where *testname* is the name of the test. Find and display any files; take corrective action, if needed:

```
# ls -l *.errors
# pg testname.errors
```

6. Log files in the directory can also contain failure messages. Find and display these messages, as follows, and take corrective action, if needed:

```
# grep -i fail *
```

7. The summary file contains the date, time, and number of times all ATP tests ran (test passes). It can also contain test abnormality/failure messages. Find and display these messages; take corrective action, if needed:

```
# pg summary
```

8. An error report can also contain test abnormality/failure messages, if any, at the end of the report. Find and display these messages; take corrective action, if needed:

```
# errpt |pg
```

The `errpt` man page describes more `errpt` command options. To display the description, type:

```
# man errpt
```

---

## 6.4 Configuring the A7000 to Phone Home

The System Console hard disk drive contains a software package called the Remote Support System (RSS) which automatically notifies the customer support center of any A7000 error information. For it to work correctly, customer data must be entered into the MCD database, RSS must be configured with this information, the contents of certain system files must be verified.

The following paragraphs explain how to configure the A7000 to phone home:

- following RSS naming conventions—page 6-13
- entering customer information into the MCD data base—page 6-14
- configuring RSS and entering the appropriate service support telephone number—page 6-17
- checking files for required information—page 6-19
- disabling and enabling the RSS Paging feature—page 6-20

## 6.4.1 Following RSS Naming Conventions

Certain conventions apply when entering up customer names and system names for use by RSS. These conventions must be strictly adhered to because they reflect underlying restrictions such as UUCP limitations.

Customer names must follow these conventions:

- Names must be no longer than 16 characters.
- The first character of a name must be uppercase.
- Characters after the first may be a mixture of lowercase and uppercase.
- No embedded spaces are permitted within names.
- Underscores are permitted within names.

System names must consist of two parts:

- The first part is an abbreviation of the customer name and must follow these conventions:
  - must be no longer than 5 characters
  - all character in a name must be lowercase letters
  - no underscores or embedded spaces are permitted
- The second part is the order number of the shipment to the customer and consists of one or two digits.

Some example of valid system names are:

- `vardn1`
- `pepsi2`
- `pepsi35`
- `usa4`

Some examples of invalid system names are:

- `transco1` — has too many letters
- `4sys9` — starts with a digit
- `fred` — lacks the second part, the order number

## 6.4.2 Entering Customer Information into MCD

1. **Open an xterm window:**
  - a. **Using the trackball/trackpad, put the mouse pointer in any open area on the root window display area.**
  - b. **Press the left mouse button. A menu appears. Drag the mouse pointer to NEW WINDOW. Release the left mouse button.**
  - c. **An xterm window is displayed. Move the mouse pointer to the xterm window.**
2. **Activate the Edit MCD tool, `editmcd`:**

```
# /usr/install/mcd/bin/editmcd &
```

When `editmcd` is activated, the Choose Class menu appears.



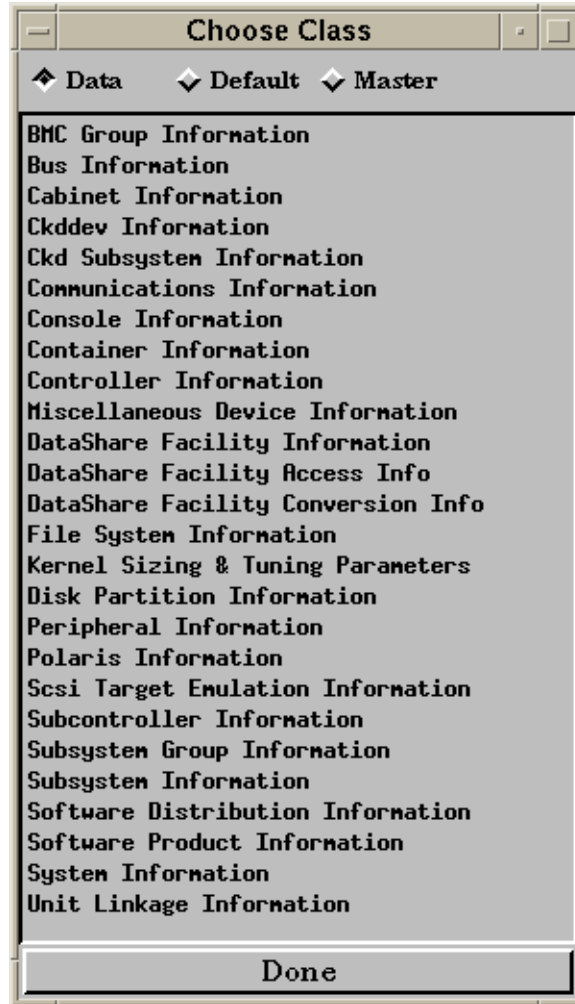


FIGURE 6-8 MCD Choose Class menu

3. From the Class selections listed on the Choose Class menu, select System Information. The System window appears.

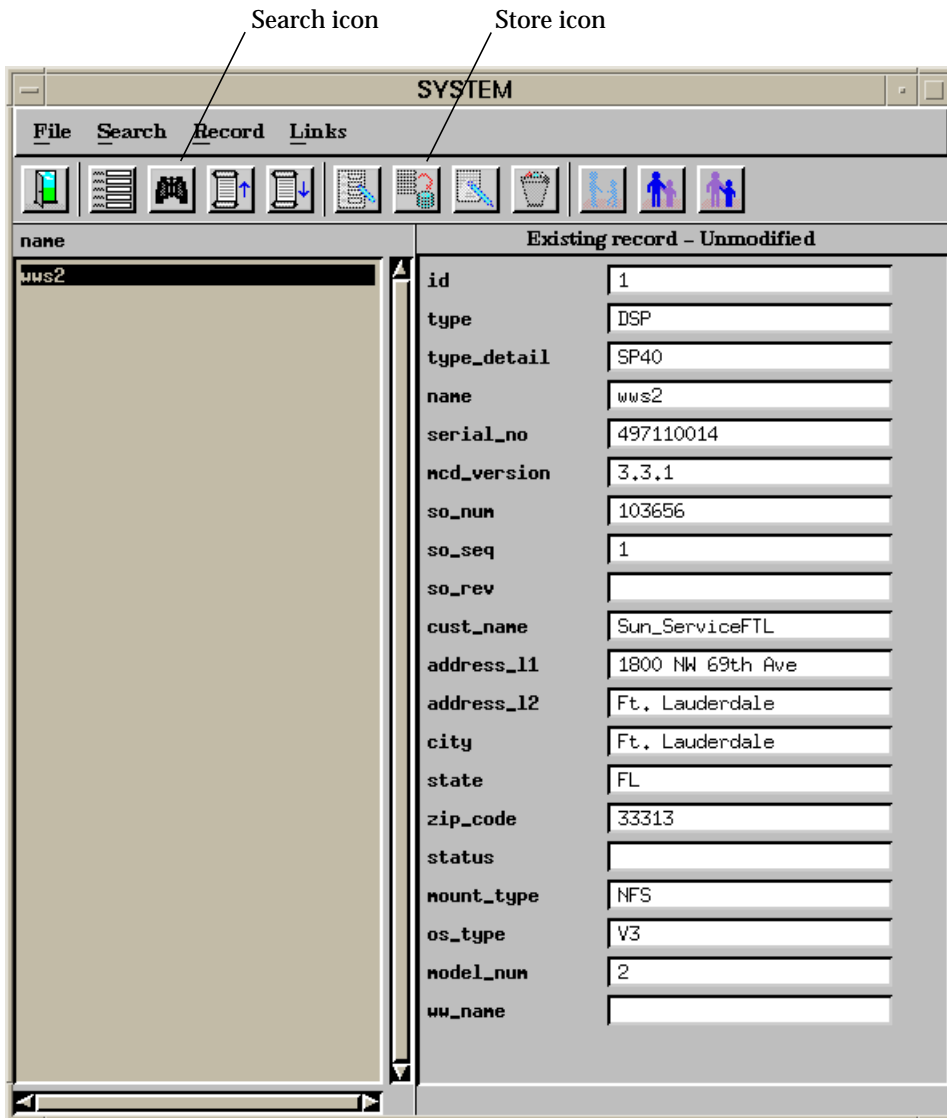


FIGURE 6-9 MCD System window

4. Click on the File menu at the top of the System window and choose Update\_Mode from the pull-down menu.

5. In the right side of the System window, click on the text fields you wish to modify and type the appropriate information in the spaces provided. All the data you type here will appear in RSS as you typed it.
6. When you have typed in the customer information, save it to the System Console hard disk by clicking on the Store icon at the top of the System window. See FIGURE 6-9.
7. To exit `editmcd`, click on Done at the bottom of the Choose Class window.

For more information on using `editmcd` to enter customer information, refer to the *CommandCenter Master Configuration Data (MCD) User's Guide*.

### 6.4.3 Configuring RSS and Entering Service Support Telephone Number

After the customer information has been entered into the MCD database, RSS must be configured with this information. Then you must type the correct service support telephone number. TABLE 6-2 lists most support center telephone numbers.

1. To configure RSS, type the following at the System Console:

```
# /var/remote.support/scripts/update_rss_console
```

The `/var/remote.support./files/mcd_params` file now reflects the customer information entered into the MCD data base.

2. The `Config_RSS` window is displayed. In the window, text containing copyright information appears for a few seconds, and then the main menu appears:

```
Select function to perform:
    1. Verify/update RSS files
    2. Quit
Enter your choice:
```

**3. Type 1 and press the Enter key.**

Text containing the current values for RSS is displayed. The values should reflect the data entered into MCD.:

```
Customer Name      :Sun_ServiceFTL
System Name        :wws2
System I.D.        :1
RSS Host Name      :Sun
RSS Host Phone     :
Phone Type (pulse or tone):tone
System Type        :DSP
Installation State or Country: FL
Installation City   : Ft_Lauderdale

      If the values are correct hit any key to continue.
      Enter <m> to modify:
```

**4. To add the Customer Support Center RSS Host Phone telephone number, press the M key.**

**5. Keep pressing the Enter key until the RSS Host Phone selection is displayed. Press the M key, and then type the Customer Support Center RSS Host Phone telephone number. Include any special key sequence (such as 9, which lets you dial outside most corporate facilities. Check with the customer's system administrator for the exact key or number). Press the Enter key.**

**6. The screen then displays the new, just-entered values. If errors appear in any of the fields displayed, you can press the M key again to correct them. Otherwise, press any key to continue, or until the Enter Customer Name entry appears. Press the Enter key to return to the main menu.**

**7. At the main menu, type 2 and press the Enter key to quit.**

**TABLE 6-2** Worldwide Support Center Telephone Numbers

Country, Worldwide Support Center	Telephone Number	Comments
United States	1 800 343 7187	
France	800 90 30 97	
Germany	0130 8 27317	
Italy	1678 74177	
United Kingdom	0800 281148	toll-free within U.K.
	0137 236 3236	direct dial toll within U.K.
	0137 281 4244	direct dial toll within U.K.
	011 44 137 236 3236	direct dial from U.S.A.
	011 44 137 281 4244	direct dial from U.S.A.
Spain	900 951452	
Korea	00308 651 4777	International Toll-Free Service
Japan	00531 65 3977	International Toll-Free Service
Thailand	001 800 65 6777	International Toll-Free Service
Hong Kong	800 90 8275	International Toll-Free Service
Taiwan	0080 65 1777	international Toll-Free Service
Malaysia	1800 80 1663	International Toll-Free Service
China	10800 650 8777	International Toll-Free Service
Australia	1800 124 275	international Toll-Free Service

## 6.4.4 Checking File Information

Each of the following files contain information the RSS requires to function:

- `/etc/uucp/System`
- `/etc/uucp/Permissions`
- `/var/remote.support/files/rss_params`

From the System Console, examine and, if necessary edit, each of these files:

- 1. Create a backup copy of each of these files before editing them.**

2. **Open the `/etc/uucp/System` file for editing and ensure that it contains the following:**

```
encore Any ACU Any wssphone ogin:--ogin Uquark ssword: phone.home
```

where *wssphone* is the Customer Support Center RSS Host Phone telephone number entered into RSS.

3. **Open the `/etc/uucp/Permissions` file for editing and ensure that it contains the following:**

```
LOGNAME=nuucp MYNAME="name of the system" MACHINE=encore
```

4. **Open the `/var/remote.support/files/rss_params` file for editing and ensure that it contains the following:**

```
UUCPHOST="encore"
```

5. **Review the other information in the `/var/remote.support/files/rss_params` file to ensure that it reflects the correct RSS information.**

## 6.4.5 Disabling or Enabling the RSS Paging Feature

During installation, you may want to disable the RSS Paging feature to avoid paging a service representative by mistake.

To disable the Paging feature, type following at the System Console:

```
# /var/remote.support/scripts/disable_paging hours
```

where *hours* in the number of hours for which the Paging feature will be disabled.

---

**Note** – Disable the Paging feature prevents the on-call pager from receiving pages but does not stop RSS from sending phone-home calls.

---

To enable the Paging feature, type following at the System Console:

```
# /var/remote.support/scripts/enable_paging
```

---

## 6.5 Configuring Modem Files (International Installation Only)

For international installations, modem files must be examined and configured for the appropriate country.

**1. Determine which country the modem is programmed for:**

**a. Begin a cu session by typing the following at the System Console:**

```
# cu -l cua/pc1
```

**b. When the connection has been established, type:**

```
# ati5
```

The alphabetical abbreviation of the country for which the modem is programmed appears on the screen. For example, if the modem is programmed for the United State, USA is displayed.

**c. Then type:**

```
# at*tp11?
```

The 3-digit numerical county code associated with the country for which the modem programmed for appears of the screen. If the number 0 or 255 appears, the country code has not been programmed and is at factory default, the United States.

**d. To end the cu session, type:**

```
# ~.
```

---

**Note** – This procedure is required only for international installations. However, Step 1 may be informative for domestic installations.

---

2. **If the modem is not programmed for the correct country, reprogram it:**
  - a. **View the list of county codes:**

```
# usr/local/bin/country
```

- b. **Scroll through the list using the Enter key until you find the appropriate country code, then exit list mode by typing Ctrl-D.**
    - c. **Type the 3-digit numerical county code for the appropriate country.**

The country code script will confirm the country selected. If the  
ERROR: /usr/local/modem/tdk/none error message is displayed, the  
selected country does not have a valid country code.
  3. **As the country script executes, it displays information to the System Console. Follow all instructions displayed, including rebooting the System Console if instructed.**

---

## 6.6 Testing the Phone-Home Feature

The following paragraphs describe:

- testing the Remote Support System phone-home feature—page 6-22
- creating a link if the phone-home feature fails—page 6-25

### 6.6.1 Testing the Remote Support System Phone-Home Feature

If an xterm window is open, skip Step 1 and start at Step 2.

1. **Open an xterm window:**
  - a. **Using the trackball/trackpad, put the mouse pointer in any open area on the root window display area.**
  - b. **Press the left mouse button. A menu appears. Drag the mouse pointer to NEW WINDOW. Release the left mouse button.**
  - c. **An xterm window is displayed. Move the mouse pointer to the xterm window.**



**2. Clear all UUCP messages:**

```
# /var/remote.support/scripts/clear_rss_xfers
```

**3. Connect the dedicated phone line into the RJ-11 jack inside the I/O Bay Cabinet. See FIGURE 6-10.**

**4. Test the RSS phone-home feature. Type the following at the xterm window:**

```
# /var/remote.support/scripts/test_rss
```

The command asks for your name and phone number.

**5. Make sure your phone-home request is in the job queue by typing the following:**

```
# uustat -a
```

This command displays job status for the phone-home request. It will display a `Successful` message when the job is in the queue.

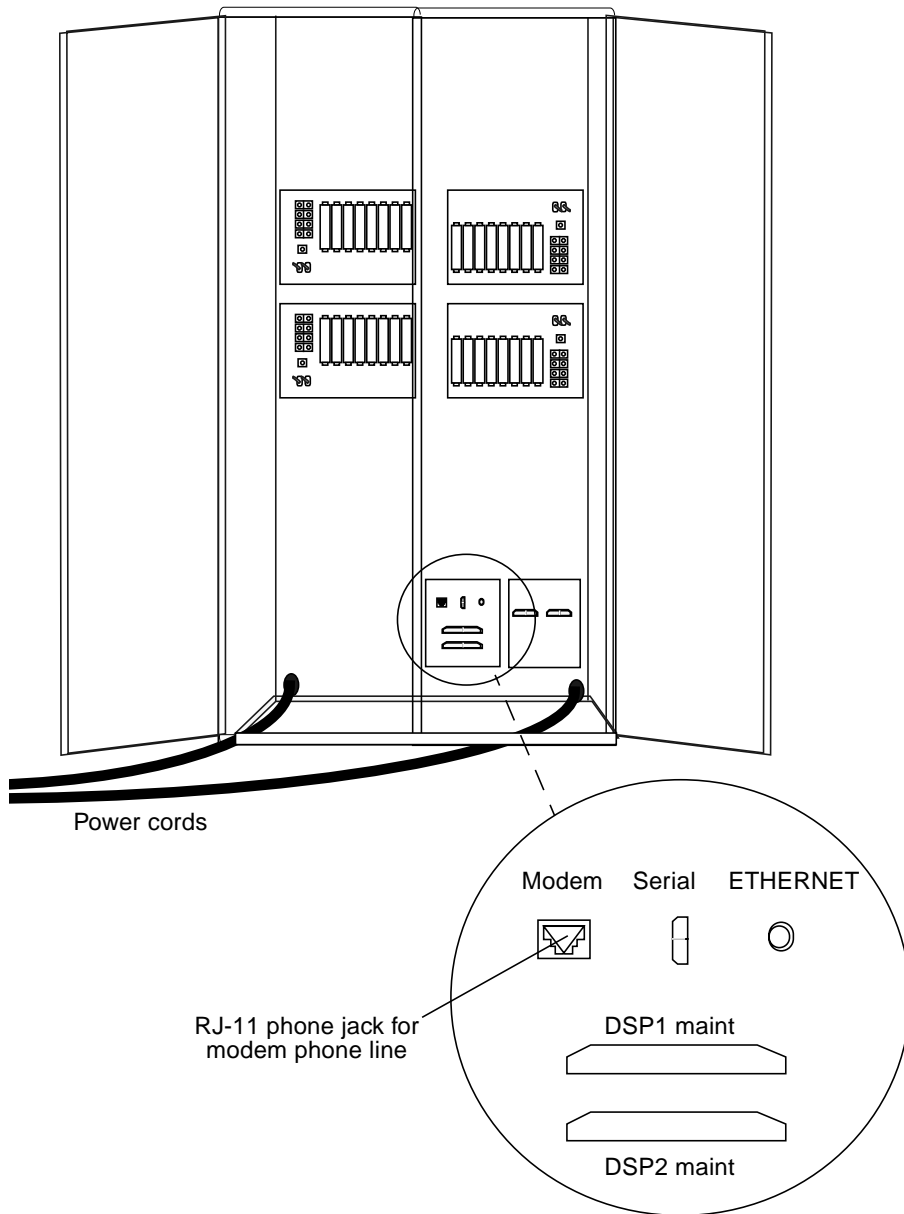
**6. Make sure the phone-home request completes successfully. Enter the following (the command assumes that the default A7000 machine name is `encore`):**

```
# uulog -f encore
```

This command will display the job log of the last job executed (the phone-home request). If the `Transfer Complete` message appears, press the Delete key to exit.

**7. Clear the uulog by typing the following:**

```
# echo > /var/uucp/.Log/uucico/encore
```



**FIGURE 6-10** Connectors Inside I/O Bay Cabinet

## 6.6.2 Creating a Link if the Phone-Home Test Fails

The above test may fail if the `/usr/spool/uucp/.Status` link does not exist.

1. Repeat Step 2 to Step 6 in the previous section.
2. Check that the link exists. At the xterm window you opened in the above steps, type the following:

```
# ls -la /usr/spool/uucp/.Status
```

If the link is not found, the following message is displayed:

```
/usr/spool/uucp/.Status: No such file or directory
```

3. If the link does not exist, create it by typing the following:

```
# ln -s /var/uucp/.Status /usr/spool/uucp/.Status
```

---

## 6.7 Entering the Date, Time, and Timezone

Check the date, time, and timezone set on each subsystem and the System Console using the `/usr/bin/date` command. To change each to the local settings, perform the following steps.

### 6.7.1 Setting Up a Subsystem

Perform the following steps for each subsystem.

1. Type the following to start the setup:

```
# sysadm syssetup
```

A SYSTEM SETUP menu appears.

**2. At the menu prompt, type 2 to change the date/time/timezone:**

```
Enter a number, a name, the initial part of a name  
or ? or <number>? for HELP, q for QUIT: 2
```

**3. Type y to change the settings; otherwise type q to quit:**

```
Current time and timezone is: 11:22 EDT  
Change the timezone> [y, n, ?, q] y
```

The following is displayed:

```
Available timezones are...  
  
1. Middle-European(MET & MDT)  
2. Greenwich(GMT)  
3. Atlantic(AST & ADT)  
4. Eastern (EST & EDT)  
5. Central (CST & CDT)  
6. Mountain(MST & MDT)  
7. Pacific (PST & PDT)  
8. Yukon (YST & YDT)  
9. Alaska (AST & ADT)  
10. Bering (BST & BDT)  
11. Hawaii (HST & HDT)  
  
Enter zone number
```

**4. At the prompt, type the appropriate zone number.**

The following is displayed:

```
Does your timezone use Daylight Savings Time (y,n,?,q)  
At the prompt, enter y or n, as appropriate.
```

## 5. Type in the appropriate choice.

The following is displayed:

```
Note: Any logins and processes running when the timezone
changes, and all their child processes, will continue to
see the old timezone. The cron(1M) will be restarted at
the end of this procedure.
```

```
Current date and time : Thu. 06/05/97 11:31
Change the date and time ? [y, n, ?, q]
```

At the prompt, type *y* or *n*, as appropriate. If you type *y*, you are prompted to change the settings. When the settings are correct, type *n*; the following is displayed:

```
The cron has been restarted to pick up the new time and/or timezone
```

## 6. Type *q* to exit the date/time/timezone setup.

# 6.7.2 Setting Up the System Console

If an xterm window is open, skip Step 1 and start at Step 2.

### 1. Open an xterm window:

- a. Put the mouse pointer in any open area on the root window display area.
- b. Press the left mouse button. A menu appears. Drag the mouse pointer to **NEW WINDOW**. Release the mouse button.
- c. An xterm window is displayed. Move the mouse pointer to the xterm window.

### 2. Find the appropriate timezone setting in the files in the

`/usr/share/lib/zoneinfo/` directory. This directory contains files listing valid timezone settings for each country.

### 3. Open the `/etc/TIMEZONE` file for editing, search for the following line and edit it:

```
TZ=: timezone
```

where *timezone* is `US/Eastern`, `US/Pacific`, etc.

4. If necessary, edit the file to reflect the appropriate timezone. For example, to change the timezone setting from Eastern Daylight Time to Pacific Standard Time, change the contents of the `/etc/TIMEZONE` file from `TZ=US/Eastern` to `TZ=US/Pacific`.

The changes you have entered will take effect when the System Console is rebooted.

---

## 6.8 Starting the PCU Software

To start the PCU software, you must:

- edit the PCU configuration file on both subsystems—page 6-28
- enable the PCU software start/stop daemons so that the PCU software starts at boot time and stops at shutdown—page 6-30
- complete the setup by rebooting and querying the subsystems to ensure that communication has been established—page 6-30

The PCU software may also be started and stopped manually after the PCU configuration file has been set up—page 6-31.

### 6.8.1 Editing the PCU Configuration Files

If windows are open for subsystems `dsp1` and `dsp2`, skip Step 1 to Step 6 and start at Step 7.

1. Move the mouse pointer to Windows at the System Console Application Menu Bar (shown in FIGURE 6-11).

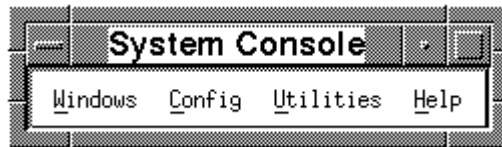


FIGURE 6-11 System Console Application Menu Bar

2. Click the left mouse button. A menu appears.
3. Drag the mouse pointer to `dsp1`.
4. Release the left mouse button. Window `dsp1` appears.

**5. Log in to dsp1 as the root user:**

```
Console Login: root
Password: (press the Return key or type the site password here)
```

**6. Repeat Step 1 through Step 5 for dsp2.**

**7. Examine and, if necessary, edit the PCU configuration file /etc/upscf on each subsystem to ensure that the ups\_port parameter and cmd\_stop command string are specified correctly in each.**

TABLE 6-3 shows how the ups\_port parameter and cmd\_stop command string should appear in each subsystem's /etc/upscf file for each of the configurations described.

**TABLE 6-3 PCU Configuration**

Physical Configuration	Specifications in /etc/upscf file
One PCU connected to A7000	<p>On subsystem dsp1: ups_port "/dev/tty03"</p> <p>On subsystem dsp2: ups_port "/dev/tty03" passive</p> <p>On both subsystems: #cmd_ckdstop "/etc/init.d/simckd stop &gt; /dev/null 2&gt;&amp;1" cmd_ckdstop "/etc/init.d/simckd stop_noswitch &gt; /dev/null 2&gt;&amp;1"</p>
Two PCUs, one connected to A7000, one connected to expansion cabinet	<p>On subsystem dsp1: ups_port "/dev/tty02" ups_port "/dev/tty03"</p> <p>On subsystem dsp2: ups_port "/dev/tty02" passive ups_port "/dev/tty03" passive</p> <p>On both subsystems: #cmd_ckdstop "/etc/init.d/simckd stop &gt; /dev/null 2&gt;&amp;1" cmd_ckdstop "/etc/init.d/simckd stop_noswitch &gt; /dev/null 2&gt;&amp;1"</p>

## 6.8.2 Enabling the PCU Start and Stop Daemons

After the PCU configuration files have been edited, enable the PCU start and stop daemons.

1. **Put the mouse pointer in the dsp1 window. Change to the `/etc/rc2.d` directory:**

```
# cd /etc/rc2.d
```

2. **Rename the `_S98ups` file to `S98ups`:**

```
# mv _S98ups S98ups
```

3. **Change to the `/etc/rc0.d` directory:**

```
# cd /etc/rc0.d
```

4. **Rename the `_K02ups` file to `K02ups`:**

```
# mv _K02ups K02ups
```

5. **Repeat for the `dsp2` subsystem.**

The PCU software will now automatically start when the system boots and stop when the system shuts down.

## 6.8.3 Completing the PCU Software Setup

Reboot and verify that the PCU software is functioning properly.

1. **Reboot. The PCU daemon will start automatically on both subsystems.**
2. **Issue this command from each subsystem.**

```
# upsmgr query
```



3. If the message `Communication not yet established` does not appear, the PCU software has been set up properly. If this message appears, wait for the number of seconds specified by the `heartbeat` parameter in the `/etc/upscf` file and then issue the `upsmgr query` command again. If the `Communication not yet established` message continues to appear, check PCU cable connections and review the PCU file setup procedure to ensure that everything was done correctly.

## 6.8.4 Performing a Manual Start or Stop

After the PCU configuration files have been set up, the PCU software can be started and stopped manually, using the `ups` utility. This is typically used when the A7000 has already been powered on and the operating system software booted.

1. If subsystems windows are not open, perform Step 1 to Step 6 in section, “Editing the PCU Configuration Files” on page 6-28.
2. Start the PCU software: type the following in the `dsp1` window:

```
# /etc/init.d/ups start
```

Repeat for the `dsp2` subsystem.

3. Stop the PCU software: type the following in the `dsp1` window:

```
# /etc/init.d/ups stop
```

Repeat for the `dsp2` subsystem.

---

## 6.9 Checking the PCU Battery

To check the PCU battery function:

1. At the PCU front panel, press the VBATT buttons. See FIGURE 6-12. The LED display should read approximately 55 V.
2. Turn the A7000 power off: at the power source, turn the main power circuit breaker for the A7000 OFF.
3. Make sure the PCU switches to battery power.
4. Turn the main power circuit breaker for the A7000 ON.

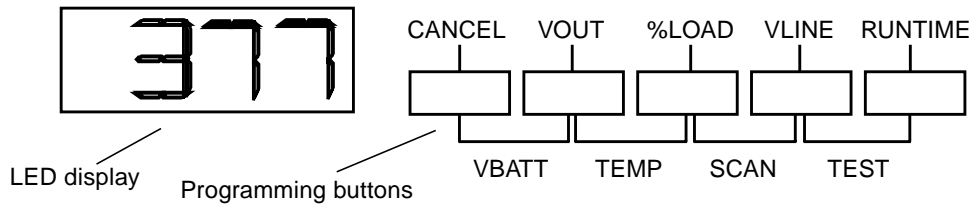


FIGURE 6-12 PCU Front Panel

---

## 6.10 Setting the A7000 Password

Make sure you are logged on at each subsystem as the root user (refer to “Starting the PCU Software” on page 6-28), before performing the following steps.

1. Type the `passwd` command:

```
# passwd
```

The window displays the following:

```
Changing password for root
New passwd:
```

2. Type the following password: `encore1`
3. Press the Enter key. To confirm the password, type it again and press the Enter key.

The `passwd` manual page describes more `passwd` command options. To display the description, type:

```
# man passwd
```

---

## 6.11 Configuring the Operating System Software for Remote Dual Copy

Perform these steps if your StorEdge A7000 server includes Remote Dual Copy (RDC) Fiber Optic REFLECTIVE MEMORY (FORM) hardware.

StorEdge A7000 servers running operating system software revision 3.6.4 and later compatible versions require that you configure this software to accept RDC. As shipped, these servers have the RDC software capability turned off.

1. If subsystems windows are not open, perform Step 1 to Step 6 in section, “Editing the PCU Configuration Files” on page 6-28.

**2. At the subsystem dsp1 window, start the configuration utility:**

```
# /usr/install/scm/configure_scm
```

**3. The utility displays a series of prompts. Answer the prompts as shown in boldfaced text.**

```
Verifying Execution Environment
Is this machine part of a 4-node configuration (y/n) [n] n

Is this machine running Campus-Wide or Metropolitan
Remote Dual Copy (RDC) (y/n) [n]: y

The following information will be used to build the default
configuration files.

CPU type: 88110
CPU memory size: 32 MB
Subsystem id: 2
System boot device is defined as type: MSD
Disk drawers enabled (Gateway is 0): 2
VME SCSI drives begin at address: 0x6800
VME SCSI board is a: Quad
Memory Channel: 1 ECCMCS (512M) board

Is this correct (y/n) >> n
```

```
Enter the Processor Type
Valid entries are : 88100 or 88110
[88110]: 88110

Enter the Processor Memory Size (MB)
Valid entries are : 32 or 128
[32]: 32

Enter the Subsystem Id
Valid entries are : 2 to 5
[2]: 4

Enter the Boot Device Location
Valid entries are : MSD or VME
[MSD]: MSD

Enter the number of Disk Drawers
Enter 0 for a Gateway machine
Valid entries are : 0 to 6
[2]: 2

Enter the VME SCSI Starting Address
Valid entries are : 0x6800 or 0x8800
[0x6800]: 0x6800

Enter the SCSI board Type
Valid entries are : Quad (4 ports using one VME address)
or Dual (4 ports using two VME addresses)
[Quad]: Quad

Enter the Memory Channel Type
Valid numeric entries are :
1 is None
2 is MCS III (256M)
3 is MCS III (512M)
4 is 1 ECCMCS (256M) board
5 is 2 ECCMCS (256M) boards
6 is 1 ECCMCS (512M) board
7 is 2 ECCMCS (512M) boards
8 is 3 ECCMCS (512M) boards
9 is 4 ECCMCS (512M) boards
[6]: 6
```

The following information will be used to build the default configuration files.

```
CPU type: 88110
CPU memory size: 32 MB
Subsystem id: 4
System boot device is defined as type: MSD
Disk drawers enabled (Gateway is 0): 2
VME SCSI drives begin at address: 0x6800
VME SCSI board is a: Quad
Memory Channel: 1 ECCMCS (512M) board
```

```
Is this correct (y/n) >> y
```

```
Backed up /etc/system to /etc/system.980922
Backed up /etc/memcf to /etc/memcf.980922
Backed up /etc/sd.cf to /etc/sd.cf.980922
```

#### **4. Rebuild and install a new operating system kernel:**

```
# cd /usr/src/uts/OBJ
# make VER=.scm
# mv /unix /unix.back
# cp unix.scm /unix.scm
# ln /unix.scm /unix
```

#### **5. Repeat Step 2 to Step 4 for subsystem dsp2.**

---

## 6.12 Checking the Master Configuration Data (MCD)

1. If subsystems windows are not open, perform Step 1 to Step 6 in section, “Editing the PCU Configuration Files” on page 6-28.
2. Update the master MCD master database with kernel, PROM, and disk information from each subsystem.
  - a. Type the follow commands in the dsp1 window:

```
# mcdkernel  
# mcduidprom  
# mcdudisks
```

- b. When all commands in Step 2a have finished executing, type them in the dsp2 window:

```
# mcdkernel  
# mcduidprom  
# mcdudisks
```

3. Verify software revisions for currently-installed software. Install any patches before continuing. Then type the following in the dsp1 window:

```
# sw_update -acvm
```

4. From the System Console window, disperse the MCD database from the master MCD to the subsystems:

```
# mcddisperse -a
```

5. From the dsp1 window, type the following to verify the master MCD database:

```
# mcdcheck  
# mcddsyscheck -local
```

Both commands should return with no errors.

---

## 6.13 Backing Up Important System Files

The following procedures ensure that duplicates of important A7000 system files exist for advanced troubleshooting/recovery purposes. For these procedures, you will need two quarter-inch cartridge (QIC) tapes.

---

**Note** – You will also need a portable maintenance box. Refer to the *Sun StorEdge A7000 Service Manual*, Appendix C for information about the portable maintenance box.

Make sure the box is cabled to the A7000 maintenance box connectors, shown in FIGURE 6-10.

---

1. **Type the following on the System Console to check database and configuration information:**

```
# mcdcheck
# mcdsyscheck -local
```

2. **Insert a tape in the portable maintenance box and back up the MCD database files and send MCD data to RSS; respond to any prompts as necessary.**

```
# /usr/install/ias/bin/subsysbak -x mcdsavedata
# sendmcd
```

3. **Insert another tape in the tape drive and back up the site-specific files.**

```
# echo < /dev/rmt/0h
# /usr/install/ias/bin/subsysbak -b /dev/rmt/0h
```

4. **Insert another tape in the tape drive and make a bootable backup installation tape.**

```
# /usr/systest/backup.tape
```

This may take up to 20 minutes to complete. When finished, remove, label, and date the tape.



5. Type the following commands to make duplicate, backup files on the subsystem disk drive; you may have to wait a few moments between commands for the prompt (#) to return:

```
# /etc/init.d/altpartmgr -c
altpartmgr: Checking primary and alternate file system sets.
# /etc/init.d/altpartmgr -b
# /etc/init.d/altpartmgr -u
```

6. Open an xterm window:

- a. Put the mouse pointer in any open area on the root window display area.
- b. Press the left mouse button. A menu appears. Drag the mouse pointer to **NEW WINDOW**. Release the mouse button.
- c. An xterm window is displayed. Move the mouse pointer to the xterm window.

7. Issue the following commands to perform an online backup.

- a. From the System Console, type the following:

```
# /usr/local/bin/subsysbak
```

- b. If subsystems windows are not open, perform Step 1 to Step 6 in section, “Editing the PCU Configuration Files” on page 6-28.

- c. From each subsystem, type the following:

```
# /usr/lbin/subsysbak
```



## Setting Up the PCU Dirty Power

---

Occasionally, the PCU delivered with the StorEdge A7000 is connected to electrically noisy (or “dirty”) AC power. Typically, this situation occurs when the PCU is connected on the same circuit as a motor-generator or other type PCU. This dirty power can inadvertently cause the PCU to switch to inverter operation for three to four seconds at a time.

Setting up the PCU for dirty power, as described in the following paragraphs, includes these steps:

- Setting the service password—page A-1
- Setting dirty power parameter values—page A-2



---

**Caution** – If possible, power off the StorEdge A7000 before performing these procedures. If you perform these procedures with the StorEdge A7000 powered on, do not change parameters other than those described next; load equipment can be damaged.

---

---

### A.1 Setting the Service Password

1. **Power the PCU on.**
  - a. **Turn on the circuit breaker in the main panel.**
  - b. **At the front of the PCU, put the keyswitch in the AUTO position.**
  - c. **At the rear of the PCU, put the circuit breaker switch in the ON position.**
2. **At the PCU front panel, press and hold the CANCEL and RUNTIME buttons at the same time for more than two seconds. Release the buttons when the display shows P-00.**

3. Press the CANCEL button. The display shows 0.
4. Press and hold the %LOAD button until the display shows 2639, and then release it. (If you press the button and it increments past 2639, press the VOUT button to go back.)
5. Press the RUNTIME button. The display shows 2.
6. Press the CANCEL button. The display shows P-00.

---

**Note** – If you do not enter anything at the front panel for 5 minutes, the password will expire. If this happens, repeat the above steps.

---

## A.2 Setting Dirty Power Parameter Values (Parameters 09, 78, 85, 86, 87)

TABLE A-1 shows the parameter values for the setup steps below.

1. Press and hold the %LOAD button until the display shows the parameter (P-xx, where xx is 09, 78, 85, 86, or 87), and then release it. (If you press the button and it increments past the parameter, press the VOUT button to go back.)
2. Press the CANCEL button to display the parameter value.
3. Press the %LOAD (increase) or VOUT (decrease) buttons to change the value.
4. Press the RUNTIME button.
5. Press the CANCEL button twice to check the parameter value.
6. Press the CANCEL button to return to the parameter number display (P-xx).
7. Repeat all steps for all parameters.
8. Press the VLINE button twice to quit the programming procedure.

**TABLE A-1** PCU Dirty Power Parameters

<b>Parameter</b>	<b>Description</b>	<b>Value for Dirty Power</b>
09	maximum slew rate	450
78	poor line	2
85	relay debounce	4
86	inverter lockout	1
87	inverter delay	5



## Installing the HDSA Expansion Cabinet

---

**Note** – This procedure requires two or more people to perform.

---

This section describes the procedure for installing the high-density storage array (HDSA) expansion cabinet. Two useful documents are the *Sun StorEdge A7000 Service Manual* (805-6489-xx) and *Sun StorEdge A7000 Installation Guide* (805-4632-xx).

FIGURE B-1 shows the StorEdge A7000 system cabinet and optional HDSA expansion cabinet, with up to four full disk drawers. These cabinets must be physically and electrically connected, with cables connecting the HDSA expansion cabinet drives to the controllers in the system cabinet.

- If you are installing the system and expansion cabinets as part of a new installation from the factory, all SCSI controller and expander cards are already installed in the system cabinet. This installation type involves physically and electrically connecting the cabinets.
- If you are installing the expansion cabinet as an x-option add-on field upgrade, you need to also install SCSI controller and expander cards in the system cabinet. Record all new component part numbers, revisions, serial numbers, and chassis card slot locations as you install the components. You will need this information for the Master Configuration Database (MCD) update procedure.

FIGURE B-2 shows an installation flowchart.

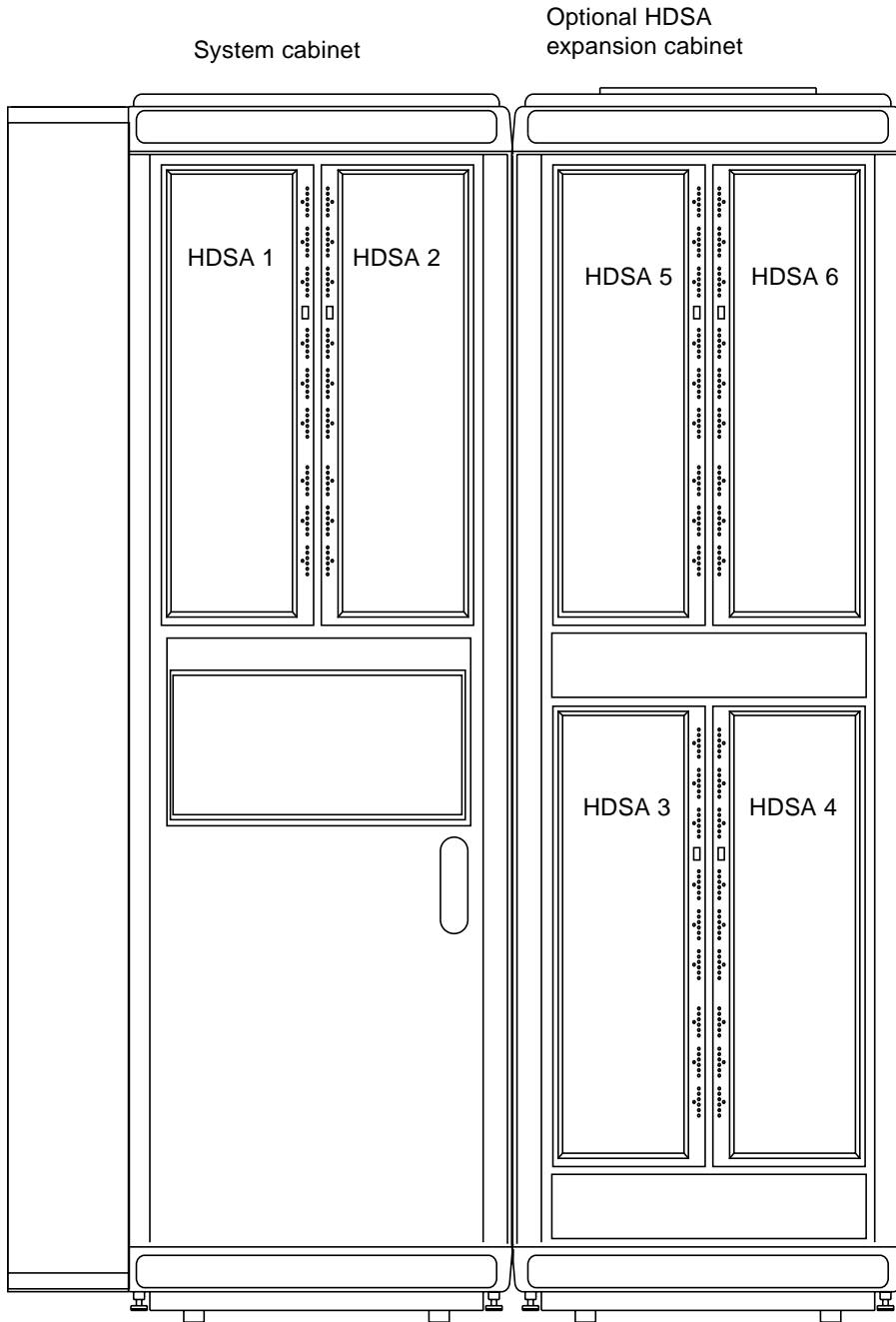
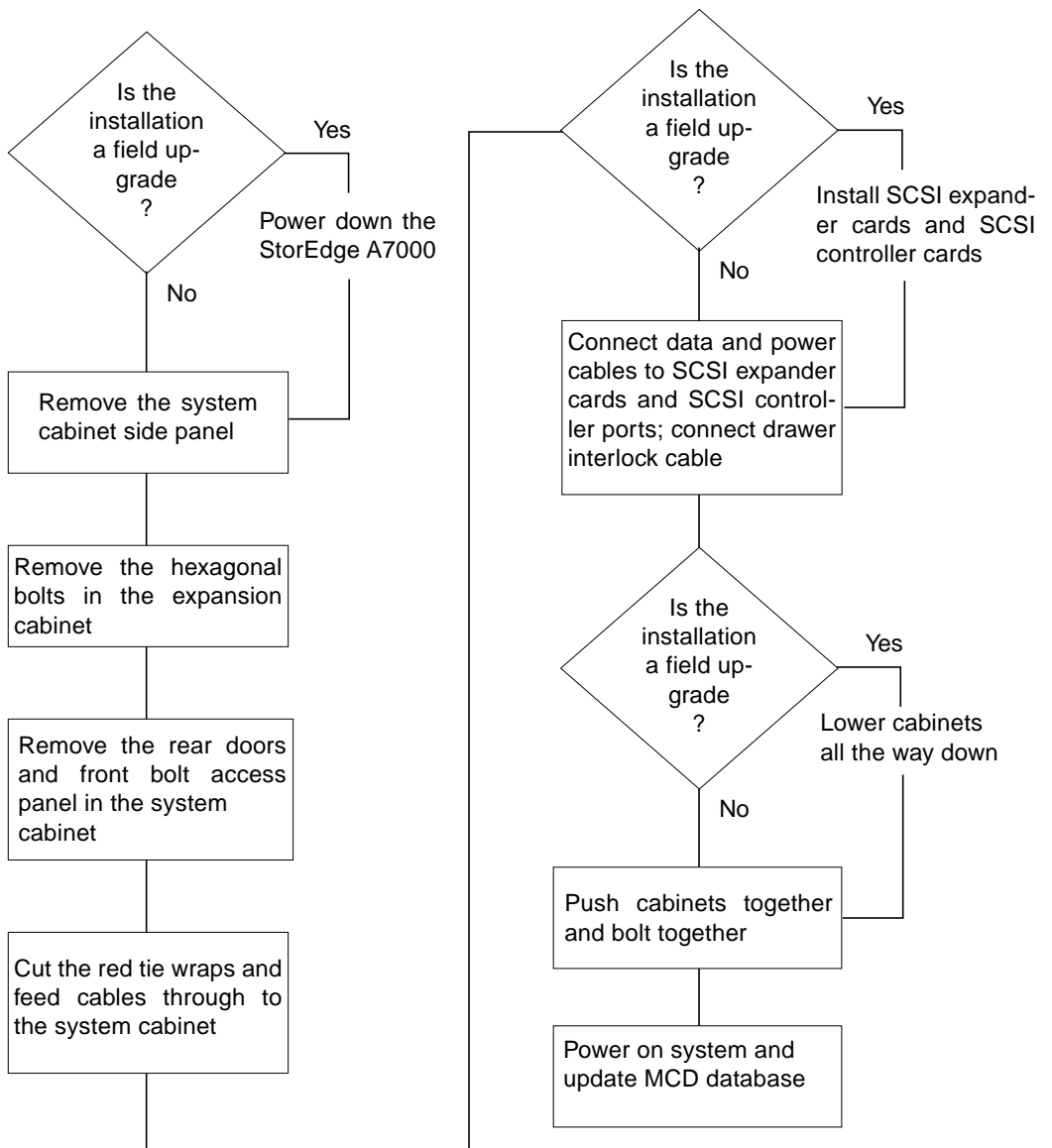


FIGURE B-1 StorEdge A7000 With Expansion Cabinet





**FIGURE B-2** Expansion Cabinet Installation Flowchart

---

## B.1 Required Tools List

- Tie wrap cables in assorted sizes
- Adjustable wrench or each of the following:
  - 5/16-inch open end wrench
  - 7/16-inch open end wrench
- Tools in English-unit sizes:
  - 5/16-inch socket
  - 7/16-inch socket
  - 1/4-inch drive socket set
  - 1/8-inch long shaft flat blade screwdriver
- Large flat blade screwdriver
- No. 1 and No. 2 Philips screwdrivers
- Needle-nosed pliers
- Small adjustable wrench
- Diagonal cutters
- Label maker with cartridges or marker
- Carpenter's level or equivalent one-foot level
- Step stool
- Flashlight

---

## B.2 Before You Begin...

- Always wear the electrostatic discharge (ESD) wrist strap that connects to the system cabinet when working inside the cabinets.
- Keep all cabinet power cords plugged into their receptacles to maintain ground during these procedures.

---

## B.3 Power Off the StorEdge A7000

Skip this section if this is a new installation and go to Section B.4 “Preparing the Cabinets” on page B-12.

Power off the StorEdge A7000 if you are installing the expansion cabinet as a field upgrade. Keep the power cords plugged into their receptacles to maintain earth ground. The power off procedure includes the following steps:

1. **Opening the System Console carrier tray and System Console cover.**
2. **Stopping the DataShare, simulation, and SCSI target software (optional).**
3. **Selecting shutdown from the System Console Application Menu Bar to shut down the subsystems. (Optional) If the autoboot feature is enabled, then abort the subsystem restart.**
4. **Shutting down the System Console.**
5. **Powering off the System Console.**
6. **Opening the front cabinet door.**
7. **Powering off the dsp2 subsystem power supply and the dsp1 subsystem power supply.**
8. **Powering off the HDSA supplies.**
9. **Powering off the cabinet power supply.**
10. **Power off the power conditioning unit.**

### B.3.1 Open the System Console Carrier Tray and Cover

1. **Turn the spring-loaded knobs on the tray clockwise to release the tray.**
2. **Fold down the front door tray.**
3. **One screen latch is on each side of the System Console. Slide the latches forward and lift the cover.**

Some System Console models have screen latches on the front left and front right sides. Slide the left latch to the left, and the right latch to the right; lift the cover.
4. **The System Console display may be blank; press any key to reactivate the display.**

## B.3.2 Stop the DataShare Facilities (Optional)

1. **Stop the DataShare Facilities on dsp1 through a dsp1 window (if it does not automatically start):**

```
dsp1# dsf stop
```

2. **Repeat for dsp2.**

## B.3.3 Stop the SCSI Target Emulation Software (Optional)

1. **Stop the simulation on dsp1 through a dsp1 window (if it does not automatically start):**

```
dsp1# ste stop
```

2. **Repeat for dsp2.**

## B.3.4 Stop the Simulation Software (Optional)

1. **Move the mouse pointer to window dsp1 and then type:**

```
dsp1# ckdadmin stop_noswitch
```

Messages display indicating that the simulation is stopping. When the procedure stops, perform the next step.

2. **Repeat for dsp2.**

## B.3.5 Shut Down All Subsystems

1. **From the System Console Application Menu Bar, choose Utilities→shutdown.**  
The shutdown window is displayed. See FIGURE 6-13.
2. **Select all nodes.**

3. Type Y at the Ready To Shutdown Now? prompt in the dsp1/dsp2 windows to immediately shut down.

The dsp1 window displays a series of shutdown messages followed by a “The System is down” type message.

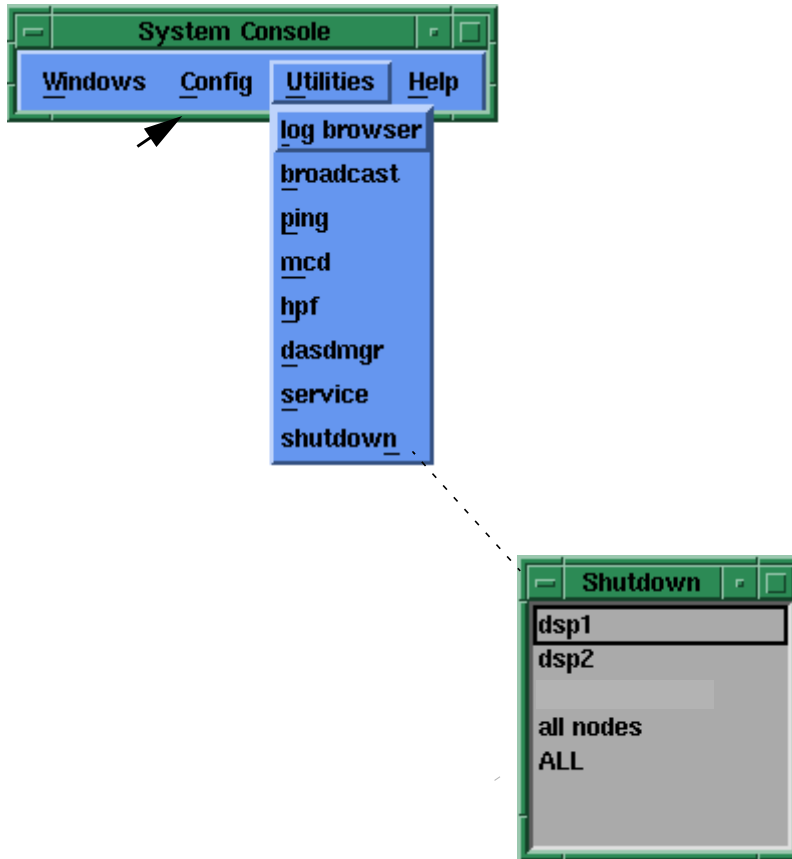


FIGURE 6-13 Shutdown Pull-down Menu and Window

## B.3.6 Abort the System Reboot (Optional)

If the autoboot feature is enabled, the subsystems attempt to reboot and startup messages start to appear.

1. **When you see the following message in the dsp1 window, press any key before 7 seconds elapse:**

```
You have 7 seconds to terminate the autoboot sequence . . .
```

If the system is not set to automatically boot, go to the next step.

2. **The following prompt appears:**

```
ROM >>
```

3. **The dsp1 window displays a series of shutdown messages followed by a “The System is down” type message.**

4. **When you see the following message in the dsp2 window, press any key before 33 seconds elapse:**

```
You have 33 seconds to terminate the autoboot sequence . . .
```

If the system is not set to automatically boot, go to the next step.

5. **The following prompt appears:**

```
ROM >>
```

The operating systems for all subsystems are now shut down.

## B.3.7 Shut Down the System Console

1. Put the mouse pointer in any open area on the display.
2. Press the left mouse button. A menu appears. Drag the mouse pointer to EXIT MWM. Release the left mouse button.
3. Drag the mouse to the OK pushbutton on the QUIT MWM dialog box; click Yes. The display goes blank momentarily, and then the `Console Login:` prompt reappears.

---

**Note** – The System Console may appear frozen after clicking Yes above; if this occurs, press Alt-PrtScr-h and type the command in Step 6. After the “Press any key to continue” message, power off the System Console.

---

4. Log in to the System Console:

```
Console Login: root
```

5. The system responds with a `Password:` prompt. Press the Enter key. The system prompt (`#`) appears.
6. Type:

```
dsp1# /etc/shutdown -y -g0 -i0
```

The System Console displays a series of shutdown messages followed by a `Shutdown complete` type message.

## B.3.8 Power Off the System Console

1. Push or slide the power switch.
2. Close the System Console cover by pushing it down until the latches engage.
3. Fold up the tray. When it is nearly closed, turn the tray latches clockwise, push the tray all the way up, and release the latches to secure the tray.

## B.3.9 Open the Front Cabinet Door

The front cabinet door is located at the lower half of the system cabinet. The front door also contains the System Console in its tray carrier. To open the front cabinet door:

1. **Insert a flat blade screwdriver in the door lock and turn it clockwise.**
2. **Pull the bottom of the latch out toward you and turn the latch assembly counterclockwise.**
3. **Pull the latch to open the door. The door must be open to perform the power off procedures.**

## B.3.10 Power Off the Subsystems

All subsystems can now be powered off.

1. **The dsp2 subsystem is the right subsystem. Slide the power supply on/off switch to the left.**
2. **The dsp1 subsystem is the left subsystem. Slide the power supply on/off switch to the left. Slide the switch to the left.**

## B.3.11 Check Other Switches

1. **Power off the LAD/SCSI Expander. See FIGURE B-3 for switch location.**
2. **Open the I/O Bay cabinet doors. Just above the right power cord are two switches labeled DSP1 and DSP2. Press the top of the switch to set them to OFF.**

## B.3.12 Power Off the HDSA Supplies

In the middle of the cabinet front just under the HDSA drawer(s) are the HDSA power supply switches. These snap switches are labelled 0 and 1. The 0 position is off and the 1 position is on.

1. **Open the cabinet door completely.**
2. **Place one HDSA on/off switch in the 0 position.**
3. **Place the other HDSA on/off switch in the 0 position.**

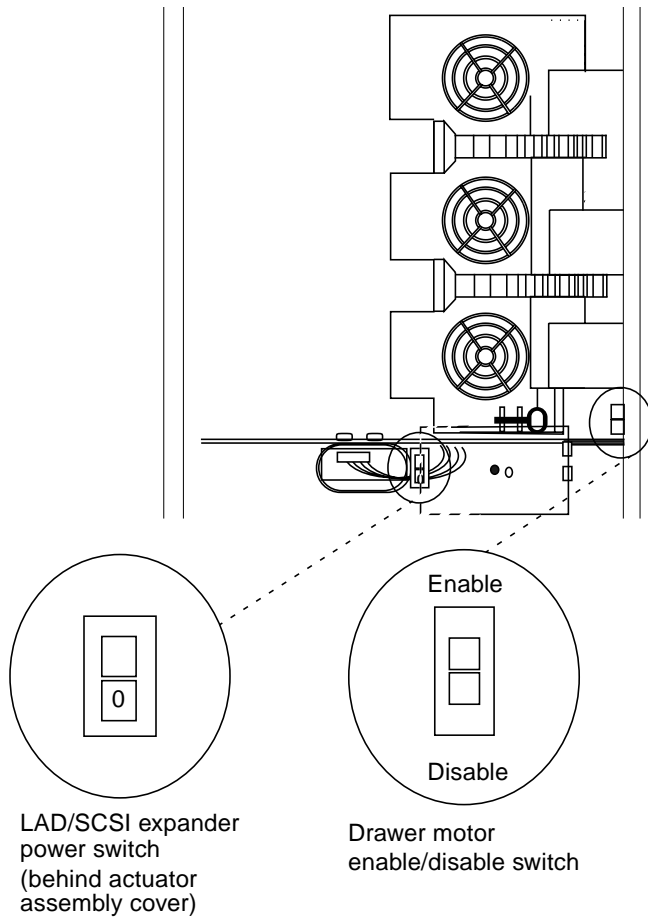


## B.3.13 Power Off the Cabinet Power Supply

1. Press the cabinet power switch to turn off power to the cabinet.
2. Throw the main circuit breaker switch CB1 switch to the left (OFF).
3. Repeat these steps for both AC boxes.

## B.3.14 Power Off the PCU

Power off any power conditioning units (PCUs) connected to the StorEdge A7000.



**FIGURE B-3** LAD/SCSI Expander Power Switch Location

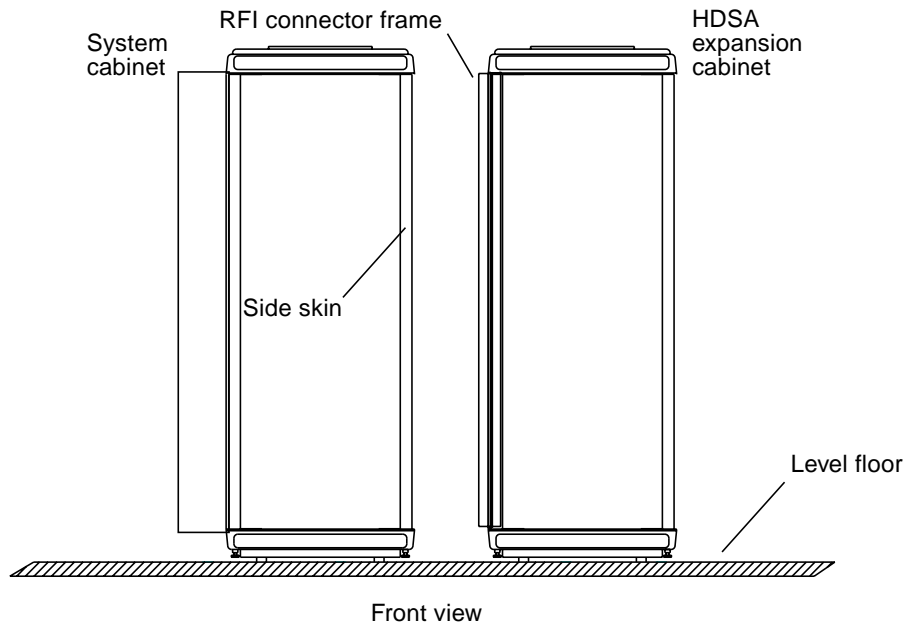
## B.4 Preparing the Cabinets

---

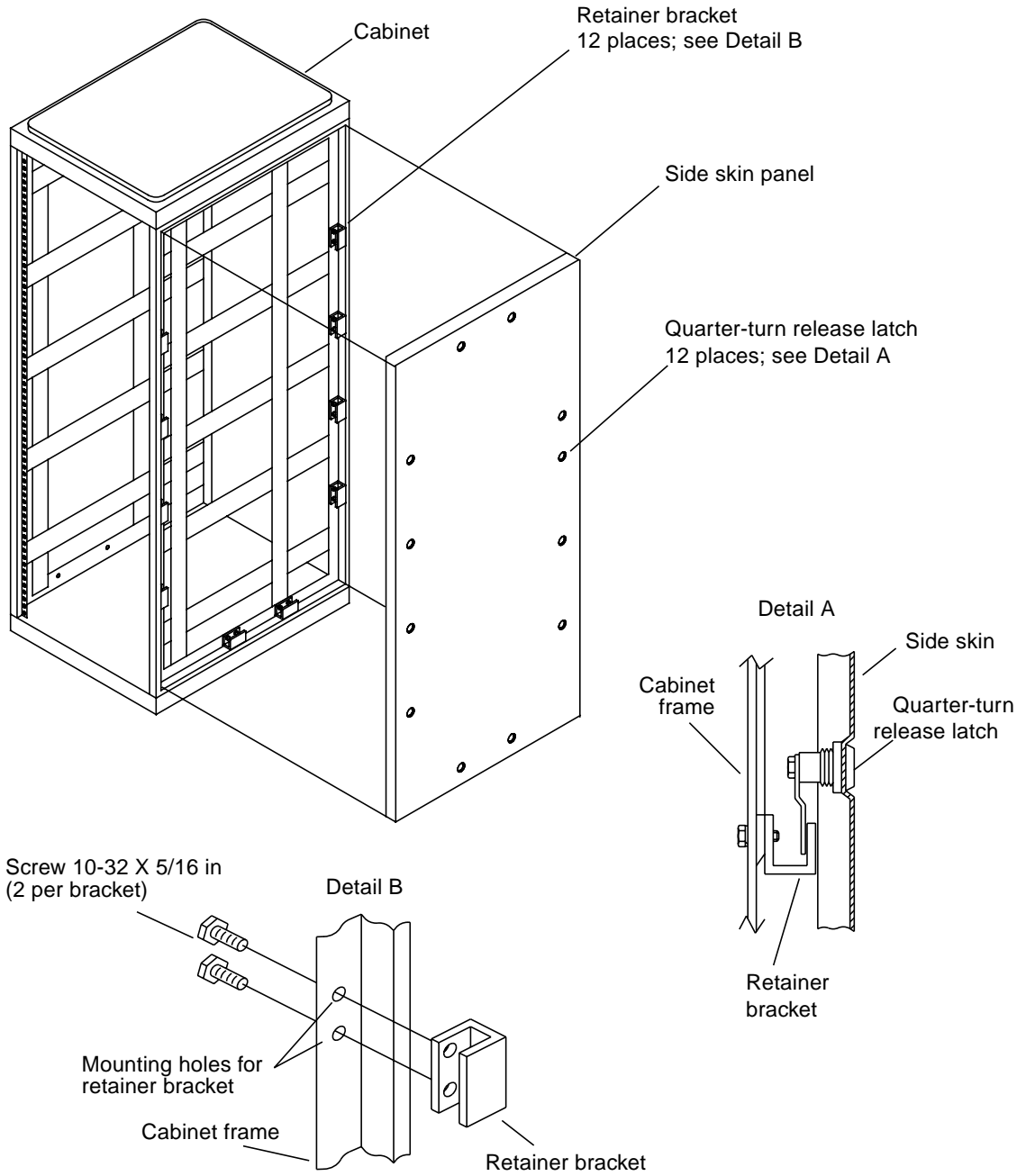
**Note** – Skip Step 2 if the base cabinet side skin panel is already removed.

---

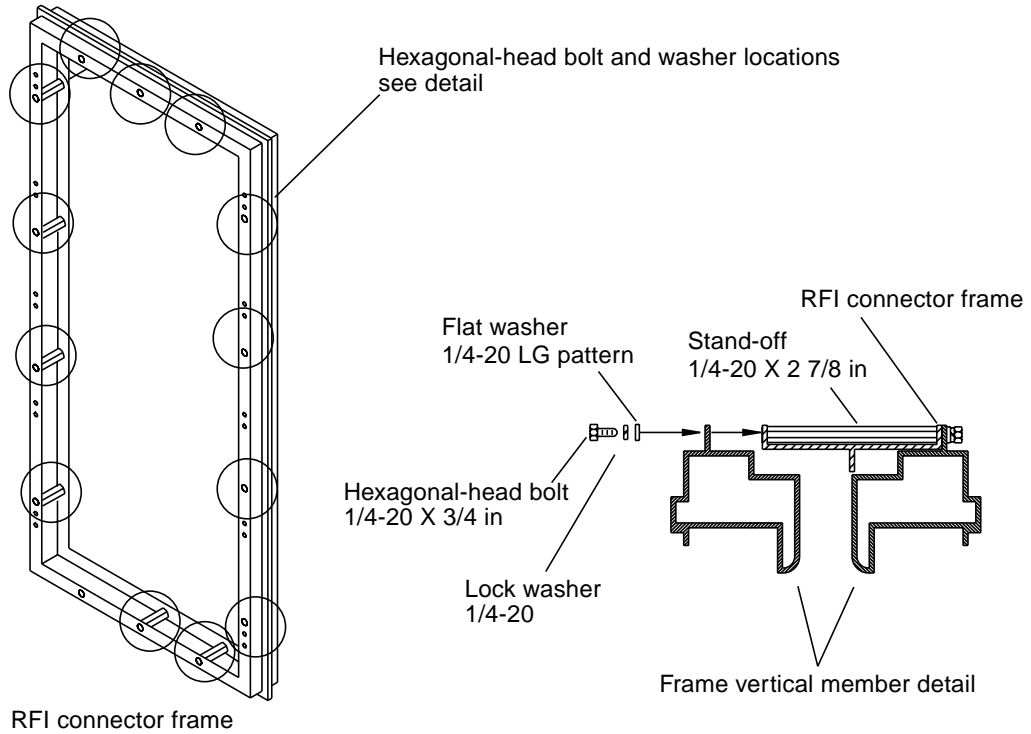
1. **Place the cabinets on a level floor, front-to-back and side-to-side as shown in FIGURE B-4.**
2. **Go to the right side of the system cabinet and remove the side-skin panel door.**  
Using a large slotted screwdriver, turn the release latches on the left side clockwise; turn the release latches on the right side counterclockwise. **See FIGURE B-5.**
3. **Remove the 12 retainer brackets with an adjustable wrench or a 5/16 open-ended wrench. Set aside the brackets and hardware.**
4. **Using a 7/16-inch socket wrench, remove the hexagonal-head bolts and washers from the free end of the RFI connector frame on the HDSA expansion cabinet. Keep this hardware for connecting the cabinets in later steps; you will need seven sets of bolts and washers. See FIGURE B-6.**



**FIGURE B-4** Cabinet Orientation

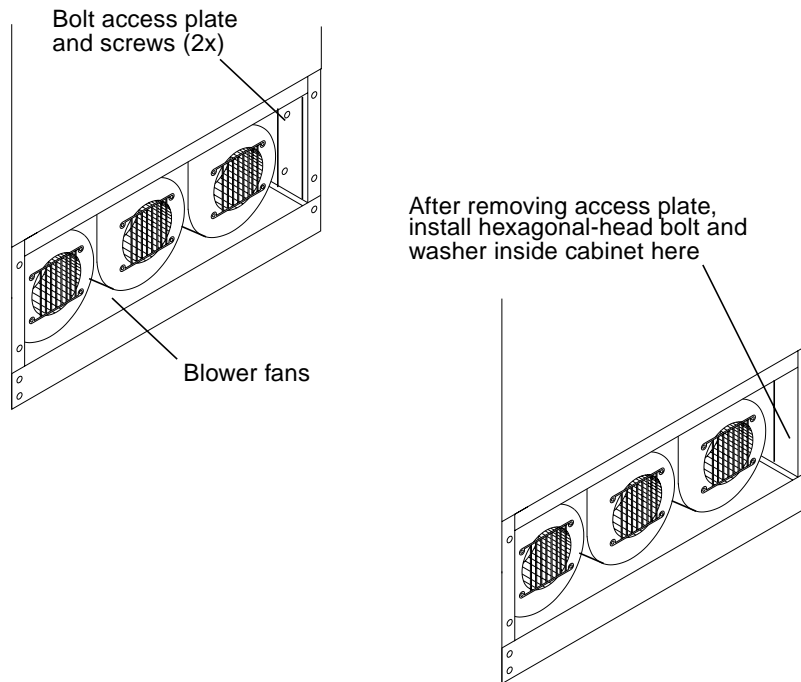


**FIGURE B-5** Side Skin Panel Removal



**FIGURE B-6** RFI Connector Frame Bolts

5. For easier access to the bolts you tighten later, remove the rear doors of each cabinet. For each cabinet:
  - a. Open the rear door.
  - b. Remove the pins at each hinge.
  - c. Lift the door up and off.
6. Open the system cabinet front door.
7. At the bottom right of the cabinet blower, remove the two Philips screws securing the bolt access plate. Set the plate and screws aside. See FIGURE B-7.



**FIGURE B-7** System Cabinet Front, Bolt Access Plate and Screws

---

## B.5 Feed Cables Into the System Cabinet

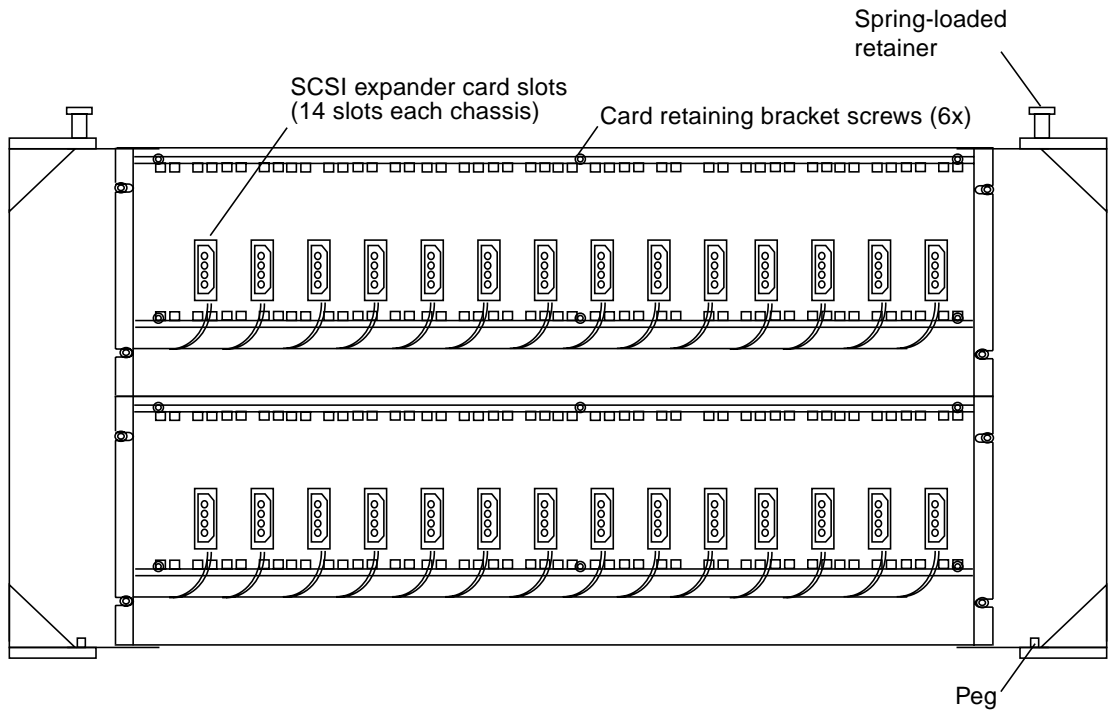
1. Inside the system cabinet and HDSA expansion cabinet, cut any red tie wraps used to secure power and data cables in place during shipping.
2. Feed the cables into the system cabinet. Pull them through and put them in a convenient place so you can work with them.

---

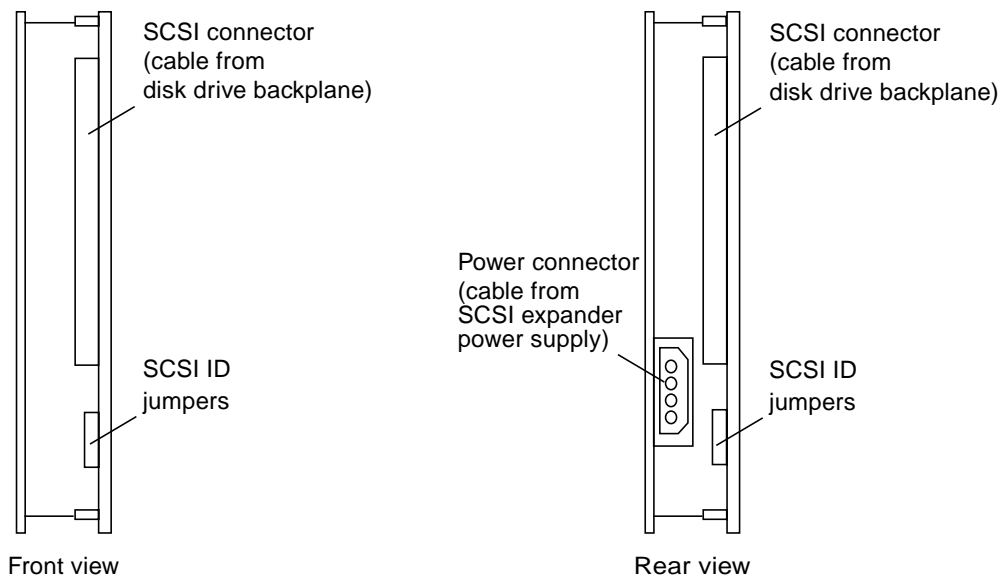
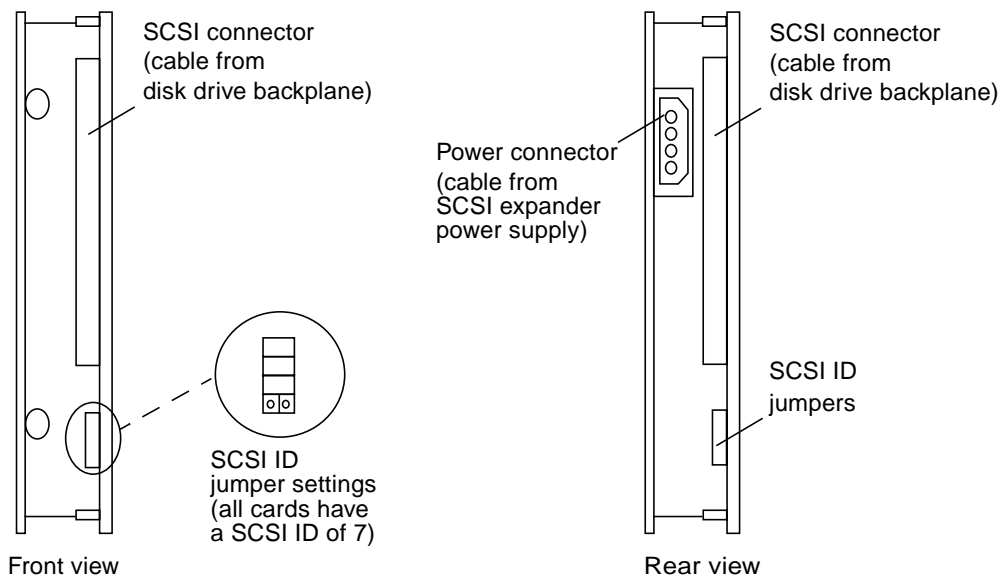
## B.6 Install or Connect the SCSI Expander Cards and Cables

If the SCSI expander cards are already installed, skip to Section B.6.1 “Connect the SCSI Expander Cables” on page B-19. Otherwise, start with Step 1. Find the SCSI expander cards (also called splitter or ATTO cards) shipped with the cabinet. Starting with the bottom row in the expander chassis, fill the open slots. Start with the first open slot and install them left to right. When the bottom row is filled, fill the top slots from left to right.

1. Lift the spring-loaded retainer screw on the top right side of the expander chassis. Lift the chassis off the peg and swing the chassis out. This provides easier access when you need to cable the cards. See FIGURE B-8.
2. Remove the card retaining bracket screws and bracket.
3. On each SCSI expander card, remove the inline terminator on the rear of the card. Set aside the terminator; you re-install it later.
4. Record the serial number, part number, and slot location of each card you install.
5. Find the power harness that contains the power connectors for the expander cards. Connect a power connector to each SCSI expander card. Depending on the configuration, you may not need to connect or use all plugs. FIGURE B-9 shows the power connectors on the cards.
6. The power harness you just installed contains a mating plug to connect to power from the expansion cabinet. Find the power cable and mated connector from the expansion cabinet and connect it.
7. Replace the card retaining bracket and screws.
8. Replace the inline terminator on each card.



**FIGURE B-8** Dual SCSI Expander Chassis



= Jumpers installed      = Jumpers not installed

**FIGURE B-9** SCSI Expander Card Connectors and Jumpers, Both Card Types



## B.6.1 Connect the SCSI Expander Cables

Some expansion cabinet cables connect to the SCSI expander cards in the SCSI expander chassis. Two SCSI cables connect to each SCSI expander card.

The cables from the disk drive bundles are labeled like the examples in FIGURE B-10 for each SCSI expander card. TABLE B-1 shows the SCSI expander card labeling. TABLE B-2 shows how each disk drive bundle is labeled in the cabinet drawers.

1. **Locate the SCSI expander card for the SCSI controller cable connector. For example, the cables from the first disk drive bundle in HDSA drawer 3 are labeled DSP2/78/P2/EXP10 and DSP1/78/P2/EXP10. See TABLE B-2. These cables correspond to the SCSI expander card in slot 10 of the bottom SCSI expander chassis. See TABLE B-1.**
2. **Connect the DSP2 labeled cable to the front connector on the SCSI expander card. Connect the DSP1 labeled cable to the rear connector on the SCSI expander cable.**
3. **Replace the chassis. Pull up the spring-loaded retainer on the right, and align the hole in right side with it. Align the chassis with the peg on the bottom.**
4. **Stow any unused cables under the SCSI expander chassis.**

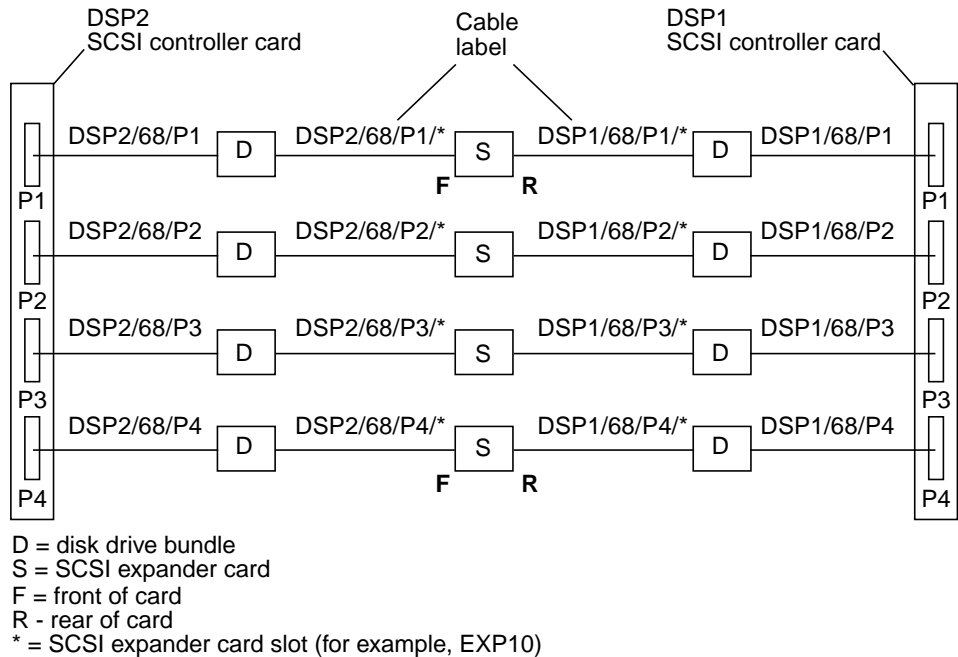


FIGURE B-10 SCSI Expander and Controller Cards Connection and Labeling Example

**TABLE B-1** SCSI Expander Card Labeling

<b>Card Slot (Left to Right)</b>	<b>Card Label, Bottom Chassis</b>	<b>Card Label, Top Chassis</b>
1	DSP1/2/6800/P1	DSP1/2/8000/P3
2	DSP1/2/6800/P2	DSP1/2/8000/P4
3	DSP1/2/6800/P3	DSP1/2/8800/P1
4	DSP1/2/6800/P4	DSP1/2/8800/P2
5	DSP1/2/7000/P1	DSP1/2/8800/P3
6	DSP1/2/7000/P2	DSP1/2/8800/P4
7	DSP1/2/7000/P3	DSP1/2/9000/P1
8	DSP1/2/7000/P4	DSP1/2/9000/P2
9	DSP1/2/7800/P1	DSP1/2/9000/P3
10	DSP1/2/7800/P2	DSP1/2/9000/P4
11	DSP1/2/7800/P3	DSP1/2/9800/P1
12	DSP1/2/7800/P4	DSP1/2/9800/P2
13	DSP1/2/8000/P1	DSP1/2/9800/P3
14	DSP1/2/8000/P2	

**TABLE B-2** System and HDSA Expansion Cabinet Disk Labeling

<b>Cabinet</b>	<b>Drawer</b>		
System Cabinet, Row	Labels, HDSA 1 (Left Drawer)		
Top	DSP2/68/P4	DSP1/68/P4	DSP2/70/P1
Middle	DSP1/68/P3	DSP2/68/P3	DSP1/68/P2
Bottom	DSP2/68/P1	DSP1/68/P1	DSP2/68/P2
	Labels, HDSA 2 (Right Drawer)		
Top	DSP1/78/P1	DSP2/78/P1	DSP1/70/P4
Middle	DSP2/70/P3	DSP1/70/P3	DSP2/70/P4
Bottom	DSP1/70/P2	DSP2/70/P2	DSP1/70/P1
Expansion Cabinet, Row	Labels, HDSA 3 (Bottom Left Drawer)		
Top	DSP2/80/P1	DSP1/80/P1	DSP2/80/P2
Middle	DSP1/78/P4	DSP2/78/P4	DSP1/78/P3
Bottom	DSP2/78/P2	DSP1/78/P2	DSP2/78/P3
	Labels, HDSA 4 (Bottom Right Drawer)		
Top	DSP1/88/P2	DSP2/88/P2	DSP1/88/P1
Middle	DSP2/80/P4	DSP1/80/P4	DSP2/88/P1
Bottom	DSP1/80/P3	DSP2/80/P3	DSP1/80/P2
	Labels, HDSA 5 (Top Left Drawer)		
Top	DSP2/90/P2	DSP1/90/P2	DSP2/90/P3
Middle	DSP1/90/P1	DSP2/90/P1	DSP1/88/P4
Bottom	DSP2/88/P3	DSP1/88/P3	DSP2/88/P4
	Labels, HDSA 6 (Top Right Drawer)		
Top	DSP1/98/P3	DSP2/98/P3	DSP1/98/P2
Middle	DSP2/98/P1	DSP1/98/P1	DSP2/98/P2
Bottom	DSP1/90/P4	DSP2/90/P4	DSP1/90/P3

---

## B.7 Install the SCSI Controller Cards

If the extra SCSI controller cards needed for the expansion cabinet disk drives are already installed, skip to Section B.8 “Connect the SCSI Controller Cables” on page B-22. Otherwise, start with Step 1.

1. **Record the serial number, part number, and slot location of each card you install.**
2. **Set the jumpers for each card. Chapter 3 of the *Sun StorEdge A7000 Service Manual* contains jumper settings for this card.**
3. **Slide the card into the slot and press it to make sure the backplane connectors engage. Fill the slots starting at slot 7 and above. Make sure that filler cards occupy any empty slots.**
4. **Using a small slotted screwdriver, secure the card to the chassis card cage with the two captive screws.**

---

## B.8 Connect the SCSI Controller Cables

---

**Note** – Do not connect any unused SCSI cables to the SCSI controller card ports. Stow these cables inside the bottom of the system cabinet.

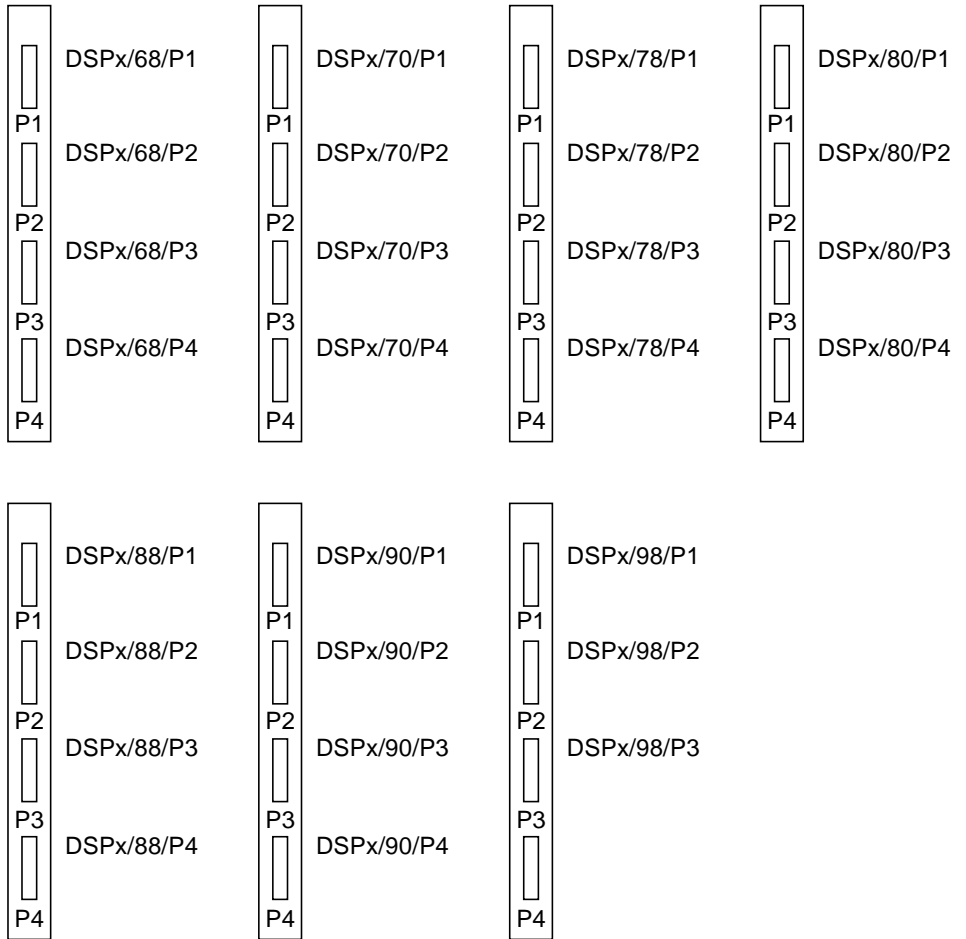
---

1. **Locate the SCSI cables from the system and expansion cabinets that connect from the disk drives to the SCSI controller card ports. These cables are labeled.**

The cables from the first disk drive bundle in HDSA drawer 3 are labeled DSP2/78/P2 and DSP1/78/P2. See TABLE B-2. These cables correspond to the SCSI controller port P2, base address 0x7800 on the cards in chassis dsp1 and dsp2.

FIGURE B-11 shows how the SCSI port are labeled and how they correspond to the labeled cables. See also FIGURE B-10.

2. **Connect the SCSI cable connectors to the SCSI controller card ports.**



**FIGURE B-11** SCSI Controller Port Labeling

---

## B.9 Physically Connecting the Cabinets



---

**Caution** – While performing the following steps, it is extremely important that the RFI gasket is not damaged, bent, or crimped while inserting the RFI connector frame. To prevent damage, bring the cabinets together in a slight “V” shape.

---

1. **If you are installing the expansion cabinet as an x-option add-on field upgrade, lower both cabinets all the way down.**

Use an adjustable wrench or an open end 7/16-inch wrench to screw down the cabinet leveling legs until contact with the floor is made. Refer to the *Sun StorEdge A7000 Installation Guide* for more information.

2. **Position the cabinets to be connected, with the RFI connector frame close to the RFI gasket of the second cabinet. See FIGURE B-12. Note the position of the bottom outside surface of the RFI connector frame to the inside of the RFI gasket.**

3. **If the RFI connector frame is free to enter the RFI gasket, push the two cabinets together to where the attachment bolts may be installed and proceed to Step 5.**

As cabinets and RFI connector frame come together, keep the faces (rear or front) even. Align all screw holes properly for final assembly.

If the RFI connector frame is not free to enter the RFI gasket, proceed to Step 4.

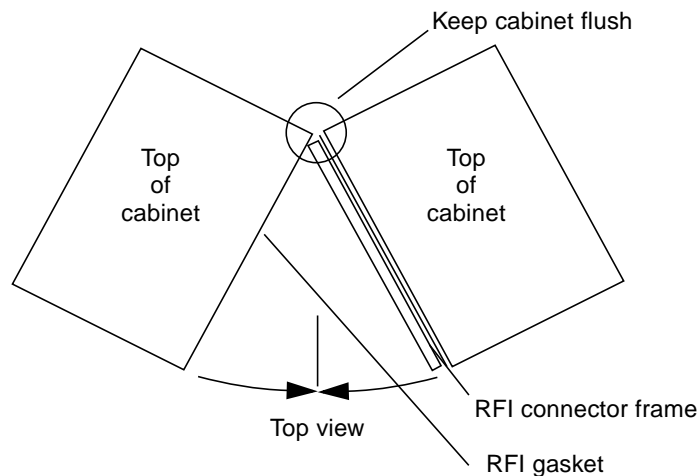


FIGURE B-12 Pushing Cabinets Together

4. If the RFI connector frame is not free to enter the RFI gasket of the second cabinet, you may need to adjust one of the two cabinets and make it level with the other cabinet. Adjust the four leveling legs down (using an adjustable wrench or an open end 7/16 inch wrench), lifting the bottom of the frame slightly above the inside face of the RFI gasket.



---

**Caution** – Do not overtighten RFI connector frame bolts. Overtightening may bend the frame.

---



---

**Caution** – In the step below, remove only one pin at a time to move a drawer. Never remove both pins at the same time. The cabinet can become unbalanced and tip, threatening personal safety.

---

5. Fully extend the system cabinet right HDSA drawer (HDSA drawer 2, shown in FIGURE B-1). A metal pin installed at the rear of the cabinet near the bottom HDSA cable track prevents the drawer from moving manually. See FIGURE B-13.
  - a. Remove the pin; the drawer may slide forward a bit.
  - b. Go to the front of the cabinet and pull the drawer all the way forward, until it is fully extended.

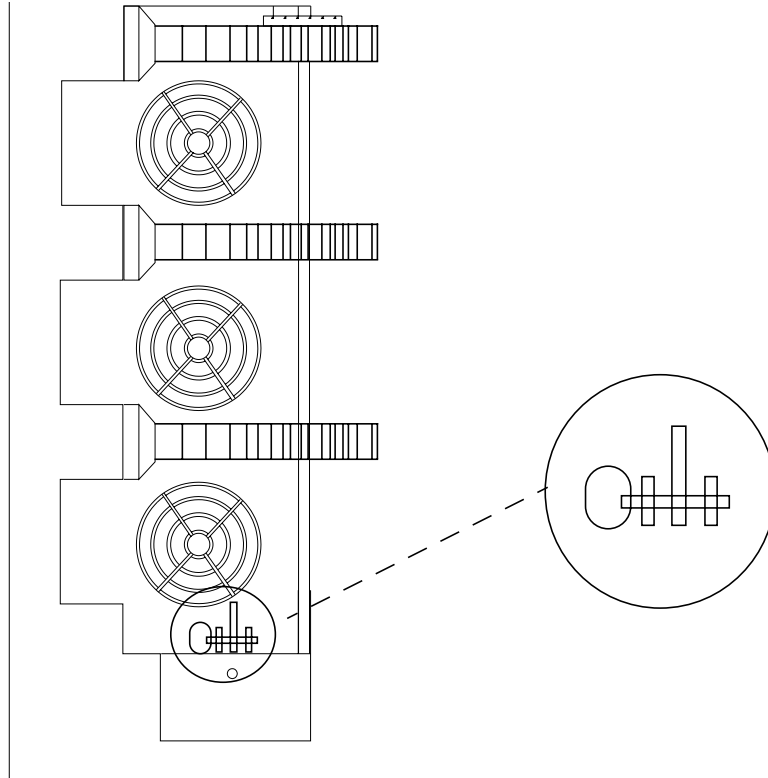
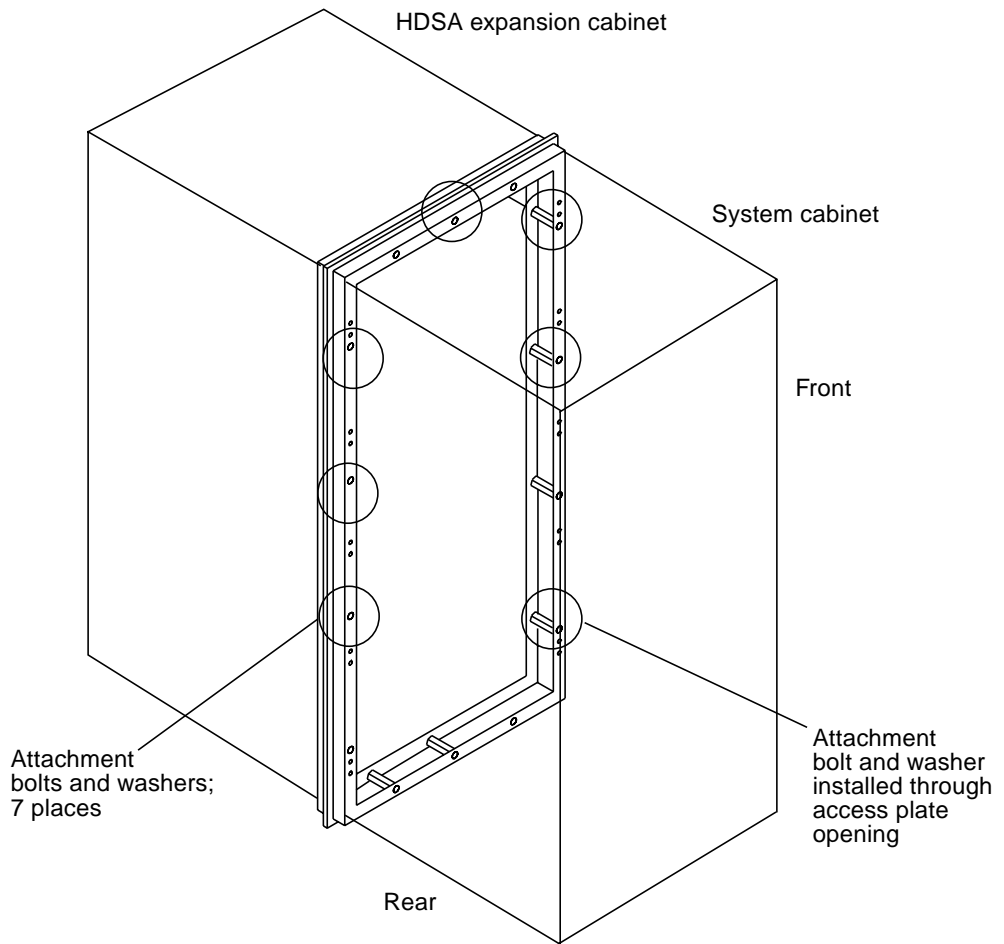


FIGURE B-13 HDSA Drawer Retractor Pin

6. **Insert the hexagonal-head attachment bolt and washers in the each of the openings at the front of the cabinet shown in FIGURE B-14 and tighten. You can access these bolt openings from the front or rear of the cabinet.**
7. **Replace the bolt access panel and close the front door.**
8. **Go to the front of the cabinet and push HDSA drawer 2 into the cabinet.**
9. **Go to the rear of the cabinet and replace the pin you removed in Step 5.**
10. **Replace the system cabinet rear doors.**





**FIGURE B-14** Attachment Bolt and Washer Locations

---

## B.10 Connect the HDSA Drawer Interlock Cables

The two drawer DC motors in the system cabinet have connectors that daisy-chain to the four drawer motors in the expansion cabinet.

**1. Open the rear door of the system and expansion cabinets.**

FIGURE B-15 shows the drawer motor connectors. Connector P4 on each motor holds the black and white twisted pair drawer interlock cables.

**2. Route these cables through the system cabinet to the expansion cabinet. Each cable has a connector labeled J1 or J2.**

**3. Connect J1 to J1/P1 and J2 to J2/P2 according to the diagram in FIGURE B-16. Note that the connections in the system cabinet are already installed.**

**4. Make sure the yellow Caution label is not removed during this procedure. If it does, re-attach it using tie-wrap cables.**

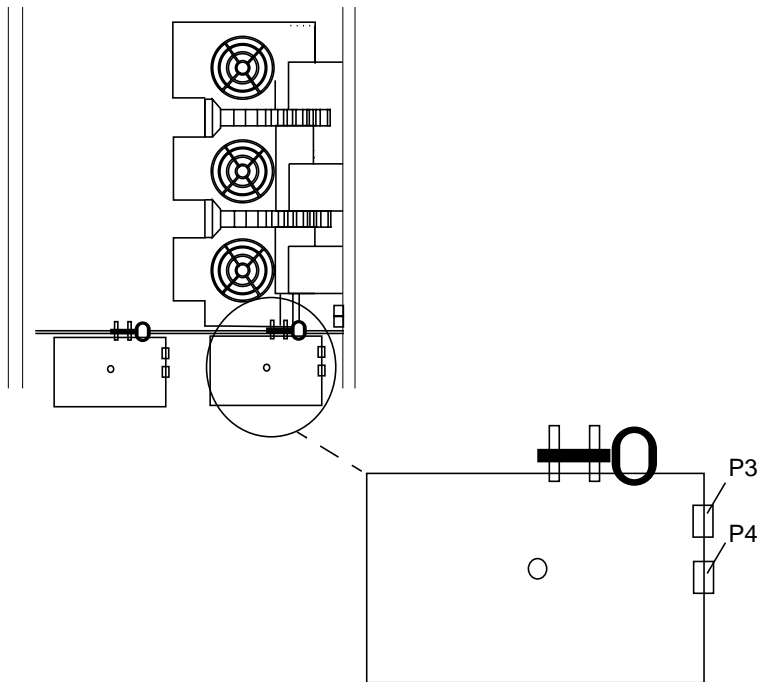
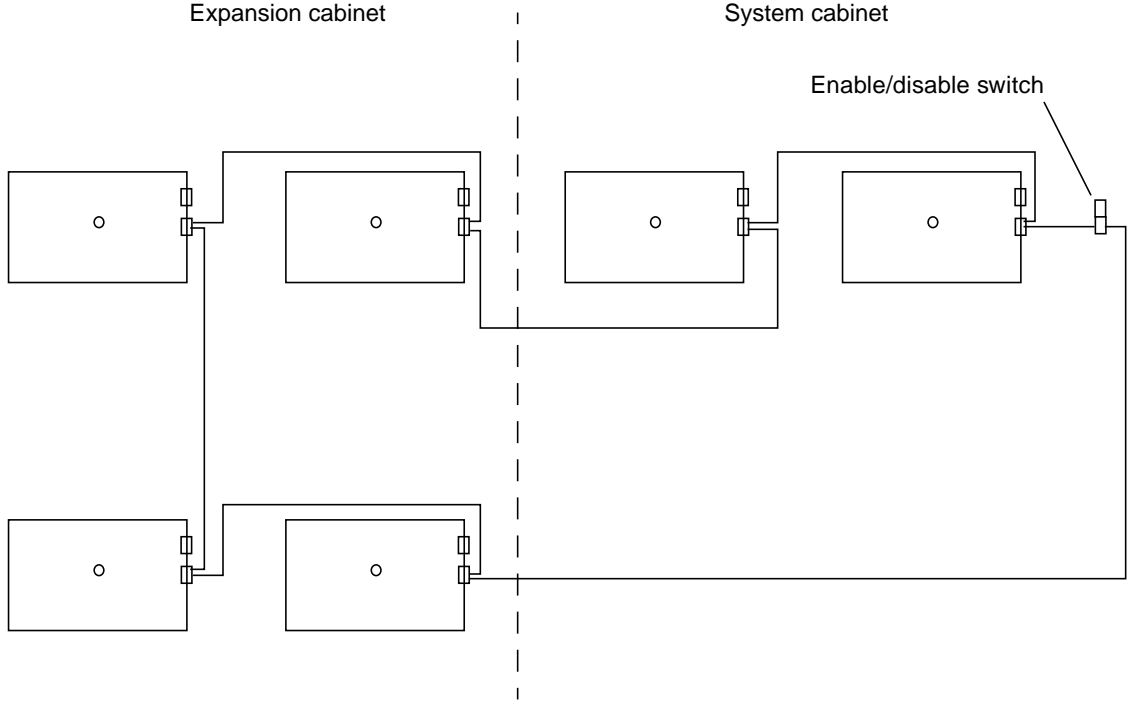


FIGURE B-15 Drawer Motor Connectors



**FIGURE B-16** Drawer Interlock Connection Diagram

---

## B.11 Completing the Installation

To complete the installation, consult the *Sun StorEdge A7000 Installation Guide* to:

- Install power conditioning units (PCUs)
- Install disk drives
- Level the cabinets
- Power on the StorEdge A7000

---

## B.12 Updating the Master Configuration Database

If you installed the expansion cabinet as an x-option add-on field upgrade, you recorded all new component part numbers, revisions, serial numbers, and chassis card slot locations as you installed the components. You need this information for the Master Configuration Database (MCD) update procedure.

To update MCD, refer to the *Master Configuration Data Hardware Modification Tool User's Guide*.

# Glossary

---

<b>AC</b>	alternating current
<b>ATP</b>	acceptance test procedure
<b>AWG</b>	American wire gauge
<b>BBM</b>	break before make
<b>BMC</b>	block mux controller
<b>DC</b>	direct current
<b>DVM</b>	digital voltmeter
<b>EMI</b>	electromagnetic interference
<b>ESCON</b>	Enterprise Systems Connection
<b>EPO</b>	emergency power off
<b>ESD</b>	electrostatic discharge
<b>FE</b>	field engineer
<b>GUI</b>	graphical user interface; operator communicates with StorEdge A7000 server through graphical icons, windows, and trackball mouse actions (such as pointing and clicking).
<b>HSDA</b>	high-density storage array; drawer containing disk drives, used in StorEdge A7000 server.
<b>HVAC</b>	heating, ventilation, and air-conditioning
<b>Hz</b>	Hertz (cycles per second)
<b>KB</b>	kilobyte
<b>kW</b>	kilowatt
<b>MBB</b>	make before break

<b>MCD</b>	master configuration data
<b>PCMCIA</b>	Personal Computer Manufacturer Card Interface Adapter; the System Console contains two PCMCIA slots.
<b>PCB</b>	printer circuit boards
<b>PCU</b>	Power conditioning unit
<b>QFR</b>	Quality feedback report
<b>RDC</b>	remote dual copy
<b>RFI</b>	radio frequency interference
<b>ROM</b>	read-only memory
<b>RSS</b>	remote service support
<b>SCSI</b>	Small Computer Systems Interface; communications bus type used by StorEdge A7000 server disk drives
<b>System Console</b>	notebook computer located in a carrier tray in the front door of the StorEdge A7000 server; the operator interface.
<b>V</b>	volts
<b>VAC</b>	volts alternating current
<b>VDC</b>	volts direct current

# Index

---

## A

- Acceptance Test Procedure (ATP)
  - analyze results, 6-9
  - summary file, 6-12
- adjust HDSA drawer, 5-17
- analyze Acceptance Test Procedure (ATP) results, 6-9
- analyze error report (errpt) results, 6-9

## B

- backup important system files, 6-38
- battery check
  - power conditioning unit (PCU), 6-32
- BMC cables
  - installation, 6-5
- brackets, HDSA shipping, 2-11
- bypass switch, 3-4, 5-2

## C

- cabinet
  - inside rear view, 2-16, 6-2
  - level, 4-2
  - power off, B-11
  - power on, 5-12
- cables
  - BMC, connect, 6-5

- channel interface, connect, 6-4
- ESCON, connect, 2-17, 6-8
- PCU data, 3-14, 6-2
- SCSI target, connect, 6-9
- channel interface cable installation, 6-4
- check
  - battery, power conditioning unit (PCU), 6-32
  - DC voltage, subsystems, 5-21
  - Master Configuration Data (MCD), 6-37
  - PCU firmware level, 5-9

## D

- damage equipment report, 2-17
- data cables, 3-14, 6-2
- date
  - modify, 6-25
- disk drives, 4-9, 4-10
  - 18-Gbyte, 4-10
  - 9-Gbyte, 4-9
  - install, 4-1, 4-8
  - labels, 4-5
  - LEDs, 4-9, 4-10
  - select LEDs, 6-10

## E

- electrical
  - installation, 3-2
  - pre-installation, 3-2
- electromagnetic interference (EMI), 1-5
- electrostatic discharge (ESD), 1-4

- protection, 1-4
- enter data, time, timezone, 6-25
- error report (errpt)
  - analyze results, 6-9
- ESCON cables
  - connect, 2-17
  - installation, 6-8

**F**  
file backup, 6-38

**G**  
ground cable, 3-11, 3-14  
ground clamp, 3-10, 3-14  
grounding, 3-8

**H**  
HDSA

- adjust drawer, 5-17
- disk select LEDs, 6-10
- drawer adjustment, 5-17
- open the drawer, 4-6, B-25
- power off, B-10
- power on, 5-23
- power supplies, 5-23
- shipping brackets, 2-11

**I**  
I/O bay cabinet, 6-7

- connectors, 6-24

inspection, 2-13

- loose or missing components, 2-14
- physical damage, 2-14

installation, 4-1

- BMC cables, 6-5
- completing, 6-1
- connect PCU to bypass switch, 3-4
- data cables, 3-14
- disable RSS Paging feature, 6-20
- disk drives, 4-1, 4-8
- electrical, 3-2
- enable RSS Paging feature, 6-20

- ESCON cables, 6-8
- HDSA expansion cabinet, 3-3
- inspection, 2-13
- internal PCU data cable, 6-2
- inventory, 1-9
- leveler feet, 2-2
- packing material removal, 2-10, 2-11, 2-12
- PCU date and time, 5-8
- power conditioning unit (PCU), 3-14
- power on cabinet, 5-12
- power on subsystems, 5-21
- preparation, 1-7
- program PCU output voltage, 5-5
- Remote Support System (RSS) software, 6-12
- SCSI target cables, 6-9
- site preparation, 1-9
- special tools and test equipment, 1-8
- steps, 1-5
- StorEdge A7000, 3-1
- System Console, 4-1, 4-14
- System Console tray location, 4-16
- unloading equipment, 2-2
- unpacking equipment, 2-2
- inventory, 1-9

**L**  
level the cabinet, 4-2  
leveler feet, 2-2

- install, 2-5

**M**  
Master Configuration Data (MCD)

- check, 6-37

missing equipment report, 2-17  
modem files, 6-21  
modify date, time, timezone, 6-25

**O**  
open HDSA drawer manually, 4-6, B-25  
open subsystem windows, 5-20  
operating system

- shutdown, subsystem, B-6
- shutdown, System Console, B-6, B-9



## **P**

- packing material, 2-8
- password
  - set, StorEdge A7000, 6-33
- phone home test (RSS), 6-22
- power conditioning unit (PCU), 3-14
  - check battery, 6-32
  - check firmware level, 5-9
  - check/program voltage, 5-4
  - connect to bypass switch, 3-4
  - installation, 3-14
  - measure PCU output voltage, 3-6
  - power on, 5-2
  - set date and time, 5-8
  - set up for noisy/dirty power, A-1
  - start software, 6-28
  - unpack, 2-13
- power off procedures, B-5
  - System Console, B-9
- power on procedures
  - cabinet, 5-12
  - HDSA power supplies, 5-23
  - power conditioning unit (PCU), 5-2
  - StorEdge A7000, 5-12
  - subsystem, 5-21
  - System Console, 5-19
- power output receptacles, 5-4
- power switches, 2-15, 5-14
- precautions, 1-2
  - electromagnetic interference, 1-5
  - electrostatic discharge, 1-4
  - radio frequency interference, 1-5
  - safety checks, 3-4

## **Q**

- quad-channel BMC card
  - replacement, B-22

## **R**

- radio frequency interference (RFI), 1-5
- Remote Dual Copy (RDC), 6-33
- Remote Support System (RSS)
  - software, 6-12
  - test phone home, 6-22
- remove packing material, 2-8, 2-10, 2-12

## **report**

- damaged equipment, 2-17
- missing equipment, 2-17

## **S**

- safety checks, 1-3
- safety procedures and practices, 1-2
- SCSI target cables
  - installation, 6-9
- SCSI Target Emulation
  - start, B-6
- set StorEdge A7000 password, 6-33
- shutdown
  - subsystem operating system, B-6
  - System Console operating system, B-9
- site preparation, 1-9
- special tools and test equipment, 1-8
- start power conditioning unit (PCU) software, 6-28
- start SCSI Target Emulation software, B-6
- subsystem
  - power off, B-5, B-10
- System Console
  - Application Menu Bar, 6-28
  - installation, 4-14
  - open windows, 5-20
  - power off, B-9
  - power on, 5-19
  - shutdown, B-9
  - timezone, modify, 6-27

## **T**

- telephone numbers
  - Worldwide Support Center, 6-18
- test equipment, 1-8
- test RSS phone home, 6-22
- time
  - modify, 6-25
- timezone
  - modify, 6-25
- tools, 1-8

## **U**

unpack

disk drives, 4-4

PCU, 2-1

StorEdge A7000, 2-1

## **W**

windows, open, 5-20

Worldwide Support Center telephone numbers, 6-18