



XCP2060-TRN I/O Transition Card Manual

for Netra™ CP2060/CP2080/CP2160
CompactPCI Boards

Sun Microsystems, Inc.
4150 Network Circle
Santa Clara, CA 95054 U.S.A.
650-960-1300

Part No. 806-6203-11
December 2002, Revision A

Send comments about this document to: docfeedback@sun.com

Copyright 2002 Sun Microsystems, Inc., 4150 Network Circle, Santa Clara, California 95054, U.S.A. All rights reserved.

Sun Microsystems, Inc. has intellectual property rights relating to technology embodied in the product that is described in this document. In particular, and without limitation, these intellectual property rights may include one or more of the U.S. patents listed at <http://www.sun.com/patents> and one or more additional patents or pending patent applications in the U.S. and in other countries.

This document and the product to which it pertains are distributed under licenses restricting their use, copying, distribution, and decompilation. No part of the product or of this document may be reproduced in any form by any means without prior written authorization of Sun and its licensors, if any.

Third-party software, including font technology, is copyrighted and licensed from Sun suppliers.

Parts of the product may be derived from Berkeley BSD systems, licensed from the University of California. UNIX is a registered trademark in the U.S. and in other countries, exclusively licensed through X/Open Company, Ltd.

Sun, Sun Microsystems, the Sun logo, AnswerBook2, docs.sun.com, Netra and Solaris are trademarks or registered trademarks of Sun Microsystems, Inc. in the U.S. and in other countries.

All SPARC trademarks are used under license and are trademarks or registered trademarks of SPARC International, Inc. in the U.S. and in other countries. Products bearing SPARC trademarks are based upon an architecture developed by Sun Microsystems, Inc.

The OPEN LOOK and Sun™ Graphical User Interface was developed by Sun Microsystems, Inc. for its users and licensees. Sun acknowledges the pioneering efforts of Xerox in researching and developing the concept of visual or graphical user interfaces for the computer industry. Sun holds a non-exclusive license from Xerox to the Xerox Graphical User Interface, which license also covers Sun's licensees who implement OPEN LOOK GUIs and otherwise comply with Sun's written license agreements.

U.S. Government Rights—Commercial use. Government users are subject to the Sun Microsystems, Inc. standard license agreement and applicable provisions of the FAR and its supplements.

DOCUMENTATION IS PROVIDED "AS IS" AND ALL EXPRESS OR IMPLIED CONDITIONS, REPRESENTATIONS AND WARRANTIES, INCLUDING ANY IMPLIED WARRANTY OF MERCHANTABILITY, FITNESS FOR A PARTICULAR PURPOSE OR NON-INFRINGEMENT, ARE DISCLAIMED, EXCEPT TO THE EXTENT THAT SUCH DISCLAIMERS ARE HELD TO BE LEGALLY INVALID.

Copyright 2002 Sun Microsystems, Inc., 4150 Network Circle, Santa Clara, California 95054, Etats-Unis. Tous droits réservés.

Sun Microsystems, Inc. a les droits de propriété intellectuelle relatants à la technologie incorporée dans le produit qui est décrit dans ce document. En particulier, et sans la limitation, ces droits de propriété intellectuelle peuvent inclure un ou plus des brevets américains énumérés à <http://www.sun.com/patents> et un ou les brevets plus supplémentaires ou les applications de brevet en attente dans les Etats-Unis et dans les autres pays.

Ce produit ou document est protégé par un copyright et distribué avec des licences qui en restreignent l'utilisation, la copie, la distribution, et la décompilation. Aucune partie de ce produit ou document ne peut être reproduite sous aucune forme, par quelque moyen que ce soit, sans l'autorisation préalable et écrite de Sun et de ses bailleurs de licence, s'il y en a.

Le logiciel détenu par des tiers, et qui comprend la technologie relative aux polices de caractères, est protégé par un copyright et licencié par des fournisseurs de Sun.

Des parties de ce produit pourront être dérivées des systèmes Berkeley BSD licenciés par l'Université de Californie. UNIX est une marque déposée aux Etats-Unis et dans d'autres pays et licenciée exclusivement par X/Open Company, Ltd.

Sun, Sun Microsystems, le logo Sun, AnswerBook2, docs.sun.com, Netra et Solaris sont des marques de fabrique ou des marques déposées de Sun Microsystems, Inc. aux Etats-Unis et dans d'autres pays.

Toutes les marques SPARC sont utilisées sous licence et sont des marques de fabrique ou des marques déposées de SPARC International, Inc. aux Etats-Unis et dans d'autres pays. Les produits portant les marques SPARC sont basés sur une architecture développée par Sun Microsystems, Inc.

L'interface d'utilisation graphique OPEN LOOK et Sun™ a été développée par Sun Microsystems, Inc. pour ses utilisateurs et licenciés. Sun reconnaît les efforts de pionniers de Xerox pour la recherche et le développement du concept des interfaces d'utilisation visuelle ou graphique pour l'industrie de l'informatique. Sun détient une licence non exclusive de Xerox sur l'interface d'utilisation graphique Xerox, cette licence couvrant également les licenciées de Sun qui mettent en place l'interface d'utilisation graphique OPEN LOOK et qui en outre se conforment aux licences écrites de Sun.

LA DOCUMENTATION EST FOURNIE "EN L'ÉTAT" ET TOUTES AUTRES CONDITIONS, DECLARATIONS ET GARANTIES EXPRESSES OU TACITES SONT FORMELLEMENT EXCLUES, DANS LA MESURE AUTORISEE PAR LA LOI APPLICABLE, Y COMPRIS NOTAMMENT TOUTE GARANTIE IMPLICITE RELATIVE A LA QUALITE MARCHANDE, A L'APTITUDE A UNE UTILISATION PARTICULIERE OU A L'ABSENCE DE CONTREFAÇON.



Adobe PostScript

Contents

Preface	v
Features	2
I/O Interfaces	3
On-Board Components	4
Software Support	5
Specifications	6
Determining Part Number, Serial Number, and Revision Number	8
Connectors	9
Transition Card I/O Face Plate Connectors	9
On-Board Interfaces/Connectors on the XCP2060-TRN I/O Transition Card	11
Backplane Interface	15
On-board PIM Card Interface	17
Installing the Transition Card in a CompactPCI Chassis	19
Safety Information	21

Preface

The XCP2060-TRN Transition Card (375-0120-xx) is a fully compatible, carrier-grade CompactPCI I/O card designed for the CP2060/CP2080/CP2160 range of Compact PCI boards. The *XCP2060-TRN I/O Transition Card Manual for CP2060/CP2080/CP2160* (806-6203-xx) describes the functions of the XCP2060-TRN Transition Card, its specifications, connectors, and installation process.

Who Should Use This Book

This manual is written for computer hardware engineers, system programmers, computer technicians, and others involved in the integration of the Netra CP2060/CP2080/CP2160 boards. References are provided for further details.

Related References

This section provides a list of related references.

Specifications and Standards

- *CompactPCI Core Specification, Release Note for PICMG 2.0 Revision 3.0, October 1999*, PCI Industrial Computers Manufacturers Group
- *IEEE Standard 1101.11-1998, Standard For Mechanical Rear Plug-in Units Specifications for Microcomputers Using IEEE 1101.1 and IEEE 1101.10 Equipment Practice*

- *VITA 36, PMC I/O Module Draft Standard*
- *Ethernet IEEE 802.3 Standard*
- *Universal Serial Bus Specification Rev. 1.1*
- *I2C-Bus Specification Version 2.1*

Related Documents

- *Netra CP2060 and CP2080 Technical Reference and Installation Manual (806-6658-xx)*
- *Netra CP2160 Installation and Technical Reference Manual (816-5772-xx)*

Using UNIX Commands

This document might not contain information on basic UNIX® commands and procedures such as shutting down the system, booting the system, and configuring devices.

See one or more of the following for this information:

- *Solaris Handbook for Sun Peripherals*
- AnswerBook2™ online documentation for the Solaris™ operating environment
- Other software documentation that you received with your system

Typographic Conventions

Typeface	Meaning	Examples
AaBbCc123	The names of commands, files, and directories; on-screen computer output	Edit your <code>.login</code> file. Use <code>ls -a</code> to list all files. % You have mail.
AaBbCc123	What you type, when contrasted with on-screen computer output	% su Password:
<i>AaBbCc123</i>	Book titles, new words or terms, words to be emphasized. Replace command-line variables with real names or values.	Read Chapter 6 in the <i>User's Guide</i> . These are called <i>class</i> options. You <i>must</i> be superuser to do this. To delete a file, type <code>rm filename</code> .

Shell Prompts

Shell	Prompt
C shell	<i>machine-name%</i>
C shell superuser	<i>machine-name#</i>
Bourne shell and Korn shell	\$
Bourne shell and Korn shell superuser	#

Accessing Sun Documentation Online

You can view and print a broad selection of Sun™ documentation, including localized versions, at:

<http://www.sun.com/documentation>

Sun Welcomes Your Comments

Sun is interested in improving its documentation and welcomes your comments and suggestions. You can email your comments to Sun at:

docfeedback@sun.com

Please include the part number (806-6203-11) of your document in the subject line of your email.

XCP2060-TRN I/O Transition Card Manual

The XCP2060-TRN I/O Transition Card (375-0120-xx) is designed to be used with the Netra™ CP2060/CP2080/CP2160 range of Compact PCI host/satellite boards and is fully compliant with the *CompactPCI Core Specification, Release Note for PICMG 2.0 Revision 3.0* (October 1999, PCI Industrial Computers Manufacturers Group).

The XCP2060-TRN I/O Transition Card is a fully compatible, carrier-grade CompactPCI I/O card for the Netra CP2060/CP2080/CP2160 boards. However, it is not compatible with other CompactPCI boards.

It is the responsibility of the system designer to integrate peripheral devices to the connectors on the backplane in a Netra CP2060/CP2080/CP2160 chassis configuration. A designer can either connect directly to the backplane signals or use an XCP2060-TRN I/O Transition Card. This document provides information only for the integration of the XCP2060-TRN I/O Transition Card in a Netra CP2060/CP2080/CP2160 board CompactPCI chassis.

This document contains the following sections:

- “Features” on page 2
- “Determining Part Number, Serial Number, and Revision Number” on page 8
- “Connectors” on page 9
- “Installing the Transition Card in a CompactPCI Chassis” on page 19

Features

This section lists the important features of the XCP2060-TRN I/O Transition Card.

The XCP2060-TRN I/O Transition Card requires a CompactPCI chassis with a backplane that accommodates front and rear CompactPCI board installation. The primary purpose of this board is to provide the connection to Netra CP2060/CP2080/CP2160 board I/O devices.

The 6U form factor, single-slot transition card supplies rear I/O connection to support additional peripherals with simplified system cabling for use with the compatible CompactPCI system host boards. The rear I/O access also enables the complementary system host boards to be replaced without disconnecting cables. Industry-standard connectors and pin assignments ensure ease of use and flexible design. The XCP2060-TRN I/O Transition Card enables the creation of high-density systems by enabling easy access to I/O.

FIGURE 1 shows the XCP2060-TRN I/O Transition Card and a typical Netra CP2160 board connected through the backplane.

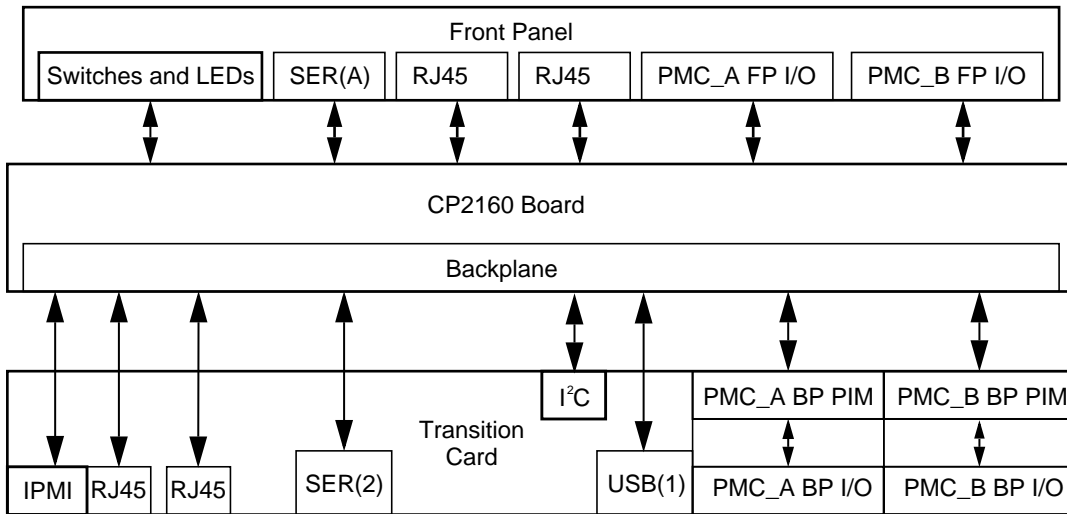

FIGURE 1 XCP2060-TRN I/O Transition Card and a typical Netra CP2160 Board Connected Through the Backplane

I/O Interfaces

The XCP2060-TRN I/O Transition Card provides additional I/O features (through the J3 and J5 CompactPCI connector interfaces) to the Netra CP2060/CP2080/CP2160 boards. Many I/O functions are provided on the transition card's own faceplate (as shown in FIGURE 2), as well as from headers mounted on the card.

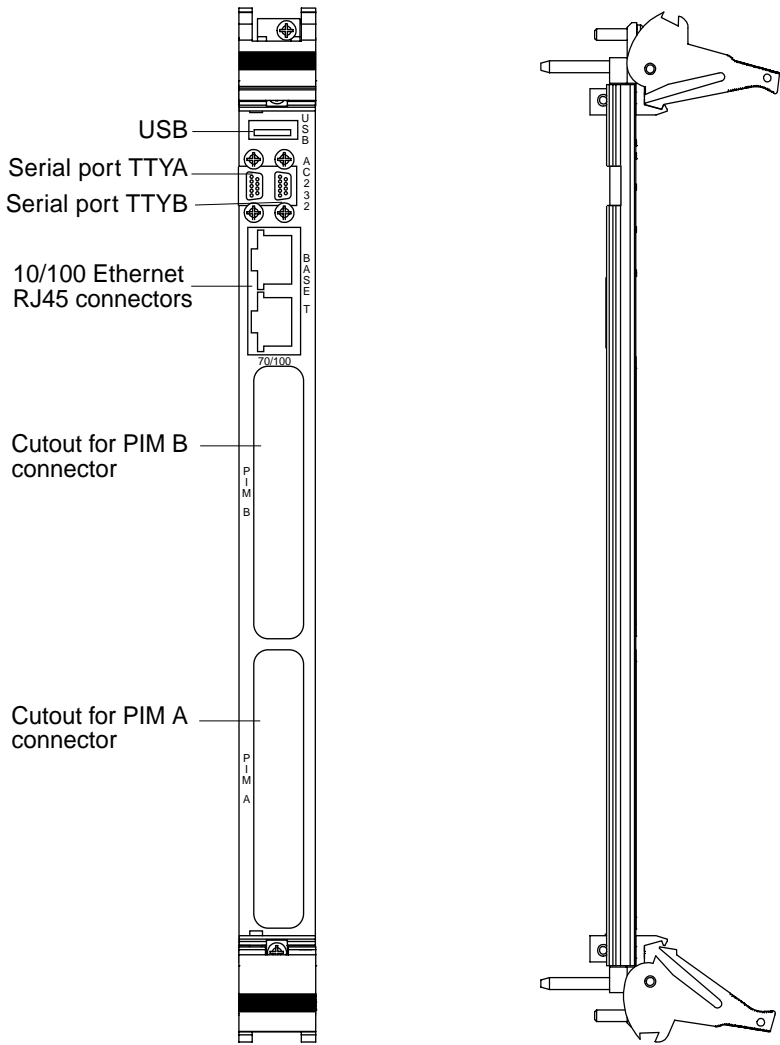

FIGURE 2 XCP2060-TRN I/O Transition Card Faceplate

These function include:

- Two PMC Interface Module (PIM) I/O connections (with user-defined I/O). Only PIM A may be used on the transition card when it is mated with a board that is using one or two single-wide memory module/s.
- Two 10/100 Fast Ethernet (RJ45) ports available (channel A and channel B)
- Two serial (mini-DB9) ports, TTYA and TTYB. TTYA is the system console port.
- Two Universal Serial Bus ports. One is accessible directly on the I/O panel, and the other accessible through the PIM A connector (see FIGURE 7 for the location of the PIM connectors.)

Refer to “Cabling Requirements” on page 7 for information on which cables to use for the transition card.

On-Board Components

- I²C Serial EEPROM (FRU ID) -- This component contains board identification and some manufacturing information such as the part number and date code information of the XCP2060-TRN I/O Transition Card. The SMC on the host board monitors and identifies the I²C interface. The Serial EEPROM is accessed through the local Netra CP2060/CP2080/CP2160 I²C bus on J5. The SW301 switch is used to enable writing to the I²C Serial EEPROM (see TABLE 1 and FIGURE 3).
- I²C Bus Access Header -- The J301 10-pin connector header provides access to the I²C bus (see the Netra CP2060/CP2080/CP2160 board specifications for more information). Backplane reset in/out pins are also available on this header. The transition card also provides access through on-board headers to test and debug signals.
- The only active component on the XCP2060-TRN I/O Transition Card is the I²C EEPROM. The board is fully passive, but some power is provided to PIM carriers A and B and to the I²C EEPROM.

TABLE 1 SW301 Switch Settings

Switch #	Setting	Description
1	no connect	Not used
2	switch closed (in direction of arrow)	When switch closed, write protect is disabled and the I ² C EEPROM can be written to.
	switch open	When switch open, write protect is enabled. This is the default.

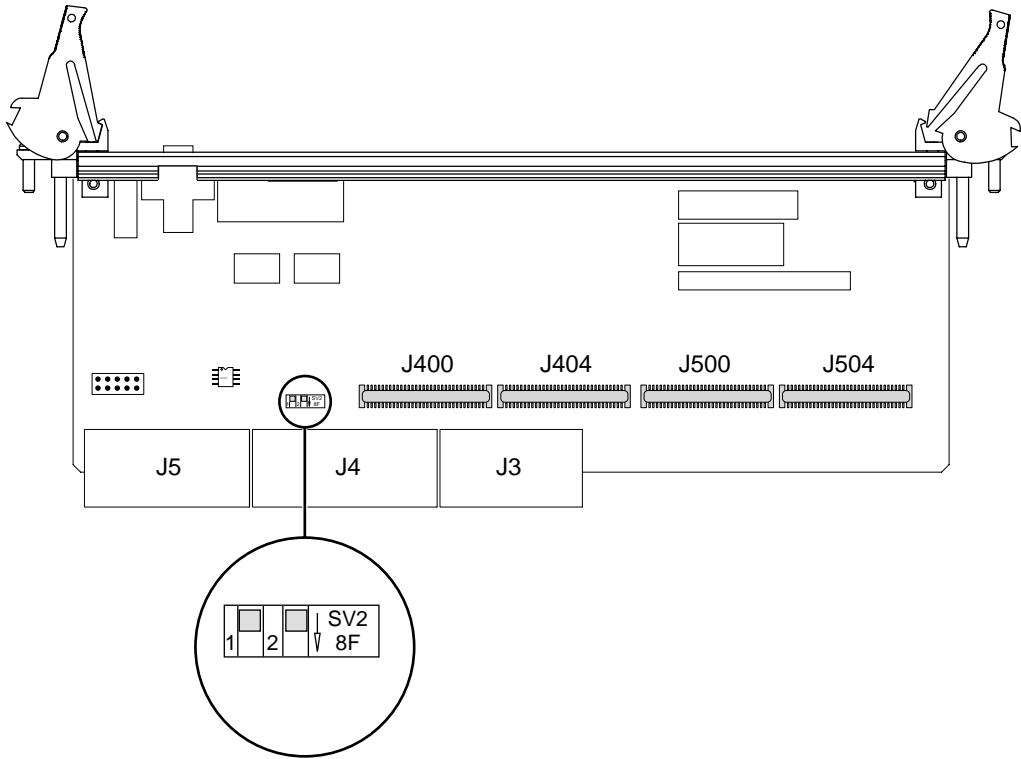

FIGURE 3 Switch Settings on the SW301 Switch

FIGURE 4 shows the location of the on-board components.

Software Support

The XCP2060-TRN I/O Transition Card is designed to support the Netra CP2060/CP2080/CP2160 host board. It therefore supports the software supported by the host boards. (See the *Netra CP2060 and CP2080 Technical Reference Manual and Installation Guide*, P/N 806-6658-xx, and the *Netra CP2160 CompactPCI Board Installation and Technical Reference Manual*, P/N 816-5772-xx, for host board software support.)

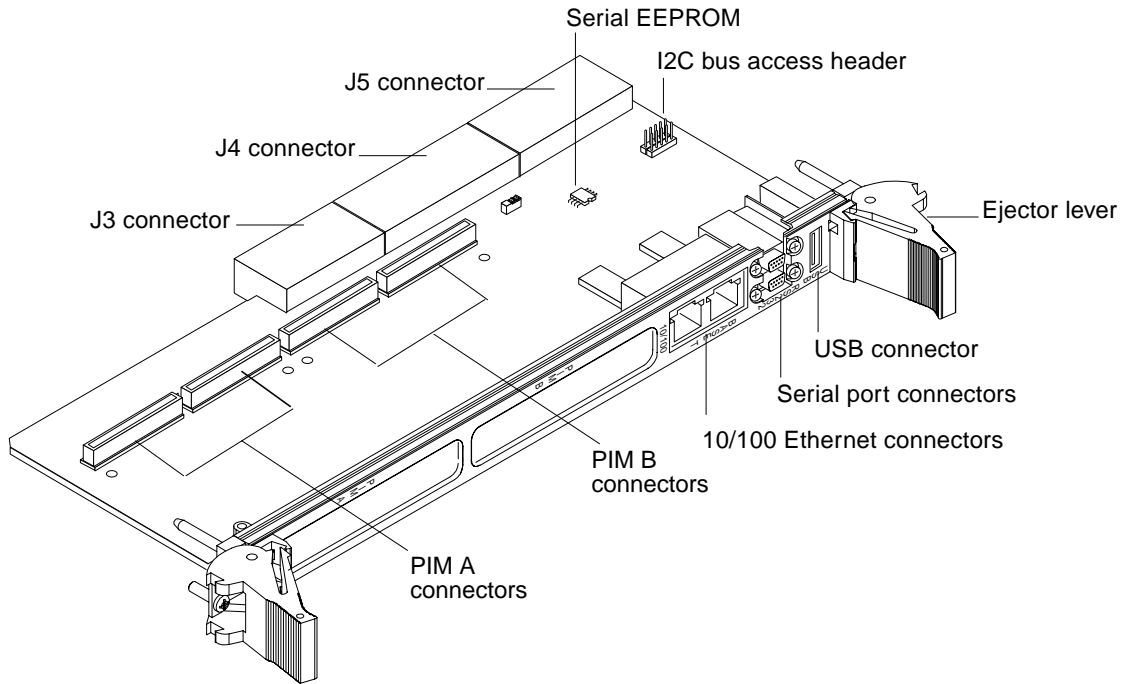

FIGURE 4 XCP2060-TRN I/O Transition Card Showing Location of On-Board Components

Specifications

This section provides mechanical, electrical, environmental, and other relevant specifications for the XCP2060-TRN I/O Transition Card.

Mechanical Dimensions

TABLE 2 shows the physical dimensions for the XCP2060-TRN I/O Transition Card.

TABLE 2 Physical Dimensions

Board Specifications	Dimensions
Form Factor	6U

TABLE 2 Physical Dimensions

Board Specifications	Dimensions
Length	9.2 inches (233.68 mm.)
Width	3.1 inches (78.84 mm.)
Height	0.54 inches (13.716 mm.)

Power Requirements

The XCP2060-TRN I/O Transition Card has mainly passive components. However, some power from the backplane is provided to PIM carriers A and B and to the I²C EEPROM.

For information on PIM allowable dissipation and limits on PIM power consumption, see *VITA 36, PMC I/O Module Standard*.

Environmental Specification, Compliance, and Reliability/Availability

For details on the environmental specifications, compliance, and reliability/availability, please see the of the *Netra CP2060 and CP2080 Technical Reference Manual and Installation Guide (806-6658-xx)* and the *Netra CP2160 CompactPCI Board Installation and Technical Reference Manual (816-5772-xx)*.

Cabling Requirements

For Class B EMI compliance on the XCP2060-TRN I/O Transition Card, note the following cabling requirements:

- When this transition card is used with the Netra CP2060 board, you must use shielded cables on all I/O ports.
- When this product is used with the Netra CP2160 board, you must use shielded cables on serial and USB I/O ports and you can use unshielded cables on Ethernet ports.
- The shields for all shielded cables must be terminated on both ends.

Determining Part Number, Serial Number, and Revision Number

The XCP2060-TRN I/O Transition Card part number, serial number, and revision number can be found on stickers located on the card (see FIGURE 5). For proper identification of the XCP2060-TRN I/O Transition Card, please see the list below along with FIGURE 5.

The Sun Microsystems barcode label provides the following information:

- Board part number (for example, 3750120) which is the first seven digits on the barcode label. The next six digits are the board serial number (for example, 005609).

The Subcon label provides the following information:

- Product part number (for example, 5762), product dash (for example, -02), and revision number (for example REV 57).
- Board date code (for example, 03/2001), which represents the third week of year 2001.
- Country of origin (for example ASSEMBLED IN CANADA)

Note – The CM barcode label in FIGURE 5 is an optional label and may or may not appear on the XCP2060-TRN transition card.

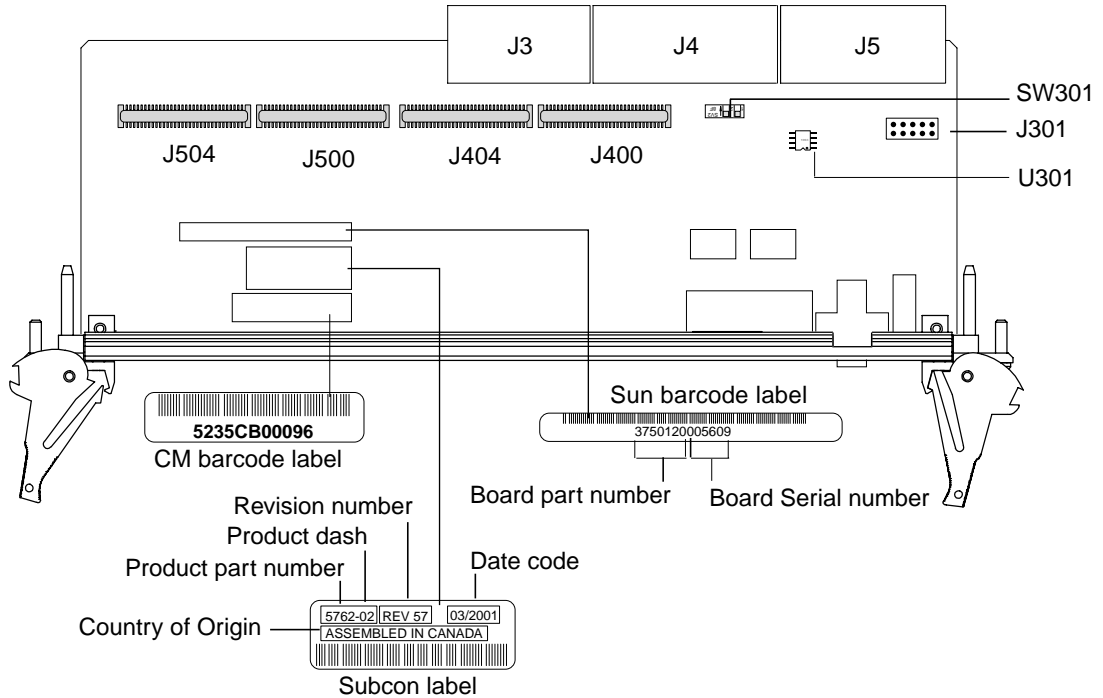

FIGURE 5 Location of XCP2060-TRN I/O Transition Card Identification Labels

Connectors

Transition Card I/O Face Plate Connectors

This section lists the pins and signal names of the I/O faceplate connectors on the transition card.

USB Ports

USB connector port A is available on the XCP2060-TRN I/O Transition Card I/O panel. If the user so desires, a second USB connector, port B, is available for use on the faceplate with the addition of a PIM module (that supports a USB connector) on the PIM A connectors.

TABLE 3 Universal Serial Bus Port A – J801 AMP440260-1

Pin	Signal
1	+5V POWER
2	POS
3	NEG
4	GND

Serial Ports

Two serial ports from the Netra CP2060/CP2080/CP2160 16552 DUART are made available through the rear panel with single-stacked 9-pin connectors. One connector is assigned to Port A and the other connector to Port B. The signal interface of the connector is as follows:

TABLE 4 Dual 16550 compatible UARTs for Serial Ports - J601

Serial A of Dual Connector		Serial B of Dual Connector	
Pin	Signal	Pin	Signal
P1A	DCD A	P1B	DCD B
P2A	RXD A	P2B	RXD B
P3A	TXD A	P3B	TXD B
P4A	DTR A	P4B	DTR B
P5A	GND A	P5B	GND B
P6A	DSR A	P6B	DSR B
P7A	RTS A	P7B	RTS B
P8A	CTS A	P8B	CTS B
P9A	RI A	P9B	RI B

Fast Ethernet

Dual Jack RJ45 Ethernet (J701) AMP1116353-8:

TABLE 5 Fast Ethernet Ports A and B

Ethernet Port A		Ethernet Port B	
Pin	Signal	Pin	Signal
1	TX (+)	1	TX (+)
2	TX (-)	2	TX (-)
3	RX (+)	3	RX (+)
4		4	
5		5	
6	RX (-)	6	RX (-)
7		7	
8		8	

On-Board Interfaces/Connectors on the XCP2060-TRN I/O Transition Card

FIGURE 6 shows the on-board interfaces/connectors on the transition card.

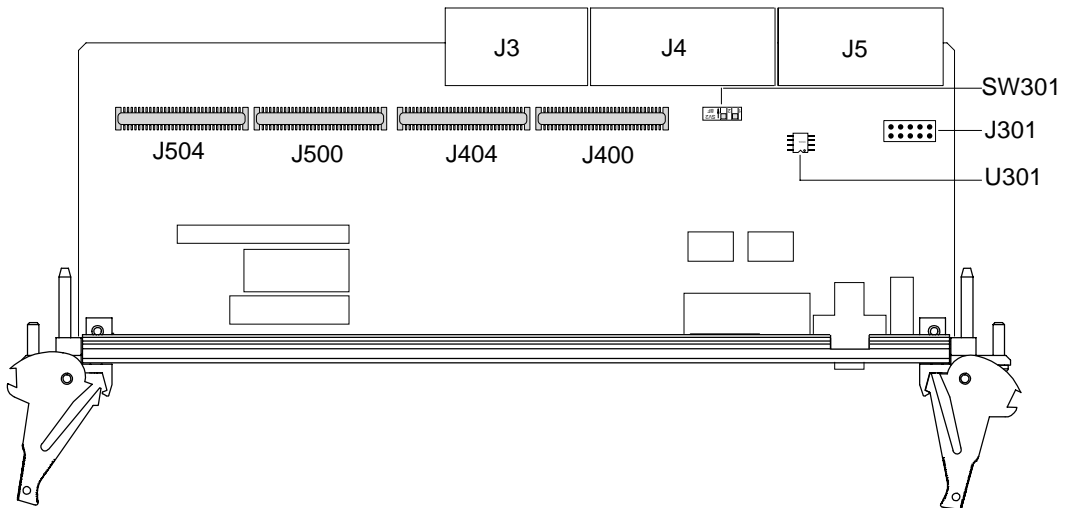

FIGURE 6 XCP2060-TRN I/O Transition Card On-Board Connectors and Interfaces

I²C Bus Access Header

TABLE 6 I²C Bus Access Header (J301)

Pin	Signal
1	I2C SDA
2	GND
3	I2C SCL
4	BP_XIR_L
5	I2C_POWER
6	
7	I2C_POWER
8	BKRST# OUT
9	GND
10	BKRST# IN

I²C Bus Access Header

TABLE 7 I²C Bus Access Header (J301)

Pin	Signal
1	I2C SDA
2	GND
3	I2C SCL
4	BP_XIR_L
5	I2C_POWER
6	
7	I2C_POWER
8	BKRST# OUT
9	GND
10	BKRST# IN

PIM Connectors

PIM A has two 64 pin connectors at J500 and J504. PIM B has two 64 pin connectors at J400 and J404 (for location see FIGURE 6).

TABLE 8 PIM A Connector J0 Pin Assignments

Pin	Signal	Pin	Signal	Pin	Signal	Pin	Signal
1	SMC TX	17	USB A (+)	33		49	
2	+12V	18	GND	34	GND	50	GND
3	SMC RX	19	PCI-B RST#	35		51	
4		20		36		52	
5	+5V	21	+5V	37	+5V	53	+5V
6		22		38		54	
7	I2C SDA	23	BPIO1	39		55	
8		24		40		56	
9	I2C SCL	25	BPIO2	41		57	
10	+3.3V	26	+3.3V	42	+3.3V	58	+3.3V
11	I2C POWER	27		43		59	
12		28		44		60	
13	GND	29	GND	45	GND	61	-12V
14		30		46		62	
15	USB A (-)	31		47		63	
16		32		48		64	

TABLE 9 PIM A Connector J1 Pin Assignments

Pin	Signal	Pin	Signal	Pin	Signal	Pin	Signal
1	PMC A I/O 1	17	PMC A I/O 17	33	PMC A I/O 33	49	PMC A I/O 49
2	PMC A I/O 2	18	PMC A I/O 18	34	PMC A I/O 34	50	PMC A I/O 50
3	PMC A I/O 3	19	PMC A I/O 19	35	PMC A I/O 35	51	PMC A I/O 51
4	PMC A I/O 4	20	PMC A I/O 20	36	PMC A I/O 36	52	PMC A I/O 52
5	PMC A I/O 5	21	PMC A I/O 21	37	PMC A I/O 37	53	PMC A I/O 53
6	PMC A I/O	22	PMC A I/O 22	38	PMC A I/O 38	54	PMC A I/O 54
7	PMC A I/O 7	23	PMC A I/O 23	39	PMC A I/O 39	55	PMC A I/O 55
8	PMC A I/O 8	24	PMC A I/O 24	40	PMC A I/O 40	56	PMC A I/O 56
9	PMC A I/O 9	25	PMC A I/O 25	41	PMC A I/O 41	57	PMC A I/O 57
10	PMC A I/O 10	26	PMC A I/O 26	42	PMC A I/O 42	58	PMC A I/O 58
11	PMC A I/O 11	27	PMC A I/O 27	43	PMC A I/O 43	59	PMC A I/O 59
12	PMC A I/O 12	28	PMC A I/O 28	44	PMC A I/O 44	60	PMC A I/O 60
13	PMC A I/O 13	29	PMC A I/O 29	45	PMC A I/O 45	61	PMC A I/O 61
14	PMC A I/O 14	30	PMC A I/O 30	46	PMC A I/O 46	62	PMC A I/O 62
15	PMC A I/O 15	31	PMC A I/O 31	47	PMC A I/O 47	63	PMC A I/O 63
16	PMC A I/O 16	32	PMC A I/O 32	48	PMC A I/O 48	64	PMC A I/O 64

TABLE 10 PIM B Connector J0 Pin Assignments

Pin	Signal	Pin	Signal	Pin	Signal	Pin	Signal
1	SMC TX	17	USB A (+)	33		49	
2	+12V	18	GND	34	GND	50	GND
3	SMC RX	19	PCI-B RST#	35		51	
4		20		36		52	
5	+5V	21	+5V	37	+5V	53	+5V
6		22		38		54	
7	I2C SDA	23	BPIO1	39		55	
8		24		40		56	
9	I2C SCL	25	BPIO2	41		57	
10	+3.3V	26	+3.3V	42	+3.3V	58	+3.3V
11	I2C_POWER	27		43		59	
12		28		44		60	
13	GND	29	GND	45	GND	61	-12V
14		30		46		62	
15	USB A (-)	31		47		63	
16		32		48		64	

TABLE 11 PIM B Connector J1 Pin Assignments

Pin	Signal	Pin	Signal	Pin	Signal	Pin	Signal
1	PMC B I/O 1	17	PMC B I/O 17	33	PMC B I/O 33	49	PMC B I/O 49
2	PMC B I/O 2	18	PMC B I/O 18	34	PMC B I/O 34	50	PMC B I/O 50
3	PMC B I/O 3	19	PMC B I/O 19	35	PMC B I/O 35	51	PMC B I/O 51
4	PMC B I/O 4	20	PMC B I/O 20	36	PMC B I/O 36	52	PMC B I/O 52
5	PMC B I/O 5	21	PMC B I/O 21	37	PMC B I/O 37	53	PMC B I/O 53
6	PMC B I/O	22	PMC B I/O 22	38	PMC B I/O 38	54	PMC B I/O 54
7	PMC B I/O 7	23	PMC B I/O 23	39	PMC B I/O 39	55	PMC B I/O 55
8	PMC B I/O 8	24	PMC B I/O 24	40	PMC B I/O 40	56	PMC B I/O 56
9	PMC B I/O 9	25	PMC B I/O 25	41	PMC B I/O 41	57	PMC B I/O 57
10	PMC B I/O 10	26	PMC B I/O 26	42	PMC B I/O 42	58	PMC B I/O 58
11	PMC B I/O 11	27	PMC B I/O 27	43	PMC B I/O 43	59	PMC B I/O 59
12	PMC B I/O 12	28	PMC B I/O 28	44	PMC B I/O 44	60	PMC B I/O 60
13	PMC B I/O 13	29	PMC B I/O 29	45	PMC B I/O 45	61	PMC B I/O 61
14	PMC B I/O 14	30	PMC B I/O 30	46	PMC B I/O 46	62	PMC B I/O 62
15	PMC B I/O 15	31	PMC B I/O 31	47	PMC B I/O 47	63	PMC B I/O 63
16	PMC B I/O 16	32	PMC B I/O 32	48	PMC B I/O 48	64	PMC B I/O 64

Backplane Interface

The XCP2060-TRN I/O Transition Card interfaces to the CompactPCI bus through J3 and J5 connectors. The pin assignments for these two sets of connectors are provided in this section.

J3 Connector

The pin assignments for J3 Connector are shown in TABLE 12 (for connector location see FIGURE 6).

TABLE 12 XCP2060-TRN Transition Card J3 Pin Assignments

Pin #	Row Z	Row A	Row B	Row C	Row D	Row E	Row F
19	GND	USR-A1	USR-A2	USR-A3	USR-A4	USR-A5	GND
18	GND	USR-A6	USR-A7	USR-A8	USR-A9	USR-A10	GND
17	GND	USR-A11	USR-A12	USR-A13	USR-A14	USR-A15	GND
16	GND	USR-A16	USR-A17	USR-A18	USR-A19	USR-A20	GND
15	GND	USR-A21	USR-A22	USR-A23	USR-A24	USR-A25	GND
14	GND	USR-A26	USR-A27	USR-A28	USR-A29	USR-A30	GND
13	GND	USR-A31	USR-A32	USR-A33	USR-A34	USR-A35	GND
12	GND	USR-A36	USR-A37	USR-A38	USR-A39	USR-A40	GND
11	GND	USR-A41	USR-A42	USR-A43	USR-A44	USR-A45	GND

TABLE 12 XCP2060-TRN Transition Card J3 Pin Assignments (Continued)

Pin #	Row Z	Row A	Row B	Row C	Row D	Row E	Row F
10	GND	USR-A46	USR-A47	USR-A48	USR-A49	USR-A50	GND
9	GND	USR-A51	USR-A52	USR-A53	USR-A54	USR-A55	GND
8	GND	USR-A56	USR-A57	USR-A58	USR-A59	USR-A60	GND
7	GND	USR-A61	USR-A62	USR-A63	USR-A64	+5V	GND
6	GND				BPIO1	BPIO2	GND
5	GND				BKRST# OUT	BKRST# IN	GND
4	GND				SMC RX	SMC TX	GND
3	GND				PCI-B RST#		GND
2	GND						GND
1	GND			BP_XIR_L			GND

Note – The USR signals are routed from the Netra CP2060/CP2080/CP2160 PMC-A signals.

J5 Connector

The pin assignments for J5 Connector are shown in TABLE 13 (for connector location see FIGURE 6).

TABLE 13 XCP2060-TRN Transition Card J5 Pin Assignments

Pin #	Row Z	Row A	Row B	Row C	Row D	Row E	Row F
22	GND	USR-B5	USR-B4	USR-B3	USR-B2	USR-B1	GND
21	GND	USR-B10	USR-B9	USR-B8	USR-B7	USR-B6	GND
20	GND	USR-B15	USR-B14	USR-B13	USR-B12	USR-B11	GND
19	GND	USR-B20	USR-B19	USR-B18	USR-B17	USR-B16	GND
18	GND	USR-B25	USR-B24	USR-B23	USR-A22	USR-A21	GND
17	GND	USR-A30	USR-A29	USR-A28	USR-A27	USR-A26	GND
16	GND	USR-A35	USR-A34	USR-A33	USR-A32	USR-A31	GND
15	GND	USR-A40	USR-A39	USR-A38	USR-A37	USR-A36	GND
14	GND	USR-A45	USR-A44	USR-A43	USR-A42	USR-A41	GND
13	GND	USR-A50	USR-A49	USR-A48	USR-A47	USR-A46	GND
12	GND	USR-A55	USR-A54	USR-A53	USR-A52	USR-A51	GND
11	GND	USR-A60	USR-A59	USR-A58	USR-A57	USR-A56	GND
10	GND		USR-A64	USR-A63	USR-A62	USR-A61	GND
9	GND	RTS A	DTR A	RI A	GND	CTS A	GND
8	GND	DCD A	TXD A	RXD A	DSR A	+5V	GND
7	GND	RTS B	DTR B	RI B	DSR B	CTS B	GND
6	GND	DCD B	TXD B	RXD B	GND	GND	GND
5	GND	I2C_SCL		-12V	ENET1 RX(+)	ENET1 RX(-)	GND
4	GND	I2C_SDA	I2C_PWR	GND	ENET1 TX(+)	ENET1 TX(-)	GND
3	GND	USB2(+)	USB2(-)	GND	GND	GND	GND
2	GND	USB1(+)	USB1(-)	GND	ENET0 R(+)	ENET0 R(-)	GND
1	GND	GND	+3.3V	+12V	ENET0 T(+)	ENET0 T(-)	GND

Note – The USR signals are routed from the PMC-B signals.

Electrical Requirements

The XCP2060-TRN I/O Transition Card is powered through the CP2060/CP2080/CP2160 board (available at 5V/3.3V/12V/-12V, maximum 2.5 W). For more information, see the *Netra CP2060 and CP2080 Board Technical Reference Manual and Installation Guide* (P/N 806-6658-xx) and the *Netra CP2160 CompactPCI Board Installation and Technical Reference Manual* (P/N 816-5772-xx).

On-board PIM Card Interface

The XCP2060-TRN I/O Transition Card supports PMC I/O modules (PIMs). PIMs are generally located on transition boards to enable rear I/O from the CompactPCI bus chassis. Custom PIMs can also provide additional I/O that does not fit on the standard transition card faceplate. (For more information on PIM slot mechanics, electrical and logical information, see *VITA 36 - PMC I/O Module Standard* available at <http://www.vita.com> and the *IEEE P1386 Standard*).

The PIM modules are available in two sizes. The single-sized PIMs measure 74 mm (2.92 inches) wide and 69 mm (2.72 inches) deep. The double-sized PIM modules measure 149 mm (5.87 inches) wide and 69 mm (2.72 inches) deep. A double-sized PIM module may also be used in place of two single-sized modules.

Note – Only one PIM card may be used when the transition card is mated to a Netra CP2080 or CP2160 board with single-wide memory. No PIM cards may be used when the transition card is mated to a Netra CP2080 or CP2160 board with double-wide memory.

FIGURE 7 and FIGURE 8 show typical views of PIM cards used with the XCP2060-TRN I/O Transition Card.

The J5 I/O on the host board, through the PIM cards on the XCP2060-TRN I/O Transition Card, provides matching I/O on the enclosure backpanel. The signals are routed through the CompactPCI J5 connector.

An IHV-supplied PIM card hardware package includes a blank PMC card with no I/O connectors on its faceplate for plugging into the PMC A connectors on the CP2060/CP2080/CP2160 board, and a PIM card that is connected on the XCP2060-TRN I/O Transition Card with I/O connectors available on the (rear) transition card panel. This enables the availability of I/O connections on the rear.



Caution – A PIM card must be used with its matching PMC; any other combination could lead to damaging the combination PIM/PMC. The reason is that when a PIM card is used, the complementary PMC card is dedicated to the use of the PIM card and does not provide any additional rear I/O connectors.

Access to the CP2060/CP2080/CP2160 board SMC serial port via SMC TX and SMC RX signals on both PIMs are available. For details on the PIM connector pins see FIGURE 2.

Note – Mount the PIM cards on the XCP2060-TRN I/O Transition Card *before* the XCP2060-TRN I/O Transition Card is inserted in a CompactPCI system.

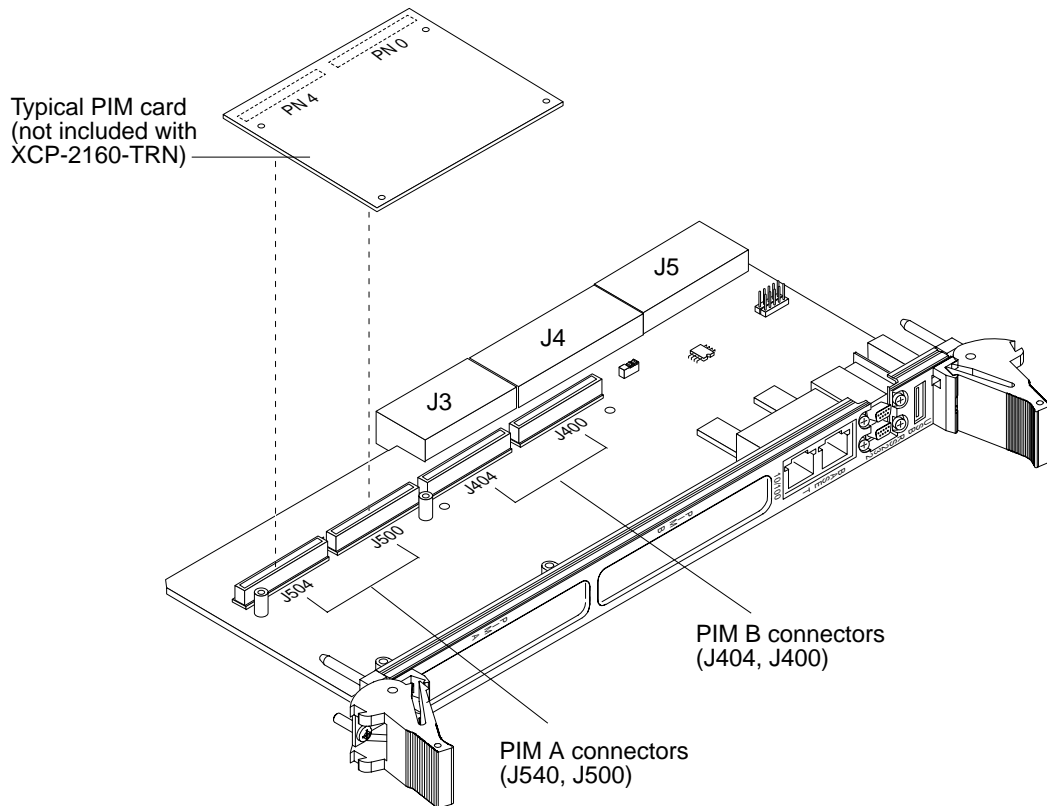

FIGURE 7 Typical View of a PIM Card and the PIM Connectors on the XCP2060-TRN I/O Transition Card

Note – The PIM cards shown in FIGURE 7 and FIGURE 8 are examples only and are not included with the XCP2060-TRN I/O Transition Card shipment.

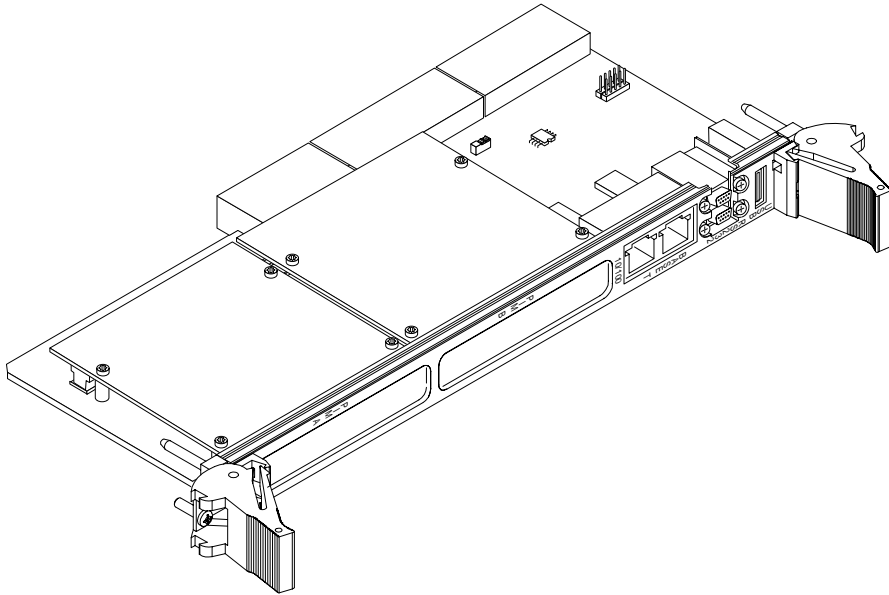

FIGURE 8 Typical View of PIM Cards when Installed on the XCP2060-TRN I/O Transition Card

Installing the Transition Card in a CompactPCI Chassis

The XCP2060-TRN I/O Transition Card installs into a CompactPCI chassis with a backplane made for front and rear board installation (see FIGURE 9). It must be installed in the slot directly behind the Netra CP2060/CP2080/CP2160 board for proper operation. These back-to-back slots have common pins to enable passing of signals between them.

Note – Before installing the transition card, its board part number must be verified to ensure that the correct transition card is being installed into the cPCI system. For information on identification of the transition card, see the section “Determining Part Number, Serial Number, and Revision Number” on page 8, and FIGURE 5 in that section.

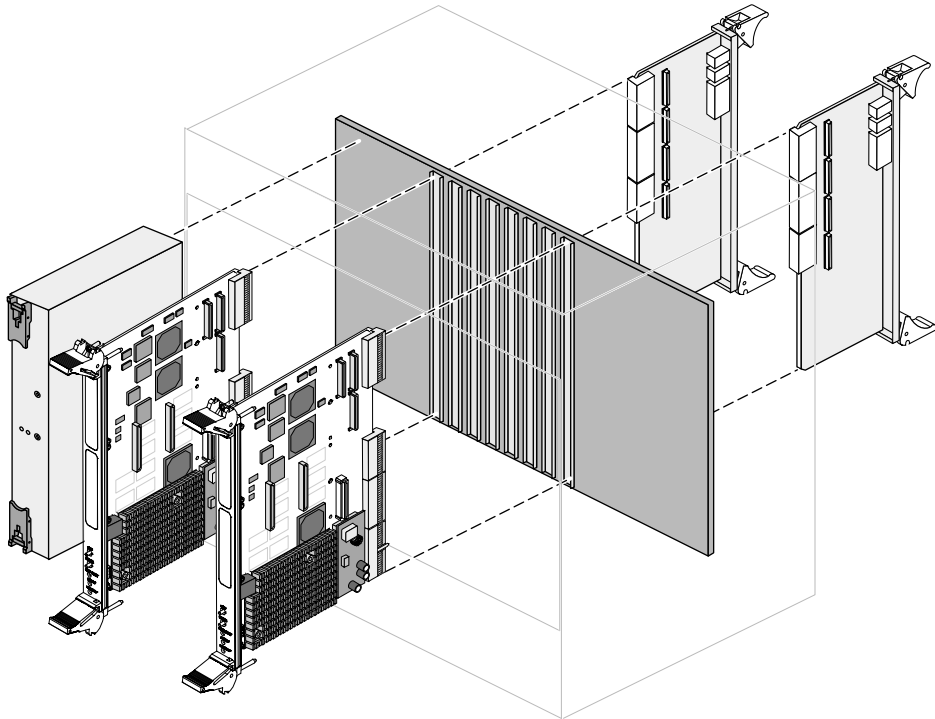

FIGURE 9 A Typical Assembly of the CP2080 System with Transition Cards to Serve the Host Processor and the Satellite Host

Safety Information

Before installing the XCP2060-TRN I/O Transition Card into a chassis, refer to the safety information in the following documents:

- *Important Safety Information for Sun Hardware Systems (816-7190-xx)* included in the ship kit for the transition card
- Safety information in the technical reference manual that corresponds to the Netra board that you are using. The technical reference and installation guides are available at the following web site:

http://www.sun.com/products-n-solutions/hardware/docs/CPU_Boards

▼ To Install the Transition Card in a CompactPCI Chassis



Caution – Ensure that you are installing an XCP2060-TRN I/O Transition Card.

You can install the XCP2060-TRN I/O transition card either with the system power on or off. If you are going to install the card with the chassis powered-on, you *must* install the transition card before the Netra CP2060 or CP2160 board.

1. Disconnect the power from the chassis, if appropriate.

If you must install the transition card with the chassis power on, you *must* install the transition card before installing the corresponding Netra CP2060 or CP2160 board.

Note that the XCP2060-TRN I/O Transition Card is not hot-swappable.

2. Check the positioning of the XCP2060-TRN I/O Transition Card extraction levers.

Ensure that the XCP2060-TRN I/O Transition Card extraction levers are aligned perpendicular to the card flange.

3. Install the XCP2060-TRN I/O Transition Card into the chassis rear connector slot that lines up directly with the Netra CP2060/CP2080/CP2160 board (see FIGURE 9).

a. Position the card such that its J5 connector is on top.

The USB connector should be uppermost.

b. Engage the board edges with the chassis card guides and slide it into the chassis (see FIGURE 10).

- c. Using the ejector handles, gently maneuver the card into registration with the keying hardware and the shoulders surrounding the backplane pins, without the card socket contacts engaging these pins.**

At this point, the card rear flange should project approximately 1/4 inch (6 mm) back from the “fully home” position.

- d. Apply pressure to engage the pins and seat the board.**

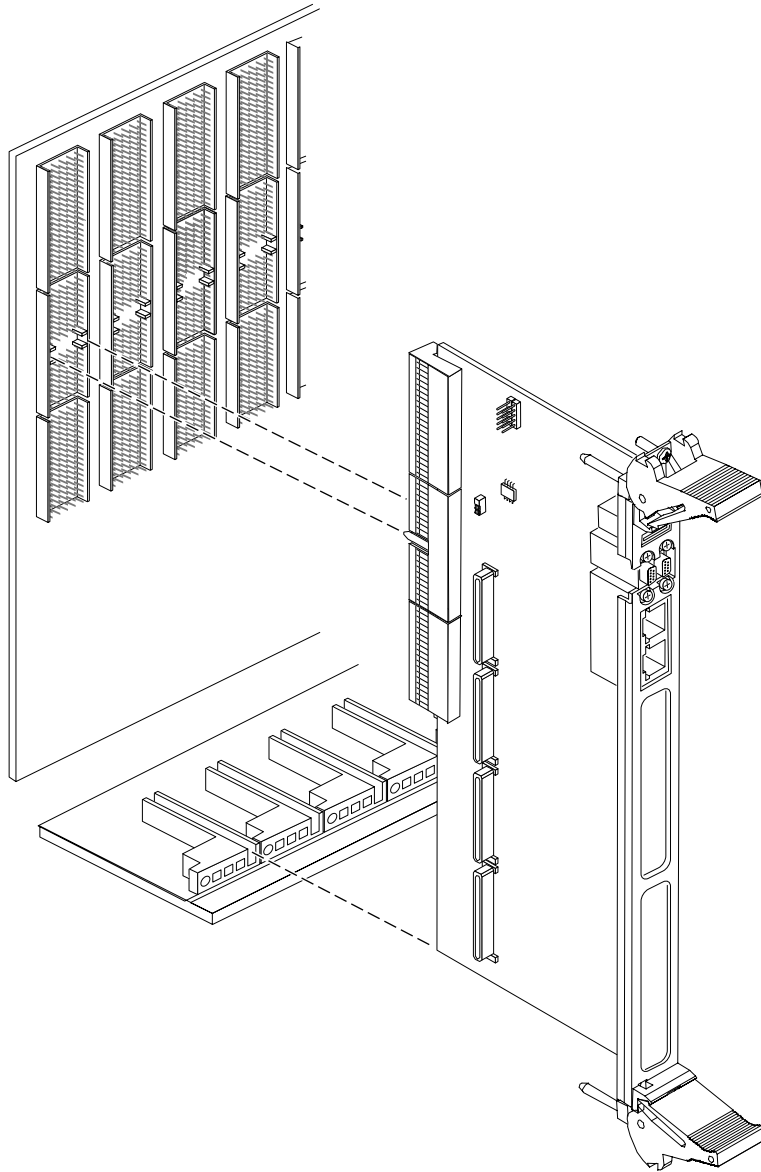

FIGURE 10 Align Transition Card During Installation in Backplane



Caution – During the above step, take care to ensure that the transition card is perpendicular to the backplane when it is moved into connection with the backplane pins. Careless vertical or angular positioning during board insertion can result in damage to the backplane and subsequent electrical destruction of the transition card and the corresponding Netra host board.

- 4. Install the Netra CP2060/CP2080/CP2160 board into the front of the chassis (see FIGURE 9) and push the board towards the backplane to make sure it is seated properly and the connectors make good contact with the XCP2060-TRN I/O Transition Card.**
- 5. Install the supported peripheral devices at the transition card connector ports as required.**

Refer to “Cabling Requirements” on page 7 for information on which cables to use for the transition card.

For further details on installation of the Netra board, see the *Netra CP2060 and CP2080 Technical Reference Manual and Installation Guide (806-6658-xx)* and the *Netra CP2160 CompactPCI Board Installation and Technical Reference Manual (816-5772-xx)*.

- 6. Power-on the system.**

Refer to your system manual for instructions on correctly powering-on the system.

Note – Step 7 only applies to Netra CP2160 board , not Netra CP2060 or CP2080 boards.

- 7. (For CP2160 only) At the `ok` prompt, set the `front-phy?` variable to enable the Ethernet ports on the rear transition card as follows:**

```
ok setenv front-phy? false
```

This will activate the Ethernet ports on the rear transition card and deactivate the Ethernet ports on the front panel of the Netra CP2160 board.

See the *Netra CP2160 Installation and Technical Reference Manual (816-5772-xx)* for more information on setting OpenBoot PROM configuration variables.

Index

B

backplane, 2, 4, 7, 15, 22, 23

C

connectors, 6, 9 to 17

console port, 4

CP2060/CP2080 board, 19

CP2060/CP2080/CP2160 board, 1, 2, 17, 20, 24

E

Ethernet port, 4, 11

F

FRU ID, 4

I

I/O interfaces, 3

see also connectors

I2C bus access header, 4, 12, 13

I2C EEPROM, 4

J

J3 connector, 15

J5 connector, 16, 17

P

part number, 8

PIM card, 4, 17, 18, 19

PIM connector, 13, 18

PMC module, 4, 17

R

revision number, 8

S

serial number, 8

serial port, 4, 10

specifications, 6 to 7

switch, SW301, 4, 5

T

transition card

and CP2060/CP2080/CP2160 board, 1, 17, 19,
20, 24

faceplate, 3

mounting PIM card on, 18

U

USB port, 4, 10