



# Netra™ CP2140 CompactPCI Board Product Note

---

Sun Microsystems, Inc.  
4150 Network Circle  
Santa Clara, CA 95054 U.S.A.  
650-960-1300

Part No.816-4870-10 (v2)  
October 2002 Revision A

Send comments about this document to: [docfeedback@sun.com](mailto:docfeedback@sun.com)

Copyright 2002 Sun Microsystems, Inc., 4150 Network Circle, Santa Clara, California 95054, U.S.A. All rights reserved.

Sun Microsystems, Inc. has intellectual property rights relating to technology embodied in the product that is described in this document. In particular, and without limitation, these intellectual property rights may include one or more of the U.S. patents listed at <http://www.sun.com/patents> and one or more additional patents or pending patent applications in the U.S. and in other countries.

This document and the product to which it pertains are distributed under licenses restricting their use, copying, distribution, and decompilation. No part of the product or of this document may be reproduced in any form by any means without prior written authorization of Sun and its licensors, if any.

Third-party software, including font technology, is copyrighted and licensed from Sun suppliers.

Parts of the product may be derived from Berkeley BSD systems, licensed from the University of California. UNIX is a registered trademark in the U.S. and in other countries, exclusively licensed through X/Open Company, Ltd.

Sun, Sun Microsystems, the Sun logo, AnswerBook2, docs.sun.com, Netra and Solaris are trademarks or registered trademarks of Sun Microsystems, Inc. in the U.S. and in other countries.

All SPARC trademarks are used under license and are trademarks or registered trademarks of SPARC International, Inc. in the U.S. and in other countries. Products bearing SPARC trademarks are based upon an architecture developed by Sun Microsystems, Inc.

The OPEN LOOK and Sun™ Graphical User Interface was developed by Sun Microsystems, Inc. for its users and licensees. Sun acknowledges the pioneering efforts of Xerox in researching and developing the concept of visual or graphical user interfaces for the computer industry. Sun holds a non-exclusive license from Xerox to the Xerox Graphical User Interface, which license also covers Sun's licensees who implement OPEN LOOK GUIs and otherwise comply with Sun's written license agreements.

Use, duplication, or disclosure by the U.S. Government is subject to restrictions set forth in the Sun Microsystems, Inc. license agreements and as provided in DFARS 227.7202-1(a) and 227.7202-3(a) (1995), DFARS 252.227-7013(c)(1)(ii) (Oct. 1998), FAR 12.212(a) (1995), FAR 52.227-19, or FAR 52.227-14 (ALT III), as applicable.

DOCUMENTATION IS PROVIDED "AS IS" AND ALL EXPRESS OR IMPLIED CONDITIONS, REPRESENTATIONS AND WARRANTIES, INCLUDING ANY IMPLIED WARRANTY OF MERCHANTABILITY, FITNESS FOR A PARTICULAR PURPOSE OR NON-INFRINGEMENT, ARE DISCLAIMED, EXCEPT TO THE EXTENT THAT SUCH DISCLAIMERS ARE HELD TO BE LEGALLY INVALID.

---

Copyright 2002 Sun Microsystems, Inc., 4150 Network Circle, Santa Clara, California 95054, Etats-Unis. Tous droits réservés.

Sun Microsystems, Inc. a les droits de propriété intellectuelle relatant à la technologie incorporée dans le produit qui est décrit dans ce document. En particulier, et sans limitation, ces droits de propriété intellectuelle peuvent inclure un ou plus des brevets américains énumérés à <http://www.sun.com/patents> et un ou les brevets plus supplémentaires ou les applications de brevet en attente dans les Etats-Unis et dans les autres pays.

Ce produit ou document est protégé par un copyright et distribué avec des licences qui en restreignent l'utilisation, la copie, la distribution, et la décompilation. Aucune partie de ce produit ou document ne peut être reproduite sous aucune forme, par quelque moyen que ce soit, sans l'autorisation préalable et écrite de Sun et de ses bailleurs de licence, s'il y en a.

Le logiciel détenu par des tiers, et qui comprend la technologie relative aux polices de caractères, est protégé par un copyright et licencié par des fournisseurs de Sun.

Des parties de ce produit pourront être dérivées des systèmes Berkeley BSD licenciés par l'Université de Californie. UNIX est une marque déposée aux Etats-Unis et dans d'autres pays et licenciée exclusivement par X/Open Company, Ltd.

Sun, Sun Microsystems, le logo Sun, AnswerBook2, docs.sun.com, Netra et Solaris sont des marques de fabrique ou des marques déposées de Sun Microsystems, Inc. aux Etats-Unis et dans d'autres pays.

Toutes les marques SPARC sont utilisées sous licence et sont des marques de fabrique ou des marques déposées de SPARC International, Inc. aux Etats-Unis et dans d'autres pays. Les produits portant les marques SPARC sont basés sur une architecture développée par Sun Microsystems, Inc.

L'interface d'utilisation graphique OPEN LOOK et Sun™ a été développée par Sun Microsystems, Inc. pour ses utilisateurs et licenciés. Sun reconnaît les efforts de pionniers de Xerox pour la recherche et le développement du concept des interfaces d'utilisation visuelle ou graphique pour l'industrie de l'informatique. Sun détient une licence non exclusive de Xerox sur l'interface d'utilisation graphique Xerox, cette licence couvrant également les licences de Sun qui mettent en place l'interface d'utilisation graphique OPEN LOOK et qui en outre se conforment aux licences écrites de Sun.

LA DOCUMENTATION EST FOURNIE "EN L'ÉTAT" ET TOUTES AUTRES CONDITIONS, DECLARATIONS ET GARANTIES EXPRESSES OU TACITES SONT FORMELLEMENT EXCLUES, DANS LA MESURE AUTORISÉE PAR LA LOI APPLICABLE, Y COMPRIS NOTAMMENT TOUTE GARANTIE IMPLICITE RELATIVE A LA QUALITE MARCHANDE, A L'APTITUDE A UNE UTILISATION PARTICULIERE OU A L'ABSENCE DE CONTREFAÇON.



# Contents

---

Check the Contents of Your Netra CP2140 CompactPCI Board Shipment	1
Safety Considerations	3
Software Information	3
Hardware Information	3
Related Documentation	3
Technical Support	4
Replacing the Serial EEPROM	6
Installation of the Board into a Non-High Availability (Non-HA) Chassis	6
Before Installing the Board in a Chassis	6
Installation of the Board into a High Availability (HA) Chassis	7
Before Installing the Board in a Chassis	8



# Netra CP2140 CompactPCI Board Product Note

---

This product note is written for users of the Netra™ CP2140 CompactPCI board. The Netra CP2140 boards are designed as host processors for application processing in High Availability CompactPCI carrier-grade systems. The Netra CP2140 boards can function as system host or satellite host boards.

The latest versions of the product documentation for the Netra CP2140 board are available at:

[http://www.sun.com/products-n-solutions/hardware/docs/CPU\\_Boards](http://www.sun.com/products-n-solutions/hardware/docs/CPU_Boards)

---

## Check the Contents of Your Netra CP2140 CompactPCI Board Shipment

Be sure to check the contents of your package.

***Please keep the Sun Microsystems packaging, as this will be required for the return of any failed units for repair.*** If any of the items are missing or damaged, contact your Sun Microsystems Field Application Engineer.

This document is shipped with one of the following CP2140 boards (see FIGURE 1):

- Assembly, CP2140S-650
  - part no. 501-6403-xx (2x512MB memory CP2140 board)
  - part no. 501-6416-xx (2x1GB memory CP2140 board)

Additional documentation in the ship kit includes:

- A Certificate of Paid Royalty for Embedded Use of Solaris™ Operating Environment (816-2663-10, Revision A)
- *Important Safety Information for Sun Hardware Systems* (816-7190-xx)

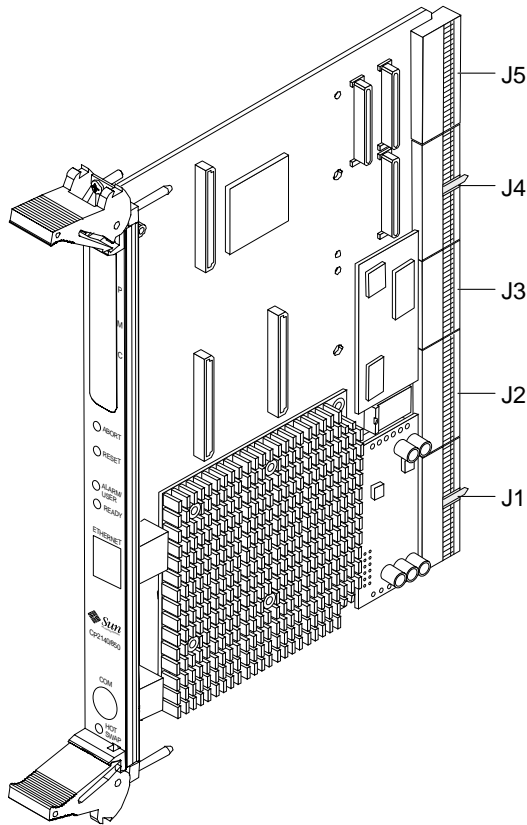

**FIGURE 1** Illustration of a Typical Netra CP2140 Board

---

**Note** – The Netra CP2140 board part number and board serial number are identified on labels. Please see FIGURE 2 for their locations.

---

---

## Safety Considerations

For information on safety considerations, refer to the *Important Safety Information for Sun Hardware Systems* (816-7190-xx), which is included the board ship kit and the *Netra CP2140 Technical Reference and Installation Manual* (816-4908-xx), which is located on the CP2140 documentation web site (see “Related Documentation” on page 3).

---

## Software Information

The Solaris™ 8 2/02 operating environment is supported by the Netra CP2140 board. The *CP2000 Supplemental CD 4.0 for Solaris 8* contains additional features for the Netra CP2140 board. *CP2000 Supplemental CD 3.1 for Solaris 8* can also be used with the Netra CP2140 board, but will not contain all of the features of CD 4.0. For information on how to obtain the CD, contact your Field Application Engineer.

---

## Hardware Information

The SMC module, the heatsink, the power module, and the front panel are an integral part of the CP2140 board. Any attempt to remove these components from the board will void your warranty. See the *Netra CP2140 Technical Reference and Installation Manual* (816-4908-xx) to determine the location of these components.

---

## Related Documentation

For all related documentation on Netra CP2140 boards, go to the documentation web site. Refer to the *Netra CP2140 Technical Reference and Installation Manual* (816-4908-xx) for comprehensive technical details. You can obtain a copy from your local Field Application Engineer or from the following documentation web site:

[http://www.sun.com/products-n-solutions/hardware/docs/CPU\\_Boards](http://www.sun.com/products-n-solutions/hardware/docs/CPU_Boards)

If you are unable to find the product documentation at that web site, go to the following web site and search for documentation for the Netra CP2140 board:

<http://www.sun.com/documentation>

Specific Netra CP2140 product information is available at:

<http://www.sun.com/products-n-solutions/nep/hardware/boards/cp2140/>

---

## Technical Support

If you have any technical questions or technical support issues that are not addressed in the Netra CP2140 documentation set or you need to return the CP2140 board, please read the details below and contact your local Field Application Engineer.

Please have the board identification information ready (see FIGURE 2). The Netra CP2140 board part number, board serial number, product part number, product dash, date code and MAC address can be found on labels located on the board labels. For proper identification of the board, please see the list below and FIGURE 2:

The Sun barcode label provides the following information:

- Board part number (for example, 5016358) which is the first seven digits on the barcode label. The next six digits are the board serial number (for example, 000230).

The Subcon label provides the following information:

- Product part number (for example, 6403), product dash (for example, 04) and revision number (for example REV 09).



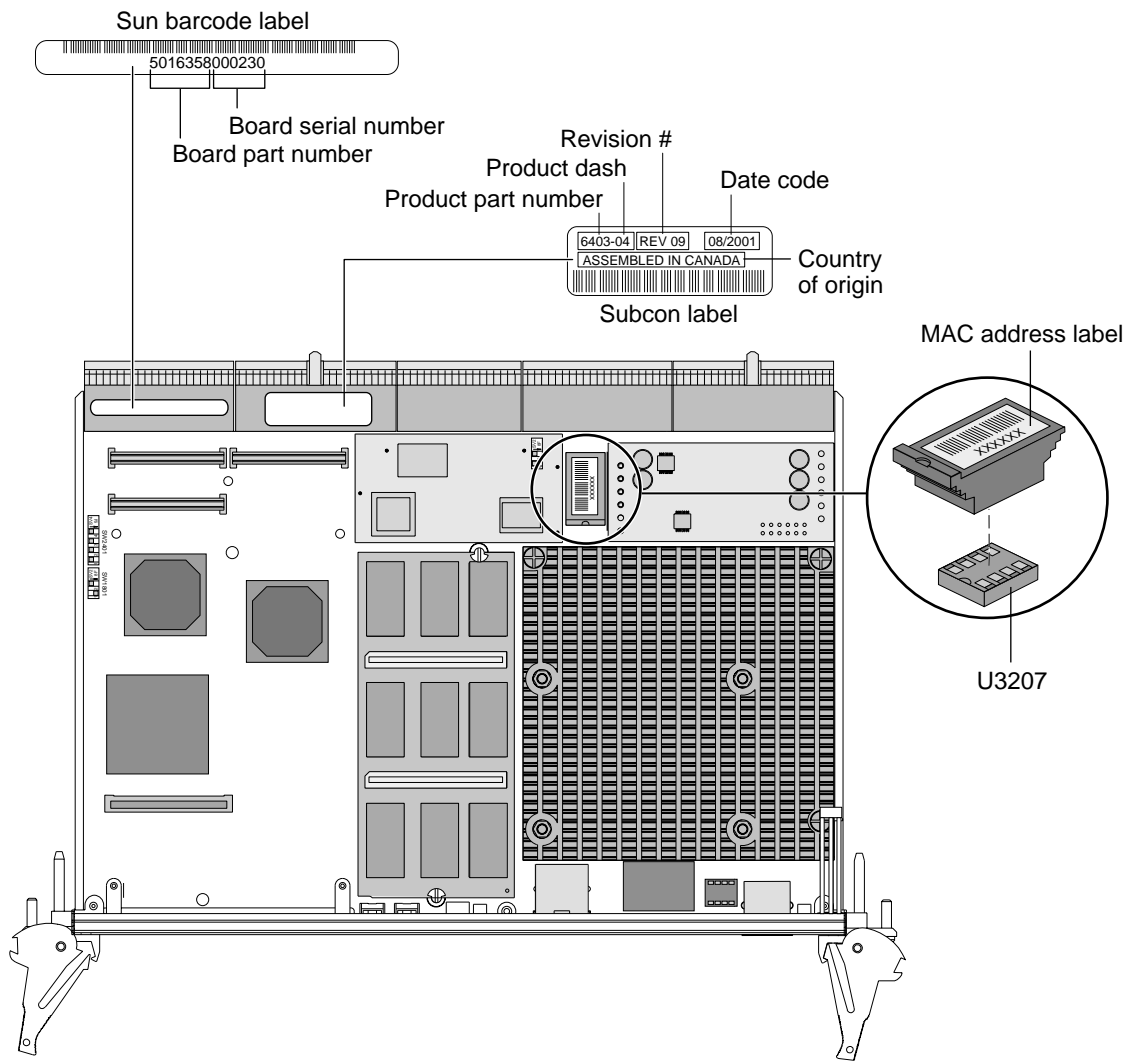

**FIGURE 2** Identification Labels and Serial I<sup>2</sup>C EEPROM on a Typical Netra CP2140 Board

---

## Replacing the Serial EEPROM

The Serial I<sup>2</sup>C EEPROM is the MAC address carrier and it stores the backup copy of the board MAC address and Host ID information. The CP2140 board supports the Serial I<sup>2</sup>C EEPROM.

If you need to replace the CP2140 board, remove the Serial I<sup>2</sup>C EEPROM from the original board and install it on the new CP2140 board. To correctly position the Serial I<sup>2</sup>C EEPROM and to precisely install it on the CP2140 board, see FIGURE 2.

---

## Installation of the Board into a Non-High Availability (Non-HA) Chassis

---

**Note** – The CP2140 board is configured for operation in a non-HA chassis by default. If you are unsure of your settings, follow the procedure below.

---

### Before Installing the Board in a Chassis

If you have a non-HA chassis, set the SMC module switch settings (on SW0501) as follows *before* powering on the board (see FIGURE 3 and FIGURE 4):

- SW0501.Switch1 ---> Closed (switch is set in direction of arrow)
- SW0501.Switch2 ---> Closed (switch is set in direction of arrow)

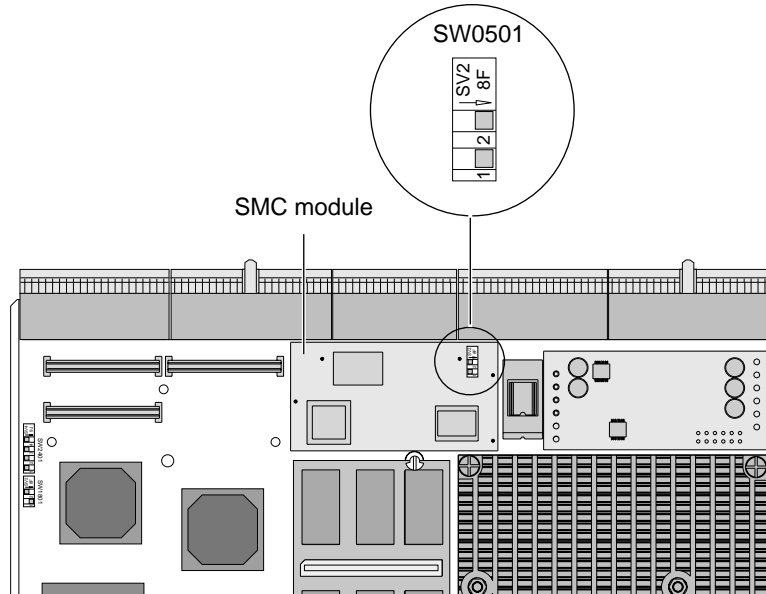

FIGURE 3 Location of SW0501 on SMC Module

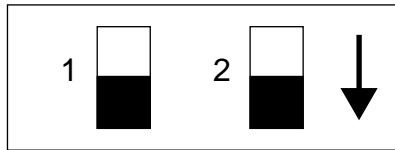

FIGURE 4 Switch SW0501 in Closed Position (Default) for Non-HA Operation

---

## Installation of the Board into a High Availability (HA) Chassis

---

**Note** – The CP2140 board is configured for operation in a non-HA chassis by default. If you need to change the settings for HA operation, follow the procedure below.

---

# Before Installing the Board in a Chassis

If you are installing the board into an HA chassis, set the SMC module switch settings (on SW0501) as follows *before* powering on the board (see FIGURE 5 and FIGURE 6):

- SW0501.Switch1 ---> Open (switch is set *opposite* to arrow direction)
- SW0501.Switch2 ---> Closed (switch is set in direction of arrow)

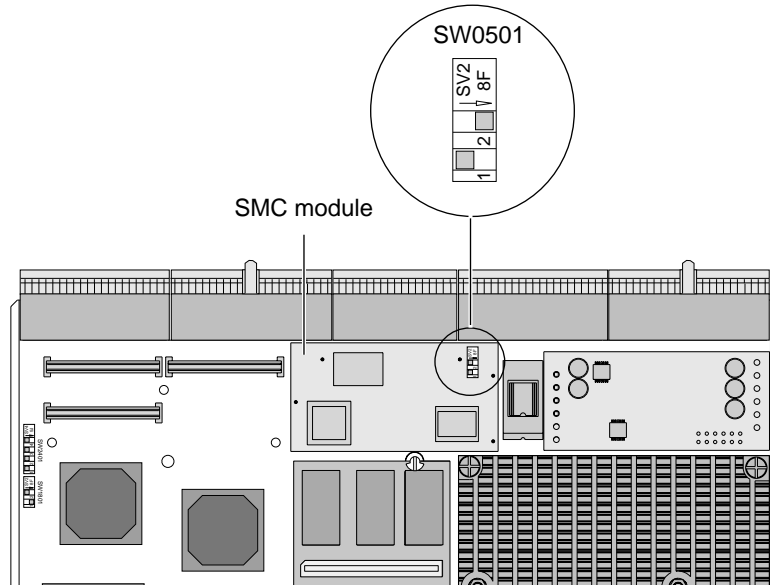

FIGURE 5 Location of SW0501 on SMC Module

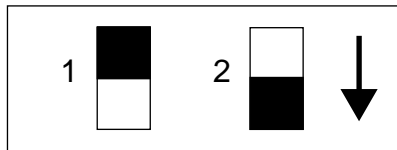

FIGURE 6 Switch SW0501 Setting for Operation in HA Chassis