



Memory Module Installation and Removal Guide

For Netra™ CP2000/CP2100 Series CompactPCI
Boards

Sun Microsystems, Inc.
4150 Network Circle
Santa Clara, CA 95054 U.S.A.
650-960-1300

Part No. 817-0654-10
January 2003, Revision A

Send comments about this document to: docfeedback@sun.com

Copyright 2003 Sun Microsystems, Inc., 4150 Network Circle, Santa Clara, California 95054, U.S.A. All rights reserved.

Sun Microsystems, Inc. has intellectual property rights relating to technology embodied in the product that is described in this document. In particular, and without limitation, these intellectual property rights may include one or more of the U.S. patents listed at <http://www.sun.com/patents> and one or more additional patents or pending patent applications in the U.S. and in other countries.

This document and the product to which it pertains are distributed under licenses restricting their use, copying, distribution, and decompilation. No part of the product or of this document may be reproduced in any form by any means without prior written authorization of Sun and its licensors, if any.

Third-party software, including font technology, is copyrighted and licensed from Sun suppliers.

Parts of the product may be derived from Berkeley BSD systems, licensed from the University of California. UNIX is a registered trademark in the U.S. and in other countries, exclusively licensed through X/Open Company, Ltd.

Sun, Sun Microsystems, the Sun logo, AnswerBook2, docs.sun.com, Netra and Solaris are trademarks or registered trademarks of Sun Microsystems, Inc. in the U.S. and in other countries.

All SPARC trademarks are used under license and are trademarks or registered trademarks of SPARC International, Inc. in the U.S. and in other countries. Products bearing SPARC trademarks are based upon an architecture developed by Sun Microsystems, Inc.

The OPEN LOOK and Sun™ Graphical User Interface was developed by Sun Microsystems, Inc. for its users and licensees. Sun acknowledges the pioneering efforts of Xerox in researching and developing the concept of visual or graphical user interfaces for the computer industry. Sun holds a non-exclusive license from Xerox to the Xerox Graphical User Interface, which license also covers Sun's licensees who implement OPEN LOOK GUIs and otherwise comply with Sun's written license agreements.

U.S. Government Rights—Commercial use. Government users are subject to the Sun Microsystems, Inc. standard license agreement and applicable provisions of the FAR and its supplements.

DOCUMENTATION IS PROVIDED "AS IS" AND ALL EXPRESS OR IMPLIED CONDITIONS, REPRESENTATIONS AND WARRANTIES, INCLUDING ANY IMPLIED WARRANTY OF MERCHANTABILITY, FITNESS FOR A PARTICULAR PURPOSE OR NON-INFRINGEMENT, ARE DISCLAIMED, EXCEPT TO THE EXTENT THAT SUCH DISCLAIMERS ARE HELD TO BE LEGALLY INVALID.

Copyright 2003 Sun Microsystems, Inc., 4150 Network Circle, Santa Clara, California 95054, Etats-Unis. Tous droits réservés.

Sun Microsystems, Inc. a les droits de propriété intellectuels relatants à la technologie incorporée dans le produit qui est décrit dans ce document. En particulier, et sans la limitation, ces droits de propriété intellectuels peuvent inclure un ou plus des brevets américains énumérés à <http://www.sun.com/patents> et un ou les brevets plus supplémentaires ou les applications de brevet en attente dans les Etats-Unis et dans les autres pays.

Ce produit ou document est protégé par un copyright et distribué avec des licences qui en restreignent l'utilisation, la copie, la distribution, et la décompilation. Aucune partie de ce produit ou document ne peut être reproduite sous aucune forme, quelquelque moyen que ce soit, sans l'autorisation préalable et écrite de Sun et de ses bailleurs de licence, s'il y ena.

Le logiciel détenu par des tiers, et qui comprend la technologie relative aux polices de caractères, est protégé par un copyright et licencié par des fournisseurs de Sun.

Des parties de ce produit pourront être dérivées des systèmes Berkeley BSD licenciés par l'Université de Californie. UNIX est une marque déposée aux Etats-Unis et dans d'autres pays et licenciée exclusivement par X/Open Company, Ltd.

Sun, Sun Microsystems, le logo Sun, AnswerBook2, docs.sun.com, Netra et Solaris sont des marques de fabrique ou des marques déposées de Sun Microsystems, Inc. aux Etats-Unis et dans d'autres pays.

Toutes les marques SPARC sont utilisées sous licence et sont des marques de fabrique ou des marques déposées de SPARC International, Inc. aux Etats-Unis et dans d'autres pays. Les produits protant les marques SPARC sont basés sur une architecture développée par Sun Microsystems, Inc.

L'interface d'utilisation graphique OPEN LOOK et Sun™ a été développée par Sun Microsystems, Inc. pour ses utilisateurs et licenciés. Sun reconnaît les efforts de pionniers de Xerox pour la recherche et le développement du concept des interfaces d'utilisation visuelle ou graphique pour l'industrie de l'informatique. Sun détient une licence non exclusive de Xerox sur l'interface d'utilisation graphique Xerox, cette licence couvrant également les licenciées de Sun qui mettent en place l'interface d'utilisation graphique OPEN LOOK et qui en outre se conforment aux licences écrites de Sun.

LA DOCUMENTATION EST FOURNIE "EN L'ÉTAT" ET TOUTES AUTRES CONDITIONS, DECLARATIONS ET GARANTIES EXPRESSES OU TACITES SONT FORMELLEMENT EXCLUES, DANS LA MESURE AUTORISEE PAR LA LOI APPLICABLE, Y COMPRIS NOTAMMENT TOUTE GARANTIE IMPLICITE RELATIVE A LA QUALITE MARCHANDE, A L'APTITUDE A UNE UTILISATION PARTICULIERE OU A L'ABSENCE DE CONTREFAÇON.

Contents

Single-Wide Memory Module Installation	2
Materials and Tools Required for Single-Wide Memory Module Installation	2
Single-Wide Memory Module Identification and Sizes	3
Single-Wide Memory Module Installation and Removal	4
Double-Wide Memory Module Installation	11
Materials and Tools Required for Double-Wide Memory Module Installation	11
Double-Wide Memory Module Identification and Sizes	12
Double-Wide Memory Module Installation and Removal	14

Memory Module Installation and Removal Guide for Netra CP2000/CP2100 Series cPCI Boards

This document describes how to install a maximum of two stackable, single-wide or double-wide, memory modules on Netra™ CP2000 series and CP2100 series CompactPCI boards. In this document, the CP2000 series boards consist of CP2040, CP2060 and CP2080 boards and the CP2100 series consists of the CP2140 and CP2160 boards.

Note – This guide is written *only* for users of Netra CP2040, CP2080, CP2140, and CP2160 boards who wish to install the stackable memory modules. This guide is *not* applicable for the Netra CP2060 board since it has all memory soldered on the board.

If a single-wide memory module is installed on the Netra CP2000/CP2100 board, the installation of one PMC card is supported on the board. If a double-wide memory module is installed on the Netra CP2000/CP2100 board, the installation of a PMC card is not supported on that board.

The memory modules are also referred to as memory cards or mezzanine modules in various other Netra CP2000/CP2100 board manuals and literature.

This document contains the following sections:

- “Single-Wide Memory Module Installation” on page 2
- “Double-Wide Memory Module Installation” on page 11

Single-Wide Memory Module Installation

This section contains instructions for installing single-wide 256 MB, 512 MB or 1 GB memory modules on a Netra CP2000/CP2100 series board.

This section contains the following subsections:

- “Materials and Tools Required for Single-Wide Memory Module Installation” on page 2
- “Single-Wide Memory Module Identification and Sizes” on page 3
- “Single-Wide Memory Module Installation and Removal” on page 4

Materials and Tools Required for Single-Wide Memory Module Installation

This section provides information on the materials and tools required to perform installation or extraction.

Memory boards are ordered separately for a Netra CP2000/CP2100 board that uses modular memory. Many boards ship with memory already installed. To obtain two memory modules, you need to order two memory board kits. Each memory board kit contains the following hardware (see FIGURE 1 and “Single-Wide Memory Module Identification and Sizes” on page 3 for identification):

- One memory board
- One memory extraction tool
- Two turrets (The two turrets are spares that may be used if the two existing turrets on the board need to be replaced.)

Note – Place the Netra CP2000/CP2100 board on an ESD protected surface prior to the memory module installation or extraction process.

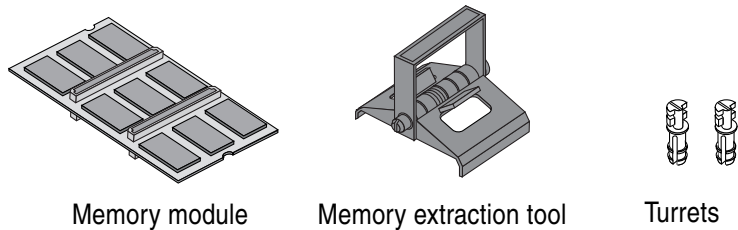

FIGURE 1 Hardware Contents of Single-wide Memory Board Kit

Single-Wide Memory Module Identification and Sizes

The Netra CP2000/CP2100 boards support two memory module kits. Details of the kits are listed below:

XCP2000-MEM-256MB (256 MB memory module - 2 in. x 4 in.) part no. 595-5940-xx

This kit contains the components shown in FIGURE 1. They can each be identified by their part numbers as follows:

- Memory module - 256MB (375-3024-xx)
- Memory extraction tool (350-1235-xx)
- Turret spacer (230-1852-xx)
- *Memory Module Product Note for Netra CP2000/CP2100 Series CompactPCI Boards* (817-0653-xx)
- *Important Safety Information for Sun Hardware Systems* (816-7190-xx)

XCP2000-MEM-512MB (512 MB memory module - 2 in. x 4 in.) part no. 595-5944-xx

This kit contains the components shown in FIGURE 1. They can each be identified by their part numbers as follows:

- Memory module - 512MB (375-3025-xx)
- Memory extraction tool (350-1235-xx)
- Turret spacer (230-1852-xx)
- *Memory Module Product Note for Netra CP2000/CP2100 Series CompactPCI Boards* (817-0653-xx)
- *Important Safety Information for Sun Hardware Systems* (816-7190-xx)

XCP2000-MEM-1GB (1 GB memory module - 2 in. x 4 in.) part no. 595-6710-xx

This kit contains the components shown in FIGURE 1. They can each be identified by their part numbers as follows:

- Memory module - 1GB (375-3125-xx)

- Memory extraction tool (350-1235-xx)
- Turret spacer (230-1852-xx)
- *Memory Module Product Note for Netra CP2000/CP2100 Series CompactPCI Boards* (817-0653-xx)
- *Important Safety Information for Sun Hardware Systems* (816-7190-xx)

TABLE 1 shows the single-wide memory cards supported by the Netra CP2000/CP2100 boards.

TABLE 1 Single-Wide Memory Cards Supported by the Netra CP2000/CP2100 Boards

Board	Supports 256MB Memory Card	Supports 512MB Memory Card	Supports 1GB Memory Card	Maximum Number of Modules Allowed
Netra CP2040	yes	yes	no	2
Netra CP2080	yes	yes	no	2
Netra CP2140	no	yes	yes	2
Netra CP2160	no	no	yes	1

Single-Wide Memory Module Installation and Removal

Before installing a Netra CP2000/CP2100 motherboard into any OEM equipment/chassis, install the memory modules onto the Netra CP2000/CP2100 board.



Caution – Follow all the safety rules set forth by the OEM equipment manufacturer before performing this procedure. The components on the Netra CP2000/CP2100 board and on the memory modules are sensitive to static electricity. Wear an anti-static wrist strap when handling the memory boards and during the installation. The Netra CP2000/CP2100 board should be placed on ESD foam during assembly. Refer to *Important Safety Information for Sun Hardware Systems* (816-7190-xx) for additional safety information.

The Netra CP2000/CP2100 boards accommodate modular memory that can be stacked. The first memory board is installed directly on the Netra motherboard. The second memory board is installed on top of the first one. When modules of two different sizes are to be stacked one on top of the other, the module with the larger

memory size must be placed at the bottom. Refer to the documentation for your Netra CP2000/CP2100 board product to determine the number of memory modules that can be installed on the board.

If you want to replace memory on a Netra CP2000/CP2100 board, remove the existing memory modules and install a replacement module, following the memory removal and installation steps described in this section.

▼ To Install a Single-Wide Memory Module on a Netra CP2000/CP2100 Board

Refer to FIGURE 2 and the following instructions to install the memory module.

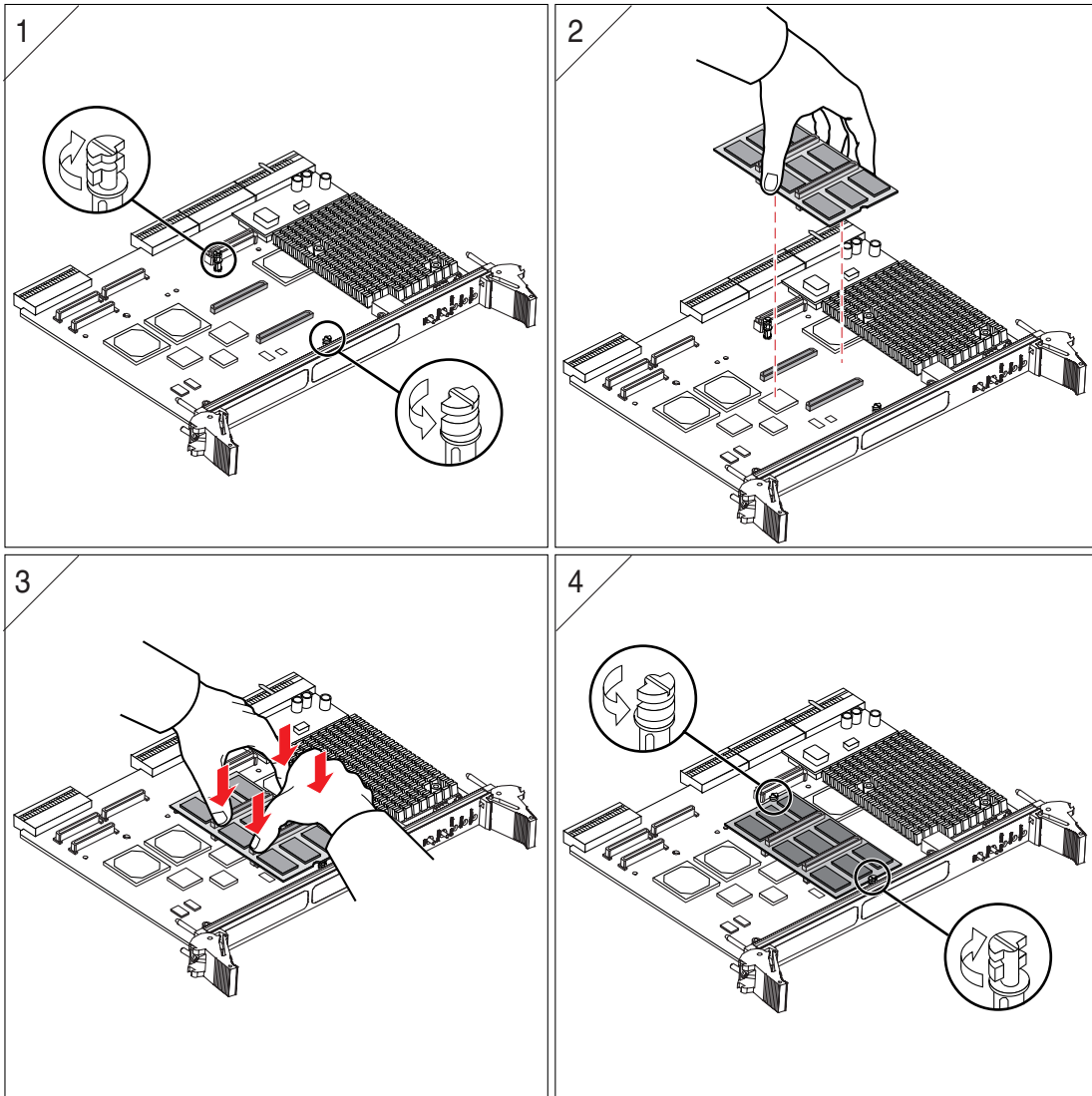

FIGURE 2 Single-wide Memory Module Installation Procedure on a Typical Netra CP2000/CP2100 Board



Caution – Follow the instructions below. By not following the installation and removal instructions properly, you can damage the connectors. Do *not* use the memory extraction tool to install memory modules, because you can damage the module.

1. **Rotate turrets to the position shown in FIGURE 2 Segment 1. Hold the memory module centered right over the memory connectors.**
2. **Align the module connectors with the memory sockets on the Netra CP2000/CP2100 board (see FIGURE 2 Segment 2). Make sure the module is right side up so that the connectors mate. While holding the connector by the long edge, orient the midway notch on the memory module towards the front panel of the cPCI board.**
3. **Seat the module firmly into position so that it fits onto the board connectors, while pressing down on the module with your fingers (see FIGURE 2 Segment 3).**
The module connectors are fully engaged with the board connectors when you hear or feel them snap into place.



Caution – Do not apply excessive pressure to connectors. Doing so can fracture the connectors or the Netra circuit board.

This procedure is an installation of one memory module on to a Netra CP2000/CP2100 board. If you wish to install a second memory module, follow Step 1 to Step 4. The only difference is that the connectors of the second memory module are positioned on the memory module connector sockets of the first module in a piggy-back style and then seated.

4. **Rotate the turrets back to the position shown in FIGURE 2 Segment 4.**

▼ To Remove a Single-Wide Memory Module from a Netra CP2000/CP2100 Board

Refer to FIGURE 3 and the following instructions to remove the memory module.

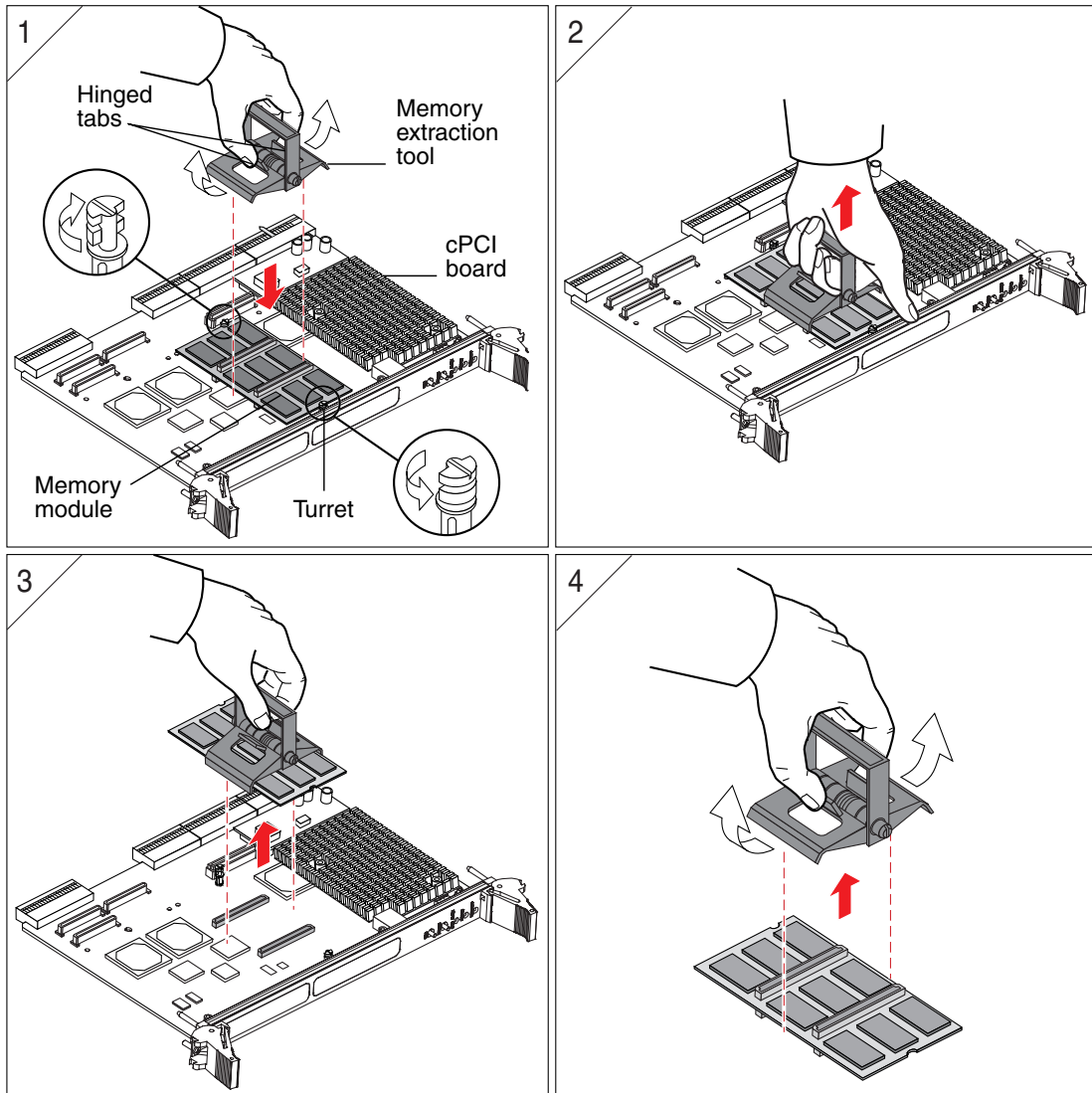

FIGURE 3 Single-wide Memory Module Extraction Procedure on a Typical CP2000/CP2100 Board



Caution – Please follow the instructions below. If you do not follow the installation and removal instructions, you can damage the connectors.

1. Pinch the hinged tabs of the memory extraction tool to open its jaws, position it over the memory module, and let go of the tabs so the tool grasps the module firmly (see FIGURE 3 Segment 1). Rotate turrets into the position shown in FIGURE 3 Segment 1.
2. Pull at the extraction tool handle while leveraging with your fingers on the faceplate to loosen, and pull out the module from the connectors on the Netra CP2000/CP2100 board (see FIGURE 3 Segment 2 and Segment 3). With your other hand, hold down the motherboard.
3. Remove the module from the jaws of the memory extraction tool by pinching the hinged tabs to open the extraction tool jaws (see FIGURE 3 Segment 4).

This procedure is an extraction of one memory module from the Netra CP2000/CP2100 board. If you wish to extract two modules from the board, follow Step 1 to Step 3. The only difference is that the connectors of the top memory module are positioned on the memory module connector sockets of the bottom module in a piggy-back style.

When two memory modules are installed on the Netra CP2000/CP2100 board, the lower module might get extracted when removing the top module. If this happens, separate the modules by gently prying the boards apart. Start with short ends of the modules. Try not to bend the modules, use only enough force to unmate the connectors.



Caution – Do *not* separate modules from each other by prying them apart at the extremities, because you could damage the modules.

▼ To Install a Turret on a Netra CP2000/CP2100 Board for Single-wide Memory Installation

There are two turrets provided on a Netra CP2000/CP2100 board that are required for single-wide memory module installation. The following procedure is provided in case either of the turrets have to be replaced by one of the two spare turrets that are shipped with the memory module.

- **Pinch the turret at the bottom and insert it into the turret mounting hole on the Netra CP2000/CP2100 board as shown in FIGURE 4.**

Follow the information and illustrations on turret rotation as provided in the memory module installation or removal procedures earlier.

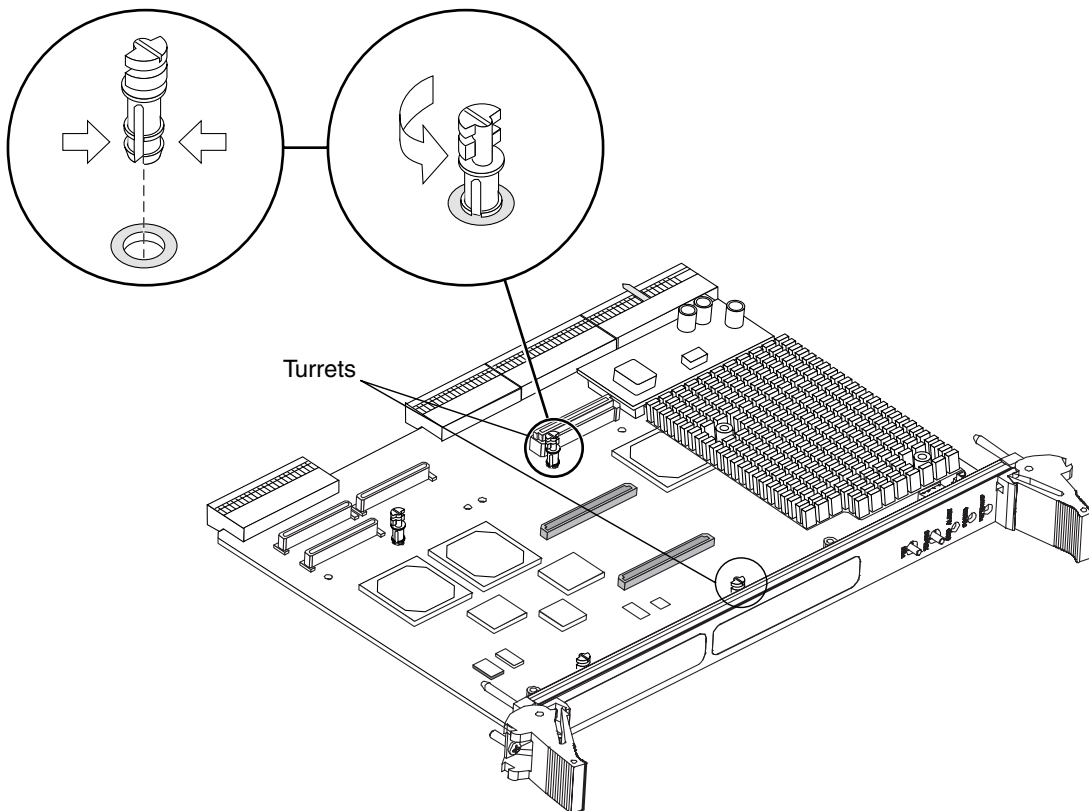

FIGURE 4 Installation of a Turret on a Typical Netra CP2000/CP2100 Board for Single-wide Memory Installation

Double-Wide Memory Module Installation

This section contains instructions for installing double-wide 1 GB or 2 GB memory modules on a Netra CP2000/CP2100 series board.

This section contains the following subsections:

- “Materials and Tools Required for Double-Wide Memory Module Installation” on page 11
- “Double-Wide Memory Module Identification and Sizes” on page 12
- “Double-Wide Memory Module Installation and Removal” on page 14

Materials and Tools Required for Double-Wide Memory Module Installation

This section provides information on the materials and tools required to perform installation or extraction.

Memory modules are ordered separately for a Netra CP2000/CP2100 board that uses modular memory. Many boards ship with memory already installed. Refer to the documentation specific to your Netra CP2000/CP2100 board to determine the memory capacity of the board.

To obtain two memory modules, you need to order two memory module kits. Each memory module kit contains the following hardware (see FIGURE 5 and “Double-Wide Memory Module Identification and Sizes” on page 12):

- One memory module
- Four turrets
 - Two of the turrets need to be installed on the board before installing the memory module (two turrets are already pre-installed on the board).
 - Two of the turrets are spares that can be used if any of the turrets on a Netra CP2000/CP2100 board need to be replaced

Note – Place the Netra CP2000/CP2100 board on an ESD protected surface prior to the memory module installation or extraction process.

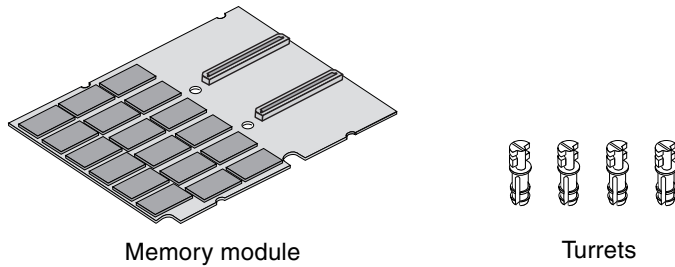

FIGURE 5 Hardware Contents of Double-wide Memory Module Kit

Double-Wide Memory Module Identification and Sizes

Details of the kit for the 1GB and 2 GB double-wide memory module for a Netra CP2000/CP2100 board are listed below:

- **XCP2000-MEM-1GB (1GB memory module - 5 in. x 4 in.) part no. 595-5947-xx** -- this kit contains the components shown in FIGURE 5 and some additional documentation. They can each be identified by their part numbers as follows:
 - Memory module - 1GB (375-3026-xx)
 - Turret spacer (230-1852-xx)
 - *Memory Module Product Note for Netra™ CP2000/CP2100 Series CompactPCI Boards* (817-0653-xx)
 - *Important Safety Information for Sun Hardware Systems* (816-7190-xx)
- **XCP2000-MEM-2GB (2GB memory module - 5 in. x 4 in.) part no. 595-6711-xx** -- this kit contains the components shown in FIGURE 5 and some additional documentation. They can each be identified by their part numbers as follows:
 - Memory module - 2GB (part no. 375-3114-xx)
 - Turret spacer (part no. 230-1852-xx)
 - *Memory Module Product Note for Netra™ CP2000/CP2100 Series CompactPCI Boards* (817-0653-xx)
 - *Important Safety Information for Sun Hardware Systems* (816-7190-xx)

TABLE 2 shows the double-wide memory cards supported by the Netra CP2000/CP2100 boards.

TABLE 2 Double-Wide Memory Cards Supported by the Netra CP2000/CP2100 Boards

Board	Supports 1GB Memory Card	Supports 2GB Memory Card	Maximum Number of Modules Allowed
Netra CP2040	yes	no	2
Netra CP2080	yes	no	2
Netra CP2140	yes	yes	2
Netra CP2160	yes	yes	1

Double-Wide Memory Module Installation and Removal

Before installing a Netra CP2000/CP2100 motherboard into any OEM equipment or chassis, install the memory modules on the Netra CP2000/CP2100 board.



Caution – Follow all the safety rules set forth by the OEM equipment manufacturer before performing this procedure. The components on a Netra CP2000/CP2100 board and on the memory modules are very sensitive to static electricity. Wear an anti-static wrist strap when handling the memory modules and during the installation. Place the Netra CP2000/CP2100 board on ESD foam during assembly.

The Netra CP2000/CP2100 boards that accommodate modular memory have memory bus connectors on their upper and lower surfaces so that they can be stacked. The first memory module is installed directly on the Netra motherboard. The second memory module is installed on top of the first one.

When modules of two different sizes are to be stacked one on top of the other, the module with the larger memory size must be placed at the bottom.

If you want to replace memory on a Netra CP2000/CP2100 board, remove the existing memory modules and install a replacement module, following the memory removal and installation steps in this section.

▼ To Install a Turret on a Netra CP2000/CP2100 Board for Double-Wide Memory Installation

Two turrets are pre-installed on the Netra CP2000/CP2100 board. Two additional turrets must be added to the board before installing the double-wide memory module. Turrets labeled 1 and 2 below are pre-installed on the board. Turrets labeled 3 and 4 below need to be installed.

- To install a turret onto the board, pinch the turret at the bottom and insert it into the turret mounting hole on the Netra CP2000/CP2100 board as shown in FIGURE 6.

Follow the information and illustrations on turret rotation provided in the memory module installation or removal procedures.

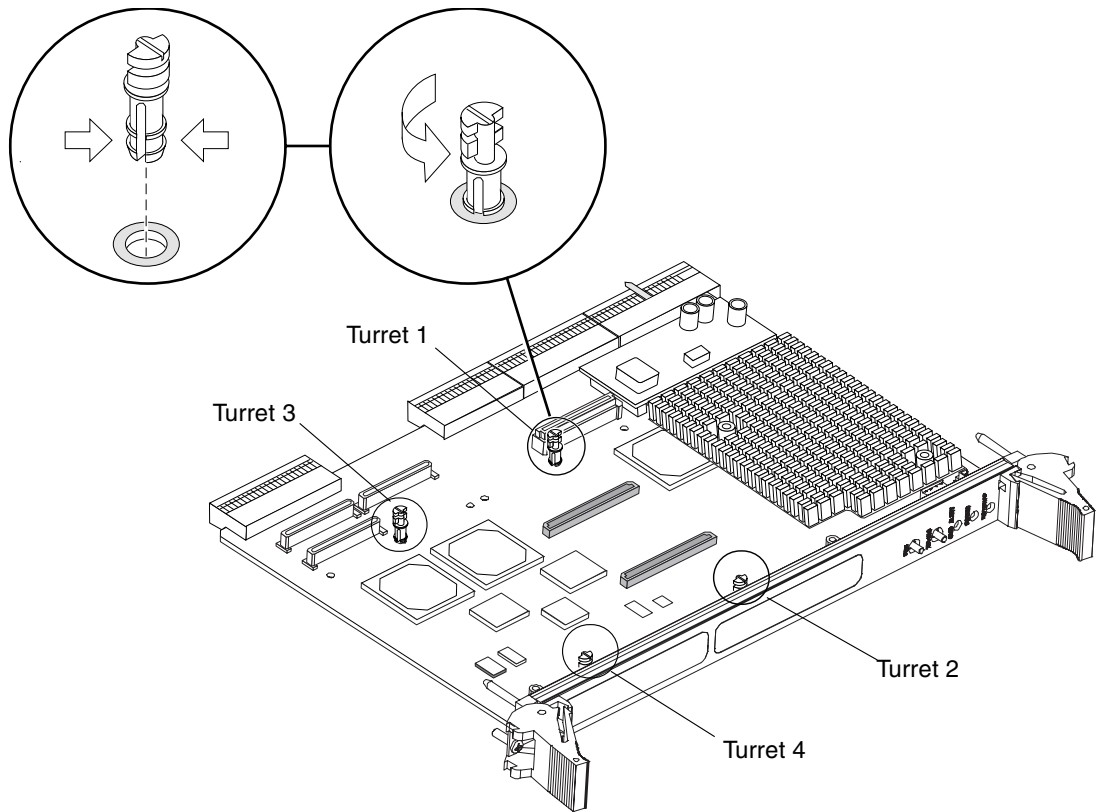

FIGURE 6 Installation of a Turret on a Typical Netra CP2000/CP2100 Board for Double-wide Memory Module Installation

Note – This procedure can also be used for installing replacement turrets.

▼ To Install a Double-Wide Memory Module on a Netra CP2000/CP2100 Board

Refer to FIGURE 7 and the following instructions to install the double-wide memory module.

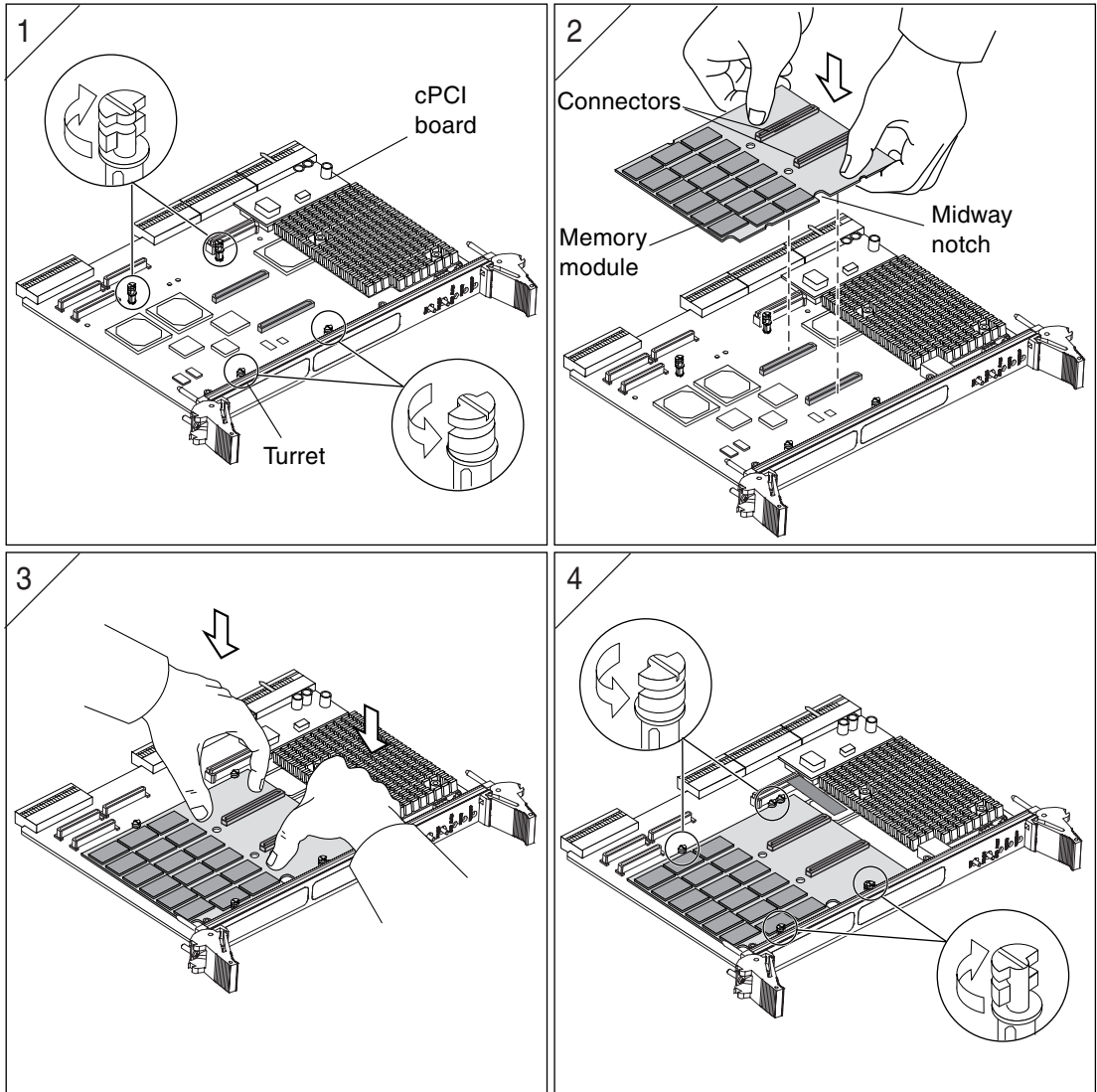

FIGURE 7 Double-wide Memory Module Installation Procedure on a Typical Netra CP2000/CP2100 Board



Caution – Follow the instructions below. If you don't follow the installation instructions properly, you can damage the connectors.

1. Rotate the turrets to the position shown in FIGURE 7 Segment 1.

2. Grasp the memory module with two hands (see FIGURE 7 Segment 2).
3. Align the module connectors with the memory sockets on the Netra CP2000/CP2100 board. Make sure the module is right side up so that the connectors mate, and orient the midway notch on the memory module towards the front panel of the cPCI board (see FIGURE 7 Segment 2).
4. Seat the module firmly into position so that it fits onto the board connectors, while pressing down on the module with your fingers (see FIGURE 7 Segment 3).
The module connectors are fully engaged with the board connectors when you hear or feel them snap into place.



Caution – Do not apply excessive pressure to connectors. Doing so may fracture the connectors or the Netra circuit board.

The above procedure describes an installation of one memory module on to the Netra CP2000/CP2100 board. If you wish to install a second memory module, follow Step 1 to Step 4. The only difference is that you position the connectors of the second memory module on the memory module connector sockets of the first module in a piggy-back style, and then seat the connectors.

5. Rotate the turrets back to the position shown in FIGURE 7 Segment 4.

▼ To Remove a Double-Wide Memory Module From a Netra CP2000/CP2100 Board

Refer to FIGURE 8 and the following instructions to remove the memory module.

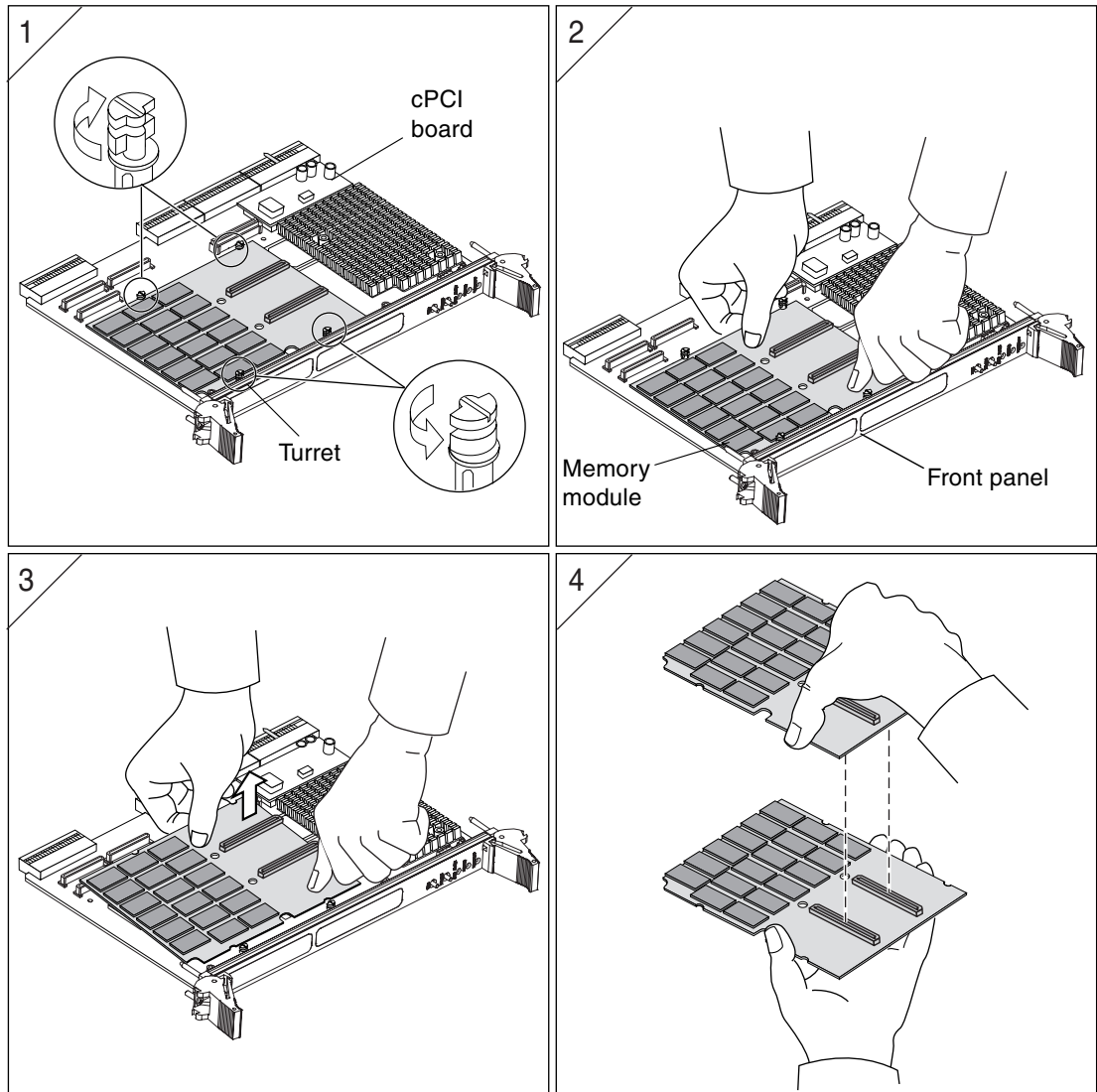

FIGURE 8 Double-wide Memory Module Extraction Procedure on a Typical Netra CP2000/CP2100 Board



Caution – Follow the instructions below. If you don't follow the removal instructions properly, you can damage the connectors.

1. **Rotate the turrets into the position shown in FIGURE 8 Segment 1.**
2. **Place your hands on the module, as shown in FIGURE 8 Segment 2.**
3. **Gently pry the module up, one connector at a time, starting from the side farthest from the front panel (see FIGURE 8 Segment 3).**

Use the hand closest to the front panel to hold the motherboard down while the other hand is lifting the memory module off.

The above procedure describes an extraction of one memory module from a Netra CP2000/CP2100 board. If you wish to extract two modules from the board, follow Step 1 to Step 3. The only difference is that the connectors of the top memory module are positioned on the memory module connector sockets of the bottom module in a piggy-back style.

When two memory modules are installed on a Netra CP2000/CP2100 board, the lower module might get extracted when removing the top module. If this happens, separate the modules by gently prying the modules apart (see FIGURE 8 Segment 4). Start with short ends of the modules. Try not to bend the modules, and use only enough force to unmate the connectors.



Caution – Do *not* separate modules from each other by prying them apart at the extremities, because you could damage the modules.
