



# Sun Fire™ V215 and V245 Servers Getting Started Guide

---

Sun Microsystems, Inc.  
www.sun.com

Part No. 819-3041-10  
September 2006, Revision 04

Submit comments about this document at: <http://www.sun.com/hwdocs/feedback>

Copyright 2006 Sun Microsystems, Inc., 4150 Network Circle, Santa Clara, California 95054, U.S.A. All rights reserved.

Sun Microsystems, Inc. has intellectual property rights relating to technology that is described in this document. In particular, and without limitation, these intellectual property rights may include one or more of the U.S. patents listed at <http://www.sun.com/patents> and one or more additional patents or pending patent applications in the U.S. and in other countries.

This document and the product to which it pertains are distributed under licenses restricting their use, copying, distribution, and decompilation. No part of the product or of this document may be reproduced in any form by any means without prior written authorization of Sun and its licensors, if any.

Third-party software, including font technology, is copyrighted and licensed from Sun suppliers.

Parts of the product may be derived from Berkeley BSD systems, licensed from the University of California. UNIX is a registered trademark in the U.S. and in other countries, exclusively licensed through X/Open Company, Ltd.

Sun, Sun Microsystems, the Sun logo, Sun Fire, Java, J2EE, OpenBoot, and Solaris are trademarks or registered trademarks of Sun Microsystems, Inc. in the U.S. and in other countries.

All SPARC trademarks are used under license and are trademarks or registered trademarks of SPARC International, Inc. in the U.S. and in other countries. Products bearing SPARC trademarks are based upon an architecture developed by Sun Microsystems, Inc.

The OPEN LOOK and Sun™ Graphical User Interface was developed by Sun Microsystems, Inc. for its users and licensees. Sun acknowledges the pioneering efforts of Xerox in researching and developing the concept of visual or graphical user interfaces for the computer industry. Sun holds a non-exclusive license from Xerox to the Xerox Graphical User Interface, which license also covers Sun's licensees who implement OPEN LOOK GUIs and otherwise comply with Sun's written license agreements.

U.S. Government Rights—Commercial use. Government users are subject to the Sun Microsystems, Inc. standard license agreement and applicable provisions of the FAR and its supplements.

DOCUMENTATION IS PROVIDED "AS IS" AND ALL EXPRESS OR IMPLIED CONDITIONS, REPRESENTATIONS AND WARRANTIES, INCLUDING ANY IMPLIED WARRANTY OF MERCHANTABILITY, FITNESS FOR A PARTICULAR PURPOSE OR NON-INFRINGEMENT, ARE DISCLAIMED, EXCEPT TO THE EXTENT THAT SUCH DISCLAIMERS ARE HELD TO BE LEGALLY INVALID.

---

Copyright 2006 Sun Microsystems, Inc., 4150 Network Circle, Santa Clara, Californie 95054, Etats-Unis. Tous droits réservés.

Sun Microsystems, Inc. a les droits de propriété intellectuels relatants à la technologie qui est décrit dans ce document. En particulier, et sans la limitation, ces droits de propriété intellectuels peuvent inclure un ou plus des brevets américains énumérés à <http://www.sun.com/patents> et un ou les brevets plus supplémentaires ou les applications de brevet en attente dans les Etats-Unis et dans les autres pays.

Ce produit ou document est protégé par un copyright et distribué avec des licences qui en restreignent l'utilisation, la copie, la distribution, et la décompilation. Aucune partie de ce produit ou document ne peut être reproduite sous aucune forme, par quelque moyen que ce soit, sans l'autorisation préalable et écrite de Sun et de ses bailleurs de licence, s'il y en a.

Le logiciel détenu par des tiers, et qui comprend la technologie relative aux polices de caractères, est protégé par un copyright et licencié par des fournisseurs de Sun.

Des parties de ce produit pourront être dérivées des systèmes Berkeley BSD licenciés par l'Université de Californie. UNIX est une marque déposée aux Etats-Unis et dans d'autres pays et licenciée exclusivement par X/Open Company, Ltd.

Sun, Sun Microsystems, le logo Sun, Sun Fire, Java, J2EE, OpenBoot, et Solaris sont des marques de fabrique ou des marques déposées de Sun Microsystems, Inc. aux Etats-Unis et dans d'autres pays.

Toutes les marques SPARC sont utilisées sous licence et sont des marques de fabrique ou des marques déposées de SPARC International, Inc. aux Etats-Unis et dans d'autres pays. Les produits portant les marques SPARC sont basés sur une architecture développée par Sun Microsystems, Inc.

L'interface d'utilisation graphique OPEN LOOK et Sun™ a été développée par Sun Microsystems, Inc. pour ses utilisateurs et licenciés. Sun reconnaît les efforts de pionniers de Xerox pour la recherche et le développement du concept des interfaces d'utilisation visuelle ou graphique pour l'industrie de l'informatique. Sun détient une licence non exclusive de Xerox sur l'interface d'utilisation graphique Xerox, cette licence couvrant également les licenciées de Sun qui mettent en place l'interface d'utilisation graphique OPEN LOOK et qui en outre se conforment aux licences écrites de Sun.

LA DOCUMENTATION EST FOURNIE "EN L'ÉTAT" ET TOUTES AUTRES CONDITIONS, DECLARATIONS ET GARANTIES EXPRESSES OU TACITES SONT FORMELLEMENT EXCLUES, DANS LA MESURE AUTORISEE PAR LA LOI APPLICABLE, Y COMPRIS NOTAMMENT TOUTE GARANTIE IMPLICITE RELATIVE A LA QUALITE MARCHANDE, A L'APTITUDE A UNE UTILISATION PARTICULIERE OU A L'ABSENCE DE CONTREFAÇON.



Please  
Recycle



Adobe PostScript

# Contents

---

Servers Overview	1
Server Installation Process	3
Site Preparation	4
Physical Specifications	5
Environmental Requirements	5
Operating Environment	6
Airflow Considerations	7
Acoustic Noise	7
Operating Power Limits and Ranges	7
Calculating Power Consumption	8
Calculating Heat Dissipation	8
Shipping Kit Contents	8
Front Panel	9
DVD Dual Drive	10
Hard Drives	10
Power and Locator Buttons	11
Status Indicators	11
Front USB Ports	12
Rear Panels	12

Power Inlets	13
Network Connectors	14
Ethernet Ports	15
Serial Ports	15
USB 2.0 Ports	16
PCI Expansion	16
Cabling Notes	17
Minimum Connections	17
System Controller Management Ports	17
Socketed System Configuration Chip	17
Preinstalled Software	18
Solaris Operating System	18
Java Enterprise System Software	19
OpenBoot PROM Diagnostics	20
Sun Advanced Lights Out Manager	20
System Reliability, Availability, and Serviceability	21
Hot-Swappable Components	21
Power Supply Redundancy	22
Environmental Monitoring	22
Sun Fire V215 and V245 Documentation	23
Documentation, Support, and Training	24
Third-Party Web Sites	24
Sun Welcomes Your Comments	24

# Introducing the Sun Fire V215 and V245 Servers

---

This guide provides you with a starting point for getting started with the Sun Fire™ V215 and V245 servers. This guide also includes links to the resources available for these servers, instructions for planning the installation of a Sun Fire V215 or V245 server, and information for locating the cable connections, configuring the server and preinstalled software, and finding more information about these servers.

---

## Servers Overview

The Sun Fire V215 and V245 servers represent follow on products of the Sun Fire V210 and V240 servers and introduce several new features:

- UltraSPARC® IIIi CPUs
- PCI-Express I/O boards
- SAS hard drives
- Hot-swap fans
- Hot-swap power supplies
- Dynamic FRU ID
- ALOM Secure Shell and SNMP support

The Sun Fire V215 and V245 servers can be mounted in a standard 19 inch rack, and they ship with the Solaris™ 10 Operating System (OS), the Java™ Enterprise System, and the Advanced Lights Out Manager (ALOM) software preinstalled as a software image on the boot drive.

These servers have the following platform names:

- SUNW, Sun-Fire-V215
- SUNW, Sun-Fire-V245

Both servers have the following common features:

- One or two CPUs
- One megabyte of L2 cache
- Eight DDR-1 DIMM slots
- Four 10/100/1000 megabit Ethernet ports
- Two USB 2.0 connectors on the rear panel
- One DVD dual drive (optional)
- One or two redundant power supplies
- One ALOM management controller with a serial and 10/100 megabit Ethernet port
- Solaris 10 6/06, plus mandatory patches, as the minimum level operating system

The servers have the following differentiating features:

**TABLE 1** Server Differentiating Features

	Sun Fire V215	Sun Fire V245
Height	1 rack unit	2 rack units
PCI-X expansion	1	1
PCI-E expansion	2	2
Front USB connectors	1	2
Hard drive bays	2	4

For a detailed list of features, available configurations, and compatible options, go to:

<http://www.sun.com/servers/>

For detailed information about these servers, go to:

<http://sunsolve.sun.com/>

See: *Sun System Handbook*

---

# Server Installation Process

This section contains a list of tasks that you must complete during the installation process. Each task includes a reference to the appropriate instructions. Each task must be completed in order.

1. Preparing the site according to the power, clearance, and environmental requirements.

If you are installing the server into a new Sun™ rack, you must fully prepare the site for the installation. If you are installing the server into an existing rack, you must conduct some site preparation to satisfy the additional power and environmental requirements. See “[Site Preparation](#)” on [page 4](#) for specific instructions.

2. Downloading the appropriate documentation.

You will need to download the *Sun Fire V215 and V245 Servers Installation Guide* and the *Sun Fire V215 and V245 Servers Product Notes* before you attempt to install the server. You can obtain these documents and other guides associated with these servers at:

<http://www.sun.com/documentation>

3. Verifying that you have received all of the components.

The Sun Fire server ships in several packages. See “[Shipping Kit Contents](#)” on [page 8](#) for a list of the shipping kit.

4. Installing the server into the rack.

The installation of the rack slides and cable management arm (CMA) represent the majority of physical work during the installation.

5. Setting up a console to communicate with the server.

To set up the console, refer to the *Sun Fire V215 and V245 Servers Installation Guide* for instructions.

6. Obtaining the latest configuration instructions for your server.

After you power the server on, you will automatically be taken through the Solaris OS configuration procedure. Therefore, before you power on the server, go to the following site to obtain the latest configuration details:

<http://www.sun.com/software/preinstall/index.xml>

7. Powering on the server and configuring the preinstalled software.

The Solaris OS and the Java Enterprise System software are preinstalled on the server.

To power on the server and configure the preinstalled software, refer to the *Sun Fire V215 and V245 Servers Installation Guide* for instructions.

8. Obtaining the latest updates and patches.

Use the appropriate links on the preinstalled software site to obtain the latest updates and patches.

9. Setting the desired OpenBoot™ PROM configuration options.

The initial boot will test the entire system. You can change the level of testing by using the OpenBoot PROM commands and configuration variables. To change the boot test level and other boot variables, refer to the *OpenBoot PROM Enhancements Diagnostics Operation*.

10. (Optional) Loading additional software from the Solaris OS media kit.

The Solaris OS media kit is sold separately. The kit includes several CDs containing software to help you operate, configure, and administer your server. Refer to the documentation provided in the media kit for a complete listing of included software and detailed instructions.

---

## Site Preparation

Before you install the Sun Fire server, you must prepare the site. This section includes information and links to information you need to prepare the site.



# Physical Specifications

[TABLE 2](#) shows the physical specifications for the Sun Fire V215 and V245 servers.

**TABLE 2** Physical Specifications

	Dimension	Value
<b>Sun Fire V215 server</b>	Height	42.7 mm
	Width	440.3 mm
	Depth	635.0 mm
	Weight	15 kg
<b>Sun Fire V245 server</b>	Height	87.36 mm
	Width	440.3 mm
	Depth	635.0 mm
	Weight	18 kg

# Environmental Requirements

You can operate and store the system safely in the conditions detailed in [TABLE 3](#).

**TABLE 3** Operating and Storage Specifications

Specification	Operating	Storage
Ambient temperature	-10° C to 35° C maximum ambient temperature is derated by 1° C (V245) and 2° C (V215) per 500 m altitude above 500 m	-40° C to 65° C
Relative humidity	5% to 80% RH noncondensing, 27° C maximum wet bulb	5% to 95% RH noncondensing, 27° C maximum wet bulb
Altitude	0 m up to 3000 m (at 35° C ambient)	0 m up to 12000 m

## Operating Environment

Your environmental control system must provide intake air for the server that complies with the limits specified in [“Environmental Requirements” on page 5](#).

To avoid overheating, *do not* direct warmed air:

- Toward the front of the cabinet or rack.
- Toward the server access panels.

---

**Note** – When you receive your system, leave it in the environment in which you will install it for 24 hours. This helps prevent thermal shock and condensation.

---

The operating environmental limits in [TABLE 3](#) reflect the limits to which the servers have been tested to meet all functional requirements. Operating computer equipment in extremes of temperature or humidity increases the failure rate of hardware components. To minimize the chance of component failure, use the server within the optimal temperature and humidity ranges.

### *Ambient Temperature*

An ambient temperature range of 21° C to 23° C is optimal for server reliability. At 22° C it is easy to maintain safe relative humidity levels. Operating in this temperature range provides a buffer in the event of the environmental support systems failing.

### *Ambient Relative Humidity*

Ambient relative humidity levels between 45% and 50% are the most suitable for data processing operations to:

- Prevent corrosion.
- Provide an operating time buffer in the event of environmental control system failure.
- Help avoid failures caused by the intermittent interference from static discharges that occur when relative humidity is too low.

Electrostatic discharge (ESD) is easily generated and less easily dissipated in areas where the relative humidity is below 35%, and it becomes critical when levels drop below 30%.

## Airflow Considerations

The Sun Fire V215 and V245 servers self-cool when operated in still air.

- Ensure unobstructed airflow through the chassis.
  - Sun Fire V215 servers use internal fans that can achieve a total airflow of 30 cfm in normal operating conditions.
  - Sun Fire V245 servers use internal fans that can achieve a total airflow of 60 cfm in normal operating conditions.
- Ensure that inlet air enters at the front of the server and exits from the back.
- Ventilation openings for both the inlet and exhaust of the system should provide:
  - Sun Fire V215 server – a minimum open area of 85 cm<sup>2</sup> (13 in<sup>2</sup>) each
  - Sun Fire V245 server – a minimum open area of 170 cm<sup>2</sup> (26 in<sup>2</sup>) each
- Allow a minimum of 88.9 mm (3.5 inches) clearance at the front and rear of the server when mounted, unless an unobstructed airflow can be ensured.

## Acoustic Noise

TABLE 4 shows the amount of acoustic noise generated by the Sun Fire V215 and V245 servers.

**TABLE 4** Acoustic Noise

Server	Noise Generated
Sun Fire V215 server	Less than 80 dBA sound power in ambient temperature of up to 24° C, measured on a standalone system to ISO 9296 requirements
Sun Fire V245 server	Less than 80 dBA sound power in ambient temperature of up to 24° C, measured on a standalone system to ISO 9296 requirements

## Operating Power Limits and Ranges

TABLE 5 shows the operating power for the Sun Fire V215 and V245 servers.

**TABLE 5** Operating Power Limits and Ranges

Description	Sun Fire V215 Server	Sun Fire V245 Server
Operating input voltage range	90 - 264 volts	90 - 264 volts

**TABLE 5** Operating Power Limits and Ranges

Description	Sun Fire V215 Server	Sun Fire V245 Server
Operating frequency range	47 - 63 Hz	47 - 63 Hz
Maximum operating current	8 Amps @ 90 VAC	8 Amps @ 90 VAC
Maximum AC input	670 watts	670 watts

## Calculating Power Consumption

The estimated power consumed in a fully powered server depends on the configuration of the server. For more information on calculating power consumption, contact your Sun sales representative.

## Calculating Heat Dissipation

To calculate the heat generated by a server so that you can estimate the heat your cooling system must dissipate, convert the figure for the server's power requirement from Watts to BTU/hr. A general formula for doing this is to multiply the power requirement figure in Watts by 3.412.

---

# Shipping Kit Contents

The server is supplied with the components described in the following list:

- Rackmount kit
- Cat5 RJ-45 cable
- Accessories kit:
  - RJ-45 adaptor
  - *Sun Fire V215 and V245 Getting Started Guide* (819-3041)
  - *Important Safety Information for Sun Servers* (816-7190)
  - *Sun Server Documentation* (819-4953)
  - *Entitlement for Solaris 10 6/06* (819-5836)
  - *Software License Agreement* (819-0764)

---

**Note** – The contents of the shipping kit might vary, depending on any options that you have ordered. Ensure that all the basic parts, as described in the list, are present in the shipping kit. If any component is missing, contact your Sun sales representative.

---

# Front Panel

This section contains views of the front panels of the servers. These views will help you become familiar with the features on the front panels so that you can install the servers, set up the cabling, or operate the servers.

On each server, the front panel contains the DVD dual drive, hard drives, status indicators, and USB port(s). [FIGURE 1](#) shows the front panel on the Sun Fire V215 server, and [FIGURE 2](#) shows the front panel on the Sun Fire V245 server.



**FIGURE 1** Front Panel on the Sun Fire V215 Server

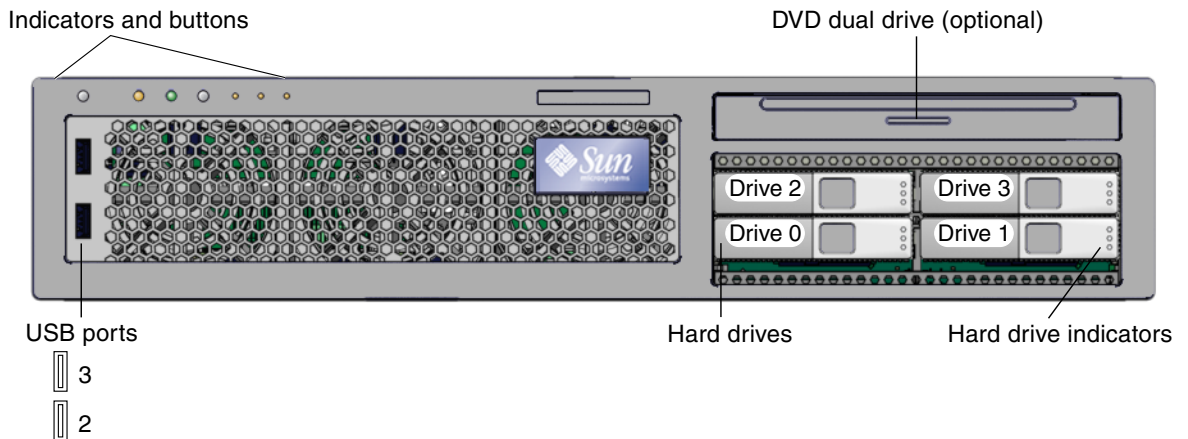

**FIGURE 2** Front Panel on the Sun Fire V245 Server

## DVD Dual Drive

Both servers support an optional, slim-line IDE DVD dual drive. The drive connects to the motherboard by a custom flex cable.

The DVD dual drive is powered by 5 volts and supports the following formats:

**TABLE 6** Supported Formats for the DVD Dual Drive

Media Types	Read	Write
CD-ROM	X	
CD-R	X	X
CD-RW	X	X
DVD-ROM	X	
DVD-R	X	X
DVD+R	X	X
DVD-RW	X	X
DVD+RW	X	X

**Note** – The DVD dual drive does not support dual-layer DVD disks.

## Hard Drives

The Sun Fire V215 server supports two 2.5 inch serial attached SCSI (SAS) hard drives, and the Sun Fire V245 server supports four 2.5 inch SAS hard drives. The drives are hot-pluggable. The preparation procedures vary depending on how the drive is used in the configuration. File systems must be unmounted and raw partitions must no longer be in use before these hard drives are removed.

Each hard drive has three status indicators associated with it. See [TABLE 7](#) for a summary of what the indicators mean.

**TABLE 7** Hard Drive Indicators

Indicator	LED color	LED State	Component Status
Removal	Blue	On	Ready to remove
		Off	Not ready to remove
Usage	Amber	On	Being used

**TABLE 7** Hard Drive Indicators

Indicator	LED color	LED State	Component Status
Activity	Green	Off	Not used
		Flashing	Active SCSI transactions
		Off	No activity

## Power and Locator Buttons

Both servers have Power buttons on the front panel and rear panels, and they have a Locator button on the front panel and a Locator LED on the rear panel. The following list provides descriptions on how these buttons and LEDs operate:

- When the main power is off, depressing the Power button once signals the power supply units to turn on the main output (+12 volts).
- When the main power is on and the Solaris OS is running, depressing the Power button once initiates a graceful shutdown of the Solaris OS. The system management processor continues to run because it operates on the 3.3 volt standby power circuit.
- When the main power is on and the Solaris OS is running, depressing and holding down the Power button for four seconds initiates an immediate shutdown of the server by signaling the power supply units to turn off the main +12 volt outputs.
- Depressing the Locator button turns on a flashing white LED.
- Depressing the Locator button again turns off the Locator LED.



---

**Caution** – When power cord is connected, standby power is still present at the service processor.

---

## Status Indicators

Both servers have indicators on the front panel. The following list contains descriptions of the indicators:

- Service Required\* (amber) – indicates that service is required
- Power OK indicator/button\* (green) – indicates the state of the server:
  - Off – not running in its normal state
  - On – powered on and running
  - Fast blink – running in standby mode
  - Slow blink – running in a transitory state

- Fan Fault (amber) – when on, indicates a fan failure event occurred
  - PSU Fault (amber) – when on, indicates that a power supply failure event occurred
  - Overtemperature (amber) – when on, indicates that a temperature failure event occurred
- \* Indicator is provided on the front and rear of the chassis.

## Front USB Ports

The Sun Fire V215 server has one USB port (Port 2) on the front panel. The Sun Fire V245 server has two USB ports (Ports 2 and 3) located on the front panel. The USB ports on the front panel on the Sun Fire V245 server cannot be used for keyboard or mouse input devices. With cable lengths of more than 2 meters or for a UDES USB device, these ports will only support USB 1.1. With cable lengths shorter than 2 meters, these ports will support USB 2.0.

---

## Rear Panels

Before you attach and route the cables, become familiar with the location of the power inlets and I/O ports on the back of the servers. [FIGURE 3](#) shows the rear panel for the Sun Fire V215 server, and [FIGURE 4](#) shows the rear panel for the Sun Fire V245 server.

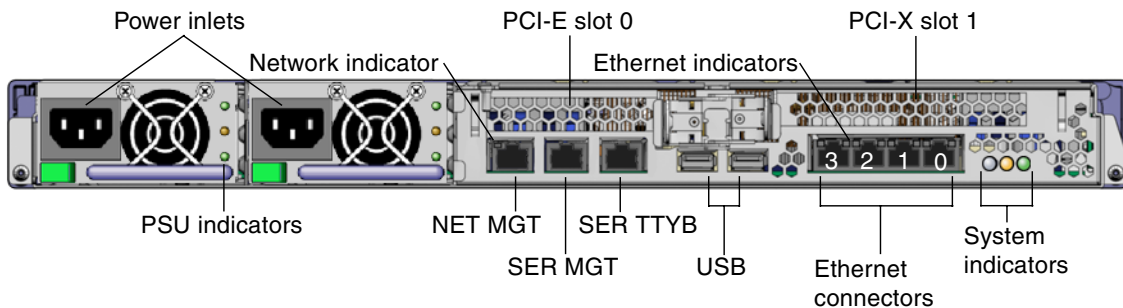

**FIGURE 3** Sun Fire V215 Server Rear Panel



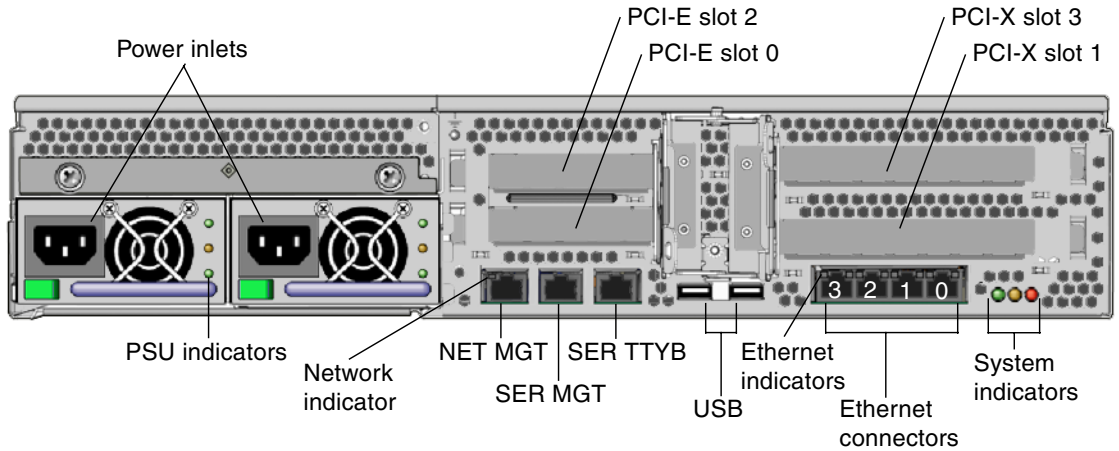

**FIGURE 4** Sun Fire V245 Server Rear Panel

## Power Inlets

The Sun Fire V215 and V245 servers can have one or two power inlets, one for each power supply unit (PSU). As long as the server is connected to a power source, the server is in Standby power mode. The only way to turn the server fully off is to remove the server from the power source by unplugging the power cable.

Do not attach power cables to the power supplies until you have finished connecting the data cables and have connected the server to a serial terminal or a terminal emulator. When the power cables are connected, the server goes into Standby mode, and the SC boots. System messages can be lost if the server is not connected to a terminal at this time.

The Sun Fire V245 and V215 servers can have dual redundant PSUs. Each PSU has three status indicators that tell you if the PSU is active, if the PSU has an internal error, or if the PSU is ready to be removed.

[TABLE 8](#) includes summaries of the function of the indicators.

**TABLE 8** Power Supply Unit Indicators

OK (green)	Fault (amber)	AC (green)	PSU Condition
Off	Off	On	Power is present, and PSU is in standby mode.

**TABLE 8** Power Supply Unit Indicators (*Continued*)

OK (green)	Fault (amber)	AC (green)	PSU Condition
On	Off	On	Power is present, and PSU is active.
Off	On	On	Power is present; however, the PSU has an internal fault and requires service.
Off	On or Off	Off	PSU has shut down due to internal fault or loss of power.

## Network Connectors

Each network connector has two status indicators. The network status indicators convey:

- Network link status
- Network speed status (does not apply to the NET MGT port)

[TABLE 9](#) includes summaries of what the Network Link Status indicators mean.

**TABLE 9** Network Link Indicators

LED color	LED State	Network Link Status
Green	On	Link is established.
	Blinking	Link is transferring data.
	Off	Link is not established.

[TABLE 10](#) includes summaries of what the network speed indicators mean.

**TABLE 10** Network Speed Indicator

LED color	LED State	Network Speed Status
Green	On	The network link is established and running at its maximum supported speed.
	Off	<ul style="list-style-type: none"> <li>• If the network activity indicator is off, the network link is established but not running at its maximum supported speed.</li> <li>• If the network activity indicator is off, network link is not established.</li> </ul>

# Ethernet Ports

The Sun Fire V215 and V245 servers each have four autonegotiating 10/100/1000BASE-T Ethernet system domain ports. All of the Ethernet ports use a standard RJ-45 connector, the transfer rates for which are given in [TABLE 11](#).

**TABLE 11** Ethernet Connection Transfer Rates

Connection Type	IEEE Terminology	Transfer Rate
Ethernet	10BASE-T	10 Mbit/s
Fast Ethernet	100BASE-TX	100 Mbits/s
Gigabit Ethernet	1000BASE-T	1000 Mbit/s

In addition, each server has one 10BASE-T Ethernet management domain interface, labeled NET MGT. For information on configuring this port for managing the server with ALOM, see the *Sun Advanced Lights Out Management (ALOM) Administration Guide*.

# Serial Ports

The server has two serial ports, labelled SER MGT and SER TTYB. The SER MGT port accepts an RJ-45 connector. Use this port *only* for server management. The port labeled SER TTYB accepts an RJ-45 connector. Use this port for general purpose, asynchronous serial data transfer.

For serial devices, use the SER TTYB port and an RJ-45 adaptor with a null modem cable. This port appears as `ttyb` in Solaris OS and OpenBoot PROM messages and is not connected to the SC serial management port.

The default serial connection settings are listed in [TABLE 12](#).

**TABLE 12** Default Serial Connection Settings

Parameter	Setting
Connector	SER MGT or SER TTYB
Rate	9600 baud

**TABLE 12** Default Serial Connection Settings

Parameter	Setting
Parity	None
Stop bits	1
Data bits	8

If you need to connect to the SER MGT port using either a DB-9 or a DB-25 connector, use an adapter to perform the cross-overs. See the *Sun System Handbook* for more information about the cross-overs.

## USB 2.0 Ports

Both servers have two USB 2.0 ports (0 and 1) on the rear panel. Use ports 0 and 1 to connect input devices such as a keyboard and mouse. The USB ports support hot-plugging. You can connect and disconnect USB cables and peripheral devices while the system is running without affecting system operations.

You can perform USB hot-plug operations only while the Solaris OS is running. You must run the `devfsadm -C` command after a USB hot-plug operation. USB hot-plug operations are not supported when the OpenBoot PROM prompt is displayed or before the system has completed booting.

## PCI Expansion

Both servers use a variety of riser cards to provide different combinations of PCI-E and PCI-X expansion slots.

For a detailed list of expansion options, go to:

<http://www.sun.com/servers/>

---

# Cabling Notes

This section contains important notes about cabling the server.

## Minimum Connections

The following list includes the minimum cable connections for the Sun Fire V215 and V245 servers:

- At least one Ethernet network connection (NET port)
- SC serial management port (SER MGT port)
- SC network management port (NET MGT port)
- Power cable(s)

## System Controller Management Ports

There are two SC management ports for use with the ALOM system controller:

- SC serial management port (labeled SER MGT) which uses an RJ-45 cable  
This port is the default connection to the SC and is always available.
- SC network management port (labeled NET MGT) which uses an RJ-45 cable  
This port is the optional connection to the SC. It is not available until you configure the network settings for the SC through the serial management port. This port does not support connections to Gigabit networks. However, it will correctly negotiate to a lower speed if connected to a 10/100/1000 Gigabit Ethernet switch.

---

## Socketed System Configuration Chip

Both servers include a socketed system configuration chip (SSCC). This device is located on the motherboard and enables the user to transport vital system information from one machine to another in the event of an unrecoverable system failure.

From an architectural perspective, the SSCC performs a function similar to the NVRAM or EEPROM devices used in previous Sun products. The SSCC contains the following data structures used by the Sun Fire V215 and V245 service processor:

- Host ID
- Ethernet MAC addresses for all host Ethernet interfaces
- Ethernet MAC addresses for ALOM Ethernet interface

---

## Preinstalled Software

The Sun Fire V215 and V245 servers are shipped with the Solaris 10 Operating System (OS) and the Java Enterprise System software. You must configure the preinstalled software as part of the installation process. However, before you begin the configuration process, go to:

<http://www.sun.com/software/preinstall/>

This site contains the latest information about the preinstalled software and links to the software updates and patches you must install.

## Solaris Operating System

The Solaris 10 OS is preinstalled on both servers and offers the following features:

- Stability, high performance, scalability, and precision of a mature 64-bit operating system.
- Support for over 12,000 leading technical and business applications.
- Solaris Containers – Isolates software applications and services using flexible, software-defined boundaries.
- DTrace – Provides comprehensive dynamic tracing framework for tuning applications and troubleshooting systemic problems in real time.
- ZFS – Provides a simple administration model.
- Security – Provides advanced security features designed to protect the enterprise at multiple levels.
- Network performance – Completely rewritten TCP/IP stack dramatically improves the performance and scalability of your networked services.

# Java Enterprise System Software

The Java Enterprise System software includes a free 90-day evaluation license for the following Java Enterprise System software applications:

- Access Manager – A security foundation that helps manage secure access to an enterprises' web applications by offering single sign-on (SSO) as well as enabling federation across trusted networks.
- Application Server – Provides a Java 2 Platform, Enterprise Edition (J2EE™ platform) 1.4 compatible platform for developing and delivering server-side Java applications and web services.
- Calendar Server – A web-based tool that facilitates team collaboration by enabling users to manage and coordinate appointments, events, tasks, and resources.
- Cluster software – Delivers high availability to enterprise system applications.
- Directory Server – User-management infrastructure for enterprises that manage high volumes of user information. The Directory Server provides a centralized repository for storing and managing user profiles and access privileges, as well as application and network resource information.
- Directory Proxy Server – Provides secure firewall-like services for the Directory Server.
- Instant Messaging – A standards-based, real-time communication and collaboration application.
- Message Queue – An enterprise-level message server using a standards-based (JMS) messaging solution.
- Messaging Server – A high-performance, highly secure messaging platform that provides security features that help ensure the integrity of communications.
- Portal Server – Provides portal services that identify users through centralized identity services using roles and policies.
- Web Server – A secure, reliable, easy-to-use web server designed for medium and large business applications.

To gain the benefits of the Java Enterprise System, you can buy a subscription license for a Java Enterprise System Suite or a combination of Java System Suites.

---

# OpenBoot PROM Diagnostics

With the upgrade to OpenBoot PROM 4.18.5 or a subsequently compatible version of the OpenBoot PROM, diagnostics are enabled by default. This ensures complete diagnostic test coverage on the initial boot and after error reset events. This change results in increased boot time.

To change the system defaults and diagnostic settings after the initial boot, refer to *OpenBoot PROM Enhancements for Diagnostic Operation* (817-6957). To obtain this document, go to:

<http://www.sun.com/products-n-solutions/hardware/docs/>

---

# Sun Advanced Lights Out Manager

The Sun Fire V215 and V245 servers ship with the Sun Advanced Lights Out Manager (ALOM) software installed. The system console is directed to ALOM by default and is configured to show server console information on startup.

ALOM enables you to monitor and control your server over either a serial connection (using the SER MGT port) or Ethernet connection (using the NET MGT port). For information about configuring an Ethernet connection, refer to the *Sun Advanced Lights Outs Manager User's Guide*.

---

**Note** – The ALOM serial port, labeled SER MGT, is for server management only. If you need a general-purpose serial port, use the serial port labeled SER TTYB.

---

You can configure ALOM to send email alerts of hardware failures, hardware warnings, and other events related to the server or to ALOM. ALOM monitors the following server components:

- CPU temperature conditions
- Hard drive status
- Enclosure thermal conditions
- Fan speed and status
- Power supply status
- Voltage conditions



The ALOM circuitry uses standby power from the server. This means that:

- ALOM is active as soon as the server is connected to a power source, and remains active until power is removed by unplugging the power cable.
- ALOM continues to be effective even when the operating system is offline and when the server is in Standby mode.

For more information about ALOM, see the *Sun Advanced Lights Out Management (ALOM) Administration Guide*.

---

## System Reliability, Availability, and Serviceability

Reliability, availability, and serviceability (RAS) are aspects of a system's design that affect its ability to operate continuously and to minimize the time necessary to service the system. Reliability refers to a system's ability to operate continuously without failures and to maintain data integrity. System availability refers to the ability of a system to recover to an operational state after a failure, with minimal impact. Serviceability relates to the time it takes to restore a system to service following a system failure. Together, reliability, availability, and serviceability features provide for near continuous system operation.

To deliver high levels of reliability, availability, and serviceability, the Sun Fire server offers the following features:

- Hot-pluggable hard drives
- Redundant, hot-swappable power supplies
- Redundant, hot-swappable fans
- Environmental monitoring
- Error detection and correction for improved data integrity
- Easy access for most component replacements

## Hot-Swappable Components

Sun Fire hardware is designed to support hot-swapping of components. You can install or remove these components while the system is running. Hot-swap technology significantly increases the system's serviceability and availability by providing the ability to replace components without service disruption.

# Power Supply Redundancy

Depending on the configuration, the Sun Fire V215 and V245 servers feature two hot-swappable power supplies, enabling the system to continue operating should one of the power supplies fail or if one power source fails.

# Environmental Monitoring

The Sun Fire servers feature an environmental monitoring subsystem that protects the server and its components against:

- Extreme temperatures
- Lack of adequate airflow through the system
- Power supply failures
- Hardware faults

Temperature sensors are located throughout the system to monitor the ambient temperature of the system and internal components. The software and hardware ensure that the temperatures within the enclosure do not exceed predetermined safe operation ranges. If the temperature observed by a sensor falls below a low-temperature threshold or rises above a high-temperature threshold, the monitoring subsystem software lights the amber Service Required indicators on the front and back panel. If the temperature condition persists and reaches a critical threshold, the system initiates a graceful system shutdown. In the event of a failure of the service processor, backup sensors protect the system from serious damage, by initiating a forced hardware shutdown.

All error and warning messages are sent to the service processor system console and logged in the ALOM console log file. Service Required indicators remain lit after an automatic system shutdown to aid in problem diagnosis.

The power subsystem is monitored in a similar fashion by monitoring power supplies and reporting any fault in the front and rear panel indicators.

If a power supply problem is detected, an error message is sent to the service processor system console and logged in the ALOM console log file. Additionally, status indicators located on each power supply light to indicate failures. The system Service Required indicator lights to indicate a system fault.

---

# Sun Fire V215 and V245 Documentation

The documentation that supports these servers is comprised of three categories:

- Documentation that is specific to the Sun Fire V215 and V245 server

This documentation provides hardware and software information about the features, installation, configuration, usage, diagnostics, and parts replacement.

- Solaris OS documentation

This documentation applies to other Sun SPARC® based systems as well as to Sun Fire V215 and V245 servers. This category includes Solaris OS installation, usage, reference, and release documents, as well as individual man page commands. Refer to the Solaris OS documentation site:

<http://docs.sun.com/app/docs/prod/solaris>

- Documentation for additional Sun software products

This documentation applies to products that are optionally installed and configured to run on the Sun Fire V215 and V245 servers. This category includes documentation about Java Enterprise System software products, Sun Management Center software, Sun Java Desktop System, and others. Refer to the general Sun documentation web site at:

<http://www.sun.com/documentation>

---

# Documentation, Support, and Training

---

Sun Function	URL
Documentation	<a href="http://www.sun.com/documentation/">http://www.sun.com/documentation/</a>
Support	<a href="http://www.sun.com/support/">http://www.sun.com/support/</a>
Training	<a href="http://www.sun.com/training/">http://www.sun.com/training/</a>

---

---

## Third-Party Web Sites

Sun is not responsible for the availability of third-party web sites mentioned in this document. Sun does not endorse and is not responsible or liable for any content, advertising, products, or other materials that are available on or through such sites or resources. Sun will not be responsible or liable for any actual or alleged damage or loss caused by or in connection with the use of or reliance on any such content, goods, or services that are available on or through such sites or resources.

---

## Sun Welcomes Your Comments

Sun is interested in improving its documentation and welcomes your comments and suggestions. You can submit your comments by going to:

<http://www.sun.com/hwdocs/feedback>

Please include the title and part number of your document with your feedback:

*Sun Fire V215 and V245 Servers Getting Started Guide*, part number 819-3041-10