Inventory

The interface board kit contains:

- One Interface board
- One 2-meter cable
- Two GBICs: one installed on the board, and one attached to the end of the cable

Handling Boards and Assemblies



Caution – The chassis AC power cord must remain connected to a power outlet for a proper ground.

For your protection, observe the following safety precautions:

- Follow all cautions and instructions marked on the equipment.
- Never push objects of any kind through openings in the equipment as they may touch dangerous voltage points or short out components that could result in fire or electric shock.
- Refer servicing of equipment to qualified personnel.



Caution – The interface board and its modules have surface-mount components that can be broken by flexing the board.

To minimize the amount of board flexing:

- Hold the board only by the edges near the middle of the board, where the board stiffener is located. Do not hold the board *only* at the ends.
- When removing the board from an antistatic bag, keep the board vertical until you lay it on the Sun ESD mat.
- Do not place the board on a hard surface. Use a cushioned antistatic mat. The board connectors and components have very thin pins that bend easily.
- Do not use an oscilloscope probe on the components. The soldered pins are easily damaged or shorted by the probe point.
- Transport the board in an antistatic bag.

Removing an Interface Board or Filler Panel

- ◆ To remove a filler panel, unfasten the captive screws at the top and bottom of the panel and grasp the handles to pull the filler panel out.

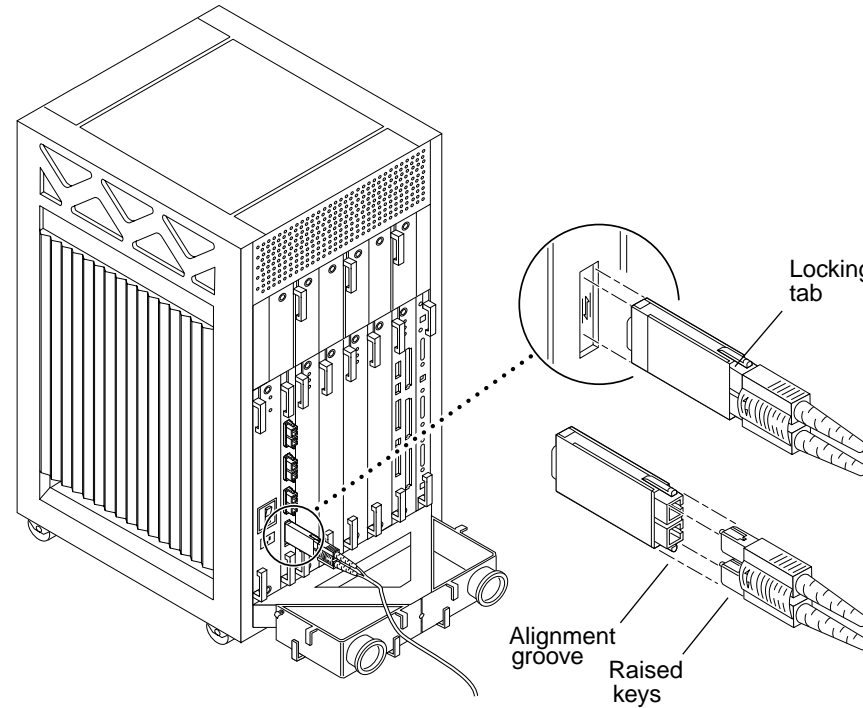

- ◆ To remove an interface board (IB):

- a. Unfasten any fiber optic cables from the board front panel, label them for identification, and set them aside.
- b. Loosen the two captive screws securing the board to the card cage.
- c. Pull the ends of both extraction levers outward simultaneously to unseat the board from the centerplane.

Installing an Interface Board

1. Carefully insert the board in the proper slot in the card cage, ensuring that the board does not slip out of the left and right card guides.
The component side of the board must face to the right.

2. Ensure that both extraction levers are in the outward position as you slide the board toward the backplane connectors.

The board will not seat fully unless the levers are in this starting position.



Caution – Do not force any board into a slot; this can cause damage to the board and system. The board should insert and seat smoothly. If it binds, remove the board and inspect the card cage slot for any obvious obstructions.

3. Use the extraction levers to seat the board.

Simultaneously swing both levers into the locked position. Do not press on board to seat it; doing so will damage the connector pins.

4. Secure the board to the chassis using the two captive screws.

5. Reconnect any fiber-optic cables to the board front panel.

Use the fiber cable organizer to route the fiber-optic cable to connect the interface board and the I/O+ board.

Removing a GBIC

Note – It is not necessary to remove the interface board from the card cage to replace GBICs. A GBIC can be removed and replaced without removing power from the system or board. However, you must take the necessary software precautions whenever the I/O path to a particular disk is to be interrupted; halt all I/O activity to the disk affected by the replacement of a GBIC. For additional information on how to replace a GBIC or fiber-optic cable, refer to the system reference manual that came with your system.

1. Remove the fiber-optic cable.

2. Compress the two locking tabs while pulling the GBIC straight out. The following table shows the drive bay supported by each GBIC location.

Disk Drives	Drive Port	GBIC Name and Location
0, 1, 2, 3	A	GBIC LA (Lower bank)
0, 1, 2, 3	B	GBIC LB (Lower bank)
4, 5, 6, 7	A	GBIC UA (Upper bank)
4, 5, 6, 7	B	GBIC UB (Upper bank)

Installing a GBIC

1. Ensure that the orientation of the alignment groove is correct and insert the GBIC into the proper slot.
2. Reconnect the fiber-optic cable (keys on cable matching notches on the GBIC).

Wrapping the Fiber Cable on the Organizer

To ensure that the fiber-optic cable minimum bend radius rule (1.0 inch) is observed, use this procedure to wrap the cable around the spool organizer:

1. Remove the two plastic caps that cover the cable connector on the GBIC module.
2. Remove the plastic cap covering the ends of the fiber cable.
3. Connect one end of the fiber cable into the GBIC module installed on the interface board rear panel.
Align the notch in the cable connector with the key notch in the module connector.
4. Route the fiber cable down toward the bottom of the system, placing it through the left side restraints on the organizer.

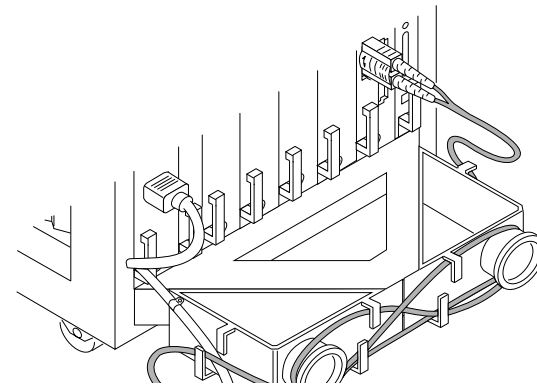

Ordering Sun Documents

SunDocsSM is a distribution program for technical documentation and is available from SunExpress. You can find a full listing of available documentation on the World Wide Web:

<http://www.sun.com/sunexpress/>

To order or for more information:

Telephone: 1-800-873-7869 (United States and Canada only)

Fax: 1-800-944-0661 (United States and Canada only)

Reader Comments

Your comments and suggestions are important to us. Please let us know what you think about the *Sun Enterprise 3500 Interface Board Installation Guide*, part number 805-4011-10.

You can send detailed comments via email to smcc-docs@sun.com, or send a fax to *SMCC Doc Feedback* at (650) 786-6443.

Copyright 1998 Sun Microsystems, Inc. All rights reserved. Use is subject to license terms. Third-party software, including font technology, is copyrighted and licensed from Sun suppliers. Sun, Sun Microsystems, the Sun Logo, SunDocs, and Solaris are trademarks or registered trademarks of Sun Microsystems, Inc. in the U.S. and other countries. **RESTRICTED RIGHTS:** Use, duplication, or disclosure by the U.S. Government is subject to restrictions of FAR 52.227-14(g)(2)(6/87) and FAR 52.227-19(6/87), or DFAR 252.227-7015(b)(6/95) and DFAR 227.7202-3(a).

Copyright 1998 Sun Microsystems, Inc. Tous droits réservés. Distribué par des licences qui en restreignent l'utilisation. Le logiciel détenu par des tiers, et qui comprend la technologie relative aux polices de caractères, est protégé par un copyright et licencié par des fournisseurs de Sun. Sun, Sun Microsystems, le logo Sun, SunDocs, et Solaris sont des marques de fabrique ou des marques déposées de Sun Microsystems, Inc. aux Etats-Unit et dans d'autres pays.

Sun Microsystems Computer Company • 901 San Antonio Road • Palo Alto, CA 94303-4900
USA • 650 960-1300 • Fax 650 969-9131



Part Number: 805-4011-10
Revision A of April 1998



SunTM EnterpriseTM 3500 Interface Board Installation Guide

