

To install a board you will need:

- Phillips #1 screwdriver
- Grounding wrist strap

A padded ESD mat is required if you perform any work on the board. The padding prevents breakage of parts on the bottom of the board.

## Hot-Plug Feature

The hot-plug feature enables you to insert a new board into a powered-on system while the system is supplied with electrical power. If a working board is added to a powered-on system with the hot-plug feature, the system cannot use the new board until the system is rebooted.



**Caution** – If the message: NOTICE: Hot Plug not supported in this system is displayed during boot, do NOT attempt to remove or install a board while the system is powered-on or damage to the hardware will occur.



**Caution** – Do not hot-plug an Enterprise system component if the peripheral power supply (PPS), in the 6x00/5x00/4x00 system, or the peripheral power supply/AC input (PPS/AC), in the 3x00 system, is inoperative. These power supplies provide the precharge voltage required for hot-plug. Use `prtdiag(1M)` to determine the peripheral power supply status.

## Removing a Board

**Note** – All empty board slots must have a filler panel (Enterprise 5x00/4x00/3x00 systems) or a load board (Enterprise 6x00 system) installed to ensure proper cooling. For further information on load boards or filler panels, refer to your server systems reference manual.

1. **Ensure that the board is in low-power mode and ready for removal.**  
If the board is not in low-power mode, halt the system and turn off the power before proceeding. The board is in low-power mode if one of the following is true:
  - The three LEDs on the board are not lit (board has no power).
  - The outer two green LEDs are not lit and the middle yellow LED is lit.



**Caution** – Use a grounding wrist strap to prevent static damage.

2. **With a Phillips #1 screwdriver, turn the two quarter-turn access slots to the unlocked position (■).**

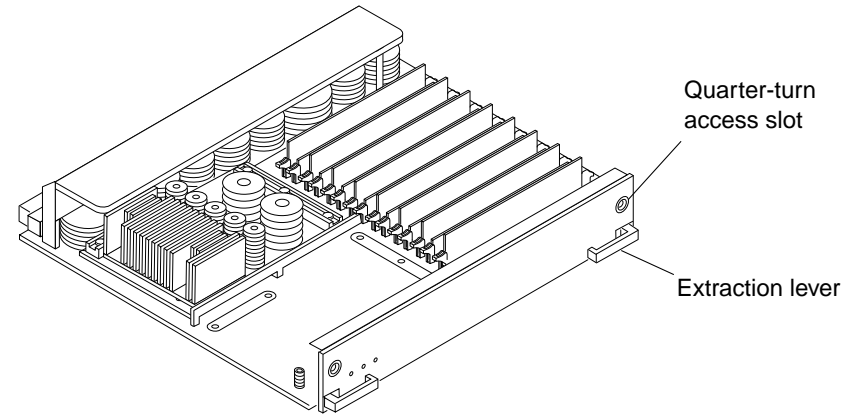

3. **Pull the ends of both extraction levers outward, then gently pull the board out of the card cage.**  
Do not let the components on the board catch on any surrounding surfaces as you pull the board.



**Caution** – The heatsinks on the board may be hot. Handle with care.

4. **Place the board on a padded ESD mat for servicing, or store the board in an antistatic bag.**

## Installing a New Board

1. **Select a board slot.**  
Refer to your server systems reference manual for selection rules.



**Caution** – Use a grounding wrist strap to prevent static damage.

2. **Open the extraction levers by pulling the ends of both levers outward.**

3. **Insert the board partway into the card cage slot.**

- For a rear slot in a 16-slot or 8-slot card cage, orient the board component-side up.
- For a front slot in a 16-slot or 8-slot card cage, orient the board component-side down.

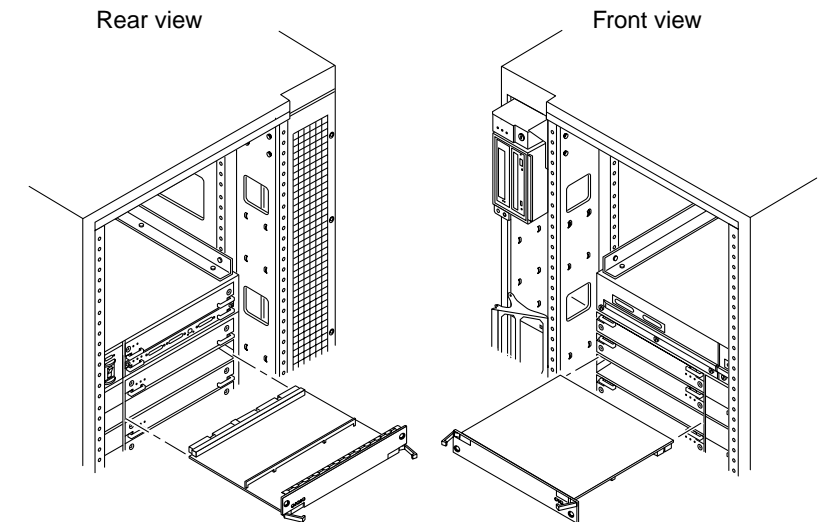

- For a 4-slot or 5-slot card cage with vertical slots, orient the board with the component side to the right.
4. **Push the board into the card cage, then simultaneously press both extraction levers to seat the board on the centerplane.**



**Caution** – When inserting a board into slot 4 or slot 10 of a 16-slot card cage, lift the board slightly to avoid damage to the centerplane connectors.



**Caution** – Do not press on the board front panel to seat it—doing so will damage the connector pins.

Pushing both levers simultaneously avoids twisting the board and bending the connector pins.

5. With a Phillips #1 screwdriver, turn the two quarter-turn access slots to the locked position (🔒).

6. If the system is running, look for a system message similar to the following example for a CPU/Memory board in slot 5:

NOTICE: CPU Board Hotplugged into Slot 5  
NOTICE: Board 5 is ready to remove

7. Reboot the system now or schedule a later time to reboot when system disruption will be minimized.

The system cannot use the new board until the system is rebooted.

## Sun Documentation on the Web

The docs.sun.com web site enables you to access Sun technical documentation on the Web. You can browse the docs.sun.com archive or search for a specific book title or subject at:

<http://docs.sun.com>

## Sun Welcomes Your Comments



We are interested in improving our documentation and welcome your comments and suggestions. You can email your comments to us at:

[smcc-docs@sun.com](mailto:smcc-docs@sun.com)

Please include the part number of your document in the subject line of your email.

Copyright 1998 Sun Microsystems, Inc. All rights reserved. Use is subject to license terms. Third-party software, including font technology, is copyrighted and licensed from Sun suppliers. Sun, Sun Microsystems, the Sun Logo, SunDocs, and Solaris are trademarks or registered trademarks of Sun Microsystems, Inc. in the U.S. and other countries. **RESTRICTED RIGHTS:** Use, duplication, or disclosure by the U.S. Government is subject to restrictions of FAR 52.227-14(g)(2)(6/87) and FAR 52.227-19(6/87), or DFAR 252.227-7015(b)(6/95) and DFAR 227.7202-3(a).

Copyright 1998 Sun Microsystems, Inc. Tous droits réservés. Distribué par des licences qui en restreignent l'utilisation. Le logiciel détenu par des tiers, et qui comprend la technologie relative aux polices de caractères, est protégé par un copyright et licencié par des fournisseurs de Sun. Sun, Sun Microsystems, le logo Sun, SunDocs, et Solaris sont des marques de fabrique ou des marques déposées de Sun Microsystems, Inc. aux Etats-Unit et dans d'autres pays.

 Sun Microsystems Computer Company • 901 San Antonio Road • Palo Alto, CA 94303-4900  
USA • 650 960-1300 • Fax 650 969-9131 

Part Number: 805-4007-10  
Revision A of April 1998



# Sun™ Enterprise™ 6x00/5x00/4x00/3x00 Systems Board Installation Guide



**Caution** – The heatsinks on the board can be damaged by incorrect handling. Do not touch the heatsinks while installing or moving the board. Hold the board only by the edges. If a heatsink is loose or broken, obtain a replacement board.



**Caution** – The heatsinks on the board can be damaged by improper packaging. When storing or shipping the board, ensure that the heatsinks have sufficient protection.

