



# Sun Fire™ 6800/4810/4800/3800 Systems Platform Administration Manual

---

Sun Microsystems, Inc.  
901 San Antonio Road  
Palo Alto, CA 94303 U.S.A.  
650-960-1300

Part No. 816-2970-10  
May 2002, [Revision A](#)

[Send comments about this document to: docfeedback@sun.com](mailto:docfeedback@sun.com)

Copyright 2002 Sun Microsystems, Inc., 4150 Network Circle, Santa Clara, CA 95054 U.S.A. All rights reserved.

This product or document is protected by copyright and distributed under licenses restricting its use, copying, distribution, and decompilation. No part of this product or document may be reproduced in any form by any means without prior written authorization of Sun and its licensors, if any. Third-party software, including font technology, is copyrighted and licensed from Sun suppliers.

Parts of the product may be derived from Berkeley BSD systems, licensed from the University of California. UNIX is a registered trademark in the U.S. and other countries, exclusively licensed through X/Open Company, Ltd.

Sun, Sun Microsystems, the Sun logo, docs.sun.com, Sun Fire, OpenBoot, Sun StorEdge, and Solaris are trademarks, registered trademarks, or service marks of Sun Microsystems, Inc. in the U.S. and other countries. All SPARC trademarks are used under license and are trademarks or registered trademarks of SPARC International, Inc. in the U.S. and other countries. Products bearing SPARC trademarks are based upon an architecture developed by Sun Microsystems, Inc.

Federal Acquisitions Commercial Software-Government Users Subject to Standard License Terms and Conditions.

DOCUMENTATION IS PROVIDED "AS IS" AND ALL EXPRESS OR IMPLIED CONDITIONS, REPRESENTATIONS AND WARRANTIES, INCLUDING ANY IMPLIED WARRANTY OF MERCHANTABILITY, FITNESS FOR A PARTICULAR PURPOSE OR NON-INFRINGEMENT, ARE DISCLAIMED, EXCEPT TO THE EXTENT THAT SUCH DISCLAIMERS ARE HELD TO BE LEGALLY INVALID.

Copyright 2002 Sun Microsystems, Inc., 4150 Network Circle, Santa Clara, CA 95054 Etats-Unis. Tous droits réservés.

Ce produit ou document est protégé par un copyright et distribué avec des licences qui en restreignent l'utilisation, la copie, la distribution, et la décompilation. Aucune partie de ce produit ou document ne peut être reproduite sous aucune forme, par quelque moyen que ce soit, sans l'autorisation préalable et écrite de Sun et de ses bailleurs de licence, s'il y en a. Le logiciel détenu par des tiers, et qui comprend la technologie relative aux polices de caractères, est protégé par un copyright et licencié par des fournisseurs de Sun.

Des parties de ce produit pourront être dérivées des systèmes Berkeley BSD licenciés par l'Université de Californie. UNIX est une marque déposée aux Etats-Unis et dans d'autres pays et licenciée exclusivement par X/Open Company, Ltd.

Sun, Sun Microsystems, the Sun logo, docs.sun.com, Sun Fire, OpenBoot, Sun StorEdge, et Solaris sont des marques de fabrique ou des marques déposées, ou marques de service, de Sun Microsystems, Inc. aux Etats-Unis et dans d'autres pays. Toutes les marques SPARC sont utilisées sous licence et sont des marques de fabrique ou des marques déposées de SPARC International, Inc. aux Etats-Unis et dans d'autres pays. Les produits portant les marques SPARC sont basés sur une architecture développée par Sun Microsystems, Inc.

L'interface d'utilisation graphique OPEN LOOK et Sun™ a été développée par Sun Microsystems, Inc. pour ses utilisateurs et licenciés. Sun reconnaît les efforts de pionniers de Xerox pour la recherche et le développement du concept des interfaces d'utilisation visuelle ou graphique pour l'industrie de l'informatique. Sun détient une licence non exclusive de Xerox sur l'interface d'utilisation graphique Xerox, cette licence couvrant également les licenciés de Sun qui mettent en place l'interface d'utilisation graphique OPEN LOOK et qui en outre se conforment aux licences écrites de Sun.

LA DOCUMENTATION EST FOURNIE "EN L'ETAT" ET TOUTES AUTRES CONDITIONS, DECLARATIONS ET GARANTIES EXPRESSES OU TACITES SONT FORMELLEMENT EXCLUES, DANS LA MESURE AUTORISEE PAR LA LOI APPLICABLE, Y COMPRIS NOTAMMENT TOUTE GARANTIE IMPLICITE RELATIVE A LA QUALITE MARCHANDE, A L'APTITUDE A UNE UTILISATION PARTICULIERE OU A L'ABSENCE DE CONTREFAÇON.



# Contents

---

**Preface xv**

**1. Introduction 1**

Domains 2

System Components 3

Partitions 3

System Controller 8

    Serial and Ethernet Ports 9

    System Controller Logical Connection Limits 9

    System Controller Software 10

Redundant Components and Minimum Configurations 13

    Redundant System Controller Boards 13

    CPU/Memory Boards 14

    I/O Assemblies 15

    Redundant Cooling 16

    Redundant Power 17

    Repeater Boards 18

    Redundant System Clocks 19

Reliability, Availability, and Serviceability (RAS) 20

Reliability	20
Availability	22
Serviceability	23
Dynamic Reconfiguration Software	24
Sun Management Center Software for the Sun Fire 6800/4810/4800/3800 Systems Software	25
FrameManager	25
<b>2. System Controller Navigation Procedures</b>	<b>27</b>
Connection to the System Controller	28
Obtaining the Platform Shell	28
▼ To Obtain the Platform Shell Using <code>telnet</code>	28
Obtaining a Domain Shell or Console	30
System Controller Navigation	32
▼ To Enter the Domain Console From the Domain Shell If the Domain Is Inactive	35
▼ To Enter the Domain Shell From the Domain Console	36
▼ To Get Back to the Domain Console From the Domain Shell	36
▼ To Enter a Domain From the Platform Shell	37
Terminating Sessions	37
▼ To Terminate an Ethernet Connection With <code>telnet</code>	37
▼ To Terminate a Serial Connection With <code>tip</code>	38
<b>3. System Power On and Setup</b>	<b>41</b>
Installing, Cabling, and Powering on the Hardware	43
Setting Up Additional Services Before System Power On	43
Powering On the Hardware	45
Powering On the Power Grids	45
Setting Up the Platform	46
▼ To Set the Date and Time for the Platform	46

▼	To Set a Password for the Platform	47
▼	To Configure Platform Parameters	47
	Setting Up Domain A	48
▼	To Access the Domain	48
▼	To Set the Date and Time for Domain A	48
▼	To Set a Password for Domain A	48
▼	To Configure Domain-Specific Parameters	49
	Saving the Current Configuration to a Server	50
▼	To Use <code>dumpconfig</code> to Save Platform and Domain Configurations	50
	Installing and Booting the Solaris Operating Environment	51
▼	To Install and Boot the Solaris Operating Environment	51
<b>4.</b>	<b>Creating and Starting Multiple Domains</b>	<b>53</b>
	Creating and Starting Domains	53
	Before Creating Multiple Domains	53
▼	To Create A Second Domain	55
	Special Considerations When Creating a Third Domain on the Sun Fire 6800 System	56
▼	To Start the Domain	57
<b>5.</b>	<b>Security</b>	<b>59</b>
	Security Threats	59
	System Controller Security	60
	<code>setupplatform</code> and <code>setupdomain</code> Parameter Settings	61
	Changing Passwords for the Platform and the Domain	61
	Domains	62
	Domain Separation	62
	<code>setkeyswitch</code> Command	64
	Solaris Operating Environment Security	64

SNMP 64

## **6. Maintenance 65**

Powering Off and On the System 65

    Powering Off the System 65

    ▼ To Power Off the System 66

    ▼ To Power On the System 68

Keyswitch Positions 69

    ▼ To Power On a Domain 70

Shutting Down Domains 70

    ▼ To Shut Down a Domain 70

Assigning and Unassigning Boards 71

    ▼ To Assign a Board to a Domain 72

    ▼ To Unassign a Board From a Domain 74

Upgrading the Firmware 75

Saving and Restoring Configurations 76

    Using `dumpconfig` 76

    Using `restoreconfig` 76

## **7. System Controller Failover 77**

How SC Failover Works 77

    What Triggers an Automatic Failover 78

    What Happens During a Failover 78

SC Failover Prerequisites 80

Conditions That Affect Your SC Failover Configuration 81

How to Manage SC Failover 81

    ▼ To Disable SC Failover 82

    ▼ To Enable SC Failover 82

    ▼ To Perform a Manual SC Failover 82

- ▼ To Obtain Failover Status Information 83
- How to Recover After an SC Failover 84
- 8. Testing System Boards 85**
  - Testing a CPU/Memory Board 85
    - Requirements 85
  - ▼ To Test a CPU/Memory Board 86
  - Testing an I/O Assembly 86
  - ▼ To Test an I/O Assembly 87
- 9. Removing and Replacing Boards 91**
  - CPU/Memory Boards and I/O Assemblies 92
    - ▼ To Remove and Replace a System Board 92
    - ▼ To Unassign a Board From a Domain or Disable a System Board 95
    - ▼ To Hot-Swap a CPU/Memory Board 95
    - ▼ To Hot-Swap an I/O Assembly 96
  - CompactPCI and PCI Cards 98
    - ▼ To Remove and Replace a PCI Card 98
    - ▼ To Remove and Replace a CompactPCI Card 99
  - Repeater Board 99
    - ▼ To Remove and Replace a Repeater Board 99
  - System Controller Board 101
    - ▼ To Remove and Replace the System Controller Board in a Single SC Configuration 101
    - ▼ To Remove and Replace a System Controller Board in a Redundant SC Configuration 103
  - ID Board and Centerplane 104
    - ▼ To Remove and Replace ID Board and Centerplane 104
- 10. Troubleshooting 107**

System Faults	107
Displaying Diagnostic Information	107
Displaying System Configuration Information	108
Assisting Sun Service Personnel	108
▼ To Determine the Cause of Your Failure	108
Domain Not Responding	109
Hung Domain	109
▼ To Recover a Hard Hung or Paused Domain	110
Board and Component Failures	112
CPU/Memory Board Failure	112
I/O Assembly Failure	113
System Controller Board Failure	113
Collecting Platform and Domain Status Information	114
Repeater Board Failure	117
Power Supply Failure	121
Fan Tray Failure	121
FrameManager Failure	121
Disabling Components	122
<b>A. Mapping Device Path Names</b>	<b>125</b>
Device Mapping	125
CPU/Memory Mapping	125
I/O Assembly Mapping	127
<b>B. Setting Up an http or ftp Server</b>	<b>139</b>
Setting Up the Firmware Server	139
▼ To Set Up an http Server	140
▼ To Set Up an ftp Server	142



**Glossary 145**

**Index 147**



# Figures

---

FIGURE 1-1	Sun Fire 6800 System in Single-Partition Mode	5
FIGURE 1-2	Sun Fire 6800 System in Dual-Partition Mode	5
FIGURE 1-3	Sun Fire 4810/4800 Systems in Single-Partition Mode	6
FIGURE 1-4	Sun Fire 4810/4800 Systems in Dual-Partition Mode	6
FIGURE 1-5	Sun Fire 3800 System in Single-Partition Mode	7
FIGURE 1-6	Sun Fire 3800 System in Dual-Partition Mode	7
FIGURE 2-1	Navigating Between the Platform Shell and the Domain Shell	33
FIGURE 2-2	Navigating Between the Domain Shell, the OpenBoot PROM, and the Solaris Operating Environment	34
FIGURE 2-3	Navigating Between the OpenBoot PROM and the Domain Shell	35
FIGURE 3-1	Flowchart of Power On and System Setup Steps	42
FIGURE 5-1	System With Domain Separation	63
FIGURE 10-1	Resetting the System Controller	114
FIGURE A-1	Sun Fire 6800 System PCI Physical Slot Designations for IB6 Through IB9	131
FIGURE A-2	Sun Fire 4810/4800 Systems PCI Physical Slot Designations for IB6 and IB8	132
FIGURE A-3	Sun Fire 3800 System 6-Slot CompactPCI Physical Slot Designations	135
FIGURE A-4	Sun Fire 4810/4800 Systems 4-Slot CompactPCI Physical Slot Designations	137
FIGURE A-5	Sun Fire 6800 System 4-Slot CompactPCI Physical Slot Designations for IB6 through IB9	138



# Tables

---

TABLE 1-1	Repeater Boards in the Sun Fire 6800/4810/4800/3800 Systems	3
TABLE 1-2	Maximum Number of Partitions and Domains Per System	4
TABLE 1-3	Board Name Descriptions	4
TABLE 1-4	Functions of System Controller Boards	8
TABLE 1-5	Serial Port and Ethernet Port Features on the System Controller Board	9
TABLE 1-6	Maximum Number of CPU/Memory Boards in Each System	14
TABLE 1-7	Maximum Number of I/O Assemblies and I/O Slots per I/O Assembly	15
TABLE 1-8	Configuring for I/O Redundancy	15
TABLE 1-9	Minimum and Maximum Number of Fan Trays	16
TABLE 1-10	Minimum and Redundant Power Supply Requirements	17
TABLE 1-11	Sun Fire 6800 System Components in Each Power Grid	18
TABLE 1-12	Repeater Board Assignments by Domains in the Sun Fire 6800 System	18
TABLE 1-13	Repeater Board Assignments by Domains in the Sun Fire 4810/4800/3800 Systems	19
TABLE 1-14	Sun Fire 6800 Domain and Repeater Board Configurations for Single- and Dual-Partitioned Systems	19
TABLE 1-15	Sun Fire 4810/4800/3800 Domain and Repeater Board Configurations for Single- and Dual-Partitioned Systems	19
TABLE 1-16	Results of <code>setkeyswitch</code> Settings During a Power Failure	23
TABLE 3-1	Services That Should Be Set Up Before System Power On	43
TABLE 3-2	Steps in Setting up Domains Including the <code>dumpconfig</code> Command	49
TABLE 4-1	Guidelines for Creating Three Domains on the Sun Fire 6800 System	57

TABLE 6-1	Displaying the Status of All Domains With the <code>showplatform -p status</code> Command	66
TABLE 6-2	Overview of Steps to Assign a Board To a Domain	71
TABLE 6-3	Overview of Steps to Unassign a Board From a Domain	71
TABLE 9-1	Repeater Boards and Domains	99
TABLE 10-1	OpenBoot PROM <code>error-reset-recovery</code> Configuration Variable Settings	111
TABLE 10-2	Solaris Operating Environment and System Controller Software Commands for Collecting Status Information	115
TABLE 10-3	Repeater Board Failure	117
TABLE 10-4	Blacklisting Component Names	122
TABLE A-1	CPU and Memory Agent ID Assignment	126
TABLE A-2	I/O Assembly Type and Number of Slots per I/O Assembly by System Type	127
TABLE A-3	Number and Name of I/O Assemblies per System	127
TABLE A-4	I/O Controller Agent ID Assignments	128
TABLE A-5	8-Slot PCI I/O Assembly Device Map for the Sun Fire 6800/4810/4810 Systems	129
TABLE A-6	Mapping Device Path to I/O Assembly Slot Numbers for Sun Fire 3800 Systems	134
TABLE A-7	Mapping Device Path to I/O Assembly Slot Numbers for Sun Fire 6800/4810/4800 Systems	135

# Code Samples

---

CODE EXAMPLE 2-1	Obtaining the Platform Shell With <code>telnet</code>	29
CODE EXAMPLE 2-2	Obtaining a Domain Shell With <code>telnet</code>	31
CODE EXAMPLE 2-3	Obtaining a Domain Shell From the Domain Console	32
CODE EXAMPLE 2-4	Obtaining a Domain Shell From the Domain Console	32
CODE EXAMPLE 2-5	Obtaining a Domain Shell From the Domain Console	36
CODE EXAMPLE 2-6	Ending a <code>tip</code> Session	39
CODE EXAMPLE 3-1	<code>password</code> Command Example For a Domain With No Password Set	49
CODE EXAMPLE 3-2	Sample Boot Error Message When the <code>auto-boot?</code> Parameter Is Set To <code>true</code>	51
CODE EXAMPLE 6-1	<code>showboards -a</code> Example Before Assigning a Board to a Domain	72
CODE EXAMPLE 7-1	Messages Displayed During an Automatic Failover	78
CODE EXAMPLE 9-1	Confirming Board ID Information	105
CODE EXAMPLE 9-2	ID Information To Enter Manually	105
CODE EXAMPLE B-1	Locating the <code>Port 80</code> Value in <code>httpd.conf</code>	140
CODE EXAMPLE B-2	Locating the <code>ServerAdmin</code> Value in <code>httpd.conf</code>	141
CODE EXAMPLE B-3	Locating the <code>ServerName</code> Value in <code>httpd.conf</code>	141
CODE EXAMPLE B-4	Starting Apache	141





# Preface

---

This book provides an overview of the system and presents a step-by-step description of common administration procedures. It explains how to configure and manage the platform and domains. It also explains how to remove and replace components and perform firmware upgrades. It contains information about security, troubleshooting, and a glossary of technical terms.

---

## How This Book Is Organized

Chapter 1 describes domains and the system controller. It provides an overview of partitions and domains, redundant system components, and minimum system configurations. This chapter also provides an overview of reliability, serviceability, and availability.

Chapter 2 explains how to navigate between the platform and domain shells, between the Solaris™ operating environment and the domain shell, or between the OpenBoot™ PROM and the domain shell. This chapter also explains how to terminate a system controller session.

Chapter 3 explains how to power on and set up the system for the first time.

Chapter 4 explains how to create and start multiple domains.

Chapter 5 presents information on security.

Chapter 6 explains how to power on and power off the system. It also explains how to update firmware.

Chapter 7 describes how system controller failover works.

Chapter 8 describes how to test boards.

Chapter 9 describes the software steps necessary to remove and install a CPU/Memory board, I/O assembly, Compact PCI card, PCI card, Repeater board, System Controller board, and ID board/centerplane.

Chapter 10 provides troubleshooting information about LEDs, system faults, the system controller loghost, and procedures such as displaying diagnostic information, displaying system configuration information, recovering from a hung domain, disabling components (blacklisting), and mapping device path names to physical system devices.

Appendix A describes how to map device path names to physical system devices.

Appendix B describes how to set up an HTTP and FTP server.

---

## Using UNIX Commands

This book assumes you are experienced with the UNIX<sup>®</sup> operating environment. If you are not experienced with the UNIX operating environment, see one or more of the following for this information:

- Documentation for the Solaris operating environment, available on `docs.sun.com` (see “Accessing Sun Documentation Online” on page xviii)
- *Sun Hardware Platform Guide*, which is available in both hard copy and online with your operating system release, describes Solaris operating environment information specific to the Sun Fire 6800/4810/4800/3800 systems.
- *Release Notes Supplement for Sun Hardware* describes late breaking information about the Solaris operating environment.
- Other software documentation that you received with your system

---

# Typographic Conventions

Typeface	Meaning	Examples
AaBbCc123	The names of commands, files, and directories; on-screen computer output	Edit your <code>.login</code> file. Use <code>ls -a</code> to list all files.
<b>AaBbCc123</b>	What you type, when contrasted with on-screen computer output	% <b>su</b> Password:
<i>AaBbCc123</i>	Book titles, new words or terms, words to be emphasized	Read Chapter 6 in the <i>User's Guide</i> . These are called <i>class</i> options. You <i>must</i> be superuser to do this.
	Command-line variable; replace with a real name or value	To delete a file, type <code>rm filename</code> .

---

---

# Shell Prompts

Shell	Prompt
C shell	<i>machine_name</i> %
C shell superuser	<i>machine_name</i> #
Bourne shell and Korn shell	\$
Bourne shell and Korn shell superuser	#
Platform shell	<i>schostrname</i> : SC>
Platform console	<i>schostrname</i> : SC>
Domain shell	<i>schostrname</i> : A> or B>, C>, D>
Domain console	ok, login:, <i>machine_name</i> %, or <i>machine_name</i> #

---

---

## Related Documentation

Type of Book	Title	Part Number
Overview	<i>Sun Fire 6800/4810/4800/3800 Systems Overview Manual</i>	805-7362
Service	<i>Sun Fire 6800/4810/4800/3800 Systems Service Manual</i>	805-7363
Service	<i>Sun Fire 4810/4800/3800 System Cabinet Mounting Guide</i>	806-6781
System Controller	<i>Sun Fire 6800/4810/4800/3800 System Controller Command Reference Manual</i>	816-2971
Release Notes	<i>Sun Fire 6800/4810/4800/3800 Systems Software Release Notes</i>	816-2972
Solaris operating environment	<i>Sun Hardware Platform Guide</i>	Varies with release.
Solaris operating environment	<i>Release Notes Supplement for Sun Hardware</i>	Varies with release.

---

## Accessing Sun Documentation Online

A broad selection of Sun system documentation is located at:

<http://www.sun.com/products-n-solutions/hardware/docs>

A complete set of Solaris documentation and many other titles are located at:

<http://docs.sun.com>

---

# Sun Welcomes Your Comments

Sun is interested in improving its documentation and welcomes your comments and suggestions. You can email your comments to Sun at:

`docfeedback@sun.com`

Please include the part number (816-2970-10) of your document in the subject line of your email.



# Introduction

---

This chapter presents an introduction of features for the family of mid-range servers—the Sun Fire™ 6800/4810/4800/3800 systems. This chapter describes:

- “Domains” on page 2
- “System Components” on page 3
- “Partitions” on page 3
- “System Controller” on page 8
- “Redundant Components and Minimum Configurations” on page 13
- “Reliability, Availability, and Serviceability (RAS)” on page 20
- “Sun Management Center Software for the Sun Fire 6800/4810/4800/3800 Systems Software” on page 25
- “FrameManager” on page 25

The term *platform*, as used in this book, refers to the collection of resources such as power supplies, the centerplane, and fans that are *not* for the exclusive use of a domain.

A partition is a group of Repeater boards that are used together to provide communication between CPU/Memory boards and I/O assemblies in the same domain.

A domain runs its own instance of the Solaris operating environment and is independent of other domains. Each domain has its own CPUs, memory, and I/O assemblies. Hardware resources including fans and power supplies are shared among domains, as necessary for proper operation.

The system controller is an embedded system on a board that connects into the centerplane of these mid-range systems. You access the system controller using either serial or Ethernet connections. It is the focal point for platform and domain configuration and management and is used to connect to the domain consoles.

The system controller configures and monitors the other hardware in the system and provides a command line interface that enables you to perform tasks needed to configure the platform and each domain, plus many other functions. The system controller also provides monitoring and configuration capability with SNMP for use

with the Sun Management Center software. For more information on the system controller hardware and software, see “System Controller” on page 8 and “System Controller Software” on page 10.

---

## Domains

With this family of mid-range systems, you can group system boards (CPU/Memory boards and I/O assemblies) into domains. Each domain can host its own instance of the Solaris operating environment and is independent of other domains.

Domains include the following features:

- Each domain is able to run the Solaris operating environment.
- Domains do not interact with each other.
- Each domain has its own peripheral and network connections.
- Each domain is assigned its own unique host ID and hostname.

All systems are configured at the factory with one domain.

You create domains using either the system controller command line interface or the Sun Management Center software for the Sun Fire 6800/4810/4800/3800 systems. How to create domains using the system controller software is described in “Creating and Starting Domains” on page 53. For instructions on how to create domains using the Sun Management Center software for the Sun Fire 6800/4810/4800/3800 systems, refer to the *Sun Management Center 3.0 Supplement for Sun Fire 6800, 4810, 4800, and 3800 Systems*.

The largest domain configuration is comprised of all CPU/Memory boards and I/O assemblies in the system. The smallest domain configuration is comprised of one CPU/Memory board and one I/O assembly.

An active domain must meet these requirements:

- Minimum of one CPU/Memory board with memory
- Minimum of one I/O assembly with one I/O card installed
- Required number of Repeater boards (not assigned to a domain)
- Minimum of one system controller for the system to work (system controllers are not assigned to a domain)

In addition, sufficient power and cooling is required. The power supplies and fan trays are not assigned to a domain.

If you run more than one domain in a partition, then the domains are not completely isolated. A failed Repeater board could affect all domains within the partition. For more information, see “Repeater Boards” on page 18.



---

# System Components

The system boards in each system consist of CPU/Memory boards and I/O assemblies. The Sun Fire 6800/4810/4800 systems have Repeater boards (TABLE 1-1), which provide communication between CPU/Memory boards and I/O assemblies.

**TABLE 1-1** Repeater Boards in the Sun Fire 6800/4810/4800/3800 Systems

System	Number of Repeater Boards
Sun Fire 6800 system	4 Repeater boards—RP0, RP1, RP2, RP3
Sun Fire 4810 system	2 Repeater boards—RP0, RP2
Sun Fire 4800 system	2 Repeater boards—RP0, RP2
Sun Fire 3800 system	Equivalent of two Repeater boards (RP0 and RP2) are built into an active centerplane.

For a system overview, including descriptions of the boards in the system, refer to the *Sun Fire 6800/4810/4800/3800 Systems Overview Manual*.

---

# Partitions

A partition is a group of Repeater boards that are used together to provide communication between CPU/Memory boards and I/O assemblies. Depending on the system configuration, each partition can be used by either one or two domains.

These systems can be configured to have one or two partitions. Partitioning is done at the Repeater board level. A single partition forms one large partition using all of the Repeater boards. In dual-partition mode, two smaller partitions using fewer Repeater boards are created each using one-half of the total number of Repeater boards in the system. For more information on Repeater boards, see “Repeater Boards” on page 18.

TABLE 1-2 lists the maximum number of partitions and domains each system can have.

**TABLE 1-2** Maximum Number of Partitions and Domains Per System

	Sun Fire 6800 System	Sun Fire 4810/4800/3800 Systems
Number of Partitions <sup>1</sup>	1 or 2	1 or 2
Number of Active Domains in Dual-Partition Mode	Up to 4 (A, B, C, D)	Up to 2 (A, C)
Number of Active Domains in Single-Partition Mode	Up to 2 (A, B)	Up to 2 (A, B)

<sup>1</sup> The default is one partition.

FIGURE 1-1 through FIGURE 1-6 show partitions and domains for the Sun Fire 6800/4810/4800/3800 systems. The Sun Fire 3800 system has the equivalent of two Repeater boards, RP0 and RP2, as part of the active centerplane. The Repeater boards are *not* installed in the Sun Fire 3800 system as they are for the other systems. Instead, the Repeater boards in the Sun Fire 3800 system are integrated into the centerplane.

All of these systems are very flexible, and you can assign CPU/Memory boards and I/O assemblies to any domain or partition. The configurations shown in the following illustrations are examples only and your configuration may differ.

TABLE 1-3 describes the board names used in FIGURE 1-1 through FIGURE 1-6.

**TABLE 1-3** Board Name Descriptions

Board Name	Description
SB0 - SB5	CPU/Memory boards
IB6 - IB9	I/O assemblies
RP0 - RP3	Repeater boards

FIGURE 1-1 shows the Sun Fire 6800 system in single-partition mode. This system has four Repeater boards that operate in pairs (RP0, RP2) and (RP1, RP3), six CPU/Memory boards (SB0 - SB5), and four I/O assemblies (IB6 - IB9).

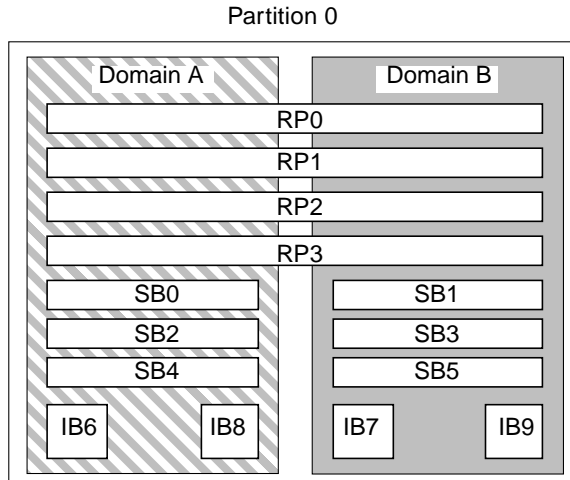

FIGURE 1-1 Sun Fire 6800 System in Single-Partition Mode

FIGURE 1-2 shows the Sun Fire 6800 system in dual-partition mode. The same boards and assemblies are shown as in FIGURE 1-1.

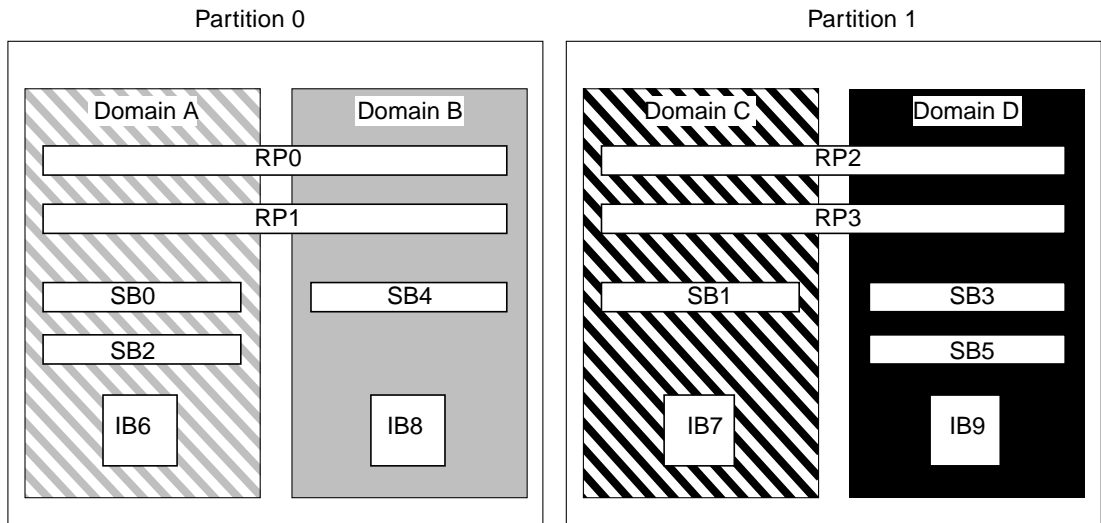
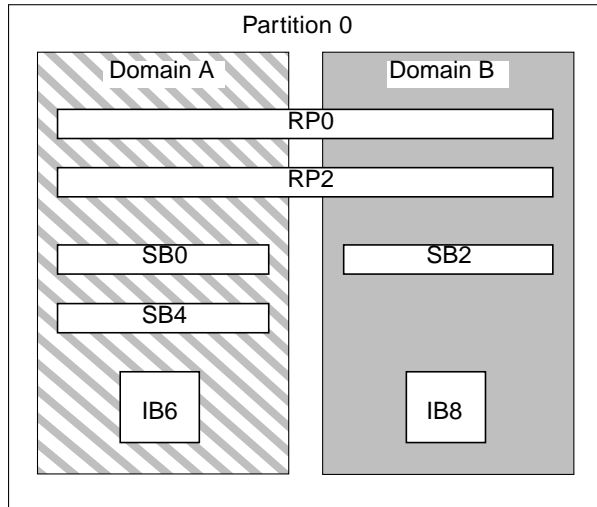

FIGURE 1-2 Sun Fire 6800 System in Dual-Partition Mode

FIGURE 1-3 shows the Sun Fire 4810/4800 systems in single-partition mode. These systems have two Repeater boards (RP0 and RP2) that operate separately (not in pairs as in the Sun Fire 6800 system), three CPU/Memory boards (SB0, SB2, and SB4), and two I/O assemblies (IB6 and IB8).



**FIGURE 1-3** Sun Fire 4810/4800 Systems in Single-Partition Mode

FIGURE 1-4 shows the Sun Fire 4810/4800 systems in dual-partition mode. The same boards and assemblies are shown as in FIGURE 1-3.

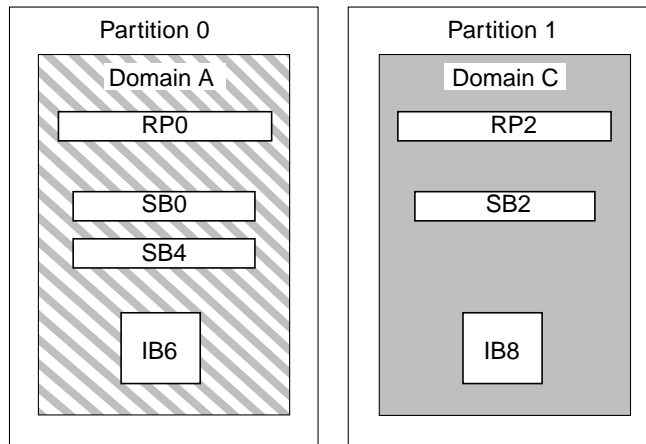

**FIGURE 1-4** Sun Fire 4810/4800 Systems in Dual-Partition Mode

FIGURE 1-5 shows the Sun Fire 3800 system in single-partition mode. This system has the equivalent of two Repeater boards (RP0 and RP2) integrated into the active centerplane, two CPU/Memory boards (SB0 and SB2), and two I/O assemblies (IB6 and IB8).

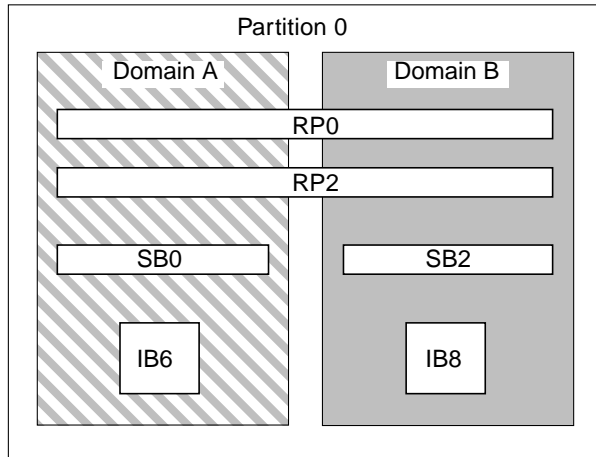

**FIGURE 1-5** Sun Fire 3800 System in Single-Partition Mode

FIGURE 1-6 shows the Sun Fire 3800 system in dual-partition mode. The same boards and assemblies are shown as in FIGURE 1-5. This system also has the equivalent of two Repeater boards, RP0 and RP2, integrated into the active centerplane.

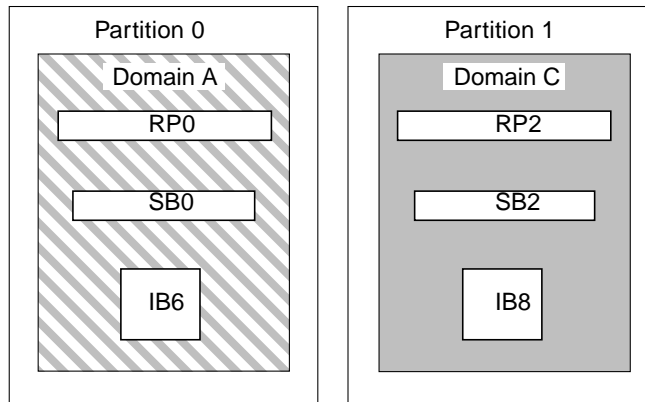

**FIGURE 1-6** Sun Fire 3800 System in Dual-Partition Mode

---

# System Controller

The system controller is an embedded system on a board that connects into the centerplane of these mid-range systems. It is the focal point for platform and domain configuration and management and is used to connect to the domain consoles.

System controller functions include:

- Managing platform and domain resources
- Monitoring the platform and domains
- Configuring the domains and the platform
- Providing access to the domain consoles
- Providing the date and time to the Solaris operating environment
- Providing the reference clock signal used throughout the system
- Providing console security
- Performing domain initialization
- Providing a mechanism for upgrading firmware on the boards installed in the system
- Providing an external management interface using SNMP

The system can support up to two System Controller boards (TABLE 1-4) that function as a main and spare system controller. This redundant configuration of system controllers supports the SC failover mechanism, which triggers the automatic switchover of the main SC to the spare if the main SC fails. For details on SC failover, see Chapter 7.

**TABLE 1-4** Functions of System Controller Boards

System Controller	Function
Main	Manages all system resources. Configure your system to connect to the main System Controller board.
Spare	If the main system controller fails and a failover occurs, the spare assumes all system controller tasks formerly handled by the main system controller. The spare system controller functions as a hot standby, and is used only as a backup for the main system controller.

# Serial and Ethernet Ports

There are two methods to connect to the system controller console:

- Serial port—Use the serial port to connect directly to an ASCII terminal or to a network terminal server (NTS).
- Ethernet port—Use the Ethernet port to connect to the network.

For performance reasons, it is suggested that the system controllers be configured on a private network. For details, refer to the article, *Sun Fire Midframe Server Best Practices for Administration*, at

<http://www.sun.com/blueprints>

TABLE 1-5 describes the features of the serial port and the Ethernet port on the System Controller board. The Ethernet port provides the fastest connection.

**TABLE 1-5** Serial Port and Ethernet Port Features on the System Controller Board

Capability	Serial Port	Ethernet Port
Number of connections	One	Multiple
Connection speed	9.6 Kbps	10/100 Mbps
System logs	Remain the system controller message queue	Remain in the system controller message queue and are written to the configured <code>syslog</code> host(s). See TABLE 3-1 for how to set up the loghosts for the platform shell and each domain shell. Setting up loghosts makes sure that error messages are captured when a system failure occurs.
SNMP	Not supported	Supported
Firmware upgrades	No	Yes (using the <code>flashupdate</code> command)
Security	Secure physical location plus secure terminal server	Password-protected access only

## System Controller Logical Connection Limits

The system controller supports one logical connection on the serial port and multiple logical connections with `telnet` on the Ethernet port. Connections can be set up for either the platform or one of the domains. Each domain can have *only one* logical connection at a time.

# System Controller Software

The sections that follow provide information on the system controller software, including:

- “Platform Administration” on page 10
- “System Controller Tasks Completed at System Power-On” on page 11
- “Domain Administration” on page 11
- “Domain Keyswitch” on page 12
- “Environmental Monitoring” on page 12
- “Console Messages” on page 13

## Platform Administration

The platform administration function manages resources and services that are shared among the domains. With this function, you can determine how resources and services are configured and shared.

Platform administration functions include:

- Monitoring and controlling power to the components
- Logically grouping hardware to create domains
- Configuring the system controller’s network, loghost, and SNMP settings
- Determining which domains may be used
- Determining how many domains can be used (Sun Fire 6800 system only)
- Configuring access control for CPU/Memory boards and I/O assemblies

### *Platform Shell*

The platform shell is the operating environment for the platform administrator. Only commands that pertain to platform administration are available. To connect to the platform, see “To Obtain the Platform Shell Using telnet” on page 28 or “Obtaining the Platform Shell” on page 28.

### *Platform Console*

The platform console is the system controller serial port, where the system controller boot messages and platform log messages are printed.

---

**Note** – The Solaris operating environment messages are displayed on the domain console.

---



## System Controller Tasks Completed at System Power-On

When you power on the system, the system controller boots the system controller real time operating system and starts the system controller application.

If there was an interruption of power, additional tasks completed at system power-on include:

- If a domain is active, the system controller turns on components needed to support the active domain (power supplies, fan trays, and Repeater boards) as well as the boards in the domain (CPU/Memory boards and I/O assemblies).
- If no domains are active, only the system controller is powered on.
- The system controller reboots any domains that were active when the system lost power.

## Domain Administration

The domain administration function manages resources and services for a specific domain.

Domain administration functions include:

- Configuring the domain settings
- Controlling the virtual keyswitch
- Recovering errors

For platform administration functions, see “Platform Administration” on page 10.

### *Domain Shell*

The domain shell is the operating environment for the domain administrator and is where domain tasks can be performed. There are four domain shells (A – D).

To connect to a domain, see “Obtaining a Domain Shell or Console” on page 30.

## *Domain Console*

If the domain is active (Solaris operating environment, the OpenBoot PROM, or POST is running in the domain), you can access the domain console. When you connect to the domain console, you will be at one of the following modes of operation:

- Solaris operating environment console
- OpenBoot PROM
- Domain will be running POST and you can view the POST output.

## *Maximum Number of Domains*

The domains that are available vary with the system type and configuration. For more information on the maximum number of domains you can have, see “Partitions” on page 3.

## *Domain Keyswitch*

Each domain has a virtual keyswitch. There are five keyswitch positions that you can set: off (default), standby, on, diag, and secure. There are several other keyswitch positions, which are transitional positions.

For information on keyswitch settings, see “Keyswitch Positions” on page 69. For a description and syntax of the `setkeyswitch` command, refer to the *Sun Fire 6800/4810/4800/3800 System Controller Command Reference Manual*.

## **Environmental Monitoring**

There are sensors throughout the system that monitor temperature, voltage, current, and fan speed. The system controller periodically reads the values from each of these sensors. This information is maintained for display using the console commands and provided with SNMP.

When a sensor is generating values that are outside of the normal limits, the system controller takes appropriate action. This includes shutting down components in the system to prevent damage. Domains may be automatically shut down as a result. If domains are shut down, be aware that an abrupt hardware shutdown occurs (it is not a graceful shutdown of the Solaris operating environment).

## Console Messages

The console messages generated by the system controller for the platform and for each domain are printed on the appropriate console. The messages are stored in a buffer on the system controller and can be logged to a syslog host. It is important to note that these messages are *not* the Solaris operating environment console messages.

To enhance accountability and for long-term storage, the messages should be sent to syslog as syslog host.

The system controller *does not have* permanent storage for console messages. Both the platform and each domain have a small buffer that maintains some history. However, this information is lost when the system is rebooted or the system controller loses power.

---

## Redundant Components and Minimum Configurations

The Sun Fire 6800/4810/4800/3800 systems are designed to increase availability by having redundant components. The sections that follow discuss the redundant hardware that can be installed:

- Redundant System Controller Boards
- “CPU/Memory Boards” on page 14
- “I/O Assemblies” on page 15
- “Redundant Cooling” on page 16
- “Redundant Power” on page 17
- “Repeater Boards” on page 18
- “Redundant System Clocks” on page 19

For troubleshooting tips to perform if a board or component fails, see “Board and Component Failures” on page 112.

## Redundant System Controller Boards

Sun Fire 6800/4810/4800/3800 systems support two System Controller boards, which serve as the main and spare system controllers. The main system controller performs all system tasks and manages system resources, while the spare system controller is available to assume the function of the main system controller if the main fails.

The SC failover software monitors the main and spare system controllers for conditions that cause the main system controller to fail. If such failure conditions are detected, the failover software causes a switchover of the main system controller to the spare. For details on system controller failover, see Chapter 7.

## CPU/Memory Boards

All systems support multiple CPU/Memory boards. Each domain *must* contain at least one CPU/Memory board.

The maximum number of CPUs you can have on a CPU/Memory board is four. CPU/Memory boards are configured with either two CPUs or four CPUs. TABLE 1-6 lists the maximum number of CPU/Memory boards for each system.

**TABLE 1-6** Maximum Number of CPU/Memory Boards in Each System

System	Maximum Number of CPU/Memory Boards	Maximum Number of CPUs
Sun Fire 6800 system	6	24
Sun Fire 4810 system	3	12
Sun Fire 4800 system	3	12
Sun Fire 3800 system	2	8

Each CPU/Memory board has eight physical banks of memory. The CPU provides memory management unit (MMU) support for two banks of memory. Each bank of memory has four slots. The memory modules (DIMMs) must be populated in groups of four to fill a bank. The minimum amount of memory needed to operate a domain is one bank (four DIMMs).

A CPU can be installed and used without any memory in one of its banks. A memory bank *cannot* be used unless the corresponding CPU is installed and functioning. If a CPU is disabled, it is not functioning.

## Redundant CPUs and Memory

A failed CPU or faulty memory will be isolated from the domain by the power-on self-test (POST).

You can operate a domain with as little as one CPU and one memory bank (four memory modules).

# I/O Assemblies

All systems support multiple I/O assemblies. For the types of I/O assemblies supported by each system and other technical information, refer to the *Sun Fire 6800/4810/4800/3800 Systems Overview Manual*. TABLE 1-7 lists the maximum number of I/O assemblies for each system.

**TABLE 1-7** Maximum Number of I/O Assemblies and I/O Slots per I/O Assembly

System	Maximum Number of I/O Assemblies	Number of CompactPCI or PCI I/O Slots
Sun Fire 6800 system	4	<ul style="list-style-type: none"><li>• 8 slots—6 slots for full-length PCI cards and 2 short slots for short PCI cards</li><li>• 4 slots for CompactPCI cards</li></ul>
Sun Fire 4810 system	2	<ul style="list-style-type: none"><li>• 8 slots—6 slots for full-length PCI cards and 2 short slots for short PCI cards</li><li>• 4 slots for CompactPCI cards</li></ul>
Sun Fire 4800 system	2	<ul style="list-style-type: none"><li>• 8 slots—6 slots for full-length PCI cards and 2 short slots for short PCI cards</li><li>• 4 slots for CompactPCI cards</li></ul>
Sun Fire 3800 system	2	6 slots for CompactPCI cards

## Redundant I/O

There are two possible ways to configure redundant I/O (TABLE 1-8).

**TABLE 1-8** Configuring for I/O Redundancy

Ways to Configure For I/O Redundancy	Description
Redundancy across I/O assemblies	You must have two I/O assemblies in a domain with duplicate cards in each I/O assembly that are connected to the same disk or network subsystem for path redundancy.
Redundancy within I/O assemblies	You must have duplicate cards in the I/O assembly that are connected to the same disk or network subsystem for path redundancy. This does not protect against the failure of the I/O assembly itself.

The network redundancy features use part of the Solaris operating environment, known as IP multipathing. For information on IP multipathing (IPMP), refer to the Solaris documentation supplied with the Solaris 8 or 9 operating environment release.

The Sun StorEdge™ Traffic Manager provides multipath disk configuration management, failover support, I/O load balancing, and single instance multipath support. For details, refer to the Sun StorEdge documentation available on the Sun Network Solutions website:

<http://www.sun.com/storage/san>

## Redundant Cooling

All systems have redundant cooling when the maximum number of fan trays are installed. If one fan tray fails, the remaining fan trays automatically increase speed, thereby enabling the system to continue to operate.



---

**Caution** – With the minimum number of fan trays installed, you *do not* have redundant cooling.

---

With redundant cooling, you do not need to suspend system operation to replace a failed fan tray. You can hot-swap a fan tray while the system is running, with no interruption to the system.

TABLE 1-9 shows the minimum and maximum number of fan trays required to cool each system. For location information, such as the fan tray number, refer to the labels on the system and to the *Sun Fire 6800/4810/4800/3800 Systems Service Manual*.

**TABLE 1-9** Minimum and Maximum Number of Fan Trays

System	Minimum Number of Fan Trays	Maximum Number of Fan Trays
Sun Fire 6800 system	3	4
Sun Fire 4810 system	2	3
Sun Fire 4800 system	2	3
Sun Fire 3800 system	3	4

Each system has comprehensive temperature monitoring to ensure that there is no over-temperature stressing of components in the event of a cooling failure or high ambient temperature. If there is a cooling failure, the speed of the remaining operational fans increases. If necessary, the system is shut down.

# Redundant Power

In order for power supplies to be redundant, you must have the required number of power supplies installed plus one additional redundant power supply for each power grid (referred to as the n+1 redundancy model). This means that two power supplies are required for the system to function properly. The third power supply is redundant. All three power supplies draw about the same current.

The power is shared in the power grid. If one power supply in the power grid fails, the remaining power supplies in the same power grid are capable of delivering the maximum power required for the power grid.

If more than one power supply in a power grid fails, there will be insufficient power to support a full load. For troubleshooting tips to perform when a power supply fails, see “Power Supply Failure” on page 121.

The System Controller boards and the ID board obtain power from any power supply in the system. Fan trays obtain power from either power grid.

TABLE 1-10 describes the minimum and redundant power supply requirements.

**TABLE 1-10** Minimum and Redundant Power Supply Requirements

System	Number of Power Grids per System	Minimum Number of Power Supplies In Each Power Grid	Total Number of Supplies In Each Power Grid (Including Redundant Power Supplies)
Sun Fire 6800 system	2	2 (grid 0)	3
Sun Fire 6800 system		2 (grid 1)	3
Sun Fire 4810 system	1	2 (grid 0)	3
Sun Fire 4800 system	1	2 (grid 0)	3
Sun Fire 3800 system	1	2 (grid 0)	3

Each power grid has power supplies assigned to the power grid. Power supplies ps0, ps1, and ps2 are assigned to power grid 0. Power supplies ps3, ps4, and ps5 are assigned to power grid 1. If one power grid, such as power grid 0 fails, the remaining power grid is still operational.

TABLE 1-11 lists the components in the Sun Fire 6800 system in each power grid. If you have a Sun Fire 4810/4800/3800 system, refer to the components in grid 0, since these systems have only power grid 0.

**TABLE 1-11 Sun Fire 6800 System Components in Each Power Grid**

Components in the System	Grid 0	Grid 1
CPU/Memory boards	SB0, SB2, SB4	SB1, SB3, SB5
I/O assemblies	IB6, IB8	IB7, IB9
Power supplies	PS0, PS1, PS2	PS3, PS4, PS5
Repeater boards	RP0, RP1	RP2, RP3
Redundant Transfer Unit (RTU)	RTUR (rear)	RTRF (front)

## Repeater Boards

The Repeater board is a crossbar switch that connects multiple CPU/Memory boards and I/O assemblies. Having the required number of Repeater boards is mandatory for operation. There are Repeater boards in each mid-range system except for the Sun Fire 3800. In the Sun Fire 3800 system, the equivalent of two Repeater boards are integrated into the active centerplane. Repeater boards are not fully redundant.

For steps to perform if a Repeater board fails, see “Repeater Board Failure” on page 117. TABLE 1-12 lists the Repeater board assignments by each domain in the Sun Fire 6800 system.

**TABLE 1-12 Repeater Board Assignments by Domains in the Sun Fire 6800 System**

Partition Mode	Repeater Boards	Domains
Single partition	RP0, RP1, RP2, RP3	A, B
Dual partition	RP0, RP1	A, B
Dual partition	RP2, RP3	C, D



TABLE 1-13 lists the Repeater board assignments by each domain in the Sun Fire 4810/4800 systems.

**TABLE 1-13** Repeater Board Assignments by Domains in the Sun Fire 4810/4800/3800 Systems

Partition Mode	Repeater Boards	Domains
Single partition	RP0, RP2	A, B
Dual partition	RP0	A
Dual partition	RP2	C

TABLE 1-14 lists the configurations for single-partition mode and dual-partition mode for the Sun Fire 6800 system regarding Repeater boards and domains.

**TABLE 1-14** Sun Fire 6800 Domain and Repeater Board Configurations for Single- and Dual-Partitioned Systems

Sun Fire 6800 System in Single-Partition Mode				Sun Fire 6800 System in Dual-Partition Mode			
RP0	RP1	RP2	RP3	RP0	RP1	RP2	RP3
Domain A				Domain A		Domain C	
Domain B				Domain B		Domain D	

TABLE 1-15 lists the configurations for single-partition mode and dual-partition mode for the Sun Fire 4810/4800/3800 systems.

**TABLE 1-15** Sun Fire 4810/4800/3800 Domain and Repeater Board Configurations for Single- and Dual-Partitioned Systems

Sun Fire 4810/4800/3800 System in Single-Partition Mode		Sun Fire 4810/4800/3800 System in Dual-Partition Mode	
RP0	RP2	RP0	RP2
Domain A		Domain A	Domain C
Domain B			

## Redundant System Clocks

The System Controller board provides redundant system clocks. For more information on system clocks, see “System Controller Clock Failover” on page 21.

---

# Reliability, Availability, and Serviceability (RAS)

Reliability, availability, and serviceability (RAS) are features of these mid-range systems. The descriptions of these features are:

- *Reliability* is the probability that a system stays operational for a specified time period when operating under normal conditions. Reliability differs from availability in that reliability involves only system failure, whereas availability depends on both failure and recovery.
- *Availability*, also known as average availability, is the percentage of time that a system is available to perform its functions correctly. Availability can be measured at the system level or in the context of the availability of a service to an end client. The “system availability” is likely to impose an upper limit on the availability of any products built on top of that system.
- *Serviceability* measures the ease and effectiveness of maintenance and system repair for the product. There is no single well-defined metric, because serviceability can include both mean time to repair (MTTR) and diagnosability.

The following sections provide details on RAS. For more hardware-related information on RAS, refer to the *Sun Fire 6800/4810/4800/3800 Systems Service Manual*. For RAS features that involve the Solaris operating environment, refer to the *Sun Hardware Platform Guide*.

## Reliability

The software reliability features include:

- POST
- Disabling of Components
- Environmental Monitoring
- System Controller Clock Failover

The reliability features also improve system availability.

## POST

The power-on self-test (POST) is part of powering on a domain. A board or component that fails POST will be disabled. The domain, running the Solaris operating environment, is booted only with components that have passed POST testing.

## Disabling of Components

The system controller provides component-level status and user-controlled disabling of components, which is also referred to as *blacklisting*. However, note that the system controller does not actually maintain a blacklist file.

You can add a faulty component to a blacklist with the `disablecomponent` command. Components in the blacklist will not be configured. You can remove a component from the blacklist with the `enablecomponent` command.

The platform blacklists supersede the domain blacklists. For example, if a component is disabled in the platform, it will always be disabled in all domains.

Blacklisting from the platform applies to all domains. Blacklisting in a domain applies only to the current domain. If you disable a component in one domain and then move the component to another domain, the component is not disabled. The `showcomponent` command displays status information about the component, including whether or not it has been disabled.

To enable a component that you previously disabled, you must enable it in the domain(s) or from the platform.

For additional information on the types of components that can be blacklisted, see “Disabling Components” on page 122.

## Environmental Monitoring

The system controller monitors the system temperature, current, and voltage sensors. The fans are also monitored to make sure they are functioning. Environmental status is not provided to the Solaris operating environment—only the need for an emergency shutdown. The environmental status is provided to the Sun Management Center software with SNMP.

## System Controller Clock Failover

Each system controller provides a system clock signal to each board in the system. Each board automatically determines which clock source to use. Clock failover is the ability to change the clock source from one system controller to another system controller without affecting the active domains.

When a system controller is reset or rebooted, clock failover is temporarily disabled. When the clock source is available again, clock failover is automatically enabled.

# Availability

The software availability features include:

- System Controller Failover Recovery
- Unattended Domain Reboot
- Unattended Power Failure Recovery
- System Controller Reboot Recovery

## System Controller Failover Recovery

Systems with redundant System Controller boards support the SC failover capability. In a high-availability system controller configuration, the SC failover mechanism triggers the switchover of the main SC to the spare if the main SC fails. Within approximately five minutes or less, the spare SC becomes the main and takes over all system controller operations. For details on SC failover, see Chapter 7.

## Unattended Domain Reboot

If the system controller detects a hardware error, the domain is rebooted. This behavior is controlled by the `reboot-on-error` parameter of the `setupdomain` command. This parameter, which is set to true by default, reboots the domain when a hardware error is detected. If you set this parameter to false and the system controller detects a hardware error, the domain is paused and it must be turned off, then on again to recover. For details, see the `setupdomain` command in the *Sun Fire 6800/4810/4800/3800 System Controller Command Reference Manual*.

If the Solaris operating environment panics, the action taken depends on the type of panic, the software configuration, and the hardware configuration. After the panic, when POST runs, it disables any components that fail testing.

## Unattended Power Failure Recovery

If there is a power outage, the system controller reconfigures active domains. TABLE 1-16 describes domain actions that occur during or after a power failure when the keyswitch is:

- Active (set to on, secure, diag)
- Inactive (set to off or standby)
- Processing a keyswitch operation

**TABLE 1-16** Results of `setkeyswitch` Settings During a Power Failure

If During a Power Failure the Keyswitch Is	This Action Occurs
on, secure, diag	The domain will be powered on after a power failure.
off, standby	The domain will not be restored after a power failure.
Processing a keyswitch operation, such as off to on, standby to on, or on to off	The domain will not be restored after a power failure.

## System Controller Reboot Recovery

The system controller can be rebooted and will start up and resume management of the system. The reboot does not disturb the currently running domain(s) running the Solaris operating environment.

## Serviceability

The software serviceability features promote the efficiency and timeliness of providing routine as well as emergency service to these systems.

## LEDs

All field-replaceable units (FRUs) that are accessible from outside the system have LEDs that indicate their state. The system controller manages all the LEDs in the system, with the exception of the power supply LEDs, which are managed by the power supplies. For a discussion of LED functions, refer to the appropriate board or device chapter of the *Sun Fire 6800/4810/4800/3800 Systems Service Manual*.

## Nomenclature

The system controller, the Solaris operating environment, the power-on self-test (POST), and the OpenBoot PROM error messages use FRU name identifiers that match the physical labels in the system. The only exception is the OpenBoot PROM nomenclature used for I/O devices, which use the device path names as described in Appendix A.

## System Controller Error Logging

You can configure the system controller platform and domains to log errors by using the `syslog` protocol to an external loghost. The system controller also has an internal buffer where error messages are stored. You can display the system controller logged events, stored in the system controller message buffer, by using the `showlogs` command. There is one log for the platform and one log for each of the four domains.

## System Controller XIR support

The system controller `reset` command enables you to recover from a hard hung domain and extract a Solaris operating environment `core` file.

---

# Dynamic Reconfiguration Software

Dynamic Reconfiguration (DR), which is provided as part of the Solaris operating environment, enables you to safely add and remove CPU/Memory boards and I/O assemblies while the system is still running. DR controls the software aspects of dynamically changing the hardware used by a domain, with minimal disruption to user processes running in the domain.

You can use DR to do the following:

- Shorten the interruption of system applications while installing or removing a board
- Disable a failing device by removing it from the logical configuration, before the failure can crash the operating system
- Display the operational status of boards in a system
- Initiate self tests of a system board while the domain continues to run
- Reconfigure a system while the system continues to run
- Invoke hardware-specific functions of a board or a related attachment

The DR software uses the `cfgadm` command, which is a command line interface for configuration administration. You can perform domain management DR tasks using the system controller software. The DR agent also provides a remote interface to the Sun Management Center software on Sun Fire 6800/4810/4800/3800 systems.

For complete information on DR, refer to the *Sun Fire 6800, 4810, 4800, and 3800 Systems Dynamic Reconfiguration User Guide* and also the Solaris documentation included with the Solaris operating environment.

---

# Sun Management Center Software for the Sun Fire 6800/4810/4800/3800 Systems Software

For information on the Sun Management Center software for the Sun Fire 6800/4810/4800/3800 systems, refer to the *Sun Management Center 3.0 Supplement for Sun Fire 6800, 4810, 4800, and 3800 Systems*, which is available online.

---

## FrameManager

The FrameManager is an LCD display that is located in the top right corner of the Sun Fire system cabinet. For a description of its functions, refer to the “FrameManager” chapter of the *Sun Fire 6800/4810/4800/3800 Systems Service Manual*.





# System Controller Navigation Procedures

---

This chapter explains step-by-step procedures with illustrations describing how to:

- Connect to the platform and the domains
- Navigate between the domain shell and the domain console
- Terminate a system controller session

Topics covered in this chapter include:

- “Connection to the System Controller” on page 28
  - “Obtaining the Platform Shell” on page 28
  - “Obtaining a Domain Shell or Console” on page 30
- “System Controller Navigation” on page 32
  - “To Enter the Domain Console From the Domain Shell If the Domain Is Inactive” on page 35
  - “To Enter the Domain Shell From the Domain Console” on page 36
  - “To Get Back to the Domain Console From the Domain Shell” on page 36
  - “To Enter a Domain From the Platform Shell” on page 37
- “Terminating Sessions” on page 37
  - “To Terminate an Ethernet Connection With telnet” on page 37
  - “To Terminate a Serial Connection With tip” on page 38

---

# Connection to the System Controller

This section describes how to obtain the following:

- The platform shell
- A domain shell or console

There are two types of connections: telnet and serial. If you are using a telnet connection, configure the system controller network settings before using telnet. You can access the system controller main menu using either the telnet or serial connections.

From the main menu, you can select either the platform shell or one of the domain consoles.

- If you select the platform, you always obtain a shell.
- If you select a domain, you obtain the:
  - Domain console (if the domain is active)
  - Domain shell (if the domain is inactive)

You can also bypass the system controller main menu by making a telnet connection to a specific port.

## Obtaining the Platform Shell

This section describes how to obtain the platform shell.

### ▼ To Obtain the Platform Shell Using `telnet`

Before you use telnet, be sure to configure the network settings for the system controllers.

1. **Obtain the system controller main menu by typing** `telnet schostname` (CODE EXAMPLE 2-1).

where:

*schostname* is the system controller host name.

The system controller main menu is displayed. CODE EXAMPLE 2-1 shows how to enter the platform shell.

**CODE EXAMPLE 2-1** Obtaining the Platform Shell With telnet

```
% telnet schostname
Trying xxx.xxx.xxx.xxx
Connected to schostname.
Escape character is '^]'.

System Controller `schostname':

    Type 0 for Platform Shell

    Type 1 for domain A
    Type 2 for domain B
    Type 3 for domain C
    Type 4 for domain D

Input: 0

Connected to Platform Shell

schostname:SC>
```

---

**Note** – *schostname* is the system controller host name.

---

**2. Type 0 to enter the platform shell.**

The system controller prompt, *schostname:SC>*, is displayed for the platform shell of the main system controller. If you have a redundant SC configuration, the spare system controller prompt is *schostname:sc>*.

▼ **To Initiate a Serial Connection with tip**

- **At the machine prompt, type *tip* and the serial port to be used for the system controller session.**

```
machinename% tip port_name
connected
```

The main system controller menu is displayed.

## ▼ To Obtain the Platform Shell Using the Serial Port

1. **Connect the system controller serial port to an ASCII terminal.**  
The system controller main menu is displayed.
2. **From the main menu type 0 to enter the platform shell.**

## Obtaining a Domain Shell or Console

This section describes the following:

- “To Obtain the Domain Shell Using telnet” on page 30
- “To Obtain the Domain Shell From the Domain Console” on page 32

## ▼ To Obtain the Domain Shell Using `telnet`

1. **Obtain the system controller main menu by typing `telnet schostname` (CODE EXAMPLE 2-2).**

The system controller main menu is displayed.

where:

*schostname* is the system controller host name.

CODE EXAMPLE 2-2 shows entering the shell for domain A.

**CODE EXAMPLE 2-2** Obtaining a Domain Shell With telnet

```
% telnet schostrname
Trying xxx.xxx.xxx.xxx
Connected to schostrname.
Escape character is '^]'.

System Controller `schostrname':

    Type 0 for Platform Shell

    Type 1 for domain A
    Type 2 for domain B
    Type 3 for domain C
    Type 4 for domain D

Input: 1

Connected to Domain A

Domain Shell for Domain A

schostrname:A>
```

**2. Enter a domain. Type 1, 2, 3, or 4 to enter the appropriate domain shell.**

The system controller prompt for the domain shell you connected to is displayed. CODE EXAMPLE 2-2 shows entering the shell for domain A, whose prompt is *schostrname:A>*.

**3. If the domain is active (the domain keyswitch is set to on, diag, or secure which means you are running the Solaris operating environment, are in the OpenBoot PROM, or are running POST), perform the following steps:**

- a. Press and hold the CTRL key while pressing the ] key, to get to the telnet> prompt.**
- b. At the telnet> prompt type send break (CODE EXAMPLE 2-3).**

**CODE EXAMPLE 2-3** Obtaining a Domain Shell From the Domain Console

```
ok Ctrl-J  
telnet> send break
```

## ▼ To Obtain the Domain Shell From the Domain Console

If the domain is active and the domain keyswitch is set to on, diag, or secure (you are running the Solaris operating environment, are in the OpenBoot PROM, or are running POST), perform the following steps:

1. **Press and hold the CTRL key while pressing the J key, to get to the `telnet>` prompt.**
2. **At the `telnet>` prompt type `send break`.**

CODE EXAMPLE 2-4 shows obtaining the shell for domain A from the domain console. Because the domain is active, you will not see a prompt.

**CODE EXAMPLE 2-4** Obtaining a Domain Shell From the Domain Console

```
ok Ctrl-J  
telnet> send break
```

---

## System Controller Navigation

This section explains how to navigate between the:

- System controller platform
- System controller domain console
- System controller domain shell

To return to the originating shell, use the `disconnect` command. In a domain shell, to connect to the domain console, use the `resume` command. To connect to a domain shell from the platform shell, use the `console` command.

FIGURE 2-1 shows how to navigate between the platform shell, the domain shell, the domain console by using the `console` and `disconnect` commands. FIGURE 2-1 also shows how to connect to both the domain shell and platform shell from the operating environment by using the `telnet` command.

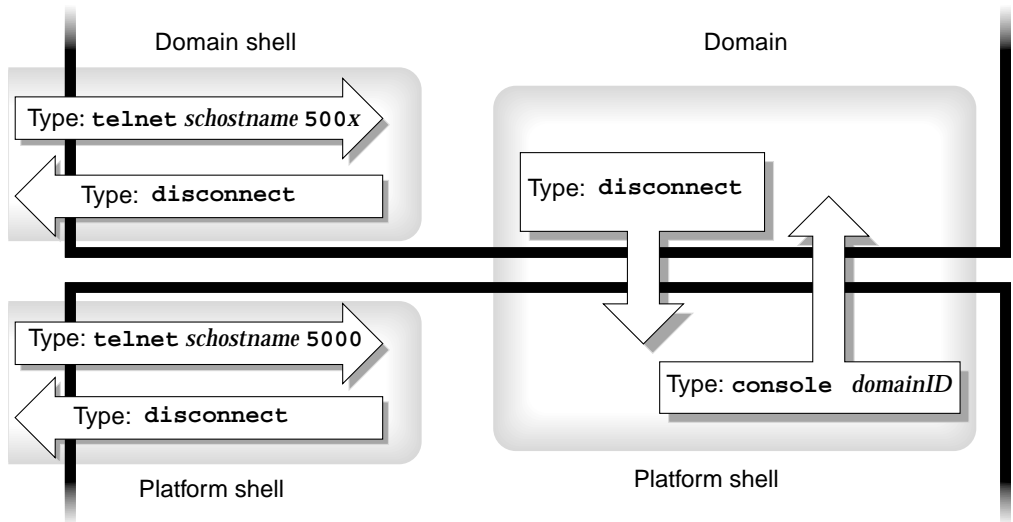

FIGURE 2-1 Navigating Between the Platform Shell and the Domain Shell

---

**Note** – You can also use the `telnet` command without the port number, as described in CODE EXAMPLE 2-1 and CODE EXAMPLE 2-2.

---

where:

In the `telnet` command in FIGURE 2-1, 5000 is the platform shell.

*x* is:

- 1 for domain A
- 2 for domain B
- 3 for domain C
- 4 for domain D

In the `console` command, *domainID* is a, b, c, or d.

---

**Note** – By typing `telnet schostname 500x`, you will bypass the system controller main menu and directly enter the platform shell, a domain shell or a domain console.

---

FIGURE 2-2 illustrates how to navigate between the Solaris operating environment, the OpenBoot PROM, and the domain shell. FIGURE 2-2 assumes that the Solaris operating environment is running.

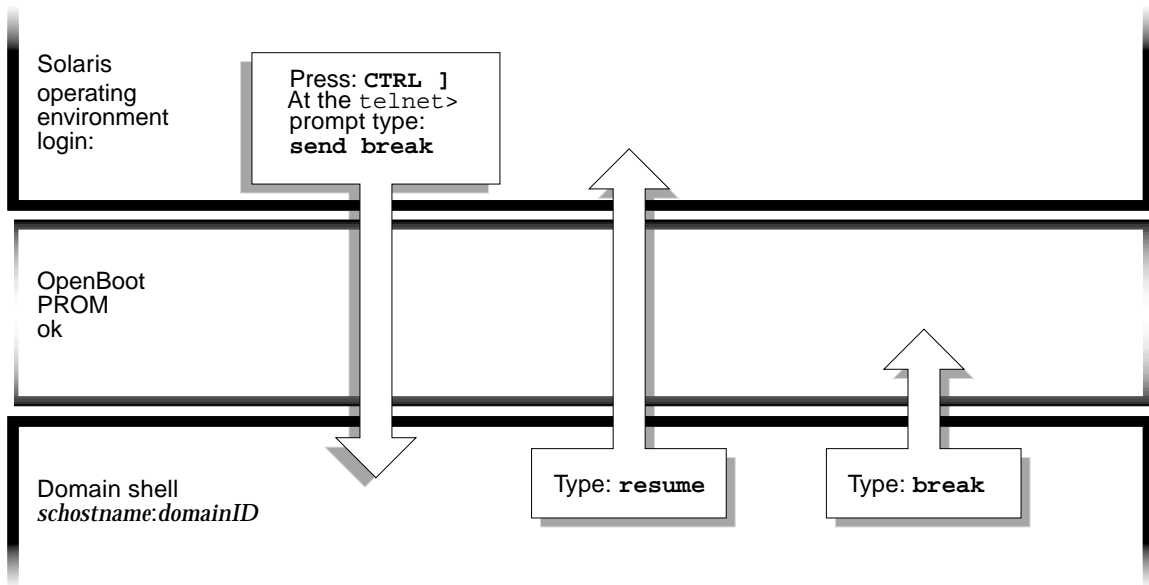

FIGURE 2-2 Navigating Between the Domain Shell, the OpenBoot PROM, and the Solaris Operating Environment



**Caution** – Note that in FIGURE 2-2 typing the `break` command suspends the Solaris operating environment.

FIGURE 2-3 illustrates how to navigate between the OpenBoot PROM and the domain shell. This figure assumes that the Solaris operating environment is *not* running.



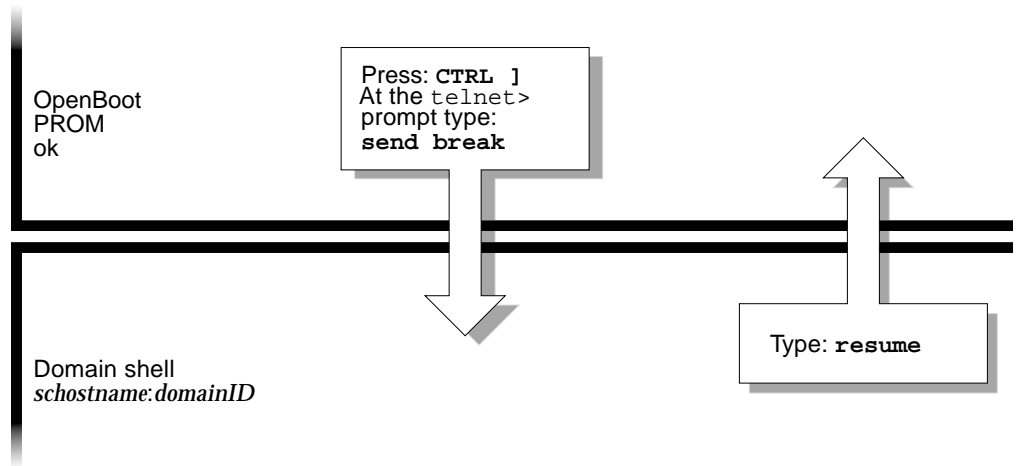

**FIGURE 2-3** Navigating Between the OpenBoot PROM and the Domain Shell

When you connect to a domain, you will be connected to the domain shell unless the domain is active in which case you will be connected to the domain console. When you connect to the console, you will be connected to the Solaris operating environment console, the OpenBoot PROM, or POST, depending of which of these is currently executing.

## ▼ To Enter the Domain Console From the Domain Shell If the Domain Is Inactive

- Type `setkeyswitch on` in the domain shell.

```
schostname:A> setkeyswitch on
```

The domain console is only available when the domain is active. To make the domain active, you must turn the keyswitch on. You will be automatically switched from the domain shell to the domain console.

This action powers on and initializes the domain. The domain will go through POST and then the OpenBoot PROM. If the OpenBoot PROM `auto-boot?` parameter is set to true, the Solaris operating environment will boot.

## ▼ To Enter the Domain Shell From the Domain Console

1. **Press and hold the CTRL key while pressing the ] key to get to the `telnet>` prompt (CODE EXAMPLE 2-5).**
2. **Type `send break` at the `telnet` prompt.**

**CODE EXAMPLE 2-5** Obtaining a Domain Shell From the Domain Console

```
ok Ctrl-]
telnet> send break
```

## ▼ To Get Back to the Domain Console From the Domain Shell

1. **Type `resume`:**

```
schostname:D> resume
```

Note that because the domain is active, you will get a blank line.

2. **Press the Return key to get a prompt.**

---

**Note** – If the domain is not active, (the Solaris operating environment or the OpenBoot PROM is *not* running), the system controller stays in the domain shell and you will obtain an error.

---

## ▼ To Enter a Domain From the Platform Shell

---

**Note** – This example shows entering an inactive domain.

---

- **Type:**

```
schostname:SC> console -d a
Connected to Domain A
Domain Shell for Domain A
schostname:A>
```

If the OpenBoot PROM is running, you are returned to the console for domain A. If the keyswitch is set to `off` or `standby`, you are returned to the shell for domain A.

---

**Note** – To enter another domain, type the proper *domainID* `b`, `c`, or `d`.

---

---

## Terminating Sessions

This section describes how to terminate system controller sessions.

### ▼ To Terminate an Ethernet Connection With `telnet`

- **Type the `disconnect` command at the domain shell prompt.**

Your system controller session terminates.

```
schostname:A> disconnect
Connection closed by foreign host.
machinename%
```

This example assumes that you are connected directly to the domain and not from the platform shell.

---

**Note** – If you have a connection to the domain initiated on the platform shell, you must type `disconnect` twice.

Typing `disconnect` the first time takes you back to the platform shell connection and keeps your connection to the system controller. Typing `disconnect` again exits the platform shell and ends your connection to the system controller.

---

## ▼ To Terminate a Serial Connection With `tip`

If you are connected to the System Controller board with the serial port, use the `disconnect` command to terminate the system controller session then use a `tip` command to terminate your `tip` session.

1. **At the domain shell or platform shell prompt, type `disconnect`.**

```
schostname:A> disconnect
```

2. **If you are in a domain shell and are connected from the platform shell, type `disconnect` again to disconnect from the system controller session.**

```
schostname:SC> disconnect
```

The system controller main menu is displayed.

**3. Type ~. to end your tip session (CODE EXAMPLE 2-6).**

**CODE EXAMPLE 2-6** Ending a tip Session

```
System Controller `shostname`:
```

```
    Type 0 for Platform Shell
```

```
    Type 1 for domain A
```

```
    Type 2 for domain B
```

```
    Type 3 for domain C
```

```
    Type 4 for domain D
```

```
Input: ~.
```

```
machinename%
```

The *machinename*% prompt is displayed.



## System Power On and Setup

---

This chapter provides information to enable you to power on your system for the first time and perform software setup procedures using the system controller command line interface. For instructions on how to subsequently power on your system, see “To Power On the System” on page 68.

---

**Note** – When you are setting up your system for the first time, it is strongly suggested that you bring up the one domain set up for you, domain A, by installing the Solaris operating environment in the domain and then booting it before creating additional domains.

Before you create additional domains, make sure that domain A is operational, can be accessed from the main menu, and you can boot the Solaris operating environment in the domain. It is good policy to validate that one domain, domain A, is functioning properly before you create additional domains. To create additional domains, see Chapter 4.

---

This chapter contains the following topics:

- “Installing, Cabling, and Powering on the Hardware” on page 43
- “Powering On the Power Grids” on page 45
- “Setting Up the Platform” on page 46
- “Setting Up Domain A” on page 48
- “Saving the Current Configuration to a Server” on page 50
- “Installing and Booting the Solaris Operating Environment” on page 51

FIGURE 3-1 is a flowchart summarizing the major steps you must perform to power on and set up the system, which are explained in step-by-step procedures in this chapter.

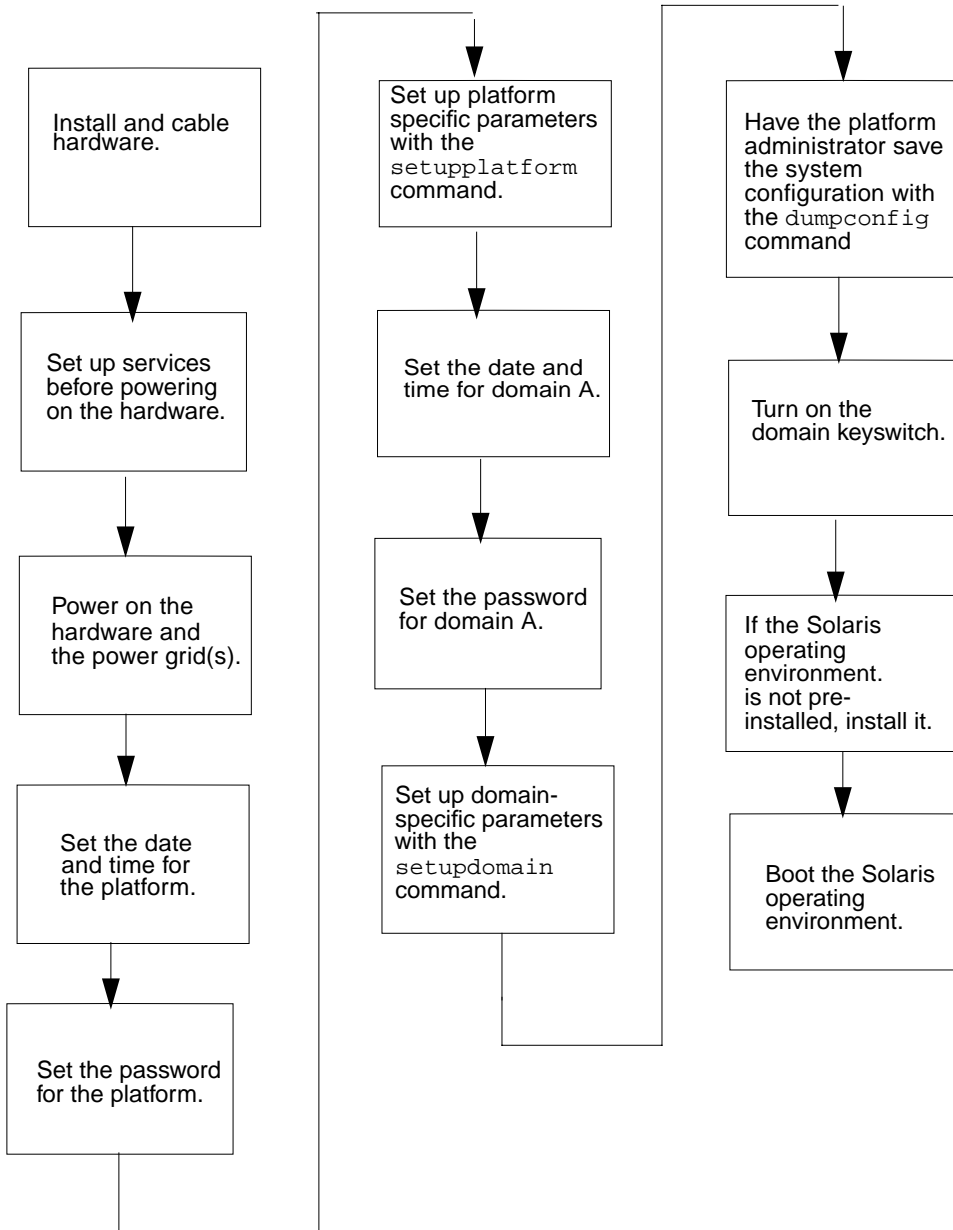

**FIGURE 3-1** Flowchart of Power On and System Setup Steps



---

# Installing, Cabling, and Powering on the Hardware

## 1. Install and cable the hardware.

See the installation guide for your system.

## 2. Connect a terminal to your system using the serial port.

Refer to the installation guide for your system.

## 3. When you set up the terminal, set the ASCII terminal to the same baud rate as the serial port.

The default serial port settings for the System Controller board are:

- 9600 baud
- 8 data bits
- No parity
- 1 stop bit

Because this is the platform console connection, log messages are displayed.

## Setting Up Additional Services Before System Power On

### ● Before you power on the system for the first time, set up the services described in

TABLE 3-1.

**TABLE 3-1** Services That Should Be Set Up Before System Power On

Service	Description
DNS services	The system controller uses DNS to simplify communication with other systems.
Sun Management Center 3.0 software*	Manage and monitor your system by using the Sun Management Center software for the Sun Fire 6800/4810/4800/3800 systems. It is suggested that you use this software to manage and monitor your system.
Network Terminal Server (NTS)	A Network Terminal Server (NTS) is used to help manage multiple serial connections. The NTS should be secured with at least a password.

\* It is not necessary to have the loghost set up before you install and boot the Solaris operating environment. You can install the Sun Management Center 3.0 software after you boot your system for the first time. Because you can install from a CD-ROM, it is not necessary to have a boot/install server set up before system power on.

**TABLE 3-1** Services That Should Be Set Up Before System Power On (Continued)

Service	Description
Boot/install server*	Allows you to install the Solaris operating environment from a network server instead of using a CD-ROM.
http/ftp server*	In order to perform firmware upgrades, you must set up either an http or an ftp server. In order to read/write the configuration backup files for the system controller <code>dumpconfig</code> and <code>restoreconfig</code> commands, you need to set up an ftp server.
Lghost*	<p>The lghost system is used to collect system controller messages. In order to permanently save lghost error messages, you must set up a lghost server.</p> <ul style="list-style-type: none"><li>• Use the <code>setupplatform -p lghost</code> command to output platform messages to the lghost.</li><li>• Use the <code>setupdomain -d lghost</code> command to output domain messages to the lghost.</li></ul> <p>There is a lghost for the platform and for each domain. For complete information and command syntax, refer to the <i>Sun Fire 6800/4810/4800/3800 System Controller Command Reference Manual</i>.</p> <p>For information on the Solaris operating environment lghost, including how to redirect error messages, refer to the <i>Sun Hardware Platform Guide</i>, which is available with your Solaris operating environment release.</p>
System controller	If you plan to put the system controller(s) on a network, each system controller installed must have an IP address. Each system controller should also have a serial connection.
Domains	Each domain you plan to use needs to have its own IP address.

---

\* It is not necessary to have the lghost set up before you install and boot the Solaris operating environment. You can install the Sun Management Center 3.0 software after you boot your system for the first time. Because you can install from a CD-ROM, it is not necessary to have a boot/install server set up before system power on.

---

## Powering On the Hardware

- Complete the hardware power-on steps detailed and illustrated in the installation guide for your system.

---

## Powering On the Power Grids

1. Access the system controller and connect to the system controller main menu.  
See “Connection to the System Controller” on page 28.
2. Connect to the platform shell.
3. Power on the power grid(s).

The `poweron gridx` command powers on power supplies in that power grid.

- If you have a Sun Fire 6800 system, you must power on power grid 0 and power grid 1.

```
schostname:SC> poweron grid0 grid1
```

- If you have a Sun Fire 4810/4800/3800 system, there is only one power grid, grid 0.

```
schostname:SC> poweron grid0
```

The `poweron grid0` system controller command powers on power supplies in power grid 0.

---

# Setting Up the Platform

After powering on the power grids, set up your system using the commands described in this chapter.

This section contains the following topics:

- To Set the Date and Time for the Platform
- To Set a Password for the Platform
- To Configure Platform Parameters

## ▼ To Set the Date and Time for the Platform

The platform and each of the four domains have separate and independent dates and times.

---

**Note** – If your time zone area is using daylight or summer time, the time and time zone are adjusted automatically. On the command line, you can enter only non-daylight time zones.

---

- **Set the date, time, and time zone for the platform, by doing one of the following:**

- Use the `setdate` command from the platform shell.

For complete command syntax, examples, a table of time zone abbreviations, time zone names, and offsets from Greenwich mean time, refer to the `setdate` command in the *Sun Fire 6800/4810/4800/3800 System Controller Command Reference Manual*.

If you have a redundant SC configuration, you must run the `setdate` command on each system controller and set the same date and time for each SC. The platform date and time must be the same on both the main and spare SC for failover purposes.

- Assign a Simple Time Network Protocol (SNTP) server through the `setupplatform` command.

You can assign an SNTP server that synchronizes the date and time between the main and spare system controller. The platform date and time must be the same on both the main and spare SC for failover purposes. To assign an SNTP server, use the `setupplatform` command, which is described in the *Sun Fire 6800/4810/4800/3800 System Controller Command Reference Manual*.

---

**Note** – Although you can set a different date and time for the platform and for each domain, it is strongly suggested that you use the same date and time for the platform and each domain.

Using the same date and time for the platform shell and each domain shell may help during interpretation of error messages and logs. The date and time set on the domains is also used by the Solaris operating environment.

---

## ▼ To Set a Password for the Platform

The system controller password that you set for the main system controller also serves as the *same* password for the spare system controller.

1. **From the platform shell, type the system controller password command.**
2. **At the `Enter new password:` prompt, type in your password.**
3. **At the `Enter new password again:` prompt, type in your password again.**

For examples, refer to the password command in the *Sun Fire 6800/4810/4800/3800 System Controller Command Reference Manual*.

## ▼ To Configure Platform Parameters

---

**Note** – One of the platform configuration parameters that can be set through the `setupplatform` command is the partition parameter. Determine if you want to set up your system with one partition or two partitions. Read “Domains” on page 2 and “Partitions” on page 3 before completing the following steps.

---

1. **From the platform shell, type `setupplatform`.**

For a description of the `setupplatform` parameter values and an example of this command, refer to the `setupplatform` command in the *Sun Fire 6800/4810/4800/3800 System Controller Command Reference Manual*.

```
schostname: SC> setupplatform
```

---

**Note** – If you press the Return key after each parameter, the current value will not be changed. If you type a dash ( - ), this clears the entry (if the entry can be blank).

---

2. If you have a second System Controller board installed, run the `setupplatform` command on the second system controller.

All of the parameters, except for the network settings (such as the IP address and hostname of the system controller) and the POST diag level, are copied from the main system controller to the spare.

---

## Setting Up Domain A

In order to set up a domain, you must complete the procedures:

- “To Access the Domain” on page 48
- “To Set the Date and Time for Domain A” on page 48
- “To Set a Password for Domain A” on page 48
- “To Configure Domain-Specific Parameters” on page 49

### ▼ To Access the Domain

- **Access the domain.**

For more information, see “System Controller Navigation” on page 32.

### ▼ To Set the Date and Time for Domain A

- **Type the `setdate` command in the domain A to set the date and time for the domain.**

---

**Note** – Because you can have up to four domains, you must eventually set the date and time for *each* domain. To start, just set the date and time for domain A.

---

For command syntax and examples, refer to the `setdate` command in the *Sun Fire 6800/4810/4800/3800 System Controller Command Reference Manual* and to “To Set the Date and Time for the Platform” on page 46.

### ▼ To Set a Password for Domain A

1. **From the domain A shell, type the `password` command (CODE EXAMPLE 3-1).**
2. **At the `Enter new password: prompt`, type your password.**

3. **At the** Enter new password again: **prompt, type your password again** (CODE EXAMPLE 3-1).

**CODE EXAMPLE 3-1** password Command Example For a Domain With No Password Set

```
schostname:A> password
Enter new password:
Enter new password again:
schostname:A>
```

## ▼ To Configure Domain-Specific Parameters

---

**Note** – Each domain is configured separately.

---

1. **From the domain A shell, type the** `setupdomain` **command.**

For a listing of parameter values and sample output, refer to the `setupdomain` command in the *Sun Fire 6800/4810/4800/3800 System Controller Command Reference Manual*.

2. **Perform the steps listed in** TABLE 3-2.

**TABLE 3-2** Steps in Setting up Domains Including the `dumpconfig` Command

If you are setting up one domain . . .	If you are setting up more than one domain . . .
1. Continue with the procedures in this chapter.	1. Install and boot the Solaris operating environment on domain A as described in “To Install and Boot the Solaris Operating Environment” on page 51. 2. Go to Chapter 4 to set up additional domains. 3. After all of the domains are set up and before you start each additional domain you set up, have the platform administrator run the <code>dumpconfig</code> command. See “To Use <code>dumpconfig</code> to Save Platform and Domain Configurations” on page 50.

---

# Saving the Current Configuration to a Server

This section describes how to use the `dumpconfig` command, which must be run by the platform administrator, to save the current system controller (SC) configuration to a server. Use `dumpconfig` to save the SC configuration for recovery purposes.

Use the `dumpconfig` command when you

- First set up your system and need to save the platform and domain configurations.
- Change the platform and domain configurations with one of the following system controller commands (`setupdomain`, `setupplatform`, `setdate`, `addboard`, `deleteboard`, `enablecomponent`, `disablecomponent`, and `password`) or install and remove a CPU/Memory board or I/O assembly.

## ▼ To Use `dumpconfig` to Save Platform and Domain Configurations

Use `dumpconfig` to save the platform and domain configurations to a server so that you can restore the platform and domain configurations to a replacement system controller (if the current system controller fails).

---

**Note** – *Do not* save the configuration to a domain on this system running the Solaris operating environment. This is because the domain will be unavailable when the system is restored.

---

- **Type the system controller `dumpconfig` command from the platform shell to save the present system controller configuration to a server.**

```
schostname:SC> dumpconfig -f url
```

For command syntax, a description, command output, and examples, refer to the `dumpconfig` command in the *Sun Fire 6800/4810/4800/3800 System Controller Command Reference Manual*.



---

# Installing and Booting the Solaris Operating Environment

## ▼ To Install and Boot the Solaris Operating Environment

### 1. Access the domain A shell.

See “Obtaining a Domain Shell or Console” on page 30.

### 2. Turn the domain A keyswitch to the on position. Type `setkeyswitch on`.

The `setkeyswitch on` command powers on the domain. If the OpenBoot PROM `auto-boot?` parameter is set to `true`, you might obtain an error message similar to CODE EXAMPLE 3-2.

**CODE EXAMPLE 3-2** Sample Boot Error Message When the `auto-boot?` Parameter Is Set To `true`

```
{0} ok boot
      ERROR: Illegal Instruction
      debugger entered.

{0} ok
```

The OpenBoot PROM displays this error message because the Solaris operating environment might not yet be installed, or perhaps you are booting off the wrong disk.

### 3. Insert the CD for the Solaris operating environment into the CD-ROM drive.

### 4. Install the Solaris operating environment on your system.

Refer to the *Sun Hardware Platform Guide* for your operating system release. That book will refer to the installation guide you will need.

### 5. Boot the Solaris operating system by typing the OpenBoot PROM `boot cdrom` command at the `ok` prompt.

```
ok boot cdrom
```



# Creating and Starting Multiple Domains

---

This chapter assumes that domain A, which was set up for you by Sun, is bootable. This chapter explains how to create additional domains and how to start domains.

---

**Note** – The system is shipped from the factory configured with one domain, domain A. All system boards are assigned to domain A.

---

---

## Creating and Starting Domains

This section explains how to set up two or more domains.

### Before Creating Multiple Domains

- 1. Determine how many domains you can have in your system and how many partitions you need.**

Read “Domains” on page 2 and “Partitions” on page 3. If you have a Sun Fire 6800 system and you are planning to set up three or four domains, you will need to set up dual partition mode (two partitions). It may be helpful to maintain at least one unused domain for testing hardware before dynamically reconfiguring it into the system.

---

**Note** – For all systems, it is strongly suggested that you use dual partition mode to support two domains. Using two partitions to support two domains provides better isolation between domains.

---

**2. Determine the number of boards and assemblies that will be in each domain.**

A domain must contain a minimum of one CPU/Memory board and one I/O assembly. However, it is suggested that you have at least two CPU/Memory boards and I/O assemblies for high availability configurations. If you have a Sun Fire 6800 system, go to the next step.

**3. If you have a Sun Fire 6800 system, complete this step. The Sun Fire 6800 system has two power grids, grid 0 and grid 1. It is strongly suggested that you set up boards in a domain to be in the same power grid in order to isolate the domain from a power failure.**

Read “Redundant Power” on page 17 to learn how boards are divided between grid 0 and grid 1.

**4. If you need to configure two partitions, turn off all domains.**

**a. If the Solaris operating environment is running in the domain, complete Step a through Step d of Step 3 in “To Power Off the System” on page 66, then return to Step 2 of this procedure.**

Otherwise, skip to Step 5.

**b. Configure the partition mode to dual.**

Refer to the `setupplatform` command in the *Sun Fire 6800/4810/4800/3800 System Controller Command Reference Manual*.

**5. If you do not need to configure two partitions and if the board that you plan to assign to a new domain is currently used by domain A, shut down domain A or use DR to unconfigure and disconnect the board out of the domain.**

To shut down the domain, complete Step a through Step d of Step 3 in “To Power Off the System” on page 66.

You can use the `cfgadm` command to remove the board from the domain, without shutting down the domain. Refer to the *Sun Fire 6800, 4810, 4800, and 3800 Systems Dynamic Reconfiguration User Guide*.

## ▼ To Create A Second Domain

---

**Note** – It is strongly suggested that you use domain C with two partitions (dual partition mode) for your second domain. It provides better fault isolation (complete isolation of Repeater boards). With one partition, use domain B for the second domain.

---

**Note** – The steps to create a second domain should be performed by the platform administrator.

---

1. Complete all steps in “Before Creating Multiple Domains” on page 53.
2. If you have boards that are assigned, type the `deleteboard` command from the platform shell to unassign the boards you want to move from one domain to another domain:

```
schostname:SC> deleteboard sbx ibx
```

where:

sbx is sb0 through sb5 (CPU/Memory boards)

ibx is ib6 through ib9 (I/O assemblies)

3. Assign the boards to the new domain with the `addboard` command.
  - If you have one partition, to add sbx and ibx to domain B, from the platform shell, type:

```
schostname:SC> addboard -d b sbx ibx
```

- If you have two partitions, to add sbx and ibx to domain C, from the platform shell, type:

```
schostname:SC> addboard -d c sbx ibx
```

4. From the platform shell access the proper domain shell.  
See “System Controller Navigation” on page 32.

**5. Set the date and time for the domain.**

You set the date and time for the second domain in exactly the same way you set the date and time for domain A. For an example of the `setdate` command, refer to the `setdate` command in the *Sun Fire 6800/4810/4800/3800 System Controller Command Reference Manual*.

**6. Set a password for the second domain.**

You set the password for the second domain in exactly the same way you set the password for domain A. For an example of the `password` command, refer to the `password` command in the *Sun Fire 6800/4810/4800/3800 System Controller Command Reference Manual*.

**7. Configure domain-specific parameters for the new domain with `setupdomain`.**

You configure domain-specific parameters for each domain separately. For more details, tables, and code examples, refer to the `setupdomain` command in the *Sun Fire 6800/4810/4800/3800 System Controller Command Reference Manual*.

**8. After creating all domains, have the platform administrator save the state of the configuration with the `dumpconfig` command.**

For details on using `dumpconfig`, see the procedure “Saving the Current Configuration to a Server” on page 50.

**9. Start each the domain after all domains have been created.**

Go to “To Start the Domain” on page 57.

## Special Considerations When Creating a Third Domain on the Sun Fire 6800 System

You create three domains in exactly the same way that you create two domains. Follow these steps:

**1. If the platform is configured as a single partition, halt the Solaris operating environment for all active domains before changing partition mode.**

Complete Step 3 in “To Power Off the System” on page 66.

**2. Configure partition mode to dual with the `setupplatform` command.**

3. **Decide which domain needs higher performance. Plan to assign the third domain to the partition that requires the lowest performance.**

TABLE 4-1 provides some best-practice guidelines to follow.

**TABLE 4-1** Guidelines for Creating Three Domains on the Sun Fire 6800 System

Description	Domain IDs
Use these domain IDs if domain A requires higher performance and more hardware isolation	A, C, D
Use these domain IDs if domain C requires higher performance and more hardware isolation	A, B, C

**On the Sun Fire 4810/4800/3800 systems, when you set the partition mode to dual, this moves the MAC address and the host ID from domain B to domain C. Use `showplatform -p mac` to view the settings.**

4. **Perform all steps in the procedure “To Create A Second Domain” on page 55 to create the third domain.**

## ▼ To Start the Domain

1. **Connect to the domain shell for the domain you want to start.**  
See “System Controller Navigation” on page 32.
2. **Turn the keyswitch on.**

```
schostname:C> setkeyswitch on
```

The OpenBoot PROM prompt is displayed.

3. **Install and boot the Solaris operating environment in the domain.**  
Refer to the *Sun Hardware Platform Guide*, which is available with your operating environment release.





# Security

---

This chapter lists the major security threats, provides important information about the system controller, explains password requirements for the platform and the domains, describes domain separation requirements, explains how to secure the system controller with the `setkeyswitch` command, provides references to Solaris operating environment security, and briefly describes SNMP.

This chapter contains the following topics:

- “Security Threats” on page 59
- “System Controller Security” on page 60
- “Domains” on page 62
- “Solaris Operating Environment Security” on page 64
- “SNMP” on page 64

---

## Security Threats

Some of the threats regarding host break-ins that can be imposed are:

- Unauthorized system controller access
- Unauthorized domain access
- Unauthorized administrator workstation access
- Unauthorized user workstation access



---

**Caution** – It is important to remember that access to the system controller can shut down all or part of the system, including active domains running the Solaris operating environment. Also, hardware and software configuration can be changed.

---

---

# System Controller Security

In order to secure the system controller in your system, read about the system controller security issues. System controller security issues have a great impact on the security of the system controller installation. Refer to the articles available online, including *Securing the Sun Fire Midframe System Controller*, at:

<http://www.sun.com/blueprints>

When you set up the software for your system, you performed software tasks needed to set up system controller security in Chapter 3. The basic steps needed in order to secure the system controller are:

1. Set the platform shell password using the `password` command.
2. Set up the platform-specific parameters using the `setupplatform` command.

A few `setupplatform` parameters involving system controller security are parameters that configure:

- Network settings
- Loghost for the platform
- SNMP community strings
- Access Control List (ACL) for hardware
- Time out period for telnet and serial port connections

3. Set the domain shell password for all domains using the `password` command.
4. Set the domain-specific parameters using `setupdomain`.

A few `setupdomain` parameters involving system controller security are parameters that configure:

- Loghost for each domain
- SNMP for each domain (Public and Private Community Strings)

5. Save the current configuration of the system using `dumpconfig`.

This list of parameters is only a partial list of what you need to set up. For step-by-step software procedures, see Chapter 3.

## setupplatform and setupdomain Parameter Settings

For technical information on the `setupplatform` and `setupdomain` settings involving system controller security, see the system controller commands in the *Sun Fire 6800/4810/4800/3800 System Controller Command Reference Manual*. Also refer to the articles available online. See “System Controller Security” on page 60 for the URL.

## Changing Passwords for the Platform and the Domain

---

**Note** – Make sure that you know who has access to the system controller. Anyone who has that access can control the system.

---

### Rules for Setting Passwords

When you set up your system for the first time:

- Make sure that you set the platform password and a different domain password for each domain (even if the domain is not used) to increase isolation between domains.
- Continue to change the platform and domain passwords on a regular basis.

---

# Domains

This section discusses domain separation and the `setkeyswitch` command.

## Domain Separation

The domain separation requirement is based on allocating computing resources to a specific domain. These mid-range systems enforce domain separation, which prevents users of one domain, who only have access to the Solaris operating environment running in that domain, from accessing or modifying the data of another domain.

This security policy enforcement is performed by the software (FIGURE 5-1). In this figure, a domain user is a person who is using the Solaris operating environment and does not have access to the system controller. The domain administrator is responsible for:

- Configuring the domain
- Maintaining domain operations
- Overseeing the domain

As this figure shows, the domain administrator has access to the domain console and domain shell for the domain the administrator is responsible for. Also note in FIGURE 5-1 that the platform administrator has access to the platform shell and the platform console. If the platform administrator knows the domain passwords, the platform administrator also has access to domain shells and consoles. You should always set the domain shell passwords for each domain.

The following are security items to consider in each domain:

- Make sure that all passwords are within acceptable security guidelines. For example, each domain and the platform should have a unique password.
- Change your passwords for the platform and each domain shell on a regular basis.
- Scrutinize log files on a regular basis for any irregularities. For more information on these log files, refer to the *Sun Hardware Platform Guide* for the operating environment installed on your system.

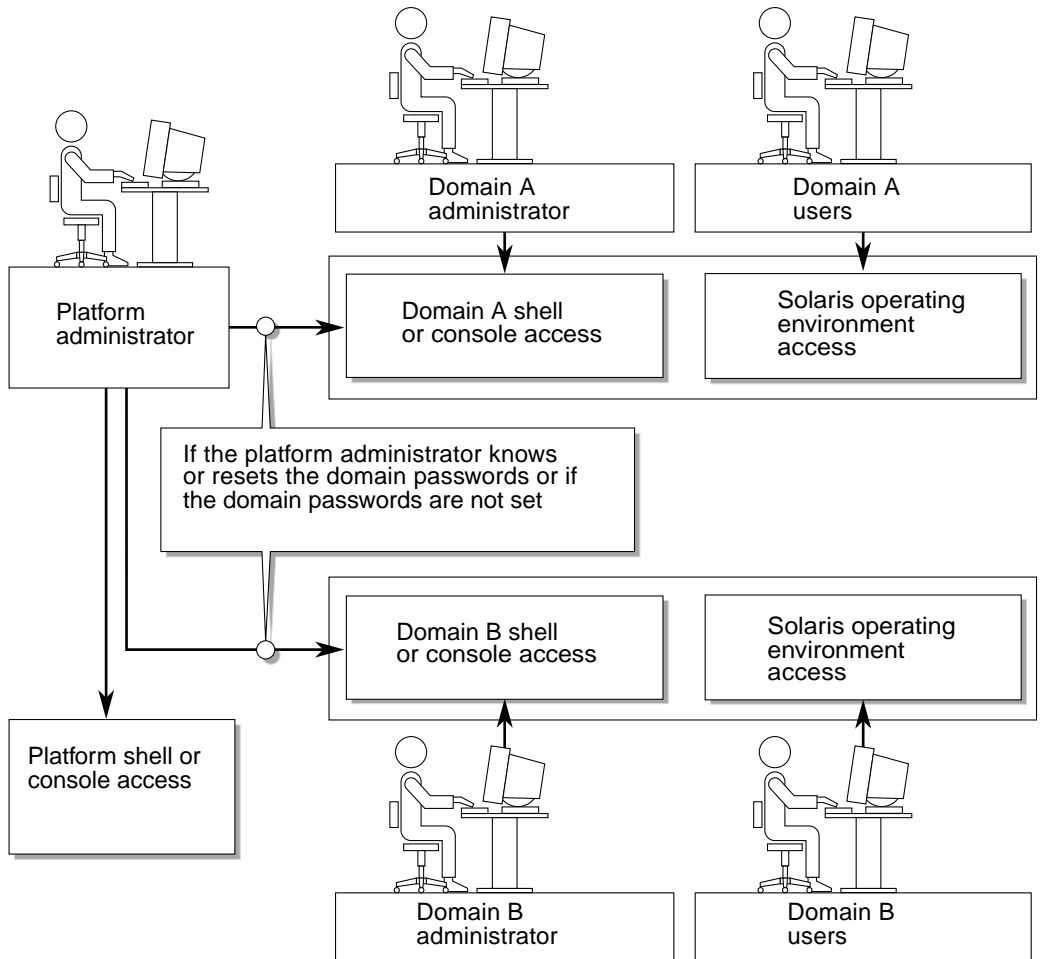

**FIGURE 5-1** System With Domain Separation

## setkeyswitch Command

The Sun Fire 6800/4810/4800/3800 systems do not have a physical keyswitch. You set the virtual keyswitch in each domain shell with the `setkeyswitch` command. To secure a running domain, set the domain keyswitch to the secure setting. For more information about `setkeyswitch`, refer to the online article, *Securing the Sun Fire Midframe System Controller* available online at

<http://www.sun.com/blueprints>

With the keyswitch set to secure, the following restrictions occur:

- Disables the ability to perform `flashupdate` operations on CPU/Memory boards or I/O assemblies. Performing `flashupdate` operations on these boards should only be done by an administrator who has platform shell access on the system controller.
- Ignores `break` and `reset` commands from the system controller. This is an excellent security precaution. This functionality also ensures that accidentally typing a `break` or `reset` command will not halt a running domain.

---

## Solaris Operating Environment Security

For information on securing the Solaris operating environment, refer to the following books and articles:

- *SunSHIELD Basic Security Module Guide* (Solaris 8 System Administrator Collection)
- *Solaris 8 System Administration Supplement* or *System Administration Guide: Security Services* in the Solaris 9 System Administrator Collection
- Solaris security toolkit articles available online at

<http://www.sun.com/blueprints>

---

## SNMP

The system controller uses SNMPv1, which is an insecure protocol. This means that the SNMPv1 traffic needs to be kept on a private network, as described in the online article, *Securing the Sun Fire Midframe System Controller* available online at

<http://www.sun.com/blueprints>

## Maintenance

---

This chapter explains how to perform the following procedures:

- “Powering Off and On the System” on page 65
- “Keyswitch Positions” on page 69
- “Shutting Down Domains” on page 70
- “Assigning and Unassigning Boards” on page 71
- “Upgrading the Firmware” on page 75
- “Saving and Restoring Configurations” on page 76

---

## Powering Off and On the System

To power off the system, you must halt the Solaris operating environment in each domain and power off each domain.

---

**Note** – Before you begin this procedure, make sure you have the following books. Also, if you have a redundant system controller configuration, review “Conditions That Affect Your SC Failover Configuration” on page 77, before you power cycle your system.

---

- *Sun Fire 6800/4810/4800/3800 Systems Service Manual*
- *Sun Hardware Platform Guide* (available with your version of the Solaris operating environment)

## Powering Off the System

When you power off the system, power off all of the active domains. Then power off the power grid(s). The last step is to power off the hardware.

## ▼ To Power Off the System

### 1. Connect to the appropriate domain shell.

See “System Controller Navigation” on page 32.

### 2. Display the status of all domains. Type the following from the platform shell:

**TABLE 6-1** Displaying the Status of All Domains With the `showplatform -p status` Command

```
schostname:SC> showplatform -p status
```

Domain	Solaris Nodename	Domain Status	Keyswitch
A	<i>Solaris nodename-a</i>	Active - Solaris	on
B	-	Powered Off	off
C	-	Powered Off	standby
D	-	Powered Off	standby

```
schostname:SC>
```

### 3. Complete these substeps for each active domain.

These substeps include halting the Solaris operating environment in each domain, turning off the domain keyswitch, and disconnecting from the session.

#### a. Enter the domain console you want to power off.

See “Obtaining a Domain Shell or Console” on page 30.

#### b. If the Solaris operating environment is running, log in as root and halt the operating environment.

Refer to the *Sun Hardware Platform Guide*, which is available with your Solaris operating environment release.

You will see the OpenBoot PROM `ok` prompt when the Solaris operating environment is shut down.

#### c. From the `ok` prompt, obtain the domain shell prompt.

- i. Press and hold the CTRL key while pressing the ] key to get to the `telnet>` prompt.



ii. At the `telnet>` prompt, type `send break`.

```
ok CTRL ]
telnet> send break
schostrname:A>
```

The domain shell prompt is displayed.

d. Turn the domain keyswitch to the off position with the `setkeyswitch off` command.

```
schostrname:A> setkeyswitch off
```

e. Disconnect from the session by typing the `disconnect` command.

```
schostrname:A> disconnect
```

#### 4. Power off the power grid(s).

This step powers off the power supplies.

- Access the platform shell.

See “Obtaining the Platform Shell” on page 28.

- If you have a Sun Fire 6800 system, you must power off power grids 0 and 1.:

```
schostrname:SC> poweroff grid0 grid1
```

Go to Step 5.

- If you have a Sun Fire 4810/4800/3800 system, there is only one power grid, grid 0. Power off power grid 0:

```
schostrname:SC> poweroff grid0
```

#### 5. Power off the hardware in your system.

Refer to the “Powering Off and On” chapter of the *Sun Fire 6800/4810/4800/3800 Systems Service Manual*.

## ▼ To Power On the System

### 1. Power on the hardware.

Refer to the “Powering Off and On” chapter of the *Sun Fire 6800/4810/4800/3800 Systems Service Manual*.

### 2. Access the system controller platform shell.

See “Obtaining the Platform Shell” on page 28.

### 3. Power on the power grids.

Power on the power supplies. Complete the following substeps.

- If you have a Sun Fire 6800 system, power on power grid 0 and power grid 1.

```
schostname:SC> poweron grid0 grid1
```

- If you have a Sun Fire 4810/4800/3800 system, there is only one power grid, grid 0:

```
schostname:SC> poweron grid0
```

### 4. Boot each domain.

#### a. Access the domain shell for the domain you want to boot.

“Obtaining a Domain Shell or Console” on page 30.

#### b. Boot the domain with the system controller `setkeyswitch on` command.

```
schostname:A> setkeyswitch on
```

This command turns on the domain and boots the Solaris operating environment if the OpenBoot PROM `auto-boot?` parameter is set to true and the OpenBoot PROM `boot-device` parameter is set to the proper boot device.

Use the `setupdomain` command (OBP `auto-boot?` parameter), which is run from a domain shell, or the OpenBoot PROM `setenv auto-boot? true` command to control whether the Solaris operating environment auto boots when you turn the keyswitch on.

Go to Step 5.

---

**Note** – If the Solaris operating environment did not boot automatically, continue with the Step c. Otherwise, go to Step 5.

---

The Solaris operating environment *will not* boot automatically if the OpenBoot PROM `auto-boot?` parameter is set to false. You will see the `ok` prompt.

- c. **At the `ok` prompt, type the `boot` command to boot the Solaris operating environment.**

```
ok boot
```

After the Solaris operating environment is booted, the `login:` prompt is displayed.

```
login:
```

5. **To access and boot another domain, repeat Step 4.**

---

## Keyswitch Positions

Each domain has a virtual keyswitch with five positions: off, standby, on, diag, and secure. The `setkeyswitch` command in the domain shell changes the position of the virtual keyswitch to the specified value. The virtual keyswitch replaces the need for a physical keyswitch for each domain. This command is also available, with limited functionality, in the platform shell.

For command syntax, examples, descriptions of `setkeyswitch` parameters, and results when you change the keyswitch setting, see the `setkeyswitch` command in the *Sun Fire 6800/4810/4800/3800 System Controller Command Reference Manual*.



---

**Caution** – During the `setkeyswitch` operation, heed the following precautions:

Do not power off any boards assigned to the domain.  
Do not reboot the system controller.

---

## ▼ To Power On a Domain

1. **Access the domain you want to power on.**  
See “System Controller Navigation” on page 32.
2. **Set the keyswitch to on, diag, or secure using the system controller setkeyswitch command.**

---

## Shutting Down Domains

This section describes how to shut down a domain.

## ▼ To Shut Down a Domain

1. **Connect to the domain console of the domain you want to shut down.**  
See “System Controller Navigation” on page 32.  
From the domain console, if the Solaris operating environment is booted you will see the %, #, or login: prompts.
2. **If the Solaris operating environment is running, halt the Solaris operating environment from the domain console as root.**  
Refer to the *Sun Hardware Platform Guide*, which is available with your Solaris operating environment release.
3. **Enter the domain shell from the domain console.**  
See “To Obtain the Domain Shell From the Domain Console” on page 32.
4. **In the domain shell, type:**

```
schostname:A> setkeyswitch off
```

5. **If you need to completely power off the system, see “Powering Off and On the System” on page 65.**

---

# Assigning and Unassigning Boards

When you assign a board to a domain, the board must be listed in the Access Control List (ACL) for the domain. It *cannot* be already assigned to another domain. The ACL is only checked when you assign a board to a domain. If the board is assigned to a domain when the domain is active, the board *is not* automatically configured to be part of that domain.

- For an overview of steps on assigning and unassigning boards to or from a domain with and without dynamic reconfiguration (DR), see TABLE 6-2 and TABLE 6-3.
- For complete step-by-step procedures *not* using dynamic reconfiguration, see “To Assign a Board to a Domain” on page 72 and “To Unassign a Board From a Domain” on page 74.
- For procedures that use dynamic reconfiguration, refer to the *Sun Fire 6800, 4810, 4800, and 3800 Systems Dynamic Reconfiguration User Guide*.

TABLE 6-2 Overview of Steps to Assign a Board To a Domain

To Assign a Board To a Domain Using DR	To Assign a Board To a Domain Not Using DR
<ol style="list-style-type: none"><li>1. Assign the disconnected and isolated board to the domain with the <code>cfgadm -x assign</code> command.</li><li>2. Use DR to configure the board into the domain. Refer to the <i>Sun Fire 6800, 4810, 4800, and 3800 Systems Dynamic Reconfiguration User Guide</i>.</li></ol>	<ol style="list-style-type: none"><li>1. Assign the board to the domain with the <code>addboard</code> command.</li><li>2. Halt the Solaris operating environment in the domain.</li><li>3. Shut down the domain with <code>setkeyswitch standby</code>.</li><li>4. Turn on the domain with <code>setkeyswitch on</code>.</li></ol>

TABLE 6-3 Overview of Steps to Unassign a Board From a Domain

To Unassign a Board From a Domain Using DR	To Unassign a Board From a Domain Not Using DR
<ol style="list-style-type: none"><li>1. Use DR to unconfigure the board from the domain. Refer to the <i>Sun Fire 6800, 4810, 4800, and 3800 Systems Dynamic Reconfiguration User Guide</i>.</li><li>2. Unassign the board from the domain with the <code>cfgadm -c disconnect -o unassign</code> command.</li></ol>	<ol style="list-style-type: none"><li>1. Halt the Solaris operating environment in the domain.</li><li>2. Turn the keyswitch to standby mode with <code>setkeyswitch standby</code>.</li><li>3. Unassign the board from the domain with the <code>deleteboard</code> command.</li><li>4. Turn on the domain with <code>setkeyswitch on</code>.</li></ol>

## ▼ To Assign a Board to a Domain

---

**Note** – This procedure *does not* use dynamic reconfiguration (DR).

---

1. **Enter the domain shell for the domain you want to assign the board to.**  
See “Obtaining a Domain Shell or Console” on page 30.
2. **Type the `showboards` command with the `-a` option to find available boards that can be used in the domain.**

In the domain shell, the command output list boards that are in the current domain and boards that are not yet assigned to a domain and are listed in the Access Control List (ACL) for the current domain. You can assign any board listed that is not currently part of the domain to the current domain.

**CODE EXAMPLE 6-1** `showboards -a` Example Before Assigning a Board to a Domain

```
schostname:A> showboards -a
```

Slot	Pwr	Component Type	State	Status	Domain
----	---	-----	----	-----	-----
/N0/SB0	On	CPU Board	Active	Passed	A
/N0/IB6	On	PCI I/O Board	Active	Passed	A

If the board you want to assign to the domain is not listed in the `showboards -a` output, complete the following substeps. Otherwise, go to Step 3.

- a. **Make sure that the board has *not* been assigned to another domain by running the `showboards` command in the platform shell.**

A board *cannot* be assigned to the current domain if it belongs to another domain.

- b. **Verify that the board is listed in the Access Control List (ACL) for the domain.**

Use the `showplatform -p acs` command (platform shell) or the `showdomain -p acs` command (domain shell).

- c. **If the board is *not* listed in the ACL for the desired domain, use the `setupplatform -p acs` command from the platform shell to add the board to the ACL for the domain.**

See “To Configure Platform Parameters” on page 47.

**3. Assign the proper board to the desired domain with the `addboard` command.**

The board must be in the Available board state. For example, to assign CPU/Memory board, `sb2`, to the current domain, type:

```
schostrname:A> addboard sb2
```

The new board assignment takes effect when you change the domain keyswitch from an inactive position (off or standby) to an active position (on, diag, or secure) using the system controller `setkeyswitch` command.

Assigning a board to a domain does not automatically make that board part of an active domain.

**4. If the domain is active (the domain is running the Solaris operating environment, the OpenBoot PROM, or POST), complete this step.**

- If the Solaris operating environment is running in the domain, log in as root to the Solaris operating environment and halt it. For details on how to halt a domain running the Solaris operating environment, refer to the *Sun Hardware Platform Guide*.
- If the OpenBoot PROM or POST is running, wait for the `ok` prompt.

**a. Obtain the domain shell.**

See “To Obtain the Domain Shell From the Domain Console” on page 32.

**b. Shut down the domain. Type:**

```
schostrname:A> setkeyswitch standby
```

By setting the domain keyswitch to standby instead of off, the boards in the domain do not need to be powered on and tested again. Setting the keyswitch to standby also decreases downtime.

**c. Turn the domain on. Type:**

```
schostrname:A> setkeyswitch on
```

---

**Note** – Rebooting the Solaris operating environment without using the `setkeyswitch` command does not configure boards that are in the Assigned board state into the active domain.

---

- d. If your environment is not set to automatically boot the Solaris operating environment in the domain after you turned the keyswitch on, boot the operating environment by typing `boot` at the `ok` prompt.

```
ok boot
```

---

**Note** – Setting up whether the Solaris operating environment auto boots or not when you turn the keyswitch on is done either with the `setupdomain` command (`OBP.auto-boot?` parameter), which is run from a domain shell, or with the OpenBoot PROM `setenv auto-boot? true` command.

---

## ▼ To Unassign a Board From a Domain

---

**Note** – This procedure *does not* use dynamic reconfiguration (DR).

---

Unassign a board from a domain with the `deleteboard` command. For a complete description of the `deleteboard` command, see the *Sun Fire 6800/4810/4800/3800 System Controller Command Reference Manual*.

---

**Note** – When you unassign a board from a domain, the domain cannot not be active. This means it must not be running the Solaris operating environment, the OpenBoot PROM, or POST. The board you are unassigning must be in the Assigned board state.

---

1. **Halt the Solaris operating environment in the domain.**  
Refer to the *Sun Hardware Platform Guide*.
2. **Enter the domain shell for the proper domain.**  
See “System Controller Navigation” on page 32.
3. **Turn the domain keyswitch off with `setkeyswitch off`.**
4. **Type the `showboards` command to list the boards assigned to the current domain.**
5. **Unassign the proper board from the domain with the `deleteboard` command:**

```
schostname:A> deleteboard sb2
```



6. Turn on the domain. Type:

```
schostrname:A> setkeyswitch on
```

7. If your environment is not set to automatically boot the Solaris operating environment in the domain after you turned the keyswitch on, boot the operating environment by typing `boot` at the `ok` prompt.

```
ok boot
```

---

## Upgrading the Firmware

The `flashupdate` command updates the firmware in the system controller and the system boards (CPU/Memory boards and I/O assemblies). There is no firmware on the Repeater boards. This command is available in the platform shell only. The source flash image can be on a server or another board of the same type.

A complete description of this command, including command syntax and examples, see the `flashupdate` command in the *Sun Fire 6800/4810/4800/3800 System Controller Command Reference Manual*.

---

**Note** – Review the `README` and `Install.info` files before you upgrade the firmware.

---

In order to upgrade the firmware from a URL, the firmware must be accessible from a ftp or http URL. Before performing the `flashupdate` procedure read the information in the “Description” section of the `flashupdate` command in the *Sun Fire 6800/4810/4800/3800 System Controller Command Reference Manual*. The “Description” section covers:

- Steps to perform before you upgrade the firmware.
- What to do if the images you installed are incompatible with the new images.



---

**Caution** – When you update the firmware on the system controller, update only one system controller at a time, as described in the `Install.info` file. DO NOT update both system controllers at the same time.

---

---

# Saving and Restoring Configurations

This section describes when to use the `dumpconfig` and `restoreconfig` commands.

## Using `dumpconfig`

Use the `dumpconfig` command to save platform and domain settings after you

- Complete the initial configuration of the platform and the domains
- Modify the configuration, or change the hardware configuration

For an explanation of how to use this command, see “Saving the Current Configuration to a Server” on page 50. For complete command syntax and examples of this command, refer to the `dumpconfig` command in the *Sun Fire 6800/4810/4800/3800 System Controller Command Reference Manual*.

## Using `restoreconfig`

Use the `restoreconfig` command to restore platform and domain settings.

For complete command syntax and examples of this command, refer to the `restoreconfig` command in the *Sun Fire 6800/4810/4800/3800 System Controller Command Reference Manual*.

# System Controller Failover

---

Sun Fire 6800/4810/4800/3800 systems can be configured with two system controllers for high availability. In a high-availability system controller (SC) configuration, one SC serves as the *main* SC, which manages all the system resources, while the other SC serves as a *spare*. When certain conditions cause the main SC to fail, a switchover or *failover* from the main SC to the spare is triggered automatically, without operator intervention. The spare SC assumes the role of the main and takes over all system controller responsibilities.

This chapter explains the following:

- How SC Failover Works
- SC Failover Prerequisites
- Conditions That Affect Your SC Failover Configuration
- How to Manage SC Failover
- How to Recover After an SC Failover

---

## How SC Failover Works

The SC failover capability is enabled by default on Sun Fire midrange servers that have two System Controller boards installed. The failover capability includes both automatic and manual failover. In automatic SC failover, a failover is triggered when certain conditions cause the main SC to fail or become unavailable. In manual SC failover, you force the switchover of the spare SC to the main.

The failover software performs the following tasks to determine when a failover from the main SC to the spare is necessary and to ensure that the system controllers are failover-ready:

- Continuously checks the heartbeat of the main SC and the presence of the spare SC.

- Copies data from the main SC to the spare SC at regular intervals so that the data on both system controllers is synchronized if a failover occurs.

If at any time the spare SC is not available or does not respond, the failover mechanism disables SC failover. If SC failover is enabled, but the connection link between the SCs is down, failover remains enabled and active until the system configuration changes. After a configuration change, such as a change in platform or domain parameter settings, the failover mechanism remains enabled, but it is not active (SC failover is not in a failover-ready state because the connection link is down). You can check the SC failover state by using commands such as `showfailover` or `showplatform`, as explained in “To Obtain Failover Status Information” on page 83.

## What Triggers an Automatic Failover

A failover from the main to the spare SC is triggered when one of the following failure conditions occurs:

- The heartbeat of the main SC stops.
- The main SC is rebooted but it does not boot successfully.
- A fatal software error occurs.

## What Happens During a Failover

An SC failover is characterized by the following:

- Failover event message

The SC failover event is logged in the platform message log file, which is viewed on the console of the new main SC or through the `showlogs` command on the SC. The information displayed indicates that a failover has occurred and identifies the failure condition that triggered the failover.

CODE EXAMPLE 7-1 shows the type of information that appears on the console of the spare SC when a failover occurs due to a stop in the main SC heartbeat:

### CODE EXAMPLE 7-1 Messages Displayed During an Automatic Failover

```
Platform Shell - Spare System Controller

sp4-sc0:sc> Nov 12 01:15:42 sp4-sc0 Platform.SC: SC Failover: enabled and
active.
```

### CODE EXAMPLE 7-1 Messages Displayed During an Automatic Failover (*Continued*)

```
Nov 12 01:16:42 sp4-sc0 Platform.SC: SC Failover: no heartbeat detected from the
Main SC
Nov 12 01:16:42 sp4-sc0 Platform.SC: SC Failover: becoming main SC ...

Nov 12 01:16:49 sp4-sc0 Platform.SC: Chassis is in single partition mode.
Nov 12 01:17:04 sp4-sc0 Platform.SC: Main System Controller
Nov 12 01:17:04 sp4-sc0 Platform.SC: SC Failover: disabled

sp4-sc1:SC>
```

- **Change in the SC prompt**

The prompt for the main SC is *hostname:SC>* . Note that the upper case letters, *SC*, identify the main SC.

The prompt for the spare SC is *hostname:sc>* . Note that the lower case letters, *sc*, identify the spare SC.

When an SC failover occurs, the prompt for the spare SC changes and becomes the prompt for the main SC (*hostname:SC>* ), as shown in the last line of CODE EXAMPLE 7-1.

- **Command execution is disabled**

When an SC failover is in progress, command execution is disabled.

- **Short recovery period**

The recovery time for an SC failover from the main to the spare is approximately five minutes or less. This recovery period consists of the time required to detect a failure and direct the spare SC to assume the responsibilities of the main SC.

- **No disturbance to running domains**

The failover process does not affect any running domains, except for temporary loss of services from the system controller.

- **Deactivation of the SC failover feature**

After an automatic or manual failover occurs, the failover capability is automatically disabled. This prevents the possibility of repeated failovers back and forth between the two SCs.

- **Telnet connections to domain consoles are closed**

A failover closes a telnet session connected to the domain console, and any domain console output is lost. When you reconnect to the domain through a telnet session, you must specify the hostname or IP address of the new main SC, unless you previously assigned a logical hostname or IP address to your main system controller (see the next section for an explanation of the logical hostname and IP address).

The remainder of this chapter describes SC failover prerequisites, conditions that affect your SC failover configuration, and how to manage SC failover, including how to recover after an SC failover occurs.

---

## SC Failover Prerequisites

This section identifies SC failover prerequisites and optional platform parameters that can be set for SC failover:

- Same firmware version required on both the main and spare SC

SC failover requires that you run the same version of the firmware (version 5.13.0) on both the main and spare system controller. Be sure to follow the instructions for installing and upgrading the firmware described in the `Install.info` file that accompanies the firmware release.
- Optional platform parameter settings

You can optionally perform the following after you install or upgrade the firmware on each SC:

  - Assign a logical hostname or IP address to the main system controller.

The logical hostname or IP address identifies the working main system controller, even after a failover occurs. Assign the logical IP address or hostname by running the `setupplatform` command on the main SC.

---

**Note** – The logical hostname or IP address is required if you are using Sun Management Center 3.0 for Sun Fire 6800/4810/4800/3800 systems.

---

- Use Simple Network Time Protocol (SNTP) to keep the date and time values between the main and spare system controllers synchronized.

The date and time between the two SCs must be synchronized, to ensure that the same time service is provided to the domains. Run the `setupplatform` command on each SC to identify the host name or IP address of the system to be used as the SNTP server (reference clock).

If you do not want to use an SNTP server to synchronize the SC date and time, you can use the `setdate` command on each SC to set the date and time.

For further information on setting the platform date and time, see “To Set the Date and Time for the Platform” on page 46.

---

# Conditions That Affect Your SC Failover Configuration

If you power cycle your system (power off your system and then on), note the following:

- After a power cycle, the first system controller that boots `scapp` becomes the main SC.

Certain factors, namely disabling or running SC POST with different diag levels, influence which SC is booted first.

- Be sure that SC failover is enabled and active before you power cycle your system, to ensure that data on both system controllers is current and synchronized.

If SC failover is disabled at the time a power cycle occurs, it is possible for the new main SC to boot with a stale SC configuration.

When SC failover is disabled, data synchronization does not occur between the main and spare SC. As a result, any configuration changes made on the main SC are not propagated to the spare. If the roles of the main and spare SC change after a power cycle, `scapp` on the new main SC will boot with a stale SC configuration. As long as SC failover is enabled and active, data on both SCs will be synchronized, and it will not matter which SC becomes the main SC after the power cycle.

---

# How to Manage SC Failover

You control the failover state through the `setfailover` command, which enables you to do the following:

- Disable SC failover.
- Enable SC failover.
- Perform a manual failover (force a failover from the main SC to the spare).

You can also obtain failover status information through commands such as `showfailover` or `showplatform`. For details, see “To Obtain Failover Status Information” on page 83.

## ▼ To Disable SC Failover

- From the platform shell on either the main or spare SC, type:

```
schostname:SC> setfailover off
```

A message indicates failover is disabled. Note that SC failover remains disabled until you re-enable it (see the next procedure).

## ▼ To Enable SC Failover

- From the platform shell on either the main or spare SC, type:

```
schostname:SC> setfailover on
```

The following message is displayed while the failover software verifies the failover-ready state of the system controllers:

```
SC Failover: enabled but not active.
```

Within a few minutes, after failover readiness has been verified, the following message is displayed on the console, indicating that SC failover is activated:

```
SC Failover: enabled and active.
```

## ▼ To Perform a Manual SC Failover

1. Be sure that other SC commands are not currently running on the main SC.
2. From the platform shell on either the main or spare SC, type:

```
schostname:SC> setfailover force
```

A failover from one SC to the other occurs, unless there are fault conditions (for example, the spare SC is not available or the connection link between the SCs is down) that prevent the failover from taking place.



A message describing the failover event is displayed on the console of the new main SC.

Be aware that the SC failover capability is automatically disabled after the failover. If at some point you need the SC failover feature, be sure to re-activate failover (see “To Enable SC Failover” on page 82).

## ▼ To Obtain Failover Status Information

Display failover information through the following commands:

- The `showfailover(1M)` command displays SC failover state information, for example:

```
schostname:SC> showfailover -v
SC: SSC0
Main System Controller
SC Failover: enabled and active.
Clock failover enabled.
```

The SC failover state can be one of the following:

- `enabled and active` - SC failover is enabled and functioning normally.
- `disabled` - SC failover has been disabled as a result of an SC failover or because the SC failover feature was specifically disabled (through the `setfailover off` command)
- `enabled but not active` - SC failover is enabled, but certain hardware components, such as the spare SC or the centerplane between the main and spare SC, are not in a failover-ready state.
- The `showplatform` and `showsc` commands also display failover information, similar to the output of the `showfailover` command.
- The `showboards` command identifies the state of the System Controller boards, either Main or Spare.

For details on these commands, refer to their descriptions in the *Sun Fire 6800/4810/4800/38000 System Controller Command Reference Manual*.

---

# How to Recover After an SC Failover

After an SC failover occurs, you must perform certain recovery tasks:

- Identify the failure point or condition that caused the failover and determine how to correct the failure.
  - Use the `showlogs` command to review the platform messages logged for the working SC. Evaluate these messages for failure conditions and determine the corrective action needed to reactivate any failed components.

If the `syslog` loghost has been configured, you can review the platform loghost to see any platform messages for the failed SC.

- If you need to replace a failed System Controller board, see “To Remove and Replace a System Controller Board in a Redundant SC Configuration” on page 103.
- If an automatic failover occurred while you were running the `flashupdate`, `setkeyswitch`, or dynamic reconfiguration commands, note that those operations are stopped and must be rerun after you resolve the failure condition.

However, if you were running configuration commands such as `setupplatform`, it is possible that some configuration changes occurred before the failover. Be sure to verify whether any configuration changes were made. For example, if you were running the `setupplatform` command when an automatic failover occurred, use the `showplatform` command to verify any configuration changes made before the failover. After you resolve the failure condition, run the appropriate commands to update your configuration as needed.

- After you resolve the failover condition, re-enable SC failover by using the `setfailover` on command (see “To Enable SC Failover” on page 82).

## Testing System Boards

---

This chapter describes how to test

- A CPU/Memory board with the system controller `testboard` command
- An I/O assembly in a spare domain with POST

The CPU/Memory board and I/O assembly are the only boards with directed tests.

---

## Testing a CPU/Memory Board

Use the `testboard` system controller command to test the CPU/Memory board name you specify on the command line. This command is available in both the platform and domain shells.

### Requirements

- Domain cannot be active
- Board power must be on
- Repeater boards used to run the domain must also be powered on. See “Repeater Boards” on page 18 for the Repeater boards needed to run the domain.
- Board *must not* be part of an active domain. The board should be in the Assigned state (if running from a domain shell). Use `showboards` to display the board state.

## ▼ To Test a CPU/Memory Board

To test a CPU/Memory board from a domain A shell, type the `testboard` command:

```
schostname:A> testboard sbx
```

where `sbx` is `sb0` through `sb5` (CPU/Memory boards).

For complete command syntax and examples, refer to the `testboard` command in the *Sun Fire 6800/4810/4800/3800 System Controller Command Reference Manual*.

---

## Testing an I/O Assembly

You test a CPU/Memory board with the `testboard` command. However, you cannot test an I/O assembly with the `testboard` command. Testing a board with `testboard` requires CPUs to test a board. No CPUs are present on an I/O assembly.

To test an I/O assembly with POST, you must construct a spare domain with the unit under test and a board with working CPUs. The spare domain must meet these requirements:

- Domain cannot be active
- Contain at least one CPU/Memory board

If your spare domain *does not* meet these requirements, the following procedure, “To Test an I/O Assembly” on page 87, explains how to:

- Halt the Solaris operating environment in the spare domain
- Assign a CPU/Memory board to the spare domain

## ▼ To Test an I/O Assembly

1. **Verify that you have a spare domain. Type the `showplatform` command from the platform shell.**

If you have a spare domain, go to Step 3. If you do not have a spare domain, go to Step 2.

2. **Complete these steps if you do not have a spare domain.**

- If you have a system with one partition and one domain, add a second domain to the partition.

See “Creating and Starting Domains” on page 53. Go to Step 3.

- If you have a system with one partition and the partition contains two domains, create a spare domain in the second partition:

- a. Shut down all running domains in the chassis.

- b. Change the partition mode to dual by running the `setupplatform` command.

See the `setupplatform` command in the *Sun Fire 6800/4810/4800/3800 System Controller Command Reference Manual*.

- c. Create a spare domain in the second partition.

See “Creating and Starting Domains” on page 53.

3. **Enter the domain shell (a through d) of a spare domain.**

See “System Controller Navigation” on page 32.

4. **If the spare domain is running the Solaris operating environment (#, % prompts displayed), halt the Solaris operating environment in the domain.**

Refer to the *Sun Hardware Platform Guide*, which is available with your Solaris release.

5. **Verify if the spare domain contains at least one CPU/Memory board by typing the `showboards` command.**

If you need to add a CPU/Memory board to the spare domain, go to Step 6. Otherwise, go to Step 7.

6. **Assign a CPU/Memory board with a minimum of one CPU to the spare domain with the `addboard` command.**

This example shows assigning a CPU/Memory board to domain B (in the domain B shell)

```
schostname:B> addboard sbx
```

where `sbx` is `sb0` through `sb5`.

**7. Assign the I/O assembly you want to test on the spare domain with the `addboard` command.**

This example shows assigning an I/O assembly to domain B (in the domain B shell).

```
schostname:B> addboard ibx
```

where *x* is 6, 7, 8, or 9.

**8. Run the `setupdomain` command to configure parameter settings, such as `diag-level` and `verbosity-level`.**

This command is an interactive command. For command syntax and a code example, refer to the `setupdomain` command in the *Sun Fire 6800/4810/4800/3800 System Controller Command Reference Manual*.

**9. Verify that the date and time are set correctly with `showdate`.**

If the date and time are not set correctly, reset the date and time with `setdate`.

For complete `setdate` command syntax and examples, refer to the `setdate` command in the *Sun Fire 6800/4810/4800/3800 System Controller Command Reference Manual*.

**10. Turn the keyswitch on in the spare domain.**

This action runs POST in the domain.

```
schostname:B> setkeyswitch on
.
.
ok
```

The I/O assembly is tested. However, the cards in the I/O assembly are not tested. To test the cards in the I/O assembly, you must boot the Solaris operating environment.

■ If the `setkeyswitch` operation succeeds:

You will see the `ok` prompt, which means that it is likely that the I/O assembly is working. However, it is possible that some components have been disabled. You can also view the output of the `showboards` command to view the status of the boards after testing.

■ If POST finds errors:

Error messages are displayed of the test that failed. Check the POST output for error messages. If the `setkeyswitch` operation fails, an error messages is displayed telling you why the operation failed. You will obtain the domain shell.

**11. Obtain the domain shell from the domain console.**

See “To Obtain the Domain Shell From the Domain Console” on page 32.

**12. Turn the keyswitch to standby.**

```
shostname:B> setkeyswitch standby
```

**13. Delete the I/O assembly in the spare domain with deleteboard.:**

```
shostname:B> deleteboard ibx
```

where *x* is the board number you typed in Step 7.

**14. Exit the spare domain shell and go back to the domain you were in before entering the spare domain.**

See “System Controller Navigation” on page 32.





## Removing and Replacing Boards

---

This chapter discusses the software steps to remove and replace the following boards, cards, and assemblies:

- “CPU/Memory Boards and I/O Assemblies” on page 92
- “CompactPCI and PCI Cards” on page 98
- “Repeater Board” on page 99
- “System Controller Board” on page 101
- “ID Board and Centerplane” on page 104

In addition, this chapter also describes how to unassign a board from a domain and disable the board.

To troubleshoot board and component failures, see “Board and Component Failures” on page 112. To remove and install the FrameManager, ID board, power supplies, and fan trays, refer to the *Sun Fire 6800/4810/4800/3800 Systems Service Manual*.

Before you begin, have the following books handy:

- *Sun Hardware Platform Guide*
- *Sun Fire 6800/4810/4800/3800 Systems Service Manual*

You will need these books for Solaris operating environment steps and hardware removal and installation steps. The first book is available with your Solaris operating environment release.

---

# CPU/Memory Boards and I/O Assemblies

The following procedures describe the software steps needed to

- Remove and replace a system board (CPU/Memory board or I/O assembly)
- Unassign a system board from a domain or disable a system board
- Hot-swap a CPU/Memory board or an I/O assembly

For details on

- Moving a CPU/Memory board or an I/O assembly between domains
- Disconnecting a CPU/Memory board or I/O assembly (leave it in the system until a replacement board is available)

refer to the *Sun Fire 6800, 4810, 4800, and 3800 Systems Dynamic Reconfiguration User Guide*.

## ▼ To Remove and Replace a System Board

The following procedure describes the steps for removing and replacing a system board without using Dynamic Reconfiguration commands.

- 1. Connect to the domain console for the domain that contains the board or assembly you want to remove and replace.**

See Chapter 2.

- 2. Halt the Solaris operating environment in the domain containing the board or assembly you want to remove.**

Refer to the *Sun Hardware Platform Guide*. You should see the `ok` prompt.

- 3. Get to the domain shell prompt.**

For details on accessing the domain shell, see Chapter 2.

4. Turn the domain keyswitch to the standby position with the `setkeyswitch standby` command. Power off the board or assembly. Type:

```
schostname:A> setkeyswitch standby
```

```
schostname:A> poweroff board_name
```

where:

`board_name` is sb0 - sb5 or ib6 - ib9

5. Verify the green power LED is off (  ).

6. Remove the board or assembly.

Refer to the *Sun Fire 6800/4810/4800/3800 Systems Service Manual*.

7. Replace a new board or assembly.

8. Power on the board or assembly. Type:

```
schostname:SC> poweron board_name
```

where `board_name` is sb0 - sb5 or ib6 - ib9

9. Check the version of the firmware that is installed on the board by using the `showboards` command:

```
schostname:SC> showboards -p version
```

The firmware version of the new replacement board must be compatible with the system controller software version.

10. If the firmware version of the replacement board or assembly is different from the board you removed, update the firmware on the board.

For a description of command syntax, refer to the `flashupdate` command in the *Sun Fire 6800/4810/4800/3800 System Controller Command Reference Manual*.

- a. If you have a CPU/Memory board of the same type installed, use the `flashupdate -c` command:

```
schostname:SC> flashupdate -c source_board destination_board
```

After completing this step, go to Step c.

If you do not have a CPU/Memory board of the same type installed, go to Step b.

- b. If you do not have a CPU/Memory board of the same type installed, use the `flashupdate -f` command. Type:

```
schostname:SC> flashupdate -f url board
```

- c. If a board was noted by the `Failed` state in `showboards`, after you `flashupdate` a compatible version, power off the board to clear the `Failed` state.

**11. Complete this step if you have an I/O assembly.**

- a. Before you bring the board back to the Solaris operating environment, test the I/O assembly in a spare domain that contains at least one CPU/Memory board with a minimum of one CPU.

- b. Enter a spare domain.

- c. Test the I/O assembly.

See “Testing an I/O Assembly” on page 86.

**12. Turn the domain keyswitch to the on position with the `setkeyswitch on` command.**

```
schostname:A> setkeyswitch on
```

This command turns the domain on and boots the Solaris operating environment if the system controller `setupdomain OBP.auto-boot?` parameter is set to true and the OpenBoot PROM `boot-device` parameter is set to the proper boot device.

- If the Solaris operating environment did not boot automatically, continue with the next step.
- If the appropriate OpenBoot PROM parameters are not set up to take you to the `login:` prompt, you will see the `ok` prompt.

For more information on the OpenBoot PROM parameters, refer to the *Sun Hardware Platform Guide*.

13. At the `ok` prompt, type the `boot` command:

```
ok boot
```

After the Solaris operating environment is booted, the `login:` prompt is displayed.

## ▼ To Unassign a Board From a Domain or Disable a System Board

If a CPU/Memory board or I/O assembly fails, complete one of the following tasks:

- Unassign the board from the domain. See “To Unassign a Board From a Domain” on page 74.

OR

- Disable the board. Refer to the `disablecomponent` command in the *Sun Fire 6800/4810/4800/3800 System Controller Command Reference Manual*. Disabling the board prevents it from re-entering the domain when the domain is rebooted.

## ▼ To Hot-Swap a CPU/Memory Board

1. Use DR to unconfigure and disconnect the CPU/Memory board out of the domain.

Refer to the *Sun Fire 6800, 4810, 4800, and 3800 Systems Dynamic Reconfiguration User Guide*.

2. Verify the state of the LEDs on the board.

Refer to the CPU/Memory board chapter of the *Sun Fire 6800/4810/4800/3800 Systems Service Manual*.

3. Remove and replace the board.

Refer to the CPU/Memory board chapter of the *Sun Fire 6800/4810/4800/3800 Systems Service Manual*.

4. Power on the board.

5. Check the version of the firmware that is installed on the board by using the `showboards` command:

```
shostname:SC> showboards -p version
```

The firmware version of new replacement board should be the same as the board you just removed.

**6. If the firmware version of the replacement board or assembly is different from the board you removed, update the firmware on the board.**

- If you have a CPU/Memory board of the same type installed, use the `flashupdate -c` command:

```
schostname:SC> flashupdate -c source_board destination_board
```

For a description of command syntax, refer to the `flashupdate` command in the *Sun Fire 6800/4810/4800/3800 System Controller Command Reference Manual*. Go to Step 7.

- If you do not have a CPU/Memory board of the same type installed, use the `flashupdate -f` command:

```
schostname:SC> flashupdate -f URL board
```

For a description of command syntax, refer to the `flashupdate` command in the *Sun Fire 6800/4810/4800/3800 System Controller Command Reference Manual*.

**7. Use DR to connect and configure the board back into the domain.**

Refer to the *Sun Fire 6800, 4810, 4800, and 3800 Systems Dynamic Reconfiguration User Guide*.

**8. Verify the state of the LEDs on the board.**

Refer to the CPU/Memory board chapter of the *Sun Fire 6800/4810/4800/3800 Systems Service Manual*.

## ▼ To Hot-Swap an I/O Assembly

The following procedure describes how to hot-swap an I/O assembly and test it in a spare domain not running the Solaris operating environment.

**1. Use DR to unconfigure and disconnect the I/O assembly out of the domain.**

Refer to the *Sun Fire 6800, 4810, 4800, and 3800 Systems Dynamic Reconfiguration User Guide*

**2. Verify the state of the LEDs on the assembly.**

Refer to the I/O assembly chapter of the *Sun Fire 6800/4810/4800/3800 Systems Service Manual*.

### 3. Remove and replace the assembly.

Refer to the I/O assembly chapter of the *Sun Fire 6800/4810/4800/3800 Systems Service Manual*.

### 4. Power on the board.:

```
schostname:SC> poweron board_name
```

### 5. Check the version of the firmware that is installed on the assembly by using the showboards command:

```
schostname:SC> showboards -p version
```

The firmware version of the new replacement assembly should be same as the assembly you just removed.

### 6. If the firmware version of the replacement assembly is a different from the assembly you removed, update the firmware on the assembly.

For a description of command syntax, refer to the `flashupdate` command in the *Sun Fire 6800/4810/4800/3800 System Controller Command Reference Manual*.

- If you have an I/O assembly of the same type installed, use the `flashupdate -c` command:

```
schostname:SC> flashupdate -c source_board destination_board
```

Go to Step 8.

- If you do not have a I/O assembly of the same type installed, use the `flashupdate -f` command:

```
schostname:SC> flashupdate -f URL board
```

### 7. Before you bring the board back to the Solaris operating environment, test the I/O assembly in a spare domain that contains at least one CPU/Memory board with a minimum of one CPU.

#### a. Enter a spare domain.

#### b. Test the I/O assembly.

For details, see “Testing an I/O Assembly” on page 86.

8. Use DR to connect and configure the assembly back into the domain running the Solaris operating environment.

Refer to the *Sun Fire 6800, 4810, 4800, and 3800 Systems Dynamic Reconfiguration User Guide*.

---

## CompactPCI and PCI Cards

If you need to remove and replace a PCI or CompactPCI card, follow the instructions below. The replacement procedure for CompactPCI cards requires that you simply remove and replace the card. For further information on physically replacing CompactPCI and PCI cards, refer to the *Sun Fire 6800/4810/4800/3800 Systems Service Manual*.

### ▼ To Remove and Replace a PCI Card

The following procedure describes the steps for removing and replacing a PCI card without using DR commands.

1. **Halt the Solaris operating environment in the domain, power off the I/O assembly, and remove it from the system.**

Complete Step 1 through Step 6 in “To Remove and Replace a System Board” on page 92.

2. **Remove and replace the card.**

Refer to the *Sun Fire 6800/4810/4800/3800 Systems Service Manual*.

3. **Replace the I/O assembly and power it on.**

Complete Step 7 and Step 8 in “To Remove and Replace a System Board” on page 92.

4. **Reconfigure booting of the Solaris operating environment in the domain.**

At the `ok` prompt, type `boot -r`.

```
ok boot -r
```



## ▼ To Remove and Replace a CompactPCI Card

- **Remove and replace the CompactPCI card from the I/O assembly.**

For details, refer to the *Sun Fire 6800/4810/4800/3800 Systems Service Manual*.

---

## Repeater Board

This section discusses the software steps necessary to remove and replace a Repeater board. Only the Sun Fire 6800/4810/4800 systems have Repeater boards. The Sun Fire 3800 system has the equivalent to two Repeater boards on the active centerplane.

## ▼ To Remove and Replace a Repeater Board

To remove and replace a Repeater board, you must halt and power off the domains that the Repeater board is connected to.



---

**Caution** – Be sure you are properly grounded before you remove and replace the Repeater board.

---

1. **Determine which domains are active by typing the `showplatform -p status` system controller command from the platform shell.**
2. **Determine which Repeater boards are connected to each domain (TABLE 9-1).**

TABLE 9-1 Repeater Boards and Domains

System	Partition Mode	Repeater Board Names	Domain IDs
Sun Fire 6800 system	Single partition	RP0, RP1, RP2, RP3	A, B
Sun Fire 6800 system	Dual partition	RP0, RP1	A, B
Sun Fire 6800 system	Dual partition	RP2, RP3	C, D
Sun Fire 4810 system	Single partition	RP0, RP2	A, B
Sun Fire 4810 system	Dual partition	RP0	A
Sun Fire 4810 system	Dual partition	RP2	C
Sun Fire 4800 system	Single partition	RP0, RP2	A, B

TABLE 9-1 Repeater Boards and Domains (Continued)

System	Partition Mode	Repeater Board Names	Domain IDs
Sun Fire 4800 system	Dual partition	RP0	A
Sun Fire 4800 system	Dual partition	RP2	C
Sun Fire 3800 system	Equivalent of two Repeater boards integrated into the active centerplane.		

**3. Complete the steps to:**

- Halt the Solaris operating environment in each domain the Repeater board is connected to.
- Power off each domain.

Complete Step 1 through Step 3 in “To Power Off the System” on page 66.

**4. Power off the Repeater board with the `poweroff` command.**

```
schostname:SC> poweroff board_name
```

*board\_name* is the name of the Repeater board (rp0, rp1, rp2, or rp3).

**5. Verify the green power LED is off (  ).**

**6. Remove and replace the Repeater board.**

Refer to the *Sun Fire 6800/4810/4800/3800 Systems Service Manual*.

**7. Boot each domain using the normal boot procedure.**

Refer to “To Power On the System” on page 68.

---

# System Controller Board

This section discusses how to remove and replace a System Controller board.

## ▼ To Remove and Replace the System Controller Board in a Single SC Configuration

To remove a defective System Controller board in a single SC configuration and replace it with a working System Controller board, follow these steps:

1. **For each active domain, use a telnet session to access the domain (see Chapter 2 for details), and halt the Solaris operating environment in the domain.**



---

**Caution** – Since you do not have access to the console, you will not be able to determine when the operating environment is completely halted. Using your best judgement, wait until you can best judge that the operating environment has halted.

---

2. **Turn off the system completely. Be sure to power off the circuit breakers and the power supply switches for the Sun Fire 3800 system. Make sure you power off all the hardware components to the system.**

Refer to the “Powering Off and On” chapter in the *Sun Fire 6800/4810/4800/3800 Systems Service Manual*.

3. **Remove the defective System Controller board and replace the new System Controller board.**

Refer to the “System Controller Board” chapter in the *Sun Fire 6800/4810/4800/3800 Systems Service Manual*.

4. **Power on the RTUs, AC input boxes, and the power supply switches.**

Refer to the “Powering Off and On” chapter in the *Sun Fire 6800/4810/4800/3800 Systems Service Manual*. When the specified hardware is powered on, the System Controller board will automatically power on.

- 5. If you previously saved the platform and domain configurations using the `dumpconfig` command, use the `restoreconfig` command to restore the platform and domain configurations from a server.**

You must have saved the latest platform and domain configurations of your system with the `dumpconfig` command in order to restore the latest platform and domain configurations with the `restoreconfig` command. For command syntax and examples, see the `restoreconfig` command in the *Sun Fire 6800/4810/4800/3800 System Controller Command Reference Manual*.

- If you did not type the `dumpconfig` command earlier, configure the system again. See Chapter 3.

---

**Note** – When you insert a new System Controller board into the system, it is set to the default values of the `setupplatform` command. It is set to DHCP, which means the system controller will use DHCP to get to its network settings.

If DHCP is not available (there is a 60-second timeout waiting period), then the System Controller board will boot and the network (`setupplatform -p net`) will need to be configured before you can type the `restoreconfig` command.

---

- 6. Check the date and time for the platform and each domain. Type the `showdate` command in the platform shell and in each domain shell.**

If you need to reset the date or time, go to Step 7. Otherwise, skip to Step 8.

- 7. Set the date and time for the platform and for each domain (if needed).**

- a. Set the date and time for the platform shell.**

See the `setdate` command in the *Sun Fire 6800/4810/4800/3800 System Controller Command Reference Manual*.

- b. Set the date for each domain shell.**

- 8. Check the configuration for the platform by typing `showplatform` at the platform shell. If necessary, run the `setupplatform` command to configure the platform.**

See “To Configure Platform Parameters” on page 47.

- 9. Check the configuration for each domain by typing `showdomain` in each domain shell. If necessary, run the `setupdomain` command to configure each domain.**

See “To Configure Domain-Specific Parameters” on page 49.

- 10. Boot the Solaris operating environment in each domain you want powered on.**

- 11. Complete Step 4 and Step 5 in “To Power On the System” on page 68.**

## ▼ To Remove and Replace a System Controller Board in a Redundant SC Configuration

To remove a defective System Controller board in a redundant SC configuration and replace it with a working System Controller board, follow these steps:

1. **Run the `showsc` or `showfailover -v` command to determine which SC is the main.**
2. **If the working system controller (the one that is not to be replaced) is not the main, perform a manual failover so that the working system controller becomes the main SC:**

```
schostname:sc> setfailover force
```

3. **Power off the system controller to be replaced:**

```
schostname:SC> poweroff component_name
```

where *component\_name* is the name of the System Controller board to be replaced, either SSC0 or SSC1.

The System Controller board is powered off, and the hot-plug LED is illuminated. A message indicates when you can safely remove the system controller.

4. **Remove the defective System Controller board and replace it with the new System Controller board.**  
The new System Controller board powers on automatically.
5. **Verify that the firmware on the new system controller matches the firmware on the working SC.**

You can use the `showsc` command to check the firmware version (the ScApp version) running on the system controller. If the firmware versions do not match, use the `flashupdate` command to upgrade the firmware on the new system controller so that it corresponds with the firmware version on the other SC.

6. **Re-enable SC failover by running the following command on the main or spare SC:**

```
schostname:SC> setfailover on
```

---

# ID Board and Centerplane

## ▼ To Remove and Replace ID Board and Centerplane

1. **Before you begin, be sure to have a terminal connected to the serial port of the system controller and have the following information available (it will be used later in this procedure):**

- System serial number
- Model number
- MAC address (for domain A)
- Host ID (for domain A)
- Know if you have a Capacity on Demand system

This information can be found on labels affixed to the system. Refer to the *Sun Fire 6800/4810/4800/3800 Systems Service Manual* for more information on label placement.

In most cases, when only the ID board and centerplane are replaced, the original System Controller board will be used. The above information was already cached by the system controller and will be used to program the replacement ID board. You will be asked to confirm the above information.

2. **Complete the steps to remove and replace the centerplane and ID board.**

Refer to the "Centerplane and ID Board" chapter of the *Sun Fire 6800/4810/4800/3800 Systems Service Manual*.

---

**Note** – The ID board can be written only once. Exercise care to manage this replacement process carefully. Any errors may require a new ID board.

---

3. **After removing and replacing the ID board, make every attempt to use the original System Controller board installed in slot ssc0 in this system.**

Using the same System Controller board allows the system controller to automatically prompt with the correct information.

4. **Power on the hardware components.**

Refer to the "Power Off and On" chapter of the *Sun Fire 6800/4810/4800/3800 Systems Service Manual*.

The system controller boots automatically.

- 5. If you have a serial port connection, access the console for the system controller because the system will prompt you to confirm the board ID information (CODE EXAMPLE 9-1).**

The prompting will not occur with a telnet connection.

#### CODE EXAMPLE 9-1 Confirming Board ID Information

```
It appears that the ID Board has been replaced.
Please confirm the ID information:
(Model, System Serial Number, Mac Address Domain A, HostID Domain A, COD Status)
Sun Fire 4800, 45H353F, 08:00:20:d8:a7:dd, 80d8a7dd, non-COD
Is the information above correct? (yes/no):
```

If you have a new System Controller board, skip Step 6 and go to Step 7.

- 6. Compare the information collected in Step 1 with the information you have been prompted with in Step 5.**
  - If the information matches, answer **yes** to the above question on the system controller console. The system will boot normally.
  - If the information does not match, answer **no** to the above question on the system controller console.
- 7. If you answer “no” to the question in Step 6 or if you are replacing both the ID board and the System Controller board at the same time, you will be prompted to enter the ID information manually.**

---

**Note** – Enter this information carefully, as you have only one opportunity to do so. Use the information collected in Step 1 to answer the questions prompted for in CODE EXAMPLE 9-2. Be aware that you must specify the MAC address and Host ID of domain A (not for the system controller).

---

#### CODE EXAMPLE 9-2 ID Information To Enter Manually

```
Please enter System Serial Number: xxxxxxxx
Please enter the model number (3800/4800/4810/6800): xxxx
MAC address for Domain A: xx:xx:xx:xx:xx:xx
Host ID for Domain A: xxxxxxxx
Is COD (Capacity on Demand) system ? (yes/no): xx
Programming Replacement ID Board
Caching ID information
```

- 8. Complete Step 3 and Step 4 in “To Power On the System” on page 68.**





# Troubleshooting

---

This chapter provides troubleshooting information for a system administrator. The chapter describes the following topics:

- “System Faults” on page 107
- “Displaying Diagnostic Information” on page 107
- “Displaying System Configuration Information” on page 108
- “Assisting Sun Service Personnel” on page 108
- “Domain Not Responding” on page 109
- “Board and Component Failures” on page 112
- “Disabling Components” on page 122

---

## System Faults

An internal fault is any condition that is considered to be unacceptable for normal system operation. When the system has a fault, the Fault LED () will turn on. You must take immediate action to eliminate an internal fault.

---

## Displaying Diagnostic Information

For information on displaying diagnostic information, refer to the *Sun Hardware Platform Guide*, which is available with your Solaris operating environment release.

---

# Displaying System Configuration Information

To display system configuration parameters, refer to the *Sun Hardware Platform Guide*, which is available with your Solaris operating environment release.

---

## Assisting Sun Service Personnel

The following procedure, lists the actions you must take to help Sun service personnel determine the cause of your failure.

### ▼ To Determine the Cause of Your Failure

- **Provide the following information to Sun service personnel so that they can help you determine the cause of your failure:**
  - The system controller log files, if the system controller has a loghost. The system controller log files are necessary because they contain more information than the `showlogs` system controller command. Also, with the system controller log files, the Sun service personnel is able to obtain a history of the system, which can help during troubleshooting.
  - A verbatim transcript of all output written to the domain console leading up to the failure. Also include any output printed subsequent to user actions. If the transcript does not show certain user actions, in a separate file include comments on what actions prompted particular messages.
  - A copy of the domain log file as well as other files from `/var/adm/messages` from the time leading up to the failure.
  - The following system controller command output from the platform shell:
    - `showsc -v`
    - `showplatform -v`
    - `showplatform -v -d domainID`
    - `showboards -v`
    - `showlogs -v`
    - `showlogs -v -d domainID`

---

# Domain Not Responding

If a domain is not responding, the domain is most likely hung or paused. This section covers how to determine if a domain is hung or paused and how to recover from a hard hung or paused domain.

## Hung Domain

If the console is not responding, the Solaris operating environment is not responding, and typing the `break` command from the domain shell did not work, the domain is hard hung.

Follow the procedure, “To Recover a Hard Hung or Paused Domain” on page 110, if:

- The domain is no longer working.
- It is not possible to log into the domain to terminate processes or reboot directly.



---

**Caution** – Completing the steps in “To Recover a Hard Hung or Paused Domain” on page 110 terminates the Solaris operating environment. Do not perform the steps in this procedure unless the domain is not working.

When the Solaris operating environment is terminated, data in memory might not be flushed to disk. This could cause a loss or corruption of the application file system data.

---

## Paused Domain

Another possibility is that the domain may be paused due to a hardware error that also may be causing this condition. If the system controller detects a hardware error, and the `reboot-on-error` parameter is set to true, the domain is automatically rebooted. If the `reboot-on-error` parameter is set to false, the domain is paused. If the domain is paused, turn the domain off with `setkeyswitch off` and then turn the domain on with `setkeyswitch on`. See the procedure “To Recover a Hard Hung or Paused Domain” on page 110 for steps to perform.

## ▼ To Recover a Hard Hung or Paused Domain

### 1. Verify that the system controller is functioning.

Access the platform shell and the domain shell of the failing domain. See “System Controller Navigation” on page 32.

### 2. If you cannot access both the platform and domain shell, reset the system controller by pressing the reset button on the System Controller board.

See “System Controller Board Failure” on page 113. Wait for the system controller to reboot.

### 3. Determine the status for the domain as reported by the system controller. Type *one* of the following system controller commands:

- `showplatform -p status` (platform shell)
- `showdomain -p status` (domain shell)

These commands provide the same type of information in the same format.

- If the output in the `Domain Status` field displays `Paused` due to an error, the domain has paused due to a hardware error. Go to Step 4.
- If the output in the `Domain Status` field displays `Not Responding`, the system controller has determined that the domain is hung. You must reset the domain. Go to Step 5.
- If the output in the `Domain Status` field displays any `Active` status, this indicates that the system controller has *not detected* that the domain is hung. You must reset the domain. Go to Step 5.

### 4. Reboot the domain manually. Complete the following substeps:

#### a. Access the domain shell.

See “System Controller Navigation” on page 32.

#### b. Turn off the domain. Type `setkeyswitch off`.

#### c. Turn on the domain. Type `setkeyswitch on`.

### 5. If the output displays `Not Responding` or any `Active` status, reset the domain. Complete the following substeps.

---

**Note** – A domain cannot be reset while the domain keyswitch is in the secure position.

---

#### a. Access the domain shell.

See “System Controller Navigation” on page 32.

**b. Reset the domain by typing `reset`.**

In order for the system controller to perform this operation, you must confirm it. For a complete definition of this command, refer to the `reset` command in the *Sun Fire 6800/4810/4800/3800 System Controller Command Reference Manual*.

**c. Perform one of the following actions depending on the setting of the `OBP.error-reset-recovery` variable in the `setupdomain` command (TABLE 10-1).**

- If the setting is `sync`, the domain should automatically produce a Solaris core file and then reboot. No further action is required.

---

**Note** – Changing the default setting of `sync` is not advised. If a core file is not obtained, the chance of identifying and fixing the failure is considerably reduced.

---

- If the setting is `none`, the domain returns to the `ok` prompt. Type `sync` at the `ok` prompt to obtain a core file.
- If the setting is `boot`, the domain should automatically reboot without obtaining a core file.

**TABLE 10-1** OpenBoot PROM `error-reset-recovery` Configuration Variable Settings

OpenBoot PROM Configuration Variable Setting for <code>error-reset-recovery</code>	Action
<code>none</code>	The domain returns immediately to the OpenBoot PROM.
<code>sync</code> (default)	The domain generates a Solaris operating environment core file and reboots the domain.
<code>boot</code>	The domain is rebooted.

---

**Note** – If the configuration variable is set to `none` and the OpenBoot PROM takes control, you can type any OpenBoot PROM command from the `ok` prompt, including rebooting the Solaris operating environment with the `boot` command.

---

**d. If no core file can be obtained after Step c:**

**i. Access the domain console from the domain shell.**

See “System Controller Navigation” on page 32.

**ii. Type `showresetstate -v` or `showresetstate -v -f URL` from the domain shell.**

This command prints a summary report of the contents of registers from every CPU in the domain that has a valid saved state. If you specify the `-f URL` option with the `showresetstate` command, the report summary is written to a URL, which can be reviewed by Sun Service personnel (see the following step) to analyze a failure or problem.

iii. **Save the output and include the command output with the information you provide to Sun service personnel as described in “To Determine the Cause of Your Failure” on page 108.**

iv. **Reboot the domain by typing `setkeyswitch off`. Then type `setkeyswitch on`.**

---

## Board and Component Failures

This section describes what to do when the following boards or components fail:

- CPU/Memory board
- I/O assembly
- Repeater board
- System Controller board
- Power supply
- Fan tray
- FrameManager

### CPU/Memory Board Failure

---

If a CPU/Memory Board Fails	Perform the Following Actions
When a CPU/Memory board fails, the domain the CPU/Memory board is in will either go down or will hang, depending on the type of failure	<ul style="list-style-type: none"><li>• Delete the board from the domain.</li><li>• If the domain is hard hung, perform the steps in “To Recover a Hard Hung or Paused Domain” on page 110.</li></ul>

---

# I/O Assembly Failure

---

If an I/O Assembly Fails	Perform the Following Actions
When an I/O assembly fails, the domain containing the I/O assembly will either go down or will hang. What event occurs depends on the failure.	<ul style="list-style-type: none"><li>• Delete the I/O assembly from the domain.</li><li>• If the domain is hard hung, perform the steps in “To Recover a Hard Hung or Paused Domain” on page 110.</li></ul>

---

# System Controller Board Failure

---

If a System Controller Board Fails	Perform the Following Actions
In a single SC configuration:	Perform the procedure “To Remove and Replace the System Controller Board in a Single SC Configuration” on page 101.
In a redundant SC configuration:	Perform the procedure “To Remove and Replace a System Controller Board in a Redundant SC Configuration” on page 103.
If you have one system controller and the clock on the system controller fails:	<ol style="list-style-type: none"><li>1. Replace the system controller. Refer to the “System Controller” chapter of the <i>Sun Fire 6800/4810/4800/3800 Systems Service Manual</i>.</li><li>2. Reboot each domain in the system.</li></ol>
If you have only one system controller in the system, and the system controller fails due to a software error, is hung, or if does not respond:	<ol style="list-style-type: none"><li>1. Reboot the system controller from the system controller platform shell prompt with the <code>reboot</code> command.</li><li>2. If the system controller cannot be rebooted or the problem is more severe, reset the system controller board by pressing the reset button on the board with the tip of a pen (FIGURE 10-1).</li></ol>
If two system controllers are installed:	Wait for automatic SC failover to occur or force a manual failover to the other SC.

---

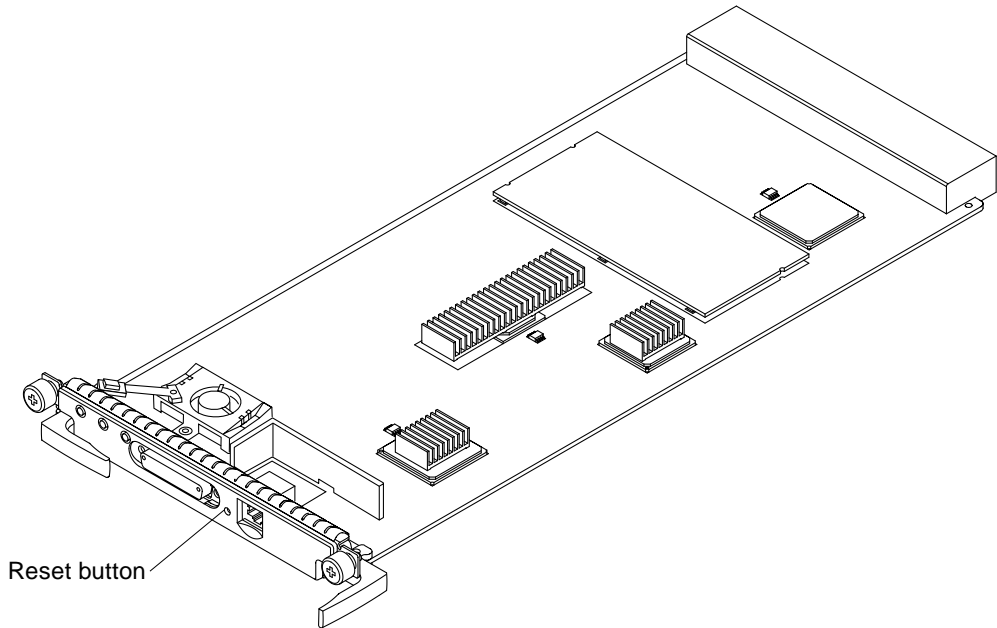

**FIGURE 10-1** Resetting the System Controller

## Collecting Platform and Domain Status Information

This section describes how to gather platform and domain status information for troubleshooting purposes.

---

**Note** – Messages diverted to external sysloghosts can be found in the `/var/adm/messages` file of the sysloghost.

---

### ▼ To Collect Platform Status Information

- 1. Be sure that the platform shell loghost is set up.**  
For details, see the description of the loghost service in TABLE 3-1.
- 2. Collect platform status information using the following system controller commands:**
  - `showsc`
  - `showboards`



- showenvironment
- showplatform
- showlogs

For details on how to use each of these commands, refer to the *Sun Fire 6800/4810/4800/3800 System Controller Command Reference Manual*.

### 3. Collect service-required LED status and data from the platform shell loghost.

---

**Note** – Before you access domain shells and collect domain information, check the platform logs first for any hardware errors. A hardware platform error could lead to subsequent domain software errors.

---

## ▼ To Collect Domain Status Information

1. If a domain is paused due to a system error, collect error messages from the designated domain sysloghost.
  - a. Be sure that the loghost for each domain is set up, as described in TABLE 3-1.
  - b. Collect error messages from the designated domain `syslog` loghost.
  - c. Collect service-required LED status and data from the designated domain `syslog` loghost.
2. If a domain is not paused or hung, collect status information from the following sources:

**TABLE 10-2** Solaris Operating Environment and System Controller Software Commands for Collecting Status Information

Command	Description
<code>/var/adm/messages</code> file	Contains error messages relative to the current operating system initialization.
<code>dmesg</code> Solaris operating environment command	Looks in a system buffer for recently printed diagnostic messages and prints them on the standard output.
<code>showboards</code> , <code>showenvironment</code> , <code>showdomain</code> , and <code>showlogs</code> system controller commands	Refer to the <i>Sun Fire 6800/4810/4800/3800 System Controller Command Reference Manual</i> for a complete description and syntax on how to use these commands.
Fault LED	Amber fault LED is lit if there is a fault
Platform logs	Check the platform logs to determine if there are any hardware errors. A hardware platform error can lead to subsequent domain software errors.

For a thorough description of `/var/adm/messages` and `dmesg`, refer to the Solaris operating environment online documentation, which is available with your version of the Solaris operating environment.

# Repeater Board Failure

TABLE 10-3 presents information on how to troubleshoot a failed Repeater board by system type, partition mode, and the number of domains.

TABLE 10-3 Repeater Board Failure

System Failure Mode	Failed Repeater Board	Repeater Board and Domain Changes
Sun Fire 4810/4800 systems 1 partition 1 domain—A	RP0	System is down. <ul style="list-style-type: none"><li>• If a replacement Repeater board is available:<ol style="list-style-type: none"><li>1. Replace RP0. Refer to the <i>Sun Fire 6800/4810/4800/3800 Systems Service Manual</i>.</li><li>2. Reboot domain A. The domain reboots normally.</li></ol></li><li>• If a spare Repeater board <i>is not</i> available:<ol style="list-style-type: none"><li>1. Replace RP0 with RP2. Refer to the <i>Sun Fire 6800/4810/4800/3800 Systems Service Manual</i>.</li><li>2. Configure the system for dual partition mode with the <code>setupplatform</code> command.</li></ol></li></ul>
Sun Fire 3800 system 1 partition 1 domain—A	RP0	System is down. <ol style="list-style-type: none"><li>1. Configure the system for dual partition mode with the <code>setupplatform</code> command. Resources from domain A can be configured into domain C. If you manually reconfigure the resources, the domain will have the <code>hostID</code> and MAC address of domain C.</li><li>2. Reboot domain C.</li><li>3. Plan to replace the centerplane.</li></ol>
Sun Fire 4810/4800 systems 1 partition 1 domain—A	RP2	System is down. <ul style="list-style-type: none"><li>• If a replacement Repeater board is available:<ol style="list-style-type: none"><li>1. Replace RP2. Refer to the <i>Sun Fire 6800/4810/4800/3800 Systems Service Manual</i>.</li><li>2. Reboot domain A. The domain reboots normally.</li></ol></li><li>• If a spare Repeater board <i>is not</i> available:<ol style="list-style-type: none"><li>1. Configure the system for dual partition mode with the <code>setupplatform</code> command.</li><li>2. Reboot domain A. The domain reboots normally.</li></ol></li></ul>

**TABLE 10-3 Repeater Board Failure (Continued)**

System Failure Mode	Failed Repeater Board	Repeater Board and Domain Changes
Sun Fire 3800 system 1 partition 1 domain—A	RP2	System is down. 1. Configure the system to be in dual partition mode with the <code>setupplatform</code> command. 2. Reboot domain A. 3. Plan to replace the centerplane.
Sun Fire 6800 system 1 partition 1 domain—A	RP0 or RP1	System is down. • If a replacement Repeater board is available: 1. Replace the defective Repeater board in the Repeater board pair. • If a replacement Repeater board <i>is not</i> available: 1. Replace RP0 or RP1 with RP3 or RP4. Refer to the <i>Sun Fire 6800/4810/4800/3800 Systems Service Manual</i> . 2. Configure the system for dual partition mode with the <code>setupplatform</code> command.
Sun Fire 6800 system 1 partition 1 domain—A	RP2 or RP3	System is down. • If a replacement Repeater board is available: 1. Replace the defective Repeater board in the Repeater board pair. • If a replacement Repeater board <i>is not</i> available: 1. Configure the system to be in dual partition mode with the <code>setupplatform</code> command. RP0 and RP1 come up as partition 0 containing domain A, which reboots automatically.
Sun Fire 4810/4800/3800 system 2 partitions 2 domains—A, C	RP0	• RP0 cannot be used. • RP2 continues without rebooting. • Domain C continues unaffected. • Domain A cannot be rebooted, even in another domain, until you replace RP0.
Sun Fire 4810/4800/3800 system 2 partitions 2 domains—A, C	RP2	• RP0 continues without rebooting. • RP2 cannot be used. • Domain A continues unaffected. • Domain C cannot be rebooted until you replace RP2.

**TABLE 10-3 Repeater Board Failure (Continued)**

System Failure Mode	Failed Repeater Board	Repeater Board and Domain Changes
Sun Fire 4810/4800 system 1 partition 2 domains—A, B	RP0	<p>System is down.</p> <ul style="list-style-type: none"> <li>• If a replacement Repeater board is available:               <ol style="list-style-type: none"> <li>1. Replace RP0.</li> <li>2. Reboot both domains.</li> </ol> </li> <li>• If a replacement Repeater board <i>is not</i> available:               <ol style="list-style-type: none"> <li>1. Configure the system for dual partition mode using <code>setupplatform</code>.</li> <li>2. Reboot domain C.</li> </ol> </li> </ul> <p><b>Note:</b> Domain A is down. Domain B becomes domain C. The MAC address and hostID <i>will not</i> change.</p>
Sun Fire 3800 system 1 partition 2 domains—A, B	RP0	<p>System is down.</p> <ol style="list-style-type: none"> <li>1. Configure the system for dual partition mode using <code>setupplatform</code>.</li> <li>2. Reboot domain C.</li> </ol> <p><b>Note:</b> Domain A is down. Domain B becomes domain C. The MAC address and hostID <i>will not</i> change.</p> <ol style="list-style-type: none"> <li>3. Plan to replace the centerplane.</li> </ol>
Sun Fire 4810/4800 system 1 partition 2 domains—A, B	RP2	<p>System is down.</p> <ul style="list-style-type: none"> <li>• If a replacement Repeater board is available:               <ol style="list-style-type: none"> <li>1. Replace RP2.</li> <li>2. Reboot both domains.</li> </ol> </li> <li>• If a replacement Repeater board <i>is not</i> available:               <ol style="list-style-type: none"> <li>1. Configure the system for dual partition mode using <code>setupplatform</code>.</li> <li>2. Reboot domain A. In dual partition mode, you can reboot only domain A.</li> </ol> </li> </ul>
Sun Fire 3800 system 1 partition 2 domains—A, B	RP2	<p>System is down.</p> <ol style="list-style-type: none"> <li>1. Configure the system for dual partition mode using <code>setupplatform</code>.</li> <li>2. Plan to replace the centerplane.</li> </ol> <p>Only domain A can be rebooted. Domain B is down.</p>
Sun Fire 6800 system 2 partitions 2 domains—A, C	RP0 or RP1	<ul style="list-style-type: none"> <li>• RP0 and RP1 cannot be used.</li> <li>• RP2 and RP3 continue without rebooting.</li> <li>• Domain C continues.</li> </ul> <ol style="list-style-type: none"> <li>1. Configure the CPU/Memory boards and I/O assemblies from domain A to domain D.</li> <li>2. Reboot domain D.</li> </ol> <p><b>Note:</b> The domain will have the hostID and MAC address.</p>

**TABLE 10-3** Repeater Board Failure (*Continued*)

System Failure Mode	Failed Repeater Board	Repeater Board and Domain Changes
Sun Fire 6800 system 2 partitions 2 domains—A, C	RP2 or RP3	<ul style="list-style-type: none"> <li>• RP0 and RP1 continue without rebooting.</li> <li>• RP2 and RP3 are not usable.</li> <li>• Domain A continues.</li> </ul> <ol style="list-style-type: none"> <li>1. Configure the CPU/Memory boards and I/O assemblies from domain C to domain B.</li> <li>2. Reboot domain B.</li> </ol> <p><b>Note:</b> The domain will have the hostID and MAC address of domain B.</p>
Sun Fire 6800 system 2 partitions 3 domains—A, B, C	RP0 or RP1	<ul style="list-style-type: none"> <li>• RP0 and RP1 are not usable.</li> <li>• RP2 and RP3 continue unaffected.</li> <li>• Domains A and B cannot reboot.</li> <li>• Domain C continues unaffected.</li> </ul>
Sun Fire 6800 system 2 partitions 3 domains—A, B, C	RP2 or RP3	<ul style="list-style-type: none"> <li>• RP0 and RP1 are not affected.</li> <li>• RP2 and RP3 are not usable.</li> <li>• Domains A and B are not affected.</li> <li>• Domain C cannot reboot.</li> </ul>
Sun Fire 6800 system 2 partitions 3 domains—A, C, D	RP0 or RP1	<ul style="list-style-type: none"> <li>• RP0 and RP1 are not usable.</li> <li>• RP2 and RP3 continue unaffected.</li> <li>• Domain A cannot reboot.</li> <li>• Domains C and D continue unaffected.</li> </ul>
Sun Fire 6800 system 2 partitions 3 domains—A, C, D	RP2 or RP3	<ul style="list-style-type: none"> <li>• RP0 and RP1 are not affected.</li> <li>• RP2 and RP3 are not usable.</li> <li>• Domain A is not affected.</li> <li>• Domains C and D cannot reboot.</li> </ul>
Sun Fire 6800 system 2 partitions 4 domains—A, B, C, D	RP0 or RP1	<ul style="list-style-type: none"> <li>• RP0 and RP1 cannot restart.</li> <li>• RP2 and RP3 continue without rebooting.</li> <li>• Domains A and B cannot reboot.</li> <li>• Domains C and D continue unaffected.</li> </ul>
Sun Fire 6800 system 2 partitions 4 domains—A, B, C, D	RP2 or RP3	<ul style="list-style-type: none"> <li>• RP0 and RP1 continue without rebooting.</li> <li>• RP2 and RP3 cannot restart.</li> <li>• Domains C and D cannot reboot.</li> <li>• Domains A and B continue unaffected.</li> </ul>

## Power Supply Failure

---

If a Power Supply Fails	Perform the Following Actions
When a power supply fails and you do not have any redundant power supplies:	The system may abruptly shut down due to insufficient power. <ol style="list-style-type: none"><li>1. Replace the defective power supply. Refer to the <i>Sun Fire 6800/4810/4800/3800 Systems Service Manual</i>.</li><li>2. Power on the system. See “To Power On the System” on page 68.</li></ol>
When a power supply fails and you have one or more redundant power supplies installed:	The redundant power supply takes over. Replace the power supply that failed. Refer to the <i>Sun Fire 6800/4810/4800/3800 Systems Service Manual</i> .

---

## Fan Tray Failure

---

If a Fan Tray Fails	Perform the Following Actions
When a fan tray fails and you do not have a redundant fan tray:	The system may overheat and shut down if there is insufficient cooling. <ol style="list-style-type: none"><li>1. Replace the defective fan tray. Refer to the <i>Sun Fire 6800/4810/4800/3800 Systems Service Manual</i>.</li><li>2. Power on the system. See “To Power On the System” on page 68.</li></ol>
When a fan tray fails and you have one or more redundant fan trays:	The redundant fan tray takes over. Replace the fan tray that failed. Refer to the <i>Sun Fire 6800/4810/4800/3800 Systems Service Manual</i> .

---

## FrameManager Failure

---

If the FrameManager Fails	Perform the Following Actions
When the FrameManager fails, there is no affect on the system.	Replace the FrameManager board.

---

---

# Disabling Components

The system controller supports the blacklisting feature, which allows you to disable components on a board (TABLE 10-4).

TABLE 10-4 Blacklisting Component Names

System Component	Component Subsystem	Component Name
CPU system		<i>board_name/port/physical_bank/logical_bank</i>
	CPU/Memory boards ( <i>board_name</i> )	SB0, SB1, SB2, SB3, SB4, SB5
	Ports on the CPU/Memory board	P0, P1, P2, P3
	Physical memory banks on CPU/Memory boards	B0, B1
	Logical banks on CPU/Memory boards	L0, L1, L2, L3
I/O assembly system		<i>board_name/port/bus</i> or <i>board_name/card</i>
	I/O assemblies ( <i>board_name</i> )	IB6, IB7, IB8, IB9
	Ports on the I/O assembly	P0 and P1
	Buses on the I/O assembly	B0, B1
	I/O cards in the I/O assemblies	C0, C1, C2, C3, C4, C5, C6, C7 (the number of I/O cards in the I/O assembly varies with the I/O assembly type).

Blacklisting provides lists of system board components that will not be tested and will not be configured into the Solaris operating environment. The blacklists are stored in nonvolatile memory.



Blacklist a component or device if you believe it might be failing intermittently or is failing. Troubleshoot a component you believe is having problems and replace it, if necessary.

There are three system controller commands for blacklisting:

- `disablecomponent`
- `enablecomponent`
- `showcomponent`

The `disablecomponent` and `enablecomponent` commands only update the blacklists. They do not directly affect the state of the currently configured system boards.

The updated lists will take effect when you do one the following:

- Reboot the domain.
- Transition a domain from an inactive state (`off` or `standby`) to an active state (`on`, `diag`, or `secure`).
- Reset the domain. This should only be done when the domain is hung. For information on how to reset a domain, see “Domain Not Responding” on page 109.

---

**Note** – Blacklisting components in the platform shell and a domain shell are treated differently.

If you blacklist a component from the platform shell and then move the component to another domain, the component is still blacklisted. However, if you blacklist a component in a domain shell and then move the component to a different domain, the component is no longer blacklisted.

---



# Mapping Device Path Names

---

This appendix describes how to map device path names to physical system devices. This appendix describes the following topics:

- “CPU/Memory Mapping” on page 125
  - “I/O Assembly Mapping” on page 127
- 

## Device Mapping

The physical address represents a physical characteristic that is unique to the device. Examples of physical addresses include the bus address and the slot number. The slot number indicates where the device is installed.

You reference a physical device by the node identifier—Agent ID (AID). The AID ranges from 0 to 31 in decimal notation (0 to 1f in hexadecimal). In the device path beginning with `ssm@0,0` the first number, 0, is the node ID.

## CPU/Memory Mapping

CPU/Memory board and memory agent IDs (AIDs) range from 0 to 23 in decimal notation (0 to 17 in hexadecimal). Depending on the platform type, a system can have up to six CPU/Memory boards.

Each CPU/Memory board can have either two or four CPUs, depending on your configuration. Each CPU/Memory board has up to four banks of memory. Each bank of memory is controlled by one memory management unit (MMU), which is the CPU. The following code example shows a device tree entry for a CPU and its associated memory:

```
/ssm@0,0/SUNW/UltraSPARC-III@b,0 /ssm@0,0/SUNW/memory-controller@b,400000
```

where:

in b,0

- b is the CPU agent identifier (AID)
- 0 is the CPU register

in b,400000

- b is the memory agent identifier (AID)
- 400000 is the memory controller register

There are up to four CPUs on each CPU/Memory board (TABLE A-1):

- CPUs with agent IDs 0–3 reside on board name SB0
- CPUs with agent IDs 4–7 on board name SB1
- CPUs with agent IDs 8–11 on board name SB2, and so on.

**TABLE A-1 CPU and Memory Agent ID Assignment**

CPU/Memory Board Name	Agent IDs On Each CPU/Memory Board			
	CPU 0	CPU 1	CPU 2	CPU 3
SB0	0 (0)	1 (1)	2 (2)	3 (3)
SB1	4 (4)	5 (5)	6 (6)	7 (7)
SB2	8 (8)	9 (9)	10 (a)	11 (b)
SB3	12 (c)	13 (d)	14 (e)	15 (f)
SB4	16 (10)	17 (11)	18 (12)	19 (13)
SB5	20 (14)	21 (15)	22 (16)	23 (17)

The first number in the columns of agent IDs is a decimal number. The number or letter in parentheses is in hexadecimal notation.

# I/O Assembly Mapping

TABLE A-2 lists the types of I/O assemblies, the number of slots each I/O assembly has, and the systems the I/O assembly types are supported on.

**TABLE A-2** I/O Assembly Type and Number of Slots per I/O Assembly by System Type

I/O Assembly Type	Number of Slots Per I/O Assembly	System Name(s)
PCI	8	Sun Fire 6800/4810/4800 systems
CompactPCI	6	Sun Fire 3800 system
CompactPCI	4	Sun Fire 6800/4810/4800 systems

TABLE A-3 lists the number of I/O assemblies per system and the I/O assembly name.

**TABLE A-3** Number and Name of I/O Assemblies per System

System Name(s)	Number of I/O Assemblies	I/O Assembly Name
Sun Fire 6800 system	4	IB6-IB9
Sun Fire 4810 system	2	IB6 and IB8
Sun Fire 4800 system	2	IB6 and IB8
Sun Fire 3800 system	2	IB6 and IB8

Each I/O assembly hosts two I/O controllers:

- I/O controller 0
- I/O controller 1

When mapping the I/O device tree entry to a physical component in the system, you must consider up to five nodes in the device tree:

- Node identifier (ID)
- ID controller agent ID (AID)
- Bus offset
- PCI or CompactPCI slot
- Device instance

TABLE A-4 lists the AIDs for the two I/O controllers in each I/O assembly.

**TABLE A-4** I/O Controller Agent ID Assignments

Slot Number	I/O Assembly Name	Even I/O controller AID	Odd I/O Controller AID
6	IB6	24 (18)	25 (19)
7	IB7	26 (1a)	27 (1b)
8	IB8	28 (1c)	29 (1d)
9	IB9	30 (1e)	31 (1f)

The first number in the column is a decimal number. The number (or a number and letter combination) in parentheses is in hexadecimal notation.

Each I/O controller has two bus sides: A and B.

- Bus A, which is 66 MHz, is referenced by offset 600000.
- Bus B, which is 33 MHz, is referenced by offset 700000.

The board slots located in the I/O assembly are referenced by the device number.

## PCI I/O Assembly

This section describes the PCI I/O assembly slot assignments and provides an example of the device path.

The following code example gives a breakdown of a device tree entry for a SCSI disk:

```
/ssm@0,0/pci@19,700000/pci@3/SUNW,ispw@4/sd@5,0
```

**Note** – The numbers in the device path are hexadecimal.

where:

in 19,700000

- 19 is the I/O controller agent identifier (AID)
- 700000 is the bus offset

in pci@3

- 3 is the device number

ispw is the SCSI host adapter

in `sd@5,0`

- 5 is the SCSI target number for the disk
- 0 is the logic unit number (LUN) of the target disk

This section describes the PCI I/O assembly slot assignments and provides an example of the device path.

TABLE A-5 lists, in hexadecimal notation, the slot number, I/O assembly name, device path of each I/O assembly, the I/O controller number, and the bus.

**TABLE A-5** 8-Slot PCI I/O Assembly Device Map for the Sun Fire 6800/4810/4810 Systems

I/O Assembly Name	Device Path	Physical Slot Number	I/O Controller Number	Bus
IB6	<code>/ssm@0,0/pci@18,700000/pci@1</code>	0	0	B
	<code>/ssm@0,0/pci@18,700000/pci@2</code>	1	0	B
	<code>/ssm@0,0/pci@18,700000/pci@3</code>	2	0	B
	<code>/ssm@0,0/pci@18,600000/pci@1</code>	3	0	A
	<code>/ssm@0,0/pci@19,700000/pci@1</code>	4	1	B
	<code>/ssm@0,0/pci@19,700000/pci@2</code>	5	1	B
	<code>/ssm@0,0/pci@19,700000/pci@3</code>	6	1	B
	<code>/ssm@0,0/pci@19,600000/pci@1</code>	7	1	A
IB7	<code>/ssm@0,0/pci@1a,700000/pci@1</code>	0	0	B
	<code>/ssm@0,0/pci@1a,700000/pci@2</code>	1	0	B
	<code>/ssm@0,0/pci@1a,700000/pci@3</code>	2	0	B
	<code>/ssm@0,0/pci@1a,600000/pci@1</code>	3	0	A
	<code>/ssm@0,0/pci@1b,700000/pci@1</code>	4	1	B
	<code>/ssm@0,0/pci@1b,700000/pci@2</code>	5	1	B
	<code>/ssm@0,0/pci@1b,700000/pci@3</code>	6	1	B
	<code>/ssm@0,0/pci@1b,600000/pci@1</code>	7	1	A
IB8	<code>/ssm@0,0/pci@1c,700000/pci@1</code>	0	0	B
	<code>/ssm@0,0/pci@1c,700000/pci@2</code>	1	0	B
	<code>/ssm@0,0/pci@1c,700000/pci@3</code>	2	0	B
	<code>/ssm@0,0/pci@1c,600000/pci@1</code>	3	0	A
	<code>/ssm@0,0/pci@1d,700000/pci@1</code>	4	1	B

**TABLE A-5** 8-Slot PCI I/O Assembly Device Map for the Sun Fire 6800/4810/4810 Systems *(Continued)*

I/O Assembly Name	Device Path	Physical Slot Number	I/O Controller Number	Bus
	/ssm@0,0/pci@1d,700000/pci@2	5	1	B
	/ssm@0,0/pci@1d,700000/pci@3	6	1	B
	/ssm@0,0/pci@1d,600000/pci@1	7	1	A
IB9	/ssm@0,0/pci@1e,700000/pci@1	0	0	B
	/ssm@0,0/pci@1e,700000/pci@2	1	0	B
	/ssm@0,0/pci@1e,700000/pci@3	2	0	B
	/ssm@0,0/pci@1e,600000/pci@1	3	0	A
	/ssm@0,0/pci@1f,700000/pci@1	4	1	B
	/ssm@0,0/pci@1f,700000/pci@2	5	1	B
	/ssm@0,0/pci@1f,700000/pci@3	6	1	B
	/ssm@0,0/pci@1f,600000/pci@1	7	1	A

In TABLE A-5, note the following:

- 600000 is the bus offset and indicates bus A, which operates at 66 MHz.
- 700000 is the bus offset and indicates bus B, which operates at 33 MHz.
- pci@3 is the device number. In this example @3 means it is the third device on the bus.

FIGURE A-1 illustrates the Sun Fire 6800 PCI I/O assembly physical slot designations for I/O assemblies IB6 through IB9.



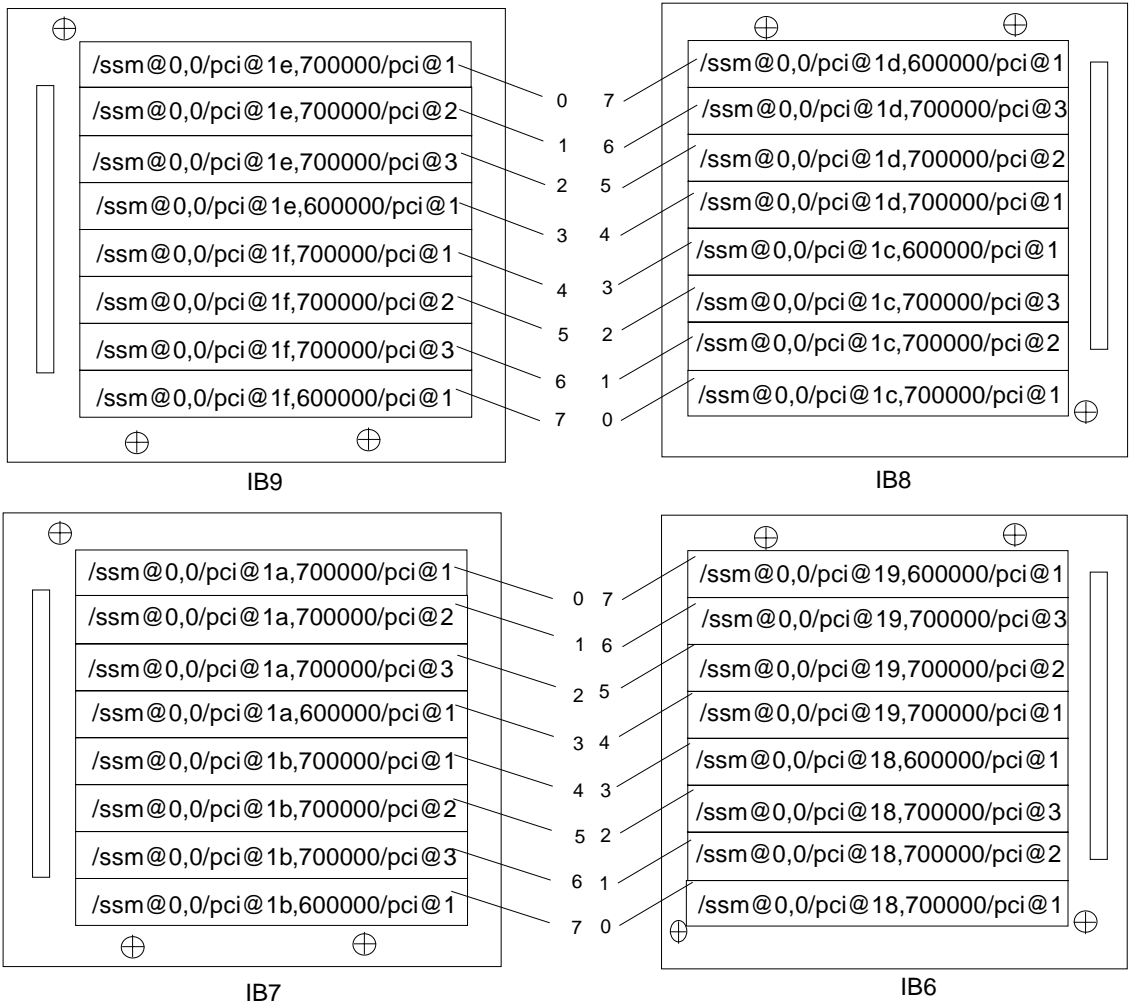

Note: Slots 0 and 1 of IB6 through IB9 are short slots.

**FIGURE A-1** Sun Fire 6800 System PCI Physical Slot Designations for IB6 Through IB9

FIGURE A-2 illustrates the comparable information for the Sun Fire 4810/4800/3800 systems.

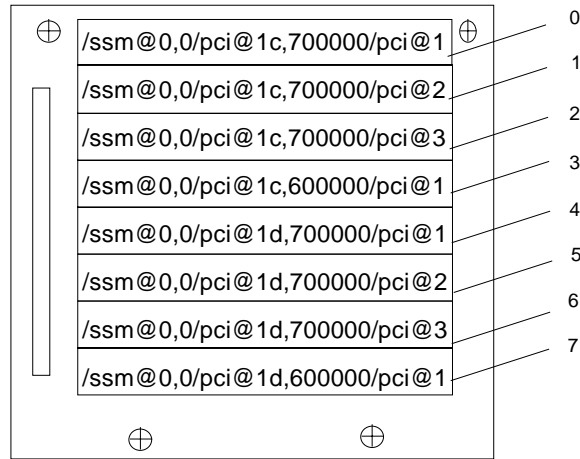

IB8

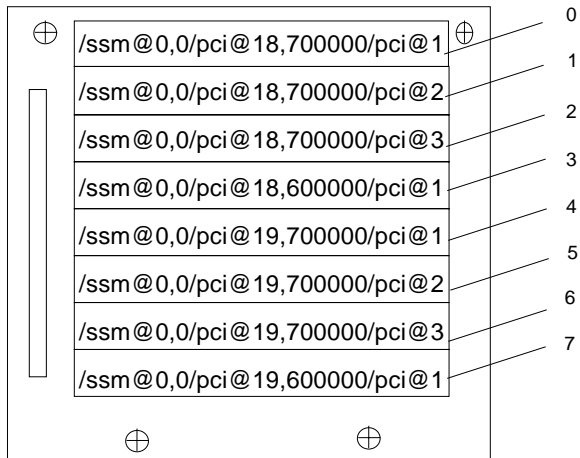

IB6

Note: Slots 0 and 1 for IB6 and IB 8 are short slots.

FIGURE A-2 Sun Fire 4810/4800 Systems PCI Physical Slot Designations for IB6 and IB8

## CompactPCI I/O Assembly

This section describes the CompactPCI I/O assembly slot assignments and provides an example on the 6-slot I/O assembly device paths.

### ▼ To Determine an I/O Physical Slot Number Using an I/O Device Path

1. Use TABLE A-6 for Sun Fire 3800 systems or to determine the:
  - I/O assembly based on the I/O controller agent identifier address.
  - Physical slot number based on the I/O assembly and the device path.
2. Use FIGURE A-3 to locate the slot based on I/O assembly and the physical slot number.

### *CompactPCI I/O Assembly Slot Assignments*

In this code example is the breakdown of the device tree for the CompactPCI I/O assembly, `ib8`.

```
/ssm@0,0/pci@1c,700000/pci@1/SUNW,ispwo@4
```

where:

in `pci@1c,700000`

- `c` is the I/O controller agent identifier (AID)
- `700000` is the bus offset

in `pci@1`

- `1` is the device number

`ispwo` is the SCSI host adapter

## 6-Slot CompactPCI I/O Assembly Device Map

TABLE A-6 lists, in hexadecimal notation, the slot number, I/O assembly name, device path of each I/O assembly, the I/O controller number, and the bus.

**TABLE A-6** Mapping Device Path to I/O Assembly Slot Numbers for Sun Fire 3800 Systems

I/O Assembly Name	Device Path	Physical Slot Number	I/O Controller Number	Bus
IB6	/ssm@0,0/pci@19,700000/pci@2	5	1	B
	/ssm@0,0/pci@19,700000/pci@1	4	1	B
	/ssm@0,0/pci@18,700000/pci@2	3	0	B
	/ssm@0,0/pci@18,700000/pci@1	2	0	B
	/ssm@0,0/pci@19,600000/pci@1	1	1	A
	/ssm@0,0/pci@18,600000/pci@1	0	0	A
IB8	/ssm@0,0/pci@1d,700000/pci@2	5	1	B
	/ssm@0,0/pci@1d,700000/pci@1	4	1	B
	/ssm@0,0/pci@1c,700000/pci@2	3	0	B
	/ssm@0,0/pci@1c,700000/pci@1	2	0	B
	/ssm@0,0/pci@1d,600000/pci@1	1	1	A
	/ssm@0,0/pci@1c,600000/pci@1	0	0	A

In TABLE A-6, note the following:

- 600000 is the bus offset and indicates bus A, which operates at 66 MHz.
- 700000 is the bus offset and indicates bus B, which operates at 33 MHz.
- pci@1 is the device number. The @1 means it is the first device on the bus.

FIGURE A-3 illustrates the Sun Fire 3800 CompactPCI physical slot designations.

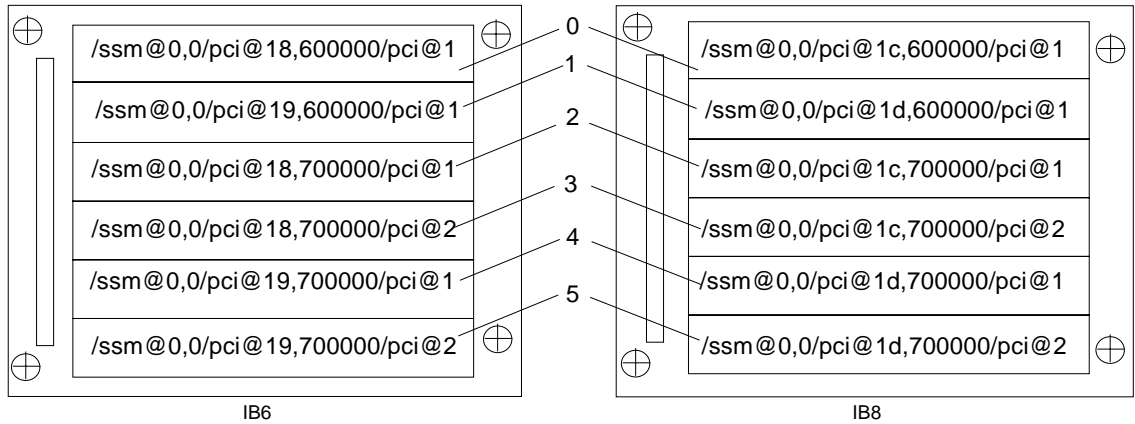

**FIGURE A-3** Sun Fire 3800 System 6-Slot CompactPCI Physical Slot Designations

### 4-Slot CompactPCI I/O Assembly Device Map

TABLE A-7 lists, in hexadecimal notation, the slot number, I/O assembly name, device path of each I/O assembly, the I/O controller number, and the bus for Sun Fire 6800/4810/4800 systems.

**TABLE A-7** Mapping Device Path to I/O Assembly Slot Numbers for Sun Fire 6800/4810/4800 Systems

I/O Assembly Name	Device Path	Physical Slot Number	I/O Controller Number	Bus
IB6	/ssm@0,0/pci@19,700000/pci@1	3	1	B
	/ssm@0,0/pci@18,700000/pci@1	2	0	B
	/ssm@0,0/pci@19,600000/pci@1	1	1	A
	/ssm@0,0/pci@18,600000/pci@1	0	0	A
IB7	/ssm@0,0/pci@1b,700000/pci@1	3	1	B
	/ssm@0,0/pci@1a,700000/pci@1	2	0	B
	/ssm@0,0/pci@1b,600000/pci@1	1	1	A
	/ssm@0,0/pci@1a,600000/pci@1	0	0	A
IB8	/ssm@0,0/pci@1d,700000/pci@1	3	1	B
	/ssm@0,0/pci@1c,700000/pci@1	2	0	B
	/ssm@0,0/pci@1d,600000/pci@1	1	1	A
	/ssm@0,0/pci@1c,600000/pci@1	0	0	A

**TABLE A-7** Mapping Device Path to I/O Assembly Slot Numbers for Sun Fire 6800/4810/4800 Systems

I/O Assembly Name	Device Path	Physical Slot Number	I/O Controller Number	Bus
IB9	/ssm@0,0/pci@1f,700000/pci@1	3	1	B
	/ssm@0,0/pci@1e,700000/pci@1	2	0	B
	/ssm@0,0/pci@1f,600000/pci@1	1	1	A
	/ssm@0,0/pci@1e,600000/pci@1	0	0	A

In TABLE A-7 note the following:

- 600000 is the bus offset and indicates bus A, which operates at 66 MHz.
- 700000 is the bus offset and indicates bus B, which operates at 33 MHz.
- pci@1 is the device number. The @1 means it is the first device on the bus.

FIGURE A-4 illustrates the Sun Fire 4810 and 4800 CompactPCI physical slot designations.

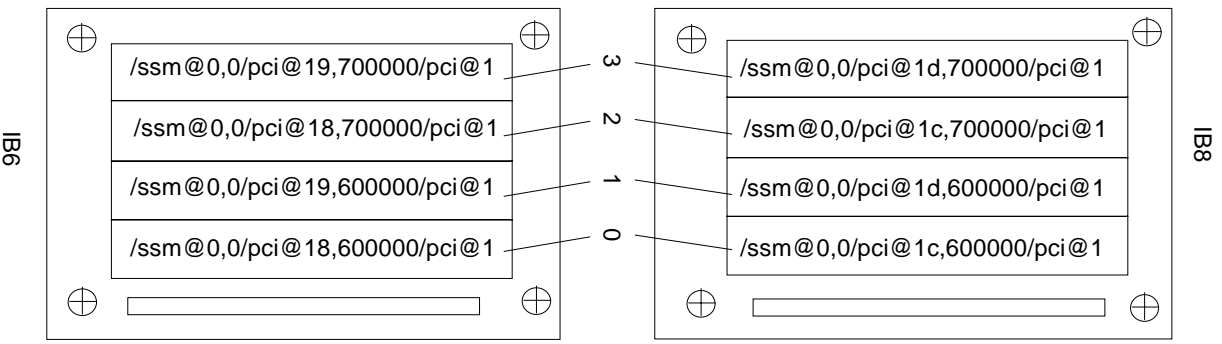

**FIGURE A-4** Sun Fire 4810/4800 Systems 4-Slot CompactPCI Physical Slot Designations

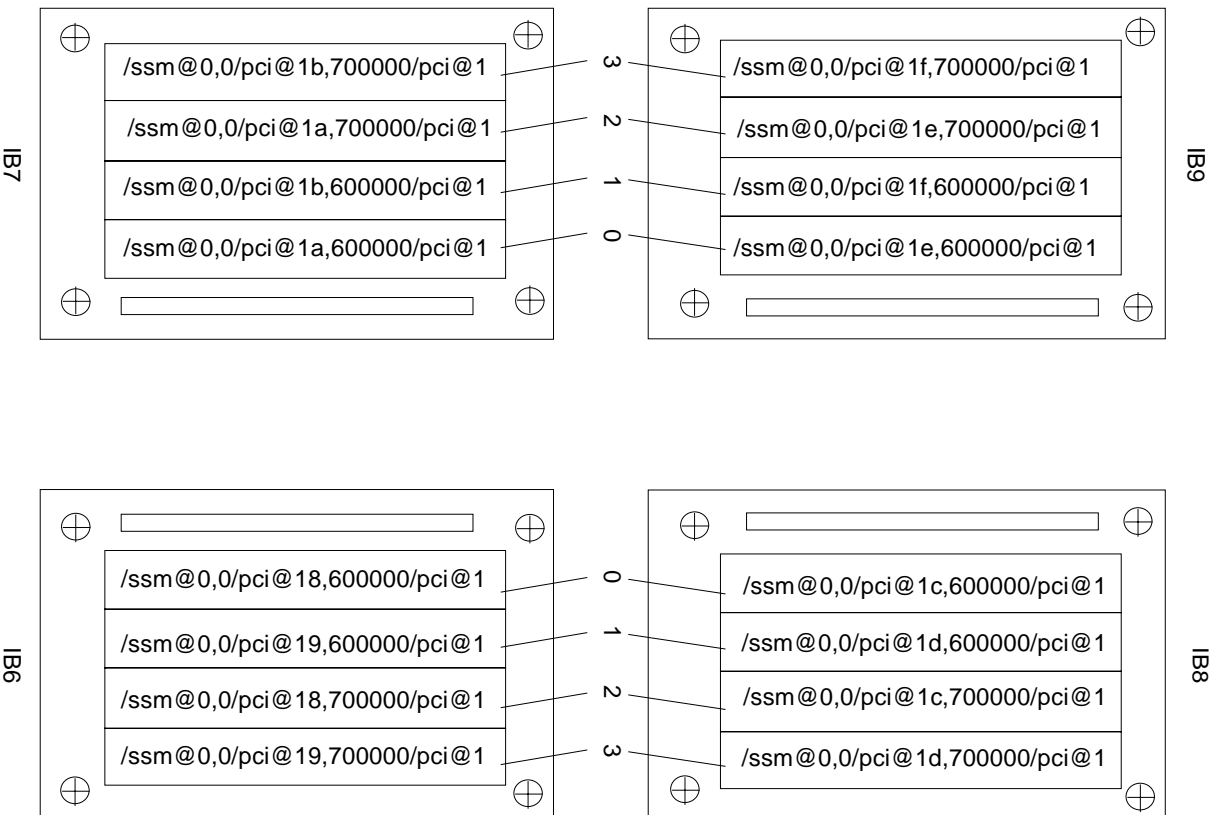

**FIGURE A-5** Sun Fire 6800 System 4-Slot CompactPCI Physical Slot Designations for IB6 through IB9



## Setting Up an http or ftp Server

---

This appendix describes how to set up a firmware server, which is necessary to invoke the `flashupdate` command. A firmware server can either be an http or a ftp server. To upgrade firmware, you can either use the ftp or http protocol.

---

**Note** – This procedure assumes you *do not* have a web server currently running. If you already have a web server set up, you can use or modify your existing configuration. For more information, see `man httpd`.

---

Before you begin to set up the http or ftp server, follow these guidelines:

- Having one firmware server is sufficient for several Sun Fire 6800/4810/4800/3800 systems.
- Connect the firmware server to the network that is accessible by the system controller.



---

**Caution** – The firmware server *must not* go down during the firmware upgrade. *Do not* power down or reset the system during the `flashupdate` procedure.

---

---

## Setting Up the Firmware Server

This section describes the following procedures:

- “To Set Up an http Server” on page 140
- “To Set Up an ftp Server” on page 142

## ▼ To Set Up an http Server

This procedure assumes that:

- A http server *is not* already running.
- The Solaris 8 operating environment is installed for the http server to be used.

### 1. Log in as superuser and navigate to the `/etc/apache` directory.

```
hostname% su
Password:
hostname # cd /etc/apache
```

### 2. Copy the `httpd.conf-example` file to replace the current `httpd.conf` file.

```
hostname # cp httpd.conf httpd.conf-backup
hostname # cp httpd.conf-example httpd.conf
```

### 3. Edit the `httpd.conf` file and add the following changes.

Port: 80

ServerAdmin:

ServerName:

- Search through the `httpd.conf` file to find the “# Port:” section to determine the correct location to add the Port 80 value as shown in CODE EXAMPLE B-1.**

#### CODE EXAMPLE B-1 Locating the Port 80 Value in `httpd.conf`

```
# Port: The port to which the standalone server listens. For
# ports < 1023, you will need httpd to be run as root initially.
#
Port 80

#
# If you wish httpd to run as a different user or group, you
# must run
# httpd as root initially and it will switch.
```

Search through the `httpd.conf` file to find the `# ServerAdmin:` section to determine the correct location to add the `ServerAdmin` value as shown in CODE EXAMPLE B-2.

**CODE EXAMPLE B-2** Locating the `ServerAdmin` Value in `httpd.conf`

```
# ServerAdmin: Your address, where problems with the server
# should be e-mailed. This address appears on some server-
# generated pages, such as error documents.

ServerAdmin root
#
# ServerName allows you to set a host name which is sent back to
```

Search through the `httpd.conf` file and search for `ServerName` (CODE EXAMPLE B-3.)

**CODE EXAMPLE B-3** Locating the `ServerName` Value in `httpd.conf`

```
#
# ServerName allows you to set a host name which is sent back to clients for
# your server if it's different than the one the program would get (i.e., use
# "www" instead of the host's real name).
#
# Note: You cannot just invent host names and hope they work. The name you
# define here must be a valid DNS name for your host. If you don't understand
# this, ask your network administrator.
# If your host doesn't have a registered DNS name, enter its IP address here.
# You will have to access it by its address (e.g., http://123.45.67.89/)
# anyway, and this will make redirections work in a sensible way.
#
ServerName oslab-mon
```

#### 4. Start Apache.

**CODE EXAMPLE B-4** Starting Apache

```
hostname # cd /etc/init.d
hostname # ./apache start
hostname # cd /cdrom/cdrom0/firmware/
hostname # mkdir /var/apache/htdocs/firmware_build_number
hostname # cp * /var/apache/htdocs/firmware_build_number
```

## ▼ To Set Up an ftp Server

This procedure assumes that the Solaris 8 operating environment is installed for the ftp server to be used.

### 1. Log in as superuser and check the ftpd man page.

```
hostname % su
Password:
hostname # man ftpd
```

In the man pages you will find the script that will create the ftp server environment. Search through the man page to find the lines shown in the example below.

```
This script will setup your ftp server for you.
Install it in the /tmp directory on the server.
Copy this script and chmod 755 script_name.
#!/bin/sh
# script to setup anonymous ftp area
#
```

### 2. Copy the entire script out of the man page (not just the portion shown in the sample above) into the /tmp directory and chmod 755 the script.

```
hostname # vi /tmp/script
hostname # chmod 755 /tmp/script
hostname # cd /tmp
hostname # ./script
```

### 3. If you need to set up anonymous ftp, add the following entry to the /etc/passwd file. You must use the following:

- Group — 65534
- Shell — /bin/false

/export/ftp was chosen to be the anonymous ftp area. This prevents users from logging in as the ftp user.

```
# ftp:x:500:65534:Anonymous FTP:/export/ftp:/bin/false
```

---

**Note** – When using anonymous ftp, you should be concerned about security.

---

4. Add the following entry to the `/etc/shadow` file. Do not give a valid password. Instead, use NP.

```
ftp:NP:6445:::::::::
```

5. Configure the ftp server on the loghost server.

```
hostname # cd /export/ftp/pub  
hostname # mkdir firmware_build_number  
hostname # cd /cdrom/cdrom0/firmware  
hostname # cp * /export/ftp/pub/firmware_build_number
```



# Glossary

---

<b>ACL</b>	Access Control List. In order to assign a board to a domain with the <code>addboard</code> command, the board name must be listed in the Access Control List (ACL). The ACL is checked when a domain makes an <code>addboard</code> or a <code>testboard</code> request on that board. On the Sun Fire 3800 system, all power supplies have switches on them to power them on. These power supplies must be listed in the ACL.
<b>active board state</b>	When the board state is active, the slot has hardware installed in it. The hardware is being used by the domain to which it was assigned. Active boards cannot be reassigned.
<b>assigned board state</b>	When a board state is assigned, the slot belongs to a domain but the hardware is not necessarily tested and configured for use. The slot can be given up by the domain administrator or reassigned by the platform administrator.
<b>available board state</b>	When a board state is available, the slot is not assigned to any particular domain.
<b>domain</b>	A domain runs its own instance of the Solaris operating environment and is independent of other domains. Each domain has its own CPUs, memory, and I/O assemblies. Repeater boards are shared between domains in the same partition.
<b>domain administrator</b>	The domain administrator manages the domain.
<b>failover</b>	The switchover of the main system controller to its spare or the system controller clock source to another system controller clock source when a failure occurs in the operation of the main system controller or the clock source.
<b>partition</b>	A partition is a group of Repeater boards that are used together to provide communication between CPU/Memory boards and I/O assemblies in the same domain. You can set up the system with one partition or two partitions using the system controller <code>setupplatform</code> command. Partitions do not share Repeater boards.
<b>platform administrator</b>	The platform administrator manages hardware resources across domains.

<b>port</b>	A board connector.
<b>Repeater board</b>	A crossbar switch that connects multiple CPU/Memory boards and I/O assemblies. Having the required number of Repeater boards is mandatory for operation. There are Repeater boards in each mid-range system except for the Sun Fire 3800. In the Sun Fire 3800 system, the equivalent of two Repeater boards are integrated into the active centerplane.
<b>RTS</b>	Redundant transfer switch.
<b>RTU</b>	Redundant transfer unit
<b>SNMP agent</b>	Simple Network Management Protocol agent. Enables or disables the SNMP agent.
<b>Sun Management Center software</b>	A graphical user interface that monitors your system.
<b>system controller software</b>	The application that performs all of the system controller configuration functions.



# Index

---

## A

administrator workstation, unauthorized  
  access, 59  
availability, 22

## B

blacklisting, 21, 122  
board  
  CompactPCI card  
    software steps, removal and installation, 91  
  CPU/Memory, 14  
    redundant, 13  
    software steps, removal and installation, 91  
    testing, 85  
  deleting from a domain, 72, 74  
  I/O assembly  
    software steps, removal and installation, 91  
  Repeater  
    definition, 18  
    description, 18  
    software steps for removing and installing, 99  
  System Controller board  
    software steps, removal and installation, 91

## C

CompactPCI card  
  software steps for removal and installation, 91  
components  
  disabling, 122

  redundant, 13  
configuration, minimum, 13  
configurations  
  I/O assemblies, 15  
configuring  
  system for redundancy, 13  
console messages, 13  
cooling, redundant, 13, 16  
CPU  
  redundant, 14  
CPU/Memory board, 14  
  hot-swapping, 95  
  software steps for removal and installation, 91  
  testing, 85  
CPU/Memory mapping, 125  
CPUs  
  maximum number per CPU/Memory board, 14  
  minimum number per CPU/Memory board, 14  
creating domains, 2  
current, monitoring, 12

## D

date, setting, 46  
deleteboard command, 72, 74  
device name mapping, 125  
device path names to physical system devices, 125  
diagnostic information, displaying, 107  
disabling a component, 122  
displaying system configuration information, 108

- domain, 1, 145
  - A, entering from the platform shell, 37
  - access, unauthorized, 59
  - active, 2
  - adding boards to, 71
  - console, 12
    - definition, 35
  - creating, 2
    - three domains on the Sun Fire 6800 system, 56
  - default configuration, 2
  - deleting boards from, 71, 72, 74
  - features, 2
  - overview, 2
  - powering on, 51, 57, 70
  - running the Solaris operating environment, 35
  - security, 62
  - separation, 62
  - setting up
    - two domains, system controller software, 55
  - starting, 57

- domain shell, 11
  - navigating to the OpenBoot PROM, 34
  - navigating to the Solaris operating environment, 34

- domain shell and platform shell
  - navigation, 33

- dual partition mode, 3

## E

- environmental monitoring, 12
- Ethernet (network) port, 9
  - System Controller board, 9

## F

- failover
  - recovery tasks, 84
- failures, determining causes, 108
- fan tray
  - hot-swapping, 16
  - redundant, 13, 16
- fault, system, 107
- features, 9
  - Ethernet (network), 9
  - serial (RS-232) port, 9

- System Controller board ports, 9
  - features, 9
- flashupdate command, 75
- Frame Manager software, 25

## G

- grids, power
  - powering on, 45

## H

- hangs, determining causes, 108
- hardware
  - powering on, 45
- hot-swapping
  - CPU/Memory board, 95
  - I/O assembly, 96
- hot-swapping, fan trays, 16

## I

- I/O assemblies
  - mapping, 127
  - redundant, 15
  - supported configurations, 15
- I/O assembly
  - hot-swapping, 96
  - software steps for removal and installation, 91
- I/O, redundant, 15
- IP multipathing software, 16

## K

- keyswitch
  - virtual, 12
- keyswitch command, 69
- keyswitch off command, 67
- keyswitch positions, virtual, 69

## L

- loghost, Solaris operating environment, 44

## M

- maintenance, 65
- mapping, 125
  - CPU/Memory, 125
  - I/O assembly, 127
  - node, 125
- memory
  - redundant, 14
- messages, console, 13
- minimum configuration, 13
- monitoring
  - current, 12
  - environmental conditions, 12
  - sensors, 12
  - temperature, 12
  - voltage, 12
- multipathing, 16

## N

- navigation
  - between domain shell and the OpenBoot PROM or the domain shell and the Solaris operating environment, 34
  - between OpenBoot PROM and the domain shell, 35
  - system controller, 33
  - to the domain shell, 34, 35
- node mapping, 125
- number of system controller boards supported, 8

## O

- OpenBoot PROM, 35

## P

- partition, 3
  - mode, 3
  - mode, dual, 3
  - mode, single, 3
- partitions
  - number of, 3
- password

- setting, 61
- passwords and users, security, 62
- platform, 1
  - setting up, 46
- platform shell
  - entering domain A, 37
- platform shell and domain shell
  - navigation, 33
- power, 17
  - redundant, 13, 17
- power grids, powering on, 45
- power on
  - flowchart, 42
  - steps performed before power on, 43
  - system controller
    - tasks completed, 11
- power on and system set up steps
  - flowchart, 42
- power supplies, 17
- powering off
  - system, 66
- powering on
  - domain, 51, 57, 70
  - hardware, 45
  - system, 11
- processors
  - maximum number per CPU/Memory board, 14
  - minimum number per CPU/Memory board, 14
  - redundant, 14

## R

- RAS, 20
- redundancy configuration, 13
- redundant, 17
  - components, 13
  - cooling, 13, 16
  - CPU, 14
  - CPU/Memory boards, 13
  - fan trays, 13
  - I/O, 15
  - I/O assemblies, 15
  - memory, 14
  - power, 13, 17
  - power supplies, 17
  - Repeater boards, 18

- reliability, 20
- Repeater board
  - definition, 18
  - descriptions, 18
  - redundant, 18
  - software steps for removing and installing, 99

## S

- security
  - domain, 62
  - domains, 62
  - threats, 59
  - users and passwords, 62
- sensors, monitoring, 12
- serial (RS-232) port, 9
  - System Controller board, 9
- server
  - setting up, 46
- serviceability, 23
- setdate command, 46
- setkeyswitch on command, 51, 57, 70
- setting the date and time, 46
- setting up
  - system (platform), 46
  - system, flowchart, 42
  - two domains, system controller software, 55
- shells, domain, 11
- single partition mode, 3
- software steps
  - removing and installing a CompactPCI card, 91
  - removing and installing a CPU/Memory board, 91
  - removing and installing a System Controller board, 91
  - removing and installing an I/O assembly, 91
  - Repeater board, removing and installing, 99
- Solaris operating environment, 34
  - loghost, 44
- starting a domain, 57
- Sun Management Center 3.0 Supplement
  - software, 25
- syslog host, 13
- system
  - administrator, tasks, 11
  - configuration information, displaying, 108

- faults, 107
  - power on, system controller
    - tasks completed, 11
  - powering off, 66
  - setting up, 46
  - setting up, flowchart, 42
- system controller
  - access, unauthorized, 59
  - definition, 1, 8
  - failover, 77
  - functions, 8
  - navigation, 33
  - tasks completed, power on, 11
- System Controller board
  - Ethernet (network) port, 9
  - ports, 9
    - features, 9
  - serial (RS-232) port, 9
  - software steps for removal and installation, 91
- System Controller boards
  - supported, 8

## T

- tasks performed by system administrator, 11
- temperature, monitoring, 12
- testboard command, 85
- three domains
  - creating on the Sun Fire 6800 system, 56
- time, setting, 46
- troubleshooting, 107

## U

- user workstation, unauthorized access, 59
- users and passwords, security, 62

## V

- virtual keyswitch, 12, 69
- voltage, monitoring, 12