

Netra™ ft 1800 Hardware Installation Manual



We're the dot in .com™

Sun Microsystems, Inc.
901 San Antonio Road
Palo Alto, CA 94303-4900 USA
650 960-1300 Fax 650 969-9131

Part No.: 806-2689-10
Revision A, December 1999

Send comments about this document to: docfeedback@sun.com

Copyright 1999 Sun Microsystems, Inc., 901 San Antonio Road • Palo Alto, CA 94303 USA. All rights reserved.

This product or document is protected by copyright and distributed under licenses restricting its use, copying, distribution, and decompilation. No part of this product or document may be reproduced in any form by any means without prior written authorization of Sun and its licensors, if any. Third-party software, including font technology, is copyrighted and licensed from Sun suppliers.

Parts of the product may be derived from Berkeley BSD systems, licensed from the University of California. UNIX is a registered trademark in the U.S. and other countries, exclusively licensed through X/Open Company, Ltd.

Sun, Sun Microsystems, the Sun logo, AnswerBook, Java, the Java Coffee Cup, Netra and Solaris are trademarks, registered trademarks, or service marks of Sun Microsystems, Inc. in the U.S. and other countries. All SPARC trademarks are used under license and are trademarks or registered trademarks of SPARC International, Inc. in the U.S. and other countries. Products bearing SPARC trademarks are based upon an architecture developed by Sun Microsystems, Inc. Registered Excellence (and Design) is a certification mark of Bellcore.

The OPEN LOOK and Sun™ Graphical User Interface was developed by Sun Microsystems, Inc. for its users and licensees. Sun acknowledges the pioneering efforts of Xerox in researching and developing the concept of visual or graphical user interfaces for the computer industry. Sun holds a non-exclusive license from Xerox to the Xerox Graphical User Interface, which license also covers Sun's licensees who implement OPEN LOOK GUIs and otherwise comply with Sun's written license agreements.

RESTRICTED RIGHTS: Use, duplication, or disclosure by the U.S. Government is subject to restrictions of FAR 52.227-14(g)(2)(6/87) and FAR 52.227-19(6/87), or DFAR 252.227-7015(b)(6/95) and DFAR 227.7202-3(a).

DOCUMENTATION IS PROVIDED "AS IS" AND ALL EXPRESS OR IMPLIED CONDITIONS, REPRESENTATIONS AND WARRANTIES, INCLUDING ANY IMPLIED WARRANTY OF MERCHANTABILITY, FITNESS FOR A PARTICULAR PURPOSE OR NON-INFRINGEMENT, ARE DISCLAIMED, EXCEPT TO THE EXTENT THAT SUCH DISCLAIMERS ARE HELD TO BE LEGALLY INVALID.

Copyright 1999 Sun Microsystems, Inc., 901 San Antonio Road • Palo Alto, CA 94303 Etats-Unis. Tous droits réservés.

Ce produit ou document est protégé par un copyright et distribué avec des licences qui en restreignent l'utilisation, la copie, la distribution, et la décompilation. Aucune partie de ce produit ou document ne peut être reproduite sous aucune forme, par quelque moyen que ce soit, sans l'autorisation préalable et écrite de Sun et de ses bailleurs de licence, s'il y en a. Le logiciel détenu par des tiers, et qui comprend la technologie relative aux polices de caractères, est protégé par un copyright et licencié par des fournisseurs de Sun.

Des parties de ce produit pourront être dérivées des systèmes Berkeley BSD licenciés par l'Université de Californie. UNIX est une marque déposée aux Etats-Unis et dans d'autres pays et licenciée exclusivement par X/Open Company, Ltd.

Sun, Sun Microsystems, le logo Sun, AnswerBook, Java, le logo Java Coffee Cup, Netra et Solaris sont des marques de fabrique ou des marques déposées, ou marques de service, de Sun Microsystems, Inc. aux Etats-Unis et dans d'autres pays. Toutes les marques SPARC sont utilisées sous licence et sont des marques de fabrique ou des marques déposées de SPARC International, Inc. aux Etats-Unis et dans d'autres pays. Les produits portant les marques SPARC sont basés sur une architecture développée par Sun Microsystems, Inc.

L'interface d'utilisation graphique OPEN LOOK et Sun™ a été développée par Sun Microsystems, Inc. pour ses utilisateurs et licenciés. Sun reconnaît les efforts de pionniers de Xerox pour la recherche et le développement du concept des interfaces d'utilisation visuelle ou graphique pour l'industrie de l'informatique. Sun détient une licence non exclusive de Xerox sur l'interface d'utilisation graphique Xerox, cette licence couvrant également les licenciés de Sun qui mettent en place l'interface d'utilisation graphique OPEN LOOK et qui en outre se conforment aux licences écrites de Sun.

CETTE PUBLICATION EST FOURNIE "EN L'ETAT" ET AUCUNE GARANTIE, EXPRESSE OU IMPLICITE, N'EST ACCORDEE, Y COMPRIS DES GARANTIES CONCERNANT LA VALEUR MARCHANDE, L'APTITUDE DE LA PUBLICATION A REpondre A UNE UTILISATION PARTICULIERE, OU LE FAIT QU'ELLE NE SOIT PAS CONTREFAISANTE DE PRODUIT DE TIERS. CE DENI DE GARANTIE NE S'APPLIQUERAIT PAS, DANS LA MESURE OU IL SERAIT TENU JURIDIQUEMENT NUL ET NON AVENU.



Contents

- 1. Before Installation 1**
 - Electrical Supply Considerations 1
 - Environmental Considerations 1
 - Dimensions 2
 - Airflow Consideration when Mounting in the Equipment Frame 2
 - Mechanical Considerations when Mounting in the Equipment Frame 6
 - Mounting Requirements 6

- 2. Hardware Installation 11**
 - Unshipping the System 11
 - Cable Bracket Assemblies 15
 - Removing and Installing Modules 16
 - Configuration Limitations 16
 - Module Injector/Ejector Mechanisms 16
 - Replacing an RMM 23
 - Replacing a Disk Chassis 25
 - Flexible Module Cabling 28
 - Installing the Filter Trays 29
 - CAF External I/O Connections 31
 - System Console Terminal Connections 32

Modem Port Connections	33
Alarms Port Connections	34
RCP Port	34
3. Electrical Supply Installation	35
System Switch	35
DC Source Site Requirements	36
Overcurrent Protection Requirements	36
Required Connection Materials	44
DC Supply and Ground Conductor	44
Dual Grounding Environment	45
Connecting the Power Leads	47
4. Powering on the System	51
Index	53

Figures

FIGURE 1-1	Netra ft 1800 Airflow Requirements (External)	4
FIGURE 1-2	Netra ft 1800 Airflow Requirements (Internal)	5
FIGURE 1-3	Chassis Mounting Hole Arrangement (all measurements in millimeters)	8
FIGURE 2-1	Shipping Brackets and Sacrificial Plinth	13
FIGURE 2-2	Cable Bracket Assembly	15
FIGURE 2-3	Module Injector/ejector Lever	17
FIGURE 2-4	Removing a CPUset Module	19
FIGURE 2-5	Removing a CAF	20
FIGURE 2-6	Removing a PCI Card Carrier	21
FIGURE 2-7	Removing a Power Supply	22
FIGURE 2-8	Removing an RMM Module	24
FIGURE 2-9	Removing a Disk Drive	26
FIGURE 2-10	Removing a DSK Module	27
FIGURE 2-11	Cable Management Shelf	28
FIGURE 2-12	Large Filter Tray	29
FIGURE 2-13	Small Filter Tray	29
FIGURE 2-14	Inserting the Environmental Filters	30
FIGURE 2-15	External I/O Connections on CAF Module	31
FIGURE 3-1	PSU Fault Situation	37

FIGURE 3-2	Circuit Breakers for Single Power Rails	39
FIGURE 3-3	Circuit Breakers for Dual Power Rails	40
FIGURE 3-4	Sided Independent Feeds with Single Pole Circuit Breakers	41
FIGURE 3-5	Side-independent Feeds to Each PSU with Single Pole Circuit Breakers (double pole can be used)	42
FIGURE 3-6	Dual Feeds with Local Common Return – Single Pole Circuit Breakers (double pole can be used)	43
FIGURE 3-7	Location of Chassis-to-Logic-0V Link and Grounding Points, and Wrist Strap Connection Point	46
FIGURE 3-8	Power Inlet Connector	47
FIGURE 3-9	Power Connector Wiring Polarity and Securing Screws	48
FIGURE 3-10	Power Lead Receptacles	49
FIGURE 3-11	Power Lead Securing Screws	49
FIGURE 3-12	Power Cable Arrangement for Strain Relief	50
FIGURE 4-1	System Switches (Front Panel)	52

Tables

TABLE 1-1	Mounting Hole Pattern Dimensions	7
TABLE 2-1	Console Connector Pinout	32
TABLE 2-2	Console and Modem Port Parameters	32
TABLE 2-3	Modem Port Pinout	33
TABLE 2-4	Alarms Port Pinout	34
TABLE 2-5	Remote Control Processor Port Pinout	34
TABLE 3-1	Overcurrent Protection Requirements	36

Preface

This document describes the installation procedures for the core hardware used in the Netra™ ft 1800.

Who Should Use This Book

This guide is intended to be read by installation engineers and service personnel. It is not intended for the end user of the system.

How This Book Is Organized

This guide is arranged as follows:

Chapter 1 “Before Installation” gives guidelines on site preparation and environmental considerations.

Chapter 2 “Hardware Installation” describes how to unpack the system and install the chassis in a rack.

Chapter 3 “Electrical Supply Installation” provides the information required to install the electrical supply.

Chapter 4 “Powering on the System” tells you how apply power to the Netra ft 1800.

Related Books

- *Netra ft 1800 Hardware Reference Manual* (Part No. 805-4531-11)
- *Netra ft 1800 Safety and Compliance Manual* (Part No. 805-7019-10)

Symbols

The following symbols mean:

Note – A note provides information which should be considered by the reader.



Caution – Cautions accompanied by this Attention icon carry information about procedures or events which if not considered may cause damage to the data or hardware of your system.



Caution – Cautions accompanied by this Hazard icon carry information about procedures which must be followed to reduce the risk of electric shock and danger to personal health. Follow all instructions carefully.

Sun Welcomes Your Comments

We are interested in improving our documentation and welcome your comments and suggestions. You can email your comments to us at:

docfeedback@sun.com

Please include the part number of your document in the subject line of your email.

Before Installation

This section provides information on what should be considered when choosing a location for a Netra ft 1800 system.

Note – This equipment is only intended for installation in a Restricted Access Location as defined by UL1950, 3rd Edition, and EN60950: 1992 / A11: 1997.

Electrical Supply Considerations

Before you install the system, verify that the correct power supply is available. Refer to “DC Source Site Requirements” on page 36 for further information.

Environmental Considerations

The system can be installed in an environment with the following specific parameter ranges:

- Ambient temperature
 - Operating: 0 to 40 degrees Celsius (short term operation up to a temperature of 50 degrees Celsius is possible; however, the operation of removable media devices cannot be guaranteed.)
 - Storage: -40 to 70 degrees Celsius

- Relative humidity
 - Operating: 5 to 85% noncondensing¹
 - Storage: 10 to 90% noncondensing¹
- Elevation
 - Operating: 0 to 3000 meters
 - Storage: 0 to 12000 meters

Dimensions

- Height: 1466.85 mm (57.75 inches) 33U NOM
- Width: 437.60 mm (17.22 inches)
- Depth: 392.8 mm (15.4 inches)
- Weight: Maximum 190.5 kg (420 lb) (excluding rack or AC converter items)
- Maximum rate of heat release for fully configured system: 3000W (10,200 Btu/hour)
- GR 63 CORE heat release calculation result: 425.4 W per square foot [3000 W / (3.25 ft x 2.17 ft)] (4579 W per square meter).

These dimensions are for the product without rack-mount flange adapters; the overall width of the flanges varies according to the equipment mounting requirements.

The depth given does not include any I/O or power connectors. The power connectors add 50 mm (2 inches) to the depth.

Airflow Consideration when Mounting in the Equipment Frame

The Netra ft 1800 system has been designed to function while mounted in a natural convection airflow, but to meet the declared environmental specification the following rules apply. Refer to FIGURE 1-1 on page 1-4 and FIGURE 1-2 on page 1-5.

1. Adequate airflow through the equipment frame must be ensured. The Netra ft 1800 system utilizes internal fans that can achieve a maximum airflow of 840 cfm in free air.
2. The inlet air must enter at the bottom of the Netra ft 1800 cabinet and in front of the Power Supply Units (PSUs); the airflow exhausts vertically from the top of the cabinet.
3. Inlet and exhaust ventilation require a minimum open area of 400 cm² (62 in²) each.

1. Subject to a maximum absolute humidity of 0.024Kg of water per Kg of dry air.

4. A minimum of 2U (88.9 mm/3.5 inches) clearance must be allowed at both top and bottom of the Netra ft 1800 cabinet when mounted unless unobstructed vertical airflow can be ensured. Refer also to “Mounting Requirements” on page 6.
5. The Netra ft 1800 system must not be mounted above any heat-generating sources within the same frame *unless* a heat deflector is used to provide fresh inlet air at ambient temperature.
6. To maintain adequate airflow, replace the environmental filters every six months (contact your local support organization for further information). The environmental filter replacement kit (X-Option No.X6952A) contains six PSU filters and three base filters.

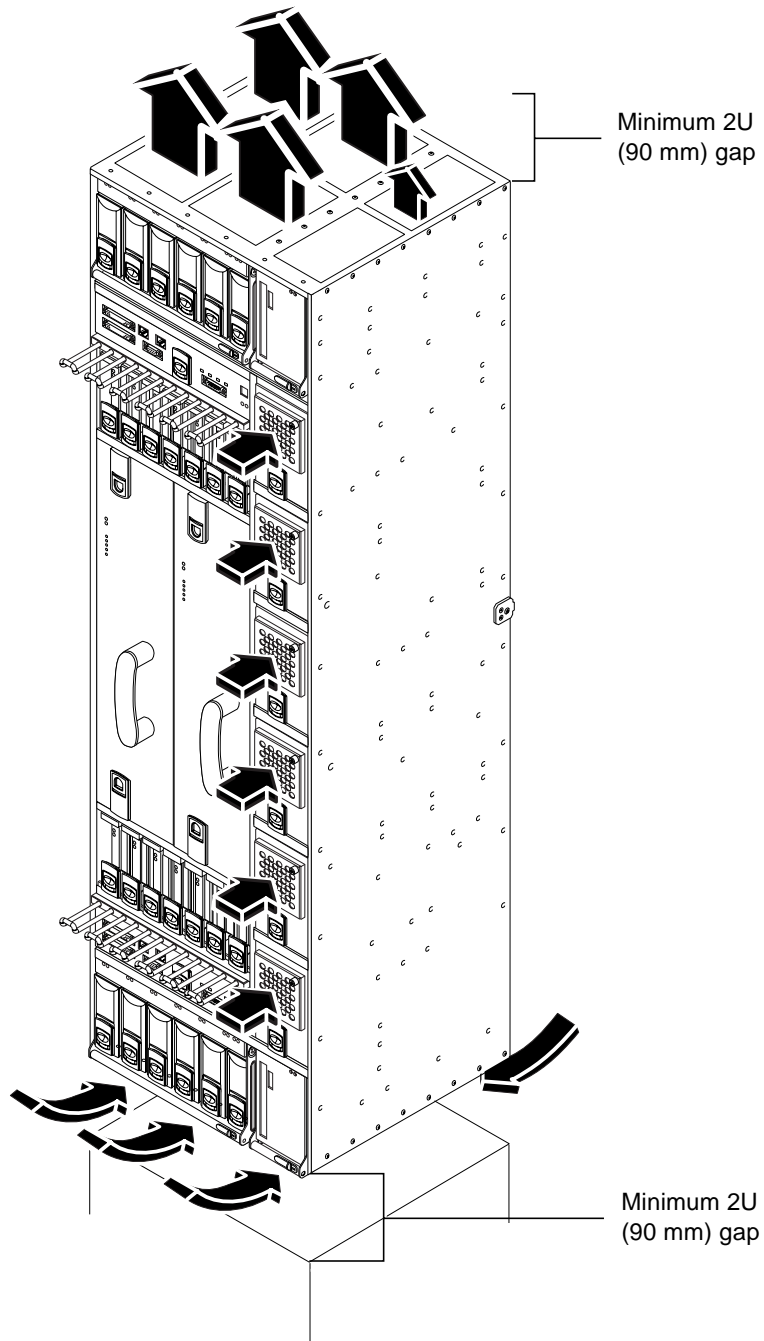

FIGURE 1-1 Netra ft 1800 Airflow Requirements (External)

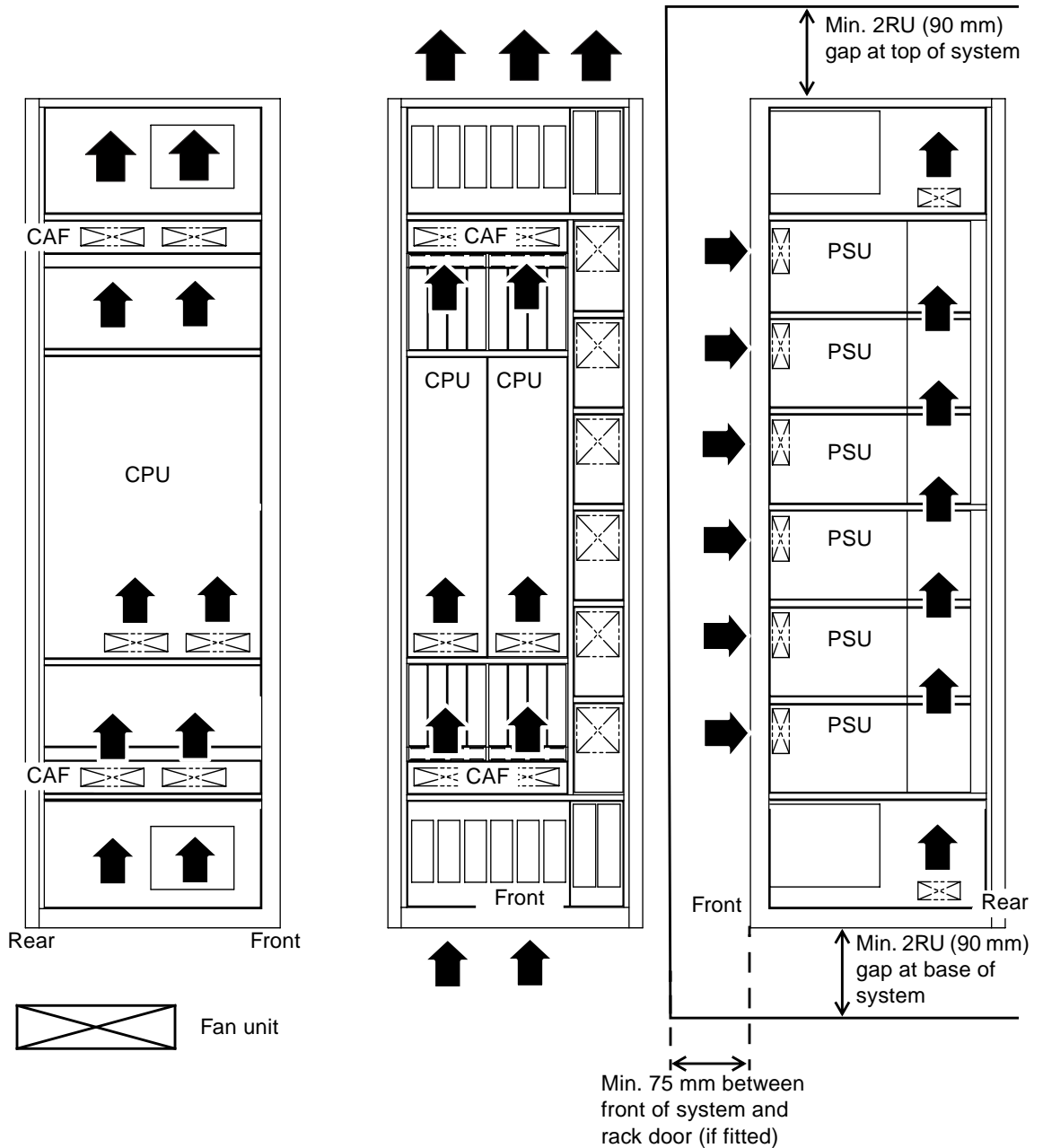

FIGURE 1-2 Netra ft 1800 Airflow Requirements (Internal)

Mechanical Considerations when Mounting in the Equipment Frame



Caution – Mechanical assistance is required if installing a loaded chassis.

If you intend not to use a lifting device for installation, all modules other than the motherboards must be removed from the system prior to lifting. The empty chassis weighs approximately 49 kg (108 lb), or 68 kg (150 lb) with the motherboards, plus the adaptors. The weight of any removable module depends on its configuration. Weight warning labels are for guidance only.

See “Removing and Installing Modules” on page 16 for information about adding modules to the motherboard.

The Netra ft 1800 chassis has been designed to accommodate most mounting configurations. Adaptor flanges to suit 19-inch, 23-inch, 24-inch and 600-mm (ETSI) rack sizes are available as required.

The Netra ft 1800 system is shipped with a plinth, which protects the bottom of the chassis during transit and handling, and also ensures that the correct airflow inlet plenum is provided during installation. The plinth must be removed once the Netra ft 1800 is installed in a rack, then stored in a safe place.

The Netra ft 1800 chassis must be mounted using screws suitable for the equipment frame. The screws should be M5, M6 or 10-32 UNF. All screws must be fitted. The recommended tightening torque value for either M5 or 10-32 UNF recess head screws is 3.8 Nm (2.8 lbf/ft), and that for M6 screws is 6 Nm (4.4 lbf/ft).

Mounting Requirements

The Netra ft 1800 is available with the following removable mounting flanges:

- 19 inch EIA pattern
- 23 inch EIA pattern
- 24 inch EIA pattern
- 600 mm IEC917 (ETSI) pattern

Any of these flanges can be fitted in the following positions:

- Flush with the front of the system
- 65 mm (2.56 inches) from front of system
- 196.1 mm (7.72 inches) from front of system

The second and third positions are intended for use with 5-inch web open frames (relay racks).

Adjustable rear flanges can be fitted. They provide a mounting face anywhere between 400 mm and 500 mm (15.75 inches and 19.7 inches) from the front of the system.

The vertical mounting hole pattern should conform to the standard dimensions given in TABLE 1-1.

TABLE 1-1 Mounting Hole Pattern Dimensions

Standard	Pattern
EIA/RETMA (RU)	Repeating pattern of 5/8 inch, 5/8 inch, 1/2 inch
IEC917/ETSI (SU)	Constant pitch of 25 mm

The tapped mounting holes on the Netra ft 1800 chassis are arranged as shown in FIGURE 1-3.

All holes are tapped M5 x 3.5 unless otherwise indicated.

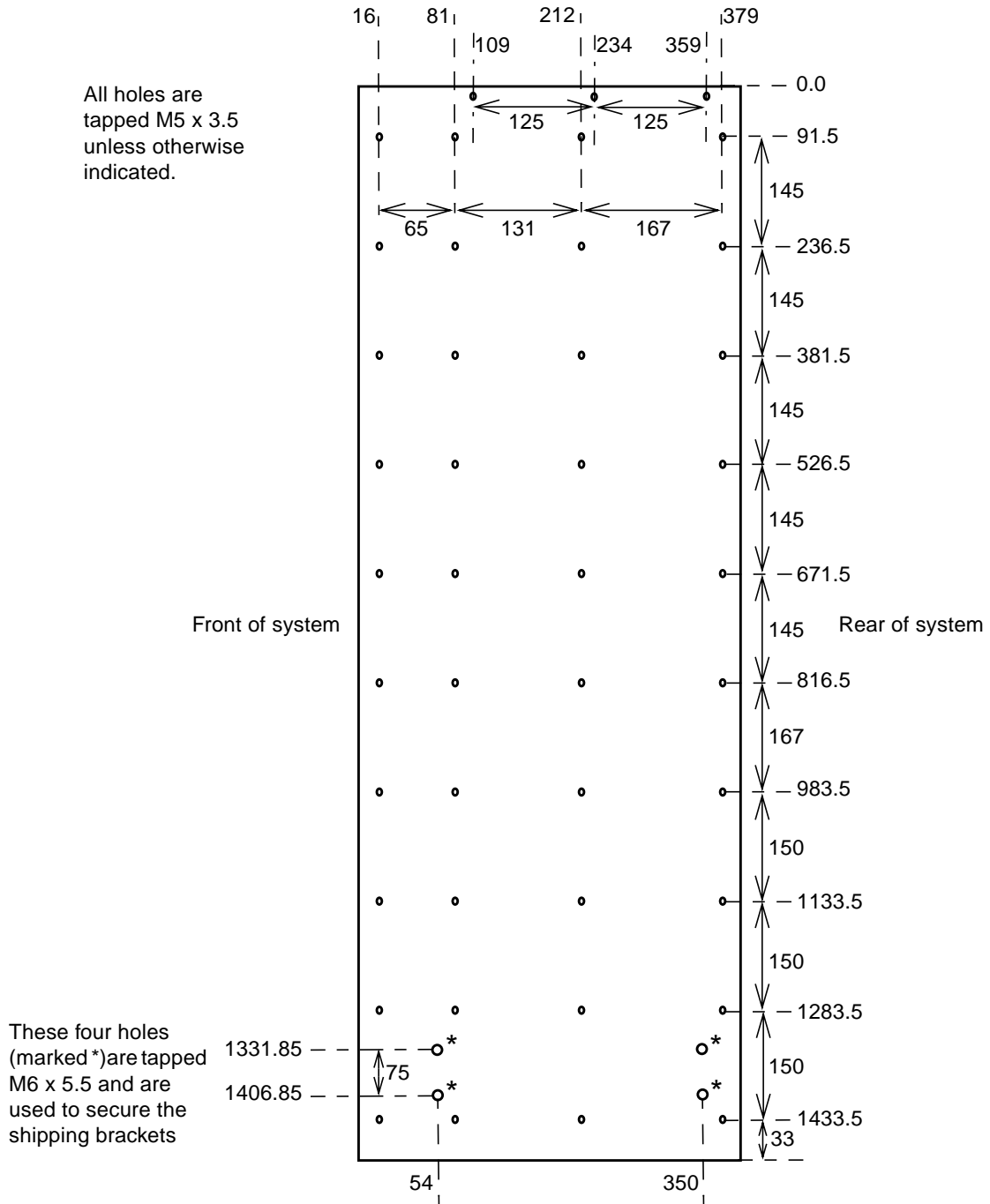

FIGURE 1-3 Chassis Mounting Hole Arrangement (all measurements in millimeters)

Loading

The rack must be capable of supporting 230 kg (500 lbs) for a fully configured and cabled Netra ft 1800.

In Seismic (Earthquake) Risk Zones 3 and 4, it is recommended that the Netra ft 1800 is installed in an appropriate secured seismic rack or cabinet.

Vertical space

The Netra ft 1800 chassis occupies 33RU (146.7 cm / 57.75 inches) of vertical height.

To allow adequate airflow, the rack must provide either:

- Unobstructed vertical airflow via vents of adequate size in the top and/or bottom panels. In this case the vertical height required is 35RU (155.6 cm / 61.25 inches). The chassis should be mounted centrally, providing a 1RU-high plenum adjacent to each vent grille.

or:

- A minimum of 37RU (164.5 cm / 74.75 inches) of rackable height, with the provision of 2RU vertical space (8.9 cm / 3.5 inches) for front and/or rear vents at both top and bottom.

If you intend to fit the Netra ft 1800 into a rack with its red transit plinth in place, 4RU (17.8 cm / 7 inches) of clearance must be provided beneath the chassis. This space permits removal of the plinth after installation.

Note – The plinth must be removed to allow fitment of the chassis environmental filters.

Depth

The front door (if fitted) must provide a minimum of 75 mm (3 inches) of clearance across the entire front surface of the Netra ft 1800 to allow for routing of I/O cables.

As all I/O cables must be routed from the front of the Netra ft 1800 system, due consideration should be made of the space required within the rack for these cables, as well as the power cables at the rear of the system.

There must be a minimum of 545 mm (21.5 inches) usable internal depth in the rack/cabinet. This dimension includes space for connector housings, cabling and the power inlet filters.

Safety

All racks must be bolted to the floor, to adjacent frames or to both. This must be done in accordance with the rack manufacturer's instructions, using the recommended hardware and fixings.

Free-standing racks with a footprint of less than 600 mm x 600 mm (23.6 inches x 23.6 inches) are likely to be unstable and should be treated with caution.

Hardware Installation

This chapter provides information on the initial hardware installation procedure, including installing modules and external I/O connections.

Unshipping the System

Once you have removed the packaging from the system, you must then unship the system from the delivery pallet and brackets before attempting to mount the chassis in a rack.



Caution – Do not attempt to remove the red plinth before the chassis has been mounted in the rack.

There is an instruction card attached to the front of the system; the instructions below are intended to supplement this.

Note – Do not discard the packaging after removing it from the system. It should be stored in safe, dry place so it can be used in the event that the system requires moving or returning for repair.

Tools

The tools required to unship the system are contained in a cloth bag in the shipkit box.

Note – Do not discard the tools after unshipping and mounting the system. They can be stored in the cloth bag supplied and attached to the rack adjacent to the system for easy access when required.

▼ To Unship and Mount the System

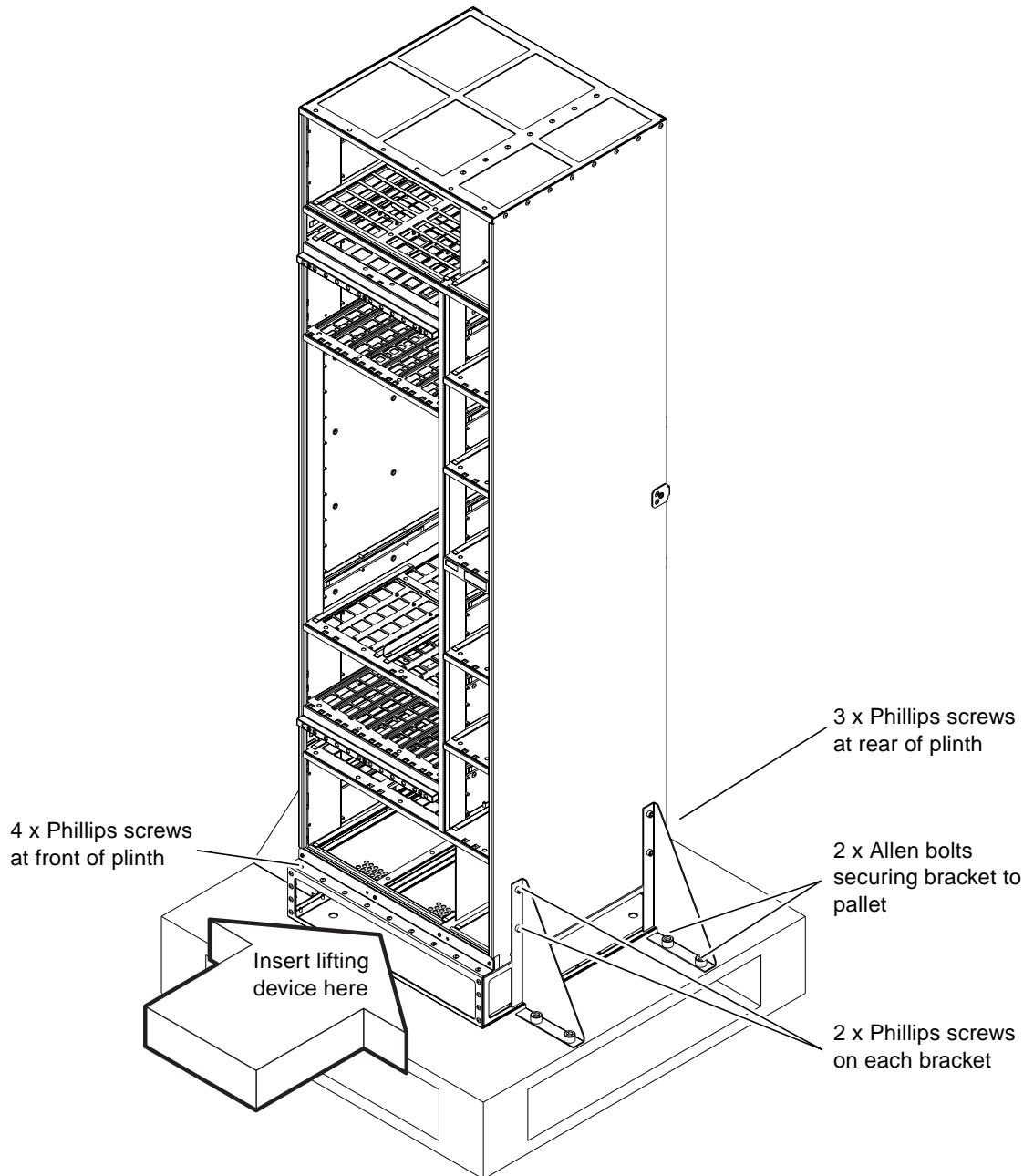

FIGURE 2-1 Shipping Brackets and Sacrificial Plinth

- 1. Remove all modules except the motherboards from the chassis and put them in a safe place.**

Refer to “Removing and Installing Modules” on page 16.

- 2. Using the Phillips No.2 screwdriver (supplied), remove the two Phillips screws securing the four red brackets (two on each side) to the chassis (see FIGURE 2-1).**

You may also need to remove the brackets from the pallet. Use the Allen key supplied to remove the two Allen screws from each bracket. The brackets are not attached to the red mounting plinth.

- 3. Install the appropriate mounting flanges.**

Refer to the documentation accompanying the mounting flange kit.

- 4. Use an appropriate lifting device to lift the chassis by the red mounting plinth, and install it in the rack.**



Caution – If using a fork-lift device, ensure the tines of the lift extend right through the mounting plinth and beyond the rear of the chassis. The chassis could deform if you use incorrect lifting techniques.

- 5. Secure the chassis into the rack using the appropriate mounting points.**

See the documentation accompanying the mounting flange kit.

- 6. Remove the mounting plinth.**

Use the No.2 Phillips screwdriver supplied to remove the four screws from the front and the three screws from the rear.

Mounting the chassis with the plinth attached ensures that the minimum amount of clearance for air flow is provided beneath the system.

- 7. Install the two large and one small filter trays in the spaces immediately beneath the chassis revealed by the removal of the plinth.**

Refer to “To Install the Filter Trays” on page 29. The filter tray thumbscrews are inserted in the tapped threads exposed by removal of the mounting plinth.

- 8. Install the modules into their appropriate locations.**

Refer to “Removing and Installing Modules” on page 16.

Cable Bracket Assemblies

Six cable bracket mounting assemblies are provided with each mounting flange kit. These can be fitted to the mounting flanges to facilitate cable management.

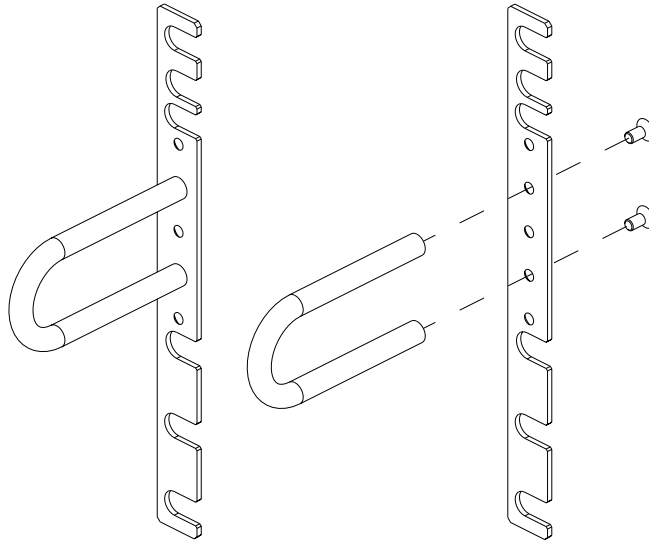

FIGURE 2-2 Cable Bracket Assembly

The brackets can be fixed to the mounting flanges in the required position, using the same screws that fix the flanges to the rack. The hooks can be fitted to the brackets in one of three positions using the countersunk M3 screws supplied. The hooks must be fitted before the brackets are fixed to the mounting flange/rack.

Removing and Installing Modules

This section describes how to remove and insert:

- CPUset, PCI, CAF and PSU modules (“To Remove a Module” on page 17)
 - CPUset modules: “CPUset Modules” on page 18
 - PCI modules: “PCI Modules” on page 21
 - CAF modules: “CAF Modules” on page 20
 - PSU modules: “PSU Modules” on page 22
- Drive chassis (“Replacing a Disk Chassis” on page 25)
- Removable media module (“Replacing an RMM” on page 23)



Caution – The wrist-strap provided must be used when replacing modules, or making cable connections to the rear of the system. The wrist-strap connection point on the Netra ft 1800 system is located on the panel at the bottom rear of the chassis.

All modules have their own guides in slots in the chassis, into which they fit exactly. No module will fit into a slot allocated to a different class of module. No module will fit into its own slot if it is upside down.

Configuration Limitations

If only one PSU is configured on each side, or two PSUs are configured in 1+1 redundancy, the configuration of optional modules on each side is limited to the following:

- A CPUset with two processors and not more than 512 Mbytes of memory
- A combined total of not more than five disks and PCI cards
- An RMM with one CD-ROM drive and one DAT drive

If two non-redundant PSUs are present on each motherboard, or three PSUs configured in 2+1 redundancy, all possible modules can be configured on each motherboard.

Module Injector/Ejector Mechanisms

All the modules except the disk chassis (DSK) and RMM have an injector/ejector lever (CPUset modules have two). They are all similar in function and usage. A common feature is a slide which engages and disengages the module’s electrical

connection to the motherboard, and a lever which physically engages and disengages the module. When the latch is disengaged, a red dot is exposed. This facilitates the identification of unlatched injectors.

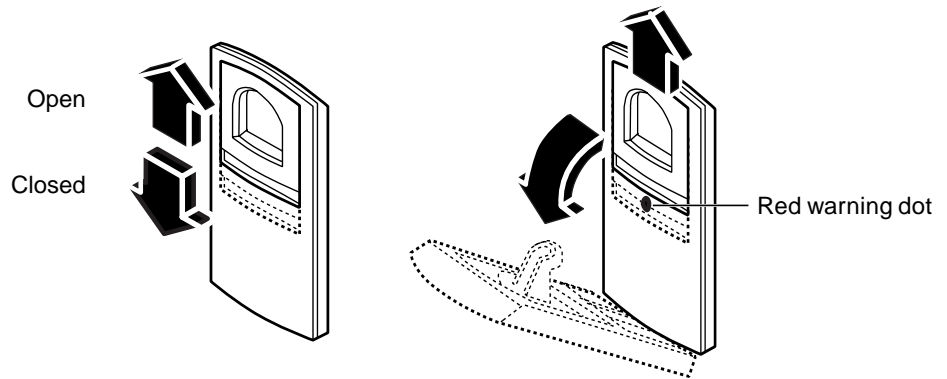

FIGURE 2-3 Module Injector/ejector Lever

The module is disengaged from its electrical connection when the slide is moved towards the rounded end of the lever, exposing the red warning dot.

The general procedure refers to CPUset, CAF, PCI and PSU modules. For more specific instructions for the RMM and disk chassis, refer to:

- “Replacing an RMM” on page 23
- “Replacing a Disk Chassis” on page 25

▼ To Remove a Module

- 1. Move the slide in the lever on the module to the disengaged position.**

This will expose the red warning dot.

- 2. Lower the lever.**

The module will slide out a small amount when the lever is fully lowered.

- 3. Slide the module out of its slot, using the handle if there is one.**

For specific procedures relating to individual modules, refer to:

- “CPUset Modules” on page 18
- “CAF Modules” on page 20
- “PCI Modules” on page 21
- “PSU Modules” on page 22

CPUset Modules

CPUset modules have two injector levers which must be operated simultaneously.

As you pull out the CPUset module, the handle in the top panel pops up and must be depressed again manually in order to withdraw the module fully from the chassis (see FIGURE 2-4). Once the handle is clear of the crossbar and has popped up again, it can be used to take the weight of the module.



Caution – CPUset modules are very heavy. The weight warning label on the CPUset is for guidance only. The actual weight of a CPUset depends on its configuration. Both the front and top handles must be used simultaneously once the module has been withdrawn as illustrated in FIGURE 2-4.

On inserting the CPUset module the handle must be depressed in order to push the module fully into the chassis.

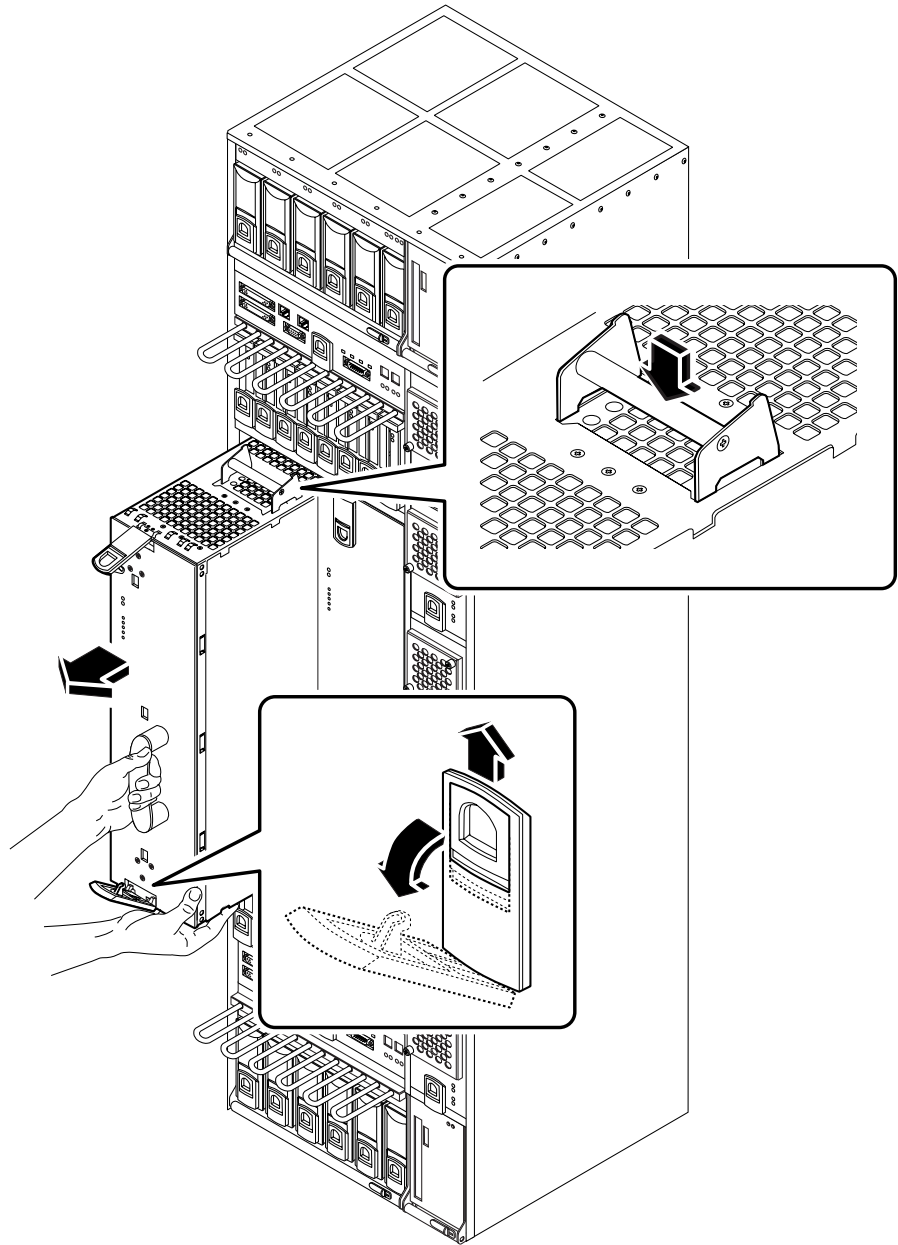

FIGURE 2-4 Removing a CPUset Module

CAF Modules

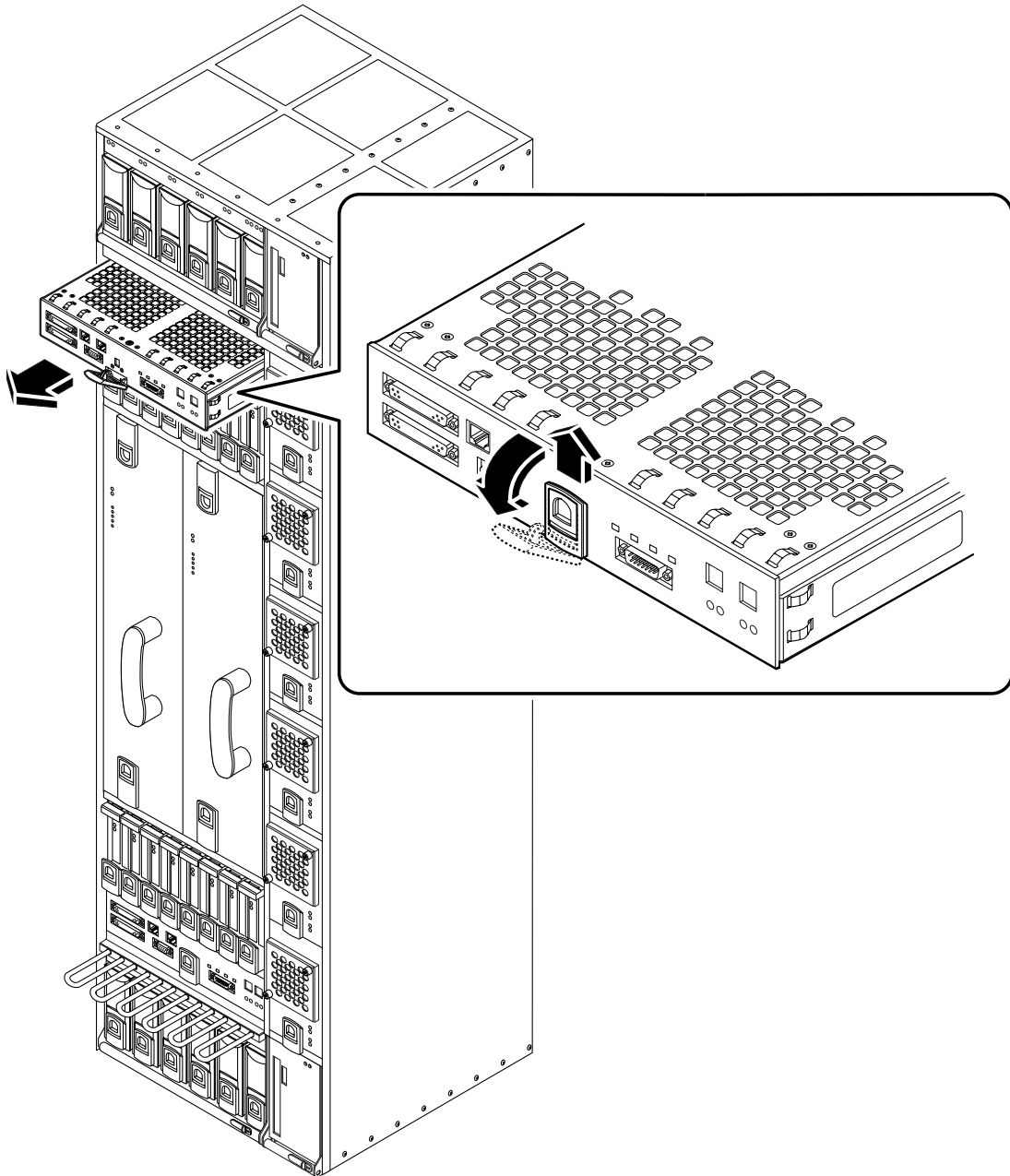

FIGURE 2-5 Removing a CAF

PCI Modules

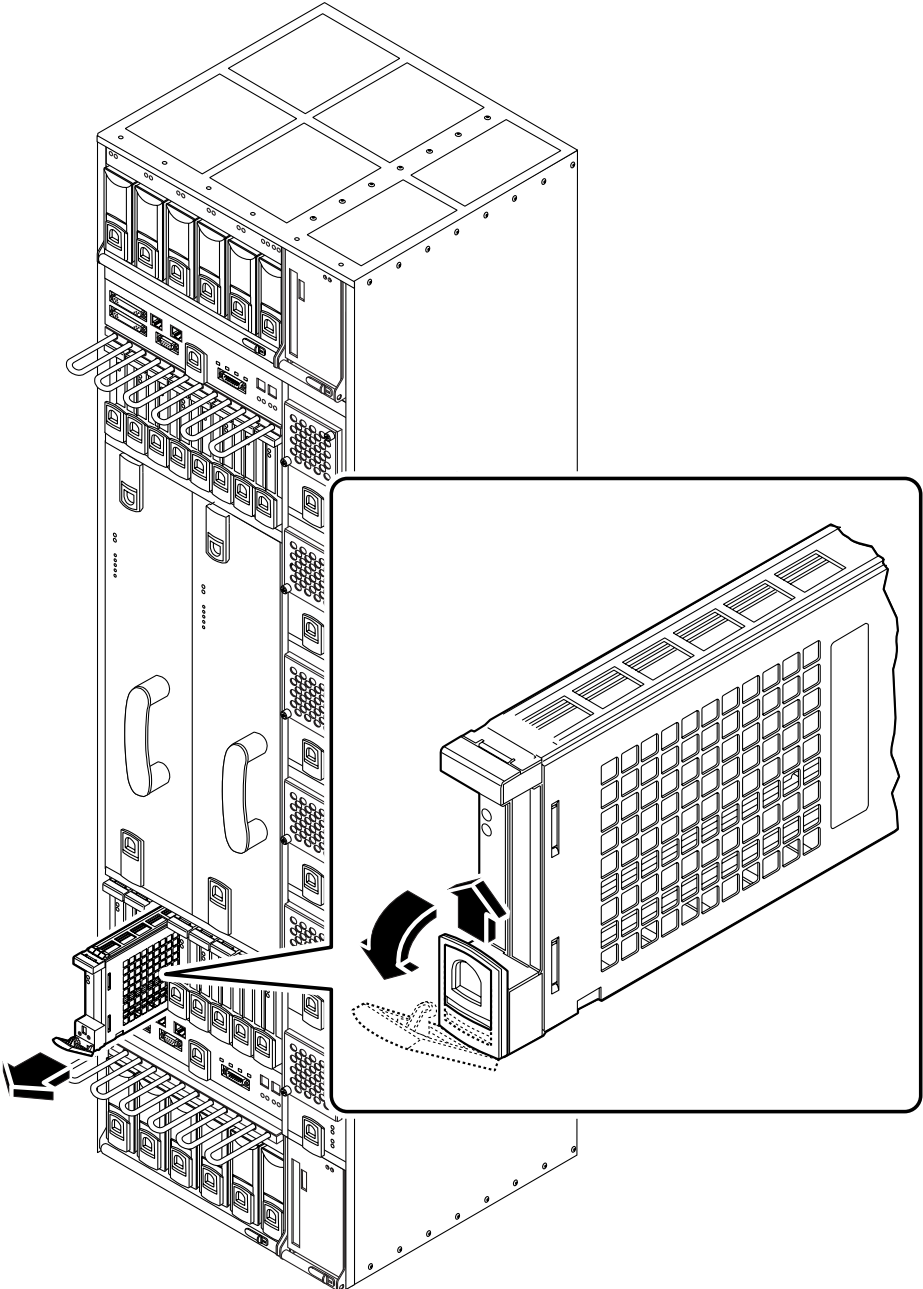

FIGURE 2-6 Removing a PCI Card Carrier

PSU Modules

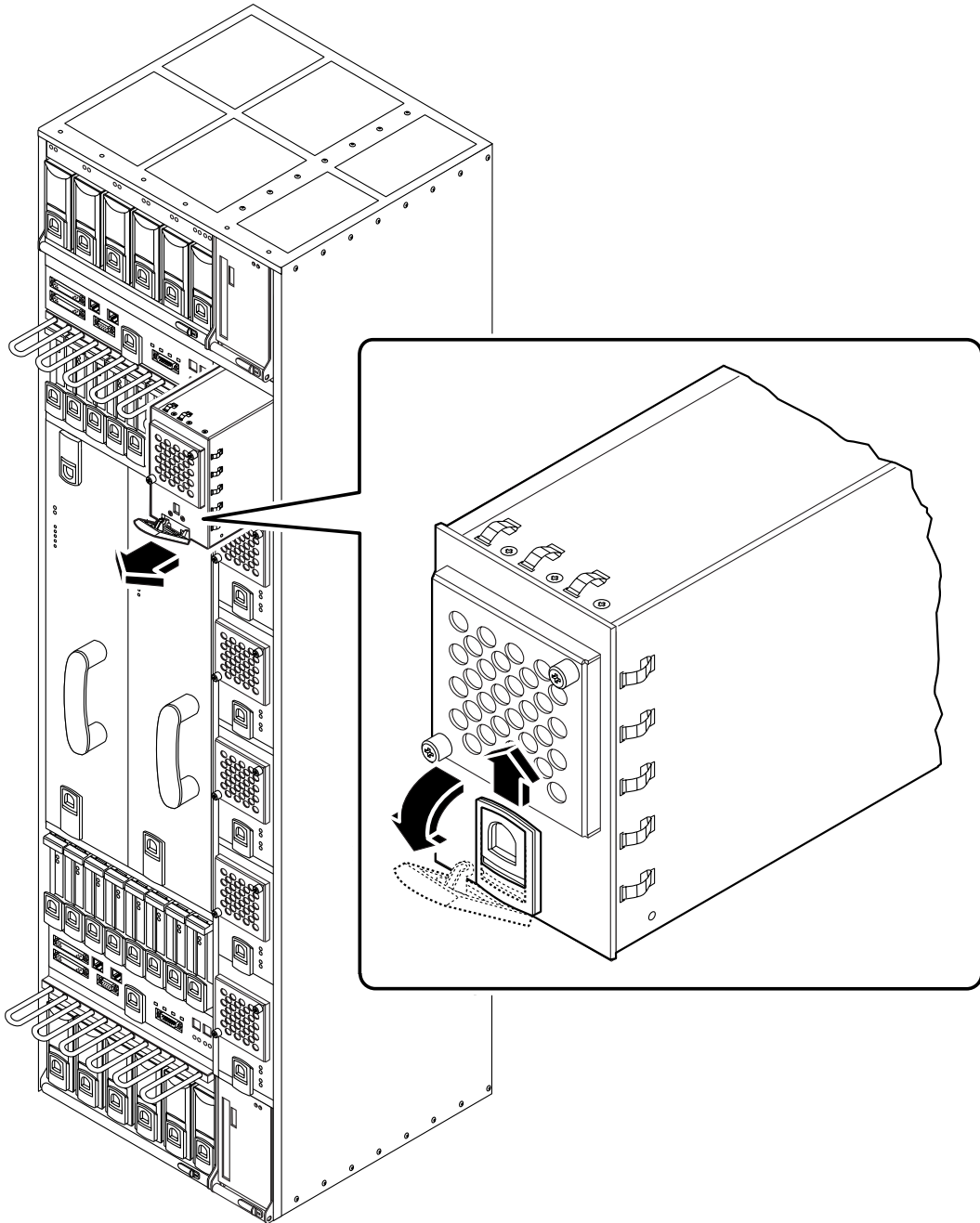

FIGURE 2-7 Removing a Power Supply

▼ To Replace a Module

1. **Slide the module into its slot but not fully home.**
A module will not fit into a slot designed for a different class of module.
2. **When the lever engages with the chassis, raise it to push the module fully home.**
3. **Move the slide in the lever into the engaged position.**

Replacing an RMM

RMM modules have a slide with an actuator microswitch on an ejector handle. The slide controls the electrical connection to the motherboard. When the slide is closed (to the right), the electrical connection is engaged; when it is open (to the left), the electrical connection is disengaged. The handle is lifted to disengage the module physically, and lowered to engage it.

▼ To Remove the RMM

1. **Slide the latch in the handle of the RMM to the left (towards the ‘unlocked’ symbol).**
2. **Lift the handle.**
3. **Slide the RMM out of its slot.**

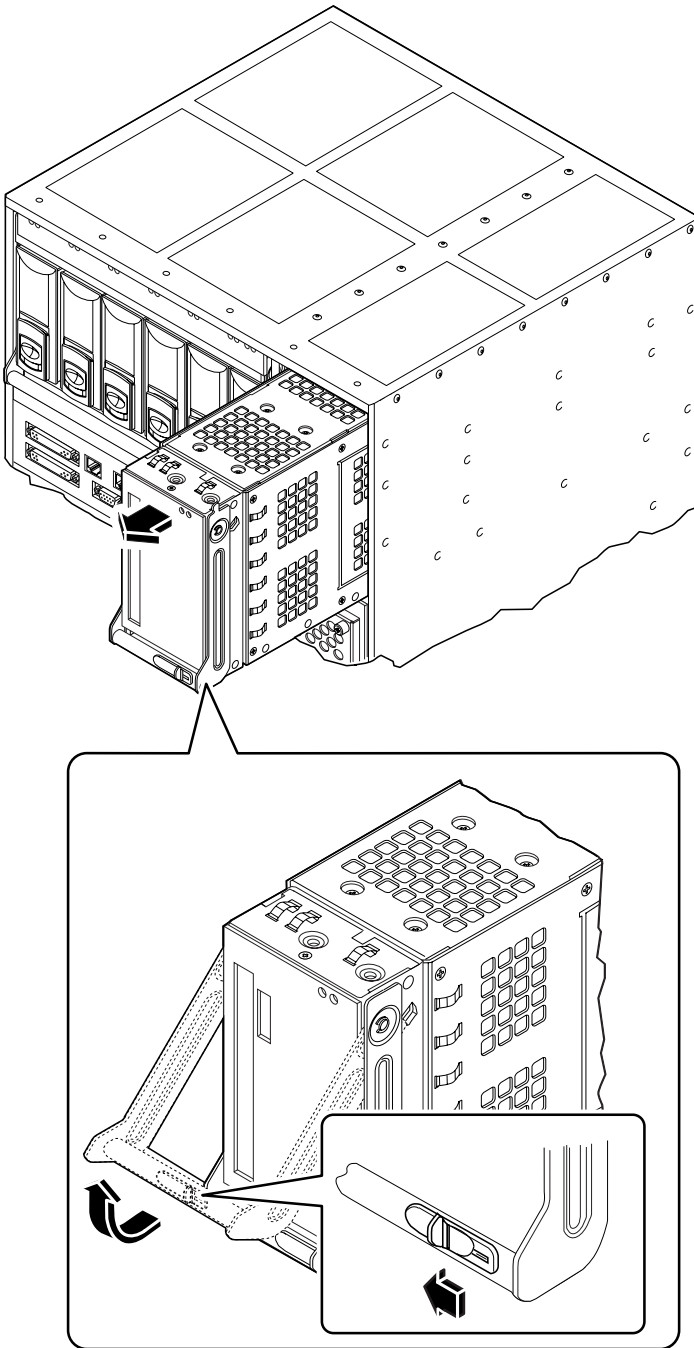

FIGURE 2-8 Removing an RMM Module

▼ To Replace the RMM

1. **Slide the RMM into its slot until it is almost completely home.**
A module will not fit into a slot designed for a different class of module.
2. **Lower the handle to engage the RMM fully in its slot.**
3. **Slide the latch in the handle to the right (towards the 'locked' symbol).**

Replacing a Disk Chassis

DSK modules have a slide on an ejector handle. The handle is lifted to disengage the module physically, and lowered to engage it.

▼ To Remove the Disk Chassis

1. **Remove any HDD modules (hard disks) in the disk chassis.**
Refer to FIGURE 2-9 on page 26.



Caution – Always remove all hard disk drive modules before removing a disk chassis. Always put a hard disk back in the same location from which you removed it.

2. **Slide the latch in the handle of the disk chassis to the left (towards the 'unlocked' symbol).**
3. **Lift the handle.**
4. **Slide the disk chassis out of its slot.**

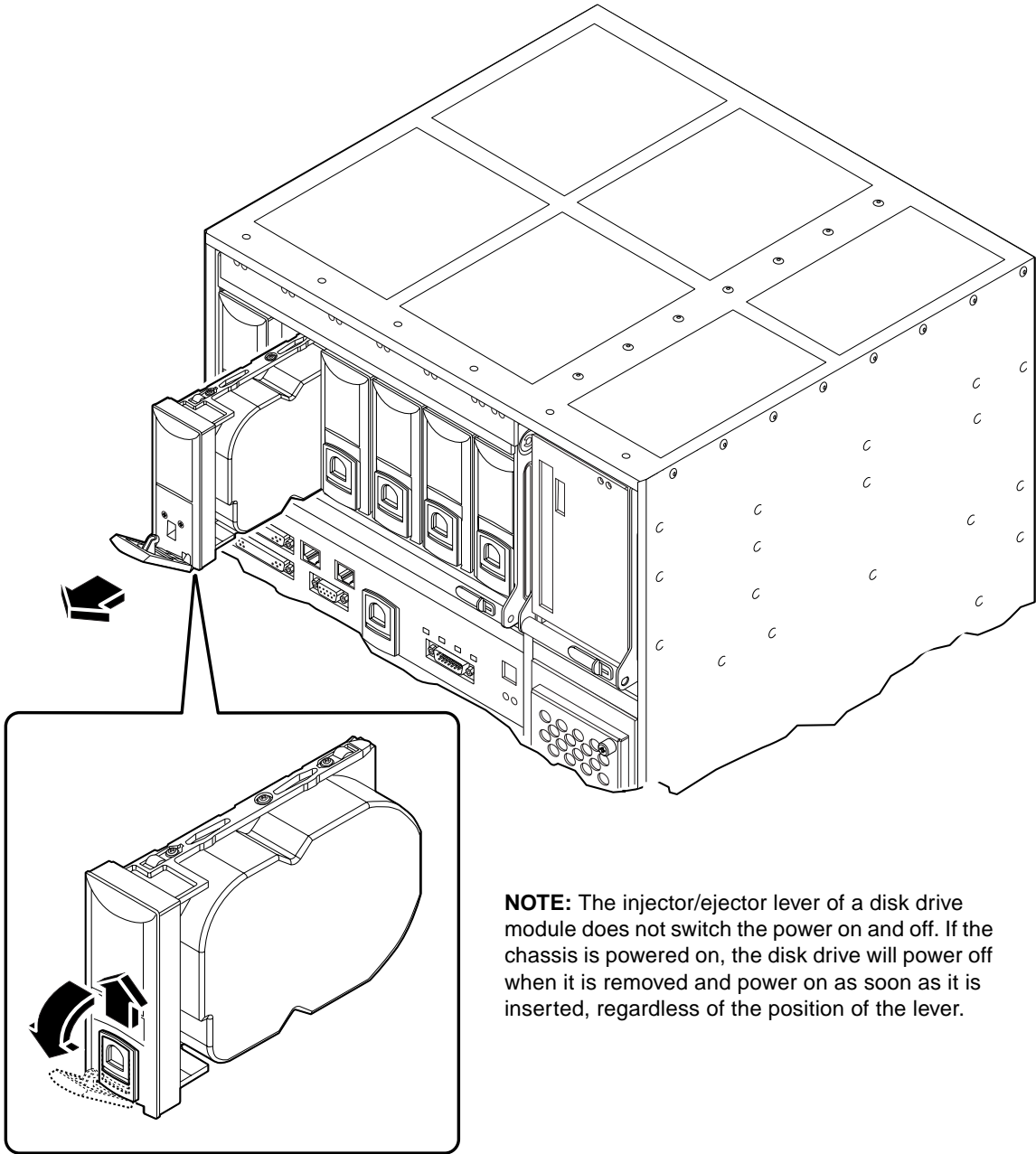

NOTE: The injector/ejector lever of a disk drive module does not switch the power on and off. If the chassis is powered on, the disk drive will power off when it is removed and power on as soon as it is inserted, regardless of the position of the lever.

FIGURE 2-9 Removing a Disk Drive

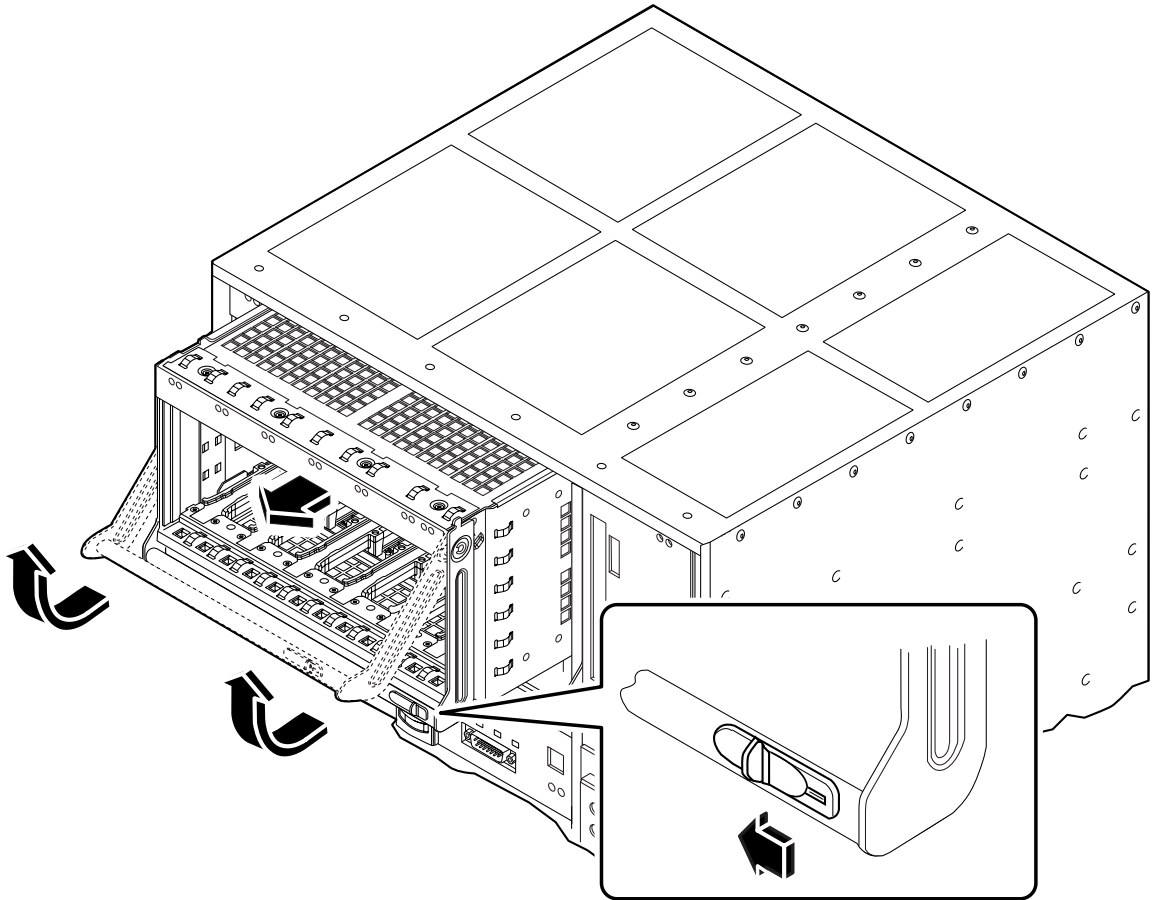

FIGURE 2-10 Removing a DSK Module

▼ To Replace the Disk Chassis

1. Slide the disk chassis into its slot until it is almost completely in.
2. Lower the handle to engage the disk chassis fully in its slot.
3. Slide the latch in the handle to the right (towards the 'locked' symbol).
4. Replace the hard disk drives.

Flexible Module Cabling

The cable management shelf is illustrated in FIGURE 2-11.

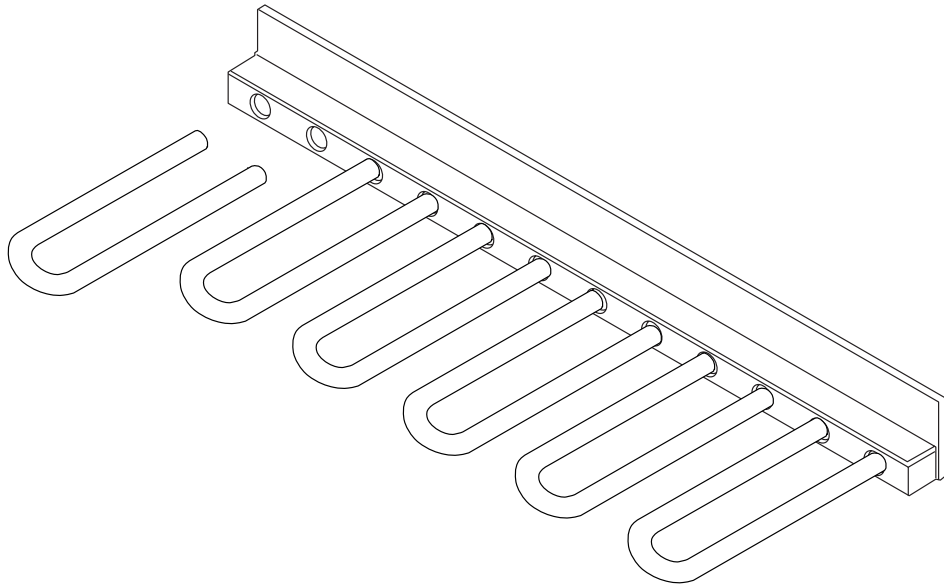

FIGURE 2-11 Cable Management Shelf

The cable management shelf adjacent to the PCI card locations is flexible and can be used in a number of different configurations. The holes are equidistant, and the hooks can be inserted in whatever position is required. The hooks are a firm push-fit into the holes.

Installing the Filter Trays

The Netra ft 1800 has three filter trays, two large and one small.

▼ To Install the Filter Trays

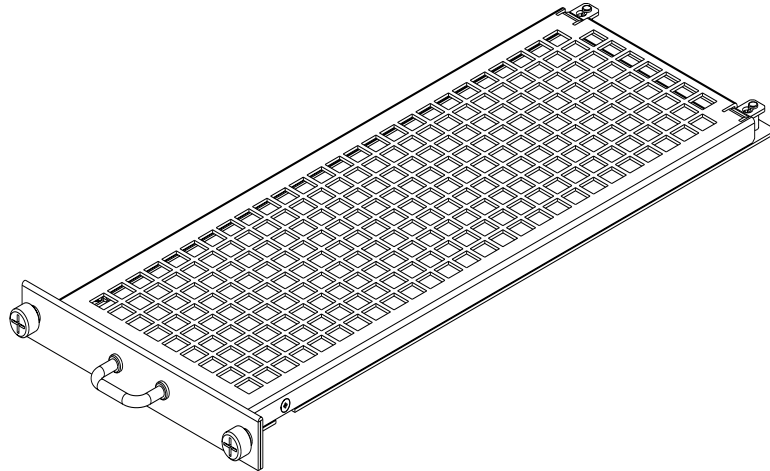

FIGURE 2-12 Large Filter Tray

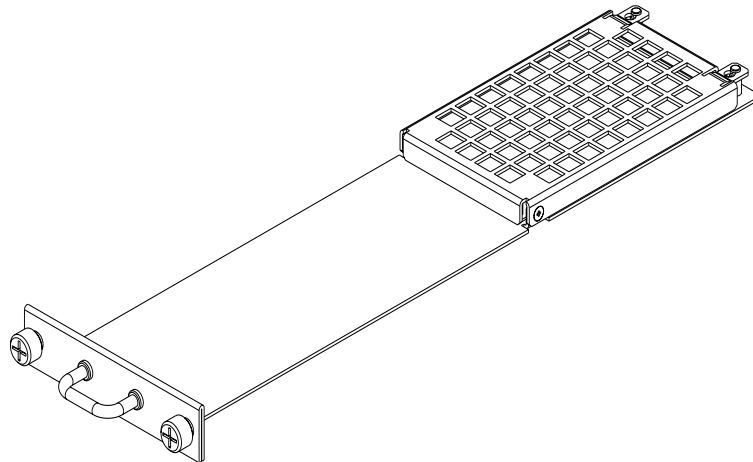

FIGURE 2-13 Small Filter Tray

- 1. Insert the trays into the appropriate apertures at the base of the chassis; the two large trays are fitted on the left and the small tray on the right.**
It is unimportant which way up the trays are fitted.

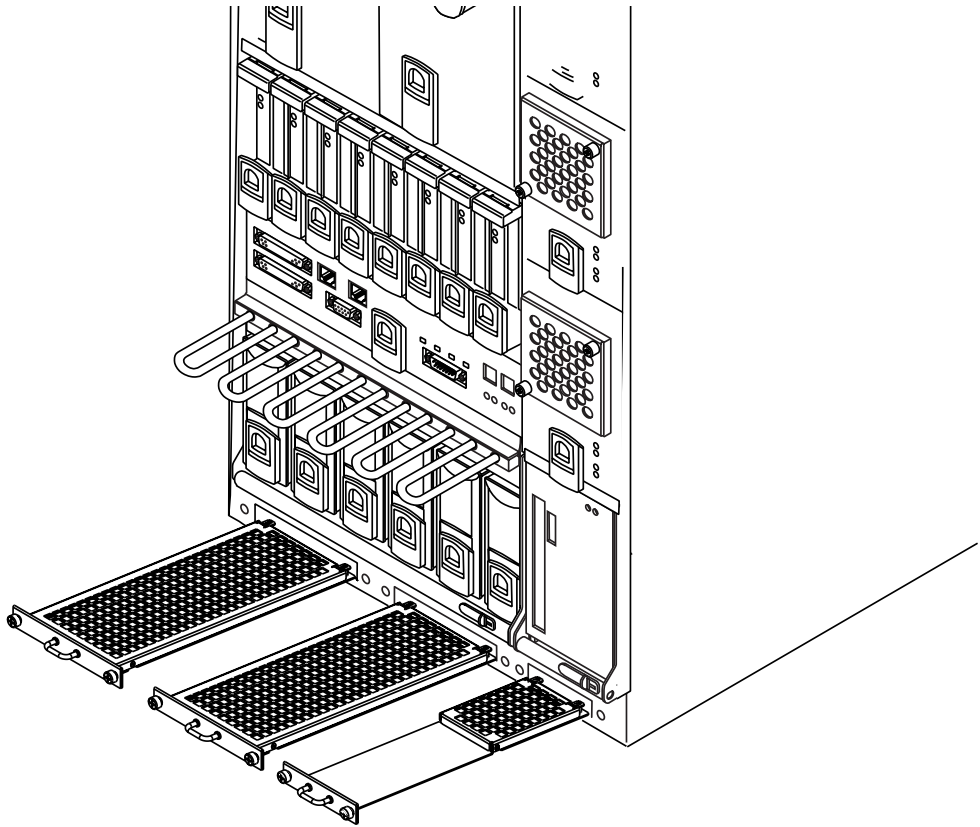

FIGURE 2-14 Inserting the Environmental Filters

- 2. Push the trays securely home and hand-tighten the two thumbscrews on each.**
The thumbscrews are inserted into the tapped threads exposed by removal of the sacrificial mounting plinth.

CAF External I/O Connections

The Netra ft 1800 system has the following connectors on each CAF module:

- Female 25-pole D-type connectors for the system console and modem ports (RS232).
- A female 9-pole D-type connector for the Remote Control Processor (RCP) ports.
- A male 15-pole D-type connector for the alarm relay/reset signals.
- Two RJ45 Ethernet ports.

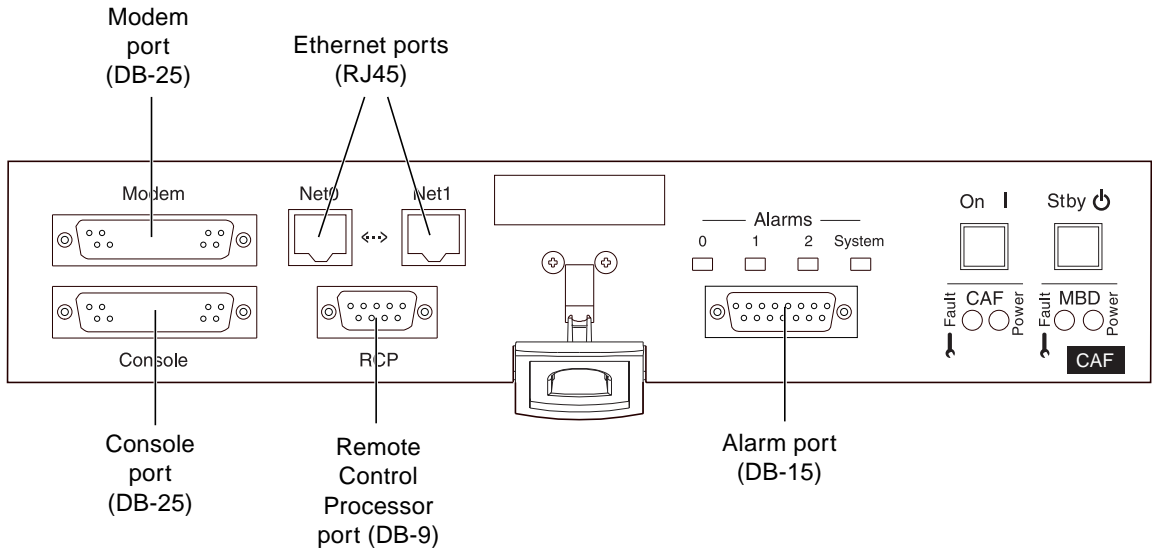

FIGURE 2-15 External I/O Connections on CAF Module

System Console Terminal Connections

The system console and modem connections are provided on separate 25-pole female D-type connectors. TABLE 2-1 shows the pin allocation on these connectors.

TABLE 2-1 Console Connector Pinout

Pin	Function	Description
1	GND	Chassis ground
2	TxD	Output data
3	RxD	Input data
7	SREF	Signal reference
Shield		Chassis ground

Except for pin 1, all pins of the console and modem connectors are isolated from the frame ground of the Netra ft 1800 system.

The connectors have two screw-threaded mounting pillars with 4-40 UNC threads. You should secure the cable headshell in place with the screws engaged in these pillars. If you use a cable headshell without securing the screws, make sure that the pillars do not prevent full engagement of the connector. This can happen with some types of cable headshell where screw heads can foul against the mounting pillars.

You must also secure the other end of the cable to the console terminal if the terminal provides some means of locking.

Note – To ensure EMC compliance always use a high quality screened cable that has metal connector shells.

TABLE 2-2 shows the console terminal configuration parameters for both console and modem ports. You can modify these parameters using Solaris utilities such as `stty(1)`. Refer to the *Solaris System Administration Guide* for more details.

TABLE 2-2 Console and Modem Port Parameters

Parameter	Setting
Transmit rate	9600 baud
Receive rate	9600 baud
Data bits	8

TABLE 2-2 Console and Modem Port Parameters (*Continued*)

Parameter	Setting
Stop bits	1
Parity enable/sense	off/off
XON/XOFF protocol	on

System consoles can be connected only to the CAF module.

Modem Port Connections

The modem port pinout is described in TABLE 2-3.

TABLE 2-3 Modem Port Pinout

Pin	Function	Description
1	GND	Chassis ground
2	TxD	Output data
3	RxD	Input data
4	RTS	Output handshake
5	CTS	Input handshake
7	SREF	Signal reference
8	DCD	Input status
20	DTR	Output status
Shield		Chassis ground

Alarms Port Connections

The alarms port pinout is described in TABLE 2-4.

TABLE 2-4 Alarms Port Pinout

Pin	Description	Pin	Description
1	RESET0+	9	ALARM0-NC
2	RESET0-	10	ALARM0-COM
3	RESET1+	11	ALARM1-NO
4	RESET1-	12	ALARM1-NC
5	SYSTEM-NO	13	ALARM1-COM
6	SYSTEM-NC	14	ALARM2-NO
7	SYSTEM-COM	15	ALARM2-COM
8	ALARM0-NO		

RCP Port

There is an RS232 connection to the Remote Control Processor (RCP) on the motherboard. Connection is via a female DB-9 whose pinout is shown in TABLE 2-5.

TABLE 2-5 Remote Control Processor Port Pinout

Pin	Function	Description
2	TxD	Output data
3	RxD	Input data
5	SREF	Signal reference
Shield		Chassis ground

Electrical Supply Installation

This chapter provides information about the Netra ft 1800 system switches and the installation of the electrical supply. See the *Netra ft 1800 Hardware Reference Manual* for full details of the electrical supply hardware.

The Netra ft 1800 has six power input feed pairs, three for each side, which plug in to the back of the system. These must be assembled by the user, as described in “Connecting the Power Leads” on page 47.

Note – This equipment is only intended for installation in a Restricted Access Location as defined by UL1950, 3rd Edition, and EN60950: 1992 / A11: 1997.

Note – In NORWAY, this equipment must only be installed in areas where equipotential bonding has been applied, e.g. a telecommunication Central Office.

Note – The system will only power up if the input voltage is in the range –40 to –60 VDC.

System Switch

The Netra ft 1800 in fault tolerant mode consists of two *sides*: processors and associated modules which function and are powered as separate systems. The system switches of the Netra ft 1800 function as standby devices for their respective sides, enabling and disabling the power supply units (PSU) outputs. The system switches are push, momentary switches. They are located on the CAF module on each side of the system.

The system does not contain any integral circuit breakers. The only means of isolating the system from power is by means of external circuit breakers, to be provided by the user.

Note – The system On and Stby switches handle low voltage signals only; the high-power circuits do not pass through these switches.

DC Source Site Requirements

The DC source site requirements are as follows:

- Suitable for use in –48 VDC (classified SELV) nominal or –60 VDC (classified TNV-2) nominal systems.
- The supply source must be electrically isolated by double or reinforced insulation from any hazardous AC or DC source.
- The DC source must be reliably connected to earth (for example, battery room positive bus is connected to the grounding electrode).
- The DC source must be capable of providing up to 925W of continuous power per feed pair. The sum of all three feeds on one side will be less than 1500W for single-feed and 3000W for dual feed.

Overcurrent Protection Requirements

Overcurrent protection devices must be provided as part of each host equipment rack.

The supply source must be electrically isolated from any AC source or other voltages by double or reinforced insulation.

Circuit breakers meeting the requirements shown in TABLE 3-1 must be fitted between the DC source and the Netra ft 1800 such that they are ON in the UP position.

TABLE 3-1 Overcurrent Protection Requirements

Current rating	30A maximum
Voltage	Maximum 60 VDC rated in –48 VDC power systems Maximum 75 VDC rated in –60 VDC power systems
Type	Fast trip

TABLE 3-1 Overcurrent Protection Requirements (*Continued*)

Protection	<p>EITHER: Double pole breaking (both grounded and ungrounded conductor open on fault) OR: Single pole breaking ungrounded conductor (-48V) to open on fault.</p> <p>Circuit breakers can be used in configurations to match those shown in FIGURE 3-4 on page 41, FIGURE 3-5 on page 42 and FIGURE 3-6 on page 43. Double Pole breakers MUST be used in the configuration shown in FIGURE 3-3 on page 40.</p>
Contact gap	Minimum 3 mm
Nuisance tripping	Circuit breaker must not operate when presented with an inrush current of 27 amps and a duration of 2.5 microseconds
Quantity	One per feed, up to 12 per system



Caution – Double pole circuit breakers are required for installations with dual feeds to any Netra ft 1800 PSU but without a local common return point. The reason for this is the possibility of high currents looping in the return conductors and through the PSU due to a fault elsewhere in the installation. FIGURE 3-1 shows the fault situation where a problem external to the Netra ft 1800 causes an unrestricted current flow through the PSU (shown by the dotted line).

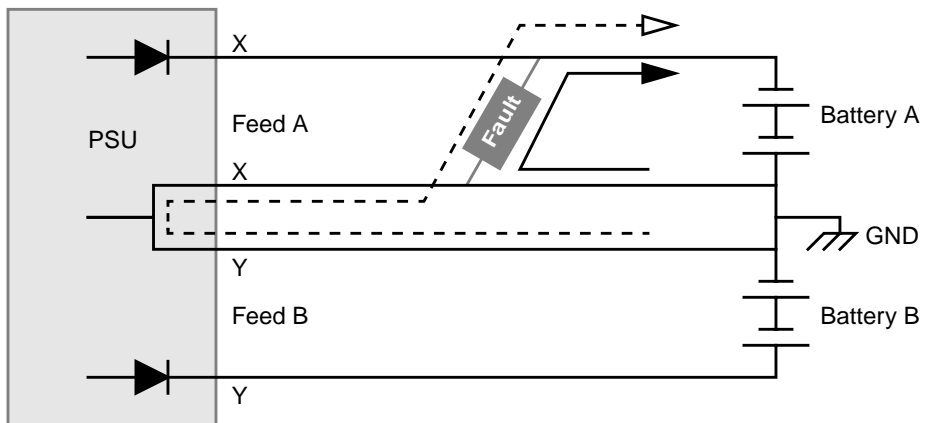

FIGURE 3-1 PSU Fault Situation



Caution – Only by placing double pole circuit breakers at X-X and Y-Y can the return path through the PSU be broken.

Note – Four single pole breakers do not provide an alternative, as one of the breakers in the return can be open without indicating a failure in the PSU.

Note – Overcurrent devices must meet applicable national and local electrical safety codes and be approved for the intended application.

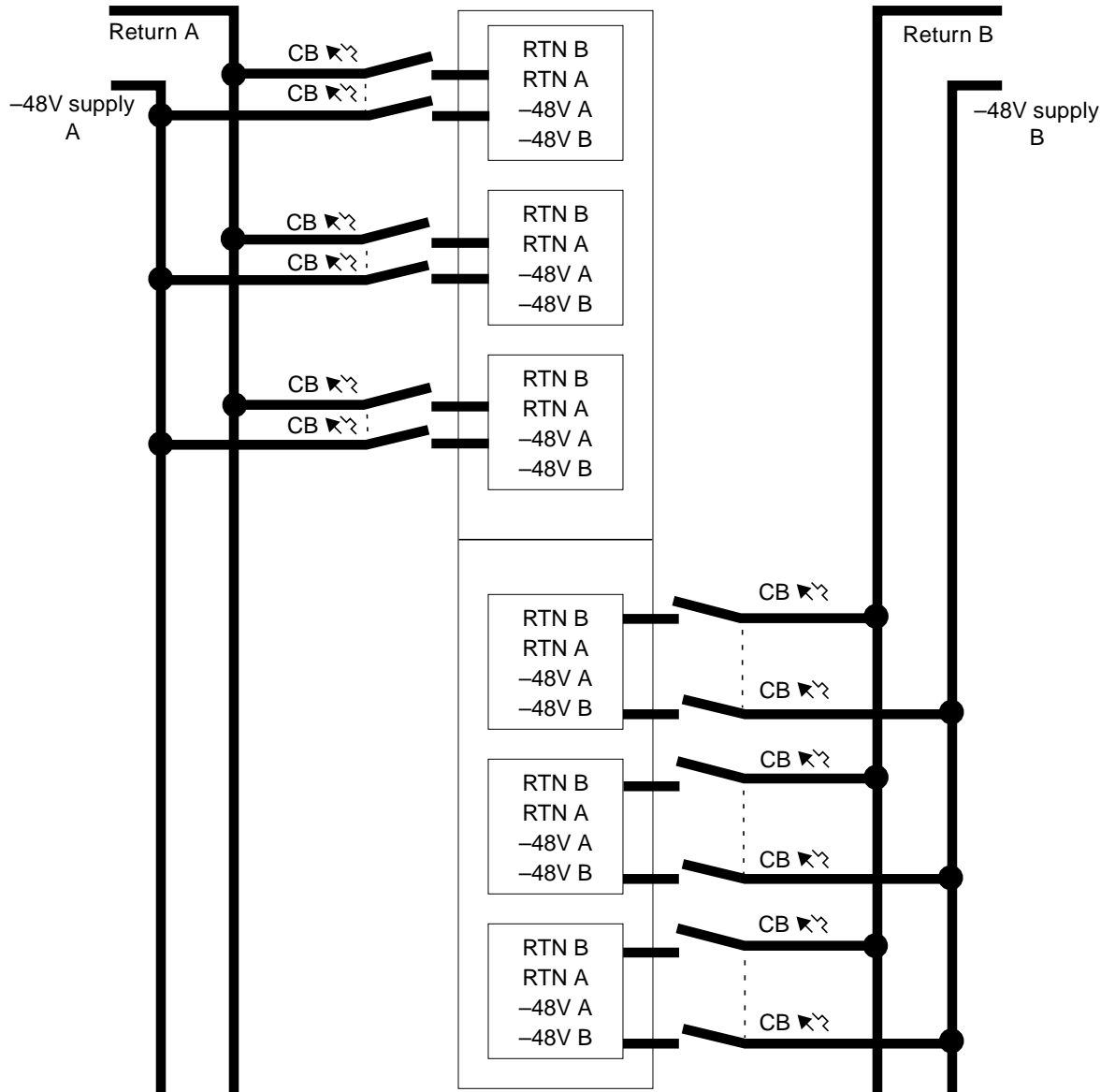

FIGURE 3-2 Circuit Breakers for Single Power Rails

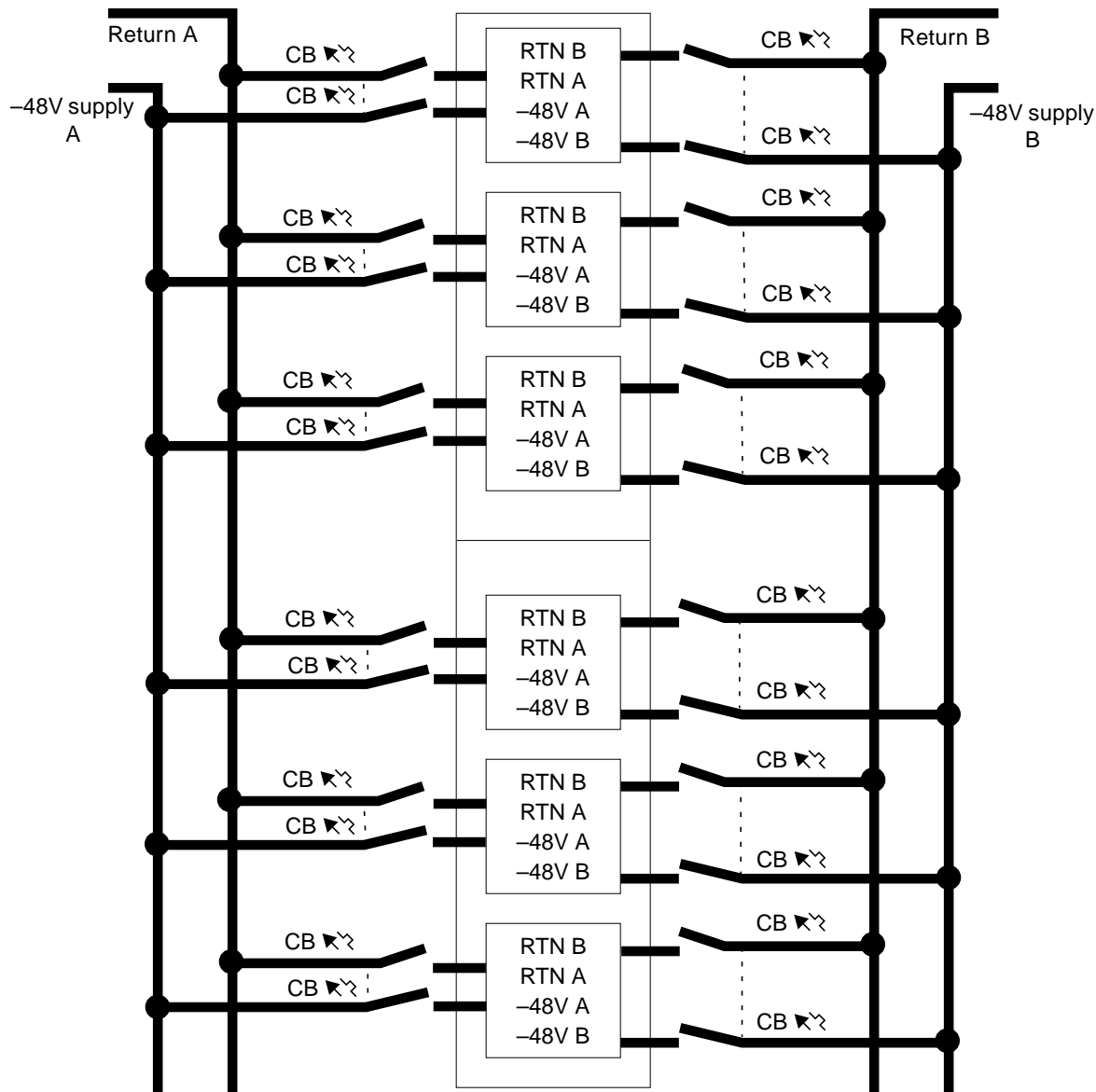

FIGURE 3-3 Circuit Breakers for Dual Power Rails

Note – Dual feed configuration with independent return circuits to source. Double pole circuit breakers must be used.

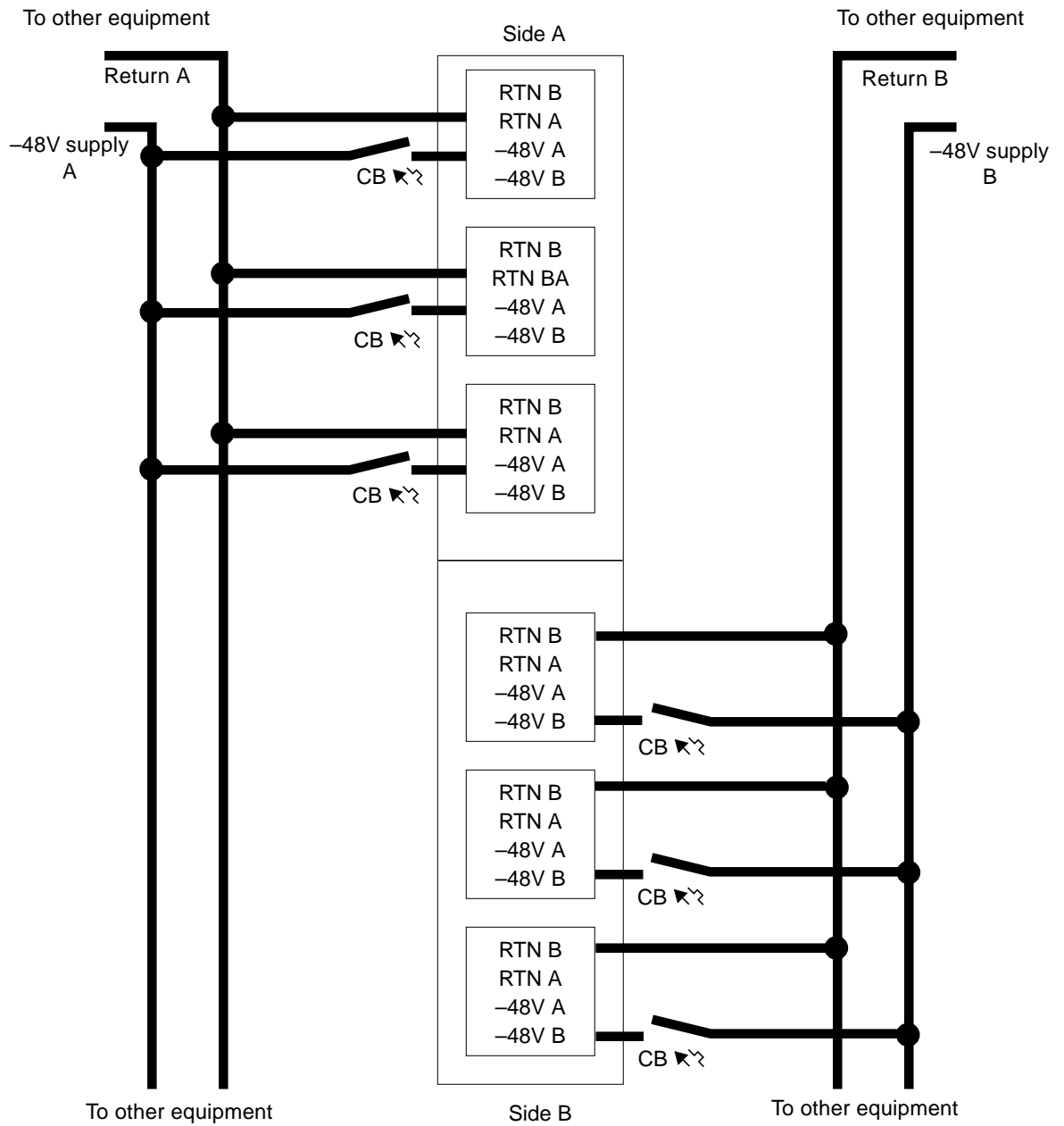

FIGURE 3-4 Sided Independent Feeds with Single Pole Circuit Breakers

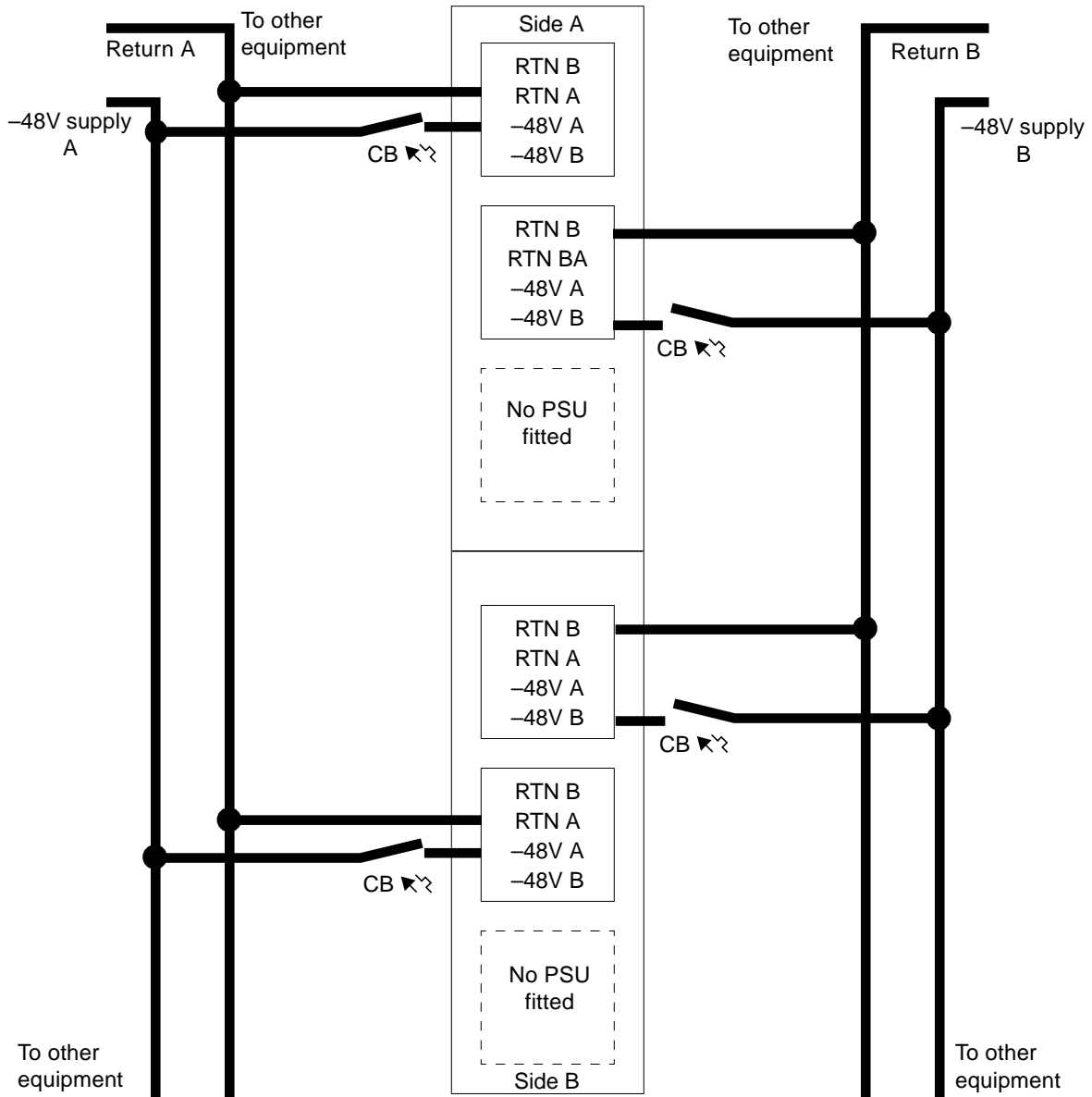

FIGURE 3-5 Side-independent Feeds to Each PSU with Single Pole Circuit Breakers (double pole can be used)

Note – This is only applicable for smaller Netra ft 1800 configurations, that is, those with only two PSUs per side configured to provide redundancy.

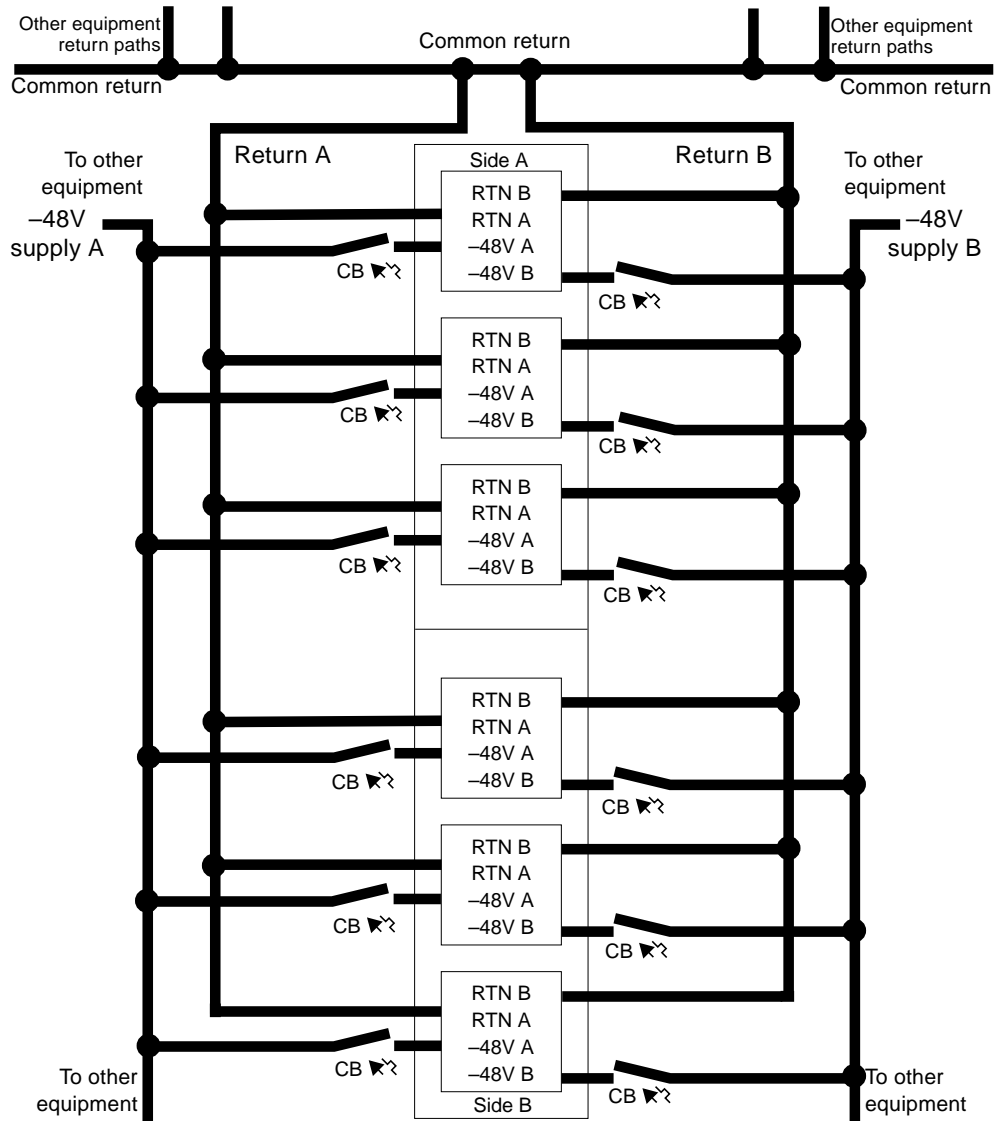

FIGURE 3-6 Dual Feeds with Local Common Return – Single Pole Circuit Breakers (double pole can be used)



Caution – To meet the criterion of a Local common return, the return lines from the Netra ft 1800 must go directly to the Common point without linking to the returns from other equipment. The Return A and Return B lines for each PSU must be adjacent on the Common point (within 100 mm of each other).

Required Connection Materials

DC branch circuits:

- The required number of field wiring kits are supplied in the shipkit with each system, according to configuration.

Grounding:

- One Thomas & Betts two-hole lug (part number: 54204-UB) suitable for 8 AWG conductor or UL/CSA approved equivalent having 5/8-inch pitch; torque value: 3.5 Nm maximum.
- A Thomas & Betts crimping tool (part number: TBM 5-S), or approved equivalent to secure the lug on to the cable.
- A grounding bus bar that is near the equipment and easily accessible.

Dual Grounding Environment:

- Additional Thomas & Betts two-hole lug for logic 0V studs.



Caution – External filtering and/or surge suppression devices may be required on the power feeds where branch circuit electromagnetic characteristics are unknown.

DC Supply and Ground Conductor

The requirements are:

- Suitable conductor material: copper only.
- Supply conductors: 8 AWG (6 sq.mm) (between the Netra ft 1800 and the circuit breaker).
- Ground conductor: 8 AWG.
- Cable insulation rating: minimum 75 degrees Celsius, Low Smoke Fume (LSF), Flame Retardant.
- Cable type must be one of:
 - UL style 1028 or other UL 1581 compliant equivalent.
 - IEEE 383 compliant.
 - IEEE 1202-1991 compliant or classified.
- Branch circuit cable insulation color: per applicable national electrical codes.
- Grounding cable insulation color: green/yellow.

Dual Grounding Environment



Caution – To be compatible with grounding environments requiring isolation between logic 0V and chassis ground, the fitted grounding bridge plate must be removed and individual connections made to logic 0V and chassis ground studs. The grounding bridge plate is located on the middle rear left edge of the unit between the motherboards. The grounding studs at the base of the chassis are M5 studs with appropriate nuts already installed.

Before installation for dual grounding systems, remove the link from the chassis to logic 0V. This exposes a 2-hole lug with tapped M5 threads (refer to FIGURE 3-7).



Caution – The use of certain PCI cards causes the frame and logic grounds to be commoned. Refer to the documentation supplied with the PCI card.

▼ To Connect the Ground Lead

- 1. Strip 9 mm of insulation from each end of the grounding lead.**
- 2. Insert the lead into the Thomas & Betts two-hole lug provided (part no. 52024-UB).**
Ensure that both the conductor and its insulation are gripped by the lug.
- 3. Position the lug and grounding lead assembly over the grounding studs.**
Refer to FIGURE 3-7 on page 46. Tighten the two M5 nuts over the locking washers provided.
- 4. Make the connection to the earthing bar at the end of the grounding lead.**
Ensure there is adequate strain relief for the cable.

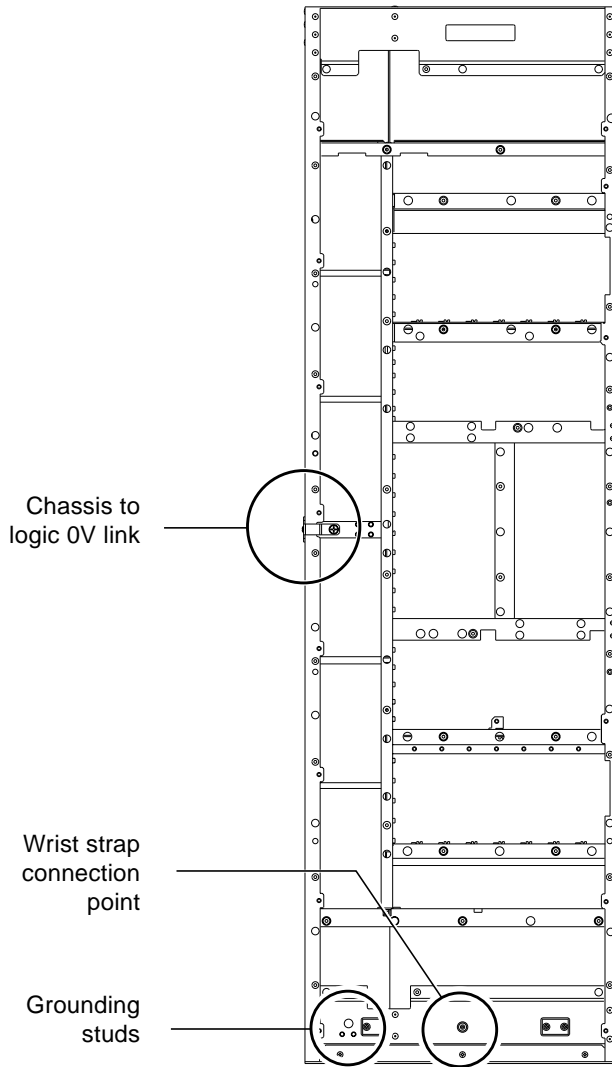

FIGURE 3-7 Location of Chassis-to-Logic-0V Link and Grounding Points, and Wrist Strap Connection Point

Connecting the Power Leads

The inlet power connector must be plugged into the power sockets on the motherboards at the back of the Netra ft 1800, then the six power leads must be attached to the input power connector.

Note – Disengage all the PSUs before you insert the power connectors. Inserting the connectors with the PSUs engaged can damage the connectors.

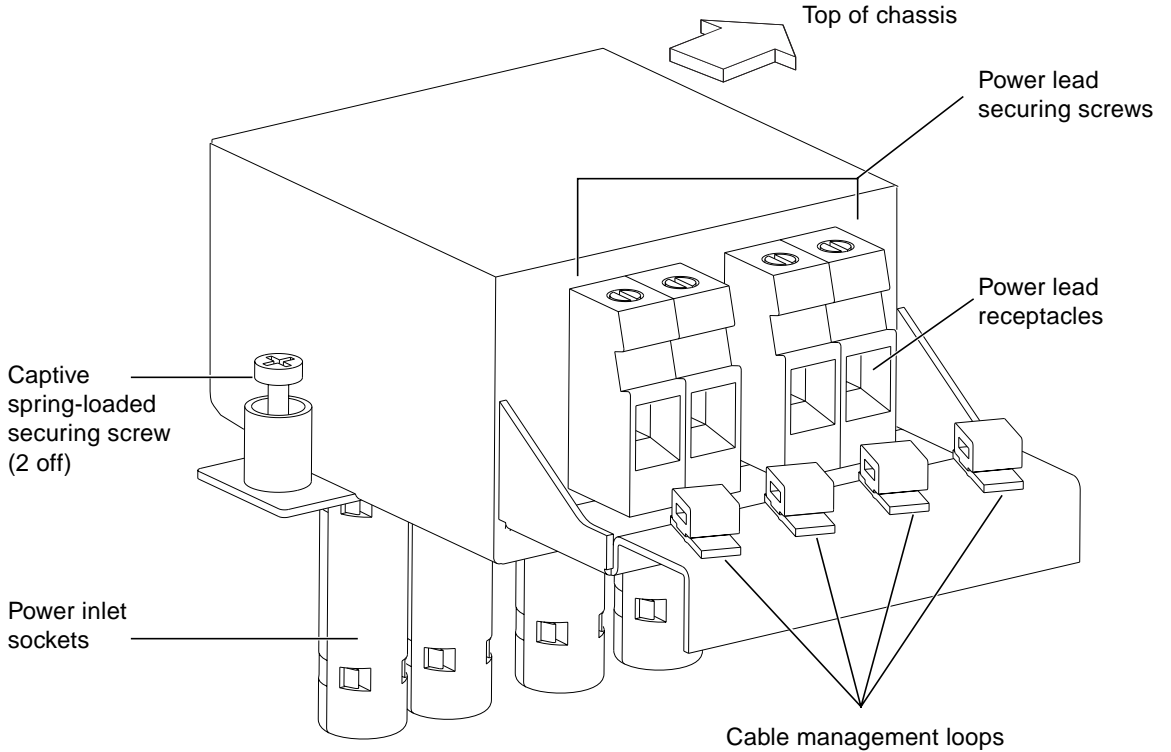

FIGURE 3-8 Power Inlet Connector

▼ To Assemble the Power Inlet and Leads

1. Insert the socket in the appropriate slot on the motherboard.

The socket can only be inserted one way round. The label on the front of the connector indicates the correct orientation.

2. Tighten the captive spring-loaded screws, preferably finger-tight only.

If you use a screwdriver, these screws should be tightened no more than 6 in-lbf (0.68 Nm). Refer to FIGURE 3-9.

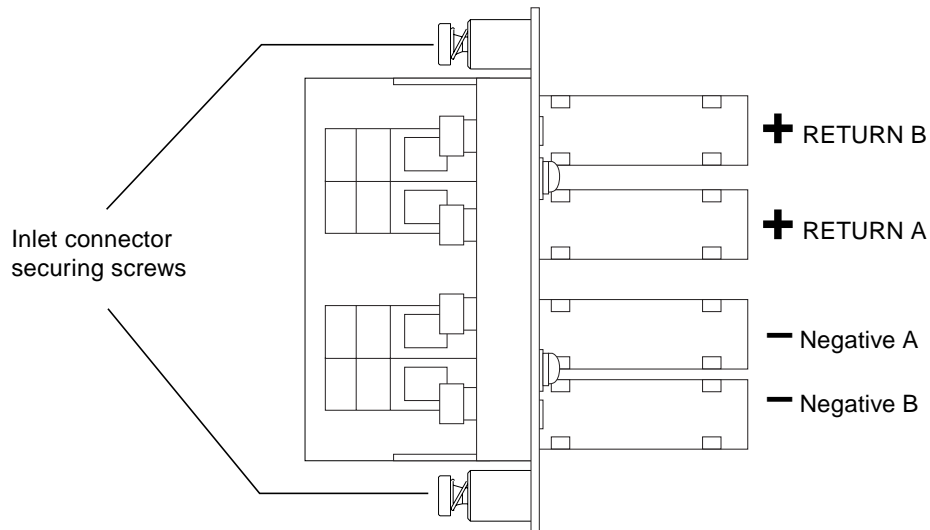

FIGURE 3-9 Power Connector Wiring Polarity and Securing Screws

3. Strip 9 mm of insulation from both ends of each power lead.

The connectors will not accommodate leads of greater than 8 AWG (6 sq.mm).

- 4. Insert the leads into the appropriate receptacles in the terminal block.**
Refer to FIGURE 3-10.

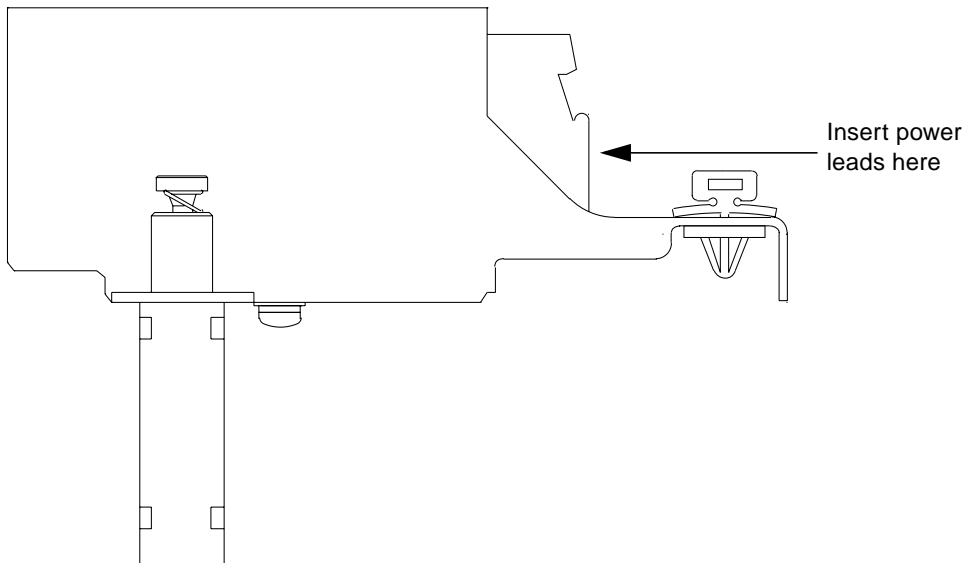

FIGURE 3-10 Power Lead Receptacles

- 5. Tighten the terminal block power lead M4 securing screws to 1.5-1.8 Nm.**
Refer to FIGURE 3-11.

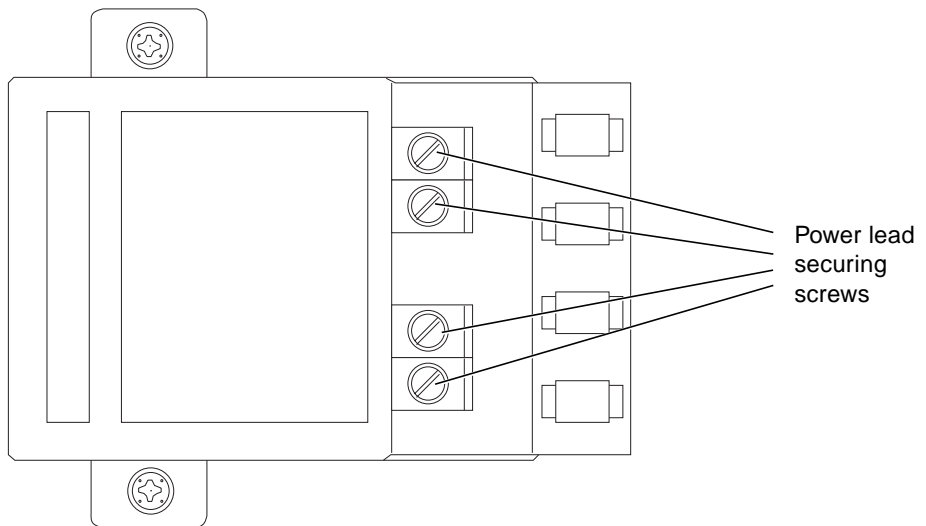

FIGURE 3-11 Power Lead Securing Screws

6. Use cable ties to secure the wires to the swivel loops in the mounting bracket (see FIGURE 3-12).

The loops can be rotated to a convenient position. This strain relief method *must* be implemented.



Caution – Observe correct working practices regarding the termination of cable ties.

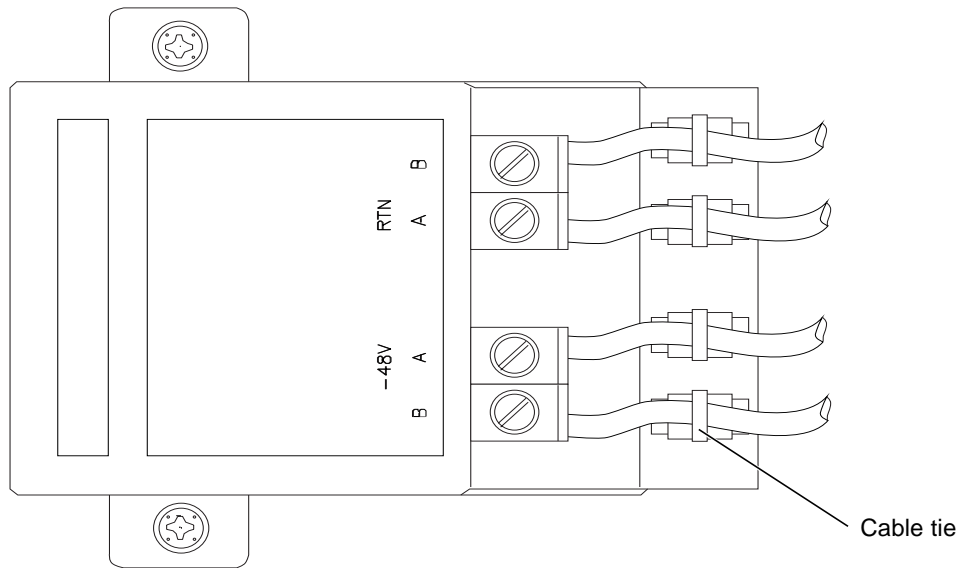

FIGURE 3-12 Power Cable Arrangement for Strain Relief

7. Ensure the circuit breakers are open, then connect the other ends of the leads to the circuit breakers.

Secure the cables using adequate strain relief.

Powering on the System

This chapter describes the procedure for powering on the Netra ft 1800.

▼ To Power On the System

1. **Prior to powering on, inspect the supply conductors for mechanical security.**
2. **Activate the external circuit breakers.**

Note – The power supply units (PSUs) remember their last requested state. They are shipped in the ON state. Because the external circuit breaker is activated when the last state of the PSU was ON, the PSU will power up at this point.

3. **Push the On (green) system switch on either CAF.**

4. Push the other On (green) system switch (on the other CAF front panel).

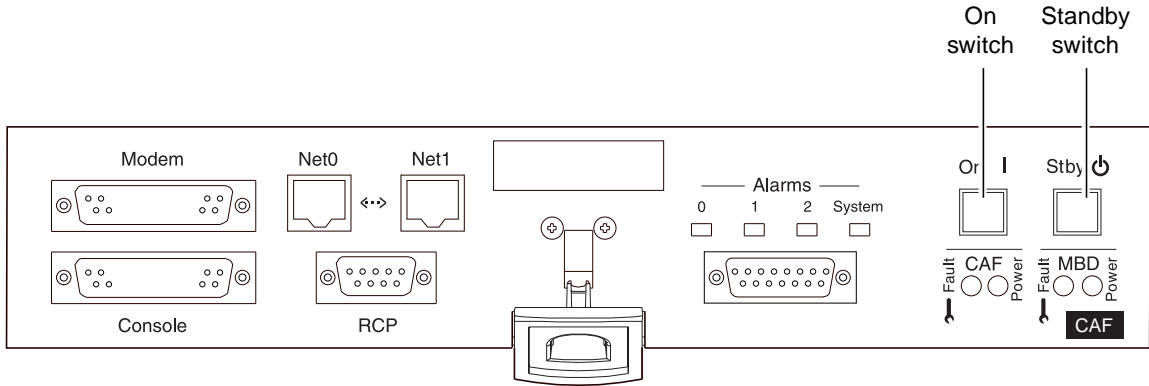

FIGURE 4-1 System Switches (Front Panel)

The PSU, CPUset and CAF *Power* LEDs will successively light, and the terminal will display the output from the Power On Self Test (POST). The POST sequence may take some time.

The CPUset LEDs will perform their own test sequence towards the end of the POST procedure, then the *Target* LED on one of the CPUsets will flash as the OBP *ok* prompt appears.

Index

A

airflow

- clearance, 3
- direction of, 2
- inlet plenum, 6
- natural convection, 2
- requirements, 2

alarms connector, 31

alarms port

- pinout, 34

B

brackets, removing, 14

C

cable bracket assemblies, 15

cable management, 28

cable routing, 9

CAF module

- connectors, 31
- removing, 20

circuit breaker

- requirements, 36

circuit breaker requirements, 36

connection materials, 44

connector

- alarms, 31
- modem port, 33

Console Alarms and Fans module, *See* CAF module

console connector, pinout, 32

console port, parameters, 32

CPUset changing, 18

D

DC source requirements, 36

dimensions, 2

disk chassis

- injector/ejector mechanism, 23, 25
- removing, 23, 25
- replacing, 25

disk drive, removing, 26

E

electricity supply installation, 35

elevation, limitations for operating and storage, 2

environmental considerations, 1

environmental filters, installing, 30

F

filter replacement kit, 3

filters, installing, 30

flanges, *See* mounting flanges

frame ground, 45

G

GR 63 Core heat release calculation result, 2

grounding

- connections, 47
- dual, 44
- isolation, 45
- materials required, 44
- requirements, 44

H

hardware installation, 11

heat release

- GR 63 Core calculation result, 2
- maximum rate of, 2

humidity, limitations for operating and storage, 2

I

I/O connections, 31

injector/ejector mechanism, 16

- disk chassis, RMM chassis, 23, 25

installation, electricity supply, 35

L

location, considerations, 1

logic ground, 45

M

modem port

- parameters, 32
- pinout, 33

modules, injector/ejector mechanism, 16

mounting configurations, 6

mounting flanges, 6

mounting platform, 14

mounting plinth, 14

mounting requirements, 6

mounting screws, 6

O

ON system switch, 52

ON/STBY switch, 35, 36

overcurrent protection, 36

P

packaging, 14

PCI card carrier

removing, 21

pinout

- alarms port, 34
- modem port, 33
- RCP port, 34

platform, shipping, 14

plinth, mounting, 14

power

- DC source requirements, 36
- DC supply and ground, 44

power cable arrangement, 50

power leads, connecting, 47

power supply

removing, 22

power switch, 35

power-on, 51

R

rack

- considerations, 6
- depth requirement, 9
- height requirement, 9
- loading capacity, 9
- mounting, 6
- safety considerations, 10

rack sizes, 6

RCP port pinout, 34

RCP ports, 31

Remote Control Processor, *See* RCP

RJ45 connectors, on CAF module, 31

RMM chassis

- injector/ejector mechanism, 23, 25
- removing, 23, 25

RS232 ports, on CAF module, 31

S

screws, mounting requirements, 6

shipping configuration, 6

system

power on, 51

unpacking, 11

unshipping, 11

T

temperature

ambient, 1

operating, 1

storage, 1

terminal configuration parameters, 32

tools supplied, 11

W

weight

empty chassis, 6

maximum, 2

removable modules, 6

