

# Netra™ ft 1800 Site Planning Guide

---



We're the dot in .com™

**Sun Microsystems, Inc.**  
901 San Antonio Road  
Palo Alto, CA 94303-4900 USA  
650 960-1300 Fax 650 969-9131

Part No. 806-2690-10  
February 2000, Revision A

Send comments about this document to: [docfeedback@sun.com](mailto:docfeedback@sun.com)

Copyright 2000 Sun Microsystems, Inc., 901 San Antonio Road • Palo Alto, CA 94303 USA. All rights reserved.

This product or document is protected by copyright and distributed under licenses restricting its use, copying, distribution, and decompilation. No part of this product or document may be reproduced in any form by any means without prior written authorization of Sun and its licensors, if any. Third-party software, including font technology, is copyrighted and licensed from Sun suppliers.

Parts of the product may be derived from Berkeley BSD systems, licensed from the University of California. UNIX is a registered trademark in the U.S. and other countries, exclusively licensed through X/Open Company, Ltd. For Netscape Communicator™, the following notice applies: Copyright 1995 Netscape Communications Corporation. All rights reserved.

Sun, Sun Microsystems, the Sun logo, AnswerBook, Java, the Java Coffee Cup logo, Netra, Netra ft and Solaris are trademarks, registered trademarks, or service marks of Sun Microsystems, Inc. in the U.S. and other countries. All SPARC trademarks are used under license and are trademarks or registered trademarks of SPARC International, Inc. in the U.S. and other countries. Products bearing SPARC trademarks are based upon an architecture developed by Sun Microsystems, Inc.

The OPEN LOOK and Sun™ Graphical User Interface was developed by Sun Microsystems, Inc. for its users and licensees. Sun acknowledges the pioneering efforts of Xerox in researching and developing the concept of visual or graphical user interfaces for the computer industry. Sun holds a non-exclusive license from Xerox to the Xerox Graphical User Interface, which license also covers Sun's licensees who implement OPEN LOOK GUIs and otherwise comply with Sun's written license agreements.

**RESTRICTED RIGHTS:** Use, duplication, or disclosure by the U.S. Government is subject to restrictions of FAR 52.227-14(g)(2)(6/87) and FAR 52.227-19(6/87), or DFAR 252.227-7015(b)(6/95) and DFAR 227.7202-3(a).

DOCUMENTATION IS PROVIDED "AS IS" AND ALL EXPRESS OR IMPLIED CONDITIONS, REPRESENTATIONS AND WARRANTIES, INCLUDING ANY IMPLIED WARRANTY OF MERCHANTABILITY, FITNESS FOR A PARTICULAR PURPOSE OR NON-INFRINGEMENT, ARE DISCLAIMED, EXCEPT TO THE EXTENT THAT SUCH DISCLAIMERS ARE HELD TO BE LEGALLY INVALID.

Copyright 2000 Sun Microsystems, Inc., 901 San Antonio Road • Palo Alto, CA 94303 Etats-Unis. Tous droits réservés.

Ce produit ou document est protégé par un copyright et distribué avec des licences qui en restreignent l'utilisation, la copie, la distribution, et la décompilation. Aucune partie de ce produit ou document ne peut être reproduite sous aucune forme, par quelque moyen que ce soit, sans l'autorisation préalable et écrite de Sun et de ses bailleurs de licence, s'il y en a. Le logiciel détenu par des tiers, et qui comprend la technologie relative aux polices de caractères, est protégé par un copyright et licencié par des fournisseurs de Sun.

Des parties de ce produit pourront être dérivées des systèmes Berkeley BSD licenciés par l'Université de Californie. UNIX est une marque déposée aux Etats-Unis et dans d'autres pays et licenciée exclusivement par X/Open Company, Ltd. La notice suivante est applicable à Netscape Communicator™ : Copyright 1995 Netscape Communications Corporation. All rights reserved.

Sun, Sun Microsystems, le logo Sun, AnswerBook, Java, le logo Java Coffee Cup, Netra, Netra ft et Solaris sont des marques de fabrique ou des marques déposées, ou marques de service, de Sun Microsystems, Inc. aux Etats-Unis et dans d'autres pays. Toutes les marques SPARC sont utilisées sous licence et sont des marques de fabrique ou des marques déposées de SPARC International, Inc. aux Etats-Unis et dans d'autres pays. Les produits portant les marques SPARC sont basés sur une architecture développée par Sun Microsystems, Inc.

L'interface d'utilisation graphique OPEN LOOK et Sun™ a été développée par Sun Microsystems, Inc. pour ses utilisateurs et licenciés. Sun reconnaît les efforts de pionniers de Xerox pour la recherche et le développement du concept des interfaces d'utilisation visuelle ou graphique pour l'industrie de l'informatique. Sun détient une licence non exclusive de Xerox sur l'interface d'utilisation graphique Xerox, cette licence couvrant également les licenciés de Sun qui mettent en place l'interface d'utilisation graphique OPEN LOOK et qui en outre se conforment aux licences écrites de Sun.

CETTE PUBLICATION EST FOURNIE "EN L'ETAT" ET AUCUNE GARANTIE, EXPRESSE OU IMPLICITE, N'EST ACCORDEE, Y COMPRIS DES GARANTIES CONCERNANT LA VALEUR MARCHANDE, L'APTITUDE DE LA PUBLICATION A REpondre A UNE UTILISATION PARTICULIERE, OU LE FAIT QU'ELLE NE SOIT PAS CONTREFAISANTE DE PRODUIT DE TIERS. CE DENI DE GARANTIE NE S'APPLIQUERAIT PAS, DANS LA MESURE OU IL SERAIT TENU JURIDIQUEMENT NUL ET NON AVENU.



# Contents

---

- 1. Introduction 1**
  - What You Will Receive 1
    - The System 1
    - The Shipkit 2
  - After Unpacking 2
  
- 2. Environmental and Airflow Considerations 7**
  - Environment 7
  - Dimensions 8
  - Airflow 8
  - Thermal Calculations 12
  
- 3. Electrical Supply Installation 15**
  - System Switch 15
  - DC Source Site Requirements 16
    - Overcurrent Protection Requirements 16
    - Required Connection Materials 24
    - DC Supply and Ground Conductor 24
    - Dual Grounding Environment 25

<b>4. Rack Mounting Guidelines</b>	<b>27</b>
Vertical Space Requirements	30
Depth	30
Loading	30
Safety	30
Seismic Applications	31
Rack Options	31
<b>5. External Connections</b>	<b>33</b>
CAF External I/O Connections	33
System Console Terminal Connections	34
Modem Port Connections	35
Alarms Port Connections	36
RCP Port	37
<b>6. Cable Management</b>	<b>39</b>
Cable Management Shelf	40
Cable Bracket Assemblies	41
<b>A. Requirements Checklist</b>	<b>43</b>
<b>B. Spare Parts Checklist</b>	<b>55</b>
<b>Index</b>	<b>57</b>

# Figures

---

FIGURE 1-1	Shipping Pallet and Mounting Plinth Dimensions (millimeters)	3
FIGURE 1-2	Shipping Brackets and Sacrificial Plinth	4
FIGURE 1-3	Netra ft 1800 System	5
FIGURE 2-1	Netra ft 1800 Airflow Requirements (External)	10
FIGURE 2-2	Netra ft 1800 Airflow Requirements (Internal)	11
FIGURE 3-1	PSU Fault Situation	17
FIGURE 3-2	Circuit Breakers for Single Power Rails	19
FIGURE 3-3	Circuit Breakers for Dual Power Rails	20
FIGURE 3-4	Sided Independent Feeds with Single Pole Circuit Breakers	21
FIGURE 3-5	Side-independent Feeds to Each PSU with Single Pole Circuit Breakers (double pole can be used)	22
FIGURE 3-6	Dual Feeds with Local Common Return – Single Pole Circuit Breakers (double pole can be used)	23
FIGURE 4-1	EIA/RETMA Mounting Hole Pattern Dimensions	28
FIGURE 4-2	Chassis Mounting Hole Arrangement (all measurements in millimeters)	29
FIGURE 5-1	External I/O Connections on CAF Module	34
FIGURE 6-1	Cable Management Shelf	40
FIGURE 6-2	Cable Bracket Assembly	41



# Tables

---

TABLE 2-1	Thermal Calculation Matrix	12
TABLE 2-2	Thermal Calculation Example 1	13
TABLE 2-3	Thermal Calculation Example 2	13
TABLE 3-1	Overcurrent Protection Requirements	16
TABLE 4-1	Mounting Hole Pattern Dimensions	28
TABLE 5-1	Console Connector Pinout	34
TABLE 5-2	Console and Modem Port Parameters	35
TABLE 5-3	Modem Port Pinout	35
TABLE 5-4	Alarms Port Pinout	36
TABLE 5-5	Remote Control Processor Port Pinout	37
TABLE A-1	Site Details	43
TABLE A-2	Physical Requirements	45
TABLE A-3	System Requirements	47
TABLE A-4	Facility Electrical Requirements	48
TABLE A-5	Environmental Requirements	49
TABLE A-6	Network Requirements	49
TABLE A-7	Access Route Requirements	50
TABLE A-8	Miscellaneous Requirements	50
TABLE A-9	Installation Schedule	51
TABLE A-10	Site Access	52

TABLE A-11	Open Items	53
TABLE B-1	Spare Parts Reliability	55
TABLE B-2	Spares Stock Levels	56



# Preface

---

This Guide provides information on what should be considered when choosing a location for a Netra ft 1800 system.

---

## How This Book Is Organized

**Chapter 1 “Introduction”** contains a list of what you will receive when you take delivery of a Netra ft 1800 and a description of the various components of the system.

**Chapter 2 “Environmental and Airflow Considerations”** describes the environmental requirements and airflow considerations for the Netra ft 1800.

**Chapter 3 “Electrical Supply Installation”** gives details of the electrical requirements for the system.

**Chapter 4 “Rack Mounting Guidelines”** explains the various rack mounting options.

**Chapter 5 “External Connections”** give details of the networking and other cables and connectors required to access the Netra ft 1800.

**Chapter 6 “Cable Management”** explains how to use the cable management system.

**Appendix A “Requirements Checklist”** provides a step-by-step check that all requirements have been fulfilled.

**Appendix B “Spare Parts Checklist”** lists the level of spares stock that should be carried according to the number of systems to be installed.

---

# Sun Welcomes Your Comments

We are interested in improving our documentation and welcome your comments and suggestions. You can email your comments to us at:

`docfeedback@sun.com`

Please include the part number (806-2690-10) of your document in the subject line of your email.

# Introduction

---

This chapter describes what you will receive when you take delivery of a Netra ft 1800, and how to handle it.

---

## What You Will Receive

When you take delivery of a Netra ft 1800 system, you will receive the system itself, mounted on a pallet, and a large box containing the shipkit.

## The System

The system itself is secured to a wooden pallet by a sacrificial mounting plinth and brackets. The whole is covered by shock-resistant packaging secured by a corrugated cardboard cover, which itself is secured by unbreakable straps.

A Tip'N'Tell unit<sup>1</sup> is fixed to the outside of the cardboard cover to enable you to establish whether the system has been dropped or otherwise mishandled in transit.

Graphics on the outside of the cover illustrate how to remove the cover and associated packaging. No special tools are required.

The modules shipped within the system depend on the configuration ordered. They may include some or all of those shown in FIGURE 1-3 on page 5.

1. The Tip'N'Tell unit is self-explanatory – it will be obvious how it works when you look at it.

# The Shipkit

The shipkit box accompanying the system contains some or all of the following items:

- Manuals:
  - Hardware Installation Manual
  - Hardware Release Notes (where necessary)
  - Compliance and Safety Manual
- Environmental filter assemblies
- Toolkit for unshipping the system (contained in a cloth bag):
  - Phillips No.2 screwdriver
  - 12 mm Allen key
- Cable hooks for the cable management system
- Software licenses:
  - Sun StorEdge Volume Manager
  - Solaris operating environment

---

**Note** – The software kit and manual set are orderable as separate items. The system is pre-loaded and pre-configured with the software, and the manuals shipped with the system are all that are required in order to install the system and start it up.

---

---

## After Unpacking

You should use the instructions given in the Netra ft 1800 Hardware Installation Manual and the Netra ft 1800 Hardware Release Notes (if present) to unship and mount the system.

---

**Note** – This equipment is only intended for installation in a Restricted Access Location as defined by UL1950, 3rd Edition, and EN60950: 1992 / A11: 1997.

---

A lifting device will be required to lift the system into a rack, even if all modules are first removed from the chassis. The system weighs at least 230 kg (500 lb) when fully loaded. After the system is unshipped from the wooden pallet, the lifting device should be inserted in the space between the top and bottom of the sacrificial mounting plinth as shown in FIGURE 1-2 on page 4. Any other lifting method or point may result in deformation of the chassis and subsequent failure of the system to function correctly.

You should ensure that doorways, corridors and aisles are wide and high enough to accommodate the system while being manoeuvred by the lifting device.

System dimensions are:

- Overall width/depth including wooden pallet: 725 mm (28.5 inches)
- Overall width/depth excluding wooden pallet and shipping brackets but including sacrificial plinth: 438 mm (17.2 inches)
- Overall height including wooden pallet: 1722 mm (67.8 inches)
- Overall height excluding wooden pallet but including sacrificial plinth: 1562 mm (61.5 inches)
- Opening in wooden pallet to accommodate lifting device: 575 mm x 90 mm (22.6 inches x 3.5 inches)
- Opening in sacrificial plinth to accommodate lifting device: 407 mm x 75 mm (16 inches x 3 inches)

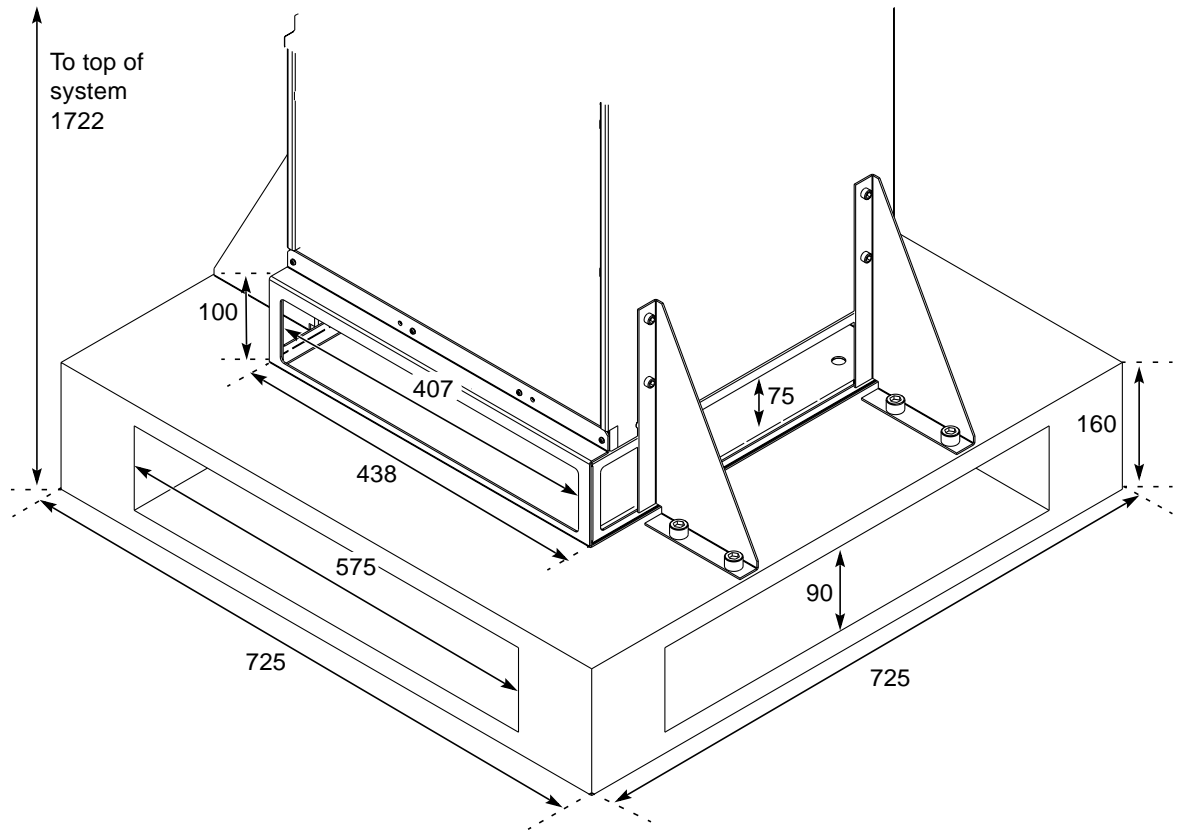
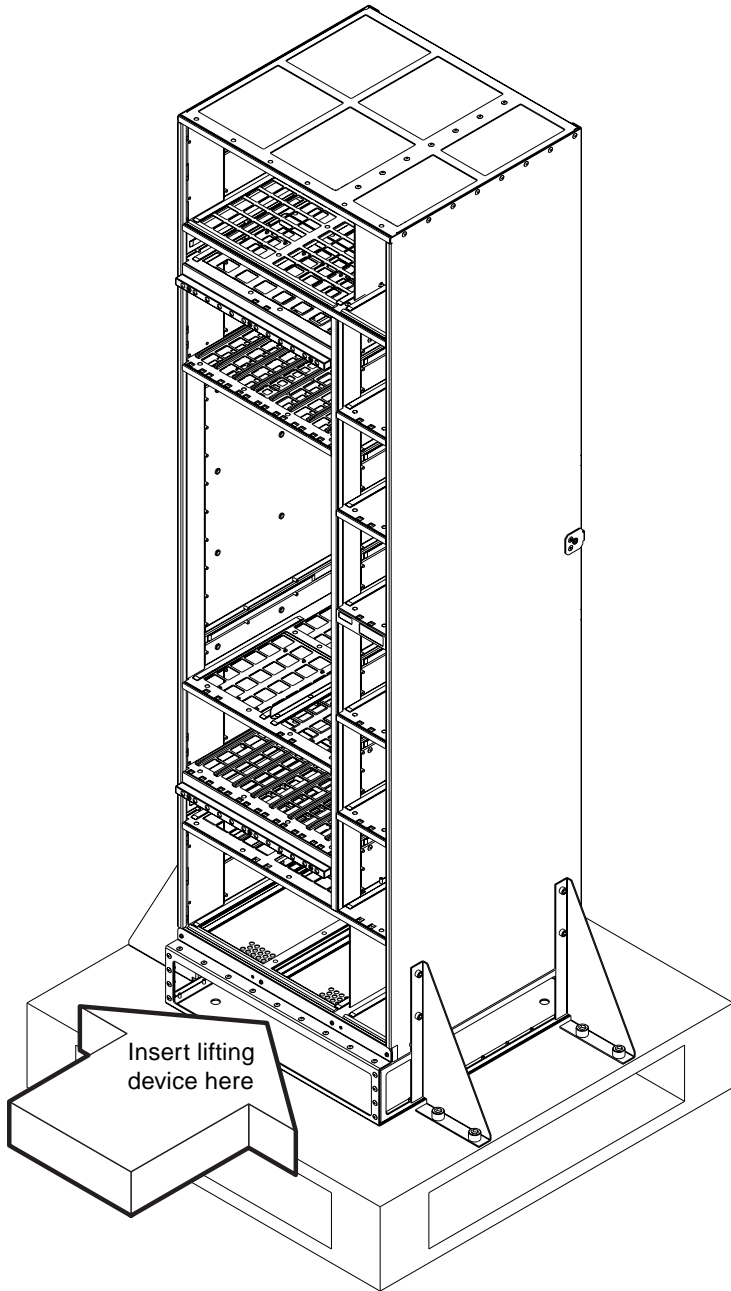

FIGURE 1-1 Shipping Pallet and Mounting Plinth Dimensions (millimeters)



**FIGURE 1-2** Shipping Brackets and Sacrificial Plinth

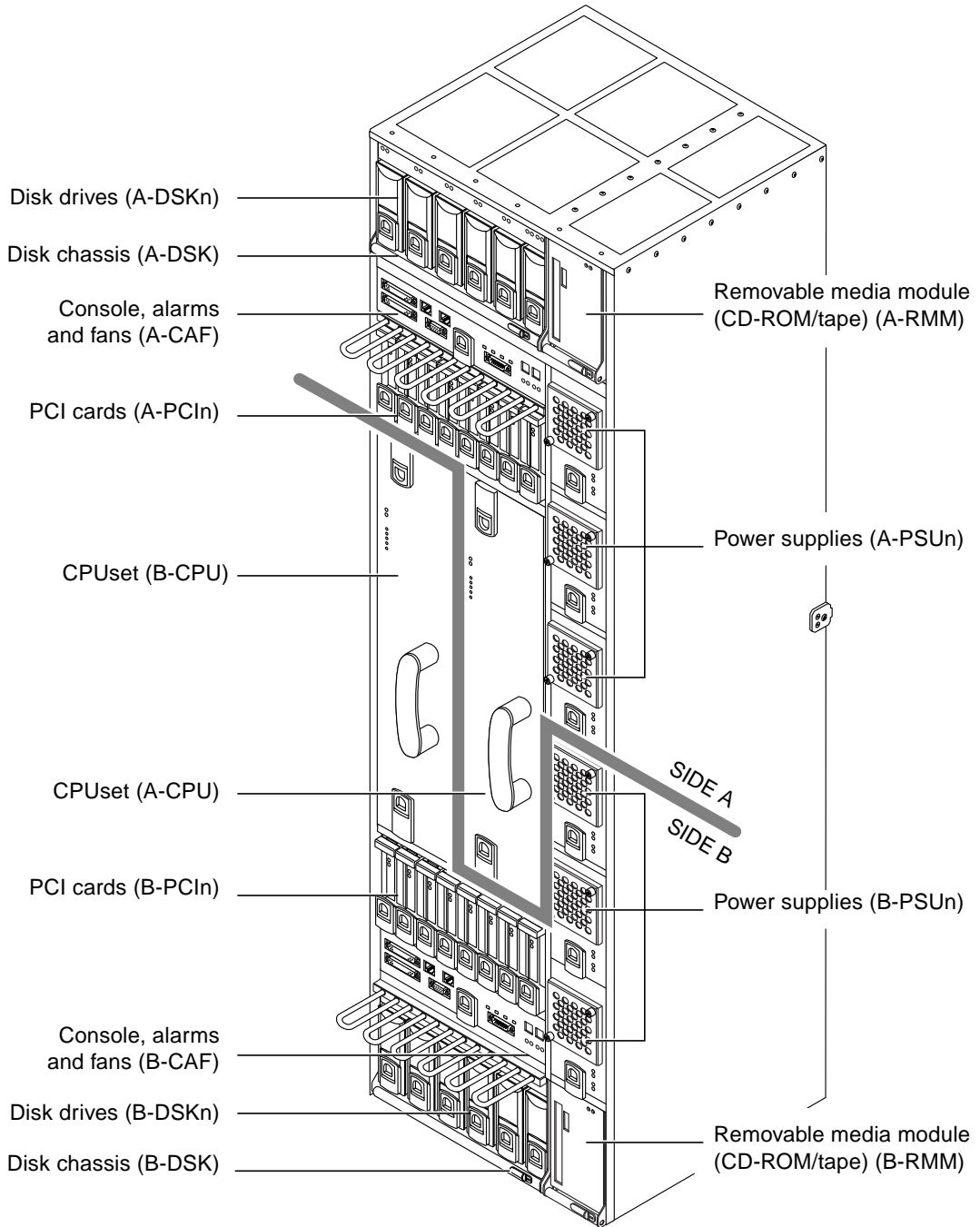

FIGURE 1-3 Netra ft 1800 System





# Environmental and Airflow Considerations

---

This chapter describes the environmental considerations and airflow requirements for a Netra ft 1800 system.

---

## Environment

The system can be installed in an environment with the following specific parameter ranges:

- Ambient temperature
  - Operating: 0 to 40 degrees Celsius (short term operation up to a temperature of 50 degrees Celsius is possible; however, the operation of removable media devices cannot be guaranteed.)
  - Storage: -40 to 70 degrees Celsius
- Relative humidity
  - Operating: 5 to 85% noncondensing<sup>1</sup>
  - Storage: 10 to 90% noncondensing<sup>1</sup>
- Elevation
  - Operating: 0 to 3000 meters
  - Storage: 0 to 12000 meters

1. Subject to a maximum absolute humidity of 0.024Kg of water per Kg of dry air.

---

## Dimensions

- Height: 1466.85 mm (57.75 inches) 33U NOM
- Width: 437.60 mm (17.22 inches)
- Depth: 392.8 mm (15.4 inches)
- Weight: Maximum 190.5 kg (420 lb)
- Maximum rate of heat release for fully configured system: 3000W (10,200 BTU/hour)
- GR 63 CORE heat release calculation result: 425.4W per square foot [3000 W / (3.25 ft x 2.17 ft)] (4579W per square meter).

These dimensions are for the product without rack-mount flange adapters; the overall width of the flanges varies according to the equipment mounting requirements.

The depth given does not include any I/O or power connectors. The power connectors add 50 mm (2 inches) to the depth.

---

## Airflow

The Netra ft 1800 system has been designed to function while mounted in a natural convection airflow, but to meet the declared environmental specification the following rules apply. Refer to FIGURE 2-1 and FIGURE 2-2.

To allow adequate airflow, the rack should provide either:

- Unobstructed vertical airflow via vents of adequate size in the top and/or bottom panels; in which case the vertical clearance required is 35RU (1556 mm / 61.25 inches). The chassis should be mounted centrally, providing a 1RU plenum adjacent to each vent grille.

or

- A minimum of 37RU (1645 mm / 74.75 inches) of rackable height, with the provision of 2RU vertical space (89 mm / 3.5 inches) for front and/or rear vents at both top and bottom.

1. Adequate airflow through the equipment frame must be ensured. The Netra ft 1800 system utilizes internal fans that can achieve a maximum airflow of 840 cfm in free air. As a fully configured system can release up to 3000W (10,000 BTU/hour), appropriate means to extract heat from an enclosed cabinet should be provided, for instance, fans mounted in the top of the cabinet.

2. The inlet air must enter at the bottom of the Netra ft 1800 cabinet and in front of the Power Supply Units (PSUs); the airflow exhausts vertically from the top of the cabinet.
3. Inlet and exhaust ventilation require a minimum open area of 400 sq cm (62 sq inches) each.
4. A minimum of 2U (88.9 mm/3.5 inches) clearance must be allowed at both top and bottom of the Netra ft 1800 cabinet when mounted unless unobstructed vertical airflow can be ensured. Refer also to “Vertical Space Requirements” on page 30.

---

**Note** – These dimensions are a minimum; more space may be required in order to physically install the system in a rack.

---

5. The Netra ft 1800 system must not be mounted above any heat-generating sources within the same frame *unless* a heat deflector is used to provide fresh inlet air at ambient temperature.
6. To maintain adequate airflow, replace the environmental filters every six months (contact your local support organization for further information). The environmental filter replacement kit (X-Option No.X6952A) contains six PSU filters and three base filters.

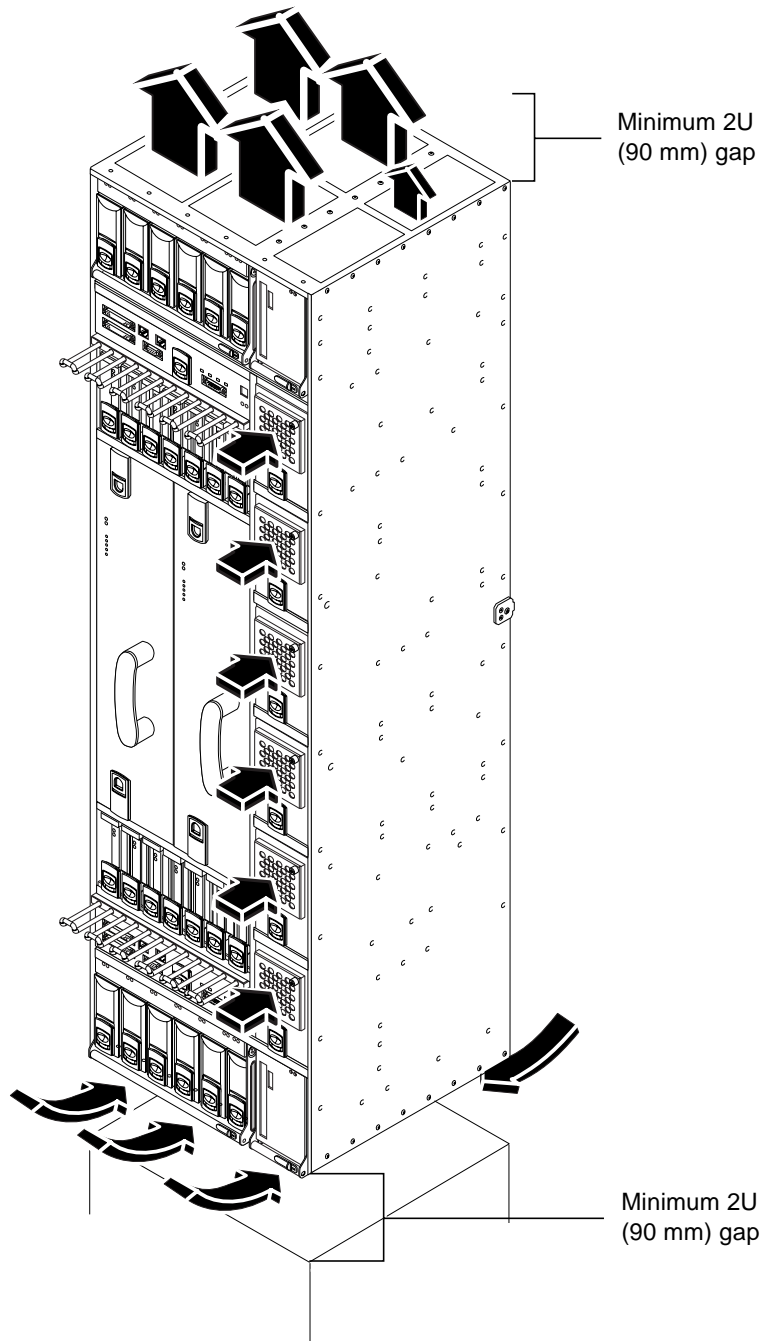

**FIGURE 2-1** Netra ft 1800 Airflow Requirements (External)

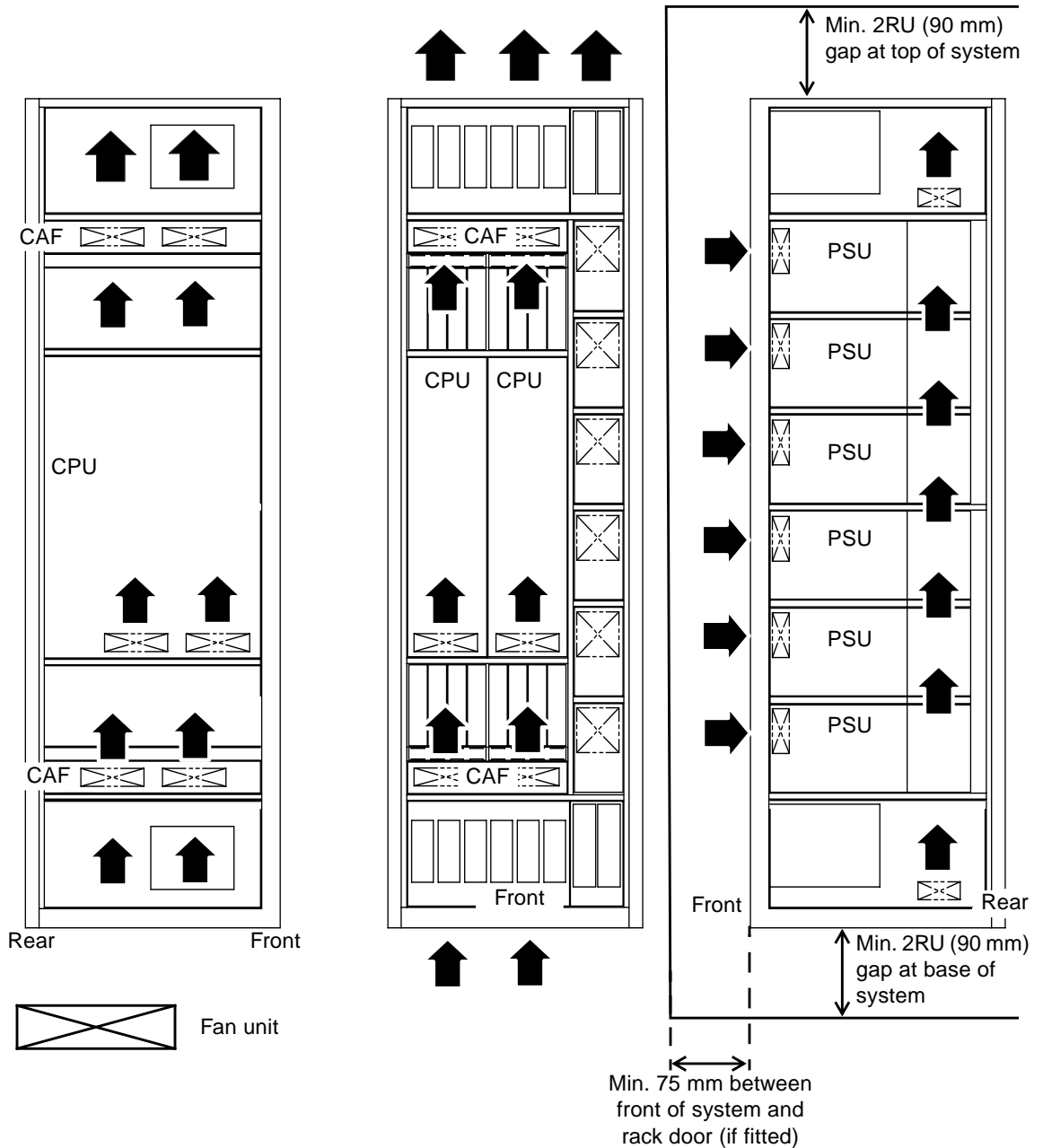

FIGURE 2-2 Netra ft 1800 Airflow Requirements (Internal)

---

# Thermal Calculations

The total heat dissipation of any particular system configuration can be calculated from the figures in TABLE 2-1. Example calculations are given in TABLE 2-2 and TABLE 2-3.

**TABLE 2-1** Thermal Calculation Matrix

Module	Heat Dissipation (watts)	Heat Release	
		BTU/hour	Kilocalories
Power Supply	100	341	86
CPUset (1P / 256 Mbytes)	301	1026	258
CPUset (2P / 512 Mbytes)			
CPUset (4P / 4 Gbytes)	397	1353	341
Removable Media Module (CD-ROM and DAT)	28	95	24
Console, Alarms and Fans	101	344	87
SAI PCI card	15	51	13
HSI PCI card	15	51	13
ATM PCI card	15	51	13
QFE PCI card	15	51	13
Dual SCSI PCI card	15	51	13
Motherboard	29	99	25
Disk Chassis	20	68	17
Hard Disk Drive	14	48	12

**TABLE 2-2 Thermal Calculation Example 1**

<b>Configuration</b>				
<b>Module</b>	<b>Number per side</b>	<b>Heat Dissipation (watts) per side</b>		
Power Supply	2	200		
CPUset (1P / 256 Mbytes)	1	301		
Removable Media Module (CD-ROM and DAT)	1	28		
Console, Alarms and Fans	1	101		
SAI PCI card	1	15		
HSI PCI card	1	15		
Motherboard	1	29		
Disk Chassis	1	20	<b>Heat Release (system)</b>	
Hard Disk Drive	3	42	<b>BTU/hour</b>	<b>Kilocalories</b>
<b>Total</b>		<b>751</b>	<b>5121</b>	<b>1290</b>

**TABLE 2-3 Thermal Calculation Example 2**

<b>Configuration</b>				
<b>Module</b>	<b>Number per side</b>	<b>Heat Dissipation (watts) per side</b>		
Power Supply	3	300		
CPUset (4P / 4 Gbytes)	1	397		
Removable Media Module (CD-ROM and DAT)	1	28		
Console, Alarms and Fans	1	101		
SAI PCI card	4	60		
HSI PCI card	2	30		
Dual SCSI PCI card	2	30		
Motherboard	1	29		
Disk Chassis	1	20	<b>Heat Release (system)</b>	
Hard Disk Drive	6	84	<b>BTU/hour</b>	<b>Kilocalories</b>
<b>Total</b>		<b>1079</b>	<b>7385</b>	<b>1861</b>





## Electrical Supply Installation

---

This chapter provides information about the Netra ft 1800 system switches and the installation of the electrical supply.

The Netra ft 1800 has six power input feed pairs, three for each side, which plug in to the back of the system. These must be assembled by the user.

---

**Note** – This equipment is only intended for installation in a Restricted Access Location as defined by UL1950, 3rd Edition, and EN60950: 1992 / A11: 1997.

---

---

**Note** – In NORWAY, this equipment must only be installed in areas where equipotential bonding has been applied, e.g. a telecommunication Central Office.

---

---

**Note** – The system will only power up if the input voltage is in the range –40 to –60 VDC.

---

---

## System Switch

The Netra ft 1800 in fault tolerant mode consists of two *sides*: processors and associated modules which function and are powered as separate systems. The system switches of the Netra ft 1800 function as standby devices for their respective sides, enabling and disabling the power supply units (PSU) outputs. The system switches are push, momentary switches. They are located on the CAF module on each side of the system.

The system does not contain any integral circuit breakers. The only means of isolating the system from power is by means of external circuit breakers, to be provided by the user.

---

**Note** – The system On and Stby switches handle low voltage signals only; the high-power circuits do not pass through these switches.

---

## DC Source Site Requirements

The DC source site requirements are as follows:

- Suitable for use in –48 VDC (classified SELV) nominal or –60 VDC (classified TNV-2) nominal systems.
- The supply source must be electrically isolated by double or reinforced insulation from any hazardous AC or DC source.
- The DC source must be reliably connected to earth (for example, battery room positive bus is connected to the grounding electrode).
- The DC source must be capable of providing up to 925W of continuous power per feed pair. The sum of all three feeds on one side will be less than 1500W for single-feed and 3000W for dual feed.

## Overcurrent Protection Requirements

Overcurrent protection devices must be provided as part of each host equipment rack.

The supply source must be electrically isolated from any AC source or other voltages by double or reinforced insulation.

Circuit breakers meeting the requirements shown in TABLE 3-1 must be fitted between the DC source and the Netra ft 1800 such that they are ON in the UP position.

**TABLE 3-1** Overcurrent Protection Requirements

<b>Current rating</b>	30A maximum
<b>Voltage</b>	Maximum 60 VDC rated in –48 VDC power systems Maximum 75 VDC rated in –60 VDC power systems
<b>Type</b>	Fast trip

**TABLE 3-1** Overcurrent Protection Requirements (*Continued*)

<b>Protection</b>	<p>EITHER:            Double pole breaking (both grounded and ungrounded conductor open on fault)            OR:            Single pole breaking ungrounded conductor (-48V) to open on fault.</p> <p>Circuit breakers can be used in configurations to match those shown in FIGURE 3-4, FIGURE 3-5 and FIGURE 3-6. Double Pole breakers <b>MUST</b> be used in the configuration shown in FIGURE 3-3.</p>
<b>Contact gap</b>	Minimum 3 mm
<b>Nuisance tripping</b>	Circuit breaker must not operate when presented with an inrush current of 27 amps and a duration of 2.5 microseconds
<b>Quantity</b>	One per feed, up to 12 per system



**Caution** – Double pole circuit breakers are required for installations with dual feeds to any Netra ft 1800 PSU but without a local common return point. The reason for this is the possibility of high currents looping in the return conductors and through the PSU due to a fault elsewhere in the installation. FIGURE 3-1 shows the fault situation where a problem external to the Netra ft 1800 causes an unrestricted current flow through the PSU (shown by the dotted line).

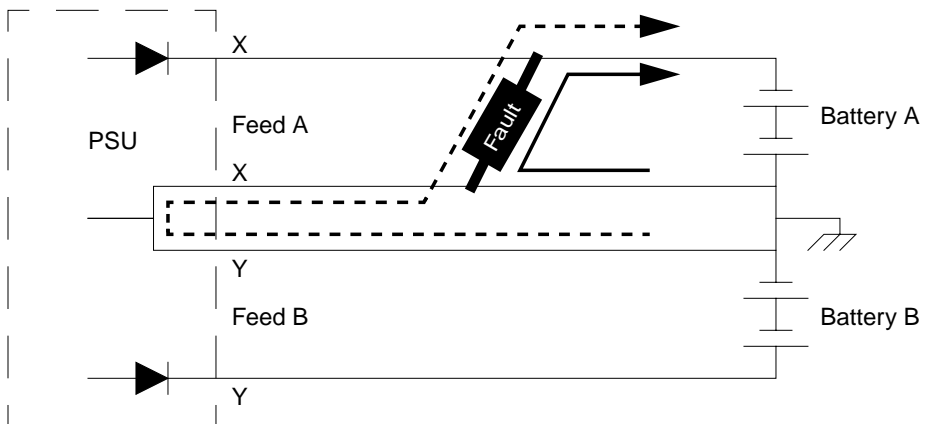

**FIGURE 3-1** PSU Fault Situation



**Caution** – Only by placing double pole circuit breakers at X-X and Y-Y can the return path through the PSU be broken.

---

**Note** – Four single pole breakers do not provide an alternative, as one of the breakers in the return can be open without indicating a failure in the PSU.

---

---

**Note** – Overcurrent devices must meet applicable national and local electrical safety codes and be approved for the intended application.

---

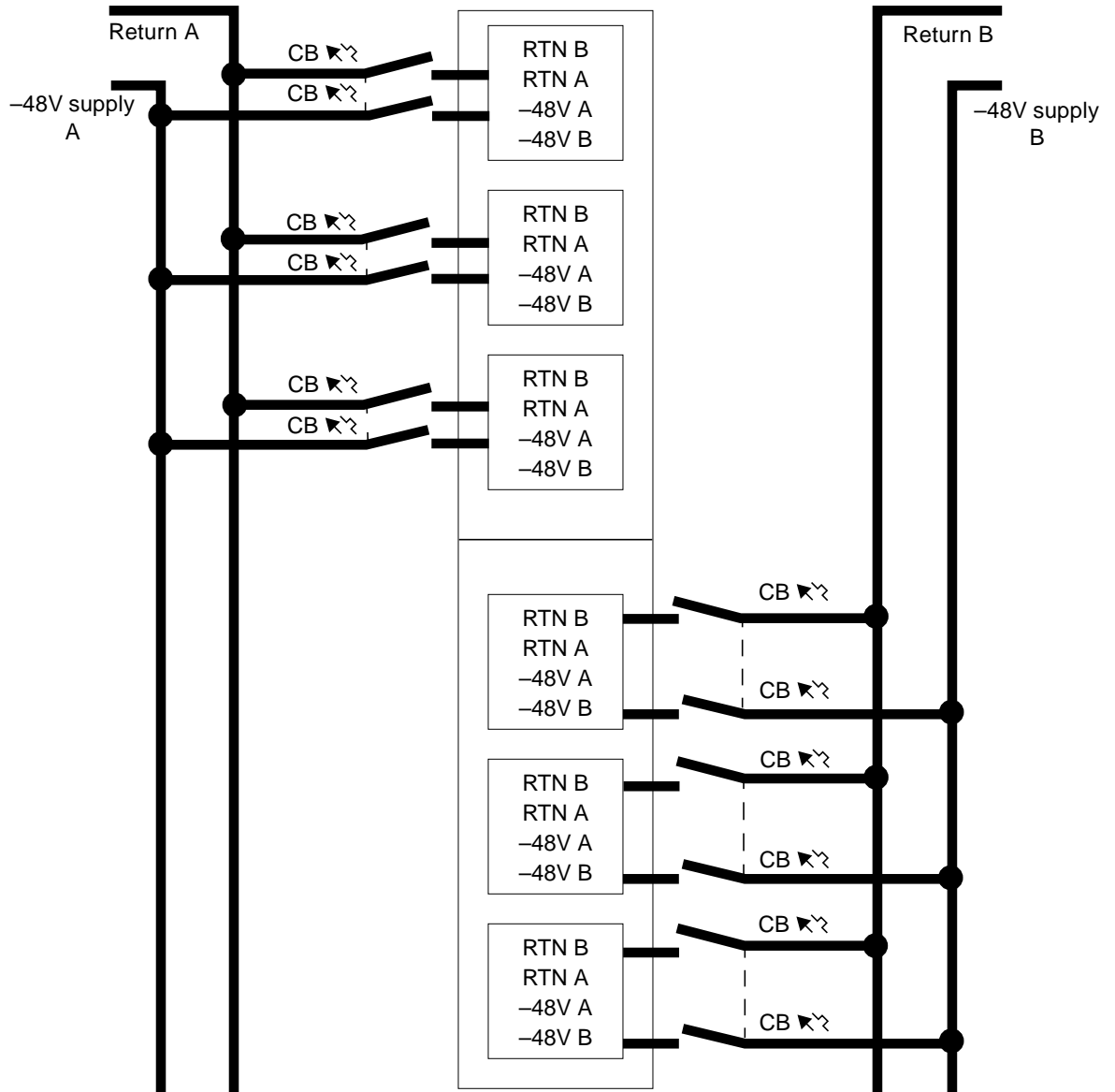

FIGURE 3-2 Circuit Breakers for Single Power Rails

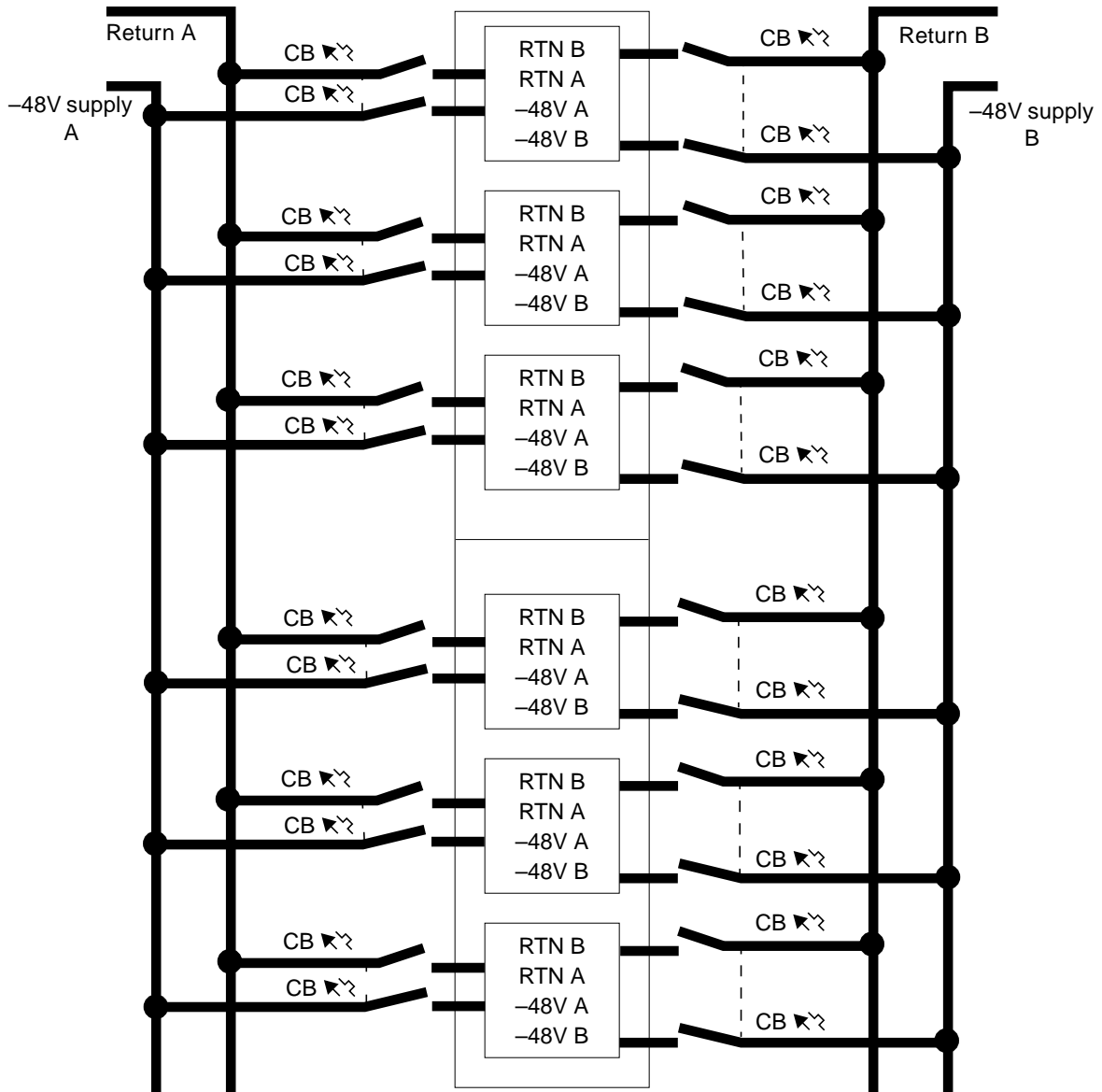

FIGURE 3-3 Circuit Breakers for Dual Power Rails

---

**Note** – Dual feed configuration with independent return circuits to source. Double pole circuit breakers must be used.

---

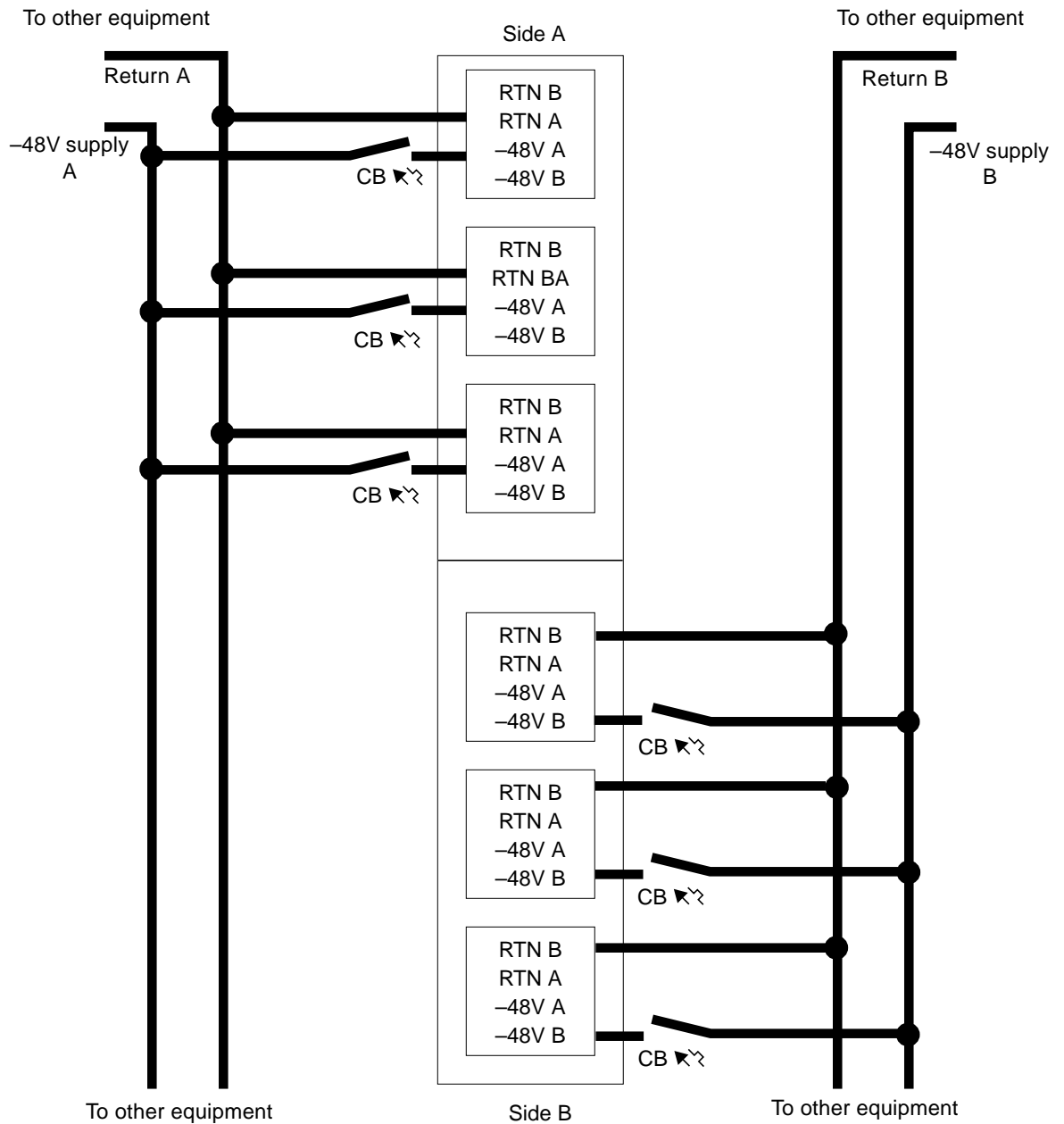
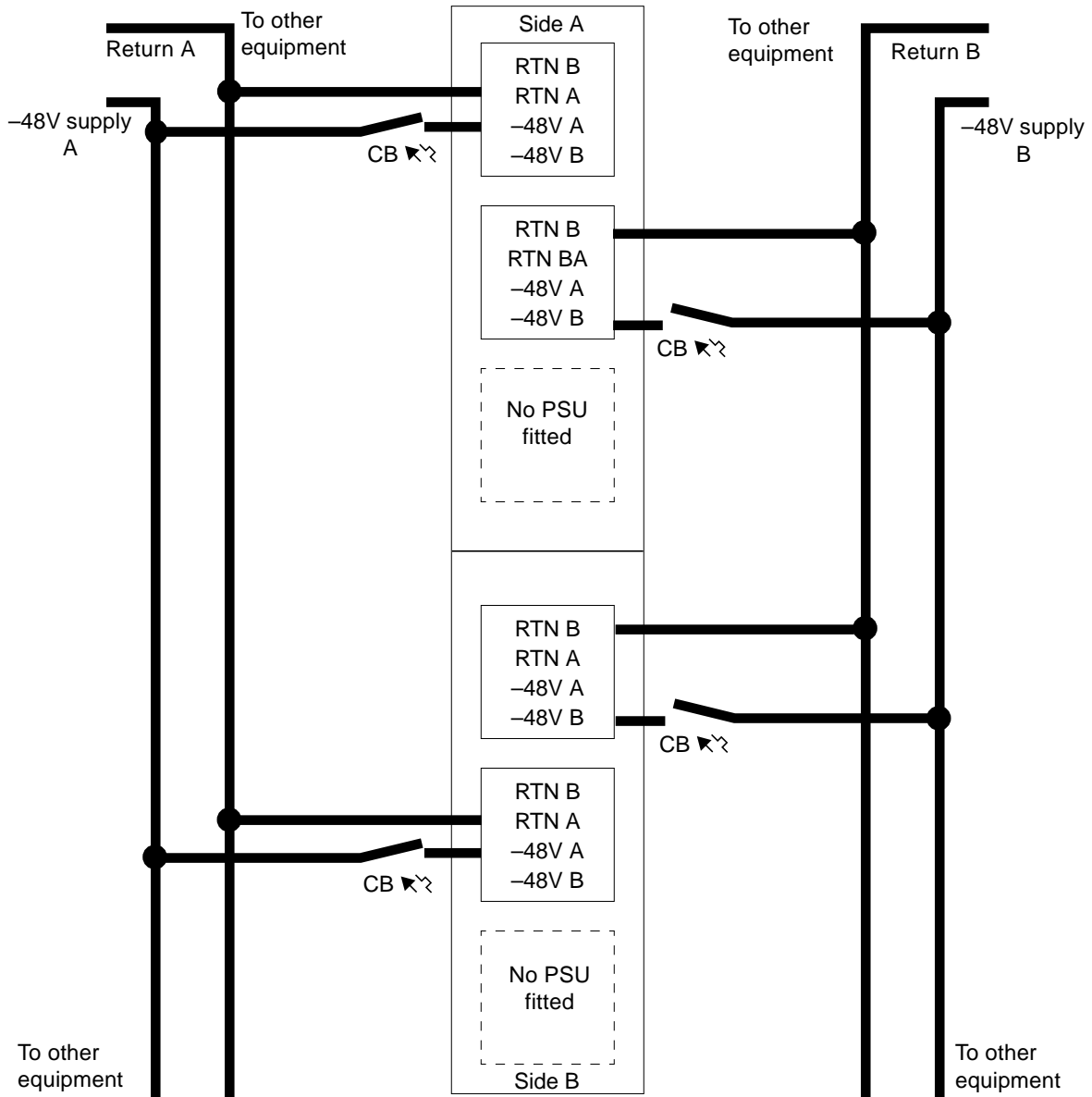

FIGURE 3-4 Sided Independent Feeds with Single Pole Circuit Breakers



**FIGURE 3-5** Side-independent Feeds to Each PSU with Single Pole Circuit Breakers (double pole can be used)

---

**Note** – This is only applicable for smaller Netra ft 1800 configurations, that is, those with only two PSUs per side configured to provide redundancy.

---



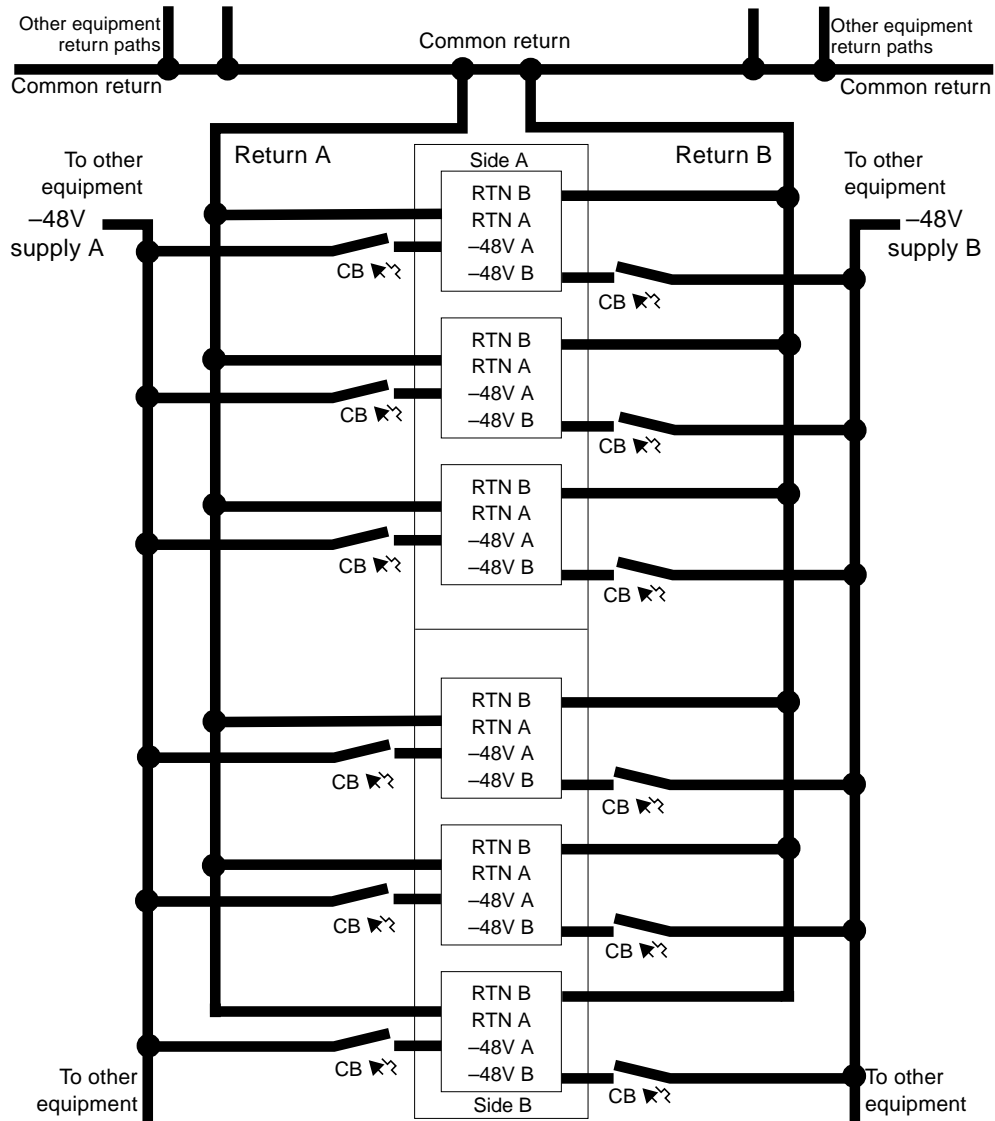

**FIGURE 3-6** Dual Feeds with Local Common Return – Single Pole Circuit Breakers (double pole can be used)



**Caution** – To meet the criterion of a Local common return, the return lines from the Netra ft 1800 must go directly to the Common point without linking to the returns from other equipment. The Return A and Return B lines for each PSU must be adjacent on the Common point (within 100 mm of each other).

# Required Connection Materials

DC branch circuits:

- The required number of field wiring kits are supplied in the shipkit with each system, according to configuration.

Grounding:

- One Thomas & Betts two-hole lug (part number: 54204-UB) suitable for 8 AWG conductor or UL/CSA approved equivalent having 5/8-inch pitch; torque value: 3.5 Nm (2.5 lbf/ft) maximum.
- A Thomas & Betts crimping tool (part number: TBM 5-S), or approved equivalent to secure the lug on to the cable.
- A grounding bus bar that is near the equipment and easily accessible.

Dual Grounding Environment:

- Additional Thomas & Betts two-hole lug for logic 0V studs.



---

**Caution** – External filtering and/or surge suppression devices may be required on the power feeds where branch circuit electromagnetic characteristics are unknown.

---

## DC Supply and Ground Conductor

The requirements are:

- Suitable conductor material: copper only.
- Supply conductors: 8 AWG (6 sq mm) (between the Netra ft 1800 and the circuit breaker).
- Ground conductor: 8 AWG.
- Cable insulation rating: minimum 75 degrees Celsius, Low Smoke Fume (LSF), Flame Retardant.
- Cable type must be one of:
  - UL style 1028 or other UL 1581 compliant equivalent.
  - IEEE 383 compliant.
  - IEEE 1202-1991 compliant or classified.
- Branch circuit cable insulation color: per applicable national electrical codes.
- Grounding cable insulation color: green/yellow.

# Dual Grounding Environment

---



**Caution** – To be compatible with grounding environments requiring isolation between logic 0V and chassis ground, the fitted grounding bridge plate must be removed and individual connections made to logic 0V and chassis ground studs. The grounding bridge plate is located on the middle rear left edge of the unit between the motherboards. The grounding studs at the base of the chassis are M5 studs with appropriate nuts already installed.

---

Before installation for dual grounding systems, remove the link from the chassis to logic 0V.



**Caution** – The use of certain PCI cards causes the frame and logic grounds to be commoned. Refer to the documentation supplied with the PCI card.

---



## Rack Mounting Guidelines

---

The Netra ft 1800 can be adapted to fit in standard, commercial 19-inch, 23-inch and metric racks via the use of removable mounting adaptors. The minimum nominal cabinet external dimensions are 600 x 600 x 2100 mm (24 x 24 x 84 inches).

If you intend not to use a lifting device for installation, all modules other than the motherboards must be removed from the system prior to lifting. The empty chassis weighs approximately 68 kg (150 lb) with the motherboards and typical mounting flanges. The weight of any removable module depends on its configuration. Weight warning labels are for guidance only.

The Netra ft 1800 chassis has been designed to accommodate most mounting configurations. Adaptor flanges to suit 19-inch, 23-inch, 24-inch and 600-mm (ETSI) rack sizes are available as required.

The Netra ft 1800 system is shipped with a plinth, which protects the bottom of the chassis during transit and handling, and also ensures that the correct airflow inlet plenum is provided during installation. The plinth must be removed once the Netra ft 1800 is installed in a rack, then stored in a safe place.

The Netra ft 1800 chassis must be mounted using screws suitable for the equipment frame. The screws should be M5, M6 or 10-32 UNF. All screws must be fitted. The recommended tightening torque value for either M5 or 10-32 UNF recess head screws is 3.8 Nm (2.8 lbf/ft), and that for M6 screws is 6 Nm (4.4 lbf/ft).

The Netra ft 1800 is able to fit in any nominal width of rack from 19-inch upwards, a minimum internal depth of 545 mm (21.5 inches) and a minimum internal height of 35RU (155 mm / 61.25 inches) (dependant upon airflow obstructions). Common standard frame heights in the CO environment are 72-inch, 84-inch and 2200-mm, and the larger height will ease the airflow requirements.

Putting the Netra ft 1800 in a cabinet of greater than 600 mm (24 inches) OA width will give more room to manage the cabling effectively.

An open frame (relay rack) has the advantage that airflow and accessibility become less of a concern. However, typical 5-inch web racks have load capacities of less than 180 kg (400 lb), which is inadequate for the Netra ft 1800 in a dynamic environment, and in general practice is not the type of frame used for computer equipment.

The Netra ft 1800 is available with the following removable mounting flanges:

- 19 inch EIA pattern
- 23 inch EIA pattern
- 24 inch EIA pattern
- 600 mm IEC917 (ETSI) pattern

Any of these flanges can be fitted in the following positions:

- Flush with the front of the system
- 65 mm (2.56 inches) from front of system
- 196.1 mm (7.72 inches) from front of system

The second and third positions are intended for use with 5-inch web open frames (relay racks).

Adjustable rear flanges can be fitted. They provide a mounting face anywhere between 400 mm and 500 mm (15.75 inches and 19.7 inches) from the front of the system.

The vertical mounting hole pattern of the rack should conform to the standard dimensions given in TABLE 4-1 and shown in FIGURE 4-1.

**TABLE 4-1** Mounting Hole Pattern Dimensions

Standard	Pattern
EIA/RETMA (RU)	Repeating pattern of 5/8 inch, 5/8 inch, 1/2 inch
IEC917/ETSI (SU)	Constant pitch of 25 mm

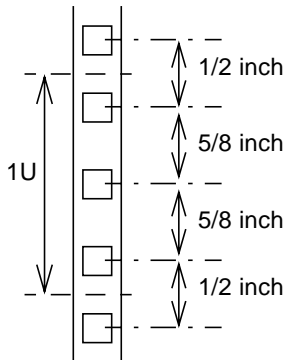

**FIGURE 4-1** EIA/RETMA Mounting Hole Pattern Dimensions

The tapped mounting holes on the Netra ft 1800 chassis are arranged as shown in FIGURE 4-2.

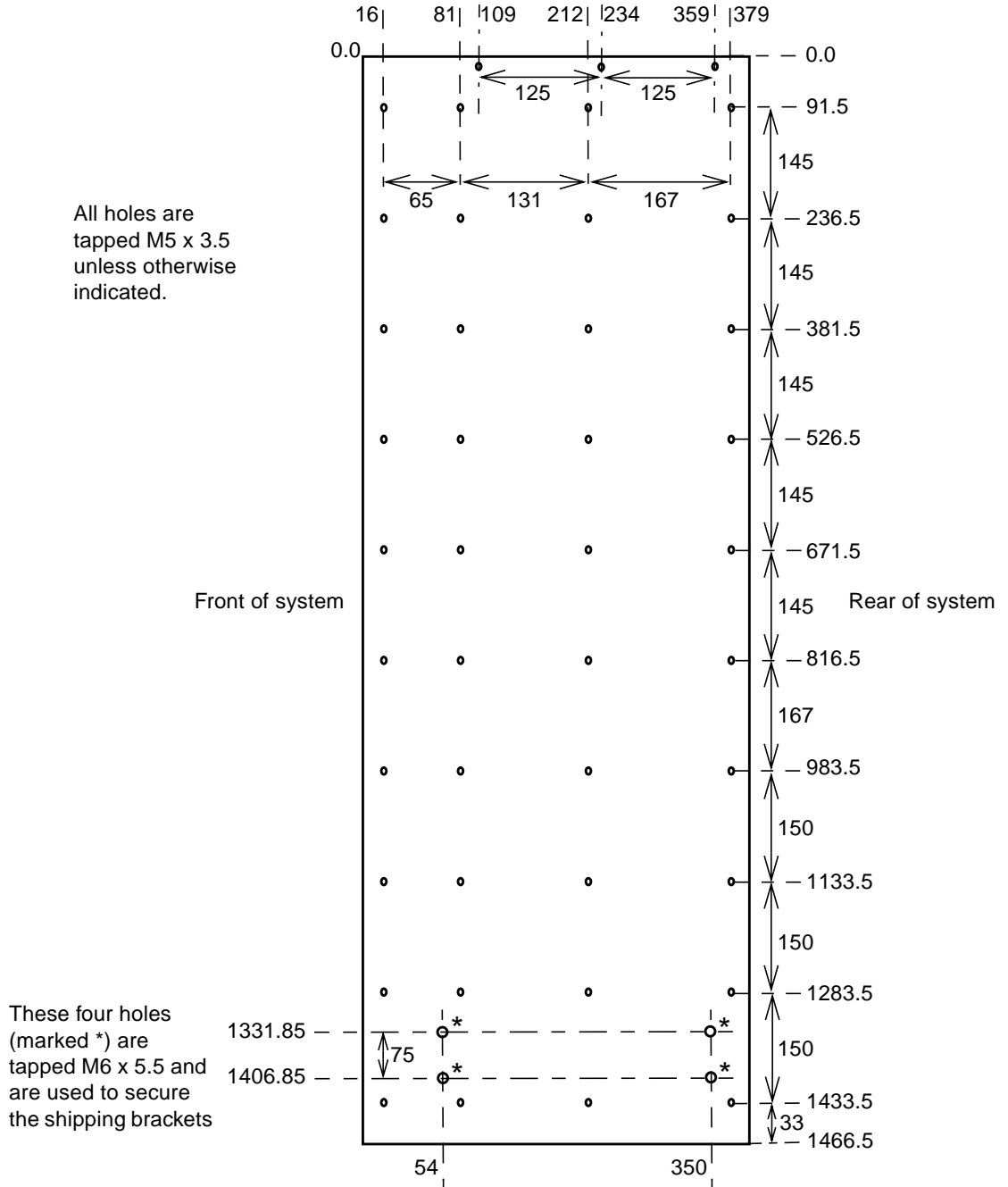

FIGURE 4-2 Chassis Mounting Hole Arrangement (all measurements in millimeters)

---

## Vertical Space Requirements

The Netra ft 1800 chassis occupies 33RU (1467 mm / 57.75 inches) of vertical height.

If it is intended to fit the Netra ft 1800 into a rack with the red transit plinth in place, then 4RU (178 mm / 7.0 inches) of clearance must be provided at the bottom of the chassis. This allows removal of the plinth after installation.

---

## Depth

The front door (if fitted) must provide a minimum of 75 mm (3 inches) of clearance across the entire front surface of the Netra ft 1800 to allow for routing of I/O cables.

There must be a minimum of 545 mm (21.5 inches) usable internal depth in the rack/cabinet.

---

## Loading

The rack must be capable of supporting a static load of 230 kg (500 lb) for a fully configured Netra ft 1800. Partially configured systems are lighter, and if requested, specific weight information can be supplied. Dynamic load considerations are subject to site location and application.

---

## Safety

We strongly recommend anchoring all racks to the floor or to adjacent frames, using the manufacturer's instructions.

Free-standing racks with a footprint of less than 600 mm x 600 mm (23.6 x 23.6 inches) are likely to be unstable and should be treated with caution.



---

## Seismic Applications

The Netra ft 1800 has been fully tested to be NEBS Level 3 compliant, which includes operation in Earthquake Zone 4 environments. These tests were performed in a NEBS2000, ETSI Part 3 compliant rack.

If you intend to use the Netra ft 1800 System in an environment that may be subject to earthquakes and Earthquake Zone 4 compliance is required, a specialist Earthquake Zone 4 compliant rack needs to be selected and independent tests undertaken to ensure system compliance in these areas.

Sun does not recommend installation of the Netra ft-1800 in 5-inch web relay racks when located in seismic zones 3 and 4.

A seismic rack should be rigid enough to result in a fundamental resonance in the horizontal axes of greater than 5 Hz with the Netra ft 1800 installed.

---

## Rack Options

The 72-inch expansion rack (SG-XARY030A) from Sun is suitable for mounting the Netra ft 1800; however, there are two limitations with the currently available mounting adaptors:

- The front door cannot be fitted.
- Currently there are no suitable rear mounting adaptors. If required, these would need to be provided by the customer or system integrator.

This cabinet is 24 inches wide x 76.5 inches high x 36 inches deep.

Possible candidates for racks are available from many commercial suppliers, such as Schroff, Rittal, Hendry, APW-Vero, Chatsworth, Knürr and SharkRack.

Listing of any rack suppliers or particular configurations of commercially available racks does not constitute a recommendation from Sun Microsystems. Sun Microsystems has not in any way qualified these racks and/or suppliers as suitable for the application referred to above.



## External Connections

---

This chapter describes the various cables and connectors which should be made available in order for the installation to be completed.

---

### CAF External I/O Connections

The Netra ft 1800 system has the following connectors on each CAF module:

- Female 25-pole D-type connectors for the system console and modem ports (RS232).
- A female 9-pole D-type connector for the Remote Control Processor (RCP) ports.
- A male 15-pole D-type connector for the alarm relay/reset signals.
- Two RJ45 Ethernet ports.

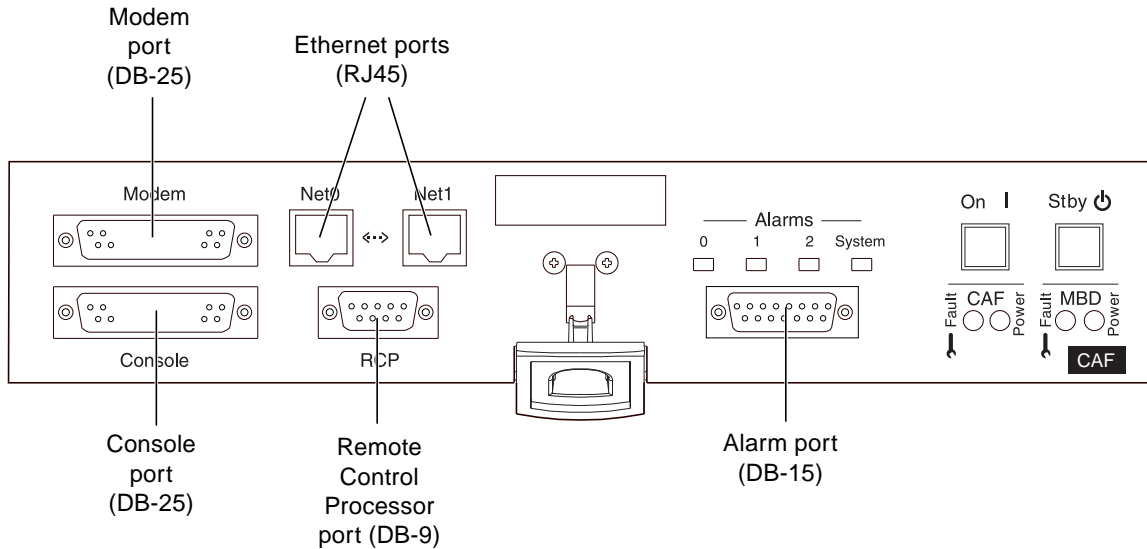

**FIGURE 5-1** External I/O Connections on CAF Module

## System Console Terminal Connections

The system console and modem connections are provided on separate 25-pole female D-type connectors. TABLE 5-1 shows the pin allocation on these connectors.

**TABLE 5-1** Console Connector Pinout

Pin	Function	Description
1	GND	Chassis ground
2	TxD	Output data
3	RxD	Input data
7	SREF	Signal reference
Shield		Chassis ground

Except for pin 1, all pins of the console and modem connectors are isolated from the frame ground of the Netra ft 1800 system.

The connectors have two screw-threaded mounting pillars with 4-40 UNC threads. You should secure the cable headshell in place with the screws engaged in these pillars. If you use a cable headshell without securing the screws, make sure that the pillars do not prevent full engagement of the connector. This can happen with some types of cable headshell where screw heads can foul against the mounting pillars.

You must also secure the other end of the cable to the console terminal if the terminal provides some means of locking.

---

**Note** – To ensure EMC compliance always use a high quality screened cable that has metal connector shells.

---

TABLE 5-2 shows the console terminal configuration parameters for both console and modem ports. You can modify these parameters using Solaris utilities.

**TABLE 5-2** Console and Modem Port Parameters

Parameter	Setting
Transmit rate	9600 baud
Receive rate	9600 baud
Data bits	8
Stop bits	1
Parity enable/sense	off/off
XON/XOFF protocol	on

System consoles can be connected only to the CAF module.

## Modem Port Connections

The modem port pinout is described in TABLE 5-3.

**TABLE 5-3** Modem Port Pinout

Pin	Function	Description
1	GND	Chassis ground
2	TxD	Output data
3	RxD	Input data
4	RTS	Output handshake

**TABLE 5-3** Modem Port Pinout *(Continued)*

Pin	Function	Description
5	CTS	Input handshake
7	SREF	Signal reference
8	DCD	Input status
20	DTR	Output status
Shield		Chassis ground

## Alarms Port Connections

The alarms port pinout is described in TABLE 5-4.

**TABLE 5-4** Alarms Port Pinout

Pin	Description	Pin	Description
1	RESET0+	9	ALARM0-NC
2	RESET0-	10	ALARM0-COM
3	RESET1+	11	ALARM1-NO
4	RESET1-	12	ALARM1-NC
5	SYSTEM-NO	13	ALARM1-COM
6	SYSTEM-NC	14	ALARM2-NO
7	SYSTEM-COM	15	ALARM2-COM
8	ALARM0-NO		

# RCP Port

There is an RS232 connection to the Remote Control Processor (RCP) on the motherboard. Connection is via a female DB-9 whose pinout is shown in TABLE 5-5.

**TABLE 5-5** Remote Control Processor Port Pinout

<b>Pin</b>	<b>Function</b>	<b>Description</b>
2	TxD	Output data
3	RxD	Input data
5	SREF	Signal reference
Shield		Chassis ground





## Cable Management

---

As all I/O cables must be routed from the front of the Netra ft 1800 system, due consideration should be made of the space required within the rack for these cables, as well as the power inlet cables at the rear.

Racks that provide a left-hand side-bay are recommended if there is likely to be a large amount of I/O cabling. This additional space can be used to ease cable routing from the front to the rear of the rack.

Two methods of arranging cables are provided with the Netra ft 1800: a cable management shelf and cable hook assemblies which attach directly to the rack.

---

# Cable Management Shelf

The cable management shelf adjacent to the PCI card locations is flexible and can be used in a number of different configurations. The holes are equidistant, and the hooks can be inserted in whatever position is required. The hooks are a firm push-fit into the holes.

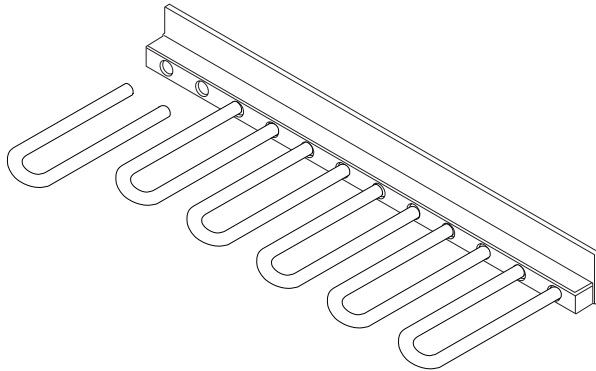
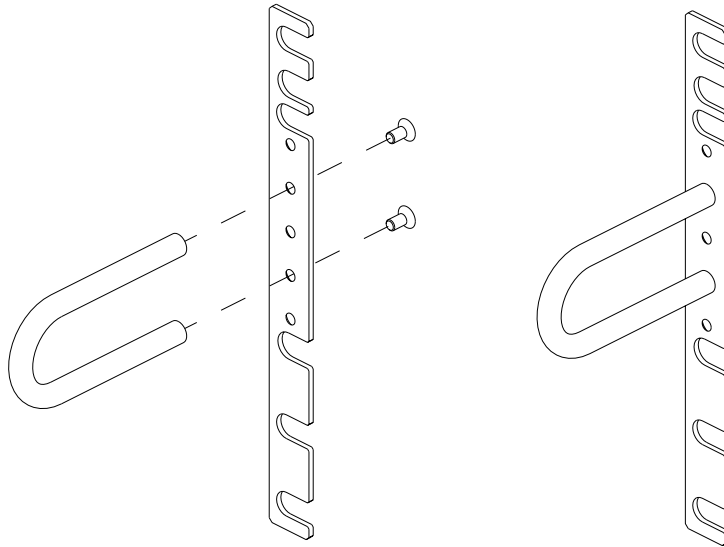

**FIGURE 6-1** Cable Management Shelf

---

## Cable Bracket Assemblies

Six cable bracket mounting assemblies are provided with each mounting flange kit. These can be fitted to the mounting flanges to facilitate cable management.



**FIGURE 6-2** Cable Bracket Assembly

The brackets can be fixed to the mounting flanges in the required position, using the same screws that fix the flanges to the rack. The hooks can be fitted to the brackets in one of three positions using the countersunk M3 screws supplied. The hooks must be fitted before the brackets are fixed to the mounting flange/rack.



# Requirements Checklist

Use this checklist to evaluate the readiness of the site for installation. An online version is available at:

[http://service.corp/HASR/TPG/p2/mission-crit1/netra\\_ft\\_1800\\_site\\_planning.current.html](http://service.corp/HASR/TPG/p2/mission-crit1/netra_ft_1800_site_planning.current.html)

Prior to system installation, confirm that the following requirements have been met. Complete the entire checklist and submit it to the Service Desk at the email alias [Netraft1800\\_desk@sf49er.Ebay](mailto:Netraft1800_desk@sf49er.Ebay) to obtain final hold release. The site preparation **MUST** be planned or checked **BEFORE** the shipment of the Netra ft 1800.

Refer to the *Netra ft 1800 Hardware Installation Manual* for detailed product installation information. You can download the manual from the High Availability Support Readiness website at the URL above.

**TABLE A-1** Site Details

<b>Site Name</b>	
<b>Sales Order Number</b>	
<b>Date</b>	
<b>Site Address</b>	
<b>Customer Representative</b>	
Phone	
e-mail address	
<b>Customer Representative</b>	

**TABLE A-1** Site Details *(Continued)*

Phone	
e-mail address	
<b>Computer Systems Sales Representative</b>	
Phone	
e-mail address	
<b>Enterprise Services Sales Representative</b>	
Phone	
e-mail address	
<b>Enterprise Services Service Account Manager (SAM):</b>	
Phone	
e-mail address	
<b>SSE</b>	
Phone	
e-mail address	

TABLE A-2 Physical Requirements

Requirement	Page ref.	YES	NO	Not Complete <sup>1</sup>
1. Has the system location been established?				
2. What type of environment will the system be installed in (central office, lab, or other)?	7			
3. Is the equipment positioned so that the exhaust air of one heat-rejecting device doesn't enter the air inlet of the Netra ft 1800 system? See .	8			
4. Are the proper inlet and exhaust ventilation minimum open areas of 400 cm <sup>2</sup> (62 in <sup>2</sup> ) each provided for?	8			
5. Is the minimum of 88.9 mm (3.5 inches) clearance at the top and bottom of the Netra ft 1800 cabinet allowed for when mounted?	8			
<b>NOTE: It is recommended that the Netra ft 1800 be installed on the lower portion of the rack or cabinet for ease of maintenance.</b>				
6. Has the customer been made aware of the environmental filter replacement schedule (every six months)?	9			
7. Has the customer or OEM ordered the environmental filter replacement kit (part number X0-X6952A)?	9			
8. Have the proper rack mount adapter flanges been ordered for the size rack into which the Netra ft 1800 will be installed?	27			
9. Is working space of one meter at the front and rear of the system cabinet available (as recommended) so that maintenance can be carried out without moving the system?	27			
10. Is the floor loading capacity where the system is to be installed capable of supporting a fully loaded chassis (230 kg/500 lbs.)?	30			
11. Is a mechanical lifting device available for installing a loaded chassis (230 kg/500 lbs.)?	2			
<b>NOTE: If not, all modules other than motherboards must be removed from the system prior to lifting. The empty chassis weighs approximately 49 kg (108 lbs.) plus the adapters.</b>				
12. Will the rack support a fully configured Netra ft 1800 system (230 kg/500 lbs.)?	30			
13. Will the rack provide a minimum of 37RU (64.75 inches) of rackable height?	30			
<b>NOTE: If the Netra ft 1800 system is intended to fit into a rack with its orange transit base frame in place, then 3RU (5 inches) of clearance must be allowed underneath it. This allows adequate clearance to permit removal of the base frame to allow replacement of the chassis environmental filters.</b>				
14. Will a front door be fitted to the Netra ft 1800 system?	31			
<b>NOTE: If so, the front door must provide a minimum of 75 mm (3inches) of clearance across the entire front surface of the Netra ft 1800 system to allow for routing of the I/O cables.</b>				

**TABLE A-2 Physical Requirements (Continued)**

Requirement	Page ref.	YES	NO	Not Complete <sup>1</sup>
15. Is a minimum 545 mm (21.5 inches) usable internal depth in the rack to allow space for connector housings, cabling, and the motherboard handles?	30			
16. Is the rack bolted to the floor, adjacent frames, or both?	30			
<b>NOTE: Free-standing racks with a footprint of less than 600mm x 600 mm (23.6 inches x 23.6 inches) are likely to be unstable and should be treated with caution.</b>				
17. Are the proper tools available for performing the installation (Phillips No.2 screwdriver, flat bladed screwdriver, utility knife, torque driver – refer to the <i>Netra ft 1800 Hardware Installation Manual</i> )?	2			

1. Describe incomplete items in TABLE A-11 on page 53.



**TABLE A-3 System Requirements**

Requirement	YES	NO	Not Complete <sup>1</sup>
18. Has the system configuration been reviewed, including third-party hardware and software			
19. Have all the required external connections been identified?			
20. Will the customer make external use of the remote control processor (RCP)?			
21. Will the alarm reset alarm port be utilized?			
22. Does the customer understand that Sun Microsystems isn't responsible for the support of the third party hardware or software?			

**NOTE: Sun is responsible for assisting in isolating the source of any problem to determine if the problem is with Sun supplied system components or with any third party components. If the problem is determined to be caused by third party components, Sun must work with the third party vendor to solve the problem expeditiously. If this is a Sun Integration project, Sun is responsible for supporting all third party components integrated into the Netra ft 1800.**

1. Describe incomplete items in TABLE A-11 on page 53.

**TABLE A-4 Facility Electrical Requirements**

Requirement	Page ref.	YES	NO	Not Complete <sup>1</sup>
23. Is the DC source suitable for use in -48VDC or -60VDC (intended for Germany only) nominal systems?	16			
24. Is the DC source reliably connected to earth (i.e. battery room positive bus is connected to the grounding electrode)?	25			
25. Is the DC source able to provide up to 925W of continuous power per feed pair?	16			
<b>NOTE: The sum of all three feeds on one side will be less than 1500W.</b>				
26. Will an Uninterruptable Power Supply (UPS) be hooked up to the Netra ft 1800 system?				
27. If so, what type?				
28. Will an AC/DC power converter be utilized?				
29. If so, what type?				
30. Are the correct number of two-pole 30A fast trip DC circuit breakers or fuse equivalent located between the DC source and the Netra ft 1800 system?	16			
<b>NOTE: Please refer to Chapter 3, "Electrical Supply Installation" for more specific details on overcurrent protection requirements.</b>				
31. Are all the required connection materials and tools available to completely install the power source?	24			
32. Has the power source setup been verified by a qualified power expert (i.e. grounding, circuit breakers, fuses, etc.)?				

1. Describe incomplete items in TABLE A-11 on page 53.

**TABLE A-5 Environmental Requirements**

Requirement	YES	NO	Not Complete <sup>1</sup>
33. Does the environment where the Netra ft 1800 system will reside meet the Sun Microsystems specifications for temperature, humidity, and elevation? See "Environment" on page 7.			
<b>NOTE: Please refer to Chapter 2, "Environmental and Airflow Considerations" for more specific details on what is required.</b>			
34. Can the environmental specifications where the Netra ft 1800 system will reside be satisfactorily maintained?			

1. Describe incomplete items in TABLE A-11 on page 53.

**TABLE A-6 Network Requirements**

Requirement	YES	NO	Not Complete <sup>1</sup>
35. Are two dedicated telephone lines for remote access via modem installed in the proper location?			
36. Will a voice telephone line be installed near the system so that a craftsperson or technician will be able to work with the system while speaking on the telephone?			
37. Have all networking cables been ordered to arrive prior to installation?			
38. Have all network connections for each configured network controller been ordered to arrive prior to installation?			
39. Have all four IP addresses been assigned?			

1. Describe incomplete items in TABLE A-11 on page 53.

**TABLE A-7 Access Route Requirements**

Requirement	YES	NO	Not Complete <sup>1</sup>
40. Has an access route to the final system location been identified?			
41. Have provisions been made to cover irregular or engraved floor patterns along the access route to reduce vibration?			
42. Will a pallet jack be available to move the system in its shipping crate to the final system location?			
43. Will the floor loading capacity of the access route be capable of supporting a fully loaded chassis (230 kg/500 lbs) and the pallet jack?			
44. Have personnel been allocated to the system during delivery?			
45. Does the loading dock meet the standard freight carrier truck requirements?			
<b>NOTE: Trucks can be between 14.6 meters (48 feet) and 18.6 meters (61 feet) in length, 2.6 meters (8.5 feet) wide, and 4.3 meters (14 feet) high.</b>			
46. If the loading dock does not meet the standard freight carrier truck requirements, has a forklift been allocated for delivery?			

1. Describe incomplete items in TABLE A-11 on page 53.

**TABLE A-8 Miscellaneous Requirements**

Requirement	YES	NO	Not Complete <sup>1</sup>
47. Are the system administrators and/or operators trained in Solaris 2.6 and the Netra ft 1800?			
48. If the answer is NO, will they be trained prior to installation of the of the Netra ft 1800?			
49. Scheduled date for Solaris 2.6			
50. Scheduled date for Solstice Enterprise Volume Manager			
51. Is a security clearance required for this site or any other special arrangements to access the system?			

**TABLE A-8** Miscellaneous Requirements (*Continued*)

Requirement	YES	NO	Not Complete <sup>1</sup>
52. If so, has the local Enterprise Services management been notified of the required security level?			
<b>NOTE: Clearances can take months to obtain, so early timely notification of this requirement is very important.</b>			
53. Was the <i>Netra ft 1800 Hardware Installation Guide</i> provided to all pertinent members of the customer staff for review during the site planning process?			

1. Describe incomplete items in TABLE A-11 on page 53.

**TABLE A-9** Installation Schedule

What is the scheduled installation date?	
Who is the customer contact for the shipment of the of the Netra ft 1800 system?	
Name:	
Title:	
Phone:	

**TABLE A-10 Site Access**

<b>Requirement</b>	<b>YES</b>	<b>NO</b>
Has access to the customer site been provided to complete this Site Planning Checklist?		
If NO, detail the contingency provision for the completion of the checklist.		

TABLE A-11 Open Items

Question No.	Comments/Contingency Plan
Detail each question previously checked <b>Not Complete</b> and describe the contingency plan for completion.	





## Spare Parts Checklist

Use this checklist to evaluate the required supply of spare parts.

Spares are grouped into two categories and defined for reliability as follows:

**TABLE B-1** Spare Parts Reliability

Description	Part Number	MTTR (mins)	MTBF (hours)	Category
CPUset – 1P, 256 Mbytes, 300 MHz	F540-4007	5	24,771	B
CPUset – 2P, 512 Mbytes, 300 MHz	F540-4008	5	24,771	B
CPUset – 4P, 4 Gbytes, 300 MHz	F540-4009	5	24,771	B
Disk drive chassis tray	F540-3885	5	500,000	A
9 Gbyte hard disk drive + ESD shield	F540-4004	5	800,000	A
RMM chassis with CD-ROM drive only	F540-4017	10	300,000	A
RMM chassis with CD-ROM and DAT drives	F540-4016	10	100,000	A
Console, Alarms and Fans module	F540-3926	5	111,111	A
-48 VDC power supply and cable kit	F300-1408	5	200,000	A
Power inlet assembly	F540-3650	5	800,000	A
HSI PCI card	F540-3982	5	285,714	A
ATM155 PCI card	F540-3984	5	285,714	A
Async PCI card	F540-3983	5	285,714	A
10/100BaseT Fast Ethernet PCI card	F540-3981	5	285,714	A
Dual Channel SCSI PCI card	F540-3980	5	285,714	A
Motherboard A	F540-3509	15	115,993	A
Motherboard B	F540-3485	15	115,993	A

Category A spares are those with a reliability of greater than 100,000 hours, and category B are those with a reliability of less than 100,000 hours.

The following table lists the number of spares that must be kept in stock in relation to the population of Netra ft 1800 systems. The population is the number of modules of a particular type, and may be several times larger than the number of machines. For instance, as there are two CPUsets per system, the population will be twice that of the number of systems.

**TABLE B-2** Spares Stock Levels

Population	Category A	Category B
1	1	1
2 to 10	2	3
11 to 25	3	3
26 to 50	3	4
51 to 100	4	5
101 to 200	5	6
201 to 300	6	7
301 to 400	6	9
401 to 500	7	10
501 to 750	8	12
751 to 1,000	10	14

# Index

---

## A

### airflow

- clearance, 9
- direction of, 9
- inlet plenum, 27
- natural convection, 8
- requirements, 8

alarms connector, 33

alarms port pinout, 36

## C

cable bracket assemblies, 41

CAF module connectors, 33

circuit breaker requirements, 16

connection materials, 24

Console Alarms and Fans module, *See* CAF module

console connector, pinout, 34

console port, parameters, 35

## D

DC source requirements, 16

dimensions, 8

## E

electricity supply installation, 15

elevation, limitations for operating and storage, 7

environmental considerations, 7

## F

filter replacement kit, 9

flanges, *See* mounting flanges

frame ground, 25

## G

GR 63 Core heat release calculation result, 8

grounding

dual, 24

isolation, 25

materials required, 24

requirements, 24

## H

heat release

GR 63 Core calculation result, 8

maximum rate of, 8

humidity, limitations for operating and storage, 7

## I

I/O connections, 33

installation, electricity supply, 15

## L

- lifting devices, 2
- logic ground, 25

## M

- manuals, 2
- mishandling in transit, 1
- modem port
  - parameters, 35
  - pinout, 35
- mounting
  - configurations, 27
  - flanges, description, 28
  - requirements, 28
  - screws, 27
- MTBF figures, 55
- MTTR figures, 55

## O

- ON/STBY switch, 15, 16
- overcurrent protection, 16

## P

- packaging, removing, 1
- pinout
  - RCP port, 37
- power
  - DC source requirements, 16
  - DC supply and ground, 24
- power switch, 15

## R

- rack
  - considerations, 27
  - mounting, 27
  - sizes, 27
- RCP port pinout, 37
- reliability of spares, 55
- Remote Control Processor ports, 33

- Remote Control Processor, *See* RCP
- RJ45 connectors, on CAF module, 33
- RS232 ports, on CAF module, 33

## S

- screws, mounting requirements, 27
- shipkit contents, 2
- shipping configuration, 27
- software licenses, 2
- space required, 3
- spares
  - reliability, 55
  - stock levels, 55
- system
  - contents, 1
  - dimensions, 3

## T

- temperature
  - ambient, 7
  - operating, 7
  - storage, 7
- terminal configuration parameters, 35
- tools, 2

## W

- weight
  - empty chassis, 27
  - maximum, 8
  - removable modules, 27