



Netra™ ct Server Installation Guide

Sun Microsystems, Inc.
901 San Antonio Road
Palo Alto, CA 94303-4900 U.S.A.
650-960-1300

Part No. 806-3294-12
September 2002, [Revision A](#)

[Send comments about this document to: docfeedback@sun.com](mailto:docfeedback@sun.com)

Copyright 2002 Sun Microsystems, Inc., 4150 Network Circle, Santa Clara, California 95054, U.S.A. All rights reserved.

Sun Microsystems, Inc. has intellectual property rights relating to technology embodied in the product that is described in this document. In particular, and without limitation, these intellectual property rights may include one or more of the U.S. patents listed at <http://www.sun.com/patents> and one or more additional patents or pending patent applications in the U.S. and in other countries.

This document and the product to which it pertains are distributed under licenses restricting their use, copying, distribution, and decompilation. No part of the product or of this document may be reproduced in any form by any means without prior written authorization of Sun and its licensors, if any.

Third-party software, including font technology, is copyrighted and licensed from Sun suppliers.

Parts of the product may be derived from Berkeley BSD systems, licensed from the University of California. UNIX is a registered trademark in the U.S. and in other countries, exclusively licensed through X/Open Company, Ltd.

Sun, Sun Microsystems, the Sun logo, AnswerBook2, docs.sun.com, Netra, and Solaris are trademarks or registered trademarks of Sun Microsystems, Inc. in the U.S. and in other countries.

All SPARC trademarks are used under license and are trademarks or registered trademarks of SPARC International, Inc. in the U.S. and in other countries. Products bearing SPARC trademarks are based upon an architecture developed by Sun Microsystems, Inc.

The OPEN LOOK and Sun™ Graphical User Interface was developed by Sun Microsystems, Inc. for its users and licensees. Sun acknowledges the pioneering efforts of Xerox in researching and developing the concept of visual or graphical user interfaces for the computer industry. Sun holds a non-exclusive license from Xerox to the Xerox Graphical User Interface, which license also covers Sun's licensees who implement OPEN LOOK GUIs and otherwise comply with Sun's written license agreements.

Use, duplication, or disclosure by the U.S. Government is subject to restrictions set forth in the Sun Microsystems, Inc. license agreements and as provided in DFARS 227.7202-1(a) and 227.7202-3(a) (1995), DFARS 252.227-7013(c)(1)(ii) (Oct. 1998), FAR 12.212(a) (1995), FAR 52.227-19, or FAR 52.227-14 (ALT III), as applicable.

DOCUMENTATION IS PROVIDED "AS IS" AND ALL EXPRESS OR IMPLIED CONDITIONS, REPRESENTATIONS AND WARRANTIES, INCLUDING ANY IMPLIED WARRANTY OF MERCHANTABILITY, FITNESS FOR A PARTICULAR PURPOSE OR NON-INFRINGEMENT, ARE DISCLAIMED, EXCEPT TO THE EXTENT THAT SUCH DISCLAIMERS ARE HELD TO BE LEGALLY INVALID.

Copyright 2002 Sun Microsystems, Inc., 4150 Network Circle, Santa Clara, California 95054, Etats-Unis. Tous droits réservés.

Sun Microsystems, Inc. a les droits de propriété intellectuelle relatant à la technologie incorporée dans le produit qui est décrit dans ce document. En particulier, et sans limitation, ces droits de propriété intellectuelle peuvent inclure un ou plus des brevets américains énumérés à <http://www.sun.com/patents> et un ou les brevets plus supplémentaires ou les applications de brevet en attente dans les Etats-Unis et dans les autres pays.

Ce produit ou document est protégé par un copyright et distribué avec des licences qui en restreignent l'utilisation, la copie, la distribution, et la décompilation. Aucune partie de ce produit ou document ne peut être reproduite sous aucune forme, par quelque moyen que ce soit, sans l'autorisation préalable et écrite de Sun et de ses bailleurs de licence, s'il y en a.

Le logiciel détenu par des tiers, et qui comprend la technologie relative aux polices de caractères, est protégé par un copyright et licencié par des fournisseurs de Sun.

Des parties de ce produit pourront être dérivées des systèmes Berkeley BSD licenciés par l'Université de Californie. UNIX est une marque déposée aux Etats-Unis et dans d'autres pays et licenciée exclusivement par X/Open Company, Ltd.

Sun, Sun Microsystems, le logo Sun, AnswerBook2, docs.sun.com, Netra, et Solaris sont des marques de fabrique ou des marques déposées de Sun Microsystems, Inc. aux Etats-Unis et dans d'autres pays.

Toutes les marques SPARC sont utilisées sous licence et sont des marques de fabrique ou des marques déposées de SPARC International, Inc. aux Etats-Unis et dans d'autres pays. Les produits portant les marques SPARC sont basés sur une architecture développée par Sun Microsystems, Inc.

L'interface d'utilisation graphique OPEN LOOK et Sun™ a été développée par Sun Microsystems, Inc. pour ses utilisateurs et licenciés. Sun reconnaît les efforts de pionniers de Xerox pour la recherche et le développement du concept des interfaces d'utilisation visuelle ou graphique pour l'industrie de l'informatique. Sun détient une licence non exclusive de Xerox sur l'interface d'utilisation graphique Xerox, cette licence couvrant également les licenciés de Sun qui mettent en place l'interface d'utilisation graphique OPEN LOOK et qui en outre se conforment aux licences écrites de Sun.

LA DOCUMENTATION EST FOURNIE "EN L'ÉTAT" ET TOUTES AUTRES CONDITIONS, DECLARATIONS ET GARANTIES EXPRESSES OU TACITES SONT FORMELLEMENT EXCLUES, DANS LA MESURE AUTORISÉE PAR LA LOI APPLICABLE, Y COMPRIS NOTAMMENT TOUTE GARANTIE IMPLICITE RELATIVE A LA QUALITE MARCHANDE, A L'APTITUDE A UNE UTILISATION PARTICULIERE OU A L'ABSENCE DE CONTREFAÇON.



Contents

- 1. Installation Overview 1**
- 2. Site Preparation 3**
 - Tools Required 3
 - Planning the Placement of the Rack 4
 - Determining If You Have a Front-Access or Rear-Access Model 4
 - Example of Server Room Layout 6
 - Planning the Rackmounting Configuration 6
 - Chassis and Server Physical Specifications 9
 - Chassis Physical Specifications 9
 - Netra ct 800 Server Physical Specifications 11
 - Netra ct 400 Server Physical Specifications 12
 - DC Source Site Requirements 13
 - DC Supply and Ground Conductor Requirements 13
 - Overcurrent Protection Requirements 14
 - Connecting Logic Ground and Chassis Ground 14
 - Cooling Requirements 15
 - Environmental Specifications 17
- 3. Mounting the Chassis in a Rack 19**

Attaching the Mounting Bracket Adapters to the Chassis 20

- ▼ To Attach the Mounting Bracket Adapters 20

Mounting the Chassis in a Rack 22

Preparing to Lift the Chassis 22

- ▼ To Remove the Servers From the Chassis 22
- ▼ To Mount the Chassis in a Rack 27
- ▼ To Connect the DC Grounding Cable 29

4. Installing a Server Into a Chassis 31

- ▼ To Unpack a Netra ct Server 31
- ▼ To Install the Servers in the Chassis 33

5. Installing Additional Cards into the Netra ct Server 41

Antistatic Precautions 41

- ▼ To Attach the Antistatic Wrist Strap 42

Installing Additional I/O Cards in the Front-Access Model Server 43

- ▼ To Install Additional I/O Cards 47

Installing Additional I/O Cards in the Rear-Access Model Server 49

- ▼ To Install a Front I/O Card and I/O Rear Transition Card 51

6. Cabling the System 55

Installing the Cable Management Brackets 55

Connecting Cables to the CompactPCI Cards 57

Cabling for the Front-Access Model 58

- ▼ To Connect Cables to the CPU Card 58
- ▼ To Connect Cables to the CPU Front Transition Card 62
- ▼ To Connect Cables to the Alarm Card (Front-Access Models Only) 77
- ▼ To Connect Cables to the CompactPCI Front-Access I/O Cards 87

Cabling for the Rear-Access Model 87

- ▼ To Connect Cables to the CPU Rear Transition Card 87
- ▼ To Connect Cables to the Alarm Rear Transition Card (Rear-Access Models Only) 97
- ▼ To Connect Cables to the Rear-Access I/O Cards 103
- Assembling and Connecting the DC Input Power Cable 103
 - Assembling the DC Input Power Cable 103
 - ▼ To Assemble the DC Input Power Cable 104
 - ▼ To Install the Strain Relief Housings 108
 - Connecting the DC Input Power Cable to the Server 110
 - ▼ To Connect the Power Cable to the Front-Access Model 111
 - ▼ To Connect the Power Cable to the Rear-Access Model 113
- 7. Powering the Server On and Off 115**
 - Connecting a Terminal Console to the Server 116
 - ▼ To Use an ASCII Terminal 116
 - ▼ To Use a Solaris Workstation 118
 - ▼ To Use a PC Laptop 120
 - Powering On the Server 122
 - Powering Off the Server 126
 - ▼ To Perform a Hardware Power-Off 127
 - ▼ To Perform a Software Power Off 129
- 8. Installing the Software 131**
 - Using a CD-ROM/DVD 131
 - ▼ To Install the Solaris Operating Environment 131
 - ▼ To Install the Netra ct Server Software 133
 - ▼ To Install Additional Software 139
 - Using JumpStart 139
 - TTYMux Information 139

TTYMux Security Information	139
Installing TTYMux Patches	140
Using TTYMux	141
▼ To Connect an External SCSI Device	143

Figures

- FIGURE 2-1 Front-Access and Rear-Access Models 5
- FIGURE 2-2 Example of a Server Room Layout 6
- FIGURE 2-3 Example Configuration 1—Three Chassis, No External SCSI Devices 7
- FIGURE 2-4 Example Configuration 2—Three Chassis, Two External SCSI Devices 8
- FIGURE 2-5 Physical Specifications for the Netra ct Chassis 10
- FIGURE 2-6 Netra ct 800 Server Physical Specifications 11
- FIGURE 2-7 Netra ct 400 Server Physical Specifications 12
- FIGURE 2-8 Installing a Grounding Plate 15
- FIGURE 2-9 Airflow (Side View) 16
- FIGURE 3-1 Center-Mounting the Chassis 19
- FIGURE 3-2 Installing the Mounting Bracket Adapters 21
- FIGURE 3-3 Loosening the Screws at the Top of a Netra ct 800 Server 23
- FIGURE 3-4 Loosening the Screws at the Top of a Netra ct 400 Server 24
- FIGURE 3-5 Loosening the Screws at the Bottom of a Netra ct 800 Server 25
- FIGURE 3-6 Loosening the Screws at the Bottom of a Netra ct 400 Server 25
- FIGURE 3-7 Removing a Netra ct 800 Server From the Chassis 26
- FIGURE 3-8 Removing a Netra ct 400 Server From the Chassis 27
- FIGURE 3-9 Mounting the Netra ct Chassis in a Rack 28
- FIGURE 3-10 Connecting the DC Grounding Cable to the DC Grounding Studs 29

FIGURE 4-1	Unpacking a Netra ct Server	32
FIGURE 4-2	Installing a Netra ct 800 Server in the Chassis	34
FIGURE 4-3	Installing a Netra ct 400 Server in the Chassis	35
FIGURE 4-4	Tightening the Screws at the Top of a Netra ct 800 Server	36
FIGURE 4-5	Tightening the Screws at the Top of a Netra ct 400 Server	37
FIGURE 4-6	Tightening the Screws at the Bottom of a Netra ct 800 Server	38
FIGURE 4-7	Tightening the Screws at the Bottom of a Netra ct 400 Server	38
FIGURE 5-1	Attaching the Antistatic Wrist Strap	42
FIGURE 5-2	I/O Card Slots (Netra ct 800 Server)	44
FIGURE 5-3	Buses for the Netra ct 800 Server Midplane (Front View)	45
FIGURE 5-4	I/O Card Slots (Netra ct 400 Server)	46
FIGURE 5-5	Buses for the Netra ct 400 Server (Front View)	47
FIGURE 5-6	Aligning the Card With the Card Cage Cutouts	48
FIGURE 5-7	Tightening the Ejection Lever Captive Screws	49
FIGURE 5-8	Buses for the Netra ct 800 Server (Rear View)	50
FIGURE 5-9	Buses for the Netra ct 400 Server (Rear View)	51
FIGURE 5-10	Aligning the Card With the Rear Card Cage Cutouts	53
FIGURE 6-1	Cable Management Brackets	56
FIGURE 6-2	Installing the Cable Management Brackets	57
FIGURE 6-3	CPU Card Locations	58
FIGURE 6-4	Connectors on the CPU Card	60
FIGURE 6-5	RJ-45 Ethernet Connector Diagram	61
FIGURE 6-6	CPU Card Front Panel TTYA Diagram	62
FIGURE 6-7	CPU Front Transition Card Location in a Netra ct 800 Server	63
FIGURE 6-8	CPU Front Transition Card Location in a Netra ct 400 Server	64
FIGURE 6-9	Connectors on the CPU Front Transition Card (Netra ct 800 Server)	65
FIGURE 6-10	Connectors on the CPU Front Transition Card (Netra ct 400 Server)	66
FIGURE 6-11	Parallel Connector	67

FIGURE 6-12	RJ-45 Ethernet Connector Diagram	68
FIGURE 6-13	TTY B Connector	69
FIGURE 6-14	TTY A Connector	70
FIGURE 6-15	SCSI-3 AMPLIMITE Connector	71
FIGURE 6-16	Parallel Connector	74
FIGURE 6-17	RJ-45 Ethernet Connector Diagram	75
FIGURE 6-18	TTY B Connector	76
FIGURE 6-19	Connectors on the Alarm Card (Front-Access Model Netra ct 800 Server)	77
FIGURE 6-20	Connectors on the Alarm Card (Front-Access Model Netra ct 400 Server)	78
FIGURE 6-21	Alarm Port	79
FIGURE 6-22	RJ-45 Ethernet Connector Diagram	80
FIGURE 6-23	COM 1 Connector	81
FIGURE 6-24	COM 2 Connector	82
FIGURE 6-25	RJ-45 Ethernet Connector Diagram	83
FIGURE 6-26	RJ-45 Ethernet Connector Diagram	84
FIGURE 6-27	Alarm Port	85
FIGURE 6-28	RJ-45 Ethernet Connector Diagram	86
FIGURE 6-29	CPU Rear Transition Card (CPU RTC) Location in a Netra ct 800 Server (Top View)	88
FIGURE 6-30	CPU Rear Transition Card (CPU RTC) Location in a Netra ct 400 Server (Top View)	88
FIGURE 6-31	Connectors on the CPU Rear Transition Card (Netra ct 800 Server)	89
FIGURE 6-32	Connectors on the CPU Rear Transition Card (Netra ct 400 Server)	90
FIGURE 6-33	Parallel Connector	91
FIGURE 6-34	TTY A Connector	92
FIGURE 6-35	TTY B Connector	93
FIGURE 6-36	RJ-45 Ethernet Connector Diagram	94
FIGURE 6-37	RJ-45 Ethernet Connector Diagram	95
FIGURE 6-38	Locating the Alarm Rear Transition Card in a Netra ct 800 Server (Top View)	97
FIGURE 6-39	Connectors on the Alarm Rear Transition Card	98

FIGURE 6-40	RJ45 Ethernet Connector Diagram	99
FIGURE 6-41	COM 2 Connector	100
FIGURE 6-42	COM 1 Connector	101
FIGURE 6-43	DC Connection Parts	104
FIGURE 6-44	Stripping the Insulation From the Wire	105
FIGURE 6-45	Opening the DC Input Plug Cage Clamp Using the Cage Clamp Operating Lever	106
FIGURE 6-46	Opening the Cage Clamp Using a Screwdriver	107
FIGURE 6-47	Assembling the DC Input Power Cable	107
FIGURE 6-48	Inserting the Bottom Portion of the Strain Relief Housing	108
FIGURE 6-49	Routing the Wires Out of the Bottom Portion of the Strain Relief Housing	109
FIGURE 6-50	Securing the Wires to the Strain Relief Housing	109
FIGURE 6-51	Assembling the Strain Relief Housing	110
FIGURE 6-52	DC Connector Locations, Front-Access Model	111
FIGURE 6-53	Connecting the DC Input Power Cable to the DC Connectors	112
FIGURE 6-54	Disconnecting the DC Input Power Cable From the DC Connector	113
FIGURE 6-55	Locating the DC Connectors	114
FIGURE 7-1	Locating the Power Supply Locking Mechanism on the Netra ct 800 Server	122
FIGURE 7-2	Locating the Power Supply Locking Mechanism on the Netra ct 400 Server	123
FIGURE 7-3	System Status Panel Locations	124
FIGURE 7-4	System Power Button and System Power LED Locations (Netra ct 800 Server)	125
FIGURE 7-5	System Power Button and System Power LED Locations (Netra ct 400 Server)	126

Tables

TABLE 2-1	Netra ct Server Chassis Physical Specifications	9
TABLE 2-2	Netra ct 800 Server Physical Specifications	11
TABLE 2-3	Physical Specifications, Netra ct 400 Server	12
TABLE 2-4	DC Power Requirements	13
TABLE 2-5	Environmental Specifications	17
TABLE 6-1	COM (TTY A) Port	59
TABLE 6-2	Ethernet A Port	59
TABLE 6-3	Ethernet Connector Pinouts, CPU Card (J2301)	61
TABLE 6-4	Parallel Port Pinouts, CPU FTC for the Netra ct 800 Server	67
TABLE 6-5	Ethernet B Connector Pinouts, CPU FTC for the Netra ct 800 Server	68
TABLE 6-6	TTY B Port Pinouts, CPU FTC for the Netra ct 800 Server	69
TABLE 6-7	TTY A Port Pinouts, CPU FTC for Netra ct 800 Server	70
TABLE 6-8	SCSI Port Pinouts, CPU FTC for Netra ct 800 Server	71
TABLE 6-9	SCSI Port Pinouts, CPU FTC for the Netra ct 400 Server	73
TABLE 6-10	Parallel Port Pinouts, CPU FTC for the Netra ct 400 Server	74
TABLE 6-11	Ethernet B Connector Pinouts, CPU FTC for the Netra ct 400 Server	75
TABLE 6-12	TTY B Port Pinouts, CPU FTC for the Netra ct 400 Server	76
TABLE 6-13	Alarm Port Pinouts, Alarm Card for the Netra ct 800 Server	79
TABLE 6-14	Ethernet Connector Pinouts, Alarm Card for the Netra ct 800 Server	80

TABLE 6-15	COM 1 Connector Pinouts, Alarm Card for the Netra ct 800 Server	81
TABLE 6-16	COM 2 Connector Pinouts, Alarm Card for the Netra ct 800 Server	82
TABLE 6-17	COM 2 Connector Pinouts, Alarm Card for the Netra ct 800 Server	83
TABLE 6-18	COM 1 Connector Pinouts, Alarm Card for the Netra ct 800 Server	84
TABLE 6-19	Alarm Port Pinouts, Alarm Card for the Netra ct 400 Server	85
TABLE 6-20	Ethernet Connector Pinouts, Alarm Card for the Netra ct 400 Server	86
TABLE 6-21	Parallel Port Pinouts, CPU RTC	91
TABLE 6-22	TTY A Port Pinouts, CPU RTC	92
TABLE 6-23	TTY B Port Pinouts, CPU RTC	93
TABLE 6-24	Ethernet Connector Pinouts, CPU RTC	94
TABLE 6-25	Ethernet Connector Pinouts, CPU RTC	95
TABLE 6-26	SCSI Port Pinouts, CPU RTC	96
TABLE 6-27	Ethernet Connector Pinout, Alarm RTC for the Netra ct 800 Server	99
TABLE 6-28	COM 2 Connector Pinouts, Alarm RTC for the Netra ct 800 Server	100
TABLE 6-29	COM 1 Connector Pinouts, Alarm RTC for the Netra ct 800 Server	101
TABLE 6-30	Alarm Port Pinouts, Alarm RTC for the Netra ct 800 Server	102
TABLE 7-1	Connecting an ASCII Terminal to a CPU or CPU Transition Card	117
TABLE 7-2	Connecting an ASCII Terminal to an Alarm or Alarm Rear Transition Card	117
TABLE 7-3	Connecting a Solaris Workstation to a CPU or CPU Transition Card	119
TABLE 7-4	Connecting a Solaris Workstation to an Alarm or Alarm Rear Transition Card	119
TABLE 7-5	Connecting a PC Laptop to a CPU or CPU Transition Card	121
TABLE 7-6	Connecting a PC Laptop to an Alarm or Alarm Rear Transition Card	121
TABLE 8-1	Mandatory Software From the Supplement CD	134
TABLE 8-2	Optional Software From the Supplement CD	134
TABLE 8-3	Mandatory Software Package Names	136
TABLE 8-4	Optional Software Package Names	136

Preface

The *Netra ct Server Installation Guide* describes how to perform the initial installation of the Netra ct server. Upon completion of the procedures in this document, your server will be functional.

The intended reader of this manual is an experienced system administrator who has experience installing hardware—systems and components—and has used the Solaris™ operating environment. The reader should be comfortable with LAN fundamentals and with networking concepts in general.

Before performing the procedures described in this book, you should review the information in the *Netra ct Server Product Overview*.

Safety and Compliance

All Netra ct servers are shipped with the *Netra ct Server Safety and Compliance Manual*, which specifies the environmental and electrical safety requirements for the product and contains compliance certification for various countries. Review the information in the *Netra ct Server Safety and Compliance Manual* before proceeding with the instructions in this document.

How This Book Is Organized

Chapter 1 gives the documentation overview for this document.

Chapter 2 gives the information you'll need to prepare your installation site for the Netra ct server.

Chapter 3 tells how to mount the Netra ct server chassis into a rack.

Chapter 4 tells how to install a Netra ct server into the chassis.

Chapter 5 tells how to install I/O cards into the Netra ct server.

Chapter 6 tells how to connect the necessary cables to the Netra ct server.

Chapter 7 tells how to power the Netra ct server on and off.

Chapter 8 gives information on installing the Netra ct server software.

Using UNIX Commands

This document may not contain information on basic UNIX[®] commands and procedures such as shutting down the system, booting the system, and configuring devices.

See one or more of the following for this information:

- *Solaris Handbook for Sun Peripherals*
- AnswerBook2[™] online documentation for the Solaris[™] operating environment
- Other software documentation that you received with your system

Typographic Conventions

Typeface	Meaning	Examples
AaBbCc123	The names of commands, files, and directories; on-screen computer output	Edit your <code>.login</code> file. Use <code>ls -a</code> to list all files. % You have mail.
AaBbCc123	What you type, when contrasted with on-screen computer output	% su Password:
<i>AaBbCc123</i>	Book titles, new words or terms, words to be emphasized	Read Chapter 6 in the <i>User's Guide</i> . These are called <i>class</i> options. You <i>must</i> be superuser to do this.
	Command-line variable; replace with a real name or value	To delete a file, type <code>rm filename</code> .

Shell Prompts

Shell	Prompt
C shell	<i>machine_name%</i>
C shell superuser	<i>machine_name#</i>
Bourne shell and Korn shell	\$
Bourne shell and Korn shell superuser	#

Related Documentation

Title	Part Number
<i>Netra ct Server Start Here</i>	806-5161
<i>Netra ct Server Product Notes</i>	806-3299
<i>Netra ct Server Safety and Compliance Manual</i>	806-3295
<i>Netra ct Server Product Overview</i>	806-3298
<i>Netra ct Server Service Manual</i>	806-3296
<i>Sun Remote System Control (RSC) User's Guide for the Netra ct Server Alarm Card</i>	806-3301

Accessing Sun Documentation Online

Technical documentation for this manual can be accessed over the Web at:

<http://www.sun.com/products-n-solutions/hw/networking>

Solaris-specific technical documentation can also be found over the Web at:

<http://docs.sun.com>

Ordering Sun Documentation

Fatbrain.com, an Internet professional bookstore, stocks select product documentation from Sun Microsystems, Inc.

For a list of documents and how to order them, visit the Sun Documentation Center on Fatbrain.com at:

<http://www.fatbrain.com/documentation/sun>

Sun Welcomes Your Comments

Sun is interested in improving its documentation and welcomes your comments and suggestions. You can email your comments to Sun at:

`docfeedback@sun.com`

Please include the part number (806-3294-12) of your document in the subject line of your email.

Installation Overview

This chapter provides an overview of the tasks to install the Netra ct server. Detailed instructions for each task are provided on the pages specified.

Task	Detailed Instructions
Prepare your site for installation by checking the room and rack spacing, and the DC power source.	Page 3
Mount the chassis in a rack.	Page 19
Connect the DC grounding cable.	Page 29
Install the Netra ct server, if necessary.	Page 31
Install optional cards, such as I/O cards.	Page 41
Connect the cables to the CPU card and/or a CPU transition card.	Page 58 (CPU card) Page 62 (CPU front transition card) Page 87 (CPU rear transition card)
Connect the cables to the alarm card or to the alarm rear transition card.	Page 77 (alarm card) Page 97 (alarm rear transition card)
Connect the cables to any additional cards you installed.	Page 87 (front-access I/O cards) Page 103 (rear-access I/O cards)
Connect any optional external SCSI devices.	Page 143
Assemble and connect the DC input power cables to the server.	Page 103
Power on the server.	Page 122
Install the server software.	Page 131
Connect any optional external SCSI devices.	Page 143

Site Preparation

This chapter describes how to prepare your site for installing the Netra ct server. This chapter contains the following topics:

- “Tools Required” on page 3
- “Planning the Placement of the Rack” on page 4
- “Planning the Rackmounting Configuration” on page 6
- “Chassis and Server Physical Specifications” on page 9
- “DC Source Site Requirements” on page 13
- “Connecting Logic Ground and Chassis Ground” on page 14
- “Cooling Requirements” on page 15
- “Environmental Specifications” on page 17

Tools Required

You will need the following tools to perform the procedures in this document:

- No. 1 Phillips screwdriver
- No. 2 Phillips screwdriver

Planning the Placement of the Rack

The Netra ct chassis and the servers within the chassis come in two models:

- Front-access model—designed so that all the cables to the CompactPCI cards are connected from the front of the chassis. This model is used in areas where the rack is positioned in a room in such a way that the rear of the chassis is inaccessible.
- Rear-access model—designed so that all the cables to the CompactPCI cards are connected from the rear of the chassis. This model is used in areas where the rack is positioned in a room in such a way that both the front and the rear of the chassis is accessible.

Determining If You Have a Front-Access or Rear-Access Model

If you are not sure whether you have a front-access or a rear-access model, go to the front of the chassis and look at the top part of the chassis.

- If you see the DC connectors at the front of the chassis, you have a *front-access* model (FIGURE 2-1).
- If you do not see DC connectors at the front of the chassis, and metal filler plates fill the gaps where the DC connectors would normally be, you have a *rear-access* model (FIGURE 2-1). The DC connectors are at the rear of the chassis for the rear-access model.

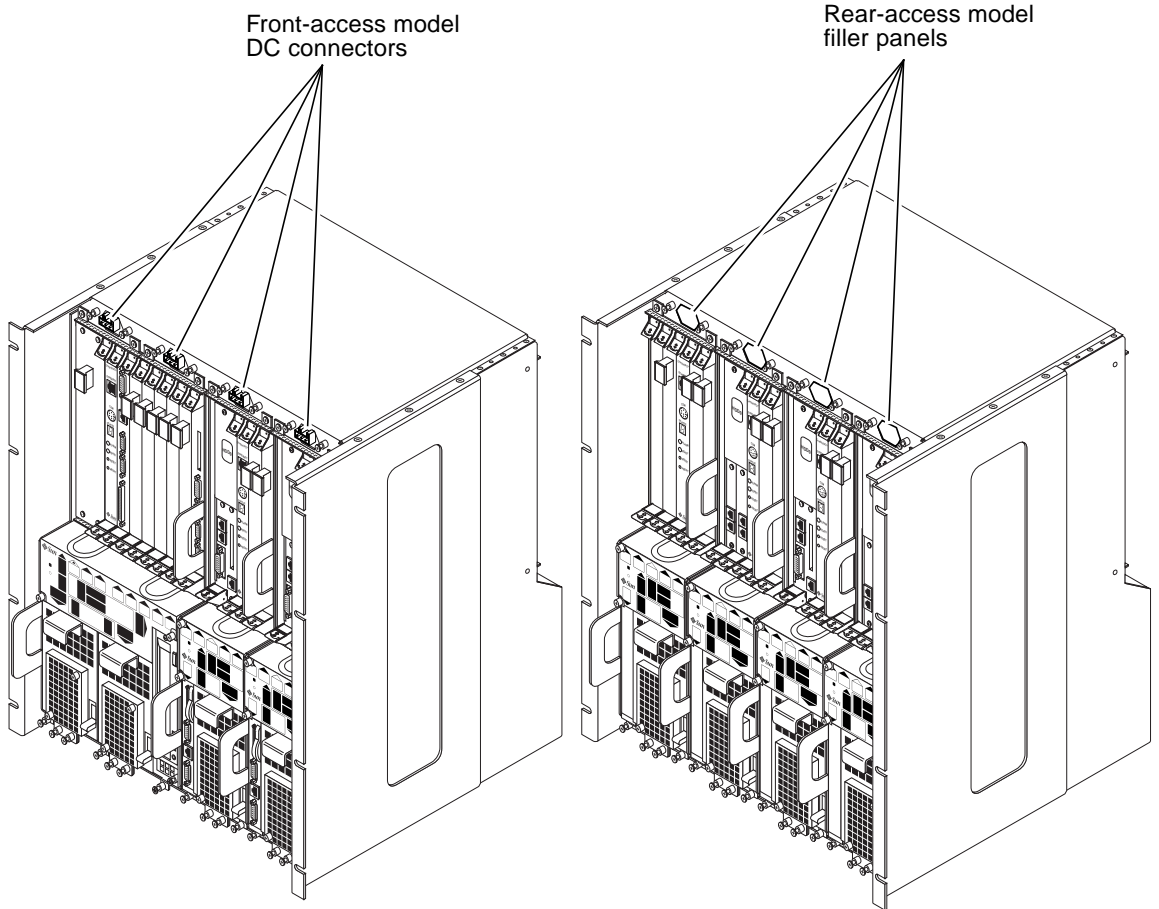

FIGURE 2-1 Front-Access and Rear-Access Models

Example of Server Room Layout

FIGURE 2-2 shows an example of a server room layout and how the front-access and rear-access model chassis and servers might be positioned.

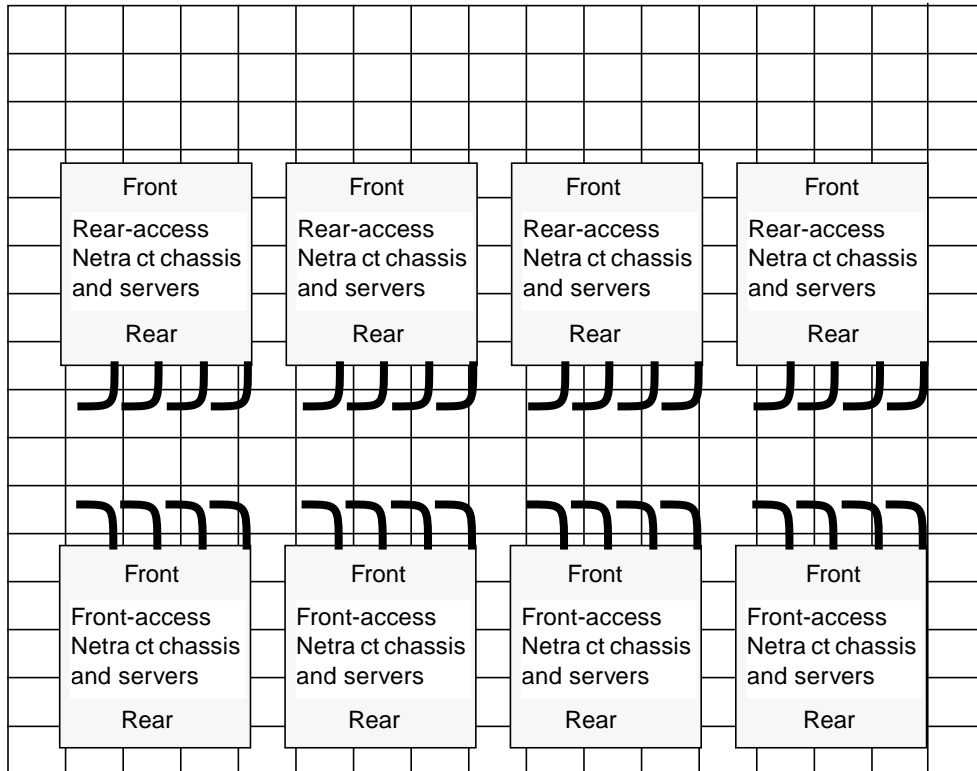

FIGURE 2-2 Example of a Server Room Layout

Planning the Rackmounting Configuration

You can mount several Netra ct chassis into a rack, depending on the size and model of the rack. For example, you could install up to three Netra ct chassis in a standard 19-inch rack, with room left over for one or more external SCSI devices, if necessary.

The following figures show how the Netra ct chassis can be installed in a rack, along with supported external SCSI devices. Note that the external SCSI device shown in the figures might be different from the one that you will be using in your configuration.

- FIGURE 2-3—Example Configuration 1—Three Chassis, No External SCSI Devices
- FIGURE 2-4—Example Configuration 2—Three Chassis, Two External SCSI Devices

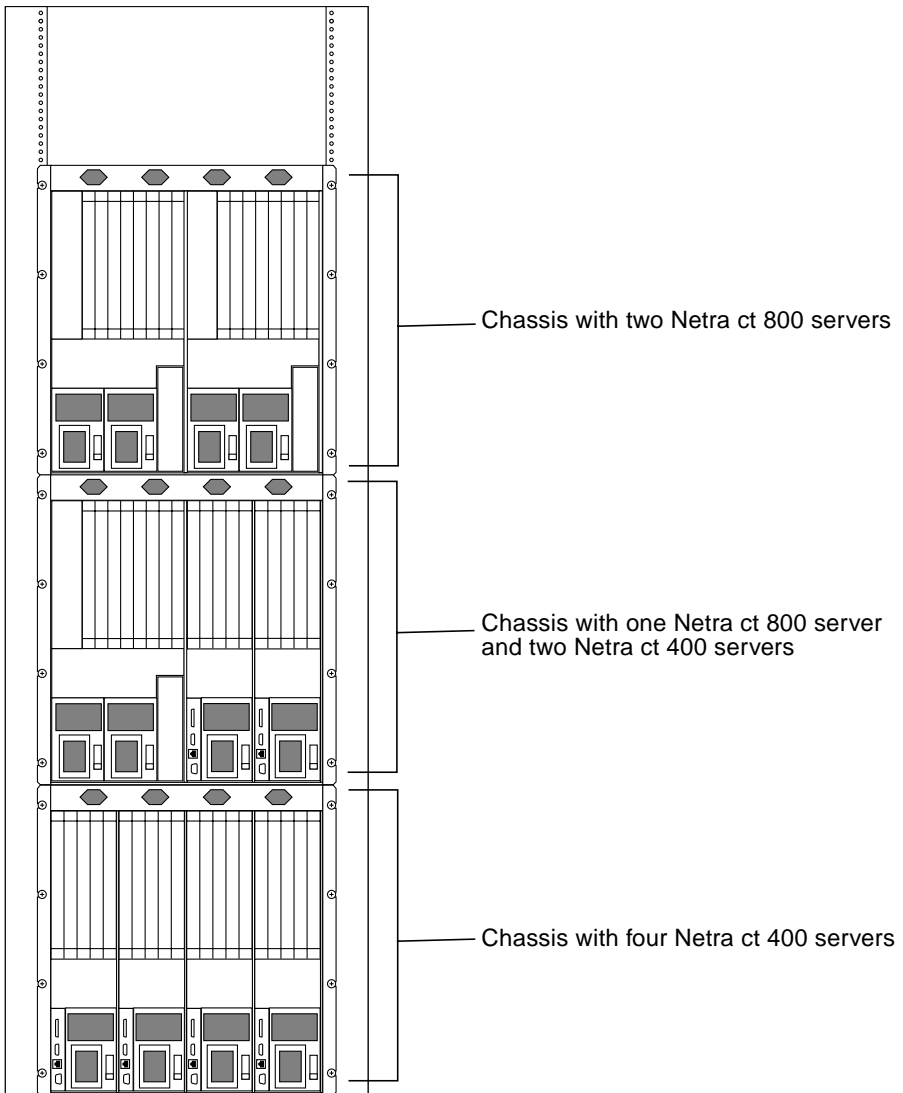

FIGURE 2-3 Example Configuration 1—Three Chassis, No External SCSI Devices

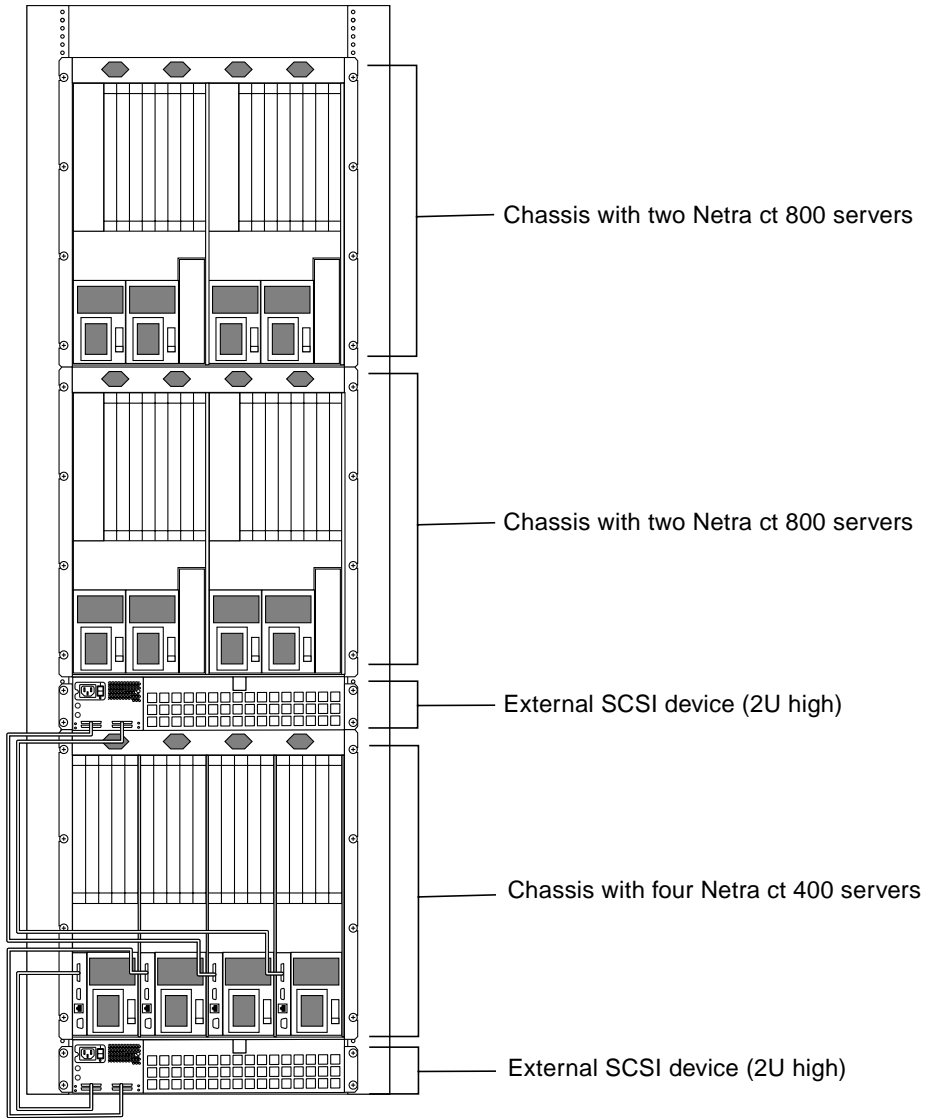

FIGURE 2-4 Example Configuration 2—Three Chassis, Two External SCSI Devices

Chassis and Server Physical Specifications

Chassis Physical Specifications

TABLE 2-1 Netra ct Server Chassis Physical Specifications

	U.S.	Metric
Width	17.5 inches	444.5 mm
Depth (default configuration, with rackmount brackets extended as shown in FIGURE 2-5)	15.75 inches	400 mm
Depth (with rackmount brackets flush against the bottom of the chassis)	13.78 inches	350 mm
Height	20.97 inches	533.64 mm
Weight (empty)	74 lbs	33.56 kg
Weight (fully-loaded)	150 lbs	68.04 kg

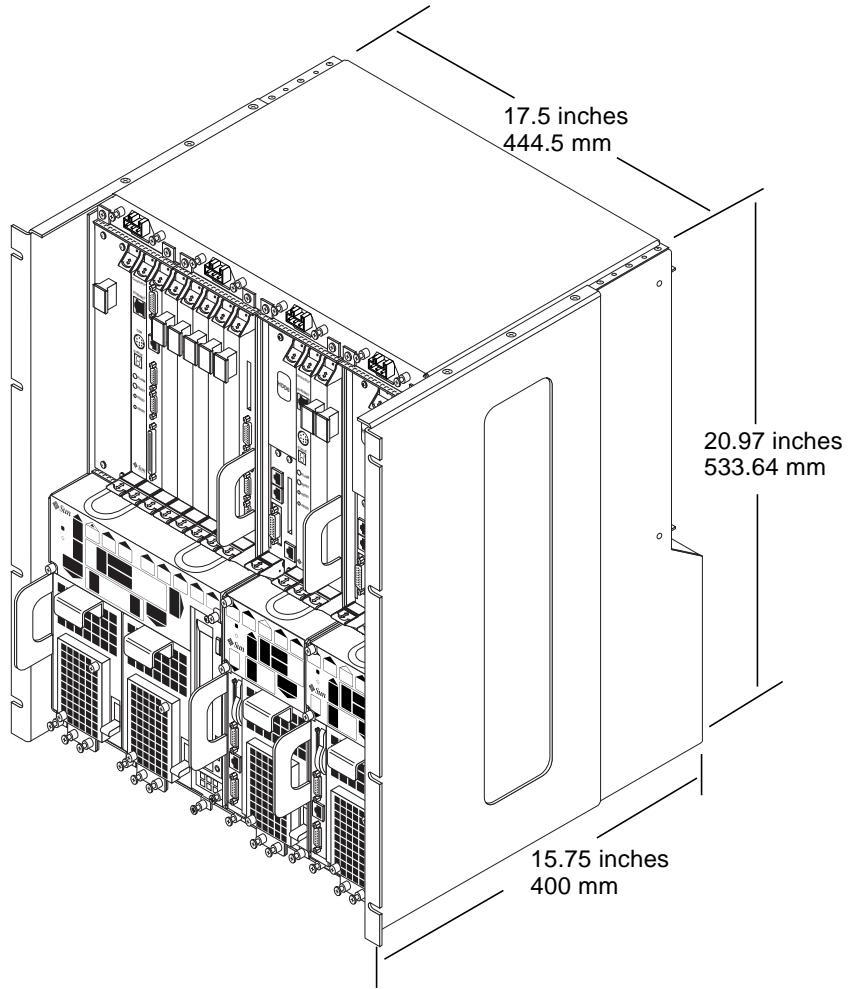

FIGURE 2-5 Physical Specifications for the Netra ct Chassis

Netra ct 800 Server Physical Specifications

TABLE 2-2 Netra ct 800 Server Physical Specifications

Measure	U.S.	Metric
Width	8.56 inches	217.5 mm
Depth	14.89 inches	378.3 mm
Height	20.18 inches	512.67 mm
Weight, fully-loaded	38 lbs	17.24 kg

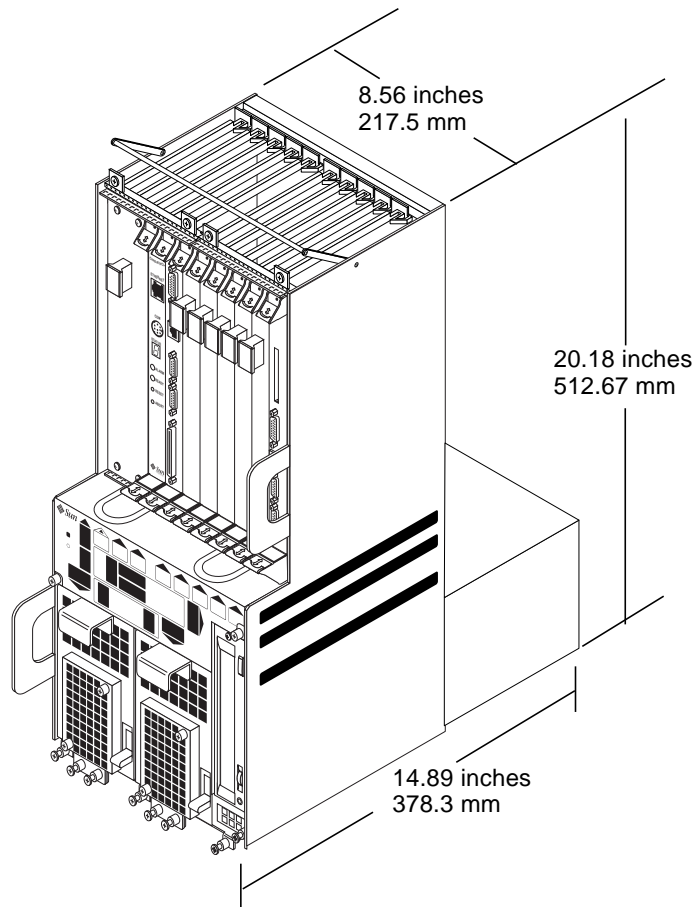

FIGURE 2-6 Netra ct 800 Server Physical Specifications

Netra ct 400 Server Physical Specifications

TABLE 2-3 Physical Specifications, Netra ct 400 Server

Measure	English	Metric
Width	4.25 inches	108 mm
Depth	14.91 inches	378.68 mm
Height	20.18 inches	512.67 mm
Weight, fully-loaded	22 lbs	9.98 kg

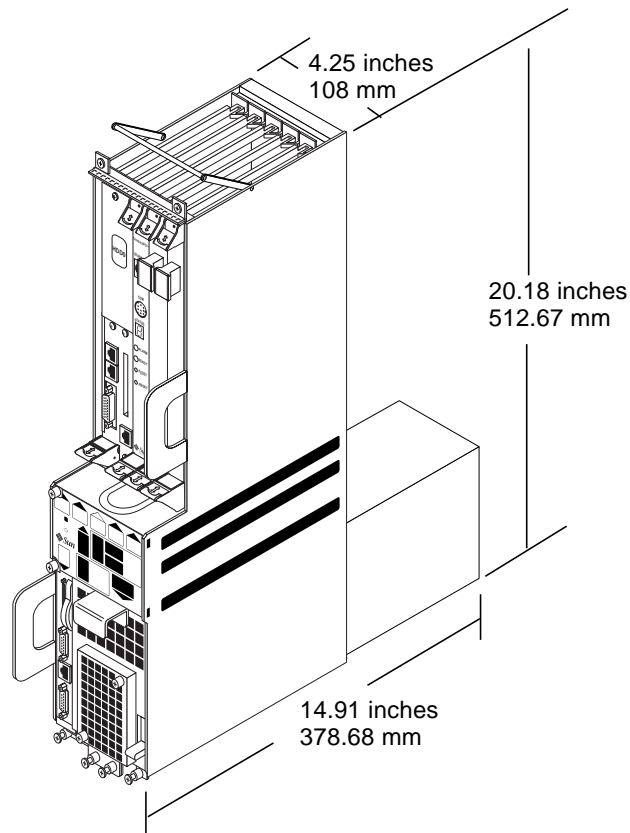

FIGURE 2-7 Netra ct 400 Server Physical Specifications

DC Source Site Requirements

TABLE 2-4 DC Power Requirements

Electrical Element	Requirement
Voltage (nominal)	-48 VDC, -60 VDC
Input current (maximum)	14 A
Max. input surge current	17 A

- Reliably connected to protected earth ground (the battery positive terminal is connected to earth ground)
- May be supplied by one or two power sources, isolated from each other
- Capable of providing up to 600 W of continuous power per feed
- Limited to TNV-2 as defined by UL 1950 and IEC 60950

Note – The DC version of the Netra ct server must be installed in a *restricted-access location*. Per the intent of the National Electrical Code, a restricted-access location is an area intended for qualified or trained personnel only and has access controlled by a locking mechanism, such as a key lock or an access card system.

DC Supply and Ground Conductor Requirements

- Suitable conductor material: use copper conductors only
- Power supply connections through the input connector: 12 AWG (between the Netra ct server and the source). There are three conductors:
 - -48V (negative terminal)
 - Chassis ground connection
 - -48V Return (positive terminal)
- System ground conductor: 12 AWG (to be connected to the chassis)
- Cable insulation rating: minimum of 75°C (167°F), low smoke fume (LSF), flame retardant
- Cable type to be one of the following:
 - UL style 1028 or other UL 1581(VW-1) compliant equivalent
 - IEEE 383 compliant
 - IEEE 1202-1991 compliant

- Branch circuit cable insulation color: per applicable National Electrical Codes
- Grounding cable insulation color: green/yellow

Overcurrent Protection Requirements

- Overcurrent protection devices must be provided as part of each equipment rack.
- Circuit breakers must be located between the DC power source and the Netra ct server. Use one 20-amp, double-pole, fast trip DC-rated circuit breaker for each power supply unit.

Note – Overcurrent protection devices must meet applicable national and local electrical safety codes and be approved for the intended application.

Connecting Logic Ground and Chassis Ground

The Netra ct servers are shipped out of the factory with the logic ground and chassis ground isolated by default. If you want to connect the logic ground and the chassis ground, follow these instructions:

- 1. Remove the Netra ct server, if you have not done so already.**
Refer to “To Remove the Servers From the Chassis” on page 22 for those instructions.
- 2. Go to the rear of the Netra ct server and locate the two M5 threaded studs on the midplane next to the ground symbols.**
- 3. Remove the two screws and install a grounding plate to connect the two studs (FIGURE 2-8).**
This connects the logic ground and chassis ground.

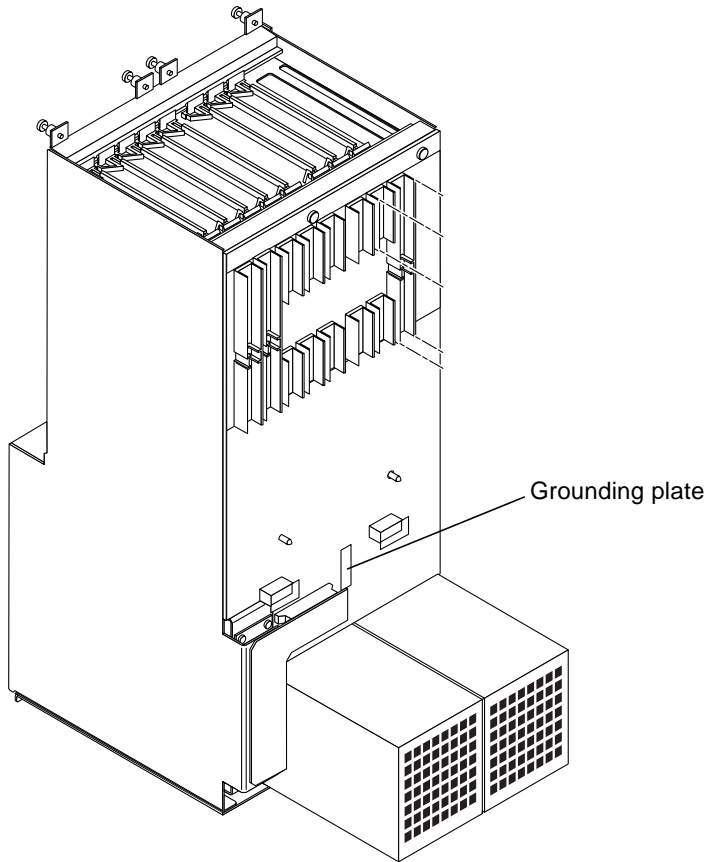

FIGURE 2-8 Installing a Grounding Plate

Cooling Requirements

The Netra ct server is cooled by having air drawn in from the front of the system and exhausted out the rear (FIGURE 2-9). You must allow 8 inches (203.2 mm) in front and at the back of the server to ensure proper cooling.

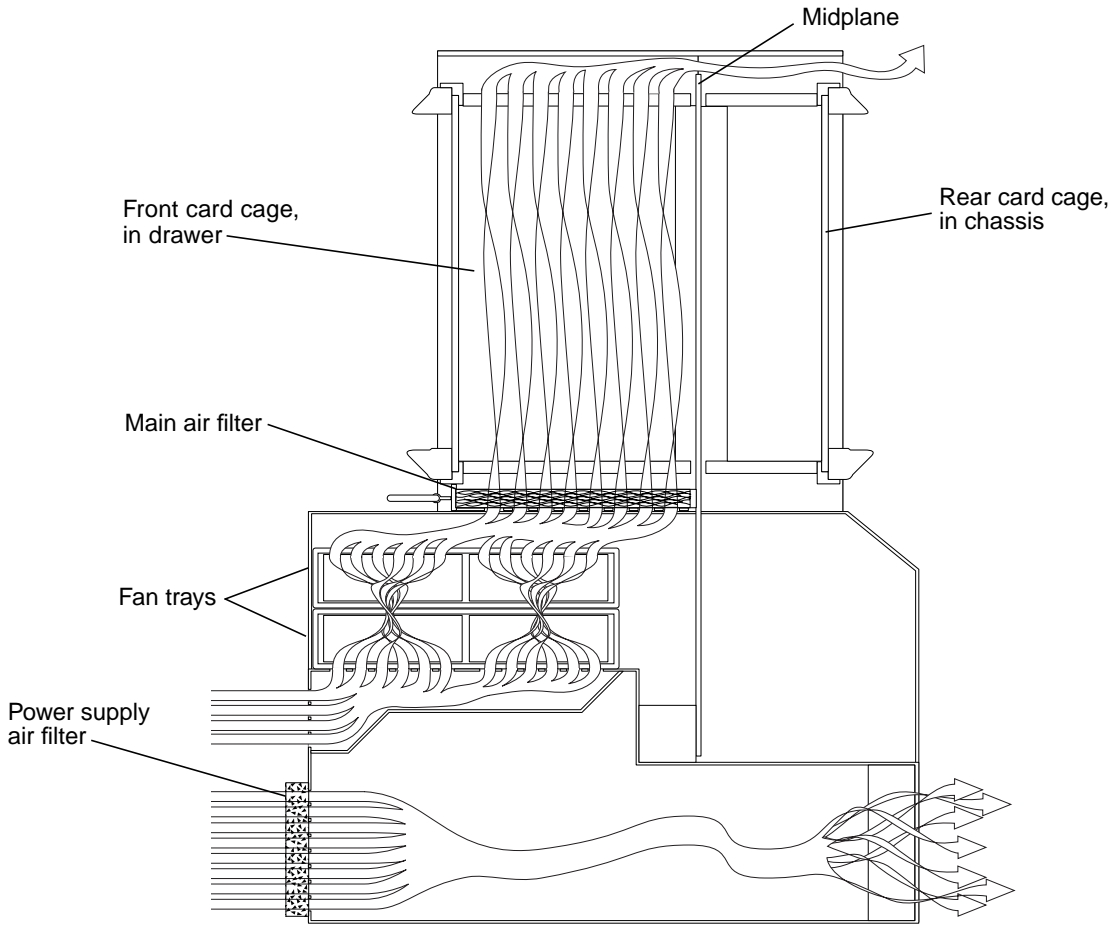

FIGURE 2-9 Airflow (Side View)

Environmental Specifications

TABLE 2-5 Environmental Specifications

Type	Location	Minimum to Maximum Range
Temperature	Operating	-5°C to 45°C (23°F to 113°F)
	Nonoperating	-40°C to 70°C (-38°F to 158°F)
Short term (less than 96 consecutive hrs)	Operating	-5°C to 55°C (23°F to 131°F)
Relative humidity (noncondensing)	Operating	5% to 93% RH
	Nonoperating	93% RH max
Altitude	Operating	0 ft to 13,123 ft (0m to 4000m)
	Nonoperating	0 ft to 39,370 ft (0m to 12,000m)
Declared noise emissions in accordance with ISO 9296		
Chassis w/two Netra ct 800 servers		Sound power LWAd Operating 6.7 B (1B = 10 dB) Idle 6.7 B
Chassis w/four Netra ct 400 servers		Sound power LWAd Operating 7.1 B (1B = 10 dB) Idle 7.1 B

Mounting the Chassis in a Rack

The Netra ct chassis fits into a standard 19-inch width rack. Note that you can move the standard mounting brackets up to six inches (152.4 mm) backward on the Netra ct chassis to center-mount the chassis (FIGURE 3-1).

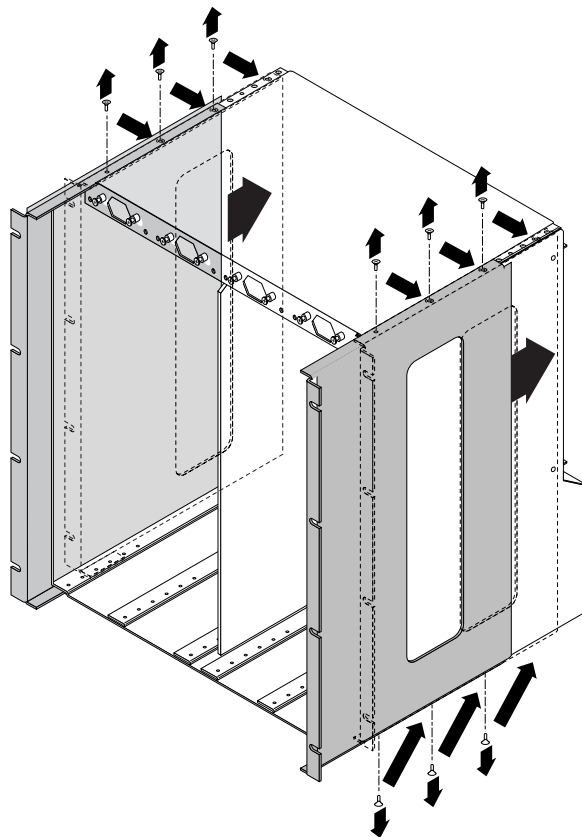

FIGURE 3-1 Center-Mounting the Chassis

You can also purchase optional adaptors that enable you to mount the chassis in 23-inch and 600-mm racks.

- If you have a *19-inch* width rack, you do not have to install any additional mounting bracket adapters. Go to “Mounting the Chassis in a Rack” on page 22.
- If you have a *23-inch* or *600-mm* width rack, you must install the mounting bracket adapters. Go to “Attaching the Mounting Bracket Adapters to the Chassis” on page 20.

Attaching the Mounting Bracket Adapters to the Chassis

If you are mounting the chassis in a 23-inch or 600-mm rack, you must first attach the mounting bracket adapters to the chassis using the following procedure.

▼ To Attach the Mounting Bracket Adapters

1. **Get the mounting bracket adapters from the ship kit.**
2. **Place one of the mounting bracket adapters behind the right chassis mounting bracket, and align the holes in the adapter with the mounting bracket (FIGURE 3-2).**

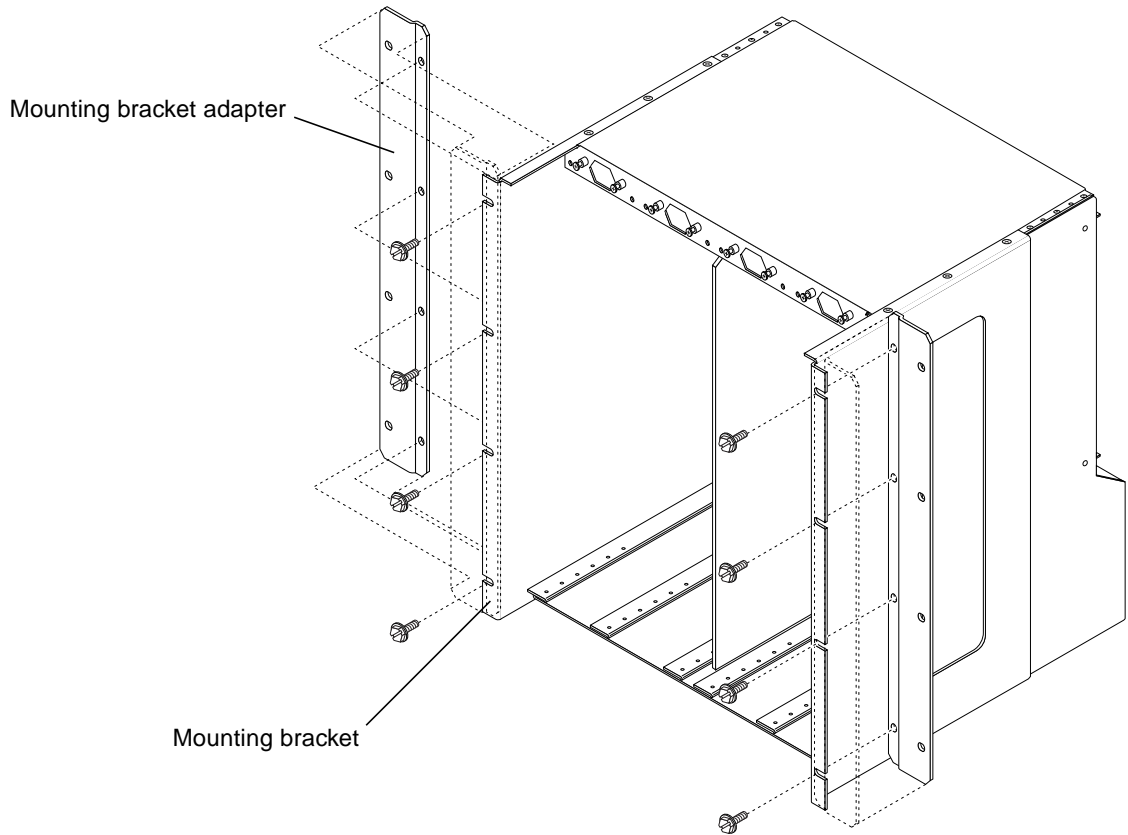

FIGURE 3-2 Installing the Mounting Bracket Adapters

- 3. Secure the mounting bracket adapter to the mounting bracket using four screws from the ship kit.**
- 4. Repeat Step 2 and Step 3 to secure the left mounting bracket adapter to the chassis.**

Mounting the Chassis in a Rack

Preparing to Lift the Chassis

The Netra ct chassis is shipped out one to four Netra ct servers installed inside. A fully loaded Netra ct chassis, including the rackmounting brackets, weighs 150 pounds (68.04 kg). If you are going to mount a fully loaded chassis into a rack, you must use a lifting device, or two people, to lift the chassis.

Alternatively, you can remove all the servers from the chassis to make the chassis lighter before you mount it in the rack. An empty chassis (with all servers removed) weighs 74 pounds (33.57 kg).

- If you want to remove the servers from the chassis before you mount it in the rack, go to “To Remove the Servers From the Chassis” on page 22.
- If you want to mount the chassis in the rack without removing the servers, go to “To Mount the Chassis in a Rack” on page 27.

▼ To Remove the Servers From the Chassis

Note – Individual Netra ct servers do not comprise an EMI enclosure unless they are installed in a Netra ct chassis. The chassis does not comprise an EMI enclosure unless it is full of Netra ct servers and/or blanking panels. If you remove a Netra ct server, you must install a blanking panel; if you don't, the unit will be in violation of 47CFR15.



Caution – If you have a rear-access model Netra ct server, do *not* attempt to remove the server from the chassis without first performing the next step or you might damage certain major system components. Skip to Step 2 only if you have a front-access model.

- 1. If you have a *rear-access* model server, unseat all the rear transition cards from the server that you are going to remove.**

You do not have to completely remove the rear transition cards from the chassis; just pull them out an inch or two so that they are disengaged from the back of the server that you are going to remove.

2. Using a No. 2 Phillips screwdriver, loosen the *black* captive screws at the top of the server.
- If you are removing a Netra ct 800 server, loosen the *four* black captives screws at the top of the server (FIGURE 3-3).
 - If you are removing a Netra ct 400 server, loosen the *two* black captive screws at the top of the server (FIGURE 3-4).

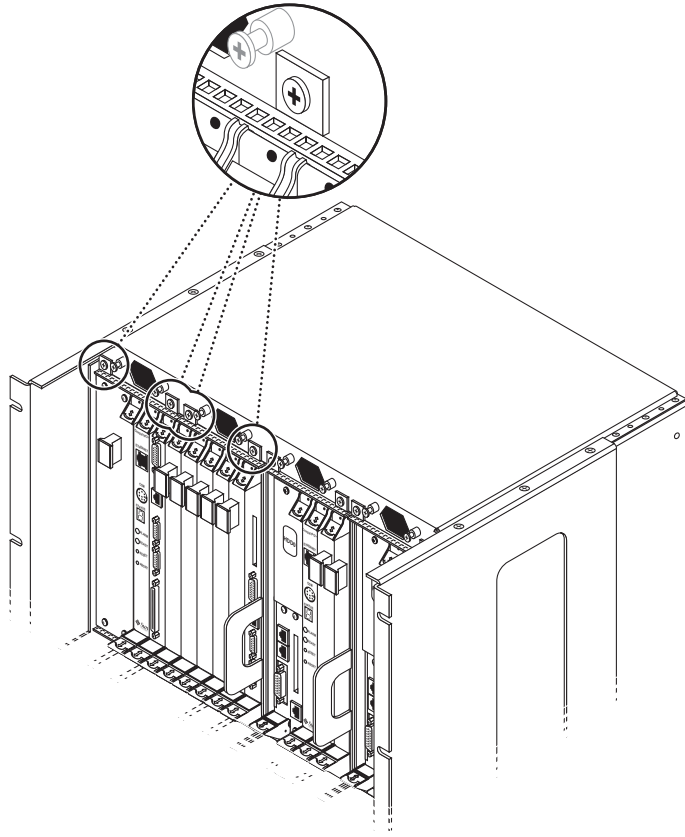

FIGURE 3-3 Loosening the Screws at the Top of a Netra ct 800 Server

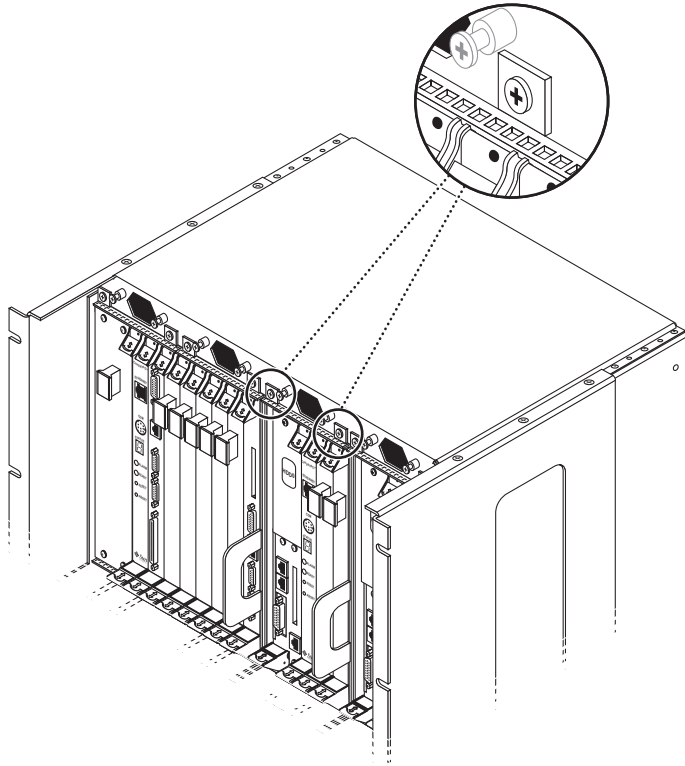

FIGURE 3-4 Loosening the Screws at the Top of a Netra ct 400 Server

3. Using a No. 2 Phillips screwdriver, loosen the *black* captive screws at the bottom of the server.
 - If you are removing a Netra ct 800 server, loosen the *three* black captive screws at the bottom of the server (FIGURE 3-5).
 - If you are removing a Netra ct 400 server, loosen the *two* black captive screws at the bottom of the server (FIGURE 3-6).

Note – Do not loosen the *silver* captive screws at the base of the server; those screws hold the power supply unit in place.

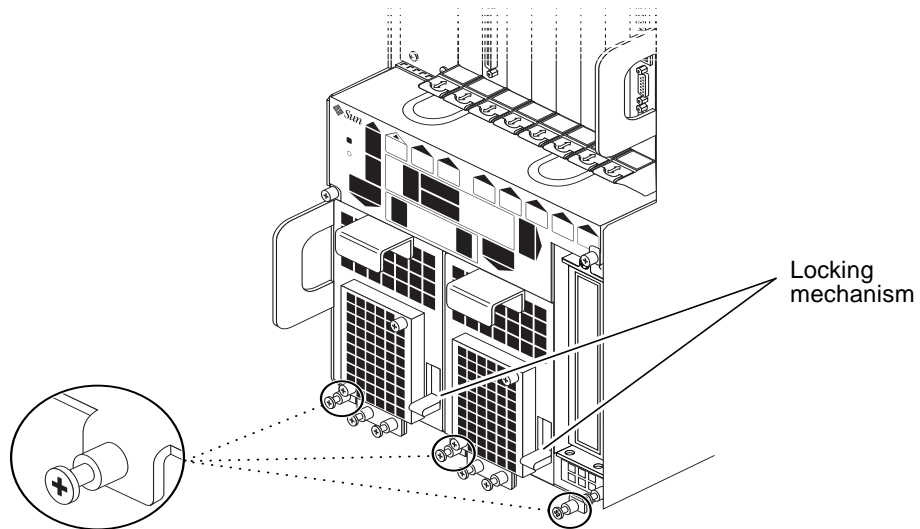

FIGURE 3-5 Loosening the Screws at the Bottom of a Netra ct 800 Server

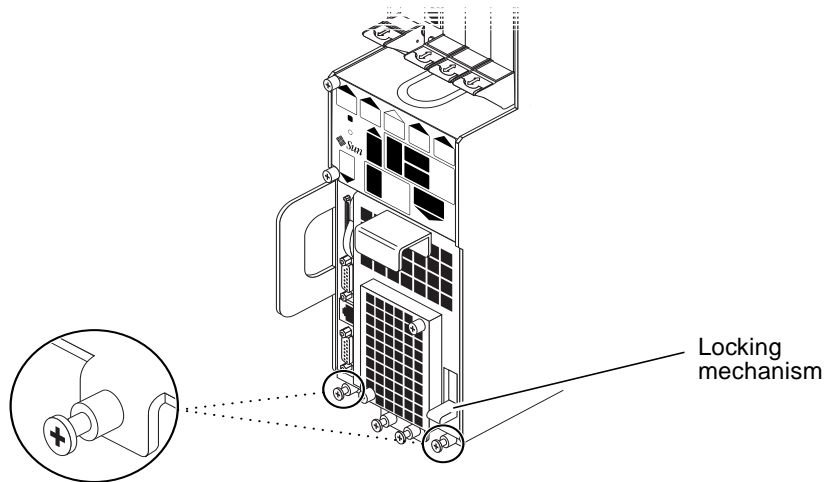

FIGURE 3-6 Loosening the Screws at the Bottom of a Netra ct 400 Server

4. Push the power supply unit locking mechanism(s) up into the unlocked (☐) position.

FIGURE 3-5 shows the location of the two power supply unit locking mechanisms on the Netra ct 800 server, and FIGURE 3-6 shows the location of the single power supply unit locking mechanism on the Netra ct 400 server. Make sure you unlock *both* power supply units if you are replacing an Netra ct 800 server, or you will not be able to remove the server from the chassis.

5. Grasp the flat vertical purple handles at the lower left and middle right of the server and slowly pull the server out of the chassis until the purple bar at the top of the server is visible.

6. With your right hand, grasp the purple bar at the top of the server, and completely pull the server out of the chassis using both the flat vertical handle and the bar.

FIGURE 3-7 shows how to remove a Netra ct 800 server from the chassis, and FIGURE 3-8 shows how to remove a Netra ct 400 server from the chassis.

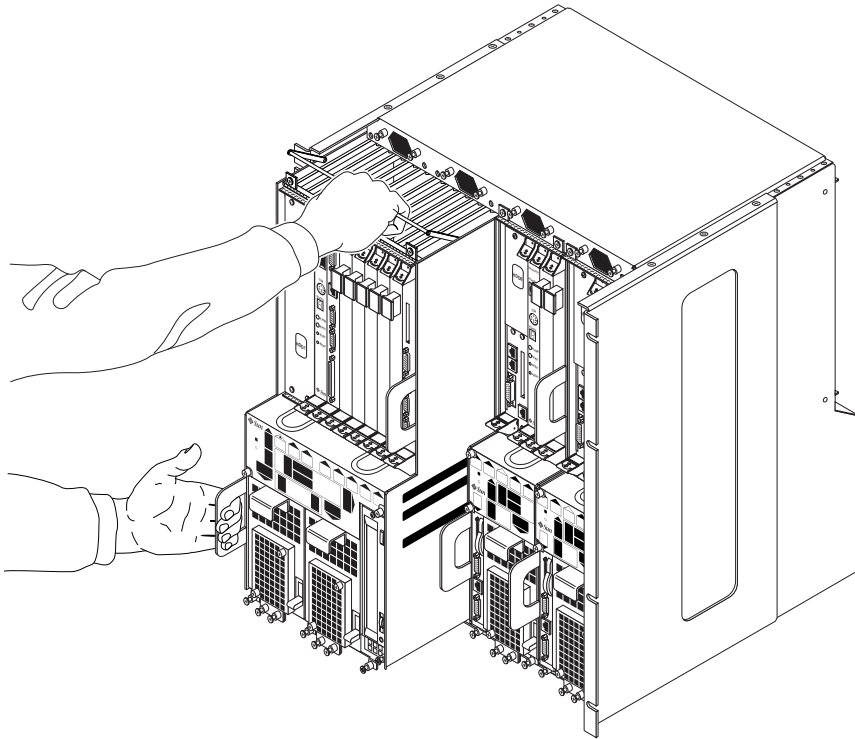

FIGURE 3-7 Removing a Netra ct 800 Server From the Chassis

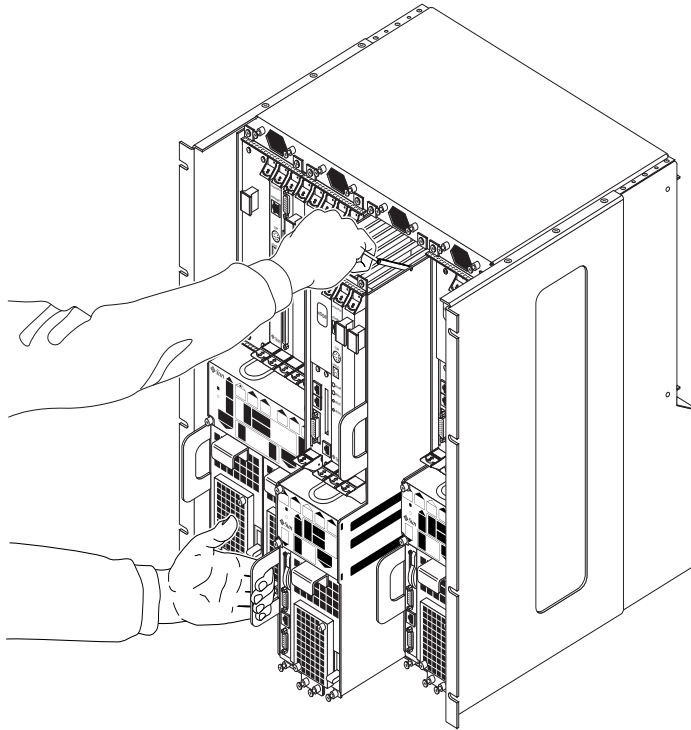

FIGURE 3-8 Removing a Netra ct 400 Server From the Chassis

7. Place the server on a flat level surface.

▼ To Mount the Chassis in a Rack



Caution – Ensure that the rack is bolted to the floor before you install the chassis in the rack. Always install the chassis starting from the bottommost position in the rack.

1. Raise the Netra ct chassis to the appropriate height in the rack and align the mounting holes on the sides of the chassis with the mounting holes in the rack rails (FIGURE 3-9).

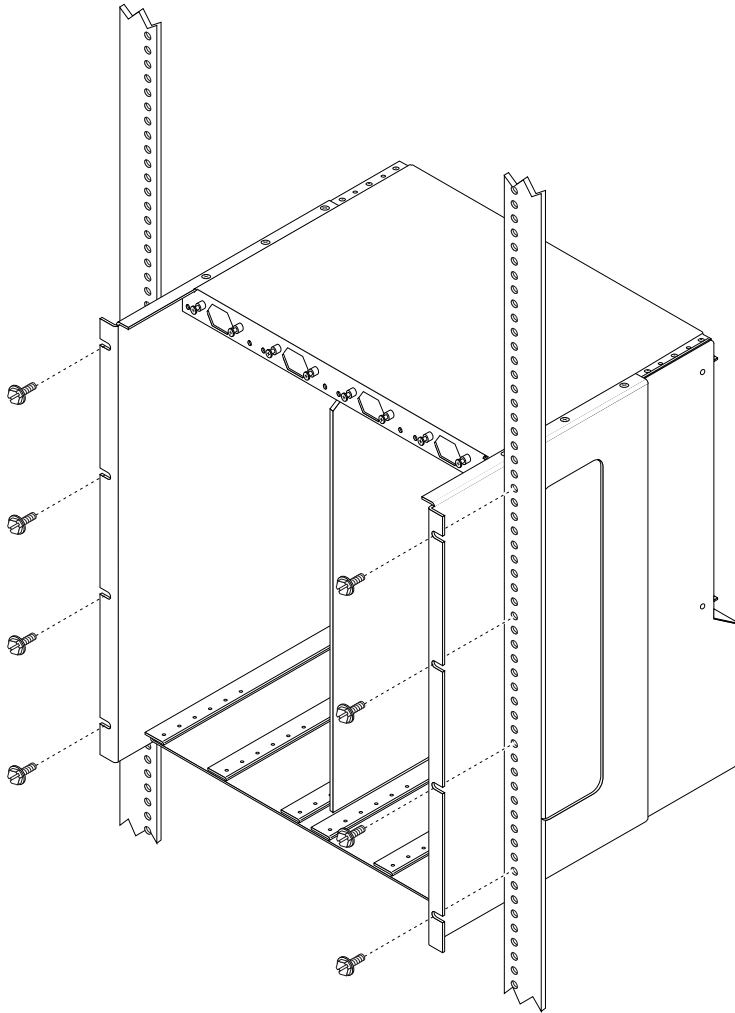

FIGURE 3-9 Mounting the Netra ct Chassis in a Rack

- 2. Secure the chassis to the rack using eight screws (four on each side).**

▼ To Connect the DC Grounding Cable

Refer to “DC Supply and Ground Conductor Requirements” on page 13 for the site requirements for this section.

1. Get a DC grounding cable and two M5 nuts with lock washers.
2. Go to the back of the chassis and locate the two DC grounding studs.

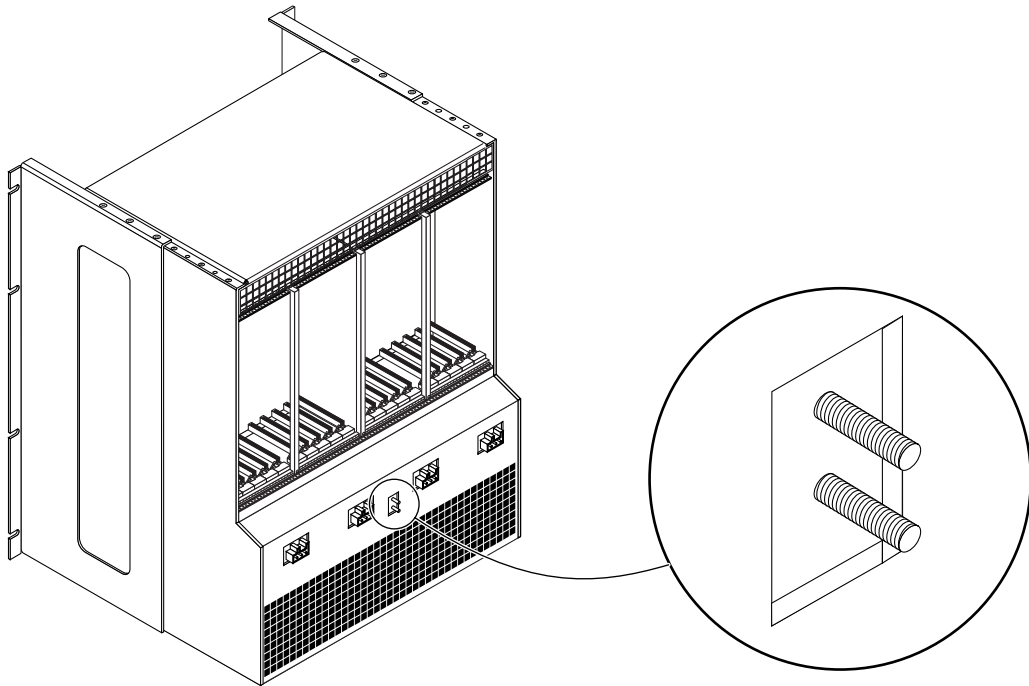

FIGURE 3-10 Connecting the DC Grounding Cable to the DC Grounding Studs

3. Remove the plastic shielding from the DC grounding studs.
4. Position and align the DC grounding cable against the two DC grounding studs at the rear of the chassis.
5. Place the star washers between the DC grounding cable and the two nuts that you will use to secure one end of the grounding cable to the two studs.
6. Tighten the two nuts to secure the grounding cable to the two studs.

7. Secure the other end of the grounding cable to the earth ground in the building.

You can secure the grounding cable to a proper grounding point on the rack, as long as the rack is properly grounded to the earth ground in the building.



Caution – If energized units are not properly grounded, an energy hazard is present.

8. Install the servers in the Netra ct chassis, if necessary.

- If you removed the servers before you installed the chassis in the rack, go to Chapter 4.
- If you did *not* remove the servers from the chassis before you installed the chassis in the rack, go to Chapter 5.

Installing a Server Into a Chassis

This chapter describes how to install a Netra ct server into a chassis.

- If you are installing a *new* Netra ct server into a chassis, go to “To Unpack a Netra ct Server” on page 31.
- If you removed an *existing* Netra ct server before you installed the chassis in the rack, go to “To Install the Servers in the Chassis” on page 33.

▼ To Unpack a Netra ct Server

1. Use the box handles to lift the Netra ct server and place it on a large, flat, secure surface.
2. Lift the lid of the box straight up to remove the lid (FIGURE 4-1).

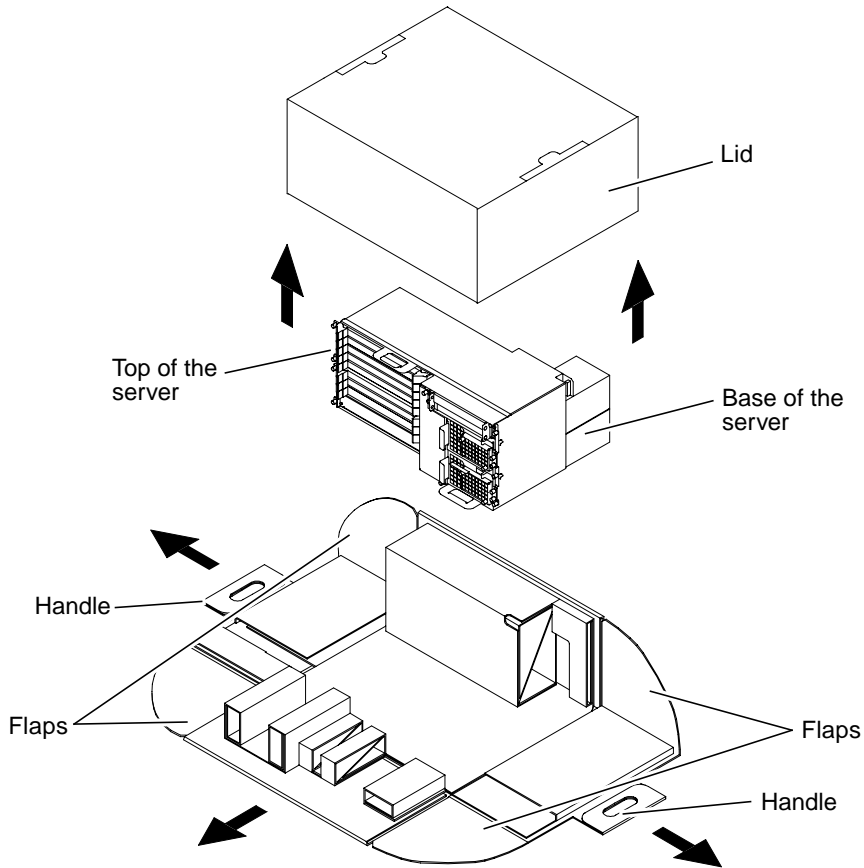

FIGURE 4-1 Unpacking a Netra ct Server

3. **Grasp one of the handles and pull the handle down and away from the box until both flaps come completely free from the box sides (FIGURE 4-1).**
Repeat this step for the handle on the opposite side of the box.
4. **Press down on the remaining sides of the box so that all four sides are flattened down.**
5. **Grasp the top of the server and tip the server up until it is resting on its base (FIGURE 4-1).**



Caution – Use extreme caution in the rest of this procedure to avoid touching the midplane. The pins on the midplane are very sensitive and could be damaged if handled improperly.

6. Carefully remove the plastic wrapping from the Netra ct server and, using the handle at the top of the server, lift it up and completely away from the box.
7. If there is a cover over the midplane, carefully remove the cover from the midplane.

▼ To Install the Servers in the Chassis



Caution – If any slots are left unfilled in the chassis, an energy hazard is present.



Caution – If you have a *rear-access* model server, you must verify that all the rear transition cards have been completely unseated before proceeding with these procedures. If you attempt to insert a server without unseating the rear transition cards, you will damage the connector pins on the midplane when you insert the server.

1. With your left hand, grasp the flat vertical purple handle to the left of the power supply unit.
2. With your right hand, grasp the purple server bar at the top of the server, and insert the server into the chassis using the flat vertical handle and the server bar.

FIGURE 4-2 shows how to insert a Netra ct 800 server into the chassis and FIGURE 4-3 shows how to insert a Netra ct 400 server into the chassis.

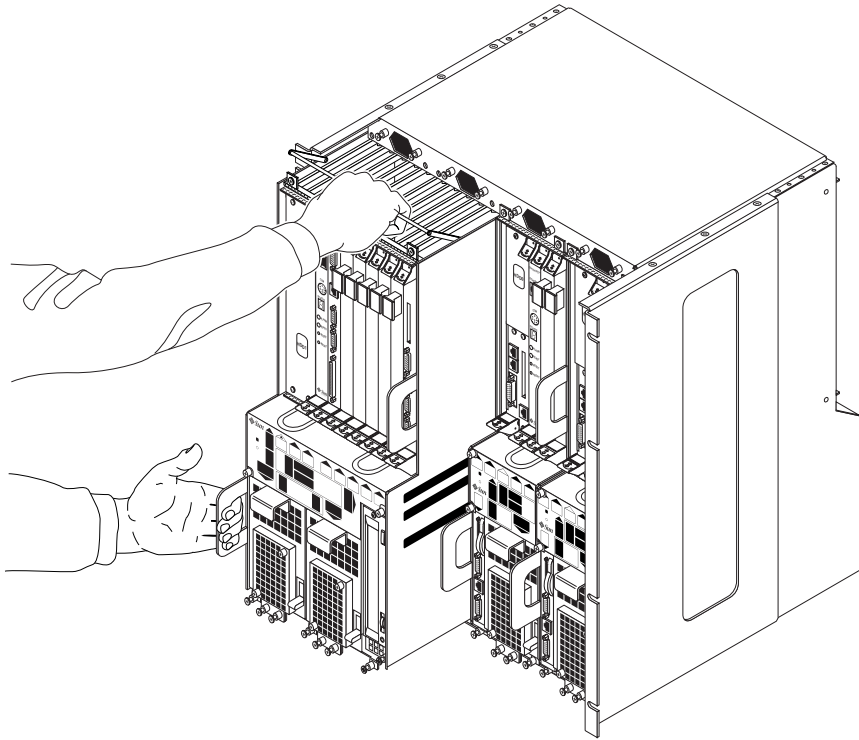

FIGURE 4-2 Installing a Netra ct 800 Server in the Chassis

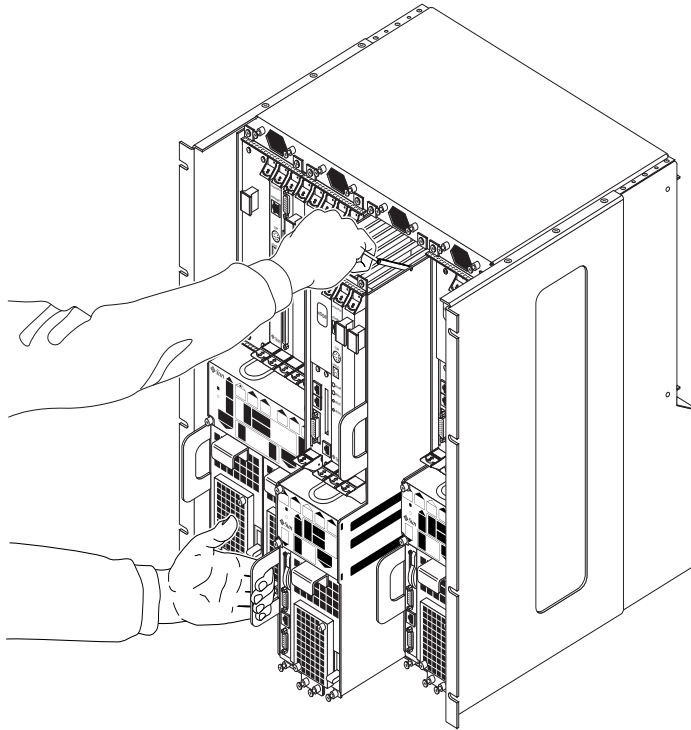

FIGURE 4-3 Installing a Netra ct 400 Server in the Chassis

- 3. Push the purple server bar at the top of the server down and gently push the server the remaining distance into the chassis.**
- 4. Using a No. 2 Phillips screwdriver, tighten the black captive screws at the top of the server.**

Tighten the screws on the server to a torque of 0.45 - 0.68 N.m (4 - 6 in.-lb).

- If you are installing a Netra ct 800 server, tighten the *four* black captives screws at the top of the server (FIGURE 4-4).
- If you are installing a Netra ct 400 server, tighten the *two* black captive screws at the top of the server (FIGURE 4-5).

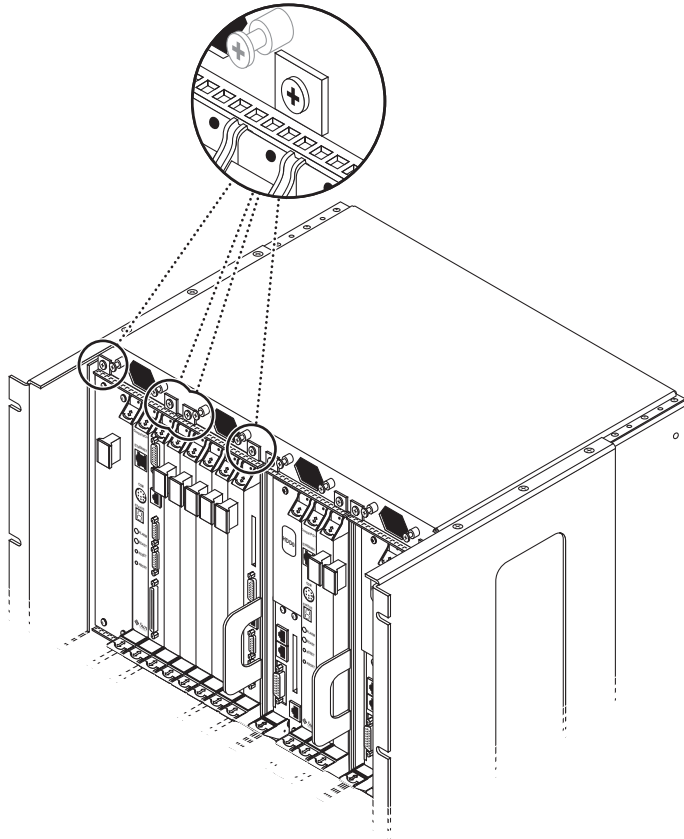

FIGURE 4-4 Tightening the Screws at the Top of a Netra ct 800 Server

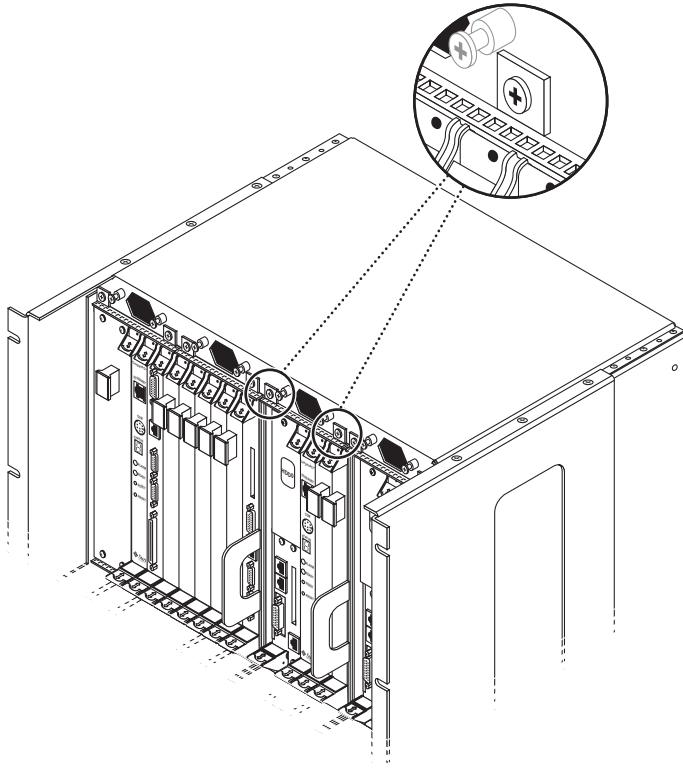

FIGURE 4-5 Tightening the Screws at the Top of a Netra ct 400 Server

5. Using a No. 2 Phillips screwdriver, tighten the black captive screws at the *bottom* of the server.

Tighten the screws on the server to a torque of 0.45 - 0.68 N.m (4 - 6 in.-lb).

- If you are installing a Netra ct 800 server, tighten the *three* black captive screws at the bottom of the server (FIGURE 4-6).
- If you are installing a Netra ct 400 server, tighten the *two* black captive screws at the bottom of the server (FIGURE 4-7).

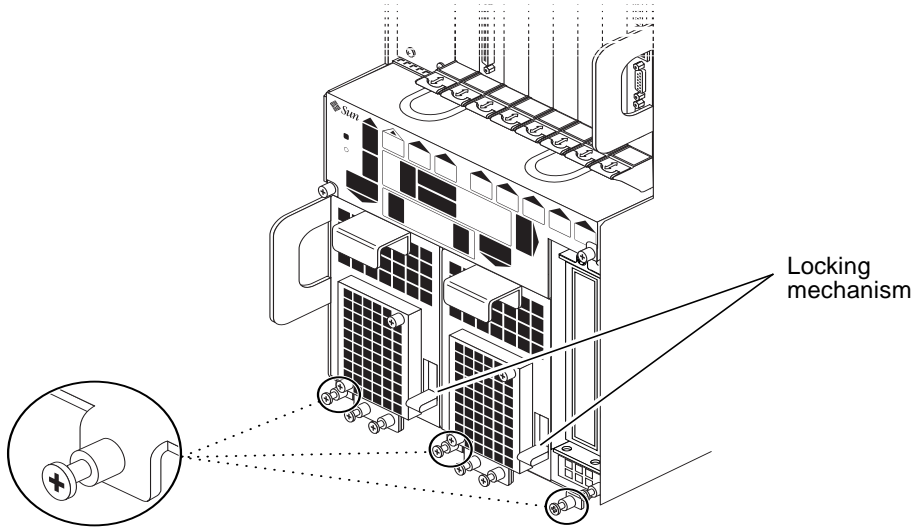

FIGURE 4-6 Tightening the Screws at the Bottom of a Netra ct 800 Server

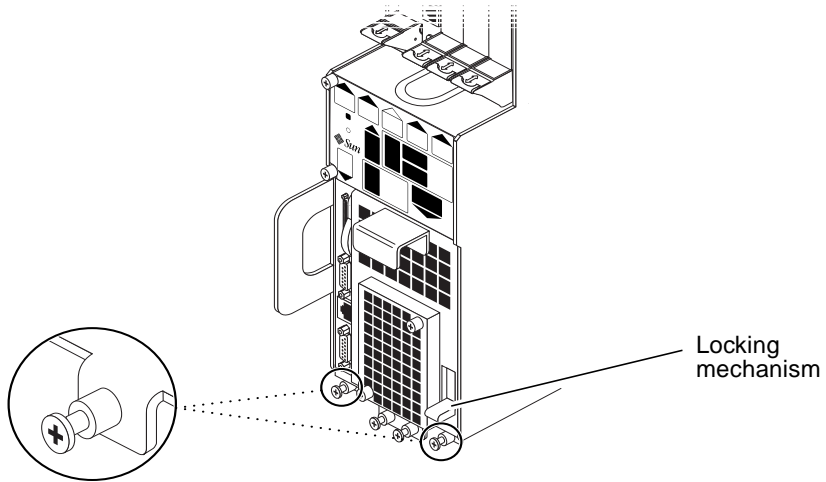

FIGURE 4-7 Tightening the Screws at the Bottom of a Netra ct 400 Server

- 6. Push the power supply unit locking mechanism(s) down into the locked () position.**

FIGURE 4-6 shows the location of the two power supply unit locking mechanisms on the Netra ct 800 server, and FIGURE 4-7 shows the location of the single power supply unit locking mechanism on the Netra ct 400 server. Make sure you lock *both* power supply units if you are replacing a Netra ct 800 server.

- 7. If you have a *rear-access* model server, reseal all the rear transition cards into the server that you just installed.**
- 8. Repeat Step 1 through Step 7 for every server that you need to install into the Netra ct chassis.**

Installing Additional Cards into the Netra ct Server

Note – The instructions in this chapter are for installing additional cards into a server as part of the overall installation process where the server is powered *off*. If you are installing additional cards into a server that is powered *on*, follow the instructions in the *Netra ct Server Service Manual*.

Every Netra ct server comes with the CPU card and, depending on whether you have the front-access model or the rear-access model, the CPU front transition card or CPU rear transition card, already installed. Every Netra ct server also comes with an alarm card, and, if you have a rear-access model server, an alarm rear transition card factory-installed.

If you have additional cards, such as any I/O cards, you will have to install those cards at your site using the instructions in this chapter. If you do not have any additional cards to install, go to Chapter 6.

Card slots designated for I/O cards and alarm cards have black rails; card slots with red rails are reserved for the CPU card. There are also labels at the front of the servers and the rear of the chassis that show the I/O slot numbers for front-access and rear-access models, as well as the cards that are supported in each slot. For front-access models, you can also determine the I/O slot numbers for your servers by using the I/O slot numbers shown on the system status panels.

Antistatic Precautions

Before you can install any additional cards into your system, you must first take the necessary antistatic precautions.

▼ To Attach the Antistatic Wrist Strap

1. Get the antistatic wrist strap from the ship kit.
2. Unwrap the first two folds of the wrist strap and wrap the adhesive side firmly against your wrist.
3. Peel the liner from the copper foil at the opposite end of the wrist strap and attach the copper end of the strap to a bare metal area on the Netra ct server or on the chassis.

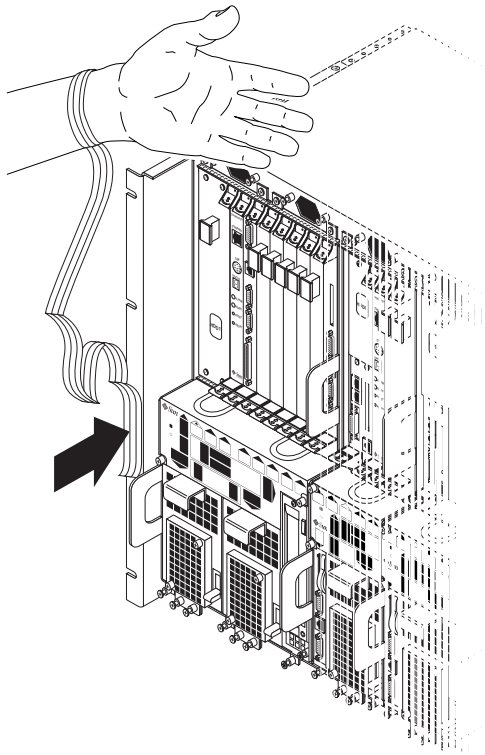

FIGURE 5-1 Attaching the Antistatic Wrist Strap

4. Place an electrostatic discharge mat close to the system.
5. Install the I/O card into your server.

The instructions for installing the additional cards into your Netra ct server will vary depending on the model that you have.

- If you have the *front-access* model, go to “Installing Additional I/O Cards in the Front-Access Model Server” on page 43.

- If you have the *rear-access* model, go to “Installing Additional I/O Cards in the Rear-Access Model Server” on page 49.

Installing Additional I/O Cards in the Front-Access Model Server



Caution – An energy hazard is present if any I/O slots are left uncovered. If you remove a card from an I/O slot, you must fill it with either a replacement card or a filler panel.

For the front-access models of both the Netra ct 800 server and the Netra ct 400 server, you install the CompactPCI cards and connect the cables at the front of the server. The back of the Netra ct server chassis is closed for front-access models.

FIGURE 5-2 shows the I/O card slots in a Netra ct 800 server.

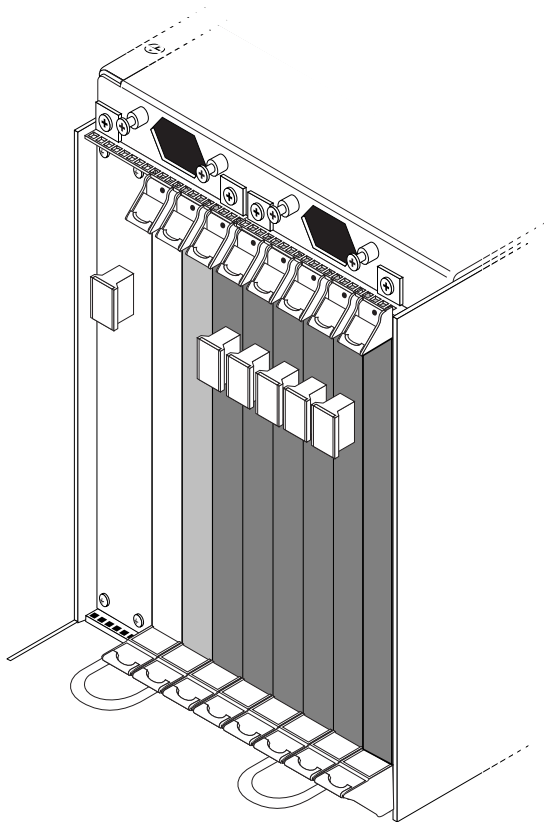

- Legend:
- CPU front transition or I/O card
 - I/O cards only
 - Alarm card only

FIGURE 5-2 I/O Card Slots (Netra ct 800 Server)

FIGURE 5-3 shows the buses on a Netra ct 800 server.

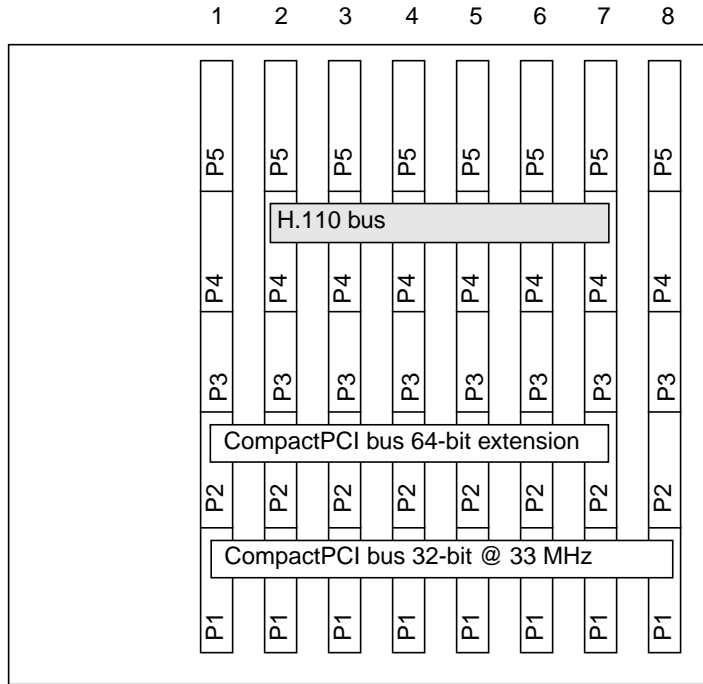
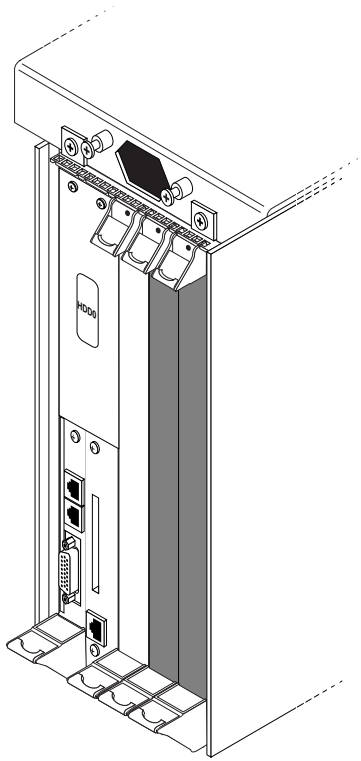

FIGURE 5-3 Buses for the Netra ct 800 Server Midplane (Front View)

FIGURE 5-4 shows the I/O card slots in a Netra ct 400 server.



Legend:  I/O cards only

FIGURE 5-4 I/O Card Slots (Netra ct 400 Server)

FIGURE 5-5 shows the buses on a Netra ct 400 server.

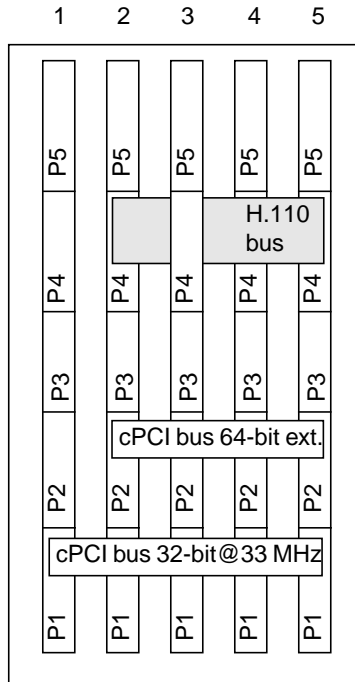

FIGURE 5-5 Buses for the Netra ct 400 Server (Front View)

▼ To Install Additional I/O Cards

1. Verify that you've taken the necessary antistatic precautions.

Refer to “To Attach the Antistatic Wrist Strap” on page 42 for those instructions.

2. Locate the I/O slot where you will be installing the I/O card.

- FIGURE 5-2 shows the I/O card slots in a Netra ct 800 server.
- FIGURE 5-4 shows the I/O card slots in a Netra ct 400 server.

3. Remove the slot filler panel, if necessary.

The slot filler panel is secured to the card cage using two screws, one at the top of the filler panel, the other at the bottom.

4. Get the I/O card from the ship kit.

5. Perform any card-specific hardware procedures, if necessary.

For example, you may want to install a PMC into the I/O card at this time, if necessary. Refer to the documentation that you received with your I/O card for more information.

6. Keeping the card vertical, slide the card into the slot between the two guides.

The teeth in the handle of the card must align with the square cutouts in the I/O slot. When the card is completely seated in the card cage, the two ejection levers should flip inward, and the teeth in the ejection levers should fit smoothly in the rectangular cutouts in the bottom and top plates.

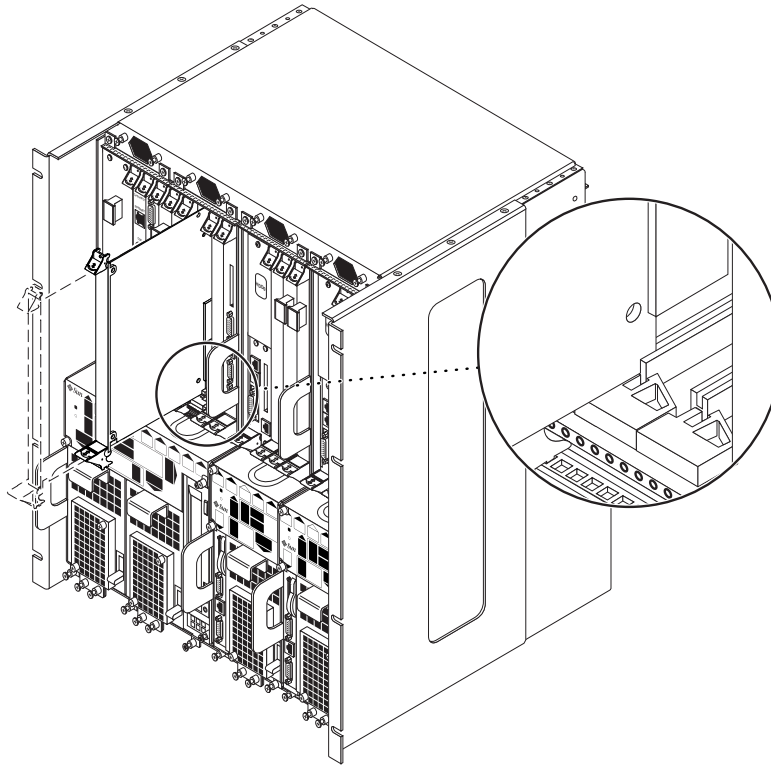

FIGURE 5-6 Aligning the Card With the Card Cage Cutouts

7. Lock the ejection levers.

The method you use to lock the ejection levers varies depending on the model of the ejection lever used on the card. Refer to the documentation that came with the I/O card for instructions on locking the ejection levers.

8. Using a No. 2 Phillips screwdriver, tighten the two captive screws inside the card's ejection levers, one on top and one on the bottom (FIGURE 5-7).

Tighten the screws to a torque of 0.28 N.m (2.5 in.-lb).

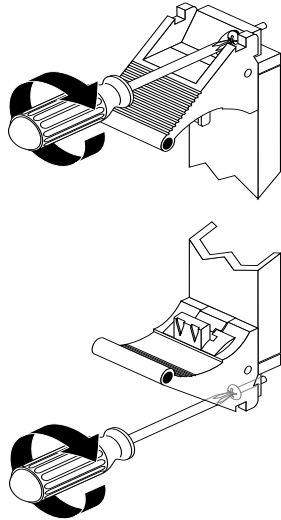

FIGURE 5-7 Tightening the Ejection Lever Captive Screws

Installing Additional I/O Cards in the Rear-Access Model Server



Caution – An energy hazard is present if any I/O slots are left uncovered. If you remove a card from an I/O slot, you must fill it with either a replacement card or a filler panel.

The I/O rear transition card for the Netra ct 800 server and the Netra ct 400 server consists of two separate cards:

- The front I/O card
- The I/O rear transition card

The front I/O card contains the ASICs for the associated I/O card and is installed from the front of the server; however, no cables connect to the front I/O card.

The I/O rear transition card brings the ports for a particular I/O card to the rear of the server. The I/O rear transition card and the front I/O card must be installed in the same slot in order for the I/O rear transition card to work. For example, if you installed an I/O rear transition card in I/O slot 3 at the rear of a Netra ct 800 server, you must also install the accompanying front I/O card in I/O slot 3 at the front of the Netra ct 800 server.

FIGURE 5-8 and FIGURE 5-9 give graphical representations of how the front I/O cards should line up with the I/O rear transition cards. Note that, facing the *front* of the server, the I/O slots read from *left-to-right*, whereas they read from *right-to-left* facing the *rear* of the server.

FIGURE 5-8 shows the buses on a Netra ct 800 server and FIGURE 5-9 shows the buses on a Netra ct 400 server.

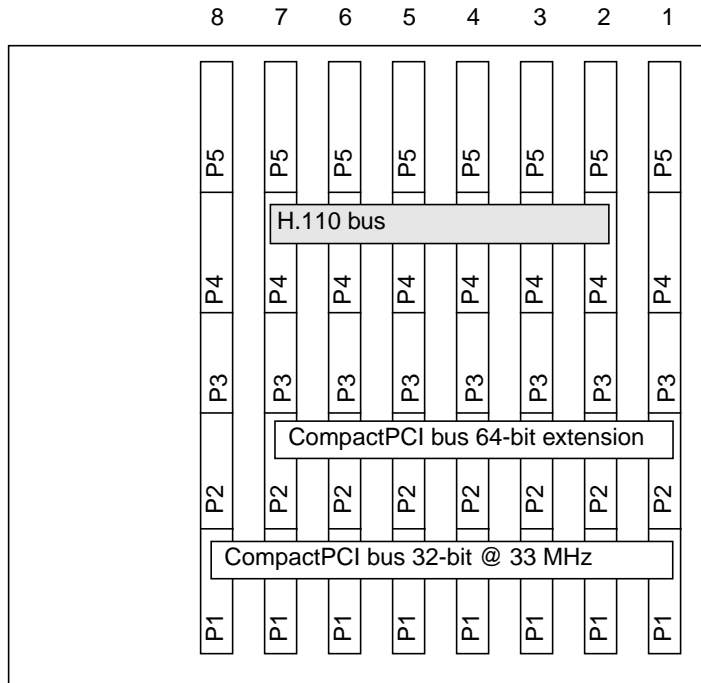

FIGURE 5-8 Buses for the Netra ct 800 Server (Rear View)

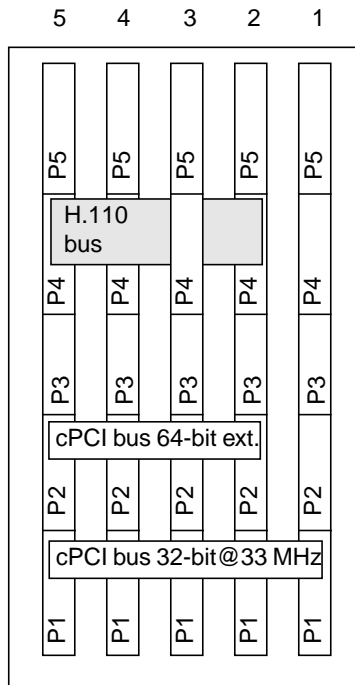

FIGURE 5-9 Buses for the Netra ct 400 Server (Rear View)

▼ To Install a Front I/O Card and I/O Rear Transition Card

1. Verify that you've taken the necessary antistatic precautions.

Refer to “To Attach the Antistatic Wrist Strap” on page 42 for those instructions.

2. Locate the I/O slot where you will be installing the front I/O and I/O rear transition cards.

- FIGURE 5-2 shows the I/O card slots in a Netra ct 800 server.
- FIGURE 5-4 shows the I/O card slots in a Netra ct 400 server.

3. Remove the slot filler panel, if necessary.

The slot filler panel is secured to the card cage using two screws, one at the top of the filler panel, the other at the bottom.

4. Get the I/O rear transition card from the ship kit.

5. Go to the back of the system and locate the I/O slot that you used for the front I/O card.

Make sure that you are installing the I/O rear transition card in the same I/O slot as the front I/O card before proceeding. The cards will not operate if you do not have them installed in the same I/O slot. There are labels under the I/O slots that give the I/O slot numbers for the Netra ct 800 server and Netra ct 400 server. Make a note of that I/O slot number.

6. Keeping the card vertical, slide the I/O rear transition card in between the two guides into the slot (FIGURE 5-10).

The teeth in the handle of the card must align with the square cutouts in the I/O slot. When the card is completely seated in the card cage, the two ejection levers should flip inward, and the teeth in the ejection levers should fit smoothly in the rectangular cutouts in the bottom and top plates.

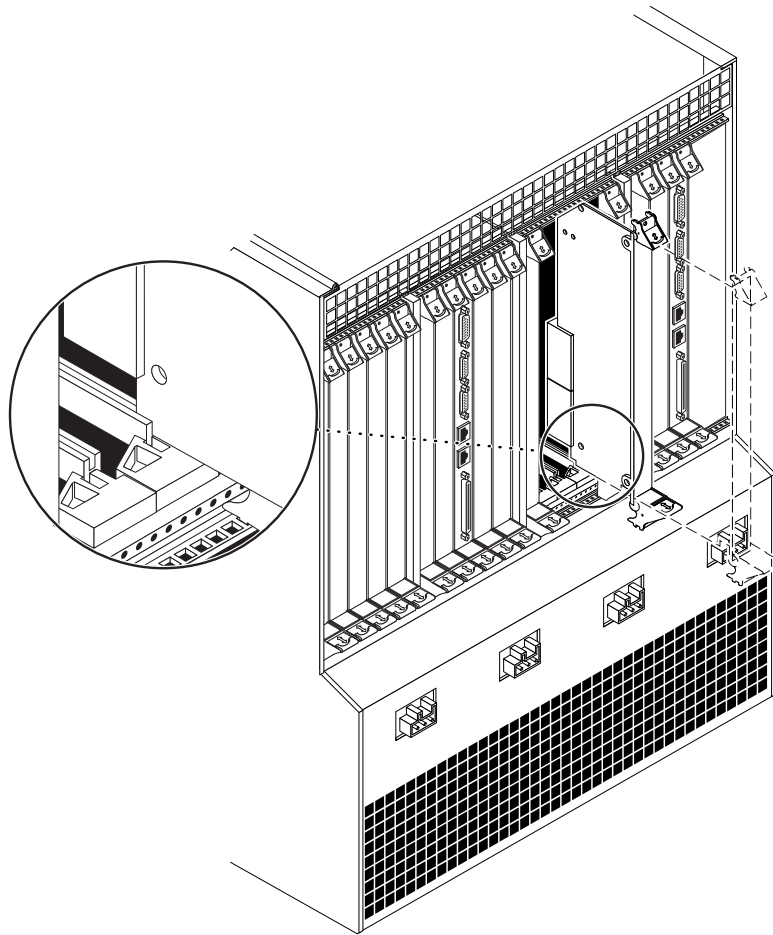

FIGURE 5-10 Aligning the Card With the Rear Card Cage Cutouts

7. Lock the ejection levers.

The method you use to lock the ejection levers varies depending on the model of the ejection lever used on the card. Refer to the documentation that came with the I/O card for instructions on locking the ejection levers.

8. Using a No. 2 Phillips screwdriver, tighten the two captive screws inside the card's ejection levers, one on top and one on the bottom (FIGURE 5-7).

Tighten the screws to a torque of 0.28 N.m (2.5 in.-lb).

9. Get the front I/O card from the ship kit.

- 10. Go to the front of the system and, keeping the card vertical, slide the front I/O card between the two guides into the slot (FIGURE 5-6).**

Make sure that you are installing the front I/O card in the same I/O slot as the I/O rear transition card before proceeding. The cards will not operate if you do not have them installed in the same I/O slot. There are labels under the I/O slots that give the I/O slot numbers for the Netra ct 800 server and Netra ct 400 server.

The teeth in the handle of the card must align with the square cutouts in the I/O slot. When the card is completely seated in the card cage, the two ejection levers should flip inward, and the teeth in the ejection levers should fit smoothly in the rectangular cutouts in the bottom and top plates.

- 11. Lock the ejection levers.**

The method you use to lock the ejection levers varies depending on the model of the ejection lever used on the card. Refer to the documentation that came with the I/O card for instructions on locking the ejection levers.

- 12. Using a No. 2 Phillips screwdriver, tighten the two captive screws inside the card's ejection levers, one on top and one on the bottom (FIGURE 5-7).**

Tighten the screws to a torque of 0.28 N.m (2.5 in.-lb).

Cabling the System

This chapter gives instructions for connecting cables to the CompactPCI cards. It also gives instructions for assembling and connecting the DC input power cable. It is divided into the following sections:

- “Installing the Cable Management Brackets” on page 55
- “Connecting Cables to the CompactPCI Cards” on page 57
- “Assembling and Connecting the DC Input Power Cable” on page 103

Installing the Cable Management Brackets

The purple cable management brackets for the chassis are located in the Netra ct server ship kit. The cable management brackets are used to keep the various cables connected to the rear of the chassis bundled together. The Netra ct server comes with four cable management brackets.

FIGURE 6-1 shows where the brackets should be installed for the front-access and rear-access models.

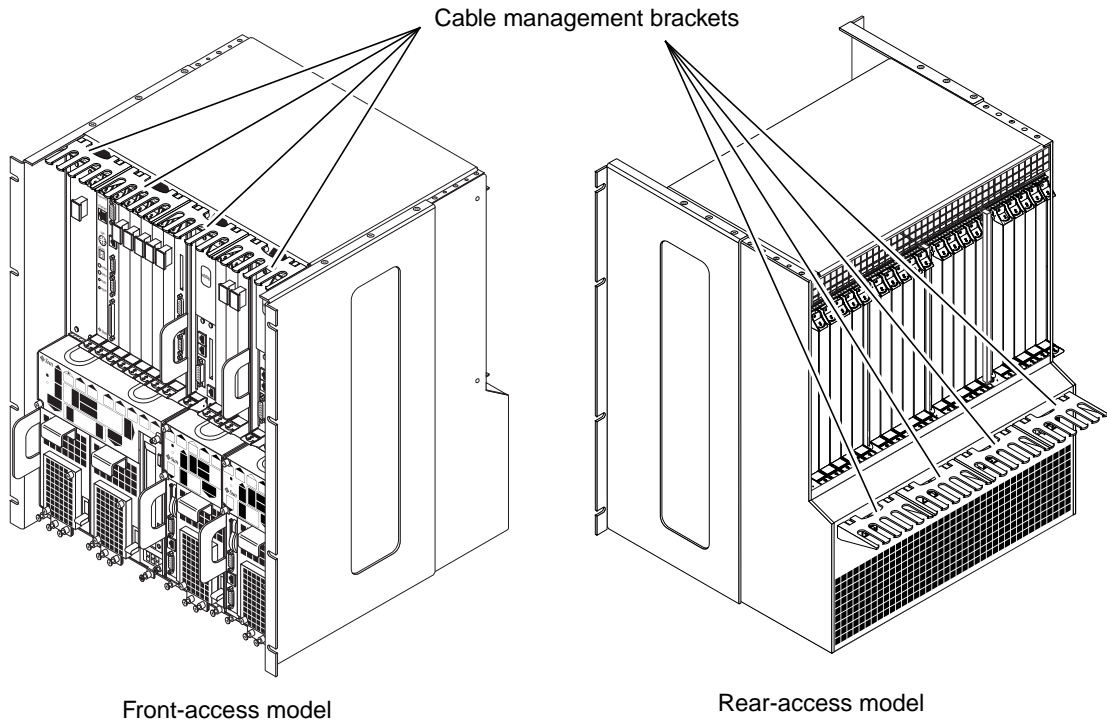

FIGURE 6-1 Cable Management Brackets

- 1. Align the notches at on the sides of the bracket to the chassis holes.**

FIGURE 6-1 shows where the brackets should be installed at the rear of the chassis.

- 2. Push the bracket straight into the chassis holes until it engages with the chassis.**
If necessary, push down slightly on the top notches to get them to engage with the holes in the chassis.
- 3. Repeat Step 1 and Step 2 until all four cable management brackets are installed.**

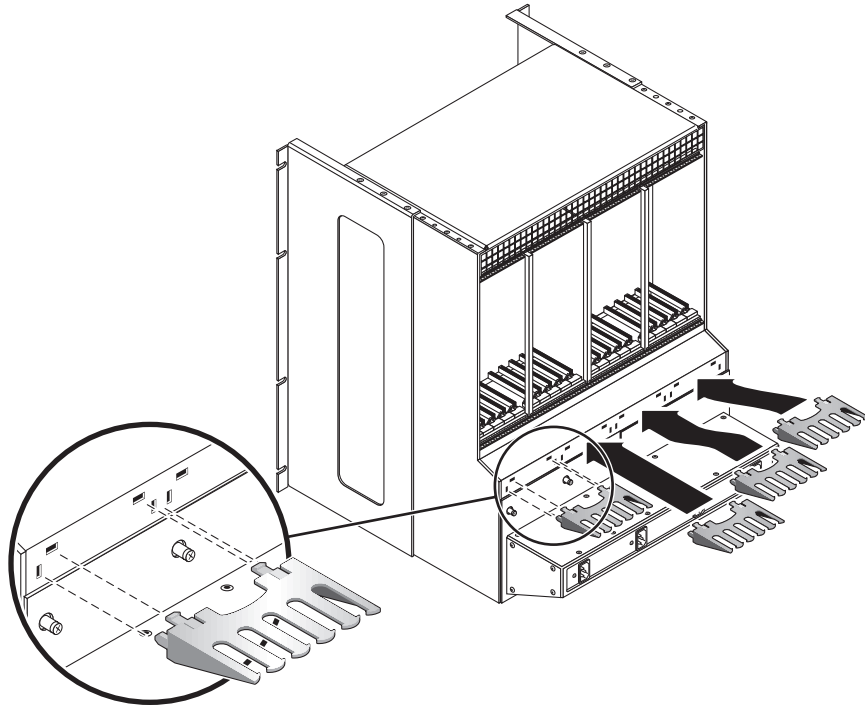

FIGURE 6-2 Installing the Cable Management Brackets

Connecting Cables to the CompactPCI Cards

The instructions for cabling your Netra ct server vary depending on the model that you have.

- If you have the *front-access* model, go to “Cabling for the Front-Access Model” on page 58.
- If you have the *rear-access* model, go to “Cabling for the Rear-Access Model” on page 87.

Cabling for the Front-Access Model

The cabling connections that you must make differ depending on the cards that you have installed in your server:

- “To Connect Cables to the CPU Card” on page 58
- “To Connect Cables to the CPU Front Transition Card” on page 62
- “To Connect Cables to the Alarm Card (Front-Access Models Only)” on page 77
- “To Connect Cables to the CompactPCI Front-Access I/O Cards” on page 87

▼ To Connect Cables to the CPU Card

1. Locate the CPU card.

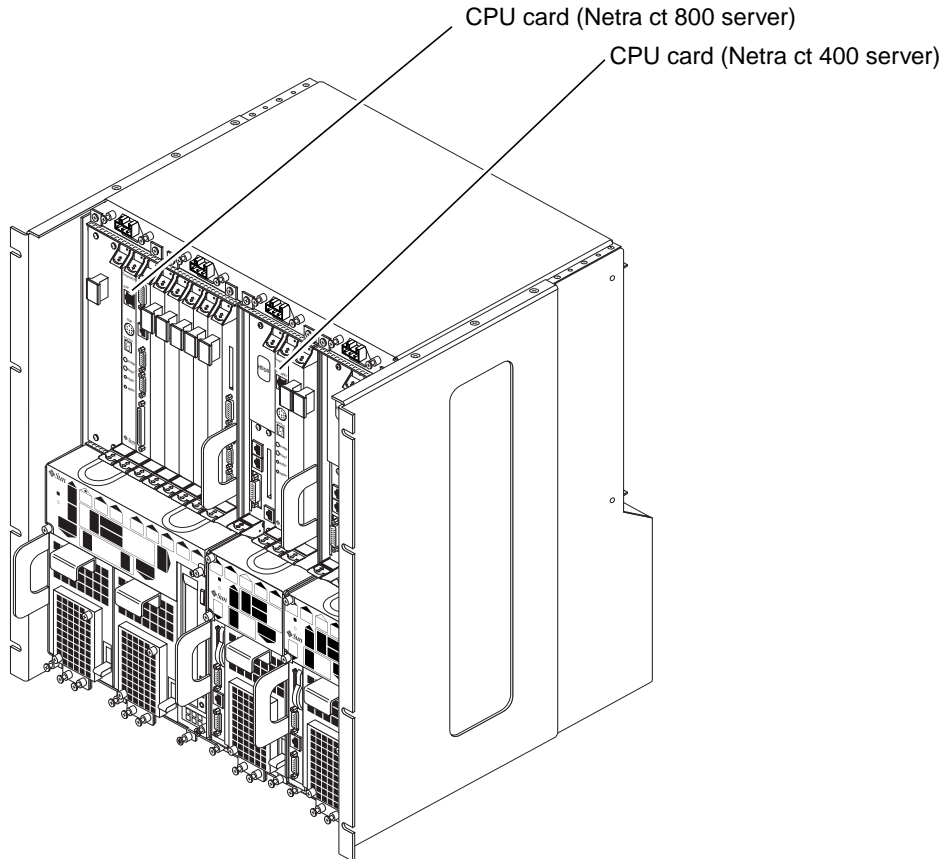

FIGURE 6-3 CPU Card Locations

2. Make the necessary cable connections to the CPU card.

Tighten the screws on the cable to a torque of 0.23 N.m (2 in.-lb).

There are two ports on the CPU card: the COM (TTY A) port and the Ethernet A port. However, depending on the model and type of server you have, you may have to use the TTY A and Ethernet A ports on the CPU front or rear transition cards instead. See TABLE 6-1 and TABLE 6-2 for information for your server model.

TABLE 6-1 COM (TTY A) Port

Server Model	Front-Access	Rear-Access
Netra ct 800 server	Use the TTY A port on the CPU front transition card. See “To Connect Cables to the CPU Front Transition Card” on page 62.	Use the TTY A port on the CPU rear transition card. See “To Connect Cables to the CPU Rear Transition Card” on page 87.
Netra ct 400 server	Use the COM port on the CPU card. See “TTY A/COM Port” on page 62.	Use the TTY A port on the CPU rear transition card. See “To Connect Cables to the CPU Rear Transition Card” on page 87.

TABLE 6-2 Ethernet A Port

Server Model	Front-Access	Rear-Access
Netra ct 800 server	Use the Ethernet A port on the CPU. See “Ethernet Port” on page 61.	Use the Ethernet A port on the CPU rear transition card. See “To Connect Cables to the CPU Rear Transition Card” on page 87.
Netra ct 400 server	Use the Ethernet A port on the CPU. See “Ethernet Port” on page 61.	Use the Ethernet A port on the CPU rear transition card. See “To Connect Cables to the CPU Rear Transition Card” on page 87.

FIGURE 6-4 shows the connectors on the CPU card for the Netra ct 800 server and Netra ct 400 server.

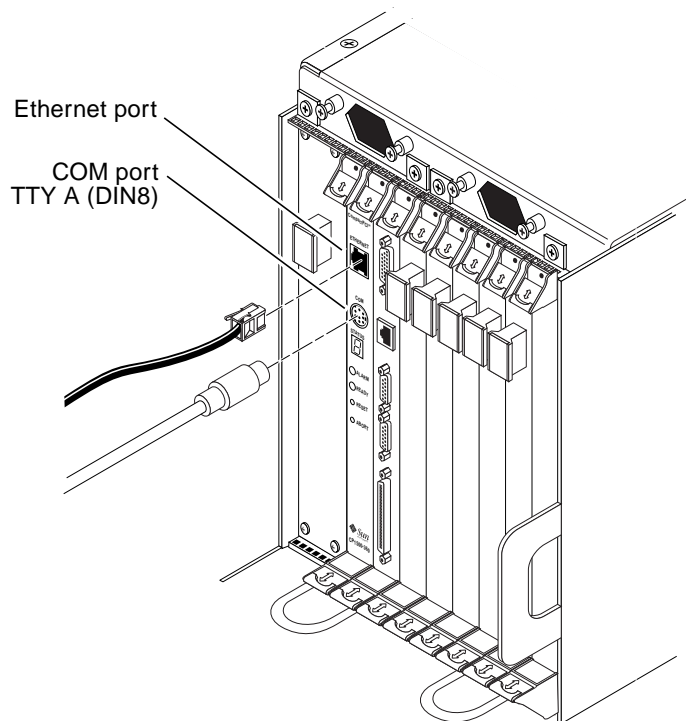

FIGURE 6-4 Connectors on the CPU Card

The following sections give the pinouts for each connector on the CPU card:

- “Ethernet Port” on page 61
- “TTY A/COM Port” on page 62

Ethernet Port

The twisted pair Ethernet connector is an R-J45 connector. The controller auto-negotiates to either 10BASE-T or 100 BASE-T.

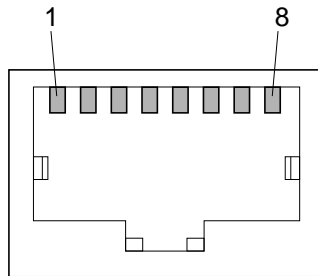

FIGURE 6-5 RJ-45 Ethernet Connector Diagram

TABLE 6-3 Ethernet Connector Pinouts, CPU Card (J2301)

Pin No.	Description
1	TXD+
2	TXD-
3	RXD+
4	Not used
5	Not used
6	RXD-
7	Not used
8	Not used

TTY A/COM Port

This port is connected logically to serial port A. It is intended to be used only for serial output to a terminal.



Caution – Serial port A is also connected through the rear cPCI connectors. No mechanism is provided to disable simultaneous input from the front panel and the rear cPCI connectors. Attempts to input data from both ports will place the board in an unknown state.

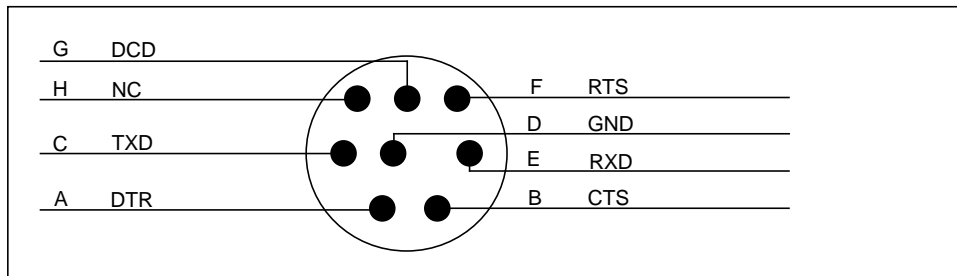

FIGURE 6-6 CPU Card Front Panel TTYA Diagram

▼ To Connect Cables to the CPU Front Transition Card

1. Locate the CPU front transition card.

FIGURE 6-7 shows the location of the CPU front transition card in a Netra ct 800 server and FIGURE 6-8 shows the location of the CPU front transition card in a Netra ct 400 server.

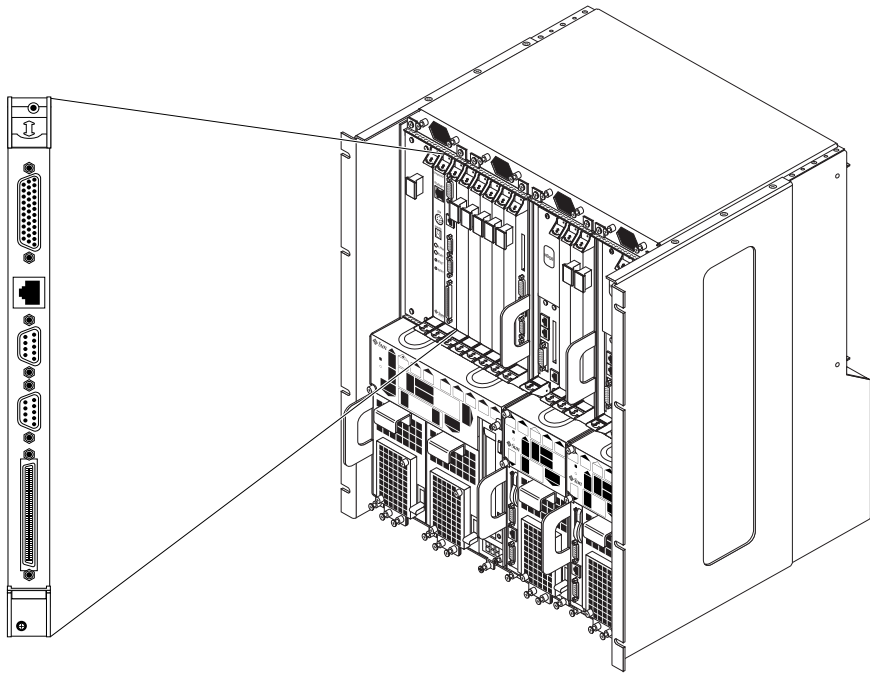

FIGURE 6-7 CPU Front Transition Card Location in a Netra ct 800 Server

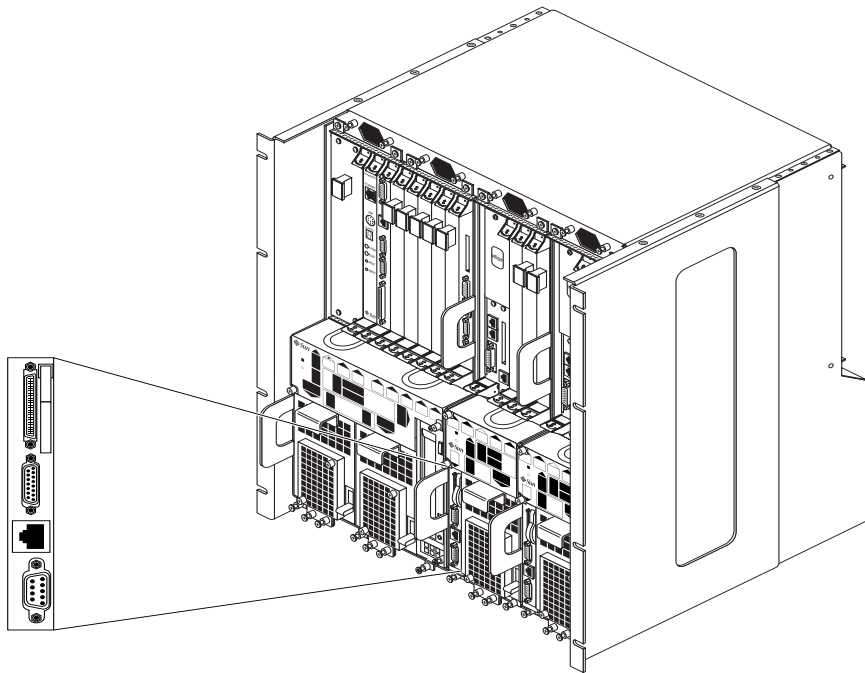

FIGURE 6-8 CPU Front Transition Card Location in a Netra ct 400 Server

2. Make the necessary cable connections to the CPU front transition card.

Tighten the screws on the cable to a torque of 0.23 N.m (2 in.-lb).

FIGURE 6-9 shows the connectors on the CPU front transition card for the Netra ct 800 server, and FIGURE 6-10 shows the connectors on the CPU front transition card for the Netra ct 400 server.

Note – If you are cabling a front-access model of the Netra ct 400 server, use the COM port on the CPU card as the TTY A port. Refer to Step 2 on page 59 for more information.

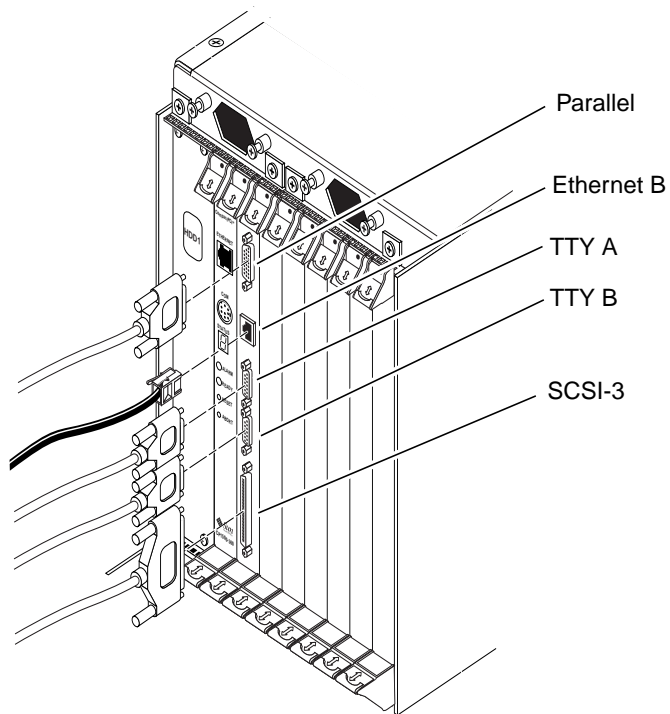

FIGURE 6-9 Connectors on the CPU Front Transition Card (Netra ct 800 Server)

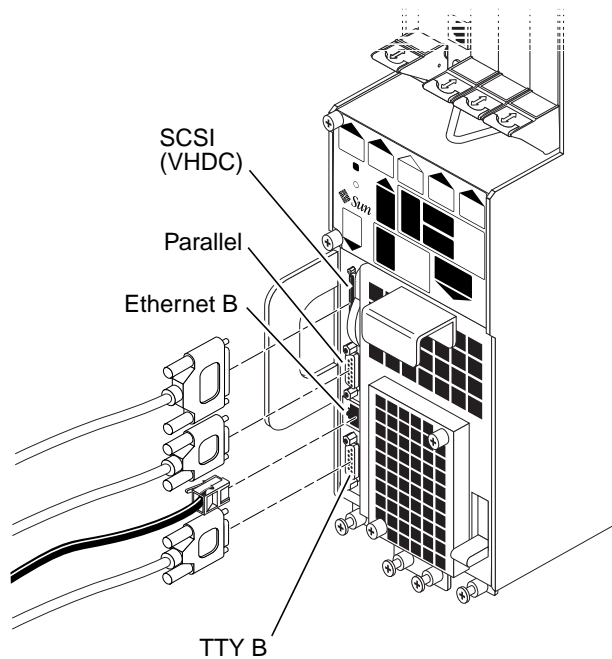

FIGURE 6-10 Connectors on the CPU Front Transition Card (Netra ct 400 Server)

Refer to the following sections for connector pinouts for the CPU front transition card for the appropriate Netra ct server:

- “CPU Front Transition Card Connector Pinouts, Netra ct 800 Server” on page 66
- “CPU Front Transition Card Connector Pinouts, Netra ct 400 Server” on page 72

CPU Front Transition Card Connector Pinouts, Netra ct 800 Server

The following sections give the pinouts for each connector on the CPU front transition card for the Netra ct 800 server:

- “Parallel Port” on page 67
- “Ethernet B Port” on page 68
- “TTY B” on page 69
- “TTY A” on page 70
- “SCSI-3” on page 71

Parallel Port

The parallel port on the CPU front transition card (FTC) for the Netra ct 800 server is a DB-25 female receptacle.

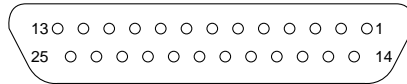

FIGURE 6-11 Parallel Connector

TABLE 6-4 Parallel Port Pinouts, CPU FTC for the Netra ct 800 Server

Pin No.	Signal	Pin No.	Signal
1	STB	14	AFD
2	PD0	15	ERR
3	PD1	16	INIT
4	PD2	17	SLIN
5	PD3	18	DGND
6	PD4	19	DGND
7	PD5	20	DGND
8	PD6	21	DGND
9	PD7	22	DGND
10	ACK	23	DGND
11	BUSY	24	DGND
12	PE	25	DGND
13	SLCT	26	DGND

Ethernet B Port

The Ethernet B port on the CPU FTC for the Netra ct 800 server is an RJ-45 connector for 10/100.

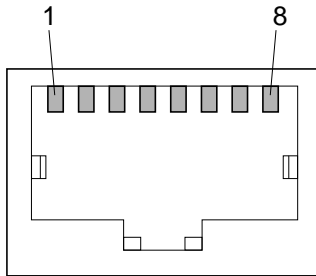

FIGURE 6-12 RJ-45 Ethernet Connector Diagram

TABLE 6-5 Ethernet B Connector Pinouts, CPU FTC for the Netra ct 800 Server

Pin No.	Description
1	TXD+
2	TXD-
3	RXD+
4	Not used
5	Not used
6	RXD-
7	Not used
8	Not used

TTY B

The TTY B port on the CPU FTC for the Netra ct 800 server is a DB-9 male connector.

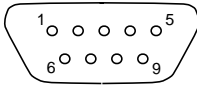

FIGURE 6-13 TTY B Connector

TABLE 6-6 TTY B Port Pinouts, CPU FTC for the Netra ct 800 Server

Pin No.	Signal Name
1	DCD
2	RXD
3	TXD
4	DTR
5	GND
6	DSR
7	RTS
8	CTS
9	RI

TTY A

The TTY A port on the CPU FTC for the Netra ct 800 server is a DB-9 male connector.

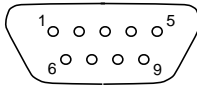

FIGURE 6-14 TTY A Connector

TABLE 6-7 TTY A Port Pinouts, CPU FTC for Netra ct 800 Server

Pin No.	Signal Name
1	DCD
2	RXD
3	TXD
4	DTR
5	GND
6	DSR
7	RTS
8	CTS
9	RI

SCSI-3

The SCSI port on the CPU FTC for the Netra ct 800 server is a 68-pin SCSI-3 AMPLIMITE connector.

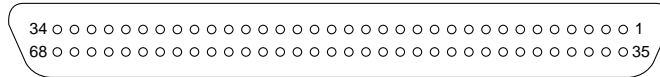

FIGURE 6-15 SCSI-3 AMPLIMITE Connector

TABLE 6-8 SCSI Port Pinouts, CPU FTC for Netra ct 800 Server

Pin No.	Signal	Pin No.	Signal
1	GND	35	DATA 12
2	PRES_L	36	DATA 13
3	GND	37	DATA 14
4	GND	38	DATA 15
5	GND	39	PH_L
6	GND	40	DATA 0
7	GND	41	DATA 1
8	GND	42	DATA 2
9	GND	43	DATA 3
10	GND	44	DATA 4
11	GND	45	DATA 5
12	GND	46	DATA 6
13	GND	47	DATA 7
14	GND	48	PL_L
15	GND	49	PRES_L
16	GND	50	GND
17	TERM PWR	51	TERM PWR
18	TERM PWR	52	TERM PWR
19	GND	53	GND
20	GND	54	GND

TABLE 6-8 SCSI Port Pinouts, CPU FTC for Netra ct 800 Server *(Continued)*

Pin No.	Signal	Pin No.	Signal
21	GND	55	ATN_L
22	GND	56	GND
23	GND	57	BSY_L
24	GND	58	ACK_L
25	GND	59	RST_L
26	GND	60	MSG_L
27	GND	61	DEL_L
28	GND	62	CD_L
29	GND	63	REQ_L
30	GND	64	IO_L
31	GND	65	DATA 8
32	GND	66	DATA 9
33	GND	67	DATA 10
34	GND	68	DATA 11

CPU Front Transition Card Connector Pinouts, Netra ct 400 Server

The following sections give the pinouts for each connector on the CPU front transition card for the Netra ct 400 server:

- “SCSI (VHDC)” on page 73
- “Parallel Port” on page 74
- “Ethernet B Port” on page 75
- “TTY B” on page 76

SCSI (VHDC)

The SCSI port on the CPU FTC for the Netra ct 400 server is a 68-pin CHAMP very high-density connector (VHDC). Note that a VHDC-to-SCSI 3 cable is included with the Netra ct server (part number 530-2454-01).

TABLE 6-9 SCSI Port Pinouts, CPU FTC for the Netra ct 400 Server

Pin No.	Signal	Pin No.	Signal	Pin No.	Signal
1	GND	24	GND	47	DATA 7
2	PRES_L	25	GND	48	PL_L
3	GND	26	GND	49	PRES_L
4	GND	27	GND	50	GND
5	GND	28	GND	51	TERM PWR
6	GND	29	GND	52	TERM PWR
7	GND	30	GND	53	GND
8	GND	31	GND	54	GND
9	GND	32	GND	55	ATN_L
10	GND	33	GND	56	GND
11	GND	34	GND	57	BSY_L
12	GND	35	DATA 12	58	ACK_L
13	GND	36	DATA 13	59	RST_L
14	GND	37	DATA 14	60	MSG_L
15	GND	38	DATA 15	61	DEL_L
16	GND	39	PH_L	62	CD_L
17	TERM PWR	40	DATA 0	63	REQ_L
18	TERM PWR	41	DATA 1	64	IO_L
19	GND	42	DATA 2	65	DATA 8
20	GND	43	DATA 3	66	DATA 9
21	GND	44	DATA 4	67	DATA 10
22	GND	45	DATA 5	68	DATA 11
23	GND	46	DATA 6		

Parallel Port

The parallel port on the CPU FTC for the Netra ct 400 server is an AMPLIMITE SLIMLINE female receptacle.

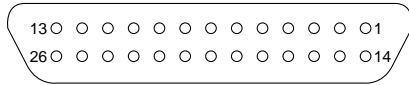

FIGURE 6-16 Parallel Connector

TABLE 6-10 Parallel Port Pinouts, CPU FTC for the Netra ct 400 Server

Pin No.	Signal	Pin No.	Signal
1	STB	14	AFD
2	PD0	15	ERR
3	PD1	16	INIT
4	PD2	17	SLIN
5	PD3	18	DGND
6	PD4	19	DGND
7	PD5	20	DGND
8	PD6	21	DGND
9	PD7	22	DGND
10	ACK	23	DGND
11	BUSY	24	DGND
12	PE	25	DGND
13	SLCT	26	DGND

Ethernet B Port

The Ethernet B port on the CPU FTC for the Netra ct 400 server is an RJ-45 connector for 10/100.

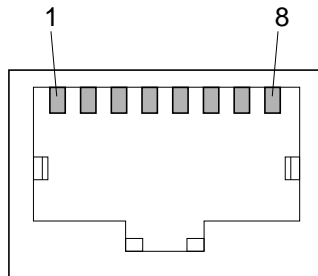

FIGURE 6-17 RJ-45 Ethernet Connector Diagram

TABLE 6-11 Ethernet B Connector Pinouts, CPU FTC for the Netra ct 400 Server

Pin No.	Description
1	TXD+
2	TXD-
3	RXD+
4	Not used
5	Not used
6	RXD-
7	Not used
8	Not used

TTY B

The TTY B port on the CPU FTC for the Netra ct 400 server is a DB-9 male connector.

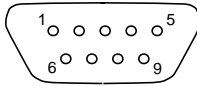

FIGURE 6-18 TTY B Connector

TABLE 6-12 TTY B Port Pinouts, CPU FTC for the Netra ct 400 Server

Pin No.	Signal Name
1	DCD
2	RXD
3	TXD
4	DTR
5	GND
6	DSR
7	RTS
8	CTS
9	RI

▼ To Connect Cables to the Alarm Card (Front-Access Models Only)

Note – If you have a rear-access model server, do *not* connect any cables to the alarm card; all cables should be connected to the alarm rear transition card for a rear-access model server. Go to “To Connect Cables to the Alarm Rear Transition Card (Rear-Access Models Only)” on page 97 for those instructions.

1. Locate the alarm card for the front-access model server.

FIGURE 6-19 shows the location of the alarm card in the front-access model Netra ct 800 server and FIGURE 6-20 shows the location of the alarm card in the front-access model Netra ct 400 server.

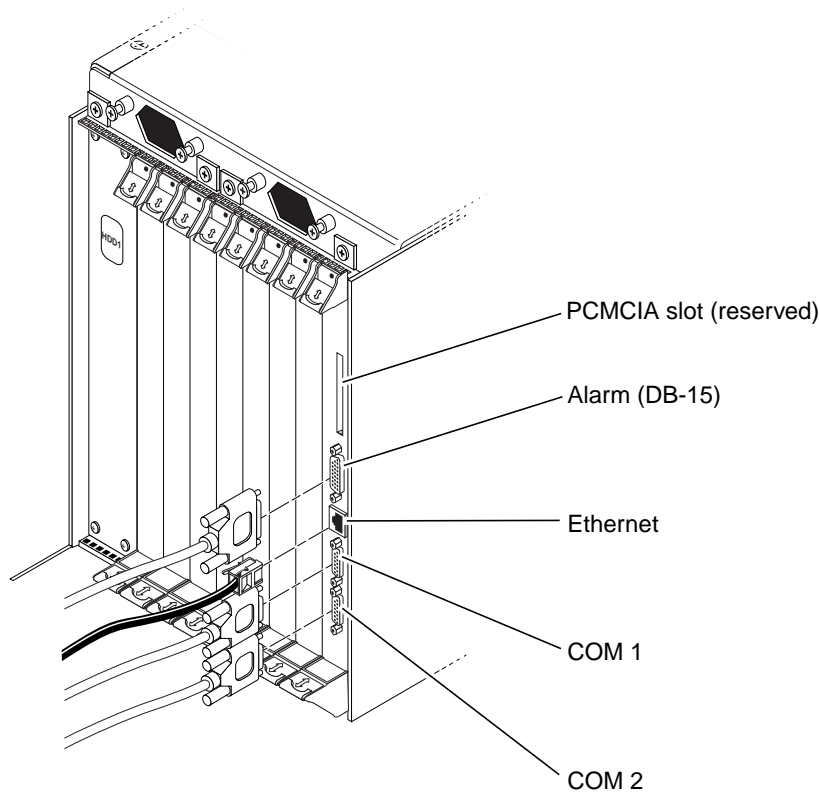

FIGURE 6-19 Connectors on the Alarm Card (Front-Access Model Netra ct 800 Server)

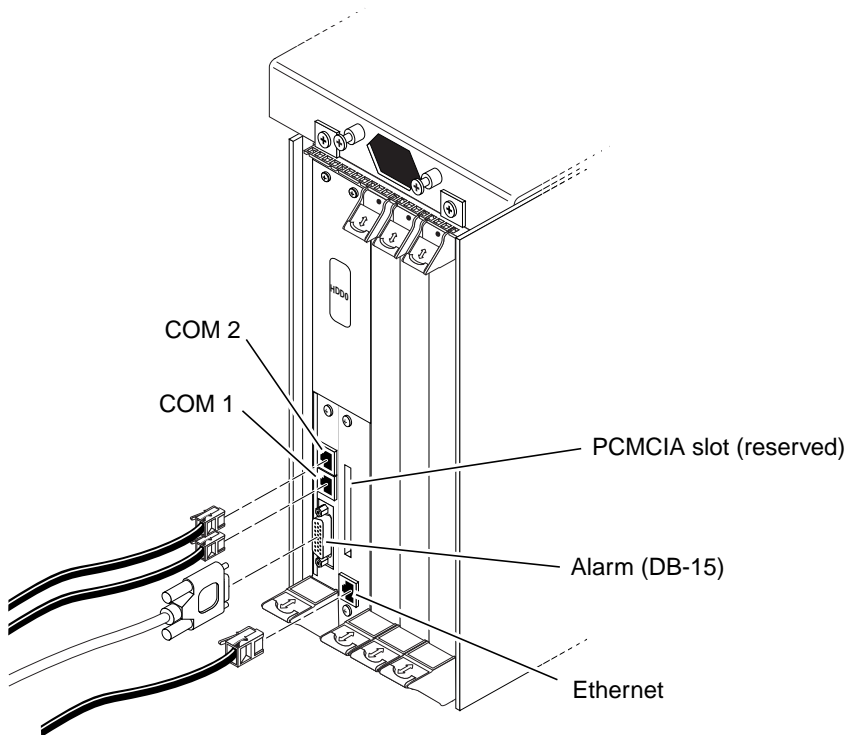

FIGURE 6-20 Connectors on the Alarm Card (Front-Access Model Netra ct 400 Server)

2. Make the necessary cable connections to the alarm card.

Tighten the screws on the cable to a torque of 0.23 N.m (2 in.-lb).

FIGURE 6-19 shows the connectors on the alarm card for the Netra ct 800 server, and FIGURE 6-20 shows the connectors on the alarm card for the Netra ct 400 server.

Refer to the following sections for connector pinouts for the alarm card for the appropriate Netra ct server:

- “Alarm Card Connector Pinouts, Front-Access Model Netra ct 800 Server” on page 79
- “Alarm Card Connector Pinouts, Front-Access Model Netra ct 400 Server” on page 82

Alarm Card Connector Pinouts, Front-Access Model Netra ct 800 Server

The following sections give the pinouts for the connectors on the alarm card for the Netra ct 800 server:

- “Alarm Port” on page 79
- “Ethernet Port” on page 80
- “COM 1” on page 81
- “COM 2” on page 82

Alarm Port

I/O connections are available through the male DB-15 alarm port.

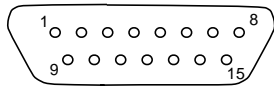

FIGURE 6-21 Alarm Port

TABLE 6-13 Alarm Port Pinouts, Alarm Card for the Netra ct 800 Server

Pin No.	Signal	Pin No.	Signal	Pin No.	Signal
1	RESET0 +	6	ALARM0_NC	11	ALARM2_NO
2	RESET0 -	7	ALARM0_COM	12	ALARM2_NC
3	RESET1 +	8	ALARM1_NO	13	ALARM2_COM
4	RESET1 -	9	ALARM1_NC	14	ALARM3_NO
5	ALARM0_NO	10	ALARM1_COM	15	ALARM3_COM

Ethernet Port

The Ethernet port on the alarm card for the Netra ct 800 server is an RJ-45 connector for 10BASE-T.

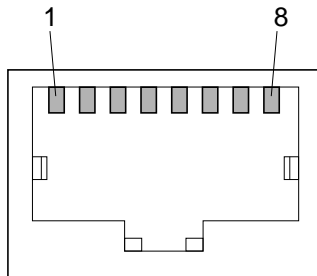

FIGURE 6-22 RJ-45 Ethernet Connector Diagram

TABLE 6-14 Ethernet Connector Pinouts, Alarm Card for the Netra ct 800 Server

Pin No.	Description	Pin No.	Description
1	TXD+	5	Not used
2	TXD-	6	RXD-
3	RXD+	7	Not used
4	Not used	8	Not used

COM 1

The COM 1 port on the alarm card for the Netra ct 800 server is a DB-9 male connector.

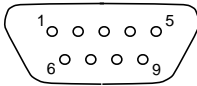

FIGURE 6-23 COM 1 Connector

TABLE 6-15 COM 1 Connector Pinouts, Alarm Card for the Netra ct 800 Server

Pin No.	Description
1	NC
2	RXD
3	TXD
4	NC
5	Isolated GND 1
6	NC
7	RTS
8	CTS
9	NC

COM 2

The COM 2 port on the alarm card for the Netra ct 800 server is a DB-9 male connector.

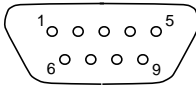

FIGURE 6-24 COM 2 Connector

TABLE 6-16 COM 2 Connector Pinouts, Alarm Card for the Netra ct 800 Server

Pin No.	Description
1	DCD
2	RXD
3	TXD
4	DTR
5	Isolated GND 2
6	DSR
7	RTS
8	CTS
9	NC

Alarm Card Connector Pinouts, Front-Access Model Netra ct 400 Server

The following sections give the pinouts for the connectors on the alarm card for the Netra ct 400 server:

- “COM 2” on page 83
- “COM 1” on page 84
- “Alarm Port” on page 85
- “Ethernet Port” on page 86

COM 2

The COM 2 port on the alarm card for the Netra ct 400 server is an RJ-45 connector.

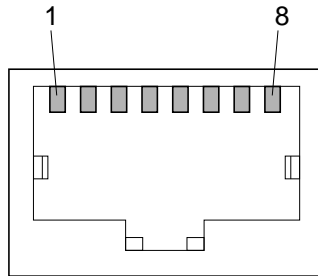

FIGURE 6-25 RJ-45 Ethernet Connector Diagram

TABLE 6-17 COM 2 Connector Pinouts, Alarm Card for the Netra ct 800 Server

Pin No.	Description
1	RTS
2	DTR
3	TXD
4	Isolated GND 2
5	Isolated GND 2
6	RXD
7	DSR
8	CTS

COM 1

The COM 1 port on the alarm card for the Netra ct 400 server is an RJ-45 connector.

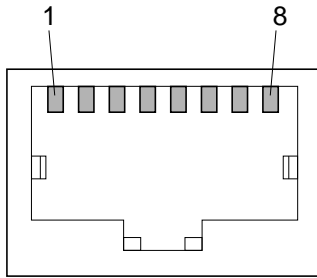

FIGURE 6-26 RJ-45 Ethernet Connector Diagram

TABLE 6-18 COM 1 Connector Pinouts, Alarm Card for the Netra ct 800 Server

Pin No.	Description
1	RTS
2	NC
3	TXD
4	Isolated GND 1
5	Isolated GND 1
6	RXD
7	NC
8	CTS

Alarm Port

I/O connections are available through the male DB-15 alarm port.

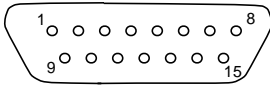

FIGURE 6-27 Alarm Port

TABLE 6-19 Alarm Port Pinouts, Alarm Card for the Netra ct 400 Server

Pin No.	Signal
1	RESET0 +
2	RESET0 -
3	RESET1 +
4	RESET1 -
5	ALARM0_NO
6	ALARM0_NC
7	ALARM0_COM
8	ALARM1_NO
9	ALARM1_NC
10	ALARM1_COM
11	ALARM2_NO
12	ALARM2_NC
13	ALARM2_COM
14	ALARM3_NO
15	ALARM3_COM

Ethernet Port

The Ethernet port on the alarm card for the Netra ct 400 server is an RJ-45 connector for 10BASE-T.

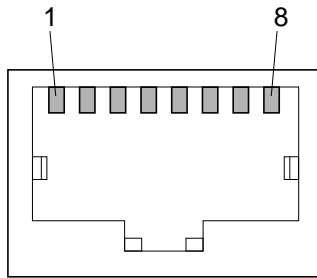

FIGURE 6-28 RJ-45 Ethernet Connector Diagram

TABLE 6-20 Ethernet Connector Pinouts, Alarm Card for the Netra ct 400 Server

Pin No.	Description
1	TXD+
2	TXD-
3	RXD+
4	Not used
5	Not used
6	RXD-
7	Not used
8	Not used

▼ To Connect Cables to the CompactPCI Front-Access I/O Cards

1. Locate the I/O card.

FIGURE 5-2 on page 44 shows the possible locations for the I/O cards in the Netra ct 800 server and FIGURE 5-4 on page 46 shows the possible locations for the I/O cards in the Netra ct 400 server.

2. Make the necessary cable connections to the CompactPCI I/O cards.

Tighten the screws on the cable to a torque of 0.23 N.m (2 in.-lb).

Refer to the documentation that you received with the CompactPCI I/O cards for more information.

Cabling for the Rear-Access Model

- “To Connect Cables to the CPU Rear Transition Card” on page 87
- “To Connect Cables to the Alarm Rear Transition Card (Rear-Access Models Only)” on page 97
- “To Connect Cables to the Rear-Access I/O Cards” on page 103

▼ To Connect Cables to the CPU Rear Transition Card

1. Go to the rear of the chassis and locate the CPU rear transition card.

FIGURE 6-29 shows the location of the CPU rear transition card in the Netra ct 800 server, and FIGURE 6-30 shows the location of the CPU rear transition card in the Netra ct 400 server.

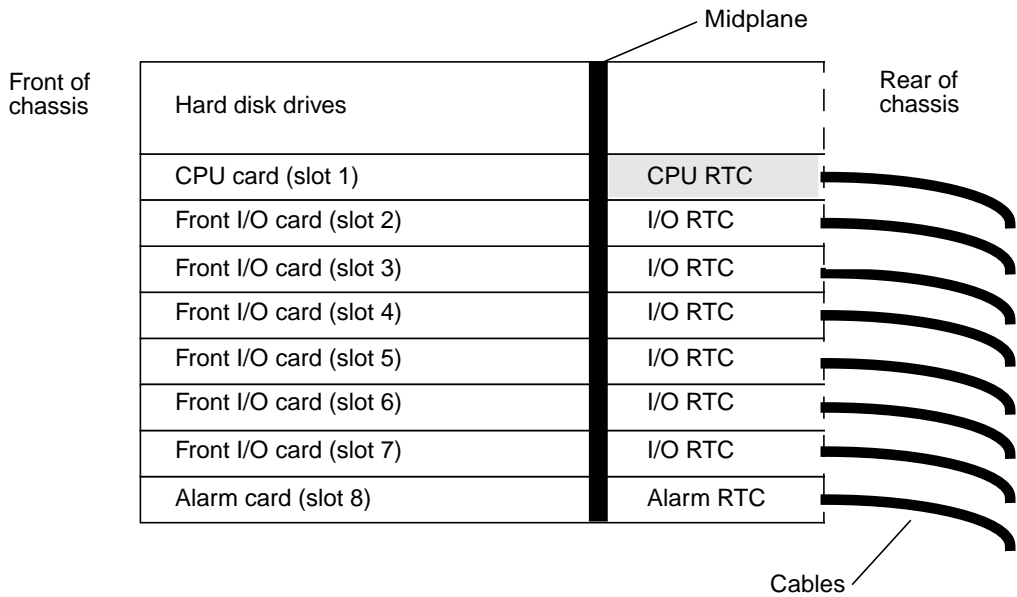

FIGURE 6-29 CPU Rear Transition Card (CPU RTC) Location in a Netra ct 800 Server (Top View)

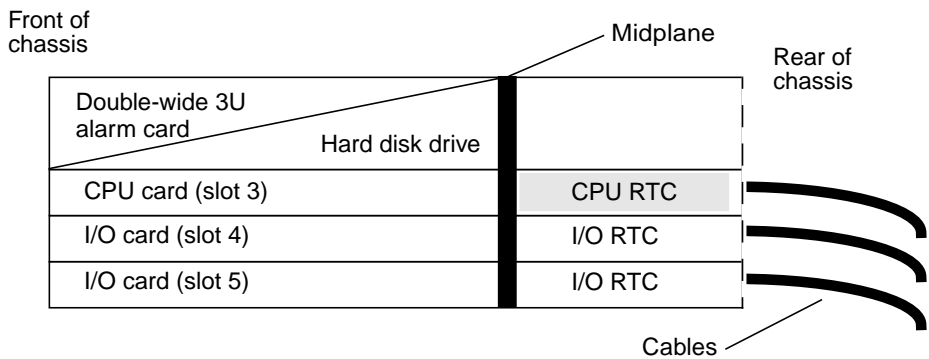

FIGURE 6-30 CPU Rear Transition Card (CPU RTC) Location in a Netra ct 400 Server (Top View)

2. Make the necessary cable connections to the CPU rear transition card.

Tighten the screws on the cable to a torque of 0.23 N.m (2 in.-lb).

FIGURE 6-31 shows the connectors on the CPU rear transition card for the Netra ct 800 server and FIGURE 6-32 shows the connectors on the CPU rear transition card for the Netra ct 400 server. The CPU rear transition card is the same for both the Netra ct 800 server and the Netra ct 400 server; only the location in the rear card cage differs.

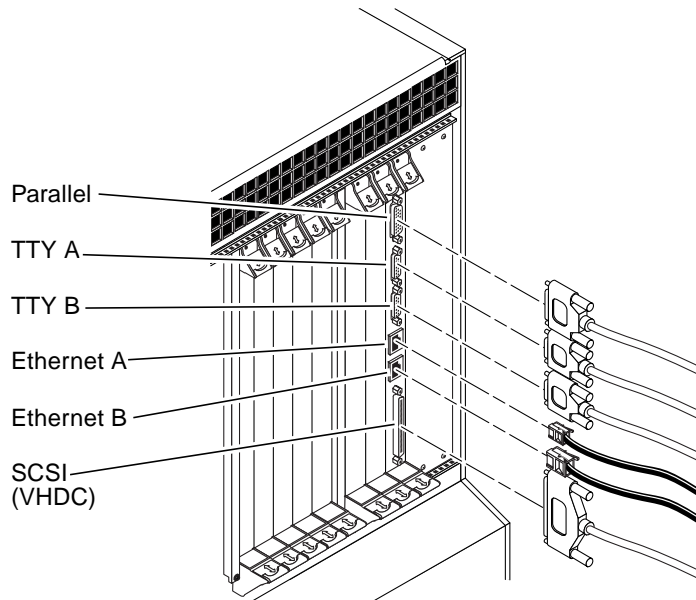

FIGURE 6-31 Connectors on the CPU Rear Transition Card (Netra ct 800 Server)

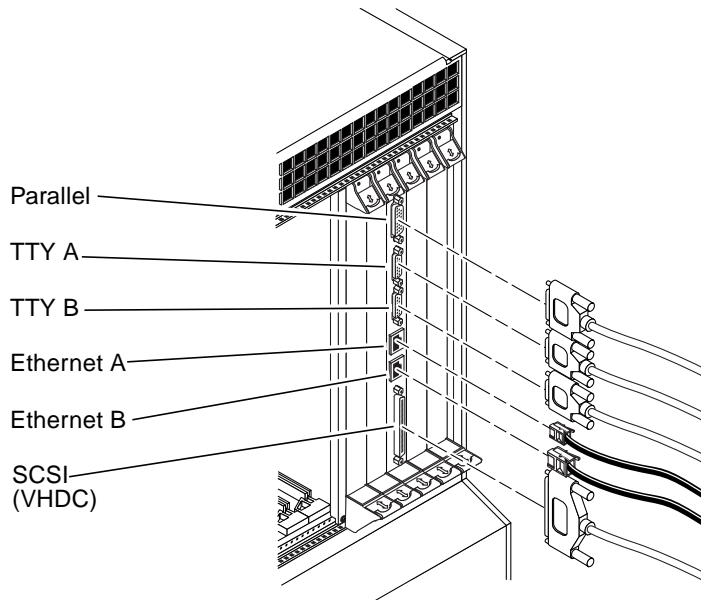

FIGURE 6-32 Connectors on the CPU Rear Transition Card (Netra ct 400 Server)

The following sections give the pinouts for the connectors on the CPU rear transition card:

- “Parallel Port” on page 91
- “TTY A” on page 92
- “TTY B” on page 93
- “Ethernet A Port” on page 94
- “Ethernet B Port” on page 95
- “SCSI (VHDC)” on page 96

Parallel Port

The parallel port on the CPU RTC is an AMPLIMITE SLIMLINE female DB-25 receptacle.

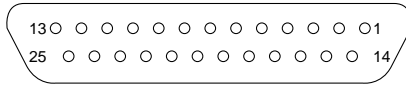

FIGURE 6-33 Parallel Connector

TABLE 6-21 Parallel Port Pinouts, CPU RTC

Pin No.	Signal	Pin No.	Signal
1	STB	14	AFD
2	PD0	15	ERR
3	PD1	16	INIT
4	PD2	17	SLIN
5	PD3	18	DGND
6	PD4	19	DGND
7	PD5	20	DGND
8	PD6	21	DGND
9	PD7	22	DGND
10	ACK	23	DGND
11	BUSY	24	DGND
12	PE	25	DGND
13	SLCT		

TTY A

The TTY A port on the CPU RTC is a DB-9 male connector.

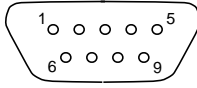

FIGURE 6-34 TTY A Connector

TABLE 6-22 TTY A Port Pinouts, CPU RTC

Pin #	Signal Name
1	DCD
2	RXD
3	TXD
4	DTR
5	GND
6	DSR
7	RTS
8	CTS
9	RI

TTY B

The TTY B port on the CPU RTC is a DB9 male connector.

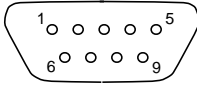

FIGURE 6-35 TTY B Connector

TABLE 6-23 TTY B Port Pinouts, CPU RTC

Pin #	Signal Name
1	DCD
2	RXD
3	TXD
4	DTR
5	GND
6	DSR
7	RTS
8	CTS
9	RI

Ethernet A Port

The Ethernet A port on the CPU RTC is an RJ-45 connector for 10/100.

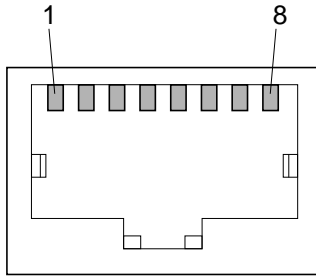

FIGURE 6-36 RJ-45 Ethernet Connector Diagram

TABLE 6-24 Ethernet Connector Pinouts, CPU RTC

Pin No.	Description
1	TXD+
2	TXD-
3	RXD+
4	Not used
5	Not used
6	RXD-
7	Not used
8	Not used

Ethernet B Port

The Ethernet B port on the CPU RTC is an RJ-45 connector for 10/100.

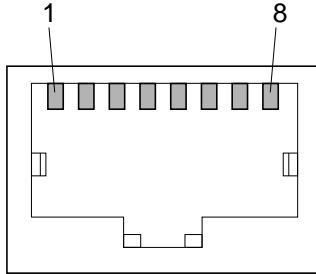

FIGURE 6-37 RJ-45 Ethernet Connector Diagram

TABLE 6-25 Ethernet Connector Pinouts, CPU RTC

Pin No.	Description
1	TXD+
2	TXD-
3	RXD+
4	Not used
5	Not used
6	RXD-
7	Not used
8	Not used

SCSI (VHDC)

The SCSI port on the CPU RTC is a 68-pin CHAMP very high-density connector (VHDC). Note that a VHDC-to-SCSI 3 cable is included with the Netra ct server (part number 530-2454-01).

TABLE 6-26 SCSI Port Pinouts, CPU RTC

Pin No.	Signal	Pin No.	Signal	Pin No.	Signal
1	GND	24	GND	47	DATA 7
2	PRES_L	25	GND	48	PL_L
3	GND	26	GND	49	PRES_L
4	GND	27	GND	50	GND
5	GND	28	GND	51	TERM PWR
6	GND	29	GND	52	TERM PWR
7	GND	30	GND	53	GND
8	GND	31	GND	54	GND
9	GND	32	GND	55	ATN_L
10	GND	33	GND	56	GND
11	GND	34	GND	57	BSY_L
12	GND	35	DATA 12	58	ACK_L
13	GND	36	DATA 13	59	RST_L
14	GND	37	DATA 14	60	MSG_L
15	GND	38	DATA 15	61	DEL_L
16	GND	39	PH_L	62	CD_L
17	TERM PWR	40	DATA 0	63	REQ_L
18	TERM PWR	41	DATA 1	64	IO_L
19	GND	42	DATA 2	65	DATA 8
20	GND	43	DATA 3	66	DATA 9
21	GND	44	DATA 4	67	DATA 10
22	GND	45	DATA 5	68	DATA 11
23	GND	46	DATA 6		

▼ To Connect Cables to the Alarm Rear Transition Card (Rear-Access Models Only)

Note – There is no rear-access version of the alarm card for the Netra ct 400 server.

1. Go to the rear of the chassis and locate the alarm rear transition card (RTC).

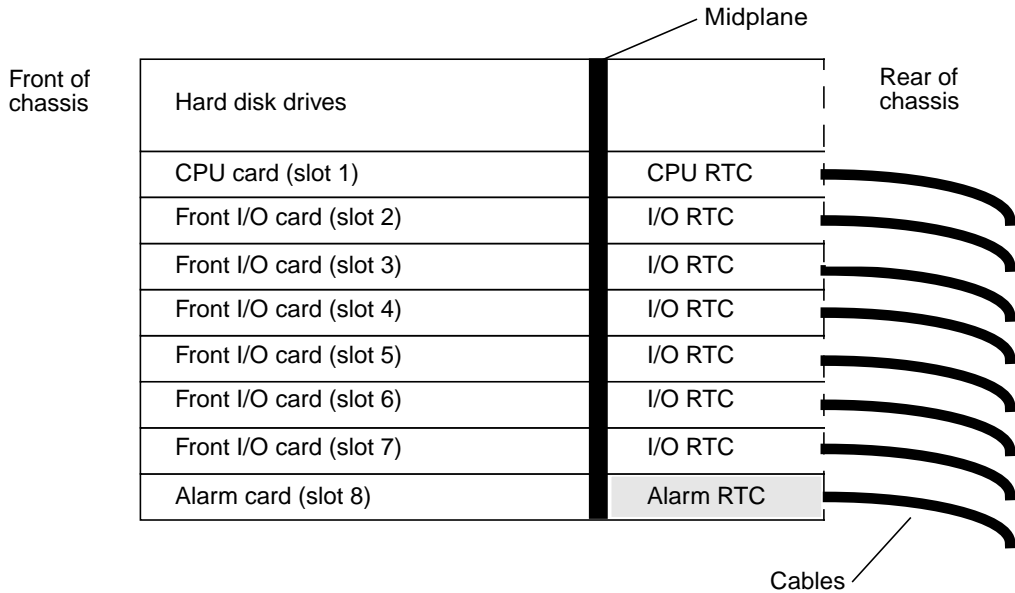

FIGURE 6-38 Locating the Alarm Rear Transition Card in a Netra ct 800 Server (Top View)

2. Make the necessary cable connections to the alarm rear transition card.

Tighten the screws on the cable to a torque of 0.23 N.m (2 in.-lb).

FIGURE 6-39 shows the connectors on the alarm rear transition card.

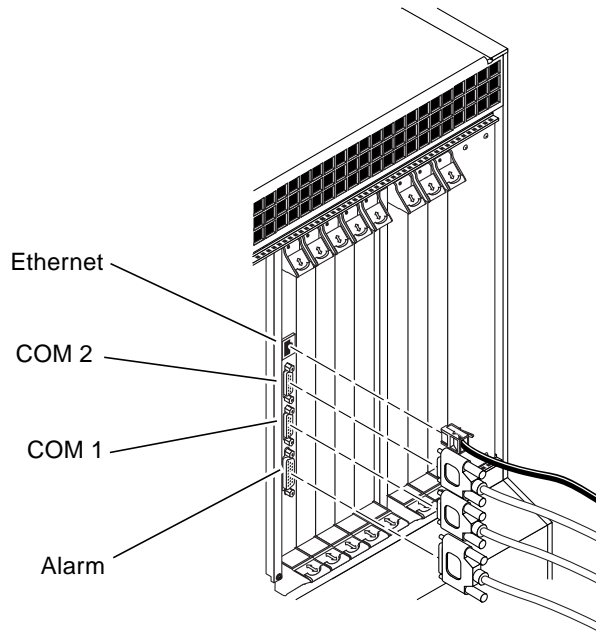

FIGURE 6-39 Connectors on the Alarm Rear Transition Card

The following sections give the pinouts for the connectors on the alarm rear transition card:

- “Ethernet Port” on page 99
- “COM 2” on page 100
- “COM 1” on page 101
- “Alarm Port” on page 102

Ethernet Port

The Ethernet port on the alarm RTC for the Netra ct 800 server is an RJ-45 connector for 10BASE-T.

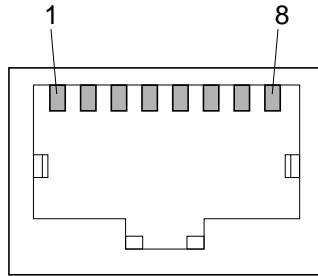

FIGURE 6-40 RJ45 Ethernet Connector Diagram

TABLE 6-27 Ethernet Connector Pinout, Alarm RTC for the Netra ct 800 Server

Pin No.	Description
1	TXD+
2	TXD-
3	RXD+
4	Not used
5	Not used
6	RXD-
7	Not used
8	Not used

COM 2

The COM 2 port on the alarm RTC for the Netra ct 800 server is a DB-9 male connector.

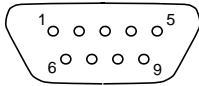

FIGURE 6-41 COM 2 Connector

TABLE 6-28 COM 2 Connector Pinouts, Alarm RTC for the Netra ct 800 Server

Pin No.	Description
1	DCD
2	RXD
3	TXD
4	DTR
5	Isolated GND 2
6	DSR
7	RTS
8	CTS
9	NC

COM 1

The COM 1 port on the alarm RTC for the Netra ct 800 server is a DB-9 male connector.

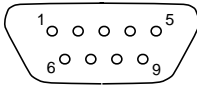

FIGURE 6-42 COM 1 Connector

TABLE 6-29 COM 1 Connector Pinouts, Alarm RTC for the Netra ct 800 Server

Pin No.	Description
1	NC
2	RXD
3	TXD
4	NC
5	Isolated GND 1
6	NC
7	RTS
8	CTS
9	NC

Alarm Port

I/O connections are available through the male DB-15 alarm port.

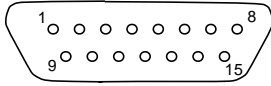

TABLE 6-30 Alarm Port Pinouts, Alarm RTC for the Netra ct 800 Server

Pin No.	Signal
1	RESET0 +
2	RESET0 -
3	RESET1 +
4	RESET1 -
5	ALARM0_NO
6	ALARM0_NC
7	ALARM0_COM
8	ALARM1_NO
9	ALARM1_NC
10	ALARM1_COM
11	ALARM2_NO
12	ALARM2_NC
13	ALARM2_COM
14	ALARM3_NO
15	ALARM3_COM

▼ To Connect Cables to the Rear-Access I/O Cards

1. Locate the I/O card.

FIGURE 5-2 on page 44 shows the possible I/O slot locations in the Netra ct 800 server and FIGURE 5-4 on page 46 shows the possible I/O slot locations in the Netra ct 400 server.

2. Make the necessary cable connections to the rear-access I/O cards.

Tighten the screws on the cable to a torque of 0.23 N.m (2 in.-lb).

Refer to the documentation that you received with the rear-access I/O cards for more information.

Assembling and Connecting the DC Input Power Cable



Caution – Verify that your site meets the source site requirements given in “DC Source Site Requirements” on page 13 before proceeding with these instructions.

Assembling the DC Input Power Cable

Note – If you have already assembled the DC input power cables, skip to “Connecting the DC Input Power Cable to the Server” on page 110.

▼ To Assemble the DC Input Power Cable

1. Identify the parts that you will use to assemble the DC input power cable (FIGURE 6-43).

The following DC connection parts are provided in this kit so that you can assemble one or more DC power input cables. These cables are used to connect the -48V DC input source(s) to the power supply units in your:

- DC input plugs
- Strain relief housings
- Cage clamp operating lever
- Tie wraps

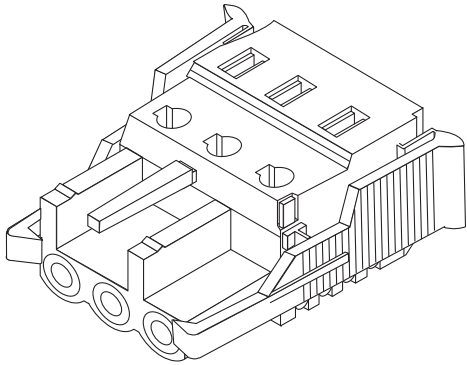

DC input plug

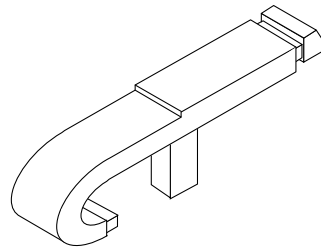

Cage clamp operating lever

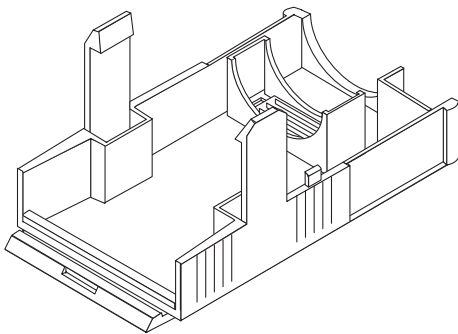

Strain relief housing

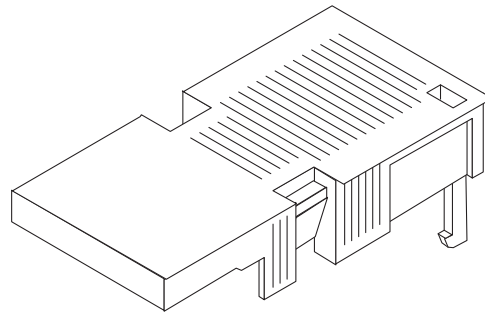

FIGURE 6-43 DC Connection Parts

2. Turn off power from the DC power source through the circuit breakers.



Caution – Do *not* proceed with these instructions until you have turned off the power from the DC power source through the circuit breakers.

3. **Get a DC input plug from the ship kit.**
4. **Locate the three wires coming from the DC power source that will be used in the connection to your unit:**
 - -48V (negative terminal)
 - Chassis ground
 - -48V Return (positive terminal)
5. **Strip 5/16 inches (8 mm) of insulation from each of the wires coming from the DC power source.**

Do not strip more than 5/16 inches (8 mm) from each wire. Doing so will leave uninsulated wire exposed from the DC connector after the assembly is complete.

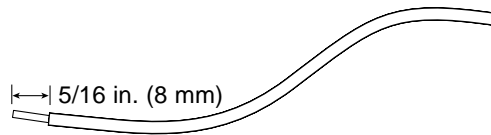

FIGURE 6-44 Stripping the Insulation From the Wire

6. **Insert the tip of the cage clamp operating lever into the rectangular hole directly above the hole in the DC input plug where you want to insert the first wire and press down on the cage clamp operating lever.**

This opens the cage clamp for this section of the DC input plug.

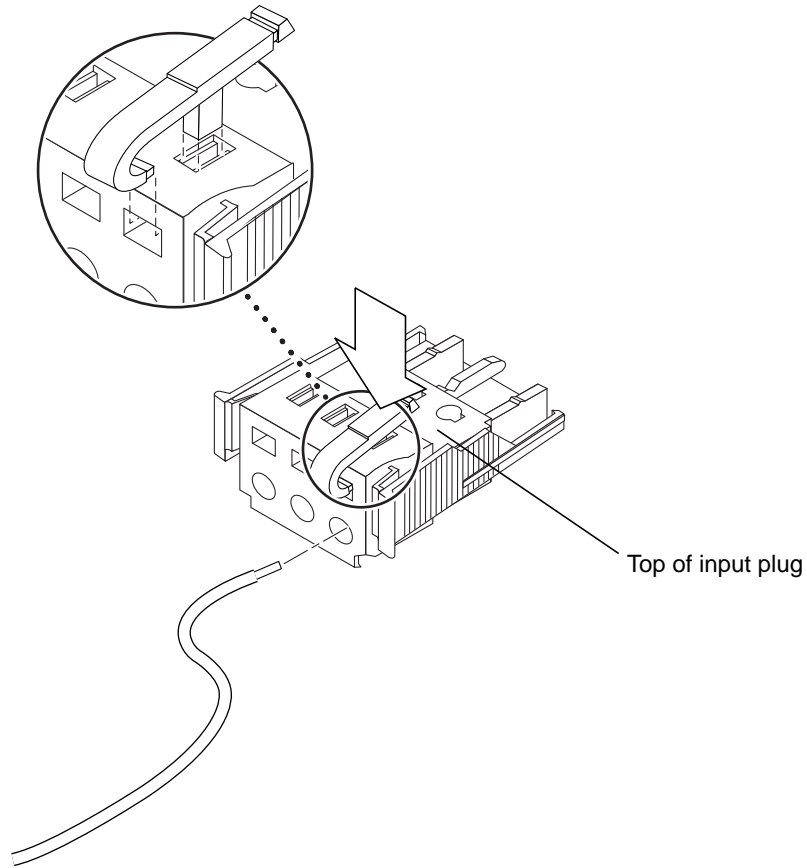

FIGURE 6-45 Opening the DC Input Plug Cage Clamp Using the Cage Clamp Operating Lever

You can also open the cage clamp by inserting a small slotted screwdriver into the rectangular hole directly above the hole in the DC input plug where you want to insert the first wire and pressing down on the screwdriver.

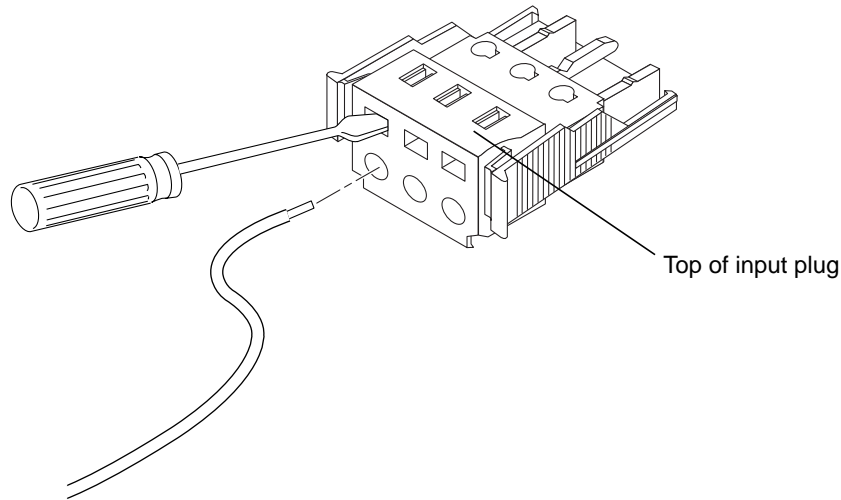

FIGURE 6-46 Opening the Cage Clamp Using a Screwdriver

- 7. Feed the exposed section of the appropriate wire into that hole in the DC input plug.**

FIGURE 6-47 shows which wires should be inserted into each hole in the DC input plug.

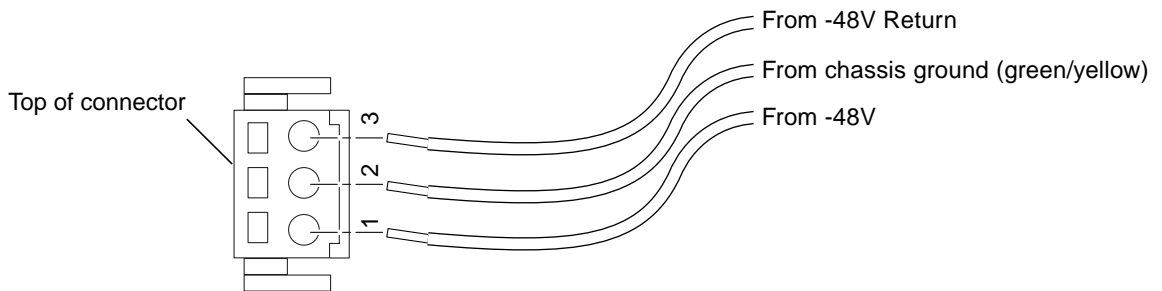

FIGURE 6-47 Assembling the DC Input Power Cable

- 8. Repeat Step 6 and Step 7 for the other two wires to complete the assembly of the DC input power cable.**
- 9. Repeat Step 4 through Step 8 to create as many DC input power cables as you need for your unit.**

You will need one DC input power cable for every power supply that you have in the Netra ct server chassis.

If you need to remove a wire from the DC input plug, insert the cage clamp operating lever or a small screwdriver into the slot directly above the wire and press down (FIGURE 6-45 and FIGURE 6-46), then pull the wire from the DC input plug.

▼ To Install the Strain Relief Housings

1. **Take the DC input plug and insert the bottom portion of the strain relief housing into the notch on the DC input plug until it snaps into place.**

Make sure the strain relief housing snaps into place on the DC input plug; you will not be able to complete the assembly correctly if the strain relief housing is not snapped into place.

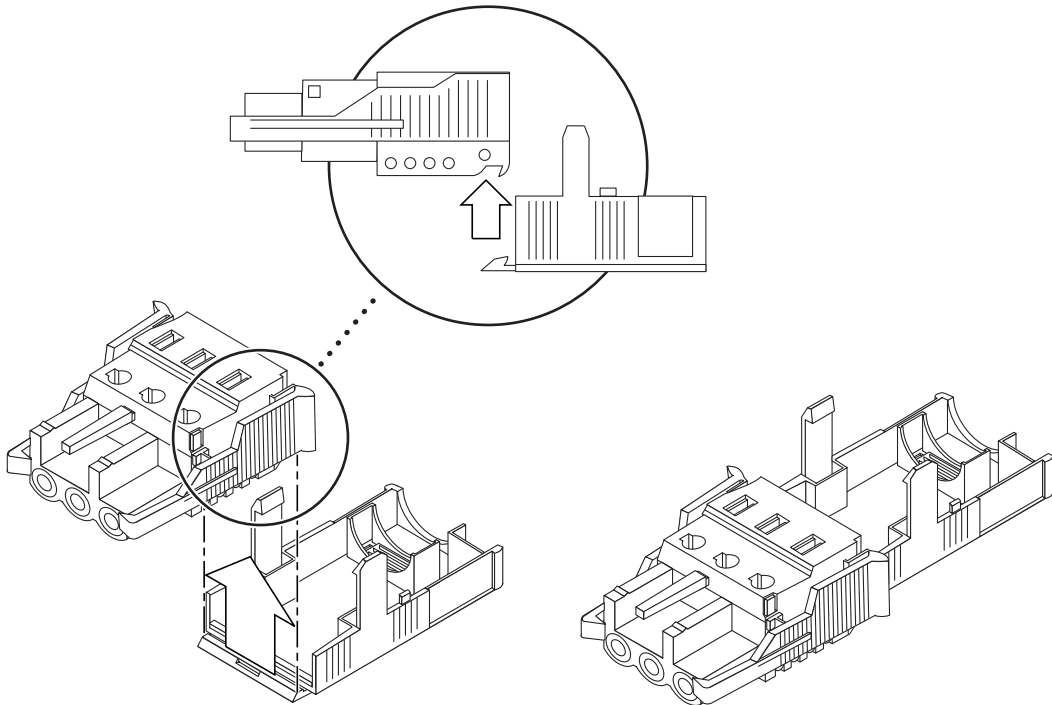

FIGURE 6-48 Inserting the Bottom Portion of the Strain Relief Housing

2. **Route the three wires coming from the DC power source through the opening at the end of the bottom portion of the strain relief housing.**

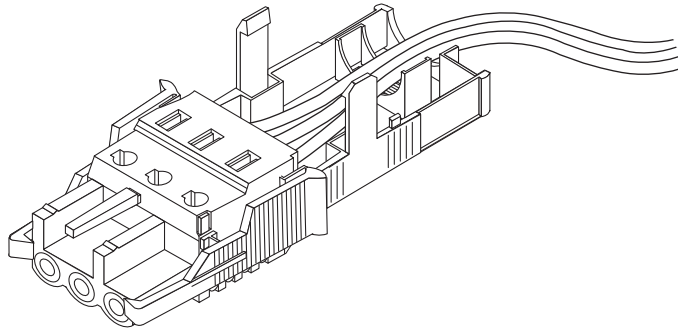

FIGURE 6-49 Routing the Wires Out of the Bottom Portion of the Strain Relief Housing

- 3. Get the tie wrap and insert it into the bottom portion of the strain relief housing.**

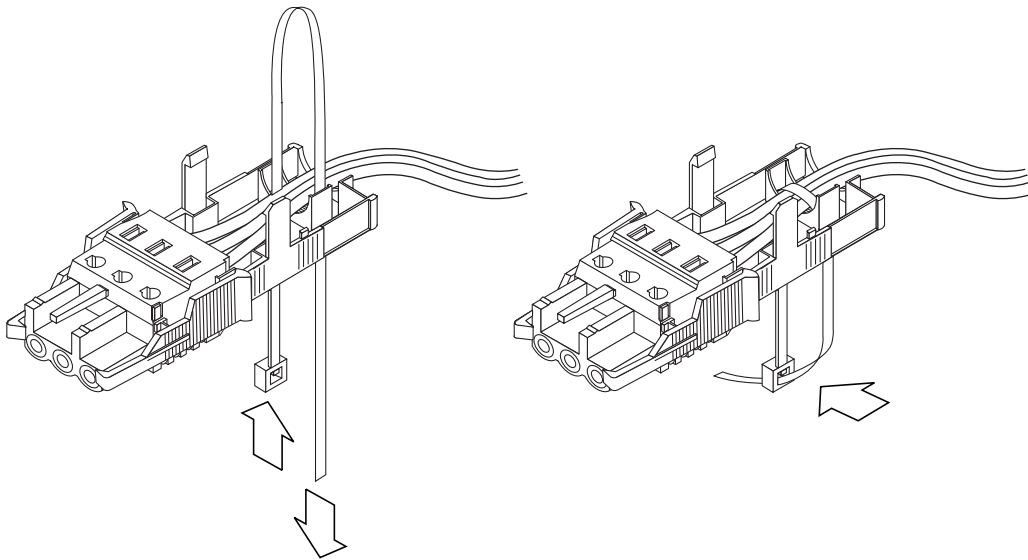

FIGURE 6-50 Securing the Wires to the Strain Relief Housing

- 4. Loop the tie wrap over the wires and back out of the strain relief housing and tighten the tie wrap to secure the wires to the strain relief housing (FIGURE 6-50).**
- 5. Lower the top portion of the strain relief housing so that the three prongs on the top portion insert into the openings in the DC input plug, and push the top and bottom portions of the strain relief housing together until they snap into place.**

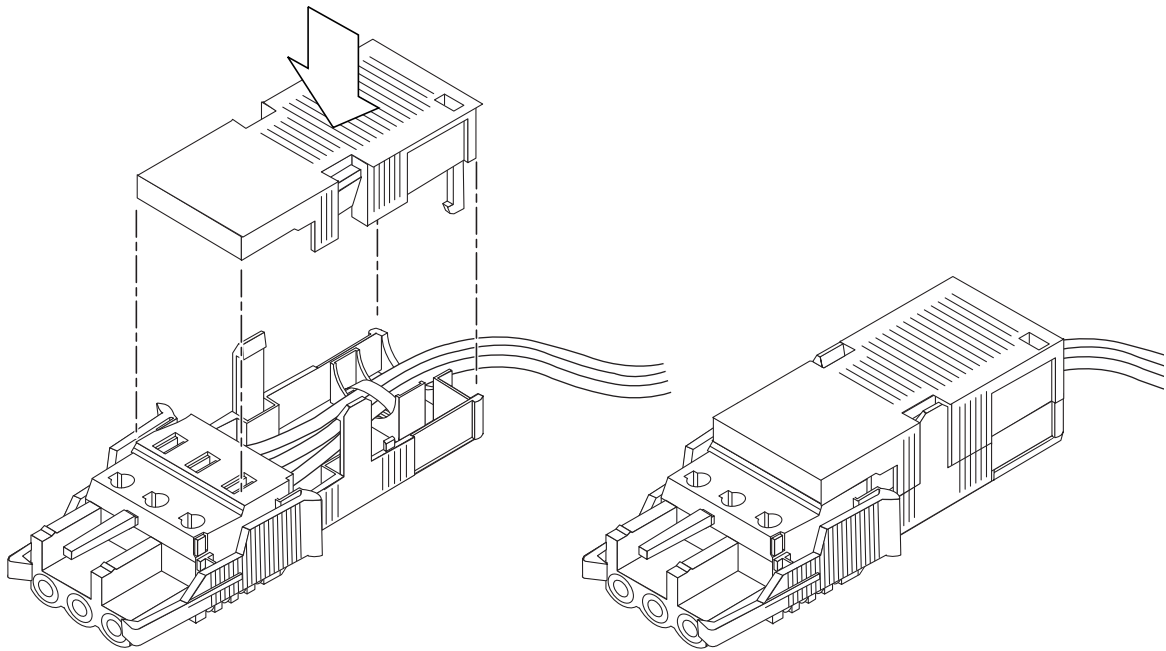

FIGURE 6-51 Assembling the Strain Relief Housing

Connecting the DC Input Power Cable to the Server



Caution – An energy hazard is present when energized units are not properly earthed.

The instructions for connecting the power cable to your Netra ct server vary depending on the model that you have.

- If you have the *front-access* model, go to “To Connect the Power Cable to the Front-Access Model” on page 111.
- If you have the *rear-access* model, go to “To Connect the Power Cable to the Rear-Access Model” on page 113.

▼ To Connect the Power Cable to the Front-Access Model

1. Go to the front of the chassis and locate the DC connectors.

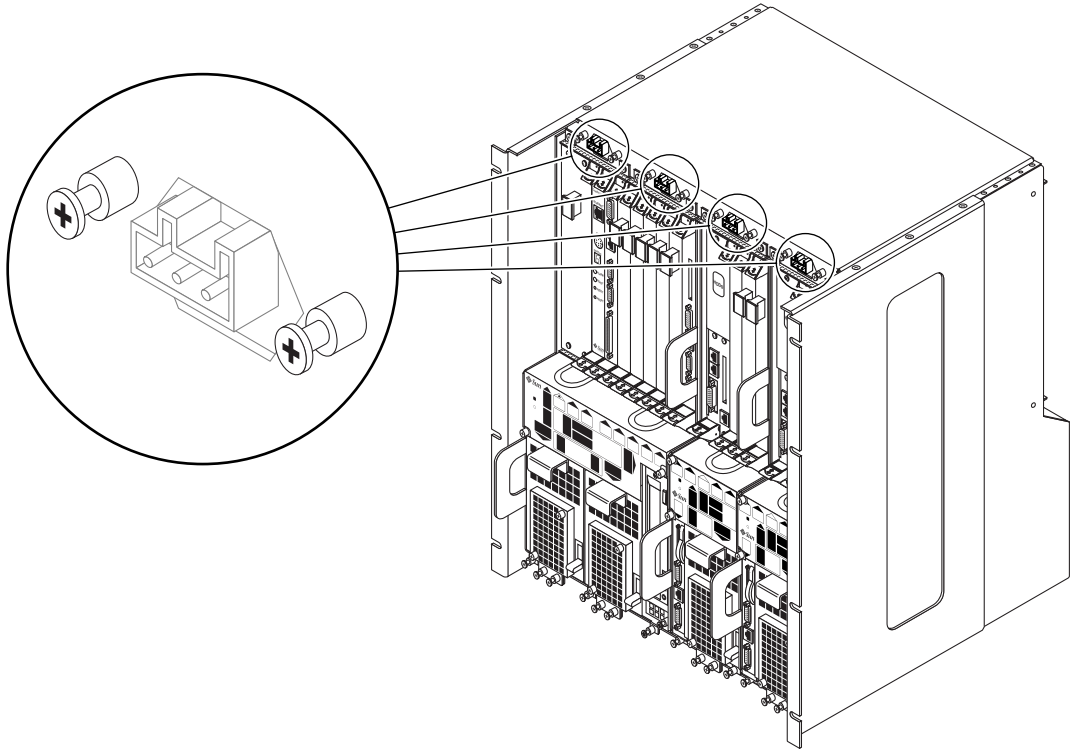

FIGURE 6-52 DC Connector Locations, Front-Access Model

2. Connect the DC input power cables to the DC connectors.

FIGURE 6-53 shows how the DC input power cable is connected to the DC connectors.

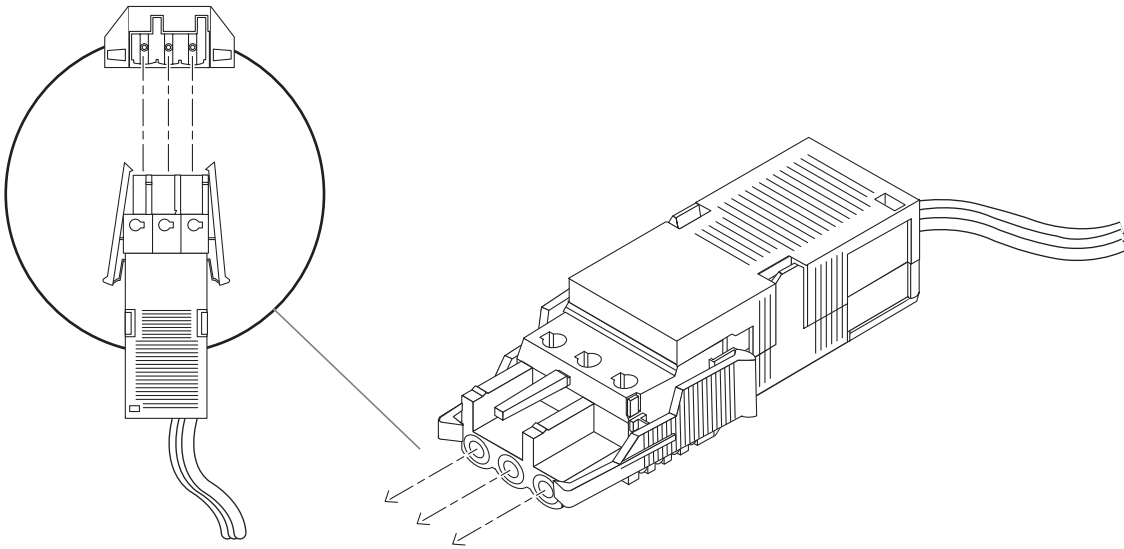

FIGURE 6-53 Connecting the DC Input Power Cable to the DC Connectors

3. Turn on the circuit breakers to provide power to the servers.

If you want to disconnect the DC input power cable from the DC connector at some point in the future, turn the circuit breakers off, then squeeze the two tabs on the sides of the DC input power cable and gently disconnect the DC input power cable from the DC power supply.



Caution – Do *not* attempt to disconnect the DC input power cable from the DC connector until you have turned off the power from the DC power source through the circuit breakers.

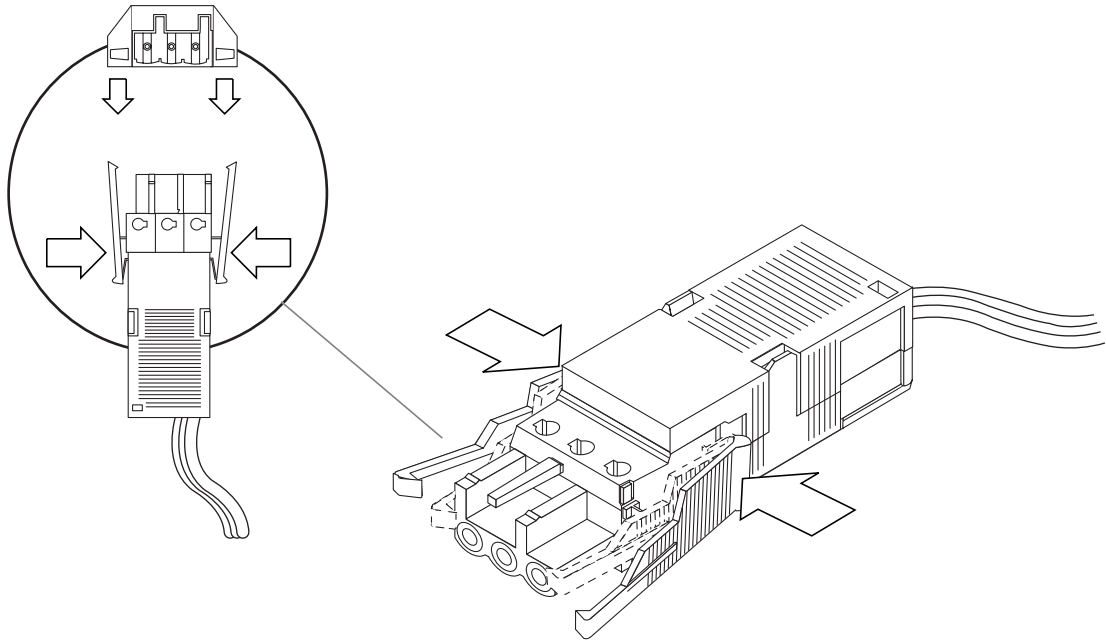

FIGURE 6-54 Disconnecting the DC Input Power Cable From the DC Connector

▼ To Connect the Power Cable to the Rear-Access Model

1. Go to the rear of the chassis and locate the DC connectors.

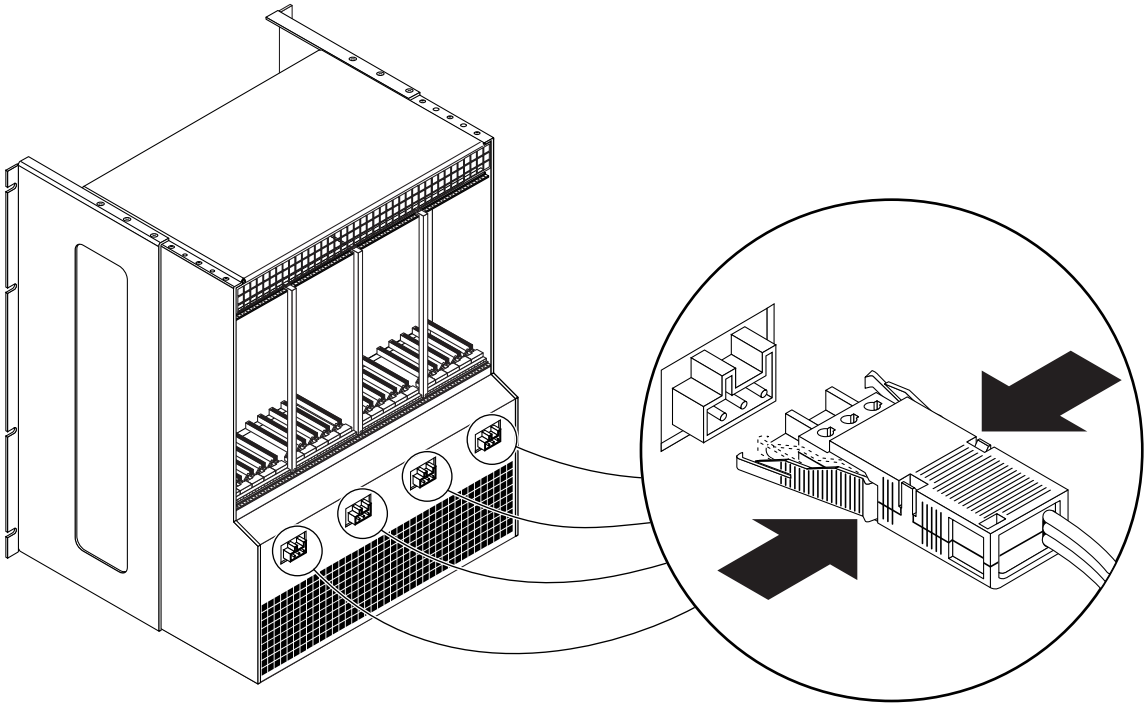

FIGURE 6-55 Locating the DC Connectors

2. Connect the DC input power cables to the DC connectors.

FIGURE 6-53 shows how the DC input power cable is connected to the DC connectors.

3. Turn on the circuit breakers to provide power to the server.

If you want to disconnect the DC input power cable from the DC connector at some point in the future, turn the circuit breakers off, then squeeze the two tabs on the sides of the DC input power cable and gently disconnect the DC input power cable from the DC power supply (FIGURE 6-54).

Powering the Server On and Off

This chapter gives instructions on powering the Netra ct server on and off.

- “Connecting a Terminal Console to the Server” on page 116
- “Powering On the Server” on page 122
- “Powering Off the Server” on page 126

Note – Whenever you reboot or power your server on and off, the hot swap states revert back to the default *basic* hot swap state for all I/O slots. If you want *full* hot swap on an I/O slot, you must manually reset the I/O slot to full hot swap after rebooting or powering your server on and off.

Note – You can also power the Netra ct server on and off through the alarm card using the `poweroff` and `poweron` commands. Refer to the *Remote System Control (RSC) User’s Guide For the Netra ct Server Alarm Card* for more information.

Connecting a Terminal Console to the Server

One way to power on and off your server is to log in to the server either remotely, where you would log in to the Netra ct server as root through another server on the network, or directly, where you would connect a terminal console directly to your Netra ct server. A terminal console can be an ASCII terminal, workstation, or PC laptop.

For a direct login, the connection you use varies depending on the Netra ct server model you have, the type of terminal console you are using, and the card that you are connecting to:

- If you are using an ASCII terminal to power on and off the Netra ct server, go to “To Use an ASCII Terminal” on page 116.
- If you are using a Solaris workstation to power on and off the Netra ct server, go to “To Use a Solaris Workstation” on page 118.
- If you are using a PC laptop to power on and off the Netra ct server, go to “To Use a PC Laptop” on page 120.

▼ To Use an ASCII Terminal

1. Get the appropriate cable(s) and adapter(s) and make the necessary connections.

You may need one or more cables and adapters in order to connect the ASCII terminal to the server. The cables and adapters you need varies, depending on the model server you have and the card that you are connecting to.

- If you are connecting an ASCII terminal to a *CPU or CPU transition card*, use the information in TABLE 7-1 to make the necessary connections.
- If you are connecting an ASCII terminal to an *alarm card or alarm rear transition card*, use the information in TABLE 7-2 to make the necessary connections.

TABLE 7-1 Connecting an ASCII Terminal to a CPU or CPU Transition Card

Server Type	TTY A Port on Netra ct Server	Adapter	Cable	Adapter	Serial Port on Terminal
Netra ct 800 server	<ul style="list-style-type: none"> • <i>Front-access</i> model: DB-9 male on the CPU front transition card. See “To Connect Cables to the CPU Front Transition Card” on page 62. • <i>Rear-access</i> model: DB-9 male on the CPU rear transition card. See “To Connect Cables to the CPU Rear Transition Card” on page 87. 	Not needed.	DB-9 female-to-DB-25 male straight-through	DB-25 female-to-DB-25 female gender changer	DB-25 male
Netra ct 400 server	<ul style="list-style-type: none"> • <i>Front-access</i> model: DIN-8 female on the CPU card. See “To Connect Cables to the CPU Card” on page 58. • <i>Rear-access</i> model: DB-9 male on the CPU rear transition card. See “To Connect Cables to the CPU Rear Transition Card” on page 87. 	Not needed.	<ul style="list-style-type: none"> • <i>Front-access</i> model: DIN-8 male-to-DB-25 male • <i>Rear-access</i> model: DB-9 female-to-DB-25 male straight-through 	DB-25 female-to-DB-25 female gender changer	DB-25 male

TABLE 7-2 Connecting an ASCII Terminal to an Alarm or Alarm Rear Transition Card

Server Type	COM 1 Port on Netra ct Server	Adapter	Cable	Adapter	Serial Port on Terminal
Netra ct 800 server	<ul style="list-style-type: none"> • <i>Front-access</i> model: DB-9 male on the alarm card. See “To Connect Cables to the Alarm Card (Front-Access Models Only)” on page 77. • <i>Rear-access</i> model: DB-9 male on the alarm rear transition card. See “To Connect Cables to the Alarm Rear Transition Card (Rear-Access Models Only)” on page 97. 	Not needed.	DB-9 female-to-DB-25 male straight-through	DB-25 female-to-DB-25 female gender changer	DB-25 male
Netra ct 400 server	<ul style="list-style-type: none"> • <i>Front-access</i> model: RJ-45 on the alarm card. See “To Connect Cables to the Alarm Card (Front-Access Models Only)” on page 77. • <i>Rear-access</i> model: Not available. 	RJ-45-to-DB-9 male	DB-9 female-to-DB-25 male straight-through	DB-25 female-to-DB-25 female gender changer	DB-25 male

2. Access the “Set Up Menu” of the ASCII terminal and bring up the Serial Communications section.

3. Set up the serial port communications parameters.

The default settings should match the values reported on the host serial port.

- Hardwired modem connection
- No parity
- 9600 baud
- 1 stop bit
- 8 bit data

4. Test the connection.

Verify that communication has been established to the server and the keyboard/display of the ASCII terminal.

▼ To Use a Solaris Workstation

1. Get the appropriate cable(s) and adapter(s) and make the necessary connections.

You may need one or more cables and adapters in order to connect a Solaris workstation to the server. The cables and adapters you need varies, depending on the model server you have and the card that you are connecting to.

- If you are connecting a Solaris workstation to a *CPU or CPU transition card*, use the information in TABLE 7-3 to make the necessary connections.
- If you are connecting a Solaris workstation to an *alarm card or alarm rear transition card*, use the information in TABLE 7-4 to make the necessary connections.

TABLE 7-3 Connecting a Solaris Workstation to a CPU or CPU Transition Card

Server Type	TTY A Port on Netra ct Server	Adapter	Cable	Adapter	Serial Port on Workstation
Netra ct 800 server	<ul style="list-style-type: none"> • <i>Front-access</i> model: DB-9 male on the CPU front transition card. See “To Connect Cables to the CPU Front Transition Card” on page 62. • <i>Rear-access</i> model: DB-9 male on the CPU rear transition card. See “To Connect Cables to the CPU Rear Transition Card” on page 87. 	Not needed.	DB-9 female-to-DB-25 male null modem	Not needed.	DB-25 female
Netra ct 400 server	<ul style="list-style-type: none"> • <i>Front-access</i> model: DIN-8 female on the CPU card. See “To Connect Cables to the CPU Card” on page 58. • <i>Rear-access</i> model: DB-9 male on the CPU rear transition card. See “To Connect Cables to the CPU Rear Transition Card” on page 87. 	Not needed.	<ul style="list-style-type: none"> • <i>Front-access</i> model: DIN-8 male-to-DB-25 male • <i>Rear-access</i> model: DB-9 female-to-DB-25 male null modem 	Not needed.	DB-25 female

TABLE 7-4 Connecting a Solaris Workstation to an Alarm or Alarm Rear Transition Card

Server Type	COM 1 Port on Netra ct Server	Adapter	Cable	Adapter	Serial Port on Workstation
Netra ct 800 server	<ul style="list-style-type: none"> • <i>Front-access</i> model: DB-9 male on the alarm card. See “To Connect Cables to the Alarm Card (Front-Access Models Only)” on page 77. • <i>Rear-access</i> model: DB-9 male on the alarm rear transition card. See “To Connect Cables to the Alarm Rear Transition Card (Rear-Access Models Only)” on page 97. 	Not needed.	DB-9 female-to-DB-25 male null modem	Not needed.	DB-25 female
Netra ct 400 server	<ul style="list-style-type: none"> • <i>Front-access</i> model: RJ-45 on the alarm card. See “To Connect Cables to the Alarm Card (Front-Access Models Only)” on page 77. • <i>Rear-access</i> model: Not available. 	RJ-45-to-DB-9 male	DB-9 female-to-DB-25 male null modem	Not needed.	DB-25 female

2. Check the `/etc/remote` file for the appropriate line.

To connect to the *TTY A or COM 1* port on the workstation, check for this line:

```
tip -9600 /dev/ttya
```

3. Type `tip` hardware at the prompt.

You should see the word `connected` as the response.

To disconnect the `tip` window, type `~.` (tilde period) at the prompt.

▼ To Use a PC Laptop

1. Get the appropriate cable(s) and adapter(s) and make the necessary connections.

You may need one or more cables and adapters in order to connect a PC laptop to the server. The cables and adapters you need varies, depending on the model server you have and the card that you are connecting to.

- If you are connecting a PC laptop to a *CPU or CPU transition card*, use the information in TABLE 7-5 to make the necessary connections.
- If you are connecting a PC laptop to an *alarm card or alarm rear transition card*, use the information in TABLE 7-6 to make the necessary connections.

TABLE 7-5 Connecting a PC Laptop to a CPU or CPU Transition Card

Server Type	TTY A Port on Netra ct Server	Adapter	Cable	Adapter	Serial Port on PC Laptop
Netra ct 800 server	<ul style="list-style-type: none"> • <i>Front-access</i> model: DB-9 male on the CPU front transition card. See “To Connect Cables to the CPU Front Transition Card” on page 62. • <i>Rear-access</i> model: DB-9 male on the CPU rear transition card. See “To Connect Cables to the CPU Rear Transition Card” on page 87. 	Not needed.	DB-9 female-to-DB-9 female null modem	Not needed.	DB-9 male
Netra ct 400 server	<ul style="list-style-type: none"> • <i>Front-access</i> model: DIN-8 female on the CPU card. See “To Connect Cables to the CPU Card” on page 58. • <i>Rear-access</i> model: DB-9 male on the CPU rear transition card. See “To Connect Cables to the CPU Rear Transition Card” on page 87. 	Not needed.	<ul style="list-style-type: none"> • <i>Front-access</i> model: DIN-8 male-to-DB-25 male • <i>Rear-access</i> model: DB-9 female-to-DB-9 female null modem 	<ul style="list-style-type: none"> • <i>Front-access</i> model: DB-25 female-to-DB-9 female • <i>Rear-access</i> model: Adapter not needed. 	DB-9 male

TABLE 7-6 Connecting a PC Laptop to an Alarm or Alarm Rear Transition Card

Server Type	COM 1 Port on Netra ct Server	Adapter	Cable	Adapter	Serial Port on PC Laptop
Netra ct 800 server	<ul style="list-style-type: none"> • <i>Front-access</i> model: DB-9 male on the alarm card. See “To Connect Cables to the Alarm Card (Front-Access Models Only)” on page 77. • <i>Rear-access</i> model: DB-9 male on the alarm rear transition card. See “To Connect Cables to the Alarm Rear Transition Card (Rear-Access Models Only)” on page 97. 	Not needed.	DB-9 female-to-DB-9 female null modem	Not needed.	DB-9 male
Netra ct 400 server	<ul style="list-style-type: none"> • <i>Front-access</i> model: RJ-45 on the alarm card. See “To Connect Cables to the Alarm Card (Front-Access Models Only)” on page 77. • <i>Rear-access</i> model: Not available. 	RJ-45-to-DB-9 male	DB-9 female-to-DB-9 female null modem	Not needed.	DB-9 male

2. Set the following connection parameters:

- No parity
- 9600 baud
- 1 stop bit
- 8 bit data

Powering On the Server

1. Verify that the power supply locking mechanism(s) on the server you are about to power on are in the locked (), or down, positions.

FIGURE 7-1 shows the location of the two power supply locking mechanisms on the Netra ct 800 server, and FIGURE 7-2 shows the location of the single power supply locking mechanism on the Netra ct 400 server. Make sure you lock *both* power supplies if you are powering on a Netra ct 800 server.

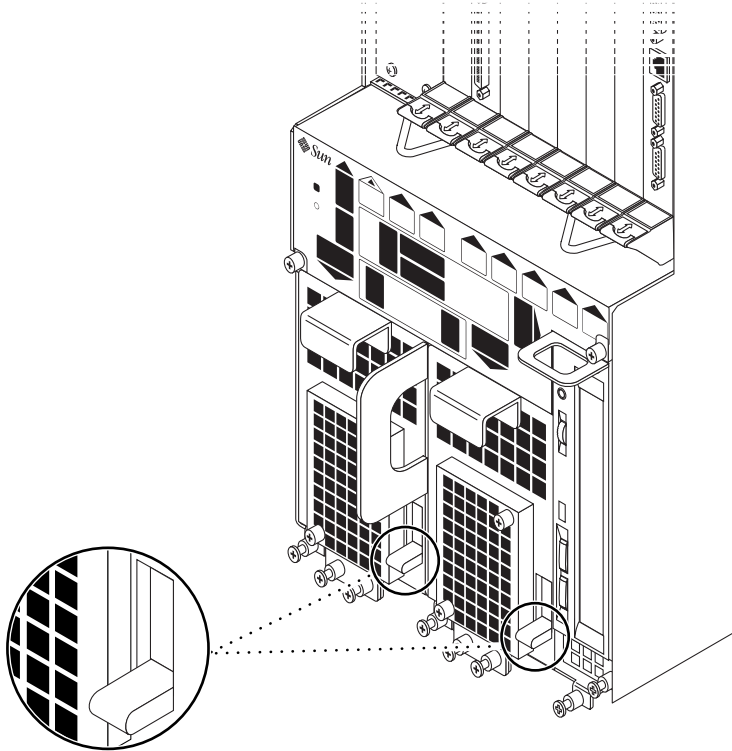

FIGURE 7-1 Locating the Power Supply Locking Mechanism on the Netra ct 800 Server

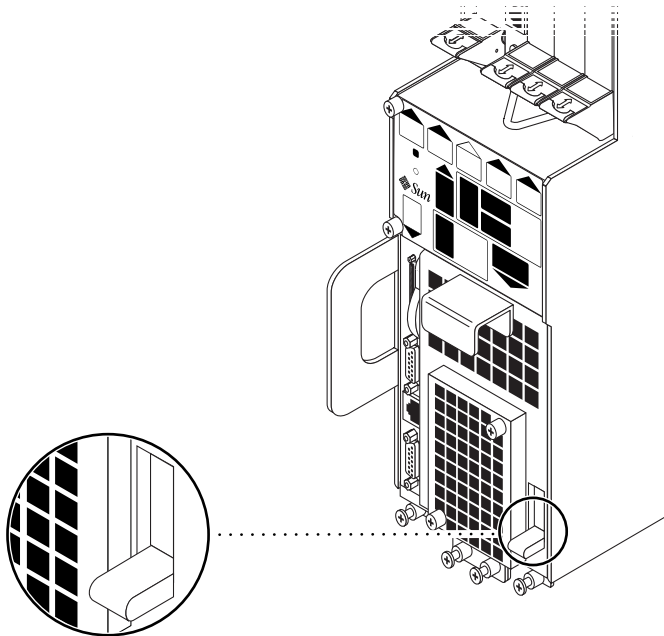

FIGURE 7-2 Locating the Power Supply Locking Mechanism on the Netra ct 400 Server

When the power supply locking mechanism is locked, the green LED on the power suppl(ies) flash, indicating that the power suppl(ies) are powered on, but the server has not been powered on yet. Also, the PDU LEDs on the system status panel should be in this state:

- Green LED (Ⓢ) is ON
- Amber LED (🔒) is OFF

This tells you that the power supply locking mechanism(s) are in the locked (down) position and the power distribution unit(s) are receiving power and functioning properly.

2. Locate the system status panel.

The location of the system status panel in the Netra ct 800 server and Netra ct 400 server is illustrated in FIGURE 7-3.

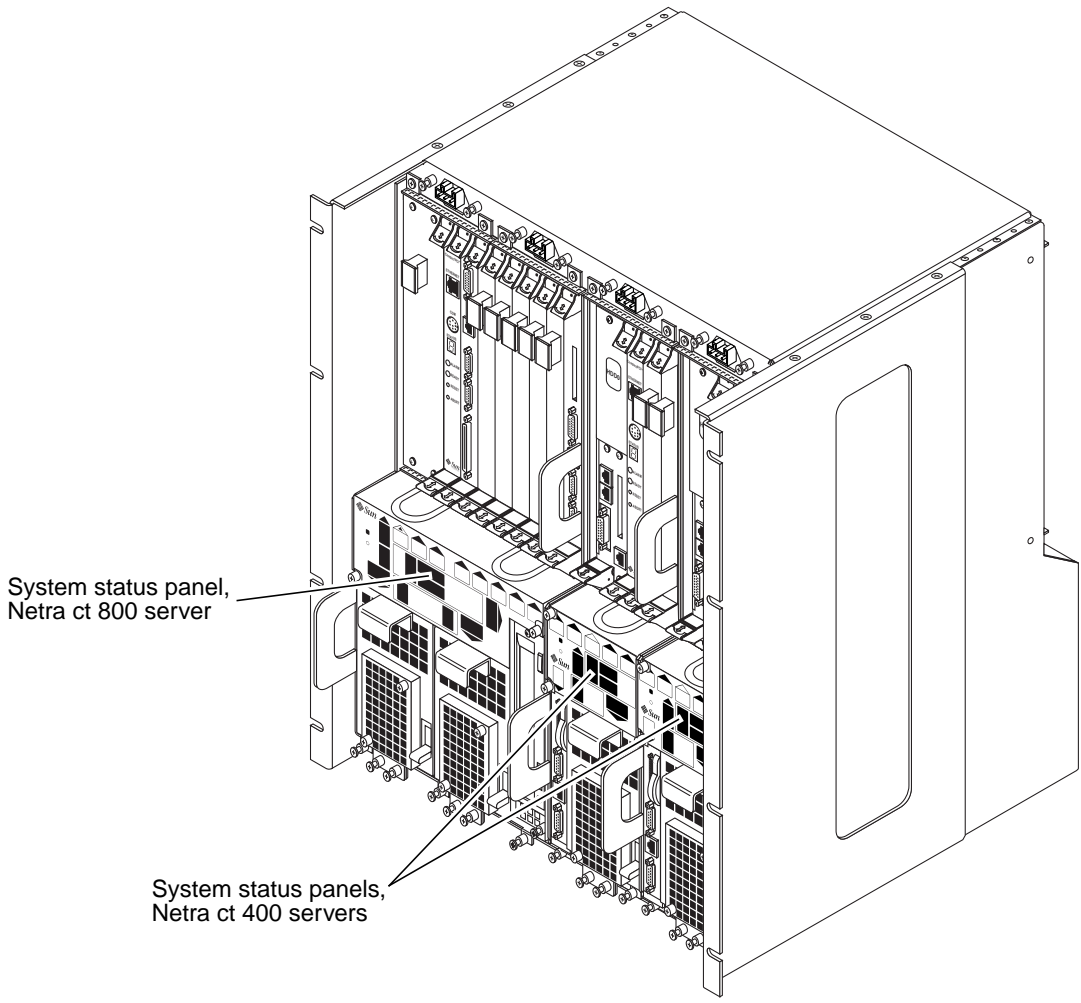

FIGURE 7-3 System Status Panel Locations

- 3. Locate the system power button on the system status panel and press the system power button to power on the server.**

FIGURE 7-4 shows the system power button location for the Netra ct 800 server, and FIGURE 7-5 shows the system power button location for the Netra ct 400 server.

When you first power-on the Netra ct server, some or all of the green Power LEDs on the system status panel flash on and off for several seconds:

- If the `diag-switch` variable is set to `true` and the `diag-level` variable is set to `max` in the OpenBoot™ PROM, then all of the green Power LEDs on the system status panel flash on and off for several seconds.
- If the variables in the OpenBoot PROM are not set as described above, then the green Power LEDs on the system status panel flash on and off for several seconds only for the components that are installed in the server.

Note – Refer to the Solaris documentation that you received with your system for instructions on setting variables in the OpenBoot PROM.

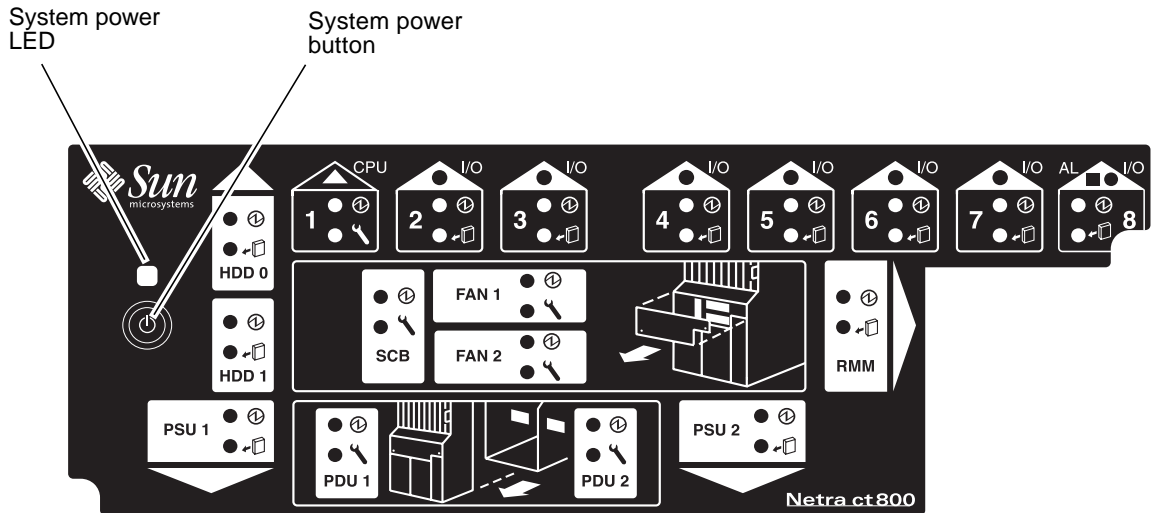

FIGURE 7-4 System Power Button and System Power LED Locations (Netra ct 800 Server)

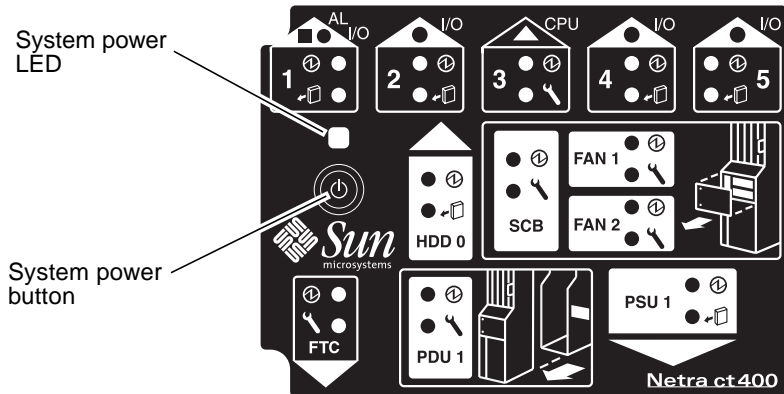

FIGURE 7-5 System Power Button and System Power LED Locations (Netra ct 400 Server)

4. Verify that the system power LED on the system status panel is on, indicating that the system is completely powered on.

FIGURE 7-4 shows the system power LED location for the Netra ct 800 server, and FIGURE 7-5 shows the system power LED location for the Netra ct 400 server.

5. Verify that the green power (Ⓜ) LED on the power supplies are on, indicating that they are powered on and functioning properly.
6. Log into your server and boot up the server.

Refer to “Connecting a Terminal Console to the Server” on page 116 for instructions on connecting a terminal to your server, if necessary.

Note – The CPU card will display the letters H-E-L-P as the system is booting up. This should go away once the system is completely booted up.

Powering Off the Server

You can power off the Netra ct server in three ways:

- Graceful hardware power-down
- Ungraceful hardware power-down
- Graceful software power-down

If you do not have a terminal hookup to your server and your CPU is functioning normally, you should go through a graceful hardware power-down for your server. For a graceful hardware power-down, you would press the system power button for *less* than four seconds. This will start the orderly power-down sequence in a manner that no persistent OS data structures are corrupted. In the orderly power-down, applications in service may be abnormally terminated and no further services will be invoked by the CPU.

If you do not have a terminal hookup to your server and your CPU is *not* functioning normally, you will not be able to go through a graceful hardware power-down; you will have to go through an ungraceful hardware power-down instead. For an ungraceful hardware power-down, you would press the system power button for *more* than four seconds. This will immediately shut the system down without making any attempts to keep the persistent OS data structures from being corrupted.

A graceful software power-down is a normal power-down using a terminal connected to your server, where you would log onto the server as root, then execute a software command to bring the server down safely.

- For hardware power-down instructions, go to “To Perform a Hardware Power-Off” on page 127.
- For software power-down instructions, go to “To Perform a Software Power Off” on page 129.

▼ To Perform a Hardware Power-Off

Note – You must have the `envmond` software package (`SUNWctevx`) installed and running on your Netra ct server in order to perform a graceful hardware power-down.

1. **In preparation for bringing down the operating system and powering off the server, ensure that all significant application activity is quiesced on the server.**
2. **Go to the front of the Netra ct server and locate the system status panel.**

The location of the system status panels in the Netra ct 800 server and Netra ct 400 server is illustrated in FIGURE 7-3.
3. **Locate the system power button on the system status panel.**

FIGURE 7-4 shows the system power button location for the Netra ct 800 server, and FIGURE 7-5 shows the system power button location for the Netra ct 400 server.

4. Press the system power button and release it to go through a graceful hardware power-down.

This will start the orderly power-down sequence in a manner that no persistent OS data structures are corrupted. In the orderly power-down, applications in service may be abnormally terminated and no further services will be invoked by the CPU. The system power LED will blink for several seconds, then it will go off.

If the server does not power off when you press the system power button and release it, this means one of two things:

- The `envmond` software package is not installed yet, or
- The CPU is unresponsive for some reason

a. Log into your server

Refer to “Connecting a Terminal Console to the Server” on page 116 for instructions on connecting a terminal to your server, if necessary.

b. Verify that the `envmond` software package is installed and running.

To verify that you’ve installed the `envmond` software package, as root, type:

```
# pkginfo SUNWcteux SUNWctevx
```

- If you see the following error messages:

```
ERROR: information for "SUNWcteux" was not found
ERROR: information for "SUNWctevx" was not found
```

then the `envmond` software package was not installed. Follow the instructions in the *Netra ct Server Installation Guide* to install the Netra ct server software on the server.

- If you see the following messages:

```
system      SUNWcteux      Netra ct EnvMon Daemon and FRU policy (Usr) (64-bit)
system      SUNWctevx      Netra ct Environment Monitor Daemon and FRU policy (64-bit)
```

then the `envmond` software package was installed, but might not be running. To verify that the `envmond` software package is running, as root, type:

```
# pgrep -l envmond
```

- If you get no output after entering the command, then the `envmond` software package is installed but is not running. Refer to the *Sun Remote System Control (RSC) User's Guide for the Netra ct Server Alarm Card* for instructions on starting the `envmond` software package.
- If you see the following message:

```
194 envmond
```

then the `envmond` software is running, so the problem must lie with the CPU card. If this is the case, press the system power button for *more than four seconds*. This immediately shuts the system down without making any attempts to keep the persistent OS data structures from being corrupted.

5. Verify that the green power (Ⓛ) LED on the power supplies are blinking, indicating that the system is in the standby mode.

FIGURE 7-4 on page 125 shows the system power LED location for the Netra ct 800 server, and FIGURE 7-5 on page 126 shows the system power LED location for the Netra ct 400 server.

6. If you want to completely power off the Netra ct server, push the purple power supply unit locking mechanism(s) up into the unlocked (Ⓛ) position (see FIGURE 7-1 on page 122 for the Netra ct 800 server or FIGURE 7-2 on page 123 for the Netra ct 400 server).

Note – You must unlock the locking mechanism on *both* power supply unit(s) on the Netra ct 800 server in order to completely power off that server.

The green power (Ⓛ) LED(s) on the power supply unit(s) should go off (unlit), indicating that the system is now completely powered off.

▼ To Perform a Software Power Off

1. In preparation for bringing down the operating system and powering down the server, ensure that all significant application activity is quiesced on the server.
2. Log in as root at the system console and enter:

```
# cd /
# shutdown -i0 -g0 -y
```

When the server is finished shutting down, the `ok` prompt is displayed.

3. Log into your server and boot up the server.

Refer to “Connecting a Terminal Console to the Server” on page 116 for instructions on connecting a terminal to your server, if necessary.

4. At the ok prompt, enter:

```
ok power-off
```

5. Go to the front of the Netra ct server and locate the system status panel (see FIGURE 7-3 on page 124).

The location of the system status panel in the Netra ct 800 server and Netra ct 400 server is illustrated in FIGURE 7-3.

6. Verify that the green power (Ⓛ) LED on the power supplies are blinking, indicating that the system is in the standby mode.

FIGURE 7-4 on page 125 shows the system power LED location for the Netra ct 800 server, and FIGURE 7-5 on page 126 shows the system power LED location for the Netra ct 400 server.

7. If you want to completely power off the Netra ct server, push the purple power supply unit locking mechanism(s) up into the unlocked (⏏) position (see FIGURE 7-1 on page 122 for the Netra ct 800 server or FIGURE 7-2 on page 123 for the Netra ct 400 server).

Note – You must unlock the locking mechanism on *both* power supply unit(s) on the Netra ct 800 server in order to completely power off that server.

The green power (Ⓛ) LED(s) on the power supply unit(s) should go off (unlit), indicating that the system is now completely powered off.

Installing the Software

This chapter gives instructions on installing the Solaris operating environment and the Netra ct server software on a Netra ct server. You will be installing software from the Solaris operating environment CDs (Solaris 8 1/01) and the *Software Supplement for the Solaris 8 1/01 Operating Environment* CD (called the *Supplement CD* throughout this chapter).

Note – The Solaris operating environment is ordered and shipped separately from the Netra ct server.

There are several different options available for installing the Solaris operating environment and Netra ct server software on your server:

- If you have a Netra ct 800 server and you have a CD-ROM/DVD installed in or connected to your server, you can install the software using the instructions in “Using a CD-ROM/DVD” on page 131. You can also install the software onto a Netra ct 400 server using these instructions, but only if you have an external CD-ROM/DVD connected to your server; there is no internal CD-ROM/DVD available for the Netra ct 400 server.
- If you do not have a CD-ROM/DVD installed in or connected to your server, follow the instructions in “Using JumpStart” on page 139 to install the software.

Using a CD-ROM/DVD

▼ To Install the Solaris Operating Environment

1. Insert the first Solaris operating environment CD into the internal CD-ROM/DVD.

2. Make the necessary connections to the TTY A port on the CPU or CPU transition card on your server.

Refer to “Connecting a Terminal Console to the Server” on page 116 for more information.

Note – Do not install the Solaris operating environment through the alarm card or alarm transition card.

3. Through the TTY A port on the CPU or CPU transition card, install the Solaris operating environment on every server in the chassis.

You must install the Solaris operating environment on every Netra ct server that you have installed in the chassis in order for that server to function. Refer to the documentation that you received with the Solaris operating environment for those installation instructions. You may have to insert several CDs into the CD-ROM/DVD in order to completely install the Solaris operating environment.

When installing the Solaris operating environment onto your Netra ct servers, you must keep the following things in mind:

1. At the Select Software portion of the installation process, you will see the following screen:

```
- Select Software -----  
Select the Solaris software to install on the system.  
  
NOTE: After selecting a software group, you can add or remove software by  
customizing it. However, this requires understanding of software  
dependencies and how Solaris software is packaged. The software groups  
displaying 64-bit contain 64-bit support.  
  
[ ] Entire Distribution plus OEM support 64-bit 1242.00 MB  
[ ] Entire Distribution 64-bit ..... 1218.00 MB  
[ ] Developer System Support 64-bit ..... 1172.00 MB  
[ ] End User System Support 64-bit ..... 881.00 MB  
[ ] Core System Support ..... 340.00 MB
```

Do not choose the *last* selection (Core System Support); doing so will install the Solaris operating environment without the Netra ct server software. Install one of the remaining four choices instead.

2. At the Power Management portion of the installation process, you will see the following screen:

```
This system is configured to conserve energy.
```

```
After 30 minutes of idle time on this system, your system state will automatically be saved to disk, and the system will power-off. Later, when you want to use the system again, and you turn the power back on, your system will be restored to its previous state, including all the programs that you were running. Do you want this automatic power-saving shutdown? (If this system is used as a server, answer n) [y,n,?]
```

Enter n (no) at this point; you do *not* want to enable the automatic shutdown feature. You will then see the following confirmation screen:

```
Autoshutdown has been disabled.
```

```
Do you want the system to ask about this again, when you next reboot? (This gives you the chance to try it before deciding whether to keep it.) [y,n,?]
```

Enter n (no) at this point; you will never want to enable the automatic shutdown feature on your Netra ct servers.

▼ To Install the Netra ct Server Software

There are several Netra ct server software packages on the *Supplement* CD that you must install on every Netra ct server in the chassis in order for the servers to run properly.

You can install the software from the Supplement CD in two ways:

- “To Install the Netra ct Server Software Using Solaris Web Start” on page 133
- “To Install the Netra ct Server Software Using pkgadd” on page 135

▼ To Install the Netra ct Server Software Using Solaris Web Start

1. Insert the *Supplement* CD into your CD-ROM drive.
2. In a shell window, type:

```
# cd /cdrom/cdrom0
# ./installer
```

3. When the Solaris Web Start screen is displayed, select Next.
4. Select Custom Install, and click Next.
5. Select the software you want to install, and click Next.

TABLE 8-1 shows the *minimum* software packages on the *Supplement* CD that you must install on your Netra ct server in order for it to function properly. TABLE 8-2 shows the remaining software packages on the *Supplement* CD that are optional installations. Note that some software packages are labeled “Optional” by the Solaris Web Start software, even though they are mandatory for a Netra ct server to function properly.

TABLE 8-1 Mandatory Software From the Supplement CD

Software	Solaris Web Start 2.0
Netra ct Platform 1.0	Optional
SunVTS™ 4.2	Installed by default

TABLE 8-2 Optional Software From the Supplement CD

Software	Solaris Web Start 2.0
OpenGL® software	Installed by default
PC launcher and PC file viewer	Installed by default
ShowMe™ TV 1.3 software	Installed by default
Solaris on Sun Hardware AnswerBook Set	Installed by default
SunFDDI™ drivers	Installed by default
SunHSI™ drivers	Installed by default
Sun GigabitEthernet driver	Installed by default
SunATM™ driver	Installed by default
SunForum™ software	Installed by default
Java 3D™ 1.1.1	Installed by default
Sun Enterprise™ 10000 SSP	Optional
Alternate Pathing	Optional
Capacity On Demand (COD)	Optional

6. Click Next, and click Install Now.

To Install the Netra ct Server Software Using `pkgadd`

1. Insert the Supplement CD into your CD-ROM drive.

The File Manager window is displayed.

2. In a shell window, become superuser using the `su` command and the superuser password.

3. Install the software packages onto your Netra ct server.

You can install the packages one at a time, or you can install all the packages within a directory at once.

- To install the packages one at a time, type:

```
# /usr/sbin/pkgadd -d /cdrom/cdrom0/directory/Product package-names
```

where *package-names* are the package names from TABLE 8-3 and TABLE 8-4.

- To install all the packages within a directory, type

```
# cd /cdrom/cdrom0/directory/Product
# pkgadd -d .
```

where *directory* is the software product directory from TABLE 8-3 and TABLE 8-4.

Note – TABLE 8-3 shows the *minimum* software packages on the Supplement CD that you must install on your Netra ct server in order for it to function properly. TABLE 8-4 shows the remaining software packages on the Supplement CD that are optional installations.

To install a particular product, choose the appropriate packages:

TABLE 8-3 Mandatory Software Package Names

Software	Version	Directory	Packages
Netra ct Platform	1.0	Netra_ct_Platform_1.0/	SUNW2jdrt SUNWctac ¹ SUNWcteux ¹ SUNWctevx SUNWctmgx
Validation Test Suite Software (SunVTS)	4.2	SunVTS_4.0/	SUNWesnta SUNWodu SUNWvts SUNWvtsol SUNWeswsa SUNWsyncfd SUNWvtsmn SUNWvtsx

1. You must have the SUNWctac package installed in order for SUNWcteux to work.

TABLE 8-4 Optional Software Package Names

Software	Version	Directory	Packages
OpenGL Runtime Libraries Software	1.2	OpenGL_1.2/	SUNWafbg1 SUNWafbgx SUNWffbg1 SUNWffbgx SUNWglh SUNWglrt SUNWglrtu SUNWglrtx
PClauncher/PC file viewer	1.0.1/ 1.0.1	PC_launcher_1.0.1_PC_fileviewe r_1.0.1/	SUNWdtpcv SUNWdtpcz SUNWdtpcp
ShowMe TV	1.3	ShowMeTV_1.3/	SUNWsmtvh SUNWsmtvr SUNWsmvtv SUNWsmtvu
SunForum	3.0	SunForum_3.0	SUNWdat SUNWdatu

TABLE 8-4 Optional Software Package Names

Software	Version	Directory	Packages
SunFDDI PCI Driver Software	3.0	SunFDDI_PCI_3.0/	SUNWpfd SUNWpfh SUNWpfm SUNWpfu
SunFDDI SBus Driver Software	7.0	SunFDDI_SBus_7.0/	SUNWnfd SUNWnfh SUNWnfm SUNWnfu
Sun GigabitEthernet Software	3.0	Sun_GigabitEthernet_3.0/	SUNWged SUNWgedm SUNWgedu
SunHSI PCI Driver Software	3.0	SunHSI_PCI_3.0/	SUNWhsip SUNWhsipm SUNWhsipu
SunHSI SBus Driver Software	3.0	SunHSI_SBus_3.0/	SUNWhsis SUNWhsism SUNWhsisu
Sun Hardware AnswerBook2	1.0	Sun_Hardware_Answerbook/	SUNWabhdw
Java 3D	1.1.2	Java3D_1.1.2/	SUNWj3doc SUNWj3dem SUNWj3drt SUNWj3dut
SunATM 5.0	5.0	SunATM_5.0/	SUNWatm SUNWatma SUNWatmu
Alternate Pathing	2.3	Alternate_Pathing_2.3/	SUNWapdoc SUNWapdv SUNWapr SUNWapu

TABLE 8-4 Optional Software Package Names

Software	Version	Directory	Packages
Sun Enterprise 10000 SSP	3.2	System_Service_Processor_3.2/	SUNWsspdf SUNWsspdo SUNWsspdr SUNWsspfp SUNWsspид SUNWsspmm SUNWsspob SUNWsspоp SUNWsspоpо SUNWssprr SUNWsspst SUNWsspue
SSP AnswerBook2	1.0	System_Service_Processor_3.2_ Answerbook/	SUNWuessp
Capacity On Demand (COD)	1.0	Capacity_on_Demand_1.0/	SUNWcod SUNWcodbk SUNWcodmn

If a problem occurs during package installation, information about the problem is displayed, followed by this prompt:

Do you want to continue with this installation?

Respond with either *yes*, *no*, or *quit*.

▼ To Verify the Software Package Installation

- To verify that you've installed all the Netra ct server software packages, type:

```
# pkginfo package-name
```

For example, to verify that all the packages from the `RSC_2.0` directory were installed, you would enter the following:

```
# pkginfo SUNWrsc SUNWrscj
```

You should see feedback similar to the following:

```
system    SUNWrsc    Remote System Control
system    SUNWrscj   Remote System Control (GUI)
```

▼ To Install Additional Software

1. **If you installed I/O cards, perform any card-specific software configuration procedures, if necessary.**

Refer to the documentation that came with your I/O card for more information.

2. **Install and configure any additional disk management software, if necessary.**

Refer to the documentation that came with your disk management software for more information.

Using JumpStart

Using JumpStart, you can install the Solaris operating environment onto a central installation server, and then install the operating environment onto individual servers using that central installation server. Refer to the documentation that you received with the Solaris operating environment for instructions on setting up and using JumpStart.

TTYMux Information

TTYMux Security Information

Use caution when enabling TTYMux to perform console input multiplexing, particularly during super-user login, because a login on one console device could mean a login on all console devices and therefore equal access privileges to the host at the same time. Because no security measures are provided by the multiplexer framework, you must clearly understand the security implications involved in using this feature and take appropriate measures to provide maximum protection to the host. You should have the console devices in a physically secure environment for maximum protection to the host because the console multiplexer framework does not provide any means of security measures.

Note – In addition, the TTYMux driver does not handle the behavioral differences in control characteristics of different terminal types (for example, an ESCAPE sequence.) As a result, multiple terminal types are not supported simultaneously.

Installing TTYMux Patches

You may have to install the TTYMux patches separately, depending on the version of Solaris that you are running:

- If your system is running on Solaris *9 or later*, then you do not have to install the TTYMux patches; they were automatically installed when you loaded your operating system.
- If your system is running on Solaris *8 or earlier*, then you will have to install the TTYMux patches separately. Following are the instructions for installing the TTYMux patches:

1. Determine if you already have the necessary generic patches installed on your system.

Following are the generic patches that you must have installed on your system first, before you can install the TTYMux patches:

- 109458-02
- 108528-10
- 111293-04
- 110790-04

To determine if you have the latest version of the patch installed already, enter the following command:

```
% showrev -p | grep 'patch_id'
```

where *patch_id* is the patch number given in Step 1, without the dash level. For example, to see if the latest version of patch 109458 is installed, enter the following command:

```
% showrev -p | grep '109458'
```

- If you see no output after entering the command, then that patch has not been installed yet. Locate the patch and install it using the `patchadd` command.
- If you see output similar to the following after entering the command:

```
% Patch: 109458-01 Obsoletes: Requires: Incompatibles: Packages:
```

then the patch has been installed already.

- If the dash level is the *same* or *higher* than that shown in Step 1, then you have the correct version of the patch installed on your server. Go to Step 2.

- If the dash level is the *lower* than that shown in Step 1, then you must install the latest version of the patch onto your server. Locate the patch and install it using the `patchadd` command.

Note – You must verify that you have the patches listed in Step 1 installed before you can install the TTYMux patches in the next step.

2. Install the TTYMux patches.

Locate and read the file `README.1111406-02` to get the latest patch information first, then locate each of the following patches and install them using the `patchadd` command.

- 111406-02
- 111407-01 (point patch)
- 111408-01 (point patch)

Using TTYMux

1. Halt your system and get to the `ok` prompt.
2. Verify that the OpenBoot PROM is version 3.14.5 or later.

At the `ok` prompt, enter:

```
ok banner
```

Search through the output until you see the line that gives the OpenBoot PROM (OBP) version, similar to the following:

```
...
      OBP 3.14.5 ...
...
```

3. At the `ok` prompt, enter:

```
ok setenv input-device input-mux
ok setenv output-device output-mux
```

4. Reboot the system.

5. **Verify that the console for the alarm card is connected through either the COM 1 or the COM 2 ports on the alarm card.**

You cannot use TTYMux if the console for the alarm card is connected through the ethernet port on the alarm card.

6. **At the rsc prompt through the alarm card, enter:**

```
rsc> console
```

You should now have console access on the host through the alarm serial port.

Connecting External SCSI Devices

▼ To Connect an External SCSI Device

1. Locate the SCSI port on your Netra ct server.

You can connect an external SCSI device to the SCSI port on an I/O card or on the CPU transition card.

- If you are connecting an external SCSI device to the SCSI port on an I/O card, refer to the documentation that came with the I/O card for the location and type of the SCSI port on the I/O card.
- If you are connecting an external SCSI device to the SCSI port on the CPU transition card, the location of the SCSI port on your Netra ct server will vary, depending on the type and model server you have:
 - If you have a *front-access model* Netra ct 800 server, the SCSI port is located on the CPU front transition card installed next to the CPU card (FIGURE A-1).

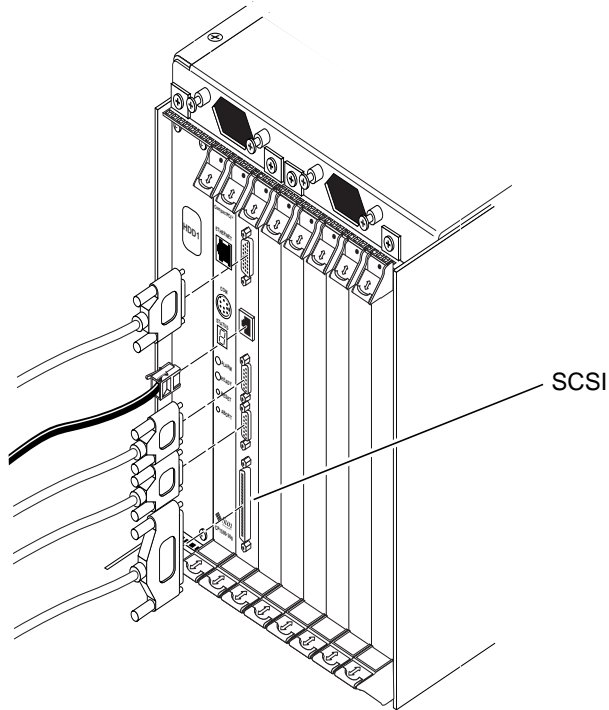

FIGURE A-1 Locating the SCSI Port on the CPU Front Transition Card (Netra ct 800 Server)

- If you have a *front-access model* Netra ct 400 server, the SCSI port is located on the CPU front transition card to the left of the power supply (FIGURE A-2).

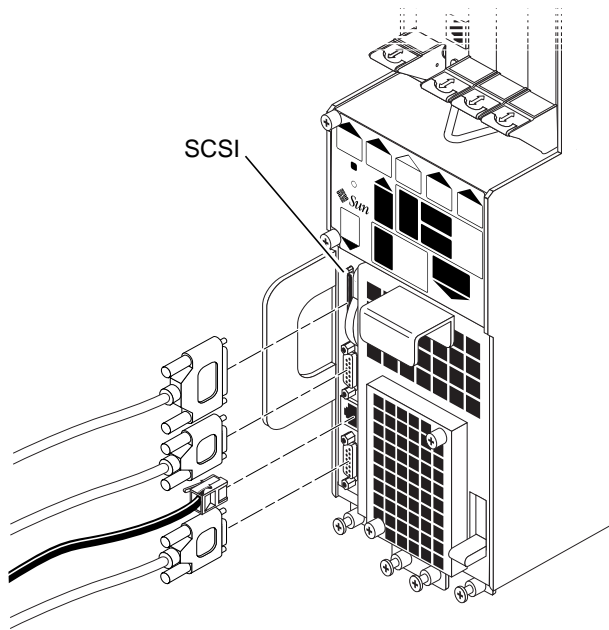

FIGURE A-2 Locating the SCSI Port on the CPU Front Transition Card (Netra ct 400 Server)

- If you have a *rear-access model* of either the Netra ct 800 server or the Netra ct 400 server, the SCSI port is located on the CPU rear transition card installed at the rear of the chassis in I/O slot 1 for the Netra ct 800 server or I/O slot 3 for the Netra ct 400 server. FIGURE A-3 shows the locations of the connectors on the CPU rear transition card for the Netra ct 800 server and FIGURE A-4 shows the locations of the connectors on the CPU rear transition card for the Netra ct 400 server. The CPU rear transition card is the same for both the Netra ct 800 server and the Netra ct 400 server; only the location in the rear card cage differs.

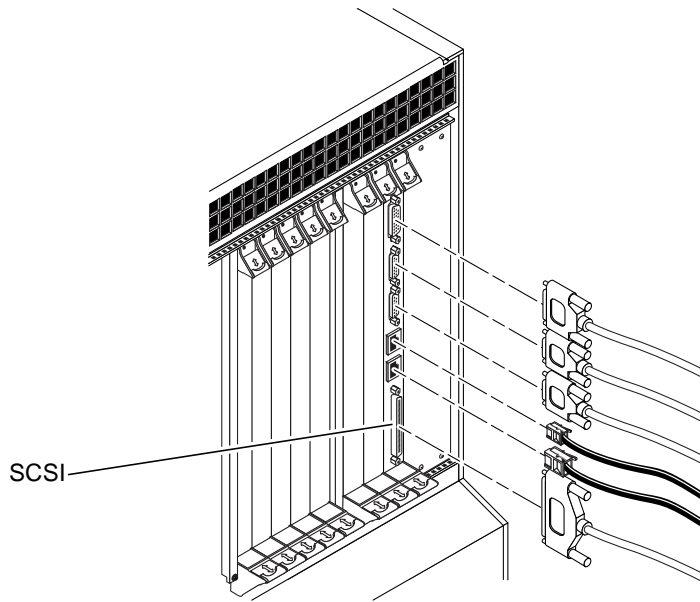

FIGURE A-3 Connectors on the CPU Rear Transition Card (Netra ct 800 Server)

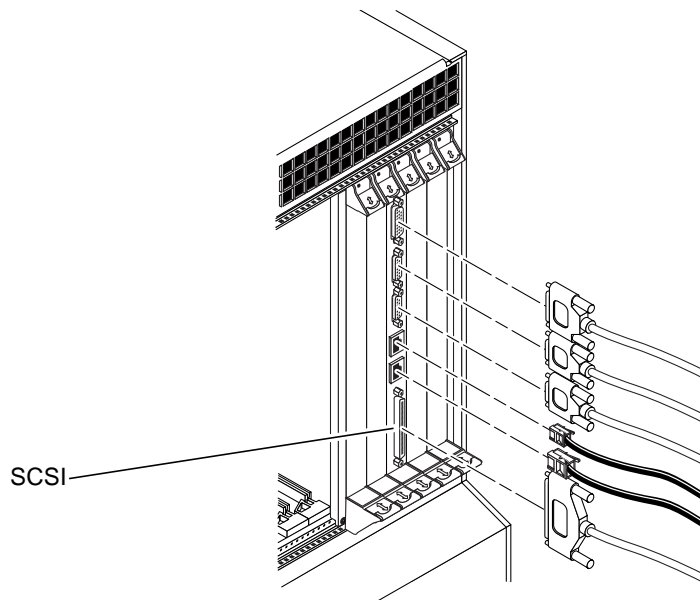

FIGURE A-4 Connectors on the CPU Rear Transition Card (Netra ct 400 Server)

2. Determine if you need to use the VHDC-to-SCSI 3 adapter cable included in the Netra ct server ship kit.

- If you are connecting an external SCSI device to the CPU front transition card for the Netra ct 800 server, you do not need the VHDC-to-SCSI 3 adapter cable. Go to Step 3.
- If you are connecting an external SCSI device to the CPU front transition card for the Netra ct 400 server or the CPU rear transition card for either Netra ct server, connect the VHDC side of the VHDC-to-SCSI 3 adapter cable to the SCSI port on the transition card (see FIGURE A-2, FIGURE A-3 or FIGURE A-4).

3. Get the SCSI cable from the external SCSI device's ship kit.

4. Connect one end of the SCSI cable to the SCSI connector on your Netra ct server.

- If you are connecting an external SCSI device to the CPU front transition card for the Netra ct 800 server, connect the SCSI cable to the SCSI port on the CPU front transition card (FIGURE A-1).
- If you are connecting an external SCSI device to the CPU front transition card for the Netra ct 400 server or the CPU rear transition card for either Netra ct server, connect the SCSI cable to the SCSI 3 end of the VHDC-to-SCSI 3 adapter cable.

5. Connect the other end of the SCSI cable to the appropriate SCSI port on the external SCSI device.

Refer to the documentation that you received with the external SCSI device for more information.

6. Set the SCSI ID on the external SCSI device to a SCSI ID that is *not* being used already by an internal SCSI device in your Netra ct server.

- If you are connecting the external SCSI device to a *Netra ct 800 server*, the following list tells what internal SCSI devices you might have installed in the Netra ct 800 server and the SCSI IDs that are assigned to each:
 - Upper hard disk drive (HDD0)—SCSI ID 0
 - Lower hard disk drive (HDD1)— SCSI ID 1
 - CD-ROM drive—SCSI ID 6
 - DAT drive—SCSI ID 5
- If you are connecting the external SCSI device to a *Netra ct 400 server*, the only internal SCSI device you would have installed in your Netra ct 400 server would be a hard disk drive, which would be set to SCSI ID 0.

Refer to the documentation that came with your external SCSI device for instructions on setting the SCSI ID on the device.

7. Power on the external SCSI device.

Refer to the documentation that you received with the external SCSI device for those instructions.

8. Determine if your Netra ct server is powered off or on.

- If the Netra ct server is powered *off*, proceed to the next appropriate section (either “Assembling and Connecting the DC Input Power Cable” on page 103 or “Powering On the Server” on page 122).
- If the Netra ct server is powered *on*, follow these instructions to enable the server to recognize the external SCSI device:

9. Log in to the Netra ct server as superuser.

Refer to “Connecting a Terminal Console to the Server” on page 116.

10. Use the `cfgadm -al` command to list all of the attachment point ID names, including the SCSI controllers.

From this list, find the attachment-point ID name of the SCSI controller where you connected the external SCSI device. The following example is from a Netra ct 800 server with three SCSI controllers (c0, c1, and c5). The c0 attachment point ID name is for the SCSI controller on the system’s CPU card and the c1 and c5 names are for SCSI controllers on an I/O card installed in the system.

```
# cfgadm -al
Ap_Id                Type           Receptacle  Occupant    Condition
c0                   scsi-bus      connected   configured  unknown
c0::dsk/c0t0d0       disk          connected   configured  unknown
c0::dsk/c0t1d0       disk          connected   configured  unknown
c1                   scsi-bus      connected   configured  unknown
c5                   scsi-bus      connected   configured  unknown
pci_pci0:cpci_slot2  unknown       empty       unconfigured unknown
pci_pci0:cpci_slot3  unknown       disconnected unconfigured unknown
pci_pci0:cpci_slot4  unknown       disconnected unconfigured unknown
pci_pci0:cpci_slot5  unknown       empty       unconfigured unknown
pci_pci0:cpci_slot6  stpcipci/fhs connected    configured  ok
pci_pci0:cpci_slot7  stpcipci/fhs connected    configured  ok
pci_pci0:cpci_slot8  stpcipci/fhs connected    configured  ok
```

11. Use the `cfgadm` command to configure the external SCSI device to the host system.

Replace *controller-ap-id* with the SCSI controller’s attachment-point ID name.

```
# cfgadm -c configure controller-ap-id
```

For example, if the attachment-point ID is c1, you would type:

```
# cfgadm -c configure c1
```

12. Use the `devfsadm` command to rebuild the `/dev` and `/devices` directories.

If you have attached a hard disk, CD-ROM, or DVD-ROM drive to the system, type:

```
# devfsadm -c disk
```

If you have attached a tape drive to the system, type:

```
# devfsadm -c tape
```

After using the `devfsadm` command, you will be able to use the devices you connected to the adapter's SCSI controller. Refer to the `devfsadm(1M)` man page for more information.

13. Use the `cfgadm -al` command to verify that the external SCSI device is connected to the system.

The following example shows a media tray CD-ROM drive, which has an attachment-point ID name of `c5::dsk/c5t4d0`, configured to the system.

```
# cfgadm -al
Ap_Id                Type          Receptacle  Occupant    Condition
c0                   scsi-bus     connected   configured  unknown
c0::dsk/c0t0d0      disk         connected   configured  unknown
c0::dsk/c0t1d0      disk         connected   configured  unknown
c1                   scsi-bus     connected   configured  unknown
c5                   scsi-bus     connected   configured  unknown
c5::dsk/c5t4d0      CD-ROM       connected   configured  unknown
pci_pci0:cpci_slot2 unknown      empty       unconfigured unknown
pci_pci0:cpci_slot3 unknown      disconnected unconfigured unknown
pci_pci0:cpci_slot4 unknown      disconnected unconfigured unknown
pci_pci0:cpci_slot5 unknown      empty       unconfigured unknown
pci_pci0:cpci_slot6 stpcipci/fhs connected   configured  ok
pci_pci0:cpci_slot7 stpcipci/fhs connected   configured  ok
pci_pci0:cpci_slot8 stpcipci/fhs connected   configured  ok
```

Refer to the Solaris documentation for instructions on how to use the devices.

Glossary

Knowledge of the following terms and acronyms is useful in the administration of the Netra ct server.

A

alarm card An optional card that occupies a slot in the Netra ct server. The alarm card responds to events, such as I/O card failures or excessive heat. Software that resides on the card can take action in response to such events.

alarms feature A set of features implemented in software and hardware that provide the operator of the Netra ct server with notifications when hardware and/or software failures occur (or when failure thresholds are being approached).

B

basic hot swap One of the hot swap states. In the basic hot swap model, the hardware connection process can be performed automatically by the hardware, while the software connection process requires operator assistance. See *hot swap*, *full hot swap*

C

CompactPCI A standard for computer boards and buses. CompactPCI is adapted from the *Peripheral Component Interconnect (PCI) Specification* for industrial and/or embedded applications requiring a more robust mechanical form factor than desktop PCI. CompactPCI is supported by the PCI Industrial Computer Manufacturers Group (PICMG), a consortium that uses PCI for embedded applications.

F

- field replaceable unit (FRU)** From a service point of view, the smallest irreducible elements of a server, such as the Netra ct server. Examples of FRUs are disk drives, I/O cards, and power supplies. Note that a server, with all of its cards and other components, is not a FRU. However, an empty server is.
- front-access** The model of the Netra ct server that is configured so that all of the cables come out from the front of the chassis.
- front transition module** Used only for the CPU in the front access models of the Netra ct server. The CPU front transition module allows for CPU cabling from the front of the chassis.
- full hot swap** One of the hot swap states. In the full hot swap model, both the hardware and the software connection process are performed automatically.
- See hot swap, basic hot swap*

H

hot swap Implies the ability to remove and replace cards from and in a running computer. *See full hot swap, basic hot swap*

M

midplane The functional equivalent of a backplane. The midplane is secured to the back of the server. The CPU card, I/O cards and storage devices plug into the midplane from the front, and the rear transition cards plug into the midplane from the rear.

N

NEBS An acronym for Network Equipment/Building System. A set of requirements for equipment installed in telco offices. These requirements cover personnel safety, protection of property, and operational continuity. "NEBS testing" involves subjecting equipment to shaking (for earthquakes), fire, and other environmental insults. There are three levels of NEBS compliance, each a superset of the preceding. NEBS level 3, the highest level, certifies that a piece of equipment can be safely deployed in an "extreme environment." A telco central office is considered an extreme environment.

The NEBS standards are maintained by Telcordia Technologies, Inc., formerly Bellcore.

P

PICMG Acronym for the PCI Industrial Computer Manufacturers Group. (PCI stands for Peripheral Component Interconnect.) PICMG is the group that promulgates the CompactPCI standard.

See *CompactPCI*.

R

rear-access The model of the Netra ct server that is configured so that all of the cables come out from the rear of the chassis.

rear transition card Used only on the rear access models of the Netra ct server. The rear transition cards extend the connectors from the midplane to the rear of the chassis.

**Reliability, Availability,
Serviceability (RAS)**

Refers to hardware or software features that implement or improve the reliability, availability and serviceability of a server. For example, the Netra ct server has a watchdog reset that prevents endless operating system “hangs”. If the operating system enters a hung state, the watchdog reset initiates a system reset upon the expiration of a timer. This feature is said to increase the server’s availability. Much of the Netra ct server’s RAS functions are provided by the *alarm card* and the firmware that resides on that card.

S

system status panel A module designed to give feedback on the status of the key components within the Netra ct servers. The system status panel has one set of LEDs for each component within that particular server.

system controller board A hot-swappable component located behind the system status panel. It feeds system status information to the system status panel, where LEDs give feedback on the status of the key components within the Netra ct servers.

U

U A unit of measure equal to 1.75 inches.

Index

A

airflow, 16

alarm card

 cabling, 77

 connectors

 Netra ct 400 server, 78

 Netra ct 800 server, 77

alarm rear transition card

 cabling, 97

 connectors, 98

C

cabling

 alarm card, 77

 alarm rear transition card, 97

 CPU card, 58

 CPU front transition card, 62

 CPU rear transition card, 87

 front I/O card and I/O rear transition card, 103

 I/O cards, 87

center-mount, 19

chassis ground

 isolating, 14

connecting

 an external SCSI device, 143

connectors

 alarm card

 Netra ct 400 server, 78

 Netra ct 800 server, 77

 alarm rear transition card, 98

 CPU card, 60

 CPU front transition card

 Netra ct 400 server, 66

 Netra ct 800 server, 65

 CPU rear transition card, 89

cooling requirements, 15

CPU card

 cabling, 58

 connectors, 60

CPU front transition card

 cabling, 62

 connectors

 Netra ct 400 server, 66

 Netra ct 800 server, 65

CPU rear transition card

 cabling, 87

 connectors, 89

D

DC grounding cables, connecting, 29

DC input power cable

 assembling, 104

 connecting, 110

DC power requirements

 overcurrent protection, 14

DC source site requirements, 13

- E**
 - environmental specifications, 17
 - external SCSI device
 - connecting, 143

- F**
 - front I/O card and I/O rear transition card
 - cabling, 103

- I**
 - I/O cards
 - cabling, 87
 - installing
 - Netra ct server software, 133
 - servers in the chassis, 33
 - Solaris operating environment, 131

- L**
 - logic ground
 - isolating, 14

- M**
 - mounting bracket adapters, attaching, 20
 - mounting the chassis in a rack
 - center-mount, 19

- N**
 - Netra ct 400 server
 - physical specifications, 12
 - Netra ct 800 server
 - physical specifications, 11
 - Netra ct chassis
 - mounting in a rack, 22
 - physical specifications, 9
 - Netra ct server software, installing, 133

- O**
 - overcurrent protection, 14
 - circuit breakers, 14

- P**
 - physical specifications
 - Netra ct 400 server, 12
 - Netra ct 800 server, 11
 - Netra ct chassis, 9
 - powering off the server, 126
 - hardware power-down, 127
 - software power-down, 129
 - powering on the server, 122

- R**
 - rack-mounting, 22
 - removing
 - servers from the chassis, 22

- S**
 - SCSI
 - external devices, connecting, 143
 - internal devices, SCSI IDs, 147
 - SCSI IDs, internal SCSI devices, 147
 - Solaris operating environment, installing, 131

- T**
 - tools required, 3
 - TTYMux
 - installing TTYMux patches, 140
 - security information, 139
 - using TTYMux, 141