



Sun StorEdge™ 2G FC PCI Dual Channel Network Adapter Installation Guide

Sun Microsystems, Inc.
www.sun.com

Part No. 816-5001-12
January 2007, Revision A

Submit comments about this document at: <http://www.sun.com/hwdocs/feedback>

Copyright 2007 Sun Microsystems, Inc., 901 San Antonio Road • Palo Alto, CA 94303-4900 USA. All rights reserved.

This product or document is protected by copyright and distributed under licenses restricting its use, copying, distribution, and decompilation. No part of this product or document may be reproduced in any form by any means without prior written authorization of Sun and its licensors, if any. Third-party software, including font technology, is copyrighted and licensed from Sun suppliers.

Parts of the product may be derived from Berkeley BSD systems, licensed from the University of California. UNIX is a registered trademark in the U.S. and other countries, exclusively licensed through X/Open Company, Ltd. For Netscape Communicator™, the following notice applies: Copyright 1995 Netscape Communications Corporation. All rights reserved.

Sun, Sun Microsystems, the Sun logo, AnswerBook2, docs.sun.com, Sun Enterprise, SunVTS, StorEdge, and Solaris are trademarks, registered trademarks, or service marks of Sun Microsystems, Inc. in the U.S. and other countries. All SPARC trademarks are used under license and are trademarks or registered trademarks of SPARC International, Inc. in the U.S. and other countries. Products bearing SPARC trademarks are based upon an architecture developed by Sun Microsystems, Inc.

The OPEN LOOK and Sun™ Graphical User Interface was developed by Sun Microsystems, Inc. for its users and licensees. Sun acknowledges the pioneering efforts of Xerox in researching and developing the concept of visual or graphical user interfaces for the computer industry. Sun holds a non-exclusive license from Xerox to the Xerox Graphical User Interface, which license also covers Sun's licensees who implement OPEN LOOK GUIs and otherwise comply with Sun's written license agreements.

RESTRICTED RIGHTS: Use, duplication, or disclosure by the U.S. Government is subject to restrictions of FAR 52.227-14(g)(2)(6/87) and FAR 52.227-19(6/87), or DFAR 252.227-7015(b)(6/95) and DFAR 227.7202-3(a).

DOCUMENTATION IS PROVIDED "AS IS" AND ALL EXPRESS OR IMPLIED CONDITIONS, REPRESENTATIONS AND WARRANTIES, INCLUDING ANY IMPLIED WARRANTY OF MERCHANTABILITY, FITNESS FOR A PARTICULAR PURPOSE OR NON-INFRINGEMENT, ARE DISCLAIMED, EXCEPT TO THE EXTENT THAT SUCH DISCLAIMERS ARE HELD TO BE LEGALLY INVALID.

Copyright 2007 Sun Microsystems, Inc., 901 San Antonio Road • Palo Alto, CA 94303-4900 Etats-Unis. Tous droits réservés.

Ce produit ou document est protégé par un copyright et distribué avec des licences qui en restreignent l'utilisation, la copie, la distribution, et la décompilation. Aucune partie de ce produit ou document ne peut être reproduite sous aucune forme, par quelque moyen que ce soit, sans l'autorisation préalable et écrite de Sun et de ses bailleurs de licence, s'il y en a. Le logiciel détenu par des tiers, et qui comprend la technologie relative aux polices de caractères, est protégé par un copyright et licencié par des fournisseurs de Sun.

Des parties de ce produit pourront être dérivées des systèmes Berkeley BSD licenciés par l'Université de Californie. UNIX est une marque déposée aux Etats-Unis et dans d'autres pays et licenciée exclusivement par X/Open Company, Ltd. La notice suivante est applicable à Netscape Communicator™: Copyright 1995 Netscape Communications Corporation. Tous droits réservés.

Sun, Sun Microsystems, the Sun logo, AnswerBook2, docs.sun.com, Sun Enterprise, SunVTS, StorEdge, et Solaris sont des marques de fabrique ou des marques déposées, ou marques de service, de Sun Microsystems, Inc. aux Etats-Unis et dans d'autres pays. Toutes les marques SPARC sont utilisées sous licence et sont des marques de fabrique ou des marques déposées de SPARC International, Inc. aux Etats-Unis et dans d'autres pays. Les produits portant les marques SPARC sont basés sur une architecture développée par Sun Microsystems, Inc.

L'interface d'utilisation graphique OPEN LOOK et Sun™ a été développée par Sun Microsystems, Inc. pour ses utilisateurs et licenciés. Sun reconnaît les efforts de pionniers de Xerox pour la recherche et le développement du concept des interfaces d'utilisation visuelle ou graphique pour l'industrie de l'informatique. Sun détient une licence non exclusive de Xerox sur l'interface d'utilisation graphique Xerox, cette licence couvrant également les licenciés de Sun qui mettent en place l'interface d'utilisation graphique OPEN LOOK et qui en outre se conforment aux licences écrites de Sun.

CETTE PUBLICATION EST FOURNIE "EN L'ETAT" ET AUCUNE GARANTIE, EXPRESSE OU IMPLICITE, N'EST ACCORDEE, Y COMPRIS DES GARANTIES CONCERNANT LA VALEUR MARCHANDE, L'APTITUDE DE LA PUBLICATION A REpondre A UNE UTILISATION PARTICULIERE, OU LE FAIT QU'ELLE NE SOIT PAS CONTREFAISANTE DE PRODUIT DE TIERS. CE DENI DE GARANTIE NE S'APPLIQUERAIT PAS, DANS LA MESURE OU IL SERAIT TENU JURIDIQUEMENT NUL ET NON AVENU.

Contents

| | |
|---|-------------|
| Preface | i |
| Declaration of Conformity | v |
| Safety Agency Compliance Statements | vii |
| Regulatory Compliance Statements | xvii |
| 1. Installation | 1 |
| Software Requirements | 1 |
| Device Drivers | 1 |
| Tools and Equipment Needed | 2 |
| Preparing for Installation | 2 |
| Sun Enterprise Systems | 3 |
| Preparing for a Sun StorEdge A5x00 Installation | 4 |
| Installing the Host Adapter | 6 |
| Testing the Installation | 11 |
| SunVTS | 11 |
| Testing Procedure | 11 |
| A. Specifications | 13 |
| PCI Card | 13 |

Fibre Channel Interface Specifications 14

Performance Specifications 14

Power Requirements 15

Physical Dimensions 15

Regulatory Compliance 15

PCI Edge Connector Pin Definitions:

32-Bit Cards 16

PCI Edge Connector Pin Definitions:

64-Bit Cards 18

B. Booting From the Network Adapter 21

The Net Install Method 22

Overview For the Net Install Method 22

To Set Up the Boot/Install Server 23

To Modify the Boot Image 25

To Set Up the Client 26

The Dump and Restore Method 28

Overview Of the Dump and Restore Method 28

Partitioning the New Boot Disk the Same As the Temporary Boot Disk 28

To Prepare To Partition the New Disk 29

To Record the Partition Layout 29

To Change To the New Boot Disk 32

To Specify Slices On the New Boot Disk 33

To Label the New Boot Disk 37

To Create File Systems on the New Boot Disk 38

To Create the New Boot Files 38

To Copy the Boot Block and Root File System Contents To the New Boot
Disk 39

To Update the `vfstab` File 40

To Copy the Contents of Non-root File Systems onto the New Boot Disk
41

To Specify the New Boot Disk as the Boot Device. 42

Preface

The *Sun StorEdge™ 2G FC PCI Dual Channel Network Adapter Installation Guide* describes how to install Sun StorEdge 2G FC PCI Dual Channel Network Adapter cards. These instructions are designed for an experienced system administrator or trained service provider.

Using UNIX Commands

This document may not contain information on basic UNIX® commands and procedures such as shutting down the system, booting the system, and configuring devices.

See one or more of the following for this information:

- *Solaris Handbook for Sun Peripherals*
- AnswerBook™ online documentation for the Solaris™ software environment
- Other software documentation that you received with your system

Typographic Conventions

| Typeface | Meaning | Examples |
|------------------|--|--|
| AaBbCc123 | The names of commands, files, and directories; on-screen computer output | Edit your <code>.login</code> file. Use <code>ls -a</code> to list all files. % You have mail. |
| AaBbCc123 | What you type, when contrasted with on-screen computer output | % su password: |
| <i>AaBbCc123</i> | Book titles, new words or terms, words to be emphasized. Command-line variable; replace with a real name or value. | Read Chapter 6 in the <i>User's Guide</i> . These are called <i>class</i> options. You <i>must</i> be superuser to do this. To delete a file, type <code>rm filename</code> . |

Shell Prompts

| Shell | Prompt |
|---------------------------------------|----------------------|
| C shell | <i>machine-name%</i> |
| C shell superuser | <i>machine-name#</i> |
| Bourne shell and Korn shell | \$ |
| Bourne shell and Korn shell superuser | # |

Related Documentation

| Application | Title | Part Number |
|--------------------------|--|-------------|
| Diagnostic Testing | <i>SunVTS 4.5 User's Guide</i> | 816-1575 |
| | <i>SunVTS 4.5 Test Reference Manual</i> | 816-1576 |
| Sun Enterprise™ Systems | PCI I/O Board Installation and Component Replacement | 805-1372 |
| Sun StorEdge Disk Arrays | <i>Sun StorEdge A5000 Hardware Configuration Guide</i> | 805-0264 |

Accessing Sun Documentation

You can view, print, or purchase a broad selection of Sun documentation, including localized versions, at:

<http://www.sun.com/documentation>

Third-Party Web Sites

Sun is not responsible for the availability of third-party web sites mentioned in this document. Sun does not endorse and is not responsible or liable for any content, advertising, products, or other materials that are available on or through such sites or resources. Sun will not be responsible or liable for any actual or alleged damage or loss caused by or in connection with the use of or reliance on any such content, goods, or services that are available on or through such sites or resources.

Contacting Sun Technical Support

If you need help installing or using this product in the United States, call 1-800-USA-4SUN, or go to:

<http://www.sun.com/service/contacting/index.html>

Sun Welcomes Your Comments

Sun is interested in improving its documentation and welcomes your comments and suggestions. You can submit your comments by going to:

<http://www.sun.com/hwdocs/feedback>

Please include the title and part number of your document with your feedback:

Sun StorEdge™ 2G FC PCI Dual Channel Network Adapter Installation Guide, part number 816-5001-12.

Declaration of Conformity

Compliance Model Number: Crystal2A
Product Family Name: Sun StorEdge 2G PCI Dual Fibre Channel Host Adapter
(SG-XPCI2FC-QF2-Z)

EMC

USA - FCC Class B

This equipment complies with Part 15 of the FCC Rules. Operation is subject to the following two conditions:

- 1) This equipment may not cause harmful interference.
- 2) This equipment must accept any interference that may cause undesired operation.

European Union

This equipment complies with the following requirements of the EMC Directive 89/336/EEC:

As Telecommunication Network Equipment (TNE) in both Telecom Centers and Other Than Telecom Centers per (as applicable):

EN300-386 V.1.3.2 (2003-05) Required Limits:

EN 55022:1994 +A1:1995 +A2:1997 Class B

EN 61000-3-2:2000 Pass

EN 61000-3-3:1995 +A1:2000 Pass

IEC 61000-4-2 6 kV (Direct), 8 kV (Air)

IEC 61000-4-3 3 V/m 80-1000MHz, 10 V/m 800-960 MHz and 1400-2000 MHz

IEC 61000-4-4 1 kV AC and DC Power Lines, 0.5 kV Signal Lines

IEC 61000-4-5 2 kV AC Line-Gnd, 1 kV AC Line-Line and Outdoor Signal Lines, 0.5 kV Indoor Signal Lines > 10m.

IEC 61000-4-6 3 V

IEC 61000-4-11 Pass

As Information Technology Equipment (ITE) Class B per (as applicable):

EN 55022:1994 +A1:1995 + A2:1997 Class B

EN 61000-3-2:2000 Pass

EN 61000-3-3:1995 +A1:2000 Pass

EN 55024:1998 +A1: 2001 +A2:2003 Required Limits

IEC 61000-4-2 4 kV (Direct), 8 kV (Air)

IEC 61000-4-3 3 V/m

IEC 61000-4-4 1 kV AC Power Lines, 0.5 kV Signal and DC Power Lines

IEC 61000-4-5 1 kV AC Line-Line and Outdoor Signal Lines, 2 kV AC Line-Gnd, 0.5 kV DC Power Lines

IEC 61000-4-6 3 V

IEC 61000-4-8 1 A/m

IEC 61000-4-11 Pass

Safety

This equipment complies with the following requirements of Low Voltage Directive 73/23/EEC.

EC Type Examination Certificates:

EN 60950-1:2001, 1st Edition

TÜV Rheinland Certificate No.

IEC 60950-1:2001, 1st Edition

CB Scheme Certificate No.

Evaluated to all CB Countries

UL 60950-1:2003, 1st Edition, CSA C22.2 No. 60950-1-03 File:

Supplementary Information: This product was tested and complies with all the requirements for the CE Mark.
This equipment complies with the Restriction of Hazardous Substances (RoHS) directive 2002/95/EC.

/S/

/S/

Dennis P. Symanski DATE
Worldwide Compliance Office
Sun Microsystems, Inc.
4150 Network Circle, MPK15-102
Santa Clara, CA 95054, USA
Tel: 650-786-3255
Fax: 650-786-3723

Donald Cameron DATE
Program Manager/Quality Systems
Sun Microsystems Scotland, Limited
Blackness Road, Phase I, Main Bldg
Springfield, EH49 7LR
Scotland, United Kingdom
Tel: +44 1 506 672 539
Fax: +44 1 506 670 011

Declaration of Conformity

Compliance Model Number: Crystal2A
Product Family Name: 2G PCI Dual FC Network Adapter (X6768A)

EMC

USA - FCC Class B

This equipment complies with Part 15 of the FCC Rules. Operation is subject to the following two conditions:

- 1) This equipment may not cause harmful interference.
- 2) This equipment must accept any interference that may cause undesired operation.

European Union

This equipment complies with the following requirements of the EMC Directive 89/336/EEC:

As Telecommunication Network Equipment (TNE) in both Telecom Centers and Other Than Telecom Centers per:

EN300-386 V.1.3.1 (09-2001) Required Limits (as applicable)::

| | |
|------------------|---|
| EN 55022/CISPR22 | Class B |
| EN 61000-3-2 | Pass |
| EN 61000-3-3 | Pass |
| EN 61000-4-2 | 6 kV (Direct), 8 kV (Air) |
| EN 61000-4-3 | 3 V/m 80-1000MHz, 10 V/m 800-960 MHz and 1400-2000 MHz |
| EN 61000-4-4 | 1 kV AC and DC Power Lines, 0.5 kV Signal Lines |
| EN 61000-4-5 | 2 kV AC Line-Gnd, 1 kV AC Line-Line and Outdoor Signal Lines, 0.5 kV Indoor Signal Lines > 10m. |
| EN 61000-4-6 | 3 V |
| EN 61000-4-11 | Pass |

As Information Technology Equipment (ITE) Class B per:

EN 55022:1998/CISPR22:1997 Class B

EN 55024:1998 Required Limits (as applicable):

| | |
|---------------|---|
| EN 61000-4-2 | 4 kV (Direct), 8 kV (Air) |
| EN 61000-4-3 | 3 V/m |
| EN 61000-4-4 | 1 kV AC Power Lines, 0.5 kV Signal and DC Power Lines |
| EN 61000-4-5 | 1 kV AC Line-Line and Outdoor Signal Lines, 2 kV AC Line-Gnd, 0.5 kV DC Power Lines |
| EN 61000-4-6 | 3 V |
| EN 61000-4-8 | 1 A/m |
| EN 61000-4-11 | Pass |

EN61000-3-2:1995 + A1,A2,A14 Pass

EN61000-3-3:1995 Pass

Safety

This equipment complies with the following requirements of Low Voltage Directive 73/23/EEC.

Supplementary Information: This product was tested and complies with all the requirements for the CE Mark.

/S/

/S/

Dennis P. Symanski
Manager, Compliance Engineering
Sun Microsystems, Inc.
901 San Antonio Road, MPK15-102
Palo Alto, CA 94303-4900, USA
Tel: 650-786-3255
Fax: 650-786-3723

DATE

Fraser Marshall
Quality Process Manager
Sun Microsystems Scotland, Limited
Springfield, Linlithgow,
West Lothian, EH49 7LR
Scotland, United Kingdom
Tel: +44 1 506 672 606 Fax: +44 1 506 670 400

DATE

Safety Agency Compliance Statements

Read this section before beginning any procedure. The following text provides safety precautions to follow when installing a Sun Microsystems product.

Safety Precautions

For your protection, observe the following safety precautions when setting up your equipment:

- Follow all cautions and instructions marked on the equipment.
- Ensure that the voltage and frequency of your power source match the voltage and frequency inscribed on the equipment's electrical rating label.
- Never push objects of any kind through openings in the equipment. Dangerous voltages may be present. Conductive foreign objects could produce a short circuit that could cause fire, electric shock, or damage to your equipment.

Symbols

The following symbols may appear in this book:



Caution – There is risk of personal injury and equipment damage. Follow the instructions.



Caution – Hot surface. Avoid contact. Surfaces are hot and may cause personal injury if touched.



Caution – Hazardous voltages are present. To reduce the risk of electric shock and danger to personal health, follow the instructions.

On – Applies AC power to the system.

Depending on the type of power switch your device has, one of the following symbols may be used:



Off - Removes AC power from the system.



Standby – The On/Standby switch is in the standby position.

Modifications to Equipment

Do not make mechanical or electrical modifications to the equipment. Sun Microsystems is not responsible for regulatory compliance of a modified Sun product.

Placement of a Sun Product



Caution – Do not block or cover the openings of your Sun product. Never place a Sun product near a radiator or heat register. Failure to follow these guidelines can cause overheating and affect the reliability of your Sun product.



Caution – The workplace-dependent noise level defined in DIN 45 635 Part 1000 must be 70Db(A) or less.

SELV Compliance

Safety status of I/O connections comply to SELV requirements.

Power Cord Connection



Caution – Sun products are designed to work with single-phase power systems having a grounded neutral conductor. To reduce the risk of electric shock, do not plug Sun products into any other type of power system. Contact your facilities manager or a qualified electrician if you are not sure what type of power is supplied to your building.



Caution – Not all power cords have the same current ratings. Household extension cords do not have overload protection and are not meant for use with computer systems. Do not use household extension cords with your Sun product.



Caution – Your Sun product is shipped with a grounding type (three-wire) power cord. To reduce the risk of electric shock, always plug the cord into a grounded power outlet.

The following caution applies only to devices with a Standby power switch:



Caution – The power switch of this product functions as a standby type device only. The power cord serves as the primary disconnect device for the system. Be sure to plug the power cord into a grounded power outlet that is nearby the system and is readily accessible. Do not connect the power cord when the power supply has been removed from the system chassis.

Lithium Battery



Caution – On Sun CPU boards, there is a lithium battery molded into the real-time clock, SGS No. MK48T59Y, MK48TXXB-XX, MK48T18-XXXPCZ, M48T59W-XXXPCZ, or MK48T08. Batteries are not customer replaceable parts. They may explode if mishandled. Do not dispose of the battery in fire. Do not disassemble it or attempt to recharge it.

Battery Pack



Caution – There is a sealed lead acid battery in Sun StorEdge 2G FC PCI Double Channel Network Adapter Installation Guide units. Portable Energy Products No. TLC02V50. There is danger of explosion if the battery pack is mishandled or incorrectly replaced. Replace only with the same type of Sun Microsystems battery pack. Do not disassemble it or attempt to recharge it outside the system. Do not dispose of the battery in fire. Dispose of the battery properly in accordance with local regulations.

System Unit Cover

You must remove the cover of your Sun computer system unit to add cards, memory, or internal storage devices. Be sure to replace the top cover before powering on your computer system.



Caution – Do not operate Sun products without the top cover in place. Failure to take this precaution may result in personal injury and system damage.

Laser Compliance Notice

Sun products that use laser technology comply with Class 1 laser requirements.

Class 1 Laser Product
Luokan 1 Laserlaite
Klasse 1 Laser Apparat
Laser Klasse 1

CD-ROM



Caution – Use of controls, adjustments, or the performance of procedures other than those specified herein may result in hazardous radiation exposure.

Einhaltung sicherheitsbehördlicher Vorschriften

Auf dieser Seite werden Sicherheitsrichtlinien beschrieben, die bei der Installation von Sun-Produkten zu beachten sind.

Sicherheitsvorkehrungen

Treffen Sie zu Ihrem eigenen Schutz die folgenden Sicherheitsvorkehrungen, wenn Sie Ihr Gerät installieren:

- Beachten Sie alle auf den Geräten angebrachten Warnhinweise und Anweisungen.
- Vergewissern Sie sich, daß Spannung und Frequenz Ihrer Stromquelle mit der Spannung und Frequenz übereinstimmen, die auf dem Etikett mit den elektrischen Nennwerten des Geräts angegeben sind.
- Stecken Sie auf keinen Fall irgendwelche Gegenstände in Öffnungen in den Geräten. Leitfähige Gegenstände könnten aufgrund der möglicherweise vorliegenden gefährlichen Spannungen einen Kurzschluß verursachen, der einen Brand, Stromschlag oder Geräteschaden herbeiführen kann.

Symbole

Die Symbole in diesem Handbuch haben folgende Bedeutung:



Achtung – Gefahr von Verletzung und Geräteschaden. Befolgen Sie die Anweisungen.



Achtung – Hohe Temperatur. Nicht berühren, da Verletzungsgefahr durch heiße Oberfläche besteht.



Achtung – Gefährliche Spannungen. Anweisungen befolgen, um Stromschläge und Verletzungen zu vermeiden.



Ein – Setzt das System unter Wechselstrom.

Je nach Netzschaltertyp an Ihrem Gerät kann eines der folgenden Symbole benutzt werden:



Aus – Unterbricht die Wechselstromzufuhr zum Gerät.



Wartezustand (Stand-by-Position) - Der Ein-/Wartezustand-Schalter steht auf Wartezustand. Änderungen an Sun-Geräten.

Nehmen Sie keine mechanischen oder elektrischen Änderungen an den Geräten vor. Sun Microsystems, übernimmt bei einem Sun-Produkt, das geändert wurde, keine Verantwortung für die Einhaltung behördlicher Vorschriften

Aufstellung von Sun-Geräten



Achtung – Um den zuverlässigen Betrieb Ihres Sun-Geräts zu gewährleisten und es vor Überhitzung zu schützen, dürfen die Öffnungen im Gerät nicht blockiert oder verdeckt werden. Sun-Produkte sollten niemals in der Nähe von Heizkörpern oder Heizluftklappen aufgestellt werden.



Achtung – Der arbeitsplatzbezogene Schalldruckpegel nach DIN 45 635 Teil 1000 beträgt 70Db(A) oder weniger.

Einhaltung der SELV-Richtlinien

Die Sicherung der I/O-Verbindungen entspricht den Anforderungen der SELV-Spezifikation.

Anschluß des Netzkabels



Achtung – Sun-Produkte sind für den Betrieb an Einphasen-Stromnetzen mit geerdetem Nulleiter vorgesehen. Um die Stromschlaggefahr zu reduzieren, schließen Sie Sun-Produkte nicht an andere Stromquellen an. Ihr Betriebsleiter oder ein qualifizierter Elektriker kann Ihnen die Daten zur Stromversorgung in Ihrem Gebäude geben.



Achtung – Nicht alle Netzkabel haben die gleichen Nennwerte. Herkömmliche, im Haushalt verwendete Verlängerungskabel besitzen keinen Überlastungsschutz und sind daher für Computersysteme nicht geeignet.



Achtung – Ihr Sun-Gerät wird mit einem dreiadrigen Netzkabel für geerdete Netzsteckdosen geliefert. Um die Gefahr eines Stromschlags zu reduzieren, schließen Sie das Kabel nur an eine fachgerecht verlegte, geerdete Steckdose an.

Die folgende Warnung gilt nur für Geräte mit Wartezustand-Netzschalter:



Achtung – Der Ein/Aus-Schalter dieses Geräts schaltet nur auf Wartezustand (Stand-By-Modus). Um die Stromzufuhr zum Gerät vollständig zu unterbrechen, müssen Sie das Netzkabel von der Steckdose abziehen. Schließen Sie den Stecker des Netzkabels an eine in der Nähe befindliche, frei zugängliche, geerdete Netzsteckdose an. Schließen Sie das Netzkabel nicht an, wenn das Netzteil aus der Systemeinheit entfernt wurde.

Lithiumbatterie



Achtung – CPU-Karten von Sun verfügen über eine Echtzeituhr mit integrierter Lithiumbatterie (Teile-Nr. MK48T59Y, MK48TXXB-XX, MK48T18-XXXPCZ, M48T59W-XXXPCZ, oder MK48T08). Diese Batterie darf nur von einem qualifizierten Servicetechniker ausgewechselt werden, da sie bei falscher Handhabung explodieren kann. Werfen Sie die Batterie nicht ins Feuer. Versuchen Sie auf keinen Fall, die Batterie auszubauen oder wiederaufzuladen.

Batterien



Achtung – Die Geräte Sun StorEdge 2G FC PCI Double Channel Network Adapter Installation Guide enthalten auslaufsichere Bleiakumulatoren. Produkt-Nr. TLC02V50 für portable Stromversorgung. Werden bei der Behandlung oder beim Austausch der Batterie Fehler gemacht, besteht Explosionsgefahr. Batterie nur gegen Batterien gleichen Typs von Sun Microsystems austauschen. Nicht demontieren und nicht versuchen, die Batterie außerhalb des Geräts zu laden. Batterie nicht ins Feuer werfen. Ordnungsgemäß entsprechend den vor Ort geltenden Vorschriften entsorgen.

Gehäuseabdeckung

Sie müssen die obere Abdeckung Ihres Sun-Systems entfernen, um interne Komponenten wie Karten, Speicherchips oder Massenspeicher hinzuzufügen. Bringen Sie die obere Gehäuseabdeckung wieder an, bevor Sie Ihr System einschalten.



Achtung – Bei Betrieb des Systems ohne obere Abdeckung besteht die Gefahr von Stromschlag und Systemschäden.

Einhaltung der Richtlinien für Laser

Sun-Produkte, die mit Laser-Technologie arbeiten, entsprechen den Anforderungen der Laser Klasse 1.

Class 1 Laser Product
Luokan 1 Laserlaite
Klasse 1 Laser Apparat
Laser Klasse 1

CD-ROM



Warnung – Die Verwendung von anderen Steuerungen und Einstellungen oder die Durchführung von Prozeduren, die von den hier beschriebenen abweichen, können gefährliche Strahlungen zur Folge haben.

Conformité aux normes de sécurité

Ce texte traite des mesures de sécurité qu'il convient de prendre pour l'installation d'un produit Sun Microsystems.

Mesures de sécurité

Pour votre protection, veuillez prendre les précautions suivantes pendant l'installation du matériel :

- Suivre tous les avertissements et toutes les instructions inscrites sur le matériel.
- Vérifier que la tension et la fréquence de la source d'alimentation électrique correspondent à la tension et à la fréquence indiquées sur l'étiquette de classification de l'appareil.

- Ne jamais introduire d'objets quels qu'ils soient dans une des ouvertures de l'appareil. Vous pourriez vous trouver en présence de hautes tensions dangereuses. Tout objet conducteur introduit de la sorte pourrait produire un court-circuit qui entraînerait des flammes, des risques d'électrocution ou des dégâts matériels.

Symboles

Vous trouverez ci-dessous la signification des différents symboles utilisés :



Attention: – risques de blessures corporelles et de dégâts matériels. Veuillez suivre les instructions.



Attention: – surface à température élevée. Évitez le contact. La température des surfaces est élevée et leur contact peut provoquer des blessures corporelles.



Attention: – présence de tensions dangereuses. Pour éviter les risques d'électrocution et de danger pour la santé physique, veuillez suivre les instructions.



MARCHE – Votre système est sous tension (courant alternatif).

Un des symboles suivants sera peut-être utilisé en fonction du type d'interrupteur de votre système:



ARRET - Votre système est hors tension (courant alternatif).



VEILLEUSE – L'interrupteur Marche/ Veilleuse est en position « Veilleuse ».

Modification du matériel

Ne pas apporter de modification mécanique ou électrique

au matériel. Sun Microsystems n'est pas responsable de la conformité réglementaire d'un produit Sun qui a été modifié.

Positionnement d'un produit Sun



Attention: – pour assurer le bon fonctionnement de votre produit Sun et pour l'empêcher de surchauffer, il convient de ne pas obstruer ni recouvrir les ouvertures prévues dans l'appareil. Un produit Sun ne doit jamais être placé à proximité d'un radiateur ou d'une source de chaleur.



Attention: – Le niveau de pression acoustique au poste de travail s'élève selon la norme DIN 45 635 section 1000, à 70 dB (A) ou moins.

Conformité SELV

Sécurité : les raccordements E/S sont conformes aux normes SELV.

Connexion du cordon d'alimentation.



Attention: – les produits Sun sont conçus pour fonctionner avec des alimentations monophasées munies d'un conducteur neutre mis à la terre. Pour écarter les risques d'électrocution, ne pas brancher de produit Sun dans un autre type d'alimentation secteur. En cas de doute quant au type d'alimentation électrique du local, veuillez vous adresser au directeur de l'exploitation ou à un électricien qualifié.



Attention: – tous les cordons d'alimentation n'ont pas forcément la même puissance nominale en matière de courant. Les rallonges d'usage domestique n'offrent pas de protection contre les surcharges et ne sont pas prévues pour les systèmes d'ordinateurs. Ne pas utiliser de rallonge d'usage domestique avec votre produit Sun.



Attention: – votre produit Sun a été livré équipé d'un cordon d'alimentation à trois fils (avec prise de terre). Pour écarter tout risque d'électrocution, branchez toujours ce cordon dans une prise mise à la terre.

L'avertissement suivant s'applique uniquement aux systèmes équipés d'un interrupteur VEILLEUSE:



Attention: – le commutateur d'alimentation de ce produit fonctionne comme un dispositif de mise en veille uniquement. C'est la prise d'alimentation qui sert à mettre le produit hors tension. Veillez donc à installer le produit à proximité d'une prise murale facilement accessible. Ne connectez pas la prise d'alimentation lorsque le châssis du système n'est plus alimenté.

Batterie au lithium



Attention: – sur les cartes CPU Sun, une batterie au lithium (référence MK48T59Y, MK48TXXB-XX, MK48T18-XXXPCZ, M48T59W-XXXPCZ, ou MK48T08.) a été moulée dans l'horloge temps réel SGS. Les batteries ne sont pas des pièces remplaçables par le client. Elles risquent d'exploser en cas de mauvais traitement. Ne pas jeter la batterie au feu. Ne pas la démonter ni tenter de la recharger.

Bloc-batterie



Attention: – Les unités Sun StorEdge 2G FC PCI Double Channel Network Adapter Installation Guide contiennent une batterie étanche au plomb (produits énergétiques portatifs n°TLC02V50). Il existe un risque d'explosion si ce bloc-batterie est manipulé de façon erronée ou mal mis en place. Ne remplacez ce bloc que par un bloc-batterie Sun Microsystems du même type. Ne le démontez pas et n'essayez pas de le recharger hors du système. Ne faites pas brûler la batterie mais mettez-la au rebut conformément aux réglementations locales en vigueur.

Couvercle

Pour ajouter des cartes, de la mémoire, ou des unités de stockage internes, vous devrez démonter le couvercle de l'unité système Sun. Ne pas oublier de remettre ce couvercle en place avant de mettre le système sous tension.



Attention: – il est dangereux de faire fonctionner un produit Sun sans le couvercle en place. Si l'on néglige cette précaution, on encourt des risques de blessures corporelles et de dégâts matériels.

Conformité aux certifications Laser

Les produits Sun qui font appel aux technologies lasers sont conformes aux normes de la classe 1 en la matière.

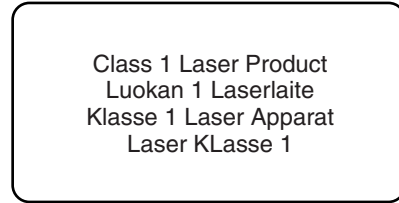

CD-ROM



Attention: – L'utilisation de contrôles, de réglages ou de performances de procédures autre que celle spécifiée dans le présent document peut provoquer une exposition à des radiations dangereuses.

Normativas de seguridad

El siguiente texto incluye las medidas de seguridad que se deben seguir cuando se instale algún producto de Sun Microsystems.

Precauciones de seguridad

Para su protección observe las siguientes medidas de seguridad cuando manipule su equipo:

- Siga todas los avisos e instrucciones marcados en el equipo.
- Asegúrese de que el voltaje y la frecuencia de la red eléctrica concuerdan con las descritas en las etiquetas de especificaciones eléctricas del equipo.
- No introduzca nunca objetos de ningún tipo a través de los orificios del equipo. Pueden haber voltajes peligrosos. Los objetos extraños conductores de la electricidad pueden producir cortocircuitos que provoquen un incendio, descargas eléctricas o daños en el equipo.

Símbolos

En este libro aparecen los siguientes símbolos:



Precaución – Existe el riesgo de lesiones personales y daños al equipo. Siga las instrucciones.



Precaución – Superficie caliente. Evite el contacto. Las superficies están calientes y pueden causar daños personales si se tocan.



Precaución – Voltaje peligroso presente. Para reducir el riesgo de descarga y daños para la salud siga las instrucciones.



Encendido – Aplica la alimentación de CA al sistema.

Según el tipo de interruptor de encendido que su equipo tenga, es posible que se utilice uno de los siguientes símbolos:



Apagado - Elimina la alimentación de CA del sistema.



En espera – El interruptor de Encendido/En espera se ha colocado en la posición de En espera.

Modificaciones en el equipo

No realice modificaciones de tipo mecánico o eléctrico en el equipo. Sun Microsystems no se hace responsable del cumplimiento de las normativas de seguridad en los equipos Sun modificados.

Ubicación de un producto Sun



Precaución – Para asegurar la fiabilidad de funcionamiento de su producto Sun y para protegerlo de sobrecalentamientos no deben obstruirse o taparse las rejillas del equipo. Los productos Sun nunca deben situarse cerca de radiadores o de fuentes de calor.



Precaución – De acuerdo con la norma DIN 45 635, Parte 1000, se admite un nivel de presión acústica para puestos de trabajo máximo de 70Db(A).

Cumplimiento de la normativa SELV

El estado de la seguridad de las conexiones de entrada/salida cumple los requisitos de la normativa SELV.

Conexión del cable de alimentación eléctrica



Precaución – Los productos Sun están diseñados para trabajar en una red eléctrica monofásica con toma de tierra. Para reducir el riesgo de descarga eléctrica, no conecte los productos Sun a otro tipo de sistema de alimentación eléctrica. Póngase en contacto con el responsable de mantenimiento o con un electricista cualificado si no está seguro del sistema de alimentación eléctrica del que se dispone en su edificio.



Precaución – No todos los cables de alimentación eléctrica tienen la misma capacidad. Los cables de tipo doméstico no están provistos de protecciones contra sobrecargas y por tanto no son apropiados para su uso con computadores. No utilice alargadores de tipo doméstico para conectar sus productos Sun.



Precaución – Con el producto Sun se proporciona un cable de alimentación con toma de tierra. Para reducir el riesgo de descargas eléctricas conéctelo siempre a un enchufe con toma de tierra.

La siguiente advertencia se aplica solamente a equipos con un interruptor de encendido que tenga una posición "En espera":



Precaución – El interruptor de encendido de este producto funciona exclusivamente como un dispositivo de puesta en espera. El enchufe de la fuente de alimentación está diseñado para ser el elemento primario de desconexión del equipo. El equipo debe instalarse cerca del enchufe de forma que este último pueda ser fácil y rápidamente accesible. No conecte el cable de alimentación cuando se ha retirado la fuente de alimentación del chasis del sistema.

Batería de litio



Precaución – En las placas de CPU Sun hay una batería de litio insertada en el reloj de tiempo real, tipo SGS Núm. MK48T59Y, MK48TXXB-XX, MK48T18-XXXPCZ, M48T59W-XXXPCZ, o MK48T08. Las baterías no son elementos reemplazables por el propio cliente. Pueden explotar si se manipulan de forma errónea. No arroje las baterías al fuego. No las abra o intente recargarlas.

Paquete de pilas



Precaución – Las unidades Sun StorEdge 2G FC PCI Double Channel Network Adapter Installation Guide contienen una pila de plomo sellada, Productos de energía portátil n° TLC02V50. Existe riesgo de estallido si el paquete de pilas se maneja sin cuidado o se sustituye de manera indebida. Las pilas sólo deben sustituirse por el mismo tipo de paquete de pilas de Sun Microsystems. No las desmonte ni intente recargarlas fuera del sistema. No arroje las pilas al fuego. Deséchelas siguiendo el método indicado por las disposiciones vigentes.

Tapa de la unidad del sistema

Debe quitar la tapa del sistema cuando sea necesario añadir tarjetas, memoria o dispositivos de almacenamiento internos. Asegúrese de cerrar la tapa superior antes de

volver a encender el equipo.



Precaución – Es peligroso hacer funcionar los productos Sun sin la tapa superior colocada. El hecho de no tener en cuenta esta precaución puede ocasionar daños personales o perjudicar el funcionamiento del equipo.

Aviso de cumplimiento con requisitos de láser

Los productos Sun que utilizan la tecnología de láser cumplen con los requisitos de láser de Clase 1.

Class 1 Laser Product
Luokan 1 Laserlaite
Klasse 1 Laser Apparat
Laser Klasse 1

CD-ROM



Precaución – El manejo de los controles, los ajustes o la ejecución de procedimientos distintos a los aquí especificados pueden exponer al usuario a radiaciones peligrosas.

GOST-R Certification Mark

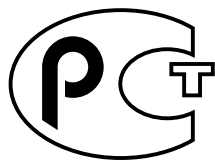

D33012

Regulatory Compliance Statements

Your Sun product is marked to indicate its compliance class:

- Federal Communications Commission (FCC) — USA
- Industry Canada Equipment Standard for Digital Equipment (ICES-003) - Canada
- Voluntary Control Council for Interference (VCCI) — Japan
- Bureau of Standards Metrology and Inspection (BSMI) — Taiwan

Please read the appropriate section that corresponds to the marking on your Sun product before attempting to install the product.

FCC Class A Notice

This device complies with Part 15 of the FCC Rules. Operation is subject to the following two conditions:

1. This device may not cause harmful interference.
2. This device must accept any interference received, including interference that may cause undesired operation.

Note: This equipment has been tested and found to comply with the limits for a Class A digital device, pursuant to Part 15 of the FCC Rules. These limits are designed to provide reasonable protection against harmful interference when the equipment is operated in a commercial environment. This equipment generates, uses, and can radiate radio frequency energy, and if it is not installed and used in accordance with the instruction manual, it may cause harmful interference to radio communications. Operation of this equipment in a residential area is likely to cause harmful interference, in which case the user will be required to correct the interference at his own expense.

Shielded Cables: Connections between the workstation and peripherals must be made using shielded cables to comply with FCC radio frequency emission limits. Networking connections can be made using unshielded twisted-pair (UTP) cables.

Modifications: Any modifications made to this device that are not approved by Sun Microsystems, Inc. may void the authority granted to the user by the FCC to operate this equipment.

FCC Class B Notice

This device complies with Part 15 of the FCC Rules. Operation is subject to the following two conditions:

1. This device may not cause harmful interference.
2. This device must accept any interference received, including interference that may cause undesired operation.

Note: This equipment has been tested and found to comply with the limits for a Class B digital device, pursuant to Part 15 of the FCC Rules. These limits are designed to provide reasonable protection against harmful interference in a residential installation. This equipment generates, uses and can radiate radio frequency energy and, if not installed and used in accordance with the instructions, may cause harmful interference to radio communications. However, there is no guarantee that interference will not occur in a particular installation. If this equipment does cause harmful interference to radio or television reception, which can be determined by turning the equipment off and on, the user is encouraged to try to correct the interference by one or more of the following measures:

- Reorient or relocate the receiving antenna.
- Increase the separation between the equipment and receiver.
- Connect the equipment into an outlet on a circuit different from that to which the receiver is connected.
- Consult the dealer or an experienced radio/television technician for help.

Shielded Cables: Connections between the workstation and peripherals must be made using shielded cables in order to maintain compliance with FCC radio frequency emission limits. Networking connections can be made using unshielded twisted pair (UTP) cables.

Modifications: Any modifications made to this device that are not approved by Sun Microsystems, Inc. may void the authority granted to the user by the FCC to operate this equipment.

ICES-003 Class A Notice - Avis NMB-003, Classe A

This Class A digital apparatus complies with Canadian ICES-003.

Cet appareil numérique de la classe A est conforme à la norme NMB-003 du Canada.

ICES-003 Class B Notice - Avis NMB-003, Classe B

This Class B digital apparatus complies with Canadian ICES-003.

Cet appareil numérique de la classe B est conforme à la norme NMB-003 du Canada.

VCCI 基準について

クラス A VCCI 基準について

クラス A VCCI の表示があるワークステーションおよびオプション製品は、クラス A 情報技術装置です。これらの製品には、下記の項目が該当します。

この装置は、情報処理装置等電波障害自主規制協議会 (VCCI) の基準に基づくクラス A 情報技術装置です。この装置を家庭環境で使用すると電波妨害を引き起こすことがあります。この場合には使用者が適切な対策を講ずるよう要求されることがあります。

クラス B VCCI 基準について

クラス B VCCI の表示  があるワークステーションおよびオプション製品は、クラス B 情報技術装置です。これらの製品には、下記の項目が該当します。

この装置は、情報処理装置等電波障害自主規制協議会 (VCCI) の基準に基づくクラス B 情報技術装置です。この装置は、家庭環境で使用することを目的としていますが、この装置がラジオやテレビジョン受信機に近接して使用されると、受信障害を引き起こすことがあります。取扱説明書に従って正しい取り扱いをしてください。

Installation

The *Sun StorEdge 2G FC PCI Dual Channel Network Adapter Installation Guide* describes how to install the Sun StorEdge 2G FC PCI Dual Channel Network Adapter card in a system. These instructions are designed for an experienced system administrator or trained service provider.

Software Requirements

Device Drivers

Please refer to the Release Notes for the complete list of Operating System support (for example, Solaris x86, Linux and Windows) on this HBA. The minimum Solaris™ SPARC operating environment releases to support the device drivers for the Sun StorEdge 2G FC PCI Dual Channel Network Adapter card is Solaris 8 update 4.

All of the drivers are unbundled with Solaris 8 SPARC operating environmen. See the *Sun StorEdge 2G FC PCI Dual Channel Network Adapter Product Notes* for a list of packages and patches and instructions for downloading them.

Note – If the required packages and patches are not installed, you can not use the network adapter.

- Once installed, Sun StorEdge 2G FC PCI Dual Channel Network Adapter boards will have device paths similar to
`/devices/pci@b,2000/pci@2/SUNW,q1c@x.`
- Under these nodes, there will be two instances of the `q1c` driver that has a device node similar to:
`/devices/pci@b,2000/pci@2/SUNW,q1c@x/fp@0,0`

- qlc driver also has a devctl node for administrative use with a name similar to `/devices/pci@b,2000/pci@2/SUNW,qlc@x,1/fp@0,0:devctl`
- For devices found, the nodes are created depending on the WWN of the device. For a WWN of 2100002037182670, the device path is similar to `/devices/pci@b,2000/pci@2/SUNW,qlc@x/fp@0,0/ssd@2100002037182670,0:a`
- Go to the <http://www.sun.com/products-n-solutions/hardware/docs> Web site, click *Storage* and then click *Adapters* and read the *Sun StorEdge 2G FC PCI Dual Channel Network Adapter Product Notes* to obtain software patch IDs.
- Go to the URL listed in the *Sun StorEdge 2G FC PCI Dual Channel Network Adapter Product Notes* to download the Fibre Channel transport device driver patches or, for updates, go to: <http://sunsolve.sun.com>.

Tools and Equipment Needed

You may need to order fiber optic cables. You can order them in the following lengths:

- 0.4 meter, part number X9721
- two-meter, part number X9722
- five-meter, part number X9723A
- 15-meter, part number X9724
- SC-SC coupler X9720A

You will also need:

- A No. 2 Phillips screwdriver
- An antistatic wrist strap
- A padded antistatic mat

Preparing for Installation



Caution – Damage to the HBA can occur as the result of careless handling or electrostatic discharge (ESD). Always handle the HBA with care to avoid damage to electrostatic sensitive components.

To minimize the possibility of ESD-related damage, Sun strongly recommends using both a workstation antistatic mat and an ESD wrist strap. You can get an ESD wrist strap from any reputable electronics store or from Sun as part number #250-1007. Observe the following precautions to avoid ESD-related problems:

- Leave the HBA in its antistatic bag until you are ready to install it in the system.
- Always use a properly fitted and grounded wrist strap or other suitable ESD protection when handling the HBA and observe proper ESD grounding techniques.
- Hold the HBA by the edge of the PCB or mounting bracket, not the connectors.
- Place the HBA on a properly grounded antistatic work surface pad when it is out of its protective antistatic bag.

Sun Enterprise Systems

The Sun StorEdge 2G FC PCI Dual Channel Network Adapter card does not support JTAG. When you install the PCI host adapter in a Sun Enterprise™ system, be sure that the corresponding PCI riser card has the JTAG jumper removed (FIGURE 1-1).

Note – If the JTAG jumper is installed, the PCI I/O board will not be recognized or initialized during POST (power-on self-test) nor will it subsequently be recognized by the operating system.

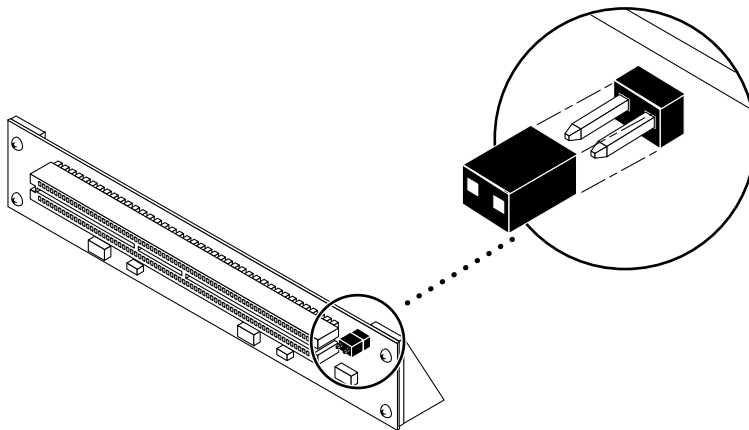

FIGURE 1-1 JTAG Jumper

Preparing for a Sun StorEdge A5x00 Installation

1. Use the array's front panel module (FPM) to ensure that the firmware level of the interface boards is at least 1.05.

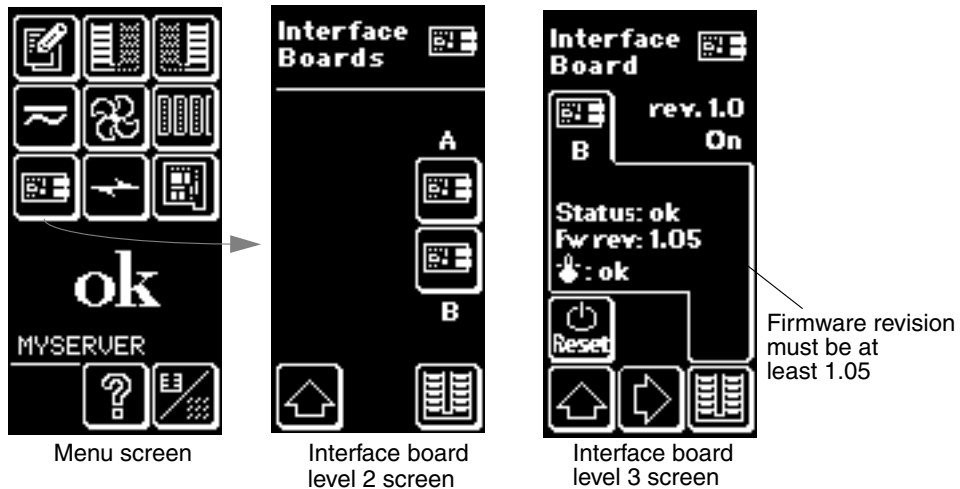

FIGURE 1-2 Checking the Sun StorEdge A5x00 Array Interface Board Firmware Level

If the firmware level is less than 1.05, you must upgrade the firmware using an SBus-based host system before you can connect the array to the Sun StorEdge PCI Dual Fibre Channel Host Adapter. The instructions for obtaining the upgrade patch are in Step 3.

2. Determine which version of the Solaris™ operating environment you are using.

Look at the `/etc/release` file and make sure the operating environment installed is at least Solaris 8. If you do not have an `/etc/release` file, you probably need to upgrade your operating environment to at least Solaris 8.

3. Get the required software:

- qlc driver
 - SunVTS™
- a. Go to the <http://docs.sun.com> Web site and read the *Sun StorEdge A5000 Installation Supplement*.
 - b. Go to the <http://www.sun.com/products-n-solutions/hardware/docs> Web site, click **Storage** and read the *Sun StorEdge 2G FC PCI Dual Channel Network Adapter Product Notes* for the software patch IDs.

- c. **Download the software patches from the URL listed in the *Sun StorEdge 2G FC PCI Dual Channel Network Adapter Product Notes* or, for updates, go to: <http://sunsolve.sun.com>.**

Contact your support service provider if you cannot access these Web sites.

Note – Be sure to read and follow the directions in the README file for each patch.

4. **Log in as root on your system.**

5. **Verify that the SUNWses, SUNWssad, and SUNWvts packages have been installed on your system.**

Use the `/usr/bin/pkginfo` command and `grep` for each of the above patches. For example:

```
# /usr/bin/pkginfo | grep SUNWvts
system SUNWvts Online Validation Test Suite
```

If you are missing any of these patches, you can get them from the *Updates for Solaris Operating Environment* of your Solaris operating environment distribution.

6. **Exit the operating environment.**

To inform any mounted users that the system will be going down, use the `shutdown` command. Otherwise, use the `init 0` command. See the Man Pages for these commands or the Solaris AnswerBook online documentation.

7. **Power off the system.**

Refer to the service documentation that came with your system.



Caution – Do not disconnect the power cord at this time. This connection provides the ground path necessary to remove and install printed circuit boards and components without damage.

8. **Choose a slot into which to install the host adapter.**

Follow the procedures in the documentation supplied with your system.

For systems that have more than one system board, you must also select and remove a system board that has an available PCI slot. Refer to your system documentation for specific instructions.

9. **Attach the antistatic wrist strap to your wrist and to a metal component on the system chassis.**

The wrist strap between you and the chassis provides the ground path necessary to safely remove and install the printed circuit boards and components without damaging them.

10. **For systems with a standby-type power switch, disconnect the power cord.**

Standby-type power switches have a  icon.

11. **Open the system.**

Refer to your system documentation for specific instructions.



Caution – If you need to remove a system board for installation, place the board on a padded antistatic mat to prevent damage.

Installing the Host Adapter

1. **Pull the two dust covers out of the 2x5 optical transceiver (OT) connectors (FIGURE 1-3).**

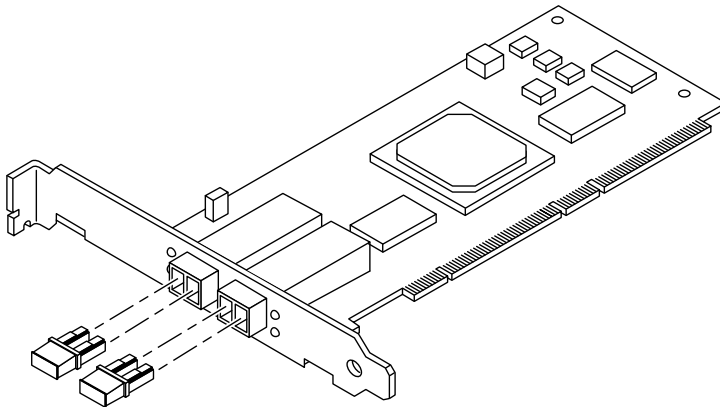

FIGURE 1-3 Sun StorEdge 2G FC PCI Dual Channel Network Adapter Dust Covers

2. Install the host adapter in the PCI slot you have chosen.

Installation details vary for each system. Refer to your system documentation for specific instructions.

3. Reassemble the system.

Refer to your system documentation for specific instructions.

4. Disconnect the wrist strap.

5. Push the fiber optic cable connector into the OT connector until you hear a click (FIGURE 1-4).



Caution – Fiber optic cables have keyed connectors; they can only be inserted into OT connectors as shown in FIGURE 1-4.

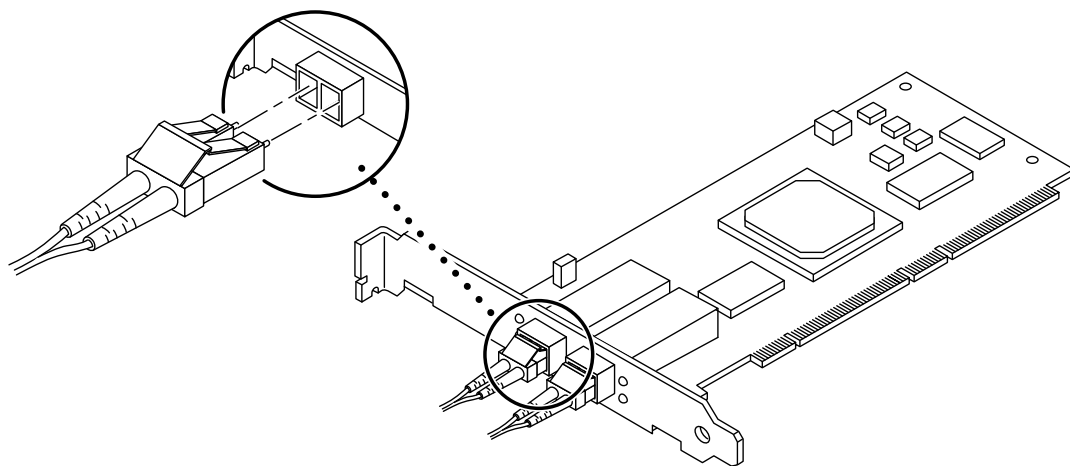

FIGURE 1-4 Connecting a Fiber Optic Cable to an OT Connector

6. Connect the other end of the fiber optic cable to a device such as an array, switch or hub.



Caution – In multiple-initiator configurations, when a Sun StorEdge 2G FC PCI Dual Channel Network Adapter is directly connected to a Sun StorEdge A5x00, each port on the host adapter must be connected to a separate loop on the A5x00.

Refer to the documentation that came with the device for specific instructions.

7. Power on your peripherals and then your system.

Note – When you power on the system, the LED lights on the host bus adapter might blink. The LEDs are intended for manufacturing use only.

Note – If your system starts to reboot, interrupt the reboot process by pressing the Stop-A keys.

The system should now be at the `ok` prompt. If a `>` prompt is showing, type `n` to switch to the `ok` prompt.

8. Make sure that the system recognizes the host adapter.

See FIGURE 1-5 on [CODE EXAMPLE 1-1 on page 1-9](#) and [CODE EXAMPLE 1-2 on page 1-10](#). [CODE EXAMPLE 1-2 on page 1-10](#) is a continuation of [CODE EXAMPLE 1-1 on page 1-9](#).

CODE EXAMPLE 1-1 System Recognition of the Host Adapter, Part 1

```
ok show-devs
/counter-timer@f,1c00
/pci@f,2000
/pci@f,4000
/counter-timer@e,1c00
/fhc@e,f8800000
/pci@e,2000
/pci@e,4000
/counter-timer@b,3c00
/fhc@a,f8800000
/sbus@a,0
/counter-timer@3,3c00
/sbus@3,0
/fhc@2,f8800000
/disk-board@6,0
/SUNW,UltraSPARC-II@5,0
/SUNW,UltraSPARC-ii@4,0
/fhc@4,f8800000
/SUNW,UltraSPARC-II@1,0
/SUNW,UltraSPARC-11@0,0
/fhc@0,f8800000
/central@1f,0
/virtual-memory
/memory@0,0
/aliases
/options
/openprom
/chosen
/packages
/pci@f,4000/SUNW,isptwo@3
/pci@f,4000/SUNW,isptwo@3/st
/pci@f,4000/SUNW,isptwo@3/sd
/fhc@e,f8800000/sbus-speed@0,500000
/fhc@e,f8800000/eprom@0,300000
/fhc@e,f8800000/flashprom@0,0
/fhc@e,f8800000/environment@0,400000
/fhc@e,f8800000/ac@0,1000000
```

CODE EXAMPLE 1-1 System Recognition of the Host Adapter, Part 1 (Continued)

```
/pci@e,2000/pci@2
/pci@e,2000/pci@2/SUNW,qlc@1
/pci@e,2000/pci@2/SUNW,qlc@1,1
/pci@e,2000/pci@2/SUNW,qlc@1/fp@0,0
/pci@e,2000/pci@2/SUNW,qlc@1/fp@0,0/disk
/pci@e,2000/pci@2/SUNW,qlc@1,1/fp@0,0
/pci@e,2000/pci@2/SUNW,qlc@1,1/fp@0,0/disk
```

CODE EXAMPLE 1-2 System Recognition of the Host Adapter, Method A, Part 2

```
ok apply show-children /pci@e,2000/pci@2/SUNW,qlc@5
LiD HA --- Port WWN --- ----- Disk description ----
_3d 3d 5080020000025a5a SUN ----- SENA ----- 1.09PZX
_30 30 21000020370e6891 SEAGATE - ST19171FCSUN9.0G177E9823U86993
_33 33 21000020370e964f SEAGATE - ST19171FCSUN9.0G177E9823V06714
_36 36 21000020370e92c9 SEAGATE - ST19171FCSUN9.0G177E9823V11851
_2d 2d 5080020000025a59 SUN ----- SENA ----- 1.09PZX
_23 23 21000020370e930d SEAGATE - ST19171FCSUN9.0G177E9823V12050
_26 26 21000020370e9b08 SEAGATE - ST19171FCSUN9.0G177E9823V15713
```

In [CODE EXAMPLE 1-2 on page 1-10](#), /pci@e,0/pci@1/pci@1/SUNW,qlc@5 is one port on the Sun StorEdge 2G FC PCI Dual Channel Network Adapter and the disks are in a Sun StorEdge A5000 array (SENA).

Note – The `probe-scsi-all` command does not function identically on all platforms, and does not in all cases probe for fiber channel devices. The `probe-fcal-all` command exists only on Sun Enterprise™ systems.

9. Reboot your system using the `boot -r` command.

Testing the Installation

SunVTS

Refer to the SunVTS documents in TABLE 1-4.

TABLE 1-1 Sun VTS Documents

| Application | Title | Part Number |
|--------------------|----------------------------------|--------------------|
| Diagnostic Testing | <i>SunVTS 4.5 User's Guide*</i> | 816-1575 |
| | <i>SunVTS 4.5 Test Reference</i> | 816-1576 |
| | <i>SunVTS 4.3 User's Guide\</i> | 806-7705 |
| | <i>SunVTS 4.3 Test Reference</i> | 806-7704 |

* Use SunVTS 4.5 with Solaris 8 update 6 operating environment.

\ Use SunVTS 4.3 with Solaris 8 update 4 operating environment.

SunVTS is a diagnostic program that exercises your system to verify the functionality, reliability, and configuration of your host adapter. You will need to install both the 32- and 64-bit versions of SunVTS.

Testing Procedure

1. To invoke SunVTS locally on a system running CDE, type the following as `root`:

```
# cd /opt/SUNWvts/bin
# ./sunvts
```

2. From the SunVTS menus select the following:
 - a. Select `devices` `None` and select `intervention`.
 - b. Select `mode` `Functional test`.
 - c. Select `HostAdapters` `qlcx` where `x` is the `qlc` number of the `qlc` port you want to run this test against.

d. If you want to run the external loopback test, place a loopback plug into the qlc port that you want to test.

If you do not have an external loopback plug, you can make one by taking apart a fiber cable and plug the same cable into the transmitter and receiver of the qlc port.

e. Right click on the qlc test and select Test Parameter Options.

f. Enable the External Loopback Test.

Note – If you do not use a loopback plug, you can connect the qlc port to storage devices. In such a case, you will be testing both the qlc and the entire fiber loop.

g. Select Start to start the test.

Note – If you select only the external loopback test, the different version diagnostic tests will not be run and the delay time between tests will be set to zero. This is a good way to test your fiber loop if you leave the qlc port attached to storage devices.

Specifications

PCI Card

The Sun StorEdge 2G FC PCI Dual Channel Network Adapter is a Fibre Channel PCI card with two onboard optical transceivers. This host adapter is PCI Version 2.1 compliant.

Fibre Channel Interface Specifications

TABLE A-1 Fibre Channel Specifications

| Specification | Value |
|----------------------|--|
| ANSI Standards | Fibre Channel FC-PH X3.230-1995 SCSI Fibre Channel Protocol X3.269-1996 |
| Optical transceiver | 200 MBytes/sec (2 Gbits/sec), full duplex Shortwave laser, Module Definition 5 |
| Fiber cable type | 50 micrometer multimode 62.5 micrometer multimode |
| Maximum cable length | 300 meters for 50 micrometer multimode 150 meters for 62.5 micrometer multimode |

Performance Specifications

The following specifications must be verified.

TABLE A-2 Performance Specifications

| Feature | Specification |
|---------------------------------|--|
| PCI clock | 133 MHz maximum |
| PCI data burst transfer rate | 528 MBytes/sec burst rate |
| FC-AL transfer rate payload | 200 MBytes/sec |
| PCI data/address lines | AD63-0 |
| PCI modes | Master/slave |
| Capacitance per PCI signal line | ≤10 pF, except for CLK between 5 to 12 pF and IDSEL ≤8 pF |
| FC Interface | 2 Gbit optical (2.1250 Gbits/sec) |

Power Requirements

TABLE A-3 Power Requirements

| Specification | Rating |
|---------------------|----------|
| Voltage and current | 5V 5%,3A |
| Ripple | 100 mV |

Physical Dimensions

TABLE A-4 Physical Dimensions

| Height | Width | Depth | Weight |
|---------|-----------|-----------|----------|
| 15 mm | 64.41 mm | 167.64 mm | 110.79 g |
| 0.6 in. | 2.536 in. | 6.6 in. | 3.9 oz. |

Regulatory Compliance

TABLE A-5 Requirements Met or Exceeded by the Host Adapter

| Category | Rating |
|----------|--|
| Safety | UL 1950 |
| | CSA 950 |
| | TUV EN 60950 |
| | Class 1 laser requirements per CFR 21, Part 1040 and IEC 825 |
| RFI/EMI | FCC Class B |
| | DOC Class B |
| | VCCI Class B |
| | EMC Directive (89/336/EEC), EN55022 |
| Immunity | EMC Directive (89/336/EEC), EN55082-1 |

PCI Edge Connector Pin Definitions: 32-Bit Cards

TABLE A-6 PCI Edge Connector Pin Definitions, 32-Bit Cards (Top)

| Pin | Description | Pin | Description | Pin | Description |
|-----|---------------|-----|-------------|-----|-------------|
| 1 | -12V | 22 | GND | 43 | +3.3V |
| 2 | TCK | 23 | AD27 | 44 | C_BE1 |
| 3 | GND | 24 | AD25 | 45 | AD14 |
| 4 | TDO | 25 | +3.3V | 46 | GND |
| 5 | +5V | 26 | C_BE3 | 47 | AD12 |
| 6 | +5V | 27 | AD23 | 48 | AD10 |
| 7 | INTB | 28 | GND | 49 | GND |
| 8 | INTD | 29 | AD21 | 50 | KEYWAY |
| 9 | GND (PRSENT1) | 30 | AD19 | 51 | KEYWAY |
| 10 | RESERVED | 31 | +3.3V | 52 | AD08 |
| 11 | GND (PRSENT2) | 32 | AD17 | 53 | AD07 |
| 12 | KEYWAY | 33 | C_BE2 | 54 | +3.3V |
| 13 | KEYWAY | 34 | GND | 55 | AD05 |
| 14 | RESERVED | 35 | IRDY | 56 | AD03 |
| 15 | GND | 36 | +3.3V | 57 | GND |
| 16 | CLK | 37 | DEVSEL | 58 | AD01 |
| 17 | GND | 38 | GND | 59 | +5V |
| 18 | REQ | 39 | LOCK | 60 | ACK64 |
| 19 | +3V/+5V | 40 | PERR | 61 | +5V |
| 20 | AD31 | 41 | +3.3V | 62 | +5V |
| 21 | AD29 | 42 | SERR | | |

TABLE A-7 PCI Edge Connector Pin Definitions, 32-Bit Cards(Bottom)

| Pin | Description | Pin | Description | Pin | Description |
|-----|-------------|-----|-------------|-----|-------------|
| 1 | TRST | 22 | AD28 | 43 | PAR |
| 2 | +12V | 23 | AD26 | 44 | AD15 |
| 3 | TMS | 24 | GND | 45 | +3.3V |
| 4 | TDI | 25 | AD24 | 46 | AD13 |
| 5 | +5V | 26 | IDSEL | 47 | AD11 |
| 6 | INTA | 27 | +3.3V | 48 | GND |
| 7 | INTC | 28 | AD22 | 49 | AD09 |
| 8 | +5V | 29 | AD20 | 50 | KEYWAY |
| 9 | RESERVED | 30 | GND | 51 | KEYWAY |
| 10 | +5V | 31 | AD18 | 52 | C_BE0 |
| 11 | RESERVED | 32 | AD16 | 53 | +3.3V |
| 12 | KEYWAY | 33 | +3.3V | 54 | AD06 |
| 13 | KEYWAY | 34 | FRAME | 55 | AD04 |
| 14 | RESERVED | 35 | IGND | 56 | GND |
| 15 | RST | 36 | TRDY | 57 | GND |
| 16 | +5V | 37 | GND | 58 | AD02 |
| 17 | GNt | 38 | STOP | 59 | +5V |
| 18 | GND | 39 | +3.3V | 60 | REQ64 |
| 19 | RESERVED | 40 | SDONE | 61 | +5V |
| 20 | AD30 | 41 | SBO | 62 | +5V |
| 21 | +3.3V | 42 | GND | | |

PCI Edge Connector Pin Definitions: 64-Bit Cards

TABLE A-8 PCI Expansion Board Pinout—Universal Board

| Pin | Side B | Side A | Pin | Side B | Side A |
|-----|----------|----------|-----|----------|--------|
| 1 | -12V | TRST# | 26 | C/BE[3]# | IDSEL |
| 2 | TCK | +12V | 27 | AD[23] | +3.3V |
| 3 | Ground | TMS | 28 | Ground | AD[22] |
| 4 | TDO | TDI | 29 | AD[21] | AD[20] |
| 5 | +5V | +5V | 30 | AD[19] | Ground |
| 6 | +5V | INTA# | 31 | +3.3V | AD[18] |
| 7 | INTB# | INTC# | 32 | AD[17] | AD[16] |
| 8 | INTD# | +5V | 33 | C/BE[2]# | +3.3V |
| 9 | PRSNT1# | Reserved | 34 | Ground | FRAME# |
| 10 | Reserved | +VI/O | 35 | IRDY# | Ground |
| 11 | PRSNT2# | Reserved | 36 | +3.3V | TRDY# |
| 12 | Keyway | Keyway | 37 | DEVSEL# | Ground |
| 13 | Keyway | Keyway | 38 | Ground | STOP# |
| 14 | Reserved | 3.3Vaux | 39 | LOCK# | +3.3V |
| 15 | Ground | RST# | 40 | PERR# | SDONE |
| 16 | CLK | +VI/O | 41 | +3.3V | SBO# |
| 17 | Ground | GNT# | 42 | SERR# | Ground |
| 18 | REQ# | Ground | 43 | +3.3V | PAR |
| 19 | +VI/O | PME# | 44 | C/BE[1]# | AD[15] |
| 20 | AD[31] | AD[30] | 45 | ad[14] | +3.3V |
| 21 | AD[29] | +3.3V | 46 | Ground | AD[13] |
| 22 | Ground | AD[28] | 47 | AD[12] | AD[11] |
| 23 | AD[27] | AD[26] | 48 | AD[10] | Ground |
| 24 | AD[25] | Ground | 49 | M66EN | AD[09] |
| 25 | +3.3V | AD[24] | 50 | Keyway | Keyway |

TABLE A-9 PCI Expansion Board Pinout—Universal Board

| Pin | Side B | Side A | Pin | Side B | Side A |
|-----|----------|----------|-----|----------|----------|
| 51 | Keyway | Keyway | 76 | Ground | AD[52] |
| 52 | AD[08] | C/BE[0]# | 77 | AD[51] | AD[50] |
| 53 | AD[07] | +3.3V | 78 | AD[49] | Ground |
| 54 | +3.3V | AD[06]# | 79 | +VI/O | AD[48] |
| 55 | AD[05] | AD[04]# | 80 | AD[47] | AD[46] |
| 56 | AD[03] | Ground | 81 | AD[45] | Ground |
| 57 | Ground | AD[02] | 82 | Ground | AD[44] |
| 58 | AD[01] | AD[00] | 83 | AD[43] | AD[42] |
| 59 | +VI/O | +VI/O | 84 | AD[41] | +VI/O |
| 60 | ACK64# | REQ64# | 85 | Ground | AD[40] |
| 61 | +5V | +5V | 86 | AD[39] | AD[38] |
| 62 | +5V | +5V | 87 | AD[37] | Ground |
| | Keyway | Keyway | 88 | +VI/O | AD[36] |
| | Keyway | Keyway | 89 | AD[35] | AD[34] |
| 63 | Reserved | Ground | 90 | AD[33] | Ground |
| 64 | Ground | C/BE[7]# | 91 | Ground | AD[32] |
| 65 | C/BE[6]# | C/BE[5]# | 92 | Reserved | Reserved |
| 66 | C/BE[4]# | +VI/O | 93 | Reserved | Ground |
| 67 | Ground | PAR64 | 94 | Ground | Reserved |
| 68 | AD[63] | AD[62] | | | |
| 69 | AD[61] | Ground | | | |
| 70 | +VI/O | AD[60] | | | |
| 71 | AD[59] | AD[58] | | | |
| 72 | AD[57] | Ground | | | |
| 73 | Ground | AD[56] | | | |
| 74 | AD[55] | AD[54] | | | |
| 75 | AD[53] | +VI/O | | | |

Booting From the Network Adapter

Booting from the network adapter requires special procedures in order to enable detection of installation devices. To boot from the small kernel image on the network adapter, you must use either a boot/install server or a temporarily directly-connected boot disk to enable bootability. The method using a boot install server is the Net Install Patching method and the method using a directly-connected boot disk is the Dump and Restore method. Both procedures should be performed by a knowledgeable UNIX system administrator.

The two methods are explained in this appendix in the sections:

- [Section “The Net Install Method” on page B-22](#)
- [Section “The Dump and Restore Method” on page B-28](#)

The Dump and Restore method is more difficult than the Net Install Patching method and you might experience complications in the loss of the boot. However, the method is available to anyone with existing systems, whether small or large configurations, and it provides a disk image when you have completed the process.

The Net Install Patching method requires a jump-start server and network connectivity, and it is more suitable for large system configurations than for small ones. This method is easier than the Dump and Restore method and mitigates the risk of data loss.

Note – These procedures are necessary if the network adapter card driver is not bundled with the Solaris operating environment on the boot server on the network. Check your Solaris operating environment to determine whether the driver is bundled with it.

Booting through a network adapter is mandatory when the host is an enterprise-level system or other system that does not have its own directly-connected disks. It is optional and preferable when a host has a directly-connected disk, you might prefer to boot through the adapter because the 2 Gb connection is faster.

The Net Install Method

This section contains a bootability method that is different from the one starting at [Section “The Dump and Restore Method” on page B-28](#). The topics in this section include:

- [Section “Overview For the Net Install Method” on page B-22](#)
- [Section “To Set Up the Boot/Install Server” on page B-23](#)
- [Section “To Modify the Boot Image” on page B-25](#)
- [Section “To Set Up the Client” on page B-26](#)

The procedures in this section explain how to install the Solaris operating environment from a boot/install server onto the host with the host adapter. Any other host on the same subnet can be set up as a boot/install server.

Note – The procedure is identical whether the you are using a boot server or an install server.¹ Therefore, the convention used in this chapter is to refer to either type of server as the “boot/install server.”

Overview For the Net Install Method

Installing a client from a boot/install server uses two images of the Solaris operating environment:

- A boot mini-root (which is referred to from here on as the *boot image*)
- A separate *install image* that gets copied onto the boot disk

This procedure assumes you know how to install Solaris software over the network as described in the Solaris installation manuals. For more information, see the man(1) pages for the commands that are used in this procedure.

Note – While you are setting up the boot/install server, you must either have the contents of the Solaris installation CD-ROM copied to a disk that is directly-connected to the boot/install server or have the Solaris installation CD inserted and mounted from an attached CD-ROM device.

1. For the distinction between these two types of server, see the Solaris system administration documentation.

You need to enable bootability using a boot/install server to make both images aware of the host adapter. At the start of the procedure, the system administrator downloads the driver and all required patches to an exported directory on the boot/install server.

The following steps explain the process. For actual instructions, begin with [Section “To Set Up the Boot/Install Server”](#) on page B-23.

1. The *boot image* is copied from a Solaris CD-ROM or from another location onto a disk that is attached to a boot/install server.
2. The driver package is added to the boot image.
You add the driver package to the boot image so that the boot/install server can then send and receive data through the host adapter on the boot client.
3. The client boots from the boot/install server, the interactive `suninstall(1M)` application starts, and the system administrator provides configuration information requested at the prompts.
4. After the system administrator provides all configuration information requested by the installation program, the installation of the Solaris operating environment begins.
5. The install image is copied to the client.
6. Before a reboot, while the client is still booted from the boot image mini-root, the driver and any needed patches are copied from the boot/install server and then installed in the *install image*.
You install the driver package and patch the install image so that the host will be able to see the host adapter after a reboot.

Note – You can not use Jump Start until you modify the install image.

7. The host boots from the boot disk through the network adapter.

To Set Up the Boot/Install Server

1. **Switch users to root on the host to be used as the boot/install server.**

```
% su
Password:
#
```

2. Use the `setup_install_server(1M)` command from the `Tools` directory in the location where the Solaris software resides.

As shown in the following screen example, the `setup_install_server` command copies the boot image to a directory on the boot/install server. (The boot directory is named `/boot_dir /<original_OS_dir>/Boot` in the example.) The example shows the command being run from the `Tools` directory on a mounted Solaris 8 installation CD-ROM.

```
# cd /cdrom/cdrom0/s0/Solaris_8/Tools
# ./setup_install_server -t /<original_OS_dir>/Boot /<new_OS_copy_dir>
```

3. Download the driver packages and the accompanying `README` file from Sun's download center into the `/<export_public>` directory on the boot/install server.
 - a. Go to the download center URL specified in the instructions on how to download the network adapter driver in the product notes.
 - b. Download the `README` file.
 - c. Remove any previously-installed packages for this network adapter as instructed in the `README`.
 - d. Download the packages as described in the instructions in the release notes.
 - e. Use the `uncompress(1M)` and `tar(1M)` commands to uncompress and expand the packages in the `tar` file, as instructed in the `README`.



Caution – Do not use the `pkgadd(1M)` command line that is given in the `README` to install the packages. See [Section “To Modify the Boot Image” on page B-25](#) to install relocatable versions of the packages.

4. Download the required patch(es) and the accompanying `README` file(s) from `sunsolve.sun.com` into the `/<export_public>` directory on the boot/install server.
 - a. See the release notes for a list of required patches.
 - b. Go to the URL specified in the instructions on how to download the network adapter driver required patch(es) in the release notes.
 - c. Download the `README` file.
 - d. Remove any previously-installed related-patches that may be specified in the `README`.
 - e. Download the patch(es) as described in the instructions in the release notes.

- f. Use the `uncompress(1M)` and `tar(1M)` commands to uncompress and expand the patch(es) in the tar file, as instructed in the README.



Caution – Do not use the `patchadd(1M)` command line that is given in the README to install the patch(es). See [Section “To Modify the Boot Image” on page B-25](#) to install relocatable versions of the patch(es).

To Modify the Boot Image

1. Install the driver packages into the boot image.

The following example installs all packages previously downloaded into the `/<export_public>` directory.

Note – Refer to the `install_order` file for the proper order in which to install the packages. You must follow this order for a successful installation so the driver will run.

```
# cd /<export_public>
# pkgadd -R /<new_OS_copy_dir>/Boot -d .
```

2. Install any needed patches into the boot image.

The following example installs any patch(es) that were previously downloaded into the `/<export_public>` directory. Repeat the `patchadd` command for all the patches you need to add.

```
# cd /<export_public>
# patchadd -C /<new_OS_copy_dir>/Boot -M /<export_public> <patch_ID>
```

3. Make sure the host name, its IP address, and its Ethernet address have been added to the name service (`/etc` files, NIS, or NIS+).

4. Run the `add_install_client(1M)` command to add the host with the host adapter as a boot/install client.

The example shows the `add_install_client` command followed by the name of the host followed by its platform name.

```
# add_install_client <host_name> <platform_name>
```

Note – You can find the platform name by running the `uname` command with the `-m` option on the host that has the host adapter.

5. **Log out of the boot/install server.**

To Set Up the Client

1. **Bring the client host (with the host adapter) down to the `ok` prompt at run level 0.**

See the Solaris system administration documentation for the commands that can be used with different configurations. The following example uses the `shutdown(1M)` command.

```
# shutdown
...
ok
```



Caution – Do not reboot the boot/install server.

2. **Boot the host from the net.**

```
ok boot net
```

The Solaris interactive installation program runs from the boot/install server.

3. **Respond to the prompts according to your configuration, as instructed in the Solaris installation guide.**

Make sure to specify the new boot disk as the destination for the operating environment installation.

4. **When prompted to choose between automatic reboot or manual reboot, click the Manual Reboot button, complete the remaining question, and start the installation.**

This question offering a choice between automatic and manual reboot is the last question before the installation starts. If you are using the `suninstall` program, choose `boot manual`.

5. Mount the `/<export_public>` directory which contains the driver packages and any needed patches onto the `/mnt` directory mount point.

Enter the mount command followed by the hostname of the boot/install server, followed by a colon (:), followed by `/<export_public>` followed by `/mnt`. The following example uses `boot_install_server` as the name of the boot/install server.

```
# mount boot_install_server:<export_public> /a/mnt
```

6. Install the driver packages into the install image.

The following example installs all packages previously downloaded into the `/<export_public>` directory. When prompted, install the packages in the order of `SUNWsan`, `SUNWcflpl`, `SUNWcflpx`.

```
# cd /a/mnt
# pkgadd -R /a -d .
```

7. Install any needed patches into the boot image.

The following example installs all patch(es) that were previously downloaded into the `/<export_public>` directory.

Note – Install the patches in their sequential numeric order to ensure the installation is successful.

```
# cd /a/mnt
# patchadd -R /a <patch_ID>
```

8. Bring the system down to the `ok` prompt at run level 0.

```
# halt
```

9. Reboot the host from the newly installed operating environment.

```
ok boot -r
```

The Dump and Restore Method

This section contains a bootability method that is different from the one starting at [Section “The Net Install Method” on page B-22](#). The topics in this section include:

- [Section “Overview Of the Dump and Restore Method” on page B-28](#)
- [Section “Partitioning the New Boot Disk the Same As the Temporary Boot Disk” on page B-28](#)
- [Section “To Create File Systems on the New Boot Disk” on page B-38](#)
- [Section “To Create the New Boot Files” on page B-38](#)

Overview Of the Dump and Restore Method

To enable bootability using a temporary boot disk, a boot disk must be directly connected, at least temporarily, to the host. The boot disk must have the following installed:

- The Solaris operating environment.
- The network adapter driver packages and any needed patches
See the release notes for how to download and install the driver packages and any needed patches.

Note – The initial boot disk can be removed if it is not needed after the boot disk is enabled.

Note – The examples in this section show disk 0 as the directly-connected boot disk, and disk 2 as the designated new boot disk that is connected through the host adapter.

Partitioning the New Boot Disk the Same As the Temporary Boot Disk

There are several sub procedures required to complete the first phase of enabling bootability from a temporarily connected boot disk. These sub procedures include:

- [Section “To Prepare To Partition the New Disk” on page B-29](#)

- Section “To Record the Partition Layout” on page B-29
- Section “To Change To the New Boot Disk” on page B-32
- Section “To Specify Slices On the New Boot Disk” on page B-33
- Section “To Label the New Boot Disk” on page B-37

To Prepare To Partition the New Disk

1. **Switch users to root on the host with the host adapter.**

```
% su
Password:
#
```

2. **If the driver and any needed patches are not already installed, download the driver package from Sun’s download center and install it on the host, following the instructions in the README file that comes with the driver.**

To download the driver, follow the instructions in the release notes.

3. **Reboot using the `reboot(1M)` command with the `-r` option.**

```
# reboot -- -r
```

4. **Log into the host as root.**

To Record the Partition Layout

After you log back into the host, you can record the layout of the partitions, or slices, on the system boot disk.

1. **Enter the `format(1M)` command.**

If needed, see the `format` man page and the instructions on adding a disk and using the `format` command in the Solaris administration documentation.

Note – These examples use disk 0 as the temporary disk (c0t0d0) and disk 2 (c7t16d0) as the new boot disk.

```
# format
Searching for disks...done

AVAILABLE DISK SELECTIONS:
  0. c0t1d0 <SUN18G cyl 7506 alt 2 hd 19 sec 248>
    /pci@8,600000/SUNW,qlc@4/fp@0,0/ssd@w2100002037e43542,0
  1. c0t2d0 <SUN36G cyl 24620 alt 2 hd 27 sec 107>
    /pci@8,600000/SUNW,qlc@4/fp@0,0/ssd@w21000020374205a1,0
  2. c7t16d0 <SUN36G cyl 24620 alt 2 hd 27 sec 107>
    /pci@8,600000/SUNW,qlc@1/fp@0,0/ssd@w500000e01002b7c1,0
  3. c7t17d0 <SUN36G cyl 24620 alt 2 hd 27 sec 107>
    /pci@8,600000/SUNW,qlc@1/fp@0,0/ssd@w500000e0100357c1,0
  4. c7t18d0 <SUN36G cyl 24620 alt 2 hd 27 sec 107>
    /pci@8,600000/SUNW,qlc@1/fp@0,0/ssd@w500000e010032331,0
  5. c7t19d0 <drive not available: formatting>
    /pci@8,600000/SUNW,qlc@1/fp@0,0/ssd@w500000e010032661,0
  6. c7t20d0 <SUN36G cyl 24620 alt 2 hd 27 sec 107>
    /pci@8,600000/SUNW,qlc@1/fp@0,0/ssd@w500000e0100369e1,0
Specify disk (enter its number):
```

2. Make a note of the device path name of the new boot disk.

For example, for disk 2, the new boot disk in this example, the device path name shown is: /pci@8,600000/SUNW,qlc@1/fp@0,0. You use this information later in [Step 4](#) in [Section "To Specify the New Boot Disk as the Boot Device."](#) on [page B-42](#).

Note – The qlc number changes, depending on the type of host and slot in use.

3. Specify the disk where the operating system is installed on the temporary boot disk.

The following screen example specifies disk 2.

```
Specify disk (enter its number): 2
```

4. Enter the **partition** command to bring up the PARTITION MENU.

```
format> partition
PARTITION MENU:
    0      - change '0' partition
    1      - change '1' partition
    2      - change '2' partition
    3      - change '3' partition
    4      - change '4' partition
    5      - change '5' partition
    6      - change '6' partition
    7      - change '7' partition
select    - select a predefined table
modify    - modify a predefined partition table
name      - name the current table
print     - display the current table
label     - write partition map and label to the disk
!<cmd>   - execute <cmd>, then return
quit
partition>
```

5. Enter the **print** command to display the partition table for the specified disk.

```
partition> print
Current partition table (original):
Total disk cylinders available: 3880 + 2 (reserved cylinders)

Part      Tag      Flag      Cylinders      Size      Blocks
0         root      wm        0 - 1937      2.00GB   (1938/0/0) 4186080
1         swap      wu        1938 - 2908   1.00GB   (971/0/0) 2097360
2         backup   wm        0 - 3879      4.00GB   (3880/0/0) 8380800
3 unassigned  wm        0              0         (0/0/0)    0
4 unassigned  wm        0              0         (0/0/0)    0
5 unassigned  wm        0              0         (0/0/0)    0
6 unassigned  wm        0              0         (0/0/0)    0
7         home      wm        2909 - 3879   1.00GB   (971/0/0) 2097360
```

As shown in the example, the temporary boot disk has three slices defined: 0 (root), 1 (swap), and 7 (home) with sizes, 2.00GB, 1.00GB, and 1.00GB.

6. Record the layout (sizes and numbers) assigned to the slices on the temporary boot disk, and enter `quit` when done.

```
partition> quit
FORMAT MENU:
    disk           - select a disk
    type           - select (define) a disk type
    partition      - select (define) a partition table
    current        - describe the current disk
    format         - format and analyze the disk
    repair         - repair a defective sector
    label          - write label to the disk
    analyze        - surface analysis
    defect         - defect list management
    backup         - search for backup labels
    verify         - read and display labels
    save           - save new disk/partition definitions
    inquiry        - show vendor, product and revision
    volname        - set 8-character volume name
    !<cmd>         - execute <cmd>, then return
    quit
format>
```

As shown in the previous example, the `quit` command returns you to the `FORMAT MENU`.

To Change To the New Boot Disk

After you record the partition layout, change to the new boot disk.

1. At the `format>` prompt, type `disk` to change the current disk to the new boot disk.

2. Enter the number of the disk to be formatted after the disk command.

The following screen example uses disk 2. The FORMAT MENU appears.

```
format> disk 2
selecting c7t16d0
[disk formatted]

FORMAT MENU:
  disk           - select a disk
  type           - select (define) a disk type
  partition      - select (define) a partition table
  current        - describe the current disk
  format         - format and analyze the disk
  repair         - repair a defective sector
  label          - write label to the disk
  analyze        - surface analysis
  defect         - defect list management
  backup         - search for backup labels
  verify         - read and display labels
  save           - save new disk/partition definitions
  inquiry        - show vendor, product and revision
  volname        - set 8-character volume name
  !<cmd>        - execute <cmd>, then return
  quit

format>
```

3. Make a note of the device name of the disk.

The device name of the disk in the previous screen example is c7t16d0.

To Specify Slices On the New Boot Disk

After you change to the new boot disk, specify one slice on the new boot disk for every slice on the temporary boot disk. The following examples specify the root slice 0 on the new boot disk to match slice 0 on the temporary boot disk.

1. Enter the partition command to bring up the PARTITION MENU.

```
format> p
PARTITION MENU:
  0      - change '0' partition
  1      - change '1' partition
  2      - change '2' partition
  3      - change '3' partition
  4      - change '4' partition
  5      - change '5' partition
  6      - change '6' partition
  7      - change '7' partition
select  - select a predefined table
modify  - modify a predefined partition table
name    - name the current table
print   - display the current table
label   - write partition map and label to the disk
!<cmd> - execute <cmd>, then return
quit
partition>
```

2. Enter the number of the slice to be defined.

Slice 0 is specified in the following example. As shown, the partition table for the new boot disk displays.

```
partition> 0
Current partition table (original):
Total disk cylinders available: 24620 + 2 (reserved cylinders)

Part      Tag      Flag      Cylinders      Size      Blocks
  0      root      wm        0 - 90         128.37MB  (91/0/0)    262899
  1      swap      wu        91 - 181       128.37MB  (91/0/0)    262899
  2      backup    wu        0 - 24619     33.92GB   (24620/0/0) 71127180
  3 unassigned  wm         0              0         (0/0/0)      0
  4 unassigned  wm         0              0         (0/0/0)      0
  5 unassigned  wm         0              0         (0/0/0)      0
  6      usr      wm       182 - 24619    33.67GB   (24438/0/0) 70601382
  7 unassigned  wm         0              0         (0/0/0)      0
Enter partition id tag[root]:
```

3. Enter the partition ID tag.

The following example shows a question mark (?) entered after the prompt. The list of accepted partition id tags displays. The example then shows the default partition id tag of root accepted by pressing the Return key.

```
Enter partition id tag[root]: ?
Expecting one of the following: (abbreviations ok):
      unassigned    boot        root        swap
      usr           backup     stand       var
Enter partition id tag[root]:
Enter partition permission flags[wm]:
```

4. Enter the partition permission flags.

The following example shows the default permission flags wm accepted by pressing the Return key.

```
Enter partition permission flags[wm]:
Enter new starting cyl[0]:
```

5. Enter the new starting cylinder.

The following example shows the default new starting cylinder of 0 accepted by pressing the Return key.

```
Enter new starting cyl[0]:
Enter partition size[262899b, 91c, 128.37mb, 0.13gb]:
```

6. Enter the partition size.

The following example shows the partition size of 2.00gb entered.

```
Enter partition size[262899b, 91c, 128.37mb, 0.13gb]: 2.00gb
partition>
```

7. Enter the print command to display the updated partition table.

The following example shows that the root tag, the wm permissions flag, and the partition size of 2.00GB are assigned to slice 0.

```
partition> print
Current partition table (unnamed):
Total disk cylinders available: 24620 + 2 (reserved cylinders)

Part      Tag      Flag      Cylinders      Size      Blocks
 0      root    wm       0 - 1451      2.00GB   (1452/0/0)  4194828
 1      swap    wu       91 - 181     128.37MB (91/0/0)   262899
 2      backup  wu       0 - 24619    33.92GB  (24620/0/0)
71127180
 3 unassigned  wm       0            0        (0/0/0)    0
 4 unassigned  wm       0            0        (0/0/0)    0
```

8. Repeat Step 2 through Step 7 as needed until all slices are defined as they are in the temporary boot disk.

9. Enter the quit command to return to the FORMAT MENU.

```
partition> quit

FORMAT MENU:
  disk          - select a disk
  type          - select (define) a disk type
  partition     - select (define) a partition table
  current       - describe the current disk
  format        - format and analyze the disk
  repair        - repair a defective sector
  label         - write label to the disk
  analyze       - surface analysis
  defect        - defect list management
  backup        - search for backup labels
  verify        - read and display labels
  save          - save new disk/partition definitions
  inquiry       - show vendor, product and revision
  volname       - set 8-character volume name
  !<cmd>       - execute <cmd>, then return
  quit

format>
```

To Label the New Boot Disk

After you specify the slices on the new boot disk, label the new boot disk with the new partition table.

1. Enter the label command

```
format> label
```

2. Enter y[es] to continue.

```
Ready to label disk, continue? y
```

3. When the labeling is complete, enter q[uit] to quit the `format` program.

```
format> q  
#
```

To Create File Systems on the New Boot Disk

- **Create a file system on each slice on the disk using the `newfs(1M)` command.**

Enter the `newfs` command followed by the device name of the slice. In this example, the device name for slice 0 of disk `c7t16d0` is `/dev/rdisk/c7t16d0s0`.

```
# newfs /dev/rdisk/c7t16d0s0
newfs: construct a new file system /dev/rdisk/c7t16d0s0: (y/n)? y
/dev/rdisk/c7t16d0s0:      4194828 sectors in 1452 cylinders of 27 tracks, 107
sectors
      2048.3MB in 46 cyl groups (32 c/g, 45.14MB/g, 7488 i/g)
super-block backups (for fsck -F ufs -o b=#) at:
 32, 92592, 185152, 277712, 370272, 462832, 555392, 647952, 740512, 833072,
925632, 1018192, 1110752, 1203312, 1295872, 1388432, 1480992, 1573552,
1666112, 1758672, 1851232, 1943792, 2036352, 2128912, 2221472, 2314032,
2406592, 2499152, 2591712, 2684272, 2776832, 2869392, 2958368, 3050928,
3143488, 3236048, 3328608, 3421168, 3513728, 3606288, 3698848, 3791408,
3883968, 3976528, 4069088, 4161648,
```

For more information, see the section on how to create file systems in the Solaris system administration documentation.

Do this step to create a file system on the new boot disk for every slice on the temporary boot disk. When you are finished, go to [Section “To Copy the Contents of Non-root File Systems onto the New Boot Disk” on page B-41](#).

To Create the New Boot Files

This section has several sub procedures, including:

- [Section “To Copy the Boot Block and Root File System Contents To the New Boot Disk” on page B-39](#)
- [Section “To Update the `vfstab` File” on page B-40](#)
- [Section “To Copy the Contents of Non-root File Systems onto the New Boot Disk” on page B-41](#)
- [Section “To Specify the New Boot Disk as the Boot Device.” on page B-42](#)

To Copy the Boot Block and Root File System Contents To the New Boot Disk

1. Install the boot block on the root (/) file system of the new disk.

The following example uses the `installboot(1M)` command to install the boot block. The boot block resides in the `/usr/platform/platform_name/lib/fs/ufs/bootblk` directory. The example shows invoking the `uname` command with the `-i` option between left single quotes on the command line to specify the platform name.

```
# /usr/sbin/installboot /usr/platform/'uname -i'/lib/fs/ufs/bootblk \  
/dev/rdisk/c7t16d0s0
```

For more information, see the instructions on how to install a boot block in the Solaris system administration documentation.

2. Mount the root file system from slice 0 of the new boot disk onto the `/mnt` mount point.

```
# mount /dev/dsk/c7t16d0s0 /mnt
```

3. Use the `ufsdump(1M)` and `ufsrestore(1M)` commands to copy the contents of the root file system from the temporary boot disk to the root slice of the new boot disk (on the `/mnt` mount point).

```
# ufsdump 0f - /dev/rdisk/c0t0d0s0 | ( cd /mnt; ufsrestore rf -)  
DUMP: Writing 32 Kilobyte records  
DUMP: Date of this level 0 dump: Tue 19 Feb 2002 02:44:35 PM PST  
DUMP: Date of last level 0 dump: the epoch  
DUMP: Dumping /dev/rdisk/c7t16d0s0 (hba2-81:/) to standard  
output.  
DUMP: Mapping (Pass I) [regular files]  
DUMP: Mapping (Pass II) [directories]  
DUMP: Estimated 1818082 blocks (887.74MB).  
DUMP: Dumping (Pass III) [directories]  
DUMP: Dumping (Pass IV) [regular files]  
Warning: ./lost+found: File exists  
DUMP: 88.77% done, finished in 0:01  
DUMP: 1818046 blocks (887.72MB) on 1 volume at 1363 KB/sec  
DUMP: DUMP IS DONE  
#
```

4. Unmount the root file system on slice 0 from the `/mnt` mount point.

```
# umount /mnt
```

To Update the `vfstab` File

After you copy the boot block and root files, update the `vfstab` file.

1. Mount the root file system from slice 0 of the new boot disk onto the `/mnt` mount point.

```
# mount /dev/dsk/c7t16d0 /mnt
```

2. Change directories to `/mnt/etc` and open the `vfstab(4)` file for editing.

The following example shows the file systems defined.

```
# cd /mnt/etc
# vi vfstab
...
/dev/dsk/c0t0d0s1      -          -          swap      -          no          -
/dev/dsk/c0t0d0s0      /dev/rdisk/c0t0d0s0    /          ufs        1          no -
/dev/dsk/c0t0d0s7      /dev/rdisk/c0t0d0s7    /home     ufs        2          yes -
```

3. Replace the name of the temporary boot disk with the name of the new boot disk, and then save and quit the file.

The following example shows the disk name `c0t0` changed to `c3t8` in the mount table entries for slices 0, 1, and 7.

```
/dev/dsk/c7t16d0s1      -          -          swap      -          no          -
/dev/dsk/c7t16d0s0      /dev/rdisk/c7t16d0s0    /          ufs        1 no          -
/dev/dsk/c7t16d0s7      /dev/rdisk/c7t16d0s7    /home     ufs        2 yes -
:wq
#
```

To Copy the Contents of Non-root File Systems onto the New Boot Disk

1. Mount the file system onto the `/mnt` mount point.

This example shows the copying of the `/home` file system from slice 7 to the new boot disk.

```
# mount /dev/dsk/c7t16d0 /mnt
```

2. Use the `ufsdump(1M)` and `ufsrestore(1M)` commands to copy the contents of the file system from the temporary boot disk to the new boot disk.

```
# ufsdump 0f - /dev/rdisk/c0t0d0s0 | ( cd /mnt; ufsrestore rf -)
DUMP: Writing 32 Kilobyte records
DUMP: Date of this level 0 dump: Tue 19 Feb 2002 02:44:35 PM PST
DUMP: Date of last level 0 dump: the epoch
DUMP: Dumping /dev/rdisk/c7t16d0s0 (hba2-81:/) to standard
output.
DUMP: Mapping (Pass I) [regular files]
DUMP: Mapping (Pass II) [directories]
DUMP: Estimated 1818082 blocks (887.74MB).
DUMP: Dumping (Pass III) [directories]
DUMP: Dumping (Pass IV) [regular files]
Warning: ./lost+found: File exists
DUMP: 88.77% done, finished in 0:01
DUMP: 1818046 blocks (887.72MB) on 1 volume at 1363 KB/sec
DUMP: DUMP IS DONE
#
```

3. Unmount the file system from the `/mnt` mount point.

```
# umount /mnt
```

4. Repeat [Step 1](#) through [Step 3](#) as needed until you have copied all the file systems' contents to the new boot disk. When finished, go to [Section "To Update the vfstab File"](#) on page B-40.

To Specify the New Boot Disk as the Boot Device.

1. Bring the host with the host adapter down to the `ok` prompt at run level 0.

See the Solaris system administration documentation on shutting down a host for the commands that can be used with different configurations. The following screen example uses the `shutdown(1M)` command.

```
# shutdown
...
ok
```

2. Use the `nvalias` command to alias the device name of the disk to a short name for the disk.

The following example uses

`/pci@8,600000/SUNW,qlc@1/fp@0,0/disk@10,0`, which was the device path name for disk 2 in [Section "To Record the Partition Layout" on page B-29](#).

```
ok nvalias disk2 /pci@8,600000/SUNW,qlc@1/fp@0,0/disk@10,0
```

3. Use the `nvstore` command to store the new alias followed by the `reset all` command.

```
ok nvstore
ok reset-all
```

4. Define the new boot disk as the default `boot-device`.

Use the data gathered in [Step 2 on page 30](#).

a. Enter the `setenv` command followed by the `boot-device` parameter followed by the name of the new disk.

```
ok setenv boot-device disk2
```

b. Enter the `reset` command.

```
ok reset
```

5. Enter the `boot` command with the `-r` option so that the Solaris operating environment can recognize the adapter.

```
ok boot -r
```

