



# Sun Fire™ Link Hardware Installation Guide

---

Sun Microsystems, Inc.  
4150 Network Circle  
Santa Clara, CA 95054 U.S.A.  
650-960-1300

Part No. 806-1396-11  
May 2003, Revision A

Send comments about this document to: [docfeedback@sun.com](mailto:docfeedback@sun.com)

Copyright 2003 Sun Microsystems, Inc., 4150 Network Circle, Santa Clara, California 95054, U.S.A. All rights reserved.

Sun Microsystems, Inc. has intellectual property rights relating to technology that is described in this document. In particular, and without limitation, these intellectual property rights may include one or more of the U.S. patents listed at <http://www.sun.com/patents> and one or more additional patents or pending patent applications in the U.S. and in other countries.

This document and the product to which it pertains are distributed under licenses restricting their use, copying, distribution, and decompilation. No part of the product or of this document may be reproduced in any form by any means without prior written authorization of Sun and its licensors, if any.

Third-party software, including font technology, is copyrighted and licensed from Sun suppliers.

Parts of the product may be derived from Berkeley BSD systems, licensed from the University of California. UNIX is a registered trademark in the U.S. and in other countries, exclusively licensed through X/Open Company, Ltd.

Sun, Sun Microsystems, the Sun logo, AnswerBook2, docs.sun.com, Sun Fire, RSM, StorEdge, and Solaris are trademarks or registered trademarks of Sun Microsystems, Inc. in the U.S. and in other countries.

All SPARC trademarks are used under license and are trademarks or registered trademarks of SPARC International, Inc. in the U.S. and in other countries. Products bearing SPARC trademarks are based upon an architecture developed by Sun Microsystems, Inc.

The OPEN LOOK and Sun™ Graphical User Interface was developed by Sun Microsystems, Inc. for its users and licensees. Sun acknowledges the pioneering efforts of Xerox in researching and developing the concept of visual or graphical user interfaces for the computer industry. Sun holds a non-exclusive license from Xerox to the Xerox Graphical User Interface, which license also covers Sun's licensees who implement OPEN LOOK GUIs and otherwise comply with Sun's written license agreements.

U.S. Government Rights—Commercial use. Government users are subject to the Sun Microsystems, Inc. standard license agreement and applicable provisions of the FAR and its supplements.

DOCUMENTATION IS PROVIDED "AS IS" AND ALL EXPRESS OR IMPLIED CONDITIONS, REPRESENTATIONS AND WARRANTIES, INCLUDING ANY IMPLIED WARRANTY OF MERCHANTABILITY, FITNESS FOR A PARTICULAR PURPOSE OR NON-INFRINGEMENT, ARE DISCLAIMED, EXCEPT TO THE EXTENT THAT SUCH DISCLAIMERS ARE HELD TO BE LEGALLY INVALID.

---

Copyright 2003 Sun Microsystems, Inc., 4150 Network Circle, Santa Clara, California 95054, Etats-Unis. Tous droits réservés.

Sun Microsystems, Inc. a les droits de propriété intellectuels relatants à la technologie qui est décrit dans ce document. En particulier, et sans la limitation, ces droits de propriété intellectuels peuvent inclure un ou plus des brevets américains énumérés à <http://www.sun.com/patents> et un ou les brevets plus supplémentaires ou les applications de brevet en attente dans les Etats-Unis et dans les autres pays.

Ce produit ou document est protégé par un copyright et distribué avec des licences qui en restreignent l'utilisation, la copie, la distribution, et la décompilation. Aucune partie de ce produit ou document ne peut être reproduite sous aucune forme, par quelque moyen que ce soit, sans l'autorisation préalable et écrite de Sun et de ses bailleurs de licence, s'il y en a.

Le logiciel détenu par des tiers, et qui comprend la technologie relative aux polices de caractères, est protégé par un copyright et licencié par des fournisseurs de Sun.

Des parties de ce produit pourront être dérivées des systèmes Berkeley BSD licenciés par l'Université de Californie. UNIX est une marque déposée aux Etats-Unis et dans d'autres pays et licenciée exclusivement par X/Open Company, Ltd.

Sun, Sun Microsystems, le logo Sun, AnswerBook2, docs.sun.com, Sun Fire, RSM, StorEdge, et Solaris sont des marques de fabrique ou des marques déposées de Sun Microsystems, Inc. aux Etats-Unis et dans d'autres pays.

Toutes les marques SPARC sont utilisées sous licence et sont des marques de fabrique ou des marques déposées de SPARC International, Inc. aux Etats-Unis et dans d'autres pays. Les produits portant les marques SPARC sont basés sur une architecture développée par Sun Microsystems, Inc.

L'interface d'utilisation graphique OPEN LOOK et Sun™ a été développée par Sun Microsystems, Inc. pour ses utilisateurs et licenciés. Sun reconnaît les efforts de pionniers de Xerox pour la recherche et le développement du concept des interfaces d'utilisation visuelle ou graphique pour l'industrie de l'informatique. Sun détient une licence non exclusive de Xerox sur l'interface d'utilisation graphique Xerox, cette licence couvrant également les licenciées de Sun qui mettent en place l'interface d'utilisation graphique OPEN LOOK et qui en outre se conforment aux licences écrites de Sun.

LA DOCUMENTATION EST FOURNIE "EN L'ÉTAT" ET TOUTES AUTRES CONDITIONS, DECLARATIONS ET GARANTIES EXPRESSES OU TACITES SONT FORMELLEMENT EXCLUES, DANS LA MESURE AUTORISEE PAR LA LOI APPLICABLE, Y COMPRIS NOTAMMENT TOUTE GARANTIE IMPLICITE RELATIVE A LA QUALITE MARCHANDE, A L'APTITUDE A UNE UTILISATION PARTICULIERE OU A L'ABSENCE DE CONTREFAÇON.



Please  
Recycle



Adobe PostScript

# Contents

---

## **Preface 1-xi**

## **1. Safety and Tools Requirements 1-1**

- 1.1 Safety Precautions 1-1
- 1.2 Symbols 1-3
- 1.3 System Precautions 1-4
- 1.4 Filler Boards and Filler Panels 1-5
  - 1.4.1 Sun Fire Link Assembly for Sun Fire 6800 Systems 1-5
  - 1.4.2 Sun Fire Link Assembly for Sun Fire 15K/12K Systems 1-5
- 1.5 Handling Boards and Assemblies 1-5
- 1.6 Tools Required 1-6

## **2. Cabling Diagrams 2-1**

- 2.1 Number of Nodes and Switches 2-1
- 2.2 Component Naming and Numbering Conventions 2-2
  - 2.2.1 Sun Fire 6800 System 2-2
  - 2.2.2 Sun Fire 15K/12K System 2-3
- 2.3 How to Read a Cabling Diagram 2-6
  - 2.3.1 Sun Fire 6800 System 2-6
  - 2.3.2 Sun Fire 15K/12K System 2-6

- 2.4 Striping 2-7
  - 2.4.1 Sun Fire Link ASIC (WCI) Striping 2-8
  - 2.4.2 Link Striping 2-8
  - 2.4.3 Four-Way Striping 2-9
- 2.5 Cabling Diagrams and Tables For Sun Fire 6800 Systems 2-9
  - 2.5.1 Two-Node Direct-Connect Configuration 2-9
  - 2.5.2 Three-Node Direct-Connect 2-11
  - 2.5.3 Three- to Four-Node Configuration With Two Switches 2-13
  - 2.5.4 Five- to Eight-Node Configuration With Four Switches 2-15
- 2.6 Cabling Diagrams and Tables for Sun Fire 15K/12K Systems 2-18
  - 2.6.1 Two-Node Direct Connect 2-19
  - 2.6.2 Three-Node Direct Connect 2-21
  - 2.6.3 Three- to Four-Node Configuration With Two Sun Fire Link Switches 2-23
  - 2.6.4 Five- to Eight-Node Configuration With Four Sun Fire Link Switches 2-26
- 3. Installing the Sun Fire Link Assembly (Sun Fire 6800 System) 3-1**
  - 3.1 About the Sun Fire Link Assembly 3-2
  - 3.2 Installing a Filler Board 3-3
  - 3.3 Removing a Sun Fire 6800 Assembly 3-4
  - 3.4 Installing a Sun Fire Link Assembly 3-5
  - 3.5 Installing Sun Fire Link Optical Modules 3-6
    - 3.5.1 About the Sun Fire Link Optical Module 3-6
    - 3.5.2 Sun Fire Link Optical Module LEDs 3-8
    - 3.5.3 Installing a Sun Fire Link Optical Module 3-10
    - 3.5.4 About Sun Fire Link Cables 3-11
    - 3.5.5 Installing Sun Fire Link Optical Cables 3-12
- 4. Installing the Sun Fire Link Assembly (Sun Fire 15K/12K System) 4-1**

4.1	About the Sun Fire Link Assembly	4-2
4.2	Filler Panels	4-4
4.2.1	Removing an I/O (slot 1) Filler Panel	4-4
4.2.2	Installing an I/O (Slot 1) Filler Panel	4-5
4.3	Removing a Sun Fire 15K/12K Assembly	4-5
4.4	Installing a Sun Fire Link Assembly	4-7
4.5	Installing Sun Fire Link Optical Modules	4-7
4.5.1	About the Sun Fire Link Optical Module	4-7
4.5.2	Sun Fire Link Optical Module LEDs	4-9
4.5.3	Installing a Sun Fire Link Optical Module	4-11
4.5.4	About Sun Fire Link Cables	4-12
4.5.5	Cabling Sun Fire Link Systems	4-13
<b>5.</b>	<b>Verifying Hardware</b>	<b>5-1</b>
5.1	Running POST In Loopback Mode	5-1
5.2	Sun Fire Link Interconnect Test ( <code>wrsmttest</code> )	5-3
5.2.1	<code>wrsmttest</code> Options	5-4
5.2.2	<code>wrsmttest</code> Test Modes	5-6
5.2.3	<code>wrsmttest</code> Command-Line Syntax	5-6
<b>A.</b>	<b>Worksheet</b>	<b>A-1</b>
<b>B.</b>	<b>Regulatory Compliance Statements</b>	<b>B-1</b>
	<b>Index</b>	<b>Index-1</b>



# Figures

---

- FIGURE 2-1 Hardware Naming Conventions in a Sun Fire 6800 System 2-2
- FIGURE 2-2 Sun Fire Link Assembly Slots in a Sun Fire 15K/12K System 2-4
- FIGURE 2-3 Sample Cabling Diagram (Sun Fire 6800 Systems) 2-6
- FIGURE 2-4 Sample Cabling Diagram (Sun Fire 15K/12K Systems) 2-7
- FIGURE 2-5 ASIC (WCI) Striping in a Two-Node Configuration 2-8
- FIGURE 2-6 Link Striping in a Two-Node Configuration 2-8
- FIGURE 2-7 Two-Node Direct Connect Configuration With Four-Way Striping 2-10
- FIGURE 2-8 Two-Node Sun Clusters Configuration 2-11
- FIGURE 2-9 Three-Node Direct Connect with Two-Way Striping 2-12
- FIGURE 2-10 Two Networks in Three-Node Direct-Connect for Sun Clusters Configurations 2-13
- FIGURE 2-11 Two- to Four-Node Configuration With Two Switches 2-14
- FIGURE 2-12 Two Networks in Two- to Four-Node Switch Configuration for Sun Clusters Configurations 2-15
- FIGURE 2-13 Five- to Eight-Node Configuration With Four Switches 2-16
- FIGURE 2-14 Two Networks in Five- to Eight-Node Switch Configuration for Sun Clusters Configurations 2-18
- FIGURE 2-15 Two-Node Direct Connect With Four-Way Striping 2-19
- FIGURE 2-16 Two-Node Sun Clusters Configuration 2-20
- FIGURE 2-17 Three-Node Direct Connect With Two-Way Striping 2-21
- FIGURE 2-18 Two Networks in Three-Node Direct-Connect for Sun Clusters Configurations 2-23
- FIGURE 2-19 Two- to Four-Node Configuration With Two Switches 2-24

- FIGURE 2-20 Two Networks in Two- to Four-Node Switch Configuration for Sun Clusters Configurations 2-25
- FIGURE 2-21 Five- to Eight-Node Configuration With Four Switches 2-26
- FIGURE 2-22 Two Networks in Five- to Eight-Node Switch Configuration for Sun Clusters Configurations 2-28
- FIGURE 3-1 Sun Fire 6800 System With Two Sun Fire Link Assemblies Installed 3-2
- FIGURE 3-2 Sun Fire Link Assembly for Sun Fire 6800 Systems 3-3
- FIGURE 3-3 Replacing a Sun Fire Link Assembly in a Sun Fire 6800 System 3-5
- FIGURE 3-4 Sun Fire Link Optical Module 3-7
- FIGURE 3-5 Card LEDs on the Optical Module 3-9
- FIGURE 3-6 Installing a Sun Fire Link Optical Module 3-11
- FIGURE 3-7 Sun Fire Link Cable 3-12
- FIGURE 4-1 Sun Fire Link Assembly Locations and Corresponding ASIC (WCI) IDs 4-2
- FIGURE 4-2 Sun Fire Link Interconnect Assembly for Sun Fire 15K/12K Systems 4-3
- FIGURE 4-3 Replacing a Sun Fire Link Assembly in a Sun Fire 15K/12K System 4-6
- FIGURE 4-4 The Sun Fire Link Optical Module 4-8
- FIGURE 4-5 Optical Module LEDs 4-10
- FIGURE 4-6 Replacing an Optical Module in a Sun Fire Link Assembly (Sun Fire 15K/12K System) 4-11
- FIGURE 4-7 Sun Fire Link Cable 4-12
- FIGURE 5-1 `wrsmtest` Test Parameter Options Dialog Box 5-4



# Tables

---

TABLE 1-1	Safety Precautions	1-2
TABLE 1-2	Symbols	1-3
TABLE 2-1	Sun Fire 15K/12K Port IDs	2-5
TABLE 2-2	Two-Node Direct Connect With Four-Way Striping	2-10
TABLE 2-3	Three-Node Direct Connect With Two-Way Striping	2-12
TABLE 2-4	Two- to Four-Node Configuration With Two Switches	2-14
TABLE 2-5	Five- to Eight-Node With Four Switches	2-16
TABLE 2-6	Two-Node Direct Connect With Four-Way Striping	2-20
TABLE 2-7	Three-Node Direct Connect With Two-Way Striping	2-22
TABLE 2-8	Two- to Four-Node Configuration With Two Switches	2-24
TABLE 2-9	Five- to Eight-Node With Four Switches	2-27
TABLE 3-1	Sun Fire Link Slot LED Functions	3-8
TABLE 3-2	Card LEDs on Optical Module	3-10
TABLE 4-1	Sun Fire 15K/12K Port IDs	4-3
TABLE 4-2	Sun Fire Link Slot LED Functions	4-9
TABLE 4-3	Card LEDs on Optical Module	4-10
TABLE 5-1	<code>wrsmtest</code> options	5-5
TABLE 5-2	<code>wrsmtest</code> Test Modes	5-6
TABLE 5-3	<code>wrsmtest</code> Command-Line Syntax	5-6
TABLE A-1	Cabling Table Worksheet	A-1



# Preface

---

This guide provides instructions for installing the Sun Fire Link assembly into Sun Fire™ 6800 and Sun Fire 15K/12K systems to build Sun Fire Link Remote Shared Memory (RSM™) cluster networks. These instructions are for an experienced systems or field engineer with networking knowledge.

---

## Before You Read This Book

In order to use the information in this document, you must have thorough knowledge of your Sun Fire 6800 and 15K/12K systems. Refer to the documentation that came with these systems.

---

# How This Book Is Organized

**Chapter 1** describes the safety and system precautions for installing the Sun Fire Link assembly in Sun Fire 6800 systems or Sun Fire 15K/12K systems.

**Chapter 2** provides cabling diagrams and cabling tables.

**Chapter 3** provides instructions on installing a Sun Fire Link assembly into a Sun Fire 6800 chassis and installing Sun Fire Link optical modules into the assembly.

**Chapter 4** provides instructions on installing a Sun Fire Link assembly into a Sun Fire 15K/12K chassis and installing Sun Fire Link optical modules into the assembly.

**Chapter 5** describes how to verify that the Sun Fire Link hardware is working correctly.

Appendix A provides a worksheet for recording cabling information for your system.

Appendix B provides information about relevant compliance statements.

---

# Using UNIX Commands

This document might not contain information on basic UNIX® commands and procedures such as shutting down the system, booting the system, and configuring devices.

See one or more of the following for this information:

- *Solaris Handbook for Sun Peripherals*
- AnswerBook2™ online documentation for the Solaris™ operating environment
- Other software documentation that you received with your system

---

# Typographic Conventions

Typeface	Meaning	Examples
AaBbCc123	The names of commands, files, and directories; on-screen computer output	Edit your <code>.login</code> file. Use <code>ls -a</code> to list all files. % You have mail.
<b>AaBbCc123</b>	What you type, when contrasted with on-screen computer output	% <b>su</b> password:
<i>AaBbCc123</i>	Book titles, new words or terms, words to be emphasized. Replace command-line variables with real names or values.	Read Chapter 6 in the <i>User's Guide</i> . These are called <i>class</i> options. You <i>must</i> be superuser to do this. To delete a file, type <code>rm filename</code> .

---

# Shell Prompts

Shell	Prompt
C shell	<i>machine-name%</i>
C shell superuser	<i>machine-name#</i>
Bourne shell and Korn shell	\$
Bourne shell and Korn shell superuser	#

---

## Related Documentation

<b>Application</b>	<b>Title</b>	<b>art Number</b>
Overview	<i>Sun Fire™ Link System Overview</i>	816-0697
Site Planning	<i>Sun Fire™ Link Systems Site Planning Guide</i>	816-6592
Task Map	<i>Task Map for Getting Started With Sun Fire™ Link Networks</i>	816-0041
Service	<i>Sun Fire™ Link Service Manual</i>	806-1394
Software Installation	<i>Sun Fire™ Link Software Installation Guide</i>	806-1401
System Administration	<i>Sun Fire™ Link Fabric Administrator's Guide</i>	806-1405
Switch Hardware and Software	<i>Sun Fire™ Link Switch Installation and Service Manual</i>	806-1397
Late Breaking Information	<i>Sun Fire™ Link Product Notes</i>	806-1404

---

---

## Accessing Sun Documentation Online

You can view, print, or purchase a broad selection of Sun documentation, including localized versions, at:

<http://www.sun.com/documentation>

---

## Contacting Sun Technical Support

If you have technical questions about this product that are not answered in this document, go to:

<http://www.sun.com/service/contacting>

---

## Sun Welcomes Your Comments

Sun is interested in improving its documentation and welcomes your comments and suggestions. You can submit your comments by going to:

<http://www.sun.com/hwdocs/feedback>

Please include the title and part number of your document with your feedback:

*Sun Fire Link Hardware Installation Guide*, part number 806-1396-11

---

## Notes, Cautions, and Warnings



---

**Caution** – This equipment contains lethal voltage. Accidental contact with centerplane, card cage, and drive areas can result in serious injury or death.

---



---

**Caution** – Improper handling by unqualified personnel can cause serious damage to this equipment. Unqualified personnel who tamper with this equipment may be held liable for any resultant damage to the equipment.

---

---

## United States Export Control Laws Notice

Product covered by and information contained in this service manual are controlled by U.S. Export Control laws and may be subject to the export or import laws in other countries. Nuclear, missile, chemical biological weapons, or nuclear maritime end uses or end users, whether direct or indirect, are strictly prohibited. Export or re-export to countries subject to U.S. embargo or to entities identified on U.S. export exclusion lists, including but not limited to the denied persons and specially designated nationals lists is strictly prohibited. Use of any spare or replacement

CPUs is limited to repair or one-for-one replacement of CPUs in products exported in compliance with U.S. export laws. Use of CPUs as product upgrades unless authorized by the U.S. Government is strictly prohibited.



# Safety and Tools Requirements

---

This chapter describes the safety and system precautions you must take when servicing or installing the Sun Fire Link assembly. It also lists the tools and equipment you will need.

- Section 1.1, “Safety Precautions” on page 1-1
- Section 1.2, “Symbols” on page 1-3
- Section 1.3, “System Precautions” on page 1-4
- Section 1.4, “Filler Boards and Filler Panels” on page 1-5
- Section 1.5, “Handling Boards and Assemblies” on page 1-5
- Section 1.6, “Tools Required” on page 1-6

---

## 1.1 Safety Precautions

For your protection, observe the following safety precautions when setting up your equipment:

- Follow all cautions, warnings, and instructions marked on the equipment.
- Never push objects of any kind through openings in the equipment as they may touch dangerous voltage points or short out components that could result in fire or electric shock.
- Refer servicing of equipment to qualified personnel.

To protect both yourself and the equipment, observe the following safety precautions:

**TABLE 1-1** Safety Precautions







<b>Item</b>	<b>Problem</b>	<b>Precaution</b>
Wrist or foot strap	ESD	Wear a conductive wrist strap or foot strap when handling printed circuit boards.
ESD mat	ESD	An approved ESD mat provides protection from static damage when used with a wrist strap or foot strap. The mat also cushions and protects small parts that are attached to printed circuit boards.

---

## 1.2 Symbols







The following symbols mean:

TABLE 1-2 Symbols

Symbol	Description	Meaning
	CAUTION	Hazardous voltages are present. To reduce the risk of electrical shock and danger, follow the instructions.
	CAUTION	Risk of personal injury. To reduce the risk, follow the instructions.
	CAUTION	Risk of equipment damage. To reduce the risk, follow the instructions.
	SURFACE	CAUTION: Hot surfaces. Avoid contact. Surfaces are hot and may cause personal injury if touched.
	AC	A terminal to which alternating current or voltage may be applied.
	SYSTEM POWER	System is receiving DC power. When the power LED is lit the system is operating normally.
	BOARD OR COMPONENT POWER	Module or component is receiving DC power. When the power LED for the module or component (top green LED) is lit, the component is operating normally.

---

TABLE 1-2 Symbols (Continued)

Symbol	Description	Meaning
	<b>FAULT</b>	System has detected a hardware failure. When the fault LED (middle, amber) is lit, the system has detected a hardware failure.
	<b>OK TO REMOVE</b>	You can safely remove module or component from the system when the Removal OK LED (bottom, amber) is lit.
	<b>PROTECTIVE EARTH</b>	Earth ground.
	<b>CHASSIS</b>	Frame or chassis ground.
	<b>FUSE REPLACEMENT MARKING</b>	For continued protection against risk of fire and electric shock, replace <b>ONLY</b> with fuse of the same type and rating.
	<b>OPTICAL LASER WARNING</b>	<b>CAUTION:</b> It is unsafe to look directly into uncovered connector receptacles on active optical modules as it can be injurious to your eyesight.

## 1.3 System Precautions

Ensure that the voltage and frequency of the power outlet to be used matches the electrical rating labels on the equipment.

Wear antistatic wrist straps when handling any magnetic storage devices, Sun Fire Link assemblies or boards, or other printed circuit boards.

Use only properly grounded power outlets as described in *Sun Fire Systems Installation Guide*.



---

**Caution** – DO NOT make mechanical or electrical modifications to the cabinet. Sun Microsystems™ is not responsible for regulatory compliance of modified cabinets.

---



---

**Caution** – The chassis AC power cord(s) must remain connected to ensure a proper ground.

---

---

## 1.4 Filler Boards and Filler Panels

### 1.4.1 Sun Fire Link Assembly for Sun Fire 6800 Systems

You must install a filler panel, which covers only the front of the board slot, within one minute of removing the Sun Fire Link assembly in a powered-on system. The assembly must also contain filler boards to fill the empty PCI and SBus slots.

### 1.4.2 Sun Fire Link Assembly for Sun Fire 15K/12K Systems

You must install a filler panel, which covers only the front of the board slot, within one minute of removing the Sun Fire Link assembly in a powered-on system. The assembly must also contain filler boards to fill the empty compactPCI and PCI cassettes.

---

## 1.5 Handling Boards and Assemblies



---

**Caution** – The chassis AC power cord must remain connected to ensure a proper ground.

---



---

**Caution** – The Sun Fire Link assembly, modules, and cards have surface-mount components that can be broken by flexing the assemblies.

---

To minimize the amount of board flexing, observe the following precautions:

- Hold the board only by the edges near the middle of the board, where the board stiffener is located. Do not hold the board *only* at the ends.
- When removing the board from an antistatic bag, keep the board vertical until you lay it on the Sun ESD mat.
- Do not place the board on a hard surface. Use a cushioned antistatic mat. The board connectors and components have very thin pins that bend easily.
- Be careful of small parts located on the component side of the board.
- Do not use an oscilloscope probe on the components. The soldered pins are easily damaged or shorted by the probe point.
- Transport the board in an antistatic bag.



---

**Caution** – The heat sinks on the assembly can be damaged by incorrect handling. Do not touch the heatsinks while installing or removing the board. Hold the board only by the edges. If a heatsink is loose or broken, obtain a replacement board.

---



---

**Caution** – The heatsinks on the board can be damaged by improper packaging. When storing or shipping the board, ensure that the heatsinks have sufficient protection.

---



---

**Caution** – The system is sensitive to static electricity. To prevent damage to the assembly, connect an antistatic wrist strap between you and the system.

---

---

## 1.6 Tools Required

For the procedures in this book, you will need these tools:

- Screwdriver, Phillips #1
- ESD mat
- Grounding wrist strap

# Cabling Diagrams

---

This chapter provides cabling diagrams and tables.

How you cable the Sun Fire Link network will depend on the configuration you are building. This chapter provides recommended cabling paths for many common Sun Fire Link configurations.

This chapter contains the following sections:

- Section 2.2, “Component Naming and Numbering Conventions” on page 2-2
- Section 2.3, “How to Read a Cabling Diagram” on page 2-6
- Section 2.4, “Striping” on page 2-7
- Section 2.5, “Cabling Diagrams and Tables For Sun Fire 6800 Systems” on page 2-9
- Section 2.6, “Cabling Diagrams and Tables for Sun Fire 15K/12K Systems” on page 2-18

---

## 2.1 Number of Nodes and Switches

A direct-connect configuration is one in which each chassis is connected directly to every other server in the configuration. Sun Fire Link networks of two- and three-nodes can be direct-connect configurations. Two- or three -node configurations may use switches, especially if future expansion of the system is planned.

A switch configuration contains either two or four Sun Fire Link switches and from two to eight nodes. No chassis is connected directly to any other chassis in the network. All communications pass through a switch.

---

## 2.2 Component Naming and Numbering Conventions

### 2.2.1 Sun Fire 6800 System

FIGURE 2-1 illustrates the naming conventions in Sun Fire 6800 systems. Each component can be referred to by its hardware location and by its software name. These naming conventions are used in all of the Sun Fire 6800 cabling diagrams and tables in this chapter.

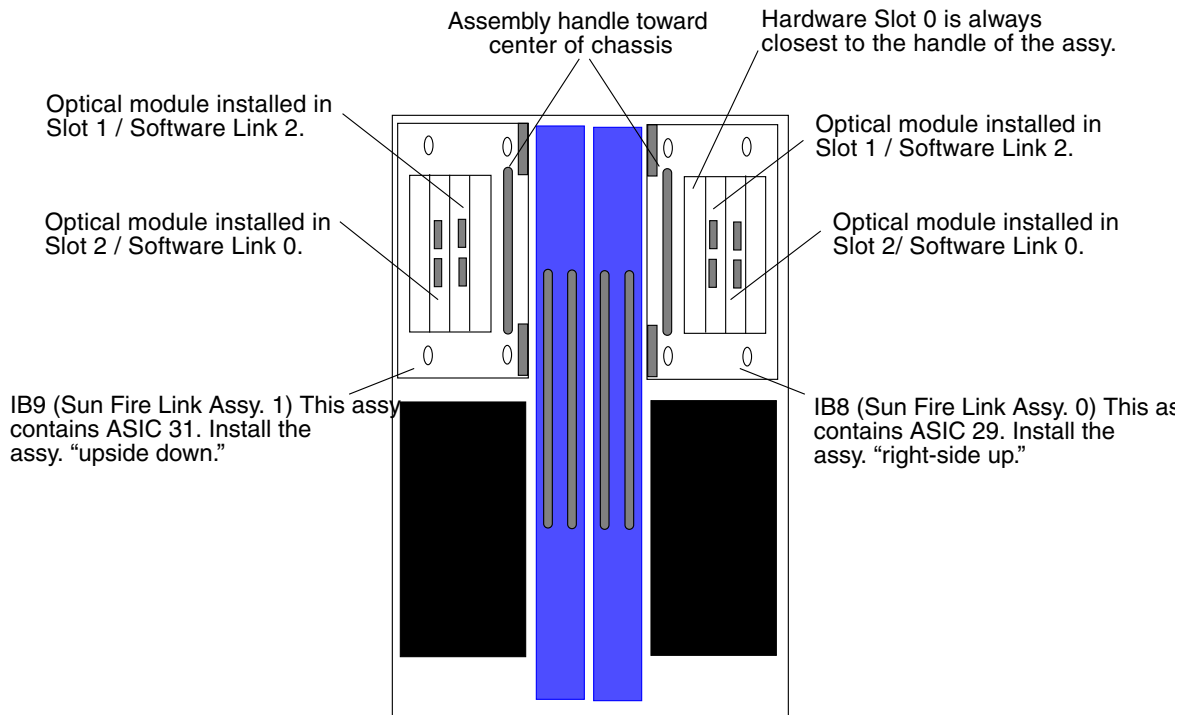

**FIGURE 2-1** Hardware Naming Conventions in a Sun Fire 6800 System

The following naming/labeling conventions apply to Sun Fire 6800 system and are shown in FIGURE 2-1:



- Sun Fire Link assemblies are supported in the two upper slots of a Sun Fire 6800 system. Those slots are labeled IB 8 and IB 9 on the chassis of a Sun Fire 6800 system.
- Each Sun Fire Link assembly contains one Sun Fire Link ASIC.
 

That ASIC has a location that you must know in order to configure a Sun Fire Link network. The Sun Fire Link assembly in slot IB 8 *always* contains ASIC 29. The assembly in slot IB 9 *always* contains ASIC 31.
- The handle on the Sun Fire Link assembly must be installed toward the center of the chassis (FIGURE 2-1).
 

This requires that the assembly installed in IB 8 must be installed “right-side up” and the assembly installed in slot IB 9 must be installed “right-side down.”
- Each assembly must contain two Sun Fire Link optical modules.
 

The optical modules are installed in the assembly in compactPCI slots 1 and 2. (Slot 0 is always the slot closest to the handle.)

  - What Sun Fire Link software refers to as “Link 2” is in the *hardware slot* labeled *Slot 1* (FIGURE 2-1).
  - Software “Link 0” is in the hardware slot labeled *Slot 2* (FIGURE 2-1).

## 2.2.2 Sun Fire 15K/12K System

FIGURE 2-2 illustrates the assembly naming conventions in a Sun Fire 15K/12K system. These naming conventions are used in all of the Sun Fire 15K/12K cabling diagrams and tables in this chapter. Each Sun Fire Link assembly contains one Sun Fire Link ASIC. Each ASIC provides two links--Link 0 and Link 2.

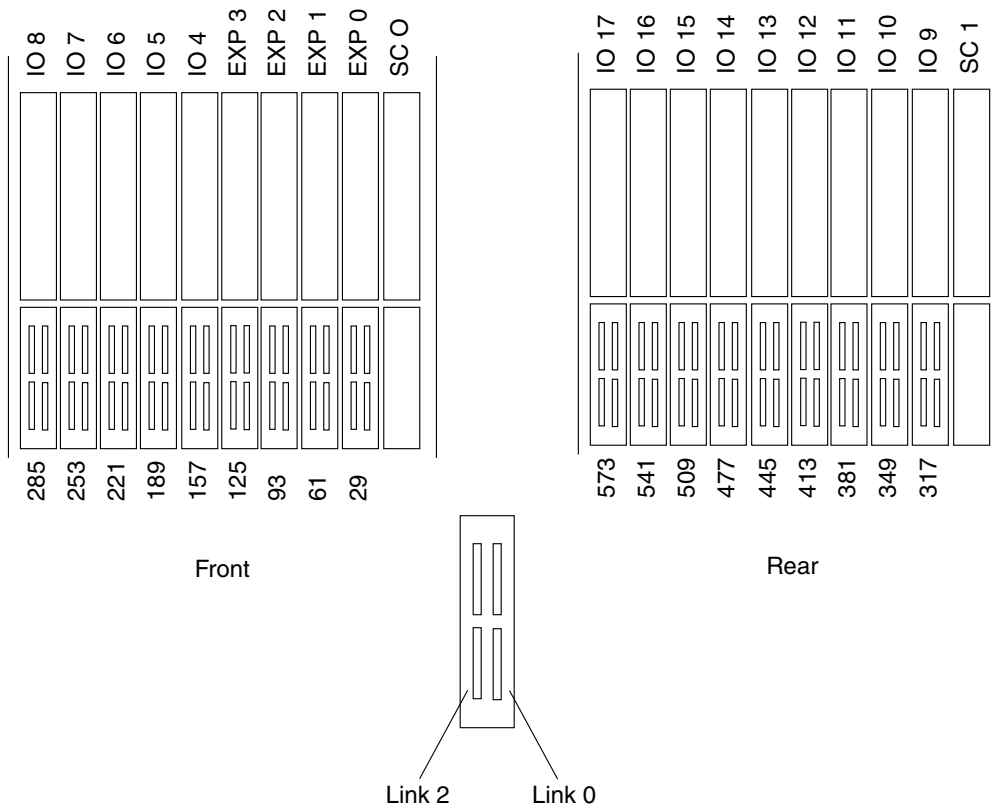

**FIGURE 2-2** Sun Fire Link Assembly Slots in a Sun Fire 15K/12K System

The following naming/labeling conventions apply to Sun Fire 15K/12K systems and are shown in FIGURE 2-2:

- Sun Fire Link assemblies must be installed in consecutive I/O slots, beginning with an even number slot, in a Sun Fire 15K/12K system, i.e., 0 and 1; 2 and 3; etc. Those slots are located near the bottom of the chassis on both the front and the rear sides. They are labeled IO 0 through IO 17.
- Each Sun Fire Link assembly contains one Sun Fire Link ASIC.

That ASIC has a location (TABLE 2-1) that you must know in order to configure a Sun Fire Link network.

- Each assembly must contain two Sun Fire Link optical modules.

The optical modules are installed in the assembly in the lower compactPCI slots in a Sun Fire Link Assembly (FIGURE 2-2).

---

**Note** – All cabling diagrams and tables for Sun Fire 15K/12K systems in this chapter are based on the Sun Fire Link assemblies being in I/O slots 0 and 1 in the Sun Fire 15K/12K system. Sun Fire Link assemblies must be installed next to each other, for example, slots 0 and 1; 2 and 3; 4 and 5; etc. The first slot must be an even-numbered slot. TABLE 2-1 provides ASIC port ID numbers for all 18 I/O slots in the Sun Fire 15K/12K system.

---

**TABLE 2-1** Sun Fire 15K/12K Port IDs

<b>Sun Fire 15K/12K Expander Slot</b>	<b>ASIC Port ID Number</b>
0	29
1	61
2	93
3	125
4	157
5	189
6	221
7	253
8	285
9	317
10	349
11	381
12	413
13	445
14	477
15	509
16	541
17	573

---

## 2.3 How to Read a Cabling Diagram

### 2.3.1 Sun Fire 6800 System

A simple Sun Fire Link network of two Sun Fire 6800 systems is shown in FIGURE 2-3.

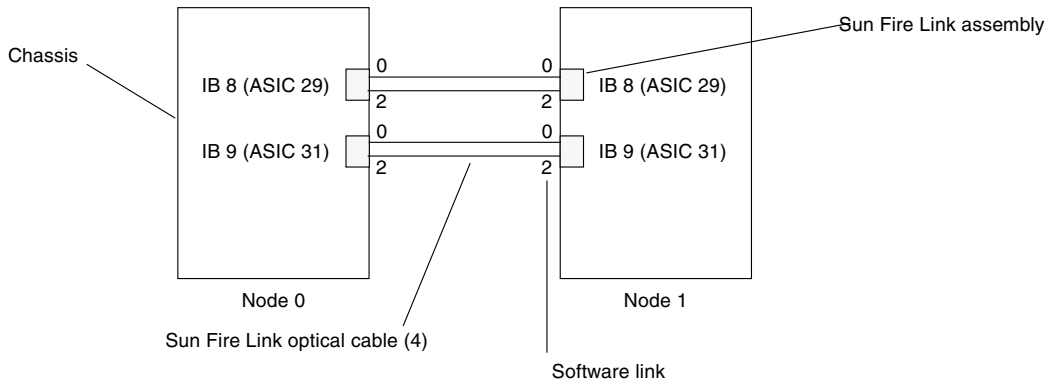

**FIGURE 2-3** Sample Cabling Diagram (Sun Fire 6800 Systems)

A cabling diagram is a virtual (logical) representation of a Sun Fire Link Interconnect network. The following details are contained in all cabling diagrams in this chapter:

- The number of nodes in the configuration.  
In FIGURE 2-3 there are two nodes: node 0 and node 1.
- The physical location of each Sun Fire Link assembly in the chassis (either IB 8 or IB 9).
- The number of Sun Fire Link optical modules installed in each Sun Fire Link assembly. In Sun Fire 6800 systems there must be two optical modules installed in each assembly.

### 2.3.2 Sun Fire 15K/12K System

A simple Sun Fire Link network of two Sun Fire 15K/12K systems is shown in FIGURE 2-4.

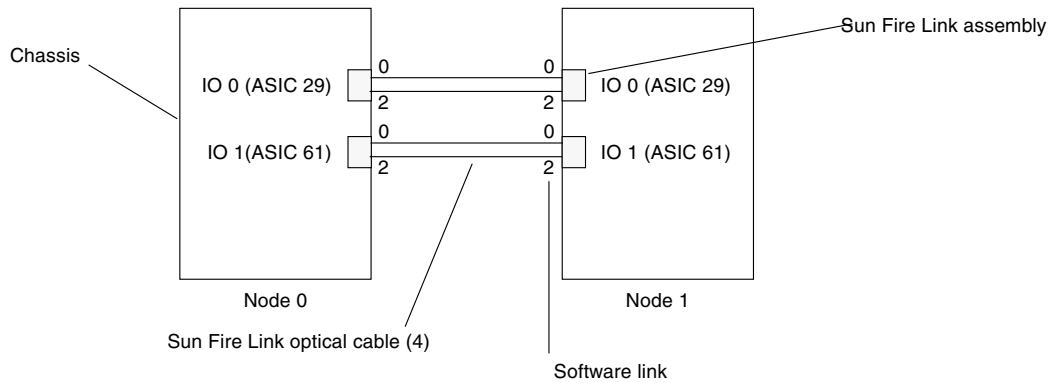

**FIGURE 2-4** Sample Cabling Diagram (Sun Fire 15K/12K Systems)

A cabling diagram is a virtual (logical) representation of a Sun Fire Link Interconnect network. The following details are contained in all cabling diagrams in this chapter:

- The number of nodes in the configuration  
In FIGURE 2-4 there are two nodes: node 0 and node 1.
- The physical location of each Sun Fire Link assembly in the chassis (IO 0 through IO 17).
- The number of Sun Fire Link optical modules installed in each Sun Fire Link assembly. In Sun Fire 15K/12K systems there must be two optical modules installed in *each* assembly.

## 2.4 Striping

You can increase the bandwidth between two nodes beyond a single optical link by *striping* data across multiple links connected between the two endpoints. Cable link bandwidth is provided by allowing the hardware striping of data across one, two or four links.

## 2.4.1 Sun Fire Link ASIC (WCI) Striping

Sun Fire Link ASIC (WCI) striping is the duplication of a link between two nodes by dividing the data and passing it through two ASICs to the other node (FIGURE 2-5). If one ASIC fails, communication between the two nodes is not disrupted as all data will *failover* and continue to move along the link that is still available. Data transfer will be slower over the one remaining link.

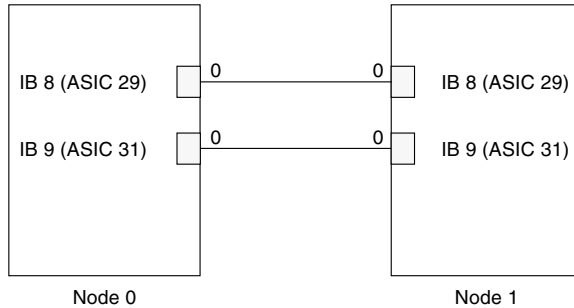

**FIGURE 2-5** ASIC (WCI) Striping in a Two-Node Configuration

## 2.4.2 Link Striping

Link striping is the duplication of communication links between two nodes by dividing the data and passing it through the same ASIC to the other node (FIGURE 2-6). If the ASIC fails, there is no communication between the two nodes. Communication will continue if the ASIC is still good and only one cable has failed.

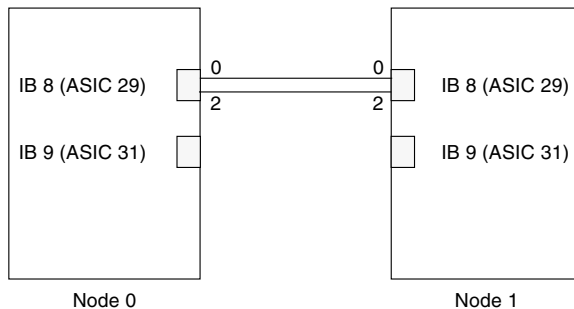

**FIGURE 2-6** Link Striping in a Two-Node Configuration

### 2.4.3 Four-Way Striping

A combination of ASIC and Link striping is recommended in Sun Fire Link networks. This provides the greatest throughput and maximum failover capabilities. Four-way striping (overlying link striping and ASIC (WCI) striping) provides maximum bandwidth and failover (FIGURE 2-7).

Due to the requirement for two networks, this is not possible in Sun Clusters configurations.

---

## 2.5 Cabling Diagrams and Tables For Sun Fire 6800 Systems

The following sections provide the recommended way to cable all approved Sun Fire Link homogeneous configurations of Sun Fire 6800 systems. While it is not required that you cable your network as shown here, it is highly recommended. Troubleshooting your Sun Fire Link network is easier if it is cabled in the recommended manner.

Each section provides a recommended cabling pattern for both Sun HPC ClusterTools™ software and for Sun Cluster software.

There is a worksheet in Appendix A to record the cabling for your Sun Fire Link network. When you call for service be sure to have this cabling information available.

### 2.5.1 Two-Node Direct-Connect Configuration

In the case of a two-node direct connect configuration, the cabling follows the pattern of link 0 always connecting to link 0 and link 2 always connecting to link 2.

#### 2.5.1.1 Sun HPC ClusterTools Configurations

FIGURE 2-7 shows the standard cabling pattern for a two-node Sun Fire Link network with four-way striping.

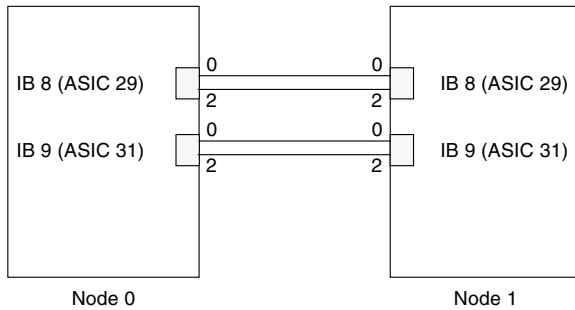

**FIGURE 2-7** Two-Node Direct Connect Configuration With Four-Way Striping

TABLE 2-2 presents the same information in a table format.

**TABLE 2-2** Two-Node Direct Connect With Four-Way Striping

Node	ASIC	Link	Connection	Node	ASIC	Link
Node 0	29	0	Connects to...	Node 1	29	0
Node 0	29	2	Connects to..	Node 1	29	2
Node 0	31	0	Connects to..	Node 1	31	0
Node 0	31	2	Connects to..	Node 1	31	2

## 2.5.1.2 Sun Clusters Configuration

Sun Clusters configurations require two networks. Although a Sun Clusters configuration (FIGURE 2-8) is cabled the same as FIGURE 2-7, there is just WCI striping (two-way striping) in this configuration because of the requirement of having two networks.



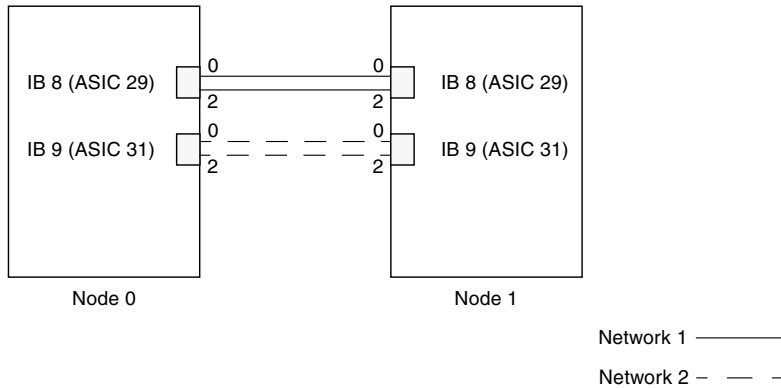

**FIGURE 2-8** Two-Node Sun Clusters Configuration

## 2.5.2 Three-Node Direct-Connect

In this configuration (FIGURE 2-9), four links follow the two-node pattern: link 0 to link 0 and link 2 to link 2, but two links connect link 0 to link 2. In a three-node direct-connect network, the maximum striping available is ASIC (WCI) striping.

---

**Note** – A three-node configuration with four-way striping requires two switches. See Section 2.5.3, “Three- to Four-Node Configuration With Two Switches” on page 2-13 for switch configurations.

---

### 2.5.2.1 Sun HPC ClusterTools Configurations

FIGURE 2-9 shows the standard cabling pattern for a three-node Sun Fire Link network with four-way striping.

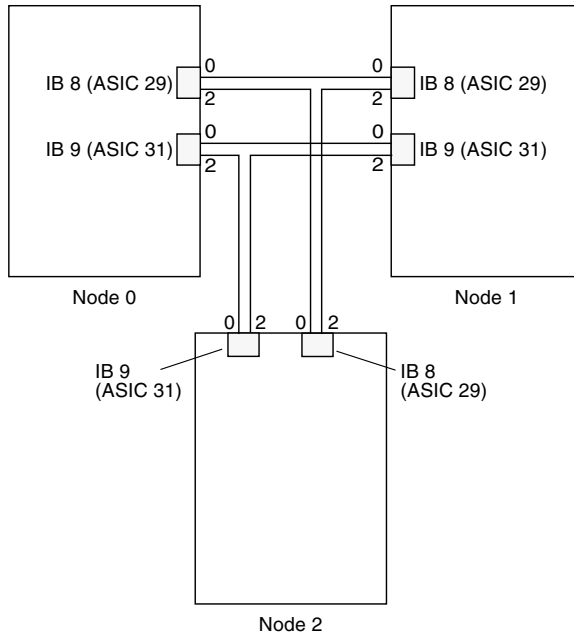

**FIGURE 2-9** Three-Node Direct Connect with Two-Way Striping

TABLE 2-3 presents the same information in a table format.

**TABLE 2-3** Three-Node Direct Connect With Two-Way Striping

Node	ASIC	Link	Connection	Node	ASIC	Link
Node 0	29	0	Connects to...	Node 1	29	0
Node 0	29	2	Connects to...	Node 2	29	0
Node 0	31	0	Connects to...	Node 1	31	0
Node 0	31	2	Connects to...	Node 2	31	0
Node 1	29	2	Connects to...	Node 2	29	2
Node 1	31	2	Connects to...	Node 2	31	2

## 2.5.2.2 Sun Clusters Configuration

Sun Clusters configurations require two networks. Although a Sun Clusters configuration (FIGURE 2-10) is cabled the same as FIGURE 2-9, there is just WCI striping (two-way striping) in this configuration because of the requirement of having two networks.

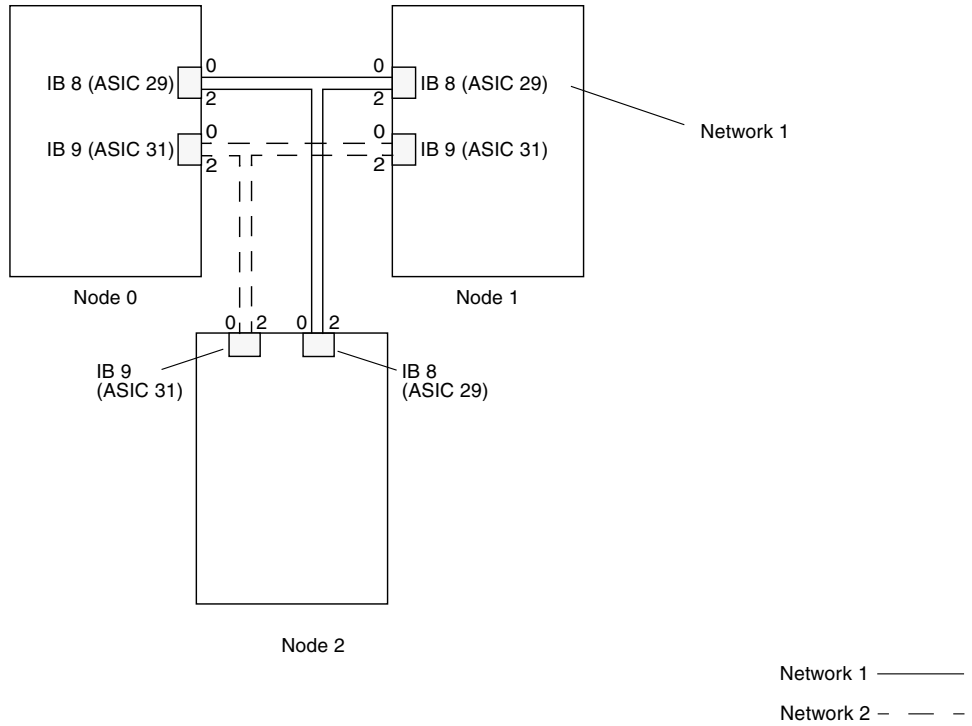

**FIGURE 2-10** Two Networks in Three-Node Direct-Connect for Sun Clusters Configurations

## 2.5.3 Three- to Four-Node Configuration With Two Switches

Sun Fire Link switches must be installed in pairs. The following configuration rules apply:

- Switch-based networks with up to four nodes require at least two Sun Fire Link switches. Four switches can be used for increased throughput and failover redundancy.
- A three-node configuration with four-way striping requires two switches (FIGURE 2-11).

### 2.5.3.1 Sun HPC ClusterTools Configurations

Figure FIGURE 2-11 shows a two- to four-node configuration with two Sun Fire Link switches.

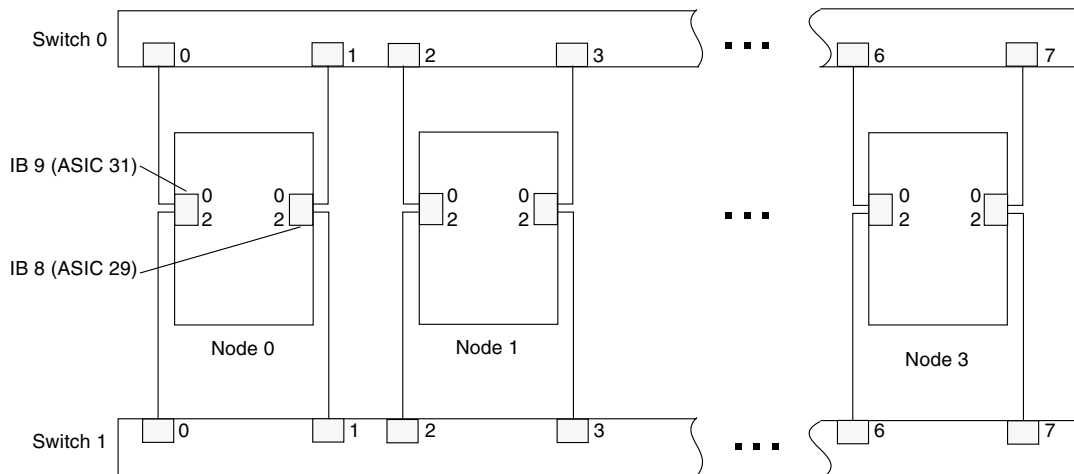

**FIGURE 2-11** Two- to Four-Node Configuration With Two Switches

TABLE 2-4 presents the same information in a table format.

**TABLE 2-4** Two- to Four-Node Configuration With Two Switches (1 of 2)

Node	ASIC	Link	Connection	Node	ASIC	Link
Node 0	31	0	Connects to...	Switch 0	0	0
Node 0	31	2	Connects to...	Switch 1	0	0
Node 0	29	0	Connects to...	Switch 0	0	1
Node 0	29	2	Connects to...	Switch 1	0	1
Node 1	31	0	Connects to...	Switch 0	0	2
Node 1	31	2	Connects to...	Switch 1	0	2
Node 1	29	0	Connects to...	Switch 0	0	3
Node 1	29	2	Connects to...	Switch 1	0	3
Node 2	31	0	Connects to...	Switch 0	0	4
Node 2	31	2	Connects to...	Switch 1	0	4
Node 2	29	0	Connects to...	Switch 0	0	5
Node 2	29	2	Connects to...	Switch 1	0	5
Node 3	31	0	Connects to...	Switch 0	0	6

**TABLE 2-4** Two- to Four-Node Configuration With Two Switches (2 of 2)

Node	ASIC	Link	Connection	Node	ASIC	Link
Node 3	31	2	Connects to...	Switch 1	0	6
Node 3	29	0	Connects to...	Switch 0	0	7
Node 3	29	2	Connects to...	Switch 1	0	7

### 2.5.3.2 Sun Clusters Configuration

Sun Clusters configurations require two networks. Although a Sun Clusters configuration (FIGURE 2-12) is cabled the same as FIGURE 2-11, there is just WCI striping (two-way striping) in this configuration because of the requirement of having two networks.

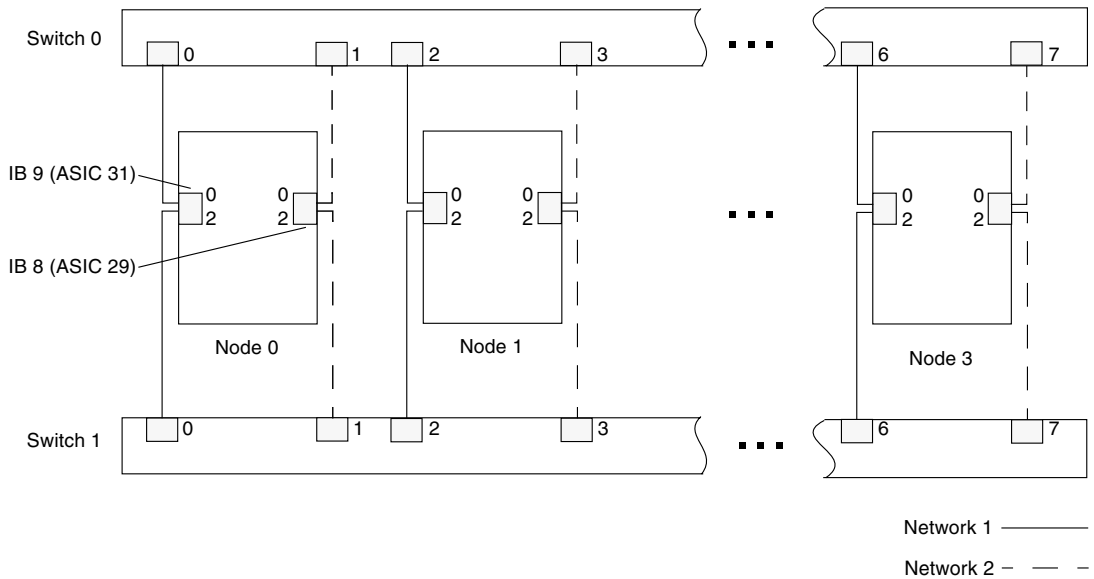

**FIGURE 2-12** Two Networks in Two- to Four-Node Switch Configuration for Sun Clusters Configurations

### 2.5.4 Five- to Eight-Node Configuration With Four Switches

Configurations of five- to eight-nodes networks require four switches since a four-node configuration uses all available slots in a configuration with two switches.

## 2.5.4.1 Sun HPC ClusterTools Configurations

FIGURE 2-13 shows a five- to eight-node configuration with four Sun Fire Link switches.

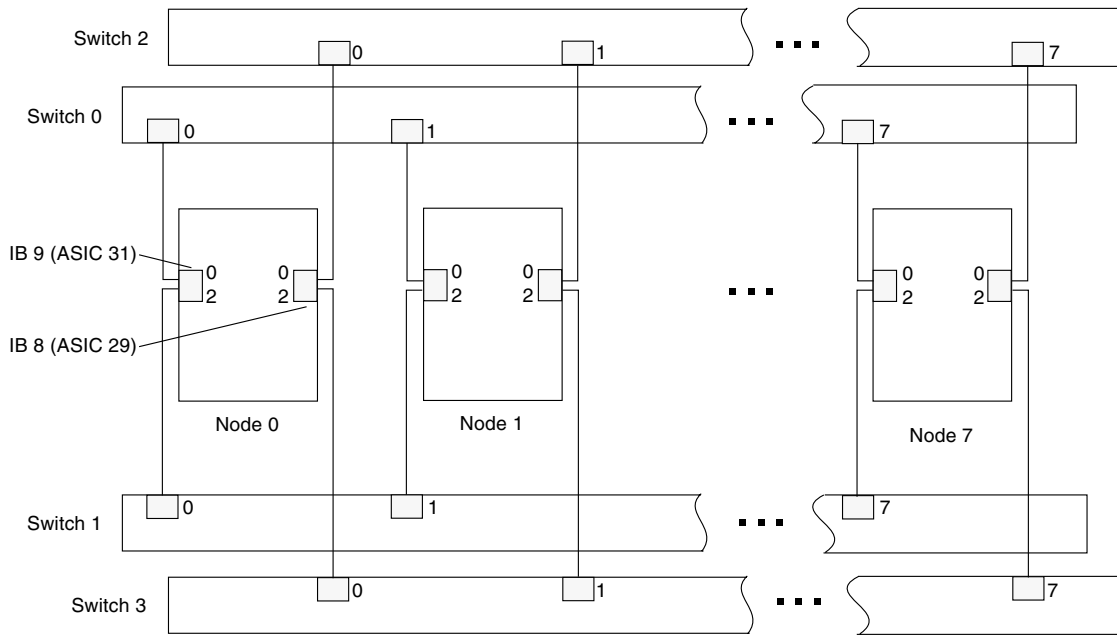

**FIGURE 2-13** Five- to Eight-Node Configuration With Four Switches

TABLE 2-5 presents the same information in a table format.

**TABLE 2-5** Five- to Eight-Node With Four Switches (1 of 2)

Node	ASIC	Link	Connection	Node	ASIC	Link
Node 0	31	0	Connects to...	Switch 0	0	0
Node 0	31	2	Connects to...	Switch 1	0	0
Node 0	29	0	Connects to...	Switch 2	0	0
Node 0	29	2	Connects to...	Switch 3	0	0
Node 1	31	0	Connects to...	Switch 0	0	1
Node 1	31	2	Connects to...	Switch 1	0	1
Node 1	29	0	Connects to...	Switch 2	0	1
Node 1	29	2	Connects to...	Switch 3	0	1

**TABLE 2-5** Five- to Eight-Node With Four Switches (2 of 2)

Node	ASIC	Link	Connection	Node	ASIC	Link
Node 2	31	0	Connects to...	Switch 0	0	2
Node 2	31	2	Connects to...	Switch 1	0	2
Node 2	29	0	Connects to...	Switch 2	0	2
Node 2	29	2	Connects to...	Switch 3	0	2
Node 3	31	0	Connects to...	Switch 0	0	3
Node 3	31	2	Connects to...	Switch 1	0	3
Node 3	29	0	Connects to...	Switch 2	0	3
Node 3	29	2	Connects to...	Switch 3	0	3
Node 4	31	0	Connects to...	Switch 0	0	4
Node 4	31	2	Connects to...	Switch 1	0	4
Node 4	29	0	Connects to...	Switch 2	0	4
Node 4	29	2	Connects to...	Switch 3	0	4
Node 5	31	0	Connects to...	Switch 0	0	5
Node 5	31	2	Connects to...	Switch 1	0	5
Node 5	29	0	Connects to...	Switch 2	0	5
Node 5	29	2	Connects to...	Switch 3	0	5
Node 6	31	0	Connects to...	Switch 0	0	6
Node 6	31	2	Connects to...	Switch 1	0	6
Node 6	29	0	Connects to...	Switch 2	0	6
Node 6	29	2	Connects to...	Switch 3	0	6
Node 7	31	0	Connects to...	Switch 0	0	7
Node 7	31	2	Connects to...	Switch 1	0	7
Node 7	29	0	Connects to...	Switch 2	0	7
Node 7	29	2	Connects to...	Switch 3	0	7

## 2.5.4.2 Sun Clusters Configuration

Sun Clusters configurations require two networks. Although a Sun Clusters configuration (FIGURE 2-14) is cabled the same as FIGURE 2-13, there is just WCI striping (two-way striping) in this configuration because of the requirement of having two networks.

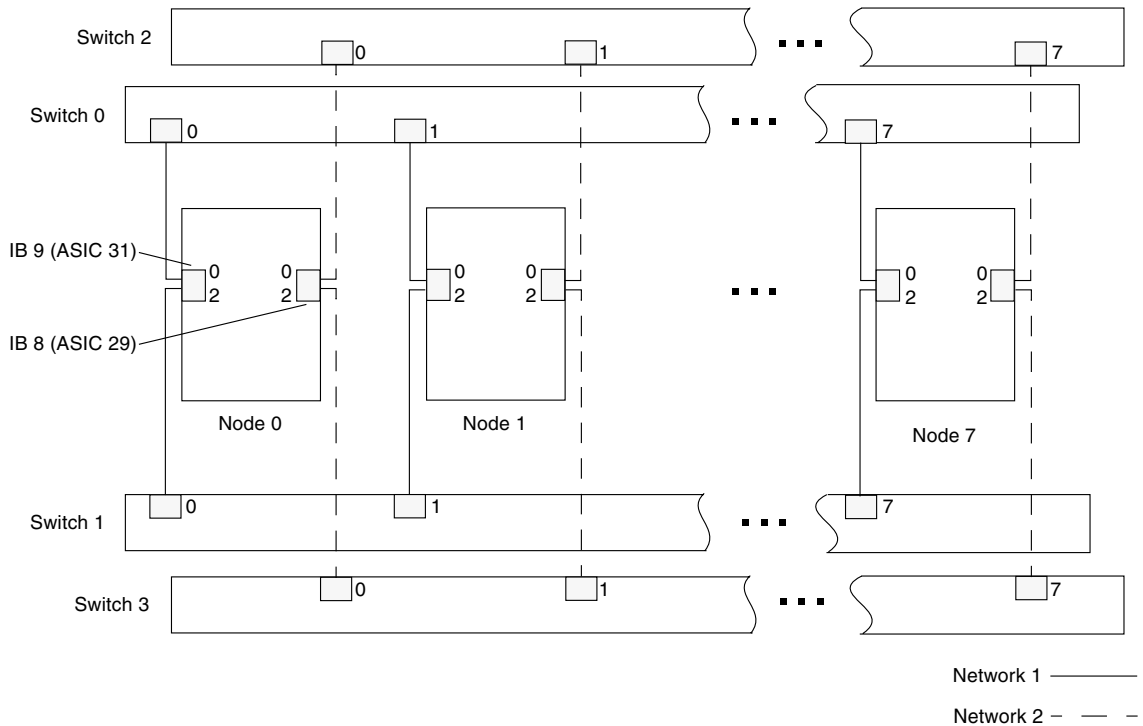

**FIGURE 2-14** Two Networks in Five- to Eight-Node Switch Configuration for Sun Clusters Configurations

## 2.6 Cabling Diagrams and Tables for Sun Fire 15K/12K Systems

The following sections provide the recommended way to cable all approved Sun Fire Link homogeneous configurations of Sun Fire 15K/12K systems. While it is not required that you cable your network as shown here, it is highly recommended. Troubleshooting your network is easier if it is cabled in the recommended manner.

**Note** – There is a worksheet in Appendix A to record the cabling for your Sun Fire Link network. When you call for service you must have your cabling information available.

Configuration rules for Sun Fire15K/12K configurations are:



- A maximum of eight Sun Fire Link assemblies per Sun Fire 15K/12K system
- Sun Fire Link assemblies must be installed in consecutive I/O slots.
- Two Sun Fire Link assemblies per domain
- Maximum of four Sun Fire Link domains in a Sun Fire 15K/12K system (eight Sun Fire Link assemblies)

---

**Note** – All of the cabling diagrams and tables in this section assume that the Sun Fire Link domains are not in the same Sun Fire 15K/12K chassis.

---

## 2.6.1 Two-Node Direct Connect

In the case of a two-node direct connect configuration, the cabling follows the pattern of link 0 always connecting to link 0 and link 2 always connecting to link 2.

### 2.6.1.1 Sun HPC ClusterTools Configurations

FIGURE 2-15 shows the standard cabling patterns for a two-node Sun Fire Link network with four-way striping.

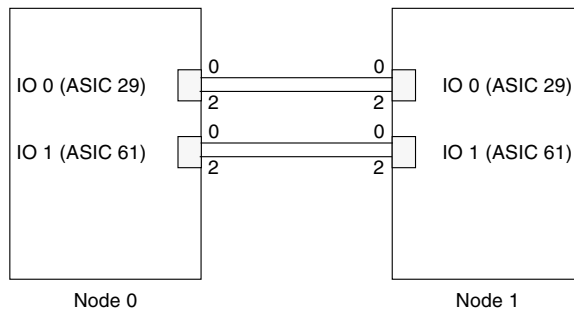

**FIGURE 2-15** Two-Node Direct Connect With Four-Way Striping

TABLE 2-6 presents the same information in a table format.

**TABLE 2-6** Two-Node Direct Connect With Four-Way Striping

Node	ASIC	Link	Connection	Node	ASIC	Link
Node 0	29	0	Connects to...	Node 1	29	0
Node 0	29	2	Connects to...	Node 1	29	2
Node 0	61	0	Connects to...	Node 1	61	0
Node 0	61	2	Connects to...	Node 1	61	2

## 2.6.1.2 Sun Clusters Configuration

Sun Clusters configurations require two networks. Although a Sun Clusters configuration (FIGURE 2-16) is cabled the same as FIGURE 2-15, there is just WCI striping (two-way striping) in this configuration because of the requirement of having two networks.

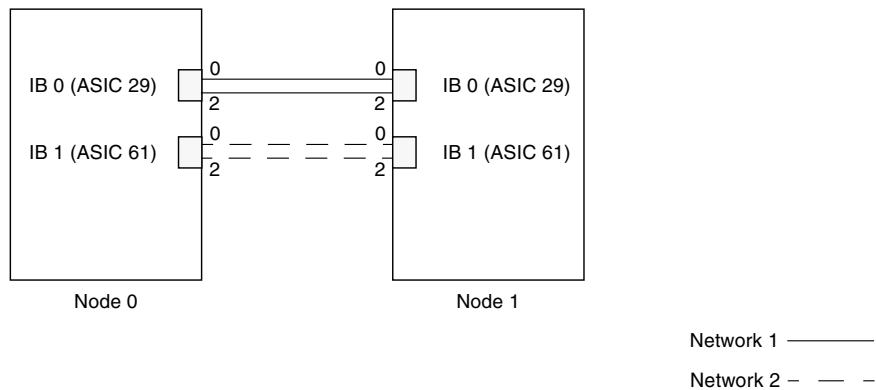

**FIGURE 2-16** Two-Node Sun Clusters Configuration

## 2.6.2 Three-Node Direct Connect

In this configuration (FIGURE 2-17) four links follow the two-node pattern: link 0 to link 0 and link 2 to link 2, but two links connect link 0 to link 2. In a three-node configuration with direct connections the maximum striping is two-way.

---

**Note** – A three-node configuration with four-way striping requires two switches. See Section 2.6.3, “Three- to Four-Node Configuration With Two Sun Fire Link Switches” on page 2-23 for switch configurations.

---

### 2.6.2.1 Sun HPC ClusterTools Configurations

Figure FIGURE 2-17 shows a three-node configuration in direct-connect mode.

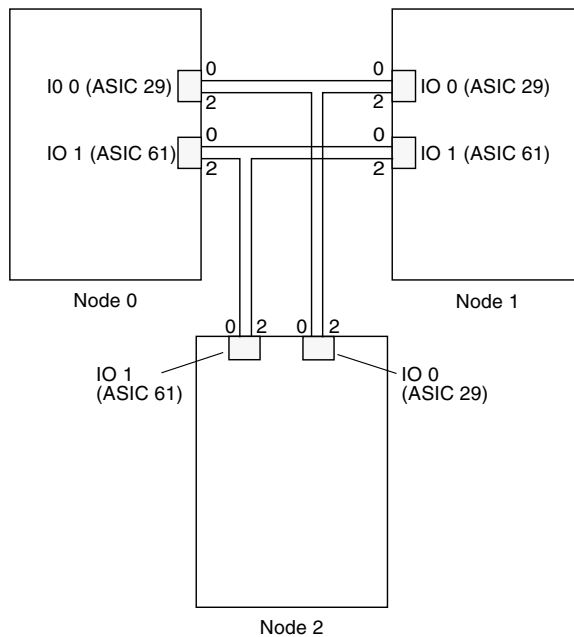

**FIGURE 2-17** Three-Node Direct Connect With Two-Way Striping

TABLE 2-7 presents the same information in a table format.

**TABLE 2-7** Three-Node Direct Connect With Two-Way Striping

<b>Node</b>	<b>ASIC</b>	<b>Link</b>	<b>Connection</b>	<b>Node</b>	<b>ASIC</b>	<b>Link</b>
Node 0	29	0	Connects to...	Node 1	29	0
Node 0	29	2	Connects to...	Node 2	29	0
Node 0	61	0	Connects to...	Node 1	61	0
Node 0	61	2	Connects to...	Node 2	61	0
Node 1	29	2	Connects to...	Node 2	29	2
Node 1	61	2	Connects to...	Node 2	61	2

## 2.6.2.2 Sun Clusters Configuration

Sun Clusters configurations require two networks. Although a Sun Clusters configuration (FIGURE 2-18) is cabled the same as FIGURE 2-17, there is just WCI striping (two-way striping) in this configuration because of the requirement of having two networks.

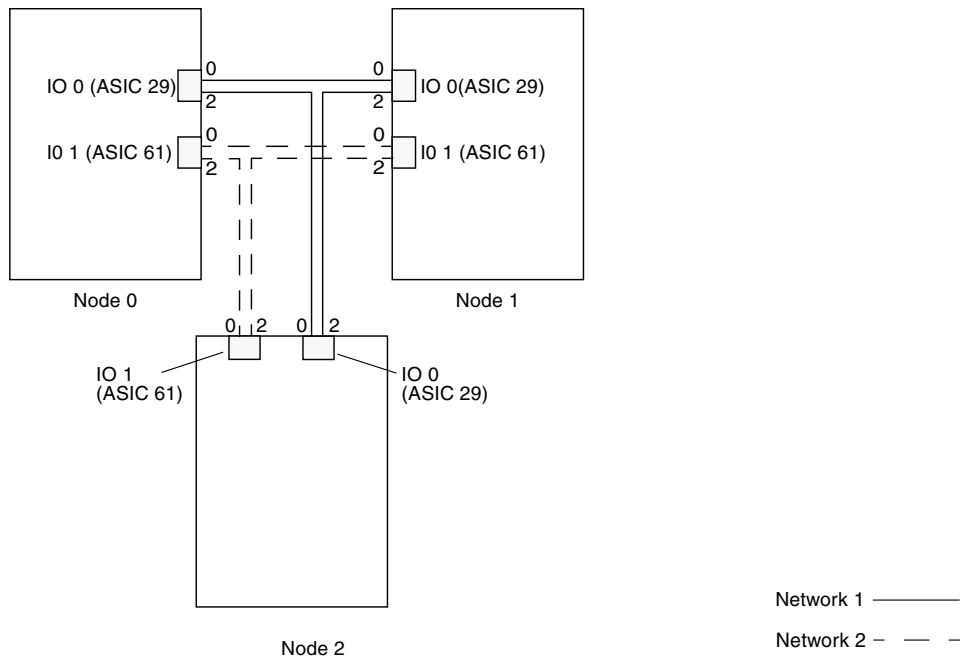

**FIGURE 2-18** Two Networks in Three-Node Direct-Connect for Sun Clusters Configurations

## 2.6.3 Three- to Four-Node Configuration With Two Sun Fire Link Switches

Sun Fire Link switches must be installed in pairs to provide failover.

The configuration rules for switch configurations are:

- Switch-based networks with up to four nodes require at least two Sun Fire Link switches. Four switches can be used for increased throughput and failover redundancy.
- A three-node configuration with four-way striping must use two switches.

### 2.6.3.1 Sun HPC ClusterTools Configuration

FIGURE 2-19 shows a two- to four-node configuration with two Sun Fire Link switches.

**Note** – In all switch configurations, it is a best practice that the links follow the pattern shown in FIGURE 2-19. Note that all link 2s, for example, are going to the same switch and all link 0s are going to the other switch. In this way, if one switch fails the is still a communication route between all nodes.

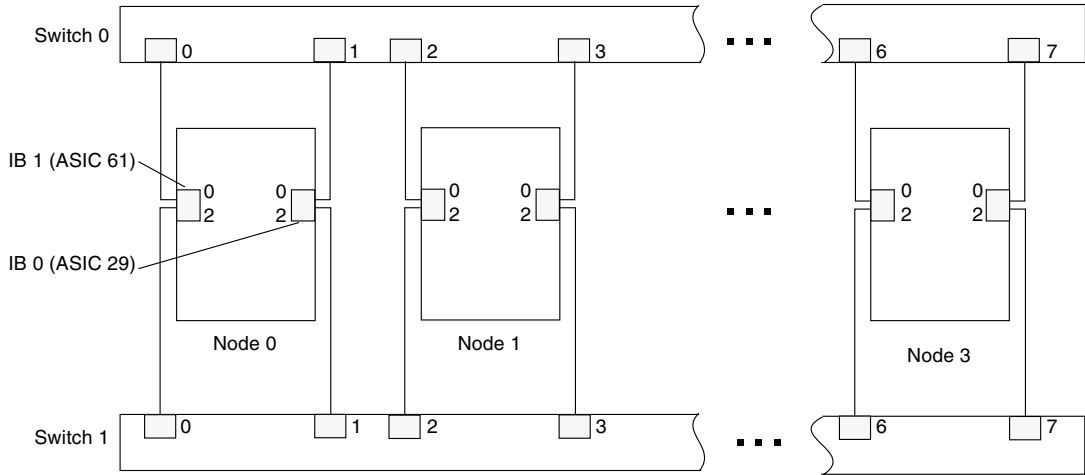

**FIGURE 2-19** Two- to Four-Node Configuration With Two Switches

TABLE 2-8 presents the same information in a table format.

**TABLE 2-8** Two- to Four-Node Configuration With Two Switches (1 of 2)

Node	ASIC	Link	Connection	Node	ASIC	Link
Node 0	61	0	Connects to...	Switch 0	0	0
Node 0	61	2	Connects to...	Switch 1	0	0
Node 0	29	0	Connects to...	Switch 0	0	1
Node 0	29	2	Connects to...	Switch 1	0	1
Node 1	61	0	Connects to...	Switch 0	0	2
Node 1	61	2	Connects to...	Switch 1	0	2
Node 1	29	0	Connects to...	Switch 0	0	3
Node 1	29	2	Connects to...	Switch 1	0	3
Node 2	61	0	Connects to...	Switch 0	0	4
Node 2	61	2	Connects to...	Switch 1	0	4

**TABLE 2-8** Two- to Four-Node Configuration With Two Switches (2 of 2)

Node	ASIC	Link	Connection	Node	ASIC	Link
Node 2	29	0	Connects to...	Switch 0	0	5
Node 2	29	2	Connects to...	Switch 1	0	5
Node 3	61	0	Connects to...	Switch 0	0	6
Node 3	61	2	Connects to...	Switch 1	0	6
Node 3	29	0	Connects to...	Switch 0	0	7
Node 3	29	2	Connects to...	Switch 1	0	7

### 2.6.3.2 Sun Clusters Configuration

Sun Clusters configurations require two networks. Although a Sun Clusters configuration (FIGURE 2-20) is cabled the same as FIGURE 2-19, there is just WCI striping (two-way striping) in this configuration because of the requirement of having two networks.

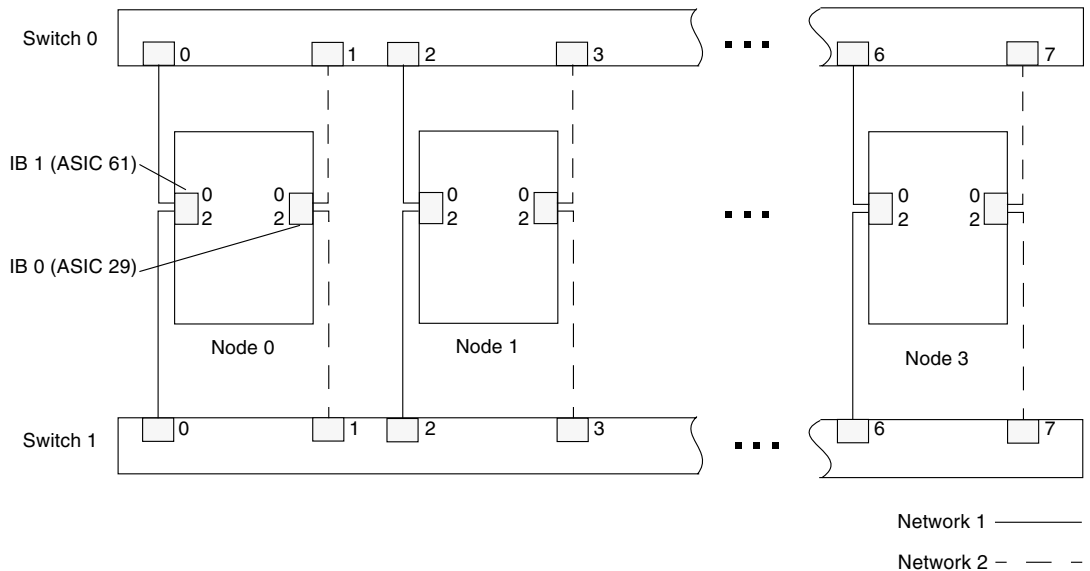

**FIGURE 2-20** Two Networks in Two- to Four-Node Switch Configuration for Sun Clusters Configurations

## 2.6.4 Five- to Eight-Node Configuration With Four Sun Fire Link Switches

Configurations of five- to eight-nodes (FIGURE 2-21) require four Sun Fire Link switches since a four-node configuration uses all available slots in a configuration with two switches.

### 2.6.4.1 Sun HPC ClusterTools Configurations

Figure FIGURE 2-21 shows a five- to eight-node configuration with four Sun Fire Link switches.

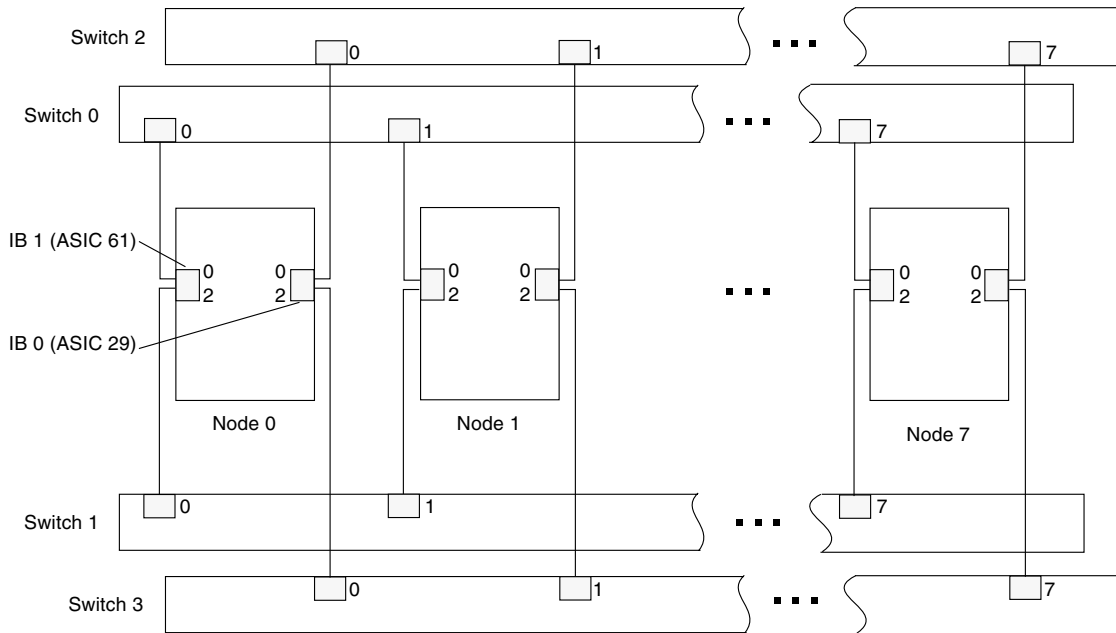

**FIGURE 2-21** Five- to Eight-Node Configuration With Four Switches



TABLE 2-9 presents the same information in a table format.

**TABLE 2-9** Five- to Eight-Node With Four Switches (1 of 2)

<b>Node</b>	<b>ASIC</b>	<b>Link</b>	<b>Connection</b>	<b>Node</b>	<b>ASIC</b>	<b>Link</b>
Node 0	61	0	Connects to...	Switch 0	0	0
Node 0	61	2	Connects to...	Switch 1	0	0
Node 0	29	0	Connects to...	Switch 2	0	0
Node 0	29	2	Connects to...	Switch 3	0	0
Node 1	61	0	Connects to...	Switch 0	0	1
Node 1	61	2	Connects to...	Switch 1	0	1
Node 1	29	0	Connects to...	Switch 2	0	1
Node 1	29	2	Connects to...	Switch 3	0	1
Node 2	61	0	Connects to...	Switch 0	0	2
Node 2	61	2	Connects to...	Switch 1	0	2
Node 2	29	0	Connects to...	Switch 2	0	2
Node 2	29	2	Connects to...	Switch 3	0	2
Node 3	61	0	Connects to...	Switch 0	0	3
Node 3	61	2	Connects to...	Switch 1	0	3
Node 3	29	0	Connects to...	Switch 2	0	3
Node 3	29	2	Connects to...	Switch 3	0	3
Node 4	61	0	Connects to...	Switch 0	0	4
Node 4	61	2	Connects to...	Switch 1	0	4
Node 4	29	0	Connects to...	Switch 2	0	4
Node 4	29	2	Connects to...	Switch 3	0	4
Node 5	61	0	Connects to...	Switch 0	0	5
Node 5	61	2	Connects to...	Switch 1	0	5
Node 5	29	0	Connects to...	Switch 2	0	5
Node 5	29	2	Connects to...	Switch 3	0	5
Node 6	61	0	Connects to...	Switch 0	0	6
Node 6	61	2	Connects to...	Switch 1	0	6
Node 6	29	0	Connects to...	Switch 2	0	6
Node 6	29	2	Connects to...	Switch 3	0	6

**TABLE 2-9** Five- to Eight-Node With Four Switches (2 of 2)

Node	ASIC	Link	Connection	Node	ASIC	Link
Node 7	61	0	Connects to...	Switch 0	0	7
Node 7	61	2	Connects to...	Switch 1	0	7
Node 7	29	0	Connects to...	Switch 2	0	7
Node 7	29	2	Connects to...	Switch 3	0	7

## 2.6.4.2 Sun Clusters Configuration

Sun Clusters configurations require two networks. Although a Sun Clusters configuration (FIGURE 2-22) is cabled the same as FIGURE 2-21, there is just WCI striping (two-way striping) in this configuration because of the requirement of having two networks.

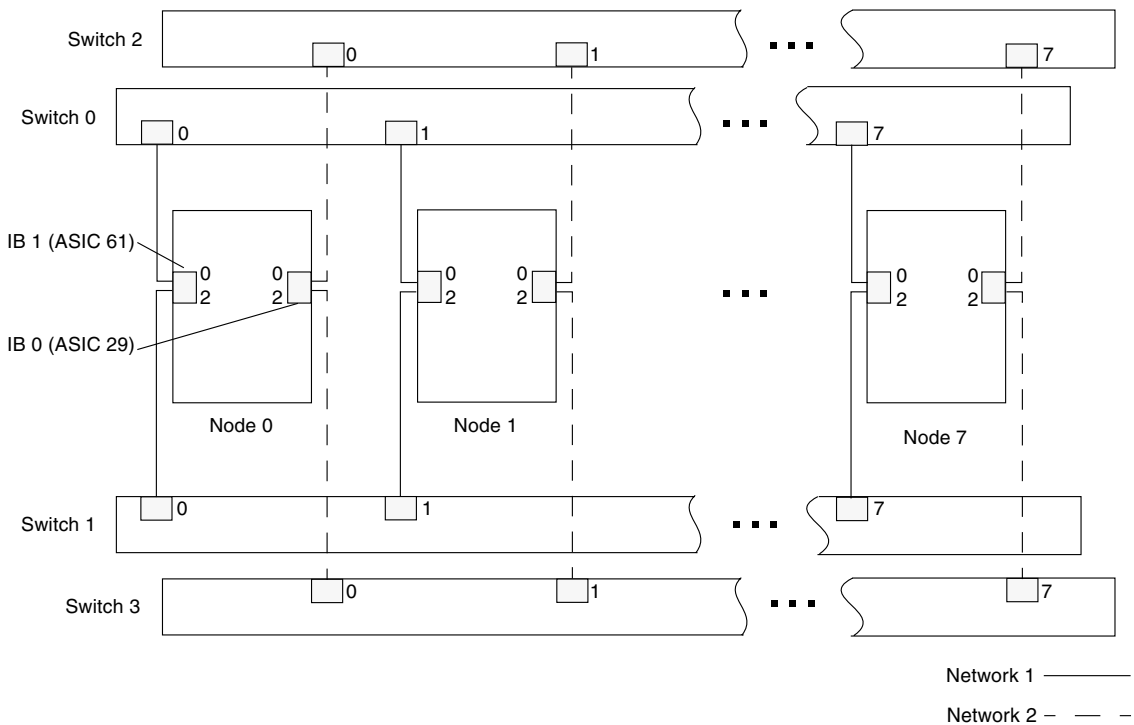

**FIGURE 2-22** Two Networks in Five- to Eight-Node Switch Configuration for Sun Clusters Configurations

# Installing the Sun Fire Link Assembly (Sun Fire 6800 System)

---

This chapter provides instructions on installing a Sun Fire Link assembly into the Sun Fire 6800 system, installing the Sun Fire Link optical modules into the Sun Fire Link assembly and installing Sun Fire Link cables.

This chapter contains the following sections:

- Section 3.1, “About the Sun Fire Link Assembly” on page 3-2
- Section 3.2, “Installing a Filler Board” on page 3-3
- Section 3.3, “Removing a Sun Fire 6800 Assembly” on page 3-4
- Section 3.4, “Installing a Sun Fire Link Assembly” on page 3-5
- Section 3.5, “Installing Sun Fire Link Optical Modules” on page 3-6

---

## 3.1 About the Sun Fire Link Assembly

The Sun Fire Link assembly is based on a Sun Fire 6800 assembly. Sun Fire Link assemblies must be installed in the two upper slots (IB8 and IB9) in a Sun Fire 6800 system (FIGURE 3-1).

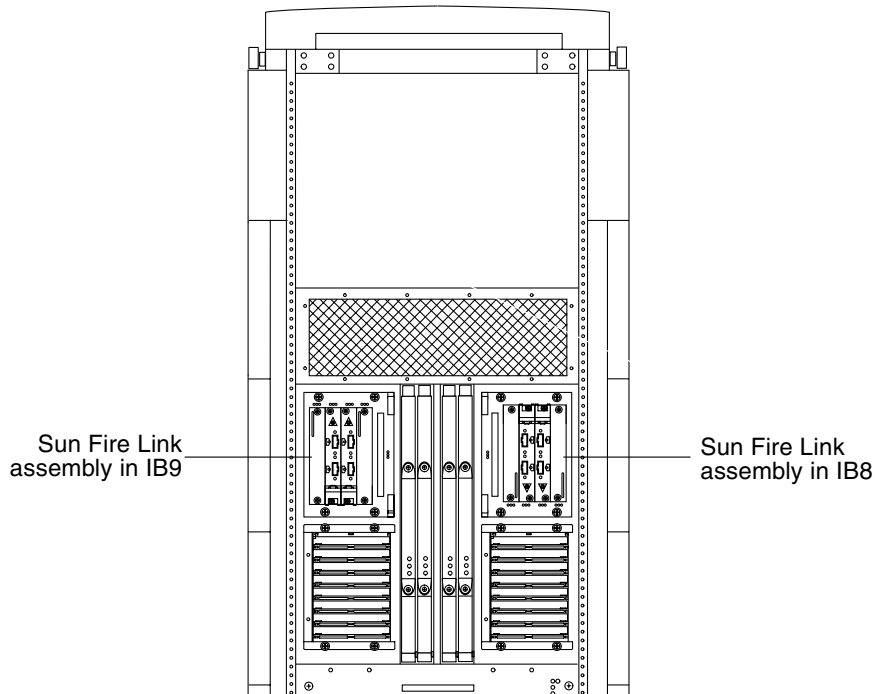

**FIGURE 3-1** Sun Fire 6800 System With Two Sun Fire Link Assemblies Installed

Each Sun Fire Link assembly (FIGURE 3-2) contains four slots. Slot 0 and Slot 3 are standard compact-PCI slots and are used for I/O. Slots 1 and 2 are CompactPCI-like and are used only for Sun Fire Link optical modules.



---

## 3.3 Removing a Sun Fire 6800 Assembly

If there is an I/O assembly in the slot in which you are going to install the Sun Fire Link assembly, you must first remove the I/O assembly.

**1. Power off the assembly.**

Refer to the *Sun Fire 6800/4810/4800/3800 Systems Platform Administration Manual* for procedures for powering off the assembly.

**2. Attach an ESD wrist strap or foot strap. Connect the strap to the system. Place a grounded ESD mat close to the system.**

**3. Loosen the four captive Phillips screws.**

**4. Simultaneously pull the two ejector levels outward to unseat the assembly.**

The ejectors must be perpendicular to the I/O assembly.

**5. With one hand holding the handle and the other hand under the assembly for support, slide the assembly out of the card cage.**

FIGURE 3-3 shows how to remove the I/O assembly from the system.

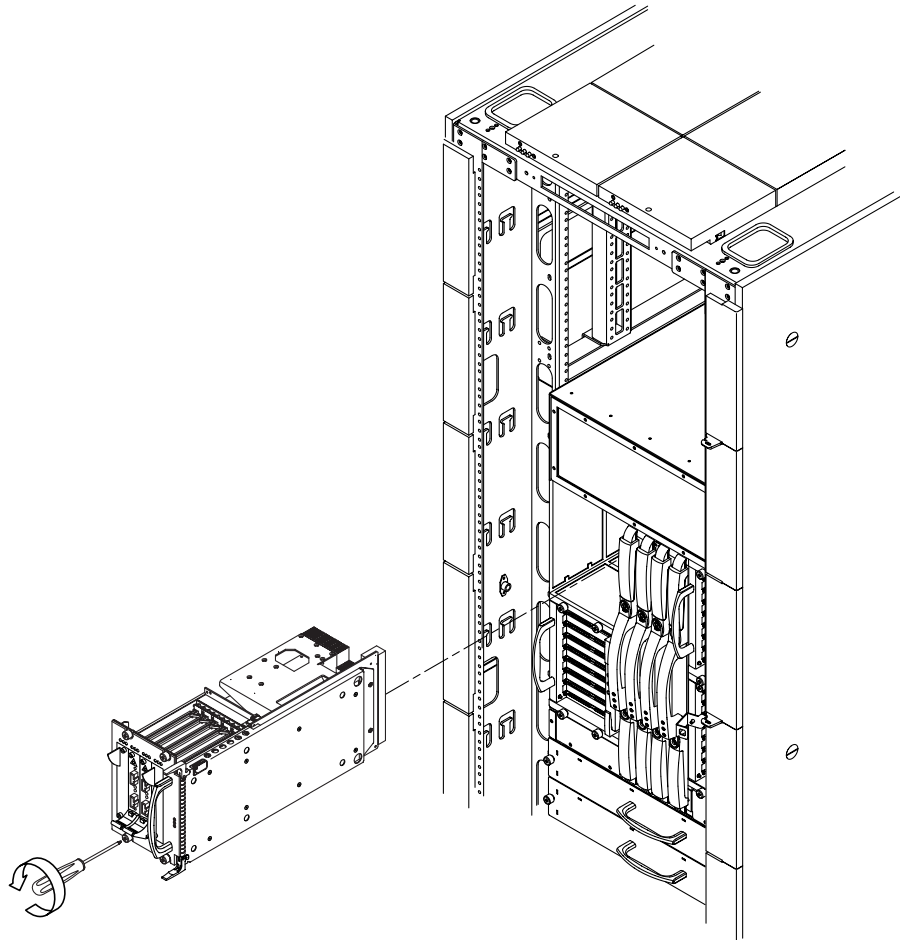

**FIGURE 3-3** Replacing a Sun Fire Link Assembly in a Sun Fire 6800 System

---

## 3.4 Installing a Sun Fire Link Assembly

1. Attach an ESD wrist strap or foot strap. Connect the strap to the system. Place an ESD mat close to the system.
2. If a filler panel is installed in the I/O assembly, remove it.



---

**Caution** – You must install an assembly within one minute of removing the filler panels.

---

3. **Move the ejector levels on the assembly to the open position.**  
The ejectors must be perpendicular to the assembly.
4. **Line up the assembly with the slots.**
5. **Holding the assembly with one hand on the handle and the other hand underneath the assembly, guide the assembly into the card cage slot (IB8 or IB9).**



---

**Caution** – DO NOT FORCE the assembly into a slot; this can cause damage to the assembly and system. The assembly should insert and seat smoothly. If it binds, remove the assembly and inspect the card cage slot for any obvious obstructions.

---

6. **After the assembly is completely inserted into the card cage, simultaneously press the two ejector levers to the closed position.**
7. **Tighten the four captive Phillips screws.**

---

## 3.5 Installing Sun Fire Link Optical Modules

Each optical module provides a single link on a hot-swappable card.

---

**Note** – When installing a new system, you can install the optical modules into the Sun Fire Link assembly either before or after you install that assembly into the Sun Fire 6800 system.

---

### 3.5.1 About the Sun Fire Link Optical Module

Sun Fire Link optical modules (FIGURE 3-4) are installed in slots 1 and 2 in the Sun Fire Link assembly.



---

**Note** – Although the optical module is based on the CompactPCI standard, the optical module is not CompactPCI-compliant. Although its form factor (size and shape) is the same as a CompactPCI card, it does not comply with CompactPCI electrical standards.

---

Each Sun Fire Link optical module provides one optical link with a receive channel and a transmit channel. You can install a maximum of four optical modules per Sun Fire 6800 system: two Sun Fire Link assemblies with two optical modules per assembly.

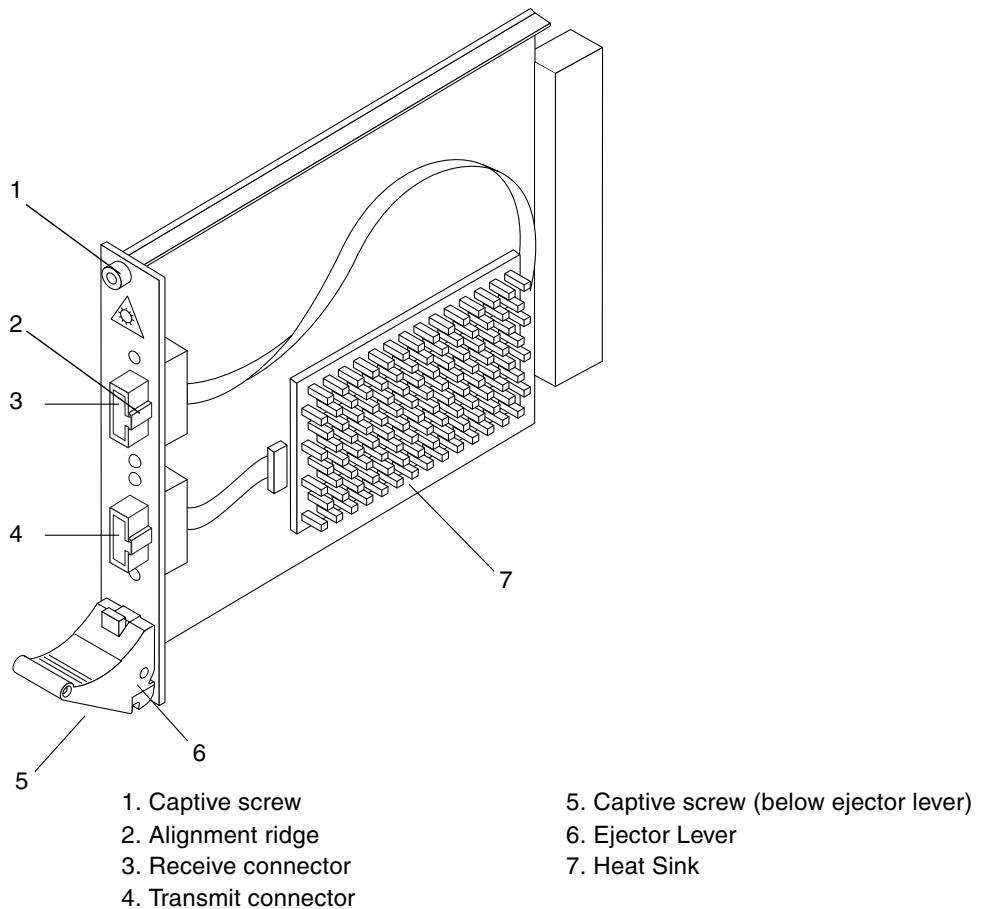



**FIGURE 3-4** Sun Fire Link Optical Module

## 3.5.2 Sun Fire Link Optical Module LEDs

There are three LEDs (*slot LEDs*) for each card slot on the Sun Fire Link assembly (FIGURE 3-2). When installed in slot IB8, the LEDs are at the bottom of the assembly. When installed in IB9, they are above the optical module. TABLE 3-1 notes the slot LED functions.

**TABLE 3-1** Sun Fire Link Slot LED Functions

LED		On	Off
Power LED (green)		Power is on; you cannot remove the optical module when this LED is on.	Power is off; you can remove the optical module when this LED is off.
Fault LED (amber)		Internal fault.	No internal fault.
Removal OK LED (amber)		You can safely remove the optical module under hot-swap conditions.	Do not remove the optical module.

Besides the LEDs that are located on the assembly, each optical link module has three LEDs (*card LEDs*) on the module itself (FIGURE 3-5 and TABLE 3-2). A single green LED

indicates whether or not power is applied; paired green and amber LEDs convey link status and configuration.

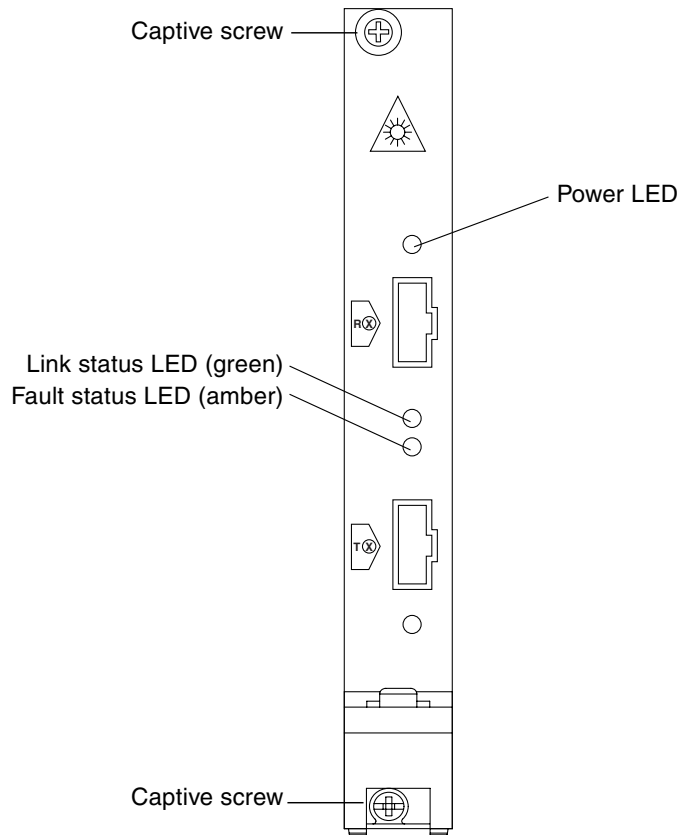

**FIGURE 3-5** Card LEDs on the Optical Module

**TABLE 3-2** Card LEDs on Optical Module

<b>Link Status LED (Green)</b>	<b>Fault status LED (Amber)</b>	<b>Meaning</b>
OFF	OFF	No External Link detected. No valid Rx Clock detected
ON	OFF	Link operational: Valid Rx clock received. Remote ID validated.
ON	ON	Degraded link detected: This combination indicates that an error threshold has been exceeded. The link is still operational but performance may be degraded.
BLINKING	OFF	Link is in the process of moving to the operational state.

### 3.5.3 Installing a Sun Fire Link Optical Module

- 1. Attach an ESD wrist strap or foot strap. Connect the strap to the system.**
- 2. If installed, remove the filler panel.**
- 3. Press the ejector lever down on the optical module.**
- 4. Hold the optical module by the two side edges or the front panel and slide it into the slot between the two guides.**

The cutouts in the handle of the optical module must align with the square cutouts on the Sun Fire Link assembly.

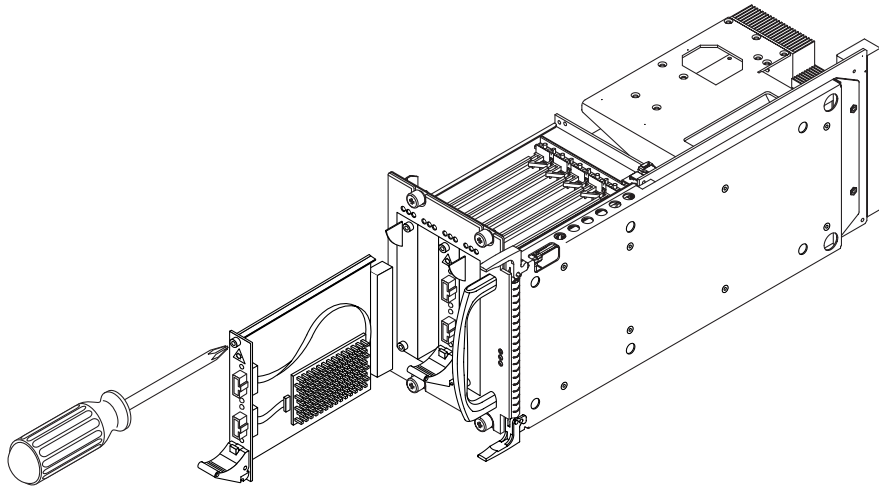

**FIGURE 3-6** Installing a Sun Fire Link Optical Module

5. Push on the front panel to completely seat the optical module in the assembly.
6. Push the ejector lever in to lock the lever. You should feel it click.
7. Tighten the two captive screws, one at each end of the optical module.

## 3.5.4 About Sun Fire Link Cables

Details about Sun Fire Link cables are listed below:

- Cables are available in 5-, 12-, and 20-meter lengths.
- Each cable has two plugs at each end (FIGURE 3-7). The white plug is the transmit cable, and the black plug is the receive cable.
- Each cable is labeled with a serial number that aids in cable route tracing (FIGURE 3-7).
- Cable changes can be made while the system is operational. Changes should be made consistent with the software intended to manage and validate these changes.
- The cable connectors have a ridge on one side of the plug (FIGURE 3-7) that indicates proper alignment of the cable with the connector.
- The connectors make a distinct clicking sound when fully inserted.

To protect the cables, be sure to:

- Keep dust caps in place whenever cables are not connected
- Maintain a minimum bend radius of at least 30 millimeter (1.2 inches)

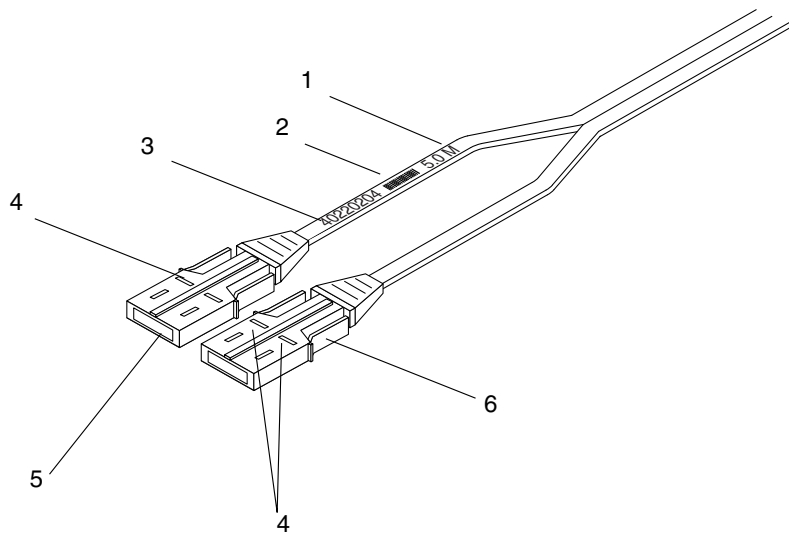

- 1. Cable length
- 2. Bar code
- 3. Unique serial number  
(at both ends of cable)
- 4. Insertion marks (disappear  
when inserted)
- 5. Transmit connector
- 6. Receive connector

**FIGURE 3-7** Sun Fire Link Cable

## 3.5.5 Installing Sun Fire Link Optical Cables

Optical cables can be added to and removed from the system while the system is operation.

- **Install cables. (The black connector is receive and the white connector is transmit.) Be sure to follow the cabling patterns you planned for your system in Appendix A.**

Make sure to insert the cable connector all the way in until you hear a clicking sound.

# Installing the Sun Fire Link Assembly (Sun Fire 15K/12K System)

This chapter provides instructions on installing a Sun Fire Link assembly into a Sun Fire 15K/12K system and installing the Sun Fire Link optical module into the assembly.

This chapter contains the following sections:

- Section 4.1, “About the Sun Fire Link Assembly” on page 4-2
- Section 4.2, “Filler Panels” on page 4-4
- Section 4.3, “Removing a Sun Fire 15K/12K Assembly” on page 4-5
- Section 4.4, “Installing a Sun Fire Link Assembly” on page 4-7
- Section 4.5, “Installing Sun Fire Link Optical Modules” on page 4-7

# 4.1 About the Sun Fire Link Assembly

The Sun Fire Link assembly is based on an hsPCI I/O Assembly for a Sun Fire 15K/12K system. These assemblies must be installed in two consecutive I/O slots, for example, slots zero and one; two and three; etc. (FIGURE 4-1)

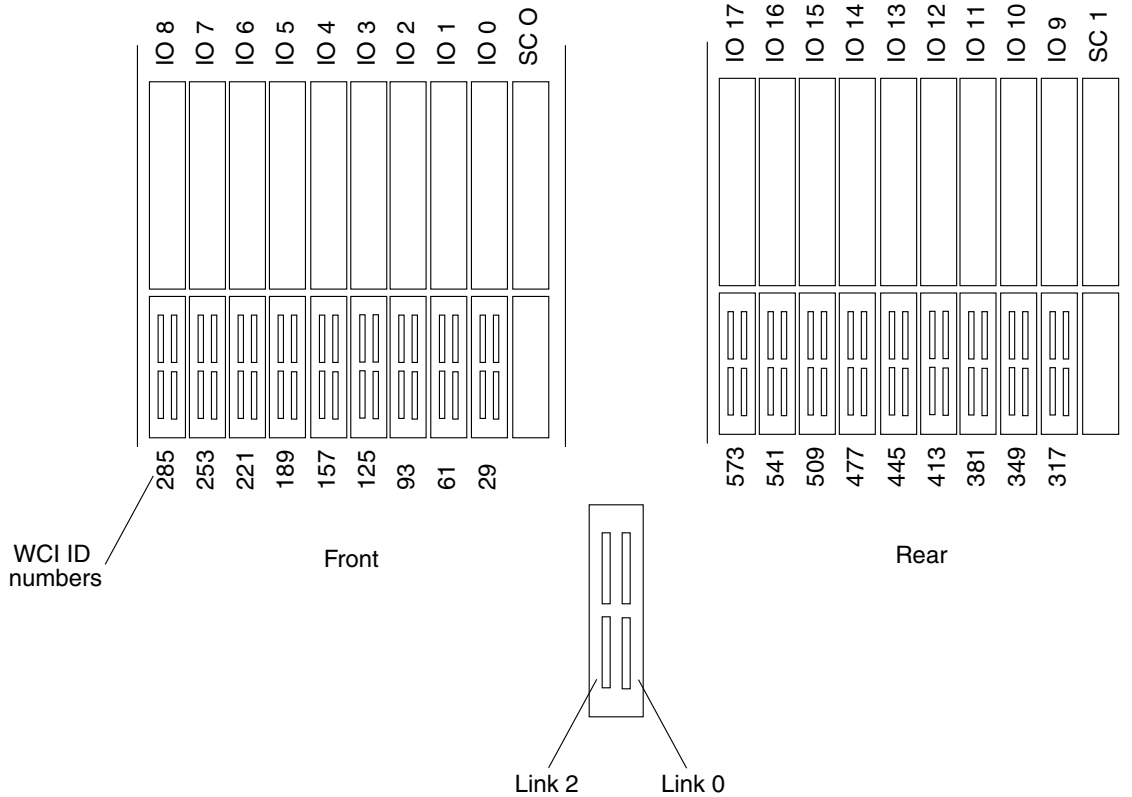

**FIGURE 4-1** Sun Fire Link Assembly Locations and Corresponding ASIC (WCI) IDs

Each Sun Fire Link assembly contains four slots. The two upper slots are standard compactPCI slots. The two lower slots, labeled LINK 0 and LINK 2, are compactPCI-like. They are used only for Sun Fire Link optical modules.



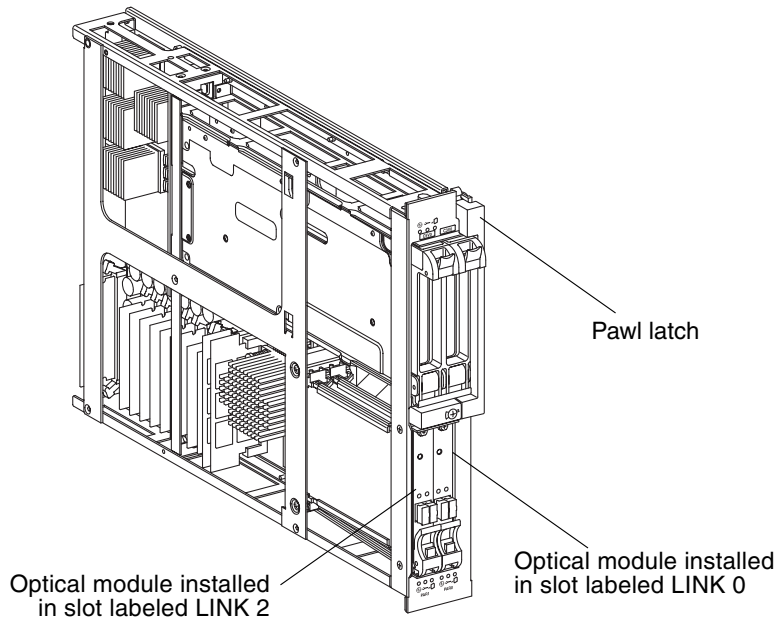

**FIGURE 4-2** Sun Fire Link Interconnect Assembly for Sun Fire 15K/12K Systems

---

**Note** – Sun Fire Link assemblies must be installed in consecutive slots, beginning with an even number slot, for example, slots 0 and 1; 2 and 3; 4 and 5; etc.

---

TABLE 4-1 provides ASIC port ID numbers for all 18 expander slots in the Sun Fire 15K/12K system.

**TABLE 4-1** Sun Fire 15K/12K Port IDs

Sun Fire 15K/12K I/O Slot	Sun Fire Link ASIC Port ID Number
0	29
1	61
2	93
3	125
4	157

**TABLE 4-1** Sun Fire 15K/12K Port IDs (Continued)

Sun Fire 15K/12K I/O Slot	Sun Fire Link ASIC Port ID Number
5	189
6	221
7	253
8	285
9	317
10	349
11	381
12	413
13	445
14	477
15	509
16	541
17	573

---

## 4.2 Filler Panels

Filler panels must be installed in all I/O slots that are not occupied by Sun Fire Link 15K/12K assemblies or Sun Fire Link Interconnect assemblies.

### 4.2.1 Removing an I/O (slot 1) Filler Panel

---

**Caution** – Be sure you are properly grounded before you begin the hardware removal and installation of the board.

---

There are four ground points on the system cabinet, two at the front top left and top right, and two at the rear top left and top right.

1. **Open the Sun Fire 15K/12K system cabinet access doors, front (side 0) or rear (side1).**

2. Insert a Phillips No. 1 screwdriver into the latches, turning counterclockwise to release the lever, and lift the ejector lever.
3. Use the front handle to extract the I/O (slot 1) filler panel, supporting the bottom with the other hand, place on a flat sturdy surface.

## 4.2.2 Installing an I/O (Slot 1) Filler Panel

1. Firmly grasp the I/O (slot 1) filler panel by the front handle, supporting the bottom with the other hand, and position it onto the carrier rail.
2. With the ejector lever extended, slide the panel into the slot until it is even with the other boards.
3. Use the front handle to fully position the panel.
4. Lock the I/O (slot 1) filler panel by sliding the ejector lever into position until it is fully nested with the front handle.

---

## 4.3 Removing a Sun Fire 15K/12K Assembly

---

**Note** – Be sure you are properly grounded before you begin the removal of the expander board. There are four ground points on the system cabinet, two at the front top left and top right, and two at the rear top left and top right.

---

1. Open the Sun Fire 15K/12K system cabinet access doors either at the front (side 0) or the rear (side 1).

---

**Caution** – Before removing a board from a powered-on system, the green activation LED must be OFF and the amber removal okay LED must be ON.

---

2. Remove and label any cables connected to the assembly.
3. Insert a Philips #1 screwdriver in the latch, turning counterclockwise to release the ejector lever, and lift the ejector lever.

---

**Caution** – Lift the assembly and place the other hand under the bottom, or back, of the assembly. Hold the assembly vertically with the connector downward. Lay the assembly down on an ESD-protected surface with the component side up. Never place the weight of the assembly on the connector as the connector is easily damaged.

---

4. Extract the assembly and place it on a flat, sturdy, ESD-protected surface with the component side up.

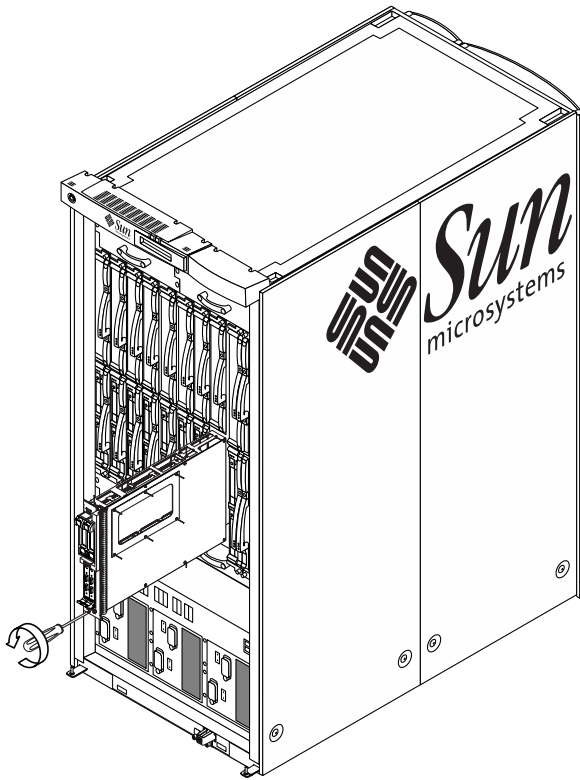

**FIGURE 4-3** Replacing a Sun Fire Link Assembly in a Sun Fire 15K/12K System

---

## 4.4 Installing a Sun Fire Link Assembly

1. To install the Sun Fire Link assembly, hold the assembly by the front handle with one hand, while supporting the bottom with your other hand, and position the board onto the carrier rail.
2. With the ejector lever extended, slide the assembly into the slot until it begins to connect with the expander connector.
3. Apply firm pressure to the face plate to properly seat the assembly with the expander connector.
4. Push the ejector lever downwards to fully seat the assembly.

---

## 4.5 Installing Sun Fire Link Optical Modules

Each Sun Fire Link optical module provides one optical link on a hot-swappable card.

---

**Note** – When installing a new system, you can install the optical modules into the Sun Fire Link assembly either before or after you install that assembly into the Sun Fire 15K/12K system.

---

### 4.5.1 About the Sun Fire Link Optical Module

Sun Fire Link optical module (FIGURE 4-4) is inserted in the lower slots (labeled LINK 0 and LINK 2) in the Sun Fire Link assembly.

---

**Note** – Although the optical module is based on the compactPCI standard, the optical module is not compactPCI-compliant. Its form factor (size and shape) is the same as a compactPCI card, but it is not electronically compliant with compactPCI standards.

---

Each Sun Fire Link optical module provides one optical link with a receive channel and a transmit channel. You can have a maximum of 16 optical modules per Sun Fire 15K/12K system: eight Sun Fire Link assemblies (in four domains) and two optical links per assembly.

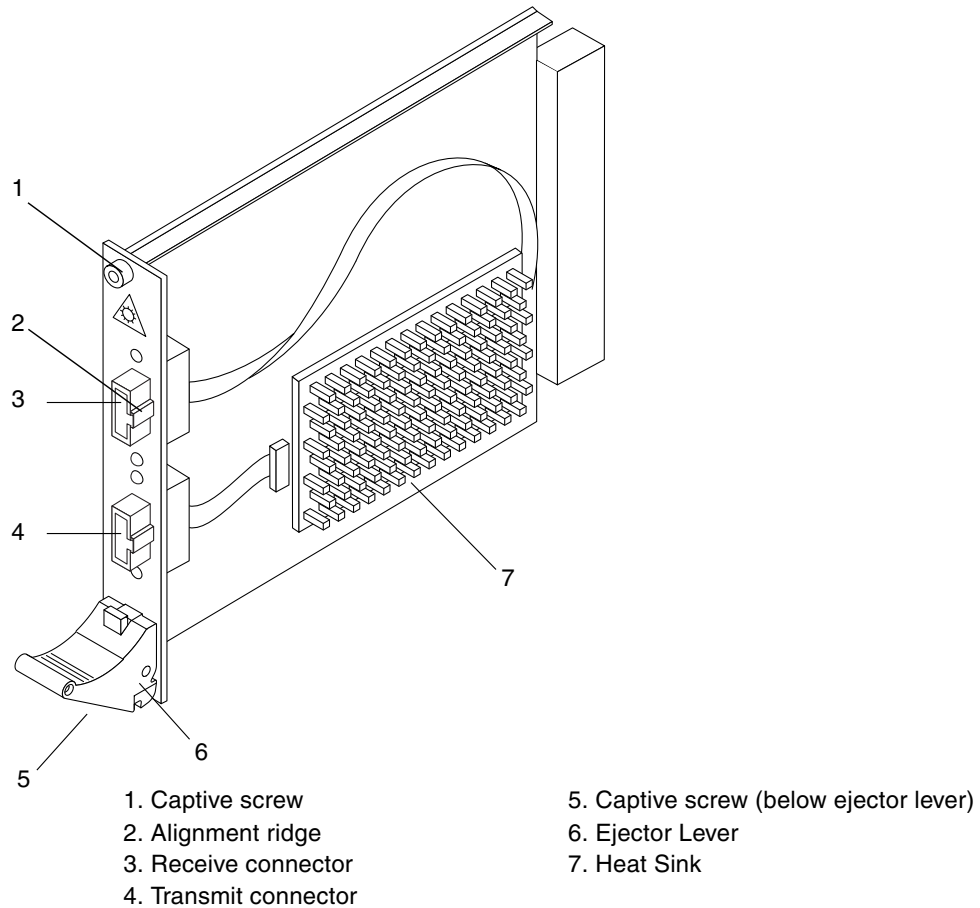



**FIGURE 4-4** The Sun Fire Link Optical Module

## 4.5.2 Sun Fire Link Optical Module LEDs

There are three LEDs (*slot LEDs*) above each optical module slot. TABLE 4-2 notes the LED functions.

**TABLE 4-2** Sun Fire Link Slot LED Functions

LED		On	Off
Power LED (green))		Power is on; you cannot remove the optical module when this LED is on.	Power is off; you can remove the optical module when this LED is off.
Fault LED (amber)		Internal fault	No internal fault
Removal OK LED (amber)		You can safely remove the optical module under hot-swap conditions.	Do not remove the optical module.

Besides the LEDs that are located on the assembly, each optical link module has three LEDs (*card LEDs*) on the module itself (FIGURE 4-5 and TABLE 4-3). A single green LED indicates whether or not power is applied; paired green and amber LEDs convey link status and configuration.

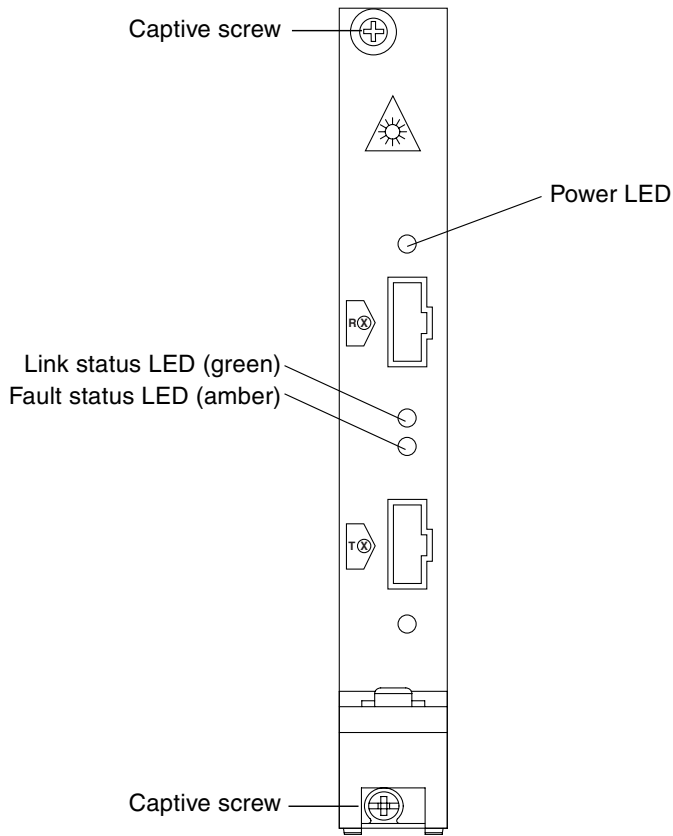

**FIGURE 4-5** Optical Module LEDs

**TABLE 4-3** Card LEDs on Optical Module

Link Status LED (Green)	Fault status LED (Amber)	Meaning
OFF	OFF	No External Link detected. No valid Rx Clock detected
ON	OFF	Link operational: Valid Rx clock received. Remote ID validated.
ON	ON	Degraded link detected: This combination indicates that an error threshold has been exceeded. The link is still operational but performance may be degraded.
BLINKING	OFF	Link is in the process of moving to the operational state.



## 4.5.3 Installing a Sun Fire Link Optical Module

1. Attach an ESD wrist strap or foot strap. Connect the strap to the system.
2. If installed, remove the filler panel.
3. Press the ejector lever down on the optical module.
4. Hold the optical module by the two side edges or the front panel and slide it into the slot in between the two guides, FIGURE 4-6.

The cuts in the handle of the optical module must align with the square cut outs on the Sun Fire Link assembly.

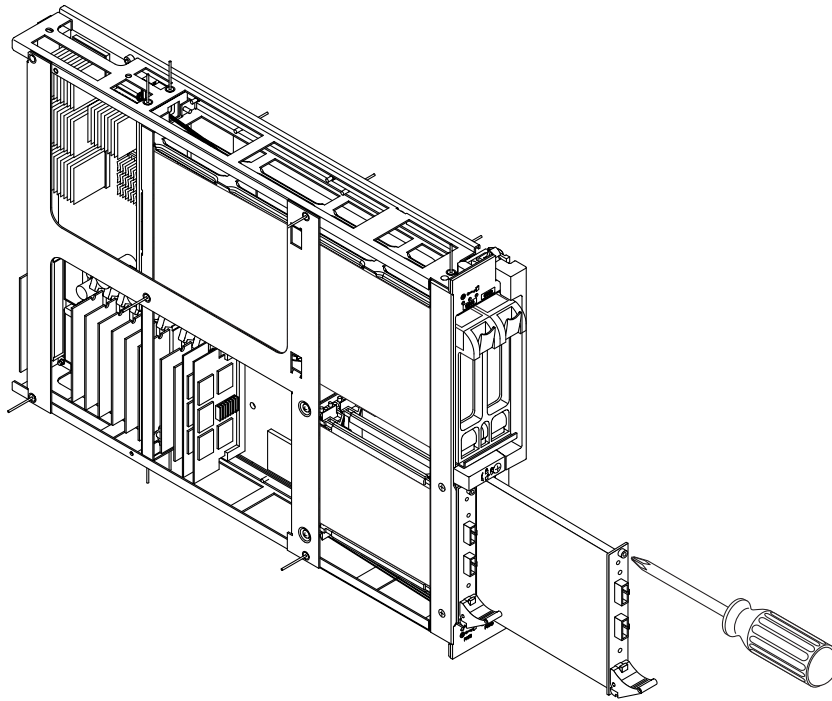

**FIGURE 4-6** Replacing an Optical Module in a Sun Fire Link Assembly (Sun Fire 15K/12K System)

5. Push on the front panel to completely seat the optical module in the assembly.
6. Push the handle in to lock the lever. You should feel it click.
7. Tighten the two captive screws, one at each end of the optical module.

## 4.5.4 About Sun Fire Link Cables

Details about the Sun Fire Link cables are listed below:

- Cables are available in 5-, 12-, and 20-meter lengths.
- Each cable has two plugs at each end, FIGURE 4-7. The white plug is the transmit cable, and the black plug is the receive cable.
- Each cable is labeled with a serial number that aids in cable route tracing.
- Cable changes can be made while the system is operational. Changes should be made consistent with the software intended to manage and validate these changes.
- The cable connectors have a ridge on one side of the plug that indicates which side must be facing up when you plug it into the optical module receiver, FIGURE 4-7.
- The connectors make a distinct clicking sound when fully inserted.

To protect the cables, be sure to:

- Keep dust caps in place whenever cables are not connected
- Maintain a minimum bend radius of at least 30mm (1.2 inches)

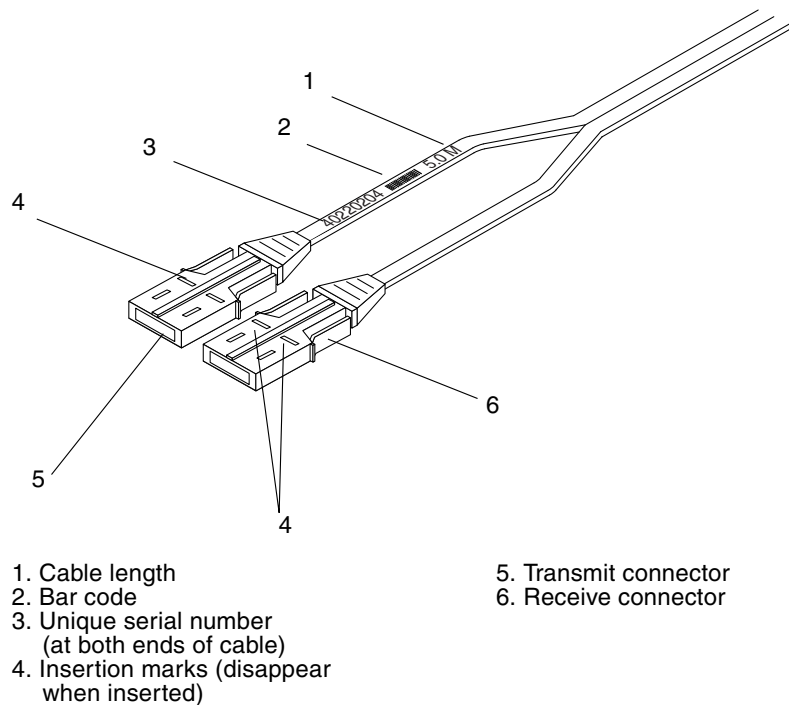

FIGURE 4-7 Sun Fire Link Cable

## 4.5.5 Cabling Sun Fire Link Systems

Cables can be added to and removed from the system while the system is an operation.

- **Install cables. (The black connector is receive and the white connector is transmit.) Be sure to follow the cabling patterns you planned for your system in Appendix A.**

Make sure to insert the cable connector all the way in until you hear a clicking sound.



## Verifying Hardware

---

This chapter provides procedures for confirming correct installation of Sun Fire Link hardware.

---

### 5.1 Running POST In Loopback Mode

When you have completed the installation of Sun Fire Link assemblies and optical modules, but before you install the cables in the full configuration, you can verify that the Sun Fire Link assemblies are recognized and that link components are capable of basic functionality by running POST on each chassis with the cables installed in loopback mode. In loopback mode, the system tests the ability of each optical module to transmit and receive data and it verifies that the cables are functioning properly.

1. **Using customer cables, install the cables in loopback mode by crossing over the white connectors.**

Connect the receive connector from one end of the cable to the receive connector on the optical module. From the opposite end of the cable, connect the transmit connector to the transmit connector on the same optical module.

2. **Power on each chassis.**

---

**Note** – To run link tests, you must set POST to “quick level” or above using the `setupdomain` command at the domain shell.

---

3. **At the OBP prompt run `show-post-results` to see a summary of the POST results.**

The following sample is an example of a successful POST test.

```
Testing IO Boards ...
```

```
.....
{/N0/SB0/P0} Serengeti PCI-WCI IO post code running from memory
{/N0/SB0/P0} @(#) lpost 5.12.52 2001/10/02 11:40
{/N0/SB0/P0} Copyright 2001 Sun Microsystems, Inc. All rights reserved.
{/N0/SB0/P0} Running PCI IO Controller Basic Tests
{/N0/SB0/P0} Subtest: PCI IO Controller Register Initialization for aid 0x1c
{/N0/SB0/P0} Running PCI IO Controller Functional Tests
{/N0/SB0/P0} Subtest: PCI IO Controller IOMMU TLB Compare Tests for aid 0x1c
{/N0/SB0/P0} Subtest: PCI IO Controller IOMMU TLB Flush Tests for aid 0x1c
{/N0/SB0/P0} Subtest: PCI IO Controller DMA loopback Tests for aid 0x1c
{/N0/SB0/P0} Subtest: PCI IO Controller block DMA loopback Tests for aid 0x1c
{/N0/SB0/P0} Subtest: PCI IO Controller Interrupt Tests for aid 0x1c
{/N0/SB0/P0} Subtest: PCI IO Controller MergeBuffer Tests for aid 0x1c
{/N0/SB0/P0} Subtest: PCI IO Controller StreamCache Tests for aid 0x1c
{/N0/SB0/P0} Running SBBC Basic Tests
{/N0/SB0/P0} Subtest: SBBC PCI Reg Initialization for aid 0x1c
{/N0/SB0/P0} Running Wci Basic Tests
{/N0/SB0/P0} Subtest: Wci Check Reset State for aid 0x1d
{/N0/SB0/P0} Subtest: Wci Register Initialization for aid 0x1d
{/N0/SB0/P0} Subtest: Wci Check SRAM Entries for aid 0x1d
{/N0/SB0/P0} Subtest: Wci Cluster Loopback Initialization for aid 0x1d
{/N0/SB0/P0} Subtest: Wci Cluster Start Performance Registers for aid 0x1d
{/N0/SB0/P0} Running Cluster Data Walk Tests
{/N0/SB0/P0} Subtest: Wci Cluster Data Walk Patterns for aid 0x1d
{/N0/SB0/P0} Subtest: Wci Cluster Data Half Patterns for aid 0x1d
{/N0/SB0/P0} Running Cluster Address Walk Tests
{/N0/SB0/P0} Subtest: Wci Cluster LoopBack Address Bits 12 to 6 for aid 0x1d
{/N0/SB0/P0} Subtest: Wci Cluster LoopBack Address Bits 21 to 13 for aid 0x1d
{/N0/SB0/P0} Subtest: Wci Cluster LoopBack Address Bits 33 to 22 for aid 0x1d
{/N0/SB0/P0} Subtest: Wci Cluster LoopBack Address Bits 41 to 34 for aid 0x1d
{/N0/SB0/P0} Running Wci Cluster Restore Test
{/N0/SB0/P0} Subtest: Wci Restore Register State for aid 0x1d
{/N0/SB0/P0} Running Optical Link LoopBack Tests
{/N0/SB0/P0} Subtest: Wci Link LoopBack for aid 0x1d
{/N0/SB0/P0} After 1 Attempt(s), Node=0 Slot=8 Port=1 WCI=1 Link=0 is in
LoopBack <-----
{/N0/SB0/P0} Node=0 Slot=8 Port=1 WCI=1 Link=1 No paroli populated
{/N0/SB0/P0} After 1 Attempt(s), Node=0 Slot=8 Port=1 WCI=1 Link=2 is in
LoopBack <-----
.....
```

During POST there are no notifications that the tests have passed. Unless the hardware fails, you will not see any notification of how the tests ran.

---

**Note** – The link one message (Node=0 Slot=8 Port=1 WCI=1 Link=1 No paroli populated) always shows that there is no optical module installed in slot one. This is normal because the Sun Fire Link ASIC supports three links, but only link zero and two are used.

---

---

## 5.2 Sun Fire Link Interconnect Test (wrsmtest)

The `wrsmtest` is part of SunVTS. It verifies the functionality of the Sun Fire Link Interconnect by checking the cluster networking hardware.

---

**Note** – For this test to be meaningful, the cluster must be configured before the test is run.

---

The `wrsmtest` uses the Internet Control Message Protocol (ICMP) that is based on the Data Link Protocol Interface (DLPI) to test the connections between cluster nodes.

First, `wrsmtest` determines the target cluster nodes to use for testing. You can specify the target hosts in the `wrsmtest` Test Parameter menu, or if no targets are specified, `wrsmtest` sends an ICMP broadcast from the private cluster network to find them. If it fails to find the necessary targets, it performs an RPC broadcast to the RPC port mapper daemon.

After finding the cluster nodes (targets), `wrsmtest` performs the following subtests:

- Random test--sends out 256 packets with random data length and random data.
- Incremental test--sends out packets with length from minimum to maximum packet size using incremental data.
- Pattern test--sends 256 packets of maximum length, where each packet contains one test pattern where all byte patterns (0 to 0xFF) are used.

---

**Note** – `wrsmtest` is a scalable test. The maximum number of instances is two per Sun Fire Link assembly.

---

---

**Note** – The wrsmdtest is only supported in a 64-bit operating environment.

---

## 5.2.1 wrsmdtest Options

To reach the dialog box below, right-click on the test name in the System Map and select Test Parameter Options. If you do not see this test in the System Map, you might need to expand the collapsed groups, or your system may not include the device appropriate to this test. Refer to the *SunVTS User's Guide* for more details.

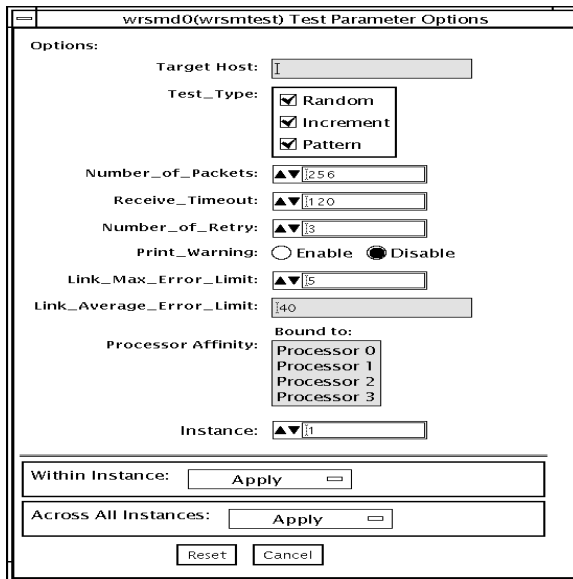

**FIGURE 5-1** wrsmdtest Test Parameter Options Dialog Box



**TABLE 5-1** wrsmtest options

<b>wrsmtest Options</b>	<b>Description</b>
Target Host	Specifies one or more cluster node targets for testing. Target host entries can be either a host name or an Internet address. When no target host is specified, the test finds the necessary targets through broadcasting. The default setting leaves this field empty.
Test Type	Specifies which subtests to run: <ul style="list-style-type: none"><li>• Random test--sends out 256 packets with random data length and random data.</li><li>• Incremental test--sends out packets with length from minimum to maximum packet size using incremental data.</li><li>• Pattern test--sends 256 packets of maximum length, where each packet contains one test pattern where all byte patterns (0 to 0xFF) are used.</li></ul> All subtests are selected by default.
Number of Packets	Specifies the number of packets to use for testing. The default is 256.
Receive Timeout	Specifies the receive timeout value in seconds. Specify a number between 0-600 seconds. The default is 120 seconds.
Number of Retries	Sets the number of retries before an error is flagged. Specify a number between 0-128. The default is 3.
Print Warning	Choose Enable to see warning errors, such as retry on timeout errors. Disabled by default.
Link Max Error Limit	Upper threshold limit for total link errors during testing for a test to pass. If the test reports link errors that exceed this limit, the device being tested will fail and report an error message.
Link Average Error Limit	Threshold limit for average link errors per hour for a test to pass. If the test reports average link errors that exceed this limit, the device being tested will fail and report an error message. The default is 40 errors per hour.

## 5.2.2 wrsmtest Test Modes

Connection, and Functional modes are supported by `wrsmtest`. Different test schemes are performed on the cluster interconnect device based on the test mode you select.

TABLE 5-2 `wrsmtest` Test Modes

Test Mode	Supported?	Description
Connection	Yes	<code>wrsmtest</code> checks if the device is connected. It searches through DLPI <code>wrsm</code> interfaces for the specified device name. If <code>wrsmtest</code> finds the device not connected, the test fails, otherwise, it returns the following message: device is connected.
Functional (Offline)	Yes	<code>wrsmtest</code> performs all three subtests (Random test, Incremental test, and Pattern test) sequentially. It allows you to specify options in such a way that <code>wrsmtest</code> performs a very stressful test.

## 5.2.3 wrsmtest Command-Line Syntax

```
/opt/SUNWvts/bin/wrsmtest standard_arguments -o dev=interface,test=type,  
packets=n,pattern=hex,delay=seconds, timeout=seconds,retry=n,warn= E|D,  
maxerr=n,avgerr=n
```

TABLE 5-3 `wrsmtest` Command-Line Syntax

Argument	Description
<code>dev=interface</code>	Identifies the cluster network interface name. The default value is <code>wrsm0</code> for DLPI cluster networks.
<code>test=type</code>	Specifies which subtests to run. Specify <code>random</code> , <code>increment</code> , or <code>pattern</code> . Use a <code>+</code> symbol to list multiple subtests. The default value is <code>random+increment+pattern</code> .
<code>packets=n</code>	Specifies the number of random/pattern packets. The default is 256.
<code>pattern=hex</code>	Specifies a data pattern in hexadecimal form. The default is all patterns from 0 to 0xff.
<code>delay=seconds</code>	Indicates the time between subtests in seconds. The default is 30 seconds.

**TABLE 5-3** wrsmttest Command-Line Syntax

Argument	Description
<b>timeout</b> = <i>seconds</i>	Indicates the number of seconds to wait before a timeout. The default is 1 second.
<b>retry</b> = <i>n</i>	Indicates the number of test timeout retries. The default is three retries.
<b>warn</b> = <i>E D</i>	When enabled, prints warning messages.
<b>maxerr</b> = <i>n</i>	Upper threshold limit for total link errors during testing for a test to pass. If the test reports link errors that exceed this limit, the device being tested will fail and report an error message.
<b>avgerr</b> = <i>n</i>	Threshold limit for average link errors per hour for a test to pass. If the test reports average link errors that exceed this limit, the device being tested will fail and report an error message. The default is 40 errors per hour.

---

**Note** – 64-bit tests are located in the `sparcv9` subdirectory: `/opt/SUNWvts/bin/sparcv9/testname`. If a test is not present in this directory, then it may only be available as a 32-bit test. For more information refer to the *SunVTS 4.6 Test Reference Manual*.

---







**TABLE A-1** Cabling Table Worksheet (3 of 3)

<b>Node</b>	<b>ASIC</b>	<b>ASIC Link</b>	<b>Node</b>	<b>ASIC</b>	<b>ASIC Link</b>





# Regulatory Compliance Statements

---

Your Sun product is marked to indicate its compliance class:

- Federal Communications Commission (FCC) — USA
- Industry Canada Equipment Standard for Digital Equipment (ICES-003) - Canada
- Voluntary Control Council for Interference (VCCI) — Japan
- Bureau of Standards Metrology and Inspection (BSMI) — Taiwan

Please read the appropriate section that corresponds to the marking on your Sun product before attempting to install the product.

---

## B.1 FCC Class A Notice

This device complies with Part 15 of the FCC Rules. Operation is subject to the following two conditions:

1. This device may not cause harmful interference.
2. This device must accept any interference received, including interference that may cause undesired operation.

---

**Note** – This equipment has been tested and found to comply with the limits for a Class A digital device, pursuant to Part 15 of the FCC Rules. These limits are designed to provide reasonable protection against harmful interference when the equipment is operated in a commercial environment. This equipment generates, uses, and can radiate radio frequency energy, and if it is not installed and used in accordance with the instruction manual, it may cause harmful interference to radio communications. Operation of this equipment in a residential area is likely to cause harmful interference, in which case the user will be required to correct the interference at his own expense.

---

**Shielded Cables:** Connections between the workstation and peripherals must be made using shielded cables to comply with FCC radio frequency emission limits. Networking connections can be made using unshielded twisted-pair (UTP) cables.

**Modifications:** Any modifications made to this device that are not approved by Sun Microsystems, Inc. may void the authority granted to the user by the FCC to operate this equipment.

---

## B.2 FCC Class B Notice

This device complies with Part 15 of the FCC Rules. Operation is subject to the following two conditions:

1. This device may not cause harmful interference.
2. This device must accept any interference received, including interference that may cause undesired operation.

---

**Note –** This equipment has been tested and found to comply with the limits for a Class B digital device, pursuant to Part 15 of the FCC Rules. These limits are designed to provide reasonable protection against harmful interference in a residential installation. This equipment generates, uses and can radiate radio frequency energy and, if not installed and used in accordance with the instructions, may cause harmful interference to radio communications. However, there is no guarantee that interference will not occur in a particular installation. If this equipment does cause harmful interference to radio or television reception, which can be determined by turning the equipment off and on, the user is encouraged to try to correct the interference by one or more of the following measures:

---

- Reorient or relocate the receiving antenna.
- Increase the separation between the equipment and receiver.
- Connect the equipment into an outlet on a circuit different from that to which the receiver is connected.
- Consult the dealer or an experienced radio/television technician for help.

**Shielded Cables:** Connections between the workstation and peripherals must be made using shielded cables in order to maintain compliance with FCC radio frequency emission limits. Networking connections can be made using unshielded twisted pair (UTP) cables.

**Modifications:** Any modifications made to this device that are not approved by Sun Microsystems, Inc. may void the authority granted to the user by the FCC to operate this equipment.

---

## B.3 ICES-003 Class A Notice - Avis NMB-003, Classe A

This Class A digital apparatus complies with Canadian ICES-003.

Cet appareil numérique de la classe A est conforme à la norme NMB-003 du Canada.

---

## B.4 ICES-003 Class B Notice - Avis NMB-003, Classe B

This Class B digital apparatus complies with Canadian ICES-003.

Cet appareil numérique de la classe B est conforme à la norme NMB-003 du Canada.

### VCCI 基準について

#### クラス A VCCI 基準について

クラス A VCCI の表示があるワークステーションおよびオプション製品は、クラス A 情報技術装置です。これらの製品には、下記の項目が該当します。

この装置は、情報処理装置等電波障害自主規制協議会 (VCCI) の基準に基づくクラス A 情報技術装置です。この装置を家庭環境で使用すると電波妨害を引き起こすことがあります。この場合には使用者が適切な対策を講ずるよう要求されることがあります。

## クラス B VCCI 基準について

クラス B VCCI の表示  があるワークステーションおよびオプション製品は、クラス B 情報技術装置です。これらの製品には、下記の項目が該当します。

この装置は、情報処理装置等電波障害自主規制協議会 (VCCI) の基準に基づくクラス B 情報技術装置です。この装置は、家庭環境で使用することを目的としていますが、この装置がラジオやテレビジョン受信機に近接して使用されると、受信障害を引き起こすことがあります。取扱説明書に従って正しい取り扱いをしてください。

---

## B.5 BSMI Class A Notice

The following statement is applicable to products shipped to Taiwan and marked as Class A on the product compliance label.

警告使用者：

這是甲類的資訊產品，在居住的環境中使用時，可能會造成射頻干擾，在這種情況下，使用者會被要求採取某些適當的對策。

# Safety Agency Compliance Statements

Read this section before beginning any procedure. The following text provides safety precautions to follow when installing a Sun Microsystems product.

## Safety Precautions

For your protection, observe the following safety precautions when setting up your equipment:

- Follow all cautions and instructions marked on the equipment.
- Ensure that the voltage and frequency of your power source match the voltage and frequency inscribed on the equipment's electrical rating label.
- Never push objects of any kind through openings in the equipment. Dangerous voltages may be present. Conductive foreign objects could produce a short circuit that could cause fire, electric shock, or damage to your equipment.

## Symbols

The following symbols may appear in this book:



---

**Caution** – There is risk of personal injury and equipment damage. Follow the instructions.

---



---

**Caution** – Hot surface. Avoid contact. Surfaces are hot and may cause personal injury if touched.

---



---

**Caution** – Hazardous voltages are present. To reduce the risk of electric shock and danger to personal health, follow the instructions.

---

---

**On** – Applies AC power to the system.

---

Depending on the type of power switch your device has, one of the following symbols may be used:



---

**Off** - Removes AC power from the system.

---



---

**Standby** – The On/Standby switch is in the standby position.

---

## Modifications to Equipment

Do not make mechanical or electrical modifications to the equipment. Sun Microsystems is not responsible for regulatory compliance of a modified Sun product.

## Placement of a Sun Product



---

**Caution** – Do not block or cover the openings of your Sun product. Never place a Sun product near a radiator or heat register. Failure to follow these guidelines can cause overheating and affect the reliability of your Sun product.

---



---

**Caution** – Noise level during normal operating condition is below 70Db(A). Noise level during over temperature condition may be above 70Db(A). Limit exposure during this temporary condition.

---

## SELV Compliance

Safety status of I/O connections comply to SELV requirements.

## Power Cord Connection



---

**Caution** – Sun products are designed to work with a line-to-neutral or line-to-line connection. To reduce the risk of electric shock, do not plug Sun products into any other type of power system. Contact your facilities manager or a qualified electrician if you are not sure what type of power is supplied to your building.

---



---

**Caution** – Not all power cords have the same current ratings. Household extension cords do not have overload protection and are not meant for use with computer systems. Do not use household extension cords with your Sun product.

---



---

**Caution** – Your Sun product is shipped with a grounding type (three-wire) power cord. To reduce the risk of electric shock, always plug the cord into a grounded power outlet.

---

The following caution applies only to devices with a Standby power switch:



---

**Caution** – The power switch of this product functions as a standby type device only. The power cord serves as the primary disconnect device for the system. Be sure to plug the power cord into a grounded power outlet that is nearby the system and is readily accessible. Do not connect the power cord when the power supply has been removed from the system chassis.

---

## Lithium Battery



---

**Caution** – On Sun SC CPU boards, there is a lithium battery molded into the real-time clock, SGS No. MK48T59Y, MK48TXXB-XX, MK48T18-XXXPCZ, M48T59W-XXXPCZ, or MK48T08. Batteries are not customer replaceable parts. They may explode if mishandled. Do not dispose of the battery in fire. Do not disassemble it or attempt to recharge it.

---

## Laser Compliance Notice

Sun products that use laser technology comply with Class 1 laser requirements.

Class 1 Laser Product  
Luokan 1 Laserlaite  
Klasse 1 Laser Apparat  
Laser Klasse 1

## CD ROM/DVD ROM



---

**Caution** – Use of controls, adjustments, or the performance of procedures other than those specified herein may result in hazardous radiation exposure.

---

## Einhaltung sicherheitsbehördlicher Vorschriften

Auf dieser Seite werden Sicherheitsrichtlinien beschrieben, die bei der Installation von Sun-Produkten zu beachten sind.

### Sicherheitsvorkehrungen

Treffen Sie zu Ihrem eigenen Schutz die folgenden Sicherheitsvorkehrungen, wenn Sie Ihr Gerät installieren:

- Beachten Sie alle auf den Geräten angebrachten Warnhinweise und Anweisungen.
- Vergewissern Sie sich, daß Spannung und Frequenz Ihrer Stromquelle mit der Spannung und Frequenz übereinstimmen, die auf dem Etikett mit den elektrischen Nennwerten des Geräts angegeben sind.
- Stecken Sie auf keinen Fall irgendwelche Gegenstände in Öffnungen in den Geräten. Leitfähige Gegenstände könnten aufgrund der möglicherweise vorliegenden gefährlichen Spannungen einen Kurzschluß verursachen, der einen Brand, Stromschlag oder Geräteschaden herbeiführen kann.

### Symbole

Die Symbole in diesem Handbuch haben folgende Bedeutung:



---

**Achtung** – Gefahr von Verletzung und Geräteschaden. Befolgen Sie die Anweisungen.

---



---

**Achtung** – Hohe Temperatur. Nicht berühren, da Verletzungsgefahr durch heiße Oberfläche besteht.

---



---

**Achtung** – Gefährliche Spannungen. Anweisungen befolgen, um Stromschläge und Verletzungen zu vermeiden.

---

---

**Ein** – Setzt das System unter Wechselstrom.

---

Je nach Netzschaltertyp an Ihrem Gerät kann eines der folgenden Symbole benutzt werden:



---

**Aus** – Unterbricht die Wechselstromzufuhr zum Gerät.

---



---

**Wartezustand** (Stand-by-Position) - Der Ein-/Wartezustand-Schalter steht auf Wartezustand. Änderungen an Sun-Geräten.

---

Nehmen Sie keine mechanischen oder elektrischen Änderungen an den Geräten vor. Sun Microsystems, übernimmt bei einem Sun-Produkt, das geändert wurde, keine Verantwortung für die Einhaltung behördlicher Vorschriften

### Aufstellung von Sun-Geräten



---

**Achtung** – Um den zuverlässigen Betrieb Ihres Sun-Geräts zu gewährleisten und es vor Überhitzung zu schützen, dürfen die Öffnungen im Gerät nicht blockiert oder verdeckt werden. Sun-Produkte sollten niemals in der Nähe von Heizkörpern oder Heizluftklappen aufgestellt werden.

---



---

**Achtung** – Unter normalen Betriebsbedingungen liegt der Geräuschpegel unter 70 Db(A). Bei erhöhten Temperaturen kann der Geräuschpegel bei über 70 Db(A) liegen. Minimieren Sie eine Überhitzung des Gerätes.

---

### Einhaltung der SELV-Richtlinien

Die Sicherung der I/O-Verbindungen entspricht den Anforderungen der SELV-Spezifikation.

## Anschluß des Netzkabels



---

**Achtung** – Sun-Produkte sind für die Verwendung mit einer Leiter-zu-Neutral- oder einer Leiter-zu-Leiter-Verbindung vorgesehen. Um die Stromschlaggefahr zu reduzieren, schließen Sie Sun-Produkte nicht an andere Stromquellen an. Ihr Betriebsleiter oder ein qualifizierter Elektriker kann Ihnen die Daten zur Stromversorgung in Ihrem Gebäude geben.

---



---

**Achtung** – Nicht alle Netzkabel haben die gleichen Nennwerte. Herkömmliche, im Haushalt verwendete Verlängerungskabel besitzen keinen Überlastungsschutz und sind daher für Computersysteme nicht geeignet.

---



---

**Achtung** – Ihr Sun-Gerät wird mit einem dreiadrigen Netzkabel für geerdete Netzsteckdosen geliefert. Um die Gefahr eines Stromschlags zu reduzieren, schließen Sie das Kabel nur an eine fachgerecht verlegte, geerdete Steckdose an.

---

Die folgende Warnung gilt nur für Geräte mit Wartezustand-Netzschalter:



---

**Achtung** – Der Ein/Aus-Schalter dieses Geräts schaltet nur auf Wartezustand (Stand-By-Modus). Um die Stromzufuhr zum Gerät vollständig zu unterbrechen, müssen Sie das Netzkabel von der Steckdose abziehen. Schließen Sie den Stecker des Netzkabels an eine in der Nähe befindliche, frei zugängliche, geerdete Netzsteckdose an. Schließen Sie das Netzkabel nicht an, wenn das Netzteil aus der Systemeinheit entfernt wurde.

---

## Lithiumbatterie



---

**Achtung** – SC CPU-Karten von Sun verfügen über eine Echtzeituhr mit integrierter Lithiumbatterie (Teile-Nr. MK48T59Y, MK48TXXB-XX, MK48T18-XXXPCZ, M48T59W-XXXPCZ, oder MK48T08). Diese Batterie darf nur von einem qualifizierten Servicetechniker ausgewechselt werden, da sie bei falscher Handhabung explodieren kann. Werfen Sie die Batterie nicht ins Feuer. Versuchen Sie auf keinen Fall, die Batterie auszubauen oder wiederaufzuladen.

---

## Einhaltung der Richtlinien für Laser

Sun-Produkte, die mit Laser-Technologie arbeiten, entsprechen den Anforderungen der Laser Klasse 1.

Class 1 Laser Product  
Luokan 1 Laserlaite  
Klasse 1 Laser Apparat  
Laser Klasse 1

## CD ROM/DVD ROM



---

**Warnung** – Die Verwendung von anderen Steuerungen und Einstellungen oder die Durchführung von Prozeduren, die von den hier beschriebenen abweichen, können gefährliche Strahlungen zur Folge haben.

---



## Conformité aux normes de sécurité

Ce texte traite des mesures de sécurité qu'il convient de prendre pour l'installation d'un produit Sun Microsystems.

### Mesures de sécurité

Pour votre protection, veuillez prendre les précautions suivantes pendant l'installation du matériel :

- Suivre tous les avertissements et toutes les instructions inscrites sur le matériel.
- Vérifier que la tension et la fréquence de la source d'alimentation électrique correspondent à la tension et à la fréquence indiquées sur l'étiquette de classification de l'appareil.
- Ne jamais introduire d'objets quels qu'ils soient dans une des ouvertures de l'appareil. Vous pourriez vous trouver en présence de hautes tensions dangereuses. Tout objet conducteur introduit de la sorte pourrait produire un court-circuit qui entraînerait des flammes, des risques d'électrocution ou des dégâts matériels.

### Symboles

Vous trouverez ci-dessous la signification des différents symboles utilisés :



---

**Attention:** – risques de blessures corporelles et de dégâts matériels. Veuillez suivre les instructions.

---



---

**Attention:** – surface à température élevée. Évitez le contact. La température des surfaces est élevée et leur contact peut provoquer des blessures corporelles.

---



---

**Attention:** – présence de tensions dangereuses. Pour éviter les risques d'électrocution et de danger pour la santé physique, veuillez suivre les instructions.

---

---

**MARCHE** – Votre système est sous tension (courant alternatif).

---

Un des symboles suivants sera peut-être utilisé en fonction du type d'interrupteur de votre système:



---

**ARRÊT** - Votre système est hors tension (courant alternatif).

---



---

**VEILLEUSE** – L'interrupteur Marche/ Veilleuse est en position « Veilleuse ».

---

### Modification du matériel

Ne pas apporter de modification mécanique ou électrique au matériel. Sun Microsystems n'est pas responsable de la conformité réglementaire d'un produit Sun qui a été modifié.

### Positionnement d'un produit Sun



---

**Attention:** – pour assurer le bon fonctionnement de votre produit Sun et pour l'empêcher de surchauffer, il convient de ne pas obstruer ni recouvrir les ouvertures prévues dans l'appareil. Un produit Sun ne doit jamais être placé à proximité d'un radiateur ou d'une source de chaleur.

---



---

**Attention:** – Pendant le fonctionnement normal, le niveau de bruit est inférieur à 70 Db (A). Pendant l'utilisation à des températures élevées, il peut être supérieur à 70 Db (A). Limitez l'utilisation pendant ces conditions temporaires.

---

### Conformité SELV

Sécurité : les raccordements E/S sont conformes aux normes SELV.

## Connexion du cordon d'alimentation.



**Attention:** – Les produits Sun sont conçus pour fonctionner avec une connexion ligne à neutre ou ligne à ligne. Pour écarter les risques d'électrocution, ne pas brancher de produit Sun dans un autre type d'alimentation secteur. En cas de doute quant au type d'alimentation électrique du local, veuillez vous adresser au directeur de l'exploitation ou à un électricien qualifié.



**Attention:** – tous les cordons d'alimentation n'ont pas forcément la même puissance nominale en matière de courant. Les rallonges d'usage domestique n'offrent pas de protection contre les surcharges et ne sont pas prévues pour les systèmes d'ordinateurs. Ne pas utiliser de rallonge d'usage domestique avec votre produit Sun.



**Attention:** – votre produit Sun a été livré équipé d'un cordon d'alimentation à trois fils (avec prise de terre). Pour écarter tout risque d'électrocution, branchez toujours ce cordon dans une prise mise à la terre.

L'avertissement suivant s'applique uniquement aux systèmes équipés d'un interrupteur VEILLEUSE:



**Attention:** – le commutateur d'alimentation de ce produit fonctionne comme un dispositif de mise en veille uniquement. C'est la prise d'alimentation qui sert à mettre le produit hors tension. Veuillez donc à installer le produit à proximité d'une prise murale facilement accessible. Ne connectez pas la prise d'alimentation lorsque le châssis du système n'est plus alimenté.

## Batterie au lithium



**Attention:** – sur les cartes SC CPU Sun, une batterie au lithium (référence MK48T59Y, MK48TXXB-XX, MK48T18-XXXPCZ, M48T59W-XXXPCZ, ou MK48T08.) a été moulée dans l'horloge temps réel SGS. Les batteries ne sont pas des pièces remplaçables par le client. Elles risquent d'exploser en cas de mauvais traitement. Ne pas jeter la batterie au feu. Ne pas la démonter ni tenter de la recharger.

## Conformité aux certifications Laser

Les produits Sun qui font appel aux technologies lasers sont conformes aux normes de la classe 1 en la matière.

Class 1 Laser Product  
Luokan 1 Laserlaite  
Klasse 1 Laser Apparat  
Laser Klasse 1

## CD ROM/DVD ROM



**Attention:** – L'utilisation de contrôles, de réglages ou de performances de procédures autre que celle spécifiée dans le présent document peut provoquer une exposition à des radiations dangereuses.

## Normativas de seguridad

El siguiente texto incluye las medidas de seguridad que se deben seguir cuando se instale algún producto de Sun Microsystems.

### Precauciones de seguridad

Para su protección observe las siguientes medidas de seguridad cuando manipule su equipo:

- Siga todas las avisos e instrucciones marcados en el equipo.
- Asegúrese de que el voltaje y la frecuencia de la red eléctrica concuerdan con las descritas en las etiquetas de especificaciones eléctricas del equipo.
- No introduzca nunca objetos de ningún tipo a través de los orificios del equipo. Pueden haber voltajes peligrosos. Los objetos extraños conductores de la electricidad pueden producir cortocircuitos que provoquen un incendio, descargas eléctricas o daños en el equipo.

### Símbolos

En este libro aparecen los siguientes símbolos:



**Precaución** – Existe el riesgo de lesiones personales y daños al equipo. Siga las instrucciones.



**Precaución** – Superficie caliente. Evite el contacto. Las superficies están calientes y pueden causar daños personales si se tocan.



**Precaución** – Voltaje peligroso presente. Para reducir el riesgo de descarga y daños para la salud siga las instrucciones.



**Encendido** – Aplica la alimentación de CA al sistema.

Según el tipo de interruptor de encendido que su equipo tenga, es posible que se utilice uno de los siguientes símbolos:



**Apagado** - Elimina la alimentación de CA del sistema.



**En espera** – El interruptor de Encendido/En espera se ha colocado en la posición de En espera.

### Modificaciones en el equipo

No realice modificaciones de tipo mecánico o eléctrico en el equipo. Sun Microsystems no se hace responsable del cumplimiento de las normativas de seguridad en los equipos Sun modificados.

### Ubicación de un producto Sun



**Precaución** – Para asegurar la fiabilidad de funcionamiento de su producto Sun y para protegerlo de sobrecalentamientos no deben obstruirse o taparse las rejillas del equipo. Los productos Sun nunca deben situarse cerca de radiadores o de fuentes de calor.



**Precaución** – El nivel de ruido en circunstancias normales de funcionamiento está por debajo de 70 Db (A). El nivel de ruido en circunstancias de temperatura excesiva podría estar por encima de 70 Db (A). En dichas circunstancias temporales limite la exposición.

### Cumplimiento de la normativa SELV

El estado de la seguridad de las conexiones de entrada/salida cumple los requisitos de la normativa SELV.

## Conexión del cable de alimentación eléctrica



**Precaución** – Los productos Sun están diseñados para funcionar con una conexión línea a neutra o línea a línea. Para reducir el riesgo de descarga eléctrica, no conecte los productos Sun a otro tipo de sistema de alimentación eléctrica. Póngase en contacto con el responsable de mantenimiento o con un electricista cualificado si no está seguro del sistema de alimentación eléctrica del que se dispone en su edificio.



**Precaución** – No todos los cables de alimentación eléctrica tienen la misma capacidad. Los cables de tipo doméstico no están provistos de protecciones contra sobrecargas y por tanto no son apropiados para su uso con computadores. No utilice alargadores de tipo doméstico para conectar sus productos Sun.



**Precaución** – Con el producto Sun se proporciona un cable de alimentación con toma de tierra. Para reducir el riesgo de descargas eléctricas conéctelo siempre a un enchufe con toma de tierra.

La siguiente advertencia se aplica solamente a equipos con un interruptor de encendido que tenga una posición "En espera":



**Precaución** – El interruptor de encendido de este producto funciona exclusivamente como un dispositivo de puesta en espera. El enchufe de la fuente de alimentación está diseñado para ser el elemento primario de desconexión del equipo. El equipo debe instalarse cerca del enchufe de forma que este último pueda ser fácil y rápidamente accesible. No conecte el cable de alimentación cuando se ha retirado la fuente de alimentación del chasis del sistema.

## Batería de litio



**Precaución** – En las placas de SC CPU Sun hay una batería de litio insertada en el reloj de tiempo real, tipo SGS Núm. MK48T59Y, MK48TXXB-XX, MK48T18-XXXPCZ, M48T59W-XXXPCZ, o MK48T08. Las baterías no son elementos reemplazables por el propio cliente. Pueden explotar si se manipulan de forma errónea. No arroje las baterías al fuego. No las abra o intente recargarlas.

## Aviso de cumplimiento con requisitos de láser

Los productos Sun que utilizan la tecnología de láser cumplen con los requisitos de láser de Clase 1.

Class 1 Laser Product  
Luokan 1 Laserlaite  
Klasse 1 Laser Apparat  
Laser Klasse 1

## CD ROM/DVD ROM



**Precaución** – El manejo de los controles, los ajustes o la ejecución de procedimientos distintos a los aquí especificados pueden exponer al usuario a radiaciones peligrosas.

# GOST-R Certification Mark

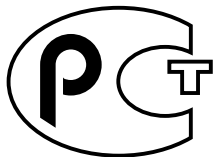

## Nordic Lithium Battery Cautions

### Norge



---

**ADVARSEL** – Litiumbatteri —  
Ekspløsjonsfare. Ved utskifting benyttes kun  
batteri som anbefalt av apparatfabrikanten.  
Brukt batteri returneres apparatleverandøren.

---

### Sverige



---

**VARNING** – Explosionsfara vid felaktigt  
batteribyte. Använd samma batterityp eller  
en ekvivalent typ som rekommenderas av  
apparatillverkaren. Kassera använt batteri  
enligt fabrikantens instruktion.

---

### Danmark



---

**ADVARSEL!** – Litiumbatteri —  
Ekspløsjonsfare ved fejlagtig håndtering.  
Udskiftning må kun ske med batteri af samme  
fabrikat og type. Levér det brugte batteri  
tilbage til leverandøren.

---

### Suomi



---

**VAROITUS** – Paristo voi räjähtää, jos se on  
virheellisesti asennettu. Vaihda paristo  
ainoastaan laitevalmistajan suosittelemaan  
tyyppiin. Hävitä käytetty paristo valmistajan  
ohjeiden mukaisesti.

---



# Index

---

## A

- ASIC striping, 2-8
- assembly
  - ASIC 29 location in Sun Fire 15K/12K system (table), 2-5
  - ASIC 31 location in Sun Fire 15K/12K system (table), 2-5
  - ASIC port ID numbers in Sun Fire 15K/12K system (table), 2-5
  - compactPCI and Fire Link slots not compatible, 3-7
  - compactPCI and Sun Fire Link slots not compatible, 4-7
  - locations in Sun Fire 6800 system, 2-3
  - optical module locations in Sun Fire 15K/12K system, 2-4
  - orientation in Sun Fire 6800 system (illustration), 2-2
  - removing Sun Fire 6800 I/O assembly, 3-4
  - safe handling, 1-6
  - slots in Sun Fire 15K/12K system must be consecutive, 2-4
  - Sun Fire 15K/12K slot and ASIC numbers (illustration), 4-2
  - Sun Fire 15K/12K slot and ASIC numbers (table), 4-3
  - Sun Fire 15K/12K slots (illustration), 2-4
  - Sun Fire 6800 ASIC 29, 2-3
  - Sun Fire 6800 ASIC 31 location, 2-3
  - Sun Fire 6800 optical module locations, 2-3

## B

- board handling safety, 1-5

## C

- cable
  - testing with POST, 5-1
  - worksheet, A-1
- cable diagrams explained, 2-6
- cables
  - illustration, 3-12
  - installation, 3-12
  - length, 3-11
- configurations
  - direct-connect general configuration described, 2-1
  - Sun Fire 15K/12K Sun Clusters
    - 2- to 4-node 2-switch connect, 2-25
    - 2-node direct connect, 2-20
    - 3-node direct connect, 2-22
    - 5- to 8-node 4-switch connect, 2-28
  - Sun Fire 15K/12K Sun HPC ClusterTools
    - 2-node direct connect, 2-19
    - 3- to 4-node 2-switch connect, 2-23
    - 3-node direct connect, 2-21
    - 5- to 8-node 4-switch connect, 2-26
  - Sun Fire 6800 Sun Clusters
    - 2- to 4-node 2-switch connect, 2-15
    - 2-node direct connect, 2-10
    - 3-node direct connect, 2-12
    - 5- to 8-node 4-switch connect, 2-17
  - Sun Fire 6800 Sun HPC ClusterTools
    - 2-node direct connect, 2-9

- 3- to 4-node 2-switch connect, 2-13
- 3-node direct connect, 2-11
- 5- to 8-node 4-switch connect, 2-16
- switch general configuration described, 2-1
- conventions
  - Sun Fire 15K/12K naming and numbering, 2-3
  - Sun Fire 6800 system
    - naming and numbering, 2-2

## D

- data striping, *See* striping
- direct-connect configuration defined, 2-1

## E

- electrical ground requirement, 1-5
- error messages
  - "no paroli populated", 5-3

## F

- filler board and filler panel requirements, 1-5
- Fire Link assembly, *See* assembly
- Fire Link cables, *See* cables
- Fire Link optical module, *See* optical module

## G

- grounding requirement, 1-5
- guidelines
  - filler board and filler panel requirements, 1-5
  - handling boards and assemblies, 1-5
  - Sun Fire 15K/12K assembly, 4-2
  - Sun Fire 15K/12K cables, 2-6, 4-12
  - Sun Fire 15K/12K optical module, 4-7
  - Sun Fire 6800 assembly, 2-2
  - Sun Fire 6800 cables, 2-6, 3-11
  - Sun Fire 6800 optical module, 3-6

## I

- IB 8 and IB 9 slot locations in Sun Fire 6800 system, 2-3
- interconnect test, 5-3

## L

- LEDs, optical module, in Sun Fire 15K/12K system, 4-9 to 4-10
- LEDs, optical module, in Sun Fire 6800 system, 3-8 to 3-10
- length of cables, 3-11
- link interconnect test, 5-3
- links
  - Link 0 and Link 2 locations in Sun Fire 15K system (illustration), 4-2
  - Sun Fire 15K/12K Link 2 and Link 1 slots (illustration), 2-4
  - Sun Fire 6800 "Link 0" is hardware slot 2, 2-3
  - Sun Fire 6800 "Link 2" is hardware slot 1, 2-3
- loopback mode for POST, 5-1

## M

- message, "no paroli populated", 5-3
- modes, test, *wrsmtest*, 5-6

## N

- naming and numbering conventions
  - Sun Fire 15K/12K system
    - naming and numbering conventions, 2-3
  - Sun Fire 6800 system, 2-2
- "no paroli populated" message, 5-3
- nodes and switches, quantities related, 2-1

## O

- optical module
  - LEDs in Sun Fire 15K/12K system, 4-9 to 4-10
  - LEDs in Sun Fire 6800 system, 3-8 to 3-10
  - slots and compactPCI slots compared, Sun Fire 6800, 3-2
  - testing with POST, 5-1
- options, *wrsmtest*, 5-4
- orientation of Sun Fire Link assembly in Sun Fire 6800 system (illustration), 2-2

## P

- POST display example, 5-2



POST, running in loopback mode, 5-1  
precautions, system, 1-4

## R

removing Sun Fire 6800 I/O assembly, 3-4  
requirements, filler board and filler panel, 1-5

## S

safe board handling, 1-5  
safety  
    grounding, 1-5  
striping  
    ASIC (WCI) striping, 2-8  
    four-way striping, 2-9  
    general information, 2-7  
    link striping, 2-8  
    WCI striping, 2-8  
Sun Clusters configurations, *See*  
    configurations, 2-10  
Sun Fire 15K/12K  
    Link 2 and Link 1 slots (illustration), 2-4  
Sun Fire 6800 naming and numbering  
    conventions, 2-2  
Sun Fire 6800 system  
    locations for Sun Fire Link assembly, 2-3  
    orientation of Sun Fire Link assembly  
        (illustration), 2-2  
Sun Fire Link assembly, *See* assembly  
Sun Fire Link cables, *See* cables  
Sun Fire Link optical module, *See* optical module  
Sun HPC ClusterTools configurations, *See*  
    configurations  
switches and nodes, quantities related, 2-1  
symbols, chassis (table), 1-3 to 1-4  
syntax, `wrsmtest`, 5-6  
system precautions, 1-4

## T

test modes, `wrsmtest`, 5-6  
testing  
    64-bit test directory, 5-7  
    link interconnect, 5-3  
    POST for Sun Fire Link hardware, 5-1

tools required, 1-6  
troubleshooting  
    using POST to test optical modules and  
        cables, 5-1  
    using `wrsmtest` to check cluster networking  
        hardware, 5-3

## W

WCI striping, 2-8  
`wrsmtest`, 5-3 to 5-7

