

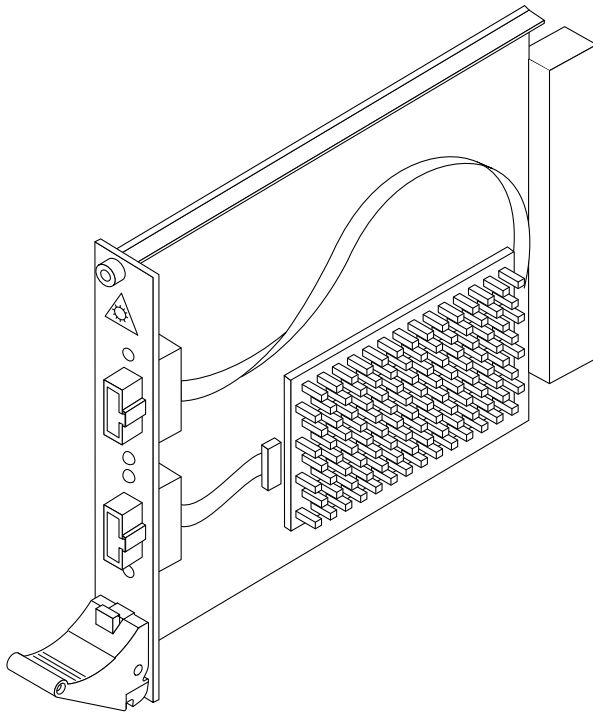

Sun Fire™ Link Optical Module Installation Guide



Note – These instructions are intended only as a reminder for those who have previous experience with this procedure. For more detailed instructions, refer to the *Sun Fire Link Hardware Installation Guide*.

This document provides instructions for installing a Sun Fire™ Link optical module in a Sun Fire 6800 chassis or a Sun Fire 15K/12K chassis.

Complete documentation for the Sun Fire Link interconnect product is available in two formats:

- In a printed version, which you can order (part number, X4190A)
- In Adobe Acrobat Exchange (.pdf) format on the Sun Fire Link CD (part number, LNKSS-B00-E99).

The CD ships with:

- Sun Fire Link Assembly (Sun Fire 6800 system)
- Sun Fire Link Assembly (Sun Fire 15K/12K system)

To read the documentation online, use the CD-ROM drive on the workstation that serves as your administration station.

These instructions are for use by trained service representatives who have been trained on Sun Fire Link interconnect hardware, and who have previously installed a Sun Fire Link assembly in the field. They are not complete instructions; they lack illustrations and precautions.

Note – When installing a new system, you can install the optical modules into the Sun Fire Link assembly either before or after you install that assembly into the chassis.

Installing a Fire Link Optical Module in a Sun Fire 6800 System

Each Fire Link optical module provides one optical link with a receive channel and a transmit channel. You can install a maximum of four optical modules per Sun Fire 6800 system: two Fire Link assemblies with two optical modules per assembly.

Fire Link optical modules are installed in slots labeled LINK 0 and LINK 2 in the Fire Link assembly.

1. **Attach an ESD wrist strap or foot strap, and connect the strap to the system.**
2. **Remove the filler panel, if installed.**
3. **Press the ejector lever down on the optical module.**

-
- 4. Hold the optical module by the two side edges or the front panel, and slide it into the slot between the two guides.**
The cutouts in the handle of the optical module must align with the square cutouts on the Sun Fire Link assembly.
 - 5. Push on the front panel to completely seat the optical module in the assembly.**
 - 6. Push the ejector lever in to lock the lever.**
You should feel it click.
 - 7. Tighten the two captive screws, one at each end of the optical module.**

Installing a Fire Link Optical Module in a Sun Fire 15K/12K System

Fire Link optical modules are installed in the two lower slots (labeled LINK 0 and LINK 2) in the Fire Link assembly.

- 1. Attach an ESD wrist strap or foot strap. Connect the strap to the system.**
- 2. Remove the filler panel, if installed.**
- 3. Press the ejector lever down on the optical module.**
- 4. Hold the optical module by the two side edges or the front panel and slide it into the slot in between the two guides.**
The cutouts in the handle of the optical module must align with the square cut outs on the Sun Fire Link assembly.
- 5. Push on the front panel to completely seat the optical module in the assembly.**
- 6. Push the handle in to lock the lever.**
You should feel it click.
- 7. Tighten the two captive screws, one at each end of the optical module.**

Copyright 2003 Sun Microsystems, Inc. All rights reserved. Use is subject to license terms. Third-party software, including font technology, is copyrighted and licensed from Sun suppliers. Portions may be derived from Berkeley BSD systems, licensed from U. of CA. Sun, Sun Microsystems, the Sun logo, Sun Fire, and Solaris are trademarks or registered trademarks of Sun Microsystems, Inc. in the U.S. and in other countries. All SPARC trademarks are used under license and are trademarks or registered trademarks of SPARC International, Inc. in the U.S. and in other countries. U.S. Government Rights—Commercial use. Government users are subject to the Sun Microsystems, Inc. standard license agreement and applicable provisions of the FAR and its supplements.

Copyright 2003 Sun Microsystems, Inc. Tous droits réservés. Distribué par des licences qui en restreignent l'utilisation. Le logiciel détenu par des tiers, et qui comprend la technologie relative aux polices de caractères, est protégé par un copyright et licencié par des fournisseurs de Sun. Des parties de ce produit pourront être dérivées des systèmes Berkeley BSD licenciés par l'Université de Californie. Sun, Sun Microsystems, le logo Sun, Sun Fire, et Solaris sont des marques de fabrique ou des marques déposées de Sun Microsystems, Inc. aux Etats-Unis et dans d'autres pays. Toutes les marques SPARC sont utilisées sous licence et sont des marques de fabrique ou des marques déposées de SPARC International, Inc. aux Etats-Unis et dans d'autres pays.



Sun Microsystems, Inc.
www.sun.com