



CERTANCE

Online User's Guide



© LTO-1/LTO-2 Tape Drives



Copyright and Trademarks

Copyright © 2003 by Certance LLC. All Rights Reserved.

Part Number 50001007

August 2003

Certance and the Certance logo are trademarks of Certance LLC. Seagate is a trademark of Seagate Technology LLC. Other product names are trademarks or registered trademarks of their respective owners.

Certance reserves the right to change, without notice, product offerings or specifications. No part of this publication may be reproduced in any form without written permission from Certance LLC.

Certance provides this manual "as is," without warranty of any kind, either expressed or implied, including, but not limited to, the implied warranties of merchantability and fitness for a particular purpose. Certance reserves the right to change, without notification, the specifications contained in this manual.

Certance assumes no responsibility for the accuracy, completeness, sufficiency, or usefulness of this manual, nor for any problem that might arise from the use of the information in this manual.

Warnings

All safety and operating instructions should be read before this product is operated, and should be retained for future reference. This unit has been engineered and manufactured to assure your personal safety. Improper use can result in potential electrical shock or fire hazards. In order not to defeat the safeguards, observe the following basic rules for installation, use and servicing.



CAUTION: This symbol should alert the user to the presence of “dangerous voltage” inside the product that might cause harm or electric shock.

Caution! Risk of electric shock! Do not open!

To reduce the risk of electric shock, do not remove the cover (or back). No user-serviceable parts are inside. Refer servicing to qualified service personnel.

- Heed warnings — All warnings on the product and in the operating instructions should be adhered to.
- Follow instructions — All operating and use instructions should be followed.
- Ventilation — The product should be situated so that its location or position does not interfere with proper ventilation.
- Heat — The product should be situated away from heat sources such as radiators, heat registers, furnaces, or other heat producing appliances.
- Power sources — The product should be connected to a power source only of the type directed in this document or as marked on the product.
- Power cord protection — The power cord should be routed so that it is not likely to be walked on or pinched by items placed upon or against it, paying particular attention to the cord at the wall receptacle, and the point where the cord exits from the product.
- To complete the disconnection of the electricity, please remove the power (electric) cord and the SCSI cable from their connections in the back of the product. The plugs should be placed near the product for easy access.
- Object and liquid entry — Care should be taken to insure that objects do not fall and liquids are not spilled into the product's enclosure through openings.
- Servicing — The user should not attempt to service the product beyond that described in the operating instructions. All other servicing should be referred to qualified service personnel.



Precautions

- Do not use oil, solvents, gasoline, paint thinners, or insecticides on the unit.
- Do not expose the unit to moisture or to temperatures higher than 151 °F (66 °C) or lower than -40 °F (-40°C).
- Keep the unit away from direct sunlight, strong magnetic fields, excessive dust, humidity, and electronic/electrical equipment, which generate electrical noise.
- Hold the power cord by the head when removing it from the AC outlet; pulling the cord can damage the internal wires.
- Use the unit on a firm level surface free from vibration, and do not place anything on top of the unit.

FCC Notice

This equipment generates and uses radio frequency energy and, if not installed and used properly — that is, in strict accordance with the manufacturer's instructions — may cause interference to radio communications or radio and television reception. It has been tested and found to comply with the limits for a Class B computing device in accordance with the specifications in Part 15 of FCC Rules, which are designed to provide reasonable protection against such interference in a residential installation. However, there is no guarantee that interference will not occur in a particular installation. If this equipment does cause interference to radio or television reception, which can be determined by turning the equipment on and off, you are encouraged to try to correct the interference by one or more of the following measures:

- Reorient the receiving antenna.
- Relocate the computer with respect to the receiver.
- Move the computer into a different outlet so that the computer and receiver are on different branch circuits.

If necessary, you should consult the dealer or an experienced radio/television technician for additional suggestions. You may find the booklet, *How to Identify and Resolve Radio-TV Interference Problems*, prepared by the Federal Communications Commission, helpful. This booklet (Stock No. 004-000-00345-4) is available from the U.S. Government Printing Office, Washington, DC 20402.



WARNING: Changes or modifications made to this equipment, which have not been expressly approved by Certance, may cause radio and television interference problems that could void the user's authority to operate the equipment.

Further, this equipment complies with the limits for a Class B digital apparatus in accordance with Canadian Radio Interference Regulations.

Cet appareil numérique de la classe B est conforme au Règlement sur brouillage radioélectrique, C. R. C., ch. 1374.

The desktop device drive described in this manual requires shielded interface cables to comply with FCC emission limits.



WARNING: To prevent fire or electrical shock hazard, do not expose the unit to rain or moisture.

To avoid electrical shock, do not open the cabinet.
Refer servicing to qualified personnel.

Contents

Chapter 1 - Introduction	10
Features	11
Using This Guide	12
Chapter 2 - Installation (and Quick Start)	13
Introduction	13
Quick Start Guide	13
Unpacking and Inspection	15
Internal Tape Drive Guidelines and Cautions	15
Drive Installation Instructions	16
Installing an Internal LTO-1 or LTO-2 Drive	16
Installing an Internal LTO-1 Fibre Channel Drive	23
Installing a Desktop Drive	28
Chapter 3 - Operation	31
Understanding the Front Panel Display	31
Blink Codes	32
Using LTO Cartridges	34
Drive Maintenance	36
Parking the Drive for Shipping	37
Chapter 4 - Theory	38
Track Layout	38
Recording Method	39
Data Buffer	40
Data Integrity	40
Data Compression	42
Chapter 5 - Specifications	44
Physical Specifications	44
Power Specifications	47
Drive Performance Specifications	48
Environmental Requirements	49
Reliability	50

Mean Time Between Failures	50
LTO Cartridge Specifications	51
Regulatory Compliance	52
Chapter 6 - Unix Settings	55
A Word About SCSI Controllers	55
Configuring for the DEC/Compaq Unix Environment	56
Configuring for the Sun Environment (Solaris 2.4, 2.5, 2.6, 7, 8, and 9)	57
Configuring for the IBM AIX Environment (AIX Version 4.1.x and later)	59
Configuring for SCO Open Server 5.0.x	60
Configuring for Linux	62
Configuring for SGI Irix	63
Configuring for HP-UX 11.0	64
Chapter 7 - Interfaces	65
Parallel SCSI Interface	65
Fibre Channel Interface	66
Commands	66
Typical System Configurations	68
Chapter 8 - Troubleshooting Guide	70
Installation Best Practices	70
Troubleshooting Suggestions	71
Emergency Reset and Emergency Cartridge Eject	75
Manually Removing a Cartridge	76

List of Figures

Figure 1. Drives Covered in this User's Guide	10
Figure 2. Connector Labels	16
Figure 3. Internal LTO-1 and LTO-2 Drive Jumper Settings	17
Figure 4. Acceptable Mounting Orientations.....	19
Figure 5. Internal LTO-1 and LTO-2 Drive Mounting Dimensions	19
Figure 6. Rear View of the Internal LTO-1 (left) and LTO-2 (right) Drives.....	20
Figure 7. Two SCSI Termination Examples for the Internal LTO-1 and LTO-2 Drives	21
Figure 8. Connectors and Jumpers on the Back of the LTO-1 FC Drive	23
Figure 9. Acceptable Mounting Orientations.....	24
Figure 10. Internal LTO-1 FC Drive Mounting Dimensions	25
Figure 11. FC Optical Connectors on the Back of the Internal LTO-1 FC Drive	26
Figure 12. FC Serial Connector on the Back of the Internal LTO-1 FC Drive.....	26
Figure 13. Power Connector on the Back of the Internal LTO-1 FC Drive.....	27
Figure 14. Switches and Connectors on the Back of Desktop LTO-1 and LTO-2 Drives..	28
Figure 15. SCSI Termination Examples for the Desktop LTO-1 and LTO-2 Tape Drives ..	29
Figure 16. Generic Front Panel Display	31
Figure 17. Ultrium Cartridge Showing Write-protect Switch	35
Figure 18. Layout of tracks on LTO Ultrium tape	38
Figure 19. Internal LTO-1 and LTO-2 HVD/LVD Drive Dimensions.....	45
Figure 20. Internal LTO-1 Fibre Channel Drive Dimensions.....	46
Figure 21. Diagram of LTO-1 and LTO-2 Drives with Leader Pin Inside LTO Cartridge (Tape Not Threaded on Take-up Hub).....	77
Figure 22. LTO-1 and LTO-2 Drive Worm Gear.....	78
Figure 23. LTO-1 and LTO-2 Drive Key Components	79
Figure 24. LTO-1 and LTO-2 Drive Lead Screw (Tape Threaded on Take-up Reel)	80
Figure 25. Underside of LTO-1 and LTO-2 Drives Showing Supply Motor Access Hole .	81
Figure 26. LTO-1 and LTO-2 drives Showing the Tape Grabber Near the Cartridge	82
Figure 27. LTO-1 and LTO-2 Drive Worm Gear.....	83

List of Tables

Table 1. SCSI IDs and Jumper Settings for LTO-1 and LTO-2 Drives.....	18
Table 2. Serial Interface Connector Pin Assignments	21
Table 3. Loop IDs and Corresponding Jumper Settings	24
Table 4. Serial Interface Connector Pin Assignments	26
Table 5. LTO-1 Tape Drive Blink Codes	32
Table 6. LTO-2 Tape Drive Blink Codes	33
Table 7. LTO-1 and LTO-2 Physical Specifications.....	44
Table 8. Voltage and Current.....	47
Table 9. Power Dissipation	47
Table 10. Drive Performance Specifications	48
Table 11. Environmental Requirements	49
Table 12. Reliability.....	50
Table 13. Environmental Tolerances.....	51
Table 14. Safety Compliance.....	52
Table 15. Electromagnetic Compatibility	53
Table 16. SCSI Controllers	55
Table 17. SCSI Message Codes.....	65
Table 18. Supported SCSI Codes and Corresponding Commands.....	67
Table 19. Tape Alert Flags	68

1. Introduction

The LTO-1 and LTO-2 are high-performance 8-channel tape drives that comply with the LTO interchange specifications. Both drives are suited for mid-range to high-end servers, mainframe systems, and tape library automation systems.

Both drives use Ultrium data cartridges. Their capacity is maximized using intelligent data compression.

- The LTO-1 drive has a native capacity of 100 Gbytes (200 Gbytes assuming 2:1 data compression).
- The LTO-2 drive has a native capacity of 200 Gbytes (400 Gbytes assuming 2:1 data compression).

The LTO-1 and LTO-2 drives have a 5¼ inch full height form factor, with automatic electromechanical cartridge soft load. Both drives are available as internal and desktop drives.

- The internal LTO-1 and LTO-2 drives are designed to fit in a 5¼-inch full-height drive bay.
- The desktop LTO-1 and LTO-2 drives are standalone units with built-in power supply.

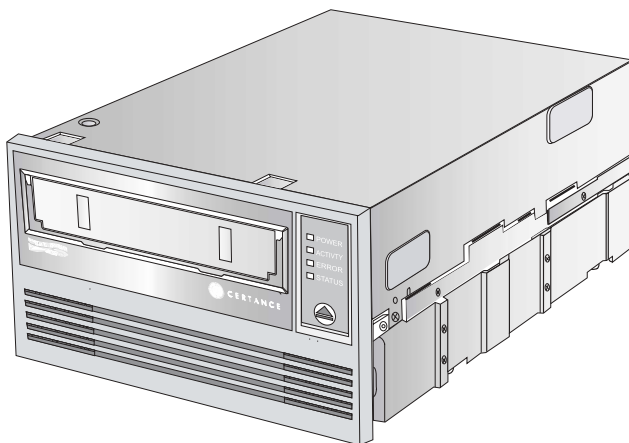

LTO-1 and LTO-2 Drives

Figure 1. Drives Covered in this User's Guide

Features

The following list summarizes the key features of the LTO-1 and LTO-2 drives.

- Performance
 - LTO-1: Up to 16 Mbytes-per-second native transfer.
 - LTO-2: Up to 34 Mbytes-per-second native transfer.
- FastSense™ — optimizes data transfers, resulting in shorter backup times and increased reliability.
- Two convenient form-factors:
 - 5¼-inch internal form-factor for installation in a 5¼-inch half-height space.
 - External desktop form-factor.
- Intelligent data compression maximizes performance and capacity by analyzing compressibility prior to recording.
- SCSI and Fibre Channel interfaces.
- Cartridge memory enables fast loading of cartridges and stores pertinent information about the media.
- 64-Mbyte data buffer for extra fast backups on high-performance systems.
- Tape Alert drive performance monitoring and reporting.
- 3rd generation read channel for increased maturity and data integrity.
- Patented head positioner for increased data integrity.
- Shock dampened isolated chassis.
- Managed airflow dynamics with isolated HTI chamber.
- Two levels of ECC for extra data safety and protection from errors.
- Reliable tape picking implementation for increased reliability.
- Custom-designed LSI circuitry for fast, efficient data processing.
- RISC processors for fast, efficient data processing.
- Supports native firmware of a wide variety of UNIX platforms.
- Remote diagnostics through monitoring and testing capabilities.
- Support for SCSI-2 and some SCSI-3 instructions.

Using This Guide

This User's Guide describes how to install, configure, and care for the LTO-1 and LTO-2 desktop and internal tape drives. Please read the appropriate chapters and appendixes carefully, and keep this Guide handy for future reference.

- **Chapter 1, Introduction** provides an overview of LTO and Ultrium technology, and summarizes the drive's key features.
- **Chapter 2, Installation** describes handling precautions, unpacking tips, and installation instructions for the internal and desktop drives, as well as a summary of cabling and connector specifications. It also provides quick-start instructions for getting the drives up and running in the shortest possible time.
- **Chapter 3, Operation** explains the use and operation of the drive and describes maintenance procedures, including drive "parking."
- **Chapter 4, Theory** describes the theory of operation behind the drives, including the technology used in various drive components.
- **Chapter 5, Specifications** contains detailed drive and cartridge specifications, as well as a summary of regulatory approvals.
- **Chapter 6, Unix Settings** describes the settings for Unix systems.
- **Chapter 7, Fibre Channel** describes the Fibre Channel settings for the LTO-1 drive.
- **Chapter 8, Troubleshooting Guide** provides troubleshooting procedures you can follow in the unlikely event you encounter a problem with your drive.

2. Installation (and Quick Start)

Introduction

This chapter explains how to install the Internal LTO-1 and LTO-2 and desktop drives.

Topics covered in this chapter are:

- “Quick Start Guide” on page 13
- “Unpacking and Inspection” on page 15
- “Internal Tape Drive Guidelines and Cautions” on page 15
- “Installing an Internal LTO-1 or LTO-2 Drive” on page 16
- “Installing an Internal LTO-1 Fibre Channel Drive” on page 23
- “Installing a Desktop Drive” on page 28

Quick Start Guide

Use the following quick-start instructions to get your tape drive up and running as quickly as possible.

Internal LTO-1 and LTO-2 Tape Drive Quick Start

Use the following procedure to install internal LTO-1 and LTO-2 tape drives. Print this page and check each step as you complete it. If you need more information about a step, turn to the section referenced in the step.

- 1.** *Unpack the contents of your drive package, and check for missing or damaged items. See “Unpacking and Inspection” on page 15.*
- 2.** *Review the drive’s default settings and change them if necessary:*
 - *SCSI ID: 6*
 - *Terminator Power: Disabled**See “Configuring an HVD or LVD Drive” on page 17.*
- 3.** *Turn off your computer, remove its covers and power cable, and select a mounting bay for the drive. See “Mounting an Internal HVD or LVD Drive” on page 19.*
- 4.** *Connect a SCSI interface cable to the drive. See “Connecting a SCSI Cable” on page 20.*
- 5.** *Terminate the SCSI bus if the internal tape drive is the last device on the SCSI bus. See “Checking the SCSI Termination” on page 20.*

- 6.** Connect a serial cable, if connecting the tape drive to a tape library.
See "Connecting a Serial Cable for Tape Libraries" on page 21.
- 7.** Connect a power cable to the drive.
See "Connecting a Power Cable" on page 22.
- 8.** Replace the computer covers and power cable, turn on the computer, and verify that the internal tape drive is operating properly.
- 9.** If you intend to use your drive with Microsoft Windows Server 2003, Windows XP, or Windows 2000, install the appropriate LTO driver.
See "Installing the LTO Driver" on page 22.
- 10.** Register your tape drive.
See "Registering Your Tape Drive" on page 22.

Internal LTO-1 Fibre Channel Tape Drive Quick Start

Use the following procedure to install an internal LTO-1 Fibre Channel tape drive. Print this page and check each step as you complete it. If you need more information about a step, turn to the section referenced in the step.

- 1.** Unpack the contents of your drive package, and check for missing or damaged items.
See "Unpacking and Inspection" on page 15.
- 2.** Review the drive's default settings and change them if necessary:
 - Loop ID: 0000000See "Configuring the Internal Fibre Channel Drive" on page 23.
- 3.** Turn off your computer, remove its covers and power cable, and select a mounting bay for the drive.
See "Mounting the Internal FC Drive" on page 24.
- 4.** Connect a Fibre Channel LC interface cable to the drive.
See "Connecting a Fibre Channel Cable" on page 25.
- 5.** Connect a serial cable, if connecting the tape drive to a tape library.
See "Connecting a Serial Cable for Tape Libraries" on page 26.
- 6.** Connect a power cable to the drive.
See "Connecting a Power Cable" on page 27.
- 7.** Replace the computer covers and power cable, turn on the computer, and verify that the internal tape drive is operating properly.
- 8.** If you intend to use your drive with Microsoft Windows Server 2003, Windows XP, or Windows 2000, install the appropriate LTO driver.
See "Installing the LTO Driver" on page 27.
- 9.** Register your tape drive.
See "Registering Your Tape Drive" on page 27.

Desktop LTO-1 and LTO-2 Tape Drive Quick Start

Use the following procedure to install desktop LTO-1 and LTO-2 tape drives. Print this page and check each step as you complete it. If you need more information about a step, turn to the section referenced in the step.

- 1.** *Unpack the contents of your drive package, and check for missing or damaged items. See "Unpacking and Inspection" on page 15.*
- 2.** *Review the drive's default settings and change them if necessary:*
 - *SCSI ID: 6**See "Setting the SCSI ID" on page 28.*
- 3.** *Connect a SCSI interface cable to the drive. See "Connecting a SCSI Cable" on page 29.*
- 4.** *Check the SCSI termination. See "Checking the SCSI Termination" on page 29.*
- 5.** *Connect a power cable to the drive. See "Connecting a Power Cord" on page 30.*
- 6.** *Turn on the computer, turn on the desktop tape drive, and verify that the desktop tape drive is operating properly.*
- 7.** *If you intend to use your drive with Microsoft Windows Server 2003, Windows XP, or Windows 2000, install the appropriate LTO driver. See "Installing the LTO Driver" on page 30.*
- 8.** *Register your tape drive. See "Registering Your Tape Drive" on page 30.*

Unpacking and Inspection

Although drives are inspected and carefully packaged at the factory, damage may occur during shipping. Follow these steps for unpacking the drive.

- 1.** Visually inspect the shipping containers and notify your carrier immediately of any damage.
- 2.** Place shipping containers on a flat, clean, stable surface; then carefully remove and verify the contents against the packing list. If parts are missing or the equipment is damaged, notify your Certance representative.
- 3.** Always save the containers and packing materials for any future reshipment.

Internal Tape Drive Guidelines and Cautions

The following guidelines and cautions apply to handling and installing internal tape drives. Keep them in mind as you install the drive.

- Handle the drive by the sides rather than by the top cover to reduce the risk of dropping the drive or damaging it during installation.
- Internal drives contain some exposed components that are sensitive to static electricity. To reduce the possibility of damage from static discharge, the drives are shipped in a protective antistatic bag. Do not remove the drive from the antistatic bag until you are ready to install it.

- Before you remove the drive from the antistatic bag, touch a metal or grounded surface to discharge any static electricity buildup from your body.
- Always lay the drive either on top of the antistatic bag or place it inside of the bag to reduce the chance of damage from static discharge.
- Install HVD drives only in an HVD environment, Fibre Channel drives only in a Fibre Channel environment, and LVD drives only in an LVD environment. Do not mix HVD and LVD devices on the same SCSI bus. Look at the label above the drive's SCSI connector to determine whether the drive is an HVD or an LVD model (see Figure 2 on page 16):



Figure 2. Connector Labels

- Due to the speed of the LTO-2 drive, it is recommended that a maximum of one LTO-2 drive be connected to one host SCSI adapter. In a switched Fibre Channel environment, the maximum number of drives that can be used simultaneously depends on the bandwidth of the loop.

Drive Installation Instructions

After unpacking and inspecting your shipping containers and reviewing the installation guidelines and cautions, proceed to the appropriate section in this chapter for instructions on installing your LTO-1 or LTO-2 tape drive.

- If you have an internal LTO-1 or LTO-2 tape drive, go to “Installing an Internal LTO-1 or LTO-2 Drive” on page 16.
- If you have an internal LTO-1 Fibre Channel tape drive, go to “Installing an Internal LTO-1 Fibre Channel Drive” on page 23.
- If you have a desktop LTO-1 or LTO-2 tape drive, go to “Installing a Desktop Drive” on page 28.

Installing an Internal LTO-1 or LTO-2 Drive

Installing an internal LTO-1 or LTO-2 tape drive with an Ultra2 SCSI LVD or Ultra SCSI HVD interface involves the following steps:

1. “Configuring an HVD or LVD Drive” on page 17
2. “Mounting an Internal HVD or LVD Drive” on page 19
3. “Connecting a SCSI Cable” on page 20
4. “Checking the SCSI Termination” on page 20
5. “Connecting a Serial Cable for Tape Libraries” on page 21
6. “Connecting a Power Cable” on page 22
7. “Registering Your Tape Drive” on page 22

If you have a Fibre Channel drive, refer to “Installing an Internal LTO-1 Fibre Channel Drive” on page 23.

Configuring an HVD or LVD Drive

Before you install the HVD or LVD tape drive in your computer, you may need to configure the drive's SCSI ID and terminator power features. The default configuration settings for the LTO-1 and LTO-2 drives are:

- SCSI ID: 6
- Terminator power: disabled

If you need to change these settings, refer to the following sections. Otherwise, skip to "Mounting an Internal HVD or LVD Drive" on page 19.

SCSI ID

Jumper Pins: 1-2, 3-4, 5-6, 7-8

Default Setting: SCSI ID 6

Each SCSI device on the bus must have its own unique SCSI ID. The internal tape drive is shipped with a default SCSI ID of 6. If another SCSI device in the SCSI chain is using this ID, use jumper pins 1-2, 3-4, 5-6, and 7-8 to change the SCSI ID of the LTO-1 or LTO-2 drive (see Figure 3 on page 17 and Table 1 on page 18), or assign a unique SCSI ID to the other SCSI device.



NOTE: The SCSI controller or host adapter generally uses ID 7. In some systems, the boot drive uses ID 0 or ID 1. Avoid setting your drive's SCSI ID to these settings.

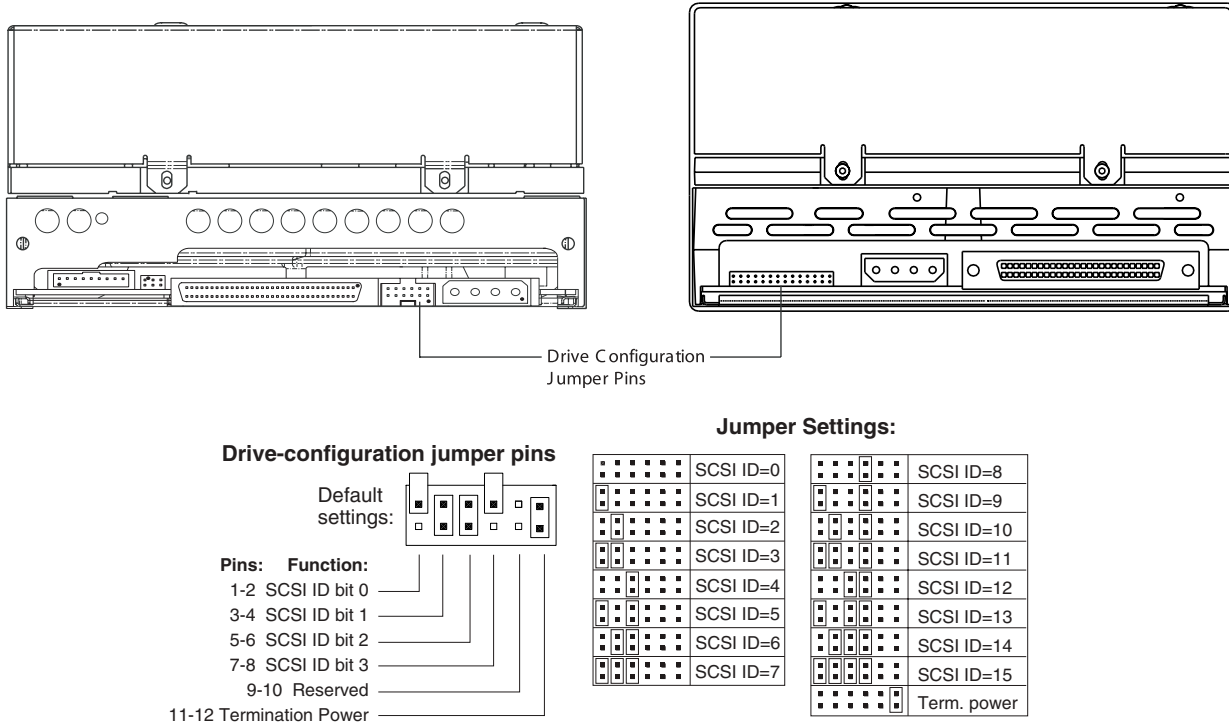

Figure 3. Internal LTO-1 and LTO-2 Drive Jumper Settings

Table 1. SCSI IDs and Jumper Settings for LTO-1 and LTO-2 Drives

SCSI ID	Jumpers			
	1-2	3-4	5-6	7-8
0	Open	Open	Open	Open
1	Shunted	Open	Open	Open
2	Open	Shunted	Open	Open
3	Shunted	Shunted	Open	Open
4	Open	Open	Shunted	Open
5	Shunted	Open	Shunted	Open
6 (default)	Open	Shunted	Shunted	Open
8	Open	Open	Open	Shunted
9	Shunted	Open	Open	Shunted
10	Open	Shunted	Open	Shunted
11	Shunted	Shunted	Open	Shunted
12	Open	Open	Shunted	Shunted
13	Shunted	Open	Shunted	Shunted
14	Open	Shunted	Shunted	Shunted
15	Shunted	Shunted	Shunted	Shunted

Terminator Power

By default, terminator power is disabled on internal LTO-1 and LTO-2 tape drives. To enable terminator power, place a jumper across pins 11 and 12.



NOTE: The internal LTO-1 and LTO-2 drives do not provide SCSI termination. Thus, a terminator must be installed on the drive if it is the last device in a SCSI chain.

Mounting an Internal HVD or LVD Drive

You can mount the internal LTO-1 and LTO-2 drives either horizontally or vertically, with the drives left side facing up (see Figure 4 on page 19).

- If you mount the drive vertically, the left side of the drive must face up and the side of the drive should be within 5 degrees of horizontal.
- If you mount the drive horizontally, the base of the drive must be within 15 degrees of horizontal and the PCB side of the drive must face down.

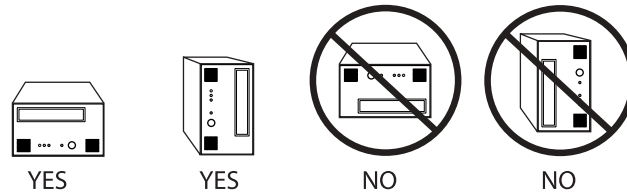

Figure 4. Acceptable Mounting Orientations

Mount the drive in a 5.25-inch, full-height drive bay and secure it using two M3.0 X 5 metric screws on each side of the drive. Do not use screws longer than 5 mm or you may damage the drive. Figure 5 on page 19 shows the locations of the mounting-screw holes on the side and bottom of the drive, respectively.

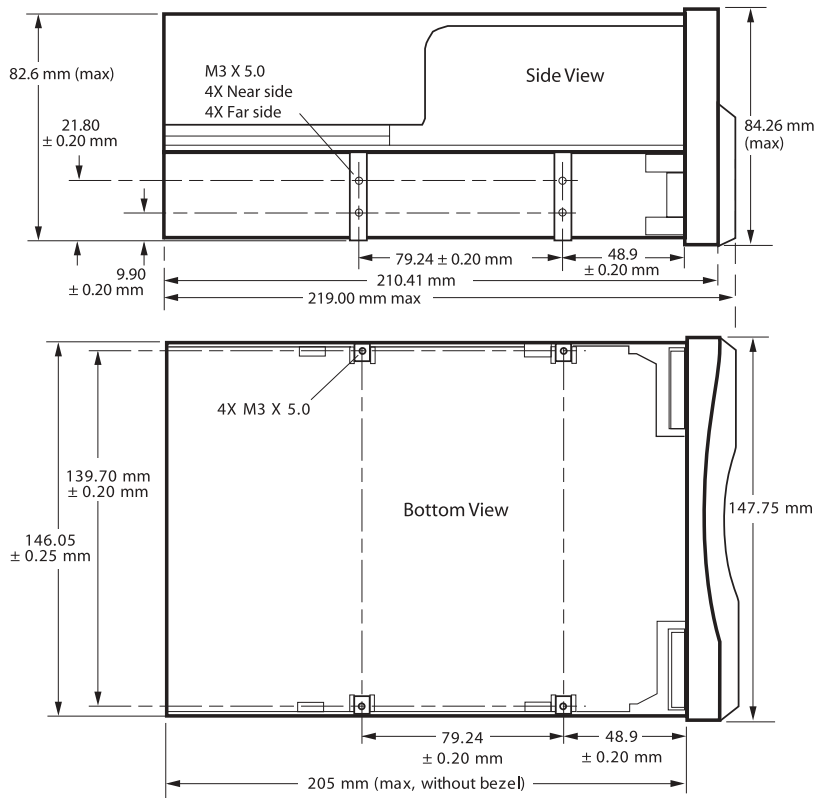

Figure 5. Internal LTO-1 and LTO-2 Drive Mounting Dimensions

Connecting a SCSI Cable

The internal LTO-1 and LTO-2 drives have an Ultra2 SCSI interface, terminated by either a 68-pin HVD or LVD SCSI connector. Use the following procedure to connect a SCSI cable to this connector.

1. Turn off all power to the drive and the computer.
2. Attach the SCSI interface cable to the 68-pin SCSI interface connector on the back of the drive (see Figure 6 on page 20).

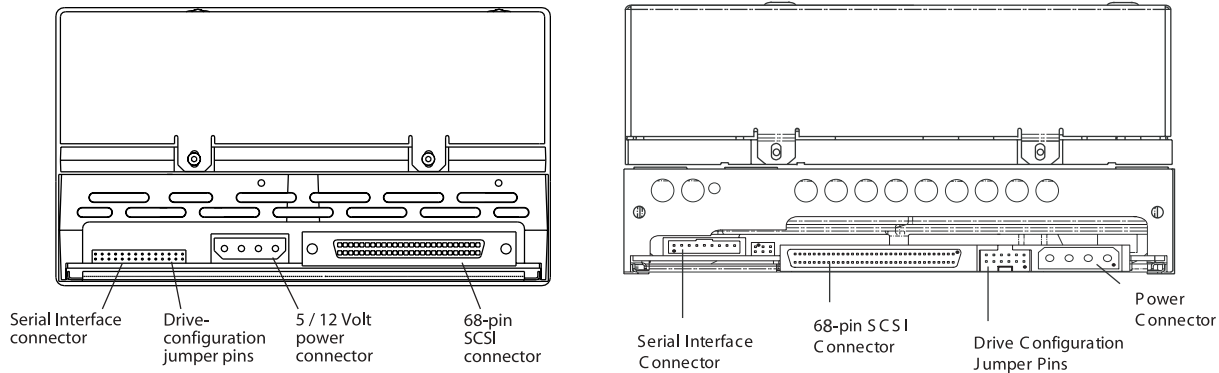

Figure 6. Rear View of the Internal LTO-1 (left) and LTO-2 (right) Drives



CAUTION: Install an HVD drive only in an HVD environment and an LVD drive only in an LVD environment. Look at the label above the drive's SCSI connector to determine if the drive is an HVD or an LVD model (see Figure 2 on page 16). Plugging an HVD drive into an LVD bus, or vice versa, makes the entire bus non-functional and may permanently damage the drive or other SCSI devices on the bus.

Checking the SCSI Termination

By default, the Internal LTO-1 and LTO-2 drives do not provide SCSI termination. If you use this default setting, you must place a SCSI bus terminator or a SCSI device with termination enabled at the end of the SCSI chain. Two examples of SCSI termination are shown in Figure 7 on page 21.

The Internal LTO-1 and LTO-2 drives will provide terminator power if a jumper is placed on the termination power jumper pins (see "Terminator Power" on page 18).

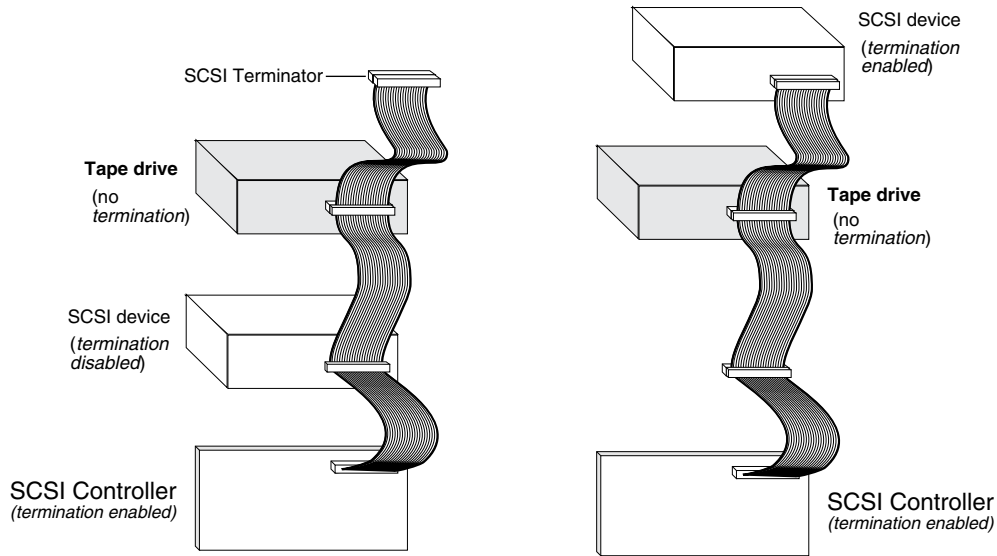

Figure 7. Two SCSI Termination Examples for the Internal LTO-1 and LTO-2 Drives

Connecting a Serial Cable for Tape Libraries

The Internal LTO-1 and LTO-2 drives include an RS-422 serial interface for tape libraries. This connector is located on the lower left side of the back of the drive (see Figure 6 on page 20).

Table 2 on page 21 shows the pin descriptions for the serial interface connector. The pins on this connector are set on 2-millimeter centers.

Table 2. Serial Interface Connector Pin Assignments

Pin Numbers	Description
1 through 8	Reserved (do not use)
9	Lib RXD-P (input to drive)
10	GND
11	Lib RXD-N (input to drive)
12	GND
13	Lib TXD-P (output from drive)
14	GND
15	Lib TXD-N (output from drive)
16	GND

Connecting a Power Cable

Attach a four-pin power cable to the power connector on the back of the drive. Figure 6 on page 20 shows the location of the power connector.

The recommended 4-pin power connector for internal drives is an AMP 1-48024-0 housing with AMP 60617-1 pins or equivalent.

Installing the LTO Driver

If you intend to use your drive with the Microsoft native backup applet on Windows Server 2003, Windows XP, or Microsoft Windows 2000 operating system, install the appropriate LTO driver. See the Tape Resource CD. This driver is not necessary with commercial backup application software.

Registering Your Tape Drive

After you install the internal tape drive, be sure to register it. Registering your drive ensures that you will receive the latest information about your drive, as well as other product, service, and support information. For your convenience, you can register your drive either through our Web site or by fax.

- If you have an Internet connection, please visit www.certance.com and select "Product Registration" from the "Products" menu.
- If you do not have an Internet connection, complete the Registration Card included with your package and either mail or fax it to the address or fax number on the Card.

Installing an Internal LTO-1 Fibre Channel Drive

This section describes how to install an internal LTO-1 drive equipped with a Fibre Channel LC Optical (FC) interface. Installing an internal LTO-1 FC drive involves the following steps:

1. "Configuring the Internal Fibre Channel Drive" on page 23
2. "Mounting the Internal FC Drive" on page 24
3. "Connecting a Fibre Channel Cable" on page 25
4. "Connecting a Serial Cable for Tape Libraries" on page 26
5. "Connecting a Power Cable" on page 27
6. "Registering Your Tape Drive" on page 27

Configuring the Internal Fibre Channel Drive

Before you install the tape drive in your computer, you may need to configure the drive's hard-assigned loop identifier. Jumpers located on the back of the drive (see Figure 8 on page 23) are used to configure the ID.

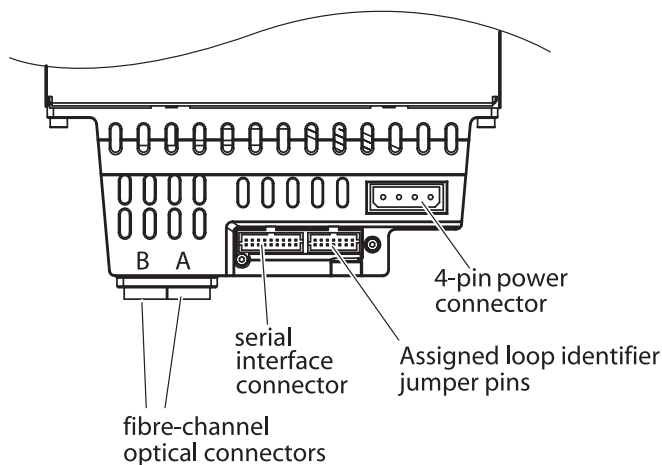

Figure 8. Connectors and Jumpers on the Back of the LTO-1 FC Drive

Loop ID

Jumper Pins: 13-14, 11-12, 9-10, 7-8, 5-6, 3-4, 1-2

Default Setting: Loop ID 0000000

By default, the LTO-1 internal FC drive uses Loop ID 0000000 (no jumpers in place). You can change this Loop ID by placing jumpers on jumper pins 13-14, 11-12, 9-10, 7-8, 5-6, 3-4, 1-2.

Table 3. Loop IDs and Corresponding Jumper Settings

Loop ID	Jumpers						
	13-14	11-12	9-10	7-8	5-6	3-4	1-2
0 (default)	Open	Open	Open	Open	Open	Open	Open
1	Shunted	Open	Open	Open	Open	Open	Open
2	Open	Shunted	Open	Open	Open	Open	Open
3	Shunted	Shunted	Open	Open	Open	Open	Open
4	Open	Open	Shunted	Open	Open	Open	Open
5	Shunted	Open	Shunted	Open	Open	Open	Open
6	Open	Shunted	Shunted	Open	Open	Open	Open
...							
125	Shunted	Shunted	Shunted	Shunted	Shunted	Open	Shunted



NOTE: Setting an invalid ID (7Fh or 7Eh) causes the drive not to participate in LHA and to instead attempt to acquire an address during the LISA (soft address) phase of IIP.

Mounting the Internal FC Drive

You can mount the internal FC drive either horizontally or vertically, with the drive's left side facing up (see Figure 9 on page 24).

- If you mount the drive vertically, the left side of the drive must face up and the side of the drive should be within 5 degrees of horizontal.
- If you mount the drive horizontally, the base of the drive must be within 15 degrees of horizontal and the PCB side of the drive must face down.

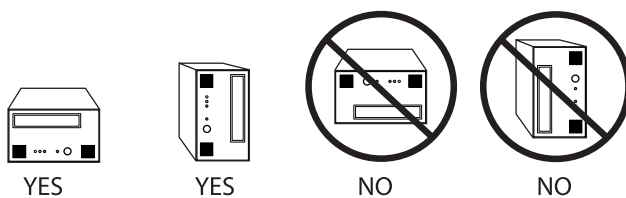

Figure 9. Acceptable Mounting Orientations

Mount the drive in a 5.25-inch, full-height drive bay and secure it using two M3.0 X 5 metric screws on each side of the drive. Do not use screws longer than 5 mm or you may damage the drive. Figure 10 on page 25 shows the locations of the mounting-screw holes on the side and bottom of the drive, respectively.

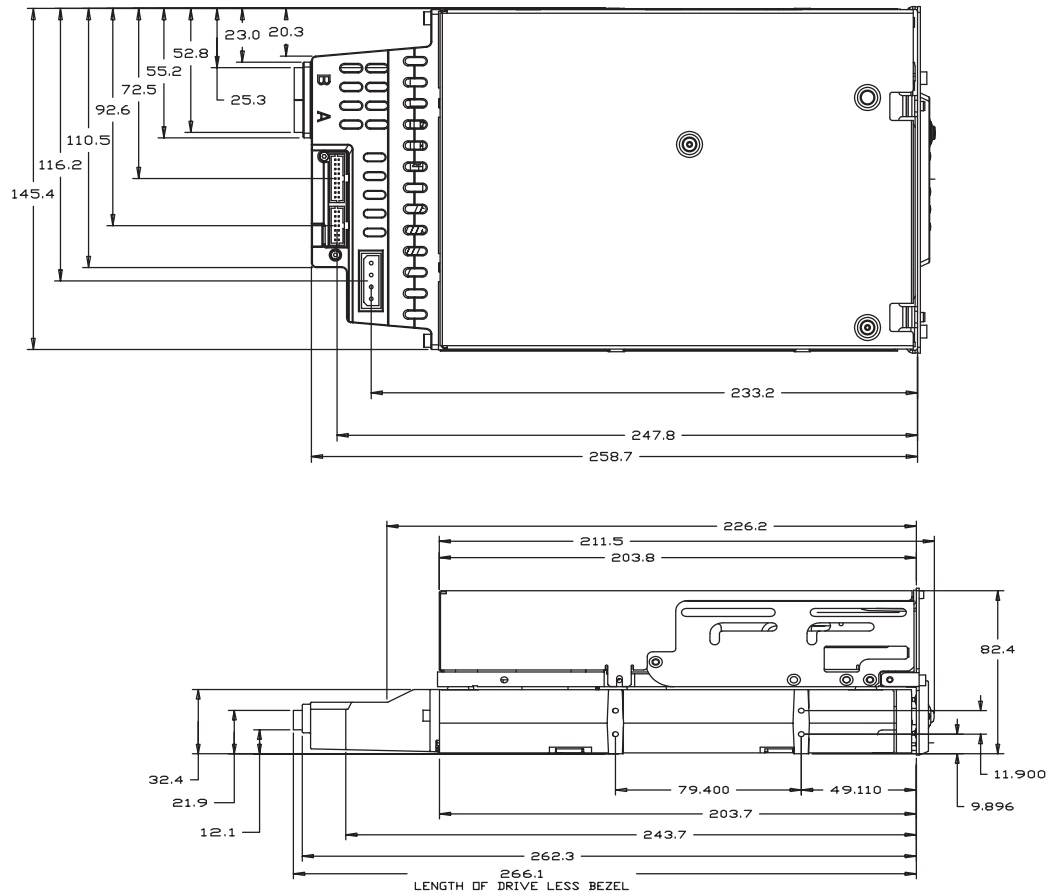

Figure 10. Internal LTO-1 FC Drive Mounting Dimensions

Connecting a Fibre Channel Cable

The internal LTO-1 FC drive has two FC connectors that can connect to either a hub or a switch. In systems that support failover, both FC connectors can be used to allow hosts to maintain a connection with the drive if one connection fails. The internal LTO-1 FC drive is 100-M5-SN-I compliant and uses LC style connectors. Either 50 or 62.5µm multimode optical fiber cables can be used.

1. Turn off all power to the drive and the computer.
2. Attach the interface cable to either of the two LC optical interface connectors on the back of the drive (labeled A and B in Figure 11 on page 26).
3. In systems that support “failover,” connect the other port through separate loops or fabrics to the same set of host computers. This way, if one connection fails, the other can be used to continue the data transfer.

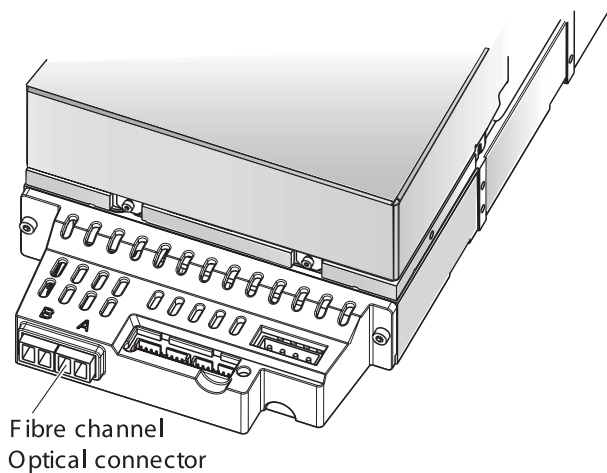

Figure 11. FC Optical Connectors on the Back of the Internal LTO-1 FC Drive

Connecting a Serial Cable for Tape Libraries

The Internal LTO-1 FC drive includes an RS-422 serial interface for tape libraries. This connector is located on the lower left side of the back of the drive (see Figure 12 on page 26).

Table 4 on page 26 shows the pin descriptions for the serial interface connector. The pins on this connector are set on 2-millimeter centers. The drive uses pin 1 to detect the presence of a tape library. The serial interface cable must connect this pin to the adjacent pin 3.

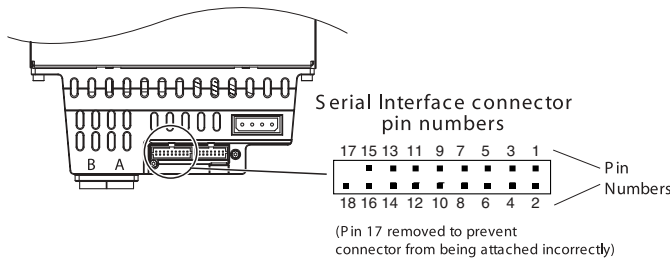

Figure 12. FC Serial Connector on the Back of the Internal LTO-1 FC Drive

Table 4. Serial Interface Connector Pin Assignments

Pin Numbers	Description
1	Library detect (cable should connect pin 1 to pin 3)
2	Lib TXn (output from drive, transmit negative)
3	GND
4	Lib TXp (output from drive, transmit positive)
5	GND
6	Lib RXn (input to drive, receive negative)
7	GND

Table 4. Serial Interface Connector Pin Assignments (Continued)

Pin Numbers	Description
8	<i>Lib RXP (input to drive, receive positive)</i>
9 through 18	<i>Reserved (do not use)</i>

Connecting a Power Cable

Attach a four-pin power cable to the power connector on the back of the drive. Figure 13 on page 27 shows the location of the power connector on internal LTO-1 FC drive. The recommended 4-pin power connector is an AMP 1-48024-0 housing, with AMP 60617-1 pins or equivalent.

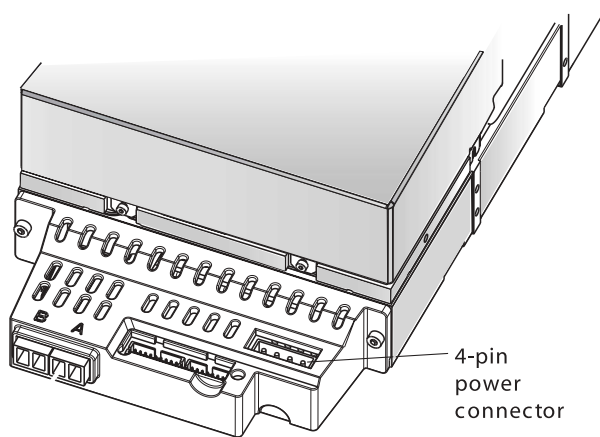

Figure 13. Power Connector on the Back of the Internal LTO-1 FC Drive

Installing the LTO Driver

If you intend to use your drive with the Microsoft Windows Server 2003, Windows XP, or Microsoft Windows 2000 operating system, install the LTO-1 FC driver. See the Tape Resource CD. This driver is not necessary with commercial backup application software.

Registering Your Tape Drive

After you install the internal FC tape drive, be sure to register it. Registering your drive ensures that you will receive the latest information about your drive, as well as other product, service, and support information. For your convenience, you can register your drive either through our Web site or by fax.

- If you have an Internet connection, please visit www.certance.com and select "Product Registration" from the "Products" menu.
- If you do not have an Internet connection, complete the Registration Card included with your package and either mail or fax it to the address or fax number on the Card.

Installing a Desktop Drive

The desktop LTO-1 and LTO-2 tape drives) are compact subsystems that connect to the host computer through a SCSI port. Installing a desktop drive involves the following steps:

1. "Setting the SCSI ID" on page 28
2. "Connecting a SCSI Cable" on page 29
3. "Checking the SCSI Termination" on page 29
4. "Connecting a Power Cord" on page 30
5. "Registering Your Tape Drive" on page 30

Setting the SCSI ID

Each SCSI device on the bus must have its own unique SCSI ID. The desktop tape drive is shipped with a default SCSI ID of 6. Avoid setting drive ID to 7. If another SCSI device in the SCSI chain is already using this ID, either use the push-button switch on the back of the drive to change the drive's SCSI ID (see Figure 14 on page 28) or assign a unique SCSI ID to the other SCSI device.

If you change the SCSI ID on the tape drive, turn off the tape drive before changing the SCSI ID. The change takes effect when you turn on the drive.



NOTE: The SCSI controller or host adapter generally uses ID 7. In some systems, the boot drive uses ID 0 or ID 1. Avoid setting your drive's SCSI ID to these settings.

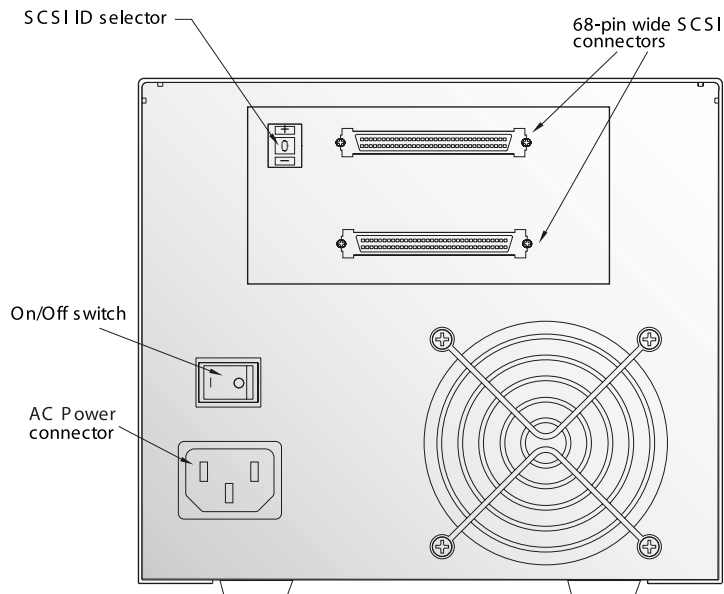

Figure 14. Switches and Connectors on the Back of Desktop LTO-1 and LTO-2 Drives

Connecting a SCSI Cable

The desktop LTO-1 and LTO-2 drives have two 68-pin, shielded SCSI interface connectors (ANSI Alternative 2) on the rear panel (see Figure 14 on page 28). These connectors consist of two rows of ribbon contacts spaced 2.16 mm (0.085 in) apart. Either connector can be used as a SCSI IN or SCSI OUT connection. This means you can use either connector to attach the drive to a host computer or to another SCSI device.

1. Turn off all power to the drive and the computer.
2. Attach the SCSI interface cable to one of the 68-pin SCSI interface connectors on the back of the drive (see Figure 14 on page 28).

Checking the SCSI Termination

If the desktop LTO-1 or LTO-2 drive is the last or only device in a SCSI chain, install a terminating plug on the unused SCSI connector. See Figure 15 on page 29 for two SCSI termination examples. You can purchase appropriate terminating plugs on the Internet at <http://shop.certance.com> (U.S. only).



NOTE: Termination power is enabled as a default for desktop drives.

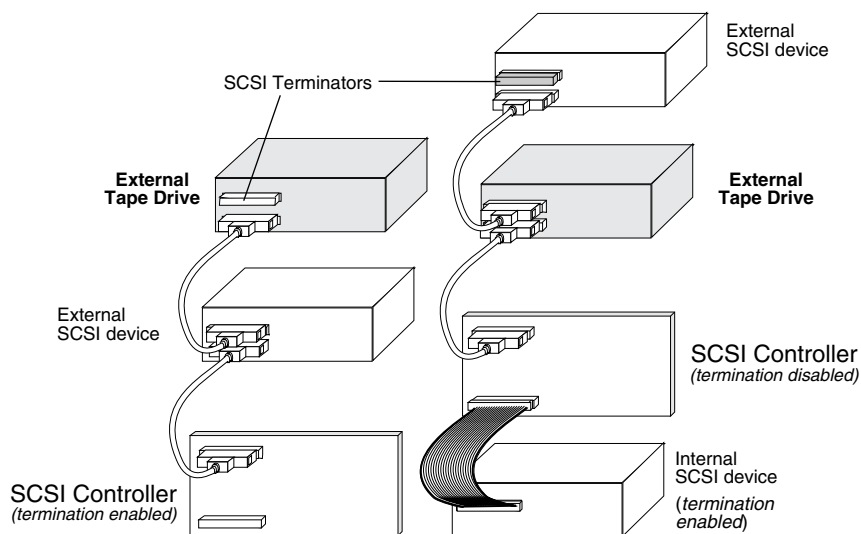

Example 1: SCSI termination in a system that has only external SCSI devices.

Example 2: SCSI termination in a system that has both internal and external SCSI devices.

Figure 15. SCSI Termination Examples for the Desktop LTO-1 and LTO-2 Tape Drives

Connecting a Power Cord

Attach the power cord securely to the power connector on the back of the desktop LTO-1 or LTO-2 drive (see Figure 14 on page 28).

Installing the LTO Driver

If you intend to use your drive with either the Microsoft Windows Server 2003, Windows XP, or Microsoft Windows 2000 operating system, install the LTO driver. See the Tape Resource CD. This driver is not necessary with commercial backup application software.

Registering Your Tape Drive

After you install the desktop tape drive, be sure to register it. Registering your drive ensures that you will receive the latest information about your drive, as well as other product, service, and support information. For your convenience, you can register your drive either through our Web site or by fax.

- If you have an Internet connection, please visit www.certance.com and select "Product Registration" from the "Products" menu.
- If you do not have an Internet connection, complete the Registration Card included with your package and either mail or fax it to the address or fax number on the Card.

3. Operation

This chapter describes how to operate the LTO-1 and LTO-2 drives.

Topics covered in this chapter are:

- “Understanding the Front Panel Display” on page 31
- “Blink Codes” on page 32
- “Using LTO Cartridges” on page 34
- “Drive Maintenance” on page 36
- “Parking the Drive for Shipping” on page 37
- “Emergency Reset and Emergency Cartridge Eject” on page 75
- “Manually Removing a Cartridge” on page 76

Understanding the Front Panel Display

The LTO-1 and LTO-2 drives have different front panels. Figure 16 on page 31 shows a generalized view of the LTO-1 and LTO-2 front-panel display.

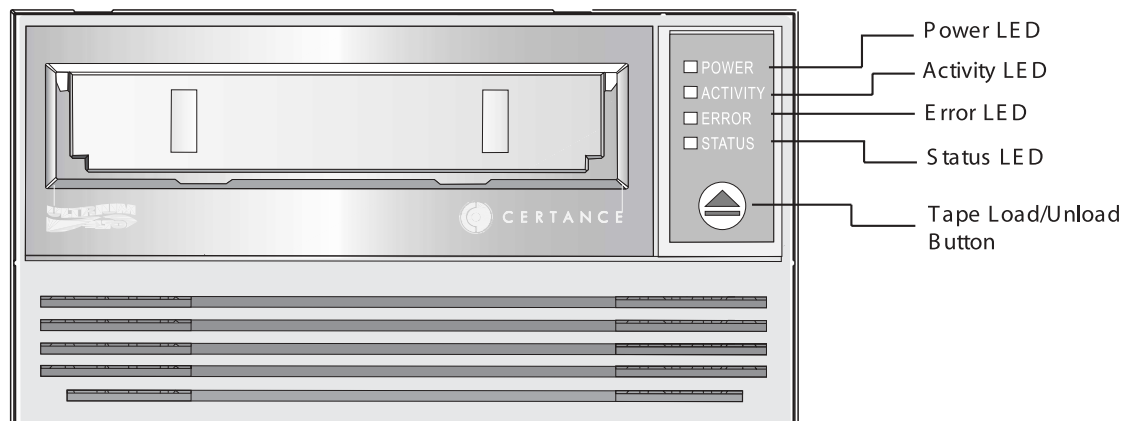

Figure 16. Generic Front Panel Display

All drives have four LEDs on the front panel. The LED colors and functions are summarized below.

- **Power LED** (green)
 - LTO-2 only: Blinks during drive power-up and Power-on Self Test (POST).
 - Remains on during normal operation.
 - Remains on along with the Status light if there is an error during the POST.
- **Status LED** (amber)
- **Error LED** (orange)
- **Drive LED** (green)

The Status, Error, and Drive LEDs blink or go on to indicate information about the tape drive. For more information about the “blink codes” associated with these LEDs, refer to “Blink Codes” on page 32.

Blink Codes

Table 5 on page 32 summarizes the blink codes for the LTO-1 tape drives. Table 6 on page 33 summarizes the blink codes for the LTO-2 tape drives.

Table 5. LTO-1 Tape Drive Blink Codes

Drive Condition	Status LED (Amber)	Error LED (Orange)	Drive LED (Green)
Cleaning Request	ON		
Write-protected	1/2 sec ON 1/2 sec OFF		
Prevent media removal mode active	1/2 sec ON 1/8 sec OFF		
Hardware or firmware error		1/8 sec ON 1/8 sec OFF	
Positioning – loading, unloading, rewinding, spacing, or locating			ON continuously
Tape Active – writing, reading, or verifying			1/2 sec ON 1/8 sec OFF
SCSI active			1/4 sec ON 1/8 sec OFF
Manual intervention required	1/8 sec ON 1/8 sec OFF	1/8 sec ON 1/8 sec OFF	
Power On Self Test (POST) failure	ON	1/2 sec ON 1/2 sec OFF	
Excessive rewrites or read C2 errors		1/4 sec ON 1/4 sec OFF	1/8 sec ON 1/8 sec OFF
Cleaning cartridge present	ON		ON
Cleaning cartridge at EOT	1/8 sec ON 1/8 sec OFF		ON

Table 5. LTO-1 Tape Drive Blink Codes (Continued)

Drive Condition	Status LED (Amber)	Error LED (Orange)	Drive LED (Green)
SCSI bus reset	1/4 sec ON 1/8 sec OFF		1/4 sec ON 1/8 sec OFF
Servo initialization	1/2 sec ON 1/2 sec OFF		1/2 sec ON 1/2 sec OFF
Power On Self Test (POST) in progress	1/4 sec ON 1/4 sec OFF	1/4 sec ON 1/4 sec OFF	1/4 sec ON 1/4 sec OFF
Cleaning failure	1/8 sec ON 1/8 sec OFF	1/8 sec ON 1/8 sec OFF	ON
Microcode download	1/8 sec ON 1/8 sec OFF	1/4 sec ON 1/4 sec OFF	1/8 sec ON 1/8 sec OFF
Microcode download error	1/8 sec ON 1/8 sec OFF	1/8 sec ON 1/8 sec OFF	1/8 sec ON 1/8 sec OFF

Table 6. LTO-2 Tape Drive Blink Codes

Drive Condition	Status LED (Amber)	Error LED (Orange)	Drive LED (Green)
Cleaning Request	ON		
Hardware error		Fast	
Positioning – loading, unloading, rewinding, spacing, or locating			Slow
Tape Active – writing, reading, or verifying			Slow
Manual intervention required		ON	
Power On Self Test (POST) failure	ON	Fast	
Cleaning cartridge present	ON		ON
Cleaning cartridge at EOT	Fast		ON
Servo initialization	Slow		Slow
Power On Self Test (POST) in progress	Slow	Slow	Slow
Cleaning failure or media error	Fast	Fast	
Microcode download	Fast	Slow	Fast
Microcode download error	Fast	Fast	Fast



NOTE: In Table 6 on page 33, ON refers to a constant light; slow refers to a blink rate of 1/2 second on, 1/2 second off; and fast refers to a blink rate of 1/8 second on, 1/8 second off.

Using LTO Cartridges

Loading a Cartridge

To load an Ultrium cartridge into LTO-1 and LTO-2 drives, place the cartridge in the slot and then gently push it. Then:

- Continue to push the cartridge the rest of the way into the drive; or,
- Press the load/unload button on the front of the drive to seat the cartridge; or,
- Use a library or host command to finish loading the tape.

Unloading a Cartridge

To unload an Ultrium cartridge from LTO-1 and LTO-2 drives, either:

- Use a library or host command to unload the tape, or
- Push the load/unload button on the front of the drive.



CAUTION: Several seconds may elapse between the time you press the load/unload button and the time the cartridge is ejected. Do not power down the tape drive or the host computer until the drive has completely ejected the cartridge.

Write-protecting a Cartridge

Ultrium cartridges have a sliding write-protect switch near the back right corner of the cartridge, as shown in Figure 17 on page 35.

- If you slide the switch to the position farthest from the corner of the cartridge, data can be read from the cartridge but not written to it.
- If you slide the switch all the way toward the corner (as shown in Figure 17 on page 35), data can be read from and written to the cartridge.



NOTE: LTO cartridges have prewritten servo patterns and should not be bulk erased.

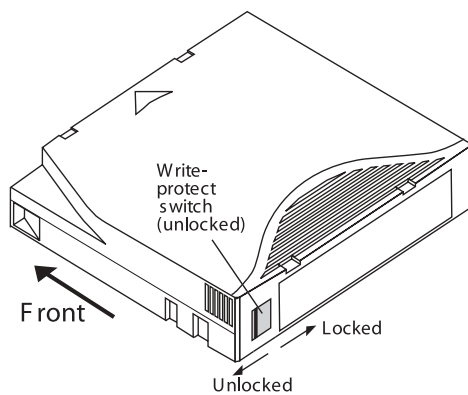

Figure 17. Ultrium Cartridge Showing Write-protect Switch

Cartridge Care and Maintenance

To protect the data on your Ultrium data cartridges, observe the following precautions:

- Always remove the cartridge from the drive when not in use and store it in its protective case.
- Do not expose cartridges to dirt, dust or moisture.
- Do not touch the tape media within a cartridge.
- Do not use data cartridges outside the specified operating conditions: 10° C to 45° C, 10% to 80% relative humidity.

If a data cartridge has been exposed to temperature or humidity changes within the limits listed above, allow the tape cartridge to acclimate to its surroundings for at least one hour before use. Then retention the tape (as described below) to allow the tape pack to become stable, for better performance.

If, during storage and/or transportation, a data cartridge has been exposed to conditions outside the above range, it must be conditioned before use in the operating environment. The conditioning process requires exposure to the operating environment for a time equal to, or greater than, the time away from the operating environment, up to a maximum of 24 hours.

- Keep the cartridge away from direct sunlight and heat sources, such as radiators, heaters or warm air ducts.
- Keep the cartridge away from sources of electromagnetic fields, such as telephones, computer monitors, dictation equipment, mechanical or printing calculators, motors, magnetic tools, and bulk erasers.
- Avoid dropping the cartridges. This can damage components inside the cartridge, possibly rendering the tape unusable. If a tape is dropped it is advisable to open the cartridge door and make sure that the leader pin is in the correct position. A dropped cartridge should be retensioned before use.
- Do not bulk erase Ultrium cartridges. Bulk-erased cartridges cannot be reformatted by the tape drive and will be rendered unusable.

Drive Maintenance

The Ultrium drive requires little or no maintenance. However, on rare occasions, the drive mechanism may need to be cleaned.

Cleaning the Tape Drive

Excessive tape debris or other material may accumulate on the tape heads if the drive is used with non-approved media or operated in a hot, dusty environment. In this case, the drive may experience excessive errors while reading or writing, and the amber Status LED remains on continuously during operation. This means that the drive heads need to be cleaned.

The LTO cleaning cartridge has the same dimensions as the data cartridge and contains an LTO-CM (Cartridge Memory), but is loaded with cleaning media instead of recording media. Always keep the cleaning cartridge in its protective case when not in use.

To clean the drive, insert a Certance-approved cleaning cartridge. During the cleaning process, both the Status and Drive LEDs remain lit. After the cleaning process is completed, the cartridge may be ejected automatically, or you may need to press the load/unload button to remove the cartridge. Each time you use the cleaning cartridge, write the date on the label for future reference.



NOTE: If the Status LED comes on continuously within 24 hours after a cleaning cycle, perform the cleaning cycle again. If, after three cleaning cycles in a 72-hour period, the Status LED lights up again, contact Technical Support.

Each time the drive is cleaned, the tape advances to a new, unused section of media. After approximately 50 cleanings, all of the media will be used up and you should discard the cleaning cartridge. When a cleaning cartridge is used up, the amber Status LED flashes, while the green Drive LED remains on. Do not reuse a spent cleaning cartridge



NOTE: The cleaning procedure will not run and the cleaning cartridge will be ejected in the following circumstances:

- The drive does not recognize the cartridge as an LTO cleaning cartridge.
- All of the tape on the cleaning cartridge has been used up (at EOT). In this case, the Status LED will flash rapidly while the Drive LED remains on.

Parking the Drive for Shipping

Certance recommends that you “park” LTO-1 and LTO-2 drives before shipping them or placing them in an environment where they may be subject to physical shock. Parking the drives moves the tape mechanism to the configuration that is resilient to shock. You can park the LTO-1 and LTO-2 drives using the Load/Unload button on the front of the drive, or by running special software on your host system. In either case, the drive must be powered up to enter park mode.

Using the Load/Unload Button to Park the Drive

To park a drive manually, press and hold the load/unload button for 15 seconds or more. After you release the load/unload button, the green Drive LED lights up and the parking process begins. During the parking process, the picker arm moves into the take-up reel.

When the process is complete, the Drive LED goes off, indicating that the drive has been successfully parked.

After parking the drive, you can turn off the drive and pack it for shipping. When you turn the drive on again, it automatically returns to normal operating mode.

If you need to unpark the drive without cycling power, press and hold the load/unload button for more than 5 seconds, but less than 15 seconds.

Using Software to Park the Drive

You can also park LTO-1 and LTO-2 drives using special software that communicates with the drive through the drive’s SCSI interface. This utility program TapeRx is available on the Tape Resource CD and from the technical support section of the Certance Web site, at <http://support.certance.com>. This utility software supports many commands, one of which can be used to park the LTO-1 and LTO-2 drives.

4. Theory

This chapter describes operational theories used in the LTO-1 and LTO-2 drives.

The topics covered in this chapter are:

- "Track Layout" on page 38
- "Recording Method" on page 39
- "Data Buffer" on page 40
- "Data Integrity" on page 40
- "Data Compression" on page 42

Track Layout

Figure 18 on page 38 shows the layout of data on an LTO tape.

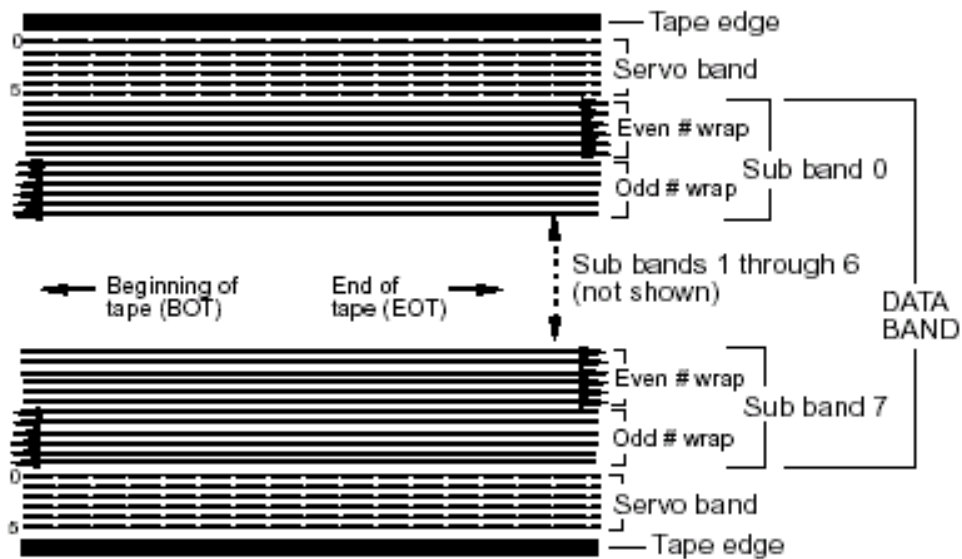

Figure 18. Layout of tracks on LTO Ultrium tape

LTO-1 Drive

With the LTO-1 drive, there are 384 data tracks on the LTO tape, numbered 0 through 383. Data track 383 is the track closest to the bottom edge of the tape (the reference edge). The area between adjacent servo bands is a data band. There are 4 data bands, each of which includes 96 data tracks. The data bands are numbered 2,0,1,3. Data band 2 is closest to the bottom edge of the tape.

A track group is a set of tracks that is recorded concurrently. The sets of 12 data tracks in a data band are data sub bands. There are 8 data sub bands per data band. The data tracks are accessed in a serpentine manner.

A wrap is a track group recorded in the physical forward or physical reverse direction. The wraps are recorded in a serpentine fashion starting in data band 0. The tape contains 48 track groups, 24 written in the forward direction and 24 written in the reverse direction. Even-numbered wraps are recorded in the forward direction (BOT to EOT), and odd-numbered wraps are recorded in the reverse direction (EOT to BOT).

LTO-2 Drive

With the LTO-2 drive, there are 512 data tracks on the LTO tape, numbered 0 through 511. Data track 511 is the track closest to the bottom edge of the tape (the reference edge). The area between adjacent servo bands is a data band. There are 4 data bands, each of which includes 128 data tracks. The data bands are numbered 2,0,1,3. Data band 2 is closest to the bottom edge of the tape.

A track group is a set of tracks that is recorded concurrently. The sets of 16 data tracks in a data band are data sub bands. There are 8 data sub bands per data band. The data tracks are accessed in a serpentine manner.

A wrap is a track group recorded in the physical forward or physical reverse direction. The wraps are recorded in a serpentine fashion starting in data band 0. The tape contains 64 track groups, 32 written in the forward direction and 32 written in the reverse direction. Even-numbered wraps are recorded in the forward direction (BOT to EOT), and odd-numbered wraps are recorded in the reverse direction (EOT to BOT).

Recording Method

The LTO-1 and LTO-2 drives record data using write-equalized (1,7) Run Length Limited (RLL) code. RLL (1,7) Data bits are defined as follows:

- A ONE is represented by a flux transition at the center of a bit-cell.
- A ZERO is represented by no flux transition in the bit-cell.

Data Buffer

In their default configuration, both the LTO-1 and LTO-2 drives have a 64-Mbyte buffer. The buffer controller has a burst transfer rate of 320 Mbytes/sec, and utilizes bank switching to achieve a maximum average bandwidth of nearly 240 Mbytes/sec. The high bandwidth is needed to support look-aside data compression in the case of compressible data being transferred from SCSI at 80 Mbytes/sec.

Data Integrity

The mechanical and electrical design of the drives ensures that drive performance does not degrade over a drive's operating life. Changes in head alignment, head wear, component drift, and other factors are minimized to ensure that data integrity and interchange capability are not compromised over the drive's operating life.

The error rate of the LTO-1 and LTO-2 drives is less than 1 hard error in 10^{17} bits. The drives' undetectable error rate is 1 in 10^{27} bits read.

Error-correction Code (ECC)

The use of Cyclic Redundancy Checking (CRC), two-level orthogonal Error Correction Coding (ECC) provides a very low probability of encountering a hard error. During the read process, ECC correction is performed on the fly without affecting tape streaming.

There are two levels of Error Correction Coding (ECC). These two levels are orthogonal — that is, an ECC codeword at one level intersects ECC codewords at the other level just once, which means there will be only one common symbol between them. The two levels are called C1 and C2.

C1 ECC

As data is written to memory from the Data Processing unit, the DMA / ECC interface generates C1 ECC bytes and writes them to memory.

As data is written to tape, the C1 ECC is checked and an interrupt generated if there is an error. The C1 ECC read from memory is the ECC that is written to tape.

When data is read from tape and stored into memory, C1 ECC is checked.

- If the C1 ECC is good, that codeword pair's "Valid" bit is set.
- Otherwise, a pointer to the invalid Codeword Pair is passed to the C1 ECC correction engine.
 - If the C1 ECC correction engine can correct the error, then the corrected bytes are written to memory, and the Valid bit is set.
 - Otherwise, the Valid bit is left cleared.

As data is read from memory to the Data Processor for decompression, the C1 ECC is again checked and an interrupt generated if it is not correct.

C2 ECC

C2 ECC involves three distinct operations:

1. **Encoding:** Generating C2 ECC bytes from data bytes (performed by ECC co-processor hardware)
2. **Decoding:** Generating ECC syndromes from data and ECC bytes, testing for all-zeroes (performed by ECC co-processor hardware)
3. **Correction:** Generating corrected data from syndromes.

The correction depends on the number and types of errors involved:

- For one known C1 codeword pair in error in a sub-data set (C2 codeword), the operation is performed by the ECC co-processor hardware.
- For two or more known C1 codeword pairs in error, the matrix is computed by firmware and the correction is performed by hardware.
- For one or more unknown C1 codeword pairs, syndromes are generated by hardware, error location is computed by firmware, the matrix is computed by firmware and the correction is performed by hardware.

Servo-tracking Faults

During a write operation, if the servo system detects an error that may result in adjacent data tracks being over-written, the write operation is aborted. The write operation will not continue until the correct servo tracking is re-established.

Data Compression

Typical data streams of text, graphics, software code, or other forms of data contain repeated information of some sort, whether it is at the text level where you can readily recognize regular repetitions of a single word, or at the binary level where the repetitions are in bits or bytes. Although most data is unique and random, the binary level data exhibits patterns of various sizes that repeat with varying degrees of regularity.

Storage efficiency is increased if the redundancies or repetition in the data are removed before the data is recorded to tape. Data compression technology significantly reduces or eliminates redundancies in data before recording the information to tape. This increases the amount of data that can be stored on a finite medium and increases the overall storage efficiency of the system.

With data compression, the redundant information in a data stream is identified and represented by codewords or symbols, which allow the same data to be recorded in a fewer number of bits. These codewords or symbols point back to the original data string, using fewer characters to represent the strings. Because these smaller symbols are substituted for the longer strings of data, more data can be stored in the same physical space.

Some important benefits result from data compression in tape drives:

- The same amount of information can be stored on a smaller length of tape.
- More data can be stored on a given length of tape.
- Performance can more closely parallel to that of high-transfer-rate computers.
- More information can be transferred in the same time interval.

Data Compression Considerations

In an effective data-compression method, several factors are important:

- The amount of compression. The amount of compression is measured by the compression ratio. This ratio compares the amount of uncompressed data to the amount of compressed data. It is obtained by dividing the size of the uncompressed data by the size of the compressed data)
- The speed with which data is compressed and decompressed relative to the host transfer rate.
- The types of data to be compressed.
- The data integrity of the compressed data.

The amount of compression possible in a data stream depends on factors such as:

- Data pattern
- Compression algorithm
- Pattern repetition length
- Pattern repetition frequency
- Object size (block of information to be compressed)
- Starting pattern chosen

The transfer rate depends on factors such as:

- Compression ratio

- Drive buffer size
- Host computer input/output (I/O) speed
- Effective disc speeds of the host computer
- Record lengths that the host computer transmits

Data compression algorithms can be tailored to provide maximum compression for specific types of data. Because varying types of data are encountered in normal day-to-day operating circumstances, however, an effective data compression method for a tape drive must serve various data types. Additionally, the data compression method must adapt to different data types, automatically providing optimum handling for all types of data.

Intelligent Data Compression

The tape's compressed capacity is maximized through the use of intelligent data compression. The intelligent data compression hardware determines the compressibility of each record. If the size of the record is larger after a compression attempt than the native (uncompressed) size, then the record is written in its native form.

The intelligent data compression utilizes two compression schemes:

- Scheme-1 is a LZ1 based compression scheme using a history buffer to achieve data compression.
- Scheme-2 is a pass-through compression scheme designed to pass uncompressible data through with minimal expansion.

There are three specific requirements for compliance with the LTO specification.

- First: the output data stream must be decompressible following LTO rules to create the input sequence of records and File Marks perfectly.
- Second: an LTO compressed data stream may not contain any of the eight reserved Control Symbols.
- Third: while control symbols allow switching to Scheme 2, this should never be used by operational software because this capability is only for diagnostic and testing purposes.

Software data compression should never be used because the LTO-1 and LTO-2 drives' built-in intelligent data compression is much more efficient than software data compression systems.

The LTO-1 and LTO-2 drives use a derivative of ALDC-2 lossless data compression that includes additional control codes for intelligent data compression.

5. Specifications

This chapter provides technical specifications for the LTO-1 and LTO-2 drives.

The topics covered in this chapter are:

- “Physical Specifications” on page 44
- “Power Specifications” on page 47
- “Drive Performance Specifications” on page 48
- “Environmental Requirements” on page 49
- “Reliability” on page 50
- “Mean Time Between Failures” on page 50
- “LTO Cartridge Specifications” on page 51
- “Regulatory Compliance” on page 52

Physical Specifications

Table 7 on page 44 lists the physical specifications of the LTO-1 and LTO-2 drives.

Table 7. LTO-1 and LTO-2 Physical Specifications

Specification	Internal SCSI Drive without Bezel	Internal Fibre Channel Drive without Bezel	Internal SCSI Drive with Bezel	Desktop SCSI Drive
<i>Height</i>	<i>3.25 inches (82.6 mm) max</i>	<i>3.25 inches (82.6 mm) max</i>	<i>3.32 inches (84.26 mm)</i>	<i>6.8 inches¹ (172.7 mm)</i>
<i>Width</i>	<i>5.75 inches (146.05 ± 0.25)</i>	<i>5.75 inches (146.05 ± 0.25 mm)</i>	<i>5.82 inches (147.75 mm)</i>	<i>7.61 inches (193.3 mm)</i>
<i>Length</i>	<i>8.06 inches (205 mm)</i>	<i>10.50 inches (267 mm) max</i>	<i>8.62 inches (219 mm) max</i>	<i>12.17 inches² (309.1 mm)</i>
<i>Weight</i>	<i>6.2 lb. (2.82 kg)</i>	<i>5.8 lb. (2.64 kg)</i>	<i>6.5 lb. (2.95 kg)</i>	<i>14.5 lb. (6.58 kg)</i>

¹ Includes rubber feet (case alone is 6.44 inches high).

² Includes front bezel and fan grill (case alone is 11.9 inches long).

Figure 19 shows the dimensions of the internal LTO-1 and LTO-2 HVD/LVD drives.

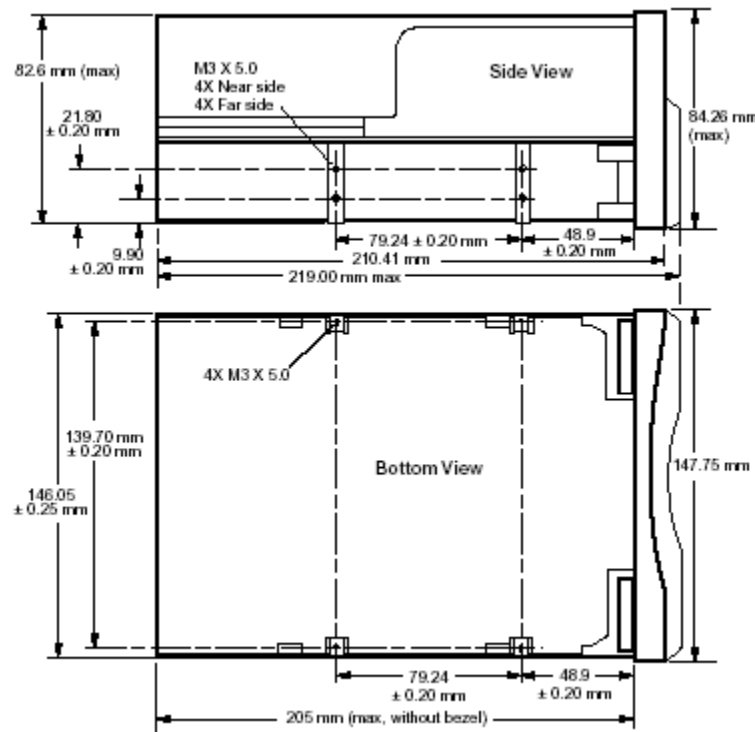

Figure 19. Internal LTO-1 and LTO-2 HVD/LVD Drive Dimensions

Figure 20 shows the dimensions of the LTO-1 Fibre Channel drive.

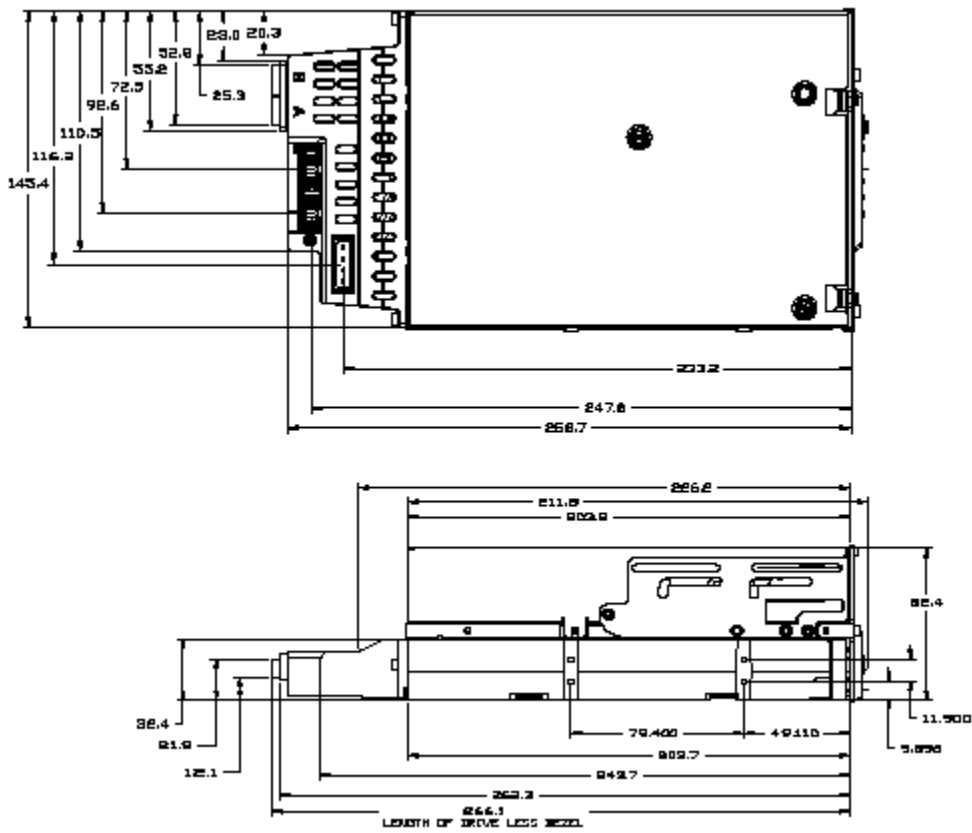

Figure 20. Internal LTO-1 Fibre Channel Drive Dimensions

Power Specifications

The desktop LTO-1 and LTO-2 drives come with a built-in 90-260VAC (47-63 Hz) automatic switching power supply.

Maximum voltage and power specifications for the internal LTO-1 and LTO-2 drives are listed in the tables below. Specifications are the same for SCSI and Fibre Channel drives unless otherwise noted.

Table 8. Voltage and Current

Specification	+12 VDC	+5VDC
DC Voltage Tolerance	+ or – 10%	+ or – 5%
Non-operating max voltage	14 Volts peak	7 Volts peak
Max operating current – LTO-1		
Continuous:		
Ultra2 SCSI LVD;	1.0 amps RMS	3.5 amps max RMS*
Ultra SCSI HVD	1.0 amps RMS	4.0 amps max RMS*
Peak:	3.0 amps (1 sec max)	N/A
Max operating current – LTO-2		
Continuous:		
Ultra2 SCSI LVD;	1.2 amps RMS	4.0 amps max RMS*
Ultra SCSI HVD	1.0 amps RMS	4.0 amps max RMS*
Peak:	4.0 amps (1 sec max)	N/A
Standby current (max) – LTO-1		
Ultra2 SCSI LVD; Ultra SCSI HVD	0.5 amps RMS	2.0 amps RMS*
Fibre Channel	0.5 amps RMS	2.5 amps RMS*
Standby current (max) – LTO-2		
Ultra2 SCSI LVD; Ultra SCSI HVD	0.5 amps RMS	1.0 amps RMS*
Fibre Channel	0.5 amps RMS	2.5 amps RMS*
Ripple (peak-to-peak)	≤ 100 mV	≤ 100 mV

* RMS parameters measured at the power connector using a true RMS digital meter.

Table 9. Power Dissipation

Specification	LTO-1	LTO-2
Max Standby Power		
Ultra2 SCSI LVD; Ultra SCSI HVD	14 watts RMS*	17 watts RMS*
Fibre Channel	19 watts RMS*	N/A
Max Continuous Operating Power		
Ultra2 SCSI LVD; Ultra SCSI HVD	30 watts RMS*	31 watts RMS*
Fibre Channel	32.5 watts RMS*	N/A

Table 9. Power Dissipation (Continued)

Specification	LTO-1	LTO-2
Max Peak Operating Power		
Ultra2 SCSI LVD; Ultra SCSI HVD	48.5 watts RMS (1 sec max)	65 watts RMS (1 sec max)
Fibre Channel	58.5 watts RMS*	N/A
* RMS parameters measured at the power connector using a true RMS digital meter.		

Drive Performance Specifications

Table 10 on page 48 lists the performance specifications for the LTO-1 and LTO-2 drives.

Table 10. Drive Performance Specifications

Specification	Value
Capacity	
LTO-2 (609 m)	200 Gbytes (native)
LTO-1	
Ultrium type A (609 m)	100 Gbytes (native)
Ultrium type B (319 m)	50 Gbytes (native)
Ultrium type C (203 m)	30 Gbytes (native)
Ultrium type D (87 m)	10 Gbytes (native)
Recording density	LTO-1: 3,660 RLL-encoded ONEs per mm LTO-2: 3,930 RLL-encoded ONEs per mm
Flux density	3,660 flux transitions per mm
Track density	3 tracks per mm
Error recovery	Read-after-write Reed Solomon ECC (2 levels)
Recording unrecoverable errors	<1 in 10 ¹⁷ data bits
Recording undetectable errors	< 1 in 10 ²⁷ data bits
Tape drive type	LTO (Ultrium)
Head configuration	16 thin-film write heads 16 MR read heads 8 MR servo heads During operation 8 write heads, 8 read heads, and 2 servo heads are active at the same
Recording format	Ultrium 8-channel (U-18)
Recording method	LTO-1: (1,7) RLL LTO-2: 0, 13/11 RLL
Transfer rate (sustained)	LTO-1: 16.137 Mbytes/second (max, native) LTO-2: 34,000 Mbytes/second (max, native)
Synchronous transfer rate (burst)	LTO-1: 80 Mbytes per sec max LTO-2: 160 Mbytes per sec max

Table 10. Drive Performance Specifications

Specification	Value
Asynchronous transfer rate (burst)	40 Mbytes per sec max
Cartridge unload time	3 seconds
Average rewind time (609-m tape)	LTO-1: ≥ 4 seconds LTO-2: ≥ 5.9 seconds
Maximum rewind time (609-m tape)	LTO-1: ≤ 152 seconds LTO-2: ≤ 103 seconds
Average data access time (609-m tape) from BOW	LTO-1: 76 seconds LTO-2: 51.5 seconds
Maximum data access time (609-m tape) from BOW	LTO-1: 152 seconds LTO-2: 103 seconds
Average rewind time (609-m tape)	< 76 seconds
Tape speed	LTO-1: Up to 4 meters per second LTO-2: Up to 5.9 meters per second

Environmental Requirements

Table 11 on page 49 lists the environmental specifications for the LTO-1 and LTO-2 drives.

Table 11. Environmental Requirements

Specification	Operational	Non-operational
Temperature	+50° to +104°F (+10° to +40°C)	-40° to +149°F (-40° to +66°C)
Airflow requirements	Internal: 9 CFM (front to back)	N/A
Thermal gradient	11°C per hour (10-40°C)	11°C per hour (10-40°C)
Relative humidity	20% to 80% non-condensing	10% to 95% non-condensing
Humidity gradient	10% per hour	10% per hour
Altitude	max 10,000 feet MSL (at 25°C)	40,000 feet (power off)
Shock (1/2 sine wave)	10 Gs peak, 11 msec	40 Gs peak, 11 msec
Vibration (sweep test)	0.005 inches DA (5-43 Hz) 0.50 G peak (43-1000 Hz) sweep rate 5-1000Hz; 0.25 octave per minute)	1.0 G (5-500Hz; sweep rate 1.0 octave per minute)
Acoustic level idling (A-wt sum)	52 dBA maximum 5.0 LwA Bels	—
Acoustic level operational (A-wt sum)	57 dBA maximum 5.5 LwA Bels	—

Injected Noise

The internal drive operates without degradation of error rates with 100 mV of noise injected between the chassis and 0 V at the power connector at any frequency between 45 Hz and 20 MHz.

Reliability

The LTO-1 and LTO-2 drives are designed for maximum reliability and data integrity. Table 12 on page 50 summarizes the reliability specifications.

Table 12. Reliability

Specification	Description
Non-recoverable error rate	< 1 in 10^{17} bits
Error recovery and control	<ul style="list-style-type: none"> • Error correction code techniques (C1 and C2 ECC) • Read-after-write (RAW) • Error monitoring and reporting (error log) • Retry on
Mean time between failures (MTBF)	250,000 hours MTBF at 100% duty cycle: power applied and tape moving continuously (Desktop drive; 50,000 hours at full load and 25°C)
Cartridge load/unload	300,000 cartridge load/unload cycles (no thread)
Mean time to replace (MTTR)	Less than 30 minutes

Mean Time Between Failures

The mean time between failures (MTBF) for the internal drive is specified at 250,000 hours minimum. This specification includes all power-on and operational time but excludes maintenance periods. Operational time is assumed to be 100 percent of the power-on time. Operational time is the time the tape is loaded.

The MTBF for the desktop drive power supply is 50,000 hours with the unit operated at full load and 25°C.



NOTE: The MTBF rating does not represent any particular drive, but is derived from a large database of test samples. Actual rates may vary from unit to unit.

Mean Time to Replace

The mean time to replace (MTTR) is the average time required by a qualified service technician to diagnose a defective drive and to install a replacement drive. The MTTR for LTO products is less than 0.5 hour (30 minutes).

The Certance LTO drives are field-replaceable units. If a problem occurs with a subassembly or component in the drive, you should replace the entire unit. Return the drive to the factory in its original packaging. Contact your distributor, dealer, your computer system company or your Certance sales representative to arrange the return.

LTO Cartridge Specifications

Environmental Considerations

Table 13 on page 51 lists the basic environmental tolerances for LTO Ultrium cartridges.

Table 13. Environmental Tolerances

Specification	Value
<i>Operating temperature</i>	LTO-1: 10°C to 45°C LTO-2: 10°C to 40°C
<i>Relative humidity</i>	10% to 80%
<i>Wet bulb temperature</i>	26° C max
<i>Max localized temperature-permanent tape damage</i>	> 52°C

If during storage and/or transportation a cartridge has been exposed to conditions outside the above values, it must be conditioned before use in the operating environment. The conditioning shall be exposure to the operating environment for a time equal to, or greater than, the time away from the operating environment, up to a maximum of 24 hours. There shall be no deposit of moisture anywhere on or in the cartridge.

The stray magnetic field at any point on the tape shall not exceed 4000 A/m.

Cartridge Memory

Each Ultrium 1 cartridge has 4 Kbytes of nonvolatile memory: 3 Kbytes are used to store tape-directory and hardware specific information. 1 Kbyte is available for application and OEM use. The cartridge memory is powered, read, and written to via a radio-frequency link.

Cartridge Reliability

Recommended cartridge use: After 5,000 load/unload cycles, replace the cartridge to insure data integrity.

See the Ultrium Tape Format section of this manual for additional cartridge information and illustrations.

Regulatory Compliance

These drives comply with the safety and EMC regulations listed in the following tables.

Safety Compliance

Table 14. Safety Compliance

Country	Regulatory Organization	Compliant to:
United States	Underwriters Laboratories (UL)	UL 1950 – 3rd edition
Canada	Canadian Standards Association (CSA)	CSA 22.2 950-95
Germany	Technischer Überwachungs-Verein (TUV) Rheinland	IEC 950 / EN60950, (including amendments A1, A2, A3, A4, A11)
Mexico	Normas Oficiales Mexicanas (NOM), similar to UL	NOM standards
Singapore	Productivity and Standards Board (PSB)	PSB safety certification
South Korea	JEON	JEON safety certification
Argentina	Instituto Argentino de Racionalización de Materiales (IRAM)	IRAM safety certification China
China	Chinese Commodity Import Bureau (CCIB)	CCIB safety certification
EU member nations	Comité Européen de Normalisation Electrotechnique – the European Committee for Electrotechnical Standardization (CENELEC)	IEC 950 / EN60950 (including amendments A1, A2, A3, A4, A11)
Member nations of IECEE*	IECEE* International Electrotechnical Commission on Electrical Equipment (IECEE) for Mutual Recognition of Test Certificates for Electrical Equipment “CB Scheme”	CB Scheme per IEC 950 / EN60950 with details and exceptions for each member country
Hungary	MEEI Budapest	CB Scheme
Czech Republic	EZU Praha	CB Scheme
Poland	PCBC BBJ-SEP	CB Scheme
Russia	GOSSTANDART (GOST)	CB Scheme
Bulgaria	CSM	CB Scheme
Malaysia	JBE SIRIM	CB Scheme
Thailand	TISI	CB Scheme
India	STQC BIS	
South Africa	SABS	CB Scheme
Israel	SII	

* Member nations of the IECEE include Austria, Australia, Belgium, Canada, China (PR), Czech Republic, Denmark, Finland, France, Germany, Hungary, India, Ireland, Israel, Italy, Japan, (South) Korea, Netherlands, Norway, Poland, Russian Federation, Singapore, Slovakia, Slovenia, South Africa, Spain, Switzerland, United Kingdom, USA, Yugoslavia.

Electromagnetic Compatibility (EMC)

Table 15. Electromagnetic Compatibility

Country	Regulatory Organization	Compliant to:
United States	Federal Communications Commission (FCC)	Title 47: Code of Federal Regulations, Part 15, Subpart B, Class B: Digital Device (47CFR15B)
Canada	Industry Canada Digital Apparatus - Interference-Causing Equipment Standard (ICES-003)	ICES-003 Class B: Digital Apparatus
EU member nations	CE	Emissions per CISPR 22:1997 - EN55022:1998 and Immunity per CISPR 24:1997 - EN55024:1998
Australia and New Zealand	Standards Australia Spectrum Management "C-Tick"	AS/NZS 3548-1995 (same as CISPR 22)
Japan	Voluntary Control Council for Interface (VCCI)	This is a voluntary compliance standard; the drives meet it via CE compliance
South Korea	Radio Research Lab of Korea (RRL)	RRL EMC certification
Taiwan	Bureau of Commodity Inspection and Quarantine (BSMI)	BSMI EMC certification
China	Chinese Commodity Import Bureau (CCIB)	CCIB EMC Certification
Poland	PREDOM-OBR	CISPR-22, Class B
Russia	GOSSTANDART (GOST)	CISPR-22, Class B
Bulgaria	CSM	CISPR-22, Class B
Israel	SII	CISPR-22, Class B



NOTE: Use these drives only in equipment where the combination has been determined to be suitable by an appropriate certification organization (for example, Underwriters Laboratories Inc. or the Canadian Standards Association in North America).

You should also consider the following safety points:

- Install the drive in an enclosure that limits the user's access to live parts, gives adequate system stability and provides the necessary grounding for the drive.
- Provide the correct voltages (+5 VDC and +12 VDC) based on the regulation applied—Extra Low Voltage (SELV) for UL and CSA, and Safety Extra Low Voltage for BSI and VDE (if applicable).

6. Unix Settings

This chapter describes how to configure various UNIX systems to recognize and obtain optimal performance from the LTO-1 and LTO-2 tape drives.

The topics covered in this chapter are:

- “A Word About SCSI Controllers” on page 55
- “Configuring for the DEC/Compaq Unix Environment” on page 56
- “Configuring for the Sun Environment (Solaris 2.4, 2.5, 2.6, 7, 8, and 9)” on page 57
- “Configuring for the IBM AIX Environment (AIX Version 4.1.x and later)” on page 59
- “Configuring for SCO Open Server 5.0.x” on page 60
- “Configuring for Linux” on page 62
- “Configuring for SGI Irix” on page 63
- “Configuring for HP-UX 11.0” on page 64

A Word About SCSI Controllers

The LTO-1 drive transfers data at 32 Mbytes per second, with 2:1 compression of the data. The LTO-2 drive transfers data at 68 Mbytes per second, with 2:1 compression of the data.

Both drives support the SCSI Ultra2 specification and can transfer data at burst rates of up to 80 Mbytes per second. To achieve maximum drive performance, it is important to choose high-performance disk drives for your system, as well as high performance SCSI controllers. The table below lists the types of SCSI controllers that Certance recommends, in order of least preferred to most preferred (top to bottom).

Table 16. SCSI Controllers

Controller Type	Maximum Transfer Rate
<i>Fast Wide SCSI</i>	<i>20 Mbytes per second, compatible, not recommended</i>
<i>Wide Ultra SCSI</i>	<i>40 Mbytes per second, minimum for LTO-1</i>
<i>Wide Ultra2 SCSI (LVD)</i>	<i>80 Mbytes per second, minimum for LTO-1</i>
<i>Ultra 3 SCSI</i>	<i>160 Mbytes per second, minimum for LTO-2</i>
<i>Ultra 320 SCSI</i>	<i>320 Mbytes per second, preferred</i>

For definitions of the terms used above, please refer to SCSI Trade Organization Web site: <http://www.scsita.org/aboutscsi/index01.html>

Configuring for the DEC/Compaq Unix Environment

Finding Existing SCSI Controllers and Devices

SCSI ID #7 is almost always dedicated to the SCSI controller. Never configure your target device for ID 7 unless you are absolutely sure that the controller is not addressed for ID 7.

Configuring Digital UNIX Version 4.0 and later/Compaq Tru64 Unix 5.x

Use File Manager to open the file `/etc/ddr.dbase` and create an entry as follows:

```
SCSIDEVICE
#
Type=tape
Name="CERTANCE" "ULTRIUM 2"
#
PARAMETERS:
    TypeSubClass=tk
    TagQueueDepth=0
    MaxTransferSize=0x0ffffff#(16MB-1)
    ReadyTimeSeconds=180#seconds
        CMD_PreventAllow=supported
        CMD_ExtReserveRelease=supported
    BlockSize=0
    PwrMgmt_capable=0
DENSITY:
#
DensityNumber=0,2,3,4,5,6,7
DensityCode=default
CompressionCode=0x0
Buffered=0x1
DENSITY:
#
DensityNumber=1
DensityCode=default
CompressionCode=0x1
Buffered=0x1
```

Save the file. Then run the following command:

```
ddr_config-c
```

`ddr_config` takes the default input file, `ddr.dbase`, and builds a new device database. This command takes effect immediately, without having to rebuild the kernel.



NOTE: `ddr.dbase` is a Unix shell script and is not written in C. This means `#` is used to signify a comment, not `/*` and `*/` or `//`, as used in C. Make sure any comments included in this file are preceded with the `#` character. If installing a Seagate LTO 1 drive, the name should be:
`"Name="SEAGATE " "ULTRIUM 06242."`

To enable the tape driver to turn on data compression when writing data to tape use the `.c.` option.

For commands that use density and tape size settings, the tape density is 124,000 bpi and the tape length is 1800 feet. For commands that use a blocking factor, we recommend a blocking factor of 64 as a minimum (128 is recommended).

Configuring for the Sun Environment (Solaris 2.4, 2.5, 2.6, 7, 8, and 9)

Use the following for attaching the LTO-1 and LTO-2 drives to Sun Sparc and Intel systems.

Finding Current SCSI Controllers and Targets

To properly attach SCSI devices to hosts it is necessary to ensure that each target device has a unique SCSI address. The commands `.modinfo.` and `.dmesg.` can be used to find the SCSI controllers in use and the SCSI target devices installed.

For example, the command `.dmesg | egrep .target. | sort | uniq.` can find all SCSI controllers and SCSI targets. The output may look similar to:

```
sd32 at ithps0: target2 lun0
sd34 at ithps0: target4 lun0
st21 at ithps1: target0 lun0
st22 at ithps1: target1 lun0
```

In this case, the LTO-1 and LTO-2 drives can be set for SCSI ID address 2 through 6 and attached to controller `ithps1` (this particular controller also supports SCSI addresses 8 through 15).

Types of Controllers

You may be able to view the main pages of three types of SCSI controllers for Sun Sparc systems:

- `esp`
- `glm`
- `isp`

We recommend that the LTO-1 and LTO-2 drives not be attached to `esp` controllers. This controller is not fast enough to work with the LTO-1 and LTO-2 drives. The minimum recommended controller would be a `glm` controller, which is an Ultra Wide controller.

We recommend Ultra2 SCSI-capable controllers capable of 80MB/s data transfer as a minimum. Slow backups will result if using slower SCSI controllers.

Configuring the Device File `st.conf`

To configure Solaris 2.4 and above to use the LTO-1 and LTO-2 drives correctly, add the following lines to the file `st.conf` in the directory `/kernel/drv`.

```
tape-config-list=
"CERTANCEULTRIUM 2", "Seagate LTO", "SEAGATE_LTO";
SEAGATE_LTO=1, 0x36, 0, 0x1d639, 4, 0x00, 0x00, 0x00, 0x00, 1;
```



NOTE: If installing a Seagate LTO 1 tape drive, replace "CERTANCEULTRIUM 2" with "SEAGATE ULTRIUM06242-XXX." The inquiry string above contains one space between SEAGATE and ULTRIUM.

The value `0x1d639` equates to the way that the LTO-1 and LTO-2 drives are configured to operate in the Solaris environment. This value enables the LTO-1 and LTO-2 drives to:

Support variable length records (variable length block size)

- Backspace over files (same as `.mt bsf.` command to backspace over filemarks)
- Backspace over records (same as `.mt bsr.`, backspace over individual tape blocks)
- Long timeout for long erase function (it is not recommended to try and erase the entire tape)
- LTO-1 and LTO-2 drives know when end of data has been encountered
- Device driver is unloadable
- Long timeouts (5 times longer than normal)
- Buffered writes supported
- Variable record size not limited to 64k
- Uses Mode Select Page 10h to enable/disable compression

Once `st.conf` has been modified, the kernel must be reconfigured by booting the system using the `boot-r` command. If you are replacing a tape device with the same SCSI ID you may want to delete the `st` devices from the `/dev/rmt` directory (recommended).

When using commands that require a blocking factor such as `tar` or `ufsdump`, we suggest a minimum factor of 64. The preferred factor is 128.

For commands that use density and tape size settings the tape density is 124,000 bpi and the tape length is 1800 feet. We suggest using the `ufsdump/ufrestore` commands. These commands automatically detect end of tape without the need of the density and tape length settings.

To enable the `st` driver to turn on data compression when writing data to tape use the `.c.` option. For example, `tar cf /dev/rmt/0c` causes the tape drive to compress the data before writing the data to tape.

Configuring for the IBM AIX Environment (AIX Version 4.1.x and later)

Finding Existing SCSI Controllers and Devices

Enter the following command: `lsdev-Cs scsi`. This shows all the SCSI target IDs known to the system. Note the SCSI target IDs and choose a SCSI ID for the LTO-1 and LTO-2 drives that will not conflict with the IDs shown from the `lsdev` command.

SCSI ID #7 is almost always dedicated to the SCSI controller. Never configure your target device for ID 7 unless you are absolutely sure that the controller is not addressed for ID 7.

Configuring the LTO-1 and LTO-2 Drives using SMIT

The LTO-1 and LTO-2 drives tape drives can be configured to work with AIX Versions 4.1.x and later by using the **SMIT .Other SCSI Tape Drive**. option.



NOTE: Record the SCSI ID of the tape drive before installing it.

To configure AIX using the SMIT utility, use the following procedure:

1. Enter SMIT at the Tape Drive menu by typing **smit tape**
2. Select **Add a tape Drive**.
3. Select the type of tape drive you will be adding. Use the **Other SCSI Tape Drive** option.
4. Select the Parent SCSI Adapter from the available list. The Add a tape Drive "Entry Fields" appears.
5. Some of the standard options can be changed to maximize drive performance and functionality:

Set the **Connection Address with the Drives Target and Lun** (always use Lun 0). In the list, the Target is the first number and the Lun is the second. For example, if the drive is ID 5, choose 5,0.

Set the **BLOCK size** to 0.

Set **Use DEVICE BUFFERS during writes** to yes.

Set **RETURN error on tape change or reset** to no.

Set **Use EXTENDED file marks** to yes.

Set **RESERVE/RELEASE support** to yes.

Set **BLOCK SIZE for variable length support (Num.)** to 0.

Set **Density 1** to 0.

6. Leave the **Set delay. . .** and **Set timeout. . .** lines at the default value.
7. Click **OK** and the drive will be installed in the system database, and devices created. There is no need to reboot the system.

8. Exit SMIT.



NOTE: We suggest using the AIX commands `.backup.` and `.restore` when transferring data to and from the LTO-1 and LTO-2 drives. These commands transfer data more quickly than other commands such as `tar` and `cpio`. For `cpio` we suggest a blocking factor of 128. For `tar` we suggest using the `.N` option and a factor of 128. Some older systems with poor video controllers may experience a reduction in performance when using the `.v` option, which prints the path names on the standard console during the backup. Unless there is a real need to see the filenames as they are backed up we suggest not using the `.v` option. For commands that use density and tape size settings the tape density is 124,000 bpi and the tape length is 1800 feet.

Configuring for SCO Open Server 5.0.x

Finding Existing SCSI Controllers and Devices

The files `/usr/adm/hwconfig` and `/var/adm/messages` list the devices found during boot up of Open Server. The current SCSI controllers can be found using the command:

```
grep adapter /usr/adm/hwconfig
```

This command produces output similar to:

```
%adapter 0x6400-0x64FF 11 type=alad ha=0
bus=0 id=7 fts=st0.
```

The current tape drives can be found using the command:

```
grep tape /usr/adm/hwconfig
```

This command produces output similar to:

```
%tape type=S ha=0 id=6 lun=0 bus=0 ht=alad
```

The information above shows that an Adaptec SCSI controller is installed (`alad`) and a SCSI tape drive (`type=S`) is installed as target id 6. SCSI ID #7 is almost always dedicated to the SCSI controller. Never configure your target device for ID 7 unless you are absolutely sure the controller is not addressed for ID 7.

Configuring the LTO-1 and LTO-2 Drives with mkdev

Once connected to the system, installation of the drive is performed using the following command:

```
mkdevtape
```

A numeric-based menu appears. If you are replacing an existing SCSI tape drive, use option 3 to remove the existing tape drive from the configuration files. Then follow the instructions below to add an LTO-1 or LTO-2 drive.

1. From the menu, choose **Configure a SCSI or Enhanced IDE tape drive.**
2. From the next menu, choose **Install a SCSI tape drive.**
3. When prompted, enter the SCSI adapter string. To view the list of supported SCSI adapters, use the `h` option.
4. Enter the number of the SCSI host adapter attached to the drive. If one SCSI adapter exists, enter the number zero (0).

5. Enter the number of the SCSI bus attached to the drive. Refer to the SCSI adapter documentation. For many adapters this will be zero (0).
6. Enter the SCSI ID of the tape drive.
7. Enter the number zero (0) for the LUN of the device.
8. When prompted to **Update the SCSI configuration? (y/n)**, enter y.
9. When prompted for Vendor Identification string, enter SEAGATE for the LTO-1 tape drive or CERTANCE for the LTO-2 tape drive.
10. When prompted to enter the SCSI version to which the tape drive conforms, enter the number three (3).
11. When prompted to enter the **Response Data Format** the tape drive uses, enter the number two (2).
12. When prompted, choose the **Generic SCSI-1/SCSI-2** tape drive option.
13. When the process takes you back to the two Main Menu screens, press q.
14. When asked to create a new kernel, enter yes.
15. When asked if you want the new kernel to boot by default press y.
16. When asked if you want the kernel environment to be rebuilt press y.
17. Reboot the system.



NOTES: Not all of the SCO "tape" commands will operate or be applicable to the Seagate LTO-1 and LTO-2 drives drive (execute the command `.man tape` for the specifics on how the tape command works). The following tape commands are not available for use with the LTO-1 and LTO-2 drives: `getcomp`, `setcomp` (the LTO-1 and LTO-2 drives will always compress the data before writing the data to tape under SCO Open Server 5.0.x), `partition`, `setpart`, `getpart`, `getspeed`, `setspeed`, `rsm`, `wsm`. The following tape commands are available for use with the LTO-1 and LTO-2 drives: `status`, `load`, `reset`, `rewind`, `retention`, `getblk`, `setblk`, `unload`, `eod`.

When using the GUI Backup Manager utility set the block size to 32768 minimum, 65536 preferred. When using commands such as `tar` we suggest using the tape command to set the block size to 512 and then using a blocking factor of 80 for the `tar` command. For commands that use density and tape size settings the tape density is 124,000 bpi and the tape length is 1800 feet.

Configuring for Linux

Finding Existing SCSI Controllers and Devices

Before installing the LTO-1 and LTO-2 tape drives, ensure that the requisite SCSI controllers and device drivers are installed on your system.

To find existing SCSI controllers execute the command:

```
dmesg | grep SCSI
```

You may see output similar to:

```
(scsi0)<Adaptec AHA-294XX Ultra2 SCSI host  
adapter> found at PCI 0/16/0
```

To find existing SCSI devices execute the command:

```
cat /proc/scsi/scsi
```

You may see output similar to:

```
Host: scsi0 Channel: 0 Id:6 Lun:00  
Vendor: SEAGATE Model: ULTRIUM06242-XXX  
Type: SequentialAccess ANSI SCSI  
Revision 03
```

Use the output of these two commands to see which SCSI target id numbers are free. In the above example a tape drive is attached at target id 6. SCSI ID #7 is almost always dedicated to the SCSI controller. Never configure your target device for ID 7 unless you are absolutely sure that the controller is not addressed for ID 7.

The widely available distributions of Linux automatically install the proper SCSI and tape device drivers. If you executed the `cat` command above, you have ensured that the SCSI driver for your controller is installed. To view currently loaded modules, execute the `lsmod` command. Ensure that one of the entries is `st`.

To view the `st` device number for your attached tape drive, execute the command:

```
dmesg | grep tape
```

You should see output similar to:

```
Detected SCSI tape st0 and scsi0 . . .
```

Using the LTO-1 and LTO-2 Drives

The LTO-1 and LTO-2 drives can be configured via the `mt` command options and a default configuration can be setup using the `'stsetoptions'` command from within the `mt` command. Refer to the man page for `mt` for details. We suggest not using the `erase` command nor commands which attempt to partition the tape. Partitioning is not supported in the LTO format.

For commands that use density and tape size settings, the tape density is 124,000 bpi and the tape length is 1800 feet. For commands that use a blocking factor, we suggest a factor of 128.

Configuring for SGI Irix

Finding Current SCSI Controllers and Targets

To properly attach SCSI devices to hosts it is necessary to ensure that each target device has a unique SCSI address. The command `hinv` can be used to find all attached SCSI controllers and target devices. To search for all SCSI controllers and devices use the command:

```
hinv -v | grep SCSI
```

The output of the command will be similar to the following:

```
Integral SCSI controller 0: Version ADAPTEC 7880
Disk drive unit 1 on SCSI controller 0
CD ROM unit 4 on SCSI controller 0
Integral SCSI controller 1: Version ADAPTEC 7880
Tape drive: unit 6 on SCSI controller 1: DAT
```

This output shows that a tape drive is present on SCSI controller 1 at SCSI ID address #6. Available SCSI IDs are

- 0,2,3,5 6, 8 - 15 on controller 0
- 1 - 5 and 8 - 15 on controller 1 (this controller supports Wide/Ultra SCSI)



NOTES: SCSI ID #7 is almost always dedicated to the SCSI controller. Never configure your target device for ID 7 unless you are absolutely sure that the controller is not addressed for ID 7. See figure 1 to view how to set the SCSI ID address jumpers for the LTO-1 and LTO-2 drives.

Modifying the IRIX Configuration File

To attach the LTO-1 and LTO-2 drives to IRIX the file `.scsi.` needs to be modified by a text editor. The file can be found in `/var/sysgen/master.d`. Open the file and use the text editor to add the following at the end of the tape device entries:

For IRIX 6.4/6.5

```
{DATTAPE, TPDAT, 8, 7, "CERTANCE", "ULTRIUM 2", 0, 0, {0},
MTCAN_BSF | MTCAN_BSR | MTCAN_APPEND | MTCAN_SETMK |
MTCAN_PREV | MTCAN_SYNC | MTCAN_SPEOD | MTCAN_CHKRDY |
MTCAN_VAR | MTCAN_SETSZ | MTCAN_SILI | MTCAN_SEEK |
M TCAN_COMPRESS,
40, 5*60, 10*60, 10*60, 3*3600, 512, 256*512,
tpsc_default_dens_count, tpsc_default_hwg_dens_names,
tpsc_default_alias_dens_names, {0}, 0, 0, 0, 0, (u_char*) 0},
```

If installing a Seagate LTO-1 tape drive, replace "CERTANCE" with "SEAGATE " and replace "ULTRIUM 2" with "ULTRIUM06242-XXX."

After modifying the configuration file, recompile the kernel with the `autoconfig` command and reboot the system. If you are replacing an existing storage device with the same SCSI ID remove the device files prior to using the `autoconfig` command and rebooting the system.

Configuring for HP-UX 11.0

Finding Current Hardware/Driver Configuration

To find currently installed SCSI controllers and devices, use the command `ioscan -f`. This command lists all the system devices and their device names.

Attaching the LTO-1 and LTO-2 drives

Choose a SCSI address that does not conflict with any already attached SCSI devices on your SCSI controller. See figure 1 for jumper installation for the LTO-1 and LTO-2 drives. Attach the LTO-1 or LTO-2 drive and apply power to the drive(s) and the host system. After the boot process completes and you log in as superuser, issue the command:

```
ioscan -C tape -f.
```

You should see output similar to:

Class	I	H/WPath	Driver	S/WState	H/Wtype	Description
Tape	7	8/12.6.0	stape	Claimed	Device	SEAGATE ULTRIUM

From the root directory and as superuser, issue the command:

```
/sbin/insf -C tape.
```

Then issue the command:

```
/sbin/mksf -d stape -H x/x.x.x -I y -c 1  
-n -u /dev/rmt/zcnb
```

Where:

- `x` is the data under `H/WPath` from the `ioscan`.
- `y` is the data under `I` from the `ioscan`.
- `z` is the tape device identifier number.

You can execute an `ls` command for the `/dev/rmt` directory to choose an identifier number that has not already been used. You can also choose a unique device name such as `cnb` to more easily remember which device name will enable data compression during write. Refer to the man pages for `mksf` to review settings for `rewind/no rewind`, Berkeley mode, and AT&T mode.

After performing the `insf` and `mksf` commands, use the command `ioscan -fn | grep -C tape` to check the installation. You should see output showing the hardware and device addressing and also the device name attached to the LTO-1 and LTO-2 drives.

7. Interfaces

This chapter describes the LTO-1 and LTO-2 drive interfaces.

Topics in this chapter are:

- “Parallel SCSI Interface” on page 65
- “Fibre Channel Interface” on page 66
- “Commands” on page 66
- “Typical System Configurations” on page 68

Parallel SCSI Interface

The LTO-1 and LTO-2 drives feature a multi-mode LVD or HVD single-ended SCSI-2 interface. The drive’s SCSI-2 interface allows for communication between the host computer and the tape drive. The SCSI-2 interface conforms to requirements outlined in ANSI X3.131, 1994. The LTO-1 and LTO-2 drives also support some SCSI-3 command extensions.

The Parallel SCSI interface for the LTO-1 and LTO-2 drives conforms with the ANSI X3.131, 1994 standard. Table 17 on page 65 lists the message codes for this interface.

Table 17. SCSI Message Codes

Code	Description	Direction¹
00h	Command Complete	In
02h	Save Data Pointer	In
04h	Disconnect	In
05h	Initiator Detected Error	Out
06h	Abort	Out
07h	Message Reject	In/Out
08h	No Operation	Out
0Ch	Bus Device Reset	Out
80h	Identify (No Disconnect/Reconnect)	In/Out
C0h	Identify (Disconnect/Reconnect)	In/Out
01h ²	Extended Message	In/Out
03h	Wide Data Transfer Request	In/Out

¹ Direction is defined as follows: In = Drive to Host; Out = Host to Drive.

² The LTO-1 and LTO-2 drives support one Extended Message: Synchronous Data Transfer Request.

SCSI-2 ANSI X3.131, 1994 conformance statement

- Disconnect/reconnect, arbitration (required in SCSI-2)
- Single-ended drivers
- Termination power supplied to cable (jumper option)
- Hard reset
- Synchronous data transfers
- Parity implemented (switch option)

Fibre Channel Interface

The Fibre Channel interface for the LTO-1 tape drive conforms with the ANSI/INCITS FCP-2, FC-PH, FC-PH-2, FC-PH-3, and FC-AL standards, as well as with the FC-TAPE, FC-MI, FC-PLDA, and FC-FLA profiles.

The drive has two independent 1.0625 GHz interfaces, using LC (small form factor) connectors to attach 850 nm multimode fiber optic cables. Logically, these are Fibre Channel NL_Ports. Either or both may be used. They should be attached to a hub, to another NL_Port (on a host), or to an FL_Port (on a fabric).

Commands

General Features

- Fixed and variable block transfer lengths
- Space blocks, filemarks and EOD
- Supports third-party reservation
- Log Sense and Log Select for managing soft error reporting
- Mode Sense/Select page to control and report operation of data compression in sequential access devices and to read from and write to the configuration EEPROM
- Supports both single and multi-initiator systems
- Fibre Channel drives support the Fibre Channel Logical Unit Control mode page (18h) and the Fibre Channel Port Control mode page (18h), as defined in the FCP-2 standard.

LTO-1 and LTO-2 drives support SCSI commands defined in the ANSI/INCITS SPC-2 and SSC Standards.

Table 18. Supported SCSI Codes and Corresponding Commands

Code	Command
00h	<i>Test Unit Ready</i>
01h	<i>Rewind</i>
03h	<i>Request Sense</i>
05h	<i>Read Block Limits</i>
08h	<i>Read</i>
0Ah	<i>Write</i>
0Bh	<i>Set Capacity (proposed for SSC-2)</i>
10h	<i>Write Filemarks</i>
11h	<i>Space</i>
12h	<i>Inquiry</i>
13h	<i>Verify</i>
15h	<i>Mode Select (6-byte version)</i>
16h	<i>Reserve Unit (6-byte version)</i>
17h	<i>Release Unit (6-byte version)</i>
19h	<i>Erase</i>
1Ah	<i>Mode Sense (6-byte version)</i>
1Bh	<i>Load/Unload</i>
1Ch	<i>Receive Diagnostic Results</i>
1Dh	<i>Send Diagnostic</i>
1Eh	<i>Prevent/Allow Medium Removal</i>
2Bh	<i>Locate</i>
34h	<i>Read Position</i>
3Bh	<i>Write Data Buffer</i>
3Ch	<i>Read Data Buffer</i>
44h	<i>Report Density Support</i>
4Ch	<i>Log Select</i>
4Dh	<i>Log Sense</i>
55h	<i>Mode Select (10-byte version)</i>
56h	<i>Reserve Unit (10-byte version)</i>
57h	<i>Release Unit (10-byte version)</i>
5Ah	<i>Mode Sense (10-byte version)</i>
5Eh	<i>Persistent Reserve In (Fibre Channel drives only)</i>
5Fh	<i>Persistent Reserve Out (Fibre Channel drives only)</i>
A0h	<i>Report LUNS</i>

Tape Alert Flags

The LTO-1 and LTO-2 drives support version 3.0 of the Tape Alert specification. The following flags are supported by the drive.

Table 19. Tape Alert Flags

Parameter	Description	Type
3	Hard Error	Warning
4	Media	Critical
5	Read Failure	Critical
6	Write Failure	Critical
9	Write Protect	Critical
11	Cleaning Media	Information
14	Irrecoverable Snapped Tape	Critical
15	Memory in Cartridge Failure	Warning
16	Forced Eject	Critical
17	Read Only Format	Warning
18	Tape Directory Corrupted	Warning
20	Clean Now	Critical
21	Clean Periodic	Warning
22	Expired Cleaning Media	Critical
23	Invalid Cleaning Cartridge	Critical
30	Hardware A	Critical
31	Hardware B	Critical
32	Interface	Warning
34	Download Fault	Warning

Typical System Configurations

Parallel SCSI Interface

The LTO-1 and LTO-2 drives support up to 16 SCSI addresses or IDs. These IDs refer to host adapters or peripheral devices such as printers, magnetic discs or tape drives.

Any combination of a single host and up to 15 additional SCSI devices can be chained together on a single SCSI cable.

Due to the speed of the LTO-1 and LTO-2 drives, it is recommended that a maximum of one LTO-1 or LTO-2 drive be connected to one host SCSI adapter.

Fibre Channel Interface

The Fibre Channel LTO-1 drive supports 128 arbitrated loop physical addresses. Up to 126 hosts and targets and one switch can be attached to a single loop.

Due to the speed of the Fibre Channel LTO-1 drive, it is recommended that a maximum of two Fibre Channel LTO-1 drives be connected on one arbitrated loop.

8. Troubleshooting Guide

This chapter contains best practices for getting the most out of your LTO-1 and LTO-2 tape drives. This chapter also contains troubleshooting information you can use to identify and resolve tape drive problems in the unlikely event you encounter a problem with your tape drive.

Topics covered in this chapter are:

- “Installation Best Practices” on page 70
- “Troubleshooting Suggestions” on page 71

Installation Best Practices

Follow SCSI Best Practices

When installing an LTO-1 or LTO-2 tape drive, follow SCSI best practices to ensure trouble-free installation and operation.

SCSI Host Bus Adapters (HBA)

We strongly recommend that you attach the LTO-1 or LTO-2 tape drive to SCSI controllers that support the SCSI Ultra2 LVD interface and 160 MBytes SCSI transfer rate only.

In addition, do not

- Attach the tape drives to a non-LVD SCSI controller, as this will degrade the performance of the tape drive and the performance of your backups.
- Attach non-LVD SCSI devices on the same bus cable, as this will degrade the performance of the tape drive and your backups.
- Connect the tape drive to a disk RAID controller, as this is not supported.

If you are installing an adapter, we recommend you use a SCSI LVD controller kit that includes the SCSI cable and terminator.

If installing a SCSI HBA, be sure it is supported by your operating system and your backup software application. In addition, ensure that you have the proper drivers for the HBA, if any are necessary.

Before you install the HBA, check and record your current system configuration. For example, in Windows 2000, you may find information on any currently installed SCSI HBA by:

- Double-clicking on **Administrative Tools** in the Control Panel.
- Clicking on **Computer Management > Device Manager**.
- Clicking on the SCSI host adapters listed.

- Clicking on **Properties** to view the Resources tab.

In Unix/Linux systems, you may find information on any currently installed SCSI HBA by viewing the boot log text file. Refer to your operating system documentation for specific information on reviewing your system configuration.

After installing the SCSI HBA, reboot the system. Then ensure that the operating system recognizes the HBA and that there are no conflicts with other adapters.

Adding the Tape Drive

We recommend that the LTO-1 or LTO-2 tape drive be attached to a dedicated SCSI HBA. In addition to enabling the best performance for your tape drive, a dedicated SCSI HBA reduces the chances of installation difficulties arising from duplicate SCSI IDs on the same bus channel.

Ensure that the SCSI cable is of high quality and conforms to Ultra 2 SCSI specifications. A lesser quality cable or a cable that does not conform to the Ultra 2 SCSI specification may cause intermittent write/read errors, SCSI timeouts, and corrupted data.

Troubleshooting Suggestions

Computer will not Boot

If the computer has booted up and operated properly prior to adding a SCSI HBA and tape drive, but does not boot now:

1. Remove the SCSI HBA controller if it is installed.
2. Reboot the system.
 - If the system boots normally, the problem is resolved.
 - Otherwise, ensure that SCSI HBA is compatible with system, does not have burnt components. Reseat the SCSI HBA in a different PCI slot and reboot the computer. If the system still does not boot, contact Technical Support.

Computer Boots but Does not Recognize the Tape Drive

1. Reboot the system and check whether the SCSI controller is seen at boot up. You should see messages similar to:

```
SCSI Adapter Manufacturer SCSI BOIS xxxxxxxx
CHA: SCSI ID #,          SCSI Device Name
SCSI ID #,          SCSI Device Name"
```

- If the SCSI Controller is not recognized during system boot, contact Technical Support.
- If the SCSI controller is recognized during system boot., determine whether the tape drive is recognized when the SCSI controller scans for devices. You should see messages similar to:

```
"SCSI ID 6 SEAGATE ULTRIUM06242 160
```

- If the tape drive is not recognized during the SCSI controller scan, check the Power LED to make sure the tape drive is receiving power.
- If the Power LED is not illuminated, check the power connections to the tape drive.

Internal tape drive:

1. Power down the system and reseal the power connector on tape drive.
2. Power on the system and check the Power LED.
3. If the Power LED is not illuminated, replace the power connector attached to the tape drive with one from a known working device such as a CD-ROM. If the Power LED is illuminated, the problem was with the power connector. Otherwise, the tape drive may be bad and Technical Support should be contacted.

Desktop tape drive:

1. Turn power off to the tape drive and reseal the AC power cord.
 2. Power on the tape drive and check the Power LED.
 3. If the Power LED is not illuminated, use an AC power cord from a known working device. If the Power LED is illuminated, the problem was with the cable. Otherwise, the tape drive may be bad and Technical Support should be contacted.
- If the Power LED is illuminated, but the tape drive is not recognized during the SCSI controller scan, use the LEDs to verify that the drive has passed its Power on Self Test (POST). See Table 5 on page 32 and Table 6 on page 33. If the tape drive LEDs indicate a POST failure, the tape drive may be bad. Contact Technical Support.
 - If the tape drive LEDs indicate that the drive has passed the POST, check the following connections:

Internal tape drive:

1. Power down the system.
2. Be sure there are no SCSI ID conflicts between the tape drive and other SCSI devices.
3. Be sure you are using a proper SCSI cable and proper termination.
4. Check the SCSI cable for bent pins.
5. Try to use SCSI cable from other SCSI controller bus chain if possible.

6. If these suggestions do not help, the tape drive may be bad and Technical Support should be contacted.

Desktop tape drive:

1. Power down system.
2. Power cycle desktop tape drive.
3. Be sure there are no SCSI ID conflict between the tape drive and other SCSI devices.
4. Be sure you are using a proper SCSI cable and proper termination.
5. Check the SCSI cable for bent pins.
6. Try to use SCSI cable from other SCSI controller bus chain if possible.
7. If these suggestions do not help, the tape drive may be bad and Technical Support should be contacted.

Tape Drive Recognized during System Boot but not by Operating System or Application

Windows Operating System

When the tape drive is installed in a Windows operating system, Windows displays a message on the screen if it does not have a driver in place for the tape drive.

If the tape drive will be used by an ISV application, you can click on the Cancel button to remove the message. When the ISV backup software application is running, the application invokes its drivers to run the tape drive. However, if you use a native Windows operating system backup utility, you must install the proper tape driver for the tape drive.

Red Hat Linux

The tape driver for Red Hat Linux is called "st". This driver is automatically installed when Red Hat Linux is installed on your system. When Red Hat Linux boots, the operating system recognizes the tape drive and installs the tape drive as a device in the `/dev` directory. If this is the first tape device in the `/dev` directory, the tape drive is known as `/dev/st0` or `/dev/nst0`.

There are various ways to view the log files to see whether Linux recognizes the tape drive. One method is to open a terminal window and issue the following command from the root directory:
`dmesg | grep SCSI`

You may see output similar to:

```
(scsi0)<Adaptec AHA-294XX Ultra2 SCSI host adapter> found at PCI 0/16/0
```

You may also be able to use the command: `cat /proc/scsi/scsi`

You may see output similar to:

```
Host: scsi0 Channel: 0 Id:6 Lun:00  
Vendor: SEAGATE Model: ULTRIUM06242-XXX  
Type: Sequential AccessANSI SCSI Revision 03
```

You can also use a text editor to view the messages in the file `/var/log/and` look for tape drive entries.

Sometimes a system may have multiple tape device names in the `/dev` directory and will not know which st number to use. To view the st device number for your attached tape drive, use the command: `dmesg | grep tape`

You should see output similar to:

```
Detected SCSI tape st0 and scsi0 . . .
```

Problems with Tape Drive and Cartridge

Tape will not Load into Tape Drive

1. Verify that the tape drive's Power Led is illuminated and that all other LEDs are off. If the Power LED is not illuminated, refer to the procedures for troubleshooting LEDs under "Computer Boots but Does not Recognize the Tape Drive" on page 72 to determine why it is not illuminated.
2. If the Power LED is illuminated but other LEDs are on or flashing, check to see if other LED activity is normal or abnormal (refer to Table 5 on page 32 and Table 6 on page 33).
3. If the Power On Self Test Failure LEDs are on, contact Technical Support.
4. If other LEDs are on, reboot the drive by holding the front panel button for more than 5 seconds and releasing it or by power cycling the drive.
5. Verify that the tape drive passed the Power On Self Test by viewing LED activity. All LEDs should be off approximately 20 to 30 seconds after the tape drive reboots.
6. If the Power On Self Test Failure LEDs are on, contact Technical Support.
7. If all the LEDs are off and a tape cannot be inserted into the tape drive, examine the tape and the inside of the tape drive.
 - Be sure there are no tape labels interfering with tape insertion.
 - Be sure tape labels are only on proper tape surfaces, and that labels are flat and not curled.
 - Ensure that tape drive opening is free of debris and tape labels.
 - Ensure that tape pin and tape are fully within the cartridge.
 - Attempt to insert a second tape if available.
8. If a tape still cannot be inserted into the tape drive:
 - If you are inserting a cleaning cartridge, be sure the cleaning tape is valid. The tape drive ejects unsupported cleaning tapes. Ensure that the cleaning tape has not expired. Refer to Table 5 on page 32 and Table 6 on page 33 for "Cleaning Cartridge at EOT." If these suggestions do not resolve the problem, contact Technical Support.
 - If you are inserting a data tape, the tape drive may be bad. Contact Technical Support.

Tape will not Eject from the Drive

1. Be sure the tape drive is powered on. If the Power LED is not illuminated, check whether power is being applied to the system and/or the desktop tape drive if the tape drive is a desktop unit. Follow troubleshooting steps under "Computer Boots but Does not Recognize the Tape Drive" on page 72 to determine why the Power LED is not illuminated.
2. If the Power LED is illuminated, determine whether the tape drive LEDs show other tape drive activity. Under normal conditions, it may take 2 to 3 minutes for the tape to eject. If only the Drive LED is blinking, wait for this LED to turn off before trying to eject the tape.
3. If the Drive LED alone is blinking, wait for it to turn off. Verify that no other LEDs are on or flashing. Push the eject button on tape drive.

4. If the Drive LED flashes, wait for the tape to eject (this may take up to 3 minutes). If the tape ejects, the problem has been resolved.
5. If a message similar to the following appears when the eject button is pushed, use the `mt offline` command to eject the tape:

You cannot eject the cartridge because the tape drive is in use. Wait until the operation is complete before ejecting the cartridge." The backup software may still have the tape drive in prevent mode so that the cartridge cannot be ejected. Use the backup software commands to eject the tape.



NOTE: In Unix/Linux the above message may not appear, but the operating system may still prevent the tape drive from ejecting the tape.

6. If the Drive LED is not blinking alone, refer to Table 5 on page 32 and Table 6 on page 33 to see whether a hardware or firmware error has occurred, or whether the "Manual Intervention" LED is flashing.
 - If there is a hardware or firmware error or the "Manual Intervention" LED is flashing — and the Drive LED is blinking — contact Technical Support.
 - If there is a hardware or firmware error or the "Manual Intervention" LED is flashing — and the Drive LED is not blinking — reboot drive by holding the front panel button for more than 5 seconds and releasing it or power cycling the drive. It may take up to 5 minutes for the tape to eject.
7. If the "Hardware or Firmware Error" or "Manual Intervention" LED is flashing after the tape drive is rebooted, the tape may be stuck. Contact Technical Support.

Emergency Reset and Emergency Cartridge Eject

In the unlikely event the LTO-1 or LTO-2 drive stops communicating with the host computer, use the following procedure to reset the drive and eject a cartridge (if necessary).



CAUTION: When you perform an emergency cartridge eject, any data currently in the drive or host's buffers will not be written to the tape and the tape record may not be correctly terminated with an End-of-Data mark. If the End-of-Data mark is not written to the tape, you will not be able to append any data to that tape unless you overwrite the existing data on the tape.

To perform an emergency reset, hold down the load/unload button between 5 to 15 seconds, and then release it.

- If there is no tape in the drive, the drive firmware reboots the drive and begins the power-on self-test sequence.
- If there is a tape in the drive, the drive ignores all outstanding SCSI commands, ejects the tape, reboots, and begins the Power On Self Test sequence.

If the procedures above do not eject the cartridge from the drive, you may need to remove the cartridge manually, as described under "Manually Removing a Cartridge" on page 76.

Manually Removing a Cartridge

The remainder of this section provides instructions for manually removing a data cartridge from an LTO-1 or LTO-2 drive. You should only perform this procedure if you cannot remove the cartridge by pushing the buttons on the front of the drive or by issuing commands from a host device. This should only be necessary if you must remove a data cartridge prior to returning the drive to Certance.



CAUTION: After following these procedures, you must return the drive to Certance for repair. Do not try to use the drive until after it has been serviced.

Before You Start

Before you manually remove a cartridge from the drive:

1. Issue all possible commands and run diagnostics.
2. Turn off all power to the drive.
3. Unplug all connectors to the drive.
4. Remove the drive from its operating environment.
5. Place the drive on a workbench with proper ESD grounding: attach a wrist strap to the bench and the other end to your wrist.
6. Remove the top cover of the drive by removing eight screws. (You will need a 1.5-mm hex driver.)



NOTE: Do NOT remove the front bezel or the bottom cover from the drive.

7. Inspect the drive to determine which procedure you should follow:
 - If the cartridge is loaded and the leader pin is still in the cartridge (see Figure 21 on page 77), go to “Cartridge is Loaded and Seated” on page 77.
 - If the cartridge is loaded and seated, and the tape is threaded or partially threaded on the take-up hub, go to “Cartridge is Loaded and Seated with Tape Threaded” on page 79.

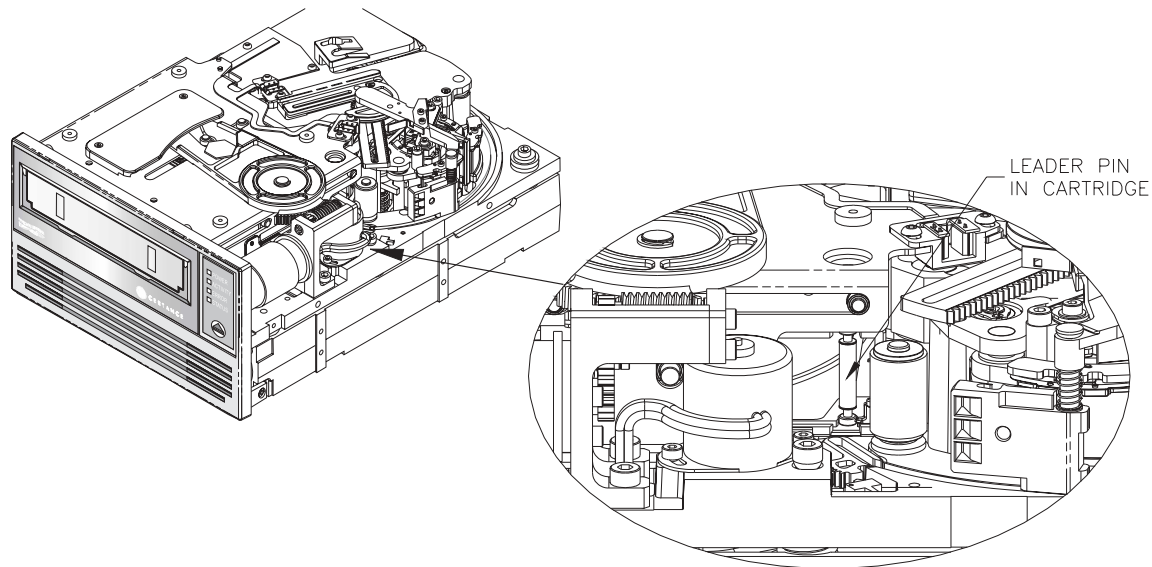

Figure 21. Diagram of LTO-1 and LTO-2 Drives with Leader Pin Inside LTO Cartridge (Tape Not Threaded on Take-up Hub)

Cartridge is Loaded and Seated

If the cartridge is loaded and seated and the leader pin is still inside the cartridge, follow these steps to remove the cartridge. To remove the cartridge you will need a small, flat-blade screwdriver

1. Verify that the leader pin is still inside the cartridge as shown in Figure 21 on page 77. If the leader pin has been pulled out of the cartridge and is still in the tape path, follow the steps in “Cartridge is Loaded and Seated with Tape Threaded” on page 79.
2. Use a flat-blade screwdriver to turn the worm gear counter clockwise (to the left). Figure 22 on page 78 shows the location of the worm gear. This will gradually raise the cartridge elevator and cause the cartridge to slide partially out of the drive.



NOTE: Do not touch any other part of the drive mechanism during this process.

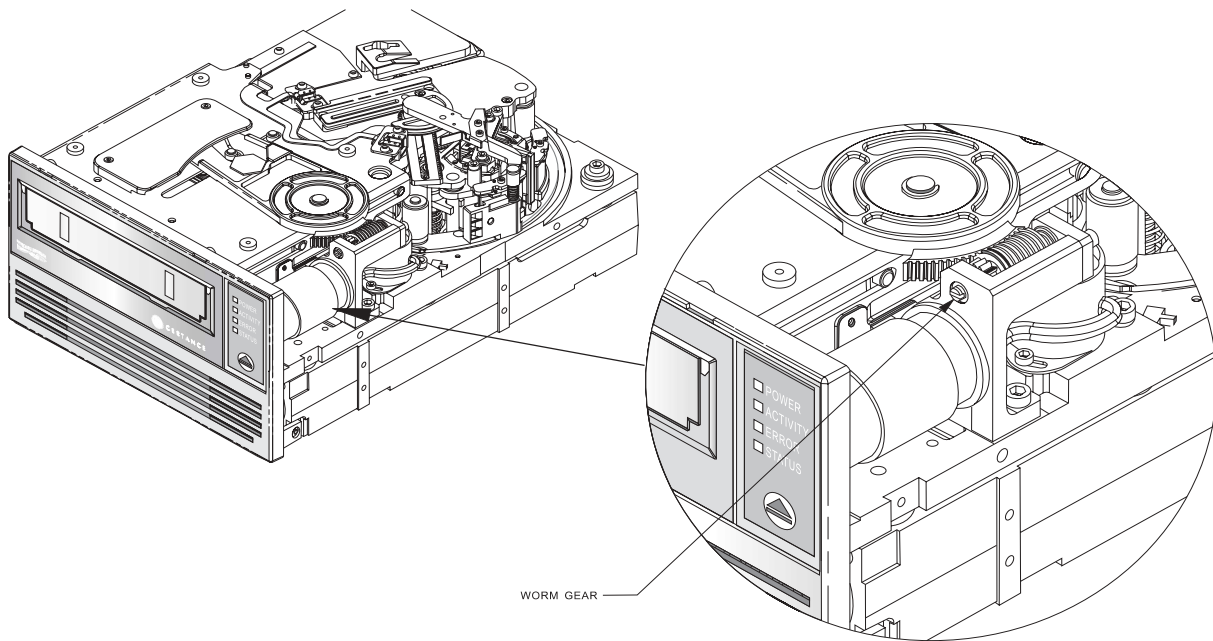

Figure 22. LTO-1 and LTO-2 Drive Worm Gear

3. Continue turning the worm gear until the cartridge is sticking out of the unit approximately 17 mm (0.66"). Then carefully pull the cartridge out by hand.
4. After you have removed the cartridge, put the top cover back on the drive; then replace and tighten the screws.
5. Return the drive to Certance.



CAUTION: Do NOT use the drive after you have removed a cartridge. The drive must be returned to Certance for servicing.

If you have any questions about this procedure, contact Technical Support.

Cartridge is Loaded and Seated with Tape Threaded

If the cartridge is loaded and seated, and the tape is entirely or partially threaded into the drive, follow these steps. To perform these steps you will need a small, flat-blade screwdriver and a 1.5-mm hex wrench. Figure 23 on page 79 shows key components of the drive mechanism that are referred to in the following procedure.



NOTE: Do not touch any part of the drive mechanism except for the components specified in the instructions. Be especially careful not to touch the tape head assembly. The MR elements in this assembly are highly susceptible to damage from static electricity.

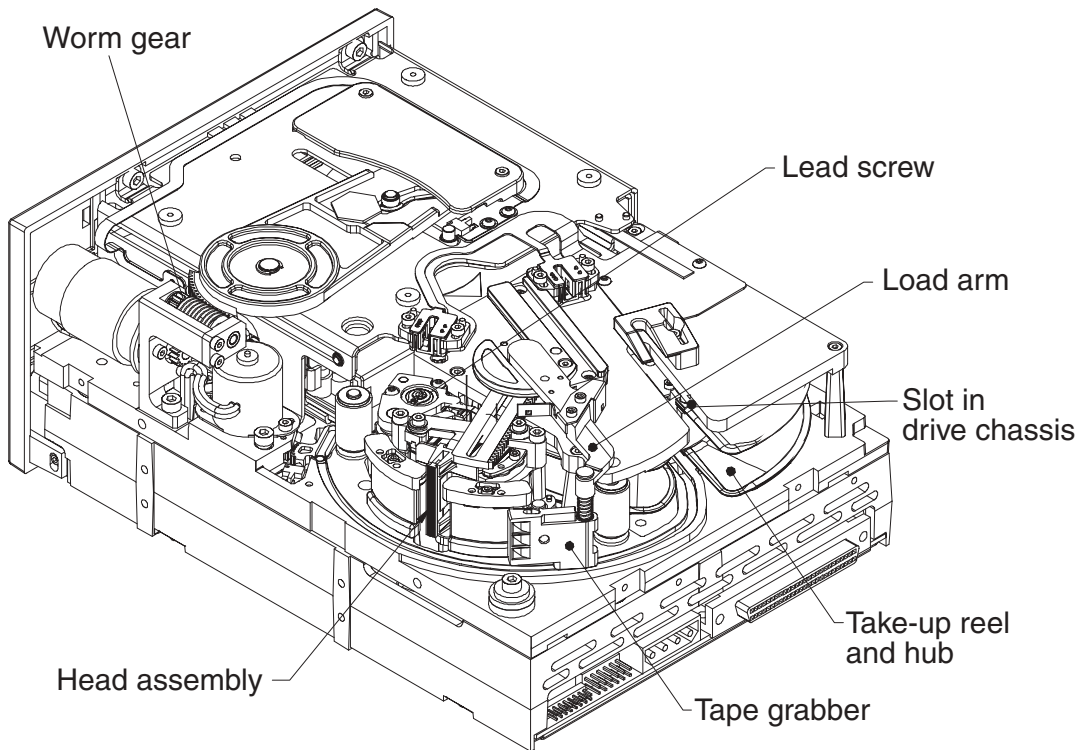

Figure 23. LTO-1 and LTO-2 Drive Key Components

1. Be sure the head assembly is in the lowered position by turning the lead screw (see Figure 24 on page 80) clockwise with the flat blade screwdriver. This is necessary to allow the load arm to clear the head assembly when it is moved back toward the cartridge.

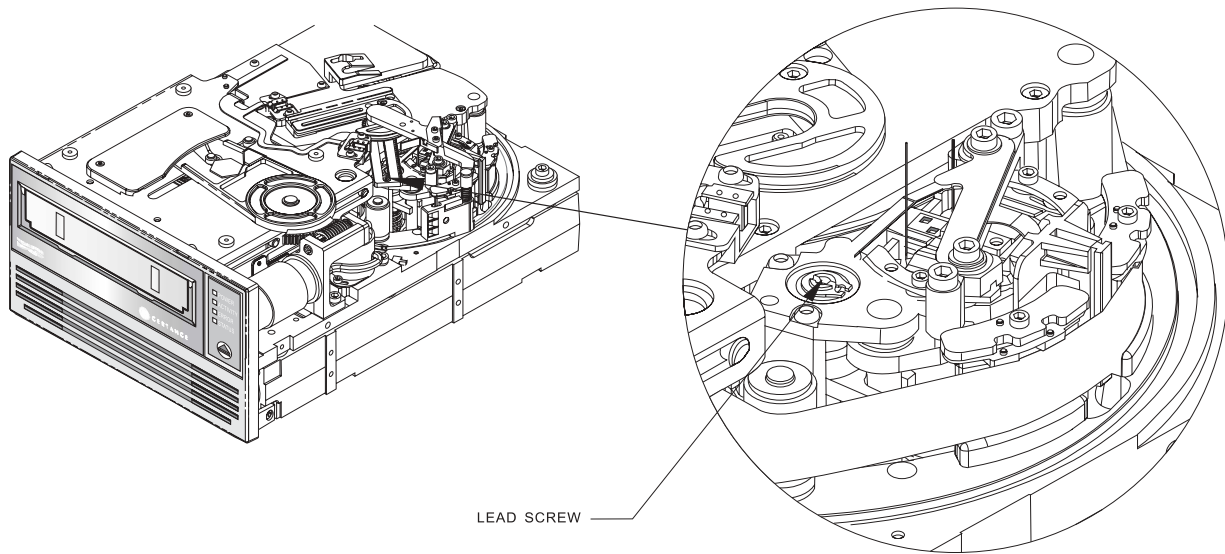

Figure 24. LTO-1 and LTO-2 Drive Lead Screw (Tape Threaded on Take-up Reel)

2. Replace the drive cover to protect the gear and spooling assemblies. You do not need to replace all the screws.
3. Turn the drive upside down.
4. Insert the 1.5-mm hex wrench through the hole in the bottom plate shown in Figure 25 on page 81. Turn the hex wrench clockwise slowly and smoothly to rewind the tape into the cartridge. This may take some time.



CAUTION: If you turn the hex wrench quickly or unevenly, you may create a tape loop, which could cause tape contamination.

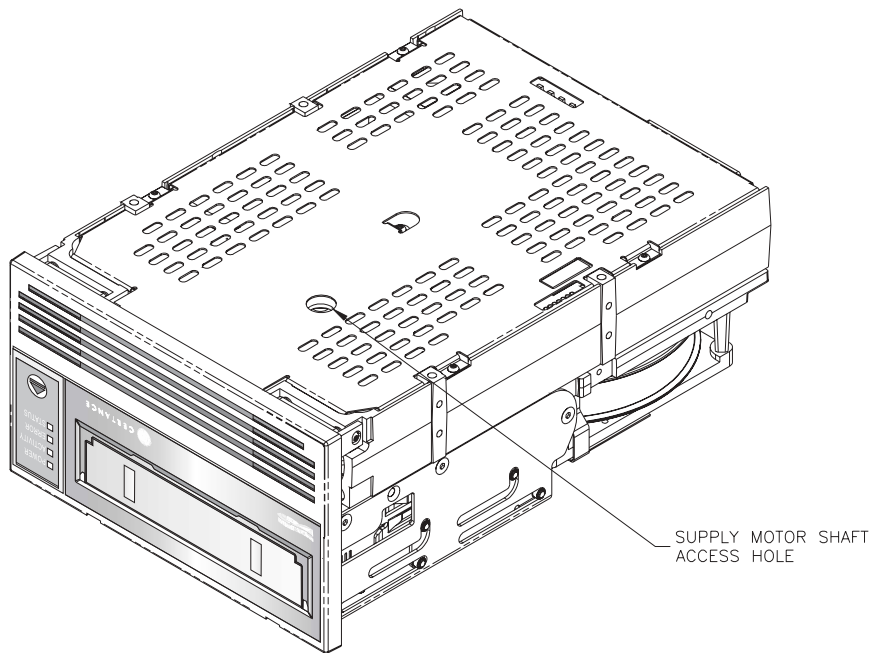

Figure 25. Underside of LTO-1 and LTO-2 Drives Showing Supply Motor Access Hole

5. When all of the tape has been spooled off of the take-up reel, turn the drive right side up.
6. Rotate the hub to align the slot in the hub with the slot on the drive chassis (see Figure 23 on page 79).
7. Set the drive on its left side. Rotate the load arm until the tape grabber clears the hub.



CAUTION: Be especially careful not to touch the tape head assembly. The MR elements in this assembly are highly susceptible to damage from static electricity.

8. Take up the slack tape again using the 1.5-mm hex wrench, as described in step 4.
9. Carefully push the grabber in toward the cartridge, as shown in Figure 26 on page 82.

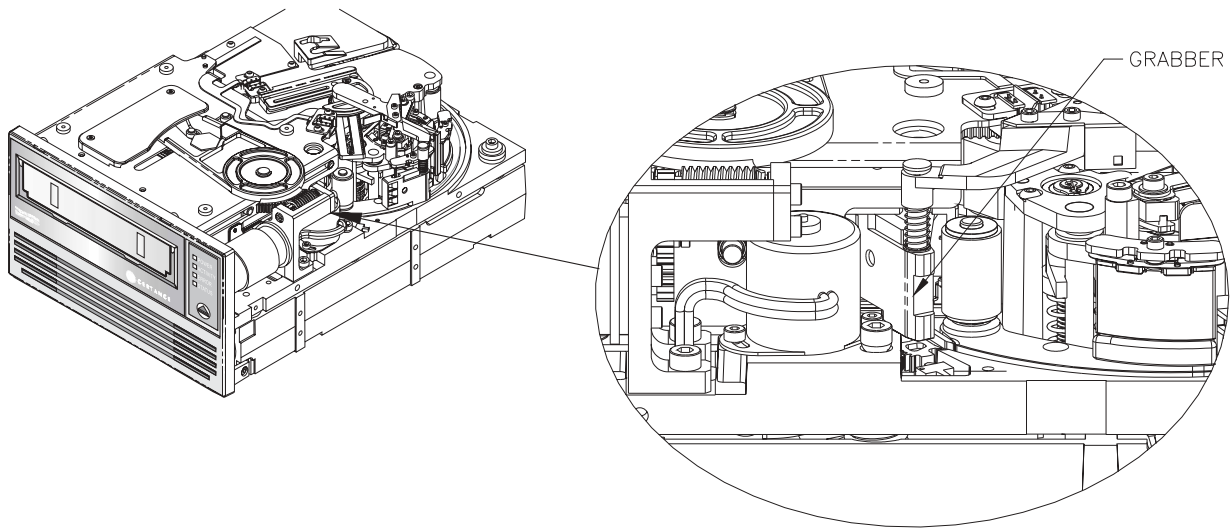

Figure 26. LTO-1 and LTO-2 drives Showing the Tape Grabber Near the Cartridge

- 10.** When the leader pin and the tape grabber reach the cartridge, gently push the grabber toward the front of the cartridge. Use the grabber to push the leader pin gently into the cartridge until it seats in place (you should hear a click).
- 11.** Using a flat-blade screwdriver, pivot the white lower track toward the drive bezel to disengage the leader pin.
- 12.** After the grabber has released the leader pin, pull the loader arm out of the way.
- 13.** Use a flat-blade screwdriver to turn the worm gear counter clockwise (to the left). Figure 27 on page 83 shows the location of the worm gear. This will gradually raise the cartridge elevator and cause the cartridge to slide partially out of the drive.

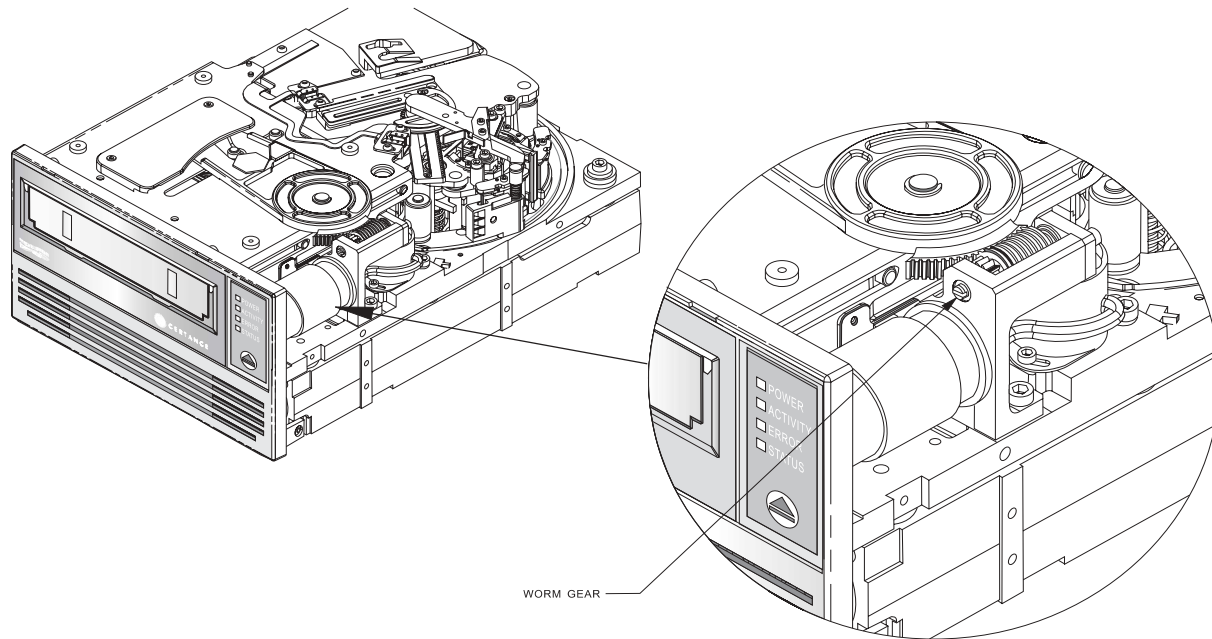

Figure 27. LTO-1 and LTO-2 Drive Worm Gear

- 14.** Continue turning the worm gear until the cartridge is sticking out of the unit approximately 17 mm (0.66"). Then carefully pull the cartridge out by hand.
- 15.** After you have removed the cartridge, put the top cover back on the drive; then replace and tighten the screws.
- 16.** Return the drive to Certance.



CAUTION: Do NOT use the drive after you have removed a cartridge. The drive must be returned to Certance for servicing.



NOTE: Any tape cartridge removed using this procedure should be retensioned before it is used for reading or writing data.

If you have any questions about this procedure, contact Technical Support.

Problems During Backup/Restore Operations

Backup Failures

A Backup failure can be caused by various reasons. The LTO-1 and LTO-2 tape drives support the TapeAlert standard. The following troubleshooting steps start when software logs a TapeAlert message. You can view the TapeAlert message either on the main console screen or in the backup software's log file. There may be more than one TapeAlert message per backup failure event.

1. The TapeAlert message or backup log shows, "The operation has stopped because an error has occurred while reading or writing data which the drive cannot correct." A media error occurred during write or read operation on the tape drive. Review the troubleshooting procedures to ensure that the proper SCSI cabling and termination practices are being followed. Restart the backup if any changes are made to the SCSI cabling or termination or if any cables or terminator are unplugged then re-plugged.

This message may also be seen with, "The tape is from a faulty batch or the tape drive is faulty." or "The tape is damaged or the drive is faulty. Call the tape drive supplier helpline." If either of these messages also appears, use a good tape to test the drive. If the problem persists, call the tape drive supplier helpline.

2. Remove the data tape and insert a cleaning cartridge. After the cleaning cartridge ejects reinsert the data tape and restart the backup. If the backup succeeds, the problem is resolved.
3. If the backup fails, try to isolate the tape media vs. tape drive. Use diagnostic software to perform a write/read test of 4GB of data. The current data on the tape WILL BE OVERWRITTEN AND ALL PREVIOUSLY WRITTEN DATA ON THE TAPE WILL BE DESTROYED. Use a second tape for the diagnostic test. If the diagnostic test passes on the second tape, use the tape for the backup process and remove the first tape from the backup process.
4. If the diagnostic test fails on the second tape, insert a cleaning tape into the drive and repeat the diagnostic write/read test. If the diagnostic test passes on the second tape, the problem is resolved.
5. If the diagnostic test fails on the second tape, the tape drive may be bad. Use the diagnostic software to perform a write/read test on the first data tape. The current data on the tape WILL BE OVERWRITTEN. ALL PREVIOUSLY WRITTEN DATA ON THE TAPE WILL BE DESTROYED. If the diagnostic test passes on the first tape, the problem is resolved. If the diagnostic fails on the first tape, the tape is bad and should not be used any longer.
6. If a second data tape is not available to test with the diagnostic software, but a cleaning tape is available, insert the cleaning tape. Remove the cleaning tape after the cleaning tape ejects and restart the backup. If backup is successful, the tape drive and tape are satisfactory.
7. If the backup fails, use the diagnostic software to perform a write/read test of 4GB of data. The current data on the tape WILL BE OVERWRITTEN. ALL PREVIOUSLY WRITTEN DATA ON THE TAPE WILL BE DESTROYED. If the tape drive passes the diagnostic write/read test, perform backup again. If the tape drive fails the diagnostic, the drive may be bad. Contact Technical Support.

Tape is Write Protected

The following troubleshooting steps start when software logged a TapeAlert message. The TapeAlert message can be viewed either on the main console screen or in the backup software's log file. There may be more than one TapeAlert message per backup failure event.

1. The TapeAlert message or backup log shows, "You are trying to write to a write-protected cartridge. Remove the write-protection or use another tape." Eject the tape from the drive and move the write protect tab to the enable position. Reinsert the tape and restart the backup.
2. If the TapeAlert message or backup log shows, "The memory in the tape cartridge has failed, which reduces performance. Do not use the cartridge for further backup operations." a Cartridge Memory chip failure may have occurred in the tape cartridge or a tape drive failure may have occurred. Use another tape to perform a backup. (This message may be seen with, "You have loaded a cartridge of a type that is read-only in this drive. The cartridge will appear as write-protected.")
3. If you insert a second tape for a backup and other TapeAlert messages appear in the backup software again, the tape drive may be bad. Insert a second tape and restart the backup. The backup should be successful. The first tape cannot be used for further backups.
4. If you start a backup and the software displays a message on the console a message similar to "Overwrite protection is set to _____. Click OK to overwrite the media or insert new media that can be overwritten." it indicates a software-related problem. Refer to the backup software instructions on overwrite and append settings.

Miscellaneous TapeAlert Messages

1. If either of the following messages appears:

"The tape drive has a hardware fault:

1. Eject the tape or magazine.
2. Reset the drive.
3. Restart the operation."

Or

"The tape drive has a hardware fault:

1. Turn the tape drive off and then on again.
2. Restart the operation.
3. If the problem persists, call the tape drive supplier helpline.

Check the tape drive users manual for device specific instructions on turning the device power on and off."

Refer to Table 5 on page 32 and Table 6 on page 33 to see whether the LED activity indicates a "Hardware or Firmware Error" or "Manual Intervention Required." If it does, power cycle the tape drive. The tape should eject. This may take several minutes.

If the tape drive ejects the tape and all LEDs are off (with the possible exception of Cleaning Request LED), the problem is resolved.

If the tape did not eject and the LEDs show "POST Failure," "Hardware or Firmware Error," or "Manual Intervention Required," the drive may be bad. Contact Technical Support.

- 2.** If you have a problem with inserting a cleaning cassette and receive the message:

```
"The last cleaning cartridge used in the tape drive has worn out:
```

1. Discard the worn out cleaning cartridge.
2. Wait for the current operation to finish.
3. Then use a new cleaning cartridge."

It means the cleaning cartridge is used up. Purchase a new cartridge to perform any more cleaning cycles. Normal operation of the drive is not affected. The drive will continue to automatically eject the expired cleaning cartridge.

- 3.** If you insert a cleaning tape that is not expired but the tape is being ejected by the tape drive without performing the cleaning, you may see the message:

```
"The last cleaning cartridge used in the tape drive was an invalid type:
```

1. Do not use this cleaning cartridge in this drive.
2. Wait for the current operation to finish.
3. Then use a valid cleaning cartridge."

This message means the tape drive does not recognize the cleaning tape as being of a valid type. You may have purchased a cleaning tape that is not supported by the tape drive. Purchase a supported cleaning tape.

- 4.** If the tape drive issues a message to backup software to instruct you to clean the tape drive, you may see the message:

```
"The tape drive needs cleaning:
```

1. If the operation has stopped, eject the tape and clean the drive.
2. If the operation has not stopped, wait for it to finish and then clean the drive.

```
Check the tape drive users manual for device specific cleaning instructions."
```

This message means you should use a supported cleaning tape.

Slow Backups

There are many factors that can make backups appear to be "slow." To achieve the highest possible transfer rate, the LTO-1 or LTO-2 tape drive **MUST** be attached to a Low Voltage Differential (LVD) SCSI controller capable of a minimum of 80 MB/s and **MUST** not share the same SCSI bus as another active SCSI device such as hard drives.

- 1.** Is the tape drive attached to an LVD SCSI controller? This can be determined by viewing the boot process of the system and looking to see what controller the tape drive is attached to. There may be boot log files that can be examined to determine what SCSI controller the tape drive is attached to.
- 2.** If the tape drive is not attached to an LVD SCSI controller, attach the tape drive to a LVD SCSI controller to achieve best possible hardware performance for best possible transfer rate.
- 3.** If the tape drive is attached to an LVD SCSI controller, see whether the tape drive the only device on the SCSI cable? This can be determined by viewing Windows Device Manager, viewing Unix/Linux logs, or by viewing SCSI controller during system boot up.
- 4.** If other SCSI devices are attached to the SCSI controller and are active during the time when a backup is performed to the tape drive, have the tape drive as the only device on the SCSI cable to achieve the best possible backup performance.

The method of performing the backups can also be a factor in "slow" backups. Data sent to the tape drive over a network connection and delays in data transfer over a network connection can cause backups to slow down.

- 1.** Perform write/read test with diagnostic software. This ensures a test of the connection between the tape drive and SCSI controller and removes the network data transfer and the backup software from the diagnosis. The write/read test **WILL OVERWRITE DATA ON THE TAPE.**
- 2.** When the test finishes, determine the megabyte per second data transfer. The resulting calculation shows the tape drive performing at an acceptable rate.
- 3.** If you believe that the write/read transfer is slow even after using the diagnostic software write/read test, use the Certance Tape Diagnostic software to perform a trace buffer retrieval. Send the file to Technical Support, so that the state of the SCSI bus can be determined.
- 4.** If the diagnostic write/read test transfer rate is acceptable, but backups still seem to be "slow," it may be attributed to the number of files and the average file size that are to be backed up. These factors can have a significant effect on the backup performance. Backups where the average file size is less than 200k bytes are slower than backups where the average file size is greater than 200k bytes. Obtain backup log files to determine number of files and average file size.

Index

A

AIX 4.1 settings 59

B

Backup/restore problems 84
Best practices 70
blink codes 32

C

Cartridges
removing manually 76
Cartridges
care and maintenance 35
ejecting 75
loading 34
specifications 51
troubleshooting 74
unloading 34
write-protecting 35, 85
Cautions, internal drives 15
Checking SCSI termination
desktop drives 29
internal drives 20, 29
Cleaning a tape drive 36
Computer boots but does not recognize tape drive 72
Computer will not boot 71
Configuring
internal drives 17
internal Fibre Channel LTO-1 drive 23
Connecting
Fibre Channel cable 25
power cable
desktop drives 30
internal drives 22
internal Fibre Channel LTO-1 drive 27
SCSI cable for desktop drives 29
SCSI cable for internal drives 20
serial cable for internal drives 21
serial cable for internal Fibre Channel LTO-1 drive 26

D

DAT 72
features 11
Data buffer 40
Data compression
considerations 42
intelligent 43
data compression 42
Data integrity 40
error-correction code 40
servo-tracking faults 41
DDS-4
features 11
DEC/Compaq Unix settings 56
Desktop drives
checking SCSI termination 29
connecting a power cable 30
connecting a SCSI cable 29

installation instructions 28
installing the LTO driver 30
quick start 15
SCSI ID 28
Drive maintenance
cleaning a tape drive 36
parking a tape drive 37
Drive performance specifications
Specifications
drive performance 48

E

Ejecting a cartridge 75
Electromagnetic compatibility 53
Emergency cartridge eject 75
Emergency reset 75
Environmental requirements 49
Error-correction code 40
External drives
quick start 15

F

Features 11
Fibre Channel cable connection 25
Fibre Channel drive
quick start 14
Fibre Channel interface 66, 69
Front panel display 31

G

Guidelines, internal drives 15

H

HP-UX 11.0 settings 64

I

IBM AIX 4.1.x and later settings 59
Injected noise 50
Inspection 15
Installation instructions
desktop drives
checking SCSI termination 29
connecting a power cable 30
connecting a SCSI cable 29
installing the LTO driver 30
overview 28
setting the SCSI ID 28
internal drives
checking SCSI termination 20
configuration 17
connecting a power cable 22
connecting a SCSI cable 20
connecting a serial cable 21
installing the LTO driver 22
mounting instructions 19
overview 16
internal Fibre Channel LTO-1 drive
configuration 23
connecting a Fibre Channel cable 25
connecting a power cable 27

- connecting a serial cable 26
- installing the LTO driver 27
- mounting instructions 24
- overview 23
- Installing the LTO driver
 - desktop drives 30
 - internal drives 22
 - internal Fibre Channel LTO-1 drive 27
- Intelligent data compression 43
- Interfaces
 - Fibre Channel 66, 69
 - parallel SCSI 65, 68
- Internal drives
 - checking SCSI termination 20
 - configuring 17
 - connecting a power cable 22
 - connecting a SCSI cable 20
 - connecting a serial cable 21
 - guidelines and cautions 15
 - installation instructions 16
 - installing the LTO driver 22
 - mounting 19
 - quick start 13, 14
 - registering 22
 - SCSI ID 17
 - terminator power 18
- Internal Fibre Channel LTO-1 drive
 - configuring 23
 - connecting a Fibre Channel cable 25
 - connecting a power cable 27
 - connecting a serial cable 26
 - installing the LTO driver 27
 - Loop ID 23
 - mounting 24
- Internal LTO-1 Fibre Channel drive
 - installation instructions 23

L

- Layout of track 38
- Linux settings 62
- Loading a cartridge 34
- Loop ID, internal Fibre Channel LTO-1 drive 23
- LTO-1 drive
 - features 11
 - overview 10
- LTO-2 drive
 - features 11
 - overview 10

M

- Manually removing a cartridge 76
- Mean time between failures 50
- Method of recording 39
- Mounting
 - internal drive 19
 - internal Fibre Channel LTO-1 drive 24

P

- Parallel SCSI interface 65
- parallel SCSI interface 68
- Parking a tape drive 37
- Physical specifications 44
- Power cable connection

- desktop drives 30
- internal drives 22
- internal Fibre Channel LTO-1 drive 27
- Power specifications 47

Q

- Quick start
 - desktop drives 15
 - external drives 15
 - Fibre Channel drive 14
 - internal drives 13, 14

R

- Recording method 39
- Registering tape drive 22, 27, 30
- Registering your tape drive 22
- Regulatory compliance 52
- Reliability 50
- Removing a cartridge manually 76
- Reset, emergency 75

S

- SCO Open Server 5.0.x Unix settings 60
- SCSI cable connection
 - desktop drives 29
 - internal drives 20
- SCSI controllers 55
- SCSI ID
 - desktop drives 28
 - internal drives 17
- Serial cable connection
 - internal drives 21
 - internal Fibre Channel LTO-1 drive 26
- Servo-tracking faults 41
- SGL Irix settings 63
- Slow backups 87
- Specifications
 - electromagnetic compatibility 53
 - environmental requirements 49
 - injected noise 50
 - LTO cartridge 51
 - mean time between failures 50
 - physical 44
 - power 47
 - regulatory compliance 52
 - reliability 50
- Sun (Solaris 2.4, 2.5, 2.6, 7, 8, 9) Unix settings 57

T

- Tape alert flags 68
- Tape drive
 - cleaning 36
 - features 11
 - parking 37
 - registering 22, 27, 30
- Tape drive not recognized by operating system or application 73
- Tape drive troubleshooting 74
- Tape drives
 - covered in this User's Guide 10
- Tape will not eject from drive 74
- TapeAlert messages 85
- Terminator power



- internal drives 18
- Track layout 38
- Troubleshooting 71
 - backup/restore problems 84
 - Computer boots but does not recognize tape drive 72
 - computer will not boot 71
 - slow backups 87
 - tape drive not recognized by operating system or application 73
 - tape drives and cartridges 74
 - tape will not eject from drive 74
 - tapeAlert messages 85
- Typical system configurations 68
 - Fibre Channel interface 69
 - parallel SCSI interface 68

U

- Unix settings
 - DEC/Compaq Unix 56
 - SCO Open Server 5.0.x 60
 - Sun (Solaris 2.4, 2.5, 2.6, 7, 8, 9) 57
- Unloading a cartridge 34
- Unpacking 15

W

- Write-protecting a cartridge 35, 85