

HP LTO Ultrium tape drives technical reference manual

Volume 1: hardware integration

LTO5 drives

Abstract

This is one of five volumes that document HP LTO Ultrium 5 tape drives (Fibre Channel and SAS). This volume provides hardware integration information. See [Chapter 12](#) on page 153 for details of the other guides.



Legal and notice information

© Copyright 2010 Hewlett-Packard Development Company, L.P.

The information contained herein is subject to change without notice. The only warranties for HP products and services are set forth in the express warranty statements accompanying such products and services. Nothing herein should be construed as constituting an additional warranty. HP shall not be liable for technical or editorial errors or omissions contained herein.

Acknowledgements

Windows is a U.S. registered trademarks of Microsoft Corporation.

UNIX is a registered trademark of The Open Group.

Warranty

WARRANTY STATEMENT: To obtain a copy of the warranty for this product, see the warranty information website:

<http://www.hp.com/go/storagewarranty>

Contents

1 Physical dimensions	11
Fixing dimensions	11
Full-height drives	11
Full-height drives: bottom panel	12
Full-height drives: side panel	12
Half-height drives	12
Half-height drives: bottom panel	13
Half-height drives: side panel	13
2 Electrical and environmental requirements	15
Electrical fit	15
Power requirements	15
Voltage and current requirements	15
Full-height drives	15
Half-height drives	16
Airflow requirements	16
Full-height drives	16
Half-height drives	17
Measuring internal drive temperatures	17
Full-height drives	17
Half-height drives	17
Airflow and cooling	17
Optional fan plate	18
Extracting internal temperature information	18
3 Front panel and LEDs	21
Front panel features	21
Full-height drives	21
Reset switch	21
Half-height drives	22
Usual meaning of LEDs	22
LED patterns	23
Full-height drives	23
Half-height drives	25
During firmware upgrade	27
Replacing the front panel	28
Parts needed	28
Replacing the front panel on an full-height LTO Ultrium drive	28
Replacing the front panel on a half-height LTO Ultrium drive	29
4 Rear panel and connectors	31
Rear panel components—full-height drives	32
Rear panel components—half-height drives	34
LEDs (full-height Fibre Channel drives only)	35

Power-on self-test failure	35
Port initialized	35
Port activity	35
Fibre Channel addressing	35
Connectors	36
Fibre Channel connector	36
SAS connector	36
Automation and remote LED connector	37
Connector pins	37
Remote LEDs	38
Automation and remote LED connector schematic	39
iADT (Ethernet) port	40
Diagnostic Serial Port connector	40
Fan control connector	41

5 Cartridges 43

Choosing cartridges	43
Labeling cartridges	43
Write-protecting cartridges	43
Cartridge life	44
Caring for cartridges	44
Avoiding condensation	44
Conditions in use	44
Conditions in storage	45
Maximizing tape life	45
LTO Cartridge Memory	45
LTO Cartridge Memory issues	46
More information	46

6 Planning your system configuration 47

Modes of usage	47
Optimizing performance	47
Dedicated bus	47
System performance	47
Data rate matching	47
Performance checklist	48

7 Installing and replacing drives 49

Installing in a server	49
Identifying the model	49
Standards and safety	49
Requirements	50
Mounting requirements	50
Server connections	50
Connecting the drive	51
SAS connector	51
Backup software	51
Installing in a tape array	52
Appropriate HP rack-mount systems	52
Airflow requirements	52
Full-height drives:	52
Half-height drives:	52
Identifying the drive	52

Modes of usage	52
Attaching to SAS	52
Connecting to a Fibre Channel router or by SAS to a server or router	53
Fibre Channel connection	53
Server SAS connection	53
Replacing a drive	53
Installing in a library	53
Rear panel and connectors	53
Installing standalone drives	54
Identifying the drive	54
Connecting the drive	54
SAS connection	54
Moving drives	55
8 Operating the drive	57
Power-on self-test	57
Loading a cartridge	58
Unloading a cartridge	59
Cleaning	59
Resetting drives in a library	60
9 Troubleshooting	61
Emergency unload (forced eject)	61
General guidelines	61
Diagnosing the problem	62
Problems with the host computer	62
Computer does not boot up	62
Computer boots, but does not recognize the drive	62
Problems with the drive and cartridge	63
Tape drive does not power up	63
The application does not recognize the drive	63
The cartridge will not eject	64
The drive will not accept a cartridge	64
The computer no longer recognizes the drive in a tape array	65
Problems with cleaning	65
10 Special features for automation	67
Introduction	67
Backup software	67
Drive Model ID String	67
Front panel for automation use	68
Full-height drives	68
Front panel for use in autoloaders	69
Half-height drives	70
Automation interface	70
Automation Control Interface (ACI)	71
Automation/Drive Interface (ADI)	71
Internet Automation Device interface (iADT)	72
Fan interface	74
Configuring autoloader and library-controlled loads	74
Cartridge positions during load and unload	75
Load scenarios	76
Load scenario 1: Autoloader	76

Load/unload forces	77
Using Cartridge Memory (LTO-CM) in libraries	77
Current libraries — barcodes	78

11 Drive error codes 79

Generic module (from 0000h)	79
Automation Control Interface (from 0400h)	79
Buffer manager (from 0800h)	83
Diagnostic control (from 1800h)	84
Drive control (from 1C00h)	87
Drive monitor (from 2000h)	88
External interfaces (from 2400h)	88
Front panel interface (from 2800h)	89
Host interface (from 2C01h)	89
Logical formatter (from 3000h)	99
Logical media (from 3400h)	103
Logical pipeline control (from 3800h)	104
Mechanism control (from 3C00h)	104
Non-volatile data manager (from 4000h)	105
Operating system (from 4400h)	110
Physical formatter (from 4C00h)	110
Physical pipeline control (from 5000h)	111
Physical side error recovery (from 5400h)	113
Read/write control (from 5800h)	113
System architecture (from 6400h)	115
Tight integ (from 6800h)	115
Trace logger (from 6C00h)	116
Mechanical interface (from 7400h)	116
Exception handler (from 7800h)	132
SPI interface (from 7C00h)	133
Cartridge Memory (from 8000h)	133
Fault log manager section (from 8400h)	134
Infrastructure section (from 8800h)	135
Critical section (from 8C00h)	136
SCSI module (from 9400h)	136
Automation/Drive Interface (from 9800h)	143
Management API (from 9C00h)	145
Servo (from A000h)	146
Certificate manager (from A400h)	150
Cryptographic algorithms (from A800h)	150

12 Support and other resources 153

Related documents	153
Documents specific to HP LTO Ultrium drives	153
Documentation map	153
Drives—general	153
Installation and configuration	153
Operation	154
Cartridges	154
Interface	154
Maintenance and troubleshooting	155
Dealing with errors	155
LTO Ultrium features	156
General documents and standardization	157

Glossary 159

Index 165

Figures

1	Rear panel components for a full-height Fibre Channel drive	32
2	Rear panel components for a full-height SAS drive	33
3	Rear panel components for a half-height FC drive	34
4	Rear panel components for a half-height SAS drive	34
5	ADI-LED connector schematic	39
6	LED driver circuit	39
7	iADT port schematic	40
8	Diagnostic Serial Port connector schematic	41
9	Fan connector schematic	41
10	Half-height automation bezel	70
11	Full-height drives: load and unload positions	75
12	Half-height drives: load and unload positions	75

Tables

1 AL_PA and Loop ID look-up table	35
---	----

1 Physical dimensions

For the physical specification of the drive, see Chapter 1, “Physical Specification” in *Specifications*, Volume 4 of the HP LTO Ultrium Technical Reference Manual.

Fixing dimensions

- All screws should be M3 threaded. Do not use spring washers.
- The recommended mounting torque is:
 - *Full-height drives*: 5.8 ±0.5 lb-in (0.60–0.70 Nm)
 - *Half-height drives*: 2.4 ±0.5 lb-in (0.24–0.30 Nm)
- HP recommends 0.3 mm mounting clearance around all covers for isolation mounting movement.

Full-height drives

The recommended screw length depends on the thickness of the rails or enclosure into which the drive is mounted:

Server or Rail Thickness	Recommended Screw Length
> 1.5 mm ≤ 2.0 mm	M3 x 6.0 mm
> 1.0 mm ≤ 1.5 mm	M3 x 6.0 mm
≤ 1.0 mm	M3 x 5.0 mm

Mounting Points	Maximum Screw Penetration
Side	5 mm
Bottom	5 mm

Full-height drives: bottom panel

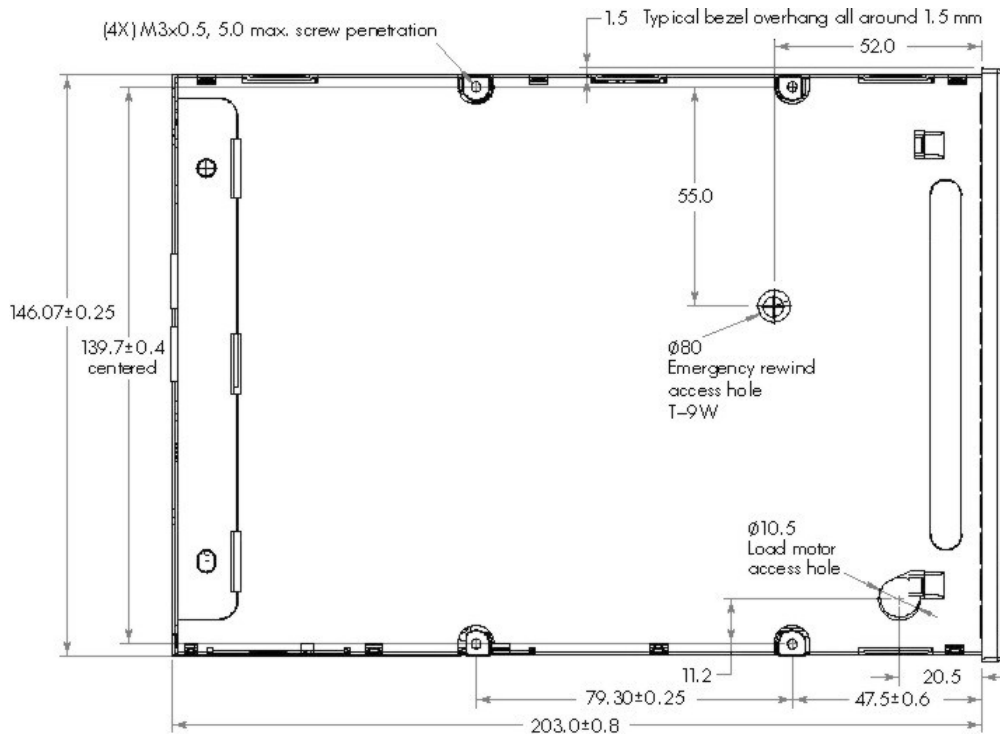

Full-height drives: side panel

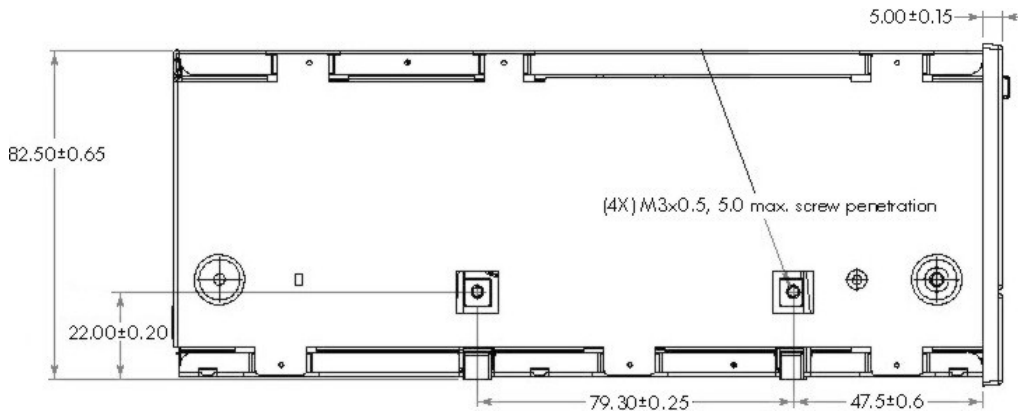

Half-height drives

Mounting Points	Maximum Screw Penetration
Side	3 mm
Bottom	2.1 mm

Half-height drives: bottom panel

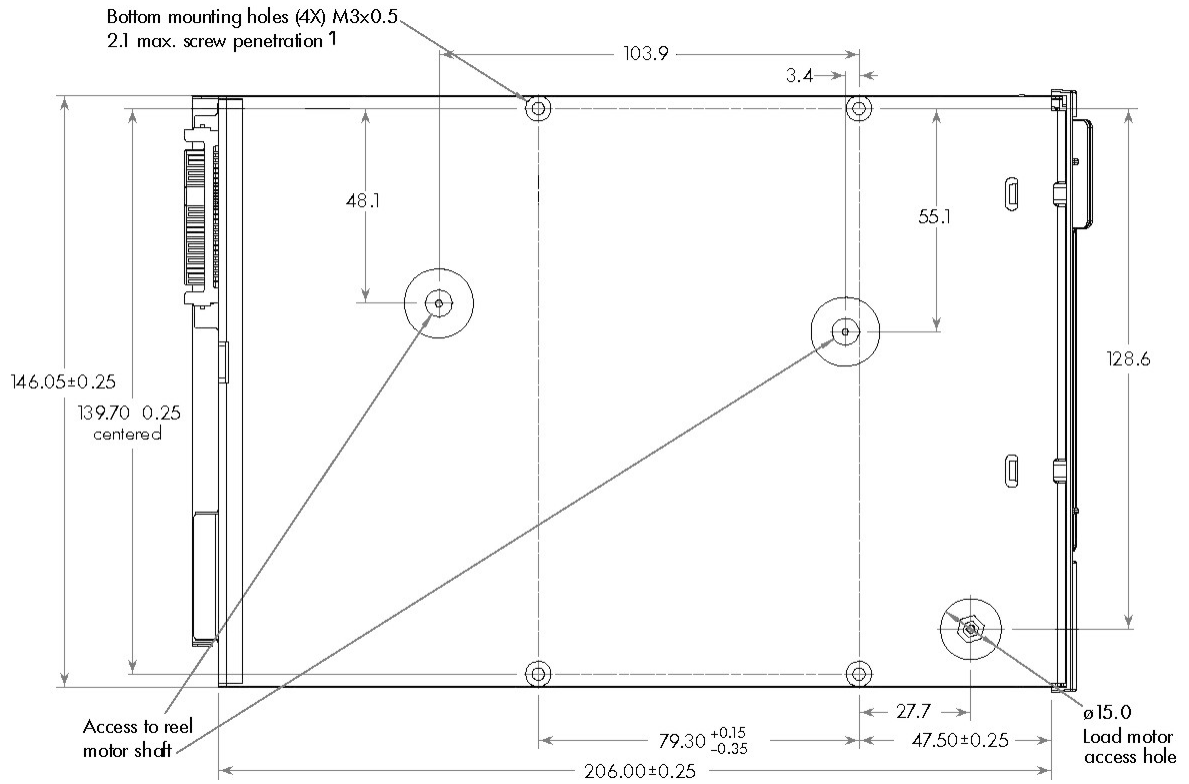

Half-height drives: side panel

FC drives:

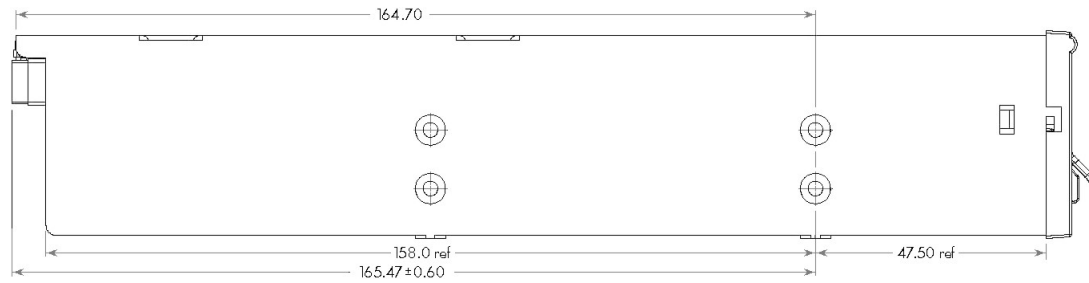

SAS drives:

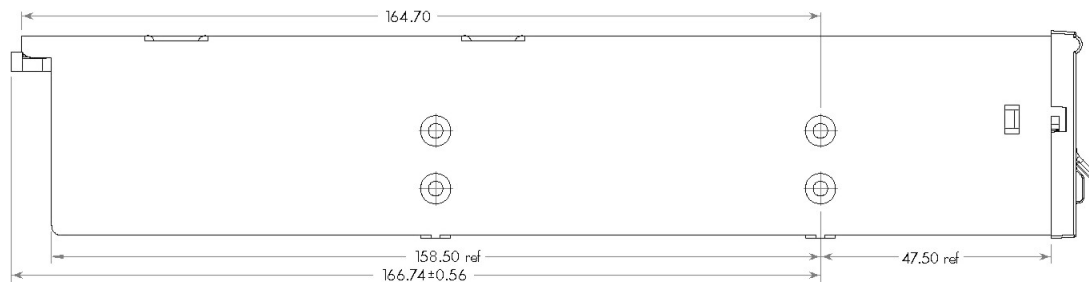

2 Electrical and environmental requirements

Electrical fit

Power requirements

 **NOTE:**

SAS drives do not have a regular 4-pin power connector and should be powered through the SAS connector.

The following are the PSU requirements for FC and SAS full-height and half-height drives:

Voltage	Typical Current	Maximum Current
5V	3.6A	<3.7A
12V	0.50A	<3.0A

See also details in Chapter 2, “Electrical Requirements” in *Specifications*, Volume 4 of the HP LTO Ultrium Technical Reference Manual.

The drive is specified to operate at $5V \pm 5\%$ and $12V \pm 10\%$.

Voltage and current requirements

Voltage and current requirement are as follows:

Full-height drives

Specification	FC Drives		SAS Drives	
	5V	12V	5V	12V
Max voltage	5.25V	13.2V	5.25V	13.2V
Min voltage	4.75V	10.8V	4.75V	10.8V
Max steady-state current	3.54A	0.62A	3.57A	0.60A
Max transient current	3.57A	2.03A	3.58A	2.03A
Max steady-state power	17.70W	7.44W	17.83W	7.15W

	FC Drives		SAS Drives	
Specification	5V	12V	5V	12V
Max transient power	17.86W	24.37W	17.90W	24.36W
Max noise/ripple	150 mVpp	150 mVpp	150 mVpp	150 mVpp

Half-height drives

	FC Drives		SAS Drives	
Specification	5V	12V	5V	12V
Max voltage	5.25V	13.2V	5.25V	13.2V
Min voltage	4.75V	10.8V	4.75V	10.8V
Max steady-state current	3.36A	0.54A	3.48A	0.56A
Max transient current	3.45A	1.70A	3.60A	2.09A
Max steady-state power	16.80W	6.48W	17.39W	6.72W
Max transient power	17.25W	20.51W	18.0W	25.09W
Max noise/ripple	150 mVpp	150 mVpp	150 mVpp	150 mVpp

NOTE:

Half-height FC drive power consumption figures are currently provisional. Final power consumption figures will be available in a future edition of this document.

Airflow requirements

HP LTO Ultrium drives require forced airflow to ensure that components never exceed critical temperatures.

Full-height drives

Airflow should be from front to back. The required flow depends on the ambient air temperature:

- 6 cfm for ambient air temperatures fluctuating in the range 10°C–35°C.
- 8 cfm for ambient air temperatures fluctuating in the range 10°C–40°C.

Half-height drives

Air-flow must be from front to back. The required flow is 5 cfm for ambient air temperatures fluctuating in the range 10°C–40°C.

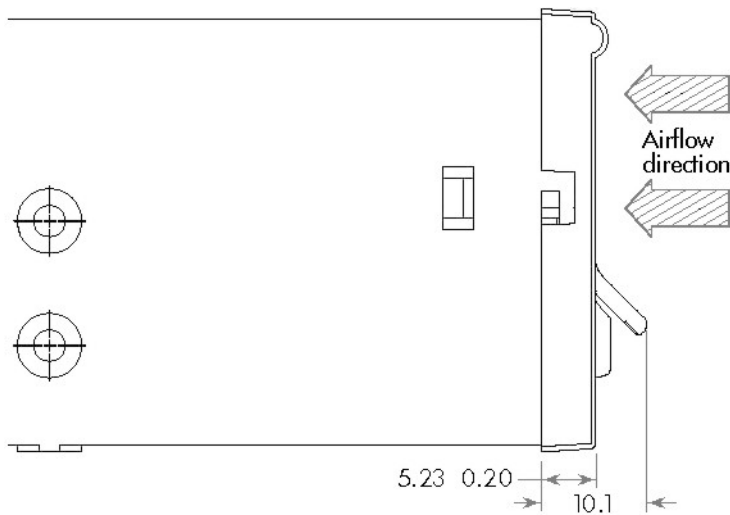

Measuring internal drive temperatures

The recommended method of measuring the temperature of critical components is to read the "Max temperature since cartridge loaded" after exercising the drive by writing data at the maximum data rate for a period of at least one hour. This temperature correlates closely with the temperature of the most critical ICs.

Full-height drives

Airflow should be from front to back. The maximum temperature at the Primary Temperature Sensor should be:

- <25°C above ambient for 40°C maximum temperature ambient environment
- <30°C above ambient for 35°C maximum temperature ambient environment

This equates to:

- <65°C at 40°C ambient (8 cfm airflow)
- <65°C at 35°C ambient (6 cfm airflow)

Half-height drives

The maximum temperature at the Primary Temperature Sensor should be <25°C above ambient for 40°C maximum temperature ambient environment, equating to <65°C at 40°C ambient.

Airflow and cooling

HP LTO Ultrium drives require forced airflow that satisfies the following conditions:

- For full-height internal drives, the airflow at 35°C ambient air operation should be at least 6 cubic feet per minute (0.17 cubic meters per minute or 10.19 cubic meters per hour) through the product.

At 40°C, it should be at least 8 cfm (0.23 m³/min. or 13.60 m³/h). The airflow should be from front to back.

- For half-height internal drives, the airflow should be at least 5 ft³/min (0.14 m³/min or 8.50 m³/h) through the product from front to back.

These requirements and the operating temperature specification should keep the internal temperature around the media to less than 45°C and ensure reliable operation.

The airflow does not require filtering if the air contamination specifications are met. See “Climatics” in Chapter 4, “Environmental Specification” in *Specifications*, Volume 4 of the HP LTO Ultrium Technical Reference Manual.

△ **CAUTION:**

Care must be taken that empty bays in the server have the appropriate blanking plates installed so that airflow is maintained. Refer to your server documentation.

For details of how to measure the internal drive temperature, see “[Measuring internal drive temperatures](#)” on page 17.

Optional fan plate

If the airflow requirements cannot be met by the existing fans in a server then the optional fan plate may be required. This is a plastic plate with an embedded fan that fits on the back of a half-height drive. The fan plugs into the Fan Connector (see “[Rear panel components—full-height drives](#)” on page 32 and “[Fan control connector](#)” on page 41) and the drive controls this fan to self-manage its own internal temperature, turning the fan on and off as needed. For details of the optional Fan Plate, contact your HP Technical Support Representative.

Extracting internal temperature information

You can extract the “Max temperature since cartridge loaded” reading via the main interface, via the ACI/ADI interface, or via the iADT (Ethernet) interface using the `send_scsi` command as follows:

1. Send a SEND DIAGNOSTICS command:

```
1D 11 00 00 08 00
```

with the following data out

```
93 00 00 04 00 00 20 2A
```

2. Then send a RECEIVE DIAGNOSTICS command:

```
1C 01 93 00 44 00
```

3. The “Max temperature since cartridge loaded” value is ASCII encoded in bytes 22–29 of the incoming data.

Example SCSI trace:

```

SendDiagnostic      |1D 11 00 00 08 00 |00008|00|00|
      Data Out |93 00 00 04 00 00 20 2A |
ReceiveDiagResults |1C 01 93 01 00 00 |0009C|00|00|
      Data In |93 00 00 98 30 30 30 30 31 41 31 32 20 30 30 30 |
      Data In |30 31 41 31 32 20 30 30 30 30 31 41 37 34 20 30 |
      Data In |30 30 30 31 39 31 37 20 0D 0A 30 30 30 30 30 30 |
      Data In |30 30 20 30 30 30 30 30 30 30 30 30 20 30 30 30 |
      Data In |33 32 30 30 20 30 30 30 30 30 30 35 30 30 20 0D 0A |
      Data In |46 46 46 46 38 30 30 30 20 46 46 46 46 38 30 30 |
      Data In |30 20 46 46 46 46 38 30 30 30 20 46 46 46 46 38 |
      Data In |30 30 30 20 0D 0A 46 46 46 46 38 30 30 30 20 46 |
      Data In |46 46 46 38 30 30 30 20 30 30 30 30 30 35 30 30 |
      Data In |20 30 30 30 30 30 35 30 30 20 0D 0A |

```

4. Translate each character received from ASCII to hex numbers.

For the example above: 30 30 30 30 31 41 37 34 = 00001A74h

5. Convert this number to decimal = 6772
6. Divide this number by 256 to give the temperature in °C = **26.4°C**

3 Front panel and LEDs

HP LTO Ultrium 5 products have three front panel designs:

- System, for use in servers, rack mounts and other non-automation applications—see “Front panel features” below
- Automation, for use when the drive is embedded in automation applications—see “Front panel for automation use” on page 68
- A third front panel allowing drives to be used in autoloaders where the front panel cannot exceed the drive form factor in height and width—see “Front panel for use in autoloaders” on page 69

The drive is not designed to operate without a front panel (even in automation applications). The front panel was designed to meet Section 508 accessibility guidelines.

Front panel features

Full-height drives

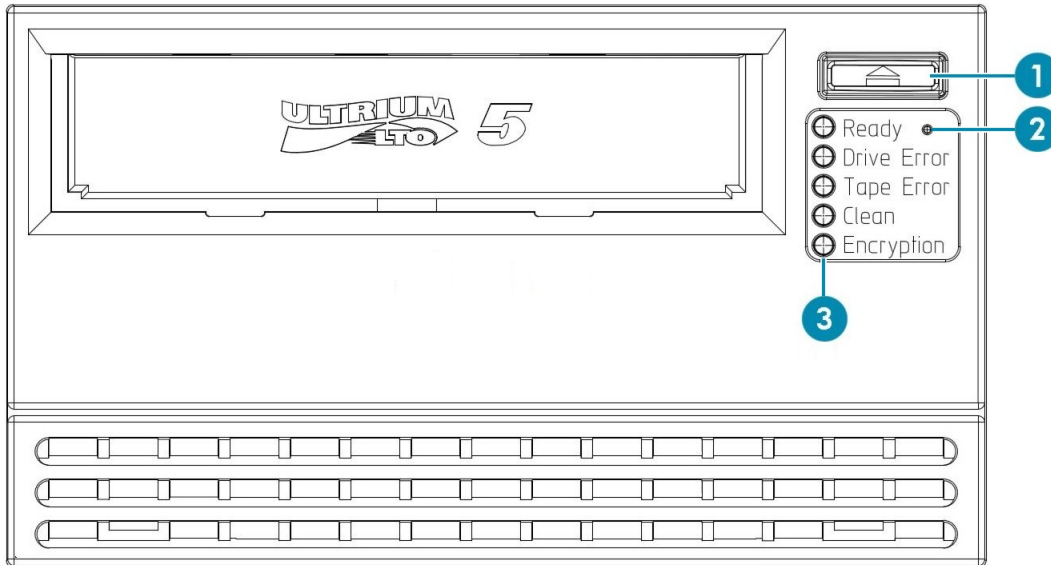

1. Eject button

2. Access hole for emergency reset switch

3. LEDs

Reset switch

The emergency reset switch allows you to reset the drive without powering off the drive and computer, for example if the drive stops responding. Access to the switch is through a small hole. It can be activated by a thin object, such as the end of a straightened paper-clip.

 **NOTE:**

Only full-height drives have a reset switch.

Half-height drives

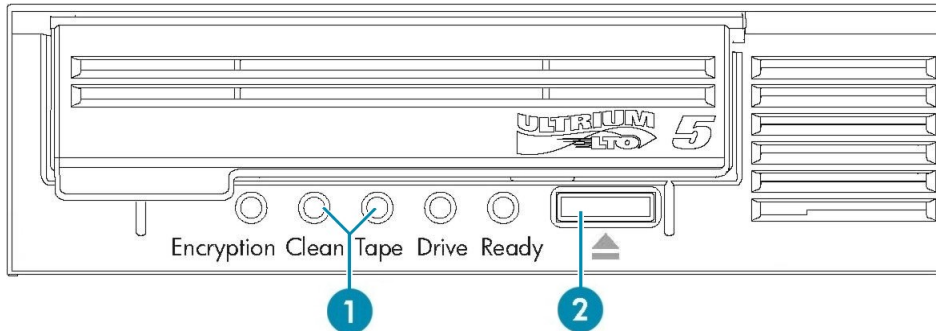

1. LEDs

2. Eject button

Usual meaning of LEDs

The five LEDs, Ready, Drive Error, Tape Error, Clean and Encryption usually have the following meanings:

Ready	Green. Indicates power and activity:	
	<i>Off</i>	Power off or self-test failure
	<i>On</i>	Powered on and ready for use, but no activity
	<i>Flashing</i>	Engaged in activity, such as responding to Read, Write or Space commands or performing a self-test
	<i>Fast flash</i>	Downloading new firmware.
	Repeating pattern	A repeating pattern of short and long flashes indicates that the drive is in OBDR mode.
Drive Error	Orange. Indicates drive problems:	
	<i>Off</i>	No fault
	<i>Flashing</i>	Unrecoverable hardware failure. A power cycle or successful tape load will turn the LED off, but the LED will start flashing again if the same operation is performed and the hardware fault is still present
Tape Error	Orange. Indicates tape problems:	
	<i>Off</i>	No fault
	<i>Flashing</i>	Current tape is faulty, such as unreadable cartridge memory or unsupported type. Do not use the cartridge; replace it. The LED will go out when a tape load begins.

Clean	Orange. Indicates whether the drive needs cleaning.	
	<i>Off</i>	Cleaning not required
	<i>On</i>	Cleaning cartridge being used. The Ready LED flashes.
	<i>Flashing</i>	Cleaning needed. The LED continues to flash if the drive is power cycled, and will only go out after a supported cleaning tape has been used.
Encryption	Blue/orange. Indicates whether encryption is enabled or not.	
	<i>Off</i>	No key is present in the drive. Encryption and decryption are not enabled.
	<i>On</i>	A key is present in the drive. Encryption and decryption are enabled.
	<i>Flashing</i>	Encryption/decryption error.

LED patterns

There are other patterns usually involving several LEDs, which have the following meanings.





NOTE:

The Encryption LED is not included in these tables because it operates independently of the other four LEDs. Its states are given in the description above.

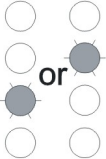

Full-height drives

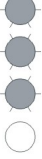

LEDs	Cause	Action required
	<p>All LEDs OFF.</p> <p>Drive may not have power, may be faulty or may have been power cycled or reset during a firmware upgrade.</p>	<ol style="list-style-type: none"> 1. Ensure the drive is switched on. 2. If the green LED on the power switch is not on, check the power cable and replace it if necessary. 3. If the drive has just been switched on or reset, the LED pattern should change after 1 second. If not, the drive has Firmware Image Corruption (caused by being switched off or reset during firmware upgrade). Return it to the factory for repair or reprogramming. 4. If power is present and all LEDs remain off, try performing an interface operations (SCSI or ACI). If the drive does not respond, or power-cycle the drive. 5. If it still fails, call for service.



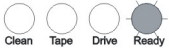
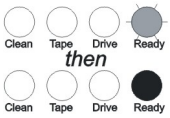

LEDs	Cause	Action required
	<p>Ready and Clean OFF. Drive Error and Tape Error FLASHING.</p> <p>The drive has failed to execute power-on self test (POST).</p>	<p>Power cycle or reset the drive.</p> <p>If the condition reappears, call for service.</p>
	<p>Ready ON.</p> <p>The drive is ready for operation.</p>	<p>None. This is normal.</p>
	<p>Firmware is being reprogrammed.</p>	<p>None.</p> <p>If the drive is upgrading firmware, do not reset or power cycle it.</p>
	<p>Ready FLASHES twice, then pauses ON, then FLASHES twice.</p> <p>The drive is in OBDR mode.</p>	<p>If you need to exit OBDR mode, power cycle or reset the drive.</p> <p>NOTE:</p> <p>OBDR is not supported in all versions of the drive.</p>
	<p>Clean FLASHING. (Other LEDs may be on or flashing.)</p> <p>The drive requires cleaning.</p>	<p>Load an LTO Ultrium Universal cleaning cartridge to clean the heads. See “Cleaning the drive” on page 59 for instructions.</p> <p>If the Clean LED is still flashing when you load a new or known data cartridge after cleaning, call for service.</p>
	<p>Ready FLASHING and Clean ON. (Other LEDs may be on or flashing.)</p> <p>Cleaning is in progress.</p>	<p>None. The cleaning cartridge will eject on completion.</p> <p>The cleaning cycle can take up to 5 minutes.</p>
	<p>Tape Error FLASHING. (Other LEDs may be on or flashing.)</p> <p>The drive believes the current tape or the tape just ejected is faulty.</p>	<p>Unload the tape cartridge. Make sure that it is a valid format: an LTO Ultrium data cartridge or LTO Ultrium Universal cleaning cartridge.</p> <p>Reload the cartridge. If the Tape Error LED still flashes or starts flashing during the next backup, load a new or known, good cartridge.</p> <p>If the Tape Error LED is now off, discard the ‘suspect’ tape cartridge. If it is still on, call for service.</p>

LEDs	Cause	Action required
	<p>Tape ejects immediately and Tape Error FLASHES. (Other LEDs may be on or flashing.)</p> <p>The tape cartridge memory (CM) may be faulty.</p>	<p>Write-protect the cartridge by sliding the red switch on the cartridge. The tape can be loaded and the data read. Once the data is recovered, discard the cartridge.</p>
	<p>Drive Error FLASHING. (Other LEDs may be on or flashing.)</p> <p>The drive mechanism has detected an error.</p>	<p>Load a new cartridge. If the error persists, power cycle or reset the drive.</p> <p>If the Drive Error LED remains on, call for service.</p>
	<p>Drive Error, Tape Error and Ready FLASH.</p> <p>There is a firmware download problem.</p>	<p>Insert a cartridge to clear the LED sequence; the drive will continue using the old firmware. If the condition persists, call for service.</p>
	<p><i>Drive Error and Ready ON with Tape Error and Clean OFF. Sequence alternates repeatedly.</i></p> <p>The drive has a firmware error.</p>	<p>Power cycle or reset the drive. If the sequence reoccurs, upgrade the firmware. If the condition persists, call for service.</p>

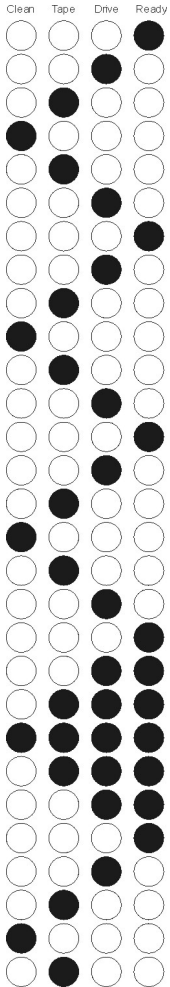
Half-height drives

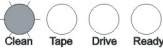
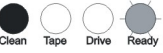
LEDs	Cause	Action required
	<p>All LEDs OFF.</p> <p>Drive may not have power, may be faulty or may have been power cycled or reset during a firmware upgrade.</p>	<ol style="list-style-type: none"> 1. Ensure the drive is switched on. 2. If the green LED on the power switch is not on, check the power cable and replace it if necessary. 3. If the drive has just been switched on or reset, the LED pattern should change after 1 second. If not, the drive has Firmware Image Corruption (caused by being switched off or reset during firmware upgrade). Return it to the factory for repair or reprogramming. 4. If power is present and all LEDs remain off, try performing an interface operations (SCSI or ACI). If the drive does not respond, or power-cycle the drive. 5. If it still fails, call for service.
	<p>Ready and Clean OFF. Drive Error and Tape Error FLASHING.</p> <p>The drive has failed to execute power-on self test (POST).</p>	<p>Power cycle or reset the drive.</p> <p>If the condition reappears, call for service.</p>

LEDs	Cause	Action required
	<p>Ready ON. The drive is ready for operation.</p>	<p>None. This is normal.</p>
	<p>Ready FLASHING. The drive is carrying out a normal activity (read, write).</p>	<p>None. If the drive is upgrading firmware, do not reset or power cycle it.</p>
	<p>Ready FLASHES twice, then pauses ON, then FLASHES twice. The drive is in OBDR mode.</p>	<p>If you need to exit OBDR mode, power cycle or reset the drive. NOTE: OBDR is not supported in all versions of the drive.</p>
	<p>Ready FLASHING fast. (Other LEDs may be on or flashing.) The drive is downloading firmware.</p>	<p>None. Do not reset or power-cycle the drive.</p>
 <p>and so on...</p>	<p>Ready OFF, others ON. Firmware is being reprogrammed.</p>	<p>None. Do not reset or power-cycle the drive.</p>

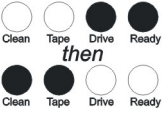
LEDs	Cause	Action required
	<p>Clean FLASHING. (Other LEDs may be on or flashing.)</p> <p>The drive requires cleaning.</p>	<p>Load an LTO Ultrium Universal cleaning cartridge to clean the heads. See “Cleaning the drive” on page 59 for instructions.</p> <p>If the Clean LED is still flashing when you load a new or known data cartridge after cleaning, call for service.</p>
	<p>Ready FLASHING and Clean ON. (Other LEDs may be on or flashing.)</p> <p>Cleaning is in progress.</p>	<p>None. The cleaning cartridge will eject on completion.</p> <p>The cleaning cycle can take up to 5 minutes.</p>
	<p>Tape Error FLASHING. (Other LEDs may be on or flashing.)</p> <p>The drive believes the current tape or the tape just ejected is faulty.</p>	<ol style="list-style-type: none"> 1. Unload the tape cartridge. Make sure that it is a valid format: an LTO Ultrium data cartridge or LTO Ultrium Universal cleaning cartridge. 2. Reload the cartridge. If the Tape Error LED still flashes or starts flashing during the next backup, load a new or known, good cartridge. 3. If the Tape Error LED is now off, discard the ‘suspect’ tape cartridge. If it is still on, call for service.
	<p>Tape ejects immediately and Tape Error FLASHES. (Other LEDs may be on or flashing.)</p> <p>The tape cartridge memory (CM) may be faulty.</p>	<p>Write-protect the cartridge by sliding the red switch on the cartridge. The tape can be loaded and the data read. Once the data is recovered, discard the cartridge.</p>
	<p>Drive Error FLASHING. (Other LEDs may be on or flashing.)</p> <p>The drive mechanism has detected an error.</p>	<p>Load a new cartridge. If the error persists, power cycle or reset the drive.</p> <p>If the Drive Error LED remains on, call for service.</p>
	<p><i>Drive Error and Ready ON with Tape Error and Clean OFF. Sequence alternates repeatedly.</i></p> <p>The drive has a firmware error.</p>	<p>Power cycle or reset the drive. If the sequence reoccurs, upgrade the firmware. If the condition persists, call for service.</p>

During firmware upgrade

△ CAUTION:

Do not reset or power-cycle the drive until the firmware upgrade is complete, otherwise the drive will not be able to operate.

If a firmware upgrade is successful, the LEDs light in sequence during the download as shown in the table above.

If a corrupt or incompatible image is downloaded from tape, the Ready LED will remain on steadily and the Tape Error LED will flash until a tape load is started. The other LEDs will be off.

Replacing the front panel

△ **CAUTION:**

At all times please observe ESD precautions as indicated in the installation manual supplied with the tape drive. Static electricity can damage electronic components. Touch a bare metal part of the computer, such as a back plate, before you attempt to install or remove the drive.

Parts needed

- Replacement front panel
- Small bladed screwdriver (125x5 slotted or smaller)

Replacing the front panel on an full-height LTO Ultrium drive

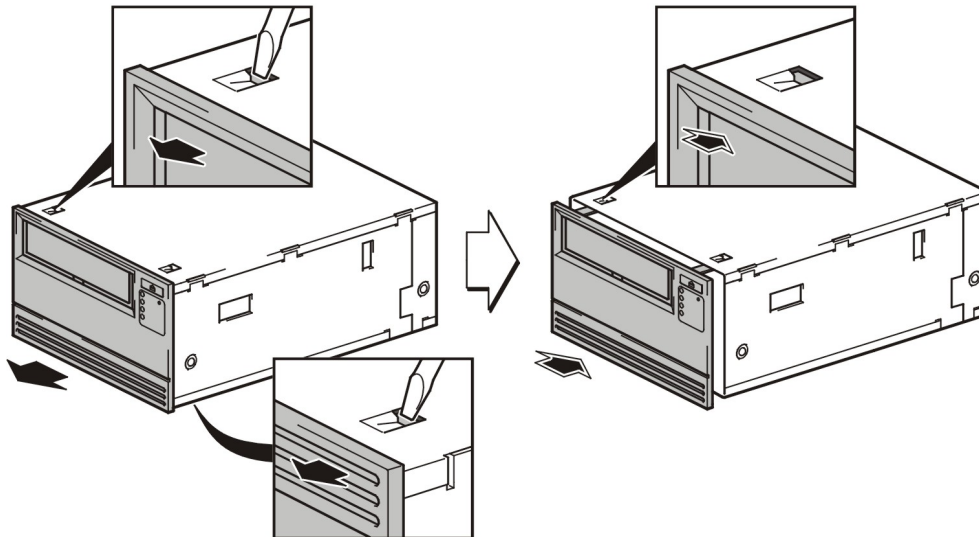

1. Use the screwdriver to release the tabs at the top of the chassis and underneath.
2. Pull the front panel towards you and away from the drive.

To replace the panel, line up the four tabs with the chassis and push the panel firmly into place. There will be a slight click when the lugs are located in the chassis.

Replacing the front panel on a half-height LTO Ultrium drive

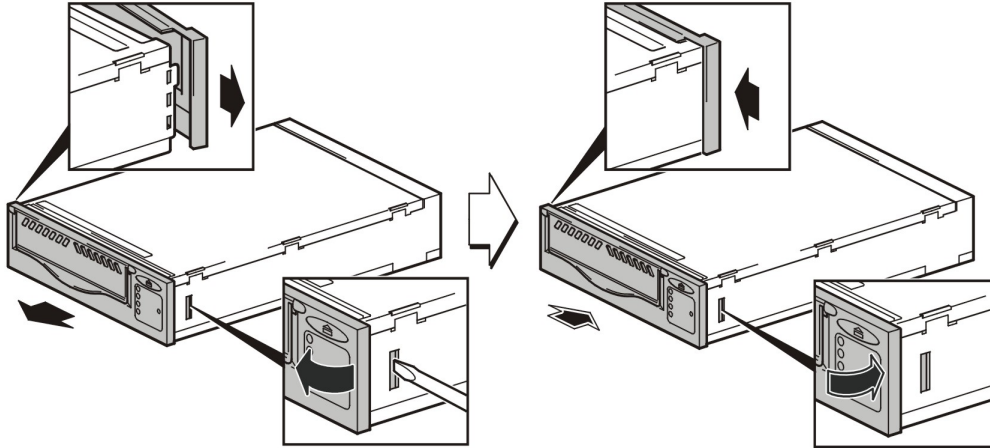

1. Use the screwdriver to release the tab on the right side of the chassis (next to the red warranty sticker).
2. Swing the front panel out slowly, pulling it gently to the left, so that the lugs release on the left side of the chassis.

 **NOTE:**

Do not swing the panel too far out or pull too hard, as the lugs are quite delicate.

3. To replace the panel, line up the lugs on the left side of the chassis and swing the panel firmly into place.

There will be a slight click when the lug is located on the right side of the chassis.

4 Rear panel and connectors

The rear panel contains the connector interface that allows the tape drive to communicate with a tape library or host computer system. The panel includes the following connectors:

- *Either:* Two SFP duplex-LC optical fibre connectors (*full-height drives* have two, though only one might be connected; *half-height drives* have a single connector)
- *Or:* An SAS connector
- Combined ACI/ADI and remote LED connector
- Diagnostic serial port
- Fan connector
- Power connector (Fibre Channel drives only)
- iADT (Ethernet) connector

Rear panel components—full-height drives

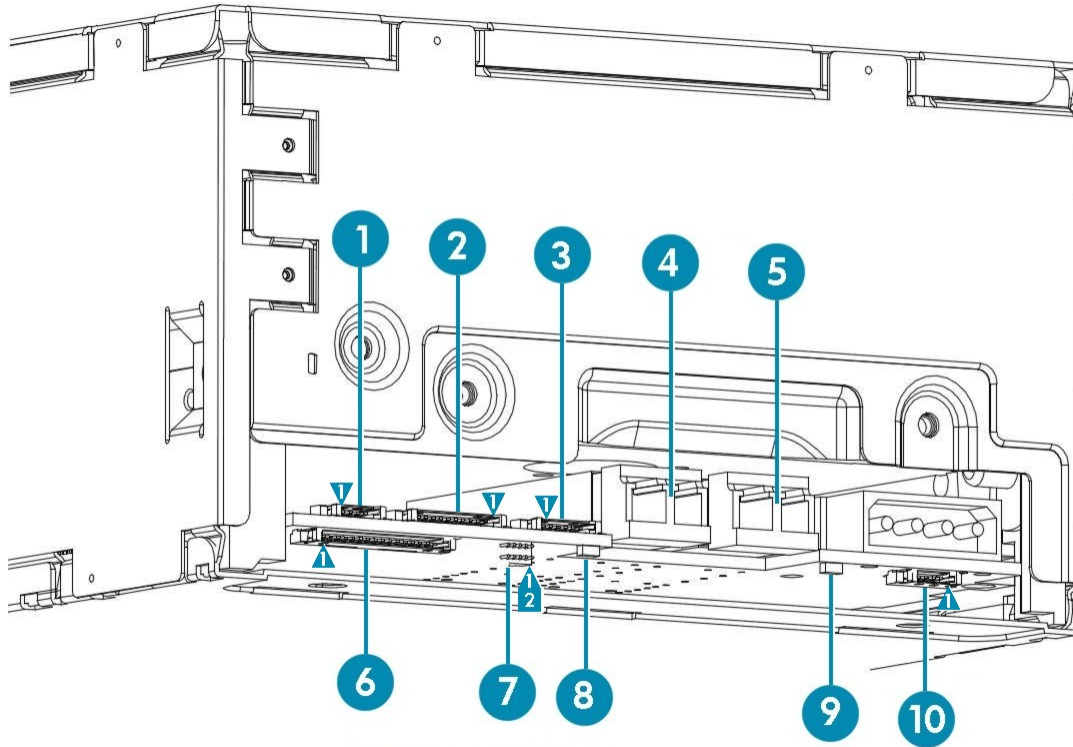

Figure 1 Rear panel components for a full-height Fibre Channel drive

- | | |
|--|--|
| 1. Diagnostic serial port (4-pin) | 2. iADT Ethernet (10-pin) |
| 3. External fan support (6-pin) | 4. Port A optical connector (standard) |
| 5. Port B optical connector (optional) | 6. Automation and remote LEDs (16-pin) |
| 7. AL_PA jumpers (may not be loaded) | 8. Port A LED |
| 9. Port B LED | 10. Diagnostic serial port (4-pin) |

▼ Position of pin 1 (which may be different from previous generation drives)

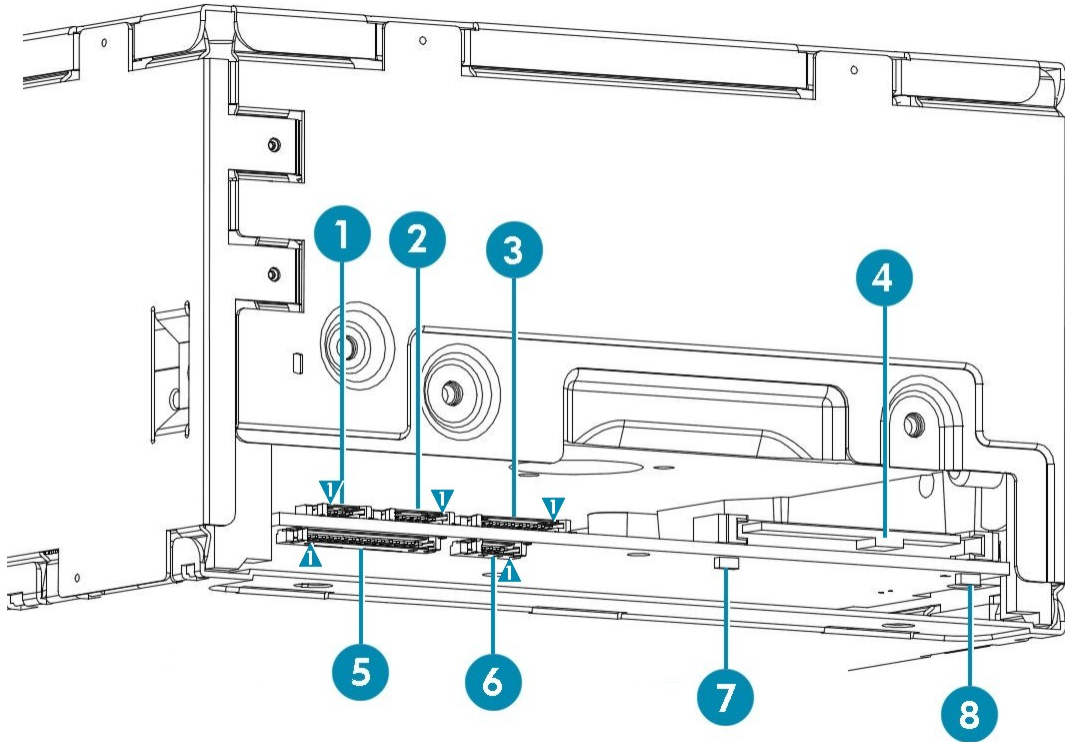

Figure 2 Rear panel components for a full-height SAS drive

- | | |
|--|-----------------------------------|
| 1. Diagnostic serial port (4-pin) | 2. External fan support (6-pin) |
| 3. iADT Ethernet (10-pin) | 4. SAS SFF 8482 connector |
| 5. Automation and remote LEDs (16-pin) | 6. Diagnostic serial port (4-pin) |
| 7. Host secondary port LED | 8. Host primary port LED |

▼ Position of pin 1 (which may be different from previous generation drives)

Rear panel components—half-height drives

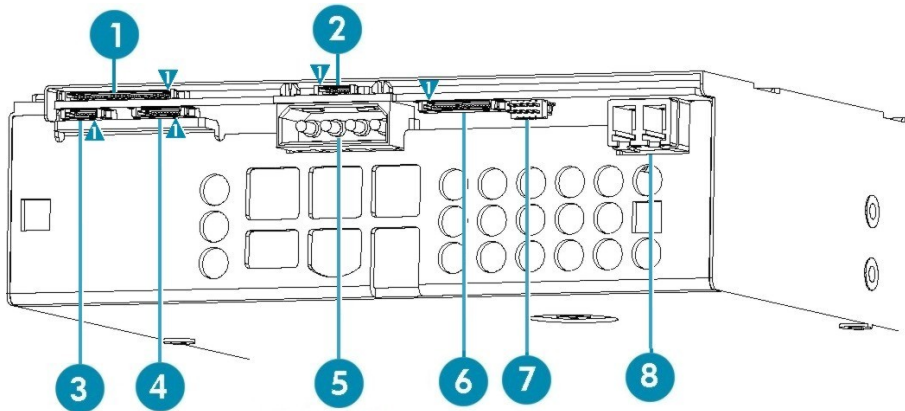

Figure 3 Rear panel components for a half-height FC drive

- | | |
|--|----------------------------------|
| 1. Automation and remote LEDs (16-pin) | 2. Alternate serial port (4-pin) |
| 3. Diagnostic serial port (4-pin) | 4. External fan support (6-pin) |
| 5. Power | 6. iADT Ethernet (10-pin) |
| 7. AL_PA jumpers (may not be loaded) | 8. FC optical connector |

▼ Position of pin 1 (which may be different from previous generation drives)

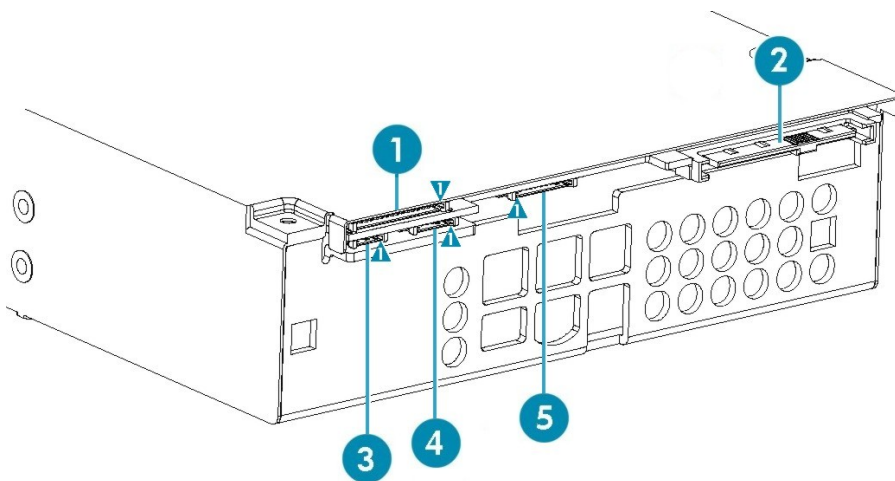

Figure 4 Rear panel components for a half-height SAS drive

- | | |
|--|-----------------------------------|
| 1. Automation and remote LEDs (16-pin) | 2. SAS connector (includes power) |
| 3. Diagnostic serial port (4-pin) | 4. External fan support (6-pin) |
| 5. iADT Ethernet (10-pin) | |

▼ Position of pin 1 (which may be different from previous generation drives)

LEDs (full-height Fibre Channel drives only)

The rear panel has two LEDs, one each for Fibre Channel Port 0 and Port 1.

Power-on self-test failure

If the Fibre Channel firmware encounters a Power-On Self-Test failure, the drive will not initialize the FC ports and so will not respond over the FC interface. The two FC port LEDs will flash together at 1 cycle/second until the drive is reset or power-cycled.

Port initialized

Once the self-test is complete, the FC Port LEDs indicate whether the respective ports have been initialized, in other words, whether successful speed negotiation and loop initialization/old port mode has occurred.

Port 0 LED	Port 1 LED	Meaning
Off	Off	Neither port is initialized
On	Off	Only port 0 is initialized
Off	On	Only port 1 is initialized
On	On	Both ports are initialized

Port activity

When there is activity on an FC port, the appropriate FC port LED will flash with a periodicity of 1/10 second.

Fibre Channel addressing

The drive's hard AL_PA can be configured through an ACI Set Drive Configuration command or ADI Mode Select command

The value set is the Loop ID, an 8-bit value which is translated by the drive into a 7-bit Arbitrated Loop Physical Address (AL_PA) according to Table 1:

Table 1 AL_PA and Loop ID look-up table

AL_PA	Loop ID	AL_PA	Loop ID	AL_PA	Loop ID	AL_PA	Loop ID	AL_PA	Loop ID	AL_PA	Loop ID
00h	–	2Eh	68h	53h	52h	76h	3Ch	ABh	25h	CEh	Fh
01h	7Dh	31h	67h	54h	51h	79h	3Bh	ACH	24h	D1h	Eh
02h	7Ch	32h	66h	55h	50h	7Ah	3Ah	ADh	23h	D2h	Dh
04h	7Bh	33h	65h	56h	4Fh	7Ch	39h	Aeh	22h	D3h	Ch

AL_PA	Loop ID	AL_PA	Loop ID	AL_PA	Loop ID	AL_PA	Loop ID	AL_PA	Loop ID	AL_PA	Loop ID
08h	7Ah	34h	64h	59h	4Eh	80h	38h	B1h	21h	D4h	Bh
0Fh	79h	35h	63h	5Ah	4Dh	81h	37h	B2h	20h	D5h	Ah
10h	78h	36h	62h	5Ch	4Ch	82h	36h	B3h	1Fh	D6h	9h
17h	77h	39h	61h	63h	4Bh	84h	35h	B4h	1Eh	D9h	8h
18h	76h	3Ah	60h	65h	4Ah	88h	34h	B5h	1Dh	DAh	7h
1Bh	75h	3Ch	6Fh	66h	49h	8Fh	33h	B6h	1Ch	DCh	6h
1Dh	74h	43h	5Eh	67h	48h	90h	32h	B9h	1Bh	E0h	5h
1Eh	73h	45h	5Dh	69h	47h	97h	31h	BAh	1Ah	E1h	4h
1Fh	72h	46h	5Ch	6Ah	46h	98h	30h	BCh	19h	E2h	3h
23h	71h	47h	5Bh	6Bh	45h	9Bh	2Fh	C3h	18h	E4h	2h
25h	70h	49h	5Ah	6Ch	44h	9Dh	2Eh	C5h	17h	E8h	1h
26h	6Fh	4Ah	59h	6Dh	43h	9Eh	2Dh	C6h	16h	EFh	-
27h	6Eh	4Bh	58h	6Eh	42h	9Fh	2Ch	C7h	15h		
29h	6Dh	4Ch	57h	71h	41h	A3h	2Bh	C9h	14h		
2Ah	6Ch	4Dh	56h	72h	40h	A5h	2Ah	CAh	13h		
2Bh	6Bh	4Eh	55h	73h	3Fh	A6h	29h	CBh	12h		
2Ch	6Ah	51h	54h	74h	3Eh	A9h	27h	CCh	11h		
2Dh	69h	52h	53h	75h	3Dh	AAh	26h	CDh	10h		

Connectors

Fibre Channel connector

Full-height FC drives are equipped with two SFP duplex-LC short-wave 8 Gb/s fibre connectors. The drives are capable of switched fabric attach, public loop or private loop and operate at 8 Gb/s, 4 Gb/s or 2 Gb/s after auto-speed negotiation.

Half-height drives have a single fixed duplex-LC short-wave 8 Gb/s fibre connector.

SAS connector

SAS drives are equipped with a standard internal SAS connector. LTO5 SAS drives do not have a regular power connector and should be powered via the SAS connector.

Automation and remote LED connector

The combined Automation and Remote LED Connector is a 16-pin wafer surface-mount right-angle connector. 10 pins are used for the ACI/ADI interface and 6 pins for the remote LEDs.

Connector pins

ACI operation

When used for ACI communications, the pins of the ACI connector are as follows:

Pin	ID	Function
1	ACI_RX+	RS-422 Receive (+ side of the differential RS-422 line)
2	ACI_RX-	RS-422 Receive (- side of the differential RS-422 line)
3	GND	Ground
4	ACI_TX-	RS-422 Transmit (- side of the differential RS-422 line)
5	ACI_TX+	RS-422 Transmit (+ side of the differential RS-422 line)
6	ACI_DRV_SEN_L	Drive Sense. It is tied low in the drive so that a library can sense the presence of the drive. The library should have a pull-up resistor on this line. <i>Low:</i> Drive present <i>High:</i> Drive not present (3.3 volts)
7	ACI_LIB_SEN_L	Library Sense. The drive will not appear on the bus until commanded when low. The line is pulled up to 5V in the tape drive. The automation controller should pull this pin low. <i>Low:</i> Drive is connected to an automation controller <i>High:</i> Drive is standalone (3.3 volts)
8	ACI_RST_L	Tape drive reset. The line is pulled up to 3.3V in the drive. The drive will perform a Drive Reset when this line is pulled low.
9	ACI_ATN_L	The drive sets this pin low to indicate to the automation controller that certain configured conditions have arisen, such as a SCSI Surrogate CDB.
10	—	No connection

Supported Baud rates

Baud Rate	Notes
9600	Default rate
19200	
38400	
57600	
115200	

For details of ACI commands, see Chapter 5 “Supporting LTO Ultrium Features” of the *Software Integration Guide*, Volume 2 of the HP LTO Ultrium Technical Reference Manual.

ADI operation

When used for ADI communications, the pins of the ADI connector are as follows:

Pin	ID	Function
1	+Tx _d -Rx _d	RS-422 Receive from automation controller
2	-Tx _d -Rx _d	RS-422 Receive from automation controller
3	Ground	Ground
4	-Tx _d -Rx _a	RS-422 Transmit from tape drive
5	+Tx _d -Rx _a	RS-422 Transmit from tape drive
6	Sense _d	Tied low in the drive so that a library can sense the presence of the drive.
7	Sense _d	The drive will not appear on the bus until commanded when low.
8	Reset _d	Hard reset (active low)
9	Signal _{aux}	Reserved for future use
10	—	No connection

The ID names correlate with the descriptions in the T10 Automation/Drive Interface Transport Protocol (ADT).

Supported Baud rates

Baud Rate	Notes
9600	Default rate
19200	
38400	
57600	
76800	
115200	
153600	

Remote LEDs

The pins for the remote LED connector are as follows:

Pin 11	Ground
Pin 12	Port 1 Status LED output

Pin 13	Port 2 Status LED output
Pin 14	Host controlled (Beacon) LED output
Pin 15	Encryption LED output
Pin 16	5V supply

Automation and remote LED connector schematic

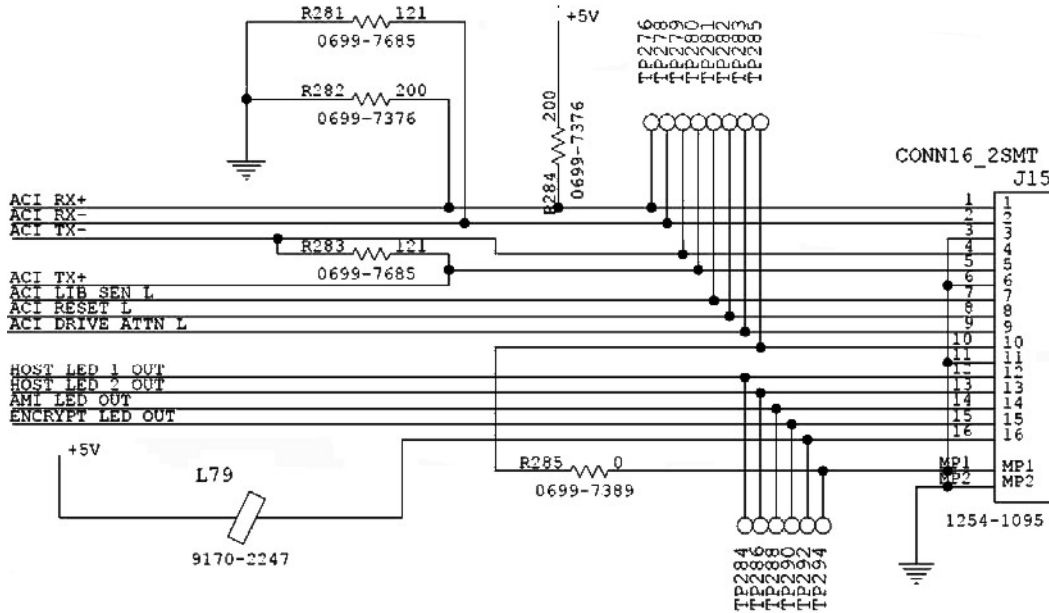

Figure 5 ADI-LED connector schematic

Notes:

- The maximum LED current supported is 25 mA.
- There should be a current limiting resistor on each LED output.
- The maximum off voltage on the transistor collector must not exceed 5.5V.
- The maximum on voltage for the transistor is 0.4V.
- The same circuit configuration as shown in Figure 6 on page 39 is used for all LED ports.
- The library-controlled or Beacon LED is driven by the AMI_LED_OUT signal.

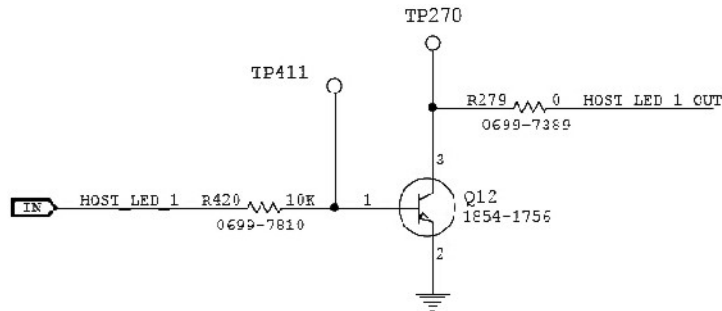

Figure 6 LED driver circuit

iADT (Ethernet) port

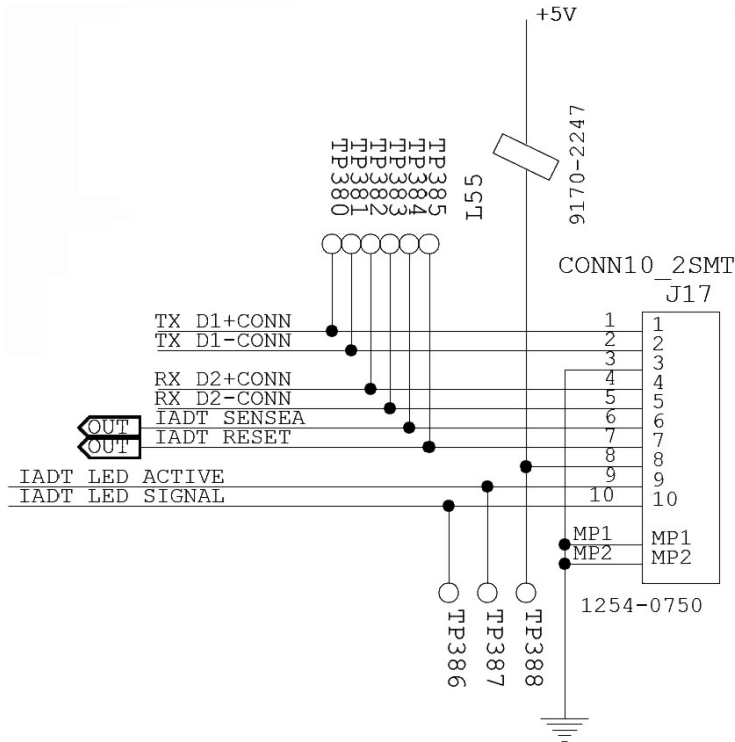

Figure 7 iADT port schematic

Notes:

- The maximum LED current supported is 25 mA.
- There should be a current limiting resistor on each LED output.
- The maximum off voltage on the transistor collector must not exceed 5.5V.
- The maximum on voltage for the transistor is 0.4V.
- The same circuit configuration as shown in Figure 6 on page 39 is used for all LED ports.

Diagnostic Serial Port connector

For products with two serial ports the same connector pin-out is used on both ports. The serial ports are identical to those on previous HP LTO products.

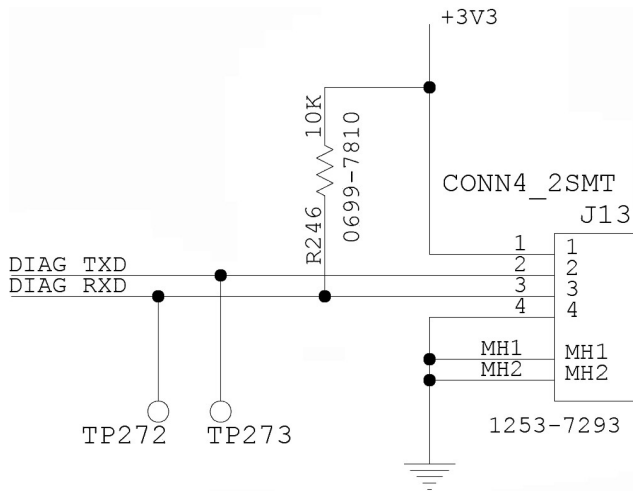

Figure 8 Diagnostic Serial Port connector schematic

Fan control connector

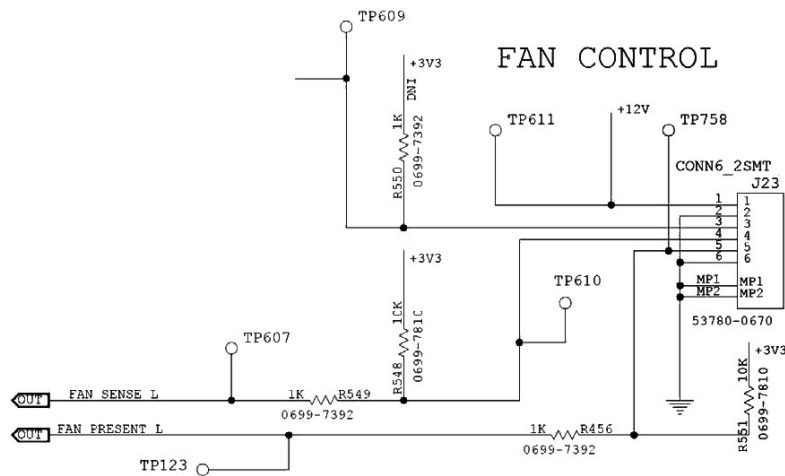

Figure 9 Fan connector schematic

Notes:

- FAN SENSE is used to detect fan rotation.
- FAN PRESENT is used to detect that a fan has been connected to the drive. A fan is deemed to be present when this line is grounded. To achieve this, it is recommended that Pins 5 and 6 are tied together on the mating half of the connector.
- The power supply to the fan is a steady 12V.
- The fan speed is controlled via a PWM signal (pin3).
- A four-wire fan is required.

NOTE:

If you intend to plug a fan into this connector to provide the necessary airflow through the drive, consult your HP Technical Support Representative for details of the fan specification required.

5 Cartridges

Choosing cartridges

HP recommends HP LTO-5 Ultrium 3000 GB (2:1 compression) cartridges.

HP LTO Ultrium drives will also support other lower capacity HP and non-HP LTO Ultrium cartridges but the performance of your drive may be restricted. Data transfer rates will be slower on LTO Ultrium 4 1600 GB cartridges compared to LTO Ultrium 5 3000 GB cartridges. Do **not** use HP DLTIII tape or DLTIV tape cartridges. The size and shape of LTO Ultrium media is very similar to that of DLT cartridges in order to make it easy for automation/library vendors to integrate LTO Ultrium into existing DLT libraries. Compatible media can be recognized by the LTO Ultrium logo, which is the same as the logo on the front of your drive.

NOTE:

HP LTO Ultrium 5 tape drives are not compatible with LTO Ultrium 1 or 2 media, which will be rejected as unsupported. The Tape Error LED will light.

HP recommends HP LTO Ultrium cartridges as follows:

- LTO Ultrium 5 3000 GB RW for multiple reading and writing
- LTO Ultrium 5 3000 GB WORM cartridges. WORM (Write-Once, Read-Many) cartridges guard against accidental or malicious alteration of data on the tape cartridge. You can append data to a WORM data cartridge to use the full capacity but not erase or overwrite existing data. WORM data cartridges have a distinctive, two-tone cartridge color. To check whether your backup or archive software application supports WORM cartridges, refer to the web site: www.hp.com/go/connect.

Labeling cartridges

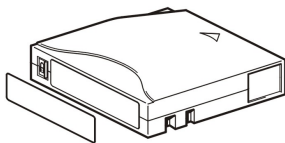

The label and write-protect switch are on the rear face of the cartridge, as illustrated.

Never use non-standard labels, and never stick anything to the cartridge other than in the label area.

Write-protecting cartridges

If you want to protect the data on a cartridge from being altered or overwritten, you can write-protect the cartridge. Do this before you load the cartridge into the drive. If you slide the write-protect tab after the cartridge is inserted in the drive, the change will not take effect until the cartridge is ejected and reloaded, and you will damage the tape drive.

△ CAUTION:

Write-protection will not prevent a cartridge being erased by bulk-erasure or degaussing. Do not bulk erase LTO Ultrium format cartridges. This will destroy pre-recorded servo information and render the cartridge unusable.

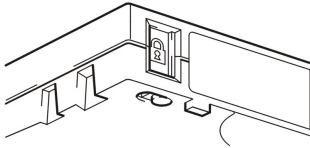

To write-protect a cartridge, slide the write-protect tab by the label area on the rear face of the cartridge to close the hole.

Note the padlock on the tab that indicates that the cartridge is protected.

To write-enable a cartridge, slide the write-protect tab back so that the hole is open, before loading the cartridge into the drive.

Cartridge life

Under optimum environmental conditions, HP LTO Ultrium cartridges are currently specified to 1,000,000 passes over any part of the tape. However, it is recommended that cartridges are used for no more than 260 full backup operations. Under severe environmental conditions, particularly where the tape drive is used at low humidity or if certain areas of the tape are accessed frequently, the number of backup operations should be limited even further.

Caring for cartridges

Avoiding condensation

Condensation is a problem for tape drives and cartridges. To minimize the chance of condensation, stay within the specifications for using and storing cartridges below and observe the following guidelines:

- Position the drive where the temperature is relatively stable—away from open windows, heat sources and doors.
- Avoid leaving cartridges in severe temperature conditions, for example, in a car standing in bright sunlight.
- Avoid transferring data (reading from and writing to cartridges) when the temperature is changing by more than 1°C (1°F) per hour.
- If you bring a cold tape drive or tape cartridge into a warm room, allow time for it to warm to room temperature before using it. For example, if you have moved the drive from a cold car to a warm room, allow time for the drive to reach room temperature (up to 24 hours if the temperature change is extreme).

Conditions in use

Only use LTO Ultrium cartridges in temperatures within the tape drive's operating range from 10°C to 40°C (50°F to 104°F) and 20 to 80% relative humidity (non-condensing). If you expose cartridges to temperatures outside the operating limits, stabilize them before you use them. To do this, leave the cartridges in the operating environment for 24 hours.

Conditions in storage

LTO Ultrium cartridges will preserve the integrity of stored data for up to 30 years if proper storage conditions are observed.

- For short-term storage, keep cartridges at temperatures between 16°C and 32°C (61°F and 90°F) with a relative humidity between 20% and 80%.
- For long-term archival storage, keep cartridges between 5°C and 23°C (41°F and 73°F) with a relative humidity between 20% and 60%. Wet bulb temperature should not exceed 26°C (78°F).
- Always keep the cartridges in a clean environment.
- Always store cartridges in their plastic cases on their side when not in use.

Maximizing tape life

- Do not touch the tape surface.
- Do not attempt to clean the tape path or tape guides inside the cartridge.
- Do not leave cartridges in excessively dry or humid conditions.
- Do not leave cartridges in direct sunlight or in places where magnetic fields are present (for example, under telephones, next to monitors or near transformers).
- Do not drop cartridges or handle them roughly.
- Stick labels onto the label area only.

LTO Cartridge Memory

Linear Tape Open—Cartridge Memory (LTO-CM) is an EEPROM that is embedded in every LTO Ultrium tape cartridge. It is non-volatile and is contactless in that it is read by inductive coupling rather than electrical contact.

The Cartridge Memory is used to store the tape directory and diagnostic and log information. Because of the speed at which it can be read, load and unload times are reduced, information is found on the tape more quickly and fewer tape passes are needed, increasing tape reliability.

The memory is primarily designed to speed up internal operations in the drive, but it also contains free space that can be used by application software. This may be used to store “common” information (shared by all software vendors) and “vendor-unique” information (specific to the application).

Hosts can use this free space using the SCSI Write Attribute and Read Attribute commands. For information on these commands, see Chapter 4 of the *Host Interface Guide*, Volume 3 of this HP LTO Ultrium Technical Reference Manual.

To support CM fully, software vendors should ensure that their company names are registered with ANSI T10 or the National Committee for Information Technology Standards (NCITS) as they are now known. The list of Vendor IDs is displayed at <http://www.t10.org/lists/vid-alph.htm>, which also contains details of how to get a new name assigned.

Cartridge Memory adheres to the Media Auxiliary Memory (MAM) standard. “MAM” indicates that the access method applies to all types of media, not just LTO Ultrium.

The MAM standard provides for the storage and access of information held as a set of pre-defined and user-definable attributes that are divided into six main sections:

- Media Common Section—hard-coded by the media manufacturer. For example: manufacturer’s name, cartridge serial number, length, media type
- Drive Common Section—updated by the drive every time it accesses the media. For example: maximum and remaining tape capacity, TapeAlert flags

- Host Common Section—updated by the host’s software application every time it uses the media. For example: software application vendor’s name and version, media text label, date last written
- Media Vendor Unique Section—optional information written by the media vendor for their own purposes. Unique to the media vendor.
- Media Vendor Unique Section—optional information written by the media vendor for their own purposes. Unique to the media vendor.
- Host Vendor Unique Section—space reserved for use by software applications for their own purposes. Unique to the software vendor. Approximately 1 kilobyte.

For details of use of LTO-CM in library applications, see “Using Cartridge Memory (LTO-CM)” on page 77.

LTO Cartridge Memory issues

The LTO Cartridge Memory stores identification and usage information such as the number of times the cartridge has been loaded, when it was last cleaned, and error logs. In the unlikely event of the Cartridge Memory becoming damaged, you may experience difficulty with the cartridge.

Use the following table to resolve LTO Cartridge Memory problems:

Problem	Cause	Solution
A new data cartridge that is write-enabled is rejected by the drive.	LTO Cartridge Memory has failed or is damaged.	Replace the data cartridge.
A new data cartridge that is write-protected is rejected in several known good drives.	LTO Cartridge Memory has failed and the drive has found no data to recover.	Replace the data cartridge.
A cartridge that has data written to it and is write-enabled is rejected by the drive.	LTO Cartridge Memory has failed or is damaged.	The data can still be recovered. Contact the tape library supplier for more information. After data recovery, replace the cartridge.
A cartridge that has data written to it and is write-protected restores very slowly.	LTO Cartridge Memory has failed and the drive cannot use the tape directory information to recover the data.	The data can still be recovered but may take longer than normal.

More information

- The latest version of the specification is incorporated into SCSI SPC-3.
- The access specification can be found at <http://www.t10.org/>.

6 Planning your system configuration

Modes of usage

HP LTO Ultrium tape drives and arrays can be used in different system configurations. They can be used in a standalone (direct attach) or network environments (both Local Area Network and Storage Area Network).

Network users may need to take additional steps to ensure that their system is configured for optimum performance.

Optimizing performance

Various factors can affect tape drive performance, particularly in a network environment or if the drive is not on a dedicated bus. If your tape drive is not performing as well as expected, consider the following points before contacting HP Support at www.hp.com/support.

Dedicated bus

For optimum performance, we recommend that the tape drive is the only device on the bus.

System performance

Drives can write data at 140 MB/s (native) or 280 MB/s (2:1 compression). However, to get this performance it is essential that your whole system can deliver this performance.

Typical areas where bottlenecks can occur are:

- Disk system (a single hard disk drive will not be able to deliver 280 MB/s transfer rates).
- Some file systems are able to transfer data faster than others.
- The type of data being backed up can affect backup performance (for example, file sizes and compressibility).
- Some backup software performs better than others.

To improve performance you may like to consider a RAIDed disk solution with a large number of physical hard disks.

Some enterprise class backup applications can be made to interleave data from multiple sources, such as clients or disks, to keep the tape drive working at optimum performance.

Data rate matching

Data Rate Matching (DRM) enables the drive to “stream” data at variable tape speed, which means that it maintains a continuous data flow to tape even when the transfer speed from the host varies. This is automatically managed by the drive to keep the drive running at best performance. When using LTO Ultrium 5 cartridges, the drive is able to keep streaming between 47 and 140 MB/s (native),

so, if possible data transfer should remain within this range. In most cases, the backup application will provide details of the average time taken at the end of the backup.



NOTE:

For optimum performance always use Ultrium 5 3000 GB cartridges.

Performance checklist

The following list summarizes factors that can affect performance. They provide guideline only of areas that may need further investigation. They do not attempt to explain how to configure individual systems. For a more detailed discussion, including information about tools that allow you to test performance, refer to our white papers on www.hp.com. (Select the product first and look at the Information Library.)

- Is the tape drive reading and writing data at the correct speed?
- Is the source system (hard disk) transferring data at the correct speed?
- Is the backup application writing buffers at the correct speed? You may need to tune the transfer, buffer and block size settings to optimize the speed that the application writes data to the tape drive. HP LTO Ultrium drives have an internal buffer of 256 MB.
- Is the operating system tuned for performance? You may need to adjust the data transfer packet size.
- If you are using an SAS drive or array in a SAN environment, are you are using one of the recommended fibre channel/SAS routers?
- Are user applications, such as Exchange or database servers, optimized for backup performance?
- Are there other factors that could be affecting performance, such as interference or fibre channel infrastructure?

7 Installing and replacing drives

If you are installing the tape drive on a UNIX system, refer to the *UNIX Configuration Guide*, Volume 5 of the HP LTO Ultrium Technical Reference Manual.

Installing in a server

Full details of how to install an internal LTO Ultrium tape drive into a server drive bay is given in the Getting Started Guide.

Identifying the model

The model name is on the front panel and the product and serial numbers are on a label on the top of the drive.

Standards and safety

Use the drive only in equipment where the suitability of the combination has been determined by an appropriate certification organization (such as Underwriters Laboratories Inc. or the Canadian Standards Association in North America, and the British Standards Institution or Verband Deutscher Elektrotechniker in Europe). Other considerations include the following:

1. A drive must be installed in an enclosure to limit an operator's access to live parts, to provide system stability, and to give the drive the necessary grounding integrity.
2. A drive must only be supplied by a Safety-Extra-Low-Voltage (secondary) circuit in accordance with DIN VDE 0805. During incorporation of the equipment, all requirements of DIN VDE 0805 must be observed and obeyed.



NOTE:

The drives are only fused to protect them from excessive currents.

Requirements

Mounting requirements

- Half-height drives require one industry standard 5¼-inch, half-height bay.
- Full-height drives require one industry standard 5¼-inch, full-height bay.

HP recommends 0.3 mm mounting clearance around all covers for isolation mounting movement.

For many servers, no mounting tray or rails are required. Devices simply slide into the computer's chassis and are fixed with screws. Other servers have built-in trays or rails. Yet others require a special mounting tray or rails to fix the drive into the empty bay.

Refer to your server documentation for details on how to install drives.

Server connections

You need a properly installed and configured SAS host bus adapter (HBA) or a built-in SAS controller on the server.

The SAS drives have a 6 GB SAS interface, and are designed to work with most SAS devices. The 6 GB SAS interface supports a maximum bus speed of 600 MB/s, as opposed to the 150 MB/s of the 1.5 GB SAS interface. Therefore, installing the drive onto a 1.5 GB bus is not recommended as this may restrict performance.

For optimum performance, use a dedicated host bus adapter for the tape drive.

Do not connect to a RAID controller channel; these are for disk drives only. Consult your supplier for details.

For a SAS internal drive, you will need:

- 6 GB SAS host bus adapter or the server's embedded HBA
- SAS-compliant cable
- Mounting hardware, if required
- Backup software that supports the tape drive

Supported bus types

SAS buses

SAS Bus Type	Transfer Speed	Supported
1.5 Gbps	Up to 150 MB/s	Yes
3.0 Gbps	Up to 300 MB/s	Yes
6.0 Gbps	Up to 600 MB/s	Yes. This is the recommended configuration.

Connecting the drive

SAS connector

For the location of the rear panel SAS connector, see [Figure 2](#) on page 33.

The SAS drive is equipped with a 6 Gbps SAS plug connector as defined in SFF8482 [5.2.3.2]. A SAS drive is hot pluggable but the connector location is not as defined in SFF8482.



NOTE:

HP LTO5 SAS tape drives do not have a normal power connector and must be powered via the SAS connector.

The rear connections of an SAS drive are as follows:

- Combined automation and remote LED connector port (for libraries)
- Standard internal SAS plug connector
- iADT (Ethernet) connector
- Fan connector
- Diagnostic Serial Port, see “[Diagnostic Serial Port connector](#)” on page 40 (contact HP for further details on this diagnostic port and its function)

Backup software

You need backup software that supports the HP LTO Ultrium drive within your system’s configuration. In a direct attach configuration, where the tape drive is attached to a standalone server, you can use backup software that is designed for a single server environment. In network and SAN configurations, you will need backup software that supports enterprise environments. As a general rule, native backup applications (such as NTBackup and tar) do not provide the required data streaming rate to get the full performance of your drive. For the latest list of backup packages that support HP LTO Ultrium drives, please consult our World Wide Web site (www.hp.com/go/connect).

Applications usually recognize tape drives by their manufacturers’ ID string rather than their model number, so check the table below for the appropriate reference.

Drive Model	ID String
LTO Ultrium 2 drive	HP Ultrium 2-SCSI
LTO Ultrium 3 drive	HP Ultrium 3-SCSI
LTO Ultrium 4 drive	HP Ultrium 4-SCSI
LTO Ultrium 5 drive	HP Ultrium 5-SCSI

Installing in a tape array

Appropriate HP rack-mount systems

HP LTO Ultrium removable tape drives can be used with any compatible rack-mount tape array system.

The tape array is designed to be installed into any compatible 19" rack-mount systems. It must be properly installed and configured. Refer to your tape array documentation for further details.

Airflow requirements

As long as the tape array is fully populated, it will provide adequate airflow for HP LTO Ultrium drives.

If you have unused bays in the tape array, you must install the blanking plates provided with the tape array. This ensures that there is adequate airflow to the drives. See the documentation with the tape array for details on installing blanking plates.

You should ensure that ventilation is adequate at the front and rear of the tape array.

HP LTO Ultrium drives require forced airflow as detailed below.

Full-height drives:

The required airflow depends on the ambient air temperature and should be from back to front:

- 6 cfm for ambient air temperatures fluctuating in the range 10°C–35°C.
- 8 cfm for ambient air temperatures fluctuating in the range 10°C–40°C.

For details of how to test if the airflow is adequate, see "[Airflow requirements](#)" on page 16.

Half-height drives:

The required flow is 5 cfm for ambient air temperatures fluctuating in the range 10°C–40°C, and must be from front to back.

Identifying the drive

The model name is on the front panel and the product and serial numbers are on a label attached to the drive.

Modes of usage

Tape arrays can be used in different system configurations; direct attach, network attach and attached to a Storage Area Network (SAN). For details of these see "[Modes of usage](#)" on page 47.

Attaching to SAS

HP LTO Ultrium SAS drives are high performance 6 GB SAS devices. When installed in a tape array in a compatible rack mount system they can be connected to a SAS connection on a server or to an expander as part of a larger SAS network. To get the optimum performance from your tape drive you need a SAS topology that can transfer data at a rate that supports the tape drive's maximum transfer speed.

Connecting to a Fibre Channel router or by SAS to a server or router

Individual SAS tape drives are connected to their hosts via the SAS connectors on the back of the tape array. They do not require any SAS cables to plug into the tape array. However, you do need cables to connect the tape array with the SAS host or expander.

Fibre Channel connection

If you are using your tape drive on a fibre channel (FC) network, you will need a FC/SAS router. If you are attaching your tape drive to a SAN environment supplied by HP, refer to your SAN solution collateral or configuration guides for further details.

Server SAS connection

If you are attaching the drive to a server, you need a properly installed and configured SAS host bus adapter (HBA) or a built-in SAS controller on your server with a spare SAS port. For optimum performance, your tape drive should only be connected to a 6 GB SAS host bus adapter or SAS controller, but the drive will also function with a 3 or 1.5 GB SAS connection.

Replacing a drive

HP LTO Ultrium removable drives can be removed and replaced without powering down the tape array and without interrupting operations to the other drives in the array. However, note the following:

- In Berkeley mode, the tape position will remain unchanged by a device close operation.
- In AT&T mode, a device close operation will cause the tape to be repositioned just after the next tape filemark (the start of the next file).

If all drives in the tape array are powered up when the system is turned on, the host will be aware of those drives. You can remove any drive and replace it with another without disrupting the system.

If a drive is not powered up or you place a drive in an empty slot after the system has been powered up, the system will have to be reset before the host will recognize the drive.

Removable drives allow modules to be replaced while powered up as long as no data is being transmitted from the system to the module or vice versa.

Installing in a library

Rear panel and connectors

△ CAUTION:

LTO Ultrium tape drives are not installable or replaceable by end-users, so the attachment or removal of FC, SAS, power and other cables between the tape drive and the tape library should only be carried out by service-trained personnel authorized by the tape library supplier. The connectors are not field upgradeable.

The rear panel contains the connectors that allows the tape drive to communicate with the tape library and host computer system. The panel includes the following connectors:

- Combined automation and remote LED connector (for automation use)
For details of the combined automation and remote LED connector, see “[Automation and remote LED connector](#)” on page 37. For details of the use of the ADI connector in libraries, see “[Automation interface](#)” on page 70.
- Diagnostic serial port connector
The proprietary serial HP LTO diagnostic port. To access this port via RS232 requires an HP LTO Diagnostic Interface Card. Diagnostic information from the drive can be accessed by connecting to the serial communications port on a computer. Contact HP for further details on this diagnostic port and its function.

On Fibre Channel drives only:

- Power connector (FC drives only)
A standard 4-pin power connector used to supply the 5V and 12V power the tape drive.
- Fibre Channel connectors
Two Small Form-factor Pluggable (SFP) duplex-LC fibre channel transceivers. Depending on the specific configuration, only one SFP FC transceiver may be installed.



NOTE:

Half-height drives only have a single fixed duplex-LC Fibre Channel transceiver.

On SAS drives:

- A standard internal SAS connector.
SAS drives do not have a normal power connector and should be powered via the SAS connector.

Installing standalone drives

If you are installing the tape drive on a UNIX system, refer to the *UNIX Configuration Guide*, Volume 5 of the HP LTO Ultrium Technical Reference Manual.

Identifying the drive

The model name is on the front panel and the product and serial numbers are on a label on the bottom of the drive.

Connecting the drive

SAS connection

The rear panel connections of external SAS standalone drives consist of a mains power connector and a Mini-SAS connector. The drive should be connected to the host server/expander with a good quality external SAS cable that is as short as possible. If you are attaching a SAS drive to a server, you need a properly installed and configured SAS host bus adapter (HBA) or a built-in SAS controller on your server with a spare SAS port. For optimum performance your tape drive should only be connected to a 6 Gbps SAS host bus adapter or SAS controller, but the drive will also work with a 1.5 or 3 Gbps SAS bus.

Moving drives

If there is a tape in the drive, unload it before powering down and moving the drive. When the drive is powered down, there is no physical lock on the tape reels. If you leave a tape threaded in the drive with the power off, the reels could rotate, causing a loop of tape to occur in the tape path. When the drive is next powered up, the tape could then fall off the guides and be damaged.

If for any reason you must move a drive with a tape threaded, move it slowly and carefully, making no sudden movements that could cause the reels to rotate.

8 Operating the drive

Power-on self-test

When powered-on, the tape drive will run its hardware self-test:

- In a server, internal drives are powered on when you switch on your computer.
- In a tape array, removable drives are powered on when you switch on your tape array and computer.
- In a tape library, installed drives are controlled through the tape library operator panel. Refer to the tape library documentation for details. see also [“Operating drives”](#) on page 60.
- For standalone drives, switch on external drives using the power switch on the front panel, and then switch on the host computer.

During the test the 'Ready' LED flashes and all the other LEDs are off. On successful completion the 'Ready' LED is on. If the self-test fails, the 'Drive Error' and 'Tape Error' LEDs flash, while the 'Ready' and 'Clean' LEDs are off. This continues until the drive is reset.

- If you have just installed the drive, check the installation for loose connections, reset the drive and repeat the self-test.
- Try the [Chapter 9](#) on page 61 to determine what the problem is.
- If the fault condition persists, call for assistance.

Loading a cartridge

 **NOTE:**

This section describes loading a cartridge in a standalone drive. The procedure is the same for internal drives and those in tape arrays and libraries.

Full-height drives:

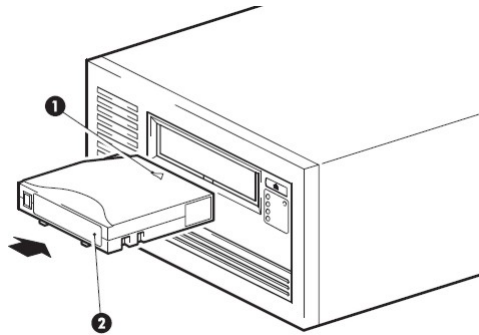

1. Arrow indicating leading direction
2. Cartridge label area

Half-height drives:

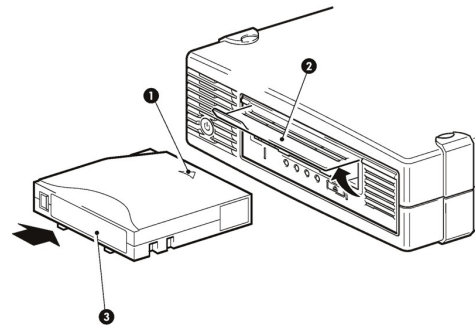

1. Arrow indicating leading direction
2. Drive door
3. Cartridge label area

 **NOTE:**

Use HP LTO Ultrium cartridges.

1. Insert the cartridge into the slot in front of the drive with the arrow uppermost and facing the drive door.
2. Apply gentle pressure on the rear of the cartridge until the drive takes the cartridge and loads it.

The Ready LED flashes green while the drive performs its load sequence. When the cartridge is loaded, the Ready LED shows steady green.

Do not try to force the cartridge if it does not load properly. The drive will eject the cartridge after about 10 seconds so you can load it again.

Unloading a cartridge

 **NOTE:**

This section describes unloading a cartridge from a standalone drive. The procedure is the same for internal drives and those in tape arrays and libraries.

Full-height drives:

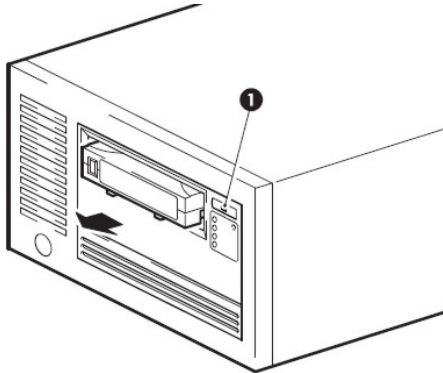

1. Eject button

Half-height drives:

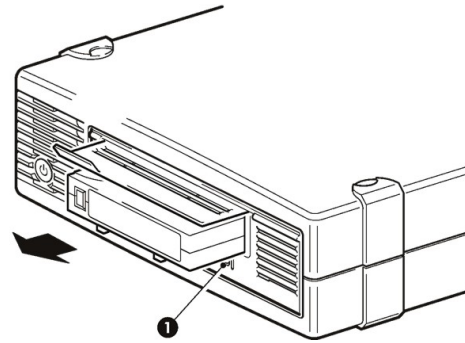

1. Eject button

1. Press the Eject button on the front panel.
During the unload sequence the READY LED flashes green. The drive completes any task it is currently performing, winds the tape to the beginning and ejects the cartridge. Once the tape has rewound, the eject cycle will take less than 13 seconds.
2. Remove the cartridge and store it in its plastic case in a cool, dry atmosphere.

Cleaning

When the drive needs cleaning:

- The orange 'Clean' LED on the front of the tape drive will flash. Only insert a cleaning cartridge into the tape drive when the LED flashes.
- The drive's TapeAlert feature will send a message to your backup application.
- In a library or tape array, the drive also tells the automation controller that a cleaning tape needs to be used via the ADI connector.

See the "[Automation interface](#)" on page 70 for details.

 **CAUTION:**

It is essential to use only LTO Ultrium Universal cleaning cartridges C7978A (Orange) with HP LTO Ultrium tape drives as other format cleaning cartridges will not load and run. Use of HP cleaning media will ensure your tape drive is fully protected. Do not use swabs or other means of cleaning the heads.

LTO Ultrium Universal cleaning cartridges can be used up to 50 times.

To clean the heads:

1. Insert a cleaning cartridge into the drive. The tape drive automatically loads the cartridge and cleans the heads.

If the cleaning cartridge ejects or returns to the ready-to-eject position immediately with the Tape Error LED on, it has expired or it is not an LTO Ultrium cleaning cartridge (or is an older unsupported LTO Ultrium cleaning cartridge). In this case, discard the cleaning cartridge and repeat the operation with a new one.

The cleaning cycle can take up to 5 minutes, during which the orange 'Clean' LED will be on steadily and the green 'Ready' LED will flash. When it has finished, the drive ejects the cartridge or returns the cartridge to the ready-to-eject position.

2. Remove the cleaning cartridge from the drive.

Resetting drives in a library

The tape drive can be reset by the automation controller via the automation connector or by pulling the ACI_RST_L line low (see "[Automation interface](#)" on page 70).

There are two levels of reset via the automation connector:

- ACI reset—resets the ACI port and all SAS/Fibre Channel ports
- Drive reset—equivalent to a power-on reset

Either reset method will interrupt the interface between the drive and host, and a reset may result in no End of Data mark being written. As a result, it is strongly recommended that a reset command is not sent unless all other recovery methods have failed. Note that certain automation commands (Load, Unload, Set Drive Configuration, Reset and Set Baud Rate) can be queued behind outstanding SCSI commands giving the impression that the drive has stopped responding over the ADI connector. (All command packages will be still be ack'ed even though the command will be queued.)

Following a Reset command with reset control set to Drive Reset or after pulling the ACI_RST_L line low, the drive will behave as if it has powered up and will go off bus and lose all automation connector configurations.

An FCP reset will not affect the automation interface.

Note that following an upgrade of the drive firmware the drive will be reset as if it had been powered up.

9 Troubleshooting

Emergency unload (forced eject)

If a cartridge fails to eject using the normal unload procedure, press and hold the Eject button for 5 seconds. This instructs the drive mechanics to perform an emergency unload. Wait for the cartridge to be ejected. This may take up to 15 minutes (the maximum rewind time).

If the cartridge is still jammed, for full-height drives press the emergency reset button (see “[Front panel features](#)” on page 21 or “[Front panel for automation use](#)” on page 68), or pull pin 8 of the Automation and Remote LED Connector low (see “[Automation and remote LED connector](#)” on page 37). For half-height drives perform an emergency reset by pressing and holding the Eject button for at least 35 seconds, and the drive will reset once the button is released. Wait for the drive to reset and recover the tape to the loaded position. This may take up to 15 minutes. Again press and hold the Eject button for 5 seconds to perform a second forced eject and emergency unload if required.

General guidelines

If you experience problems when using the tape drive, you need to isolate the cause of the problem. For example, if you have just installed a new host bus adapter and your system will not start, the cause of the problem is likely to be the adapter.

When installing multiple items of hardware and software, we recommend that you install each in turn and restart the system each time. Similarly if you have already installed multiple devices and software and you experience problems, remove or uninstall each in turn to establish which one is causing the problem.

Remember that the system recognizes devices during boot-up. If you swap or connect a product when your system is running, you will need to reboot the system. Rebooting the system will reset devices and will often resolve problems. It is good practice to reboot every time you add a driver or install firmware.

Most modern host bus adapters locate and display attached devices when the system is booting up. On Windows systems, if you swap or connect a product when your system is running, you will need to reboot the system. IA32 systems also usually need to be rebooted. UNIX systems may have pluggable drivers, which allow drives to be attached to a running system and detected without rebooting.

If the device is not detected on boot up, there is probably a problem with the physical hardware: cables, termination, connections, power or the host bus adapter. If the device is displayed during boot up but cannot be found in the operating system, this is more likely to be a software problem.

Diagnosing the problem

The first step in problem-solving is establishing whether the problem lies with the cartridge, the drive, the host computer and its connections, or with the way the system is being operated.

 **NOTE:**

If the drive is installed in a library, refer to troubleshooting information provided with the tape library, the host or the backup software if the problem seems to lie in one of these areas.

If none of the following advice helps you solve the problem, contact your tape library supplier.

Problems with the host computer

Most modern host bus adapters locate and display attached devices when the system is booting up. If the device is not detected at this stage, there is probably a problem with the physical hardware: cables, termination, connections, power or the HBA itself.

If your drive is found on system boot up but cannot be found in the operating system, this is more likely to be a software problem.

Computer does not boot up

Possible Cause	Potential Solution
You have installed an additional host bus adapter and its resources are clashing with an existing adapter.	Remove the new host bus adapter and check the server documentation.
You have disconnected the power or cable from the computer's boot disk during the drive installation process.	Check that the cables to all devices are firmly connected.

Computer boots, but does not recognize the drive

Possible Cause	Potential Solution
The power or interface cable is not connected properly.	Check that the cables to the tape drive are firmly connected. Ensure that the cable is compliant and that it is not damaged. Replace, if necessary.

Problems with the drive and cartridge

Tape drive does not power up

Possible Cause	Potential Solution
The power cable is not connected properly.	<ol style="list-style-type: none">1. Check that the cables to the tape drive are firmly connected.2. Make sure that the power cable is firmly connected.3. Try another power connector. <i>Note:</i> For standalone drives, the power on/off switch incorporates a green LED. If this is not on, check the power cable connection and replace the cable if necessary. You can use the power cable from your monitor or another device to check that the connection is working.4. If the power supply is present and all LEDs remain off, call support
The self-test fails (Ready LED is off and the other LEDs are on steadily).	If there is a cartridge in the drive, remove it. Power down the drive and power it up again. If the self-test still fails, call support.

The application does not recognize the drive

Possible Cause	Potential Solution
The application does not support the tape drive.	Check the drive is installed properly. Refer to our World Wide Web site (www.hp.com/go/connect) for details of backup applications that support HP LTO Ultrium tape drives. Load any service packs as necessary.
Some applications require drivers to be loaded.	Check the correct drivers are installed. Consult the backup application's installation notes for details.

The cartridge will not eject

Possible Cause	Potential Solution
The cartridge is jammed in the drive, or the backup application cannot eject the cartridge. This is most likely to be a communication problem between the drive and the system.	<ol style="list-style-type: none"> 1. Check there is power to the drive. 2. The Prevent Media Removal function may be enabled. This is on a per-host basis, but all hosts must allow media removal for any of them to do so. Check each host for the status of the PMR function. 3. Press and hold the Eject button for 10 seconds. Allow the drive up to 15 minutes to eject (this is the maximum rewind time of the cartridge.) 4. If the cartridge is still jammed, for full height drives press the emergency reset button (see "Reset switch" on page 21) or for half height drives perform an emergency reset by pressing and holding the Eject button for 20 seconds, and the drive will reset. Wait for the drive to reset and get back to the loaded position. This may take up to 15 minutes. Again press and hold the Eject button to perform a second forced eject and emergency unload if required. 5. If the cartridge is still jammed, call for support

The drive will not accept a cartridge

Possible Cause	Potential Solution
The cartridge is not compatible with your tape drive.	<ol style="list-style-type: none"> 1. Check you are using LTO Ultrium 3, 4 or 5 media. LTO Ultrium 5 drives do not accept LTO Ultrium 1 or 2, or other non-LTO Ultrium media. 2. Check the orientation of the cartridge when loading into the drive.
The cartridge has been damaged.	<ol style="list-style-type: none"> 1. Check the cartridge case is not cracked or split. 2. Check the leader pin is not damaged. If it is, discard the cartridge. 3. Check the cartridge teeth are not damaged. If they are, discard the cartridge. 4. If the drive will still not accept the cartridge, try using a new or known good cartridge. If it loads, the original cartridge is faulty and should be discarded. 5. If the original cartridge is accepted in another tape drive, the original tape drive may be at fault. Check the interface connection and that the tape drive is recognized by the backup application.
The tape drive is faulty.	<ol style="list-style-type: none"> 1. Check the drive is powered on. 2. If the drive still will not accept the cartridge, there may be a problem with the drive's cartridge memory. Call for support.

The computer no longer recognizes the drive in a tape array

Possible Cause	Potential Solution
You powered up the drive or added it to the tape array after the host system was turned on.	Most modern host bus adapters/host systems will only locate and display attached devices when the system is booting up. Try rebooting your host system after the tape array is powered up.
The drive is not inserted correctly.	Check the drive is properly inserted into the tape array so that it mates with the connections at the rear of the enclosure. The extraction lever should be pushed in, locking the drive in position.
There is a fault with the host system.	<ol style="list-style-type: none"> 1. Make sure that the system is configured to recognize the device. 2. Ensure that the correct driver for the tape drive is installed. Look at the host adapter documentation and backup software documentation for further advice.

Problems with cleaning

Use the following table to resolve cleaning problems:

Problem	Solution
Recurring cleaning message.	<p>Clean the drive with an LTO Universal Cleaning Cartridge as instructed in the tape library documentation. If the message reappears, replace the cleaning cartridge with a new one.</p> <p>If the message reappears when a particular data cartridge is used, verify that the data cartridge is readable by clearing the message and reading the tape again.</p> <p>If the data cartridge can be read, back up the data to another cartridge and then discard the damaged one.</p>
The cleaning cartridge is ejected immediately after loading.	Make sure that you are using an approved LTO Ultrium Universal cleaning cartridge and that the cleaning cartridge is not expired.

If the drive is installed in a library:

Problem	Solution
A brand new data cartridge is used, and the library operator panel indicates that cleaning is required.	<p>Clean the outside of the data cartridge with a barely damp, clean, lint-free cloth. Clean the drive as instructed by your tape library documentation.</p> <p>If the operator panel indicates cleaning is required within a short period of time, replace the data cartridge.</p>

10 Special features for automation

Introduction

This chapter contains information that relates to placing an HP LTO Ultrium drive in an automated device, such as an autochanger or a tape library:

- Drives for use in libraries have different front panels from drives mounted individually in servers and standalone drives. There is also a special front panel for use in autoloaders. These are described in [“Front panel for automation use”](#) on page 68.
- For notes on the requirements and other details for the installation of drives into libraries, see [“Installing drives”](#) on page 53.
- For notes on the operation of drives in libraries, see [“Operating drives”](#) on page 60.
- For troubleshooting information, see [Chapter 9](#) on page 61.

This chapter contains information about using special features of LTO Ultrium drives in libraries:

- The [“Automation interface”](#) (ACI/ADI), or the iADT (Ethernet) interface, allows the activities of the drive to be coordinated within a library. See [Automation interface](#), page 70 for details.
- [“Configuring autoloader and ACI-controlled loads”](#) on page 74 allows you to configure whether automatic or ACI-controlled loads and unloads occur.
- LTO Cartridge Memory (LTO-CM) or Cartridge Memory is EEPROM memory that is embedded in every LTO Ultrium tape cartridge. It is non-volatile and is contactless in that it is read by RF coupling rather than electrical contact.

For suggestions of how to make use of cartridge memory in libraries, see [“Using Cartridge Memory \(LTO-CM\)”](#) on page 77.

Drives for inclusion in automated devices have different front panels from individual drives.

Backup software

You need backup application software that supports your LTO Ultrium drive and tape library.

Suitable backup applications will include driver software that establishes the interface between the tape drive and the software. Applications usually recognize tape drives by their manufacturers’ ID string rather than their model numbers, so check the following table for the appropriate reference.

Drive Model ID String

<i>LTO5 FC drive</i>	<code>“HP Ultrium 5-SCSI”</code>
<i>LTO5 SAS drive</i>	<code>“HP Ultrium 5-SCSI”</code>

Front panel for automation use

Full-height drives

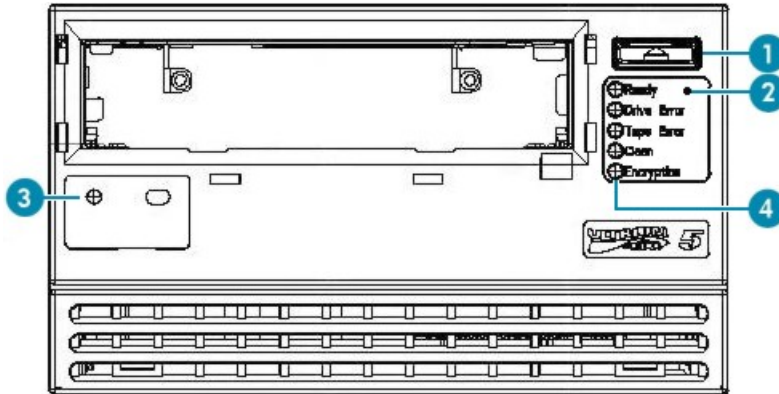

- 1. Eject button
- 2. Access hole for emergency reset switch
- 3. Holes for optical sensors
- 4. LEDs

The automation front panel has the following features:

- There is an eject button for manually ejecting a cartridge. Press this for approximately ten seconds to start a “forced eject” for recovering a cartridge manually. See “[Emergency unload](#)” on page 61 for details.
- Indicator LEDs provide a visible indicator of the state of health of the drive. See “[Other LED patterns](#)” on page 23 for details.
- There is no door. Instead there are two fixed guides to guide the cartridge into the drive.
- The indent for a label on the left just under the cartridge opening is left blank, exposing two holes. These can be used to provide a target for the optical position sensor of a library picker.
- There are additional holes around the cartridge opening to allow a throat to be fitted if necessary, to help the smooth loading of cartridges.

Front panel for use in autoloaders

A special front panel is available for autoloader applications. The front panel fits within the drive form factor in height and width:

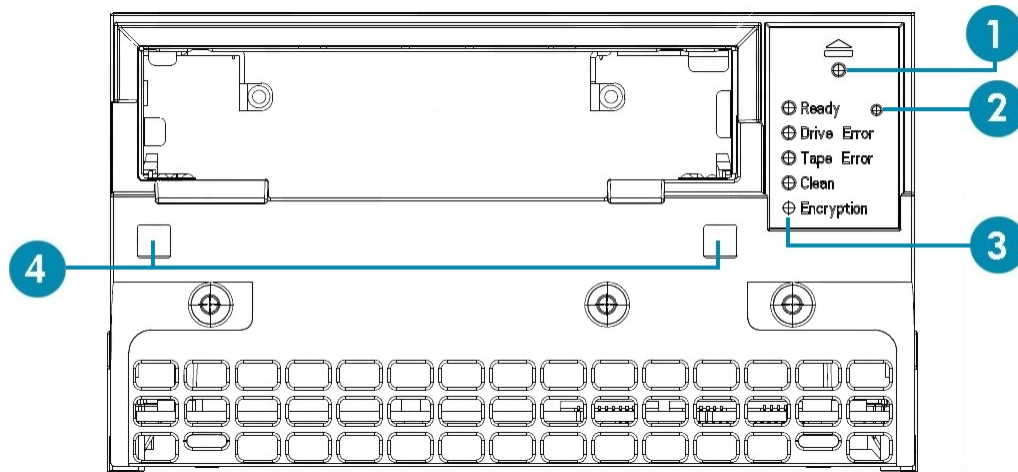

1. Access to Eject button
2. Access hole for emergency reset switch
3. LEDs
4. Access to datum surfaces on the front of the drive

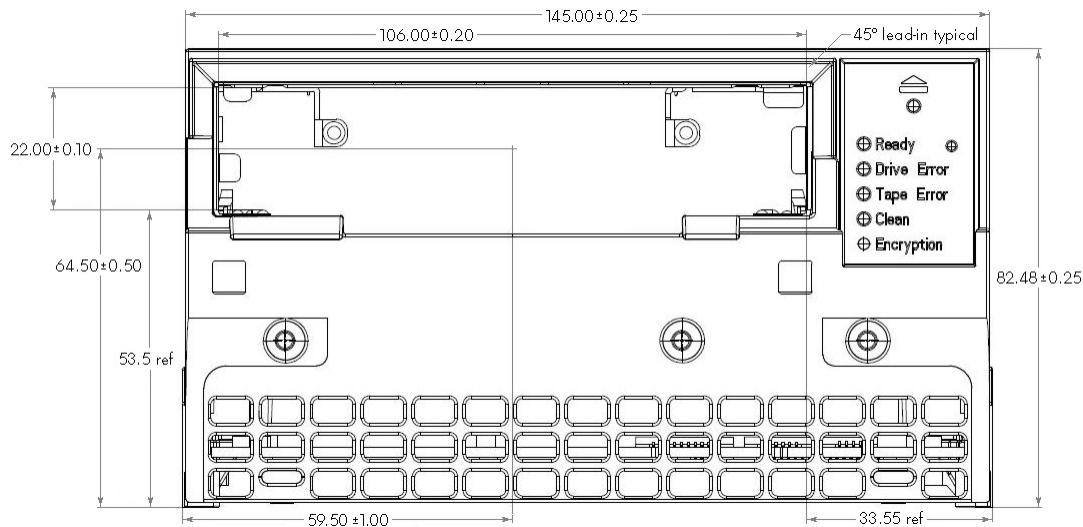

The autoloader front panel has the following features:

- Simple one-piece plastic design
- Pinhole access to the eject switch on the drive for manually ejecting a cartridge. Press this for approximately ten seconds to start a “forced eject” for recovering a cartridge manually. See “[Emergency unload](#)” on page 61 for details.
- Indicator LEDs provide a visible indicator of the state of health of the drive. See “[Other LED patterns](#)” on page 23 for details. The LEDs are viewed through holes in the autoloader front panel; no light pipes are present.
- Clearance for picker finger access to the right-side cartridge-handling notch
- Two square holes through the panel to provide access to a datum surface on the front of the drive
- Cartridge lead-in features to improve cartridge load and unload operations

Half-height drives

The half-height automation panel has very similar features to the full-height version. The exterior dimensions of the panel are smaller than those of the equivalent panels for drives designed for installing on servers and panels for standalone drives, in order to allow the whole drive to be fitted into the half-height form factor with no overlap.

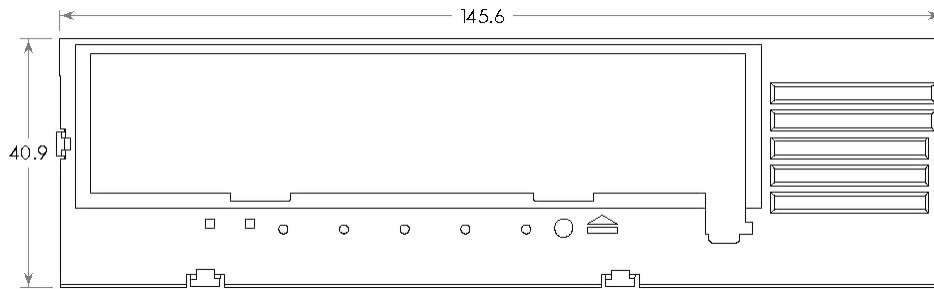

Figure 10 Half-height automation bezel

The bezel is 4.1 mm thick.

Automation interface

The HP LTO-5 tape drive supports connection to an automation device via the serial ADI port or via an Ethernet port. The ADI port supports the HP proprietary ACI protocol for connection to legacy libraries and the sADT protocol. The Ethernet port supports the Internet ADT (iADT) and iADT Discovery (iADT_DISC) protocols defined in the ADT-2 draft standard.

 **NOTE:**

The sADT protocol is covered by two standards:

- For ADT-2, see the T10 ADT-2 Standard and the relevant ANSI standard when it is released.
- For ADC-3, see the T10 ADC-3 Standard and the relevant ANSI standard when it is released.

As the Ethernet port can be connected to devices outside the library, the drive provides support for security in the form of optional authenticated connections. Authentication makes use of X.509 certificates which are installed in the drive via SCSI commands defined in the proprietary Security Configuration Protocol.

The serial automation controller connection supports a HP proprietary Automation Controller Interface (ACI) protocol and the Automation/Drive Interface (ADI) transport protocol (ADT). Because of the differences in these two protocols it is not possible to interleave ACI and ADI frames/commands. It is therefore necessary for the serial automation controller connection to operate in either ACI or ADI Mode. The tape drive defaults to ACI Mode after a power-on or hard reset if the Sensea/ACI_LIN_SEN_L input is activated on the ADI/ACI connector. Otherwise the drive defaults to ADI Mode. See “Automation interface” on page 70.

Connections between the library and the drive may use either or both of the physical connections:

- sADT only
- iADT only
- iADT and sADT

The drive also supports ADI bridging as defined in the INCITS T10 ADC-3 standard over both sADT and iADT.

Automation Control Interface (ACI)

The Automation Control Interface (ACI) allows the activities of the drive to be coordinated within a library. The protocol has been designed so that it can be made into a standard feature of tape drives. It provides a rich and extensible functionality to allow automation manufactures to add value in their application of it.

The interface is a serial bus with additional control lines, designed to connect the LTO Ultrium tape drive to an automation controller in a tape library. Each tape drive position has a separate automation controller. The RS-422 serial port on the rear of the drive allows for ACI connection.

The ACI protocol provides the following fundamental functions:

- Coordinating the automation controller and the tape drive for Load and Unload operations
- Allowing the automation controller to retrieve information from the tape drive
- Setting tape drive configuration information

In addition, the following functions may be supported depending on the way that the tape library is configured:

- Providing upload and download of firmware images
- Providing access to the contents of the Cartridge Memory
- Providing a protocol for passing SCSI commands to the tape drive
- Providing a protocol for passing SCSI commands from the host to the library (surrogate SCSI).

NOTE:

These notes refer to the “standard” automation drive variant.

For details of using ACI commands and the ACI protocol, see Chapter 5 of the *Software Integration Guide*, volume 2 of the HP LTO Ultrium Technical Reference Manual.

Automation/Drive Interface (ADI)

The INCITS T10 (SCSI) committee has a working group devoted to the development of a common Automation-Drive Interface (ADI). ADI consists of two standards:

- *Automation/Drive Interface—Commands (ADC-2)*, ANSI INCITS 441-2008, which specifies the SCSI command set used over ADI.
- *Automation/Drive Interface—Transport Protocol (ADT-2)*, ANSI INCITS TBD, which specifies a transport protocol for ADI.

The drive operates in either ACI or ADI mode. It is not possible to interleave ACI and ADI commands because they are handled very differently. The drive defaults to ACI mode after a power-on or hard reset. The Automation Controller can then instruct the tape drive to switch to ADI mode by sending a Port Login frame under the following conditions:

1. No ACI commands are outstanding. This not only means that the tape drive must have received acknowledgement for all responses to all ACI commands received, but also that all immediate response commands have also finished. For example, if an Automation Controller initiates an immediate response Load command (see section 5.3 of ACI specification), it cannot issue an ADI command until the tape drive has finished physically loading the cartridge. If an ACI command is outstanding when an ADI frame is received the drive will transmit an ACI <NAK> character in response.
2. An Encoded ADI frame received when the tape drive is in ACI Mode must not exceed the Receive Buffer size (see section 5.16 of the ACI Specification for details) and the frame must be received within the ACI Transmission Period (see section 4.6.6.3.2 of the ACI Specification). If either of these conditions is exceeded the tape drive will transmit a <NAK> character.
3. ADI frames received in ACI Mode must be Port Login frames otherwise the tape drive will revert to ACI Mode after transmitting the appropriate ADI response.
4. The ADI protocol must be enabled; see the Set Drive Configuration command (section 5.6 of the ACI Specification) for details. If the tape drive receives an ADI frame when the ADI protocol has been disabled the drive will transmit a <NAK> character.

When the tape drive is in ADI Mode it will not acknowledge or respond to any ACI command until the ADI port becomes logged out, either with an explicit Port Logout frame or an ADI Reset.

When the tape drive transitions from one mode to the other (ACI to ADI or ADI to ACI) it will not implicitly change the drive's configuration. However, Automation/Drive Interface [ADC-2] SCSI mode parameters only apply when the tape drive is in ADI Mode, so the tape drive behavior may change after transitioning between the two modes.

HP recommends that the drive is used in either exclusively ACI or ADI modes of operation. Avoid mixing operation of the two modes.

Internet Automation Device interface (iADT)

The iADT or Ethernet port provides all the same functionality as the ACI/ADI port but can also be used for:

- drive management
- encryption control/key management
- diagnostic extraction

The iADT port supports the following network services via the 10/100 Mbpa Ethernet port:

Service Name	Port Number/Base Protocol	Description
iADT	4169/TCP	Internet Automation Device Interface using non-secure ADT protocol over TCP (see ADT-2).
iADI-TLS	9614/TCP	Internet Automation Device Interface using secure ADT protocol over TCP (see ADT-2).
iADT-DISC	4169/TCP	iADT Discovery over UDP (see ADT-2).
iDTI	4167/TCP	Internet Diagnostic Tools Interface using non-secure ADT protocol over TCP.

How the LTO-5 drive will be configured depends upon the overall configuration of the data storage site. The site consists of a number of entities:

- Host computers performing backups
- Tape libraries (automation devices)
- LTO-5 tape drives installed in tape libraries (drives may provide connectivity between the library and hosts)
- Management hosts performing security configuration
- Encryption key managers (EKMs)
- Hosts accessing the drives for debugging information

It may be necessary for a drive to communicate directly with a network entity, such as an external Key Manager, which requires network traffic to pass through a router on the edge of the library. This requires careful configuration of the router to ensure security of the network inside the library.

The network inside a library is configured using techniques unique to that library. This section only gives guidance on the goals of that configuration. The library network configuration has two purposes:

- To permit communication among the library, all drives, and any other entities.
- To ensure the security of those communications.

If the network connects only the library and drives, there should be no physical connection between the network and any network outside the library. If this is not feasible, then IP packets to or from the following port numbers should be blocked:

- iADT (TCP/4169)
- iADT-TLS (TCP/9614)
- iADT-DISC (UDP/4169)

If an external host (such as an external Key Manager) requires access to the library only and the library has two Ethernet ports with a firewall between them, then one port should be used only for external access and the other for internal access. This is effectively the same as the situation in the previous paragraph.

If an external host requires access to drives, only the minimum number of protocols should be allowed to pass into and out of the library, and any connections carrying SCSI commands should be secured either by using IKEv2-SCSI and ESPSCSI on the iADI port or by using the iADI-TLS port. Either of these will require security configuration to be performed on the drive.

Public Key Infrastructure (PKI) credentials used by the HP LTO-5 drives consist of three classes of X.509 certificates: root certification authority (CA), device, and management host. If the drive has not received a root CA certificate and a device certificate, then SSL/TLS connections (such as iADT-TLS) will not be accepted.

- The root CA certificate is stored in non-volatile memory in the drive and is used to verify credentials presented to the drive in the course of the TLS and IKEv2-SCSI protocols. To permit this, it is used to sign the other certificates.
- The device certificate stored in non-volatile memory identifies the drive and contains the public key programmed into the drive during manufacturing. The subject name field of the certificate is provided by the system administrator during certificate creation.
- The management host certificates are stored in volatile memory, and are used to verify and authorize security configuration operations.

Use of PKI credentials requires the system administrator to replace compromised and expired certificates, and (when certificate validity dates are checked) ensure that the drive's real-time clock is valid. The LTO-5 drive does not support certificate revocation lists (CRLs). In some circumstances, you can disable the checking of certificate validity dates.

Fan interface

The HP Ultrium LTO5 drive has the capability to control an external fan. The purpose of this is to provide the necessary airflow through the drive to keep the internal temperatures within normal parameters. For details of the Fan Connector, see “[Fan control connector](#)” on page 41. When the drive detects a fan is present it will control the fan as required. Any fan used for this purpose should be able to meet the following criteria:

- 12V supply
- 4-wire fan (Power, Ground, Speed Control and Fan Speed)
- Minimum airflow requirements as detailed in the environmental specification
- The enclosure used to house the fan and drive must be designed in such a way as to ensure that the airflow generated by the fan is only pulled through the drive. There should be no path outside the drive.



NOTE:

If you intend to plug a fan into this connector to provide the necessary airflow through the drive, consult your HP Technical Support Representative for details of the fan specification required.

Configuring autoload and library-controlled loads

HP LTO Ultrium tape drives can be configured so that loads either occur automatically or under the control of the library. A SCSI MODE SELECT command can set the Autoload field to do this. The field is byte 5, bits 0–2 of the Control Mode page, 0Ah.

If the Autoload field = 0, Autoload is set and the drive automatically loads a cartridge when it is inserted and threads the tape so that it is ready for use.

If the Autoload field = 1 or 2, the drive pulls the cartridge into the drive but does *not* thread the tape. In this position, the LTO-Cartridge Memory can be read. The drive requires a Load command to thread the tape and make it ready for use.

Cartridge positions during load and unload

The following diagrams show the positions of importance during load and unload.

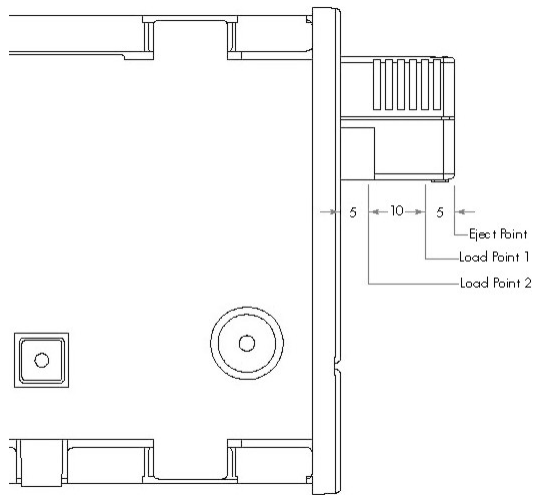

Figure 11 Full-height drives: load and unload positions

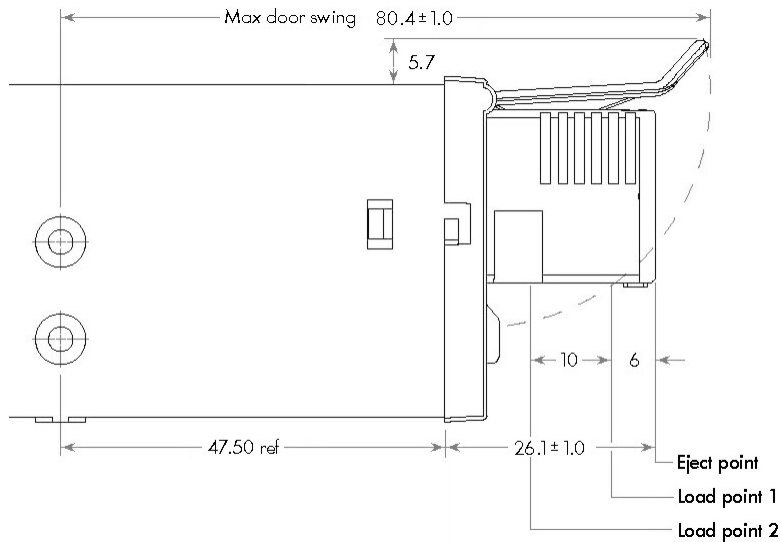

Figure 12 Half-height drives: load and unload positions

 **NOTE:**

Drives for library use the automation front panel, which has no door. The illustration shows a standalone drive.

Eject Point

Cartridges are ejected to this point, which is 26.1 mm beyond the front of the mechanism. The position tolerance is ± 1 mm. The automation controller cannot configure the location of this position.

- Load Point 1** If Autoload is set (Autoload field = 0), the drive will start to load the cartridge when it reaches this point.
If Autoload is not set (Autoload field = 1 or 2), the library must insert the cartridge into the drive to a position between Load Point 1 and Load Point 2. The library can then issue a Load command over the ADI connector to instruct the drive to load and thread the cartridge.
Load Point 1 is the recommended minimum load point for commanded loads.
- Load Point 2** The maximum distance a cartridge can be inserted for optimal loading performance, so that autoload or a Load command can load the cartridge. The automation controller cannot configure the location of this position.
The maximum speed for inserting a cartridge into the drive is 80 mm/s.

There is one other point of note, the **ready-to-eject position**. If Auto-Eject is not set then when an unload command is received by the drive, the tape will be rewound and unthreaded. The drive will then wait at this point until it is commanded to eject the cartridge by the ACI Unload command.

Load scenarios

The following scenarios describe the operation during the various types of load.

Load scenario 1: Autoload

1. The library sends a Set Configuration command to enable Autoload. This is only necessary after a drive power-on.
2. The host sends a Move Medium command to the robotics.
3. The picker gets a cartridge from a storage slot.
4. The picker inserts the cartridge into the drive aperture.
5. The picker lets go of the cartridge and pushes the cartridge to between Load Point 1 and Load Point 2.
6. The drive automatically takes the cartridge, loads it and threads it.

Load scenario 2: Library controlled

1. The host sends a Move Medium command to the robotics.
2. The picker gets a cartridge from a storage slot.
3. The picker inserts the cartridge to between Load Point 1 and Load Point 2.
4. The picker lets go of the cartridge.
5. The library sends a Load command to the drive.
6. The drive takes the cartridge, then loads and threads it.

Unload scenario 1: Autoload

1. The library sends a Set Configuration command to enable Auto-Eject. This is only necessary after a drive power-on.
2. The host sends an Unload command to the tape drive.
3. The drive rewinds, unthreads and ejects the cartridge to Eject Point.

4. The host sends a Move Medium command to the robotics.
5. The picker takes the cartridge from the tape drive and places it in its storage slot.

Unload scenario 2: Library controlled

1. The host sends an Unload command to the drive.
2. The drive rewinds and unthreads the tape. It then pauses with the cartridge at ready-to-eject position.
3. The library sends an Unload command to eject the cartridge.
4. The drive ejects the tape to Eject Point.
5. The picker takes the cartridge from drive and places it in its storage slot.

Load/unload forces

The *load* force varies according to the speed at which the cartridge is inserted into the drive. The peak load force occurs when the cartridge begins to accelerate the drive carrier and only lasts for a short time. In any automation environment, it is recommended that the cartridge is inserted into the drive with a speed of between 25 mm/s to 55 mm/s. Going slower than this raises the possibility that the Autoload may not trigger (half-height drives only) and going much faster increases the risk of damaging the load mechanism.

The *unload* force is 5.8N maximum; this is the force that an external mechanism must exert to remove a fully ejected cartridge from the drive.

Using Cartridge Memory (LTO-CM) in libraries

Cartridge memory offers possibilities for use in libraries as an adjunct to or replacement for barcodes. The following diagram shows the architecture required.

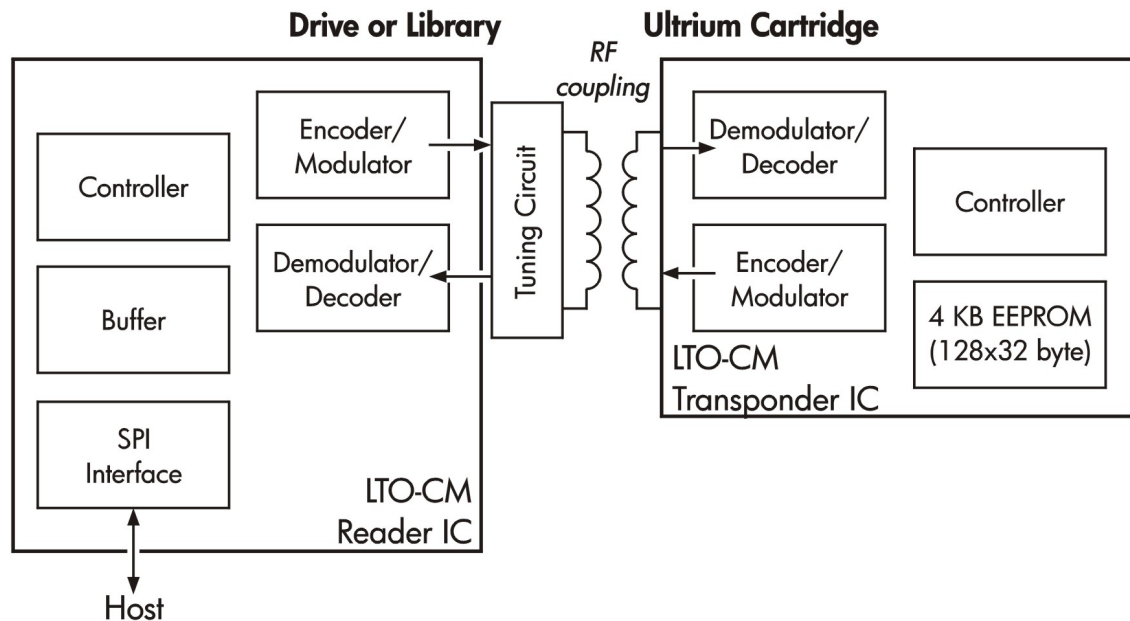

Current libraries — barcodes

Many libraries use sticky labels with barcodes on cartridges to identify them. These are read by a barcode reader attached to the picker arm. The application then needs to hold information as to the contents of the tape to which it can relate the bar code.

Cartridge Memory can be used as a substitute for these barcodes. No human interaction is needed to fix barcode labels, reducing errors, though cartridges may still need labels that humans can read. A cartridge can be identified by its serial number.

However, because Cartridge Memory has space that can be written by applications, it can hold details of the contents and nature of the tape. This obviates the need for this information to be held by the application. HP is working with other industry leaders, both hardware and software, on an Industry Common Implementation Guide.

11 Drive error codes

The following error codes may be reported in bytes 16 and 17 of the Request Sense data and also reported in ACI Get Error Info RDATA, bytes 3 and 4. See the REQUEST SENSE command in Chapter 4 of the *Host Interface Guide*, Volume 3 of the HP LTO Ultrium Technical Reference Manual.

Generic module (from 0000h)

Code	Description
0000h	Good.
0001h	Bad.
0002h	Done.
0003h	Aborted.
0004h	Invalid configuration values.
0005h	Invalid configuration name.
0006h	Place holder until real status is known.
0007h	Invalid parameter supplied to function.

Automation Control Interface (from 0400h)

Code	Description
0401h	Unsupported command opcode.
0402h	Busy—command rejected.
0403h	RAMBIST failed.
0404h	Invalid command checksums.
0405h	Invalid baud rates.
0406h	Invalid command while load/unload pending.
0407h	Time-out waiting to end immediate command.
0408h	RAM framing error.
0409h	RAM overrun error.

Code	Description
040Ah	Invalid command length .
040Bh	Byte buffer framing error.
040Ch	Byte buffer overrun error.
040Dh	Command active abort rejected.
040Eh	Invalid response acknowledgement.
040Fh	Transmission time-out.
0410h	Did not receive ETX.
0411h	Cancel command packet timer error.
0412h	Custom byte error.
0413h	Response acknowledgement time-out.
0414h	Cancel response acknowledgement timer error.
0415h	Unexpected byte received.
0416h	Zero length command.
0417h	Invalid command reserved field.
0418h	RAMBIST did not complete.
0419h	Ignored a byte received while transmitting response.
041Ah	Invalid CDB data length.
041Bh	Firmware image too big.
041Ch	ACI response is longer than the available buffer.
041Dh	Did not receive acknowledgement to program flash.
041Eh	Attempt to create a polling object instance without a polling function.
041Fh	Attempted to create more polling object instances than the maximum allowed.
0420h	Attempted to access a polling object instance that does not exist.
0421h	ACI command length is greater than the available buffer.
0422h	ACI has run out of CRAM.
0423h	ACI has received a firmware image larger than expected.
0424h	An ACI command parameter contains an invalid value.
0425h	ACI <code>acMalloc()</code> failed, insufficient memory available to process command.
0426h	ACI Control queue is full.
0427h	ACI Response queue is full.

Code	Description
0428h	ACI Control queue is empty.
0429h	ACI Response queue is empty.
042Ah	ACI Response packet was NAKed.
042Bh	ACI attempted to execute an unsupported PPL command.
042Ch	ACI has detected a command with a parameter out of range.
042Dh	ACI attempted to execute a PPL command before the previous command completed.
042Eh	ACI received more raw data than expected; see the Write Buffer PPL command.
042Fh	Internal status indicating a <i>slow</i> ACI command rather than a fast one.
0430h	Internal status indicating an operation has initiated a DMA transfer.
0431h	Internal status indicating that a firmware image has been downloaded so the firmware should have been upgraded.
0432h	Internal status indicating that a firmware image download has been aborted.
0433h	Surrogate SCSI command terminated due to a SCSI reset/abort for the LUN.
0434h	ACI has not been allocated the amount of DRAM it requires.
0435h	ACI has not been allocated the amount of CRAM it requires.
0436h	An ACI surrogate SCSI command packet contained an invalid Exchange ID.
0437h	A CDB contained an invalid exchange ID.
0438h	ACI Surrogate SCSI queue is full.
0439h	ACI Surrogate SCSI queue is empty.
043Ah	A request for an invalid entry in Surrogate SCSI queue has been made.
043Bh	ACI has received an <code>acSurrogateNotifyOp</code> with an unknown SCSI CDB type.
043Ch	The SCSI Data Length parameter has changed unexpectedly.
043Dh	Internal status indicating a PPL Command is being executed.
043Eh	ACI too busy for fast command. Used in tracepoints to identify cause of <code>AC_BUSY_CMD_REJECTED</code> error.
043Fh	ACI too busy for immediate command. Used in tracepoints to identify cause of <code>AC_BUSY_CMD_REJECTED</code> error.
0440h	ACI too busy for slow command. Used in tracepoints to identify cause of <code>AC_BUSY_CMD_REJECTED</code> error.
0441h	ACI too busy for SCSI command. Used in tracepoints to identify cause of <code>AC_BUSY_CMD_REJECTED</code> error.
0442h	ACI too busy because of overlapped commands. Used in tracepoints to identify cause of <code>AC_BUSY_CMD_REJECTED</code> error.

Code	Description
0443h	ACI too busy because of comms resync. Used in tracepoints to identify cause of AC_BUSY_CMD_REJECTED error.
0444h	ACI too busy because upgrading. Used in tracepoints to identify cause of AC_BUSY_CMD_REJECTED error.
0445h	ACI too busy because out of memory. Used in tracepoints to identify cause of AC_BUSY_CMD_REJECTED error.
0446h	ACI is resynchronising comms with library after persistent comms failure.
0447h	SCSI opcode is not supported in this firmware release.
0448h	Internal status indicating an ACI reset is required.
0449h	Internal status indicating a full drive reset is required.
044Ah	Command contains an invalid Memory ID.
044Bh	All Command Control Blocks have been allocated.
044Ch	The returned or referenced Command Control Block is invalid.
044Dh	Response Time-out — command aborted and response sent.
044Eh	Response Time-out — response sent but command allowed to continue.
044Fh	Response Time-out — ACI failed to send response within the Response Period.
0450h	ACI too busy because the CCB queue is full. Used in tracepoints to identify the cause of AC_BUSY_CMD_REJECTED error.
0451h	ACI command contains the sequence number of the previous command. The command is ignored.
0452h	Internal status indicating a slow ACI command being executed before Drive Ready event.
0453h	Failed to transmit ACK/NAK within the Packet Acknowledgement period.
0454h	Internal status indicating a direct ACI command rather than a fast or slow one.
0455h	ACI too busy for a direct command. Used in tracepoints to identify cause of AC_BUSY_CMD_REJECTED error.
0456h	Cannot perform operation because the SCSI burst size is zero or unknown.
0457h	Command not supported because the primary interface has not been enabled.
0458h	Unable to get a new task object.
0459h	An ADI frame has been received while one or more ACI commands are outstanding.
045Ah	An SOF was received in ACI Mode which was not a valid frame.
045Bh	The SSC device has not requested the amount of data supplied with the ACI SCSI command.
045Ch	The specified automation port is not supported.

Code	Description
045Dh	A function will send a response when it has finished.
0480h	ACI self-test failure — ACI should not be executing a direct Command while performing the self-test.
0481h	ACI self-test failure — ACI should not be executing a slow Command while performing the self-test.
0482h	ACI self-test failure — if ACI is idle, the Control queue should be empty.
0483h	ACI self-test failure — if ACI is idle, the Response queue should be empty.
0484h	ACI self-test failure — if ACI is idle, the Surrogate SCSI queue should be empty.
0485h	ACI self-test failure — if ACI is idle, only the self-test command should be allocated in the small Data Region.
0486h	ACI self-test failure — if ACI is idle, no memory from the Large Data Region should be allocated.
0487h	ACI self-test failure — if ACI is idle, no CRAM memory should be allocated.
0488h	ACI self-test failure — if ACI is idle, only one CCB should be allocated.

Buffer manager (from 0800h)

Code	Description
0800h	The buffer manager failed to initialize correctly.
0801h	No Buffer Allocation description exists for the supplied Module ID
0802h	The request queue has overflowed.
0803h	The priority request queue has overflowed.
0804h	Dataset index error: <code>BMMDataSetIdxToAddr()</code> has been passed an invalid <code>Idx</code> .
0805h	Dataset information table index error: <code>BMMDataSetIdxToDSITAddr()</code> has been passed an invalid <code>Idx</code> .
0806h	ACN index error: <code>BMMDataSetIdxToACNandLPOSAddr()</code> has been passed an invalid <code>Idx</code> .
0807h	Wrap index error: <code>BMMDataSetIdxToWrapAddr()</code> has been passed an invalid dataset <code>Idx</code> .
0808h	The Notification queue has overflowed. See <code>BMMXferComplete()</code> .
0809h	The notification was not SDL signal for DSIT read. See <code>BMMXferComplete()</code> .
080Ah	The Notification queue has underflowed. See <code>BMMXferComplete()</code> .

Diagnostic control (from 1800h)

Code	Description
1800h	No errors.
1801h	Invalid command.
1802h	Invalid parameters.
1803h	Drive not ready.
1804h	Command failed.
1805h	Command aborted.
1806h	Too few parameters.
1807h	Too many parameters.
1808h	Command denied.
1809h	Operation code not supported in diagnostic CDB command.
180Ah	Page code not supported in diagnostic CDB command.
180Bh	Buffer code not supported in read/write buffer command.
180Ch	Parity error on serial receive.
180Dh	Framing error on serial receive.
180Eh	Overflow error on serial receive.
180Fh	Excessive input length, exceeding 220 characters.
1810h	Power-on self-test not executed.
1820h	Error detected during the Register Walking 1 test.
1821h	Built-in self-test failure.
1822h	No test available for the parameters provided.
1823h	Error detected during the Memory test.
1830h	Power-on self-test failed the processor internal SRAM data bus test.
1831h	Power-on self-test failed the processor internal SRAM address bus test.
1840h	Power-on self-test failed the DRAM MPU Port test.
1841h	Power-on self-test failed the DRAM Data Bus test.
1842h	Power-on self-test failed the DRAM Addr Bus test.
1843h	Power-on self-test failed the Formatter ASIC Register test.
1844h	Power-on self-test failed the Formatter ASIC built-in self-test).

Code	Description
1845h	Power-on self-test failed the Firmware Image Checksum.
1846h	Power-on self-test failed the CRAM Data Bus test.
1847h	Power-on self-test failed the CRAM Address Bus test.
1848h	Power-on self-test failed the SCSI ASIC Register test.
1849h	Power-on self-test failed the SCSI ASIC Buffer Data Bus test.
184Ah	Power-on self-test failed the SCSI ASIC Buffer Address Bus test.
184Bh	Internal status instructing DI to exit Data Collection Mode.
184Ch	Internal status instructing DI to execute the command as a Slow command.
184Dh	Diagnostic Control has rejected a command because it is already executing a command.
184Eh	Attempted to release Diagnostic Results memory that has not been allocated.
184Fh	Unable to perform a Diagnostic command as the Diagnostic Results memory is already reserved.
1850h	Diagnostic Results data has overflow the memory allocated for results.
1851h	DI has received an unsupported SCSI opcode in <code>diExecScsiDiagOp</code> .
1852h	DI attempted to set an illegal baud rate.
1853h	Set Config attempted to set a read-only configuration.
1854h	Indicates DI needs to send response in the Port buffer before completing the command.
1855h	Power-on self-test failed the external SRAM Data Bus test.
1856h	Power-on self-test failed the external SRAM Address Bus test.
1857h	Internal status indicating that a Log command specifies an FLM log.
1858h	Returned by some log extraction functions to indicate there is more data to extract.
1859h	Comms error (such as framing or overrun) detected on the Serial Test port.
185Ah	The Serial Test port has timed-out while receiving data.
185Bh	A device server has requested an operation not supported by <code>diPortIF</code> .
185Ch	Unable to get a new task object.
185Dh	SCSI Command cannot be executed in Limited Operation Mode
185Eh	Internal status instructing DI to send status before starting the protocol test.
185Fh	Memory access denied to a READ/WRITE BUFFER command.
1860h	Memory access denied to a READ/WRITE MEMORY command.
1861h	Power-on self-test failed; unrecoverable ECC error detected.

Code	Description
1862h	A field is invalid in a diagnostic CDB command.
1863h	POST failed. The image checksum is invalid.
1864h	POST failed. The checksum is incomplete.
1865h	Invalid length/address in READ/WRITE MEMORY command.
1866h	The Drive Configuration Table returned permission denied in response to a Write CM/EEPROM operation.
1867h	Verify root key failed as no root key found in OTP.
1868h	Root key is incorrect.
1869h	Drive unexpectedly in unsecured state.
186Ah	RSA public key not found.
186Bh	RSA private key not found.
186Ch	RSA key pair not found.
186Dh	Data following encryption/decryption with RSA key is incorrect.
186Eh	Root key generated when one already exists.
186Fh	Drive in unexpected security state.
1870h	RSA key storage was attempted when one already exists.
1871h	OTP public key already exists.
1872h	OTP public key not found.
1873h	Management ARM testid is not supported.
1874h	Unable to obtain Humidity value.
1875h	Unable to obtain Humidity value.
1876h	Unable to perform OTP write.
1877h	Unable to perform OTP read.
1878h	Unable to perform OTP write, write-protect set.
1879h	Unable to perform OTP write; the bank has been previously written to.
187Ah	OTP write has taken too long.
187Bh	OTP STATUS_RDY not set when expected.
187Ch	OTP STATUS_RDY not set for bank re-read following write.
187Dh	POST failed OTP security state in debug mode.
187Eh	Checking OTP banks blank, parameters out of bounds.

Code	Description
187Fh	Supplied parameters out of bounds for this Buffer ID.

Drive control (from 1C00h)

Code	Description
1C00h	Bad cartridge type. Attempted to load a cartridge of a type that drive control cannot handle.
1C01h	Attempted to unload a cartridge when Prevent Medium Removal is on.
1C02h	There is no firmware image available for upgrade.
1C03h	Firmware image is incomplete.
1C04h	Firmware image has checksum or other errors.
1C05h	Firmware image is not compatible with the drive configuration.
1C06h	Firmware image is too big to upgrade from.
1C07h	Internal error in the Drive Control firmware upgrade code.
1C08h	A firmware upgrade cartridge was in the drive when it powered on.
1C09h	A load without threading has been requested for a cartridge with unusable Cartridge Memory.
1C0Ah	Tried to load a writable cartridge with an unusable Cartridge Memory.
1C0Bh	The write-protect tab setting was changed during a load.
1C0Ch	A non-HP cleaning cartridge has been inserted in the drive.
1C0Dh	Cannot determine the manufacturer of the cleaning cartridge.
1C0Eh	No DRAM space reserved to hold the firmware image.
1C0Fh	A cleaning cartridge was in the drive when it powered on.
1C10h	Drive Control did an eject during the power-on sequence.
1C11h	A firmware upgrade cartridge has been loaded when a data cartridge was expected.
1C12h	A firmware upgrade cartridge was expected but some other type of cartridge has been inserted.
1C13h	Failure due to drive temperature being out of acceptable range.
1C14h	Cleaning cartridge initialized by a non-HP drive.
1C15h	Trying to convert a non-data cartridge into a firmware upgrade cartridge.
1C16h	Operation failed because cartridge is not present or not ready.
1C17h	Cleaning cartridge loaded when a data cartridge was expected.

Code	Description
1C18h	Expected a cleaning cartridge but got something else on load.
1C19h	Cartridge Memory is unusable and failed to read the FID.
1C1Ah	Firmware upgrade image information is unavailable.
1C1Bh	Could not find firmware information in the new image.
1C1Ch	A tape load has failed.
1C1Dh	The EOD Validity field is not Good.
1C1Eh	Firmware image is not compatible with drive sub-personality configuration.
1C1Fh	A TMR timer fired but the ID does not match what was expected.
1C20h	Firmware image has incorrect signature.
1C21h	The firmware upgrade image is too old.
1C22h	Firmware upgrade image version is too large.
1C23h	Unknown tape format encountered during firmware upgrade.

Drive monitor (from 2000h)

Code	Description
2000h	No error. Synonymous with GOOD status.
2001h	Invalid parameter. The value of a parameter received with a Drive Monitor operation falls outside its valid range.

External interfaces (from 2400h)

Code	Description
2400h	Command holder full.
2401h	Bad command handle.
2402h	Empty command handle.
2403h	No tape loaded.
2404h	Already loaded.
2405h	In diagnostic mode.
2406h	Not in diagnostic mode.
2407h	Tried to write to write protected cartridge.

Code	Description
2408h	Aborted an active command.
2409h	Aborted a command before it became active.
240Ah	Tried to abort a command that was not queued.
240Bh	Invalid state requested of the EII State Manager.
240Ch	The EII tried to process a firmware upgrade type that is not supported.
240Dh	The EII state manager could not handle an abort request.
240Eh	Tried to abort a command that was already being aborted.
240Fh	Tried to get a command for the wrong module.
2410h	Command specified in <code>eiNotifyOp</code> would not have been top of queue.
2411h	Attempt to delete a queued EII command.
2412h	Multiple attempts to delete an executing EII command.
2413h	Attempt to queue a queued EII command.
2414h	Attempt to queue an executing EII command.
2415h	Attempt to remove a command from empty EII command queue.
2416h	Attempt to execute a command still on the EII command queue.
2417h	Attempt to execute an EII command when another is executing.
2418h	Attempt to stop executing an EII command that was not executing.
2419h	The module putting a command on the EII command queue is not the module that allocated it.

Front panel interface (from 2800h)

Code	Description
2801h	Failure due to use of forced eject.

Host interface (from 2C01h)

Code	Description
2C01h	Unknown opcode.
2C02h	Reserved field set.
2C03h	Unknown mode page.

Code	Description
2C04h	Firmware bug.
2C05h	Parameter list length error.
2C06h	Already prevented.
2C07h	Not prevented.
2C08h	Too many hosts.
2C09h	32-bit overflow.
2C0Ah	Invalid space code.
2C0Bh	Bad inquiry page.
2C0Ch	Not the reserver.
2C0Dh	Not reserved.
2C0Eh	Third-party bad.
2C0Fh	Third-party host.
2C10h	Reserved.
2C11h	Read Buffer ID.
2C12h	Read Buffer mode.
2C13h	Write Buffer ID.
2C14h	Write Buffer mode.
2C15h	Main Buffer mode.
2C16h	Write Buffer header.
2C17h	No EVPD.
2C18h	Drive not ready.
2C19h	Density medium no tape.
2C1Ah	ARM firmware error code 0, used by the embedded ARM firmware.
2C1Bh	ARM POST fail.
2C1Ch	TX fail.
2C1Dh	Inf host interface ARM POST — SDRAM test failed.
2C1Eh	Inf host interface ARM POST — SDRAM BIST time-out.
2C1Fh	Inf host interface ARM POST — SDRAM memory access.
2C20h	Inf host interface ARM POST — Atmel memory test.
2C21h	Inf host interface ARM POST — no Olga connected.

Code	Description
2C22h	Inf host interface ARM POST — FC diagnostic CC1
2C23h	Inf host interface ARM POST — FC diagnostic counters.
2C24h	Inf host interface ARM POST — FC diagnostic FIFO test.
2C25h	Inf host interface ARM POST — FC diagnostic interface.
2C26h	Inf host interface ARM POST — FC diagnostic register check.
2C27h	SPI host interface report parity error status.
2C28h	SPI host interface ARM POST — register diagnostics failed.
2C29h	SPI host interface ARM POST — PDC BIST time-out.
2C2Ah	SPI host interface ARM POST — PDC RAM BIST error.
2C2Bh	SPI host interface ARM POST — BC BIST time-out.
2C2Ch	SPI host interface ARM POST — BC RAM BIST error.
2C2Dh	SPI buffer channel 1 CRC error.
2C2Eh	SPI buffer channel 1 FIFO parity error.
2C2Fh	SPI sync offset error.
2C30h	SPI illegal write error.
2C31h	SPI illegal command error.
2C32h	SPI FIFO overflow or underflow error.
2C33h	SPI IDE message received.
2C34h	SPI BDR message received.
2C35h	SPI abort task message received.
2C36h	SPI parity error message received.
2C37h	SPI host interface ARM POST record manager diagnostics failed.
2C38h	SPI host interface ARM POST host port diagnostics failed.
2C39h	Buffer manager Titov host port control premature DREQ.
2C3Ah	Buffer manager Titov host port control parity error.
2C3Bh	Buffer manager Titov host port control CRC error.
2C3Ch	Buffer manager Titov host port control FIFO overflow.
2C3Dh	Buffer manager Titov host port control DMA overrun.
2C3Eh	Buffer manager Titov host port control outstanding error.
2C3Fh	Buffer manager Titov host port control sync data error.

Code	Description
2C40h	Buffer manager check buffer CRCs mismatch.
2C41h	Buffer manager check CRC passed.
2C50h	Illegal SCSI command. The hardware or firmware does not recognize the CDB.
2C51h	The SCSI Macro command was aborted because the drive was selected first.
2C52h	ATN was pulled by the initiator.
2C53h	Initiator did not respond to reselect within the reselect time-out period.
2C54h	The internal port interface task queue was empty.
2C55h	Too many port interface tasks. There is no room left in the internal port interface task queue.
2C56h	Parity error on the SCSI bus.
2C57h	Parity error in the mini-buffer.
2C58h	Attempted to use an invalid value internally.
2C59h	The SCSI FIFO was not empty when attempting to write to it.
2C5Ah	Not connected. Attempted to issue SCSI macro target command while not in target mode.
2C5Bh	Wrong host. Attempted to communicate with Host X while connected to Host Y.
2C5Ch	Wrong bus state. Attempted SCSI macro command while in the incorrect bus phase.
2C5Dh	No information on host. This host has not communicated with us previously.
2C5Eh	Invalid speed. The saved SCSI bus speed for this host is corrupt.
2C5Fh	Invalid SCSI ID, outside the range 0-15.
2C60h	The group code in CDB is not supported.
2C61h	The host attempted to issue an overlapped command.
2C62h	Not enough buffer space. The internal requestor asked for more space than was available in the mini-buffer.
2C63h	The mini-buffer is non-functional.
2C64h	Buffer in use. The internal requestor was denied access to the mini-buffer.
2C65h	Status interrupted; the SCSI status phase failed.
2C66h	Received an IDE (Initiator Detected Error) message.
2C67h	Received an MPE (Message Parity Error) message.
2C68h	Received a BDR (Bus Device Reset) message.
2C69h	Received an Abort message.
2C6Ah	Failed the Media Information check.

Code	Description
2C6Bh	There is no tape in the drive.
2C6Ch	Loading a tape.
2C6Dh	Media changed. A tape is present in the drive but not loaded.
2C6Eh	Cleaning the tape heads.
2C6Fh	Received a PON or SCSI reset.
2C70h	A mode change (LVD/SE) occurred on the SCSI bus.
2C71h	Gross error detected by the SCSI Macro.
2C72h	Illegal length record (ILI) — too long.
2C73h	Illegal length record (ILI) — too short.
2C74h	CRC error on read.
2C75h	The requested burst size was larger than the drive supports.
2C76h	There was an invalid field in the mode parameter list for this MODE SELECT command
2C77h	Unloading the tape.
2C78h	A parameter supplied by the internal requestor was out of range.
2C79h	The allocation length exceeded the permitted length.
2C7Ah	Invalid (unsupported) page code.
2C7Bh	Invalid (unsupported) page code in parameter list.
2C7Ch	BOT encountered on space.
2C7Dh	EOT encountered on space.
2C7Eh	Blank Check, EOD was encountered. Returned by <code>hiPerformPreExeChecks</code> if a space or read is attempted on a virgin tape.
2C7Fh	Position lost. A temporary code for returning status after a write-behind error.
2C80h	PCR error in the Log Select command.
2C81h	The supplied Page Code is not a resettable page.
2C82h	The supplied Page Code is not a writable page.
2C83h	The reserved bit in the Log Page header has been set.
2C84h	The Log Select Page Length is incorrect.
2C85h	There is an error with the Log Parameter Header.
2C86h	Log Select Parameter list length error.
2C87h	The Log Sense Page Code is invalid.

Code	Description
2C88h	The Log Sense PC Code is in error.
2C89h	Log Select: error in the parameter header.
2C8Ah	Restart the Logical Pipeline after a format error.
2C8Eh	The Buffer Manager has been interrupted with an error.
2C8Fh	Check the cables. The Host Interface has exhausted all of the retries for a data phase.
2C90h	Log Select parameter list length error.
2C91h	<code>hiPopulateSenseBuffer()</code> could not find any free sense data buffers.
2C92h	The failure prediction threshold has been exceeded. This error code is sent when a check condition is generated for a CDB as a result of the Test flag being set in the Information Exceptions Mode page.
2C93h	Reset after GE. Triggers the power-on self-test UA 2900 after LTO 1 SCSI ASIC GE has been detected.
2C94h	Return GOOD status. Used to force GOOD status to be returned.
2C95h	There is a firmware bug in the handling of an inquiry page.
2C96h	There is a firmware bug in the execution of the Prevent/Allow Medium Removal command.
2C97h	There is a firmware bug in the parsing of a Mode page.
2C98h	An attempt was made to write data or filemarks inside EW-EOM.
2C99h	Firmware incorrectly programmed the SCSI macro.
2C9Ah	An unsupported LUN was specified in the SCSI Identify message.
2C9Bh	Aborting a previous command.
2C9Ch	Aborting and no disconnect. A command was rejected that could not be queued while an abort was in progress.
2C9Dh	The host interface has exhausted all of the retries for a command phase.
2C9Eh	Parameter not supported. A request for an invalid page code has been sent.
2C9Fh	Buffer offset good. This is used internally by the Read Write Buffer code and should never be reported to the host.
2CA0h	Operation in progress. Reported when an Immediate command is executing and a subsequent command is received.
2CA1h	Illegal length record (ILI) — too long, and there is an EOR in FIFO. This occurs when a record is long by less than the FIFO length.
2CA2h	Illegal length record (ILI) — too short with bad CRC.
2CA3h	Illegal length record (ILI) — too long with bad CRC.
2CA4h	LUN not configured. The drive is the process of becoming ready.

Code	Description
2CA5h	ILL long has been detected but a read error was encountered during the residue flush.
2CA6h	An init command is required; a tape has been loaded but not threaded.
2CA7h	ILL long has been detected but flushing the residue timed out.
2CA8h	LTO 1 drives only: The CD-ROM El Torito identifier is corrupt.
2CA9h	The LTO 1 Formatter ASIC is not supported any more.
2CAAh	The LTO 1 SCSI ASIC is an invalid revision.
2CABh	MAM attribute header truncated. The specified parameter list length has caused an attribute header to be truncated.
2CACH	Reserved field set in a MAM attribute header.
2CADh	MAM attribute IDs were not ascending order.
2CAEh	The MAM attribute header specified an unsupported attribute value.
2CAFh	A MAM attribute ID is unsupported.
2CB0h	A MAM attribute ID is in an incorrect format.
2CB1h	The MAM attribute header specifies an incorrect length for this attribute.
2CB2h	The host attribute area in MAM is full.
2CB3h	A Write Attribute command attempted to delete a non-existent attribute.
2CB4h	An invalid MAM service action was requested.
2CB5h	A Read attribute command failed because the Host Attribute area was not valid.
2CB6h	There is an invalid field in the MAM attribute data.
2CB7h	Failure prediction threshold exceeded. A Tape Alert flag has been set and the next SCSI command needs to be check conditioned.
2CB8h	GWIF idle error, cause unknown. This will never be returned to the host.
2CB9h	GWIF idle, read error. This will never be returned to the host.
2CBAh	GWIF idle, write error. This will never be returned to the host.
2CBBh	MAM is accessible but the cartridge is in the load "hold" position. Unit Attention is generated.
2CBCh	MAM is accessible but the cartridge is in the load "hold" position. Not Ready is generated.
2CBDh	Internal port interface task queue error — invalid task.
2CBEh	Unable to write due to bad Cartridge Memory.
2CBFh	Selway ignored ATN on REQUEST SENSE.
2CC0h	Invalid number of wraps requested for LEOT.
2CC1h	Invalid LEOT request compared to current position.

Code	Description
2CC2h	MAM not accessible for some indeterminate reason.
2CC3h	SCSI sequencer was asked to reconnect during invalid nexus.
2CC4h	SCSI sequencer received a hiRetryDataBurst which failed.
2CC5h	INQUIRY data too long.
2CC6h	REQUEST SENSE data too long.
2CC7h	Invalid LUN for storing INQUIRY data in the mini-buffer.
2CC8h	No free slot to store REQUEST SENSE data.
2CC9h	Surrogate SCSI not configurable.
2CCAh	Surrogate SCSI LUN not a valid LUN.
2CCBh	Surrogate SCSI command arrived.
2CCCh	Incompatible tape type.
2CCDh	The supplied exchange is invalid.
2CCEh	Invalid value for Dev Cfg SDCA.
2CCFh	Bad length for WRITE BUFFER command.
2CD0h	Echo buffer has been overwritten by another host.
2CD1h	Never reported to host — used to signify a special entry in the Fault Log.
2CD2h	Never reported to host—port interface gave good status
2CD3h	Port interface detected a bus error.
2CD4h	Port interface detected an unknown internal opcode
2CD5h	Port interface detected a bad context ID.
2CD6h	Port interface detected bad parameters for an internal operation.
2CD7h	Port interface has encountered a FM/EOD. Should not be reported.
2CD8h	Port interface SCSI reselection timeout
2CD9h	Port interface internal operation failed due to a PIF/MIF buffer parity error
2CDAh	Command outstanding. Should not be reported.
2CDBh	No command outstanding. Should not be reported.
2CDCh	Not in automode status. Should not be reported.
2CDDh	ARM POST failure.
2CDEh	Port interface detected Bad Data Length—FC_DPL mismatch to CDB allocation length.
2CDFh	Selected while reselecting. Never reported to the host.

Code	Description
2CE0h	Bad state—firmware defect.
2CE1h	Bad configuration—firmware defect.
2CE2h	The Host Interface ASIC has not responded to a mail-box operation within 10 ms.
2CE3h	Got an internal firmware reboot.
2CE4h	SCSI Bus Reset signal asserted by host.
2CE5h	Bus Device Reset message sent by host.
2CE6h	Transceivers changed to SE.
2CE7h	Transceivers changed to LVD.
2CE8h	Got a power-on reset.
2CE9h	Checksum failure when copying bootloader code into Lucan dual-port RAM.
2CEAh	Amunsden has been reset before receiving the <code>hiPowerOneEvent</code> from Iona.
2CEBh	LF stall on reads.
2CECh	Tape is threaded but the drive shows it as unloaded.
2CEDh	The ARM FW has determined that this is not a DR tape.
2CEEh	There has been a change in the support Logical Unit inventory.
2CEFh	An invalid Port ID has been logged in.
2CF0h	An invalid LUN opcode has been passed to <code>hiConfigureSurrogateLun()</code> .
2CF1h	Fixed mode request was too large.
2CF2h	Decompression size mismatch while expanding and programming the Lucan FPGA code.
2CF3h	Host interface has more to do.
2CFDh	SCSI command failed because another host has changed the log pages.
2CFEh	SCSI command failed because new firmware has been downloaded.
2CFFh	SCSI command failed because another host has changed the mode pages.
2D00h	Hebrides is reporting a failure due to a read-ahead error.
2D01h	Hebrides is reporting a failure due to a write-behind error.
2D04h	Drive requested single shot read/write while streaming.
2D05h	Search for a handle for a given context ID failed.
2D06h	The dispatcher has completed the handling of the extended reset rewind.
2D07h	Firmware upgrade or unknown cartridge loaded but not threaded.
2D08h	Cleaning tape loaded but not threaded.

Code	Description
2D09h	Drive control has set <code>drDriveStatus</code> to <code>DR_FW_UPGRADE</code> .
2D0Ah	Immediate LOAD/UNLOAD in progress.
2D0Bh	Reported when an Immediate command is executing and a subsequent command is received.
2D0Ch	I_T nexus loss occurred.
2D0Dh	The maximum number of surrogate logical units have been defined.
2D0Eh	The supplied surrogate inquiry page is incorrect.
2D0Fh	The surrogate logical unit inquiry area is full.
2D10h	The surrogate logical unit inquiry area has been corrupted.
2D11h	The operation has been denied as the SCSI port is currently enabled.
2D12h	ACI has attempted a surrogate SCSI status operation without first setting up any sense data.
2D13h	This is no nexus live for this surrogate logical unit.
2D14h	An invalid SCSI status value has been supplied.
2D15h	Can not process this command, for some reason send it to lib.
2D16h	The <code>hiConfigureSurrogateLunOp</code> has resulted in a LUN being deleted.
2D17h	Unsupported Sub pagecode
2D18h	First burst.
2D19h	ACK NAK timeout.
2D1Ah	NAK received.
2D1Bh	Initiator response timeout.
2D1Ch	Data offset error.
2D1Dh	Information Unit too short.
2D1Eh	Too much write data.
2D1Fh	Chan1 detected a CRC error and a subsequent check of the buffer found the CRC good.
2D20h	Chan1 detected a CRC error and a subsequent check of the buffer found the CRC bad.
2D21h	Test function in progress.
2D22h	Invalid configuration action.
2D23h	Firmware defect; caller specified an invalid Relative Target Port.

Logical formatter (from 3000h)

Code	Description
3000h	No error. Synonymous with GOOD status.
3001h	Operation of the Logical Formatter has been aborted.
3002h	Busy. A Logical Formatter process has received a operation request while in a transient state.
3003h	The value of a parameter received with a Logical Formatter operation request falls outside its valid range.
3004h	Unsupported operation. A Logical Formatter process received an operation request while in a mode that does not support that operation.
3010h	An error condition occurred during execution of the Logical Formatter power-on self-test or reset algorithm,.
3011h	Unexpected interrupt. A Logical Formatter process received a signal from the hardware at an unexpected time.
3012h	A Logical Formatter process has received a <code>DiscardComplete</code> signal from the hardware at an unexpected time.
301Fh	The Codeword Packer contains data bits that cannot be self-flushed.
3020h	Data path not empty. The Hardware Functional Blocks that form the Logical Formatter data path contain data.
3021h	Filemark encountered.
3022h	Recoverable format error. The Logical Formatter has encountered a recoverable format error while unformatting the data stream.
3023h	Unrecoverable format error. The Logical Formatter has encountered an unrecoverable format error while unformatting the data stream.
3024h	End marker not required. The Logical Formatter has not inserted an end marker in the current dataset because the dataset is empty.
3025h	One or more Hardware Functional Blocks in the Logical Formatter are paused.
3026h	The Logical Formatter has a filemark pending, meaning that it is logically before the filemark but physically after it.
3027h	Restart the Logical Formatter hardware.
3028h	The Logical Formatter has provided a dataset with an access point beyond the target position.
3029h	The Logical Formatter has encountered a CRC error while unformatting the data stream.
302Ah	The Logical Formatter's C1LFI Hardware Functional Block has failed to prime.
302Bh	The Logical Formatter has encountered a zero-length record error.
302Ch	The Logical Formatter has encountered a reserved codeword error.
302Dh	The Logical Formatter has encountered a filemark in record error.

Code	Description
302Eh	The Logical Formatter has encountered a decompression error.
302Fh	The Logical Formatter has encountered EOD.
3030h	The Logical Formatter failed to write a filemark — aborted.
3031h	The Logical Formatter failed to write a filemark — data path not empty.
3032h	The Logical Formatter failed to write a filemark — unsupported operation.
3033h	The Logical Formatter has received a non-user data set.
3034h	The Logical Formatter failed to write a filemark — packer paused.
3035h	The Logical Formatter received an unexpected Access Point interrupt.
3036h	The Logical Formatter was unable to insert an end marker.
3037h	The Logical Formatter was unable to complete the new LTO5 Data Key process.
3040h	Logical Media not able to supply any more datasets.
3301h	Operation of the Logical Formatter's Hardware Abstraction Layer has been aborted.
3302h	Invalid parameter passed to a function in the Logical Formatter's Hardware Abstraction Layer.
3303h	A function in the Logical Formatter's Hardware Abstraction Layer has detected an illegal combination of variable values.
3304h	A function in the Logical Formatter's Hardware Abstraction Layer has received a request while in a mode that does not support that request.
3305h	The Logical Formatter's hardware has failed to signal (issue an interrupt for) an event expected by the firmware.
3306h	During a buffer transfer that ended with a final burst of ten bytes or less, the Logical Formatter's hardware failed to signal the transfer completion.
3307h	During a buffer transfer of ten bytes or less, the Logical Formatter's hardware failed to signal the transfer completion.
3308h	During a buffer transfer that ended with a final burst of ten bytes or less within the first 1k DRAM page, the Logical Formatter's hardware failed to signal the transfer completion.
3309h	A parity error was detected transferring data between Iona/Lucan and Amundsen.
330Ah	Wanted to start a timer for a potential missing <code>NextDAEmpty</code> interrupt but the pipeline was not empty.
330Bh	LF's C1LFI block detected a parity error while reading a byte out of its FIFO.
330Ch	Logical Formatter detected a correctable SDRAM corruption during Restore.
330Dh	Logical Formatter detected an uncorrectable SDRAM corruption during Restore.
330Eh	Logical Formatter SDRAM corruption.
3310h	Logical Formatter pipeline stalled.

Code	Description
3311h	Logical Formatter compressor reset.
3312h	Logical Formatter stall timer ID confusion.
3320h	Logical Formatter packer overrun.
3321h	Logical Formatter non-empty packed segment.
3322h	Logical Formatter packer missed EOR.
3323h	Logical Formatter unpacker overrun.
3324h	Logical Formatter packer aligned EOR.
3325h	Logical Formatter packer data in packer.
3326h	Logical Formatter compressor at record boundary.
3327h	Logical Formatter record boundary status.
3330h	Logical Formatter unexpected current register value.
3331h	Logical Formatter unexpected next register value.
3332h	LF bad access point value detected while writing.
3333h	LF bad access point value detected while reading.
3334h	LF adjusting bad access point while writing.
3335h	LF adjusting bad access point while reading.
3336h	LF unable to find a good access point while writing.
3337h	LF unable to find a good access point while reading.
3340h	Logical Formatter compressor not hung when expected.
3341h	LF TRNG BIST failure.
3342h	LF RNG monobit test failure.
3343h	LF RNG twobit test failure.
3344h	LF RNG failure.
3345h	LF ignoring TRNG BIST failure.
3346h	LF TRNG BIST failed in an unexpected way.
3347h	LF skipping an all-zero sample from the True Random Number Generator.
3350h	Bad encryption key index detected.
3351h	Encrypt decompression error detected.
3352h	Encrypt record CRC error detected.
3353h	Encrypt Crypt error detected.

Code	Description
3354h	Encrypt UnpackerLite error detected.
3355h	Crypt GCM tag error detected.
3356h	Crypt EoR alignment error.
3357h	Crypt EoR before tag error detected.
3358h	Crypt If_data_valid error detected.
3359h	Crypt EoR found error detected.
335Ah	LF post-key wrap failure.
335Bh	LF post-key unwrap failure.
335Ch	LF post-key unwrap IV failure.
335Dh	LF key unwrap IV failure.
3360h	Encryption boundary detected.
3361h	Encryption key mismatch detected.
3362h	Encryption AAD mismatch detected.
3363h	Encryption UAD mismatch detected.
3364h	Unencryption boundary detected.
3365h	Encryption key signature mismatch detected while in RAW read mode.
3366h	RAW read attempted on encrypted data.
3367h	Externally encrypted data detected.
3368h	Non-externally encrypted data detected.
3369h	LF RAW read M-KAD mismatch detected.
3370h	Encryption known answer test has failed.
3371h	Decryption known answer test has failed.
3372h	Random number generator known answer test has failed.
3373h	Random number generator continuous test has failed.
3374h	RSA signature known answer test has failed.
33FFh	A non-specific error has occurred in the Logical Formatter.

Logical media (from 3400h)

Code	Description
3400h	Cache overflow. A dataset has been received when the cache is already full.
3401h	A dataset has been located in the cache where it should not be.
3402h	A tag dataset has been located in the cache where it should not be.
3403h	Attempted to unlock a dataset which is not locked.
3404h	Cache empty. Expected at least one dataset in the cache.
3405h	The dataset index appears in the cache more than once.
3406h	The dataset index is too large to be valid.
3407h	The cache entry does not contain valid datasets.
3408h	End-Of-Data has been encountered.
3409h	The number of tag datasets in the cache exceeds the limit.
340Ah	A dataset is positioned in the cache incorrectly.
340Bh	One or more dataset indices are missing from the cache.
340Ch	Not a recognized Virtual Mode.
340Dh	The operation is not supported when more than one dataset locked.
340Eh	The tape is unformatted or contains no user datasets.
340Fh	One or more cache pointers are invalid.
3410h	No datasets in the cache to fulfil the request.
3411h	Operation is not supported while there are operations outstanding.
3412h	Operation is not supported while datasets are locked.
3413h	The target dataset has not been located.
3414h	The target dataset has been located.
3415h	The cache has not be initialized.
3416h	Received an operation which is not supported in the current mode.
3417h	LF has attempted to rewrite a read-only dataset.
3418h	A test has taken too long to complete.
3419h	Too many pending LP cache operations.
341Ah	Too many pending PP cache operations.
341Bh	Received an inappropriate response.

Code	Description
341Ch	Linked-list 'next' pointer is invalid.
341Dh	CRAM transfer started but not finished.
341Eh	Allocated insufficient CRAM.
341Fh	Dataset is available in LM but the drive is not positioned to append.
3420h	Datasets in LM, Flush WITH_EOD required before the current operation
3421h	LM flushed but EOD is required before the current operation.
3422h	The specified dataset type is not supported by the operation.
3423h	The specified CRAM dataset type is not supported.
3424h	LF has attempted an operation away from EOD that can only be performed at EOD.
3425h	Search dataset available dataset number does not match the DSIT contents.
3426h	LF has requested a dataset while LM is changing to backup mode.
37FFh	Undefined error.

Logical pipeline control (from 3800h)

Error	Description
3800h	No error. Synonymous with GOOD status.
3801h	Aborted operation.
3802h	Busy. An operation request was received while in a transient state.
3803h	The value of a parameter received with a Logical Pipeline Control operation request falls outside its valid range.
3804h	Received an operation request while in a mode that does not allow that operation.
3805h	Operation aborted because of a write-behind error.
3806h	Logical Pipeline Control has detected an unexpected File Mark during a Space operation.
3BFFh	A non-specific error has occurred in Logical Pipeline Control.

Mechanism control (from 3C00h)

Error	Description
3C00h	No error.
3C01h	Aborted command error.

Error	Description
3C02h	Unsupported command error.
3C03h	Bad parameter error.
3D01h	Undefined data object error.
3E0Eh	Cleaning cartridge could not be threaded.
3E01h	Wait for signal.
3E02h	Object create failed.
3E03h	Object execute failed.
3E04h	Cartridge memory LPOS values suspect.
3E05h	Notify client list full.
3E06h	Position notify list full.
3E07h	Notify exists parameter different.
3E08h	Notify event create failed.
3E09h	Notify key map failed.
3E0Ah	Notify index too large.
3E0Bh	Too many MC command objects.
3E0Ch	Cleaning cartridge expired.
3E0Dh	Cannot determine, or do not recognize, the cartridge format.
3FFEh	C++ pure virtual function called.
3FFFh	Undefined error.

Non-volatile data manager (from 4000h)

Error	Description
4002h	Invalid parameter.
4003h	Data length exceeds table length.
4004h	Not a valid EEPROM.
4005h	Checksum error. A write to EEPROM failed because the EEPROM is invalid.
4006h	Checksum read did not match the checksum written.
4007h	An unsupported data type was requested from the Non-Volatile Data Manager.
4008h	An unsupported data type was requested to be set in Non-Volatile Data Manager.

Error	Description
4011h	PCA EEPROM missing.
4012h	PCA EEPROM void.
4013h	PCA EEPROM corrupt.
4014h	PCA table invalid.
4015h	A failure occurred while trying to update the Read ERT log in the PCA EEPROM.
4016h	A failure occurred while trying to update the Write ERT log in the PCA EEPROM.
4017h	A failure occurred while trying to update the Write Fault Counters log in the PCA EEPROM.
4018h	A failure occurred while trying to update the Tapes Used logs in the PCA EEPROM.
4019h	nv_PCA_TABLE1 invalid.
401Ah	nv_PCA_TABLE2 invalid.
4021h	Head EEPROM absent.
4022h	Head EEPROM void.
4023h	Head EEPROM corrupt.
4024h	Head table invalid.
4025h	Head table 1 invalid.
4026h	Head table 2 invalid.
4027h	Head table 3 invalid.
4028h	Head table 4 invalid.
4031h	Mechanism EEPROM absent.
4032h	Mechanism EEPROM void.
4033h	Mechanism EEPROM corrupt.
4034h	Mechanism table invalid.
4035h	A failure occurred while trying to update the Drive Fault logs in the PCA EEPROM.
4036h	An Algorithm error occurred while trying to update the Drive Fault Logs in the EEPROM.
4037h	Mechanism table 3 invalid.
4038h	Mechanism table 4 invalid.
4039h	The Servo Fault could not be logged because of EEPROM access failure.
403Ah	nv_MECH_TABLE2 invalid.
403Bh	nv_MECH_TABLE1 invalid.
4041h	CM EEPROM absent.

Error	Description
4042h	CM EEPROM void.
4043h	The CM could not be written before an unload causing probable corruption in the CM.
4044h	An invalid protected page table was found.
4045h	A CRC error was discovered over the unprotected page table.
4046h	CM initialized. This is not really an error, it indicates a fresh cartridge.
4047h	CM invalid CRC.
4048h	An invalid CRC over the Cartridge Manufacturers Information page was found.
4049h	An invalid CRC over the Media Manufacturers Information page was found.
404Ah	An invalid CRC over the Initialization Data page was found.
404Bh	An initialization table was request to be created for a CM with a valid initialization table in it.
404Ch	A failure occurred while trying to add a page descriptor to the unprotected page table.
404Dh	An unprotected page table entry was attempted with an invalid page ID.
404Eh	An invalid CRC over the Drive Manufacturers Support page was found.
4050h	An access to the tape directory was requested before it was read from the CM.
4051h	A CRC error was detected in the tape directory while being read.
4052h	Data for an illegal wrap section was requested from the tape directory.
4053h	The Buffer Manager does not have enough CRAM to hold the CM.
4054h	The write-protect operation was aborted because of a bogus initialization data address in CRAM.
4055h	A consistency error was detected in the Tape Directory while being read.
4056h	No more entries can be added to the Suspended Appends page.
4060h	An access to a non-existent EOD page was attempted.
4061h	An invalid CRC over the EOD page was found.
4062h	An access to a non-existent Initialization page was attempted.
4070h	An access to a non-existent Tape Write Pass page was attempted.
4080h	An access to a non-existent Tape Alert page was attempted.
4090h	There is no usage data available in the Cartridge Memory.
4091h	Usage pages are out of order and cannot be accessed.
4092h	The last updated usage page has a CRC error. The data is invalid.
40A0h	There is no mechanism sub-page data available in the Cartridge Memory.

Error	Description
40A1h	The last updated mechanism sub-page has a CRC error. The data is invalid.
40A2h	There has been a failure executing self-test. This failure is logged in the Fault Log.
40A3h	Cartridge Memory TapeAlert CRC error.
40A4h	Cartridge Memory EOD page CRC error.
40A5h	Cartridge Memory suspend append CRC error.
40A6h	Cartridge Memory Media Manufacturer CRC error.
40A7h	Cartridge Memory mechanism CRC error.
40A8h	Cartridge Memory application specific CRC error.
40A9h	Unknown cartridge type in Cartridge Memory.
40AAh	A Cartridge Memory flush operation (CRAM to CM) was aborted, probably because of a time-out condition.
40ABh	PCA persistent reservation table invalid.
40ACh	A specific request to check the consistency between the FID and CM pages shows that an inconsistency exists.
40ADh	Unable to read a word from either the head or PCA EEPROM.
40AEh	A call to <code>nvInvalidateTuningRevNo</code> was made with an incorrect parameter.
40AFh	General information about NVDS.
40B0h	An invalid CRC over the Fatal Error page was found.
40B1h	Not enough information was available to form a correct Unique Cartridge Identity.
40B2h	<code>nvSetPersonalityByte</code> was asked to change the personality but this variant of code has a fixed personality.
40B3h	<code>nvSetPersonalityByte</code> was asked to change the personality but the key provided did not allow this.
40B4h	<code>nvSetPersonalityByte</code> was asked to change the personality but cannot change zero to non-zero or non-zero to zero.
40B5h	A protected page table entry was attempted with an invalid page ID.
40B6h	The Cartridge Content data page has a CRC error. The data is invalid.
40B7h	An access to a non-existent Cartridge Content data page was attempted.
40B8h	The requested field to be accessed does not exist in his version of the page.
40B9h	This product's EEPROM configuration does not support the persistent storage for the Host Access table.
40BAh	The persistent storage area for the Host Access table has never been written to and is therefore not initialized.

Error	Description
40BBh	The persistent storage area for the device ID has never been written to and is therefore not initialized.
40BCh	The persistent storage area for the device ID only supports storage for 2 LUNs—more has been requested.
40BDh	A request to access an area of CM which is out of bounds has occurred. The access was disallowed.
40BEh	Not enough information was available to form a correct Alternative Unique Cartridge Identity.
40BFh	<code>nvCMGetMechRelatedKAD()</code> was asked to retrieve the KAD in the mechanism-related pages but no KAD has been stored.
40C0h	The KAD length in the mechanism-related page which was asked to be stored or retrieved was too large.
40C1h	The mechanism-related page has not been created (or the tape not loaded) so storage or retrieval of the KAD data is not allowed.
40C2h	A request to access a STTF log index was outside the permitted range.
40C3h	The EEPROM does not contain previously saved snapshot event configuration data.
40C4h	An access to a non-existent Suspended Append page was attempted.
40C5h	An access to a non-existent Fatal Error page was attempted.
40C6h	An access to a non-existent Mechanism Specific page was attempted.
40C7h	An access to a non-existent Fatal Error page was attempted.
40C8h	The Mechanism Specific page has a CRC error. The data is invalid.
40C9h	<code>nvCMGetMechSpecificKAD()</code> was asked to retrieve the KAD in the Mechanism Specific page but no KAD has been stored.
40CAh	The Mechanism Specific page has not been created (or tape not loaded,) so storage or retrieval of the KAD data is not allowed now.
40CBh	The Certificate Storage table does not have an entry for the security parameter requested (in other words, it is not stored in the table).
40CCh	The Certificate Storage table does not have a free slot to place the security parameter into.
40CDh	An unknown security parameter was asked for.
40CEh	The security parameter to be stored is too large to fit in the table.
40CFh	This security parameter is not allowed to be cleared.
40D0h	The Initialization check of the security table showed a bad CRC on the directory entries. The whole table must be cleared and rebuilt.
40D1h	Mechanism table 8 is invalid.
40D2h	The security parameter was encrypted, but the encrypted record size is too large for storage.
40D3h	The KMS security parameter to be stored is too large to fit in the table.

Error	Description
40D4h	The PCA2 EEPROM is not supported on this platform.
40D5h	An unknown KMS security parameter was asked for.
40D6h	The KMS security parameter was encrypted, however the encrypted record size ends up being too large for storage
40D7h	The Initialization check of the KMS security table showed a bad CRC on the directory entries. The whole table must be cleared and rebuilt.
40D8h	The KMS Security table does not have an entry for the KMS security parameter requested (that is, it is not stored in the table).
40D9h	The Secure EEPROM storage will only allow encryption of field sizes divisible by 16, such as 16, 32, 48 and so on.

Operating system (from 4400h)

Error	Description
4400h	'vGiveSem' failed to signal a semaphore.

Physical formatter (from 4C00h)

Error	Description
4C00h	C1 has finished before C2 is ready for the dataset.
4C01h	The physical formatter has been sent an invalid configuration name.
4C02h	The physical formatter has been sent an invalid configuration value
4C03h	C2 hardware is busy. The physical formatter C2 hardware is currently processing a dataset.
4C04h	The physical formatter C2 control DS0 register go bit is set.
4C05h	The physical formatter C2 control DS1 register go bit is set.
4C06h	The physical formatter C1 control register go bit is set.
4C07h	The physical formatter CCQ Reader control register go bit is set.
4C08h	The physical formatter Read Chain Controller control register go bit is set
4C09h	The physical formatter has been asked for the error rate log for a channel which does not exist
4C0Ah	The physical formatter has been asked for the error rate logs for a channel which does not exist.
4C0Bh	The physical formatter could not set the callback timer to enable the Hyperion read gate.

Error	Description
4C0Ch	The physical formatter Read Chain Controller DS0 is stuck.
4C0Dh	The physical formatter Read Chain Controller DS1 is stuck.
4C0Eh	Physical formatter WP update.
4C0Fh	Format other than LTO1 or LTO2.
4C10h	SDRAM error has been detected.
4C11h	The number of CCPs presented has fallen below the warning threshold.
4C12h	A CCP has been overwritten.
4C13h	A C2 error has been reported.
4C14h	General physical formatter information.
4C15h	Unexpected format complete signal arrived.
4C16h	Check CCQ Write Rewrite log: param 1 = CCQSetsWritten, param2 = CCQSetRewrites, param 3 = pfStatus.

Physical pipeline control (from 5000h)

Error	Description
5000h	EOD not found.
5001h	Black tape.
5002h	EOD encountered.
5003h	Undefined error.
5004h	The start LPOS of the dataset is before the LPOS of the previous dataset.
5005h	The start LPOS is more than 1 metre after the previous dataset.
5008h	Invalid configuration has been requested.
5009h	Abort reject continue not used.
501Eh	Search in progress.
501Fh	Mechanism command time-out; the control command never responded.
5020h	Command not allowed in this variant.
5080h	Invalid tape type.
5081h	The Error Rate Test has been aborted.
5083h	PF reported a write error (excessive RWWs).
5084h	PF reported a read error (C2).

Error	Description
5086h	PF reported a streamfail.
5087h	The error-rate test reached the C1 threshold.
5088h	Unknown notification. An unexpected mechanism control.
5089h	Data miscompare.
508Ah	The drive has gone 4 metres since last dataset was reported.
508Bh	The speed requested for ERT s out of valid range.
508Ch	The notify for 4m give-up point is missing.
508Dh	EOT was reached before requested datasets were written.
508Eh	Start position requested for ERT s out of valid range
508Fh	Cannot find the expected dataset number
5090h	Blank check. Could not read anything off the tape in the last 4 metres.
5091h	Too many datasets returned while flushing.
5092h	Could not find the target during a space operation.
5093h	Could not find the target ACN during a search operation.
5094h	Write Pass on write has been corrupted.
5095h	ERT read more datasets than expected.
5096h	Logical Media has supplied an invalid dataset index.
5097h	Dataset written before BOW.
5098h	EOT reached during reading.
5099h	Warning: Dataset flags non-zero.
509Ah	EOD has been read, but is not the one in the Cartridge Memory.
509Bh	The dataset that has been read should not be on this wrap.
509Ch	The SPACE command is to a logical position that is beyond EOD.
509Dh	The current cartridge cannot be written to —Write ERT is not allowed.
509Eh	The dataset that was reported as C2 uncorrectable is considered good.
509Fh	The DSIT contains an invalid UCI.
50A0h	The drive has determined that the WORM data may have been tampered with.
50A1h	The logical media has given a illegal dataset index for an append.
50A2h	A search operation appears to have found the target too early.
50A3h	An LTO5 dataset was encountered whose encryption algorithm ID was not 01h.

Error	Description
50A4h	The value of TapeWritePassValue CurrentWrap and SDL sheet has been set.
50A5h	Shows the value that the Max ATS has been set.
50A6h	An error code of 7501h (Loss of LPOS) has been detected, causing a reduction in the servo MR bias.
50A7h	A RampToSpeedRsp signal has arrived while trying to abort.
50A8h	Excessive offtracks have been seen on a Fuji tape.
50A9h	The drive tried to perform an ERT whilst the tape was not threaded.
50AA	The firmware may have followed a path in which the formatter was not aborted before a re-write.
50ABh	The firmware has managed to write a dataset that finishes past EOW.
50ACh	An LTO 5 dataset was encountered whose Encryption Algorithm ID was not 02h.

Physical side error recovery (from 5400h)

Error	Description
5400h	Not an error—just requests a trace log bank switch.
5401h	Shows the LPOS and MM position for the start of tuning.

Read/write control (from 5800h)

Error	Description
5800h	Success.
5801h	Null point.
5802h	Invalid parameter.
5803h	No hardware.
5804h	SPI transfer error.
5805h	Prometheus set error.
5806h	Hyperion set error.
5807h	Daughter set error.
5808h	Calibration did not complete.
5809h	Servo bias status false.

Error	Description
5810h	Wrong number of parameters.
5820h	Could not set Prometheus 0 to default values.
5821h	Could not set Prometheus 1 to default values.
5822h	Could not set Prometheus 2 to default values.
5823h	Could not set Prometheus 3 to default values.
5824h	A valid Mod level was not received from the PCA EEPROM.
5825h	Could not set Prometheus 4 to default values.
5826h	A failure was detected during a Write Element Resistance test for Artemis.
5827h	A failure was detected during a Read Element Resistance test for Apollo.
5828h	Artemis did not achieve PLL lock. Parameter 1 is Artemis (0=BumpA, 1=BumpB, FFh=No Artemis was specified). Parameter 2 is value of the Artemis PLL register.
5830h	Could not set Hyperion 0 to default values.
5831h	Could not set Hyperion 1 to default values.
5840h	Could not initialize the Diagnostic Data <code>rwInitDiagnosticData</code> .
5841h	Did not get either <code>INTODRIVE</code> or <code>INTOCARTRIDGE</code> .
5850h	Delilah failed to autocalibrate.
5851h	Gideon failed to autocalibrate: param1 = GideonRegisters, param2 = RegisterValue, param3 = nothing.
5852h	Gideon HyperTransport PLL failed to come out of reset: param1 = GideonRegisters, param2 = RegisterValue, param3 = nothing.
5853h	HyperTransport sync failure: param1 = bus, param2 = count, param3 = type.
5854h	HyperTransport parity failure: param1 = bus, param2 = count, param3 = type.
5855h	HyperTransport unexpected parity state at power-on: param1 = HT Parity Error, param2 = HT Parity Error count 0, param3 = HT Parity Error count 1.
5856h	A valid Blo Dac Gideon Register setting could not be determined in the manual calibration mode.
5857h	The Mech Interface firmware returned a failure to RVC firmware when requested to set an ATS clock frequency for Gideon calibration.
5858h	The Random Bit Sequence generator failed to collect the required samples in the allowed time.
5859h	A valid Blo Dac Gideon register setting could not be determined in the manual calibration mode, retrying the Gideon offset calibration.
5860h	Expected a compatible data tape but got something else.

Error	Description
5861h	An invalid control word was found while parsing the Cal table to program a ASIC. Param 1 = control word, Param 2 = an integer value unique to each ASIC.
5870h	Could not write to Amundsen's WEQ Control register.
5871h	Illegal WEQ setup requested.
5880h	The EEPROM calibration table area contains at least one invalid entry.
5881h	The Per Drive Cal table in the EEPROM contains one invalid entry.
5882h	The Per Drive Cal table in the EEPROM contains a revision number that is less than the revision number found in the base Cal table.
5890h	rwc_estimate_boost.
5891h	rwc_adjust_boost.
5892h	rwc_boost_datasets.
5893h	A request to reset the Afirs on the channel, Parameter1, was made to the RWC.
58F0h	Setup Servo.
58F1h	SMUX.
58F2h	BEN.
58FFh	Undefined error.

System architecture (from 6400h)

Error	Description
6401h	Formatter ASIC revision check failed. The ASIC is not a LTO 1 Formatter ASIC.
6402h	The processor idle time is less than 30%.

Tight integ (from 6800h)

Error	Description
6801h	The Cmicro error handler function has been called (<code>cm_ErrorHandler</code>).
6802h	An implicit signal consumption has occurred.
6803h	No free SDL timer storage (in <code>SDLTimerFreeList</code>) to set new timer — increase <code>MAX_SDL_TIMERS</code> in <code>TightInteg/cmTmr.c</code> .

Trace logger (from 6C00h)

Error	Description
6C00h	TraceLogger initialization failed. BMM returned no good.
6C01h	The last Live Trace entry has been reached. Not an error.
6C02h	The drive has insufficient resources to set more Live Traces.
6C03h	A flush has started and the initiator must wait to receive the SDL signal <code>diTraceLogFlushed</code> .
6C04h	An operation has started but the caller must wait for the callback function to be executed.

Mechanical interface (from 7400h)

Error	Description
7400h	No error.
7401h	Aborted command.
7402h	Unsupported command.
7403h	Wrong number of parameters.
7404h	Invalid parameter.
7405h	This command is already in progress.
7406h	This command is not allowed now.
7407h	Command processing error.
7408h	A DSP event has occurred (most likely an off-track event unless the default was changed).
7409h	The command is obsolete.
740Ah	Incomplete initialization of the mechanism
740Bh	There was a timing fault in the servo interrupt.
740Ch	The mechanism type (<code>SensorRev</code>) specified in the mechanism EEPROM is either obsolete or unsupported.
740Dh	Obsolete command 300C.
740Eh	Obsolete command 300D.
740Fh	Invalid task. The current task for the servo system is of an unknown type. This is most likely caused by a firmware bug.
7410h	A Load command is not allowed at this time.
7411h	An Unload command is not allowed at this time.

Error	Description
7412h	A shuttle tape command cannot be executed at this time.
7413h	A Set Cartridge Type command cannot be executed at this time.
7414h	A Set Mechanism Type command cannot be executed at this time.
7415h	A Set Tension command cannot be executed at this time.
7416h	A Set Speed command cannot be executed at this time.
7417h	An Adjust Speed command cannot be executed at this time.
7418h	A Set Position command cannot be executed at this time.
7419h	The Cancel Set Position command cannot be executed at this time. Most likely because there is no previous set position command active.
741Ah	A Set Position and Speed command cannot be executed at this time.
741Bh	A Servo Calibration command cannot be executed at this time.
741Ch	An End of Tape Servo Calibration command cannot be executed at this time.
741Dh	A Servo Initialization command cannot be executed at this time.
741Eh	A Load Cartridge command cannot be executed at this time.
741Fh	A Grab Leader Pin command cannot be executed at this time.
7420h	A Load and Grab leader pin command cannot be executed at this time.
7421h	An Ungrab Leader Pin command cannot be executed at this time.
7422h	An Unload cartridge command cannot be executed at this time.
7423h	A Thread command cannot be executed at this time.
7424h	An Unthread command cannot be executed at this time.
7425h	A Recover Tape command cannot be executed at this time.
7426h	A Head Clean command cannot be executed at this time.
7427h	A Power-on Calibration command cannot be executed at this time.
7428h	A Set Notify command cannot be executed at this time.
7429h	A Wait Until Event command cannot be executed at this time, probably because the tape is not moving.
742Ah	A Set Head Position command cannot be executed at this time, probably because a servo calibration is in progress.
742Bh	A Set Tracking Offset command cannot be executed at this time, probably because a servo calibration is in progress.
742Ch	A DSP command to learn the VI offset is not allowed now because the tape is moving or another task is in progress.

Error	Description
742Dh	The Set Gen command is not allowed now. The format cannot be changed at this time.
742Eh	A Forced Eject command is not allowed at this time. Most likely another operation is in progress.
742Fh	Debug ERROR code.
7430h	Sensors are in a state that indicate that the sensors or Callisto is not working correctly.
7431h	Sensors are in a state that indicate that the sensors or Callisto is not working correctly on a load.
7432h	Sensors are in a state that indicate that the sensors or Callisto is not working correctly on a grab.
7433h	Sensors are in a state that indicate that the sensors or Callisto is not working correctly on an ungrab.
7434h	Sensors are in a state that indicate that the sensors or Callisto is not working correctly on an unload.
7435h	The RD sensor has stopped toggling, probably because the loader mechanism is blocked or the motor is not working.
7436h	It is unsafe to load the cartridge. A runaway condition of the FRM has been detected, probably because the tape is broken.
7437h	Unexpected LP on a grab. One (and only one) of the LP sensors has been asserted at the beginning of the grab.
7438h	Unexpected LP at the start of a grab. One (and only one) of the LP sensors has been asserted at the beginning of the grab. This is logged but not a failure.
7439h	The write protect sensor does not match the expected state.
743Ah	The Cartridge Present sensor does not match the expected state.
733Bh	Rotate reel command can not be executed at this time.
733Ch	Measure Kt command can not be executed at this time.
7440h	Callisto Bus test error.
744Fh	In transit after initialization—no cartridge present.
7450h	In transit after initialization.
7451h	Ungrab after initialization.
7452h	Unknown after initialization.
7453h	Timed out waiting to send a command to get DSP head-cleaning information.
7454h	Timed out waiting for DSP response with head-cleaning information.
7455h	Timed out waiting to set up DSP for a head-cleaning command.
7456h	Timed out waiting for DSP response to head-cleaning setup.

Error	Description
7457h	Timed out waiting for DSP to complete the head-cleaning command.
7458h	Head-cleaning engagement time-out.
7459h	Head-cleaning parking time-out.
745Ah	Head-cleaning cycling time-out.
745Bh	The state of the sensor read at initialization are illegal. The results make no sense.
745Ch	Timed out waiting to restore DSP after a head-cleaning command.
745Dh	Timed out waiting for DSP during post-head-cleaning restoration.
745Fh	Unable to send DSP compensator coefficients.
7460h	DSP download error.
7461h	Invalid DSP opcode error.
7462h	Unable to send a DSP command.
7463h	Unable to send a DSP seek command.
7464h	DSP failed to complete a seek command.
7465h	Send long-term DSP command time-out.
7466h	Send short-term DSP command time-out.
7467h	DSP long-term command protocol error.
7468h	DSP short-term command protocol error.
7469h	Too many parameters on DSP Long-term command.
746Ah	Too many parameters on DSP Short-term command.
746Bh	Too many results on DSP Long-term command.
746Ch	Too many results on DSP Short-term command.
746Dh	Long-term DSP command already in progress.
746Eh	Short-term DSP command already in progress.
746Fh	Long-term DSP command completed but not in progress.
7470h	Short-term DSP command completed but not in progress.
7471h	Unable to send a DSP Learn VI offset command.
7472h	DSP failed to complete a Learn VI offset.
7473h	Unable to send a DSP Calibrate VI command.
7474h	DSP failed to complete a Calibrate VI command.
7475h	Too many data points requested.

Error	Description
7476h	No scope data available from DSP
7477h	DSP failed to complete the command during the initialization process.
7478h	Unable to send DSP tuning parameters.
7479h	DSP failed to boot properly.
747Ah	Time-out on sending the Clear DSP Fault log.
747Bh	Time-out on completing the Clear DSP Fault log.
747Ch	Unable to send DSP Head Clean command.
747Dh	An abort command was requested while one is already in progress.
747Eh	An abort command has timed-out while waiting for the tape to stop.
747Fh	An Adjust Speed command was requested while one is already in progress.
7480h	General load failure.
7481h	EP sensor did not transition on a load, probably because no cartridge was present.
7482h	CD sensor did not transition on a load.
7483h	CG sensor did not transition on a grab.
7484h	LP sensor did not transition on a grab.
7485h	Too many retries to recover on a load or unload.
7486h	Cartridge not free to rotate when Cartridge Down.
7487h	The RD sensor stopped toggling while EP during a load.
7488h	The RD sensor stopped toggling while IT during a load.
7489h	The RD sensor stopped toggling while CD during a load.
748Ah	The RD sensor stopped toggling while CD during a grab.
748Bh	The RD sensor stopped toggling while LP during a grab.
748Ch	Invoked tension ramp retry.
748Dh	FRM runaway. Too much rotation was detected in the cartridge before it was threaded.
748Eh	A grab was requested but the cartridge was not loaded.
748Fh	Sensors indicate that the grabber unexpectedly moved into a grab position during a load operation.
7490h	While parking the LP, the LM voltage was increased from 0.25V to 0.5V.
7491h	While parking the LP, the LM voltage was increased from 0.5V to 0.75V.
7492h	While parking the LP, the LM voltage was increased from 0.75V to 1.0V.

Error	Description
7493h	While threading, the LM voltage was increased from 0.25V to 0.5V.
7494h	While threading, the LM voltage was increased from 0.5V to 0.75V.
7495h	While threading, the LM voltage was increased from 0.75V to 1.0V.
749Ah	Load command failed and no CM was detected, therefore it is likely there is no cartridge present.
74A0h	General unload failure.
74A1h	EP sensor did not transition while unloading.
74A2h	CD sensor did not transition while unloading.
74A3h	CG sensor did not transition while ungrabbing
74A4h	LP sensor did not transition while ungrabbing
74A6h	RD sensor stopped toggling while CG during ungrab.
74A7h	RD sensor stopped toggling while LP during ungrab.
74A8h	RD sensor stopped toggling while CD during ungrab.
74A9h	RD sensor stopped toggling while CD during unload.
74AAh	RD sensor stopped toggling while IT during unload.
74ACh	Too much rotation of the cartridge was detected while the tape was not threaded.
74ADh	The load, unload, grab or ungrab operation timed out.
74C0h	Time-out while deslacking the cartridge.
74C1h	Emergency stop error.
74C2h	Already past target position.
74C3h	Set speed time-out error.
74C4h	Time-out waiting for an LPOS.
74C5h	Reels not synchronized.
74C6h	Safety limit stop reached.
74C7h	LPOS calculation with invalid LPO.
74C8h	Missed target position.
74C9h	Previous tape motion command in progress.
74CBh	Unthreading time-out error.
74CCh	Remove slack process timed-out.
74CDh	Leader may have disconnected.

Error	Description
74CEh	Time-out waiting for radii estimate.
74CFh	Radii estimation process failed.
74D0h	Recover tape time-out error.
74D1h	Invalid cartridge type.
74D2h	Cal reel driver offset time-out.
74D3h	Time-out waiting for the specified event.
74D4h	Front-reel motor hall sensor fault.
74D5h	Back-reel motor hall sensor fault.
74D6h	The deslacking process timed out and did not complete, probably because the back reel motor failed to rotate.
74D7h	Threading time out while waiting for half moon to pass the first roller.
74D8h	Timed out waiting for tape to reach position for speed-up during a thread.
74D9h	Time out while waiting for tape to reach the position to stop threading.
74DAh	An unthread command was issued and aborted a tape motion operation that was already in progress.
74DBh	The cartridge type has not been specified either from LTO-CM or through a serial port command.
74DCh	The tape speed reported by the DSP is significantly different from the tape speed indicated by the hall sensors.
74DDh	Specified value of tension is either too high or too low.
74DEh	The panic stop process timed out and did not complete properly.
74DFh	Timed-out waiting for the proper tape tension to be established.
74E0h	Head selection time-out.
74E1h	Unable to position the head.
74E2h	Speed too low for enabling the heads.
74E3h	Speed too low for the head servo.
74E4h	Speed too low for sensor calibration.
74E5h	A DSP seek command was attempted while the tape speed was zero.
74E6h	DSP sensor calibration command was attempted while the tape speed was zero.
7500h	First write fault.
7501h	Write fault: it has been too long since a valid LPOS was read, so writing is not allowed.
7502h	Write fault: DSP tracking recovery operations are in progress so writing is not allowed.

Error	Description
7503h	Write fault: tape motion start-up operations are incomplete so writing is not allowed.
7504h	Write fault: DSP is not tracking properly on the tape, writing is not allowed.
7505h	Write fault: the current tape speed is too low so writing is not allowed.
7508h	Write fault: ATS clock frequency clipped, or DSP in idle mode.
7509h	Write fault: DSP calibrating.
750Ah	Write fault: DSP VI track follow.
750Bh	Write fault: DSP tape off-track.
750Ch	Write fault: DSP demod channel out.
750Dh	Write fault: DSP seek.
750Eh	Write fault: DSP uPVI.
750Fh	Write fault: write unsafe.
7510h	Unknown write fault.
7511h	Multiple write faults.
7512h	Last write fault.
7513h	Write is not allowed; a power-on or reset occurred.
7514h	Write is not allowed; a micro-jog is being applied.
7515h	Write fault last.
7600h	Set Speed command invalid parameter.
7601h	Adjust Speed command invalid parameter.
7602h	Set Position command invalid parameter.
7603h	Set Head Position command invalid parameter.
7604h	Set Head Table command invalid parameter.
7605h	DSP Statistics command invalid parameter.
7606h	Get Servo Fault command invalid parameter.
7607h	Set Tracking Offset command invalid parameter.
7608h	Set Notify command invalid parameter.
7609h	Clear Notify command null handle.
760Ah	ATS Diagnostics command invalid parameter.
760Bh	Hall Calibrate command invalid parameter.
760Ch	Radius Calibrate command invalid parameter.

Error	Description
760Dh	Wait Until Event command invalid parameter.
760Eh	Convert LPOS command invalid parameter.
760Fh	Shuttle command invalid parameter.
7610h	Get DSP fault log invalid parameter.
7611h	Set General Command Invalid parameter.
7612h	Set TestMode command parameter is out of range or is invalid.
7613h	EEPROM servo table command parameter is out of range or is invalid.
7614h	Rotate command — invalid parameter.
7615h	Measure Kt command — invalid parameter.
7620h	Set speed operation timed out during a recover tape command.
7621h	Timed out waiting for the pin sensors to indicate almost parked.
7622h	Timed out waiting for the pin sensors to indicate fully parked.
7623h	An unthread timed out waiting for the full leader pin seating tension to be established.
7624h	Cycling the pull-in tension did not achieve pin-park.
7625h	Rethreading and then unthreading again did not get the leader pin parked.
7626h	Timed out during the rethread/re-unthread recovery while waiting for almost parked.
7627h	All recovery algorithms have been exhausted and still unable to park leader pin.
7628h	Rethread recovery operation timed out waiting for the tape to come to a stop.
7629h	Rethreading timed out while waiting for the tape to reach the required position.
762Ah	Deslacking process did not complete., probably because the back reel motor failed to rotate.
762Bh	The leader pin was parked as indicated by both LP sensors but then came unparked.
762Ch	The tape has been recovered and leader pin parked but the original operation failed and was abandoned.
762Dh	Rethreading timed out while waiting for the tape to reach the required position.
762Eh	Rethread recovery operation timed out waiting for the tape to come to a stop.
762Fh	A special unthreading recovery operation was needed to un-jam the leader block.
7630h	An iteration of the special unthreading recovery operation did not succeed.
7631h	The stop tape operation took longer than expected.
7632h	An attempt was made to stop the tape while still too far away from the specified position.
7633h	An abort command was issued and stopped the tape motion operation that was already in progress.

Error	Description
7634h	The tape thickness is too great to be handled properly by the servo system.
7635h	An ATS speed change operation (AdjustSpeed) timed out waiting for tape to reach target speed.
7636h	An ATS speed change operation (AdjustSpeed) was attempted while the tape was not moving.
7637h	While trying to park the pin, LP2 was seen, but LP1 was not seen after rotating the grabber CCW.
7638h	Threading timed out while waiting for the half moon to seat onto the back reel.
7639h	Tape motion apparently stopped while waiting for head positioning to complete.
763Ah	Unthread timed out during the initial rewind of tape back into the cartridge.
763Bh	Timed out during an operation to set tape position and speed.
763Ch	Timed out during an operation to set the tape position.
763Dh	Timed out during a RecoverTape operation.
763Eh	The front reel did not rotate during the tape slack removal process.
763Fh	Timed out waiting for back reel to reach position where leader block is fully seated.
7640h	Timed out waiting for back reel to rotate to the threading reversal point.
7641h	Timed out waiting for back reel to rotate to the reverse threaded position.
7642h	Timed out waiting for tension to be established during the reverse threading process.
7643h	Timed out waiting for the reverse threading target position.
7644h	Timed out waiting for leader block to detach during an unthread.
7645h	Timed out waiting for tension to be established during the reverse unthreading process.
7646h	Timed out waiting for speed to be established during the reverse unthreading process.
7647h	A fatal reel fault occurred during the time when the tape was being stopped.
7648h	Back reel stalled and was not rotating when determining thread direction.
7649h	An operation that determines thread direction timed out.
764Ah	Warning: Tape speed error integrator value is very large.
764Bh	Timed out waiting for back reel to rotate to the unthreading reversal point.
764Ch	Timed out waiting for tape to reach unthreading reversal slow down point.
764Dh	Timed out waiting for tape to reach unthreading turn around point.
764Eh	Front reel turning CCW but should be CW after going through critical point during recover tape process.
764Fh	Tape motion unexpectedly stopped during recover tape process of rewinding based on radius estimate.

Error	Description
7650h	Unable to detach leader block during recover tape operation when reverse threaded.
7651h	Unable to detach leader block during recover tape operation when forward threaded.
7652h	Unable to identify cartridge type during recover-tape operation.
7653h	The tape thickness reported by the Cartridge Memory is too large or too small.
7654h	The tape thickness reported by the CM is invalid and cannot be used.
7655h	The full pack radius reported by the CM appears to be invalid and will not be used.
7656h	The tape length reported by the CM appears to be invalid and will not be used.
7657h	The empty reel inertia reported by the CM appears to be invalid and will not be used.
7658h	The empty reel radius reported by the CM appears to be invalid and will not be used.
7659h	The front reel is not rotating properly. It is possible that some tape was spilled out from the back reel.
765Ah	Recovery process was unable to determine the best direction in which to move the tape.
765Bh	Front reel did not reverse direction after passing through the critical region for threading reversal.
765Ch	Back reel did not stop as expected during a tape recovery process.
765Dh	Warning: Leader block demate process resorted to pushing the back reel clockwise.
765Eh	Rethreading position time-out during the leader block demate retry process.
765Fh	Leader block demate retry process was unsuccessful.
7660h	It was necessary to tug the tape to detach the leader block.
7661h	Timed out waiting for the required number of layers to overwrap the leader block.
7662h	Timed out waiting for the tape to unwrap from the leader block during a reverse thread.
7663h	Timed out waiting for a return to the original lock-in position during a reverse thread.
7664h	DSP tuning parameters were reloaded into the DSP before a VI-sensor calibration command. This is a recovery algorithm.
7665h	A special test mode has been enabled that will generate specific faults.
7666h	The special test mode has now been disabled. Normal operation will resume.
7667h	The front reel is not running in the reverse direction after the tension ramp after passing through the critical region during a thread.
7668h	The front reel did not reverse direction after passing through the critical region during an unthread, step 1.
7669h	The front reel did not reverse direction after passing through the critical region during an unthread, step 2.
766Ah	Timed out waiting for speed to reduce while approaching the critical region during a thread.

Error	Description
766Bh	Recovery process is using a secondary head set to perform a sensor calibration operation.
766Ch	Recovery process is using a secondary head set to perform an azimuth calibration operation.
766Dh	Servo calibration cannot be done now because it is too close to BOT.
766Eh	Timed out waiting for half moon to approach head during a thread.
766Fh	Timed out waiting for half moon to approach head during an unthread.
7670h	Timed out waiting for half moon to pass head during a thread.
7671h	Timed out waiting for half moon to pass head during an unthread.
7672h	Timed out waiting for half moon to enter guide during an unthread.
7673h	Servo timing reference mismatch during timing reference calibration
7674h	Set position and speed operation missed the target objectives by too much, probably due to DSP retries.
7675h	Timed out waiting for the grabber to rotate enough to deactivate the tape lifter and lower the tape onto the head
7676h	Cartridge Memory read after threading; mechanism parameters cannot be updated at this time.
7677h	Mechanism sensors not in the expected state after a load command.
7678h	Mechanism sensors not in the expected state after an unload command.
7679h	Mechanism sensors not in the expected state after a grab command.
767Ah	Mechanism sensors not in the expected state after an ungrab command.
767Bh	Deslacking process did not complete, probably due to the back reel motor failing to rotate.
767Ch	FRM tension ramp process did not complete, probably due to excessive tape slippage in the cartridge.
767Dh	FRM rotation was unexpectedly detected while ungrabbing the cartridge leader pin.
767Eh	The calculated LPOS media manufacturers string checksum does not match what was read from the tape.
767Fh	The LP sensor was asserted before loading, possibly because of a stuck or faulty sensor
7680h	The DSP was commanded to re-lock onto servo code. (This is a recovery algorithm.)
7681h	A retry was necessary on a DSP seek command. (This is a recovery algorithm.)
7682h	A retry was necessary on a DSP VI-sensor cal command. (This is a recovery algorithm.)
7683h	A retry was necessary on a DSP azimuth cal command. (This is a recovery algorithm.)
7684h	A retry was necessary on a DSP command to learn the VI-offset. (This is a recovery algorithm.)
7685h	Unable to thread. An ungrab/regrab/rethread recovery process will now be attempted.

Error	Description
7686h	The thread operation is being retried because the pin detect sensor indicates parked when not parked.
7687h	The threading recovery could not get the tape stopped in a reasonable time period.
7688h	Timed out waiting for a regrab to complete before threading.
7689h	Timed out trying to read the media manufacturer's information.
768Ah	A faulty LP sensor has made it necessary to detect pin parking via FRM stall.
768Bh	Attempt to park failed. An LP sensor was most likely asserted when it should not have been.
768Ch	A VI cal was necessary to recover a DSP seek command failure. (This is a recovery algorithm.)
768Dh	The FRM driver required a reset and was restarted. This is not a fault.
768Eh	The BRM Driver required a reset and was restarted. This is not a fault.
768Fh	The reel motor flex continuity check failed, the line is stuck high.
7690h	The reel motor flex continuity check failed, the line is stuck low.
7691h	Unable to read the media manufacturers information from the LPOS bit stream.
7692h	A full eject was invoked as part of a load fault recovery.
7693h	Gently nudged grabber in order to help park leader pin. Information only, not a fault.
7694h	Leader pin may have come ungrabbed. Regrabbing pin.
7695h	A cartridge load as part of init failed.
7696h	A special recovery to try to free a stuck LP sensor is in progress.
7697h	The recovery effort to try to free a stuck LP sensor failed.
7698h	The BRM over rotated during leader block demate in recover tape. Info only.
7699h	The front reel motor DAC offset is too large or too small.
769Ah	The back reel motor DAC offset is too large or too small.
769Bh	A forced eject command was invoked. This is not a fault.
769Ch	The LPOS lock-up process 1 produced a value that does not pass the basic sanity check.
769Dh	The LPOS lock-up process 2 produced a value that does not pass the basic sanity check.
769Eh	The removing slack operation timed out while trying to determine the best direction for recovery.
769Fh	The radii estimation process in recover tape yielded a negative result.
76A0h	Unable to send a <code>DspSetGen</code> command.
76A1h	Failed to complete a <code>SetGen</code> command.
76A2h	Empty Dsp interrupt.

Error	Description
76A3h	Time-out during ReadDspFaultLog.
76A4h	Time-out during ClearDspFaultLog.
76A5h	Unable to send a DspWriteDataMem command.
76A6h	Dsp failed to complete a WriteDataMem command.
76A7h	Unable to send DSP sample rate parameters.
76A8h	A threading fault has occurred.
76A9h	An unthreading fault has occurred.
76AAh	Unable to send CSP PCA diagnostic command.
76ABh	DSP failed to complete PCA diagnostic command.
76ACh	Unable to initiate tape motion. The tape is stuck.
76ADh	Unable to initiate tape motion even after using the tape lifter. The tape is stuck.
76AEh	Unable to initiate tape motion even after relaxing hard pull. The tape is stuck.
76AFh	The tape speed error integrator value is very large. The tape is stuck and not moving.
76B0h	Unable to initiate tape motion even after pulling in the opposite direction. The tape is stuck.
76B1h	The tape finally came free after pulling in the opposite direction.
76B2h	Unable to read enough valid LPOS words from any servo head to determine LPOS.
76B3h	Switching to a different speed or different head as part of a Servo Cal retry and recovery process.
76B4h	This fault code is for firmware debug only. It simulates a DSP fault code.
76B5h	Relaxed grabber during thread to help pull leader pin out of cartridge. This is for information only; it is not a fault.
76B6h	An Orion command returned more results than the maximum allowed.
76B7h	The servo ASIC interrupted the system processor for no good reason.
76B8h	The LPOS lock-up process produced a value that does not pass the basic sanity check.
76B9h	The LPOS lock-up process produced a value that does not pass the basic sanity check.
76BAh	RecoverTape completed successfully. This is for information only; it is not a fault.
76BBh	An Orion command was sent with more than the maximum number of parameters allowed.
76BCh	Hardware detected offtrack. This is for information only.
76BDh	The servo ARM reported an unexpected reset.
76BEh	No Orion command mailboxes were available
76BFh	The write-protect sensor does not match the specified high state.

Error	Description
76C0h	The write-protect sensor does not match the specified low state.
76C1h	EEPROM values unavailable. Invalid table revision. Default servo tuning values are being used instead.
76C2h	EEPROM values unavailable. Invalid table revision. Default values are being used instead.
76C3h	The drive is not in the correct state to allow the power mode to be changed.
76C4h	The power mode requested is invalid.
76C5h	The cooling fan is stalled or running significantly below normal operating speed.
76C6h	The cooling fan was stalled but is now operating normally.
76C7h	A servo ARM memory parity error was detected. The drive must be reset.
76C8h	A servo ARM memory parity error was detected. The drive must be reset.
76C9h	A servo ARM memory parity error was detected. This is for information only.
76CAh	A servo ARM memory parity error was detected. The drive must be reset.
76CBh	Mechanism Interface resetting the drive. A fatal servo ARM memory parity error was detected.
76CCh	The servo ARM did not respond within the allotted timeout, shutting down the actuator motor.
76CDh	The drive is LOAD inhibited. The reel driver offset is out of range. Loading a tape would put it at risk.
76CEh	Deceleration to the head turn-off speed took longer than expected.
76E8h	The reel motor flex connection is suspect; the dataset field in the fault log indicates which lines are in error.
76E9h	Tape tilt calibration failed. Drive write inhibited.
76EAh	EEPROM values unavailable. Default DSP servo compensator values are being used.
76EBh	The drive has cooled and the cooling fan has been turned off.
76ECh	The drive is getting too hot and the cooling fan has been turned on.
76EDh	The drive has cooled; resuming normal tape speeds.
76EEh	The drive is getting too hot; tape speed is now being reduced to a minimum.
76EFh	ASIC temperatures are too high. Operations must stop and the cartridge must be ejected.
76F0h	The address into the main DRAM buffer must be on an even byte boundary.
76F1h	The address into the main DRAM buffer is outside the range allowed for the servo system to use.
76F2h	The specified mode is not valid.
76F3h	The specified scope channel bit width is not supported.

Error	Description
76F4h	The specified scope trigger position is too large compared to the specified number of data packets in the trace.
76F5h	The length of the buffer must be larger than zero and an even number.
76F6h	The specified source number is not valid.
76F7h	The specified scope buffer format parameter is not valid.
76F8h	A reel driver calibration factor is out of range.
76F9h	A reel driver calibration factor for static torque loss is out of range.
76FAh	A reel driver calibration factor for dynamic torque loss is out of range.
76FBh	The temperature is above the maximum limit.
76FCh	The temperature is below the minimum limit.
76FDh	EEPROM values are unavailable. The default servo tuning values are being used instead.
76FEh	Previous fault conditions have made it unsafe to thread this cartridge.
76FFh	The tape temperature is too high. Operations must stop and the cartridge must be ejected.
7700h	The base number for constructing DSP error codes. This is not an actual error.
7701h	DSP fault: TMS320 was just reset due either to hardware pin assertion or receipt of the Reset command.
7702h	DSP fault: the DSP checksum failed after a hardware/software reset.
7703h	DSP fault: unsupported command opcode
7704h	DSP fault: illegal command sequence.
7705h	DSP fault: the Alert bit was set during a seek or CalibrateVI command.
7706h	DSP fault: the DSP was asked to do a tape seek when the microprocessor said this was not a safe operation to do.
7707h	DSP fault: a seek or VI calibration command was issued but the mechanism has not learned the VI offset yet.
7708h	DSP fault: the stroke measured by the VI sensor hardware was not large enough.
7709h	DSP fault: excessive actuator power amp offset.
770Ah	DSP fault: main memory microprocessor time-out.
770Bh	DSP fault: the tracking PLL in the servo front end did not lock up at power up. Info only.
770Ch	DSP fault: the servo firmware was sent a command it could not interpret .
770Dh	DSP fault: no timers were available for use in the servo firmware.
770Eh	DSP fault: spare
770Fh	DSP fault: spare

Error	Description
7710h	DSP fault: unable to find a top servo band.
7711h	DSP fault: unable to lock to track 0 on a top servo band.
7712h	DSP fault: unable to verify band ID on a top servo band.
7713h–771Fh	DSP faults: spare.
7720h	DSP fault: the track-following loop could not stay at the desired set point.
7721h–772Fh	DSP faults: spare.
7730h	DSP fault: could not stay locked to the tape servo code.
7731h–773Fh	DSP faults: spare.
7740h	DSP fault: no tape servo data during seek acceleration phase.
7741h	DSP fault: acceleration time-out fault.
7742h	DSP fault: spare.
7743h	DSP fault: no tape servo data during the seek deceleration phase.
7744h–7745h	DSP faults: spare.
7746h	DSP fault: seek failure during VI gross settle.
7747h	DSP fault: seek failure during tape gross settle.
7748h–774Ah	DSP faults: spare.
774Bh	DSP fault: no tape servo data during seek fine settle phase.
774Ch	DSP fault: too few samples to generate an azimuth correction.
774Dh	DSP fault: too few samples to generate a valid timing reference.
774Eh–774Fh	DSP faults: spare.
77nn h (nn=50h–FEh)	DSP fault Code nn.
77FFh	Denotes the end of DSP error codes. This is not an actual error.

Exception handler (from 7800h)

Error	Description
7800h	Unrecognized exception.
7801h	A Fatal assert has been seen. Parameter 1 shows the PC, parameter 2 the error code for the assert.
7802h	A Logged assert has been called. Parameter 1 shows the PC, parameter 2 shows the File ID, parameter 3 the line number.

Error	Description
7803h	An assert has been called. Parameter 1 shows the PC.

SPI interface (from 7C00h)

Error	Description
7C01h	Buffer overflow.
7C02h	Time-out error.
7C10h	EEPROM write did not complete. It is still in progress.
7C11h	Flash write did not complete.

Cartridge Memory (from 8000h)

Error	Description
8000h	Address out of limits.
8001h	SPI writing problems.
8002h	Wrong number of bits returned.
8003h	Nack error.
8004h	Unrecognized data received.
8005h	SPI reading problems.
8006h	Parity error.
8007h	Collision error.
8008h	Overflow error.
8009h	Underflow error.
800Ah	Overflow error on sending.
800Bh	Number of bits on data receive error.
800Ch	Impossible address situation.
800Dh	Invalid configuration name.
800Eh	Invalid configuration value.
800Fh	CRC error.
8010h	The serial number check failed.

Error	Description
8011h	Error bit set.
8012h	Type of transponder not recognized.
8013h	RF channel already opened.
8014h	RF channel already closed.
8015h	EOT polled to.

Fault log manager section (from 8400h)

Error	Description
8400h	Log not yet implemented.
8401h	No more entries to extract.
8402h	Uninitialized NV logs.
8403h	An <code>SPIxferRequest</code> failed.
8404h	Some fault entries were not placed in the log due to flushing occurring.
8405h	The size of operation of an entry is different to what the logging system expects.
8406h	A tape has been loaded and the fault log entry shows the load count and cartridge serial number.
8407h	The requested operation cannot be performed at this time as a flush to NV is currently in progress.
8480h	A snapshot change is not allowed because a snapshot is currently in progress.
8481h	A request to read a snapshot log failed because the requested log number does not exist.
8482h	Snapshotting is not allowed now as one or more preconditions have not been passed.
8483h	A request to stop reading a log found the log was not being read in the first place.
8484h	An attempt was made to insert too many CDBs for snapshotting.
8485h	The end of the snapshot command set has been reached.
8486h	An attempt was made to access the log snapshot command set while it is being updated.
8487h	A snapshot command requested more SCSI data (out) than was available.
8488h	The SCSI infrastructure requested a snapshot PortIF operation with an invalid/obsolete TaskPtr.
8489h	The specified snapshot log is unavailable because it is being filled or created.
848Ah	The specified snapshot log is unavailable because it is being read.
848Bh	The specified snapshot log is unavailable because its status is unexpected.

Error	Description
848Ch	The command set cannot be changed while it is being read.
848Dh	The data structure that contains status has an illegal value.
848Eh	The specified snapshot LogSize is too small.

Infrastructure section (from 8800h)

Error	Description
8800h	Inf OnEvent: EventSet – the event list is full, so the event has not been set.
8801h	Inf OnEvent: the event has not been found in the list.
8802h	Inf OnEvent: EventGetIdx – the index is out of bounds.
8803h	Inf ARM exception vector taken: undefined instruction.
8804h	Inf ARM exception vector taken: software interrupt.
8805h	Inf ARM exception vector taken: prefetch abort.
8806h	Inf ARM exception vector taken: data abort.
8807h	Inf ECC event: recoverable ECC error detected.
8808h	Inf ECC event: unrecoverable ECC error detected.
8809h	Inf Boot failure: firmware image failed to boot.
880Ah	The ACI_RST_L input on the ACI connector has been activated.
880Bh	Inf ECC event: Recoverable ITCM ECC error detected.
880Ch	Inf ECC event: Recoverable DTCM ECC error detected.
880Dh	Inf the System ARM is about to enter DiagLite.
880Eh	Inf the True Random Number Generator's init routine failed at the start.
880Fh	Inf the True Random Number Generator's BIST never completed.
8810h	Inf the True Random Number Generator's BIST SIG never became non-zero.
8811h	Inf the True Random Number Generator has failed to re-seed.
8812h	Inf the True Random Number Generator has failed to fill its cache.

Critical section (from 8C00h)

Error	Description
8C00h	End section not begun. CRSEndCritIntSect was ended without CRSBegIntSect.
8C01h	Begin section ints off. CRSBegCritIntSect found ints already off.

SCSI module (from 9400h)

Error	Description
9401h	Power-on reset Unit Attention.
9402h	Firmware reboot after upgrade Unit Attention.
9403h	SCSI bus reset Unit Attention.
9404h	BDR reset Unit Attention.
9405h	Soft reset Unit Attention.
9406h	Transceivers changed to SE Unit Attention.
9407h	Transceivers changed to LVD Unit Attention.
9408h	Nexus lost Unit Attention.
9409h	Media changed Unit Attention.
940Ah	Mode parameters changed Unit Attention.
940Bh	Log values changed Unit Attention.
940Ch	Unsupported task management function.
940Dh	LUN has too many task objects.
940Eh	Unsupported LUN.
940Fh	Invalid field in CDB.
9410h	Unsupported opcode.
9412h	Unsupported command handler request.
9413h	Unavailable opcode.
9414h	Not a fast ACI command.
9415h	Response pending.
9416h	Aborted.
9417h	Reserved.

Error	Description
9418h	Invalid group code.
9419h	Truncated mode page.
941Ah	Invalid field mode data.
941Bh	BOT encountered on space to record.
941Ch	BOT encountered on to space to filemark.
941Dh	Firmware bug.
941Eh	Echo buffer overwritten.
941Fh	REPORT DENSITY media not present.
9420h	Overlapped command.
9421h	Erase operation in progress.
9422h	Locate operation in progress.
9423h	Rewind operation in progress.
9424h	Write inhibit tape drive.
9425h	Device ID changed Unit Attention.
9426h	Truncated Log data.
9427h	Non-clearable Log page.
9428h	Invalid field Log data.
9429h	Forward task to library. Not a reportable error code.
942Ah	Invalid surrogate SCSI LUN.
942Bh	Invalid surrogate SCSI inquiry pages.
942Ch	Too many surrogate SCSI LUNs.
942Dh	Inquiry cache corrupted.
942Eh	Inquiry cache full.
942Fh	Invalid Exchange ID.
9430h	No sense data provided.
9431h	Invalid SCSI status.
9432h	Reported LUNs data has changed Unit Attention.
9433h	Parameter not supported in CDB.
9434h	Load operation in progress.
9435h	Unload operation in progress.

Error	Description
9436h	Early Warning EOM encountered.
9437h	Invalid field in Write buffer descriptor.
9438h	Prediction threshold exceeded false failure.
9439h	Prediction threshold exceeded failure.
943Ah	Echo buffer invalid.
943Bh	LUN not configured.
943Ch	Invalid field in PR Out data.
943Dh	PR Out parameter list length error in CDB.
943Eh	PR Out truncated data.
943Fh	Reservations released Unit Attention.
9440h	Registrations preempted Unit Attention.
9441h	Reservations preempted Unit Attention.
9442h	Invalid release persistent reservation.
9443h	WORM overwrite attempted.
9444h	WORM cannot erase.
9445h	Drive cleaning in progress.
9446h	Loading media.
9448h	Unloading media.
9449h	Firmware upgrade in progress.
944Ah	Cartridge is write-protected.
944Bh	Writing inhibited, caused by bad Cartridge Memory.
944Ch	Unknown cartridge loaded but not threaded.
944Dh	Tape is loaded but not threaded, initialize command is required.
944Eh	MAM is accessible but the cartridge is in load 'hold' position — not ready.
944Fh	The tape is threaded but the drive shows it as unloaded.
9450h	No media loaded.
9451h	An invalid Port ID has been logged in.
9452h	The RMC logical unit has been taken offline by the ADC RMC Logical Unit Mode page.
9453h	Write inhibit—the media is the wrong generation.
9454h	Tape position is past BOM.

Error	Description
9455h	No default WWN. Used by the WWN module.
9456h	No current WWN. Used by the WWN module.
9457h	WWN not changed.
9458h	No default value for the WWN. Used by the WWN module.
9459h	Library check condition surrogate SCSI command. Used in surrogate SCSI to cause the siSetScsiStatus to set task SCSI status to 2.
945Ah	Insufficient registration resources. Used in Fibre Channel when the maximum number of WWN has been reached.
945Bh	Write inhibit caused by suspect integrity.
945Ch	Busy command during LU Reset. This command should receive BUSY during the resetting of the LU.
945Dh	Operation complete.
945Eh	The maximum number of bridge LUNs has been reached.
945Fh	Unit Attention condition has been detected for this initiation to the SMC LUN.
9460h	The remote SMC device server is in the Not Ready state.
9461h	The Bridging Mode Sense cache has become corrupt due to a firmware defect.
9462h	The Bridging Mode Sense cache is full, caching operation failed.
9463h	Unable to forward command to the automation device because the ADT port is logged out.
9464h	Used to instruct the Bridge Device server to resend a SCSI command to the remote SMC LUN.
9465h	Cleaning cartridge is seated but not threaded.
9466h	Firmware upgrade cartridge is seated but not threaded.
9467h	Invalid value in supplied drive serial number.
9468h	siCheckWWN has detected that the supplied WWN is already assigned.
9469h	Tagged overlapped command.
946Ah	Returned GOOD status.
946Bh	Lock SMC cache failed. Internal return status indicating the SMC cache was not locked.
946Ch	SMC cache locked. Reported is siSmcLockCache() is called when the cache is not unlocked.
946Dh	Bridge ready but operation in progress. The Bridging Manager is busy. It already has an open exchange with the remote SMC device server.
946Eh	Bridge not ready and operation in progress. The Bridging Manager is busy. It already has an open exchange with the remote SMC device server.
946Fh	Invalid Vendor ID.

Error	Description
9470h	Invalid Product ID.
9471h	Medium removal prevented.
9472h	Forward task to drive. Not a reportable error code.
9473h	Logout in bad state. The Bridging Manager received notification of an ADT port Logout while waiting for TMF response to abort synchronizing PAMR command.
9474h	Not reserved. If the OIR bit is set in Device Config mode page, commands will return this if there is no persistent reservation.
9475h	Initialization in progress. The Automation Controller is initializing the drive.
9476h	Invalid field in medium attribute. An invalid field is the SCSI Set Medium Attribute command parameter list.
9477h	Truncated medium attribute. A medium attribute in a SCSI Set Medium Attribute parameter list is truncated.
9478h	Invalid field in Log Data cache. An invalid field in the SCSI Set Log Data Cache command parameter list.
9479h	Truncated log page descriptor. A log page descriptor in a SCSI Set Log Date Cache command is truncated.
947Ah	Invalid field in parameter list.
947Bh	Invalid field in SP Out data.
947Ch	SP Out parameter list length error in CDB.
947Dh	Data encryption parameters changed by another initiator Unit Attention.
947Eh	Data encryption parameters changed by vendor specific event Unit Attention.
947Fh	SP Key instance CTR changed.
9480h	Unsupported encryption cartridge.
9481h	Firmware upgrade already in progress. Another initiator has already started a FW download sequence.
9482h	Firmware upgrade image not MOD4.
9483h	Firmware upgrade image has bad CS on first chunk.
9484h	Firmware upgrade reboot in progress.
9485h	The boot info area of the serial flash is corrupt. EnFUG command set will not work.
9486h	No key is available when asked to encrypt or decrypt.
9487h	SetManagementURI command is only allowed when the drive is not ready.
9488h	Parameter list length specified has too many URI descriptors. Only used with the SetManagementURI command.
9489h	Logical EOT has been detected.

Error	Description
948Ah	Decrypt key fail limit reached. Exhaustive search attack prevention.
948Bh	Stored HAT count in NV is greater than Max HAT Retries.
948Ch	Stored default Map ID for this port is invalid.
948Dh	Write command allocation length error. If encryption mode is set to encrypt, only 8 MB record size is allowed.
948Eh	Too many stalled auto mode commands already exist in the slow device server queue.
948Fh	The drive has detected invalid sense data from the remote SMC device server.
9490h	KMS did not provide a key.
9491h	Parameter list length error in the CDB.
9492h	A command descriptor in the Set Snapshot Command Set parameter list was truncated.
9493h	The configuration descriptor in the Set Snapshot Config parameter list was truncated.
9494h	Failed to start the Service Buffer snapshot because one is already in progress.
9495h	SI RSA Signature Known Answer Test has failed.
9496h	Cannot set security parameters, the drive has been (externally) configured not to accept security parameters.
9497h	KMS reported it failed to obtain security parameters, without which the command cannot be executed.
9498h	KMS reported it failed to obtain security parameters, unrecoverable error.
9499h	KMS reported it failed to obtain security parameters; error when trying to access the key.
949Ah	KMS reported it failed to obtain security parameters, key not found.
949Bh	KMS reported it failed to obtain security parameters, incorrect key.
949Dh	Timer expired when waiting for security parameters from KMS.
949Eh	Encryption UA.
949Fh	KMS reported it failed to obtain security parameters, request not authorized (for example, the loaded tape is not encryption capable).
94A0h	The drive is in a special maintenance or self-test mode.
94A1h	The parameter list of a SET LIVE TRACE POINTS/VARIABLES command was truncated.
94A2h	The parameter data of a SET TIMESTAMP command was truncated.
94A3h	Timestamp changed UA.
94A4h	Failed to initiate an SPI transfer to read an STTF log from flash memory.
94A5h	The parameter data of a SET SERVICE LOCATION command was truncated.
94A6h	Cannot enable an NPIV port when the physical port is in Loop mode.

Error	Description
94A7h	The parameter data of a SET PREVENT MEDIUM REMOVAL command was truncated.
94A8h	The device server does not have sufficient recourses to process all the initiators in the parameter list.
94A9h	SET PREVENT MEDIUM REMOVAL command not allowed when SMC LUN enabled.
94AAh	SET PREVENT MEDIUM REMOVAL command not allowed when an NPIV is not associated with the SMC logical unit.
94ABh	SET LEGACY RESERVATION command not allowed when SMC LUN enabled.
94ACh	SET LEGACY RESERVATION command not allowed when an NPIV is not associated with the SMC logical unit.
94ADh	The parameter data of a SET LEGACY RESERVATIONS command was truncated.
94AEh	The parameter data of a SET PERSISTENT RESERVATIONS command was truncated.
94AFh	The device server does not have sufficient recourses to process all the reservation keys in the parameter list.
94B0h	Error detected in an SP OUT command or its data, either when attempting to establish a CCS, or after decrypting when the integrity is checked.
94B1h	Error detected in an SP OUT command Authentication step; SAI_AC or SAI_DS is wrong.
94B2h	Error detected in an SP OUT command Authentication step; authentication failed.
94B3h	A host tried to initiate a new SA while another is in progress.
94B4h	The creation of a SA is in progress, the command is not allowed.
94B5h	FUGImage too large for flash.
94B6h	The bridging manager has attempted to send a SCSI command to the remote SMC LUN before the bridging port has been registered or configured.
94B7h	A Cryptographic Algorithm function returned an unexpected length.
94B8h	The Set Beacon LED Config parameter list is truncated.
94B9h	No task objects available in the SCSI Task Manager. This is a fatal error.
94BAh	The Set IP Config parameter list is truncated.
94BBh	A Certificate Manager function returned an unexpected length.
94BCh	A Certificate Manager function returned an unexpected length on a Security Configuration command.
94BDh	A Cryptographic Algorithm function returned an unexpected length on a Security Configuration command.
94BEh	The SPOUT signature could not be authenticated because the Management Host Certificate public key is not present.
94BFh	A Set Symbolic Name descriptor is truncated.

Error	Description
94C0h	A cartridge is not loaded but it has been detected in the drive.
94C1h	An Automation Device Attribute Descriptor header was truncated.
94C2h	The Automation Device Attribute value was truncated.
94C3h	The AER Control descriptor was truncated.
94C4h	The status indicates that the specified symbolic name is the same as the current symbolic name.
94C5h	The SET ADVANCED PORT SETTINGS parameter list was truncated.
94C6h	The specified symbolic name exceeds the maximum permitted length.
94C7h	The specified symbolic name is not null-terminated.
94C8h	The specified Live Trace point has been specified multiple times in the parameter list.
94C9h	The specified Live Trace point ID is invalid. It must be 0000h.
94CAh	The firmware file sent is too big.

Automation/Drive Interface (from 9800h)

Error	Description
9801h	<i>Resource issue:</i> The ADI failed to queue an object because the queue is full.
9802h	The ADI failed to get a queue item because the queue was empty.
9803h	<i>Resource issue:</i> The ADI was unable to allocate a new Frame Control Block.
9804h	<i>Resource issue:</i> The ADI does not have sufficient memory to complete the current operation.
9805h	<i>Firmware defect:</i> An invalid queue was referenced.
9806h	<i>Resource issue:</i> Unable to allocate a new exchange ID; all Exchange IDs are in use.
9807h	<i>Firmware defect:</i> The firmware generated an invalid state-machine event.
9808h	<i>Firmware defect:</i> The firmware referenced an invalid firmware state-machine.
9809h	<i>Firmware defect:</i> The firmware referenced an invalid FCB handle.
980Ah	Unable to get a new task object.
980Bh	The SCSI Exchange ID table is full.
980Ch	A new exchange has been started with an ID of an existing exchange.
980Dh	The ADT Port interface received a SCSI Command IU containing an invalid field.
980Eh	The ADT Port interface received a SCSI Data IU containing an invalid field.
980Fh	The ADT Port interface received a SCSI Response IU containing an invalid field.

Error	Description
9810h	The ADT Port interface received a SCSI operation from a device server with an invalid Context ID.
9811h	Unable to generate a frame because it exceeds the maximum payload size.
9812h	The ADT Port interface received more SCSI data than is permitted within a burst.
9813h	The ADI Port interface has received a Data IU with an offset outside the current burst.
9814h	The ADT Port interface received a command from a device server that it cannot support.
9815h	The ADT Port did not receive an ACK for a frame it transmitted.
9816h	Temp need to replace with <code>SI_ERR_TASK_QUEUE_FULL</code> when available.
9817h	<i>Self-test failed:</i> Unexpected FCBs allocated.
9818h	<i>Self-test failed:</i> Unexpected exchange open.
9819h	<i>Self-test failed:</i> Queue not empty.
981Ah	<i>Self-test failed:</i> SCSI Exchange not in the state IDLE.
981Bh	The ADT port has detected an excessive number of framing errors.
981Ch	<i>Self-test failed:</i> Non-zero library ACK offset.
981Dh	Received Transfer Ready IU contained an invalid Buffer Offset field.
981Eh	Received an ACK frame but not for frame it was expecting.
981Fh	Received an NAK frame but not for frame it was expecting.
9820h	Giving up initiating a Port Login after a number of failed attempts.
9821h	Discarding an ACK frame it received after the acknowledgement timeout.
9822h	Did not receive acknowledgement within the Acknowledgement Period.
9823h	Received a frame with a checksum error.
9824h	Received a frame when the port was disabled.
9825h	Received Transfer Ready IU was shorter than expected.
9826h	Received Transfer Ready IU was longer than expected.
9827h	Received Transfer Ready IU contained a Burst Length value of zero.
9828h	Failed to execute a SCSI operation because it is logged-out.
9829h	Failed to execute a SCSI operation because it is busy doing something else.
982Ah	Aborted bridged SCSI command due to a communication failure.
982Bh	Unsupported task management function.
982Ch	Invalid SCSI response code.

Error	Description
982Dh	Invalid field in SCSI IU.
982Eh	More data transferred than requested.
982Fh	Task management function failed.
9830h	Service delivery failed.
9831h	Invalid LUN in task management IU.
9832h	Failed to transmit SCSI command or Task Management Function IU.
9833h	Received zero length SCSI data IU.
9834h	Received a data IU unexpectedly.
9835h	Unexpected null frame pointer.
9836h	The drive has detected a library firmware defect.
9837h	Specified port is not a recognized ADT port.
9838h	Instructs Bridging Manager not to resend a command with a UNIT ATTENTION sense key.
9839h	A function will send a response when it has finished.
983Ah	The library NAKed a frame from the drive. Reported in the ADI/AMI command history log.
983Bh	Reported in the ADI/AMI Command History log to indicate a PORT RESET event occurred due to a diagnostic command.
983Ch	Not reported to a host but indicates a firmware defect sequencing a firmware reboot related to an ADT RESET IU.
F801h	GWIF pending.
F802h	GWIF no change.

Management API (from 9C00h)

Error	Description
9C01h	The Ethernet RESET line has been activated.
9C02h	The System ARM <code>maHandleEvent ()</code> function has received an illegal event.
9C03h	An invalid iADT port was specified for connection.
9C04h	The iADT SENSEa input is asserted by the library controller.
9C05h	The iADT SENSEa input is not asserted by the library controller.
9C06h	The iADT SENSEa input has not been read yet.
9C07h	Failure during socket read.

Error	Description
9C08h	Failure during socket write.
9C09h	MgmtArm rejected the maConfigNetworkIF options.
9C0Ah	Requested self-test passed.
9C0Bh	Requested self-test failed.
9C0Ch	Fatal condition caused the Management ARM to fail.
9C0Dh	Could not queue the message, the Mailbox is full.
9C0Eh	Could not allocate memory to copy an ADT frame.
9C0Fh	The awaited event has occurred.
9C10h	The Mailbox is empty.
9C11h	The command failed because the requested port does not exist.
9C12h	Failed to connect to the remote host.
9C13h	POST status not available.
9C14h	Unable to get a new task object.
9C15h	Cannot execute the SCSI command because another is in progress.
9C16h	The KMS Agent Port interface received more SCSI data than permitted within a burst.
9C17h	PKI type invalid.
9C18h	PKI format invalid.
9C19h	PKI conversion error.
9C1Ah	PKI processing error.

Servo (from A000h)

Error	Description
A000h	No error.
A001h	The servo system has shutdown due to panic conditions.
A002h	The Servo Task fault buffer has overflowed. Some entries have been lost.
A003h	The Servo Interrupt fault buffer has overflowed. Some entries have been lost.
A005h	The servo firmware requested a timer when none was available.
A006h	Timeout occurred while waiting to report servo statistics.
A007h	The current servo firmware task is not a valid task.

Error	Description
A008h	The acceleration phase of the seek did not complete within the allotted time.
A009h	The deceleration phase of the seek did not complete within the allotted time.
A00Ah	Settle window criterion was not met at the end of the deceleration phase of the seek.
A00Bh	Hand-off to the tracking phase of the seek did not complete within the allotted time.
A00Ch	Servo mode was not recognized during a seek.
A00Dh	A timer fault occurred during a negative stiction pulse.
A00Eh	A timer fault occurred during a positive stiction pulse.
A00Fh	A timer fault occurred during the bottom crash stop calibration.
A010h	A timer fault occurred during the top crash stop calibration.
A011h	The measured actuator stroke size is too small.
A012h	A timer fault occurred during TSB calibration.
A013h	TSB0 calibration did not complete within the allotted time.
A014h	TSB1 calibration did not complete within the allotted time.
A015h	TSB2 calibration did not complete within the allotted time.
A016h	TSB3 calibration did not complete within the allotted time.
A017h	An invalid servo track number was specified for a seek.
A018h	The calculated final target for a VI seek was out of range.
A019h	The calculated final target for a Tape seek was out of range.
A01Ah	Unable to find the requested TSB.
A01Bh	Unable to find Servo code on the tape; bad head.
A01Ch	Unable to identify the current Top Servo band.
A01Dh	Unable to identify the requested Seek type.
A01Eh	Unable to lock to tape when not tracking on VI.
A01Fh	Unable to lock to tape servo code within the allotted time.
A020h	Primary servo bump went out while writing.
A021h	System ARM is not allowing tape servo operations.
A022h	VI offset calibration has not been done.
A023h	The specified servo scope mode is not valid.
A024h	The specified servo scope channel bit width is not supported.
A025h	The specified servo source number is not valid.

Error	Description
A026h	The specified servo scope trigger position is too large compared with the specified number of data packets in the trace.
A027h	The specified servo scope source address was not found in the address array.
A028h	The specified servo scope source bit size was not found in the size array.
A029h	A Measure Servo Heads command did not complete within the allotted time.
A02Ah	The main system ARM flagged the need to revert to VI.
A02Bh	Band ID had good skew values from both bumps but was unable to identify the band.
A02Ch	Band ID had good skew values from both bumps but identified different valid bands for each bump.
A02Dh	Tape servo code available from at least one channel but unable to achieve tape lock. The head is suspect.
A02Eh	Not enough good demod channels to attempt band ID whilst searching for tape servo during TSB calibration.
A02Fh	Tape servo code available from at least one channel but unable to achieve tape lock. The head is suspect.
A030h	The servo command is incorrectly formatted.
A031h	The servo command cannot be executed now.
A032h	Servo fault.
A033h	Servo fault.
A034h	Servo fault.
A035h	Servo fault.
A036h	Servo fault.
A037h	One or more of the command parameters are invalid.
A038h	The servo command sent is not supported.
A039h	The servo command sent is out of sequence.
A03Ah	The mechanism interface did not respond within the allotted timeout, shutting down the reel motors.
A03Bh	Init servo command already in progress.
A03Ch	Write memory servo command already in progress.
A03Dh	Read memory servo command already in progress.
A03Eh	Set generation servo command already in progress.
A03Fh	Set scope mode servo command already in progress.
A040h	PCA diagnostic servo command already in progress.

Error	Description
A041h	Live statistics servo command already in progress.
A042h	Seek command already in progress.
A043h	Report TSBs servo command already in progress.
A044h	Define Scope Sources servo command already in progress.
A045h	Configure Oscillator servo command already in progress.
A046h	Define Signal Nodes servo command already in progress.
A047h	Calibrate VI Stroke servo command already in progress.
A048h	Calibrate TSBs servo command already in progress.
A049h	Report Servo Status servo command already in progress.
A04Ah	Configure Test DACs servo command already in progress.
A04Bh	Report Servo Configuration servo command already in progress.
A04Ch	Measure Servo Heads servo command already in progress.
A04Dh	Copy Memory Block servo command already in progress.
A04Eh	Report Enum Address servo command already in progress.
A04Fh	Set Compensator Coefficients servo command already in progress.
A050h	Set Head Position Tuning Parameters servo command already in progress.
A051h	Clean Head servo command already in progress.
A052h	Accelerometer Self-Test servo command already in progress.
A053h	TSB calibration routine did not complete within the allotted time.
A054h	The servo interrupt flagged the need to revert to VI. Most likely cause is that the tape position data went away while tracking.
A055h	The servo system attempted to recover the actuator to a known state.
A060h	The mechanism revision was not recognized while trying to configure the compensator.
A061h	Timer unavailable for motion to the top crash stop as part of a head-clean routine.
A062h	Timer unavailable for motion to the bottom crash stop as part of a head-clean routine.
A063h	Timer unavailable for motion to the bottom crash stop as part of a head-clean routine.
A064h	Seek at the top crash stop during a head-clean.
A065h	Seek at the bottom crash stop during a head-clean.
A066h	Compensator configuration already set from the EEPROM content or a mechanism revision parameter missing.
A067h	The specified head mode is not recognized.

Error	Description
A068h	Target VI gain for use at seek destination could not be determined.
A069h	A defect scan is already in progress.

Certificate manager (from A400h)

Error	Description
A401h	A Root CA certificate already exists and authentication is not possible without a Management Host certificate.
A402h	The Management Host certificate was rejected because the Root CA does not exist.
A403h	Unknown or unexpected Certificate Manager state.
A404h	The Management Host certificate failed verification.
A405h	The Public Key length returned does not match the length in the Public Key descriptor.

Cryptographic algorithms (from A800h)

Error	Description
A801h	Algorithm ID indicated an unsupported algorithm.
A802h	Invalid key length specified.
A803h	Algorithm index not found.
A804h	One or more pointer arguments were null.
A805h	Invalid algorithm database.
A806h	Initiator message signature is invalid.
A807h	Message digest buffer is too small.
A808h	Insufficient entropy.
A809h	Decryption authentication failure.
A80Ah	Certification authority hash mismatch.
A80Bh	Random number generation failed.
A80Ch	Diffie-Hellman public value creation failed.
A80Dh	Bignum conversion failed.
A80Eh	Message digest failure.
A80Fh	Signature failure.

Error	Description
A810h	Encryption argument error.
A811h	Encryption failure.
A812h	OpenSSL initialization failure.
A813h	OpenSSL d2i conversion failure.
A814h	Buffer is too small.

12 Support and other resources

Related documents

The following documents provide additional information:

Documents specific to HP LTO Ultrium drives

- *Software Integration Guide*, volume 2 of the HP LTO Ultrium Technical Reference Manual
- *Host Interface Guide*, volume 3 of the HP LTO Ultrium Technical Reference Manual
- *Specifications*, volume 4 of the HP LTO Ultrium Technical Reference Manual
- *UNIX, Linux and OpenVMS Configuration Guide*, volume 5 of the HP LTO Ultrium Technical Reference Manual

Please contact your HP supplier for copies.

- The features and benefits of HP LTO Ultrium drives are discussed in the *HP LTO Ultrium Technology White Paper*.
- For a general background to LTO technology and licensing, go to <http://www.lto-technology.com>.

Documentation map

The following will help you locate information in the Technical Reference Manual. A reference like “1 HW Integration: ch. 7” means Volume 1, Hardware Integration Guide, of the HP LTO Ultrium Technical Reference Manual, chapter 7.

Drives—general

	FC Drives	SAS Drives
Connectors	1 HW Integration: ch. 4	1 HW Integration: ch. 7
Front panel LEDs	1 HW Integration: ch. 3	1 HW Integration: ch. 6
Specifications	4 Specifications	

Installation and configuration

	FC Drives	SAS Drives
Connectors	1 HW Integration: ch. 4	1 HW Integration: ch. 7
Determining the configuration	2 SW Integration: ch. 2	

	FC Drives	SAS Drives
External drives	n/a	1 HW Integration: <i>ch. 5</i>
In libraries	1 HW Integration: <i>ch. 1</i>	
In servers	n/a	1 HW Integration: <i>ch. 4</i>
In tape arrays	n/a	1 HW Integration: <i>ch. 3</i>
Linux configuration	5 UNIX, Linux, OpenVMS Configuration	
Modes of usage	n/a	1 HW Integration: <i>ch. 8</i>
OpenVMS configuration	5 UNIX, Linux, OpenVMS Configuration	
Optimizing performance	n/a	1 HW Integration: <i>ch. 8</i>
	2 SW Integration: <i>ch. 4</i>	
UNIX configuration	5 UNIX, Linux, OpenVMS Configuration	

Operation

	FC Drives	SAS Drives
External drives	n/a	1 HW Integration: <i>ch. 5</i>
In libraries	1 HW Integration: <i>ch. 1</i>	
In servers	n/a	1 HW Integration: <i>ch. 4</i>
In tape arrays	n/a	1 HW Integration: <i>ch. 3</i>

Cartridges

	FC Drives	SAS Drives
Cartridge Memory (LTO-CM)	2 SW Integration: <i>ch. 5</i>	
Cartridges	1 HW Integration: <i>ch. 5</i>	1 HW Integration: <i>ch. 9</i>
Managing the use of cartridges	2 SW Integration: <i>ch. 1</i>	
Use of cartridges	2 SW Integration: <i>ch. 3</i>	

Interface

	FC Drives	SAS Drives
FC, SCSI and SAS host interface guide	3 Host Interface	

	FC Drives	SAS Drives
Commands	3 Host Interface: <i>ch. 5</i>	
Error codes	1 HW Integration: <i>ch. 6</i>	1 HW Integration: <i>ch. 10</i>
Implementation	3 Host Interface: <i>ch. 1</i>	
Interpreting sense data	2 SW Integration: <i>ch. 3</i>	
Messages	3 Host Interface: <i>ch. 2</i>	
Mode pages —see the MODE SENSE command	3 Host Interface: <i>ch. 5</i>	
Pre-execution checks	3 Host Interface: <i>ch. 4</i>	
Responding to sense keys and ASC/Q	2 SW Integration: <i>ch. 6</i>	
Sense keys and ASC/Q —see REQUEST SENSE command	3 Host Interface: <i>ch. 5</i>	
Task management functions	n/a	3 Host Interface: <i>ch. 3</i>

Maintenance and troubleshooting

	FC Drives	SAS Drives
Cleaning	2 SW Integration: <i>ch. 5</i> 2 SW Integration: <i>ch. 7</i>	
External drives	n/a	1 HW Integration: <i>ch. 5</i>
In libraries	1 HW Integration: <i>ch. 1</i>	
In servers	n/a	1 HW Integration: <i>ch. 4</i>
In tape arrays	n/a	1 HW Integration: <i>ch. 3</i>
Monitoring drive and tape condition	2 SW Integration: <i>ch. 7</i>	
Software troubleshooting techniques	2 SW Integration: <i>ch. 1</i>	

Dealing with errors

	FC Drives	SAS Drives
Error codes	1 HW Integration: <i>ch. 6</i>	1 HW Integration: <i>ch. 10</i>
Handling errors	2 SW Integration: <i>ch. 5</i>	
Logs—see the LOG SENSE command	3 Host Interface: <i>ch. 4</i>	
Recovering from write and read errors	2 SW Integration: <i>ch. 7</i>	

	FC Drives	SAS Drives
Software response to error correction	2 SW Integration: <i>ch. 3</i>	
Software response to logs	2 SW Integration: <i>ch. 3</i>	
TapeAlert log	2 SW Integration: <i>ch. 7</i>	

LTO Ultrium features

	FC Drives	SAS Drives
Autoload	1 HW Integration: <i>ch. 2</i>	
Automation Control Interface (ACI)	1 HW Integration: <i>ch. 2</i>	
Cartridge Memory (LTO-CM)	1 HW Integration: <i>ch. 2</i> 2 SW Integration: <i>ch. 5</i>	
Data compression, managing	2 SW Integration: <i>ch. 5</i>	
OBDR and CD-ROM emulation	2 SW Integration: <i>ch. 7</i>	
Performance optimization	n/a	1 HW Integration: <i>ch. 8</i>
	2 SW Integration: <i>ch. 1</i>	
Performance, factors affecting	2 SW Integration: <i>ch. 4</i>	
Software design	2 SW Integration: <i>ch. 1</i>	
Supporting LTO Ultrium features	2 SW Integration: <i>ch. 5</i>	

General documents and standardization

See http://www.t10.org/t10_main.htm for INCITS SCSI Primary Commands—3 (SPC-3), SCSI Streaming Commands (SSC-3) and other specifications

Copies of documents of other standards bodies can be obtained from:

INCITS 11 West 42nd Street New York, NY
10036-8002 USA

ISO CP 56
CH-1211 Geneva 20
Switzerland

ECMA 114 Rue du Rhône
CH-1204 Geneva
Switzerland

Tel: +41 22 849 6000
Web URL: <http://www.ecma.ch>

Global Engineering Documents 2805 McGaw
Irvine, CA 92714
USA

Tel: 800 854 7179 or 714 261 1455

Glossary

AL_PA *Arbitrated Loop Physical Address.* A 1-byte value used in the arbitrated loop topology used to identify L_ports. This value will then also become the last byte of the address identifier for each public L_port on the loop. The AL_PA can be set through an ACI Set Drive Configuration command.

ANSI *American National Standards Institute,* which sets standards for, amongst other things, Fibre Channel, SCSI and the safety of electrical devices.

arbitrated loop One of the three Fibre Channel topologies. Up to 126 NL_ports and 1 FL_port, or 127 NL_ports, are configured in a unidirectional loop. Ports arbitrate for access to the loop based on their AL_PA. Ports with lower AL_PAs have higher priority than those with higher AL_PAs.

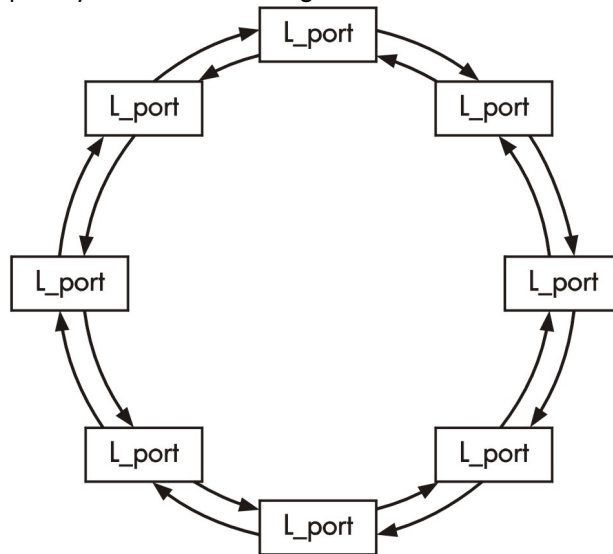

autoload When a tape cartridge is inserted, a tape drive with autoload will automatically load it without the host having to send a load command. If a drive does not have autoload, the drive will take no action until it receives a load command.

BOM *Beginning Of Media.* The first point on the tape that can be accessed by the drive.

buffered mode A mode of data transfer in write operations that facilitates tape streaming. It is selected by setting the Buffered Mode Field to **1** or **2** in the SCSI MODE SELECT Parameter List header.

channel A means of data communication between processors and between processors and peripherals. A channel provides a direct or switched point-to-point connection between the communicating devices. A channel is typically hardware-intensive and transports data at the high speed with low overhead. Contrast this with **Networks**.

compression	A procedure in which data is transformed by the removal of redundant information in order to reduce the number of bits required to represent the data.
compression ratio	A measure of how much compression has occurred, defined as the ratio of the amount of uncompressed data to the amount of compressed data into which it is transformed. The LTO-DC algorithm can typically achieve a compression ratio of between 2:1 and 4:1 depending on the nature of the data.
decompression	A procedure in which the original data is generated from compressed data.
DFA	<i>Direct Fabric Attach</i> . The connection between an N_port and an F_port.
ECMA	<i>European Computer Manufacturers Association</i> . The European equivalent of ANSI.
EOD	<i>End Of Data</i> . An area that signifies the end of the valid data. If new data is written over a larger quantity of old data, it is possible for data to exist after EOD, but because it is after EOD, this old data is no longer valid.
EOM	<i>End Of Media</i> format. The last usable point on the tape.
EW-EOM	<i>Early Warning End Of Media</i> . A physical mark or a device-computed position on the tape that tells the drive that it is approaching EOM.
F_port	<i>Fabric port</i> . A port on a fabric switch operating according to point-to-point topology, to which N_ports may be directly connected. An F_port uses the address identifier FFFFFEh.
fabric	See switched fabric
fabric zoning	Isolation of two separate switched fabric (FC_SW) zones by the switch.
FC	See fibre channel
FC_FL A	<i>Fibre Channel Fabric Loop Attach</i> . An ANSI standard that describes the rules by which NL_ports and FL_ports communicate with each other.
FC_GS	<i>Fibre Channel Generic Service</i> . An ANSI standard that describes services such as Directory Service that allow a host to identify which storage devices are available and what their addresses are.
FC_SW	<i>Fibre Channel Switch Fabric</i> . An ANSI standard that describes how fibre channel switches are required to behave. See also switched fabric
FC-AL	<i>Fibre Channel Arbitrated Loop</i> . An ANSI standard that describes how several Fibre Channel ports can share a single communication ring. Using optical fiber to connect devices, FC-AL is compatible with SCSI for high-performance storage systems. See also arbitrated loop[
FCP	<i>Fibre Channel Protocol</i> . There are three: arbitrated loop, point-to-point and switched fabric.
fibre channel	Fibre Channel provides an inexpensive yet expendable means of quickly transferring data between workstations, mainframes, supercomputers, desktop computers, storage devices, displays and other peripherals. Although it is called Fibre Channel, its architecture represents neither a channel nor a real network

topology. It allows for an active intelligent interconnection scheme, called a fabric, to connect devices. All a Fibre Channel port has to do is to manage a simple point-to-point connection between itself and the fabric. Several common ULPs (Upper Level Protocols) including IP and SCSI can be used with Fibre Channel, merging high-speed I/O and network functionality in a single connectivity technology.

filemark	A mark written by the host. It does not necessarily separate files; it is up to the host to assign a meaning to the mark.
FL_port	<i>Fabric-Loop</i> port. An F_port which is capable of supporting an attached arbitrated loop. An FL_port on a loop will have the AL_PA 00h, giving the fabric highest priority access to the loop. An FL_port is the gateway to the fabric for NL_ports on a loop.
forced eject	Functionality in the drive that should unload the cartridge in an emergency of if the cartridge fails to eject normally. To force ejection, press and hold the Eject button for 20 seconds. Wait for the cartridge to be ejected. This may take up to 15 minutes (the maximum rewind time). On full height drives, there is also an emergency reset button—see “ Automation interface ” on page 70.
FRU	<i>Field Replaceable Unit</i> , an assembly or group of components that is replaced in its entirety by Service Engineers when it contains a fault.
hard error	An uncorrectable data error.
host	The host computer system acting as controller for the drive.
L_port	<i>Loop</i> port. A generic term for an NL_port or FL_port, in other words, any Fibre Channel port that supports the arbitrated loop topology.
load	The process in which the drive takes in an inserted cartridge and goes online.
LUN	<i>Logical Unit Number</i> , by which different devices at a particular SCSI ID can be addressed individually. The drive has a fixed LUN of 0.
LVD	<i>Low-Voltage Differential</i>
N_port	<i>Node</i> port. A port on a a device such as a computer system host bus adapter, disk drive or tape drive, through which the device connects to a point-to-point or fabric Fibre Channel topology.
network	A collection of connected nodes (like workstations, file servers or peripherals) with its own protocol that supports interaction among these nodes. A network has relatively high overhead since it is software-intensive, and consequently slower than a channel. Networks can handle a more extensive range of tasks than channels as they operate in an environment of unanticipated connections, while channels operate among only a few devices with predefined addresses.
NL_port	<i>Node-Loop</i> port. An N_port which can operate on the arbitrated loop topology.
node	A device that has at least one N_port or NL_port.
offline	The drive is offline if the tape is currently unloaded or not in the drive. The host has limited access, and cannot perform any commands that would cause tape motion. The host can, however, load a tape, if one is inserted, and can execute any diagnostic tests that do not require tape motion.

online	The drive is online when a tape is loaded. The host has access to all command operations, including those that access the tape, set configurations and run diagnostic tests.
point-to-point	A Fibre Channel topology in which two points communicate directly. 
port	An access point in a device to which a link attaches.
private loop	An arbitrated loop that has no attached switch port (NL-port to NL_port). In theory, private loop devices can only communicate with other devices on the same loop.
private NL_port	An NL_port that only communicates with other ports on the loop, not with the fabric. A private NL_port may exist on either a private loop or a public loop.
public loop	An arbitrated loop where one of the ports on the loop is a switch port (an FL_port), thus allowing ports or devices on the loop to communicate with hosts or devices attached to other switch ports.
public NL_port	An NL_port that can communicate with other ports on the loop as well as through an FL_port to other N_ports connected to the fabric.
RAW	See read-after-write
read-after-write	RAW improves data integrity by reading data immediately after it is written and writing the data again if an error is found.
ready-to-eject position	A point at which a cartridge is held after an unload command is received by the drive (when Auto-Eject is not set) and the tape has been rewound and unthreaded. The drive will then wait at this point until it is commanded to eject the cartridge by the ACI Unload command
SAN	<i>Storage Area Network.</i> A dedicated, high-speed network that establishes a direct connection between storage elements and servers. The hardware that connects workstations and servers to storage devices in a SAN is referred to as a fabric. The SAN fabric enables any-server-to-any-storage device connectivity through the use of Fibre Channel switching technology.
SFP	<i>Small Form Pluggable</i> transceiver. See transceiver .
switched fabric	One of the three Fibre Channel topologies. An interconnected network of Fibre Channel host ports, device ports and switch ports. In the fabric topology, N_ports are connected to F_ports on a switch. The link is the two unidirectional fibres transmitting in opposite directions. Each fibre is attached to a transmitter of a port at one end and a receiver of another port at the other end. It is possible for fabric switches to be connected to support up to 16 million+ N_ports on a single network.

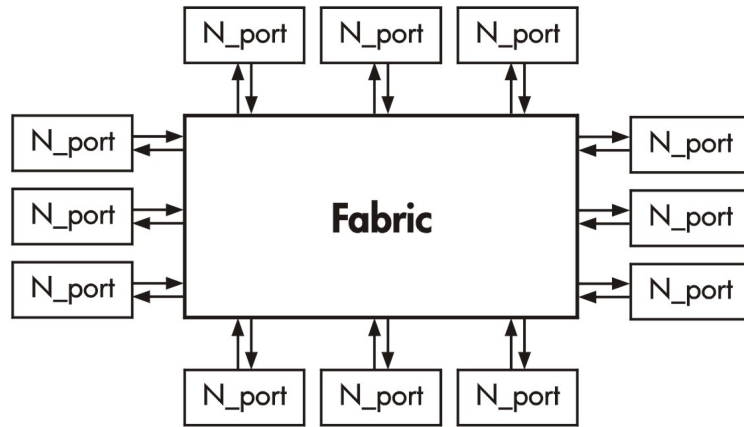

- TapeAlert** A set of 64 flags is held in the TapeAlert log that indicate faults or predicted faults with the drive or the media. By reading this log, host software can inform the user of existing or impending conditions, and can, for example, advise the user to change the tape.
- transceiver** A device used to convert electrical signals in the drive to optical signals for transmission in a fibre optic cable. Used in Fibre Channel drives only.
- ULP** *Upper Level Protocol*. The protocol which runs on top of Fibre Channel. Typical ULPs running over Fibre Channel are SCSI (Small Computer System Interface), IP (Internet Protocol), HIPPI (High Performance Parallel Interface, and IPI (Intelligent Peripheral Interface).
- VHD** *Very High Density*
- zoning** A logical grouping of fabric-attached devices that is isolated from other devices and other zones by the switch.

Index

A

- ACI, 67, 69, 70
 - connector, 31, 37
 - connector pins, 37
 - controlling loads, 74
 - error codes, 79
 - reset, 60
- addresses, fibre channel, 35
- ADI, 70
 - pin layout, 38
- ADT, 70
- airflow, 17
 - tape arrays, 52
- airflow requirements, 16
- AL_PAs, 35, 159
- ANSI, 153, 157, 159
- arbitrated loop, 159
- arbitrated loop physical address, 159
- autochangers, 67
- autoload, configuring, 74
- autoloader front panel, 69
- autoloaders, 67
- autoloading, 159
- automation controller interface
 - See ACI
- automation control interface see ACI, 67, 69
- automation device interface
 - See ADI
- automation drive interface, error codes, 143
- automation front panel, 68
- automation/drive interface
 - See ADT

B

- backup software, 51, 67
- BOM, 159
- buffer manager error codes, 83
- buffered mode, 159
- bus types, supported, 50
- bus, dedicated, 47

C

- cartridge memory, 45, 67, 77
 - access via ACI, 71
 - error codes, 133
 - problems with, 46
- cartridges, 43
 - jammed, 61
 - life, 44
 - loading, 58
 - not ejected, 64
 - positions during load and unload, 75
 - problems with, 63
 - unloading, 59
- certificate manager, error codes, 150
- channel, 159
- cleaning
 - problems with, 65
- cleaning the heads, 59
- CM see cartridge memory, 67
- compression, 160
 - ratio, 160
- condensation, avoiding, 44
- connecting to server, 50
- connectors, 31, 53
 - automation, 37
 - FC, 36
 - internal SAS, 51
 - remote LED, 37
 - SAS, 31, 36
- contactless memory, 67
- cooling, 16, 17
- critical section error codes, 136
- cryptographic algorithms, error codes, 150
- current requirements, 15

D

- data compression, 160
- data rate matching, 47
- DC_GS, 160
- decompression, 160
- DFA, 160
- diagnostic control error codes, 84
- diagnostic port, 68, 69
- dimensions, 11

- direct fabric attach, 160
- DLT cartridges, 43
- documents, related, 153
- drive
 - ID, 51
 - not recognized, 62, 63
- Drive Error LED, 22
- drive monitor error codes, 88
- drives
 - control error codes, 87
 - error codes, 79
 - ID, 67
 - moving, 55
 - operating, 57
 - problems with, 63
 - resetting, 60
 - resetting in libraries, 60
- DRM, 47
- duplex-LC connectors, 31

E

- ECMA, 157, 160
- eject button, 68, 69
- eject point, 75
- eject, forced, 61
- electrical fit, 15
- emergency reset switch
 - internal drives, 21
- emergency unload, 61
- Encryption LED, 23
- EOD, 160
- EOM, 160
- error codes, 79
- errors, hard, 161
- Ethernet port
 - See iADT
- EW-EOM, 160
- exception handler error codes, 132
- external drives
 - loading a cartridge, 58
 - unloading a cartridge, 59
- external fan, 74
- external interfaces error codes, 88

F

- F_port, 160
- fabric, 162
- fabric zoning, 160
- fan interface, 74
- FC connection, 53
- FC-AL, 160
- FC/SCSI router, 52
- FC_FLA, 160

- FC_SW, 160
- FCP, 160
- fibre channel, 160
 - addressing, 35
 - arbitrated loop, 160
 - fabric loop attach, 160
 - generic service, 160
 - ports, 35
 - switched fabric, 160
- fibre channel connector, 36
- filemarks, 161
- filtering, 18
- firmware upgrade, LED patterns, 27
- fixing dimensions, 11
- FL_port, 161
- forced airflow, 16
- forced eject, 61, 161
- formatter ASIC, 17
- front panel
 - automation, 68
 - interface error codes, 89
 - LEDs, 22
 - replacing, 28
- front panels
 - autoloader, 69
- FRU, 161
- fusing, 49

G

- generic module error codes, 79
- grounding integrity, 49

H

- hard error, 161
- HBA, 50
- head cleaning, 59
- host, 161
 - interface error codes, 89
 - problems with, 62

I

- iADT, 70, 72
- ID
 - drive, 51, 67
 - loop, 35
- identifying the drive
 - external, 54
 - internal, 49
- INCITS, 157
- infrastructure, memory codes, 135

- installing drives
 - in libraries, 53
 - internal, 49
- internal drives
 - reset switch, 21
- ISO, 157

L

- L_port, 161
- labeling cartridges, 43
- LEDs, 35
 - front panel, 22
 - rear panel, 35
- libraries, 67
 - installation in, 53
 - resetting drives in, 60
- life of cartridges, 44
- load points, 76
- loading, 161
- loading cartridges
 - configuring, 74
 - external drives, 58
 - positions, 75
 - positions of importance, 74
- logical formatter error codes, 99
- logical media error codes, 103
- logical pipeline control error codes, 104
- logs, TapeAlert, 163
- loop IDs, 35
- loop topology, 159
- LTO-CM, 45, 67, 77
- LUNs, 161

M

- Management API, error codes, 145
- mechanical interface error codes, 116
- mechanism control error codes, 104
- modes of usage, 47
- mounting requirements, 50
- moving drives, 55

N

- N_port, 161
- NL_port, 161
 - private, 162
 - public, 162
- node, 161
- non-volatile data manager error codes, 105

O

- offline, 161

- online, 162
- operating drives, 57
- operating system error codes, 110
- optimizing performance, 47

P

- physical formatter error codes, 110
- physical pipeline control error codes, 111
- pins
 - ACI connector, 37
 - ADI connector, 38
- point-to-point, 162
- port LEDs, 35
- ports, 35, 162
- power
 - requirements, 15
- power-on self-test, 57
- primary temperature sensor, 17
- private loop, 162
- private NL_port, 162
- PSU requirements, 15
- public loop, 162
- public NL_port, 162

R

- rack-mount systems, 52
- RAW, 162
- read/write control error codes, 113
- Ready LED, 22
- ready-to-eject position, 76, 162
- rear panel, 31, 53
 - LEDs, 35
- removable drives
 - identifying the drive, 52
 - installing, 52
- replacing drives in tape array, 53
- replacing front panel, 28
- reset switch
 - internal drives, 21
- resetting drives in libraries, 60
- resetting drives via ACI, 60

S

- safety, 49
- SAN, 162
 - attaching a tape array, 52
- SAS
 - connection for internal drives, 51
- SAS connector, 36
- SAS connectors, 31
- SCSI module, error codes, 136
- self-test, 57

- self-test failure, [35](#)
- serial numbers
 - external drives, [54](#)
 - internal drives, [49](#)
- server
 - installing drive in, [49](#)
- Servo, error codes, [146](#)
- software, backup, [51](#)
- SPI interface error codes, [133](#)
- storage area network, [162](#)
- storing cartridges, [45](#)
- switched fabric, [162](#)
- system architecture error codes, [115](#)
- system configurations, [47](#)
- system performance, [47](#)

T

- tape arrays
 - airflow, [52](#)
 - installing drives, [52](#)
 - replacing a drive, [53](#)
- Tape Error LED, [22](#)
- tape libraries see libraries, [67](#)
- tape life, maximizing, [45](#)
- TapeAlert log, [163](#)
- temperature
 - measuring, [17](#)
- tight integ error codes, [115](#)
- trace logger error codes, [116](#)

U

- ULP, [163](#)
- UNIX configuration, [11](#)
- unloading cartridges
 - external drives, [59](#)
 - in emergency, [61](#)
 - positions of importance, [74](#)
- Use Cleaning Tape LED, [23](#)

V

- voltage requirements, [15](#)
- voltage supply requirements, [15](#)

W

- write-protecting cartridges, [43](#)

Z

- zoning, [163](#)