

Virtual Tape Control System

Command and Utility Reference

MVS Software

Version 6.1

docs.sun update only



October 2010, Revision AD

Submit comments about this document by clicking the Feedback [+] link at: <http://docs.sun.com>

Copyright © 2006, 2010, Oracle and/or its affiliates. All rights reserved.

This software and related documentation are provided under a license agreement containing restrictions on use and disclosure and are protected by intellectual property laws. Except as expressly permitted in your license agreement or allowed by law, you may not use, copy, reproduce, translate, broadcast, modify, license, transmit, distribute, exhibit, perform, publish, or display any part, in any form, or by any means. Reverse engineering, disassembly, or decompilation of this software, unless required by law for interoperability, is prohibited.

The information contained herein is subject to change without notice and is not warranted to be error-free. If you find any errors, please report them to us in writing.

If this is software or related software documentation that is delivered to the U.S. Government or anyone licensing it on behalf of the U.S. Government, the following notice is applicable:

U.S. GOVERNMENT RIGHTS Programs, software, databases, and related documentation and technical data delivered to U.S. Government customers are "commercial computer software" or "commercial technical data" pursuant to the applicable Federal Acquisition Regulation and agency-specific supplemental regulations. As such, the use, duplication, disclosure, modification, and adaptation shall be subject to the restrictions and license terms set forth in the applicable Government contract, and, to the extent applicable by the terms of the Government contract, the additional rights set forth in FAR 52.227-19, Commercial Computer Software License (December 2007). Oracle USA, Inc., 500 Oracle Parkway, Redwood City, CA 94065.

This software or hardware is developed for general use in a variety of information management applications. It is not developed or intended for use in any inherently dangerous applications, including applications which may create a risk of personal injury. If you use this software or hardware in dangerous applications, then you shall be responsible to take all appropriate fail-safe, backup, redundancy, and other measures to ensure the safe use. Oracle Corporation and its affiliates disclaim any liability for any damages caused by use of this software or hardware in dangerous applications.

Oracle is a registered trademark of Oracle Corporation and/or its affiliates. Oracle and Java are registered trademarks of Oracle and/or its affiliates. Other names may be trademarks of their respective owners.

AMD, Opteron, the AMD logo, and the AMD Opteron logo are trademarks or registered trademarks of Advanced Micro Devices. Intel and Intel Xeon are trademarks or registered trademarks of Intel Corporation. All SPARC trademarks are used under license and are trademarks or registered trademarks of SPARC International, Inc. UNIX is a registered trademark licensed through X/Open Company, Ltd.

This software or hardware and documentation may provide access to or information on content, products, and services from third parties. Oracle Corporation and its affiliates are not responsible for and expressly disclaim all warranties of any kind with respect to third-party content, products, and services. Oracle Corporation and its affiliates will not be responsible for any loss, costs, or damages incurred due to your access to or use of third-party content, products, or services.

About this Book

Virtual Tape Control System 6.1.0 (VTCS 6.1.0, hereafter referred to as “VTCS”) is Revision A host software, which together the portions of NCS 6.1.0 that support VTCS and the Virtual Tape Storage Subsystem (VTSS), comprises Virtual Storage Manager (VSM).

Audience

This reference provides VTCS and NCS reference information for StorageTek or customer personnel who are responsible for all VTCS tasks. Also see the following:

- *VTCS Installation and Configuration Guide* for information about installing and configuring VTCS.
- *VTCS Administrator’s Guide* for information about VTCS administration tasks.

Contact Us!

Oracle welcomes your feedback.

Visit the Oracle Documentation site at <http://docs.sun.com> and click on the FEEDBACK link at the bottom right of the screen to access the Opinion Lab feedback system.

Prerequisites

To perform the tasks described in this guide, you should already understand the following:

To perform the tasks described in this guide, you should already understand the following:

- MVS operating system
- JES2 or JES3
- System Management Facility (SMF)
- System Modification Program Extended (SMP)
- Nearline Control Solution (NCS)
- VTCS and VSM

About the Software

This guide applies to VTCS/MVS 6.1.0 and NCS/MVS 6.1.0 and above. VTCS executes in the native MVS environment.

How this Guide is Organized

This guide contains the following sections:

- Chapter 1 “VTCS Utilities and Commands”
- Chapter 3 “HSC Enhancements and Additions for VSM”
- Chapter 4 “LibraryStation Enhancements and Additions for VSM”
- Chapter 5 “MVS/CSC Enhancements and Additions for VSM”
- Appendix A “VTCS SMF Record Format”
- Appendix B “VTD Command Reference”
- Appendix Appendix C. “NCS/VTCS Alphabetic Volsers”
- Appendix Appendix D. “Using the HSC Significant Event Notification Facility”
- “Glossary”
- “Index”

What’s New in This Reference?

Revision AD

Revision AD contains technical updates and corrections.

Revision AC

Revision AC provides the enhancements described in Table 1.

Table 1. Updates to Command and Utility Reference, Revision AC

This enhancement...	...is described here...	...and requires the following PTFs
INVENTORY utility	“INVENTORY” on page 102	L1H14NU for SWS6100, L1H14NT for SOS6100, L1H14NS for SMS6100
Display RTD Output	“Display RTD Output” on page 62	L1H14K5 for SWS6100
MVCMaint enhancements	“MVCMaint” on page 117	L1H14JJ

VTCS 6.1, Revision AB

Revision AB resets the revisions of this book at the AB level, and incorporates all previous technical corrections and SPE updates.

Contents

About this Book	iii
Audience	iii
Prerequisites	iii
About the Software	iv
How this Guide is Organized	v
What's New in This Reference?	v
Revision AD	v
Revision AC	v
VTCS 6.1, Revision AB	v
Chapter 1. VTCS Utilities and Commands	1
Using VTCS Utilities	2
Sample REXX Execs	3
Using VTCS Commands	4
AUDIT	5
Syntax	5
Parameters	5
Interfaces	6
Usage	6
JCL Requirements	6
JCL Example	6
Audit Report	7
CANCEL	11
Syntax	11
Parameters	11
Interfaces	11
Usage	12
Command Example	12
JCL Requirements	12
JCL Example	12
CONFIG	13
CONFIG Statement	13
Interfaces	14
GLOBAL Statement	15
RECLAIM Statement	19
VTVOL Statement	20
MVCVOL Statement	21
VTSS Statement	22
RTD Statement	25

VTD Statement	26
CLUSTER Statement	27
CLINK Statement	28
HOST Statement	30
Usage	32
JCL Requirements	34
JCL Examples	35
CONSolid	40
Syntax	40
Parameters	40
Interfaces	41
Usage	41
JCL Requirements	42
JCL Examples	43
Consolidation Reports	44
DECOM	45
Syntax	45
Parameters	45
Interfaces	45
Usage	45
JCL Requirements	45
JCL Example	46
DECOM Output	46
DELETSCR	48
Syntax	48
Parameters	48
Interfaces	49
Optional and Required JCL	49
DELETSCR Report	50
DISPLAY	52
Syntax	53
Parameters	54
Interfaces	56
Usage	56
Command Examples	57
JCL Requirements	57
JCL Examples	58
Output	59

EXPORT	89
Syntax	89
Parameters	90
Interfaces	90
Usage	91
Optional and Required JCL	91
JCL Examples	92
IMPORT	93
Syntax	93
Parameters	94
Interfaces	95
Usage	95
JCL Requirements	98
JCL Examples	99
INVENTORY	102
Syntax	102
Parameters	102
MERGMFST	104
Syntax	104
Parameters	104
Interfaces	104
Usage	104
JCL Requirements	105
JCL Examples	105
MIGRATE	107
Syntax - Format 1	107
Parameters - Format 1	107
Syntax - Format 2	108
Parameters - Format 2	108
Interfaces	109
Usage	109
Command Examples	109
JCL Requirements	109
JCL Examples	110
MVCDEF	111
Syntax	111
Parameters	111
Interfaces	111
Usage	112
Example	112

MVCDRAIN.....	113
Syntax.....	113
Parameters.....	113
Interfaces.....	114
Usage.....	115
Command Example.....	115
JCL Requirements.....	115
JCL Example.....	116
MVCMMAINT.....	117
Syntax.....	117
Parameters.....	118
Interfaces.....	120
Usage.....	121
JCL Requirements.....	123
JCL Examples.....	123
MVCMMAINT Reports.....	124
MVCPLRPT.....	125
Syntax.....	125
Parameters.....	125
Interfaces.....	125
Usage.....	125
JCL Requirements.....	126
JCL Example.....	126
Named MVC Pool Report.....	127
MVCRPT.....	132
Syntax.....	132
Parameters.....	132
Interfaces.....	133
Usage.....	133
JCL Requirements.....	133
JCL Examples.....	134
MVC Reports.....	136
Flat File Record Format.....	143
QUERY.....	145
RECALL.....	146
Syntax.....	146
Parameters.....	146
Interfaces.....	147

Usage	147
Command Example	147
JCL Requirements	148
JCL Example	148
RECLAIM	149
Syntax	149
Parameters	149
Interfaces	150
Usage	151
Command Examples	151
JCL Requirements	151
JCL Examples	152
RTV Utility	153
Syntax	153
Parameters	153
Interfaces	155
Usage	155
JCL Requirements	157
JCL Examples	158
RTV Utility Report Messages	159
RTV LISTONLY Listing	163
RTV Decompress Listing	164
SET MIGOPT	165
Syntax	165
Parameters	165
Interfaces	166
Usage	166
Command Examples	166
JCL Requirements	166
JCL Examples	167
TRACE	168
Syntax	168
Parameters	168
Usage	168
Interfaces	168
Command Example	168
JCL Requirements	168
JCL Example	169
VARY CLINK	170
Syntax	170
Parameters	170
Interfaces	170

Usage	171
Command Example.....	171
JCL Requirements.....	171
JCL Example.....	171
VARY RTD	172
Syntax	172
Parameters.....	172
Interfaces.....	172
Usage	172
Command Example.....	172
JCL Requirements.....	173
JCL Example.....	173
VARY VTSS	174
Syntax	174
Parameters.....	174
Interfaces.....	174
Usage	175
Command Example.....	177
JCL Requirements.....	178
JCL Example.....	178
VTVMaint	179
Syntax	179
Parameters.....	179
Interfaces.....	180
Usage	180
JCL Requirements.....	182
JCL Examples.....	182
VTVMaint Report.....	183
VTVRPT	184
Syntax	184
Parameters.....	184
Interfaces.....	185
Usage	185
JCL Requirements.....	185
JCL Examples.....	186
VTV Report	188
VTV Flat File Record Format.....	192

Chapter 2. SMC Enhancements and Additions for VSM	193
TAPEREQ Control Statement	194
Syntax	194
Parameters	195
Usage	197
Examples	198
SMC ALLOCDEF Command Enhancements	199
Chapter 3. HSC Enhancements and Additions for VSM	201
DISPLAY Command	203
Syntax	203
Parameters	203
Usage	203
Examples	203
FEATURES Control Statement	204
Syntax	204
Parameters	204
Usage	204
Example	204
MERGECDS Utility	205
Syntax	205
Parameters	205
Usage	206
JCL Requirements	210
JCL Examples	212
MGMTCLAS Control Statement	214
Syntax - Basic Management Feature	214
Parameters - Basic Management Feature	215
Syntax - Advanced Management Feature	218
Additional Parameters - Advanced Management Feature	219
Usage	221
Examples	222
MGMTDEF Command	223
Syntax	223
Parameters	223
Usage	224
Examples	224
MOUNT Command	225
Syntax	225
Parameters	225
Usage	225
Examples	225

MVCPPOOL Control Statement	226
Syntax	226
Parameters	226
Usage	228
Example	228
STORCLAS Control Statement	229
Syntax	229
Parameters	229
Usage	230
Examples	233
STORLST Control Statement	234
Syntax	234
Parameters	234
Usage	235
Examples	235
STORSEL Control Statement	236
Syntax	236
Parameters	237
Usage	238
Examples	238
VOLATTR Control Statement	239
Syntax	239
Parameters	239
Usage	240
Example	240
VTSSLST Control Statement	241
Syntax	241
Parameters	241
Usage	242
Examples	242
VTSSSEL Control Statement	243
Syntax	243
Parameters	244
Usage	246
Examples	246
HSC Programmatic Interface Enhancements	247
HSC User Exit Enhancements	248
HSC Batch API Enhancements	248

Batch API Mapping Macros	249
SLSUREQ QCDS Request	252
Library Element Mapping	252
HSC Operator Command Enhancements	253
HSC WARN SCRATCH Command Enhancements	254
HSC DISPLAY THRESHLD Command Enhancements	255
HSC DISPLAY SCRATCH Command Enhancements	257
HSC DELDISP Parameter Enhancements	259
Chapter 4. LibraryStation Enhancements and Additions for VSM.....	261
SPNUM Statement	262
Syntax	262
Parameters	262
Usage	263
Examples	264
VIRTACS Statement	265
Syntax	265
Parameters	265
Usage	265
Examples	265
SLGDIAG VIRTUAL_DRIVE Parameter	266
Chapter 5. MVS/CSC Enhancements and Additions for VSM.....	267
MVS/CSC Startup Parameter Enhancements	268
DEFER	268
FETCH	268
MVS/CSC DISPLAY Command Enhancements	268
MVS/CSC User Exit Enhancements	268
MVS/CSC Programmatic Interface Enhancements	269
MVS/CSC DELDISP Parameter Enhancements	269
Appendix A. VTCS SMF Record Format	271
SLSSMF10 - VTCS SMF Subtype 10 Record	272
Function	272
SLSSMF11 - VTCS SMF Subtype 11 Record	277
Function	277
SLSSMF13 - VTCS SMF Subtype 13 Record	279
Function	279
SLSSMF14 - VTCS SMF Subtype 14 Record	281
Function	281
SLSSMF15 - VTCS SMF Subtype 15 Record	283
Function	283

SLSSMF16 - VTCS SMF Subtype 16 Record	285
Function	285
SLSSMF17 - VTCS SMF Subtype 17 Record	287
Function	287
SLSSMF18 - VTCS SMF Subtype 18 Record	288
Function	288
SLSSMF19 - VTCS SMF Subtype 19 Record	290
Function	290
SLSSMF20 - VTCS SMF Subtype 20 Record	292
Function	292
SLSSMF21 - VTCS SMF Subtype 21 Record	293
Function	293
SLSSMF25 - VTCS SMF Subtype 25 Record	294
Function	294
SLSSMF26 - VTCS SMF Subtype 26 Record	295
Function	295
SLSSMF27 - VTCS SMF Subtype 27 Record	296
Function	296
SLSSMF28 - VTCS SMF Subtype 28 Record	298
Function	298
SLSSMF29 - VTCS SMF Subtype 29 Record	299
Function	299
SLSSMF30 - VTCS SMF Subtype 30 Record	300
Function	300
SLSSMF31 - SMF Subtype 31 Record	301
Function	301
Appendix B. VTD Command Reference	303
Overview	303
Bit Naming Conventions	303
Discussion of 3480/3490 Terms	303
Command Overview	305
Characteristics of the VTD	305
Product and Media Type Emulation	305
Command Summary	306
Command Dependent Unit-Checks	309
Command Dependent Execution Status	309
Retry Status	312

Differentiated Channel Command Descriptions	313
Data Security Erase Command	313
Erase Gap Command	313
Load Display Command	313
Locate Block	313
Mode Set Command	314
Perform Subsystem Function Command	314
Activate Access Control Order	315
Deactivate Access Control Order	315
Read Backwards Command	316
Read Block ID Command	316
Read Buffer Command	316
Read Buffered Log Command	316
Read Configuration Data Command	316
Read Device Characteristics Command	319
Read Forward Command	320
Read Message ID Command	320
Read Subsystem Data Command	320
Sense ID Command	323
Set Interface Identifier	323
Set Tape Write Immediate Command	323
Synchronize Command	324
Write Command	324
Path Management Commands	325
Status and Sense Bytes	326
Status Byte	326
Sense and Log Data Formats	326
Error Recovery Action (ERA) Codes Support	331
Control Unit Images	333
Introduction	333
Dual Control Units - DCUs	333
Virtual Control Units - VCUs	333
DCU versus VCU	333
System Reset Effects	334
Path Group Effects	334
SPID Command -- Path versus Device -- Deep Background	334
VCU Effects on SPID and SNID	335
Appendix C. NCS/VTCS Alphabetic Volser	337
Alphabetic Volser Examples	340
Appendix D. Using the HSC Significant Event Notification Facility	343

Overview of the SEN Macro Interface	344
SEN Macro Interface Authorization Requirements and Module Attributes	345
The SLSXSEN Macro	345
List Form - Syntax and Parameters.	345
Execute Form - Syntax and Parameters	347
The SEN Listener Exit Routine	357
Input Registers	357
Output Registers	357
Entry Environment	357
Listener Exit Routine Programming Considerations	358
The SWSPGMIA Data Area.	358
Detecting Duplicate Listen Requests	361
Display SEN Command	362
Syntax	362
Parameters.	362
Supported HSC and VTCS SEN Events.	363
HSC Events.	363
VTCS SEN Events	363
SEN Messages	365
VTCS and HSC Events XML Tags	367
VTCS Events XML Tags	368
HSC Events XML Tags	372
Index	383

Chapter 1. VTCS Utilities and Commands

This chapter contains reference information for the following VTCS commands and utilities, where the “Interfaces” section describes the valid interfaces (command only, utility only, or both). For more information, see “Using VTCS Utilities” on page 2 and “Using VTCS Commands” on page 4.

- “AUDIT” on page 5
- “CANCEL” on page 11
- “CONFIG” on page 13
- “CONSolid” on page 40
- “DISPLAY” on page 52
- “DELETSCR” on page 48
- “DECOM” on page 45
- “EXPORT” on page 89
- “IMPORT” on page 93
- “INVENTORY” on page 102
- “MERGMFST” on page 104
- “MIGRATE” on page 107
- “MVCDEF” on page 111
- “MVCDRAIN” on page 113
- “MVCMAINT” on page 117
- “MVCPLRPT” on page 125
- “MVC RPT” on page 132
- “QUERY” on page 145
- “RECALL” on page 146
- “RECLAIM” on page 149
- “RTV Utility” on page 153
- “SET MIGOPT” on page 165
- “TRACE” on page 168
- “VARY CLINK” on page 170
- “VARY RTD” on page 172
- “VARY VTSS” on page 174
- “VTVMMAINT” on page 179
- “VTVRPT” on page 184



Note: Both VTCS commands and utilities have a limit of 32000 bytes per command string (even continued over multiple lines).

Using VTCS Utilities

You use the SWSRTV program to run the RTV utility. To invoke all other VTCS utilities, you use the SWSADMIN program, which follows the same syntax rules and accepts the same input parameters as the HSC SLUADMIN utility program (including that the maximum length of a control statement is 32,767 characters).

The SWSADMIN program determines the HSC Primary CDS as follows:

- If your JCL **does not** specify the CDS and HSC is up, SWSADMIN queries HSC for the Primary CDS and SWSADMIN uses that CDS. The JCL examples in this chapter show this method.
- If your JCL specifies all defined copies of the CDS, SWSADMIN queries these copies and uses the correct copy. Note that for the CONFIG utility, you must explicitly specify the CDS in your JCL because you should run CONFIG when HSC is down.



Caution: As described in “Using VTCS Commands”, entering VTCS commands requires a .VT before the command name. The SWSADMIN program does not require a .VT before the utility name, and adding a .VT produces an error.



Note: You can produce utility reports in structured XML format. You can then process the XML output as described in “Sample REXX Execs” on page 3.



Hint: HSC provides utilities that manage library resources. These utilities are also available to VSM, and include the Scratch Update utilities, which you can use to manage the scratch status of VTVs and MVCs. For more information about the HSC utilities, see Chapter 5, “Utility Functions” in the *HSC System Programmer’s Guide for MVS*.

Note that you cannot use the Scratch Update utilities to scratch MVCs unless you have removed them from the MVC pool.

Sample REXX Execs

Two sample REXX execs are provided in the NCS SAMPLIB (ncs_610.SLSSAMP) to process the XML output from MVC and VTV reports:

- SWSMVCXM - processes MVC report XML output.
- SWSVTVXM - processes VTV report XML output.

These execs convert the XML tags and data into a file containing comma separated variables that can be loaded into a Microsoft Excel spreadsheet.

Using the Sample  REXX Execs

To use the sample execs:

- 1. Produce an MVC or VTV report with XML output.**

For more information, see “MVC RPT” on page 132 and “VTV RPT” on page 184.

- 2. Run the REXX in foreground or batch TSO to generate the CSV file.**
- 3. Download the CSV file to a PC using a file transfer program that specifies translation from EBCDIC to ASCII.**
- 4. Open the CSV file in MicroSoft Excel and process as desired.**

Using VTCS Commands

Like HSC commands, VTCS commands consist of the HSC command prefix character followed immediately by a command name and required or optional positional parameters and keyword parameters.

The VTCS command prefix is the same command prefix used by the HSC with which the VTCS is communicating. This allows HSC to intercept and interpret the command. For example, to cancel all active and queued VSM processes that use an RTD, enter the following:

```
.VT CAN T(ALL)
```

For more information about the rules governing commands, refer to Chapter 2, “Commands, Control Statements, and Utilities,” in *HSC Operator’s Guide for MVS*.

AUDIT

AUDIT updates the MVC and VTV information in the HSC CDS.

Syntax

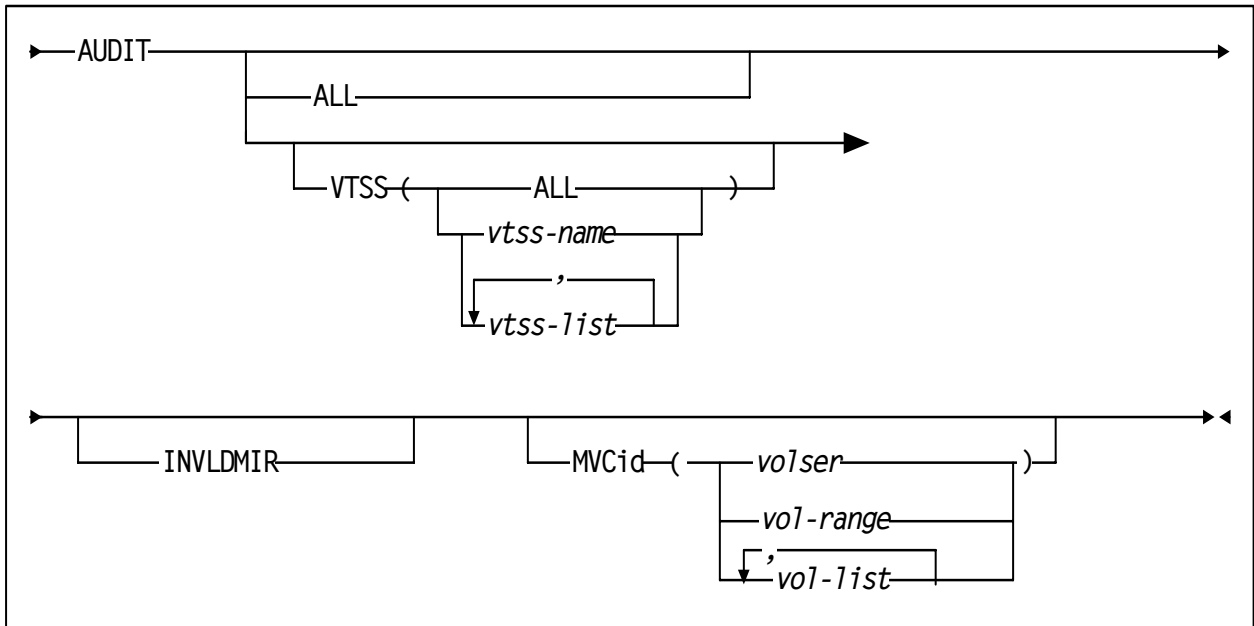

Figure 1. Audit syntax

Parameters

ALL

specifies an audit of your entire VSM system, including all VTSSs and all MVCs.



Note: The ALL parameter causes VTCS to attempt to audit all defined MVCs. If any MVC is outside the ACS, HSC will prompt you to enter the MVC into the correct LSM.

VTSS

specifies an audit of one or more VTSSs.

ALL

specifies all VTSSs.

vtss-name **or** *vtss-list*

the names of one or more VTSSs.

INVLDMIR

specifies an audit of MVCs with invalid MIRs.

MVCid

specifies an audit of one or more MVCs.

volser, *vol-range* **or** *vol-list*

the volsers of one or more MVCs.

Interfaces

SWSADMIN utility only.

Usage

Use the AUDIT to update the MVC and VTV information in the HSC CDS.

When you run the AUDIT, VTCS splits the work into multiple audit subtasks which can use all available RTDs. The audit subtasks compete for RTDs with other VTCS tasks, such as recalls. When an audit subtask for an individual MVC completes, the RTD becomes available for other tasks, such as recalls or other audit subtasks.

Note, however, that VTCS will only run one AUDIT batch job at a time. If you submit multiple AUDIT batch jobs, all audit tasks for jobs after the first job submitted are queued behind tasks for the first job.

For more information on using AUDIT to do CDS recovery, see *VTCS Administrator's Guide*.

JCL Requirements

The following are the required and optional statements for the AUDIT JCL:

STEPLIB

specifies the link library (SLSLINK) that contains the VTCS and HSC modules.

SLSPRINT

specifies the destination for the AUDIT report.

SLSIN

specifies the input to the SWSADMIN program (AUDIT utility name and parameters).

JCL Example

Figure 2 shows example JCL to run AUDIT for your entire VSM system.

```
//AUDIT      EXEC PGM=SWSADMIN
//STEPLIB    DD DSN=h1q.SLSLINK,DISP=SHR
//SLSPRINT   DD SYSOUT=*
//SLSIN      DD *
            AUDIT ALL
```

Figure 2. Example JCL for the AUDIT utility

Audit Report

An audit report lists the VTVs and MVCs that are different from those listed in the CDS as shown in Figure 3. In this figure, the report shows all MVCs or VTVs as new entries in the CDS, which is typical of the output of a VTCS audit run after you lost all copies of the CDS, then ran the recovery procedure described in “Usage” on page 6.

```
SWSADMIN (6.1.0)                STORAGETEK VTCS SYSTEM UTILITY
TIME 03:15:42                    VTCS AUDIT

AUDIT REPORT FOR MVC EVT500
X28955 VTV ADDED AS PRIMARY COPY (BLOCK:00000000)
X20000 VTV ADDED AS PRIMARY COPY (BLOCK:0940044D)
===== AUDIT OF MVC EVT500 COMPLETED SUCCESSFULLY =====

AUDIT REPORT FOR MVC EVT501
X28956 VTV ADDED AS PRIMARY COPY (BLOCK:00000000)
X20007 VTV ADDED AS PRIMARY COPY (BLOCK:0940044D)
X20010 VTV ADDED AS SECONDARY COPY (BLOCK:11400899)
X20069 VTV NOT CURRENT (BLOCK:1A400CE5)
X20067 VTV NOT CURRENT (BLOCK:334016AB)
===== AUDIT OF MVC EVT501 COMPLETED SUCCESSFULLY =====

AUDIT REPORT FOR VTSS HBVTSS17
X20000 VTV VALID
X20002 VTV VALID
X20005 VTV VALID
X20006 VTV VALID
X20007 VTV VALID
X30052 VTV VALID
X30053 VTV VALID
X30054 VTV VALID
===== AUDIT OF VTSS HBVTSS17 COMPLETED SUCCESSFULLY =====

AUDIT REPORT FOR VTSS HBVTSS16
X20183 VTV VALID
X20185 VTV VALID
X20188 VTV VALID
X20190 VTV VALID
X20191 VTV VALID
X20194 VTV VALID
X41091 VTV VALID
X41093 VTV VALID
===== AUDIT OF VTSS HBVTSS16 COMPLETED WITH 1 WARNING =====
AUDIT EXCEPTION REPORT

VTSS HBVTSS16: 1 WARNINGS REPORTED
SLS1315I SWS500.V5.CDS WAS SELECTED AS THE PRIMARY CONTROL DATA SET
```

Figure 3. Example AUDIT utility report



Note: An audit also generates:

- MVC summary and detail reports. For more information, see “Output” on page 59.
- Display VTSS summary and detail output. For more information, see “Output” on page 59.
- For every VTV resident on the VTSS, the VTV volser, size in Mb, and Management Class.

Audit Report Messages

For every VTV found on an MVC or VTSS, the audit report lists one of following:

vvvvvv VTV possibly corrupt (Block:*bbbbbb*)

Explanation: During the audit, an I/O error occurred for VTV *vvvvvv* at block *bbbbbb* on the MVC being audited.

vvvvvv VTV not found [, no MVC copies left]

Explanation: The audit did not find VTV *vvvvvv* on the MVC or VTSS being audited. If no MVC copies left appears, no MVCs contain copies of the VTV.

vvvvvv VTV not found on CDS (Block:*bbbbbb*)

Explanation: The audit expected but did not find VTV *vvvvvv* at block *bbbbbb* on the MVC being audited.

vvvvvv VTV not current (Block:*bbbbbb*)

Explanation: The audit found a non-current copy of VTV *vvvvvv* at block *bbbbbb* on the MVC being audited.

vvvvvv VTV copy valid (Block:*bbbbbb*)

Explanation: The audit found a valid copy VTV *vvvvvv* at block *bbbbbb* of the MVC being audited; its location matches the CDS entry for the VTV.

vvvvvv VTV Added as primary copy (Block:*bbbbbb*)

Explanation: The audit found the most current copy of VTV *vvvvvv* at block *bbbbbb* of the MVC being audited; the audit added this location to the CDS as the primary MVC copy of the VTV.

vvvvvv VTV Added as secondary copy (Block:*bbbbbb*)

Explanation: The audit found the second most current copy of VTV *vvvvvv* at block *bbbbbb* of the MVC being audited; the audit added this location to the CDS as the secondary MVC copy of the VTV.

vvvvvv Duplicate copy ignored (Block:bbbbbb)

Explanation: The audit found a duplicate copy of VTV vvvvvv at block bbbbbbb and ignored this copy.

vvvvvv Link to old version on MVC mmmmmm removed

Explanation: The audit found a newer version of the VTV and removed the link to the old version from the CDS.

vvvvvv Old VTV version deleted from VTSS ssssssss

Explanation: The audit found an old version of the VTV and deleted it from the VTSS.

vvvvvv Old version of VTV retained [VTSS ssssssss]

Explanation: The audit found an old version of the VTV, which is the only copy, and retained this version. If VTSS ssssssss appears, the audit found the VTV on a different VTSS than the one that was audited.

vvvvvv Version older than MVC copies [VTSS ssssssss]

Explanation: The audit found an version of the VTV that is older than copies on the MVC. If VTSS ssssssss appears, the audit found the VTV on a different VTSS than the one that was audited.

vvvvvv Newer version of VTV found [on VTSS ssssssss]

Explanation: The audit found a newer version of the VTV and updated the CDS with this location. If on VTSS ssssssss appears, the audit found the VTV on a different VTSS than the one that was audited.

vvvvvv VTV discovered [VTSS ssssssss]

Explanation: The audit found a current version of the VTV on a VTSS whose location was unexpected and updated the CDS with this location. If on VTSS ssssssss appears, the audit found the VTV on a different VTSS than the one that was audited.

vvvvvv VTV valid [VTSS ssssssss]

Explanation: The audit found a valid version of the VTV and updated the CDS with this location. If VTSS ssssssss appears, the audit found the VTV on a different VTSS than the one that was audited.

*** vvvvvv no access to VTSS ssssssss ***

Explanation: The audit found a valid version of the VTV which is on a VTSS that the host cannot access.

MVC *mmmmmm* STATUS CHANGED FROM EXPORT TO CONSOLIDATE VOLUME

Explanation: The audit discovered current VTVs on an export MVC that was created by export by VTV or Management Class. The audit changed the MVC status from export to consolidate and updated the CDS to add the MVC and its VTVs.

EXPORT MVC *mmmmmm* IS NOW MADE EMPTY IN THE CDS

Explanation: The audit discovered no current VTVs on an export MVC that was created by export by VTV or Management Class. The audit marked the MVC as empty.

WARNING MVC *mmmmmm* IS AN OUTPUT MVC FROM AN EXPORT OPERATION - FORCING READONLY

Explanation: The audit forced read-only status on export MVC *mmmmmm*.

Audit terminated. Unable to determine the position of the end of VTV *vvvvvv* on MVC *mmmmmm*

Explanation: VTCS issued an Inventory MVC ECAM request to determine the position and volser of a VTV on the MVC being audited. VTSS indicated, in the ECAM response, that it was unable to determine the position of the end of the VTV. Because VTCS needs that information to determine the position of the next VTV on the MVC (assuming end of tape has not been reached), VTCS had to terminate the audit with RC=8. The MVC is left in Audit status. To resolve the condition, drain the MVC. If you cannot drain the MVC, contact StorageTek Software Support.

CANCEL

CANce1 stops active and queued processes that use an RTD.

Syntax

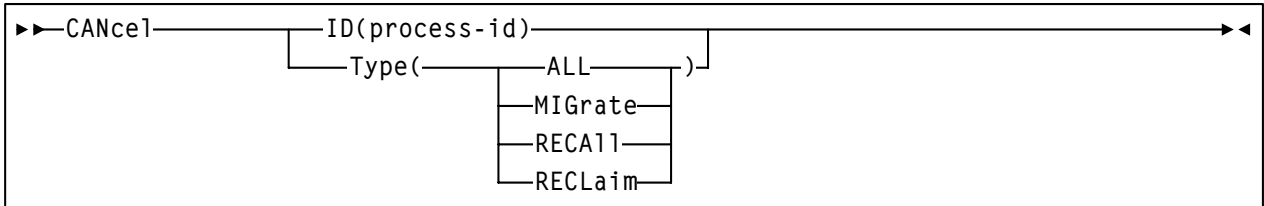

Figure 4. CANce1 syntax

Parameters

- ID
 - specifies a process to cancel.
 - process-id*
the process ID.
- Type
 - specifies the type of process to cancel.
 - ALL
 - cancel all processes.
 - MIGrate
 - cancel all migration processes.
 - RECALL
 - cancel all recall processes.
 - RECLAIM
 - cancel all reclaim processes.

Interfaces

SWSADMIN utility and VT command.

Usage

For exception conditions only, use CANCEL to stop all active and queued processes. VTCS tries to stop processes without affecting system resources or information; therefore, the cancellation may not occur immediately. For example, VTCS may wait for hardware time out periods before terminating a process using a specific RTD. See “DISPLAY” on page 52 for information about determining process IDs.

Note: If you cancel a parent request, you stop the parent and all child requests. If you cancel a child request, the parent request continues processing. See “Command Examples” on page 57 for an example of parent and child requests.



Caution: If you cancel a task associated with migration scheduler (either with the MIGRATE parameter or by specific process ID), this task will terminate but migration scheduler will start another migration task at its next timer interval. You can, however, use migrate-to-threshold to stop automigration by specifying a value greater than the current DBU. For more information, see “MIGRATE” on page 107.

Command Example

To cancel a process with an ID of 10, enter the following:

```
.VT CAN ID(10)
```

JCL Requirements

The following are the required and optional statements for the AUDIT JCL:

STEPLIB

specifies the link library (SLSLINK) that contains the VTCS and HSC modules.

SLSPRINT

specifies the destination for the AUDIT report.

SLSIN

specifies the input to the SWSADMIN program (AUDIT utility name and parameters).

JCL Example

Figure 2 shows example JCL to cancel a process with an ID of 10.

```
//AUDIT EXEC PGM=SWSADMIN
//STEPLIB DD DSN=h1q.SLSLINK,DISP=SHR
//SLSPRINT DD SYSOUT=*
//SLSIN DD *
CANCEL ID(10)
```

Figure 5. Example JCL for the CANCEL utility

CONFIG

CONFIG defines or modifies the VSM configuration stored in the HSC CDS.

The following sections show the syntax of the CONFIG utility and of the input statements to CONFIG. As shown in “JCL Examples” on page 35, you create a single file that contains the CONFIG statement and its input statements.

CONFIG Statement

The CONFIG statement specifies whether this a new or updated configuration (via the RESET parameter). This statement is required.

Syntax

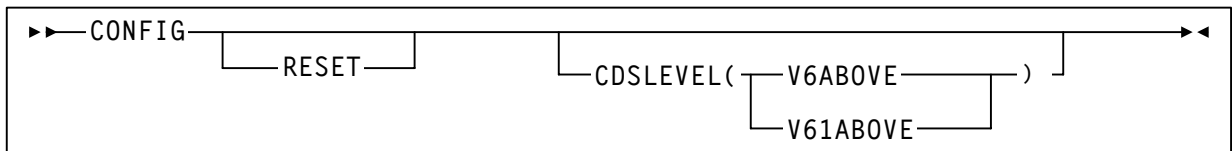

Figure 6. CONFIG *statement syntax*

Parameters

RESET

is required as described in Table 1.

Table 1. VTCS 6.1 CONFIG RESET Requirements

CDS is at “F” Level	CDS is below “F”
Required only when changing the CDS level.	You must specify RESET when you make hardware changes such as: <ul style="list-style-type: none"> • Adding a VTSS to your configuration. • Adding RTDs, removing RTDs, or reordering their sequence in your configuration. • Physically removing a VTSS from your configuration. • Changing the CDS level. • You do not need to specify RESET if you: <ul style="list-style-type: none"> • Change VSM volumes (such as adding VTVs and MVCs). • Change VSM policies (such as changing AMT values).

Note: HSC must be down on all hosts when you run CONFIG RESET. The changes you made to RTD definitions will take effect when you restart HSC.

CDSLEVEL

One of the following CDS levels:

V6ABOVE

creates an “E” level CDS, which supports the following features:

- Full VSM4 Support
- 4 MVC copies
- 800 Mb VTVs (see for additional requirements)

V61ABOVE

creates an “F” level CDS, which supports the following features:

- Full VSM4 Support
- 4 MVC copies
- 800 Mb VTVs (see for additional requirements)
- Near Continuous Operations (NCO)
- Bi-directional clustering

Interfaces

SWSADMIN utility only.

GLOBAL Statement The GLOBAL statement specifies global values for MVCs. This statement is required.

Syntax

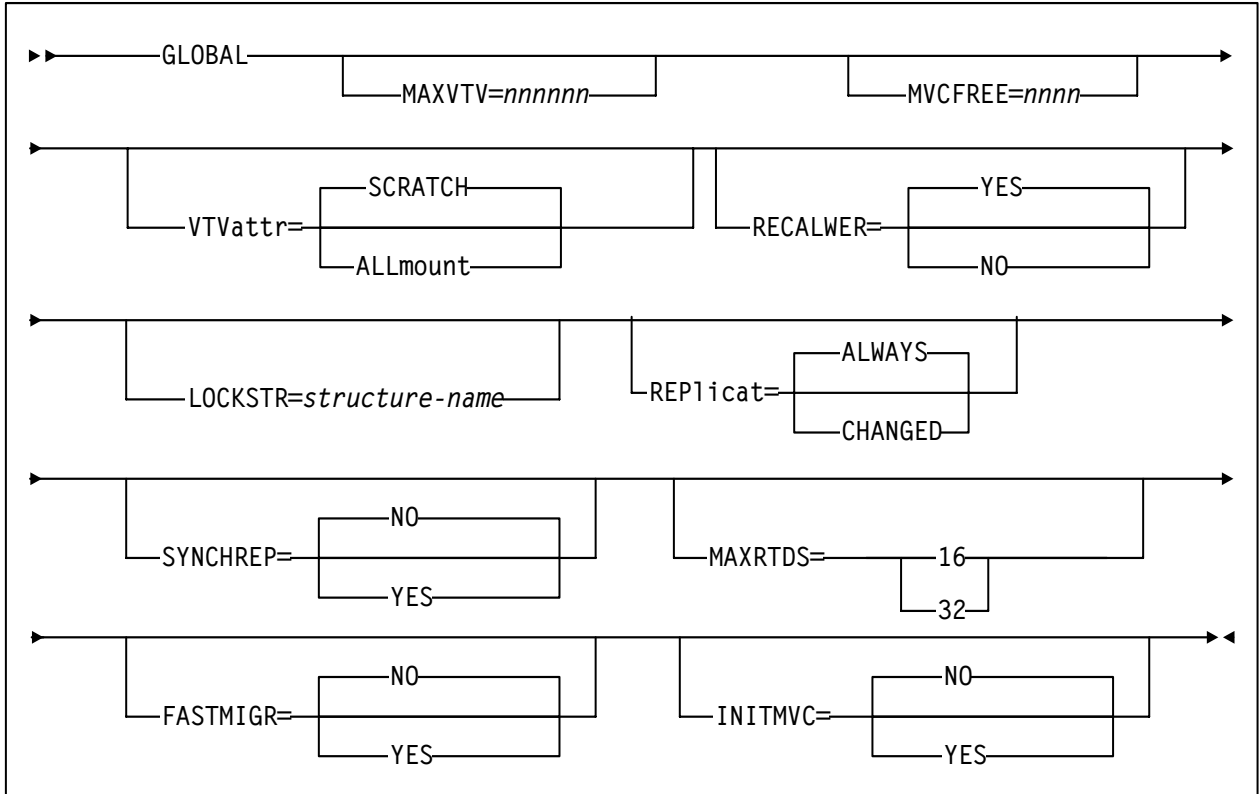

Figure 7. GLOBAL *statement syntax*

Parameters

MAXVTV=*nnn*

specifies the maximum number of VTVs that can be migrated to a single MVC. Valid values are 4 to 32000. The default is 32000.

MVCFREE=*nnn*

specifies the minimum number of free MVCs in the MVC pool. A free MVC has 100% usable space and does not contain any migrated VTVs. Valid values are 0 to 255. The default is 40.

If free MVCs is equal or less than this value, VTCS issues message SLS6616I and starts an automatic space reclamation.

Note: If you set MVCFREE=0, VTCS actually uses the default value (40).

VTVattr=SCRATCH | ALLmount

specifies when VTCS assigns a Management Class to a VTV.

SCRATCH

Assign a Management Class only when VTCS does a scratch mount of the VTV (the default).

ALLmount

Assign a Management Class whenever VTCS mounts the VTV.



Caution: If you specify that VTCS assigns a Management Class whenever VTCS mounts a VTV, these attributes can change, which can cause undesirable or unpredictable results.

For example, if an application writes data set PROD.DATA to VTV100 with a Management Class of PROD, then writes data set TEST.DATA to VTV100 with a Management Class of TEST, then the VTV (and both data sets) has a Management Class of TEST. Similarly, it is possible to write TAPEREQ statements or SMS routines that assign different Management Classes to the same data set (for example, based on jobname), which can also cause a VTV's Management Class to change.

RECALWER

specifies whether VTCS recalls VTVs with read data checks (applies to recall and drain operations).

YES

recall VTVs with read data checks (the default).

NO

Do not recall VTVs with read data checks.

LOCKSTR=*structure-name*

specifies the Coupling Facility Structure that holds VTCS Lock Data. The Structure Name must be 16 characters or less and conform to IBM's standard for naming Coupling Facility Structures. For more information, see *Installing ELS*.



Caution: CONFIG RESET is required to add LOCKSTR=*structure-name* to a CDS that did not previously use LOCKSTR=*structure-name* and to remove LOCKSTR=*structure-name* from a CDS. CONFIG RESET is **not** required to change lock structure names (for example, going from LOCKSTR=VTCSL1 to LOCKSTR=VTCSL2).

REPLicat

specifies when VSM replicates the VTV.

ALWAYS

The replicate request is added to the VTCS replication queue every time the VTV is dismounted, regardless of whether the VTV was changed while it was mounted (the default).

CHANGED

The replicate request is added to the VTCS replication queue if the VTV:

- Was changed while it was mounted **or**
- Was only read while mounted but less than the expected number of MVC copies of the VTV exist.

Note: **Regardless** of the CONFIG GLOBAL REPLicat setting, replication **also** requires that:

- The VTV must be dismounted in a VTSS that supports replication **and** there cannot be an identical copy of the VTV in the other VTSS in the Cluster.
- In addition to the CONFIG GLOBAL REPLicat value, you **must** specify REPLicat(YES) or REPLicat(YES_SYNCH) on a VTV's Management Class for replication to occur. For more information, see "REPLICAT" on page 220.

SYNCHREP

specifies whether VTV synchronous replication feature is enabled.

NO

Synchronous replication is not enabled (the default).

YES

Synchronous replication is enabled.

Note: SYNCHREP=YES merely enables synchronous replication. To actually implement synchronous replication, you must create a Management Class that specifies REPLicat(YES_SYNC). For more information, see "REPLICAT" on page 220.

MAXRTDS

specifies the maximum number of RTDs supported.

16

up to 16 RTDs supported.

32

up to 32 RTDs supported.

Note: MAXRTDS = 32 has the prerequisites described in Table 2. on page 18.

FASTMIGR

Specifies if the stacked migrates feature is enabled for all VTSSs that support this feature.

YES

Enable stacked migrates.

No

Disable stacked migrates (the default).

Note: FASTMIGR=YES has the prerequisites described in Table 2. For this feature to be enabled, **all hosts** must be running the prerequisites, otherwise:

- If a host is active that does not support or tolerate stacked migrates, this will cause the CONFIG utility to return an error.
- If a host is started and does not tolerate or support this feature, the host will shut down.

Table 2. MAXRTDS/FASTMIGR Prerequisites

32 RTDs/Stacked Migrates Support requires...	..the following VSM4/VSM5 microcode...	...and CDS level...
FICON RTDs and FICON ports for the CLINKs	D02.05.00.00 or higher	“F” or higher

INITMVC

specifies whether uninitialized MVCs in the named MVC Pool are initialized when first mounted on an RTD.

NO

Uninitialized MVCs are not initialized.

YES

Uninitialized MVCs are initialized.

Note:

- MVCPOOL INITMVC overrides GLOBAL INITMVC. There is no default for MVCPOOL INITMVC; if not specified for a named MVC Pool the CONFIG GLOBAL value (or default) is used.
- Initialization of MVCs in the DEFAULTPOOL is controlled by the GLOBAL INITMVC specification (or default).
- MVC Initialization applies only to VSM4/5 and requires microcode level D02.05.00.00 or higher. If this level of microcode is not installed on all VTSSs in the configuration, MVC initialization will be limited to the VTSSs that have it installed.

RECLAIM Statement The RECLAIM statement controls demand and automatic MVC space reclamation. This statement is required.

Syntax

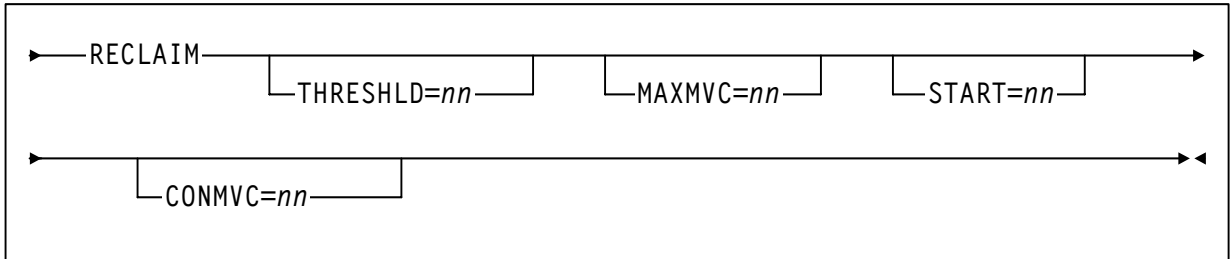

Figure 8. RECLAIM *statement syntax*

Parameters

THRESHLD=nn

specifies the percentage of fragmented space that makes an MVC eligible for demand or automatic reclamation. Valid values are 4 to 98. The default is 40.

MAXMVC=nn

specifies the maximum number of MVCs that will be processed by a single space reclamation task. Valid values are 1 to 98. The default is 40.

For automatic space reclamation to start, the number of eligible MVCs (determined by the THRESHLD parameter) must also exceed the MAXMVC value.

START=nn

specifies the level at which automatic space reclamation starts for each ACS (not globally for all ACSs). Specify a percentage value, which is equal to:

$$(Reclaim\ Candidates / Reclaim\ Candidates + Free\ MVCs) * 100$$

Where:

Reclaim Candidates

is the number of Reclaim Candidates determined by the CONFIG RECLAIM THRESHLD parameter.

Reclaim Candidates + Free MVCs

equals the number of Reclaim Candidates plus the number of free MVCs. Valid values are 1 to 98. The default is 35.

CONMVC=nn

specifies the maximum number of MVCs that VTCS concurrently processes for both drain and reclaim.

Valid values are 1 to 99. The default is 1.

VTVVOL Statement

The VTTVOL statement defines a range of VTTVs.

You can only add new VTTV ranges. A range can consist of a single volume. You cannot delete or modify existing ranges. You can, however, respecify existing VTTV ranges when you add new ranges (for example, by adding new VTTV ranges to the output of the DECOM utility).



Note: The following restrictions when you respecify existing ranges:

- If you respecify any existing range, you must respecify all existing ranges.
- The high and low volume serial numbers of each respecified range must exactly match the previously specified range.
- The volume type for each respecified range must be the same as the original specification (MVC or VTTV).
- Each range can be respecified only once.

Syntax

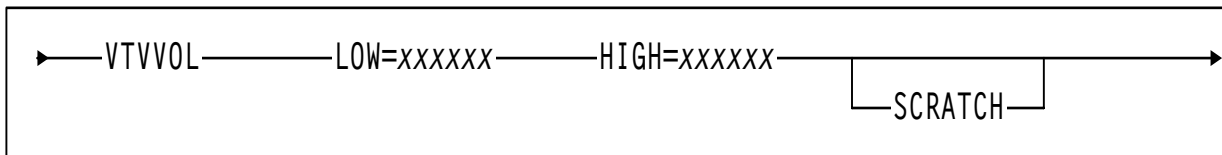

Figure 9. VTTVOL *statement syntax*

Parameters

LOW=xxxxxxx

specifies the start of a range of VTTVs.

HIGH=xxxxxxx

specifies the end of a range of VTTVs.



Note: The incremental part of a range cannot exceed 5 characters for numeric and 4 characters for alpha ranges.

SCRATCH

specifies that the VTTVs added to the CDS are placed in scratch status, which is not the default for the VTTVOL parameter.



Warning: If you are using the ExLM SYNCVTV function for VTTV scratch synchronization, StorageTek recommends that you define VTTV ranges in scratch status. If you do not, you must use the HSC SLUADMIN utility to scratch these volumes.

MVCVOL Statement

The MVCVOL statement defines a range of MVCs available to VTCS.

You can only add new MVC ranges. A range can consist of a single volume. You cannot delete or modify existing ranges. You can, however, respecify existing MVC ranges when you add new ranges (for example, by adding new MVC ranges to the output of the DECOM utility).



Note: The following restrictions when you respecify existing ranges:

- If you respecify any existing range, you must respecify all existing ranges.
- The high and low volume serial numbers of each respecified range must exactly match the previously specified range.
- The volume type for each respecified range must be the same as the original specification (MVC or VTV).
- Each range can be respecified only once.

Syntax

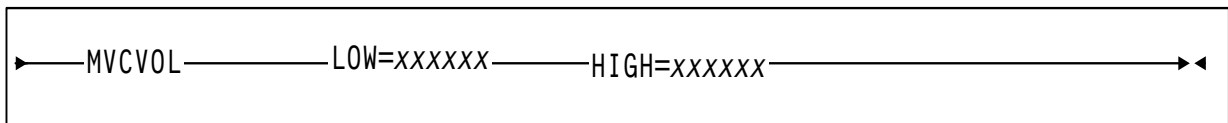

Figure 10. MVCVOL *statement syntax*

Parameters

LOW=xxxxxx
specifies the start of a range of MVCs.

HIGH=xxxxxx
specifies the end of a range of MVCs.

VTSS Statement

The VTSS statement defines a VTSS and sets its operating values. This statement is required.

When you define a new VTSS, place its definition after any existing VTSS definitions, which must remain in their original order. You must specify RESET when you add a VTSS to your configuration as described in “RESET” on page 13.

Syntax

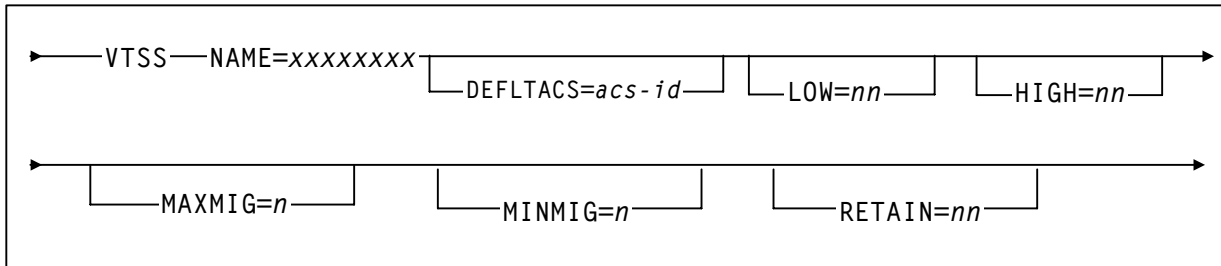

Figure 11. VTSS statement syntax

Parameters



Note: If you physically remove a VTSS from your configuration, reconfigure the VTSS with a VTSS statement only and no parameters. See Figure 21 on page 39 for an example.

NAME=xxxxxxx

specifies the VTSS identifier. This parameter is required; there is no default value.



Caution: Note the following:

- You specify the VTSS identifier *only* via the NAME parameter, which sets the VTSS identifier in both the VTSS microcode (as displayed in the Subsystem Name field in the LOP) and in the configuration area of the HSC CDS. After VSM is put into operation, the VTSS identifier is also stored in each VTV record in the CDS. Each VTV record contains the VTSS identifier on which that VTV is resident or, if the VTV is migrated, the VTV record contains the VTSS identifier from which the VTV was migrated.

- Once you set the VTSS identifier via the NAME parameter, you *cannot* change this identifier in the HSC CDS. That is, the CONFIG utility *will not* let you change the NAME parameter after an initial setting and changing the VTSS identifier using the Subsystem Name field of the LOP *cannot* change the VTSS identifier in the HSC CDS.
- It is especially critical that you *do not* attempt to rename a VTSS that contains data on VTVs, which includes VTSS-resident VTVs and migrated VTVs!
- For an initial setting *only* (not a change), you can set the VTSS identifier in the NAME parameter only if the VTSS identifier value in the VTSS microcode is:
 - The factory setting (all blanks).
 - A value of 99999999 (eight 9s).

Therefore, for an initial setting *only*, if the name in the VTSS microcode *is not* all blanks or 99999999, your StorageTek hardware representative must use the VTSS LOP to set the VTSS identifier to 99999999 so you can set the VTSS identifier to the value you want via the NAME parameter.

DEFLTACS=*acs-id*

VTCS supports multi-VTSS confirmations, and supports connecting two ACSs to each VTSS. In configurations where a VTSS is connected to two ACSs, you can use the DEFLTACS parameter to specify the default ACS from which MVCs will be selected for migration, consolidation, and reclaim processing.

If you do not specify DEFLTACS, the default value is x'FF', which allows VTCS to select MVCs from either ACS.



Note: VTCS ignores the value on the DEFLTACS parameter if you specify the DEFLTACS parameter and do either of the following:

- Specify the ACSlist parameter of the MGMTclass statement.
- Use a Storage Class.

LOW=*nn*

specifies the low automatic migration threshold (LAMT) for this VTSS.

Valid values are 5 to 95 and must be less than the HIGH default threshold. The default is 70.

HIGH=*nn*

specifies the high automatic migration threshold (HAMT) for this VTSS.

Valid values are 6 to 95 and must be greater than the LOW default threshold. The default is 80.

MAXMIG=*n*

specifies the maximum number of concurrent automatic migration, immediate migration, and migrate-to-threshold tasks for this VTSS.

Valid values are 1 to the number of RTDs on the VTSS or 8, whichever is less. The default is half the number of RTDs attached to the VTSS.

MINMIG=*n*

specifies the minimum number of concurrent automatic migration, immediate migration, and migrate-to-threshold tasks for this VTSS.

Valid values are 1 to the MAXMIG setting. The default is 1 task.

RETAIN=*nn*

specifies the number of minutes that VTCS will retain an MVC on an RTD in idle mode after a migration or recall. Retaining the MVC can reduce MVC mounts.

Valid values are 1 to 60. The default is 10.

RTD Statement

The RTD statement defines the RTDs connected to the VTSS. This statement is required and must follow the VTSS statement that defines the VTSS to which the RTDs are connected. For a VSM2 or VSM3, you can specify a maximum of 8 RTDs. For a VSM4, you can specify a maximum of 16 RTDs.



Note: You must specify the RESET parameter to change RTD definitions; for more information, see “RESET” on page 13. For an initial RTD definition, if the RTD name displayed at the VTSS LOP is anything other than all blanks, you must also specify RESET.

Syntax

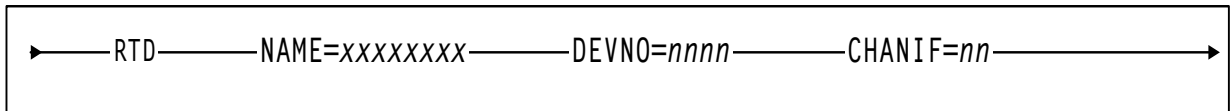

Figure 12. RTD *statement syntax*

Parameters

NAME=XXXXXXXX

specifies the 1 to 8 character identifier of the RTD.

You set or change the RTD identifier *only* via the RTD NAME parameter; to do so, the RTD identifier must be all blanks as displayed at the VTSS LOP.

This parameter is required; there is no default value.

DEVNO=nnnn

specifies the unit address of the RTD.

This parameter is required; there is no default value.

CHANIF=nn

specifies the channel interface on the VTSS that communicates with the RTD. This value must match the Nearlink channel interface defined at the VTSS LOP by your StorageTek hardware representative at VTSS installation and configuration.

This parameter is required; there is no default value.

The value must be two characters in length and have a value from 0A to 1P. The first digit is the VTSS cluster ID (valid values are 0 or 1). The second digit is the group or adapter ID (valid values are A to P).



Caution: Do not use the LINK number shown at the LOP instead of the VTSS cluster ID for the first character of the CHANIF value!

VTD Statement

The VTD statement defines the MVS unit address range of the VTDs in a VTSS. This statement is required and must follow the VTSS statement where the VTDs reside.



Note: VSM2s and VSM3s provide 64 VTDs per VTSS. VSM4s provide 256 VTDs per VTSS.

You can specify the VTD unit addresses to either apply to all hosts or to define which VTDs are available to specific hosts; for more information, see “Specifying VTD Unit Addresses” on page 33.

Syntax

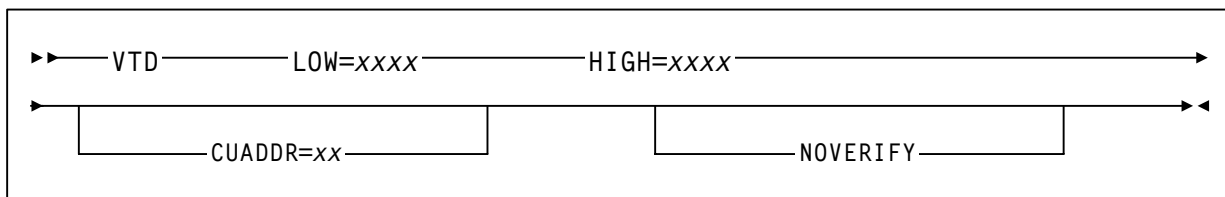

Figure 13. VTD *statement syntax*

Parameters

LOW=xxxx

specifies a four character valid MVS unit address as the start of a range of VTDs.

HIGH=xxxx

specifies a four character valid MVS unit address as the end of a range of VTDs.

CUADDR=xx

specifies a control unit identifier that matches its value in the IOCP. Valid values are 0 through 15 for VSM4 and 0 through 3 for VSM2/3. This statement is required only if a partial VTD range is specified for a host and the host does not have a path to the VTDs.

NOVERIFY

specifies that VTCS will attempt the verification of all predicted VTD identifiers associated with Virtual Tape Drives. In order to do this each MVS I/O address must be available in order that the associated Host may issue the ECAM-T request Virtual_Device_Identify.

In specific cases where, for example, VTCS is providing support for a remote client Host connected via MVS/CSC, the local host, acting as a server for the remote client, may not have paths to the MVS I/O address. In these cases, any attempt at verification of the predicted VTD identifier will fail and will result in error messages posted to the operator.

CLUSTER Statement The CLUSTER statement defines two VTSSs in a Cluster.

Syntax

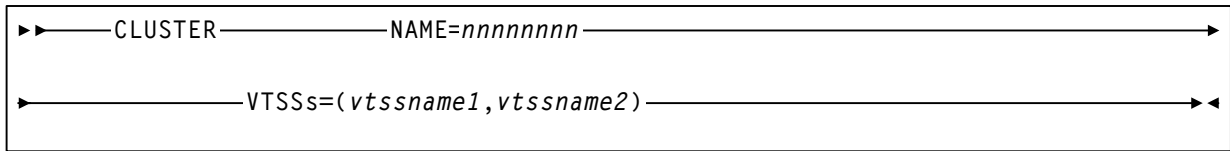

Figure 14. CLUSTER *statement syntax*

Parameters

NAME=nnnnnnnn

specifies the 1 to 8 character identifier of the Cluster.

This parameter is required; there is no default value.

VTSSs=(vtssname1,vtssname2)

Specifies the names of two VTSSs in a cluster. The relationship between the two VTSS is defined by the CONFIG CLINK statement; for more information, see “CLINK Statement” on page 28.

There is no default value. This parameter replaces and is mutually exclusive with the PRIMARY and SECONDRY parameters.



Note: The VTSS names that you specify on a CLUSTER statement must be known to VTCS. That is, the VTSS names must be already defined in the CDS or must be specified in VTSS statements that already exist in the current set of CONFIG statements. For, example, the following is valid:

```
VTSSNAME=VTSS1  LOW=70 HIGH=80  MAXMIG=3  RETAIN=5
VTSSNAME=VTSS2  LOW=70 HIGH=80  MAXMIG=3  RETAIN=5
CLUSTER NAME=CLUSTER1  VTSSs=(VTSS1,VTSS2)
```

The following is **not** valid unless VTSS1 and VTSS2 are already defined in the CDS:

```
CLUSTER NAME=CLUSTER1  VTSSs=(VTSS1,VTSS2)
VTSSNAME=VTSS1  LOW=70 HIGH=80  MAXMIG=3  RETAIN=5
VTSSNAME=VTSS2  LOW=70 HIGH=80  MAXMIG=3  RETAIN=5
```

CLINK Statement

The CLINK statement defines the channel interface between two VTSSs in a Cluster. The VTSSs can be in one of two modes:

- Primary-Secondary, in which case you write CLINK statements for *only* the Primary.
- Peer-to-Peer, in which case you write CLINK statements for both VTSSs to enable bi-directional VTV replication.

For examples, see *VTCS Administrator's Guide*.

Syntax

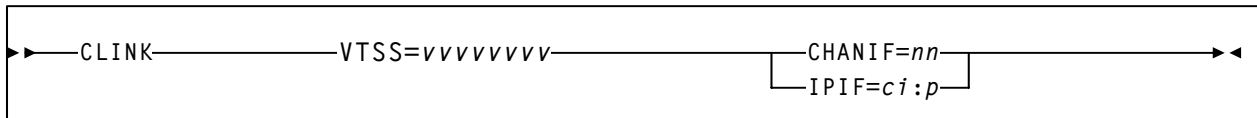

Figure 15. CLINK *statement syntax*

Parameters

VTSS=vvvvvvvvv

specifies the name of the one VTSS in a Cluster.

This parameter is required; there is no default value.

CHANIF=nn

specifies the channel interface for communication between two VTSSs in a Cluster. This value must match the Nearlink channel interface defined at the VTSS LOP by your StorageTek hardware representative at VTSS installation and configuration.

This parameter is required; there is no default value.

The value must be two characters in length and have a value from 0A to 1P. The first digit is the VTSS Cluster ID (valid values are 0 or 1). The second digit is the group or adapter ID (valid values are A to P).



Caution: Do not use the LINK number shown at the LOP instead of the VTSS Cluster ID for the first character of the CHANIF value!

Note: The VTSS name that you specify on a CLINK statement must be known to VTCS. That is, the VTSS name must be already defined in the CDS or it must be specified in a VTSS statement that already exists in the current set of CONFIG statements. For, example, the following is valid:

```
VTSSNAME=VTSS1  LOW=70  HIGH=80  MAXMIG=3  RETAIN=5
CLINK VTSS=VTSS1  CHANIF=0A
```

The following is **not** valid unless VTSS1 is already defined in the CDS:

```
CLINK VTSS=VTSS1  CHANIF=0A
VTSSNAME=VTSS1  LOW=70  HIGH=80  MAXMIG=3  RETAIN=5
```

CLINK IPIF=*ci:p*

specifies Ethernet connection of two Native IP (IFF3 card) ports, where:

c

is the VTSS cluster number (0 or 1)

i

is the IP interface letter (A or I)

p

is the path on the interface (0 to 3)

Note:

- The CLINK statement must contain either the CHANIF or the IPIF parameter, but not both.
- The *ci:p* values are shown on the VTSS IFF IP Configuration Status screen for each IFF Ethernet port.

HOST Statement

The HOST statement is an optional statement that defines an MVS host and, optionally, the NOMIGRAT and/or NORECLAM parameters.

Note the following:

- If specified, the HOST statement must follow the VTSS statement for the VTSS attached to that host.
- You must either specify all host definitions or none; if you specify only some of the hosts attached to a VTSS, VTCS will issue an error.

Syntax

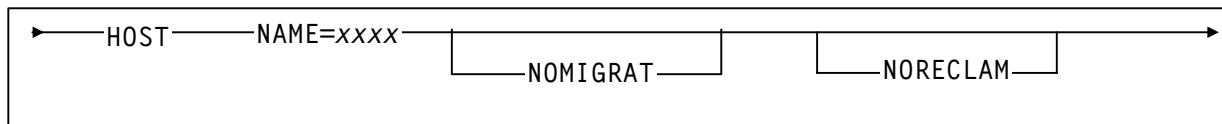

Figure 16. HOST *statement syntax*

Parameters

NAME=xxxx

specifies the LIBGENed hostname.

NOMIGRAT

specifies that this host cannot do migrations, consolidations, or export by VTV or Management Class from the VTSS(s) that the host accesses. NOMIGRAT controls both automatic and demand migrations and consolidations. This parameter is optional.



Note: Specifying NOMIGRAT also causes NORECLAM to be set.

IMMEDmig KEEP and IMMEdmig DELETE are mutually exclusive with CONFIG HOST NOMIGRAT. If you specify both, the IMMEdmig value overrides NOMIGRAT, and VTCS does not issue a message about this override.

NORECLAM

specifies that this host cannot initiate automatic or demand reclaim processing using the VTSS(s) that the host accesses (the host can still do demand MVC drains via MVCDRain). This parameter is optional.



Note: If you use the HSC SET utility to add a new host ID, or change an existing host ID, then you must run the VTCS CONFIG utility after the HSC SET utility is complete. The SET Utility adds or modifies a record to the native tape portion of the CDS for the host that you're adding/modifying, but does **not** modify the VTCS section of the CDS.



To modify the VTCS section of the CDS:

1. After you've run the HSC SET utility, run the VTCS DECOM utility...

...to see what accesses your hosts have to your VTSSs. Modify the DECOM output to what you would like your access to be for any hosts that were changed with the HSC SET utility.

2. Use that edited DECOM output as the input to the VTCS CONFIG utility.

Note that if you are only accommodating a new host ID or a change in host IDs, it is not necessary to use the RESET parameter with CONFIG. Therefore, no hosts **other** than the one you are modifying will need to shut down HSC.

When HSC is started on the host that you have added or modified, any changes to CONFIG for that host will take effect.

Usage

Use the CONFIG utility to define or modify the VSM configuration stored in the HSC CDS. An asterisk (*) in column 1 denotes comments in the file that contains the CONFIG utility statements.

You typically run the CONFIG utility when you:

- Initially install and configure your VSM system; see Figure 17 on page 35 and Figure 18 on page 36 for examples.
- Change VSM hardware (such as adding RTDs); see Figure 19 on page 37 for an example.
- Change VSM volumes (such as adding VTVs and MVCs); see Figure 20 on page 38 for an example.
- Change VSM policies (such as AMT values); see Figure 20 on page 38 for an example.
- Physically remove a VTSS from your configuration, see Figure 21 on page 39 for an example.



Note: You must specify RESET to change your existing RTD definitions by adding RTDs, removing RTDs, or reordering the sequence of RTDs; see “RESET” on page 13. HSC must be down on all hosts when you run CONFIG RESET. The changes you made to RTD definitions will take effect when you restart HSC. You must also specify RESET when you add a VTSS to your configuration.

You can run CONFIG without RESET concurrently with an active HSC, but you must then restart HSC for the changes to take effect.

Specifying VTD Unit Addresses

You can specify VTD addresses by doing one of the following:

- Specify the VTD unit addresses on a VTD statement following a VTSS statement and do *not* specify any HOST statements following the VTSS statement. All hosts physically connected to the VTSS have access to its VTDs by the default addresses specified on the VTD statement. See Figure 17 on page 35 for an example of this configuration.
- Do *not* specify the VTD unit addresses on the VTD statement following a VTSS statement. Instead, place a VTD statement after a HOST statement for only those hosts for which you want to define connections to the previously defined VTSS. You must specify a placeholder (HOST NAME with no VTD parameter) for any hosts that you do not want connected to this VTSS.

Note that the VTDs created and MVCs initially written to from a VTSS are considered that VTSS's resources, so only hosts with access to a VTSS also have access to its VTDs and MVCs. In this type of "restricted" access configuration, therefore, each host should have a separate VTD scratch pool to ensure that each host has accurate scratch counts. Similarly, free MVCs and MVC reclaim counts are reported on each host for the MVCs associated with the VTSS to which the host is connected.

See Figure 18 on page 36 for an example of this configuration. You can specify different address ranges for each host, although StorageTek recommends that you specify the same address ranges for all hosts for consistency of operations. If you specify different address ranges for different hosts, use the HSC SET DRVHOST and SMC DRIVEMAP statements if you have a client/server configuration.



Caution: In a multi-host, multi-VTSS configuration, you can use this VTD addressing method to deny access to VTSSs to which hosts are physically connected. You **must**, however, use this method to deny access from hosts that are *not* physically connected to a VTSS. If you do not deny access, VTCS on a host that does not have physical connections to a VTSS may wait trying to communicate with the VTSS while VSM operations may be stalled on all other hosts.

JCL Requirements

STEPLIB

specifies the link library (SLSLINK) that contains the VTCS and HSC modules.

SLSPRINT

specifies the destination for the CONFIG report.

SLSIN

specifies the input to the SWSADMIN program (CONFIG utility name and parameters).

JCL Examples



Note: See *VTCS Installation and Configuration Guide* for VSM4 CONFIG examples.

CONFIG Example:
VSM2 or VSM3 Initial
Configuration - All
Hosts Access All
VTDs

Figure 17 shows example CONFIG JCL to initially define a VSM2 or VSM3 configuration as follows:

- The VTD statements specify default VTD addresses 8900 - 893F for VTSS1 and addresses 9900 - 993F for VTSS2.
- No HOST statements follow the VTSS statements, so all hosts have access to all VTDs in both VTSSs by the default addresses specified on the VTD statements.

```
//CREATECFG EXEC PGM=SWSADMIN, PARM='MIXED'  
//STEPLIB DD DSN=h1q.SLSLINK, DISP=SHR  
//SLSCNTL DD DSN=FEDB.VSMLMULT.DBASEPRM, DISP=SHR  
//SLSCNTL2 DD DSN=FEDB.VSMLMULT.DBASESEC, DISP=SHR  
//SLSSTBY DD DSN=FEDB.VSMLMULT.DBASEBY, DISP=SHR  
//SLSPRINT DD SYSOUT=*  
//SLSIN DD *  
CONFIG  
GLOBAL MAXVTV=32000 MVCFREE=40  
RECLAIM THRESHLD=70 MAXMVC=40 START=35  
VTVVOL LOW=905000 HIGH=999999 SCRATCH  
VTVVOL LOW=C00000 HIGH=C25000 SCRATCH  
VTVVOL LOW=RMM000 HIGH=RMM020 SCRATCH  
MVCVOL LOW=N25980 HIGH=N25989  
MVCVOL LOW=N35000 HIGH=N35999  
VTSS NAME=VTSS1 LOW=70 HIGH=80 MAXMIG=3 RETAIN=5  
RTD NAME=VTS18800 DEVNO=8800 CHANIF=0A  
RTD NAME=VTS18801 DEVNO=8801 CHANIF=0I  
RTD NAME=VTS18802 DEVNO=8802 CHANIF=1A  
RTD NAME=VTS18803 DEVNO=8803 CHANIF=1I  
VTD LOW=8900 HIGH=893F  
VTSS NAME=VTSS2 LOW=70 HIGH=80 MAXMIG=3 RETAIN=5  
RTD NAME=VTS28804 DEVNO=8804 CHANIF=0A  
RTD NAME=VTS28805 DEVNO=8805 CHANIF=0I  
RTD NAME=VTS28806 DEVNO=8806 CHANIF=1A  
RTD NAME=VTS28807 DEVNO=8807 CHANIF=1I  
VTD LOW=9900 HIGH=993F
```

Figure 17. CONFIG example: initial VSM2 or VSM3 configuration, all hosts access all VTDs

CONFIG Example:
 Initial Configuration -
 All Hosts Access
 VTDs in One VTSS,
 Only Selected Hosts
 Access VTDs in
 Second VTSS

Figure 18 shows example CONFIG JCL to initially define a VSM configuration as follows:

- The VTD statement specifies default VTD addresses 8900 - 893F for VTSS1. All hosts have access to these VTDs by their default addresses.
- No default VTD addresses are specified for VTSS2. The HOST statements for MVS1 and MVS2 specify that only these hosts can access the VTDs in VTSS2 by the addresses 9900 - 993F. HOST statement MVS3 is a placeholder; this host cannot access the VTDs in VTSS2.

```
//CREATECFG EXEC PGM=SWSADMIN, PARM='MIXED'
//STEPLIB DD DSN=h1q.SLSLINK, DISP=SHR
//SLS_CNTL DD DSN=FEDB.VSMLMULT.DBASEPRM, DISP=SHR
//SLS_CNTL2 DD DSN=FEDB.VSMLMULT.DBASESEC, DISP=SHR
//SLSSTBY DD DSN=FEDB.VSMLMULT.DBASEBY, DISP=SHR
//SLSPRINT DD SYSOUT=*
//SLSIN DD *

CONFIG
GLOBAL MAXVTV=32000 MVCFREE=40
RECLAIM THRESHLD=70 MAXMVC=40 START=35
VTVOL LOW=905000 HIGH=999999 SCRATCH
VTVOL LOW=C00000 HIGH=C25000 SCRATCH
VTVOL LOW=RMM000 HIGH=RMM020 SCRATCH
MVCVOL LOW=N25980 HIGH=N25989
MVCVOL LOW=N35000 HIGH=N35999
VTSS NAME=VTSS1 LOW=70 HIGH=80 MAXMIG=3 RETAIN=5
RTD NAME=VT128800 DEVNO=8800 CHANIF=0A
RTD NAME=VTS18801 DEVNO=8801 CHANIF=0I
RTD NAME=VTS18802 DEVNO=8802 CHANIF=1A
RTD NAME=VTS18803 DEVNO=8803 CHANIF=1I
VTD LOW=8900 HIGH=893F
VTSS NAME=VTSS2 LOW=70 HIGH=80 MAXMIG=3 RETAIN=5
RTD NAME=VTS28804 DEVNO=8804 CHANIF=0A
RTD NAME=VTS28805 DEVNO=8805 CHANIF=0I
RTD NAME=VTS28806 DEVNO=8806 CHANIF=1A
RTD NAME=VTS28807 DEVNO=8807 CHANIF=1I
HOST NAME=MVS1
VTD LOW=9900 HIGH=993F
HOST NAME=MVS2
VTD LOW=9900 HIGH=993F
HOST NAME=MVS3 NOMIGRAT NORECLAM
```

Figure 18. CONFIG example: initial configuration, all hosts access VTDs in one VTSS, selected hosts access VTDs in second VTSS

CONFIG Example:
Update Configuration
to Add RTDs

Figure 19 shows example JCL to run CONFIG to add RTDs VTS18811 and VTS18813 (connected to VTSS1) to the configuration shown in Figure 18 on page 36. In this example, you specify the RESET parameter to clear the existing RTD definitions, then respecify the existing RTDs and add new definitions for RTDs VTS18811 and VTS18813.

```
//UPDATECFG EXEC PGM=SWSADMIN, PARM='MIXED'  
//STEPLIB DD DSN=h1q.SLSLINK, DISP=SHR  
//SLSCNTL DD DSN=FEDB.VSMLMULT.DBASEPRM, DISP=SHR  
//SLSCNTL2 DD DSN=FEDB.VSMLMULT.DBASESEC, DISP=SHR  
//SLSSTBY DD DSN=FEDB.VSMLMULT.DBASETBY, DISP=SHR  
//SLSPRINT DD SYSOUT=*  
//SLSIN DD *  
CONFIG RESET  
GLOBAL MAXVTV=32000 MVCFREE=40  
RECLAIM THRESHLD=70 MAXMVC=40 START=35  
VTVVOL LOW=905000 HIGH=999999 SCRATCH  
VTVVOL LOW=C00000 HIGH=C25000 SCRATCH  
VTVVOL LOW=RMM000 HIGH=RMM020 SCRATCH  
MVCVOL LOW=N25980 HIGH=N25989  
MVCVOL LOW=N35000 HIGH=N35999  
VTSS NAME=VTSS1 LOW=70 HIGH=80 MAXMIG=3 RETAIN=5  
RTD NAME=VTS18800 DEVNO=8800 CHANIF=0A  
RTD NAME=VTS18801 DEVNO=8801 CHANIF=0I  
RTD NAME=VTS18802 DEVNO=8802 CHANIF=1A  
RTD NAME=VTS18803 DEVNO=8803 CHANIF=1I  
RTD NAME=VTS18811 DEVNO=8811 CHANIF=0E  
RTD NAME=VTS18813 DEVNO=8813 CHANIF=1E  
VTD LOW=8900 HIGH=893F  
VTSS NAME=VTSS2 LOW=70 HIGH=80 MAXMIG=3 RETAIN=5  
RTD NAME=VTS28804 DEVNO=8804 CHANIF=0A  
RTD NAME=VTS28805 DEVNO=8805 CHANIF=0I  
RTD NAME=VTS28806 DEVNO=8806 CHANIF=1A  
RTD NAME=VTS28807 DEVNO=8807 CHANIF=1I  
HOST NAME=MVS1  
VTD LOW=9900 HIGH=993F  
HOST NAME=MVS2  
VTD LOW=9900 HIGH=993F  
HOST NAME=MVS3
```

Figure 19. CONFIG example: updating configuration to add RTDs

CONFIG Example:
Update Configuration
to Add MVCs and
VTVs and Change
AMTs

Figure 20 shows example JCL to run CONFIG to modify the configuration shown in Figure 19 on page 37 by:

- Respecifying the existing VTV and MVC ranges.
- Adding VTVs C25001 to C50000 as scratch.
- Adding MVCs N45000 to N45999. For more information about adding MVCs to VSM.
- Changing the LAMT to 50 and the HAMT to 85 on both VTSS1 and VTSS2.

```
//UPDATECFG EXEC PGM=SWSADMIN, PARM='MIXED'  
//STEPLIB DD DSN=h1q.SLSLINK, DISP=SHR  
//SLSCNTL DD DSN=FEDB.VSMLMULT.DBASEPRM, DISP=SHR  
//SLSCNTL2 DD DSN=FEDB.VSMLMULT.DBASESEC, DISP=SHR  
//SLSSTBY DD DSN=FEDB.VSMLMULT.DBASEBY, DISP=SHR  
//SLSPRINT DD SYSOUT=*  
//SLSIN DD *  
CONFIG  
GLOBAL MAXVTV=32000 MVCFREE=40  
RECLAIM THRESHLD=70 MAXMVC=40 START=35  
VTVVOL LOW=905000 HIGH=999999 SCRATCH  
VTVVOL LOW=C00000 HIGH=C25000 SCRATCH  
VTVVOL LOW=RMM000 HIGH=RMM020 SCRATCH  
VTVVOL LOW=C25001 HIGH=C50000 SCRATCH  
MVCVOL LOW=N25980 HIGH=N25989  
MVCVOL LOW=N35000 HIGH=N35999  
MVCVOL LOW=N45000 HIGH=N45999  
VTSS NAME=VTSS1 LOW=50 HIGH=85 MAXMIG=3 RETAIN=5  
RTD NAME=VTS18800 DEVNO=8800 CHANIF=0A  
RTD NAME=VTS18801 DEVNO=8801 CHANIF=0I  
RTD NAME=VTS18802 DEVNO=8802 CHANIF=1A  
RTD NAME=VTS18803 DEVNO=8803 CHANIF=1I  
RTD NAME=VTS18811 DEVNO=8811 CHANIF=0E  
RTD NAME=VTS18813 DEVNO=8813 CHANIF=1E  
VTD LOW=8900 HIGH=893F  
VTSS NAME=VTSS2 LOW=50 HIGH=85 MAXMIG=3 RETAIN=5  
RTD NAME=VTS28804 DEVNO=8804 CHANIF=0A  
RTD NAME=VTS28805 DEVNO=8805 CHANIF=0I  
RTD NAME=VTS28806 DEVNO=8806 CHANIF=1A  
RTD NAME=VTS28807 DEVNO=8807 CHANIF=1I  
HOST NAME=MVS1  
VTD LOW=9900 HIGH=993F  
HOST NAME=MVS2  
VTD LOW=9900 HIGH=993F  
HOST NAME=MVS3
```

Figure 20. CONFIG example: updating configuration to add MVCs and VTVs and change AMTs

CONFIG Example:
Denying Host Access
to a Physically
Removed VTSS

Figure 21 shows example JCL to run CONFIG to update the configuration shown in Figure 18 on page 36 to deny host access to VTSS2 that you physically removed from your configuration. In this example, you:

- Specify the RESET parameter to clear the existing RTD definitions.
- Respecify the VTSS statement for VTSS2 with no parameters to deny host access to this VTSS.

```
//UPDATECFG EXEC PGM=SWSADMIN, PARM='MIXED'  
//STEPLIB DD DSN=h1q.SLSLINK, DISP=SHR  
//SLSCNTL DD DSN=FEDB.VSMLMULT.DBASEPRM, DISP=SHR  
//SLSCNTL2 DD DSN=FEDB.VSMLMULT.DBASESEC, DISP=SHR  
//SLSSTBY DD DSN=FEDB.VSMLMULT.DBASESTBY, DISP=SHR  
//SLSPRINT DD SYSOUT=*  
//SLSIN DD *  
CONFIG RESET  
GLOBAL MAXVTV=32000 MVCFREE=40  
RECLAIM THRESHLD=70 MAXMVC=40 START=35  
VTSS NAME=VTSS1 LOW=70 HIGH=80 MAXMIG=3 RETAIN=5  
RTD NAME=VTS18800 DEVNO=8800 CHANIF=0A  
RTD NAME=VTS18801 DEVNO=8801 CHANIF=0I  
RTD NAME=VTS18802 DEVNO=8802 CHANIF=1A  
RTD NAME=VTS18803 DEVNO=8803 CHANIF=1I  
RTD NAME=VTS18811 DEVNO=8811 CHANIF=0E  
RTD NAME=VTS18813 DEVNO=8813 CHANIF=1E  
VTD LOW=8900 HIGH=893F  
VTSS NAME=VTSS2
```

Figure 21. CONFIG example: updating configuration to deny host access to a physically removed VTSS

CONSolid

CONSolid consolidates VTVs on MVCs; for more information, see “Usage” on page 41.

Syntax

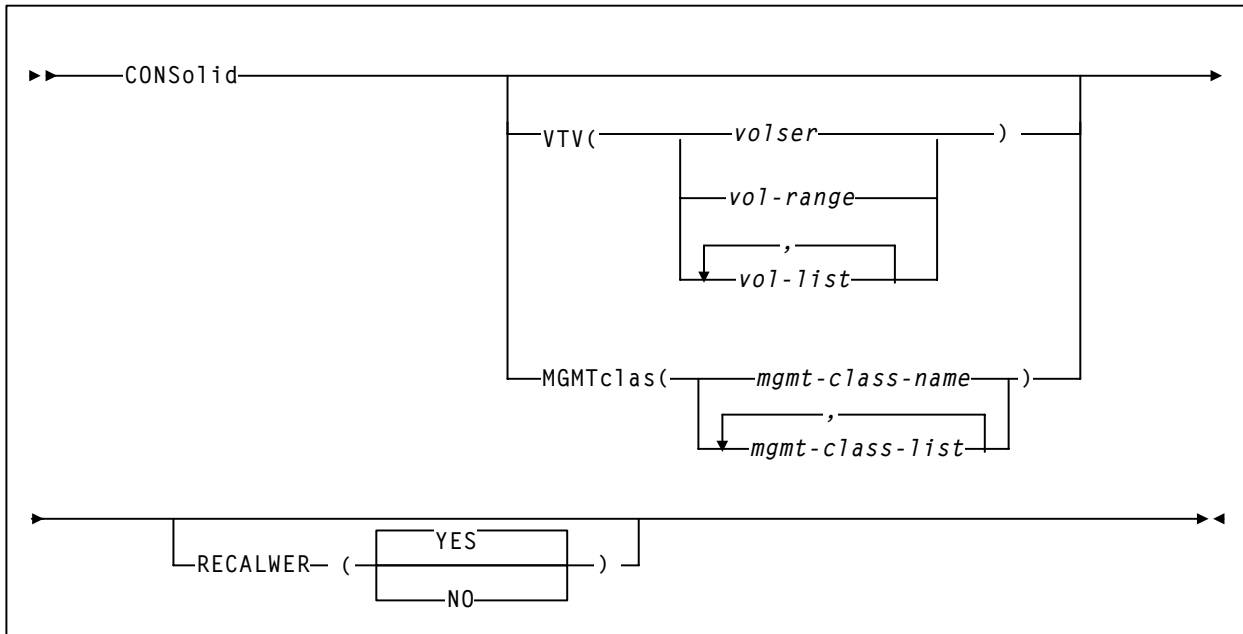

Figure 22. CONSolid utility syntax

Parameters

VTV

specifies one or more VTVs to consolidate.

volser, *vol-range* **or** *vol-list*

the volsers of one or more VTVs. You can specify a maximum of 2,000 VTVs.

MGMTclas

specifies the names of one or more Management Classes that determine the VTVs to consolidate.

mgmt-class-name | *mgmt-class-list*

the names of one or more Management Classes that you defined on the MGMTclas control statement; for more information, see “MGMTCLAS Control Statement” on page 214. You can consolidate a maximum of 2,000 VTVs by specifying a Management Class.

RECALWER

specifies whether VTCS recalls VTVs with read data checks.

YES

recall VTVs with read data checks (the default).

NO

Do not recall VTVs with read data checks.

Interfaces

SWSADMIN utility only.

Usage

The following sections tell how to use the `CONSolid` utility to consolidate VTVs on MVCs:

- “Consolidating VTVs by Specifying VTVs on the `VTV Parameter`”
- “Consolidating VTVs by Specifying a Management Class on the `MGMTclas Parameter`”



Note: If you need to run a VSM audit, rerun any consolidation jobs that may have been impacted by the loss of the CDS or VSM resources. For more information, see *VTCS Administrator's Guide*.

Consolidating VTVs by Specifying VTVs on the `VTV Parameter`

You can consolidate VTVs by specifying VTVs on the `VTV` parameter. VTCS will consolidate every VTV you specify that is not mounted, non-scratch, not in-use or in recovery, and not already consolidated.

To use this method, first run a tape management system or ExLM data set name report to select the VTVs to consolidate. Figure 23 on page 43 shows a JCL example of specifying VTVs to consolidate on the `VTV` parameter.

Consolidating VTVs by Specifying a Management Class on the MGMTclas Parameter



You can also consolidate VTVs by specifying a Management Class or list of Management Classes on the MGMTclas parameter.

To consolidate VTVs by specifying a Management Class, do the following:

1. **Define a Management Class or use an existing Management Class.**

Note: Note if the Management Class you use for consolidation specifies the DUPlex parameter, duplexing is ignored for consolidation for this Management Class but duplexing *is* supported for migration for this Management Class.

2. **Create a TAPEREQ statement or use the HSC/DFSMS interface to route data to the Management Class you defined in Step 1.**
3. **Use the CONSolid utility to specify the Management Class you defined in Step 1.**

The CONSolid utility will query the CDS to determine which VTVs have been created with this Management Class, then build a list of VTVs to consolidate. VTCS consolidates all VTVs in the list that are not mounted, non-scratch, not in-use or in recovery, and not already consolidated.

JCL Requirements

STEPLIB

specifies the link library (SLSLINK) that contains the VTCS and HSC modules.

SLSPRINT

specifies the destination for the CONSolid report.

SLSIN

specifies the input to the SWSADMIN program (CONSolid utility name and parameters).

JCL Examples

Figure 23 shows example JCL to run the CONSolid utility. In this example, the VTV parameter specifies consolidating VTV100 to VTV200.

```
//CONSOLIDATE EXEC PGM=SWSADMIN, PARM='MIXED'  
//STEPLIB DD DSN=h1q.SLSLINK, DISP=SHR  
//SLSPRINT DD SYSOUT=*  
//SLSIN DD *  
CONS VTV(VTV100 - VTV200)
```

Figure 23. CONSolid utility example: specifying VTVs to consolidate

Figure 24 shows example JCL to run the CONSolid utility. In this example, the MGMT parameter specifies consolidating VTVs in Management Class PAYRVLT.

```
//CONSOLIDATE EXEC PGM=SWSADMIN, PARM='MIXED'  
//STEPLIB DD DSN=h1q.SLSLINK, DISP=SHR  
//SLSPRINT DD SYSOUT=*  
//SLSIN DD *  
CONS MGMT(PAYRVLT)
```

Figure 24. CONSolid example: specifying Management Class to consolidate

Consolidation Reports

The consolidation report displays the following messages:

MIGRATE ONLY FROM VTSS *vtssname*

Explanation: The VTV is resident on VTSS *vtssname*.

REMIGRATE FROM MVC *mvname* VIA VTSS *vtssname*

Explanation: VTCS is recalling a VTV from MVC *mvname* to consolidate the VTV.

VTV *vtvname* NOT SELECTED; VTV IS SCRATCH

Explanation: VTCS will not consolidate the specified VTV, which is either scratch or not initialized.

VTV *vtvname* NOT SELECTED; VTV ALREADY CONSOLIDATED

Explanation: The specified VTV is already consolidated.

VTV *vtvname* NOT SELECTED; VTV RECORD NOT FOUND

Explanation: VTCS will not consolidate the specified VTV, which has no record in the CDS.

VTV *vtvname* NOT SELECTED; VTV STILL MOUNTED ON DRIVE

Explanation: VTCS cannot consolidate the specified VTV, which is mounted or in recovery.

REDRIVING REQUEST BECAUSE OF ERROR

Explanation: VTCS is retrying an unsuccessful consolidation request.

CONSOLID CMD PROBLEM DECODING VCI REQUEST FROM HSC

Explanation: The consolidation failed.

VTV *vtvnumber* NOT SELECTED: LIMITED ACCESS TO VTSS

Explanation: The consolidation request failed because a host not enabled for consolidation (via the NOMIGRAT parameter) issued the request.

MIGRATE NO MVCS AVAILABLE

Explanation: Sufficient free MVCs are not available to complete the request.

DECOM

DECOM lists the VSM configuration information in the HSC CDS.

Syntax

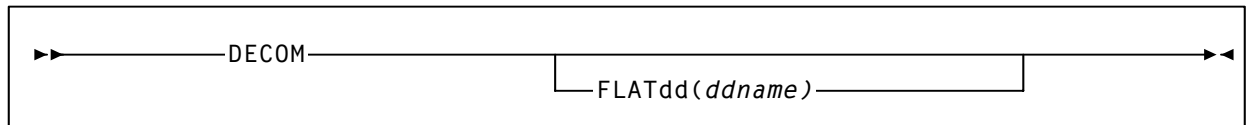

Figure 25. DECOM utility syntax

Parameters

FLATdd
specified the output destination ddname if a flat file is required.

ddname
the ddname of the flat file included in the JCL.

Interfaces

SWSADMIN utility only.

Usage

Use the DECOM utility to list the VSM configuration stored in the HSC CDS. If you need to rerun the CONFIG utility but no longer have the input file to CONFIG, run the DECOM utility with the FLATdd parameter or to SLSPRINT. You can then edit the output file from DECOM and use it as input to the CONFIG utility. For more information, see “DECOM Output” on page 46.



Hint: The output file contains all statements (including CONFIG) from the original CONFIG input. Also note that the CONFIG utility allows you to respecify existing MVC and VTV ranges, which are also included in the DECOM output. For more information, see “VTVOL Statement” on page 20 and “MVCVOL Statement” on page 21.

JCL Requirements

STEPLIB
specifies the link library (SLSLINK) that contains the VTCS and HSC modules.

SLSPRINT
specifies the destination for the DECOM report.

SLSIN
specifies the input to the SWSADMIN program (DECOM utility name and parameters).

JCL Example

Figure 26 shows example JCL to run the DECOM utility with output to flat file CFG22202.

```
//DECOM      EXEC PGM=SWSADMIN, PARM='MIXED'  
//STEPLIB   DD DSN=h1q.SLSLINK, DISP=SHR  
//CFG22202  DD DSN=FEDB.VSMLMULT.CFG22202, DISP=SHR  
//SLSPRINT  DD SYSOUT=*  
//SLSIN     DD *  
            DECOM FLATDD(CFG22202)
```

Figure 26. Example JCL for the DECOM utility

DECOM Output

FLATDD Parameter Output

Figure 27 shows an example of DECOM output with the FLATDD parameter.

```
CONFIG  
GLOBAL      MAXVTV=32000MVCFREE=40  
RECLAIM     THRESHLD=70MAXMVC=40  START=35  
VTVVOL LOW=905000 HIGH=999999 SCRATCH  
VTVVOL LOW=C00000 HIGH=C25000 SCRATCH  
VTVVOL LOW=RMM000 HIGH=RMM020 SCRATCH  
MVCVOL LOW=N25980 HIGH=N25989  
MVCVOL LOW=N35000 HIGH=N35999  
VTSS NAME=VTSS1  LOW=70 HIGH=80  MAXMIG=3  RETAIN=5  
  RTD  NAME=VTS18800 DEVNO=8800 CHANIF=0A  
  RTD  NAME=VTS18801 DEVNO=8801 CHANIF=0I  
  RTD  NAME=VTS18802 DEVNO=8802 CHANIF=1A  
  RTD  NAME=VTS18803 DEVNO=8803 CHANIF=1I  
  VTD  LOW=8900 HIGH=893F  
VTSS NAME=VTSS2  LOW=70 HIGH=80  MAXMIG=3  RETAIN=5  
  RTD  NAME=VTS28804 DEVNO=8804 CHANIF=0A  
  RTD  NAME=VTS28805 DEVNO=8805 CHANIF=0I  
  RTD  NAME=VTS28806 DEVNO=8806 CHANIF=1A  
  RTD  NAME=VTS28807 DEVNO=8807 CHANIF=1I  
  VTD  LOW=9900 HIGH=993F
```

Figure 27. Example DECOM FLATDD output

SLSPRINT Output

Figure 28 shows an example of DECOM output to SLSPRINT.

```
SWSADMIN (5.0.0)          STORAGETEK VTCS SYTEM UTILITY          PAGE 0002
TIME 09:07:06 CONTROL CARD IMAGE LISTING
DECOM
SLS1315I SSRDMP.P775644.TESTCDS WAS SELECTED AS THE PRIMARY CONTROL DATA SET
TIME 09:07:06 VTCS DECOMPILE
CONFIG VER(NEW)
GLOBAL          MAXVTV=32000MVCFREE=40
RECLAIM        THRESHLD=70MAXMVC=40  START=35
VTVVOL LOW=905000 HIGH=999999 SCRATCH
VTVVOL LOW=C00000 HIGH=C25000 SCRATCH
VTVVOL LOW=RMM000 HIGH=RMM020 SCRATCH
MVCVOL LOW=N25980 HIGH=N25989
MVCVOL LOW=N35000 HIGH=N35999
VTSS  NAME=VTSS1  LOW=70 HIGH=80  MAXMIG=3  RETAIN=5
      RTD  NAME=VTS18800 DEVNO=8800 CHANIF=0A
      RTD  NAME=VTS18801 DEVNO=8801 CHANIF=0I
      RTD  NAME=VTS18802 DEVNO=8802 CHANIF=1A
      RTD  NAME=VTS18803 DEVNO=8803 CHANIF=1I
      VTD  LOW=8900 HIGH=893F
VTSS  NAME=VTSS2  LOW=70 HIGH=80  MAXMIG=3  RETAIN=5
      RTD  NAME=VTS28804 DEVNO=8804 CHANIF=0A
      RTD  NAME=VTS28805 DEVNO=8805 CHANIF=0I
      RTD  NAME=VTS28806 DEVNO=8806 CHANIF=1A
      RTD  NAME=VTS28807 DEVNO=8807 CHANIF=1I
      VTD  LOW=9900 HIGH=993F
```

Figure 28. Example DECOM SLSPRINT output

DELETSCR

DELETSCR deletes scratch VTVs from VTSSs and unlinks any migrated VTVs from MVCs.

Syntax

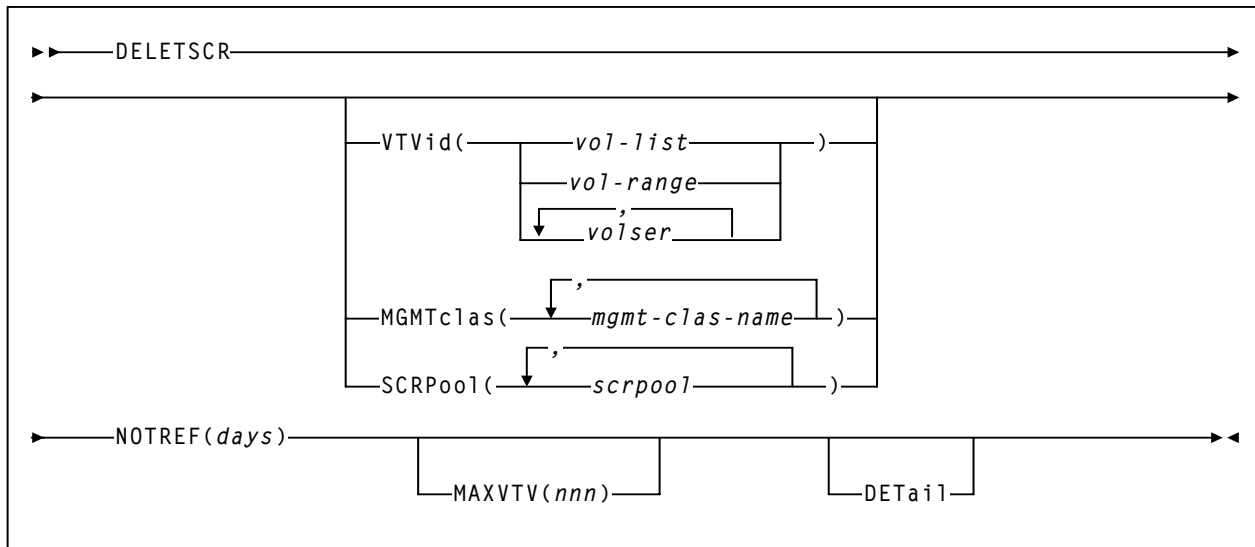

Figure 29. DELETSCR syntax

Parameters

VTVid

specifies the VTVs.

volser, vol-range or vol-list

the volsers of one or more VTVs.

MGMTclas

the Management Class(es) of the VTVs.

mgmt-class-name

the Management Class name that you specified on the MGMTclas control statement.

SCRPool

specifies the scratch pool(s) to be deleted. If the pool contains VTVs and real volumes, DELETSCR deletes only VTVs.

scrpool

an existing HSC scratch pool.

Note: VTVid, MGMTclas, and SCRPool are mutually exclusive. If you do not specify one of these parameters, VTCS processes **all** scratch VTVs.

NOTREF

specifies the number of days since a VTV was last referenced for it to be deleted by DELETSCR.

days

the number of days (1-999).

MAXVTV

specifies the maximum number of VTVs that DELETSCR deletes. Note that this is a maximum, not a target.

nnn

the maximum number of VTVs (0-999). If not specified, DELETSCR deletes all scratch VTVs. If you specify 0, DELETSCR does not delete any VTVs, but the summary report shows how many VTVs would have been deleted...at the point at which you ran DELETSCR (that is, the report is just a snapshot).

DETAil

Produce a detailed report that also shows detail and summary of VTVs that fall within the NOTREF period.

Interfaces

SWSADMIN utility only.

Optional and Required JCL

STEPLIB

specifies the link library (SLSLINK) that contains the VTCS and HSC modules.

SLSPRINT

specifies the destination for the utility report.

SLSIN

specifies the input to the SWSADMIN program (utility name and parameters).

DELETSCR Report

Figure 30 shows an example of a DELETSCR report for the following batch invocation:

DELETSCR MGMTCLAS(MC1) NOTREF(60) MAXVTV(10) DET

```
SWSADMIN (6.2.0)                STORAGETEK VTCS SYTEM UTILITY                PAGE 0002
TIME 06:32:03                    SCRATCH VTV DELETE                            DATE 2006-10-19
SLS6833I VTV VTV100 deleted from MVC M00001
SLS6835I VTV VTV101 excluded - referenced within 60 days
SLS6833I VTV VTV102 deleted from MVC M00003
SLS6835I VTV VTV103 excluded - referenced within 60 days
SLS6835I VTV VTV104 excluded - referenced within 60 days
SLS6833I VTV VTV105 deleted from MVC M00007
SLS6833I  VTV VTV106 deleted from MVC M00157
SLS6834I VTV VTV107 deleted
SLS6833I VTV VTV108 deleted from MVC M00072
SLS6833I VTV VTV110 deleted from MVC M00757
SLS6833I VTV VTV111 deleted from MVC M00767
SLS6833I VTV VTV112 deleted from MVC M01057
SLS6834I VTV VTV113 deleted

SUMMARY:
10 scratch VTVs deleted
1 VTV EXCLUDED - NOT SCRATCH VOLUME
0 VTVS EXCLUDED - NOT INITIALIZED
3 SCRATCH VTVS EXCLUDED - REFERENCED WITHIN 60 DAYS
6 scratch VTV delete candidates bypassed after MAXVTV limit 10 reached
```

Figure 30. DELETSCR Report

DELETSCR Report
Contents

A DELETSCR report shows:

- A line for each deleted VTV.
- If DETail is specified, a line for each VTV excluded (did not fall within the NOTREF period).
- A summary showing:
 - Total VTVs deleted.
 - Total VTVs excluded - not scratch.
 - Total VTVs excluded - not initialized.
 - Total VTVs excluded - not resident or migrated.
 - Total VTVs excluded - referenced within the NOTREF period.
 - Total VTVs excluded - MAXVTV limit has been reached.
 - Total VTVs excluded - not in the specified Management Class.

DISPLAY

Display displays the status of the following:

- VTSSs.
- VTDs.
- RTD usage or the status of active or queued processes that use an RTD. Use Display to determine the ID of a process you want to cancel with the CANCEL on page 11.
- Scratch subpools.
- MVC pools.
- Specific VTVs and MVCs.
- CONFIG parameter settings.
- Migrations.
- Tasks.
- Locks.
- Cluster links.
- Clusters.
- VTV replications.
- Usage information about a VTCS command or help information about an HSC message (including but not limited to the messages listed in the “HSC Messages for VTCS Events” section of *VTCS Messages*).

Syntax

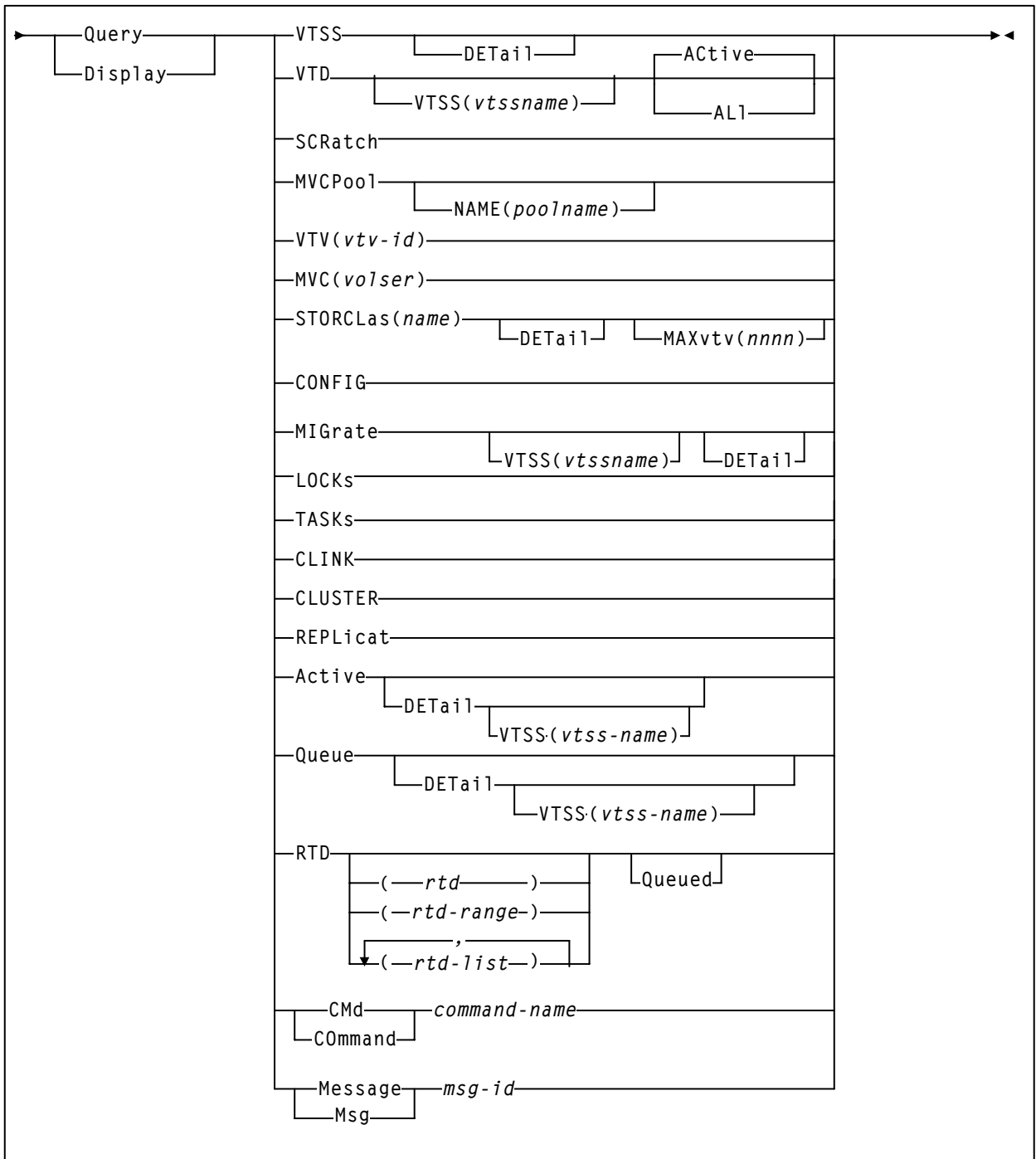

Figure 31. Query Display **syntax**

Parameters

VTSS
display VTSS information.

DETAil
display detailed host status.

VTD
display VTD information. Lists and ranges of RTDs are limited to 64 items for VSM2s and VSM3s and 256 items for VSM4s.

VTSS
display status for the VTDs connected to the specified VTSS.

vtss-name
the VTSS name.

ACTive | AL1
display status for VTDs that have VTVs mounted (ACTive) or all VTDs (AL1).

SCRATCH
display scratch subpool information.

MVCPool
display MVC pool information.

NAME
display information for the specified Named MVC Pool.

poolname
the name of an MVC Pool that you defined on the MVCPool control statement; for more information, see “MVCPOOL Control Statement” on page 226. Alternatively, you can specify ALL to display information for all Named MVC pools (including the default pool DEFAULTPOOL).

VTV
display information about a specific VTV.

vtv-id
the ID of the VTV.

MVC
display information about a specific MVC.

volser
the volser of the MVC.

CONFIG
display CONFIG parameter settings.

MIGrate
 display migration status.

DETail
 display migration status by Storage Class.

VTSS
 the VTSS whose migration status you want to display.
vtssname
 the VTSS identifier.

TASKs
 display task status.

LOCKs
 display lock status.

CLINK
 display Cluster link status.

CLUSTER
 display Cluster status.

REPLicat
 display VTV replication status.

Active
 display active processes.

DETail
 display detailed status.

VTSS
 display processes for the specified VTSS.
vtss-name
 the VTSS name.

Queue
 display queued processes.

DETail
 display detailed status.

VTSS
 display processes for the specified VTSS.
vtss-name
 the VTSS name.

RTD
 display usage information for the specified RTDs. Lists and ranges of RTDs are limited to 8 items for VSM2s and VSM3s and 16 items for VSM4s.
rtd-id, rtd-range, or rtd-list
 the unit addresses of one or more RTDs.

CMD or Command
display syntax and use information for a VTCS command.

cmd-name
the command name.

Msg or Message
display detailed HSC message information.

msg-id
the four-digit numerical portion of the message identifier. Leading zeros are not required.

Interfaces

SWSADMIN utility and VT command **except** for the following, which are only valid as commands:

- VT Display CMD or VT Query CMD
- VT Display MSG or VT Query MSG

Usage

Use DISPLAY to display the status of the VSM system, including the following:

- The capacity, VTSS count, and operating policies for all VTSSs
- VTD configuration and usage
- RTD usage or the status of active or queued processes that use an RTD.
- Available scratches in each scratch subpool
- The number of free MVCs and reclaim candidates in each ACS (optionally, by Named MVC Pool)
- Information about specific VTVs and MVCs
- CONFIG parameter settings
- Migrations
- Tasks
- Locks
- Cluster links
- Clusters
- VTV replications
- Usage information about a VTCS command or help information about an HSC message (including but not limited to the messages listed in the “HSC Messages for VTCS Events” section of *VTCS Messages*.)

Command Examples

To display the number of free MVCs and MVC reclaim candidates in each MVC pool, enter:

```
.VT QU MVCP
```

To display detailed status of all active processes, enter:

```
.VT QU A DET
```



Note: Display shows both parent and child requests. All child requests appear immediately after their parent requests. This includes children of children. For example, Figure 32 shows example of the output from the following command:

```
.VT QU A DET
```

FUNCTION	ID	VTV	MVC	RTD	VTSS
DRAIN@	02064	-	-	-	-
MVCDRAIN	02065=	-	022522	-	-
VTVMover	02066=	-	022522	-	-
Recall	02069=	Y03054	022522	2A07	HBVTSS19
Migrate	02070=	Y05088	022680	2A08	HBVTSS19

Figure 32. Example output from a Display Active DETail command: parent and child requests

In Figure 32, the function DRAIN@ has the parent request ID of 00191 and the subsequent child requests (indicated by the equal sign (=)).

JCL Requirements

The following are the required and optional statements for the DISPLAY command JCL:

STEPLIB

specifies the link library (SLSLINK) that contains the VTCS and HSC modules.

SLSPRINT

specifies the destination for the DISPLAY command output.

SLSIN

specifies the input to the SWSADMIN program (DISPLAY command and parameters).

JCL Examples

Figure 33 shows example JCL to display the number of free MVCs and MVC reclaim candidates in each MVC pool.

```
//MVCR EXEC PGM=SWSADMIN, PARM='MIXED'  
//STEPLIB DD DSN=h1q.SLSLINK, DISP=SHR  
//SLSPRINT DD SYSOUT=*  
//SLSIN DD *  
QU MVCP
```

Figure 33. Example JCL to display the number of free MVCs and MVC reclaim candidates in each MVC pool

Figure 34 shows example JCL to display detailed status of all active processes.

```
//MVCR EXEC PGM=SWSADMIN, PARM='MIXED'  
//STEPLIB DD DSN=h1q.SLSLINK, DISP=SHR  
//SLSPRINT DD SYSOUT=*  
//SLSIN DD *  
QU A DET
```

Figure 34. Example JCL to display detailed status of all active processes

Output

Display VTSS Output Figure 35 shows an example of Display VTSS output.

VTSSNAME	CAPACITY (MB)	DBU	HI AMT	LOW AMT	VTV COUNT	MX MT	MN MT	DEF ACS	AUTOMIG	STATE
HBVTSS16	56,209	9	35	30	204	6	1	--		ONLINE-P
HBVTSS17	56,209	7	35	30	218	4	3	02		ONLINE-P
HBVTSS18	N/A	N/A	35	30	N/A	3	1	01		OFFLINE
HBVTSS19	93,184	5	35	30	110	3	1	01		ONLINE

Figure 35. Example output from Display VTSS

VTSSNAME

the name of the VTSS.

CPCTY(MB)

the total physical capacity in megabytes of the specified VTSS.

DBU

the percentage of disk buffer used of the total buffer capacity.

HI AMT

the high AMT.

LOW AMT

the low AMT.

VTV COUNT

the number of VTVs resident on the VTSS.

MX MT

the current MAXMIG value.

MN MT

the current MINMIG value.

DEF ACS

the default ACS.

AUTOMIG

indicates which host is performing the auto migration and the threshold to which the VTSS is migrating.

STATE

one of the following global VTSS states (described in Table 8 on page 175) for all hosts:

QUIESCING

Quiescing state.

QUIESCED

Quiesced state.

OFFLINE

Offline state.

OFFLINE-P

Offline pending state.

ONLINE

Online state.

ONLINE-P

Online pending state.

STARTED

The VTSS is initialized and in process of going to the requested state (online, offline, or quiesced).

Display VTSS DEtail
Output

Figure 36 shows an example of the additional fields for Display VTSS DEtail output.

HOST	VTSSNAME	NOMIGRAT?	NORECLAM?	STATE
EC104	HBVTSS16	Y	Y	ONLINE
EC21	HBVTSS16	N	Y	ONLINE
EC21	HBVTSS17	N	Y	QUIESCED
EC10	HBVTSS17	Y	Y	OFFLINE

Figure 36. Example additional output from Display VTSS DEtail

HOST

the hosts that have access to the VTSSs in the **VTSSNAME** field.

VTSSNAME

the VTSSs that the hosts in the **HOST** field can access.

NOMIGRAT

whether NOMIGRAT is set on for this host.

NORECLAM

whether NORECLAM is set on for this host.

STATE

one of the following VTSS states (described in Table 8 on page 175) for this host:

QUIESCING

Quiescing state.

QUIESCED

Quiesced state.

OFFLINE

Offline state.

OFFLINE-P

Offline pending state.

ONLINE

Online state.

ONLINE-P

Online pending state.

STARTED

The VTSS is initialized and in process of going to the requested state (online, offline, or quiesced).

Display VTD Output

Figure 37 shows an example of Display VTD output.

DRIVE	LOCATION	VTV	STATUS
A800	HBVTSS16	X00778	MOUNTED
A801	HBVTSS16		AVAILABLE
A802	HBVTSS16		AVAILABLE
A803	HBVTSS16		AVAILABLE

Figure 37. Example output from Display VTD

DRIVE

the MVS device address of the VTD.

LOCATION

the VTSS that contains the VTD.

VTV

the VTV volser if **STATUS** is **Mounted**.

STATUS

one of the following VTD statuses:

Mounted

the VTV volser shown in the **VTV** column is mounted on the VTD.

Available

the VTD is available for work.

Display RTD Output

Figure 38 shows an example of Display RTD output.

RTD	Mount	Alloc	Host	VTSS	Status
2A00	-	-	-	DVTSS16	Online/free
2A01	-	-	-	DVTSS16	Online/free
2A02	-	-	-	DVTSS16	Online/free
2A03	-	-	-	DVTSS16	Online/free
2A04	-	-	-	-	Online/free
2A05	-	-	-	-	Offline
2A06	-	-	-	DVTSS18	Fail/offline
2A07	-	-	-	DVTSS18	Path offline
2A08	-	-	-	DVTSS19	Online/free
2A09	-	-	-	DVTSS19	Online/free
2A0A	-	-	-	-	Online/free
				DVTSS17	Online/free
				DVTSS18	Path offline
				DVTSS19	Online/free
2A0B	-	-	-	-	Online/free
				DVTSS17	Online/free
				DVTSS18	Path offline
				DVTSS19	Online/free

Figure 38. Example output from a VT Display RTD command

Note: As shown in Figure 38. on page 62:

- For the shared RTDs only, the current single line is displayed if the global status of the shared RTD applies to all of the connected VTSSs (for example, RTDs 2A04 and 2A05 above).
- If the status of a shared RTD from any VTSS is different from the global status, an individual line is displayed for each VTSS (for example, RTDs 2A0A and 2A0B above).

RTD

the unit address of the RTD.

Status

One of the following RTD statuses:

RECOVER RTD

The RTD is being reset after a problem, a vary, or an initialization.

MIGRATE VTV

The RTD is migrating a VTV.

RECALL VTV

The RTD is recalling a VTV.

UNLOAD MVC

A forced unload of the RTD is occurring.

VTV TRANSFER

The RTD is migrating a VTV before recalling it on another VTSS.

AUDIT MVC

An MVC is being audited.

BUSY

The RTD is busy (non-specific task).

IDLE

An MVC is allocated to the RTD but the MVC is not being used.

ONLINE/FREE

The RTD is online and available.

MAINTENANCE

The RTD is in maintenance mode.

OFFLINE

The RTD is offline and unavailable to all hosts and VTSSs

RECOVERY

The RTD is being reset following an error or a vary online mode.

INITIALIZE

The host is verifying RTD status and availability.

SUSPEND

The RTD operations are suspended. This occurs when two RTDs are connected to two separate ports on the same VSM4 ICE3 card CIP. When one RTD is active, the other is in Suspend mode.

PATH OFFLINE

The RTD status is unknown because the VTSS cannot contact the RTD or if the paths were not correctly configured.

MOUNT

the volser of the MVC currently mounted (an * indicates an in-process mount).

ALLOC

the volser of the MVC allocated for mounting on the RTD.

HOST

the host that currently owns the RTD.

VTSS

the VTSS that is currently connected to the RTD.

Display Active and Display Queue Output

Figure 39 shows an example of Display Active output.

MIGRATES=3	RECALLS=2	RECLAIMS=0
------------	-----------	------------

Figure 39. Example output from the VT Display command (no detail)

Figure 40 shows example of Display Active DETail output.

FUNCTION	ID	VTV	MVC	RTD	VTSS	Task
Reclaim@	00003	-	-	-	-	RCM
.ReclmMVC	00009	-	DMV055	-	-	RCM
. VtvMover	00012	-	DMV055	-	-	RCM
. Migrate	00024	DY069	DMV068	2A00	DHSS16	RTD
Display@	00027	-	-	-	-	DSP

Figure 40. Example output from a VT Display Active DETail command



Note: *ABORT appears in the display of reclaim requests if the request has cancelled or abended.

Figure 41 shows an example Display Queue DETail output.

FUNCTION	ID	VTV	MVC	RTD	VTSS	Task	REASON
Reclaim@	00003	-	-	-	-	RCM	Child finish
.ReclmMVC	00008	-	DMV053	-	-	RCM	Child finish
. VtvMover	00010	-	DMV053	-	-	RCM	Child finish
. Migrate	00020	-	DMV068	-	DHSS16	DRV	RTD allocation
.ReclmMVC	00009	-	DMV055	-	-	RCM	Child finish
. VtvMover	00012	-	DMV055	-	-	RCM	Child finish
. Recall	00013	DY069	DMV055	2A00	DHSS16	RTD	MVC mount

Figure 41. Example output from a VT Display Queue DETail command

The Function column shows the hierarchy of requests by indenting. The VTSS column shows either a VTSS name or a VTSS list. The Task column shows which task is currently servicing the request (same information as reported in Display Tasks).

Function

One of the following processes:

Audit#

Audit utility request.

Cancel@

Cancel command.

CONSOLID

CONSOLID utility subtask.

CONSOLd#

CONSolid utility task.

Dismount

VTV dismount.

Display@

Display command.

Drain

Drain VTVs from MVC.

Drain@

Drain command.

Migrate

A child of a **VTVMover** request, which is responsible for the migrate portion of the VTV movement.

Migrate@

Migrate command or utility.

Mig_set@

Set migration threshold command.

Mig_thr@

Migrate to threshold command.

Mount

VTV mount.

MVC_chek

Display MVC.

MVCDrain

There is one **MVCDrain** request per MVC being drained.
MVCDrain, which is a child request of a **Drain@** request, is responsible for managing the entire drain process for a single MVC.

MVC_inv

Audit of an MVC.

MVCReclm

There is one **MVCReclm** request per MVC being reclaimed.
MVCReclm, which is a child request of a **Reclaim@** request, is responsible for managing the entire reclaim process for a single MVC.

MVC_upd

Reset MVC status.

QRY/SET@

Display or set command.

Recall

A child of a **VTVMover** request, which is responsible for the recall portion of the VTV movement.

Recall@

Recall command or utility.

Reclaim@

Reclaim command or auto reclaim request.

Scratch

Scratch VTV.

Sel_scr

PGMI select scratch.

Transfer

Transfer VTV between VTSSs.

Unload

Unload MVC from RTD.

Unscratch

Unscratch VTV.

Vary@

Vary RTD.

VTV_chek

Display VTV.

VTSS_inv

Audit of a VTSS.

VTVMover

There is one **VTVMover** request per MVC being drained or reclaimed. This is a child request of either an **MVCDRain** or **MVCReclm** request. This request is responsible for the movement of VTVs from one MVC to another.

VTV_upd

Resynchronize VTV status and CDS.

ID

The process ID, which is a unique number in the range 0 - 65536. When the process ID reaches 65536 it wraps back to zero.

VTV

the volser of the VTV used in the process.

MVC

the volser of the MVC used in the process. **-TERM-** can also appear in this field for reclaim requests. **-TERM-** indicates that the reclaim request is waiting to terminate because it has outstanding child requests, which are usually the outstanding migrate requests.

VTSS

the name of the VTSS that initiated the process.

RTD

the unit address of the RTD used in the process.

REASON

why the request is queued (queued processes only):

CANCELLED

The request is terminating after being cancelled or another failure.

CHILD FINISH

The request has child requests and is waiting for them to finish.

DEVICE LOCK

The device that the request requires is currently locked.

TASK LOCK

The request is waiting for a general task lock to free.

MVC LOCK

The request is waiting for a lock on an MVC to free.

VTV LOCK

The request is waiting for a lock on a VTV to free.

VTD LOCK

The request is waiting for a lock on a VTD to free.

RTD LOCK

The request is waiting for a lock on an RTD to free.

QUEUED

The request is sitting in the input queue of the task.

WAIT RESOURCE

The request is held awaiting a (non-specific) resource becoming available.

RTD ONLINE

The request requires an RTD to be brought online to continue.

RTD ALLOCATION

The request is queued awaiting a RTD to become idle or free.

MVC SELECTION

The request is queued awaiting a MVC or migration slot becoming available.

STEAL A RTD

The request is waiting to steal an RTD allocation from another request.

DBU DROP

The request is currently held because the DBU is high.

MVC MOUNT

The request is waiting for a MVC to be mounted.

Display SCRATCH
Output

Figure 42 shows an example of Display SCRATCH output.

SUBPOOL-NAME	SCRATCH-COUNT
VIR000	14,364
VIR0002	13,582
VIRTUAL	19,132
VIRTUAL1	9,905

Figure 42. Example output from Display SCRATCH

SUBPOOL-NAME

the name of the scratch subpool. Note that VTCS **does not** display scratch counts for non-subpool VTVs. If there are no VTV subpools defined, VTCS defines the Virtual Tapes pool for all VTVs.

SCRATCH-COUNT

the number of available scratch VTVs in the subpool.

Display MVCPool Output

Figure 43 shows an example of Display MVCPool NAME (POOL1) output.

MVCPOOL (POOL1) INFORMATION							
ACS	MEDIA	FREE-MVCS		RECLAIM-MVCS		USED-MVCS	
		VOLS	GB	VOLS	GB	VOLS	GB
00	ECART	120	96	2	0.5	90	45
00	STK1R	30	600	1	3.5	25	350
00	TOTAL	150	696	3	4.0	115	395

Figure 43. Example output from Display MVCPool NAME (POOL1)

Figure 44 shows an example of Display MVCPool output (no pool name specified).

MVCPOOL INFORMATION							
ACS	MEDIA	FREE-MVCS		RECLAIM-MVCS		USED-MVCS	
		VOLS	GB	VOLS	GB	VOLS	GB
00	ECART	310	248	4	1.2	100	65
00	ZCART	120	192	1	0.5	250	400
00	TOTAL	430	440	5	1.7	350	465
01	ECART	90	144	15	6.2	322	485
01	ZCART	35	700	3	11.3	43	675
01	TOTAL	125	844	18	17.5	365	1160
NON-LIB	STK2P	22	1100	0	0	12	1565
NON-LIB	TOTAL	22	1100	0	0	12	1565

Figure 44. Example output from Display MVCPool (no pool name specified)

ACS

the ACS containing the MVC pool. **NONLIB** counts are for initialized MVCs that are now outside the library.

MEDIA

the MVC media type.

FREE-MVCS

MVCs that have 100% usable space and do not contain any migrated VTVs. The storage shown is the total free space based on media type capacity.

RECLAIM-MVCS

MVCs eligible for space reclamation by this host. The storage shown is the total wasted space including those MVCs not yet eligible for space reclaim.

USED-MVCS

Initialized MVCs that are partially or completely full.

Display VTV Output

Figure 45 shows an example of Display VTV output.

VOLSER:	X52638
VTSS:	HBVTSS17
MOUNTED:	8900
UNCOMPRESSED SIZE (MB)	15.30
COMPRESSED SIZE (MB)	3.90
MAXIMUM VTV SIZE (MB)	800
CREATION DATE:	2003JUN18 10:44:08
LAST USED DATE:	2003JUL15 03:10:05
MVC(S):	EVS124 TIM744 EVS122 TIM778
BLOCK-ID(S):	0140065B 0140079 024008ED 0240089F
MANAGEMENT CLASS:	MIG22
STATUS:	INITIALIZED
	RESIDENT
	MIGRATED 4 VTV COPIES

Figure 45. Example output from Display VTV

VOLSER

the volser of the VTV specified in the query.

VTSS

the VTSS where the VTV resides.

MOUNTED

if the VTV is mounted on a VTD, the VTD unit address is displayed.

UNCOMPRESSED SIZE(MB)

the uncompressed size of the VTV (MB).

COMPRESSED SIZE (MB)

the compressed size of the VTV (MB).

MAXIMUM VTV SIZE (MB)

the maximum size of the VTV (400 or 800).

CREATION DATE

the date when the VTV was created in the VTSS.

LAST USED DATE

the date when the VTV was last mounted in the VTSS.

MANAGEMENT CLASS

the VTV's Management Class.

MVC(S)

the MVC(s) where the VTV resides. This entry only appears when the VTV is migrated.

BLOCK-ID

the logical block ID of the beginning of the VTV on the MVC.

STATUS

one or more of the following statuses:

CONSOLIDATED

VSM has consolidated the VTV.

DUPLEXED

The DUPLEX attribute has been assigned to this VTV. When VSM migrates the VTV, a copy will be written to two MVCs.

INITIALIZED

VTCS has used the VTV at least once.

MIGRATED

VSM has migrated the VTV.

RESIDENT

The VTV is resident on the VTSS.

SCRATCH

The VTV is in scratch status.

UNINITIALIZED

The VTV has been defined via the CONFIG utility, but has not ever been used.

REPLICATION REQUIRED

This VTV should be replicated and is currently waiting for replication.

REPLICATION STARTED

Replication is active for this VTV but not yet complete.

REPLICATION COMPLETE

A fully replicated copy of this VTV is now resident in the Secondary VTSS.

Display MVC Output

Figure 46 shows an example of Display MVC output.

VOLSER:	9940245
VTV COUNT:	1
MEDIA:	STK2P
ACSID:	00
SIZE(MB):	10240
%USED:	0.01
%FRAGMENTED:	5.66
%AVAILAABLE	94.33
%USABLE	0.00
TIMES MOUNTED:	4
LAST MOUNTED	2003APR21 05:53:28
OWNER:	LOCAL
VTSS:	HBVTSS08
MVCPPOOL:	POOL1
SECURITY ACCESS:	UPDATE
STATUS:	INITIALIZED
	IN ERROR
	DATA CHECK

Figure 46. Example output from Display MVC

VOLSER

the volser of the MVC.

VTV COUNT

the number of VTVs on the MVC.

MEDIA

the volume media.

ACSID

the ACS that contains the MVC.

SIZE(MB)

the size of the MVC in megabytes

%USED

the percentage of the MVC used by valid VTVs.

%FRAGMENTED

the percentage of the MVC that has invalid VTV space that is not available for use until it is reclaimed or the MVC is drained.

%AVAILABLE

the percentage of the MVC that is physically available for use.

%USABLE

the percentage of space on the MVC that can be used by VTCS. This may be zero even if there is still space physically available. For instance, if the VTV per MVC limit is reached then the %Usable will be reported as 0%. Similarly, if an error has been reported against an MVC then VTCS will not use this MVC for output and the %Usable will be reported as %0.

TIMES MOUNTED

the number of times the MVC has been mounted for writing or reading since it was added to the MVC inventory.

LAST MOUNTED

the date and time the MVC was last mounted.

OWNER

the Storage Class that owns the MVC.

VTSS

the last VTSS that wrote to the MVC. CONSOLIDATE appears in this field for consolidated VTVs.

MVCPPOOL

either an MVC Pool Name (including DEFAULTPOOL) or **NO** if the MVC is not defined on an MVCPool statement.

SECURITY ACCESS

VTCS permissions for the MVCs defined in an MVCPPOOL statement (**UPDATE**, **NO UPDATE**, or **NO PROFILE**).

STATUS

one of the following statuses:

BROKEN

This is a generic error that indicates the MVC, drive, or combination of the two has a problem. VTCS attempts to de-preference MVCs with this state. **In general**, to clear this state:

- If the MVC caused the problem, use a DRAIN(EJECT) command to remove the MVC from service.
- If the RTD caused the problem, use the MVCMAINT utility to reset the MVC state.

Note also that one or more of the following messages is issued for BROKEN status: SLS6686, SLS6687, SLS6688, SLS6690. For detailed recovery procedures for these messages, see *VTCS Messages and Codes*.

DATA CHECK

A data check condition has been reported against this MVC. VTCS attempts to de-preference MVCs with this state. To clear this state:

- If all VTVs on the MVC are duplexed, use MVCDRAIN on the MVC without the Eject option. This recovers all VTVs and removes the MVC from service.
- If all VTVs on the MVC are not duplexed, VTCS AUDIT the MVC. The audit will probably fail. After the audit, do an MVCDRAIN (no eject). This recalls the VTVs before the data-check area in ascending block-id order and the VTVs after the data-check area in a descending block-id order. Processing the VTVs in this sequence ensures that VTCS recovers as many VTVs as possible from the media. You then need to recreate the data for any VTVs still on the MVC.

DRAINING

The MVC is either currently being drained or has been the subject of a failed MVCDRAIN.

IN ERROR

An error occurred while the MVC was mounted.

INITIALIZED

the MVC has been initialized.

LOST - FAILED TO MOUNT

VTCS attempted to mount an MVC and the mount did not complete within a 15-minute time-out period. VTCS is attempting to recover from a situation that may be caused by hardware problems, HSC problems, or by the MVC being removed from the ACS. VTCS attempts to de-preference MVCs with this state.

If VTCS does perform a subsequent successful mount of an MVC with LOST(ON) state, VTCS sets the state to LOST(OFF).

Determine the cause of the error and fix it. You can also use the VTCS MVCMAINT utility to set LOST(OFF) for the following events:

- LOST(ON) was set due to LSM failures or drive errors that have been resolved
- LOST(ON) was set because the MVC was outside the ACS and has been reentered.

MARKED FULL

The MVC is full and is not a candidate for future migrations.

MOUNTED

The MVC is mounted on an RTD.

NOT-INITIALIZED

The MVC has been defined via the CONFIG utility, but has not ever been used.

READ ONLY

The MVC has been marked read-only because of one of the following conditions:

- The MVC being the target of an export or consolidation process. The read-only state protects the MVC from further updates.
- The MVC media is set to file protect. Correct the error and use the MVCMAINT utility to set READONLY (OFF).
- The MVC does not having the appropriate SAF rules set to enable VTCS to update the MVC. Correct the error (for more information, see “Defining a Security System User ID for HSC, SMC, and VTCS” in Chapter 2 of *VTCS Installation and Configuration Guide*) and use the MVCMAINT utility to set READONLY (OFF).

BEING AUDITED

The MVC is either currently being audited or has been the subject of a failed audit. If the audit failed, VTCS will not use the MVC for migration. To clear this condition, rerun the AUDIT utility against this MVC.

LOGICALLY EJECTED

The MVC has either been the subject of an MVCDRAIN Eject or the MVC was ejected for update by a RACROUTE call. The MVC will not be used again for migration or recall. To clear this condition, use MVCDRAIN against the MVC without the Eject option.

RETIRED

The MVC is retired. VTCS will recall from, but not migrate to, the MVC. Replace the MVC as soon as possible.

WARRANTY HAS EXPIRED

The MVC’s warranty has expired. VTCS continues to use the MVC. You should start making plans to replace the MVC when it reaches Retired state.

INVALID MIR

VTCS has received status from an RTD to indicate the MIR (media information record) for a 9x40 media is invalid. An invalid MIR does not prevent access to data but may cause significant performance problems while accessing records on the tape. The MVC is not capable of high-speed searches on areas of the tape that do not have a valid MIR entry.

VTCS attempts to de-preference MVCs with this condition. For recalls, if the VTV resides on multiple MVCs, VTCS selects MVCs with valid MIRs ahead of MVCs with invalid MIRs. VTCS avoids using MVCs with invalid MIRs for migration, unless the migration is at the beginning of the tape. Migrating from the beginning of tape will correct the MIR.

VTCS detects the invalid MIR condition at either mount time or dismount time. If detected at mount time and the operation can be completed with another MVC, VTCS dismounts the first MVC and selects the alternate MVC. **Note that** VTCS has only a limited ability to switch to an alternate MVC. That is, it is mainly used for migrate and virtual mount.

For MVCs with invalid MIRs, determine the cause of the error, which may be caused by media or drive problems, and fix the error.

To recover an MVC with an invalid MIR, you simply need to read the MVC to the end of the tape, which can be done via a VTCS audit. If the media is the problem, run an MVCDRAIN EJECT to recall the VTVs and cause the MVC to be removed from the MVC pool.

Display CONFIG
Output

Figure 47 shows an example of Display CONFIG output.

MAXVTV	MVCFREE	VTVATTR	RECALWER			
4000	10	SCRATCH	YES			
CDS LEVEL SUPPORT:	V5	V5.1	V6	V6+		
				*		
RECLAIM:	THRESHOLD	MAXMVC	START	CONMVC		
	30	10	10	2		
VTSSNAME		AUTO MIGR THR		MIGR TASKS	DEFAULT	RETAIN
	LOW	HIGH	MIN	MAX	ACS	
HBVTSS16	60	80	1	1	FF	10
HBVTSS17	60	80	1	4	02	10
HBVTSS18	60	80	4	4	01	10
HBVTSS19	60	80	1	1	01	10
VTSSNAME	RTD NAME	RTD DEVNO	RTD TYPE	RTD-ACS	RTD-CHANIF	
HBVTSS16	SS162A00	2A00	9490	00	0A	
HBVTSS16	SS162A01	2A01	9490	00	0K	
HBVTSS16	SS162A02	2A02	9490	00	0I	
HBVTSS16	SS162A0C	2A0C	9840	02	1C	

Figure 47. Example output from Display CONFIG

MAXVTV

the GLOBAL MAXVTV setting.

MVCFREE

the GLOBAL MVCFREE setting.

VTVATTR

the GLOBAL VTVattr setting (**SCRATCH** or **ALLmount**).

RECALWER

the GLOBAL RECALWER setting (**YES** or **NO**).

CONMVC

the RECLAIM CONMVC setting.

CDSLEVEL SUPPORT

the VTCS level(s) that can access the active CDS. For more information, see VTCS Installation and Configuration Guide, Chapter 4, “Reconfiguring NCS,” “Converting the Formatted CDS to VSM Extended Format.”

THRESHOLD

the RECLAIM THRESHLD setting.

MAX MVC

the RECLAIM MAXMVC setting.

START

the RECLAIM START setting.

VTSSNAME

the VTSS identifiers (VTSS NAME settings).

AUTO MIGR THR, LOW

The low automatic migration threshold setting (LAMT) for the VTSS.

AUTO MIGR THR, HIGH

The high automatic migration threshold setting (HAMT) for the VTSS.

MIGR TASKS, MIN

The minimum number of concurrent automatic migration tasks setting (MINMIG) for the VTSS.

MIGR TASKS, MAX

The maximum number of concurrent automatic migration tasks setting (MAXMIG) for the VTSS.

DEFAULT ACS

The default ACS setting (DEFLTACS) for the VTSS.

DEVNO

the RTD MVS device numbers for the VTSS (RTD DEVNO settings).

RTD TYPE

the RTD type.

ACS

the ACS that contains the RTD.

RETAIN

the VTSS RETAIN setting.

VTSSNAME

the VTSS identifiers (VTSS NAME settings) of the VTSSs connected to the RTD.

RTD NAME

the RTD names for the VTSS (RTD NAME settings).

RTD-CHANIF

the RTD channel interface (RTD CHANIF settings).

**Display MIGrate
Output**

Figure 48 shows an example of Display MIGrate output.

```
VTSSNAME: HBVTSS16    ACTIVE MIGRATION TASKS: 4
IMMEDIATE MIGRATE: MAX WAIT: 5 MINUTES
AUTO MIGRATE: HOST: EC2OMIGRATION TARGET: 70%
```

Figure 48. Example output from Display MIGrate

ACTIVE MIGRATION TASKS

the total number of migration tasks (automatic, immediate, and migrate-to-threshold).

IMMEDIATE MIGRATE

either **Not active** if there are no current or pending immediate migrations or the maximum time that any VTV has been waiting for immediate migration.



Note: This field only shows status for the LPAR on which the query was issued.

AUTO MIGRATE

either **Not active** or the name of the host and migration target (LAMT or specified threshold for a migration-to-threshold) if auto migration is active on any host.

Display MIGrate
DEtail Output

Figure 49 shows an example of the additional fields from Display MIGrate DEtail output.

STORAGE	ACS	MAX	ONL RTD	ACTIVE	AUTO	IMMED	WEIGHT	TIMES
CLASS		TASKS	TASKS	TASKS	?	?	PERCENT	SKIPPED
HBVTSS16	00	4	4	2	Y	N	50	0
HBVTSS16	01	2	1	1	Y	N	25	0
STORCL100	00	5	4	1	Y	N	15	0
!ERROR	01	3	3	0	Y	N	10	1
** Error time: 2003Aug29 08:58:39 Reason: All RTDs offline								

Figure 49. Example additional output from Display MIGrate DEtail

STORAGE CLASS

the Storage Class associated with the migration.

Note: If you do not explicitly assign a Storage Class, an MVC’s default Storage Class is the name of the last VTSS that wrote to the MVC for reclamation or migration and this class has the VTCS default media selections. To change these defaults, create a Storage Class with the VTSS name and specify the desired media selection order.

ACS

the ACS defined for the Storage Class.

MAX TASKS

the maximum number of RTD tasks based on the Storage Class and RTD configuration definitions.

ONL RTD TASKS

the maximum number of tasks for those RTDs that are actually online (**MAX TASKS** minus the number of offline RTDS).

ACTIVE TASKS

the number of migration tasks currently active for the Storage Class.

AUTO ?

indicates whether the Storage Class contains automatic migration VTVs.

IMMED ?

indicates whether the Storage Class contains immediate migration VTVs.

WEIGHT PERCENT

the priority of the Storage Class compared to other Storage Classes for the VTSS. Storage Classes with higher priorities are assigned a greater proportion of migration tasks.

TIMES SKIPPED

the number of times the scheduling process skipped this Storage Class.



Note: Any Storage Classes in error (shown as !ERROR) also display an additional line indicating the last time the error was detected and the type of error (no RTDs available, all RTDs offline, no MVCs available).

Display TASKs Output

Figure 50 shows an example of Display TASKs output.

TASK NBR	TASK TYPE	VTSS	RTD	CURRENT PROCESS	WAITQ COUNT	PENDQ COUNT
000	DSP			518		
001	SS	HBVTSS16	SS16B200			
002	RTD	HBVTSS16	SS16B201			
003	RTD	HBVTSS16	SS160B79			
004	RTD	HBVTSS16	SS160B7A		1	
005	RTD	HBVTSS16	SS160B7C			

Figure 50. Example output from Display TASKs

TASK

the task number for each task on the current host.

TYPE

the task type.

VTSS

the VTSS name.

RTD

the RTD name for RTD tasks.

CURRENT PROCESS

the current process ID.

WAITQ COUNT

the count of requests waiting for locks.

PENDQ COUNT

the count of pending requests.

Display LOCKs Output

Figure 51 shows an example of Display LOCKs output.

SLOT	OWNING	TASK	TASK	VTD	MVC	VTV	WAITING	WAITING
ID	HOST	NBR	TYPE				HOST	TASK
002	EC21	006	RTD		EVS101		EC10	007
003	EC20	010	RTD		EVS145	X15328		
004	EC20	010		A91E		X153234		

Figure 51. Example output from Display LOCKs

SLOT ID

Slot ID of the lock within the lock buffer.**OWNING HOST**
the host that owns the lock.

TASK NBR

the task number associated with the lock.

TASK TYPE

the task type.

VTD

the associated VTD address on the issuing host.

MVC

the locked MVC.

VTV

the locked VTV.

WAITING HOST

the host waiting for the lock or **ALL** if multiple hosts are waiting.

WAITING TASK

the task waiting for the lock or **ALL** multiple tasks are waiting.

Display CLINK Output

Figure 52 shows an example of Display CLINK output.

VTSS	CLINK	STATUS	USAGE	HOST
HBVTSS19	7	ONLINE	REPLICATING	EC21
	6	ONLINE	FREE	
	5	ONLINE	FREE	
	4	ONLINE	FREE	

Figure 52. Example output from Display CLINK

VTSS

the Primary or Sending VTSS name.

CLINK

the link ID.

STATUS

one of the following link statuses:

Maint

The link has failed or it has been varied into maintenance mode.

Offline

The link is offline and unavailable to all hosts and VTSSs.

Online

Available for replication.

P_offline

The link is pending offline

P_online

The link is pending online

Recovery

The link is being reset following an error or a vary online operation.

Unusable

Not available for replication due to hardware errors or assigned-elsewhere conditions.

USAGE

one of the following link usages:

Assigned

Link is assigned to the host in the HOST field but is not currently replicating. This usage occurs when VTCS is starting or terminating link use or is attempting error recovery on the link after a replication failure.

Free

Link is idle (not doing replications).

Replicating

Link is actively doing replications.

HOST

the host that the link is assigned to.

Display CLUSTER Output

Figure 53 shows an example of Display CLUSTER output.

NAME	VTSS	STATE	DIRECTION	VTSS	STATE	MODE
CLUSTER1	HBVTSS16	ONLINE	----->	HBVTSS17	ONLINE	FULL-FUNCTION
CLUSTER2	HBVTSS18	ONLINE	<-----	HBVTSS19	QUIESCED	DEGRADED
CLUSTER3	HBVTSS20	ONLINE	<-----	HBVTSS21	ONLINE	FULL-FUNCTION
CLUSTER4	HBVTSS22	QUIESCED	<----->	HBVTSS23	ONLINE	DEGRADED

Figure 53. Example output from Display CLUSTER

NAME

the Cluster name.

VTSS

one of the VTSS in a Cluster.

DIRECTION

One of the following:

----->

OR

<-----

Indicates the direction of VTV replication in uni-directional Cluster. VTVs can only be replicated from the Sending to the Receiving VTSS.

<----->

Indicates that the VTSSs are configured as a Bi-Directional (Peer-to-Peer) Cluster. VTVs can be replicated from either VTSS to the other.

STATE

one of the following VTSS states:

QUIESCING

Quiescing state.

QUIESCED

Quiesced state.

OFFLINE

Offline state.

OFFLINE-P

Offline pending state.

ONLINE

Online state.

ONLINE-P

Online pending state.

STARTED

The VTSS is initialized and in process of going to the requested state (online, offline, or quiesced).

MODE

one of the following Cluster operating modes:

FULL-FUNCTION

Both VTSSs in the Cluster are online to VTCS. Production workload can go to either VTSS, but in the case of a Uni-Directional (Primary/Secondary) Cluster, VTVs can only be replicated from the Sending VTSS.

DEGRADED

One of the two VTSSs in a Bi-Directional (Peer-to-Peer) Cluster is either offline or quiesced. Production workload can go to the remaining online VTSS. VTVs requiring replication, however, are allocated to the remaining VTSS only if no other Full-Function clusters are available and suitable. In this case, replicate VTVs are migrated immediately with keep and queued for replication when the other VTSS comes online.

When the other VTSS comes online, VTCS reconciles the contents of both VTSSs.

DEGRADED SECONDARY

The Primary is online to VTCS and the Secondary is either offline or quiesced. Workload can run on the Primary. VTVs requiring replication, however, are allocated to the Primary only if no other Full Function Clusters are available. In this case, Replicate VTVs are migrated immediately with keep and are queued for replication, which occurs when the Secondary comes online.

DEGRADED PRIMARY

The Secondary is online to VTCS and the Primary is either offline or quiesced. Workload can run on the Secondary. VTVs requiring replication, however, are allocated to the Secondary only if no other Full Function Clusters are available. When the Primary comes back Online, VTCS reconciles the contents of the Primary and Secondary.

NON-OPERATIONAL

No workload is possible on this Cluster.

Display REPLICat Output

Figure 54 shows an example of Display REPLICat output.

VTSS	HOST	QDEPTH
HBVTSS19	EC10	0
	EC20	0
	EC21	1
	ECCL	0
	ECCY	1
	EC31	0

Figure 54. Example output from Display REPLICat

VTSS

the Primary VTSS name.

HOST

the hosts attached to the Primary VTSS.

QDEPTH

the number of VTVs waiting to be replicated.

EXPORT

EXPORT consolidates VTVs (if required) and creates a manifest file that lists the VTVs and MVCs available for export from a VSM system.



Note: EXPORT is valid only if FEATures VSM(ADVMGMT) is specified; for more information, see “FEATURES Control Statement” on page 204.

Syntax

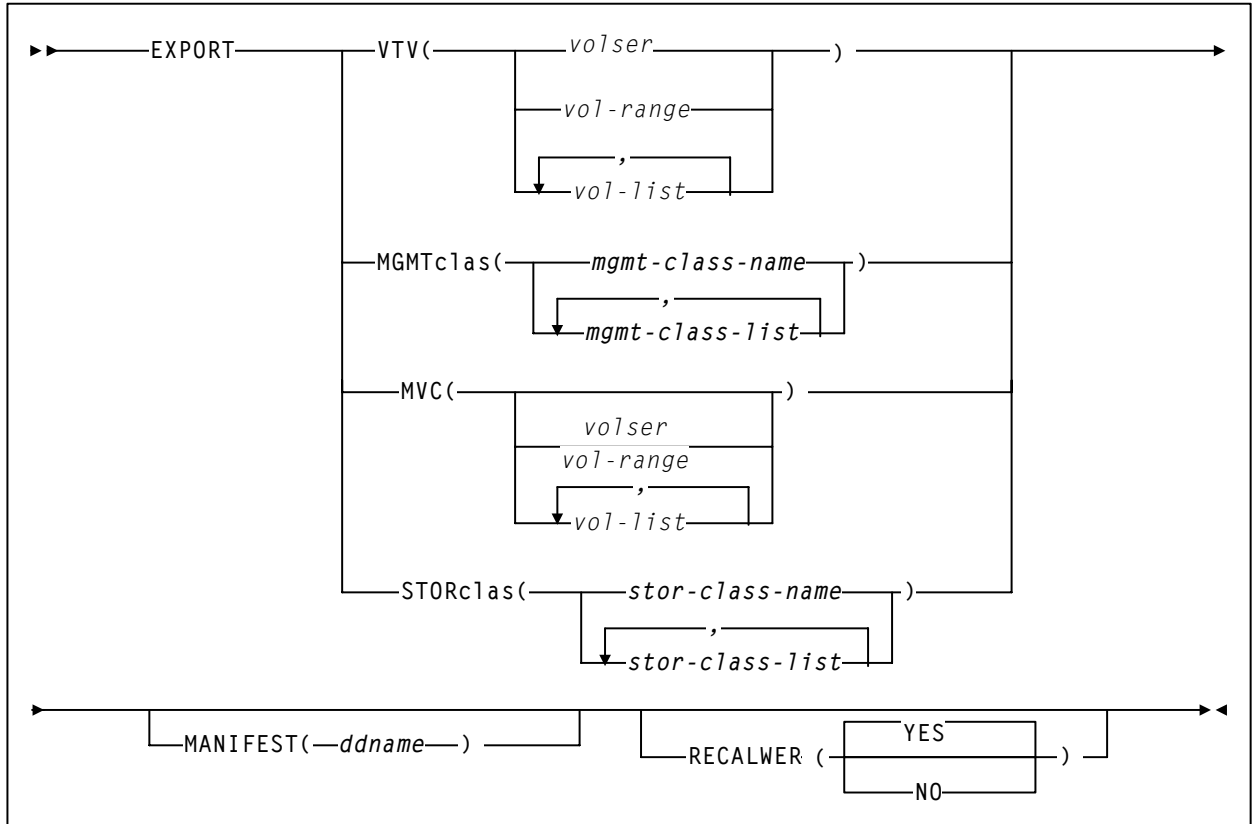

Figure 55. EXPORT utility syntax

Parameters

- VTV**
specifies one or more VTVs to consolidate for export.
volser, *vol-range* **or** *vol-list*
the volsers of one or more VTVs. You can specify an unlimited number of VTVs.
- MGMTclas**
specifies one or more Management Classes that determine one or more VTVs to consolidate for export.
mgmt-class-name | *mgmt-class-list*
the names of one or more Management Classes that you defined on the MGMTclas control statement; for more information, see “MGMTCLAS Control Statement” on page 214.
- MVC**
specifies one or more MVCs for export.
volser, *vol-range* **or** *vol-list*
the volsers of one or more MVCs.
- STORclas**
specifies one or more Storage Classes that determine one or more MVCs for export.
stor-clas-name | *stor-clas-list*
the names of one or more Storage Classes that you defined on the STORclas control statement; for more information, see “STORCLAS Control Statement” on page 229.
- MANIFEST**
specifies the output destination ddname of the manifest file.
ddname
ddname of the manifest file. The default is MANIFEST.
- RECALWER**
specifies whether VTCS recalls VTVs with read data checks.
YES
recall VTVs with read data checks (the default).
NO
Do not recall VTVs with read data checks.

Interfaces

SWSADMIN utility only.

Usage

Use the EXPORT utility to create a manifest file that lists the VTVs and MVCs (which are marked readonly) available for export from a VSM system. You can create this manifest file by specifying either:

- The VTV or MGMT parameters, which select the VTVs for export and consolidates the selected VTVs. These type of exports require that HSC is running and the CDS is active.
- The MVC or STOR parameters, which select the MVCs (and the VTVs they contain) for export. These type of exports can be run when HSC is down and the CDS is inactive. For example, if you lose all resources at the source VSM system except a copy of the CDS and MVCs containing all the source system's VTVs, you can run EXPORT against the CDS copy at the target VSM system to create a manifest file, then do an import to recreate the source system resources.



Note: The manifest file includes a checksum, which is written at the end of the file, and which covers the entire file. If a manifest file is changed, including writing to it with DISP=MOD, the checksum is invalid and the manifest file is unusable for import.



Note: An export also generates MVC summary and detail reports. For more information, see “MVC RPT” on page 132.

Optional and Required JCL

STEPLIB

specifies the link library (SLSLINK) that contains the VTCS and HSC modules (required).

manifest file DD

DD statement for the manifest file (optional).

SLSPRINT

specifies the destination for the EXPORT report (required).

SLSIN

specifies the input to the SWSADMIN program (EXPORT utility name and parameters) (required).

JCL Examples

Figure 56 shows example JCL to run the EXPORT utility. In this example, the VTV parameter specifies consolidating VTV100 to VTV200 to MVCs for export. The output manifest file is REMOTE1.

Figure 56. EXPORT utility example: specifying VTVs to consolidate for export

```
//EXPORT EXEC PGM=SWSADMIN, PARM='MIXED'  
//STEPLIB DD DSN=h1q.SLSLINK, DISP=SHR  
//REMOTE1 DD DSN=FEDB.VSMLMULT.REMOTE1, DISP=(,CATLG,DELETE),  
// UNIT=SYSDA, SPACE=(CYL,(1,1),RLSE),  
// DCB=(RECFM=FB,LRECL=80,BLKSIZE=27920)  
//SLSPRINT DD SYSOUT=*  
//SLSIN DD *  
EXPORT VTV (VTV100 - VTV200) MANIFEST(REMOTE1)
```

Figure 57 shows example JCL to run the EXPORT utility. In this example, the STOR parameter specifies making available for export the MVCs in Storage Class REMOTE. The output manifest file is REMOTE2.

```
//EXPORT EXEC PGM=SWSADMIN, PARM='MIXED'  
//STEPLIB DD DSN=h1q.SLSLINK, DISP=SHR  
//REMOTE2 DD DSN=FEDB.VSMLMULT.REMOTE2, DISP=(,CATLG,DELETE),  
// UNIT=SYSDA, SPACE=(CYL,(1,1),RLSE),  
// DCB=(RECFM=FB,LRECL=80,BLKSIZE=27920)  
//SLSPRINT DD SYSOUT=*  
//SLSIN DD *  
EXPORT STOR (REMOTE) MANIFEST(REMOTE2)
```

Figure 57. EXPORT utility example: specifying Storage Class to determine MVCs for export

IMPORT

IMPORT imports VTVs and MVCs listed on a manifest file into a VSM system.



Note: IMPORT is valid only if FEATures VSM(ADVMGMT) is specified; for more information, see “FEATURES Control Statement” on page 204.

Syntax

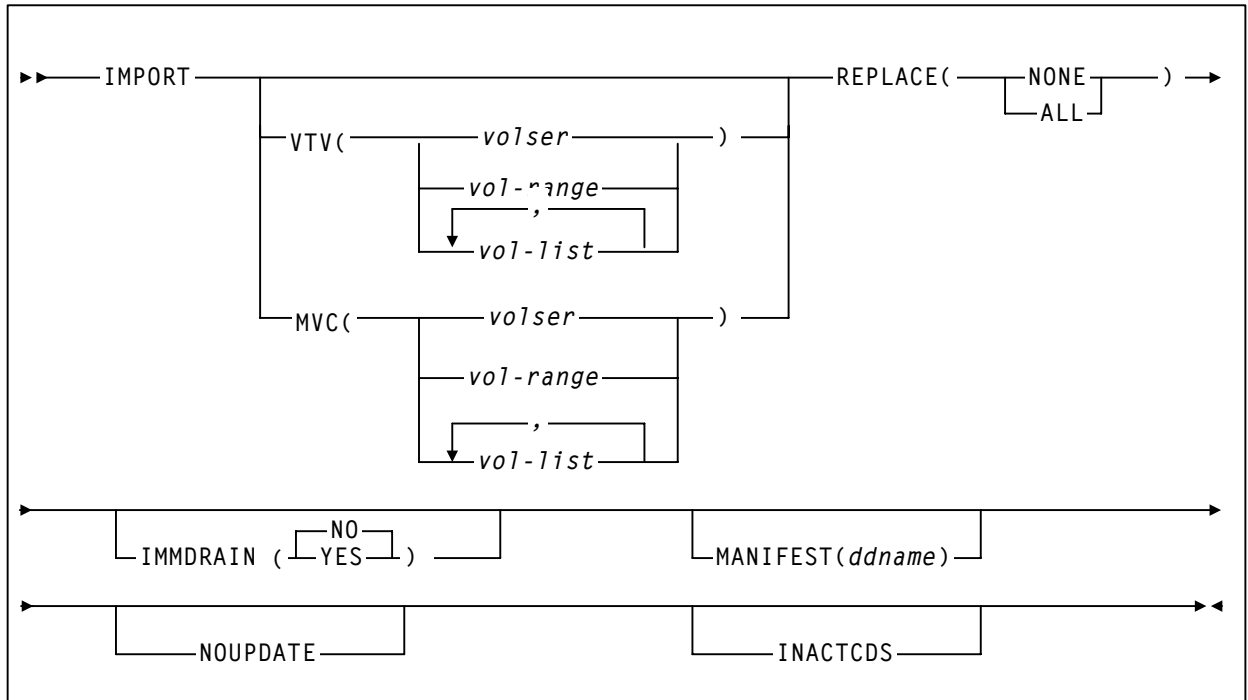

Figure 58. IMPORT utility syntax

Parameters

VTV

specifies one or more VTVs to import.

volser, *vol-range* **or** *vol-list*
the volsers of one or more VTVs.

MVC

specifies one or more MVCs to import.

volser, *vol-range* or *vol-list*
the volsers of one or more MVCs.

REPLACE

specifies whether VSM replaces the VTV record in the target CDS. There is no default; you must specify a value.

NONE

Do not replace the VTV record. VTCS only creates new records for VTVs that are not duplicates and replaces records for VTVs not initialized in the target CDS.

ALL

Replace any duplicate VTV records in the target CDS.



Caution: Ensure that you actually want to replace duplicate VTV records in the target CDS before you specify the ALL parameter! You may want to do a “validate” run with NOUPDATE to see which VTV records will be replaced.

Also note that if a VTV record is replaced, all existing VTSS and MVC copies of the VTV are invalidated.

Finally, you cannot import an MVC if the target CDS records show that the MVC contains VTVs, even if you specify REPLACE(ALL). In this situation, you must first drain (with eject) the MVC on the target system and eject it from the ACS. You can then import the MVC that you exported from the source system.

IMMDRAIN

specifies whether VSM will immediately drain imported MVCs.

NO

Do not drain MVCs (the default).

YES

Drain MVCs.

MANIFEST

specifies the input ddname of the manifest file.

ddname

ddname of the manifest file. The default is MANIFEST.

NOUPDATE

specifies that VSM does not update the CDS, validates the import operation, and writes information messages to the job log.

INACTCDS

specifies that the import uses a different CDS from the CDS currently active on the HSC system where you are running the import job. You specify the alternate CDS in the SWSADMIN JCL. **Note that** if HSC is down on the system where you are running the import job, the CDS on that system is assumed to be inactive, so you do not need to specify INACTCDS.

Interfaces

SWSADMIN utility only.

Usage

Use the IMPORT utility to import VTVs and MVCs listed on a manifest file into a VSM system. Typically, you do a “validation” import run, as shown in Figure 59 on page 99, followed by an actual import, as shown in Figure 60 on page 99. Imported MVCs are readonly; for information on making them writable, see “MVCMAINT” on page 117.

Note that you can specify a merged manifest file or multiple manifest files.



Note: For each VTV imported, the only MVC copies that will be created will be for MVCs that have been exported and imported via the same statements.

This has a particular significance when importing Duplexed VTVs. Such a VTV will only have copies on both MVCs after the import if both MVCs are present in the same Manifest file and imported as a result of the same IMPORT statement.



Note: An import also generates MVC summary and detail reports. For more information, see “MVC RPT” on page 132.

Importing to an Active or Inactive CDS

As described in “INACTCDS” on page 95, you can import to an inactive CDS in two ways: (1) HSC is down on the system where you are running the import job and the CDS is inactive. This **does not** require you to specify the INACTCDS parameter or (2) You specify the INACTCDS parameter and on the SWSADMIN JCL you specify an alternate CDS (not the CDS being used by HSC/VTCS on the system where you are running the import job).

How does import to an inactive CDS work? Basically, as follows:

1. The CDS is reserved **for the duration of the import** to prevent HSC (on any host) from using the CDS while the import is active. When it starts, the import job checks that the CDS is not in use by HSC on any host. The reserve also ensures that HSC is not started while the import job is running. Additionally the Utilities Reserve (major name STKENQNM, minor name -SLUDBRSV) is obtained **for the duration of the import**, which stops other utilities from running against any CDS while import is running.
2. All MVC/VTV records from the CDS are copied to a data space.
3. The data space is updated with the imported MVCs/VTVs.
4. All MVC/VTV updates are written back to the CDS from the data space.
5. The CDS is Released, as is the Utilities Reserve.

What are guidelines for choosing to import to an active vs. an inactive CDS? **In general**, if you are importing a small amount of data to a large CDS, import to an active CDS runs faster. If you are importing a large amount of data, **generally speaking**, import to an inactive CDS runs faster. Table 3 summarizes the differences between importing to an active or inactive CDS.

Table 3. Comparison: Importing to Active or Inactive CDS

Import to Active CDS	Import to Inactive CDS
Requires HSC/VTCS to be active on the system where the import job runs. HSC/VTCS must be at FULL service mode (that is, HSC cannot be at BASE mode).	If INACTCDS is not specified, HSC should be inactive on the system where the import job runs. If INACTCDS is specified, HSC can be inactive or active and at FULL service level on the system where the import job runs. If HSC is active, it must be using a different CDS than the one used by import.
The IMPORT JCL must either not specify a CDS or must specify the same CDS as is used by HSC/VTCS on the system where the import job runs.	The IMPORT JCL must specify (via //SLSCNTL and, if appropriate, //SLSCNTL2 and //SLSSTBY) the CDS that is to be updated with the imported data. The specified CDS cannot be in use by HSC on any host.
Supports IMMRAIN(YES).	Does NOT support IMMRAIN(YES) because the import job requires an active HSC/VTCS, using the same CDS as used by IMPORT, to drain an MVC.
Deletes, from the relevant VTSS, any VTVs that are being imported and replaced that were resident before the import began.	Does not delete, from the relevant VTSS, any VTVs that are being imported and replaced that were resident before the import began. VTCS issues a message that the deletion cannot be performed. An Audit of the relevant VTSS will be required to resynchronize the VTSS and the CDS.
Writes SMF records.	Does not write SMF records.

JCL Requirements

STEPLIB

specifies the link library (SLSLINK) that contains the VTCS and HSC modules.

manifest file DD

DD statement for the manifest file.

SLSPRINT

specifies the destination for the IMPORT report.

SLSIN

specifies the input to the SWSADMIN program (IMPORT utility name and parameters).

SLSCNTL

Specifies the Primary CDS. **Not required** if importing to the CDS being used by the HSC/VTCS system that is active on the system where the import job runs. Otherwise it is required, to specify the Primary CDS to be updated by import.

If you specify the INACTCDS parameter, this CDS must be **different** from the CDS being used by HSC/VTCS (if active).

SLSCNTL2

Specifies the Secondary CDS, if it exists. **Not required** if importing to the CDS being used by the HSC/VTCS system that is active on the system where the import job runs. Otherwise it is required, to specify the Secondary CDS to be updated by import.

If you specify the INACTCDS parameter, this CDS must be **different** from the CDS being used by HSC/VTCS (if active).

SLSSTBY

Specifies the Standby CDS, if it exists. **Not required** if importing to the CDS being used by the HSC/VTCS system that is active on the system where the import job runs. Otherwise it is required, to specify the Standby CDS to be updated by import.

If you specify the INACTCDS parameter, this CDS must be **different** from the CDS being used by HSC/VTCS (if active).

JCL Examples

JCL Example: IMPORT Validation Run, HSC is Active

Figure 59 shows example JCL to run the IMPORT utility. In this example, the MANIFEST parameter specifies importing all MVCs and VTVs listed on input manifest file REMOTE1. This example shows a “validation” run where:

- REPLACE(NONE) (the default) specifies that VTCS does not overwrite duplicate VTVs.
- IMMDRAIN(NO) (the default) specifies that VTCS does not drain all imported VTVs to VTSS space.
- NOUPDATE specifies that the CDS is not updated.
- HSC is active.

```
//IMPORT EXEC PGM=SWSADMIN,PARM='MIXED'  
//STEPLIB DD DSN=h1q.SLSLINK,DISP=SHR  
//REMOTE1 DD DSN=FEDB.VSMLMULT.REMOTE1,DISP=SHR  
//SLSPRINT DD SYSOUT=*  
//SLSIN DD *  
IMPORT MANIFEST(REMOTE1) NOUPDATE
```

Figure 59. IMPORT utility example: validation import run, HSC is active

JCL Example: Import Production Run, HSC is Active

Figure 60 shows example JCL to run the IMPORT utility. In this example, the MANIFEST parameter specifies importing all MVCs and VTVs listed on input manifest file REMOTE1. This example shows an actual import run where:

- REPLACE(ALL) specifies that VTCS overwrites all duplicate VTVs.
- IMMDRAIN(YES) specifies that VTCS drains all imported VTVs to VTSS space.
- The NOUPDATE parameter is not specified so that the CDS is updated.
- HSC is active.

```
//IMPORT EXEC PGM=SWSADMIN,PARM='MIXED'  
//STEPLIB DD DSN=h1q.SLSLINK,DISP=SHR  
//REMOTE1 DD DSN=FEDB.VSMLMULT.REMOTE1,DISP=SHR  
//SLSPRINT DD SYSOUT=*  
//SLSIN DD *  
IMPORT MANIFEST(REMOTE1) REPLACE(ALL) IMMDRAIN(YES)
```

Figure 60. IMPORT utility example: actual import run, HSC is active

JCL Example:
IMPORT Using
Multiple File
Generations, HSC is
Active

Figure 61 shows example JCL to run the IMPORT utility. In this example, the MANIFEST parameter specifies importing multiple generations of a file, HSC is active, and VTCS overwrites all duplicate VTVs via the REPLACE(ALL) parameter.

```
//IMPORT EXEC PGM=SWSADMIN, PARM='MIXED'  
//STEPLIB DD DSN=h1q.SLSLINK, DISP=SHR  
//ALLGEN DD DISP=SHR, DSN=EXPORT(0)  
// DD DISP=SHR, DSN=EXPORT(-1)  
// DD DISP=SHR, DSN=EXPORT(-2)  
// DD DISP=SHR, DSN=EXPORT(-3)  
// DD DISP=SHR, DSN=EXPORT(-4)  
// DD DISP=SHR, DSN=EXPORT(-5)  
//SLSPRINT DD SYSOUT=*  
//SLSIN DD *  
IMPORT MANIFEST(ALLGEN) REPLACE(ALL)
```

Figure 61. IMPORT utility example: import multiple file generations, HSC is active

JCL Example:
IMPORT with No HSC
Active on the System
Where Import is to
Run, No Hosts Using
the CDS

Figure 62 shows example JCL to run the IMPORT utility with Manifest File DMFST. In this example:

- No HSC is active on the system where IMPORT is to run, so the SLSCNTL, SLSCNTL2, and SLSSTBY DD statements are specified.
- When HSC is active it uses FEDB.PROD.DBASExxx.
- No hosts are using the CDS.
- VTCS overwrites all duplicate VTVs via the REPLACE(ALL) parameter.

```
//IMPORT EXEC PGM=SWSADMIN, PARM='MIXED'  
//STEPLIB DD DSN=h1q.SLSLINK, DISP=SHR  
//SLSPRINT DD SYSOUT=*  
//SLSCNTL DD DSN=FEDB.PROD.DBASEPRM, DISP=SHR  
//SLSCNTL2 DD DSN=FEDB.PROD.DBASESEC, DISP=SHR  
//SLSSTBY DD DSN=FEDB.PROD.DBASETBY, DISP=SHR  
//DMFST DD DSN=FEDB.PROD.DMFST, DISP=SHR  
//SLSIN DD *  
IMPORT MANIFEST(DMFST) REPLACE(ALL)
```

Figure 62. IMPORT utility example: IMPORT with No HSC Active on the System Where Import is to Run, No Hosts Using the CDS

JCL Example:
IMPORT to An
Alternate CDS

Figure 63 shows example JCL to run the IMPORT utility with Manifest File ALTMFST. In this example:

- HSC is active on the system where Import runs, but is using a different CDS (FEDB.PROD.DBASExxx)
- The INACTCDS parameter specifies importing to an alternate CDS specified by the SLSCNTL, SLSCNTL2, and SLSSTBY DD statements.
- No hosts are using the CDS.
- VTCS overwrites all duplicate VTVs via the REPLACE(ALL) parameter.

```
//IMPORT EXEC PGM=SWSADMIN, PARM='MIXED'  
//STEPLIB DD DSN=h1q.SLSLINK, DISP=SHR  
//SLSPRINT DD SYSOUT=*  
//SLSCNTL DD DSN=FEDB.VSMALT.DBASEPRM, DISP=SHR  
//SLSCNTL2 DD DSN=FEDB.VSMALT.DBASESEC, DISP=SHR  
//SLSSTBY DD DSN=FEDB.VSMALT.DBASETBY, DISP=SHR  
//ALTMFST DD DSN=FEDB.VSMALT.ALTMFST, DISP=SHR  
//SLSIN DD *  
IMPORT MANIFEST(ALTMFST) REPLACE(ALL) INACTCDS
```

Figure 63. IMPORT utility example: IMPORT to An Alternate CDS

INVENTORY

The INVENTORY utility lists all VTVs on specified MVCs. Additionally, you can use INVENTORY to:

- Request that the contents of the specified MVCs are cross-checked with the information recorded in the CDS.
- Terminate the processing based on the end-of-tape position recorded in the CDS for the MVC, rather than at the MVC's physical end-of-tape.
- Have the processing terminated for an MVC the first time a VTV is discovered that is incompatible with the information in the CDS.

Syntax

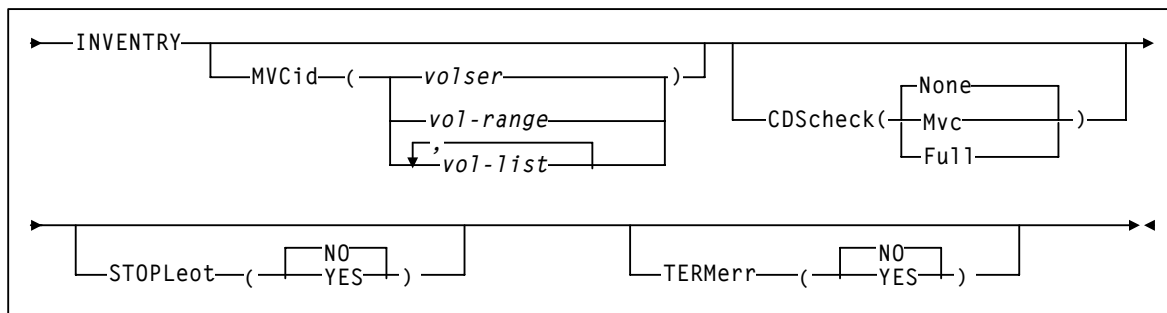

Parameters

MVCid

specifies the MVC(s) to be inventoried.

CDScheck

specifies whether the contents of each inventoried MVC is checked against the information recorded in the CDS.

None

Each VTV found on an inventoried MVC is listed via message SLS6933I. The CDS is not checked. None is the default.

Mvc

Each VTV found on an inventoried MVC is listed via message SLS6933I. The details of the VTV are obtained from the CDS. The MVC and CDS copies of the VTV are compared and listed as a comment on SLS6933I. If the CDS shows a resident or MVC copy of the VTV exists that differs from the copy listed in SLS6933I, its details are listed via message SLS6934I.

Full

Each VTV found on an inventoried MVC is listed via message SLS6933I.

The details of the VTV are obtained from the CDS. The MVC and CDS copies of the VTV are compared and listed as a comment on SLS6933I. If the CDS shows a resident or MVC copy of the VTV exists that differs from the copy listed in SLS6933I, its details are listed

via message SLS6934I. For each inventoried MVC, the CDS is checked to see which VTVs are shown to have a copy on the MVC. Any VTVs that were not found on the MVC are listed via message SLS6935E.

STOPl eot

specifies whether processing is to terminate when the logical end-of-tape position is reached. The logical end-of-tape position is the end-of-tape position recorded in the CDS for this MVC.

NO

All VTVs are to be processed on each inventoried MVC. NO is the default.

YES

VTVs are processed on each inventoried MVC until:

- The MVC's physical end-of-tape is reached, or
- The first VTV is found on the MVC that is beyond the logical end-of-tape position, if this is earlier than the physical end-of-tape position. Invalid with CDScheck(None).

TERMerr

specifies whether the inventory of an MVC is to terminate when it encounters the first inconsistency between the contents of the MVC and the VTVs that the CDS indicates are on the MVC. Such inconsistencies are listed via message SLS6935E, SLS6936E or SLS6938E.

NO

The inventory of an MVC is not to terminate when it encounters the first inconsistency between the contents of the MVC and the VTVs that the CDS indicates are on the MVC. NO is the default.

YES

The inventory of an MVC is to terminate when it encounters the first inconsistency between the contents of the MVC and the VTVs that the CDS indicates are on the MVC. Invalid with CDScheck(None).

MERGMFST

MERGMFST merges multiple manifest files produced by EXPORT into a single file.

Syntax

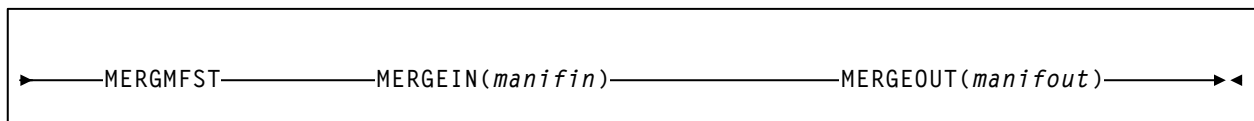

Figure 64. MERGMFST utility syntax

Parameters

MERGEIN

specifies the DD statement for one or more input manifest files.

manifin

the DD name.

MERGEOUT

specifies the DD statement for the merged manifest file.

manifout

the DD name.

Interfaces

SWSADMIN utility only.

Usage

Use MERGMFST to merge multiple manifest files into a single file, which can be used as input to the following:

- IMPORT
- MVCMAINT
- MVCRPT
- VTVRPT



Note: For VTCS 5.0 and above, running MERGMFST produces an MVC Detail Report.

JCL Requirements

STEPLIB
specifies the link library (SLSLINK) that contains the VTCS and HSC modules.

manifin DD
DD statement for the input manifest file(s).

manifout DD
DD statement for the merged manifest file.

SLSPRINT
specifies the destination for the MERGMFST report.

SLSIN
specifies the input to the SWSADMIN program (MERGMFST utility name and parameters).

JCL Examples

Figure 59 shows example JCL to run the MERGMFST utility to merge 5 manifest files. **Note that** because each file is explicitly specified, they can be specified in any order.

```
//MERGMFST EXEC PGM=SWSADMIN, PARM='MIXED'  
//STEPLIB DD DSN=h1q.SLSLINK, DISP=SHR  
//SLSPRINT DD SYSOUT=*  
//manifin DD DISP=SHR, DSN=EXPORT1  
// DD DISP=SHR, DSN=EXPORT2  
// DD DISP=SHR, DSN=EXPORT3  
// DD DISP=SHR, DSN=EXPORT4  
// DD DISP=SHR, DSN=EXPORT5  
//manifout DD DSN=mergefile, DISP=(,CATLG), UNIT=SYSALLDA,  
DCB=(EXPORT5), SPACE=CYCL, (1,1)  
//SLSIN DD *  
MERGMFST MERGEIN(manifin) MERGEOUT(manifout)
```

Figure 65. MERGMFST utility example: merge 5 specified manifest files

Figure 66 shows example JCL to run the MERGMFST utility to merge 5 generations of manifest files.

```
//MERGMFST EXEC PGM=SWSADMIN, PARM='MIXED'  
//STEPLIB DD DSN=h1q.SLSLINK, DISP=SHR  
//SLSPRINT DD SYSOUT=*  
//manifin DD DISP=SHR, DSN=EXPORT(0)  
// DD DISP=SHR, DSN=EXPORT(-1)  
// DD DISP=SHR, DSN=EXPORT(-2)  
// DD DISP=SHR, DSN=EXPORT(-3)  
// DD DISP=SHR, DSN=EXPORT(-4)  
//manifout DD DSN=MERGFIL.MANIFEST(+1)  
//SLSIN DD *  
MERGMFST MERGEIN(manifin) MERGEOUT(manifout)
```

Figure 66. MERGMFST utility example: merge 5 generations of manifest files

Figure 67 shows example JCL to run the MERGMFST utility to merge all generations of manifest files.

```
//MERGMFST EXEC PGM=SWSADMIN, PARM='MIXED'  
//STEPLIB DD DSN=h1q.SLSLINK, DISP=SHR  
//SLSPRINT DD SYSOUT=*  
//manifin DD DISP=SHR, DSN=EXPORT  
//manifout DD DSN=mergefile, MANIFEST(+1)  
//SLSIN DD *  
MERGMFST MERGEIN(manifin) MERGEOUT(manifout)
```

Figure 67. MERGMFST *utility example: merge all generations of manifest files*

Figure 68 shows example JCL to run the MERGMFST utility to merge the current manifest file into a cumulative manifest file.

```
//MERGMFST EXEC PGM=SWSADMIN, PARM='MIXED'  
//STEPLIB DD DSN=h1q.SLSLINK, DISP=SHR  
//SLSPRINT DD SYSOUT=*  
//manifin DD DISP=SHR, DSN=EXPORT(0)  
// DD DISP=SHR, DSN=MERGED.MANIFEST(0)  
//manifout DD DSN=MERGED, MANIFEST(+1)  
//SLSIN DD *  
MERGMFST MERGEIN(manifin) MERGEOUT(manifout)
```

Figure 68. MERGMFST *utility example: merge the current manifest file into a cumulative manifest file*

MIGRATE

MIGRATE migrates VTVs to MVCs.

Syntax - Format 1

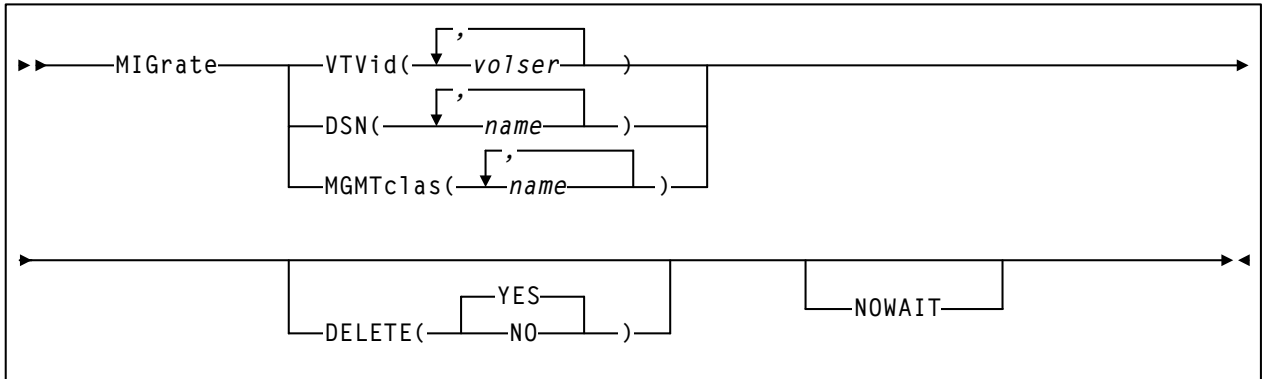

Figure 69. MIGRATE utility syntax - Format 1

Parameters - Format 1

VTid

specifies the VTVs that VSM migrates.

volser

the volsers of one or more VTVs. You can also specify one or more ranges.

DSN

specifies data sets used to select VTVs to migrate.

name

the data set name. Table 4 describes the valid wild cards for data set names. You cannot address a member of a GDG using a wildcard.

Note: Wildcards are only supported on MVS systems running DFSMS/MVS 1.4 or greater. At systems below this level the catalog search does not support wildcard.

Table 4. Data Set Name Wildcards

Wildcard	Stands for...
*	A qualifier or one or more characters within a qualifier. An asterisk can precede or follow a set of characters.
**	zero or more qualifiers. A double asterisk cannot precede or follow any characters; it must be preceded or followed by either a period or a blank.
% or ?	Exactly one alphanumeric or national character.

Table 4. Data Set Name Wildcards

Wildcard	Stands for...
%% or ??	One to eight percent signs or question marks can be specified in each qualifier.

MGMTCLAS

specifies one or more Management Classes that determine one or more VTVs to migrate.

mgmt-class-name | mgmt-class-list

the names of one or more Management Classes that you defined on the MGMTclas control statement; for more information, see “MGMTCLAS Control Statement” on page 214.

Note: The VTVID, DSN, and MGMTCLAS parameters are mutually exclusive.

DELETE

specifies whether VSM deletes VTVs from the VTSS after migrating the VTVs.

NO

do not delete VTVs from the VTSS after migrating the VTVs.

YES

delete VTVs from the VTSS after migrating the VTVs (the default).

NOWAIT

specifies that the utility does not wait for the operation to complete and returns after the request is submitted.

Syntax - Format 2

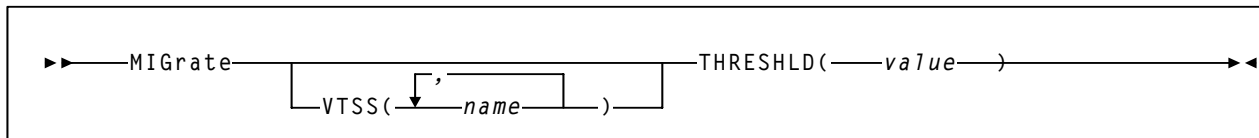

Figure 70. MIGRATE utility syntax - Format 2

Parameters - Format 2

VTSS

specifies one or more VTSSs to migrate to the specified threshold.

name

the names of one or more VTSSs.

THRESHLD

specifies that VTCS runs the VTSS space management/VTV migration cycle until VTSS space reaches the specified threshold. Valid values are 0 to 95%.

value

the threshold to migrate to (percent of VTSS space).

Interfaces

SWSADMIN utility and VT command.

Usage

Use the MIGRATE utility to do demand migrations of VTVs to MVCs.

You can do two types of demand migrations:

- Migrate specified VTVs by specifying the VTVid, DSN, or MGMTCLAS parameter (and, optionally, the DELETE (NO) parameter to prevent VSM from deleting the VTVs after migration).
- Use the THRESHLD parameter to force the VTSS space management/VTV migration cycle to run to a specified threshold for specified VTSSs.



Note: The SET HIGHthld and SET HIGHthld parameters are no longer supported on the MIGRATE command and utility. To change the low and high AMT, use the SET MIGOPT command and utility. For more information, see “SET MIGOPT” on page 165.

Command Examples

To run MIGRATE to migrate VTVs determined by Management Class MCLAS1 and not delete them immediately from VTSS space., enter the following:

```
.VT MIGRATE MGMTCLAS(MCLAS1) DELETE(NO)
```

To run MIGRATE to migrate VTSS1 to a threshold of 10%, enter the following:

```
.VT MIGRATE VTSS(VTSS1) THRESHLD(10)
```

JCL Requirements

The following are the required and optional statements for the MIGRATE JCL:

STEPLIB

specifies the link library (SLSLINK) that contains the VTCS and HSC modules.

SLSPRINT

specifies the destination for the migrate report.

SLSIN

specifies the input to the SWSADMIN program (MIGRATE utility name and parameters).

JCL Examples

Figure 71 shows example JCL to run MIGRATE to migrate VTVs determined by Management Class MCLAS1 and not delete them immediately from VTSS space.

```
//MIGRATE EXEC PGM=SWSADMIN, PARM='MIXED'  
//STEPLIB DD DSN=h1q.SLSLINK, DISP=SHR  
//SLSPRINT DD SYSOUT=*  
//SLSIN DD *  
MIGRATE MGMTCLAS(MCLAS1) DELETE(NO)
```

Figure 71. Example JCL for the MIGRATE utility (migrate by Management Class)

Figure 72 shows example JCL to run MIGRATE to migrate VTSS1 to a threshold of 10%.

```
//MIGRATE EXEC PGM=SWSADMIN, PARM='MIXED'  
//STEPLIB DD DSN=h1q.SLSLINK, DISP=SHR  
//SLSPRINT DD SYSOUT=*  
//SLSIN DD *  
MIGRATE VTSS(VTSS1) THRESHLD(10)
```

Figure 72. Example JCL for the MIGRATE utility (migrate to threshold)

MVCDEF

The VT MVCDEF command loads the MVCPool statements from a specified definition data set.

Syntax

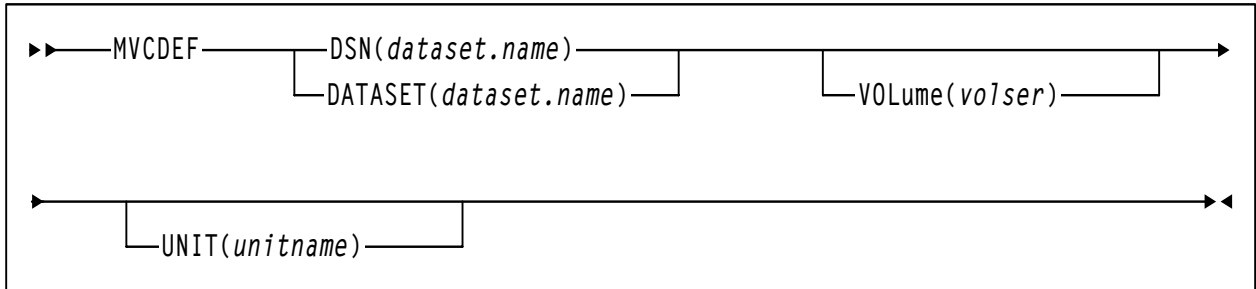

Figure 73. VT MVCDEF command *syntax*

Parameters

DSN or DATASET

specifies the definition data set that contains the MVCPool statements to load.

dataset.name

the data set name. If the data set name includes a member name, enclose the data set name in quotes.

VOLume

specifies the DASD volume where the definition data set resides. This parameter is optional, unless the data set is not cataloged, or the data set resides on a volume other than the volume indicated by the catalog.

volser

the DASD volser.

UNIT

specifies the DASD device where the definition data set resides.

unitname

the DASD unit name. If the definition data set is not cataloged and this parameter is omitted, the unit name defaults to SYSALLDA.

Interfaces

VT command only.

Usage

Use the `VT MVCDEF` command to load `MVCPool` statements in a specified definition data set; for more information, see “`MVCPool Control Statement`” on page 226. The `VT MVCDEF` command is valid for base and full service levels of HSC. For more information about using the `VT MVCDEF` command and the `MVCPool` statement.

You can enter the `VT MVCDEF` command as an operator command or specify the `VT MVCDEF` command as a statement in the `HSC PARMLIB`. If you specify a `VT MVCDEF` statement in the `PARMLIB`, HSC startup loads the specified `MVCPool` statements. After HSC startup, you can enter the `VT MVCDEF` command as a command to dynamically reload another set of `MVCPool` statements from a different definition data set. If you restart HSC, it reloads the `MVCPool` statements specified by the `VT MVCDEF` command statement in the `PARMLIB`.

Note that if you dynamically reload another set of `MVCPool` statements, any MVCs that were in the previous MVC pool but are not in the current MVC pool definition are removed from the MVC pool unless the MVC contains valid VTVs. These MVCs are removed from the pool once those VTVs become invalid.

If the `MVCPool` definition data set contains errors when the `VT MVCDEF` command is entered, HSC issues message `SLS5627I`, which identifies the `MVCPool` parameter in error, describes the problem, and gives the line number where the error occurred. If an error occurs, VSM does not load the specified `MVCPool` statements. Correct the `MVCPool` statements problem and reissue the `VT MVCDEF` command.

Example

To load the `MVCPool` statements in data set `VSM.MVCPool`, enter:

```
.VT MVCDEF DSN(VSM.MVCPool)
```

MVCDRAIN

MVCDRAIN recalls all current and scratched VTVs from an MVC and, optionally, “virtually” ejects the MVC (makes it unavailable for VSM use without physically ejecting it from the library). You can use the MVCDRAIN to override the CONFIG RECLAIM CONMVC setting.

Syntax

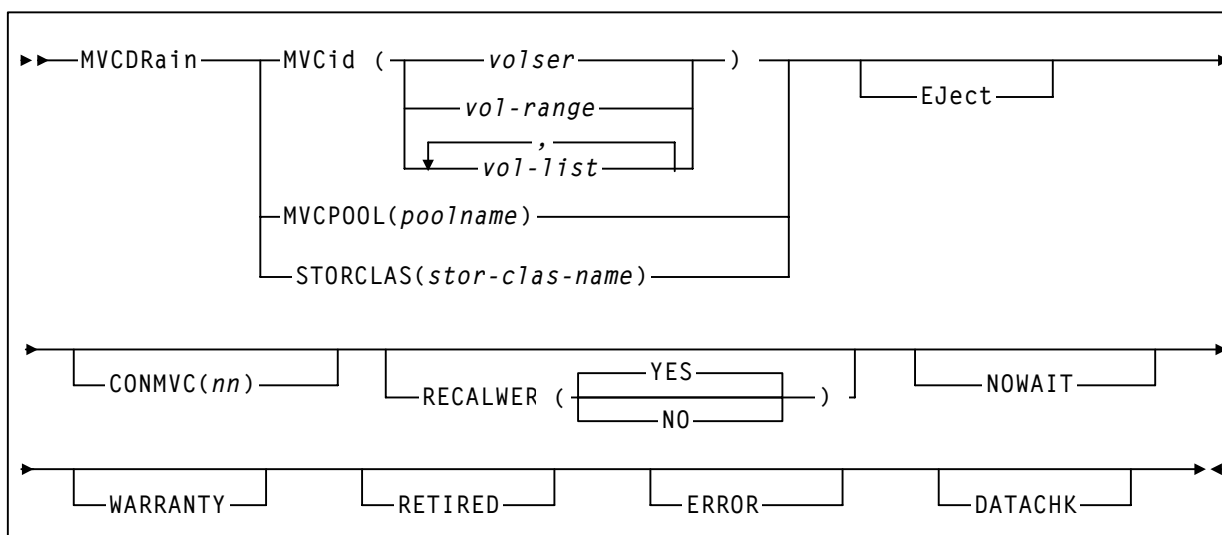

Figure 74. MVCDRAIN syntax

Parameters

- MVCid**
drain one or more MVCs by volser.
volser, *vol-range*, or *vol-list*
the volsers of one or more MVCs up to a maximum of 50.
- MVCPool**
drain the MVCs in the specified Named MVC Pool.
poolname
the name of an MVC Pool that you defined on the MVCPOOL control statement; for more information, see “MVCPool Control Statement” on page 226.
- STORCLAS**
drain the MVCs in the specified Storage Class.
stor-class-name
the name of a Storage Class that you defined on the STORCLAS control statement; for more information, see “STORCLAS Control Statement” on page 229.
- Eject**
specifies that VTCS “virtually” ejects the MVC (the MVC will not be used for output).

CONMVC(*nn*)
specifies the maximum number of MVCs that VTCS concurrently processes for both drain and reclaim.
Valid values are 1 to 99. If not specified, the default is the CONMVC value specified on the CONFIG RECLAIM statement.

RECALWER
specifies whether VTCS recalls VTVs with read data checks.

YES
recall VTVs with read data checks (the default).

NO
Do not recall VTVs with read data checks.

NOWAIT
specifies that the utility does not wait for the operation to complete and returns after the request is submitted.
returns after the request is submitted.

WARRANTY
selects MVCs with expired warranties (denoted by a W in the Status T column on an MVC Report).

RETIRED
selects MVCs that are retired (denoted by a T in the Status T column on an MVC Report).

ERROR
selects MVCs that are in error (denoted by a B in the Status B column on an MVC Report).

DATACHK
selects MVCs that have a data check (denoted by a D in the Status D column on an MVC Report).

Interfaces

SWSADMIN utility and VT command.

Usage

Use the `MVCDRAIN` to “drain” an MVC. The recall follows the same recall policy used for `RECALL`; for more information, see “`RECALL`” on page 146.

To select the MVCs to drain, you can specify one of the following parameters:

- `MVCID` to drain one or more MVCs by volser.
- `MVCP00L` to drain the MVCs in a Named MVC Pool. For more information on Named MVC Pools.
- `STORCLAS` to drain the MVCs in a Storage Class. For more information on Storage Classes.

You typically drain an MVC for the following reasons:

- An MVC report or `Display` shows data check errors for the MVC. VSM will not migrate to the MVC and you should remove it from the MVC pool.
- An MVC report or `Display` shows errors other than data check errors for the MVC.
- A Storage Class or Named MVC Pool is no longer in use and you want to remove or reuse the associated MVCs.

You can use the `MVCDRAIN` to override the `CONFIG RECLAIM CONMVC` setting. You can run the `MVCDRAIN` from each host, which starts drain tasks on that host equal to the `CONMVC` value. These drain tasks can run concurrently with drain tasks initiated by other hosts.

Note: VTCS and HSC must be active to process an `MVCDRAIN` request.

Command Example

To run the `MVCDRAIN` to drain the MVCs in Storage Class `STORCL1`, virtually eject the MVCs, and return after the request is submitted, enter the following:

```
.VT MVCDRAIN STORCLAS(STORCL1) EJECT NOWAIT
```

JCL Requirements

`STEPLIB`

specifies the link library (SLSLINK) that contains the VTCS and HSC modules.

`SLSPRINT`

specifies the destination for the `MVCDRAIN` report.

`SLSIN`

specifies the input to the `SWSADMIN` program (`MVCDRAIN` utility name and parameters).

JCL Example

Figure 75 shows example JCL to run MVEDRAIN to drain the MVCs in Storage Class STORCL1, virtually eject the MVCs, and return after the request is submitted.

```
//MVEDRAIN EXEC PGM=SWSADMIN, PARM='MIXED'  
//STEPLIB DD DSN=h1q.SLSLINK, DISP=SHR  
//SLSPRINT DD SYSOUT=*  
//SLSIN DD *  
MVEDRAIN STORCLAS(STORCL1) EJECT NOWAIT
```

Figure 75. MVEDRAIN utility example: draining MVCs by Storage Class

MVCMaint

MVCMaint sets MVC attributes.

Syntax

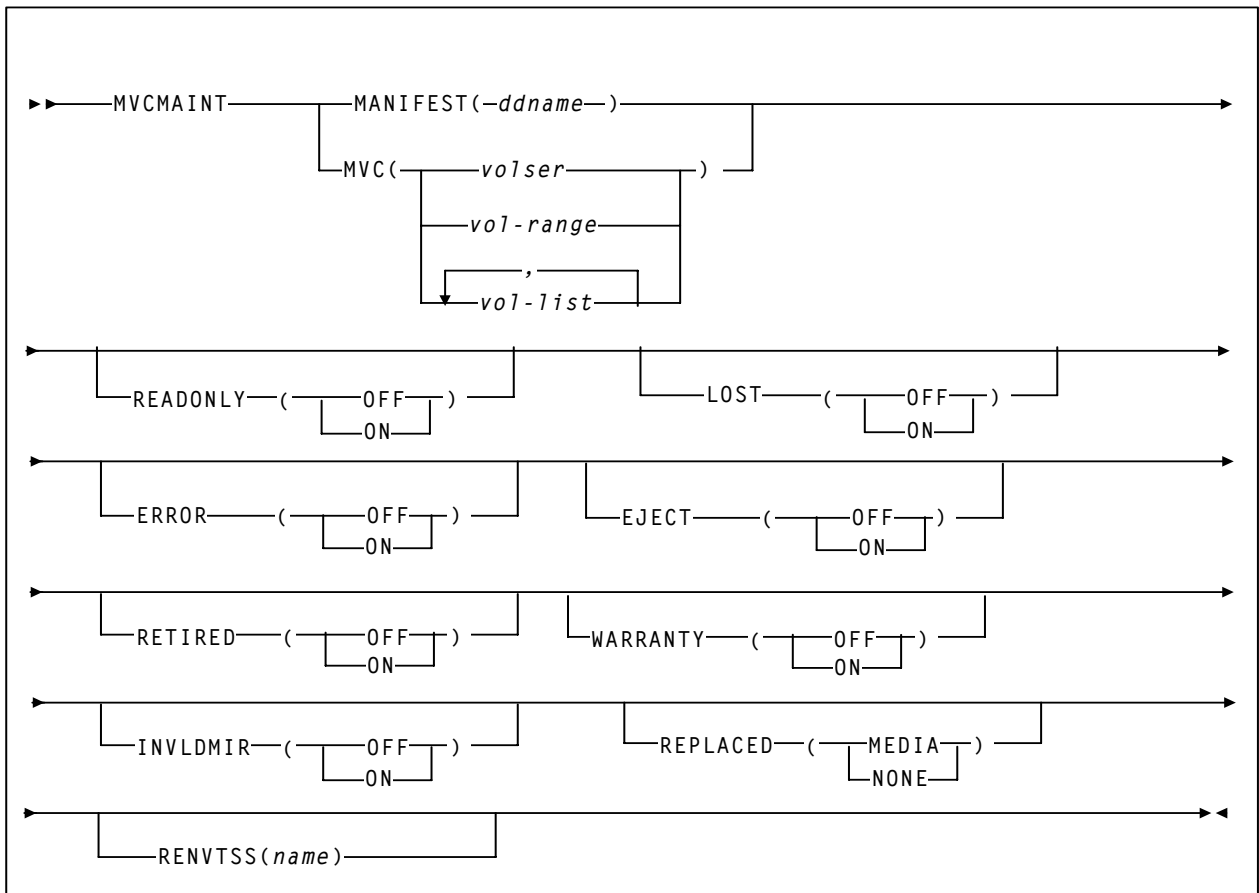

Figure 76. MVCMaint syntax

Parameters

- MANIFEST**
specifies the input ddname of the manifest file. **Note that** you can specify a merged manifest file or multiple manifest files. Figure 61 on page 100 shows example JCL to run the MVCMAINT utility where the MANIFEST parameter specifies importing multiple generations of a file.
- ddname*
ddname of the manifest file. The default is MANIFEST.
- MVC**
specifies the MVCs whose read/write attribute is changed.
- volser, vol-range or vol-list*
the volsers of one or more MVCs.
- READONLY**
sets the read/write status of the MVC. There is no default; you must specify a value.
- ON
MVC is readonly.
- OFF
MVCs is writable.
- LOST**
sets the “lost” status of the MVC. There is no default; you must specify a value.
- ON
MVC is lost.
- OFF
MVC is not lost.
- ERROR**
sets the error status of the MVC. There is no default; you must specify a value.
- ON
MVC is in error.
- OFF
MVC is not in error.
- EJECT**
sets the “logical eject” status of the MVC. There is no default; you must specify a value.
- ON
MVC is “logically ejected”.
- OFF
MVC is not “logically ejected”.

RETIRED

sets the “retired” status of the MVC. There is no default; you must specify a value.

ON

MVC is retired.

OFF

MVC is not retired but is still in “expired warranty” state (still selectable for output).

WARRANTY

sets the “expired warranty” status of the MVC. There is no default; you must specify a value.

ON

MVC’s warranty has expired.

OFF

MVC’s warranty has not expired.

Note: RETIRED and WARRANTY are mutually exclusive. That is, you cannot specify RETIRED and WARRANTY on the same MVCMAINT command.

INVLMIR

sets the invalid MIR status of the MVC. There is no default; you must specify a value.

ON

MIR is invalid.

OFF

MIR is not invalid.

REPLACED

Resets or clears various fields in the MVC record after physically replacing an MVC. There is no default; you must specify a value.

NONE

Makes no updates to the MVC record.

MEDIA

Update the MVC record. The MVC must be empty (contain zero VTVs) and unmounted or this parameter will fail.

REPLACED (MEDIA) updates the following MVC fields as follows:

- Media type of the MVC is cleared
- Count of times mounted is set to zero
- Warranty Expired Flag is turned off
- Invalid MIR Flag is turned off
- Retired Flag is turned off
- Broke/Error Flag is turned off
- Lost Flag is turned off
- Data Check Flag is turned off
- VTSS Last Written By is cleared
- Date/Time MVC was last written to is cleared
- Storage Class is cleared
- Date/Time of Last Drain/Reclaim is cleared
- Date/Time of Migrate from Empty State is cleared

Note: The REPLACED parameter is mutually exclusive with the LOST, ERROR, EJECT, RETIRED, WARRANTY, and INVLDMIR parameters.

RENTSS

Sets the name of the owning VTSS to *name*.

name

the VTSS name.

Note: To set the VTSS name:

- The host on which the utility is run must have access to the VTSS, and
- The new VTSS name must be the name of an existing VTSS in the VTCS CONFIG deck.

Interfaces

SWSADMIN utility only.

Usage

Use the MVCMAINT to set the following MVC attributes:

- Read/write status (including exported and imported MVC)s.
- “Lost” status. If a VTCS initiated mount of an MVC on an RTD fails to complete (as opposed to completes with an error), VTCS updates the MVC record in the CDS to indicate that the MVC is “lost”. An MVC in “lost” status is deprefferenced where ever possible. Duplexed VTVs that reside on this MVC are recalled from their alternate MVC. VTCS does not attempt to use “lost” MVCs for migration unless there are no other valid MVCs. When an MVC in “lost” status is successfully mounted, the “lost” status is removed from the MVC record.

You can use the LOST parameter to explicitly set the “lost” status of an MVC in to recover from known conditions. For example, if an ACS is in manual mode, you can set LOST(ON) for the MVCs in that ACS to deprefference their use.

- Error status. The following are typical error conditions and corrective actions. After correcting the error, you can use MVCMAINT to set ERROR OFF for the MVC.
 - VTCS does not recognize the volume mounted on the RTD as an MVC. This can be caused by some MVS job overwriting the MVC. Determine what happened to the MVC. If it no longer contains valid VTV data, reinitialize the volume and return it to the MVC pool.
 - The MVC is not writeable, which can be caused by the thumbwheel being set to readonly, or by the security package not allowing VTCS to write to the volume. Reset the thumbwheel, or change the rules in the security package to allow the MVC to be written to.
 - A bad block ID has been detected. Audit the MVC to try to correct the condition. For more information, see “AUDIT” on page 5.
- “Logical eject” status.
- For 9840/T9940 media:
 - VTCS also detects media warranty expiration and sets the WARRANTY status to ON. Alternatively, you can use SMF or LOGREG data to detect MVCs approaching end-of-life and use the MVCMAINT to manually set WARRANTY OFF. Knowing that the warranty has expired lets you plan for media replacement before media end-of-life occurs.

You can also use the MVCMAINT to set WARRANTY OFF for MVCs erroneously marked as warranty expired.
 - VTCS also automatically detects media end-of-life and sets the RETIRED status to ON. Alternatively, you can use SMF or LOGREG data to detect MVCs approaching end-of-life and use the MVCMAINT to manually set RETIRED ON.

You can also use the MVCMAINT to set RETIRED OFF for MVCs erroneously marked as retired.
 - VTCS automatically detects an invalid Media Information Region (MIR) and sets the INVLMIR status to ON. You can recover the MIR by using either the utility available through the operator panel for the transport or by using the utility available through MPST. After you recreate the MIR, you can use the MVCMAINT to set INVLMIR OFF for the MVC.
 - The MVC report, MVC Pool Report, and Display MVC command report “retired” and invalid MIR status; for more information, see:
 - “MVC Reports” on page 136
 - “Named MVC Pool Report” on page 127
 - “Display MVC Output” on page 73



Note: Running MVCMAINT also produces an MVC report of the volumes affected by the MVCMAINT job.

JCL Requirements

STEPLIB
specifies the link library (SLSLINK) that contains the VTCS and HSC modules.

manifest file DD
DD statement for the manifest file.

SLSPRINT
specifies the destination for the MVCMAINT report.

SLSIN
specifies the input to the SWSADMIN program (MVCMAINT utility name and parameters).

JCL Examples

Figure 77 shows example JCL to run MVCMAINT to make writable all MVCs listed on input manifest file REMOTE1.

```
//MVCMAINT EXEC PGM=SWSADMIN, PARM='MIXED'  
//STEPLIB DD DSN=h1q.SLSLINK, DISP=SHR  
//REMOTE1 DD DSN=FEDB.VSMLMULT.REMOTE1, DISP=SHR  
//SLSPRINT DD SYSOUT=*  
//SLSIN DD *  
MVCMAINT MANIFEST(REMOTE1) READONLY(OFF)
```

Figure 77. MVCMAINT utility example: making MVCs writable

Figure 78 shows example JCL to run MVCMAINT to set on the “lost” status on for MVCs MVC001-MVC100.

```
//MVCMAINT EXEC PGM=SWSADMIN, PARM='MIXED'  
//STEPLIB DD DSN=h1q.SLSLINK, DISP=SHR  
//REMOTE1 DD DSN=FEDB.VSMLMULT.REMOTE1, DISP=SHR  
//SLSPRINT DD SYSOUT=*  
//SLSIN DD *  
MVCMAINT MVC(MVC001-MVC100) LOST(ON)
```

Figure 78. MVCMAINT utility example: setting MVCs “lost” status on

MVCMaint Reports

Figure 79 shows an example of an MVCMaint report for the following command:

MVCMaint MVC(022577-022579) READONLY=OFF

```

SWSADMIN (6.1.0)                STORAGETEK VTCS SYTEM UTILITY                PAGE 0002
TIME 09:26:54                   MVC MAINTENANCE                                DATE 2003-05-14

MVCMaint SUMMARY REPORT
MVC      RC
022577   00
022578   08
022578   08

MVCMaint EXCEPTION REPORT
*SLS6737I MVC 022578 ALREADY HAS READONLY(OFF); REQUEST IGNORED
*SLS6737I MVC 022579 ALREADY HAS READONLY(OFF); REQUEST IGNORED
SLS1315I SWS500.V5.CDS WAS SELECTED AS THE PRIMARY CONTROL DATA SET

SWSADMIN (6.1.0)                STORAGETEK VTCS SYTEM UTILITY                PAGE 0002
TIME 09:26:54                   VTCS MVC SUMMARY REPORT                       DATE 2003-05-14
MVC      NUMBER %USED %AVAIL %FRAG  MEDIA  TIMES STATUS          <-----LAST MOUNTED----->  ACS OWNER/
VOLSER   OF VTVS                SIZE (MB) MOUNTED I B L D R U T M  DATE      TIME      VTSS  ID  CONSOLIDATE TIME

022577    0  0.00  99.96  0.04   400    142  I - - - - C - -   2003MAY14  06:23:23          00  2003MAY14
                                                06:09:23
022578    0  0.00  99.96  0.04   400    197  I - - - - U - -   2003MAY14  06:23:23  VTSS16 00  VTSS16
022579    0  0.00  99.96  0.04   400    142  I - - - - U - -   2003MAY14  16:23:23          00  2003MAY14
                                                16:09:23

      3  INITIALIZED MVCS PROCESSED
      0  NON-INITIALIZED MVCS PROCESSED
      0  NON-LIBRARY MVCS PROCESSED
    
```

Figure 79. Example MVCMaint report

As shown in Figure 79, the MVCMaint report shows:

- Status of MVCs processed - volser and return code (0 - all updates completed, 4 - some updates completed, 8 - no updates completed).
- An exception report of the reason for all uncompleted updates.
- An MVC summary report; for more information, see “MVC Summary Report” on page 136.

MVCPLRPT

The MVCPLRPT reports the status of a Named MVC Pool or MVC Storage Class.

Syntax

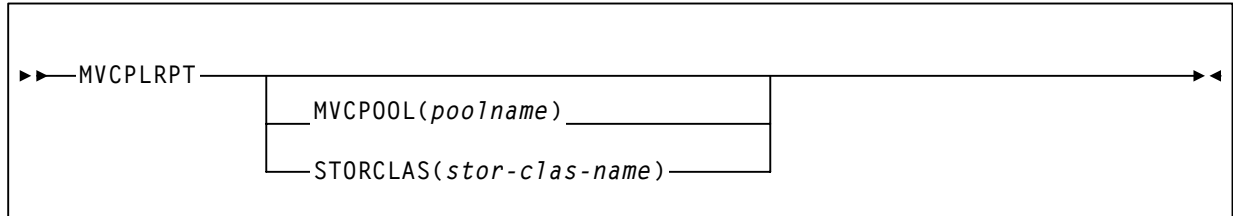

Figure 80. MVCPLRPT **syntax**

Parameters

MVCPOOL

report on the MVCs in the specified Named MVC Pool.

poolname

the name of an Named MVC Pool that you defined on the MVCPool control statement; for more information, see “MVCPOOL Control Statement” on page 226.

To report on all Named MVC Pools (including DEFAULTPOOL), specify ALL or omit the MVCPOOL parameter.

STORCLAS

report on the MVCs in the specified Storage Class. The report is produced as if the associated MVC pool name had been specified.

stor-class-name

the name of a Storage Class that you defined on the STORclas control statement; for more information, see “STORCLAS Control Statement” on page 229.

Interfaces

SWSADMIN utility only.

Usage

Use the MVCPLRPT to report the status of a Named MVC Pool or MVC Storage Class. Figure 81 on page 126 shows example JCL to run MVCPLRPT to produce a report by Named MVC Pool and Figure 82 on page 127 shows the report format.

JCL Requirements

The following are the required and optional statements for the MVCPLRPT JCL:

STEPLIB

specifies the link library (SLSLINK) that contains the VTCS and HSC modules.

SLSPRINT

specifies the destination for the MVC report.

SLSIN

specifies the input to the SWSADMIN program (MVCPLRPT utility name and parameters).

JCL Example

Figure 81 shows example JCL to run MVCPLRPT to produce a report for Named MVC Pool CUST1POOL.

```
//MVCPLR EXEC PGM=SWSADMIN, PARM='MIXED'  
//STEPLIB DD DSN=h1q.SLSLINK, DISP=SHR  
//SLSPRINT DD SYSOUT=*  
//SYSOUT DD SYSOUT=*  
//SLSIN DD *  
MVCPLRPT MVCPOOL(CUST1POOL)
```

Figure 81. Example JCL for the MVCPLRPT utility (report by Named MVC Pool)

Named MVC Pool Report

Figure 82 and Figure 83 on page 128 show an example of a report for Named MVC Pool CUST1P00L.

MVC		NUMBER	%USED	%AVAIL	%FRAG	MEDIA	TIMES	STATUS	<-----LAST MOUNTED----->			ACS	OWNER/
VOLSER	OF VTVS					SIZE (MB)	MOUNTED	I B L D R U T M	DATE	TIME	VTSS	ID	CONSOLIDATE TIME
EVS99	200	10.80	84.57	4.63	2000	310	I - - - - U - M	2003MAR15	03:20:23	VTSS8	00	S1	
EVS100	0	0.00	100.00	0.00	UNKNOWN	206	- - L - - U - -	2003MAR10	05:24:04	VTSS8	--		
EVS101	1009	99.00	0.00	1.00	400	306	I - - - - U - -	2003MAR15	03:20:23	VTSS8	00	S1	
EVS102	5	8.25	91.75	0.00	400	6	I - - - - U - -	2003MAR15	04:23:04	VTSS8	00	S3	
EVS103	EXPVT	0.12	99.88	0.00	400	194	I - - - - J - -	2003MAR15	03:20:28	VTSS10	00	VTSS10	
EVS104	0	0.00	100.00	0.00	400	5	I - - - R C - -	2003MAR18	03:49:14	VTSS8	00	2003APR12	03:49:14
EVS105	200	10.80	84.57	4.63	102040	254	I - - - R U T -	2003MAR18	04110:09	VTSS8	00		
EVS106	0	0.00	100.00	0.00	400	202	I - - - - C - -	2003MAR18	03:49:20	VTSS8	00		
EVS107	0	0.00	100.00	0.00	400	171	I - - - R E - -	2003MAR18	04:13:00	VTSS8	00		
SUMMARY FOR MVCPOOL=CUST1P00L													
	ACS	MEDIA	FREE-MVCS		RECLAIM-MVCS		USED-MVCS						
			VOLS	GB	VOLS	GB	VOLS	GB					
	00	ECART	120	96	2	0.5	90	45					
	00	STK1R	30	600	1	3.5	25	350					
	00	TOTAL	150	696	3	4.0	115	395					

Figure 82. Example MVCPLRPT report (Part 1)

```

SUMMARY OF MVCS BY USAGE:

137 TOTAL MVCS PROCESSED
135 INITIALIZED MVCS PROCESSED
  2 UN-INITIALIZED MVCS PROCESSE
41 FREE MVCS AVAILABLE
  0 MVCS WITH STATUS AUDIT
  6 MVCS WITH STATUS DRAIN
  4 MVCS WITH STATUS EXPORT
  0 MVCS MARKED EJECTED
60 MVCS MARKED FULL
  0 MVCS WITH MAXIMUM VTVS
82 MVCS MARKED READ-ONLY
  3 MVCS WITH STATUS BROKEN
  7 MVCS WITH STATUS LOST
  0 MVCS MARKED RETIRED
  0 MVCS WITH EXPIRED WARRANTY
  0 MVCS HAVE INVALID MIRS
  1 MVCS HAVE DATACHECKS
  5 MVCS WITH STATUS CONSOLIDATE

```

Figure 83. Example MVCPLRPT report (Part 2)

MVCPLRPT Fields

The following list describes the Named MVC Pool report fields. The Summary fields are either for a Storage Class or a Named MVC Pool, depending on which was specified on the report JCL. If a Storage Class specifies a Named MVC Pool, the report gives information for that subpool.

MVC Volser

the MVC volser.

Number of VTVS

the number of current VTVs on the MVC. If the MVC has been used for VTV export, this field reports **EXPVTV**.

%Used

the percentage of the MVC used by current VTVs.

%Avail

the percentage of the MVC that is physically available for use.

%Frag

the percentage of the MVC that contains non-current VTVs. This space is not usable until it is reclaimed or the MVC is drained.

Media Size (MB)

the size of the MVC (MB). This will only be determined after VTCS has used an MVC. "UNKNOWN" appears in this field until VTCS migrates a VTV to the MVC.

Times Mounted

the number of times that the MVC has been mounted for writing or reading since it was added to the MVC inventory.

STATUS

one or more of the following statuses:

I

The MVC has been initialized.

B

The MVC has an error that should be investigated. The error may not make the MVC unusable, but VTCS will not select the MVC for migration for 12 hours after it is marked "B". After the 12 hour period, the MVC will be least preferred for subsequent migrations, and recalls from the MVC may cause VTCS to drain it. This error condition may be accompanied by messages SLS6686, SLS6687, SLS6688, SLS6690, and/or SLS6693.

Any of the following conditions can cause this MVC error:

- MVC corrupted by another job (other than VTCS/VTSS).
- Attempt to use a read-only MVC for migration.
- A DDR swap failure.
- An RTD failure.

L

The MVC was not mounted in response to the last mount request. The MVC can still be used for migration, but will not select the MVC for migration for 12 hours after it is marked "L". After the 12 hour period, the MVC will be least preferred. This condition will clear itself the next time that the MVC is mounted.

D

A data check was reported for this MVC. VSM will not use this MVC again for migration.

R

the MVC has been marked read-only.

U

one of the following usage statuses:

U

the MVC is available for output (migration, reclamation, export, or consolidation).

-

the MVC is not available for output (migration, reclamation, export, or consolidation).

A

The MVC is either being audited or the audit failed. If the audit failed, VTCS will not use the MVC for migration. To clear this condition, rerun the `AUDIT` against this MVC.

C

The MVC is a consolidation MVC.

E

The MVC is an export MVC.

F

There is no space available on the MVC.

J

Either you issued a `MVCDRAIN EJECT` for the MVC or the MVC was ejected for update by a `RACROUTE` call. The MVC will not be used again for migration or recall. To clear this condition, use `MVCDRAIN` against MVC without the `EJECT` option.

N

Either:

- The MVC is being drained because of:
 - An automatic drain or demand reclaim.
 - An explicit `MVCDRAIN` command.

OR

- The previous `DRAIN` request failed, in which case VTCS will not use the MVC for migration. To clear this condition, enter `MVCDRAIN` against MVC without the `EJECT` option.

X

The MVC has reached the maximum VTVs per MVC.

T

One of the following statuses:

T

The MVC is retired.

W

The MVC's warranty has expired.

M

The MVC has an invalid MIR.

Last Mounted

the date and time that the MVC was last mounted and the VTSS where the MVC was last used.

ACS ID

the ACS where the MVC resides.

Owner/Consolidate Time

If the MVC is empty, this field is null. If the MVC is a consolidation MVC, this field displays the time of the consolidation. If the MVC is a migration MVC and contains current VTVs, this field displays the MVC's Storage Class. If no Storage Class was explicitly assigned via the `MGMTclass` statement, the default Storage Class is the name of the last VTSS that wrote to the MVC for reclamation or migration.

If VTCS receives a request to migrate a VTV that is assigned to an invalid Management Class, VTCS will dynamically create the `!ERROR` Storage Class and migrate the VTVs defined by the invalid Management Class to the `!ERROR` Storage Class. Use this Storage Class to identify and correct invalid Management Classes, drain the affected MVCs, and resubmit the request.

Summary for Storage Class or Named MVC Pool

This section shows number of MVCs (**Vols**) and total storage (**Gb**) by ACS and media type for the following categories:

Free-MVCs

MVCs that have 100% usable space and do not contain any migrated VTVs. The storage shown is the total free space based on media type capacity.

Reclaim-MVCs

MVCs eligible for space reclamation. The storage shown is the total wasted space including those MVCs not yet eligible for space reclaim.

Used-MVCS

Initialized MVCs that are partially or completely full.

Total MVCs

Total MVCs for the Storage Class or Named MVC Pool with subtotals for initialized, uninitialized, and free MVCs.

Summary of MVCs by Usage

This section shows number of MVCs by the task that last used the MVC.

MVCRPT

The MVCRPT reports the status of your VSM system's MVCs.

Syntax

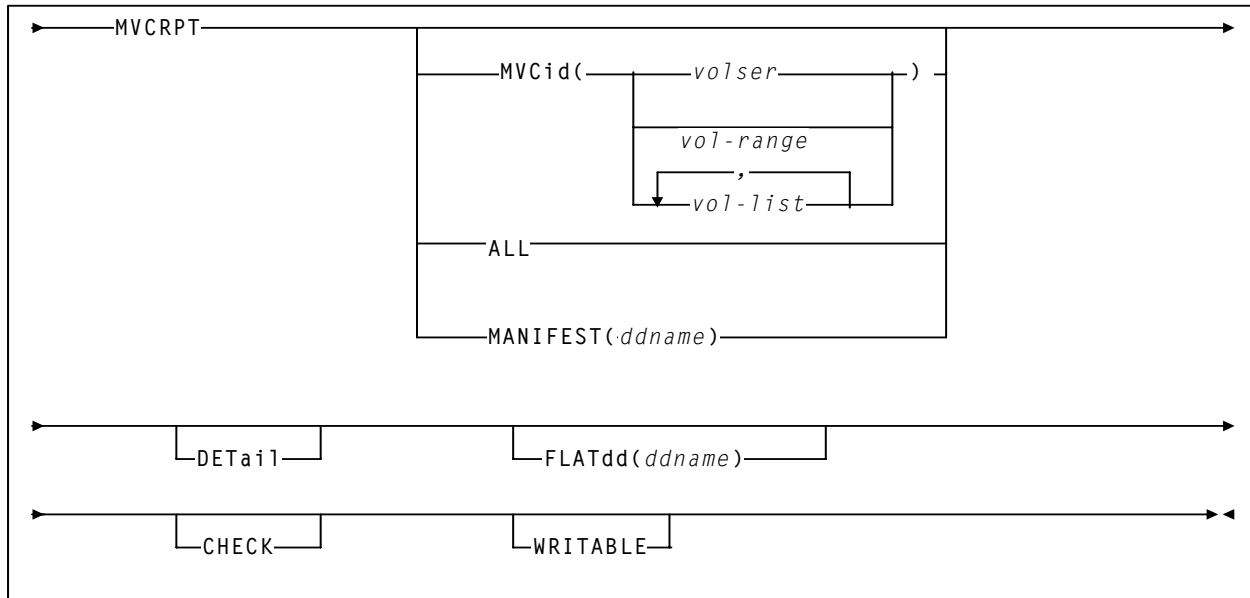

Figure 84. MVCRPT syntax

Parameters

MVCid

specifies the MVCs for the report. If you do not specify the MVCs, the report includes all MVCs in your VSM system.

volser, *vol-range* or *vol-list*

the volsers of one or more MVCs.

MANIFEST

specifies the input ddname of the manifest file used to generate the report.

ddname

ddname of the manifest file. **Note that** you can specify a merged manifest file or multiple manifest files. Figure 61 on page 100 shows example JCL to run the MVCMAINT utility where the MANIFEST parameter specifies importing multiple generations of a file.

DETAil

produce a detailed MVC report; see Figure 90 on page 141 for an example. If you do not specify this option, the default is to produce a summary MVC report; see Figure 89 on page 136 for an example.

FLATdd

specifies the destination of the optional flat file output.

ddname

name of the DD in the JCL that describes the output data set if a flat file is required.

CHECK

MVCRPT does limited MVC integrity checking, during which the CDS is reserved. Use **only** if directed by StorageTek Software Support.

WRITABLE

MVCRPT ignores readonly MVCs on MVC detailed reports and when you specify the CHECK parameter.

Interfaces

SWSADMIN utility only.

Usage

Use the MVCRPT to report the status of your VSM system's MVCs. For more information, see "MVC Reports" on page 136. Figure 85 shows example JCL to run MVCRPT to produce a report and Figure 89 on page 136 and Figure 90 on page 141 show the report formats. MVC reports only list MVCs that have been used, not MVCs that are defined but have not been used, but non-initialized MVCs will be included in the report totals. As shown in Figure 86 on page 134, you can specify the MANIFEST parameter to generate a report from an export manifest file instead of from the HSC CDS.

To produce reports for VSM, ExPR requires a flat file format of the MVC report as input. Figure 87 on page 134 shows example JCL to produce flat file format of the report for ExPR. Table 5 on page 143 shows the flat file record format.

Also note that you can produce MVC reports in structured XML format. You can then process the XML output in a programming language of your choice. For information on the VTCS sample REXX execs, see "Sample REXX Execs" on page 313.

JCL Requirements

The following are the required and optional statements for the MVCRPT JCL:

STEPLIB

specifies the link library (SLSLINK) that contains the VTCS and HSC modules.

SLSPRINT

specifies the destination for the MVC report.

SLSIN

specifies the input to the SWSADMIN program (MVCRPT utility name and parameters).

SYSOUT

specifies the output destination for SORT messages. This is only required for DETAIL MVC reports.

SLSXML

specifies the output destination for XML output. Allocate this file as RECFM=VB, LRECL=255.

JCL Examples

Figure 85 shows example JCL to run MVC RPT to produce a detailed report of all MVCs in your VSM system.

```
//MVCR      EXEC PGM=SWSADMIN, PARM='MIXED'  
//STEPLIB   DD DSN=h1q.SLSLINK, DISP=SHR  
//MVCOUT    DD DSN=FEDB.FLAT, UNIT=SYSALLDA, DISP=OLD  
//SLSPRINT  DD SYSOUT=*  
//SYSOUT    DD SYSOUT=*  
//SLSIN     DD *  
           MVC RPT DET
```

Figure 85. Example JCL for the MVC RPT utility (detailed report)

Figure 86 shows example JCL to run MVC RPT to produce a detailed report using manifest file REMOTE1 as input.

```
//MVCR      EXEC PGM=SWSADMIN, PARM='MIXED'  
//STEPLIB   DD DSN=h1q.SLSLINK, DISP=SHR  
//REMOTE1   DD DSN=FEDB.VSMLMULT.REMOTE1, DISP=SHR  
//SLSPRINT  DD SYSOUT=*  
//SYSOUT    DD SYSOUT=*  
//SLSIN     DD *  
           MVC RPT MANIFEST(REMOTE1) DET
```

Figure 86. Example JCL for the MVC RPT utility (detailed report, manifest file input)

Figure 87 shows example JCL to run MVC RPT to produce a detailed report of all MVCs in flat file format for input to ExPR.

```
//MVCR      EXEC PGM=SWSADMIN, PARM='MIXED'  
//STEPLIB   DD DSN=h1q.SLSLINK, DISP=SHR  
//MVCOUT    DD DSN=FEDB.FLAT, UNIT=SYSALLDA, DISP=OLD  
//SLSPRINT  DD SYSOUT=*  
//SYSOUT    DD SYSOUT=*  
//SLSIN     DD *  
           MVC RPT DET FLATDD(MVCOUT)
```

Figure 87. Example JCL for the MVC RPT utility (detailed report, flat file output for ExPR)

Figure 88 shows example JCL to run MVCRPT to produce a detailed report of all MVCs in structured XML format.

```
//MVCREPT JOB x,CHRIS,CLASS=A,MSGCLASS=E
//*
//*
//*
//MVCRPT EXEC PGM=SWSADMIN
//STEPLIB DD DSN=ncs610.LINKLIB,DISP=SHR
//SLSCNTL DD DSN=h1q.V61.CLUSTER.CDS,DISP=SHR
//SLSPRINT DD SYSOUT=*
//SYSOUT DD SYSOUT=*
//SLSXML DD DISP=(,CATLG),DSN=h1q.MVCREPT.XML,
// DCB=(RECFM=VB,LRECL=255,BLKSIZE=4096),
// UNIT=SYSDA,SPACE=(CYL,(x,y))
//SLSIN DD *
MVCRPT
/* */
//TSO EXEC PGM=IKJEFT01,DYNAMNBR=128
//SYSPROC DD DSN=ncs610.SLSSAMP,DISP=SHR
//SYSTSPRT DD SYSOUT=*
//SLSPRINT DD SYSOUT=*
//INFILE DD DISP=SHR,DSN=h1q.MVCREPT.XML
//OUTFILE DD DISP=(,CATLG),DSN=h1q.MVCREPT.CSV,
// DCB=(RECFM=VB,LRECL=1024,BLKSIZE=4096),
// UNIT=SYSDA,SPACE=(CYL,(x,y))
//SYSTSIN DD *
%MVCXML
/*
//
```

Figure 88. Example JCL for the MVCRPT utility (structured XML format)



Note: XML output can consume **considerable** space. You may want to consider routing your XML output to a VTV so that the output is compressed.

MVC Reports

The following sections describe the MVC summary and detailed reports that the MVC RPT produces.

MVC Summary Report

Figure 89 shows an example of an MVC summary report.

SWSADMIN (6.1.0)		STORAGETEK VTCS SYTEM UTILITY										PAGE 0002	
TIME 09:26:54		VTCS MVC SUMMARY REPORT										DATE 2003-04-13	
MVC	NUMBER	%USED	%AVAIL	%FRAG	MEDIA	TIMES	STATUS	<-----LAST MOUNTED----->			ACS	OWNER/	
VOLSER	OF VTVS				SIZE (MB)	MOUNTED	I B L D R U T M	DATE	TIME	VTSS	ID	CONSOLIDATE TIME	
EVS99	200	10.80	84.57	4.63	2000	310	I - - - - U - M	2003MAR15	03:20:23	VTSS8	00	S1	
EVS100	0	0.00	100.00	0.00	UNKNOWN	206	- - L - - U - -	2003MAR10	05:24:04	VTSS8	--		
EVS101	1009	99.00	0.00	1.00	400	306	I - - - - U - -	2003MAR15	03:20:23	VTSS8	00	S1	
EVS102	5	8.25	91.75	0.00	400	6	I - - - - U - -	2003MAR15	04:23:04	VTSS8	00	S3	
EVS103	EXPVTV	0.12	99.88	0.00	400	194	I - - - - J - -	2003MAR15	03:20:28	VTSS10	00	VTSS10	
EVS104	0	0.00	100.00	0.00	400	5	I - - - R C - -	2003MAR18	03:49:14	VTSS8	00	2003APR12 03:49:14	
EVS104	200	10.80	84.57	4.63	102040	254	I - - - R U T -	2003MAR18	04110:09	VTSS8	00		
EVS105	300	15.80	54.57	4.63	102040	154	I - - - R U W -	2003MAR18	04110:09	VTSS8	00		
EVS106	0	0.00	100.00	0.00	400	202	I - - - - C - -	2003MAR18	03:49:20	VTSS8	00		
EVS107	0	0.00	100.00	0.00	400	171	I - - - R E - -	2003MAR18	04:13:00	VTSS8	00		
		137	Initialized MVCs processed										
		8	Non-Initialized MVCs processed										

Figure 89. Example MVC summary report

The following list describes the MVC summary report fields.

MVC Volser

the MVC volser.

Number of VTVS

the number of current VTVs on the MVC. If the MVC has been used for VTV export, this field reports **EXPVTV**.

%Used

the percentage of the MVC used by current VTVs.

%Avail

the percentage of the MVC that is physically available for use.

%Frag

the percentage of the MVC that contains non-current VTVs. This space is not usable until it is reclaimed or the MVC is drained.

Media Size (MB)

the size of the MVC (MB). This will only be determined after VTCS has used an MVC. “UNKNOWN” appears in this field until VTCS migrates a VTV to the MVC.

Times Mounted

the number of times that the MVC has been mounted for writing or reading since it was added to the MVC inventory.

STATUS

one or more of the following statuses:

I

The MVC has been initialized.

B

This is a generic error that indicates the MVC, drive, or combination of the two has a problem. VTCS attempts to de-preference MVCs with this state. To clear this state:

- If the MVC caused the problem, use a DRAIN(EJECT) command to remove the MVC from service.
- If the RTD caused the problem, use the MVCMAINT utility to reset the MVC state.

Note also that one or more of the following messages is issued for BROKEN status: SLS6686, SLS6687, SLS6688, SLS6690. For detailed recovery procedures for these messages, see *VTCS Messages and Codes*.

L

VTCS attempted to mount an MVC and the mount did not complete within a 15-minute time-out period. VTCS is attempting to recover from a situation that may be caused by hardware problems, HSC problems, or by the MVC being removed from the ACS. VTCS attempts to de-preference MVCs with this state.

If VTCS does perform a subsequent successful mount of an MVC with LOST(ON) state, VTCS sets the state to LOST(OFF).

Determine the cause of the error and fix it. You can also use the VTCS MVCMAINT utility to set LOST(OFF) for the following events:

- LOST(ON) was set due to LSM failures or drive errors that have been resolved
- LOST(ON) was set because the MVC was outside the ACS and has been reentered.

D

A data check condition has been reported against this MVC. VTCS attempts to de-preference MVCs with this state. To clear this state:

- If all VTVs on the MVC are duplexed, use MVCDRAIN on the MVC without the Eject option. This recovers all VTVs and removes the MVC from service.
- If all VTVs on the MVC are not duplexed, VTCS AUDIT the MVC. The audit will probably fail. After the audit, do an MVCDRAIN (no eject). This recalls the VTVs before the data-check area in ascending block-id order and the VTVs after the data-check area in a descending block-id order. Processing the VTVs in this sequence ensures that VTCS recovers as many VTVs as possible from the media. You then need to recreate the data for any VTVs still on the MVC.

R

The MVC has been marked read-only because of one of the following conditions:

- The MVC being the target of an export or consolidation process. The read-only state protects the MVC from further updates.
- The MVC media is set to file protect. Correct the error and use the MVCMAINT utility to set READONLY(OFF).
- The MVC does not having the appropriate SAF rules set to enable VTCS to update the MVC. Correct the error (for more information, see “Defining a Security System User ID for HSC, SMC, and VTCS” in Chapter 2 of *VTCS Installation and Configuration Guide*) and use the MVCMAINT utility to set READONLY(OFF).

U

one of the following usage statuses:

U

the MVC is available for output (migration, reclamation, export, or consolidation).

-

the MVC is not available for output (migration, reclamation, export, or consolidation).

A

The MVC is either being audited or the audit failed. If the audit failed, VTCS will not use the MVC for migration. To clear this condition, rerun the AUDIT against this MVC.

C

The MVC is a consolidation MVC.

E

The MVC is an export MVC.

F

There is no space available on the MVC.

J

Either you issued `MVCDRAIN EJECT` for the MVC or the MVC was ejected for update by a `RACROUTE` call. The MVC will not be used again for migration or recall. To clear this condition, use `MVCDRAIN` against MVC without the `EJECT` option.

N

Either:

- The MVC is being drained because of:
 - An automatic drain or demand reclaim.
 - An explicit `MVCDRAIN` command.

OR

- The previous `DRAIN` request failed, in which case VTCS will not use the MVC for migration. To clear this condition, enter `MVCDRAIN` against MVC without the `EJECT` option.

X

The MVC has reached the maximum VTVs per MVC.

T

One of the following statuses:

T

The MVC is retired. VTCS will recall from, but not migrate to, the MVC. Replace the MVC as soon as possible.

W

The MVC's warranty has expired. VTCS continues to use the MVC. You should start making plans to replace the MVC when it reaches Retired state.

M

VTCS has received status from an RTD to indicate the MIR (media information record) for a 9x40 media is invalid. An invalid MIR does not prevent access to data but may cause significant performance problems while accessing records on the tape. The MVC is not capable of high-speed searches on areas of the tape that do not have a valid MIR entry.

VTCS attempts to de-preference MVCs with this condition. For recalls, if the VTV resides on multiple MVCs, VTCS selects MVCs with valid MIRs ahead of MVCs with invalid MIRs. VTCS avoids using MVCs with invalid MIRs for migration, unless the migration is at the beginning of the tape. Migrating from the beginning of tape will correct the MIR.

VTCS detects the invalid MIR condition at either mount time or dismount time. If detected at mount time and the operation can be completed with another MVC, VTCS dismounts the first MVC and

selects the alternate MVC. **Note that** VTCS has only a limited ability to switch to an alternate MVC. That is, it is mainly used for migrate and virtual mount.

For MVCs with invalid MIRs, determine the cause of the error, which may be caused by media or drive problems, and fix the error.

To recover an MVC with an invalid MIR, you simply need to read the MVC to the end of the tape, which can be done via a VTCS audit. If the media is the problem, run an MVEDRAIN EJECT to recall the VTVs and cause the MVC to be removed from the MVC pool.

Last Mounted

the date and time that the MVC was last mounted and the VTSS where the MVC was last used.

ACS ID

the ACS where the MVC resides.

Owner/Consolidate Time

If the MVC is empty, this field is null. If the MVC is a consolidation MVC, this field displays the time of the consolidation. If the MVC is a migration MVC and contains current VTVs, this field displays the MVC's Storage Class. If no Storage Class was explicitly assigned via the MGMTclas statement, the default Storage Class is the name of the last VTSS that wrote to the MVC for reclamation or migration.

If VTCS receives a request to migrate a VTV that is assigned to an invalid Management Class, VTCS will dynamically create the !ERROR Storage Class and migrate the VTVs defined by the invalid Management Class to the !ERROR Storage Class. Use this Storage Class to identify and correct invalid Management Classes, drain the affected MVCs, and resubmit the request.

MVC Detailed Report

The MVC detailed report provides all the fields from the MVC summary report and a separate section that lists additional fields. Figure 90 shows an example of these additional fields from an MVC detailed report.

SWSADMIN (6.1.0)		STORAGETEK VTCS SYTEM UTILITY				PAGE 0003
TIME 11:28:30		MVC EVS102 DETAIL REPORT				DATE 2003-06-03
VTV	SIZE	BLOCK	MANAGEMENT	MIGRATION	BLOCK	MESSAGE
VOLSER	(MB)	ID	CLASS	DATE	COUNT	
X20041	76.00	00000000	M5	2004JAN08	10	
X20043	76.00	134009C7	M5		9	
X20044	76.00	2A40138D	M5	2004JAN08	9	
X20045	76.00	C6401D53	M3		10	
X20047	76.00	A5402719	M3		10	
5 VTVS FOUND FOR MVC:EVS102						
WARNING VTV COUNT:5 DOES NOT MATCH MVC SUMMARY RECORD VTV COUNT:22 FOR MVC:EVS102						

Figure 90. Example MVC detailed report (additional fields)

MVC Detailed Report Additional Fields. The following list describes the additional fields for the MVC detailed report.

VTV Volser

the volsers of the VTVs on the MVC.

Size (MB)

the uncompressed size of the VTV (MB).

Block ID

the logical block ID of the beginning of the VTV on the MVC.

Management Class

the VTV's Management Class.

Migration Date

for migrates done by a 6.0 system or above **only**, the approximate date that the VTV copy was migrated. This date is approximate because it is recorded in the CDS as the number of days since VTV creation, and time zone adjustments can cause the value to slip a day.

Block Count

the decimal number of blocks of data that the VTV occupies on the MVC.

Message

reports the results of MVC integrity checking. Any message **not** listed below should be reported to StorageTek, as it may indicate a serious problem with the CDS.

nnnn empty space to previous

Explanation: Informational message, indicating that there are *nnnn* (decimal) blocks of free space before this VTV on the MVC.

Migrated size was not as expected

Explanation: If output for VTV *v* on MVC *m*, it indicates that the (compressed) size of VTV *v* migrated to MVC *m* was different to the (compressed) size of VTV *v* recorded in the CDS.

This is normal if VTV *v* had previously been recalled with error. Otherwise this indicates a possible error which should be reported to Sun StorageTek software support.

Flat File Record Format

Table 5 shows the record format of the flat file produced by MVCRPT.

Table 5. MVCRPT flat file record format

Decimal Offset	Hexadecimal Offset	Type	Length	Description
0	0	start of record		start of MVC flat file record
0	0	integer	4	record length
4	4	character	1	character set type of text fields
		X'61'		ASCII
		X'6E'		EBCDIC
5		character	1	record type 'M' (indicates an MVC report)
6	5	character	6	MVC volser
12	C	integer	4	number of current VTVs on the MVC
16	10	integer	4	percentage of the MVC used by current VTVs
20	14	integer	4	percentage of the MVC that is available for use
24	18	integer	4	percentage of the MVC that contains non-current VTVs, which is not available for use until it is reclaimed or the MVC is drained
28	1C	integer	4	number of times that the MVC has been mounted for writing or reading since it was added to the MVC inventory
32	20	time_t	4	TOD - MVC was last Mounted (starting from 01/01/1970)
36	24	integer	4	size of the MVC (MB)
40	28	time_t	4	Consolidation date/time (time_t format) or X'00'
44	2C	character	1	MVC exported (Y or N)
45	2D	character	1	MVC initialized (I or -)
46	2E	character	1	MVC broken (B or -)
47	2F	character	1	MVC lost (L or -)
48	30	character	1	MVC has data check (D or -)
49	31	character	1	MVC readonly (R or -)

Table 5. MVC RPT flat file record format

Decimal Offset	Hexadecimal Offset	Type	Length	Description
50	32	character	1	MVC Usage status: - Not usable A AUDIT status CSet CONSOLIDATE status E EXPORT status FFULL status JEJECT status NDRAIN status UUsable
51	33	character	1	MVC Retired (T or -)
52	34	character	1	MVC has invalid MIR (M or -)
53	35	character	2	ACS location of MVC
55	37	character	8	MVC was last mounted on this VTSS
63	3F	character	8	Owning VTSS name or Storage Class name

QUERY

See “DISPLAY” on page 52.

RECALL

The RECALL does demand recalls of VTVs to a VTSS.

Syntax

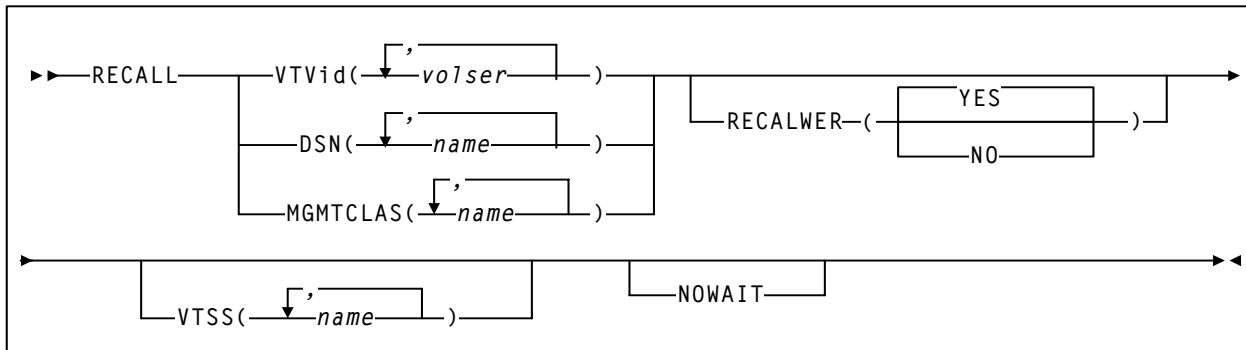

Figure 91. RECALL *syntax*

Parameters

VTVid

specifies the VTVs that VSM recalls.

volser, *vol-range*, or *vol-list*

the volsers of one or more VTVs. You can also specify one or more ranges.

DSN

specifies data sets used to select VTVs to recall.

name

the data set name. Table 4 on page 107 describes the valid wildcard for data set names.

MGMTCLAS

specifies one or more Management Classes that determine one or more VTVs to recall.

mgmt-class-name | *mgmt-class-list*

the names of one or more Management Classes that you defined on the MGMTclas control statement; for more information, see “MGMTCLAS Control Statement” on page 214.

Note: The VTVid, DSN, and MGMTCLAS parameters are mutually exclusive.

VTSS

specifies where the VTVs are recalled as follows:

- If you do not specify a VTSS (the default), VTCS attempts to recall the VTVs to the VTSS of creation if it is accessible. Otherwise VTCS recalls the VTVs to the VTSS with the lowest DBU.
- If you specify a single VTSS, VTCS attempts to recall the VTVs to the specified VTSS if it is accessible. Otherwise, VTCS recalls the VTVs to the VTSS with the lowest DBU.
- If you specify a list of VTVs, VTCS attempts to recall the VTVs to the VTSS of creation if it is on the list and accessible, otherwise VTCS recalls the VTVs to the VTSS with the lowest DBU on the list.

vtss-name

the names of one or more VTSSs.

RECALWER

specifies whether VTCS recalls VTVs with read data checks.

YES

recall VTVs with read data checks (the default).

NO

Do not recall VTVs with read data checks.

NOWAIT

specifies that the utility does not wait for the operation to complete and returns after the request is submitted.

Interfaces

SWSADMIN utility and VT command.

Usage

Use the RECALL to do demand recalls of VTVs to a VTSS; for more information.

Command Example

To run RECALL to recall VTVs determined by Management Class MCLAS1 to VTSS1 and return immediately, enter the following:

```
.VT RECALL MGMTCLAS(MCLAS1) VTSS(VTSS1) NOWAIT
```

JCL Requirements

The following are the required and optional statements for the RECALL JCL:

STEPLIB

specifies the link library (SLSLINK) that contains the VTCS and HSC modules.

SLSPRINT

specifies the destination for the migrate report.

SLSIN

specifies the input to the SWSADMIN program (RECALL utility name and parameters).

JCL Example

Figure 92 shows example JCL to run RECALL to recall VTVs determined by Management Class MCLAS1 to VTSS1 and return immediately.

```
//MIGRATE EXEC PGM=SWSADMIN, PARM='MIXED'  
//STEPLIB DD DSN=h1q.SLSLINK, DISP=SHR  
//SLSPRINT DD SYSOUT=*  
//SLSIN DD *  
RECALL MGMTCLAS(MCLAS1) VTSS(VTSS1) NOWAIT
```

Figure 92. Example JCL for the RECALL utility (recall by Management Class)

RECLAIM

The RECLAIM does demand MVC space reclamation. The RECLAIM can also override the CONFIG RECLAIM settings for the THRESHLD, MAXMVC, and CONMVC parameters.

Syntax

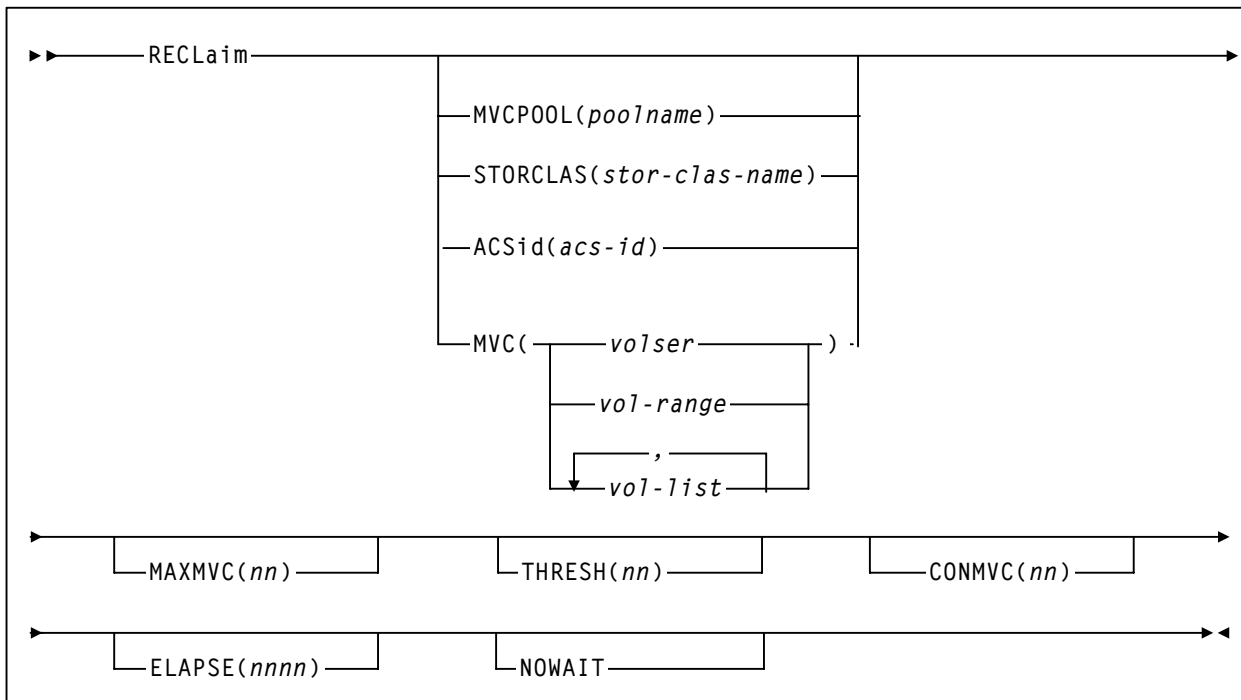

Figure 93. RECLAIM syntax

Parameters

MVCPOOL

reclaim the MVCs in the specified Named MVC Pool.

poolname

the name of a Named MVC Pool that you defined on the MVCPOOL control statement; for more information, see “MVCPOOL Control Statement” on page 226.

STORCLAS

reclaim the MVCs in the specified Storage Class.

stor-class-name

the name of a Storage Class that you defined on the STORCLAS control statement; for more information, see “STORCLAS Control Statement” on page 229.

ACSid
reclaim the eligible MVCs in the specified ACS.
acs-id
The specified ACS.

MVC
reclaim the specified MVC(s).
volser, vol-range or *vol-list*
the volsers of one or more MVCs. You can also specify individual MVCs and ranges in a list. For example:
(MVC000-MVC005,MVC010,MVC015)

MAXMVC(nn)
specifies the maximum number of MVCs that will be processed by a single space reclamation task. Valid values are 1 to 98. There is no default; if not specified, the CONFIG RECLAIM value (or default) is used.
For automatic space reclamation to start, the number of eligible MVCs (determined by the THRESH parameter) must also exceed the MAXMVC value.

THRESH(nn)
specifies the percentage of fragmented space that makes an MVC eligible for demand or automatic reclamation. Valid values are 4 to 98. If not specified, the CONFIG RECLAIM value (or default) is used.

NOWAIT
specifies that the utility does not wait for the operation to complete and returns after the request is submitted.

CONMVC(nn)
specifies the maximum number of MVCs that VTCS concurrently processes for both drain and reclaim.
Valid values are 1 to 99. If not specified, the default is the CONMVC value specified on the CONFIG RECLAIM statement.

ELAPSE(nnnn)
specifies the maximum time for the reclaim in minutes. If the maximum time expires, VTCS issues message SLS6682I. If there are no MVCs currently mounted, reclaim stops when the ELAPSE value is reached. If any MVCs are currently mounted when the ELAPSE value is reached, reclaim processes the mounted MVCs and then stops.
Valid values are 1 to 1440. If not specified, there is no time limit on the reclaim process.

Interfaces

SWSADMIN utility and VT command.

Usage

Use the RECLAIM to do demand MVC space reclamation.

To select the MVCs to reclaim, you can specify one of the following parameters:

- MVCP00L to reclaim the MVCs in a Named MVC Pool.
- STORCLAS to reclaim the MVCs in a Storage Class.
- ACSid to reclaim the eligible MVCs in a single ACS.
- MVC to reclaim the reclaim the specified MVC(s).

You can specify only one of the MVCP00L, STORCLAS, ACSid, or MVC parameters. If you do not specify one of these parameter, space reclamation selects MVCs from the Named MVC Pool (if implemented) or media type (for multiple MVC media environments) most in need of free space.

VSM reclaims space on only those MVCs whose percentage of fragmentation and the resources required to move the VTVs justify the reclamation. The CONFIG RECLAIM THRESHLD parameter determines when an MVC is considered for reclamation, and free space must exist on the MVC for reclamation processing. The CONFIG RECLAIM MAXMVC parameter specifies the maximum number of MVCs that will be processed by the RECLAIM. You can use the RECLAIM to override the CONFIG RECLAIM THRESHLD, MAXMVC, and CONMVC settings.

You can also specify the maximum time for the reclaim in minutes on the ELAPSE parameter. Note that there are several limiting factors that influence reclaims (for example, MAXMVC and ELAPSE). VTCS enforces the strictest limiting factor. For example, if you run RECLAIM and specify ELAPSE equal to 5 hours and MAXMVC equal to 10 *and* VTCS reclaims 10 MVCs in one hour, then VTCS terminates the reclaim before the ELAPSE value expires.

VTCS and HSC must be active to process a RECLAIM request.

Command Examples

To reclaim the MVCs in Storage Class STORCL1, override the CONFIG RECLAIM MAXMVC and THRESHLD settings, and return after the request is submitted, enter the following:

```
.VT RECLAIM STORCLAS(STORCL) MAXMVC(20) THRESH(70)
```

To reclaim MVCs MVC000 - MVC015, override the CONFIG RECLAIM MAXMVC and THRESHLD settings, and return after the request is submitted, enter the following:

```
.VT RECLAIM MVC(MVC000-MVC015) MAXMVC(20) THRESH(70)
```

JCL Requirements

STEPLIB

specifies the link library (SLSLINK) that contains the VTCS and HSC modules.

SLSPRINT

specifies the destination for the RECLAIM report.

SLSIN

specifies the input to the SWSADMIN program (RECLAIM utility name and parameters).

JCL Examples

Figure 94 shows example JCL to reclaim the MVCs in Storage Class STORCL1, override the CONFIG RECLAIM MAXMVC and THRESHLD settings, and return after the request is submitted.

```
//RECLAIM EXEC PGM=SWSADMIN,PARM='MIXED'  
//STEPLIB DD DSN=h1q.SLSLINK,DISP=SHR  
//SLSPRINT DD SYSOUT=*  
//SLSIN DD *  
RECLAIM STORCLAS(STORCL) MAXMVC(20) THRESH(70)
```

Figure 94. RECLAIM utility example: reclaiming MVCs by Storage Class

Figure 95 shows example JCL to reclaim MVCs MVC000 - MVC015, override the CONFIG RECLAIM MAXMVC and THRESHLD settings, and return after the request is submitted.

```
//RECLAIM EXEC PGM=SWSADMIN,PARM='MIXED'  
//STEPLIB DD DSN=h1q.SLSLINK,DISP=SHR  
//SLSPRINT DD SYSOUT=*  
//SLSIN DD *  
RECLAIM MVC(MVC000-MVC015) MAXMVC(20) THRESH(70)
```

Figure 95. RECLAIM utility example: reclaiming MVCs by MVC ID

RTV Utility

The RTV utility converts VTVs contained on MVCs to data sets on Nearline volumes (real tape volumes).

Syntax

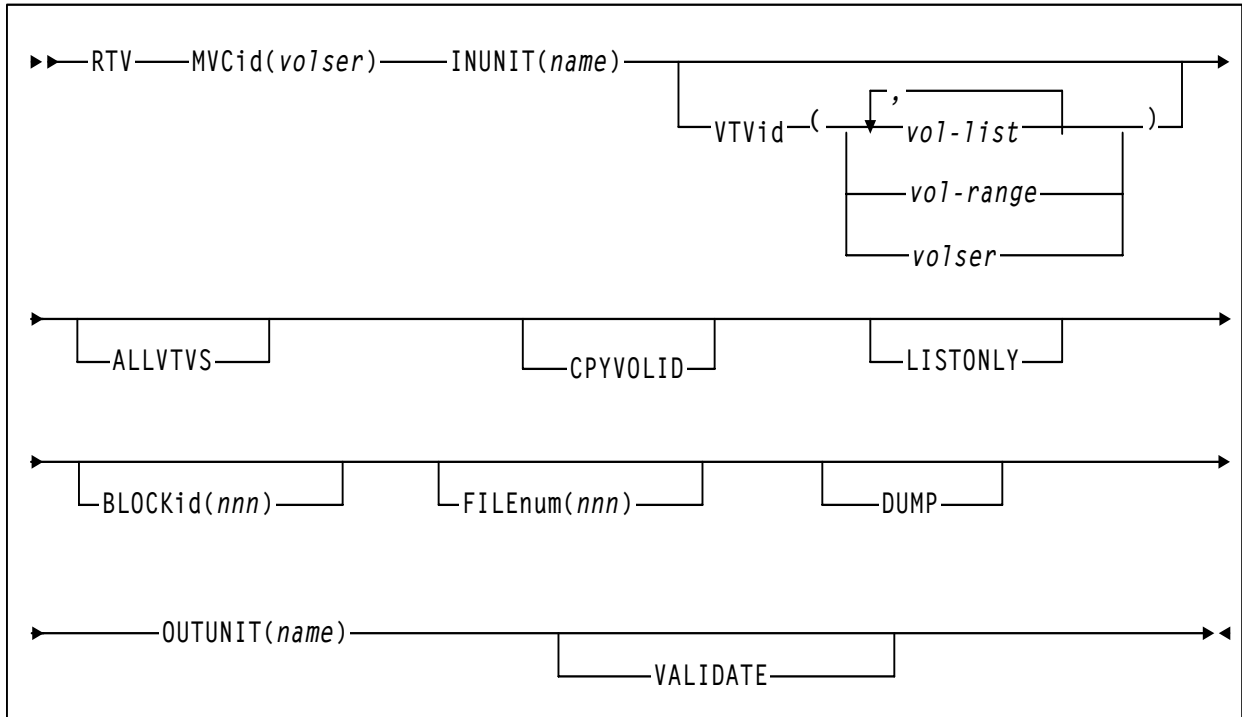

Figure 96. RTV utility syntax

Parameters

MVCid

specifies the MVC that contains the VTVs that RTV converts to Nearline volume(s) which become real tape versions of the VTVs.

volser

the MVC volser.

INUNIT

the name to use to allocate the input tape unit. You can specify an MVS unit address, an esoteric name, or a generic name. The valid values are the same as for the UNIT= JCL parameter.

name

the unit name.

VTVid

specifies one or more VTVs to convert.

volser, *vol-range*, or *vol-list*

the volsers of one or more VTVs.

ALLVTVS

convert the most current copy of all VTVs on the specified MVC. That is, if there are multiple copies of a VTV on the specified MVC, RTV only converts the most current copy of the VTV.

Note: The VTVid and ALLVTVS parameters are mutually exclusive.

CPYVOLID

copy the VTV internal volser from the VTV to the output volume VOL1 record. The default is to not copy the VTV VOLID.



Caution: Use the CPYVOLID parameter carefully! The volser of the output tape will be changed to the volser of the VTV. If the output tape has an external label or if the output is directed to another VTV, this will cause label mismatches and can cause unpredictable and undesirable results.

Note:

- If the output tape is non-labelled or has a non-standard tape label, CPYVOLID will be automatically specified for this VTV decompression, and a standard label tape will be created on the output device.
- RTV supports VTVs created with standard or ANSI labels. If you do not specify CPYVOLID, RTV processes these label types as described in Table 6. Note that this only applies to the VOL1 record. The HDR1/HDR2 labels are always copied from the VTV by RTV for every VTV processed.

Table 6. RTV VTV Label Processing (CPYVOLID Not Specified)

VTV Label Type	Output Standard Label	Output ANSI Label	Output Non-Label
Standard label	VOL1 label not copied	WTOR issued	VOL1 label is copied
ANSI label	WTOR issued	VOL1 label not copied	VOL1 label is copied

In Table 6, the WTOR is as follows:

SWSRTV - Label mismatch - Reply RELABEL, RETRY, or CANCEL

The operator responses produce the following results:

RELABEL

Decompress the RTV and overwrite the volser on the output volume.

RETRY

Mount another output volume and retry the operation.

CANCEL

Do not decompress the RTV.

LISTONLY

lists (but does not convert) the VTVs on the specified MVC. For more information, see “RTV LISTONLY Listing” on page 163.

BLOCKID

the logical block ID where the VTV begins on the MVC.

nnn

the logical block ID (8 hexadecimal characters).



Hint: The LISTONLY parameter listing on “RTV LISTONLY Listing” on page 163 supplies a Block ID value that you can use as input to the RTV utility to convert a VTV to a Nearline volume.

FILEnum

the logical data set number of VTV on the MVC.

nnnnn

the logical data set number (1 to 5 decimal characters).

Note: The LISTONLY, BLOCKid, and FILEnum parameters are mutually exclusive. In addition, if you specify the ALLVTVs parameter, or if a list or range of VTVs is specified, the FILEnum parameter is ignored.

DUMP

produce a SOC3 abend dump if RTV cannot decompress a VTV. If you specify DUMP, create a SYSMDUMP DD JCL statement to capture the dump.

OUTUNIT

the name to use to allocate the output tape unit. You can specify an MVS unit address, an esoteric name, or a generic name. The valid values are the same as for the UNIT= JCL parameter. This parameter is required if you do not specify LISTONLY.

name

the unit name.

Interfaces

SWSRTV only.

Usage

Use the RTV utility when data is required that resides on VTVs that have been migrated to MVCs and no active VSM system is available. RTV takes a VTV from an MVC, decompresses the VTV, then writes the data to a single output tape (real tape volume) so the data can be read by user applications. The RTV utility is a stand-alone utility; that is, you can run this utility when VSM is down but the MVS system is up. Also note that the RTV utility is included on the VTCS product tape and is also available for download from the StorageTek Customer Resource Center (CRC). Both versions are identical.

If you downloaded the RTV utility from the CRC for use at a site that does not have NCS/VTCS software installed, you must do the following:

- Install the downloaded version of RTV per instructions on the CRC.
- APF authorize the RTV load library you just created.
- In “JCL Examples” on page 158, substitute the DSN you picked for the RTV load library for DSN h1q.SLSLINK on the STEPLIB DD statement(s).

What the RTV Utility Can Recover

The RTV utility can recover:

- All or specified VTVs from a specified MVC. If you do not know the location of the most current version of a VTV on the MVC, specify only the VTV volser, and RTV will convert the most current version of the VTV it finds on this MVC.
- A VTV at a specified block ID on a specified MVC. The LISTONLY parameter listing on “RTV LISTONLY Listing” on page 163 supplies a Block ID value that you can use as input to the RTV utility to convert a VTV to a Nearline volume. Specifying the volser and Block ID speeds positioning time.
- A VTV specified by logical data set number on a specified MVC. Specifying the volser and logical data set number will have a much longer positioning time compared to specifying volser and Block ID. Using volser and Block ID is the preferred method to access a single VTV.



Note: If more than one VTV is specified, or if no BLOCKID or FILENUM parameter is specified, the entire MVC will be read and the MVC contents displayed as part of the output. Reading of the entire MVC is necessary to insure that only the most current copy of a VTV is decompressed.

General Usage Guidelines

- The output volume that contains the converted VTV(s) must be at least 800 Mb (capacity of a 3490E cartridge) to ensure that it can contain an individual VTV.
- The VTCS MVCRPT on page 132 and VTCS VTVRPT on page 184 produce VTV and MVC reports that provide information to specify which copy of a VTV you want RTV to recover. Ensure that you have a current copy of these reports before you run the RTV utility. In addition, to help identify the VTVs you want to convert, you can use the LISTONLY parameter to produce a list of the VTVs on an MVC.

Because multiple copies of the same VTV can exist on the same or different MVCs, **study carefully** your VTV and MVC reports and LISTONLY listings to ensure that you are using the correct MVC to convert the most current copy of a VTV!

- The RTV utility does not update the system catalog or TMC with information about the converted volumes; you must do this manually.

Security Considerations

- You must have read access both to the VTVs you want to convert and to the MVC that contains these VTVs or your system's security application cannot be running. Otherwise, the conversion will fail.
- Ensure that you APF authorize the RTV utility load library.
- RTV makes no attempts to bypass any TMS protection. All RTV tape mounts are subject to full TMS control.

JCL Requirements

The following are required or optional statements for the RTV utility JCL:

STEPLIB

specifies the link library (SLSLINK) that contains the RTV modules.

SLSPRINT

specifies the destination of the RTV utility report.

SLSIN

specifies the input to the SWSRTV program (RTV utility name and parameters).

SYSDUMP

optional DD to capture dump.

Note: Because the RTV utility must be capable of rewriting the tape standard labels on the output unit and positioning over label information on the input unit, Dynamic Allocation is used to invoke bypass label processing (BLP) on the tape volumes. This requires that the library that contains the SWSRTV executable code be APF authorized.

JCL Examples

Listing the VTVs on an MVC

Figure 97 shows example JCL to lists the VTVs on MVC MVC001.

```
//JOBVRECJOB (account),programmer
//RUNRTV EXEC PGM=SWSRTV,PARM='MIXED'
//STEPLIB DD DSN=h1q.SLSLINK,DISP=SHR
//SLSPRINT DD SYSOUT=A
//SLSIN DD *
RTV MVC(MVC001) INUNIT(/1AB4) LISTONLY
/*
//
```

Figure 97. Example JCL to run the RTV utility: LISTONLY run

Converting a Single VTV by Specifying Its Volser

Figure 98 shows example JCL to run the RTV utility to convert VTV VTV200 on MVC MVC001, which will be mounted on a 3490E transport. The output (converted VTV VTV200) goes to the output volume mounted on transport 280, and RTV copies the VTV VOLID from the VTV to the output volume.

```
//JOBVRECJOB (account),programmer
//RUNRTV EXEC PGM=SWSRTV,PARM='MIXED'
//STEPLIB DD DSN=h1q.SLSLINK,DISP=SHR
//SLSPRINT DD SYSOUT=A
//SLSIN DD *
RTV MVC(MVC001) INUNIT(3490E) VTV(VTV200) CPYVOLID OUTUNIT(280)
/*
//
```

Figure 98. Example JCL to run the RTV utility: single VTV by volser

Converting a Single VTV by Specifying Its Volser and Block ID

Figure 99 shows example JCL to run the RTV utility to convert VTV VTV200 at block ID x'8EA484AB' on MVC MVC001, which will be mounted on a 3490E transport. The output (converted VTV VTV200) goes to the output volume mounted on transport 480.

```
//JOBVRECJOB (account),programmer
//RUNRTV EXEC PGM=SWSRTV,PARM='MIXED'
//STEPLIB DD DSN=h1q.SLSLINK,DISP=SHR
//SLSPRINT DD SYSOUT=A
//SLSIN DD *
RTV MVC(MVC001) INUNIT(3490E) VTV(VTV200) BLOCK(8EA484AB)
OUTUNIT(480)
```

Figure 99. Example JCL to run the RTV utility: single VTV by volser and block ID

RTV Utility Report Messages

The RTV report displays the following messages:

Block number too large in compressed data

Explanation: An error was found in a compressed data record while processing a VTV. Further processing of this VTV is stopped. The VTV will be marked in the RTV Decompress Report output. The utility will continue to process other VTVs as necessary.

Chunked record logic error

Explanation: An error was found while processing a chunked data record for a VTV. Further processing of this VTV is stopped. The VTV will be marked in the RTV Decompress Report output. The utility will continue to process other VTVs as necessary.

Decompress invalid length parameter

Explanation: This indicates a program logic error. Further processing of this VTV is stopped. The VTV will be marked in the RTV Decompress Report output. The utility will continue to process other VTVs as necessary.

Decompress invalid parameter list

Explanation: This indicates a program logic error. Further processing of this VTV is stopped. The VTV will be marked in the RTV Decompress Report output. The utility will continue to process other VTVs as necessary.

Decompress logic error

Explanation: This indicates a program logic error. Further processing of this VTV is stopped. The VTV will be marked in the RTV Decompress Report output. The utility will continue to process other VTVs as necessary.

Decompress pointer to work area is zero

Explanation: This indicates a program logic error. Further processing of this VTV is stopped. The VTV will be marked in the RTV Decompress Report output. The utility will continue to process other VTVs as necessary.

Dynamic allocation error. Reason Code = xxxx-xxxx

Explanation: An error was encountered while attempting to dynamically allocate the INUNIT or OUTUNIT device. Refer to the IBM manual *MVS Authorized Assembler Services Guide* for a description of the dynamic allocation reason codes.

FILEnum of zero is invalid

Explanation: A FILEnum() value of 0 is invalid. The utility terminates with return code 12.

I/O error on input MVC

Explanation: An I/O error was encountered while reading a MVC. Further processing is stopped. The utility terminates with return code 12.

I/O error on output volume

Explanation: An I/O error was encountered while writing the output VTV. Further processing of this VTV is stopped. The VTV will be marked in the RTV Decompress Report output. The utility will continue to process other VTVs as necessary.

Invalid compressed data block read

Explanation: This indicates that an invalid data record was found while processing this VTV. Further processing of this VTV is stopped. The VTV will be marked in the RTV Decompress Report output. The utility will continue to process other VTVs as necessary.

Invalid VTV page number encountered

Explanation: A record sequence error was found in a compressed data record while processing a VTV. Further processing of this VTV is stopped. The VTV will be marked in the RTV Decompress Report output. The utility will continue to process other VTVs as necessary.

Invalid VTV record encountered

Explanation: An error was found in a compressed data record while processing a VTV. Further processing of this VTV is stopped. The VTV will be marked in the RTV Decompress Report output. The utility will continue to process other VTVs as necessary.

MVC volser # does not match requested volser #

Explanation: The volume mounted as the input MVC did not match that requested by the MVCid() parameter. The utility terminates with return code 12.

MVC record length error

Explanation: A length error was found in a compressed data record while processing a VTV. Further processing of this VTV is stopped. The VTV will be marked in the RTV Decompress Report output. The utility will continue to process other VTVs as necessary.

No algo byte found in compressed data

Explanation: An error was found in a compressed data record while processing a VTV. Further processing of this VTV is stopped. The VTV will be marked in the RTV Decompress Report output. The utility will continue to process other VTVs as necessary.

No HDR1 record found for requested VTV

Explanation: Following positioning by a BLOCKid() statement, there was no HDR1 record located at the desired position. Remove the BLOCKid statement and rerun the utility. The utility terminates with return code 12.

No HDR1 record found on input MVC

Explanation: The volume mounted as a MVC contained no HDR1 record. The utility terminates with return code 12.

No UHL1 record found on input MVC

Explanation: The volume mounted as a MVC contained no UHL1 record. The utility terminates with return code 12.

No VOL1 record found on input MVC

Explanation: The volume mounted as a MVC contained no VOL1 record. The utility terminates with return code 12.

NULL input buffer pointer

Explanation: This indicates a program logic error. Further processing of this VTV is stopped. The VTV will be marked in the RTV Decompress Report output. The utility will continue to process other VTVs as necessary.

NULL output buffer pointer

Explanation: This indicates a program logic error. Further processing of this VTV is stopped. The VTV will be marked in the RTV Decompress Report output. The utility will continue to process other VTVs as necessary.

Requested VTV not found on MVC

Explanation: The volser requested by the VTVid() parameter was not found on the MVC. The utility terminates with return code 12.

Spanned length final error

Explanation: An error was found while processing a spanned data record for a VTV. Further processing of this VTV is stopped. The VTV will be marked in the RTV Decompress Report output. The utility will continue to process other VTVs as necessary.

Spanned length intermediate error

Explanation: An error was found while processing a spanned data record for a VTV. Further processing of this VTV is stopped. The VTV will be marked in the RTV Decompress Report output. The utility will continue to process other VTVs as necessary.

Unexpected request on input I/O

Explanation: This indicates a program logic error. Further processing is stopped. The utility terminates with return code 12.

Unexpected end of tape on output volume

While writing the output VTV, an end of tape indication was encountered. The VTV must be completely contained on a single output volume. Further processing of this VTV is stopped. The VTV will be marked in the RTV Decompress Report output. The utility will continue to process other VTVs as necessary.

Unexpected request on output I/O

Explanation: This indicates a program logic error. Further processing of this VTV is stopped. The VTV will be marked in the RTV Decompress Report output. The utility will continue to process other VTVs as necessary.

Unexpected tape mark on input MVC

Explanation: An unexpected tape mark was found on a MVC. Further processing is stopped. The utility terminates with return code 12.

VTVid range parameter is invalid

Explanation: An invalid range value was found in the VTVid() specification. The utility terminates with return code 12.

VTV logical data check encountered

Explanation: A data check indicator was found in a compressed data record while processing a VTV. Further processing of this VTV is stopped. The VTV will be marked in the RTV Decompress Report output. The utility will continue to process other VTVs as necessary.

VTV volser # does not match requested volser #

Explanation: Following positioning by a BLOCKid() or FILEnum() statement, the VTV volser did not match that requested by the VTVID() parameter. The utility terminates with return code 12. Remove the BLOCKid or FILEnum() statement and rerun the utility.

RTV LISTONLY Listing

Figure 100 shows an example of the listing that RTV produces when you specify the LISTONLY parameter.

```
SWSRTV          (1.0.0)          StorageTek VTCS RTV Utility
PAGE 0001
TIME 14:23:33          Control Card Image Listing
DATE 12/01/00
      RTV MVC(C83107) LISTONLY
SWSRTV          (1.0.0)          StorageTek VTCS RTV Utility
PAGE 0002
TIME 14:23:33          MVC C83107 Contents Report
DATE 12/01/00
VTV          File      Block          <---Last Used--->          VTV
Volser      #          ID              Date          Time          Status
VV6825      1          00000000      20020Nov30    12:07:56
VV6863      2          92002F0F      20030Sep27    12:57:54
VV6893      3          92002F18      20030Aug18    08:57:26
VV0403      4          92002F21      20030Aug18    08:57:26
```

Figure 100. Example RTV LISTONLY listing

This report lists the VTV's:

- Volser
- Logical file number on the MVC
- Block ID on the MVC
- Last used time
- Status - Not Current, or if blank, the VTV is current

RTV Decompress Listing

Figure 101 shows an example of the listing that RTV produces when you do not specify the LISTONLY parameter (that is, you run RTV to convert VTVs to Nearline volumes).

```

SWSRTV          (1.0.0)          StorageTek VTCS RTV Utility
PAGE 0001
TIME 14:28:33          Control Card Image Listing          DATE 2003-1-18
          RTV MVC(C8228) VTV(VV6800-VV6900) CPYVOLID
SWSRTV          (1.0.0)          StorageTek VTCS RTV Utility
PAGE 0002
TIME 14:28:33          MVC C83223 Contents Report          DATE 2003-1-18
VTV          File   Block          <---Last Used--->          VTV
Volser      #     ID             Date           Time           Status
VV6070      1     00000000    20020Nov30    12:07:56
VV0874      2     2B001384    20030Sep27    12:57:54
VV0772      3     A3002707    20030Aug18    08:57:26
VV6828      4     9B002AB9    20030Aug18    08:57:26          Not current
VV6828      5     9B002AC2    20030Aug18    08:57:26
VV6826      6     9B002ACB    20030Aug18    08:57:26
SWSRTV          (1.0.0)          StorageTek VTCS RTV Utility
PAGE 0003
TIME 14:28:33          MVC C83223 Decompress Report          DATE 2003-1-18
VTV          Mounted          Final          Decompress
Volser          Volser          Volser          Status
VV6826          XX0772          VV6826          Successful
VV6828          XX0773          VV6828          Successful

```

Figure 101. Example RTV Decompress Listing

In addition to the contents fields shown in Figure 100 on page 163, the decompress listing shown in Figure 101 on page 164 lists the VTV's:

- Volser of the output Nearline volume as initially mounted
- Final volser of the output Nearline volume; if CPYVOLID is specified, the final volser will be identical to the VTV volser, otherwise is final volser is identical to the volser of the output Nearline volume as initially mounted
- Decompress status

SET MIGOPT

SET MIGOPT changes the following migration parameters:

- Maximum and minimum concurrent automatic migration, immediate migration, and migrate-to-threshold tasks
- High and low AMTs

Syntax

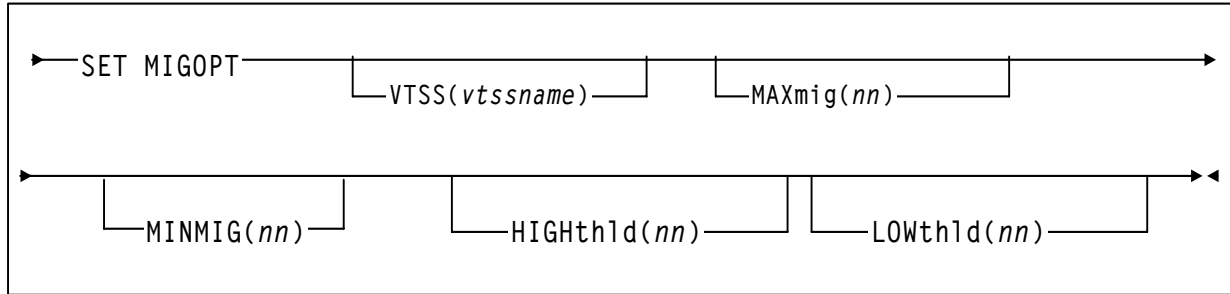

Figure 102. SET MIGOPT syntax

Parameters

VTSS

the VTSS whose migration parameters you want to change. If you do not specify a VTSS, the changes affect all VTSSs.

vtssname

the VTSS identifier.

MAXMIG(*nn*)

specifies the maximum number of concurrent automatic migration, immediate migration, and migrate-to-threshold tasks.

Valid values are 1 to the number of RTDs on the VTSS or 8, whichever is less. There is no default; if you do not specify a value, the current value is unchanged.

MINMIG(*nn*)

specifies the minimum number of concurrent automatic migration, immediate migration, and migrate-to-threshold tasks.

Valid values are 1 to the MAXMIG setting. There is no default; if you do not specify a value, the current value is unchanged.

HIGHthld

specifies the new high AMT.

high-thr

the new high AMT as a percent of VTSS space. Valid values are 5 to 95 and must be greater than the LOWthld value.

LOWthld

specifies the new low AMT.

low-thr

the new low AMT as a percent of VTSS space. Valid values are 5 to 95 and must be less than the HIGHthld value.

Interfaces

SWSADMIN utility and VT command.

Usage

Use SET MIGOPT to change following:

- Maximum and minimum concurrent automatic migration, immediate migration, and migrate-to-threshold tasks.
- High and low AMTs.

.Using SET MIGOPT:

- You can change the LAMT, the HAMT, or both.
- Changes to the AMTs take effect immediately.
- If you try to change global values (no VTSS specified) and the values are not valid for one VTSS (for example, MAXMIG(5) and one VTSS only has 4 RTDs connected), VTCS will not change values for any VTSSs.



Note: You can also change the AMTs with either the MIGRATE or the CONFIG VTSS LOW and HIGH parameters; see “MIGRATE” on page 107 and “VTSS” on page 5. Note, however, that a future release of VTCS will drop support of the MIGRATE SET HIGHthld and LOWthld parameters.

Command Examples

To change MAXMIG to 5 and MINMIG to 3, enter:

```
.VT SET MIGOPT MAXMIG(5) MINMIG(3)
```

To change the high AMT to 70% and the low AMT to 25%, enter:

```
.VT SET MIGOPT HIGH(70) LOW(25)
```

JCL Requirements

STEPLIB

specifies the link library (SLSLINK) that contains the VTCS and HSC modules.

SLSPRINT

specifies the destination for the RECLAIM report.

SLSIN

specifies the input to the SWSADMIN program (RECLAIM utility name and parameters).

JCL Examples

Figure 103 shows example JCL to change MAXMIG to 5 and MINMIG to 3.

```
//RECLAIM EXEC PGM=SWSADMIN,PARM='MIXED'  
//STEPLIB DD DSN=h1q.SLSLINK,DISP=SHR  
//SLSPRINT DD SYSOUT=*  
//SLSIN DD *  
SET MIGOPT MAXMIG(5) MINMIG(3)
```

Figure 103. RECLAIM JCL example to change MAXMIG to 5 and MINMIG to 3

Figure 104 shows example JCL change the high AMT to 70% and the low AMT to 25%.

```
//RECLAIM EXEC PGM=SWSADMIN,PARM='MIXED'  
//STEPLIB DD DSN=h1q.SLSLINK,DISP=SHR  
//SLSPRINT DD SYSOUT=*  
//SLSIN DD *  
SET MIGOPT HIGH(70) LOW(25)
```

Figure 104. RECLAIM JCL to change the high AMT to 70% and the low AMT to 25%

TRACE

TRace starts or stops event tracing for specified VTCS components.

Syntax

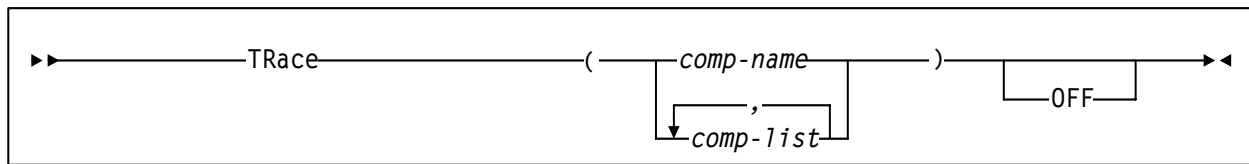

Figure 105. TRace **syntax**

Parameters

OFF

stops tracing for the specified components.

comp-name

specifies one of the following components:

VTCS

traces the VTCS component.

comp-list

specifies a list of components separated by commas or blanks.

Use TRace to start or stop event tracing for specified VTCS components.

Usage

Do not run a trace unless a StorageTek software support representative asks you to do so. You then send the trace file to StorageTek for diagnosis.

Interfaces

SWSADMIN utility and VT command.

Command Example

To start tracing for the VTCS component requests, enter the following:

```
.VT TR VTCS
```

JCL Requirements

STEPLIB

specifies the link library (SLSLINK) that contains the VTCS and HSC modules.

SLSPRINT

specifies the destination for the RECLAIM report.

SLSIN

specifies the input to the SWSADMIN program (function name and parameters).

JCL Example

Figure 106 shows example JCL start tracing for the VTCS component requests.

```
//RECLAIM EXEC PGM=SWSADMIN, PARM='MIXED'  
//STEPLIB DD DSN=h1q.SLSLINK, DISP=SHR  
//SLSPRINT DD SYSOUT=*  
//SLSIN DD *  
TR VTCS
```

Figure 106. JCL example to start tracing for the VTCS component requests

VARY CLINK

Vary CLink changes CLINK states.

Syntax

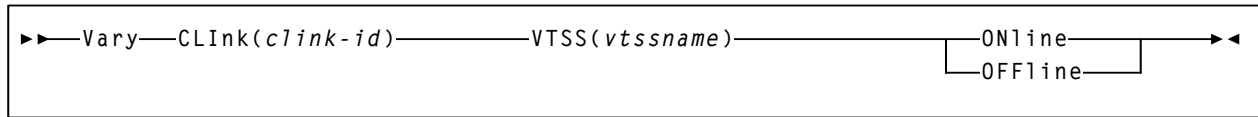

Figure 107. Vary CLINK **syntax**

Parameters

- CLink
the specified CLINK.
- clink-id*
the link ID.
- VTSS
the sending VTSS in the Cluster.
- vtssname*
the 1 to 8 character identifier of the sending VTSS.
- ONline
vary the specified CLINK online.
- OFFline
vary the specified CLINK offline.

Interfaces

SWSADMIN utility and VT command.

Usage

Use Vary CLINK to change CLINK states. For example, if a CLINK fails or requires service, you can enter a VT Vary CLink OFFline command to vary the CLINK offline. You enter a VT Vary CLink ONline command to vary the CLINK online.

Table 7 describes CLINK states.

Table 7. CLINK States

If you specify the following Vary CLink parameter...	The CLINK first goes to state...	And then goes to state...
ONline	Online Pending - In online pending state, the online process has started but has not completed.	Online - In online state, the CLINK is online and available for replication work.
OFFline	Offline Pending - In offline pending state, the offline process has started but has not completed. Current allocations continue to complete the replication of any VTVs being handled when the VARY OFF was issued. When all current allocations complete, the CLINK goes to offline state for all active hosts.	Offline - in offline state, The CLINK is offline to all hosts and does not accept replication work.

Command Example

To vary online CLINK 7 on the Cluster with VTSS VTSS01 as the sending VTSS, enter:

```
.VT V CLI(7) VTSS(VTSS01) ON
```

JCL Requirements

STEPLIB

specifies the link library (SLSLINK) that contains the VTCS and HSC modules.

SLSPRINT

specifies the destination for the RECLAIM report.

SLSIN

specifies the input to the SWSADMIN program (function name and parameters).

JCL Example

Figure 108 shows example JCL to vary online CLINK 7 on the Cluster with VTSS VTSS01 as the sending VTSS.

```
//RECLAIM EXEC PGM=SWSADMIN, PARM='MIXED'
//STEPLIB DD DSN=h1q.SLSLINK, DISP=SHR
//SLSPRINT DD SYSOUT=*
//SLSIN DD *

V CLI(7) VTSS(VTSS01) ON
```

Figure 108. JCL example to vary CLINK 7 on Cluster CLUSTER1 online

VARY RTD

Vary RTD changes RTD states.

Syntax

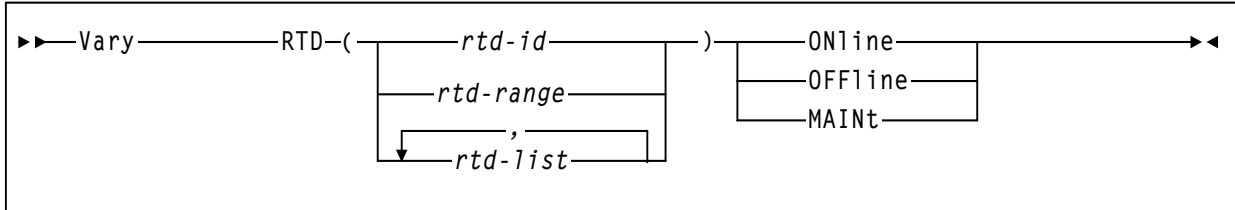

Figure 109. Vary RTD syntax

Parameters

RTD

change the state of the specified RTDs.

rtd-id, *rtd-range*, or *rtd-list*

the unit addresses of one or more RTDs. Lists and ranges of RTDs are limited to 64 items for VSM2s and VSM3s and 256 items for VSM4s.

ONline

vary the specified RTDs online to their connected VTSSs.

OFFline

vary the specified RTDs offline to their connected VTSSs.

MAINT

vary the specified RTDs offline (maintenance mode) to their connected VTSSs.

Interfaces

SWSADMIN utility and VT command.

Usage

Use Vary RTD to change RTD states. The state change applies to all VTSSs connected to the specified RTDs. That is, an RTD must be in the same state to all connected VTSSs.



Caution: If you are sharing transports with MVS, make sure to vary the transports offline to all MVS systems before varying these RTDs online to VSM and vice versa.

Command Example

To vary RTD B10 online, enter:

```
.VT V RTD(B10) ON
```

JCL Requirements

- STEPLIB
specifies the link library (SLSLINK) that contains the VTCS and HSC modules.
- SLSPRINT
specifies the destination for the RECLAIM report.
- SLSIN
specifies the input to the SWSADMIN program (function name and parameters).

JCL Example

Figure 110 shows example JCL to vary RTD B10 online.

```
//RECLAIM EXEC PGM=SWSADMIN, PARM='MIXED'  
//STEPLIB DD DSN=h1q.SLSLINK, DISP=SHR  
//SLSPRINT DD SYSOUT=*  
//SLSIN DD *  
  
V RTD(B10) ON
```

Figure 110. JCL example to vary RTD B10 online

VARY VTSS

Vary VTSS changes VTSS states on all hosts.

Syntax

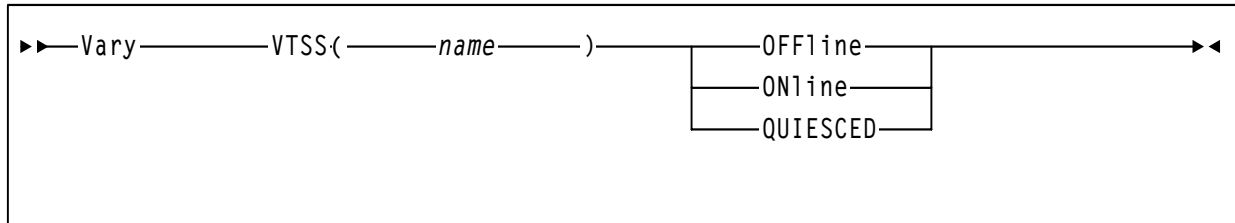

Figure 111. Vary VTSS *syntax*

Parameters

VTSS

change the state of the specified VTSS. For more information about VTSS states, see Table 8 on page 175.

vtssname

the VTSS identifier.

ONline

vary the specified VTSS online.

OFFline

vary the specified VTSS offline.

QUIESCED

vary the specified VTSS to quiesced state.



Note: Vary VTSS **does not** change the state of the VTDs or RTDs associated with the specified VTSS!

Interfaces

SWSADMIN utility and VT command.

Usage

Table 8 describes VTSS states.

Table 8. VTSS States

If you specify the following Vary VTSS parameter...	The VTSS first goes to state...	And then goes to state...
ONline	Online Pending - In online pending state, the online process has started but has not completed on all hosts.	Online - In online state, the VTSS is online, available, and accepts both front-end and back-end work. If the VTSS was offline, when it goes online, VTCS issues a warning message recommending a VTSS audit.
QUIESCED	Quiescing - In quiescing state, VTCS does not direct any DD allocation to the VTSS, which still accepts pending mounts to allow those long running jobs with unit=aff chains to complete. When all VTDs are no longer in use (their UCBs are not allocated on MVS), the VTSS goes to quiesced state. In quiescing state, the VTSS continues to accept and process back-end work; for example, migrates, recalls, and audits.	Quiesced - In quiesced state, the VTSS continues to accept and process back-end work; for example, migrates, recalls, and audits. That is, you can use the recall and migrate commands and utilities to do these operations using the quiesced VTSS.
OFFline	Offline Pending - In offline pending state, the offline process has started but has not completed on all hosts. VTCS immediately shuts down the VTSS and interrupts and purges all active tasks and purges all queued tasks. The VTSS server task terminates and no longer accepts new front-end and back-end work. VTCS creates new VTVs and mounts/dismounts existing VTVs only on alternate VTSSs, if they are available.	Offline - in offline state, The VTSS is offline to all hosts and does not accept either front-end or back-end work. If a copy of a VTV is resident on an offline VTSS and also on an MVC and a job requires the VTV, VTCS automatically recalls the VTV to an alternate VTSS, if available.

Use Vary VTSS to change VTSS states as described in Table 9.

Note: Vary VTSS changes VTSS states on all hosts regardless of which host issued the command or ran the utility.

Table 9. Vary VTSS *Usage Scenarios*

If...	And you want to...	Do the following...
A VTSS fails	Take the VTSS offline and continue processing by recalling migrated VTVs to an alternate VTSS.	Vary the failed VTSS offline. Jobs that require VTVs that have migrated from the failed VTSS are automatically recalled to the alternate VTSS.
A VTSS requires maintenance or will be taken out of service.	Take the VTSS offline and continue processing by recalling migrated VTVs to an alternate VTSS.	<ol style="list-style-type: none"> 1. Vary the VTSS to quiesced state. 2. If the VTSS will be taken out of service or the maintenance requires a "clean" VTSS, Do a migrate-to-threshold 0%. When the migrate completes, do a VTSS audit to ensure that all VTVs were successfully migrated. 3. Vary the VTSS offline so that maintenance can be applied or it can be taken out of service. Jobs that require VTVs that have migrated from the failed VTSS are automatically recalled to the alternate VTSS. <p>Note: It may also be necessary to vary VTDs and associated paths offline to MVS.</p>

If...	And you want to...	Do the following...
An offline VTSS is ready to come back online.	Use the VTSS.	<ol style="list-style-type: none"> 1. Dismount any VTVs still mounted in the VTSS (MVS perspective), by doing either of the following: <ul style="list-style-type: none"> • Use the MVS UNLOAD command to dismount the VTVs. • Use the VARY OFFLINE command to vary offline the VTD where the VTV is mounted, which will also dismount the VTV. 2. Clear any boxed VTD conditions. 3. Vary the VTSS to quiesced state. 4. Audit the VTSS. 5. Vary the VTSS online.

Command Example

To vary VTSS VTSS01 online, enter:

.VT V VTSS(HVTSS10) ON

The following shows sample output from this VT Vary VTSS ONline command:

```
Vary submitted to VSM system
Vary completed (0)
Vary online of VTSS HVTSS10 initiated from host ECCY
RTD task starting for device V0EE22F0
RTD task starting for device V0EE22F1
RTD task starting for device V08A22F4
VTSS HVTSS10 now online on host ECCL
VTSS HVTSS10 now online on host MVSU
VTSS HVTSS10 now online on host EC31
Vary online (local) of VTSS HVTSS10 complete
VTSS HVTSS10 has been offline; a VTSS audit is recommended
VTSS HVTSS10 server ready; state is online
VTSS HVTSS10 now online on host ECCY
Vary online (global) of VTSS HVTSS10 complete
```

JCL Requirements

STEPLIB

specifies the link library (SLSLINK) that contains the VTCS and HSC modules.

SLSPRINT

specifies the destination for the RECLAIM report.

SLSIN

specifies the input to the SWSADMIN program (function name and parameters).

JCL Example

Figure 110 shows example JCL to vary VTSS VTSS01 online.

```
//RECLAIM EXEC PGM=SWSADMIN, PARM='MIXED'  
//STEPLIB DD DSN=h1q.SLSLINK, DISP=SHR  
//SLSPRINT DD SYSOUT=*  
//SLSIN DD *  
  
V VTSS(HVTSS10) ON
```

Figure 112. JCL example to vary VTSS VTSS01 online

VTVMaint

VTVMaint does the following:

- Unlinks VTVs from MVCs,
- Sets the VTV Management Class, and
- Logically dismounts specified VTVs in an offline VTSS.

Syntax

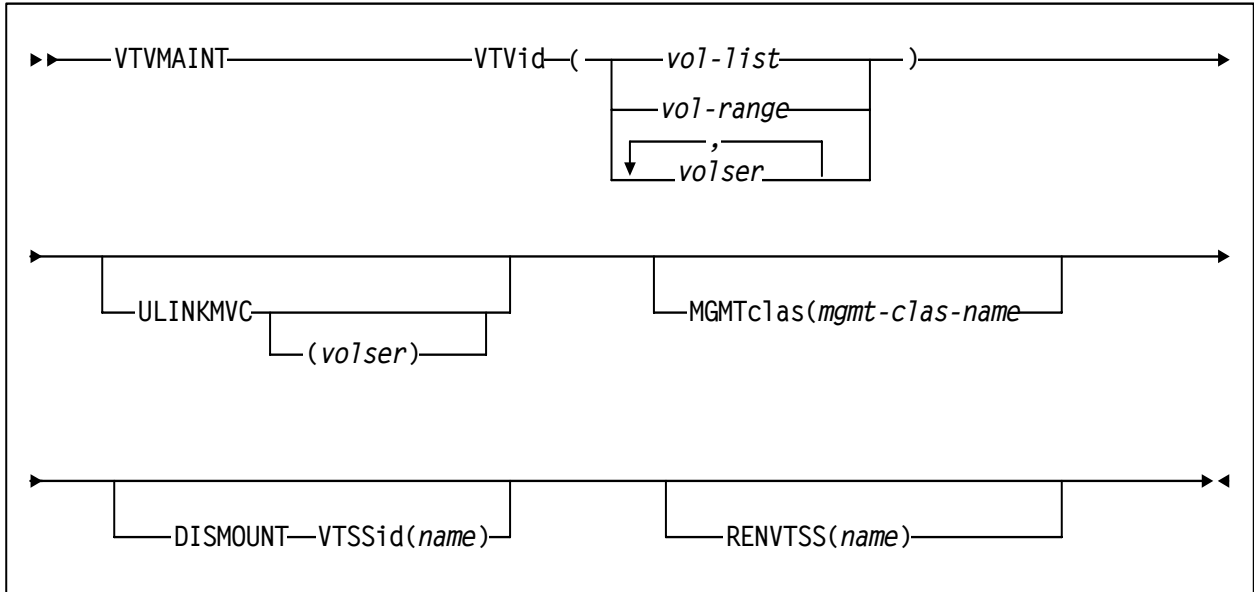

Figure 113. VTVMaint syntax

Parameters

VTVid

specifies the VTVs.

volser, *vol-range* or *vol-list*
the volsers of one or more VTVs.

ULINKMVC

unlink the specified VTVs.

volser

unlink the specified VTVs from the specified MVC.

MGMTclas

set the Management Class of the VTVs.

mgmt-class-name

the Management Class name that you specified on the MGMTclas control statement. For more information, see “MGMTCLAS Control Statement” on page 214.

DISMOUNT VTSSid

logically dismount the specified VTVs in the specified VTSS.

name

the VTSS name.

RENTSS

Sets the name of the VTSS where the VTV was last mounted to *name*.

name

the VTSS name.

Note: To set the VTSS name:

- The host on which the utility is run must have access to the VTSS, and
- The new VTSS name must be the name of an existing VTSS in the VTCS CONFIG deck.

Interfaces

SWSADMIN utility only.

Usage

Use VTMVAINT to do the following:

- Unlink VTVs from MVCs,
- Set the VTV Management Class, and
- Logically dismount specified VTVs in an offline VTSS.

Note: Running VTMVAINT also produces an MVC report of the volumes affected by the VTMVAINT job.

Changing VTV Management Class and Unlinking VTVs from MVCs

You can use VTMVAINT to change a VTV's Management Class. If the new Management Class specifies a different Storage Class, the VTV's current location on 1 or 2 MVCs is incorrect. The following procedure tells how to use VTMVAINT to change a VTV's Management Class and Storage Class.



To change a VTV's Management Class and Storage Class:

- 1. Recall the VTV.**

The VTV must be VTSS-resident for the unlink to succeed in Step 2.

- 2. Use VTMVAINT ULINKMVC to unlink the VTV from the MVC(s) where it is located.**

- 3. Use VTMVAINT MGMTclas to assign a new management class.**

- 4. Remigrate the VTV to place it on the correct MVCs.**

Logically Dismounting VTVs in an Offline VTSS

If a VTV is mounted when a VTSS goes offline and a copy of the VTV exists on an MVC, VTCS will not recall the migrated VTV to an alternate VTSS because the VTV is in mounted status on the offline VTSS. In this situation, you can use the `VTVMaint` to logically dismount VTVs in the offline VTSS (turn off the “mounted” bit in the CDS), then recall the VTV to an alternate VTSS. VTCS records each successful VTV dismount in the `SMF14STA` field of the SMF Subtype 14 record. For more information, see “`SLSSMF14 - VTCS SMF Subtype 14 Record`” on page 281. The `VTVRPT (UNAVAIL)` option reports the status of unavailable VTVs in an offline VTSS. For more information, see “`VTVRPT`” on page 184.



Warning: Don’t dismount an unavailable VTV in an offline VTSS unless you are absolutely sure that the MVC copies, if any, of the VTV, are identical in content to the unavailable VTV! Otherwise, you risk recalling a VTV with back-level data to an alternate VTSS! For example, a VTV mounted for read is probably safe to dismount for recall to an alternate VTSS. A VTV mounted for write, however, is probably not safe to dismount because it has probably been updated and the MVC copies are therefore back-level.

The following procedure provides the general steps you use to logically dismount a VTV and access that VTV from a different VTSS.

To logically dismount a VTV and access that VTV from a different VTSS:

1. Vary the VTSS offline to VTCS with the following command:

```
VT VARY VTSS(name) OFFLINE
```

If I/O was active and the VTSS failed, MVS should box the VTDs and dismount any mounted VTVs *from the MVS perspective*. However, if communication with the VTSS failed before the VTSS actually dismounted any mounted VTVs, they may still be online to VTCS. Therefore, you first need to vary the VTSS offline to VTCS.

If MVS boxed the VTDs and dismounted any mounted VTVs, go to Step 3. Otherwise, continue with Step 2.

2. Dismount the VTV (MVS perspective).

You cannot remount the VTV on a VTD in another VTSS if MVS still considers it mounted in the offline VTSS. Do either of the following:

- Use the `MVS UNLOAD` command to dismount the VTV.
- Use the `VARY OFFLINE` to vary offline the VTD where the VTV is mounted, which will also dismount the VTV.

3. Run VTMMAINT, specifying the offline VTSS and VTV(s) you want to logically dismount.

For example, to logically dismount VTVs VV6823, VV6825, and VV6688 in offline VTSS01, code the following SLSIN DD statement in your JCL:

```
VTMMAINT DISMOUNT VTV(VV6823, VV6825, VV6688) VTSS(VTSS01)
```

If migrated copies of the dismounted VTVs exist that an online VTSS can access, you can now use this VTSS to access the VTVs.



Caution: If the VTV copy mounted in the offline VTSS was modified and not migrated, the MVC copy that you recall to an alternate VTSS is not current! Therefore, StorageTek strongly recommends that you do not recall these non-current MVC copies!



Hint: When the offline VTSS is ready to be brought back online, StorageTek strongly recommends that you audit the VTSS before running production jobs that use the VTSS. Also ensure that you clear any boxed VTD conditions before issuing the VTSS VARY ONLINE command.

JCL Requirements

STEPLIB

specifies the link library (SLSLINK) that contains the VTCS and HSC modules.

SLSPRINT

specifies the destination for the VTMMAINT report.

SLSIN

specifies the input to the SWSADMIN program (VTMMAINT utility name and parameters).

JCL Examples

Figure 77 shows example JCL to run the VTMMAINT utility.

```
//VTMMAINT EXEC PGM=SWSADMIN, PARM='MIXED'  
//STEPLIB DD DSN=h1q.SLSLINK, DISP=SHR  
//SLSPRINT DD SYSOUT=*  
//SLSIN DD *  
VTMMAINT DISMOUNT VTV(VV6823, VV6825, VV6688) VTSS(VTSS01)
```

Figure 114. VTMMAINT utility example

VTVMAINT Report

Figure 90 shows an example of a VTVMAINT report for the following command:

VTVMAINT VTV(X00000-X00002) ULINKMVC MGMTCLAS(M1)

```
SWSADMIN (5.1.0)                STORAGETEK VTCS SYTEM UTILITY                PAGE 0001
TIME 06:32:03                    VTV MAINTENANCE                                DATE 2003-04-19
VTV          RC
X00000       04
X00001       04
X00002       04
VTVMAINT EXCEPTION REPORT
VTV X00000 IS ALREADY IN MGMTCLAS M1
VTV X00001 IS ALREADY IN MGMTCLAS M1
VTV X00002 IS ALREADY IN MGMTCLAS M1
SLS1315I SWS500.V5.CDS WAS SELECTED AS THE PRIMARY CONTROL DATA SET
SWSADMIN (5.1.0)                STORAGETEK VTCS SYTEM UTILITY                PAGE 0002
TIME 06:32:03                    VTCS VTV REPORT                                DATE 2003-04-19
VTV          SIZE  COMP% <----CREATION-----> <----LAST USED---->  MIGR  SCRT  RESD  REPL  MGMT  MVC1  MVC2  MVC3  MVC4  MAX  VTSSNAME
VOLSER      (MB)          DATE    TIME    DATE    TIME          CLASS          VTV
X00000     0.01          0  2003MAY19  05:02:08  2003MAY19  05:22:08  -  -  R  -  M1  022550 022551 022552 022553 800
X00001     0.01          0  2003MAY19  05:02:08  2003MAY19  05:22:08  -  -  R  -  M1  033550 033551 033552 033553 800
X00002     0.01          0  2003MAY19  05:02:08  2003MAY19  05:22:08  -  -  R  -  M1  044550 044551 044552 044553 800
      3 INITIALIZED VTVS PROCESSED
      0 NON-INITIALIZED VTVS PROCESSED
```

Figure 115. VTVMAINT Report

As shown in Figure 115, the VTVMAINT report shows:

- Status of VTVs processed - volser and return code (0 - all updates completed, 4 - some updates completed, 8 - no updates completed).
- An exception report of the reason for all uncompleted updates.

A VTV report; for more information, see “VTV Report” on page 188.

VTVRPT

The VTVRPT reports the status of your VSM system's VTVs.

Syntax

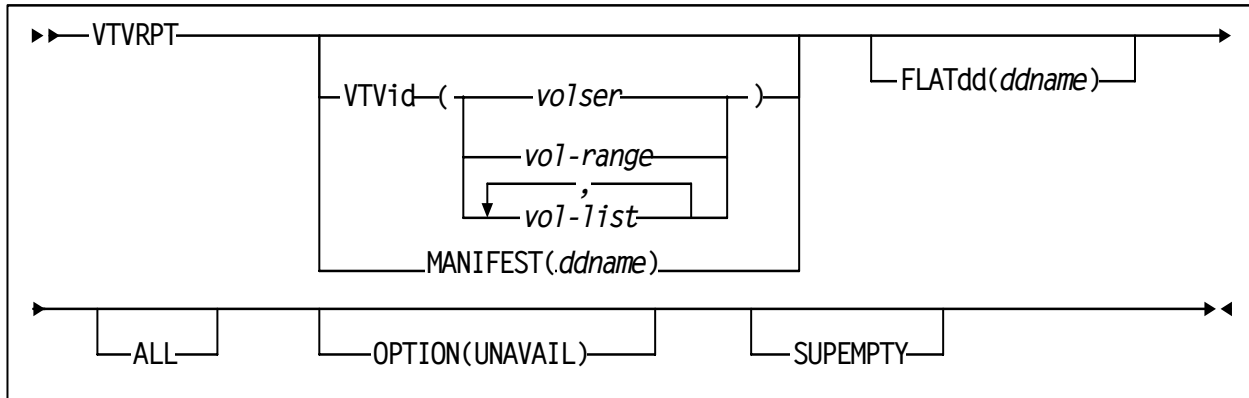

Figure 116. VTVRPT syntax

Parameters

VTVid

specifies the VTVs for the report. If you do not specify the VTVs, the report includes all initialized VTVs in your VSM system. A VTV is initialized when VTCS has used it at least once.

volser, *vol-range*, or *vol-list*

the volsers of one or more VTVs.

MANIFEST

specifies the input ddname of the manifest file used to generate the report.

ddname

ddname of the manifest file. **Note that** you can specify a merged manifest file or multiple manifest files. Figure 61 on page 100 shows example JCL to run the MVCMAINT utility where the MANIFEST parameter specifies importing multiple generations of a file.

FLATdd

specifies the output destination ddname if a flat file is required.

ddname

the ddname of the flat file included in the JCL.

ALL

specifies to report on all VTVs (including non-initialized volumes). If you do not specify ALL, the flat file reports only initialized VTVs.

OPTION(UNAVAIL)

specifies to report only on unavailable VTVs (VTVs in an offline VTSS).

SUPEMPTY

suppresses the printing of empty VTVs. That is, the VTV report does not contain details of VTVs that have no data on them or VTVs that are fenced. SUPEMPTY is mutually exclusive with ALL and OPTION(UNAVAIL).

Interfaces

SWSADMIN utility only.

Usage

Use the VTVRPT to report the status of your VSM system's VTVs. The report includes all VTVs that contain current data and all scratched VTVs. For more information, see "VTV Report" on page 188. Figure 117 on page 186 shows example JCL to run VTVRPT to produce a report and Figure 122 on page 188 shows the report format. VTV reports only list VTVs that have been used, not VTVs that are defined but have not been used. Note that you can specify the MANIFEST parameter to generate a report from an export manifest file instead of from the HSC CDS.

You can also report on only unavailable VTVs (VTVs in offline VTSSs). For more information, see Figure 119. on page 186 and "VTV Report" on page 188.

To produce reports for VSM, ExPR requires a flat file format of the VTV report as input. Figure 119 on page 186 shows example JCL to run VTVRPT to produce flat file format of the report for ExPR. Table 10 on page 192 Table 10 shows the record format of the flat file produced by VTVRPT. shows the flat file record format.

You can produce VTV reports in structured XML format. You can then process the XML output in a programming language of your choice. For information on the VTCS sample REXX execs, see "Sample REXX Execs" on page 313.

JCL Requirements

The following are the required and optional statements for the VTVRPT JCL:

STEPLIB

specifies the link library (SLSLINK) that contains the VTCS and HSC modules.

SLSPRINT

specifies the destination for the VTV report.

SLSIN

specifies the input to the SWSADMIN program (VTVRPT utility name and parameters).

SLSXML

specifies the output destination for XML output. Allocate this file as RECFM=VB, LRECL=255.

JCL Examples

Figure 117 shows example JCL to run VTVRPT to produce a report of all VTVs in your VSM system.

```
//VTVR EXEC PGM=SWSADMIN,PARM='MIXED'  
//STEPLIB DD DSN=h1q.SLSLINK,DISP=SHR  
//SLSPRINT DD SYSOUT=*  
//SLSIN DD *  
VTVRPT
```

Figure 117. Example JCL for the VTVRPT utility

Figure 118 shows example JCL to run VTVRPT to produce a report using manifest file REMOTE1 as input.

```
//VTVR EXEC PGM=SWSADMIN,PARM='MIXED'  
//STEPLIB DD DSN=h1q.SLSLINK,DISP=SHR  
//REMOTE1 DD DSN=FEDB.VSMLMULT.REMOTE1,DISP=SHR  
//SLSPRINT DD SYSOUT=*  
//SLSIN DD *  
VTVRPT MANIFEST(REMOTE1)
```

Figure 118. Example JCL for the VTVRPT utility (manifest file input)

Figure 119 shows example to run VTVRPT to produce a flat file report format of all VTVs for input to ExPR.

```
//VTVR EXEC PGM=SWSADMIN,PARM='MIXED'  
//STEPLIB DD DSN=h1q.SLSLINK,DISP=SHR  
//VTVOUT DD DSN=FEDB.FLAT,UNIT=SYSALLDA,DISP=OLD  
//SLSPRINT DD SYSOUT=*  
//SLSIN DD *  
VTVRPT FLATDD(VTVOUT)
```

Figure 119. Example JCL for the VTVRPT utility (flat file output for ExPR)

Figure 120 shows example to run VTVRPT to report only on unavailable VTVs (VTVs in an offline VTSS).

```
//VTVR EXEC PGM=SWSADMIN,PARM='MIXED'  
//STEPLIB DD DSN=h1q.SLSLINK,DISP=SHR  
//VTVOUT DD DSN=FEDB.FLAT,UNIT=SYSALLDA,DISP=OLD  
//SLSPRINT DD SYSOUT=*  
//SLSIN DD *  
VTVRPT OPTION(UNAVAIL)
```

Figure 120. Example JCL for the VTVRPT utility (unavailable VTVs only)

Figure 121 shows example to run VTVRPT to report only on unavailable VTVs (VTVs in an offline VTSS) in structured XML format.

```
//VTVREPT JOB x,CHRIS,CLASS=A,MSGCLASS=E
//*
//*
//*
//VTVRPT EXEC PGM=SWSADMIN
//STEPLIB DD DSN=ncs610.LINKLIB,DISP=SHR
//SLSCNTL DD DSN=h1q.V61.CLUSTER.CDS,DISP=SHR
//SLSPRINT DD SYSOUT=*
//SYSOUT DD SYSOUT=*
//SLSXML DD DISP=(,CATLG),DSN=h1q.VTVREPT.XML,
// DCB=(RECFM=VB,LRECL=255,BLKSIZE=4096),
// UNIT=SYSDA,SPACE=(CYL,(x,y))
//SLSIN DD *
VTVRPT
/* */
//TSO EXEC PGM=IKJEFT01,DYNAMNBR=128
//SYSPROC DD DSN=ncs610.SLSSAMP,DISP=SHR
//SYSTSPRT DD SYSOUT=*
//SLSPRINT DD SYSOUT=*
//INFILE DD DISP=SHR,DSN=h1q.VTVREPT.XML
//OUTFILE DD DISP=(,CATLG),DSN=h1q.VTVREPT.CSV,
// DCB=(RECFM=VB,LRECL=1024,BLKSIZE=4096),
// UNIT=SYSDA,SPACE=(CYL,(x,y))
//SYSTSIN DD *
%VTVXML
/*
//
```

Figure 121. Example JCL for the VTVRPT utility (unavailable VTVs only, structured XML format)

Note: XML output can consume **considerable** space. You may want to consider routing your XML output to a VTV so that the output is compressed.

VTV Report

Figure 122 shows an example of a VTV report and Figure 123. on page 189 shows an example of a VTV report with the UNAVAIL option. This report lists only unavailable VTVs in three sections--unavailable mounted on a VTD, unavailable VTSS-resident, and unavailable VTSS-resident and fenced.

SWSADMIN (5.1.0)		STORAGETEK VTCS SYTEM UTILITY										PAGE 0002					
TIME 06:32:03		VTCS VTV REPORT										DATE 2003-03-20					
VTV	SIZE	COMP%	<----CREATION----->		<----LAST USED----->		MIGR	SCRT	RESD	REPL	MGMT	MVC1	MVC2	MVC3	MVC4	MAX	VTSSNAME
VOLSER	(MB)		DATE	TIME	DATE	TIME					CLASS						VTV
X00T00	0.04	84	2003JUL16	05:02:08	2003JUL19	05:41:00	M	-	R	-	VCL4	022550	022551	022552	022553	800	VTSS16
X00002	<MOUNT>		2003JUL14	06:54:35	2003JUL19	07:43:46	M	-	R	-	VCL4	033550	033551	033552	033553	800	VTSS17
X00003	15.60	84	2003JUL14	10:05:05	2003JUL19	05:41:28	M	-	R	-	VCL2	044550	044551			400	VTSS16
X00004	0.36	84	2003MAY28	08:51:20	2003JUL19	05:41:30	M	S	R	-	VCL3	022550	022551	022552		800	VTSS16
X00005	15.60	84	2003JUL14	10:05:14	2003JUL19	05:41:31	M	-	R	-	VCL1	033550				400	VTSS16
X00006	15.60	84	2003JUL14	10:08:23	2003JUL19	08:45:31	C	-	-	-	VCL4	044550	044551	044552	044553	800	VTSS17

Figure 122. Example output from VTVRPT

SWSADMIN (5.1.0)		STORAGETEK VTCS SYTEM UTILITY										PAGE 002			
TIME 06:59:03		UNAVAIL MOUNTED VTV REPORT										DATE 2003-03-20			
VTV	SIZE	COMP%	<----CREATION----->	<----LAST USED----->	MIGR	SCRT	RESD	REPL	MGMT	MVC1	MVC2	MVC3	MVC4	MAX	VTSSNAM
VOLSER	(MB)		DATE	TIME	DATE	TIME			CLASS						VTV
Y09053	<MOUNT>		2003MAR19	09:34:14	2003MAR20	05:55:44	-	-	R	-	M9			800	BBVTSS1
SWSADMIN (5.1.0)		STORAGETEK VTCS SYTEM UTILITY										PAGE 003			
TIME 06:59:03		UNAVAIL RESIDENT VTV REPORT										DATE 2003-03-20			
VTV	SIZE	COMP%	<----CREATION----->	<----LAST USED----->	MIGR	SCRT	RESD	REPL	MGMT	MVC1	MVC2	MVC3	MVC4	MAX	VTSSNAM
VOLSER	(MB)		DATE	TIME	DATE	TIME			CLASS						VTV
X01007	156.24	89	2003JAN10	03:00:02	2003MAR01	04:51:47	-	S	R	-					BBVTSS1
X01010	3.90	0	2003MAR01	09:10:37	2003MAR01	09:10:37	-	-	R	-					BBVTSS1
X01014	3.90	0	2003MAR01	09:11:08	2003MAR01	09:11:08	-	-	R	-					BBVTSS1
X01021	3.90	0	2003MAR01	09:21:11	2003MAR01	09:21:11	-	-	R	-					BBVTSS1
SWSADMIN (5.1.0)		STORAGETEK VTCS SYTEM UTILITY										PAGE 004			
TIME 06:59:03		UNAVAIL FENCED VTV REPORT										DATE 2003-03-20			
VTV	SIZE	COMP%	<----CREATION----->	<----LAST USED----->	MIGR	SCRT	RESD	REPL	MGMT	MVC1	MVC2	MVC3	MVC4	MAX	VTSSNAM
VOLSER	(MB)		DATE	TIME	DATE	TIME			CLASS						VTV
X01280	<FENCED>						-	-	-	-					
X04762	<FENCED>						-	-	-	-					
X04776	<FENCED>						-	-	-	-					
X02019	<FENCED>						-	-	-	-					
X10066	<FENCED>						-	-	-	-					
X10068	<FENCED>						-	-	-	-					

Figure 123. Example output from VTVRPT (UNAVAIL option)

VTVRPT Report
Fields

The following list describes the VTV report fields.

VTV Volser

the VTV volser.

Size (MB)

the uncompressed size of the VTV (MB). <**MOUNT**> indicates that the VTV was mounted when the report ran. <**FENCED**> indicates that the VTV's state is unknown. If <**FENCED**> appears, contact StorageTek software support.

Comp %

the VTV compression percentage achieved. This is the difference between the uncompressed and compressed VTV size expressed as a percentage of the uncompressed VTV size. For example if a 100MB VTV compresses to 40MB then the compression% will be given as 60%. A compression of 0% indicates that no compression was possible on the VTV.

Creation Date and Time

the date and time that the VTV was created.

Last Used Date and Time

the date and time that the VTV was last used. This date and time value is updated by successful completion of a VTV mount, migrate, recall, or scratch.

Migr

indicates whether the VTV has been migrated (M) or consolidated (C). If the VTV is both migrated and consolidated, a 'C' appears in this field. If the VTV has not been migrated, it is either VTSS resident or non-existent (not created or used, scratched, and deleted).

Scrt

indicates whether the VTV has been scratched.

Resd

indicates whether the VTV is resident in a VTSS.

Repl

one of the following VTV replication statuses:

-
the VTV has no replication requirements or the VTV has replication requirements but is not resident.

R

replication is required but has not started.

S

replication has started.

C

replication has completed.

Note: The **Repl** column displays R, S, or C only if the VTV is resident, otherwise a '-' appears.

MGMT Class

the name of the Management Class for the VTV specified.

MVC1, MVC2, MVC3, MVC4

the MVC(s) that contain the VTV (for both migration and consolidation). If all of these fields are empty, the VTV has not been migrated or consolidated. If 1 or more of these fields list an MVC volser, the VTV was migrated to each of these MVCs.

MAX VTV

the maximum size of the VTV in Mb (400 or 800).

VTSSNAME

the VTSS where the VTV resides, or, if the VTV is migrated, the VTSS where the VTSS was last resident. If this field is empty, the VTV is non-existent (not created or used, scratched, and deleted).

VTV Flat File Record Format

Table 10 shows the record format of the flat file produced by VTVRPT.

Table 10. VTVRPT flat file record format

Decimal Offset	Hexadecimal Offset	Type	Length	Description
0	0	start of record		start of VTV flat file record
0	0	integer	4	record length
4	4	character	1	character set type of text fields
		X'61'		ASCII
		X'6E'		EBCDIC
5	5	character	1	record type 'V' (indicates VTV report)
6	6	character	6	VTV volser
12	C	character	8	VTSS where the VTV resides
20	14	integer	4	uncompressed VTV size (MB)
24	18	character	1	VTV migrated? (Y, N, or C)
25	19		1	reserved
26	1A	character	6	MVC volser (first copy)
32	20	character	6	MVC volser (second copy)
38	26	character	1	always set to N
39	27	character	1	VTV scratched? (Y or N)
40	28	time_t	4	date VTV created (time_t format)
44	2C	time_t	4	date VTV last referenced (time_t format)
48	30		8	reserved
56	38	integer	2	compression percentage for VTV
58	3A	character	1	replicate indicator: C, R, S, or - For more information, see "VTV Report" on page 188.
59	3B	character	1	fenced indicator (Y or N)
60	3C	character	1	mounted indicator (Y or N)
61	3D	character	8	Management Class name
69	45	character	6	MVC volser (third copy)
75	4B	character	6	MVC volser (fourth copy)
81	51			reserved
82	52	integer	2	maximum VTV size (400 or 800)

Chapter 2. SMC Enhancements and Additions for VSM

Note: For NCS 6.1:

- The TAPEREQ statement (and the accompanying TREQDEF command) has been moved from HSC and MVS/CSC to SMC. For more information, see “TAPEREQ Control Statement” on page 194 and *SMC Configuration and Administration Guide*.
- The UNITATTR statement has been moved from HSC to SMC and is **no longer required** for VTDs. An SMC UNITATTR statement is required **only** to set the real transport model type for non-library transports (which are not supported for VSM). For more information, see *SMC Configuration and Administration Guide*.
- The HSC ALLOC command has been moved from HSC to SMC and renamed the ALLOCDEF command. For more information, see “SMC ALLOCDEF Command Enhancements” on page 199 and *SMC Configuration and Administration Guide*.

TAPEREQ Control Statement

The TAPEREQ control statement can route tape data sets to VSM and pass a Management Class to VSM.

Syntax

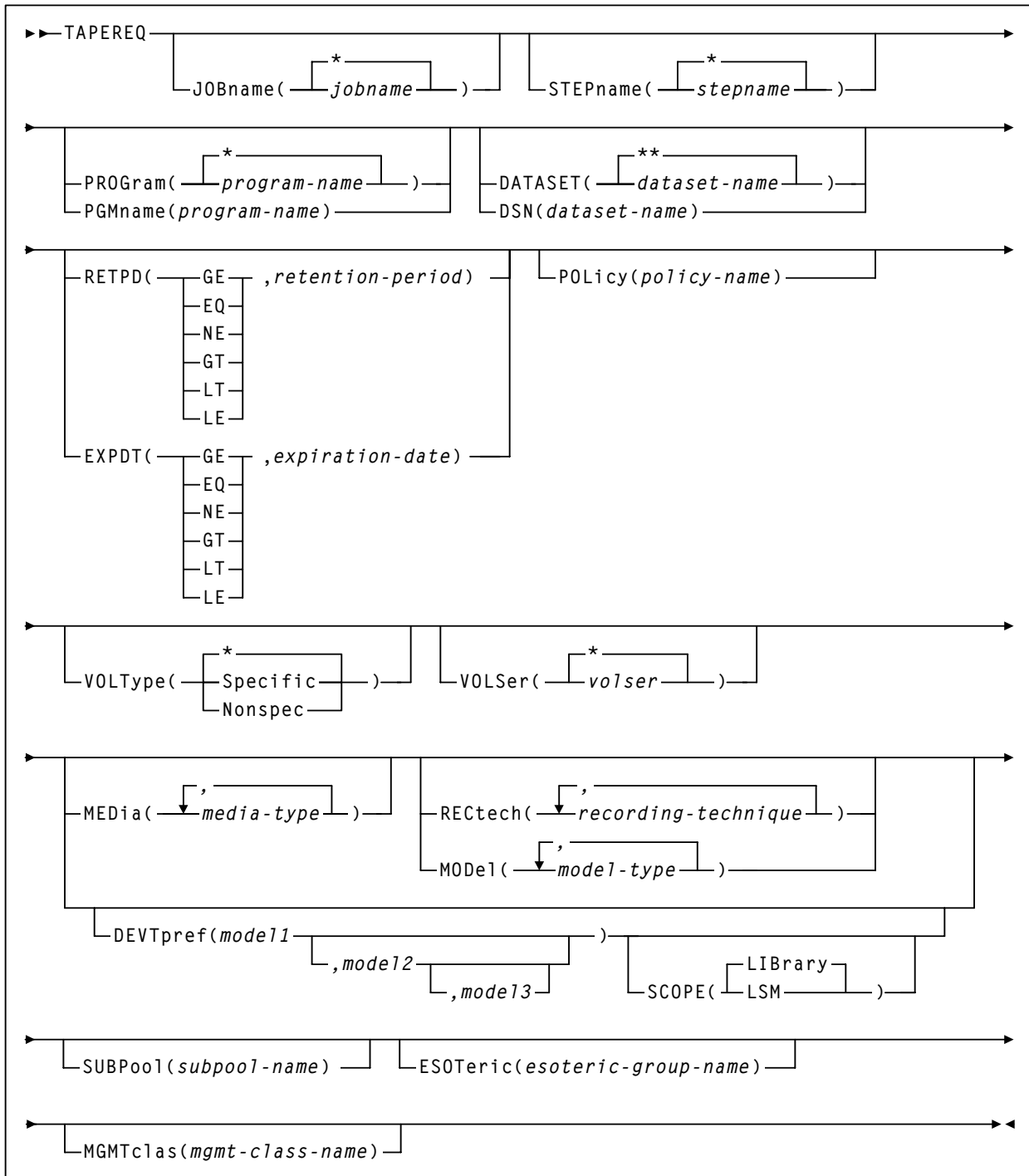

Figure 1. TAPEREQ Control Statement Syntax

Parameters

Unchanged TAPEREQ Parameters

The following TAPEREQ parameters are unchanged but apply to VSM. Figure 1. on page 194 shows valid values for these parameters; see *SMC Configuration and Administration Guide* for more information.

- JOBname
- STEPname
- PROGram
- PGMname
- DATASET
- DSN
- RETPD
- EXPDT
- VOLType
- DEVTpref
- SCOPE

New or Enhanced TAPEREQ Parameters

The following TAPEREQ parameters apply to both VSM and NCS without VSM installed.

SUBPool

specifies the scratch subpool that contains volumes used to satisfy nonspecific requests. For more information about scratch subpool management, see *SMC Configuration and Administration Guide*.

poolname

the subpool name.

ESOTeric

specifies the esoteric that defines the list of eligible transports to be used to satisfy a tape request.

To route a data set to a VTD, specify one of the esoteric names that you defined during configuration. For more information on creating and using VSM esoterics for TAPEREQ statements, see *VTCS Installation and Configuration Guide*.

For more information on using esoteric substitution to route a data set to Nearline transports that are *not* RTDs, see Chapter 9, “User Exits” in *HSC System Programmer’s Guide for MVS*.

esoteric-name

the esoteric name.

TAPEREQ Parameters for VSM

The `MEDia`, `RECtech`, and `MODEl` parameters have a value of `Virtual` for VSM only. Specifying `Virtual` on any of these three parameters will route the data set to a VTV mounted on a VTD. `Virtual` does not apply to NCS without VSM installed. The `MGMTclas` parameter does not apply to NCS without VSM installed.



Caution: If you specify a Management Class on the `MGMTclas` parameter, you must specify both `MEDia(V)` and `RECtech(V)`.

`MEDia`

specifies the volume media.

`Virtual`

specifies that VSM will route the data set to a VTV mounted on a VTD.

`RECtech`

specifies the recording technique.

`Virtual`

specifies that VSM will route the data set to a VTV mounted on a VTD.

`MODEl`

specifies the transport model.

`Virtual`

specifies that VSM will route the data set to a VTV mounted on a VTD.

`MGMTclas`

specifies a Management Class you defined on the `MGMTclas` control statement; for more information, see “MGMTCLAS Control Statement” on page 214.

mgmt-class-name

the Management Class name.

Note: NCS does not support the `DUPlex` parameter on `TAPEREQ` statements, only on `MGMTclas` statements. For more information, see “MGMTCLAS Control Statement” on page 214.

Usage

To route data sets to VSM with TAPEREQ statements, do one of the following:

- Specify `Virtual` on the `MEDIA`, `MODEL`, or `RECTECH` parameter. If you specify `Virtual`, VSM selects an available VTD in your system and routes the data set to that VTD.

In a multi-VTSS environment, therefore, specifying `Virtual` does *not* direct the VTD allocation to a specific VTSS, but lets the allocation occur in any VTSS in the configuration.

- Specify an esoteric that represents VTDs on the `ESOTERIC` parameter.

For more information on creating and using VSM esoterics for TAPEREQ statements, see *VTCS Installation and Configuration Guide*.

You can also specify a Management Class on the `MGMTCLAS` parameter. You define Management Classes with the `MGMTCLAS` statement; for more information, see “MGMTCLAS Control Statement” on page 214. You use the `MGMTDEF` command to load `MGMTCLAS` statements from a specified definition data set; for more information, see “MGMTCLAS Control Statement” on page 214.

Note: If you specify a Management Class on a TAPEREQ statement and an SMS routine, the Management Class on the SMS routine takes precedence.

You must use the `TREQDEF` command to load TAPEREQ control statements from a specified definition data set; see *SMC Configuration and Administration Guide* for more information.



Note: Multiple TAPEREQ statements that specify the same or overlapping selection criteria (such as `jobname`, `stepname`, or `data set`) can cause undesirable results (such as assignment of `MEDIA Virtual` and an esoteric). For example:

```
TAPEREQ DSN(AA22*.* ) MEDIA(V) RECT(V)
TAPEREQ DSN(**) MEDIA(LONGITUD) RECT(36) ESOT(ACS0)
```

In this case, because the second TAPEREQ statement is a “catchall” statement with a wildcard for *any* data set, SMC will actually attempt to assign real media and esoteric ACS0 to any data set that meets the data set mask of AA22*.* instead of routing it to VSM. Let’s say that what you really want is to route all data sets selected by mask of AA22*.* to VSM, but you want to route all data sets selected by a mask of PROD17.* to 36-track tape in ACS0 (represented by esoteric ACS0). To do this, delete the catchall TAPEREQ statement and instead code the following:

```
TAPEREQ DSN(AA22*.* ) MEDIA(V) RECT(V)
TAPEREQ DSN(PROD17.* ) MEDIA(LONGITUD) RECT(36) ESOT(ACS0)
```

Examples

To route all data sets with the HLQ of PAYROLL to a VTV mounted on a VTD that VSM selects, create the following TAPEREQ statement:

```
TAPEREQ DSN(PAYROLL.**) MED(VIRTUAL) RECT(VIRTUAL)
```

To route all data sets with the HLQ of PAYROLL to a VTV mounted on one of the VTDs represented by the VTSS1 esoteric, create the following TAPEREQ statement:

```
TAPEREQ DSN(PAYROLL.**) ESOT(ES0VTSS1)
```

To route volumes created by jobs with jobname PRODSL2 to a VTV mounted on a VTD that VSM selects and specify Management Class MGMTCLS1:

```
TAPEREQ JOB(PRODSL1) RECT(VIRTUAL) MGMT(MGMTCLS1)
```

SMC ALLOCDEF Command Enhancements

As described in *SMC Configuration and Administration Guide*, the ALLOCDEF command sets or changes NCS device allocation options.

In the JES environment, regardless of the value you specify, the DEFER parameter is always set to ON for VTVs. That is, for VTVs, deferred mount processing is enabled, which overrides the mount processing specified in the user's JCL. The VTV mount is deferred until the JCL job step opens a data set on the VTV. This value helps minimize VTV recalls. If a data set resides on a migrated VTV, VSM does not recall the VTV until the job actually opens the data set on the VTV.

Note that if a unit affinity chain includes a mixture of incompatible drives (including VTDs), NCS SMC device exclusion always ensures that the chain will be broken.

Chapter 3. HSC Enhancements and Additions for VSM

Note: For NCS 6.1:

- The TAPEREQ statement (and the accompanying TREQDEF command) has been moved from HSC and MVS/CSC to SMC. For more information, see “TAPEREQ Control Statement” on page 194 and *SMC Configuration and Administration Guide*.
- The UNITATTR statement has been moved from HSC to SMC and is **no longer required** for VTDs. An SMC UNITATTR statement is required **only** to set the real transport model type for non-library transports (which are not supported for VSM). For more information, see *SMC Configuration and Administration Guide*.
- The HSC ALLOC command has been moved from HSC to SMC and renamed the ALLOCDEF command. For more information, see “SMC ALLOCDEF Command Enhancements” on page 199 and *SMC Configuration and Administration Guide*.

This chapter contains reference information about the following enhancements and additions to HSC to support VSM:

- “DISPLAY Command” on page 203, that accepts the following parameters:
 - FEATures, that displays the HSC features set by the FEATures PARMLIB control statement.
 - MGMTDEF, that displays the data set and date and time loaded if MGMTclas control statements are active.
 - MVCDEF, that displays the data set and date and time loaded if MVCPool control statements are active.
- “FEATURES Control Statement” on page 204, that specifies which VSM features are enabled.
- “MERGECDS Utility” on page 205, that can update a CDS or merge CDSs with VSM volume records.
- “MGMTCLAS Control Statement” on page 214, an HSC control statement that defines VSM Management Classes.
- “MGMTDEF Command” on page 223, a new HSC command that loads the MGMTclas statements from a specified definition data set.
- “MOUNT Command” on page 225, that can mount a specific or scratch VTV on a VTD and optionally assign a Management Class to the VTV.
- “MVCPOOL Control Statement” on page 226, an HSC control statement to define a pool of HSC volumes as MVCs
- “STORCLAS Control Statement” on page 229, an HSC control statement that defines VSM Storage Classes.

- “STORLST Control Statement” on page 234, an HSC control statement that specifies a list of Storage Classes and their corresponding preferencing.
- “STORSEL Control Statement” on page 236, an HSC control statement that defines a Storage Class usage rule that applies to the Storage Class list and its preferencing specified on a referenced STORLST control statement.
- “VTSSLST Control Statement” on page 241, an HSC control statement that specifies a list of VTSSs and their corresponding preferencing.
- “VTSSSEL Control Statement” on page 243, an HSC control statement that defines a VTSS usage rule that applies to the VTSS list and its preferencing specified on a referenced VTSSLST control statement.
- “VOLATTR Control Statement” on page 239, that specifies VTV attributes, including the volser and media type (virtual).
- “HSC Programmatic Interface Enhancements” on page 247
- “HSC User Exit Enhancements” on page 248
- “HSC Batch API Enhancements” on page 248

Note: The following HSC enhancements are available via PTF as described below:

- The HSC MOUNT command can now mount a scratch or specific VTV on a VTD and optionally assigns a Management Class to the VTV. For more information, see “MOUNT Command” on page 225.
- The Programmatic Interface MOUNT request now supports an additional parameter of MGMTCLAS that can assign a VSM Management Class to the VTV. For more information, see “HSC Programmatic Interface Enhancements” on page 247.
- “HSC Operator Command Enhancements” on page 253
- “HSC DELDISP Parameter Enhancements” on page 259

DISPLAY Command

For VSM, the HSC Display command displays the data set and date and time loaded if MGMTclas and/or MVCPool control statements are active and the HSC features set by the FEATures PARMLIB control statement.

Syntax



Figure 1. Display **Command**

Parameters

FEATures

displays the HSC features set by the FEATures PARMLIB control statement.

MGMTDEF

displays the data set and date and time loaded if MGMTclas control statements are active.

MVCDEF

displays the data set and date and time loaded if MVCPool control statements are active.

Usage

Use the HSC Display command to display the data set and date and time loaded if MGMTclas and or MVCPool control statements are active and the HSC features set by the FEATures PARMLIB control statement.

Examples

To display the data set and date and time loaded of an active MGMTclas statement, enter:

D MGMTDEF

To display the data set and date and time loaded of an active MVCPool statement, enter:

D MVCDEF

To display the HSC features set by the FEATures PARMLIB control statement, enter:

D FEAT

FEATURES Control Statement

The HSC FEATures control statement specifies which VSM features are enabled.

Syntax

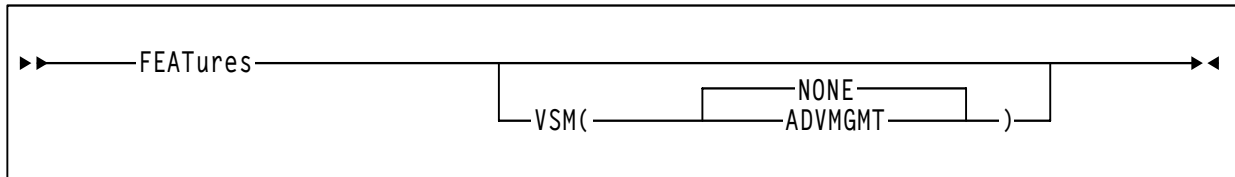

Figure 2. FEATures Control Statement

Parameters

VSM

specifies which VSM Management Features are enabled.

NONE

Basic Management only is enabled; the Advanced Management Feature is not enabled (the default). STORclas statements, the MGMTclas statement MIGpol, RESTIME, CONSRC, CONTGT and REPLICAT parameters, and EXPORT and IMPORT are disabled. For more information about the MGMTclas parameters that are valid for Basic Management, see “Parameters - Basic Management Feature” on page 215.

ADVMGMT

Both Basic and the following Advanced Management Features are enabled:

- STORclas statements; for more information, see “STORCLAS Control Statement” on page 229.
- MGMTclas statement MIGpol, RESTIME, CONSRC, CONTGT, and REPLICAT parameters; for more information, see “Additional Parameters - Advanced Management Feature” on page 219.
- EXPORT and IMPORT; for more information, see “EXPORT” on page 89 and “IMPORT” on page 93.

If the FEATures PARMLIB control statement is not specified, Basic Management only is enabled.

Usage

Use the HSC FEATures control statement to specify which VSM features are enabled.

Example

To enable the Advanced Management Feature, create the following statement:

```
FEAT VSM(ADVMGMT)
```

MERGECDs Utility

The enhanced MERGEcds utility can reconfigure a CDS or merge CDSs with VSM volume records.

Syntax

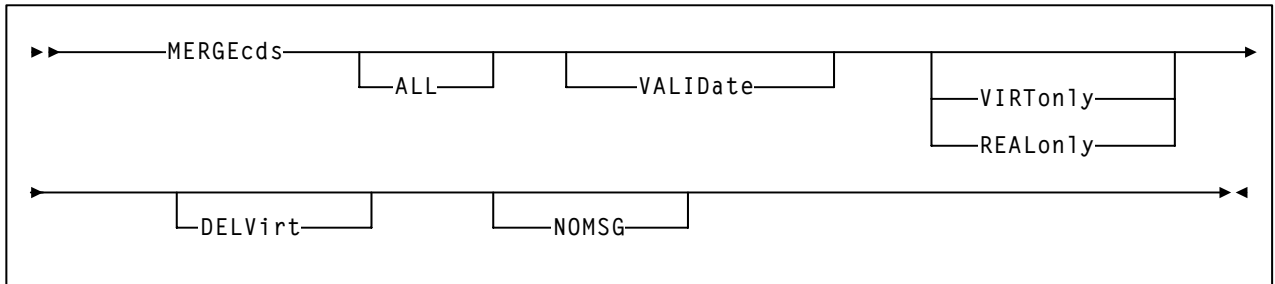

Figure 3. MERGEcds *Utility Syntax*

Parameters

VALIDate

specifies to only validate that the configurations to be reconfigured or merged are compatible, but not do the operation. MERGEcds VALIDate reports any duplicate, in-transit, and errant volumes.

ALL

specifies to copy volume information for all ACSs and VTSSs from the "from" CDS to the "to" CDS. For a CDS merge, the ACS ID and LSM IDs, and VTSS identifiers must match.

If you do not specify ALL, MERGEcds reads the parameters specified in the SLSMERGE DD statement, which specify the ACSs, LSMs, and VTSSs whose volume information you want to merge or reconfigure. ALL and SLSMERGE DD are mutually exclusive.

You also specify the ALL parameter to convert a CDS to extended format.

VIRToNly

specifies to use only VSM volume records.

REALoNly

specifies to use only real Nearline volume records.

As shown in Figure 3, VIRToNly and REALoNly are mutually exclusive. See Table 1. on page 209 for more information about the MERGEcds parameter interactions.

DELVirt

specifies that VTV and MVC volume information is not copied to the “to” CDS if **both** of the following are true:

- The VTVs and MVCs defined in the "from" CDS are either uninitialized or empty. An empty VTV is not VTSS resident and has no current MVC copies. An empty MVC contains no current VTVs.
- The uninitialized or empty VTVs and MVCs in the "from" CDS are not defined in the "to" CDS. That is, no duplicate volsers exist.

NOMSG

suppresses message SLS4245I, which displays the volser of an MVC or VTV that was not copied to the “to” CDS. NOMSG has no effect if you do not also specify DELVirt.

Usage

Use the enhanced MERGEcds utility to update a CDS or merge CDSs with VSM volume records. For more information, see the following sections:

- “MERGEcds Procedure for VSM Environments”
- “MERGEcds Parameter Interactions” on page 209

You also specify the ALL parameter to convert a CDS to extended format.

MERGEcds Procedure for VSM Environments

This procedure is for using MERGEcds in a VSM environment. For information about using MERGEcds in a Nearline environment without VSM installed, see “MERGEcds Utility” in Chapter 5 of *HSC System Programmer's Guide*.



To run MERGEcds in a VSM environment:

1. Before running MERGEcds, do the following:

- a. Create VTV and MVC reports for each CDS that contains VSM records for comparison after the merge is complete.
- b. Ensure that the “to” CDS contains enough space to hold the VSM volume records from all CDSs to be merged **and** any new VTV and/or MVC ranges to be created. You may need to expand the “to” CDS if it does not contain enough space. If you are deleting VTV and/or MVC ranges, you must create a new “to” CDS, because you cannot to remove existing records from an existing CDS.
- c. Quiesce all real and virtual tape activity on the “from” CDS by shutting down HSCs that reference the “from” CDS to avoid losing active real and/or virtual operations during the merge. The “from” CDS is defined in the JCL for MERGEcds as shown in Figure 6 on page 212 and Figure 7 on page 213.

- d. You run MERGEcds on the MVS system that contains the “to” CDS, which must already be defined. You can run MERGEcds without stopping HSC on the MVS system that contains the “to” CDS, but HSC on this system should be running at base level (no tape activity) until MERGEcds completes and until you have verified the results of the merge and backed up the “to” CDS.

Note: If you want rename the “to” and “from” CDSs, StorageTek recommends that you shut down HSC on **both** the “to” and “from” systems. See the *HSC System Programmer's Guide* (“Control Statements and Start Procedure” in Chapter 3 and “Renaming Control Data Sets” in Chapter 2).

- e. Before running MERGEcds in a VSM environment, you must run VTCS CONFIG **even if there are no changes** to the VSM configuration to prepare for merging VTCS volume records.

Note: With CONFIG, you can only add MVC and VTV volsers, you cannot remove them. You can, however, use the DELVirt parameter to not copy MVC or VTV volsers to the “to” CDS; for more information, see “DELVirt” on page 206 and “MERGEcds Example: Merging CDSs with Duplicate VTSS Identifiers, Do Not Copy Volume Information for MVCs and VTVs” on page 213.

- f. If you also run MERGEcds to merge CDSs with Nearline volume information (for example, merging two ACSs where the “from” ACS contains MVCs), you may also need to do some or all of the tasks described in:
 - “Define and Select Nearline Volumes” in *VTCS Installation and Configuration Guide*.
 - “MERGECDs Utility” in Chapter 3, “Control Statements and Start Procedure” in *HSC System Programmer's Guide for MVS*.
 - “Renaming Control Data Sets” in Chapter 2, “Host Software Component Functions” in *HSC System Programmer's Guide for MVS*.

2. Run MERGEcds as follows:

- To merge CDSs, both of which contain *different* VSM volume records, specify MERGE ALL or MERGE ALL VIRTonly. You would typically do this, for example, if the “from” CDS defines VTVs and MVCs for VTSS01 and VTSS02 and the “to” CDS defines VTVs and MVCs for VTSS05 and VTSS06 and there are no duplicate MVC or VTV volsers; see Figure 5 on page 212.
- To merge CDSs which have duplicate VTSS identifiers:
 1. Specify MERGE or MERGE VIRTonly.
 2. Rename the duplicate VTSS identifier by specifying a new identifier on the SLSMERGE TVTSS subparameter.

You would typically do this, for example, if the “from” CDS defines VTVs and MVCs for VTSS01 and VTSS02 and the “to” CDS defines VTVs and MVCs for “populated” VTSSs VTSS01 and VTSS02 and there are no duplicate MVC or VTV volsers; see Figure 6 on page 212.

Note: Before running MERGEcds to rename a VTSS, you must set the identifier to 99999999 at the LOP.

The virtual part of a CDS merge fails if either of the following occurs:

- There are duplicate MVC or VTV volsers or duplicate volsers between MVCs or VTVs and standard Nearline volumes in the “from” and “to” CDS.
- You specify DELVirt and the affected VTVs and MVCs do not meet the conditions described in “DELVirt” on page 206.

Note: If you also specify a merge of real volumes, it will complete even if the virtual merge fails.

3. After running MERGEcds, do the following:

- a. Produce VTV and MVC reports for the “to” CDS and compare with the reports you produced before the merge.
- b. If the “from” CDS contained MVC records or if you deleted one or more MVC ranges, you need to update the VOLATTR statements.
- c. Restart HSC on all LPARs where you shut down HSC and return HSC to full service level on all LPARs running at base service level.

MERGEcds
Parameter
Interactions

Table 1 describes the interactions of the MERGEcds parameters.

Table 1. MERGEcds *Parameter Interactions*

If you specify...	The SLSMERGE DD file is...	And MERGEcds...
MERGE ALL	not read	uses both real Nearline volume records and VSM volume records but does not allow renaming the VTSS.
MERGE ALL REALonly	not read	uses only real Nearline volume records (current MERGEcds behavior).
MERGE ALL VIRToNy	not read	uses only VSM volume records but does not allow renaming the VTSS.
MERGE	read	uses both real Nearline volume records and VSM volume records and allows renaming the VTSS.
MERGE REALonly	read and MERGEcds honors the FACS/TACS and FLSM/TLSM subparameters.	uses only real Nearline volume records (current MERGEcds behavior).
MERGE VIRToNy	read and MERGEcds honors the FVTSS/TVTSS subparameters.	uses only VSM volume records and allows renaming the VTSS.
MERGE REALonly VIRToNy	not read	operation fails, REALonly and VIRToNy are mutually exclusive.

JCL Requirements

The following are the required and optional statements for the MERGEcds JCL:

SLSFCNTL

specifies the current primary copy of the “from” HSC CDS.

SLSFCTL2

specifies the current secondary copy of the “from” HSC CDS. This is only required if HSC has been set up to run with a secondary copy.

SLSFSTBY

specifies the current standby copy of the “from” HSC CDS. This is also only required if HSC has been set up to run with a standby copy.

SLSIN

specifies the input to the SLUADMIN program (MERGEcds utility name and parameters).

SLSMERGE

specifies the "from" and "to" ACSs, LSMs, or VTSSs to use for a merge. This parameter is optional and is mutually exclusive with the MERGEcds ALL parameter.

Syntax

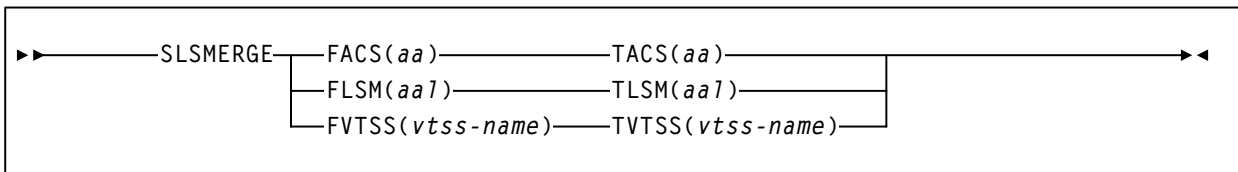

Figure 4. SLSMERGE DD Statement Syntax

ACS and LSM IDs are valid hexadecimal values for Nearline systems. The *vtss-name* is a VTSS identifier.

FACS=*acs-id*
specifies the “from” ACS.

TACS=*acs-id*
specifies the “to” ACS.

FLSM=*lsm-id*
specifies the “from” LSM.

TLSM=*lsm-id*
specifies the “to” LSM.

FVTSS=*vtss-name*
specifies the “from” VTSS.

TVTSS=*vtss-name*
specifies the “to” VTSS.



Caution: Note that the “real” parameters (FACS, TACS, FLSM, TLSM) act as selection criteria, while the “virtual” parameters (FVTSS, TVTSS) do not act as selection criteria, they act only as rename criteria as follows:

- If you specify FACS/FLSM, only volume records for real tapes in the specified ACS/LSM are copied to the new CDS.
- If you specify FVTSS/TVTSS, all VTV records in the old CDS are copied to the new CDS. For example:

MERGE FVTSS(VTSS18) TVTSS(VTSS17)

In this example, all VTV records are copied to the new CDS, but the Resident VTSS field is changed from VTSS18 to VTSS17.

Also note that you **cannot** specify the same TOVTSS statement multiple times in a single MERGECDS job. For example, if you want to change the Resident VTSS field to VTSS17 for VTVs where the current field is set to VTSS18 **and** those where the current field is set to VTSS19, you must run two separate MERGECDS and the corresponding SLICREAT(e) jobs for each rename operation.

Example:

1. Run SLICREAT(E) to build a temporary CDS
2. Run MERGECDS FVTSS(VTSS18) TVTSS(VTSS17) using the old CDS as input.
3. Run SLICREAT(E) to build a new permanent CDS.
4. Run MERGECDS FVTSS(VTSS19) TVTSS(VTSS17) using the temporary CDS from Step 1. as input.

JCL Examples

MERGEcds Example:
Reconfiguring a CDS
with VSM Volume
Information or
Merging CDSs with
Different VTSS
Identifiers

Figure 5 shows example MERGEcds JCL to update a CDS with VSM volume information, such as for an initial VSM configuration. You can also use JCL such as shown in this example to merge CDSs with different VTSS identifiers.

```
//UPDATEVSM EXEC PGM=SLUADMIN, PARM='MIXED'  
//SLSFCNTL DD DSN=FEDB.VSMLMULT.DBASEPRM, DISP=SHR  
//SLSFCTL2 DD DSN=FEDB.VSMLMULT.DBASESEC, DISP=SHR  
//SLSFSTBY DD DSN=FEDB.VSMLMULT.DBASESBY, DISP=SHR  
//SLSPRINT DD SYSOUT=*  
//SLSIN DD *  
MERGE ALL VIRT  
/*  
//
```

Figure 5. MERGEcds *example: updating a CDS or merging CDSs with different VTSS identifiers*

MERGEcds Example:
Merging CDSs with
Duplicate VTSS
Identifiers

Figure 6 shows example MERGEcds JCL to merge CDS with duplicate VTSS identifiers, VTSS01 and VTSS02, that are renamed to VTSS03 and VTSS04 in the “to” CDS.

```
//MERGEVSM EXEC PGM=SLUADMIN, PARM='MIXED'  
//SLSFCNTL DD DSN=FEDB.VSMLMULT.DBASEPRM, DISP=SHR  
//SLSFCTL2 DD DSN=FEDB.VSMLMULT.DBASESEC, DISP=SHR  
//SLSFSTBY DD DSN=FEDB.VSMLMULT.DBASESBY, DISP=SHR  
//SLSPRINT DD SYSOUT=*  
//SLSIN DD *  
MERGE VIRT  
//SLSMERGE DD *  
MERGE FVTSS(VTSS01) TVTSS(VTSS03)  
MERGE FVTSS(VTSS02) TVTSS(VTSS04)  
/*  
//
```

Figure 6. MERGEcds *example: merging CDSs with different VTSS identifiers*

MERGEcds Example:
Merging CDSs with
Duplicate VTSS
Identifiers, Do Not
Copy Volume
Information for MVCs
and VTVs

Figure 7 shows example MERGEcds JCL to merge CDS with duplicate VTSS identifiers, VTSS01 and VTSS02, that are renamed to VTSS03 and VTSS04 in the "to" CDS. This example also specifies the:

- DELVirt parameter so that volsers of uninitialized or empty VTVs and MVCs are not copied to the "to" CDS.
- NOMSG parameter that suppresses message SLS42451.

```
//MERGEVSM EXEC PGM=SLUADMIN, PARM='MIXED'  
//SLSFCNTL DD DSN=FEDB.VSMLMULT.DBASEPRM, DISP=SHR  
//SLSFCTL2 DD DSN=FEDB.VSMLMULT.DBASESEC, DISP=SHR  
//SLSFSTBY DD DSN=FEDB.VSMLMULT.DBASEBY, DISP=SHR  
//SLSPRINT DD SYSOUT=*  
//SLSIN DD *  
MERGE VIRT DELV NOMSG  
//SLSMERGE DD *  
MERGE FVTSS(VTSS01) TVTSS(VTSS03)  
MERGE FVTSS(VTSS02) TVTSS(VTSS04)  
/*  
//
```

Figure 7. MERGEcds *example: merging CDSs with different VTSS identifiers*

MGMTCLAS Control Statement

The MGMTclas control statement defines a VSM Management Class. As shown in the following sections, the VSM feature you enable determines which MGMTclas parameters are valid; for more information, see “FEATURES Control Statement” on page 204.

Syntax - Basic Management Feature

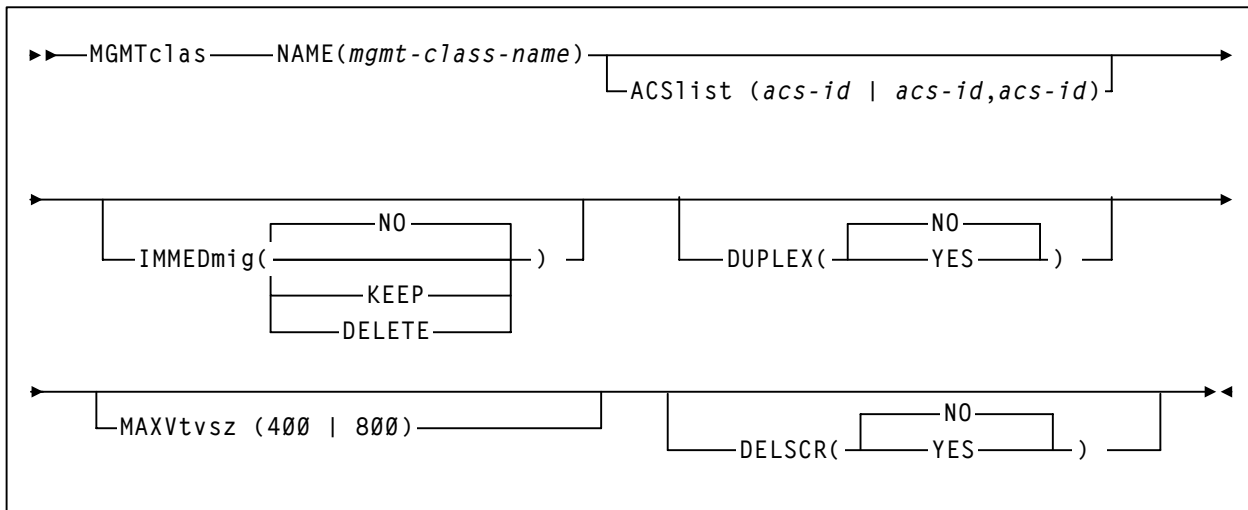

Figure 8. MGMTclas Control Statement Syntax - Basic Management Feature

Parameters - Basic Management Feature

NAME

specifies the name of the Management Class.

mgmt-class-name

the Management Class name. This name must be 1 to 8 alphanumeric characters beginning with an alpha character and must follow SMS naming conventions.

ACSlist

specifies the ACSs from which RTDs and MVCs are selected.

ACSlist is optional; if not specified, the default is the ACS specified on the CONFIG DEFLTACS parameter; for more information, see “DEFLTACS=acs-id” on page 23.

The ACSlist and MIGpol parameters are mutually exclusive.

See Table 2. on page 222 for information about using the DUPlex and ACSlist parameters.

Note: Regardless of the number of host to ACS connections in your configuration, VSM supports a maximum of two ACSs connected to each VTSS.

acs-id | acs-id, acs-id

Specify either one or two ACS IDs. An ACS ID has a hexadecimal value from 00 through FF.

IMMEDmig

specifies whether VSM immediately migrates a VTV after dismounting it.

NO

specifies that VSM does not immediately migrate the VTV, but migrates it according to standard VSM migration criteria (the default).

KEEP

specifies that VSM immediately migrates a VTV and keeps a copy resident on the VTSS until the VTV become eligible for deletion.

DELETE

specifies that VSM immediately migrates the VTV and then deletes it from the VTSS.

Note: IMMEdmig KEEP and IMMEdmig DELETE are mutually exclusive with CONFIG HOST NOMIGRAT. If you specify both, the IMMEdmig value overrides NOMIGRAT, and VTCS does not issue a message about this override.

DUPlex

specifies whether VSM will migrate two copies of the VTV to two MVCs. The DUPlex and MIGpo1 parameters are mutually exclusive.

See Table 2. on page 222 for information about using the DUPlex and ACSlist parameters.

NO

Do not duplex the VTV (the default).

YES

Duplex the VTV.

MAXVtvsz

specifies the maximum size for VTVs in this Management Class. MAXVtvsz requires you to specify CDSLEVEL(V6ABOVE) or CDSLEVEL(V61ABOVE) on the CONFIG statement. For more information, see “CONFIG Statement” on page 13.

400

400Mb (the default, if not specified).

800

800 Mb.



Note:

- The MAXVtvsz parameter applies to **only** VSM3s and VSM4s with the following microcode levels:
 - For VSM3s: microcode level N01.00.69.04 **or** microcode level N01.00.71.00 and above
 - For VSM4s: microcode level D01.00.04.03 **or** microcode level D01.00.06.03 and above
- The size of a VTV will only change once it goes through a scratch cycle. Therefore, if you change the Management Class and DISP=MOD, then it will still retain the original size.

DELSCR

specifies whether VSM deletes scratched VTVs.

This parameter is optional.

NO

do not delete scratched VTVs (the default).

YES

delete scratched VTVs.



Warning: When you scratch a VTV with DELSCR YES attribute, **VSM erases the VTV data at scratch synchronization time**, which eliminates the ability “unscratch” a VTV to recover data!

Also note that when using HSC to perform scratch synchronization, **it is possible that a volume that is scratch** in the TMC at the beginning of scratch synchronization run and also scratch in the CDS from the previous scratch update run (and thus is in the list for HSC to scratch in the CDS) is accessed by a job during the scratch update run and written to and **made non-scratch** by the TMS in the TMC. **In this case, it is still possible for HSC to scratch the volume** because it was in the originally extracted list of volumes to be scratched. Therefore, **StorageTek strongly recommends** that you **do not** run any jobs that use scratches during HSC scratch synchronization. For more information about HSC scratch synchronization with the Scratch Conversion Utility (SLUCONDB), see Chapter 5, “Utility Functions” of *HSC System Programmer’s Guide for MVS*.

For more information about ExLM scratch synchronization with the SYNCVTV function, see “Using ExLM with VTCS (All Versions)” in Chapter 2, “Using ExLM to Manage Nearline and VTCS Resources” of *ExLM System Administrator’s Guide*.

Syntax - Advanced Management Feature

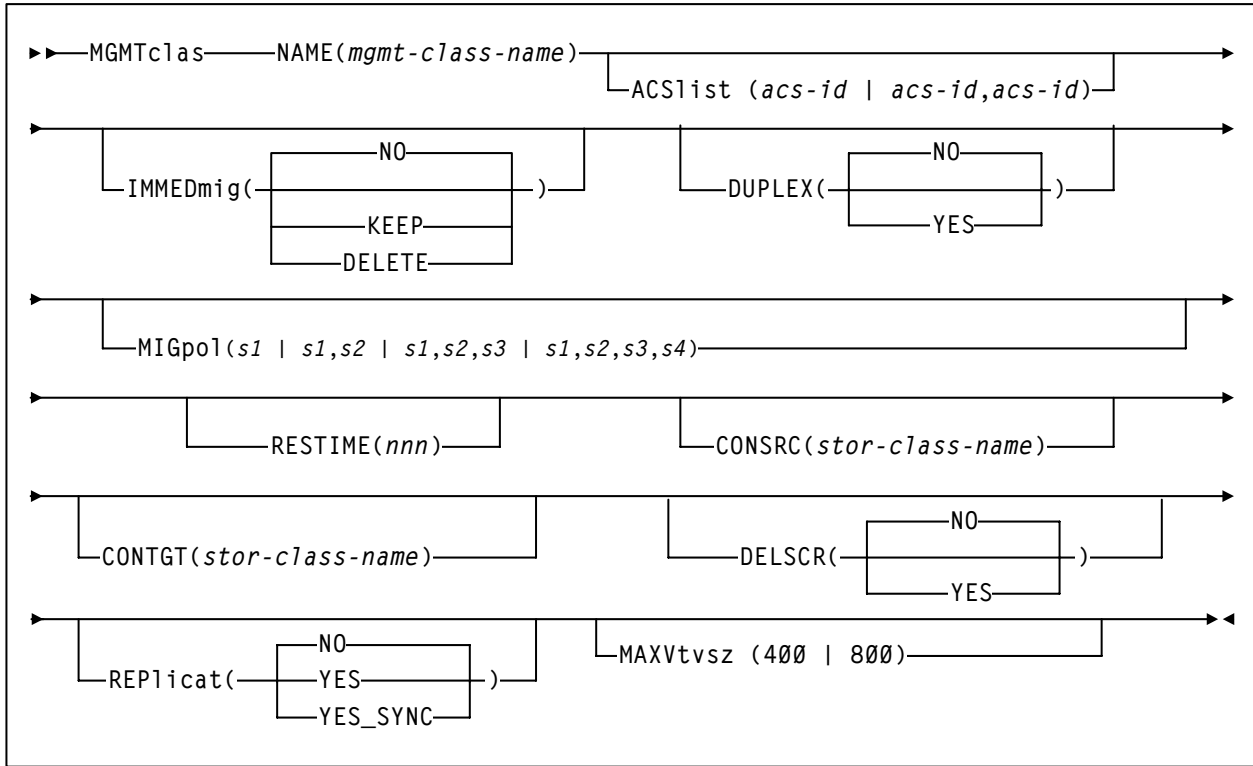

Figure 9. MGMTclas Control Statement Syntax - Advanced Management Feature

Additional Parameters - Advanced Management Feature

The following MGMTclas parameters are valid for the Advanced Management Feature in addition to the Basic Management Feature parameters described in “Parameters - Basic Management Feature” on page 215.

MIGpo1

specifies up to four Storage Classes that specify the ACS and media type of migration MVCs. If you specify:

- One Storage Class, VTCS migrates one copy of a VTV.
- Multiple Storage Classes (with different ACS values, different MEDIA values, or both), VTCS makes multiple copies the VTV to different MVCs in different ACSs.
- Multiple Storage Classes with identical ACS and MEDIA values, VTCS makes multiple copies of the VTV to the same ACS and media type but to different MVCs.

Note: Multiple Storage Classes on MIGpo1 also affects how:

- VTV recall works.
- MVC space reclamation works.
- How VTV consolidation works

The DUPlex and MIGpo1 parameters are mutually exclusive.

This parameter is optional; there is no default value.

s1 | *s1,s2* | *s1,s2,s3* | *s1,s2,s3,s4*

the names of either up to 4 Storage Classes that you defined on the STORclas control statement; for more information, see “STORCLAS Control Statement” on page 229 and “Using the STORclas MEDIA Parameter for MVC Media Preferencing” on page 232. Greater than two copies requires you to specify CDSLEVEL(V6ABOVE) or CDSLEVEL(V6ABOVE) on the CONFIG statement. For more information, see “CONFIG Statement” on page 13.

RESTIME

specifies how long VTCS attempts to keep a VTV as VTSS-resident before becoming a preferred automatic migration candidate.

This parameter is optional; there is no default value. Valid values are 1 to 9999.

The RESTIME and IMMEdmig (DELETE) parameters are mutually exclusive.

nnnn

the residency time in hours.

CONSRC

specifies the Storage Class that species a preference for the source MVC ACS and media for consolidation of VTVs that are migrated and copied to multiple different MVC locations or media types. If the MVC in the specified Storage Class is unavailable, and the specified Storage Class is not the last (in order specified in the migration policy), VTCS will use the MVC associated with the last Storage Class. If the MVC in the specified Storage Class is unavailable and the specified Storage Class is the last (in order specified in the MIGPOL parameter), VTCS will use the MVC associated with the previous Storage Class (in order specified in the MIGPOL parameter, which is a corequisite for CONSRC).

This parameter is optional; there is no default value.

stor-class-name

the name of a Storage Class that you defined on the STORCLAS control statement; for more information, see “STORCLAS Control Statement” on page 229.

CONTGT

specifies the Storage Class that determines the output MVC ACS and media for VTV consolidation. Note that the media preferencing is in the opposite order of the list of media types specified on the Storage Class.

This parameter is optional; there is no default value. If you do not specify a value for CONTGT, VTCS selects the output MVC as follows:

- For single-ACS and dual-ACS configurations, the media selection order for VTV consolidation.
- For dual-ACS systems, VTCS selects MVCs from the default ACS specified by the CONFIG DEFLTACS parameter; for more information, see “DEFLTACS=acs-id” on page 23.

stor-class-name

the name of a Storage Class that you defined on the STORCLAS control statement; for more information, see “STORCLAS Control Statement” on page 229.

REPLICAT

specifies whether VSM replicates the VTV.

NO

Do not replicate the VTV (the default).

YES

Replicate the VTV asynchronously.

YES_SYNC

Replicate the VTV synchronously.

Usage

Use the `MGMTclas` control statement to specify the name of a VSM Management Class and define policies for that class.

You can also specify a Storage Class on the `MIGpol`, `CONSRC`, and `CONTGT` parameters of the `MGMTclas` control statement. The `MIGpol`, `RESTIME`, `CONSRC`, `CONTGT`, and `REPLICAT` parameters are only valid if `FEATures VSM(ADVMGMT)` is specified; for more information, see “FEATURES Control Statement” on page 204.

You use the `MGMTDEF` command to load `MGMTclas` and `STORclas` control statements, which must reside in the same data set for cross-validation; for more information, see “MGMTDEF Command” on page 223.

Storage Classes are never mixed on the same MVC. If you do not specify a Storage Class on the `MGMTclas` statement, the Storage Class defaults to the VTSS name.

For more information, see: “STORCLAS Control Statement” on page 229.

If you specify the `ACSlist` parameter of the `MGMTclas` statement and the `CONFIG VTSS DEFLTACS` parameter, VTCS ignores the value on the `DEFLTACS` parameter.

Using the DUPlex parameter

Table 2 describes possible scenarios using the DUPlex and ACSlist parameters.

Table 2. MGMTclas ACSlist/DUPlex Scenarios

If DUPlex is set to...	And ACSlist specifies...	Then VSM...
YES	two ACSs	migrates the VTVs to two MVCs, one in each ACS. (This scenario is the normal one for duplexing to two ACSs.)
YES	one ACS	migrates the VTVs to two MVCs in the ACS specified
NO	two ACSs	ignores the DUPlex policy and migrates the VTVs to two MVCs, one in each ACS.
NO	one ACS	migrates the VTVs to one MVC in the ACS specified

Examples

In the following example, Management Class MGMTCLS1 specifies VTV duplexing to two MVCs, one in ACS 00 and one in ACS 01 with an immediate migration of the VTV on dismount and a copy of the VTV kept in the VTSS.

```
MGMTclas NAME(MGMTCLS1) ACSL(00,01) IMMED(KEEP) DUP(YES)
```

In the following example, Management Class MGMT4CP specifies VTV duplexing to four MVCs with an immediate migration of the VTV on dismount and a copy of the VTV kept in the VTSS.

```
MGMTclas NAME(MGMT4CP) MIGPOL(LOCAL1,LOCAL2,REM1,REM2) IMMED(KEEP)
```

MGMTDEF Command

The MGMTDEF command loads the MGMTclas, STORclas, VTSSLST, VTSSSEL, STORLST, and STORSEL statements from a specified definition data set.

Syntax

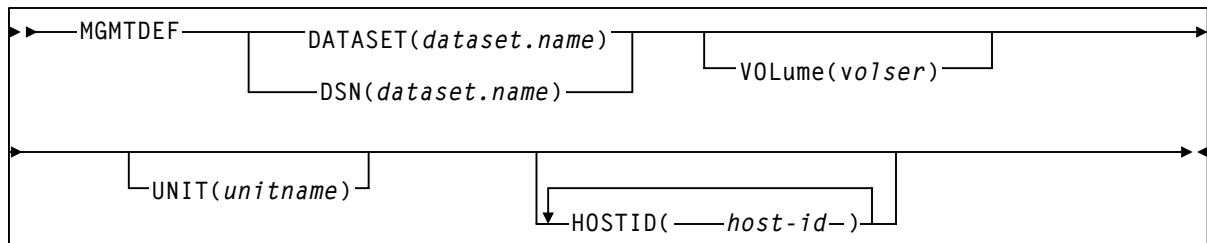

Figure 10. MGMTDEF Command

Parameters

DATASET or DSN

specifies the definition data set that contains the MGMTclas and STORclas statements to load.

dataset.name

the data set name.

VOLume

specifies the DASD volume where the definition data set resides. This parameter is optional, unless the data set is not cataloged, or the data set resides on a volume other than the volume indicated by the catalog.

volser

the DASD volser.

UNIT

specifies the DASD device where the definition data set resides.

unitname

the DASD unit name. If the definition data set is not cataloged and this parameter is omitted, the unit name defaults to SYSALLDA.

HOSTID

specifies the host for execution of the MGMTDEF command. This parameter is only valid when MGMTDEF is specified as a PARMLIB control statement.

host-id

specifies the name of one or more hosts from which to execute the MGMTDEF command. Multiple hosts must be separated by commas.

Usage

Use the `MGMTDEF` command to load `MGMTclas`, `STORclas`, `VTSSLST`, `VTSSSEL`, `STORLST`, and `STORSEL` statements, which must reside in the same data set for cross-validation.

For more information, see

- “MGMTCLAS Control Statement” on page 214
- “STORCLAS Control Statement” on page 229
- “STORLST Control Statement” on page 234
- “STORSEL Control Statement” on page 236
- “VTSSLST Control Statement” on page 241
- “VTSSSEL Control Statement” on page 243

The `MGMTDEF` command is valid for base and full service levels of HSC. You can enter `MGMTDEF` as an operator command or specify `MGMTDEF` as a statement in the `HSC PARMLIB`. If you specify a `MGMTDEF` statement in the `PARMLIB`, HSC startup loads the specified `MGMTDEF` statements. Note that the `HOSTID` parameter is only valid when you specify `MGMTDEF` as a statement in the `HSC PARMLIB`. After HSC startup, you can enter a `MGMTDEF` command to dynamically reload another set of `MGMTclas` statements from a different definition data set. If you restart HSC, it reloads the `MGMTclas` statements specified by the `MGMTDEF` command in the `PARMLIB`.

Examples

To load the `MGMTclas` and `STORclas` statements in data set `hsc.parms` on a host, enter:

```
MGMTDEF DSN(hsc.parms)
```

MOUNT Command

The enhanced MOUNT command mounts a scratch or specific VTV on a VTD and optionally assigns a Management Class to the VTV.

Syntax

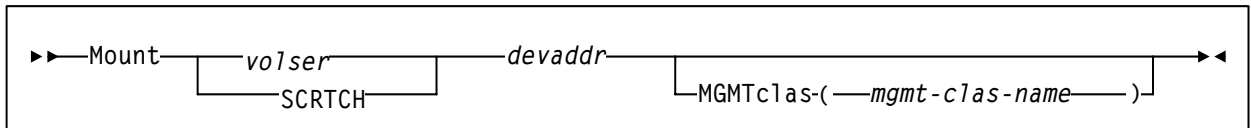

Parameters

volser | SCRATCH

specifies a specific VTV *volser* or the scratch VTV attribute (SCRATCH).

volser

the *volser* of a specific VTV.

devaddr

specifies the MVS device address of the VTD to use to mount the VTV.

MGMTclass

specifies a Management Class you defined on the MGMTclass control statement; for more information, see “MGMTCLAS Control Statement” on page 214.

mgmt-class-name

the Management Class name.

Usage

Use the enhanced MOUNT command to mount a scratch or specific VTV on a VTD and optionally assign a Management Class to the VTV.

Note: For a non-scratch VTV, the MOUNT command assigns a Management Class **only** if:

- The CONFIG GLOBAL statement specifies VTVattr=ALLmount as described in “GLOBAL Statement” on page 15, and
- The VTV is either resident in or can be recalled to an online VTSS.

Examples

To mount a scratch VTV on the VTD at device address 8900 and assign Management Class VSMLLOCAL, enter:

```
M SCRATCH 8900 MGMT(VSMLLOCAL)
```

MVCPool Control Statement

The MVCPool control statement defines your system's MVC pool and, optionally, Named MVC Pools within that pool.

Syntax

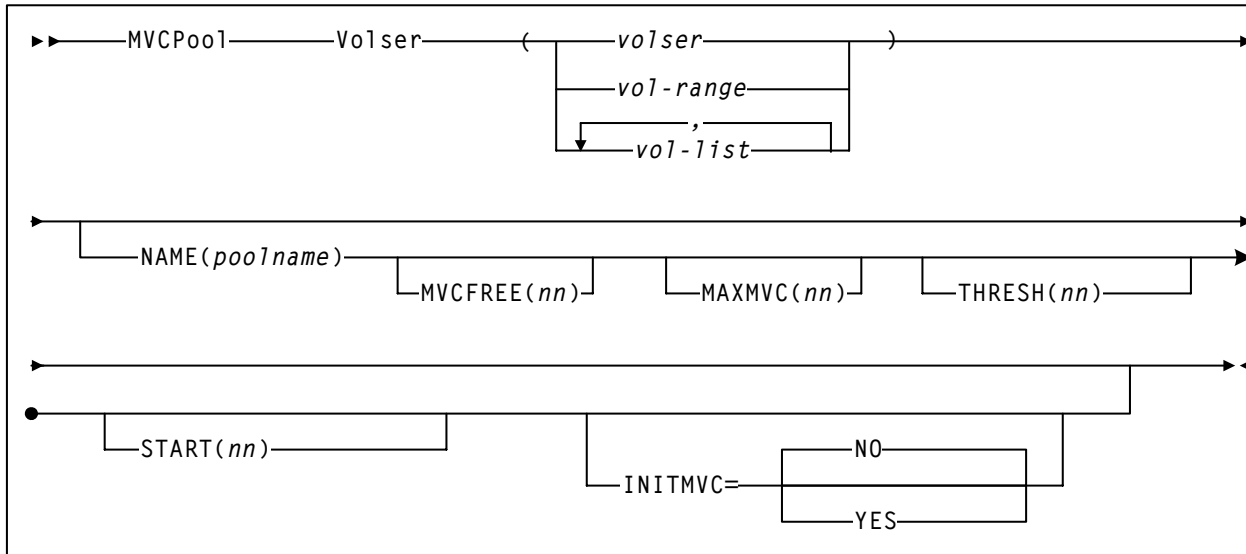

Figure 11. MVCPool Control Statement Syntax

Parameters

Volser

defines the MVCs.

volser, *vol-range*, or *vol-list*

the volsers of one or more MVCs. If you specify multiple volume ranges, do not overlap them.

NAME

defines a Named MVC Pool. If you do not specify the MVCPool NAME parameter, VTCS does not create a Named MVC Subpool and assigns the specified volumes to the default pool (DEFAULTPOOL). You cannot create Named MVC Pools with the reserved names DEFAULTPOOL and ALL.

poolname

the MVC Pool name (up to 13 characters).

Note: You can use the optional MVCFREE, MAXMVC, THRESH, and START parameters to specify values for the Named MVC Pool that override the global values specified on CONFIG.

MVCFREE(*nnn*)

specifies the minimum number of free MVCs in the MVC pool. A free MVC has 100% usable space and does not contain any migrated VTVs. Valid values are 0 to 255. There is no default; if not specified, the CONFIG RECLAIM value (or default) is used.

If free MVCs is equal or less than this value, VTCS issues message SLS6616I and starts an automatic space reclamation.

Note: If you set MVCFREE=0, VTCS actually uses the default value (40).

MAXMVC(*nn*)

specifies the maximum number of MVCs that will be processed in a single space reclamation run. Valid values are 1 to 98. There is no default; if not specified, the CONFIG RECLAIM value (or default) is used. For automatic space reclamation to start, the number of eligible MVCs (determined by the THRESH parameter) must also exceed the MAXMVC value.

THRESH(*nn*)

specifies the percentage of fragmented space that makes an MVC eligible for demand or automatic reclamation. Valid values are 4 to 98. There is no default; if not specified, the CONFIG RECLAIM value (or default) is used.

START(*nn*)

specifies the level at which automatic space reclamation starts for each ACS (not globally for all ACSs) or, if specified, for a Named MVC Pool. Specify a percentage value, which is equal to:

$$(MVCs\ eligible\ for\ reclamation / Total\ available\ MVCs) * 100$$

Where:

MVCs eligible for reclamation

is the number of eligible MVCs determined by the THRESHLD parameter.

Total available MVCs

equals the number of eligible MVCs *plus* the number of free MVCs. A free MVC has 100% usable space and does not contain any migrated VTVs.

Valid values are 1 to 98. There is no default; if not specified, the CONFIG RECLAIM value (or default) is used.

INITMVC

specifies whether uninitialized MVCs in the named MVC Pool are initialized when first mounted on an RTD.

NO

Uninitialized MVCs are not initialized.

YES

Uninitialized MVCs are initialized.

Note:

- MVCPOOL INITMVC overrides GLOBAL INITMVC. There is no default for MVCPOOL INITMVC; if not specified for a named MVC Pool the CONFIG GLOBAL value (or default) is used.
- Initialization of MVCs in the DEFAULTPOOL is controlled by the GLOBAL INITMVC specification (or default).
- MVC Initialization applies only to VSM4/5 and requires microcode level D02.05.00.00 or higher. If this level of microcode is not installed on all VTSSs in the configuration, MVC initialization will be limited to the VTSSs that have it installed.

Usage

Use the MVCPool control statement to define your system's MVC pool.

You use the VT MVCDEF command on page 111 to load the MVCPool control statements. For more information about using the VT MVCDEF command and the MVCPool statement.

You can use the NAME parameter to define a Named MVC Pool. You can use the optional MVCFREE, MAXMVC, THRESH, and START parameters to specify values for the Named MVC Pool that override the global values specified on CONFIG.

Example

The following MVCPool statement defines volsers 900000 - 909999 as MVCs:

```
MVCP V(900000 - 909999)
```

STORCLAS Control Statement

The STORCLAS control statement defines a VSM Storage Class.



Note: The STORCLAS control statement is valid only if FEATURES VSM(ADVGMGT) is specified; for more information, see “FEATURES Control Statement” on page 204.

Syntax

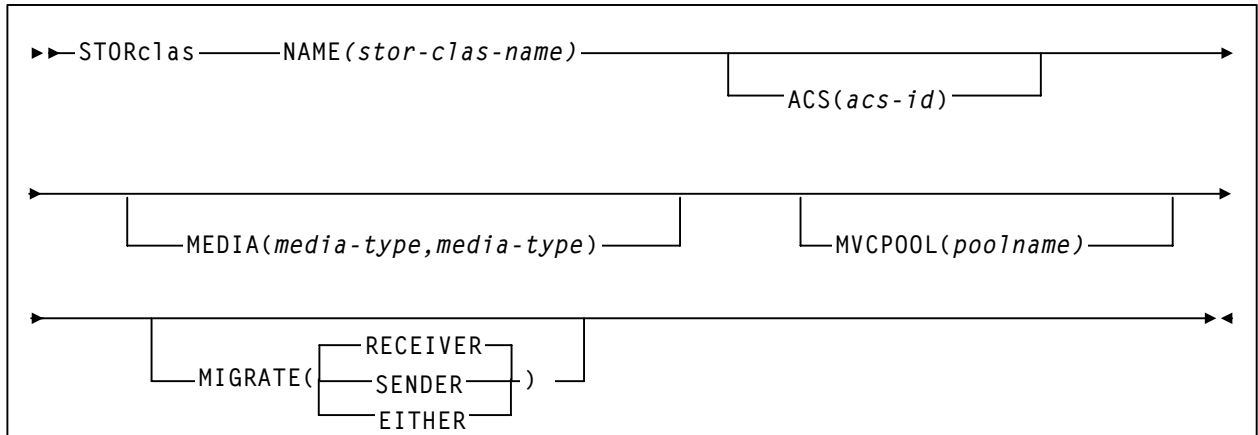

Figure 12. STORCLAS Control Statement Syntax

Parameters

NAME

specifies the name of the Storage Class.

stor-clas-name

the Storage Class name. This name must be 1 to 8 alphanumeric characters beginning with an alpha character and must follow SMS naming conventions.

ACS

specifies the ACSs from which RTDs and MVCs are selected.

acs-id

Specifies the ACS ID. An ACS ID has a hexadecimal value from 00 through FE.

MEDIA

specifies a preference list of MVC media types. This list supersedes the default media selection list.

For migration and consolidation, VSM attempts to select MVC media in the specified order. For reclamation, VTVs are read from MVCs in the specified order, and written back to MVCs in the reverse of the specified order.

media-type

Species a media type.

MVCP00L

specifies the Named MVC Pool from which volumes are selected. If you do not specify an MVC Pool name, the volumes are selected from the default pool (DEFAULTP00L).

poolname

the name of an MVC Pool that you defined on the MVCPool control statement; for more information, see “MVCP00L Control Statement” on page 226.

MIGRATE

for Management Classes with REPLICAT(YES) that reference this Storage Class, specifies the source VTSS (in a Cluster) for VTV migration.

RECEIVER

VTSS that receives the replicated VTV (the default), which is the Secondary VTSS in a Primary-Secondary Cluster.

SENDER

VTSS that sends the replicated VTV, which is the Primary VTSS in a Primary-Secondary Cluster.

EITHER

Either VTSS in a Peer-to-Peer Cluster.

Usage

Use the STORclas control statement to define a VSM Storage Class. The STORclas control statement is only valid if FEATures VSM(ADVMGMT) is specified; for more information, see “FEATURES Control Statement” on page 204. You can define a Storage Class for the Named MVC Pool specified on the MVCP00L parameter.

The MGMTclas control statement can specify a Storage Class on the MIGpool, CONSRC, and CONTGT parameters. For more information, see “MGMTCLAS Control Statement” on page 214. You use the MGMTDEF command to load MGMTclas and STORclas control statements, which must reside in the same data set for cross-validation; for more information, see “MGMTDEF Command” on page 223.

Storage Classes are never mixed on the same MVC. If you do not specify a Storage Class on the MGMTclas statement, the Storage Class defaults to the VTSS name.



Caution: Note the following when using Named MVC pools:

- If you specify the MVCPOOL parameter, ensure that specified Named MVC Pool exists. Otherwise, the Storage Class is invalid, and VTCS reverts to the default Storage Class (the name of the last VTSS that wrote to the MVC for reclamation or migration) and a ‘no MVCs available’ condition will occur. Either correctly define the Named MVC Pool or add Storage Class definitions for all VTSSs and associated them with the appropriate Named MVC pool(s).
- If you specify the MEDIA and MVCPOOL parameters, ensure that the Named MVC Pool contains MVCs of the specified media type(s); otherwise, a ‘no MVCs available’ condition will occur.

Note: If you do not explicitly assign a Storage Class, an MVC’s default Storage Class is the name of the last VTSS that wrote to the MVC for reclamation or migration and this class has the VTCS default media selections. To change these defaults, create a Storage Class with the VTSS name and specify the desired media selection order.



Caution: You cannot use the default Storage Class to group or segregate workloads.

For more information, see “MGMTCLAS Control Statement” on page 214.

Using the STORclas
MEDIA Parameter for
MVC Media
Preferencing

- By default, in mixed-media VSM systems, VTV automatic and demand migrations (and consolidations) go to MVCs by media type in this order:
 1. STANDARD
 2. ECART
 3. ZCART
 4. STK1RAB
 5. STK1RC
 6. STK2PA
 7. STK2PB
- By default, for automatic and demand space reclamations, VSM writes VTVs to output MVCs by media type in this order:
 1. STK2PB
 2. STK2PA
 3. STK1RC
 4. STK1RAB
 5. ZCART
 6. ECART
 7. STANDARD

Note that the preceding default media orders are composed of values from **either** the MEDIA **or** RECTECH value (but **not** both) of the VOLATTR statement for the media as shown in Table 3.

Table 3. MVC Media Types

Media	Description	VOLATTR Parameter
STANDARD	standard length 3480 cartridge	MEDIA
ECART	3490E cartridge	MEDIA
ZCART	3490EE cartridge	MEDIA
STK1RAB	T9840A/B cartridge	RECTECH
STK1RC	T9840C cartridge	RECTECH
STK2PA	T9940A cartridge	RECTECH
STK2PB	T9940B cartridge	RECTECH

- The MEDIA parameter of the STORclas statement (which defines Storage Classes) specifies a preference list of MVC media types. This list supersedes the default media selection list. **Note that** for reclamation, VTVs are written back to MVCs in the **reverse** of the order specified on the MEDIA parameter.

For example, if you specify the following on the MEDIA parameter of the STORclas statement...

MEDIA (STK1RAB, STK1RC, STK2PB)

- ...to select an MVC for migration to this Storage Class, VTCS searches for a usable MVC in the order STK1RAB, STK1RC, STK2PB.
- ...to select an MVC for the output of reclaim to this Storage Class, VTCS searches for a usable MVC in the order STK2PB, STK1RC, STK1RAB.
- You can specify the media and ACS preferencing via the Storage Class(es) specified on the MIGpol parameter of the MGMTclas control statement; for more information, see “MGMTCLAS Control Statement” on page 214.
- To optimize recall processing in mixed-media systems, ensure that your MVC pool has at least one media type compatible with each RTD type.

Examples

See *VTCS Installation and Configuration Guide* and *VTCS Administrator's Guide*.

STORLST Control Statement

The STORLST control statement specifies a list of Storage Classes and their corresponding preferencing.

Note: The STORLST control statement is valid only if FEATURES VSM(ADVMGMT) is specified; for more information, see “FEATURES Control Statement” on page 204.

Syntax

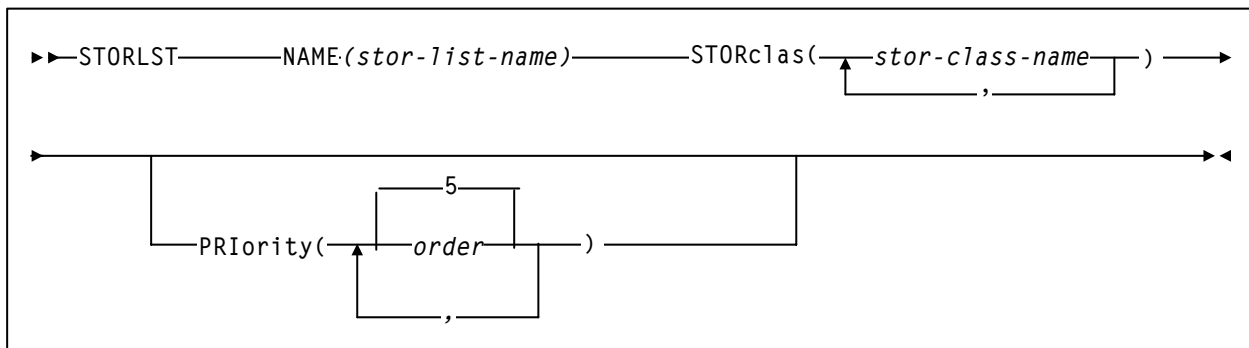

Figure 13. STORLST Control Statement Syntax

Parameters

NAME

specifies the name of the Storage Class list.

stor-list-name

the list name (a maximum of 8 alphanumeric characters).

STORclas

specifies one to four Storage Classes on the Storage Class list.

stor-class-name

the name of a Storage Class that you defined on the STORclas control statement; for more information, see “STORCLAS Control Statement” on page 229.

PRIority

a list of priorities corresponding to the Storage Classes specified on the STORclas parameter.

order

the specified priority. Valid values are 0 to 9 (highest priority), and the default is 5. You can assign the same priority to multiple Storage Classes. For example, if two Storage Classes both have a priority of 9, VTCS selects randomly from the two. A 0 (zero) priority specifies that

VTCS selects the Storage Class only if all other Storage Classes are unavailable (for example, no free MVCs available for write).

Note: The Storage Class list is further qualified by the criteria specified by the `MGMTclas` and `VTSS` parameters of the `STORSEL` statement.

Usage

Use the `STORLST` control statement to specify a list of Storage Classes and their corresponding preferencing. The `STORSEL` statement, which defines a Storage Class usage rule, specifies a Storage Class preferencing list. For more information, see “`STORSEL` Control Statement” on page 236.

You use the `MGMTDEF` command to load the following statements, which must all reside in the same data set for cross-validation:

- `MGMTclas`
- `STORclas`
- `VTSSLST`
- `VTSSSEL`
- `STORLST`
- `STORSEL`

For more information, see “`MGMTDEF` Command” on page 223.

The `STORLST` control statement is only valid if `FEATures VSM(ADVGMGT)` is specified; for more information, see “`FEATURES` Control Statement” on page 204.

Examples

The following `STORLST` statement specifies list of local Storage Classes with MVCs in ACSs connected to a local `VTSS` with a priority of 1 for Storage Class `SACS00` and a priority of 9 for Storage Class `SACS01`:

```
STORLST NAME(LOCALACS) STOR(SACS00,SACS01) PRI(1,9)
```

See also *VTCS Installation and Configuration Guide*.

STORSEL Control Statement

The STORSEL control statement defines a Storage Class usage rule that applies to the Storage Class list and its preferencing specified on a referenced STORLST control statement.



Note: The STORSEL control statement is valid only if FEATures VSM(ADVMGMT) is specified; for more information, see “FEATURES Control Statement” on page 204.

Syntax

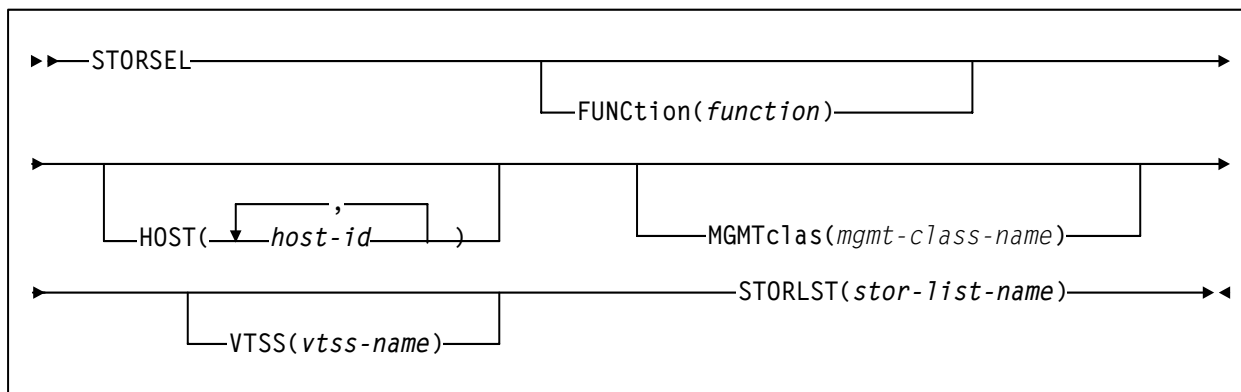

Figure 14. STORSEL Control Statement Syntax

Parameters

FUNCTION

specifies the VSM function to which the rule applies.

function

the function name, as described in Table 2.

Table 4. STORSEL Functions

Function	Explanation
SPECIFIC	Applies to automatic recall of a specific VTV for mounting. The list of Storage Classes is determined by the specified STORLST statement. This list influences the list of RTDs eligible to mount the MVC in the Storage Class to recall the VTV.
RECALL	Applies to demand recall of a specific VTV for mounting. The list of Storage Classes is determined by the specified STORLST statement. This list influences the list of MVC copies of a VTV to select the optimal MVC for recall of the VTV.
EXPORT	Applies to export. The list of Storage Classes is determined by the specified STORLST statement. This list influences the list of MVC copies of a VTV to select the optimal MVC for export of the VTV.
CONSOLID	Applies to consolidate. The list of Storage Classes is determined by the specified STORLST statement. This list influences the list of MVC copies of a VTV to select the optimal MVC for consolidation of the VTV.

Note: The HOST, MGMTclas, and VTSS parameters are optional and have no default values.

HOST

specifies one or more hosts to which the rule applies. Any hosts not specified on this parameter ignore the rule.

host-id

a host identifier (maximum 8 characters).

Note: The Storage Class list specified on the STORLST parameter is further qualified by the criteria specified by the MGMTclas and VTSS parameters.

MGMTclas

specifies a Management Class.

mgmt-class-name

the name of a Management Class that you defined on the MGMTclas control statement; for more information, see “MGMTCLAS Control Statement” on page 214.

VTSS

specifies a VTSS as follows:

- For automatic recalls, the VTSS where the recall is performed.
- For all other functions, the VTSS where the VTV previously resided.

STORLST

specifies a list of Storage Classes and their corresponding preferencing.

stor-list-name

the name of a Storage Class list that you defined on the STORLST control statement; for more information, see “STORLST Control Statement” on page 234.

Usage

Use the STORSEL statement to define a Storage Class usage rule that applies to the Storage Class list and its preferencing specified on a referenced STORLST control statement. For more information, see “STORLST Control Statement” on page 234.

You use the MGMTDEF command to load the following statements, which must all reside in the same data set for cross-validation:

- MGMTclas
- STORclas
- VTSSLST
- VTSSSEL
- STORLST
- STORSEL

For more information, see “MGMTDEF Command” on page 223.

The STORSEL control statement is only valid if FEATures VSM(ADVGMGT) is specified; for more information, see “FEATURES Control Statement” on page 204.

Examples

The following STORSEL statement VTV mounts for automatic recall for host MVS8 to a preference list (LOCALACS) of ACSs connected to local VTSSs.

```
STORSEL FUNC(RECALL) HOST(MVS8) STORLST(LOCALACS)
```

See also *VTCS Installation and Configuration Guide*.

VOLATTR Control Statement

For VSM, the enhanced HSC VOLATTR control statement specifies VTV attributes, including the volsers and media type (virtual).

Syntax

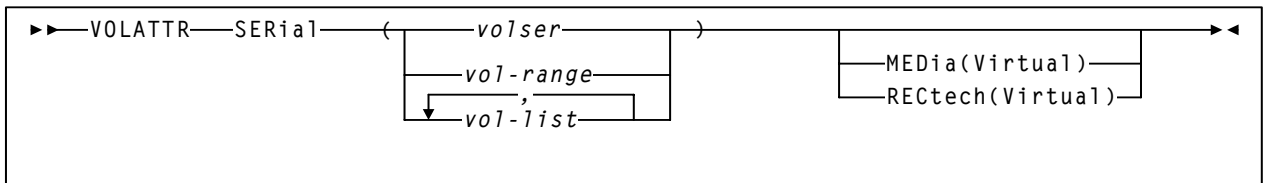

Figure 15. VOLATTR Control Statement Syntax

Parameters

Unchanged VOLATTR Parameters

The SERIAL VOLATTR parameter is unchanged but applies to VSM. Figure 1 shows valid values for this parameter; see Chapter 3, “Control Statements and Start Procedure” of *HSC System Programmer’s Guide for MVS* for more information.



Hint: When you create VOLATTR statements for VTVs, you use the SERIAL parameter to specify the VTV volsers.



Caution: On VOLATTR statements for VTVs, do *not* specify duplicate volsers or overlapping volsers ranges. In addition, after you define an initial set of VTV volsers, you can add more volsers but you should not change your initial set of VTV volsers, which wastes HSC CDS space. For example, if you initially define VTVs V00000 - V99999, you can later add VTVs W00000 - W99999 by specifying both volsers ranges when you update the VOLATTR statement that specifies your system’s VTVs. If you update the VOLATTR statement to change the volsers range from V00000 - V99999 to W00000 - W99999, hosts can still access the original range (V00000 - V99999). If a host scratches a VTV in the original range, however, the VTV cannot be reused, but continues to take up space in the CDS.

VOLATTR Parameters Enhanced for VSM

The following VOLATTR parameters have a new *required* value of `Virtual` for VTVs only. `Virtual` does *not* apply to physical HSC volumes.

MEDIA

specifies the volume media.

Virtual

specifies that VSM will route data sets to a VTV mounted on a VTD.

RECTECH

specifies the recording technique.

Virtual

specifies that VSM will route the data set to a VTV mounted on a VTD.

Note: To define a volume as virtual, you must specify the `Virtual` keyword for either the `MEDIA` or `RECTECH`. You can also specify both `MEDIA` or `RECTECH`; the keyword must be `Virtual` for both parameters to define the volume as virtual.

Usage

For VSM, use the enhanced HSC VOLATTR control statement to specify VTV attributes, including the volses and media type (`virtual`).

You must use the VOLDEF command to load VOLATTR control statements from a specified definition data set; see Chapter 3, “Control Statements and Start Procedure” of *HSC System Programmer’s Guide for MVS* for more information.

Example

To define VTVs to be all volumes whose volses begin with VT, create the following VOLATTR statement:

```
VOLATTR SERIAL(VT*) MEDIA(Virtual)
```

VTSSLST Control Statement

The VTSSLST control statement specifies a list of VTSSs and their corresponding preferencing.

Note: The VTSSLST control statement is valid only if FEATures VSM(ADVMT) is specified; for more information, see “FEATURES Control Statement” on page 204.

Syntax

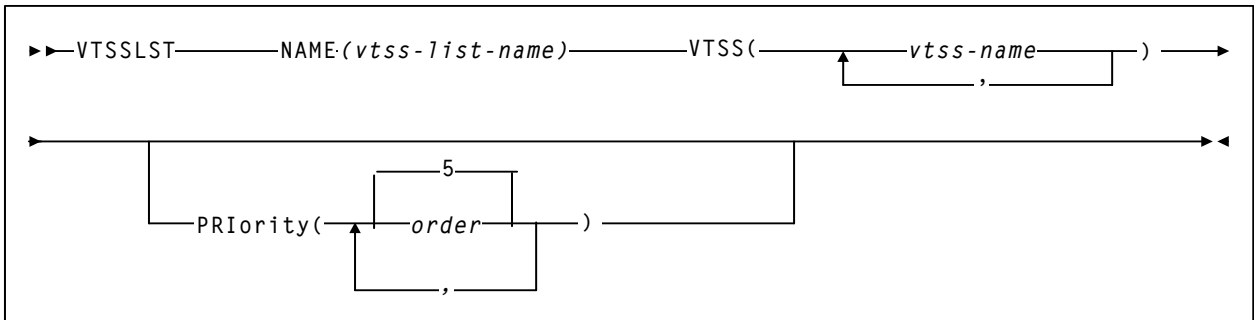

Figure 16. VTSSLST Control Statement Syntax

Parameters

NAME
specifies the name of the VTSS list.
vtss-list-name
the list name (a maximum of 8 alphanumeric characters).

VTSS
specifies one to eight VTSSs on the VTSS list.
vtss-name
a VTSS identifier.

PRIority

a list of priorities corresponding to the VTSS identifiers specified on the VTSS parameter.

order

the specified priority. Valid values are 0 to 9 (highest priority), and the default is 5. You can assign the same priority to multiple VTSSs. For example, if two VTSSs both have a priority of 9, VTCS selects randomly from the two (according to factors such as DBU and VSM model). A 0 (zero) priority specifies that VTCS selects the VTSS only if all other VTSSs are unavailable (for example, unavailable due to DBU > 95%, VTSS offline, or RTDs offline).

Note: The VTSS list specified on the VTSSLST parameter is further qualified by:

- The function specified on VTSSSEL statement.
- The criteria specified by the MGMTclas, VTSS, STORclas, and MVCpool parameters of the VTSSSEL statement.
- Other factors such as RTD connectivity.

For example, in scratch allocation, the list of VTSSs is reduced to the VTSSs that can meet Management Class policies (such as REPLICAT(YES)). If the list of VTSSs is reduced to zero, the request fails.

Usage

Use the VTSSLST control statement to specify a list of VTSSs and their corresponding preferencing. The VTSSSEL statement, which defines a VTSS usage rule, specifies a VTSS preferencing list. For more information, see “VTSSSEL Control Statement” on page 243.

You use the MGMTDEF command to load the following statements, which must all reside in the same data set for cross-validation:

- MGMTclas
- STORclas
- VTSSLST
- VTSSSEL
- STORLST
- STORSEL

For more information, see “MGMTDEF Command” on page 223.

The VTSSLST control statement is only valid if FEATures VSM(ADVMGMT) is specified; for more information, see “FEATURES Control Statement” on page 204.

Examples

The following VTSSLST statement specifies list of local VTSSs with a priority of 1 for VTSS01 and a priority of 9 for VTSS02:

```
VTSSLST NAME(LOCAL) VTSS(VTSS01,VTSS02) PRI(1,9)
```

See also *VTCS Installation and Configuration Guide*.

VTSSSEL Control Statement

The VTSSSEL control statement defines a VTSS usage rule that applies to the VTSS list and its preferencing specified on a referenced VTSSLST control statement.

Note: The VTSSSEL control statement is valid only if FEATures VSM(ADVMGMT) is specified; for more information, see “FEATURES Control Statement” on page 204.

Syntax

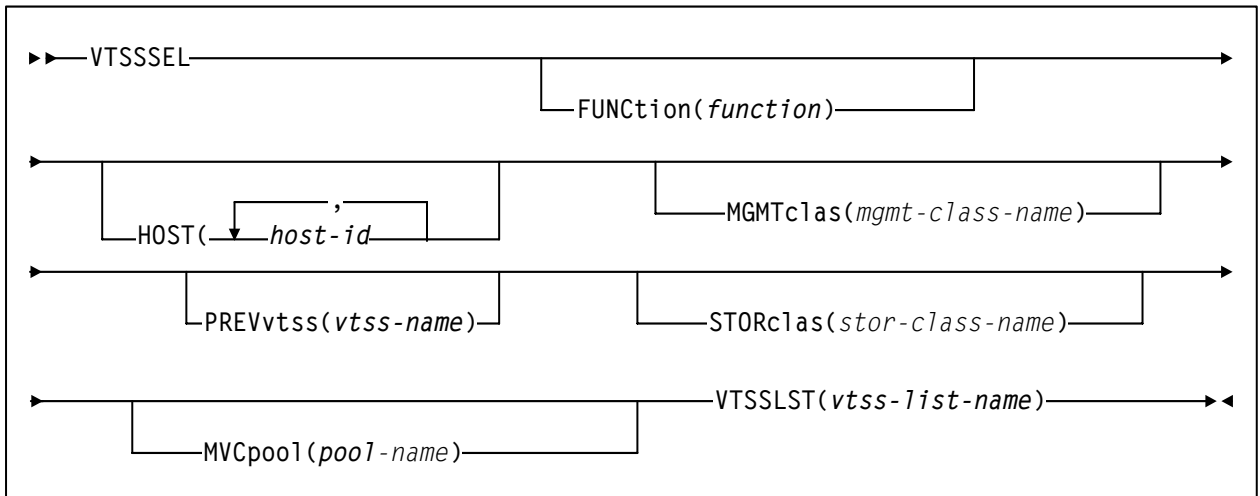

Figure 17. VTSSSEL Control Statement Syntax

Parameters

FUNCTION

specifies the VSM function to which the rule applies.

function

the function name, as described in Table 5.

Table 5. VTSSSEL Functions

Function	Explanation
SCRATCH	Applies to non-specific (scratch) VTV allocation. The list of eligible VTDs is determined by the specified VTSSLST statement. The PREVVTSS, STORclas and MVCpool parameters do not apply.
SPECIFIC	Applies to specific VTV allocation. The list of eligible VTDs is determined by the specified VTSSLST statement. The STORclas and MVCpool parameters do not apply.
RECALL	Applies to demand recall. The list of eligible VTSSs for recall is determined by the specified VTSSLST statement. The VTSS list also determines the search order for an RTD to service the MVCs selected for recall (derived from the VTVs selected). The MGMTclas parameter does not apply.
RECLAIM	Applies to reclaim. The list of eligible VTSSs for reclaim is determined by the specified VTSSLST statement. The VTSS list also determines the search order for an RTD to service the MVCs selected for reclaim. The MGMTclas parameter does not apply.
DRAIN	Applies to drain. The list of eligible VTSSs for drain is determined by the specified VTSSLST statement. The VTSS list also determines the search order for an RTD to service the MVCs selected for drain. The MGMTclas parameter does not apply.
AUDIT	Applies to MVC audit. The list of eligible VTSSs for audit is determined by the specified VTSSLST statement. The VTSS list also determines the search order for an RTD to service the MVCs selected for audit. The MGMTclas parameter does not apply.
EXPORT	Applies to export. The list of eligible VTSSs for export is determined by the specified VTSSLST statement. VTSS list also determines the search order for an RTD to service the MVCs selected for export. The MGMTclas parameter does not apply.
CONSOLID	Applies to consolidate. The list of eligible VTSSs for consolidation is determined by the specified VTSSLST statement. TTSS list also determines the search order for an RTD to service the MVCs selected for consolidation. The MGMTclas parameter does not apply.

HOST

specifies one or more hosts to which the rule applies. Any hosts not specified on this parameter ignore the rule.

host-id

a host identifier (maximum 8 characters).

Note: The VTSS list specified on the VTSSLST parameter is further qualified by the criteria specified by the MGMTclas, VTSS, STORclas, and MVCpool parameters.

MGMTclas

specifies a Management Class.

mgmt-class-name

the names of a Management Class that you defined on the MGMTclas control statement; for more information, see “MGMTCLAS Control Statement” on page 214.

PREVvtss

specifies a VTSS where a VTV:

- Is or resident.
- Was migrated from.

STORclas

specifies a Storage Class and applies only when MVCs are used to select VTSSs.

stor-clas-name

the name of a Storage Class that you defined on the STORclas control statement; for more information, see “STORCLAS Control Statement” on page 229.

MVCpool

specifies a Named MVC Pool that contains and MVC and applies only when MVCs are used to select VTSSs.

poolname

the name of an MVC Pool that you defined on the MVCPool control statement; for more information, see “MVCPOOL Control Statement” on page 226.

VTSSLST

specifies a list of VTSSs and their corresponding preferencing.

vtss-list-name

the name of a VTSS list that you defined on the VTSSLST control statement; for more information, see “VTSSLST Control Statement” on page 241.

Usage

Use the VTSSSEL statement to define a VTSS usage rule that applies to the VTSS list and its preferencing specified on a referenced VTSSLST control statement. For more information, see “VTSSLST Control Statement” on page 241.

You use the MGMTDEF command to load the following statements, which must all reside in the same data set for cross-validation:

- MGMTclas
- STORclas
- VTSSLST
- VTSSSEL
- STORLST
- STORSEL

For more information, see “MGMTDEF Command” on page 223.

The VTSSSEL control statement is only valid if FEATures VSM(ADVGMGT) is specified; for more information, see “FEATURES Control Statement” on page 204.

Examples

The following VTSSSEL statement restricts scratch VTV mounts for host MVS8 to a preference list (LOCAL) of VTSSs.

```
VTSSSEL FUNC(SCRATCH) HOST(MVS8) VTSSLST(LOCAL)
```

See also *VTCS Installation and Configuration Guide*.

HSC Programmatic Interface Enhancements

The MOUNT, QDRLIST, and SELSCR requests support an additional value of VIRTUAL (to specify a VTV) for the MEDIA and RECTECH parameters.

For these requests for VSM:

- For scratch requests, within a VTSS, VSM selects the first available VTD with the lowest device address.

In a multi-VTSS system, VSM will determine which VTSS is optimal for the request, then select the first available VTD with the lowest device address in that VTSS. For a given request, VSM limits VTD selection to the first 8 VTSSs, but will select from all VTSSs for a series of requests.

- For specific requests, depending on the level of VTCS, VSM will either return a list of all VTDs or preferred VTDs.
- The SCRPOOL parameter is invalid; specify SUBPOOL instead.
- The MOUNT request supports an additional parameter of MGMTCLASS that can assign a VSM Management Class to the VTV.

The volume information element returned for a QVOLUME request or a MOUNT request for a virtual volume includes a value of VIRTUAL for media type (SLXVMED) and an x'01' for volume status (SLXVSTA).

For more information on these requests, see Appendix E, "Programmatic Interface" of the *HSC System Programmer's Guide for MVS*.

HSC User Exit Enhancements

Use return code UX02VIRT (32) in register 15 in HSC User Exit SLSUX02 (JES), which you use to control transport allocation for scratch mounts. To satisfy a scratch mount request, return code UX0xVIRT causes VSM to select an available VTD in your system and routes the job to a VTV mounted on that VTD.

For more information about HSC User Exits, see Chapter 9, “User Exits” of *HSC System Programmer’s Guide for MVS*.

HSC Batch API Enhancements

The HSC Batch API supports bulk reading of CDS VTV and MVC records. For more information about the Batch API, see Appendix F, “Batch Application Interface (API)” of *HSC System Programmer’s Guide for MVS*.



Hint: Appendix F, “Batch Application Interface (API)” of *HSC System Programmer’s Guide for MVS* provides an example of a QCDS request that retrieves VTV records.

For more information about the HSC Batch API enhancements for VSM, see the following sections:

- “Batch API Mapping Macros” on page 249
- “SLSUREQ QCDS Request” on page 252
- “Library Element Mapping” on page 252

The HSC Batch API provides additional data in the following records returning from a Batch API Query CDS request:

- The VTV record now provides the compressed and uncompressed size of the VTV. For more information, see “SLUVTDAT Macro Record Format” on page 251.
- The MVC record now provides an MVC status indicator. For more information, see “SLUVMDAT Macro Record Format” on page 249.

**Batch API Mapping
Macros**

The following sections described the macros to support VSM:

- “SLUVM DAT Macro Record Format”
- “SLUVTDAT Macro Record Format” on page 251

**SLUVM DAT Macro
Record Format**

Table 6 describes the SLUVM DAT macro record format.

Table 6. SLUVM DAT Macro Record Format					
Dec	Hex	Type	Length	Label	Description
SLUVM DAT - FLAT FILE MVC DATA DSECT					
FUNCTION: DESCRIBES THE MVC DATA WHICH IS GENERATED TO THE FLAT FILE BY THE BATCH API					
0	(0)	STRUCTURE		MDREC	FLAT FILE RECORD
0	(0)	SIGNED-FWORD	4	MDRECRDW	RECORD DESCRIPTOR WORD
4	(4)	SIGNED-FWORD	4	MDRECL	LENGTH
8	(8)	CHARACTER	1	MDRECC	CHARACTER EBCDIC/ASCII
9	(9)	CHARACTER	1	MDRECT	TYPE M - MVC
10	(A)	CHARACTER	6	MDRECM	MVC VOLSER
16	(10)	SIGNED-FWORD	4	MDRECV C	VTV COUNT
20	(14)	SIGNED-FWORD	4	MDRECP U	PERCENT USED
24	(18)	SIGNED-FWORD	4	MDRECP A	PERCENT AVAILABLE
28	(1C)	SIGNED-FWORD	4	MDRECP W	PERCENT WASTED
32	(20)	SIGNED-FWORD	4	MDRECP M	MOUNTED COUNT
36	(24)	SIGNED-FWORD	4	MDRECT L	TIME LAST USED HIGH ORDER WORD FROM STACK INSTRUCTION
40	(28)	SIGNED-FWORD	4	MDRECP M S	MEDIA SIZE
44	(2C)	LENGTH		MDRECP L E N	LENGTH OF RECORD WHEN USING VERSIONS 1 AND 2 OF SLSUREQM
44	(2C)	BITSTRING	1	MDRECP E R R	MVC STATUS INDICATOR
		X'80'		MDINIT D	MVC INITIALIZED FROM A MIGRATE
		X'40'		MDMOUNT	MVC IS MOUNTED ON AN RTD
		X'20'		MDBROKE	MVC HAS AN ERROR

Table 6. SLUVM DAT Macro Record Format

Dec	Hex	Type	Length	Label	Description
		X'10'		MDFULL	MVC CANNOT CONTAIN ANY MORE VTVS
		X'08'		MDDRAIN	MVC IS BEING DRAINED
		X'04'		MDLOST	MVC IS LOST (LAST MOUNT TIMED OUT)
		X'02'		MDDATCK	MVC SWAPPED (NOT IN RECOVERY)
		X'01'		MDREADO	MVC IS READONLY
45	(2D)	RESERVED	3		
48	(30)	LENGTH		MDRECLN3	LENGTH OF RECORD LENGTH OF RECORD WHEN USING VERSIONS 3 OF SLSUREQM

SLUVTDAT Macro
Record Format

Table 7 describes the SLUVTDAT macro record format.

Table 7. SLUVTDAT Macro Record Format					
Dec	Hex	Type	Length	Label	Description
SLUVMTDAT - FLAT FILE VTV DATA DSECT					
FUNCTION: DESCRIBES THE VTV DATA WHICH IS GENERATED TO THE FLAT FILE BY THE BATCH API					
0	(0)	STRUCTURE		VDREC	FLAT FILE RECORD
0	(0)	SIGNED-FWORD	4	VDRECRDW	RECORD DESCRIPTOR WORD
4	(4)	SIGNED-FWORD	4	VDRECL	LENGTH
8	(8)	CHARACTER	1	VDRECC	CHARACTER EBCDIC/ASCII
9	(9)	CHARACTER	1	VDRECT	TYPE V - VTV
10	(A)	CHARACTER	6	VDRECV	VTV VOLSER
16	(10)	CHARACTER	8	VDRECVT	VTSS
24	(18)	SIGNED-FWORD	4	VDRECSZ	SIZE (MB)
28	(1C)	CHARACTER	1	VDRECM	MIGRATED Y/N
29	(1D)	CHARACTER	1	VDRECD	DUPLEX Y/N
30	(1E)	CHARACTER	6	VDRECM1	MVC VOLSER OF FIRST/ONLY COPY
36	(24)	CHARACTER	6	VDRECM2	MVC VOLSER OF SECOND COPY
42	(2A)	CHARACTER	1	VDRECI	INVALID Y/N
43	(2B)	CHARACTER	1	VDRECS	SCRATCH Y/N
44	(2C)	SIGNED-FWORD	4	VDRECTC	HIGH ORDER WORD OF TOD CLOCK (GMT) RETURNED BY STCK INSTRUCTION
48	(30)	SIGNED-FWORD	4	VDRECTL	HIGH ORDER WORD OF TOD CLOCK (GMT) RETURNED BY STCK INSTRUCTION
52	(34)	CHARACTER	8	VDRECMC	MANAGEMENT CLASS
60	(3C)	LENGTH		VDRECLEN	LENGTH OF RECORD WHEN USING SLSUREQM VERSIONS 1 AND 2
60	(3C)	SIGNED-FWORD	4	VDUCMPSZ	VTV UNCOMPRESSED SIZE (BYTES)
64	(40)	SIGNED-FWORD	4	VDCOMPSZ	VTV COMPRESSED SIZE (BYTES)
68	(44)	CHARACTER	6		RESERVED

Table 7. SLUVTDAT Macro Record Format

Dec	Hex	Type	Length	Label	Description
74	(4A)	CHARACTER	6		RESERVED
80	(50)	LENGTH		VDRECLEN	LENGTH OF RECORD WHEN USING SLSUREQM VERSION 3

SLSUREQ QCDS Request

The following TYPE= values are valid on the SLSUREQ QCDS request:

MVC

specifies the VTCS MVC record area of the CDS.

VTV

specifies the VTCS VTV record area of the CDS.

Library Element Mapping

Table 8 describes the Library Element Record Mapping additions.

Table 8. Library Element Record Mapping Additions

Request	Records Returned
READ MVC	VTCS MVC records mapped by the SLUVM DAT macro
READ VTV	VTV records mapped by the SLUVT DAT macro

HSC Operator Command Enhancements

With HSC:

- You can dynamically reload SCRPOOL statements via the SCRPCODEF command. For more information, see “Scratch Subpool Definition (SCRPCODEF) Command and Control Statement” in Chapter 3, “HSC Control Statements and HSC Start Procedure” of *HSC System Programmer’s Guide for MVS*.
- The Warn SCRatch, Display SCRatch, and Display THReshld commands are enhanced to let you manage and monitor scratch VTVs. For more information, see:
 - “HSC WARN SCRATCH Command Enhancements” on page 254
 - “HSC DISPLAY THRESHLD Command Enhancements” on page 255
 - “HSC DISPLAY SCRATCH Command Enhancements” on page 257
- You can expand the CDS using the CDS EXPAND command.
- You can use the TRACELKP command to trace HSC definition data sets, including the following:
 - VOLATTR
 - LMUPDEF
 - MVCPOOL
 - MGMTCLAS
 - STORCLAS

For more information, see Chapter 2, “Commands, Control Statements, and Utilities,” in *HSC Operator’s Guide for MVS*.

HSC WARN SCRATCH Command Enhancements

For VSM, the enhanced HSC Warn SCRatch command sets scratch warning thresholds for HSC subpools that contain VTVs.

Syntax

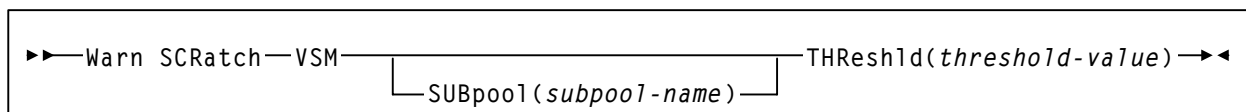

Figure 18. Warn SCRatch VSM **Command Syntax**

Parameters	<p>VSM Specifies that the command applies to VTVs only.</p> <p>SUBpool Specifies an HSC subpool that contains VTVs. If not specified, the command applies to the total VSM scratch count.</p> <p><i>subpool-name</i> The specified subpool.</p> <p>THReshd Specifies the scratch warning threshold. If the number of scratches goes below the specified threshold, HSC issues a warning message. Valid values are 0 to 9999.</p> <p><i>threshold-value</i> The specified threshold.</p>
Usage	Use Warn SCRatch to set scratch warning thresholds for HSC subpools that contain VTVs.
Example	To set a threshold of 50 VTVs for subpool VIRT01, enter the following: W SCR VSM SUB(VIRT01) THR(50)

**HSC DISPLAY
THRESHLD
Command
Enhancements**

For VSM, the enhanced HSC Display THReshd command displays scratch thresholds for HSC subpools that contain VTVs.

Syntax

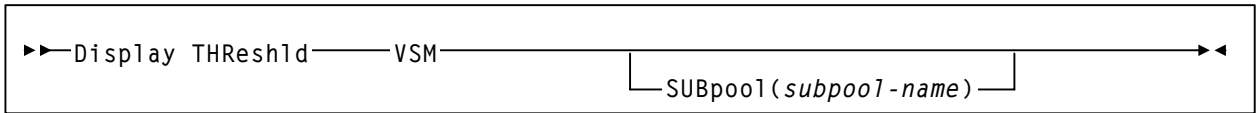

Figure 19. Display THReshd VSM **Command Syntax**

Parameters

VSM
Specifies that the command applies to VTVs only.

SUBpool
Specifies an HSC subpool that contains VTVs. If not specified, the command applies to the total VSM scratch count.

subpool-name
The specified subpool.

Usage

Use Display THReshd to display scratch thresholds for HSC subpools that contain VTVs.

Example

To display the scratch threshold for subpool VIRT01, enter the following:
D THR VSM SUB(VIRT01)

Output

Figure 22 shows an example of HSC Display THR VSM output.

ACS/LSM	SUBPOOL	NAME	MEDIA	RECTECH	COUNT	THRESH
VSM	SUBPOOL	VIRT01	TOTAL		20	10
VSM	SUBPOOL	VIRT02	TOTAL		20	10
VSM	NON-SUBPOOL		TOTAL		60	50
VSM	TOTAL				100	100

Figure 20. Example output from HSC Display THR VSM

Note: VSM information is displayed if:

- You explicitly specify `Display THReshd VSM`.
- You specify `Display THReshd` (no keywords) and VSM is active.

When there are no subpools defined for VSM, the VSM summary includes only the “Non-Subpool” and “Total” lines. If VSM is not active when an explicit request is made for VSM thresholds, the will indicates “Nothing to Display”.

**HSC DISPLAY
SCRATCH
Command
Enhancements**

For VSM, the enhanced HSC Display SCRatch command displays scratch counts for HSC subpools that contain VTVs.

Syntax

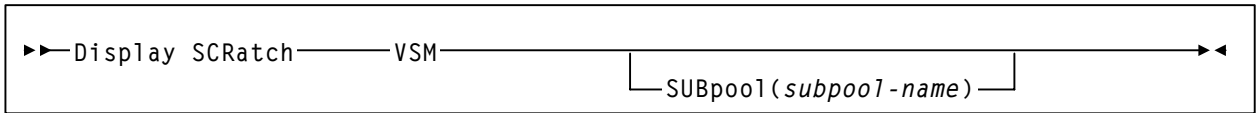

Figure 21. Warn SCRatch VSM **Command Syntax**

Parameters

VSM

Specifies that the command applies to VTVs only.

SUBpool

Specifies an HSC subpool that contains VTVs. If not specified, the command applies to the total VSM scratch count.

subpool-name

The specified subpool.

Usage

Use Display SCRatch to display scratch counts for HSC subpools that contain VTVs. Scratch counts are reported as follows:

- Scratch counts are reported for all subpools that have a warning threshold set, even if the scratch count is zero.
- If a calculation of the “non-subpool” count results in a negative number, a count of zero is displayed.

Example

To display the scratch count for subpool VIRT01, enter the following:

D SCR VSM SUB(VIRT01)

Output

Figure 22 shows an example of HSC Display SCR VSM output.

ACS/LSM	SUBPOOL	NAME	MEDIA	RECTECH	COUNT
VSM	SUBPOOL	VIRT01	TOTAL		20
VSM	SUBPOOL	VIRT02	TOTAL		20
VSM	NON-SUBPOOL		TOTAL		60
VSM	TOTAL				100

Figure 22. Example output from HSC Display SCR VSM

Note: VSM information is displayed if:

- You explicitly specify Display SCRatch VSM.
- You specify Display SCRatch (no keywords) and VSM is active.

When there are no subpools defined for VSM, the VSM summary includes only the “Non-Subpool” and “Total” lines. If VSM is not active when an explicit request is made for VSM scratch counts, the will indicates “Nothing to Display”.

HSC DELDISP Parameter Enhancements

HSC provides two new settings for the LIBGEN DELDISP parameter of the SLILIBRY macro:

ASCRTCH

(All scratch). Both real tape volumes and VTVs are made scratch if they were mounted scratch and the disposition on the dismount message is delete ('D').

VSCRTCH

(Virtual scratch). Only VTVs are made scratch if they were mounted scratch and the delete disposition on the dismount message is delete ('D').

The current DELDISP settings (SCRTCH and NOSCRTCH) define scratch handling at dismount **only** for real volumes. If DELDISP is set to either of these values, VTVs are **never** scratched at dismount.

On pre-5.0 HSC systems, acting against a CDS where the DELDISP is set to ASCRTCH, the setting is handled as SCRTCH. Similarly, if the DELDISP has been set to VSCRTCH, the setting is handled as NOSCRTCH.

Note: A LIBGEN and MERGECDS or RECONFIG utility is not required to change the DELDISP setting in an existing system. The DELDISP setting can be changed with the HSC SET utility; it now accepts the two new settings. Active systems must be recycled to affect the change for DELDISP. Once set, the DELDISP setting is persistent across HSC initializations.

Chapter 4. LibraryStation Enhancements and Additions for VSM

This chapter contains reference information about the following enhancements and additions to LibraryStation to support VSM:

- “SPNUM Statement” on page 262, a new LibraryStation LSDEF file statement that which defines a LibraryStation subpool that corresponds to an HSC subpool.
- “VIRTACS Statement” on page 265, a new LibraryStation LSDEF file statement that defines a virtual ACS that maps to a VTSS to let clients connect to VSM.
- “SLGDIAG VIRTUAL_DRIVE Parameter” on page 266, which you can use to verify VSM and HSC operation with LibraryStation in the same SLGDIAG job.

SPNUM Statement

The enhanced SPNUM statement, which defines a LibraryStation subpool that corresponds to an HSC subpool, lets MVS/CSC and non-MVS/CSC clients request VTV mounts and pass a Management Class to VSM.

Syntax

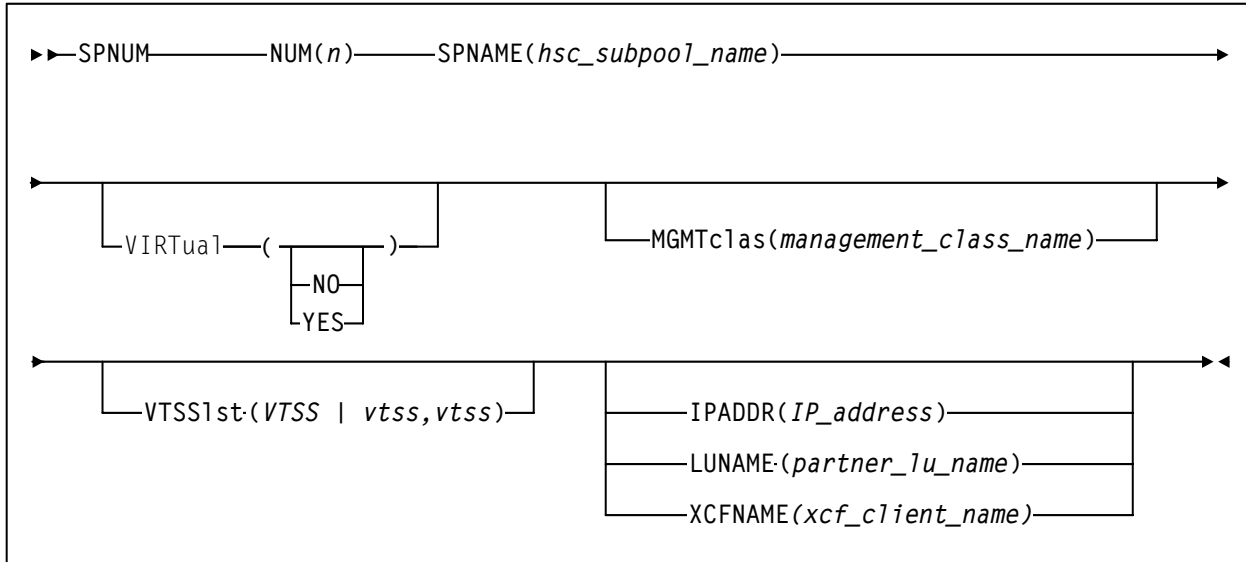

Figure 1. SPNUM Statement Syntax

Parameters

Unchanged SPNUM Parameters

The following SPNUM parameters are unchanged but apply to VSM. Figure 1 shows valid values for these parameters; see Chapter 10, “Configuring the LSDEF Data Set” of *LibraryStation Configuration Guide* for more information.

- NUM
- SPNAME
- IPADDR
- LUNAME
- XCFNAME

New SPNUM Parameters

The following new SPNUM parameters apply to LibraryStation in VSM environments. These parameters allow MVS/CSC and non-MVS/CSC clients to request VTV mounts.

VIRTua1

specifies whether the subpool contains VTVs.

NO

the subpool does not contain VTVs.

YES

the subpool contains VTVs.

Note: If VIRTua1 is not specified, the subpool can contain both real volumes and VTVs.

MGMTclas

specifies the name of a Management Class you defined on the HSC MGMTclas control statement; for more information, see “MGMTCLAS Control Statement” on page 214.

mgmt-class-name

the Management Class name.



Caution: For MVS/CSC clients, if you specify a Management Class when routing data to VSM (on a TAPEREQ statement, for example), StorageTek recommends that you do **not** specify a Management Class on the SPNUM statement.

VTSS

specifies one or two VTSSs used to satisfy the mount request.

vtssname | *vtssname, vtssname*

the names of one or two VTSSs.

Note: Each VTSS name must correspond to a VTSS name specified on a VIRTACS statement; for more information, see “VIRTACS Statement” on page 265.

Usage

Use the enhanced SPNUM statement to define a LibraryStation VTV subpool that corresponds to an HSC subpool. This subpool lets MVS/CSC and non-MVS/CSC clients request VTV mounts and pass a Management Class to VSM. You can also use the VTSSLST parameter to specify one or two VTSSs used to satisfy the mount request. You use the LibraryStation VIRTACS statement to define a virtual ACS that maps to a VTSS to let clients connect to VSM; for more information, see “VIRTACS Statement” on page 265.

Note: LibraryStation subpools can contain mixtures of VTVs and real Nearline volumes. If your client allows it, however, to simplify volume management, StorageTek recommends that you define subpools that contain only VTVs or real Nearline volumes, not mixtures of them.

You specify a Management Class on the `MGMTclas` parameter to pass this Management Class to VSM for each VTV mount. You define Management Classes with the `MGMTclas` statement; for more information, see “MGMTCLAS Control Statement” on page 214. You use the `MGMTDEF` command to load `MGMTclas` statements from a specified definition data set (which resides on the HSC/LibraryStation server); for more information, see “MGMTDEF Command” on page 223.

Examples

For example, for non-MVS/CSC clients, create the following `SPNUM` statement to:

- Define VTV subpool 7 that corresponds to HSC subpool `LSVIRT1`
- Pass Management Class `MGMTCLS7` to VSM when a VTV is mounted
- Specify VTSSs `VTSS01` and `VTSS02` are used to satisfy VTV mounts
- Restrict VTV mount requests to the client at IP address `129.80.57.16`

```
SPNUM NUM(07) SPNAME(LSVIRT1) VIRT(YES) MGMT(MGMTCLS7)  
VTSSL(VTSS01,VTSS02) IPADDR(129.80.57.16)
```

VIRTACS Statement

The VIRTACS statement defines a virtual ACS that maps to a VTSS to let clients connect to VSM.

Syntax

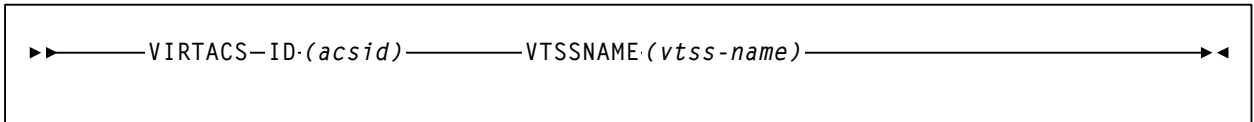

Figure 2. VIRTACS *Statement Syntax*

Parameters

ID

specifies a virtual ACS ID.

acsid

a decimal virtual ACS ID.

VTSSNAME

specifies the VTSS identifier that maps to the virtual ACS ID.

vtss-name

a VTSS identifier.

Usage

Use the VIRTACS statement to define a virtual ACS that maps to a VTSS to let clients connect to VSM.

Examples

To define virtual ACS 126 and map it to VTSS VTSS02, create the following VIRTACS statement:

```
VIRTACS ID(126) VTSSNAME(VTSS02)
```

SLGDIAG VIRTUAL_DRIVE Parameter

The SLGDIAG utility now provides VIRTUAL_DRIVE parameter that verifies LibraryStation operation with VSM in the following format (all decimal numbers):

=VIRTUAL_DRIVE=*ascid,lsmid,panelid,driveid*

See *VTCS Installation and Configuration Guide* for more information on VTD drive addresses for LibraryStation and NCS clients.

You can use SLGDIAG to verify LibraryStation operation with VSM in either of the following ways:

- To verify LibraryStation operation with only VSM (but not with HSC), specify the =VIRTUAL_DRIVE= parameter to query the specified VTD.
- To verify LibraryStation operation with VSM and HSC in the same batch job, specify the =VIRTUAL_DRIVE= parameter and also the existing =DRIVE= and =VOLUME= parameters (which request a mount/dismount on the specified Nearline transport).

For more information on the SLGDIAG utility, see Chapter 5, “Administration and Maintenance” in *LibraryStation Operator and System Programmer’s Guide*.

Chapter 5. MVS/CSC Enhancements and Additions for VSM

This chapter contains reference information about the following enhancements and additions to MVS/CSC to support VSM:

- “MVS/CSC Startup Parameter Enhancements” on page 268 for the DEFER and FETCH parameters.
- “MVS/CSC DISPLAY Command Enhancements” on page 268.
- “MVS/CSC User Exit Enhancements” on page 268.
- “MVS/CSC Programmatic Interface Enhancements” on page 269.
- “MVS/CSC DELDISP Parameter Enhancements” on page 269

Note: For NCS 6.1, the TAPEREQ statement (and the accompanying TREQDEF command) has been moved from HSC and MVS/CSC to SMC. For more information, see “TAPEREQ Control Statement” on page 194 and *SMC Configuration and Administration Guide*.



Caution: If you are using MVS/CSC to request mounts of scratch VTVs from an HSC scratch subpool, if the subpool is empty, MVS/CSC will not issue a message indicating that the subpool is empty. Instead, VTCS issues a message SLS6671E and continues to retry the scratch mount until you make scratch VTVs available!

MVS/CSC Startup Parameter Enhancements

The following sections describe the MVS/CSC startup parameter enhancements for VSM. For more information about MVS/CSC startup parameters, see Chapter 3, “Defining MVS/CSC Startup Parameters” in *MVS/CSC Configuration Guide*.

DEFER

In the JES2 environment, regardless of the value you specify, the DEFER parameter is always set to ON for VTVs. That is, for VTVs, deferred mount processing is enabled, which overrides the mount processing specified in the user’s JCL. The VTV mount is deferred until the JCL job step opens a data set on the VTV. This value helps minimize VTV recalls. If a data set resides on a migrated VTV, VSM does not recall the VTV until the job actually opens the data set on the VTV.

In the JES3 environment, regardless of the value you specify, the DEFER parameter is always set to JES3 for VTVs, which causes all mounts to be JES3 deferred. A volume is not mounted until a step begins execution.

Note that if a unit affinity chain includes a mixture of incompatible drives (including VTDs), NCS SMC device exclusion always ensures that the chain will be broken.

FETCH

FETCH specifies whether JES3 operator fetch message IAT5110 is issued during VTD allocation.

MVS/CSC DISPLAY Command Enhancements

In a VSM configuration, the DISPLAY LIBUNITS command displays VIRTUAL for VTDs in the Model column. For more information about the DISPLAY LIBUNITS command, see Chapter 3, “Issuing MVS/CSC Operator Commands” of *MVS/CSC Operator’s Guide*. Note that you can use VTCS commands and reports on another host to produce additional VSM information.

MVS/CSC User Exit Enhancements

MVS/CSC User Exit SCSUX02 (JES2 and JES3 without TAPE setup environments), which you use to control transport allocation for scratch mounts, now supports return code UX02VIRT in register 15. SCSUX04 (JES3 with TAPE setup environment) also supports return code UX04VIRT in register 15. To satisfy a scratch mount request, these return codes cause VSM to select an available VTD in your system and route the data set to a VTV mounted on that VTD. In a multi-VTSS environment, therefore, these return codes do *not* direct the VTD allocation to a specific VTSS, but let the allocation occur in any VTSS in the configuration.

Information returned from SCSUX09 (JES2 and JES3 without TAPE setup environments) and SCSUX11 (JES3 with TAPE setup environment) applies to real transports only and is ignored for VTDs. VTD mounts are automatically deferred. For more information about MVS/CSC User Exits, see Chapter 8 or Chapter 9 in *MVS/CSC System Programmer’s Guide*.

MVS/CSC Programmatic Interface Enhancements

The SCSXREQM macro mappings are updated to support VSM as follows:

- The SCXVMED field can now display a value of VIRTUAL for VTVs.
- In the Volume Information Element, the formerly reserved field at decimal offset 24 is now an 8 byte character field with label SCXVTSSN. If SCXVMED is VIRTUAL, the volume is VTSS-resident, and MVS/ CSC controls the VTD in the VTSS in which the VTV resides, SCXVTSSN displays the VTSS name. If the VTV is migrated, SCXVTSSN is blank.
- The field SCXVLC is hexadecimal zero for a VTV.

For more information about the SCSXREQM macro, see Appendix A, “SCSXREQM Macro Mappings” of *MVS/CSC System Programmer’s Guide*.

MVS/CSC DELDISP Parameter Enhancements

MVS/CSC provides two new settings for the DELDISP startup parameter which is specified in a sequential file (usually a PDS member) at initialization:

ASCRTCH

(All scratch). Both real tape volumes and VTVs are made scratch if they were mounted scratch and the disposition on the dismount message is delete ('D').

VSCRTCH

(Virtual scratch). Only VTVs are made scratch if they were mounted scratch and the delete disposition on the dismount message is delete ('D').

The current DELDISP settings (SCRTCH and NOSCRTCH) define scratch handling at dismount **only** for real volumes. In an MVS/CSC system, if DELDISP is set to either of these values, VTVs are **never** scratched at dismount.

Each MVS/CSC system can define its own startup parameter file and can have different settings for DELDISP. A recycle of an MVS/CSC system is not necessary to change the DELDISP setting. The MVS/CSC ALTER command can change the setting for DELDISP; it accepts the two new settings. When changing the DELDISP setting via the ALTER command, it goes into affect immediately for that MVS/CSC system. However, if the MVS/CSC is recycled, the DELDISP setting is set to the value defined in the startup parameter file; if omitted it defaults to NOSCRTCH.

Appendix A. VTCS SMF Record Format

This appendix describes the formats of the HSC SMF record subtypes for VTCS events.

Note: In the record descriptions in this appendix, all generated timestamps, regardless of whether they are ttime or TOD values, are based on GMT time, not local time.

SLSSMF10 - VTCS SMF Subtype 10 Record

Function Records a VTSS subsystem performance request.

Table 1. SLSSMF10 Record Format

Decimal Offset	Hexadecimal Offset	Type	Length	Label	Description
0	0	start of record		SLSSMF10	VTCS SMF record subtype 10

Decimal Offset	Hexadecimal Offset	Type	Length	Label	Description
0	0	character	8	SMF10VTS	VTSS ID
8	8	hexstring	2	SMF10BCH	base cache size (MB), where base cache is system space reserved for VTSS processing
10	A	hexstring	2	SMF10CCH	customer cache size (MB)
12	C	hexstring	4	SMF10OCH	offline cache size
16	10	hexstring	4	SMF10PCH	pinned cache size
20	14	hexstring	2	SMF10NSZ	nvs size (MB)
22	16	hexstring	8	SMF10TCT	reserved
30	1E	hexstring	8	SMF10TCP	total back end capacity
38	26	hexstring	8	SMF10FCT	reserved
46	2E	hexstring	8	SMF10FCP	total free back end capacity
54	36	hexstring	8	SMF10CFT	reserved
62	3E	hexstring	8	SMF10CFP	collected free back end capacity
70	46	hexstring	8	SMF10BRT	reserved
78	4E	hexstring	8	SMF10BRP	bytes read for free space collection
86	56	hexstring	8	SMF10SCT	reserved
94	5E	hexstring	8	SMF10SCP	total amount of free space collection
102	66	hexstring	2	SMF10RGC	redundancy group count
104	68	hexstring	8	SMF10CDT	reserved
112	70	hexstring	8	SMF10CDP	standard capacity defined
120	78	hexstring	4	SMF10EMP	count of ECAM-T messages processed
124	7C	hexstring	4	SMF10EBS	count of ECAM-T messages bypassed because no buffer space available
128	80	hexstring	4	SMF10EBC	count of ECAM-T messages bypassed because configuration was busy
132	84	hexstring	4	SMF10ECP	number of ECAM-T channel programs

SLSSMF11 - VTCS SMF Subtype 11 Record

Function Records a VTSS channel interface performance request.

Table 2. SLSSMF11 Record Format

Decimal Offset	Hexadecimal Offset	Type	Length	Label	Description
0	0	start of record		SLSSMF11	VTCS SMF record subtype 11
0	0	character	8	SMF11VTS	VTSS ID
8	8	hexstring	2	SMF11CNT	count of entries in this record the following fields repeat for each interface in this record
10	A	data		SMF11ENT	start of entry
10	A	character	8	SMF11INM	channel interface name
18	12	bitstring	2	SMF11CI	channel interface installed (y/n)
		X'0000'		SMF11CIN	no
		X'0001'		SMF11CIY	yes
20	14	bitstring	2	SMF11CE	channel interface enabled (y/n)
		X'0000'		SMF11CEN	no
		X'0001'		SMF11CEY	yes
22	16	hexstring	2	SMF11NAT	number of addresses trapped

Decimal Offset	Hexadecimal Offset	Type	Length	Label	Description
24	18	hexstring	2	SMF11CSP	Channel type
			X'0200'	SMF11CSE	ESCON channel
			X'1000'	SMF11CSI	IP link
			X'2000'	SMF11CSF	FICON channel
26	1A	hexstring	8	SMF11NIO	number of I/Os
34	22	hexstring	8	SMF11CUB	control unit busy (in v -seconds)
42	2A	bitstring	2	SMF11TOL	type of link
		X'0000'		SMF11TLH	host
		X'0001'		SMF11TLR	RTD
44	2C	length		SMF11ENL	length of each entry

SLSSMF13 - VTCS SMF Subtype 13 Record

Function Records a VTV mount request.

Table 3. SLSSMF13 Record Format

Decimal Offset	Hexadecimal Offset	Type	Length	Label	Description
0	0	start of record		SLSSMF13	VTCS SMF record subtype 13
0	0	character	8	SMF13VTS	VTSS ID
8	8	character	6	SMF13VID	VTV volser ID
14	E	character	2	SMF13DID	VTD device ID
16	10	bitstring	2	SMF13RWS	read/write state (thumbwheel)
		X'0001'		SMF13RRO	read only
		X'0002'		SMF13RRW	read/write
18	12	bitstring	2	SMF13VMT	virtual mount type
		X'0001'		SMF13EXT	mount existing VTV
		X'0002'		SMF13SSL	mount sl scratch VTV
		X'0003'		SMF13SNL	mount existing VTV as scratch
		X'0004'		SMF13SAL	mount ANSI label scratch VTV
20	14	hexstring	4	SMF13TIM	VTV timestamp (time format, seconds since 1/1/70)
24	18	bitstring	2	SMF13RCI	recall indicator
		X'0001'		SMF13MNR	mounted without a recall
		X'0002'		SMF13MRC	mounted after a recall
26	1A	bitstring	2	SMF13CTP	cartridge type
		X'0000'		SMF13SCT	S-cart (max 400 Mb size)
		X'0001'		SMF13ECT	E-cart (max 800 Mb size)

Decimal Offset	Hexadecimal Offset	Type	Length	Label	Description
28	1C	character	10		reserved
38	26	character	8	SMF13JNM	MVS jobname
46	2E	character	8	SMF13SNM	MVS stepname
54	36	character	44	SMF13DSN	MVS data set name
98	62	hexstring	8	SMF13MST	mount start timestamp (TOD), where mount start occurs when VTCS receives a mount request from HSC (or VTCS generates the request), generates a new thread to handle the mount request, then determines whether the request is for an existing, new, or scratch VTV
106	6A	hexstring	8	SMF13MET	mount end timestamp (TOD), where mount end occurs when VTSS generates a successful response to the ECAM-T request to mount the VTV on the selected RTD
114	72	character	8	SMF13MGT	VTV Management Class
122	7A	character	8	SMF13HST	Originating host name

SLSSMF14 - VTCS SMF Subtype 14 Record

Function Records a VTV dismount request.

Decimal Offset	Hexadecimal Offset	Type	Length	Label	Description
0	0	start of record		SLSSMF14	VTCS SMF record subtype 14
0	0	character	8	SMF14VTS	VTSS ID
8	8	character	6	SMF14VID	VTV volser ID
14	E	bitstring	2	SMF14STA	VTV state
		X'0001'		SMF14MNT	VTV mounted
		X'0002'		SMF14DSM	VTV dismounted
		X'0003'		SMF14NON	VTV does not exist
		X'0004'		SMF14MIG	VTV is being migrated
		X'0005'		SMF14REC	VTV is being recalled
		X'0006'		SMF14VTM	VTV logically dismounted by VTVMaint
16	10	hexstring	2	SMF14DID	MVS device address
18	12	hexstring	4	SMF14VSZ	uncompressed size of the VTV in bytes
22	16	hexstring	4	SMF14MSZ	the number of virtual tape pages in 32K increments required to migrate the VTV to an RTD
26	1A	hexstring	4	SMF14TIM	the last time the VTV was successfully mounted on a VTD (ttime format, seconds since 1/1/70)
30	1E	hexstring	2	SMF14UL#	number of MVCs to unlink
32	20	bitstring	2	SMF14CTP	cartridge type
		X'0000'		SMF14SCT	S-cart (max 400 Mb size)
		X'0001'		SMF14ECT	E-cart (max 800 Mb size)
34	22	bitstring	2	SMF14VMT	virtual mount type
		X'0001'		SMF14EXT	mount existing VTV
		X'0002'		SMF14SSL	mount sl scratch VTV

Decimal Offset	Hexadecimal Offset	Type	Length	Label	Description
36	24	character	8	SMF14JNM	MVS jobname
44	2C	character	8	SMF14SNM	MVS stepname
52	34	character	44	SMF14DSN	MVS data set name
96	60	character	8	SMF14MGT	VTM Management Class
104	68	character	8	SMF14HST	Originating host name

Table 4. SLSSMF14 Record Format

SLSSMF15 - VTCS SMF Subtype 15 Record

Function Records a delete VTV request.

Table 5. SLSSMF15 Record Format

Decimal Offset	Hexadecimal Offset	Type	Length	Label	Description
0	0	start of record		SLSSMF15	VTCS SMF record subtype 15
0	0	character	8	SMF15VTS	VTSS ID (blanks if migrated)
8	8	character	6	SMF15VID	virtual volser ID
14	E	character	4	SMF15TIM	VTV creation time (time format, seconds since 1/1/70)
18	12		4		reserved
22	16	character	4	SMF15LTR	time VTV last referenced (high order TOD value)
26	1A	bitstring	2	SMF15CTP	cartridge type
		X'0000'		SMF15SCT	S-cart (max 400 Mb size)
		X'0001'		SMF15ECT	E-cart (max 800 Mb size)
28	1C		2		reserved
30	1E	bitstring	2	SMF15RSN	VTV delete reason code
		X'0001'		SMF15NMM	VTV migrated then deleted
		X'0002'		SMF15MPR	VTV previously migrated
		X'0003'		SMF15SPR	VTV reclaimed
		X'0004'		SMF15CON	VTV consolidated
		X'0005'		SMF15OLD	invalid VTV version found
		X'0006'		SMF15DSC	VTV deleted on scratch
		X'0007'		SMF15IMP	VTV deleted by import
32	20	character	8	SMF15MGT	VTV Management Class
40	28	bitstring	2	SMF15LRI	last residency indicator
		X'0001'		SMF15LRR	last residency was for recall
		X'0002'		SMF15LRC	last residency was for create

SLSSMF16 - VTCS SMF Subtype 16 Record

Function Records an RTD mount request.

Table 6. SLSSMF16 Record Format

Decimal Offset	Hexadecimal Offset	Type	Length	Label	Description
0	0	start of record		SMF16VTS	VTCS SMF record subtype 16
0	0	character	8	SMF16VTS	VTSS ID
8	8	hexstring	2	SMF16RID	RTD ID (0-F)
10	A	character	6	SMF16MID	MVC volser ID

Decimal Offset	Hexadecimal Offset	Type	Length	Label	Description
16	10	character	6	SMF16AID	actual volser from VOL1 label
22	16	bitstring	2	SMF16RWS	read/write state (thumbwheel)
		X'0001'		SMF16RRO	read only state
		X'0002'		SMF16RRW	read/write state
24	18	bitstring	2	SMF16MT	mount request type
		X'0001'		SMF16MTM	migrate
		X'0002'		SMF16MTR	recall
		X'0003'		SMF16MTL	reclaim
		X'0004'		SMF16MTD	drain
		X'0005'		SMF16MTA	audit
		X'0006'		SMF16MTC	consolidate
		X'0007'		SMF16MTX	export
		X'0008'		SMF16MTI	INVENTORY utility
26	1A	hexstring	32	SMF16SNS	RTD sense data (all zeros or all X'FF's unless RTD errors occur)
58	3A	hexstring	8	SMF16MST	mount start timestamp (TOD), where mount start occurs when HSC receives a successful request to load the requested MVC
66	42	hexstring	8	SMF16MET	mount end timestamp (TOD), where mount end occurs when the VTSS receives a successful ECAM-T request to mount the requested MVC on an RTD
74	4A	character	2	SMF16SCL	MVC Storage Class
82	52	hexstring	2	SMF16IN	RTD Channel Interface ID
84	54	character	4	SMF16ADR	MVS address of RTD

SLSSMF17 - VTCS SMF Subtype 17 Record

Function Records an RTD dismount request.

Table 7. SLSSMF17 Record Format

Decimal Offset	Hexadecimal Offset	Type	Length	Label	Description
0	0	start of record		SLSSMF17	VTCS SMF record subtype 17
0	0	character	8	SMF17VTS	VTSS ID
8	8	hexstring	2	SMF17RID	RTD ID (0-F)
10	A	hexstring	64	SMF17BLD	RTD buffered log data
74	4A	hexstring	32	SMF17SNS	RTD sense data (all zeros or all X'FF's unless RTD errors occur)
106	6A	character	8	SMF17SCL	MVC Storage Class
114	72	character	6	SMF17MVC	MVC volser
120	78	hexstring	2	SMF17IN	RTD Channel Interface ID
122	7A	character	4	SMF17ADR	MVS address of RTD
126	7E	hexstring	1	SMF17DFL	Dismount flag
		X'80'		SMF17DRX	Retention period reduced
		X'40'		SMF17DAR	Auto recall
		X'20'		SMF17DMF	Full MVC
		X'10'		SMF17DVY	RTD vary command
		X'08'		SMF17DSW	MVC required on another drive or RTD required for another volume
		X'01'		SMF17DRT	Retain period applied

SLSSMF18 - VTCS SMF Subtype 18 Record

Function Records a migrate VTV request.

Table 8. SLSSMF18 Record Format

Decimal Offset	Hexadecimal Offset	Type	Length	Label	Description
0	0	start of record		SLSSMF18	VTCS SMF record subtype 18
0	0	character	8	SMF18VTS	VTSS ID
8	8	hexstring	2	SMF18RID	RTD ID (0-F)
10	A	character	6	SMF18VID	VTV volser ID
16	10	character	6	SMF18MID	MVC volser ID
22	16	hexstring	4	SMF18VPO	VTV position on this MVC (block ID)
26	1A	character	6	SMF18AID	actual volser from VOL1 label
32	20	hexstring	4	SMF18MSZ	uncompressed size of the VTV in bytes
36	24	hexstring	4	SMF18BCM	the number of virtual tape pages in 32K increments required to migrate the VTV to an RTD
40	28	hexstring	4	SMF18TIM	the last time the VTV was successfully mounted on a VTD (time format, seconds since 1/1/70)
44	2C	bitstring	2	SMF18MT	migrate request type
		X'0001'		SMF18MTA	auto
		X'0002'		SMF18MTI	immediate
		X'0003'		SMF18MTD	demand
		X'0004'		SMF18MTR	reclaim
		X'0005'		SMF18MTC	consolidate
		X'0006'		SMF18MTX	export
46	2E	bitstring	2	SMF18CTP	cartridge type
		X'0000'		SMF18SCT	S-cart (max 400 Mb size)

Decimal Offset	Hexadecimal Offset	Type	Length	Label	Description
		X'0001'		SMF18ECT	E-cart (max 800 Mb size)
48	30	hexstring	4	SMF18NPO	next MVC position (block ID)
52	34	hexstring	32	SMF18SNS	RTD sense
84	54	hexstring	8	SMF18MST	migrate start timestamp (TOD)
92	5C	hexstring	8	SMF18MET	migrate end timestamp (TOD)
100	64	character	8	SMF18MGT	VTV Management Class
108	6C	character	8	SMF18SCL	MVC Storage Class

SLSSMF19 - VTCS SMF Subtype 19 Record

Function Records a recall VTV request.

Table 9. SLSSMF19 Record Format

Decimal Offset	Hexadecimal Offset	Type	Length	Label	Description
0	0	start of record		SMF19VTS	VTCS SMF record subtype 19
0	0	character	8	SMF19VTS	VTSS ID
8	8	hexstring	2	SMF19RTD	RTD ID (0-F)
10	A	character	6	SMF19VID	VTV volser ID
16	10	character	6	SMF19MID	MVC volser ID
22	16	hexstring	4	SMF19VPO	VTV position on this MVC (block ID)
26	1A	bitstring	2	SMF19RE	recall with error
		X'0000'		SMF19REN	no
		X'0001'		SMF19REY	yes
28	1C	character	6	SMF19AID	actual volser from VOL1 label
34	22	hexstring	4	SMF19MSZ	VTV media size
38	26	hexstring	4	SMF19BCM	number of bytes currently recalled
42	2A	hexstring	4	SMF19TIM	the last time the VTV was successfully mounted on a VTD (time format, seconds since 1/1/70)
46	2E	bitstring	2	SMF19MT	recall request type
		X'0001'		SMF19MTA	auto
		X'0002'		SMF19MTN	drain
		X'0003'		SMF19MTD	demand
		X'0004'		SMF19MTR	reclaim
		X'0005'		SMF19MTC	consolidate
		X'0006'		SMF19MTX	export

Decimal Offset	Hexadecimal Offset	Type	Length	Label	Description
48	30	bitstring	2	SMF19CTP	cartridge type
		X'0000'		SMF19SCT	S-cart (max 400 Mb size)
		X'0001'		SMF19ECT	E-cart (max 800 Mb size)
50	32	hexstring	32	SMF19SNS	RTD sense
82	52	hexstring	8	SMF19RST	recall start timestamp (TOD)
90	5A	hexstring	8	SMF19RET	recall end timestamp (TOD)
98	62	character	8	SMF19MGT	VTV Management Class
106	6A	character	8	SMF19SCL	MVC Storage Class

SLSSMF20 - VTCS SMF Subtype 20 Record

Function Records an RTD performance request.

Table 10. SLSSMF20 Record Format

Decimal Offset	Hexadecimal Offset	Type	Length	Label	Description
0	0	start of record		SLSSMF20	VTCS SMF record subtype 20
0	0	character	8	SMF20VTS	VTSS ID
8	8	hexstring	2	SMF20CNT	count of entries in this record the following fields repeat for each RTD in this record
10	A	area		SMF20ENT	start of entry
10	A	character	8	SMF20RNM	RTD name
18	12	bitstring	2	SMF20ST	RTD state
		X'0000'		SMF20STU	unconfigured
		X'0001'		SMF20STC	configured
20	14	hexstring	8	SMF20ATM	device available time (v -seconds), which is the time the MVC is mounted on the RTD
28	1C	hexstring	8	SMF20ACT	device activity (initial selects)
36	24	hexstring	8	SMF20BTR	bytes transferred - read
44	2C	hexstring	8	SMF20BTW	bytes transferred - write
52	34	hexstring	8	SMF20DUT	device utilization time (v -seconds), which is the accumulated time of each CCW chain to device end
60	3C	hexstring	8	SMF20DCT	device connect time (v -seconds), which is the accumulated time of each CCW chain to device end

SLSSMF21 - VTCS SMF Subtype 21 Record

Function Records a vary RTD.

Table 11. SLSSMF21 Record Format

Decimal Offset	Hexadecimal Offset	Type	Length	Label	Description
0	0	start of record		SLSSMF21	VTCS SMF record subtype 21
0	0	character	8	SMF21VTS	VTSS ID
8	8	hexstring	2	SMF21RTD	RTD ID (0-F)
10	A	bitstring	2	SMF21STA	new device state
		X'0001'		SMF21OFF	offline
		X'0002'		SMF21ON	online
		X'0003'		SMF21MAI	maintenance

SLSSMF25 - VTCS SMF Subtype 25 Record

Function Records MVC status.

Table 12. SLSSMF25 Record Format

Decimal Offset	Hexadecimal Offset	Type	Length	Label	Description
0	0	start of record		SLSSMF25	VTCS SMF record subtype 25
0	0	character	6	SMF25MID	MVC volser ID
6	6	hexstring	4	SMF25TFS	total free space (includes any space for invalid VTVs)
10	A	hexstring	4	SMF25UFS	usable free space (after the last valid VTV on the MVC)
14	E	hexstring	4	SMF25NAV	number of active VTVs
18	12	character	8	SMF25SCL	MVC Storage Class
26	1A	hexstring	4	SMF25TUS	space in Kb used by current VTVs
30	1E	hexstring	4	SMF25NDV	number of "holes" (deleted VTVs)
34	22	hexstring	4	SMF25LUT	top 4 bytes of the TOD clock when the MVC was last used
38	26	hexstring	4	SMF25LWT	top 4 bytes of the TOD clock when the MVC was last updated

SLSSMF26 - VTCS SMF Subtype 26 Record

Function Records VTV movement.

Table 13. SLSSMF26 Record Format

Decimal Offset	Hexadecimal Offset	Type	Length	Label	Description
0	0	start of record		SLSSMF26	VTCS SMF record subtype 26
0	0	character	8	SMF26VTS	VTSS ID
8	8	character	6	SMF26VID	VTV volser ID
14	E	character	6	SMF26OMI	old MVC volser ID
20	14	character	6	SMF26NMI	new MVC volser ID
26	1A	hexstring	4	SMF26VPO	VTV position on new MVC (block ID)
30	1E	hexstring	8	SMF26MST	move start timestamp (TOD)
38	26	hexstring	8	SMF26MET	move end timestamp (TOD)
46	2E	character	8	SMF26MGT	VTV Management Class

SLSSMF27 - VTCS SMF Subtype 27 Record

Function Records VTV scratch status.

Table 14. SLSSMF27 Record Format

Decimal Offset	Hexadecimal Offset	Type	Length	Label	Description
0	0	start of record		SLSSMF27	VTCS SMF record subtype 27
0	0	character	6	SMF27VID	VTV volser ID
6	6	character	8	SMF27MCL	VTV Management Class
14	E	bitstring	2	SMF27STP	VTV scratch type
		X'0001'		SMF27STN	no delete on scratch
		X'0002'		SMF27STD	delete on scratch
16	10	hexstring	4	SMF27MSZ	VTV media size
20	14	hexstring	4	SMF27TIM	the last time the VTV was updated (time format, seconds since 1/1/70)
24	18	hexstring	4	SMF27LUS	the last time the VTV was used (TOD format)
28	1C	hexstring	6	SMF27MV1	volser of MVC 1 that contains the VTV
34	22	hexstring	6	SMF27MV2	volser of MVC 2 that contains the VTV
40	28	character	8	SMF27VTS	VTSS name
48	30	bitstring	1	SMF27RES	VTV last resident indicator
			X'80'	SMF27RVT	resident on VTSS
			X'40'	SMF27RM1	resident on MVC1
			X'20'	SMF27RM2	resident on MVC2
			X'10'	SMF27RM3	resident on MVC3
			X'08'	SMF27RM4	resident on MVC4
49	31		1	SMF27SPR	reserved
50	32	bitstring	2	SMF27CTP	cartridge type
		X'0000'		SMF27SCT	S-cart (max 400 Mb size)

Decimal Offset	Hexadecimal Offset	Type	Length	Label	Description
		X'0001'		SMF27ECT	E-cart (max 800 Mb size)
52	34		4	SMF27SP2	reserved
56	38	character	6	SMF27MV3	volser of MVC3 that contains the VTV
62	3E	character	6	SMF27MV4	volser of MVC4 that contains the VTV

SLSSMF28 - VTCS SMF Subtype 28 Record

Function Records a VTV replication.

Table 15. SLSSMF28 Record Format

Decimal Offset	Hexadecimal Offset	Type	Length	Label	Description
0	0	start of record		SLSSMF28	VTCS SMF Record sub-type 28
0	0	character	8	SMF28VTS	Primary VTSSname
8	8	character	8	SMF28SVT	Secondary VTSSname
16	10	character	8	SMF28CLN	Cluster Name
24	18	character	6	SMF28VID	VTV Volser
30	1E	hexstring	2	SMF28AID	CLINK CHANIF
32	20	hexstring	1	SMF28DID	CLINK device-id
Note: SMF28AID and SMF28DID will contain binary zeros if the replication is synchronous.					
33	21	hexstring	1		reserved
34	22	bitstring	2	SMF28CTP	cartridge type
		X'0000'		SMF28SCT	S-cart (max 400 Mb size)
		X'0001'		SMF28ECT	E-cart (max 800 Mb size)
36	24	hexstring	4		reserved
40	28	hexstring	4	SMF28BCR	Bytes replicated for VTV
44	2C	hexstring	4	SMF28TIM	VTV last updated timestamp (seconds since 1/1/70)
48	30	hexstring	32	SMF28SNS	Sense data from CLINK
80	50	hexstring	8	SMF28RST	Replicate Start Time (TOD format)
88	58	hexstring	8	SMF28RET	Replicate End Time (TOD format)
96	60	hexstring	8	SMF28MGT	VTV Management Class

SLSSMF29 - VTCS SMF Subtype 29 Record

Function Records a VTV and MVC unlink event.

Table 16. SLSSMF29 Record Format

Decimal Offset	Hexadecimal Offset	Type	Length	Label	Description
0	0	start of record		SLSSMF29	VTCS SMF Record sub-type 29
0	0	character	6	SMF29VID	VTV volser
6	6	character	6	SMF29MVC	MVC volser
12	C	character	2	SMF29MV#	number of remaining MVCs
14	E	bitstring	2	SMF29RSN	reason for unlink
		X'0001'		SMF29NLC	VTV no longer current (dismount)
		X'0002'		SMF29DRN	MVC drain/reclaim
		X'0003'		SMF29DOS	delete on scratch
		X'0004'		SMF29IMP	VTV import
		X'0005'		SMF29VMN	VTVMAINT utility
		X'0006'		SMF29MVC	MVC inventory
		X'0007'		SMF29VTS	VTSS inventory
		X'0008'		SMF29VAD	VTV audit
16	10		6		reserved

SLSSMF30 - VTCS SMF Subtype 30 Record

Function Records a Vary Clink event.

Table 17. SLSSMF30 Record Format

Decimal Offset	Hexadecimal Offset	Type	Length	Label	Description
0	0	start of record		SLSSMF30	VTCS SMF Record sub-type 30
0	0	character	8	SMF30CLU	Cluster name
8	8	character	8	SMF30VTS	Primary or Sending VTSS name
16	10	character	8	SMF30PAR	Partner VTSS name
24	18	bitstring	2	SMF30CLI	Clink Id
26	1A	bitstring	2	SMF30STA	New Clink status
		X'0001'		SMF30OFF	Offline
		X'0002'		SMF30ON	Online

SLSSMF31 - SMF Subtype 31 Record

Function Records information about each dynamically added or deleted transport.

Table 18. SLSSMF31 Record Format

Decimal Offset	Hexadecimal Offset	Type	Length	Label	Description
0	0	start of record		SLSSMF31	SMF Record sub-type 31
0	0	character	6	SMF31DRV	"DRIVE" character string
6	6	character	12	SMF31DYN	"DYNAMICALLY" character string
18	12	character	8	SMF31TYP	Type of drive modification: <ul style="list-style-type: none"> • ADDED - Drive has been dynamically added • DELETED - Drive has been dynamically deleted
26	1A	character	6	SMF31CH1	"UNIT:" character string
32	20	character	4	SMF31UNT	transport unit address
36	24	character	10	SMF31CH2	"LOCATION:" character string
46	2E	character	11	SMF31LOC	transport location
57	39	character	7	SMF31CH3	"MODEL:" character string
64	40	character	8	SMF31MOD	HSC model type

Appendix B. VTD Command Reference

Overview

This appendix describes *only* that portion of the Virtual Tape Storage Subsystem (VTSS) that responds to 3490 style tape commands. This appendix is intended to be a programmer's guide for defining how the VTD behaves.

This appendix is meant to be read in conjunction with the *IBM 3490 Magnetic Tape Subsystem Models A01, A02, A10, A20, B02, B04, B20, and B40 Hardware Reference* (referred to in this book as the *IBM 3490 Hardware Reference*) and as such is not intended to be a stand-alone document. This appendix contains only that functionality which is different from the *IBM 3490 Hardware Reference*. Please review that document before reading this appendix.

Bit Naming Conventions

Please be aware that the IBM convention of numbering bits has been used within this document. This means bit 0 is the most significant bit of a unit (byte, word, etc.) to be described and that the max bit N is the least significant bit.

Discussion of 3480/3490 Terms

This section expands upon IBM terms such as tape products, media, and media formats as they relate to VTDs. It is only important in the fact that the VTSS must respond accurately to the commands described within this document.

See "Product and Media Type Emulation" on page 305 for how the VTD responds in command data.

Table 1. Product Designators and Capabilities

Product or Model Designators	Commands Respond as...	18 track capable	IDRC capable	36 track capable	long tape capable
3480 B02 or B04	3480 02 or 04	yes	opt		
3490 B02 or B04	3480 02 or 04	yes	std		
3490 B20 or B40 (a.k.a. 3490E)	3490 20 or 40	read only	yes	yes	yes

Table 2. Media and Media capabilities

Media Name	with this Model	can support 18 track	can support IDRC	can support 36 track	can support long tape
3480	3480 B02 or B04	yes	opt.		
3480	3490E	read only	yes	yes	

Media Name	with this Model	can support 18 track	can support IDRC	can support 36 track	can support long tape
3490E "Enhanced" i.e. long tape	3490E	NO	yes	yes	yes

Table 3. Formatted Media Designators

if IDRC blocks exist	if 36 track	then, media is known to be formatted as a
-	-	3480
yes	-	3480 XF
yes	yes	3480-2 XF
-	yes	3480 XF

Summary:

1. An "E" in a product designator always has IDRC, 36 track, and long tape capability (using 3490E media). The E in a product is the same as a 3490E or B20 or B40 product capability
2. An "E" in the media designator (a.k.a. 3490E media) always means long tape.
3. All 36 track machines always have IDRC capability
4. A 3490 B02 or B04 is a repackaged 3480 B02 OR B04 but responds in a command as a 3480. The B02 refers to 2 drives in a frame. The B04 refers to 4 drives in a frame.
5. The B20 refers to 2 drives in a frame. The B40 refers to 4 drives in a frame.

Command Overview

Characteristics of the VTD

Although the Virtual Tape Device (VTD) emulates a 3490 type of device, it does have certain characteristics that differentiate it from that of a physical tape I/O system.

Defects. Data written to and recalled from virtual tape volumes are free of defects and gaps. Once this data is migrated to and recalled from real tape, the possibility of defects arises. If the VTSS encounters a data error recalling a volume from real tape, that error will be preserved when the data is eventually read by the host.

IDRC always Enabled. Data is *always* compressed when it is written to the VTSS and then uncompressed when it is read back to the channel. It is not possible to disable IDRC within the VTSS.

Product and Media Type Emulation

Throughout the descriptions of command data, the VTD responds as described in Table 4. The Virtual Tape Volume (VTV) media always appears as a 400 MB (compressed) 36 track 3480 style cartridge. Command data refers to this as a 3480-2 XF format.

The amount of customer data that can be compressed into 400 MB varies with the data, but compression in the VTSS is better than that of standard IDRC rates.

Refer to “Discussion of 3480/3490 Terms” on page 303 for a discussion of what these terms mean.

Table 4. VTSS Type Emulation

	command response
Control Unit type	3490 A20
Tape Unit type	3490 B40
Media type	3480 (standard)
Media formatted as...	3480-2 XF

The commands that return this data include the Read Buffered Log, Read Subsystem Data, Read Device Characteristics, Sense ID and Read Configuration Data commands.

Command Summary

Table 5 represents a summary of commands described in the *IBM 3490 Command Reference* manual. They are grouped by their type along with their command codes. This table also indicates whether this command operates differently than that described in the *IBM 3490 Command Reference* manual. For those commands that are different, a unique command description is contained later on in this document.

Table 5. Command Difference Summary

Command	Mnemonic	Hex	Cmd Differences	Typical Functionality
DATA TRANSFER COMMANDS				
Write	WRT	01	Yes	Only command that writes user data to tape.
Read Forward	RDF	02	Yes	Reads data in the forward direction
Read Backward	RDB	0C	Yes	Reads data in the backwards direction
Read Buffer	RBF	12	Yes	Returns any non-written buffered device data
TAPE CONTROL COMMANDS				
Rewind	REW	07	-	Positions the tape to the beginning of tape
Rewind Unload	RUN	0F	-	Rewinds and unloads the tape
Erase Gap	ERG	17	Yes	Used in error handling
Write Tape Mark	WTM	1F	-	Writes a tape mark on tape
Backward Space Block	BSB	27	-	Positions backward past the previous tape mark or block
Backward Space File	BSF	2F	-	Positions backward past the previous tape mark
Forward Space Block	FSB	37	-	Positions to the next tape mark or block
Forward Space File	FSF	3F	-	Positions to the next tape mark
Data Security Erase	DSE	97	Yes	Writes a random pattern from current position to the end of tape
DEVICE MANAGEMENT COMMANDS				
Test I/O	TIO	00	-	Not used in ESCON attached CUs
No-Operation	NOP	03	-	Indicates device readiness or returns pending status
Channel Path No-Operation	CPNOP	13	-	Indicates channel path readiness or returns pending status

Command	Mnemonic	Hex	Cmd Differences	Typical Functionality
Read Block ID	RBID	22	Yes	Returns current positional information
Synchronize	SYNC	43	Yes	Flushes buffered write data to device
Locate Block	LOC	4F	Yes	Positions the tape at the desired block ID
Load Display	LDD	9F	Yes	Controls the drive display panel; Also provides ECAM-T hand-shake.
Set Tape Write Immediate	TWI	C3	Yes	Controls the immediate mode of operation
3420 Compatibility Commands	-	CB D3	Yes	Not supported
Mode Set	MDS	DB	Yes	Controls various modes of operations
SUBSYSTEM COMMANDS				
Sense	SNS	04	-	refer to Sense format descriptions
Read Buffered Log	RBL	24	Yes	Returns statistics on the current device and volume
Read Subsystem Data	RSSD	3E	Yes	Returns data indicated by preceding PSF or Set Interface ID command
Read Message ID	RMID	4E	Yes	Returns status of asynchronous operations
Read Device Characteristics	RDC	64	Yes	Returns model and device characteristics
Set Interface Identifier	SII	73	Yes	With Read Subsys Data command following this command, NDs and NQs are returned (1)
Perform Subsystem Function	PSF	77	Yes	Performs various operations. One of which initiates asynchronous operations.
Sense ID	SNSID	E4	Yes	Returns mode, type and CIWs (2)
Read Configuration Data	RCD	FA	Yes	Returns various NED's and NEQs for the subsystem (1)
PATH MANAGEMENT COMMANDS				
Sense Path Group ID	SNID	34	(3)	Returns pathing information
Suspend Multipath Reconnection	SMR	5B	(3)	Suspends multipath reconnections

Command	Mnemonic	Hex	Cmd Differences	Typical Functionality
Set Path Group ID	SPID	AF	(3)	Controls grouping of paths and devices to a controlling computer
Assign	ASN	B7	(3)	Assigns the device to a channel path ID
Unassign	UNA	C7	(3)	Unassigns the device from a channel path ID
Control Access	CAC	E3	(3)	Provides password protected overrides of Assign facility
<p>Notes:</p> <p>(1) For more information, see <i>ESA/390 Common I/O-Device Commands and Self Description</i>. The contents of the VTSS's NEDs, NEQs, NDs, and NQs may vary slightly from that of an actual 3490 subsystem.</p> <p>NED - Node Element Descriptor - contains data such as type of device, model, manufacturer, plant, serial-number.</p> <p>NEQ - Node Element Qualifier -</p> <p>ND - Node Descriptor - similar but different than NEDs</p> <p>NQ - Node Qualifier - similar but different than NEQs</p> <p>(2) CIW - Channel Information Word - Identifies to channel which commands to use for Read Configuration, Set Interface Identifier, Read Node Identifier</p> <p>(3) Functions identically to an IBM 3490E tape drive, whose functionality differs from the commands' descriptions in the <i>IBM 3490E Hardware Reference</i>. See "Path Management Commands" on page 325.</p>				

Command Dependent Unit- Checks

There are very few changes to Command Dependent Unit-Checks described in the *IBM 3490E Hardware Reference*.

Any command used in an active ECAM-T chain is exempt from the “Assigned Elsewhere” unit Check.

Any command issued to an unconfigured virtual tape address can receive a “Device Offline” Unit-Check.

Virtual Not-Ready

As with a real 3490E, when there is no volume (VTV) mounted on a virtual tape, the unit can return a “Not Ready” Unit-Check to all eligible commands. While a real 3490E can also return a “Not Ready” Unit-Check for a mounted volume when the operator has toggled a Not-Ready state by depressing the “READY” key on the unit, no such manual facility exists for a VTSS virtual tape unit.

However, when an “Out-of-Capacity” condition exists in a VTSS, any Write command issued to a VTV mounted on that VTSS will create a “Virtual Not-Ready” condition at that virtual tape unit. The initial Write command will receive a “Drive Switched Not-Ready” Unit-Check, and all subsequent eligible commands will receive a “Not Ready” Unit-Check until the “Out-of-Capacity” condition is handled (by VTV migration or deletion).

When the “Out-of-Capacity” condition no longer exists, the VTSS will signal “Attention/Ready” to all paths which received a “Not Ready” Unit-Check.

In all aspects, the VTSS “Virtual Not-Ready” condition appears identical to an operator toggle of the “READY” key on a real 3490E.

Command Dependent Execution Status

Table 6 on page 310 shows the normal status that is generated for the commands as a result of command acceptance and execution. The VTSS status is different from that of a physical tape I/O subsystem

Note that the VTSS does not disconnect from the channel using CE only status. It always uses CCR (Disconnect Channel Command Retry) to disconnect. As a result, the possibility of a third status does not exist.



Note: Whenever the term CCR is used within this specification, it always refers to Disconnect Channel Command Retry (represented by a hex 4A). In ESCON I/O specifications this is also referred to as Deferred Command Retry.

When a CCRed command results in Unit Check or Unit Exception, the UC or UE indication can be presented combined with Device End in the final status. This will result in 0x06 or 0x05 final status instead of the 0x0E or 0x0D seen on the 3490e.

The column labeled CCR describes those conditions unique to this command for using CCR to disconnect. Those reasons are as follows.

b

The necessary buffer and data for performing the operation is not available.

p

The necessary data transfer path for performing the operation is not available.

Table 6. Command Dependent Execution Status

Command	Mnemonic	Hex value	Initial Status	Second Status	CCRB p	Other Status
DATA TRANSFER COMMANDS						
Write	WRT	01	CMR	CE+DE	y y	UC, UE
Read Forward	RDF	02	CMR	CE+DE	y y	UC, UE
Read Backward	RDB	0C	UC	-	--	-
Read Buffer (no data is ever transferred)	RBF	12	CMR	CE+DE	--	-
TAPE CONTROL COMMANDS						
Rewind	REW	07	CE+DE	-	--	UC
Rewind Unload	RUN	0F	CE+DE	-	y-	UC
Erase GAP	ERG	17	CE+DE	-	--	-
Write Tape Mark	WTM	1F	CE+DE	-	y-	UC, UE
Backward Space Block	BSB	27	CE+DE	-	y-	UC, UE
Backward Space File	BSF	2F	CE+DE	-	y-	UC
Forward Space Block	FSB	37	CE+DE	-	y-	UC, UE
Forward Space File	FSF	3F	CE+DE	-	y-	UC
Data Security Erase	DSE	97	CE+DE	-	y-	UC
DEVICE MANAGEMENT COMMANDS						
Test I/O	TIO	00	not issued to ESCON devices			
No-Operation	NOP	03	CE+DE	-	--	UC
Channel Path No-Operation	CPNOP	13	CE+DE	-	--	UC
Read Block ID	RBID	22	CMR	CE+DE	--	UC

Command	Mnemonic	Hex value	Initial Status	Second Status	CCRB p	Other Status
Synchronize	SYNC	43	CE+DE	--	--	UC
Locate Block	LOC	4F	CMR	CE+DE	y-	UC
Load Display	LDD	9F	CMR	CE+DE	--	UC
Set Tape Write Immediate	TWI	C3	CE+DE	-	--	UC
Mode Set	MDS	DB	CMR	CE+DE	y-	UC
SUBSYSTEM COMMANDS						
Sense	SNS	04	CMR	CE+DE	--	UC
Read Buffered Log	RBL	24	CMR	CE+DE	--	UC, UE
Read Subsystem Data	RSSD	3E	CMR	CE+DE	--	UC
Read Message ID	RMID	4E	CMR	CE+DE	--	-
Read Device Characteristics	RDC	64	CMR	CE+DE	--	UC
Set Interface Identifier	SII	73	CMR	CE+DE	--	UC
Perform Subsystem Function	PSF	77	CMR	CE+DE	y-	UC
Sense ID	SNSID	E4	CMR	CE+DE	--	UC
Read Configuration Data	RCD	FA	CMR	CE+DE	--	UC
PATH MANAGEMENT COMMANDS						
Sense Path Group ID	SNID	34	CMR	CE+DE	--	UC
Suspend Multipath Reconnection	SMR	5B	CE+DE	-	--	UC
Set Path Group ID	SPID	AF	CMR	CE+DE	--	UC
Assign	ASN	B7	CMR	CE+DE	--	UC
Unassign	UNA	C7	CMR	CE+DE	--	UC
Control Access	CAC	E3	CMR	CE+DE	--	UC

Command	Mnemonic	Hex value	Initial Status	Second Status	CCRB p	Other Status
Notes: For many of the immediate commands, IBM documents them as returning CE in initial status to be followed by DE. The VTSS has the capability to present CE+DE in initial status when it can immediately execute the command. This behavior is the same as the Timberline Tape Subsystem.						

Retry Status

The VTSS does not issue command retry for various buffer synchronization scenarios that exist in typical tape I/O systems for buffer management, read to write switches, direction changes, and so forth.

The VTSS, however, does issue command retry when either:

- The necessary buffer and data for performing the operation is not available.
- The necessary data transfer path for performing the operation is not available.

Table 6 on page 310 details when these are issued for each command.

The VTSS also uses command retry to temporarily disconnect from the interface when the CU must perform certain recovery scenarios. These scenarios can occur at any time and will occur on *any* command. These scenarios arise when the VTSS must perform a restart of its internal microcode.

Differentiated Channel Command Descriptions

Data Security Erase Command

On physical tape I/O subsystems, the Data Security Erase command writes a random pattern from the position of the tape where the command is issued to the physical end of tape.

Due to the manner in which VTSS can store multiple versions of a given tape volume on various Multi-Volume-Cartridges (MVCs), it is not practical to perform an erase on these various MVCs. As such this command does not perform a physical erase of previous versions of the volume. It does, however, perform an erase of data from the current position on the tape to the end of the virtual tape. The erase is performed logically with no actual writing of data.

Erase Gap Command

The Erase Gap command writes a unique erase gap pattern on physical tape for the purposes of skipping over media.

Writes to VTSS have no such media problems, and as such this command performs no real function other than effecting a read-to-write change.

Load Display Command

For normal tape subsystems, this command controls the text of messages on the message display of the selected device. It also controls the operation of an automatic cartridge loader.

The VTSS has neither a message display nor an automatic cartridge loader. As such, this command is accepted but has no standard effect on the control unit. If the "Index Automatic Load" function-byte bit is set, a Command Reject results.

However, the Load Display command IS used by the VTSS for a special purpose: to signal that this channel program follows the ECAM-T protocol for special host-to-VTSS communications.

Note that the Assigned-Elsewhere Unit-Check does not apply to an LDD used for the "ECAM-T Handshake"; for the non-ECAM-T case it is a low-priority check.

Locate Block

The Locate Block command moves the tape into position on the addressed tape drive so the controlling computer can write or read a specific block on the tape. For normal tape I/O systems, the search first occurs on the segment or physical level and then proceeds to search for the Logical Block by reading data. For the VTSS, the search is performed logically using table lookup means and does not suffer from any typical media vagaries such as defects.

Mode Set Command

The Mode Set command controls specific aspects of command processing within a given command chain. The VTSS accepts this command but has the following characteristics.

- If the parameters specify that Tape-Write-Immediate Mode be turned off, it will be ignored because the VTSS always operates in non-buffered mode.
- If the parameters specify that IDRC be turned off, it too will be ignored because the VTSS always attempts to compress data - it cannot be disabled.
- The Supervisor Inhibit bit is implemented as described.

Perform Subsystem Function Command

The actual functionality of the Perform Subsystem Function command is determined by an order byte (byte 0 of the data). Only a few of these orders have any real functionality, and they are documented in the Table 7. If no support is provided for an order, the order and the following data is accepted and checked for parameter compliance. If the parameters are not legal, the command is rejected with ERA 27 (Command Reject). If the parameters are correct, the command is unit checked with ERA 29 (Function Not Compatible).

Table 7. Perform Subsystem Function orders

Order (hex)	Description	Support
18	Prepare for Read Subsystem Data	No
1B	Set Special Intercept Condition	No
1C	Message Not Supported	No
80	Activate Forced Error Logging	No
81	Deactivate Forced Error Logging	No
82	Activate Access Control	Yes
83	Deactivate Access Control	Yes
90	Reset Volume Fence	No
A1	Pin Device	No
A2	Unpin Device	No

Table 8. Perform Subsystem Function data

Byte	Description
0	Perform Subsystem Function order (refer to prior table)
1	Perform Subsystem Function flag
2-N	Order parameters (refer to following sections for parameters)

Activate Access Control Order

This order allows the control program to activate various access control mechanisms for the device. For any bit that is set to 1 that the VTSS supports, that feature is activated until another Activate or Deactivate Access Control Order is received OR the volume is unloaded.

Table 9. Activate Access Control Order parameters

Byte	Bit	Description
0		Order, set to x80
1		Flag byte, set to 0
2	0	Logical Write Protect
	1-2	Reserved, set to 0
	3	Data Compaction Default - NOT SUPPORTED The VTSS <i>always</i> writes data using Compaction. It is not possible to disable this functionality. This bit is ignored.
	4-5	Reserved, set to 0
	6	Data Check Recovery - NOT SUPPORTED This bit is ignored.
	7	Extended Recovery - NOT SUPPORTED This bit is ignored.
3		Reserved, set to 0

Deactivate Access Control Order

This order allows the control program to *de*-activate various access control mechanisms for the device. For any bit that is set to 1 that the VTSS supports, that feature is *de*-activated until another Activate or Deactivate Access Control Order is received OR the volume is unloaded.

Table 10. De-activate Access Control Order parameters

Byte	Bit	Description
0		Order, set to x81
1		Flag byte, set to 0
2	0	Logical Write Protect
	1-2	Reserved, set to 0
	3	Data Compaction Default - NOT SUPPORTED The VTSS <i>always</i> writes data using Compaction. It is not possible to disable this functionality. This bit is ignored.
	4-5	Reserved, set to 0
	6	Data Check Recovery - NOT SUPPORTED This bit is ignored.
	7	Extended Recovery - NOT SUPPORTED This bit is ignored.
3		Reserved, set to 0

Read Backwards Command

A Read Backward command causes data for one logical block to be transferred from the control unit to the channel. The logical block transferred is the next sequential logical block in the backward direction from the program's perspective. The data is transferred in reverse order (last byte first, first byte last).

The VTSS does not directly support this command. Instead, it always positions in front of the desired block, and if that block is not a tape mark, returns unit check status with an ERA code of 26 (Read Opposite) which forces the IOS driver to issue a Read Forward command followed by a Back Space Block command. If the desired block was a tape mark, the VTSS returns unit exception status indicating that end-of-file has been encountered.

Read Block ID Command

The Read Block ID command transfers 8 bytes of information from the control unit to the channel that identifies the next block to be read or written in the forward direction. For buffered physical tape I/O, the data returned identifies positional data for the channel side of the buffer and the physical side of the buffer.

Since VTSS tape I/O always operates in a non-buffered mode, the positional data for the channel side and physical side of the buffer are always the same. The positional data is fully emulated for a 400 MB cartridge.

Read Buffer Command

The Read Buffer command transfers data from the control unit to the channel if any buffered write data is in the control unit's buffer. This data is retrieved via this command typically when the tape CU is unable to write the data to the media.

But since all write data to the VTSS is held in non-volatile storage until it can be moved to either back-end RAID or physical type devices, write data is always immediately committed to permanent storage and as such no data is ever in the "buffer".

On receipt of this command, "no data available" or "buffer empty" is indicated by transferring zero bytes.

Read Buffered Log Command

For VTSS, the Read Buffered Log command always transfers 64 bytes (Format 30) of buffered log data from the control to the channel. Format 30 is presented since compression is always enabled. Refer to "Status and Sense Bytes" on page 326 for a description of the buffered log data. Note that as with a 3490, if all log counters are zero, the VTSS returns unit exception status.

Read Configuration Data Command

A Read Configuration Data command causes 160 bytes of data to be transferred from the control unit to the channel. The specific data returned by the VTSS is defined in Table 11.

Table 11. Read Configuration Data Command data

Byte	Bit	Description
DEVICE NED		
0		Flags = 1100 1100
1		Type = x01 (I/O Device)

Byte	Bit	Description
2		Class = x02 (Magnetic Tape)
3	0-6	0
	7	Level = 0 (no hierarchic Relationship)
4-9		Type Number = xF0F0F3F4F9F0 (EBCDIC for 003490)
10-12		Model Number = xC2F4F0 (EBCDIC for B40)
13-15		Manufacturer = xE2E3D2 (EBCDIC for STK)
16-17		Plant of Manufacture
18-20		Family code which identifies this subsystem as a VTSS (EBCDIC)
21-29		Sequence Number in EBCDIC
30-31		Tag = x00XX where XX=VTape Address (0-F) (xFF & VDID)
CONTROL UNIT NED		
32		Flags = 1101 0100 (or 1100 1100)
33		Type = x02 (Control Unit)
34		Class = x00 (Unspecified class)
35	0-6	0
	7	Level = 0 (no hierarchic Relationship)
36-41		Type Number = xF0F0F3F4F9F0 (EBCDIC for 003490)
42-44		Model Number = xC1F2F0 (EBCDIC for A20)
45-47		Manufacturer = xE2E3D2 (EBCDIC for STK)
48-49		Plant of Manufacture
50-51		Family code which identifies this subsystem as a VTSS (EBCDIC)
52-61		Lower bytes of the Sequence Number in EBCDIC
62-63		Tag = x00XX where XX = Control-Unit-Image-# (VCU/Cluster) ... = ((xC0 & VDID) + (x01 & ClusterID)) [See "Control Unit Images" on page 6-43.]
LIBRARY NED		
64-95		0
TOKEN NED		
96		Flags = 1110 1100
97		Type = x00 (Unspecified)
98		Class = x00 (Unspecified class)
99	0-6	0
	7	Level = 0 (no hierarchic Relationship)

Byte	Bit	Description
100-105		Type Number = xF0F0F3F4F9F0 (EBCDIC for 003490)
106-108		Model Number = xC2F4F0 (EBCDIC for B40)
109-111		Manufacturer = xE2E3D2 (EBCDIC for STK)
112-113		Plant of Manufacture
114-116		Family code which identifies this subsystem as a VTSS (EBCDIC)
117-125		Sequence Number in EBCDIC
126-127		Tag = x0000
GENERAL NEQ		
128		Flags = 1000 0000
129		Record Selector = x80 for Control Unit 0 == Cluster 0 x81 for Control Unit 1 == Cluster 1
130-131		Interface ID (Refer to the "Tag or Interface ID" table under Read Subsys Data command)
132		Device Dependent Time-out = x00
133-135		Reserved = 0 (tbd: MIHPTO / MIHSTO)
136		Extended Information = x00 for logical addresses x0 - x7 x01 for logical addresses x8 - xF
137-159		0

Read Device Characteristics Command

The Read Device Characteristics command transfers 64 bytes of data from the control unit to the channel. The information fields are defined in Table 12 for the VTSS.

Table 12. Read Device Characteristics Command data

Byte	Bit	Description
0-1		Control unit type = x3490
2		Control unit model = x20
3-4		Tape unit type = x3490
5		Tape unit model = 0x40
6-7		0
8	0-3	0
	4	0 - Set special intercept condition
	5	1 - Channel Path no operation
	6	1 - Logical Write Protect
	7	1 - Extended Buffered Log
9	0	0
	1	1 - IDRC
	2	0
	3-7	0
10		Device class code = x80
11		Device type code = x80
12-31		0
32-39		0
40		Miscellaneous data record = x42 (Model A10 or A20)
41		Outboard recorder (OBR) ID = x81 (Model A10 or A20)
42-63		0

Read Forward Command

This command transfers data from the control unit to the channel. It operates as described in the *IBM 3490 Command Reference*.



Note: When data chaining a Read Forward command, the VTSS supports a minimum data chained update count as determined by the following formula:

$$T_{\text{update}} * (65152 / \text{Update_Count}) < 400\text{ms}$$

Where:

T_{update} = the time between data chained command updates (in milliseconds)

Update_Count = CCW count for the data chained update (in bytes, rounded up)

As an example, if T_{update} is 50 usec (0.050 msec), the data chain update CCW count must be greater than 17 bytes.

Read Message ID Command

The Read Message ID command is used to read the message identifier that was assigned by the control unit to commands that indicated the message-required flag requesting notification when an asynchronous operation is complete.

This command must be chained to a sequence of PSF and PSR commands, and the VTD does not implement this sequence. The Read Message ID command always returns unit check status with ERA code 27.

Read Subsystem Data Command

This command is used to obtain information from the subsystem. The data returned by the subsystem depends on the command immediately preceding this command. If the Read Subsystem Data command is the first command in a command chain or it is not immediately preceded by a Set Interface Identifier command, a sequence error is detected and it is unit checked with ERA code 27. The data returned is dependent on the Node Selector value in the Set Interface Identifier data.

Table 13. Identification of Current Interface (node selector=0)

Byte	Bit	Description
Node Descriptor (ND)		
0		Flags = 0
1		Reserved = 0
2		Class = 0 (unspecified)
3		Reserved = 0
4-9		Type Number = xF0F0F3F4F9F0 (EBCDIC for 003490)
10-12		Model Number = xC2F4F0 (EBCDIC for B40)
13-15		Manufacturer = xE2E3D2 (EBCDIC for STK)
16-17		Plant of Manufacture
18-29		Sequence Number in EBCDIC

Byte	Bit	Description
30-31		Tag (or Interface ID) (refer to Tag or Interface ID table)
Node Qualifier (NQ)		
32		Flags = 0
33-39		Reserved = 0
40-43		Node Qualifier Information Port 0 = 0x42010080 (which is comprised of the following individual bits)
	0-1	Entry type = 01 (contains interface ID)
	2-3	Reserved = 0
	4-7	Interface Protocol Type = 0010 (ESCON I/O)
	8-11	Reserved = 0
	12-15	SAT (Subassembly Type) = 0001 (LED Fiber optic)
	16-31	Interface ID (refer to Tag or Interface ID table)

Table 14. Identification of Specified Interface 1D(node selector=1)

Byte	Bit	Description
Node Descriptor (ND)		
0		Flags = 0
1		Reserved = 0
2		Class = 0 (unspecified)
3		Reserved = 0
4-9		Type Number = xF0F0F3F4F9F0 (EBCDIC for 003490)
10-12		Model Number = xC2F4F0 (EBCDIC for B40)
13-15		Manufacturer = xE2E3D2 (EBCDIC for STK)
16-17		Plant of Manufacture
18-29		Sequence Number in EBCDIC
30-31		Tag (or Interface ID) (refer to Tag or Interface ID table)

Table 15. Identification of Specified Interface 1D(node selector=2)

Byte	Bit	Description
Node Descriptor (ND)		
0		Flags = 0
1-3		Reserved = 0

Byte	Bit	Description
4-9		Type Number
10-12		Model Number
13-15		Manufacturer
16-17		Plant of Manufacture
18-29		Sequence Number in EBCDIC
30-31	0-15 Tag (refer to Tag or Interface ID table)	

Table 16. Identification of Specified Interface 1D(node selector=2) but attached node is unknown

Byte	Bit	Description
Node Descriptor (ND)		
0		Flags = 0
1-31		0

Table 17. Tag or Engraves ID

Bit	Description
0-15	Tag (or Interface ID)
00000000 0ssc00pp where ss = Card slot in cluster (00-11) c = Cluster (0 or 1) pp = ESCON port id (00-01)	

Sense ID Command

The Sense ID command transfers 20 bytes of data from the control unit to the channel. Table 18 shows specific data returned for this product. The CIW format does not differ from that of the *IBM 3490 Hardware Reference* but is included here for convenience.

Table 18. Sense ID Command data

Byte	Description
0	xFF
1-2	Control unit type = x3490 (Model A10 or A20)
3	Control unit model = x20 (Model A20)
4-5	Tape unit type = x3490 (model B20 or B40)
6	Tape unit model = x40 (Model B20 or B40)
7	0
8-11	CIW Read Configuration Data = x40FA00A0
12-15	CIW Set Interface Identifier = x41730004
16-19	CIW Read Node Identifier = x423E0060 (specifies the Read Subsystem Data)

Table 19. Channel Information Word (CIW) Format

Bit	Description
0-1	Entry Type - 0,1 (for CIW)
2-3	0,0
4-7	Command type specified x0 (Read Configuration Data) x1 (Set Interface Identifier) x2 (Read Node Id)
8-15	Command Code
16-31	Maximum bytes by specified command

Set Interface Identifier

The valid Interface ID's for VTSS are: 0x0000, 0x0001, 0x0010, 0x0011, 0x0020, 0x0021, 0x0030, 0x0031, 0x0040, 0x0041, 0x0050, 0x0051, 0x0060, 0x0061, 0x0070, and 0x0071. The actual Interface ID for an addressed device-path pair can be determined from the RCD command.

Set Tape Write Immediate Command

On physical tape I/O subsystems, the Set Tape-Write-Immediate command causes all subsequent Write commands in the channel program to perform as write-immediate commands.

For the VTSS, this command has no effect since tape writes *always* operate in non-buffered write mode.

Synchronize Command

On physical tape I/O subsystems, the Synchronize command causes synchronization between the tape drive and the controlling computer after buffered write operations.

Since the VTSS tape I/O does not “buffer” writes, this command performs no real operations and as such executes immediately without disconnection.

Write Command

The Write command causes data for one logical block to be transferred from the channel to the control unit. This command executes as described with the exception that it only operates in Non-buffered Write Mode.



Hint: When data chaining a Write command, the VTSS supports a minimum data chained update count as determined by the following formula:

$$T_{\text{update}} * (65152 / \text{Update_Count}) < 400\text{ms}$$

Where:

T_{update} = the time between data chained command updates (in milliseconds)

Update_Count = CCW count for the data chained update (in bytes, rounded up)

As an example, if T_{update} is 50 usec (0.050 msec), the data chain update CCW count must be greater than 17 bytes.

**Path Management
Commands**

The VTSS attempts to perform path management commands in a manner identical to the 3490E tape controller. For detailed information on how path management commands are designed to be handled by tape control units, refer back to one of the following:

- *IBM 3480 Magnetic Tape Subsystem Reference*
- *IBM 3480 Installation Guide and Reference*

While these describe their operation in the 3480 tape subsystem, the architecture of the commands for managing path groups, especially for “Selectable Devices”, does not appear to have been changed. In fact, to be compatible across multiple generations of equipment, they cannot be changed, only extended.

Assign (ASN)	No Change from the 3490E.
Control Access (CAC)	No Change from the 3490E.
Sense Path Group ID (SNID)	(See “Path Group Effects” on page 334.)
Set Path Group ID (SPID)	(See “Path Group Effects” on page 334.)
Suspend Multipath Reconnection (SMR)	As for an IBM 3490, this is effectively a non-operation as Multipath Reconnect mode for a path group is not supported.
Unassign (UNA)	No Change from the 3490E.

Status and Sense Bytes

Status Byte

The status byte provides response information regarding the current channel command word (CCW). This is the information that is contained in bits 32-39 of the System/370 channel status word (CSW) and also in the CSW formatted by the I/O Supervisor components of MVS Extended Architecture. The VTSS status byte is identical to the status byte described in the *IBM 3490 Hardware Reference*.

Sense and Log Data Formats

Sense and log data record and report subsystem error and error correction information. The Sense command transfers 32 bytes of data from the control unit to the channel. If the Sense command follows a Rewind Unload command, Format 22 data is transferred. Otherwise, it is Format 20 data. Both formats contain 32 bytes of information. The Read Buffered Log command transfers 64 bytes of Format 30 buffered log data to the channel. The other formats described in the *IBM 3490 Hardware Reference* are not applicable to VTSS.

The contents of bytes 0-7 and 27-30 are common to all formats (for the 3490, it is only bytes 0-7, 27-29 that are common). The contents of the remaining bytes are determined by the format, which is reported in sense byte 7. Differences between the VTSS sense and log data and those of the 3490 and fields whose values are constant or limited for VTSS are described in the following tables.

Formats 20, 22, and
30 Sense bytes 0-7

Table 20. Sense bytes 0-7

Sense Byte	Description		
0	Bits	Value	Description
	0	x	Command Reject
	1	x	Intervention Required
	2	0	Bus Out Check (FIPS only)
	3	x	Equipment Check - this bit is set for: - Control Unit ERP failure (ERA 4A) - Physical end of tape
	4	x	Data Check - VTSS detected an invalid condition in the absence of a detected hardware malfunction
	5	0	Overrun (synchronous mode only; not supported by VTSS)
	6	x	Deferred Unit Check - Unit Check not associated with current cmd
	7	x	Assigned elsewhere

Sense Byte	Description		
1	Bits	Value	Description
	0	x	Locate Failure
	1	1	Drive Online to Control Unit
	2	0	Reserved
	3	0	Record Sequence Error - not applicable to VTSS
	4	x	Beginning of Tape
	5	x	Write Mode - most recent command was a write-type command
	6	x	Write Protect
	7	0	Not Capable - not applicable to VTSS
2	Bits	Value	Description
	0-3	xxxx	Reporting Channel Path
	4	x	Reporting Control Unit
	5	0	Automatic Cartridge Loader Active - not applicable to VTSS
	6	0	Tape Synchronous Mode - not applicable to VTSS
	7	x	Tape Positioning - must be set to enable Read Opposite Recovery implementation of Read Backward command
3	Error Recovery Action (ERA)		
4	Bits	Value	Description
	0-1	01	3480-2 XF format
	2-3	00	Reserved
	4-7	xxxx	High order bits of Channel Logical Block Number - the next data block or tape mark to be read or written in a forward direction
5-6	Last 16 bits of Channel Logical Block Number		
7	Identifies format of remaining sense or log bytes: 0x20, 0x22, or 0x30		

Format 20 Sense
Bytes 8-31

Table 21. Format 20 - Sense bytes 8-31

Sense Byte	Description		
8	0		
9	VTSS Extended Path Info		
	Bits	Value	Description
	0-1	0	Reserved (HPID expansion)
	2-3	00bb	ESCON adapter Host-Path number (HPID)
	4-7	0	Reserved (VDID expansion, Most Sig Bits >8)
10-11	Information for service representative - Fault Symptom Code (FSC)		
12-13	Information for service representative - Reason Code		
14-21	0		
22-23	Reserved (Iceberg compatibility FSC)		

Sense Byte	Description
24	Channel Adapter and Data-Transfer Mode Bits Value Description 0-3 xxxx Channel adapter 4-7 0xE Data-transfer mode - ESCON 9.0 MB/s
25	Control Unit Features Installed Bits Value Description 0 1 Dual Control Unit Communication Coupler 1-3 0 Reserved 4 1 Improved Data Recording Capability enabled 5 0 Reserved 6 0 Upgraded Buffer 7 0 Automatic Cartridge Loader
26	Microcode EC Level - (not applicable) VTSS Sense-Bytes Revision Level (0x01)
27-29	Subsystem Configuration Bits Value Description 0-3 0010 Model Definition - Model A20/B40 4-23 x..x Sequence Number (lower order 12 bits plus virtual drive id in hex)
30	Virtual tape drive identifier 0-255 (VDID)
31	0 Buffered Write Data Bytes - not applicable

Format 22 Sense Bytes 8-31

Format 22 is presented when a Sense command follows a Rewind Unload command.

Table 22. Format 22 Sense Bytes 8-31

Sense Byte	Description
8	0
9	VTSS Extended Path Info Bits Value Description 0-1 0 Reserved (HPID expansion) 2-3 00bb ESCON adapter Host-Path number (HPID) 4-7 0 Reserved (VDID expansion, Most Sig Bits >8)
10-11	Information for service representative - Fault Symptom Code (FSC)
12-21	0 Reserved
22-23	Reserved (Iceberg compatibility FSC)
24-26	0 Reserved
27-29	Subsystem Configuration Bits Value Description 0-3 0010 Model Definition - Model A20/B40 4-23 x..x Sequence Number (lower order 12 bits plus virtual drive id in hex)
30	Virtual tape drive identifier 0-255 (VDID)
31	0 Reserved

Format 30 Sense and Log Bytes 8-63

Format 30 is presented in response to a Read Buffered Log command.

Table 23. Format 30 - Sense Bytes 8-31

Log Byte	Description
8-23	0
24	Count of Data-Request Errors (Excludes Data-request Time-outs) (used to represent internal data transfer errors, i.e. CRC errors)
25	0
26	Cleaning the Tape Drives and Volume Format. Bit 0-3 0000 (no cleaning support) 4-5 00 (no tape mounted) 10 (3480-2 XF format) 6 0 (Volume format changed) 7 0 (no forced error logging active)
27-29	Subsystem Configuration Bits Value Description 0-3 0010 Model Definition - Model A20/B40 4-23 x..x Sequence Number (lower order 12 bits plus virtual drive id in hex)

Log Byte	Description
30	Virtual tape drive identifier 0-255 (VDID)
31	Length of Tape Currently Mounted 0x00 Tape is unloaded 0x90 Enhanced Capacity Cartridge System Tape

Format 30 Log Bytes
32-63

Table 24. Format 30 Log Bytes 32 - 63

Log Byte	Description
For bytes 32-43, counts of bytes processed, each count is equal to 4K bytes (4096) and rounded up to the nearest 4K byte increment for blocks of less than 4K bytes. For example, a 3456-byte block of data is counted as '01', and a 5678-byte block of data is counted as '02'.	
32-34	Count of Channel Read Bytes Processed (uncompressed)
35-37	Count of Channel Write Bytes Processed (uncompressed)
38-40	Count of Device Read Bytes Processed (compressed)
41-43	Count of Device Write Bytes Processed (compressed)
44-46	Count of Channel Read Blocks (including tape marks) Processed
47-49	Count of Channel Write Blocks (including tape marks) Processed
50-52	Count of Device Read Blocks (including tape marks) Processed
53-55	Count of Device Write Blocks (including tape marks) Processed
56-63	0

Error Recovery Action (ERA) Codes Support

Many of the Error Recovery Action (ERA) codes that are appropriate for a physical tape I/O device are not appropriate in a virtual tape device. Therefore the VTSS only supports a subset of the possible ERAs. They are identified by an X in Table 25.

Table 25. Error Recovery Action Codes

VTSS	Code	Description
X	00	Unsolicited Sense
	21	Data Streaming Not Operational
	22	Path Equipment Check
X	23	Read Data Check
	24	Load Display Check
	25	Write Data Check
X	26	Read Opposite
X	27	Command Reject
	28	Write ID Mark Check
X	29	Function Incompatible
	2A	Unsolicited Environmental Data
X	2B	Environmental Data Present
	2C	Permanent Equipment Check
	2D	Data Security Erase Failure
X	2E	Not Capable (BOT Error)
X	30	Write Protected
	31	Tape Void
	32	Tension Loss
	33	Load Failure
	34	Unload Failure
X	35	Drive Equipment Check
X	36	End of Data
	37	Tape Length Error
X	38	Physical End of Tape
X	39	Backward at BOT
X	3A	Drive Switched Not Ready
	3B	Manual Rewind/Rewind-Unload

VTSS	Code	Description
	40	Overrun
	41	Record Sequence Error
	42	Degraded Mode
X	43	Drive Not Ready
X	44	Locate Block Unsuccessful
X	45	Drive Assigned Elsewhere
X	46	Drive Not Online
	47	Volume Fenced
X	48	Unsolicited Informational Data
	49	Bus-Out Check
	4A	Control Unit ERP Failed
	4B	Control Unit and Drive Incompatible
	4C	Recovered Check-One Failure
X	4D	Resetting Event
X	4E	Maximum Block Size Exceeded
X	50	Read Buffered Log (Overflow)
X	51	Read Buffered Log (EOV)
X	52	End of Volume Complete
X	53	Global Command Intercept
	54	Channel Interface Recovery (Temporary)
	55	Channel Interface Recovery (Permanent)
X	56	Channel Protocol Error
X	57	Global Status Intercept
	5A	Tape Length Incompatible
	5B	3480 XF Incompatible
	5C	Format 3480-2 XF Incompatible
	5D	Tape Length Violation
	5E	Compaction Algorithm Incompatible

Control Unit Images

Introduction

Unlike recent prior generations of tape drives where the trend has been to “1-by-1” devices (a separate controller for each drive), the VTSS has an “N-by-N” architecture. Each Virtual Tape Unit (VTU) can be accessed from more than one Control Unit (CU), and each CU accesses multiple VTUs. This provides a high availability for every VTU due to the elimination of any single point of hardware failure or contention.

“Multiple Control Units” does not refer to multiple VTSS subsystems. Rather it refers to how an single VTSS behaves as if it were comprised of multiple CUs. It appears so for physical reasons (multiple hardware Clusters) and logical reasons (Virtual Controller images).

Dual Control Units - DCUs

A single VTSS subsystem is comprised of two fully redundant hardware “Clusters”. Each Cluster has its own set of ESCON physical paths and can access any VTU. Since it presents the same appearance as a 3490 “Dual Control Unit” (DCU), the VTSS reports itself a “Dual Control Unit” (DCU) type in all sense data. This includes the RCD, RDC, RSSD, and SNSID commands as well as the SNS command.

The selected ESCON path determines which half of the DCU is involved in an operation. Thus the DCU number (0,1) is based on a physical construct - the ESCON physical path.

Virtual Control Units - VCUs

Since a VTSS has so many more available data-paths and tape units than a 3490 subsystem, it cannot appear as a single “2-by-N” 3490E subsystem. An actual 3490 subsystem may have a maximum N of 16. But the VTSS supports 64 virtual tape units, which is 4 times the maximum supported by a single 3490 subsystem. The solution is have the VTSS present multiple Virtual Control Unit images (VCUs) to the host.

To support 64 VTUs the VTSS must appear as 4 separate VCUs, each controlling a range of 16 VTUs. Note that a range of VTUs is always comprised of sequential device addresses. So VTUs x40-x4F all appear to be attached to the same VCU, whereas VTUs x00, x40, x80, and xC0 appear attached to 4 distinct VCUs.

Thus the VCU number (0-3) is based on a virtual construct - the VTU device address.

DCU versus VCU

Note that VCUs are entirely distinct from the “Dual Control Unit” construct. VCUs are virtual and dependent upon VTU device address but independent of ESCON path, whereas DCUs are physical and dependent upon ESCON path but independent of VTU device address. This means that each VCU appears to be a DCU.

In other words, while the VTU device address determines the VCU image, the ESCON path address determines which Cluster is involved, and so which half of the DCU is involved. This means that a VTSS subsystem appears to be comprised

of 8 individual CU images arranged as 4 DCUs, with each DCU controlling 16 VTUs.

Whenever an operation selects a particular ESCON path and device address, this determines which of the 8 CU images has been selected.

Note that not every Sense-type command directly reflects the VCU and DCU image. The basic SNS command data does, and so does the RCD data. The RSSD command data reflects DCU, but the RDC and SNSID commands' data does not. The VCU/DCU address information is reported directly only in the RCD data, in the Control Unit NED Tag field.

System Reset Effects

Under ESCON, a System Reset must be addressed not just to a path, but to a particular Control Unit. As the DCU is tied to a particular path, and System Reset is issued to a specific path, DCU construct has no particular effect upon System Reset processing that deviates from a 3490 subsystem.

But VCU cuts across path-address. Each VCU must be defined to ESCON as a distinct and separate CU (because of the 16 device per 3490 CU limitation). Hence, *to reset an ESCON path to a VTSS one must issue 4 System Resets - one to each VCU* "attached" to that path.

Path Group Effects

The DCU construct has no effect upon path grouping. This is no different than in a 3490 subsystem. Any combination of pathing commands issues to a single VTU over multiple paths is not affected by whether or how the paths used are split across DCUs.

But the VCU construct does have an effect, and it does not map precisely to any 3490 subsystem effects.

All path management commands are addressed to a particular ESCON path and VTU. All may affect the path grouping and partitioning state of the device and/or path (or path-group). However, the effect of VCUs is noticed in the SPID and SNID commands.

SPID Command -- Path versus Device - Deep Background

The SPID command "Establishes" or "disestablishes" a particular device-path (specific ESCON path to a specific VTU device). The "disestablish" operations have two flavors: "Resign" and "Disband". But for purposes of this discussion, the difference is irrelevant., and no distinction will be made.

The SPID command also "establishes" the *path* over which it is issued, regardless of the selected VTU device and *regardless of whether the specified operation establishes or disestablishes the selected device*. In other words, if a SPID command is sent down a "not-previously-established" ESCON path, *the path itself is always "Established"*, even if the specified operation was "Resign" or "Disband" and no device-path is established.

This behavior is explained by analyzing the SNID command. The SNID command reports both pathing status and partitioning status.

Partitioning Status refers to the implicit or explicit assignment state (Enabled or Disabled) for the selected device-path. It is affected directly by the ASN, UNA,

and CAC commands, and indirectly by the SPID command and System Reset. Note that it has no path-specific meaning independent of a specific device. It is *unaffected by the VCU or DCU* construct.

Pathing Status refers to path and path-group status for the selected path and device-path. It is affected solely by the SPID command and System Reset. It depends upon both the pathing state of the path and of the device-path, which are partially independent. The device-path can either be “Grouped” or “Ungrouped”, and in addition the path itself can also be “Reset”.

The device-path state is set to “Grouped” in response to a SPID-Establish command, and is set to “Ungrouped” in response to a SPID Resign or Disband command. The path state is set to “Reset” in response to a System Reset signal. The “Reset” status is cleared by the first subsequent SPID command (of any type) issued down this path.

When a System Reset occurs, all device-path pathing and partitioning states associated with this path are reset (cleared, forgotten). Hence the SNID issued to any device on this path will return “Reset” as its Pathing Status and zeroes as a Path-Group-ID. (Note that this is distinct from the “Resetting-Event” Unit-Check, which is returned for the first command issued to a device-path after a System Reset. The “Reset” pathing status will continue to be presented by a SNID to any device-path associated with the path until a SPID command is accepted by any device on that path. After that, a SNID to any device on that path will present either “Grouped” or “Ungrouped”.

While in “Reset” Pathing Status, a device-path can accept other commands, including ASN and UNA, which may change its Partitioning Status, but will not affect its Pathing Status.

So to summarize, a path is “established” independent of the device-paths associated with it, and this consists of clearing the path’s “Reset” Pathing Status and also in setting the path’s Path-Group-ID (both reported by SNID). Note that once a path’s Path-Group-ID has been set, any subsequent SPID command must specify the same Path-Group-ID, or it will be rejected.

VCU Effects on SPID and SNID

The effects of VCU upon SPID and SNID are counter-intuitive from the way VCU affects System Reset processing. Basically, when a SPID is issued to a path which is in the “Reset” Pathing Status, it clears the “Reset” status and sets the Path-Group-ID for the path ***for all VCUs, regardless of the VCU to which it was addressed.*** In other words, a SPID (of any type) to *any* VCU establishes that path for *all* VCUs.

Note that this is opposite of the effect for System Reset, which only resets the path for a particular VCU.

Appendix C. NCS/VTCS Alphabetic Volsers

NCS/VTCS supports alphabetic volser ranges for all commands and utilities. The rules for alphabetic volser ranges are as follows:

1. An alphabetic volser range consists of a pair of volsers (start volser and end volser) containing an incrementing alphabetic portion of 1 to 6 characters. For example: 00000A-00000Z, ABCAAA-ABCZZZ, 9AA000-9CC000, A00A00-A00M00.
 - a. A volser is composed of sequence of one to six numerics, (upper case) alphabetic or national characters (#, @ and the primary national currency symbol).
 - b. A volser of less than six characters is left justified and blank padded. Each volser element in a range must have the same number of characters specified. For example, if the first volser element is 4 characters, the second must be exactly 4 characters.
2. The start and end volsers forming a volser range consists of the following sub-elements: an optional prefix, an incremental portion, and an optional suffix. Table 4. on page 340 shows examples of alphabetic volser ranges.
 - a. The optional prefix consists of identical leading characters (if any) in the start and end volsers.
 - b. The incremental portion starts at the first non-identical leading character in the start and end volsers forming a range. The incremental portion is either:
 - All numeric (contains characters 0 through 9 only).
 - All alphabetic (contains character A through Z only).

The incremental portion of a volser range, therefore, terminates where a change of character type (numeric -> alphabetic or alphabetic -> numeric) is detected.

The incremental type is derived from the character type of the first character in the incremental part (numeric/alphabetic). Table 1 shows example incremental ranges.

Table 1. Example Incremental Ranges

volser Range	Incremental Portion	Data Type
00000A-00000Z	A-Z	Character
ABC AAA-ABC ZZZ	AAA-ZZZ	Character
9AAZ00-9CCZ00	AAZ-CCZ	Character
A00B00-A99B00	00-99	Numeric
A00A00-A00M00	A-M	Character
A00B00-A00B99	00-99	Numeric

Note the following rules for incremental ranges:

- The expansion of an alphabetic incremental part is derived from a collating sequence of A-Z (it will not include the national character set).
 - The data types of the incremental portions in the start and end volsers must be identical.
 - The position of the incremental portion of the start volser must match that of the end volser.
 - The length of the incremental portion of the start and end volsers must be identical.
 - The incremental portion of the end volser must be greater than or equal to the start volser.
- c. The optional suffix consists of the trailing characters from the end of the incremental portion onwards. Table 2 shows an example range suffix.

Table 2. Example Range Suffix

Volser Range	Incremental Portion	Suffix
A00B00-A00B99	00-99	none
A00B@0-A00D@0	B-D	@0
9AAZ00-9CCZ00	AAZ-CCZ	00 (not Z00)
900A@A-950A@A	900-950	A@A
ABC AAA-ABC ZZZ	AAA-ZZZ	none

For a range to be valid the suffix of the start and end volsers forming the range must be identical.

3. The number of volumes generated from an alphabetic volser range is dependent on the number of elements in the incremental portion of the volser elements. For an A to Z range in each character position, the number of volumes can be calculated by 26 to the power of the number of positions that are being incremented as shown in Table 3.

Table 3. Size of Alphabetic Volser Ranges

Range	Calculation	Number of Volumes
A-Z	26^1	26
AA-ZZ	26^2	676
AAA-ZZZ	26^3	17,576
AAAA-ZZZZ	26^4	456,976



Warning: Per Table 3, it is possible to define 26^4 VTVs in a single range. **Note, however, that** the more VTVs you define, the bigger your CDS has to be.

Alphabetic Volser Examples

Table 4 and Table 5. on page 341 describe valid and invalid alphabetic ranges.

Table 4. Valid Alphabetic Ranges

Range	Subcomponents			Number of VTVs
	Prefix	Incremental Portion	Suffix	
AAA000-AAZ000		AAA-AAZ	000	26
A00A00-A00A99	A00A	00-99		100
0AAAA0-0ZZZZ0	0	AAAA-ZZZZ	0	456,976
A00A00-A99A00	A	00-99	A00	100
99AA##-99ZZ##	99	AA-ZZ	##	676
A9A000-A9Z000	A9	A-Z	000	26
#####-#####	#####			1
AA00##-ZZ00##		AA-ZZ	00##	676
AA00##-AA99##	AA	00-99	##	100
PROD00-PROD99	PROD	00-99		100
PROD00-PROZ00	PRO	D-Z	00	23
A4Z#@0-A9Z#@0	A	4-9	Z#@0	6
A4Z#@0-Z4Z#@0		A-Z	4Z#@0	26
A4Z#@0-A4Z#@6	A4Z#@	0-6		7
AAAAAA-AAACCC		AAAAAA-AAACCC		1407
A3BZZ9-A3CDE9	A3	BZZ-CDE	9	84
999AM8-999CM8	999	AM-CM	8	53
111AAA-111ZZZ	111	AAA-ZZZ		17576

Table 5. Invalid Alphabetic Ranges

Range	Subcomponents			Number of VTVs	Comments
	Prefix	Incremental Portion	Suffix		
0AAAAA-0BAAAA	0	AAAAA-BAAAA		456,977	Greater than 456,976 VTVs
A9A000-A9Z999					Cannot mix incremental portions
#####-#####@					National characters cannot increment
AA00##-ZZ99##					Invalid range
CCNNZZ-CDNZAA		CCNNZZ-CDNZAA		464,414	Greater than 456,976 VTVs
A4Z#@0-A9Z#@9					Invalid range

Appendix D. Using the HSC Significant Event Notification Facility

HSC provides a Significant Event Notification Facility (SEN). The SEN has a macro interface that allows an application to request notification of specific HSC and VTCS events. The application can then process the data passed by the SEN. SEN notification requests are maintained across HSC warm starts and are purged on HSC cold starts. When HSC is cold started, therefore, all previously established notification requests must be reestablished.

The SEN macro interface is supported at HSC base service level. There is no operator interface for the SEN itself, but the HSC 5.0.0 and above `Display` command lists SEN notification requests.

For information on the XML format output of the supported SEN events, see “VTCS and HSC Events XML Tags” on page 367.



Caution: When HSC initializes, the SEN facility is disabled, so you must enable via the HSC `OPTION SEN=ON` operator command. For example, to enable the SEN, enter the following:

```
.OPTION SEN=ON
```

Overview of the SEN Macro Interface

You invoke the SLSXSEN macro to make SEN requests. The SLSXSEN macro has two forms:

- A **list form** that generates a parameter list. The parameter list is mapped by macro SLSXSENM and must be included in routines invoking SLSXSEN.
- The **execute form** that populates the parameter list and calls the SEN request module SLSXSENR. Modules using the SLSXSEN macro must have an authorization code of 1 and reside in an APF authorized library.

The SLSXSEN macro supports the following four requests:

LISTEN

Request notification for SEN defined events, which requires providing a routine to be invoked when the event occurs.

DELETE

Remove a specific event notification request.

DISABLE

Disable the LISTEN routine for event notification request.

ENABLE

Enable the LISTEN routine for event notification request.

Programs invoking SLSXSEN LISTEN requests must supply the entry points of two routines:

- The SEN request module SLSXSENR.
- The listener routine to get control when an event occurs.

SLSXSENR must be loaded from an APF authorized library. The listener routine must reside in common storage. The invoking program is responsible for managing this storage.

The listener routine is validated during LISTEN request processing by invoking the routine with general purpose register 1 set to zeros. Therefore, the listener routine must be sensitive to this condition and process it accordingly. The listener routine can simply return back to the caller on this condition or perform any type of initialization required. If LISTEN request processing detects an abend during validation, the request is rejected. A successful LISTEN request returns a token. Programs invoking SLSXSEN with DELETE, DISABLE, or ENABLE requests must provide this token to target a specific LISTEN request. The HSC SAMPLIB contains a sample program showing the use of SLSXSEN.

When events occur for which there is a listener routine, it is invoked and receives data that describes the event. The data passed is in XML format, which is provided on the StorageTek Customer Resource Center (CRC). For more information on the supported events, see “Supported HSC and VTCS SEN Events” on page 363.

When SEN request processing completes and control is returned to the requesting program, the parameter list and Register 15 contain the return code. Return codes are described in “Execute Form - Syntax and Parameters” on page 347.

If HSC detects an abend while the listener routine is in control, the associated request is disabled and must be programmatically reenabled or deleted. When a notification request is disabled, the listener routine is not invoked.



Note: The HSC 5.0 `OPTION` command and control statement lets you set the `SEN` facility ON or OFF:

`OPTION SEN(ON) | OPTION SEN(OFF)`

Note that even if `SEN` is disabled, `SLSXSEN` requests can still be processed.

SEN Macro Interface Authorization Requirements and Module Attributes

Modules invoking the `SEN` macro interface must:

- Have an authorization code of 1 and reside in an APF authorized library, **or**
- Be running in key 0 - 7 or supervisor state and be running in AMODE 31.

The listener routine must be running in TCB mode (not in SRB mode) and must be re-entrant.

The SLSXSEN Macro

The `SLSXSEN` macro has two forms:

- A **list form** that generates a parameter list. The parameter list is mapped by macro `SLSXSENM` (see “`SLSXSENM` Macro Format” on page 346) and must be included in routines invoking `SLSXSEN`. On completion of `SEN` request processing, the `SEN` parameter list contains the return code and token response areas.
- The **execute form** that populates the parameter list and calls the `SEN` request module `SLSXSEN`.

List Form - Syntax and Parameters

Syntax

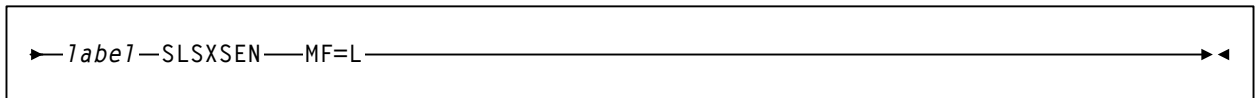

Figure 1. SLSXSEN Macro Syntax - List Form

Parameters

`MF=L`

Specifies that a remote parameter list is generated. All other options are ignored.

SLSXSENM Macro
Format

Table 1 shows the format of macro SLSXSENM, which generates a DSECT that maps the SEN parameter list generated by the list form of macro SLSXSEN.

Table 1. SLSXSENM Macro Format

Decimal Offset	Hexadecimal Offset	Type	Length	Label	Description
0	0			SLSXSENM	Start of DSECT
0	0	hexstring	2	SLSXSLEN	Length of parameter list
2	3	bitstring	1	SLSXSFC	SEN request code
		X'01'		SLSXLIS	LISTEN
		X'02'		SLSXSDEL	DELETE
		X'03'		SLSXSDIS	DISABLE
		X'04'		SLSXSENA	ENABLE
3	3	bitstring	1	SLSXSFLG	Processing flag
		X'80'		SLSXSEOT	EOT = YES
		X'40'		SLSXSEOM	EOM = YES
4	4	hexstring	8	SLSXSEM	Event mask
12	C	hexstring	4	SLSXSLA	Listener routine address
16	10	hexstring	4	SLSXSRT	Current TCB of requestor
20	14	hexstring	4	SLSXSRA	ASCB of requestor
22	16	hexstring	2	SLSXSTOK	Listen request token
30	1E	character	8	SLSXSREQ	Requestor name
38	26	character	8	SLSXSLNR	Listener routine name
40	28	hexstring	2	SLSXSQA	SEN queue entry address
42	2A	hexstring	2	SLSXSRC	SEN return code
			36	SLXRDI	Duplicate request encountered, request ignored
			32	SLXRNHSC	HSC not active or at proper level
			28	SLXRBADA	Authorization requirements not met
			24	SLXRBILR	Listener failed validation
			20	SLSXRSAB	Abend in HSC SEN processing
			16	SLSXRIR	Invalid request
			12	SLSXRNSQ	No LISTEN request found for DELETE, DISABLE, or ENABLE

Table 1. SLSXSENM Macro Format

Decimal Offset	Hexadecimal Offset	Type	Length	Label	Description
			08	SLSXRDR	Duplicate listener encountered
			04	SLSXRDK	SEN request successful, however the SEN facility is disabled
44	2C			SLSXSMLN	Length

**Execute Form -
Syntax and
Parameters**

Syntax

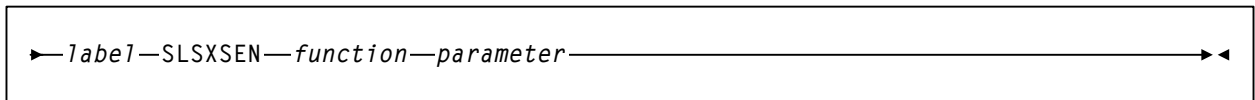

Figure 2. SLSXSEN Macro Syntax - Execute Form

Parameters

function is one of the following:

- LISTEN; see “LISTEN” on page 348.
- DELETE; see “DELETE” on page 352.
- DISABLE; see “DISABLE” on page 353.
- ENABLE; see “ENABLE” on page 355.

LISTEN

LISTEN requests notification for the events described in “Supported HSC and VTCS SEN Events” on page 363. Also see “The SEN Listener Exit Routine” on page 357.



Note: A sample program of a LISTEN request (SENQRST) is provided in file SLSSAMP during SMP/E installation.

Syntax.

```
label  SLSXSEN LISTEN,  
        EVENT=(event_1, event_2, ..),  
        RTOKEN=token,  
        LNRADR=listener_address,  
        SENRADR=SLSXSENR_address,  
        EOT=YES/NO,  
        EOM=YES/NO,  
        REQNAME=requestor_name,  
        LNRNAME=listener_name,  
        MF=(E, parm_list)
```

Parameters.

EVENT=

Specifies the event(s) requiring notification. For more information, see “Supported HSC and VTCS SEN Events” on page 363. You can specify the event name or the numeric equate. Event names are case sensitive. You can specify a single event or EVENT=ALL. This parameter is required and there is no default.



Note: To specify multiple events on a single LISTEN request, StorageTek recommends that you use the numeric equates to ensure that the parameter value specified will not exceed IBM’s 256 byte size limitation for macro variables.

RTOKEN=

Specifies the address of a fullword token associated with a successful LISTEN request. Valid values are any RX-type address or registers 2 through 12. This parameter is required and there is no default.

LNRADR=

Specifies the entry point address of the listener routine that is invoked when the events specified occur. This program must reside in persistent common storage (that is, subpool 241) if EOT = YES or EOM=YES. It is your responsibility to delete the listener routine and free the storage associated with it. Valid values are any RX-type address or registers 2 through 12. This parameter is required and there is no default.

SENADR=

Specifies the entry point address of the SEN request module (SLSXSEN) that is provided with HSC. SLSXSEN must be loaded before invoking macro SLSXSEN. Valid values are any RX-type address or registers 2 through 12. This parameter is required and there is no default.

EOT=

Specifies whether the listener routine associated with this request is invoked if the task that issued the LISTEN request ends.

YES

Invoke the listener routine if the associated task ends.

NO

Do not invoke the listener routine if the task associated with this request ends.

This parameter is optional and NO is the default.

EOM=

Specifies whether the listener routine associated with this request is invoked if the address space that issued the LISTEN request ends.

YES

Invoke the listener routine if the associated address space ends.

NO

Do not invoke the listener routine if the address space associated with this request ends.

This parameter is optional and NO is the default.



Caution: EOT and EOM control execution of the listener routine, so make sure you set them to specify how you want the listener routine to operate.

REQNAME=

Specifies the name of the requestor and is used to uniquely identify a specify request for display purposes. The name must be an eight byte field containing a combination of uppercase alphanumeric values (A-Z,0-9), national characters (\$,@,#) with no embedded blanks. Valid values are any RX-type address or registers 2 through 12. This parameter is optional if LNRNAME is not specified and has no default.

LNRNAME=

Specifies the name of the listener routine. The name must be an eight byte field containing a combination of uppercase alphanumeric values (A-Z,0-9), national characters (\$,@,#) with no embedded blanks. Valid values are any RX-type address or registers 2 through 12. If LNRNAME is specified, REQNAME must also be specified. Otherwise, this parameter is optional and has no default.



Hint: Although not required, REQNAME and LNRNAME are very useful when displaying active SEN requests. For more information, see “The listener routine must be running in TCB mode (not in SRB mode) and must be re-entrant.” on page 345.

MF=(E,*parm_list*)

Specifies the execute form of the macro using the specified parameter list generated by the list form. The parameter list, *parm_list*, can be specified as any RX-type address or registers 2 through 12.

Responses. The return code is set in register 15 and the SEN parameter list. If the return code is zero, the address specified by RTOKEN contains the token representing this LISTEN request. This token is used when deleting, disabling or enabling a request. Table 2 describes the SLSXSEN LISTEN return codes.

Table 2. SLSXSEN LISTEN Return Codes

Return Code	Meaning
00	SEN LISTEN request successful
04	SEN LISTEN request successful however the SEN facility is disabled.
08	Listen request with conflicting event lists. For more information, see “Detecting Duplicate Listen Requests” on page 361.
12	N/A
16	Invalid parameter list received.
20	Indicates that an abend occurred in HSC SEN processing, request rejected.
24	Indicates that listener routine validation failed, request rejected
28	The HSC determined that the SLSXSEN macro is being invoked by a program that does not meet the authorization requirements specified in “SEN Macro Interface Authorization Requirements and Module Attributes” on page 345.
32	The HSC is not active or at the proper initialization level for SEN services.
36	An identical LISTEN request already exists, request ignored. For more information, see “Detecting Duplicate Listen Requests” on page 361.
40	Indicates that the REQNAM or LNRNAME syntax is invalid. Valid syntax is uppercase A-Z, 0-9, valid national characters (\$,#,@), with no embedded blanks.

DELETE

Syntax.

```
label SLSXSEN DELETE,  
      RTOKEN=token,  
      MF=(E,parm_list)
```

Parameters.

RTOKEN=

Specifies the address of a fullword token representing the request to be removed. This token was returned from a successful LISTEN request. This parameter is required and there is no default.

MF=(E,*parm_list*)

Specifies the execute form of the macro using the specified parameter list generated by the list form. The parameter list, *parm_list*, can be specified as any RX-type address or registers 2 through 12.



Note: All other parameters are ignored if entered on the DELETE request.

Responses. The return code is set in register 15 and the SEN parameter list. Table 3 describes the SLSXSEN DELETE return codes.

Table 3. SLSXSEN DELETE Return Codes

Return Code	Meaning
00	SEN DELETE request successful.
04	N/A
08	N/A
12	No existing LISTEN request was found using the TOKEN specified on the DELETE request.
16	Invalid request received (not LISTEN, DELETE, DISABLE, or ENABLE).
20	An abend occurred in HSC SEN processing, request rejected.
24	N/A
28	The HSC determined that the SLSXSEN macro is being invoked by a program that does not meet the authorization requirements specified in “SEN Macro Interface Authorization Requirements and Module Attributes” on page 345.
32	HSC is not active or at the proper initialization level for SEN services.
36	N/A

DISABLE

Disable notification for a specific LISTEN request. The targeted request remains but the associated listener routine is not invoked when the specified events occur.

Syntax.

```
label SLSXSEN DISABLE,  
      RTOKEN=token,  
      MF=(E,parm_list)
```

Parameters.

RTOKEN=

Specifies the address of a fullword token representing the request to be disabled. This token was returned from a successful LISTEN request. This parameter is required and there is no default.

MF=(E,*parm_list*)

Specifies the execute form of the macro using the specified parameter list generated by the list form. The parameter list, *parm_list*, can be specified as any RX-type address or registers 2 through 12.



Note: All other parameters are ignored if entered on the DISABLE request.

Responses. The return code is set in register 15 and the SEN parameter list. Table 4 describes the SLSXSEN DISABLE return codes.

Table 4. SLSXSEN DISABLE Return Codes

Return Code	Meaning
00	SEN DISABLE request successful.
04	SEN DISABLE request successful however the SEN facility is already disabled.
08	N/A
12	No existing LISTEN request was found using the TOKEN specified on the DISABLE request.
16	Invalid request received (not LISTEN, DELETE, DISABLE, or ENABLE).
20	An abend occurred in HSC SEN processing, request rejected.
24	N/A
28	The HSC determined that the SLSXSEN macro is being invoked by a program that does not meet the authorization requirements specified in "SEN Macro Interface Authorization Requirements and Module Attributes" on page 345.
32	HSC is not active or at the proper initialization level for SEN services.
36	N/A

ENABLE

Enable notification for a specific LISTEN request. The targeted request's listener routine is now invoked when the specified events occur.

Syntax.

```
label SLSXSEN ENABLE,  
        RTOKEN=token,  
        MF=(E,parm_list)
```

Parameters.

RTOKEN=

Specifies the address of a fullword token representing the request to be enabled. This token was returned from a successful LISTEN request. This parameter is required and there is no default.

MF=(E,*parm_list*)

Specifies the execute form of the macro using the specified parameter list generated by the list form. The parameter list, *parm_list*, can be specified as any RX-type address or registers 2 through 12.



Note: All other parameters are ignored if entered on the ENABLE request.

Responses. The return code is set in register 15 and the SEN parameter list. Table 5 describes the SLSXSEN ENABLE return codes.

Table 5. SLSXSEN ENABLE Return Codes

Return Code	Meaning
00	SEN ENABLE request successful.
04	SEN ENABLE request successful however the SEN facility is disabled.
08	N/A
12	No existing LISTEN request was found using the TOKEN specified on the ENABLE request.
16	Invalid request received (not LISTEN, DELETE, DISABLE, or ENABLE).
20	An abend occurred in HSC SEN processing, request rejected.
24	N/A
28	The HSC determined that the SLSXSEN macro is being invoked by a program that does not meet the authorization requirements specified in “SEN Macro Interface Authorization Requirements and Module Attributes” on page 345.
32	HSC is not active or at the proper initialization level for SEN services.
36	N/A

The SEN Listener Exit Routine

To use the SEN, you must write a listener exit routine that is invoked when the requested event(s) occur. The following sections describe the requirements and implementation of this exit.

Input Registers

Registers on entry to the SEN listener routine are as follows:

- R1 points to the address of input parameter list (mapped by macro SWSPGMIA) or zero.
- R13 points to the address of register save area.
- R15 points to the listener routine entry point address.
- All other registers are undefined.

On entry, Register 1 always contains the address of the SWSPGMIA data area except during SEN event registration. When requesting an event, you must provide the address of a listener exit routine that is invoked whenever the specified event(s) occur (for more information, see “LNRADR=” on page 349). As part of this process, HSC invokes the listener exit routine to ensure the address provided is valid. When this validation call is made, Register 1 contains zeros, indicating validation is being performed. During validation, the listener routine can simply return control or perform any routine specific initialization. If the validation call is not successful, the SEN request fails.

Output Registers

Registers on exit from the SEN listener exit routine must be as follows:

- R13 points to the address of original register save area.
- All other registers are undefined (however R15 can be set to 4 upon return to instruct SEN to stop passing any further XML data. For more information, see “How to Tell SEN to Stop Calling Your Listener Routine During Event Processing” on page 360).

Entry Environment

On entry, the SEN listener exit receives control as follows:

- STATE - supervisor
- KEY - key 0
- AMODE: 24 or 31 bit
- LOCKS - none

Listener Exit Routine Programming Considerations

During the SEN registration process each successful request is queued in FIFO order. When a SEN defined event occurs all registered listener exits are invoked serially, in the order in which registration requests were received. A potential performance degradation can occur if a listener exit performs long running units of work. This is particularly critical because each SEN event causes listener exits to be invoked multiple times.



Warning: StorageTek **strongly recommends** that you design “short running” listener exit routines. In addition, the use of facilities that can result in “wait conditions”, such as WAIT/POST, STIMER/STIMERM and file I/O, should be used with caution or avoided all together.

The SWSPGMIA Data Area

On entry to the SEN listener exit during event processing, Register 1 contains the address of a data area mapped by macro SWSPGMIA. This storage area contains pointers to the XML defined elements describing each SEN defined event. For more information on the XML structures and tags, see “VTCS and HSC Events XML Tags” on page 367.

The listener exit XML interface basically consists of three types of tag definitions:

- Structure start tags
- Structure end tags
- Data tags and associated data

Structure start tags are passed to the listener exit, without any other data, and are used to indicate a set of logically grouped tags will follow.

Data tags (both start and end) along with the associated data are self defining XML elements.

Structure end tags are passed to the listener exit, without any other data, and are used to indicate the set of logically grouped tags has ended.

The following fields of SWSPGMIA support these XML tag structures:

PGMIRSVA

Address of complete XML element being passed.

PGMIRSVL

Length of the start tag plus, optionally, data length plus end tag length.

PGMIRSTA

Address of XML start or end tag.

PGMIRSTL

Length of the XML tag.

PGMIRSDA

Address of associated data, or zero.

PGMIRSDL

Length of associated data, or zero.

Fields PGMIRSVL, PGMIRSTA, and PGMIRSTL always contain values. PGMIRSVL contains the address of either a structure start tag, a structure end tag or a data start tag. If PGMIRSVL points to a structure start or end tag, PGMIRSVL contains the length of the tag (including both the leading and trailing '<','>'). If PGMIRSVL points to a data tag, PGMIRSVL contains the length of the tag (including both the leading and trailing '<','>'), plus the length of the data, plus the length of the data end tag.

Fields PGMIRSTA and PGMIRSTL always contain values. PGMIRSTA contains the address of either a structure start tag or a structure end tag. PGMIRSTL contains the length of the tag (including both the leading and trailing '<','>'),

Fields PGMIRSDA and PGMIRSDL optionally contain values. If PGMIRSVL points to either a structure start or structure end tag, PGMIRSDA and PGMIRSDL will contain zero since there is no data associated with these tags. But if PGMIRSVL points to a data start tag, then PGMIRSDA will contain the address of the associated data, and PGMIRSDL will contain the data's length. The following sections show examples of how the listener exit routine processes XML structures and tags.

Example 1. XML tag `<libvol_insert_event>` is passed to the listener exit, which produces the following:

- PGMIRSVL points to: `<libvol_insert_event>`.
- PGMIRSVL contains: 00000015.
- PGMIRSTA points to: `<libvol_insert_event>`.
- PGMIRSTL contains: 00000015.

Because `<libvol_insert_event>` is a structure tag and has no related data:

- PGMIRSDA contains: 0.
- PGMIRSDL contains: 0.

Example 2. XML tag `<hsc_version>5.0.0</hsc_version>` is passed to the listener exit, which produces the following:

- PGMIRSVL points to: `<hsc_version>`.
- PGMIRSVL contains: 00000020.
- PGMIRSTA points to: `<hsc_version>`.
- PGMIRSTL contains: 0000000D.

Since `<hsc_version>` is a data start tag, it does have related data. As a result:

- PGMIRSDA points to: 5.0.0.
- PGMIRSDL contains: 00000005.

As described in “Listener Exit Routine Programming Considerations” on page 358, each SEN defined event causes multiple invocations of registered listener exit routines. For example, when an HSC insert volume event occurs the following XML structure is built. The listener routine will be invoked for each of the tag sets:

```
<libvol_insert_event> (passed on the 1st call to listener exit)
<header> (passed on 2nd call to the listener exit)
<hsc_version>5.0.0</hsc_version> (passed on 3rd call to the listener exit)
<date>2002Mar19</date> (passed on 4th call to the listener exit)
<time>17:53:17</time> (passed on 5th call to the listener exit)
<host_name>HOSTA</host_name> (passed on 6th call to the listener exit)
</header> (passed on 7th call to listener exit)
<libvol_data> (passed on 8th call to listener exit)
<vol_status>xx</vol_status> (passed on 9th call to listener exit, xx is a 1
byte flag field documented in member SLSUX06P of the SLSMAC installation
file, field UX06FLGS)
<volser>VOL001</volser> (passed on 10th call to listener exit)
<volume_location> (passed on 11th call to listener exit)
<acs>00</acs> (passed on 12th call to listener exit)
<lsm>000</lsm> (passed on 13th call to listener exit)
<panel>07</panel> (passed on 14th call to listener exit)
<row>02</row> (passed on 15th call to listener exit)
<column>10</column> (passed on 16th call to listener exit)
</volume_location> (passed on 17th call to listener exit)
<select_count>0</select_count> (passed on 18th call to listener exit)
</libvol_data> (passed on 19th call to listener exit)
</libvol_insert_event> (passed on 20th and final call to listener exit)
```

How to Tell SEN to Stop Calling Your Listener Routine During Event Processing

Because listener routines are invoked to process each XML tag for the event, the data required by the listener may be satisfied before the last tag for the event is passed. For example, your listener routine only requires ACS and LSM number when a cartridge is entered into an LSM. Using “Example 2” on page 359, the listener routines requirements are satisfied on the 13th call. In this situation, a listener routine can set general purpose register 15 to 4 prior to returning control. This instructs SEN not to call it any more for this event. The remaining XML tags are bypassed.

Detecting Duplicate Listen Requests

When an application attempts to register a Listen request with the SEN facility, HSC first validates the request. As part of this validation, HSC insures duplicate registration requests are not accepted to prevent the same user exit routine from being called multiple times for a single event. The following list differentiates between a unique and a duplicate registration request:

- If a new Listen request specifies an exit routine entry point address that is different than all other previously registered entry point addresses, the Listen request is accepted.
- If a new Listen request specifies an exit routine entry point address that matches a previously registered entry point address but their respective event lists contain no common events (that is, each Listen request specified a unique event list), the Listen request is accepted.
- If a new Listen request specifies an exit routine entry point address that matches a previously registered entry point address and their respective event lists contain all common events (that is, each Listen request specified identical event lists), the Listen request is rejected as an identical duplicate and terminates with a return code of 36.
- If a new Listen request specifies an exit routine entry point address that matches a previously registered entry point address and their respective event lists contain some common events but not all (that is, each Listen request specified partially matching event lists), the Listen request is rejected as a duplicate with conflicting event lists and terminates with a return code of 8.

Display SEN Command

You can use the `Display SEN` command to display the `SEN LISTEN` requests and their statuses. The display can either show a specific request, using the requestor and listener names, a list of related requests using only the requestor name, or all `SEN` requests. The information displayed includes:

- Requestor name and listener name if any.
- EOT/EOM settings.
- Disable/enable status.
- The token associated with the request.
- The event list of the request.

Syntax

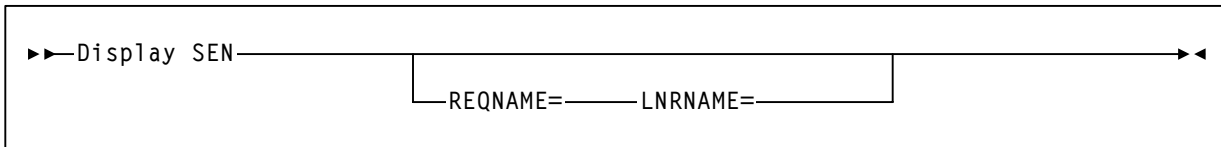

Figure 3. Display SEN Syntax

Parameters

`REQNAME=`

Specifies the name of the requestor, which is a unique name eight byte alphanumeric field, and is used to uniquely identify a specific request for display purposes. Valid values are any `RX`-type address or registers 2 through 12. This parameter is optional if `LNRNAME` is not specified and has no default.

`LNRNAME=`

Specifies the name of the listener routine. The name must be an eight byte alphanumeric field. Valid values are any `RX`-type address or registers 2 through 12. If `LNRNAME` is specified, `REQNAME` must also be specified. Otherwise, this parameter is optional and has no default.



Note: `REQNAME=` and `LNRNAME=` are optional. If you specify one, however, you must specify the other.

Supported HSC and VTCS SEN Events

HSC Events

Table 6 describes the supported HSC SEN events.

Table 6. HSC SEN Events

Event Name	Numeric Equate
libvol_insert_event	18
libvol_delete_event	19
hsc_termination_event	20
ACS_added_event	23
ACS_removed_event	24
lsmrail_added_event	25
lsmrail_removed_event	26
libdrive_added_event	27
libdrive_removed_event	28

VTCS SEN Events

Table 7 describes the supported VTCS SEN events.

Table 7. VTCS SEN Events

Event Name	Numeric Equate
vtss_performance_event	01
vtss_chanif_performace_event	02
vtv_mount_event	03
vtv_dismount_event	04
vtv_delete_event	05
mvc_mount_event	06
mvc_dismount_event	07
vtv_migrate_event	08
vtv_recall_event	09
rtd_performance_event	10
rtd_vary_event	11
mvc_usage_event	12
vtv_movement_event	13
vtv_scratch_event	14

Table 7. VTCS SEN Events

Event Name	Numeric Equate
vtss_performance_event	01
vtv_replicate_event	15
vtv_unlink_from_mvc_event	16
clink_vary_event	17

SEN Messages

SLS4970I SEN QUEUE DISPLAY STATUS CURRENT REQUESTORS *99999999* REQNAME
RRRRRRRR LNRNAME *LLLLLLLL* TOKEN *TTTTTTTT* FLAGS *FFFFFFF* EVENT
EEEEEEEE

Explanation: This is the output from the Display SEN Queue command. The output produced varies depending on the parameters specified. If no parameters are specified all entries in the SEN QUEUE are displayed. If REQname is specified then only Requestors matching REQname will be displayed. If LNRname is specified REQname must be specified. If LNRname is specified then only Requestors and Listeners matching REQname and LNRname will be displayed.

99999999 Number of Requestors on the SEN QUEUE *RRRRRRRR*
Requestor name

LLLLLLLL Listener name

TTTTTTTT Hex display of the Requestor Token

FFFFFFF Description of the processing flags for the SEN QUEUE
ENTRY

EEEEEEEE Description of the Event to be listened for.

System Action: None.

User Response: None.

SLS4971I Significant Event Notification facility not active

Explanation: An attempt was made to display SEN Queue entries. However, Significant Event Notification facilitate is not active.

System Action: The DISPLAY SEN command is rejected.

User Response: Make certain you are running the correct version of HSC. If you are certain you are running the correct version contact StorageTek HSC support.

SLS4972I SEN QUEUE IS EMPTY

Explanation: An attempt was made to display SEN Queue entries. However, the SEN QUEUE contained no entries.

System Action: Processing continues.

User Response: Make certain you have run the task to add entries to the SEN QUEUE. If the task has run corselette contact StorageTek HSC support.

SLS4973I REQNAME *nnnnnnnn* NOT FOUND

Explanation: An attempt was made to display a specific Requestor on the SEN QUEUE. However, the specified Requestor was not found.

System Action: Processing continues.

User Response: Make certain you have spelled the Requestor name correctly.

SLS4974I LNRNAME *nnnnnnnn* NOT FOUND

Explanation: An attempt was made to display a specific Listener on the SEN QUEUE. However, the specified Listener was not found.

System Action: Processing continues.

User Response: Make certain you have spelled the Listener name correctly.

VTCS and HSC Events XML Tags

This section describes the XML output of the VTCS and HSC events processed by the HSC Significant Event Notification (SEN) facility as follows:

- Listing of the data tags.
- Tag definitions.
- Cross reference of data tags to structure or event tags.

For more information, see the following sections:

- “VTCS Events XML Tags” on page 368
- “HSC Events XML Tags” on page 372

VTCS Events XML Tags

Table 8. VTCS Events XML Tags

XML Tag	Definition	Where Used
<addresses_trapped>	From SMF11NAT in turn from NOADRTRP parm returned from Channel Interface Performance ECAM-T request. Contains the number of unit addresses trapped by a channel interface.	<chanif_data>
<async_end_tod>	Structure that contains date and time that the asynchronous event completed. Date is supplied as: <date>yyyymmdd</date> Time is supplied as: <time>hh:mm:ss.thm</time>	<vtv_mount_event>
		<vtv_dismount_event>
		<mvc_mount_event>
		<vtv_migrate_event>
		<vtv_recall_event>
		<vtv_replicate_event>
<async_start_tod>	Structure that contains date and time that the asynchronous event started. Contains <date> and <time> as in <async_end_tod>.	<vtv_mount_event>
		<vtv_dismount_event>
		<mvc_mount_event>
		<vtv_migrate_event>
		<vtv_recall_event>
		<vtv_replicate_event>
<base_cache_size>	Cache size in MB of VTSS	<vtss_performance_event>
<bytes_read_freespace_collection>	Bytes read for free space collection within a partition.	<part_data>
<bytes_xfered_read>	Bytes transferred for read	<rtd_preformance_event>

Table 8. VTCS Events XML Tags

XML Tag	Definition	Where Used
<bytes_xfered_write>	Bytes transferred for write	<rttd_preformance_event>
<chanif_data>	Structure that contains all the information for a single channel IF. Contains:	<vtss_chanif_performance_event>
	<name>	
	<installed>	
	<enabled>	
	<link_type>	
	<addresses_trapped>	
	<speed>	
	<io_count>	
	<cu_busy_count>	
<collected_free_backend_capacity>	Bytes read for free space collection with the VTSS partition.	<part_data>
<cu_busy_count>	Count of control unit busy events on a chan IF	<chanif_data>
<customer_cache_size>	Customer cache size in MB	<vtss_performance_event>
<dev_activity>	RTD activity (initial selects)	<rttd_preformance_event>
<dev_available_time>	RTD mounted time	<rttd_preformance_event>
<dev_connect_time>	RTD connected time	<rttd_preformance_event>
<dev_util_time>	RTD utilized time	<rttd_preformance_event>
<dsname>	Data set name of the VTV being mounted/dismounted	<vtv_mount_event>
		<vtv_dismount_event>
<ecam_bypassed_bufferspace_count>	Count of ECAM-T requests bypassed – no buffer space	<vtss_performance_event>
<ecam_bypassed_configbusy_count>	Count of ECAM-T requests bypassed – configuration busy	<vtss_performance_event>
<ecam_processed_count>	Count of ECAM-T requests processed	<vtss_performance_event>
<enabled>	Indicates if a channel if is enabled - contains YES/NO	<chanif_data>
<installed>	Indicates if a channel if installed - contains YES/NO	<chanif_data>

Table 8. VTCS Events XML Tags

XML Tag	Definition	Where Used
<io_count>	Number of I/Os on this channel interface since last report.	<chanif_data>
<jobname>	MVS jobname requesting the mount/dismount	<vtv_mount_event>
		<vtv_dismount_event>
<link_type>	Identifies the link type contains HOST/RTD	<chanif_data>
<mount_type>	Indicates the type of mount performed. Contains:	<vtv_mount_event>
	EXISTING-SPECIFIC	
	CREATE-SL	
	CREATE-AL	
	EXISTING-SCRATCH	
<name>	The configured name of the channel IF.	<chanif_data>
<new_mvc>	Structure that describes the target MVC on a VTV move. Contains <mvc_data>	<vtv_movement_event>
<nvs_size>	NVS Size (MB)	<vtss_performance_event>
<offline_cache_size>	Offline cache size	<vtss_performance_event>
<old_mvc>	Structure that describes the source MVC on a VTV move. Contains <mvc_data>	<vtv_movement_event>
<part_data>	Structure containing all the information from a VTSS partition. Contains:	<vtss_performance_event>
	<total_backend_capacity>	
	<total_free_backend_capacity>	
	<collected_free_backend_capacity>	
	<bytes_read_freespace_collection>	
	<standard_capacity_defined>	

Table 8. VTCS Events XML Tags

XML Tag	Definition	Where Used
< name>	Name of a VTSS partition	<part_data>
<pinned_cache_size>	Pinned Cache Size	<vtss_performance_event>
<read_buffered_log>	64-byte rbl data represented as 128 characters	<mvc_dismount_event>
<read_only>	Indicates whether or not the VTV was mounted READONLY – contains YES/NO	<vtv_mount_event>
<reason>	The reason for the VTV delete, MVC mount, VTV migrate, VTV recall or the VTV/MVC unlink.	<vtv_delete_event>
		<mvc_mount_event>
		<vtv_migrate_event>
		<vtv_recall_event>
		<vtv_unlink_from_mvc_event>
<recall_required>	Indicates whether or not a recall was required in order to mount the VTV – contains YES/NO	<vtv_mount_event>
<recall_with_error>	Indicates if the recall was performed with error – contains YES/NO	<vtv_recall_event>
<sense_data>	32-byte sense data represented as 64 characters	<mvc_mount_event>
		<mvc_dismount_event>
		<vtv_recall_event>
		<vtv_replicate_event>
<speed>	The speed of a channel IF.	<chanif_data>
<standard_capacity_defined>	Standard capacity defined for the partition	<part_data>
<stepname>	MVS stepname of the job requesting the mount/dismount of the VTV	<vtv_mount_event>
		<vtv_dismount_event>
<total_backend_capacity>	Total backend capacity for a partition	<part_data>

Table 8. VTCS Events XML Tags

XML Tag	Definition	Where Used
<total_free_backend_capacity>	Total free backend capacity for a partition.	<part_data>

HSC Events XML Tags

Table 9. HSC Events XML Tags

Head Tag	Structure/Data Tags		Definition
<header>			header structure, occurs in: <libvol_insert_event> <libvol_delete_event> <hsc_termination_event> Note: Any x22 abends resulting from the cancellation of HSC will not generate the HSC termination event. <libdrive_added_event> <libdrive_removed_event> <ismrail_added_event> <ismrail_removed_event>
	<hsc_version>		HSC Version
	<date>		date

Table 9. HSC Events XML Tags

Head Tag	Structure/Data Tags		Definition	
	<time>		time	
	<host_name>		host name	
<libdrive_added_event>			dynamically added drive event	
	<libdrive_data>		drive data	
		<location_data>	drive location	
			<acs>	ACS
			<lsm>	LSM
			<panel>	panel
			<libdrive_number>	drive number
		<libdrive_model>		drive model (for example, 9840C)
		<libdrive_unit_address>		MVS unit address

Table 9. HSC Events XML Tags

Head Tag	Structure/Data Tags			Definition
<libdrive_removed_event>				dynamically removed drive event
	<libdrive_data>			drive data
		<location_data>		drive location
			<acs>	ACS
			<lsm>	LSM
			<panel>	panel
			<libdrive_number>	drive number
		<libdrive_model>		drive model (for example, 9840C)
		<libdrive_unit_address>		MVS unit address

Table 9. HSC Events XML Tags

Head Tag	Structure/Data Tags			Definition
<lsmrail_added_event>				dynamically added LSM rail event (SL8500 only)
	<lsmrail_data>			LSM rail data
		<location_data>		rail location
			<acs>	ACS
			<lsm>	LSM
<lsmrail_removed_event>				dynamically removed LSM rail event (SL8500 only)
	<lsmrail_data>			LSM rail data
		<location_data>		rail location
			<acs>	ACS
			<lsm>	LSM

Additional Information

Oracle Corporation (Oracle) offers several methods for you to obtain additional information.

Oracle's External Web Site

Oracle's external Web site provides marketing, product, event, corporate, and service information. The external Web site is accessible to anyone with a Web browser and an Internet connection. The URL for the Oracle external Web site is: <http://www.oracle.com/us/index.html>

The URL for Oracle's StorageTek storage information for is:

<http://www.oracle.com/us/products/servers-storage/storage/index.html>

Oracle's StorageTek Documentation

The URL for Oracle's StorageTek documentation is:

<http://docs.sun.com/app/docs>

Oracle Global Partners

The Oracle Global Partners site provides information about solutions available with Oracle's partners:

<http://www.oracle.com/partners/index.html>

Third-Party Web Sites

Oracle is not responsible for the availability of third-party web sites mentioned in this document. Oracle does not endorse and is not responsible or liable for any content, advertising, products, or other materials that are available on or through such sites or resources. Oracle will not be responsible or liable for any actual or alleged damage or loss caused by or in connection with the use of or reliance on any such content, goods, or services that are available on or through such sites or resources.

Oracle's Global Offices

You may contact any of Oracle's worldwide offices to discuss complete storage, service, and support solutions for your organization. You can find contact information at:
<http://www.oracle.com/corporate/contact/global.html>

Customer Support

For more information about Oracle support (including for StorageTek branded products) see:
<http://www.oracle.com/us/support/index.html>

Conventions for Reader Usability

Conventions are used to shorten and clarify explanations and examples within this book.

Typographic

The following typographical conventions are used in this book:

- **Bold** is used to introduce new or unfamiliar terminology.
- Letter Gothic is used to indicate command names, filenames, and literal output by the computer.
- Letter Gothic Bold is used to indicate literal input to the computer.
- *Letter Gothic Italic* is used to indicate that you must substitute the actual value for a command parameter. In the following example, you would substitute your name for the “username” parameter.
- Logon *username*
- A bar (|) is used to separate alternative parameter values. In the example shown below either username or systemname must be entered.
- Logon *username|systemname*
- Brackets [] are used to indicate that a command parameter is optional.
- Ellipses (...) are used to indicate that a command may be repeated multiple times.
- The use of mixed upper and lower case characters (for non–case sensitive commands) indicates that lower case letters may be omitted to form abbreviations. For example, you may simply enter **Q** when executing the **Quit** command.

Keys

Single keystrokes are represented by double brackets [[]] surrounding the key name. For example, press [[ESC]] indicates that you should press only the escape key.

Combined keystrokes use double brackets and the plus sign (+). The double brackets surround the key names and the plus sign is used to add the second keystroke. For example, press [[AL]] + [[C]] indicates that you should press the alternate key and the C key simultaneously.

Enter Command

The instruction to “press the [[ENTER]] key” is omitted from most examples, definitions, and explanations in this book.

For example, if the instructions asked you to “enter” **Logon pat**, you would type in **Logon pat** and press [[ENTER]].

However, if the instructions asked you to “type” **Logon pat**, you would type in **Logon pat** and you would *not* press [[ENTER]].

Warnings, Cautions, and Notes - Software

The following are used in software documentation.

Caution – Information necessary to keep you from corrupting your data.

Tip – Information that can be used to shorten or simplify your task or they may simply be used as a reminder.

Note – Information that may be of special interest to you. Notes are also used to point out exceptions to rules or procedures.

Warnings, Cautions, and Notes - Hardware

The following are used in hardware documentation.

Note – A note provides additional information that is of special interest. A note might point out exceptions to rules or procedures. A note usually, but not always, follows the information to which it pertains.

Caution – A caution informs you of conditions that might result in damage to hardware, corruption of data, or corruption of application software. A caution always precedes the information to which it pertains.



Warning – Possible Physical Injury. A warning alerts you to conditions that might result in long-term health problems, injury, or death. A warning always precedes the information to which it pertains.



Syntax

Syntax flow diagram conventions include the following:

Flow Lines—Syntax diagrams consist of a horizontal baseline, horizontal and vertical branch lines and the command text. Diagrams are read left to right and top to bottom. Arrows show flow and direction.

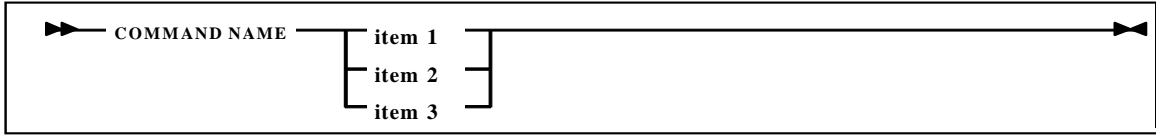

Single Required Choice—Branch lines (without repeat arrows) indicate that a single choice must be made. If one of the items to choose from is on the baseline of the diagram, one item must be selected.

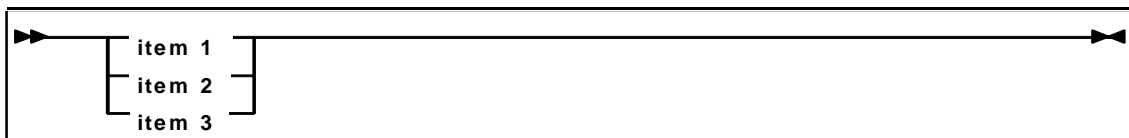

Single Optional Choice—If the first item is on the line below the baseline, one item may optionally be selected.

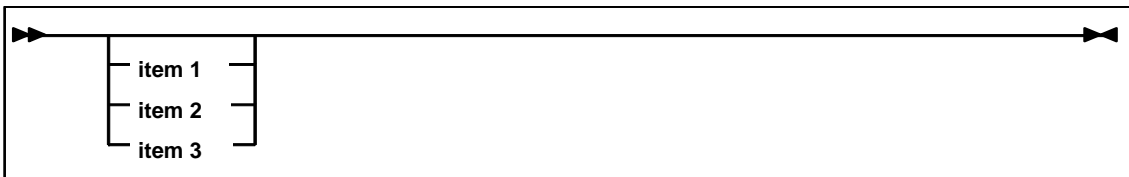

Defaults—Default values and parameters appear above the baseline.

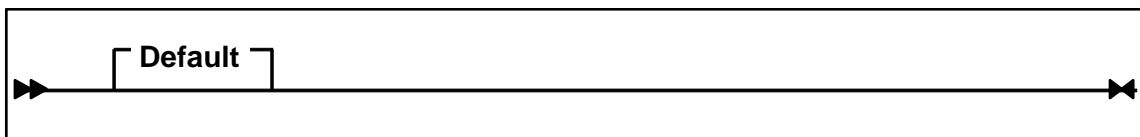

Repeat Symbol—A repeat symbol indicates that more than one choice can be made or that a single choice can be made more than once. The repeat symbol shown in the following example indicates that a comma is required as the repeat separator.

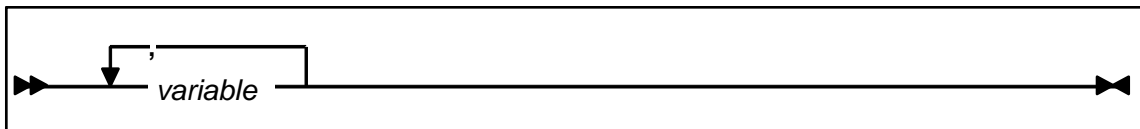

Keywords—All command keywords are shown in all upper case or in mixed case. When commands are not case sensitive, mixed case implies that the lowercase letters may be omitted to form an abbreviation.

Variables—Italic type is used to indicate a variable.

Alternatives—A bar (|) is used to separate alternative parameter values.

Optional—Brackets [] are used to indicate that a command parameter is optional.

Delimiters—If a comma (,), a semicolon (;), or other delimiter is shown with an element of the syntax diagram, it must be entered as part of the statement or command.

Ranges—An inclusive range is indicated by a pair of elements of the same length and data type, joined by a dash. The first element must be strictly less than the second element.

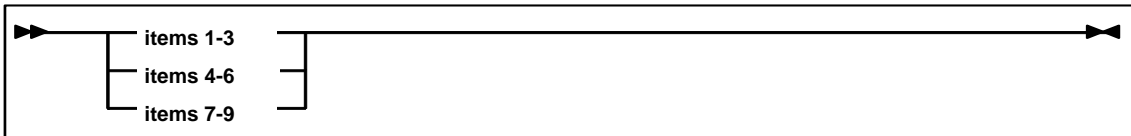

Lists—A list consists of one or more elements. If more than one element is specified, the elements must be separated by a comma or a blank and the entire line must be enclosed by parentheses.

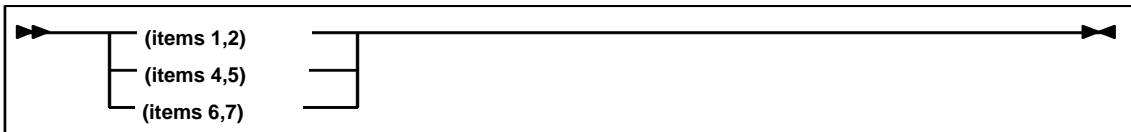

Index

A

AUDIT, 5

B

Batch Application Program Interface (API)
 SLUVC DAT, Flat File Static Configuration Data
 DSECT, 249

C

CANcel, 11
caution, description of, 380
CLINKs
 VT Display command, 84
clusters
 VT Display command, 86
CONFIG utility, 13
CONSolid utility, 40
consolidating VTVs
 procedures, 41
Control statements
 VOLATTR, 239, 254, 255, 257
Customer Resource Center (CRC), 377
customer support, 378

D

DECOM utility, 45
DEFER, 266
Display, 52
Display command, 203, 204

E

EPORT utility, 89
Execute, 347
execute form, SLSXREQ macro, 347
ExLM
 VTV flat file format, 185
ExPR
 VTV flat file format, 185

H

HSC
 ALLOC command enhancements, 199, 268
 enhancements for VSM
 Display command, 203, 204
 MERGEcds utility, 205
 MGMTclas control statement, 214
 MGMTDEF command, 223
 MVCPool control statement, 226
 overview, 201
 programmatic interface, 247
 STORCLAS control statement, 229
 STORLST control statement, 234
 STORSEL control statement, 236
 TAPEREQ control statement, 194
 user exits, 248
 VTSSSEL control statement, 243
 VTSSLST control statement, 241
 SMF records for VSM, 271
HSC (Host Software Component)
 operator commands
 Mount, 225
HSC enhancements for VSM
 ALLOC command, 199, 268
 programmatic interface enhancements, 267
 VOLATTR control statement, 239, 254, 255, 257

I

IMPORT utility, 93

J

JES2 environment
 ALLOC command, 199, 268
 user exit SLSUX02, 248
JES3 environment
 ALLOC command, 199, 268
 user exit SLSUX04, 248

L

list form, SLSXREQ macro, 345

M

Management Class
 consolidating VTVs by specifying, 42
mapping macros
 SLUVC DAT, Flat File Static Configuration Data
 DSECT, 249
MEDia
 parameter for VOLATTR, 240
MERGEcds utility, 205
MERGMST utility, 104
MF parameter, 345
MGMTclas control statement, 214
MGMTDEF command, 223
MIGrate command and utility, 107
MVC pools
 VT Display command, 70
MVCDRain, 113
MVCMAINT utility, 117
MVCPLRPT utility, 125
MVCPool control statement, 226
MVCRPT utility, 132
MVCs
 space reclamation
 VT REClaim command, 149
 VT Display command, 73

N

notes, description, 380

O

Operational Changes to the MVS/CSC
 Startup Parameter Changes, 266
 DEFER, 266

P

Parameters
 VOLATTR control statement, 239, 254, 255, 257
parameters
 threshold-value, 254
partners web site, Oracle, 377
Programmatic Interface (PGMI)
 execute form, SLSXREQ, 347
 List form, SLSXREQ, 345

Q

QUery command and utility, 145

R

RECALL command and utility, 146
recalling VTVs
 VT RECALL command, 146, 147
recovery utility, 153
RECtech
 parameter for VOLATTR, 240
reports
 MVCPLRPT utility, 125
 MVCRPT utility, 132
 VTV report utility, 184
RTDs
 VT Vary CLInk command, 170
 VT Vary RTD command, 172
RTV utility, 153

S

scratch subpools
 VT Display command, 69
SET MIGOPT, 165
SLUVC DAT, Flat File Static Configuration Data
 DSECT, 249, 251
Startup Parameter Changes, 266
STORCLAS control statement, 229
STORLST control statement, 234
STORSEL control statement, 236

T

TAPEREQ control statement, 194

U

user exits
 SLSUX02, 248
 SLSUX04, 248
user exits for VSM, 248

V

VOLATTR control statement, 239, 254, 255, 257
 examples, 240
 for MVCs, 239, 254, 255, 257
 parameters, enhanced, 240
 parameters, unchanged, 239
 usage, 240
volume report records
 SLUVC DAT, Flat File Static Configuration Data
 DSECT, 249

VT MVCDEF command, 111
VT RECLaim command, 149
VT TRace command, 168
VT Vary CLInk command, 170
VT Vary RTD command, 172
VT Vary VTSS command, 174
VTCS

commands

VT MVCDEF, 111
VT QUery, 145
VT RECALL, 146
VT RECLaim, 149
VT SET MIGOPT, 165
VT TRace, 168
VT Vary RTD, 170, 172
VT Vary VTSS, 174

utilities

AUDIT, 5
CONFIG, 13
CONSolid, 40
DECOM, 45
IMPORT, 93
MRGMFST, 104
MVCMAINT, 117
MVCPLRPT, 125
MVC RPT, 89, 132
overview, 1
recovery, 153
RTV, 153
VTVMaint, 48, 179
VTVRPT, 184

VTDs

command reference, 303
VT Display command, 62

VTSSSEL control statement, 243

VTSSLST control statement, 241

VTSSs

VT Display command, 59, 61
VT QUery command, 256, 258
VT Vary VTSS command, 174

VTVMaint utility, 48, 179

VTVRPT utility, 184

VTVs

consolidating by specifying Management Class, 42
consolidating by specifying VTVs, 41
VT Display command, 71, 88
VT MIGrate, 107
VT RECALL command, 146, 147

THReshld, 254
warning, description of, 380
web site, Oracle, 377
worldwide offices, Oracle, 378

W

Warn command

parameter explanations