



Sun StorEdge™ 5310 NAS Appliance and Gateway System Getting Started Guide

Installing and Configuring the System

Sun Microsystems, Inc.
www.sun.com

Part No. 819-3237-10
August 2005, Revision A

Submit comments about this document at: <http://www.sun.com/hwdocs/feedback>

Copyright 2005 Sun Microsystems, Inc., 4150 Network Circle, Santa Clara, California 95054, U.S.A. All rights reserved.

Sun Microsystems, Inc. has intellectual property rights relating to technology that is described in this document. In particular, and without limitation, these intellectual property rights may include one or more of the U.S. patents listed at <http://www.sun.com/patents> and one or more additional patents or pending patent applications in the U.S. and in other countries.

This document and the product to which it pertains are distributed under licenses restricting their use, copying, distribution, and decompilation. No part of the product or of this document may be reproduced in any form by any means without prior written authorization of Sun and its licensors, if any.

Third-party software, including font technology, is copyrighted and licensed from Sun suppliers.

Parts of the product may be derived from Berkeley BSD systems, licensed from the University of California. UNIX is a registered trademark in the U.S. and in other countries, exclusively licensed through X/Open Company, Ltd.

Sun, Sun Microsystems, the Sun logo, docs.sun.com, Sun Fire, Sun StorEdge, Java, and Solaris are trademarks or registered trademarks of Sun Microsystems, Inc. in the U.S. and in other countries.

All SPARC trademarks are used under license and are trademarks or registered trademarks of SPARC International, Inc. in the U.S. and in other countries. Products bearing SPARC trademarks are based upon an architecture developed by Sun Microsystems, Inc.

Mozilla and Netscape are trademarks or registered trademark of Netscape Communications Corporation in the United States and other countries.

The OPEN LOOK and Sun™ Graphical User Interface was developed by Sun Microsystems, Inc. for its users and licensees. Sun acknowledges the pioneering efforts of Xerox in researching and developing the concept of visual or graphical user interfaces for the computer industry. Sun holds a non-exclusive license from Xerox to the Xerox Graphical User Interface, which license also covers Sun's licensees who implement OPEN LOOK GUIs and otherwise comply with Sun's written license agreements.

U.S. Government Rights—Commercial use. Government users are subject to the Sun Microsystems, Inc. standard license agreement and applicable provisions of the FAR and its supplements.

DOCUMENTATION IS PROVIDED "AS IS" AND ALL EXPRESS OR IMPLIED CONDITIONS, REPRESENTATIONS AND WARRANTIES, INCLUDING ANY IMPLIED WARRANTY OF MERCHANTABILITY, FITNESS FOR A PARTICULAR PURPOSE OR NON-INFRINGEMENT, ARE DISCLAIMED, EXCEPT TO THE EXTENT THAT SUCH DISCLAIMERS ARE HELD TO BE LEGALLY INVALID.

Copyright 2005 Sun Microsystems, Inc., 4150 Network Circle, Santa Clara, Californie 95054, Etats-Unis. Tous droits réservés.

Sun Microsystems, Inc. a les droits de propriété intellectuels relatants à la technologie qui est décrit dans ce document. En particulier, et sans la limitation, ces droits de propriété intellectuels peuvent inclure un ou plus des brevets américains énumérés à <http://www.sun.com/patents> et un ou les brevets plus supplémentaires ou les applications de brevet en attente dans les Etats-Unis et dans les autres pays.

Ce produit ou document est protégé par un copyright et distribué avec des licences qui en restreignent l'utilisation, la copie, la distribution, et la décompilation. Aucune partie de ce produit ou document ne peut être reproduite sous aucune forme, par quelque moyen que ce soit, sans l'autorisation préalable et écrite de Sun et de ses bailleurs de licence, s'il y ena.

Le logiciel détenu par des tiers, et qui comprend la technologie relative aux polices de caractères, est protégé par un copyright et licencié par des fournisseurs de Sun.

Des parties de ce produit pourront être dérivées des systèmes Berkeley BSD licenciés par l'Université de Californie. UNIX est une marque déposée aux Etats-Unis et dans d'autres pays et licenciée exclusivement par X/Open Company, Ltd.

Sun, Sun Microsystems, le logo Sun, docs.sun.com, Sun Fire, Sun StorEdge, Java, et Solaris sont des marques de fabrique ou des marques déposées de Sun Microsystems, Inc. aux Etats-Unis et dans d'autres pays.

Toutes les marques SPARC sont utilisées sous licence et sont des marques de fabrique ou des marques déposées de SPARC International, Inc. aux Etats-Unis et dans d'autres pays. Les produits portant les marques SPARC sont basés sur une architecture développée par Sun Microsystems, Inc.

Mozilla et Netscape sont des marques de fabrique ou des marques deposes de Netscape Communications Corporation aux Etats-Unis et à d'autres pays.

L'interface d'utilisation graphique OPEN LOOK et Sun™ a été développée par Sun Microsystems, Inc. pour ses utilisateurs et licenciés. Sun reconnaît les efforts de pionniers de Xerox pour la recherche et le développement du concept des interfaces d'utilisation visuelle ou graphique pour l'industrie de l'informatique. Sun détient une licence non exclusive de Xerox sur l'interface d'utilisation graphique Xerox, cette licence couvrant également les licenciées de Sun qui mettent en place l'interface d'utilisation graphique OPEN LOOK et qui en outre se conforment aux licences écrites de Sun.

LA DOCUMENTATION EST FOURNIE "EN L'ÉTAT" ET TOUTES AUTRES CONDITIONS, DECLARATIONS ET GARANTIES EXPRESSES OU TACITES SONT FORMELLEMENT EXCLUES, DANS LA MESURE AUTORISEE PAR LA LOI APPLICABLE, Y COMPRIS NOTAMMENT TOUTE GARANTIE IMPLICITE RELATIVE A LA QUALITE MARCHANDE, A L'APTITUDE A UNE UTILISATION PARTICULIERE OU A L'ABSENCE DE CONTREFAÇON.



Contents

1. System Overview	1
System Features	1
Supported File Access Protocols	2
Network Security and Protocol Integration	2
Supported Clients	2
Network Connection	2
Automatic IP Address Assignment	2
RAID Controllers (Non-Gateway Systems)	3
SAN Storage (Gateway Systems)	3
Data Management	3
Setup and Configuration	3
Client Data Backup	3
Hardware Overview	4
Sun StorEdge 5310 NAS Appliance Server	4
Back-End Storage	7
SAN Storage	8
Software Overview	9
Web Administrator	9

Command-Line Interface	10
Licensed Options	10
2. Installing Storage Enclosures	11
Preparing for the Installation	12
Before You Begin	12
Grounding Procedure	13
Preparing the CAM100 3RU Rackmount Kit	14
Preparing the Controller and Expansion Enclosures	15
Preparing the Cabinet	15
Unit Placement in the Cabinet	16
Attaching the CAM100 3RU Rails to a Cabinet	17
Attaching the Rails to the Sun StorEdge Expansion Cabinet	18
Attaching the Rails to the Sun Rack 900/1000 Cabinet	23
Installing an Enclosure in a Cabinet	29
Connecting the Power Cables	34
Setting the Tray ID	35
Back-End Storage Cabling	36
3. Connecting the Sun StorEdge 5310 NAS Appliance	37
Before You Begin	38
Connecting the Sun StorEdge 5310 NAS Appliance to Back-End Storage	38
Connecting the Sun StorEdge 5310 NAS Appliance to Controller Enclosures	39
Connecting Controller Enclosures to Expansion Enclosures	43
Connecting to the Network	50
Connecting to Copper Fast Ethernet or Gigabit Ethernet Networks	50
Connecting to Optional Optical Gigabit Ethernet Networks	51
Powering On the Sun StorEdge 5310 NAS Appliance, Controller Enclosures, and Expansion Enclosures	51

Powering On the Sun StorEdge 5310 NAS Appliance System	52
Initial Sun StorEdge 5310 NAS Appliance Configuration	53
IP Address Configuration	54
Accessing the Web Administrator	55
4. Installing the Sun StorEdge 5310 Cluster	59
Before You Begin	59
Connecting the Sun StorEdge 5310 Cluster to Back-End Storage	60
Connecting the Sun StorEdge 5310 Cluster to Controller Enclosures	61
Connecting the Controller Enclosures to Expansion Enclosures	66
Connecting the Server	
Health-Monitoring and Network Cables	73
Connecting to Copper Fast Ethernet or Gigabit Ethernet Networks	74
Connecting to Optional Optical Gigabit Ethernet Networks	75
Powering On the Sun StorEdge 5310 Cluster, Controller Enclosure, and Expansion Enclosures	76
Powering On the Sun StorEdge 5310 Cluster System	77
Initial Sun StorEdge 5310 Cluster Configuration	78
Setting IP Addresses	79
Configuring the System	80
Rebooting Server H2 Manually	82
Assigning LUN Ownership	82
Assigning LUN Paths	83
Configuring the Partner	83
5. Installing the Sun StorEdge 5310 NAS Gateway System	85
Before You Begin	86
Installation and Configuration Task Overview	86
Storage Concepts	87

Connecting the Sun StorEdge 5310 NAS Gateway System to the Sun StorEdge 6920 System	87
Connecting Directly to the Sun StorEdge 6920 System	88
Using the Fabric Switches to Connect to the Sun StorEdge 6920 System	93
Connecting the Sun StorEdge 5310 NAS Gateway System to the Sun StorEdge 9970/9980	104
Connecting Directly to the Sun StorEdge 9970/9980	104
Using Fabric Switches to Connect to the Sun StorEdge 9970/9980	109
Connecting to the Network	120
Connecting Single Head Servers	120
Connecting Dual Head HA Servers	121
Powering On the Sun StorEdge 5310 NAS Gateway System	123
Initial Sun StorEdge 5310 NAS Gateway System Single Server Configuration	124
Setting the IP Address	124
Configuring the Single Server System	125
Storage and LUN Configuration on a Single Server System	127
Initial Sun StorEdge 5310 NAS Gateway System Dual Server HA Configuration	129
Setting IP Addresses	129
Basic Dual Server System Configuration	130
Storage and LUN Configuration on a Dual Server System	133
LUN Path Configuration	136
A. Hardware Technical Specifications	139
Sun StorEdge 5310 NAS Appliance and Sun StorEdge 5300 RAID EU and EU Technical Specifications	139
Glossary	141
Index	145

Figures

FIGURE 1-1	Sun StorEdge 5310 NAS Appliance Front View	4
FIGURE 1-2	Sun StorEdge 5310 NAS Appliance With Faceplate Removed	4
FIGURE 1-3	Sun StorEdge 5310 NAS Appliance Back Panel With Single HBA Card	5
FIGURE 1-4	Sun StorEdge 5310 Cluster Back Panel With Two HBA Cards	6
FIGURE 1-5	Sun StorEdge 5300 RAID EU Controller Enclosure Front, With Fibre Channel Disk Drives	7
FIGURE 1-6	Sun StorEdge 5300 RAID EU Controller Enclosure Back Panel	7
FIGURE 1-7	Sun StorEdge 5300 EU F Expansion Enclosure Front, With Fibre Channel Disk Drives	8
FIGURE 1-8	Sun StorEdge 5300 EU Expansion Enclosure Back Panel	8
FIGURE 2-1	Recommended Rackmounting Order	17
FIGURE 2-2	Loosening the Rail Screws to Adjust the Rail Length	18
FIGURE 2-3	Inserting Mounting Hole Screws and Positioning the Rack Alignment Template	19
FIGURE 2-4	Hanging the Left Rail	20
FIGURE 2-5	Securing the Left Rail to the Front of the Cabinet	21
FIGURE 2-6	Inserting Screws in the Lower Side Mounting Holes of the Cabinet	22
FIGURE 2-7	Loosening the Rail Screws to Adjust the Rail Length	23
FIGURE 2-8	Positioning the Rack Alignment Template	24
FIGURE 2-9	Securing the Left Rail to the Front of the Cabinet	25
FIGURE 2-10	Adjusting the Length of the Left Rail at the Back of the Cabinet	26
FIGURE 2-11	Securing the Right Rail to the Back of the Cabinet	27
FIGURE 2-12	Tightening the Adjusting Screws	28
FIGURE 2-13	Removing the End Caps on the Enclosure	29

FIGURE 2-14	Positioning the Enclosure in the Cabinet	30
FIGURE 2-15	Sliding the Enclosure Into the Cabinet	31
FIGURE 2-16	Securing the Enclosure to the Front of a Sun StorEdge Expansion Cabinet	32
FIGURE 2-17	Securing the Enclosure to the Front of a Sun Rack 900/1000 Cabinet	33
FIGURE 2-18	Securing the Enclosure to the Back of the Cabinet	34
FIGURE 2-19	Tray ID Switch	35
FIGURE 3-1	Sun StorEdge 5310 NAS Appliance HBA Cards and Controller Enclosure Ports	39
FIGURE 3-2	Connecting the Sun StorEdge 5310 NAS Appliance to the Controller Enclosure	40
FIGURE 3-3	Connecting Two HBA Cards to the Controller Enclosure	41
FIGURE 3-4	Connecting the Sun StorEdge 5310 NAS Appliance to Two Controller Enclosures	42
FIGURE 3-5	Controller Enclosure and Expansion Enclosure Ports	43
FIGURE 3-6	Controller Enclosure and One Expansion Enclosure Cable Interconnection	44
FIGURE 3-7	Controller Enclosure and Two Expansion Enclosures Cable Interconnection	45
FIGURE 3-8	Controller Enclosure and Three Expansion Enclosures Cable Interconnection	46
FIGURE 3-9	Controller Enclosure and Seven Expansion Enclosures Cable Interconnection	48
FIGURE 3-10	Connecting to a Fast Ethernet or Gigabit Ethernet Network	50
FIGURE 3-11	Connecting to an Optical Gigabit Network	51
FIGURE 3-12	Power Button and Front Panel Detail	53
FIGURE 4-1	Sun StorEdge 5310 Cluster HBA Cards and Controller Enclosure Ports	61
FIGURE 4-2	Connecting Pairs of HBA Cards to One Controller Enclosure	62
FIGURE 4-3	Connecting the Sun StorEdge 5310 Cluster to Two Controller Enclosures, Steps 1-4	64
FIGURE 4-4	Connecting the Sun StorEdge 5310 Cluster to Two Controller Enclosures, Steps 5-8	65
FIGURE 4-5	Controller Enclosure and Expansion Enclosure Ports	66
FIGURE 4-6	Controller Enclosure and One Expansion Enclosure Cable Interconnection	67
FIGURE 4-7	Controller Enclosure and Two Expansion Enclosures Cable Interconnection	68
FIGURE 4-8	Controller Enclosure and Three Expansion Enclosures Cable Interconnection	69
FIGURE 4-9	Controller Enclosure and Seven Expansion Enclosures Cable Interconnection	71
FIGURE 4-10	Connecting to a Fast Ethernet Network	73
FIGURE 4-11	Connecting to an Optical Gigabit Ethernet Network	74

FIGURE 4-12	Power Button and Front Panel Detail	78
FIGURE 5-1	Connecting Two HBA Ports to the Sun StorEdge 6920 System	89
FIGURE 5-2	Connecting All HBA Ports to the Sun StorEdge 6920 System	90
FIGURE 5-3	Connecting Two HBA Ports per HA Server to the Sun StorEdge 6920 System	91
FIGURE 5-4	Connecting All HBA Ports per HA Server to the Sun StorEdge 6920 System	92
FIGURE 5-5	Connecting Two HBA Ports Using Fabric Switches to the Sun StorEdge 6920 System	94
FIGURE 5-6	Connecting All HBA Ports Through Fabric Switches to the Sun StorEdge 6920 System	95
FIGURE 5-7	Connecting All HBA Ports Through Two Fabric Switches to the Sun StorEdge 6920 System	97
FIGURE 5-8	Connecting Two HBA Ports per HA Server Through Fabric Switches to the Sun StorEdge 6920 System	99
FIGURE 5-9	Connecting Two HBA Ports per HA Server Through Fabric Switches to the Sun StorEdge 6920 System with Additional Switch Connections	101
FIGURE 5-10	Connecting All HBA Ports per HA Server Through Two Fabric Switch Zones to the Sun StorEdge 6920 System	103
FIGURE 5-11	Connecting Two HBA Ports to the Sun StorEdge 9970/9980	105
FIGURE 5-12	Connecting All HBA Ports to the Sun StorEdge 9970/9980	106
FIGURE 5-13	Connecting Two HBA Ports per HA Server to the Sun StorEdge 9970/9980	107
FIGURE 5-14	Connecting All HBA Ports per HA Server to the Sun StorEdge 9970/9980	108
FIGURE 5-15	Connecting Two HBA Ports Through Fabric Switches to the Sun StorEdge 9970/9980	110
FIGURE 5-16	Connecting All HBA Ports Through Fabric Switches to the Sun StorEdge 9970/9980	111
FIGURE 5-17	Connecting All HBA Ports Through Two Fabric Switches to the Sun StorEdge 9970/9980	112
FIGURE 5-18	Connecting Two HBA Ports per Independent Server Through Fabric Switches to the Sun StorEdge 9970/9980	114
FIGURE 5-19	Connecting Two HBA Ports per HA Server Through Fabric Switches to the Sun StorEdge 9970/9980	116
FIGURE 5-20	Connecting Two HBA Ports per HA Server Through Fabric Switches to the Sun StorEdge 9970/9980 With Additional Switch Connections	117
FIGURE 5-21	Connecting All HBA Ports per HA Server Through Two Fabric Switches to the Sun StorEdge 9970/9980	119
FIGURE 5-22	Connecting to a Fast Ethernet or a Gigabit Ethernet Network	120
FIGURE 5-23	Connecting to an Optical Gigabit Ethernet Network	121
FIGURE 5-24	Dual Head HA NIC Ports	121

FIGURE 5-25	Dual Head HA Optical Gigabit Ethernet and NIC Ports	122
FIGURE 5-26	Power Button and Front Panel Detail	123

Preface

The *Sun StorEdge 5310 NAS Appliance and Gateway System Getting Started Guide* is a combined installation, configuration, and getting started guide for the Sun StorEdge™ 5310 NAS Appliance, the Sun StorEdge 5310 Cluster, and the Sun StorEdge™ 5310 NAS Gateway System. This guide describes how to install rackmounting rails and external storage arrays, how to connect servers and storage, and how to configure the system.

Before You Read This Book

Before you begin to install the system, you must have already prepared the site as described in these books:

- *Sun StorEdge 5310 NAS Appliance Safety and Regulatory Manual*
- *Sun StorEdge 5300 RAID Expansion Unit and Sun StorEdge 5300 Expansion Unit Safety and Regulatory Manual* (if using external storage arrays)
- *Sun Rack Installation Guide* or *Sun StorEdge Expansion Cabinet Installation and Service Manual*

How This Document Is Organized

This guide contains instructions for installing and configuring all variations of the Sun StorEdge 5310 NAS Appliance, the Sun StorEdge 5310 Cluster, and the Sun StorEdge 5310 NAS Gateway System. These configurations are each described in a separate chapter. You only need to read the chapters pertinent to your installation.

Chapter 1 provides an overview of system features.

Chapter 2 describes railmounting, applicable to Sun StorEdge 5310 NAS Appliance and Sun StorEdge 5310 Cluster configurations.

Chapter 3 describes how to set up the Sun StorEdge 5310 NAS Appliance with external storage arrays (Sun StorEdge 5300 RAID EU controller enclosure and optional Sun StorEdge 5300 EU expansion enclosures) and applies only to that setup.

Chapter 4 describes how to set up the Sun StorEdge 5310 Cluster with external storage arrays (Sun StorEdge 5300 RAID EU controller enclosure and optional Sun StorEdge 5300 EU expansion enclosures) and applies only to that setup.

Chapter 5 describes how to set up the Sun StorEdge 5310 NAS Gateway System with SAN storage and applies only to that setup.

Appendix A is a brief technical specification of the Sun StorEdge 5310 NAS Appliance system hardware.

Glossary is a list of words and phrases and their definitions.

Index is an alphabetical list of topics.

Typographic Conventions

Typeface*	Meaning	Examples
AaBbCc123	The names of commands, files, and directories; on-screen computer output	Edit your <code>.login</code> file. Use <code>ls -a</code> to list all files. % You have mail.
AaBbCc123	What you type, when contrasted with on-screen computer output	% su Password:
<i>AaBbCc123</i>	Book titles, new words or terms, words to be emphasized. Replace command-line variables with real names or values.	Read Chapter 6 in the <i>User's Guide</i> . These are called <i>class</i> options. You <i>must</i> be superuser to do this. To delete a file, type <code>rm filename</code> .

* The settings on your browser might differ from these settings.

Related Documentation

The documents listed as online are available at
http://www.sun.com/hwdocs/Network_Storage_Solutions/nas.

Application	Title	Part Number	Format	Location
Installation	<i>Sun StorEdge 5210 and 5310 NAS Appliance Release Notes</i>	819-2857- <i>nn</i>	PDF	Online
NAS Appliance Installation (non-Gateway)	<i>Setting Up the Sun StorEdge 5310 NAS</i>	819-1168- <i>nn</i>	Printed PDF	Shipping kit Online
Gateway	<i>Sun StorEdge 5310 NAS Gateway System</i>	819-3240- <i>nn</i>	Printed PDF	Shipping kit Online
GUI Usage	<i>Sun StorEdge 5310 NAS Appliance and Gateway System Administration Guide</i>	819-3238- <i>nn</i>	PDF	Online

Documentation, Support, and Training

Sun Function	URL	Description
Documentation	http://www.sun.com/documentation/	Download PDF and HTML documents, and order printed documents
Support and Training	http://www.sun.com/supporttraining/	Obtain technical support, download patches, and learn about Sun courses

Third-Party Web Sites

Sun is not responsible for the availability of third-party web sites mentioned in this document. Sun does not endorse and is not responsible or liable for any content, advertising, products, or other materials that are available on or through such sites or resources. Sun will not be responsible or liable for any actual or alleged damage or loss caused by or in connection with the use of or reliance on any such content, goods, or services that are available on or through such sites or resources.

Sun Welcomes Your Comments

Sun is interested in improving its documentation and welcomes your comments and suggestions. You can submit your comments by going to:

<http://www.sun.com/hwdocs/feedback>

Please include the title and part number of your document with your feedback:

Sun StorEdge 5310 NAS Appliance and Gateway System Getting Started Guide, part number 819-3237-10

System Overview

This chapter describes the components and terminology of the Sun StorEdge™ 5310 NAS Appliance, the Sun StorEdge 5310 Cluster, and the Sun StorEdge™ 5310 NAS Gateway System. It includes the following sections:

- "System Features" on page 1
 - "Hardware Overview" on page 4
 - "Software Overview" on page 9
-

System Features

The Sun StorEdge 5310 NAS Appliance is the Sun Microsystems modular, scalable network-attached storage solution and is available in several configurations:

- Sun StorEdge 5310 NAS Appliance single head server, with RAID controller enclosure and optional expansion enclosures available for back-end storage
- Sun StorEdge 5310 Cluster with two NAS servers for high availability and failover protection, with RAID controller enclosure and optional expansion enclosures available for back-end storage
- Sun StorEdge 5310 NAS Gateway System single head server that shares storage with other servers in a SAN
- Sun StorEdge 5310 NAS Gateway System with two servers in a cluster configuration for high availability and failover protection that share storage with other servers in a SAN

Note – For the most current support information, contact your Sun sales representative.

Supported File Access Protocols

- Microsoft networks (CIFS/SMB)
- UNIX® (NFS V2 and V3)
- File Transfer Protocol (FTP)

Network Security and Protocol Integration

- Network Logon (Netlogon) client
- Windows Domain support
- Multiple Master Domain (MMD) support
- CIFS Security Descriptors (SD) on file and directories
- Discretionary Access Control Lists (DACL) on files and directories
- NIS
- NIS+
- Unicode
- Windows Active Directory Service (ADS) support
- Windows Dynamic DNS support
- Windows-compatible Kerberos (v5) security
- Windows-compatible Lightweight Directory Access Protocol (LDAP)
- LDAP authentication for NFS
- Network Time Protocol (NTP)
- SYSLOGD Remote Logging
- Simple Network Management Protocol (SNMP)

Supported Clients

A client is any computer on the network that requests file services from the Sun StorEdge 5x10 NAS Appliance. In general, if a client implementation follows the NFS version 2 or 3 protocol or the CIFS specifications, it is supported with the Sun StorEdge 5x10 NAS Appliance.

Network Connection

- Autosensing 10/100/1000 BASE-TX, dual RJ-45 network connector
- Optional dual port optical gigabit Ethernet NIC card

Automatic IP Address Assignment

- Supports DHCP and ARP for automatic assignment of IP address

RAID Controllers (Non-Gateway Systems)

- Controller enclosure with two RAID controllers configured for Fibre Channel (FC) or for Serial ATA (SATA) disk drives

SAN Storage (Gateway Systems)

- Direct attachment or fabric connection to Sun StorEdge 6920 system or Sun StorEdge 9970/9980

Data Management

- Sun StorEdge File Checkpoint facility allows users to recover accidentally damaged or deleted data with a simple file copy operation
- Directory Tree Quotas
- User and Group Quotas

Setup and Configuration

- Web-based user interface for system configuration and administration
- Command-line interface for use by service personnel (refer to the *Sun StorEdge 5310 NAS Appliance and Gateway System Administration Guide*)

Client Data Backup

- Network Data Management Protocol (NDMP), V2 and V3
- Enterprise Backup Software 7.2
- Veritas NetBackup 5.x
- Compatible with BakBone NetVault 7, supported by BakBone

Hardware Overview

The following system configurations are available:

- Sun StorEdge 5310 NAS Appliance with back-end storage
- Sun StorEdge 5310 Cluster with back-end storage
- Sun StorEdge 5310 NAS Gateway System (single server) with SAN storage
- Sun StorEdge 5310 NAS Gateway System High-Availability dual server in a cluster configuration with SAN storage

The sections that follow describe each of the system components.

Sun StorEdge 5310 NAS Appliance Server

The Sun StorEdge 5310 NAS Appliance server is the basic server unit for all system configurations.



FIGURE 1-1 Sun StorEdge 5310 NAS Appliance Front View



FIGURE 1-2 Sun StorEdge 5310 NAS Appliance With Faceplate Removed

In the Sun StorEdge 5310 NAS Appliance configuration, the server can contain one or two dual port HBA cards and an optional dual port optical gigabit Ethernet card.

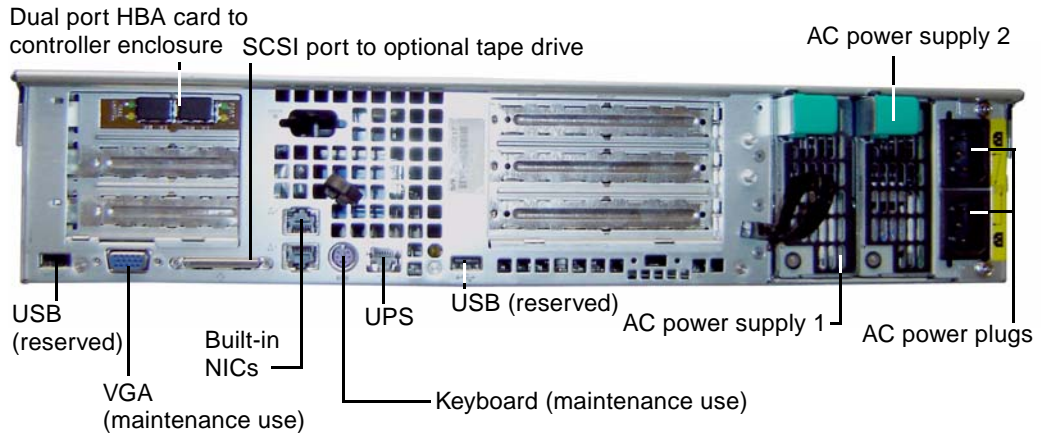

FIGURE 1-3 Sun StorEdge 5310 NAS Appliance Back Panel With Single HBA Card

In the Sun StorEdge 5310 Cluster configuration, two High-Availability (HA) servers are sold as a matched pair and are identified as server “-H1” and server “-H2” in their software serial numbers (printed on the software license serial number label on the left side of the chassis). Each server contains two dual port HBA cards and a 10/100 BASE-T NIC card. Optionally, the servers contain dual port optical gigabit Ethernet cards instead of 10/100 BASE-T NIC cards.

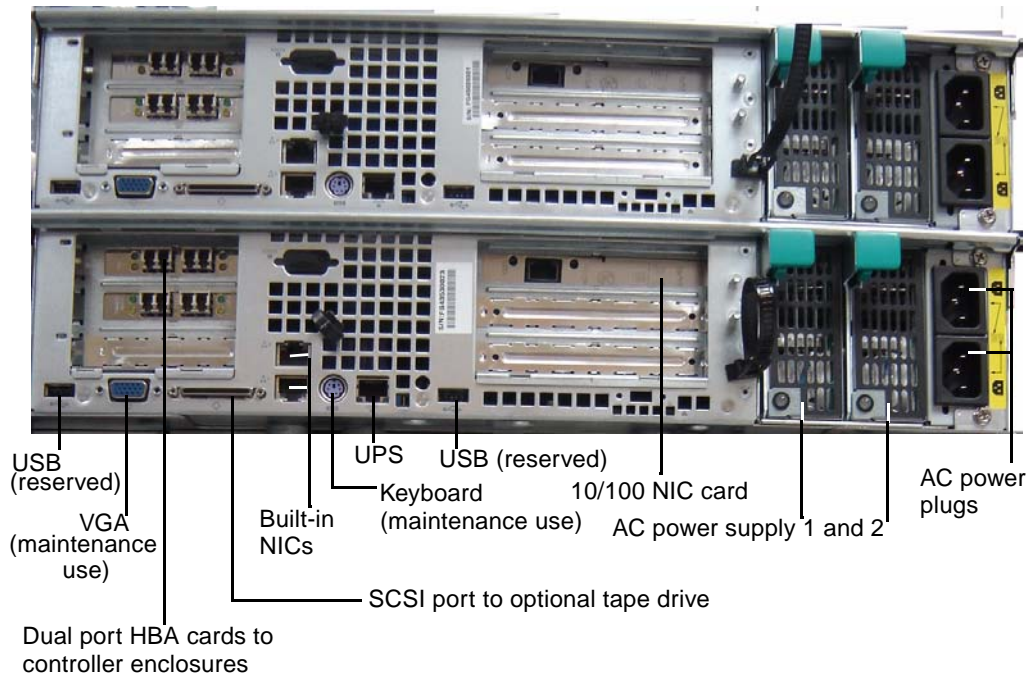

FIGURE 1-4 Sun StorEdge 5310 Cluster Back Panel With Two HBA Cards

In the Sun StorEdge 5310 NAS Gateway System single server configuration, the server contains two dual port HBA cards and an optional dual port optical gigabit Ethernet card.

In the Sun StorEdge 5310 NAS Gateway System dual server HA cluster configuration, the servers are sold as a matched pair and are identified as server “-H1” and server “-H2.” Each server contains two dual port HBA cards and two 10/100 BASE-T NIC cards. Optionally, the servers contain dual port optical gigabit Ethernet cards instead of 10/100 BASE-T NIC cards.

Back-End Storage

The Sun StorEdge 5300 RAID EU Controller Enclosure provides direct-attached back-end storage for the Sun StorEdge 5310 NAS Appliance or Sun StorEdge 5310 Cluster. Systems can be set up with one or two controller enclosures using all Fibre Channel disk drives or all SATA disk drives in one enclosure.



FIGURE 1-5 Sun StorEdge 5300 RAID EU Controller Enclosure Front, With Fibre Channel Disk Drives

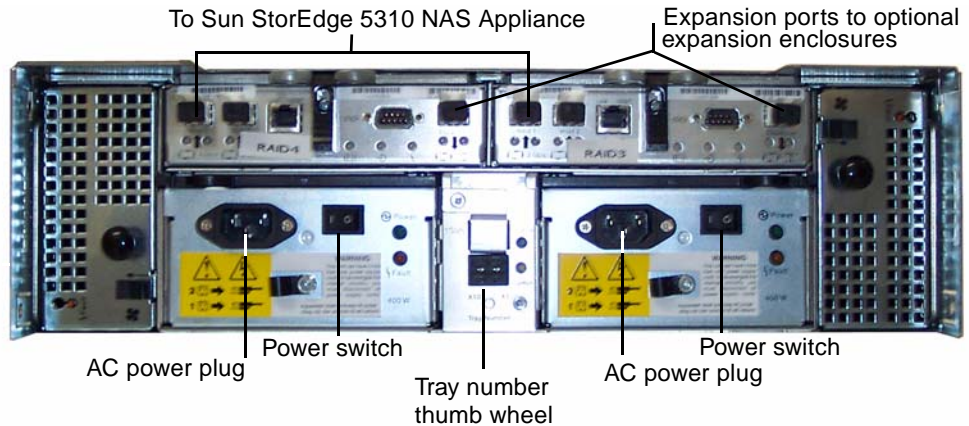

FIGURE 1-6 Sun StorEdge 5300 RAID EU Controller Enclosure Back Panel

There are two kinds of Sun StorEdge 5300 EU Expansion Enclosures that can be used with the controller enclosures: Sun StorEdge 5300 EU F (Fibre Channel disk drives only) and Sun StorEdge 5300 EU S (SATA disk drives only).



FIGURE 1-7 Sun StorEdge 5300 EU F Expansion Enclosure Front, With Fibre Channel Disk Drives

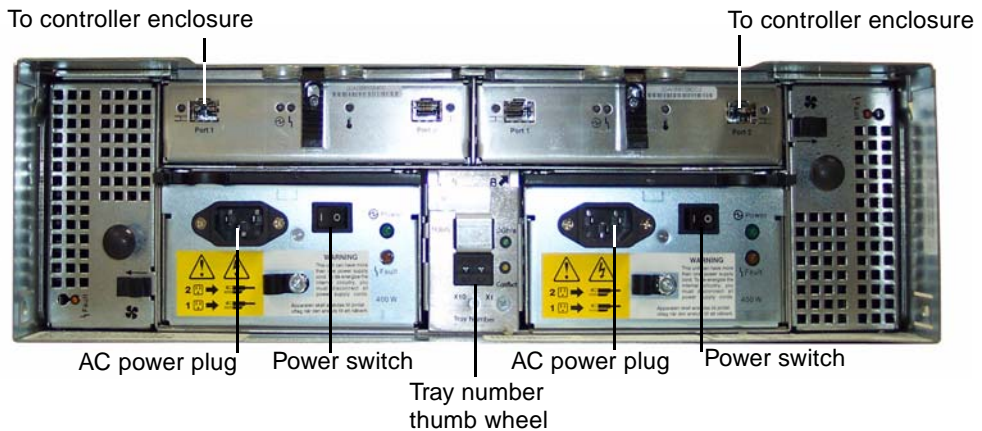

FIGURE 1-8 Sun StorEdge 5300 EU Expansion Enclosure Back Panel

SAN Storage

The Sun StorEdge 5310 NAS Gateway System can connect directly or through fabric switches to the following SAN storage:

- Sun StorEdge 6920 system
- Sun StorEdge 9970/9980

Software Overview

There are three major software components to consider:

- Web Administrator
- Command-line interface
- Licensed options

The software is described in detail in the *Sun StorEdge 5310 NAS Appliance and Gateway System Administration Guide*.

Web Administrator

The Sun StorEdge 5310 NAS Appliance ships with the Web Administrator software installed. Other than a standard web browser, you do not need to install any software to manage your system.

The Web Administrator graphical user interface (GUI) is easy to use and lets you configure system parameters through a series of menus and tab screens, or panels. These tab screens and settings are discussed in the *Sun StorEdge 5310 NAS Appliance and Gateway System Administration Guide*.

Web Administrator Requirements

To access the Web Administrator management interface, you must have the following software:

- Windows® 98/NT/2000/XP/2003, Sun Solaris™ Operating System 5.7 (minimum version), or Red Hat Linux
- Internet Explorer 5.5 (minimum version) on systems using Windows 98/NT/2000/XP/2003

or

- Netscape™ software 4.77 (minimum version) on systems using Windows 98/NT/2000/XP/2003 and Sun Solaris OS. *Netscape 6.0 and 6.01 are not supported.*
- Mozilla™ browser.
- Java™ platform-enabled browser with Java Plug-In 1.3.1 (minimum version).

Note – To download the latest Java Plug-In, go to <http://java.com>.

Command-Line Interface

An alternative to the Web Administrator is the command-line interface (CLI). You can use a number of protocols such as Telnet, SSH, or RLogin to connect to the CLI as long as the application you use has an ANSI-compatible terminal emulator. The CLI is described in Appendix A in the *Sun StorEdge 5310 NAS Appliance and Gateway System Administration Guide*.

Licensed Options

There are several licensed options you can purchase for the system. The following options are available:

- Sun StorEdge File Replicator, which allows you to duplicate data from one volume onto a mirrored volume on a different Sun StorEdge 5310 NAS Appliance, Sun StorEdge 5310 Cluster, or Sun StorEdge 5310 NAS Gateway System (typically used for transaction-oriented systems)
- Compliance Archiving Software, which allows you to enable volumes to follow strict compliance archiving guidelines for data retention and protection

Note – The Compliance Archiving Software is not supported on the Sun StorEdge 5310 NAS Gateway System.

- Sun StorEdge NAS Gateway System, which allows you to use your system as a gateway connection to SAN storage

The options and how to activate them are described in Chapter 9 in the *Sun StorEdge 5310 NAS Appliance and Gateway System Administration Guide*.

Installing Storage Enclosures

Use the procedures in this chapter to install Sun StorEdge 5310 NAS Appliance back-end storage in a Sun StorEdge Expansion or Sun™ Rack 900/1000 cabinet.

Note – This chapter does not apply to installing a Sun StorEdge 5310 NAS Gateway System. To install the Sun StorEdge 5310 NAS Gateway System servers, refer to the rail-mounting installation instructions contained in the rackmount kit.

The number of storage enclosures you need to install depends on your overall storage requirements. You can install a maximum of eight storage enclosures (one controller enclosure and up to seven expansion enclosures) in a Sun cabinet.

This chapter describes the process of installing Sun StorEdge 5310 NAS Appliance heads, controller enclosures, and expansion enclosures. It contains the following sections:

- “Preparing for the Installation” on page 12
- “Attaching the CAM100 3RU Rails to a Cabinet” on page 17
- “Installing an Enclosure in a Cabinet” on page 29
- “Connecting the Power Cables” on page 34
- “Setting the Tray ID” on page 35
- “Back-End Storage Cabling” on page 36

The installation procedures in this chapter require the following items:

- No. 2 Phillips screwdriver
- No. 3 Phillips screwdriver
- Antistatic protection



Caution – Electrostatic discharge can damage sensitive components. Touching the array or its components without using a proper ground might damage the equipment. To avoid damage, use proper antistatic protection before handling any components.

Preparing for the Installation

Use the following procedures to prepare for installation:

- “Preparing the CAM100 3RU Rackmount Kit” on page 14
- “Preparing the Controller and Expansion Enclosures” on page 15
- “Preparing the Cabinet” on page 15

Before You Begin

Before you begin rackmounting, do the following:

- Check that the maximum ambient operating temperature in the rack does not exceed 95° F (35° C).
- Pick a location that allows unrestricted air flow for the cooling fans.
- Make sure that mounting the units into the rack will not tip over the rack, even when the units are fully extended from the rack.
- Install the components so that the rack is stable. Begin loading from the bottom of the rack to the top.



Caution – Uneven loading of the rack can cause dangerous instability.

- Make sure the rack cabinet has two power sources connected to two separate power circuits.
- Make sure the power outlets are close enough to the units for the power cords to reach the cabinet properly and supply power to the units.
- Make sure the power cables are properly grounded.

Grounding Procedure

You must maintain reliable grounding of this equipment. Review specifications in Appendix A to determine the appropriate AC branch circuit size for the quantity of units in your configuration and your operating voltage. Always follow your local electrical codes for loading circuits.



Caution – The Sun StorEdge 5310 NAS Appliance, controller enclosure, and expansion enclosures contain several components sensitive to static-electrical discharge. Surges of static electricity (caused by shuffling your feet across a floor and touching a metallic surface, for example) can cause damage to electrical components. For this reason, it is important that proper packaging and grounding techniques be observed. Follow the procedures below.

- Transport products in static-safe containers.
- Cover work stations with approved static-dissipating material.
- Wear a wrist strap, and always be properly grounded when touching static-sensitive equipment or parts.
- Use only properly grounded tools and equipment.
- Avoid touching pins, leads, or circuitry.

To avoid damaging any internal components with static electricity, follow these instructions before performing any installation procedures.

1. **For all units, make sure that the units are turned off and that both power cables are plugged in.**
2. **Wear a wrist strap, and always be properly grounded when touching static-sensitive equipment or parts.**

If a wrist strap is not available, touch any unpainted metal surface on the back panel of any unit to dissipate static electricity. Repeat this procedure several times during installation.

3. **Avoid touching exposed circuitry, and handle components by their edges only.**



Caution – Do not power on any units until after you have connected the Sun StorEdge 5310 NAS Appliance to the network.

Review specifications in Appendix A to determine isolation and continuous power requirements.

Mains AC Power Disconnect—You are responsible for installing an AC power disconnect for the entire rack unit. This power source disconnect must be readily accessible, and it must be labeled as controlling power to the entire rack unit, not only to the servers.

Grounding the Rack Installation—To avoid the potential for an electrical shock hazard, you must include a third-wire safety ground conductor with the rack installation. The safety grounding conductor must be a minimum 14 AWG connected to the earth ground stud on the rear of the server. The safety ground conductor should be connected to the chassis stud with a two-hole crimp terminal with a maximum width of 0.25 inch. The nuts on the chassis should be installed with a 10 in/lb torque. The safe ground conductor provides proper grounding only for the Sun StorEdge 5310 NAS Appliance. You must provide additional proper grounding for the rack and other devices installed in it.

Preparing the CAM100 3RU Rackmount Kit

Note – For NAS head installation, refer to the Sun LX50/Sun Fire V60x/Sun Fire V65x rail-mounting kit rail kit instructions.

Unpack the rackmount kit and check the contents. The CAM100 3RU rail kit contains the following items:

- Left front (P/N 341-04443-01) and back (P/N 341-0444) rails
- Right front (P/N 341-04445-01) and back (P/N 341-0446) rails
- Mounting hardware as listed below:

Quantity	Type	Used With
8	8-32 (small) panhead screw	All Sun cabinets
8	10-32 (medium) panhead screw	Sun StorEdge Expansion cabinet
12	Metric M6 (large) panhead screw	Sun Rack 900/1000 cabinet

Note – The kit may have extra screws.

The rails can be adjusted to fit the cabinets.

Preparing the Controller and Expansion Enclosures



Caution – Two people are needed to lift and move the controller enclosure and expansion enclosures. Use care to avoid injury. An enclosure can weigh up to 95 pounds (43 kg). Do not lift the front of the enclosure; this can cause damage to the drives.

1. **Unpack the enclosure.**
2. **Check the contents of the box for the following items:**
 - Sun StorEdge 5300 enclosure (controller or expansion)
 - Ship kit for the controller enclosure
 - Two 5-meter optical Fibre Channel (FC) cables for connecting the RAID controller enclosure to your Sun StorEdge 5310 NAS Appliance
 - Two 6-meter RJ45 -RJ45 Ethernet cables
 - Sun StorEdge 6130 Array Rack Alignment Template
 - Documentation URL brochure
 - Ship kit for the expansion enclosure
 - Two 2-meter copper FC cables
 - Documentation URL brochure

Preparing the Cabinet

Select the cabinet in which you will be installing the Sun StorEdge 5310 NAS Appliance system. Be sure the cabinet is installed as described in the installation instructions provided with it.

1. **Stabilize the cabinet as described in the cabinet documentation.**
2. **If the cabinet has casters, make sure the casters are locked to prevent the cabinet from rolling.**
3. **Remove or open the top front panel.**
4. **Remove or open the vented back panel.**

Note – Sun Microsystems makes no warranties or guaranties as to fit, form, or function of the Sun StorEdge 5310 NAS Appliance system installed in third-party racks or cabinets. It is the customer’s responsibility to ensure that the rack or cabinet can house the Sun StorEdge 5310 NAS Appliance system in all conditions that may exist. All racks and cabinets must comply with local building and construction codes.

Unit Placement in the Cabinet

Consider these requirements before you attach the rails to the cabinet.

Note – If you are using two RAID EU controller enclosures, first mount the expansion enclosures for the second controller, then mount the second controller enclosure, and then follow steps 1-3.

Mount the units in the following order, from the bottom up:

1. Each EU expansion enclosure (if any) - from the bottom up

Leave room for any planned expansion.

2. The RAID EU controller enclosure

3. The Sun StorEdge 5310 NAS Appliance - on the top

If you are installing a cluster, install the servers as follows:

a. Sun StorEdge 5310 NAS Appliance server H2 (serial number ending “-H2”)

The serial number is printed on the software license serial number label on the left side of the chassis.

b. Sun StorEdge 5310 NAS Appliance server H1 (serial number ending “-H1”)



Sun StorEdge 5310 NAS Appliance (top)

5300 RAID EU controller enclosure (middle)

5300 EU expansion enclosure (bottom)

Front View - single controller enclosure, single expansion enclosure



Sun StorEdge 5310 NAS Appliance (top)

5300 RAID EU controller enclosure (middle)

5300 EU expansion enclosure (bottom)

Rear View - single controller enclosure, single expansion enclosure

FIGURE 2-1 Recommended Rackmounting Order

Starting at the bottom distributes the weight correctly in the cabinet.

Attaching the CAM100 3RU Rails to a Cabinet

The CAM100 3RU rails must be used to install the enclosures.

Note – For NAS head installation, refer to the Sun LX50/SunFire V60x/SunFire V65x rail-mounting kit instructions.

Depending on the type of Sun cabinet you have, use one of the following procedures to attach the rails:

- Attaching the Rails to the Sun StorEdge Expansion Cabinet
- Attaching the Rails to the Sun Rack 900/1000 Cabinet

Because this rail kit can be adapted for several cabinets, closely follow the procedures; they may require actions that you have not previously taken.

Note – In this section, you will loosely hang the rails from screws you attach to the side walls *before* connecting the rails to the front and back.

Attaching the Rails to the Sun StorEdge Expansion Cabinet

The procedure for attaching the rails to the Sun StorEdge Expansion cabinet and Sun Fire™ cabinet are the same, with one exception. For the Sun Fire cabinet, the rail extensions are not required, and the following procedure instructs you to remove the screws and the extension from each rail.

1. Use the No. 2 Phillips screwdriver to loosen the side-rail screws, and adjust each rail to its maximum length (FIGURE 2-2).

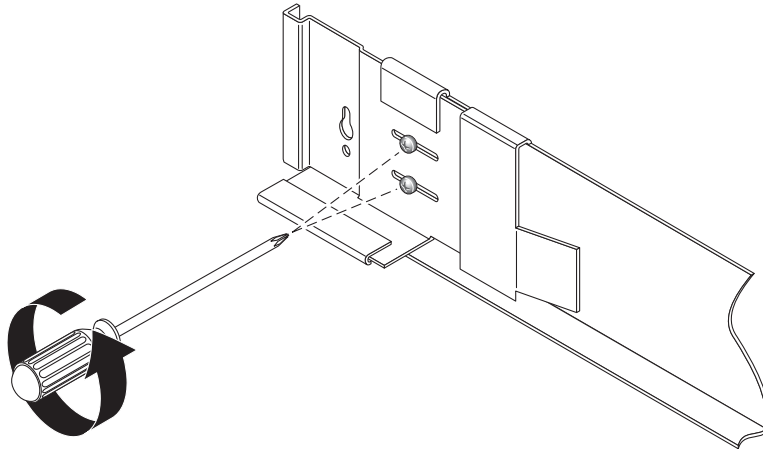

FIGURE 2-2 Loosening the Rail Screws to Adjust the Rail Length

2. Insert four 10-32 screws (two per side) in the front and back mounting holes of the cabinet (FIGURE 2-3). Do not tighten at this time. You will hang the side rails on these screws.

Use the numbered marks on the inside of the cabinet to be sure that all four screws are aligned and mounted at the same height. Use hole 10 for the first tray and hole 19 for the second.

3. Locate the proper mounting holes by using the rack alignment template for the Sun StorEdge Expansion cabinet (FIGURE 2-3).

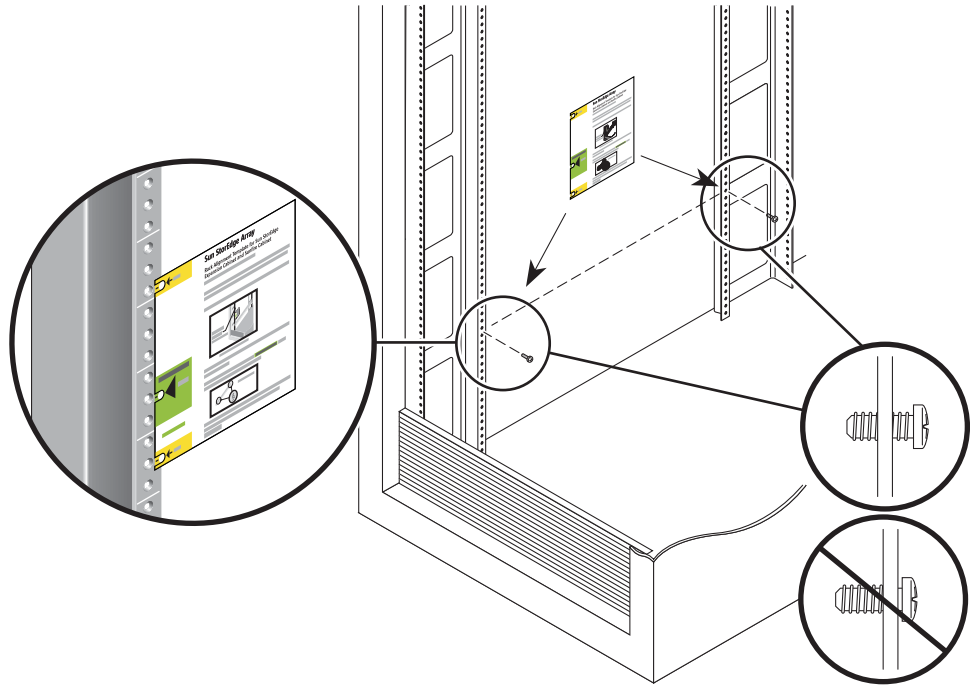

FIGURE 2-3 Inserting Mounting Hole Screws and Positioning the Rack Alignment Template

4. Place the template over the front left rail inside the cabinet.
5. Slide the template up and down until all three holes line up with the cabinet rail holes.
6. Note the screw hole number of the mounting hole that will be used by the keyhole slots in the rail (FIGURE 2-4).

You will use the same screw hole number for the front and back mounting holes on the left and right sides inside the cabinet.

7. Hang the left rail by aligning the large slots of the rail over the front and back screws and then pulling the rail down so that each screw is at the top of the slot (FIGURE 2-4). Repeat for the right rail.

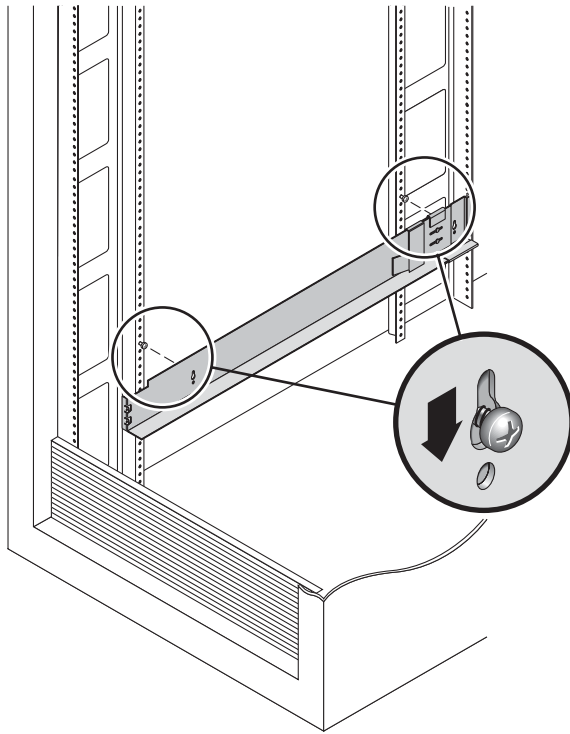

FIGURE 2-4 Hanging the Left Rail

8. Adjust the length of each rail to fit the cabinet.

- Using the No. 2 Phillips screwdriver, insert two 8-32 screws in the front of the left rail to secure the rail to the front of the cabinet (FIGURE 2-5). Repeat for the right rail.

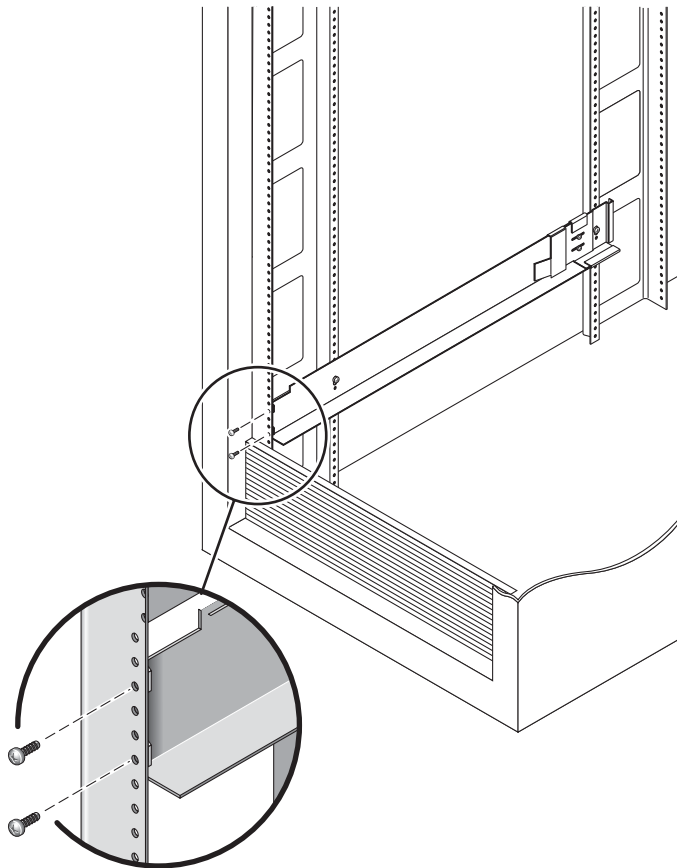

FIGURE 2-5 Securing the Left Rail to the Front of the Cabinet

- Using the No. 2 Phillips screwdriver, insert two 10-32 screws in the lower side mounting holes of the side rails (FIGURE 2-6). Use hole 8 for the first tray and hole 11 for the second tray. Repeat for the right rail.

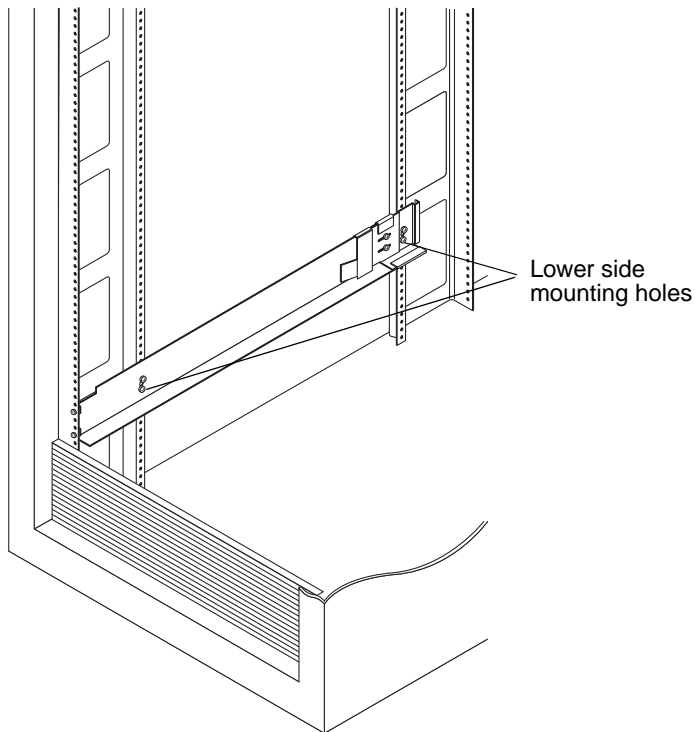

FIGURE 2-6 Inserting Screws in the Lower Side Mounting Holes of the Cabinet

- Tighten all six screws on the left and right rails.

Attaching the Rails to the Sun Rack 900/1000 Cabinet

1. Using the No. 2 Phillips screwdriver, loosen the side-rail screws and adjust each rail to its maximum length (FIGURE 2-7).

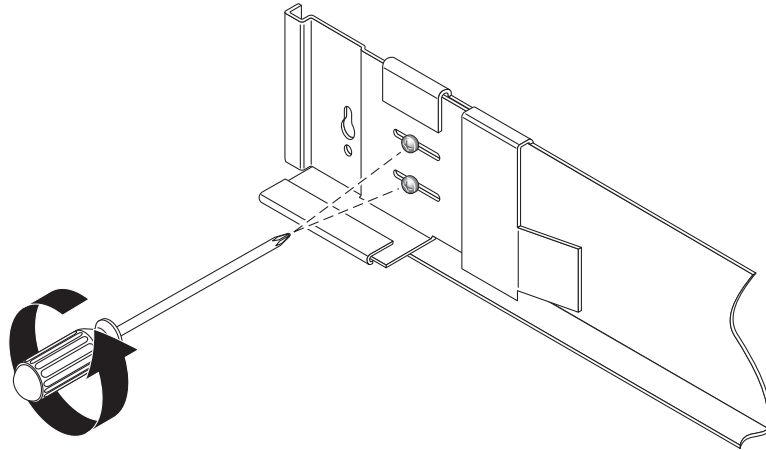

FIGURE 2-7 Loosening the Rail Screws to Adjust the Rail Length

2. **Locate the proper mounting holes by placing the rack alignment template for the Sun Rack 900/1000 cabinet over the front left cabinet rail (FIGURE 2-8).**

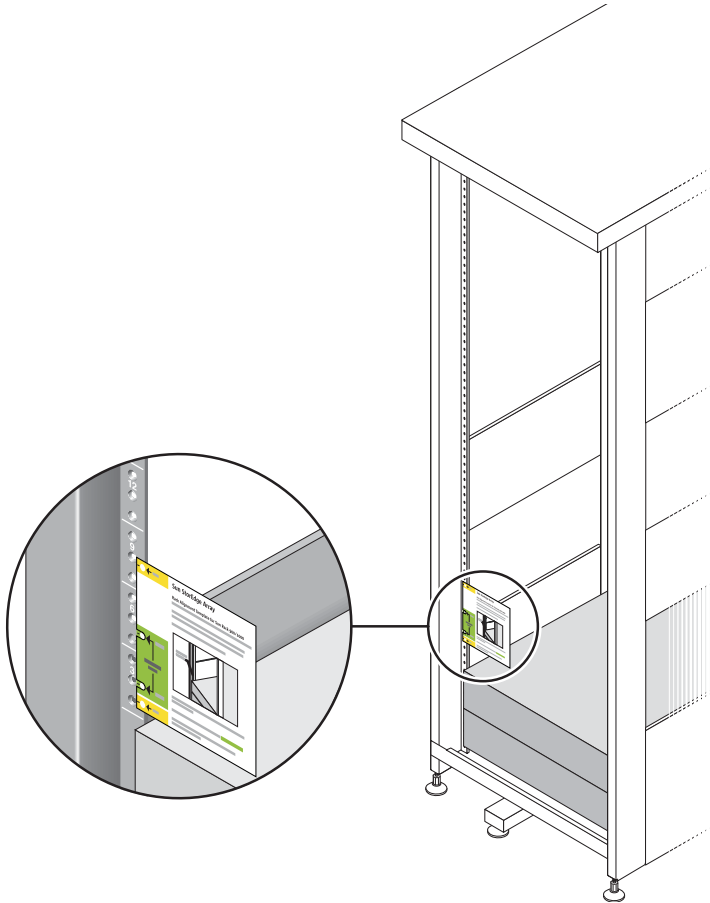

FIGURE 2-8 Positioning the Rack Alignment Template

3. **Slide the template up and down until all four holes line up with the cabinet rail holes.**
4. **Note the screw hole numbers of the two mounting holes.**

You will use the same screw hole numbers for the rest of this installation.

- Using the No. 2 Phillips screwdriver, insert and tighten two 8-32 screws to secure the left rail to the front of the cabinet (FIGURE 2-9). Repeat for the right rail.

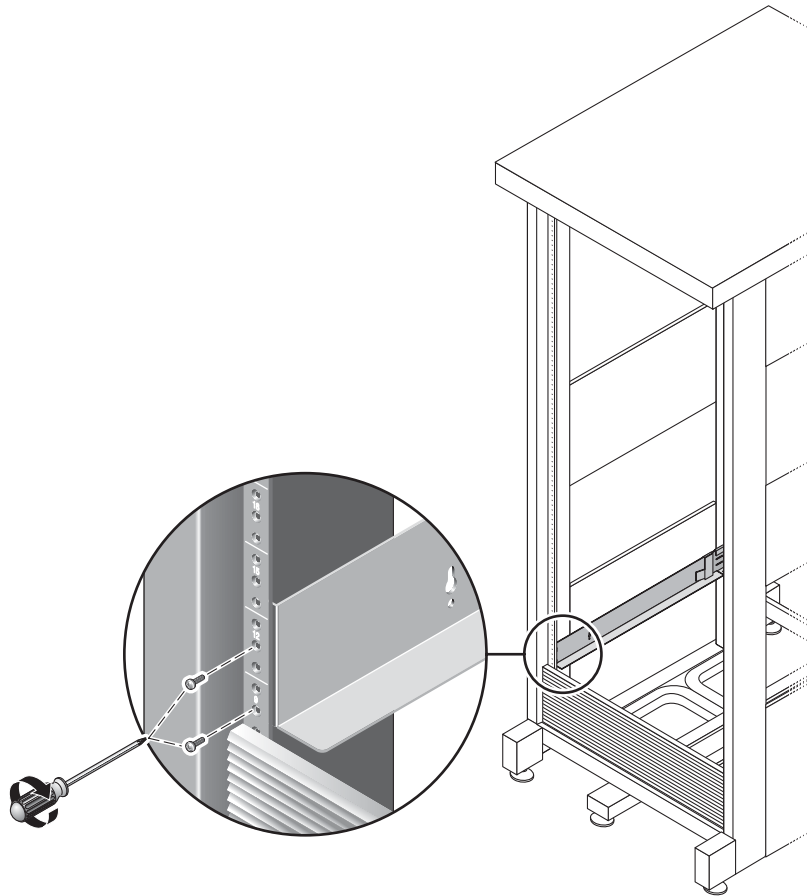

FIGURE 2-9 Securing the Left Rail to the Front of the Cabinet

6. At the back of the cabinet, adjust the length of each rail as needed to fit the cabinet, and position the rail flange over the vertical rail (FIGURE 2-10).

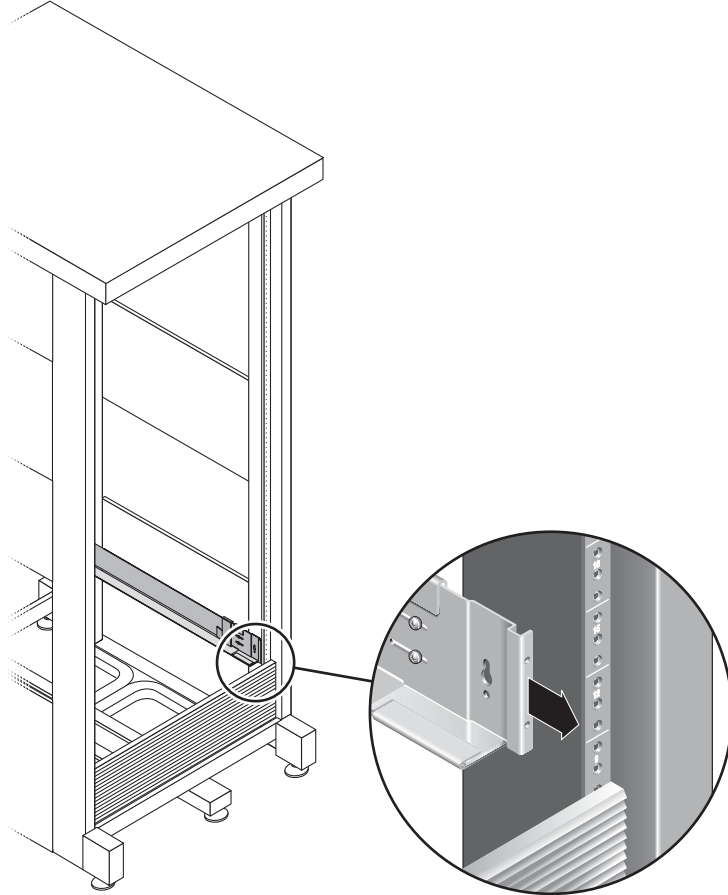

FIGURE 2-10 Adjusting the Length of the Left Rail at the Back of the Cabinet

7. Using the No. 3 Phillips screwdriver, insert and tighten the M6 screws on each side at the back of the rail (FIGURE 2-11).

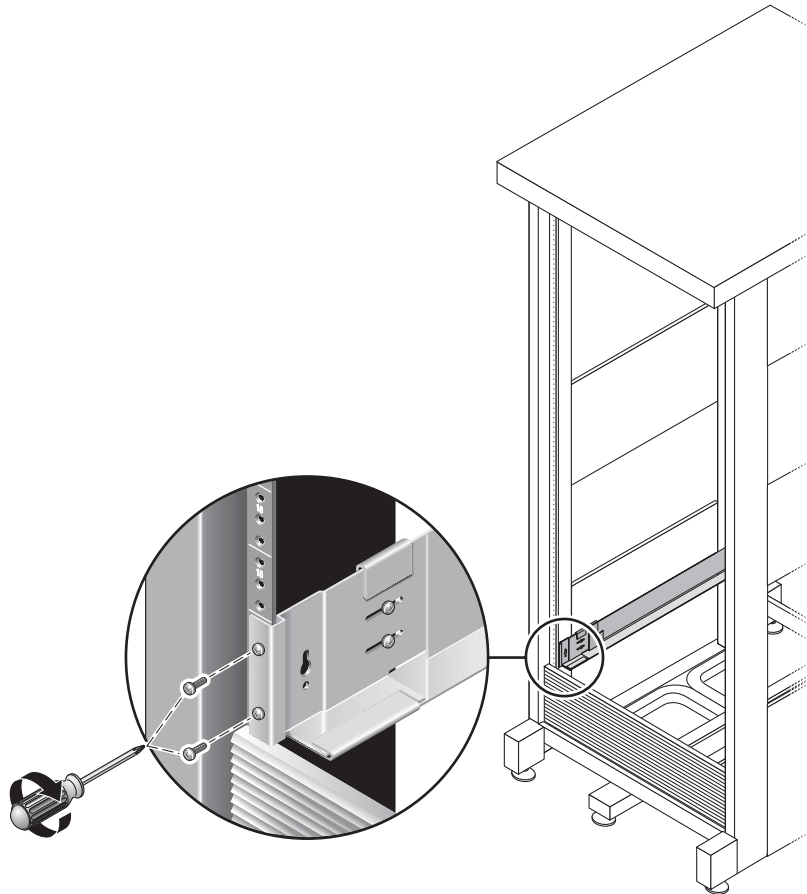

FIGURE 2-11 Securing the Right Rail to the Back of the Cabinet

- Using the No. 2 Phillips screwdriver, tighten the four adjusting screws (two on each side) toward the back of each rail (FIGURE 2-12).

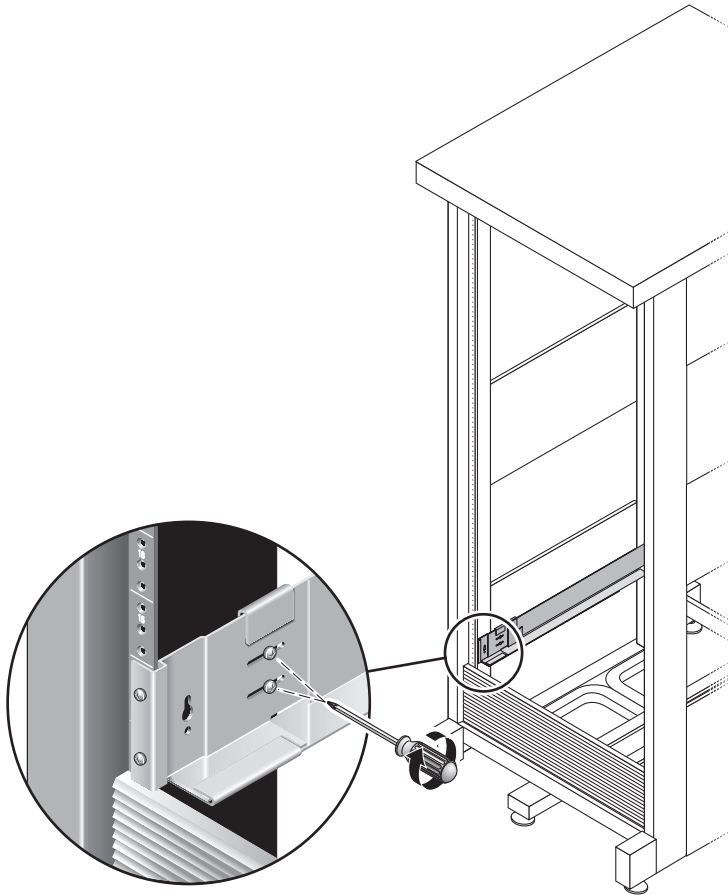

FIGURE 2-12 Tightening the Adjusting Screws

Installing an Enclosure in a Cabinet

If you are installing expansion enclosures, install the first one in the first empty slot at the bottom of the cabinet, and continue installing any additional expansion enclosures from the bottom up, followed by the controller enclosure. For information about order of enclosure installation, refer to "Unit Placement in the Cabinet" on page 16.

After installing each enclosure, you must connect its power cables and set the tray ID as described in "Setting the Tray ID" on page 35.

1. **Unsnap and remove the left and right end caps on the enclosure to permit access to the screw mounting holes (FIGURE 2-13).**

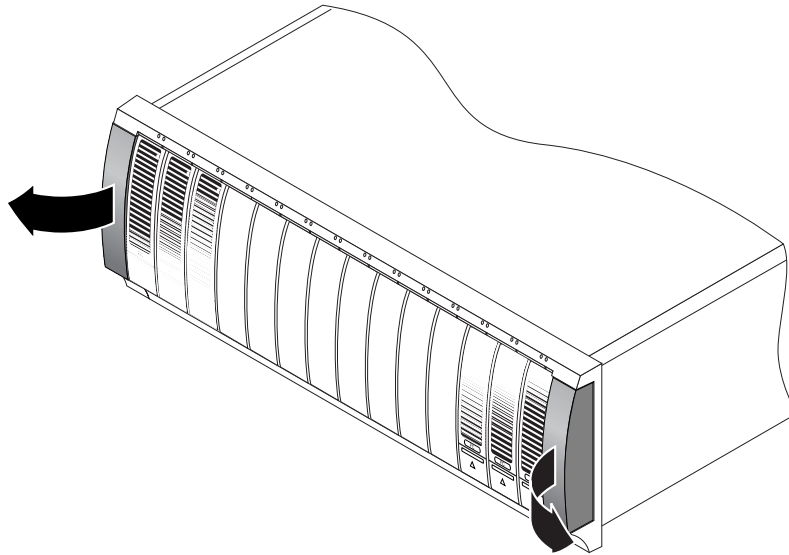

FIGURE 2-13 Removing the End Caps on the Enclosure

2. Using two people, one at each side of the enclosure, carefully lift and rest the enclosure on the bottom ledge of the left and right rails (FIGURE 2-14).



Caution – Use care to avoid injury. An enclosure can weigh up to 95 pounds (45 kg).

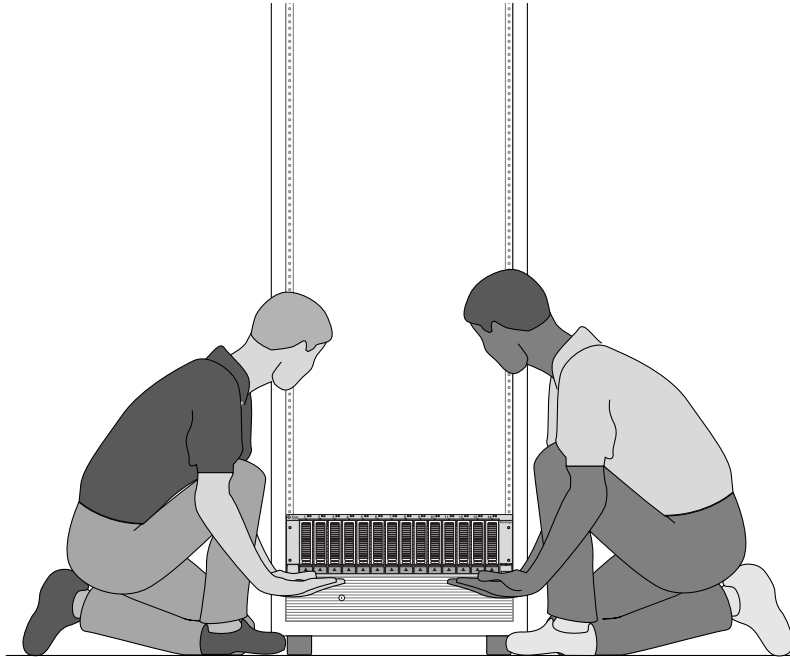

FIGURE 2-14 Positioning the Enclosure in the Cabinet

3. Carefully slide the enclosure into the cabinet until the front flanges of the enclosure touch the vertical face of the cabinet (FIGURE 2-15).

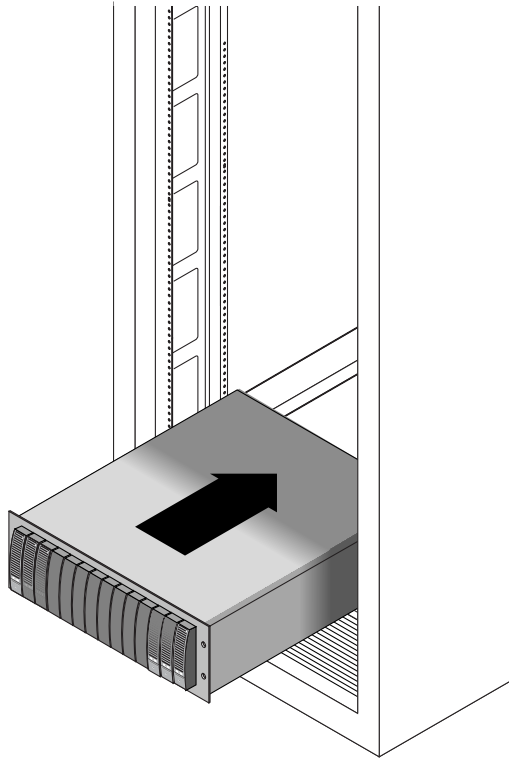

FIGURE 2-15 Sliding the Enclosure Into the Cabinet

4. Depending on the type of cabinet you have, do one of the following:

- For a Sun StorEdge Expansion cabinet, use the No. 2 Phillips screwdriver to insert and tighten four 10-32 screws (two per side) to secure the enclosure to the front of the cabinet (FIGURE 2-16).

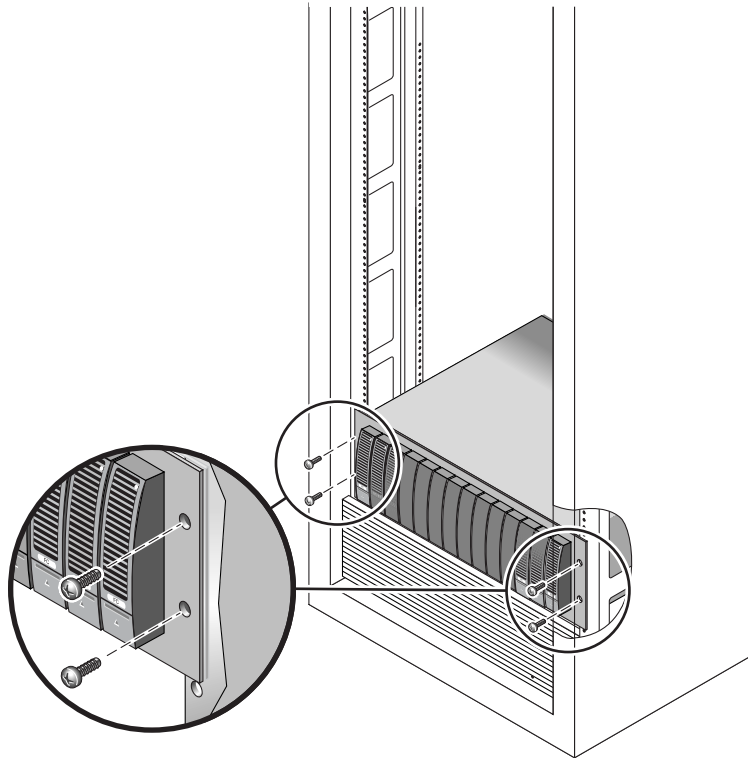

FIGURE 2-16 Securing the Enclosure to the Front of a Sun StorEdge Expansion Cabinet

- For a Sun Rack 900/1000 cabinet, use the No. 3 Phillips screwdriver to install and tighten four M6 screws (two per side) to secure the enclosure to the front of the cabinet (FIGURE 2-17).

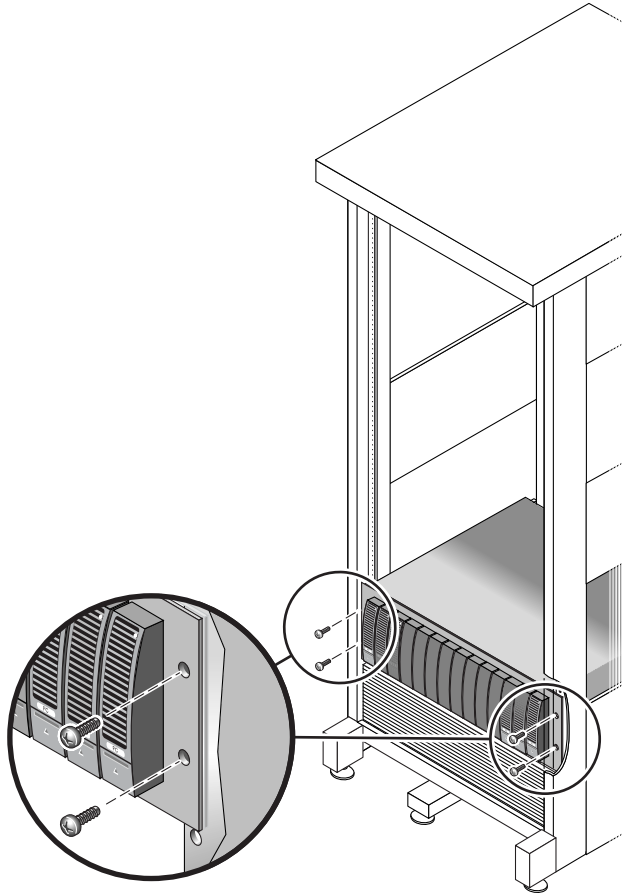

FIGURE 2-17 Securing the Enclosure to the Front of a Sun Rack 900/1000 Cabinet

5. **Replace the left and right end caps to hide the front mounting screws.**
The end caps snap onto the front bezel of the tray.

6. At the back of the enclosure, install and tighten two 8-32 screws (one per side) to secure the back of the enclosure to the cabinet (FIGURE 2-18).

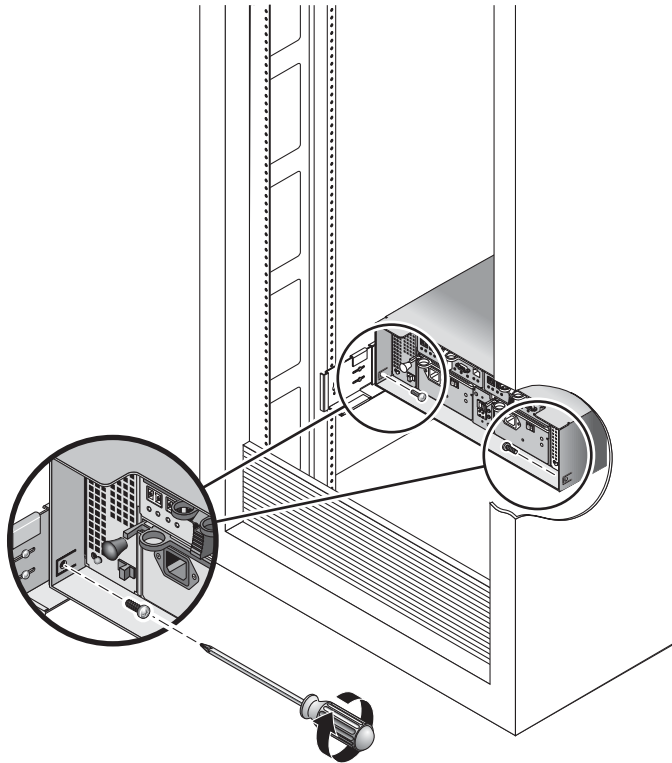

FIGURE 2-18 Securing the Enclosure to the Back of the Cabinet

Connecting the Power Cables

1. Verify that both power switches are off for each enclosure in the cabinet.
2. Connect each power supply in each enclosure to a separate power source in the cabinet.



Caution – The cabinet must have two power sources connected to two separate power circuits.

3. Connect each power supply in the Sun StorEdge 5310 NAS Appliance to a separate power source in the cabinet.

4. Connect the primary power cables from the cabinet to the external power source.

Note – Do not power on the units until you complete the procedures in this chapter. The power-on sequence is described in detail in "Powering On the Sun StorEdge 5310 NAS Appliance, Controller Enclosures, and Expansion Enclosures" on page 51.

Setting the Tray ID

You set the tray ID using the Tray ID switch at the back of the expansion enclosures and controller enclosures. You must set the tray ID of each enclosure to a unique number from 00 to 76.

1. Locate the Tray ID switch at the back of the controller enclosure, between the two power supplies (FIGURE 2-19).

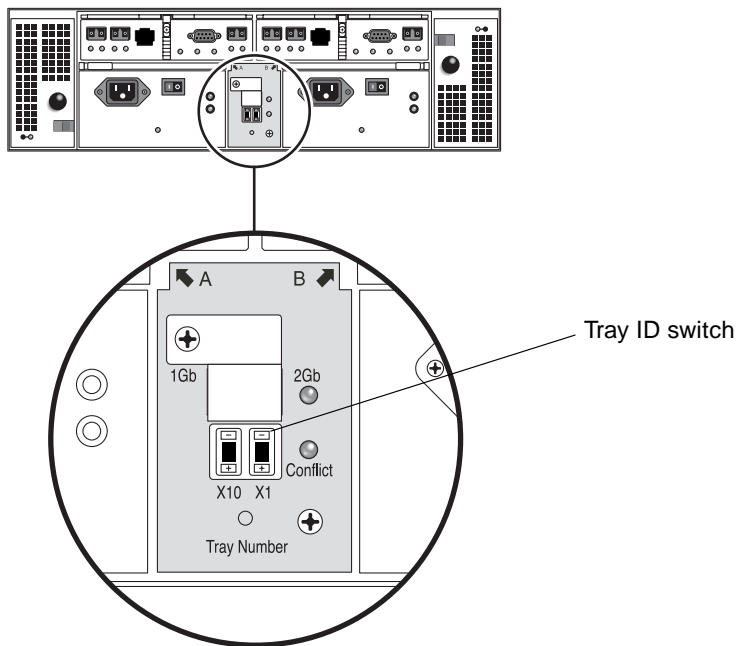

FIGURE 2-19 Tray ID Switch

2. Use a pen tip to press the plus and minus buttons on the X10 and X1 switch to the appropriate setting.

The X10 switch at the left sets the tens place of the tray ID, and the X1 switch sets the ones place. For example, to set the tray ID to 11, set the X10 switch to 1 and the X1 switch to 1.

By convention, tray ID 00 refers to the controller enclosure. The first expansion enclosure located above the controller enclosure is tray ID 01. The second expansion enclosure is tray ID 02. The tray ID increments by 01 for each expansion enclosure installed in the cabinet.

Back-End Storage Cabling

When you have finished installing all enclosures and NAS heads, connecting their power cables, and setting the tray IDs, you are ready to connect the Sun StorEdge 5310 NAS Appliance to the controller enclosures and the controller enclosures to the (optional) expansion enclosures as described in subsequent chapters.

Use the chapter appropriate to the system that you are setting up.

Note – To connect SAN storage to a Sun StorEdge 5310 NAS Gateway System, refer to the instructions in Chapter 5.

Connecting the Sun StorEdge 5310 NAS Appliance

This chapter provides comprehensive instructions for connecting the Sun StorEdge 5310 NAS Appliance, the Sun StorEdge 5300 RAID EU controller enclosure, and the optional Sun StorEdge 5300 EU expansion enclosures. It also provides initial configuration instructions for the system.

Note – This chapter contains single head Sun StorEdge 5310 NAS Appliance installation and configuration instructions *only*. If you are installing a different system, refer to the appropriate chapter.

Note – The Sun StorEdge 5310 NAS Appliance ships with the operating system installed.

This chapter contains the following sections:

- "Before You Begin" on page 38
- "Connecting the Sun StorEdge 5310 NAS Appliance to Back-End Storage" on page 38
- "Connecting to the Network" on page 50
- "Powering On the Sun StorEdge 5310 NAS Appliance, Controller Enclosures, and Expansion Enclosures" on page 51
- "Initial Sun StorEdge 5310 NAS Appliance Configuration" on page 53

Before You Begin

Before connecting the system, you must install the units in the rack. Refer to "Installing Storage Enclosures" on page 11 for rackmount instructions.

Connecting the Sun StorEdge 5310 NAS Appliance to Back-End Storage

This section describes how to cable the Sun StorEdge 5310 NAS Appliance to the controller enclosures and the controller enclosures to the optional expansion enclosures for several different configurations.

This section includes the following tasks:

- "Connecting the Sun StorEdge 5310 NAS Appliance to Controller Enclosures" on page 39
- "Connecting Controller Enclosures to Expansion Enclosures" on page 43

Connecting the Sun StorEdge 5310 NAS Appliance to Controller Enclosures

The Sun StorEdge 5310 NAS Appliance connects to each controller enclosure with a pair of optical fiber cables. Optical SFP transceivers have been installed in the controller enclosure host ports to interface with the optical fiber cable's LC connectors. Refer to FIGURE 3-1 for port locations.

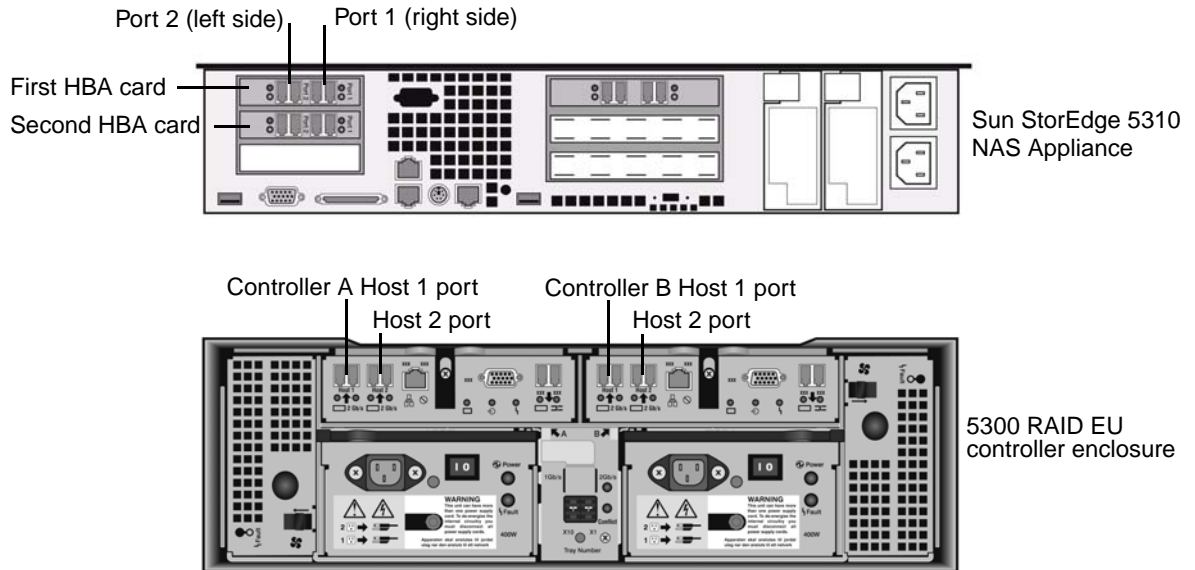

FIGURE 3-1 Sun StorEdge 5310 NAS Appliance HBA Cards and Controller Enclosure Ports

Note – HBA cards are inserted only in the far left on the low-profile riser assembly of the Sun StorEdge 5310 NAS Appliance.

This section contains details on the following:

- “Connecting One Controller Enclosure” on page 39
- “Connecting Two Controller Enclosures” on page 41

Connecting One Controller Enclosure

Use the instructions in this section if you are connecting one controller enclosure to the Sun StorEdge 5310 NAS Appliance.

For a Sun StorEdge 5310 NAS Appliance with one dual port HBA card (FIGURE 3-2):

1. Connect the HBA port 2 on the Sun StorEdge 5310 NAS Appliance to the Controller A host 1 port.
2. Connect the HBA port 1 on the Sun StorEdge 5310 NAS Appliance to the Controller B host 1 port.

Note – The host 2 port on the controller A and controller B remain empty.

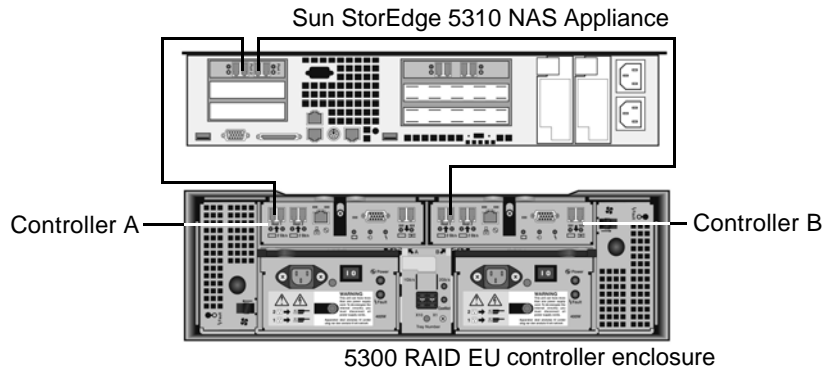

FIGURE 3-2 Connecting the Sun StorEdge 5310 NAS Appliance to the Controller Enclosure

For a Sun StorEdge 5310 NAS Appliance with two dual port HBA cards (FIGURE 3-3):

1. Connect the HBA port 2 of the first HBA card to the Controller A host 1 port.
2. Connect the HBA port 2 of the second HBA card to the Controller B host 1 port.

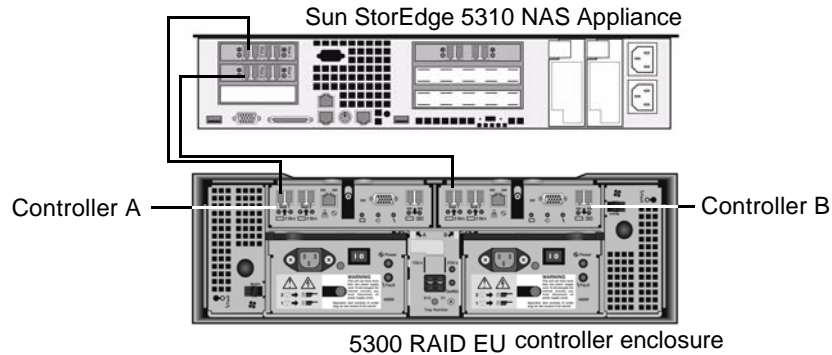

FIGURE 3-3 Connecting Two HBA Cards to the Controller Enclosure

Note – The host 2 port on the controller A and controller B remain empty.

Connecting Two Controller Enclosures

Use the instructions in this section and refer to FIGURE 3-4 if you are connecting two controller enclosures to the Sun StorEdge 5310 NAS Appliance.

Note – The Sun StorEdge 5310 NAS Appliance must have two HBA cards to connect to two controller enclosures.



Caution – One array can contain Fibre Channel disk drives in the controller enclosure and expansion enclosures, and the other array can contain SATA disk drives in the expansion enclosures only. However, you cannot mix EU F (Fibre Channel) and EU S (SATA) expansion enclosures attached to a controller enclosure.

1. Connect the HBA port 2 of the first HBA card to the Controller A host 1 port on the first controller enclosure.
2. Connect the HBA port 2 of the second HBA card to the Controller B host 1 port on the first controller enclosure.

3. Connect the HBA port 1 of the first HBA card to the Controller A host 1 port on the second controller enclosure.
4. Connect the HBA port 1 of the second HBA card to the Controller B host 1 port on the second controller enclosure.

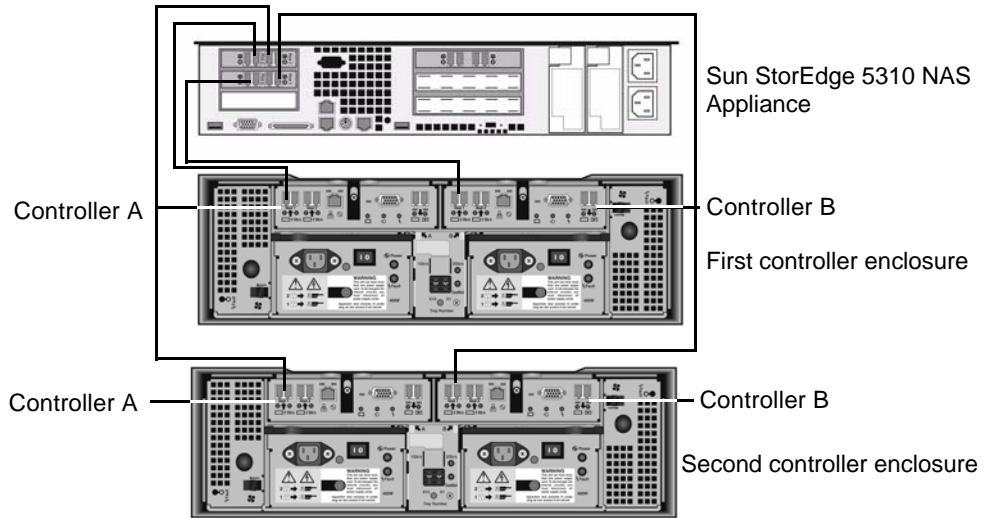

FIGURE 3-4 Connecting the Sun StorEdge 5310 NAS Appliance to Two Controller Enclosures

Connecting Controller Enclosures to Expansion Enclosures

A controller enclosure uses Controller A and Controller B expansion ports to connect to FC-AL ports at the back of an expansion enclosure (FIGURE 3-5).

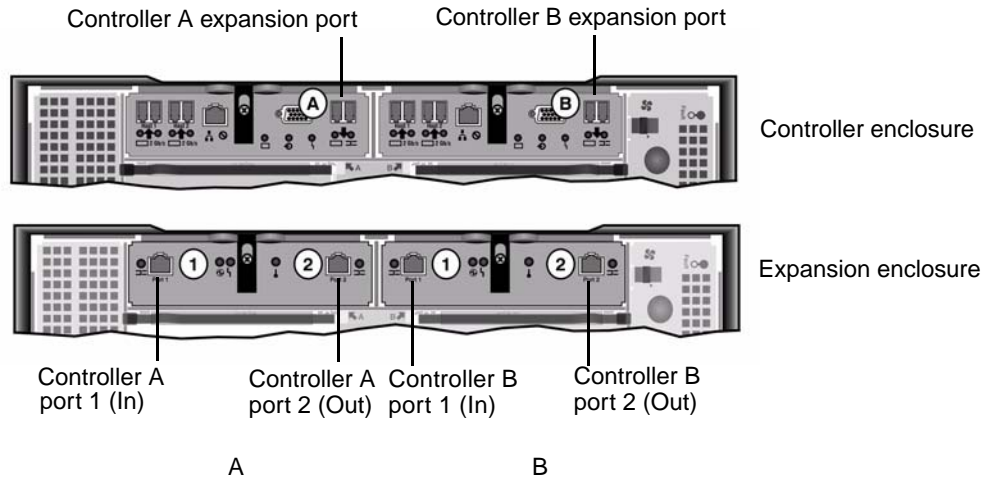

FIGURE 3-5 Controller Enclosure and Expansion Enclosure Ports

The controller enclosures and the expansion enclosures connect with a pair of Active Copper cables. These copper cables have transceiver electronics built into their connector ends. They plug directly into the SFP ports of the controllers and expansion enclosures.

Note – This section contains instructions for connecting controller enclosures and expansion enclosures. These instructions apply to one controller enclosure or to two controller enclosures. If you are using two controller enclosures, follow the same instructions to connect expansion enclosures to *each* controller enclosure.



Caution – One array can contain Fibre Channel disk drives in the controller enclosure and expansion enclosures, and the other array can contain SATA disk drives in the expansion enclosures only. However, you cannot mix EU F (Fibre Channel) and EU S (SATA) expansion enclosures attached to a controller enclosure.

Note – A maximum of seven EU F or eight EU S expansion enclosures can be attached to a controller enclosure.

The cabling differs depending on the number of expansion enclosures you are connecting:

- For one expansion enclosure, refer to "Cabling a Controller Enclosure to One Expansion Enclosure" on page 44.
- For two expansion enclosures, refer to "Cabling a Controller Enclosure to Two Expansion Enclosures" on page 45.
- For three expansion enclosures, refer to "Cabling a Controller Enclosure to Three Expansion Enclosures" on page 46.
- For four to seven expansion enclosures, refer to "Cabling a Controller Enclosure to Seven Expansion Enclosures" on page 48.

Cabling a Controller Enclosure to One Expansion Enclosure

To connect a controller enclosure and one expansion enclosure, two 2-meter Active Copper cables are required. Refer to FIGURE 3-6.

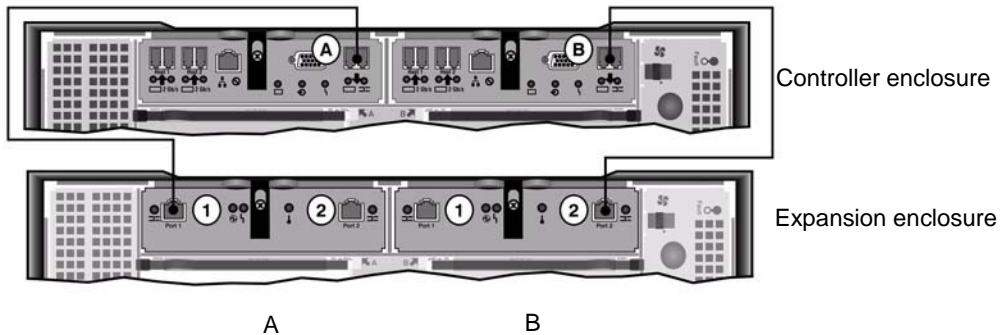

FIGURE 3-6 Controller Enclosure and One Expansion Enclosure Cable Interconnection

1. Connect one Active Copper cable between the A side expansion port of the controller enclosure and the A side port 1 of the expansion enclosure.
2. Connect one Active Copper cable between the B side expansion port of the controller enclosure and the B side port 2 of the expansion enclosure.

Note – The A side port 2 and B side port 1 of the expansion enclosure remain empty.

Cabling a Controller Enclosure to Two Expansion Enclosures

To connect a controller enclosure and two expansion enclosures, four 2-meter Active Copper cables are required. Refer to FIGURE 3-7.

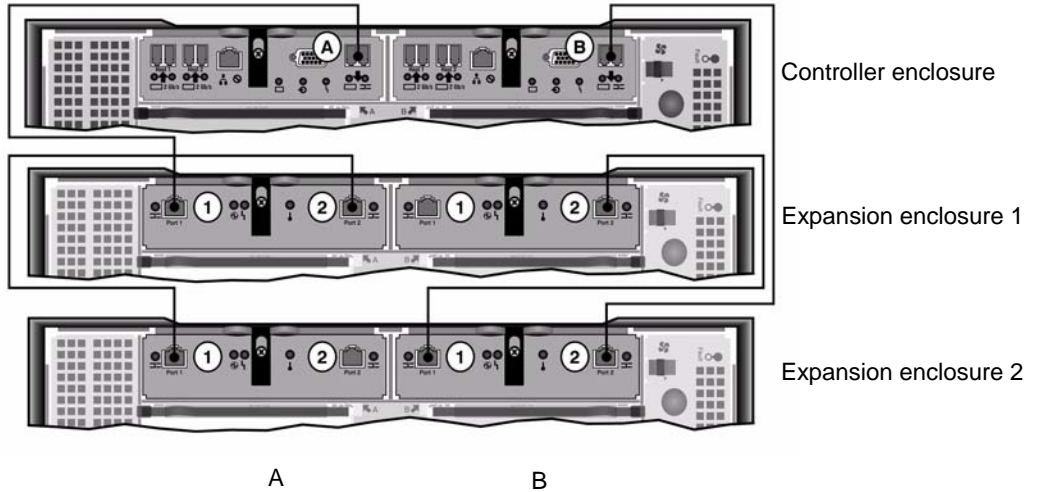

FIGURE 3-7 Controller Enclosure and Two Expansion Enclosures Cable Interconnection



Caution – Do not mix EU F (Fibre Channel) and EU S (SATA) expansion enclosures attached to a controller enclosure.

1. Connect one Active Copper cable between the A side expansion port of the controller enclosure and the A side port 1 of expansion enclosure 1.
2. Connect one Active Copper cable between the A side port 2 of expansion enclosure 1 and the A side port 1 of expansion enclosure 2.
3. Connect one Active Copper cable between the B side expansion port of the controller enclosure and the B side port 2 of expansion enclosure 2.
4. Connect one Active Copper cable between the B side port 1 of expansion enclosure 2 and the B side port 2 of expansion enclosure 1.

Note – The A side port 2 of expansion enclosure 2 and the B side port 1 of expansion enclosure 1 remain empty.

Cabling a Controller Enclosure to Three Expansion Enclosures

To connect a controller enclosure and three expansion enclosures, six 2-meter Active Copper cables are required. Refer to FIGURE 3-8.

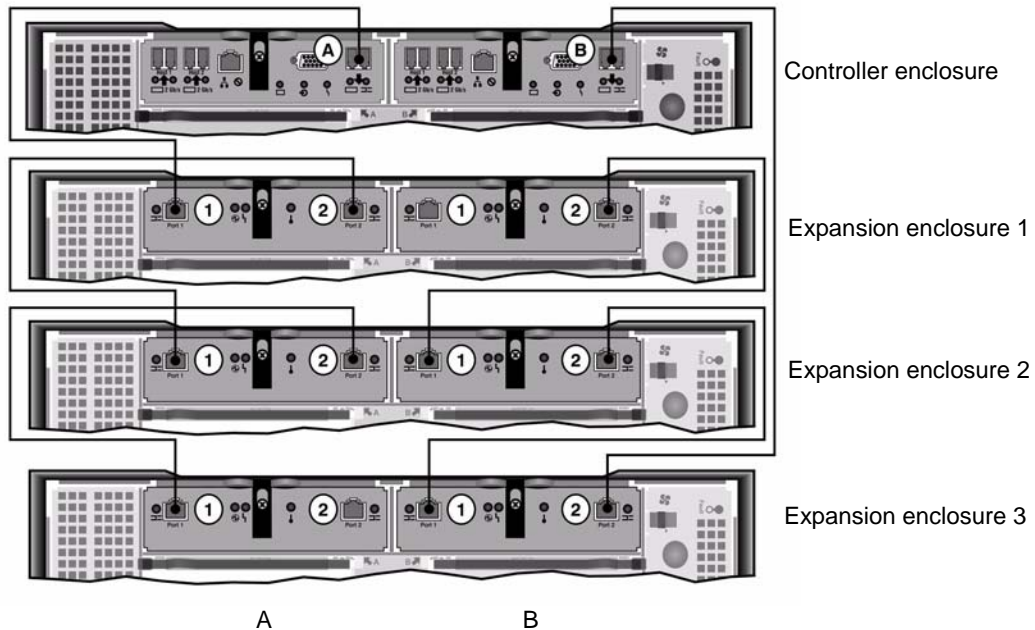

FIGURE 3-8 Controller Enclosure and Three Expansion Enclosures Cable Interconnection



Caution – Do not mix EU F (Fibre Channel) and EU S (SATA) expansion enclosures attached to a controller enclosure.

1. Connect one Active Copper cable between the A side expansion port of the controller enclosure and the A side port 1 of expansion enclosure 1.
2. Connect one Active Copper cable between the A side port 2 of expansion enclosure 1 and the A side port 1 of expansion enclosure 2.
3. Connect one Active Copper cable between the A side port 2 of expansion enclosure 2 and the A side port 1 of expansion enclosure 3.
4. Connect one Active Copper cable between the B side expansion port of the controller enclosure and B side port 2 of expansion enclosure 3.
5. Connect one Active Copper cable between the B side port 1 of expansion enclosure 3 and the B side port 2 of expansion enclosure 2.

6. Connect one Active Copper cable between the B side port 1 of expansion enclosure 2 and the B side port 2 of expansion enclosure 1.

Note – The A side port 2 of expansion enclosure 3 and the B side port 1 of expansion enclosure 1 remain empty.

Cabling a Controller Enclosure to Seven Expansion Enclosures

To connect a controller enclosure and seven expansion enclosures, fourteen 2-meter Active Copper cables are required. Refer to FIGURE 3-9.

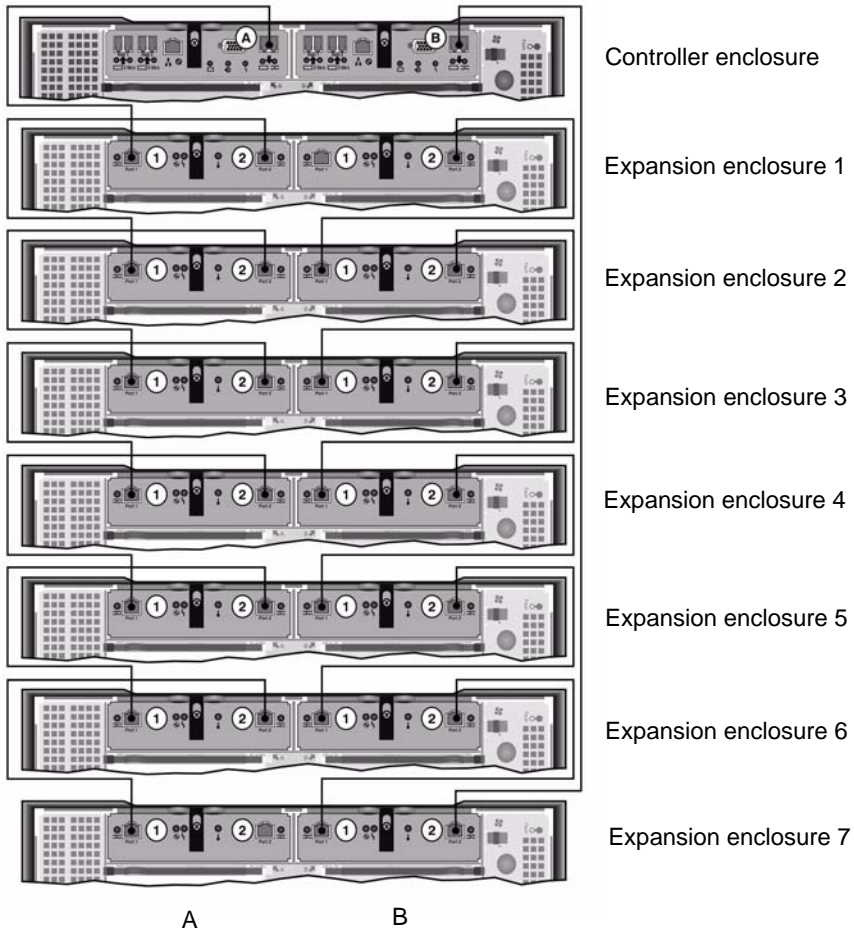

FIGURE 3-9 Controller Enclosure and Seven Expansion Enclosures Cable Interconnection



Caution – Do not mix EU F (Fibre Channel) and EU S (SATA) expansion enclosures attached to a controller enclosure.

1. Connect one Active Copper cable between the A side expansion port of the controller enclosure and the A side port 1 of expansion enclosure 1.

2. Connect one Active Copper cable between the A side port 2 of expansion enclosure 1 and the A side port 1 of expansion enclosure 2.
3. Continue to connect one Active Copper cable between the A side port 2 of each expansion enclosure and the A side port 1 of the expansion enclosure directly below it, until the A sides of all expansion enclosures are interconnected with Active Copper cables.
4. Connect one Active Copper cable between the B side expansion port of the controller enclosure and the B side port 2 of expansion enclosure 7.
5. Connect one Active Copper cable between the B side port 1 of expansion enclosure 7 and the B side port 2 of expansion enclosure 6.
6. Continue to connect one Active Copper cable between the B side port 1 of each expansion enclosure and the B side port 2 of the expansion enclosure directly above it, until the B sides of all expansion enclosures are interconnected with Active Copper cables.

Note – The A side port 2 of expansion enclosure 7 and the B side port 1 of expansion enclosure 1 remain empty.

Connecting to the Network

Use the following procedures to connect the Sun StorEdge 5310 NAS Appliance to the network. The available network connectors depend on your system configuration: Fast Ethernet or optical gigabit Ethernet. Each configuration is described in the following sections.

Connecting to Copper Fast Ethernet or Gigabit Ethernet Networks

Refer to FIGURE 3-10 for NIC port locations.

To connect the Sun StorEdge 5310 NAS Appliance to a 100BASE-T Fast Ethernet network or to a 1000BASE-T gigabit Ethernet network, connect an RJ-45 unshielded twisted-pair cable from your local area network (LAN) to the Port emc1 or the Port emc2 on the rear of the Sun StorEdge 5310 NAS Appliance.

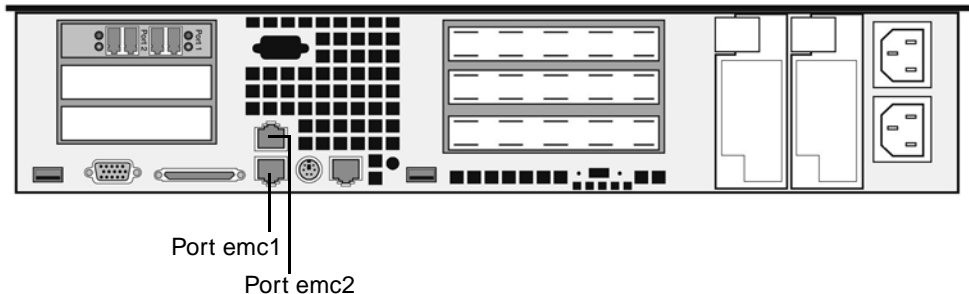

FIGURE 3-10 Connecting to a Fast Ethernet or Gigabit Ethernet Network

Connecting to Optional Optical Gigabit Ethernet Networks

Refer to FIGURE 3-11 for NIC and optical gigabit Ethernet port locations.

To connect the Sun StorEdge 5310 NAS Appliance to an optical gigabit Ethernet network, you must have the optional add-in optical gigabit Ethernet connections.

Connect an LC cable from the network to the right (Port emf3) optical gigabit Ethernet connector on the rear of the Sun StorEdge 5310 NAS Appliance.

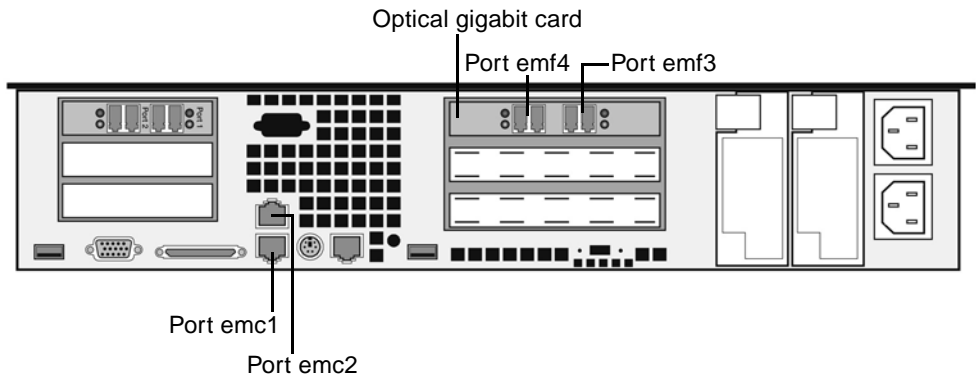

FIGURE 3-11 Connecting to an Optical Gigabit Network

Powering On the Sun StorEdge 5310 NAS Appliance, Controller Enclosures, and Expansion Enclosures



Caution – *Always* power on the units in the following order:

1. Sun StorEdge 5300 EU expansion enclosures first.
2. Sun StorEdge 5300 RAID EU controller enclosures next.
3. Sun StorEdge 5310 NAS Appliance.

Note – If you are using a UPS, connect all units to the UPS.

Power on the expansion enclosures *first*, followed by controller enclosures, and then the Sun StorEdge 5310 NAS Appliance. The redundant power supplies and separate power cords provide fault tolerance if properly connected.



Caution – The expansion enclosures and controller enclosures must always be powered on and properly connected to each other and the main appliance before powering on the Sun StorEdge 5310 NAS Appliance. The expansion enclosures must be powered on *first*, before the controller enclosures and Sun StorEdge 5310 NAS Appliance. If these instructions are not followed, the system could start slowly.

Note – To achieve fault tolerance, units with two power supplies should receive power from two different AC circuits.



Caution – When you power off the controller enclosures and expansion enclosures, wait five seconds before you power them back on. If you power the units off and on too quickly, unexpected results may occur.

Powering On the Sun StorEdge 5310 NAS Appliance System

To turn on each unit:

1. Verify that all cables between the Sun StorEdge 5310 NAS Appliance, controller enclosures, and expansion enclosures are properly secured according to the instructions in "Connecting the Sun StorEdge 5310 NAS Appliance to Controller Enclosures" on page 39 and "Connecting Controller Enclosures to Expansion Enclosures" on page 43.
2. Power on each expansion enclosure by setting the two power supply switches to the On position.
3. Check that all LEDs on the expansion enclosure front panels turn solid green to indicate good operation.
4. Power on each controller enclosure by setting the two power supply switches to the On position.
5. Check that all LEDs on the controller enclosure front panels turn solid green to indicate good operation.
6. Verify that the Sun StorEdge 5310 NAS Appliance is connected to the network.

7. Press the Power button (FIGURE 3-12) on the front panel (behind the faceplate).

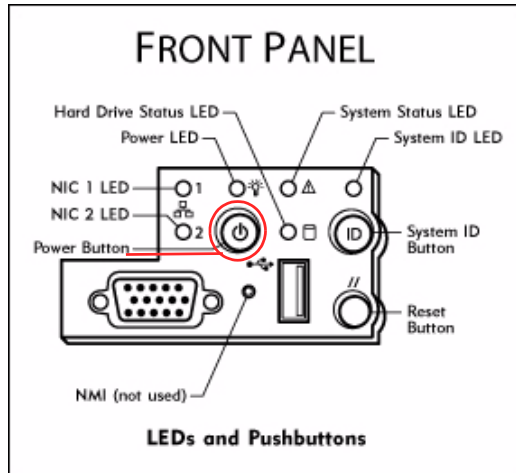

FIGURE 3-12 Power Button and Front Panel Detail

Initial Sun StorEdge 5310 NAS Appliance Configuration



Caution – These instructions apply to the Sun StorEdge 5310 NAS Appliance *only*. For cluster configuration instructions, refer to Chapter 4. For Gateway configuration instructions, refer to Chapter 5.

To complete the initial Sun StorEdge 5310 NAS Appliance configuration, you must do the following:

- Provide an IP address
- Access the Wizard through the Web Administrator
- Follow the instructions provided by the Wizard

IP Address Configuration

To configure the Sun StorEdge 5310 NAS Appliance, you must have an IP address for the system. You can assign an IP address in one of two ways:

- Automatic IP address assignment through a Dynamic Host Configuration Protocol (DHCP) server
- Manual IP address assignment through the Liquid Crystal Display (LCD) panel on the Sun StorEdge 5310 NAS Appliance

Automatic (DHCP) IP Address Configuration

To dynamically acquire an IP address through a DHCP server, you must either have an existing DHCP server on the network or have a DHCP relay agent on the network with an accessible DHCP server on another network. If a DHCP server is not available, you must input the IP address through the LCD panel on the front panel of the Sun StorEdge 5310 NAS Appliance.

Note – If your system uses DHCP to assign Domain Name System (DNS) and Windows Internet Naming Service (WINS) as well as IP and gateway addresses, the corresponding fields in the Wizard and Web Administrator screens are dynamically configured. Verify the information when it is presented by the Wizard during system configuration.

If your system supports DHCP, the DHCP server automatically assigns an IP address when the Sun StorEdge 5310 NAS Appliance boots for the first time.

Note – To avoid waiting for DHCP discovery, during the boot sequence when the LCD panel displays “DHCP Discovery NIC X”, you can press any key on the LCD panel and confirm the “Abort DHCP?” message by pressing the right arrow key on the panel. Then you can manually set the static IP address using the following instructions.

Manual IP Address Configuration

If a DHCP server is not available, you must configure the IP address using the LCD panel.

To configure the IP address using the LCD panel:

1. **Turn on the Sun StorEdge 5310 NAS Appliance and wait for the boot sequence to complete. The LCD panel displays the following:**

```
DHCP Discovery NIC X  
No Offers
```

Note – To avoid waiting for DHCP discovery, during the boot sequence when the LCD panel displays “DHCP Discovery NIC X”, you can press any key on the LCD panel and confirm the “Abort DHCP?” message by pressing the right arrow key on the panel.

2. **Press the SEL button once, and then select Set Static IP.**
3. **Enter or accept the following values listed, and then move the cursor to the far right to save them:**
 - IP address
 - Subnet mask
 - Broadcast address
 - Gateway address (if necessary)

To enter data, use the up and down arrows to select digits, dots, or spaces. Then use the right arrow to accept each character.

Accessing the Web Administrator

Note – Before you can access Web Administrator, you must have connected the Sun StorEdge 5310 NAS Appliance to your network, provided an IP address, and prepared a client browser on the same network as the Sun StorEdge 5310 NAS Appliance.

Connecting to the Web Administrator

When you connect to the Web Administrator for the first time, the Configuration Wizard launches automatically.

To connect to the Web Administrator:

1. **From a client on the same network, open a web browser and type the IP address of the Sun StorEdge 5310 NAS Appliance in the address or location field, for example:**

http://123.111.78.99

and press **Enter**.

Note – If you are using a proxy server and have trouble connecting, try enabling the browser option to bypass the proxy server for local addresses. See your browser's online help or documentation for more information.

The Web Administrator GUI interface for the Sun StorEdge 5310 NAS Appliance appears in your browser with a login screen.

Note – After you reach the login screen, you may want to bookmark it or add it to your favorites so that you do not have to remember the IP address in the future.

2. **On the Web Admin login screen, click Apply.**

The password can be set later. Refer to the *Sun StorEdge 5310 NAS Appliance and Gateway System Administration Guide*.

3. **On the Set Time and Date panel, select the date, the time, and the time zone, and click Apply, and then click Yes to confirm.**

This will set the secure clock to the same time and date. Make sure you set the time and date accurately as you can only set the secure clock once.

4. **Accept the license agreement to start the Configuration Wizard.**

If you decline, Web Administrator returns you to the main login screen.

5. **Follow the on-screen prompts, entering information as requested.**

For more detailed descriptions of the Wizard screens, refer to the *Sun StorEdge 5310 NAS Appliance and Gateway System Administration Guide*.

6. **If your system uses DHCP to assign DNS, WINS, or IP and gateway addresses, these fields are automatically configured. When you reach these screens in the Wizard, verify the information, then continue with the Wizard.**

Note – When adding your DNS server, click **Add** to ensure the DNS server has been added.

7. **On the Confirmation screen, review the configuration information you have added.**

Note – Be sure the configuration information is accurate before continuing.

8. Click Finish on the Wizard Confirmation Screen.

The system will configure the settings and indicate it in the Save Configuration screen. It will also display a message that both servers must reboot for the failover changes to be applied.

9. Click Close on the Save Configuration screen.

10. Use the Web Admin to configure file systems.

Refer to "Creating the File System" on page 37 in the *Sun StorEdge 5310 NAS Appliance and Gateway System Administration Guide*.

Installing the Sun StorEdge 5310 Cluster

Note – This chapter contains Sun StorEdge 5310 Cluster installation and configuration instructions *only*. If you are installing a different system, refer to the appropriate chapter.

This chapter provides comprehensive instructions for installing the Sun StorEdge 5310 Cluster, the Sun StorEdge 5300 RAID EU controller enclosures, and the optional Sun StorEdge 5300 EU expansion enclosures. It also provides initial configuration instructions for the system.

Note – The Sun StorEdge 5310 Cluster ships with the operating system installed.

This chapter contains the following sections:

- "Before You Begin" on page 59
- "Connecting the Sun StorEdge 5310 Cluster to Back-End Storage" on page 60
- "Connecting the Server Health-Monitoring and Network Cables" on page 73
- "Powering On the Sun StorEdge 5310 Cluster, Controller Enclosure, and Expansion Enclosures" on page 76
- "Initial Sun StorEdge 5310 Cluster Configuration" on page 78

Before You Begin

Before connecting the system, you must install the units in the rack. Refer to "Installing Storage Enclosures" on page 11 for rackmount instructions.

Connecting the Sun StorEdge 5310 Cluster to Back-End Storage

This section describes how to cable the Sun StorEdge 5310 Cluster to the controller enclosures and the controller enclosures to the optional expansion enclosures for several different configurations.

This section includes the following tasks:

- "Connecting the Sun StorEdge 5310 Cluster to Controller Enclosures" on page 61
- "Connecting the Controller Enclosures to Expansion Enclosures" on page 66

Connecting the Sun StorEdge 5310 Cluster to Controller Enclosures

The Sun StorEdge 5310 Cluster and the controller enclosures each connect with a pair of optical fiber cables. Optical SFP transceivers have been installed in the controller enclosures' host ports to interface with the optical fiber cable's LC connectors. Refer to FIGURE 4-1 for port locations.

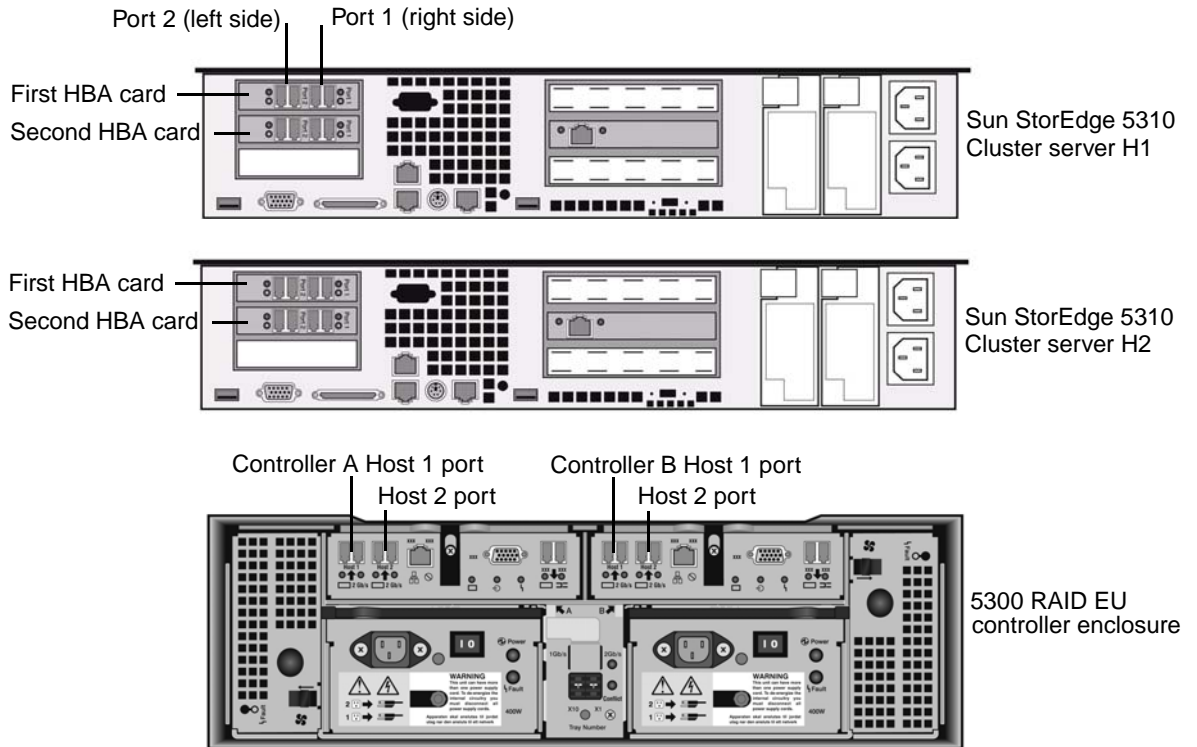

FIGURE 4-1 Sun StorEdge 5310 Cluster HBA Cards and Controller Enclosure Ports

Note – HBA cards are inserted only in the far left on the low-profile riser assembly of the Sun StorEdge 5310 Cluster.

This section contains details on the following:

- “Connecting One Controller Enclosure” on page 62
- “Connecting Two Controller Enclosures” on page 63

Connecting One Controller Enclosure

Use the instructions in this section if you are connecting one controller enclosure to the Sun StorEdge 5310 Cluster.

1. Connect the HBA port 2 of the first HBA card on the Sun StorEdge 5310 Cluster server H1 to the Controller A host 1 port.
2. Connect the HBA port 2 of the second HBA card on the Sun StorEdge 5310 Cluster server H1 to the Controller B host 1 port.
3. Connect the HBA port 1 of the first HBA card on the Sun StorEdge 5310 Cluster server H2 to the Controller A host 2 port.
4. Connect the HBA port 1 of the second HBA card on the Sun StorEdge 5310 Cluster server H2 to the Controller B host 2 port.

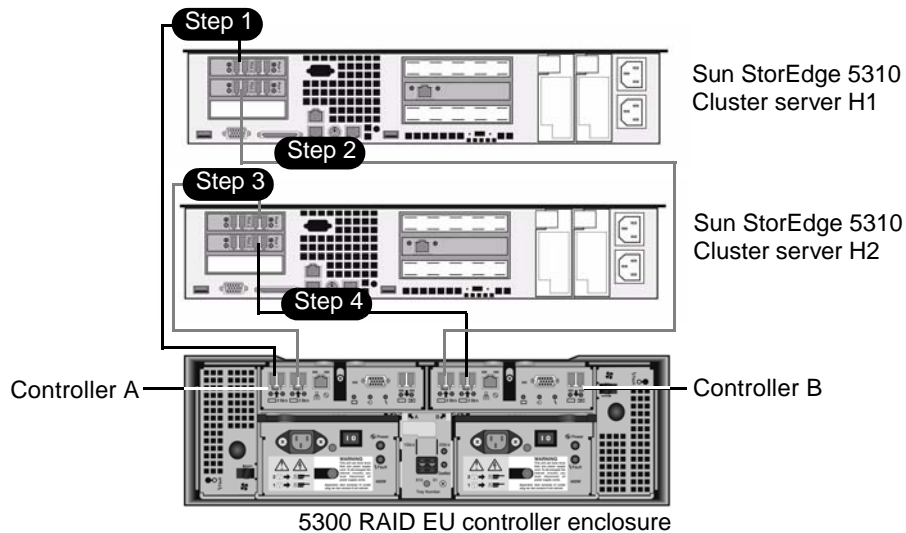

FIGURE 4-2 Connecting Pairs of HBA Cards to One Controller Enclosure

Connecting Two Controller Enclosures

Use the instructions in this section and refer to FIGURE 4-3 and FIGURE 4-4 if you are connecting two controller enclosures to the Sun StorEdge 5310 Cluster.



Caution – One array can contain Fibre Channel disk drives in the controller enclosure and expansion enclosures and the other array can contain SATA disk drives in the expansion enclosures only. However, you cannot mix EU F (Fibre Channel) and EU S (SATA) expansion enclosures attached to a controller enclosure.

1. Connect the HBA port 2 of the first HBA card on the Sun StorEdge 5310 Cluster server H1 to the Controller A host 1 port on the first controller enclosure.
2. Connect the HBA port 1 of the first HBA card on the Sun StorEdge 5310 Cluster server H1 to the Controller B host 1 port on the second controller enclosure.
3. Connect the HBA port 2 of the second HBA card on the Sun StorEdge 5310 Cluster server H1 to the Controller B host 1 port on the first controller enclosure.

4. Connect the HBA port 1 of the second HBA card on the Sun StorEdge 5310 Cluster server H1 to the Controller A host 1 port on the second controller enclosure.

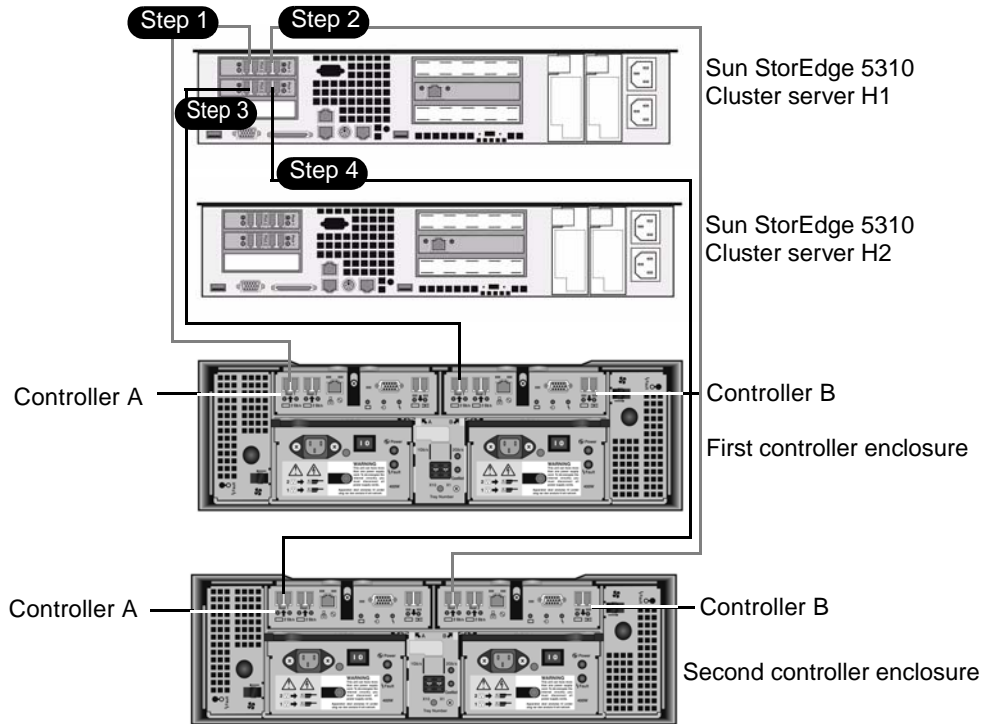

FIGURE 4-3 Connecting the Sun StorEdge 5310 Cluster to Two Controller Enclosures, Steps 1-4

5. Connect the HBA port 2 of the first HBA card on the Sun StorEdge 5310 Cluster server H2 to the Controller A host 2 port on the first controller enclosure.
6. Connect the HBA port 1 of the first HBA card on the Sun StorEdge 5310 Cluster server H2 to the Controller B host 2 port on the second controller enclosure.
7. Connect the HBA port 2 of the second HBA card on the Sun StorEdge 5310 Cluster server H2 to the Controller B host 2 port on the first controller enclosure.

8. Connect the HBA port 1 of the second HBA card on the Sun StorEdge 5310 Cluster server H2 to the Controller A host 2 port on the second controller enclosure.

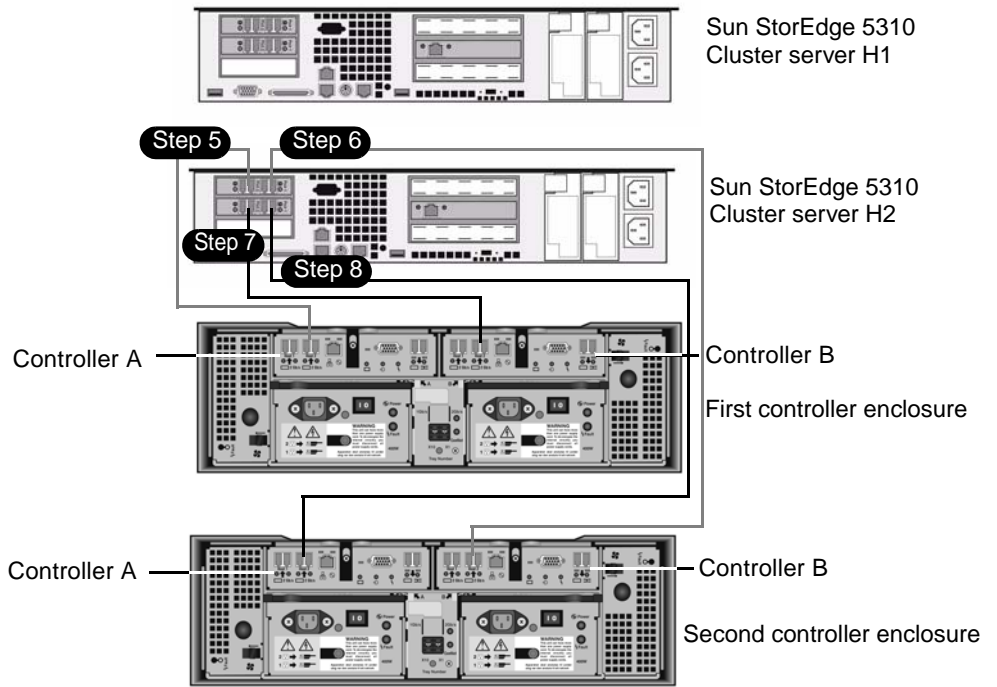

FIGURE 4-4 Connecting the Sun StorEdge 5310 Cluster to Two Controller Enclosures, Steps 5-8

Connecting the Controller Enclosures to Expansion Enclosures

Each controller enclosure uses Controller A and Controller B expansion ports to connect to FC-AL ports at the back of an expansion enclosure (FIGURE 4-5).

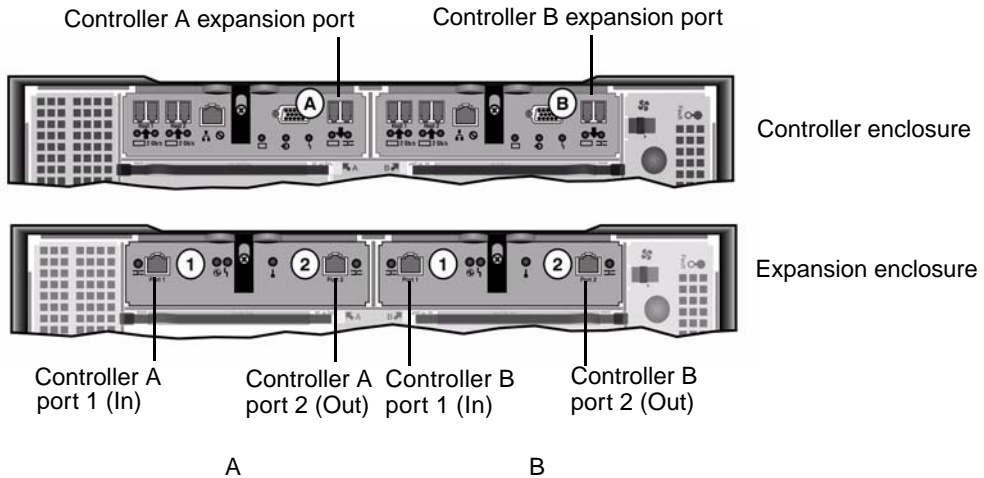

FIGURE 4-5 Controller Enclosure and Expansion Enclosure Ports

The controller enclosures and the expansion enclosures connect with a pair of Active Copper cables. These copper cables have transceiver electronics built into their connector ends. They plug directly into the SFP ports of the controllers and expansion enclosures.

Note – This section contains instructions for connecting controller enclosures and expansion enclosures. These instructions apply to one controller enclosure or to two controller enclosures. If you are using two controller enclosures, follow the same instructions to connect expansion enclosures to *each* controller enclosure.



Caution – One array can contain Fibre Channel disk drives in the controller enclosure and expansion enclosures and the other array can contain SATA disk drives in the expansion enclosures only. However, you cannot mix EU F (Fibre Channel) and EU S (SATA) expansion enclosures attached to a controller enclosure.

Note – A maximum of seven EU F or eight EU S expansion enclosures can be attached to a controller enclosure.

The cabling differs depending on the number of expansion enclosures you are connecting:

- For one expansion enclosure, refer to "Cabling a Controller Enclosure to One Expansion Enclosure" on page 67.
- For two expansion enclosures, refer to "Cabling a Controller Enclosure to Two Expansion Enclosures" on page 68.
- For three expansion enclosures, refer to "Cabling a Controller Enclosure to Three Expansion Enclosures" on page 69.
- For four to seven expansion enclosures, refer to "Cabling a Controller Enclosure to Seven Expansion Enclosures" on page 71.

Cabling a Controller Enclosure to One Expansion Enclosure

To connect a controller enclosure and one expansion enclosure, two 2-meter Active Copper cables are required. Refer to FIGURE 4-6.

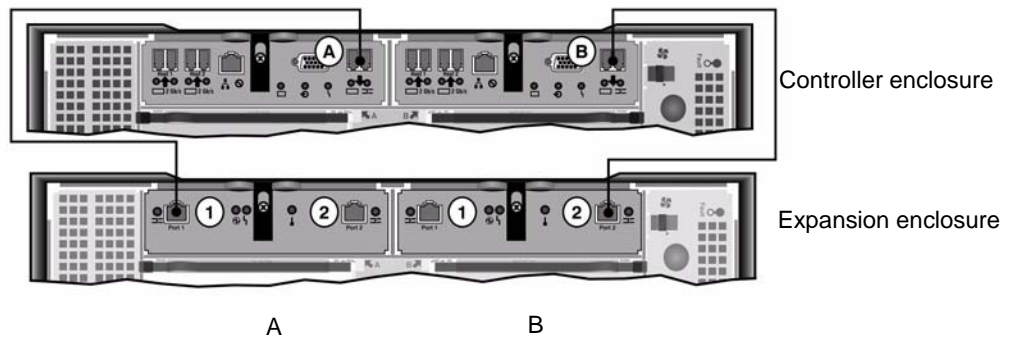

FIGURE 4-6 Controller Enclosure and One Expansion Enclosure Cable Interconnection

1. Connect one Active Copper cable between the A side expansion port of the controller enclosure and the A side port 1 of the expansion enclosure.
2. Connect one Active Copper cable between the B side expansion port of the controller enclosure and the B side port 2 of the expansion enclosure.

Note – The A side port 2 and B side port 1 of the expansion enclosure remain empty.

Cabling a Controller Enclosure to Two Expansion Enclosures

To connect a controller enclosure and two expansion enclosures, four 2-meter Active Copper cables are required. Refer to FIGURE 4-7.

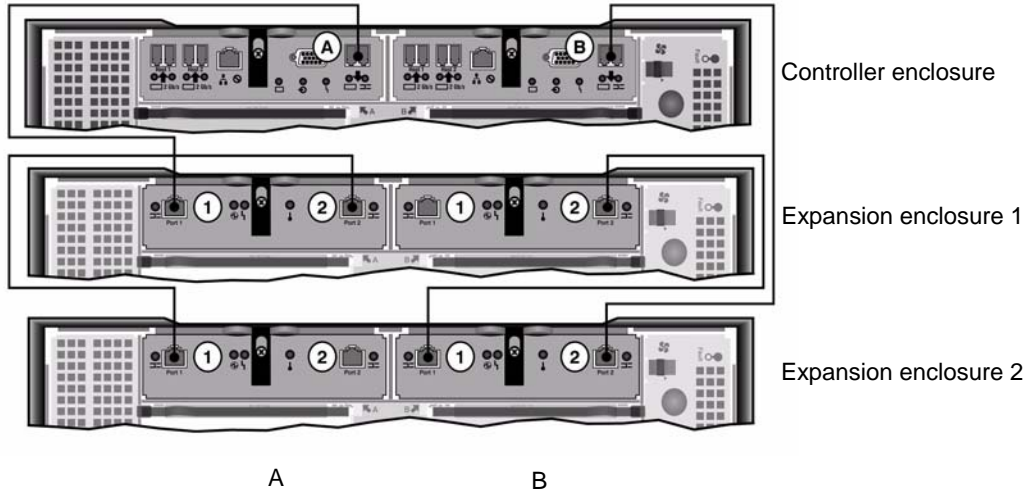

FIGURE 4-7 Controller Enclosure and Two Expansion Enclosures Cable Interconnection



Caution – Do not mix EU F (Fibre Channel) and EU S (SATA) expansion enclosures attached to a controller enclosure.

1. Connect one Active Copper cable between the A side expansion port of the controller enclosure and the A side port 1 of expansion enclosure 1.
2. Connect one Active Copper cable between the A side port 2 of expansion enclosure 2 and the A side port 1 of expansion enclosure 1.
3. Connect one Active Copper cable between the B side expansion port of the controller enclosure and the B side port 2 of expansion enclosure 2.
4. Connect one Active Copper cable between the B side port 1 of expansion enclosure 2 and the B side port 2 of expansion enclosure 1.

Note – The A side port 2 of expansion enclosure 2 and the B side port 1 of expansion enclosure 1 remain empty.

Cabling a Controller Enclosure to Three Expansion Enclosures

To connect a controller enclosure and three expansion enclosures, six 2-meter Active Copper cables are required. Refer to FIGURE 4-8.

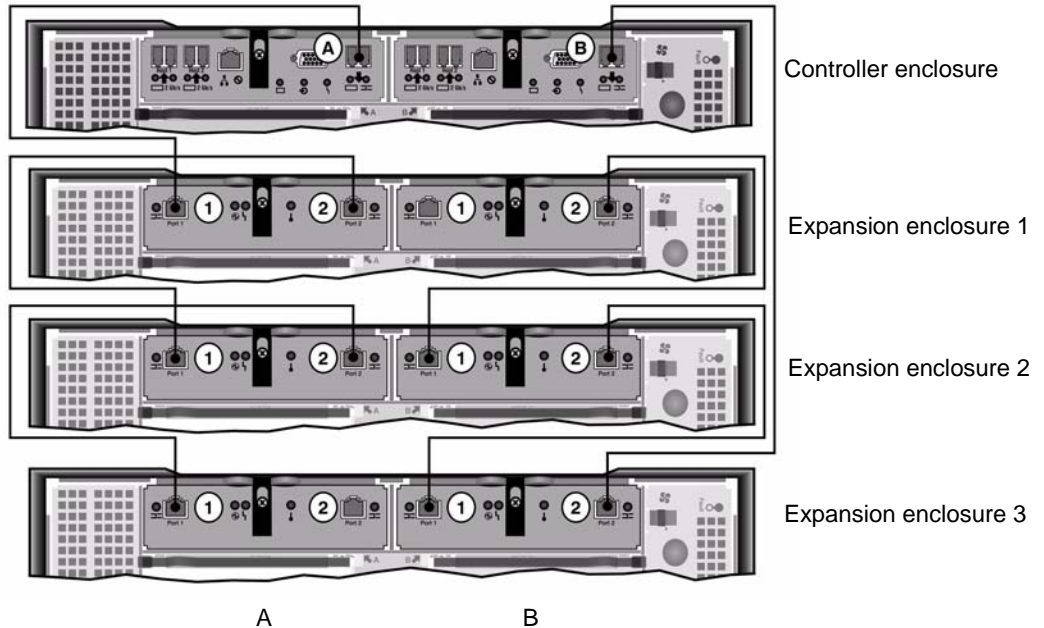

FIGURE 4-8 Controller Enclosure and Three Expansion Enclosures Cable Interconnection



Caution – Do not mix EU F (Fibre Channel) and EU S (SATA) expansion enclosures attached to a controller enclosure.

1. Connect one Active Copper cable between the A side expansion port of the controller enclosure and the A side port 1 of expansion enclosure 1.
2. Connect one Active Copper cable between the A side port 2 of expansion enclosure 1 and the A side port 1 of expansion enclosure 2.
3. Connect one Active Copper cable between the A side port 2 of expansion enclosure 2 and the A side port 1 of expansion enclosure 3.
4. Connect one Active Copper cable between the B side expansion port of the controller enclosure and B side port 2 of expansion enclosure 3.

5. Connect one Active Copper cable between the B side port 1 of expansion enclosure 3 and the B side port 2 of expansion enclosure 2.
6. Connect one Active Copper cable between the B side port 1 of expansion enclosure 2 and the B side port 2 of expansion enclosure 1.

Note – The A side port 2 of expansion enclosure 3 and the B side port 1 of expansion enclosure 1 remain empty.

Cabling a Controller Enclosure to Seven Expansion Enclosures

To connect a controller enclosure and seven expansion enclosures, fourteen 2-meter Active Copper cables are required. Refer to FIGURE 4-9.

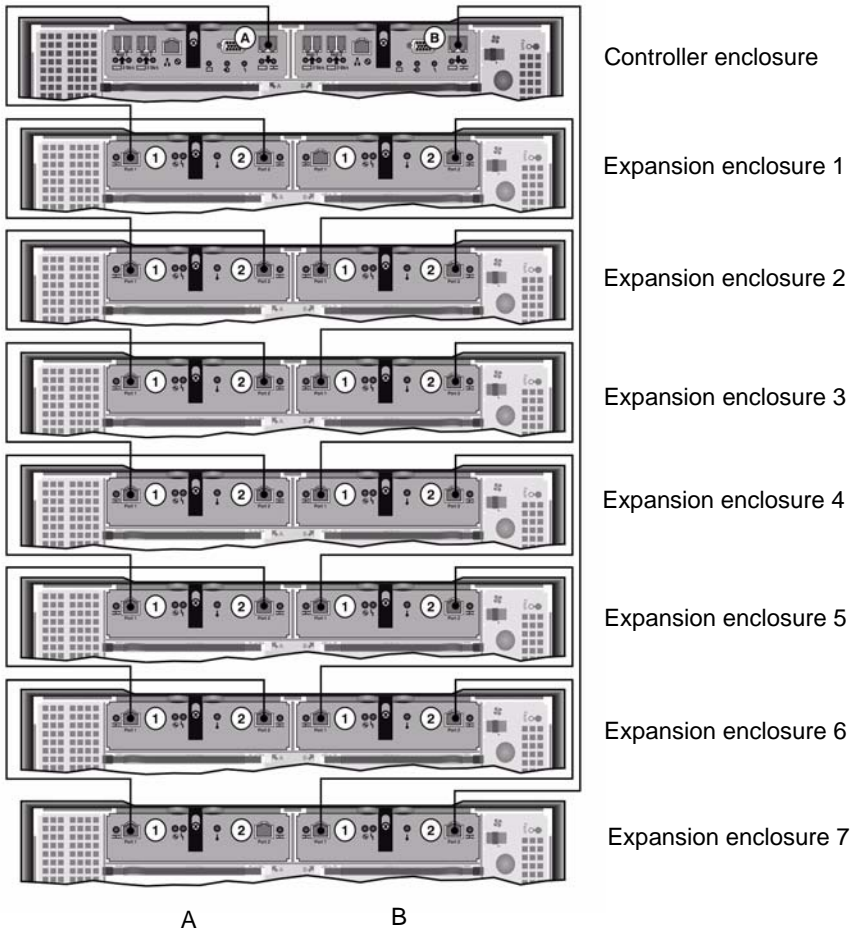

FIGURE 4-9 Controller Enclosure and Seven Expansion Enclosures Cable Interconnection



Caution – Do not mix EU F (Fibre Channel) and EU S (SATA) expansion enclosures attached to a controller enclosure.

1. Connect one Active Copper cable between the A side expansion port of the controller enclosure and the A side port 1 of expansion enclosure 1.

2. Connect one Active Copper cable between the A side port 2 of expansion enclosure 1 and the A side port 1 of expansion enclosure 2.
3. Continue to connect one Active Copper cable between the A side port 2 of each expansion enclosure and the A side port 1 of the expansion enclosure directly below it, until the A sides of all expansion enclosures are interconnected with Active Copper cables.
4. Connect one Active Copper cable between the B side expansion port of the controller enclosure and the B side port 2 of expansion enclosure 7.
5. Connect one Active Copper cable between the B side port 1 of expansion enclosure 7 and the B side port 2 of expansion enclosure 6.
6. Continue to connect one Active Copper cable between the B side port 1 of each expansion enclosure and the B side port 2 of the expansion enclosure directly above it, until the B sides of all expansion enclosures are interconnected with Active Copper cables.

Note – The A side port 2 of expansion enclosure 7 and the B side port 1 of expansion enclosure 1 remain empty.

Connecting the Server

Health-Monitoring and Network Cables

Each server in a Sun StorEdge 5310 Cluster uses a dedicated Ethernet connection to communicate with its partner and perform periodic “health checks.”

On systems using 10/100/1000BASE-T as the primary network connections (using the two on-board LAN ports), an additional 10/100BASE-T NIC is installed in each server, used exclusively for the health check connection and referred to as the *heartbeat port* (FIGURE 4-10).

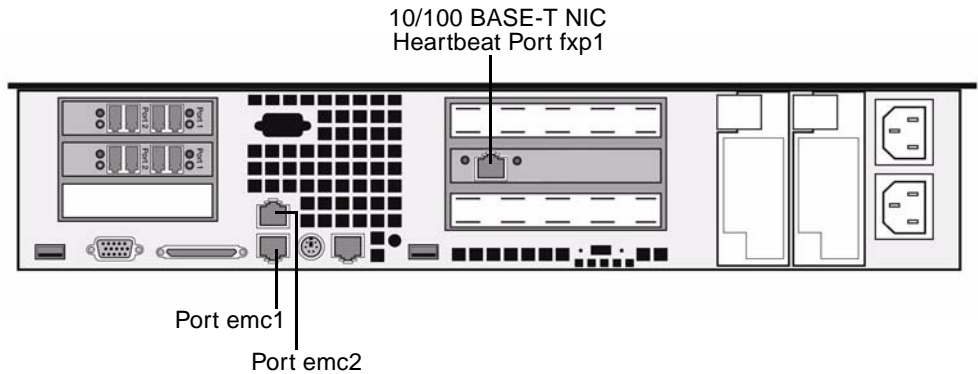

FIGURE 4-10 Connecting to a Fast Ethernet Network

Systems using the optional optical gigabit Ethernet ports as their primary network connections use the onboard LAN port 1 (Port emc1) for the health check connection (FIGURE 4-11).

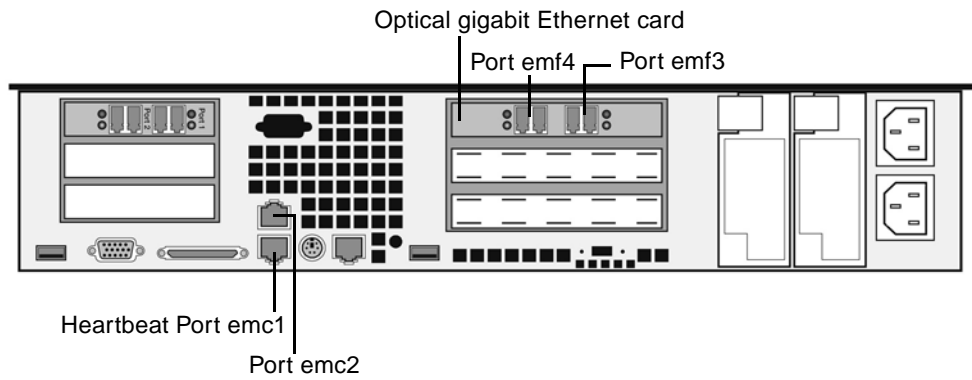

FIGURE 4-11 Connecting to an Optical Gigabit Ethernet Network

To use this feature, use the Cat5 Ethernet crossover cable to connect the two servers using the appropriate heartbeat ports.

Connecting to Copper Fast Ethernet or Gigabit Ethernet Networks

If your system is configured for Fast Ethernet or gigabit Ethernet networking, refer to FIGURE 4-10 for NIC port locations.

To connect the Sun StorEdge 5310 Cluster to a Fast Ethernet network, connect an RJ-45 unshielded twisted-pair cable from your local area network (LAN) to the NIC Port emc1 Fast Ethernet connector on the rear of each of the Sun StorEdge 5310 Cluster servers.

To connect the Sun StorEdge 5310 Cluster to a gigabit Ethernet network, connect an RJ-45 unshielded twisted-pair cable to a 1000BASE-T connection on your LAN and to the NIC Port emc2 on the rear of each of the Sun StorEdge 5310 Cluster servers.

Connecting to Optional Optical Gigabit Ethernet Networks

If your system is configured with the optical gigabit Ethernet cards, refer to FIGURE 4-11 for NIC and optical gigabit Ethernet port locations.

To connect the Sun StorEdge 5310 Cluster to an optical gigabit Ethernet network, you must have the optional add-in optical gigabit Ethernet connections on each server.

Connect an LC cable from your LAN to the right (Port emf3) optical gigabit Ethernet connector on the rear of each of the Sun StorEdge 5310 Cluster servers.

Powering On the Sun StorEdge 5310 Cluster, Controller Enclosure, and Expansion Enclosures



Caution – *Always* power on the units in the following order:

1. Sun StorEdge 5300 EU expansion enclosures first.
 2. Sun StorEdge 5300 RAID EU controller enclosures next.
 3. Sun StorEdge 5310 NAS Appliance.
-

Note – If you are using a UPS, connect all units to the UPS.

Power on the expansion enclosures *first*, followed by controller enclosures, and then the Sun StorEdge 5310 Cluster. The redundant power supplies and separate power cords provide fault tolerance if properly connected.



Caution – The expansion enclosures and controller enclosures must always be powered on and properly connected to each other and the Sun StorEdge 5310 Cluster before powering on the Sun StorEdge 5310 Cluster. The expansion enclosures must be powered on *first*, before the controller enclosures and Sun StorEdge 5310 Cluster. If these instructions are not followed, the system could start slowly.

Note – To achieve fault tolerance, units with two power supplies should receive power from two different AC circuits.



Caution – When you power off the controller enclosures and expansion enclosures, wait five seconds before you power them back on. If you power the units off and on too quickly, unexpected results may occur.

Powering On the Sun StorEdge 5310 Cluster System

To turn on each unit:

1. Verify that all cables between the Sun StorEdge 5310 Cluster, controller enclosures, and expansion enclosures are properly secured according to the instructions in "Connecting the Sun StorEdge 5310 Cluster to Controller Enclosures" on page 61 and "Connecting the Controller Enclosures to Expansion Enclosures" on page 66.
2. Verify that the Cat5 Ethernet crossover cable is connected between the heartbeat ports according to the instructions in "Connecting the Server Health-Monitoring and Network Cables" on page 73.
3. Power on each expansion enclosure by setting the two power supply switches to the On position.
4. Check that all LEDs on the expansion enclosure front panels turn solid green to indicate good operation.

Note – If the expansion enclosure contains SATA disk drives, only the power LED will turn solid green. The drive LEDs turn solid green only after powering on the controller enclosure.

5. Power on each controller enclosure by setting the two power supply switches to the On position.
6. Check that all LEDs on the controller enclosure front panels turn solid green to indicate good operation.
7. Verify that the Sun StorEdge 5310 Cluster is connected to the network.

Note – You will power up and configure one server at a time.

8. Power on the server H1 (serial number ending in “-H1”) by pressing the Power button (FIGURE 4-12) on the front panel (behind the faceplate).

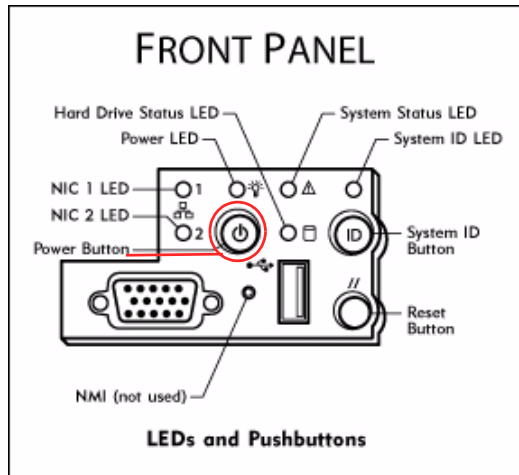

FIGURE 4-12 Power Button and Front Panel Detail



Caution – Do not power up server H2 until directed in the instructions that follow.

9. Verify server H1 has completed booting up: the LCD should display “QUIET.”
10. To complete the power up sequence, continue with the next section "Initial Sun StorEdge 5310 Cluster Configuration".

Initial Sun StorEdge 5310 Cluster Configuration



Caution – These instructions apply to the Sun StorEdge 5310 Cluster *only*. For Sun StorEdge 5310 NAS Appliance configuration instructions, refer to Chapter 3. For Sun StorEdge 5310 NAS Gateway System configuration instructions, refer to Chapter 5.

To complete the initial Sun StorEdge 5310 Cluster configuration, you must specify the following:

- IP addresses
- Basic configuration information

- Failover configuration informaton
- LUN ownership
- LUN paths

Setting IP Addresses

If your network supports DHCP, an IP address will automatically be assigned to your LAN ports.

Note – To avoid waiting for DHCP discovery, during the boot sequence when the LCD panel displays “DHCP Discovery NIC X”, you can press any key on the LCD panel and confirm the “Abort DHCP?” message by pressing the right arrow key on the panel. Then you can manually set the static IP address using the following the instructions.

If DHCP is not available, assign a static IP address using the server H1’s LCD panel:

1. **Select Menu.**
2. **Select A. Network Config.**
3. **Select A. Set Gateway and enter the gateway address.**
4. **Select C. Set Port-emx1 or C. Set Port-emx2 (depending on which port is the first regular LAN port) and enter the IP address, subnet mask, and broadcast address as prompted.**

This IP address information is assigned to the first regular (non-heartbeat) LAN port on your system.
5. **Select Exit twice to return to the main menu.**



Caution – Do not change the private IP address on the network port that is used for the HB Port (heartbeat port).

Note – If you would like to verify your settings on the LCD panel, HB Port will show a private IP address, and Port emx1 or Port emx2 (the first regular LAN port) will show the information you just entered.

You can edit the port information and assign addresses to other ports in the same way.

6. **From server H1’s LCD menu, select C. Take All LUNs and press the SEL button.**

7. When prompted to “take all LUNs,” press the up arrow to select “Yes,” and press the SEL button or right arrow to start taking LUNs.

The LCD will display “Taking LUNs” followed by a message “Took *n* LUNs.” After a few seconds, the display returns to the Network Config menu.

8. Select Exit to return to the main menu.

Server H1 is now in the ALONE state.

9. Power up the server H2 (serial number ending in “-H2”) by pressing the Power button.

10. Wait until server H2’s LCD display status is “QUIET.”

11. Use instructions in Steps 1.- 5. to assign server H2’s IP address and gateway address.

Configuring the System

To configure the system using the Web Admin application, follow these instructions:

1. From a client on the same network, open a Java platform-enabled web browser with Java Plug-In and enter the IP address for server H1.
2. Accept the “Applet Security Certificate” and wait until the Web Admin applet is loaded on this system.
3. On the Web Admin login screen, click Apply.

The password can be set later. Refer to the *Sun StorEdge 5310 NAS Appliance Administration Guide*.

4. On the Set Time and Date panel, select the date, the time, and the time zone, and click Apply, and then click Yes to confirm.

This will set the secure clock to the same time and date. Make sure you set the time and date accurately as you can only set the secure clock once.

5. Read the license agreement in the Configuration Wizard dialog box, and click Accept.

6. Click Next in the Welcome dialog box, and proceed with the following steps:

- a. From the Select Environment screen, configure Windows, UNIX, or both environments, and click Next to continue.

You can add additional configuration information later.

- b. From the Set Server Name screen, enter the server name and populate the other fields accordingly, and then click Next.

- c. **From the Enable Failover screen, select Automatic Failover and Enable Link Failover.**

A default value of 60 seconds is assigned in both the Down Timeout and Restore Timeout fields.

- d. **Enter the Partner Configuration Name and the Gateway IP address for server H2 (Partner Name factory default is “head2”), and click Apply.**

The information you enter here is used to start server H2 through the heartbeat connection. The Partner Name is the host name you want to assign to server H2. Any network information server H2 obtained through DHCP or manually through the LCD panel will be displayed here and can be corrected, if necessary.

The field for Private IP for the heartbeat connection should already be populated (IP 10.10.10.2 private network) and should not be changed.

- e. **Click Next.**

- f. **On the Configure Network Adapters screen, verify that the information is correct.**

You may configure additional network interfaces at this time. However, if you change the configuration of the port to which the browser is attached, the browser session will be disconnected.

- g. **Click Next to continue.**

- h. **On the Set Gateway Address screen, verify that the address is correct, and, if not, enter the gateway address, and click Next to continue.**

7. **For all the other wizard configuration steps, refer to the *Sun StorEdge 5310 NAS Appliance and Gateway System Administration Guide* for more information.**

Note – When adding your DNS server, click **Add** to ensure the DNS server has been added.

8. **On the Confirmation screen, review the configuration information you have added.**

Note – Be sure the configuration information is accurate before continuing.

9. **Click Finish on the Wizard Confirmation Screen.**

The system will configure the settings and indicate it in the Save Configuration screen. It will also display a message that both servers must reboot for the failover changes to be applied.

10. **Click Close on the Save Configuration screen.**

Rebooting Server H2 Manually

Note – Server H1 reboots automatically, but you must manually reboot server H2.

To manually reboot server H2:

1. On server H2's LCD panel, select **B. Shutdown Server** from the menu.
2. Select **B. Reboot**. The LCD displays "Are you sure? No." Press the up arrow to change to "Yes." Then press SEL or the right arrow to reboot.

After a few minutes, server H1 should come up in the ALONE state, and server H2 should come up in the QUIET state. Verify this by looking at the LCD panel.

Assigning LUN Ownership

To finish the configuration process, you must assign LUN ownership for both servers.

1. Launch a new browser window and enter server H1's IP address.
2. On the Web Admin login screen click **Apply**. A password is not required.
The password can be set later. Refer to the *Sun StorEdge 5310 NAS Appliance and Gateway System Administration Guide*.
3. From the navigation panel, select **High Availability > Recover**.
Check the status of the recover process in the logging window (bottom pane).
4. In the **Restore Raid Configuration** window, assign some of the LUNs to server H2.

Note – You must assign at least one LUN to each server. In most situations, you will want approximately equal amounts of storage assigned to each server in the cluster.

5. Click **Apply**.

Note – The appropriate LUN assignments are saved in the (New) Restore Raid Configuration window.

6. Click **Recover**, and the LUNs will be distributed between both the servers.
At this point, both servers change to the NORMAL state.

Note – Verify that both servers are in the NORMAL state on the LCD Panel display or on the Web Admin main page, where the Head Status and Partner Status should display NORMAL.

Assigning LUN Paths

You should assign LUN paths on each server to balance multipath access from each server to each storage controller.

1. **In the navigation panel, select High Availability > Set LUN Path.**
2. **Select a LUN and click Edit.**
3. **Select the desired controller from the Primary Path drop-down menu.**

Evenly divide the assignment of LUNs to the two available paths. For example, the first and third LUN to 1/0 and the second and fourth LUN to 1/1.

4. **Click Apply.**

Refer to the *Sun StorEdge 5310 NAS Appliance and Gateway System Administration Guide* for additional information about LUNs and other detailed software setup and use.

Configuring the Partner

For server H2 repeat all steps in "Configuring the System" on page 80 with the following exceptions:

- In Step 6.d., enter the information for the partner H1 server.
- As you complete the configuration process, there is no message to reboot the servers, since you do not need to reboot the servers.

Installing the Sun StorEdge 5310 NAS Gateway System

This chapter provides comprehensive instructions for connecting a Sun StorEdge 5310 NAS Gateway System to SAN storage. It also provides initial configuration instructions for the system.

Note – If you are installing a different system, refer to the appropriate chapter.

This chapter contains the following sections:

- "Before You Begin" on page 86
- "Installation and Configuration Task Overview" on page 86
- "Connecting the Sun StorEdge 5310 NAS Gateway System to the Sun StorEdge 6920 System" on page 87
- "Connecting the Sun StorEdge 5310 NAS Gateway System to the Sun StorEdge 9970/9980" on page 104
- "Connecting to the Network" on page 120
- "Powering On the Sun StorEdge 5310 NAS Gateway System" on page 123
- "Initial Sun StorEdge 5310 NAS Gateway System Single Server Configuration" on page 124
- "Initial Sun StorEdge 5310 NAS Gateway System Dual Server HA Configuration" on page 129

Note – The Sun StorEdge 5310 NAS Gateway System ships with the operating system installed.

Before You Begin

Before connecting the system, do the following:

- If desired, install the Sun StorEdge 5310 NAS Gateway System and switch or switches, if used, in a cabinet. Follow the rail mount instructions included with the rail mount kits.
- Set up the SAN storage devices, referring, if necessary, to your SAN storage documentation.

You will configure storage after the Sun StorEdge 5310 NAS Gateway System is installed and set up.

Installation and Configuration Task Overview

To set up Sun StorEdge 5310 NAS Gateway System, you perform the following tasks:

1. Connect to SAN storage.

Refer to "Connecting the Sun StorEdge 5310 NAS Gateway System to the Sun StorEdge 6920 System" on page 87 or "Connecting the Sun StorEdge 5310 NAS Gateway System to the Sun StorEdge 9970/9980" on page 104.

2. Connect to the network.

Refer to "Connecting to the Network" on page 120.

3. Power on the system.

Refer to "Powering On the Sun StorEdge 5310 NAS Gateway System" on page 123.

4. Configure the system by doing the following:

a. Set up IP addresses.

b. Configure the basic system.

c. Activate the license.

d. Configure SAN storage.

e. Configure Sun StorEdge 5310 NAS Gateway System storage.

f. For cluster configuration only, configure failover.

g. Set LUN paths.

For the single server configuration, refer to "Initial Sun StorEdge 5310 NAS Gateway System Single Server Configuration" on page 124.

For the cluster configuration, refer to "Initial Sun StorEdge 5310 NAS Gateway System Dual Server HA Configuration" on page 129.

Storage Concepts

Each Sun StorEdge 5310 NAS Gateway System server contains two dual port HBA cards. Using pairs of optical fiber cables, you can connect to storage directly or by using Fibre Channel switches.

When the Sun StorEdge 5310 NAS Gateway System is connected directly to storage without using a Fibre Channel switch, it is referred to as a "direct attach." Storage is configured using LUN masking.

Most Sun StorEdge 5310 NAS Gateway Systems are connected to SAN storage using a Fibre Channel switch, which is referred to as a "fabric attach." Because a switch can be a single point of failure, multiple switches can be used. Multiple switches can be configured with LUN masking to allocate storage to specific servers.

To ensure redundancy, you should connect to SAN storage port pairs.

Connecting the Sun StorEdge 5310 NAS Gateway System to the Sun StorEdge 6920 System

This section describes how to cable the Sun StorEdge 5310 NAS Gateway System directly or through fabric switches to the Sun StorEdge 6920 system:

- "Connecting Directly to the Sun StorEdge 6920 System" on page 88
- "Using the Fabric Switches to Connect to the Sun StorEdge 6920 System" on page 93

After connecting the systems, proceed to "Connecting to the Network" on page 120.

Connecting Directly to the Sun StorEdge 6920 System

The following direct attach configurations are described in this section:

- "Single Head Direct Attach to Sun StorEdge 6920 System" on page 88
- "Dual Head Direct Attach to Sun StorEdge 6920 System" on page 90

Note – Do not power on the server until instructed in "Powering On the Sun StorEdge 5310 NAS Gateway System" on page 123.

Single Head Direct Attach to Sun StorEdge 6920 System

You can connect to SAN storage with one or two pairs of optical fiber cables. Using two pairs to connect all HBA ports ensures redundancy and improves processing speed.

- 1. Connect the HBA port 2 of the first HBA card to the first available port on the Sun StorEdge 6920 system.**

2. Connect the HBA port 2 of the second HBA card to the next available port on the Sun StorEdge 6920 system.

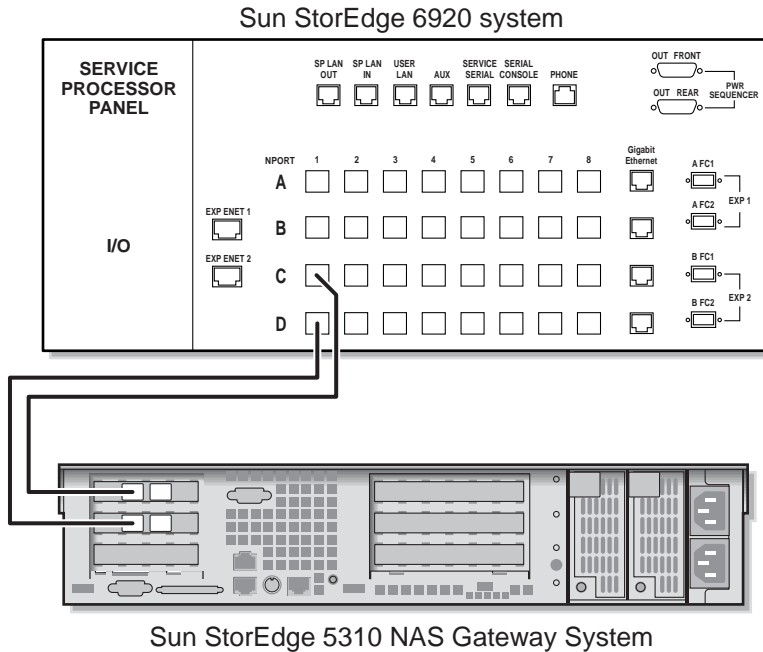

FIGURE 5-1 Connecting Two HBA Ports to the Sun StorEdge 6920 System

For redundancy and increased processing speed, you can also attach the additional HBA ports:

1. Connect the HBA port 1 of the first HBA card to the next available port on the Sun StorEdge 6920 system.

2. Connect the HBA port 1 of the second HBA card to the next available port on the Sun StorEdge 6920 system.

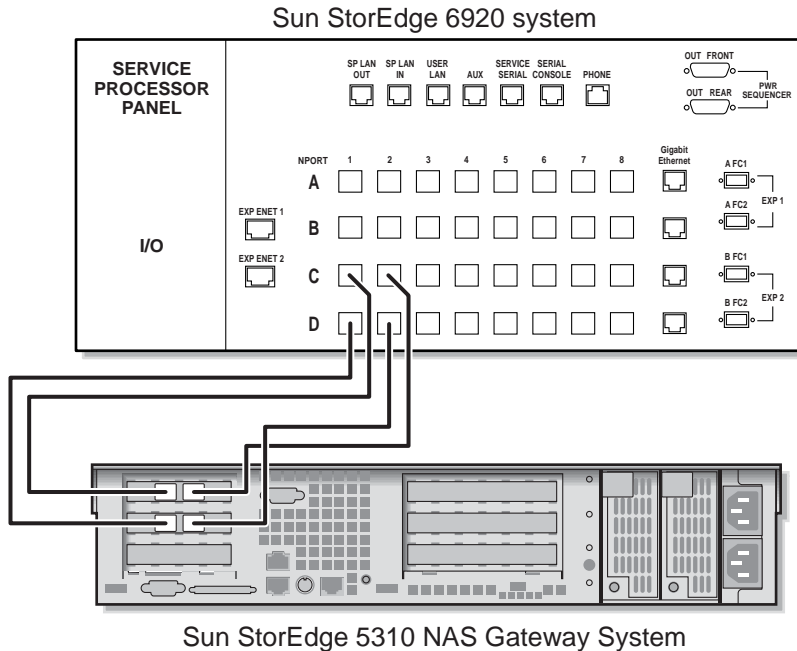

FIGURE 5-2 Connecting All HBA Ports to the Sun StorEdge 6920 System

Dual Head Direct Attach to Sun StorEdge 6920 System

You can connect a dual head High-Availability (HA) Sun StorEdge 5310 NAS Gateway System to SAN storage with two or four pairs of optical fiber cables. Using four pairs to connect all HBA ports simulates a dual array and ensures redundancy and improves processing speed.

1. Connect the HBA port 2 of the first HBA card on server H1 to the first available port on the Sun StorEdge 6920 system.
2. Connect the HBA port 2 of the second HBA card on server H1 to the next available port on the Sun StorEdge 6920 system.
3. Connect the HBA port 2 of the first HBA card on server H2 to the next available port on the Sun StorEdge 6920 system.

4. Connect the HBA port 2 of the second HBA card on server H2 to the next available port on the Sun StorEdge 6920 system.

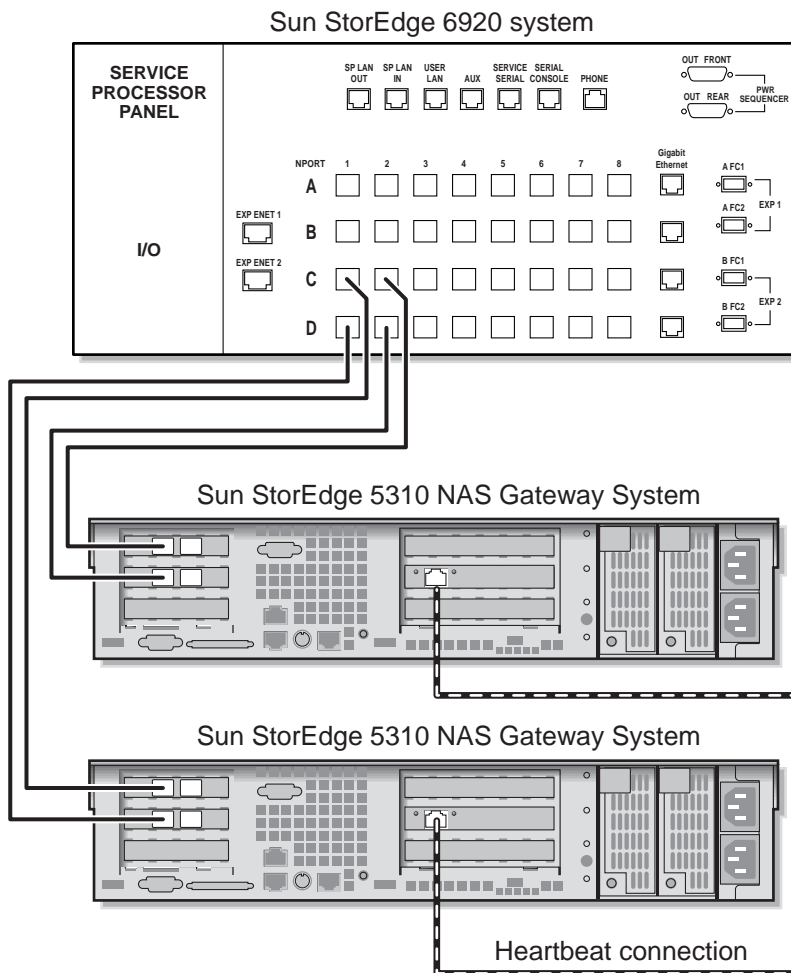

FIGURE 5-3 Connecting Two HBA Ports per HA Server to the Sun StorEdge 6920 System

To simulate a dual array, you can also attach the additional HBA ports:

1. Connect the HBA port 1 of the first HBA card on server H1 to the first available port on the Sun StorEdge 6920 system.
2. Connect the HBA port 1 of the second HBA card on server H1 to the next available port on the Sun StorEdge 6920 system.
3. Connect the HBA port 1 of the first HBA card on server H2 to the next available port on the Sun StorEdge 6920 system.

4. Connect the HBA port 1 of the second HBA card on server H2 to the next available port on the Sun StorEdge 6920 system.

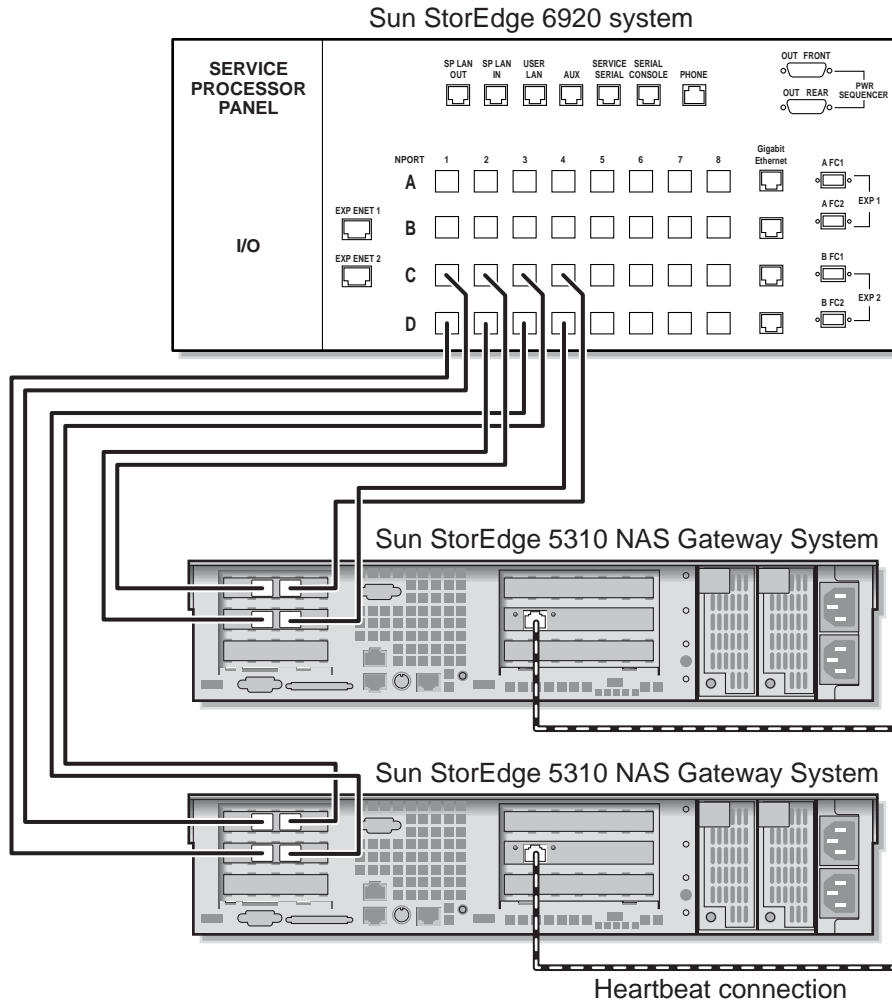

FIGURE 5-4 Connecting All HBA Ports per HA Server to the Sun StorEdge 6920 System

Using the Fabric Switches to Connect to the Sun StorEdge 6920 System

The following fabric attach configurations are described in this section:

- “Single Head Fabric Attach to Sun StorEdge 6920 System” on page 93
- “Sharing All Sun StorEdge 6920 System LUNs Between All Port Pairs” on page 96
- “Dual Head High-Availability Fabric Attach to Sun StorEdge 6920 System” on page 98

Note – Do not power on the server until instructed in "Powering On the Sun StorEdge 5310 NAS Gateway System" on page 123.

Single Head Fabric Attach to Sun StorEdge 6920 System

You can connect to SAN storage with one or two pairs of optical fiber cables. Using two pairs to connect all HBA ports and using two switches ensures redundancy and improves processing speed.

1. **Connect the HBA port 2 of the first HBA card to the first available port of the first fabric switch.**
2. **Connect the HBA port 2 of the second HBA card to the first available port of the second fabric switch.**
3. **Connect an available port on the first switch to the first available port on the Sun StorEdge 6920 system.**

4. Connect an available port on the second switch to the next available port on the Sun StorEdge 6920 system.

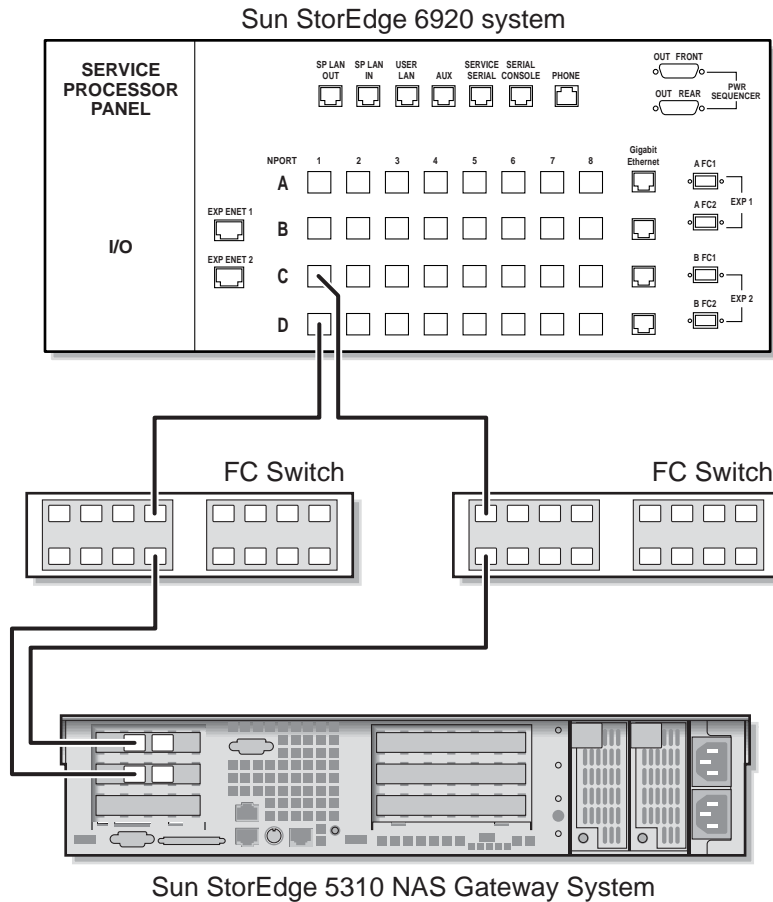

FIGURE 5-5 Connecting Two HBA Ports Using Fabric Switches to the Sun StorEdge 6920 System

For redundancy and increased processing speed, you can also attach the additional HBA ports:

1. Connect the HBA port 2 of the first HBA card to the next available port of the first fabric switch.

2. Connect the HBA port 2 of the second HBA card to the next available port of the second fabric switch.

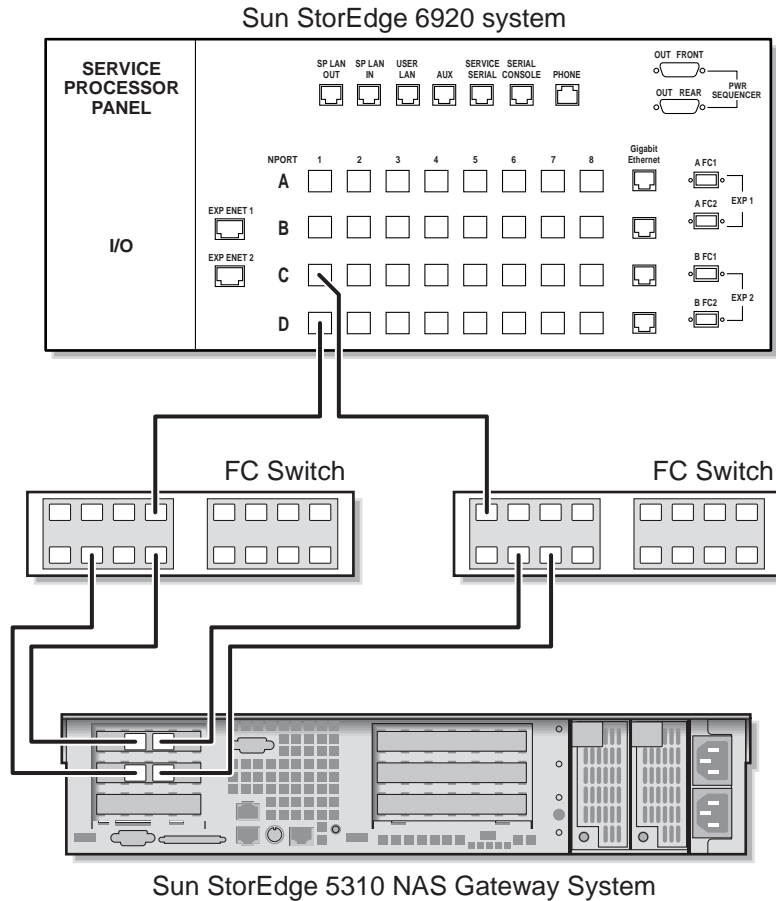

FIGURE 5-6 Connecting All HBA Ports Through Fabric Switches to the Sun StorEdge 6920 System

Sharing All Sun StorEdge 6920 System LUNs Between All Port Pairs

To enable all LUNs to be shared between all port pairs, attach the four HBA ports to two switches and use four cables to attach the switches to the Sun StorEdge 6920 system:

1. **Connect the HBA port 2 of the first HBA card to the first available port of the first fabric switch.**
2. **Connect the HBA port 2 of the second HBA card to the first available port of the second fabric switch.**
3. **Connect the HBA port 1 of the first HBA card to the first available port of the first fabric switch.**
4. **Connect the HBA port 1 of the second HBA card to the first available port of the second fabric switch.**
5. **Connect an available port on the first switch to the first available port on the Sun StorEdge 6920 system.**
6. **Connect an available port on the second switch to the next available port on the Sun StorEdge 6920 system.**
7. **Connect the next available port on the first switch to the next available port on the Sun StorEdge 6920 system.**

- Connect the next available port on the second switch to the next available port on the Sun StorEdge 6920 system.

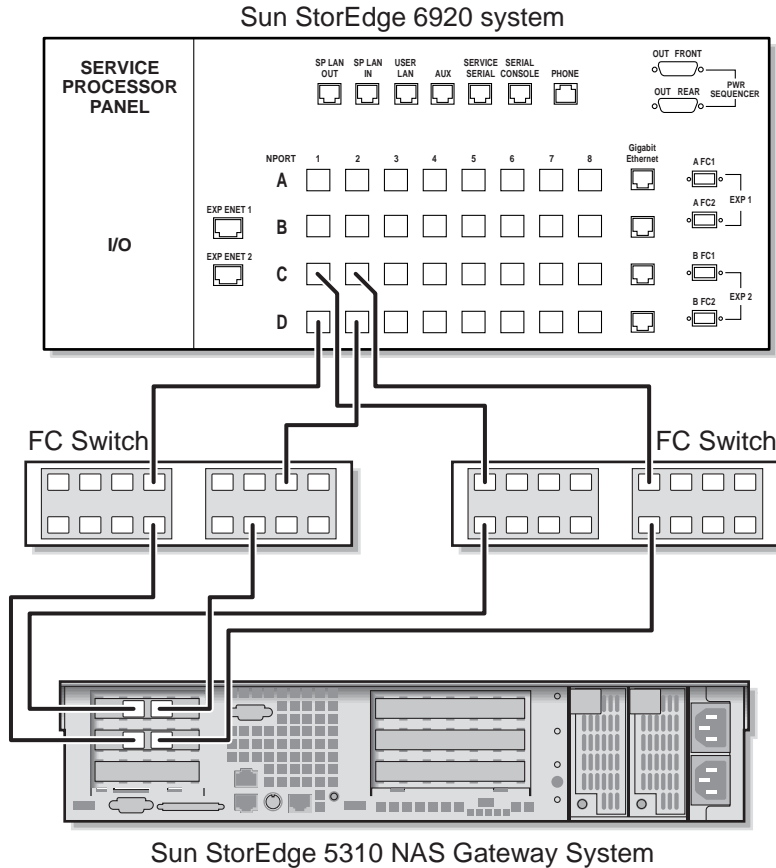

FIGURE 5-7 Connecting All HBA Ports Through Two Fabric Switches to the Sun StorEdge 6920 System

Dual Head High-Availability Fabric Attach to Sun StorEdge 6920 System

You can connect a dual head High-Availability Sun StorEdge 5310 NAS Gateway System to SAN storage with two or four pairs of optical fiber cables, with or without additional switch connections. Using four pairs to connect all HBA ports ensures redundancy and improves processing speed.

- 1. Connect the HBA port 2 of the first HBA card in the server H1 to the first available port of the first fabric switch.**
- 2. Connect the HBA port 2 of the second HBA card in the server H1 to the first available port of the second fabric switch.**
- 3. Connect the HBA port 2 of the first HBA card in the server H2 to the next available port of the first fabric switch.**
- 4. Connect the HBA port 2 of the second HBA card in the server H2 to the next available port of the second fabric switch.**
- 5. Connect an available port on the first switch to the first available port on the Sun StorEdge 6920 system.**

- Connect an available port on the second switch to the next available port on the Sun StorEdge 6920 system.

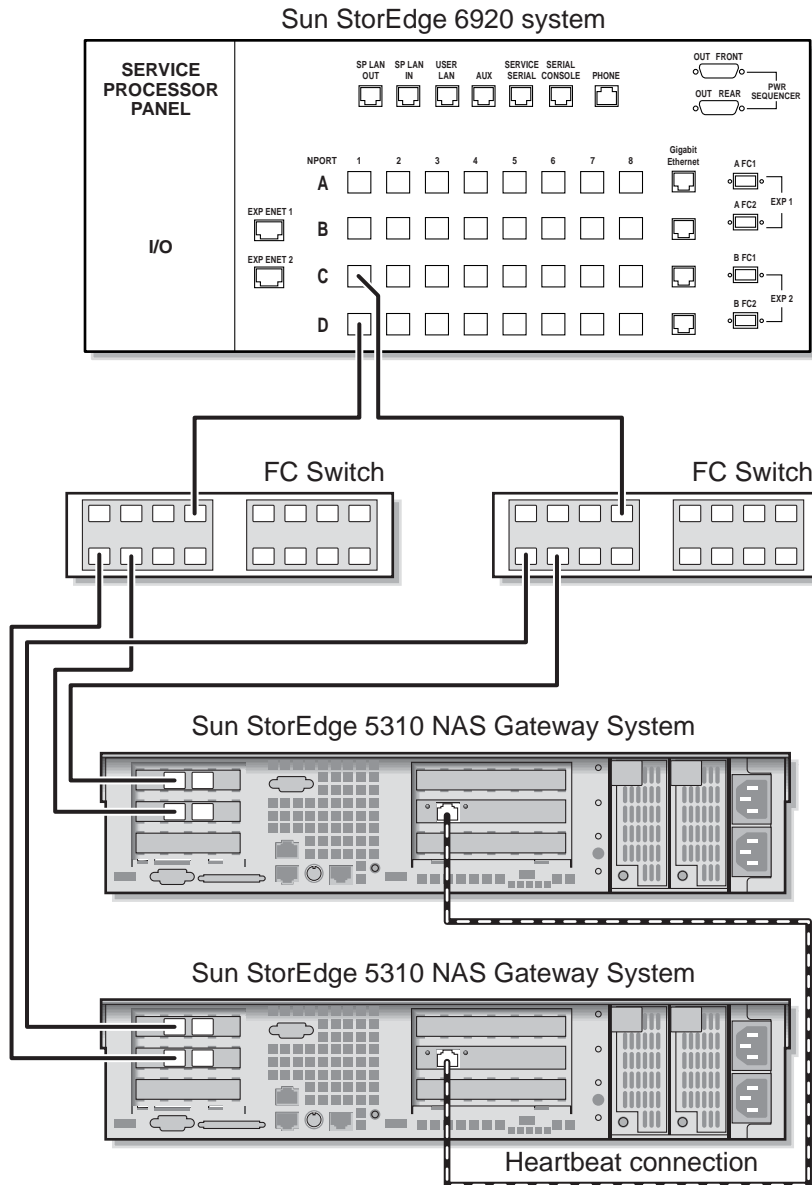

FIGURE 5-8 Connecting Two HBA Ports per HA Server Through Fabric Switches to the Sun StorEdge 6920 System

To enable all LUNs to be shared between all port pairs, attach additional cables from the two switches:

- 1. Connect the next available port on the first switch to the next available port on the Sun StorEdge 6920 system.**

2. Connect the next available port on the second switch to the next available port on the Sun StorEdge 6920 system.

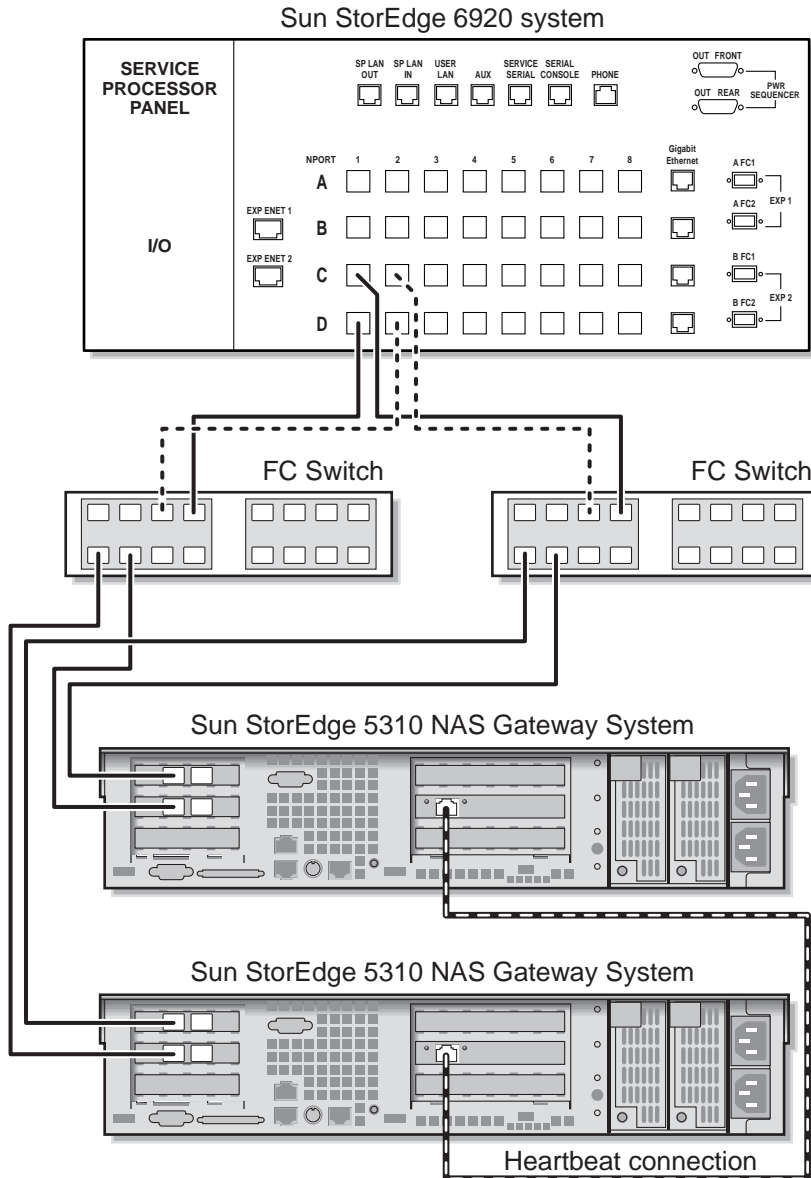

FIGURE 5-9 Connecting Two HBA Ports per HA Server Through Fabric Switches to the Sun StorEdge 6920 System with Additional Switch Connections

For maximum redundancy, use all four HBA ports on each server and attach additional cables from the two switches:

1. **Connect the HBA port 1 of the first HBA card on server H1 to the next available port of the first fabric switch.**
2. **Connect the HBA port 1 of the second HBA card on server H1 to the next available port of the second fabric switch.**
3. **Connect the HBA port 1 of the first HBA card on server H2 to the next available port of the first fabric switch.**
4. **Connect the HBA port 1 of the second HBA card on server H2 to the next available port of the second fabric switch.**
5. **Connect an available port on the first switch to the next available port on the Sun StorEdge 6920 system.**
6. **Connect an available port on the second switch to the next available port on the Sun StorEdge 6920 system.**
7. **Connect the next available port on the first switch to the next available port on the Sun StorEdge 6920 system.**

- Connect the next available port on the second switch to the next available port on the Sun StorEdge 6920 system.

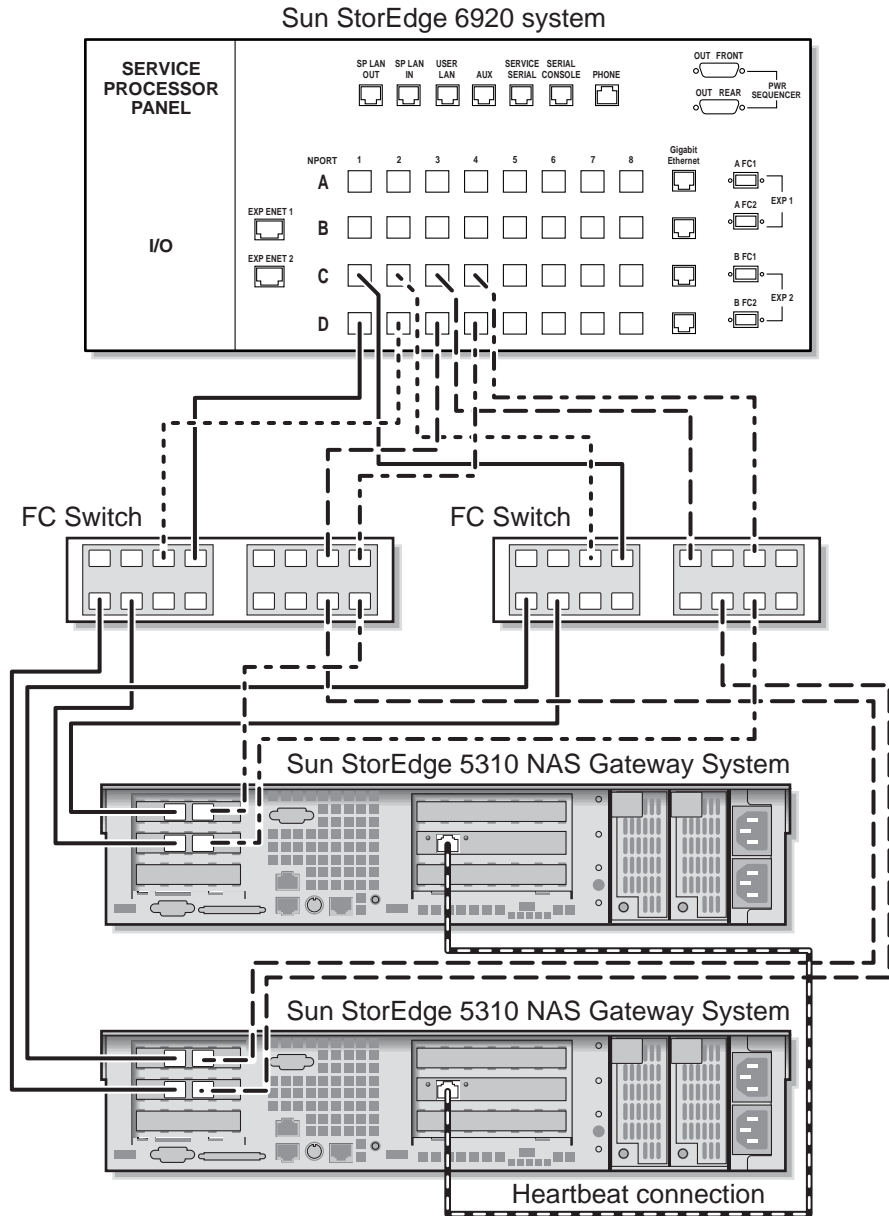

FIGURE 5-10 Connecting All HBA Ports per HA Server Through Two Fabric Switch Zones to the Sun StorEdge 6920 System

Connecting the Sun StorEdge 5310 NAS Gateway System to the Sun StorEdge 9970/9980

This section describes how to cable the Sun StorEdge 5310 NAS Gateway System directly or through fabric switches to the Sun StorEdge 9970/9980:

- "Connecting Directly to the Sun StorEdge 9970/9980" on page 104
 - "Using Fabric Switches to Connect to the Sun StorEdge 9970/9980" on page 109
- After connecting the systems, proceed to "Connecting to the Network" on page 120.

Connecting Directly to the Sun StorEdge 9970/9980

The following direct attach configurations are described in this section:

- "Single Head Direct Attach to Sun StorEdge 9970/9980" on page 104
- "Dual Head Direct Attach to Sun StorEdge 9970/9980" on page 106

Note – Do not power on the server until instructed in "Powering On the Sun StorEdge 5310 NAS Gateway System" on page 123.

Single Head Direct Attach to Sun StorEdge 9970/9980

You can connect to SAN storage with one or two pairs of optical fiber cables. Using two pairs to connect all HBA ports ensures redundancy and improves processing speed.

1. **Connect the HBA port 2 of the first HBA card to the first available port on the Sun StorEdge 9970/9980.**

2. Connect the HBA port 2 of the second HBA card to the next available port on the Sun StorEdge 9970/9980.

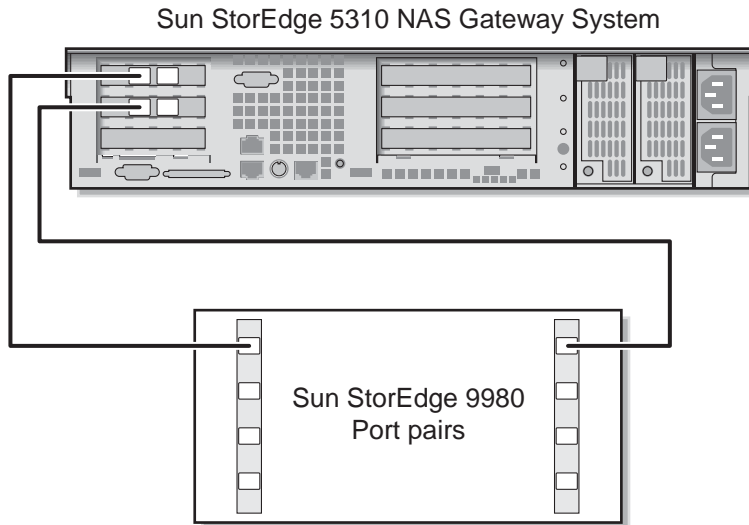

FIGURE 5-11 Connecting Two HBA Ports to the Sun StorEdge 9970/9980

For redundancy and increased processing speed, you can also attach the additional HBA ports:

1. Connect the HBA port 1 of the first HBA card to the next available port on the Sun StorEdge 9970/9980.

2. Connect the HBA port 1 of the second HBA card to the next available port on the Sun StorEdge 9970/9980.

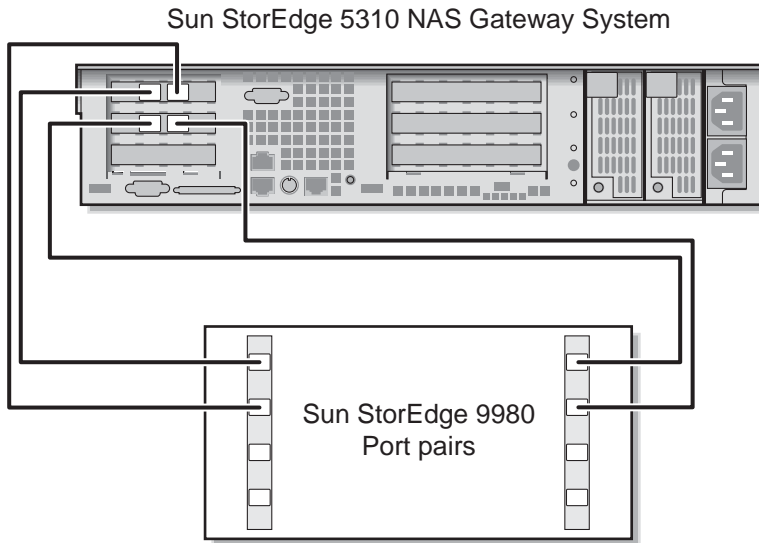

FIGURE 5-12 Connecting All HBA Ports to the Sun StorEdge 9970/9980

Dual Head Direct Attach to Sun StorEdge 9970/9980

You can connect a dual head High-Availability (HA) Sun StorEdge 5310 NAS Gateway System to SAN storage with two or four pairs of optical fiber cables. Using four pairs to connect all HBA ports simulates a dual array and ensures redundancy and improves processing speed.

1. Connect the HBA port 2 of the first HBA card on server H1 to the first available port on the Sun StorEdge 9970/9980.
2. Connect the HBA port 2 of the second HBA card on server H1 to the next available port on the Sun StorEdge 9970/9980.
3. Connect the HBA port 2 of the first HBA card on server H2 to the next available port on the Sun StorEdge 9970/9980.

4. Connect the HBA port 2 of the second HBA card on server H2 to the next available port on the Sun StorEdge 9970/9980.

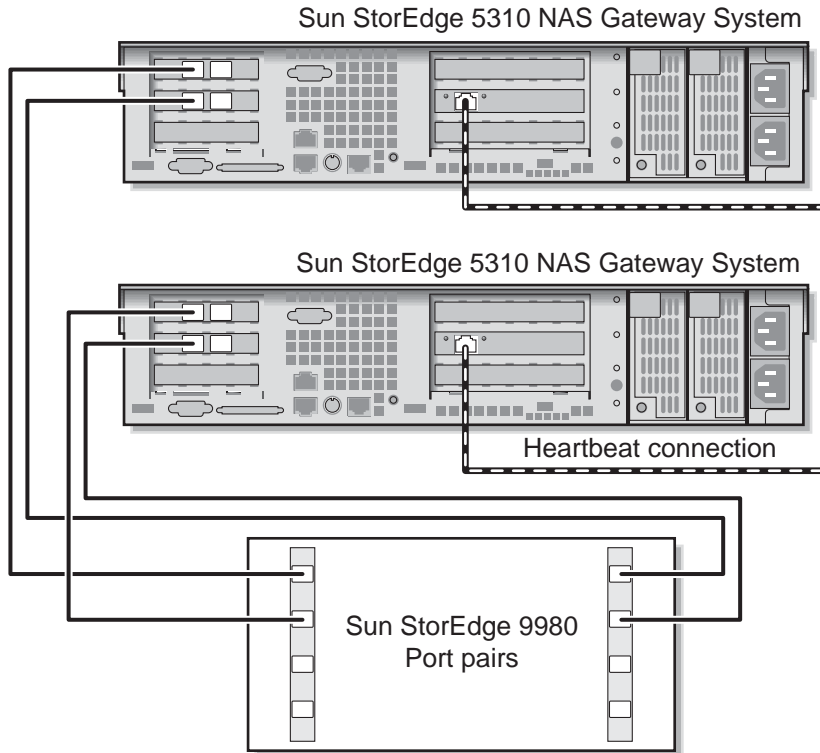

FIGURE 5-13 Connecting Two HBA Ports per HA Server to the Sun StorEdge 9970/9980

To simulate a dual array, you can also attach the additional HBA ports:

1. Connect the HBA port 1 of the first HBA card on server H1 to the first available port on the Sun StorEdge 9970/9980.
2. Connect the HBA port 1 of the second HBA card on server H1 to the next available port on the Sun StorEdge 9970/9980.
3. Connect the HBA port 1 of the first HBA card on server H2 to the next available port on the Sun StorEdge 9970/9980.

4. Connect the HBA port 1 of the second HBA card on server H2 to the next available port on the Sun StorEdge 9970/9980.

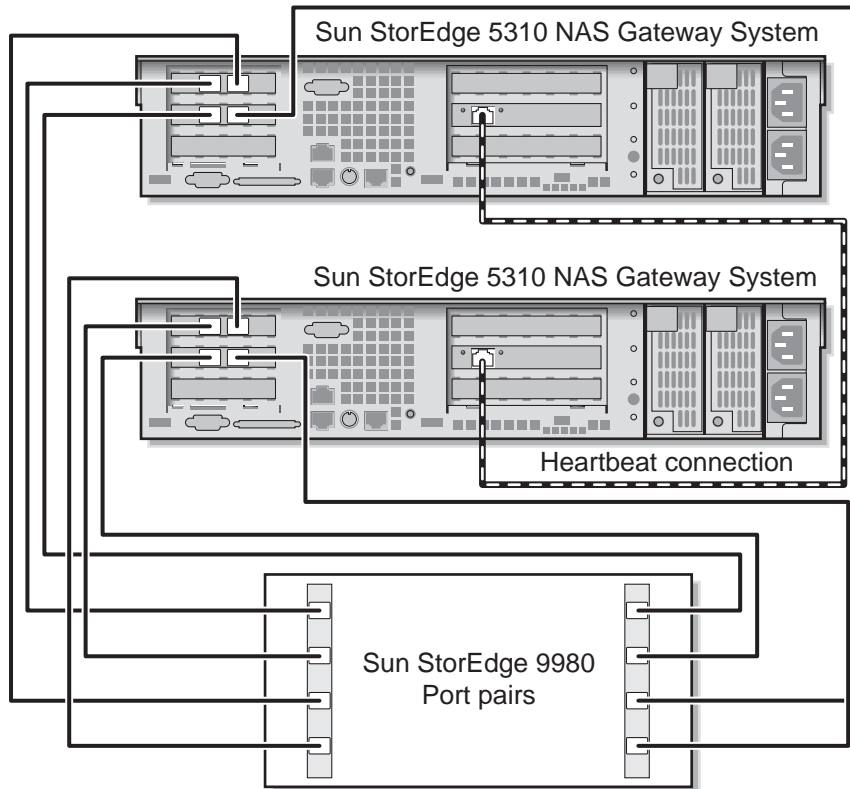

FIGURE 5-14 Connecting All HBA Ports per HA Server to the Sun StorEdge 9970/9980

Using Fabric Switches to Connect to the Sun StorEdge 9970/9980

The following fabric attach configurations are described in this section:

- "Single Head Fabric Attach to Sun StorEdge 9970/9980" on page 109
- "Sharing All Sun StorEdge 9970/9980 LUNs Between All Port Pairs" on page 111
- "Independent Dual Server Fabric Attach to Sun StorEdge 9970/9980" on page 113
- "Dual Head High-Availability Fabric Attach to Sun StorEdge 9970/9980" on page 115

Note – Do not power on the server until instructed in "Powering On the Sun StorEdge 5310 NAS Gateway System" on page 123.

Single Head Fabric Attach to Sun StorEdge 9970/9980

You can connect to SAN storage with one or two pairs of optical fiber cables. Using two pairs to connect all HBA ports and using two switches ensures redundancy and improves processing speed.

1. **Connect the HBA port 2 of the first HBA card to the first available port of the first fabric switch.**
2. **Connect the HBA port 2 of the second HBA card to the first available port of the second fabric switch.**
3. **Connect an available port on the first switch to the first available port on the Sun StorEdge 9970/9980.**

4. Connect an available port on the second switch to the next available port on the Sun StorEdge 9970/9980.

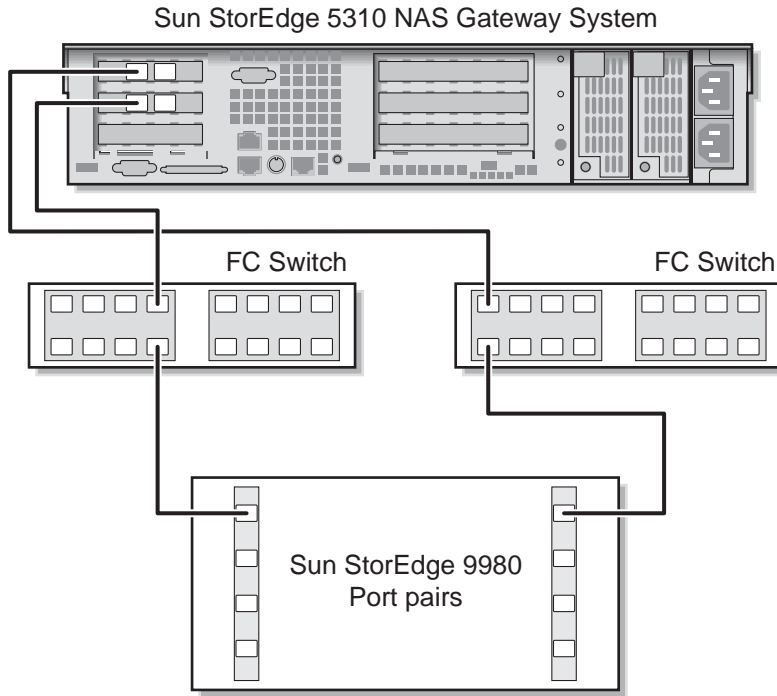

FIGURE 5-15 Connecting Two HBA Ports Through Fabric Switches to the Sun StorEdge 9970/9980

For redundancy and increased processing speed, you can also attach the additional HBA ports:

1. Connect the HBA port 2 of the first HBA card to the next available port of the first fabric switch.

2. Connect the HBA port 2 of the second HBA card to the next available port of the second fabric switch.

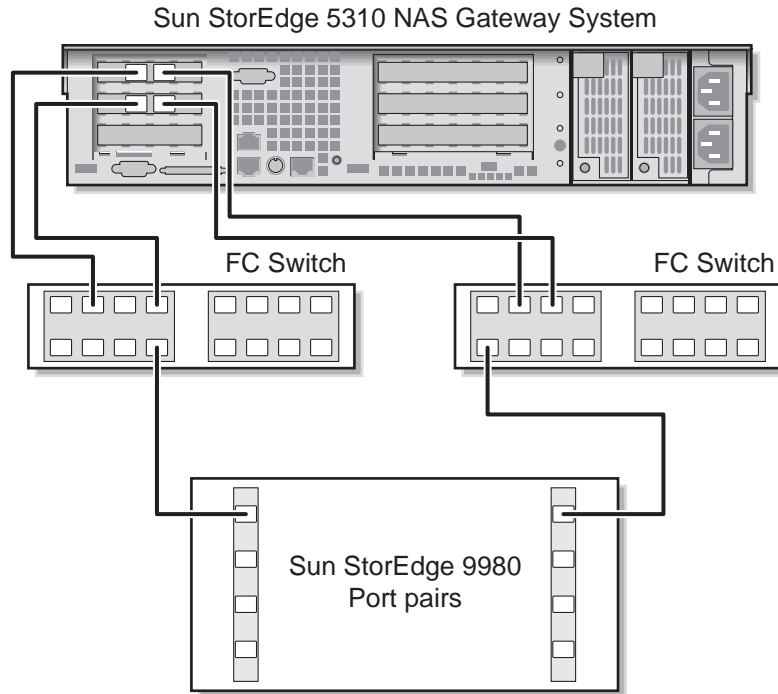

FIGURE 5-16 Connecting All HBA Ports Through Fabric Switches to the Sun StorEdge 9970/9980

Sharing All Sun StorEdge 9970/9980 LUNs Between All Port Pairs

To enable all LUNs to be shared between all port pairs, attach the four HBA ports to two switches and use four cables to attach the switches:

1. Connect the HBA port 2 of the first HBA card to the first available port of the first fabric switch.
2. Connect the HBA port 2 of the second HBA card to the first available port of the second fabric switch.
3. Connect the HBA port 1 of the first HBA card to the next available port of the first fabric switch.
4. Connect the HBA port 1 of the second HBA card to the next available port of the second fabric switch.

5. Connect an available port on the first switch to the first available port on the Sun StorEdge 9970/9980.
6. Connect an available port on the second switch to the next available port on the Sun StorEdge 9970/9980.
7. Connect the next available port on the first switch to the next available port on the Sun StorEdge 9970/9980.
8. Connect the next available port on the second switch to the next available port on the Sun StorEdge 9970/9980.

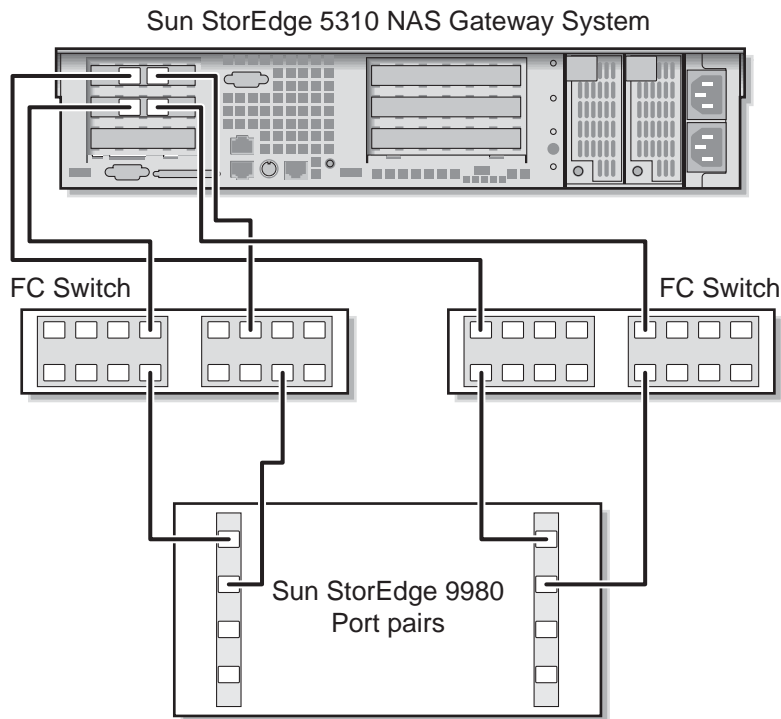

FIGURE 5-17 Connecting All HBA Ports Through Two Fabric Switches to the Sun StorEdge 9970/9980

Independent Dual Server Fabric Attach to Sun StorEdge 9970/9980

You can connect two independent (not high availability) Sun StorEdge 5310 NAS Gateway System servers.

- 1. Connect the HBA port 2 of the first HBA card in the first server to the first available port of the first fabric switch.**
- 2. Connect the HBA port 2 of the second HBA card in the first server to the first available port of the second fabric switch.**
- 3. Connect the HBA port 2 of the first HBA card in the second server to the next available port of the first fabric switch.**
- 4. Connect the HBA port 2 of the second HBA card in the second server to the next available port of the second fabric switch.**
- 5. Connect an available port on the first switch to the first available port on the Sun StorEdge 9970/9980.**

6. Connect an available port on the second switch to the next available port on the Sun StorEdge 9970/9980.

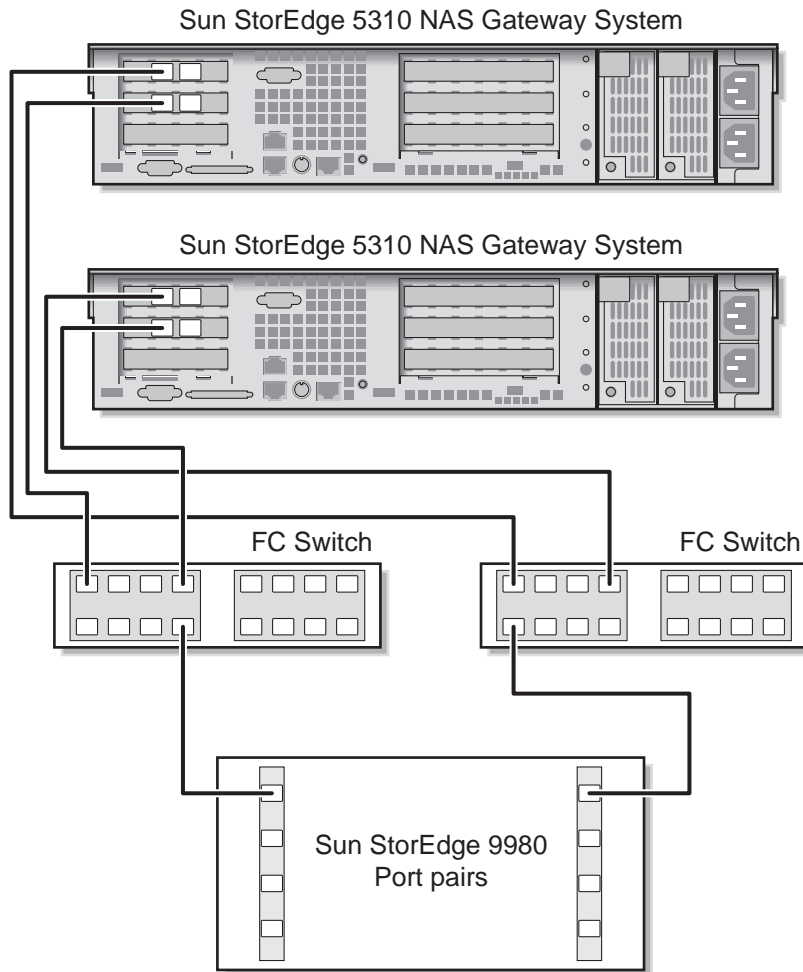

FIGURE 5-18 Connecting Two HBA Ports per Independent Server Through Fabric Switches to the Sun StorEdge 9970/9980

Dual Head High-Availability Fabric Attach to Sun StorEdge 9970/9980

You can connect a dual head High-Availability Sun StorEdge 5310 NAS Gateway System to SAN storage with two or four pairs of optical fiber cables, with or without additional switch connections. Using four pairs to connect all HBA ports ensures redundancy and improves processing speed.

- 1. Connect the HBA port 2 of the first HBA card in the server H1 to the first available port of the first fabric switch.**
- 2. Connect the HBA port 2 of the second HBA card in the server H1 to the first available port of the second fabric switch.**
- 3. Connect the HBA port 2 of the first HBA card in the server H2 to the next available port of the first fabric switch.**
- 4. Connect the HBA port 2 of the second HBA card in the server H2 to the next available port of the second fabric switch.**
- 5. Connect an available port on the first switch to the first available port on the Sun StorEdge 9970/9980.**

6. Connect an available port on the second switch to the next available port on the Sun StorEdge 9970/9980.

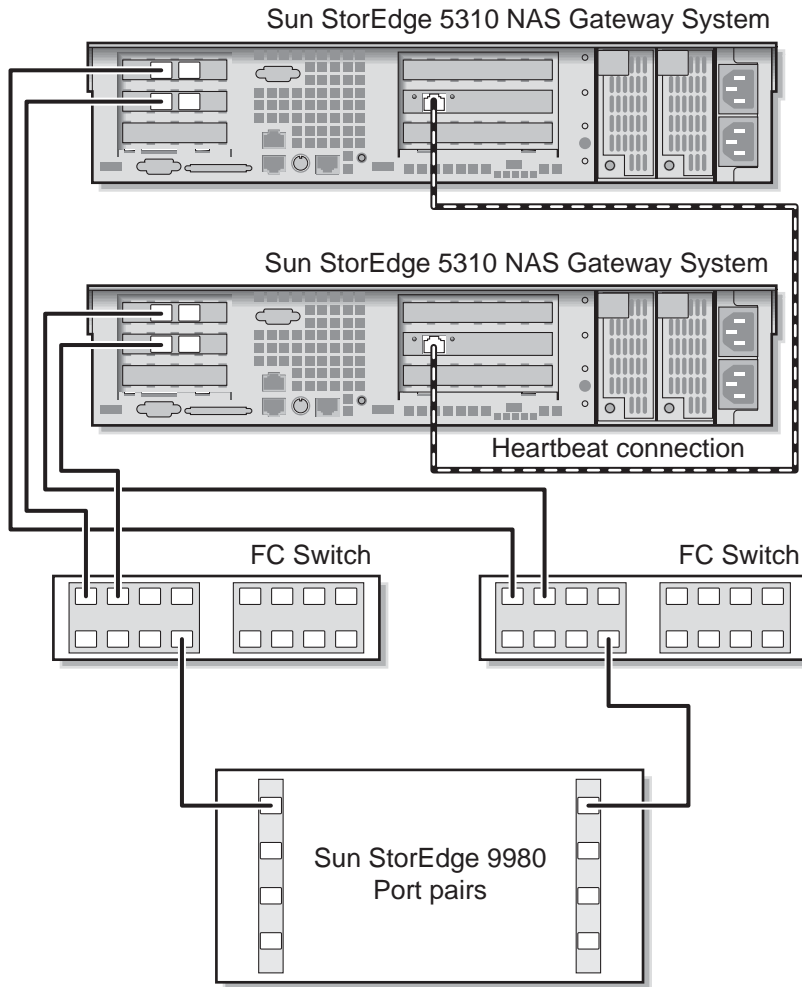

FIGURE 5-19 Connecting Two HBA Ports per HA Server Through Fabric Switches to the Sun StorEdge 9970/9980

To enable all LUNs to be shared between all port pairs, attach additional cables from the two switches:

1. Connect the next available port on the first switch to the next available port on the Sun StorEdge 9970/9980.

2. Connect the next available port on the second switch to the next available port on the Sun StorEdge 9970/9980.

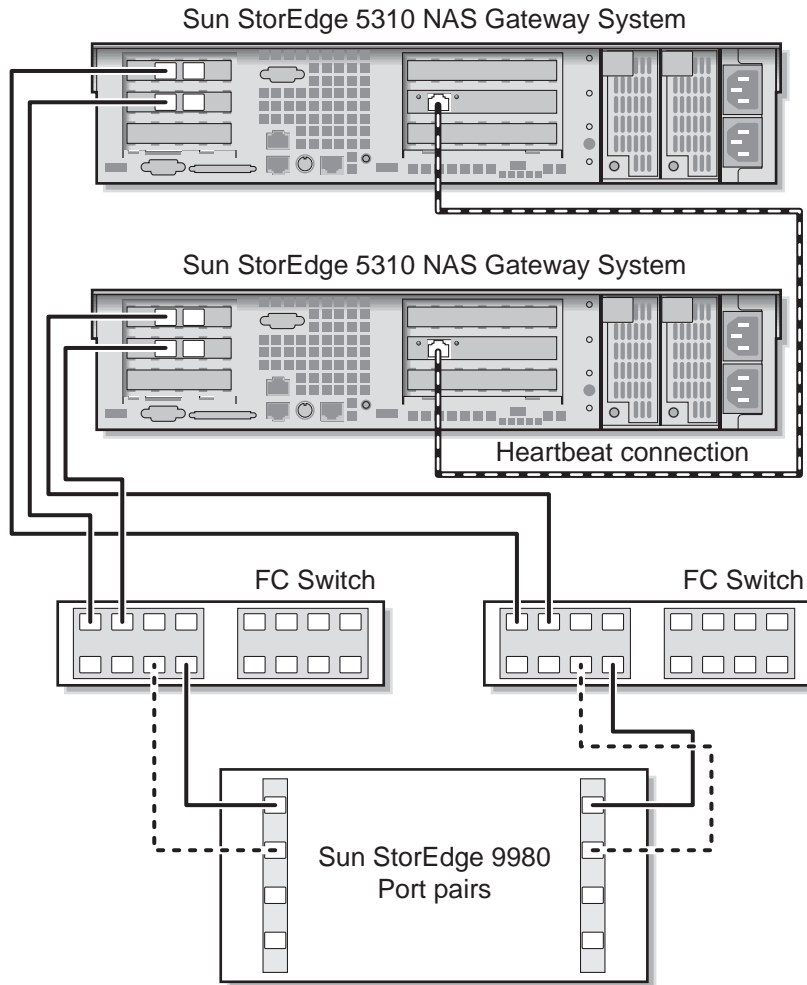

FIGURE 5-20 Connecting Two HBA Ports per HA Server Through Fabric Switches to the Sun StorEdge 9970/9980 With Additional Switch Connections

For maximum redundancy, use all four HBA ports on each server and attach additional cables from the two switches:

1. Connect the HBA port 1 of the first HBA card on server H1 to the first available port of the first fabric switch.
2. Connect the HBA port 1 of the second HBA card on server H1 to the first available port of the second fabric switch.

3. Connect the HBA port 1 of the first HBA card on server H2 to the next available port of the first fabric switch.
4. Connect the HBA port 1 of the second HBA card on server H2 to the next available port of the second fabric switch.
5. Connect an available port on the first switch to the next available port on the Sun StorEdge 9970/9980.
6. Connect an available port on the second switch to the next available port on the Sun StorEdge 9970/9980.
7. Connect the next available port on the first switch to the next available port on the Sun StorEdge 9970/9980.

8. Connect the next available port on the second switch to the next available port on the Sun StorEdge 9970/9980.

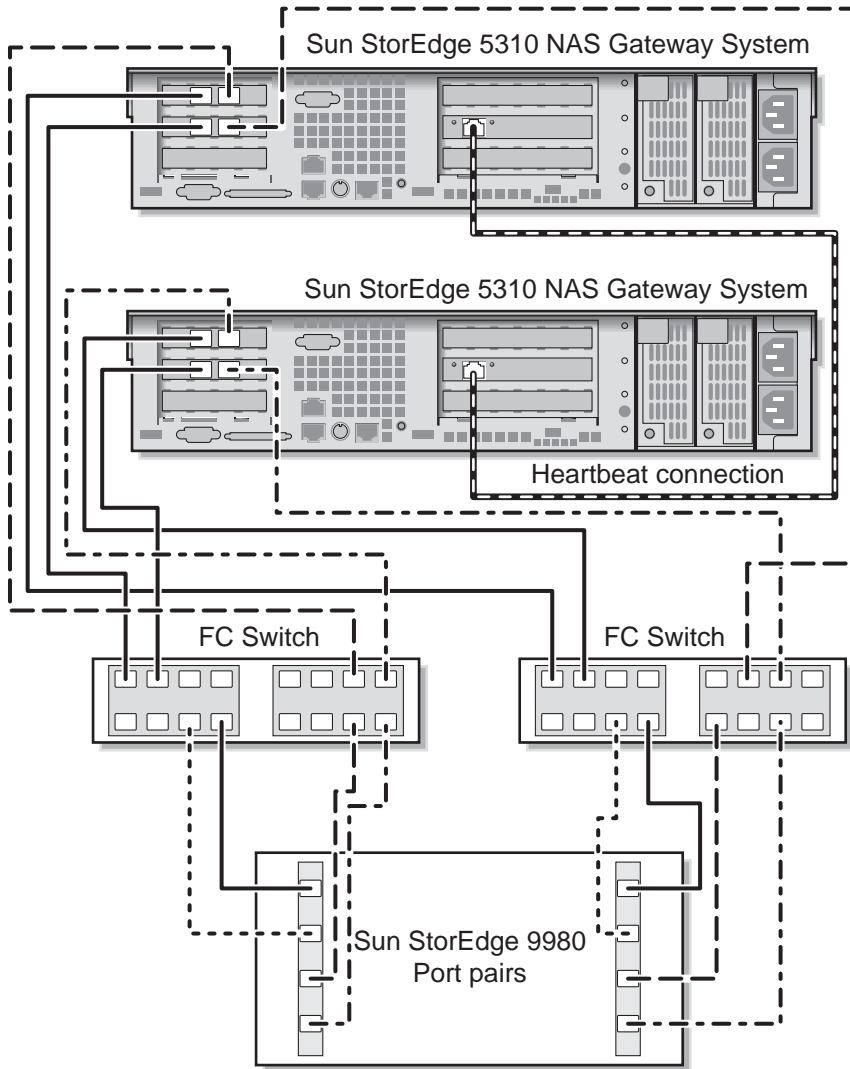

FIGURE 5-21 Connecting All HBA Ports per HA Server Through Two Fabric Switches to the Sun StorEdge 9970/9980

Connecting to the Network

The Sun StorEdge 5310 NAS Gateway System network connections depend on your system configuration. Each configuration is described in this section.

Connecting Single Head Servers

The available network connectors depend on your system configuration: Fast Ethernet or optical gigabit Ethernet (optional card installation required).

▼ To Connect to a 100BASE-T Fast Ethernet Network or to a 1000BASE-T Gigabit Network

Connect an RJ-45 unshielded twisted-pair cable from your local area network (LAN) to the Port emc1 or the Port emc2 on the rear of the Sun StorEdge 5310 NAS Gateway System.

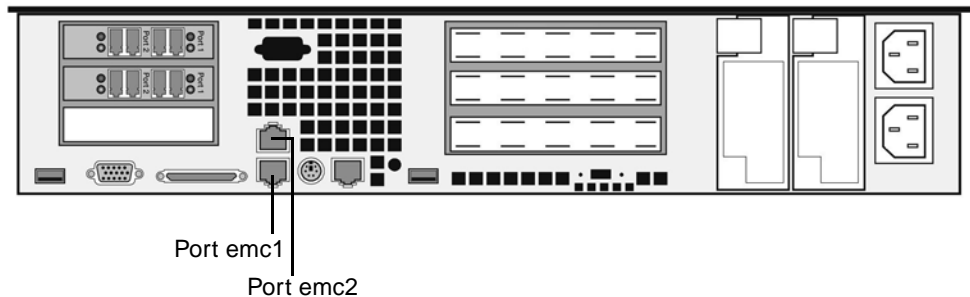

FIGURE 5-22 Connecting to a Fast Ethernet or a Gigabit Ethernet Network

▼ To Connect to an Optical Gigabit Ethernet Network

Connect an LC cable from the network to the right (Port emf3) optical gigabit Ethernet connector on the rear of the Sun StorEdge 5310 NAS Gateway System.

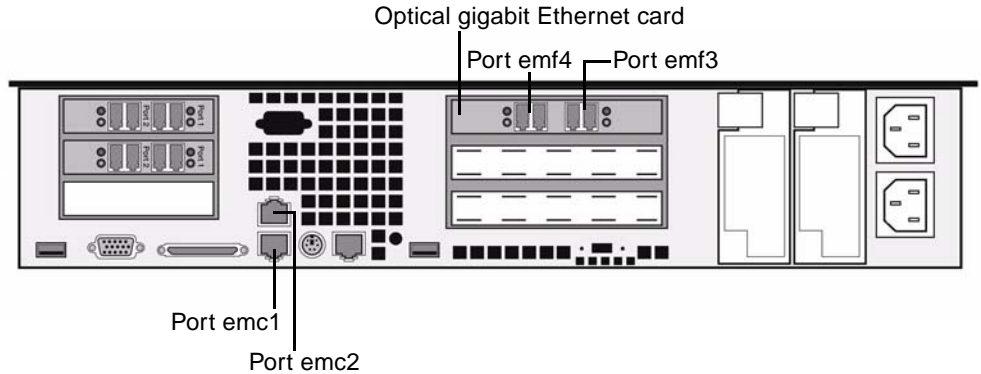

FIGURE 5-23 Connecting to an Optical Gigabit Ethernet Network

Connecting Dual Head HA Servers

Each server in a dual head High-Availability Sun StorEdge 5310 NAS Gateway System uses a dedicated Ethernet connection to communicate with its partner and perform periodic “health checks.”

On systems using 10/100/1000BASE-T NICs as the primary network connections (using the two on-board LAN ports), an additional 10/100BASE-T NIC is installed in each server, for use exclusively for this health check connection (FIGURE 5-24).

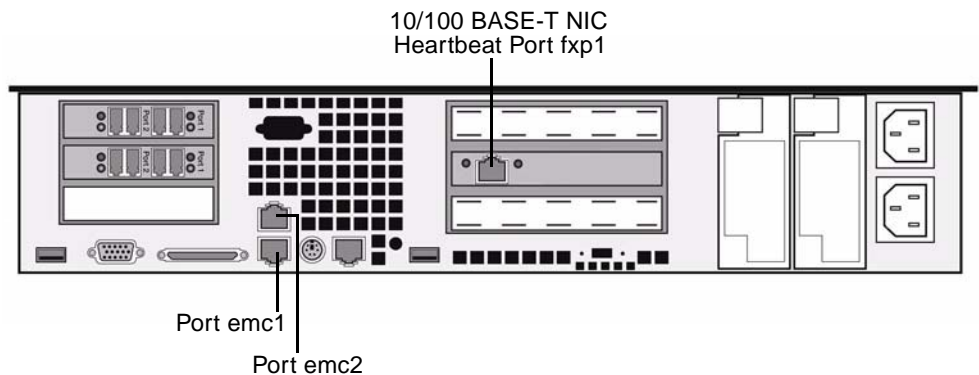

FIGURE 5-24 Dual Head HA NIC Ports

Systems using the optional optical gigabit Ethernet ports as their primary network connections use the onboard LAN port 1 (Port emc1) for this health check connection (FIGURE 5-25).

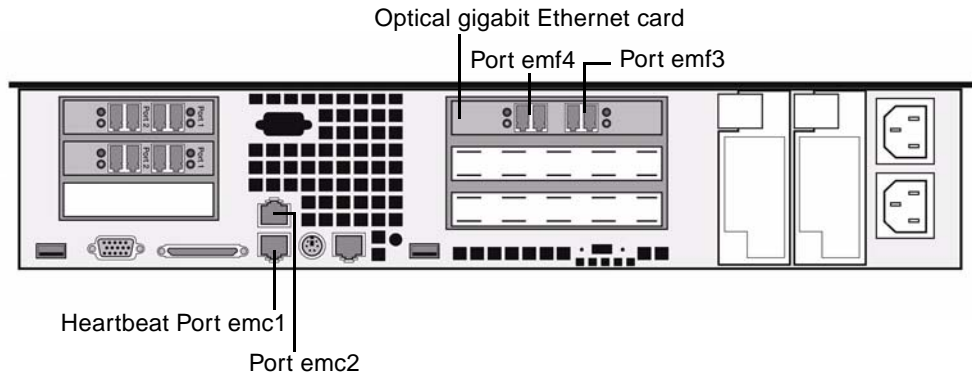

FIGURE 5-25 Dual Head HA Optical Gigabit Ethernet and NIC Ports

▼ To Connect the Health-Monitoring Cable

Use the Cat5 Ethernet crossover cable to connect the two servers using the appropriate heartbeat ports.

▼ To Connect to a Fast Ethernet Network

Connect an RJ-45 unshielded twisted-pair cable from your LAN to the NIC Port emc1 Fast Ethernet connector on the rear of each of the servers (see FIGURE 5-24 for NIC port locations).

▼ To Connect to a Gigabit Ethernet Network

Connect an RJ-45 unshielded twisted-pair cable to a 1000BASE-T connection on your LAN and to the NIC Port emc2 on the rear of each of the servers (see FIGURE 5-24 for NIC port locations).

▼ To Connect to an Optical Gigabit Ethernet Network

Connect an LC cable from your LAN to the right (Port emf3) optical gigabit Ethernet connector on the rear of each of the servers (see FIGURE 5-25 for NIC and optical gigabit Ethernet port locations).

Powering On the Sun StorEdge 5310 NAS Gateway System

Before you proceed with initializing the system, you should power on the Sun StorEdge 5310 NAS Gateway System.

1. **Verify that all cables between the Sun StorEdge 5310 NAS Gateway System and SAN storage have been connected.**

Refer to "Connecting the Sun StorEdge 5310 NAS Gateway System to the Sun StorEdge 6920 System" on page 87 or "Connecting the Sun StorEdge 5310 NAS Gateway System to the Sun StorEdge 9970/9980" on page 104.

2. **Verify that the Sun StorEdge 5310 NAS Gateway System is connected to the network.**

Refer to "Connecting to the Network" on page 120.

3. **For the Sun StorEdge 5310 NAS Gateway System dual server HA cluster configuration, verify that the health-monitoring cable is connected.**

Refer to "To Connect the Health-Monitoring Cable" on page 122.

4. **Press the Power button (FIGURE 5-26) on the front panel (behind the faceplate).**

For the Sun StorEdge 5310 NAS Gateway System dual server HA cluster configuration, power on both servers.

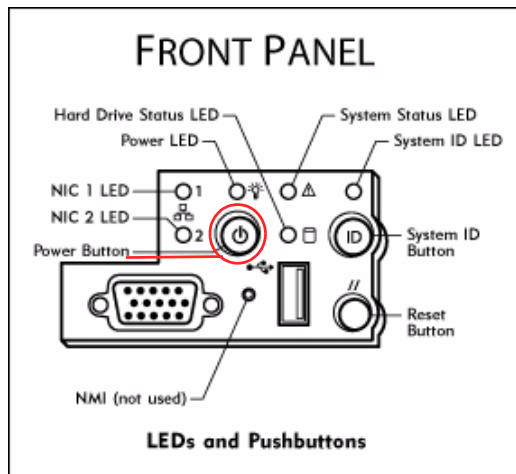

FIGURE 5-26 Power Button and Front Panel Detail

5. Wait for the system to boot up and display the Menu on the LCD panel.

The NIC, system status, and system ID LEDs should be green. On the back of the server the link lights for the HBA ports should be green.

6. Proceed to the appropriate initial configuration instructions.

For the Sun StorEdge 5310 NAS Gateway System single server configuration, refer to "Initial Sun StorEdge 5310 NAS Gateway System Single Server Configuration" on page 124.

For the Sun StorEdge 5310 NAS Gateway System cluster configuration, refer to "Initial Sun StorEdge 5310 NAS Gateway System Dual Server HA Configuration" on page 129.

Initial Sun StorEdge 5310 NAS Gateway System Single Server Configuration



Caution – These instructions apply to the Sun StorEdge 5310 NAS Gateway System single server *only*. For Sun StorEdge 5310 NAS Gateway System dual server High Availability configuration instructions, refer to "Initial Sun StorEdge 5310 NAS Gateway System Dual Server HA Configuration" on page 129. For Sun StorEdge 5310 NAS Appliance configuration instructions, refer to Chapter 3.

To complete the initial Sun StorEdge 5310 NAS Gateway System configuration, you must specify the following:

- IP address
- Basic configuration information
- Storage/LUN configuration

Setting the IP Address

If your network supports DHCP, an IP address will automatically be assigned to your LAN port.

If DHCP is not available or you want to assign a static IP address, use the server's LCD panel:

- 1. Select Menu.**
- 2. Select A. Network Config.**

3. Select A. Set Gateway and enter the gateway address.

To enter data, use the up and down arrows to select digits, dots, or spaces. Then use the right arrow to accept each character.

4. Select C. Set Port-emx1 or C. Set Port-emx2 (depending on which port is the first regular LAN port) and enter the IP address, subnet mask, and broadcast address as prompted.

This IP address information is assigned to the first regular LAN port on your system.

5. Select Exit twice to return to the main menu.

Configuring the Single Server System

To configure the system, you must set up basic system configuration and activate the license for the server.

Note – You must perform both tasks before proceeding to "Storage and LUN Configuration on a Single Server System" on page 127.

▼ To Set Up Basic Configuration

1. From a client on the same network, open a Java platform-enabled web browser with Java Plug-In and enter the IP address for the server.

2. Accept the "Applet Security Certificate" and wait until the Web Admin applet is loaded on this system.

3. On the Web Admin login screen, click Apply.

The password can be set later. Refer to the *Sun StorEdge 5310 NAS Appliance and Gateway System Administration Guide*.

4. On the Set Time and Date panel, select the date, the time, and the time zone, and click Apply, and then click Yes to confirm.

This will set the secure clock to the same time and date. Make sure you set the time and date accurately as you can only set the secure clock once.

5. Read the license agreement in the Configuration Wizard dialog box, and click Accept to proceed with the following wizard steps:

a. Click Next in the Welcome dialog box.

b. From the Select Environment screen, configure Windows, UNIX, or both environments, and click Next to continue.

You can add additional configuration information later.

c. From the Set Server Name screen, enter the server name and populate the other fields accordingly, and then click Next.

d. On the Configure Network Adapters screen, verify that the information is correct, and click Next to continue.

You may configure additional network interfaces at this time. However, if you change the configuration of the port to which the browser is attached, the browser session will be disconnected.

e. On the Set Gateway Address screen, verify that the address is correct, and, if not, enter the gateway address, and click Next to continue.

f. For all the other wizard configuration steps, refer to the *Sun StorEdge 5310 NAS Appliance and Gateway System Administration Guide* for more information.

Note – When adding your DNS server, click **Add** to ensure the DNS server has been added.

g. In the Confirmation screen, review the configuration information you have added.

Note – Be sure the configuration information is accurate before continuing.

h. Click Finish on the Wizard Confirmation Screen.

The system will configure the settings and indicate it in the Save Configuration screen. It will also display a message that both servers must reboot for the failover changes to be applied.

i. Click Close on the Save Configuration screen.

▼ To Activate the Sun StorEdge NAS Gateway License

1. In the navigation panel, select System Operations > Activate Options.

2. Click the Temporary Licenses button.

3. Select Sun StorEdge NAS Gateway, and click Apply.

The State displays “valid” and the Status displays “active.”

4. Logout of the Web Admin, and close *all* browser instances.

Note – You *must* close *all* browser windows you have open. If you don’t, the license feature will not set up properly.

5. Restart the Web Admin using steps 1.- 3. in "To Set Up Basic Configuration" on page 125.
6. When you have logged on to the Web Admin, on the main System Status window, check the Features Enabled to be sure that "Sun StorEdge NAS Gateway" appears.
7. In the navigation panel, select RAID > View HBA Information to view the port World Wide Names (WWNs) of the HBA ports.

Each HBA port is delineated by a tab at the top of the window. HBA port numbering refers to the physical HBA ports from right to left and bottom to top, as shown in the following table.

TABLE 5-1 HBA Port Numbering

HBA Port Number	HBA Port Physical Location
1	Right side port bottom HBA card
2	Left side port bottom HBA card
3	Right side port top HBA card
4	Left side port top HBA card

For each HBA port, the port WWN is listed in the upper portion of the window. The port WWNs are used to map the LUNs on the SAN storage device or to zone these ports on the fabric switch.

8. Write down the port WWNs of all the HBA ports.
WWNs consist of 16 characters which start after the "x" and do not include the "."
9. Logout of the Web Admin and close the browser.

Storage and LUN Configuration on a Single Server System

To configure storage, you must first configure the SAN storage system and then finish configuration on the Sun StorEdge 5310 NAS Gateway System.

Note – You must perform all the storage and LUN configuration tasks to complete the initial configuration.

If you are using fabric switches, use the switch user interface (UI) to include all WWNs of the SAN storage and of the HBAs on the Sun StorEdge 5310 NAS Gateway System.

▼ To Configure Storage on the Sun StorEdge 6920 System

1. Using the Sun StorEdge™ 6920 Configuration Service, select the NAS storage profile `nfs_stripe` for RAID 5 or `nfs_mirror` for RAID 1/0.
2. Create a storage pool to be used by the Sun StorEdge 5310 NAS Gateway System.
3. Create volumes in the storage pool.
4. Map the initiators associated with the Sun StorEdge 5310 NAS Gateway System HBA WWNs to the Sun StorEdge 6920 storage volumes.

▼ To Configure Storage on the Sun StorEdge 9970/9980

1. Using the Sun StorEdge 9970/9980 user interface (UI), set fabric to ON.
2. If you are directly attaching to storage (not using a fabric switch), choose FC-AL connection.
3. If you are using a fabric switch, choose point-to-point connection.
4. Select a 00 host group node type.
5. Enable LUN Manager.
6. Build Array Groups.

▼ To Configure Storage on the Sun StorEdge 5310 NAS Gateway System Single Server

1. Reboot the Sun StorEdge 5310 NAS Gateway System server so that it can detect the storage.
You can reboot using the the Web Admin or the LCD panel.
2. To use the Web Admin to reboot:
 - a. In the navigation panel, select System Operations > Shut Down the Server.
 - b. Select Reboot This Head, and click Apply.
3. To use the LCD panel to reboot:
 - a. On the server's LCD panel, select B. Shutdown Server from the menu.
 - b. Select B. Reboot. The LCD displays "Are you sure? No." Press the up arrow to change to "Yes." Then press SEL or the right arrow to reboot.
4. After the server has rebooted, use the Web Admin to configure file volumes.
Refer to the *Sun StorEdge 5310 NAS Appliance and Gateway System Administration Guide*.

Initial Sun StorEdge 5310 NAS Gateway System Dual Server HA Configuration



Caution – These instructions apply to the Sun StorEdge 5310C Gateway System cluster configuration *only*. For Sun StorEdge 5310 NAS Gateway System configuration instructions, refer to "Initial Sun StorEdge 5310 NAS Gateway System Single Server Configuration" on page 124. For Sun StorEdge 5310 Cluster configuration instructions, refer to Chapter 4.

To complete the initial Sun StorEdge 5310 NAS Gateway System dual server HA configuration, you must specify the following:

- IP addresses
- Basic system configuration
- Storage/LUN configuration
- Failover configuration
- LUN paths

Setting IP Addresses

If your network supports DHCP, an IP address will automatically be assigned to your LAN ports.

Note – You can bypass DHCP discovery if you have a fixed IP address. However, there is a possibility that aborting the DHCP process will cause the server to reboot. To bypass DHCP discovery, during the boot sequence when the LCD panel displays "DHCP Discovery NIC X," you can press any key on the LCD panel and confirm the "Abort DHCP?" message by pressing the right arrow key on the panel. Then you can manually set the static IP address using the following the instructions.

If DHCP is not available or you want to assign a static IP address, use server H1's LCD panel:

1. **Select Menu.**
2. **Select A. Network Config.**
3. **Select A. Set Gateway and enter the gateway address.**

To enter data, use the up and down arrows to select digits, dots, or spaces. Then use the right arrow to accept each character.

4. **Select C. Set Port-emx1 or C. Set Port-emx2 (depending on which port is the first regular LAN port) and enter the IP address, subnet mask, and broadcast address as prompted.**

This IP address information is assigned to the first regular (non-heartbeat) LAN port on your system.

5. **Select Exit twice to return to the main menu.**



Caution – Do not change the private IP address on the network port that is used for the HB Port (heartbeat port).

Note – If you would like to verify your settings on the LCD panel, HB Port will show a private IP address, and Port emx1 or Port emx2 (the first regular LAN port) will show the information you just entered.

You can edit the port information and assign addresses to other ports in the same way.

Basic Dual Server System Configuration

To configure the system, you must set up basic system configuration and activate the license for server H1, and then repeat the steps for server H2.

Note – You must perform all basic system configuration tasks on both servers before proceeding to "Storage and LUN Configuration on a Dual Server System" on page 133.

▼ To Set Up Basic Configuration

1. **From a client on the same network, open a Java platform-enabled web browser with Java Plug-In and enter the IP address for server H1.**
2. **Accept the "Applet Security Certificate" and wait until the Web Admin applet is loaded on this system.**
3. **On the Web Admin login screen, click Apply.**

The password can be set later. Refer to the *Sun StorEdge 5310 NAS Appliance and Gateway System Administration Guide*.

4. **On the Set Time and Date panel, select the date, the time, and the time zone, and click Apply, and then click Yes to confirm.**

This will set the secure clock to the same time and date. Make sure you set the time and date accurately as you can only set the secure clock once.

5. **Read the license agreement in the Configuration Wizard dialog box, and click Accept to proceed with the following wizard steps:**
 - a. **Click Next in the Welcome dialog box.**
 - b. **From the Select Environment screen, configure Windows, UNIX, or both environments, and click Next to continue.**

You can add additional configuration information later.
 - c. **From the Set Server Name screen, enter the server name and populate the other fields accordingly, and then click Next.**
 - d. **On the Enable Failover screen, skip the screen by clicking Next.**



Caution – Do not enable failover at this time. Storage must be configured before failover can be enabled.

In the partner configuration part of the screen, the system initially sets default server names head1 and head2. You can change these defaults later when you configure failover (see "To Configure Failover" on page 135).

- e. **On the Configure Network Adapters screen, verify that the information is correct, and click Next to continue.**

You may configure additional network interfaces at this time. However, if you change the configuration of the port to which the browser is attached, the browser session will be disconnected.
- f. **On the Set Gateway Address screen, verify that the address is correct, and, if not, enter the gateway address, and click Next to continue.**
- g. **For all the other wizard configuration steps, refer to the *Sun StorEdge 5310 NAS Appliance and Gateway System Administration Guide* for more information.**

Note – When adding your DNS server, click **Add** to ensure the DNS server has been added.

- h. **In the Confirmation screen, review the configuration information you have added.**

Note – Be sure the configuration information is accurate before continuing.

i. Click Finish on the Wizard Confirmation Screen.

The system will configure the settings and indicate it in the Save Configuration screen.

j. Click Close on the Save Configuration screen.

▼ **To Activate the Sun StorEdge NAS Gateway License**

1. In the navigation panel, select System Operations > Activate Options.

2. Click the Temporary Licenses button.

3. Select Sun StorEdge NAS Gateway, and click Apply.

The State displays "valid" and the Status displays "active."

4. Logout of the Web Admin, and close *all* browser instances.

Note – You *must* close *all* browser windows you have open. If you don't, the license feature will not set up properly.

5. Restart the Web Admin using steps 1.- 3. in "Basic Dual Server System Configuration" on page 130.

6. When you have logged on to the Web Admin, on the main System Status window, check the Features Enabled to be sure that "Sun StorEdge NAS Gateway" appears.

7. In the navigation panel, select RAID > View HBA Information to view the port World Wide Names (WWNs) of the HBA ports.

The port WWNs are used to map the LUNs on the SAN storage device or to zone these ports on the fabric switch.

Each HBA port is delineated by a tab at the top of the window. HBA port numbering refers to the physical HBA ports from right to left and bottom to top. Refer to TABLE 5-1, "HBA Port Numbering" on page 127.

For each HBA port, the port WWN is listed in the upper portion of the window. The port WWNs are used to map the LUNs on the SAN storage device or to zone these ports on the fabric switch.

8. Write down the port WWNs of all the HBA ports.

WWNs consist of 16 characters which start after the "x" and do not include the "."

9. Logout of the Web Admin and close the browser.

▼ To Set Up Server H2

1. Assign server H2's IP address and gateway address using instructions in "Setting IP Addresses" on page 129.
2. Set up server H2's basic configuration using instructions in "To Set Up Basic Configuration" on page 130.
3. Activate server H2's license using the instructions "To Activate the Sun StorEdge NAS Gateway License" on page 132.

Storage and LUN Configuration on a Dual Server System

To configure storage, you must first configure the SAN storage system. Then you configure LUNS on the Sun StorEdge 5310 NAS Gateway System server H1, configure failover, and assign LUNs to server H2.

Note – You must perform all the storage and LUN configuration tasks to complete the initial configuration.

If you are using fabric switches, use the switch user interface (UI) to include all WWNs of the SAN storage and of the HBAs on the Sun StorEdge 5310 NAS Gateway System.

▼ To Configure Storage on the Sun StorEdge 6920 System

1. Using the Sun StorEdge™ 6920 Configuration Service, select the NAS storage profile `nfs_stripe` for RAID 5 or `nfs_mirror` for RAID 1/0.
2. Create a storage pool to be used by the Sun StorEdge 5310 NAS Gateway System.
3. Create volumes in the storage pool.
4. Map the initiators associated with the Sun StorEdge 5310 NAS Gateway System HBA WWNs to the Sun StorEdge 6920 storage volumes.

▼ To Configure Storage on the Sun StorEdge 9970/9980

1. Using the Sun StorEdge 9970/9980 user interface (UI), set fabric to ON.
2. If you are directly attaching to storage (not using a fabric switch), choose FC-AL connection.
3. If you are using a fabric switch, choose point-to-point connection.

4. Select a 00 host group node type.
5. Enable LUN Manager.
6. Build Array Groups.

▼ To Configure Storage on the Sun StorEdge 5310 NAS Gateway System Dual Server

1. Reboot server H1 using the the Web Admin or the LCD panel:
 - a. Using the Web Admin, in the navigation panel, select System Operations > Shut Down the Server. Then select Reboot Both Heads, and click Apply.
or
 - b. Using the LCD panel, select B. Shutdown Server from the menu. Then select B. Reboot. The LCD displays "Are you sure? No." Press the up arrow to change to "Yes." Then press SEL or the right arrow to reboot.
2. Power off server H2 using the the Web Admin or the LCD panel:
 - a. Using the Web Admin, in the navigation panel, select System Operations > Shut Down the Server. Then select Halt Both Heads, and click Apply.
or
 - b. Using the LCD panel, select B. Shutdown Server from the menu. Then select A. Power Off. The LCD displays "Are you sure? No." Press the up arrow to change to "Yes." Then press SEL or the right arrow to shut down.
3. When server H1 has restarted and the LCD panel displays QUIET, press the SEL or right arrow button. Then press the down arrow until the flashing cursor is on C. Take All LUNs.
4. Press the SEL button or the right arrow to select C. Take All LUNs.
5. When prompted to "Take All LUNs? No," press the up arrow to select "Yes," and press the SEL button or right arrow to start taking LUNs.
The LCD will display "Taking LUNs" followed by a message "Took *n* LUNs." After a few seconds, the display returns to the Network Config menu.

Note – If server H2 is still powered on when you select C. Take All LUNs, you will be prompted to shut down the partner (server H2). After you power off server H2, the display on server H1 will change to "Taking All LUNs."

6. Select Exit to return to the main menu.

Server H1 is now in the ALONE state.

▼ To Configure Failover

1. Launch a new browser window and enter server H1's IP address.
2. If necessary, accept the "Applet Security Certificate" and wait until the Web Admin applet is loaded.
3. On the Web Admin login screen, click Apply.
4. In the navigation panel, select High Availability > Recover.
5. In the Current Raid Configuration and Restore Raid Configuration panels, confirm that all the LUNs are listed in the Head 1 columns.
There will be nothing listed under any Head 2 column.
6. In the navigation panel, select High Availability > Enable Failover.
7. Select Automatic Failover and Enable Link Failover.
A default value of 60 seconds is assigned in both the Down Timeout and Restore Timeout fields.
8. Enter the Partner Configuration Name and the Gateway IP address for server H2 (Partner Name factory default is "head2"), using the tab key to move between fields.
The information you enter here is used to start server H2 through the heartbeat connection. The Partner Name is the host name that you assigned to server H2. Any network information server H2 obtained through DHCP or manually through the LCD panel will be displayed here and can be corrected, if necessary.
The field for Private IP for the heartbeat connection should already be populated (IP 10.10.10.2 private network) and should not be changed.
9. Click Apply.
10. A message appears stating that the system will be rebooted for changes to take effect. Confirm that you want to reboot both servers.
Server H1 reboots automatically, and you need to manually restart server H2.
11. If server H2 is powered off, power it on. Otherwise, reboot server H2 by using the Web Admin for server H2 and selecting System Operations > Shut Down the Server or by using the LCD panel on server H2.
12. When the servers have restarted, log in to the Web Admin on server H1.
13. In the main Server Status window, check the Head Status is ALONE and the Partner Status is QUIET.

▼ To Assign LUNs to Server H2

1. Using the Web Admin on server H1, in the navigation panel, select **High Availability > Recover**.
2. In the **Restore Raid Configuration** window, assign some of the LUNs to server H2.

Note – You must assign at least one LUN to each server. In most situations, you will want approximately equal amounts of storage assigned to each server in the cluster.

3. Click **Apply**.

Note – To verify the LUN assignments, check that the **Current Raid Configuration** window shows them.

4. Click **Recover**, and the LUNs will be distributed between both the servers.

At this point, both servers change to the **NORMAL** state.

Note – Verify that both servers are in the **NORMAL** state on the LCD display or on the Web Admin main **Server Status** window, where the **Head** and **Partner Status** should display **NORMAL**.

5. Using the Web Admin on server H1, in the navigation panel, select **Network Configuration > Configure TCP/IP > Configure Network Adapters**.
6. Check that the emc or emf NIC port being used displays the partner IP alias address.
7. Repeat steps 5.- 6. on server H2.

LUN Path Configuration

You should assign LUN paths on each server to balance multipath access from each server to storage.

1. On server H1 in the Web Admin navigation panel, select **High Availability > Set LUN Path**.
2. Select a LUN and click **Edit**.

3. Select the desired storage from the Primary Path drop-down menu.

Evenly divide the assignment of LUNs to the two available paths. For example, the first and third LUN to 1/0 and the second and fourth LUN to 1/1.

4. Click Apply.

5. Repeat steps 1-4 for server H2.

Refer to the *Sun StorEdge 5310 NAS Appliance and Gateway System Administration Guide* for additional information about LUNs and other detailed software setup and use.

Hardware Technical Specifications

This appendix contains information about the environmental and physical characteristics as well as the power requirements of the Sun StorEdge 5310 NAS Appliance, the Sun StorEdge 5300 RAID EU controller enclosure, and the EU expansion enclosure.

Sun StorEdge 5310 NAS Appliance and Sun StorEdge 5300 RAID EU and EU Technical Specifications

1. Power Specification

- | | |
|--|--|
| 1.1. Voltage | · 100-120 V ~ or 200-240 V |
| 1.2. Frequency | · 50/60 Hz ±5%Hz |
| 1.3. AC Current Input (typical) | |
| • Appliance | · 5.2A (115 V~), or 2.6 A (230 V~) |
| • RAID EU & EU | · 3.9A (115 V~), or 1.65A (230 V~) |
| 1.4 Power Consumption | |
| • Appliance | · 568 VA (from AC source), 426 W (from power supply) Typical |
| Power Availability | · 500W maximum (from power supply) |
| • RAID EU & EU | · 532 VA, 400 W (typical unit) |
| Power Availability | · 21 W (133 GB drives) |
| | · 390 W (typical unit) |

- 1.5 Power Cord**
 - SJT or SVT 18 SWG min, 3 conductor, w/250V, 10A plug/socket
 - IEC 320, 250V, 10A

Socket

- 1.6 Head Dissipation (BTU/hr)**
 - **Appliance** · 1448 BTU/hr (typical)
 - **RAID EU & EU** · 1332 BTU/hr (typical)
 - **Hard Drive (133 GB)** · 119 BTU/hr (typical)

2. Physical Characteristics

- 2.1. Appliance**
 - Dimension (HxWxD) · 8.9 cm x 43 cm x 64.8 cm (3.5 in x 16.93 in x 25.51 in)
 - Weight · 34.8 kg (76.6 lbs)
 - Rack Height · 2U

- 2.2 RAID EU & EU**
 - Dimension (HxWxD) · 13.2 cm x 48.2cm x 59.7cm (5.2in x 19in x 23.5 in)
 - Weight · 42 kg (93 lbs)
 - Rack Height · 3U

3. Environmental Specifications

- 3.1. Temperature**
 - **Appliance**
 - Operating · +10°C to +35°C (+50°F to +95°F)
 - Non-operating/storage · -20°C to +60°C (-4°F to +140°F)
 - **RAID EU & EU**
 - Operating · +10°C to +40°C (+50°F to +104°F)
 - Non-operating/storage · 0°C to +50°C (+32°F to +122°F)

- 3.2. Humidity**
 - **Appliance**
 - Operating · 20% to 80%, non-condensing
 - Non-operating · 10% to 90%, non-condensing
 - **RAID EU & EU**
 - Operating · 20% to 80%, non-condensing
 - Non-operating · 8% to 80%, non-condensing

Glossary

- AC** AC stands for alternating current. AC power is supplied to the computer through an electrical outlet.
- Active/Active Cluster** A pair of identical high-availability servers that offer NAS services to client communities. In the event of a failure, the surviving server takes on the services and client community of its failed peer.
- Array** The entire storage system consisting of Sun StorEdge 5300 RAID EU controller enclosures and connected Sun StorEdge 5300 EU expansion enclosures. An array must contain all Fibre Channel or all SATA storage. A dual array system can contain one Fibre Channel array and one SATA array.
- AWG** American Wire Gauge, which is used to measure thickness of wire.
- Cluster** A pair of identical servers providing redundant high-availability NAS services with failover protection.
- Controller enclosure** The Sun StorEdge 5300 RAID EU which contains two array controllers. Sometimes referred to as “controller tray.”
- Configuration** (1) The manner in which the software and hardware of an information processing system are organized and interconnected. (2) The physical and logical arrangement of programs and devices that make up a data processing system. (3) The devices and programs that make up a system, subsystem, or network.
- DC** DC stands for direct current. DC power is typically supplied through a DC adapter or battery.
- Driver** A software program that enables a computer to communicate with a peripheral device. Examples include a SCSI driver, a CD-ROM driver, and printer drivers.
- Dual head** A reference to the Sun StorEdge 5310 Cluster system, which consists of a pair of identical servers or “heads.”

- Expansion enclosure** The Sun StorEdge 5300 EU, which contains hard drives in RAID 5 groups. An expansion enclosure containing Fibre Channel hard drives is called "EU F." An expansion enclosure containing SATA hard drives is called "EU S."
- Failure** A detectable physical change in hardware or software that disrupts normal (proper) operation. A failure is repaired by the replacement of a physical component or software.
- Fast Ethernet (Single and Multiport)** A high-speed version of Ethernet transmitting data at 100 Mbps. Fast Ethernet networks use the same media access control method that 10BASE-T Ethernet networks use, but achieve 10 times the data transmission speed.
- Flash memory** A special type of read-only memory (ROM) that enables users to upgrade the information contained in the memory chips.
- Gigabyte (GB)** A unit of information equal to 1024 megabytes.
- Gigabit Ethernet** An Ethernet technology that enables data transfer rates of up to 1 Gbps using optical fiber cable or unshielded twisted-pair cable.
- Hot Replacement of Components (Hot Swap)** The ability to replace a failed component without interruption of system service.
- Interface cable** A cable designed to connect a computer to a peripheral device, or a peripheral device to another peripheral device, allowing each device to communicate with one another.
- Kilobyte (KB)** A unit of information equal to 1024 bytes.
- LCD** Liquid Crystal Display. A low-power display technology that uses rod-shaped crystal molecules that change their orientation when an electrical current flows through them.
- LED** Light Emitting Diode. A semiconductor device that converts electrical energy into light.
- Megabyte (MB)** A unit of information equivalent to 1,048,576 bytes or 1024 kilobytes. Most uses of megabytes, however, refer to exactly 1 million bytes.
- Megahertz (MHz)** A measure of frequency equivalent to 1 million cycles per second.
- Motherboard** A large circuit board that contains the computer's central processing unit (CPU), microprocessor support chips, random-access memory (RAM), and expansion slots.
- MTBF** Mean Time Between Failures. The estimated time a device operates before a failure occurs.

NAS	Network Attached Storage. A storage appliance that connects directly to the network. NAS does not usually perform network directory services or function as an application server; instead, it augments storage capacities. Quick and easy to set up, NAS appliances also typically provide cross-platform file sharing.
NIC	Network Interface Card. An adapter that lets you connect a network cable to a microcomputer. The card includes encoding and decoding circuitry and a receptacle for a network cable connection.
Parity	Parity information is data created by combining the bits in the information to be stored and creating a small amount of data from which the rest of the information can be extracted.
RAID	Redundant Array of Independent Disks. A group of hard disks under the control of array management software that work together to improve performance and decrease the odds of losing data to mechanical or electronic failure by using techniques such as data striping.
RAID 5	The most commonly used RAID implementation. RAID 5 uses striping and parity information.
RAM	Random Access Memory. Semiconductor-based memory that can be read and written by the microprocessor or other hardware devices. Generally understood to refer to volatile memory, which can be written as well as read.
SCSI	Small Computer Systems Interface. It is a standard interface for PCs that allows you to connect up to 15 peripheral devices, such as CD-ROM drives.
SCSI bus	A pathway between SCSI hardware devices. In the case of SCSI devices, the bus usually consists of a circuit board and cable system, in a computer or other device and disk drives, tape backup or the like.
SCSI host Adapter	A printed circuit board (also called an interface card) that enables the computer to use a peripheral device for which it does not already have the necessary connections or circuit boards.
SCSI ID	Priority number (address) of a SCSI device in a SCSI device chain. Only one device at a time can transmit through a SCSI connection (port), and priority is given to the device with the highest priority address. SCSI IDs range from 0 to 15, and each SCSI device must be given a unique and unused SCSI ID.
Single head	A reference to the Sun StorEdge 5310 NAS Appliance which consists of a single server or "head."
SMB	Server Message Block. A Microsoft-compatible network protocol for exchanging files. SMB is typically used by Windows for Workgroups, OS/2 Warp Connect, and DEC Pathworks. <i>See also</i> CIFS.

- Striping** A RAID-based method for data storage in which data is divided into “stripes.” One stripe is written to the first drive, the next to the second drive, and so on. The primary advantage of striping is the ability for all drives in the array to process reads and writes simultaneously.
- Termination** The electrical connection at each end of the SCSI bus, composed of a set of resistors on internal SCSI devices or an active or passive SCSI terminator block on external SCSI devices.

Index

A

- Acquiring IP address
 - dynamically 54
 - manually 54
- Active/Active cluster
 - definition 141
- array
 - definition 141
- attaching rails to a cabinet
 - Sun Rack 900/1000 17
 - Sun StorEdge Expansion/Sun Fire 17

C

- cabling
 - summary 52
- clients 2
- cluster
 - definition 141
- configuring
 - initial Sun StorEdge 5310 NAS Appliance configuration 53
 - TCP/IP
 - with DHCP 54
 - without DHCP 55
- connecting the power cables during tray installation 34
- connecting to Web Administrator 55
- connections
 - network 2
 - power 13

- controller enclosure
 - definition 141

D

- DHCP
 - configuring TCP/IP 54
 - defined 54
- DNS
 - defined 54
- Domain Name Server
 - see DNS
- Dynamic Host Configuration Protocol
 - see DHCP
- Dynamic IP address acquisition 54

E

- electrical grounding 13
- expansion enclosure
 - definition 142

G

- grounding requirements 13

- I**
 - Initial configuration, Sun StorEdge 5310 NAS Appliance 53
 - IP address
 - entering through LCD panel 54
 - options for providing 53
- L**
 - LCD
 - defined 54
 - entering IP address 54
- M**
 - Manual IP address acquisition 54
- N**
 - navigating Web Administrator 9
 - network
 - connections 2
- P**
 - power
 - connections 13
 - power cable connections 34
 - preparing the cabinet for tray installation 15
 - preparing the tray for installation 15
 - protocols 2
 - Providing, IP address 53
- R**
 - rackmount kit preparation 14
 - applicable Sun cabinets 14
 - rails
 - attaching to a cabinet 17
 - Sun Rack 900/1000 23
 - Sun StorEdge Expansion 18
 - requirements
 - software 9
 - grounding 13
- S**
 - security 2
 - setting the tray ID in tray installation 35
 - software
 - requirements 9
 - supported 9
 - Sun StorEdge 5310 NAS Appliance
 - initial configuration 53
 - software requirements 9
 - supported clients 2
- T**
 - TCP/IP
 - configuring
 - with DHCP 54
 - without DHCP 55
 - tools required for tray installation 11
 - tray installation
 - preparing the rackmount kit for 14
 - applicable Sun cabinets 14
 - tools required for 11
- W**
 - Web Administrator
 - connecting 55
 - navigating in 9
 - WINS
 - defined 54