



# Sun Cluster Data Service for SAP Guide for Solaris OS

---

SPARC Platform Edition

Sun Microsystems, Inc.  
4150 Network Circle  
Santa Clara, CA 95054  
U.S.A.

Part No: 817-4647-10  
April 2004, Revision A

Copyright 2004 Sun Microsystems, Inc. 4150 Network Circle, Santa Clara, CA 95054 U.S.A. All rights reserved.

This product or document is protected by copyright and distributed under licenses restricting its use, copying, distribution, and decompilation. No part of this product or document may be reproduced in any form by any means without prior written authorization of Sun and its licensors, if any. Third-party software, including font technology, is copyrighted and licensed from Sun suppliers.

Parts of the product may be derived from Berkeley BSD systems, licensed from the University of California. UNIX is a registered trademark in the U.S. and other countries, exclusively licensed through X/Open Company, Ltd.

Sun, Sun Microsystems, the Sun logo, docs.sun.com, AnswerBook, AnswerBook2, Java, and Solaris are trademarks, registered trademarks, or service marks of Sun Microsystems, Inc. in the U.S. and other countries. All SPARC trademarks are used under license and are trademarks or registered trademarks of SPARC International, Inc. in the U.S. and other countries. Products bearing SPARC trademarks are based upon an architecture developed by Sun Microsystems, Inc.

The OPEN LOOK and Sun™ Graphical User Interface was developed by Sun Microsystems, Inc. for its users and licensees. Sun acknowledges the pioneering efforts of Xerox in researching and developing the concept of visual or graphical user interfaces for the computer industry. Sun holds a non-exclusive license from Xerox to the Xerox Graphical User Interface, which license also covers Sun's licensees who implement OPEN LOOK GUIs and otherwise comply with Sun's written license agreements.

U.S. Government Rights – Commercial software. Government users are subject to the Sun Microsystems, Inc. standard license agreement and applicable provisions of the FAR and its supplements.

DOCUMENTATION IS PROVIDED "AS IS" AND ALL EXPRESS OR IMPLIED CONDITIONS, REPRESENTATIONS AND WARRANTIES, INCLUDING ANY IMPLIED WARRANTY OF MERCHANTABILITY, FITNESS FOR A PARTICULAR PURPOSE OR NON-INFRINGEMENT, ARE DISCLAIMED, EXCEPT TO THE EXTENT THAT SUCH DISCLAIMERS ARE HELD TO BE LEGALLY INVALID.

---

Copyright 2004 Sun Microsystems, Inc. 4150 Network Circle, Santa Clara, CA 95054 U.S.A. Tous droits réservés.

Ce produit ou document est protégé par un copyright et distribué avec des licences qui en restreignent l'utilisation, la copie, la distribution, et la décompilation. Aucune partie de ce produit ou document ne peut être reproduite sous aucune forme, par quelque moyen que ce soit, sans l'autorisation préalable et écrite de Sun et de ses bailleurs de licence, s'il y en a. Le logiciel détenu par des tiers, et qui comprend la technologie relative aux polices de caractères, est protégé par un copyright et licencié par des fournisseurs de Sun.

Des parties de ce produit pourront être dérivées du système Berkeley BSD licenciés par l'Université de Californie. UNIX est une marque déposée aux Etats-Unis et dans d'autres pays et licenciée exclusivement par X/Open Company, Ltd.

Sun, Sun Microsystems, le logo Sun, docs.sun.com, AnswerBook, AnswerBook2, Java, et Solaris sont des marques de fabrique ou des marques déposées, ou marques de service, de Sun Microsystems, Inc. aux Etats-Unis et dans d'autres pays. Toutes les marques SPARC sont utilisées sous licence et sont des marques de fabrique ou des marques déposées de SPARC International, Inc. aux Etats-Unis et dans d'autres pays. Les produits portant les marques SPARC sont basés sur une architecture développée par Sun Microsystems, Inc.

L'interface d'utilisation graphique OPEN LOOK et Sun™ a été développée par Sun Microsystems, Inc. pour ses utilisateurs et licenciés. Sun reconnaît les efforts de pionniers de Xerox pour la recherche et le développement du concept des interfaces d'utilisation visuelle ou graphique pour l'industrie de l'informatique. Sun détient une licence non exclusive de Xerox sur l'interface d'utilisation graphique Xerox, cette licence couvrant également les licenciés de Sun qui mettent en place l'interface d'utilisation graphique OPEN LOOK et qui en outre se conforment aux licences écrites de Sun.

CETTE PUBLICATION EST FOURNIE "EN L'ETAT" ET AUCUNE GARANTIE, EXPRESSE OU IMPLICITE, N'EST ACCORDEE, Y COMPRIS DES GARANTIES CONCERNANT LA VALEUR MARCHANDE, L'APTITUDE DE LA PUBLICATION A REpondre A UNE UTILISATION PARTICULIERE, OU LE FAIT QU'ELLE NE SOIT PAS CONTREFAISANTE DE PRODUIT DE TIERS. CE DENI DE GARANTIE NE S'APPLIQUERAIT PAS, DANS LA MESURE OU IL SERAIT TENU JURIDIQUEMENT NUL ET NON AVENU.



040206@7940



# Contents

---

**Preface** 5

**Installing and Configuring Sun Cluster HA for SAP** 9

Sun Cluster HA for SAP Overview 10

Installing and Configuring Sun Cluster HA for SAP 11

Planning the Sun Cluster HA for SAP Installation and Configuration 12

Configuration Restrictions 13

Configuration Requirements 13

Standard Data Service Configurations 14

Configuration Considerations 15

Configuration Planning Questions 17

Packages and Support 17

Upgrading Sun Cluster HA for SAP 18

▼ How to Upgrade a Resource Type or Convert a Failover Application Resource to a Scalable Application Resource 18

Preparing the Nodes and Disks 19

▼ How to Prepare the Nodes 19

Installing and Configuring SAP and Database 20

▼ How to Install SAP and the Database 20

▼ How to Install and Enable an SAP Scalable Application Server 21

▼ How to Enable Failover SAP Instances to Run in a Cluster 24

▼ How to Configure an SAP J2EE Engine Cluster with your Sun Cluster HA for SAP with an Application Server 26

▼ How to Configure an SAP J2EE Engine with your Sun Cluster HA for SAP with Central Instance 27

▼ How to Configure an SAP Web Dispatcher With Your Sun Cluster HA for SAP 27

Configuring Your Highly Available Database	28
Where to Go From Here	29
Verifying the SAP Installation	29
▼ How to Verify SAP and the Database Installation with Central Instance	29
▼ How to Verify an SAP Failover Application Server	30
Verifying an SAP Scalable Application Server	31
Installing the Sun Cluster HA for SAP Packages	32
▼ How to Install the Sun Cluster HA for SAP Packages by Using the Web Start Program	32
▼ How to Install the Sun Cluster HA for SAP Packages by Using the <code>scinstall</code> Utility	33
Registering and Configuring Sun Cluster HA for SAP	34
Sun Cluster HA for SAP Extension Properties	34
▼ How to Register and Configure Sun Cluster HA for SAP with Central Instance	39
▼ How to Register and Configure Sun Cluster HA for SAP as a Failover Data Service	40
▼ How to Register and Configure Sun Cluster HA for SAP as a Scalable Data Service	41
Setting Up a Lock File	43
▼ How to Set Up a Lock File for Central Instance or the Failover Application Server	43
▼ How to Set Up a Lock File for Scalable Application Server	44
Verifying the Sun Cluster HA for SAP Installation and Configuration	45
▼ How to Verify Sun Cluster HA for SAP Installation and Configuration and Central Instance	45
▼ How to Verify the Installation and Configuration of Sun Cluster HA for SAP as a Failover Data Service	46
▼ How to Verify Sun Cluster HA for SAP Installation and Configuration of as a Scalable Data Service	46
Understanding Sun Cluster HA for SAP Fault Monitor	47
Sun Cluster HA for SAP Fault Probes for Central Instance	47
Sun Cluster HA for SAP Fault Probes for Application Server	49
<b>Index</b>	<b>51</b>

# Preface

---

*Sun Cluster Data Service for SAP Guide for Solaris OS* explains how to install and configure Sun™ Cluster HA for SAP.

This document is intended for system administrators with extensive knowledge of Sun software and hardware. Do not use this document as a planning or presales guide. Before reading this document, you should have already determined your system requirements and purchased the appropriate equipment and software.

The instructions in this document assume knowledge of the Solaris™ Operating System and expertise with the volume manager software that is used with Sun Cluster.

---

## UNIX Commands

This document contains information about commands that are specific to installing and configuring Sun Cluster data services. The document does *not* contain comprehensive information about basic UNIX® commands and procedures, such as shutting down the system, booting the system, and configuring devices. Information about basic UNIX commands and procedures is available from the following sources:

- Online documentation for the Solaris Operating System
- Solaris Operating System man pages
- Other software documentation that you received with your system

---

# Typographic Conventions

The following table describes the typographic changes that are used in this book.

**TABLE P-1** Typographic Conventions

Typeface or Symbol	Meaning	Example
AaBbCc123	The names of commands, files, and directories, and onscreen computer output	Edit your <code>.login</code> file. Use <code>ls -a</code> to list all files. <code>machine_name%</code> you have mail.
<b>AaBbCc123</b>	What you type, contrasted with onscreen computer output	<code>machine_name%</code> <b>su</b> Password:
<i>AaBbCc123</i>	Command-line placeholder: replace with a real name or value	To delete a file, type <b>rm</b> <i>filename</i> .
<i>AaBbCc123</i>	Book titles, new terms, or terms to be emphasized	Read Chapter 6 in <i>User's Guide</i> . These are called <i>class</i> options. You must be <i>root</i> to do this.

---

# Shell Prompts in Command Examples

The following table shows the default system prompt and superuser prompt for the C shell, Bourne shell, and Korn shell.

**TABLE P-2** Shell Prompts

Shell	Prompt
C shell prompt	<code>machine_name%</code>
C shell superuser prompt	<code>machine_name#</code>
Bourne shell and Korn shell prompt	<code>\$</code>
Bourne shell and Korn shell superuser prompt	<code>#</code>

---

## Related Documentation

Information about related Sun Cluster topics is available in the documentation that is listed in the following table. All Sun Cluster documentation is available at <http://docs.sun.com>.

Topic	Documentation
Data service administration	<i>Sun Cluster Data Services Planning and Administration Guide for Solaris OS</i> Individual data service guides
Concepts	<i>Sun Cluster Concepts Guide for Solaris OS</i>
Overview	<i>Sun Cluster Overview for Solaris OS</i>
Software installation	<i>Sun Cluster Software Installation Guide for Solaris OS</i>
System administration	<i>Sun Cluster System Administration Guide for Solaris OS</i>
Hardware administration	<i>Sun Cluster 3.x Hardware Administration Manual for Solaris OS</i> Individual hardware administration guides
Data service development	<i>Sun Cluster Data Services Developer's Guide for Solaris OS</i>
Error messages	<i>Sun Cluster Error Messages Guide for Solaris OS</i>
Command and function reference	<i>Sun Cluster Reference Manual for Solaris OS</i>

For a complete list of Sun Cluster documentation, see the release notes for your release of Sun Cluster at <http://docs.sun.com>.

---

## Accessing Sun Documentation Online

The [docs.sun.com](http://docs.sun.com)<sup>SM</sup> Web site enables you to access Sun technical documentation online. You can browse the [docs.sun.com](http://docs.sun.com) archive or search for a specific book title or subject. The URL is <http://docs.sun.com>.

---

## Ordering Sun Documentation

Sun Microsystems offers select product documentation in print. For a list of documents and how to order them, see “Buy printed documentation” at <http://docs.sun.com>.

---

## Help

If you have problems installing or using Sun Cluster, contact your service provider and provide the following information:

- Your name and email address (if available)
- Your company name, address, and phone number
- The model and serial numbers of your systems
- The release number of the Solaris Operating System (for example, Solaris 8)
- The release number of Sun Cluster (for example, Sun Cluster 3.0)

Use the following commands to gather information about each node on your system for your service provider.

Command	Function
<code>prtconf -v</code>	Displays the size of the system memory and reports information about peripheral devices
<code>psrinfo -v</code>	Displays information about processors
<code>showrev -p</code>	Reports which patches are installed
SPARC: <code>prtdiag -v</code>	Displays system diagnostic information
<code>scinstall -pv</code>	Displays Sun Cluster release and package version information

Also have available the contents of the `/var/adm/messages` file.



# Installing and Configuring Sun Cluster HA for SAP

---

This chapter contains the procedures on how to install and configure Sun Cluster HA for SAP.

This chapter contains the following procedures.

- “How to Upgrade a Resource Type or Convert a Failover Application Resource to a Scalable Application Resource” on page 18
- “How to Prepare the Nodes” on page 19
- “How to Install SAP and the Database” on page 20
- “How to Install and Enable an SAP Scalable Application Server” on page 21
- “How to Enable Failover SAP Instances to Run in a Cluster” on page 24
- “How to Verify SAP and the Database Installation with Central Instance” on page 29
- “How to Verify an SAP Failover Application Server” on page 30
- “How to Install the Sun Cluster HA for SAP Packages by Using the Web Start Program” on page 32
- “How to Install the Sun Cluster HA for SAP Packages by Using the `scinstall` Utility” on page 33
- “How to Register and Configure Sun Cluster HA for SAP with Central Instance” on page 39
- “How to Register and Configure Sun Cluster HA for SAP as a Failover Data Service” on page 40
- “How to Register and Configure Sun Cluster HA for SAP as a Scalable Data Service” on page 41
- “How to Set Up a Lock File for Central Instance or the Failover Application Server” on page 43
- “How to Set Up a Lock File for Scalable Application Server” on page 44
- “How to Verify Sun Cluster HA for SAP Installation and Configuration and Central Instance” on page 45
- “How to Verify the Installation and Configuration of Sun Cluster HA for SAP as a Failover Data Service” on page 46
- “How to Verify Sun Cluster HA for SAP Installation and Configuration of as a Scalable Data Service” on page 46

---

# Sun Cluster HA for SAP Overview

Use the information in this section to understand how Sun Cluster HA for SAP makes SAP highly available.

For conceptual information on failover and scalable services, see the *Sun Cluster Concepts Guide for Solaris OS*.

Sun Cluster HA for SAP provides fault monitoring and automatic failover for the SAP application to eliminate single points of failure in an SAP system. The following table lists the data services that best protect SAP components in a Sun Cluster configuration. You can configure Sun Cluster HA for SAP as a failover application or a scalable application.

**TABLE 1-1** Protection of SAP Components

SAP Component	Protected by
SAP database	The data service for the database that you are using, for example: <ul style="list-style-type: none"><li>■ For the SAP DB database, the data service is Sun Cluster HA for SAP DB.</li><li>■ For the Oracle database, the data service is Sun Cluster HA for Oracle.</li></ul>
SAP central instance	Sun Cluster HA for SAP The resource type is <code>SUNW.sap_ci</code> or <code>SUNW.sap_ci_v2</code> .
SAP application server	Sun Cluster HA for SAP The resource type is <code>SUNW.sap_as</code> or <code>SUNW.sap_as_v2</code> .
NFS file system	Sun Cluster HA for NFS

Sun Cluster HA for SAP requires a functioning cluster with the initial cluster framework already installed. See the *Sun Cluster Software Installation Guide for Solaris OS* for details on initial installation of clusters and data service software. Register Sun Cluster HA for SAP after you successfully install the basic components of the Sun Cluster and SAP software.

---

# Installing and Configuring Sun Cluster HA for SAP

Table 1-2 lists the tasks for installing and configuring Sun Cluster HA for SAP. Perform these tasks in the order that they are listed.

**TABLE 1-2** Task Map: Installing and Configuring Sun Cluster HA for SAP

Task	For Instructions, Go To
Plan the SAP installation	"Planning the Sun Cluster HA for SAP Installation and Configuration" on page 12
Upgrade Sun Cluster HA for SAP	"How to Upgrade a Resource Type or Convert a Failover Application Resource to a Scalable Application Resource" on page 18
Prepare the nodes and disks	"How to Prepare the Nodes" on page 19
Install SAP and the database	"How to Install SAP and the Database" on page 20
Install the SAP application server	If you plan to install the SAP application server as a failover service, go to "How to Enable Failover SAP Instances to Run in a Cluster" on page 24  If you plan to install the SAP application server as a scalable service, go to "How to Install and Enable an SAP Scalable Application Server" on page 21
Configure your highly available database	"Configuring Your Highly Available Database" on page 28
Verify the SAP installation	If you plan to install a failover SAP application server, go to the following sections: <ul style="list-style-type: none"><li>■ "How to Verify SAP and the Database Installation with Central Instance" on page 29</li><li>■ "How to Verify an SAP Failover Application Server" on page 30</li></ul> If you plan to install a scalable SAP application server, go to "Verifying an SAP Scalable Application Server" on page 31.
Install Sun Cluster HA for SAP packages	"Installing the Sun Cluster HA for SAP Packages" on page 32

**TABLE 1-2** Task Map: Installing and Configuring Sun Cluster HA for SAP (Continued)

Task	For Instructions, Go To
Register and configure Sun Cluster HA for SAP	<p>If you plan to configure Sun Cluster HA for SAP as a failover data service, go to:</p> <ul style="list-style-type: none"><li>■ "How to Register and Configure Sun Cluster HA for SAP with Central Instance" on page 39</li><li>■ "How to Register and Configure Sun Cluster HA for SAP as a Failover Data Service" on page 40</li></ul> <p>If you plan to configure Sun Cluster HA for SAP as a scalable data service, go to:</p> <ul style="list-style-type: none"><li>■ "How to Register and Configure Sun Cluster HA for SAP with Central Instance" on page 39</li><li>■ "How to Register and Configure Sun Cluster HA for SAP as a Scalable Data Service" on page 41</li></ul>
Set up a lock file	"Setting Up a Lock File" on page 43
Verify Sun Cluster HA for SAP installation and configuration	<p>If you plan to configure Sun Cluster HA for SAP as a failover data service, go to:</p> <ul style="list-style-type: none"><li>■ "How to Verify Sun Cluster HA for SAP Installation and Configuration and Central Instance" on page 45</li><li>■ "How to Verify the Installation and Configuration of Sun Cluster HA for SAP as a Failover Data Service" on page 46</li></ul> <p>If you plan to configure Sun Cluster HA for SAP as a scalable data service, go to "How to Verify Sun Cluster HA for SAP Installation and Configuration of as a Scalable Data Service" on page 46.</p>
Understand Sun Cluster HA for SAP fault monitor	"Understanding Sun Cluster HA for SAP Fault Monitor" on page 47

---

## Planning the Sun Cluster HA for SAP Installation and Configuration

This section contains the information you need to plan your Sun Cluster HA for SAP installation and configuration.

## Configuration Restrictions



---

**Caution** – Your data service configuration might not be supported if you do not observe these restrictions.

---

Use the restrictions in this section to plan the installation and configuration of Sun Cluster HA for SAP. This section provides a list of software and hardware configuration restrictions that apply to Sun Cluster HA for SAP.

For restrictions that apply to all data services, see the release notes for your release of Sun Cluster.

- **Limit node names as outlined in the SAP installation guide** – This limitation is an SAP software restriction.

## Configuration Requirements



---

**Caution** – Your data service configuration might not be supported if you do not adhere to these requirements.

---

Use the requirements in this section to plan the installation and configuration of Sun Cluster HA for SAP. These requirements apply to Sun Cluster HA for SAP only. You must meet these requirements before you proceed with your Sun Cluster HA for SAP installation and configuration.

For requirements that apply to all data services, see “Planning for Sun Cluster Data Services” in *Sun Cluster Data Services Planning and Administration Guide for Solaris OS*.

- **After you create all of the file systems for the database and for SAP software, create the mount points, and put the mount points in the `/etc/vfstab` file on all of the cluster nodes** – See the SAP installation guides, *Installation of the SAP R/3 on UNIX* and *R/3 Installation on UNIX-OS Dependencies*, for details on how to set up the database and SAP file systems.
- **Create the required groups and users on all of the cluster nodes** – See the SAP installation guides, *Installation of the SAP R/3 on UNIX* and *R/3 Installation on UNIX-OS Dependencies*, for details on how to create SAP groups and users.
- **Configure Sun Cluster HA for NFS on the cluster that hosts the central instance if you plan to install some external SAP application servers** – See *Sun Cluster Data Service for Network File System (NFS) Guide for Solaris OS* for details on how to configure Sun Cluster HA for NFS.

- **Install application servers on either the same cluster that hosts the central instance or on a separate cluster** – If you install and configure any application server outside of the cluster environment, Sun Cluster HA for SAP does not perform fault monitoring and does not automatically restart or fail over those application servers. You must manually start and shut down application servers that you install and configure outside of the cluster environment.
- **Use an SAP software version with automatic enqueue reconnect mechanism capability** – Sun Cluster HA for SAP relies on this capability. SAP 4.0 software with patch information and later releases should have automatic enqueue reconnect mechanism capability.

## Standard Data Service Configurations

Use the standard configurations in this section to plan the installation and configuration of Sun Cluster HA for SAP. Sun Cluster HA for SAP supports the standard configurations in this section. Sun Cluster HA for SAP might support additional configurations. However, you must contact your Enterprise Services representative for information on additional configurations.

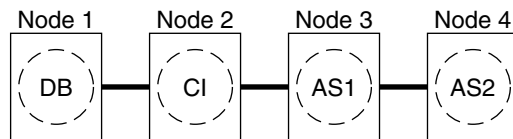

CLUSTER 1

**FIGURE 1-1** Four-Node Cluster with Central Instance, Application Servers, and Database

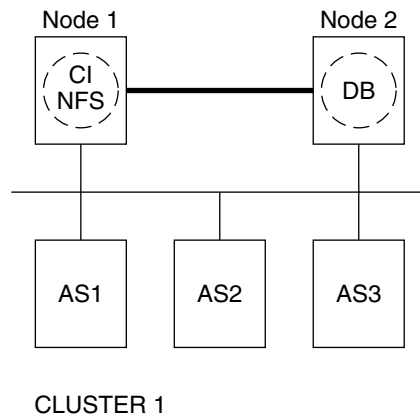
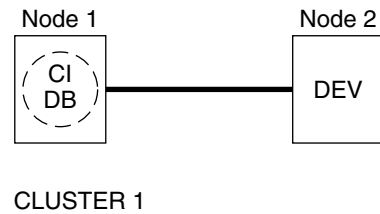

**FIGURE 1-2** Two-Node Cluster with Central Instance, NFS, Database, and Non-HA External Application

---

**Note** – The configuration in Figure 1-2 was a common configuration under previous Sun Cluster releases. To use the Sun Cluster software to the fullest extent, configure SAP as shown in Figure 1-1 or Figure 1-3.

---



**FIGURE 1-3** Two-Node Cluster With Central Instance, Database, and Development Node

## Configuration Considerations

Use the information in this section to plan the installation and configuration of Sun Cluster HA for SAP. The information in this section encourages you to think about the impact your decisions have on the installation and configuration of Sun Cluster HA for SAP.

## Failover and Scalable Applications

- **Retrieve the latest patch for the `sapstart` executable** – This patch enables Sun Cluster HA for SAP users to configure a lock file. For details on the benefits of this patch in your cluster environment, see “Setting Up a Lock File” on page 43.
- **Read all of the related SAP online service-system notes for the SAP software release and database that you are installing on your Sun Cluster configuration** – Identify any known installation problems and fixes.
- **Consult SAP software documentation for memory and swap recommendations** – SAP software uses a large amount of memory and swap space.
- **Generously estimate the total possible load on nodes that might host the central instance, the database instance, and the application server, if you have an internal application server** – This consideration is especially important if you configure the cluster to ensure that the central instance, database instance, and application server will all exist on one node if failover occurs.

## Scalable Applications

- **Ensure that the `SAPSIDadm` home directory resides on a cluster file system** - This consideration enables you to maintain only one set of scripts for all application server instances that run on all nodes. However, if you have some application servers that need to be configured differently (for example, application servers with different profiles), install those application servers with different instance numbers, and then configure them in a separate resource group.
- **Install the application server’s directory locally on each node instead of on a cluster file system** - This consideration ensures that another application server does not overwrite the `log/data/work/sec` directory for the application server.
- **Use the same instance number when you create all application server instances on multiple nodes** - This consideration ensures ease of maintenance and ease of administration because you will only need to use one set of commands to maintain all application servers on multiple nodes.
- **Place the application servers into multiple resource groups if you want to use the `RGOffload` resource type to shut down one or more application servers when a higher priority resource is failing over** - This consideration provides flexibility and availability if you want to use the `RGOffload` resource type to offload one or more application servers for the database. The value you gain from this consideration supersedes the ease of use you gain from placing the application servers into one large group. See “Freeing Node Resources by Offloading Non-critical Resource Groups” in *Sun Cluster Data Services Planning and Administration Guide for Solaris OS* for more information on using the `RGOffload` resource type.
- **Create separate scalable application server instances for each SAP logon group.**
- **Create an SAP lock file on the local instance directory** - This consideration prevents a system administrator from manually starting an application instance that is already running.



## Configuration Planning Questions

Use the questions in this section to plan the installation and configuration of Sun Cluster HA for SAP. Insert the answers to these questions into the data service worksheets in “Configuration Worksheets” in *Sun Cluster Data Services Planning and Administration Guide for Solaris OS*. See “Configuration Considerations” on page 15 for information that might apply to these questions.

- What resource groups will you use for network addresses and application resources and the dependencies between them?
- What is the logical hostname (for failover services) for clients that will access the data service?
- Where will the system configuration files reside?

See “Configuration Guidelines for Sun Cluster Data Services” in *Sun Cluster Data Services Planning and Administration Guide for Solaris OS* for the advantages and disadvantages of placing the SAP binaries on the local file system as opposed to the cluster file system.

## Packages and Support

Table 1–3 and Table 1–4 list the packages that Sun Cluster HA for SAP supports.

**TABLE 1–3** Sun Cluster HA for SAP Packages From Sun Cluster 3.0 7/01

Resource Type	Description
SUNW.sap_ci	Added support for failover central instance.
SUNW.sap_as	Added support for failover application servers.

The \*\_v2 resource types are the latest version of the resource types (RT) for Sun Cluster HA for SAP. The \*\_v2 resource types are a superset of the original RTs. Whenever possible, use the latest RTs provided.

**TABLE 1–4** Sun Cluster HA for SAP Package From Sun Cluster 3.0 12/01

Resource Type	Description
SUNW.sap_ci	Same as Sun Cluster 3.0 7/01. See Table 1–3.
SUNW.sap_as	Same as Sun Cluster 3.0 7/01. See Table 1–3.
SUNW.sap_ci_v2	Added the <code>Network_resources_used</code> resource property to the Resource Type Registration (RTR) file.
	Retained support for failover central instance.

**TABLE 1-4** Sun Cluster HA for SAP Package From Sun Cluster 3.0 12/01 (Continued)

Resource Type	Description
SUNW.sap_as_v2	Added the <code>Network_resources_used</code> resource property to RTR file. Added support for scalable application servers.
	Retained support for failover application servers

---

## Upgrading Sun Cluster HA for SAP

As Table 1-3 and Table 1-4 illustrate, the Sun Cluster HA for SAP package from Sun Cluster 3.0 7/01 does not support a scalable application server and the `Network_resources_used` resource property. Therefore, you have the following upgrade options.

- Retain (do not upgrade) the existing `SUNW.sap_ci` and `SUNW.sap_as` resource types. Choose this option if any of the following statements apply to you.
  - You cannot schedule down time.
  - You do not want the `Network_resources_used` resource property.
  - You do not want to configure a scalable application server.
- Upgrade a resource type.

See “How to Upgrade a Resource Type or Convert a Failover Application Resource to a Scalable Application Resource” on page 18 for the procedure on how to upgrade a resource type.
- Convert a failover application resource to a scalable application resource.

See “How to Upgrade a Resource Type or Convert a Failover Application Resource to a Scalable Application Resource” on page 18 for the procedure on how to convert a failover application resource to a scalable application resource.

### ▼ How to Upgrade a Resource Type or Convert a Failover Application Resource to a Scalable Application Resource

Use this procedure to upgrade a resource type or to convert a failover application server resource to a scalable application server resource. This procedure requires that you schedule down time.

1. **Disable the existing resource.**
2. **Delete the existing resource from the resource group.**

3. **Delete the existing resource type if no other resource uses it.**
4. **Register the new resource type.**
5. **Which task are you performing?**
  - If you are upgrading the resource type for the central instance, skip to Step 7.
  - If you are converting a failover application server resource to a scalable application server resource, proceed to Step 6.
6. **Create the new application server resource group.**
7. **Add the scalable application resource to the resource group.**

## Where to Go From Here

Go to “How to Prepare the Nodes” on page 19.

---

# Preparing the Nodes and Disks

This section contains the procedures you need to prepare the nodes and disks.

## ▼ How to Prepare the Nodes

Use this procedure to prepare for the installation and configuration of SAP.

1. **Become superuser on all of the nodes.**
2. **Configure the `/etc/nsswitch.conf` so that Sun Cluster HA for SAP starts and stops correctly in the event of a switchover or a failover.**

On each node that can master the logical host that runs Sun Cluster HA for SAP, include one of the following entries for `group` in the `/etc/nsswitch.conf` file.

```
group:  
group: files [NOTFOUND=return] nis  
group: file [NOTFOUND=return] nisplus
```

Sun Cluster HA for SAP uses the `su user` command to start and probe SAP. The network information name service might become unavailable when a cluster node's public network fails. When you add one of the entries for `group` in the `/etc/nsswitch.conf` file, you ensure that the `su(1M)` command does not refer to the NIS/NIS+ name services if the network information name service is unavailable.

## Where to Go From Here

Go to “How to Register and Configure Sun Cluster HA for SAP as a Scalable Data Service” on page 41.

---

# Installing and Configuring SAP and Database

This section contains the procedures you need to install and configure SAP and the database.

## ▼ How to Install SAP and the Database

Use this procedure to install SAP and the database.

1. **Become superuser on one of the nodes in the cluster where you are installing the central instance.**
2. **Install SAP binaries on a cluster file system.**

---

**Note** – Before you install SAP software on a cluster file system, use the `scstat(1M)` command to verify that the Sun Cluster software is fully operational.

---

- a. **For all of the SAP-required kernel parameter changes, edit the `/etc/system` file on all of the cluster nodes that will run the SAP application.**

After you edit the `/etc/system` file, reboot each node. See the SAP document *R/3 Installation on UNIX-OS Dependencies* for details on kernel parameter changes.

- b. **See the SAP document *Installation of the SAP R/3 on UNIX* for details on how to install the central instance, the database, and the application server instances.**

See “How to Install and Enable an SAP Scalable Application Server” on page 21 for the procedure on how to install a scalable application server in a Sun Cluster environment.

## Where to Go From Here

Go to “How to Enable Failover SAP Instances to Run in a Cluster” on page 24 or “How to Install and Enable an SAP Scalable Application Server” on page 21.

### ▼ How to Install and Enable an SAP Scalable Application Server

Use this procedure to install scalable application server instances. This procedure assumes that you installed the central instance and the database. This procedure includes additional steps for SAP 6.10 and SAP 6.20 users to ensure that Sun Cluster HA for SAP can manage and bring online SAP 6.10 and SAP 6.20 services. SAP 6.10 and SAP 6.20 create one `startsap` script and one `stopsap` script. Other SAP versions create one of each of these scripts for each service you create. This difference accounts for the additional steps for SAP 6.10 and SAP 6.20 users.

To configure a J2EE engine cluster with your Sun Cluster HA for SAP, after you complete this procedure, complete the additional steps in “How to Configure an SAP J2EE Engine Cluster with your Sun Cluster HA for SAP with an Application Server” on page 26.

To configure an SAP Web dispatcher with your Sun Cluster HA for SAP agent, after you complete this procedure, complete the additional steps in “How to Configure an SAP Web Dispatcher With Your Sun Cluster HA for SAP” on page 27.

---

**Tip** – The following file system layout ensures ease of use and prevents data from being overwritten.

---

- Cluster File Systems

- `/sapmnt/SID`

- `/usr/sap/SID` -> all subdirectories except the *app-instance* subdirectory

- `/usr/sap/SID/home` -> the SAPSIDadm home directory

- `/usr/sap/trans`

- Local File Systems

- `/usr/sap/local/SID/app-instance`

1. **Create all SAP directories on cluster file systems.**

- Ensure that the central instance and the database can fail over.
- Set up the lock file on cluster file system for the central instance to prevent a multiple startup from a different node.

For the procedure on how to set up a lock file on the central instance, see “How to Set Up a Lock File for Central Instance or the Failover Application Server” on page 43.

- Ensure that all application servers can use the SAP binaries on a cluster file system.

**2. Install the central instance and the database on a cluster file system.**

See the SAP document *Installation of the SAP R/3 on UNIX* for details on how to install the central instance and the database.

**3. On all nodes that will host the scalable application server, create a local directory for the `data/log/sec/work` directories and the log files for starting and stopping the application server.**

Create a local directory for each new application server.

Example:

```
# mkdir -p /usr/sap/local/SID/D03
```



---

**Caution** – You must perform this step. If you do not perform this step, you will inadvertently install a different application server instance on a cluster file system and the two application servers will overwrite each other.

---

**4. Set up a link to point to the local application server directory from a cluster file system, so the application server and the `startup log file` and the `stop log file` will be installed on the local file system.**

Example:

```
# ln -s /usr/sap/local/SID/D03 /usr/sap/SID/D03
```

**5. Install the application server.**

**6. Are you using SAP 6.10 or SAP 6.20?**

- If no, skip to Step 11
- If yes, proceed to Step 7.

**7. Become user `sapsidadm`.**

**8. Make a copy of the `startsap` script and the `stopsap` script, and save these files in the `SAPSIDADm` home directory. The filenames that you choose specify this instance.**

```
# cp /usr/sap/SID/SYS/exe/run/startsap \
  $SAPSID_HOME/startsap_instance-number
```

```
# cp /usr/sap/SID/SYS/exe/run/stopsap \
  $SAPSID_HOME/stopsap_instance-number
```

9. Make backup copies of the following files because you will modify them. In the SAP profile directory, modify all the filenames for this instance. The filenames that you choose must be specific to this instance, and they must follow the same naming convention you chose in Step 8.

```
# mv SPSID_Service-StringSystem-Number_physical-hostname \  
SPSID_Service-StringSystem_instance-number  
  
# mv START_Service-StringSystem-Number_physical-hostname \  
START_Service-StringSystem_instance-number
```

10. Modify the contents of the files you created in Step 9 to replace any reference to the physical host with the instance number.



---

**Caution** – It is important that you make your updates consistent so that you can start and stop this application server instance from all the nodes that will run this scalable application server. For example, if you make these changes for SAP instance number 02, then use 02 where this instance number appears. If you do not use a consistent naming convention you will be unable start and stop this application server instance from all the nodes that will run this scalable application server.

---

11. Edit the start script and the stop script so that the startup log file and the stop log file will be node specific under the home directories of users *sapsidadm* and *orasapsid*.

Example:

```
# vi startsap_D03
```

Before:

```
LOGFILE=$R3S_LOGDIR/`basename $0.log`
```

After:

```
LOGFILE=$R3S_LOGDIR/`basename $0`_`uname -n`.log
```

12. Copy the application server (with the same SPSID and the same instance number) on all nodes that run the scalable application server.

The nodes that run the scalable application server are in the scalable application server resource group *nodelist*.

13. Ensure that you can startup and stop the application server from each node, and verify that the log files are in the correct location.

14. Create the SAP logon group if you use a logon group.

## Where to Go From Here

To configure a J2EE engine cluster with your Sun Cluster HA for SAP, go to “How to Configure an SAP J2EE Engine Cluster with your Sun Cluster HA for SAP with an Application Server” on page 26.

To configure an SAP Web dispatcher with your Sun Cluster HA for SAP agent, go to “How to Configure an SAP Web Dispatcher With Your Sun Cluster HA for SAP” on page 27.

If you are not using a J2EE engine cluster or an SAP Web dispatcher with your Sun Cluster HA for SAP, go to “Configuring Your Highly Available Database” on page 28.

## ▼ How to Enable Failover SAP Instances to Run in a Cluster

During SAP installation, the SAP software creates files and shell scripts on the server on which you installed the SAP instance. These files and scripts use physical server names. To run the SAP software with Sun Cluster software, replace references to a physical server with references to a network resource (logical hostname). Use this procedure to enable SAP to run in a cluster.

To configure a J2EE engine cluster with your Sun Cluster HA for SAP with a Central Instance, after you complete this procedure, complete the additional steps in “How to Configure an SAP J2EE Engine with your Sun Cluster HA for SAP with Central Instance” on page 27.

To configure a J2EE engine cluster with your Sun Cluster HA for SAP with an SAP Application Server, go to “How to Configure an SAP J2EE Engine Cluster with your Sun Cluster HA for SAP with an Application Server” on page 26.

To configure SAP Web dispatcher with your Sun Cluster HA for SAP agent, after you complete this procedure, complete the additional steps in “How to Configure an SAP Web Dispatcher With Your Sun Cluster HA for SAP” on page 27.

1. **Make backup copies of the files you will modify in Step 5 through Step 8.**
2. **Log in to the node on which you installed the SAP software.**
3. **Shut down the SAP instances (central instance and application server instances) and the database.**
4. **Are you using SAP 6.10 or SAP 6.20?**
  - If no, skip to Step 6.
  - If yes, proceed to Step 5.



5. Make a copy of the `startsap` script and the `stopsap` script, and save these files in the `SAPSIDadm` home directory. The filenames that you choose must specify this instance.

```
# cp /usr/sap/SID/SYS/exe/run/startsap \  
$SAPSID_HOME/startsap_logical-hostname_instance-number  
# cp /usr/sap/SID/SYS/exe/run/startsap \  
$SAPSID_HOME/stopsap_logical-hostname_instance-number
```

6. Become user `sapsidadm`, and then perform the following tasks.

- In the `SAPSIDadm` home directory, modify all of the file names that reference a physical server name.
- In the `SAPSIDadm` home directory, modify all of the file contents—except log file contents—that reference a physical server name.
- In the SAP profile directory, modify all of the file names that reference a physical server name.

7. As user `sapsidadm`, add entries for the parameter `SAPLOCALHOST`.

Add this entry to the `SAPSID_Service-StringSystem-Number_logical-hostname` profile file under the `/sapmnt/SAPSID/profile` directory.

For Central Instance:

```
SAPLOCALHOST=ci-logical-hostname
```

This entry enables the external application server to locate the central instance by using the network resource (logical hostname).

For Application Server:

```
SAPLOCALHOST=as-logical-hostname
```

8. Become user `orasapsid`, and then perform the following tasks.

- In the `oraSAPSID` home directory, modify all of the file names that reference a physical server name.
- In the `oraSAPSID` home directory, modify all of the file contents—except log file contents—that reference a physical server name.

9. Ensure that the `/usr/sap/tmp` directory owned by user `sapsidadm` and group `sapsys` exists on all nodes that can master the failover SAP instance.

## Where to Go From Here

To configure a J2EE engine cluster with your Sun Cluster HA for SAP with a Central Instance, go to “How to Configure an SAP J2EE Engine with your Sun Cluster HA for SAP with Central Instance” on page 27.

To configure a J2EE engine cluster with your Sun Cluster HA for SAP with an SAP Application Server, go to “How to Configure an SAP J2EE Engine Cluster with your Sun Cluster HA for SAP with an Application Server” on page 26.

To configure an SAP Web dispatcher with your Sun Cluster HA for SAP agent, go to “How to Configure an SAP Web Dispatcher With Your Sun Cluster HA for SAP” on page 27.

If you are not using a J2EE engine cluster or an SAP Web dispatcher with your Sun Cluster HA for SAP agent, go to “Configuring Your Highly Available Database” on page 28.

## ▼ How to Configure an SAP J2EE Engine Cluster with your Sun Cluster HA for SAP with an Application Server

After you have completed “How to Install and Enable an SAP Scalable Application Server” on page 21, perform the following steps.

---

**Note** – The SAP J2EE engine is started by the SAP dispatcher which is under the protection of the Sun Cluster HA for SAP. If the SAP J2EE engine goes down, the SAP dispatcher will restart it.

---

1. Using the SAP J2EE Admintool GUI, change ClusterHosts parameter to list the logical host for the central instance and port pair under the dispatcher/Manager/ClusterManager.

```
logical-host-ci:port
```

2. Change the file *j2ee-install-dir/additionalproperties* as follows:

```
com.sap.instanceId = logical-host-as_SID_SYSNR
```

3. Change the file *j2ee-install-dir/server/services/security/work/R3Security.properties* as follows:

```
sapbasis.ashost = logical-host-as
```

## Where to Go From Here

Go to “Configuring Your Highly Available Database” on page 28

## ▼ How to Configure an SAP J2EE Engine with your Sun Cluster HA for SAP with Central Instance

After you have completed “How to Enable Failover SAP Instances to Run in a Cluster” on page 24 or “How to Enable Failover SAP Instances to Run in a Cluster” on page 24, perform the following steps.

---

**Note** – The SAP J2EE engine is started by the SAP dispatcher which is under the protection of the Sun Cluster HA for SAP. If the SAP J2EE engine goes down, the SAP dispatcher will restart it.

---

1. Using the SAP J2EE Admintool GUI, change the ClusterHosts parameter to list all logical hosts for the application server and port pair under dispatcher/Manager/ClusterManager. For example,

*as1-1h:port;as2-1h:port ...*

2. Change the file *j2ee-install-dir/additionalproperties* as follows:

*com.sap.instanceId = logical-host-ci\_SID\_SYSNR*

3. Change the file *j2ee-install-dir/server/services/security/work/R3Security.properties* as follows:

*sapbasis.ashost = logical-host-ci*

4. Change the file *SDM-dir/program/config/flow.xml*

*host = logical-host-ci*

### Where to Go From Here

Go to “Configuring Your Highly Available Database” on page 28

## ▼ How to Configure an SAP Web Dispatcher With Your Sun Cluster HA for SAP

After you have configured the SAP Web dispatcher with your Sun Cluster HA for SAP, perform the following steps.

---

**Note** – The SAP Web dispatcher has the capability of auto restart. If the SAP Web dispatcher goes down, the SAP Web dispatcher watch dog process will restart. Currently, there is no Sun Cluster agent available for the SAP Web dispatcher.

---

1. **Ensure that SAP Web dispatcher has an instance number different than the Central Instance and the application server instances.**  
For example, SAPSYSTEM = 66 is used in the profile for the SAP Web dispatcher.
2. **Activate the Internet Communication Frame Services manually after you install the SAP Web Application Server.**  
See SAP OSS note 517484 for more details.

## Where to Go From Here

Go to “Configuring Your Highly Available Database” on page 28.

---

# Configuring Your Highly Available Database

SAP supports various databases. See the appropriate Sun Cluster data services book for details on how to configure the resource type, resource group, and resource for your highly available database. For example, see the following documentation for more information:

- If you plan to use SAP DB with SAP, see *Sun Cluster Data Service for SAP DB Guide for Solaris OS*.
- If you plan to use Oracle with SAP, see *Sun Cluster Data Service for Oracle Guide for Solaris OS*.

Additionally, see the appropriate Sun Cluster data services book and the appropriate chapter of your database installation book for details on other resource types to configure with your database. The Sun Cluster data services books include details on how to configure other resource types for databases. For example, if you plan to use the SAP DB database or the Oracle database, set up the `SUNW.HAStoragePlus` resource type. For more information, see the following sections:

- If you plan to use the SAP DB database, see “Synchronizing the Startups Between Resource Groups and Disk Device Groups” in *Sun Cluster Data Services Planning and Administration Guide for Solaris OS* and “Configuring the `SUNW.HAStoragePlus` Resource Type to Work With Sun Cluster HA for SAP DB”

in *Sun Cluster Data Service for SAP DB Guide for Solaris OS*.

- If you plan to use the Oracle database, see “Synchronizing the Startups Between Resource Groups and Disk Device Groups” in *Sun Cluster Data Services Planning and Administration Guide for Solaris OS*.

## Where to Go From Here

Go to “How to Verify SAP and the Database Installation with Central Instance” on page 29 or “Verifying an SAP Scalable Application Server” on page 31.

---

# Verifying the SAP Installation

This section contains the procedures you need to verify the SAP installation.

## ▼ How to Verify SAP and the Database Installation with Central Instance

Use this procedure to verify SAP central instance. Perform the following steps on all of the potential nodes on which the central instance can run.

1. **Create the failover resource group to hold the network and central instance resources.**

```
# scrgadm -a -g sap-ci-resource-group [-h nodelist]
```

---

**Note** – Use the `-h` option to the `scrgadm(1M)` command to select the set of nodes on which the SAP central instance can run.

---

2. **Verify that you have added to your name service database all of the network resources that you use.**
3. **Add a network resource (logical hostname) to the failover resource group.**

```
# scrgadm -a -L -g sap-ci-resource-group  
-l ci-logical-hostname [-n netiflist]
```

4. **Enable the resource group.**

Run the `scswitch(1M)` command to move the resource group into a managed state and bring the resource group online.

```
# scswitch -z -g sap-ci-resource-group
```

5. Log in to the cluster member that hosts the central instance resource group.
6. Ensure that the database is running.
7. Manually start the central instance.
8. Start the SAP GUI using the logical hostname, and verify that SAP initializes correctly.  
The default dispatcher port is 3200.
9. Manually stop the central instance.
10. Switch this resource group to another cluster member that can host the central instance.

```
# scswitch -z -h node -g sap-ci-resource-group
```

11. Repeat Step 5 through Step 9 until you verify startup and shutdown of the central instance on each cluster node that can host the central instance.

## Where to Go From Here

Go to “How to Verify an SAP Failover Application Server” on page 30.

## ▼ How to Verify an SAP Failover Application Server

Use this procedure to verify SAP and the database installation for the failover application server. Perform the following steps on all of the potential nodes on which the failover application server can run.

1. Create the failover resource group to hold the network and application server resources.

```
# scrgadm -a -g sap-as-fo-resource-group
```

---

**Note** – Use the `-h` option to the `scrgadm` command to select the set of nodes on which the SAP application server can run.

```
# scrgadm -a -g sap-as-fo-resource-group \  
[-h nodelist]
```

---

2. Verify that you added to your name service database all of the network resources that you use.
3. Add a network resource (logical hostname) to the failover resource group.

```
# scrgadm -a -L -g sap-as-fo-resource-group\  
-l as-fo-logical-hostname [-n netiflist]
```

**4. Enable the resource group.**

Run the `scswitch(1M)` command to move the resource group into a managed state and bring the resource group online.

```
# scswitch -z -g sap-as-fo-resource-group
```

**5. Log in to the cluster member that hosts the application server resource group.**

**6. Manually start the application server.**

**7. Start the SAP GUI using the logical hostname, and verify that SAP initializes correctly.**

**8. Manually stop the application server.**

**9. Switch this resource group to another cluster member that can host the application server.**

```
# scswitch -z -h node -g sap-as-fo-resource-group
```

**10. Repeat Step 5 through Step 7 until you verify startup and shutdown of the application server on each cluster node that can host the application server.**

## Where to Go From Here

Go to “Installing the Sun Cluster HA for SAP Packages” on page 32.

## Verifying an SAP Scalable Application Server

If you installed scalable application server instances in “How to Install and Enable an SAP Scalable Application Server” on page 21, you verified the installation of an SAP scalable application server in Step 13 of “How to Install and Enable an SAP Scalable Application Server” on page 21.

## Where to Go From Here

Go to “Installing the Sun Cluster HA for SAP Packages” on page 32.

---

# Installing the Sun Cluster HA for SAP Packages

If you did not install the Sun Cluster HA for SAP packages during your initial Sun Cluster installation, perform this procedure to install the packages. Perform this procedure on each cluster node where you are installing the Sun Cluster HA for SAP packages. To complete this procedure, you need the Sun Java Enterprise System Accessory CD Volume 3.

If you are installing more than one data service simultaneously, perform the procedure in “Installing the Software” in *Sun Cluster Software Installation Guide for Solaris OS*.

Install the Sun Cluster HA for SAP packages by using one of the following installation tools:

- The Web Start program
- The `scinstall` utility

---

**Note** – The Web Start program is *not* available in releases earlier than Sun Cluster 3.1 Data Services 10/03.

---

## ▼ How to Install the Sun Cluster HA for SAP Packages by Using the Web Start Program

You can run the Web Start program with a command-line interface (CLI) or with a graphical user interface (GUI). The content and sequence of instructions in the CLI and the GUI are similar. For more information about the Web Start program, see the `installer(1M)` man page.

1. **On the cluster node where you are installing the Sun Cluster HA for SAP packages, become superuser.**
2. **(Optional) If you intend to run the Web Start program with a GUI, ensure that your `DISPLAY` environment variable is set.**
3. **Load the Sun Java Enterprise System Accessory CD Volume 3 into the CD-ROM drive.**

If the Volume Management daemon `vold(1M)` is running and configured to manage CD-ROM devices, it automatically mounts the CD-ROM on the `/cdrom/cdrom0` directory.

4. **Change to the Sun Cluster HA for SAP component directory of the CD-ROM.**



The Web Start program for the Sun Cluster HA for SAP data service resides in this directory.

```
# cd /cdrom/cdrom0/\
components/SunCluster_HA_SAP_3.1/
```

**5. Start the Web Start program.**

```
# ./installer
```

**6. When you are prompted, select the type of installation.**

- To install only the C locale, select Typical.
- To install other locales, select Custom.

**7. Follow instructions on the screen to install the Sun Cluster HA for SAP packages on the node.**

After the installation is finished, the Web Start program provides an installation summary. This summary enables you to view logs that the Web Start program created during the installation. These logs are located in the `/var/sadm/install/logs` directory.

**8. Exit the Web Start program.**

**9. Unload the Sun Java Enterprise System Accessory CD Volume 3 from the CD-ROM drive.**

- a. To ensure that the CD-ROM is not being used, change to a directory that does *not* reside on the CD-ROM.
- b. Eject the CD-ROM.

```
# eject cdrom
```

## Where to Go From Here

Go to “Registering and Configuring Sun Cluster HA for SAP” on page 34.

## ▼ How to Install the Sun Cluster HA for SAP Packages by Using the `scinstall` Utility

1. Load the Sun Java Enterprise System Accessory CD Volume 3 into the CD-ROM drive.
2. Run the `scinstall` utility with no options.  
This step starts the `scinstall` utility in interactive mode.
3. Choose the Add Support for New Data Service to This Cluster Node menu option.

The `scinstall` utility prompts you for additional information.

4. **Provide the path to the Sun Java Enterprise System Accessory CD Volume 3.**  
The utility refers to the CD-ROM as the “data services cd.”
5. **Specify the data service to install.**  
The `scinstall` utility lists the data service that you selected and asks you to confirm your choice.
6. **Exit the `scinstall` utility.**
7. **Unload the CD-ROM from the drive.**

## Where to Go From Here

Go to “Registering and Configuring Sun Cluster HA for SAP” on page 34.

---

# Registering and Configuring Sun Cluster HA for SAP

This section contains the procedures you need to configure Sun Cluster HA for SAP.

## Sun Cluster HA for SAP Extension Properties

Use the extension properties in “Sun Cluster HA for SAP Extension Properties for the Central Instance” on page 34 and “Sun Cluster HA for SAP Extension Properties for the Application Servers” on page 37 to create your resources. Use the command line `scrgadm -x parameter=value` to configure extension properties when you create your resource. Use the procedure in “Administering Data Service Resources” in *Sun Cluster Data Services Planning and Administration Guide for Solaris OS* to configure the extension properties if you have already created your resources. You can update some extension properties dynamically. You can update others, however, only when you create or disable a resource. The Tunable entries indicate when you can update each property. See “Standard Properties” in *Sun Cluster Data Services Planning and Administration Guide for Solaris OS* for details on all Sun Cluster properties.

## Sun Cluster HA for SAP Extension Properties for the Central Instance

SAP configuration extension properties are as follows:

SAPSID  
SAP system ID or SID.

**Default:** None

**Tunable:** When disabled

Ci\_instance\_id  
Two-digit SAP system number.

**Default:** 00

**Tunable:** When disabled

Ci\_services\_string  
String of central instance services.

**Default:** DVEBMGS

**Tunable:** When disabled

Starting SAP extension properties are as follows:

Ci\_start\_retry\_interval  
The interval in seconds to wait between attempting to connect to the database before starting the central instance.

**Default:** 30

**Tunable:** When disabled

Ci\_startup\_script  
Name of the SAP startup script for this instance in your *SIDadm* home directory.

**Default:** None

**Tunable:** When disabled

Stopping SAP extension properties are as follows:

Stop\_sap\_pct  
Percentage of stop-timeout variables that are used to stop SAP processes. The SAP shutdown script is used to stop processes before calling Process Monitor Facility (PMF) to terminate and then kill the processes.

**Default:** 95

**Tunable:** When disabled

Ci\_shutdown\_script  
Name of the SAP shutdown script for this instance in your *SIDadm* home directory.

**Default:** None

**Tunable:** When disabled

Probe extension properties are as follows:

Message\_server\_name

The name of the SAP Message Server.

**Default:** sapms *SAPSID*

**Tunable:** When disabled

Lgtst\_ms\_with\_logicalhostname

How to check the SAP Message Server with the SAP lgtst utility. The lgtst utility requires a hostname (IP address) as the location for the SAP Message Server. This hostname can be either a Sun Cluster logical hostname or a local host (loopback) name. If you set this resource property to TRUE, use a logical hostname. Otherwise, use a localhost name.

**Default:** TRUE

**Tunable:** Any time

Check\_ms\_retry

Maximum number of times the SAP Message Server check fails before a total failure is reported and the Resource Group Manager (RGM) starts.

**Default:** 2

**Tunable:** When disabled

Probe\_timeout

Timeout value in seconds for the probes.

**Default:** 120

**Tunable:** Any time

Monitor\_retry\_count

Number of PMF restarts that are allowed for the fault monitor.

**Default:** 4

**Tunable:** Any time

Monitor\_retry\_interval

Time interval in minutes for the fault monitor restarts.

**Default:** 2

**Tunable:** Any time

Development system extension properties are as follows:

Shutdown\_dev

Whether the RGM should shut down the development system before starting up the central instance.

**Default:** FALSE

**Tunable:** When disabled

Dev\_sapsid

SAP System Name for the development system (if you set Shutdown\_dev to TRUE, Sun Cluster HA for SAP requires this property).

**Default:** None

**Tunable:** When disabled

Dev\_shutdown\_script

Script that is used to shut down the development system. If you set Shutdown\_dev to TRUE, Sun Cluster HA for SAP requires this property.

**Default:** None

**Tunable:** When disabled

Dev\_stop\_pct

Percentage of startup timeouts Sun Cluster HA for SAP uses to shut down the development system before starting the central instance.

**Default:** 20

**Tunable:** When disabled

## Sun Cluster HA for SAP Extension Properties for the Application Servers

SAP configuration extension properties are as follows:

SAPSID

SAP system name or *SAPSID* for the application server.

**Default:** None

**Tunable:** When disabled

As\_instance\_id

Two-digit SAP system number for the application server.

**Default:** None

**Tunable:** When disabled

`As_services_string`  
String of application server services.

**Default:** D

**Tunable:** When disabled

Starting SAP extension properties are as follows:

`As_db_retry_interval`  
The interval in seconds to wait between attempting to connect to the database and starting the application server.

**Default:** 30

**Tunable:** When disabled

`As_startup_script`  
Name of the SAP startup script for the application server.

**Default:** None

**Tunable:** When disabled

Stopping SAP extension properties are as follows:

`Stop_sap_pct`  
Percentage of stop-timeout variables that are used to stop SAP processes. The SAP shutdown script is used to stop processes before calling Process Monitor Facility (PMF) to terminate and then kill the processes.

**Default:** 95

**Tunable:** When disabled

`As_shutdown_script`  
Name of the SAP shutdown script for the application server.

**Default:** None

**Tunable:** When disabled

Probe extension properties are as follows:

`Probe_timeout`  
Time-out value in seconds for the probes.

**Default:** 60

**Tunable:** Any time

`Monitor_retry_count`  
Number of PMF restarts that the probe allows for the fault monitor.

**Default:** 4

**Tunable:** Any time

Monitor\_retry\_interval

Time interval in minutes for fault monitor restarts.

**Default:** 2

**Tunable:** Any time

## ▼ How to Register and Configure Sun Cluster HA for SAP with Central Instance

Use this procedure to configure Sun Cluster HA for SAP with central instance.

1. **Become superuser on one of the nodes in the cluster that hosts the central instance.**

2. **Register the resource type for the central instance.**

```
# scrgadm -a -t SUNW.sap_ci | SUNW.sap_ci_v2
```

3. **Add the HASToragePlus resource to the central instance resource group.**

```
# scrgadm -a -t SUNW.HASToragePlus
# scrgadm -a -j ci-storage-resource \
-g sap-ci-resource-group \
-t SUNW.HASToragePlus -x filesystemmountpoints=mountpoint, ... |
```

For more details on how to set up an HASToragePlus resource, see “Enabling Highly Available Local File Systems” in *Sun Cluster Data Services Planning and Administration Guide for Solaris OS*.

4. **Enable the central instance storage resource.**

```
# scswitch -e -j ci-storage-resource
```

5. **Create SAP central instance resources in this failover resource group.**

```
# scrgadm -a -j sap-ci-resource \
-g sap-ci-resource-group \
-t SUNW.sap_ci | SUNW.sap_ci_v2
-x SAPSID=SAPSID -x Ci_instance_id=ci-instance-id \
-x Ci_startup_script=ci-startup-script \
-x Ci_shutdown_script=ci-shutdown-script \
-y resource_dependencies=ci-storage-resource
```

See “Sun Cluster HA for SAP Extension Properties” on page 34 for a list of extension properties.

6. **Enable the failover resource group that now includes the SAP central instance resource.**

```
# scswitch -Z -g sap-ci-resource-group
```

If you configure the central instance resource to shut down a development system, you will receive the following console message.

```
ERROR : SAPSYSTEMNAME not set  
Please check environment and restart
```

This message is displayed when the central instance starts on a node that does not have the development system installed and that is not meant to run the central instance. SAP renders this message, and you can safely ignore it.

## Where to Go From Here

Go to “How to Register and Configure Sun Cluster HA for SAP as a Failover Data Service” on page 40 or “How to Register and Configure Sun Cluster HA for SAP as a Scalable Data Service” on page 41.

## ▼ How to Register and Configure Sun Cluster HA for SAP as a Failover Data Service

Use this procedure to configure Sun Cluster HA for SAP as a failover data service.

1. **Become superuser on one of the nodes in the cluster that hosts the application server.**

2. **Register the resource type for the failover application server.**

```
# scrgadm -a -t SUNW.sap_as | SUNW.sap_as_v2
```

3. **Add the HAStoragePlus resource to the failover application server resource group.**

```
# scrgadm -a -t SUNW.HAStoragePlus  
# scrgadm -a -j sap-as-storage-resource -g sap-as-fo-resource-group \  
-t SUNW.HAStoragePlus \  
-x filesystemmountpoints=mountpoint, ...
```

For more details on how to set up an HAStoragePlus resource, see “Enabling Highly Available Local File Systems” in *Sun Cluster Data Services Planning and Administration Guide for Solaris OS*.

4. **Enable the failover application server storage resource.**

```
# scswitch -e -j sap-as-storage-resource
```

5. **Create SAP application server resources in their failover resource group.**

```
# scrgadm -a -j sap-as-resource \  
-g sap-as-fo-resource-group \  
-t SUNW.sap_as | SUNW.sap_as_v2
```



```
-x SAPSID=SAPSID -x As_instance_id=as-instance-id \  
-x As_startup_script=as-startup-script \  
-x As_shutdown_script=as-shutdown-script \  
-y resource_dependencies=sap-as-storage-resource
```

See “Sun Cluster HA for SAP Extension Properties” on page 34 for a list of extension properties.

6. Enable the failover resource group that now includes the SAP application server resource.

```
# scswitch -Z -g sap-as-fo-resource-group
```

## Where to Go From Here

Go to “How to Verify Sun Cluster HA for SAP Installation and Configuration and Central Instance” on page 45.

## ▼ How to Register and Configure Sun Cluster HA for SAP as a Scalable Data Service

Use this procedure to configure Sun Cluster HA for SAP as a scalable data service.

1. Become superuser on one of the nodes in the cluster that hosts the application server.
2. Create a scalable resource group for the application server.

```
# scrgadm -a -g sap-as-sa-appinstanceid-resource-group \  
-y Maximum primaries=value \  
-y Desired primaries=value
```

---

**Note** – Sun Cluster HA for SAP as a scalable data service does not use shared addresses because the SAP logon group performs the load balancing of the application server.

---

---

**Note** – If you are using the SUNW.RGoffload resource type to offload an application server within this scalable application server resource group, then set `Desired primaries=0`. See “Freeing Node Resources by Offloading Non-critical Resource Groups” in *Sun Cluster Data Service Planning and Administration Guide for Solaris OS* for more information about using the SUNW.RGoffload resource type.

---

3. Register the resource type for the scalable application server.

```
# scrgadm -a -t SUNW.sap_as_v2
```

4. Add the HAStoragePlus resource to the failover application server resource group.

```
# scrgadm -a -t SUNW.HAStoragePlus
# scrgadm -a -j sap-as-storage-resource -g \
-g sap-as-sa-appinstanceid-resource-group \
-t SUNW.HAStoragePlus \
-x filesystemmountpoints=mountpoint, ... \
```

For more details on how to set up an HAStoragePlus resource, see “Enabling Highly Available Local File Systems” in *Sun Cluster Data Services Planning and Administration Guide for Solaris OS*.

5. Enable the failover application server storage resource.

```
# scswitch -e -j sap-as-storage-resource
```

6. Create SAP application server resources in this scalable resource group.

```
# scrgadm -a -j sap-as-resource \
-g sap-as-sa-appinstanceid-resource-group \
-t SUNW.sap_as_v2 \
-x SAPSID=SAPSID \
-x As_instance_id=as-instance-id \
-x As_startup_script=as-startup-script \
-x As_shutdown_script=as-shutdown-script \
-y resource_dependencies=sap-as-storage-resource
```

See “Sun Cluster HA for SAP Extension Properties” on page 34 for a list of extension properties.

7. Enable the scalable resource group that now includes the SAP application server resource.

- If you *do not* use the RGOffload resource type with this application server, use the following command.

```
# scswitch -Z -g sap-as-sa-appinstanceid-resource-group
```

- If you use the RGOffload resource type with this application server, use the following command.

```
# scswitch -z -h node1, node2 -g sap-as-sa-appinstanceid-resource-group
```

---

**Note** – If you use the SUNW.RGOffload resource type with this application server, you must specify which node you want to bring the resource online by using the -z option instead of the -j option.

---

## Where to Go From Here

Go to “How to Verify Sun Cluster HA for SAP Installation and Configuration and Central Instance” on page 45.

---

## Setting Up a Lock File

Use the procedure in this section to perform the following tasks.

- Set up a lock file for the central instance or the failover application server.
- Set up a lock file for a scalable application server.

Set up a lock file to prevent multiple startups of the SAP instance when the instance is already active on one node. Multiple startups of the same instance crash each other. Furthermore, the crash prevents SAP shutdown scripts from performing a clean shutdown of the instances, which might cause data corruption.

If you set up a lock file, when you start the SAP instance the SAP software locks the file `startup_lockfile`. If you start up the same instance outside of the Sun Cluster environment and then try to bring up SAP under the Sun Cluster environment, the Sun Cluster HA for SAP data service will attempt to start up the same instance. However, because of the file-locking mechanism, this attempt will fail. The data service will log appropriate error messages in `/var/adm/messages`.

The only difference between the lock file for the central instance or the failover application server and the lock file for a scalable application server is that the lock file for scalable application server resides on the local file system and the lock file for the central instance or the failover application server resides on a cluster file system.

### ▼ How to Set Up a Lock File for Central Instance or the Failover Application Server

Use this procedure to set up a lock file for the central instance or the failover application server.

1. **Install the latest patch for the `sapstart` executable, which enables Sun Cluster HA for SAP users to configure a lock file.**
2. **Set up the central instance lock file or the failover application server lock file on a *cluster* file system.**
3. **Edit the profile that `sapstart` uses to start the instance such that you add the new SAP parameter, `sapstart/lockfile`, for central instance or failover**

application server. This profile is the one that is passed to `sapstart` as a parameter in the `startsap` script.

For central instance, enter the following.

```
sapstart/lockfile =/usr/sap/SID/ Service-StringSystem-Number/work/startup_lockfile
```

For failover application server, enter the following.

```
sapstart/lockfile =/usr/sap/SID/ Dinstance-id/work/startup_lockfile
```

```
sapstart/lockfile
```

New parameter name.

```
/usr/sap/SID/Service-StringSystem-Number/work
```

Work directory for the central instance.

```
/usr/sap/SID/Dinstance-id/work
```

Work directory for failover application server.

```
startup_lockfile
```

Lock file name that Sun Cluster HA for SAP uses.

SAP creates the lock file.

---

**Note** – You must locate the lock file path on a cluster file system. If you locate the lock file path locally on the nodes, a startup of the same instance from multiple nodes cannot be prevented.

---

## ▼ How to Set Up a Lock File for Scalable Application Server

Use this procedure to set up a lock file for a scalable application server.

1. Install the latest patch for the `sapstart` executable, which enables Sun Cluster HA for SAP users to configure a lock file.
2. Set up the application server lock file on the *local* file system.
3. Edit the profile that `sapstart` uses to start the instance such that you add the new SAP parameter, `sapstart/lockfile`, for scalable application server. This profile is the one that is passed to `sapstart` as a parameter in the `startsap` script.

```
sapstart/lockfile =/usr/sap/local/SID/Dinstance-id/work/startup_lockfile
```

```
sapstart/lockfile
```

New parameter name.

```
/usr/sap/local/SID/Dinstance-id/work
```

Work directory for the scalable application server.

startup\_lockfile

Lock file name that Sun Cluster HA for SAP uses.

SAP creates the lock file.

---

**Note** – The lock file will reside on the local file system. The lock file does not prevent multiple startups from *other* nodes, but the lock file does prevent multiple startups on the *same* node.

---

---

## Verifying the Sun Cluster HA for SAP Installation and Configuration

This section contains the procedure you need to verify that you installed and configured your data service correctly.

### ▼ How to Verify Sun Cluster HA for SAP Installation and Configuration and Central Instance

Use this procedure to verify the Sun Cluster HA for SAP installation and configuration and central instance.

1. **Log in to the node that hosts the resource group that contains the SAP central instance resource.**
2. **Start the SAP GUI to check that Sun Cluster HA for SAP is functioning correctly.**
3. **As user *sapsid*adm, use the central instance *stopsap* script to shut down the SAP central instance.**  
The Sun Cluster software restarts the central instance.
4. **As user *root*, switch the SAP resource group to another cluster member.**  

```
# scswitch -z -h node2 -g sap-ci-resource-group
```
5. **Verify that the SAP central instance starts on this node.**
6. **Repeat Step 1 through Step 5 until you have tested all of the potential nodes on which the SAP central instance can run.**

## Where to Go From Here

Go to “How to Verify the Installation and Configuration of Sun Cluster HA for SAP as a Failover Data Service” on page 46 or “How to Verify Sun Cluster HA for SAP Installation and Configuration of as a Scalable Data Service” on page 46.

### ▼ How to Verify the Installation and Configuration of Sun Cluster HA for SAP as a Failover Data Service

Use this procedure to verify the installation and configuration of Sun Cluster HA for SAP as a failover data service.

1. **Log in to the node that currently hosts the resource group that contains the SAP application server resource.**
2. **As user *sapsidadm*, start the SAP GUI to check that the application server is functioning correctly.**
3. **Use the application server *stopsap* script to shut down the SAP application server on the node you identified in Step 1.**  
The Sun Cluster software restarts the application server.
4. **As user *root*, switch the resource group that contains the SAP application server resource to another cluster member.**  

```
# scswitch -z -h node2 -g sap-as-resource-group
```
5. **Verify that the SAP application server starts on the node you identified in Step 4.**
6. **Repeat Step 1 through Step 5 until you have tested all of the potential nodes on which the SAP application server can run.**

### ▼ How to Verify Sun Cluster HA for SAP Installation and Configuration of as a Scalable Data Service

Use this procedure to verify the installation and configuration of Sun Cluster HA for SAP as a scalable data service.

1. **Log on to one of the nodes that runs the application server.**
2. **Become user *sapsidadm*.**
3. **Start the SAP GUI to check that the application server is functioning correctly.**

4. Use the application server `stopsap` script to shut down the SAP application server on the node you identified in Step 1.  
The Sun Cluster software restarts the application server.
5. Repeat Step 1 through Step 3 until you have tested all of the potential nodes on which the SAP application server can run.

---

## Understanding Sun Cluster HA for SAP Fault Monitor

The Sun Cluster HA for SAP fault monitor checks SAP process and database availability. SAP process availability impacts SAP resources' failure history. SAP resources' failure history in turn drives the fault monitor's actions, which include no action, restart, or failover.

In contrast to SAP process availability, SAP database availability uses has no impact on SAP resources' failure history. Database availability does, however, trigger the SAP fault monitor to log any `syslog` messages to `/var/adm/messages` and to set the status accordingly for the SAP resource that uses the database.

## Sun Cluster HA for SAP Fault Probes for Central Instance

For the central instance, the fault probe executes the following steps.

1. Retrieves the process IDs for the SAP Message Server and the dispatcher
2. Loops infinitely (sleeps for `Thorough_probe_interval`)
3. Checks the availability of the SAP resources
  - a. **Abnormal exit** – If the Process Monitor Facility (PMF) detects that the SAP process tree has failed, the fault monitor treats this problem as a complete failure. The fault monitor restarts or fails over the SAP resource to another node based on the resources' failure history.
  - b. **Availability check of the SAP resources through probe** – The probe uses the `ps(1)` command to check the SAP Message Server and main dispatcher processes. If any of the SAP Message Server or main dispatcher processes are missing from the system's active processes list, the fault monitor treats this problem as a complete failure.

If you configure the parameter `Check_ms_retry` to have a value greater than zero, the probe checks the SAP Message Server connection. If you have set the extension property `Lgtst_ms_with_logicalhostname` to its default value `TRUE`, the probe completes the SAP Message Server connection test with the utility `lgtst`. The probe uses the logical hostname interface that is specified in the SAP resource group to call the SAP-supplied utility `lgtst`. If you set the extension property `Lgtst_ms_with_logicalhostname` to a value other than `TRUE`, the probe calls `lgtst` with the node's local hostname (loopback interface).

If the `lgtst` utility call fails, the SAP Message Server connection is not functioning. In this situation, the fault monitor considers the problem to be a partial failure and does not trigger an SAP restart or a failover immediately. The fault monitor counts two partial failures as a complete failure if the following conditions occur.

- i. You configure the extension property `Check_ms_retry` to be 2.
- ii. The fault monitor accumulates two partial failures that happen within the retry interval that the resource property `Retry_interval` sets.

A complete failure triggers either a local restart or a failover, based on the resource's failure history.

- c. **Database connection status through probe** – The probe calls the SAP-supplied utility `R3trans` to check the status of the database connection. Sun Cluster HA for SAP fault probes verify that SAP can connect to the database. Sun Cluster HA for SAP depends, however, on the highly available database fault probes to determine database availability. If the database connection status check fails, the fault monitor logs the message, `Database might be down`, to `/var/adm/messages`. The fault monitor then sets the status of the SAP resource to `DEGRADED`. If the probe checks the status of the database again and the connection is reestablished, the fault monitor logs the message, `Database is up`, to `/var/adm/messages` and sets the status of the SAP resource to `OK`.

#### 4. Evaluates the failure history

Based on the failure history, the fault monitor completes one of the following actions.

- no action
- local restart
- failover



## Sun Cluster HA for SAP Fault Probes for Application Server

For the application server, the fault probe executes the following steps.

1. Retrieves the process ID for the main dispatcher
2. Loops infinitely (sleeps for `Thorough_probe_interval`)
3. Checks the availability of the SAP resources
  - a. **Abnormal exit** – If the Process Monitor Facility (PMF) detects that the SAP process tree has failed, the fault monitor treats this problem as a complete failure. The fault monitor restarts or fails over the SAP resource to another node, based on the resources' failure history.
  - b. **Availability check of the SAP resources through probe** – The probe uses the `ps(1)` command to check the SAP Message Server and main dispatcher processes. If the SAP main dispatcher process is missing from the system's active processes list, the fault monitor treats the problem as a complete failure.
  - c. **Database connection status through probe** – The probe calls the SAP-supplied utility `R3trans` to check the status of the database connection. Sun Cluster HA for SAP fault probes verify that SAP can connect to the database. Sun Cluster HA for SAP depends, however, on the highly available database fault probes to determine database availability. If the database connection status check fails, the fault monitor logs the message, `Database might be down`, to `/var/adm/messages` and sets the status of the SAP resource to `DEGRADED`. If the probe checks the status of the database again and the connection is reestablished, the fault monitor logs the message, `Database is up`, to `/var/adm/messages`. The fault monitor then sets the status of the SAP resource to `OK`.
4. Evaluates the failure history

Based on the failure history, the fault monitor completes one of the following actions.

- no action
- local restart
- failover

If the application server resource is a failover resource, the fault monitor fails over the application server.

If the application server resource is a scalable resource, after the number of local restarts are exhausted, RGM will bring up the application server on a different node if there is another node available in the cluster.



# Index

---

## C

- C locale, 33
- commands, node information, 8
- configuring
  - SAP database, 20
  - Sun Cluster HA for SAP, 39, 40, 41

## D

- directories, /var/sadm/install/logs, 33

## E

- extension properties
  - Sun Cluster HA for SAP
    - As\_db\_retry\_interval (Application Servers), 37
    - As\_instance\_id (Application Servers), 37
    - As\_services\_string (Application Servers), 37
    - As\_shutdown\_script (Application Servers), 37
    - As\_startup\_script (Application Servers), 37
    - Check\_ms\_retry (Central Instance), 34
    - Ci\_instance\_id (Central Instance), 34
    - Ci\_services\_string (Central Instance), 34
    - Ci\_shutdown\_script (Central Instance), 34

- extension properties, Sun Cluster HA for SAP (Continued)

- Ci\_start\_retry\_interval (Central Instance), 34
- Ci\_startup\_script (Central Instance), 34
- Dev\_sapsid (Central Instance), 34
- Dev\_shutdown\_script (Central Instance), 34
- Dev\_stop\_pct (Central Instance), 34
- Lgtst\_ms\_with\_logicalhostname (Central Instance), 34
- Message\_server\_name (Central Instance), 34
- Monitor\_retry\_count (Application Servers), 37
- Monitor\_retry\_count (Central Instance), 34
- Monitor\_retry\_interval (Application Servers), 37
- Monitor\_retry\_interval (Central Instance), 34
- Probe\_timeout (Application Servers), 37
- Probe\_timeout (Central Instance), 34
- SAPSID (Application Servers), 37
- SAPSID (Central Instance), 34
- shutdown\_dev (Central Instance), 34
- Stop\_sap\_pct (Application Servers), 37
- Stop\_sap\_pct (Central Instance), 34

## F

fault monitor, Sun Cluster HA for SAP, 47  
files, installation logs, 33

## I

installing  
SAP database, 20  
SAP scalable application server, 21  
Sun Cluster HA for SAP  
by using `scinstall` utility, 33  
by using Web Start program, 32  
database, 28  
log files created, 33

## L

locales, 33  
lock file  
for central instance  
Sun Cluster HA for SAP, 43, 44  
Sun Cluster HA for SAP, 43  
log files, installation, 33

## O

overview, Sun Cluster HA for SAP, 10

## P

`prtconf -v` command, 8  
`prtdiag -v` command, 8  
`psrinfo -v` command, 8

## R

registering  
Sun Cluster HA for SAP as a failover data  
service, 40  
Sun Cluster HA for SAP as a scalable data  
service, 41

registering (Continued)

Sun Cluster HA for SAP with central  
instance, 39

## S

### SAP

*See also* Sun Cluster HA for SAP  
database  
installing and configuring, 20  
installing  
enabling failover SAP instances, 24  
preparing the nodes, 19  
scalable application server  
installing, 21  
scalable installation  
verifying, 31  
verifying installation  
database with central instance, 29  
failover application server, 30

`scinstall -pv` command, 8

`showrev -p` command, 8

### Sun Cluster HA for SAP

*See also* SAP

#### Application servers extension properties

`As_db_retry_interval`, 37  
`As_instance_id`, 37  
`As_services_string`, 37  
`As_shutdown_script`, 37  
`As_startup_script`, 37  
`Monitor_retry_count`, 37  
`Monitor_retry_interval`, 37  
`Probe_timeout`, 37  
`SAPSID`, 37  
`Stop_sap_pct`, 37

#### Central instance extension properties

`Check_ms_retry`, 34  
`Ci_instance_id`, 34  
`Ci_services_string`, 34  
`Ci_shutdown_script`, 34  
`Ci_start_retry_interval`, 34  
`Ci_startup_script`, 34  
`Dev_sapsid`, 34  
`Dev_shutdown_script`, 34  
`Dev_stop_pct`, 34  
`Lgtst_ms_with_logicalhostname`, 34  
`Message_server_name`, 34

- Sun Cluster HA for SAP, Central instance extension properties (Continued)
  - Monitor\_retry\_count, 34
  - Monitor\_retry\_interval, 34
  - Probe\_timeout, 34
  - SAPSID, 34
  - shutdown\_dev, 34
  - Stop\_sap\_pct, 34
- configuration
  - considerations, 15
  - database, 28
  - planning, 12
  - planning questions, 17
  - requirements, 13
  - restrictions, 13
  - standard, 14
- fault monitor, 47
  - central instance, 47
  - fault probes, 49
- installing
  - by using scinstall utility, 33
  - by using Web Start program, 32
  - planning, 12
- overview, 10
- registering and configuring
  - as a failover data service, 40
  - as a scalable data service, 41
  - with central instance, 39
- setting up a lock file, 43
  - central instance, 43, 44
- supported packages, 17
- task map, 11
- upgrading, 18
- verifying installation
  - central instance, 45
  - failover installation, 46
  - scalable installation, 46

## T

- task map, Sun Cluster HA for SAP, 11

## U

- upgrading, Sun Cluster HA for SAP, 18

## V

- /var/sadm/install/logs directory, 33
- verifying
  - SAP installation
    - database installation with central instance, 29
    - failover application server, 30
  - SAP scalable installation, 31
  - Sun Cluster HA for SAP, 45
    - central instance installation, 45
    - failover installation, 46
    - scalable installation, 46

## W

- Web Start program, 32

